

World-Radio

THE BBC FOREIGN PROGRAMME JOURNAL ★ EVERY FRIDAY

WITH FULL INFORMATION FOR THE LISTENER AND VIEWER

2^D



Sports, including a Gaelic football match, occupy a prominent place in the St. Patrick's Day programme from Radio Eireann on Thursday. This photograph shows a game—very different from English football—in progress at the Dublin Stadium.

St. Patrick's Day: European Concert Broadcast from Eire

Radio Assists Indian Health Crusade

The BBC Police Station of the Air: Frequency Checking



World Radio



plus all the Stars of the record firmament

Three Specially Recommended Best Sellers!

Get your dealer to play them on a Marconiphone Radiogram

STANLEY HOLLOWAY

in His Latest Successes

The 'Ole in the Ark Columbia DX621 (4s.)
Jonah and the Grampus (4s.)

CARROLL GIBBONS

and Savoy Hotel Orpheans

Bei mir bist du schoen Columbia FB1885 (2s.)
Remember Me FB1855 (2s.)

VICTOR SILVESTER

and His Ballroom Orchestra

Once in a While Parlophone F1013 (2s.)
Giannine Mia (2s.)

There are so many brilliant artists of every kind who seldom, if ever, broadcast that you must have a radiogramophone if you are ever fully to enjoy modern home entertainment . . . only with a radiogramophone can you make your own musical programmes and indulge your own musical tastes . . . only a radiogramophone can give you *dance music* whenever you wish it . . . or music to suit the moment . . . only a radiogramophone offers you the beautiful piece of furnishing which your home entertainer deserves to be. A radiogram is an investment every home lover should make—but remember in making your choice the important facts given below.

Easy terms from **5/-** per week

- Only Marconiphone radiograms combine the world's best gramophone (made at Hayes, Middlesex), with the finest of all radio — a Marconi.
- The tone quality of the Marconiphones is recognised as unsurpassed—see foot of this advertisement.
- There are models from 23 to 67 guineas for A.C. or D.C. mains.
- **EVERY MODEL IS GUARANTEED FOR A FULL YEAR.**
- Easy Hire Purchase terms (an initial supply of records included if desired) ranging from £3 deposit and weekly payments of only 5/-.
- Marconiphones are sold only through your local Marconi-men—the most dependable suppliers in your district.

You get the best of two worlds with the world's best Radiograms

Marconiphone

as installed in the: — Royal Academy of Music; Royal College of Music; Guildhall School of Music and Drama; Royal Opera House; Royal Philharmonic Society; Theatre Royal, Drury Lane; Grotian Hall; Wigmore Hall, London, etc., etc.



a last reminder!

Fill in your name and address clearly and post to The Marconiphone Company Limited, Radio House, Tottenham Court Road, London, W.1, and learn how you can qualify for one of the many very valuable prizes in this £2,000 Radiogramophone Competition. (Please mark your envelope R.G.C. in left-hand, top corner). **CLOSING DATE MARCH 19th.**

NAME
ADDRESS



NELLY von PECKENSEN, the German soprano, one of the singers in the Millocker play which will be broadcast from Munich at 6.10 p.m. on Thursday

Gigli's First Fee

WE are to have the good fortune of hearing Beniamino Gigli, the great Italian tenor, twice this week—on Sunday, at 2.30 p.m., in Ponchielli's *La Gioconda*, from the Naples group; and on Tuesday, at 8 p.m., in *Cavalleria rusticana*, from the Rome group. The latter transmission, by the way, will also be taken by Kalundborg, and by a number of German stations. Gigli will be supported by Ebbe Stignani as Santuzza, and Ettore Nava as Alfio. *Apropos* of Gigli's broadcast on Sunday, it is interesting to recall that it was in the tenor part of *La Gioconda* that he made his first appearance on the stage for the magnificent sum of ten shillings—an experience which he vividly recalled when I met him on his last appearance in London.

A third outstanding operatic broadcast, Massenet's *Werther*, is announced by the Turin group of stations for 8 p.m. on Wednesday, when Tito Schipa is to sing the title-part. (See Opera Story, p. 9.)

An Ibsen Play

GRIEG'S music to Ibsen's play, *Peer Gynt*, is so universally known that most listeners must have some idea of the action. Conceived, as Ibsen himself recorded, in the mood of "a crusader's song of triumph," it is a work of audacious high spirits. Much of it is a reminiscence of Ibsen's own experience, and Adse, *Peer Gynt's* mother, is, in the main, a portrait from life.

The irony which flavours the laughter and tragedy of the drama gave the Norwegians of an older day the impression that it was a satire on themselves, but Ibsen did not mean that; it is a story which needs no such addition to its own interest. Paris (PTT) is to broadcast it in French with all the Grieg music on Sunday, at 8.30 p.m.

German "Heroes'" Day

SUNDAY next is Heroes' Commemoration Day in Germany, and the broadcast programmes

THE PICK of the PROGRAMMES

are in conformity with the solemnity of the occasion. At 11 a.m. all stations will broadcast the Government's official ceremony from the State Opera House.

Symphonic music—including Beethoven's *Eroica* and Strauss's *Death and Transfiguration*—forms part of the evening programmes; and from Leipzig, at 5 p.m., there will be a complete performance of *Tristan and Isolde*, which will also be relayed by Sottens.

An Exquisite Play

WHEN Brussels No. 1 broadcasts Jean Sarmant's play *Les plus beaux yeux du monde* (The Most Beautiful Eyes in the World), at 8 p.m. on Wednesday, listeners will hear one of the most moving and beautiful plays of our time. Sarmant has aptly been described by many critics as the "modern Musset." "From the latter," writes one of them, "he has inherited the literary nobility of expression and form, the gracious mixture of maturity and adolescence, the grace of Ariel and the easy abundance of divine poetry."

"The most beautiful eyes in the world" are those of Lucie, who is loved by Napoléon, a poet and an impenitent Bohemian, and by the latter's friend Arthur, a great opportunist. She marries Arthur, who has been successful while Napoléon has drifted. But twelve years later

Lucie, who has gone blind and is neglected by her husband, meets Napoléon again. There are some exquisite passages in the closing scene.

"High-Brow," but Fascinating

BACH'S last work, which Brussels No. 1 is to perform in full, beginning at 8 p.m. on Tuesday, is a gigantic series of fugues, nineteen in all, built on one twelve-note theme, embodying every known device. Originally keyboard music, it was arranged by a brilliant young German, Wolfgang Graeser, for orchestra, organ, and two harpsichords, and in that form it can be thoroughly enjoyed by many who would find it boring if it were presented in one medium tone throughout.

By common consent the greatest piece of "high-brow" music in existence, it has become, in Graeser's arrangement, a fascinating series of richly varied pieces.

Beethoven's Toughest Job

THE *Missa Solennis*, which is to be performed before the 9th Symphony in the Lamoureux concert on Saturday, March 19, at 5 p.m. (broadcast by Strasbourg), occupied Beethoven for about four and a half years. Schindler, his biographer, gives a vivid picture of the master wrestling with the composition of the *Credo*, shouting and stamping about his room for twenty-four hours on end, with never a thought of food or sleep, and then emerging, tired, dishevelled, and starving. But with all that frenzied energy the work was three years late for the occasion for which it was designed—the installation of Beethoven's patron, the Archduke Rudolph, as Archbishop of Olmütz.

Joyous "Gipsy Love"

IN Lehár's *Gipsy Love*, which Budapest will broadcast on Saturday, March 19, at 6.30 p.m., the music is so vivacious and tuneful that most listeners may well be content to enjoy it without bothering much about the story. Zorika, the heroine, is destined by her father Dragotin, to be the bride of the well-to-do Bolesku, a suitor who would be quite welcome were it not that Zorika is in love with the gipsy Joszi. In a dream, however, she sees him grown cold and indifferent to her, and, taking that as an omen, she falls in with her father's wish and marries Bolesku.

The gipsy atmosphere pervades a good deal of the music, but no more need be said of its vividness and its infectious charm than that it is by Lehár.



JO VINCENT, the Dutch soprano, is one of the singers in Bach's *St. John's Passion*, to be broadcast by Brussels 2 at 4 p.m. on Saturday

THE WORLD

Radio Boon for Exiles



INGRID LARSEN, a popular German radio star, who is also an expert saxophonist. Listeners will regret to learn that she was recently badly injured in a motor smash in Berlin

NBC SYMPHONY CONCERTS

SIR ADRIAN BOULT is to direct two performances of the NBC Symphony Orchestra, in New York, on May 14 and 21 next. The

THE IMPORTANCE OF KNOWING HOW TO LEARN LANGUAGES

THE only satisfactory method of learning a foreign language is the direct method. In other words, you must learn French in French, German in German, Spanish in Spanish, and Italian in Italian. That is the Pelman method, and it is the only way.

It naturally follows from this that the old-fashioned method of memorising long lists of foreign words is entirely abolished when you learn a language by the "direct" way. You get to know each word by using it, and by using it in different ways and relationships. No long months trying to memorise lengthy vocabularies and dreary rules! You are guided naturally and instinctively, as a child is taught to quickly grasp words and their meanings, their fitness, their use—and their pronunciation.

Another consequence is that it practically eliminates the difficulties and drudgeries of learning complicated grammatical rules and exceptions. It teaches you not only to read a foreign language, but to write, speak and understand it thoroughly and efficiently.

The Pelman method of learning languages is explained in four little books, one for each language:

FRENCH, SPANISH, GERMAN, ITALIAN
(Also Courses in Afrikaans and Urdu)

State which book you want and it will be sent to you by return, together with a specimen lesson, free and post free. Write or call to-day.

Pelman Institute

87, Languages House, Bloomsbury Street, London, W.C.1
PELMAN (OVERSEAS) INSTITUTES: PARIS, 176, Boulevard Haussmann. NEW YORK, 271 North Avenue, New Rochelle. MELBOURNE, 396 Flinders Lane. JOHANNESBURG, P.O. Box 4928. DURBAN, Natal Bank Chambers (P.O. Box 1489). CALCUTTA, 102 Clive Street. DELHI, 10 Alipore Road. AMSTERDAM, Damrak, 68. JAVA, Malabarweg, Malang.

orchestra has just concluded a notable series of Saturday evening concerts under Arturo Toscanini. The success of the broadcasts has led the NBC to extend the series well into June, with Bernardino Molinari, *maestro* of the Augusteo concerts in Rome, scheduled to follow Sir Adrian as guest conductor. The Toscanini concerts ended on March 5. Those of March 12 and 19 will be directed by Carlos Chavez, conductor of the Symphony Orchestra of Mexico City.

Three later programmes are to be given under Artur Rodzinski, who trained the orchestra for its *début* under the famous Italian conductor; and two by Pierre Monteux, leader of the San Francisco Orchestra.

The broadcasts, which are relayed by short waves from Bound Brook (3 a.m. G.M.T. Sun.), have a large following in this country,

THE "WHITE MAN'S GRAVE"

READERS who remember *White Cargo*, will realise what a boon wireless is to European "exiles" on the West Coast of Africa. For many years, writes a correspondent, the Government of Nigeria has provided houses, or quarters, for its European employees, but now it has gone a step further, and supplies a wireless set as well—that is, if you are willing to pay 5/- a month, and who would not, just to hear the Empire programmes alone?

Officials on the "Coast" are a nomadic body, and tours of from one year to eighteen

months mean constant staff movements. Under the scheme when you move you leave your set behind for the next tenant, and provided you are not going into the "bush," you will in all probability find another set waiting for you in your new quarters.

These sets are of uniform make, of course, and are not designed to give a wide range of stations. But to men who are far from the Old Country, the sound of "Big Ben" in the still tropic night is more comforting than the harsh cries of whistling frogs, or the wailing discord of natives chanting around their cooking pots.

NEGRO CHOIR ON SHORT WAVES

A NEGRO choir of thirty-five selected singers, together with prominent Negro leaders as speakers, are being presented in a new CBS music series entitled "Wings over Jordan," which is transmitted from the Wayne short-wave station each Sunday from 2.00 to 2.30 p.m. G.M.T. The choir was organised by the Rev. Glenn Settle, pastor of the Gethsemane Baptist Church in Cleveland, and is directed by a 17-year-old boy, James Tait. The organisation began a series of broadcasts over WGAR six months ago and has given one Columbia network programme.

In America the programme, which is backed by the outstanding Negro churchmen, educationists, and laymen, has drawn considerable comment from influential groups of the white as well as the Negro race.



The "EL-MOUTRIBIA" (the troubadours) broadcast every day from the Algiers station. The band's performances are very popular among Europeans as well as natives. For Arab women and girls the concerts have become the "high spot" of the day. They make it a social occasion, and meet at each other's houses, to listen to songs sung in their native tongue.

There are fifty members of the band, who play, without a music score, on native instruments: a reed flute, the "Kouittra" (a guitar with violin strings), and the "Kanoun" (a zither with over 120 strings).

Their music was originally imported from Spain, centuries ago, when the Moors were expelled from that country, the tunes are called "andalusias." The themes are generally love, the greatness of Allah, and the deeds of the Prophet's followers.

OF RADIO

Ultra-S.W. for Education

AN EDUCATION SPEED-UP

THE development of a large number of local stations is expected to follow the allocation, by the U.S. Federal Communications Commission, of 25 ultra-high-frequency channels to be used exclusively for educational broadcasting.

Since the "educators' channels," as they are described, are designed for purely local use, it will be possible for every city and county in the country to have its own educational radio station. In most cases they will not even have state wide coverage, since ultra-high signals do not reach that far at the present stage of radio progress. Federal officials believe, however, that technical progress is so rapid that a marked improvement in coverage will occur in the near future.

While plans for the new educational stations are still far from fruition, Dr. John W. Studebaker, Federal Commissioner of Education, pointed out that the frequencies will be a boon to isolated rural schools, since county or district supervisors will be able to keep in constant touch with all schools and the school curricula will be greatly enriched through radio programmes. The stations will have a "service area" of only 5 to 15 miles from the transmitter, and the "educational channels" are confined to the 41 Mc/s band. This presents an initial problem because at present few receivers tune much higher than 20 Mc/s. An appeal has been made to manufacturers to include the "41" band in future sets.

LEIPZIG FAIR

THE radio section of the Leipzig Spring Fair, which opened on Sunday, is handicapped by the agreement among radio manufacturers not to introduce new models or improvements, except at the Berlin Radio Show in August. But as this restriction does not apply to portables or export receivers, some firms have new models in these lines. Special attention has been paid to the requirements of the tropics, and a new export short-wave receiver has been specially constructed for use in hot countries.

Three well-known firms introduce an inexpensive inverter which permits any AC receiver to be used on DC mains. The apparatus costs roughly four pounds and gives 80 watts, sufficient for any medium-sized receiver.

ESPERANTO BOOMS

ESPERANTO lessons and news broadcasts have been given for some years from various Continental stations, but it is only recently that the language has been used in radio entertainment. The Czechoslovak station, Brno, was the pioneer in transmitting radio plays and concerts in Esperanto, and during the last few months some of the monthly programmes have been relayed simultaneously from Lyons (PTT), and the Lithuanian stations, Kaunas and Klaipeda. This year Radio-Paris and Paris (PTT) have also broadcast plays in Esperanto

on alternate weeks. This is the outcome of the Esperanto in Modern Life conference, held in Paris last Whitsuntide.

Following the success of the recent relays a special cultural programme of Lithuanian songs and music, from Kaunas and Klaipeda, is announced for Tuesday. Nearer home, the Eire stations have just started talks on Irish culture on the first Sunday of each month.

AN O.B. MAN IN THE DESERT

M. PAUL-EDMOND DECHARME, a well-known radio-reporter of Poste Parisien, has just returned from a 10,000-mile journey across the Sahara desert and French West Africa which he undertook in order to make recordings of everything he could hear which was likely to interest European listeners.

It is the first experiment of the kind, and he has had great success, capturing not only native dances and songs, but also sandstorms! He has experienced the astonishing hospitality of the desert lords no less than the arduous of desert treks.

He has met what he thought was a man with the loneliest job in what is claimed to be the world's smallest village—a twenty-five-year-old Arab watchman, who, however, insisted that he has "a splendid job." "Every fortnight, I see in the sky an aeroplane; every fortnight, too, I receive the visit of a motor-car. That is quite enough to occupy my thoughts."

PERSONALITY CORNER

Hans Weisbach

Chief conductor of Leipzig station orchestra, and famous for his renderings of Bach and Bruckner. A native of Silesia, before coming to Leipzig he worked in Hagen and was *Generalmusik-direktor* in Düsseldorf. Guest concerts in Scheveningen during the summer season led to a first concert with the London Symphony Orchestra in London. Since then has regularly given concerts in London. The work there which has made greatest popular appeal is the last one written by Bach—The Art of the Fugue.

Weisbach greatly enjoys conducting the series of popular concerts arranged by the Leipzig station in factory halls for the benefit of the workers in their lunch hour; he usually prefaces a concert with a few words of explanation. At the first concert of this series he felt a few words were required to break the ice with an audience which had probably never heard a symphony before. He said: "You always want to hear waltz tunes. That is just as though you wanted to manufacture only prams and considered motor-cars too highbrow for you. Those who admire a waltz only are like those who prefer the 60 ft. Scherbel Mountain [a local ornamental refuse-heap] to the heights of the Alps."



GEORGE BURNS, who, with his wife, Gracie Allen (see last week's "World-Radio"), appears in a popular short-wave programme from W8XAL (Cincinnati) every Tuesday at 1 a.m. G.M.T.

THE MAYOR OBJECTS

THE Mayor of La Rochelle in France is not in favour of school broadcasting, and he has turned down a request, made by the Prefect of Charente-Inférieure in the name of the Government, for the schools of the town to be supplied with radio receivers. His objection is that educational broadcasts that might have a bias according to the Government in power would constitute a veritable danger for the mentality of the children. "Wireless official truth is not necessarily the truth, and it would do great harm to try to standardise young brains in the manner of Hitler, Stalin, or Mussolini."

ALL TALK!

AMERICA has a habit of capturing championships, and their latest—for talking—is no staggering surprise! Neither is it necessary to add that the new champion is a woman—Miss Berenice Forester, a radio announcer, who claims to be able to speak intelligibly at the incredible rate of 350 words per minute.

The literary gentleman who is setting out to review new Swedish, Norwegian, Flemish, and Chinese books in fifteen minutes from Radio Brno on Wednesday night must also be near to Miss Forester's class.

FAMOUS AMERICANS

"AMERICAN PORTRAITS" (see WORLD-RADIO, February 18), is being broadcast over W3XAL's (Bound Brook) directional beams to Europe and Latin America in four time periods every Friday. The stories are narrated in French at 1.30 p.m.; in German at 2.15 p.m.; in Portuguese at 7.30 p.m.; and in Spanish at 9.15 p.m.—all times E.S.T. A period for narration in Italian is to be added at an early date.

While using the same subjects as those presented in the NBC home programmes, the short-wave series are in the form of narration, instead of dramatisation, to give foreign listeners a complete picture of the outstanding figures in American history.



Indian villagers listening to a communal radio set

MEDICINE WITH MUSIC

Radio Assists in an Indian Health Crusade

THE main function of the Silver Jubilee Travelling Dispensary (known actually as the King George V. Travelling Dispensary) is to dispense, not, as you might think, medicine, but wisdom on matters of health. The one is often as unpalatable as the other, particularly that form of wisdom which impinges on the habits and customs of centuries.

Health talks must be sugared as effectively as the doctor's pill. In fact, the average villager shows far less reluctance to swallow the physic than to absorb the pearls of wisdom offered to him. Hence the Travelling Dispensary—ostensibly and in fact a means of providing the often isolated villagers with treatment for their minor ailments and through this treatment to gain their confidence in advising and their adopting prophylactic measures. The earlier a sore is treated the less liable is it to become serious. The Dispensary must therefore attract both the sick to heal and the healthy to reach.

Wireless for the Dispensary

The first essential for success is therefore popularity. Some means had to be devised to bring the villagers to the Dispensary like flies to the honey-pot. The gramophone and the magic lantern were pressed into service as a means of propitiation. Both did well in their own spheres—but wireless brought the greatest measure of success.

Let us take a trip on the van to a typical village to see what happens. The van is mounted with a special body which is fitted with racks to take bottles, and cupboards to hold its small stock of medicine, its magic lantern, its tents and camp equipment and wireless receiving apparatus. The crew consists of a Doctor, a driver, and a *peon* (messenger).

The villagers are mostly busy with their crops, the women are at the wells drawing water; the children are playing round the village pond or tending the cattle. Our arrival excites little

curiosity—the lorry being a familiar feature to-day on the Indian landscape.

Suddenly we switch on and the strains of a band or a giant voice singing or talking invade the stillness of the countryside.

"Whatever can this be?" The question flies from lip to lip. They look around, they listen; they are bewildered and amused. Soon they begin to trickle towards the van, first one, then another, then two or three together, until there is a rush which threatens to overwhelm the car.

By courtesy of "The Indian Listener" the following extracts are taken from an interesting talk which was recently broadcast by Major W. H. Crichton, Health Officer at Delhi, and printed in that journal. It deals mainly with the part played by wireless in helping the Travelling Dispensary in its health crusade through Indian villages.

"A gramophone? Ah, that's what it is," says someone in the seething crowd. But what a strange gramophone, to be sure. So powerful—and then, where is it? The press becomes thicker. They look round the car.

"Hey! You who talk about gramophones," they jeer, "where is the gramophone?"

However, the programme continues. There is no time for further speculation at present. They squat all round the van and listen—entranced. Presently, the programme comes to an end.

"Yeh Dillhi hai!"

There is a sudden silence. Just then the *peon*, who has been busy in the inner recesses of the car, happens to come out. There is an immediate shout of derision.

"Here is the explanation at last. He has been inside working a gramophone!"

The crowd yell and cheer and laugh at the "joke" they think has been played upon them. "A voice from Delhi forsooth—without a wire! Ha! That was a good one to try and pull on honest village folk."

But what's this? The voice again—and the *peon* is out of the car. They all rush round to look inside. It's empty.

Can there be something in this after all?

Hai! Hai! But there is something queer in all this. Here is a sahib's voice coming through and now and then some queer music.

"Here, Babuji, do switch on the same thing we had before."

Patiently Babuji explains why this cannot be done, but promises them better fare when the special rural programme starts. Here it is. Two men talking their own language. Why this is good, even though it is a dialogue on "Personal Cleanliness."

"It is necessary for one's health," says one voice, "that one's clothes should be always kept clean."

"Without a doubt," concedes Ram Lall, the zamindar, "Did I not wash mine three weeks ago?"

There is a roar of delighted laughter—but the lesson has got home.

The Bird in the Box

That programme ends, and there is a general moan of disappointment. Unconvinced by the Doctor's previous explanation they ask him to "put it on again."

"Can't you speak to Delhi then, Babuji, and make them change the tune?"

Explanations are useless. They must be content with high-flown Indian music which is beyond them. They are ribald.

"This man's voice needs your medicine doctor," they say.

But still they listen on. The elders murmur. Truly they must have some explanation to offer for this strange bird in the box—this voice from Delhi. They assume an air of profound sagacity.

"Of course," they say, "our Yogis have communicated with each other in this manner for centuries—and they did not need expensive instruments. This is as near as the sahib can get to the Yogis' practices."

Then there are others, politically-minded, who see in this machinations of the Sirkar. There is much solemn wagging of heads and many knowing nudges. "The Sirkar now controls the air—ai! ai! a clever, more, 'a masterly stroke.'"

Such were the first reactions. The van has now covered 6,000 miles and has paid over 700 visits to the villages. With these frequent visits familiarity and sophistication have grown, and to-day the villagers come running up to the van as soon as it arrives and clamour for the wireless programme. They are prepared to wait any length of time for it, and meanwhile what about attending to that nasty cut on your finger? You get the idea?

The van has not only adhered to its village routine tour programme. It has broken fresh ground by attendance at the rural fairs and exhibitions where it is a never-failing source of interest, not only for the *dawai* you can get, but because of the "bird in the box" you can listen to.

At the Ex-Service Men's camp at Purana Killa during Armistice celebrations the van is there to heal, and to entertain, and to teach the lessons which it is always fondly hoped the old warriors will carry back with them to their villages. Its popularity there last year is sure to make the van a permanent feature of the camp, and judging by the number of invitations the doctor in charge is getting to village weddings, it may quite well become an essential feature on these happy occasions.

EUROPEAN CONCERT FROM EIRE

A St. Patrick's Day concert from Dublin will be relayed by many European stations.

(By our Dublin Correspondent)

ST. PATRICK'S DAY is Ireland's great national holiday. On March 17 each year Irish people in every corner of the globe pause to do honour to the Saint who brought the gospel to Ireland over 1,500 years ago, and the shamrock is worn as the symbol of the doctrine of the Most Blessed Trinity which he expounded.



Mr. de Valera

Whether at home in "the Ould Country" or abroad, no Irish man or woman is without a sprig of shamrock on March 17. Very green it looks in the coats of the young colleens and the hats of the old countrymen in Ireland, but though its freshness may have suffered on the journey, it is worn with as much pride by the exile, to whom the faded trefoil brings memories of rushing mountain streams and the hushed stillness of great lakes.

By way of illustration of the sacred regard in which the shamrock is held by Irish people, irrespective of creed, the following true story is of interest: At the beginning of the present century, two Irishmen (a Dublin Catholic and a Belfast non-Catholic), strangers to each other, were present in a public bar in a great seaport town of South Africa when a big backveld Boer made a slighting reference in the Taal dialect to the shamrock worn by the "new chum" from Dublin; whereupon the diminutive Belfast Protestant, who understood the Taal, leaped upon the burly Boer and proceeded to trounce him for his insulting reference to the Irish national emblem.

A Day of Sports

At 10.30 a.m. on this St. Patrick's Day, listeners will hear broadcast from the Cathedral of Tuam, in the West of Ireland, the voices of 200 Irish children raised in honour of the Saint at the High Mass, while in the capital city of Dublin, the Prime Minister of Eire and his colleagues will drive in State to attend Mass, when the guidance and protection of St. Patrick will be asked for all the Irish, at home and abroad.

The religious ceremonies of the morning ended, the picked troops of the National Army will parade the city, and then the day will be given over to the enjoyment of sport of all kinds. The principal sporting event will be broadcast from the National Stadium, Dublin, where the inter-provincial championships of the national games of hurling and Gaelic football will be decided. Hurling was played in Ireland before the advent of St. Patrick. It is a tremendously fast game, similar to the Scotch game of shinty, and has the capacity for raising the onlookers to an intense pitch of excitement. Even hardened radio commentators are hard put to it to retain a judicial calm if the men of their particular province are battling for championship honours.

The *pièce de résistance* of the Radio Eireann programme for the day is the European Concert at 8 p.m.; and musically-minded listeners are

specially recommended to note the progress of Irish composers in their adaptation of traditional folk tunes to modern harmonic development.

When the *Union Internationale de Radiodiffusion* selected Radio Eireann to give a European Concert, the feast day of St. Patrick was an obvious choice; and, naturally, this meant the performance of native music.

In the actual selection of the items, the "embarrassment of riches" made itself felt: and, out of the hundreds of native airs available, four Irish composers have chosen and arranged a programme of Irish vocal and instrumental items.

The Ministers of the various European countries accredited to Eire, in Dublin, many of them musicians themselves, have shown a lively interest in Irish music, and, with their co-operation greetings will be given in their respective languages to the countries taking the European broadcast—namely, Germany, Norway, Switzerland, Czechoslovakia, Italy (seven stations), BBC Regional, and Belgium.

The Extempore Poet

Irish music is unmistakable in character, and, as is only to be expected of the one-time "most distressful country," it gives a cross-section of life which is not "all beer and skittles." The music which St. Patrick found flourishing in Ireland in A.D. 432 was played on the small Irish harp, as an accompaniment to a recital of warlike deeds and praises of heroic youth. A natural diplomat, the Saint taught the bards to sing the *Psalms of David*, and the hymns of the Church while, at the same time, preserving the native music.

Down through the ages the bardic tradition of a narration of events to a musical accompaniment persisted, and not so long ago, the writer, when having a pint of beer in the kitchen of a mountain-side tavern near Dublin, heard a "man who goes the roads" reciting an account of modern Irish history to a vocal accompaniment of his own making.

Ancient Irish music falls into three categories: the music to induce sorrow, sleep, and joy; and in Thursday's programme all three kinds of music are featured. Listeners will be afforded the opportunity of noting the contrasts when Mr. Sean Curteis sings, with orchestral accompaniment, three songs—a lamentation, a love song, and a beautiful lullaby arranged by E. Gallagher to the words of the eighteenth-century poet, Owen Roe O'Sullivan.

Mr. Leo Rowsome, a great exponent of that difficult art, the playing of the Irish pipes, will perform old Irish airs on his instrument, and listeners will observe the great difference in the quality of the music compared with that of the more familiar bagpipe of the Scottish variety.

In the "Spirit of the Nation" section, arranged by Vincent O'Brien, teacher of John McCormack (the greatest missionary for Irish music in modern times), the Irish exile song will be sung by the Irish Vocal Quartet. This song, "Three thousand miles away" is American in thought, and is set to an Irish air.

The Irish Radio Orchestra will perform "The Irish Rhapsody" by Victor Herbert, an Irish



The Harpists. The Irish instrument is smaller than the ordinary harp

musician who spent his life in New York, and died in 1924. In this work the heartache for his native land of the city-dwelling exile in America finds expression.

Musical Discoveries

London-born Carl Hardebeck, blind composer, came to Ireland in 1893, and has remained ever since. Falling under the spell of Irish traditional music, he toured the country-side, taking down from the lips of old men and women the traditional airs, which he afterwards incorporated in his *Irish Fantasia*. This work, which the Irish Radio Orchestra will perform, was written by Hardebeck to show that the traditional music of Ireland could be given an orchestral representation, without sacrificing the original folk melody. Following the Hardebeck work, the Irish Vocal Quartet will render Moore's "At the midnight hour," arranged by Dr. J. F. Larchet, whose contributions to Irish composition have been marked by his adaptation of the native musical idiom to modern harmonic development.

The Irish Radio Orchestra, which will perform the major portion of the European Concert programme, is singularly fortunate in its conductor. When Colonel Fritz Brase, Director of the Irish Army School of Music, was touring Ireland with his crack No. 1 Band some years ago, he chanced to hear a youngster playing a piano in a hotel lounge in Tralee, Co. Kerry. Col. Brase encouraged the youth to join the Army School of Music, and in little over a decade that youth had the experience of conducting an Army Band for the first time in his native town of Tralee. Since then, he has secured numerous musical awards, and he has now been honoured with the baton at the St. Patrick's Day European Concert. His name is Lieut. Dermot P. O'Hara, and he is just 28 years old.

At 9.15 p.m. the Prime Minister of Eire, Mr. Eamon de Valera, will talk to the Irish people at home and abroad for fifteen minutes. In view of the recent meetings of the Irish Cabinet Ministers with those of Great Britain, his remarks are expected to be of more than usual interest, and it is hoped that the national holiday this year will mark the beginning of happier relations with our neighbours across the Channel. From 10.45 p.m. until midnight Ceildhe, or Irish dance music, will be broadcast by the Dublin Metropolitan Garda Ceildhe Band

READERS' FORUM

"Dear Friends and Listeners"

SIR,—May I, as an enthusiastic short-wave listener, endorse the views of your correspondent, from Harrow, who mentions the Zeesen station? The "Talks in English," announced in so friendly a fashion, are the most interesting feature of a continuously enjoyable programme from this station, and merit the attention of all listeners, when in the mood for real listening. (I know most of us short-wavers care only to plod round the waveband and "log.")

Zeesen always has excellent music, as well as the talks, and manages to create an "atmosphere" as your correspondent suggests, of a "friendly gathering by the fireside."

I consider our own "Empire" programmes a good "first" on the short waves, but I would class Zeesen as a good second, and should you print any of this letter, I hope whoever produces them will accept the thanks of one quite large, ordinary English household.

"ALL HOURS."

London, W.14, February 25.

I shall probably be accused of cynicism and other unpleasant characteristics when I say that "the familiar Zeesen sentence, 'And now, dear friends and listeners,'" which fills your correspondent's bosom with a glow of philanthropic warmth; has quite a different effect on me. (I do not claim, it will be noted, the support of all my friends—I haven't asked them.) To me, the endearment is faintly reminiscent of the greetings of the Rev. Mr. Stiggins—just a little *too* friendly.

I would not be misunderstood: the opening words "liebe Hörer" or "chers auditeurs" from a German or a French station are unexceptionable; but I cannot think that "Dear friends and listeners" by a BBC announcer would seem quite —! I will go further: such a greeting would have on many the effect of the injection of a long passage of Contemporary Music into the middle of an Old English Ballad concert—or *vice versa*.

After all, it will be argued, the greeting is addressed to the isolated listener overseas and, therefore, to one who needs a little extra friendliness and informality. I entirely agree; but I cannot believe that those qualities are necessarily shown by a form of words which is foreign to the British section of Zeesen's listeners. I believe they might even prefer the bluff, if rude, greeting of the Western Brothers.

London, W.1.

CYNICUS.

AURORAE AND SUNSPOTS

Apropos of Mr. Hallows's interesting article in this week's WORLD-RADIO on Sunspots and Auroræ and his deductions of want of proof that the latter are due to sunspot activity, it may be of interest to you and your readers to state that, in addition to the phenomenal display of January 25, which was brilliantly evident here, there were minor recurrences of Auroræ on Sunday evening, February 6, between 6 and 8 p.m., and again on Tuesday, February 8, between 8 and 9 p.m., while in the corresponding date predicted for the return revolution of the sunspot radius of the sun, the weather here was overcast and dark with clouds for two nights, hardly a star being visible. Both the latter appearances, as well as the earlier and more splendid display, were followed with stormy and unsettled weather of gale force, indicating that, whatever the cause, atmospheric disturbance invariably follows the phenomenon.

The Sunday evening apparition took the form of white bands resembling great flashlights or streams of luminous white moving clouds of broad-band circles, while that of the following

appearance was in white cloudy bunches with shafts of flitting striæ over a broad part of the sky covering the north-east. The Sunday evening display was east to west. This was the direction observed here on January 25 also, with no inclination to the north. In fact, at times the extremely cloudy masses of red were mostly in a southerly direction, their misty atmospheric accompaniment at times covering Sirius, then low in the southern sky. There were no colour effects with the later appearances.

Previous observations and comparisons with the sun-spot causation theory has convinced the writer that their relative appearances have no coincident connexion. It happened *once* on January 25, but the astronomer's theory has received no corroboration. Mr. Hallows's able exposition and sceptical acumen is welcome among all the positive prophets.

B. G. HOARE.

Ravenswood, Inverness, February 27.

In this week's WORLD-RADIO, "Log-Roller" refers to the non-appearance of the Aurora on February 21 or 22, which dates correspond closely to a complete rotation of the sun on its axis since the great display of January 25. Referring to the cloudy conditions prevailing during the preceding week, he writes: "But on the few occasions when the sun did show itself, I had a good look at its disk both with the naked eye and with a small glass, and could find no visible trace of the great sunspot group."

In reply to these remarks, I would like to say that the "glass" used must have been of exceptionally low magnifying power as, during the time mentioned, there were, at the same

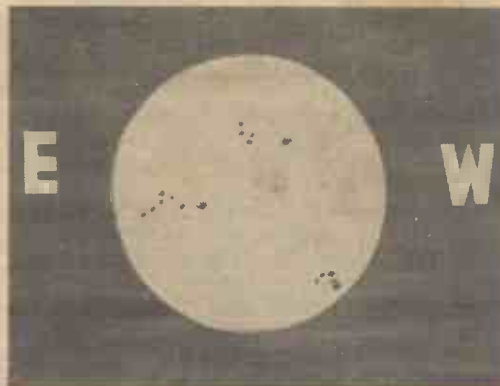

period, three distinct groups of sunspots covering an area of many thousands of square miles on the solar surface. The group of greatest length formed an irregular line near the eastern limb in the sun's equatorial region. A second group, consisting of six, and later five, larger spots in the form of a horseshoe, gradually moved towards the south-western limb and passed out of sight on the sun's rotation. A smaller group was situated about midway between the north pole and the centre of the sun's disk. As a radio experimenter for the past 14 years, I

Letters should be addressed to the Editor, "WORLD-RADIO," Broadcasting House, London, W.1. Letters intended for publication should be as brief as possible, and should always be accompanied by the full name and address of the writer, though not necessarily for publication.

SUBSCRIPTION RATES

12 months Inland and Canadian, 13s.
12 months (Foreign), 15s.

Other periods pro rata. Prices include postage.
Subscriptions to Publications Dept., Broadcasting House, London, W.1, or 35, Marylebone High St., London, W.1.

have read with interest correspondence in WORLD-RADIO relating to the effect of the Aurora on radio reception on the short-wave transmissions. I am doubtful if anything definite or really helpful has yet been learned on the propagation of wireless waves from observations while the Aurora was visible or known to be active. Great changes in the reflective layers above the earth's surface and variations in the earth's magnetic field often occur without such visible indication as that occasioned by displays of the Aurora. Wireless "surprises" and freak reception may be noted from time to time, while the mystery of such happenings cannot as yet be explained with certainty.

SYDNEY M. JAMESON.

Butterwick, Barton-le-Street, Malton, March 4.

"THE MYSTERIOUS PIPS"

Re the "Mystery Pips," might I suggest that they come from a neighbour's receiver, the delay being due to the slowness of travel of sound in the air, and the reason for their audibility being the extraordinary penetrating power of the "pips"? I once observed this effect, and proved the theory by simply switching off my receiver! (Q.E.D.)

R. G. YOUNG.

Wimbledon, S.W.19, February 25.

I am still convinced that at least one of your correspondents was listening to a Hamburg time-signal. These signals are rather complicated, and may easily mislead a casual listener. They appear to consist of a number of "pips" at one-second intervals to indicate the local time, one hour later than Greenwich Mean Time, followed by three "pips" at five-second intervals, and then by three at one-second intervals. The last "pip" of all is the "exact" time.

My conviction was strengthened recently, when I found that this signal led our Greenwich signal by approximately one-third second.

D. G. ANDREWS.

King's College, Cambridge, March 4.

PECULIARITIES IN RECEPTION

I wonder if any reader could explain a curious experience I had this afternoon. At 4.15 p.m. I was exploring round about 150 metres when suddenly I came upon what sounded like a flute and pianoforte recital mixed up with morse.

On listening more closely, I discovered that the music could be heard only as each "pip" of the morse came through, and as the latter was rapid, the music sounded almost continuous. The fact that the music came through only with the morse was proved when both ceased abruptly. On looking up the programmes, I found that London Regional was giving a flute and pianoforte recital at the time, but why it should be heard on 150 metres and only in the above manner completely mystifies me.

A. W. CURTIS.

Shortlands, Kent, February 21.

ECHOES ROUND THE WORLD

Referring to Mr. Fells's letter in to-day's issue, I tested the two stations DJA and DJN, and found them exactly as stated. I presume they are second-channel readings.

"Log-Roller" also refers to the case of W2X3, which was mentioned in earlier correspondence and supposed to be this station working on another frequency. I tested it at the time, and found the reading on about 22.5 as stated, but, alas! at the appropriate reading, quite close to the other, I found also GSH—clearly another case of second channels. My receiver appears to be cleverly contrived so that these second-channel readings of powerful stations do not occur in inconvenient positions.

W. T. S. BEAUCLERK.

Wimbledon, February 25.

LEAVES FROM MY LOG

By "Log-Roller"

RELAYS BETTER THAN MAINS

IN a recent issue "Senex" inquired why with this set he received a good many relays better than their parent stations, despite their much smaller power. It may have been noticed that all of the smaller stations mentioned have wavelengths below 240 metres and that he told us that his set was almost silent above 449 metres. "Senex" did not say what kind of set he was using, but my deduction is that it is a straight receiver yoked to a not very efficient aerial. The straight receiver is markedly most sensitive and least selective towards the bottom of any wave band covered and most selective but least sensitive towards the top. This is due to the fact that near the bottom of the band there is comparatively little capacity in parallel with the tuning inductances, but very much more near the top. Thus with a bad aerial such a set may be able to bring in medium-wave stations below 240 metres, giving progressively worse results as the wavelength is increased and becoming almost useless beyond 449 metres.

"BREAK-THROUGH"

From Birmingham comes the letter of a sorely puzzled writer. "I thought," writes my correspondent, "that harmonics occurred only on shorter wavelengths or higher frequencies than the fundamental; thought, too, that they must be associated with whole numbers—the second, the third, the fourth, and so on. How can you explain this? On my set I can tune in the Midland Regional just below Tifis, whose wavelength is 1,060 metres and frequency 283 kilocycles. This means a greater wavelength or a lower frequency than the fundamental, and no whole number will fit in if one multiplies the former or divides the latter." This has nothing whatever to do with harmonics or even with superheterodyne beats. It is purely and simply

an instance of what is known as "break-through." Break-through was unknown as a wireless phenomenon until high-powered stations made their appearance. It was then discovered, to the no small discomfiture of designers, that unless precautions were taken a high-powered medium-wave station at shortish range might force its way through into the lower part of the long-wave band, making a reappearance at a dial reading between 750 and 1,000 metres. Break-through is undoubtedly what is causing the symptoms which bewilder the Birmingham reader.

S.W. BAND-SPREADING

It is much to be hoped that those who make our wireless sets won't let the question of band-spreading on the short waves escape their attention whilst they are engaged in designing their new models. On some that I have tried during the last few months tuning on the short waves is far too cramped for good results to be easily obtained. I have found, for instance, the entire 19-metre band, which contains over a score of stations shown in the WORLD-RADIO lists, represented by something like a quarter of an inch on the tuning scale. This sort of thing calls for more fiddling and more patience than most of us care about.

SETS NOT LESS SENSITIVE

Recently I dug out a six-year-old straight 3-valve set with velvet-smooth reaction which was a wonder in its day. I wanted to see how it compared for sensitiveness with a good modern superhet. One or two readers have been doing the same kind of thing, and I am glad to have their reports, which confirm my own experiences. There's no question that a superhet with an efficient high-frequency stage is considerably more sensitive than the old three-valver. In the early part of the evening the latter can hardly

be expected to get a look-in owing to its much inferior selectivity. Mine was found at such times to bring in a very fair number of stations on the medium waves, but none whose output rating did not run into double figures. Later on, when comparatively few stations were at work, not a few of the smaller ones were heard with the old straight; but most, if not all, of them were very much better heard when a change-over was made to the superhet. The straight had often to be worked far too near to the point of oscillation for even moderate quality on stations which the superhet brought in with the volume control a long way from the maximum position. We can feel pretty sure, then, that the reason why we don't nowadays hear much of the very small medium-wave stations with wavelengths of their own is not that sets are less sensitive, but just that these little stations are drowned by their big neighbours.

PETO-SCOTT

Replace your old set with this

5-valve ALL-WAVE A.C. SUPERHET RADIO/GRAM CHASSIS

with 5 British Valves and Moving Coil Speaker

LIST VALUE £10:0:0

Bargain £6:6:0

Guaranteed fully tested

Tour the World on this modern 6-stage All-Wave Receiver 18-50: 200-550: 900-2,000 metres. Automatic Volume and Tone Controls. Wavechange and Gramo. Switch. Illuminated station-named Dial. Output 3 Watts. Size: 10" high x 11 1/2" wide x 8 1/2" deep. For A.C. Mains 200-250 volts: 40-80 cycles. Complete with specially matched energised speaker, all knobs and escutcheon. 6 Gns. Cash or C.O.D., or 7/6 down, and 17 monthly payments of 8/9.



7/6
DOWN

NEW PILOT

8-in-1 SHORT-WAVE KIT

Every Circuit a Winner

Buy this new Kit at once and you can build 8 short-wave sets one after another. Never before has the constructor been given such a wonderful opportunity for experimenting.

The Peto-Scott Pilot 8-in-1 Kit comprises all highest grade components, ready drilled chassis, panel, and crackle finished steel cabinet. 8 coils and 16 working drawings to build 8 sets. Cash or C.O.D. £4:8:0, or 7/6 deposit and 11 monthly payments of 8/-. Set of 4 valves. £1:7:6, or add 2/9 to deposit and 2/6 to each monthly payment.



7/6
DOWN

FREE

Send for copy of Pilot Short-Wave Experimenter with full details of all circuits.

B.T.S. SHORT-WAVE ADAPTOR

★ MAKES YOUR SET AN ALL-WAVER ★

12-52 METRES LIST VALUE OUR PRICE

HEAR AMERICA DIRECT. Covering 12 to 52 metres, this wonderful unit simply plugs into your battery or A.C. Mains set. 100-1 ratio aerial tuning and slow-motion reaction: for use either as plug-in or Superhet Adaptor. Walnut finished Cabinet (illustrated). With 2 plug-in coils 12-26, 22-52 metres. Ready assembled. Cash or C.O.D. Carr. Paid.



2/6
DOWN

39/6 or 2/6 down and 11 monthly payments of 4/-. Extra coils, 41-94 metres, 3/6; 76-170 metres, 3/9.

Please cross P.O.'s and register currency.

PETO-SCOTT CO. 77 (W.R.9), City Road, London, E.C.1
Ltd. 62 (W.R.9), High Holborn, London, W.C.1
Telephones: Clissold 9875; Holborn 3248.
Est. 1919

TELEVISION NOTES AND PROGRAMMES

Televising the Light Heavyweight Championship

By "THE SEER"

TELEVISION'S best "after-dark" outside broadcast occurs on March 23, when the mobile unit will be installed at Harringay Stadium to show viewers the whole of the 15-round contest for the Light Heavyweight Championship of Great Britain between Jock McAvoy, the holder, and Len Harvey.

Three cameras will be used, two for long shots and one for comparative close-ups, so viewers should miss little or nothing. Although the fight is also being broadcast, a special commentary for television will be given by Lionel Seccombe, who served his apprenticeship in this difficult art by commenting on amateur bouts at Alexandra Palace. As viewers are able to see for themselves what is going on, a television commentary must be explanatory rather than descriptive. Technically, there is every hope of a good picture. The Harringay Stadium is within optical distance of Alexandra Palace, so the ratio of signal strength to interference should be high enough to defeat any of the ordinary forms of disturbance.

Major G. C. Tryon, the Postmaster-General, accompanied by Lord Selsdon, Chairman of the Television Advisory Committee, paid his second visit to Alexandra Palace on Monday afternoon last to examine the progress made since he opened the station in November, 1936. Cameras installed on the terrace gave viewers a clear picture of the P.M.G. and Lord Selsdon as they alighted from their car.

"One-man" shows are ideally suited to the

small television screen. On March 16 viewers are to have their first "One-Woman Entertainment," the artist being Marcella Salzer, a young Viennese actress who specialises in character parts and who will be remembered for a brilliant humorous study in television with Rudolph Brandt in *The Bombardon*. Miss Salzer will play five different characters in fifteen minutes, ranging from a temperamental film star to a dish-washer in a French restaurant. In another characterisation she will perform a verbal duet with her "other self"—on a gramophone record.

Among the welcome signs of spring at Alexandra Palace is the spectacle of Mr. C. H. Middleton standing in the Television Garden, that blessed plot which viewers came to know so well last summer and autumn. Mr. Middleton is now laying plans for an energetic season. He believes, and viewers will agree, that a television picture should be full of action, so our weekly peeps at the Garden will give practical guidance on such matters as setting the mower, planting seeds, weeding, building the rock garden, and waging war on insect pests.

Watching Mr. Middleton at work, many viewers must have wished they could ask him questions on the spot. This summer he will be accompanied in the picture by an average amateur gardener, who, it is hoped, will anticipate just those questions which the interested viewer would ask if he were standing at Mr. Middleton's elbow.

PROGRAMMES

Frequencies—Vision: 45 Mc/s; Sound: 41.5 Mc/s. All programme times shown below are approximate. From 11.0 a.m. to 12.0 noon each day, films intended for demonstration purposes will be shown.

MONDAY, March 14

3.0 p.m.—Cabaret.
3.40—Gaumont-British News.
3.50-4.0—Music Makers: Moiseiwitsch. 9.0—Cabaret.
9.40-10.0—Comedy Film: "Tell Me If It Hurts."

TUESDAY, March 15

3.0 p.m.—"The Crooked Billet," by Dion Titheradge, with Dorothy Hyson, Basil Gill, Francis L. Sullivan, Charles Farrell, Ernest Jay, Noel Dainton, Eric Noels, Barbara Gott, Brian Hayes.
9.0—Jane Carr, songs at the piano.
9.5—Design for Industry: Anthony Bertram.
9.20—Gaumont-British News.
9.30-10.0—"The Cup That Cheers," by V. C. Clinton-Baddeley, and "The Split in the Cabinet," by Stephen Leacock.

WEDNESDAY, March 16

3.0 p.m.—Marcella Salzer in a one-woman entertainment.
3.15—Gaumont-British News.
3.25—Diana Ward in songs.
3.30-4.0—"The Words upon the Window Pane:" a play by W. B. Yeats.
9.0—Charles Heslop with Maidie Field and Sydney Smith in "On the Sands," by Greatrex Newman.
9.10—"The Cruise of M.Y. 'Rosaura'."
9.20—British Movietonews.
9.30-10.0—"The Post-Bag:" an operetta in one act.

THURSDAY, March 17

3.0 p.m.—Douglas Byng in "Byng-Ho!"
3.20—British Movietonews.
3.30-4.0—"Picture Page." 9.0—See 3.0.
9.20—Gaumont-British News.
9.30-10.0—"Picture Page."

FRIDAY, March 18

3.0 p.m.—"On the Sands." (See Wednesday, 9.0.)
3.10—Gaumont-British News.
3.20—"The Post-Bag:" an operetta in one act.
3.50-4.0—Highlights of next week.
9.0—Diana Ward in songs.
9.5—Artists and their Work.
9.20—Cartoon Film: "The Spider and the Fly."
9.25—Highlights of next week.
9.30—British Movietonews.
9.40-10.10—"The Words upon the Window Pane:" a play by W. B. Yeats.

SATURDAY, March 19

2.50 p.m.-3.40 and 3.50-4.30—England v. Scotland Rugby Football commentary.
3.40—Jane Carr, songs at the piano.
9.0-10.0—"The Crooked Billet." (See Tuesday, 3.0.)

Which station was that?

This feature is intended for the use of readers who desire the identification of broadcasting stations only, whether on long, medium, or short waves. For particulars of amateur transmissions, readers are referred to the red

interference, probably chose one of these channels; (26) believe new station on 30.79 m. a channel reserved for Japan, but no call-letters are published against it; there is U.S.S.R. station RKI on 39.79 m. KIERMON (New Mills): (1) LKC, Jeløy (Norway) on 9.53 Mc/s; (2) tallies with sixth harmonic of Poste Parisien (5.75 Mc/s).

Free Queries

Each query should be numbered and the questions on the coupon carefully answered. Letters must be addressed to the Editor, WORLD-RADIO, Broadcasting House, London, W.1.

The Alternative Postal Service

In addition to the free service of "Which Station Was That?" printed in these columns, replies to station identification queries can be obtained within forty-eight hours of receipt of details on payment of 6d. per query, in stamps, or P.O., accompanied by stamped addressed envelope (marked in left-hand top corner "Postal Query Service"), and coupon as per conditions for "Free Queries."

FOOTBALL FAN (N.12): (16) cannot identify possibly altered programme from Basle or Berne; (17) surely Dublin and Cork; a relay of a talk on Foreign Affairs broadcast through Athlone; (18) Radio Salamanca now works on 238.5 m. **AARON (Cambridge):** Stavange relaying from Oslo a broadcast carried out by the NBC (New York). **GOLDEN DANE (New Cross):** (1) do you mean "between W2XAF and GSB"?; if so, W1XK Millis on 31.35 m. Most of the U.S.A. short-wave stations took this broadcast. **BULL'S EYE (Rosyth):** COGF Matanzas (25.41 m.); Address: Radio Transmisora COGF Gral Betancourt, 51, Matanzas, Cuba. **SCHOOLBOY (E.11):** (1) DZH, Zeesen (20.75 m.). **CONTINENTAL (Williton):** (1) HJ1ABP, Cartagena (Colombia) on 9.61 Mc/s; (2) apparently a test, cannot identify. **CLARINDA (N.13):** (1) HJ1ABP, Cartagena. Address: Apartado Postal 37, Cartagena Republic of Colombia, South America; (2) Radio Renascenca, CS2WD, Lisbon, on 5.97 Mc/s. **SOLO (Birmingham):** See Continental (Williton). **D.E.L. (Cambridge):** (1) LKC, Jeløy on 9.53 Mc/s relaying a sacred service from Oslo; (2) SBP, Motala (11.70 Mc/s); (3) regret, cannot trace. **INOUNOT (Hayward's Heath):** Amateur experimental transmitter at Heliopolis (Egypt); please see note re amateur transmitters. **DIAL-GAZER (Liverpool):** T14NRH, Heredia on 31.02 m. address: Apartado Postal 40, Heredia, Costa Rica. **HBW (Bickley):** (1) TGWA, Guatemala City (19.78 m.); (2) CS2WD, Lisbon; (3) VQ7LO, Nairobi (Kenya Colony) on 49.33 m. **KREISLER (Heswall):** WKD and WEL Rocky Point, New York (U.S.A.) on 13.43 and 8.59 Mc/s respectively; heard through the latter. These are commercial radiotelephony transmitters occasionally used for point-to-point transmissions, namely for a relay to another

Short-Wave Entertainment WITHOUT NOISE

The NEW IMPERIAL All-wave Receiver is remarkable for its wide wave-range, selectivity and efficient signal-to-noise ratio. It does not spoil short-wave reception by emitting harsh noises. Unusual, you say. Well, this receiver is unusual in many ways. It brings in programmes from the ends of the earth, and sound transmissions from Alexandra Palace, with brilliant clarity. It has been described by experts as a triumph of advanced radio technique and hand-construction by skilled engineers. For enjoyment in world-wide reception, you should hear this set.

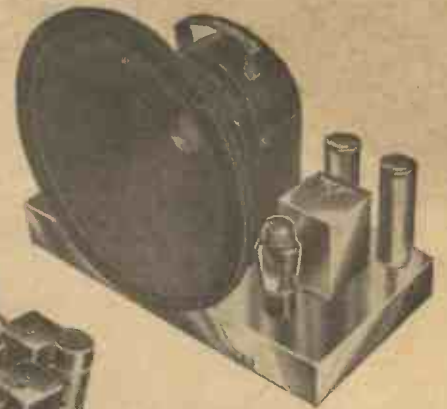
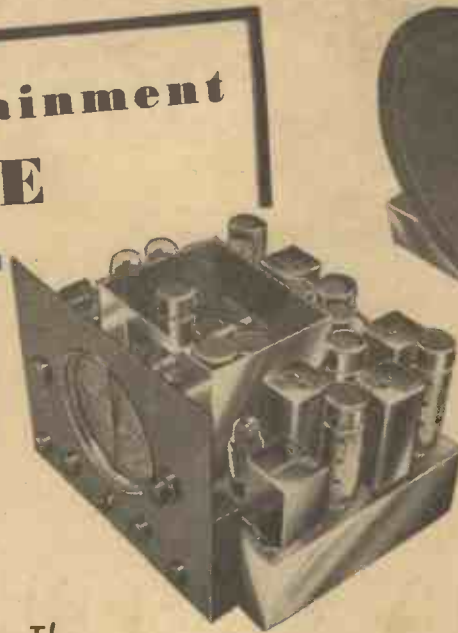

DUAL CHASSIS

Construction admits of maximum efficiency in screening and adjustment.

(On Left) The separate tuning chassis.

(Above) Power pack with giant 12" Theatre Sonic High Fidelity Reproducer.

★ The chassis are available for building into your own Cabinet.

4½ to 2,400 METRES

- Selectivity—genuine 9 Kilocycle separation.
- Advanced A.V.C. gives strong reception without fading of even weakest signals.
- Improved signal-to-noise ratio, due to use of single purpose valves.
- Automatic wave-band selector.
- World time comparison clock, automatically controlled tuning knob.
- Power output 15 watts.

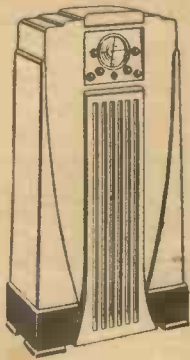

The 15 valve NEW IMPERIAL "YORK" Receiver—in handsome walnut cabinet.

The NEW IMPERIAL 15-valve 6 WAVE-BAND Receiver

BRITISH MADE

WE CAN GIVE IMMEDIATE DELIVERY OF ALL MODELS FROM STOCK

★ Write for fully descriptive Art Catalogue No. WR.7

DEMONSTRATIONS
at our showrooms daily 9-8,
(Tuesday 9-6). Open all day
Saturday.

MIDWEST RADIO (MFG.) CO. LTD.
16, OLD TOWN, CLAPHAM, LONDON, S.W.4

Near Clapham Common
Tube Station, Edgware-Morden line.

Telephone: MACaulay 5005

ENGINEERING OPPORTUNITIES

Free!
This unique Handbook shows the easy way to secure A.M.I.C.E., A.M.I.Mech.E., A.M.I.E.E., A.M.I.A.E., A.M.I.W.T., A.M.I.R.E., and similar qualifications. **WE GUARANTEE—NO PASS—NO FEE.** Details are given of over 150 Diploma Courses in all branches of Civil, Mech., Elec., Motor, Aero., Radio and Television Engineering, Building, Government Employment, etc. Write for this enlightening Handbook to-day **FREE** and post free.
British Institute of Engineering Technology, 278, Shakespeare House, 17, 18, 19, Stratford Place, W.1.

Almost every householder in the United Kingdom has bought and used an

ELECTRON AERIAL FROM 6^d.

to improve his radio reception **HAVE YOU?** or are you failing to get the best Results?

PROOF!
Ask any one of Millions of delighted ELECTRON ENTHUSIASTS.
FROM DEALERS EVERYWHERE OR WRITE TO:—
The NEW LONDON ELECTRON WORKS, Ltd.
1, EAST HAM, LONDON, E.6.

PRE-PAID CLASSIFIED ADVERTISEMENTS

RATES for Small Advertisements in "World-Radio" are as follows:—2s. 6d. per line (average of 6 words) with a minimum of 2 lines, box number 6d. extra. Series discounts, 5% on 13 insertions, 10% on 26 insertions, 20% on 52 insertions. All advertisements, which should be accompanied by a remittance and the full name and address of the advertiser, must reach The

Advertisement Director, BBC Publications, 35, Marylebone High Street, W.1, not later than Friday of the week prior to publication.

In the case of box numbers, readers should reply to the box number mentioned in the advertisement, c/o Advertisement Department, "World-Radio," 35, Marylebone High Street, W.1.

REPAIRS (AMERICAN)

"SERVICE WITH A SMILE"—HENRY FORD RADIO LTD. —American valves, components, spares, line-cords; leading trade repairs; send us your American and British receivers; estimates free. —Electronic House, 22, Howland Street, Tottenham Court Road, W.1. Museum: 5675.

SPECIALISED TRAINING

WIRELESS CAREERS. Increased Salaries and Pensions make Radio a profitable and interesting profession. We train students for all branches and guarantee appointments. Britain's Leading Colleges. Boarders accepted. Write for free prospectus—**WIRELESS COLLEGE, COLWYN BAY, or WIRELESS COLLEGE, CALMORE, SOUTHAMPTON.**

SPECIALISED TRAINING

CALEDONIAN WIRELESS COLLEGE—principal training centre for the Marconi Company—guarantees appointments to students on qualifying for first or second class P.M.G. Certificate. ALL RECORDS including SHORTEST TIME to qualify for both P.M.G. and London City and Guilds Certificates held by this College. 19, Woodside Crescent, Glasgow, or 22, Walker Street, Edinburgh.

ALL successful students guaranteed posts in WIRELESS Services. Young men urgently needed. Write or phone, Box W—London Radio College, Grove Pk. Rd., W.4 (CHI. 3244).

PHILATELY

"PHILATELIC MAGAZINE," stamp newspaper with largest Net Sale. 3d. fortnightly, any bookstall.

TRAINED MEN WANTED

For Radio & Television

We can train you for a successful radio career and help you secure employment, or teach you how to earn good money in your spare time. We specialise in Radio and all our energies are concentrated on helping our students to become money-earning Radio Engineers.

Read what students say:—"I was engaged on the spot as Engineer-in-Charge." "I have much pleasure in announcing an increase in salary and promotion." "He engaged me at a big increase in salary. I couldn't have got the situation without your help." "My engagement was due entirely to the knowledge I gained from your training." "I am already earning more money." "I could not have obtained this job without your Course." "I have obtained a position at double the pay." Etc., etc.

What they have done, you can do. Without interfering with your ordinary occupation you can learn in your own home how to become a Qualified Radio Engineer.

★ POST COUPON NOW FOR FREE COPY OF "RADIO AS A CAREER" AND FREE SPECIMEN LESSON. ★

TECHNICAL AND COMMERCIAL RADIO COLLEGE

Fairfax House, High Holborn, London, W.C.1.

Post in unsealed envelope: 1d. stamp.
To: T. & C. RADIO COLLEGE,
Fairfax House, High Holborn, London, W.C.1.
Please send me Free Specimen Lesson and free copy of "Radio as a Career," in plain envelope.

NAME

ADDRESS

W.R.94

An INVITATION To SCEPTICS

Are you one of those who have been forced into believing that a language can only be acquired through hard and bitter toil? Have you had unfortunate experience of specious promises? You are invited to send for the new Hugo booklet "Languages Can Be SO Easy." This will throw much new and revealing light on the subject. It will show you quite definitely that languages need no longer be a "closed book" to you.

HUGO Postal Self-Tuition Courses in FRENCH, GERMAN, SPANISH, or ITALIAN Write to **HUGO'S LANGUAGE INSTITUTE,** 64-66, Oxford Street, London, W.1, & branches. **MONTHLY 5!**

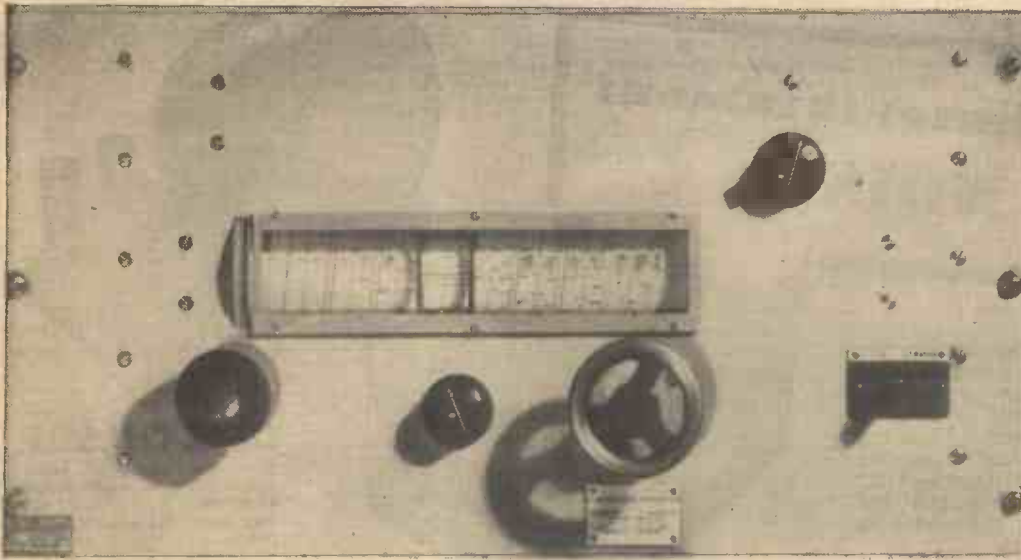

FREQUENCY MEASUREMENT

By H. V. Griffiths,

Engineer-in-Charge of the BBC Receiving Station at Tatsfield

THE activities of the BBC receiving station at Tatsfield, Surrey, in the sphere of high-quality reception of short and medium-wave signals, are frequently mentioned in the technical and general Press. The Measurement Service is less well known, and it is this work, carried out in a separate part of the building and demanding entirely different equipment, which will be discussed in this article.

The Measurement Room service may itself be sub-divided into two convergent duties—(a) accurate checking of the carrier-frequencies of BBC transmitters and also those of numerous foreign stations, and (b) the detection, measurement, and identification of broadcast, telephony, or telegraphy signals causing interference to BBC transmissions. It will be obvious that the two jobs are co-related, in that BBC transmissions are checked in order, primarily, that they shall conform to the frequencies and "tolerances" internationally agreed upon and so avoid interfering with other transmissions. Foreign telegraph or telephone transmissions on frequencies other than those allocated form the "interference" which has to be investigated and—sometimes more difficult—identified.

The demands made upon Tatsfield in these respects are therefore affected by the number of BBC transmissions in daily service, by the increasing number of broadcasting and other stations working on medium and short waves, by the frequency-bands and times of day occupied by these transmissions, by the simultaneous use of one allocated frequency by two or more transmitters (so-called "common-wave working," either national or international), and by the stability and precision of transmitting equipment.

Many of these factors vary from hour to hour and day to day, but it will be realised that the number of stations tends to increase steadily and that the full benefit of international arrangements such as the Lucerne Plan cannot be obtained except by more careful regulation of transmitter frequencies, necessitating more accurate measurement.

Some years ago it was sufficient for Tatsfield to measure the frequencies of transmitters to an accuracy of 1 part in five or ten thousand, the band over which such measurements were required being confined to 150 to 1,500 kc/s (long and medium waves). Nowadays, not only has the accuracy necessary become several hundred times greater, but the band has increased so as to include the Empire transmissions from Daventry and other short-wave

stations, as well as the vision and sound carrier-frequencies of the Alexandra Palace transmissions.

Moreover, the exact determination of audio-frequencies is required for the calibration of L.F. oscillators used at Tatsfield and elsewhere, for the alignment of valve-maintained master oscillators driven by tuning forks and quartz crystals and destined for transmitters, and for the needs of the BBC Research Department. The measuring equipment must, therefore, be suitable for any part of the frequency-spectrum between audio-frequencies and 60 megacycles per second.

Receiving Equipment

As almost all the measurements required are of radiated signals, suitable receiving equipment is the primary necessity. The less usual cases when the unknown frequency is either local or is sent to Tatsfield by line need not be mentioned further. The type of receiver most suitable for the Measurement Room will tend to be somewhat different from that required for relaying work. High quality can be sacrificed in favour of extreme selectivity, but the controls of the receiver must be as few and as simple as possible, since there will be unavoidable complexity in the controls of the measuring equipment proper. Time is also an important factor and quick searching a necessity.

The receivers used for detecting the radio-frequency signals to be measured are, therefore, very selective and sensitive units of small size, with ganged tuning-controls. Internal beat-oscillators are available for C.W. telegraphy reception, and high-speed telegraph signals can be recorded for identification. Associated circuits provided include crystal-filters and low-frequency band-elimination networks in order to improve intelligibility when loud heterodynes are present.

At present, there are three receivers which cover the 150 to 1,500 kc/s band, two of these being effective also on the short waves from 1.5 to 30 Mc/s. Additional units function between 15 and 150 kc/s (low radio-frequencies) and 30 to 60 Mc/s (ultra-short waves).

It should be noted that different receivers have different intermediate frequencies and there is one "straight" receiver for broadcast reception. This variation of type of receiver is very useful when investigating unusual phenomena, such as the "gyro frequency" effect, the reported presence of summation and difference-frequencies or "spurious radiations" believed to be due to transmitter faults. It is obviously necessary to

take every precaution to verify such types of emission which may otherwise be confused with unwanted spurious signals of the type liable to be produced in superheterodyne reception.

Before leaving the receiving equipment it may be mentioned that both frame and open-wire type aerials are available on medium waves and

Precision low-frequency interpolation oscillator calibrated directly in frequency. Range: 600-1,800 c/s. Accuracy: 0.2 c/s at 1,000 c/s + 10 c/s; 0.5 c/s all ranges

a choice of directional or non-directional aerials on short waves.

Accuracy Required

Modern transmitters having quartz-crystal, tuning-fork, or tuned-circuit drives operating under conditions of controlled temperature may have stabilities of from two to one hundred parts in ten million (*i.e.*, from 0.00002 to 0.001 per cent) from day to day. The stability and accuracy of the measuring equipment should therefore be better than this. But the first-mentioned figure is already so good that the measurement equipment cannot expect to be much more than ten times better than the average "stable" transmitter. A limit of 1 part in 10^8 or 0.000001 per cent, has actually been adopted as the present "ideal" stability over long periods.

At the time of writing, routine curvilinear measurements are limited to a maximum accuracy of 1 to 2 parts in 10^7 , but experimental frequency-standard circuits are being developed in conjunction with the BBC Research Department which are expected to have a stability equal to the ideal mentioned above. It is hoped that they will be in regular use shortly.

The value of accuracy in enhancing the prestige of the measuring station must not be neglected. Complaints to foreign administrations of interference caused by stations under their control carry more weight if the measured frequency of the offender is stated precisely, and if it is known fairly widely that the measurement centre originating the complaint is invariably both accurate and careful.

Such occasions as the International Comparisons of Frequency Standards in which Tatsfield has frequently participated have, it is hoped, established its reputation for accuracy. The regular interchange of daily measurements between Tatsfield and the Control Centre of the U.I.R. at Brussels provides continuous opportunity for comparison and liaison which is extremely valuable.

Before discussing modern equipment likely to fulfil the requirements outlined above, a review of the earlier equipment may be of interest and may assist in assessing future development.

Simple "Wavemeters"

There have been numerous methods evolved for measuring the frequency or wavelength of radio signals. Of these, the Lecher-wire was perhaps the earliest.

The simple absorption-wavemeter is another familiar device, the frequency of the radiation being obtained by reference to the known values of inductance and capacitance at resonance.

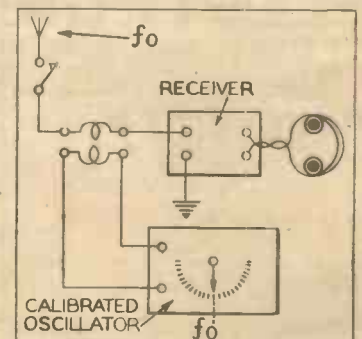

Fig. 1—Calibrated valve oscillator

Since neither of these arrangements is suitable for the measurement of weak distant signals, the first development for this service was the calibrated valve-oscillator adjusted to heterodyne the unknown frequency (see Fig. 1). A later modification of the heterodyne wavemeter made use of two such oscillators, one of which was closely calibrated and was used for the actual measurement, the other being used to produce a steady audible heterodyne with the signal, in order to overcome the difficulty of detecting the zero-beat position when using only one oscillator.

The accuracy of measurement was improved from about 1 part in 10^3 to 1 part in 10^4 by the design of coils and condensers of low temperature coefficient, and until about six years ago this comparatively simple equipment was in almost universal use for such work. The original Tatsfield wavemeter, manufactured by Messrs. H. W. Sullivan, is still in existence, although not in service. A more accurate instrument of later manufacture by the same maker is still used as a part of the present measuring equipment, modified in certain details. Its calibration is not used directly in the measurement, however, as will be seen later.

As improvements in the design and operation of transmitters became necessary by reason of the greater number of stations radiating within strictly defined bands, the accuracy of the measurement centres had also to be improved. The advent of the valve-maintained tuning-fork and of the crystal oscillator suggested methods by which the calibration of the variable-frequency heterodyne wavemeter could be checked by reference to the more stable fixed frequencies generated by these new circuits.

Both at Tatsfield and elsewhere tuning-forks were installed which operated at a temperature which was maintained constant independently of the fluctuations in room temperature.

Fixed Frequency Standards

It is obvious that the single-frequency "standards" mentioned above could be designed to be more stable than the variable heterodyne-

then compared daily with the most accurate British time-signals and the departure from normal of the fork calculated therefrom.

The output from the multi-vibrator was passed through a flatly tuned radio-frequency amplifier which enabled harmonics of the 1 kc/s fork to be detected as high as the two-thousandth. These harmonics were at first used only to verify the calibration of the heterodyne wavemeter.

It is obvious that if the scale of the heterodyne-oscillator is reasonably linear, improved accuracy may be obtained by interpolation of the unknown frequency between the scale readings corresponding to two known adjacent harmonics of the fork (see Fig. 2).

Linear-Scale Interpolation

The unknown frequency, f_0 , is heterodyned at zero-beat and the corresponding scale reading θ_0 noted. Scale readings of the adjacent "harmonics" θ_1 and θ_2 are also noted. The difference between θ_1 and θ_2 becomes the denominator of a fraction; the numerator makes use of the difference between θ_0 and θ_1 and, by simple calculation, the frequency of the reading θ_0 is obtained without any additional equipment to that already mentioned.

In addition to the error of the frequency-standard (if any) other errors are introduced which limit the accuracy of this system, although it may easily be better than the calibration-checking scheme. The care with which the heterodyne is adjusted to zero-beat, the accuracy of reading the scale and the linearity of the scale will all affect the resultant figures and a further improvement was therefore suggested, requiring slightly increased equipment, but eliminating reliance upon quasi-linear scales and care in slide-rule computations. This improved method is known as "audio-frequency interpolation" and is now in general use in one form or another at most of the accurate measurement-centres.

The accuracy of the linear-scale interpolation system cannot generally be made greater than 1 part in 10^5 . The limit of the audio-frequency interpolation method is probably about 1 in 10^7 with modern apparatus. Before describing it in detail, however, we should return to the subject of frequency-standards and consider what was being done at Tatsfield about the year 1933.

Short-Wave Working

It was at this time that the increasing use of short waves for broadcasting made it necessary to extend the frequency band over which measurement was made. The two-thousandth harmonic of the fork was no longer a useful upper limit, measurement being required on 15 and 21 Mc/s instead of 2 Mc/s. Television on ultra-short waves would increase the upper limit still further. The heterodyne oscillators at Tatsfield, as well as the fork harmonics, were limited to 2 Mc/s and the stability of the tuning-fork standard was not better than 3 parts in 10^6 . It was necessary to take action quickly to increase the band-coverage in order to control the new Empire transmitters. An improved primary frequency-standard was also required.

All modern systems of measurement depend primarily upon the harmonics generated from a standard oscillator. Although tuning-forks

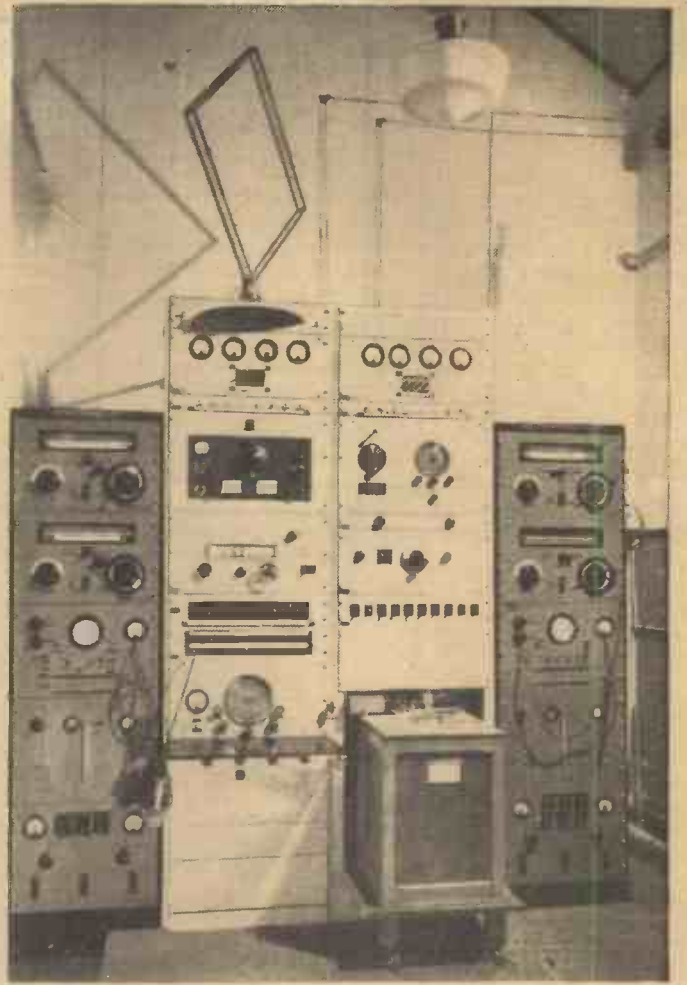

Tatsfield Measurement Room: Multivibrators, H.F. and L.F. Interpolation Oscillators, and Receivers

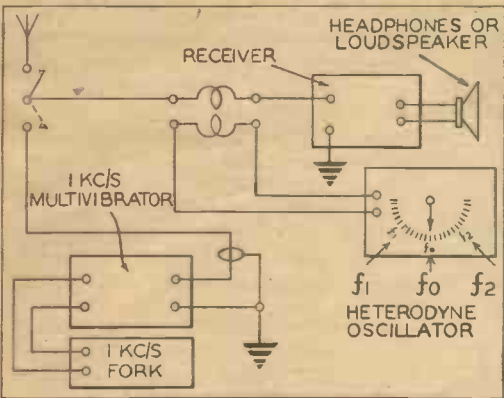

Fig. 2—Arrangement for scalar interpolation measurements

oscillators. If multiples or other derivatives of these single frequencies could be obtained, they could be used as calibration-points. The device known as the Abrahams-Bloch "multivibrateur" is a relaxation oscillator capable of being locked so that its fundamental and harmonic frequencies are completely controlled by that derived from the primary standard. Exact multiples of the standard frequency could be detected at intervals of one kilocycle per second throughout the broadcasting bands on medium and long waves, using a tuning-fork vibrating at one kilocycle per second as a primary standard.

A multivibrator was coupled to the fork through a suitable buffer-amplifier, and a Muirhead synchronous electric clock also driven from this amplifier permitted the frequency of the fork to be defined by the time shown by the clock. Time impulses from the clock were

have some advantages such as the simplicity and directness of the circuits associated with the synchronous-clock and the lesser number of multivibrator circuits required, they have certain disadvantages when compared with the quartz-crystal-controlled oscillator.

In brief, tuning-forks require more elaborate precautions to avoid the effects of variations in barometric pressure and temperature. If a quartz crystal is suitably cut its temperature coefficient is very low.

There had recently been placed upon the market several sets of equipment which had stable quartz-crystal master-oscillator, suitable multivibrators to provide a wide range of harmonic-intervals, and a heterodyne oscillator having ranges up to 10 or 15 Mc/s. One such equipment was the Marconi 482-C equipment. Although it was designed to be used according to the scalar interpolation system already described, it could be adapted for audio-frequency interpolation by making minor modifications and the addition of the audio-frequency circuits.

One equipment of this type was acquired and modified without delay. After a period of successful use, a second equipment with a heterodyne-oscillator calibrated for ultra-short waves was also obtained. There were thus duplicate medium-wave and short-wave oscillators, one ultra-short-wave oscillator and two crystal frequency-standards, and multivibrators with separate synchronous clocks.

Tatsfield had, by then, extended its service to cover the short waves down to 5 metres, using the audio-frequency interpolation method (to be described next week). The accuracy of all measurements was increased from 1 part in 10^5 early in 1930, to ± 1 part in 10^6 in 1931, thence to ± 5 parts in 10^7 or better depending upon the closeness of the adjustment of the transmitter concerned to its allotted frequency.

(To be concluded next week)

Temperatures in the Stratosphere

By CHAS. G. PHILP, *Author of "The Conquest of the Stratosphere," etc.*

(Continued from page 12 of last week's issue)

THE fact that the maximum ionisation in Region F on a summer noon was found to be less than on a winter noon appeared, at first sight, so startling that some workers concluded the critical frequency method of measuring atmospheric ionisation, as adopted by Professor Appleton, was untrustworthy, and that observations made by it could not be accepted.

But Professor Appleton, rather than accept this conclusion, prefers to explain the contrast by assuming that the abnormally low value of the summer noon ionisation density in Region F can only be the result of a reduced summer air density. (In other words, if there are fewer air molecules per unit area there will be reduced ionisation.) And that such a reduced air density can again only be the result of an increased temperature. Put into quantitative form, he concludes that the molecular temperature must be from three to nine times as high on a summer noon in Region F as on a winter noon, and that the absolute temperature at a level of 300 km. (186.4 miles) must be at least 1,000° C. on a summer day.

As a preamble to his "furnace belt" theory, Professor Appleton refers briefly to the principal theories which support the belief that belts of high temperature exist in the Stratosphere. Because of their "trustworthy evidence" he is led to examine the effects at still higher levels. It will be gathered, however, from the analyses herein made of the theories in question—referred to as (a) and (b)—that the evidence is, perhaps, not quite so trustworthy as he imagines.

With the exception of a brief reference to the fact that the great heights of the ionosphere "cannot be reached by manned balloons, and that most of the detailed information we possess concerning the ionosphere has been made by radio methods," Professor Appleton appears to me to show nowhere in his articles that he had appreciated the immense amount of competent scientific research work which had been devoted to ionisation phenomena in the upper regions for many years past, culminating in the manned stratosphere balloon ascents which had taken place in the four years immediately preceding the announcement of his discovery.

Ionisation at High Altitudes

So long ago as 1911-13 Hess had discovered that ionisation at great altitudes was markedly in excess of its ground value; also that such ionisation was due to a radiation from outer space—now known as cosmic rays—which, since it had the same intensity by night as by day, could not, in his opinion, be due to solar radiation.

The observations of Hess were confirmed and extended by Kohlhorster (1913-14), who was able to show that at a height of 9,000 metres (5.59 miles) ionisation was 40 times its ground value.

Regener measured ionisation up to an altitude of 30 km. (18.64 miles), where it attained maximum intensity. Millikan and Bowen did similar work.

And, finally, the spectacular stratosphere ascents of Professor Auguste Piccard (1931 and 1932); Lt.-Comdr. T. G. W. Settle (1933); Major Kepner, Dr. Cosyns, and Dr. Jean Piccard (separate ascents by each during 1934); and Captain Albert Stevens (1935), who reached the greatest altitude yet attained by man (13.71 miles), by their collective results added enormously to our knowledge of the ionisation taking place at great heights in the atmosphere.

The highly efficient and thoroughly competent manner in which these studies were conducted

is not generally realised. Captain Stevens took aloft with him no fewer than 64 instruments and pieces of scientific equipment, weighing in the aggregate over a ton, and remained at his maximum altitude for more than an hour and a half. One of his instruments—an electroscope for measuring cosmic ray intensities—weighed 600 lb. alone! A special feature of the equipment was that it was of the automatic self-recording type, so that the data obtained were photographically recorded for subsequent analysis.

At the outset, Professor Appleton makes it quite clear he reached his conclusions by comparing the observed diurnal and seasonal variations of ionisation at earth levels with those expected in the ionosphere according to a simple theory of photo-ionisation by solar radiation. (*Nature*, p. 52.) According to this theory, the summer noon value of ionisation at ground levels in South-East England should be 1.84 times that experienced on a winter noon.

Having first obtained by wireless frequency penetration methods the maximum ionisation density in Regions E and F on a winter noon, he calculates similar summer figures by the aid of the ratio 1.84, referred to in the previous paragraph, and then compares these calculated figures with the figures obtained by radio methods, in the hope they will prove to be more or less in agreement.

Such a relation could logically be expected to exist provided the originating causes of the ionisation taking place at ground levels were the same as the originating causes of the ionisation taking place in the ionosphere.

Causes of Ionisation

That there might be different causes originating ionisation in the ionosphere, as compared with that operating at ground levels, does not appear to have occurred to Professor Appleton and he adumbrates his theory on the (unproved) assumption that the known dominant cause of ionisation at ground levels—the ultra-violet section of solar radiations—is also the dominant cause of ionisation in the ionosphere. We will now see how far such an assumption was logical and justifiable.

So far as is known by science to-day, the causes of atmospheric ionisation, at ground levels, are (a) ultra-violet rays from solar radiations, (b) evaporation of water, (c) escape of earth gases, (d) radio-active matter in the soil, (e) breaking up of crystalline substances, and (f) cosmic rays, whose origin is as yet unknown. Whether cosmic rays are produced in far-off nebulae, or in the stars, or the mysterious depths of infinite space, or in the sun, or conceivably by the action of corpuscles shot out by the sun in the upper layers of the earth's atmosphere, science has yet to learn.

And of all these causes—cosmic rays included—it is generally accepted that the action of ultra-violet rays in the production of atmospheric ionisation at ground levels is ten times as great as any other known cause.

So far, then, Professor Appleton had every justification for ignoring cosmic ray action and in assuming that the only predominant cause of atmospheric ionisation was the action of solar radiations (ultra-violet rays).

When we come to analyse the causes of ionisation in the higher reaches of the atmosphere, however, we find quite a different story to tell. On the occasion of the most recent ascent into the Stratosphere, Captain Stevens took with him no fewer than six different kinds of full-sized laboratory instruments for recording various



The National Geographic Society Army Air Corps stratosphere balloon "Explorer," with fabric torn, during the last 7,000 feet of its descent near Holdrege, Nebraska, in November, 1935

phenomena in connexion with cosmic rays. By actual photographic records of the numbers and intensity of cosmic rays it is now known conclusively that at a height of 13.71 miles the dominant cause of atmospheric ionisation is cosmic rays, and that, relatively to cosmic rays, the effect of solar radiation in the shape of ultra-violet rays is negligible! Moreover, there is every reason to believe that cosmic ray intensity increases with altitude, and that its dominance in atmospheric ionisation is maintained the higher we ascend.

Cosmic Rays

In a paper on the scientific results garnered by his world record flight, Captain Stevens states: "At very high altitudes the shortest of the sun's ultra-violet rays have not been screened by the atmosphere, and they cause ionisation. However, throughout most of the region we explored, ionisation is thought to be due almost entirely to cosmic radiation."

Space will not permit of a description of cosmic rays or of the quantitative and qualitative results for different altitudes obtained and recorded by the various stratosphere ascents. Full details are given in my book *The Conquest of the Stratosphere*, to which the reader is referred.

We see then, that Professor Appleton's assumption that the dominant cause of ionisation in the ionosphere was solar radiation (ultra-violet rays) was not subsequently supported by the most elaborate and painstaking analysis of atmospheric ionisation ever made by science. In point of recorded fact, stratospheric research indicates that atmospheric ionisation all the way up through the earth's atmosphere is due much more probably to cosmic ray action than to the action of solar radiation.

At this juncture it may perhaps be objected that the eclipse of 1927 definitely proved that the Heaviside Layer of ionised atmosphere was due to solar radiation—ultra-violet rays.

If so, let us now consider a more recent eclipse, that of the sun which took place on August 31, 1932, with totality visible in Eastern Canada, and Northern New England. On the occasion of this eclipse, the radio eclipse began two hours before the visible eclipse, and at a considerable distance east where nothing unusual could be seen about the sun!

Observations During Eclipse

In his description of the radio effects caused by this eclipse, Dr. E. F. W. Alexanderson, the distinguished radio engineer, stated:—"... at Conway, N.H., the radio eclipse started at 1.30 p.m." (The visible eclipse was total at 3.28.) "As the moon began to cast its shadow over the earth, the radio signals gradually became stronger, and were back to full strength about half an hour before the totality of the optical eclipse."

Now the ultra-violet light of the sun travels with the visible light, and must be eclipsed at practically the same time. Hence, whatever may be the cause of the ionisation of the upper ionosphere—the wavelength used by Dr. Alexanderson being 34.64 metres (8.655 kc/s) it would have been reflected from Region F—it could not have been caused by ultra-violet rays, since the radio eclipse should coincide with the optical eclipse. And at the time of the optical eclipse there was no loss in signal strength.

It has been urged that the radio eclipse on this occasion was caused by the interruption by the moon of a stream of corpuscles, shot out by the sun at a velocity around 1,000 miles a second. But in our present analysis we are not concerned with any other form of solar radiation, since it has never been suggested that the dominant cause of

ionisation at ground levels is other than ultra-violet rays. And it is the seasonal variation in ionisation at ground levels that forms the basis of the "furnace belt" argument.

It seems impossible to deny, from the evidence accumulated by stratospheric research, that cosmic ray ionisation must play a part, if not the most important part, in the ionisation of the ionosphere. Once this is admitted, any theory based on the assumption that ultra-violet radiation is the dominating—if not the sole—cause of ionisation of the ionosphere must collapse.

For, unlike ultra-violet radiation which is an etheric wave with a definite velocity, a definite origin, and a definite unchanging frequency, cosmic rays are believed to be corpuscular, with varying velocities, and an unknown origin—or, more probably, origins.

Moreover cosmic rays are strongly subject to the earth's magnetic field, and only those with the greatest velocities can get anywhere near the earth. In such circumstances there would be a tendency to belt formation of the ionising effects they produce, and it would be perfectly feasible, for cosmic rays to cause "seasonal" and "diurnal" effects, in so far as some of them at least originated in the sun, and exactly the opposite in so far as they came from nebulae or stars or other unknown source. And there is also the strong probability that other "rays" or "corpuscles," as yet unknown, take a hand in the ionisation of the ionosphere.

Summing up the results of our analyses of the three theories (a), (b) and (c)—quoted in the beginning of the first of these articles—which seek to demonstrate the existence of belts of heated air high up in the atmosphere, we find:—

Theory (a). Is at variance with new theoretical discoveries which show that the heat generated by meteors is generated adiabatically and for that reason the refraction and tempera-

ture of the atmosphere play no important part in the heat generated. Also the suggested means by which the atmosphere might be warmed—by the formation of ozone from oxygen by solar radiation—is contrary to known physical laws.

Theory (b). The "heat belt" assumed to exist at a height of 25 miles is proved not to exist by "sounding" balloon test. And it is shown in the discussion that if such a belt exists higher than 25 miles, the return, from it, of audible sound waves is a physical impossibility.

Theory (c). This theory is based on the unproved assumption that the dominant cause of ionisation at earth levels (ultra-violet rays) is the same as the dominant cause of ionisation in the ionosphere. Subsequent stratospheric research proves that at a height of 13.71 miles the dominant cause of ionisation of the atmosphere at this level is cosmic rays, and there are good reasons for supposing that the intensity of cosmic ray ionisation increases with altitude. By confining his argument to ionisation effects from solar radiation, and ignoring the vastly more important cosmic ray action, Professor Appleton has vitiated his whole argument by the inadequacy of his treatment of the problem. The assumed proof by eclipses is sometimes the reverse, and recent experimental work by competent radio engineers has once again thrown doubt on the Heaviside Layer theory and, with it, the theory of the ionosphere itself.

Laws, theories, and hypotheses are all on probation, and however plausible or convincing they may have been in the past, as soon as they fail to unite and co-ordinate new facts, their work is finished. The three theories, herein analysed, which sought to prove the existence of "heat belts" in the Stratosphere have failed to interpret the new discoveries brought to light by the entirely new technique of stratosphere research. For that reason they should each now be modified or discarded.

CUT THE CRACKLE OUT OF RADIO

Notes on Interference Suppression.—No. 16

POINTING THE WAY TO PEACE

*Type 300 Suppressor (3-stage choke and condenser fitted with self-contained earth choke) is fitted at the plug point supplying the mains-driven receiver. Ensures that no conducted interference gets through. Particularly useful in flats, terrace houses, etc. If unsatisfactory in your case, you get your money back (purchase price, less postage).

Where the interference is known to reach the receiver via the aerial, from such sources as trams and trolley buses, or when it is desired to feed more than one receiver from one aerial, and without interaction, the †"Eliminoise" is required.

In severe cases of interference, both types of suppressors may be found necessary. It is frequently so; but in any event you must have a good aerial and earth to get the best out of your set. Consult your dealer.

*Type 300 Mains Filter for set lead, 10 to 2,000 metres. Price, 25s.

†"Eliminoise" (Trade Mark) Anti-Interference Aerial, 10 to 2,000 metres; Transformers only, 37/6d. Complete Kit, already wired with 60ft. aerial and 50ft. screened cable, in gold box, 55s.



Please send, FREE, 8-pp. booklet (P261 H) "Wireless Without Crackling."

Name

Address

W.R.11/3/38



WORLD'S RECORD LOG
secured with a **TROPHY**

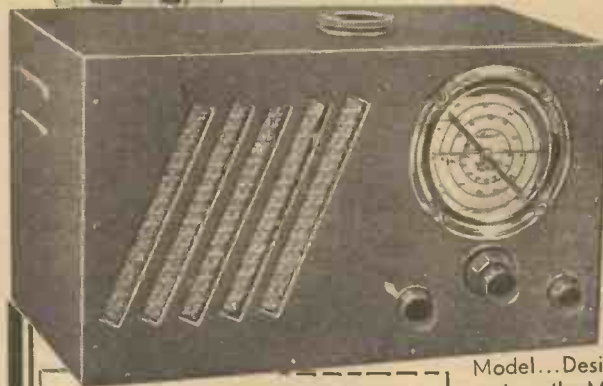

SHORT WAVE RECEIVER

In putting before you details of the wonderful Trophy Receivers, B.T.S. are proud to sponsor a series of Short Wave Receivers that so amply support the claims of the designers... Based on the circuit design used by the World's Champion Short Wave Station "logger." Three models to choose from... the Trophy 2, a duplicate of the set used by the designer, who secured 247 for his Trophy record. The Trophy 3 in two versions, A.C. Mains Model and Battery

Model... Designed for the reception of the World's Broadcasts on the Moving-Coil Speaker incorporated. Supplied complete with all valves and two of the famous B.T.S. One-shot Inductors covering 12-52 metres and housed in beautiful black crystalline finished steel cabinet. Effective Waverange of the TROPHY 3 Receivers, 6-550 metres using extra (Type "S.L.") B.T.S. One-Shot Inductors available.

B.T.S. "ONE-SHOT" Self-Locating INDUCTORS

Plug-In Coils with a difference! A twist, a push, and the coil is firmly home... The new B.T.S. Inductors are a boon to every constructor. Special spirally cut slots in the coil pins and sockets ensure 100% efficiency on all wavebands. B.T.S. One-Shot Inductors supersede ordinary 6-pin plug-in coils.

TYPE	RANGE	PRICE EACH
9/MW	190-550 metres	2/9
9/LW	900-2000 "	3/3
9/S2	15-43 "	2/6
9/S3	24-70 "	2/6
9/S1	9.5-27 "	2/6
9/S0	Television Sound	2/9

The above waveband coverages are with .0005 mfd. Tuning Condenser. A further range of B.T.S. One-Shot Inductors (Type "S.L.") is available for .00016 mfd. tuning as used in the Trophy Receivers.

★ B.T.S. One-Shot Inductor chassis mounting Bases 1/- each ★

B.T.S. Products are obtainable from all good Dealers. If difficulty is experienced, write to us direct.

TROPHY 2 BATTERY MODEL

Supplied complete with 2 specially matched valves, lightweight headphones, and 2 One-shot Inductors, less Batteries. Not illustrated

£4:15:0
or 7/6 down and 12 monthly payments of 8/3

TROPHY 3 BATTERY MODEL

Supplied complete with 3 matched valves, 2 B.T.S. One-shot Inductors and speaker, housed in cabinet as illustrated above, less Batteries

£5:15:0
or 9/6 down and 12 monthly payments of 9/11

TROPHY 3 A.C. MODEL

Supplied complete with 2 matched valves and rectifier, 2 B.T.S. One-shot Inductors and housed in cabinet as illustrated, 200/250 v., 40/100 cycles

£6:6:0
or 10/- down and 12 monthly payments of 10/9

BRITISH TELEVISION SUPPLIES Ltd.
Faraday House, W.R.1, 8/10 Charing Cross Road, LONDON, W.C.1. Telephone: Temple Bar 0134

Short-Wave News-Reel

Compared by "RANGER"

Fifty per cent of the contributions sent in this week deal with the dramatic "O.B." from the flooded area around Hollywood, and selection was rather difficult. However, I consider the following story best conveys the essential facts and the general atmosphere of the broadcast. The type of receiver was not stated.

THE HOLLYWOOD FLOODS

WHILST listening to W2XE on Friday, March 4, at 20.15 G.M.T., we were taken to Hollywood to hear a description of the serious flooding.

Southern California, we learned, was isolated. Water, fallen trees, and telephone poles blocked the roads. This broadcast was only possible through the medium of a short-wave station. The worst was past, they hoped, and the sun was now shining. The floods were the most serious for 25 years.

Thousands had been rendered homeless, and millions of dollars' worth of damage had been done. The four days' rain had broken a 62-years' record. Seven inches of rainfall was recorded in one day! Schools and shops were closed, and it will be a day or two before the railroads are in full operation. Streams that had been mere trickles of water were now raging torrents. Hundreds of stamps were destroyed by water flooding the Post Office.

The Mayor of Los Angeles spoke. He said that although a good deal of damage had been done it was in no sense a major calamity, and that many rumours circulating regarding the number of fatalities were unfounded. "Los Angeles," he concluded, "is still smiling."

Back in the Hollywood studio further graphic details were given. Youths swimming in the main streets—women crossing roads barefoot—hundreds of houses inundated. We seemed to be transported to this swirling, seething, mad rush of waters.

Then came the calm. We were returned to New York, and another outstanding American O.B. was over.

Aberdeen.

D. M.

"MARDI GRAS" IN NEW ORLEANS

From "nature in the raw" we turn to the gay festivities associated with this now-celebrated annual event in New Orleans.

LISTENERS to W2XE at 21.15 on March 1 were taken to New Orleans, where the "Mardi Gras" festivities were in progress. With the strains of a swing band in the background the announcer explained the history of these festivities, which, he said, were also being held in France. It was exactly 111 years ago that a party of young men returned to New Orleans from Paris, and they decided to hold a small party to celebrate their return home. This celebration had increased through the years and is now known throughout the world. People from all over the States visited New Orleans to participate in the festival.

"This," the announcer continued, "was 'Mardi Gras.' A day of a hundred parades—processions of gaily decorated cars—the crowds excited to a crazy mob by the swing bands on every street corner." Tom Rex, "King of all Carnival," was introduced and sent greetings to the President and to every listener throughout the world. The high-spot of the day, we were told, would be at 9.0 p.m., when 40,000 people dressed as mascots would gather at the City Hall for a "grand show."

Then we were taken into the streets to hear the excitement of the crowds, and the announcer's words, "So ends the broadcast of the famous 'Mardi Gras,'" brought a most enjoyable programme to a close.

Chadwell Heath, Essex.

E. L. P.

WE, THE PEOPLE

The regular programme feature described below is, in many respects, similar to our BBC item "In Town Tonight," and every bit as interesting. It certainly affords listeners unexpected glimpses of American life and people.

"WE, THE PEOPLE," broadcast from W2XE every Friday morning at 00.30 G.M.T., began, on March 4, with two East-side boys doing a very "un-Bowery-like" thing—namely, singing the praises of their little sisters! Next we heard the son of our famous Dr. Watson. Dr. Cositer Smith told of his father meeting Conan Doyle during their college careers at Edinburgh. A professor there, Sir Joseph Bell, remarkable for his powers of observation, was the forerunner of Doyle's well-known Sherlock Holmes. Dr. Smith's father also received world-wide publicity by becoming the Dr. Watson of Holmes's adventures.

After this came a choral piece by waiters of a New York hotel, followed by an appeal by a jeweller whose shop had been ransacked. The burglars had stolen 700 dollars and a photo of the jeweller's only son who had been killed in a smash. This heart-broken father pleaded with the thieves to send back his boy's picture.

A baseball player describing a famous match was heard next, followed by an explorer giving an account of a cave discovered in New Mexico. A humorous touch was supplied by a "country cousin" who had created a sensation in his home town on his wedding day. He had been married in his father's wedding "pants"!

Aberdeen.

A. L. S. A.

AS OTHERS SEE US

The last episode this week presents, in very general terms, the opposite side of the picture to the preceding item. One of "the people" gives his impression of his fellow-men in Europe.

It was very interesting to hear—from W2XAD, at 19.15 on March 6—an impression of Europe, and more particularly of England, from an American just back from our side of the Atlantic.

The speaker declared that, despite all the talk of war which is so rife in Europe at the present time, he did not for a moment believe a major catastrophe was imminent. The ordinary citizen, he said, was far too antagonistic to war for any Government (including the dictators) to risk a conflict for some years to come.

Most of the "scare talk," he said, originated, in the first place, in the Press. Americans had been told that Britain would keep the peace until after the Coronation, and that then the fireworks would start. The Coronation had been over a long time now and yet there was no war. He had only just read in one American paper that the war was now postponed until after the Glasgow Empire Exhibition! Such sensational journalism was, he said, greatly to be deplored.

Having seen for himself the great preparations being made at Glasgow, he advised all his countrymen who could possibly do so to pay

Below 100 Metres By "SCOTIAN"

(February 27—March 4)

VERY favourable conditions have prevailed on most evenings on all wavelengths from 16 m. upwards. The U.S.A. stations have provided many fine transmissions and W8XK on 13.93 m. and 19.72 m. is now giving improved reception owing to the new aerial system in use. Below 13 m. has been quiet in the evenings during the early part of the week but became active again from Thursday.

On Sunday afternoon (February 27) W2XE (13.94 m.) and W3XAL (16.87 m.), were both reliable U.S. channels at R8 and R7 respectively, and JIB (28.49 m.) gave an R6-7 signal. Around 23.00 some "flutter" was noticeable on 25 m.; nevertheless, W2XE, W1XAL, and JZJ were quite good, while COCQ, LRX, W1XK, and W2XAF could easily be heard on the 31 m. band.

The 16 m. and 19 m. U.S. broadcasters were all active during the early evening on Monday, the best heard being W3XAL. At 19.40, W2XAD (19.57 m.) was the outstanding signal (R8) on the 19 m. band, whilst W8XK (19.72 m.), though R7, was affected by a peculiar form of distortion at times. Later, conditions generally became "fluttery" and not too good for distant listening.

When radiating the daily sports bulletin at 08.45 on Tuesday, VLR (31.32 m.) was R5-6 with good intelligibility. In the evening conditions had become rather poor, practically all distant transmissions being affected by "flutter." LRX (31.06 m.), however, came in at 22.00 (R7) apparently unaffected by the prevailing conditions.

VLR was noticeably better at 08.45 on Wednesday (R6-7). At 13.45, W2XE and W8XK (13.93 m.) were R8 and R6 respectively. The 16 m. and 19 m. U.S. stations maintained a reliable strength until declining between 21.00 and 22.00. W2XE—R6-7 when opening his 25.36 m. transmission at 19.30 with the "School of the Air" feature—soon improved to R8. On the same band W1XAL was also R8 at 22.15, and JZJ was R6. At this time COCQ (30.77 m.) and LRX were R7 whilst W2XAF and W1XK both attained R7 around 23.00. At 23.00 FZF6 (31.01 m.)—easily identified by the chime and call "Radio Martinique"—was surprisingly good, being R6-7.

Excellent conditions prevailed on Thursday evening and the 16 m. and 19 m. Americans gave very strong signals until a late hour. The eye-witness accounts of the floods in Los Angeles—relayed by short-wave radio link to the main networks owing to the failure of the landlines and heard *via* W2XE and W8XK—enabled listeners to hear up-to-the-minute news of the situation.

The 10 m. and 9 m. bands were quite active until around 19.00 on Friday whilst W9XJL and W6XKG were both audible on 11 m. at 18.20. W2XAD—R8 during the early evening—signed-off at 19.43 for about an hour. All bands continued to be very lively and give strong signals though some "flutter" was in evidence on 19 m. Among the many stations well heard around 23.00 PSH (R8) was worthy of special mention.

Schedule Changes at W2XE

As a result of reports on reception of programmes in Great Britain recently, W2XE, the CBS short-wave station, has made changes in its operating schedule from March 7, so as to utilise more favourable frequencies under present technical conditions affecting the station's European beam.

The station opens on 21.52 Mc/s (13.94 m.) as usual, but after the change at 18.00 G.M.T. to 15.27 Mc/s (19.65 m.), it remains on the same channel until signing off, 22.30 G.M.T. Hitherto, two frequencies were used during the latter half of the daily schedule. On Saturdays and Sundays, W2XE broadcasts on 15.27 Mc/s from 19.30-23.00 G.M.T. instead of on the previously-used frequency of 11.83 Mc/s (25.36 m.). The station is using—for the first time for many months—the frequency of 6.12 Mc/s (49.02 m.) during the final hour of transmission on its South America aerial, namely, 04.00-05.00 G.M.T.

a visit to this wonderful event, which he described as "the shop window of the world's greatest League of Nations."

Birmingham.

N. D.

Short-Wave Programmes

All times are given in G.M.T.

* Electrical Recordings.
† Gramophone Records.
‡ A second transmitter and aerial working on the same frequency.

SUNDAY, Mar. 13

EMPIRE

The Empire Programmes are printed in outline for the convenience of overseas readers.

Transmission 1 (GSG, GSO, GSF, GSD, GSB).

07.00—Big Ben; Wales v. Ireland Rugby Football commentary.*

07.15—Victor Olof Sextet: Olive Dyer (Soprano).

08.00—Service (R.C.).*

08.45-09.15—Big Ben; Newsletter; Sports Summary.

Transmission 2 (GSJ, GSH, GSG, GSO, GSF).

10.45—Big Ben; Life on the Island of Mull.*

11.20—Frederick Grinke (Violin).

11.35—Service (C. of E.).*

12.10—Talk: "For the Colonial Service."*

12.30—Band: Ronald Murgatroyd (Tenor).

13.10—Wales v. Ireland Rugby Football commentary.*

13.25-13.55 — Newsletter, Sports Summary.

Transmission 3 (GSJ to 15.30, GSH, GSG, GSF, GSD from 15.45, GSO to 15.00).

13.55—Opening Announcements.

14.00—Big Ben; A Visit to Weobley, Herefordshire.*

14.30—Falkman's Apache Band.

15.00—Concert.

15.45—Big Ben; Newsletter, Sports Summary.

16.05—Service (R.C.).*

16.50-17.00—Organ Music.†

Transmission 4 (GSG, GSD, GSB; GSP from 18.45; GSP, GSC, 17.20-18.15, Arabic transmission; 21.00-22.45 GSO, GSF, GSD, GSB, GSB†).

17.20—Tom Jenkins (Violin).

17.40—Talk: "For the Colonial Service."*

18.00—Big Ben; Newsletter, Sports Summary.

18.20—Clara Butt.†

18.30—Ethel Bartlett and Rae Robertson (Pftes.); BBC Orchestra (Section B); Conductor, Sir Adrian Boult.

19.55-20.45—Empire Service from St. Paul's Cathedral, London.

21.00—Big Ben; Newsletter, Sports Summary.

21.20—Mario de Pietro and his Estudiantina.

21.35—Songs and Duets from famous operettas.

22.30-22.45—Epilogue.

Transmission 5 (GSP, GSD, GSC, GSB, GSB†).

23.05—Handel's Pft. Music.

23.35—Talk: "For the Colonial Service."*

23.55—Lionel Monckton Melodies.†

00.05—Service (C. of E.).*

00.40—Newsletter, Sports Summary.

01.00-01.30—Big Ben; BBC Theatre Organ.

Transmission 6 (GSD, GSC, GSC†, GSB).

02.20—Scenes from "The Merry Wives of Windsor" (Shakespeare).*

02.55—Chopin's Pft. Music.

03.10—Newsletter, Sports Summary.

03.30-04.20—Big Ben; Empire Service from St. Paul's Cathedral, London.*

BARCELONA

(42.7 m.)

23.00—News (Foreign Languages).

(21.35 m.)

00.30-01.30—News (Eng.).

BOSTON

(19.67 m.)

16.00—Service from Trinity Church.

(25.45 m.)

18.00—Goodwill Programme from Boston to Athens.

(49.67 m.)

01.00—Esther Mott Tripp (Songs) from Boston Public Library.

BOUND BROOK

(16.87 m.)

14.00—Coast to Coast; Music; News.

17.20—Southernaire; Music-Hall.

18.30—Tuskegee Institute Singers.

19.00—Magic Key; Variety.

22.00—Metropolitan Auditions.

22.30—News.

(49.18 m.)
23.00-05.00—For Latin America.
05.00-06.00—Rebroadcasts.

BUDAPEST

(19.52 m.)

14.00-15.00—Music; Talk; Songs; Talk (Eng.).

(32.88 m.)

00.00-01.00—See 14.00.

BUENOS AIRES

(19.62 m.)

12.00—News; Records; Bargains.

(31.06 m.)

14.30—Music; at 17.00—News.

18.00—Markets; Music; Humour.

19.45—"Mundo Argentino."

20.00—Radio Drama; Music.

21.00—Jazz and Tango Bands.

00.30—Feature Programmes; Jokes.

03.00—News; Music.

04.00-04.30—Dance Music.

CARACAS

(51.72 m.)

13.30—R.C. Service; Music.

20.30—Opera and Dance Music.

00.30—World Melodies.

01.00-02.30—Dance Music.

HUIZEN

(16.88 m.)

12.25—For Asia.

13.25-15.30—For the Dutch Indies.

(31.28 m.)

19.00-20.00—For Africa.

00.00—For the Western Hemisphere.

01.00-02.00—For Latin America.

LYNDHURST

(31.32 m.)

08.00—Songs; Talk; News.

09.00—Alice in Orchestralia.

09.30—Records; Talk; Octet.

11.15—Two Plays.

13.15-12.30—News; Epilogue.

MILLIS

(31.35 m.)

23.45—The News behind Tomorrow's Headlines.

02.30—Walter Winchell.

MOSCOW

(25 m.)

11.00—Talks, etc. (Eng., Ger.).

13.00—Talks (Dutch, Fr.).

15.00—Talks, etc. (Eng., Ger.).

(39.79 m.)

18.00—Programme in German.

(50 m.)

20.00—Talks, etc. (It., Ger.).

21.00—Talks, etc. (Eng., Ger.).

(31.25 m.)

23.00—Programme in Spanish.

(31.25 m.; 39.79 m.)

00.00—Programme in English.

(50 m.)

01.30—Programme in French.

(25 m.)

03.15—Programme in English.

PARIS (Radio-Colonial)

(25.24 m.)

07.00-09.40—News; Records.

09.40-10.00—News (Eng., It.).

(19.68 m.)

11.00—Concert; at 12.00—News (Eng.); at 12.45—Review.

13.30—News; Talks; Records.

14.30-16.00—To be announced.

(25.24 m.)

16.15—News (Fr., Arabic); Music.

19.00—News.

20.10—News (Eng., It.).

20.30—To be announced.

22.30—Sports; News (Port.).

(25.6 m.)

23.15-01.15—Music; at 00.15—News (Fr., Sp., Port.).

03.00—Records; News.

04.30—News (Eng.); Records.

05.45-06.00—News (Ger.).

PITTSBURGH

(19.71 m.)

14.00—For Children; Variety.

16.00—Presbyterian Service; Songs.

17.30—Music-Hall; Talk.

19.00—R.C.A. Magic Key.

20.00—On Broadway; Band; Organ.

21.30—Shadyside Church.

22.00—Ed. McConnell; Hirsch.

23.00—Broadway Stars; Variety.

(25.26 m.)

00.00—Variety; Concert.

02.00—Hollywood Playhouse.

02.30—Winchell; Irene Rich.

03.00—Martin's Music; Cheerio.

(48.83 m.)

04.00—Music; News.

04.15—Missionary Broadcast.

05.00-06.00—Orchestras.

PODEBRADY

(31.41 m.)

For Europe.

18.00—News (Czech, Ger.); Band; Orchestras.

21.00—News; Talk (Fr.).

21.30-21.40—News (Eng.).

REYKJAVIK

(24.52 m.)

Programme not received.

ROME

(25.4 m.)

10.00—News; Folk Music.

11.00—News (Eng.); Music; News.

12.30-13.45—Concert; News.

15.00—News (It., Eng.); Music.

17.06-17.56—Music and Talk (Arabic).

(31.13 m.)

18.19—News (Romanian, Hung., Serb., Fr.).

19.36—News and Talk (Eng.).

19.57—Notes (Fr., Eng., Ger.).

20.00—From Rome (No. 1); at 21.00—Talk (Dan.); at 21.45—Notes (Fr., Eng., Ger.).

22.30—News (Sp., Greek).

23.00—For S. America; News; Music; Talk; News (Sp., Port.).

00.30-02.00—For U.S.A. News (Eng.); Opera; News.

SCHENECTADY

(13.95 m.)

13.00-17.00—Variety; Music; at 16.00—News; College Services.

(19.57 m.)

17.30—Talk; Music; Variety; at 20.00—Radio Newsreel.

(19.57 m.; 31.48 m.)

21.00—Organ; Soprano.

22.30—Mickey Mouse's Theatre.

23.00—R.C. Hour; A Tale.

(31.48 m.)

00.00—Variety; at 00.30—Talks.

02.00—Manhattan Merry-Go-Round.

02.30—Familiar Music; Variety.

04.30-05.00—News; Orchestra.

(31.4 m.)

00.30-05.00—To be announced.

TOKIO

(25.42 m.; 31.46 m.)

Programme not received.

VATICAN CITY

(50.36 m.)

10.00—For Invalids (Latin, Fr.).

WARSAW

(22 m.; 26.01 m.)

23.00-02.00—News (Pol., Eng.); Talk (Eng.); For Children; Talk; Music; Talk (Eng.); Poems.

WAYNE

(13.94 m.)

13.00—Organ; Salon Musicale.

13.45—Variety.

14.00—Wings over Jordan.

14.30—Aubade for Strings.

14.55—News; Congregational Service.

15.30—For Children.

16.30—Major Bowes' Amateurs.

17.30-18.00—Salt Lake City Tabernacle Choir and Organ.

(25.36 m.)

19.30—Dramatic Programme.

20.00—New York Philharmonic. Conductor: Barbieroli.

22.00—Magazine of the Air.

22.30-23.00—Dance Band.

23.30-05.00—For S. America.

23.30—Variety.

02.00—Orchestra, Choir, Conductor: Sir Ernest MacMillan.

03.00—Drama; Music.

03.30—Headlines.

04.00—Dance Music.

ZEESEN

(13.99 m.; 16.89 m.; 19.63 m.; 19.74 m.; 31.38 m.)

05.05—Call (Ger., Eng.); Music.

06.00—News; Music; Greetings.

07.00—News (Eng.).

07.15—Eroica Symphony (Beethoven).

08.15—Folk Music.

09.30—News; Symphony Concert.

11.00—Heroes' Day.

13.00—News; "Sunday"; Talk.

14.00—News (Eng., Dutch).

14.15—Cantata (Hoffmann).

15.00-16.00—Heroes' Day.

(19.85 m.; 25.49 m.; 49.83 m.)

15.40—Call (Ger., Eng.); Music.

16.15—For Girls; "Sunday."

16.45 — Greetings; Concert; Marches.

17.45—News; Heroes' Day.

19.00—News (Eng.); Orchestra.

20.15—Cantata (Hoffmann); Sports.

21.00-21.25—News (Ger., Eng.).

(19.74 m.; 25.49 m.)

16.10-17.25—Symphony Concert.

21.50—Call (Ger., Eng.); Talks.

ROME
(25.4 m.)
10.00—News; Music; at 11.00—
News (Eng., Chin.)
12.30-13.45—Music; Talk; News.
15.00—News (It., Eng.); Music.
17.06—News, Music (Arabic).
(31.13 m.)
18.01—Talk (Fr.).
18.19—News and Italian Lessons
(Romanian, Hung., Serb., Fr.).
19.36—News (Eng.).
19.57—Notes (Fr., Eng., Ger.).
20.00—From Turin (No. 1); Notes
(Esp., Fr., Eng., Ger.).
22.30—News (Sp., Greek).
23.00—For S. America: News;
Concert; Italian Lesson (Port.);
News (Sp., Port.).
00.30-02.00—For U.S.A.: News
(Eng.); Music; Talk; News.

SCHENECTADY
(13.95 m.)
13.00-17.00—Variety; Music*
(19.57 m.)
17.30—Farm Programme; Music;
Variety; Talk (Fr.).
20.15—Rochester Civic Orchestra.
(19.57 m.; 31.48 m.)
21.00—Music; Variety; at 22.00—
News Tower and at 23.30, News.
(31.48 m.)
00.00—News (Sp.); Stocks;
Music.
02.00—Hollywood Gossip (Sp.).
02.30-05.00—Orchestras.
(31.4 m.)
00.30-05.00—To be announced.

SUVA
(31.47 m.)
10.30-12.00—Records.

VATICAN CITY
(19.84 m.)
15.30—Church Notes (It.).
(50.26 m.)
19.00—Church Notes (It.).

WARSAW
(22 m.; 26.01 m.)
23.00-01.00—News (Pol., Eng.);
Talk; Music; Talk (Eng.).

WAYNE
(13.94 m.)
12.30—Daily Almanac—Phil Cook.
12.55—News; Light Music.
14.25-15.00—News; Light Music.
(19.65 m.)
18.00—Variety.
19.00-19.15—For Women.
(25.36 m.)
19.30—School of the Air.
20.00—Manhattan Matinée.
20.30—To be announced.
20.45—Walter Knick (Pfte.).
21.00—Sing and Swing.
21.30—Light Classical Music.
21.45—Dr. Dafoe—Talk; Music.
22.00-23.00—News; Dance Music.
23.30-05.00—For S. America.
23.30—Boake Carter; News (Sp.).
00.00—Variety; Dance Music.
01.00—Mary Roberts Rinehart Play.
01.30—Variety.
02.00—Radio Theatre; Dance
Music.
03.30—Brave New World.
04.00-05.00—Dance Music.

ZEESEN
(13.99 m.; 16.89 m.; 19.63 m.;
19.74 m.; 31.38 m.)
05.05—Call (Ger., Eng.); Music.
06.00—News; Music.
07.00—News (Eng.); Talks; Music.
09.00—Talk (Eng.); Sports; News.
10.00—Variety; Music.
12.00—News (Eng.); Music.
13.00—News; Songs; Sports.
14.00—News (Eng., Dutch); Talk.
14.30—Japanese Pite. Music.
14.45—Talk (Eng., Dutch); Music.
15.45-16.00—Topical.
(19.85 m.; 25.49 m.; 49.83 m.)
15.40—Call (Ger., Eng.); Music;
Songs.
16.30—Talk (Eng.); Music.
17.15—Hugo Wolf Music.
17.45—News; Folk Songs; 'Cello.
19.00—News (Eng.); Talk; Songs.
20.45-21.25—Talk; News (Ger.,
Eng.).
(19.74 m.; 25.49 m.)
21.50—Call (Ger., Eng.); Music.
22.45—News; Music.
23.15—Eroica Symphony (Beet-
hoven).
00.15—Talk; Folk Songs.
01.15—News (Eng.); Music.
02.00—News; Talk; Variety.
03.15-03.45—Talk; News (Eng.).

TUESDAY, Mar. 15
EMPIRE

Transmission 1 (GSG, GSO,
GSF, GSD, GSB)
07.00—Big Ben; Music-Hall.*
08.00—"Empire Exchange."*
08.15—Band.
08.50-09.15—News.

Transmission 2 (GSJ, GSH,
GSG, GSO, GSF)
10.45—Big Ben; "Dancing Time."*
11.30—Talk: "Round Hyde Park."
11.45—Chamber Music.
12.15—"Pixie Led," a fantasy
by L. du Gardie Peach.
12.55—Selections from the Pre-
War Musical Comedies.†
13.30-13.55—Big Ben; News.

Transmission 3 (GSJ to 15.30,
GSH, GSG, GSF, GSD from
15.45, GSO to 15.00)
13.55—Opening Announcements.
14.00—Big Ben; "Take Your
Choice."
14.30—Autumn Songs.
14.40—Impression of life on the
Isle of Mull.*
15.15—Torquay Municipal Orches-
tra: Winifred Radford (So-
prano).
16.00—Big Ben; News.
16.20-17.00—Hungarian Gipsy
Party.

Transmission 4 (GSG, GSD,
GSB; GSP from 18.45; GSP,
GSC, 17.20-18.15, Arabic trans-
mission; 21.15-23.00,
GSO, GSF, GSD, GSB, GSB†)
17.20—New Dance Numbers.†
17.30—"Swift Serenade."*
18.00—Big Ben; News.
18.25—Reginald Foort (BBC
Theatre Organ).
19.00—Big Ben; Records.
19.30—Pipe Band.
19.50—Martini and his Music.
20.00—"Snow White and the
Seven Dwarfs."
20.45-21.00—Song Recital.
21.15—Big Ben; Musical Inter-
lude.†
21.20—"America Speaks."
21.40—News.
22.00—Impression of life on the
Isle of Mull.*
22.35-23.00—Grosvenor House
Dance Band.

Transmission 5 (GSP, GSD,
GSC, GSB, GSB†)
23.20—"Topics of the Day," by
Collin Brooks.
23.35—Pipe Band.†
23.45—"Take Your Choice."*
00.15—Songs of the Seasons.*
00.25—The Barrington Quartet.
00.40—News.
01.00-01.30—Big Ben; "Swift
Serenade."*
Transmission 6 (GSD, GSC,
GSC†, GSB)
02.20—London Mozart Orchestra:
Harry Blech (Violin).
03.10—"America Speaks."*
03.30—Big Ben; News.
03.50-04.20—"Empire Variety
Theatre."*

BARCELONA
(42.7 m.)
23.00—News (Foreign Languages).
(21.35 m.)
00.30-01.30—News (Eng.).

BOSTON
(19.67 m.)
19.30—Monitor views the News.
(25.45 m.)
21.50—Science News; URSIgram.
23.00—Monitor views the News.
(49.67 m.)
00.00—Dinner Hour Music.
00.30—Splendours of Literature—
Chivalry.
01.00-01.30—Harvard University
Series: Great Astronomers—
Daniel Norman.

BOUND BROOK
(16.87 m.)
14.00—Variety; at 14.55—News.
15.45—Women in the News.
16.00—News (It.); Music; News.
17.45—Hollywood High Hatters.
18.00—News and Talk (Fr.);
Songs.
19.00—News; Talks (Ger.);
Music.
20.00—News (Fr.); Talk.
20.30—U.S. Marine Band.
21.00—News (Ger.); Recordings.
21.30-21.40—News.
22.00-23.45—For Latin America.
(49.18 m.)
00.00-05.00—For Latin America.
05.00-06.00—Rebroadcasts.

BUENOS AIRES
(19.62 m.)
12.00—News; Records; Bargains.
(31.06 m.)
14.30—Music; at 17.00—News.
18.00—Markets; Music; Humour.
19.45—"Mundo Argentino."
20.00—Play; Music; Markets.
23.30—Feature Programmes; Jokes.
03.30-04.30—News; Music.

CARACAS
(51.72 m.)
12.00-13.00—News.
15.30-18.30—Records and Songs.

20.45—Music and Songs.
22.15—For Children; Dancing.
23.00—News; Talks; Variety.
02.00—Classical Music.
02.30-03.30—Dance Band.

HUIZEN
(19.71 m.)
08.30-10.00—Variety for Asia.
(16.88 m.)
13.25-15.30—For the Dutch Indies.
(31.28 m.)
18.45—Religious Address.
19.00-20.30—Variety for Africa.

LYNDHURST
(31.32 m.)
02.35—Watchman; Music.
03.00—News; Music; Racing.
05.00—For Schools.
05.15-07.15—Music; Racing.
08.30—Music; Sports; Markets.
09.20—News (Eng., Fr.); Music.
10.00—ABC (Brisbane) Concert Or-
chestra and Choir; Sketch.
11.15—Dino Borgioli (Tenor).
12.00—Dance Music.
12.30—News; Dance Music;
Records.
13.20-13.30—News Breveitas.

MILLIS
(31.35 m.)
16.45—Edward MacHugh—Gospel
Singer.
03.00—Gen. Hugh S. Johnson.

MOSCOW
(25 m.)
11.00 and 17.15—Talks (Ger.).
(50 m.)
20.00—Talks, etc. (It., Ger.).
21.00—Talks (Dutch, Port.).
(31.25 m.)
23.00—Programme in Spanish.
(31.25 m.; 39.79 m.)
00.00—Programme in English.
(50 m.)
01.30—Programme in French.
(25 m.)
03.15—Programme in English.

PARIS (Radio-Colonial)
(25.24 m.)
07.00-09.40—News; Records.
09.40-10.00—News (Eng., It.).
(19.68 m.)
11.00—Records; Talk (Jap.).
12.00—News (Eng.); Music; Talks;
at 13.30—News.
14.30—Play (Rosemonde Gérard).
15.55-16.00—Exchange.
(25.24 m.)
16.15—News (Fr., Arabic); Music.
18.50—Shipping; News.
20.10—News (Eng., It.).
20.30—To be announced.
22.30—Markets; News (Port.).
(25.6 m.)
23.15-01.15—Records; at 00.15—
News (Fr., Sp., Port.).
03.00—Records; News.
04.30—News (Eng.); Records
05.45-06.00—News (Ger.).

PITTSBURGH
(13.93 m.)
11.45—Farm Markets; Variety
13.15—News; Musical Clock.
(19.71 m.)
14.00—Shopping; Variety.
16.30—Vic and Sade; MacHugh.
17.00—News; Harding's Wife.
17.30—Farm and Home; Music.
19.00—Ranch Boys; Topical.
19.30—Home Forum; Music.
20.15—U.S. Marine Band; Clubs.
21.15—News Reeler; Variety.
23.00—News; Broadway Stars.
23.45—Lowell Thomas.
(25.26 m.)
00.00—Variety; Music.
03.00—NBC Jamboree, with
Armida (Mexican Singing Star),
Oscar and Elmer (Hollywood
Comedy Team), Bill Thompson
(Comedian), Sylvia Clark (Mono-
logues), Jackie Heller (Tenor),
Lynn Chalmers (Contralto),
Vivian Della Chiesa (Soprano),
The Vagabonds and The Cadets
(Vocal Quartets), and Don
McNeill as Master of Ceremonies.
(48.83 m.)
04.00-06.00—News; Music.

PODEBRADY
(31.41 m.)
For Europe.
18.00—News (Czech, Ger.); Music;
Talk (Fr.); at 21.00—News (Fr.).
21.30-21.40—News (Eng.).

ROME
(25.4 m.)
10.00—News; Chamber Music.
11.00—News (Eng.); Opera; News.
12.30-13.45—Music; Talk; News.
15.00—News (It., Eng.); Music.
17.06—News, Music (Arabic).
(31.13 m.)
18.01—Talk (Eng.).
18.19—News and Talks (Romanian,
Hung., Serb., Fr.).
19.36—News and Talk (Eng.).

19.57—Notes (Fr., Eng., Ger.).
20.00—From Turin (No. 1); Notes
(Czech, Fr., Eng., Ger.).
22.30—News (Sp., Greek).
23.00—For S. America: News;
Opera; Talk; News (Sp., Port.).
00.30-02.00—For U.S.A.: News
(Eng.); Concert; Talk; News.

SCHENECTADY
(13.95 m.)
13.00-17.00—Variety; Music; at
16.30—Musical Newsy.
(19.57 m.)
17.30—Farm Programme; Variety;
at 19.30—Science Forum.
20.00—U.S. Marine Band.
(19.57 m.; 31.48 m.)
21.00—Variety; Music; at 22.00—
News Tower; at 23.00—Science
and at 23.30—News; Mail.
(31.48 m.)
00.00—English Lesson (Sp.);
Songs.
00.30—Stocks; News (Sp.);
Music.
02.00—Vox Pop; Hollywood
Variety.
03.30—Talks (Sp., Eng.); Songs.
04.15-05.00—Orchestras.
(31.4 m.)
00.30-05.00—To be announced.

SUVA
(31.47 m.)
10.30-12.00—Records.

VATICAN CITY
(19.84 m.)
15.30—Church Notes (Eng.).
(50.26 m.)
19.00—Church Notes (Eng.).

WARSAW
(22 m.; 26.01 m.)
23.00-01.00—News (Pol., Eng.);
Music; Talks; at 00.25—Talk
(Eng.).

WAYNE
(13.94 m.)
12.30—Daily Almanac—Phil Cook.
12.55—News; Music.
14.25-15.00—News; Music.
(19.65 m.)
18.00-19.15—Variety; Songs
(25.36 m.)
19.30—School of the Air.
20.00—Tuesday Matinée.
20.30—Hollace Shaw (Soprano)
21.00—Academy of Medicine.
21.15—Quartet; Light Classics.
21.45—Questions before the House.
22.00—Light and Dance Music.
22.55-23.00—News.
23.30-05.00—For S. America.
23.30—Boake Carter; News (Sp.).
00.00—Variety; Hollywood News.
00.30—Stars of Stage and Screen.
01.00—"Big Town"—Play, with
Edward G. Robinson.
01.30—Al Jolson; Variety.
04.00-05.00—Dance Music.

ZEESEN
(13.99 m.; 16.89 m.; 19.63 m.;
19.74 m.; 31.38 m.)
05.05—Call (Ger., Eng.); Music;
Talk.
06.00—News; Music.
07.00—News (Eng.); Talk; Songs.
08.45—"Cello"; Talk; Schopen-
hauer.
09.30—News; Review.
09.45—Talk (Eng.); Music.
12.00—News (Eng.); Music.
13.00—News; Folk Songs.
14.00—News (Eng., Dutch); Talk.
14.30-16.00—Songs; Variety; Talk.
(19.85 m.; 25.49 m.; 49.83 m.)
15.40—Call (Ger., Eng.); Music.
16.10—Hints; Handel Music.
16.50—Concert.
17.15—Talks (Eng., Ger.); News.
18.00—Opera Concert.
19.00—News (Eng.); Talk;
Dances.
20.00—Heidelberg Programme;
Choir.
21.00-21.25—News (Ger., Eng.).
(19.74 m.; 25.49 m.)
21.50—Call (Ger., Eng.); Music;
Songs.
22.45—News; Songs; Talk.
00.30—Concert.
01.15—News (Eng.); Talk (Eng.,
Ger.).
02.00—News; Talk (Eng.).
02.30—"Cello"; Poems; Radio
Hints.
03.30-03.45—News (Eng.); Greet-
ings.

WEDNESDAY, Mar. 16
EMPIRE
Transmission 1 (GSG, GSO,
GSF, GSD, GSB)
07.00—BBC Empire Orchestra.
07.50—"America Speaks."*
08.10—"Take Your Choice."*
08.40—Autumn Songs.*
08.50-09.15—News.

Transmission 2 (GSJ, GSH,
GSG, GSO, GSF)

10.45—Big Ben; Backstage at
Bellahouston.
11.5—"Take Your Choice."*
11.35—Autumn Songs.*
11.45—BBC Northern Orchestra.
12.45—"Voices from the Past."†
13.00—Chamber Music of Grieg.
13.30-13.55—Big Ben; News.

Transmission 3 (GSF to 15.30,
GSH, GSG, GSF, GSD from
15.45, GSO to 15.00)
13.55—Opening Announcements.
14.00—Big Ben; Music-Hall.*
15.00—"Ireland Dances."
15.40—Pipe Band.*
16.00—Big Ben; News.
16.20—Eileen Ralph (Pfte.).
16.40-17.00—"World Affairs."

Transmission 4 (GSG, GSD,
GSB; GSP from 18.45; GSP,
GSC, 17.20-18.15, Arabic trans-
mission; 20.55-23.00, GSO,
GSF, GSD, GSB, GSB†)
17.20—Dance Music.
18.00—Big Ben; News.
18.20—"Take Your Choice."*
18.50—Autumn Songs.*
19.00—Big Ben; "World Affairs."*
19.15—Sonata Recital.
19.45—"Unicorns."*
20.15-20.40—Excerpt from "Going
Greek" with Leslie Henson.
20.55—News.
21.15—Sir Harry Lauder.
21.45—BBC Variety Orchestra.
22.00—"World Affairs."*
22.15-23.00—"Pixie Led," by
L. du Gardie Peach.*

Transmission 5 (GSP, GSD,
GSC, GSB, GSB†)
23.20—"The House in the
Country."*
00.05—"Empire Exchange."*
00.20—Organ recital.
00.40—News.
01.00-01.30—Big Ben; Sonata
Recital.

Transmission 6 (GSD, GSC,
GSC†, GSB)
02.20—"World Affairs."*
02.35—BBC Empire Orchestra:
Stuart Robertson (Bass-Baritone).
03.30—Big Ben; News.
03.50-04.20—Vest-pocket Vaude-
ville.*

BARCELONA
(42.7 m.)
23.00—News (Foreign Languages).

BOSTON
(19.67 m.)
19.30—Monitor views the News.
(25.45 m.)
21.30—Harvard University Series.
23.00—Monitor views the News.
(49.67 m.)
00.30—Looking Starwards.
00.45—Continuity of the Drama.

BOUND BROOK
(16.87 m.)
14.00—Variety; at 14.55—News.
15.45—Women in the News.
16.00—News (It.); Music.
17.00—News (Eng., Fr.); Variety.
19.00—News, Talks (Ger.);
Waltzes.
20.00—News (Fr.); Recordings.
21.00—News (Ger.); Recordings.
21.30-21.40—News.
22.00-23.35—For Latin America.
(49.18 m.)
00.00-05.55—For Latin America.

BUDAPEST
(32.88 m.)
00.00-01.00—Choir; Poems; Music;
News.

BUENOS AIRES
(19.62 m.)
12.00—News; Records; Bargains.
(31.06 m.)
14.30—Music; at 17.00—News.
18.00—Markets; Music; Humour.
19.45—"Mundo Argentino."*
20.00—Play; Music; Markets.
23.30—Feature Programmes;
Jokes.
03.00-04.30—News; Music.

CARACAS
(51.72 m.)
12.00-13.00—News.
15.30-18.30—Records and Songs.
20.45—Music and Songs.
22.15—For Children; Dancing.
23.00—News; Variety; Music.
02.30-03.30—Dance Band.

CHICAGO
(49.18 m.)
23.15—Rex Maupin's Orchestra.

HUIZEN
(19.71 m.)
08.40-17.00—For Asia.
(31.28 m.)
00.00—For the Western Hemi-
sphere.
01.00-02.30—For Latin America.

LYNDHURST (31.32 m.) 02.35—Watchman; Music. 03.00-07.15—News; Music; Racing. 08.30—Music; Sports; Markets. 09.20—News; Talk; Music. 10.00—"The Bartered Bride" (Smetana). 11.15—Dance Band; Travel Letter. 12.00—Music; News; Records. 13.20-13.30—News Brevities.

MILLIS (31.35 m.) 14.00—Breakfast Club. 23.45—Lowell Thomas—News.

MOSCOW (25 m.) 11.00 and 17.15—Talks (Ger.); at 11.30—Talks, etc. (Eng.). (50 m.) 20.00—Talks, etc. (It., Ger.). 21.00—Talks (Fr., Ger.). (31.25 m.) 23.00—Programme in Spanish. (31.25 m.; 39.79 m.) 00.00—Programme in English. (50 m.) 01.30—Programme in Dutch. (25 m.) 03.15—Programme in English.

PARIS (Radio-Colonial) (25.24 m.) 07.00-09.40—News; Records. 09.40-10.00—News (Eng., It.). (19.68 m.) 11.00—Records; Talk (Fr., Russ.). 12.00—News (Eng.); Music; Talks; at 13.30—News. 14.30—Orchestra, Baritone. 15.55-16.00—Exchange. (25.24 m.) 16.15—News (Fr., Arabic); Music. 18.50—Talk; News. 20.10—News (Eng., It.). 20.30—To be announced. 22.30—Markets; News (Port.). (25.6 m.) 23.15-01.15—Records; at 00.15—News (Fr., Sp., Port.). 03.00—Records; News. 04.30—News (Eng.); Records. 05.45-06.00—News (Ger.).

PITTSBURGH (13.93 m.) 11.45—Farm Markets; Variety. 13.15—News; Musical Clock. (19.71 m.) 14.00—Shopping; Variety. 16.30—Vic and Sade; MacHugh. 17.00—News; Harding's Wife. 17.30—Farm and Home; Variety. 19.15—Talks; Home Forum; Music. 21.00—Clubs; News Reeler. 21.30—PTA; Variety. 23.00—News; Sports; Variety. 23.45—Lowell Thomas. (25.26 m.) 00.00—Easy Aces; Variety. 00.45—Science; Revue. 01.30—Topical; Choir; Variety. 02.30—Federal Symphony Orch. 03.00—NBC Night Club; Variety. (48.83 m.) 04.00-06.00—News; Music.

PODEBRADY (31.41 m.) For Europe. 18.00—News (Czech, Ger.); Music; Talk (Ger.). 20.15—Mass in B minor (Bach) from London (National); at 21.20—News (Fr.); and 21.30-21.40—News (Eng.).

ROME (25.4 m.) 10.00—News; Opera Music. 11.00—News (Eng.); Music; Talk (Jap.); News. 12.30-13.45—Music; Talk; News. 15.00—News (It., Eng.); Talk; Music. 17.06—News, Music (Arabic). (31.13 m.) 18.01—Talk (Ger.). 18.19-18.35—News and Italian Lesson (Romanian). 18.55—News and Talk (Serb.). 19.15—News and Italian Lesson (Fr.). 19.36—News (Eng.). 19.57—Notes (Fr., Eng., Ger.). 20.00—From Turin (No. 1); Notes (Fr., Eng., Ger.). 22.30—News (Sp., Greek). 23.00—For S. America; News; Music; Talk; News (Sp., Port.). 00.30-02.00—For U.S.A.: Light Music; News.

SCHENECTADY (13.95 m.) 13.00-17.00—Variety; Music. (19.57 m.) 17.30—Farm Programme; Variety; at 19.00—Health Talk. (19.57 m.; 31.48 m.) 21.00—Variety; Talk; at 22.00—News Tower; at 23.30—News.

(31.48 m.) 00.00—Sketch (Sp.); Uncle Ezra. 00.30—Stocks; News (Sp.). 01.00—Latin-American Concert. 02.00—Town Hall. 03.00—Hollywood-Parade. 04.00-05.00—Talk; Orchestras. (31.4 m.) 00.30-05.00—To be announced.

SUVA (31.48 m.) 10.30-12.00—Records.

VATICAN CITY (19.84 m.) 15.30—Church Notes (Sp.). (50.26 m.) 19.00—Church Notes (Sp.).

WARSAW (22 m.; 26.01 m.) 23.00-01.00—News (Pol., Eng.); Sports; Music; Talk; at 00.20—Talk (Eng.).

WAYNE (13.94 m.) 12.30—Daily Almanac—Phil Cook. 12.55—News; Salon Musicale. 13.30—Greenfield Village Chapel. 13.45-15.00—Music; at 14.25—News. (19.65 m.) 18.00—Variety. 19.00-19.15—For Women. (25.36 m.) 19.30—School of the Air. 20.00—Variety; Music. 20.45—Curtis Institute of Music. 21.30—Light Classical Music. 21.45—Dr. Dafeo—Talk; Music. 22.00—Melody Corner. 22.25-23.00—News; Swing Music. 23.30-05.00—For S. America. 23.30—Boake Carter; News (Sp.). 00.00—Variety. 00.45—Educational. 01.00—Cavalcade of America. 01.30—Eddy Cantor. 02.00—Kostelanetz Orchestra, Lawrence Tibbett (Baritone). 02.30—Variety. 03.00—Crime Crusade; Songs; Talk. 04.00—Dance Music.

ZEESEN (13.99 m.; 16.89 m.; 19.63 m.; 19.74 m.; 31.38 m.) 05.05—Call (Ger., Eng.); Music. 06.00—News; Music. 07.00—News (Eng.); Music. 07.30—Opera Music; Choir. 09.00—Hugo Wolf Music. 09.30—News; Variety; Music. 12.00—News (Eng.); Music. 13.00—News; Old Songs. 14.00—News (Eng., Dutch); Talk. 14.30—Talk (Eng.); Dance Music. 15.15-16.00—Cello; Press Review. (19.85 m.; 25.49 m.; 49.83 m.) 15.40—Call (Ger., Eng.); Concert. 16.15—Books; Music. 17.15—For Young People; News. 18.00—Talk (Eng.); Königsberg. 18.30—Folk Dance Band. 19.00—News (Eng.); Talk; Press. 19.45—Variety; Music. 21.00-21.25—News (Ger., Eng.). (19.74 m.; 25.49 m.) 21.50—Call (Ger., Eng.); Choir. 22.30—Records; News; Music. 00.15—Talk; For Youth. 01.00—Nocturne (Trapp). 01.15—News (Eng.); Press; Records. 02.00—News; Opera Music. 03.15-03.45—Mozart Music; News (Eng.).

THURSDAY, Mar. 17

EMPIRE Transmission 1 (GSG, GSO, GSF, GSD, GSB) 07.00—Big Ben; Irish Songs. 07.30—"Pixie Led," by L. du Gard Peach. 08.10—Corelli's Violin Sonatas. 08.35—"World Affairs." 08.50-09.15—News.

Transmission 2 (GSJ, GSH, GSG, GSO, GSF) 10.45—Big Ben; Variety.* 11.15—"The Count of Monte Cristo," serial play.* 11.45—Irish Guards Band. 12.30—"At the Black Dog." 13.00—Music of Kertelby.† 13.15—"World Affairs."† 13.30-13.55—Big Ben; News.

Transmission 3 (GSJ to 15.30, GSH, GSG, GSF, GSD from 15.45, GSO to 15.00) 13.55—Opening Announcements. 14.00—Big Ben; Irish Songs.* 14.30—"Unicorns."* 15.00—Royal Air Force Band. 16.00—Big Ben; News. 16.20—Talk for listeners in India. 16.35-17.00—Tomorrow's Songs. Transmission 4 (GSG, GSD, GSB; GSP from 18.45; GSP,

GSC, 17.20-18.15, Arabic transmission; 21.15-23.00 GSO, GSF, GSD, GSB, GSB†) 17.20—Orchestral Music.† 17.30—"At the Black Dog."* 18.00—Big Ben; News. 18.20—BBC Empire Orchestra. 19.00—Talk: "All Kinds of People." 19.20—St. Patrick's Day programme. 20.00—Variety. 20.30-21.00—Talk: "The Way of Peace." 21.15—Big Ben; News. 21.35—Irish Guards Band.* 22.25—Talks. 22.45-23.00—Michael Flome and his Band.

Transmission 5 (GSP, GSD, GSC, GSB, GSB†) 23.20—"The Count of Monte Cristo," serial play.* 23.50—Cinema Organ. 00.10—Talk: "The Way of Peace."* 00.40—News. 01.00-01.30—Big Ben; Pfte. Music.

Transmission 6 (GSD, GSC, GSC†, GSB) 02.20—Talks.* 02.40—Irish Guards Band.* 03.30—Big Ben; News. 03.50-04.20—"At the Black Dog."*

BARCELONA (42.7 m.) 23.00—News (Foreign Languages). (21.35 m.) 00.30-01.30—News (Eng.).

BOSTON (19.67 m.) 19.30—Monitor views the News. 20.00—World Youth speaks. (25.45 m.) 21.50—Science News; URISGram. 23.00—Monitor views the News. (49.67 m.) 00.30—To be announced.

BOUND BROOK (16.87 m.) 14.00—Variety; at 14.55—News. 15.45—Women in the News. 16.00—News (It.); Music. 17.00—News (Eng., Fr.); Variety. 19.00—News; Talk (Ger.); Variety. 20.00—News (Fr., Ger.); Music. 21.30-21.40—News. 22.00-23.35—For Latin America. (49.18 m.) 00.00-05.00—For Latin America. 05.00-06.00—Rebroadcasts.

BUENOS AIRES (19.62 m.) 12.00—News; Records; Bargains. (31.06 m.) 14.30—Music; at 17.00—News. 18.00—Markets; Music; Humour. 19.45—"Mundo Argentino." 20.00—Play; Music; Markets. 23.30—Feature Programmes; Jokes. 03.00-04.30—News; Music.

CARACAS (51.72 m.) 12.00-13.00—News. 15.30-18.30—Records and Songs. 20.45—Music and Songs. 22.15—For Children; Dancing. 23.00—News; Music; Variety. 02.15-03.30—Talk; Dance Band.

CHICAGO (49.18 m.) 01.30 (Fri.)—The March of Time.

HUIZEN (16.88 m.) 13.25-15.25—For the Dutch Indies.

LYNDHURST (31.32 m.) 02.35—Watchman; Music; News. 03.15-07.00—Music; Racing. 08.30—Music; Sports; Markets. 09.20—News (Eng., Fr.); Music. 10.00—Irish Plays: "The Pot of Broth" (Yeates); "The Rising of the Moon" (Lady Gregory). 11.00—Irish Songs by Clement Williams (Baritone). 11.15—Sextet; Choir. 12.00—World Affairs; Dance Music.

MILLIS (31.35 m.) 23.45—Lowell Thomas—News. MOSCOW (25 m.) 11.00 and 17.15—Talks (Ger.). (50 m.) 20.00—Talks, etc. (It., Ger.). 21.00—Talks, etc. (Fr., Sp.). (31.25 m.) 23.00—Programme in Spanish. (31.25 m.; 39.79 m.) 00.00—Programme in English.

(50 m.) 01.30—Programme in French. (25 m.) 03.15—Programme in English.

PARIS (Radio-Colonial) (25.24 m.) 07.00-09.40—News; Records. 09.40-10.00—News (Eng., It.). (19.68 m.) 11.00—Records; Talk (Sp.). 12.00—News (Eng.); Music; Talks; at 13.30—News. 14.30—Quartet; Tenor; Pfte. 15.55-16.00—News. (25.24 m.) 16.15—News (Fr., Arabic); Music. 18.45—Poems; News. 20.10—News (Eng., It.). 20.30—To be announced. 22.30—Markets; News (Port.). (27.6 m.) 23.15—Records. 00.5—News (Fr., Sp., Port.). 0.00 01.15—Talk. 01.00—Records; News. 04.30—News (Eng.); Records. 05.45-05.00—News (Ger.).

PITTSBURGH (13.93 m.) 11.45—Farm Markets; Variety. 13.15—News; Musical Clock. (19.71 m.) 14.00—Shopping; Variety. 16.30—Vic and Sade; MacHugh. 17.00—News; Harding's Wife. 17.30—Farm and Home; Variety. 19.15—Talk; Home Forum; Music. 21.00—Clubs; News Reeler; Variety. 23.00—News; Broadway Stars. 23.45—Lowell Thomas. (25.26 m.) 00.00—Easy Aces; Variety. 01.00—March of Time; Music. 02.30—Town Meeting; Variety. (48.83 m.) 04.00-06.00—News; Music.

PODEBRADY (31.41 m.) For Europe. 18.00—News (Czech, Ger.); Variety; Talk (Eng.); at 21.00—News (Fr.). 21.30-21.40—News (Eng.).

ROME (25.4 m.) 10.00—News; Music; Talk; at 11.00—News (Eng.). 12.30-13.45—Talk; Music; News. 15.00—News (It., Eng.); Music. 17.06—News; Music (Arabic). (31.13 m.) 18.01—Talk (Sp.). 18.19—News and Talks (Romanian, Hung., Serb., Fr.). 19.36—News and Talk (Eng.). 19.57—Notes (Fr., Eng., Ger.). 20.00—From Turin (No. 1); at 21.00—Talk (Serb.); and at 21.45—Notes (Fr., Eng., Ger.). 22.30—News (Sp., Greek). 23.00—For S. America; News; Music; Italian Lesson (Sp.); News (Sp., Port.). 00.30-02.00—For U.S.A.: News (Eng.); Opera; Talk; News.

SCHENECTADY (13.95 m.) 13.00-17.00—Variety; Music; at 16.30—Musical Newsy. (19.57 m.) 17.30—Farm Programme; Music; Variety; at 19.00—NBC Music Guild. (19.57 m.; 31.48 m.) 21.00—Talk; Music; Variety; at 22.00—News Tower. 23.30—News; Stocks. (31.48 m.) 00.00—Music and News (Sp.). 00.30—Science Forum. 01.00—Rudy Vallee. 02.00—Good News of 1938. 03.00-05.00—Bing Crosby; Music. (31.4 m.) 00.30-05.00—To be announced.

SUVA (31.47 m.) 10.30-12.00—Records.

VATICAN CITY (19.84 m.) 15.30—Church Notes (Fr.). (50.26 m.) 19.00—Church Notes (Fr.).

WARSAW (22 m.; 26.01 m.) 23.00-01.00—News (Pol., Eng.); Talk; Music; Talk; at 00.20—Talk (Fr.).

WAYNE (13.94 m.) 12.30—Daily Almanac—Phil Cook. 12.55—News; Music. 14.25-15.00—News; Light Music. (19.65 m.) 18.00-19.15—Variety; Light Music.

(25.36 m.) 19.30—School of the Air. 20.00—Variety. 20.30—U.S. Army Band. 21.00—Science; Music. 21.15—Address by Mr. de Valera from Dublin; Variety. 22.00—Light and Dance Music. 22.55-23.00—News. 23.30-05.00—For S. America. 23.30—Boake Carter; News (Sp.). 00.00—Variety; at 00.30—We, the People. 04.00—Dance Music.

ZEESEN (13.99 m.; 16.89 m.; 19.63 m.; 19.74 m.; 31.38 m.) 05.05—Call (Ger., Eng.); Music. 06.00—News; Music; Greetings. 07.00—News (Eng.); Talk; Music. 07.45—Dances; Variety; Music. 09.30—News; Talk (Eng.); Concert. 12.00—News (Eng.); Music. 13.00—News; Youth; Books. 14.00—News (Eng., Dutch). 15.00—Talk (Eng.); Königsberg. 15.30-16.00—Folk Dance Band. (19.85 m.; 25.49 m.; 49.83 m.) 15.40—Call (Ger., Eng.); Music. 16.15—Talk; Music. 17.45—News; Military Music. 19.00—News (Eng.); Topical. 19.30—"Agnes Bernauer"—Play (Hebbel). 20.30-21.25—Songs; News (Ger., Eng.). (19.74 m.; 25.49 m.) 21.50—Call (Ger., Eng.); Music. 22.45—News; Folk Music. 23.15—Variety; Talk. 00.30—Handel Music; Books. 01.15—News (Eng.); Variety. 01.45—Talk (Eng.); Eugenics. 02.00—News Talk (Eng.); Königsberg. 02.45-03.45—Variety; News (Eng.).

FRIDAY, Mar. 18

EMPIRE. Transmission 1 (GSG, GSO, GSF, GSD, GSB) 07.00—Big Ben; "At the Black Dog."* 07.30—"Swift Serenade."* 08.00—Dale Smith (Baritone). 08.20—For New Zealand listeners. 08.40—"Next Week's Programmes." 08.50-09.15—News.

Transmission 2 (GSJ, GSH, GSG, GSO, GSF) 10.45—Big Ben; Cinema Organ. 11.15—Hughie Green and his Gang.* 11.45—"Pipe Band." 12.05—Talks.* 12.25—Dance Band. 13.00—Julius Kantrovitch and his Orchestra. 13.20—"Next Week's Programmes." 13.30-13.55—Big Ben; News. Transmission 3 (GSJ to 15.30, GSH, GSG, GSF, GSD from 15.45, GSO to 15.00) 13.55—Opening Announcements. 14.00—Big Ben; BBC Empire Orchestra. 15.00—"America Speaks."* 15.20—"Dancing Time."* 16.00—Big Ben; News. 16.20—"Next Week's Programmes." 16.30-17.00—"Will You Be Mine ...?"

Transmission 4 (GSG, GSD, GSB; GSP from 18.45; GSG, GSC, 17.20-18.15, Arabic transmission; 21.15-23.00 GSO, GSF, GSD, GSB, GSB†) 17.20—Troise and his Mandoliers. 17.45—Talk by Sir Josiah Stamp. 18.00—Big Ben; News. 18.20—"Next Week's Programmes." 18.30—Brian Lawrence and his Dance Orchestra. 19.00-21.00—"La Rondine" a Lyric comedy by Puccini. 21.15—Big Ben; News. 21.35—"Next Week's Programmes." 21.45—Some glimpses of London's old pleasure gardens. 22.45-23.00—Dance Band.

Transmission 5 (GSP, GSD, GSC, GSB, GSB†) 23.20—"Will You Be Mine ...?"* 23.50—Talk by Sir Josiah Stamp.* 00.05—Song recital. 00.30—"Next Week's Programmes." 00.40—News. 01.00-01.30—Big Ben; the Luton Band.

Transmission 6 (GSD, GSC, GSC†, GSB) 02.20—"Dancing Time."* 03.05—Two Sketches. 03.20—"Next Week's Programmes." 03.30—Big Ben; News. 03.50-04.20—John McKenna (Tenor); Peter Beaven (Cello). BARCELONA (42.7 m.) 23.00—News (Foreign Languages).

BOSTON

(19.67 m.)
19.30—Monitor views the News.
(25.45 m.)
21.50—Science News.
22.00—Modern Radio; URSIgram.
23.00—Monitor views the News.
(49.67 m.)
00.00—Dinner-Hour Music.
02.00—For Latin America: Modern Latin-American Literature.

BOUND BROOK

(16.87 m.)
14.00—Variety; at 14.45—News.
15.45—Women in the News.
16.00—News and Talk (It.); Music.
17.00—News (Eng., Fr.); Music.
19.00—News and Talk (Ger.).
19.30—NBC Music Appreciation.
20.00—News (Fr., Ger.); Recordings.
21.30—21.40—News.
22.00—23.35—For Latin America.
(49.18 m.)
00.00—05.55—For Latin America.

BUENOS AIRES

(19.62 m.)
12.00—News; Records; Bargains.
(31.06 m.)
14.30—Music; at 17.00—News.
18.00—Markets; Music.
19.00—Roman Catholic Hour.
19.30—Music.
19.45—"Mundo Argentino."
20.00—Play; Music.
21.00—Foreign Affairs (Eng., Fr., Sp., Ger.)
22.00—22.15—Markets.
23.30—Feature Programmes; Jokes.
03.00—04.30—News; Music.

CARACAS

(51.72 m.)
12.00—13.00—News.
15.30—18.30—Records and Songs.
20.45—Music and Songs.
22.15—For Children; Dancing.
23.00—News; Variety.
02.00—Classical Music.
02.30—03.30—Dance Band.

HUIZEN

(16.88 m.)
13.25—15.25—For the Dutch Indies.

LYNDHURST

(31.32 m.)
02.35—Watchman; Music.
03.00—News; Music.
05.04—07.00—For Schools; Music.
08.30—Music; Sports; Markets.
09.20—News; Talk; Music.
16.00—Band; Baritone.
10.40—Dance Band; Quartet.
11.45—Light Orchestral.
12.30—News; Records.
13.20—13.30—News Brevities.

MILLIS

(31.35 m.)
14.40—News.
23.15—Sports—Bill Williams.

MOSCOW

(25 m.)
11.00 and 17.15—Talks (Ger.).
(50 m.)
20.00—Talks, etc. (It., Ger.).
21.00—Talks, etc. (Eng., Ger.).
(31.25 m.)
23.00—Programme in Spanish.
(31.25 m.; 39.79 m.)
00.00—Programme in English.
(50 m.)
01.30—Programme in Portuguese.
(25 m.)
03.15—Programme in English.

PARIS (Radio-Colonial)

(25.24 m.)
07.00—09.40—News; Records.
09.40—10.00—News (Eng., It.).
(19.68 m.)
11.00—Records; Talk (Roum.).
12.00—News (Eng.); Music; Talks; at 13.30—News.
14.30—"La-Haut" (Yvain).
15.55—16.00—Exchange.
(25.24 m.)
16.15—News (Fr., Arabic); Music.
18.30—Concert; Talk; News.
20.10—News (Eng., It.).
20.30—To be announced.
22.30—Markets; News (Port.).
(25.6 m.)
23.15—01.15—Music; at 00.15—News (Fr., Sp., Port.).
03.00—Records; News.
04.30—News (Eng.); Records.
05.45—06.00—News (Ger.).

PITTSBURGH

(13.93 m.)
11.45—Farm Markets.
12.00—Utah Slim's Sunset Riders.
12.15—Musical Clock.
12.45—Bob White.
13.00—Uncle Russ.
13.15—News; Musical Clock.
(19.71 m.)
14.00—Shopping Circle.
14.15—The Editor's Daughter.
14.30—Linda's First Love.

14.45—Ma Perkins.
15.00—Margot of Castlewood.
15.15—Aunt Jemima.
15.30—Attorney at Law.
15.45—Kitchen Cavalcade.
16.00—Mary Marlin.
16.15—Pepper Young.
16.30—Vic and Sade.
16.45—Edward MacHugh—Gospel Singer.
17.00—News; Harding's Wife.
17.30—Farm and Home.
18.30—Home Forum; Grace and Eddie.
19.00—Music Appreciation Hour.
20.00—Music by Cugat.
20.15—D.A.R. Programme.
20.30—Paul Gannon (Tenor).
20.45—Career Women.
21.00—Club Matinée.
21.15—Press News Reeler.
21.30—Club Matinée.
22.00—Junior Nurse Corps.
22.15—For Children.
22.45—Tom Mix Straight Shooters.
23.00—News; Sports.
23.15—Under the Sea with Jack Westaway.
23.30—Weather; Dot and Pat.
23.45—Lowell Thomas.
(25.26 m.)
00.00—Variety.
01.00—Grand Central Station.
01.30—Death Valley Days.
02.00—Orchestra; Tim and Irene.
02.30—Paul Martin's Music.
03.00—Heavyweight Bout.
(49.83 m.)
04.00—News; Music you want.
05.00—Orchestra.
05.15—06.00—DX Club; Orchestras.

ZEESEN

(13.99 m.; 16.89 m.; 19.63 m.; 19.74 m.; 31.38 m.)
05.05—Call (Ger., Eng.); Music.
06.00—News; Concert; Greetings.
07.00—News (Eng.); Talk; Concert.
09.30—News; Music.
12.00—News (Eng.); Music.
13.00—News; Concert.
14.00—News (Eng., Dutch); Talks.
14.45—Military Music.
15.45—16.00—German Economics.
(19.85 m.; 25.49 m.; 49.83 m.)
15.40—Call (Ger., Eng.); Music.
16.50—Music; Talks.
17.45—News; Cabaret.
19.00—News (Eng.); Talk; Markets.
19.45—Folk Songs and Dances.
20.30—Coronation Concerto (Mozart).
21.00—21.25—News (Ger., Eng.).
(19.74 m.; 25.49 m.)
21.50—Call (Ger., Eng.); Schubert and Mozart Music.
22.45—News; Review.
23.00—"Agnes Bernauer"—Play (Hebbel).
00.15—Talks; Heidelberg Programme.
01.15—News (Eng.); Folk Music.
01.45—German Economics.
02.00—News; Military Music.
03.30—03.45—News (Eng.); Greetings.

PODEBRADY

(31.41 m.)
For Europe.
18.00—News (Czech, Ger.); Music.
21.00—News, Talk (Fr.).
21.30—21.40—News (Eng.).

RADIO-NATIONS

League of Nations Reports.
(26.31 m.)
19.00—Report in English.
(32.1 m.)
19.30—Report in French.
00.30—Reports (Eng., Sp.).

ROME

(25.4 m.)
10.00—News; Concert.
11.00—News (Eng.); Opera; News.
12.30—13.45—Music; Talk; News.
15.00—News (It., Eng.); Music.
17.06—News, Music (Arabic).
(31.13 m.)
18.01—Talk (Dutch).
18.19—News and Italian Lessons (Romanian, Hung., Serb., Fr.).
19.36—News (Eng.).
19.57—Notes (Fr., Eng., Ger.).
20.00—From Turin (No. 1); Notes (Fr., Eng., Ger.).
22.30—News (Sp., Greek).
23.00—For S. America; News; Music; Talk; News (Sp., Port.).
00.30—02.00—For U.S.A.; News (Eng.); Music; Talk; News.

SCHENECTADY

(13.95 m.)
13.00—17.00—Variety; Music.
(19.57 m.)
17.30—Farm Programme; Music.
19.00—NBC Music Appreciation Hour, Damrosch conducting.
20.00—Radio Guild.
(19.57 m.; 31.48 m.)
21.00—Talks; Variety; at 22.00—News Tower.
23.30—News; Home Talks (Sp.).
(31.48 m.)
00.00—Dances; Uncle Ezra.
00.30—Stocks; News (Sp.); Songs.
01.30—Farm Forum; Waltzes.
02.30—Literature (Sp.); Play.
03.30—Hollywood Gossip; Talk.
04.00—05.00—Orchestras.
(31.4 m.)
00.30—05.00—To be announced.

SUVA

(61.47 m.)
13.00—12.00—Records.

VATICAN CITY

(19.84 m.)
15.30—Church Notes (Ger. or It.).
(50.26 m.)
19.00—Church Notes (Ger.).

WARSAW

(22 m.; 26.01 m.)
23.00—01.00—News (Pol., Eng.); Talk; Music; Poems; at 00.20—Talk (Eng.).

WAYNE

(13.94 m.)
12.30—Daily Almanac—Phil Cook.
12.55—News; Variety; Music.
14.25—15.00—News; Music.
(19.65 m.)
18.00—Variety.
19.00—19.15—For Women.

(25.36 m.)
19.30—School of the Air.
20.00—U.S. Marine Band.
20.30—Questions before the Senate.
20.45—Lincoln Cathedral Choir.
21.00—Music from the Gold Coast.
21.30—Light Classical Music.
21.45—Dr. Dafoe—Talk; Music.
22.00—Light and Dance Music.
22.55—23.00—News.
23.30—05.00—For S. America.
23.30—Boake Carter.
23.45—News (Sp., Port.); Variety.
00.30—Margaret Daum (Songs).
01.00—Hammerstein Music-Hall.
01.30—Paul Whiteman's Orchestra.
02.00—Variety; Talk.
04.00—05.00—Dance Music.

ZEESEN

(13.99 m.; 16.89 m.; 19.63 m.; 19.74 m.; 31.38 m.)
05.05—Call (Ger., Eng.); Music.
06.00—News; Concert; Greetings.
07.00—News (Eng.); Talk; Concert.
09.30—News; Music.
12.00—News (Eng.); Music.
13.00—News; Concert.
14.00—News (Eng., Dutch); Talks.
14.45—Military Music.
15.45—16.00—German Economics.
(19.85 m.; 25.49 m.; 49.83 m.)
15.40—Call (Ger., Eng.); Music.
16.50—Music; Talks.
17.45—News; Cabaret.
19.00—News (Eng.); Talk; Markets.
19.45—Folk Songs and Dances.
20.30—Coronation Concerto (Mozart).
21.00—21.25—News (Ger., Eng.).
(19.74 m.; 25.49 m.)
21.50—Call (Ger., Eng.); Schubert and Mozart Music.
22.45—News; Review.
23.00—"Agnes Bernauer"—Play (Hebbel).
00.15—Talks; Heidelberg Programme.
01.15—News (Eng.); Folk Music.
01.45—German Economics.
02.00—News; Military Music.
03.30—03.45—News (Eng.); Greetings.

SATURDAY, Mar. 19

EMPIRE
Transmission 1 (GSG, GSO, GSF, GSD, GSB)
07.00—Big Ben; Geraldo and his Orchestra.*
07.45—Talk on the late King Albert of the Belgians.*
08.00—Cinema Organ.
08.20—"London Log."*
08.30—Pipe Band.*
08.50—09.15—News.

Transmission 2 (GSJ, GSH, GSG, GSO, GSF)
10.45—Big Ben; "Swift Serenade."**
11.15—"Will You Be Mine...?"**
11.45—BBC Northern Orchestra; Anne Stuart (Soprano).
12.50—"London Log."**
13.00—Luigi Voselli's Hungarian Orchestra.
13.30—13.55—Big Ben; News.

Transmission 3 (GSJ, GSH, GSG, GSO, GSF, GSD from 15.45, GSO to 15.00)
13.55—Opening Announcements.
14.00—Big Ben; Tessa Deane (Soprano); Doris Hardcastle (Pfte.).
14.25—Geraldo and his Orchestra.*
14.55—England v. Scotland Rugby Football match.
16.35—Records.
16.50—17.20—News.

Transmission 4 (GSG, GSD, GSB; GSP from 18.45; GSF, GSC, 17.20—18.15, Arabic transmission; 21.15—23.00 GSO, GSF, GSD, GSB, GSB)*
17.20—Geraldo and his Orchestra.
18.00—Big Ben; News.
18.30—"London Log."**
18.40—Adelaide Newman (Pfte.).
19.00—Big Ben; England v. Scotland Rugby football match.
19.30—"In Town Tonight."
20.00—21.00—"Palace of Varieties."
21.15—Big Ben; News.
21.45—Popular Ballad recital.
22.00—"Will You Be Mine...?"**
22.30—23.00—Ambrose and his Orchestra.

Transmission 5 (GSP, GSD, GSC, GSB)*
23.20—"Palace of Varieties."**
00.10—England v. Scotland Rugby Football commentary.*
00.40—News.
01.10—01.30—"Haunting Harmonics."

Transmission 6 (GSD, GSC, GSB)*
02.20—"Ice-Hockey in Great Britain" talk.
02.30—Some glimpses of London's old pleasure gardens.*

03.30—Big Ben; News.
04.00—Big Ben; Selections from the Gilbert and Sullivan Operas.*
04.10—04.20—"London Log."**

BARCELONA

(42.7 m.)
23.00—News (Foreign Languages).

BOSTON

(25.45 m.)
22.00—World of Youth speaks.
23.00—Monitor views the News.

BOUND BROOK

(16.87 m.)
13.00—Southernaires; Variety.
14.55—News; Talks; Variety.
16.30—Our Barn.
17.00—News; Baily Axton.
17.30—Rex Battle Ensemble.
18.00—News (Fr., Ger.); Music.
18.30—Campus Capers.
18.55—Metropolitan Opera House.
22.00—Orchestra; News.
(49.18 m.)
23.00—06.00—For Latin America.
23.00—Marek Weber's Orchestra.
23.30—News; Songs; Music.
00.30—Tex O'Rourke's Boys.
00.45—Jean Sablon.
01.00—Musical Variety.
01.30—02.00—News; Songs.
02.25—News (Sp.).
02.30—Barn Dance.
03.00—NBC Symphony Orchestra.
Conductor: Rodzinsky.
04.30—News (Sp., Port.); Music.
05.00—06.00—Rebroadcasts.

BUDAPEST

(32.88 m.)
23.00—00.00—Music; News; Band; Play; Talk.

BUENOS AIRES

(19.62 m.)
12.00—News; Records; Bargains.
(31.06 m.)
14.30—Music; at 17.00—News.
18.00—Markets; Music; Humour.
19.45—"Mundo Argentino."
20.00—Play; Music; Markets.
23.30—Feature Programmes.
02.00—04.30—Dance Music.

CARACAS

(51.72 m.)
12.00—13.00—News.
15.30—18.30—Records; Songs.
20.45—Music and Songs.
22.15—For Children; Dancing.
23.00—News; Music; Talk.
00.00—Light Music; Variety.
01.30—03.30—Dance Music.

HUIZEN

(16.88 m.)
13.25—15.30—For the Dutch Indies.

LYNDHURST

(31.32 m.)
02.35—Records; News.
03.15—07.30—Music; Racing.
08.30—Markets; Sports; Mail.
09.05—Music; News; Sports.
10.00—Lauri and Dorothy Kennedy (Cello and Pfte.) and the A.B.C. (Sydney) Symphony Orchestra.
10.50—Tauber Records.
11.00—Big Business.
11.15—Pfte. and Violin.
11.45—Ballads; Music.
12.30—News; Mail.
13.00—14.00—Dance Music.

MILLIS

(31.35 m.)
14.00—Breakfast Club.
02.00—National Barn Dance.

MOSCOW

(25 m.)
11.00 and 17.15—Talks, etc. (Ger.).
(50 m.)
20.00—Talks, etc. (It., Ger.).
21.00—Talks, etc. (Fr., Sp.).
(31.25 m.)
23.00—Programme in Spanish.
(31.25 m.; 39.79 m.)
00.00—Programme in English.
(50 m.)
01.30—Programme in French.
(25 m.)
03.15—Programme in English.

PARIS (Radio-Colonial)

(25.24 m.)
07.00—09.40—News; Records.
09.40—10.00—News (Eng., It.).
(19.68 m.)
11.00—Records; Talk (Yugoslav).
12.00—News (Eng., Fr.); Music.
14.30—16.00—Goidy Orchestra.
(25.24 m.)
16.15—News (Fr., Arabic); Music.
18.50—Talk; News.
20.10—News (Eng., It.).
20.30—To be announced.
22.30—Markets; News (Port.).
(25.6 m.)
23.15—Concert.
00.15—News (Fr., Sp., Port.).
03.00—Records; News.
04.30—News (Eng.); Records.
05.45—06.00—News (Ger.).

PITTSBURGH

(13.93 m.)
11.45—Farm Markets; Variety.
13.15—News; Musical Clock.
(19.71 m.)
14.00—Breakfast Club; Variety.
17.00—News; Novelties.
17.30—Farm and Home; Clubs.
18.55—Metropolitan Grand Opera.
22.00—News Reeler; Music.
23.00—News; Music; Talk.
(25.26 m.)
00.00—Message of Israel.
00.30—Uncle Jim; Variety.
01.30—NBC Spelling Bee.
02.00—National Barn Dance.
03.00—NBC Symphony Orchestra.
Conductor: Toscanini.
(48.83 m.)
04.30—News; Orchestras.
05.30—06.00—Far North Messages.

PODEBRADY

(31.41 m.)
For Europe.
18.00—News (Czech, Ger.); Music; Foreign Affairs (Eng.); at 21.00—News (Fr.).
21.30—21.40—News (Eng.).

ROME

(25.4 m.)
10.00—News; Opera Music.
11.00—News (Eng., Fr.); Music; News (Jap., It.).
12.30—13.45—Music; Talk; News.
15.00—News (It., Fr., Hindu, Eng.); Music.
(31.13 m.)
17.06—News; Music (Arabic).
18.00—Talk (Esperanto).
18.19—News and Talks (Romanian, Hung., Serb., Fr.).
19.36—News (Eng., Fr., Ger.).
20.00—From Turin (No. 1); Talks (Ger., Fr., Eng.).
22.30—News (Sp., Greek).
23.00—For S. America; News; Opera; Talk; News (Sp., Port.).
00.30—02.00—For U.S.A.; News (Eng.); Music; Talk; News.

SCHENECTADY

(13.95 m.)
13.00—Music; at 16.00—Forum.
(19.57 m.)
17.30—Farm Programme; Music.
19.30—Buffalo; Music.
(19.57 m.; 31.48 m.)
21.00—Stamp Collectors; Music.
22.00—Great Plays.
23.00—El Chico—Spanish Revue.
23.30—News; Religious News.
(31.48 m.)
00.00—Kindergarten.
00.30—Stock Reports.
01.00—Ripley; Variety; Music.
02.30—05.00—Portraits; Music.
(31.4 m.)
00.30—05.00—To be announced.

SUVA

(31.47 m.)
10.30—12.00—Records.

VATICAN CITY

(19.84 m.)
15.30—Church Notes (Polyglot).
(50.26 m.)
19.00—Church Notes (Polyglot).

WARSAW

(22 m.; 26.01 m.)
23.00—02.00—News, Variety (Pol., Eng.); Music; Talk (Eng.).

WAYNE

(13.94 m.)
13.00—Music; at 14.55—News.
16.00—Cincinnati Conservatoire.
17.00—18.00—Dance Music.
(25.36 m.)
19.30—Music; at 20.00—Economics.
22.00—23.00—Talk; Swing.
23.30—05.00—For S. America; Variety; at 02.00—Prof. Quiz; at 03.00—Hit Parade.

ZEESEN

(13.99 m.; 16.89 m.; 19.63 m.; 19.74 m.; 31.38 m.)
05.05—Call (Ger., Eng.); Music.
06.00—News; Music; Greetings.
07.00—News (Eng.); Talk; Music.
08.30—Women's Cabaret.
09.30—News; Markets; Music.
12.00—News (Eng.); Music.
13.00—News; Cantata; Markets.
14.00—News (Eng., Dutch); Talk.
14.30—16.00—Dancing Lesson; Talks.
(19.85 m.; 25.49 m.; 49.83 m.)
15.40—Call (Ger., Eng.); Music.
16.15—"Punch"; Music; Talks.
17.45—News; Variety.
19.00—News (Eng.); Talk.
19.30—Dancing Lesson and Talk.
21.00—21.25—News (Ger., Eng.).
(19.74 m.; 25.49 m.)
21.50—Call (Ger., Eng.); Cabaret.
22.45—News; Songs and Dances.
00.15—Topical; "Punch"; Music.
01.15—News (Eng.); Music.
02.00—News; Cabaret.
03.30—03.45—News (Eng.).

It comes out
at night!



Its music comes out of your radio — but how? Does it come out recognisable as a saxophone (because that's what it is)? To make sure it always sounds like one you'd better get an Exide Battery.

R.34



Exide

BATTERIES FOR RADIO

'Still keep going when the rest have stopped'

EXIDE 'HYCAP' BATTERY (High Capacity L.T. Battery)

For modern multi-valve sets—lasts longer on one charge. For small sets use the Exide 'D' Type. Both have the Exide Charge Indicator. Your dealer will tell you which to use. For High Tension use Drydex.

From reputable dealers and Exide Service Stations. Exide Service Stations give service on every make of battery.

The Chloride Electrical Storage Company Ltd. (Exide and Drydex Batteries) Exide Works, Clifton Junction, near Manchester. Also at London, Manchester, Birmingham, Bristol, Glasgow and Belfast.

What Would You

	SUNDAY, Mar. 13	MONDAY, Mar. 14	TUESDAY, Mar. 15
Symphony Concerts Operas	2.10 Hilversum 1: Bruno Walter. 2.30 Naples group: "La Gioconda." 3.0 Brussels 1: Rasse, Backhaus. 4.0 Brussels 2: Brahms Requiem. 4.45 Paris (PTT): Wagner. 5.0 Leipzig, Sottens: "Tristan." 7.0 German stations: Heroes Day. 8.25 Lille: "Tales of Hoffmann." 8.25 Vienna: Brahms pfte. concerto. 8.30 Radio-Paris: French music. 11.0 Frankfurt, Stuttgart: "Hans Sachs" (Lortzing).	5.55 Vienna: "Djamileh," "Ivan Sergejevitch Tarassenko." 6.55 Beromünster: Brahms. 7.10 Budapest 1: Missa Solennis (Beethoven), etc. 7.15 Kalundborg: Mozart, Ibert. 8.0 Deutschlandsender: Ansermet. 8.30 Swiss stations: "Le Cris du Monde" (Honegger). 9.0 Warsaw: Strauss, Reger, Reznick. 9.15 Stockholm: "Tannhäuser," 2.	6.30 Budapest 1: Hungarian operas. 7.15 Beromünster: Basle concert. 7.15 Stuttgart, Prague (8.0): "Rodelinde" (Handel). 8.0 Brussels 1: "Kunst der Fuge." 8.0 Rome group, Deutschlandsender, Kalundborg: "Cavalleria." 8.0 Turin group: Beethoven, Brahms. 8.30 Eiffel Tower: National Orch. 9.0 Sottens: Mozart programme. 9.10 Hilversum 2: Classics.
Chamber Music Recitals	2.40 Vienna: Brahms quartet. 3.5 Warsaw: Pfte., 'Cello. 5.15 Königsberg: Pianoforte. 5.30 Radio Eireann: Carillon. 6.10 Vienna: Violin. 6.15 Oslo: Violin, viola, pfte. 7.0 Brussels 2: Tenor arias. 7.35 Radio Eireann: Violin, pfte. 8.0 Eiffel Tower: Pfte., violin. 9.5 National: Sir Walford Davies. 9.30 Stockholm: Quartet (Brahms). 9.55 Kalundborg: Heise songs.	2.45, 4.0 Radio-Paris: Pfte., song, 'cello. 4.0 Paris (PTT): Organ. 5.25 Deutschlandsender: Wolf songs. 6.30 Stockholm: English part-songs. 7.0 Sottens: Bach organ music. 7.30 Regional: Janssen (songs). 7.55 Hilversum 2: Organ music. 8.0 Eiffel Tower: Song, pfte. 9.0 Rome group: 'Cello. 9.15 Oslo: Soetens (violin). 9.20 Kalundborg: Debois Quartet. 9.45 Hilversum 1: Choir.	2.45, 4.0 Radio-Paris: Pfte., songs. 3.25 Hilversum 1: Violin. 5.10 Deutschlandsender: Quartets. 5.20 Sottens: String orchestra. 6.30 Strasbourg: Haydn Quartet. 7.0 Breslau: Organ, violin. 7.15 Bucharest: Sacred music. 8.0 Eiffel Tower: Pfte., violin. 8.0 Frankfurt: Italian music. 8.0 Warsaw: Szeluta programme. 9.15 Stockholm: Song, pfte. 9.20 Vienna: The Rome Quartet. 10.15 Radio-Paris: Old instruments.
Plays and Feature Programmes	4.0 Radio Paris: "Documents secrets." 5.0 Cologne: "Einsiedel" (Klucke). 8.20 Kalundborg: "An Heir." 8.30 Nice, etc.: Radio play. 8.30 Paris (PTT): "Peer Gynt." 9.10 Rome group: "Il sigaro."	6.15 Sottens: Micro-Magazine. 8.0 Turin group: "Pianterreno rialzato." 8.30 Strasbourg: Three sketches. 10.45 Paris (PTT): Esperanto play.	7.0 Sottens: "Le roman d'un jeune homme pauvre." 8.0 National: "Snow White and the Seven Dwarfs" (Disney). 8.15 Radio-Paris: "La Lumière." 8.15 Vienna: "Homes of Famous Poets."
Light Orchestral Bands Operettas	12.30 Radio-Paris: Pascal Orchestra. 2.25 Kalundborg: Czech music. 3.0 Munich, Deutschlandsender: Orch. and instrumental. 6.0 Budapest 1: Radio Orchestra. 6.40 Vienna: Potpourri. 6.45 Stockholm: Navy Band. 7.0 Bucharest: "The Bird Fancier." 7.15 Kalundborg: Radio Orchestra. 8.0 Brussels 1: "Les cloches de Corneville." 8.0 Hilversum 1: Orch., songs. 8.0 Rome group: Band concert. 8.0 Turin group: Tirindelli prog. 8.10 Hilversum 2: Popular prog. 8.30 Budapest 1: Cigány Band. 9.15 Turin group: Marches, waltzes. 9.30 Berlin: Bands. 9.30 Breslau: Orch., soprano, pfte. 9.30 Deutschlandsender: Rambour Band. 9.35 National: Gitta Alpar, Joseph Schmidt. 9.40 Budapest 1: Military Band.	12.10 Hilversum 1: VARA Orch. 1.35 Kalundborg: Radio Orchestra. 3.0 Deutschlandsender: Orchestra. 5.0 Radio-Paris: Bailly Orchestra. 5.10 Hilversum 1: Light opera music. 6.10 Cologne: Waltzes from operas. 6.15 Stuttgart, etc.: Variety music. 7.0 Frankfurt: Military Bands. 7.0 Oslo: Bergen Radio Orchestra. 7.0 Warsaw: Light orchestral. 8.0 Brussels 1: Massenet prog. 8.0 Radio Eireann: Orch., songs. 8.0 Rome group: Operetta music. 8.0 Stockholm: Operetta music. 8.10 Munich: Hamburg composers. 8.15 Swiss stations: For Swiss abroad. 8.30 Lyons, etc.: "Hans the flute-player." 8.40 Hilversum 2: NCRV Orch. 9.30 Cologne, etc.: Light and dance music. 9.30 Nice, etc.: Orchestra, arias. 10.0 National: Orch., Jo Vincent.	12.20 Radio-Paris: Cantrelle Orch. 12.40 Hilversum 1: Orch., pfte. 1.30 Kalundborg: Folk music. 3.0 Königsberg, etc.: Orchestra. 5.0 Radio-Paris: Ellis Orchestra. 5.0 Stockholm: Popular prog. 5.45 Hilversum 2: KRO Orchestra. 6.10 Hamburg: Potpourri. 6.10 Munich: Military Band. 6.15 Cologne: Viennese music. 6.30 Warsaw: Polish choral music. 6.50 Vienna: Ziehrer programme. 7.0 Oslo: Opero music. 7.0 Radio Eireann: Band, songs. 8.0 Berlin: Old dances, etc. 8.30 Paris (PTT): "Monsieur Beaucaire." 9.0 Budapest 1: Cigány Band. 9.45 Hamburg, etc.: Light and dance music. 10.0 Budapest 1: Military Band. 10.20 Hilversum 2: Pop. orchestral. 10.50 Hilversum 1: Gipsy music.
Talks (including News in English) Commentaries	2.50—Paris (PTT): Belgian Army v. French Army (football). 6.55, 9.0 Swiss stations: Swiss Skiing championships. 7.36 Rome 2: News in English. 9.0 Moscow: English programme.	3.40 Regional: Sale v. Oxford (Rugby). 7.10 Lille: English talk. 7.36 Rome 2: English News. 9.0 Moscow: English programme. 10.15 Brussels 1: Poems.	5.30 Cologne: English talk. 6.45 Radio-Paris: "French folklore." 6.55 Beromünster: "The Conductor." 7.36 Rome 2: News in English. 10.0 Prague: English News.
Variety Cabaret	8.15 Warsaw: Variety. 8.30 Eiffel Tower: Variety. 9.5 Poste Parisien: Amateurs' Hour. 9.30 Strasbourg: Musical Variety.	6.10 Breslau: "Blue Monday." 7.0 National: "Monday at Seven." 9.0 Regional: Television Cabaret. 10.30 Poste Parisien: Cabaret.	8.0 Brussels 2: Musical Variety. 8.10 Hilversum 1: "The Tuesday Night Special." 8.30 Rennes, etc.: Variety.
Dance Music	9.15 Oslo; 9.25, Hilversum 2; 9.35, Prague, Vienna; 10.10, Brussels 2; 10.15, Kalundborg, Rome, Turin groups; 10.50, Hilversum 1; 11.0, Brussels 1, Paris (PTT), Radio-Paris, Strasbourg.	7.0 Munich; 9.30, Vienna; 9.35, Königsberg; 9.45, Rome group; 9.55, Kalundborg; 10.10, Brussels 2; 10.15, Turin group; 10.25, Regional; 10.30, Brussels 1; 11.0, National.	5.0 Brussels 2; 6.10, Königsberg; 7.30, Cologne, etc.; 8.10, Poste Parisien; 8.45, Warsaw; 10.0, Vienna; 10.15, Kalundborg, Turin group; 10.25, Regional; 11.0, National.

Like To Hear ?

WEDNESDAY, Mar. 16	THURSDAY, Mar. 17	FRIDAY, Mar. 18	SATURDAY, Mar. 19
<p>6.0 Bucharest: Wagner programme. 6.25 Vienna: Schubert, Schumann. 6.30 Stockholm: Göteborg Orch. 7.0 Berlin, Leipzig: Bruckner's Sixth. 7.30 Oslo: Tchaikovsky programme. 8.0 Rome group: Mengelberg. 8.0 Turin group: "Werther." 8.15 National, Prague: Mass in B minor (Bach). 8.30 Strasbourg: Nancy Conservatoire.</p>	<p>6.25 Vienna: Mass (Gassmann). 7.10 Kalundborg: Wagner concert. 7.15 Bucharest: The Berlin Phil. 7.25 Hilversum 2: St. Matthew Passion. 8.0 Hilversum 1: Walter, Krenek. 8.0 Rome group: "Carmen." 8.30 Radio-Paris: Two operas. 9.15 Brussels 2: Modern music. 9.15 Strasbourg: Dvořák. 9.25 Budapest 1: Old Hungarian. 11.0 Frankfurt, Stuttgart: Records.</p>	<p>7.0 Frankfurt: "The Barber of Seville." 7.0 National: "La Rondine." 7.0 Warsaw: Ansermet, Krasner. 7.30 Sottens: Kleiber. 7.55 Hilversum 2: Phil. Orch., choir. 8.0 Rome group: Brahms, Bruckner. 8.30 Paris (PTT): Symphonies. 8.30 Strasbourg: Beethoven. 9.15 Stockholm: Lalo, Brahms. 11.0 Radio-Paris, Strasbourg: Dukas, Rimsky-Korsakov.</p>	<p>3.10 Hilversum 1: Haydn, Brahms. 4.0 Brussels 2: St. John Passion. 5.0 Strasbourg: Beethoven, Missa Solennis, 9th Symphony. 7.0 National: "Carmen" (from Metropolitan, New York). 8.0 Turin group: "Andréa Chénier." 8.35 Vienna: Violin concerto (Dvořák).</p>
<p>2.45, 4.0 Radio-Paris: Pfte., song. 5.15 Deutschlandsender: Kreutzer Sonata. 5.15 Strasbourg: String quartets. 6.15 Brussels 1: Basle Trio. 7.0 Brussels 2: Candaël songs. 7.45 Sottens: Conservatoire. 7.50 Radio Eireann: Organ, songs. 8.0 Eiffel Tower: Song, pfte. 8.0 Warsaw: Chopin. 8.40 Beromünster: Vocal quartet. 9.20 Königsberg: Quartet (Haydn). 10.40 Hilversum 1: Violin, pfte.</p>	<p>6.0 Budapest 1: Hungarian songs. 6.5 Bucharest: Pfte., songs. 6.10 Cologne: German folk songs. 6.30 Paris (PTT): Organ. 7.5 Oslo: Song, pianoforte. 8.0 Eiffel Tower: Song, pfte. 8.0 Munich: Quartet, pfte. 8.0 Paris (PTT): Songs. 8.30 Stuttgart: Pianoforte (Mozart). 9.15 Warsaw: Old Italian songs. 9.20 National: Violin, pfte. 9.35 Prague: Křenek, Milhaud. 11.20 Hilversum 1: Organ.</p>	<p>5.0 Radio-Paris: Quartet, songs. 5.45 Brussels 2: Pfte., 'cello. 6.15 Budapest 1: Sigrid Schneevoigt (pfte.). 6.30 Kalundborg: Workers' choir. 7.40 Hilversum 1: 'Cello, pfte. 8.10 Stockholm: Choir. 8.30 Eiffel Tower: Vocal, instr. 9.40 Kalundborg: Pfte. (Brahms). 10.10 Brussels 2: Old Netherlands music. 10.30 National: Volkslieder from Berlin.</p>	<p>3.0 Stockholm: Songs (Beethoven, Schubert), pfte. 4.15 Paris (PTT): Song, violin. 5.10 Munich: Pianoforte (Niemann). 5.30 Stockholm: Harp Quintet. 5.40 Hilversum 1: Organ. 6.15 Brussels 2: Transvaal songs. 6.25 Vienna: Vienna Male Voice Choir, horn quartet. 6.30 Brussels 1: Pianoforte. 9.30 Deutschlandsender: Serenade (Zilcher). 10.25 National: 'Cello, pianoforte.</p>
<p>6.15 Sottens: Micro-Magazine. 8.0 Brussels 1: "Les plus beaux yeux du monde (Sarment)." 8.0 Paris (PTT): Sketch. 8.40 Vienna: Scenes from "Der Bauernkalender."</p>	<p>5.0 Radio-Paris: "La jeunesse de Henri V." 6.10 Munich: A Millöcker play. 7.0 Cologne: "Agnes Bernauer." 8.30 Paris (PTT): Two plays. 9.0 Turin group: "Il giudice Bertrand."</p>	<p>7.0 Vienna: "Baumeister Solness." 8.0 Deutschlandsender: Comedy. 8.10 Breslau: "Tabakskollegium." 8.30 Radio-Paris: "Resurrection." 8.40 Kalundborg: "The Son." 9.30 Strasbourg: "Une larme du diable."</p>	<p>7.15 Radio Eireann: "H.D.G." (Sidney Carroll). 8.0 Rome group: "Chi m'ha ucciso." 9.10, 11.0 Paris (PTT): Plays.</p>
<p>12.0 Radio-Paris: Garde Républicaine Band. 12.10 Hilversum 1: Popular orch. 1.30 Kalundborg: Rydahl Ensemble. 3.0 Deutschlandsender: Pop. orch. 4.10 Munich: Variety concert. 5.0 Radio-Paris: Giardino Orch. 6.10 Frankfurt, etc.: Opera music. 6.25 Prague: "Spring is Here." 7.0 Breslau: Band, choir. 7.0 Cologne: "Glückliche Reise." 7.20 Kalundborg: Radio Orchestra. 8.0 Berlin: "Spring is coming." 8.0 Brussels 2: "The Queen Commands" (operetta). 8.10 Beromünster: Bohemian music. 8.10 Hamburg: Orchestra. 8.30, 9.20 Kalundborg: Radio Orch. 8.50 Hilversum 1: Potpourri. 9.0 Warsaw: Opera music. 9.20 Budapest 1: Conductor, de Sabata. 9.30 Frankfurt, etc.: Light music. 9.35 Vienna: Light orchestral.</p>	<p>12.20 Radio-Paris: Bailly Orchestra. 12.40 Hilversum 1: Light music. 2.0 Kalundborg: Wivex Orchestra. 3.0 Deutschlandsender: Band. 5.10 Hilversum 1: Radio Orchestra. 5.20 Sottens: English music. 6.10 Frankfurt: Musical Landscapes. 6.10 Hamburg: Orchestral dances. 6.15 Brno: Operetta and film music. 6.30 Stockholm: Radio Rhapsody. 7.0 Beromünster: Orchestral. 7.0 Warsaw: Musical mosaic. 7.5 Vienna: "Brüderlein fein" (L. Fall). 7.30 Sottens: Contemporary Swiss. 8.0 Brussels 1: Film music. 8.0 Radio Eireann and many European stations: St. Patrick's Day Concert. 8.30 Eiffel Tower: "La Sérénade." 9.15 Oslo: Orchestral. 9.15 Stockholm: Light music. 9.20 Munich: Serenade. 9.30 Stuttgart, etc.: Folk music, etc.</p>	<p>1.30 Kalundborg: Preil's Ensemble. 2.10 Hilversum 1: Light music. 3.0 Frankfurt: Orchestra, choir. 5.0 Berlin: Waltzes. 6.10 Cologne: Variety concert. 6.25 Vienna: Light music, dances. 6.30 Stockholm: Waldimir's Orch. 6.30 Warsaw: Students' Choir. 6.55 Beromünster: Radio Orchestra. 7.0 Leipzig: Orch., soprano, bass. 7.25 Budapest 1: Radio Orchestra. 7.45 Radio Eireann: Orchestra. 8.0 Brussels 1: Radio Orch., songs. 8.0 Prague: Schubert, Haydn, Dvořák. 8.0 Turin group: "Armi ed amori" (operetta). 9.0 Budapest 1: Cigány Band. 9.0 Hilversum 2: Popular orch. 9.0 Regional: Adolf Wiklund. 9.15 Oslo: Old dances. 9.20 Vienna: Radio Orchestra. 9.30 Berlin, etc.: Serenade (Bands). 11.0 Stuttgart, Frankfurt: Records.</p>	<p>12.15 Radio-Paris: Cantrelle Orch. 1.35 Kalundborg: Radio Orchestra. 5.15 Brussels 1: "Ciboulette." 6.0 Warsaw: For Poles abroad. 6.20 Prague: Folk music. 6.30 Budapest 1: "Gipsy Love." 7.0 Berlin: "Aennchen von Tharau." 7.0 Beromünster: "Der fidele Bauer." 7.0 Kalundborg: Schubert music. 7.0 Warsaw: Polish music. 7.5 Vienna: Variety concert. 7.20 Oslo: Orchestra. 7.55 Bratislava, Prague: Operetta music. 7.55 Hilversum 1: Orchestra, tenor. 7.55 Radio Eireann: Variety music. 8.45 Brussels 1: Opera music. 9.0 Brussels 2: Belgian music. 9.0 Regional: "Katinka" (Friml). 9.35 Vienna: Viennese music. 10.10 Budapest 1: Cigány Band. 11.0 Frankfurt, Stuttgart: Serenade.</p>
<p>5.0 Cologne: Topical Talks. 6.35 Radio-Paris: "French Opera." 7.10 Lille: English talk. 7.36 Rome 2: News in English. 10.0 Budapest 1: News (French, Italian).</p>	<p>7.5 Budapest 1: "John Keats." 7.36 Rome 2: News in English. 8.30 National: "The Way of Peace." 9.0 Brussels 1: Topical talk. 9.30 Regional: Ice Hockey.</p>	<p>7.36 Rome 2: News in English. 8.0 Eiffel Tower: Poetry reading. 9.0 Brussels 1: "Woman in China." 9.0 Moscow: English programme. 9.35 Prague: Sokol Exercises. 10.0 Budapest 1: News in English.</p>	<p>2.55 National, Radio Eireann (3.10): Rugby International. 7.0 Sottens: International Horse Show. 7.10 Lille: Talk in English. 7.36 Rome 2: News in English.</p>
<p>6.55 Beromünster: Variety hour. 8.15 Regional: Leslie Henson. 9.0 Radio-Paris: "France in song." 9.10 Poste Parisien: Max Regnier. 9.15 Regional: Harry Lauder.</p>	<p>8.15 Poste Parisien: "Plaisirs de Paris." 10.20 National: Cabaret records.</p>	<p>5.40 Hilversum 1: Amateurs' Hour. 7.0 Berlin: Variety. 7.30 Regional: Music-Hall. 9.30 Eiffel Tower: "Night."</p>	<p>3.0 Cologne, etc.: Variety. 8.0 Brussels 1: "Radio-Jadis." 8.0 National: Variety. 8.15 Radio-Paris, 9.50 Paris (PTT): "Un soir de Paris."</p>
<p>5.40 Hilversum 1; 9.0, Sottens; 9.15, Stockholm; 9.20, Leipzig; 9.30, Breslau, etc.; 9.35, Oslo; 10.10, Budapest 1; 10.15, Kalundborg, Rome group; 10.25, Regional; 11.20, National.</p>	<p>6.45 Hilversum 1; 7.0, Berlin; 8.0, Cologne; 9.0, Vienna; 10.15, Kalundborg, Turin group; 10.25, Regional; 10.40, Hilversum 1; 11.0, National.</p>	<p>3.55 Hilversum 2: 9.0, Beromünster; 9.30, Sottens; 10.5, Budapest 1; 10.10, Brussels 1; 10.15, Kalundborg, Rome; Turin groups; 10.20, Hilversum 2; 10.25, Regional; 11.15, National.</p>	<p>8.0 Kalundborg: Radio Ball; 9.5, Budapest 1; 9.15, Stockholm; 9.30, Berlin, Prague; 9.45, Oslo; 10.10, Brussels 1; 10.15, Rome group; 10.30, Regional; 11.0, Brussels 2, National, Radio-Paris.</p>

Long and Medium Wave Programmes

SUNDAY MARCH 13

National

Time Signals: Big Ben, 12.30, 10.45 p.m. Greenwich, 10.30 a.m., 4.0, 9.0 p.m. D=Droitwich.

- 9.30-10.5 a.m. (D)—Service (C.E.).
10.30-10.45 (D)—Weather Forecast.
12.30 p.m. (D)—Creswell Colliery Band: Ronald Murgatroyd (Tenor).
1.20 (D)—Isidore Schwiller and his String Sextet.
2.0 (D)—"Rose Pruning." C. H. Middleton and A. Norman.
2.20 (D)—Falkman and his Apache Band, with Tessa Deane.
3.0 (D)—New Metropolitan Symphony Orchestra; Conductor, Serge Krish.
4.0—"Sunday in England in the Fourteenth Century."
4.30—Reginald New (BBC Theatre Organ).
5.0—"The Bible in the World." The Rt. Hon. Ernest Brown, M.C., M.P.
5.20—Chamber Music: John Francis (Flute); Pauline Juler (Clarinet); Brosa String Quartet with Gwendolen Mason (Harp).
6.15—Extracts from the diary of a Sheffield hatter who came to London.
6.30—Harry Davidson and his Orchestra.
7.20—Voyage to the Sun: feature programme by Jonquil Antony.
7.55 (D)—Service from St. Martin-in-the-Fields; Address by the Rev. Pat McCormick, D.S.O.
8.45 (D)—Appeal on behalf of the North Cambridgeshire Hospital.
8.50—The News.
9.5—Melodies of Christendom; Sir Walford Davies.
9.55—Songs and Duets from Famous Operettas: Gitta Alpar (Soprano); Joseph Schmidt (Tenor); Theatre Orchestra.
10.30—Epilogue.

London Regional

- Time Signals: Big Ben, 12.30, 10.45 p.m. Greenwich, 4.0, 9.0 p.m.
12.30 p.m.—National.
4.0—Alfredo Campoli Trio.
4.20—"Music of the Week." Sir Adrian Boult.
4.30—Children's Service from Bloomsbury Baptist Church.
5.0—BBC Military Band.
5.40—Reading from George Bourne's Memoirs.
6.0—Charles Ernesco's Quintet, with Webster Booth.
6.30—Ethel Bartlett, Rae Robertson (Pftes.); BBC Orchestra (Section E); Conductor, Sir Adrian Boult: Eine kleine Nachtmusik, Concerto (Mozart); Symphony (Haydn).
7.55—National.
8.45—Appeal on behalf of The Veterans' Association.
8.50—The News.
9.5—Mario De Pietro and his Estudiantina, with Max Oldaker.
9.35—"The Temple Church."
10.15—Shepherd Munn (Pfte.).
10.30—Epilogue.

Midland

- 4.0 p.m.—Regional.
5.0—Jan Berenska's Orchestra: Edmond Letts (Baritone).
6.0—Regional.
7.55—National.
8.45—Appeal.
8.50—The News.
9.5—Northern.
10.30—Epilogue.

Northern

- 12.30 p.m.—National.
4.0—Regional.
5.40—Open-Air Notebook.
5.55—Huddersfield Glee and Madrigal Society.
6.30—Regional.
7.55—National.
8.45—Appeal.
8.50—The News.
9.5—"Warwick the Kingmaker." by D. G. Bridson.
10.30—Epilogue.

Western

- 4.0 p.m.—Regional.
5.40—Northern.
6.30—Music to Shakespeare: The Clifton Light Orchestra, conducted by Reginald Redman, and BBC West of England Singers.

Welsh

- 7.30—"Journey to Scilly."
7.55—National.
8.45—Appeal.
8.50—The News.
9.5—Northern.
10.30—Epilogue.

Welsh

- 12.30 p.m.—National.
4.0—Records.
4.20—Regional.
4.30—"Methodistiaeth—Ei Chyfrinach." E. Tegla Davies.
4.50—BBC Welsh Orchestra: Ifor Hughes (Bass)—Handel, Bach-Gounod, Mendelssohn, Meirion Williams, Glazunov.
5.40—Regional.
7.55—Welsh Service from Methodist Chapel, Pontardawe.
8.45—Appeal.
8.50—The News.
9.5—Regional.
10.15—Reading in Welsh from Devotional Literature.
10.30—Epilogue.

N. Ireland

- 12.30 p.m.—National.
4.0—Regional.
5.40—"The Irish Ballad." Shane Leslie.
6.0—Roland Powell's Quintet.
6.30—Regional.
7.55—National.
8.45—Appeal.
8.50—The News.
9.5—Regional.
10.30—Epilogue.

Scottish

- 12.30 p.m.—National.
2.0—"Old Man by the Sea," by Elizabeth Macpherson.
2.20—National.
4.0—Regional.
5.0—Scottish Studio Orchestra: Hungarian Folk Music.
5.20—"What may we pray for?" discussion.
5.40—Regional.
7.55—National.
8.45—Appeal.
8.50—The News.
9.5—Regional.
10.30—Epilogue.

Hours of Transmission in Greenwich Mean Time.

BERLIN (Germany)

- 841 kc/s (356.7 m.); 100 kW.
5.0 a.m.—Call; Weather; Gym.
5.30—Concert from Hamburg.
7.0—Gym; Records.
8.0—Organ.
8.30—For Hitler Youth.
9.0—Weather.
9.5—Rink Band.
10.0-10.45—Band. Conductor: Teichmann.
11.0—Heroes' Day—Manifestation from the Opera.
12.30 p.m.—Band (cont'd).
1.0—Greetings.
1.5—Records. Overture, "Iphigenia in Aulis" (Gluck). Conductor: R. Strauss. Brahms and Reger Songs by Maria Müller (Soprano). Sarabande and Tambourin (Handel). Conductor: Sir Thomas Beecham. Consolation (Liszt) by Walter Rehberg (Pfte.). Aria, "Don Carlos" (Verdi) by Hans Reinmar. Lyric Suite (Grieg). Conductor: Sir Landon Ronald.
2.0—Echoes from the Kurmark.
2.30—Overtures and Folk Songs (Recorded). Overture, "Jessonda" (Spohr). Folk Song, Am Brunnen vor dem Tore. Overture, "Hans Heiling" (Marschner). Folk Songs: (a) Innsbruck, ich muss dich lassen, (b) In stiller Nacht. Overture, "Peter Schmolli" (Weber).
3.0—Station Orchestra. Conductor: Willy Steiner. Schneidewind Band. Erwin Hansche and Max Nahrath (Pftes.).
5.30—Letters of Soldiers killed in the War.
6.0—News; Sports.
6.25—Records: German Opera Music. Overture, "Fidelio" (Beethoven). Conductor: Clemens Schmalstich. Overture, "Undine" (Lortzing). Conductor: Knappertsbusch. Aria, "Undine" (Lortzing) by Emmy Bettendorf, and Gerhard Hüsch. Excerpt, "Das Herz" (Pfitzner). Conductor: The Composer. Aria, "Lo-

SERVICES—SACRED MUSIC

- A.M.
9.0—Kalundborg: Service.
10.0—Italian Stations: Mass.
10.10—Hilversum 1: Service.
P.M.
5.0—Radio-Paris: Lenten sermon.
5.0—Stockholm: Evensong.
7.0—Brussels 1: Mgr. Picard.
7.15—Beromünster: Church music.

- hengrin" (Wagner), by Franz Völker.
7.0—Military Band. Libiszowski Band. Krepela Sextet.
9.0—News; Sports.
9.30-11.0—Serenade. Noack and Fröhlich Bands.

BEROMÜNSTER

- (Switzerland)
556 kc/s (539.6 m.); 100 kW. Relayed by Basle and Berne, 1,375 kc/s (218.2 m.).
9.0 a.m.—Roman Catholic Service.
9.45—German Hymns.
10.15—The Pfte. Quintet—Lecture-Recital.
10.35—Talk: Rousseau and Pestalozzi.
11.0—Chamber Music.
11.30—Weather; News.
11.40—French and Italian Music. Zürich Radio Orchestra. Conductor: Hofmann.
12.30—History Talk: Swiss Mercenaries.
12.50—Marches; Talk.
1.30—Accordion Band.
4.0—Talk; Record.
4.30—Young People's Church Choir from St. Gall.
5.45—To be announced.
6.0—Mozart Wind Instrument Music.
6.15—Talk; Sports.
6.45—Weather; News.
6.55—Talk: The Wengen Skiing Races.
7.15—Church Music.
8.0—"The Button" — Sketch (Fabrizius).
8.5—Lanigiro Dance Band.
9.0—To be announced.
9.25-9.30—News; Programmes.

BRATISLAVA

- (Czechoslovakia)
1,004 kc/s (298.8 m.); 13.5 kW.
5.45-8.0 a.m.—See Prague.
8.0—Roman Catholic Service from the Franciscan Church.
9.5—Roman Catholic Address.
9.20—Johann Strauss Concert. Station Orchestra. Conductor: Dyk. Overture, "Cagliostro." Waltz, Tales from the Vienna Woods. Overture, "Prince Methusalem." Waltz, Frühlingsstimmen. Polka, Tritsch-Tratsch.
9.55—Hungarian Poets of Czechoslovakia—Talk and Reading.
10.25—See Prague.
10.30—Station Orchestra.
11.0 a.m.—12.30 p.m.—See Prague.
12.50—For Farmers; Record.
1.10—For Workers.
1.25—For Farmers (Hungarian).
1.40-1.45—Water Level.
2.0—Talk from Kosice.
2.30—See Prague.
3.40—Introductory Talk and Play from Kosice.
4.25—Dance Records.
5.0—Hungarian Transmission: Literary Talk; Music.
5.45—Sports.
5.50-7.30—See Prague; at 6.55—Talk.
7.30-8.55—Programme from Kosice.
7.30—"The Last Afternoon"—Play (Fiedler, trans. Beno).
7.50—Station Orchestra.
8.55-10.30—See Prague; at 9.20—News (Hungarian).

BRESLAU (Germany)

- 950 kc/s (315.8 m.); 100 kW. Relayed by Gleiwitz and Görlitz, 1,231 kc/s (243.7 m.).
5.0 a.m.—See Hamburg.
7.0—Motto.
7.15—Records of the Regensburg Cathedral Choir and the Vienna Singing Boys.
7.50—Time; News; Greetings.
8.0—Religious Address.
8.30—Brazilian Music by Francisco Mignone (Pfte.).
9.0—The Masurian Lakes—Report (Recorded).
9.25—Records.
10.0-10.45—"Heroic Deeds"—Sequence.
11.0 a.m.—1.0 p.m.—See Berlin.
1.0—News; A Story.

- 1.30 (from Gleiwitz)—Light Orchestral. Conductor: Gielnik.
2.30—"Pardon nahmen sie nicht..."—Sequence (Paul Majunke-Lange).
3.0—A Musical Journey into the Past—Records.
4.0—Maria Neuss (Violin), Max Zimolong (Horn) and Kurt Hattwig (Pfte.). Fantasia in C for Violin and Pfte. (Schubert). Horn and Pfte.: (a) Adagio and Allegro (Schumann), (b) Fantasia on Schubert's Sehnsuchtswalzer (Strauss).
5.0—Günther Hohenstein, Wolfgang Schwarz and Hanns Gottschalk read from their own Books.
5.30—Sports.
6.0—News; Records.
6.30—"Vermächtnis der graunen Front"—Sequence (Spfnuth).
7.35—Third Symphony—the Eroica (Beethoven), by the Station Orchestra. Conductor: Prade.
8.30—Heroes' Day—Manifestation in the Jahrhunderthalle.
9.0—News; Sports.
9.30-11.0 (from Gleiwitz)—Light Orchestral. Conductor: Humpert. Martha Haböck (Soprano). Margarete Hansel (Pfte.).

BRNO (Czechoslovakia)

- 922 kc/s (325.4 m.); 32 kW. Transmits at intervals from 5.45 a.m.
4.35 p.m.—German Transmission: Talk. Czech and German Culture in Moravia; Reading; Mracek Anniversary Concert: Prelude and Intermezzo from the Pfte. Quintet in E flat. Three Songs. Intermezzo and Scene from "Abele."
5.50-7.30—See Prague; at 6.55—Discussion: Czechs and Germans.
7.30—Station Orchestra. Conductor: Plichta. Kaff (Pfte.). Invitation to the Waltz (Weber). Polka and Furiant (Weis). Pfte. and Orchestra: Krakoviak (Chopin). Little Cossack (Dargomizhsky). Waltz, Dorfschwalben aus Oesterreich (Strauss). Hungarian Rhapsody (Liszt).
8.30—Dance Records, with Pfte. Interludes by Knechtsberger.
8.55-10.0—See Prague.

BRUSSELS (No. 1)

- (Belgium)
620 kc/s (483.9 m.); 15 kW.
6.30-9.2 a.m.—Records; Gym; News.
9.2—Records.
10.0—Pepita Dieguez (Violin).
10.15—Marceau Burton Ensemble. Malchair (Songs).
10.45—Records of Russian and Czech Chiors.
11.0—French Operetta Music. Conductor: Souris. Mme Liedts (Songs). Overture, "Kosiki" (Lecocq). Song, "Les noces de Jeannette" (Massé). Selection, "La Roussotte" (Hervé). Song, "Les Dragons de Villars" (Mailart). Selection, "Tales of Hoffmann" (Offenbach). Pas de femmes, from "Le Petit Duc" (Lecocq).

- 11.30—Do you know this?
11.35—Records.
11.45—Two Monologues (Records).
11.50—Song Records.
12.0 noon—Viennese Operetta Music. Conductor: Souris. Bartholomez (Baritone). Overture, "Eva" (Lchár). Song, "The Count of Luxembourg" (Lchár). Waltz Suite, "The Chocolate Soldier" (O. Strauss). Song, "The Merry Widow" (Lchár). Czardas (Lchár). Selection, "The Bayadère" (Kálmán).
12.30 p.m.—Weather; Shipping.
12.35—Espagne (Cinema Organ) from the Liège Palace.

- 1.0—News.
1.10—Belgian Operetta Music. Conductor: Souris. Bartholomez (Baritone). Mme Liedts (Songs). Selection, "Beulemans marie sa fille" (Van Oost). Duet, "Le roi du Cirque" (Alexys). Selection, "Réve de Gitane" (D'Archambeau).
1.35—Art Notes.
1.40—For Farmers.
2.0-2.15—Mme Jaspas (Pfte.).
2.30—Records.
2.40—The Ardennes in Songs.
2.50—Records.
3.0—Symphony Concert from the Royal Conservatoire, Liège. Conductor: Rasse. Wilhelm Backhaus (Pfte.). Symphony (Saint-Saëns). Pfte. Concerto in D (Bach). Eloge de la Folie (de Bourguignon).

- La valse (Ravel). Overture, "Euryanthe" (Weber). In the intervals—Records.
5.0—Football Results.
5.5—Light Orchestral. Conductor: Souris. Lauwers (Clarinet), Suite, "Carmen" (Bizet). Scherzo (Philippe). Adagio from the Clarinet Concerto (Mozart). Overture, "Le petit Faust" (Hervé).
5.30—"L'Obole d'un soir ancien"—Poem (Sarment), by Mme Beaufre, Deluc, Josz, and Génicot.
5.45—Light Orchestral (cont'd). René Durand (Songs). Pasodoble, Vallado (Radoux). Waltz, Andaluca (Popy). Tango (de Hervé). March, Folies-Bergères (Lincke).
6.0—For Young People.
7.0—Address. Mgr. Picard.
7.15—Records.
7.30—News.
8.0—"Les Cloches de Corneville" (Planquette), from the Théâtre Royal, Ghent. Conductor: Gaillard. Cast: Mmes D'Ardenne, Essler, Elsy, José, Quinaux, and Nicaise. Ede Herry, Delva, Remyo, Saint-Prax, Bourlard, Meesen, Jacob, and Ray.
9.0—Commentary on the Opera.
9.15—Act II, "Les Cloches de Corneville" (Planquette).
10.5—News and Opera Commentary.
10.20—Act III, "Les Cloches de Corneville" (Planquette).
11.0-12.0 m't.—Brenders Jazz Band.

BRUSSELS (No. 2)

- (Belgium)
932 kc/s (321.9 m.); 15 kW. Programme in Flemish.
6.30-9.5 a.m.—Records; Gym; News.
9.5—Act II, "Don Giovanni" (Mozart), by the Glyndebourne Festival Orchestra. Conductor: Fritz Busch. Cast: John Brownlee, David Franklin, Ina Souez, Koloman von Pataky, Luis Hellegruber, Salvatore Baccaloni, Audrey Mildmay, and Roy Henderson (Recordings).
10.15—Vas (Cinema Organ).
11.0—Jef Van Hoof Brass Band; at 11.20-11.40—Records of Monteverdi Music.
12.0 noon—Records. Les Préludes (Liszt). Conductor: Meyrovitz. Italian Caprice (Tchaikovsky), by the Philadelphia Orchestra. Conductor: Stokowski.
12.30 p.m.—Weather.
12.31—Salon Orchestra. Conductor: Féron. Simple avec (Thomé). Records of Martha Eggerth. Naika (Stalin). Valse mélancolique (Chopin). Pas des fleurs (Delibes).
1.0—News; Shipping.
1.10-2.0—Orchestra (cont'd). Plaisanterie musicale (Aston). Records of Miliza Korjus. Spanish Dance (Granados—Kreisler). Italian Serenade (Czibulka). Records of Gigli. Negro Lullaby (Clutsam). Ireland for ever (Myddleton). Le mariage du Roi des Nains (Massin).
2.15—Request Records.
2.45—Van den Broeck (Pfte.).
3.15—For Children.
4.0—Concert from Bruges Theatre. Conductor: Ryelandt. Germaine Teugels (Soprano) and Achiel Van Beveren (Bass). Overture to the Concerto in D minor (Handel). Bass: Arias (Mozart). Soprano: (a) Aria, "Agnus Dei" (Ryelandt), (b) Pie Jesu, "The Requiem" (Fauré). German Requiem (Brahms); at 4.25-4.35—Records.
5.55—Sports.
6.0—Excerpts, De Heiligenbron ("The Well of the Saints")—Play (Synge-Cool).
6.30—Records: Allegro moderato and Nocturne from the Quartet in D (Borodin), by the Pro Arte Quartet.
6.45—Religious Address.
7.0—Frans Schell (Tenor Arias).
7.30—Film Review.
8.0—I.N.R. Symphony Orchestra. Conductor: Dejoncker. Ria Lenssens (Songs). Alfred Dubois (Violin). Overture, "Tannhäuser" (Wagner). Violin Concerto in G minor (Vivaldi). Pastorale (Worhoff). Lamentation (Roels). Prelude and Finale from Kaatje (Buffin). Songs. Violin and Orchestra: Poème (Chausson); at 8.45-9.0—A Policeman at the Microphone.
9.40—Records. Chaliapin and Choir: (a) The Creed (Archangel-

sky, (b) Credo (Gretchaninov). Margherita Ferras: (a) One fine day, from "Madame Butterfly" (Puccini), (b) Aria, "La Traviata" (Verdi). Jaroff Cossack Choir: (a) Serenade (Abt), (b) Vetscherny svon (arr. Jaroff).

BUCHAREST (Romania)

823 kc/s (364.5 m.); 12 kW. Relayed by Radio-Romania, 160 kc/s (1,875 m.). Transmits at intervals from 5.30 a.m. 7.55 a.m.—Chimes; Service. 11.0—Time; News; Water-Level. 11.15—Dinico Orchestra; at 12.10 p.m.—Time; News. 1.0—For Peasants. 2.0—For Young People. 4.5—Military Band. 5.0—Medical Talk. 5.15—Dance Records. 5.50—Sports Results. 6.0—P.T.T. Choir. 7.0—Excerpts, "The Bird Fancier" (Zeller). 7.30—Dance Records. 8.0—News. 8.10—Operetta Records. 8.30—Sports Results. 8.45—Radio Orchestra. Conductor: Rogalski. 10.0-11.0—Concert on Records.

BUDAPEST (No. 1)

(Hungary) 546 kc/s (549.5 m.); 120 kW. 8.0 a.m.—Unitarian Service. 8.45—News. 9.0—Roman Catholic Service. 11.30—Opera Orchestra. Conductor: Fridl. Overture, "The Caliph of Bagdad" (Boieldieu). Ballet Suite, "Etienné Marcel" (Saint-Saëns). Overture, "Raymond" (Thomas). Overture, "Le Maçon" (Auber). Ballet Suite (Grétry-Mottl). Excerpt, "Sylvia" (Delibes); at 12.0 noon — Programme by János Folba. 1.0 p.m.—Records. 2.0—For Farmers. 2.45—Ilonka Lévy (Songs). 3.20—Talk: Films in Schools. 3.50—Nándor Ember (Pfte.). 4.25—Ferenc Jankovich reads his own Poems. 4.45—Sándor Kalmás (Hungarian songs) accompanied by the Sárai Cigány Band. 5.30—Talk: Attila. 6.0—Station Orchestra. Conductor: Bertha. Overture, "Morning, Noon and Night" (Suppé). Suite, "A Day in Venice" (Nevin). Selection, "The Rose of Stamboul" (Fall). Selection, "The Princess of Chicago" (Kálmán). Slow Foxtrot, Budapest (Zakál). 7.0—Sports. 7.10—A Play (Büky and Somogyváry). 8.20—News. 8.40—Pertis Cigány Band from the Hotel Vadászúrt. 9.40—Military Band. Conductor: Seregi. Rakoczy Overture (Kéler-Béla). Excerpt, "Bánk bán" (Erkel). Folk Song Potpourri, Hungaria (Leopold). Old Hungarian Dances (Seregi). Waltz, Gold and Silver (Lehar). 11.5—News for Hungarians Abroad.

BUDAPEST (No. 2)

(Hungary) 359.5 kc/s (834.5 m.); 18 kW. 10.15 a.m.—Salon Quintet. 2.0 p.m.—Records. 5.35—Cigány Band; Records. 7.20—News. 7.45—Tamás Magyar (Violin).

COLOGNE (Germany)

658 kc/s (455.9 m.); 100 kW. 5.0 a.m.—See Hamburg. 6.55—Weather; Water Level. 7.0—See Königsberg. 7.25—Organ, Soprano, Violin and Pfte. 8.0—For Hitler Youth. 8.30—Records. 9.30—"Heroes' Day"—War Poems (Grobben). 9.40—Fritzsche (Flute), Schwamberger (Viola da Gamba) and Pillney (Harpisichord). Trio Sonata (Valentini). Trio in D (Haydn). Sonata in G (Bach). 10.30-10.45—News; Greetings. 11.0—See Berlin. 12.30 p.m.—Concert (Recorded). 1.0—Station Sextet. Two Guitars (Ferraris). Serenade, Anita (Meisel). Klänge der Pusztá (Müller). Landmädel (Fiaconne). Kisses in the Dark (de Micheli-Weninger). Im Rosenhag (Lautenschläger).

Liebesweisen (Zander). Dorfpolka (Pogorelow). Ungarisch (Knümann). An der schönen grünen Narenta (Komzak). Der kleine Reiter (Lincke). Marcelle (Burgois). Polka, Die Alpenpost (Eilenberg).

2.0—Programme by Children. 2.30—Male Voice Choir. 3.0—Station Orchestra. Conductor: Eysoldt. Overture, "The Seraglio" (Mozart). Minuet (Bolzoni). Scherzo in B flat (Schubert). Selection, "Ariadne auf Naxos" (R. Strauss). Träume (Wagner). Minuet (Beethoven). Concert Waltz (Glazunov). Ave Maria (Bach-Gounod). Intermezzo, "I Pagliacci" (Leoncavallo). Aufschwang (Schumann). Tarantella (Bizet).

4.0—Talk: Burial Places. 4.5—Wind Band. 5.0—"Einsiedel"—Play (Klücke). 6.0—News. 6.10—Contemporary Austrian Music. Bruno Seidlhofer and Walter Panhofer (Pftes.). Toccata in D (Walter Pach). Allegretto (Dichter). Toccata in F sharp minor (Schaffer). 6.40—Sunday Review; Sports. 7.0—Music for Heroes' Day. Station Choir and Orchestra. Conductor: Schulz - Dornburg. Schicksal (Knorr). Die heilige Linde (S. Wagner). Trommelschläge (Schoeck). Excerpt, "Schlacht bei Vittoria" (Beethoven). Der grimme Tod (Erpf). Excerpt from an Oratorio (Handel). Vaterländische Ouverture (Reger). Einer baut einen Dom (Dransmann). 9.0—News. 9.30-11.0—See Deutschlandsender.

DEUTSCHLANDSENDER

(Germany) 191 kc/s (1,571 m.); 60 kW. 5.0 a.m.—Gym; Band. 7.0—Weather; Records; Reports. 8.0—Wind Band Music for Heroes' Day. 9.0—Service. 9.40—Pfte. Concerto in C (Beethoven) by Hugo Steurer and the Berlin Philharmonic. Conductor: Schuricht (Recorded). 10.15—Weather. 10.30-10.45—Schubert Records. 11.0—See Berlin. 12.30 p.m.—Records. 12.45—Songs we sang at the Front. Military Band. Conductor: Tumforde. Soldiers' Chorus. Conductor: Gollasch. Charlotte Minckwitz and Oskar Höcker (Speakers). 1.30—"King Drosselbart"—Fairy Play (Grimm-Wollmann) (Recorded). 2.0—Krüger Band and Walter Liesske (Cello). Selection, "La Bohème" (Puccini). Valse triste (Sibelius). Serenade (Schulenburg). None but the Weary Heart (Tchaikovsky). Entr'acte from "Rosamunde" (Schubert). Waltz-Song Wasserrosen (Dobrnitz). Swedish Song, Tonerna (Sjöberg). Gavotte tendre (Ganne). Kleine Romanze (Alex). Unter dem Sternenzelt (Roland). Cello: Spanish Dance (Granados). Winterlied (von Koss). Herbstgold (Brusso). 3.0—See Munich. 5.0—Heroic Deeds—Sequence (Reimesch), with Military Marches. 6.0—Motto; News. 6.10—"Loyalty"—Play (Tügel) (Recorded). 7.0—Wagner Concert. Station Orchestra. Conductor: Krasselt. Hildegard Ranczak (Soprano). Prelude to "Parsifal". Aria, "Lohengrin". Siegfried Idyll. Songs: (a) Schmerzen, (b) Im Treibhaus, (c) Träume. 8.0—Childhood Memories of the Great War. 8.15—Symphony in C (Schumann) by the Station Orchestra. Conductor: Krasselt. 9.0—News; Announcements. 9.30-11.0—Light Music by the Rambour Band; at 9.45-10.0—Weather.

HAMBURG (Germany)

904 kc/s (331.9 m.); 100 kW. Relayed by Bremen, Flensburg, Hanover, Magdeburg and Stettin, 1,330 kc/s (225.6 m.). 5.0 a.m.—Harbour Concert. 7.0—News; Talk; Gym. 7.35—Classical Music (Recorded). 8.0—For Hitler Youth—Address from Saarbrücken. 8.30—Orchestra. Conductor: Rudolph. 9.15—Protestant Service from the University Church, Kiel. 10.0—"Heldengedenken"—Cantata (Hammer) to Text by Binding, Anacker and Schuster. Orchestra and the Altona A-capella Choir. Conductor: The Composer. Engers Clausen (Speaker). 10.30-10.45—"Germany"—Patriotic Programme. 11.0 a.m.—1.0 p.m.—See Berlin. 1.0—"Snow-white"—Fairy Play (Erna Schumann). Music by Girmatis. 1.45 (from Stettin)—Stettin Concert Orchestra. Conductor: Quast. Overture, "Euryanthe" (Weber). Zu den Sternen empor (Lautenschläger). Fredericus-Suite (Roland). Intermezzo, Im Tempel der Schönheit (Hummel). Memories of Lortzing (Rosenkranz). Concert Overture, Flamme empor (Zimmer). 2.45—Programme Announcements. 3.0—Light Classical Music from Saarbrücken.

FRANKFURT (Germany)

1,195 kc/s (251 m.); 25 kW. Relayed by Cassel, Coblenz, Freiburg and Trier, 1,195 kc/s (251 m.). 5.0 a.m.—See Hamburg. 7.0—Water Level; Weather; Gym. 7.30—Protestant Service. 8.10—Road Report; Recitations. 8.30—Male Voice Choir from Wiesbaden. 9.0—"Friedrich Gottlieb Klopstock"—Sequence (Frotscher) with Gluck, Schulz, Reichardt, Ph. E. Bach, Zelter, Zumsteeg, and Neefe Music. 9.45-10.45—Meyer-Stephan (Bartone) and Braun (Pfte.). 11.0 a.m.—1.0 p.m.—See Berlin.

1.0—"The Goose-Girl"—Fairy Play (Grimm). 1.30—Records of Karl Erb and the Calvet Quartet. 2.15 (from Freiburg)—A Sunday in the Goldhaubental. 3.0—Orchestra. Conductor: Cujé. Two Marches (Gluck). Overture, Coriolanus (Beethoven). Theme with Variations from "Mozartiana" (Tchaikovsky). Les Préludes (Liszt). Concert Overture, Hamlet (Gade). Old Norwegian Song with Variations (Grieg). From Finland (Palmgren). In the intervals, Talk and Sports Results. 5.0—"Comrades, as we marched along"—Sequence (Nebhut). 5.30—Im Memoriam—Records. Tragic Overture (Brahms) by the BBC Symphony Orchestra. Die Toteninsel (Reger) by the Leipzig Symphony Orchestra. Conductor: Buschkötter. Totenklage (Egk) by the Berlin Opera Orchestra. Conductor: The Composer. 6.0—Time; News. 6.10—German Composers who died



Exclusive "World-Radio" Picture Pascal and his orchestra, who play for Radio-Paris listeners at 12.30 p.m.

in the Great War. Elise Lampmann (Contralto). Otto Braun (Pfte.). Introductory Talk and Commentary by Adalbert Kutz. Songs (Jürgens): (a) Die Lilie, (b) Seele. Songs (Rudi Stephan): (a) Abendlied, (b) Dir. Songs (Ernst Kunsemüller): (a) Was treibst du, Wind, (b) Zwischen Tag und Abend. Songs (Siegfried Kuhn): (a) Vögelin Schermmut, (b) Durch die Nacht. 6.40—Sports. 7.5—Fourth Sunday Concert arranged by the Museum Society from the Saalbau. Augmented Station Orchestra. Conductor: Rosbaud. Georg Kulenkampf (Violin). First Item to be announced. Violin Concerto (Glazunov). Fifth Symphony (Bruckner). 9.0—Time; News; Sports. 9.30—See Deutschlandsender. 11.0 p.m.—1.0 a.m. (Monday)—"Hans Sachs" (Lortzing). Berlin Station Choir and Orchestra. Conductor: Frickhoeffler. Cast: Lothar Körner, Burchard Kaiser, Hedwig Jungkurth, Rosl Seegers, Hans Wocke, Erich Zimmermann, Gerhard Witting, Paul Rehkopf, H. Werner Henning, and August Richter (Recorded).

HILVERSUM (No. 1)

(Holland) 160 kc/s (1,875 m.); 10 kW until 4.40 p.m.; 150 kW from 4.40 p.m. Also on Jaarsveld, 722 kc/s (415.4 m.); 17 kW. 8.35-9.40 a.m.—VARA Programme. 8.35—Records; Football Notes. 8.45—For Gardeners; Records; Talks. 9.40-11.40—VPRO Programme. 9.40—For Children. 10.10—Service from Zeist. 11.40 a.m.—4.40 p.m.—AVRO Programme. 11.40—Time; The Week's Motto. 11.45—Ray Ventura and his Collegians. 12.50 p.m.—Talk. 1.5—Pierre Palla (Organ); Topy Glerum (Songs). 1.40—Weekly Book Talk. 2.10—Concertgebouw Orchestra from the Concertgebouw, Amsterdam. Guest Conductor: Bruno Walter; Louis Zimmermann (Violin); Raphael Lanes ("Cello). Overture, "A Midsummer Night's Dream" (Mendelssohn). Prospero's Beschworungen (Wellisz). Concerto in A minor for Violin and Cello (Brahms). Excerpts, "Tristan and Isolde" (Wagner). 3.40—Records. 3.55—AVRO Dance Band. 4.25—Talk: Sports Records. 4.40—VPRO Talk. 5.10-7.40—VARA Programme. 5.10—For Children. 5.40—Orchestra. Conductor: de Groot. 6.10—Sports; Records. 6.40—Popular Music. Mulder (Saxophone), Jong (Organ and Pfte.), Wins (Pfte.), etc. 7.40 till Close Down—AVRO Programme. 7.40—Time; News; Records. 8.0—AVRO Orchestra. Conductor: van Raalte. Margit Bokor (Songs). 9.5—Radio Journal. 9.20—Records. 9.40—"Inspector Hornleigh Investigates"—Radio Play (Priwin). 10.0—Aeolian Orchestra. 10.40—News. 10.50—AVRO—Dance Band. 11.20-11.40—Records.

HILVERSUM (No. 2)

(Holland) 995 kc/s (301.5 m.); 15 kW until 6.10 p.m.; 60 kW from 6.10 p.m. 8.10-9.10 a.m.—NCRV Religious Programme, with Bode (Baritone) and Kloek (Organ). 9.10 a.m.—4.40 p.m.—KRO Programme. 9.10—High Mass from "the Daughters of Mary and Joseph" Convent, Bois-le-Duc.

SUNDAY (March 13)

5.0—"Lady"—Play about a German Officer (Heuer). 6.0—News. 6.10—Friedrich Brinkmann (Organ). Romance (Reger). Fantasia and Fugue on B-A-C-H (Liszt). 6.30—Sports; Weather. 7.0—Eleventh People's Concert from the Musikhalle. Station Orchestra. Conductor: Röder. Hans Reinmar (Baritone). Bernhard Hamann (Violin). Death and Transfiguration (R. Strauss). Scene and Baritone Aria from "Euryanthe" (Weber). Violin Concerto in A (Mozart). Kleist-Ouverture (Wetz). Baritone and Orchestra: Herr Oluf (Pfitzner). Prelude to Act II, "Palestrina" (Pfitzner). Wotan's Song from "The Rhinegold" (Wagner). Festliche Musik (Lauer). 9.0—News. 9.30-11.0—See Deutschlandsender.

10.10—Records. 11.40—Talk. 11.55—KRO Orchestra. Conductor: van 't Woud. Overture, "Ruy Blas" (Mendelssohn). Variations on a Tchaikovsky Theme (Arensky). Slav Dance (Dvořák). Hindu Song (Bemberg). Le soir (Debussy). Ouvre tes yeux bleus (Massenet). Excerpt, "Le Cid" (Massenet). 12.40 p.m.—Book Review. 1.0—KRO Melodists. 1.40—Letter-box. 2.25—Brabant Programme: Carillon Recital by v. Balkom; Hemel (Pfte.); Talk; Carillon (contd.). 3.25—KRO Orchestra. Conductor: van 't Woud. Prelude, "The Cricket on the Hearth" (Goldmark). Tales from the Vienna Woods (Strauss). Selection, "Der Freischütz" (Weber). 3.55—For Invalids. 4.35—Sports Notes. 4.40-7.25—NCRV Programme. 4.40—Records: Sacred Music. 5.0—Service from Utrecht; Records; Sacred Music. 7.25 till Close—KRO Programme. 7.25—Football Notes. 7.30—Religious Address. 7.50—News; KRO Notes; Records. 8.10—Popular Music. KRO Orchestra, KRO Melodists, Rosman (Clarinet), François (Pfte.). 9.10—Records. 9.25—KRO Melodists, Soester (Tenor). 10.10—News; Epilogue by the KRO Choir. 10.40-11.10—Talk (Esperanto).

KALUNDBORG (Denmark)

240 kc/s (1,250 m.); 60 kW. Relays Copenhagen, 1,176 kc/s (255.1 m.). 7.0 a.m.—Gym; Weather. 7.45—French Talk: Talleyrand. 8.0—German Talk: Aus Eisen wird Stahl. 8.15—English Reading. 8.30—Talk: Hospital Libraries. 9.0—Service from Ribe Cathedral. 10.28—Weather; News. 11.0—Preil's Ensemble. Le père la victorie (Ganne). Overture, "Morning, Noon and Night" (Suppé). Meditation (Bach-Gounod). Juanita (Georges Boulanger). Krolls Balklange (Lumbye). La forêt intacte (Andersen). Excerpts, "Thrymskviden" (Hartmann). Gipsy Czardas (Kotschka). Melody (Rydahl). The Merry Fiddler (Weizel). Song, "The Merry Widow" (Lehar). Viennese Dance (Friedman - Gärtner). Tango, Jealousy (Jacob Gade). Selection, "The Gipsy Princess" (Kálmán); at 11.50—Reading. 1.0 p.m.—For Children. 1.45—Ebba Nissen (Violin). 2.5—Records. 2.25—Eighteenth People's Concert—Czech Music. Symphony Orchestra. Guest Conductor: Manzer. Elise Schott (Songs). Prelude, "Libussa" (Smetana). Aria, "The Bartered Bride" (Smetana). Slav Scherzo-Caprice (Karel). Triumph des Lebens (Peterka). Aria, "Rusalka" (Dvořák). Am Abend (Fibich). Egerland Rhapsody (Pleier). Carnival Overture (Dvořák). 4.0—Service from Christiansborg Castle Church. 5.20—Talk: Men and Animals in Folklore. 5.50—Weather; News; Sports. 6.30—Art Talk. 7.0—Reading (Gross). 7.15—Radio Orchestra. Conductor: Tuxen. Fingal's Cave (Mendelssohn). Excerpts, "Peer Gynt" (Grieg). Prélude à l'après-midi d'un faune (Debussy). Polovtsian Dančes (Borodin). 8.20—"An Heir"—Play (Tutein). 9.0—News; Weather. 9.15—Variety, with the Golden Blonde; Records. 9.55—Song Cycle, Bertran de Born (Heise) by Holger Bruusgaard. 10.15-11.30—Preil's Dance Band; at 11.0—Chimes. 1,031 kc/s (291 m.); 100 kW. Relayed by Danzig, 1,303 kc/s (230.2 m.). 5.0 a.m.—See Hamburg. 7.0—Report; Records. 8.10—Protestant Service. 9.0—Address from Saarbrücken. 9.30—Weather; Announcements. 9.50—Talk: The Work of the German War Graves-Committee.

SUNDAY (March 13)

10.5-10.45—Sonata in A (Beethoven) by Franz Fassbaender (Cello) and Margarete Schuchmann (Pfte.).

11.0—See Berlin.

12.30 p.m.—Concert.

1.0—Chess.

1.30—Variety.

2.15—Reading.

2.30—Old Music. Heiti Böhnke (Soprano). Edith Fedtke (Harp-sichord). Songs: (a) Kein Halmlein wächst auf Erden (W. Fr. Bach), (b) Willst du dein Herz mir schenken (Bach). Sonata in A (Joh. Chr. Bach). Songs: (a) Schäferlied (Hurlerbusch), (b) The Water Nymph (Neefe). Prelude and Fugue in B flat minor (Bach). Songs: (a) Vergänglichkeit (Schulz), (b) Veilchen (Reichardt), (c) Nähe des Geliebten (Reichardt).

3.0—Light Classical Music from Saarbrücken.

5.0—Sports.

5.15—Annemarie Heyne (Pfte.). Impromptu in E flat (Schubert). Rhapsody in B minor (Brahms). Etude in C sharp minor (Chopin). Waltz in E minor (Chopin).

5.35—"Comrade, where are you?"—Programme for Ex-Servicemen.

6.0—News; Weather.

6.10—Acts I and III, "Tristan and Isolde" (Wagner), with Introductory Talk. Station Male Voice Choir and Orchestra. Conductor: Wolfgang Brückner. Cast: Eyvind Laholm, Elsa Larcen, Ruth Patzschke, Fritz Zöllner, Wilhelm Rode, Carl-Horst Schröder and Wilhelm Ulbricht.

9.0—News; Sports.

9.40—11.0—Programme from Deutschlandsender.

LEIPZIG (Germany)

785 kc/s (382.2 m.); 120 kW. Relayed by Dresden, 1,285 kc/s (233.5 m.).

5.0 a.m.—See Hamburg.

7.0—Georg Winkler (Organ).

7.30—Classical Records.

8.0—For Hitler Youth—Address from Saarbrücken.

8.30—Classical Records.

9.30—"Heroes"—Sequence (Drescher).

11.0—See Berlin.

12.30 p.m.—Records.

1.0—Time; Weather.

1.5—Fuchs Band. Präludium (Jännefelt). Overture (Haydn). Romance (Tchaikovsky). Suite, In Memoriam (de Micheli). Intermezzo, Darinka (Köster). Overture, "Pique Dame" (Suppe). Golden Mist (Brusso). Spanish Serenade (de Micheli). Ilona (Brunhofer). Scandinavian Legend (Bohne). Rusticella (Cortopassi). Nolette (Gebhardt). Slav Rhapsody (Friedemann). Homage March (Grieg).

2.35—Reading (Clemens Laar).

3.0—Soldier Songs by a Soldiers' Chorus. Conductor: Pallmann.

3.50 (from Dresden)—Sudetic German Marches—Musical Sequence (Reimesch). Trumpeter Corps. Conductor: Reimesch.

5.0—"Tristan and Isolde" (Wagner). Station Choir and Leipzig Symphony Orchestra. Conductor: Weisbach. Cast: Joachim Sattler, Josef v. Manowarda, Margarete Bäumer, Theodor Horand, Inger Karén, Philipp Göpelt, Hans Remagen and Paul Reinecke; and at 6.15-6.30—News; and at 7.35-7.50—Talk.

9.0—News; Sports.

9.30-11.0—See Deutschlandsender.

LILLE (Radio PTT Nord)

(France)

1,213 kc/s (247.3 m.); 60 kW. Transmits at intervals from 7.0 a.m.

4.45 p.m.—See Paris (PTT).

6.30—Notes; Records.

7.30—News; Song Records.

8.9—Sports; Records.

8.25 (also Limoges (PTT) and Toulouse (PTT))—"Tales of Hoffmann" (Offenbach) from the Opéra-Comique, Paris. After the Programme, News.

MONTE CENERI

(Switzerland)

1,167 kc/s (257.1 m.); 15 kW.

10.30 a.m.—Bible Reading.

11.0—St. Cecilia Choir of Lugano. Conductor: Vicari. Chorus, "Cavalleria rusticana" (Mas-cagni). Song, Breitenbach. La Notte (Vicari). L'Inverno e la Primavera (Tarenghi). Songs (Vicari): (a) Come le foglie, (b) La Zingarera.

11.30—News; Weather.

11.40—Radio Orchestra. Conductor: Casella. Overture, "The Force of Destiny" (Verdi). Selection, "The Huguenots" (Meyerbeer). Austrian Folk Dances (Schön-herr).

12.30-1.0 p.m.—Song Records.

1.25-3.10—Commentary on the International Football Match, Switzerland v. Poland, from Zürich.

4.0—"A San Provino"—Play (Alberti).

4.30—Café Concert.

5.15—Sports.

5.30—Mandoline and Guitar Band from Bellinzona.

6.15—Sports; Song Records.

6.50—News.

7.0—Camillo Oblach (Cello); Herschel (Pfte.). Sonata in G (Brevall). Variations on a Mozart Theme (Beethoven). Goyescas (Granados). Schön Rosmarin (Kreisler). Nocturne (Casella). Guitar (Moszkowski).

7.35—Talk: Films.

7.50—Radio Orchestra. Conductor: Casella. Marguerite Gradmann-Lüscher (Soprano). Non sa che sia dolore (Bach). Overture, "Der Schauspieler" (Mozart). Bella mia fiamma (Mozart). Overture, "Prometheus" (Beethoven). Soprano Aria (Beethoven).

8.35—Records of American Film Stars.

9.0-9.5—A Poem.

MOSCOW (No. 1) (Russia)

172 kc/s (1,744 m.); 500 kW.

1.0 p.m.—Programme in Swedish.

4.30—News for the Arctic.

5.0—Music; Provincial Programme.

7.0—Dramatic Programme; Music.

8.30—News; Kremlin Chimes.

9.0—Programme in English.

10.0—Programme in French.

11.0-12.0 m.—Talks in Spanish.

MUNICH (Germany)

740 kc/s (405.4 m.); 100 kW. Relayed by Nürnberg, 1,267 kc/s (236.8 m.).

5.0 a.m.—See Hamburg.

7.0—Religious Address.

7.30—Wind Band Music.

8.0—Records.

9.0—Heroes' Day—Address; Gustav Schoedel (Organ).

9.30—Beethoven Music. Karl Schwamberger (Cello). Variations on a Mozart Theme. Sonata in D.

10.5—Heldemorgel-Suite (Kanetschneider), by Gustav Schoedel (Organ).

10.35—Time; Weather; Road Report.

11.0—See Berlin.

12.30 p.m.—Beautiful Voices—Records.

2.0—"A Night on Monte Tomba"—War Reminiscences.

2.15—Songs of Farewell and Death—Boys' Choir. Conductor: Meister.

3.0—Orchestra. Conductor: Michalski. Karl Ranftl (Violin) Ludwig Kusche (Pfte.). Ludwig Schmidmeier (Pfte. and Organ). Selection, "Die toten Augen" (d'Albert). Paraphrase on a Liszt Theme (Schmid). Two American Folk Songs (Busch). Pastoral (Kusche). Meeresleuchten (Ortleb). Une Larne (Rachmaninoff). Spring (Palmgren). Minuet (Palmgren). Canzonetta (Wittwer). Concert Piece on "Sah ein Knab' ein Röslein steh'n" (Klentsch). Theme with Variations (Sinding). Violin and Strings: Largo (Zöllner). Lönslieder-Suite (Künneke). Sphärenmusik (Dohnányi). Frieden (Ehrenberg). Selection, "Manon Lescaut" (Puccini).

5.0—To be announced.

6.0—Time; News; Road Report.

6.10—Winter Relief Fund Concert.

6.40—Sports.

7.0—Heroes' Day Concert. Station Choir and Orchestra. Conductor: Winter. Gerda Nette (Pfte.). Concerto grosso in D (Handel). Pfte. Concerto in C minor (Beethoven). Siegfried's Death-scene (Hebbel). Nänie (Brahms). Heldenklage (Seyboth).

9.0—Time; News; Sports.

9.30-11.0—See Deutschlandsender.

NAPLES GROUP (Italy)

Naples, 1,104 kc/s (271.7 m.); 10 kW. Florence (No. 1) 610 kc/s (491.8 m.); Rome (No. 3), Bari (No. 2), Milan (No. 2), Turin (No. 2) and Genoa (No. 2), 1,357 kc/s (221.1 m.).

2.30 p.m.—"La Gioconda" (Ponchielli) from La Scala, Milan. Conductor: Gino Marinuzzi;

Chorus-Master: Veneziani. Cast: Gina Cigna, Ebe Stignani, Beniamino Gigli, Ettore Nava, Tancredi Pasero, Vittoria Palombini, Giuseppe Menni, Piero Girardi, Domenico Malatesta, Dario Caselli, Nello Palai. In the intervals, Sports; Announcements.

6.0—De Angelis Tipica Orchestra.

6.35—Sports; Light Music.

7.0—Time; News; Talk.

7.30—Radio Potpourri from Vienna, Switzerland v. Poland, from Zürich.

8.25 (approx.)—"A Family Discussion."

8.35—"Cric e Croc al museo delle scimmie"—Sketch (Basco).

9.10—Accordion and Guitar Trio.

9.30—Dance Music.

10.0—News.

10.15-10.55—Dance Music.

NICE-COTE D'AZUR

(France)

1,185 kc/s (253.2 m.); 60 kW. Transmits at intervals from 7.0 a.m.

4.45-6.40 p.m.—See Paris (PTT).

7.0—For Farmers.

7.30—News; Weather.

8.0—News (Italian); Sports.

8.30—"The Sumiduro Diamonds"—Play (Elmut Weiss—G. Weisz).

9.30—See Strasbourg.

10.45—News.

OSLO (Norway)

260 kc/s (1,153.8 m.); 60 kW. Relayed by Fredrikstad, 722 kc/s (415.4 m.); Hamar, 519 kc/s (578 m.); Notodden, 1,357 kc/s (221.1 m.); Porsgrund, 850 kc/s (352.9 m.); Rjukan, 1,348 kc/s (222.6 m.); and Trøndelag, 629 kc/s (476.9 m.).

7.30 a.m.—Gym; Weather.

8.5—French Lesson.

8.35—German Lesson.

9.0—Concert on Records.

9.55—Service.

11.40—Weather; News.

12.0 noon—Report on the Ski-ing Championships.

3.30 p.m.—Norwegian Folk-Music—Hardanger Fiddle, Men's Choir.

4.0—Weather; Terminology.

4.25—Light Music—Station Orchestra. Conductor: Fjeldstad.

5.30—Talk.

5.55—News; Press Review.

6.15—Fjeldstad (Violin), Gunström (Viola), Petra Hendriksen (Pfte.). Duo (Mozart). Movement, Violin Sonata in G (Grieg). Pfte.: Scherzo and Caprice (Kjerulf). Serenades (Schjelderup; Haaland). Excerpts, Suite montagnarde (Ribcaupierre).

6.45—"Carnival"—One-Act Play (Howalt).

8.0—To be announced.

8.40—News; Sports.

9.15—Dance Records.

9.50-10.10—News.

PARIS (Eiffel Tower)

(France)

1,456 kc/s (206 m.); 7 kW. Transmits at intervals from 7.0 a.m.

3.15 p.m.—Nadia de Cléry (Songs) and Suzanne Berthon (Pfte.). Pfte.: (a) Caprice in E minor (Mendelssohn); (b) eux d'eau à la Villa d'Este (Liszt); (c) Nocturne in D flat (Fauré); (d) Impromptu (Fauré). Songs: An die ferne geliebte (Beethoven).

4.0—Records.

4.45—See Paris (PTT).

6.30—For Farmers.

7.0—Light Music from Toulouse (PTT).

7.30—Radio Journal; News.

8.0—Excerpts from the Sonata (Febvre-Longeray) by Mme Ruff-Longray (Pfte.) and Mme J. Isnard (Violin).

8.30—Variety.

10.30—Records.

11.0—News; Weather.

PARIS (Poste Parisien)

(France)

959 kc/s (312.8 m.); 60 kW.

8.0 a.m.—News; Notes; Records.

9.5—News; Records.

10.10—Old Dances; Flamenco Songs; Records.

10.50—Opera Records. Excerpts, "Carmen" (Bizet), "Madame Butterfly" (Puccini), "Manon" (Massenet), "The Valkyrie" (Wagner) and "Tosca" (Puccini).

11.10—Records.

11.55—News; Records.

12.15 p.m.—"Le bonheur"—Records.

12.43—"Si je gagnais les trois millions," with Line Viola.

12.58—Amusement Guide.

1.0—"La course au trésor," with Pierre Dac.

1.10—Vocal Quintet with Raymond Souplex and Jane Sourza.

1.45—Lecture-Recital: Lehár.

2.0-2.20—News; Records.

5.0—Records: Light Music.

7.0—Racing; News.

7.5—For Young People.

7.8—Sports; Amusements.

7.20—Cinema Organ Records.

7.50—Film Talk: "The Unfinished Symphony."

8.0—Topical Talk.

8.5—Les Frères Jacasse.

8.10—Light Music.

8.25—Coco Aslan and his Friends, with Ded Rysel.

8.45—"La bonne histoire."

9.0—News.

9.5—Amateurs.

9.55—News.

10.5—Dance Music.

10.30-11.30—Records: Light Music.

PARIS (PTT) (France)

695 kc/s (431.7 m.); 120 kW.

7.0 r.m.—News; Records.

7.45 8.30—News; Talk; Records.

9.0—For Farmers; Records.

10.0—"Les Vagabonds Mélomanes." Orchestra. Conductor: Warmis; and at 10.30—Sound News; Sports.

12.0 noon—Gras Orchestra. Marche des Vichysoises (Danjaume). Overture, "La Mascotte" (Audran). Waltz (Giland). Intermezzo, Coquette (Danjaume). Saxophone Piece. Suite, L'Arlesienne (Bizet). Mai (Hahn). Foxtrot, Toujours (Chapelier). Rumba (Yvain). Marche lorraine (Ganne). Feuilles de voyage (Fl. Schmitt). Paysage (Hahn). Foxtrot (Ourdine). Selection, "Véronique" (Messager). Slow Foxtrot, Solitude (Duke Ellington). Alibert Fantasia (Scott). Waltz (Yvain). One-Step (Trenet-Emer); at 12.45 p.m.—News.

1.30—Report.

2.0—Records.

2.50—Commentary from Brussels: The International Army Football Match, France v. Belgium.

4.45—Lamoureux Concert—Wagner Music. Conductor: Eugène Bigot. Eine Faust Ouverture. Prelude "Lohengrin." Selection, "The Flying Dutchman." Prelude, "Tristan and Isolde." Overture, "The Mastersingers." Prelude, "Parsifal." Overture, "Tannhäuser."

6.40—Records.

7.0—Topical; News.

8.0—Les Frères Jacques present Jacqueline Claude and Ded Rysel.

8.30 (also Alpes-Grenoble (PTT) and Marseilles (PTT))—"Peer Gynt" (Ibsen). Music by Grieg, from the Odéon.

10.30—News; Records.

11.0—See Paris (Radio-Paris).

PARIS (Radio-Paris)

(France)

182 kc/s (1,648 m.); 80 kW.

6.58 a.m.—Programmes; Records.

7.15—Time; News; Gym; Records.

8.0—Time; News; Press Review.

8.30—German Lesson.

8.45—Book-keeping; For Farmers.

9.30—English Lessons.

10.10—Spanish Lesson.

10.30—Italian Lessons.

11.0—Programme Notes.

11.5—Saint-Saëns Records.

11.30—Gaston Litaize (Organ). Choral (Bach). L'Ascension (Messiaen). Intermezzo (Barié). Prelude and Fugue (Litaize). Westminster Chimes (Viene).

12.0 noon—Roman Catholic Address by the Rev. Fr. Padé.

12.20 p.m.—Records: Sacred Music.

12.50—Pascal Orchestra. March (Wachs). Valse des bruns (Ganne). Excerpt, "Louise" (Charpentier). Zingaresca (Curzon). Morning (Grieg). La Dolorés (Breton).

1.0—Time; News.

RADIO-NORMANDIE

(France)

- 1,113 kc/s (269.5 m.); 15 kW. 6.45 a.m.—Military Band. 7.0—Light Music. 7.15—News; Press Review. 7.45—Studio Service from Rouen. 8.0—In Search of Melody. 8.15—Light Music. 8.45—Masters of Rhythm. 9.0—Musical Alphabet. 9.15—Highlights of Hollywood — Interview with Karen Morley; News and Music. 9.30—Musical Cavalcade with Webster Booth, Edward Reach, Olive Groves and the Showlanders. 9.45—Light Music. 10.0—Waltzes—Billy Bissett's Orchestra, Hugh French, Esther Coleman and the Waltz Timers. 10.15—Carson Robison and his Pioneers. 10.30—Eddie Pola (Pfte.). 10.45—Harry Roy's Band with Bill Currie. 11.0—Donald Peers, Cavalier of Song. 11.15—Radio Parade. 11.45—Artists of the Théâtre Français, Rouen. 12.25 p.m.—Address by the Rev. Fr. Laby, O.P. 12.45—Radio Journal; News. 1.0—Request Music. 1.30—Louis Levy's Orchestra, with Eve Becke and Gerry Fitzgerald. 2.0—Billy Cotton's Orchestra, with Alan Breeze, Peter Williams, Jack Doyle, and Max Miller. 2.30—Phil Park Organ. 2.45—The Open Road. 3.0—A Serenade to Melody. 3.30—The Gaieties, with Leslie Henson, Roy Royston, Ginger Matthews, Yvonne Ortner, George Neil and Bob Currie. 3.45—Music in the Mayfair Manner—Al Collins' Band. 4.0—Debroy Somers Band, with Billy Milton, Vic Oliver, Mary Lawson, Niela Godelle, Jane Carr, Bert Yariett, the Rhythm Brothers, and Dick Powell. 5.0—Backstage, with Seymour Hicks. 5.15—Carroll Levis and his Radio Discoveries — Norma Cleland, Jack Ansell, Walter Charles, the Coleman Brothers, Foord Instrumental Quartet. 5.30—Hutch, Romantic Singer. 5.45—Variety. 6.0—Harold Ramsay (Organ). 6.15—Musical Cavalcade, with Edward Reach, Olive Groves and the Showlanders. 6.30—Jack Hylton's Band, with Pat Taylor, Sam Browne, Tommy Handley, the Rhythmeers. Compère: Eddie Pola. 7.0—Ace of Hearts Orchestra. 7.15—The Biggest-Little Programme, with Louise Brown, Peggy Desmond, Paul England and Monia Litter. 7.30—News; Sports. 8.0—Light Music. 9.0—Humorous Programme. 9.50—Talk. 10.0—Song Favourites of Yesterday and Today. 10.15—Request Programme. 10.30—John Goodwood and Quintet. 10.45—Invitation to Czechoslovakia. 11.0—Vaudeville. 11.15—The Changing West. 11.30—Normandie Playbill — Announcements; Music. 11.45—Soul of the South. 12.0 m't.—Melody at Midnight. 12.30-1.0 a.m. (Monday)—Dance Music.

RENNES-BRETAGNE

(France)

- 1,040 kc/s (288.5 m.); 120 kW. Transmits at intervals from 7.0 a.m. 2.0 p.m.—Les Béatitudes (César Franck) from the Cirque-Théâtre, Angers. Conductor: Ropartz. 4.45—See Paris (PTT). 6.0—For Farmers. 6.30—Concert. 7.0—News; Sports; Records. 8.0-10.30—See Paris (PTT). 10.30—News; Concert.

ROME GROUP (Italy)

- Rome (No. 1) 713 kc/s (420.8 m.); 100 kW. Bari (No. 1) 1,059 kc/s (283.3 m.); Palermo, 565 kc/s (531 m.); Bologna, 986 kc/s (304.3 m.). 7.0 a.m.—Amharic Lesson. 7.30-7.50—Time; News. 8.20—For Soldiers. 9.0—Rural Programme. 10.0—See Turin Group. 11.0-11.15—Bible Reading. 11.20 a.m.-1.15 p.m.—See Turin Group. 3.0—Football Match Report. 3.45—Sports.

- 4.0—String Orchestra. Conductor: Petralia. 4.30—Song Potpourri by the Station Orchestra. After the Programme: Sports. 6.25—Sports; Light Music. 7.0—News; Talk; Music. 8.0—Band of the Carabineers. Conductor: Cirenei. March (Cherubini). Overture, "Norma" (Bellini). Sul Trasmeno (Cirenei). German Serenade (Burgmeier). Intermezzo, "Fedora" (Giordano). Saltarello, "Tilda" (Cilea). Mattina nel bosco (Santoliquido). Invitation to the Waltz (Weber). 9.0—Talk in Danish. 9.10—"The Cigar" — One-Act Play (Duvernois). 9.45 (approx.)—Dance Music. 10.0—News; Weather. 10.15-10.55—Dance Music.

SOTTENS (Switzerland)

- 677 kc/s (443.1 m.); 100 kW. Relayed by Geneva. 401 kc/s (748 m.). 8.55 a.m.—Chimes. 9.0—Protestant Service from St. Peter's Cathedral, Geneva. 10.15—Records. Part I, Sixteenth Century Spanish Music and Songs to the Lute. Part II, Quintet in C (Beethoven) by the Lener Quartet and William Primrose. 11.0—Talk; Books. 11.15—Handel and Sibelius Songs by Marian Anderson (Records). 11.30—News; Weather. 11.40 a.m. - 1.0 p.m.—Records. 2.0-3.50—Squibbs on Sport. 4.0—Protestant Address. 4.20 (from Geneva)—Psalms and Chorals — Lecture-Recital by Frédéric Mathil and the "Chanteurs de Saint-Jean." 5.0—See Leipzig. In the intervals, News and Sports. 9.0—Report: The Swiss Skiing Championships at Wengen. 9.30-10.0 (from Geneva)—Report: The Eighth International Horse Show—The Jumping Contests.

STOCKHOLM (Sweden)

- 704 kc/s (426.1 m.); 55 kW. Relayed by Motala, 216 kc/s (1,389 m.); Göteborg, 941 kc/s (318.8 m.); Hörby, 1,131 kc/s (265.3 m.); and Boden, 392 kc/s (765 m.). 8.0 a.m.—For Farmers. 8.30—Debussy and Ravel Records. 9.15-9.45—Talk: Public Libraries. 10.0—Service. 11.40—News. 12.0 noon—Light Orchestral. 12.45 p.m.—Talk. 1.15 (from Göteborg)—Tillius (Pfte.). Pieces (Raminoff): (a) Prelude in D, (b) Serenade, (c) Elegy. The Musical Snuff-box (Lyadov). Two Etudes (Scriabin). 1.40—Norwegian Reading. 2.0—Radio Orchestra. Conductor: Grevillius. Karpe (Violin). Concerto in F (Handel). Air in D (Bach). The Unfinished Symphony (Schubert). Violin: (a) Romance in A (Stenhammar), (b) Havanaise (Saint-Saëns). Danse macabre (Saint-Saëns). 3.0—Cabaret for Children. 3.30—English Lesson. 4.5—Records. 5.0—Evensong. 6.15—News. 6.30—Talk with Records: Birds. 6.45—Navy Band. Conductor: Widner. Four Marches. Quand Madelon (Robert). It's a long way to Tipperary (Douglas). Overture, "Light Cavalry" (Suppé). Potpourri, The good old Times (Brandt). Potpourri, I kronans kläder (Widner). Three Marches: (a) Krigarfest (Apixius), (b) Donau Gruss (Kral), (c) Regimental March (Lundvall). 7.40—"Milady's Son"—Play after Dumas (Wilson). 9.0—News; Sports. 9.30-10.0—Pfte. Quartet in G minor (Brahms).

STRASBOURG (France)

- 859 kc/s (349.2 m.); 100 kW. 6.45 a.m.—Gymnastics. 7.0-8.30—News (French and German). 9.0—For Farmers; Records. 10.45—Protestant Service. 11.30—Roman Catholic Service (German). 12.0 noon—Orchestra. Conductor: Bour. Grégoire (Violin). Overture, "Le grand Mogol" (Audran). Suite, Trianon (Lachaux). Violin and Pfte. Canzonetta. En badinant (d'Ambrosio). Viennese Potpourri (Ziehrer). 12.35 p.m.—News. 1.0—Orchestra (contd.). Two Slav Dances (Dvořák). Waltz (Fetras). Suite, Illys (Ganne). Three Wishes (Rust). Marche bohémienne (Chauvet).

- 1.45—Talk: Animals. 2.0—See Rennes-Bretagne. 4.45—"Lauterborch"—Alsatian Variety Programme from Lauterbourg. 6.0—For Farmers; Records. 7.0—News; Song Records. 7.45—News (German, French). 8.30—See Nice-Côte d'Azur. 9.30—Léon Raiter and his Musi-comedians with Pierrette Thouret. Potpourri, Voilà Montmartre (Domaine). Espada (Raiter). Ce qui me vient de toi (Charly-Sylvain-Raiter). Song of Songs (Koger-Sylvain-Raiter). Un rendezvous (Charly-Sylvain-Raiter). On n'a pas tous les jours vingt ans (Pothier-Raiter). Les roses blanches (Pothier-Raiter). On plante (Pothier-Koger-Raiter). Waltz Potpourri (Domaine). La rosée du matin (Cariolato). Dans un petit coin (Koger-Raiter). The Student passes by (Ibanez). Cuba je t'aime (Eler). Dans les bals musette (Koger-Leval). Prenez garde au tango (Charly-Sylvain-Raiter). Les vaches du Tyrol (Koger-Raiter). Il n'est jamais trop tard. 10.45—News. 11.0—See Paris (Radio-Paris).

STUTTGART (Germany)

- 574 kc/s (522.6 m.); 100 kW. 5.0 a.m.—See Hamburg. 7.0—Water Level; Weather; For Peasants; Gym. 7.30 (from Mannheim)—Roman Catholic Address.

Pepi Wichart, who contributes to Vienna's merry programme at 6.40 p.m., sends a greeting to "World-Radio" readers



- 8.0—See Deutschlandsender. 9.0—For Hitler Youth (Recorded). 9.30—Records. 10.0-10.45—Theodor Scheidl (Bari-tone), Claudio Arrau (Pfte.), Otto Hohn (Violin), Jelena Reichel ('Cello). Pfte.: Sonetto del Petrarca (Liszt). 'Cello: Scherzo (Goens). Songs (Pfitzer). Sonatina in D (Schubert). Songs (Trunk). 'Cello Pieces (Reger): (a) Air, (b) Romance. 11.0—See Berlin. 12.30 p.m.—Symphony in D—The Clock (Haydn).

- 1.0—Classical Records. Overture in G minor (Bruckner), by the Queen's Hall Orchestra. Hugo Wolf Songs by Margarete Teschemacher. Tragic Overture (Brahms), by the BBC Orchestra. Excerpts, "Lohengrin" (Wagner), by Tiana Lemnitz, Franz Völker and the Bayreuth Festspielhaus Choir and Orchestra. 2.0—Gay Companions in the Labour Service — Programme from Württemberg Theatre. 3.0—Heroes' Day—Musical Festival from Ulm Cathedral. 4.0—Martha Fuchs (Soprano), Karl Erb (Tenor) and Gerhard Hüsch (Baritone). 5.0—Kyffhäuser Band. Conductor: Benning. Choir. Conductor: Engelbert Grimm. 6.0—News; Sports. 6.30—"Beatrice" (Henrich). Karlsruhe Municipal Theatre Choir and Orchestra. Conductor: Köhler. Cast: Paula Baumann, Helmuth Seiler, Theo Strack,

SUNDAY (March 13)

- Wilma Fichtmüller, Eugen Ramponi, Eugen Kalmbach, and Karl Mathias. 7.45—Chromatic Fantasia and Fugue (Bach), by Claudio Arrau (Pfte.). 8.0—Music for Heroes' Day. Station Choir and Orchestra. Conductor: Buschkötter. Requiem (Bleye). "Der letzte Mann von Notre Dame"—Short Story (Steigerwald). Fifth Symphony in C minor (Beethoven). 9.0—Time; News; Sports. 9.30—See Deutschlandsender. 11.0 p.m.-1.0 a.m. (Monday)—See Frankfurt.

TOULOUSE (Radio-Toulouse) (France)

- 913 kc/s (328.6 m.); 60 kW. 11.40 a.m.—Viennese Orchestra. 11.48—Roman Catholic Address; Ave Maria (Bach). 12.0 noon—News. 12.30 p.m.—Songs. Les ânes du Caire (Nerini). Au clair de la lune (Lully). Die Forelle (Schubert). Solveig's Song (Grieg). Serenata (Toselli). 12.40—Talk. 12.45—Musette Refrains. 1.15—Excerpts, "Ciboulette" (Hahn). 1.45—Orchestra. 2.0—News. 2.5-2.15—Protestant Address.

- 4.0—Symphony Concert from the Teatro Adriano, Rome. Conductor: Molinari. Concerto grosso (Manfredini-Toni). Jeux de cartes (Stravinsky). Prelude and Walter's Prize Songs, "The Mastersingers" (Wagner). Rome Narrative, "Tannhäuser" (Wagner). Siegmund greets the Spring Night from "The Valkyrie" (Wagner). Prelude and Lohengrin's Farewell from "Lohengrin" (Wagner). In the interval, Announcements; Sports. 6.25-7.30—See Rome Group. 7.30—Light Music; at 7.36 (Rome No. 2) only—News and Talk in English. 8.0—Tirindelli Concert. Conductor: Malatesta; Paola Della Torre (Soprano); Giannino Carpi (Violin). Orchestra: Interlude. Soprano and Orchestra: Mística. Violin and Orchestra: Burlesca. Soprano and Orchestra: Strana. Soprano and Pfte. (a) La gioia mista alle lagrime, (b) Vatinicio. Violin and Orchestra: Pasquinade. 8.30—Talk. 8.40—Choir. Conductor: Consoli. 9.15—Marches and Waltzes. Conductor: Gallino. 10.0—News; Weather. 10.15-10.55—Dance Music.

VIENNA (Austria)

- 592 kc/s (506.8 m.); 100 kW. Relayed by Graz and Linz, 886 kc/s (338.6 m.); Innsbruck, 519 kc/s (578 m.); Klagenfurt and Vorarlberg, 1,294 kc/s (231.8 m.) and Salzburg, 1,348 kc/s (222.6 m.). Transmits at intervals from 6.45 a.m. 10.45 a.m.—Ballads, Vienna Symphony Orchestra and the "Dreizehnlinden" Choir, etc. 11.55—Winter Relief Fund Concert—Vienna Chamber Orchestra. 1.20 p.m.—Programme Trailer. 2.0—News; Notes; Books. 2.40—String Quartet in A minor (Brahms), by the Samohyl Quartet. 3.10—Talk: Among the Head Hunters. 3.35—Songs; Instrumental. 4.15—Talk: Roofing Slate. 4.35—Josef Ponten reads. 5.0—"Snowed In"—Sketch (Breslauer and Marey), with Music. 5.25—Humorous Skiing Songs. 5.40—Reading; Sports. 6.10—Wanda Luzzato (Violin). Sonata in D (Handel). Sicilienne (Paradis). Schmetterling (Hubay). Estrellita (Ponce-Heftetz). Tallahassee (Cyril Scott). 6.40—"Einst und jetzt"—Radio Potpourri (Riedinger). Mixed Choir, Station Band and Orchestra, Wichart Quartet, etc. 8.25—Pfte. Concerto in B flat (Brahms) by Alfred Hoehn and the Vienna Symphony Orchestra. Conductor: Kabasta. 9.10—News; Sports. 9.35—Stöckl Jazz Band. 10.0-10.30—Stöckl Jazz Band.

WARSAW (Poland)

- 224 kc/s (1,339 m.); 120 kW. Relayed by Cracow, 1,022 kc/s (293.5 m.); Katowice, 758 kc/s (395.8 m.); Łódź, 1,339 kc/s (224 m.); Lwów, 795 kc/s (377.4 m.); Poznań, 868 kc/s (345.6 m.); Toruń, 986 kc/s (304.3 m.); and Wilno, 536 kc/s (559.7 m.). Transmits at intervals from 7.0 a.m. 11.3 a.m. (from Łódź)—Łódź Philharmonic. Conductor: Pietruszko. Overture, "Phèdre" (Massenet). Scènes pittoresques (Massenet). Suite algérienne (Saint-Saëns). 12.0 noon—Review; Reading. 12.30 p.m. (from Lwów)—The Nursery—Concert by the Sereydynski Orchestra, a Vocal Quartet and Szafran (Pfte.). 1.45—For Country People. 2.45—For Children. 3.5—Zofia Rabeciewicz (Pfte.), Lifań ("Cello). Sonata in A minor (Schubert). Variations on a Theme from "The Magic Flute" (Mozart-Beethoven). 3.45—Reading. 4.0 (from Katowice)—Variety Concert. 6.0—"The Tournament at Perpignan"—Sequence (Gedrus). 6.35—Records of Wanda Ladowska (Harpischord and Pfte.), Toti Dal Monte (Soprano) and Tito Schipa (Tenor). 7.35—Programmes; Review. 7.50—News; Sports. 8.15—"Down with Women!" — Variety. 9.0—Beethoven — Sequence with Music (Hulewicz). 9.50-10.0—News.

TURIN GROUP (Italy)

- Turin (No. 1) 1,140 kc/s (263.2 m.); 7 kW. Milan (No. 1) 814 kc/s (368.6 m.); Genoa (No. 1) and Trieste, 1,140 kc/s (263.2 m.); Bolzano, 536 kc/s (559.7 m.); Florente (No. 2) 1,258 kc/s (238.5 m.); and Rome (No. 2) 1,222 kc/s (245.5 m.). 7.0-10.0 a.m.—See Rome Group. 10.0—Mass from the Church of the Annunciation, Florence. 11.0-11.15—Bible Reading. 11.20—Sports; Light Music. 12.0 noon—Time; News. 12.15 p.m.—Film Songs and Dances. 12.45-1.15—Opera Records. 3.0-4.0—See Rome Group.

MONDAY Mar. 14

National

Time Signals (normally): Big Ben, 10.15 a.m., 5.15 p.m., 12 midnight. Greenwich, 10.30 a.m., 2.0, 6.0, 9.0, 11.30 p.m.

10.15 a.m. (D)—Service.
 10.30 (D)—Weather Forecast.
 10.45 (D)—"Famous Houses and Families of Wales;" Glyn Roberts.
 11.0 (D)—Cinema Organ.
 11.30 (D)—German for Schools.
 11.45 (D)—Records.
 12.0 (D)—Church History.
 12.25 p.m. (D)—"Round the London Organs."
 1.0 (D)—Records.
 1.30 (D)—Yascha Krein and his Gipsy Orchestra.
 2.5 (D)—For Schools.
 3.0 (D)—Arthur Salisbury and his Orchestra.
 3.35 (D)—German for Schools.
 4.0 (D)—Cinema Organ.
 4.30 (D)—Records.
 5.0—Helen Alston (Mezzo-Soprano).
 5.20—Gershon Parkinson Quintet.
 6.0—The First News.
 6.20—Records.
 6.30—"Music and the Ordinary Listener," Constant Lambert.
 7.0—Monday Night at Seven.
 8.0—The Cinema: Bruce Woolfe and A. C. Cameron.
 8.30—"The Count of Monte Cristo;" serial play.
 9.0—The Third News.
 9.20—World Affairs.
 9.35—Schubert: May Blyth (Soprano).
 10.0—BBC Theatre Orchestra: Jo Vincent (Soprano).
 11.0—Joe Loss and his Band.
 11.30-12.0—Jack Harris and his Orchestra.

London Regional

Time Signals (normally): Big Ben, 10.15 a.m., 5.15 p.m., 12 midnight. Greenwich, 10.30 a.m., 7.0, 10.0, 11.30 p.m.

10.15-10.45 a.m.—National.
 10.45—BBC Scottish Orchestra: Joyce Fleming (Soprano).
 11.30—Ballad Concert.
 12.0—Records from the Films.
 12.30 p.m.—Philip Whiteway Ensemble.
 1.0—BBC Welsh Orchestra: Ethel Gomer-Lewis (Soprano).
 1.50—Anita Harrison (Pfte.).
 2.20—The Pipe Band of the 1st Bn. The Gordon Highlanders.
 2.40—Short story.
 3.0—Hastings Municipal Orchestra.
 3.40—Sale v. Oxford University Rugby Football match.
 4.30—Vest-pocket Vaudeville.
 5.0—The Children's Hour.
 6.0—Songs Without Words: The Little Orchestra.
 6.30—BBC Military Band.
 7.0—The Second News.
 7.30—Herbert Janssen (Baritone).
 8.0—Reginald Foort (BBC Theatre Organ).
 8.30—BBC Northern Orchestra.
 9.0—Television Cabaret, with Nelson Keys, Neila Goodelle, Walsh and Barker, Marjorie Dale, the Six Grosvenor House Charm Girls and the BBC Television Orchestra.
 9.40—Records.
 10.0—News Summary.
 10.25—Joe Loss and his Band.
 11.30—Records.
 11.50-12.0—Late News Summary.

Midland

10.15 a.m.—6.0 p.m.—Regional.
 6.0—Vincent Norman and his Band.
 6.30—Regional.
 7.20—"This Week's Programmes."
 7.30—Songs for Schools.
 8.0—Sutton Coldfield Philharmonic Society, Eda Kersey (Violin); City of Birmingham Orchestra: Overture, Figaro (Mozart); Adagio—Symphony No. 5 (Mahler); Concerto in A (Mozart).
 8.45—Variety.
 9.0-12.0—Regional.

Northern

10.15 a.m.—7.20 p.m.—Regional.
 7.20—Bulletin for Farmers.
 7.30—Liverpool Cathedral Choir, Organist, H. Goss-Custard.
 8.10—Cinema Organ.
 8.30—BBC Northern Orchestra.
 9.0—Regional.
 9.40—Metropolitan Miscellany for the North.
 10.0-12.0—Regional.

Western

10.45 a.m.—6.0 p.m.—National.
 6.0—Regional.

6.30—Reginald Porter - Brown (Organ).
 7.0—The Second News.
 7.20—Market Prices.
 7.30—Regional.
 8.0—Mixed Menu of Light Fare.
 8.30—Regional.
 9.0—"Robinson Crusoe's Island;" Lt.-Commander C. E. R. Alford.
 9.15—Records.
 9.40-10.35—Regional.

Welsh

10.15 a.m.—3.0 p.m.—Regional.
 3.0—For Schools in Wales.
 3.25-6.0—Regional.
 6.0—Cardigan and St. Dogmaels Children's Choir.
 6.30—Regional.
 7.20—Welsh Announcements.
 7.25—"The Land of Gwent;" feature programme.
 8.0—Regional.
 8.30—BBC Welsh Chamber Music Players and The Lottie Wakelin Quartet.
 9.0—Regional.
 9.40—"Pawb A'i Farn."
 10.0-12.0—Regional.

N. Ireland

10.15 a.m.—6.0 p.m.—Regional.
 6.0—Frank Rea and his Orchestra.
 6.45—Agricultural Review.
 7.0—The Second News.
 7.20—Bulletin for Farmers.
 7.30—"Pig Diseases;" H. G. Lamont, M.Sc., M.R.C.V.S.
 7.50—Records.
 8.0-12.0—Regional.

Scottish

10.15 a.m.—2.0 p.m.—National.
 2.0—For Schools.
 2.25—Herring Bulletin.
 2.30—For Schools.
 3.35-6.30—Regional.
 6.30—Violet Davidson presents "The North Stars."
 7.0—The Second News.
 7.20—Gaelic News and Announcements.
 7.30—Regional.
 8.30—Scots Folk Songs.
 9.0-12.0—Regional.

Hours of Transmission in Greenwich Mean Time.

BERLIN (Germany)

841 kc/s (356.7 m.); 100 kW. Transmits at intervals from 5.0 a.m.

11.0 a.m.—See Leipzig.
 1.0 p.m.—News; Water Level.
 1.15—Libiszowski Band.
 2.15—Exchange; Markets.
 2.35—Fierke Band.
 3.30—Reading; Talk.
 4.0—"Nun will der Lenz uns grüssen!" (Lamy) for Choir and Wood-Wind Quartet.
 4.30—An ex-Cowboy at the Microphone.
 5.0—Goronyz Band.
 6.0—News.
 6.10—Records: Dances of Many Lands.
 6.45—Evening Echoes.
 7.0—Station Orchestra. Conductor: Kähler. Overture, "The Bohemian Girl" (Balfe). Wedding Music (Jensen). Selection, "Cavalleria rusticana" (Mascagni). Two Slav Dances (Dvořák). Tesoro mio (Buccucc). Per aspera ad astra (Urbach).
 8.0—"The Magic of the Voice"—Records.
 9.0—News; Sports.
 9.30-11.0—See Cologne.

BEROMÜNSTER (Switzerland)

556 kc/s (539.6 m.); 100 kW. Relayed by Basle and Berne. 1.375 kc/s (218.2 m.).
 5.30-5.50 a.m. (from Berne)—Gym.
 11.0 a.m.—12.45 p.m.—Records; at 11.29—News; Exchange.
 3.0—Reading: "East Wind—West Wind" (Pearl Buck).
 3.30—Light and Dance Records.
 4.0—Jean Louis' Band.
 5.0—For Children.
 5.30—Talk.
 6.0—Astronomy Talk; Records.
 6.20—Romansh Lesson.
 6.45—Weather; News.
 6.55—Brahms Concert.
 8.10—Announcements.
 8.15—Weekly Review for Swiss Abroad.
 8.30-9.45—See Sottens.

BRATISLAVA (Czechoslovakia)

1,004 kc/s (298.8 m.); 13.5 kW. Transmits at intervals from 5.15 a.m.

6.15 p.m.—Czech Music. Conductor: Dyk.
 7.0—See Prague.
 7.15—See Brno.
 7.30—A Play (Turgenev) in Slovak.
 8.25—Pfte. Trio in D minor (Mendelssohn) by the Bratislava Trio.
 8.55-9.15—See Prague.
 9.15—News (Hungarian).
 9.30-10.0—Records.

BRESLAU (Germany)

950 kc/s (315.8 m.); 100 kW. Relayed by Gleiwitz and Görlitz, 1,231 kc/s (243.7 m.). Transmits at intervals from 4.30 a.m.

11.0 a.m.—Colliers' Band.
 1.0-2.0 p.m.—News; Exchange; Records.
 3.0—See Deutschlandsender; at 4.0—Books.
 5.0—Talks; Programmes.
 6.0—News; Markets.
 6.10—Blue Monday: "Old Vienna"—a Musical Peep-show (Fortner), with Gluck, Mozart, Schubert, Lanner, and Strauss Music and Folk-Melodies.
 8.0—Motto.
 8.10—Ostland Orchestra, Leyendecker (Baritone), etc.
 9.0—News.
 9.15—To be announced.
 9.30-10.30—See Cologne.

BRNO (Czechoslovakia)

922 kc/s (325.4 m.); 32 kW. Transmits at intervals from 5.15 a.m.

7.15 p.m.—Three Songs of Home (Jirák) by Bednář (Baritone) and the Station Orchestra.
 7.30—"Marius"—Play (Pagnol; trans. Horejsi).
 8.55-10.0—See Prague.

BRUSSELS (No. 1) (Belgium)

620 kc/s (483.9 m.); 15 kW.
 6.30-9.5 a.m.—Records; Gym; News.
 12.0 noon—Records.
 12.30 p.m.—Shipping; Spanish Music by the Radio Orchestra. Conductor: Gason.
 1.0—News; Belgian Music.
 1.30—Records: Russian Music.
 2.0-2.3—Review of the Arts.
 4.55—News.
 5.0—Request Concert by Brenders Jazz Band.
 5.30—Talk; Parodies.
 5.40—Brenders Jazz Band.
 6.0—Talk: The Faculties of Law and Political Economy at Ghent University.
 6.15—Records: Peer Gynt Suite (Grieg).
 6.30—A Tour of Brittany.
 7.0—Hygiene and Sports Reviews; Interview; Records.
 7.30—News.
 8.0—Massenet Concert. Radio Orchestra. Conductor: Gason. Bethune (Violin). Overture, "Phdre." Violin: Meditation from "Thais." Suite, Le roman d'Arlequin.
 8.20—Radio Artists at the Microphone.
 8.40—Radio Orchestra. Conductor: Gason. Two Symphonic Rhapsodies (Coates). Prelude and Allegro (Pugnani-Kreisler). Tabloid (Grove). Scènes d'enfants (Mompou). Cortège, "Sylvia" (Delibes).
 9.15—The Wiertz Museum—Report.
 9.45—Orchestra (contd.). Valse des bruns (Ganne). Emperor Waltz (Strauss).
 10.0—News; Record, 10.15—Poems.
 10.30-11.0—Brenders Jazz Band.

BRUSSELS (No. 2) (Belgium)

932 kc/s (321.9 m.); 15 kW. Programme in Flemish.
 6.30-9.5 a.m.—Records; Gym; News.
 12.0 noon—Records.
 12.31 p.m.—Light Orchestra.
 1.0—News; Shipping; Orchestra.
 1.30-2.0—Records.
 4.55—News.
 5.0—Salon Orchestra; Bantz (Tenor).
 5.45—For Children.
 6.30—Records: "Madame Butterfly" (Puccini).
 6.45—Talk: Local Politics.
 7.0—Records (contd.).
 7.30—Theatre and Sports Notes.
 8.0—Salon Orchestra. Bantz (Tenor). Overture, "Gri-Gri" (Lincke). Selection, "Il est charmant" (Moretti). Songs: (a) Hemelbroekje (Ball), (b) Caro mio ben (Giordano), (c) "Die Loreley" (Silcher). Servus Wien (Dostal).
 8.45—Reading: Shéhérazade (Raymond Brulez).
 9.0—Orchestra (contd.). March, Spearmint (Turine). Die Nachtschwärmer (Zehrer). Les forains

(Berger). Violin: Réverie (Vieuxtemps). Selection, "Zaza" (Leoncavallo). Ballet, "Lakmé" (Delibes). Overture, "William Tell" (Rossini).
 10.0—News.
 10.10-11.0—The Collegian Amateur Dance Orchestra, from Antwerp.

BUCHAREST (Romania)

823 kc/s (364.5 m.); 12 kW. Relayed by Radio-Romania, 160 kc/s (1,875 m.). Transmits at intervals from 4.30 a.m.

4.20 p.m.—Motoi Orchestra; at 5.0—Topical Talk.
 5.45—Talk.
 6.0—Ballet Music Records.
 6.50—Talk.
 7.15—Records of Lilly Pons, Miliza Korjus and Adela Kern.
 7.45—Quartet in F (Beethoven).
 8.10—Folk Songs (Dragoi) sung by Maxin Vasiliu.
 8.30—News; Sports Notes.
 8.45—Café Concert.
 9.45—News (French, German).



Hans Bund and his band make music for Cologne listeners at 8.10 p.m.

BUDAPEST (No. 1) (Hungary)

546 kc/s (549.5 m.); 120 kW. Transmits at intervals from 5.45 a.m.

11.5 a.m.—Frau Tamásy (Pfte.).
 11.30—News.
 11.40—Janigro (Cello).
 12.30 p.m.—Rácz Cigány Band.
 1.40—News.
 3.15—For Schools.
 4.0—Árpád Markó.
 4.30—Police Band.
 5.10—The Pests Floods—Reports (Recorded).
 5.45—Records.
 6.40—Talk.
 7.10—Concert for the Two hundred and fiftieth Anniversary of the Choir and Orchestra of the Coronation Church, from the Academy of Music. Ilona Szabó, Anna Németh, János Harangozó and Rezső Hoffman (Singers). National Anthem. Tu es Petrus (Szabó). Missa solennis (Beethoven). Te Deum (Kodály).
 9.15—News.
 9.40 (approx.)—Mursi Cigány Band.
 10.0—News (German).
 10.5—Salon Quintet.
 11.5—News.

BUDAPEST (No. 2) (Hungary)

359.5 kc/s (834.5 m.); 18 kW.
 5.15 p.m.—Police Band.
 5.40—German Lesson.
 7.45—Records.

COLOGNE (Germany)

658 kc/s (455.9 m.); 100 kW. Transmits at intervals from 5.0 a.m.

11.0 a.m.—Concert.
 12.0 noon—News; Greetings.
 12.15 p.m.—Concert from Hamburg.
 1.0—News.
 1.15—Schrammel Quartet.
 2.0—For Children.
 2.30—German for Germans; Markets.
 3.0—Orchestra; at 4.0—Talk.
 5.0—Report: Hospital Nurses.
 5.15—Cesar Bresgen Music by the Composer (Pfte.) and Schwamberger (Cello).
 5.50—"What do you think?"
 6.0—News.
 6.10—"Waltz-time in Opera"—Station Orchestra, Choir and Singers. Conductor: Breuer. Overture, "The Nuremberg Doll" (Adam). Chorus and Waltz, "Der Wildschütz" (Lortzing). Gipsy Dance and Waltz, "Mignon" (Thomas). Drinking Song, "La Traviata" (Verdi). Waltz and

Chorus, "Faust" (Gounod). Ariette-Waltz, "Romeo and Juliet" (Gounod). Entr'acte, "Der Corregidor" (Wolf). Entr'acte and Waltz, "Eugene O'Neill" (Tchaikovsky). Waltz and Musette, "La Bohème" (Puccini). Entr'acte, "The Jewels of the Madonna" (Wolf-Ferrari). Waltz, "Der Rosenkavalier" (Richard Strauss). Waltz, "Hansel and Gretel" (Humperdinck). Waltz, "Friedrich Wilhelm von Steuben" (Bullerian).
 7.40—Weekly Review.
 8.0—Records of Kullmann (Tenor).
 8.10—Bund Dance Band.
 9.0—News; Records.
 9.30-11.0—Light and Dance Music. Station Orchestra, the Six Merry Singers and a Pfte. Duo.

DEUTSCHLANDSENDER (Germany)

191 kc/s (1,571 m.); 60 kW. Transmits at intervals from 5.0 a.m.

11.0 a.m.—See Hamburg.
 12.45 p.m.—News.
 1.0—Variety—Jäger Band and Records.
 2.0—Exchange; Markets; Records.
 2.40—Reading; Programmes.
 3.0—Station Orchestra; at 4.0—Topical.
 5.0—Dance Music.
 5.25—Six Songs (Wolf) by Wocke (Baritone).
 5.40—"Sugar from Wood"—Friedrich Bergius describes his Discovery.
 6.0—Motto; News.
 6.10—"Als mei Ahndel zwanzig Jahr..."—Musical Memories from Grandmother's Day.
 7.45—Topical.
 8.0—Ninth Philharmonic Concert from the Philharmonic, Berlin. Berlin Philharmonic. Guest Conductor: Arnermet. Tibor de Machula (Cello). Cello Concerto (Dvořák). La mer (Debussy).
 9.20-9.45—News; Topical.
 10.0-11.0—Serenade from Hamburg.

FRANKFURT (Germany)

1,195 kc/s (251 m.); 25 kW. Cassel, etc. See Sunday.
 Transmits at intervals from 5.0 a.m.

11.0 a.m.—See Hamburg.
 1.0 p.m.—News; Records.
 2.0—Violin and Pfte.
 2.30—For Children.
 3.0—Orchestra, etc. Schrammel Quartet.
 5.0—Topical; Records.
 5.45—See Leipzig.
 6.0—News; Weather.
 6.10—"Silesia"—Literary Sequence (Kaergel).
 7.0—Winter Relief Fund Request Concert. Military Bands and Soldiers' Chorus.
 9.0—News; Sports.
 9.30—See Cologne.
 11.0 p.m.—1.0 a.m. (Tuesday)—See Stuttgart.

HAMBURG (Germany)

904 kc/s (331.9 m.); 100 kW. Bremen, etc. See Sunday.
 Transmits at intervals from 5.10 a.m.

11.0 a.m.—Hanover Castle Concert.
 1.0 p.m.—News; Music.
 2.0—Shipping.
 2.25—Niemann and Debussy Records.
 2.50—Ice Report.
 3.0—Variety Concert. Talks in the intervals.
 5.0—Seidhofer and Panhofer (Pftes.).
 5.40—Farmers and the Food Supply.
 5.50—Weather; Shipping.
 6.0—News.
 6.15—See Stuttgart.
 8.0—"A Film in the Making"—From Conception to Showing.
 9.0—News.
 9.30-11.0—Serenade—Bremen Stadtmusikanten and a Pfte. Duo.

HILVERSUM (No. 1) (Holland)

160 kc/s (1,875 m.); 10 kW until 4.40 p.m.; 150 kW from 4.40 p.m. Also on Jaarsveld, 722 kc/s (415.4 m.); 17 kW.
 VARA Programme.
 7.40 a.m.—Records.
 9.40—VPRO Service.
 10.0—Recitations; Pfte.
 10.50—Recitation; Steyn (Organ).
 11.40—Records.
 12.10 p.m.—VARA Orchestra. Conductor: de Groot.
 12.55-1.25—Records.
 1.40—Mendelssohn Concert (Recorded)—Residentie Orchestra. Conductor: Votto. Maria Last (Soprano).
 2.30—Eva Janssen (Recitation).
 3.0—Wagner Concert (Recorded)—Residentie Orchestra. Conduc-

tor: Votto. Mlle Maria Last (Soprano).
 3.40—Records.
 4.10—For Children.
 4.45—Records.
 5.10—VARA Orchestra. Conductor: de Groot. Overtures, "Poet and Peasant" (Suppé), "Si j'étais roi" (Adam), "The Caliph of Bagdad" (Boïeldieu), "Zampa" (Hérold), "La belle Hélène" (Offenbach). Comedy Overture (Keler-Bela). Overture, "William Tell" (Rossini).
 6.10—Music Talk with Records.
 6.40—Talk: The Utrecht Fair.
 6.50—Talk: Natural History.
 7.10—French Folk Songs by Berthe Seroen.
 7.40—S.O.S. Messages; News; Records.
 8.10—"Esmeralda" Septet, Mlle Tilly van Vliet (Songs) and Holman (Tenor).
 8.40—Records.
 9.10—Rambliers Dance Band.
 9.40—News.
 9.45—"Vox Jubilans" Women's Choir. Conductor: Uyttenboogaard; Fiolet (Recitation), Beths (Violin), Jong (Organ), Wins (Pfte.), Kreté (Horn) and Margot Bröderers (Harp). Gesang auf Fingal. Young Olaf (von Schilling). Song (Brahms). Romance in F (Beethoven). Solitario bosco ombroso (Cherubini). Les nymphes des bois (Delibes). On Wings of Song (Mendelssohn).
 10.40-11.40—Records.

HILVERSUM (No. 2) (Holland)

995 kc/s (301.5 m.); 15 kW until 6.10 p.m.; 60 kW from 6.10 p.m.
 NCRV Programme
 7.40 a.m.—Bible Reading; Meditation; Records: Sacred Music.
 8.10—Records.
 9.10—Greetings; Records.
 10.10—Religious Address.
 10.40—Bible Reading; Records.
 11.40—Police Notes; Records.
 12.10 p.m.—"All Round" Sextet.
 1.40—For Schools.
 2.15—Records; Talk.
 3.25—Bible Reading; Records.
 4.55—For Children.
 5.55—Records.
 6.10—Letter-box; at 6.40-6.55 — Police Notes; News.
 7.25—Report.
 7.40—News; Sports.
 7.55—Bouwmeester (Organ). 'k Zal met mijn gansche hart Uw ecr. Chaconne (Pachelbel). Sacred Songs. Chorus (Grey). Sacred Songs. Postlude (Duncan). Improvisation.
 8.40—Suite, Roma (Bizet) by the NCRV Orchestra. Conductor: v. d. Hurk.
 9.10—Address by H.E. Viscount de Geer, Minister of State (Recorded).
 9.55—News.
 10.0—NCRV Orchestra. Conductor: v. d. Hurk. Ankie v. Wickevoort Crommelin (Soprano). Viennese Dances (Beethoven). Der Hirt auf dem Felsen (Schubert).
 10.25—Gymnastics.
 10.40—NCRV Orchestra (contd.). Salve Regina (Handel). Suite (Schnittelbach).
 11.10-11.40—Records; Bible Reading.

KALUNDBORG (Denmark)

240 kc/s (1,250 m.); 60 kW. Relays Copenhagen 1,176 kc/s (255.1 m.).
 Transmits at intervals from 6.0 a.m.
 11.0 a.m.—1.0 p.m.—Kai Julian's Orchestra.
 1.15—Gym for Children.
 1.35—Radio Orchestra. Conductor: Tuxen. Lise Andersen (Songs). Overture, "La Mascotte" (Audran). Intermezzo (Arensky). Troika (de Bottari). The Three Bears (Coates). Two Pieces (Ganne). Overture, "Isabella" (Suppé). "Le cheval de bronze" (Auber). Scandianville Suite (Juel-Frederiksen). German Dances (Haydn). Laura Waltz (Millöcker). Au Village (Gillet). Selection, "Die Faschingssee" (Kálmán); at 2.15—For Women.
 3.30—For Children; Notes.
 4.0—Talk: The Czechoslovaks.
 4.25—Weather; Exchange; Markets.
 4.50—Folk Songs.
 5.15—Talk: Economics.
 5.35—English Lesson.
 6.0—Time; News.
 6.30—Foreign Affairs.
 6.50—For Young People.
 7.15—Aarhus Municipal Orchestra from Esbjerg. Conductor: Jensen. Symphony in C, the Jupiter (Mozart). Excerpts from the Paris Suite (Ibert).

8.0—A Literary Evening at Esbjerg High School.
 9.0—News; Weather.
 9.20—String Quartet (Debois) by the Rafn Quartet.
 9.55-11.30—Ewans' Dance Band; at 11.0—News.

KÖNIGSBERG (Heilsberg) (Germany)

1,031 kc/s (291 m.); 100 kW. Relayed by Danzig, 1,303 kc/s (230.2 m.).
 Transmits at intervals from 5.0 a.m.
 11.0 a.m.—See Hamburg.
 1.0 p.m.—News; Talk; Music.
 1.55-2.0—Exchange.
 2.35—Careers for Girls.
 2.45—"Blue Hawaii"—Scene.
 3.0—Orchestra; at 3.50—Talk.
 4.40—Ferdinand Schulz Programme.
 5.0—"The 1928 Class"—Parents, Boys, Hitler Youth Leaders and a Hitler Youth Doctor at the Microphone.
 5.50—Announcements.
 6.0—News; Weather.
 6.10—"Old Fritz"—Sketches and Anecdotes about Frederick the Great.
 8.0—Topical.
 8.15—Eggert (Baritone), Käte Grandt (Violin) and Maria Fischer (Pfte.). Canzonetta (d'Ambrosio). Romance in G (Reger). Gipsy Songs (Dvořák). Andante (Hubay). Gopak (Musorgsky). Gipsy Songs (Dvořák). Romance (Grecchaninov). Scherzo (Tchaikovsky). March (Dohnányi).
 9.0—News; Sports.
 9.20—Review of Periodicals.
 9.35-11.0—Dance and Light Music.

LEIPZIG (Germany)

785 kc/s (382.2 m.); 120 kW. Relayed by Dresden, 1,285 kc/s (233.5 m.).
 Transmits at intervals from 5.0 a.m.
 11.0 a.m.—Fricke Band.
 1.0 p.m.—News; Records; Talk.
 2.30—"Our Mother's Songs."
 3.0—See Deutschlandsender.
 5.0—Talk: Dithmarsch.
 5.20—Spanish Music by Manuela del Rio (Castanets), Alfonso (Pfte.), Rosa (Guitar).
 5.45—Report: New German Materials.
 6.0—News.
 6.10—"Tanz 'rüber—tanz 'nüber"—a Merry Cantata (Schäfer).
 7.0—Dresden Orchestra, etc. Conductor: Kretschmar. Overture, "The Thieving Magpie" (Rossini). Ständchen (Heykens). Minuet (Meister). Pfte.: Perpetuum mobile (Weber). Excerpts, "L'Arlesienne" (Bizet). Berceuse de Jocelyn (Godard). Rustle of Spring (Sinding). 'Cello and Pfte.: Spanish Dance (Casado). Radetzky March (Strauss). Pfte.: Wedding Day at Troldhaugen (Grieg). Flower Waltz (Tchaikovsky). La capriciosa (Ries). Entrance, "The Arabian Nights" (Strauss). Pfte.: To Spring (Grieg). Waltz, "Polenblut" (Nedbal). Scherzo in D (van Goens). Ballet Music (Helmberger). Destiny Waltz (Baynes). Czardas (Monti). Minuet (Boccherini). Brise de mer (Leoncavallo). Overture, "Donna Diana" (Reznicek).
 9.0—News; Sports.
 9.25—Science Review.
 9.40-11.0—Music from Cologne.

LILLE (Radio PTT Nord) (France)

1,213 kc/s (247.3 m.); 60 kW. Transmits at intervals from 6.30 a.m.
 7.10 p.m.—Talk in English; Record.
 7.30—Radio Journal.
 8.0—For Students.
 8.30—Symphony Concert from Roubaix Conservatoire. Conductor: Bousquet. Marcelle Blaquart (Harp), Declercq (Double Bass). Part I. Harp and Orchestra: Danse sacrée et danse profane (Debussy). Suite, Donizade (Gaujac)—Conductor: The Composer. Fantasia (Gaujac)—Conductor: The Composer. Part II, Ravel. Mother Goose Suite. La Valse. After the Concert, News.

LYONS (PTT) (France)

648 kc/s (463 m.); 100 kW. Transmits at intervals from 6.30 a.m.
 8.30 p.m.—"Hans the Flute-Player" (Ganne). Conductor: Waerseggers. After the Programme, News (French, German).

MONTE CENERI (Switzerland)

1,167 kc/s (257.1 m.); 15 kW. Transmits at intervals from 11.0 a.m.
 6.50 p.m.—News.
 7.0—Overture (Boccherini)—Station Orchestra. Conductor: Casella.
 7.20—A Century Ago—March Anniversaries.
 7.35—Martucci Music by the Station Orchestra. Conductor: Casella. Canzonetta. Tempo di gavotta. Gigue. Nocturne.
 7.55—Verdi Opera Records.
 8.15—See Beromünster.
 8.30-9.45—See Sottens.

MOSCOW (No. 1) (Russia)

172 kc/s (1,744 m.); 500 kW.
 5.30 p.m.—Literature; Concert.
 8.30—News; Kremenin Chimes.
 9.0—Programme in English.
 10.0—Programme in Hungarian.
 11.0-12.0 m't.—Talks in Spanish.

MUNICH (Germany)

740 kc/s (405.4 m.); 100 kW. Relayed by Nürnberg, 1,267 kc/s (236.8 m.).
 Transmits at intervals from 5.0 a.m.
 11.0 a.m.—Popular Orchestral.
 12.0 noon—News; Records.
 1.0 p.m.—News; Exchange.
 1.15—See Berlin.
 2.0-2.30—For Children.
 3.0—Chamber Music; Books.
 4.0—Weather; Markets.
 4.10—Opera Records; Talk.
 6.0—News; Road Report.
 6.10—Winter Relief Fund Concert.
 7.0—Station Dance Band.
 8.0—Sonnets from the Portuguese (Elizabeth Barrett Browning, trans. Rilke).
 8.10—Hamburg Composers, Old and Modern. Station Orchestra. Conductor: Kruttge. Aufzüge, Mascheraden und fremde Tänze samt schönen lieblichen Frühlings- und Sommerblümlen (Brade). Wassermusik (Telemann). Hamburgische Abendmusik (Helmut Paulsen). Gartenmusik (Girnatius).
 9.0—News; Sports.
 9.30-11.0—See Cologne.

NAPLES GROUP (Italy)

Naples, 1,104 kc/s (271.7 m.); 10 kW. Florence (No. 1), etc. See Sunday.
 6.0 p.m.—Light Music; Topical.
 6.20—See Rome Group.
 6.45—Light Music.
 7.0-7.30—See Rome Group.
 7.30—Tamburini (Pfte.), Parigi (Tenor). Tenor: Filla non m'ami più (Carissimi). Pfte.: Aria (Pergolesi-Thalberg). Tenor: (a) Star vicino (Rosa), (b) Le violette (Scarlatti). Pfte.: (a) Liebesleid (Kreisler), (b) Two Sonatas (Scarlatti). Tenor: (a) Folk Song (Benvenuti), (b) Ruvanello (Montanaro). Pfte.: Goyescas (Granados). Tenor: Gondoliera Veneziana (Sadero).
 8.0—Sketch.
 8.15—Rhythm - String Orchestra. Conductor: Petralia.
 8.45—To be announced.
 9.0—"Allegria" Quartet.
 9.30—Dance Music.
 10.0—News.
 10.15-10.55—Dance Music.

NICE-COTE d'AZUR (France)

1,185 kc/s (253.2 m.); 60 kW. Transmits at intervals from 6.50 a.m.
 9.30 p.m.—Station Orchestra. Mme Besneux-Gautheron (Songs). Prelude and Elsa's Dream, "Lohengrin" (Wagner). Suite, "La Pantoufle de Vair" (Delannoy). Songs: (Chausson, Duparc). Excerpts, "Prince Igor" (Borodin).
 10.30—News.

OSLO (Norway)

260 kc/s (1,153.8 m.); 60 kW. Fredrikstad, etc. See Sunday.
 Transmits at intervals from 9.30 a.m.
 5.15 p.m.—Thorsen (Pfte.); Ihle (Songs).
 5.45—News; Economics.
 6.40—Erichsen and Marida (Accordions); Reading (Moc).
 7.0—Bergen Radio Orchestra.
 7.45—Report.
 8.10—Talk; International Law.
 8.40—News; Topical.
 9.15-10.0—Soloists (Violin), Suzanne Roche (Pfte.). Sonata (Leclair). Sonata (Milhaud). Berceuse (Ravel). Habanera (Ravel). Minstrels (Debussy).

PARIS (Eiffel Tower) (France)

1,456 kc/s (206 m.); 7 kW. Transmits at intervals from 6.30 a.m.
 8.0 p.m.—Jane Hervé (Songs),

MONDAY (March 14)

Maillard-Verger (Pfte.). Songs (Piermé, Tchaikovsky). Pfte. Sonatina (Gallon). Songs (Laparra, Delvincourt).
 8.30—Clarisse Dieterlen (Pfte.).
 8.45—Viviane Tubiana (Songs).
 9.0—Corradina Mola (Harpischord).
 9.15—"Triton" Concert from the Ecole Normale de Musique. Yvonne Gouvernée Choir, Blanche Honegger, Georges Auric, Harsanyi, Merckel, Fournier, M. Moysé, L. Moysé. Sonata for Pfte. and 'Cello (Harsanyi). A-cappella Choir: Benedictiones (Roland Manuel). Trio for Flute, Violin and Bassoon (Martini). Duet for Violin and 'Cello (Rivier). Chœurs a-cappella (Poulenc). Choir and Pfte.: Récréations (Auric). Sonata for Pfte. and 'Cello (Debussy).

10.30—Records.
 11.0—News; Weather.

PARIS (Poste Parisien) (France)

959 kc/s (312.8 m.); 60 kW. Transmits at intervals from 7.10 a.m.
 12.0 noon—Exchange; Records.
 12.25 p.m.—News; Exchange.
 12.39—Mascagni Records.
 12.45—"Les Invités de Zepilli." 1.0—La course au trésor, with Pierre Duc.
 1.30—Messenger Records.
 1.38—Les Invités de Zepilli.
 1.52—Records.
 2.0—Exchange; News.
 3.45 and 4.35—Exchange.
 5.0—News; Cabaret.
 6.0—Exchange.
 6.10—Records: Sonata in B flat minor (Chopin) by Brailowsky (Pfte.).
 6.30—Poems (Mockel).
 6.50—Record of George Thill.
 6.55—For Young People.
 6.58—Racing; Talks; Sports.
 7.20—Chabrier Records. Overture, "Gwendoline." Fête polonaise, "Le Roi malgré lui."
 7.50—Three Felix Paquet Successes.
 8.0 Topical Talk.
 8.10—Germaine Sablon.
 8.15—Variety Records.
 8.30—"Glamour of the Radio."
 8.45—"La bonne histoire."
 9.0—News.
 9.5—Max Regnier and Company.
 9.50—News.
 10.0—Classical Songs—Talk by Théodore Mathieu, with Illustrations by Violette Andreossi.
 10.30-11.0—Cabaret.

PARIS (PTT) (France)

695 kc/s (431.7 m.); 120 kW. Transmits at intervals from 6.30 a.m.
 4.0 p.m.—Noëlie Pierront (Organ), from the Schola Cantorum.
 4.30—Records; Songs.
 5.0—Talk: Men and Books.
 5.15—Records: 18th Century French Violin Music.
 5.30—Records; For Gardeners; Talk.
 5.50—Art Review.
 6.0—Talks.
 6.30—Paul Pierné Music presented by Paul Le Flem. Mlle Pifteau (Songs), Madeleine La Candela (Pfte.). Songs: (a) L'Horloge, (b) L'Escargot, (c) La Souris, (d) L'Etang. Excerpts, "Shéhérazade."
 7.0—Radio-Journal.
 8.0—Jean Florence (Songs).
 8.15—Josée Bernard (Songs).
 8.30—Guild Songs—Talk by Guillot de Saix with Illustrations by Suzanne Nivette.
 9.0—Chamber Music. Instrumental Trio, Elsa Ruhlmann (Songs), Jeanne Leleu (Pfte.). Alys Lautemann (Harp). Trio: Pieces en concert (Rameau). Pfte.: Rondo in D (Beethoven). Harp: The Harmonious Blacksmith (Handel). Songs (Haydn, Scarlatti). Sonata for Harp and Flute (Vinci). Sonata in G for Harp and Bassoon (Serveto). Songs (Debussy). Pfte. Pieces (Florent Schmitt): (a) Lied tendre, (b) Souvenir.
 10.0—Russian Vocal Ensemble. Conductor: Bobtchenok. Potpourri (Ivanov). Legend (Tchaikovsky). Song (Arkangelsky). Aria, "Ruslan and Ludmilla" (Glinka). On the Volga (Bobtchenok). Polka (Agrénev). March (Bobtchenok).
 10.30—News; Weather.
 10.45—Excerpts, "Mystery of Sorrow"—Play (Adria Gual); Esperanto Translation by Pjula and Valles.

PARIS (Radio-Paris) (France)

182 kc/s (1,648 m.); 80 kW.
 6.28 a.m.—Programmes; Records.
 6.40—News; Gym; Records.
 7.15—News; Records.
 8.0-9.20—Time; News; Records.
 10.15—Programmes; Records; Reading.
 11.0—Records.
 11.45—Markets; Exchange.
 12.0 noon—French Opera Records.
 1.0 p.m.—Time; News; Exchange.
 1.30—Lina Falk (Contralto).
 1.45—Records; Programmes.
 2.5—"Un moyen infallible"—One-Act Play (Vercel).
 2.30—Exchange; Markets.
 2.45—Gilberte Lyon (Pfte.).
 3.0—Simone George (Songs).
 3.15—Women's Journals.
 3.25—Talk: Somerset Maugham's Autobiography.
 3.30—Talk: Famous Contemporaries.
 3.45—Exchange; Markets.
 4.0—Mlle Dumaine (Songs).
 4.15—Constance Moroney ('Cello).
 4.30—The Week's Anniversaries.
 4.40—Talk; Markets; Exchange.
 5.0—Bailly Orchestra. Overture, "Cosi fan tutte" (Mozart). Dance (Turina). Scènes napolitaines (Massenet). Réverie (Hüe). Excerpts, "Le bourgeois gentilhomme" (Richard Strauss). Canzonetta (Filippucci). Roses from the South (Strauss). The Shepherd's Lottery (Boyce). Ballet, "Parysatis" (Saint-Saëns).
 6.0—Educational; Art Review; Talks.
 7.0—Educational; Books; Talks.
 7.50—Time; Foreign Affairs.
 8.8—Home Affairs.
 8.15—Mlle Lebon (Songs).
 8.30—See Lyons (PTT).
 10.30—Records.
 10.45—Time; News; Programmes.

PRAGUE (Czechoslovakia)

638 kc/s (470.2 m.); 120 kW. Transmits at intervals from 5.15 a.m.
 5.10 p.m.—German Talks.
 5.45—News (German); Records.
 6.0—Time; News; Radio Notes.
 6.15—See Bratislava.
 6.45—"Masaryk"—Sequence.
 7.15-8.55—See Brno.
 8.55—News; Sports.
 9.15—German Lesson; Record.
 9.40-10.0—News and Talk (German).

RADIO EIREANN (Eire)

565 kc/s (531 m.); 100 kW. Dublin, etc. See Sunday.
 1.30 p.m.—Records.
 2.30-3.0—For Schools.
 5.30—Among the Children.
 6.0—St. Finbarr's Pipers Band, Cork.
 6.20—New Talent.
 6.35—Irish News Feature.
 6.45—News.
 7.0—Sonata in G minor (Handel, arr. Pochon) and Trio (Schubert, arr. Rehfeld) by Madalene Mooney, Rosalind Dowse and Chrissie Fagan.
 7.30—Talk by John Gibbons: Irish Pitfalls for English Authors. 7.45—Stella Seaver (Accordion).
 8.0—Irish Radio Orchestra, Conductor: Lieut. D. P. O'Hara; Doreen Hogan (Soprano).
 8.45—Talk by John Mackay: Shady Trees and the Irish Roadside Tree Association.
 9.0—Myra Feis Song Prizewinners.
 9.30—Variety Programme.
 10.30—News.
 11.0—National Anthem.

RADIO-NORMANDIE (France)

1,113 kc/s (269.5 m.); 15 kW.
 6.45 a.m.—Band; Records.
 7.15—News; Press Review.
 7.45—Physical Exercises.
 8.0—Music in the Morning.
 8.15—And all's well—Browning and Starr.
 8.30—Musical Barometer.
 8.45—Jane and John.
 9.0—The Open Road.
 9.15—Around the Shows.
 9.30—A Song and a Guitar.
 9.45—Hildegard.
 10.0—Variety.
 10.30—In Search of Melody.
 10.45—Light Orchestral.
 11.0—Dance Music.
 11.15—Something for Everybody.
 11.30—Debussy and Prokofiev Music.
 12.0 noon—Light Music.
 12.20 p.m.—Scotto Film Music.
 12.45—Radio Journal; News.
 1.0—Concert.

MONDAY (March 14)

2.0-Variety. 2.30-Arthur Young and Friend. 2.45-Beauty and Romance. 3.0-Film Notes; Music. 3.15-Favourites, Old and New. 3.45-Film Rhythm. 4.15-What's on. 4.30-From the Land of Guitars. 4.45-Normandie Playbill - Announcements; Music. 5.0-Blackbirds. 5.15-Bohemian Holiday. 5.30-For Boys and Girls. 5.45-Request Music. 6.0-Markets; Children's Corner. 6.45-Talk; News; Racing. 7.0-Chansonnettes. 7.25-News; Sound News. 8.0-Variety. 9.0-Concert. 11.0-Café Concert. 12.0 m.t.-Melody at Midnight. 12.30-1.0 a.m. (Tuesday) - Dance Music.

RENNES-BRETAGNE

(France) 1,040 kc/s (288.5 m.); 120 kW. Transmits at intervals from 6.30 a.m. 6.45 p.m.-News (English, French). 7.30-To be announced. 8.0-News; Records. 8.30 - "The Letter" - Play (Somerset Maugham); French translation by Carbuccia. After the Play, News; Music.

ROME GROUP (Italy)

Rome (No. 1), 713 kc/s (420.8 m.); 100 kW. Bari (No. 1), etc. See Sunday. Transmits at intervals from 6.45 a.m. 4.0 p.m.-News. 4.15-Tipica Orchestra. 4.50-5.5-Aviation Notes; Poems. 6.0-Talk (French); Royal Geographical Society's Report. 6.20-German Lesson. 6.40-Records. 7.0-Time; News. 7.20-Government Review; Music. 8.0-Excerpts, "Don Gill dalle calze verdi" (Carabella). Conductor: Mancini. 8.50-Radio Notes. 9.0-Brunelli (Cello). 9.45-Dance Music. 10.0-News. 10.15-10.50-Dance Music.

SOTTENS (Switzerland)

677 kc/s (443.1 m.); 100 kW. Relayed by Geneva, 401 kc/s (748 m.). 11.30 a.m.-News. 11.40 - Records; at 12.0 noon, Talk. 12.30 p.m.-Records: Sonatas (Scarlatti) by Landowska (Harpsichord). 4.0-5.0-See Beromünster. 5.0-Jazz Records. 5.20-Esperanto Lesson. 5.30-For Chess Players. 5.50-Talk; Opera. 6.15-Micro-Magazine. 6.50-News; Weather. 7.0 - Bach Music by Montillet (Organ) from the Temple des Eaux-Vives, Geneva. Sonata in C. By the Waters of Babylon. 7.20-Talk; Modern Finance. 7.40-Sasselli Orchestra. 8.15-See Beromünster. 8.30 (from Geneva) - For Swiss Abroad: "Les Cris du Monde" (Honegger) by the Romand Orchestra, the Solothurn St. Cecilia Choir, Berthe de Vigier (Soprano), Lina Falk (Contralto) and Panzéra (Baritone)-Conductor: Schild (Recorded). 9.45-10.15-League of Nations Report.

STOCKHOLM (Sweden)

704 kc/s (426.1 m.); 55 kW. Motala, etc. See Sunday. Transmits at intervals from 6.20 a.m. 5.40 p.m.-Parliamentary Report. 6.0-News. 6.30-English Songs by the Radio Choir. Madrigal, All the World is glad (Benet). It's Oh! to be a wild wind (Elgar). Full fathom five thy father lies (Wood). The foggy dew (Stanford). The Campbells are coming (Mansfield). Fair Phyllis (Farmer). My lovely maiden smiles (German). Bobby Shaftoe (Whitaker). 7.0 - Students Association Discussion from Uppsala: Contemporary Politics. 8.0-Operetta Music. Conductor: Grevillius. Selection, "Giuditta"

(Lehár), "The Desert Song" (Romberg), "Berlinerluft" (Lincke), "Ritter Pasman" (Strauss), "The Geisha" (Jones) and "No, No, Nanette" (Youmans). 9.0-News. 9.15-10.20-Act II, "Tannhäuser" (Wagner) from the Royal Opera, Conductor: Sandberg. Cast: Carl Hartmann, Brita Hertzberg, Conny Molin, Leon Björker, Simon Edwardsen, Sigurd Björking, Olle Strandberg and Gösta Lindberg.

STRASBOURG (France)

859 kc/s (349.2 m.); 100 kW. Transmits at intervals from 6.30 a.m. 5.15 p.m.-Light Orchestral. 6.0-Economic and Social Notes. 6.30-Palette Nathan (Songs) and Wind Ensemble. 7.0-Radio Journal. 7.30-To be announced. 8.0-News (German, French). 8.30-Dramatic Programme by the Groupe de l'Art Social. (a) "A la manière de... Jonas" - Sketch (Millette-Pitch). (b) "M'aime-t-il" - Dialogue (Suzette Desty). (c) "Fausse monnaie" - One-Act Play (d'Herவில்-Cléray). 9.30-See Nice-Côte d'Azur. 10.30-News (French, German).

STUTT GART (Germany)

574 kc/s (522.6 m.); 100 kW. Transmits at intervals from 5.0 a.m. 11.0 a.m.-Concert. 1.0-2.0 p.m.-Records. 3.0-Concert. 5.0-Claudio Arrau (Pfte.), Juan Manén (Violin) and Jelena Reichel (Cello). 5.30-Topical. 6.0-News.

LAST NEWS BULLETINS (daily, but subject to slight alterations)

8.40 Oslo; 8.45, Stockholm; 9.0, German Stations, Prague; 9.10, Vienna; 9.20, Beromünster; 9.45, Bucharest; 9.50, Warsaw; 10.0, Brussels, Italian stations; 10.30, Radio Eireann, Paris (PTT); 10.45, Radio-Paris; 11.5, Budapest 1.

6.15-Variety Concert. 8.0-"In deinem Lager ist Oesterreich" - Radetzky Anniversary Sequence. 9.0-Time; News; Sports. 9.30-Station Orchestra. Conductor: Buschkötter. Abwandlung eines alt-englischen Volksliedes (Dressel). La valse (Ravel). 10.0-Music from Cologne. 11.0 p.m.-1.0 a.m. (Tuesday) - Serenade (Recorded). Impromptu in F sharp (Chopin). Ballad in A flat (Chopin). Pite. Quintet in A (Dvořák). Ballad and Passacaglia (Atterberg). Second Symphony (Sibelius).

TOULOUSE (Radio-Toulouse) (France)

913 kc/s (328.6 m.); 60 kW. Transmits at intervals from 8.0 a.m. 6.0 p.m.-Dance Music. 6.15-Songs. 6.40-Opera Music. Excerpts from "The Damnation of Faust" (Berlioz), "Der Freischütz" (Weber), "Il Trovatore" (Verdi). 6.55-News; Sports. 7.15-Operetta Songs. "Madame l'Archiduc" (Offenbach), "Passionnément" (Messager), "Toi c'est moi" (Simons), "Malvina" (Hahn), "Mariska" (Cazes). 7.45-Light Music. 8.0-Variety. 8.30-Talk; Light Music. 9.10-Talk. 9.15-Accordion Band. 10.0-News. 10.15-English Concert. 11.15-Bal Champêtre. 11.30-Light Music. 11.50-12.0 m.t.-News.

TURIN GROUP (Italy)

Turin (No. 1), 1,140 kc/s (263.2 m.); 7 kW. Milan (No. 1), etc. See Sunday. Transmits at intervals from 6.45 a.m. 4.0 p.m.-News. 4.15-4.50-Rosa Savina (Pfte.). 6.10-Royal Geographical Society's Report. 6.20-7.30-See Rome Group. 7.30-Radio Orchestra; at 7.36 (Rome (No. 2) only) - News (English). 8.0 - "Pianterreno rialzato" - Three-Act Play (Rosso).

9.30 (approx.)-Song Potpourri by the Cetra Orchestra. 10.0-News; Weather. 10.15-10.55-Grassi Dance Band.

VIENNA (Austria)

592 kc/s (506.8 m.); 100 kW. Graz, etc. See Sunday. Transmits at intervals from 5.45 a.m. 3.5 p.m.-Records; Film Music. 3.45-Budapest University Choir. Conductor: Vaszy. Blumenlieder (Veress), Songs (Bartók), Frühling (Liszt), Folk-Song Cycle (Vaszy), Serenade (Demény), The Broad Danube (Bardós), Songs of Karad (Kodály). 4.5 - "Modelled Landscapes" - Eduard Ratzler, Sculptor, interviewed. 4.25-Rachmaninoff Music by Frotzler (Pfte.). Prelude in G sharp minor. Prelude in E flat. Variations on a Chopin Theme. 4.55-Talk: St. Clement Maria Hofbauer and the Pinkafeld Romantic Circle. 5.20-English Lesson by Thomas MacCallum. 5.35-Announcements; News. 5.55-From the State Opera: (a) "Djamiéh" (Bizet), (b) "Ivan Sergejevitch Tarassenko" (Salmhofer). In the interval-Talk by Dr. Joseph Braunstein on the present Production. 9.10-News; Books. 9.30-10.30-Dance Band; at 9.55-News.

WARSAW (Poland)

224 kc/s (1,339 m.); 120 kW. Cracow, etc. See Sunday. Transmits at intervals from 5.15 a.m. 4.15 p.m.-Liszt Music by Sari Hir (Pfte.). Sursum corda. Eglogue. Polanaise (Tchaikovsky-Liszt). Au bord du lac Wallenstein. Hungarian Rhapsody in F minor. 4.50-Sports; Records; Notes. 5.35-Talks. 7.0 - Light Music. Orchestra, Quartet, etc.; at 7.45-News; Topical. 8.40-Literary Review. 9.0-Station Symphony Orchestra. Guest Conductor: Ignaz Neumark. Serenade in E flat for Wind Instruments (Richard Strauss). Variations and Fugue on a Theme of Mozart (Reger). Overture, "Donna Diana" (Rezniczek). 9.50-10.0-News.

TUESDAY Mar. 15

National

For Time Signals, see Monday.

10.15 a.m. (D)-Service. 10.30 (D)-Weather Forecast. 10.45 (D)-Dressmaking talk. 11.0 (D)-Cinema Organ. 11.25 (D)-History for Schools. 11.45 (D)-The Canadian Trio. 12.15 p.m. (D)-"Pixie Led," a fantasy by L. du Garde Peach. 12.55 (D)-Records. 2.5 (D)-For Schools. 4.0 (D)-Englemans Quintet. 4.30 (D)-Records. 5.0-Medvedeff's Balalaika Orchestra: Max Turganoff (Tenor); Gerald Cassen (Bass). 6.0-The First News. 6.25-Reginald Foort (BBC Theatre Organ). 7.0-"Music for Worship;" Gilbert Mills (Organ); BBC Midland Singers and Birmingham Philharmonic String Orchestra. 7.30-"Can Progress be traced in Human History;" H. A. Mess, Ph.D. 7.50-Martini and his Music. 8.0-Walt Disney's "Snow White and the Seven Dwarfs;" broadcasting version, with Wynne Ajello as "Snow White." 9.0-The Third News. 9.20-"America Speaks." 9.40-BBC Orchestra (Section D) conducted by Malcolm Sargent. 10.40-Reading from J. M. Synge. 11.0 - Grosvenor House Dance Band. 11.30-12.0-Dance Records.

London Regional

For Time Signals, see Monday. 10.15-10.45 a.m.-National. 10.45-BBC Northern Ireland Orchestra: Edward Selwyn (Oboe). 11.30-Records of operetta. 12.15 p.m.-MacArthur Quintet. 1.0-Studies from the Russian Masters; Lydia Lopokova. 1.15-Hirsch String Quartet: Op. 56 (Sibelius); in D Op. 64 (Haydn).

2.0-The Wessex Players. 2.45-Pfte. Syncopation. 3.0-Torquay Municipal Orchestra: Winifred Radford (Soprano). 4.0-Short story by Jerome. 4.15-Hungarian Gipsy Party. 5.0-The Children's Hour. 6.0-Victor Olof Sextet. 6.25-Short story. 6.40-Schubert: May Blyth (Soprano). 7.0-The Second News. 7.30-Glasgow Corporation Transport Department Pipe Band. 7.50-The Life of Richard Trevithick. 8.30-BBC Orchestra (Section E) conducted by Clarence Raybould: Dorothea Braus (Pfte.). 9.20-Billy Thorburn's Music. 10.0-News Summary. 10.25-Grosvenor House Dance Band. 11.30-Records of excerpts from "The Magic Flute" (Mozart). 11.50-12.0-Late News Summary.

Midland

10.15 a.m.-6.0 p.m.-Regional. 6.0-Cinema Organ. 6.25-Regional. 7.20-Midland Announcements. 7.30-Hereford Male Voice Society: Roy Henderson (Bass); Norman Franklin (Pfte.). 8.10 - Birmingham Philharmonic String Orchestra. 8.50-"The Gods in the Greenhouse," a Derbyshire play by Edward and Jessie Kaulfuss, presented by The Ashbourne Players. 9.20-12.0-Regional.

Northern

10.15 a.m.-4.0 p.m.-Regional. 4.0-Evening from York Minster. 4.45-Regional. 7.50-Gladys Willis (Pfte.). 8.10 - "The Fashion of these Times;" discussion.

8.55-"After Dinner," with The Three Semis, Violet Carson, Taylor Frame and Alan Holmes's Swing Sextet. 9.20-12.0-Regional.

Western

10.45 a.m.-5.0 p.m.-National. 1.0-Regional. 6.40-A Ravel recital by Moura Lympny (Pfte.). 7.0-Regional. 7.20-Western Announcements. 7.30-Regional. 9.20-The Wessex Players. 10.0-News Summary.

Welsh

10.15 a.m.-6.0 p.m.-Regional. 6.0-BBC Welsh Orchestra. 6.40-Regional. 7.20-Welsh Announcements. 7.30-Welsh News. 7.45-"Anglo-Welsh Authors." 8.0 - Cwm Town Workmen's Band: Roderick Jones (Baritone). 8.45 - Discussion in Welsh on Education. 9.20-12.0-Regional.

N. Ireland

10.15 a.m.-6.25 p.m.-Regional. 6.25 - "Irish Highwaymen and Tories"-Nece O'Haughan." 6.40-Regional. 7.20-Northern Ireland News. 7.30-Regional. 8.30-BBC N. Ireland Orchestra: Frederick Stone, May Curran (Pftes.); Mozart, Saint-Saëns. 9.20-12.0-Regional.

Scottish

10.15-11.0 a.m.-National. 11.0-For Schools. 11.25-2.0 p.m.-National. 2.0-For Schools. 2.25-Herring Bulletin. 2.30-For Schools. 3.0-Songs. 3.20-Records. 3.45-Gaelic Songs. 4.0-5.0-National. 5.0-The Children's Hour. 6.0-Variety by new artists. 6.25-Regional. 7.20-Scottish Announcements. 7.30-Regional. 8.30-"Backstage at Bellahouston. 8.45-"Glenara;" a ballad for tenor solo, chorus, and orchestra by W. B. Moonie. 9.20-12.0-Regional.

Hours of Transmission in Greenwich Mean Time.

BERLIN (Germany)

841 kc/s (356.7 m.); 100 kW. Transmits at intervals from 5.0 a.m. 11.0 a.m.-1.0 p.m.-See Munich; at 12.0 noon-Midday Echoes. 1.0-News. 1.15-Berlin Opera Preview. 2.0-Fierce Band. 3.0-See Königsberg. 4.30-Report: The Discovery of a New Planet. 4.50-Books. 5.0-Libiszowski Band. 6.0-News; Topical. 6.10-Fierce Band. Mein Ideal (Blon). Liebesserenade (Löhr). Canzonetta (Buchholz). Capriziöser Walzer (Richardt). Ungarwein (Friedl). Episode (Steiner). Rusticanelle (Cortopassi). 6.45-Evening Echoes. 7.0-Merry Music by the Jahn Band. 8.0-Old Festival and Dance Music. Conductor: Willy Steiner. 9.0-News. 9.30-Light Music. 9.45-11.0-See Hamburg.

BEROMÜNSTER

(Switzerland) 556 kc/s (539.6 m.); 100 kW. Relayed by Basle and Berne, 1,375 kc/s (218.2 m.). 5.30-5.50 a.m. (from Basle)-Gym. 9.20-9.50-For Schools. 11.0-Records. 11.29-Time; News; Exchange. 11.40 a.m.-12.45 p.m.-Records. 3.0-Book Review: Kurt Goetz. 3.20-Swiss Songs by a Berne Girls' Choir. 3.35-Orchestral Records. 4.0-5.0-See Sottens. 5.0-Records of Village Bands. 5.15-A Hat Factory visited. 5.45-Lanigiro Band. 6.25-League of Nations Report from Geneva. 6.40-Announcements; News. 6.55-A Concert Conductor interviewed. 7.10-Talk on the following Concert. 7.15-Basle Music Society's Symphony Concert from the Musiksaal. Conductor: Hans Münch. 9.10-Reading (Rita Eckenstein). 9.25-News Programmes.

BRATISLAVA

(Czechoslovakia) 1,004 kc/s (298.8 m.); 13.5 kW. Transmits at intervals from 5.15 a.m. 7.30 p.m.-Slovak Soldiers' Songs from Kosice. 7.55-See Brno. 9.0-See Prague. 9.15-News in Hungarian. 9.30-10.0-Records.

BRESLAU (Germany)

950 kc/s (315.8 m.); 100 kW. Relayed by Gleiwitz and Görlitz, 1,231 kc/s (243.7 m.). Transmits at intervals from 4.30 a.m. 11.0 a.m.-1.0 p.m.- (from Görlitz)-Bunzlau Municipal Orchestra. Conductor: Arndt; at 12.0 noon-Time; News. 1.0-News; Exchange. 1.15-2.0-See Hamburg. 2.30-Songs for Children. 3.0-Concert for Schools. Station Orchestra. Conductor: Prade. Grohmann and Krömer (Violins); at 4.0-4.10-Reading. 5.0-Recitations to Music: "Die Fiddeliieder" (Theodor Storm). 5.30 - "Lazy Greta and Big Bertha" - the Nicknames of famous Cannons. 5.45-For Farmers; Programmes. 6.0-News; Markets; Records. 6.20-Talk: Renaissance and Reformation Period Art. 6.40-Pfte. Music. 7.0-Zenke (Organ) and Palmedo (Violin). 7.50-Motto. 8.0-Dance Music from Cologne. 9.0-News. 9.20-Political Press Review. 9.35-Music. 9.45-10.30-See Hamburg.

BRNO (Czechoslovakia)

922 kc/s (325.4 m.); 32 kW. Transmits at intervals from 5.15 a.m. 7.25 p.m.-Songs (Bendl) by the "Opus" Male Voice Choir. 7.50-See Prague. 7.55-Revue on Records. 9.0-See Prague. 9.15-10.0-Dance Revue. In the interval, Knechtberger (Pfte.).

BRUSSELS (No. 1)

(Belgium) 620 kc/s (483.9 m.); 15 kW. 6.30-9.0 a.m.-Records; Gym; News.

12.0 noon—Messenger Records.
 12.30 p.m.—Shipping; Brenders Jazz Band.
 1.0—News.
 1.10—Brenders Jazz Band.
 1.30—Records of Belgian Singers.
 2.0-2.45—Art Notes; For Schools.
 4.55—News.
 5.0—Records: "Antar" (Rimsky-Korsakov).
 5.30—For Children.
 6.5—Literary Review.
 6.15—Songs (Joseph Ryelandt), by Marguerite Thys.
 6.30—Divertissement in the Style of Louis XV (Tailleferre). Oracion del Torero (Turina).
 6.45—"L'Offrande Lyrique"—Song Cycle (Jean Cras) to Poems of Rabindranath Tagore, sung by Marguerite Thys.
 7.0—Roman Catholic Review; Film Review.
 7.15—"Ma Mère" (Ribaux), with Schubert and Mendelssohn Music.
 7.30—News.
 8.0—"The Art of Fugue" (Bach, arr. Graeser) Symphony Orchestra. Conductor: André Rachal Thuavoy and Van Lancker (Harpichords), and Hens (Organ); at 9.0-9.15—Extracts from an Address on Cardinal Mercier, by Mgr. Grete of the Académie Française.
 10.0—News; Records.
 10.55-11.0—Christus vincit (Liszt).

BRUSSELS (No. 2) (Belgium)

932 kc/s (321.9 m.); 15 kW. Programme in Flemish.
 6.30-9.0 a.m.—Records; Gym; News.
 12.0 noon—Records.
 1.0—News; Shipping; Records.
 2.0-3.15—For Schools.
 4.55—News.
 5.0—Brenders Jazz Band.
 5.45—For Children.
 6.30—Records; Talk.
 7.0—Records. Schubert Potpourri (Melichar) Song, Kijk niet naar de heeren (Holländer). Selection, "The Bayadere" (Kálmán). Song, "Poet and Peasant" (Suppé). Potpourri (Grothe).
 7.30—Art Notes with Livina Caroly-Vos, Lia Martin (Songs), Pierre Boyen (Comedian), De Groodt (Mandoline) and the Radio Orchestra. Conductor: Douliez.
 8.45—Report: "The Workers' Touring Club."
 9.0—Variety (contd.).
 10.0—News.
 10.10-11.0—Request Records.

BUCHAREST (Romania)

823 kc/s (364.5 m.); 12 kW. Relayed by Radio-Romania, 160 kc/s (1,875 m.).
 Transmits at intervals from 4.30 a.m.
 4.20 p.m.—Berlioz Records.
 5.0—Science Talk.
 5.35—Trio in B flat (Beethoven).
 5.45—To be announced.
 6.0—Ventura and Cavadia Songs sung by Aurel Alexandresco.
 6.25—Violin Concerto in D (Mozart) by Yehudi Menuhin (Violin) and Orchestra. Conductor: Enesco (Recorded).
 6.55—Educational Talk.
 7.15—Sacred Concert from the Athenaeum. "Carmen" Choir and Radio Orchestra. Part I. "Requiem" (Fauré).
 8.0—News; Sports.
 8.15—Sacred Concert. Part II. "Stabat Mater" (Pergolesi).
 9.5—Records: Light Music.
 9.45—News (French, German).

BUDAPEST (No. 1) (Hungary)

546 kc/s (549.5 m.); 120 kW. Transmits at intervals from 5.45 a.m.
 11.30 a.m.—Opera Orchestra. Conductor: Rajter; at 12.15 p.m.—Poems.
 1.0—Records.
 2.0—Ernö Fonyad.
 2.30—Children's Choir.
 3.10—Gyula Halász.
 3.30—Station Band.
 4.45—Talk: Ethnography.
 5.15—Lecture-Recital with the Bura Cigány Band: Hungarian Music.
 6.30—Gala Programme from the Opera: (a) "Székelyfő" — Singspiel (Kodály), (b) "Scenes from the Czardas" — Ballet on Themes of Hubay; (c) "Pester Karneval" — Ballet on Themes of Liszt; at 8.0 and 8.55—News.
 9.0—Pertis Cigány Band.
 10.0—Military Band.
 11.5—News.

BUDAPEST (No. 2) (Hungary)

359.5 kc/s (834.5 m.); 18 kW.
 5.15 p.m.—For Farmers.
 5.45—French Lesson.
 7.25—Records.

COLOGNE (Germany)

658 kc/s (455.9 m.); 100 kW. Transmits at intervals from 5.0 a.m.
 11.0 a.m.-1.0 p.m.—See Munich.
 1.0—News; Riddles; Markets.
 2.0—Dialect Programme with Music.
 2.30—Review: War Books.
 2.45—Markets.
 3.0—See Deutschlandsender.
 4.0—Variety.
 5.0—Suite in G (Tchaikovsky) by the Station Orchestra. Conductor: Kühn.
 5.30—English Talk; Snapshot.
 6.0—News.
 6.10—Report: The German Gymnastic and Sports Festival, Breslau.
 6.15—Viennese Music. Conductor: Kühn. Military March (Schubert). Minuet (Mozart). Waltz, Die Romantiker (Lanner). Pieces (Strauss): (a) Overture, "Cagliostro in Wien," (b) Donauweibchen, (c) Intermezzo, "The Arabian Nights," (d) Excerpts, "The Gipsy Baron." Waltz, Wiener Bürger (Ziehrer).
 7.10—Film Notes.
 7.30-11.0—Gala Ball from the Rheinhotel Dreesen, Bad Godesberg; at 9.0-9.15—News.



Cardinal Mercier, to whom Brussels No. 1 devotes its 9 p.m. broadcast

DEUTSCHLANDSENDER (Germany)

191 kc/s (1,571 m.); 60 kW. Transmits at intervals from 5.0 a.m.
 11.0 a.m.-12.45 p.m.—See Stuttgart; 11.55—Time; and at 12.0 noon—Greetings.
 12.45—News.
 1.0—Jäger Band and Records.
 2.0—Exchange; Markets; Records.
 2.40—Books; Programmes.
 3.0—Light Music—Station Orchestra; at 4.0-4.10—Talk.
 5.0—A Story.
 5.10—Chamber Music (Recorded). Lily Weiss and Lotte Selka (Violins), Edith Steinbauer (Viola) and Frieda Krause (Cello). Quartet (Haydn). Quartet in G (Mozart).
 5.55—Genealogy.
 6.0—Motto; News; Weather.
 6.10—"Hand on Heart"—Variety with the Albrecht Band, Else Kochhann, Mühlen and Voelkner.
 7.0—"Light Music"—Station Orchestra. Conductor: Dobrindt.
 7.45—Political Press Review.
 8.0—See Rome group.
 9.25—News.
 10.0-11.0—Dance Music from Cologne.

FRANKFURT (Germany)

1,195 kc/s (251 m.); 25 kW. Cassel, etc. See Sunday.
 Transmits at intervals from 5.0 a.m.
 11.0 a.m.-1.0 p.m.—See Munich.
 1.0—Time; News; Records.
 2.0—Weekly Picture Book; Talk.
 2.45—Monthly Review of World Economics.
 3.0—Station Orchestra.
 4.0—Winter Relief Fund Request Concert by a Labour Service Band.
 5.0—Topical.
 5.30—"Germany's History in her Songs" (arr. Jank).
 6.0—Time; News.
 6.10—"German Proverbs"—Sequent to Music of Haydn. Station Choir. Conductor: Bruchhaus.
 7.0—Station Orchestra. Conductor: Frickhoffer, Lueder (Pfte.). Sinfonia in B flat (Haydn). Pfte. Concerto in A minor (Schumann).
 8.0—Italian Music Old and New, by the Gruppo strumentale of Venice. Conductor: Gatti. Sonata for Oboe, String Quartet and Harpsichord (Marcello).

Quintet for Flute, Oboe, Viola, Cello and Harp (Rota). Music for a Ballet for Strings and Wind Instruments (Mortari). Divertimento for Wood-Wind Quintet, Viola, Cello and Harp (Lupi). Divertimento for Eight Instruments (Gorini).
 9.0—Time; News.
 9.30—Music.
 9.45—See Hamburg.
 11.0 p.m.-1.0 a.m. (Wednesday)
 —Serenade on Records. Overture, "Notre Dame" (Schmidt). Pfte. Concerto in B flat (Brahms). Eroica Symphony (Brahms).

HAMBURG (Germany)

904 kc/s (331.9 m.); 100 kW. Bremen, etc. See Sunday.
 Transmits at intervals from 5.10 a.m.
 11.0 a.m.—Bremen Stadtmusikanten and Meta Köhler (Soprano).
 12.5 p.m.—Topical.
 12.15—Orchestra from Munich.
 1.0—News.
 1.15—Light Music.
 2.0—Shipping; Markets.
 2.25—Chamber Music by Stauch (Pfte.). Goetschel (Violin), and Steinhage (Cello).
 2.50—Ice Report.
 3.0—Station Orchestra. Jakschat (Baritone). In the interval, Books.
 4.15—"How to be rich and happy"—A Word for the Discontented.
 5.0—"Buur un Fischer, Bäcker un Discher"—Dialect Picture Book (arr. Tenne). Station Orchestra. Conductor: Girnatis. Songs. Pfte., Speakers, etc.
 5.45—Weather; Harbour Notes.
 6.0—News.
 6.10—"Perpetuum mobile"—Potpourri with the Station Choir, Orchestra, and Dance Band.
 8.0—See Rome group.
 9.30—News.
 9.45-11.0—Light Music and Dance Music.

HILVERSUM (No. 1) (Holland)

160 kc/s (1,875 m.); 10 kW until 4.40 p.m.; 150 kW from 4.40 p.m. Also on Jaarsveld. 722 kc/s (415.4 m.); 17 kW.
 AVRO Programme.
 7.40 a.m.—Time; Records.
 9.40—Service; Records.
 10.10—Jetty Cantor Orchestra.
 10.40—Cookery Talk.
 11.10—AVRO Orchestra, Georg Robert (Organ) and Mrs. M. Struycken v. d. Adel (Soprano).
 11.55—Jetty Cantor Orchestra.
 12.40 p.m.—AVRO Orchestra. Conductor: Treep.
 1.25—Records.
 1.40—AVRO Orchestra. Conductor: Treep. Rie Beute (Pfte.).
 2.25—Dressmaking Lesson.
 3.25—Lou Biloen (Violin).
 4.10—AVRO Children's Choir. Conductor: Hamel.
 4.40—For Children.
 5.10—Aeolian Orchestra.
 5.55—Renova Quintet.
 6.40—For Children.
 6.45—Poltronicer Quartet.
 7.10—English Lesson.
 7.40—Time; News; Recordings.
 8.10—"Tuesday Night Special"—Variety. AVRO Vaudeville Orchestra. Conductor: Mossel. Rie Hellmig (Songs), Guido Giardini (Flute), Bruno Hoffmann, Mischa Motte, Clinge Dorenbos, B. Veldkamp and C. Veldkamp.
 9.10—Choir.
 9.40—Variety; Records.
 10.40—News.
 10.50-11.40—Gipsy Music.

HILVERSUM (No. 2) (Holland)

995 kc/s (301.5 m.); 15 kW until 6.10 p.m.; 60 kW from 6.10 p.m.
 7.40 a.m.-3.40 p.m.—KRO Programme.
 7.40-8.55—Records.
 9.40—Records.
 11.10—Religious Address.
 11.40—Police Messages; Weather.
 11.55—KRO Melodists; Records.
 1.40—For Women.
 2.40—Dressmaking Lesson.
 3.40-4.50—HIRO Programme.
 3.40—Records; Talk.
 4.10—Records; HIRO Notes.
 4.20—Records; Talk.
 4.50 till Close—KRO Programme.
 4.50—KRO Melodists, Klein (refrains).
 5.25—Greetings.
 5.45—KRO Orchestra. Conductor: Reinards.
 6.20—Esperanto Lesson.
 6.40—Police Messages.
 6.55—KRO Orchestra (contd.).
 7.15—Sports Talk.
 7.40—News; KRO Notes.
 7.55—Lenten Service.
 9.10—Maastricht Municipal Orches-

TUESDAY (March 15)

tra. Conductor: Hermans; Dahmen (Violin). Divertimento (Trapp). Violin Concerto in E (Mendelssohn). Academic Festival Overture (Brahms).
 10.10—News.
 10.20—KRO Orchestra. Conductor: Reinards. Overture, "Figaro" (Mozart). Minuet in G (Beethoven). Ballet Music, "Rosamunde" (Schubert). Die Schönbrenner (Lanner). Buona sera, signorita (Stolz). You are my Heart's Delight (Lehár). Selection, "Zigeunerprimas" (Kálmán).
 11.10-11.40—Records.

KALUNDBORG (Denmark)

240 kc/s (1,250 m.); 60 kW. Relays Copenhagen, 1,176 kc/s (255.1 m.).
 Transmits at intervals from 6.0 a.m.
 11.0 a.m.-1.0 p.m.—Preil's Ensemble.
 1.30—Radio Orchestra. Conductor: Grøndahl. March, Alte Kameraden (Teike). Fantasia on Swedish Folk Songs and Dances (van Eysden). Paraphrase on Hungarian Folk Melodies (Padouk). Russian Dance in A (arr. Grøndahl). Norwegian Folk Song (arr. Halvorsen). Vienna, City of my Dreams (Siczynski). Finnish Cavalry March. Overture, "Banditenstreiche" (Suppé). Excerpt, "The Violin-Maker of Cremona" (Hubay). Suite, "The Sleeping Beauty" (Tchaikovsky). Venetian Serenade (Svendsen). Aftensang (Hansen). Gallop (Lincke); at 2.20—Reading.
 3.30—For Children; Notes.
 4.0—Talk: A Woman's Point of View.
 4.25—Weather: Exchange; Markets.
 4.50—Excerpts, "On Wings of Song."
 5.15—Talk.
 5.35—German Lesson.
 6.0—News.
 6.30—Talk: The Fishing Industry.
 7.0—A Film Première.
 7.30—"Inspector Hornleigh Investigates"—Sketch (Priwin), trans. Meyer.
 7.50—Talk on the following Programme.
 8.0—See Rome Group.
 9.25—News; Weather.
 9.45—Radio Orchestra. Conductor: Tuxen. Pfte. Concerto (Koppel) with the Composer (Pfte.). Excerpts, "The Tuppenny Halfpenny Opera" (Weill).
 10.15-11.30—Preil's Dance Band; at 11.0—Chimes.

KÖNIGSBERG (Heilsberg) (Germany)

1,031 kc/s (291 m.); 100 kW. Relayed by Danzig, 1,303 kc/s (230.2 m.).
 Transmits at intervals from 5.0 a.m.
 11.0 a.m.-1.0 p.m.—See Munich.
 1.0—News; Talk; Music.
 1.55-2.0—Exchange.
 2.30—For Women.
 2.40—Fairy Tales and Songs.
 3.0—Station Orchestra, Flute.
 5.0—Merry Songs and Idylls.
 5.25—Short Stories (Nikolaus von Jeroschin).
 5.50—Local News.
 6.0—News.
 6.10—Dance Music—Station Orchestra. Börschel Band and Soloists.
 7.40—Topical.
 8.0—See Rome group.
 9.25—News.
 9.45—Political Press Review.
 10.0-11.0—Serenade on Records.

LAHTI (Finland)

166 kc/s (1,807 m.); 150 kW. Relays Helsinki, 895 kc/s (335.2 m.).
 Transmits at intervals from 7.0 a.m.
 3.0 p.m.—Robert v. Essen Ensemble. Viennese Potpourri (Hrubý). Prelude (Fanchery). Lyric Waltz (Sibelius). Berceuse (Rimsky-Korsakov). Réves en fleurs (Lederer). Crépuscule (Schroder). A Lobau (Uhl).
 4.0—Talk for Farmers.
 4.20—Kyllikki Solanterä (Songs).
 4.40—Records.
 5.15—Astronomy Report.
 5.40—Recitations.
 6.25—Talk: America.
 6.40—Radio Orchestra. Conductor: Haapanen, Karolyi (Pfte.).
 8.10—Report: The Finland v. Estonia Boxing Match.
 8.25—Records: Dance and Light Music.
 9.30-10.0—Concert on Records.

LEIPZIG (Germany)

785 kc/s (382.2 m.); 120 kW. Relayed by Dresden, 1,285 kc/s (233.5 m.).
 Transmits at intervals from 5.0 a.m.
 11.0 a.m.-1.0 p.m.—See Munich.
 1.0—News; Exchange; Records.
 2.20—Talk; Books.
 3.0—Leipzig Chamber Orchestra; at 4.0-4.10—Markets.
 5.0—Talk; Music; Reading.
 5.45—Music; Topical.
 6.0—News.
 6.10—"Tempo"—Verses, Songs and Music (arr. Duvinéau and Munkel) with Edith Hasselmann (Soprano), Göpel (Baritone), Else Pfaff (Speaker) and the Fricke Band.
 7.45—"Ein Traumspiel vom Leben"—Play (Bauer).
 9.0—News; Art Notes.
 9.35—Sonata in D minor (Szymanowski) by Meta Heuser (Pfte.) and Willy Heuser (Violin).
 10.0-11.0—Music from Hamburg.

LILLE (Radio PTT Nord) (France)

1,213 kc/s (247.3 m.); 60 kW. Transmits at intervals from 6.30 a.m.
 7.0 p.m.—Records.
 7.30—Radio Journal; Weather.
 8.0—See Paris (PTT).
 8.30—Station Orchestra. Conductor: Soret. Germaine Dauphin (Songs) and Roberville (Baritone). Overture, "Iphigénie en Aulide" (Gluck). Overture, "Fervaa" (d'Indy). The Unfinished Symphony (Schubert). Songs from: (a) "Marouf" (Rabaud), (b) "La Rôtisserie de la Reine Pédauque" (Lévaé), (c) "La Dame blanche" (Boieldieu). Excerpts from "A Midsummer Night's Dream" (Mendelssohn). Excerpts, Suite Algérienne (Saint-Saëns). Excerpts, "Shylock" (Fauré). Ballet Music, "Le Cid" (Massenet). Songs: (a) Si tu savais (Ackermans), (b) Tanianouska (Ackermans), (c) La promenade du paysan (Dupont). Caucasian Sketches (Ippolitov-Ivanov). Feux follets et Gnomes (Hofmann). Napoli from Impressions d'Italie (Charpentier). Suite (Tchaikovsky). Overture, "St. Paul" (Mendelssohn). After the Concert, News.

LYONS (PTT) (France)

648 kc/s (463 m.); 100 kW. Transmits at intervals from 6.30 a.m.
 6.30 p.m.—Notes; Records.
 7.30—News; Talks; Record.
 8.30—See Paris (Eiffel Tower).
 10.30—News (French, German).

MONTE CENERI (Switzerland)

1,167-ke/s (257.1 m.); 15 kW. Transmits at intervals from 11.0 a.m.
 6.50 p.m.—News.
 7.0—To be announced.
 7.10-9.25—See Beromünster.
 9.30 (approx.)—See Rome Group.

MOSCOW (No. 1) (Russia)

172 kc/s (1,744 m.); 500 kW.
 4.30 p.m.—Music and Literature.
 8.30—News; Kremlin Chimes.
 9.0—Talks (Dutch, Swedish).
 11.0-12.0 m.t.—Talks in Spanish.

MUNICH (Germany)

740 kc/s (405.4 m.); 100 kW. Relayed by Nürnberg, 1,267 kc/s (236.8 m.).
 Transmits at intervals from 5.0 a.m.
 11.0 a.m.-1.0 p.m.—Station Orchestra and Schrammel Ensemble.
 1.0—News; Exchange.
 1.15—See Hamburg.
 2.0-2.30—For Children.
 3.0—Soprano, Baritone and Pfte.
 3.40—Readings.
 4.0—Time; Weather; Markets.
 4.10—Station Orchestra. Conductor: Schwarz. Maria Weiss (Soprano), Lohmann (Trumpet), Oertel (Pfte.), Speakers, etc. In the intervals, Sketches.
 5.50—Anniversaries.
 6.0—Time; News.
 6.10—Military Band.
 7.0—To be announced.
 7.50—Talk on the following Programme.
 8.0—See Rome Group.
 9.25—Time; News.
 9.45-11.0—See Hamburg.

NAPLES GROUP (Italy)

Naples, 1,104 kc/s (271.7 m.); 10 kW. Florence (No. 1), etc. See Sunday.
 6.0 p.m.—Light Music; Topical.

TUESDAY (March 15)

6.20—Instrumental Records.
7.0-7.30—See Rome Group.
7.30—Band. Conductor: Arlandi. Military March (Mascagni). Mazurka (Tarditi). Waltz, Magic Lantern (Kneip). Polka (Ferrari). Pasodoble (Mildiego).
8.0—"Snow White and the Seven Dwarfs," from London (National).
9.0—Dance Music.
10.0—News.
10.15-10.55—Dance Music.

OSLO (Norway)

260 kc/s (1,153.8 m.); 60 kW. Fredrikstad, etc. See Sunday. Transmits at intervals from 9.30 a.m.
4.15 p.m.—Café Concert.
5.15—For Women.
5.45—News; Press Review.
6.20—Norwegian Folk-Music—Aslag Sørle (Songs) and Kjerland (Hardanger Fiddle).
6.45—Talk: Careers.
7.0—Opera Music—Station Orchestra. Conductor: Kramm. Excerpts. "Faust" (Gounod), "The Bartered Bride" (Smetana), "Die Königsinder" (Humperdinck) and "Tosca" (Puccini).
8.0—Talk: Film Music.
8.40—News; Topical Talk.
9.15-9.45—Norwegian and Swedish Music—Station Orchestra. Conductor: Kramm.

PARIS (Eiffel Tower)

(France)

1,456 kc/s (206 m.); 7 kW. Transmits at intervals from 6.30 a.m.
8.0 p.m.—Ginette Doyen (Pfte.), Casadesu (Violin). Romance in F (Beethoven). Pfte. Sonatina (Hahn). Violin Pieces (Casadesu). (a) Minuet after Guignon, (b) Tambourin after Guillemin.
8.30 (also for Bordeaux-Lafayette, Lyons (RTT) and Montpellier (PTT))—Symphony Concert by the National Orchestra. Conductor: Inghelbrecht. Ricardo Vines (Pfte.). First Symphony (Balakirev). Fantasia for Pfte. (Aubert). Symphonic Suite, La belle au bois dormant (Silver). Iberia (Albeniz).
10.30—Records.
11.0—News; Weather.

PARIS (Poste Parisien)

(France)

959 kc/s (312.8 m.); 60 kW. Transmits at intervals from 7.10 a.m.
12.0 noon—Exchange; Records.
12.25 p.m.—News; Exchange; Records.
1.0—"La course au trésor," with Pierre Dac.
1.18—Amusement Guide; Records.
2.0—Exchange; News.
3.45 and 4.35—Exchange.
5.0—News; Classical Records.
6.0—Exchange; News.
6.10—Religious Notes.
6.20—Hahn Records.
6.55—For Young People.
6.58—Racing; Topical; Sports.
7.10—Amusement Guide.
7.13—Film Notes.
7.43—Gino Bordin.
7.58—Talk; Topical.
8.10—Ady Rosner Jazz Band.
8.45—"La bonne histoire."
8.55—News.
9.0-12.0 m't.—To be announced.

PARIS (PTT) (France)

695 kc/s (431.7 m.); 120 kW. Transmits at intervals from 6.30 a.m.
5.0 p.m.—Francisco Alfonso (Guitar).
5.15—Records: Fantasia in C (Schubert) by Adolph Busch (Violin) and Rudolph Serkin (Pfte.).
5.45—Music Talk by Dumesnil.
6.0—Talk; Report.
6.30—Pierre Marty (Songs).
6.45—Marguerite Myrtil (Songs). Songs from Dans la maison (Haudebert).
7.0—Radio Journal; News.
8.0—Mlle Tant Mieux and M. Tant Pis.
8.30—"Monsieur Beaucaire" (Messenger). Conductor: Labis.
10.30—News; Records.

PARIS (Radio-Paris)

(France)

182 kc/s (1,648 m.); 80 kW.
6.28 a.m.—Programmes; Records.
6.40—Time; News; Gym; Records.
7.15—News; Records.
8.0-9.20—Time; News; Records.
10.15—Programmes; Records.
10.45—Reading; Records.
11.45—Markets; Exchange.

12.0 noon—Jewish Talk.
12.20 p.m.—Humour in Music—Cantrelle Orchestra.
1.0—Time; News; Exchange.
1.30—Peyron (Songs).
1.45—Cantrelle Orchestra.
2.0—Programmes; Talk; Poets.
2.25—Talk; Exchange; Markets.
2.45—Mme Claviv-Marius (Pfte.).
3.0—Yvonne Aubert (Songs).
3.15—Political Press Review.
3.30—Talk: Folklore and Literature.
3.45—Exchange.
4.0—Maryse de Pommerol (Songs).
4.15—Hauschild (Songs).
4.30—English Lesson; Markets.
5.0—Ellis Orchestra. Overture, "The Magic Flute" (Mozart). Ballet, "Lakmé" (Delibes). Symphonic Prelude (Sporck). Scherzo-Valse (Chabrier). Diverstissement (Ibert). Berceuse (Ellis). Overture, "Mozart" (Hahn). On the Road to the Alhambra (Turina). Bacchanal.

6.0—Educational.
6.30—Racing; English Books.
6.45—Talk: French Folklore.
6.58—Programmes; Educational.
7.30—Talks.
7.59—Time; Home Affairs.
8.8—Foreign Affairs.
8.15—"La Lumière"—Four-Act Play (Duhamel); at 9.30—News; Press Review.
10.15—Chamber Music arranged by the "Société des Instruments Anciens," and Lise Daniels (Songs). Ballet de la reine (Monsigny). Viola da gamba: Sérénade pour Infante (Dalayrac). Songs (Couperin, Rameau). Rondo for Harpsichord (Rameau). Pastorale variée (Mozart). Songs (Clément, Monsigny). Le jardin des amours (Mouret); at 10.45—Time; News.
11.30—Programme Notes.

PRAGUE (Czechoslovakia)

638 kc/s (470.2 m.); 120 kW. Transmits at intervals from 5.15 a.m.
4.30 p.m.—Sonata for Violin and Pfte. (Axman).
5.0—Markets.
5.10—German Talk and Songs.
5.45—News and Review (German).
6.0—News.
6.15—Songs and Dances of the Nations from Moravska-Ostrava.
7.10—Talk.
7.15-9.0—See Stuttgart.
9.0—News.
9.15—See Brno.
10.0-10.15—News (English).

RADIO EIREANN (Eire)

565 kc/s (531 m.); 100 kW. Dublin, etc. See Sunday.
1.30 p.m.—Records.
2.30-3.0—For Schools.
3.30—Homeworks for Women.
5.45—"St. Patrick"—Play in Verse produced by Ursula White.
6.10—Sean Neeson (Songs) and Geraldine Neeson (Pfte.).
6.35—Irish News Feature.
6.45—News.
7.0—Unemployed Musicians' Brass and Reed Band and Singer.
8.0—Talk by Kathleen Mackay: Bird Watching.
8.15—Song and its Story by Jean Nolan.
8.45—Where your Light comes from—An Electric Supply Board Programme.
9.20—Vincent J. Walker (Mouth Organ).
9.30—Variety Programme.
10.30—News.
10.45—Talk by Mlle S. Kemeny: Hungarian National Independence Day.
11.0—National Anthem.

RADIO-NORMANDIE

(France)

1,113 kc/s (269.5 m.); 15 kW.
6.45 a.m.—Band; Records.
7.15—News; Press Review.
7.45—Physical Exercises.
8.0—Charlie Kunz with Judy Shirley and George Barclay. Compère: Ralph Truman.
8.15—Jane and John.
8.30—Contrasts.
8.45—Music from the Movies.
9.15—Davy Burnaby; Variety.
9.45—Waltz Time—Billy Bissett's Orchestra, with Hugh French, Esther Coleman and the Waltz Timers.
10.0—Crystal Gazing.
10.15—The Open Road.
10.30—Popular Music.
10.45—Shower of Notes.
11.0—Leisure at Eleven.
11.15—Something for Everybody

11.30—Light Music.
12.0 noon—Concert.
12.45 p.m.—Radio Journal; News.
1.0—Concert.
2.0—Variety; Light Fare.
2.45—Beauty and Romance.
3.0—Oliver Kimball.
3.15—Musical Mirror.
3.30—The Magic Carpet.
4.0—Song Hits by Harry Woods.
4.15—Organ Interlude.
4.30—Continental Dance Music.
5.0—Two and a Piano.
5.15—For Boys and Girls.
5.30—Paul Oliver, Olive Palmer.
6.0—Children's Corner.
6.45—Talk; News; Racing.
7.0—Light Music.
7.25—Radio Journal; News.
7.50—Variety Items.
8.0—Records of Annette Lajon.
8.20—Variety.
9.0—Marjal and Company.
11.0—Café Concert.
12.0—Melody at Midnight.
12.30-1.0 a.m. (Wednesday)—Dance Music.

RENNES-BRETAGNE

(France)

1,040 kc/s (288.5 m.); 120 kW. Transmits at intervals from 6.30 a.m.
6.30 p.m.—The Jupiter Symphony (Mozart). Conductor: Henderick.
7.30—Radio Journal.
7.30—Light Music from Limoges (PTT).
8.0—News; Amusements; Records.
8.10—Talk: The History of Brittany.
8.30—Variety from Nantes.
10.30-11.0—See Paris (PTT).

REYKJAVIK (Iceland)

208 kc/s (1,442 m.); 16 kW. Transmits at intervals from 11.0 a.m.
8.10 p.m.—Weather (Icelandic, German, English).
8.20—Parliamentary Notes.
8.40—News; Foreign Affairs.
9.15—Reading.
9.45—Domestic Science.
10.0—Brahms-Tchaikovsky Concert.

ROME GROUP (Italy)

Rome (No. 1), 713 kc/s (420.8 m.); 100 kW. Bari (No. 1), etc. See Sunday.
Transmits at intervals from 6.45 a.m.
4.15 p.m.—Pina Pitini (Pfte.). Concerto in D minor (Vivaldi). Humoresque (Nordio). Prelude on Gregorian Themes (Respighi). Il prode Anselmo (Ferrari-Trecate).
4.50-4.55—Aviation; Morse.
5.45—Talk: Infant Welfare.
6.0-6.20—Talk (English).
6.30—See Turin Group.
7.0—News; Talk; Music.
8.0 till Close—Programme from La Scala, Milan. Conductor: Marinuzzi. Chorus Master: Veneziani.
8.0—"Cavalleria rusticana" (Mascagni). Cast: Ebe Stignani, Beniamino Gigli, Ettore Nava.
9.30 (approx.)—"L'Impresario in angustie" (Cimarosa). Cast: Margherita Carosio, Vittoria Palombini, Nadia Kovacewa, Luigi Fort, Salvatore Baccaloni, Vincenzo Bettoni. In the interval, Talk. After the Programme, News.

SOTENS (Switzerland)

677 kc/s (443.1 m.); 160 kW. Relayed by Geneva, 401 kc/s (748 m.).
11.29 a.m.—12.45 p.m.—News;
4.0—Radio Suisse romande Orchestra. Conductor: Haug. Excerpts, "The Italian Girl in Algiers" (Rossini). Selection, "Aida" (Verdi). Aux étoiles (Duparc). Le Rouet d'Omphale (Saint-Saëns). Suite algérienne (Saint-Saëns).
5.0—Talk: The Hands.
5.20—Suisse romande String Orchestra. Conductor: Appia. Moser (Pfte.). Suite, Saint Paul (Holst). Variations on a Tchaikovsky Theme (Arensky). Four Dances (Niemann). Suite (Olsen).
6.0—Theatre Notes.
6.10—What history teaches us.
6.20—Medical Talk.
6.30—Music.
6.50—News.
7.0—"Le roman d'un jeune homme pauvre"—Five-Act Play (Feuillet) by the Compagnie des Deux-Masques.
9.0-10.0—Mozart Concert—Radio Suisse romande Orchestra. Conductor: Haug. Bertrand (Violin). Adagio for Violin and Orchestra. Serenade in D. Violin Concerto in D. Overture, "Der Schauspielerspieltheater."

STOCKHOLM (Sweden)

704 kc/s (426.1 m.); 55 kW. Motala, etc. See Sunday. Transmits at intervals from 6.20 a.m.
5.0 p.m.—Skane Orchestra, Conductor: Lidner. Waltz (Waldteu-

fel). Two Slav Dances (Dvořák). Suite, I anledning av... (Riisager). Overture, "Carnival in Rome" (Strauss). Judek, "Mors et Vita" (Gounod). Six Bellman Songs (arr. Söderman).
6.0—News.
6.30—Talk: Colour Sense and Colour Blindness.
6.45—Love Song Records.
7.30—"Skalholt"—Historical Play (Kamban-Hjelmqvist).
9.0—News.
9.15-10.0—Opera and Light Music. Inez Köhler (Songs), Witkowski (Pfte.). Zigeunerlieder (Dvořák). Etude in G (Glazunov). Polka (Merwold). March (Prokofiev). Songs (Lehár) from "Gipsy Love," "Paganini" and "Giuditta." Pfte.: Wine, Woman and Song (Strauss-Godovsky). Reading in the interval.

STRASBOURG (France)

859 kc/s (349.2 m.); 100 kW. Transmits at intervals from 6.30 a.m.
5.15 p.m.—Paulette Nathan (Soprano). Exil et retour (Monpou). Sérénade vénitienne (Tomasi). Five Songs (Delannoy). Excerpts, "La Paix" (Delannoy).
5.30—Light Music.
6.0—For Workers.
6.30—String Quartet (Haydn).
7.0—Radio Journal.
7.30—Light Music from Limoges (PTT).
8.0—News (German, French).
8.30—See Rennes-Bretagne.
10.30—News (French, German).

STUTTGART (Germany)

574 kc/s (522.6 m.); 100 kW. Transmits at intervals from 5.0 a.m.
11.0 a.m.—1.0 p.m.—Orchestra, Cello, Pfte., Songs.
1.0-2.0—Records.
3.0—Orchestra. Stuttgart Folk Music Ensemble, Flügel (Tenor), etc.; at 4.0-4.10—Talk.
5.0—"Schlageter"—Sequence (von Gemmingen).
5.30—Topical.
6.0—News.
6.15—"Baden"—Radio Pictures with music.
7.15—Handel Cycle VI—London, Beginning of 1725. "Rodelinde"—Opera. Station Choir and Orchestra. Conductor: Leonhardt. Cäcilie Reich, Gerhard Hüsch, Kraus, Emma Mayer, Baum, Duerue.
9.0—Time; News.
9.20—Political Press Review.
9.35—Dance and Light Music.
11.0 p.m.—1.0 a.m. (Wednesday)—See Frankfurt.

TOULOUSE (Radio-Toulouse) (France)

913 kc/s (328.6 m.); 60 kW. Transmits at intervals from 8.0 a.m.
6.0 p.m.—Dance Music.
6.15—Musical Comedy Music.
6.40—Opera Music. Excerpts, "The Song of Happiness" (Lehár), "The Merry Widow" (Lehár), "La Donna perduta" (Pietri).
6.55—News; Sports.
7.15—Songs.
7.45—Light Music.
8.25—Talk; Sketch.
9.10—Talks.
9.30—Lehár Operetta Music.
10.0—News.
10.15—English Concert.
11.15—Light Music. Czardas (Delibes). Chanson sans paroles (Tchaikovsky). Valse bluette (Drigo). Shepherd's Dance (German). Bacchanale (Gounod).
11.35—Light Music.
11.50-12.0 m't.—News.

TURIN GROUP (Italy)

Turin (No. 1), 1,140 kc/s (263.2 m.); 7 kW. Milan (No. 1), etc. See Sunday.
Transmits at intervals from 6.45 a.m.
4.0 p.m.—News.
4.15—Colombo and Ferrari (Pftes.). Sonatina in B flat (Pergolesi). Three Songs (Pizzetti). Aria italiana (Caltabiano). La caccia (Cambini).
4.50-4.55—Aviation; Weather.
5.45-6.0—See Rome Group.
6.30—Radio Orchestra.
7.0-7.30—See Rome Group.
7.30—String Orchestra. Conductor: Petralia; at 7.36 (Rome No. 2 only)—News (English).
8.0—Symphony Concert. Conductor: Tansini. Gieseking (Pfte.). Part I. Overture, "The Siege of Corinth" (Rossini). Pfte. Concerto in E flat (Beethoven). Part II. Pfte. Concerto in B flat (Brahms).
10.0 (approx.)—News.
10.15-10.55—Grassi Dance Band.

VIENNA (Austria)

592 kc/s (506.8 m.); 100 kW. Graz, etc. See Sunday. Transmits at intervals from 5.45 a.m.
11.0 a.m.—Chimes; Orchestra.
12.0 noon—Time; News.
12.10 p.m.—Station Band.
1.0—Records of Winfried Wolf (Pfte.).
1.30—Announcements.
2.0—Markets.
2.15—Vienna Children's Orchestra.
2.40—For Women.
3.0—News; Exchange.
3.5—Concert by the Station Orchestra and Bands, Wanasek (Flute), Karl Mikulas (Hawaiian Guitar), Seidl (Songs), Josef Mikulas (Accordion). Waltz, "Faust" (Gounod-Popp). Fantasia on American Songs (Karl Mikulas). Pieces (Altmann): (a) Ein Frühlingslied ist unsere Liebe, (b) Ein Laute mit verblestem Band. Cavatina, "The Barber of Seville" (Rossini). The Selfish Giant (Coates). Variations on the Folk Song, "Kommt ein Vogel geflogen" (Ochs).
4.0—Handwork for Boys.
4.25—Cultural Review.
4.35—Czermak ('Cello). Sonata in D (Beethoven). Andante (Bach). Spanish Dance (Granados). Vito (Popper).
5.5—French Lesson.
5.25—Talk with Records: Norwegian Peasants.
5.50—Astronomy.
6.0—Time; News.
6.10—From Workshop and Office—Report from the Steyr Motor Works.
6.50—"Carl Michael Ziehrer"—Radio Potpourri (arr. Skurawy) with the Station Orchestra. Conductor: Holzer (Pfte.). Grete Holm and Ernst Arnold (Songs).
7.45—Ballad, "Die Beiden" (Hugo von Hofmannstahl).
7.50—Siegfried Trebitsch reads.
8.15—"Homes of Famous Poets"—From the Schottentor to Hernalis.
9.10—News.
9.20—The Rome Quartet. String Quartet in D (Bocherini). String Quartet in E flat (Mozart).
9.55—Announcements.
10.0-10.30—Station Dance Band.

WARSAW (Poland)

224 kc/s (1,339 m.); 120 kW. Cracow, etc. See Sunday. Transmits at intervals from 5.15 a.m.
10.15 a.m.—For Schools.
10.40—Records of Ninon Vallin and Armand Crabbé (Songs).
10.57—Time; Fanfare.
11.3-12.0 noon—To be announced.
2.30 p.m.—Economics.
2.45—"George Stephenson"—Sequence for Children (Pauszer).
3.10—Financial and Economic Review.
3.20—Band. Conductor: Spitzer. Potpourri (Spitzer). Cigany Waltz, Monte Christo (Kotlar). Wedding Procession of the Enchanted Princess (Rhode).
3.50—Topical Talk.
4.0 (from Lwów)—Talk: The Grand Canyon.
4.15—Pfte. Quartet in B minor (Mendelssohn).
4.50 (from Poznań)—Talk: Salt-petre.
5.0—Sports Notes; Letter-box.
5.25—Programme Notes.
5.35—For Country People.
6.0—Young Authors at the Microphone.
6.30 (from Lwów)—Polish Music by the Lwów Mixed Choir. Conductor: Kolaczowski. Two Songs (Szymanowski). Regina coeli lactare (Szelligowski). Two Songs (Maklakiewicz).
6.50—Topical Talk.
7.0 (from Lwów)—Instrumental Ensemble. Conductor: Altenberg. Kiss Sérénade (de Micheli). Grieg Potpourri (Urbach). Air de ballet (Massenet). Two Ptes.: Coronation March (Kretzschmar). Polonaise (Wieniawski). Czardas, "Der Geist des Wojewoden" (Grossmann).
7.45—News; Topical.
7.50 (from Poznań)—Polish Composers—Apollinary Szeluta Chamber Music with Introductory Talk. Sonata in F for 'Cello and Pfte. Four Soprano-Songs Pfte. Pieces: (a) Nocturne in D, (b) Improptu in D flat, (c) Mazurka in F sharp, (d) Polonaise in E.
8.45—Dance Music by the Station Orchestra, Aston (Refrains).
9.50-10.0—News.

Mar. 16 WEDNESDAY

National
For Time Signals, see Monday.
10.15 a.m. (D)—Service.
10.30 (D)—Weather Forecast.
10.45 (D)—Backstage at Bella-houston—The British Govern-ment Pavilion.
11.0 (D)—Records.
11.30 (D)—French for Schools.
11.45 (D)—BBC Northern Orchestra: Lee Thistlethwaite (Baritone).
12.45 p.m. (D)—Dance Records.
1.15 (D)—Theatre Orchestra.
2.5 (D)—For Schools.
3.30 (D)—Lydia Stace (Pfte.).
4.0 (D)—Evensong from St. Paul's Cathedral.
5.0—Records.
5.20—Henry Hall and his Orchestra.
6.0—The First News.
6.20—"Egg Marketing:" G. Scott Robertson, D.Sc., and Anthony Hurd.
6.40—Leslie Bridgewater Harp Quintet.
7.15—Band Waggon.
8.15—BBC Symphony Concert from Queen's Hall, London: Bach's Mass in B Minor: Jo Vincent (Soprano); Mary Jarred (Contralto); Heddle Nash (Tenor); William Parsons (Bass). BBC Choral Society and Symphony Orchestra, Conductor: Sir Adrian Boult.
9.20—The Third News.
9.40—Symphony Concert, contd.
10.55—"The Moon:" a mosaic of words and music.
11.20—Bram Martin and his Dance Orchestra.
11.30-12.0—Swing Records.

London Regional
For Time Signals, see Monday.
10.15-10.45 a.m.—National.
10.45—BBC Scottish Orchestra: Robert Wilson (Tenor).
11.30—Cinema Organ.
12.0—Records.
12.30 p.m.—Jack Wilson and his Versatile Five.
1.0—"Wild Fowling on the Essex Marshes:" Edward Allen.
1.20—Records.
2.0—BBC Welsh Orchestra: Nancy Ellis (Soprano).
3.0—"Ireland Dances."
3.40—Commentary on The British Amateur Billiards Championship.
4.0—Theatre Orchestra.
4.45—"Mistress and Maid:" The Rt. Hon. Margaret Bondfield, LL.D.
5.0—The Children's Hour.
6.0—BBC Midland Orchestra, conducted by Leslie Heward.
6.40—Talk—"Fruits of the Earth."
7.0—The Second News.
7.20—Regional Announcements.
7.30—The World Goes By: a Radio Magazine.
8.0—Schubert: Harold Child.
8.15—Excerpt from "Going Greek," with Leslie Henson.
9.0—Commentary on The British Amateur Billiards Championship.
9.15—Harry Lauder and the BBC Variety Orchestra.
9.45—"Interlude:" BBC Variety Orchestra.
10.0—News Summary.
10.25—Bram Martin and his Dance Orchestra.
11.30—Records.
11.50-12.0—Late News Summary.

Midland
10.15 a.m. - 6.40 p.m.—Regional.
6.40—"Spring Spraying of Fruit Trees:" Christopher Norbury.
7.0—The Second News.
7.20—Midland Announcements.
7.30—Regional.
10.25—Reading from "The House Under the Water," by Francis Brett Young.
10.45-12.0—Regional.

Northern
10.15 a.m. - 6.0 p.m.—Regional.
6.0—BBC Northern Orchestra, conducted by F. H. Shera.
6.45—"Anglers' Arms:" the Trout Season opens on the Wharfe.
7.0—The Second News.
7.20—Northern Bulletin for Farmers.
7.30—Regional.
8.15—"Saga at Storr:" a play by C. B. Pulman.
9.0-12.0—Regional.

Western
10.45 a.m. - 6.0 p.m.—National.
6.0—Regional.
6.40—Cinderford Sylvan Male Voice Quartet.
7.0—The Second News.
7.20—Western Announcements.
7.30—Regional.
9.0—Dance Cabaret.
10.0-10.25—Regional.

Welsh
10.15 a.m.—Welsh Service.
10.30-11.0—Regional.
11.0—For Schools in Wales.
11.30-6.0 p.m.—Regional.
6.0—"Byd Merched;" "Gwledydd eraill, Dulliau eraill:" Lillian Jones, Catherine Williams.
6.20—Records.
6.40—Regional.
7.20—Welsh Announcements.
7.30—Welsh News.
7.45—"Can the Welsh Nation survive the Population Crisis?" A Discussion.
8.5—Melodies of Wales: Tom Pickering (Tenor); Katie Griffiths (Soprano).
8.45—"Trem ar Hen Gymeriadau Pontardulais:" T. Williams (Parcwysion).
9.0-12.0—Regional.
N. Ireland
10.15 a.m. - 2.40 p.m.—Regional.
2.40—The opening ceremony of Belfast Harbour Airport by Mrs. Neville Chamberlain.
3.0-6.0—Regional.
6.0—"The Growing Child:" Charles S. Thomson, M.D.
6.20—Hymn Recital from First Presbyterian Church, Londonderry.
6.40—Ireland v. Wales, Association Football.
6.45—"Saturday Night at the Ulster Hall:" T. O. Corrin.
7.0—The Second News.
7.20—Northern Ireland News.
7.30-12.0—Regional.

Scottish
10.15 a.m. - 2.0 p.m.—National.
2.0—For Schools.
2.25—Herring Bulletin.
2.30—For Schools.
3.0-5.0—National.
5.0—The Children's Hour.
6.0—Cinema Organ.
6.15—"Mu'n Cuairt Na Cagailte:" Alasdair Cameron.
6.30—Coltress Works Silver Band.
7.0—The Second News.
7.20—Scottish Announcements.
7.30—A Ceilidh evening in Ardour.
8.0—Regional.
9.0—"Sea- Trout Fishing."
9.15—Regional.
10.30—Evening Worship.
10.45-12.0—Regional.

Hours of Transmission in Greenwich Mean Time.

BERLIN (Germany)
841 kc/s (356.7 m.); 100 kW.
Transmits at intervals from 5.0 a.m.
11.0 a.m.-1.0 p.m.—See Stuttgart.
1.0—News; Water Level.
1.15—Fierke Band.
2.15—Exchange; Records.
3.30—A Story.
4.0—Pfte. Trio in D (Beethoven) by Ely Noy's Trio.
4.30—Report from the KdF Community Centre, Berlin.
5.0—Libiszowski Band.
6.0—News.
6.10—Waltz Records.
6.45—Evening Echoes.
7.0—Sixth Symphony (Bruckner) by the Station Orchestra and Leipzig Symphony Orchestra, Conductor: Weisbach.
8.0—"Spring is coming"—a Merry Concert.
9.0—News.
9.30-11.0—See Breslau.

BEROMÜNSTER (Switzerland)
556 kc/s (539.6 m.); 100 kW.
Relayed by Basle and Berne, 1,375 kc/s (218.2 m.).
5.30-5.50 a.m. (from Berne) —Gym.
11.0—Radio Orchestra.
11.29—News; Exchange.
11.40—Radio Orchestra.
12.20-12.45 p.m.—Records.
3.0—For Housewives.
3.25—Lecture-Recital: Women Composers.
3.50—Records.
4.0—Orchestral Records.
4.15—Dialect Songs.
4.25—Music of Young Composers.
5.0—Play for Children.
5.30—Records; Talk; Markets.
6.10—Records; Interview.
6.45—Weather; News.
6.55 (from Berne)—Variety.
7.50—Pierre Doriaan in his Repertoire.
8.10—Bohemian Music — Radio Orchestra. Conductor: Bernhard.
8.40—Quartet (Brahms) by the Radio Berne Vocal Quartet.
8.55—Radio Berne Pfte. Trio.
9.25—Announcements.

BORDEAUX-LAFAYETTE (France)
1,077 kc/s (278.6 m.); 35 kW.
Transmits at intervals from 6.30 a.m.
8.30 p.m.—"Figaro" (Mozart) by Artists of the Vienna Opera and Salzburg Festival, from the Grand Théâtre. After the Opera—News.

BRATISLAVA (Czechoslovakia)
1,004 kc/s (298.8 m.); 13.5 kW.
Transmits at intervals from 5.15 a.m.
5.45-10.55 p.m.—See Prague; at 9.35—News in Hungarian.

BRESLAU (Germany)
950 kc/s (315.8 m.); 100 kW.
Relayed by Gleiwitz and Görlitz, 1,231 kc/s (243.7 m.).
Transmits at intervals from 4.30 a.m.
11.0 a.m.—Light Orchestral.
1.0-2.0 p.m.—News; Exchange; Records.
2.35—For Children.
3.0—Orchestra; at 4.0—A Story.
5.0—Talk: Ulrich von Hutten.
5.25—Martha Bartling (Pfte.), Maschat (Tenor).
5.55—Programmes.
6.0—News; Markets.
6.25—"The Wenzeslaus Mines."
7.0—Military Band, Soldiers' Chorus, and Hitler Youth Ensemble.
9.0—News.
9.20—To be announced.
9.30-11.0—Dance Music.

BRNO (Czechoslovakia)
922 kc/s (325.4 m.); 32 kW.
Transmits at intervals from 5.15 a.m.
4.40 p.m.—German Transmission: "The Bear"—Play (Chekhov); Strauss, Dostal and Granichstaedt-ten Songs.
5.15—News; Talk.
5.30—Review of New Swedish, Norwegian, Flemish and Chinese Books.
5.45-10.55—See Prague; at 7.55—Discussion: Czech High Schools.

BRUSSELS (No. 1) (Belgium)
620 kc/s (483.9 m.); 15 kW.
6.30-9.5 a.m.—Records; Gym; News.
12.0 noon—Records: Light Music.
12.30 p.m.—Weather; Shipping.
12.32—Symphonic Jazz.
1.0—News.
1.10—Radio Orchestra, Conductor: Gason.
1.30—Rossini Records.
2.0—Review of the Arts.
2.3-3.15—For Schools.
4.55—News.
5.0—Radio Orchestra. Rhythmic Fantasia (Poot). Humoresque (Soudant).
5.15—Talk: The Soldier's Leisure.
5.30—Radio Orchestra, Conductor: Gason. Variations aimables (Chevreuille). Légende de Saint-Hubert (Marsick). Papillons (Rogister). Danse funambulesque (Strens).
6.0—Talk: The Faculty of Science at Ghent University.
6.15—Trios (Wolf-Ferrari and Boieldieu) by the Basle Trio.
7.0—Reviews: (a) for Ex-Servicemen, (b) Periodicals, (c) Economics.
7.15—Records: Light Music.
7.30—News.
8.0—"Les plus beaux yeux du monde"—Three-Act Play (Sarmant).
10.0—News.
10.10—Record: "Roberta" (Kern).
10.15—Talk: Walloon Literature.
10.25-11.0—Records. Pacific 231 (Honegger). Les amours de Ronsard (Milhaud). American Panorama (Amfitheatrof).

BRUSSELS (No. 2) (Belgium)
932 kc/s (321.9 m.); 15 kW.
Programme in Flemish.
6.30-9.5 a.m.—Records; Gym; News.
12.0 noon—Records.
12.31 p.m.—Orchestra; Records.
1.0—News; Shipping.
1.10-2.0—Orchestra; Records.
4.40—Announcements; Talk.
5.0—Salon Orchestra; Records.
5.30—Pfte. Records.
6.45—Protestant Address.
7.0—Karel Candaal Songs by Minne Bolotine.
7.30—Tourist Report.
8.0—"Die Königin befiehlt" (Eulner). Operetta Orchestra and I.N.R. Choir, Conductors: Walpot and Gras. In the interval at 9.0—Variety.
10.0—News; Poems.
10.30-11.0—Records: Light Music.

BUCHAREST (Romania)
823 kc/s (364.5 m.); 12 kW.
Relayed by Radio-Romania, 160 kc/s (1,875 m.).
Transmits at intervals from 4.30 a.m.
4.5 p.m.—Giurgea Orchestra.
5.15—The History of Music — Lecture-Recital.
6.0—Wagner Concert — Radio Orchestra. Conductor: Alessandresco. Mme Aida Helta and Nicolesco-Bassu (Songs).
6.50—Talk.
7.5—Georges Cocca ('Cello).
7.30—Cabaret.
8.30—News; Sports Notes.
8.45—Café Concert.
9.45—News (French, German).

BUDAPEST (No. 1) (Hungary)
546 kc/s (549.5 m.); 120 kW.
Transmits at intervals from 5.45 a.m.
11.5 a.m.—Petry and Szomolányi (Songs).
12.30 p.m.—Municipal Orchestra.
1.40—News.
3.15—For Schools.
4.0—Lakatos Cigány Band.
5.0—Dr. Mihályi Kerek.
5.30—Station Orchestra. Chinese Festival (Naggiar). Romantic Avowal (Forteres). Hymn to the Sun (Rimsky-Korsakov). Spanish Serenade (Szántó). Waltz (Stephanides). Caprice (Járay). Tarantella (Farkas).
6.0—A Play (Szalay) (Recorded).
7.50—News.
8.20—Budapest Concert Orchestra, from the Municipal Theatre, Conductor: de Sabata. Hungarian Suite (Weiner). Prelude, "Fedra" (Pizzetti). A Sera (Catalani). Bolero (Ravel).
9.10—Records.
10.0—News in French and Italian.
10.10—Kertész Jazz Band from the Café Spolarich.
11.5—News for Hungarians Abroad.

BUDAPEST (No. 2) (Hungary)
359.5 kc/s (834.5 m.); 18 kW.
5.30 p.m.—Italian Lesson.
6.5—Station Band.
7.10—Budapest Concert Orchestra. Conductor: de Sabata.
8.15—Dance Records.

COLOGNE (Germany)
658 kc/s (455.9 m.); 100 kW.
Transmits at intervals from 5.0 a.m.
11.0 a.m.—Band.
12.0 noon—News; Greetings.
12.15 p.m.—See Stuttgart.
1.0—News.
1.15—Soprano and Pfte.
2.0—For Children; Dialect; News.
3.0—Genealogy.
3.30—Orchestra, Baritone.
4.30—The "R" Trio of Vienna. Variations on "Ich bin der Schneider Kakadu" (Beethoven). Trio (Mozart).
5.0—Topical Talks.
6.0—News; Records.
6.45—Political Press Review.
7.0—"Glückliche Reise" (Künneke).
8.30—Station Pfte. Trio.
9.0—News; Records.
9.30-11.0—See Frankfurt.

DEUTSCHLANDSENDER (Germany)
191 kc/s (1,571 m.); 60 kW.
Transmits at intervals from 5.0 a.m.
11.0 a.m.—Police Band.
12.45 p.m.—News.
1.0—Jäger Band, and Records.
2.15—Caruso Records.
2.40—Talk; Programmes.
3.0—Orchestra; at 4.0—Talk.
5.0—Klaehn reads.
5.15—The Kreutzer Sonata (Beethoven).
5.45—Sports Notes.
6.0—Motto; News.
6.10—See Frankfurt.
8.0—What Three Years of Con-scription has given us—Reports.
8.30—Records with Krüger-Lorenzen and Freundorfer.
9.0—News.
9.30-9.45—Kleine Sonate (Welter) by Thiele (Pfte.).
10.0-11.0—Light and Dance Music from Frankfurt.

FRANKFURT (Germany)
1,195 kc/s (251 m.); 25 kW.
Cassel, etc. See Sunday.
Transmits at intervals from 5.0 a.m.
11.0 a.m.—Military Band.
12.0 noon—Time; News.

12.15 p.m.—See Stuttgart.
1.0—News; Records.
2.0—New German Songs (Philipp Braun, Graener) by Sophie Hoepfel (Soprano).
2.30—For Boys.
3.0—Orchestra, Conductor: Körner. In the interval, Talk.
5.0—The Wendling Quartet and Dreisbach (Clarinet).
5.45—Talk: German Aviation.
6.0—Time; News.
6.10—Station Choir and Orchestra, Hüsch (Baritone), Elisabeth Friedrich (Soprano). Overture, "Ruslan and Ludmila" (Glinka). Aria, "Cosi fan tutte" (Mozart). Minuet and Trio (Mozart). Aria, "The Magic Flute" (Mozart). Excerpts, "Der Pfeifertag" (Schillings). Excerpts, "A Masked Ball" and "Othello" (Verdi). "La Boutique Fantasque" (Rossini-Respighi). Die Heintzelmännchen (Pfitzner). Piece for Orchestra (Blumer). Excerpt, "The Bartered Bride" (Smetana). Two Songs (Marx). Märchensuite (Lobertz). Two Songs (Graener). Tarantella (Kienzl). Two Songs (Wetz). The Flight of the Bumble-Bee (Rimsky-Korsakov).
8.0—"Versprich mir nichts"—Play (Rissmann).
9.0—Time; News.
9.20—"Where are you, Comrade?"
9.30—Light and Dance Music with Schneider (Bass Baritone).
11.0-1.0 a.m. (Thursday) — See Stuttgart.

HAMBURG (Germany)
904 kc/s (331.9 m.); 100 kW.
Bremen, etc. See Sunday.
Transmits at intervals from 5.10 a.m.
11.0 a.m.—Station Orchestra.
12.0 noon—Topical Talk.
12.15 p.m.—See Stuttgart.
1.0—News.
1.15—Music.
2.0—Shipping; Markets.
2.25—Serenade (Fiedler) by the Station Orchestra.
2.50—Ice Report.
3.0—Café Concerts and Talks.
5.0—Nature Study.
5.15—Aida Montes (Brahms and Strauss Songs).
5.40—Talk: Weather; Shipping.
6.0—News.
6.10—"Der Liebeslotse"—Musical Adventure aboard a Yacht (Albrecht); Music by Hahn.
8.0—Topical Talk.
8.10—Station Orchestra, Conductor: Röder. Overture in E minor (Schubert). Ländliches Fest (Raff). Heiteres Vorspiel (Vogt). Dutch Rhapsody, Piet Hein (van Anrooy). Scherzo (Eik). Concert Overture, Cockaigne (Elgar).
9.0—News.
9.20—March Almanac.
9.35-11.0—Dance Music from Breslau.

HILVERSUM (No. 1) (Holland)
160 kc/s (1,875 m.); 10 kW until 4.40 p.m.; 150 kW from 4.40 p.m. Also on Jaarsveld, 722 kc/s (415.4 m.); 17 kW.
7.40-9.40 a.m.—VARA Programme.
7.40—Records.
9.10—Talk: Dietics.
9.40—VPRO Service.
10.0—VARA Programme: Residentie Orchestra. Conductor: Votto (Recorded).
10.40—RVU Educational Talk.
11.10 a.m. - 6.10 p.m.—VARA Programme.
11.10—Talk for the Unemployed.
11.40—Records.
12.10-1.25 p.m.—VARA Orchestra. Conductor: de Groot. Nelly Lunoff (Songs); Records.
1.40—Dressmaking Lesson.
2.10—For Women.
2.40—For Children.
5.10—Records.
5.40—VARA Dance Band.
6.10—RVU Talk.
6.40-7.10—VARA Programme.
6.40—Records; Songs.
7.10—VPRO Talk.
7.40-11.40—VARA Programme.
7.40—SOS Messages; News; Variety; Records.
8.25—Excerpts, "Frank van Wezels roemruchte jaren"—Play (de Jong).
8.50—Radio Potpourri (arr. Brandjes). VARA Orchestra, "De Stem des Volks" Men's Choir, Conductor: Krelage. Gobets (Tenor) and Jong (Pfte.). Over-

WEDNESDAY (March 16)

ture, "Rosamunde" (Schubert). Der Lindenbaum (Schubert). Caro mio ben (Giordano). A Highland Lad my Love was born. Loch Lomond. Wiegeltel (Brahms). Autumn (Toselli). Paraphrase on "Das Heidenroslein" (Schubert-Weninger). The Sacred Hour (Ketelbey). Berceuse, "Jocelyn" (Godard). Hungarian Dance (Brahms). Pomp and Circumstance (Elgar). 9.40—News. 9.45—Emeralda Septet. 10.10—"Sweetness and Rhythm"—Jong (Organ), v. Helvoirt (Trumpet), Poppink (Saxophone) and Kranenburg (Percussion). 10.40—Mme Schwabe - Franken (Violin); Simon (Pfte.). 11.10-11.40—Records.

HILVERSUM (No. 2) (Holland) 995 kc/s (301.5 m.); 15 kW until 6.10 p.m.; 60 kW from 6.10 p.m. NCRV Programme. 7.40 a.m.—Bible Reading; Meditation; Records. 9.10—Greetings; Records. 10.10—Religious Address. 10.40—Records. 10.55—v. d. Horst Ensemble. 11.40—Police Notes; Records. 12.10 p.m.—v. d. Horst Ensemble. 1.10—Records. 1.40—Valstar (Bass-Baritone). Arias, "The Seasons" (Haydn), "Elijah" (Mendelssohn) and "St. Paul" (Mendelssohn). Records. Songs (Schumann). Records. Songs (Schubert). 2.40—Bible Reading. 3.5—Records. 3.20—Sacred Songs (de Heer), by Mlle Albers (Contralto). In the intervals, Records. 4.20-4.35—Greetings. 4.40—For Children; Records. 5.40—For Farmers. 6.10—Shipping. 6.40—Police Notes; Church Notes. 6.55—Literary Talk. 7.25—Report. 7.40—News. 7.50—Choral Concert by Frisian Protestant Choirs. Address by M. Dikkerboom. 8.50—Religious Address. 9.20—Choral Concert (contd.). 9.50—News; Draughts Lesson. 10.10—Records; Gym. 10.40—11.40—Records; Bible Reading.

KALUNDBORG (Denmark) 240 kc/s (1,250 m.); 60 kW. Relays Copenhagen, 1,176 kc/s (255.1 m.). Transmits at intervals from 6.0 a.m. 11.0 a.m.-1.0 p.m.—Louis Prell's Ensemble. 1.10—Reading (Uhrskov). Astrid Reisinger (Pfte.). Overture; "Joseph and his Brethren" (Méhul). Moonlight on the Alster (Fétras). October, "The Months" (Tchaikovsky). Bornholm Suite (Prenn). Minuet (Danning). Serenade (Moszkowski). March (Rydahl). Pfte. Suite (Nielsen). Overture, "Marie Grubbe" (Rosenberg). Suite ancienne (Schroder). Spanish Serenade (Gyldmark). Rapsodietta (Jacobe Gade). Romance (Thielemann). Intermezzo (Albech). Humoresque (Poulsen). Kunstnermarch (Ryming). 3.30—For Children; Notes. 4.0—Talk. 4.25—Weather; Exchange; Markets. 4.50—Records. 5.15—Talk by a Clock-maker. 5.35—French Lessons. 6.0—Time; News. 6.30—For Farmers. 7.0—Dialogue (Mogens Dam). 7.10—Talk: Anders Bundgaard, the Sculptor. 7.20—Radio Orchestra, Conductor; Grøndahl. "In Autumn" (Grieg). Romance (Gaubert). Slav Dance in A (Weinberger). Rondo capriccioso (Saint-Saëns). Amid Nature (Dvořák). 8.10—Discussion: Reader and Author. 8.30—Danish Theatre Music. Radio Orchestra, Conductor: Grøndahl. Overture, "Lulu" (Kuhlau). Excerpts, "The Valkyrie" (Hartmann). Excerpt, "Thrymskviden" (Hartmann). Overture, "Renaissance" (Lange-Müller). 9.0—News. 9.20—Radio Orchestra, Conductor: Grøndahl. Overture, "Lucio Silla" (J. C. Bach). Ballet Suite, "Alcina" (Handel). Move-

ments from the Serenade in D (Mozart). Overture, "The Barber of Seville" (Rossini). 10.15-11.30—Prell's Dance Band; at 11.0—Chimes.

KÖNIGSBERG (Heilsberg) (Germany) 1,031 kc/s (291 m.); 100 kW. Relayed by Danzig 1,303 kc/s (230.2 m.). Transmits at intervals from 5.0 a.m. 11.0 a.m.—See Stuttgart. 1.0 p.m.—News; Talk; Music. 1.55-2.0—Exchange. 2.30—Practical Hints. 2.40—Visit to a Girls' League Leaders' Training School. 3.0—Records; at 3.40—Talk. 4.30—Variety in Dialect. 5.0—Brückner and Schlegler (Pftes.). 5.25—Vocational Competitions Results. 5.50—Local News. 6.0—News. 6.10—"The Escapades of Nasreddin Hodscha"—Sketches based on Turkish Anecdotes, with Music (Faiss). 7.0—Light Orchestral, Conductor: Wilcken. 8.0—Topical Talk. 8.15—"German Songs from outside the Reich"—Station Choir, etc. 9.0—News. 9.20—String Quartet in D (Haydn) by the Veidt Quartet. 9.40-11.0—Dance and Light Music.

LEIPZIG (Germany) 785 kc/s (382.2 m.); 120 kW. Relayed by Dresden, 1,285 kc/s (233.5 m.). Transmits at intervals from 5.0 a.m. 11.0 a.m.—Workers' Band. 12.0 noon—Time; News. 12.15 p.m.—See Stuttgart. 1.0—Time; News; Exchange. 1.15—Waltzes and Marches. 2.25—Talk: Unmarried Mothers. 2.40—Sonatina for Flute and Pfte. (Giesekeing). 3.0—See Deutschlandsender; at 4.0—Industrial News. 4.50—Talk. 5.10—Songs and Humour by the NSD Students Society of Leipzig Conservatoire. 5.50—Topical Talk. 6.0—News. 6.10—"Unser das Land"—Sequence on Poems of Alverdes, Claudius, Goethe, Hölderlin, etc.; to music of Gastoldi, Lang, and Others (arr. Pallmann). 7.0—See Berlin. 8.0—Eichendorff Anniversary Programme. 9.0—News. 9.20-11.0—Light and Dance Music.

LILLE (Radio PTT Nord) (France) 1,213 kc/s (247.3 m.); 60 kW. Transmits at intervals from 6.30 a.m. 5.45 p.m.—Brasserie Concert. 6.30—Educational. 7.0—For Gardeners. 7.10—Talk in English. 7.25—Records. 7.30—Radio Journal. 8.0—See Paris (PTT). 8.30 (also Limoges (PTT) and Toulouse (PTT))—Richard Strauss Concert. National Suite, Conductor: Rosenthal. Overture, "Le Bourgeois Gentilhomme." "Ariadne auf Naxos." Mmes Lissitschikina, Beronita, Turbaraber, Cernay, and Blanc-Audra. MM Arnoult, Prigent, Cathelat, Balbon, and Rey. After the Programme, News.

MONTE CENERI (Switzerland) 1,167 kc/s (257.1 m.); 15 kW. Transmits at intervals from 11.0 a.m. 6.50 p.m.—News. 7.0—Nina Cheridjian (Pfte.). Sonata in C minor (Cantallós). Sonata in G minor (Solér). Quatre danses bigarrées (Dalcroze). Suite in G minor (Marsiccotti). Jeux (Ravel). Pastorale and Toccata (Poulenc). Toccata and Prelude (Prokofiev). Toccata (Schoeck). 7.40—"Le figurine di Cera"—Play (Calgari). 8.5-9.0—Italian Music. Radio Orchestra, Conductor: Casella. Overture, "The Barber of Seville" (Paisiello). Suite, Gli uccelli (Respighi). Two Folk Melodies (arr. Alalocna): (a) La mamma lontana, (b) Canzone a ballo. Nocturne, Un tramonto in Laguna (Bettinelli). Sinfonia per una fiaba (Porriño).

MOSCOW (No. 1) (Russia) 172 kc/s (1,744 m.); 500 kW. 5.30 p.m.—Literature and Music. 8.30—News; Kremlin Chimes. 9.0—Talks (French, German). 11.0-12.0 m't.—Talks in Spanish.

MUNICH (Germany) 740 kc/s (405.4 m.); 100 kW. Relayed by Nürnberg, 1,267 kc/s (236.8 m.). Transmits at intervals from 5.0 a.m. 11.0 a.m.—To be announced. 12.0 noon—Time; News. 12.15 p.m.—Records: Light Music. 1.0—News; Exchange. 1.15—See Berlin. 2.0-2.30—Musical Fairy Play. 3.0—Chamber Music. 3.40—Talk: Ludwig Steub. 4.0—Time; Weather; Markets. 4.10—Schneider Band, etc. 5.45—Talk. 6.0—Time; News. 6.10—A World Tour with the Augsburg Dance Band. 8.0—Sudetic German Composers—Station Orchestra, Conductor: Manzer. Triumph des Lebens (Péterka). Variations on a Ländler Theme (Wizina). Adagio (Zitterbart). Scherzo (Manzer). Egerland Rhapsody (Pleier). 9.0—Time; News. 9.20-11.0—Béky Band from the Kaffee Luitpold.

NAPLES GROUP (Italy) Naples, 1,104 kc/s (271.7 m.); 10 kW. Florence (No. 1), etc. See Sunday. 6.0 p.m.—Light Music; Talk. 6.20—See Rome Group. 6.40—The Turin "Stefano Tempia" Choir. Conductor: Pistone. 7.0—See Rome Group. 7.30—"Acquazzoni in Montagna"—Three-Act Play (Giacosa). Talk in the intervals. 8.40 (approx.)—Dance Music. 10.0—News. 10.15-10.55—Dance Music.

OSLO (Norway) 260 kc/s (1,153.8 m.); 60 kW. Fredrikstad, etc. See Sunday. Transmits at intervals from 9.30 a.m. 6.30 p.m.—Mme Sandra Droucker (Pfte.). Sonata in G (Haydn). Waltzes (Brahms). Prelude (Prokofiev). Etude-tableau in G minor (Rachmaninoff). Scherzo (Mussorgsky). Terek (Lyapunov). 7.0—Talk from the University. 7.30—Tchaikovsky Concert—Station Orchestra. Conductor: Kramm. Orbech (Violin). Violin Concerto in D. Valse mélancolique. Symphonic Poem, Romeo and Juliet. 8.40—News; Topical Talk. 9.15—Bridge Lesson. 9.35-10.15—Dance Records.

PARIS (Eiffel Tower) (France) 1,456 kc/s (206 m.); 7 kW. Transmits at intervals from 6.30 a.m. 7.30 p.m.—Radio Journal. 8.0—Marthe Guy (Songs), Jeanne Leleu (Pfte.). Songs (Scarlatti, Mozart, Debussy, Rosenthal, Larmantjat). 8.15 (also Lyons (PTT), Montpellier (PTT), and Bordeaux (PTT))—"La Samaritaine"—Biblical Opera (Max d'Ollone) to words of Rostand; Conductor: The Composer; "Alexandre le Grand," Ballet (Philippe Gaubert), Conductor: The Composer.

PARIS (Poste Parisien) (France) 959 kc/s (312.8 m.); 60 kW. Transmits at intervals from 7.10 a.m. 12.0 noon—Exchange; Records. 12.25 p.m.—News; Exchange; Records. 1.0—"La course au trésor," with Pierre Dac. 1.18—Amusements; Songs. 1.35—Records; Film Review. 2.0—Exchange; News. 3.45 and 4.35—Exchange. 5.0—News. 5.5—Haydn and Ravel Records. 6.0—Exchange; News. 6.10—Jewish Programme. 6.20—Musical Competition. 6.35—"Il y a un an, signorette..." 6.45—Record; Talk: Electricity. 6.55—For Young People. 6.58—Racing; Topical; Sports. 7.10—Amusement Guide. 7.15—"Arc-en-ciel"—presented by Roger François. 7.45—Records: "Passionément" (Messenger). 8.0—Topical. 8.10—Jean Sablon's Song of Songs. 8.15—"En Correctionnelle" (Diamant-Berger). 8.45—Talk. 8.50—"La bonne histoire." 9.0—News.

9.10—Max Regnier and Company. 9.45—News. 10.0—Dance Music. 10.30-11.0—From the Shéhérazade.

PARIS (PTT) (France) 695 kc/s (431.7 m.); 120 kW. Transmits at intervals from 6.50 a.m. 2.30 p.m.—Concert for the Blind by the Paris String Quartet, Pergola (Pfte.) and Mme Gomant. (Songs). 4.0—Reading; Records; Talks. 4.30—Marie Simon (Songs). 4.45—Record; Science Talk. 5.0—André Pascal (Violin). Andante (Bach). Rigaudon (Lermoyte). La Chasse (Cartier). 5.15—Records; Talks. 6.0—Educational. 6.30—Germaine Salomon (Pfte.). In the Gardens of Murcia (Turina). Miramar (Turina). Bruyères (Debussy). Minstrels (Debussy). Le retour des muletiers (de Séverac). 6.45—Andrée Fontaine (Songs). 7.0—Radio Journal; News. 8.0—"Au Café de Commerce"—Sketch (Schwaebe). 8.30—To be announced. 10.30—U.S.A. Bulletin; Records. 11.0—News.

PARIS (Radio-Paris) (France) 182 kc/s (1,648 m.); 80 kW. 6.28 a.m.—Programmes; Records. 6.40—Time; News; Gym. 7.5—Records; at 7.15—News. 8.0—Time; News; For Women. 8.55-9.20—Records. 10.15—Programmes; Records. 10.30—Records; Poems. 11.0—Records. 11.45—Markets; Exchange. 12.0 noon—Garde Républicaine Band. 1.0 p.m.—Time; News; Exchange. 1.30—Denise Cam (Songs). 1.45—Band (contd.). 2.0—Programme Notes. 2.5—Music Notes by Wanda Landowska. 2.15—Talk; Markets; Exchange. 2.45—Jacques Mamy (Pfte.). 3.0—Paulette Nathan (Songs). 3.15—Talks. 3.30—Talk; Exchange. 4.0—Jane Montange (Songs). 4.15—Bonnonon (Songs). 4.30—Books; Markets; Exchange. 5.0—Giardino Orchestra. 6.0—Books on Spain; English Press Review. 6.30—Racing Results. 6.35 (approx.)—Lecture-Recital by Landormy: The History of French Opera—Rabaud, d'Ollone and Ducasse. 6.58—Programmes; Educational. 7.30—History Talk: 1848-1852. 7.45—Talk: French Poetry from Villon to Chénier. 7.59—Time; Home Affairs. 8.8—Foreign Affairs. 8.15—For Young People. 8.30—Else Popp Müller (Violin) and Marguerite Michels-Kirchhofer (Pfte.). Pfte.: Pastorale variée (Mozart). Violin: Chanson, Allegro (Luttringshausen). Pfte.: Fugue (Luttringshausen). Il Trillo del diavolo (Tartini). Pfte.: (a) Soirée de Vienne (Strauss-Grunfeld), (b) Shepherds' Hey (Grainger). 9.0—"France in Song" presented by Armand Maistre; at 9.30—News; Review by Divoire. 10.30—Records: Light Music. 10.45—Time; News; Programmes.

Exclusive "World-Radio" Picture Madame Jane Montange, who gives a song recital at Radio-Paris (4 p.m.)

PRAGUE (Czechoslovakia) 638 kc/s (470.2 m.); 120 kW. Transmits at intervals from 5.15 a.m. 5.5 p.m.—Songs to the Guitar and Talks in German. 5.45—News in German; Record. 6.0—News; Talk; Local News. 6.25—"Spring is here!"—Variety. FOC Orchestra, Station Choir; etc. 7.55—Talk: The Mysterious Hejaz. 8.10—Talk on the following Programme. 8.15—Mass in B minor (Bach), from London (National). 9.20—News. 9.35—Talk on Bach's Mass in B minor. 9.40-10.55—Mass in B minor (Bach) from London (National) (contd.).

RADIO EIREANN (Ire) 565 kc/s (531 m.); 100 kW. Dublin, etc. See Sunday. 1.30 p.m.—Records. 2.30-3.0—For Schools. 5.30—Irish Radio Orchestra. Conductor: Lieut. D. P. O'Hara. 6.5—Dora Sigerson Shorter Programme—Biographical Note and Personal Sketch by Hester Sigerson Piatt; Critical Assessment and Poetry Reading by W. F. P. Stockley. 6.35—Irish News Feature. 6.45—News. 7.0—Thornton and Earls (Songs at the Pfte.). 7.20—"Uisce Casactaigh" (M. O'Suilleabhain), presented by An Comhar Dramuictha. 7.50—Muriel Graham (Organ) and a Singer from Harold's Cross Church. 8.20—Illustrated Talk by Cathal O'Byrne. 8.50—Programme from the Queen's Theatre, Dublin. 9.20—Unpainted Pictures No. 1. A Wedding in Drumcondra, interpreted by Josephine Fitzgerald. 9.30—Variety Programme. 10.30—News. 11.0—National Anthem.

RADIO-NORMANDIE (France) 1,113 kc/s (269.5 m.); 15 kW. 6.45 a.m.—Band; Records. 7.15—News; Press Review. 7.45—Physical Exercises. 8.0—Music in the Morning. 8.15—Prosperity Programme: Careers for Women. 8.30—The Musical Barometer. 8.45—Songs you will never forget—Fred Hartley's Orchestra, Brian Lawrence and John Stevenson. 9.0—Light Music. 9.15—Immortals—a Musical Problem. 9.30—Tunes we all know. 9.45—Popular Music. 10.0—Light Music. 10.30—From Stage and Screen. 11.0—Variety. 11.30—Instrumental Music. 12.0 noon—Concert. 12.45 p.m.—Radio Journal; News, 1.0—Concert. 2.0—Miniature Matinée. 2.15—In Search of Melody. 2.30—From the New World. 2.45—Beauty and Romance. 3.0—Film Notes; Music. 3.15—Gracie Fields in New Songs and Old Favourites. 3.30—Morton Downey (Songs). 3.45—Masters of Rhythm. 4.0—Dance Tunes of Today. 4.30—Gay Melodies. 4.45—Fingering the Frets. 5.0—A Programme for Men. 5.15—Bohemian Holiday. 6.0—Variety. 6.0—Markets. 6.45—Talk; News; Racing. 7.0—Chansonnettes. 7.25—News. 7.45—Records of the Berlin Philharmonic. Selection, "Tosca" (Puccini), "Madame Butterfly" (Puccini). 8.0—Variety. 8.20—Revue with Roméo Carls and Pierre Ferrary. 9.0—Variety from Rouen. Lydia Mistral and Mary Robert (Songs). Bourdet (Baritone), Courbe (Violin), Slave (Cello), Pipo and Leoni (Clowns), Dalmet, Marietti and Donay (Entertainers) and Queval (Pfte.). 11.0—Café Concert. 12.0 m't.—Melody at Midnight. 12.30-1.0 a.m. (Thursday)—Dance Music.

RENNES-BRETAGNE (France) 1,040 kc/s (288.5 m.); 120 kW. Transmits at intervals from 6.30 a.m. 6.45 p.m.—News in English. 7.0—Radio Journal. 7.30—Reynaldo Hahn Concert. Conductor: Bilewski. Suite, "La Fête chez Thérèse." Songs. Pavane d'Angelo. Waltz, O, mon bel inconnu. Nocturne. March, Les jeunes lauriers. 8.0—News; Records; Talk.

WEDNESDAY (March 16)

8.30—Concert of the Brest Music Academy, from the Municipal Theatre, Brest. Orchestra and Choir, Conductor: Rulland Pepper (Violin) Overture, "Oberon" (Weber). Violin Concerto in E flat (Mozart). Choir and Orchestra: (a) Gavotte (Martini); (b) Brunette (Anon); (c) Le Mai (16th Century); (d) Duo des clochettes (Fauchey). Violin: (a) Prelude and Dances (Pepper); (b) The Fountain of Arethusa (Szymanowski). Suite for Wind Instruments (Rulland). Torch March (Meyerbeer).

10.30—U.S.A. Bulletin; Music. 11.0—News.

ROME GROUP (Italy) Rome (No. 1), 713 kc/s (420.8 m.); 100 kW. Bari (No. 1), etc. See Sunday. Transmits at intervals from 6.45 a.m. 4.0 p.m.—News. 4.15-4.55—Iole Baccara (Violin), Olga Brogno Cesareo at the Pfte. Sonata (Rota). Sonatina (Paganini). Alba (Respighi). 5.40—Government Notes. 6.0—Talk (German). 6.20—English Lesson. 6.40—Light Music. 7.0—Time; News. 7.20—Government Report; Music. 8.0—Symphony Concert, from the Politeama Fiorentino. Guest Conductor: Mengelberg. Symphony in B flat (Bach). Psyché (César Franck). Concerto for Orchestra (Casella). Sixth Symphony (Beethoven).

10.0—News. 10.15-10.50—Dance Music.

SOTTENS (Switzerland) 677 kc/s (443.1 m.); 100 kW. Relayed by Geneva, 401 kc/s (748 m.).

9.10-9.50 a.m.—Songs for Schools. 11.29—News; Records. 12.0 noon-12.45 p.m. (from Geneva)—News Reel. 4.0-5.0—See Beromünster. 5.0 till Close—For Geneva. 5.0-5.45—For Young People. 5.50-6.5—Art Talk. 6.15—Micro-Magazine. 6.50—News. 7.0—Variety with Accordion Band and Brightini (Baritone). 7.35—Talk. 7.45—Concert arranged by the

Dante Alighieri National Society from the Conservatoire. Romand Orchestra, Conductor: Tocchi (Pfte.). Ada Ruata-Sassoli (Harp). Maria-Teresa Pediconi (Soprano). Adagio and Allegro (Ghedini). Arias, "Gli Orazii ed i Curiazii" (Cimarosa) and "Rosalande" (Veracini). Harp: (a) Siciliana (16th Cent.). (b) Pastorale (Scarlati). (c) Bourrée (Bach). Songs (arr. Trillat): (a) Tendres plaintes, (b) L'innocente, Arlechino (Tocchi). Cradle Song (Petrassi). Song (Mozart). Harp: (a) Cucu (Masetti), (b) Autunno (Grandjany), (c) Tourbillons (Salzedo). Strapæes Songs (arr. Tocchi). 9.0-9.30—Jazz Music.

STOCKHOLM (Sweden) 704 kc/s (426.1 m.); 55 kW. Motala, etc. See Sunday. Transmits at intervals from 6.20 a.m. 6.0 p.m.—News.

6.30—Göteborg Radio Orchestra. Conductor: Tor Mann. Gimpel (Pfte.). Overture to an Opéra-bouffe (Rosenberg). Suite, "Pelléas and Mélisande" (Sibelius). Pfte. Concerto in F minor (Chopin). 7.30—A Visit to a Farm. 8.0—Film Songs with Sonja Estelle, Margit Rudcrantz and Henry Freeman. 8.30—Talk: George Sand. 9.0—News. 9.15-10.0—Eichwald's Dance Band.

STRASBOURG (France) 859 kc/s (349.2 m.); 100 kW. Transmits at intervals from 6.30 a.m. 5.15 p.m.—"Pro Nova" String Quartet. Quartet in E flat (Beethoven). Quartet in D minor (Cartan).

6.0—Economic and Social Notes. 6.30—For Young People. 7.0—Radio Journal. 7.30—See Rennes-Bretagne. 8.0—News in German. 8.15—News; Time. 8.30—Nancy Conservatoire Concert from the Salle Pörel. Orchestra, Conductor: Bachelet; Jeanne-Marie Darré (Pfte.), Andrée de Pardieu (Soprano), and the Conservatoire and Alsace-Lorraine Choirs. Part I. Three Symphonic Sketches (M. and Y. Aaron). Poem for Pfte. and

Orchestra, Rouen (Sporck), conducted by the Composer. Mirages (Florent Schmitt). Pfte.: (a) Burlesque (Strauss), (b) Hungarian Fantasia (Liszt). Part II. "Rédemption"—Oratorio (Franck). 10.30—News (French, German).

STUTT GART (Germany) 574 kc/s (522.6 m.); 100 kW. Transmits at intervals from 5.0 a.m. 11.0 a.m.—Light German Music. 12.0 noon—Time; News. 12.15 p.m.—New Film Music. 1.0-2.0—Variety Concert. 3.0—"18 19 0"—Winter Relief Concert. 5.0—Peasant Band and the Merry Five. 5.30—Topical Talks. 6.0—News; Talk. 6.45—"18 19 0"—Winter Relief Request Concert. 8.15—"The Kreuznach Command"—War Reminiscences by Staff Officers of the Old Army. 9.0—News. 9.30—Orchestra. Conductor: Hollinger, Oswald (Violin), Spittel (Flute), etc. 11.0 p.m.—1.0 a.m.—Concert. Part I: Records. Pastoral in F for Organ (Bach). Flute and Harpsichord: (a) Bourrée (Scarlati), (b) Larghetto (Handel). Pfte. en concert (Rameau). Pfte. Fantasia in D minor (Mozart). Ecossaise (Haydn). Part II: Overtures (Recorded).

TOULOUSE (Radio-Toulouse) (France) 913 kc/s (328.6 m.); 60 kW. Transmits at intervals from 8.0 a.m. 6.0 p.m.—Dance Music. 6.15—Songs of Marseilles. 6.40—Opera Arias from "Manon Lescaut" (Auber), "Samson and Delilah" (Saint-Saëns), "Tales of Hoffmann" (Offenbach), "Tosca" (Puccini). 6.55—News; Sports. 7.15—Light Music. 7.45—Variety. 7.55—Talks. 8.20—Revue with Pierre Ferrari and Romeo Carlés. 8.55—Talk. 9.0—Ray Ventura and his Collegians. 9.30—Excerpts, "Philippine" (Delannoy).

National

For Time Signals, see Monday. 10.15 a.m. (D)—Service. 10.30 (D)—Weather Forecast. 10.45 (D)—"At Home Today." 11.5 (D)—Records. 11.25 (D)—Geography for Schools. 11.45 (D)—Irish Guards Band. 12.30 p.m. (D)—"At the Black Dog." 1.0 (D)—Records. 1.20 (D)—Eugene Pini and his Tango Orchestra. 2.5 (D)—For Schools. 2.50 (D)—"Empire Exchange." 3.15 (D)—Bournemouth Municipal Orchestra: Jan Smotherlin (Pfte.); Symphony in E minor (Rachmaninoff); Concerto in A (Mozart); La Valse (Ravel). 4.45 (D)—"Why I like the English." Mrs. Saerchinger. 5.0—Records. 5.20—Jerry Hocy Dance Band. 6.0—The First News. 6.20—"Autobiographies:" Desmond MacCarthy. 6.40—Haydn Wood, Music in Manuscript: BBC Orchestra (Section E) conducted by the Composer. 7.20—St. Patrick's Day programme from N. Ireland and Canada. 8.0—Variety Broadcast from The Holborn Empire. 8.30—"The Way of Peace:" R. W. Seton Watson. 9.0—The Third News. 9.20—Eda Kersey (Violin); John Wills (Pfte.); Sonata in E flat (Beethoven); Romantic Pieces, Op. 75 (Dvořák); Sonata (Debussy). 10.0—Mid-Week Service from St. Michael's Chester Square, London. 10.20—Cabaret Records. 11.0—Michael Flome and his Band. 11.30-12.0—Dance Records.

London Regional

For Time Signals, see Monday. 10.15-10.50 a.m.—National. 10.50—"The Launching of H.M.S. 'Belfast,'" by Mrs. Neville Chamberlain.

Midland

11.20 app.—Cinema Organ. 11.50—Ernest Frank (Baritone); New English String Quartet—Schumann, Mozart, Wolf. 12.30 p.m.—Mendelssohn's Part Songs: BBC Singers (A). 1.0—Short story. 1.20—Records of Schubert's music. 2.0—Billy Mayerl (Pfte.). 2.20—The Life of Richard Trevithick. 3.0—Royal Air Force Band. 4.0—Hotel Victoria Orchestra. 4.30—Tomorrow's Songs. 5.0—The Children's Hour. 5.20—Walt Disney's "Snow White and the Seven Dwarfs:" a broadcasting version, with Wynne Ajello as "Snow White." 7.0—The Second News. 7.30—"Horners' Corners:" a Canadian Village Episode. 8.0—European Concert from Eire: The Orchestra of the Irish Broadcasting Service with Violet Pearson (Soprano); Robert McCullagh (Tenor); Mairin Fenning (Contralto); John Lynskey (Baritone); Leo Rowsome (Piper); Seon Curteis (Tenor), from Dublin. 8.40—Joe Loss and his Dance Band. 9.30—Brighton Tigers v. Wembley Lions Ice Hockey commentary. 10.0—News Summary. 10.25—Michael Flome and his Band. 11.30—Records. 11.50-12.0—Late News Summary.

Northern

10.15 a.m.-7.30 p.m.—Regional. 7.30—Denis Noble (Baritone); The Hallé Chorus and Orchestra conducted by Sir Thomas Beecham. 8.40-12.0—Regional.

Western

10.45 a.m.-5.0 p.m.—National. 5.0—The Children's Hour. 6.10—Records, presented by Maurice Miles. 6.45—"For Young Farmers." 7.0—Regional. 9.30—"Westward Ho!" Radio Magazine. 10.0-10.25—Regional.

Welsh

10.15 a.m.-3.0 p.m.—Regional. 3.0—For Schools in Wales. 3.25—Regional. 5.0—The Children's Hour. 6.0—Regional. 7.30—Welsh News. 7.45—The Pontypridd and District Powell Duffryn Men's Choir; Mary Jarred (Contralto). 8.30—Constance Izard (Violin); Megan Lloyd (Cello); Patrick Piggott (Pfte.). 9.15—At Y Cymry: Llythyr. 9.45—Harry J. Rowland in Character Studies. 10.0-12.0—Regional.

N. Ireland

10.15 a.m.-5.0 p.m.—Regional. 5.0—The Children's Hour. 6.0—Regional. 7.20—National. 8.0—Regional. 8.40—N. Ireland News. 8.45—N. Ireland Weather Forecast. 8.50—Rugby Football: The Ulster Schools' Cup Final. 9.0—Les Thorpe and his Dance Band with Joseph Seal (Organ); and Bertie Johnston (Piano). 9.30-12.0—Regional.

Scottish

10.15 a.m.-2.0 p.m.—National. 2.0—For Schools. 2.30—Herring Bulletin. 2.40—For Schools. 3.30—Mid-Week Service from St. John's Church, Hawick. 4.1—National. 5.0—The Children's Hour. 6.0—Regional. 7.20—Scottish Announcements. 7.30—"Harmonica Harry." 7.40—For Scottish Farmers. 8.0—Regional. 9.20—"Yon Antrin Days:" reminiscences of people and things in Scotland in 1890. 10.0-12.0—Regional.

10.0—News. 10.15—English Concert. 11.15—"Cloches et Carillons"—Fantasy. 11.35—Light Music. 11.50-12.0 m't.—News.

TURIN GROUP (Italy) Turin (No. 1), 1,140 kc/s (263.2 m.); 7 kW. Milan (No. 1), etc. See Sunday. Transmits at intervals from 6.45 a.m. 4.0 p.m.—News. 4.15-4.50—Dance Music. 6.20-7.30—See Rome Group. 7.30—Light Music; at 7.36 (Rome No. 2 only)—News in English. 8.0—"Werther" (Massenet), from the Royal Opera, Rome. Conductor: Serafin. Chorus Master: Conca. Cast: Tito Schipa, Giuseppe Manacchini, Adolfo Pacini, Nino Mazziotti, Giuseppe Taddei, Blando Giusti, Pia Tassinari, Liana Cortini, Maria Mariani. In the intervals, News and Talks.

VIENNA (Austria) 592 kc/s (506.8 m.); 100 kW. Graz, etc. See Sunday. Transmits at intervals from 5.45 a.m. 3.5 p.m.—Pfte. Records. 4.0—For Teachers; Art Notes. 4.30—Contemporary Austrian Music. Erika Rokyta (Soprano), Gerda Redlich (Contralto), Sophie Guggenberger (Pfte.), and the Samohyl Quartet. Six Songs (Wiener). Five Miniatures for Pfte. (Springer). Two Movements from the String Quartet in E minor (Springer). 5.20—Talks. 6.0—Time; News. 6.25—Vienna Symphony Orchestra from the Grosser Konzerthausaal. Conductor: Böhm. Kulenkampff (Violin). Seventh Symphony (Schubert). Concerto grosso in C (Handel, arr. Seifert). Violin Concerto in A minor (Schumann). Prelude, "The Mastersingers" (Wagner); at 7.25—Talk on the Concert by Roland Tentschert. 8.40—Scenes from "The Peasant Calendar."

9.10—News; Programmes; Talk. 9.35-10.30—Light Orchestral; at 9.55—News.

WARSAW (Poland) 224 kc/s (1,339 m.); 120 kW. Cracow, etc. See Sunday. Transmits at intervals from 5.15 a.m. 10.15 a.m.—For Schools. 10.40—Records: "A Midsummer Night's Dream" (Mendelssohn). 10.57—Time; Fanfare. 11.3-12.0 noon—To be announced. 2.30 p.m.—Economics. 2.45—For Children. 3.0—Letter-box. 3.15 (from Lodz)—Light Orchestral. 3.50—Topical Talk. 4.0—Talk: Aerial Defence. 4.15 (from Torun)—M. Wilkómirska (Pfte.), K. Wilkómirski (Cello). Sonata in G minor for Pfte. and Cello (Beethoven). Sonata in D arranged for Solo Cello (Locatelli). 4.50—Topical Talks; Sports. 5.10—Records of Louis Levy's Band. 5.30—Programme Notes. 5.35—For Country People. 6.0—Sketch after Roger Martin du Gard (Hulka-Laskowski). 6.20—Vera Gran (Songs). 6.35—Talk: The Loneliness of Old Age. 6.50—Topical Talk. 7.0—Records: Light Music. 7.45—News; Topical. 8.0—Chopin Music by Halina Sembrat (Pfte.). Sonata in B flat minor. Nocturne in C sharp minor. Waltz in E minor. Etudes in A minor, F major and C minor. Polonaise in F sharp minor. 8.45—Poems. 9.0—Station Orchestra. Conductor: Straszynski. Zabyeda - Sumicki (Tenor). Overture, "The Barber of Seville" (Rossini). Aria, "L'Elisir d'Amore" (Donizetti). Mazurka (Glinka). Aria, "The Tsar's Bride" (Rimsky-Korsakov). Krakowiaks (Rybicki). Aria (Zelenski). Aria, "Manru" (Paderewski). Waltz and March, "Pan Twardowski" (Rózycki). 9.50-10.0—News.

THURSDAY Mar. 17

Hours of Transmission in Greenwich Mean Time.

BERLIN (Germany) 841 kc/s (356.7 m.); 100 kW. Transmits at intervals from 5.0 a.m. 11.0 a.m.-1.0 p.m.—See Frankfurt. 1.0—News; Water Level. 1.15—Libiszowski Band. 2.15—Exchange; Markets. 2.35—Band. 3.30—"To Horse!"—Poems and Tales (arr. von Klöden). 4.0—Symphony in E flat (Mozart) by the Station Orchestra. Conductor: Heinrich Steiner (Recorded). 4.30—Arts and Crafts of the Kurmark—Radio Reports. 5.0—Stanke Band. 6.0—News; Announcements. 6.10—Schubert Records. 6.45—Evening Echoes. 7.0—Dance Music—Station Orchestra, Conductor: Willy Steiner, and the Waldemar Hass Band. 9.0—News; Sports. 9.30-11.0—See Stuttgart.

BRATISLAVA (Czechoslovakia) 1,004 kc/s (298.8 m.); 13.5 kW. Transmits at intervals from 5.15 a.m. 5.0 p.m.—Hungarian Transmission: Medical Talk; Nine Hungarian Dances (Brahms) by the Station Orchestra. 5.45-6.15—See Prague. 6.15—Military Band. 7.0—Talk on the following Concert. 7.5—Slovak Culture League's Concert from the Slovak National Theatre. Bratislava Symphony Orchestra. Conductor: Karel Nedbal. Bratislava Massed Choir, Slovak Teachers' Choir, Slovak University Students' Choir, and the "Zora" Glee Club. Fifth Symphony (Tchaikovsky). Psalm of Carpathian Russia (Suchon). In the interval, Interview with the Composer, Suchon. 9.0—See Prague. 9.15—News (Hungarian). 9.30-10.0—Records.

BEROMÜNSTER (Switzerland) 556 kc/s (539.6 m.); 100 kW. Relayed by Basle and Berne, 1,375 kc/s (218.2 m.). 5.30-5.50 a.m.—Gym. 9.20-9.50 (from Basle)—For Schools. 11.0—Carillon Records; News. 11.40 a.m.-12.45 p.m.—The Lanigiro Band, Hot Players. 3.0—For Invalids; Records. 4.0-5.0—See Sottens. 5.0—Cookery; Records. 5.30—For Children; Talk. 6.0—Time; Traffic Notes; Reading. 6.40—Do you know...? 6.45—News; Announcements. 7.0—Zürich Radio, Orchestra. Conductor: Neppach. 7.40—"Der Marschall" and "Der Todspieler" (Münchhausen). 7.55—Talk on the following Programme. 8.0—European Concert from Eire (for details, see Radio Eireann).

9.0—Talk: The Lindenhof Excavations. 9.25—Announcements.

9.0—Talk: The Lindenhof Excavations. 9.25—Announcements.

BRATISLAVA (Czechoslovakia)

1,004 kc/s (298.8 m.); 13.5 kW. Transmits at intervals from 5.15 a.m. 5.0 p.m.—Hungarian Transmission: Medical Talk; Nine Hungarian Dances (Brahms) by the Station Orchestra. 5.45-6.15—See Prague. 6.15—Military Band. 7.0—Talk on the following Concert. 7.5—Slovak Culture League's Concert from the Slovak National Theatre. Bratislava Symphony Orchestra. Conductor: Karel Nedbal. Bratislava Massed Choir, Slovak Teachers' Choir, Slovak University Students' Choir, and the "Zora" Glee Club. Fifth Symphony (Tchaikovsky). Psalm of Carpathian Russia (Suchon). In the interval, Interview with the Composer, Suchon. 9.0—See Prague. 9.15—News (Hungarian). 9.30-10.0—Records.

BRESLAU (Germany) 950 kc/s (315.8 m.); 100 kW. Relayed by Gleiwitz and Görwitz, 1,231 kc/s (243.7 m.). Transmits at intervals from 4.30 a.m. 12.0 noon—Time; News. 12.15 p.m.—Liegnitz Orchestra. 1.0—News; Exchange. 1.15-2.0—See Berlin. 3.0—"A Musical Stroll"—Station Orchestra, Conductor: Weisshaupt; at 4.0-4.10—A Modern Lexicon. 5.0—War Books; Talk. 5.35—Topical Report; Notes. 6.0—News; Markets. 6.10—Silesian Composers—Station Orchestra. Conductor: Prade. Movements, Symphony in A (Koschinsky). Ballet Music (Szuká). Movements, Second Symphony (Rietz).

THURSDAY (March 17)

7.10—Sea Shanties and Yarns (arr. Wittkowski)—Dance Band, Men's Choir. Solo Voices.
8.0—European Concert from Eire (for details see Radio Eireann).
9.0—News; Topical Talk.
9.30-10.30—See Stuttgart.

ERNO (Czechoslovakia)
922 kc/s (325.4 m.); 32 kW.
Transmits at intervals from 5.15 a.m.
6.15 p.m.—Operetta and Film Music. Mikolasek Jazz Band, Station Orchestra, etc.
7.40—See Prague.
7.55—Concert from Bratislava.
9.0-9.35—See Prague.
9.35-10.0—Records

BRUSSELS (No. 1) (Belgium)
620 kc/s (483.9 m.); 15 kW.
6.30-9.0 a.m.—Records; Gym; News.

12.0 noon—Records.
12.30 p.m.—Weather; Shipping.
12.35—Radio Orchestra.
1.0—News.
1.10—Delibes Music.
1.30—Records.
2.0—Art Notes.
4.55—News.
5.0—Brenders Dance Band.
5.30—For Children.
6.0—Art Notes; Records.
7.0—For Workers.
7.15—Records: Song Hits.
7.30—News.
8.0—Film Music. Radio Orchestra. Conductor: Gason, March (Heymann). Le fugitif de Chicago (Carste). Prends la route (Van Parys). Records: Excerpts, "Au son des guitares" (Scotto) by Tino Rossi. Selection, "Le chemin du Paradis" (Heymann). Records: "Sanders of the River" (Spolianski), by Paul Robeson. Selection, "The Love Parade" (Schertzingler).

9.0—Topical Talk.
9.15—Radio Orchestra. Conductor: Gason. Overture, "A Night in Venice" (Strauss). Serenade, "Frasquita" (Lehar). Selection, "The Chocolate Soldier" (O. Strauss). Suite, Mascarade (Lacome). In a Monastery Garden (Ketelbey). Valse des fleurs (Tchaikovsky).

10.0—News.
10.10-11.0—Serenade.
BRUSSELS (No. 2) (Belgium)
932 kc/s (321.9 m.); 15 kW.
Programme in Flemish.
6.30-9.5 a.m.—Records; Gym; News.
12.0 noon—Records.
12.31 p.m.—Salon Orchestra.
1.0—News; Shipping.
1.10—Brenders Jazz Band.
1.30—Songs in Folk Style.
1.40-2.0—Records.
4.55—News.
5.0—Salon Orchestra; Records.
5.45—For Children.
6.30—Hullebroeck Songs; Talk.
7.0—K.V.R.O. Notes; Film Review.
7.3—Readings: Albe, Demeds, Verbeek and Verammen.
7.30—Economic Review.
8.0—European Concert from Eire (for details see Radio Eireann).
9.0—Talk by Abbé Lepoutre: Irish Humour.
9.15—I.N.R. Symphony Orchestra. Conductor: Franz André. Resnik (Songs). Overture to a Tragicomedy (de Roos). Excerpts, Triumph der Empfindsamkeit (Krenek). Songs (Mussorgsky, Rimsky-Korsakov). Symphonic Poem, Vlaanderen (Neuville). Suite, Jeanne d'Arc (Rosenthal); at 10.0—News.
10.30—Records.
10.50-11.0—Records: Vespers by the Don Cossacks Choir. Conductor: Jaroff.

BUCHAREST (Romania)
823 kc/s (364.5 m.); 12 kW.
Relayed by Radio-Romania, 160 kc/s (1,875 m.).
Transmits at intervals from 4.30 a.m.
4.5 p.m.—Radio Dance Band; at 5.0—Book Review.
5.50—Educational Talk.
6.5—Mme Else Kraus (Pfte.). Impromptu (Schubert). In der Nacht (Schumann). Traumeswirren (Schumann). Ihr wandelt droben im Licht (Brahms).
6.35—French Songs sung by Felicie Volaneseo. Arias, "Esclarmonde" (Massenet), "Lakmé" (Delibes), and "La Marquise" (Massenet). Madrigal (Chaminade). Waltz Song, "Romeo and Juliet" (Gounod).
6.55—Talk on the 7.15 Concert.

7.15—Berlin Philharmonic from the Athenaeum. Guest Conductor: von Benda. Symphony, La chasse (Haydn). Serenade for Strings (Dvorak). Concerto for Wind Instruments and Strings (Handel). Symphony (Mozart). In the interval, News and Sports Notes.
9.0—Records.
9.45—News (French, German).

BUDAPEST (No. 1) (Hungary)
546 kc/s (549.5 m.); 120 kW.
Transmits at intervals from 5.45 a.m.
11.5 a.m.—Operetta Records.
11.30—News; Operetta Records.
12.30 p.m.—Station Band.
1.40—News.
3.15—Blanka Simon.
4.0—For Farmers.
4.30—Literary Evening of the Pázmány Society, from the Redoute.
6.0—Hungarian Songs by Margit Matolcsy with the Csorba Cigány Band.
7.5—Talk: John Keats.
8.0—European Concert from Eire (for details see Radio Eireann).
9.0—News.
9.25—Old Hungarian Music—Opera Orchestra. Conductor: Dohnanyi. Overture, The Bride of Messina (Fusz). Second Symphony (Moór). Overture, Romeo and Juliet (Szabados).
11.5—News for Hungarians Abroad.

BUDAPEST (No. 2) (Hungary)
359.5 kc/s (834.5 m.); 18 kW.
4.40 p.m.—Records.
6.0—English Lesson.
7.0—Symphony Orchestra. Conductor: Melles.

COLOGNE (Germany)
658 kc/s (455.9 m.); 100 kW.
Transmits at intervals from 5.0 a.m.
11.0 a.m.—German Opera Music.
12.0 noon—News; Greetings.
12.15 p.m.—European Dances.
1.0—News.
1.15—Light Music—Sextet.
2.0—Variety.
2.30—Legal Hints; Talk; Books.
3.0—See Deutschlandsender.
4.0—Tummler, Tyrolese Poet.
4.20—Contemporary Composers—Wind Instrument Ensemble. Divertimento (Pannier). Suite (Weismann). Grottesque Suite (Bettingen).
5.0—For Gardeners; Songs.
5.40—Poems (Schnack).
5.50—Snapshots; News.
6.10—German Folk-Songs and Ballads—Station Choir, Baritone.
7.0—"Agnes Bernauer"—Play (Hebbel).
8.0—Bund Dance Band.
9.0—News.
9.20—Italian Lesson.
9.35-11.0—Light and Dance Music.

DEUTSCHLANDSENDER (Germany)
191 kc/s (1,571 m.); 60 kW.
Transmits at intervals from 5.0 a.m.
11.0 a.m.—12.45 p.m.—See Breslau.
12.45—News.
1.0—Variety—Jäger Band and Records.
2.0—Weather; Exchange; Markets.
2.15—Chamber Music.
3.0—Eschrich Band; at 4.0-4.10—Reading.
5.0—Wikarski (Pfte.).
5.25—Trautonium and Pfte.; Talk.
6.0—Motto; News.
6.10—"A Merry Roundelay"—Saxophone Quartet, Women's Trio, etc. (Recorded).
7.0—Concert—Orchestra and Solo Voices. Conductor: List.
8.0—Evening Echoes.
8.15—Concert (contd.).
9.0—News; Sports; Topical.
9.30-9.45—Suite (Busoni).
10.0-11.0—Music from Hamburg.

FRANKFURT (Germany)
1,195 kc/s (251 m.); 25 kW.
Cassel, etc. See Sunday.
Transmits at intervals from 5.0 a.m.
11.0 a.m.—Station Orchestra.
12.0 noon—Time; News.
12.15 p.m.—Station Orchestra.
1.0—News; Labour Exchange.
1.10—Records; Viennese Music.
2.0—Picture-Book of the Week.
2.30—Götz von Berlichingen Programme (Recorded); Sports.
3.0—Wagner Records.
4.0—Opera and Operetta Music by the Constance Municipal Orchestra. Conductor: Fender.
5.0—Topical Review; Records.
6.0—Time; News.
6.10 (from Cassel)—"Landscapes"—Orchestra. Conductor: Seidler.
7.10 (from Cassel)—Voices of the Landscape—Waldeck.

8.0—European Concert from Eire (for details see Radio Eireann).
9.0—Time; News; Sports.
9.30—See Stuttgart.

11.0 p.m.—1.0 a.m. (Friday)—Serenade on Records. Part 1, "Susanna's Secret" (Wolf-Ferrari). Part 11, Prelude, Das Fest auf Solhaug (Pfitzner). Pfte. Concerto in G (Schumann). Nänic (Brahms). Symphonic Poem, Hamlet (Liszt).

HAMBURG (Germany)
904 kc/s (331.9 m.); 100 kW.
Bremen, etc. See Sunday.
Transmits at intervals from 5.10 a.m.
11.0 a.m.—Kiel Orchestra.
12.0 noon—Weather; Review.
12.15 p.m.—See Frankfurt.
1.0—News; Music.
2.0—Shipping; Markets.
2.25—Records; Overtures.
2.50—Ice Report.
3.0—Light Music—Station Dance Band, Songs. In the interval, Talk.
4.15—"Hi! Taxi!"—Variety.
5.0—Tales and Songs by Hitler Youth; Records.
5.45—Weather; Shipping; News.
6.10—Dances—Station Orchestra.
7.0—Topical Review.
7.10—"Melodies of Spring" (arr. Kulenkampf and Wirth), with Records.
8.0—European Concert from Eire (for details see Radio Eireann).
9.0—News.
9.20—An Organ Builder talks about his Work.
9.30-11.0 (from Hanover)—Symphony Orchestra. Conductor: von Sosen.

HILVERSUM (No. 1) (Holland)
160 kc/s (1,875 m.); 10 kW until 4.40 p.m.; 150 kW from 4.40 p.m. Also on Jaarsveld, 722 kc/s (415.4 m.); 17 kW.
AVRO Programme.
7.40 a.m.—Time; Records.
9.40—Service; Records.
10.10—AVRO Orchestra.
10.40—Dressmaking Lesson.
11.10—AVRO Orchestra. Conductor: Treep.
12.10 p.m.—Records.
12.40—Concert by the Palladians.
1.40—For Women.
2.10—Pierre Boessen (Songs).
2.40—Dressmaking Lesson.
3.25—Pierre Palla (Organ).
3.40—For Hospitals; Records.
4.30—Play for Children.
5.10—AVRO Orchestra. Conductor: Treep.
6.10—Sports Talk; For Children.
6.45—AVRO Dance Band.
7.10—English Lesson.
7.40—News; Records.
8.0—Concertgebouw Orchestra from the Concertgebouw, Amsterdam. Conductor: Bruno Walter. Ernst Krenek (Pfte.). Symphonic Poem, Death and Transfiguration (R. Strauss). Pfte. Concertino (Krenek). Symphony in D (Brahms).
10.10—Records.
10.40—AVRO Dance Band. Conductor: Mossel.
11.20-11.40—Palla (Organ).

HILVERSUM (No. 2) (Holland)
995 kc/s (301.5 m.); 15 kW until 6.10 p.m.; 60 kW from 6.10 p.m.
7.40-8.55 a.m.—KRO Programme: Records.
9.40-10.40—NCRV Programme.
9.40—Salvation Army Records.
9.55—Service; Records.
10.40 a.m.—1.40 p.m.—KRO Programme: Records.
11.10—Religious Address.
11.40—Police Messages; Weather.
11.55—KRO Orchestra. Conductor: van 't Woud.
1.40 till Close—NCRV Programme.
1.40—Handicrafts Lesson.
2.40—Arthur Gray (Organ).
3.25—Bible Reading.
4.25—Records.
4.40—Handicrafts for Children.
5.10—Hartvelt (Violin), Hermann (Violin and Viola). Sonata in G for Two Violins (Leclair). Duet for Violin and Viola (Mozart). Sonatina for Two Violins (Beck). Records in the intervals.
5.55—Records; Talk.
6.40—Police Messages; Church Notes; Records.
7.10—News; SOS Messages.
7.25—St. Matthew Passion (Bach). Haarlem Oratorio Choir, Boys' Choir, Utrecht Municipal Orchestra. Conductor: George Robert. To v.d. Sluys (Soprano), Annie Woud, (Contralto), v. Tulder (Tenor), Bogtman (Bass); at 8.55-9.15—Meditation on the Passion.
10.40—News.
11.5-11.40—Records; Bible Reading.

KALUNDBORG (Denmark)
240 kc/s (1,250 m.); 60 kW.
Relays Copenhagen, 1,176 kc/s (255.1 m.).
Transmits at intervals from 6.0 a.m.
11.0 a.m.—1.0 p.m.—Louis Preil's Ensemble.
1.15—Gym for Schools.
1.35—Reading (Wied).
2.0—Wivex Orchestra.
3.30—For Children; Notes.
4.0—Recitations by Budtz.
4.25—Weather; Exchange; Markets.
4.50—Hartwigsen (Accordion).
5.15—Talk by Julius Clausen.
5.35—English Lessons.
6.0—Time; News.
6.30—Discussion: Private Enterprise or Co-operation?
7.0—Records: Alt-Wien (Schubert-Friedman).
7.10—Twenty-Second Thursday Concert. Wagner Music: Symphony Orchestra, Guest Conductor: Fritz Busch; Ingeborg Steffensen, Betty van den Bosch, Martin Ohman and Holger Byrding (Singers). Act 2, "Tristan and Isolde." Ten Minutes Interval. Scene, "Segfried."
9.0—News.
9.20—Marcus Lauesen reads.
9.40—Russian Music. Balalaika Sextet, Hilmar Biehe (Tenor). Potpourri, Gipsy Romance (Prisgashawo). Folk Song (Vasiliev). Russian Gipsy Song (Orlov). Troika, Mazurka (Wieniawski). Magnolia (Vertinsky). Good-bye to the Gipsy Camp. Gipsy Song (Artemiev). March (arr. Andreev).
10.15-11.30—Louis Preil's Dance Band; at 11.0—Chimes.

KÖNIGSBERG (Heilsberg) (Germany)
1,031 kc/s (291 m.); 100 kW. Relayed by Danzig, 1,303 kc/s (230.2 m.).
Transmits at intervals from 5.0 a.m.
11.0 a.m.—1.0 p.m.—See Frankfurt.
1.0—News; Talk; Variety.
1.55-2.0—Exchange.
2.30—Children's Choir; Reading.
3.10—Station Orchestra, Oboc, Two Pftes.; at 4.0—Week-end Hints.
4.50—For Girls.
5.0—"The German Farmhouse"—Word Pictures (Würpel).
5.20—Rafalski (Bass), Hildegard Scharnick (Pfte.).
5.50—Announcements; News.
6.10—Songs, Melody and Humour (arr. Witt)—Station Orchestra. Conductor: Wöllner.
8.10—Topical Review.
9.0—News; Sports.
9.20—Talk: German Economics.
9.40-11.0—Music from Stuttgart.

LAHTI (Finland)
166 kc/s (1,807 m.); 150 kW. Relays Helsinki, 895 kc/s (335.2 m.).
Transmits at intervals from 9.15 a.m.
3.0 p.m.—Radio Sextet. March, Wien bleibt Wien (Schrammel). Salut d'Amour (Elgar). Minuet (Boltoni). Excerpts, "The Maid of the Black Forest" (Jessel). Nocturne (Becke). Waltz, Moonlight on the Aister (Fetras). Humoresque (Dvorak). Marche militaire (Schubert).
3.50—Talk: Nineteenth Century Hungarian Painting.
4.10—Helga Virkkunen (Songs).
4.30—Topical Talk.
5.15—Arno Erfurt (Pfte.). French Suite (Bach). Sonata (Beethoven).
5.45—Discussion.
6.10—Finnish Music—Radio Orchestra. Conductor: Linko.
7.0—Recitations.
7.25—Lehar Records.
7.35—News (Finnish, Swedish).
7.55—Talk on the following Concert.
8.0—European Concert from Eire (for details see Radio Eireann).
9.0-10.0—Records: Light Music.

LEIPZIG (Germany)
785 kc/s (382.2 m.); 120 kW. Relayed by Dresden, 1,285 kc/s (233.5 m.).
Transmits at intervals from 5.0 a.m.
11.0 a.m.—1.0 p.m.—See Frankfurt.
1.0—News; Exchange; Records.
2.5—Books about Russia.
2.25—"The Lucky Shoe"—Fairy tale (Vetter).
2.50—Brazilian Bulletin.
3.0—Opera and Operetta Records; at 4.0-4.10—Time; Notes.
5.0—Mme de Staël's Impressions of Germany.
5.20—Krietsch, v. Frankenstein, and Trunk Songs by Hamer (Bartok).
5.45—Talk: Labour Problems.
6.0—News.

6.10—Egerland Folk Music.
6.50—Talk: Careers.
7.0—"Life's Joyous Melody"—Dresden Orchestra and Singers.
9.0—News; Sports; Books.
9.40-11.0—Music from Stuttgart.

LILLE (Radio PTT Nord) (France)
1,213 kc/s (247.3 m.); 60 kW.
Transmits at intervals from 6.30 a.m.
7.0 p.m.—"La soirée d'hier"—Play (Timmory).
7.30—News; Variety.
8.30—Thursday Night Variety. Lens Workers Band. After the Programme, News.

MONTE CENERI (Switzerland)
1,167 kc/s (257.1 m.); 15 kW.
Transmits at intervals from 4.0 a.m.
6.50 p.m.—News.
7.0—Records: Arie e danze antiche (Respighi).
7.15—Talk: The Cultural Collaboration of the three Races in Switzerland.
7.30—Gina Bernelli (Soprano). Arias from "A Carnival in Venice" (Thomas), "La Sonnambula" (Bellini), "Rigoletto" (Verdi), "Lucia di Lammermoor" (Donizetti), and "Don Pasquale" (Donizetti).
8.0-9.0—European Concert from Eire (for details, see Radio Eireann).

MOSCOW (No. 1) (Russia)
172 kc/s (1,744 m.); 500 kW.
4.30 p.m.—From the Opera.
8.30—News; Kremlin Chimes.
9.0—Programme in French.
10.0-12.0 m't.—Talks in Spanish.

MUNICH (Germany)
740 kc/s (405.4 m.); 100 kW. Relayed by Nürnberg, 1,267 kc/s (236.8 m.).
Transmits at intervals from 5.0 a.m.
11.0 a.m.—Concert on Records.
12.0 noon—News; Topical.
12.15 p.m.—Station Orchestra, Pfte.
1.0—News; Exchange.
1.15—See Cologne.
2.0-2.30—Puppet Play.
3.0—Fidel Trio (Records); Books.
4.0—Time; Weather; Markets.
4.10—Light Orchestra. In the interval, Report: Nürnberg, City of Artists.
5.45—Topical; News.
6.10—"Festival in Millöcker's Family"—Musical Play, with the Composer's Music (arr. Hartung)—Station Orchestra. Choir, etc.
8.0—"Friendship"—Sequence in Words and Music (arr. Würzbach) with the Walter Quartet, Schmidmeier (Pfte.). Excerpts, Double Violin Concerto (Bach). Reading (Dach). Quartet Movement (Mozart). Reading (Schiller, Körner). Quartet Movement (Mozart). Reading (Hölderlin). Quartet Movement (Mozart). Reading (v. d. Marwitz). Quartet Movement (Mozart). Reading (Nietzsche). Allegro. Double Violin Concerto (Bach).
9.0—News; Sports.
9.20-11.0—Serenade—Station Orchestra, Soprano, Pfte., Accordion.

NAPLES GROUP (Italy)
Naples, 1,104 kc/s (271.7 m.); 10 kW. Florence (No. 1), etc. See Sunday.
6.0 p.m.—Music and Songs; Topical.
6.20—"I virtuosi campagnoli."
7.0—See Rome Group.
7.30—"The Cinema Star" (Gilbert).
9.0 (approx.)—Dance Music.
10.0—News.
10.15-11.0—Dance Music.

OSLO (Norway)
260 kc/s (1,153.8 m.); 60 kW. Fredrikstad, etc. See Sunday.
Transmits at intervals from 9.30 a.m.
5.0 p.m.—Service.
5.25—Cigany Music.
5.45—News; Report; Talk.
7.5—Mme Hulda Frisk Gran (Songs) and Ilnka Bartok Kopsland (Pfte.). Songs (Rachmaninoff, Tchaikovsky, Rimsky-Korsakov, Mussorgsky, Tcherpnin). Pfte.: (a) Two Pieces (Kodaly), (b) Hungarian Folk Melodies (Bela Bartok).
7.40—Talk.
8.0—European Concert from Eire (for details see Radio Eireann).
9.0—News; Topical.
9.15-9.45—Orchestral Concert.

PARIS (Eiffel Tower) (France) 1,456 kc/s (206 m.); 7 kW. Transmits at intervals from 6.30 a.m. 7.30 p.m.—News. 8.0—Alice Raveau (Songs) and Ginette Guillemat (Pfte.). Songs (Duparc). Sonatina (Ravel). Songs (Duparc). 8.30—Concert by "La Sérénade." 10.30—Records. 11.0—News.

PARIS (Poste Parisien) (France) 959 kc/s (312.8 m.); 60 kW. Transmits at intervals from 7.10 a.m. 12.0 noon—Exchange; Records. 12.15 p.m.—Talk for Children. 12.25—News; Exchange. 12.39—Variety Concert. 1.10—"La course au trésor," with Pierre Dac. 1.20—For Children; Amusements. 1.45—Bible Stories in Pictures. 2.0—Exchange; News; Records. 2.15-3.0—For Children. 3.45 and 4.35—Exchange. 5.0—News; Cabaret. 6.0—Exchange; News. 6.10—"The Adventure Club." 6.25—Thérèse Dorny and Jaboune. 6.58—Racing; Topical; Sports. 7.10—Amusements; Variety. 7.40—Legal Talk. 7.45—Paris Programme, with Jean Rieux. 8.0—Topical. 8.10—"Les Frères Jacasse." 8.15—"Plaisirs de Paris"—Variety, with Choir, etc. Conductor: Stello. 8.45—Talk. 9.0—News. 9.10—"Special Edition" (Diamant-Berger). 9.20—"International Stars." 10.0—Records: "Faust" (Gounod). 10.30-11.0—Cabaret.

PARIS (PTT) (France) 695 kc/s (431.7 m.); 120 kW. Transmits at intervals from 6.30 a.m. 4.0 p.m.—Marcelle Branca (Songs). 4.15—Talks; For Children. 4.45—Records. 5.45—Grammar Lesson. 5.50—Talks. 6.30—Mignard (Organ), from the Schola Cantorum. Prelude in E minor (Bach). Choral, Mein Jesu der du mich (Brahms). Excerpt, Third Symphony (Vierne). Prelude in C (Saint-Saëns). 7.0—Radio Journal; News. 8.0—Robert Buguet (Songs). 8.15—Paule Sandra (Songs). 8.30—Plays: (a) "Dernières manœuvres"—Drama (Denyse and Marc Denis), (b) "Kleist, le poète méconnu"—Romantic Tragedy (Fieldman). 10.30—News; Weather. 10.45—The Children's Corner (Debussy) by Gieseking (Pfte.)

PARIS (Radio-Paris) (France) 182 kc/s (1,648 m.); 80 kW. 6.28 a.m.—Programmes; Records. 6.40—Time; News; Gym; Records. 7.15—News; Records. 8.0—News; Programmes. 8.35—Talk for Boy Scouts: Lord Baden-Powell. 8.50-9.20—Records. 10.15—Programmes; Records. 10.45—Reading; Records. 11.45—Exchange; Markets. 12.0 noon—Protestant Address. 12.20 p.m.—Bailly Orchestra. 1.0—Time; News; Exchange. 1.30—Songs. 1.45—Bailly Orchestra. 2.0—Programmes; Talk: Novels. 2.15—Talk: The Cinema. 2.30—Exchange; Markets. 2.45—Simone Jacson (Pfte.). 3.0—Songs; Talk; Poetry. 3.25—Colonial Review. 3.35—For Sportsmen. 3.45—Exchange; Markets; Records. 4.15—Educational. 4.30—Music Talk (Mme Landowska). 4.45—Exchange; Markets. 5.0—"La jeuneuse de Henri V"—Play (Duvai). 6.0—Lenten Address from the Reformed Church, Passy. 6.58—Programmes; Talk; Music. 7.30—Medical Talk; Reading. 7.59—Time; Foreign and Home Affairs. 8.15—Paulette Fouquet (Songs). 8.30—"Le médecin malgré lui"—Comedy (Molière); "L'éducation manquée"—One-Act Play (Chabrier), from the Opéra-Comique. In the intervals, News; Review. After the Programme, Time; News.

PRAGUE (Czechoslovakia) 638 kc/s (470.2 m.); 120 kW. Transmits at intervals from 5.15 a.m. 5.45 p.m.—News and Review (German). 6.0—Time; News; Weather; Local News. 6.15—See Brno. 7.40—Talk: The Military College. 7.55—Talk on the following Programme. 8.0—European Concert from Eire (for details see Radio-Eireann). 9.0—Time; News; Sports. 9.15—Russian Lesson. 9.35-10.20—Krenek and Milhaud Music by the Prague Wind Quintet, Peska Quartet, etc. Symphonic Music for Nine Solo Instruments (Krenek). Pieces (Milhaud): (a) Le printemps, (b) Pastorale, (c) Sérénade.

RADIO EIREANN (Eire) 565 kc/s (531 m.); 100 kW. Dublin, etc. See Sunday. 11.30 a.m.—High Mass and Sermon in Irish from the Cathedral, Tuam. Children's Choir. Mass sung by his Lordship, the Most Rev. Dr. Walsh, Titular Bishop of Cella and Auxiliary Bishop of Tuam. 12.45 p.m.—Talk in Irish by Muir O'Dubhghadhl: St. Patrick and Politics. 1.0—Records. 3.0—Running Commentary on the Railway Cup Finals—Hurling and Football, from Croke Park, Dublin. 5.30—Keating Branch Choir and Orchestra. 6.15—Review of Irish News by Cearbhall Ua Dalaigh. 6.45—News in English. 7.0—Vocal Quartet. 7.20—Leo Rowsome (Pipes). 7.30—Sean Curtis (Tenor). 7.40—"How does she stand?"—A Discussion by Pioneers of the Gaelic League of Ireland.



Exclusive "World-Radio" Picture Mademoiselle Violette Sarailion, "Rosette" in the play, "Kleist" at Paris (PTT), at 8.30 p.m.

8.0—European Concert of Irish Music. The Orchestra of the Irish Broadcasting Service, a Vocal Quartet, Leo Rowsome (Pipes), Sean Curtis (Tenor), from Dublin. Orchestra and Vocal Quartet: National Anthem. Mo Thir (My Country) (arr. Brendan Rogers). Orchestra: The Wearing of the Green. National Marches (arr. Vincent O'Brien): (a) The Eagle's Whistle, (b) Oro se do bheatha bhaile (Welcome to the Home), (c) Fianna Marches. Orchestra and Vocal Quartet: The Spirit of the Nation (arr. Vincent O'Brien): (a) Step Together, (b) Three thousand miles away, (c) A Shamrock from the Irish Shore, (d) Oh! the Sight Entrancing, (e) Brian Boru's March. Pipes: (a) The Dear Little Shamrock, (b) St. Patrick was a Gentleman, (c) St. Patrick's Day. Songs for Tenor and Orchestra (arr. E. O. Gallchohair): (a) Lament, An raibh tu ag an Rock? (Have you been to the Rock?), (b) Love Song, Caire na mBan (Women's Laughter), (c) Lullaby, Seo leo thoil (Nurse's Tale). 8.40—To be announced. 8.50—Dublin Metropolitan Garda Cellidhe Band. Conductor: Superintendent O'Donnell Sweeney. 9.0—Nan Mulligan's Choir. 9.15—Mr. de Valera speaks to the Irish abroad. 9.30—Variety. 10.30—News. 10.45-12.0 m't.—Dublin Metropolitan Garda Cellidhe Band.

RADIO-NORMANDIE (France) 1,113 kc/s (269.5 m.); 15 kW. 6.45 a.m.—Band; Records. 7.15—News; Press Review. 7.45—Physical Exercises. 8.0—Surprise Programme with Ruth Dunning. 8.15—"Musical Contrasts"—Songs Old and New. 8.30—Popular Tunes. 8.45—Normandie Playbill—Announcements; Music. 9.0—Variety. 9.15—Pat Hyde and Dinay Miller, Bob Walker and Arthur Young. 9.30—Favourite Melodies. 9.45—Hildegard. 10.0—Radio Favourites. 10.15—The Open Road. 10.30—Parade. 10.45—Cinema Organ. 11.0—Dance Music. 11.15—Popular Programme. 11.30—Chansonnettes. 12.0 noon—Orchestra. 12.20 p.m.—Military Band. 12.45—Radio Journal; News. 1.0—For Children. 2.30—Variety. 2.45—Beauty and Romance. 3.0—Familiar Tunes. 3.30—Hawaiian Magic. 3.45—"The Musical Mirror." 4.0—Jane and John. 4.15—Tapping in Rhythm. 4.30—Variety. 4.45—On with the Show. 5.15—For Boys and Girls. 5.30—Paul Oliver; Olive Palmer. 6.0—Markets. 6.5—Orchestra. Overture, "Don Pasquale" (Donizetti). Excerpts, "The Valkyrie" (Wagner), "Tannhäuser" (Wagner) and "A Country Girl" (Monckton). 6.45—Talk; News; Racing. 7.0—Light Music. 7.25—Radio Journal; News. 7.45—Band. 8.0—Rina Ketty and Jean Sirjo. 8.40—Concert. 8.40—Café Concert. 12.0 m't.—Melody at Midnight. 12.30-1.0 a.m. (Friday)—Dance Music.

RENNES-BRETAGNE (France) 1,040 kc/s (288.5 m.); 120 kW. Transmits at intervals from 6.30 a.m. 7.0 p.m.—News; Records. 8.0—European Concert from Eire (for details see Radio Eireann). 9.0—Records. 9.15—See Strasbourg. After the Concert, News and Light Music.

ROME GROUP (Italy) Rome (No. 1), 713 kc/s (420.8 m.); 100 kW. Bari (No. 1), etc. See Sunday. Transmits at intervals from 6.45 a.m. 4.0 p.m.—News. 4.15—Gianna Peria Labia (Soprano) and Harvedo Felicioli (Tenor). 4.45—Aviation Notes; Talk. 5.0-5.25—For Merchant Shipping. 6.0—Talk in Spanish. 6.20—Dopolavoro Notes; Records. 7.0—Time; News. 7.20—Italian Lesson; Music. 8.0—"Carmen" (Bizet) from the San Carlo Theatre, Naples. Cast: Francesco Battaia, Mario Basiola, Oscar Cipparone, Sante Messina, Mattia Sassanelli, Attilio Bordonali, Giana Pedersini, Elisa Fironi, Maria Rubino, Olga De Franco. In the interval—Talks and News.

SOTTENS (Switzerland) 677 kc/s (443.1 m.); 100 kW. Relayed by Geneva, 401 kc/s (748 m.). 11.30 a.m.—News; Records. 12.15 p.m.—Records: Sonata in G (Beethoven). 12.30-12.45—Chaliapin Records. 4.0—Radio-Genève Ensemble. 4.40—Conchita Milanes (Spanish Songs). 5.0—Cookery Hints. 5.20—English Music by the Radio Suisse romande Orchestra. Conductor: Appia. Rustic Revels (Percy Fletcher). Irish Melody (Grainne). The Jester at the Wedding (Eric Coates). A Manx Rhapsody (Haydn Wood). 6.0—For Farmers. 6.10—Review: Arts and Letters. 6.20—Announcements; Music. 6.50—News; Weather. 7.0—Dancing Contest—Jo Baur and his Six Cadets; Report by Squibbs. 7.30—Contemporary Swiss Music. Radio Suisse romande Orchestra. Conductor: Haug. Suite enfantine (Haug). Three Sketches (Reichel). 8.0-9.0—European Concert from Eire (for details, see Radio Eireann).

THURSDAY (March 17) 9.0-9.30—Reports: The Eighth International Horse Show at Geneva—the Geneva Grand Prix and the Jumping Contests.

STOCKHOLM (Sweden) 704 kc/s (426.1 m.); 55 kW. Motala, etc. See Sunday. Transmits at intervals from 6.20 a.m. 4.5 p.m.—Service. 4.30—Gunno Södersten plays his own Pfte. Music. Introduction and Fugue in C minor, Preludium dolente, Nocturne, Humoresque. Varbäcken, Etude in D flat. 4.45—For Children. 5.5—Records. 6.0—News. 6.30—Radio Rhapsody (arr. Jerico) Music by Waldimir, with Waldimir's Orchestra, etc. 7.20—Talk by an Old Swedish-American Emigrant. 8.0—European Concert from Eire (for details see Radio Eireann). 9.0—News. 9.15-10.0—Septimian Orchestra.

STRASBOURG (France) 859 kc/s (349.2 m.); 100 kW. Transmits at intervals from 6.30 a.m. 6.30 p.m.—Orchestra. Conductor: de Villers. Mme A. van Barentzen (Pfte.) Overture, "Titus" (Mozart). Second Pfte. Concerto (Jerzy-Fitelberg). 7.0—News. 7.30—Mme A. van Barentzen (Pfte.). Nolette (Poulenc). Toccata (Vellones). Sonatine (Roussel). 7.45—News (German). 8.0—côte Rennes-Bretagne and Nice-Côte d'Azur—European Concert from Eire (for details see Radio Eireann). 9.0—Time; News. 9.15—Dvořák Concert. Station Orchestra. Conductor: de Villers. Rémond (Cello). Carnival. "Cello Concerto. Slav Dances. 10.30—News (French, German).

STUTT GART (Germany) 574 kc/s (522.6 m.); 100 kW. Transmits at intervals from 5.0 a.m. 11.0 a.m.-1.0 p.m.—See Frankfurt. 1.0-2.0—Records. 3.0—Concert from Karlsruhe and Mannheim—Orchestra, Band, etc. 5.0—"The People's Library"—Sequence (Weis). 5.30—Topical Review. 6.0—News; Topical. 6.15—Orchestral Records. 7.0—"As you like it"—Musical Sketch-Book (arr. Ganss). 8.15—Lina Staab Poems. 8.30—Mozart Music by Kusche and Sonnen (Pftes.). Fantasia in D minor. Sonata in B flat. 9.0—News; Sports. 9.30—Folk and Light Music—Folk Music Ensemble, etc. 11.0 p.m.-1.0 a.m. (Friday)—See Frankfurt

TOULOUSE (Radio-Toulouse) (France) 913 kc/s (328.6 m.); 60 kW. Transmits at intervals from 8.0 a.m. 6.55 p.m.—News; Sports. 7.15—Oleretta Songs. 7.45—Soldier Songs. 8.0—Light Music. 8.25—Talk. 8.30—Variety. 8.45—Light Music. 9.10—Talk; Light Music. 9.30—Léhar Music. Excerpts, "The Land of Smiles." Russian Dances. 10.0—News. 10.15—English Concert. 11.15—Dance Music. 11.35—Light Music. 11.50-12.0 m't.—News.

TURIN GROUP (Italy) Turin (No. 1), 1,140 kc/s (263.2 m.); 7 kW. Milan (No. 1), etc. See Sunday. Transmits at intervals from 6.45 a.m. 4.0 p.m.—News. 4.15—Renzo Ferrari (Soprano), Alessandro Carnevali (Baritone). Arias, "Faust" (Gounod), "The Pearl Fishers" (Bizet), and "Amleto" (Faccio). 4.45-5.25—See Rome Group. 6.20-7.30—See Rome Group. 7.30—Cetra Orchestra. 8.0—European Concert from Eire (for details see Radio Eireann). 9.0—"Judge Bertrand's Cases"—One-Act Play. 10.0—News. 10.15-10.55—Dance Music.

VIENNA (Austria) 592 kc/s (506.8 m.); 100 kW. Graz, etc. See Sunday. Transmits at intervals from 5.45 a.m. 11.0 a.m.—Records of Willy Schneider (Songs).

12.0 noon—Weather; News. 12.10 p.m.—César Franck Records. Symphonic Variations, by Cortot and the London Philharmonic. Conductor: Sir Landon Ronald. Symphony in D minor, by the Philadelphia Symphony Orchestra. Conductor: Stokowski.

1.0—Records: The Reiter Quartet (Haydn), by the Buxbaum Quartet. 1.15—Announcements. 1.30—Talk: Popular Education in Vienna. 2.0—Weather; Exchange; Markets. 2.15—Fairy-Tales, Stories and Legends—Elisabeth Markus (Reading). Adelheid Bergmann (Songs). 2.40—For Unemployed Youth. 3.0—News; Markets. 3.5—Ketebeby Records. By the Blue Hawaiian Waters. Birthday Greetings. Chal Romano. Moonlit Glade. In a Chinese Temple Garden. Sanctuary of the Heart. In a Monastery Garden. Bachanal in Montmartre. Rhapsody. Adagio cantabile. Agitato furioso. Bells across the Meadows. Fate. Amaryllis. In a Persian Market. 4.0—Talk: Ignaz Konta. 4.10—Talk by Marcella d'Arle: My Visit to the Grand Mufti of Jerusalem. 4.25—Reger Music by Georg Steiner (Violin), and Hedeliese Haupt (Pfte.). Suite in A minor. Petite caprice. Capriccio. 4.55—Art and Theatre Review. 5.10—For Young People. 5.55—Cultural Review. 6.0—News; Weather; Snow Report. 6.25—Mass in C (Gassmann). Vienna Hofmusikkapelle. Conductor: Grossmann. Wilhelm Kretschmer (Treble), Hans Frank (Alto), Tomek (Tenor), Schramm (Bass). 7.5—"Brüderlein fein" (Fall). State Opera Chorus and Station Orchestra. Conductor: Holzer. Cast: Hans Duhau, Margit Bokor, Hilde Schlitter, Maria Schober. 7.35—Leo Fall Records. 8.0-9.0—European Concert from Eire (for details see Radio Eireann). 9.0-10.30—Keyda Dance Band; at 9.10-9.20—News; and at 9.55-10.0—Announcements.

WARSAW (Poland) 224 kc/s (1,339 m.); 120 kW. Cracow, etc. See Sunday. Transmits at intervals from 5.15 a.m. 10.57 a.m.—Time; Fanfare. 11.3-12.0 noon—To be announced. 2.30 p.m.—Economic Notes. 2.45—For Children. 3.15 (from Torun)—Lisicki and Rösler (Pftes.). Variations on a Beethoven Theme (Saint-Saëns). Impromptu on a Schumann Theme (Reinecke).

3.50—Topical Talk. 4.0 (from Wilno)—Books. 4.15 (from Poznan)—Salon Quintet, Paszkiet (Violin) and Bienkowski (Tenor). The Juggler (Rosey). French Comedy Overture (Kéler-Béla). Songs: (a) Cradle Song (Tchaikovsky), (b) Two Italian Folk Songs. Violin: Danse diabolique (Hubay). Barcarolle (Ferras). Polish Dance (Sewern). 4.50—Sports Notes. 5.10—Letter-Box; Programmes. 5.35—For Country Children. 6.0—Play (Hoomann; trans. Sawicki). 6.30—Excerpts, "The Sleeping Beauty" (Tchaikovsky). 6.50—Topical Talk. 7.0—A Musical Mosaic with Huzarska, Grelichowska, Szpilman, Prokopowicz, Górski and Górzynski. 7.40—News; Topical. 8.0—European Concert from Eire (for details see Radio Eireann). 9.0—Reading. 9.15 (from Wilno)—Sixteenth Century Italian Songs. Pro Arte Double Quartet, etc. Conductor: Ludwig. Io non so come vivo (Stabile). Fuggite amanti (Stabile). Mentr'io fuggivo (Dragone). O mio soavo foco (Stabile). Ohime, crudele amore (Barera). Vedrasi prima senza luce il sole (Palestrina). Bella d'amor guerriera e valorosa (Giovannelli). Spesso il canto ad amare (Griffi). Tal da vostri occhi foco (Quagliato). 9.50-10.0—News.

FRIDAY Mar. 18

National
 For Time Signals, see Monday.
 10.15 a.m. (D)—Service.
 10.30 (D)—Weather Forecast.
 10.45 (D)—The Common Cold : conversation between Doctor and Patient.
 11.0 (D)—For Schools.
 11.50 (D)—Frederick Dalrymple (Organ).
 12.0 p.m. (D)—Jack Hart and his Band.
 1.0 (D)—"As I See It : " James R. Mageean.
 1.15 (D)—Birmingham Philharmonic String Orchestra conducted by Arthur Catterall.
 2.5 (D)—For Schools.
 4.0 (D)—Records—Paul Whiteman.
 4.30 (D)—"Will You Be Mine . . ." with extracts from the novels or plays of Charlotte Brontë, Charles Dickens, William Shakespeare, and St. John Ervine.
 5.0—Alan Bartlett (Violin) : Tempo di minuetto (Kreisler) ; Romance in A (Schumann) ; Four English Sketches (Hurlstone).
 5.0—Troise and his Mandoliers.
 6.0—The First News.
 6.25—Brian Lawrance and his Orchestra.
 7.0—"La Rondine : " a Lyric Comedy with music by Giacomo Puccini. Magda—Ina Souez ; Lisette—Rose Alper ; Ruggero—Heddie Nash ; Prunier—Ivor John ; Rambaldo—Norman Walker ; Conductor—Stanford Robinson. Act 1, Magda's House in Paris ; Act 2, A Ball, Chez Bullier ; Act 3, A Cottage on the Côte d'Azur.
 9.0—The Third News.
 9.20—Britain's Battle Fleet and Other Navies : Lord Strabolgi.
 9.40—"The Ghost Knows Best : " a new Radio-Fantasy—Burlesque by Mabel and Denis Constanturos.
 10.30—Volkslieder of the Sixteenth and Seventeenth Centuries, read by Matthias Wiemann, from Berlin.
 10.45—New Georgian Trio.
 11.15—Jack Jackson and his Band.
 11.30—12.0—Recent Dance Records.

London Regional
 For Time Signals, see Monday.
 10.15-10.45 a.m.—National.
 10.45—Cinema Organ.
 11.15—The Harp Trio.
 11.45—Records of Music by Purcell.
 1.15 p.m.—Alfred Barker (Violin) : Romance (Rachmaninoff) ; Pale Moon (Logan) ; Legend (Delius) ; The Yellow Mayfly (Hubay).
 12.45—Julius Kantrovitch and his Orchestra.
 1.30—Reginald Foort (BBC Theatre Organ).
 2.0—BBC Empire Orchestra.
 3.0—Carlton Hotel Orchestra.
 3.30—Records.
 3.45—BBC Midland Orchestra, conducted by Leslie Heward.
 5.0—The Children's Hour.
 6.0—BBC Military Band.
 6.30—Schubert : John McKenna (Tenor).
 7.0—The Second News.
 7.30—Regional Bulletin for Farmers.
 7.30—Music-Hall Parade. A Tour of Northern Music-Halls.
 8.25—Impression of life in Ardroue.
 9.0—BBC Orchestra (Section D), conducted by Adolf Wiklund. Overture (Larsson) ; Legend (Alfven) ; The Garden of Fand (Bax) ; Karelia (Sibelius).
 10.0—News Summary.
 10.25—Jack Jackson and his Band.
 11.30—Records of Songs by Delius.
 11.50-12.0—Late News Summary.

Midland
 10.15 a.m.—6.0 p.m.—Regional.
 6.0—Ivan Cousins (Pfte.).
 6.30—Regional.
 8.5—"What Industry Offers Your Child : " The Building and Construction Trades—discussion.
 8.45—Jack Wilson's Versatile Five.
 9.15—John Goss (Tenor) ; Norman Tucker (Pfte.).
 10.0-12.0—Regional.

Northern
 10.15 a.m.—6.0 p.m.—Regional.
 6.0—Newcastle String Players.
 6.40—"The Market Garden" on the Moor : " A. G. Britten.
 7.0—The Second News.
 7.20—"Brief Chronicle."
 7.30—Regional.
 8.25—"Masque of Tyne," by John F. Dunby.
 9.0-12.0—Regional.

Western
 10.45 a.m.—6.0 p.m.—National.
 6.0—Regional.
 6.30—Pfte. Medley : records.
 7.0—The Second News.
 7.20—Western Announcements.
 7.30—"Shrubs : " D. Harris and F. G. Cousins.
 7.45—Music of the Church.
 8.20—Short story by Evelyn Waugh.
 8.35—The West of England Ball-room Dancing Championship.
 9.0-10.25—Regional.

Welsh
 10.15 a.m.—6.0 p.m.—Regional.
 6.0—Cinema Organ.
 6.30—Regional.
 3.25—"Ar Nos Wener."
 8.45—Schubert : Haydn Adams (Tenor) ; BBC Welsh Orchestra.
 9.40—"Boys' Clubs in South Wales : " J. Glyn Jones.
 10.0-12.0—Regional.

N. Ireland
 10.15 a.m.—6.20 p.m.—Regional.
 6.30—J. T. Frankland (Organ).
 7.0—The Second News.
 7.20—N. Ireland News.
 7.30—Regional.
 9.0—Wind Ensemble : Quintet in G minor, Op. 14 (Sobeck) ; Quintet, Op. 71 (Beethoven).
 9.45—"As I See It : " James R. Mageean.
 10.0-12.0—Regional.

Scottish
 10.15 a.m.—2.0 p.m.—National.
 2.0—For Schools.
 2.25—Herring Bulletin.
 2.30—For Schools.
 4.0-5.0—National.
 5.0—Regional.
 6.30—Saturday Sport.
 6.40—"Next Week You'll Hear."
 6.50—"The New Education Code."
 Sir James Peck, C.B., F.R.S.E.
 7.0—The Second News.
 7.20—Scottish Announcements.
 7.30—Regional.
 9.40—Lowland Tongue : " Angus."
 10.0-12.0—Regional.

Hours of Transmission in Greenwich Mean Time.

BERLIN (Germany)
 841 kc/s (356.7 m.) ; 100 kW.
 Transmits at intervals from 5.0 a.m.
 11.0 a.m.—1.0 p.m.—See Stuttgart.
 1.0—News.
 1.15—Schneidewind Band.
 2.15—Exchange ; Markets.
 2.35—Fierke Band.
 3.30—Sports Notes.
 4.0—Hamer (Baritone).
 4.10—Jules de Zarembski Pfte. Music by Demetriescu. Mazurka in G sharp minor. Concert Etude in G. Gavotte in B minor. Polonaise in F sharp.
 4.30—Poems ; Hitler Youth.
 5.0—Waltzes—Fierke Band.
 6.0—News ; Opera Records.
 6.45—Evening Echoes.
 7.0—Variety—Station Orchestra. Conductor : Willy Steiner. Schuricke Trio, etc.
 9.0—News ; Sports Notes.
 9.30-11.0—Serenade—Schneidewind and Derksen Bands.

BEROMÜNSTER (Switzerland)
 556 kc/s (539.6 m.) ; 100 kW.
 Relayed by Basle and Berne, 1,375 kc/s (218.2 m.).
 5.30-5.50 a.m. (from Berne)—Gym.
 11.0—Records : Opera Overtures.
 11.29—News ; Exchange.
 11.40-12.45 p.m.—Records.
 3.0—For Women ; Records.
 4.0—Zürich Radio Orchestra. Conductor : Bernhard.
 5.0—For Children ; Talks.
 6.0—Time ; Markets ; Sports.
 6.10—Sound News.
 6.25—Wind Instrument Music of Swiss Composers.
 6.45—Weather ; News.
 6.55—Station Orchestra. Conductor : Bernhard.
 7.15—Old Masters. Berne Male Voice Choir and Karl Erb (Tenor).
 7.55—Ballet Suite (Gluck-Mottl) by the Station Orchestra. Conductor : Bernhard.
 8.10—"The Visit"—Sketch (Victor).
 9.0—Lanigiro Dance Band.
 9.25-9.30—Announcements.

BRATISLAVA (Czechoslovakia)
 1,004 kc/s (298.8 m.) ; 13.5 kW.
 Transmits at intervals from 5.15 a.m.
 7.25 p.m.—"Deep in the Mire"—Comedy (Nadassy-Rejtó, trans. Guttman).
 8.0-10.5—See Prague ; at 9.20—News in Hungarian.

BRESLAU (Germany)
 950 kc/s (315.8 m.) ; 100 kW.
 Relayed by Glewitz and Görlitz, 1,231 kc/s (243.7 m.).
 Transmits at intervals from 4.30 a.m.
 11.0 a.m.—See Hamburg.
 1.0-2.9 p.m.—News ; Exchange ; Records.
 3.0—Orchestra ; at 4.0-4.10—Reading.
 5.0—Talk : Friedrich Hebbel.
 5.20—Reading ; Talk.
 5.55—For Housewives.
 6.0—News.
 6.10—Music of the Nations—Station Orchestra. Conductor : Topitz. Elise Schölzel (Soprano), Malig and Pischner (Two Pfes.). Festival Overture (Lortzing). Three German Dances (Mozart). Three Songs (Brahms). Petite Suite (Debussy). La belle Griselidis (Reinecke). Suite, "The Sleeping Beauty" (Tchaikovsky). Three Songs (Grechaninov). Solweig's Song (Grieg). Suite, "A Masked Ball" (Palmgren). Ballet, "Ritter Pasman" (Joh. Strauss). Aquarallen-Walzer (Strauss).
 8.0—Motto.
 8.10—"Das Tabakskollegium"—Sequence (Hora), with Music arranged by Szuka, Male Voice Choir, Small Orchestra. Dramatic Ensemble, Bertermann (Baritone), and Hattwig (Harpischord).
 9.0—News.
 9.20-10.30—Concert—Mildner (Violin), Hattwig and Zur (Pfes.). and Margarethe Schirdewahn (Soprano).

BRUSSELS (No. 2) (Belgium)
 932 kc/s (321.9 m.) ; 15 kW.
 Programme in Flemish.
 6.30-9.0 a.m.—Records ; Gym ; News.
 12.0 noon—Records ; Orchestra.
 1.0 p.m.—News ; Orchestra.
 1.30—Song Records.
 2.0-3.15—For Schools.
 4.55—News.
 5.0—Salon Orchestra ; Nadine Dechagny (Songs).
 5.45—Sonata (Pizzetti) by Yvonne Van den Bergh (Pfte.) and André Felleman (Cello).
 6.15—Talk : Alexander the Great.
 6.30—Organ Records ; Recitation.
 7.0—Romanian Folk-Songs with Commentary.
 7.30—News.
 8.0—Light Orchestral. Conductor : Walpot. Ferari (Violin). Overture, "Le Postillon de Longjumeau" (Adam). Chinese Dance (Eilenberg). Moment musical (Schubert). Tambourin chinois (Kreisler). Moskova (Leemans).
 8.30—Programme by "Group III" with Lon Landau.
 9.20—Light Orchestral (contd.). Florentine March (Fucik). Emperor Waltz (Strauss). Suite (Guiraud). La Danza (Rossini).
 10.0—News.
 10.10-11.0—Old Netherlands Music—I.N.R. Mixed Choir, Conductor : Gras ; Francine Lepage (Songs) and Watelet (Organ). Fantasie-écho in C (Sweelinck). Psalm (Sweelinck). Songs from a Seventeenth Century Manuscript, "Libellus cantionum catholiarum." Prelude and Fugue in D (Van den Kerckhoven). Psalm (Sweelinck). "Songs from Libellus cantionum catholiarum." Prelude in C (Van den Gheyn).



Professor Kulenkampff, who plays at Brno at 8.5 p.m. On Wednesday and on Saturday he plays for Vienna listeners

BRNO (Czechoslovakia)
 922 kc/s (325.4 m.) ; 32 kW.
 Transmits at intervals from 5.15 a.m.
 6.30 p.m.—Station Orchestra. Conductor : Plichta.
 7.25—See Prague.
 8.0—Talk on the following Concert.
 8.5—Concert from the Philharmonic. The German Philharmonic Orchestra, with Kulenkampff (Violin).
 9.0-10.5—See Prague.

BRUSSELS (No. 1) (Belgium)
 620 kc/s (483.9 m.) ; 15 kW.
 6.30-9.0 a.m.—Records ; Gym ; News.
 12.0 noon—Records.
 12.30 p.m.—Weather ; Shipping.
 12.35—Salon Orchestra. Conductor : Féron.
 1.0—News.
 1.10—Vallez (Musical Saw).
 1.30—Records.
 2.0—Art Notes.
 4.55—News.
 5.0—Casino Concert by the Radio Orchestra. Conductor : Gason. Rachel Piette (Songs), Magnée (Flute).
 6.0—Fashion Review ; Art Review.
 6.15—Lecture-Recital with Records : "Tales of Hoffmann" (Offenbach).
 6.45—Deleuze (Accordion).
 7.0—Dialogue ; Book Review.
 7.15—Records.
 7.30—News.

8.0—Radio Orchestra. Conductor : Gason. Bellemans (Songs). Excerpts, "Sigurd Josalfr" (Grieg). Polonaise brillante (Wieniawski). Songs (Schubert, Chopin). Valse triste (Sibelius). Hungarian Rhapsody (Liszt). Arabesque (Debussy). Spanish Caprice (Rimsky-Korsakov).
 9.0—Talk : Chinese Women.
 9.15—Radio Orchestra (contd.). Minnehaha Suite (Coleridge-Taylor). Scandinavian Dance (Fremolle). Songs (Fauré, Chopin). La Nursery (Inghelbrecht). Summer Days (Coates). Record : Solida Marche (d'Hazet).
 10.0—News.
 10.10—Dance Music by Brenders Jazz Band and Rigueux (Songs).
 11.0—La Brabançonne.

BUCHAREST (Romania)
 823 kc/s (364.5 m.) ; 12 kW.
 Relayed by Radio-Romania, 160 kc/s (1,875 m.).
 Transmits at intervals from 4.30 a.m.
 4.5 p.m.—Predesco Orchestra ; at 5.0—Art Notes.
 5.40—Educational Talk.
 5.55—Sextet in E flat (Beethoven) by the Sextet of the Berlin Philharmonic.
 6.35—Opera.
 9.15—Records : Light Music.
 9.45—News (French, German).

BUDAPEST (No. 1) (Hungary)
 546 kc/s (549.5 m.) ; 120 kW.
 Transmits at intervals from 5.45 a.m.
 11.5 a.m.—Station Orchestra.
 12.30 p.m.—Janesi Toll Cigány Band.
 1.40—News.
 3.15—For Schools.
 4.0—Masa Fesztay.
 4.30—Records of Bing Crosby and Ruth Etting.
 6.0—Foreign Affairs.
 6.15—Sigrid Schnéevoigt (Pfte.).
 6.45—Miklós Surányi Commemoration Programme.
 7.25—Station Orchestra. Sleeping Beauty Overture (Poldini). Transfiguration (Ganne). Seliger Tod (Liszt). Excerpts, "Kaiserin Josephine" (Kálmán). Ewiges Walzer (Fall). Prelude (Vincze). Selection, "Hans the Flute-Player" (Ganne). Hungarian Dance (Rozsavögyi). Flower Waltz (Tchaikovsky).
 8.35—News.
 9.0—Rezső-Horvath Cigány Band from the Keszezy Restaurant.
 10.0—News in English.
 10.5—Szebő Jazz Band from the Café Belvárosi.
 11.5—News for Hungarians abroad.

BUDAPEST (No. 2) (Hungary)
 359.5 kc/s (834.5 m.) ; 18 kW.
 5.30 p.m.—"Tristan and Isolde" (Wagner), from the Royal Opera.

COLOGNE (Germany)
 658 kc/s (455.9 m.) ; 100 kW.
 Transmits at intervals from 5.0 a.m.
 11.0 a.m.—Band.
 12.0 noon—News ; Greetings.
 12.15 p.m.—Station Orchestra.
 1.0—News ; Schrammel Quartet, Zither.
 2.0—Fairy-tales (Andersen), and Music.
 2.30—Book Talk ; Markets.
 3.0—Orchestra. Conductor : Eysoldt ; at 4.0-4.20—Talk by Prigol Robakids.
 5.0—Talk : The Göring Hitler Youth Hostel.
 5.15—The Forum.
 5.45—Talk.
 6.0—News.
 6.10—Variety Concert. Station Orchestra. Conductor : Hagestedt. Workers' Band. Conductor : Warwas. Schrammel Ensemble, The Six Merry Singers and Melitta Wittenbecher (Soprano).
 8.0—For Soldiers—Military Band.
 9.0—News ; Records.
 9.30-11.0—See Berlin.

DEUTSCHLANDSENDER (Germany)
 191 kc/s (1,571 m.) ; 60 kW.
 Transmits at intervals from 5.0 a.m.
 11.0 a.m.—12.45 p.m.—See Hamburg.
 12.45—News.
 1.0—Variety—Jäger Band and Records.
 2.0—Exchange ; Markets.
 2.15—Children's Choir.
 2.40—Play for Girls.
 3.0—Station Orchestra ; at 4.0-4.10—Topical Talk.
 5.0—Old Ballads to Music of Young Composers—Charlottenburg Academy of Music Choir. Conductor : Stumme (Recorded).
 5.25—Sonata in G (Sammartini) by Kötscher (Cello) and Puchelt (Pfte.).
 5.40—Talk : Motto ; News.
 6.10—Mother's Mistake—Humorous Programme.
 7.0—Topical Events.
 7.15—Hippmann Band.
 8.0—"Ein ganzer Kerl"—Comedy (Buch).
 9.0—News ; Sports Notes.
 9.20—U.S.A. Bulletin.
 9.30-9.45—Sonatina in G minor (Schubert) by Margarete Lettermann (Violin) and Dorothea Klotz (Pfte.).
 10.0-11.0—Malachowski Orchestra.

FRANKFURT (Germany)
 1,195 kc/s (251 m.) ; 25 kW.
 Cassel, etc. See Sunday.
 Transmits at intervals from 5.0 a.m.
 11.0 a.m.—1.0 p.m.—See Stuttgart.
 1.0—Time ; News ; Records.
 2.0—Schumann, Brahms and Wolf Songs by Franziska von Dobay (Soprano).
 2.30—For Mothers ; Talk.
 3.0—Orchestra and Choir.
 5.0—Topical Talks ; Records.
 6.0—Time ; News.
 6.10—Variety.
 6.50—Talk on the following Programme.
 7.0—"The Barber of Seville" (Rossini) from the Opera. Conductor : Grüber. Cast : Willy Treffner, Carl Ebert, Maria Madlen Madsen, Herbert Hesse, Matthias Mrakitsch, Marion Hüntten, Emil Staudenmeyer, Oskar Wittzschek, Karl Boosen and Arthur Bahrdt.
 9.30—Time ; News ; Sports.
 9.45—Music from Berlin.
 11.0 p.m.—1.0 a.m. (Saturday)—See Stuttgart.

HAMBURG (Germany)
 904 kc/s (331.9 m.) ; 100 kW.
 Bremen, etc. See Sunday.
 Transmits at intervals from 5.10 a.m.
 11.0 a.m.—Concert from Bremen.
 1.0—News.
 1.15—Music.
 2.0—Shipping ; Markets.
 2.25—New Saxophone Music.
 2.50—Ice Report.
 3.0—Orchestra and Dance Band. In the intervals—Talks.
 5.0—For Children.
 5.10—Sonata in F (Beethoven) by Schöne (Violin) and Gregor (Pfte.).
 5.40—Talk ; Shipping.
 6.0—News.
 6.10—See Cologne.
 7.25—"The First Violets"—Scenes (Neubert) with Dance Music.
 8.0—Variety Records.
 9.0—News ; U.S.A. Bulletin.
 9.30-11.0—See Berlin.

HILVERSUM (No. 1)

(Holland) 160 kc/s (1,875 m.); 10 kW until 4.40 p.m.; 150 kW from 4.40 p.m. Also on Jaarsveld, 722 kc/s (415.4 m.); 17 kW. 7.40 a.m.—VARA Programme: Records. 9.40—VPRO Service. 10.0-11.40—VARA Programme. 10.0—Recitations; Records. 10.50—Jong (Organ); Records. 11.40 a.m.—3.40 p.m.—AVRO Programme. 11.40—Time; Records. 1.40 p.m.—Book Talk. 2.10—Light Music. 3.4-7.16—VARA Programme. 3.46—Records. 4.46—For Children. 5.10—Records. 5.40—Amateurs' Hour. 6.10—Weekly Political Review. 6.30—Jong (Organ). 6.40—Talk: The Dutch Indies and Holland. 7.0—Records; News. 7.10-8.40—VPRO Programme. 7.10—Church Notes; Talk. 7.40—v. Wexel (Cello) and de Nobel (Pfte.). 8.10—Talk. 8.40-10.20—VARA Programme. 8.40—Records. 9.10—A Play with Music by the VARA Orchestra. Conductor: de Groot. 9.40—Concert by the Fantasia. 10.10—News. 10.70—VPRO Service. 10.40-11.40—VARA Programme. 10.40—Olga Prager - Coelho (Songs). 11.10-11.40—Records.

HILVERSUM (No. 2)

(Holland) 995 kc/s (301.5 m.); 15 kW until 6.10 p.m.; 60 kW from 6.10 p.m. KRO Programme. 7.40-8.55 a.m.—Records. 9.40—Records. 11.10—Religious Address. 11.40—Police Messages; Records. 12.55 p.m.—KRO Orchestra, Conductor: Reinards. 1.40—Haak (Organ); Records. 2.40—Erdelman (Recitations). 2.55—KRO Chamber Orchestra, Conductor: Reinards. Symphony in G (Frederick the Great). Flute Concerto (Quantz). Symphony in C (Hoffmeister). 3.40—Records. 3.55—KRO Melodists. Conductor: Reinards. 4.30—Records. 4.55—KRO Melodists. Klein (Songs). 5.40—For Farmers. 6.0—KRO Melodists (contd.). 6.40—Police Messages; Talk. 7.15—Report from a Factory. 7.40—Press Review. 7.55—Rotterdam Philharmonic Choir, the "Orpheus" Male Voice Choir, Suze Luger (Contralto) and the Rotterdam Philharmonic Orchestra, Conductor: Flipse. Psalms (Boulanger). Pie Jesu—for Contralto, String Orchestra, Harp and Organ (Boulanger). Rhapsody (Brahms). 8.50—Records. 9.0—KRO Orchestra, Conductor: Reinards. Overture, "Jean de Paris" (Boieldieu). Ballet Music, "Faust" (Gounod). Greek Dance (Ganne). Villanelle (Ganne). Page d'amour (Guillaume). Excerpts, "The Pearl Fishers" (Bizet). 9.50—Juan Marcu's Romanian Orchestra. 10.10—Press Review. 10.20—KRO Melodists. 11.0-11.40—Records.

KALUNDBORG (Denmark)

240 kc/s (1,250 m.); 60 kW. Relays Copenhagen, 1,176 kc/s (255.1 m.). Transmits at intervals from 6.0 a.m. 11.0 a.m.—1.0 p.m.—Wivex Orchestra. Conductor: Bendix. 1.30—Preil's Ensemble; at 2.15—For Women. 3.30—For Children; Notes. 4.0—Talk with Readings: Icelandic Poets—Jonas Gudlaugsson and Johann Sigurjonsson. 4.25—Weather; Exchange; Markets. 4.50—Records. 5.15—Talk: Joseph Lister. 5.35—German Lessons. 6.0—Time; News. 6.30—Valby Workers' Choir. 7.0—Time; Per Knutzen. 7.10—Discussion on Housekeeping from the Women's Institute. 8.40—"The Son"—Play (Yerrick). 9.5—News; Weather. 9.25—A Film. 9.40—Sonata in F minor (Brahms) by Aage Forlev (Pfte.). 10.15-11.30—Preil's Dance Band; at 11.0—Chimes.

KÖNIGSBERG (Heilsberg)

(Germany) 1,031 kc/s (291 m.); 100 kW. Relayed by Danzig, 1,303 kc/s (230.2 m.). Transmits at intervals from 5.0 a.m. 11.0 a.m.—1.0 p.m.—See Stuttgart. 1.0—News; Anniversaries. 1.15—Variety. 1.55-2.0—Exchange. 2.30—Guessing Competition. 2.50—For Women. 3.10—Börschel Band. 4.30—Eleven Combatants and a Ball. 5.0—Talk. 5.20—Hartung (Organ), Dusterbehn (Violin) and Wendt (Oboe). Movements from the Oboe and Organ Sonata (Schindler). Choral Prelude for Organ (Kaminski). Prelude and Fugue for Violin and Organ (Kaminski). 5.50—Announcements; News. 6.10—Ship Ahoy!—Potpourri of Swedish Sea Shanties (arr. Waldimir) by Karin Juell, Harry Brandelius, Sailors' Choir and Accordion Band, from Stockholm (Recorded). 6.40—Goods Trains—Radio Report. 7.0—Peter Arco and the Börschel Band. 8.0—Scholars' Wanderlust—Sequence (Bartels) with the Station Orchestra, etc. Conductor: Wilcken. 9.0—News; Sports; Reading. 9.35-11.0—Serenade on Records.

LEIPZIG (Germany)

785 kc/s (382.2 m.); 120 kW. Relayed by Dresden, 1,285 kc/s (233.5 m.). Transmits at intervals from 5.0 a.m. 11.0 a.m.—Military Band. 12.0 noon—Time; News. 12.15 p.m.—Orchestra from Saarbrücken. 1.0—News; Exchange; Records. 2.0—Talk: Christine Hebbel. 2.20 (from Dresden)—Contralto and Pfte. 2.45—Talk: Helium. 3.0—Orchestra and Choir. Schadel (Clarinet). 2.45—Talk: Helium. 5.0—Talk: Synthetic Fuels. 5.20—Delitzsch Wind Band. 5.50—Evening Review; News. 6.10—Soldiers' Choir. 7.0—Dresden Orchestra. Conductor: Kretzschmar, Marta Rohs (Soprano) and Kamann (Bass). Overture, "König Enzo" (Wagner). Aria, "Tannhäuser" (Wagner). Mазeppа (Liszt). Two Songs (Wolf). Concert Suite, "Idomeneo" (Mozart-Busoni). Bass Aria: Bald muss ich dich verlassen (Mozart). Excerpts, "Egmont" (Beethoven). Songs (Reger, Schubert). Finale from the First Symphony (Brahms). 9.0—News; Weather; Sports. 9.30-11.0—See Berlin.

LILLE (Radio PTT Nord)

(France) 1,213 kc/s (247.3 m.); 60 kW. Transmits at intervals from 6.30 a.m. 8.30 p.m.—See Paris (Radio-Paris). 10.45 (approx.)—News; Weather.

MONTE CENERI (Switzerland)

1,167 kc/s (257.1 m.); 15 kW. Transmits at intervals from 11.0 a.m. 6.50 p.m.—News. 8.0—Provincial Programme. 8.0-9.0—Hanno ucciso il Giudice Robinson—Detective Play in Three Acts after Goldman's Book "Judge Robinson murdered" (Bianchi).

MOSCOW (No. 1) (Russia)

172 kc/s (1,744 m.); 500 kW. 3.30 p.m.—Literature and Music. 8.30—News; Kremlin Chimes. 9.0—Programme in English. 10.0—Programme in French. 11.0-12.0 m.t.—Talk in Spanish.

MUNICH (Germany)

740 kc/s (405.4 m.); 100 kW. Relayed by Nürnberg, 1,267 kc/s (236.8 m.). Transmits at intervals from 5.0 a.m. 11.0 a.m.—See Stuttgart. 12.0 noon—Time; News; Records. 1.0—News; Exchange. 1.15—See Hamburg. 2.0—For Women and Girls. 2.40—A Fairy-Tale. 3.0—Vocal and Instrumental. 3.40—Talk: Economics. 4.0—Weather; Markets; Records. 5.45—Talk: Dyes. 6.0—Time; News; Road Report. 6.10—Schubert and Wolf Songs by Hann (Baritone) (Recorded). 6.40—Fifth Symphony (Bruckner) by the Berlin Philharmonic (Recorded).

6.0—The Roving Microphone. 9.0—Time; News; Sports. 9.20—For Ski-ers.

9.30-11.0 (from Nürnberg)—Serenade—Station Orchestra. Conductor: Schwarz. Büttner Trio, Else Baumann (Contralto) and Karl (Baritone). Polonaise (Tchaikovsky). Wiegeliend (Weber). Nachtgesang (Schubert). Allegro ma non agitato from the Pfte. Trio (Smetana). Nacht am Rheine (Marschner). Margret am Tore (Jensen). Overture, "Prince Igor" (Borodin). Wanderers' Nachtlied (Schubert). An den Traum (Comelius). Andante cantabile from the Quartet (Tchaikovsky). Waltz from "Faust" (Gounod). Königin der Nacht (Kaun). Waltz (Künneke). Kleines Menuett (Richardt). Cocktail Suite (Englemann).

NAPLES GROUP (Italy)

Naples, 1,104 kc/s (271.7 m.); 10 kW. Florence (No. 1), etc. See Sunday. 6.0 p.m.—Light Music; Talk. 6.30—Mandoline Band. Conductor: Bucci. 7.0—See Rome Group. 7.30—Light Music—String Orchestra. Conductor: Petralia. 8.0—Reading. 8.10—"La mandorla amara" (The Bitter Almond)—One-Act Play (Donaudy). 8.45—Opera Records. 9.15 (approx.)—Dance Music. 10.0—News. 10.15-10.55—Dance Music.

OSLO (Norway)

260 kc/s (1,153.8 m.); 50 kW. Fredrikstad, etc. See Sunday. Transmits at intervals from 9.30 a.m. 4.5 p.m.—Café Concert. 4.55—French Lesson. 5.20—Röberg (Violin). Adagio (Mozart). Minuet (Leclair). Love Song (Suk). Norwegian Dance (Lie). Berceuse (Brustad). 5.45—News; For Farmers. 6.35—For Children. 7.0—Bergen Radio Orchestra. 7.45—Talk. 8.10—Nordsjö (Songs). 8.40—News; Topical Talk. 9.15-9.45—Old Dance Music.

PARIS (Eiffel Tower)

(France) 1,456 kc/s (206 m.); 7 kW. Transmits at intervals from 6.30 a.m. 3.30 p.m.—"X-33"—Detective Play (Delamare) by the "Art et Liberté" Players. 5.0—Concert from Bordeaux-Lafayette. 5.45—Concert from Lyons (PTT). 6.30—Talks. 7.0—Sonata in B flat (Mozart) by Doyen (Pfte.) and Zighera (Violin). 7.30—Radio Journal; Time. 8.0—"Poetry"—Robert Honnert and Mme Darius Milhaud. 8.30—Chamber Music by the Conservatoire Old Students' Association and Yvonne Gall (Songs). Sonata for Eighteen "Cellos" (Handel-Ronchini). Aria (Gluck). Konzertstücke for "Cellos" (Schumann). Songs (Büsser). Jazz (Karjinsky). "Cello Ensemble: Le petit nègre (Debussy). 9.30—"Night"—de Musset Programme with Songs and Music by the Station Ensemble: (a) "La nuit vénitienne," (b) "La nuit d'octobre." 10.30—Records. 11.0—News.

PARIS (Poste Parisien)

(France) 959 kc/s (312.8 m.); 60 kW. Transmits at intervals from 7.10 a.m. 12.0 noon—Exchange; Records. 12.25 p.m.—News; Exchange; Records. 1.0—"La course au trésor" with Pierre Dac. 1.18—Amusements; Records. 2.0—Exchange; News. 3.45 and 4.35—Exchange. 5.0—News; Cabaret. 6.0—Exchange; News; Talk. 6.35—Verdi Records; Talk. 6.55—For Young People. 6.58—Racing; Topical; Sports. 7.10—Amusement Guide; Anniversaries; Records. 7.50—Three Ninon Vallin Successes. 8.0—Topical. 8.10—"La Clef des Songs" (Arnaud-Desnos). 8.25—Fred Adison Orchestra. 8.40—"La bonne histoire." 8.55—News. 9.0-12.0 m.t.—From the Michodière Theatre.

FRIDAY (March 18)

PARIS (PTT) (France)

695 kc/s (431.7 m.); 120 kW. Transmits at intervals from 6.30 a.m. 3.0 p.m.—Lecture by M. Siegfried: Canals and International Trade Routes. 4.0—Denise Soriano (Violin). Andantino (Martini). Minuet (Porpora). Scherzo (Tchaikovsky). 4.15—Reading (Sylvestre). 4.30—Singing Lesson. 5.0—Orchestra. Conductor: Ellis. Overture, "Tancred" (Rossini). Selection, "Pelléas et Mélisande" (Fauré). Sicilian Dances, "Carmosine" (Février). La jeunesse d'Hercule (Saint-Saëns). Suite, "A Midsummer Night's Dream" (Mendelssohn). 6.0—Educational. 6.30—Milani (Songs). 6.45—Yane Michel (Songs). 7.0—Radio Journal. 8.0—Lecture-Recital by Paul Le Flem: Spring and Music. 8.30 (also Alpes-Grenoble (PTT) and Marseilles (PTT))—Symphony Concert—National Orchestra. Conductor: Borchard. Symphony in D (Mozart). Third Symphony (Roussel). First Symphony (Brahms). 10.30—Radio Journal. 10.45—Records: Light Music.

PARIS (Radio-Paris)

(France) 182 kc/s (1,648 m.); 80 kW. 6.28 a.m.—Programmes; Records. 6.40—Time; News; Gym; Records. 7.15—News; Records. 8.0—Time; News; Programmes. 8.35-9.20—Records. 10.15—Programmes; Records. 10.45—Reading; Records. 11.45—Exchange; Records. 1.0 p.m.—Time; News; Exchange. 1.30—Marie Simon (Songs). 1.45—Records: Light Music. 2.0—Programme Notes. 2.5—Talk by Edouard Guyot; English Literature up to the Eighteenth Century. 2.25—Review; Exchange; Records. 3.0—Mlle Torossian (Songs). 3.15—Review of Periodicals. 3.25—Aphorisms—Talk and Readings. 3.35—The Humorous Press. 3.45—Exchange. 4.0—Talk: French Moralists. 4.15—Marthe Guy (Songs). 4.30—English Lesson; Exchange. 5.0—Chamber Music—Touche Quartet, Cotta (Songs). Quartet (Beethoven). Songs (Gluck, Beethoven, Rameau). Pfte.: Fugue in E minor (Mendelssohn). Songs (Fauré, Franck, Auzende-Castrisann). Pfte. Pieces: (a) La fille aux cheveux de lin (Debussy), (b) Malaga (Albeniz). 6.0—Educational. 6.30—Racing Results; For Women. 6.55—Film Review; Programmes. 7.0—Educational. 7.30—Talk: Books and the French Colonies. 7.45—Talk. 7.59—Time; Home Affairs. 8.8—Foreign Affairs. 8.15—Elisabeth-Claire Lobrot (Songs). 8.30—"Resurrection"—Five-Act Play after Tolstoy (Bataille), by the Art et Travail Players; at 9.30 (approx.)—News; Press Review; For Ex-Servicemen. 10.45—Time; News. 11.0—Concert. Conductor: Rhené-Baton. Cathelat (Songs). Symphony (Dukas). Songs (Chausson, de la Presle). Easter Overture (Rimsky-Korsakov). 12.30 a.m. (Saturday)—Programme Notes.

PRAGUE (Czechoslovakia)

638 kc/s (470.2 m.); 120 kW. Transmits at intervals from 5.15 a.m. 3.30 p.m.—String Quartet in F (Bendl) by the Ondricek Quartet. 4.10—Reading; Review; Markets. 4.45—News in Russian. 5.0—For Workers. 5.10—German Transmission: Talks: (a) Jan Amos Komensky, (b) Landscape Painting, (c) For Workers. 5.45—News and Cultural Review in German. 6.0—Time; News; Talk. 6.30—See Brno. 7.25—"Fear is knocking at the Door!"—Comedy (Rybrant, trans. Wenig). 8.0—Time; Station Orchestra. Conductor: Krejci. Smetáček (Oboe). Military Marches (Schubert). Oboe Concerto (Haydn). Serenade in D minor for Wind Instruments (Dvořák).

9.0—Time; News; Sports. 9.15—Snow Report; Records. 9.35-10.5—For Sokols.

RADIO EIREANN (Eire)

565 kc/s (531 m.); 100 kW. Dublin, etc. See Sunday. 1.30 p.m.—Records. 2.30-3.0—For Schools. 5.30—Cookery Talk by Bernadette Plunkett. 5.45—Artane Band, Songs. 6.35—Irish News Feature. 6.45—News. 7.0—Vierne and Widor Commemoration—Swanton (Organ) from St. Philip and St. James's Church, Bootstown. 7.30—I liked this Book by A. E. Malone. 7.45—Irish Radio Orchestra. Conductor: Lieut. O'Hara. 8.15—Discussion on Ireland's Population by George Duncan, Stanley Lyons, James Meenan, George O'Brien and R. C. Getry, with Joseph Brennan (Chairman). 8.50—Myra Feis Prizewinners—Instrumentalists. 9.10—Programme from M. V. Leinster North Wall Dublin. 9.30—Variety. 10.30—News. 11.0—National Anthem.

RADIO-NORMANDIE (France)

1,113 kc/s (269.5 m.); 15 kW. 6.45 a.m.—Band; Records. 7.15—News; Press Review. 7.45—Physical Exercises. 8.0—Music in the Morning. 8.15—"And All's Well"—Brown-ing and Starr. 8.30—Pictures on the Wall. 8.45—The Glories of England, III: The Shires. 9.0—Round the World. 9.15—Orchestra and Singers. 9.30—Radio Favourites. 9.45—Popular Music; Variety. 10.15—Dream Waltzes. 10.30—Songs and Music from Stage and Screen. 10.45—Crystal Gazing. 11.0—Something for Everybody. 11.30—Beethoven Music by the Pasquier Trio. 12.0 noon—Concert. 12.45 p.m.—News; Talk. 1.10—Concert. 2.0—The Magic Carpet. 2.30—Out-of-door Songs. 2.45—Beauty and Romance. 3.0—Musical Cavalcade. 3.15—Cinema Organ. 3.30—Jane and John. 3.45—In Search of Melody. 4.0—Friday at Four. 4.15—What's on. 4.30—Fingers of Harmony. 4.45—Popular Pairs. 5.0—Dancing Reminiscences. 5.15—For Young People. 5.30—The Musical Magazine. 6.0—Children's Corner. 6.45—Talk; News; Racing. 7.0—Chansonnettes. 7.25—Radio Journal; News. 7.55—Variety. 9.0—Concert. Les Pastouraux Children's Choir. Conductor: Fléchelles. Mme Goupilchanière and Mlle Duin (Songs), Jenny May (Songs to the Accordion), Vaccaro (Violin) and David (Pfte.). 11.0—Café Concert. 12.0 m.t.—Melody at Midnight. 12.30-2.0 a.m. (Saturday)—Dance Music.

RENNES-BRETAGNE (France)

1,040 kc/s (288.5 m.); 120 kW. Transmits at intervals from 5.45 a.m. 6.30 p.m.—Orchestra, Conductor: Henderick. Overture, "The Merry Wives of Windsor" (Nicolaï). Selection, "La cocarde de Mimi Pinson" (Goublier). Three Military Marches (Dalcroze). 7.0—Radio Journal; Weather. 7.30—Concert from Limoges (PTT). 8.0—News; Programmes; Records. 8.15—For Winegrowers. 8.30—Concert from Angers. Conductor: Bilewski. Flo (Songs). Aquarelles napolitaines (Culotta). Two Songs (Staub-Oudine). Hindu Song (Rimsky-Korsakov). American Suite (Porret). Villanelle (Ganne). Venise (Richepin). Christine Song Potpourri (Salabert). Joyeuse idylle (Pesse). Excerpt, "Trois jeunes filles nues" (Moretti). Dance, Kikkapco et Sioux (Pouget-Gauwin). Waltz (Strauss). Ma Gretchen (Pearly-Salabert). After the Concert, News and Concert from Paris.

FRIDAY (March 18)

ROME GROUP (Italy)

Rome (No. 1), 713 kc/s (420.8 m.); 100 kW. Bari (No. 1), etc. See Sunday.

Transmits at intervals from 6.45 a.m. 4.0 p.m.—News.

4.15—From the Institute of Roman Studies; Address by C. Galassi Paluzzi; First and Second Quintets for Pfte. and Strings (Perosi).

4.50—Aviation Notes; Weather.

5.50—News in Brazilian.

6.0-6.20—Talk in Dutch.

6.30—See Turin Group.

7.0—Time; News.

7.20—Government Notes; Music.

8.0—Symphony Concert. Orchestra. Conductor: La Rosa Parodi. Choir. Conductor: Consoli. Od-noposoff (Violin); Fernanda Ciani (Soprano); Anna Bassi (Mezzo-Soprano); Emilio Renzi (Tenor); Luciano Neroni (Baritone). Overture, "Der Freischütz" (Weber). Violin Concerto in D (Brahms). Choir and Orchestra: Ode sinfonica (Cilea). Three Songs to Tagore Text (Alfano): (a) Perché siedi là, (b) Non nascondere il segreto, (c) Corro come il cervo muschiato. Te Deum (Bruckner). In the interval, Talk.

10.0—News; Weather.

10.15-10.50—Dance Music.

SOTTENS (Switzerland)

677 kc/s (443.1 m.); 100 kW. Relayed by Geneva, 401 kc/s (748 m.).

11.29 a.m.—12.45 p.m.—News; Records.

4.0-5.0—See Beromünster.

5.0—Dance Band Records.

5.15—Talk; Sports Review.

5.40—For Alpinists.

5.50—Parliamentary Review.

6.5-6.10—Football Notes.

6.15—Micro-Magazine.

6.50—News.

7.0 (from Geneva) — Financial Review.

7.20—Records.

7.30—Symphony Concert from the Municipal Theatre. Romand Orchestra. Conductor: Kleiber.

Symphony for Two Orchestras (Joh. Chr. Bach). Ballet Music and Entr'actes from "Rosamunde" (Schubert). Symphony in A (Beethoven).

9.30-10.30—Dancing Competition from the Splendid. Jo Baux and his Cadets, and Willy Girard. Commentator: Squibbs.

STOCKHOLM (Sweden)

704 kc/s (426.1 m.); 55 kW. Motala, etc. See Sunday.

Transmits at intervals from 6.20 a.m.

4.5 p.m.—French Talk: Nouvelles contemporaines.

4.30—Records.

5.30—German Lesson.

6.0—News

6.30—Waldimir's Orchestra.

7.30—"Travel Fever"—Play (Sjögren).

8.10—"Spring"—Radio Choir. Conductor Nylander. Haquinus (Pfte.). In the interval, Reading.

9.0—News.

9.15-10.0—Radio Orchestra. Conductor: Grevillius. Soetens (Violin). Symphonie espagnole (Lalo). Variations on a Haydn Theme (Brahms).

STRASBOURG (France)

859 kc/s (349.2 m.); 100 kW.

Transmits at intervals from 6.30 a.m.

5.15 p.m.—Mme Guth-Quénel (Soprano), Mme Briançon-Kauffmann (Harp), and Marguerite Canal (Songs). Songs (Boëllmann, Saint-Saëns, Lazzari, Cadier). Harp Sonata (Bach). Songs. Pieces for Harp.

6.0—Talks.

6.30—See Rennes-Bretagne.

7.0—News; Weather.

7.30—Concert from Limoges (PTT).

8.0—News (German, French).

8.30—Part of the C.C.O.C. Concert from Mulhouse. Beethoven—Orchestra with Merckel (Violin). Overture, "Prometheus." Violin Concerto; at 9.30 (approx.)—"Une larme du diable"—Play (Gautier).

10.30—News (French, German).

11.0 p.m.—12.30 a.m. (Saturday)—See Paris (Radio-Paris).

STUTTGART (Germany)

574 kc/s (522.6 m.); 100 kW.

Transmits at intervals from 5.0 a.m.

11.0 a.m.—Orchestra from Saarbrücken.

1.0-2.0 p.m.—Italian Opera Records.

3.0—Concert. Part I: Records.

Part II: Baden-Baden Symphony Orchestra.

5.0—"Garten der Kindheit"—Eichendorff and Hebbel Sequence (Blanch) with Jautz (Tenor) and Meister (Pfte.).

5.30—Topical Talks.

6.0—News; Topical Talk.

6.15—Station Orchestra. Conductor: Bara. Ladewig and Meister (Two Pfes.). Erna Schott von Werden (Contralto).

7.15—"Crosswords," Table-turning and "Telepathy,"—Humorous Scenes (Schwerta); Folk Music Ensemble, Folk Songs.

8.15—Station Orchestra. Conductor: Buschkötter. Hohn (Violin) and Hinze-Reinhold (Pfte.). Violin Concerto (Schumann). Pfte. Concerto in A (Liszt).

9.0—Time; News; Sports.

9.20—U.S.A. Bulletin.

9.30—Dance and Light Records.

11.0 p.m.—1.0 a.m. (Saturday)—Serenade on Records. Part I: Marches by Famous Composers. Part II: Operetta Music.

TOULOUSE (Radio-Toulouse) (France)

913 kc/s (328.6 m.); 80 kW.

Transmits at intervals from 6.0 a.m.

6.55 p.m.—News; Sports.

7.15—Film Music.

7.45—Light Music.

8.30—Talk.

8.45—Light Music.

9.15—Accordion Band.

10.0—News.

10.15—English Concert.

11.15—Songs.

11.35—Light Music.

11.50-12.0 m't.—News.

TURIN GROUP (Italy)

Turin (No. 1), 1,140 kc/s (263.2 m.); 7 kW. Milan (No. 1), etc. See Sunday.

Transmits at intervals from 6.45 a.m.

3.0 p.m.—The Poetry of Chopin's Music—Lecture-Recital by Alfred Cortot (Pfte.), with Twenty-four Preludes, from the Royal Academy of St. Cecilia, Rome. In the interval, News.

4.50-4.55—Aviation Notes; Weather.

6.30—Cetra Orchestra.

7.0—See Rome Group.

7.30—Radio Orchestra; at 7.36 (Rome (No. 2) only)—News in English.

8.0—"Armi ed amori" (Werney). Conductor: Gallino. In the interval, Talk; Notes.

10.0—News.

10.15-10.55—Dance Music.

VIENNA (Austria)

592 kc/s (506.8 m.); 100 kW. Graz, etc. See Sunday.

Transmits at intervals from 5.45 a.m.

11.0 a.m.—Chimes; Station Orchestra.

12.0 noon—News; Programmes. Records.

1.0 p.m.—Fifth Symphony in C minor (Beethoven) by the Berlin Philharmonic. Conductor: Furtwängler (Records).

1.30—Announcements.

2.0—Time; Weather; Exchange.

2.15—Marianne Kuranda (Pfte.). Rondo in C minor. (Chopin). Papillons (Schumann).

2.40—Reading.

3.0—News; Exchange; Records.

3.50—For Children.

4.10—Talk by Mgr. Jakob Fried: The Eucharistic Congress in Budapest.

4.20 (from Graz)—Häsi Gigler (Violin). Violin Concerto (Spohr). The Pathetic Sonata in C minor (Beethoven).

5.0—Weekly Sports Review.

5.10—Travel Talk.

5.25—Talk: Philosophy.

5.50—Weekly Science Review.

6.0—Time; News; Topical.

6.25—Light and Dance Music—Station Band. Conductor: Sandauer. Anna Maria Hardegg-Chorinsky and Walter Ernst (Songs).

7.0—"The Master Builder"—Three-Act Play (Ibsen).

9.10—News; Announcements.

9.20—Station Orchestra. Nahlitschek (Violin). March, Horid-Hussassa (Männecke). Overture, "Der fröhliche Wald" (Leuschner). Violin: Grottesco (Rosner). Waltz, Wiener Rathausmann (Randweg). Danse diabolique (Hellmesberger).

9.55—Announcements.

10.0-10.30—Orchestra (cont'd.). March, Junges Blut (Sliva). Potpourri, Draussen in Grinzing (Recktenwald). Der am besten busselein kann (Friedl). Schnuckerl, mein Zuckerl (Löbl). Waltz, Unsere Wiener Herzen (Ertl). March, Es gibt nur a Wien (Holzer).

WARSAW (Poland)

224 kc/s (1,339 m.); 120 kW. Cracow, etc. See Sunday.

Transmits at intervals from 5.15 a.m.

10.57 a.m.—Time; Fanfare.

11.3-12.0 noon—To be announced.

2.30 p.m.—Economic Notes.

2.45—For Children.

3.0—Talk for Invalids.

3.15 (from Wilno)—Military Band. March (Pawlista). Soldier Song

Potpourri (Dorozynski). Polonaise (Moniuszko). Song (Moniuszko).

Waltz (Zygmuntowicz). Mazurkas (Wrónski). March (Grabowski).

3.50—Topical Talk.

4.0 (from Katowice)—Talk: Health Centres.

4.15 (from Cracow)—Polish Songs by H. Zboinska-Ruszkowska.

4.50—Review of Periodicals.

5.0—Snow Report; Sports.

5.10—Records: Polish Folk Dances in European Ballet Music.

5.30—Programme Notes.

5.35—For Country People.

6.0 (from Torun)—"Pan Geldhab"—Play (Fredro) with Introductory Talk.

6.30—Students' Choir.

6.50—Topical Talk.

7.0—Warsaw Philharmonic Orchestra from the Philharmonie, Guest Conductor: Ansermet. Krasner (Violin). Introductory Talk by Freiteiger; at 8.0 (approx.)—News.

9.50-10.0—News.

SATURDAY Mar. 19

National

For Time Signals, see Monday.

10.15 a.m. (D)—Service.

10.30 (D)—Weather Forecast.

10.45—The Week in Westminster.

11.0—Records of Music by Falla.

11.50—Cinema Organ.

12.20 p.m.—Records.

1.0—Hungarian Orchestra.

2.0—Harry Isaacs (Pfte.).

2.30—Records.

2.55—England v. Scotland.

4.35—Records.

5.0—Geraldo and his Sweet Music.

6.0—The First News

6.30—"Scotland at Twickenham": Kenneth Rankin.

6.45—Records: Cortot (Pfte.).

7.0—Part of Act I, "Carmen" (Bizet), from the Metropolitan Opera House, New York.

7.30—In Town Tonight.

8.0—Palace of Varieties: Caryll and Mundy; Fred Hutchings; Bennett and Gratton; Al Bowly; Ella Reford; Ward and Draper; Harry Hemsley; BBC Variety Orchestra.

9.0—The Third News.

9.20—American Commentary.

9.35—"The Trial of Eugene Aram."

10.25—Antoni Sala (Cello); Gerald Moore (Pfte.).

11.0—Ambrose and his Orchestra.

11.30—Reginald Foort (BBC Theatre Organ).

11.50-12.0—Late News Summary.

London Regional

For Time Signals, see Monday.

10.15-10.45 a.m.—National.

10.45—Gilbert Stacey and his Sextet.

11.15—Frederick Stone (Pfte.).

11.45—BBC Northern Orchestra: Anne Stuart (Soprano).

12.45 p.m.—Some Reflections on Travel in the British Empire.

1.0—Laurence Holmes (Baritone); The New English Trio.

2.0—Mantovani Orchestra.

2.30—Reginald Foort (BBC Theatre Organ) with Anne Lenner,

George Melachrino and Ivor Dennis in Rhythm Music.

3.0—BBC Scottish Orchestra.

3.50—"The Ghost Knows Best": by Mabel and Denis Constanduros.

4.40—Serial Reading from "A Tale of Two Cities."

5.0—"The Children's Hour."

6.0—"Ireland Dances": James Moody (Pfte.); George Beggs (Baritone); Jack McCafferty (Tenor); Patrick Kealey (Fiddler); John Barrett (Liliter); Harold Stewart (Fiddler).

6.40—BBC Orchestra (Section C) conducted by Joseph Lewis—Schumann, Grieg.

7.20—Bulletin for Farmers.

7.30—Schubert: John McKenna.

7.45—Cardiff Ensemble Chamber Music Concert: Frank Thomas, Gwen Griffiths (Viols); Nina Rochard (Viola); Ronald Harding (Cello); Mabel Draper (Pfte.).

8.40—"Is Art Any Use?" written by Denis Constanduros.

9.0—"Katinka": a Musical Play by Rudolf Friml.

10.0—News Summary.

10.30—Ambrose and his Orchestra.

11.30-12.0—National.

Midland

10.15 a.m.—6.40 p.m.—Regional.

6.40—Football commentary.

6.50—City of Nottingham Education Weeks: H. A. S. Wortley, Principal, Nottingham University College, and A. H. Whipple, Director of Education; Massed Choir from Senior Schools.

7.20—Bulletin for Farmers.

7.30—City of Birmingham Orchestra.

8.0—The Musician at the Gramophone: Leslie Huggins.

8.40—Regional.

10.0-12.0—Regional.

Northern

10.15 a.m.—6.40 p.m.—Regional.

6.40—Jack Nixon's Novelty Concertina Quintet.

6.55—Eric Kershaw and his Rhythmic Guitars.

7.10—"Speedway Racing": Bernard Gray.

7.20—Bulletin for Farmers.

7.30—The Liverpool Welsh Choral Union Concert: Ina Souez (Soprano); Solomon (Pfte.); Liverpool Welsh Choir.

8.40-12.0—Regional.

Western

10.45 a.m.—6.0 p.m.—National.

6.0—May Busby (Soprano); Joan Boulter (Pfte.).

6.40—Regional.

7.20—Western Announcements.

7.30—Regional.

7.45—"A Winter Walk in Somerset": S. P. B. Mais.

8.0—City of Bristol Orchestra, conducted by Malcolm Sargent: Beryl Tichbon and Norman Jones (Pfes.).

9.0-10.30—Regional.

Welsh

10.15 a.m.—6.40 p.m.—Regional.

6.40—Around and About: William Eames.

6.55—Stop Press for Sport.

7.20—Welsh Announcements.

7.30—Welsh News.

7.45—National.

8.40—Regional.

9.0—Cyn Y Steddfof.

9.30—Len Morris and Frank Studen in Rhythm and Song.

10.0-12.0—Regional.

N. Ireland

10.15 a.m

12.15 p.m.—Orchestra (contd.).
 1.0—News; Exchange; Records.
 2.0—"Spring is here!"—Sketch for Girls (Ursula von Niebelschütz).
 2.30—Talk: The Land Year.
 2.40—Young Girls at Work in Zimpel—Report (Recorded).
 3.0—"O Beautiful Spring!"—Programme arranged by Kuhlmann. Station Orchestra, Dance Band and Choir. Graumann (Tenor), Domgraf - Fassbaender (Baritone), Berko (Humour at the Pfte.), Claire Rapmund and Richard Odda (Compères).
 5.0—Review of Periodicals and Books.
 5.30—Rhapsody on Swedish Folk Melodies (arr. Sköld) from Stockholm (Recorded).
 5.55—Announcements; News.
 6.10—"Today we are so happy!"—Variety. with Will Meisel. Station Orchestra. Conductors: Meisel and Gielnik. Lillie Claus (Coloratura-Soprano), Hilde Scipp (Soprano), Hartung (Tenor), Reimann (Entertainer).
 8.0—The Day's Motto.
 8.10—Music of the Nations—A Musical Peepshow (arr. Wirth).
 9.0-9.15—News.
 9.30-11.0—Music from Munich.

BRNO (Czechoslovakia)
 922 kc/s (325.4 m.); 32 kW.
 Transmits at intervals from 5.15 a.m.
 4.40 p.m.—German Transmission: Quartet in F minor (Beethoven), by the Brno String Quartet; Talk.
 5.15—News; Literary Review.
 5.30—Moravian Cultural Review.
 5.45-6.20—See Prague.
 6.20—Hraniče Military College Programme from Moravská-Ostrava.
 7.0-7.55—See Prague.
 7.55—See Bratislava.
 8.55-9.30—See Prague.

BRUSSELS (No. 1) (Belgium)
 620 kc/s (483.9 m.); 15 kW.
 6.30-9.5 a.m.—Records; Gym; News.
 12.0 noon—Records: Light Music.
 12.30 p.m.—Weather; Shipping.
 12.32—Parcy Orchestra.
 1.0—News.
 1.10—Orchestra (contd.).
 1.30—Verdi Records.
 2.0—Review of the Arts.
 2.3—For Women.
 3.0—Lecture Recital: Till Eulenspiegel's Merry Pranks (Strauss).
 4.0—De Busscher (Accordion).
 4.15—Reading.
 4.25—Records: Violin and Pfte. Sonata (Lekeu).
 4.55—Announcements.
 5.0—Talk: Cotton Manufacture.
 5.15—Selection, "Ciboulette" (Hahn). Conductor: Souris.
 6.0—Talk; Records.
 6.30—Variations in C minor (Beethoven), by Felicia Blumenthal (Pfte.).
 6.40—Reading.
 6.50—Felicia Blumenthal (Pfte.) (contd.). La menuise de tortues d'or (Ibert). Le petit âne blanc (Ibert). La Campanella (Paganini-Liszt).
 7.0—Reviews of Walloon Art and Music; Interview.
 7.15—Cortège carnavalesque (Razigade). Gerbault Potpourri. Blumenlied (Lange).
 7.30—News.
 8.0—"Radio-Jadis"—Programme with the Salon Orchestra, Conductor: Féron. Mme. and M. Alberty, Jozs, etc.
 8.45—Popular Opera. I.N.R. Symphony Orchestra, Conductor: Dejoncker, Mme. Ritter-Ciampi (Soprano). Overture, "Les Dragons de Villars" (Maillart). Songs: (a) Mon coeur soupire (Mozart), (b) Aria from "I Puritani" (Bellini), (c) Aria from "Rigoletto" (Verdi). Waltz from "Faust" (Gounod).
 9.15—Talk: Ghent University.
 9.30—Popular Opera (contd.). Overture, "Norma" (Bellini). Gavotte, "Manon" (Massenet). Aria, "Don Giovanni" (Mozart). Overture, "William Tell" (Rossini).
 10.0—News.
 10.10—Brenders Jazz Band, Jane Smile (Songs).
 11.0-12.0 m't.—Records. Overture, "Der Freischütz" (Weber). Concertstück for Pfte. (Weber). Italian Symphony (Mendelssohn). Hungarian March (Berlioz).

BRUSSELS (No. 2) (Belgium)
 932 kc/s (321.9 m.); 15 kW.
 Programme in Flemish.
 6.30-9.5 a.m.—Records; Gym; News.
 12.0 noon—Film Records.

12.31 p.m.—Radio Orchestra, Conductor: Douliez.
 1.0—News; Shipping.
 1.10—Radio Orchestra.
 1.30—Records: Part I: Light Music. Part II: Classical Music.



Mademoiselle Jane Smile, singer in Brussels No. 1's 10.10 p.m. programme

3.0—For Women; Records.
 4.0—The St. John Passion (Bach) from the Royal Flemish Theatre, Antwerp. The Cecilia Choir, the Royal Flemish Conservatoire Concert Society's Orchestra, Conductor: De Voedt, Jo Vincent (Soprano), Theodora Versteegh (Contralto), Noort (Tenor), Ravelli and De Becker (Bass).
 6.0—Records: Children's Choirs.
 6.15—Transvaal Folk-Songs by Louiza Aeris (Soprano) and De Meyer (Baritone). Commentary by De Meyer. Liefde-lag en liefde-leed. Kleuterklankies. Vroolikhed en Olikheid. Levenswel en Levenswee. Picknickliedjes. Volk en Vaderland.
 6.45—Talk: Modern Intellectual Trends.
 7.0—Salon Orchestra, Conductor: Féron.
 7.30—News; To be announced.
 9.0—Radio Orchestra, Conductor: Douliez. Vos-Mendes (Tenor). Michot (Violin). La parade des animaux savants (Albert). Songs. Suite (Gilson). Violin: Polonaise concertante (d'Agreves). Symphonic Prelude (Van den Broeck).
 10.0—News.
 10.10—Radio Orchestra, etc. (contd.). Overture, "Poet and Peasant" (Suppé). Selection, "Paganini" (Lehár). Songs. Cortège de Bacchus (Delibes).
 11.0-12.0 m't.—Dance Records.

BUCHAREST (Romania)
 823 kc/s (364.5 m.); 12 kW.
 Relayed by Radio-Romania, 160 kc/s (1,875 m.).
 Transmits at intervals from 4.30 a.m.
 11.10 a.m.—Lehár Records.
 12.10 p.m.—Time; News.
 12.25—Records: Romanian Music.
 1.0—Foreign Affairs.
 2.45—For Young People.
 4.0—Time; Weather.
 4.5—Military Band.
 5.0—Talk.
 5.15—Musical Programme.
 6.5—Educational Talk.
 6.20—Petre Alexandru (Songs).
 6.40—Song Records.
 7.0—Letter-box.
 7.15—Radio Dance Band. Conductor: Bobesco.
 8.30—News; Sports Notes.
 8.45—Café Concert.
 9.45—News (French, German).
 10.0-11.0—Concert on Records.

BUDAPEST (No. 1) (Hungary)
 546 kc/s (549.5 m.); 120 kW.
 Transmits at intervals from 5.45 a.m.
 11.5 a.m.—Station Band.
 12.30 p.m.—Records.
 1.40—News.
 3.15—Fairy Tales.
 3.30—Walt Disney Records.
 4.0—Visit to a Paprika Research Station.
 4.30—Ilinczy Jazz Band.
 5.0—Lajos Gogolák.
 5.30—Horváth Cigány Band.
 6.0—"Rádíoélet" Guessing Competition.
 6.30—"Gipsy Love" (Lehár), Conductor: Marthon; at 8.40—News.
 9.5—Dance Records.
 10.10—Kiss Cigány Band from the Kis Royal Restaurant.
 11.5—News.

BUDAPEST (No. 2) (Hungary)
 359.5 kc/s (834.5 m.); 18 kW.
 5.30 p.m.—For Farmers.
 7.0—News; Records.

COLOGNE (Germany)
 658 kc/s (455.9 m.); 100 kW.
 5.0 a.m.—Hymn; Weather; Gym.
 5.30—See Berlin; 6.0—News.
 7.0—Weather; Water Level; Talk.
 7.10—Gym for Women.
 7.30—See Königsberg.
 8.30—Records.
 8.45—News.
 9.0—See Leipzig.
 9.30-10.0—For Children.
 10.45—Markets; For Farmers.
 11.0—Military Band.
 12.0 noon—News; Greetings.
 12.15 p.m.—Osnabrück German Theatre Orchestra. Conductor: Hinrichs.
 1.0—News; Sports.
 1.15—Orchestra (contd.).
 2.0—Talk: Local Museums in the Osnabrück District.
 2.15—For Girls.
 2.50—Markets.
 3.0—Winter Relief Variety Concert—Station Orchestra. Conductor: Eysoldt. The Three Merry Fellows, Wilhelm and his Magic Lantern, Köttler (Tenor), Giesen (Violin) and the Cologne Accordion Quartet.
 5.0—Programme Trailer.
 5.10—The Osnabrück District—Sequence.
 6.0—News.
 6.10—Jack Alban Dance Band.
 7.0—Dance Music from the Town Hall, Osnabrück. A Military Dance Band, Military Band and Artists of the German Theatre, Osnabrück; at 9.0-9.15—News.
 10.0-12.0 m't.—Light and Dance Music by the Engel Band, etc., from the Hotel Germania, Osnabrück.

DEUTSCHLANDSENDER (Germany)
 191 kc/s (1,571 m.); 60 kW.
 5.0 a.m.—Chimes; Weather; Records.
 5.30-7.0—See Hamburg; at 6.0—News.
 9.0-9.30—See Hamburg.
 9.30-10.0—For Children.
 10.15—Weather Report.
 10.30—Records; Weather.
 11.0—See Königsberg; at 11.55—Time and Greetings.
 12.45 p.m.—News.
 1.0—Variety—Jäger Band with Records.
 2.0—Weather; Exchange; Markets.
 2.15—Records: Light Music.
 3.0—See Cologne.
 5.0—Stanke Band. Der kleine Stabstrompeter (Reising). Dutch Clog Dance (Winkler). Piccolo Cosacco (Rosati). Max and Moritz (Zimmer). Am Fischerkrug (Damp). Serenade (Popowski). Tango (Stanke). Darinka (Koeser). In meinem Märchenbuch (Illert). Humoresque (Bortz). Kindermärchen (Hippmann). Sonne, die brauch' ich zum Leben (Kallies).
 5.45—Sports Bulletin.
 6.0—Motto; News; Weather.
 6.10—"Auf der Alm"—Rural Melodies (Recorded).
 7.0—Variety Concert. Station Orchestra. Conductor: Dobrindt; Gaden Dance Band; The Humoresk - Melodios; Marta Hübner. Charlotte Schütze, Heinz Förster-Ludwig, Küster-Kiermeir (Pfte. Duo), Schmidt (Compère).
 9.0—News; Sports; Topical.
 9.20—Serenade (Zilcher) by Riha (Oboe). Heinke (Clarinet), Leonards (Horn) and Seiler (Viola).
 9.45—Weather.
 10.0-11.55—Light and Dance Music—Kaufmann Band and the Schmidt Neuhaus Pfte. Duo (Recorded).

FRANKFURT (Germany)
 1,195 kc/s (251 m.); 25 kW.
 Cassel, etc. See Sunday.
 5.0 a.m.—Music; Motto; Gym.
 5.30—See Berlin; at 6.0—News.
 7.0—Time; Water Level.
 7.5—Weather; Snow Report; Gym.
 7.30—Trier Orchestra, Conductor: Schuster; Bost (Violin).
 8.30—Local News; Talk.
 9.0-9.30—See Hamburg.
 9.30—Programmes; Markets; Weather; Road Report.
 10.40—Talk; Labour Exchange.
 11.0—See Breslau.
 12.0 noon—News.
 12.15 p.m.—See Breslau.
 1.0—Time; News.
 1.10—Records: Light Music.
 2.0—Picture-Book of the Week.
 2.30—A Merry Programme by the

SATURDAY (March 19)

Hitler Youth Radio Ensemble, a Wind Quartet and a String Orchestra.
 3.0—See Breslau.
 5.0—Topical Review.
 5.30—Rhapsody on Swedish Folk Melodies (arr. Sköld) from Stockholm (Recorded).
 6.0—Time; News.
 6.10—"Marching Feet"—Programme arranged by Willy Hartmann.
 7.0—"The Sunny Side"—Variety. Station Orchestra, etc. Conductor: Hauck.
 9.0—Time; News; Sports.
 9.30—Music from Munich.
 11.0 p.m.-1.0 a.m. (Sunday)—Serenade. Part I. Beautiful Melodies—Station Orchestras, Sabel (Tenor), Ilse von Tschurtzschenthaler (Pfte.). Part II. Hussar Music (Recorded)—Otto Dobrindt Klaviersinfoniker, the Meister Sextet, Erna Sack (Coloratura-Soprano), etc. (Recorded).

HAMBURG (Germany)
 904 kc/s (331.9 m.); 100 kW.
 Bremen, etc. See Sunday.
 5.10 a.m.—Call; Motto; Weather; Gym.
 5.20—For Farmers.
 5.30—Naval Band, Conductor: Asmussen; at 6.0—News.
 7.0-7.20—Water Level; For Housewives.
 9.0—"The Battle of the Dogger Bank"—Pages from the Diaries of Participants (arr. Esmarch).
 9.30—Stettin Orchestra. In the interval, Talk.
 10.40—Ice Report.
 10.45—Shipping; Weather.
 11.0—Stettin Concert Orchestra (contd.).
 12.0 noon—Weather.
 12.5 p.m.—Midday Review.
 12.15—See Breslau.
 1.0—News; Music.
 2.0—Shipping; Markets.
 2.20—Greor (Organ).
 2.50—Ice Report.
 3.0—See Cologne.
 5.0—War Reminiscences.
 5.30—Folk-Songs by Eve Schlee (Soprano) and Bernhard Jakschkat (Bass-Baritone). Wohlauf noch getrunken (Schumann). Mein Mädal hat einen Rosenmund (Brahms). Duet, So wahr die Sonne scheint (Schumann). Songs (Brahms): (a) Sandmännchen, (b) Die Blümelein, sie schlafen, (c) Die Sonne scheint nicht mehr. Duet, Und der Hans schleicht umher.
 5.50—Weather; News.
 6.10—"As the golden Sun is sinking"—Old and New Battle Songs and Marches by a Military Band and Choir. Conductor: Ohlendorf. Hitler Youth Ensemble.
 6.55—Topical Review.
 7.10—"Week-end Finale"—"From the Ems to the Oder." Station Orchestra. Conductor: Secker. Station Dance Band, and Choir. Erna Kroll-Lange, Otto Stadelmeier, Bernhard Jakschkat.
 9.0—News.
 9.30-12.0 m't.—See Berlin.

HILVERSUM (No. 1) (Holland)
 160 kc/s (1,875 m.); 10 kW until 4.40 p.m.; 150 kW from 4.40 p.m. Also on Jaarsveld, 722 kc/s (415.4 m.); 17 kW.
 VARA Programme.
 7.40 a.m.—Records.
 9.40—VPRO Service.
 10.0—Records; Jong (Organ), Talk.
 11.40—Records.
 12.25-1.25 p.m.—VARA Orchestra. Conductor: de Groot. Overture, "Gri-Gri" (Lincke). Waltz, "The Count of Luxembourg" (Lehár). Selection, "The Betrothal by Lanternlight" (Offenbach). Serenade, Pepita (Padilla). Selection, "No, No, Nanette" (Youmans). Excerpt, "The Arabian Nights" (Strauss). Selection, "The Mikado" (Sullivan).
 1.40—Talk.
 1.55—Mlle Roos Boelsma (Contralto), Blom (Viola) and Schoute (Pfte.). Two Songs (Brahms): (a) Gestillte Sehnsucht, (b) Geistliches Wiegenlied. Allegro agitato (Winkler). Piece (Loeffler).
 2.25—Records.
 2.55—Talk: Chess.
 3.10—Residentie Orchestra, Conductor: Szell. Oloff (Violin). Symphony in G (Haydn). Violin Concerto in D (Brahms).
 4.10—Esperanto Talk; Records.
 4.40—Symphony in C (Schumann)

by the Residentie Orchestra. Conductor: Szell.
 5.20—Literary Talk.
 5.40—Steyn (Organ).
 6.10—For Young People.
 6.40—A Film.
 7.10—VPRO Talk.
 7.40—S.O.S. Messages; News.
 7.55—VARA Orchestra: Conductor: de Groot; "Esmeralda" Septet; Hofman (Tenor).
 8.55—Variety Programme, with Loc Cohen Orchestra, "The Four Blue Stars" and Peter Pech.
 10.10—Press Review.
 10.20—Steyn Accordion Band.
 10.55—News.
 11.0-11.40—Records.

HILVERSUM (No. 2) (Holland)
 995 kc/s (301.5 m.); 15 kW until 6.10 p.m.; 60 kW from 6.10 p.m.
 KRO Programme.
 7.40-8.55 a.m.—Records.
 9.40—High Mass from St. Joseph's Church, Smakt.
 10.55—Records.
 11.40—Police Messages; Weather.
 11.55—KRO Orchestra, Conductor: van 't Woud; Records in the interval.
 1.40 p.m.—For Young People.
 2.10—Records; For Children.
 3.40—KRO Melodists, Conductor: Lustenhouwer, Klein (Songs); and Records.
 5.10—News in Esperanto.
 5.25—"KRO Nightingales," Conductor: Arny Bonarius.
 5.55—Record.
 6.0—Review of Periodicals.
 6.25—Records; Police Messages.
 6.55—Legal Talk.
 7.15—Topical; News; Notes.
 7.55—Meditation; Records.
 8.40—KRO Orchestra. Conductor: van 't Woud. Overture, "Mignon" (Thomas). Record. March, "The Queen of Sheba" (Gounod). Records. Waltz, "Eugene Onegin" (Tchaikovsky). Record. Meditation, "Thais" (Massenet). Records. Ballet, "Samson and Delilah" (Saint-Saëns). Records.
 9.40—KRO Melodists, Conductor: Lustenhouwer, Klein (Songs).
 10.10—Press Review; Sports.
 10.35-11.40—Records.

KALUNDBORG (Denmark)
 240 kc/s (1,250 m.); 60 kW Relays Copenhagen, 1,176 kc/s (255.1 m.).
 6.0 a.m.—Time; Gym.
 7.30—Service from Copenhagen Cathedral.
 7.55—Weather.
 9.58—Weather; Fish Markets.
 10.45—Gym for Schools.
 11.0 a.m.-1.0 p.m.—Preil's Ensemble.
 1.15—Gym for Schools.
 1.35—Radio Orchestra. Conductor: Tuxen. Boland (Songs). Overture, "The Wasps" (Vaughan Williams). Suite, I Anledning af (Riisager). Waltz, "Der Rosenkavalier" (Strauss). Elegy (Tchaikovsky). Selection, "Paganini" (Lehár). March, "Der Teufelsreiter" (Kálmán). Songs (Loewe, Heise). Overture, "Morning, Noon, and Night" (Suppé). Two Folk Songs (arr. Sandby). Selection, "Samson and Delilah" (Saint-Saëns). Die Schönbrunner (Lanner). Minuet (Suk). Selection, "The Gipsy Princess" (Kálmán).
 3.30-3.50—For Children.
 4.0—Talk.
 4.25—Weather; Exchange; Markets.
 4.50—Records. Aria, "Lucia di Lammermoor" (Donizetti) by Toti dal Monte. Aria, "The Magic Flute" (Mozart) by Gerhard Hüsch. Morgenblätter (Strauss) by the Vienna Philharmonic. Conductor: Clemens Kraus. Es führt kein anderer Weg zur Seligkeit (Heymann) by the Comedy Harmonists.
 5.15—Talk: Books on Democracy and Dictatorship.
 5.35—French Lesson.
 6.0—Time; News.
 6.20—Talk: Road Traffic and Children.
 6.30—Talk: The Province of Szechuan, China.
 7.0—Schubert Concert—Radio Orchestra. Conductor: Grøndahl. Overture in C in Italian Style. Ballet, "Rosamunde." Waltz. Hungarian March.
 7.30—A Visit to a Printing Works—The Block Department.
 8.0 p.m.-1.0 a.m. (Sunday)—Station Radio Ball.
 8.0—Sid Merriman's Orchestra.

SATURDAY (March 19)

8.50—Speech by Professor Victor Kuhr from the Danish Literary Society's Punch Evening.
9.5—News; Weather.
9.25—Sid Merriman's Orchestra.
10.15—Preil's Dance Band; at 11.0—Time; Chimes.
11.30—Julian Dance Band from "Kilden," Aalborg.
12.5-1.0 a.m. (Sunday)—Magnussen Dance Band from the Nimb Restaurant.

KÖNIGSBERG (Heilsberg) (Germany)

1,031 kc/s (291 m.); 100 kW. Relayed by Danzig, 1,303 kc/s (230.2 m.).
5.0 a.m.—Weather; Records; Gym.
5.30—See Berlin; at 6.0—News.
7.0—Prayers; Gym.
7.30-8.30—Danzig Orchestra. Conductor: Koschnik.
9.0-9.30—See Hamburg.
9.45-9.55—Weather.
10.35—Talk: Engineering and the Industrial Revival.
10.50—Markets; Weather.
11.0—Station Orchestra. Conductor: Brückner. Marianne Thomas (Coloratura-Soprano); at 11.55 a.m.-12.15 p.m.—News.
1.0—News; Anniversaries.
1.15—Variety.
1.55-2.0—Exchange.
2.30—"Winter will soon be over"—Children's Choir.
3.0—See Cologne.
5.0—Sports Review.
5.15—"Soldiers of Today and Tomorrow"—Programme of Marches and Songs of the Hitler Youth and the Defence Forces, from Allenstein. Ensembles of the Hitler Youth and Hitler Maidens, Conductor: Gumia, and a Military Band.
5.50—Announcements; News.
6.10—Peter Arco and Records.
7.0—"Fellow Countrymen!"
8.0—"Love's Pilot"—Fantasy (Albrecht).
9.0—News; Sports.
9.40-11.0—Light and Dance Music—Station Orchestra. Conductor: Wilcken.

LEIPZIG (Germany)

785 kc/s (382.2 m.); 120 kW. Relayed by Dresden, 1,285 kc/s (233.5 m.).
5.0-7.0 a.m.—See Berlin; at 5.50—News.
7.0—Gym; Halbauer (Pfte.).
7.30-8.30—See Königsberg.
8.35—Water Level.
9.0—"von Plauen kämpft um das Ordensland"—Play (Maruschak).
9.30-9.45—Weather; Notes.
10.35—Anniversaries; Talk.
10.55—Time; Weather.
11.0—See Breslau.
12.0 noon—Time; News.
12.15 p.m.—See Breslau.
1.0—Time; News; Records.
2.20—"Latest Fashions for Dolly"—Handwork for Children.
2.50—Weather; Exchange.
3.0—See Cologne.
5.0—A Modern Dictionary.
5.15—Folk Songs of Saxony (arr. Donath)—Concert from Halle. Halle Radio Choir. Conductor: Donath. Edith Grimm (Soprano), Annelotte Sees (Soprano), Werner Reitmann (Tenor), Sprung (Bass).
5.45—Evening Review; News.
6.10—Records. Choral Prelude, Wachet auf, ruft uns die Stimme (Bach-Kempff), by Kempff (Pfte.). Ave Maria (Schubert), by Manén (Violin), and Kuntzsch (Pfte.). Bravura Variations (Adam) by Lea Piltti (Soprano), Kurt Günther (Flute) and the Leipzig Symphony Orchestra. Conductor: Kretzschmar. Adagio, from the Trio in E (Haydn), by the Weitzmann Trio. Waldensamkeit (Reger), by Ursula van Diemen, Nachtwache (Brahms), by the Deutschlandsender Chamber Choir. Zärtliche Gavotte (Hillemacher), by Paul Casals (Cello). Goldfish (Debussy), by Gieseking (Pfte.). Novelette (Bridge), by the Virtuoso String Quartet.
6.45—"It's like this..."
7.0—Winter Relief Variety Concert from Chemnitz. Request Dance Numbers by the Fricke and Steinbach Bands and the Station Orchestra. Conductor: Kretzschmar. Betty Sedlmayr, Hilde Crass and Erwin Hartung (Song Hits), Harry Langewisch and Siegfried Niemann (Comperes).
9.0—News; Sport.
9.20-12.0 m.t.—Variety Concert (contd.).

LILLE (Radio PTT Nord) (France)

1,213 kc/s (247.3 m.); 60 kW. Transmits at intervals from 6.30 a.m.
4.0 p.m.—Jazz by Dehette and Duchêne.
5.0—Educational Talk.
5.30—Dance Song Records.
5.45—Wiedague (Accordion). Turkish March (Mozart). In a Persian Market (Kerelbey). Polka (Basile).
6.0—Talk; Records.
6.20—For Housewives; Records.
6.50—Sports Notes.
7.0—Talk: The University.
7.10—Talk in English; Records.
7.30—Radio Journal.
8.0—"La Maison Claire."
8.30 (also Limoges (PTT) and Toulouse (PTT))—"Le Marquis de Villemer"—Four-Act Play (Georges Sand) from the Odéon, Paris.

MONTE CENERI (Switzerland)

1,167 kc/s (257.1 m.); 15 kW.
11.0 a.m.—Records.
11.30 a.m.-12.30 p.m.—News; Records; Light Music.
4.0—Orchestra. Conductor: Casella. Parigi (Tenor). Overture, "La Scuffiara" (Paisiello-Piccini). Arias, "Erminia in riva al Giordano" (Pasquini), "Il Sedecia Re di Gerusalemme" (Scarlatti) and "Armida e Rinaldo" (Sarti). Overture, "Don Giovanni" (Mozart). Arias, "Don Giovanni" (Mozart) and "The Secret Marriage" (Cimarosa). Pastoral (Sammartini). Tenor and String Orchestra: Recitative, Aria and Largo (Pasquini-Boghen). Elegy for Strings (Pedrolo). Tenor and Orchestra: Psyche (Falla). Concert Overture (Larsen).
5.0—For Children.
5.30—Light Music.
5.45—English Lesson.
6.0—Records.
6.50—News.
7.0—"Poulenc-Bernac Pfte. Duo." Part I: Debussy. Les cloches. En sourdine. Le faune, Mandoline. Part II: Poulenc. Suite française. Suite, Tel jour telle nuit.
7.40—San Carlo and the Ticino—Talk for the Fourth Centenary of his Birth.
7.55—"I Pagliacci" (Leoncavallo), by the Cast of La Scala, Milan. Conductor: Molajoli. Chorus Master: Veneziani (Recorded).
8.45-9.15—Dance Music from the Campione Casino.

MOSCOW (No. 1) (Russia)

172 kc/s (1,744 m.); 500 kW.
12.0 noon—Programme in Dutch.
4.30 p.m.—For the Arctic; Music.
6.0—Provincial Programme.
7.0—Dramatic Programme; Music.
8.30—News; Kremlin Chimes.
9.0—Programme in French.
10.0-12.0 m.t.—Talks in Spanish.
MUNICH (Germany)
740 kc/s (405.4 m.); 100 kW. Relayed by Nürnberg, 1,267 kc/s (236.8 m.).
5.0 a.m.—Motto; Weather; Gym.
5.30-7.0—See Berlin.
7.0—Motto; Gym.
7.30-8.30—See Königsberg.
9.0-9.30—See Hamburg.
10.0—Markets; Orchestra; For Farmers; News; Markets; Orchestra.
11.0 (from Nürnberg)—Orchestra from the Ufa-Palast; Kirch (Organ). Conductor: Böhm. Overture, "William Tell" (Rossini). La Lisanjera (Chaminade). Romanian Dance (Hoffmann). Norwegian Church Procession (Zander). Waltz, "Der Feldprediger" (Millbeker). Der Wind hat mir ein Märchen erzählt (Brühne). Selection, "Lauf ins Glück" (Raymond). Ein Reigen unter blauem Himmel (Prager).
12.0 noon—News; Topical.
12.15 p.m.—Station Orchestra.
1.0—News; Exchange.
1.15—Sports; Records.
2.40—Dialect Reading.
3.0—See Breslau.
5.0—Weather; Markets.
5.10—Walter Niemann plays his own Pfte. Music. Ballet Suite, "Rococo." Suite on Carl Spitzweg Pictures.
5.45—Topical Review.
6.0—Time; News; Road Report.
6.10—Winter Relief Concert.

7.10—"Anno Dazumal"—A Merry Picture-Book of Old Munich, the Biedermeier Family and other Famous Personalities (Schröder-Justin); Musical arrangement by Schweiger. Station Orchestra, Munich Schrammel Ensemble, the Teutonia Quartet, Lilly Preisig, Mizzi Seibold Georg Biadel, Josef Voggenauer, etc. (Recorded).
9.0—Time; News; Sports.
9.20-11.0 (from Nürnberg)—Dance Music. Nürnberg Station Orchestra and Dance Band. Conductor: Carl Schwarz. The Franconian Village Musicians, the Tous Allersbergers and Erich Drechsel (Violin).

NAPLES GROUP (Italy)

Naples, 1,104 kc/s (271.7 m.); 10 kW. Florence (No. 1), etc. See Sunday.
6.0 p.m.—Music; Topical.
6.20—Choir.
7.0—See Rome Group.
7.30—Pastorales and Musettes—Orchestra. Conductor: Mancini.
8.0—"La pelliccia di visione"—Sketch (Riccardo). 8.20—"I virtuosi campagnoli."
9.30 (approx.)—Dance Music.
10.0—News.
10.15-10.55—Dance Music.

OSLO (Norway)

260 kc/s (1,153.8 m.); 60 kW. Fredrikstad, etc. See Sunday. Transmits at intervals from 9.30 a.m.
3.0 p.m.—Bergen Radio Orchestra.
3.45—Announcements.
4.5—For Children.
4.35—Variety Programme.
5.45—News.
6.20—Paliamentary Review.
6.35—Accordion.
6.50—Talk.
7.20—Station Orchestra.
8.20—Reading (Krohn).
8.40—News; Topical Talk.
9.15—Trio.
9.45-10.30—Dance Records.

PARIS (Eiffel Tower) (France)

1,456 kc/s (206 m.); 7 kW. Transmits at intervals from 6.30 a.m.
6.30 p.m.—Jeanne Andral (Songs).
6.45—Patard (Songs).
7.0—Talk; Music.
7.30—News; Time.
8.30 (also Bordeaux - Lafayette, Lyons (PTT) and Montpellier (PTT))—Programme from the Opéra. After the Programme, News.

PARIS (Poste Parisien) (France)

959 kc/s (312.8 m.); 60 kW.
7.10 a.m.—Fanfare; Records.
7.20—News; Records.
8.10—Menus; Records.
8.30—News; Records.
10.30—Records. Overtures and Duets from Opera.
11.25—"Maizena"; Lola Robert.
11.45—Dance Music; Talk.
12.0 noon—Exchange.
12.5 p.m.—From the Winter Circus.
12.20—For Children.
12.30—News.
12.40—Lajarrige (Cinema Organ); Records.
1.0—"La course au trésor" with Pierre Dac.
1.18—Amusement Guide.
1.20—Antoinette Soulas; Records.
1.30—Exchange.
1.35—"Session of the S.D.L."—Sequence with Pierre Dac, etc.
2.5—News; Records.
2.35—Talk; Records.
3.0—Variety Programme; at 4.45—Exchange.
6.0—Exchange.
6.10—Roman Catholic Review.
6.30—For Young People.
6.58—Racing; News; Sports.
7.10—Amusement Guide.
7.15—"Pictures of Paris."
7.45—Delmet Records.
8.0—News.
8.10—Max Regnier and Company.
8.45—"La bonne histoire"; News.
9.5—Cabaret.
9.45—News.
10.0-11.0—Dance Music.

PARIS (PTT) (France)

695 kc/s (431.7 m.); 120 kW.
6.30 a.m.—News; Records.
7.0-8.30—News and Records.
8.30-8.45—Commercial Lav.
9.15—Records.
9.45—Fred Adison Band.
10.30—Records.
11.0—Fred Adison Band.
11.45—Light Orchestral from Marseilles (PTT).
12.15 p.m.—Quintet from Lyons (PTT).

12.45—News.
1.0—See Strasbourg.
1.45—Tourist Report.
2.10—Theatre Review.
2.30—Concert for Hospitals. In the interval, "Dans l'Isle"—One-Act Play (Bauche) with Berthe d'Yd, Vainys and Paul Castan.
3.30—Literary Talk.
3.50—Talk: English Art at the Louvre.

4.0—Aviation Report.
4.15—Juliette Stora (Songs).
4.30—Madeleine Peltier (Pfte.).
4.45—Lamoureux Concert. The Gouverneur Choir. Conductor: Bigot. Marie-Thérèse Ibos (Violin). Mme Doniau-Blanc (Songs). Symphony in E flat (Mozart). Violin Concerto in E (Bach). Aria, "Oberon" (Weber). Illuminations (Bondeville). La fête de la lumière (Fl. Schmitt).
6.40—Records: Light Music.
7.0—Radio Journal; News.
8.0—Lyane Mairève and Toni-Bert.
8.30-10.30—Soirée tournante.
8.30—Orchestra. Conductor: Tomasi. Tennenbaum (Violin). Overture, "Arteveld" (Guiraud). Spanish Symphony for Violin and Orchestra (Lalo).

9.10—Dramatic Programme. Part I: "Le Paralytique"—Play after Magog (Berger), with Suzanne Perrault, Jean d'Yd, etc. Part II: "Léonard"—One-Act Play after Renard (Berger), with Prélier in the Title Rôle.
9.50—"Un soir de Paris"—Variety with Mmes Denysis, Germaine Brédy, Maistre, Trénet, Milani and the Adelaide Hall Orchestra.
10.30—News; Programmes.
11.0—One-Act Plays by the "May 36" Players: (a) "Intimité" (Pellerin); (b) "Printemps" (Zimmer).

PARIS (Radio-Paris) (France)

182 kc/s (1,648 m.); 80 kW.
6.28 a.m.—Programmes; Records.
6.40—Time; News; Gym; Records.
7.15—News; Records.
8.0—News; Programmes; Records.
9.0-9.45—Records: Spain in French Music.
10.15—Programmes; Records.
10.45—Reading.
11.0—Records: Polish Music.
11.15—Records of Ninon Vallin.
11.30—Excerpts, "La Belle Hélène" (Offenbach).
11.45—Exchange; Markets.
12.0 noon—Mille Française Soulé (Violin). Allegro (Fiocco). Tango (Albeniz - Kreisler). Nocturne (Boulanger). Tambourin chinois (Kreisler).
12.15 p.m.—Spring in Music—Cantrelle Orchestra. The Rustle of Spring (Sinding). Valse des fleurs (Tchaikovsky). Spring Song (Mendelssohn). Movement from the Pastoral Symphony (Beethoven). To Spring (Grieg). Au village (Mouquet). Berceuse tendre (Lederer). Waltz, Premier bouquet (Waldteufel).
1.0—Time; News.
1.15—Cantrelle Orchestra (contd.). Suite, L'Arlesienne (Bizet).
1.30—Hazard (songs).
1.45—Cantrelle Orchestra (contd.). March (Hawkill). La féria (Lacôme).
1.58—Programmes: Educational.
2.30—Metal Prices; Markets.
2.45—Talk: The Colonies.
3.0—Yvonne Thibout ("Cello"). Intermezzo, "Goyescas" (Granados). Images (Karjinsky). Requiebro (Cassado).
3.15—Topical: Aviation.
3.45—Mme Maryse Tenneval (Songs).
4.0—Sports Talk.
4.10—Talk: Theatre Reminiscences.
4.20—Talks; Review; Markets.
5.0—For Children.
5.45—Edi and Jan (Duetists).
6.0—Mlle de Vito (Violin).
6.30—Shipping; Racing; Talk.
6.58—Programmes; Educational.
7.30—Talk; Dancing.
7.40—Talk; French Poetry.
7.55—Talk: The French Police.
7.59—Time; Home and Foreign Affairs.
8.15—Clément Duhour (Songs).
8.30-10.30—Soirée tournante.
8.30—"Au Caveau de la Villette"—Play in Three Scenes (Marcel Berger-Jacques Cossin). Cast: Mme Lyne Clevers. Mme Berthe d'Yd. Mme Simone Bonelli, Jacques Cossin. Paul Castan, etc.
9.10—"Un soir de Paris"—Variety. Mmes Denysis and Brédy, Maistre, Trénet, Milani and Adelaide Hall and Orchestra.

9.50—News; Press Review.
10.5—Orchestra. Conductor: Tomasi; Christiane Gaudel (Songs). Songs (Lecocq, Hüe, Messager, Gallon). Ballet, "Le Roi de Paris" (Hüe).
10.35—Sound News; News.
11.0 p.m.-1.0 a.m. (Sunday)—Bouillon Dance Band.

PRAGUE (Czechoslovakia)

638 kc/s (470.2 m.); 120 kW. Transmits at intervals from 5.15 a.m.
11.0 a.m.—Time; For Farmers.
11.10—Water Level; Records.
11.25—News; Weather.
11.35 a.m.-12.30 p.m.—Film and Operetta Music by the FOC Orchestra. Conductor: Pekárek.
12.30—Industrial Notes; Records.
12.50—Exchange (Czech, German).
1.0-1.20—"Merry Weekend"—Sketch in German.
2.15-3.45—Variety Concert from Kosice; at 3.0—Weather.
3.45—For Housewives.
3.50—"Johnny, the Bachelor of Paris"—Play for Young People (Nezval).
4.35—For Farmers and Workers.
4.55—German Transmission: "Josef Hoffmann"—Biographical Sequence, with the German Theatre Orchestra.
5.45—News and Talk (German).
6.0—Time; News; Review.
6.20—Folk Programme, with Milinovsky's Band, and Leiss (Tenor).
7.0—Light Orchestral Concert from Moravská-Ostrava.
7.40—Talk.
7.55-8.55—See Bratislava.
8.55—Records; News; Sports.
9.30-10.30—Jezek Swing Band (Recorded).

RADIO EIREANN (Eire)

565 kc/s (531 m.); 100 kW. Dublin, etc. See Sunday.
1.30 p.m.—Records.
3.10—Commentary on the International Rugby Match, England v. Scotland.
4.50—"My Twelve Favourite Records"—P. E. Murphy.
5.50—Talk by Sean O'Muimhneachain; Seamus Mór O'Muimhneachain, his Life and Poetry.
6.5—Records of Chaliapin (Bass) and Albert Sammons (Violin).
6.35—Irish News Feature.
6.45—News.
7.0—Hamlyn Benson (Bass).
7.15—"H.D.G."—Play (Sidney Carroll).
7.55—Variety—Irish Radio Orchestra and Trombone Duet. Conductor: O'Hara.
8.50—Radio Diary by Eric Boden.
9.20—W. J. Rafter (Siffleur).
9.30—Variety.
10.30—News.
10.45—Eye-Witness Account by Hector G. C. Legge of the International Hockey Match—Eire v. England.
11.0—National Anthem.

RADIO-NORMANDIE (France)

1,113 kc/s (269.5 m.); 15 kW.
6.45 a.m.—Band; Records.
7.15—News; Press Review.
7.45—Physical Exercises.
8.0—Music in the Morning.
8.15—"Animals"—Light Music.
8.30—Happy Days.
8.45—For Young People.
9.45—Light Music.
9.5—"Immortals"—A Musical Problem.
9.30—For Mothers and Children.
9.45—Pat Hyde; Dinah Miller.
10.0—Thirty Minutes of Bright Music, Songs and Humour—Carroll Gibbons Orchestra, with Anne Lenner, George Melachroino, Smeddie Brothers, Joan Turner and Ruff Carr.
10.30—Request Music; Variety.
11.15—Something for Everybody.
11.30—Chansonnettes.
12.0 noon—Artistes of the Folies Bergère of Le Havre.
12.45 p.m.—Radio Journal; News.
1.0—Concert.
2.0—Military Band.
2.15—Operettas of Yesterday.
2.30—Arthur Young and Friend.
2.45—Whirl of the World.
3.0—Film Notes; Light Music.
3.15—Love is Everywhere.
3.30—Dance Music.
4.0—Swing Music.
4.15—Mandoline Orchestras.
4.30—Variety.
5.0—Light Music.
5.15—For Men.
5.30—Football; Light Music.
6.0—Children's Corner.
6.45—Talk; News; Racing.
7.0—Light Music.
7.25—Radio Journal; News.

- 7.45—Dance Records.
- 8.0—Records of Georges Thill (Songs).
- 8.20—Operetta Music. Excerpts, "Yana" (Richepin), "Au soleil du Mexique" (Vvain), "Three Waltzes" (O. Straus) and "Un de la musique" (Dumas).
- 9.0—To be announced.
- 11.0—Café Concert.
- 12.0 m't.—Melody at Midnight.
- 12.30 a.m. (Sunday)—Melody Calling.
- 12.45-2.0—Dance Music.

RENNES-BRETAGNE (France)

- 1,040 kc/s (288.5 m.); 120 kW. Transmits at intervals from 6.30 a.m.
- 3.0 p.m.—Orchestra, Conductor: Henderick. Overture, "Martha" (Flow). Selection, "Gillette de Narbonne" (Audran). Songs. Nece Gasconne (Lacombe). Three Alsatian Dances (Levadé). Waltz, Pomone (Waldteufel).
- 4.0—See Lille.
- 5.0—Concert from Angers. Conductor: Bilewski. Symphony (Clementi-Casella). Song, Ballet, "Cinq-Mars" (Gounod-Damare). Song. Four Sketches (Gaubert-Elgé). La farandole (Dubois). Les estampes fleuries (Paulin).
- 6.30—Sports Talk.
- 6.45—News in English.
- 7.0—Radio Journal.
- 7.30—Chamber Music.
- 8.0—Announcements; Records.
- 8.15—Talk: The French Language.
- 8.45—Saint-Brieuc Philharmonic Society's Concert from Saint-Brieuc. Orchestra, Conductor: Fournier. Gravrand (Violin). Gervais (Cello). Alice Gauvet-Duhamel (Viola). Coriolanus Overture (Beethoven). Concert Piece (Honnore). Cello: (a) Cantilène (van Goens), (b) Villageoise (Hekking). Trio for Strings (Cras). Two Pieces for String Trio (Gervais): (a) Badinerie, (b) Caquetage. Allegro for Cello and Orchestra (Boccherini). Paysage breton (Ropartz). Movement from the Violin Concerto (Lalo). Overture, "Le roi d'Ys" (Lalo). After the Concert, News.

ROME GROUP (Italy)

- Rome (No. 1), 713 kc/s (420.8 m.); 100 kW. Bari (No. 1), etc. See Sunday.
- 7.30-7.40 a.m.—Time; News.
- 10.0—See Turin Group.
- 11.0-11.15—Religious Address.
- 11.30—Sports.
- 11.40—See Turin Group.
- 12.0 noon—Time; News.
- 12.15 p.m.—"From A to Z"—Musical Encyclopaedia.
- 12.40—A Film; Light Music.
- 1.0-1.25—News; Exchange.
- 3.40—For Children.
- 4.0—News; Lottery Results.
- 4.15—Dance Music.
- 4.55—For Workers.
- 5.10-5.50—For Farmers.
- 6.0—Talk in Esperanto.
- 6.20—Dopolavoro Notes.
- 6.30—See Turin Group.
- 7.0—News; Talk; Music.
- 8.0—"Chi m'ha ucciso"—Three-Act Play (Pio de Flavii).
- 9.15—Song Potpourri by the Cetra Orchestra. Conductor: Barzizza.
- 10.0—News.
- 10.15-11.30—Dance Music.

SOTTENS (Switzerland)

- 677 kc/s (443.1 m.); 100 kW. Relayed by Geneva, 401 kc/s (748 m.).
- 11.29 a.m.—Time; News.
- 11.40—Dancing Competition—Commentator: Squibbs—Jo Baur and his Ten Cadets and Willy Girard.
- 12.0 noon—For Skiers.
- 12.10-1.0 p.m.—Records.
- 3.59—Time.
- 4.0—See Monte Ceneri.
- 5.0—Lausanne Cathedral Chimes.
- 5.5—For Children.
- 5.40—Bal Musette Records.
- 6.0—Talk: The Next Lausanne Choral Society's Concert.
- 6.10—Talks; Music.
- 6.50—News.
- 7.0-10.0 (approx.) (from Geneva)—Report: Eighth International Horse Show at Geneva.

STOCKHOLM (Sweden)

- 704 kc/s (426.1 m.); 55 kW. Motala, etc. See Sunday.
- Transmits at intervals from 6.20 a.m.
- 11.0 a.m.—Town Hall Chimes—Poem; Accordion Music.
- 11.30—News; Exchange.
- 12.0 noon—Military Band.
- 1.0 p.m.—Reading (Mark Twain).

- 1.30—Göteborg Radio Orchestra. Conductor: Tor Mann. Asti (Violin). Overture, "Morning, Noon and Night" (Suppé). Three German Dances (Mozart). Meditation, "Thais" (Massenet). Humoresque (Dvořák). Ballet, "Ritter Pasman" (Strauss). Military March (Schubert).
- 2.30—Talk: The Bahamas.
- 3.0 (from Göteborg)—Temko (Violin). Strandberg (Songs). Song Cycle, An die ferne Geliebte (Beethoven). Violin: (a) Sarabande (Handel-Holländer), (b) Capriccio (Haydn-Holländer), (c) Piece (Schumann-Press). Songs (Schubert).
- 3.30—For Children.
- 4.5—Records.
- 5.0—Talk: Voice and Speech.
- 5.30—Janine Moreau's Harp Quintet. Minuet and Gigue (Lully). Air (Reynold). Irish Piece (O'Neill).
- 5.45—"Engineer Björck and Family"—Sketch (Alice Svensk).
- 6.0—News.
- 6.30—Old Dance Music by Agren's Band and Feringborg (Songs).
- 7.15—Reading.
- 7.45—Cabaret.
- 8.45—A Visit to Jämtland.
- 9.0—News.
- 9.15-10.0—Radio Dance Band.

A scene from "Andrea Chénier," which the Turin group broadcasts at 8 p.m.

Photo: Paganini



STRASBOURG (France)

- 859 kc/s (349.2 m.); 100 kW. Transmits at intervals from 6.30 a.m.
- 1.0 p.m.—Orchestra, Conductor: de Villers. Hungarian Rhapsody (Liszt). Le pas des fleurs (DeLibes). Suite, Gitanilla (Lacôme). Pieces (Glazunov): (a) Arab Dance, (b) Serenade, (c) Oriental Dance. Czardas (Grossmann).
- 1.45—Economic and Social Notes.
- 2.0—Talk for Farmers (in German).
- 2.15—Art Review.
- 2.50—Light Music by the Golden Orchestra and Singers.
- 4.0—Records.
- 4.15—French Lesson.
- 4.30—Jazz from Lille.
- 5.0—Beethoven Concert by the Colonne Concert Society. Conductor: Paray. Mass in D. Ninth Symphony.
- 7.0—Radio Journal.
- 7.30—See Rennes-Bretagne.
- 8.0—News in German.
- 8.15—News.
- 8.30—Station Orchestra. Conductor: Bour. Mme Kuntzmann (Soprano). Omeyer (Tenor). Movements from the Symphony in B flat (Bach). Recitative and Arias, "Figaro" and "The Magic Flute" (Mozart). Rondino in E flat (Beethoven). Songs (Schubert): (a) Des Mädchens Klage, (b) Die Post. Overture, Scherzo and Finale in E (Schumann). Italian Serenade (Wolff-Reger). Songs (Horn): (a) Tönt Lerchenlied, (b) Kannst du's verstehen. Duet, "Die tote Stadt" (Korngold). In the Steppes of Central Asia (Borodin). Songs: (a) The Rose and the Nightingale (Rimsky-Korsakov), (b) Berceuse (Grechaninov), (c) Tout est si beau (Rachmaninoff). Slav March (Tchajkovsky).
- 10.30—News.
- 10.45—News in German.
- 11.0—Dance Music from Paris.

STUTTGART (Germany)

- 574 kc/s (522.6 m.); 100 kW.
- 5.0 a.m.—Hymn; Time; Weather; For Farmers; Gym.
- 5.30—See Berlin; at 6.0—News.

- 7.0-7.30—See Frankfurt.
- 7.30-8.30—Records.
- 9.0-9.30—See Leipzig.
- 10.30—Folk Music with Country Calendar and Weather.
- 11.0—Military Band. Conductor: Schulz. The Karl Kromer Swabian Singers, Käthe Tellheim (Yodeller). The Stuttgart Folk Music Ensemble. March, Regimentsgruss (Steinbeck). Overture, "The lovely Galatea" (Suppé). "Is ist nirgends wie bei uns daheim (Kromer). Aus dem Hochwald (Kaulich). March, In die weite Welt (Gnauck). Two Austrian Folk Minuets. D'r Necker und d'Mosel (Kromer). Waltz, Am Neckerstrand (Millöcker). Folk Melody, Am Necker, am Necker. Mercedes-Marsch (Mönch). Folk Melody. Der Appenzeller March, Die Freundschaftsflagge (v. Blon). Polka, Madel tanz mit mir (Hantz). Es zieht die kleinen Vögelein (Kromer). Wandermarsch (Ritter). The Gladiators' Farewell (Blankenburg).
- 12.0 noon—Time; News.
- 12.15 p.m.—Station Orchestra. Conductor: Bara. Wilhelm Strienz (Bass).
- 1.0—Records of Swabian and Bavarian Folk Dances.
- 2.0—Weekend Music from Mann-

- heim. Mannheim Dance Band, Schery (Pfte.), Gustl Schön (Soprano). Krenz (Xylophone).
- 3.0—"Musical Sketch-Book"—Saturday Afternoon Variety.
- 5.0—Weekly Sound News.
- 6.0—News.
- 6.15—Soldiers' Chorus and Military Band from Karlsruhe. Conductor: Sonntag.
- 7.15—Karl Valentin Programme.
- 8.15—Dance Records.
- 9.0—Time; News; Sports.
- 9.30—See Berlin.
- 11.0 p.m.-1.0 a.m. (Sunday)—See Frankfurt.

TOULOUSE (Radio-Toulouse) (France)

- 913 kc/s (328.6 m.); 60 kW. Transmits at intervals from 8.0 a.m.
- 12.0 noon—News.
- 12.30 p.m.—Operetta Songs from "Lilac Time" (Schubert-Berté), "Les Noces de Jeannette" (Masse), "The Land of Smiles" (Youmans), "No, No, Nanette" (Youmans), "La belle Marseillaise" (Sellers).
- 12.45—Light Music. Dans l'ombre du passé (Periot). Romance, "The Pearl Fishers" (Berlioz). Bolero (Ravel). Rosine (Deprince).
- 1.15—Excerpts, "Cavalleria rusticana" (Mascagni).
- 1.45—Viennese Orchestra.
- 2.0-2.5—News.
- 3.30—English Concert.
- 6.40—Musical Comedy Music.
- 6.55—News; Sports.
- 7.15—For Children.
- 7.45—Operetta Music. Excerpts, "A Waltz Dream" (O. Straus), "Normandie" (Mistraki), "Cin-cilla" (Ranzato), "Yana" (Richepin).
- 8.10—Talk.
- 8.15—Provincial Dances—Bourrées corréziennes (Segurel). Alsatian Folk-Dance. Roussillon Songs and Dances (Ripol). Hegl (Vogel). Farandole, "L'Ariésienne" (Bizet).
- 9.30—Dance Music.
- 10.0—News.
- 10.15—English Concert.
- 11.15—Light Music.
- 11.50-12.0 m't.—News.

SATURDAY (March 19)

TURIN GROUP (Italy)

- Turin (No. 1), 1,140 kc/s (263.2 m.); 7 kW. Milan (No. 1), etc. See Sunday.
- 7.30-7.40 a.m.—Time; News; Markets.
- 10.0—Mass from the Church of the Annunciation, Florence.
- 11.0-11.15—Bible Reading.
- 11.30—Sports.
- 11.40—Radio Orchestra.
- 12.0 noon—Time; News.
- 12.15-1.0 p.m.—See Rome Group.
- 1.0-1.20—News; Music.
- 3.40—For Children.
- 4.0—News.
- 4.15—Lecture-Recital by Mizi Brusotti (Pfte.): Old Dances. The Allemande, with Music by Lully, Couperin, Purcell, Handel, Bach and Martini.
- 4.55-5.50—See Rome Group.
- 6.0—News and Talk (German).
- 6.20—Dopolavoro Notes.
- 6.30—Light Music.
- 7.0—See Rome Group.
- 7.30—Light Music.
- 8.0—"Andrea Chénier" (Giordano) from the Teatro San Carlo, Naples. In the intervals, News, Talks.

Grundgens, Deine Mutter bleibt immer bei dir (Jurmman) by Richard Tauber. Song, "The Tsarevitch" (Lehár), by Marcel Wittrich. Jeder kommt einmal dran (Klose) by Gloria Astor. Song, "Die Schützenliesel" (Eysler) by Herbert Ernst Groh. Song: Almenrausch und Edelweiss, by the Buchberger Sisters, Johann Strauss Potpourri by the Dajos Bela Orchestra.

4.35—Richard Plattensteiner reads. 5.0—Music Lessons from the Konzerthausaal: (a) Folk Songs; (b) Chamber Music. 5.30—The Folk-Song Broadcasts—a Discussion. 6.0—Time; News. 6.10—Film Talk. 6.25—Vienna Male Voice Choir from the Musikvereinssaal. Conductor: Ferdinand Grossmann. Laurens Bogtman (Bass-Baritone), Josef Maschkan (Tenor), Eva Tauchner (Contralto), Maria Durant, Elisabeth Ranic, and a Horn Quartet. Part I, Schubert. Gott meine Zuversicht, Grab und Mond. Part II, Bruckner. O könnt ich dich beglücken. Um Mitternacht. Abendzauber. Part III. Bass-Baritone: Lieder (Schubert).

7.5—Variety Concert. Station Band. Conductor: Sandauer. Station Schrammel Ensemble. Annemarie Hegener and Anny Coty (Songs). Anny Vilany (Instrumentalists). Lenz and Scheimbauer (Old Viennese Songs). Franz Resl and Hieronymus Lang (Entertainers). Kubin Accordion Trio. Heinz Sandauer (Pfte.).

8.35—Violin Concerto in A minor (Dvořák), by Georg Kulenkampf and the Vienna Symphony Orchestra. Conductor: Kabasta.

9.10—News; Announcements. 9.20—Report on the 1938 Arlberg-Kandahar Races.

9.35—Viennese Music. Schrammel Quartet. Fritz Jelinek and Ludwig Strabl (Songs). Turl-Marsch (Dudar). Im Glücksrausch der ersten Liebe (Stambader). Warum ist die Welt so begeistert von Wien? (Föderl). Mein Himmelreich (Kronegger). Wer ist a guater Mensch (Domanigg-Roll).

9.55—Announcements. 10.0-10.30—Viennese Music (contd.). Potpourri, Erinnerung an Franz Paul Fiebrich (Mühl-dräxler). Hörst du sie klingen, die Walzer von Strauss (Trauner). Mein Osterreich, wie bist du schön (Grobader). Sing und pfeif dir ans (Jäger). I hab' kan Zins noch 'zahl (Frankowski). Putschlögl-Marsch (Schrammel).

10.55—Weather Reports. 11.0—Chimes. 11.5—"Davide penitente"—Oratorio (Mozart) from the Elisabeth-Kirche. State Music Academy Mixed Choir and the Vienna Symphony Orchestra. Conductor: Kabasta. Erika Rokyta and Betty Rutgers (Sopranos), Heinrich Klapsia (Tenor).

WARSAW (Poland)

- 224 kc/s (1,339 m.); 120 kW. Cracow, etc. See Sunday.
- 5.15 a.m.—Hymn.
- 5.20—Gym.
- 5.40—Records.
- 6.0—News.
- 6.15—Records.
- 7.0-7.10—For Schools.
- 10.15—Songs for Schools.
- 10.40—Paderewski Records.
- 10.57—Time; Fanfare.
- 11.3-12.0 noon—To be announced. 2.30 p.m.—Economic Notes. 2.45—"The First Lesson"—Play for Children (after Gomulicki). 3.15 (from Lwów)—Tymolski Music by a Mandoline Band. 3.50—Topical Talk. 4.0—Reading (Sliwinski). 4.15 (from Poznan)—From Athens to Bayreuth (VII)—Gluck, Programme arranged by Kamienski. 4.50—Programme Notes. 5.0—Sports; Social Notes. 5.15—Records: Polish Music. 5.30—Programme Notes. 5.35—For Country People. 6.0—For Poles Abroad: (a) "The Fête at Belveder"—Sequence (Szczinska); (b) "The Polish Mountains"—Sequence (Kuczawa). 6.50—Address by President Moscicki on Marshal Pilsudski. 7.0—Polish-Music Station Orchestra. Conductor: Görzynski; a Mixed Choir, Aniela Szieminska (Soprano), Marrot (Baritone); at 7.45—News. 9.0—Light Music by the Wilno Orchestra. Conductor: Szczepanski. 9.50-10.0—News.

STATIONS IN ORDER OF FREQUENCIES AND WAVELENGTHS

kc/s	m.	kW	Station	kc/s	m.	kW	Station	kc/s	m.	kW	Station
Band No. 1. 150-300 kc/s.											
152	1973.5	5	Ankara (Turkey)	722	415.4	1	Fredrikstad (Norway)	1131	265.3	100	Hörby (Sweden)
153	1961	7	Kaunas (Lithuania)			0.1	Assiut (Egypt)			10	Genoa (No. 1) (Italy)
		150	Hilversum (No. 1) (Holland)	731	410.4	3	Madrid (EAJ2) (Spain)	1140	263.2	10	Trieste (Italy)
			(10kW only until 4.40 G.M.T.)			5.5	Seville (Spain)			7	Turin (No. 1) (Italy)
160	1875		Radio-Romania (Romania)	740	405.4	20	Tallinn (Estonia)	1149	261.1	20	LONDON NATIONAL
		150	Radio-Romania (Romania)	749	400.5	100	Munich (Germany)			20	NORTH NATIONAL
166	1807	150	Lahti (Finland)			100	Marseilles (PTT) (France)			50	SCOTTISH NATIONAL
172	1744	500	Moscow (No. 1) (U.S.S.R.)	758	395.8	1	Pori (Finland)	1158	259.1	10	Kosice (Czechoslovakia)
182	1648	80	Radio-Paris (France)	767	391.1	12	Katowice (Poland)	1167	257.1	15	Monte Ceneri (Switzerland)
185	1622	5	Istanbul (Turkey)			60	BURGHEAD	1176	255.1	10	Copenhagen (Denmark)
187.5	1600	20	Irkoutsk (U.S.S.R.)			70	SCOTTISH REGIONAL	1185	253.2	60	Nice-Côte d'Azur (France)
191	1571	60	Deutschlandsender (Germany)	776	386.6	0.25	Sortavala (Finland)			0.5	Cassel (Germany)
200	1500	150	DROITWICH			10	Stalino (U.S.S.R.)			2	Coblenz (Germany)
		35	Minsk (U.S.S.R.)	785	382.2	120	Toulouse (PTT) (France)	1195	251	25	Frankfurt (Germany)
208	1442	16	Reykjavik (Iceland)			120	Leipzig (Germany)			5	Freiburg-im-Breisgau (Ger.)
216	1389	150	Motala (Sweden)	795	377.4	7.5	Barcelona (EAJ1) (Spain)			2	Trier (Germany)
217.5	1379	100	Novosibirsk (U.S.S.R.)			50	Lwów (Poland)	1204	249.2	5	Prague (No. 2) (Czechoslovakia)
224	1339	120	Warsaw (No. 1) (Poland)	804	373.1	5	PENMON (Anglesey)	1213	247.3	60	Lille (Radio PTT Nord) (France)
232	1293	150	Luxembourg			70	WELSH REGIONAL	1222	245.5	0.3	Narvik (Norway)
		100	Moscow (No. 2) (U.S.S.R.)	814	368.6	50	Milan (No. 1) (Italy)			60	Rome (No. 2) (Italy)
240	1250	60	Kalundborg (Denmark)			12	Bucharest (Romania)	1231	243.7	5	Gleiwitz (Germany)
		0.5	Vienna Experimental (Austria)	823	364.5	0.4	Rueil-Malmaison (Radio 37) (France)	1235	242.9	1	Görlitz (Germany)
248	1209.6	100	Kiev (No. 1) (U.S.S.R.)			1.5	Agen (France)	1249	240.2	17	Saarbrücken (Germany)
256.4	1170	25	Tashkent (U.S.S.R.)	832	360.6	10	Stavanger (Norway)			1	Florence (No. 2) (Italy)
		1	Bergen (Norway)			35	Kiev (No. 2) (U.S.S.R.)	1258	238.5	15	Riga (Latvia)
260	1153.8	60	Oslo (Norway)	841	356.7	100	Berlin (Germany)			1	Salamanca (Spain)
		10	Vigra (Aalesund) (Norway)			10	Bodö (Norway)	1267	236.8	2	Nürnberg (Germany)
271	1107	100	Leningrad (No. 1) (U.S.S.R.)			1	Porsgrund (Norway)	1276	235.1	27	Radio-Méditerranée (France)
282	1065	10	Tromsø (Norway)	850	352.9	100	Sofia (Bulgaria)			2	Varna (Bulgaria)
283	1060	35	Tiflis (U.S.S.R.)			3	Valencia (Spain)	1285	233.5	1	ABERDEEN
Band No. 2. 300-500 kc/s.											
300	1000	100	Moscow (No. 3) (U.S.S.R.)	859	349.2	10	Simferopol (U.S.S.R.)			0.25	Dresden (Germany)
340	882.3	20	Saratov (U.S.S.R.)			100	Strasbourg (France)	1294	231.8	5	Klagenfurt (Austria)
347	864	10	Finmark (Norway)	868	345.6	16	Poznań (Poland)			5	Vorarlberg (Austria)
350	857.1	10	Archangel (U.S.S.R.)	877	342.1	70	LONDON REGIONAL	1303	230.2	0.5	Danzig (Danzig Free City)
355	845.1	20	Rostov-on-Don (U.S.S.R.)			15	Graz (Austria)			0.25	Karlstad (Sweden)
359.5	834.5	18	Budapest (No. 2) (Hungary)	886	338.6	15	Linz (Austria)	1312	228.7	2.5	Malmö (Sweden)
375	800	40	Sverdlovsk (U.S.S.R.)			10	Helsinki (Finland)			0.25	Norrköping (Sweden)
		30	Banská-Bystrica (Czecho.)	895	335.2	1.5	Limoges (PTT) (France)			0.25	Trollhättan (Sweden)
			(Power 15 kW after 5 p.m.)	904	331.9	100	Hamburg (Germany)	1321	227.1	1.25	Magyaróvár (Hungary)
392	765	0.6	Boden (Sweden)			10	Dnepropetrovsk (U.S.S.R.)			2	Bremen, Hanover, Kiel, Stettin (Germany)
		1.3	Geneva (Switzerland)	913	328.6	60	Toulouse (Radio - Toulouse) (France)	1330	225.6	0.5	Magdeburg (Germany)
401	748	0.6	Östersund (Sweden)			32	Brno (Czechoslovakia)	1333.3	225		Thessaloniki (Greece)
413.5	726	10	Voronezh (U.S.S.R.)	922	325.4	15	Brussels (No. 2) (Belgium)	1339	224	2	Lódz (Poland)
431	696	10	Oulu (Ulcaborg) (Finland)	932	321.9	12	Algiers (North Africa)			1.5	Montpellier (PTT) (France)
				941	318.8	10	Göteborg (Sweden)			0.5	Cairo (No. 2) (Egypt)
		0.5	Tartu (Estonia)	950	315.8	100	Breslau (Germany)			0.5	Dublin (Eire)
512	586	0.7	Hamar (Norway)	959	312.8	60	Poste Parisien (France)	1348	222.6	2	Königsberg (No. 2) (Germany)
519	578	1	Innsbruck (Austria)			30	Bordeaux-Sud-Ouest (France)			0.15	Rjukan (Norway)
		6.3	Ljubljana (Yugoslavia)	968	309.9	10	Odessa (U.S.S.R.)			2	Salzburg (Austria)
527	569.3	10	Viipuri (Finland)			100	NORTHERN IRELAND REGIONAL			0.7	Tampere (Finland)
		10	Bolzano (Italy)	977	307.1	50	Bologna (Radio - Marconi) (Italy)	1357	221.1	2	Bari (No. 2) (Italy)
536	559.7	50	Wilno (Poland)			24	Torun (Poland)			5	Genoa (No. 2) (Italy)
546	549.5	120	Budapest (No. 1) (Hungary)	986	304.3	60	Hilversum (No. 2) (Holland)			4	Milan (No. 2) (Italy)
556	539.6	100	Beromünster (Switzerland)			60	(Power 15 kW only until 6.10 G.M.T.)	1366	219.6	0.3	Notodden (Norway)
		100	Radio Eireann (Eire)	995	301.5	13.5	Bratislava (Czechoslovakia)			1	Rome (No. 3) (Italy)
565	531	10	Klaipeda (Lithuania)			4	Chernigov (U.S.S.R.)	1375	218.2	0.2	Turin (No. 2) (Italy)
		3	Palermo (Italy)	1004	298.8	70	MIDLAND REGIONAL			2	L'Île de France (France)
574	522.6	100	Stuttgart (Germany)			3	Barcelona (EAJ15) (Spain)	1384	216.8	0.5	Basle (Switzerland)
		20	Alpes-Grenoble (PTT) (France)	1013	296.2	2	Crucow (Poland)	1384	216.8	0.5	Berne (Switzerland)
583	514.6	50	Madona (Latvia)			0.7	Oviedo (Spain)	1393	215.4	7	Warsaw (No. 2) (Poland)
592	506.8	100	Vienna (Austria)	1022	293.5	100	Königsberg (No. 1) (Heilsberg) (Germany)	1402	214	25	Radio-Lyons (France)
		15	Athens (Greece)			100	Paris (Radio - Marconi) (France)	1420	211.3	2	Stara-Zagora (Bulgaria)
601	499.2	25	Rabat (Morocco)			2	W. OF ENGLAND REG'L.	1420	211.3	10	Vaasa (Finland)
		10	Sundsvall (Sweden)	1031	291	5	Paredo (Portugal)			0.5	Alexandria (No. 2) (Egypt)
610	491.8	20	Florence (No. 1) (Italy)			10	Leningrad (No. 2) (U.S.S.R.)	1429	209.9	2.5	Kaiserslautern (Germany)
620	483.9	20	Brussels (No. 1) (Belgium)	1040	288.5	120	Rennes-Bretagne (France)			0.5	Turku (Finland)
625	480	...	Cairo (No. 1) (Egypt)			50	W. OF ENGLAND REG'L.	1438	208.6	1.25	Miskole (Hungary)
		20	Christiansand (Norway)	1050	285.7	20	Bari (No. 1) (Italy)	1456	206	7	Eiffel Tower (Paris) (France)
629	476.9	15	Lisbon (Emissora Nacional) (Portugal)			20	Radio-Cité (Paris) (France)	1465	204.8	0.1	Antwerp (Belgium)
		20	Trondelag (Norway)	1059	283.3	2	Radio-Cité (Paris) (France)			0.1	Courtrai (Belgium)
638	470.2	120	Prague (No. 1) (Czechoslovakia)	1068	280.9	10	Tiraspol (U.S.S.R.)			1.25	Pécs (Hungary)
		100	Lyons (PTT) (France)	1077	278.6	35	Bordeaux-Lafayette (France)	1474	203.5	1	BOURNEMOUTH
648	463	10	Petrozavodsk (U.S.S.R.)			2	Falun (Sweden)			0.3	PLYMOUTH
658	455.9	100	Cologne (Germany)	1086	276.2	0.7	Zagreb (Yugoslavia)	1487	201.7	0.1	Binche (Belgium)
		20	Jerusalem (Palestine)			5	Madrid (EAJ7) (Spain)			0.2	Albacete (Spain)
668	449.1	70	NORTH REGIONAL	1095	274	10	Vinnitsa (U.S.S.R.)	1492	201.1	0.1	Chatelineau (Belgium)
		100	Sottens (Switzerland)			10	Kuldiga (Latvia)			0.7	Nimes (France)
677	443.1	20	Belgrade (Yugoslavia)	1104	271.7	10	Naples (Italy)			0.5	Santiago (Spain)
686	437.3	120	Paris (PTT) (France)			11.2	Moravská-Ostrava (Czecho.)			0.1	Wallonia (Belgium)
695	431.7	55	Stockholm (Sweden)	1113	269.5	15	Radio-Normandie (Fécamp) (France)	1500	200	0.1	Liège Experimental, Radio-Cointe (Belgium)
704	426.1	100	Rome (No. 1) (Italy)			0.5	Alexandria (No. 1) (Egypt)			0.25	Pietersaari (Finland)
713	420.8	17	Hilversum (Jaarsveld) (Holland)	1122	267.4	6.25	Nyiregyháza (Hungary)			0.2	Radio-Alcañá (Spain)
		10	Kharkov (U.S.S.R.)			60	STAGSHAW (Newcastle)	1530	196	0.1	Seraing, Verviers, Wallonia (Belgium)
								1734	173	0.1	Karlskrona (Sweden)
											Liepāja (Latvia)

ALL ADVERTISEMENTS FOR "WORLD-RADIO" should be addressed to the Advertisement Director, BBC, 35, Marylebone High Street, W.1.—Telephone: Welbeck 4468. Coupons should be sent direct to the Advertiser.

Printed in England by WATERLOW & SONS LTD., Twyford Abbey Road, Park Royal, N.W.10, and published by the British Broadcasting Corporation at 35, Marylebone High Street, London, W.1, England—March 11, 1938.