

# World-Radio

THE BBC FOREIGN PROGRAMME JOURNAL ★ EVERY FRIDAY **2<sup>D</sup>**  
WITH FULL INFORMATION FOR THE LISTENER AND VIEWER

The Romances  
of Great  
Musicians—  
No. 1. Schumann

The Multilingual  
Announcer

“Log-Roller’s”  
Weekly  
Miscellany

Virtues of the  
Really Big Set

New Programme  
and Feature  
Pages



A picture of a famous French military band—that of the Garde Republicaine—which is broadcasting from Radio-Paris on Wednesday.

# A GOOD START TO EACH DAY



A comfortable shave means a good start to the day. If you find shaving a bore in the morning, give Parke-Davis Shaving Cream a trial. It really does soften the beard quickly and effectively, and yet protects the skin from irritation. The liberal seven-shave tube which we offer you free will prove it. Use the coupon and confirm our claims. Large tube 1'6. From all Chemists.



## PARKE-DAVIS Shaving Cream

Made by the Makers of Euthymol Tooth Paste

Box 137/37 EUTHYMOL, 50 Beak St., London, W.1  
Please send FREE sample tube Shaving Cream

Name.....

Address.....

(Use Block letters please)

### PRE-PAID CLASSIFIED ADVERTISEMENTS

**R**RATES for Small Advertisements in "World-Radio" are as follows:—2s. 6d. per line (average of 6 words) with a minimum of 2 lines, box number 6d. extra. Series discounts, 5% on 13 insertions, 10% on 26 insertions, 20% on 52 insertions. All advertisements, which should be accompanied by a remittance and the full name and address of the advertiser, must reach The

Advertisement Director, BBC Publications, 35, Marylebone High Street, W.1, not later than Friday of the week prior to publication.

In the case of box numbers, readers should reply to the box number mentioned in the advertisement, c/o Advertisement Department, "World-Radio," 35, Marylebone High Street, W.1.

### SPECIALISED TRAINING

**A**LL successful students guaranteed posts in WIRELESS Services. Young men urgently needed. Write or phone. Box W—London Radio College, Grove Pk. Rd., W.4. (CHI. 3244.)

**S**HORTHAND in 24 hours of study. Practice brings high speeds. Test the simplicity of Dutton's by sending for a free lesson to Dept. R., 92/3, Great Russell Street, W.C.1.

### REPAIRS (AMERICAN)

**"SERVICE WITH A SMILE"**—HENRY FORD RADIO, LTD. —American valves, components, spares, line-cords: leading trade repairs: send us your American and British receivers: estimates free. —Electronic House, 22, Howland Street, Tottenham Court Road, W.1. Museum: 5675.

### REPAIRS

#### SCOTT-SESSIONS & CO.

**E**VERY type of British and American set repaired, modernised or rebuilt. Short-wave sets a speciality. Fifteen years' experience and thousands of satisfied customers throughout the world are your guarantee of a sound job. Send your set to-day for free quotation (we collect London).—Scott-Sessions & Co., Exchange Works, Muswell Hill, London, N.10. **PHONE: TUDOR 4101**

### MISCELLANEOUS

**R**ADIO turned Radiogram. Electric Motor 25/-; Pickups 9/6; Gramophone 12/-. Components cheapest.—List, RegentRAD, 120, Old Street, London, E.C.1. CLE 5770.

**B**ILLIARDS—the most popular game for all seasons. Over 700 New and Reconditioned Tables in stock. Send for Free Lists and Terms.—W. JELKS & SONS, LTD., 263-275, HOLLOWAY RD., N.7. NORTH 2747 (6 lines).

### LANGUAGES

**G**ERMAN, FRENCH conversation. Gramophone course with book 10/6. Postage 1/-. Record Tutors, 24, Buckingham Street, London, W.C.2.

### A reading case to hold current copies of WORLD-RADIO

Stoutly made, from good quality binding-cloth, distinctly blocked in gold, corded so that the journal remains in place, and provided with a convenient pencil—it costs 2/6 by post direct from BBC Publications, (W.69), 35, Marylebone High Street, W.1.

### ★ Hear AMERICA on your OWN Set!

Connect this Eclax Short Wave Converter to your set and the world's programmes are yours! Simple to install and operate. Switch controls two short wavebands and floodlights waveband in use, also disconnecting unit, leaves set free for normal use without alteration! Suitable for every type of mains receiver (AC and AC/DC models available). Acroplane dial with station names, wavelengths and megacycles, 100-1 geared knob control for extremely fine tuning. Handsome walnut cabinet.

Price Complete AC or AC/DC models **£4:14:6**

J.J. EASTICK & SONS, Dept. D58, 118 Bunhill Row, London, E.C.1

★ Watch for our special announcement next week!

# CAREERS IN RADIO

## Train by the Postal Method

The International Correspondence Schools offer a number of highly specialised Courses of Instruction in Radio. They include American as well as British broadcasting practice. Here are their titles representing the ground they cover:

Complete Radio Engineering  
Complete Radio  
Radio Servicemen's  
Elementary Radio  
Radio Service and Sales

Television Exams: I.E.E. Grad., I.W.T., C. & G. Radio Communication, P.M.G. Certif. in Wireless Tel., Air Ministry's Provisional Certif.

Write to-day for our Free "Radio" Booklet (40 pages)  
**INTERNATIONAL CORRESPONDENCE SCHOOLS, LTD.,**  
Dept. 30, International Buildings, Kingsway, London, W.C.2.

**O**FTEN you would like a permanent record of a broadcast talk which you particularly enjoyed. Often, too, you miss hearing a talk which you would have enjoyed. It is precisely to meet this need that the BBC publishes

## The Listener

which prints and illustrates the best of the broadcast talks. It is obtainable every Wednesday from newsagents, book-stalls and booksellers everywhere, price 3d.



M. PIERRE DUPONT, conductor of the famous Garde Républicaine band, which is giving a broadcast performance from Radio-Paris at 12 noon on Wednesday.

### Schumann's "Lost" Concerto

THE long-awaited first performance of Schumann's "Lost" Concerto will take place in the German Opera House on Friday, and I think it may be taken for granted that it will be the most discussed broadcast of the week.

The Concerto is included in a programme arranged in connexion with the anniversary of the foundation of the Ministry of Cultural Arts, which is being relayed at noon (G.M.T.) by all the German stations.

### The Strange Bequest

THIS Concerto for violin and orchestra was Schumann's last work, and it has lain in the archives of the Berlin State Library since 1907. It was composed by Schumann in 1853, and given by him to his friend, Joseph Joachim.

When Joachim died, his executors handed it to the German State Library with the proviso that it should not be performed until 1956, 100 years after Schumann's death. Wilhelm Strecker, the German music publisher, however, recently obtained the permission of the State Library authorities, and of Schumann's and Joachim's heirs for its performance.

### The Cuckoo's Morals

A TALK from Radio-Paris on Saturday, November 27, at 4.35 p.m., has the intriguing title "The Morals of Animals: the Cuckoo." It may be news to some listeners that it has any.

The reputation it enjoys—quite unfairly, it may be—is like that of the islanders in some distant ocean on whose "manners and customs" a naval expedition was instructed to prepare a report. After making an exhaustive study on the spot, the officer in command delivered his report with true naval conciseness, to the effect that "manners they have none and their customs are beastly."

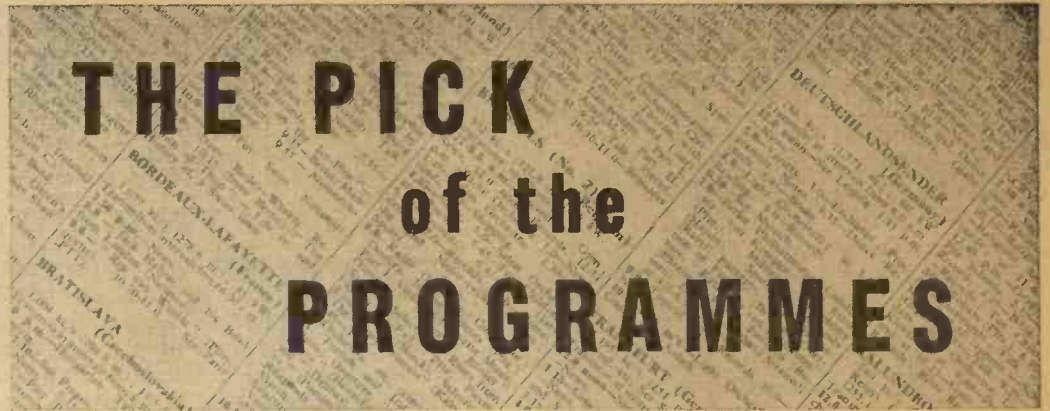

### Brave New World

A NEW series of weekly broadcasts, centred largely on the interests and activities of Latin-America and produced by the Office of Education in Washington, is not without interest to listeners in this country.

The programme, which is described as "a peace pageant on the airways that will bring to millions of people in twenty-one republics the sense of their unity and their kinship," is relayed by CBS for both the Wayne and Philadelphia short-wave stations every Tuesday at 3.30 a.m. G.M.T. In an inaugural address to the series President Roosevelt declared: "I would dedicate this nation to the policy of the good neighbour—the neighbour who resolutely respects himself and, because he does so, respects the rights of others."

### English Musicians Abroad

ON Thursday, November 25, Stockholm's evening concert consists of English music by Vaughan Williams, Butterworth, Walton, and Elgar. It is to be conducted by Clarence Raybould, who only recently returned from a similar mission on behalf of English music in Germany.

The following week he is conducting at Copenhagen (Kalundborg programme, November 28) and at Oslo on December 4. Cyril Smith also takes part in the Stockholm concert, as solo pianist in Walton's *Sinfonia Concertante*.



Mme. SLAVA ORŁOWSKA-CZERWINSKA, lyric soprano of the Warsaw Opera, who will broadcast from Warsaw at 3.15 p.m. on Monday.

### Paris Concerts

DESPITE the unusual hour—9.30 to 11.30 a.m.—there must be many listeners like myself who, having heard the Radio-Paris Saturday morning broadcasts from the Paris Conservatoire, will welcome the news that a new series has started.

Next Saturday's programme is of the usual high standard, including a Haydn Symphony, a Mozart Pianoforte Concerto, and Chabrier's "Fête polonaise."

### An Irish Soprano

MISS RENEE FLYNN, who, readers may remember, was the soloist in the BBC broadcast of Dr. Vaughan Williams's *Dona Nobis Pacem*, will be heard on Sunday at 7.15 p.m. from Athlone, where she is taking part in the first broadcast of new compositions for the organ. The relay is from the Methodist Church, St. Stephen's Green, Dublin.

From the same station at 9 p.m. the following night a programme devoted to the works of John Ireland will inaugurate a new series dealing with modern English composers.

### The Young Schiller

THE philosophy of freedom, which was the underlying motive of Schiller's early works, lends additional interest to a broadcast from Stuttgart at 7.15 p.m. on Tuesday, dealing with the early life of the great German poet.

Listeners will be taken to the scenes of Schiller's youth and early manhood, when he was engrossed with *Die Räuber*, the first of his plays to be produced. He wrote *Die Räuber* while studying at a military academy, and it expresses his discontent with discipline and an urge for mental freedom.

### Famous Pictures

AN afternoon in one of the world's most famous art galleries, browsing among priceless masterpieces—that is the pleasure which Leipzig will afford on Sunday from 4.45 to 6 p.m., when there will be a microphone tour of the Dresden State Gallery.

The pictures which will be "on view" to listeners include such treasures as Raphael's "Sistine Madonna," Correggio's "Holy Night," Giorgione's "The Slumbering Venus," and the masterpieces of Cranach, Dürer, Holbein, and many others. The works will be described by a commentator, and there will be an accompaniment of music by contemporary composers.

ALL-WAVE

## Calling All Readers!

Space is valuable, but for once we feel that you would like us to talk a little about ourselves. WORLD-RADIO comes out this week in a new form.

For twelve years it has held the position, of which, frankly, we are proud, of the only complete international broadcasting programme journal in the world. It is not giving up that unique position. On the contrary, we hope in future to be still more helpful and more interesting to listeners.

With the increase in modern receiving sets, a growing number of listeners are able to hear foreign programmes and to follow the rapidly developing short-wave services.

WORLD-RADIO aims at "bringing alive" these programmes from every continent for listeners in this country and elsewhere.

The new chief features which you will see in this week's issue, and in future numbers, are:—

Two pages of CLASSIFIED PRINCIPAL EVENTS, showing at a glance all the main broadcasts of the week on the long and medium waves.

PROGRAMME ITEMS better displayed, giving greater legibility.

SHORT-WAVE SECTION.—Complete short-wave programmes similarly arranged; list of short-wave stations with wavelengths; and news about this increasingly popular branch of broadcasting. The Short-Wave News Reel is enlarged and compered by an expert short-wave listener.

"THE PICK OF THE PROGRAMMES."—"All-Waver's" commentaries on forthcoming programmes.

"THE WORLD OF RADIO."—Two pages of up-to-date news collected by WORLD-RADIO correspondents in all the principal broadcasting centres.

"ROMANCES OF GREAT MUSICIANS."—The first of a series of articles on men whose names are household words.

"MICROPHONE PERSONALITIES."—A weekly feature giving listeners an intimate picture of broadcasting celebrities.

THESE ARE JUST SOME OF THE FEATURES WHICH WILL BE FOUND IN *World-Radio*. IT WILL ENDEAVOUR WEEK BY WEEK TO JUSTIFY ITS TITLE BY PRESENTING ALL THAT IS BEST IN THE WORLD OF RADIO.

### "SELLING" AMERICA

LAUNCHED last March by the General Electric stations W2XAD and W2XAF, a short-wave programme series, designed to make known to the world the scenic and historic beauties of the United States, has met with such world-wide appreciation that the broadcasts will be continued for another year.

The programmes have ranged over America's national parks, natural caves, medicinal springs, industries, colleges, cities, and resorts. It is now proposed by Mr. James W. Gerard (the celebrated War-time Ambassador to Germany), who is collaborating in a campaign to encourage tourists to visit the country, that the weekly "travelogues" should describe one state each week. They are broadcast on Mondays in French at 9 p.m. G.M.T., in English at 11.15 p.m. G.M.T., and in Spanish at 12.15 (midnight).

# THE WORLD

## Singer's Tragic Homecoming

### INDIA'S NEW STATIONS

THE first of the new 10 kW short-wave stations for India, which is to be installed at Delhi, is expected to be operating regularly by the end of the year. The short-wave transmitter for Bombay, which will be the second of the four short-wave stations, is also arriving this month. The new equipment embodies the very latest developments in broadcasting technique and will provide India with the nucleus of a highly efficient broadcasting system.

Of the medium-wave transmitting stations, that at Lahore will also be in operation before the end of the year. Transmitter buildings for the new stations at Lucknow, Bombay, and Madras are in course of erection, and construction work will begin shortly on the stations at Trichinopoly and Dacca.

### A STATION FOR BESSARABIA

THE Directorate of the Romanian Broadcasting Company has decided to erect a transmitter at Chisinau (Kishinev), the capital of Bessarabia, to counteract, it is announced, broadcast propaganda from abroad. It is proposed to transfer the 20 kW transmitter, which had served in a temporary capacity at Bod, near Brasov.

The new station will be named "Radio Bessarabia," and it will operate on the Romanian common-wave of 201.2 metres. It is also intended to install studios at Chisinau, and the town council have put the former Pushkin Theatre at the disposal of the broadcasting authorities.

### A TRAGIC FLIGHT

MME. ELVIRA ORLICZ-DRESZER, who frequently broadcasts from Warsaw (she is in Wednesday's programme at 8.20), was one of the central figures in a poignant tragedy in the Baltic in 1936. Mme. Orlicz-Dreszer was returning from a visit to America, which is her motherland, on the Polish liner *Batory*. They were about to enter the inner port at Gdynia, when a large aeroplane appeared overhead.

The machine made several circles over the boat, and then, suddenly, while making a spiral, dived almost perpendicularly into the sea. Before the first lifeboat arrived on the scene, the machine and her crew of three had sunk. Among the victims was General Orlicz - Dreszer, Inspector of the Aviation, Mme.



Mme. Orlicz-Dreszer

Dreszer's husband, who was making a surprise flight to greet his wife on her return home. A bouquet of red roses was found on the dead General's knees.

### BROADCASTS FOR SOLDIERS

A SPECIAL weekly feature for the Army is now included in the Italian programmes. Every Sunday morning, between 9.30 and 10 (8.30 and 9 G.M.T.) this is radiated from all stations for the benefit of troops in barracks or on service in the Italian colonies. General Pariani, Under-Secretary for War, gave the inaugural broadcast.

Military bands, soldiers' choruses, and talks on discipline, courage, and other military virtues are to be included in the feature. One of the items will be a talk by an N.C.O. on military life in Libya; while later there may be a link-up with Ethiopia.

### MARCONI MEMORIAL DAY

AT the instigation of Signor Mussolini the Italian Government has made the birthday of the late Marchese Marconi a National Memorial Day.

The decree states: "Marconi as a scientist was one of the greatest benefactors of mankind, and the anniversary of his birth on April 25 will always be remembered with solemnity." The decree expressly speaks of a Memorial Day and not a festival or holiday.

### A ROYAL FLAUTIST

THE chamber music programme which will be broadcast from Cologne at 8.10 p.m. on Friday includes a trio for flute, viola, and harpsichord by Quantz, who was flute-master to Frederick the Great. The Prussian King was a good flute-player, excelling in the *Adagio*, but less confident in the *Allegro* passages.

One day his teacher brought along a young player who struck the King as excellent. He asked Quantz why he had taught this young man to play so very much better than he did. Quantz replied that he had used a different method. "What was it?" inquired the King. Quantz replied that he had used frequent boxes on the ear. The King smiled and said: "No, no, then I prefer your other method."

### BROADCASTS FROM GREENLAND

TWO scientific expeditions, one in the Arctic, the other in the tropics, are reporting progress by radio over NBC networks. A description of the McGregor Arctic Expedition's preparations for winter encampment 600 miles from the North Pole was broadcast by some of the members from Reindeer Point, in northernmost Greenland, on short waves, and carried more than 4,000 miles to Radio City. Even the team leader of the dogs barked a greeting to the whole of the United States.

The Holden expedition, which, as already announced in WORLD-RADIO, is guided by radio direction bearings during its trek through the South American bush to study the diseases and drugs of primitive natives at the head of the Amazon, reports that it has encountered intense heat and that half its Indians were down with malaria.

# OF RADIO

## America's Radio Priest

### THE QUALITY OF EMPIRE

LORD TWEEDSMUIR, Governor-General of Canada, speaking recently on the occasion of his acceptance of an honorary degree of Doctor of Literature from McMaster University, said that, a few months before, when he took part in a broadcast whereby messages from various Governors-General in the Empire were listened to by a London audience, he had a fresh realisation of the value of wireless.

"But," he said, "I reflected that our amiable platitudes were scarcely worthy of such an august transmission. . . . To us in the British Commonwealth mere size has no value in itself. It is only an added responsibility. We realise that quantity is a debit, not an asset, unless it can be translated into quality." In the course of his address he outlined a new conception of the British Empire which, he said, has "banished boastfulness" and acquired "a new humility, and with humility, wisdom."

### POLAND'S S.W. PROGRESS

SINCE Warsaw short-wave transmitter SPW, on 22 m., has been augmented by SPD, on 26.01 m., numbers of letters have reached Polskie-Radio from the British Isles, Canada, and the U.S.A. From the last, naturally, come the greatest number, since some 3,000,000 Poles reside there. Many, I hear, write in broken English, interspersed with rather poor Polish, but the sincerity of the writers' sentiments leaves no doubt of their genuine pleasure in the daily contact with their homeland.

The times of transmissions have been revised in response to requests. The Saturday and Sunday transmissions now take place from 11 p.m. to 2 a.m., and, from November 29 onwards, the transmission times for the other days of the week will be 11 p.m. to 1 a.m. The total weekly broadcasts will amount to 16 hours of transmission.

### COFFEE CALLING!

THE Brazil Departamento Nacional de Cafe (National Coffee Department) is considering the construction and equipment of a powerful broadcasting station (50 kW) for the purpose of disseminating coffee propaganda in the United States and Europe under the direction of the National Department of Propaganda.

Two directional beam aerials will be used for short-wave broadcasts to Europe and the United States. Three aerials are planned for long-wave broadcasts.

### FOR MUSIC-LOVERS

DURING its Festival week, from December 5 to 10, Austria's "Friends of Music" Society (a short history of it appeared in our issue of October 29 last) will worthily celebrate the 125th anniversary of its foundation in those far-off days when Beethoven and Schubert were members. Among the conductors of its concerts have been Brahms and Schubert.

In the course of this Festival Haydn's

Creation will be conducted by Furtwängler; among other conductors will be Bruno Walter and Oswald Kabasta (who is the Ravag chief selector of serious music). Haydn's skull is one of the cherished treasures of the Society.

The Conservatorium, founded 120 years ago, is carried on by the State, and among its most famous pupils have been Anton Brückner and Fritz Kreisler.

### FATHER COUGHLIN'S SUCCESSOR

FATHER COUGHLIN, the famous American radio priest, has not broadcast since his recent visit to this country, and it is announced that the big independent network of private stations which he employed have been taken over by the Rev. Gerald Smith, another crusading clergyman.

Mr. Smith, who was at one time associated with the late Senator Huey Long, will spend close on \$100,000 for time on forty to fifty stations for a series of one-hour Sunday afternoon speeches, starting at 4 o'clock (9 p.m. G.M.T.). He stated in New York, where WMCA and WHN will both carry his talks, that he was enabled to buy the "time on the air" at regular commercial rates through subscriptions from his followers.

### MRS. ROOSEVELT'S FEE

ONE of the highest-paid radio personalities isn't paid at all. She is Mrs. Franklin D. Roosevelt, wife of the President of the United States, who speaks on a "sponsored" programme every Wednesday night. She doesn't do any advertising in her "copy" — simply speaks on any subject she feels is of interest.

She doesn't even see her cheques, which are said to be \$3,000 for each broadcast. The money goes directly to one of her pet philanthropies — the American Friends' Service Committee at Philadelphia.

This organisation is devoted to the rehabilitation of workers in the coal areas of West Virginia, Pennsylvania, and Ohio, where unemployment is an acute problem.

### NOBEL PRIZE-WINNER

DR. SZENT-GYÖRGYI, professor at Szeged University, Hungary, who has been awarded the 1937 Nobel prize for medicine, broadcast his thanks to his legion of well-wishers from the Budapest studio. "But for the boon of radio, I should have had to devote the rest of my life to replying to the thousands of congratulatory messages," he said.

Professor Szent-Györgyi who was formerly a student under Professor Hopkins at Cam-



Father Coughlin, the famous "priest of the air," whose weekly broadcast talks were, till recently, one of the outstanding events in American broadcasting (see col. 2).

bridge University, is now widely known for his chemical research work, especially in relation to vitamins.

## VARIETY

.. with the  
8.42 as top  
of the bill!



Your favourite comedian just coming to his best joke . . . and the 8.42 train crackles its way right through the biggest laugh of the programme . . . .

The K.B. "Rejectostat" All-Wave Aerial System definitely rejects all "man-made" interference on all wave-lengths from 13 to 2,000 metres. The efficiency of your receiver is in no way impaired.

A K.B. "Rejectostat" Aerial is easily erected. The outfit and accessories are obtainable from any K.B. dealer.

Prices:  
K.B. 461 "Rejectostat" All-Wave Aerial Outfit - - - - 35/-  
K.B. "Rejectostat" Receiver Transformer, if purchased separately (one required for each additional receiver) - - - 12/6  
K.B. "Rejectostat" Shielded Cable, type F. Superior copper braided flexible cable of high electrical efficiency - 8d per yd.

# KB "REJECTOSTAT"

REGD TRADE MARK PAT. NO. 423516

## ALL-WAVE ANTI-DISTURBANCE AERIAL SYSTEM

KOLSTER-BRANDES LTD., CRAY WORKS, SIDCUP, KENT

## ROMANCES OF GREAT MUSICIANS

# Schumann's Legal Battle for a Wife

*Robert Schumann, whose much discussed "Lost" Concerto will have its first performance broadcast from the German Opera House, Berlin, on Friday, went through the ignominy of a protracted lawsuit before he was allowed to marry Clara Wieck. This is the first of a series of authentic accounts of the domestic lives of great musicians, whose fame grows even greater with the passing of time.*

AMONG famous musicians there is one married couple, Robert and Clara Schumann, for whom successive generations have always felt a special affection. Their lives in which equal artistic striving and thinking resulted in a perfect partnership. Their story reads almost like a fairy tale.



Schumann as a young man

Schumann was the son of a Saxon bookseller, who forsook the study of law for music. There is no doubt that he had come under the influence of Jean Paul, in whose poetry he heard music, and of Schubert, in whose music he heard poetry. Both affected the young student's outlook greatly, but a nine-year-old child, whom he was to meet when he became a student at Leipzig University, was to become the most powerful influence in his life. When they first met, Clara Wieck was a nine-year-old prodigy who, with her pianoforte-playing, had delighted the world. She had been taught by her father, Friedrich Wieck, an eminent *maestro* at that time. From him Schumann had lessons, which he resumed on his return to Leipzig from Heidelberg University. It was Wieck who finally induced him to drop the study of the law and to take up music. He became a boarder in Wieck's house, where in the evenings he told fairy tales to Clara and her two brothers. Meanwhile, the fame of the prodigy Clara continued to grow. The young pianist played before Goethe, and the great poet and philosopher sent her his signed photograph. Schumann was overjoyed with her successes; he wrote her enthusiastic letters, and composed music for her. At that time their relations were only those of warmest friendship. Schumann, probably unconsciously, looked to Clara for inspiration, but the charm of her maturing womanhood had, as yet, not affected him. Indeed, it was with another—Ernestine von Fricken, whom he had met at Wieck's—that he believed himself to be in love, and when the

two became engaged, Clara's father, who had grown suspicious of the relationship between Clara and Schumann, was greatly relieved. But this engagement proved to be another way round to Clara's heart. In the autumn of 1835 Schumann wrote to a friend: "Clara grows daily more charming—inwardly no less than outwardly." Soon afterwards he made his decision. One evening as he was leaving Herr Wieck's house, Clara guiding him by the light of a candle down the stairs, they exchanged their first kiss. That sealed the break with Ernestine.

This unexpected development infuriated Professor Wieck, and he removed his daughter from Leipzig. Then followed a conflict with parental authority which lasted from February, 1836, to September, 1840. On the part of the father it was fought with a mean and slanderous tongue, and with increasing bitterness. There were

### By Dr. Erwin Kroll

times when the love between the young people seemed to have been submerged by the forces against them; when the old man believed that he had regained complete domination over his daughter, who had, meanwhile, grown into a mature virtuoso and whose fame had spread. Finally Schumann obtained the consent of the Courts to marry Clara. These proceedings, which he had taken with Clara's agreement, lasted for thirteen months, and among other malicious accusations he had to disprove the charge of being a drunkard.

The struggle for the woman who became his wife affected Schumann in two ways—as a man it hurt him deeply; as a musician it helped him to maturity. While his F Sharp Minor pianoforte sonata, for instance—a work which he dedicated to Clara when his love for her first began—expresses the wonderment and romance of young love, his beautiful C Major Fantasy can only be described as an intense expression of longing for Clara. After he had won her, a few immortal pianoforte compositions were followed by an output of *Lieder*, the abundance of which has probably not had its equal.

The young couple's diaries at this time are a delight to read. They matured side by side, and their great love penetrated their art more and more. But there were days when Schumann's restless, creative spirit displayed the first dark signs of a troubled mind. After writing the extraordinarily great number of *Lieder* he began his composition of symphony and chamber music, producing works of great originality. The dark shadow on his mind was, however, spreading. His inclination towards melancholy, loneliness, and introspection was growing. In 1844 the Schumanns moved from Leipzig to Dresden, and happiness appeared to have been achieved at last. Referring to their six children, Schumann says: "One can never have enough of them." To his wife he is "the nicest man ever." New works matured, among them the music to *Faust* and *Manfred*. Wagner and Liszt were friends of those days, but the friendship never grew very intimate. Then followed an event which was

to have ominous consequences for Schumann—his appointment as Director of Music at Düsseldorf. Almost completely lacking in every qualification as a conductor, he was a failure, and in the midst of the happy and joyous atmosphere of the Rhineland he fell more and more under the spell of his fateful malady. But



Clara Wieck, before her marriage

Robert and Clara were yet to experience some sunny days. The young Brahms appeared on the horizon of music, and Schumann proclaimed him to the world as his heir. On September 12, 1853, the anniversary of their wedding-day, Clara makes the following entry in her diary: "What can there be nicer than to celebrate the anniversary of one's wedding by the side of a loving and loved husband and six healthy and beautiful children? My heart is full for such rich blessings. May the heavens preserve this happiness for us for many years to come!"

Only a few months later the tragedy happened. Schumann jumped into the Rhine to escape from the tortures of madness which threatened to overpower him. However, he was saved from drowning by a passing boat, and on being brought home he himself asked to be taken to an asylum. They removed him to Eendenich, near Bonn, where his condition improved. In his letters, full of pensive melancholy, he reviewed his whole artistic life retrospectively as through a misty veil. Relentlessly and unceasingly the bodily and mental decline of the master continued. Only after an interval of two years, when his end was approaching, was Clara able to visit her stricken husband. For two whole days she remained by his side, and from the dying genius a last ray of loving recognition met her eye. Then he passed to eternal rest.

In the remaining years Clara devoted her art to popularising the life-work of her husband and that of his pupil Brahms. She died in 1896, one year before Brahms.

# COSSOR

## Radio

MORE WIDELY USED  
IN BRITISH HOMES  
THAN ANY OTHER MAKE

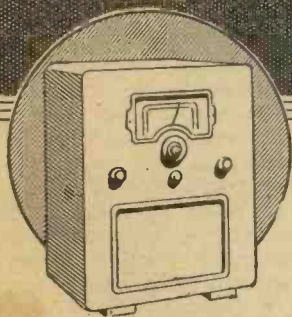

### COSSOR "MELODY MAKER" RECEIVERS

BATTERY Model 238 for medium and long waves only. Price (without batteries) £5.12.6.  
A.C. MAINS Model 388 for medium and long waves only. Price 6 Gns.  
ALL-WAVE BATTERY Model 338 for short, medium, and long waves. Price (without batteries) £6.15.0.  
ALL-WAVE A.C. MAINS Model 348 as Model 338 but for A.C. only. Price £7.7.0.

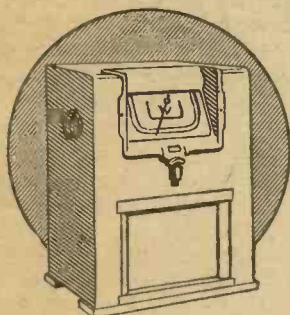

### COSSOR Series "48" ALL-WAVE SUPERHETS

BATTERY SUPERHET Model 483, 3 valves. For short, medium and long waves. Price (without batteries) 8 gns.  
BATTERY SUPERHET Model 485, as Model 483 but with 4 valves including Q.P.P. Output. Price (without batteries) 9½ gns.  
A.C. MAINS SUPERHET Model 484, 4 valves (inc. rect.). For short, medium and long waves. Price 9½ gns.  
Similar Model (484U) for D.C./A.C. Mains Operation. Price 10 gns.

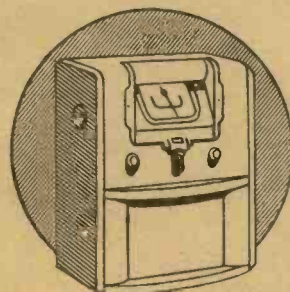

### COSSOR Series "58" ALL-WAVE SUPERHETS

BATTERY SUPERHET Model 583 for short, medium and long waves. 5 valves, Q.P.P. Output. Price (without batteries) 11½ gns.  
A.C. MAINS SUPERHET Model 584 for short, medium and long waves. 5 valves (inc. rect.). Price 13 gns.  
Similar Model (584U) for D.C./A.C. Mains Operation. Price 13½ gns.

Efficiency—reliability—value-for-money—these are the factors that really count in choosing your new Wireless—the factors that will, inevitably, bring you to Cossor Radio. For ten years the name Cossor has been associated with EFFICIENCY—brilliant, sparkling performance—with RELIABILITY—day-in day-out freedom from trouble and breakdowns—with VALUE—the most generous 20/- worth of up-to-date Radio obtainable for each £1 you spend. Go to any good Wireless Shop and try Cossor Radio for yourself—study its beautifully finished cabinet work—its simplicity—its fine reproduction, and you'll know what real value means.

#### TECHNICAL FEATURES OF COSSOR ALL-WAVE SUPERHETS include:—

Full-floating sub-chassis to eliminate microphony—new direct action positive wave-change switch—"finger-tip" controls for rapid searching—high "Q" coils for maximum efficiency—coupled volume and regeneration controls—controlled band-width tuning—new 8" and 10" moving coil speakers with response curve sensibly flat to 6,000 cycles etc.

SUPERB ALL-WAVE SUPERHET CONSOLE

11 GNS



### MODEL 438 for A.C. MAINS

This magnificent Console (illustrated above) is 33½" high and will bring you a wide choice of programmes on short, medium and long waves. It incorporates 4 valves (inc. rect.) and is fitted with a 10" energised Concert Grand M.C. Speaker giving superlative reproduction. For A.C. Mains only.

ALL COSSOR RADIO RECEIVERS ARE AVAILABLE ON H.P. TERMS.

Prices do not apply in I.F.S.

MODEL 438U. As Model 438 (above) but for use on D.C. or A.C. Mains without alteration. Price 11½ gns.

POST THIS COUPON FOR FREE 24-PAGE CATALOGUE

Please send me a copy of your new 24-page fully illustrated catalogue giving full details of all Cossor Radio Receivers and Radiograms.

To A. C. Cossor Ltd., Melody Dept., Highbury Grove, London, N.5.

Name .....

Address .....  
W.R. 19/11/37

B.37 .....

A. C. Cossor Ltd., Highbury Grove, London, N.5. Branches throughout the country.

## MICROPHONE PERSONALITIES

# The Announcer of Many Tongues

FOR a world-transmitter, which broadcasts to people of all races and colours the world over, it is all to the good that the chief announcer should be a cosmopolitan at heart, not caring where he was born or whence came his ancestors.

Versatile Edward Startz, earliest, and still the chief announcer of the Philips stations at Eindhoven and Huizen, entirely fits the part. Listeners to the Huizen tenth anniversary celebrations on Tuesday and Wednesday last will have heard him, for he had a large share in the announcements of the birthday-party programmes.

He admits to having been born, and that it was on February 20, 1899, but that is all he will admit regarding his birth. A brilliant conversationalist, with abundant enthusiasm for the subject of the moment, and an unfailing love of his present job, ready to go anywhere, willing to meet anybody and everybody, he has never been betrayed into revealing that secret. He is, and wishes to be, a cosmopolitan in the widest and most complete sense. A linguist of a calibre of which there are all too few in the world, he doesn't stop at speaking a large number of languages fluently—he becomes for the moment a national of the one which he is speaking. He knows, instinctively, what such very different characters as the Englishman, the South American Spaniard, or the Malay feel and think, and meets each on his own ground.

## A Varied Career

Apart from his natural gifts in this direction, his experience of life has provided him with an ample endowment. He has travelled all over the world at the urge of a restless nature, always seeking new experiences, making new acquaintances. He has been a sailor, a commercial traveller, an advertising manager, and has filled many more miscellaneous posts less easily tabu-



lated. The lure of a secure position has never been able to hold him to one place. To avoid monotony, or getting in a rut, he would throw up a good position in America to find himself shortly afterwards making but a bare existence in the streets of Hong Kong.

This characteristic is discernible even in his movements in an ordinary room. Quick, spontaneous, dynamic, enthusiastic for whatever may be on hand, his face beams with an interest that will not be satisfied with mere superficialities. He cannot sit still in a room, any more than he can remain in a small town for any length of time. The exception to this is the studio, where he feels he can travel the world over. He talks with, rather than to, the people at the other end of the beam, and in his own

mind puts himself into the country and the circumstances of those who are listening. He has friends in every nook and corner of the earth; he knows it and is proud of it, but he is also intensely grateful for their friendship.

## Impromptu Programmes

When first he started on the (then) PCJJ station he was put to the severe test of improvising as he went along, with only a rough sketch of each programme before him. He revelled in it—and so did his hearers. Now that the PHOHI stations are established broadcasting stations, with regular programmes transmitted under the eagle eye of the censor, his duties in this matter are more regular and his Pegasus-like utterances more bridled. In the experimental broadcasts to America and Australia, however, he still has his chances of dialectic and imaginative flights in the running comments he makes to introduce the various works broadcast from gramophone records, and to link one with another, however widely different they may be in character and style.

He has one hobby: talking; and it is his trade. He has a single passion: meeting and knowing and entertaining his fellow-creatures, and that also is his work. As a radio announcer he might have been born "in the saddle," or more exactly, before the microphone. Perhaps that is why he has lost track of the geographical spot. And while he has been riding his hobby for the last ten years or so, he was doing it in a slower way—in the only way that could make his present manner possible—for nearly a quarter of a century before that, while as a youth and man he was wandering through the world.

For him and for his listeners the short-wave transmissions are a boon in that they eliminate all time and space in communicating with each other. This is his "life"—the living "world of radio." H. A.

## LEAVES FROM MY LOG

By "Log-Roller"

### VARIETY IN TUNING

NOT so very long ago there was really only one kind of tuning arrangement: a slow-motion dial (or it might be two or even three) with a semi-circular scale marked off into 100 divisions or 180 degrees. The dial showing station names is now found on every set, but it takes many different forms, and the drive is of many different kinds. There are large dials, there are small dials, there are round dials, there are oval dials, there are oblong dials; on some the names of stations are printed in horizontal rows, on some radially, on some at an angle; some dials have a white background, others a dark one; others, again, one of an intermediate shade of buff; sometimes large type is used for the names, sometimes small. As regards the drive, there may be two concentric knobs, one for fast and one for slow motion; or you may "change gear" by pushing in or pulling out the tuning knob; or the gear-change may be automatic when you change the direction in which you are turning; or, again, there may be only one speed, a fly-wheel enabling you to spin the knob when you want to change quickly from one station to another some distance away.

### IS THERE A BEST ARRANGEMENT?

That's a fairly long list, but probably there are a good many kinds of dials and drives that I

haven't mentioned in it. Readers must have tried a number of them in the various sets that they have had from year to year, and I wonder which system finds the greatest favour. I suppose that there must be a best tuning arrangement, but I can't quite make up my mind what it is. I have a feeling that what I should really like is a whacking great black-and-white dial, with the names printed horizontally in large type, and big, open scales of kilocycles or megacycles. I am told, though, that that would spoil the look of the wireless set. Would not some sacrifice of beauty in the name of usefulness be justified? Again, I have a sneaking affection for the two concentric tuning knobs, though a single one with either automatic or push-pull gear change may be neater. What are your views?

### YOU NEEDN'T SIT UP-NOWADAYS

Once upon a time "sitting up for America" used to be a very popular pastime with wireless men, though it wasn't perhaps so popular with other and less enthusiastic members of the household. Many of us have incurred censure for disturbing slumberers just because we wanted to see how strongly WGY or KDKA could be brought in on the loudspeaker at 2 a.m. Happy homes have come near to being broken up when excited husbands dragged sleepy wives from their warm beds in the small hours to hear

America in rooms where the fire had long since gone out. Now, thanks to the short waves and to the "all-wave" receiver, such occurrences are things of the past. On days when conditions are not too unfavourable you may hear a score of American stations (South American as well as U.S.) between tea-time and early bed. It is rather a pity, though, that they aren't often of much use in the mornings. I have never heard any of them before 2 p.m., though as some of the U.S.A. transmitters start up at 6 o'clock E.S.T., which is 11 a.m. with us, I can't quite see why. I wonder who holds the record for the earliest morning reception of an American station—morning to count from after breakfast-time. I doubt whether anyone can claim U.S.A. short-wave broadcast reception before 1 p.m.

### ON TEN METRES AND BELOW

Ultra-short-wave reception is growing increasingly popular, and I don't wonder. Quite a simple receiving set, which doesn't cost much to make, can give remarkably good results, and there's nothing very difficult about the tuning for those who have previously done short-wave work. It is certainly one of the most interesting of all the fields of long-distance wireless nowadays, for you never know what you are going to find or when you are going to find it. The best time for ten-metre reception is probably the afternoon and early evening between 2 o'clock and 6 o'clock, but there seems to be no hard-and-fast rule, for ultra-short-wave signals from great distances are often heard both earlier and later than these times.



## READERS' FORUM

*G.B.S. into French*

## "PYGMALION" IN PARIS

SIR,—Having seen in *WORLD-RADIO* that Paris (PTT) was to broadcast *Pygmalion* on Saturday, November 6, at 11 p.m., I made a point of listening to it, curious to hear how the Cockney Eliza and her dustman father, and especially the prim old English housekeeper, would stand translation into Parisian characters.

Eliza Doolittle, guttersnipe and Court débutante re-born French Eliza Colombe, made her début on the French ether with apparent success, but one would like to know what Mr. Shaw ("Sho" the announcer called him) thought of this production of his play, if he heard it, and whether or not he compared favourably this Madame of the Comédie française with his brilliant first Eliza of twenty years ago.

Enough was heard of the broadcast to prove that in Paris classical traditions persist. Alfred Doolittle—francisé Colombe—was a joy to hear. From him our present-day actors might have learnt something had they been listening. For the great elocutionists are no more, and now the last curtain has fallen on Forbes-Robertson, of the noble voice. Yet we still have our George Bernard Shaw, ever pointing out his path of perfection to playwrights and to play actors. *Fidus Achates*—long may he live!

Braemar, November 7.

K. GERARD.

## "CARMEN" FROM TOULOUSE

After trying in vain on Sunday evening, November 14, to hear *Carmen* which you announced as being broadcast by Lille from the Opéra-Comique, I was delighted to find it very clearly audible from Toulouse (PTT), which you showed as sharing in the transmission. At times, indeed, it was so loud that regard for neighbours made me moderate the volume considerably. It was a very fine performance, though marred, to an old opera-lover's way of thinking, by the constant interruptions of applause and frequent encores. None the less, it kept my household sitting up later than they are wont to do on Sunday evening, and I would thank you for letting me know of such a chance.

Kent, November 15.

G. S. GREEN.

## "LEAVES FROM MY LOG"

I am very interested to see the creation of the "Leaves from my log" feature. I have been interested in long-distance reception for quite a long time and should like to report extraordinary reception on the medium waves this afternoon, November 13, in daylight.

Nearly every medium-wave station was audible, amongst them Falun (276.2 m.), R4, and Pori (400.5 m.) at R7, this station being identified by tuning in Lahti (1,807 m.). Algiers gave an R3 background to Göteborg, R7.

The weather, incidentally, was cold and clear, which I always find advantageous for medium-wave reception. My set is a 5-valve superhet. A.C. All-Wave, with outdoor aerial, the far end of which rests on the ground having been blown down last September!

In my log I have CMQ Havana, Cuba (340 m.).

PHILIP M. BAMBAUT.

Priory Cottage, Northampton, Nov. 13.

## THE POWER OF RADIO 37

I should like to know if anyone can explain how it is possible for a station with a power of only 0.4 kW to be heard in this town, as is Rueil-Malmaison (Radio 37).

Brighton, October 19.

P. CRAIG.

## SOFIA AND GENOA No. 2

I noticed the other day in a radio weekly paper of the technical type reference to the new stations of Sofia and Genoa No. 2. Referring to them, the writer suggested they would be of little use to the listener here owing to interference. My experiences tell a different tale.

True Sofia (100 kW) does not equal the other station Belgrade (20 kW) in that part of the world, but on Sunday, November 7, reception was good. It easily overpowered the other stations on the same waveband, and the only interference was a slight hum, which judicious use of volume and tone controls minimised greatly. Valencia, however, proved occasionally troublesome later, but reduced volume eased matters.

Tuning in first of all with earphones I obtained Genoa No. 2 at half volume, then switched over with plenty of volume for the loudspeaker. Occasionally, there was interference of the "swishy" background type, but generally, reproduction was clear.

How are other readers finding it with these stations?

RONALD J. C. YOUNG.

Hertford, November 7, 1937.

## Short-Wave Number

The next issue of *WORLD-RADIO* will be a special Short-Wave Number.

In addition to all the usual features there will be articles on all aspects of Short-Wave Reception, as well as an interesting survey of "Ten Years of Short-Wave Broadcasting" by Sir Noel Ashbridge, B.Sc., M.I.E.E., Controller (Engineering), BBC.

Order your copy now. *WORLD-RADIO—THE ONLY COMPLETE FOREIGN PROGRAMME JOURNAL.*

## MORSE INTERFERENCE

The two letters explaining the cause of the morse interference about which I and others have complained are very welcome.

I cannot help sensing a certain amount of resentment, however, which is, I suppose, understandable to a certain extent, even if it is unjustified. I had suspected that the trouble was probably emanating from ships' morse and, of course, appreciate its necessity, but owing to its extreme loudness and persistence, I began to wonder if the annoyance might not be traceable to some other source.

Things being as they are, we must naturally bow to the inevitable and give way gracefully.

L. DENNYS.

London, N.W.2, November 12.

*The Forum of WORLD-RADIO is provided to enable readers to express opinions and exchange ideas on matters of common interest.*

*Letters, which must be as brief as possible, should be addressed: "Editor, WORLD-RADIO, Broadcasting House, London, W.1."*

*The name and address of the writer should be enclosed, not necessarily for publication, but as proof of authenticity.*

## Italian Radio Plans

THE Director-General of the EIAR has published in the *Giornale d'Italia* a lengthy article in which he reviews the position attained by radio at the present time, and foreshadows approaching developments. Below we give some extracts from the part devoted to "Coup d'œil sur l'avenir" (A Glance at the Future).

"The activity of the Italian broadcasting organisation (EIAR) must be considered from the following triple aspect: (a) Internal service; (b) Empire and foreign service; (c) Television.

"With regard to the first, the plans ensuring for Italy a strong and clear reception in all areas of the kingdom will be continued even more intensively. As far as the number and power of the transmitters are concerned, it may be said that when the installations in course of construction are completed all quarters of Italy will be served so as to provide good reception of one, two, or even three programmes on simple apparatus and with small expenditure.

"As regards programmes, given the very large number of listeners the keynote of the broadcasting programme scheme—on the cultural as well as the entertainment side—will continue to be 'variety,' that is to say, an equal distribution of the different types of music and spoken matter (lyric operas, symphonic music, operettas, chamber music, comedies, etc.).

"In accordance with this conception, and in order to mark a division between the programmes, Italian stations will be grouped into three, instead of into two as at present; in this way it is possible to transmit simultaneously three different programmes which will be enjoyed by different classes of listeners."

With regard to (b), the article continues:—

"The Empire and Continental services will be completely and efficiently systemised when the new Imperial short-wave Transmitter Centre, which is now in the course of construction at Rome, begins operations. The said Centre will comprise five transmitters (two with an aerial power of 100 kW and one of 50 kW) and it will be endowed with an imposing and elaborate system of directional and omnidirectional aeriels. These will, first of all, provide reception in the Italian Empire, which will be served by four stations with four separate wavelengths; and will afford very good transmission to North, South and Central America, to the Far and to the Near East."

Lastly, television:—

"The EIAR which, since 1928, has effected in its own laboratories, research and experiments in television, is now preparing, by means of a primary installation which is in the course of construction at Rome, to begin television transmissions intended for the general public.

"With the addition of the element of vision to that of sound, it will be possible to transmit, in their complete ensemble, artistic works as they have been conceived. It will also be possible to prepare in the auditoriums and to transmit especially composed shows having the vision part expressly created (choreography for ballets) and one will have recourse to the cinematographic reel for transmitting topical events and sometimes even short-reel films prepared by sketches."

WE have received the "Wireless World Diary for 1938" (1s. 6d. net). As usual the diary embraces a wide range of information for the broadcast listener and the technical man—lists of stations, with frequencies, receiving licence regulations, useful formulæ, practical hints and tips—in fact, an encyclopædia on a highly condensed scale.

OWING to pressure of space the list of Esperanto transmissions had unavoidably to be held over.

# TELEVISION NOTES AND PROGRAMMES

## Nervous Viewers, Beware!

By "THE SEER"

HOW long can one concentrate attention on the television screen? At one time it was thought that an hour would involve strain, and perhaps this was true a year ago, when the pictures were often muddy and were described by one observer as "a mass of grey junket." But conditions are different to-day, thanks to better studio lighting and improved cameras, with the result that the 75-minute transmission of *Journey's End* last week left many viewers wishing for more.

More they will have on December 6, when *Once in a Lifetime*, the gloriously funny satire on American film methods, by Moss Hart and George Kaufmann, will be given in a special television version lasting an hour and a half. The play is well chosen, for it is packed with fast-moving episodes and rapid dialogue, and should give good scope for multi-camera work. Joan Miller, the television "Picture Page" girl, will appear as May, member of an unsuccessful music-hall team, who "cashes in" on the arrival of talking pictures by opening a school of elocution for the panic-stricken stars of the silent films.

By general consent, the television from the Cenotaph last week excelled in every respect. Soft sunlight and a slight mist gave exactly the right kind of diffused light, while perfect sound transmitted by the ultra-short waves completed the illusion for many viewers that they were privileged spectators on the spot.

Much of the success was due to the careful handling of the cameras. From 10.30, when the transmission began, until the conclusion of the Cenotaph service, there were more than fifty camera "mixes," ranging from views of Big Ben as the hands drew nearer the hour, to comparative close-ups of the King and Cabinet and the

flags upon the Cenotaph. Various camera lenses were used, with angles of 5 degrees on Big Ben to 40 degrees on the general views of Whitehall.

If certain types of broadcast play—in sound alone—can administer shocks to the sensitive, how much more potent in this direction must be the same sort of play when televised. Once or twice it has been necessary to warn nervous listeners to be on their guard, and for the first time a similar warning will be issued to nervous viewers on November 26, when Reginald Berkeley's one-act play, *Eight O'Clock*, is included in the evening television programme.

Russell Thorndike will take the leading part in this poignant little drama, the scene of which is the condemned cell in the Aldgate prison on a raw winter's morning. The story—if, indeed, it can be called a story—revolves round the condemned man, who, in the last thirty minutes before execution, wavers between hope and despair. A reprieve may come, or it may not.

## The Eiffel Tower

THE following new schedule of television transmissions from the Eiffel Tower is now in force:—

Daily.—3 p.m. to 3.30 p.m.: outside transmissions (street interviews, etc.).

Weekdays.—4 p.m. to 5 p.m.: studio transmissions.

Sundays.—4 p.m. to 6 p.m.: studio transmissions.

While test transmissions may be made at other times, in principle no transmissions take place on Tuesdays and Wednesdays.

The sound transmissions are on 42 Mc/s, with a power of 6 kW, and the vision on 46 Mc/s, with a peak power of 15 kW.

The aerial for sound is situated at the top of the Eiffel Tower, and that for the vision transmissions is on the first platform.

## PROGRAMMES

Frequencies—Vision: 45 Mc/s; Sound: 41.5 Mc/s. All programme times shown below are approximate. From 11.0 a.m. to 12.0 noon each day, films intended for demonstration purposes will be shown.

### MONDAY, November 22

- 3.0 p.m.—Pamela Norris (Pfte.).
- 3.10—Gaumont-British News.
- 3.20—Characters from "Bleak House": a talk by Hugh Miller.
- 3.30-4.0—Jack Hylton and his Band.
- 9.0—"Quarter," with Irene Prador, Wendy Toye, Russell Swann, Cyril Fletcher, BBC Television Orchestra. 9.30—British Movietone.
- 9.40-10.0—"The Policeman's Serenade": an opera in one act by A. P. Herbert.

### TUESDAY, November 23

- 3.0 p.m.—Round the Film Studios, No. 3—Elstree.
- 3.15—Fashion Forecast.
- 3.30—British Movietone.
- 3.40-4.0—"Comic Strip," No. 2: a programme of American humour.
- 9.0—Round the Film Studios, No. 3—Elstree.
- 9.15—Speaking Personally: W. D. H. McCullough.
- 9.25—Gaumont-British News.
- 9.35—Fashion Forecast. 9.50-10.0—Starlight.

### WEDNESDAY, November 24

- 3.0 p.m.—Round the Film Studios—Elstree.
- 3.15—Mr. Gillie Potter.
- 3.25—Gaumont-British News.
- 3.35-4.0—"Picture Page."
- 9.0—Round the Film Studios—Elstree.
- 9.15—Naughton Wayne.
- 9.20—British Movietone.
- 9.30-10.0—"Picture Page."

### THURSDAY, November 25

- 3.0 p.m.—Round the Film Studios—Elstree.
- 3.15—British Movietone.
- 3.25-4.0—"The Habima Theatre in scenes from 'Uriel Acosta'."
- 9.0—Round the Film Studios—Elstree.
- 9.15—Clothes-Line, No. 5.
- 9.30—Gaumont-British News.
- 9.40-10.0—Television Follies.

### FRIDAY, November 26

- 3.0 p.m.—Round the Film Studios—Elstree.
- 3.15—Gaumont-British News.
- 3.25—Friends from the Zoo.
- 3.40—Cartoon Film: "Mickey's Gala Premiere."
- 3.45—Highlights of next week.
- 3.50-4.0—Starlight: Charles Heslop.
- 9.0—Round the Film Studios—Elstree.
- 9.15—Friends from the Zoo.
- 9.25-10.0—British Movietone.
- 9.35-10.0—Russell Thorndike in "Eight O'Clock," a play by Reginald Berkeley.

### SATURDAY, November 27

- 3.0 p.m.—"The Policeman's Serenade": an opera in one act by A. P. Herbert.
- 3.20—British Movietone.
- 3.30-4.0—Cabaret Cartoons.
- 9.0—"Pride o' the Green": a Very Grand Opera by Rae Elrick. 9.35—Gaumont-British News.
- 9.45-10.0—Sigurd Rascher (Saxophone); BBC Television Orchestra.

## Which station was that?

This feature is intended for the use of readers who desire the identification of broadcasting stations only, whether on long, medium, or short waves. For particulars of amateur transmissions readers are referred to the relevant paragraph below.

### The Alternative Postal Service

In addition to the free service of "Which Station Was That?" printed in these columns, replies to station identification queries can be obtained within forty-eight hours of receipt of details on payment of 6d. per query, in stamps, or P.O., accompanied by stamped addressed envelope (marked in left-hand top corner "Postal Query Service"), and coupon as per conditions for "Free Queries."

**AVITE (Farnborough):** Saarbrücken (Germany). **AMICO (Hertford):** Apparently Rome, 420.8 m.; the station may be heard broadcasting almost nightly a news bulletin in Spanish; we cannot trace a Spanish transmitter working on or about 426 m. **ZAKATOI (Mossend):** Surely Moscow, RW59, on 6 Mc/s. **CASTLE KEEP (Guildford):** Too vague; regret, cannot trace; we feel convinced that your estimated wavelength is wrong. **BUTCH (E.15):** PMN, Bandoeng (Java), on 10.26 Mc/s. **SUFFOLK PUNCH (Ipswich):** **EX DOT KING (Kenton):** OLR2B, Podébrady (Prague), on 49.75 m. **HEY (N.3):** The Air Ministry weather reports for aviation are broadcast on 1181 m. from Borough Hill (Northants) almost half-hourly throughout the day from 07.15 G.M.T. **RAM (Edinburgh):** (1) yes, this is Moscow (RW59); (2) cannot identify any Moscow station working on or near this channel excepting RNE on 25 m.; (3) RKI, Moscow (19.88 and 19.94 m.); FVA, Algiers, on 33.48 m. **MAN OF KENT (Portsmouth):** HJ1ABP, Cartagena, on 31.25 m.; address: Apartado Postal 37, Cartagena, Colombia. **GIBBY (Oxford):** Would tally with EDR3, El Tablero, Tenerife (Canary Is.), on 28.94 m. **RASTUS (Old Trafford):** Possibly WMN, Lawrenceville (N.J.), on 20.56 m.; a relay from Great Britain. **REN (Wath-on-Dearne):** (1) see "Gibby"; (2) for this broadcast a number of commercial transmitters were also brought into operation; RW96, Moscow, is entitled to use 48.94 m. and 49.1 m., and RW98, 49.34 m. and 49.5 m.; (3) possibly RRE, Moscow, 39.22 m.; (4) RKB, Moscow, 38.53 m.; RKI, Moscow, 19.88 m., and RNE, Moscow, on 24.99 m. **PLUM (Bradford):** See reply to "Rex"; (1) RKI,

Moscow on 19.88 m. and (2) 19.94 m.; (3) possibly RRRG, Archangel (20.41 m.); (4) RRRG is also entitled to work on 33.04 m.; (5) regret, cannot trace. **DERBUCK (Stretford):** There is no broadcasting station working on the 1000 metre channel; possibly a background of Athlone on a slightly lower wavelength. **LUXEMBOURGIAN (Banstead):** (53) there is no broadcast transmission on 1000 metres, the nearest are Tiflis, 1060 m., and Tromsø, 1065 m.; (53b) Warsaw (No. 2) on 216.8 m. has as neighbours Radio-Lyons (215.4 m.) and the Swiss common wave on 218.2 m.; L'île de France (Paris) working on 219.6 m. may be the cause of the interference. **WANINO (Glasgow):** (1) cannot say; the only BBC station anywhere near that channel is North Regional; (2) would tally with the sixth harmonic; there is no S.W. relay of the Dublin broadcast. **ROSART (Hastings):** Regret, cannot trace; W3XL is a Bound Brook (N.J.) station working on 17.33 m. and 46.7 m.; the only Chicago short-wave station is W9XAA, 11.83 Mc/s, operating on the same frequency as W2XE. **SEACREST (West Looe):** KZRM, Manila (Phil. Is.) on 9.57 Mc/s. **FRASER (N.W.10):** The name of a receiver must not be used as a *nom-de-plume*. Regret, cannot trace the call-sign given in your query No. 1; there are many call-signs starting W9X. **KOVAG (Kirk Michael):** CJHX, Halifax (Nova Scotia), on 48.94 m. **R. A. M. (Barwell):** 12R03, Rome (31.13 m.). **MARINO (Sandycove):** (1) if wavelength approximately correct more likely to be PLP, Bandoeng, on 27.27 m.; (2) regret, cannot trace. **A. N. TENNAE (Poole):** CXA2, Montevideo, on 49.98 m. **NOB TWIDDLER (Windsor):** (1) probably sixth harmonic of Poste Parisien (Paris) on 52.133 m.; (2) RIF, Moscow (18.04 Mc/s) or RRE, Moscow (18.11 Mc/s); (3) the only short-wave Italian broadcasting station operating in that band is 12R03, Rome, 31.13 m. **MARLBOROUGH (N.W.3):** (1) HJ1ABP, Cartagena (Colombia), on 31.25 m.; (2) YV5RC, Caracas (Ven.), 51.72 m.; concludes the broadcast with the IBC march; (3) YV4RB, Valencia (Ven.), on 46 m.; (4) YV1RI, Coro (Ven.), on 48.31 m. **DECAV (Tralee):** (6) regret, cannot trace; (7) FVA, Algiers (33.48 m.); (8) COCX, Havana (Cuba), last reported on 26.11 m. **QUESTO (Barrow-in-Furness):** Vague but possibly RKI, Moscow, on 39.79 m. No. 1 **SQUAD (Glasgow):** W1XK, Millis (Mass.), on 31.35 m., relating WBZ and WBZA, Boston. **ACCORDIONIST (Bolton):**

(1) 12R03, Rome, on 31.13 m.; (2) probably a relay by one of the Drummondville (Quebec) commercial transmitters on 21.83 or 22.58 m. **X. Y. Z. (Liverpool):** PMN, Bandoeng (Java), on 29.24 m. **BBUMMY (Birmingham):** (7) if wavelength correct might tally with W6XKG, Los Angeles, on 11.56 m., but if below this channel possibly W9XAZ, Milwaukee, 11.36 m.; (8) yes, PMA, Bandoeng, on 15.5 m.; (9) yes, W9XAA, Chicago; W2XE, Wayne (N.J.), works from G.M.T. 11.30-04.00.

### AMATEUR TRANSMITTERS

The identity of amateur transmitters may be found in the "Radio Amateur Call Book." The Autumn Edition (price 6s. post free) can be obtained from the BBC Publications Management Offices, 35, Marylebone High Street, London, W.1. The 1937 Edition of the "Radio Amateur Handbook," price 5s. 6d. post free, can also be had from the above address.

### IDENTIFICATION COUPON (No. 458)

This coupon is valid for ONE QUESTION only and should be cut out and attached to a separate sheet, upon which the following questions should be answered in the order shown. A copy of the answers should be enclosed with FREE queries. No coupon more than one month old is valid. A coupon is not required from readers living in countries outside Europe who desire identification of transmissions.

1. Time and date of reception.
2. Approximate frequency in kilocycles (or, for short waves, in megacycles) per sec. (or wavelength in metres).
3. Nearest known stations, above and below.
4. Call or interval signal, if heard.
5. Language.
6. Type of receiver in use and strength of signals.
7. Details of programme or signal received.
8. Name and address.
9. Nom de plume. (Proprietary names must not be used.)

# Still Bigger Sets! By R. W. HALLOWS

The interest aroused by the article "Where the Big Set Scores," published on October 15, has inspired our contributor to go even one better. Here he describes the performance of receivers of comparatively gargantuan proportions

A SHORT time ago (October 15) I described in WORLD-RADIO some of the advantages to be obtained from receiving sets using from eight to twelve valves. But twelve valves are a long way from being the greatest number that can be usefully employed in the receiving set. In the present article I hope to tell you something of what can be done with circuits incorporating from fifteen to thirty valves or more.

I have heard it suggested that in sets of this kind a good many of the valves don't do very much or make any particular difference to reception; that their presence is, in fact, rather in the nature of "eye-wash." Believe me, this isn't so: the skilled designer who is striving towards perfection in reception regardless, within reason, of cost can find useful work for every one of a small army of valves to perform.

Let us decide first of all what the perfect set would be; we shall then be able to see how the use of many valves helps towards producing it. We shall, I think, agree upon the following desirable qualities:—

- (1) It must be highly sensitive on all the wavelengths covered.
- (2) There must, when required, be sufficient selectivity to enable stations on adjacent channels to be separated.
- (3) It must be able to counteract the effects of any but the worst kind of fading.
- (4) It must show no tendency to detune itself once a station has been tuned in.
- (5) It must be free from "noise."
- (6) The output from its loudspeaker must be as free as possible from any kind of distortion, and as nearly as possible a faithful copy of the sounds occurring in studio or concert hall.
- (7) It must be easy to handle.

If you will look at the accompanying diagram you will see the essential or basic valves for an A.C. mains superheterodyne of any kind indicated by heavy lines. Any superhet circuit must contain a first detector, an oscillator, an intermediate-frequency valve, a second detector, an automatic-volume-control valve (strictly, this is not essential, but no one would use the simplest superhet without it to-day), a low-frequency amplifier, and a rectifier. In small superhets a multi-electrode valve usually acts as a frequency-changer, or combined first detector and oscillator. A second compound valve may perform the three duties of second detector, A.V.C., and L.F. amplifier or output valve. Thus the number in a small A.C. mains superhet can actually be reduced to four or five.

The great advantage of such an arrangement is that it enables a set to be produced at small cost which, besides being sensitive and selective, provides reproduction of reasonably good quality and is simple to handle.

## ONE VALVE ONE JOB

We saw in the article already referred to, how performance could be improved by the addition of a few valves to the basic circuit. If we take a small superhet using five valves (two of them compound), the twenty-six-valve circuit shown in the block diagram represents an increase of twenty-one valves. What are all these newcomers doing to justify their presence? The first thing that may strike you is that each valve in the circuit is doing one job, and one job only. Where the cost of the set is no particular object this has technical advantages into which I needn't enter here.

A high degree of sensitiveness was the first requirement that we agreed upon for the perfect set. By adding two high-frequency valves, and a second and a third to the original single I.F. amplifier, we can readily obtain all the sensitiveness that we require without ever having to make our valves work "all out." Just as a high-powered engine, always working well within its power, produces the smooth and apparently effortless running of the big car, so these extra H.F. and I.F. stages help to build up a set whose working gives you the impression of being smooth, quiet, and without strain.

These extra valves also ensure selectivity of a very high order when it is required. You will observe that a further addition has been made to the H.F. and I.F. stages. Some small and medium-sized superhets have an H.F. stage, but the same automatic volume control operates both on this and on the I.F. valve. In our twenty-six-valve circuit both the H.F. valves and the I.F. valves have their own source of A.V.C. The reason is this. Ability to separate any station from its neighbour would be comparatively easy to obtain if all were equally strongly received. It is difficult to design a set that will pick out a little station from a powerful one working on the next-door channel. The big station is apt to overload the set and to cause an apparent loss of selectivity. This is obviated by the use of a separate H.F./A.V.C. source.

The duties of the oscillator amplifier were explained in the previous article. The tuning indicator control helps to make the visual indicator effective on even weak signals. The

beat oscillator is very useful if you are searching for faint and distant stations on the short waves. It cannot possibly annoy your friends and neighbours by causing re-radiation, but when it is brought into action by means of its switch, faint stations that might easily have been passed over otherwise, call attention to themselves by squeals in the loudspeaker.

So far we've dealt only with the high and intermediate-frequency departments of the set up to and including the second detector. The number of valves up to this point is thirteen.

## REPRODUCTION FIDELITY

We now come to the low-frequency side of the set, which, in the small superhet, might consist of one valve—or even of no more than one set of electrodes in a compound valve, such as the double-diode-pentode. In our diagram there are no fewer than eleven valves on the low-frequency side. This number may seem surprising, but it must be remembered that real fidelity of reproduction is the most difficult and costly of all qualities to obtain in a receiving set. It is for the sake of quality rather than for that of enormous volume that all these valves are used.

You know that it is not easy to find a set whose "tone" is satisfactory to all kinds of people. Some like a great deal of bass with little treble; others like the higher notes strongly brought out, and so on. See how this is overcome in the circuit illustrated.

The output from the first L.F. valve passes through two filters not shown in the diagram. One of these admits only the upper notes, the other only the lower ones. You have thus separate treble and bass amplifiers, each with its own volume control and its special loudspeaker.

True push-pull is used for the second L.F. and output stages of both amplifiers. The virtue of this type of amplification is that it minimises one of the most important kinds of distortion.

Two valves are used for automatic volume expansion, a description of which was given in the previous article.

We have added one more valve to the original small number—a second rectifier—which is required owing to the number of high-tension circuits to be served. This brings our total to twenty-six, though we could easily use several more valves and find real work for each. We might, for example, have automatic selectivity control and automatic tuning control on the high-frequency side. The low-frequency amplifier might be rearranged to include inverse feedback, another sworn foe of distortion.

The ideal receiver must, I am afraid, be and continue to be a luxury set costing a great deal of money. Meantime most of us will manage to rub along with smaller receivers, which don't do too badly after all!

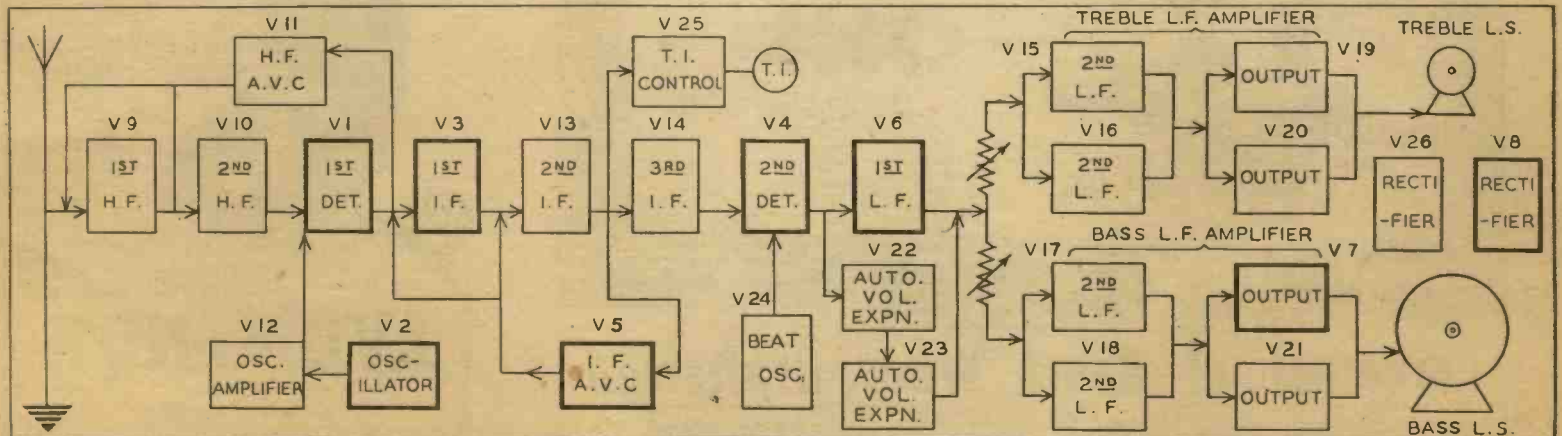

Schematic diagram showing how 26 valves may be used in an A.C. mains receiver. The essential valves (V1-V8) for a typical superhet are indicated by heavy lines

SHORT-WAVE SECTION

W3XAL: Growth of U.S. Short-Wave Service

AMERICA's bid for supremacy in the highly competitive field of international short-wave radio broadcasting was strengthened during the month of September by a marked increase in the number and diversity of the National Broadcasting Company's schedule of special programmes expressly designed for particular foreign countries.

Thirteen different countries in Europe, South America, and Central America are now tuning their radio sets to these special programmes which supplement the regular sixteen-hour daily round-the-world international broadcasting services of W3XAL, NBC's short-wave station.

Nations now receiving special programmes are as widely separated geographically as Argentina and Norway. They include, in addition, France, Germany, Italy, and Switzerland, in Europe; Brazil and Chile, in South America; and Costa Rica, Guatemala, Honduras, Nicaragua, and Salvador, in Central America.

Seven different languages have been used in special programmes which have been broadcast or which are now scheduled for broadcasting—English, French, German, Italian, Spanish, Portuguese, and Romanche (Swiss). The special foreign broadcasts constitute another step in the steady development of NBC's international service which was recently augmented and extended to carry the best in America's cultural programmes and entertainment to the ends of the earth.

Broadcast from NBC's short-wave station, W3XAL, which has its transmitter at Bound Brook, N.J., the international service is sent to the whole world over non-directional aerials and

to Europe and Latin America over two new directional-beam aerials. Daily, in six languages—English, French, German, Spanish, Italian, and Portuguese—the service carries to foreign radio listeners the best of NBC's Blue and Red Network programmes and a varied assortment of the special "one-nation" and "group-of-nations" programmes.

These special programmes were first added—in July 1936—to the regular NBC network broadcasts which W3XAL had for several years been sending abroad. Since July 26, 1937, when the international service was put on a regular basis and when it was extended to European countries, the special programmes have been markedly increased.

SIGNAL STRENGTH

THE usual method of indicating, numerically, the strength of signals, is not very accurate as it depends so much upon the human element. An "old hand" might say that certain signals were R5, while the enthusiastic builder of a new short-wave receiver would say "R9 and then some."

Here is a system, the scheme of which is not new, but which nevertheless has interesting possibilities for short-wave use. It consists briefly of a variable resistance connected in parallel with the loudspeaker or 'phones. The maximum value of this resistance is best determined by experiment, but as a guide, it may have a value the same as that of the load impedance. This impedance may either be the output transformer primary or the output choke.

The measure of audibility is given by the formula:  $A = \frac{I}{R_m}$ , where A is the measure of audibility; I the valve load impedance; and Rm, the value of the resistance in parallel. As I is the constant, Rm is the only variable, thus it may be calibrated in terms of A.

To obtain the measure of audibility, Rm is adjusted so that the signals are just audible. It will be seen that this system differs from the "R method" inasmuch as the signals are read at their minimum value; the position in which the ear is best able to distinguish their intensity.

Here is an example. Let the load impedance be 2000Ω, and the actual value of resistance in parallel 100Ω. Then  $A = \frac{2000}{100}$ , i.e., A = 20. This method was in use before the War. V. S. K.

New to the Log  
By "RADIO GUIDE"

PANAMA has blossomed forth with another station at the low-frequency end of the 25 m. band—i.e., on 25.64 m. Identification is simplified by the familiar English-speaking voice of George Williams, whose news commentaries used to be heard from HP5J. Reference is made to the "Radio Teatro Estrella de Panama," while a programme sponsored by a Panama tourist association may be heard around midnight, inviting the audience to "visit Panama." The postal address is Apartado 954, Panama City.

In the vicinity of 30.4 m., another Cuban station is causing a great deal of interest; it is COCM, a relay of CMCM. Fortunately the English-speaking listener is favoured with English announcements in the form of "Transradio Columbia, CMCM long wave and COCM short wave, Box 33, Havana, Cuba," or in Spanish as "Transradio Columbia Sociedad Anonima; CMCM onda larga y COCM onda corta, en Habana, Cuba."

Short Wave Masterpieces-

Ultra Short Wave Interchangeable Coil, Cat. No. 1050. Price 1/8d.

Split Stator Transmitting Condenser, 50 x 50 mmfd. Cat. No. 1081. Price 17/6d.

Short Wave H.F. Choke, 5-180 metres. Cat. No. 1010. Price 2/-.

Microdenser for High Frequency tuning, Calit insulation. Cat. No. 900/20. Price 3/9d.

EDDY TON

By EDDYSTONE

Foremost of Short Wave Craftsmen

1938 ILLUSTRATED CATALOGUE Free on Request.

STRATTON & CO. LTD., EDDYSTONE WORKS, Bromsgrove St., BIRMINGHAM

London Service, Webb's Radio Stores, 14, Soho St., Oxford St., W.1.

To find the word

... consult the dictionary. A simple matter! And you can trace faults in your set just as easily when the D.C. Avominor is on the job. This precision instrument 13 meters in one. Its ranges provide for all radio tests—milliamp ranges for testing valves; voltage ranges for L.T., H.T., Grid Bias, Mains and Eliminator Tests; ohms ranges for all resistance tests.



In case, complete with testing prods, crocodile clips, leads and instruction booklet.

- 13 Meters in ONE
- CURRENT: 0-6 milliamps, 0-30, 0-120
  - VOLTAGE: 0-6 volts, 0-12, 0-120, 0-240, 0-300, 0-600
  - RESISTANCE: 0-10,000 ohms, 0-60,000, 0-1,200,000, 0-3 megohms
- BRITISH MADE

45/-

The D.C.

Deferred terms if desired.

AVOMINOR

Write for descriptive pamphlet

AUTOMATIC COIL WINDER & ELECTRICAL EQUIPMENT CO. LTD. Winder House, Douglas Street, London, S.W.1. phone: Victoria 3404-7

# Short-Wave News-Reel

Compered  
by "RANGER"

*On the whole, a good week for short-wave listening. I expected to be overwhelmed by news-reels, but they are not so numerous after all. It may be that readers report only the "high spots." We shall see as we get better acquainted. For a start, however, there is a fair selection, but I often find keen human interest in quite unexpected quarters. In fact, that is one of the attractions of short-wave listening. I have selected the following five items for this week. I consider them representative; encouraging to the newcomer and, I feel sure, interesting to the experienced listener, who, however skilful and enthusiastic, cannot listen everywhere at once! First we have two accounts of Armistice Day Commemoration—one from Los Angeles (W2XAF) and the second from no fewer than six different continents.*

## ARMISTICE DAY

LISTENERS to W2XAF on Nov. 11 learned that W2XAD and W2XAF programmes would be extended to 02.30 E.S.T. and would conclude with a special Armistice Day programme from Los Angeles.

At 07.00 (G.M.T.) we were taken over to Los Angeles for a world-wide broadcast from the Fiesta Room of the Ambassador Hotel, Los Angeles, of the Armistice Day Celebration held annually by the British War Veterans' League.

C. Aubrey Smith opened the relay, reciting Binyon's "They shall grow not old," followed, in turn, by Ray Noble's orchestra, Kenny Baker, the world's Scotch sweetheart, Ella Morgan, Tony Martin (in the absence of Alice Faye, who was ill), and Bing Crosby.

Then, with Boris Karloff, Ken Baker, Bing Crosby, Tony Martin, Allen Mowbray, and Ella Morgan leading, community singing began. "Tipperary" fell flat, only Ella Morgan of the six leaders knowing the words, so, after one chorus, it was "Pack up Your Troubles." Bing was heard to say that "those songs were concerned with the other side, what about something to do with this side?" So he started "Over There" and "Keep the Home Fires Burning."

The assembly was then told . . . "as this is a world-wide broadcast, you must have someone somewhere in the world, to say good-night to, so for fifteen seconds the air is yours—Let it Go!" And they did!

London, W.I.

E. W. G. H.

## - IN SIX CONTINENTS

SHORT-WAVE listening, on November 11, supplied convincing evidence of the commemoration of Armistice Day in six continents. An Armistice Day play from Melbourne (VK3LR), opened the day's listening at 10.00, and the Cenotaph Service followed at 10.25. War-time tunes replaced Hong Kong ZBW3's usual Chinese programme at 14.30, a similar programme also being heard from Nairobi, VQ7LO, at 17.40. At 18.00 W2XAD relayed speeches by President Roosevelt and others from the Armistice Day Gathering at the Canadian Club, New York City. Messages from the King and the British and Canadian Premiers were also read.

The next item heard was the Albert Hall Festival of Remembrance at 19.55. At 00.15 (Friday) Georgetown, VP3MR, announced a "special Armistice programme," which included recordings of war-time choruses sung at the Albert Hall on a previous Armistice Day, a Poppy-Day appeal by the former Prince of Wales, "Land of Hope and Glory," etc. Finally, from W2XAF at 07.00 (Friday) came an Armistice Day variety programme in aid of charity.

Bristol.

J. E. O.

## THE HOLLYWOOD "EXTRA"

*The following is an interesting sidelight from W2XE on glamorous Hollywood, the story of "one of the many" for whom life is a struggle and stardom only a dream.*

THE high-light of my week's listening was the visit to a studio in Hollywood via W2XE at 18.45 on November 12.

"This is Bob Baker wishing you all a very good morning from sun-bathed Hollywood." He then remarked that the name "Hollywood" conjured up visions of glamour, luxury, and fine clothes, but how many thought of the "extra" girl? Listeners were then introduced to a young lady described by Bob Baker as the typical "extra" girl, who drew a vivid word-picture of the life of "one of the many." "Of the 12,000 names on the list," she said, "only 1,000 could hope for a job." When asked why she came to Hollywood she said she had won a beauty competition and a free trip to film-land. She described how crowds hung around the studios daily, praying that their chance might come. For the lucky ones it meant fine dresses, and diamond bracelets. "What?" said Bob Baker, "diamond bracelets?" "Well, anyhow, they glitter," was the laughing reply.

Bristol.

W. J. C.

## NEXT WEEK'S WORLD-RADIO

will be a

## SHORT-WAVE NUMBER

with Special Articles and Station Lists, Time-Zone Map of the World, etc., etc. Make sure of your copy by ordering in advance.

## ARMY v. NOTRE DAME

*And now for the breezy, quick-fire commentary of the typical American "ball game" reporter—name not given on this occasion (strange!). The printed account cannot adequately convey the atmosphere of excitement present in the actual broadcast. I recommend you to listen to one. The station this time is W2XAD.*

"It's so wet here at the Yankee Stadium that it's a good job the goalposts are well anchored, or they might float away." This remark greeted me when I tuned in to W2XAD on Saturday, Nov. 13, at 18.35 G.M.T. Army and Notre Dame teams were playing their annual football "classic" in a wet, drizzly rain that made the field a sea of mud.

"Notre Dame on Army's three-yard line . . . second down and goal to go . . . it's a delayed line buck with Simonich carrying the ball . . . he's over for a touchdown! Notre Dame lead 7-0.

"Now Army are making a determined bid for a touchdown, but they are stopped on Notre Dame's 31-yard line. Oh! a spectator rushes out on to the field . . . he wants to shake hands with a Notre Dame player . . . but two burly policemen gently lead him off while the crowd gets a good laugh!"

So the game ends, as it started, in the rain; with Notre Dame victors by 7-0.

Edinburgh.

T. J. D.

## A TOUR OF THE FAR EAST

*Finally, one of the "tour" news reels, which illustrate so well the unexpectedness of short-wave listening.*

DURING the afternoon of Sunday, Nov. 14, as conditions on short waves were good, I was able to make an interesting tour of the Far East via some of the lesser-known broadcasting stations.

I started at 12.50 in Dirien (Manchukuo), where station JDY (30.3 m.) was broadcasting a talk in English on the present situation in the Far East. This concluded at 13.00, and, tuning a little higher on the dial, I discovered XGOX of Nanking, on 30.6 m. This station was broadcasting a news bulletin, which was followed by a programme of stirring military music.

Then an unexpected "catch" was made in the form of Penang, ZHJ, which was radiating a programme of European light music. After announcements, the programme continued, but unfortunately soon faded out altogether. At 15.05 weird native music with chanting accompaniments was heard from Bandoeng, PMH (44.6 m.).

Finally at 15.30 I turned again to 49 m. and found a station on 49.36 m. believed to be VUM, Madras. Here, too, native music was being broadcast, but of rather a different nature to the Javanese music. Then at 15.45 I switched off, and came back regretfully to a cold English November.

Reading, Berks.

J. B. B.

*I think a brief indication of the type of receiver used by contributors would be appreciated. Will they please add the necessary details at the foot of each item submitted? Thank you.*

## Below 100 Metres

By "SCOTIAN"

(November 7-12)

NOW that winter conditions are well established, more consistent results are being obtained. Generally 16 m. and below give good afternoon reception, followed by the 19 m. band in the early evening with 25 m. and 31 m. opening up around 20.00. The late period finds many strong DX signals available on 46-49 m.

W2XE (13.94 m.) performed well on Sunday, being never less than R7 until signing-off at 18.00, and many fine amateur 'phone signals were heard on 10 m. PMN (29.24 m.) came in an R7 signal at 14.30 radiating popular recordings. U.S. programmes could be heard without difficulty from W3XAL (16.87 m.) and W2XAD—both R8 until declining around 21.00—also from W1XK (31.35 m.), R7 at 19.40, and W2XAF R7 when signing-on. JZJ (25.42 m.), now the best channel for reception of Tokio, was R7 shortly after 20.00.

In addition to the usual U.S. afternoon channels on Monday, W2XGB (17.33 m.) was heard at R7 testing, apparently "closing-down" around 16.30. HS8PJ (15.77 m.) and PMN were logged, at R6 and R7 respectively, shortly before 15.00. After midnight, on 31 m., COCM, COCQ, and W1XK were all R7, and among the best heard of the many stations on the 46-49 m. band were YV5RH, TIPG, and W8XK.

The usual U.S. channels on 13 m. and above were received consistently on Tuesday; the higher frequencies, however, were somewhat quieter. By 22.30, W1XAL was an excellent R8. HP5A and CB1170 were moderately well heard at 22.55 and W3XAU (31.28 m.) gave a good R7 signal.

The following day results from W3XAL were good until the aerial was changed at 22.45, and W2XAD was really excellent. W1XAL, now transmitting from 19.30 on 19.68 m., was R7 and JZJ returned to form with a fine R8 signal.

On Thursday and Friday the 16 m. and 19 m. U.S. broadcasters provided strong signals until becoming weak and affected by flutter shortly after 20.00. The 19 m. transmitters, however, became fully intelligible again by 22.00. The 25 m. band was not so good as on previous evenings, and distant stations on 31 m. were later in attaining a useful strength.

# SHORT-WAVE BROADCASTING STATIONS

Frequencies are shown in megacycles per second (Mc/s). Times of operation are given on the "twenty-four-hour clock" system, "G.M.T." For transmission times of stations shown in black type see Short-Wave Programmes. The various broadcasting wavebands are indicated by heavy vertical lines.

Mc/s	m.	kW	Call	Station	Mc/s	m.	kW	Call	Station
3.94	98.68	10	YDA	Batavia (Tandjongpriok), (Java). 10.30—15.00.			10	W3XAU	Philadelphia (Pa.) (U.S.A.). 17.00—01.00.
4.27	70.2	20	RW15	Khabarovsk (U.S.S.R.) 07.00—14.00.	9.59	31.28	20	VK2ME	Sydney (Australia). SUN., 06.00—08.00 ; 09.30—13.30 ; 14.00—16.00.
5.15	58.31	1	PMY	Bandoeng (Java).			2	VK6ME	Perth (W. Australia). W'days. 11.00—13.00.
5.80	51.72	1	YV5RC	Caracas (Venez.).			60	PCJ	Huizen (Holland). Exp'tl.
5.83	51.49	0.5	TIGPH	San José (Costa Rica) 00.00—05.00.			20	RAN	Moscow (U.S.S.R.).
5.85	51.28	0.25	YV1RB	Maracaibo (Venez.) 22.00—02.00.	9.60	31.26	25	YV5RA	Caracas (Venezuela).
5.97	50.26	15	HVJ	Vatican City (Italy).	9.63	31.13	2	I2RO3	Rome (Italy).
6.00	50	1	XEBT	Mexico City. 00.00—05.00.	9.65	31.09	10	CS2WA	Lisbon (Portugal). TUES., THURS., and SAT., 21.00—00.00.
6.00	49.96	0.1	CFCX	Montreal (Canada). Weekdays, 12.45—06.00 ; SUN., 14.00—04.15.	9.66	31.06	1	LRX	Buenos Aires (Argentine). 14.30—04.00.
6.01	49.92	2.5	COCO	Havana (Cuba). 22.00—05.00.	9.74	30.8	10	COCQ	Havana (Cuba). 17.00—06.00.
		30	OLR2A	Poděbrady (Prague) (Czecho.).	9.83	30.52	10	EAQ1	Madrid (Spain). 21.00—00.00.
		1	CJCX	Sydney (Nova Scotia) 12.00—18.30 ; 21.00—01.30.	9.83	30.51	5	COCM	Havana (Cuba). 21.00—05.00.
6.01	49.9	1	HJ3ABH	Bogotá (Colombia). 22.30—04.00.	9.94	30.18	3	CSW	Lisbon (Portugal).
6.02	49.83	5-40	DJC	Zeesen (Germany).	10.26	29.24	9	PMN	Bandoeng (Java). 10.30—16.00 ; 23.00—00.30 ; 03.30—06.00.
6.03	49.75	0.2	HP5B	Panama (Pan. Rep.) 15.30—19.00 ; 22.00—03.00.	10.33	29.04	12	ORK	Ruysselede (Belgium).
6.04	49.67	10	W1XAL	Boston (Mass.) (U.S.A.).	10.35	28.99	4	LSX	Buenos Aires. FRI., 21.00—21.45.
		5	W4XB	Miami (Florida) (U.S.A.).	10.36	28.94	3	EAJ43	Tenerife Radio Club (Canary Is.). 19.45—21.15 ; 22.45—00.45 ; 01.15—02.45.
		10	YDA	Batavia (Tandjongpriok), (Java).	11.00	27.27	5	PLP	Bandoeng (Java) (as PMN, 29.24 m.).
6.05	49.61	1	HJ1ABG	Barranquilla (Col.). 00.00—04.00.	11.04	27.17	20	CSW	Lisbon (Portugal).
6.05	49.59	10-50	GSA	Daventry.	11.40	26.31	1	HBO	Radio-Nations (Switzerland).
		10	W8XAL	Cincinnati (U.S.A.). Weekdays, 10.45—01.00 ; 04.00—07.00 ; SUN., from 13.00.	11.49	26.11	10	COCX	Havana (Cuba). 13.00—06.00.
6.06	49.5	10	W3XAU	Philadelphia (U.S.A.). 01.00—04.00.	11.53	26.01	10	SPD	Warsaw (Poland).
6.06	49.46	0.75	SBO	Motala (Sweden). Relays Stockholm.	11.70	25.63	0.75	SBP	Motala (Sweden). Relays Stockholm.
6.07	49.44	0.15	VP3MR	Georgetown (British Guiana). SUN., 12.45—15.15. Weekdays, 21.45—01.45.	11.72	25.6	2	CB1170	Santiago (Chile). 14.00—03.00.
6.07	49.42	1	HJ5ABD	Cali (Colombia). 22.00—04.00.	11.77	25.57	12	TPA4	Winnipeg (Canada). Weekdays, 23.00—05.00 ; SUN., 22.00—03.00.
6.07	49.41	1.5	OER2	Vienna (Austria). W'days, 14.00—22.00.	11.75	25.53	25	PHI	Radio-Colonial (Paris) (France).
6.08	49.36	15	OAX4Z	Lima (Peru). 23.30—04.30.	11.75	25.53	10-50	GSD	Huizen (Holland).
6.08	49.34	0.05	ZHJ	Penang (S.S.). Weekdays, 12.40—14.40.	11.77	25.49	5-40	DJD	Daventry.
6.08	49.33	0.5	W9XAA	Chicago (Ill.) (U.S.A.) 01.00—07.00.	11.79	25.45	10	W1XAL	Zeesen (Germany).
		0.5	VQ7LO	Nairobi (Kenya). SUN., 16.15—19.15 ; MON. to SAT., 11.00—11.30 ; 16.45—19.45 ; TUES. and THURS., 13.45—14.45.	11.80	25.42	50	JZJ	Boston (Mass.) (U.S.A.).
6.09	49.28	0.5	CFRX	Toronto (Canada). 23.00—04.00.	11.81	25.4	1.5	OER3	Tokio (Japan).
6.09	49.26	2.6	ZBW2	Hong Kong.	11.82	25.38	25	I2RO4	Vienna Exp'tl. Weekdays, 14.00—22.00.
6.10	49.2	5	ZTJ	Johannesburg (S. Africa).	11.83	25.36	10-50	GSN	Rome (Italy).
6.10	49.18	15-35	W3XAL	Bound Brook (N.J.) (U.S.A.).	11.84	25.34	5	W9XAA	Daventry.
		10	W9XF	Chicago (Ill.) (U.S.A.).	11.85	25.29	30	OLR4A	Chicago (Ill.) (U.S.A.). 12.00—02.00 ; 17.00—19.00.
		1	YUA	Belgrade (Yugoslavia).	11.85	25.31	5	CSW	Poděbrady (Prague) (Czecho.).
6.11	49.12	1	HJ4ABB	Manizales (Colombia). 22.30—03.00.	11.86	25.29	5-40	DJP	Lisbon (Portugal).
6.11	49.1	10-50	GSL	Daventry.	11.87	25.27	10-50	GSE	Zeesen (Germany).
		0.5	VUC	Calcutta (India).	11.89	25.23	40	W8XK	Daventry.
6.12	49.02	1	LKJ	Jeløy (Norway). 16.30—22.00.	12.00	25	12	TPA3	Pittsburgh (U.S.A.).
6.13	48.92	1	COCD	Havana (Cuba). 15.00—05.00.	12.23	24.52	40	TPA3	Radio-Colonial (Paris) (France).
6.13	48.9	0.5	VE9HX	Halifax (Nova Scotia). 12.00—04.00.	13.63	22	20	RNE	Moscow (U.S.S.R.).
6.14	48.86	40	W8XK	Pittsburgh (U.S.A.).	14.92	20.11	7.5	TFJ	Reykjavik (Iceland).
6.15	48.78	2	CJRO	Winnipeg (Canada). Weekdays, 23.00—05.00 ; SUN., 22.00—03.00.	15.11	19.85	10	SPW	Warsaw (Poland).
6.24	48.04	0.75	HIN	Trujillo City (D.R.). 21.40—02.40.	15.12	19.84	1.5	LZA	Sofia (Bulgaria). Relays Sofia (352.9 m.).
6.32	47.5	0.1	HIZ	Trujillo City (D.R.). 21.45—00.45.	15.14	19.82	5-40	DJL	Zeesen (Germany).
6.41	46.8	1	TIPG	San José (Costa Rica). 00.00—05.00.	15.15	19.8	10	HVJ	Vatican City (Italy).
6.52	46	0.3	YV4RB	Valencia (Venezuela). 22.00—02.30.	15.16	19.79	10-50	GSF	Daventry.
6.63	45.25	2	HC1FG	Riobamba (Ecuador). 02.00—04.00.	15.18	19.76	50	SM5SX	Stockholm Tech. University. MON. to SAT., 16.00—22.00 ; SUN., 14.00—22.00.
6.63	45.23	0.1	HIT	Trujillo City (D.R.). 21.45—00.45.	15.18	19.76	3	YDC	Bandoeng (Java) (as PMN, 29.34 m.).
7.54	39.79	25	RK1	Guayaquil (Ecuador). 02.00—04.00.	15.19	19.75	5	JZK	Tokio (Japan).
7.80	38.48	20	HBP	Moscow (U.S.S.R.).	15.20	19.74	10-50	GSO	Daventry.
8.83	33.98	0.15	HCJB	Radio-Nations. SAT., 22.30—23.00.	15.21	19.72	2.6	ZBW4	Hong Kong.
9.12	32.88	6	HAT4	Quito (Ecuador). 00.00—03.30.	15.22	19.71	5-40	DJB	Zeesen (Germany).
9.34	32.1	20	HBL	Budapest (Hungary).	15.23	19.7	40	W8XK	Pittsburgh (U.S.A.).
9.43	31.8	10	COCH	Radio-Nations (Switzerland).	15.24	19.69	60	PCJ	Huizen (Holland). Exp'tl.
9.48	31.63	10	EAR	Havana (Cuba). 17.00—04.30.	15.25	19.67	30	OLR5A	Poděbrady (Prague) (Czecho.).
		12	PRF5	Madrid (Spain). 21.00—00.00.	15.26	19.66	12	TPA2	Radio-Colonial (Paris) (France).
9.50	31.58	10-50	HJU	Rio de Janeiro (Brazil).	15.27	19.65	10	W1XAL	Boston (Mass.) (U.S.A.).
		1.5	VK3ME	Buenaventura (Colombia).	15.28	19.63	10-50	GSJ	Daventry.
9.51	31.55	20	HS8PJ	Daventry.	15.29	19.62	7	W2XE	Wayne (N.J.) (U.S.A.).
9.52	31.51	5	OZF	Melbourne. Weekdays, 09.00—12.00.	15.31	19.6	5-40	DJQ	Zeesen (Germany).
		2.6	ZBW3	Bangkok (Siam). THURS., 13.00—15.00.	15.33	19.57	10-50	LRU	Buenos Aires (Argentine). 12.00—14.00.
9.53	31.48	1	LKC	Skamleback (Denmark). 19.00—23.40.	15.34	19.56	18	GSP	Daventry.
		25	W2XAF	Hong Kong. 04.30—06.15 ; 08.00—14.30.	15.37	19.52	5-40	W2XAD	Schenectady (N.Y.) (U.S.A.).
9.54	31.46	2	VPD2.	Jeløy (Norway). 10.00—13.00.	15.37	19.52	18	DJR	Zeesen (Germany).
9.54	31.45	5-40	DJN	Schenectady (N.Y.) (U.S.A.).	17.31	17.33	6	HAS3	Budapest (Szekesfehervar) (Hungary).
9.55	31.41	30	OLR3A	Suva (Fiji Islands).	17.76	16.89	5	W2XGB	Hicksville (N.Y.) (U.S.A.). MON. to FRI. 16.00—18.00.
9.55	31.4	1	YDB	Zeesen (Germany).	17.77	16.88	5-40	DJE	Zeesen (Germany).
9.56	31.38	5-40	DJA	Poděbrady (Prague) (Czecho.).	17.78	16.87	10	W2XE	Wayne (N.J.) (U.S.A.).
9.56	31.37	10	OAX4T	Sourabaya (Java). Daily, 09.30—14.30.	17.79	16.86	25	PHI	Huizen (Holland).
9.56	31.36	4.5	VUB	Zeesen (Germany).	18.11	16.56	15-35	W3XAL	Bound Brook (U.S.A.).
		10	W1XK	Lima (Peru). 16.30—18.30.	18.11	16.56	10-50	GSG	Daventry.
9.57	31.35	6	KZRM	Bombay (India).	18.83	15.93	12	LSY	Buenos Aires (Argentine).
		10-50	GSC	Millis (Mass.) (U.S.A.) Weekdays, 11.00—06.00 ; SUN., 13.00—06.00.	19.02	15.77	60	PLE	Bandoeng (Java).
9.58	31.32	1	VK3LR	Manila (Phil. Is.). 21.30—23.00 ; 02.00—14.00.	19.35	15.5	20	HS8PJ	Bangkok (Siam). MON., 13.00—15.00.
		1	VK3LR	Daventry.	21.47	13.97	60	PMA	Bandoeng (Java).
		1	VK3LR	Lyndhurst (Australia). 02.45—07.15 ; 08.30—13.30.	21.52	13.94	10-50	GSH	Daventry.
		1	VK3LR		21.53	13.93	10	W2XE	Wayne (N.J.) (U.S.A.).
		1	VK3LR		21.54	13.93	10-50	GSJ	Daventry.
		1	VK3LR		21.55	13.92	40	W8XK	Pittsburgh (U.S.A.).
		1	VK3LR				10-50	GST	Daventry.

# Short-Wave Programmes

All times are given in G.M.T.

MONDAY, Nov. 22

\* Electrical Recordings.  
† Gramophone Records.  
‡ A second transmitter and aerial working on the same frequency.

## SUNDAY, Nov. 21

**EMPIRE**  
The Empire Programmes are printed in outline for the convenience of overseas readers.

**Transmission 1** (GSG, GSO, GSD, GSB).  
08.15—Big Ben; Band; Baritone.  
08.55—Newsletter, Sports.  
09.20—Empire Service from St. Paul's Cathedral, London.\*  
10.10-10.25—"This is England:" talk.\*

**Transmission 2** (GSJ, GSH, GSG, GSO).  
10.45—Big Ben; "Samuel Johnson of the City of Lichfield."\*  
11.10—Molly De Gunst (Soprano); Bernard Davis (Viola).  
11.40—Service (C. of E.).\*  
12.30—"This is England:" talk.\*  
12.45—BBC Military Band; Songs.  
13.30-13.55—Big Ben; Newsletter, Sports Summary.

**Transmission 3** (GSJ, until 15.30 G.M.T.), GSD (from 15.45 G.M.T.), GSH, GSG, GSF).  
14.15—Big Ben; Scottish Golfers: Andrew Kirkaldy.\*  
14.45—"Sportsmen Talking:" H. W. Austin.\*  
15.00—Tchaikovsky: BBC Orchestra (Section E) conducted by Constant Lambert; Graudan (Cello).  
15.45—Big Ben; Newsletter, Sports  
16.10-17.00—Empire Service from St. Paul's Cathedral, London.\*

**Transmission 4** (17.20-20.45 GSG, GSP from 18.45, GSI, GSD, GSB; 21.00-22.45 GSO, GSD, GSD, ‡ GSB).  
17.20—John Pauer (Pfte.).  
17.40—"For the Colonial Service:" talk.\*  
18.00—Big Ben; Newsletter, Sports.  
18.20—Musical Interlude.†  
18.30—BBC Orchestra (Section D) conducted by Pau Casals.  
19.50—Musical Interlude.†  
19.55-20.45—Service from Southwark Cathedral, London.  
21.00—Big Ben; Newsletter, Sports.  
21.20—Scenes from "The Merchant of Venice" (Shakespeare).\*  
22.00—Leslie Jeffries and The Grand Eastbourne Orchestra.  
22.30-22.45—Epilogue.

**Transmission 5** (GSD, GSD, ‡ GSC, GSB).  
23.05—Corelli: Frederick Grinke (Violin); Dorothy Manley (Pfte.).  
23.30—Service (Congregational).\*  
00.20—"For the Colonial Service:" talk.\*  
00.40—Newsletter, Sports.  
01.00-01.30—Big Ben; Scottish Golfers: Andrew Kirkaldy.\*

**Transmission 6** (GSD, GSC, GSC, ‡ GSB).  
02.00—Big Ben; Band; Tenor.  
02.50—Newsletter, Sports.  
03.10-04.00—Service from Southwark Cathedral, London.\*

**BOUND BROOK** (W3XAL), 17.78 mc/s (16.87 m.); 6.10 mc/s (49.18 m.).  
(16.87 m.) 14.00—For Children.  
15.00—Music; Variety.  
16.00—News; Variety.  
17.20—Southernaires.  
17.30—Music-Hall.  
18.30—Choir.  
19.00—Magic Key (anncts. Fr., Ger., Eng.).  
20.00—Tapestry of Melodies.  
20.30—Variety.  
22.00—M. Talley (Soprano).  
22.30—News (Fr., Fr.).  
23.00—Orchestra; Sing Band.  
00.00-02.00—For South America.  
00.00—Variety; Orchestra.  
(49.18 m.) 02.25-06.00—For South America.  
02.25—News and Music (Sp.).  
03.00—Science.  
03.30—Cherio.  
04.00—Orchestras and Choir (anncts. Eng., Sp.).

**BUDAPEST** (HAS3), 15.37 mc/s (19.52 m.); (HAT4), 9.12 mc/s (32.88 m.).  
(19.52 m.) 14.00-15.00—Music; Poems; News (Eng.); Anthem.  
(32.88 m.) 00.00—See 14.00.

**HUIZEN** (PCJ), 15.22 mc/s (19.71 m.); 9.59 mc/s (31.28 m.).

(31.28 m.) 19.00-20.00—For Africa: Music; Talks; News.  
00.00—For the Americas: Music; Talks; News.  
01.00-02.00—For the West.

**HUIZEN** (PHI), 17.77 mc/s (16.88 m.); 11.73 mc/s (25.57 m.).  
(16.88 m.) 12.25—For Asia: Music; Talks; News.  
13.25—For the Dutch Indies: Talks; Records; Berlin Philharmonic, Kulenkampf (Violin), Don Cossacks Choir.  
14.10-15.30—News; Talks; Music.

**LYNDHURST** (VK3LR), 9.58 mc/s (31.32 m.).  
08.00—Music; Talk; Reading.  
10.15—New Note Octet.  
10.50—Foreign Affairs.  
11.10-12.30—Film; Epilogue.

**MOSCOW** (RNE), 12.00 mc/s (25 m.); (RAN), 9.60 mc/s (31.26 m.); (RK1), 7.54 mc/s (39.79 m.).  
(25 m.) 11.00—For England.  
12.00—For Germany.  
13.00—For Holland.  
14.00—For France.  
15.00—For England.  
(25 m. and 39.79 m.) 17.15—For Germany.  
(25 m.) 20.00—For Italy.  
20.30—For Germany.  
21.00—For England.  
22.00—For Germany.  
(31.26 m.) 23.00—For Spain.  
(31.26 m. and 39.79 m.) 00.00—For England.  
(25 m.) 01.30—For France.  
03.15—For England.

**PARIS** (Radio-Colonial) (TPA2), 15.24 mc/s (19.69 m.); (TPA3), 11.89 mc/s (25.23 m.); (TPA4), 11.72 mc/s (25.6 m.).  
(25.23 m.) 17.15—News (Fr., Arabic).  
18.00—Concert.  
19.00—News; Exchange.  
20.10—News (Eng., It.).  
20.30—To be announced.  
22.30—Sports; Markets.  
22.45—News (Port.).  
(25.6 m.) 23.15—Dance Band.  
00.15—News (Fr., Sp., Port.).  
01.00-01.15—Records.  
03.00—Records.  
04.00—News.  
04.30—News (Eng.); Records.  
05.45-06.00—News (Ger.).

**PITTSBURGH** (W8XK), 21.54 mc/s (13.93 m.); 15.21 mc/s (19.72 m.); 11.87 mc/s (25.27 m.); 6.14 mc/s (48.86 m.).  
(19.72 m.) 14.00-16.00—Variety.  
16.00—Calvary P.E. Church.  
17.00—Southernaires.  
17.30—Music-Hall.  
18.30—Dinner Hour; Pop Corn Time.  
19.00—R.C.A. Magic Key.  
20.00—Variety.  
21.00 (Sunday)—Songs.  
21.30—Vespers—Shady-side Church.  
22.00—Metropolitan Auditions.  
22.30—Smiling Ed. McConnell.  
23.00—Variety.  
(25.27 m.) 00.00—Popular Classics.  
00.30—Orchestra.  
01.00—Concert.  
02.00—Hollywood Playhouse.  
02.30—George Fischer.  
02.45—Irene Rich.  
(48.86 m.) 03.00—Zenith Foundation. 03.30—Cherio.  
04.00—Music; News.  
04.15—Missionary Broadcast.  
05.00—Williams' Orchestra.  
05.30-06.00—New Penn Orchestra.

**PODEBRADY** (OLR), 15.23 mc/s (19.70 m.); 11.84 mc/s (25.34 m.); 9.55 mc/s (31.41 m.); 6.01 mc/s (49.92 m.).  
(25.34 m.) 19.00—News.  
(31.41 m.) 19.30—News; Music.  
20.00—News (Eng.); Songs.  
20.20—News (Ger.); Music.  
20.55—Mail.  
21.00-21.25—News (Fr.); Music.  
(25.34 m.) 00.00-02.10—For America.  
00.00—Band; Talk.  
00.30—Choir; News.  
00.55—Foerster Opera Music.  
01.30—News (Eng.).  
01.40—Slav Dances (Dvorak).  
02.00-02.10—Mail.

**ROME**, 11.81 mc/s (25.4 m.).  
13.20—News; Songs; Talk.  
14.00-15.30—News (Eng.); Opera Music; Talk (Chin.); Pfte. and Soprano; News.  
16.20-17.20—News; Band.  
17.30—Music; News (Arabic).  
18.08—News (Ger.).  
18.26-19.00—News (Eng., Fr.).  
22.30—South American Bulletin.  
23.00—American Hour from Rome: U.S.A. Bulletin; News (Eng.); "Mefistofele" (Boito); Talk; Arias; Mail; News.

**REYKJAVIK** (TFJ), 12.23 mc/s (24.52 m.).  
18.40—Talks and News (Eng., Ice.); Music.  
19.05-19.30—Talk and News (Ger.); Music.

**ROME**, 11.81 mc/s (25.4 m.).  
10.00-11.00—Mass.  
13.20-13.55—News; Variety.  
16.20-17.20—News; Opera Music.  
23.00-23.15—U.S.A. Bulletin.

**SCHENECTADY** (W2XAD), 15.33 mc/s (19.57 m.); (W2XAF), 9.53 mc/s (31.48 m.).  
(19.57 m.) 16.00—News; Pfte. Duo.  
16.15—Silver Flute.  
16.45—Orchestra; Soprano.  
17.30—Chicago University Discussion.  
18.00—Paul Martin's Music.  
18.30—Tuskegee Institute Choir.  
19.00—Sunday Drivers.  
19.30—Back Home.  
20.00—Roman Newsreel.  
20.30—Bicycle Party.  
(19.57 m.) and 31.48 m.) 21.00—Chapel Organ.  
22.00—Soprano.  
22.30—Time of Your Life.  
23.00—Roman Catholic Hour.  
23.30—Tale of Today.  
00.00—Variety.  
(31.48 m.) 02.00—Manhattan Merry-Go-Round.  
02.30—Familiar Music.  
03.00—Rising Musical Stars.  
03.30—Coddolan and his Violin.  
04.00—Orchestra.  
04.30-05.00—News; Orchestra.

**TOKIO** (JZK), 15.16 mc/s (19.79 m.); (JZJ), 11.80 mc/s (25.42 m.).  
(For Europe)  
20.00—News (Eng.).  
20.15—Talk.  
20.25—Dance Music.  
20.30-21.00—News (Ger., Fr., Jap.).

**VATICAN CITY** (HVJ), 15.12 mc/s (19.84 m.); 5.97 mc/s (50.26 m.).  
(50.26 m.) 10.00—For Invalids (Latin, Fr.).

**WARSAW** (SPW), 13.63 mc/s (22 m.).  
23.00—News (Pol., Eng.); Songs.  
23.30—Topical Talk; Songs.  
00.00-02.00—Music; Reading; Records; Polish Dances.

**WAYNE** (W2XE), 21.52 mc/s (13.94 m.); 17.76 mc/s (16.89 m.); 15.27 mc/s (19.65 m.).  
(13.94 m.) 13.00—Organ.  
13.30-13.45—Lyric Serenade.  
16.30-17.30—Major Bowes' Theatre.  
(19.65 m.) 20.00—New York Philharmonic. Conductor: Barbirolli. (16.89 m.) 00.00—Jeanette MacDonald, etc.  
02.00—Symphony Orchestra; Kullmann (Tenor).  
03.00-05.00—Variety.

**ZEESSEN** (DJA), 9.56 mc/s (31.38 m.); (DJB) 15.20 mc/s (19.74 m.); (DJE) 17.75 mc/s (16.89 m.); (DJN) 9.54 mc/s (31.45 m.); (DJQ) 15.28 mc/s (19.63 m.).  
**On all Wavelengths.**  
05.05—Call (Ger., Eng.); Music.  
06.00—News; Music.  
07.00—News (Eng.); Music.  
08.45—"In Memoriam."  
09.30—News; Music.  
12.00—News (Eng.); Music.  
13.00—News.  
13.15—"In Memoriam"; Quartet.  
14.00—News (Eng., Dutch).  
14.15—Concert.

**ZEESSEN** (DJD), 11.77 mc/s (25.49 m.); (DJE) 15.11 mc/s (19.85 m.); (DJC) 6.02 mc/s (49.83 m.).  
**On all Wavelengths.**  
05.10—Concert.  
06.00—News; Concert.  
11.00-13.00—Concert.  
15.40—Call (Ger., Eng.); Concert; Fairy Tales.  
16.30—"In Memoriam"; Concert.  
17.15—News; Band; Concert.  
19.00—News (Eng.); Music; Poems; Concert; Sports.  
21.00—News (Ger., Eng.).

**ZEESSEN** (DJD), 11.77 mc/s (25.49 m.); (DJB) 15.20 mc/s (19.74 m.); (DJC) 6.02 mc/s (49.83 m.).  
**On all Wavelengths.**  
16.10-17.25—Symphony Concert.  
21.50—Call (Ger., Eng.).  
22.00—Fairy Tales; Songs.  
22.45—News.  
23.00—"Sunday."  
23.15—Concert.  
00.15—Sports.  
00.30—"In Memoriam."  
01.15—News (Eng.); Organ.  
02.00—News; Orchestra.  
03.30—News (Eng., Ger.).

**EMPIRE**  
**Transmission 1** (GSG, GSO, GSD, GSB).  
08.15—Big Ben; "In Town Tonight."\*  
08.45—BBC Empire Orchestra: Moura Lympany (Pfte.).  
09.35—News.  
09.55-10.25—"Long-Distance Listening:" Sir Walford Davies.  
**Transmission 2** (GSJ, GSH, GSG, GSO).  
10.45—Big Ben; Music-Hall.\*  
11.45—"Westward from Liverpool."\* 12.25—Orchestra.  
13.00—"Empire Exchange."  
13.15—Mercia Stotesbury (Violin).  
13.30-13.55—Big Ben; News.

**Transmission 3** (GSJ (until 15.30 G.M.T.), GSD (from 15.45 G.M.T.), GSH, GSG, GSF).  
14.15—Big Ben; Variety.†  
14.30—Norman Tucker (Pfte.).  
15.00—Talk by A. G. Street.\*  
15.15—Geiger and his Orchestra.  
15.30—"In Town Tonight."\*  
16.00—Big Ben; News.  
16.20—The Adventures of Shorty and Conky in "Fishing."  
16.30-17.00—Cinema Organ.

**Transmission 4** (17.20-20.45 GSG, GSP from 18.45, GSI, GSD, GSB; 21.00-23.00 GSO, GSD, GSD, ‡ GSB).  
17.20—Light Orchestra.  
18.00—Big Ben; News.  
18.20—Gladys Knight (Contralto); David Lloyd (Tenor).  
18.45—"Empire Exchange."\*  
19.00—"Monday at Seven."\*  
19.45—"The Plums."  
20.00—Sybil Eaton (Violin).  
20.15-20.45—Scottish Golfers: Andrew Kirkaldy.\*  
21.00—Big Ben; News.  
21.20—"Baker's Dozen:" revue.  
21.55—Talk by A. G. Street.\*  
22.10—"At the Black Dog."\*  
22.40-23.00—Dance Music.

**Transmission 5** (GSD, GSD, ‡ GSC, GSB).  
22.30—"Tobacco:" a feature.\*  
23.20—Plantation Songs.†  
00.00—Beethoven: Orchestra.  
00.40—News.  
01.00-01.30—Big Ben; Variety.  
**Transmission 6** (GSD, GSC, GSC, ‡ GSB).  
02.00—Big Ben; Talk by A. G. Street.\*  
02.15—"Chu Chin Chow."†  
03.15—News.  
03.35-04.00—Howard-Jones (Pfte.).

**BOUND BROOK** (W3XAL), 17.78 mc/s (16.87 m.); 6.10 mc/s (49.18 m.).  
(16.87 m.) 14.00—Breakfast Club.  
14.45—News; Variety.  
17.00—News (Fr.); Music.  
18.00—News (It.); Music.  
19.00—News (Ger.); Music.  
20.00—News (Fr.); Music.  
21.00—News (Ger.); Music.  
22.00—News; Music.  
22.30—News (Fr., Ger.); Music.  
23.00—U.S. Army Band.  
23.30—News.  
00.00-02.00—For South America.  
00.00—News (Sp., Port.); Films.  
01.30—Margaret Speaks (Soprano) (49.18 m.) 03.15-06.00—For South America.  
03.15—News (Sp.); Review.  
04.00—Orchestras (anncts. Eng., Sp.).

**HUIZEN** (PHI), 17.77 mc/s (16.88 m.); 11.73 mc/s (25.57 m.).  
(16.88 m.) For the Dutch Indies.  
13.25—Stocks; Variety; Records.  
14.00—Talks; Cabaret.  
14.50-15.00—News.

**LYNDHURST** (VK3LR), 9.58 mc/s (31.32 m.).  
02.35—Watchman; Music.  
03.00—News; Music.  
04.15-07.15—Cricket Match; For Schools.  
08.30—Music; Talks.  
09.25—News; Reading.  
10.30—Watchman; Music.  
11.00—Band; Topical.  
12.30—News; Music.  
13.10-13.30—League of Nations Report.

**MOSCOW** (RNE), 12.00 mc/s (25 m.); (RAN), 9.60 mc/s (31.26 m.); (RK1), 7.54 mc/s (39.79 m.).  
(25 m.) 11.00—For Germany.  
(25 m. and 39.79 m.) 17.15—For Germany.  
20.00—For Italy.  
20.30—For Germany.  
21.00—For England.  
22.00—For Hungary.  
(31.26 m.) 23.00—For Spain.  
(31.26 m. and 39.79 m.) 00.00—For England.

(25 m.) 01.30—For Portugal.  
03.15—For England.  
**PARIS** (Radio-Colonial) (TPA2), 15.24 mc/s (19.69 m.); (TPA 3), 11.89 mc/s (25.23 m.); (TPA 4), 11.72 mc/s (25.6 m.).  
(25.23 m.) 17.15—News (Fr., Arabic); Concert.  
18.50—Art Review.  
19.00—News; Exchange.  
20.10—News (Eng., It.).  
20.30—To be announced.  
22.30—Markets; News (Port.). (25.6 m.) 23.15—Records.  
00.15—News (Fr., Sp., Port.).  
01.00—Records.  
03.00—Records.  
04.00—News; Markets.  
04.30—News (Eng.); Records.  
05.45—News (Ger.).

**PITTSBURGH** (W8XK), 21.54 mc/s (13.93 m.); 15.21 mc/s (19.72 m.); 11.87 mc/s (25.27 m.); 6.14 mc/s (48.86 m.).  
(19.72 m.) 14.00—Variety.  
16.45—Edward MacHugh.  
17.00—News.  
17.15—Grace and Eddie.  
17.30—Farm and Home.  
18.30—Utility Hall.  
18.45—Strollers' Matinée.  
19.30—Home Forum.  
20.00—Music by Cugat.  
20.15—Welfare.  
20.30—Rochester Orchestra.  
21.00—Club Matinée.  
22.00—Junior Nurse Corps.  
22.15—Weston Sisters.  
22.30—Singing Lady.  
22.45—Tom Mix.  
23.00—News.  
23.15—Orchestra.  
23.30—News; Lowell Thomas. (25.27 m.) 00.00—To be announced.  
00.20—Frolics.  
00.45—Lois Miller (Organ).  
01.00—Gen. Hugh S. Johnson.  
01.15—Roy Campbell's Royalists.  
01.30—Variety Fair.  
02.00—Philadelphia Symphony Orchestra. (48.86 m.) 03.00—Behind Prison Bars.  
03.30—Radio Forum.  
04.00—News.  
04.15—Music as you desire it.  
05.00—New Penn Orchestra.  
05.30-06.00—Orchestras.

**PODEBRADY** (OLR), 15.23 mc/s (19.70 m.); 11.84 mc/s (25.34 m.); 9.55 mc/s (31.41 m.); 6.01 mc/s (49.92 m.).  
(25.34 m.) 19.00—News.  
(31.41 m.) 19.30—News; Music.  
20.00—News (Eng.); Songs.  
20.20—News (Ger.); Music.  
20.55—Mail.  
21.00-21.25—News (Fr.); Music.  
(25.34 m.) 00.00-02.10—For America.  
00.00—Band; Talk.  
00.30—Choir; News.  
00.55—Foerster Opera Music.  
01.30—News (Eng.).  
01.40—Slav Dances (Dvorak).  
02.00-02.10—Mail.

**ROME**, 11.81 mc/s (25.4 m.).  
13.20—News; Songs; Talk.  
14.00-15.30—News (Eng.); Opera Music; Talk (Chin.); Pfte. and Soprano; News.  
16.20-17.20—News; Band.  
17.30—Music; News (Arabic).  
18.08—News (Ger.).  
18.26-19.00—News (Eng., Fr.).  
22.30—South American Bulletin.  
23.00—American Hour from Rome: U.S.A. Bulletin; News (Eng.); "Mefistofele" (Boito); Talk; Arias; Mail; News.

**SCHENECTADY** (W2XAD), 15.33 mc/s (19.57 m.); (W2XAF), 9.53 mc/s (31.48 m.).  
(19.57 m.) 16.00—Variety.  
17.30—Farm Programme; Tenor.  
18.15—Words and Music.  
18.45—Dan Harding's Wife.  
19.00—U.S. Travel (French).  
19.15—W.P.A. Programme.  
19.30—Pfte. Duo; Variety.  
(19.57 m. and 31.48 m.) 21.00—Variety.  
22.00—American News Tower.  
22.15—Sports in America.  
22.30—Jack Armstrong.  
22.45—Orphan Annie.  
23.00—Bass.  
23.15—U.S. Travel.  
23.30—News; Songs; Sports.  
00.00—Amos 'n' Andy.  
00.15—U.S. Travel (Spanish).  
00.30—Stocks.  
00.45—News and Music—Spanish.  
01.30—Soprano.  
(31.48 m.) 02.00—Fibber McGee.  
02.30—Charm.  
03.00—Contented Hour.  
03.30—Music for Moderns.  
04.00-05.00—Orchestras.

**TOKIO** (JZK), 15.16 mc/s (19.79 m.); (JZJ), 11.80 mc/s (25.42 m.).  
(For Europe)  
20.00—News (Eng.).

20.15—Music and Songs.  
 20.30-21.00—News (Ger., Fr., Jap.).  
**VATICAN CITY (HVJ)**, 15.12 mc/s (19.84 m.); 5.97 mc/s (50.26 m.).  
 (19.84 m.) 15.30—Church Notes (It.).  
 (50.26 m.) 19.00—See 15.30.  
**WARSAW (SPW)** 13.63 mc/s (22 m.).  
 23.00-00.00—News (Pol., Eng.); Records; Reading; Orchestra.  
**WAYNE (W2XE)** 21.52 mc/s (13.94 m.); 17.76 mc/s (16.89 m.); 15.27 mc/s (19.65 m.).  
 (13.94 m.) 12.30—Fiddler's Fancy.  
 13.00-13.30—Morning Almanac.  
 (19.65 m.) 19.00-19.15 — News through a Woman's Eyes.  
 (16.89 m.) 23.30—News; Variety.  
 03.00—Wayne King's Orchestra.  
 03.30-04.00—Brave New World.  
 04.00-05.00—Variety.  
**ZEESSEN (DJA)** 9.56 mc/s (31.38 m.); (DJB) 15.20 mc/s (19.74 m.); (DJE) 17.76 mc/s (16.89 m.); (DJN) 9.54 mc/s (31.45 m.); (DJQ) 15.28 mc/s (19.63 m.).

21.20—The Rt. Hon. Margaret Bondfield.  
 21.35—Musical Interlude.†  
 21.40—BBC Theatre Organ.  
 22.00—BBC Orchestra (Section E): Albert Voorsanger (Violin).  
 22.45-23.00—"World Affairs."\*\*  
**Transmission 5 (GSD, GSD†, GSC, GSB).**  
 23.20—Reginald Foort (BBC Theatre Organ).  
 23.45—"This is England:" talk.\*  
 00.00—BBC Empire Orchestra.  
 00.40—News.  
 01.00-01.30—Big Ben; Welsh Music: John Pennar Williams (Bass); Tom Bryant (Harp).\*  
**Transmission 6 (GSD, GSC, GSC†, GSB).**  
 02.00—Big Ben; "World Affairs."\*\*  
 02.15—Songs of Old London.  
 02.30—"At the Black Dog."\*\*  
 03.00—Light Orchestra.†  
 03.10—News.  
 03.30-04.00—Big Ben; "Mrs. Beeton," by Joan Easdale.\*

09.00—News (Fr., Eng.); Music.  
 10.05—"L'Allegro" (Burnard).  
 11.00—Play; Harpsichord; Chorus.  
 12.30-13.30—News; Dancing.  
**MOSCOW (RNE)** 12.00 mc/s (25 m.); (RAN) 9.60 mc/s (31.26 m.); (RKI) 7.54 mc/s (39.79 m.).  
 (25 m.) 11.00—For Germany.  
 (25 m. and 39.79 m.) 17.15 — For Germany.  
 (25 m.) 20.00—For Italy.  
 20.30—For Germany.  
 21.00—For Holland.  
 22.00—For Portugal.  
 (31.26 m.) 23.00—For Spain.  
 (31.26 m. and 39.79 m.) 00.00—For England.  
 (25 m.)—01.30—For France.  
 03.15—For England.  
**PARIS (Radio-Colonial) (TPA2)** 15.24 mc/s (19.69 m.); (TPA3) 11.89 mc/s (25.23 m.); (TPA4) 11.72 mc/s (25.6 m.).  
 (19.69 m.) 14.30—"La fille et le garçon"—Play (Birabeau-Dolley).

23.30—News.  
 23.45—Lowell Thomas.  
 (25.27 m.) 00.00—Variety.  
 01.00—Husbands and Wives.  
 01.30—Variety.  
 (48.86 m.) 03.00—Gen. Hugh S. Johnson.  
 03.15—Choir Symphonette.  
 03.30—Orchestra.  
 04.00—News; Music.  
 05.15—New Penn Orchestra.  
 05.30-06.00—Orchestras.  
**PODEBRADY (OLR)**, 15.23 mc/s (19.70 m.); 11.84 mc/s (25.34 m.); 9.55 mc/s (31.41 m.); 6.01 mc/s (49.92 m.).  
 (25.34 m.) 19.00—News.  
 (31.41 m.) 19.30—News; Music.  
 20.00—News (Eng.).  
 20.05—Sonata (Beethoven).  
 20.20—News (Ger.); Czech Music.  
 20.50—Serenade (Haydn).  
 21.00—News (Fr.).  
 21.05-21.25—Duo concertante (Stravinsky).

00.00—Amos 'n' Andy.  
 00.15—Vocal Varieties.  
 00.30—Stocks.  
 00.45—News (Sp.).  
 01.00—Celebrated Musicians — Spanish.  
 01.30—Serenade.  
 (31.48 m.) 02.00—Vox Pop.  
 02.30—Hollywood Mardi Gras.  
 03.30—Hollywood Gossip.  
 03.45—Serenade.  
 04.00—Violin.  
 04.15-05.00—Orchestras.  
**TOKIO (JZK)**, 15.16 mc/s (19.79 m.); (JZI) 11.80 mc/s (25.42 m.).  
 (For Europe).  
 20.00—News (Eng.).  
 20.15—"Kuruma-Biki"—Kabuki Play with Explanations (Eng., Ger., Fr.).  
 20.30-21.00—News (Ger., Fr., Jap.).  
**VATICAN CITY (HVJ)**, 15.12 mc/s (19.84 m.); 5.97 mc/s (50.26 m.).  
 (19.84 m.) 15.30—Church Notes (Eng.).  
 (50.26 m.) 19.00—See 15.30.  
**WARSAW (SPW)**, 13.63 mc/s (22 m.).  
 23.00-00.00—News (Pol., Eng.); Talks; Records.  
**WAYNE (W2XE)**, 21.52 mc/s (13.94 m.); 17.76 mc/s (16.89 m.); 15.27 mc/s (19.65 m.).  
 (13.94 m.) 12.30—Serenade.  
 (19.65 m.) 20.30—Orchestra, Soloist.  
 (16.89 m.) 23.30—News; Variety.  
 02.00—Al Pearce's Gang.  
 02.30-05.00—Variety.  
**ZEESSEN (DJA)**, 9.56 mc/s (31.38 m.); (DJB), 15.20 mc/s (19.74 m.); (DJE), 17.76 mc/s (16.89 m.); (DJN), 9.54 mc/s (31.45 m.); (DJQ), 15.28 mc/s (19.63 m.).

### PRINCIPAL EVENTS

#### SUNDAY, November 21

10.15 Lyndhurst (31.32 m.). Octet.  
 16.20 Rome (25.4 m.) News; Music.  
 17.30 Bound Brook (16.87 m.) Music-Hall.  
 17.30 Schenectady (19.57 m.) Discussion.  
 21.30 Pittsburgh (19.72 m.) Vespers.  
 23.00 Bound Brook (16.87 m.) Orchestra; Sing Band.  
 23.15 Radio-Colonial (19.68 m.) Dance Music; 00.15, News.  
 02.25 Bound Brook (49.18 m.) For South America.  
 04.00 Schenectady (31.48 m.) Orchestras.

#### MONDAY, November 22

14.00 Rome (25.4 m.) News; Music.  
 21.00 Pittsburgh (19.72 m.) Club Matinée; 22.45, Tom Mix.  
 23.00 Bound Brook (16.87 m.) Army Band.  
 23.00 Rome (31.13 m.) American Hour.  
 23.45 Pittsburgh (19.72 m.) Lowell Thomas.  
 00.00 Bound Brook (16.87 m.) For South America.  
 02.00 Schenectady (31.48 m.) Variety.

#### TUESDAY, November 23

11.00 Lyndhurst (31.32 m.) Play.  
 21.00 Pittsburgh (19.72 m.) Club Matinée.  
 22.30 Bound Brook (16.87 m.) News; Songs.  
 02.00 Schenectady (19.57 m., 31.48 m.) Vox Pop; 02.30, Hollywood prog.

#### WEDNESDAY, November 24

16.20 Rome (25.4 m.) News; Light Music.  
 17.00 Bound Brook (16.87 m.) News; Music.  
 19.45 Zeesen (25.49 m., 19.85 m., 49.83 m.) Tenor Songs.  
 21.00 Schenectady (19.57 m., 31.48 m.) Variety; 00.00, Amos 'n' Andy.  
 23.00 Rome (31.13 m.) U.S.A. Bulletin.

02.25 Bound Brook (16.87 m.) South American Night.  
 03.00 Pittsburgh (25.27 m.) Gen. Johnson Songs.

#### THURSDAY, November 25

14.00 Rome (25.4 m.) "Andrea Chénier."  
 18.00 Bound Brook (16.87 m.) News; Music.  
 22.45 Pittsburgh (19.72 m.) Tom Mix.  
 00.00 Bound Brook (16.87 m.) News; Pianoforte Duo.  
 03.00 Schenectady (31.48 m.) Bing Crosby; 04.00, Orchestra.

#### FRIDAY, November 26

14.00 Pittsburgh (19.72 m.) Variety; 16.45, Edward MacHugh.  
 18.00 Bound Brook (16.87 m.) News; Music.  
 19.00 Radio-Nations (26.31 m.), (11.40 Mc/s) English; 19.30 (32.10 m.), (9.34 Mc/s) French; 00.30 (32.10 m.), (9.34 Mc/s) English; 01.00 (32.10 m.), (9.34 Mc/s) Spanish.  
 20.30 Pittsburgh (19.72 m.) Variety.  
 00.00 Pittsburgh (25.27 m.) Mary Small.  
 00.00 Schenectady (19.57 m., 31.48 m.) Amos 'n' Andy.  
 02.25 Bound Brook (49.18 m.) Music.  
 03.30 Schenectady (31.48 m.) Hollywood.

#### SATURDAY, November 27

17.15 Bound Brook (16.87 m.) Three Marshalls.  
 19.00 Schenectady (19.57 m., 31.48 m.) Buffalo; Music.  
 19.45 Schenectady (19.57 m., 31.48 m.) Football; Variety.  
 23.00 Pittsburgh (19.72 m.) News; Variety.  
 00.00 Schenectady (31.48 m.) Top Hatters.  
 03.00 Pittsburgh (48.86 m.) NBC Symphony Orchestra.

### TUESDAY, Nov. 23

**EMPIRE**  
**Transmission 1 (GSG, GSO, GSD, GSB).**  
 08.15—Big Ben; Peggy Cochrane (Violin).  
 08.35—Music-Hall.\*  
 09.35—News.  
 09.55—"Empire Exchange."\*\*  
 10.10-10.25—Lancashire Dialect Songs; Hamilton Harris (Bass), with Male Voice Chorus.  
**Transmission 2 (GSJ, GSH, GSG, GSO).**  
 10.45—Big Ben; Dance Band.  
 11.15—BBC Symphony Orchestra; Symphony No. 5 (Tchaikovsky).  
 12.05—Pfte. Music.†  
 12.15—A Pageant of Radio.  
 13.00—Organ Recital.  
 13.30-13.55—Big Ben; News.  
**Transmission 3 (GSJ (until 15.30 G.M.T.), GSD (from 15.45 G.M.T.)), GSH, GSG, GSF).**  
 14.15—Big Ben; Welsh Music: John Pennar Williams (Bass); Tom Bryant (Harp).  
 14.45—"At the Black Dog."\*\*  
 15.15—Torquay Municipal Orchestra—John McKenna (Tenor).  
 16.00—Big Ben; News.  
 16.20—Chopin; Ireen MacLaren (Pfte.).  
 16.45-17.00—"World Affairs."  
**Transmission 4 (17.20-20.45 GSG, GSP from 18.45, GSI, GSD, GSB; 21.00-23.00 GSO, GSD, GSD†, GSB).**  
 17.20—"This is England:" talk.  
 17.35—Light Orchestra.  
 18.00—Big Ben; News.  
 18.20—"World Affairs."\*\*  
 18.35—Pini Tango Orchestra.  
 19.00—BBC Military Band.  
 19.30—"Tobacco:" a feature.\*  
 20.00—Joyce Kadish (Pfte.).  
 20.15-20.45—Variety.\*  
 21.00—Big Ben; News.

**BOUND BROOK (W3XAL)** 17.78 mc/s (16.87 m.); 6.10 mc/s (49.18 m.).  
 (16.87 m.) 14.00—Breakfast Club.  
 14.45—News.  
 15.00—Variety.  
 17.00—News (Fr.); Music.  
 18.00—News (Ger.); Music.  
 19.00—News (It.).  
 19.30—NBC Music Guild (anncts. Eng., It.).  
 20.00—News (Fr.); Music.  
 21.00—News (Ger.); Music.  
 22.00—News; Pfte.  
 22.30—News (Fr., Ger.); Songs.  
 23.00—Stringtime.  
 23.30—News.  
 00.00-02.00—For South America.  
 00.00—News (Sp., Port.); Tenor.  
 01.00—Sports (Sp.).  
 01.30—Wayne King Orchestra.  
 (49.18 m.) 02.25-06.00—For South America; Variety.

**HUIZEN (PHI)** 17.77 mc/s (16.88 m.); 11.73 mc/s (25.57 m.).  
 (16.88 m.) For the Dutch Indies.  
 13.25—Stocks; Topical.  
 14.00—A Play.  
 14.50-15.00—News.

**LYNDHURST (VK3LR)**, 9.58 mc/s (31.32 m.).  
 02.35—Watchman; Music.  
 03.00—News; Music.  
 04.15-07.15—Cricket Match; For Schools.  
 08.30—Music; Sports.

15.55—Markets.  
 (25.23 m.) 17.15 — News (Fr., Arabic).  
 18.00—Concert.  
 18.50—Shipping; News.  
 20.10—News (Eng., It.).  
 20.30—To be announced.  
 22.30—Markets; News (Port.).  
 (25.6 m.) 23.15—Records.  
 00.15—News (Fr., Sp., Port.).  
 01.00-01.15—Records.  
 03.00—Records.  
 04.00—News; Exchange.  
 04.30—News (Eng.); Records.  
 05.45—News (Ger.).

**PITTSBURGH (W8XK)** 21.54 mc/s (13.93 m.); 15.21 mc/s (19.72 m.); 11.87 mc/s (25.27 m.); 6.14 mc/s (48.86 m.).  
 (19.72 m.) 14.00—Variety.  
 16.45—Edward MacHugh; News.  
 17.15—Novelties.  
 17.30—Farm and Home.  
 18.30—Songsters; Orchestra.  
 19.15—Clark Dennis (Tenor).  
 19.30—Home Forum.  
 20.00—Music by Cugat.  
 20.15—Congress of Clubs.  
 20.30—U.S. Marine Band.  
 21.00—Club Matinée; As I see it.  
 21.35—To be announced.  
 22.00—Junior Nurse Corps.  
 22.15—Janet Ross.  
 22.30—Singing Lady.  
 22.45—Tom Mix.  
 23.00—News.  
 23.15—Comedy Stars of Broadway.

**ROME**, 11.81 mc/s (25.4 m.).  
 13.20—News; Folk Music.  
 14.00-15.30—News (Eng., Chin.); Trio; Songs; Pfte.; News.  
 16.20—News; Songs; Dance Music.  
 17.30—Arab Music.  
 17.50-18.00—Talk (Turk.).  
 18.08—News (Ger.).  
 18.26-19.00—News (Eng., Fr.).  
 23.00—U.S.A. Bulletin.  
 23.20—For South America; Call. (It., Sp., Port.); News; Songs; News (Port.).  
 00.00—For Uruguay; String Quartet (Verdi); News (Sp.).

**SCHENECTADY (W2XAD)**, 15.33 mc/s (19.57 m.); (W2XAF) 9.53 mc/s (31.48 m.).  
 (19.57 m.) 16.00—Variety.  
 17.30—Farm Programme.  
 18.00—Betty's Escorts.  
 18.15—Words and Music.  
 18.45—Dan Harding's Wife.  
 19.00—Fun in Music.  
 19.30—Women's Clubs.  
 19.45—Armchair Quartet.  
 20.00—Variety.  
 (19.57 m. and 31.48 m.) 21.00—Variety.  
 22.00—American News Tower; Music.  
 22.30—Jack Armstrong.  
 22.45—Little Orphan Annie.  
 23.00—Science.  
 23.15—Don Winslow.  
 23.30—News; Mail.

**WARSAW (SPW)**, 13.63 mc/s (22 m.).  
 23.00-00.00—News (Pol., Eng.); Talks; Records.  
**WAYNE (W2XE)**, 21.52 mc/s (13.94 m.); 17.76 mc/s (16.89 m.); 15.27 mc/s (19.65 m.).  
 (13.94 m.) 12.30—Serenade.  
 (19.65 m.) 20.30—Orchestra, Soloist.  
 (16.89 m.) 23.30—News; Variety.  
 02.00—Al Pearce's Gang.  
 02.30-05.00—Variety.  
**ZEESSEN (DJA)**, 9.56 mc/s (31.38 m.); (DJB), 15.20 mc/s (19.74 m.); (DJE), 17.76 mc/s (16.89 m.); (DJN), 9.54 mc/s (31.45 m.); (DJQ), 15.28 mc/s (19.63 m.).

**On all Wavelengths.**  
 05.05—Call (Ger., Eng.); Music.  
 06.00—News; Music; Greetings.  
 07.00—News (Eng.); Topical; Music.  
 09.30—News; Interview.  
 10.00—Concert.  
 11.00—Light Music.  
 12.00—News (Eng.), etc.; Music.  
 13.00—News; Songs.  
 14.00—News (Eng., Dutch); Topical.  
 14.30—Steiner (Violin).  
 15.00—Fairy Play; Interview.

**ZEESSEN (DJD)**, 11.77 mc/s (25.49 m.); (DJL), 15.11 mc/s (19.85 m.); (DJC), 6.02 mc/s (49.83 m.).  
**On all Wavelengths.**  
 05.10—Concert.  
 15.40—Call (Ger., Eng.); Concert.  
 17.15—News, etc.; Music.  
 19.00—News (Eng.); Topical.  
 19.30—Dialect Programme.  
 20.00—Selection, "Prinz Caramo" (Lortzing).  
 21.00—News (Ger., Eng.).

**ZEESSEN (DJD)**, 11.77 mc/s (25.49 m.); (DJB), 15.20 mc/s (19.74 m.); (DJC), 6.02 mc/s (49.83 m.).  
**On all Wavelengths.**  
 21.50—Call (Ger., Eng.); Songs.  
 22.45—News; Music.  
 00.15—Topical; Music.  
 01.15—News (Eng.); Songs.  
 01.45—Interview.  
 02.00—News; Music.  
 03.30—News (Eng., Ger.).

### WEDNESDAY, Nov. 24

**EMPIRE**  
**Transmission 1 (GSG, GSO, GSD, GSB).**  
 08.15—Big Ben; Al Bollington (BBC Theatre Organ).  
 08.40—"World Affairs."\*\*  
 08.55—Beethoven; Orchestra.\*  
 09.35—News.  
 09.55—Ballad Concert.  
 10.10-10.25—Talk by A. G. Street.\*  
**Transmission 2 (GSJ, GSH, GSG, GSO).**  
 10.45—Big Ben; Beethoven: Kutchur String Quartet.  
 11.15—BBC Military Band Songs.\*  
 12.00—"Tobacco:" a feature.\*  
 12.30—Variety.\*  
 13.00—"World Affairs."\*\*  
 13.15—Dance Music.†  
 13.30-13.55—Big Ben; News.  
**Transmission 3 (GSJ (until 15.30 G.M.T.), GSD (from 15.45 G.M.T.)), GSH, GSG, GSF).**  
 14.15—Big Ben; Beethoven: BBC Empire Orchestra.\*  
 14.55—Pfte. Interlude.†  
 15.00—Music-Hall.\*  
 16.00—Big Ben; News.  
 16.20—Talk for listeners in India.  
 16.35-17.00—Light Orchestra.



**Transmission 4** (17.20-20.45 GSG, GSP from 18.45, GSI, GSD, GSB; 21.00-23.00 GSO, GSD, GSD, GSB).  
 17.20—"Westward from Liverpool."  
 18.00—Big Ben; News.  
 18.20—Variety.\*  
 18.35—Cinema Organ.†  
 18.55—"A Wisp of Lace;" a play with music.  
 19.30—Royal Tennis; broadcast from King Henry VIII's court.  
 19.45—"Music from the Movies."  
 20.15-20.45—Fred Hartley's Sextet.  
 21.00—Big Ben; News.  
 21.25—Scottish Dances.\*  
 21.45—Musical Interlude.†  
 21.50—BBC Symphony Concert from Queen's Hall, London; Conductor, Sir Adrian Boult.  
 22.40-23.00—Talks.  
**Transmission 5** (GSD, GSD, GSC, GSB).  
 23.20—Olive Groves (Soprano).  
 23.40—"Empire Exchange."\*  
 23.55—"A Pageant of Radio."\*  
 00.40—News.  
 01.00-01.30—Big Ben; Joseph Meus and his Dance Band.\*  
**Transmission 6** (GSD, GSC, GSB).  
 02.00—Big Ben; Talks.\*  
 02.20—BBC Empire Orchestra; Mahry Dawes (Soprano).  
 03.10—News.  
 03.30-04.00—Big Ben; "Ezra Pitt and Elmer."\*

**BOUND BROOK** (W3XAL) 17.78 mc/s (16.87 m.); 6.10 mc/s (49.18 m.).  
 (16.87 m.) 14.00—Breakfast Club.  
 14.45—News.  
 15.00—Sweethearts.  
 15.15—Variety.  
 17.00—News (Fr.); Music.  
 17.30—Three Marshalls.  
 17.45—Joe White (Tenor).  
 18.00—News (Ger.); Music.  
 19.00—News (It.); Music.  
 20.00—News (Fr.); Music.  
 20.30—Continental Varieties; (anncts. Fr., Eng.).  
 20.45—Orchestra.  
 21.00—News (Ger.); Music.  
 21.15—News (Eng., Fr., Ger.).  
 22.45—Orchestra, Soloists.  
 23.30—News.  
 00.00-02.00—For South America.  
 00.00—News (Sp., Port.); Songs.  
 01.00—Woman Today; Music.  
 (49.18 m.) 02.25-06.00—For South America; Variety.

**BUDAPEST** (HAS3) 15.37 mc/s (19.52 m.); (HAT4) 9.12 mc/s (32.88 m.).  
 (32.88 m.) 00.00-01.00 (Thurs.) Music; Talk; News.  
**HUIZEN** (PCJ) 15.22 mc/s (19.71 m.); 9.59 mc/s (31.28 m.).  
 (31.28 m.) 01.00-02.00 (Thurs.) — For the West.  
**LYNDHURST** (VK3LR) 9.58 mc/s (31.32 m.).  
 02.35—Watchman; Music.  
 03.00—News; Music.  
 03.30-07.15—Racing; Records.  
 08.30—Music; Talks.  
 09.20—News.  
 10.00—Band; Shanties; Talk.  
 11.10—Orchestral Hour.  
 12.30-13.30—News; Music.

**MOSCOW** (RNE) 12.00 mc/s (25 m.); (RAN) 9.60 mc/s (31.26 m.); (RKL) 7.54 mc/s (39.79 m.).  
 (25 m.) 11.00—For England.  
 (25 m. and 39.79 m.) 17.15—For Germany.  
 (25 m.) 20.00—For Italy.  
 20.30—For Germany.  
 21.00—For France.  
 22.00—For Germany.  
 (31.26 m.) 23.00—For Spain.  
 (31.26 m. and 39.79 m.) 00.00—For England.  
 (25 m.) 01.30 and 03.15 — For England.

**PARIS** (Radio-Colonial) (TPA2) 15.24 mc/s (19.69 m.); (TPA3) 11.89 mc/s (25.23 m.); (TPA4) 11.72 mc/s (25.6 m.).  
 (19.69 m.) 14.30—Symphony Concert.  
 15.55—Exchange.  
 (25.23 m.) 17.15—News (Fr., Arabic).  
 18.00—Concert.  
 18.50—Topical; News.  
 20.10—News (Eng., It.).  
 20.30—To be announced.  
 22.30—Markets; News (Port.).  
 (25.6 m.) 23.15—Concert. 00.15—News (Fr., Sp., Port.).  
 01.00-01.15—Records.  
 03.00—Records.  
 04.00—News.  
 04.30—News (Eng.); Records.  
 05.45—News (Ger.).

**PITTSBURGH** (W8XK), 21.54 mc/s (13.93 m.); 15.21 mc/s (19.72 m.); 11.87 mc/s (25.27 m.); 6.14 mc/s (48.86 m.).  
 (19.72 m.) 14.00—Variety.  
 16.45—Edward MacHugh.  
 17.00—News.  
 17.15—Grace and Eddie.  
 17.30—Farm and Home.  
 18.30—Songsters.  
 18.45—Stroller's Matinée.  
 19.30—Home Forum.  
 20.00—Variety.  
 20.45—Swing Serenade.  
 21.00—Club Matinée.  
 21.30—Parents and Teachers.  
 22.00—Junior Nurse Corps.  
 22.15—Weston Sisters.  
 22.30—Singing Lady.  
 22.45—Tom Mix.  
 23.00—News.  
 23.15—Rube Appleberry.  
 23.30—News.  
 23.45—Lowell Thomas.  
 (25.27 m.) 00.00—Variety.  
 02.00—Musical Comedy Hits.  
 02.30—NBC Minstrel Show. (48.86 m.) 03.00—Gen. Hugh S. Johnson.  
 03.15—Nola Day (Songs).  
 03.30—Waltzes.  
 04.00—News.  
 04.15—Music as you desire it.  
 05.00-06.00—Orchestras.

**PODEBRADY** (OLR), 15.23 mc/s (19.70 m.); 11.84 mc/s (25.34 m.); 9.55 mc/s (31.41 m.); 6.01 mc/s (49.92 m.).  
 (25.34 m.) 19.00—News.  
 (31.41 m.) 19.30—News; Music.  
 20.00—News (Eng.); Songs.  
 20.20—News (Ger.); Music.  
 21.00-21.25—News (Fr.); Music.  
**ROME**, 11.81 mc/s (25.4 m.).  
 13.20—News; Songs; Talk.  
 14.00-15.30—News (Eng.); Organ; Talk; Band; Mail; News.  
 16.20—News; Light Music.  
 17.30—Music; News (Arabic).  
 18.00—News (Ger.).  
 18.26-19.00—News (Eng., Fr.).  
 23.00—American Hour from Rome; U.S.A. Bulletin; News (Eng.); Choir; Talk (Eng.); Folklore; News.

**SCHENECTADY** (W2XAD), 15.33 mc/s (19.57 m.); (W2XAF), 9.53 mc/s (31.48 m.).  
 (19.57 m.) 16.00—Variety.  
 17.30—Farm Programme.  
 18.00—Three Rancheros.  
 18.15—Words and Music.  
 18.45—Dan Harding's Wife.  
 19.00—Music.  
 19.30—Piano Team.  
 19.45—Men of the West.  
 20.00—Variety.  
 (19.57 m. and 31.48 m.) 21.00—Variety.  
 22.00—American News Tower.  
 22.15—Sports in America.  
 22.30—Jack Armstrong.  
 22.45—Little Orphan Annie.  
 23.00—America's Schools.  
 23.15—Don Winslow.  
 23.30—News; Songs.  
 23.45—Spanish Musical Programme.  
 00.00—Amos 'n' Andy.  
 00.15—Sketch in Spanish.  
 00.30—Stocks.  
 00.45—News (Sp.).  
 01.00—Latin-American Concert. (31.48 m.) 02.00—Town Hall.  
 03.00—Hit Parade.  
 03.45—Alistair Cooke.  
 04.00-05.00—Orchestras.

**TOKIO** (JZK) 15.16 mc/s (19.79 m.); (JZI) 11.80 mc/s (25.42 m.).  
 (For Europe).  
 20.00—News (Eng.).  
 20.15—Koto Trio.  
 20.30-21.00—News (Ger., Fr., Jap.).

**VATICAN CITY** (HVJ) 15.12 mc/s (19.84 m.); 5.97 mc/s (50.26 m.).  
 (19.84 m.) 15.30—Church Notes (Sp.).  
 (50.26 m.) 19.00—See 15.30.  
**WARSAW** (SPW) 13.63 mc/s (22 m.).  
 23.00-00.00—News (Pol., Eng.); Records; Reading; Choir.

**WAYNE** (W2XE) 21.52 mc/s (13.94 m.); 17.76 mc/s (16.89 m.); 15.27 mc/s (19.65 m.).  
 (13.94 m.) 12.55—News.  
 (19.65 m.) 18.00—Variety.  
 19.00—For Women; Variety.  
 20.00—Variety.  
 21.45—Talks; Variety.  
 (16.89 m.) 23.40—News; Variety.  
 00.45—News; Cavalcade.  
 01.30—Eddie Cantor.  
 01.00—Lotte Lehmann (Soprano), Kostelanetz Orchestra, etc.  
**ZEESEN** (DJA) 9.56 mc/s (31.38 m.); (DJB) 15.20 mc/s (19.74 m.); (DJE) 17.76 mc/s (16.89 m.).

(m.); (DJN) 9.54 mc/s (31.45 m.); (DJQ) 15.28 mc/s (19.63 m.).  
**On all Wavelengths.**  
 05.05—Call (Ger., Eng.); Concert.  
 06.00—News; Concert.  
 07.00—News (Eng.); Topical.  
 07.30—Steiner (Violin).  
 08.00—Lortzing Music; Play.  
 09.30—News; Talk.  
 10.30—Folk-Songs; Music.  
 12.00—News (Eng.); Music.  
 13.00—News; Concert.  
 14.00—News (Eng., Dutch).  
 14.15—Talk; Music; Review.

**ZEESEN** (DJD) 11.77 mc/s (25.49 m.); (DJI) 15.11 mc/s (19.85 m.); (DJC) 6.02 mc/s (49.83 m.).  
**On all Wavelengths.**  
 05.10—Concert.  
 15.40—Call (Ger., Eng.), etc.; Concert.  
 17.15—News; Talks; Dances.  
 19.00—News (Eng.); Topical.  
 19.45—Groh (Tenor).  
 21.00—News (Ger., Eng.).  
**ZEESEN** (DJD) 11.77 mc/s (25.49 m.); (DJB) 15.20 mc/s (19.74 m.); (DJC) 6.02 mc/s (49.83 m.).

**On all Wavelengths.**  
 21.50—Call (Ger., Eng.); Dialect.  
 22.30—Selection, "Prince Caramo" (Lortzing).  
 22.45—News.  
 23.00—"Prince Caramo" (contd.).  
 23.45—Talks; Music.  
 01.15—News (Eng.).  
 01.30—News; Ptte.  
 02.00—News; Music.  
 03.30—News (Eng., Ger.).

**THURSDAY, Nov. 25**

**EMPIRE**  
**Transmission 1** (GSG, GSO, GSD, GSB).  
 08.15—Big Ben; A Pageant of Radio.\*  
 09.00—Royal Tennis; a broadcast from King Henry VIII's court at Hampton Court.\*  
 09.15—Talks.\*  
 09.35—News.  
 09.55-10.25—Brahms; Frank Merriker (Pfte.).

**Transmission 2** (GSJ, GSH, GSG, GSO).  
 10.45—Big Ben; "Fire I" a play by A. J. Alan.\*  
 11.05—Ballet Music.†  
 11.15—"Sportsmen Talking;" "Dixie" Dean and Ivan Sharpe.  
 11.30—Cinema Organ.  
 12.00—Quintet.  
 12.30—"At the Black Dog."  
 13.00—Sea Shanties.† 13.10—Talks.\*  
 13.30-13.55—Big Ben; News.  
**Transmission 3** (GSJ (until 15.30 G.M.T.), GSD (from 15.45 G.M.T.), GSH, GSG, GSF).  
 14.15—Big Ben; Dr. Ernest Bullock (Organ), from Westminster Abbey.\*  
 14.45—A Pageant of Radio.\*  
 15.30—Joseph Meus Band.\*  
 16.00—Big Ben; News.  
 16.20—The Rt. Hon. Margaret Bondfield.  
 16.35-17.00—Light Orchestra.

**Transmission 4** (17.20-20.45 GSG, GSP from 18.45, GSI, GSD, GSB; 21.00-23.00 GSO, GSD, GSD, GSB).  
 17.20—"At the Black Dog."\*  
 17.50—Dance Band.  
 18.00—Big Ben; News. 18.25—Talk.  
 18.40—"From the London Theatre."  
 19.00—Empire Orchestra: Geraldine and Mary Peppin (Pftes.).  
 20.00-20.45—A Pageant of Radio.\*  
 21.00—Big Ben; News.  
 21.20—Hadrian's Wall.  
 22.00—"Long-Distance Listening;" Sir Walford Davies.\*  
 22.30-23.00—Dance Music.

**Transmission 5** (GSD, GSD, GSC, GSB).  
 23.20—For Canadian Listeners.  
 23.40—Eda Kersey (Violin).  
 00.00—"Westward from Liverpool."\* 00.40—News.  
 01.00—Big Ben; Scottish Dances.\*  
 01.20-01.30—Shorty and Conky in "A Day's Fishing."\*  
**Transmission 6** (GSD, GSC, GSB).  
 02.00—Big Ben; Science talk.  
 02.15—Norina Semino (Cello).  
 02.30—Scenes from "The Merchant of Venice" (Shakespeare)\*  
 03.10—News.  
 03.30-04.00—Big Ben; Variety.\*

**BOUND BROOK** (W3XAL), 17.78 mc/s (16.87 m.); 6.10 mc/s (49.18 m.).  
 (16.87 m.) 14.00—Breakfast Club.  
 14.45—News.

15.00—Music and Sketch.  
 17.00—News (Fr.); Music.  
 18.00—News (Ger.); Music.  
 19.00—NBC Music Guild.  
 19.30—News (It.); Orchestra.  
 20.00—News (Fr.); Music.  
 20.45—Swing Serenade (anncts. Eng., Fr.).  
 22.00—News.  
 22.15—Gracey (Baritone).  
 22.30—News (Fr., Ger.); Quartet.  
 23.00—Kogen Orchestra.  
 23.30—News.  
 00.00-02.00—For South America.  
 00.00—News (Sp., Port.).  
 00.30—Pfte. Duo (anncts. Eng., Sp.).  
 01.00—Sports (anncts. Sp.).  
 01.15—American Composers—Orchestra and Soloists (anncts. Port.).  
 (49.18 m.) 03.30-06.00—For South America.  
 03.30—News (Sp.); Variety.

**HUIZEN** (PHI), 17.77 mc/s (16.88 m.); 14.73 mc/s (25.57 m.).  
 (16.88 m.) For Dutch Indies.  
 13.25—Stocks; Topical.  
 14.00—Pfte. Recital; Talk.  
 14.40-14.55—News.  
**LYNDHURST** (VK3LR) 9.58 mc/s (31.32 m.).  
 02.35—Watchman; Music.  
 03.00 07.00—News; Music.  
 08.30—Music; Sports.  
 09.00—News (Fr., Eng.).  
 10.00—A Play; Songs.  
 11.20—Budapest String Quartet.  
 12.30-13.30—News; Dancing.

**MOSCOW** (RNE), 12.00 mc/s (25 m.); (RAN), 9.60 mc/s (31.26 m.); (RKL), 7.54 mc/s (39.79 m.).  
 (25 m.) 11.00—For Germany.  
 (25 m. and 39.79 m.) 17.15—For Germany.  
 (25 m.) 20.00—For Italy.  
 20.30—For Germany.  
 21.00—For France.  
 22.00—For Spain.  
 (31.26 m.) 23.00—For Spain.  
 (31.26 m. and 39.79 m.) 00.00—For England.  
 (25 m.) 01.30—For France.  
 03.15—For England.

**PARIS** (Radio - Colonial) (TPA2), 15.24 mc/s (19.69 m.); (TPA3), 11.89 mc/s (25.23 m.); (TPA4), 11.72 mc/s (25.6 m.).  
 (19.69 m.) 14.30—Chamber Music.  
 15.55—Exchange.  
 (25.23 m.) 17.15—News (Fr., Arabic).  
 18.00—Records; Poems.  
 19.00—News; Exchange.  
 20.10—News (Eng., It.).  
 20.30—To be announced.  
 22.30—Markets; News (Port.).  
 (25.6 m.) 23.15—Records.  
 00.15—News (Fr., Sp., Port.).  
 01.00—Talk.  
 03.00—Records.  
 04.00—News.  
 04.30—News (Eng.); Records.  
 05.45—News (Ger.).

**PITTSBURGH** (W8XK), 21.54 mc/s (13.93 m.); 15.21 mc/s (19.72 m.); 11.87 mc/s (25.27 m.); 6.14 mc/s (48.86 m.).  
 (19.72 m.) 14.00—Variety.  
 16.45—Edward MacHugh.  
 17.00—News; Novelties.  
 17.30—Farm and Home.  
 18.30—Variety.  
 19.30—Home Forum; Music.  
 20.15—Rochester Philharmonic.  
 21.00—Variety.  
 22.30—Singing Lady.  
 22.45—Tom Mix.  
 23.00—News; Comedy Stars of Broadway; Sports.  
 23.45—Lowell Thomas.  
 (25.27 m.) 00.00—Variety.  
 01.00—Gen. Johnson.  
 01.15—The Liedersingers.  
 01.30—March of Time.  
 02.00—News; Town Meeting.  
 (48.86 m.) 03.30—NBC Jamboree.  
 04.00—News; Music.  
 05.00-06.00—Orchestras.

**PODEBRADY** (OLR), 15.23 mc/s (19.70 m.); 11.84 mc/s (25.34 m.); 9.55 mc/s (31.41 m.); 6.01 mc/s (49.92 m.).  
 (25.34 m.) 19.00—News.  
 (31.41 m.) 19.30—News; Band.  
 20.00—News (Eng.); Orchestra.  
 20.20—News (Ger.); Music.  
 21.00-21.25—News (Fr.); Orchestra.  
 (25.34 m.) 00.00-02.10 — For America.  
 00.00—Concerto (Myslivecek).  
 00.25—News (Ruthenian).  
 00.30—Orchestra; News.  
 00.55—Zich Music.  
 01.30—News (Eng.); Band.  
 02.00-02.10—Mail.

**ROME**, 11.81 mc/s (25.4 m.).  
 13.20—News; For Children.  
 14.00-15.30—News (Eng., Jap.); "Andrea Chénier" (Giordano); News.

16.20—News; Songs; Music.  
 17.30—Music; News (Arabic).  
 17.50—Turkish Music.  
 18.08—News (Ger.).  
 18.26-19.00—News (Eng., Fr.).  
 23.00—U.S.A. Bulletin.  
 23.20—For South America; Call (It., Sp., Port.); News; Symphony Concert; Talk; Soprano; News (Sp., Port.).

**SCHENECTADY** (W2XAD), 15.33 mc/s (19.57 m.); (W2XAF), 9.53 mc/s (31.48 m.).  
 (19.57 m.) 16.00—Variety.  
 17.30—Farm Programme.  
 18.00—Orchestra.  
 18.15—Words and Music.  
 18.45—Dan Harding's Wife.  
 19.00—NBC Music Guild.  
 19.30—Alissa Keir.  
 19.45—Men of the West.  
 20.00—Variety.  
 (19.57 m. and 31.48 m.) 21.00—Variety.  
 22.00—American News Tower.  
 22.15—Golden Melodies.  
 22.30—Jack Armstrong.  
 22.45—Little Orphan Annie.  
 23.00—Orchestra.  
 23.15—Don Winslow.  
 23.30—News.  
 23.35—Stocks.  
 00.00—Amos 'n' Andy.  
 01.15—News (Sp.).  
 00.30—Science Forum.  
 01.00—Rudy Vallee.  
 (31.48 m.) 02.00—Showboat.  
 03.00—Bing Crosby.  
 04.00—Orchestra.  
 04.30-05.00—Northern Lights.

**TOKIO** (JZK), 15.16 mc/s (19.79 m.); (JZI), 11.80 mc/s (25.42 m.).  
 (For Europe).  
 20.00—News (Eng.).  
 20.15—Variety.  
 20.30-21.00—News (Ger., Fr., Jap.).

**VATICAN CITY** (HVJ), 15.12 mc/s (19.84 m.); 5.97 mc/s (50.26 m.).  
 (19.84 m.) 15.30—Monthly Review of the Sciences in Latin.  
 (50.26 m.) 19.00—See 15.30.  
**WARSAW** (SPW) 13.63 mc/s (22 m.).  
 23.00—News (Pol., Eng.); Music.  
 23.30-00.00—Topical; Polish Folk Music; Talk (Eng.).

**WAYNE** (W2XE) 21.52 mc/s (13.94 m.); 17.76 mc/s (16.89 m.); 15.27 mc/s (19.65 m.).  
 (13.94 m.) 12.55—Poetic Strings.  
 (19.65 m.) 20.45—Do you remember?  
 (16.89 m.) 23.30—Football News.  
 23.45—Music; Variety.  
 03.30—Victor Bay Orchestra.

**ZEESEN** (DJA) 9.56 mc/s (31.38 m.); (DJB) 15.20 mc/s (19.74 m.); (DJE) 17.76 mc/s (16.89 m.); (DJN) 9.54 mc/s (31.45 m.); (DJQ) 15.28 mc/s (19.63 m.).  
**On all Wavelengths.**  
 05.05—Call (Ger., Eng.); Variety.  
 06.00—News, etc.; Variety.  
 07.00—News (Eng.); Topical.  
 07.30—Music; Books.  
 09.30—News; Talk (Eng.); Music.  
 12.00—News (Eng.); Music.  
 13.00—News; Play; Ptte.  
 14.00—News (Eng., Dutch); Topical; Songs.  
 15.45—Talk (Eng.).

**ZEESEN** (DJD) 11.77 mc/s (25.49 m.); (DJI) 15.11 mc/s (19.85 m.); (DJC) 6.02 mc/s (49.83 m.).  
**On all Wavelengths.**  
 05.10—Concert.  
 15.40—Call (Ger., Eng.), etc.; Concert.  
 17.15—News; Talk (Eng.); Band.  
 19.00—News (Eng.); Topical.  
 19.30—Play (Brockmeier).  
 20.30—Beethoven.  
 21.00—News (Ger., Eng.).

**ZEESEN** (DJD) 11.77 mc/s (25.49 m.); (DJB) 15.20 mc/s (19.74 m.); (DJC) 6.02 mc/s (49.83 m.).  
**On all Wavelengths.**  
 21.50—Call (Ger., Eng.); Books.  
 22.15—Ptte.  
 22.45—News; Songs; Talk.  
 00.30—Thanksgiving Day.  
 01.15—News (Eng.); Variety.  
 01.45—Talk (Eng.).  
 02.00—News; Concert.  
 03.30—News (Eng., Ger.).

**FRIDAY, Nov. 26**

**EMPIRE**  
**Transmission 1** (GSG, GSO, GSD, GSB).  
 08.15—Big Ben; "Samuel Johnson of the City of Lichfield."\*

08.40—Sextet.  
 09.05—The Rt. Hon. Margaret Bondfield.  
 09.20—Stars of Variety† 09.30—News.  
 09.55-10.25—"At the Black Dog."\*  
 Transmission 2 (GSJ, GSH, GSG, GSO).  
 10.45—Big Ben; Scottish Dances.\*  
 11.05—Scottish Golfers: Andrew Kirkaldy.\*  
 11.35—"A Wisp of Lace": a play with music.\*  
 12.10—A Visit to Davenport.\*  
 12.30—Henry Hall's Orchestra.  
 13.10—English Folk-Songs.  
 13.30-13.55—Big Ben; News.  
 Transmission 3 (GSJ [until 15.30 G.M.T.], GSD [from 15.45 G.M.T.], GSH, GSG, GSF).  
 14.15—Big Ben; BBC Empire Orchestra: Lance Dossor (Pfte.).  
 15.00—Variety.\*  
 15.30—Operatic Arias.†  
 16.00—Big Ben; News.  
 16.25—Musical Interlude.†  
 16.30-17.00—"London Buildings": Southwark Cathedral.  
 Transmission 4 (17.20-21.00 GSG, GSP [from 18.45], GSI, GSD, GSB; 21.15-23.00 GSO, GSD, GSD, GSB).  
 17.20—A Visit to Davenport.\*  
 17.40—Scottish Dances.\*  
 18.00—Big Ben; News.  
 18.25—Musical Interlude.†  
 18.30—The Rt. Hon. Margaret Bondfield.  
 18.45—Dave Frost Dance Band.  
 19.15—Salt Water Ballads.  
 19.30—The Hawaiian Islanders.  
 19.45—Variety.\*  
 20.00-21.00—The Kentucky Minstrels. 21.15—Big Ben; News.  
 21.40—"Sportsmen Talking": "Dixie" Dean and Ivan Sharpe.\*  
 21.55—Musical Interlude.†  
 22.00-23.00—BBC Orchestra (Redvers Llewellyn (Baritone)).  
 Transmission 5 (GSD, GSD, GSC, GSB).  
 23.20—Sousa's Marches.†  
 23.30—The Rt. Hon. Margaret Bondfield.  
 23.45—English Folk Songs.  
 00.00—Scenes from "The Merchant of Venice" (Shakespeare).\*  
 00.40—News.  
 01.00—Big Ben.  
 01.05-01.30—Sextet.  
 Transmission 6 (GSD, GSC, GSG, GSB).  
 02.00—Big Ben; A Visit to Davenport.\*  
 02.20—David Wise (Violin).  
 02.40—"Famous London Buildings": Southwark Cathedral.\*  
 03.10—News. 03.30—Big Ben.  
 03.35—Syncopation.†  
 03.45-04.00—Hawaiian Islanders.\*  
**BOUND BROOK (W3XAL)**, 17.78 mc/s (16.87 m.); 6.10 mc/s (49.18 m.).  
 (16.87 m.) 14.00—Breakfast Club.  
 14.45—News; Variety.  
 17.00—News (Fr.); Music.  
 18.00—News (Ger.); Music.  
 19.00—News (It.).  
 19.15—Matinée (annets. Eng., Ger.)  
 20.00—News (Fr.); Music.  
 21.00—News (Ger.); Music.  
 22.00—News; Escorts and Betty.  
 22.30—News (Fr., Ger.); Music.  
 23.30—News.  
 00.00-02.00—For South America.  
 00.00—News (Sp., Port.).  
 00.30—Concert (annets. Eng., Sp.). (49.18 m.) 02.25-06.00—For South America.  
 02.25—Music (annets. Sp.).  
 03.00—News (Sp.); Music.  
 03.30—The Liedersingers (annets. Eng., Sp.).  
 03.45—Stringing Along.  
 04.00—Promenade Concert (annets. Eng., Sp.).  
 05.00—Dance Band, Orchestra (annets. Eng., Sp.).  
**HUIZEN (PHI)**, 17.77 mc/s (16.88 m.); 11.73 mc/s (25.57 m.). (16.88 m.) For the Dutch Indies.  
 13.25—Stocks; Talk.  
 14.00—Variety Ensemble.  
 14.30—Weekly Review.  
 14.50-15.00—News.  
**LYNDHURST (VK3LR)** 9.58 mc/s (31.32 m.).  
 02.35—Watchman; Music.  
 03.00—News; Music.  
 05.00-07.00—Schools; Music.  
 08.30—Music; Talks.  
 09.20—News.  
 10.0—Bands; Songs.  
 11.15—Orchestra; Choir.  
 12.30-13.30—News; Records.  
**MOSCOW (RNE)**, 12.00 mc/s (25 m.); (RAN), 9.60 mc/s (31.26 m.); (RKI), 7.54 mc/s (39.79 m.).  
 (25 m.) 11.00—For Germany.  
 (25 m. and 39.79 m.) 17.15 — For Germany.  
 (25 m.) 20.00—For Italy.  
 20.30—For Germany.  
 21.00—For France.

22.00—For Germany.  
 (31.26 m.) 23.00—For Spain.  
 (31.26 m. and 39.79 m.) 00.00—For England.  
 (25 m.) 01.30—For Portugal.  
 03.15—For England.  
**PARIS (Radio-Colonial) (TPA2)**, 15.24 mc/s (19.69 m.); (TPA3), 11.89 mc/s (25.23 m.); (TPA4), 11.72 mc/s (25.6 m.).  
 (19.69 m.) 14.30—"Le voile du bonheur" (Clemenceau-Février). Music by Pons.  
 15.55—Exchange.  
 (25.23 m.) 17.15—News (Fr., Arabic).  
 18.00—Concert.  
 18.50—Talk; News.  
 20.10—News (Eng., It.).  
 20.30—To be announced.  
 22.30—Markets; News (Port.). (25.6 m.) 23.15—Concert.  
 00.15—News (Fr., Sp., Port.).  
 01.00—Records.  
 03.00—Records.  
 04.00—News (Fr.).  
 04.30—News (Eng.); Records.  
 05.45—News (Ger.).  
**PITTSBURGH (W8XK)**, 21.54 mc/s (13.93 m.); 15.21 mc/s (19.72 m.); 11.87 mc/s (25.27 m.); 6.14 mc/s (48.86 m.).  
 (19.72 m.) 14.00—Variety.  
 16.45—Edward MacHugh.  
 17.00—News; Novelties.  
 17.30—Farm and Home.  
 18.30—Home Forum.  
 19.00—Music Appreciation.  
 20.00—Music by Cugat.  
 20.15—Pen Women.  
 20.30—Variety.  
 23.00—News.  
 23.15—Rube Appleberry.  
 23.30—Weather; Football.  
 23.45—Lowell Thomas.  
 (25.27 m.) 00.00—Mary Small.  
 00.15—Talk.  
 00.30—Variety.  
 01.00—Grand Central Station.  
 01.30—Variety.  
 (48.86 m.) 03.00-03.30 — Russian Rhapsody.  
 04.00—News; Music.  
 05.00—Orchestra.  
 05.15—DX Club.  
 05.30-06.00—Orchestras.  
**PODEBRADY (OLR)** 15.23 mc/s (19.70 m.); 11.84 mc/s (25.34 m.); 9.55 mc/s (31.41 m.); 6.01 mc/s (49.92 m.).  
 (25.34 m.) 19.00—News.  
 (31.41 m.) 19.30—News; Music.  
 20.00—News (Eng.); Music.  
 20.20—News (Ger.).  
 20.25—Third Symphony (Brahms).  
 21.00—News (Fr.).  
 21.05-21.25—Dance Music.  
**RADIO NATIONS (HBO)** 11.40 mc/s (26.31 m.); (HBL) 9.34 mc/s (32.10 m.).  
 League of Nations Reports :  
 (26.31 m.) 19.00—In English.  
 (32.10 m.) 19.30—In French.  
 00.30—In English.  
 01.00—In Spanish.  
**ROME** 11.81 mc/s (25.4 m.).  
 13.20—News; Band.  
 14.00-15.30—News (Eng.); Music ; Talk; Songs; News.  
 16.20—News; Light Music.  
 17.30—Music; Talk (Arabic).  
 18.00—News (Ger.).  
 18.26-19.00—News (Eng., Fr.).  
 22.30—South American Bulletin.  
 23.00—American Hour from Rome: U.S.A. Bulletin; News (Eng.); Music; Topical; News.  
**SCHENECTADY (W2XAD)** 15.33 mc/s (19.57 m.); (W2XAF) 9.53 mc/s (31.48 m.).  
 (19.57 m.) 16.00—Variety.  
 17.30—Farm Programme.  
 (19.57 m. and 31.48 m.) 18.00—Orchestra.  
 18.15—Words and Music.  
 18.45—Dan Harding's Wife.  
 19.00—NBC Music Appreciation.  
 20.00—Variety.  
 22.00—American News Tower.  
 22.15—Sports in America.  
 22.30—Jack Armstrong.  
 22.45—Little Orphan Annie.  
 23.00—Education in the News.  
 23.15—Don Winslow.  
 23.30—News; Spanish Programme.  
 00.00—Amos 'n' Andy.  
 00.15—Uncle Ezra.  
 00.30—Stocks.  
 00.45—News (Sp.).  
 01.00—Soprano.  
 01.30—Farm Forum.  
 (31.48 m.) 02.00—Waltzes.  
 02.30—Talk (Sp.).  
 03.00—First Nighter.  
 03.30—Hollywood Gossip.  
 03.45—Dorothy Thompson.  
 04.00—Pfte.; George R. Holmes.  
 04.15-05.00—Orchestras.  
**TOKIO (JZK)** 15.16 mc/s (19.79 m.); (JZJ) 11.80 mc/s (25.42 m.).  
 (For Europe).  
 20.00—News (Eng.); Orchestra.  
 20.30-21.00—News (Ger., Fr.).

**VATICAN CITY (HVJ)**, 15.12 mc/s (19.84 m.); 5.97 mc/s (50.26 m.).  
 (19.84 m.) 15.30—Notes (It.).  
 (50.26 m.) 19.00—Notes (Ger.).  
**WARSAW (SPW)**, 13.63 mc/s (22 m.).  
 23.00-00.00—News (Pol., Eng.); Records; For Poles Abroad; Records; Poems; Record.  
**WAYNE (W2XE)**, 21.52 mc/s (13.94 m.); 17.76 mc/s (16.89 m.); 15.27 mc/s (19.65 m.).  
 (13.94 m.) 12.30—Novelties.  
 13.00—Morning Almanac.  
 (16.89 m.) 23.30—News; Orchestra.  
 00.45—Boake Carter; Music-Hall.  
 (19.65 m.) 01.30—Music from Hollywood.  
**ZEESEN (DJA)**, 9.56 mc/s (31.38 m.); (DJB) 15.20 mc/s (19.74 m.); (DJE) 17.76 mc/s (16.89 m.); (DJN) 9.54 mc/s (31.45 m.); (DJQ) 15.28 mc/s (19.63 m.).  
**On all Wavelengths.**  
 05.05—Call (Ger., Eng.); Variety.  
 06.00—News; Variety.  
 07.00—News (Eng.); Talk; Music.  
 09.30—News; Notes.  
 10.00—Play; Music.  
 12.00—News (Eng.); Music.  
 13.00—News; Dances; Talk.  
 14.00—News (Eng., Dutch); Talk.  
 14.30—Band; Notes.  
**ZEESEN (DJD)**, 11.77 mc/s (25.49 m.); (DJE) 15.11 mc/s (19.85 m.); (DJC) 6.02 mc/s (49.83 m.).  
**On all Wavelengths.**  
 05.10—Concert.  
 15.40—Call (Ger., Eng.); Music.  
 17.15—News; Music.  
 19.00—News (Eng.); Topical.  
 19.30—"We praise Friendship."  
 20.00—Chamber Music.  
 21.00—News (Ger., Eng.).  
**ZEESEN (DJD)**, 11.77 mc/s (25.49 m.); (DJB) 15.20 mc/s (19.74 m.); (DJC) 6.02 mc/s (49.83 m.).  
**On all Wavelengths.**  
 21.50—Call (Ger., Eng.); Pfte.  
 22.30—Brahm's Songs.  
 22.45—News; Talk.  
 23.15—Play; Talk.  
 00.30—Concert.  
 01.15—News (Eng.); Ballad.  
 01.45—Stage and Screen.  
 02.00—News; Band.  
 03.30—News (Eng., Ger.).

SATURDAY, Nov. 27

**EMPIRE**  
 Transmission 1 (GSG, GSO, GSD, GSB).  
 08.15—Big Ben; "London Log."  
 08.25—"Sportsmen Talking": "Dixie" Dean, Ivan Sharpe.\*  
 08.40—Popular Classics.  
 09.30—News. 09.50-10.25—"A Wisp of Lace": a play with music.\*  
 Transmission 2 (GSJ, GSH, GSG, GSO).  
 10.45—Big Ben; Cinema Organ.  
 11.15—Darts: The Hanbury Arms v. The Caledonian Arms.\*  
 11.30—Musical Comedy Stars.†  
 11.45—BBC Welsh Orchestra.  
 12.30—The Rt. Hon. Margaret Bondfield.  
 12.45—"London Log."\*  
 12.55—"For the Children."  
 13.25—News. 13.50-14.05—The Manchester November Handicap: running commentary.  
 Transmission 3 (GSJ [until 15.30 G.M.T.], GSD [from 15.45 G.M.T.], GSH, GSG, GSF).  
 14.25—"Chu Chin Chow": a musical tale of the East.\*  
 15.30—The Hawaiian Islanders.\*  
 15.45—Royal Tennis: broadcast from King Henry VIII's court.\*  
 16.00—Big Ben; News.  
 16.20-17.00—Kentucky Minstrels.  
 Transmission 4 (17.20-21.00 GSG, GSP from 18.45, GSI, GSD, GSB; 21.15-23.00 GSO, GSD, GSD, GSB).  
 17.20—"London Log."\*  
 17.30—Henry Hall's Orchestra.  
 18.00—Big Ben; News.  
 18.25—The Manchester November Handicap: running commentary.\*  
 18.40—Band; Tenor.  
 19.20—The Adventures of Shorty and Conky in "Fishing."\*  
 19.30—"In Town Tonight."  
 20.00-21.00—Variety.  
 21.15—Big Ben; News.  
 21.40—"A Wisp of Lace": a play with music.\*  
 22.15—Gilbert and Sullivan Opera selection.†  
 22.30-23.00—Dance Music.  
 Transmission 5 (GSD, GSD, GSC, GSB).  
 23.20—Variety.\*

00.20—"Sportsmen Talking": "Dixie" Dean, Ivan Sharpe.\*  
 00.35—Musical Interlude.†  
 00.40—News. 01.00—Big Ben.  
 01.05—The Manchester November Handicap: running commentary.\*  
 01.20-01.30—"Tunes to Remember."  
 Transmission 6 (GSD, GSC, GSG, GSB).  
 02.00—Big Ben; "In Town Tonight."  
 02.30—Van Straten Dance Band.  
 03.10—News. 03.30—Big Ben.  
 03.35—Lance Fairfax (Baritone).  
 03.50-04.00—Shorty and Conky in "A Day's Fishing."\*  
**BOUND BROOK (W3XAL)** 17.78 mc/s (16.87 m.); 6.10 mc/s (49.18 m.).  
 (16.87 m.) 14.00—Breakfast Club—Bob Brown, Master of Ceremonies; Annette King (Contralto); Jack Baker (Baritone); Vagabonds, Negro Male Quartet.  
 14.45—News; Variety.  
 17.00—News (Fr.).  
 17.15—Three Marshalls.  
 18.00—News (Ger.); Music.  
 19.00—News (It.); Music.  
 20.00—News (Fr.).  
 20.30—Ricardo's Caballeros.  
 21.00—News (Ger.); Music.  
 22.00—News; Variety.  
 22.30—News (Fr., Ger.).  
 23.30—News.  
 00.00-02.00—For South America: News; Variety.  
 (49.18 m.) 02.30-06.00—For South America. 02.30—Music.  
 03.00—News (Sp.); Music.  
**BUDAPEST (HAS3)** 15.37 mc/s (19.52 m.); (HAT4) 9.12 mc/s (32.88 m.).  
 (32.88 m.) 23.00-00.00—"Cello Concerto (Dohnányi); News; Music; Reading.  
**HUIZEN (PHI)** 17.77 mc/s (16.88 m.); 11.73 mc/s (25.57 m.). (16.88 m.)—For the Dutch Indies.  
 13.25—Stocks; Music; Talk.  
 14.15—Film Cocktail 1937.  
 14.30—Music; Talks; News.  
 15.30-15.40—News.  
**LYNDHURST (VK3LR)** 9.58 mc/s (31.32 m.).  
 02.35—Music; News.  
 03.15-07.30—Racing; Records.  
 08.30—Talks; Mail.  
 09.20—News.  
 10.00—Musical Comedy.  
 11.00—Pfte.; Play; Band.  
 11.30—A Play.  
 12.30-14.00—News; Dancing.  
**MOSCOW (RNE)** 12.00 mc/s (25 m.); (RAN) 9.60 mc/s (31.26 m.); (RKI) 7.54 mc/s (39.79 m.).  
 (25 m.) 11.00—For Germany.  
 (25 m. and 39.79 m.) 17.15 — For Germany.  
 (25 m.) 20.00—For Italy.  
 20.30—For Germany.  
 21.00—For France.  
 22.00—For Spain.  
 (31.26 m.) 23.00—For Spain.  
 (31.26 m. and 39.79 m.) 00.00 — For England.  
 (25 m.) 01.30—For France.  
 03.15—For England.  
**PARIS (Radio-Colonial) (TPA2)**, 15.24 mc/s (19.69 m.); (TPA3), 11.89 mc/s (25.23 m.); (TPA4), 11.72 mc/s (25.6 m.).  
 (25.23 m.) 17.15—News; Exchange.  
 17.45—News (Arabic); Concert.  
 18.50—Talk; News.  
 20.10—News (Eng., It.).  
 20.30—To be announced.  
 22.80—Markets; News (Port.). (25.6 m.) 23.15—Concert.  
 00.15—News (Fr., Sp., Port.).  
 01.00—Talk.  
 03.00—Records.  
 04.00—News.  
 04.30—News (Eng.); Records.  
 05.45-06.00—News (Ger.).  
**PITTSBURGH (W8XK)**, 21.54 mc/s (13.93 m.); 15.21 mc/s (19.72 m.); 11.87 mc/s (25.27 m.); 6.14 mc/s (48.86 m.).  
 (19.72 m.) 14.00—Variety.  
 17.00—News; Novelties.  
 17.30—Farm and Home; Clubs.  
 18.45—Football Game.  
 23.00—News; Variety.  
 (25.27 m.) 00.00—Message of Israel.  
 00.30—Uncle Jim; Music.  
 02.00—National Barn Dance.  
 (48.86 m.) 03.00—NBC Symphony Orchestra.  
 04.30—News; Music.  
 05.30-06.00—Far North Messages.  
**PODEBRADY (OLR)**, 15.23 mc/s (19.70 m.); 11.84 mc/s (25.34 m.); 9.55 mc/s (31.41 m.); 6.01 mc/s (49.92 m.).  
 (25.34 m.) 19.00—News.  
 (31.41 m.) 19.30—News; Waltzes.

20.00—News (Eng.); Organ.  
 20.20—News (Ger.); Variety.  
 21.00—News (Fr.).  
 21.05-21.30—Beethoven.  
**ROME**, 11.81 mc/s (25.4 m.).  
 13.20—News; Violin; Talk.  
 14.00-15.30—News (Eng.); Programme in Hindustani.  
 16.20—News; "Andrea Chenier" (Giordano).  
 17.30—Music; News (Arabic).  
 17.50—News (Turkish).  
 18.08—News (Ger.).  
 18.26-19.00—News (Eng., Fr.).  
 23.00—U.S.A. Bulletin.  
 23.20—For South America: Call (It., Sp., Port.); News; Music; News (Sp., Port.).  
**SCHENECTADY (W2XAD)**, 15.33 mc/s (19.57 m.); (W2XAF), 9.53 mc/s (31.48 m.).  
 (19.57 m.) 16.00—Forum; Variety.  
 (19.57 m. and 31.48 m.) 17.00—Continental.  
 17.30—Farm Programme; Variety.  
 19.00—Buffalo; Music.  
 19.45—Football Game; Variety.  
 23.00—El Chico, Spanish Revue.  
 23.30—News; Songs, etc.  
 00.00—Top Hatters.  
 00.30—Stocks.  
 01.00—Ripley; Log Cabin.  
 (31.48 m.) 02.00—Orchestra.  
 02.30—"Special Delivery."  
 03.00—NBC Symphony Orchestra.  
 04.30-05.00—Orchestra.  
**TOKIO (JZK)**, 15.16 mc/s (19.79 m.); (JZJ), 11.80 mc/s (25.42 m.).  
 (For Europe).  
 20.00—News (Eng.); Variety.  
 20.30-21.00—News (Ger., Fr.).  
**VATICAN CITY (HVJ)**, 15.12 mc/s (19.84 m.); 5.97 mc/s (50.26 m.).  
 (19.84 m.) 15.30—Notes (It.).  
 (50.26 m.) 19.00—Notes (Dutch).  
**WARSAW (SPW)**, 13.63 mc/s (22 m.).  
 23.00-02.00—News (Pol., Eng.); Songs; For Women; Music.  
**WAYNE (W2XE)**, 21.52 mc/s (13.94 m.); 17.76 mc/s (16.89 m.); 15.27 mc/s (19.65 m.).  
 (13.94 m.) 12.30—Organ.  
 14.00—Ray Block (Pfte.).  
 14.15—Variety.  
 16.00—Cincinnati Conservatoire.  
 (19.65 m.) 19.30—To be announced.  
 20.30—Waltzes of the World.  
 (16.89 m.) 23.30—Eddie Dooley's Last Minute Football News.  
 23.45-01.00—Syncopation Piece.  
 01.30—Variety.  
 03.00—Your Hit Parade.  
 03.45-05.00—Songs; Orchestra.  
**ZEESEN (DJA)**, 9.56 mc/s (31.38 m.); (DJB), 15.20 mc/s (19.74 m.); (DJE), 17.76 mc/s (16.89 m.); (DJN), 9.54 mc/s (31.45 m.); (DJQ), 15.28 mc/s (19.63 m.).  
**On all Wavelengths.**  
 05.05—Call (Ger., Eng.); Music.  
 06.00—News; Concert.  
 07.00—News (Eng.); Talk; Band.  
 08.45—Pfte. Concerto (Beethoven).  
 09.15—Baritone; News; Talk.  
 10.00—Dance and Light Music.  
 12.00—News (Eng.); Music.  
 13.00—News; Variety.  
 14.00—News (Eng., Dutch); Talk.  
 14.30—Variety.  
 15.45—Talk.  
**ZEESEN (DJD)**, 11.77 mc/s (25.49 m.); (DJE), 15.11 mc/s (19.74 m.); (DJC), 6.02 mc/s (49.83 m.).  
**On all Wavelengths.**  
 15.40—Call (Ger., Eng.); Music.  
 16.15—"The Spinning Room."  
 16.50—Concert.  
 17.15—News; Talk.  
 17.45—"The Lovely Galatea" (Suppé).  
 19.00—News (Eng.); Topical.  
 19.30—Music Report.  
 19.45—Club of Notions.  
 21.00—News (Ger., Eng.).  
**ZEESEN (DJD)**, 11.77 mc/s (25.49 m.); (DJB), 15.20 mc/s (19.74 m.); (DJC), 6.02 mc/s (49.83 m.).  
**On all Wavelengths.**  
 21.50—Call (Ger., Eng.).  
 22.00—Operetta Concert.  
 22.45—News; Music.  
 23.00—Concert.  
 00.15—Topical.  
 00.30—In Praise of Friendship.  
 01.15—News (Eng.); Music; Talk.  
 02.00—News; Club of Notions.  
 03.30—News (Eng., Ger.).

# Long and Medium Wave Programmes

## NATIONAL

**Time Signals:** Big Ben, 12.30, 10.45 p.m. Greenwich, 10.30 a.m., 4.0, 9.0 p.m. D = Droitwich.  
**9.25-10.15 a.m. (D)**—Service (C. of E.).  
**10.30-10.45 (D)**—Weather Forecast.  
**12.30 p.m. (D)**—BBC Military Band: Tom Williams (Baritone).  
**1.30 (D)**—Willie Walker Octet.  
**2.0 (D)**—Gardening talk.  
**2.20 (D)**—Records: Act II, "Don Pasquale" (Donizetti).  
**3.0 (D)**—Tchaikovsky: BBC Orchestra (Section E), conducted by Constant Lambert; Nicolai Graudan ("Cello").  
**4.0**—Talk: "The Influence of Christianity on Art." 4.20—Quintet.  
**5.0**—"Popular Fallacies about the Christian Faith: " The Rev. Donald O. Soper, Ph.D.  
**5.20**—Margaret Godley (Soprano); Bradbridge White (Tenor); Stanley Riley (Bass); Griller String Quartet.  
**6.15**—The Cinema. 6.30—Brass Quintet.  
**6.50**—Songs and Duets from famous operettas. 7.55—Service (C. of E.).  
**8.45**—Appeal. 8.50—News.  
**9.5**—Carol Goodner in "Daisy Miller," a Study by Henry James.  
**10.30**—Epilogue.

## REGIONAL

**Time Signals:** Big Ben, 12.30, 10.45 p.m. Greenwich, 4.0, 9.0 p.m.  
**12.30 p.m. (ex. Midland, Western)**—National.  
**2.0 (Scottish)**—Short Story.  
**2.20 (Scottish)**—National.  
**4.0 (ex. Welsh)**—Bronkhurst Trio.  
**4.0 (Welsh)**—Percy Turnbull (Pfte.).  
**4.20**—"Music of the Week: " Sir Adrian Boult, Director of Music.  
**4.30 (ex. Welsh)**—For the Children.  
**4.30 (Welsh)**—Welsh talk.  
**4.50 (Welsh)**—"Praise Our God" (Bach); "Spring"—The Seasons—(Haydn).  
**5.0 (ex. Midland, Northern, Welsh)**—Richard Crean Orchestra.  
**5.0 (Midland, Northern)**—Theatre Orchestra.  
**5.45 (ex. Welsh, N. Ireland, Scottish)**—Short story.  
**5.45 (N. Ireland)**—"Houses of Ulster."  
**5.45 (Scottish)**—"Am I My Brother's Keeper?" Lord Wark.  
**5.50 (Welsh)**—Records.  
**6.0 (N. Ireland)**—Orchestra.  
**6.5 (ex. Northern, Western, N. Ireland)**—BBC Men's Chorus: Harold Williams (Baritone).  
**6.5 (Northern)**—Male Voice Choir.  
**6.5 (Western)**—Records: Selection from Act I, "Fedora" (Giordano).  
**6.30 (ex. Western, N. Ireland)**—BBC Orchestra (Section D), conducted by Pau Casals.  
**6.30 (Western)**—"Doctor Knock:" a Comedy by Jules Romains.  
**6.55 (N. Ireland)**—Service (C. of Ireland).  
**7.55 (Regional, N. Ireland, 8.0)**—Services.  
**8.45**—Appeals. 8.50—News.  
**9.5 (ex. Western)**—"Melodies of Christendom:" BBC Singers.  
**9.5 (Western)**—Carolare.  
**9.35 (ex. Northern, Welsh)**—Leslie Jeffries and Orchestra.  
**9.35 (Northern)**—Merseyside Symphony Orchestra, conducted by Albert Coates: Vera de Villiers (Contralto).  
**9.35 (Welsh)**—"Welsh Elegies."  
**9.55 (Welsh)**—Margaret Tann-Williams (Contralto); Beatrice Botterill (Harp).  
**10.30**—Epilogue.

Hours of Transmission in Greenwich Mean Time.

## ALPES-GRENOBLE (PTT) (France)

583 kc/s (514.6 m.); 20 kW.  
 Transmits at intervals from 7.0 a.m.  
**5.30 p.m.**—Station Orchestra. Overture, "Silvana" (Weber). Tales from the Vienna Woods (Strauss). Minuet (Bolzoni). Serbian Dance (Colin). Tournoi (Boëllmann). Ronde de nuit (Boëllmann). Selection, "Thérèse" (Massenet). Trianon Suite (Lachaume).  
**6.30**—Songs from Marseilles (PTT).  
**7.0-8.15**—See Paris (Radio-Paris).  
**8.15**—Sports; Records.  
**8.30**—See Paris (PTT).

## ATHLONE (Ireland)

565 kc/s (531 m.); 100 kW.  
 Relayed by Dublin, 1,348 kc/s (222.6 m.); and Cork, 1,235 kc/s (242.9 m.).  
**1.30-3.0 p.m.**—Records.  
**5.30**—Concert from the Regal Cinema, Ringsend.  
**6.0**—Programme from Cloinhin an Mhargaidh, compered by Pdraig O'Morain.  
**6.35**—The Last of the Kings, No. 6, by Denis Carey, produced by May Carey.  
**7.15**—First Performance of New Organ Compositions from the Methodist Church, St. Stephen's Green, Dublin. Renée Flynn (Soprano) and Thomas Attwooll (Baritone).  
**8.0**—Sports Review by J. L. Brennan.  
**8.10**—An Ceol Cumann presents a Programme of Irish Orchestral Works by Eamonn O Gallcobhair with the Irish Radio Orchestra and Michael O'Higgins (Baritone).  
**9.10**—Catholicism and the Arts and Sciences, No. 4—Economics and Catholicism by the Rev. Dr. Arthur H. Ryan.  
**9.30**—Variety Programme.  
**10.30**—News.  
**10.50**—Gaelic Sports Talk by Sean O'Ceallachain.  
**11.0**—National Anthem.

## BERLIN (Germany)

841 kc/s (356.7 m.); 100 kW.  
**5.0 a.m.**—Call; Weather; Gym.  
**5.30-7.0**—Concert from Hamburg.  
**7.0**—Gym; Records.  
**7.55**—Chimes and Service from Potsdam Garrison Church.  
**8.30**—Faith is Nothing without Sacrifice—A Sunday Programme.  
**9.0**—Weather.  
**9.5**—Light Music. Raatzke Quintet, Erwin Hansche and Max Nahrath (Two Pftes.).  
**10.15**—See Leipzig.  
**11.0**—Station Orchestra. Conductor: Willy Steiner. Saal (Harp), Sala (Trautonium), Schröder (Harpsichord and Pfte.), Steiner (Violin), Rockstroh and Gottschalk (Two Pftes.). Overture, "Martha" (Flotow). Serenade (Haydn). Harp: Prelude (Bitner). Träumerei (Schumann). Liebestraum (Damp). Fantasia on Two Pftes. (Schubert). Album Leaf (de Micheli). Consolation (Liszt). Selection, "Die toten Augen" (d'Albert). Harp: Adagio (Horn). Ideale (Tosti).  
**12.15 p.m.**—Orchestra, etc. (contd.). Prelude (Rachmaninov). Meditation (Bach-Gounod). Largo (Tartini). Introduction and Bass Solo (Gailard). Allemande (Corelli). Albumblatt (Reger). Sarabande and Tambourin (Leclair). None but the

# NOVEMBER 21 SUNDAY

## Services and Sacred Music

**A.M.**  
**9.0** Kalundborg: Service.  
**10.0** Italian stations: Mass.  
**10.15** Leipzig: Bach Cantatas.  
**P.M.**  
**4.5** Stockholm: Evensong.  
**5.30** Hilversum (1,875 m.): Service.

weary Heart (Tchaikovsky). La Serenata (Braga). Harp: Acolsharfe (Hasselmann). Episode (Steiner). Violin: Minuet (Mozart). Die Uhr (Loewe). Intermezzo (Mascagni).  
**1.0**—Records.  
**2.0**—Raatzke Quintet.  
**2.30**—Records.  
**3.0**—Light Classical Music from Saarbrücken.  
**5.0**—"Der Tod des Malers Matthias Grünewald" (The Death of the Painter, Matthias Grünewald) (Rehberg) (Recorded).  
**5.30**—Chamber Music Records.  
**6.0**—News; Sports.  
**6.25**—Raatzke Quintet.  
**7.0**—Station Orchestra. Conductor: Heinrich Steiner. Domgraf-Fassbaender, Carl Steiner (Violin), Schröder (Flute), Schulz (Flute). Overture, "Don Giovanni" (Mozart). Baritone Arias (Mozart): (a) Serenade, "Don Giovanni," (b) Aria, "Figaro." Concertino for Two Flutes and Orchestra (Cimarosa). Baritone Aria from "Der Wildschütz" (Lortzing). Violin Concerto in G minor (Bruch). Overture, "William Tell" (Rossini). Baritone Aria from "Il Trovatore" (Verdi). Concert Overture, "Romeo and Juliet" (Tchaikovsky).  
**9.0**—News; Sports.  
**9.30-11.0**—See Deutschlandsender.

## BEROMÜNSTER (Switzerland)

556 kc/s (539.6 m.); 100 kW. Relayed by Basle and Berne, 1,375 kc/s (218.2 m.).  
**9.0 a.m.**—Roman Catholic Service.  
**9.45**—Jenny Deuber Trio.  
**10.30**—The Book of Tobias.  
**11.0**—French Music—Radio Orchestra. Conductor: Hofmann.  
**11.30**—News.  
**11.40**—Opera and Viennese Music—Radio Orchestra. Conductor: Hofmann.  
**12.30-2.0 p.m.**—Programme from Basle.  
**12.30**—Swiss Dialect Songs.  
**1.0**—Dialect Reading.  
**1.25-2.0**—Records.  
**4.0**—Tchaikovsky Records.  
**4.25**—Schubert Concert by the Cecilia Society of St. Clara's Church.  
**5.0**—Talk: The Modern Drama.  
**5.20**—Chamber Music.  
**6.0**—Acts I and II, "The Valkyrie" (Wagner), from Zürich Municipal Theatre; News in the interval.  
**9.15 (approx.)**—Records.  
**9.25-9.30**—Announcements.

## BRATISLAVA (Czechoslovakia)

1,004 kc/s (298.8 m.); 13.5 kW.  
**5.45-7.45 a.m.**—See Prague.  
**7.45**—Meditation.  
**8.0**—High Mass.  
**9.0**—Roman Catholic Address.  
**9.15**—Yugoslav Music—Maria Perslová (Songs) and Fuchsová (Pfte.).  
**9.40**—Discussion and Reading: Rudolf Dilong.  
**10.15 a.m.-12.50 p.m.**—See Prague.

**12.50**—For Farmers (Hungarian).  
**1.5**—Record; For Workers.  
**1.25**—Water Level.  
**1.30-4.35**—See Prague.  
**4.35**—"Technical Progress"—One-Act Play (Lörincz. trans. Borská).  
**5.0**—Hungarian transmission: Talk; Moszi Cigány Band.  
**5.45**—Sports.  
**5.50-6.10**—See Prague.  
**6.10**—Talk from Kosice.  
**6.25**—Marches and Waltzes—Orchestra, from Kosice.  
**7.25**—One-Act Play (Dumas, Père), from Kosice.  
**8.10-9.20**—See Prague.  
**9.20**—News (Hungarian).  
**9.35-10.30**—Orchestral Serenade. Conductor: Dyk.

## BRESLAU (Germany)

950 kc/s (315.8 m.); 100 kW. Relayed by Gleiwitz and Görlitz, 1,231 kc/s (243.7 m.).  
**5.0-7.0 a.m.**—See Hamburg.  
**7.0**—Silesian Greetings.  
**7.10**—Records.  
**7.50**—News; Greetings.  
**8.0**—Service.  
**8.30**—Rossander (Violin), Pischner (Harpsichord).  
**9.5**—Records.  
**9.40**—Sequence in Memory of German Poets who fell in the Great War (Speth).  
**10.10**—Old German Folk Songs by Moser (Baritone).  
**10.55**—Weather.  
**11.0 (from Gleiwitz)**—Orchestra. Conductor: Peter.  
**1.0 p.m.**—Announcements.  
**1.10**—Once upon a time...—Reading (Recorded).  
**1.30**—Voices now Silent—Sequence (Sonnabend).  
**2.30**—Hans Brandenburg reads.  
**3.0**—Station Orchestra. Conductor: Prade. Greulich (Cello), Bertermann (Baritone), Hattwig (Pfte.). Overture, "Tannhäuser" (Wagner). Siegfried Idyll (Wagner). Cello and Orchestra: Rococo Variations (Tchaikovsky). Das Wunder am Meer—Song Cycle (Brust). Romantic Fantasia (Graener). Serenade (Trunk).  
**4.45**—"Farewell to Life"—Sequence (Close). Bertermann (Baritone), Hattwig (Pfte.) and the Station Dramatic Troupe.  
**5.30**—Report (Recorded): Second Half of the Football Match, Germany v. Sweden, at Altona.  
**6.0**—News.  
**6.10 (from Görlitz)**—Wenzel (Organ), from St. Peter's Church. Passamezzo-Variationen (Scheidt). Three Choral Preludes (Wenzel). Ciaconna (Richter). Prelude and Fugue in B minor (Bach).  
**6.55**—Trio in G (Haydn). Trio in B flat (Schubert), by the Hattwig Trio.  
**7.45 (from Görlitz)**—"Lobgesang des Lebens" (In Praise of Life)—Radio Cantata (Margarete Koch), Music by Koschinsky. Görlitz Theatre Orchestra and Folk Choir. Conductor: Schartner. Irene Lucius (Soprano), Petersen (Tenor).  
**9.0**—News; Sports.  
**9.30-11.0**—See Deutschlandsender.

## BRNO (Czechoslovakia)

922 kc/s (325.4 m.); 32 kW.  
**5.45-7.45 a.m.**—See Prague.  
**7.45**—See Bratislava.  
**8.0**—See Prague.

## SUNDAY (November 21)

- 8.35—For Workers.  
8.55—See Prague.  
9.10—Marie Dvoraková (Pfte.). Barcarolle (Bendel). Love Songs (Suk). Concert Etude in F sharp (Friml).  
9.30—Records.  
9.40 a.m.—12.50 p.m.—See Prague.  
12.50—For Farmers.  
1.5—For Farmers (Germañ).  
1.30-4.35—See Prague.  
4.35—German Transmission: Choir, Vocal Quartet, etc.  
5.50-6.10—See Prague.  
6.10—To be announced.  
6.25-9.35—See Prague.  
9.35-10.30—See Bratislava.

## BRUSSELS (No. 1) (Belgium)

- 620 kc/s (483.9 m.); 15 kW.  
6.30-9.2 a.m.—Records; Gym; News.  
9.2—Request Records.  
10.0—Germaine Marville (Old French Songs).  
10.15—Records and Yvan Fadel (Entertainer).  
10.45—Pfte. Records. Etudes (Czerny). Sonatina (Gurlitt). Caprice (De Boeck).  
11.0—Loiseau Orchestra. Marche militaire française (Saint-Saëns). Selection, "The Merry Wives of Windsor" (Nicolai). Selection, "Louise" (Charpentier). Selection, "New Moon" (Romborg). Babillage (Gillet). Hymne à Sainte-Cécile (Gounod). Fête romaine (Fourdrain). Sambre et Meuse (Planquette).  
12.0 noon—Time; Records.  
12.15 p.m.—"Cambriolage à l'amiable"—Sketch (Lauville).  
12.25—Record: Kol Nidrei (Bruch), by Cassado (Cello).  
12.30 p.m.—Shipping; Radio Orchestra. Conductor: Gason.  
1.0—News; Orchestra (contd.).  
1.35—Art Notes; For Farmers; Record.  
2.5-2.15—Dialect Programme.  
2.30—Burton Musette Ensemble.  
3.0—Symphony Concert from Charleroi Conservatoire. Uninsky (Pfte.). Concerto grosso (Corelli). Concerto in B flat minor (Tchaikovsky). The Swan of Tuonela (Sibelius). Pieces (Chopin): (a) Nocturne in C minor, (b) Two Etudes in G flat, (c) Polonaise in A flat. Symphony in D minor (Franck).  
5.0—Records: "Falstaff" (Verdi). In the interval, Football Results.  
6.0—For Youth.  
7.0—Religious Address by the Rev. Fr. Draime.  
7.15—Records.  
7.30—News; Topical.  
8.0—Variety, with the Radio Orchestra, etc. Conductor: Gason. Excerpts, "Paris" (Haydn Wood) and "Manon" (Massenet). "La Farce du cordonnier"—Play (Rosenfeld). Spanish Songs (Nin). Humorous Records. Mixed Choir and Pfte.: German Dances (Schubert). Scenes, "La Porteuse de Pain" (Montépín-Dornay). Overture, "William Tell" (Rossini). Popular Choruses. Rhapsody in Blue (Gershwin). Recitations. Polonaise, "Le roi malgré lui" (Chabrier).  
10.0—News; Topical.  
10.10—Brenders Dance Band.  
11.0-12.0 m't.—Records.

## BRUSSELS (No. 2) (Belgium)

- 932 kc/s (321.9 m.); 15 kW.  
Programme in Flemish.  
6.30-9.5 a.m.—Records; Gym; News.  
9.5—Ketélbey Records.  
9.30—Talk by Paul Collaer, with Records: The Evolution of the Orchestra.  
10.15—Vaes (Cinema Organ).

- 11.0—Carillon Recital by Denijn and Nees, from Malines Cathedral. Cecillialied (Denijn). Leggiera (Fiocco). Tambourin (Rameau). Ballad, "Geneviève de Brabant" (Candaël). Serenade (Thomé). Le sacristain de Wambeek (Van Beers). Romanesca (Herrmann).  
11.30—Sonatas by Rosa Granjé (Pfte.) and Nuyts (Cello). Sonata in G (Bach). Sonata in G minor (Eccles).  
11.50—Review of Reviews.  
12.0 noon—Records: Vocal and Instrumental Duets.  
12.31 p.m.—Salon Orchestra. Conductor: Féron.  
1.0—News.  
1.10—Brenders Dance Band.  
1.30-2.0—Records: Light Music.  
2.15—Request Records.  
2.40—Broeckx (Pfte.). Sonata appassionata (Beethoven). Nocturne in D flat (Fauré). Fandango, "Goyescas" (Granados).  
3.15—The Blind Accordionists' Club of Antwerp. In the interval, Records.  
3.50—"Goose"—Sketch (Mostkova-Lamblot) after Avertchenko.  
4.0—Jozef Schuy (Flemish Songs).  
4.30—For Children.  
5.15—Records: Dichterliebe (Schumann) by Charles Panzera. In the interval, Football Results.  
5.45—Chamber Music by the Belgian Pfte. Quartet. Sonata (Loeillet). Quartet in C minor (Brahms).  
6.45—Religious Address by the Abbé Eiebaers.  
7.0—Salon Orchestra. Conductor: Féron. Madeleine De Beurme (Songs). Kamarinskaya (Glinka). Songs (Benoit): (a) Heeft het roosje milde geuren, (b) Denderliedeken. Turkish March (Mozart). Patrouille nocturne (Boëllmann). Songs: (a) Lentelust (Lebrun), (b) Een droom (Verhoeven). Spanish Dance (Granados).  
7.30—Film Review; Report: The Brussels Amateur Theatrical Congress.  
8.0—Variety. Orchestra. Conductor: Walpot. Polly and Louis Noiret (Dutch Duo). I.N.R. Mixed Choir, etc.  
8.45—A Circus Artist at the Microphone.  
9.0—Variety (contd.).  
10.0—News.  
10.10—Records. Overture, "Undine" (Lortzing). Concerto in C minor (Beethoven). Excerpts, "Iberia" (Albéniz). Islamey (Balakirev-Casella).  
11.15-12.0 m't.—Brenders Dance Band.

## BUCHAREST (Romania)

- 823 kc/s (364.5 m.); 12 kW.  
Relayed by Radio-Romania, 160 kc/s (1,875 m.).  
5.30-6.30 a.m.—To be announced.  
7.55—Chimes; Service; Address.  
11.0—Time; News; Water Level.  
11.10—Christea Orchestra.  
12.10 p.m.—News; Orchestra; Variety.  
1.0-2.0—For Peasants.  
4.0—Time; Military Band; Talk.  
5.15—Dance Music by the Radio Salon Orchestra. Conductor: Bobesco.  
6.55—A Play.  
8.0—News; Topical.  
8.10—Radio Orchestra, Conductor: Rogalski; Stroesco (Duparc and Debussy Songs).  
8.30—Sports Report.  
8.45-10.0—Orchestra, etc. (contd.).

## BUDAPEST (No. 1) (Hungary)

- 546 kc/s (549.5 m.); 120 kW.  
8.30 a.m.—News.  
9.0—Protestant Service.  
10.0—Roman Catholic Service.  
11.30—Opera Orchestra. Conductor: Fridl. Overture, "Sakuntala" (Goldmark). Viora-Walzer (Szabados). Hungarian Suite (Országh). Variations (Buttykay). Serenade (Weiner); at 12.10 p.m.—Talk.  
1.0—Records.  
2.0—For Farmers.  
2.45—Orchestra. Conductor: Eördögh.  
3.30—Talk.  
4.0—Ráduly (Cello), with the Bura Cigány Band.  
4.50—Reading, "Tod in Schönbrunn" (Akos Bakos).  
5.30—Ferenc Hochstrasser (Flute).  
5.45—Programme by Arpad Latabár.  
6.20—Maria Budanovits (Songs).  
6.50—Sports.  
7.0—"Verlobung am Andreas Tag"—Comedy (Dezso Urai), with the University Vocal Quartet and the Budapest Concert Orchestra. Conductor Polgár.  
8.20—News.  
8.40—Station Orchestra. Conductor: Bertha. Overture, "Le cheval de bronze" (Auber). Serbian Song (Gál). Waltz, Fata Morgana (Dinzi). Operetta Potpourri (Szirmai). Kleiner Walzer (Schwalb). Melody (Rubinstein). Selection, "La Rondine" (Puccini).  
10.0—Lantos Dance Band from the Hotel Britannia.  
11.5—News.



Fraulein Edith Scholz, announcer at Hamburg

## BUDAPEST (No. 2) (Hungary)

- 359.5 kc/s (834.5 m.); 18 kW.  
10.30 a.m.—Farkas Cigány Band.  
2.0 p.m.—Post Office Band. Conductor: Eördögh.  
3.35—Raduly (Cello).  
4.55—Hochstrasser (Flute).  
5.20—Talk.  
5.50—Records.  
6.20—Dr. István Bory.  
7.0—News.  
7.35—Programme by the "Soli Deo Gloria" Students' Society.

## COLOGNE (Germany)

- 658 kc/s (455.9 m.); 100 kW.  
5.0 a.m.—See Hamburg.  
7.0—Weather; Water Level.  
7.5—Reading (Adalbert Stifter).  
7.15—Ottersbach Trio, Elisabeth Delseit (Soprano) and Edmund Kirst (Pfte.).  
8.0—Reading (Gerstner).  
8.30—Records.  
9.55—A Visit to the Old Cemetery in Bonn.  
10.15—See Leipzig.  
11.0—See Berlin.

- 1.0 p.m.—Baroque Music. Paul Heltinger (Oboe) and Adelheid Kroeber (Harpsichord).  
1.30—Hints for Everyone.  
2.5—See Hamburg.

- 3.0—Light Classical Music from Saarbrücken.  
5.0—"The Silent Greeting"—Play (Brües).  
6.0—News; Sunday Review.  
6.30—"Es geht eine dunkle Wolk' herein."  
7.5—Prisca Quartet and Else Schmitz-Gohr (Pfte.). String Quartet in F (Beethoven). Pfte. Quintet in A (Schumann).  
8.0—"Wirket, solanges es tag ist!"—Cantata (Bungert). Station Choir and Orchestra. Conductor: Schulz-Dornburg. Heinrich Blasel (Bari-tone). Gisela Derpsch (Soprano). Anni Bernards (Contralto). Ludwig Matern (Tenor). Siegfried Tappolet (Bass).  
9.0—News.  
9.30-11.0—See Deutschlandsender.

## DEUTSCHLANDSENDER (Germany)

- 191 kc/s (1,571 m.); 60 kW.  
5.0 a.m.—See Hamburg.  
7.0—Weather; Records.  
7.20—A Visit to the "Roter Ochs," Sassenfeld.  
8.0—Classical Music. Wilhelm Strienz (Bass). Armin Lutz (Violin). Kurt Hosemann (Cello). Herbert Jäger (Pfte.). Helma Elsner (Harpsichord).  
9.0—Address and Music.  
9.45—French Opera Records.  
10.15—Weather.  
10.30—Horst Schimmelpfennig (Wurlitzer Organ), from the Ufa-Palast, Hamburg.  
11.0—Records.  
12.0 noon—Greetings.  
12.10 p.m.—Music from Munich.  
1.0—"Falada"—Play after Grimm (Wollmann).  
1.30—Polish Folk Music (Recorded).  
2.5—See Hamburg.  
3.0—Beautiful Melodies. Station Orchestra. Conductor: Dobrindt.  
5.0—Forgotten Voices—Sequence (Krug) with Records.  
6.0—Motto; News.  
6.10—Light Music. Herbert Harum (Pfte.). Michael Danzi (Guitar). Anna Tassopoulou (Songs).  
6.45—Sports.  
7.0—Station Orchestra. Conductor: Stange. Maria Milkowa-Zolotowitsch (Soprano), Oskar Schmidt (Violin). Overture, "Oberon" (Weber). Arias, "The Magic Flute" (Mozart). Violin Concerto in D (Brahms).  
8.0—Baron von Gablenz, Director of Lufthansa, tells of his flight to the Far East.  
8.30—The Unfinished Symphony in B minor (Schubert) by the Station Orchestra. Conductor: Stange.  
9.0—News; Announcements.  
9.30-11.0—Serenade. Rambuor Band. Records of Horst Schimmelpfennig (Wurlitzer Organ); at 9.45—Weather.

## FRANKFURT (Germany)

- 1,195 kc/s (251 m.); 25 kW.  
Relayed by Cassel, Coblenz, Freiburg and Trier, 1,195 kc/s (251 m.).  
5.0 a.m.—See Hamburg.  
7.0—Water Level; Weather.  
7.10—Gym.  
7.30—For Peasants.  
7.45—Paul Kessler (Organ).  
8.0—Service from the Ludwigskirche, Freiburg.  
8.45—Address.  
9.0 (from Cassel)—for Hitler Youth.  
9.30—Songs to the Lute.  
10.15—"The Willow-Tree"—Sequence after Andersen (Straenger) with Music.

11.0—Orchestra and Band from the Rhine-Main Radio Exhibition.  
 1.0 p.m.—See Stuttgart.  
 1.30 (from Cassel)—Schroeder Quartet. String Quartet in A minor (Brahms). Movement in C minor (Schubert).  
 2.5—See Hamburg.  
 3.0—Concert from the Rhine-Main Radio Exhibition. Station Orchestra. Conductor: Frickhoeffer. Rose Stein (Harp). Josef Peischer (Violin). Carl Vöhse (Cello). Otto Plath (Cor anglais). Henny Schmitt (Soprano). Heinz Schröter (Pfte.). Overture, "The Water-Carrier" (Cherubini). Violin and Orchestra: Adagio, In memoriam (Bruch). Poco Adagio and Rondo from the Harp Concerto (Schenk). Overture, "Fierabras" (Schubert). Cor anglais, Harp and Strings: Serenade (Scheimpflug). Orpheus (Liszt). Songs (Schubert). Pfte. Sonata in A minor (Schubert). Songs (Brahms); at 4.0-4.10—A Story.  
 5.0—"Loneliness"—Sequence with Readings from the Works of Goethe, Grabbe, Lenau, and Nietzsche (arr. Eggers).  
 6.0—Time; News.  
 6.10—A German Requiem (Brahms) from the Rhine-Main Radio Exhibition. Station Choir and Orchestra. Conductor: Bruchhaus.  
 6.40—Sports.  
 7.0—"Das Nachtlager in Granada" (Kreutzer), from Constance. Constance Municipal Theatre Choir and Orchestra. Conductor: Merten. Cast: Hedwig Schöning-Weismann, Hans Reinmar, Richard Sengeleitner, Sandeas Schier, Hans Kügel and Jürgen Uloff.  
 9.0—Time; News; Sports.  
 9.30—See Deutschlandsender.  
 11.0 p.m.—12.0 m.t.—Serenade (Records). Les Sirènes (Debussy). Pfte.

Concerto in E flat (Liszt). Symphony in C minor (Brahms).

**HAMBURG (Germany)**

904 kc/s (331.9 m); 100 kW. Relayed by Bremen, Flensburg, Hanover, Magdeburg and Stettin, 1,330 kc/s (225.6 m).  
 5.0 a.m.—Harbour Concert.  
 7.0—News; Talk.  
 7.25—Orchestra from Magdeburg; at 7.35-7.45—Gym.  
 9.0—Programme Notes.  
 9.15—Service from Kiel University Church.  
 10.0—Bruno. Hinze-Reinhold (Pfte.);  
 10.30—Records: Arpeggione Sonata (Schubert).  
 10.45—A Story.  
 11.0—Concert from Magdeburg.  
 1.0 p.m.—"The Lucky Shoes"—Fairy Play (Vetter).  
 1.45—Station Orchestra. Conductor: Dobrindt (Recorded).  
 2.5—Commentary on the Second Half of the International Football Match, Germany v. Sweden, from the Volkspark, Altona.  
 3.0—Light Classical Music from Saarbrücken.  
 5.0—"Vadder Dood"—Dialect Play (Hecker). Music by Tenne.  
 5.45—Choral in E (César Franck) by Gerhard Gregor (Organ).  
 6.0—News.  
 6.10—Willi Althoff (Mandoline and Guitar) and Gregor (Harpsichord). Sonatina in C minor (Beethoven). Adagio in E flat (Beethoven). Suite (Albert).  
 6.30—Sports; Weather.  
 7.0—Fourth People's Concert from the Musikhalle. Station Orchestra. Gerhard Hüsich (Baritone). Overture, "Agrippina" (Handel). Song (Handel). Tragische Ouverture (Brahms). Six Songs (Kilpinen).

**SUNDAY (November 21)**

Fourth Symphony in E flat (Bruckner).  
 9.0—News. 9.30-11.0—See Deutschlandsender.  
**HILVERSUM (1,875 m.) (Holland)**  
 160 kc/s; 10 kW until 2.40 p.m.; 150 kW from 2.40 p.m.  
 8.10 a.m.—KRO Service.  
 9.10—NCRV Programme. Service; Records: Sacred Music.  
 11.55 a.m.-4.40 p.m.—KRO Programme.  
 11.55—KRO Orchestra, Conductor: van 't Woud; at 12.40 p.m.—Talk.  
 1.40—Scripture Lesson.  
 2.10—Records.  
 2.45—KRO Melodists, Conductor: Lustenhouwer, Klein (Songs); at 3.15—Records.  
 4.10—For Invalids.  
 4.35—Sports.  
 4.40-7.25—NCRV Programme.  
 4.40—Sacred Music.  
 5.30—Service; Records: Sacred Music.  
 7.25 till Close—KRO Programme.  
 7.25—Sports; Talk; News; Records.  
 8.10—KRO Orchestra, Conductor: van 't Woud; KRO Boys, Conductor: Lustenhouwer.  
 9.10—Records.  
 9.25—KRO Melodists. Conductor: Lustenhouwer, Klein (Songs), Vos Mendes (Tenor).  
 10.10—News.  
 10.20-10.40—Epilogue.  
**HILVERSUM (301.5 m.) (Holland)**  
 995 kc/s; 15 kW until 6.10 p.m.; 60 kW from 6.10 p.m.  
 8.35-9.40 a.m.—VARA Programme.  
 8.35—Records; News; Talk.

9.10—Records; Talk.  
 9.40-11.40—VPRO Programme.  
 9.40—For Children.  
 10.10—Service.  
 11.40 a.m.-4.40 p.m.—AVRO Programme.  
 11.40—Flentrop (Organ) from the Church at Westzaan.  
 11.50—Film Review.  
 12.15 p.m.—Aeolian Orchestra.  
 12.40—Records: Irish Music.  
 1.10—Aeolian Orchestra.  
 1.40—Book Talk.  
 2.10—Chamber Music. Curtis String Quartet, Max Kloos (Songs).  
 3.45—Palla (Organ).  
 4.5—AVRO Dance Band. Conductor; Mossel.  
 4.35—Sports.  
 4.40—VPRO Talk.  
 5.10-7.40—VARA Programme.  
 5.10—For Children.  
 5.40—Orchestra. Conductor: de Groot.  
 6.10—Sports; News; Records.  
 6.40—"The Lucky Birds," etc. Conductor: Vogel.  
 7.40 till Close Down—AVRO Programme.  
 7.40—Time; News.  
 7.55—Records.  
 8.25—"Inspector Hornleigh investigates" (Priwin).  
 8.45—AVRO Orchestra. Conductor: van Raalte. Thibaud (Violin).  
 9.25—Topical.  
 9.40—"L'Heure exquise." Conductor: van Cappelle. Marguerite Pauquet (Songs).  
 10.10—Palla (Organ), Bruyns (Trumpet), Nina Dolce (Violin), Reverelly (Yodels).  
 10.40—News.

For "Atmospheric Effect" results you must use



**SUPER SENSITIVE TELEPHONES**



If you hope to obtain the very finest and most interesting results from your investigations on the "Atmospheric Effect" you must have Ericsson Super Sensitive Telephones hooked up to your set. Wonderfully sensitive, they will give you astonishing and maximum results. Very comfortable in wear. Wonderfully sensitive and very pure in tone, they have come to be regarded as standard for the keen short-wave enthusiast.

Three Resistances—one price: 120, 2,000 and 4,000 ohms.

**15/-**

At all good radio dealers. If you have any difficulty in procuring, write direct to:

**ERICSSON TELEPHONES, LTD., 22, Lincoln's Inn Fields, London, W.C.2.**

Telephone: 6936 Holborn.

# What Would You

	SUNDAY, Nov. 21	MONDAY, Nov. 22	TUESDAY, Nov. 23
<b>Symphony Concerts Operas</b>	1.35 Prague: "Russalka" (Dvořák). 4.0 Rome, Turin: Guarnieri. 5.15 Radio-Paris: Paris Symphony Orchestra, Schnabel. 6.0 Beromünster: "Die Walküre." 6.10 Frankfurt: Brahms Requiem. 6.30 Regional: Conductor, Casals. 7.0 Frankfurt: "Das Nachtlager." 8.0 Turin: "Andrea Chénier." 8.30 Deutschlandsender: Schubert. 8.30 Radio-Paris: Mendelssohn, etc. 8.45 Hilversum (301.5 m.): Thibaud.	6.20 National: Leslie Heward. 6.25 Vienna: "The Barber of Seville." 6.30 Leipzig: "Black Peter" (opera). 6.35 Prague: Ostrčil opera. 7.10 Hilversum (301.5 m.): "Prince Igor." 8.0 Rome, Turin: Opera music. 8.30 Lyons, etc.: Dvořák's "New World." 8.50 Warsaw: "Fantastique" (Berlioz).	6.10 Deutschlandsender: Bizet, Zilcher, Kodály, Smetana. 7.15 Beromünster: Basle Concert. 7.55 Hilversum (1,875 m.): Orch., 'cello. 7.55 Prague: Brahms, Kálik, etc. 8.0 Rome: "Andrea Chénier." 8.0 Warsaw: Classics. 8.15 Stuttgart: Cantata (Gade). 8.20 Regional: Mass (Bruckner). 8.30 Eiffel Tower: French music. 9.0 Sottens: Mozart programme.
<b>Chamber Music Recitals</b>	4.0 Brussels 2: Folk song. 4.25 Beromünster: Choir (Schubert). 5.45 Brussels 2: Pfte. quartets. 6.10 Breslau: Organ; trios (6.55). 6.30 Leipzig: Rehberg (pfte.). 6.30 Paris (PTT): Choir. 6.35 Vienna: Violoncello. 7.0 Sottens: Pfte., 'cello (Rachmaninoff). 7.5 Cologne: Beethoven, Schumann. 7.15 Athlone: Organ, songs. 8.0 Eiffel Tower: Pfte., song. 9.15 Stockholm: Song, violin, pfte.	4.25 Beromünster: Fauré quartet. 5.15 Strasbourg: Rachmaninoff. 5.25 Hilversum (1,875 m.): Bass, pfte. 6.30 Paris (PTT): Song, 'cello. 7.0 Athlone: Pfte. (Beethoven). 7.30 Regional: Dijon Choir. 7.45 Budapest 1: Segovia (guitar). 8.0 Eiffel Tower: Song, pfte. 8.25 Brno: Viola, pfte. (Juon). 8.40 Cologne: Wolf songs. 9.0 Paris (PTT): Vocal, instr. 9.15 Kalundborg: Old music.	3.55 Hilversum (1,875 m.): Chamber Orchestra. 4.0 Radio-Paris: Song, violin. 4.30 Prague: Chopin. 5.0 Deutschlandsender: Pizzetti. 5.15 Strasbourg: French trios. 5.30 Budapest 1: Soetens (violin). 6.30 Budapest 1: Hungarian songs. 7.5 Stockholm: St. Cecilia Choir. 8.15 Radio-Paris: Quartet, pfte. 9.0 Warsaw: Telmányi (violin). 9.25 Budapest 1: The Roth Quartet. 9.40 National: BBC Theatre Organ.
<b>Plays and Feature Programmes</b>	4.0 Radio-Paris: "L'instinct." 5.0 Cologne: "Der stumme Gruss." 5.0 Vienna: "Viennese Characters of Yesterday and To-day." 7.15 Stuttgart: "Herrgottsdome." 8.30 Paris (PTT): "Le veau gras." 9.15 Kalundborg: "Jungle Voices."	6.10 Deutschlandsender: "November." 8.0 Brussels 1: "Antony and Cleopatra." 8.0 Stuttgart: "Andreas Hofer." 8.30 Strasbourg: Three prize plays. 9.35 National: A Yeats play.	7.0 Munich: "Leonce and Lena." 7.30 Sottens: "Le voyage de M. Perrichon." 8.5 Vienna: "Das Sternlenien." 9.0 Regional: "Berkeley Square." 9.10 Turin group: "La diva." 9.30 Radio-Paris: "Les hommes."
<b>Light Orchestral Bands Operettas</b>	12.30 Radio-Paris: Ibos Orchestra. 2.25 Kalundborg: Lington Band. 3.0 Deutschlandsender: Orchestra. 4.30 Paris (PTT): Francy Orch. 7.0 Berlin: Light classics. 7.0 Leipzig: Potpourri. 7.0 Munich: Opera music. 7.5 Vienna: Operetta music. 7.15 Kalundborg: Opera music. 7.40 Sottens: Orchestra. 7.45 Breslau: "Praise of Life." 8.0 Brussels 1: Light orchestral. 8.0 Rome group: Band concert. 8.10 Athlone: Irish music. 8.10 Hilversum (1,875 m.): Orch. 8.10 Moravská - Ostrava, Prague: Orchestra, violin. 8.20 Kalundborg: Lehár music. 8.30 Strasbourg: Lorraine prog. 8.40 Budapest 1: Radio Orchestra. 9.0 Warsaw: Orch., Marx songs. 9.30 Deutschlandsender: Band. 9.30 Munich: Augsburg Orchestra. 9.35 Bratislava, Prague: Serenade.	1.35 Kalundborg: Radio Orchestra. 3.0 Deutschlandsender: Joost Band. 5.0 Radio-Paris: Cantrelle Orch. 6.10 Berlin: Variety concert. 6.15 Stuttgart: Orch., songs. 6.35 Brno: Operetta Music. 6.55 Beromünster: Mozart. 7.0 Berlin: Danzig-Berlin prog. 7.15 Kalundborg: Lange - Müller. 7.45 Stockholm: Orch., arias. 7.55 Hilversum (1,875 m.): Orch. 8.0 Brussels 2: Dostal operetta. 8.10 Munich: Orch., choir. 8.15 Swiss stations: For Swiss abroad. 8.30 Radio-Paris: "Les mousquetaires au couvent." 9.0 Athlone: John Ireland music. 9.0 Budapest 1: Cigány Band. 9.0 Stockholm: Old time music. 9.30 Cologne, etc.: Serenade, dances. 9.30 Deutschlandsender: Joost Band. 9.45 Hilversum (301.5 m.): Orch. 11.0 Stuttgart, Frankfurt: Serenade.	12.20 Radio-Paris: Giardino Orch. 1.30 Kalundborg: Radio Orchestra. 1.40 Hilversum (301.5 m.): Orch. 3.0 Breslau: Operetta music. 3.0 Deutschlandsender: Orchestra. 4.25 Kalundborg, National (5.0): Preil's Ensemble. 5.20 Sottens: Light French music. 7.0 Frankfurt: Künneke music. 7.0 Warsaw: Light music, dances. 7.10 Hamburg: Variety concert. 7.15 Athlone: Schumann music. 7.30 Monte Ceneri: Flute, strings. 8.0 Berlin: Marches. 8.0 Brussels 1: Young artists. 8.0 Brussels 2: Radio Orchestra. 8.0 Turin group: Light music. 8.30 Paris (PTT): "La fille de Mme. Angot." 8.35 Breslau: Band and choir. 9.0 Stockholm: Light orchestral. 9.10 Hilversum (1,875 m.): Orch. 9.20 Kalundborg: Danish music. 11.0 Frankfurt, Stuttgart: Records.
<b>Talks (including News in English) Commentaries</b>	2.5 Hamburg, etc., Stockholm (1.10): Germany v. Sweden (football) (from the Altona Park). 4.45 Leipzig: "With the microphone in the Dresden State Gallery."	7.0 Lille: Talk in English. 9.30 Sottens: League of Nations Report. 9.45 Budapest 1: "The Eucharistic Congress" (in French).	7.15 Stuttgart: "Young Schiller." 8.0 Regional: "Oscar Wilde." 9.30 Cologne: English talk. 10.0 Prague: News in English. 10.25 Hilversum (301.5 m.): Chess: Euwe v. Alekhine.
<b>Variety Cabaret</b>	8.0 Brussels 2: Variety. 8.15 Warsaw: French Cabaret. 8.30 Eiffel Tower: Variety. 9.30 Athlone: Variety.	6.10 Breslau: "Blue Monday." 7.0 Warsaw: Variety. 8.30 National: Broadway Matinée—Variety from U.S.A. 10.30 Poste Parisien: Cabaret.	6.40 Vienna: "Stadtpark"—Variety. 7.0 Leipzig: Variety programme. 7.55 Hilversum (301.5 m.): Variety—"The Tuesday Night Train." 8.0 Stockholm: Cabaret.
<b>Dance Music</b>	9.0 Sottens; 9.25, Hilversum (1,875 m.); 9.30, Vienna; 10.0, Budapest 1, Kalundborg; 10.5, Poste Parisien; 10.10, Brussels 1; 10.15, Rome group; 10.50, Hilversum (301.5 m.); 11.0, Paris (PTT), Radio-Paris, Strasbourg; 11.15, Brussels 2.	9.20 Vienna; 9.30, Leipzig; 10.0, Brussels 2, Kalundborg; 10.5, Budapest 1; 10.15, Rome, Turin groups.	9.20 Vienna; 9.30, Hamburg, Stuttgart; 10.0, Deutschlandsender; 10.15, Turin group; 10.20, Hilversum (1,875 m.); 10.25, Regional; 10.30, Budapest 1, Kalundborg; 10.50, Hilversum (301.5 m.); 11.15, National.

# Like To Hear ?

WEDNESDAY, Nov. 24	THURSDAY, Nov. 25	FRIDAY, Nov. 26	SATURDAY, Nov. 27
5.15 Strasbourg: "Martha," excerpts. 6.10 Berlin: Bruckner No. 1. 6.35 Vienna: Wolf, Mozart, Beethoven. 7.30 Sottens: Ansermet, Milstein (violin). 8.0 Brussels 2: Louvain Concert. 8.0 Budapest 1: Bruckner No. 5. 8.15 National: Sir Adrian Boult. 8.20 Munich: Brahms. 8.30 Strasbourg: Classics. 11.0 Stuttgart, Frankfurt: Classics.	3.15 National: Feuermann (cello). 6.10 Breslau: Bruckner No. 1, etc. 7.0 Cologne: "Undine" (Lortzing). 7.10 Kalundborg: Hindemith, Ravel. 7.30 Regional: Beecham. 8.0 Turin group: A new opera. 8.30 Radio-Paris: French music. 8.30 Strasbourg: "Louise." 9.0 Brussels 2: "Hiawatha" (De Jong). 9.10 Hilversum (301.5 m.): Mengelberg; Berlioz.	12.5 Berlin, etc., Hilversum (301.5 m.): Schumann vin. Concerto. 6.10 Munich: New German music. 6.30 Budapest 1: From the Opera. 7.0 Warsaw: Abendroth, Backhaus. 7.45 Regional: "King Olaf" (Elgar). 8.0 Hilversum (1,875 m.): Oratorio. 8.0 Turin group: Bruno Walter. 9.0 Brussels 2: Mozart Requiem. 11.0 Radio-Paris, Strasbourg: Beethoven, Lazzari.	9.30 (a.m.), Radio-Paris: From the Conservatoire. 5.0 Paris (PTT), Strasbourg: Colonne Concert. 7.0 Prague: "Tsar and Carpenter," Sottens: Haydn, Fauré, etc. 8.0 Brussels 2: "Pan" (Schoemaker), "Vikings" (Meulemans). 8.0 Rome group: "Ginevra degli Almieri." 8.30 Radio-Paris: "Pearl Fishers." 8.30 Strasbourg: Choral concert.
4.0 Radio-Paris: Song, pfte. 7.0 Brussels 2: Jewish songs. 8.0 Eiffel Tower: Song, pfte. 8.0 Warsaw: Chopin. 8.15 Athlone: Trios. 8.15 Stuttgart: Pozniak Trio. 8.25 Hilversum (1,875 m.): Choir. 8.30 Cologne: Violin, pfte. (Beethoven). 8.35 Prague: Chopin pfte. sonata. 8.30 Radio-Paris: Song, pfte. 9.0 (approx.), Turin group: Pfte. 9.15 Hilversum (1,875 m.): Organ.	4.30 Stockholm: Violoncello. 5.10 Hilversum (1,875 m.): String Quartet. 6.10 Berlin: Brahms Liebeslieder. 7.15 Frankfurt: Opera arias. 8.0 Stuttgart: Haydn quartet. 8.20 Bratislava: Sacred music. 9.0 Warsaw: Septet (Hummel), etc. 9.15 Rome group: Lutz Quartet. 9.20 Budapest 1: Zeitinger (pfte.). 9.35 Prague: Violin. 10.10 Brussels 1: Contemporary. 11.20 Hilversum (301.5 m.): Organ.	1.40 Hilversum (1,875 m.): Organ. 3.25 Prague: Mozart, Debussy. 4.0 Berlin: von Hausegger, Grieg. 5.10 Hilversum (301.5 m.): Organ. 5.10 Königsberg: Choir, organ. 6.30 Paris (PTT): Song, pfte. 6.55 Beromünster: Berg songs. 7.0 Brussels 2: Greek songs. 7.0 Stockholm: Chopin; Friedman. 7.15 Bratislava: Suk pfte. music. 8.10 Cologne: Old music. 8.20 Stockholm: Strindberg Songs. 10.40 Hilversum (301.5 m.): Songs.	2.15 Vienna: Teachers' Choir. 3.0 Stockholm: Vln., song. 5.5 Cologne: Spohr, Liszt, Weber. 5.20 Vienna: Folk songs, etc. 5.30 Beromünster: Pianoforte Duo. 6.15 Brussels 2: Songs; 7.0, Pfte. 6.30 Budapest: Two pftes. (Jazz). 7.0 Kalundborg: Quartets (Janáček, Dvořák). 7.30 Strasbourg: Children's Choir. 8.0 Eiffel Tower: Song, pfte. 8.45 Regional: Thalben-Ball (organ). 8.45 Vienna: Grieg pfte. music.
6.40 National: "Berkeley Square." 7.10 Kalundborg: Radio play. 8.0 Hamburg: "The Harbour." 8.30 Frankfurt: "Animals' Day." 8.45 Athlone: Irish play. 9.15 Brussels 1: "1890."	6.35 Budapest 1: "The Black Tulip." 7.0 Beromünster: "1812." 7.25 Prague: Historical play. 8.0 Rome group: "Giulia Szendry." 8.30 Stuttgart: "Heidelberg."	6.15 Sottens: "Micro-Magazine." 7.5 Vienna: "Don Juan Tenorio." 8.0 Deutschlandsender: "Zwei Frauen und ein Schiff." 8.0 Leipzig: Three sketches. 8.15 Frankfurt: "Rufendes Land." 8.55 Poste-Parisien: "Famille."	4.55 Prague: "The Peasant War" (Hauptmann) (in German). 7.0 Sottens: "Friends" (Dorly). 8.0 Turin group: Pirandello comedy. 8.30 Eiffel Tower: "L'argent"; 9.10, "France in Song." 9.10 Paris (PTT): Shaw play.
12.0 Radio-Paris: Garde Républicaine Band. 1.30 Kalundborg: Radio Orchestra. 3.0 Deutschlandsender: Band. 5.0 Radio-Paris: Bailly Orchestra. 6.10 Cologne: Operetta music, etc. 6.10 Frankfurt: Operetta music. 6.10 Hamburg: Band, choir; 7.0, orchestra. 6.20 Budapest 1: Light orchestral. 6.25 Prague: Military Band. 6.30 Stockholm: Operetta music. 7.0 Deutschlandsender: Joost Band. 7.0 Königsberg: Orchestra, violin, trumpets. 7.15 Stuttgart: Heidelberg Orch. 7.30 Prague: Opera music. 7.45 Kalundborg: Radio Orchestra. 8.0 Brussels 1: Jazz programme. 8.0 Rome group: Orchestra, 'cello. 8.0 Turin group: Choral concert. 9.0 Vienna: Military Band. 9.0 Warsaw: Radio Orchestra. 9.10 Hilversum (301.5 m.): Accdms.	1.35 Kalundborg: Aarhus Orch. 5.10 Hilversum (301.5 m.): Orch. 6.10 Munich: "Extrablätter" (Operetta, Dostal). 6.35 Brno, Prague: Orch., flute. 6.45 Leipzig: Military marches. 7.0 8.5, Athlone: Orch., vln., songs. 7.0 Königsberg: Light orchestral. 7.0 Stockholm: Raybould, Cyril Smith—English music. 7.0 Warsaw: Orch., choir, pftes. 7.10 Hamburg: "Peasants' Day." 8.0 Brussels 1: Radio Orchestra. 8.0 Vienna: Orch., songs, 'cello. 8.5 Sottens: Erik Satie prog. 8.15 Beromünster: Choral Concert. 8.30 Eiffel Tower: "Le Sire de Vergy" (Terrasse). 9.20 Hamburg: Orchestral variety. 9.30 Stuttgart, etc.: Folk music. 10.0 Budapest 1: Radio Orchestra. 10.0 Kalundborg: Jutland melodies. 11.0 Frankfurt, Stuttgart: French records.	12.45 Hilversum (301.5 m.): Kovacs Lajos. 1.30 Kalundborg: Young artists. 3.0 Hamburg: Vocal, instrumental. 5.0 Brussels 2: Light orchestral. 6.10 Frankfurt: Serenades. 6.10 Hamburg: Opera, operetta and light classical music. 6.10 Leipzig, etc.: Opera music. 7.0 Breslau: Rarely-heard records. 8.0 Berlin: Opera music. 8.0 Brussels 1: Band concert. 8.0 Rome group: "La Mascotte" (Audran). 8.5 Beromünster: Variety concert. 8.30 Athlone: Orch., pfte., songs. 8.30 Paris (PTT): French music. 9.0 Stockholm: Light orchestral. 9.20 Kalundborg: Banjo, saxophone, songs. 9.30 Deutschlandsender: Joost Band. 9.35 Königsberg: Light orchestral.	12.15 Radio-Paris: Giardino Orch. 1.35 Kalundborg: Radio Orchestra. 3.0 Breslau: Request concert (till 11 p.m.). 3.0 Cologne, etc.: Vocal, instr. 3.0 Frankfurt: Village programme. 5.0 Deutschlandsender: Joost Band. 6.0 Warsaw: For Poles abroad. 6.15 Brussels 1: Salon orchestra. 6.30 Vienna: "Eva" (Lehár). 6.55 Beromünster: Popular prog. 7.0 Leipzig: Military Bands, etc. 7.10 Hamburg, etc.: Gala concert. 7.15 Berlin: Variety concert. 7.30 Naples group: "Colibri" (operetta). 8.0 Athlone: Offenbach to Lehár. 8.15 Stockholm: Sea Shanties. 9.0 Warsaw: Popular orchestral. 9.20 Kalundborg: Dances. 9.20 Vienna: Band concert. 9.25 Budapest 1: Military Band. 9.25 Poste-Parisien: Lewis Orch. 11.0 Frankfurt, Stuttgart: Records.
5.50 Sottens: "18th century Art—Porcelain and Earthenware." 7.0 Lille: Talk in English. 7.30 Regional: Tennis Commentary. 10.10 Poste-Parisien: "Follow the Guide."	5.30 Beromünster: "Carnegie." 9.5 Budapest 1: "Professor Szent-Gyorgi, Nobel Prize Winner." 9.30 Sottens: For tourists. 10.15 Hilversum (301.5 m.): Chess: Euwe v. Alekhine.	7.0 Athlone: "Japan to Tunis." 8.0 Stuttgart: "Eichendorff." 8.45 Sottens: League of Nations. 10.0 Budapest 1: News in English. 10.10 Vienna: Franz Gruber, composer of "Stille Nacht."	1.50 National: Manchester November Handicap. 2.30 National: Oxford v. Cambridge (Athletics). 7.0 Lille: Talk in English. 9.20 Cologne: Women's swimming.
5.40 Hilversum (301.5 m.): Variety. 6.10 Leipzig: Bavarian Variety. 9.0 Radio-Paris: "Les ondes de Paris." 9.20 Regional: Variety.	6.25 Vienna: A Braunau Evening. 8.15 Poste-Parisien: "Plaisirs de Paris." 9.0 Stockholm: Cabaret. 11.0 Paris (PTT): Paris fête.	6.15 Stuttgart: Variety. 7.45 Sottens: Revue excerpts. 8.0 National: "Kentucky Minstrels." 8.30 Eiffel Tower: Variety.	4.0 Regional: "Kentucky Minstrels." 8.0 Brussels 1: Variety. 8.0 National: Variety. 8.15 Poste-Parisien: Max Regnier. 10.40 Hilversum (301.5 m.): Variety.
9.0 Stockholm; 9.30, Breslau; 10.0, Deutschlandsender; 10.10, Budapest 1; 10.15, Kalundborg, Turin group; 10.25, Regional; 11.15, National.	7.10 Berlin; 8.0, Brussels 2; 9.30, Leipzig; 9.50, Vienna; 10.0, Deutschlandsender; 10.15, Rome group; 10.30, Poste-Parisien; 10.50, Hilversum (301.5 m.); 11.30, Paris (PTT).	2.55 Hilversum (301.5 m.); 3.55, Hilversum (1,875 m.); 9.30, Frankfurt, Stuttgart; 10.5, Budapest 1; 10.15, Rome group; 10.25, Regional; 11.0, National.	8.55 Hilversum (301.5 m.); 9.0, Beromünster, Stockholm; 9.5, Sottens; 9.20, Munich; 9.30, Berlin, Prague; 10.0, Kalundborg; 10.5, Poste-Parisien; 10.30, Budapest 1; 11.0, Brussels 2, Paris (PTT), Strasbourg; 11.45, Radio-Paris.



My

hat!

Curiously enough, it is a hat  
—the bowler hat “mute” for a trumpet.  
Bit tricky to recognise—like trying to recognise a trumpet on a set that badly needs a Drydex Battery. What a difference a Drydex makes!

# Drydex

THE Exide  
**DRY BATTERY**  
FOR RADIO

*‘Still keeps going when the rest have stopped’*

DX. 33.



★ USE DRYDEX TORCH BATTERIES for a bright and lasting light. Your dealer has a wide and attractive range of Drydex Torches, Cycle Lamps and Gas Lighters.

From reputable dealers and Exide Service Stations. Exide Service Stations give service on every make of battery.

Exide Batteries, Exide Works, Clifton Junction near Manchester. Also at London, Manchester, Birmingham, Bristol, Glasgow, Dublin and Belfast.

10.50—AVRO Dance Band. Conductor Mossel.  
11.20-11.40—Records.

### KALUNDBORG (Denmark)

240 kc/s (1,250 m.); 60 kW. Relays Copenhagen, 1,176 kc/s (255.1 m.).

7.0 a.m.—Gymnastics.  
7.35—Weather.  
7.45—Topical Talk (French).  
8.0—German Talk: Struwelpeter.  
8.15—English Talk: Robert Owen.  
8.30-8.55—Talk: Reading Material.  
9.0—Service from Copenhagen Cathedral.  
10.28—Weather.  
10.40—News.  
11.0—Concert for Children. Radio-Orchestra. Conductor: Grøndahl. Commentary by Finn Høffding.  
12.0 noon—Reading (Ernest Raymond).  
12.20 p.m.—Wagner Records.  
12.30—The Unveiling of the Memorial to Fishermen and Seamen in Frederikshavn Cemetery. Addresses; Songs.  
1.20—Love Songs (Dowland) by Dagmar Schou, with Harpsichord Accompaniment. Away with these self-loving Lads. Come again. Weep you no more, sad Fountains. Fine knacks for Ladies. Now, o now, I needs must part. Come away.

1.40—Records: “Carmen” (Bizet).  
2.25—Seventh People’s Concert. Swing Music by “The Three,” Lington’s Band and Bødker and Nørrevig (Pftes.). It don’t mean a thing (Duke Ellington). New street swing (Bulterman). Harlem (Carrel). I’m gettin’ sentimental over you (Bassman). Louisiana (Razaf). House hop (Goodman). Home Town (Kennedy). Pfte. Duets (Robin-Hollander, Gershwin, Kjaer). Swingin’ on the reservation (Webb). Goodbye (Fiehn). November in Swing (Bødker). Midnight (Bentzon). Take a Cab to Harlem (Mathiesen). Bysladder (Kjaer). Bass-drum Dan (Trumbauer). Ole King Cole (Schuster). Swingtime in the Rockies (Goodman). Chinatown, my Chinatown (Schwartz). Bugle Call Rag (Mills).

4.0—Service from Christiansborg Castle Church.  
5.20—Talk: Johanne Luise Heiberg.  
5.50—Weather.  
6.0—News.  
6.30—Talk: Islam and Radio.  
7.0—“The Hansens” — Sketch (Locher).  
7.15—Opera Music—Radio Orchestra. Conductor: Tuxen. Inge Thorsen (Soprano). Overture, “Titus” (Mozart). Aria, “Don Giovanni” (Mozart). Overture, “Lodoiska” (Cherubini). Aria, “The Pearl Fishers” (Bizet). Ballet, “The Bartered Bride” (Smetana). Aria, “The Merry Wives of Windsor” (Nicolai). Overture, “The Daughter of the Regiment” (Donizetti).

8.0—Martin Andersen Nexø reads.  
8.20—Lehár Music by the Radio Orchestra. Conductor: Tuxen. Overture, “Eva.” Selection, “Giuditta.” Dances, “Tatiana.” Gold and Silver. Overture, “Gipsy Love.”  
9.0—News.  
9.15—Jungle Voices. Reading: The New Jungle Book (Kipling). Jungle Impressions (Cyril Scott).  
10.0-11.30—Preil’s Dance Band; at 11.0—Chimes.

10.50—Records: “Carmen” (Bizet).  
2.25—Seventh People’s Concert. Swing Music by “The Three,” Lington’s Band and Bødker and Nørrevig (Pftes.). It don’t mean a thing (Duke Ellington). New street swing (Bulterman). Harlem (Carrel). I’m gettin’ sentimental over you (Bassman). Louisiana (Razaf). House hop (Goodman). Home Town (Kennedy). Pfte. Duets (Robin-Hollander, Gershwin, Kjaer). Swingin’ on the reservation (Webb). Goodbye (Fiehn). November in Swing (Bødker). Midnight (Bentzon). Take a Cab to Harlem (Mathiesen). Bysladder (Kjaer). Bass-drum Dan (Trumbauer). Ole King Cole (Schuster). Swingtime in the Rockies (Goodman). Chinatown, my Chinatown (Schwartz). Bugle Call Rag (Mills).

4.0—Service from Christiansborg Castle Church.  
5.20—Talk: Johanne Luise Heiberg.  
5.50—Weather.  
6.0—News.  
6.30—Talk: Islam and Radio.  
7.0—“The Hansens” — Sketch (Locher).  
7.15—Opera Music—Radio Orchestra. Conductor: Tuxen. Inge Thorsen (Soprano). Overture, “Titus” (Mozart). Aria, “Don Giovanni” (Mozart). Overture, “Lodoiska” (Cherubini). Aria, “The Pearl Fishers” (Bizet). Ballet, “The Bartered Bride” (Smetana). Aria, “The Merry Wives of Windsor” (Nicolai). Overture, “The Daughter of the Regiment” (Donizetti).

8.0—Martin Andersen Nexø reads.  
8.20—Lehár Music by the Radio Orchestra. Conductor: Tuxen. Overture, “Eva.” Selection, “Giuditta.” Dances, “Tatiana.” Gold and Silver. Overture, “Gipsy Love.”  
9.0—News.  
9.15—Jungle Voices. Reading: The New Jungle Book (Kipling). Jungle Impressions (Cyril Scott).  
10.0-11.30—Preil’s Dance Band; at 11.0—Chimes.

### KÖNIGSBERG (Heilsberg)

(Germany)  
1,031 kc/s (291 m.); 100 kW. Relayed by Danzig, 1,303 kc/s (230.2 m.).  
5.0 a.m.—See Hamburg.

7.0—Announcements.  
7.30—Records.  
8.10—Protestant Service.  
9.0—See Frankfurt.  
9.30—Hans Eggert (Baritone).  
10.15—See Leipzig.  
11.0—See Berlin.  
1.0 p.m.—Chess.  
1.30—Käte Grandt (Violin), Maria Fischer (Pfte.) and Richard Sengleitner (Tenor).  
2.5—See Hamburg.  
3.0—Light Classical Music from Saarbrücken.  
5.0—Sun, Moon and Stars—Literary and Musical Sequence (Rukscheol). Station Choir. Conductor: Firschow.  
5.40—Pfte. Trio in A minor (Tchaikovsky), by the Ninke Trio.  
6.0—News.  
6.10—Comrade, where are you?  
6.40—Sports.  
7.0—Beethoven Concert. Station Orchestra. Conductor: Brückner. Alfred Hoehn (Pfte). Egmont Overture. Pfte. Concerto in E flat. Third Symphony—the Eroica.  
9.0—News.  
9.20—Report: The Football Match, Insterburg v. Königsberg.  
9.30—Swimming Report.  
9.40-11.0—Serenade from Deutschlandsender.

### LAHTI (Finland)

166 kc/s (1,807 m.); 150 kW. Relayed by Helsinki, 895 kc/s (335.2 m.).

Transmits at intervals from 6.45 a.m.

9.50 a.m.—News.  
10.0—Concert. National Choir. Conductor: Maasal. Ilona Juutilainen (Harp) and Ryyänänen (Songs).  
10.50—Weather (Finnish, Swedish).  
10.55—News (Swedish).  
11.0—Service in Swedish.  
12.30 p.m.—Popular Concert by the Helsinki Municipal Orchestra.

1.30—Literary Programme.  
3.25—Records for Children.  
3.40—For Schools.  
4.10—Talk.  
4.25—Records: Sailor Songs and Waltzes.  
4.35—Interview.  
5.0—Weather (Finnish, Swedish).  
5.10—Talk.

5.25—Martha Wasastjerna (Pfte.). Chaconne (Handel). Blumenstück (Schumann). Novelette in E (Schumann). Two Preludes (Scriabin).  
5.45—Talk.

6.20—Valter Kilpi recites his own Poems.  
6.45—Radio Orchestra. Conductor: Haapanen. Lea Piltti (Songs).  
7.45—News (Finnish, Swedish).

8.10—Pfte. Concerto in D minor (Mozart) by Mitja Wikisch and the Berlin Philharmonic. Conductor: Rudolf Schulz-Domburg (Recorded).

### LEIPZIG (Germany)

785 kc/s (382.2 m.); 120 kW. Relayed by Dresden, 1,285 kc/s (233.5 m.).

5.0-7.0 a.m.—See Hamburg.  
7.0—Music of Old Italian Masters—Winkler (Organ).

7.30—Light Music. Station Orchestra. Conductor: Schröder.  
9.0—See Frankfurt.

9.30—Records. Prelude to Act III, “Kunihild” (Kistler). Melody (Tchaikovsky). Two Baritone Songs (Schubert). Andante from the Serenade in C minor for Wind Instruments (Mozart).

9.55—Talk: New German War Memorials in France, Yugoslavia, and Italy.



9.15. 10.0

12-0-124

SUNDAY (November 21)

10.15—Cantatas (Bach): (a) Wer weiss, wie nahe mir mein Ende?, (b) Nun ist das Heil und die Kraft. St. Thomas Choir and the Municipal and Gewandhaus Orchestras, etc. Conductor: Straube.  
 11.0—See Berlin.  
 1.0 p.m.—News; Records.  
 2.5—See Hamburg.  
 3.0—Light Orchestral Music from Saarbrücken.  
 4.45—Dresden Picture Gallery and its Treasures — A Description (Hohrath) with Music by Palestrina, Corelli, de Rore, Isaac, Senf, Hassler, Ammerbach, and Veracini. Instrumental Ensemble and Speakers.  
 6.0—News.  
 6.10—Hermann Busse reads.  
 6.30—Sonata in C (Schubert) by Rehberg (Pfte.).  
 6.55—Sports.  
 7.0—Leipzig Kaleidoscope. Station Choir and Symphony Orchestra. Conductor: Kretschmar. Else Lampmann (Contralto), Decker (Tenor), Horand (Baritone), Burgert (Harpischord).  
 9.0—News; Sports.  
 9.30-11.0—See Deutschlandsender.

**LILLE (Radio PTT Nord) (France)**  
 1,213 kc/s (247.3 m.); 60 kW.  
 Transmits at intervals from 7.0 a.m.  
 4.45 p.m.—Band.  
 5.30—Records of Kreisler.  
 6.0—A Visit to a Sugar-Refinery.  
 6.30—See Paris (Eiffel Tower).  
 7.0—Records.  
 7.30—News; Band Records.  
 8.9—Sports; Records.  
 8.30—Station Orchestra. Conductor: Soret. Lefebvre (Tenor). Overture, "Peter Schmolle" (Weber). Minuet (Bolzoni). Spanish Caprice (Rimsky-Korsakov). Canzonetta (d'Ambrosio). Slav Rhapsody (Dvořák). Chant élégiaque (Fl. Schmitt). Songs, Prelude, "Hélène" (Messenger). Romance and Tarantella (Saint-Saëns). Minuet (Mozart). Contes de fées (Engleman). Selection, "Faust" (Gounod).

**MONTE CENERI (Switzerland)**  
 1,167 kc/s (257.1 m.); 15 kW.  
 10.30 a.m.—Bible Reading.  
 11.0—Station Orchestra. Conductor: Herschel.  
 11.30—News.  
 11.40—Station Orchestra (contd.).  
 12.0 noon—Records.  
 12.40-1.0 p.m.—Old Dances.  
 2.15—Sports.  
 3.15—Records.  
 4.0—For Hospitals.  
 4.30—Records. In the intervals, Sports.  
 4.45—Male Voice Choir from Bellinzona. Conductor: Gargano. Jägerlied (Sturm). La Montanara (Ortelli). Glocken der Heimat (Bröll). Neuer Frühling (Requette). Nostalgia ticinese (Cattabeni). Das Land der Ahnen (Suter).  
 5.15—Sports.  
 5.30—Records.  
 6.15—Sports.  
 6.30—Song Records of Rosetta Pampolini.  
 6.45—News.  
 7.0—"The Voice of Judgment"—Play (Erminia zur Muehlen).  
 7.45—Station Orchestra. Conductor: Herschel. Antiche danze (Respighi). Ballet Music, "Platée" (Rameau). Boston (Niemann). Tango (Niemann). Golliwog's Cakewalk (Debussy). Habanera (Ravel). Danza fantastica (Turina).  
 8.30—Records: Symphonic Jazz.  
 9.0—Poem.

**MOSCOW (No. 1) (Russia)**  
 172 kc/s (1,744 m.); 500 kW.  
 1.0 p.m.—Swedish Programme.  
 4.30—Music.  
 5.0—Literary Programme.  
 5.30—Concert.  
 9.0—English Programme.  
 10.0—French Programme.  
 11.0-12.0 m't.—Spanish Programme.

**MUNICH (Germany)**  
 740 kc/s (405.4 m.); 100 kW.  
 Relayed by Nürnberg, 1,267 kc/s (236.8 m.).  
 5.0 a.m.—See Hamburg.  
 7.0—Classical Records.  
 7.55—Religious Address.  
 8.30—Franz Bruckbauer (Violin) and Gabriele von Lottner (Pfte.).  
 9.0—"Death Conquered!"—Literary and Musical Programme.  
 9.30—"The Melody of Death"—Sequence (Weitnauer), with the Augsburg Radio Orchestra.  
 10.40—"In the Stable"—Radio Picture (Schauer).  
 11.0—Classical Records.  
 12.0 noon—Station Orchestra, etc. Conductor: Mihalovic. Overture, "L'isola disabitata" (Haydn). Violin: Romance (Svendsen). Praeludium (Järnefelt). Minuet (Schneider). Selection, "Die toten Augen" (d'Albert). Fantasia in A minor (Reuss). Flute: Melody (Gluck). Romance (Tchaikovsky). Largo (Carulli). Overture, "William Tell" (Rossini). Excerpt, "I promessi Sposi" (Ponchielli). Hymn to the Sun (Rimsky-Korsakov). The Flight of the Bumble Bee (Rimsky-Korsakov). Schumann Variations (Brahms). Einsame Feldwacht (Graener). Excerpt from the Clarinet Quintet (Mozart). Hexentanz (MacDowell). Bourrée (Bach). Excerpt from the Lyric Suite (Grieg). Prelude (Rachmaninoff).

2.5 p.m.—See Hamburg.  
 3.0—Light Classical Music from Saarbrücken.  
 4.45—Arras and Flanders—War Reminiscences.  
 5.0—"Grief and Consolation"—Literary and Musical Sequence (Irene Kohl). In the intervals, Records.  
 6.0—News; Records; Sports.  
 7.0—German Opera Music. Station Orchestra. Conductor: Winter. Nelly von Peckensen (Soprano). Elisabeth Waldenau (Contralto) and Marius Andersen (Tenor). Part I. Lortzing. Overture and Aria from "Der Waffenschmied." Ballet, "Undine." Aria, "Tsar and Carpenter." Part II. Introduction and Aria, "The Lorelei" (Bruch). Part III. Aria and Overture, "The Taming of the Shrew" (Götz). Part IV. Overture and Arias, "Der Freischütz" (Weber). Part V. Wagner. Prelude and Legend of the Grail from "Lohengrin." Overture, "Tannhäuser."  
 9.0—Time; News.  
 9.30-11.0 (from Augsburg)—Augsburg Orchestra. Conductor: Adolf Schmid-Bresten. Hugo Orloff (Violin). Alois Seifert (Cello). Vilma Lessik (Soprano). Wachholz (Pfte.). The Death of Ase (Grieg). Violin: Romance in F (Beethoven). Prelude to "Kunihild" (Kistler). Cello Pieces (Schumann): (a) Träumerei, (b) Abendlied. Andante from the Symphony in B minor (Schubert). Songs: (a) Wieder muss ich dir begegnen (Liszt), (b) Der Freund (Wolf), (c) Liebestreu (Brahms). Air (Bach). Pfte.: Wanderer-Fantasie (Schubert). Andante (Rust). Violin: Nocturne (Chopin). Ave verum (Mozart). Cello: Romance (Suderland). Albumblatt (Wagner).

**NAPLES GROUP (Italy)**  
 Naples, 1,104 kc/s (271.7 m.); 10 kW. Florence (No. 1), 610 kc/s (491.8 m.); Rome (No. 3), Bari (No. 2), Milan (No. 2), Turin (No. 2), and Genoa (No. 2), 1,357 kc/s (221.1 m.).  
 6.0 p.m.—Young People's Choir. Conductor: Consoli. Largo (Handel). Heidenröslein (Schubert). Tarantella (Rossini). Ave Maria (Gounod). Two Piedmontese Songs (Sinigaglia). Il maritimo (Sinigaglia). Lucciole (Brogi). Funiculi, funiculà (Denza).  
 7.0—Time; News.  
 7.20—See Rome.  
 7.30—Sketch; Songs and Dances.  
 8.30—"Round the World."  
 9.15 (approx.)-10.55—Dance Music.

**OSLO (Norway)**  
 260 kc/s (1,153.8 m.); 60 kW.  
 Relayed by Fredrikstad, 722 kc/s (415.4 m.); Hamar, 519 kc/s (578 m.); Notodden, 1,357 kc/s (221.1 m.); Porsgrund, 850 kc/s (352.9 m.); Rjukan, 1,348 kc/s (222.6 m.); and Trøndelag, 629 kc/s (476.9 m.).  
 8.0 a.m.—News.  
 8.5—French Lesson.  
 8.35—German Lesson.  
 9.0—Records—Symphony (Mozart). Ich liebe dich (Beethoven). Octet in E flat (Mendelssohn).  
 9.55—Service; Records.  
 11.45—News.  
 12.0 noon-12.45 p.m.—Variety Concert.  
 3.10—Norwegian Music by Groven (Hardanger Fiddle) and Ustvedt (Songs).  
 3.40—Talk: Norwegian Terminology.  
 4.0—Scandinavian Folk Songs by Unni Bugge-Hansen (Soprano), Alfhild von Trepka (Mezzo-Soprano), and Solveig Borthen (Contralto).  
 4.20—Report.  
 4.40—Records.  
 5.25—Talk.  
 5.45—Winding-Sørensen (Pfte.). Fantasia and Fugue in A minor (Bach). Variations on a Norwegian Air (Olsen). Cubana (Falla). Fire Dance (Falla).  
 6.10—News and Announcements.  
 6.30—Requiem in D minor (Cherubini). Conductor: Simonsen.  
 7.15—Talk. 7.45—Station Orchestra. Conductor: Kramm. Overture, "The Merry Wives of Windsor" (Nicolai). Ballet, "Hiawatha" (Coleridge-Taylor). Andante Melodioso (Rachmaninov). Gavotte (Larsen). Swedish Folk Song (Sandby). Bergensiana Variations (Halvorsen). 8.40—News; Sports.  
 9.15-10.0—Dance Records.

**PARIS (Eiffel Tower) (France)**  
 1,456 kc/s (206 m.); 7 kW.  
 Transmits at intervals from 7.0 a.m.  
 2.30-4.0 p.m.—One-Act Plays: (a) "A House of Gentlefolk" (Turgenyev), (b) "La nuit étoilée" (Violet), (c) "Jacques Damour" (Zola-Hennique).  
 4.0—Concert.  
 4.45—See Lille.  
 5.30—See Alpes-Grenoble (PTT).  
 6.30—For Farmers.  
 7.0—See Toulouse (PTT).  
 7.30—News.  
 8.0—Mme Dominique Jeanès (Pfte.) and Clément Duhour (Songs). Songs: (a) Se tu vorresti (Tosti), (b) La dernière escale (Gabiello-Bousquet). Pfte: (a) Dance, (Falla), (b) Valse impromptu (Liszt), (c) Nocturne in A flat (Fauré), (d)

Napoli (Poulenc). Songs: (a) Ouvrez votre coeur, mon amour (Messis-Jeanès), (b) Les vieux bateaux (De Richler-Pierlas).  
 8.30—Soldier Songs and Refrains. Plays: (a) "Lidoire" (Courtelaine), (b) "A la chambrée" (Matrat-Fordyre).  
 10.30—Records.  
 11.0-11.15—News.

**PARIS (Poste Parisien) (France)**  
 959 kc/s (312.8 m.); 60 kW.  
 7.52 a.m.—Records.  
 8.2—News; Menus.  
 8.36—Records.  
 9.1—News; Records.  
 10.0—Songs; Records.  
 10.38—Records of Jack Hylton and Orchestra.  
 10.41—Records: Russian Music.  
 11.0—S.D.L. Session, with Pierre Dac, etc.  
 11.20—Records: Duets, "The Merry Widow" (Lehár).  
 11.26—Classical Records.  
 11.45—Records: Tangos.  
 12.5 p.m.—Records for Children.  
 12.15—Song Records.  
 12.30—The Adventures of Prince Lumen, with Mireille Perry and Robert Burnier.  
 12.45—Harmonica Boys' Trio, presented by Pierre Bergerac.  
 1.0—Vocal Quintet with Raymond Souplex and Jane Sourza.  
 1.30—Records.  
 1.45—Lecture-Recital: Paul Delmet.  
 2.0—Football Match Report.  
 5.0—Records.  
 6.58—Racing.  
 7.0—Topical; Sports.  
 7.10—Amusement Guide.  
 7.15—Records: Rode Cigány Band.  
 7.40—Records of André Baugé (Songs).  
 7.50—Film Talk by Roger François: Meg Lemonnier.  
 8.10—Les Frères Jacasse.  
 8.15—Records: Arias, "Lakmé" (Delibes), "Rigoletto" (Verdi).  
 8.30—"Le Miroir à trois Faces."  
 8.45—La bonne histoire.  
 9.0—News.  
 9.5—Amateurs' Programme.  
 9.55—News.  
 10.5-11.30—Dance Music.

**PARIS (PTT) (France)**  
 695 kc/s (431.7 m.); 120 kW.  
 7.0 a.m.—News. 7.20—Records and Talk.  
 7.45—News; Review.  
 8.15-8.30—Records.  
 9.0—For Farmers.  
 9.15—Orchestral Records.  
 9.30—Robert Milani (Songs).  
 9.45—Records.  
 10.0—Locatelli Orchestra.  
 10.30—Programme Notes.  
 10.45—Locatelli Orchestra.  
 11.15—Madeleine Le Bergy (Songs).  
 11.30—Locatelli Orchestra.  
 12.0 noon—Yatove Orchestra.  
 12.45 p.m.—News; Sports.  
 2.0—"Tourterelle"—Three-Act Play (Puget).  
 4.0—Maud Laury and Sonia Alny (Songs).  
 4.30—Francy Orchestra. Balta (Accordion). Sirjo (Songs).  
 6.0—For Farmers.  
 6.30—Sainte-Cécile Choir. Conductor: Mlle Turin. Gentils galants de France (Gevaert). Il est bel et bon (Passereau). Les paysans de Chatou (Gevaert). Je vois des glissantes eaux (Costeley). Viens amour (De Bois-mortiers). Hymne à Saint-Cécile. Ronde (Gevaert). Berceuse. Pavane (Thoinot-Arbeau). Commençons la semaine.

## SUNDAY (November 21)

- 7.0—Radio Journal: News.  
8.0—Les frères Jacques present Marie Dubas, with the Cazaux Orchestra.  
8.30—"Le veau gras"—Four-Act Play (Zimmer) by the "Mai 36" Players.  
10.30—News; Sports.  
10.45—Records: Sardanas.  
11.0—See Paris (Radio-Paris).

## PARIS (Radio-Paris) (France)

- 182 kc/s (1,648 m.); 80 kW.  
7.0 a.m.—Records.  
7.15—News; Gym.  
7.45—Records; Programme Notes.  
8.0—News.  
8.30—German Lesson.  
8.45—Book-keeping.  
9.15—For Wine-growers.  
9.30—English Lessons. X  
10.10—Spanish Lesson.  
10.30—Italian Lessons.  
11.0—Programme Notes.  
11.5—Radio Paris Guignol by Bilboquet and Troupe: Le diable en prison (Crozière). In the interval, Polichinelle.  
11.30—Mlle Zilgien (Organ).  
12.0 noon—Roman Catholic Address by the Rev. Father Carré.  
12.20 p.m.—Records: Sacred Music.  
12.30—Ibos Orchestra.  
1.0—Time; News.  
1.15—Ibos Orchestra.  
1.30—Georges Chepfer.  
1.45—Ibos Orchestra.  
2.0—Sound News.  
2.10—For Young People.  
3.0—Adison Orchestra. 3.30—Marthe Daumont and M. Priolet (Songs).  
4.0—"L'Instinct"—Play in Three Acts (Kistemaekers).  
5.0—Records.  
5.15—Paris Symphony Orchestra. Artur Schnabel (Pfte.). Excerpts, "Der Freischütz" (Weber). Pfte. Concerto (Brahms). Symphony—the Eroica (Beethoven).  
7.0—Talk.  
7.15—Lina Margy (Songs).  
7.30—Talk.  
7.45—Laffon (Monologues).  
7.57—Time; Programme Notes.  
8.0—Home Affairs.  
8.8—Foreign Affairs.  
8.15—Jean Clément (Songs).  
8.30—Symphony Concert. Maréchal (Cello). Italian Symphony (Mendelssohn). The Haunted Castle (Fl. Schmitt). 'Cello and Orchestra: Schelomo (Bloch). Masques et Bergamasques (Fauré). Symphony No. 2 (Emmanuel); at 9.30—News.  
10.35—Sound News.  
10.45—Time; News.  
11.0 p.m.—Bouillon Dance Band.  
1.0 a.m. (Monday)—Programme Notes.
- PRAGUE (Czechoslovakia)**  
638 kc/s (470.2 m.); 120 kW.  
5.45 a.m.—News; Records; Police Messages.  
6.30—Karlsbad Municipal Orchestra.  
7.15—Gymnastics.  
7.45—Service from Bratislava.  
8.0—Sacred Music by Nemeč (Organ); Talks.  
9.10—Salon Quartet.  
9.40—Talk and Reading; Books.  
10.15—Station Orchestra, Harpsichord, Organ. Conductor: Ančéril.  
11.0—Chimes; Record.  
11.10—News; Weather.  
11.20—FOC Orchestra. Conductor: Smetáček.  
12.20 p.m.—For Farmers.  
1.5—For German Farmers.

- 1.20—For German Workers.  
1.30—Talk on the following Programme.  
1.35—"Russalka" (Dvořák), from the State Opera. Conductor: Skvor.  
4.20—Talk; Record.  
4.35—German Transmission: Review; Orchestra, Choir, etc.  
5.50—News (German); Record.  
6.0—News; Reading.  
6.25—Marches and Waltzes from Kosice.  
7.25—"In the Servants' Hall"—Play (Stroupeznicky).  
8.10—Orchestra and Violin from Moravská-Ostrava.  
8.55—Record.  
9.0—News; Records.  
9.30—News (German).  
9.35-10.30—See Bratislava.



Vilém Zitek, who takes the part of "The Waterman" in Dvořák's opera at Prague at 1.35 p.m.

## RADIO-MEDITERRANÉE (France)

- 1,276 kc/s (235.1 m.); 27 kW.  
Transmits at intervals from 12.15 p.m.  
7.0 p.m.—La Mer (Debussy)—Symphony Orchestra, Conductor: Coppola (Recorded).  
7.25—Amusement Guide.  
7.30—Roman Catholic Address.  
8.10—Sports.  
8.30—Records: Light Music.  
9.5—Weather.  
9.10—Request Programme.  
10.0—News.  
10.15—Dance Music. X

## RADIO-NORMANDIE (France)

- 1,113 kc/s (269.5 m.); 15 kW.  
6.45 a.m.—Band; Announcements. X  
7.15—News; Records. X  
8.15—Sacred Music. X  
8.30—Light Music. X  
9.30—Campoli's Orchestra. X  
9.45—Light Music. X  
10.15—Carson Robinson Orchestra. X  
10.30—Eddie Pola and Partners, Records. X  
11.0—Light Music. X  
11.45—Songs of Normandy by Théâtre Français Artists. X  
12.20 p.m.—Roman Catholic Programme: Bach Music and Address by the Rev. Fr. Baeteman. X  
12.45—News; Topical. X  
1.0—Variety Concert. X  
2.0—Billy Cotton's Band. X  
2.30—Records; Music. X  
3.0—Serenade. X  
3.30—Songs. X  
3.45—Jack Jackson Orchestra. X  
4.0—Light Music. X  
5.30—Hildegarde. X  
5.45—Records; Light Music. X  
6.15—Alfredo Campoli Orchestra. X

- 6.30—Music-Hall. X  
7.0—Records; Light Music. X  
7.30—News; Sports. X  
8.0—Variety Concert. X  
9.30—Humorous Sketches. X  
10.0—Popular Music. X  
11.0—Light Music. X  
12.0 m't.—Midnight Melodies. X  
12.30-1.0 a.m. (Monday)—Dance Music. X

## REYKJAVIK (Iceland)

- 208 kc/s (1,442 m.); 16 kW.  
10.45 a.m.—Musicians of the Past.  
11.40—Weather (Icelandic, English, German).  
12.0 noon—Service from the Cathedral.  
4.0 p.m.—Music.  
4.0—Light Classical Music.  
7.30—For Children.  
8.10—Weather (Icelandic, German, English).  
8.20—Film Music.  
8.55—Announcements.  
9.0—Time; News.  
9.30—Talk.  
9.55—Björnson Songs.  
10.15—To be announced.  
10.40 p.m.-1.0 a.m. (Monday)—Dance Music.

## ROME GROUP (Italy)

- Rome (No. 1), 713 kc/s (420.8 m.); 50 kW. Bari (No. 1), 1,059 kc/s (283.3 m.); Palermo, 565 kc/s (531 m.); Bologna, 986 kc/s (304.3 m.).  
7.30-7.50 a.m.—News.  
8.30—For Soldiers.  
9.0—Rural Programme.  
10.0—See Turin.  
11.0—Bible Reading.  
11.20 a.m.-1.15 p.m.—See Turin.  
1.20-2.0—News; Light Music.  
2.30-3.15—Football Match.  
3.45—Sports.  
4.0—Symphony Concert from the Teatro Adriano. Conductor: Guarneri. Overture, "La Scala di seta" (Rossini). Symphony in E minor (Brahms). Nocturne (Martucci). Gavotte, "Idomeneo" (Mozart). Panatenaiche (Pizzetti). Prelude and Death of Isolde, "Tristan and Isolde" (Wagner). In the interval, Weather; Sports.  
6.30—Sports.  
6.47—Talk.  
7.0—Time; News.  
7.20—Talk.  
7.30—Music.  
8.0—Air Force Band. Conductor: Di Miniello. March, "Norma" (Bellini). Selection, "Fedora" (Giordano). Barcarolle, June (Tchaikovsky). Prelude (Rachmaninov). Prelude, "I Rantzau" (Mascagni). Overture, "Le baruffe chiozzotte" (Sinigaglia). In the interval, Talk.  
9.10—Popular Melodies. Conductor: Mancini.  
9.46—News in Danish.  
10.0—News.  
10.15-10.50—Dance Music. X

## SOTTENS (Switzerland)

- 677 kc/s (443.1 m.); 100 kW. Relayed by Geneva, 401 kc/s (748 m.).  
8.55 a.m.—Chimes.  
9.0—Protestant Service from the Church of St. Gervais.  
10.15—William Montillet (Organ) from Geneva Conservatoire.  
10.45—Records.  
11.0—Daily Wisdom.  
11.20—Interlude.  
11.30—News.  
11.40 a.m.-1.0 p.m. (from Geneva)—Records.  
2.45-3.45—Sports Report.  
5.0—Records.  
5.40—Religious Address.  
6.10—Liturgical Music from the Church of the Holy Cross.

- 6.30—Sports.  
6.50—News.  
7.0—Sonata (Rachmaninoff) by Engelbert Kreml (Pfte.) and Henry Buenzod ('Cello).  
7.30—Fridolin and Partner.  
7.40—Radio Suisse romande Orchestra.  
8.40—Interlude.  
8.45—Musical Mosaic. X  
9.0—Dance Records. X  
10.0—Weather.

## STOCKHOLM (Sweden)

- 704 kc/s (426.1 m.); 55 kW. Relayed by Motala, 216 kc/s (1,389 m.); Göteborg, 941 kc/s (318.8 m.); Hörby, 1,131 kc/s (265.3 m.); and Boden, 392 kc/s (765 m.).  
8.0 a.m.—For Farmers.  
8.30—Bach Records. Triple Fugue from Die Kunst der Fuge. Excerpts, "Wachet auf." Concerto in G for Harpsichord, Two Violins, and 'Cello.  
9.15-9.45—Talk: Adult Education in Holland.  
10.0—Service.  
11.40—News.  
12.0 noon—Reading: American Poems.  
12.15 p.m.—American Music by Manne Ohrvall (Songs) and Bertil André (Violin). Songs: (a) Trees (Rasbach), (b) Sylvia (Speaks), (c) Give a man a horse he can ride (O'Hara). Violin: (a) Variationette, Intermezzo and Humoresque (Wilson), (b) An Old Love Tale (Branscombe), (c) Melody (Dawes), (d) The Rosary (Nevin). Songs: (a) Pirate Dreams (Huerter), (b) Pale Moon (Logan).  
12.45—For Children.  
1.10—Commentary on the Germany v. Sweden Football Match, from the Volkspark, Altona.  
3.0—Records.  
3.30—English Lesson.  
4.5—Service.  
5.15 (from Göteborg)—Stenhammar Commemoration. Göteborg Radio Orchestra. Conductor: Tor Mann. Intermezzo, "Sagen." Symphony in G minor. In the Interval, Talk.  
6.15—News.  
6.30—A Play.  
7.30—Radio Dance Band. X  
8.15—Report.  
8.45—News.  
9.0—Sports.  
9.15-10.0—Björn Forsell (Songs), Beatrice Griffin-Ekström (Violin) and Fritjof Kjellberg (Pfte.). Songs: (a) Junker Nils sjunger till luta (Hallén), (b) Korsspindeln (Sibelius), (c) Det far ett skepp (Stenhammar), (d) Positivissa (Stenhammar). Violin: (a) Hymn to the Sun (Rimsky-Korsakov), (b) Marguerite (Rachmaninov-Kreisler), (c) Cherry Ripe (Scott), (d) Serenade (d'Ambrosio). In the interval, Reading.
- STRASBOURG (France)**  
859 kc/s (349.2 m.); 100 kW. Transmits at intervals from 7.0 a.m.  
10.45 a.m.—Protestant Address.  
11.30—Roman Catholic Service (German).  
12.0 noon—Folk Music. School Choir and Accordion.  
12.35 p.m.—News.  
1.0—Orchestra from Limoges (PTT).  
1.45—Sunday Review.  
2.0—Football Report from Montpellier (PTT).  
4.0—To be announced.  
4.15—Medical Talk.  
4.30—Nancy Conservatoire Symphony Concert from the Salle Poiré, Nancy. Conductor: Bachelard. André Navarra ('Cello). Symphony

NOVEMBER 19, 1937]

WORLD-RADIO

SUNDAY (November 21)

in C (Paray). 'Cello Concerto (Dvořák).  
6.0—See Paris (PTT).  
6.30—Songs from Marseilles (PTT).  
7.0—News.  
7.30—Light Orchestral.  
7.45—News (German).  
8.0—News; Records.  
8.30—Lorraine Evening from Stiring-Wendel (Moselle). Talks and Songs in Dialect.  
10.30—News.  
10.45—News (German).  
11.0—Dance Music.

**STUTTGART (Germany)**

574 kc/s (522.6 m.); 100 kW.  
5.0 a.m.—See Hamburg.  
7.0—Announcements; Gym.  
7.30—Roman Catholic Address.  
8.0—Records.  
9.0—See Frankfurt.  
9.30—Station Orchestra and Hans Kohl (Bass).  
10.30—Contemporary Music from Mannheim. Ellen Pfeil (Soprano). Jula Kaufmann (Pfte.). Songs (Trunk): (a) Vision, (b) Nachtgesang. Fantasia in G sharp minor (Peters). Songs: (a) Vor dem Frühling (Haas), (b) Elfe (Weismann). Dorische Toccata (Hermann).  
11.0—See Berlin; at 12.0 noon-12.15 p.m.—Topical.  
1.0—"Punch and the Magic Philtre"—Play (Vetter).  
1.30—Records: Light Music.  
2.5—See Hamburg.  
3.0—Variety Programme.  
5.0—"Ein alemannischer Liechtgang"—Play (Werner) from Karlsruhe.  
6.0—News; Records.  
7.15—"Herrgottsdom"—Musical Sequence (Richter).  
7.45—Station Choir and Orchestra. Conductor: Buschkötter. Lore Fischer (Contralto). Arias (Handel) from (a) "Partenope," (b) "Theodora." Requiem (Reger). Eroica Symphony (Beethoven).  
9.0—Time; News.  
9.30—See Deutschlandsender.  
11.0 p.m.-12.0 m't.—See Frankfurt.

**TOULOUSE (PTT) (France)**

776 kc/s (386.6 m.); 120 kW.  
Transmits at intervals from 7.0 a.m.  
7.0 p.m.—Orchestra. Conductor: Tartanac. Overture, "La fête au village voisin" (Boieldieu). Serenade (Widor). Selection, "Aida" (Verdi). Suite, "Izeyl" (Piermé).  
7.30—Topical.  
8.15—News; Records.  
8.30—See Lille (Radio PTT Nord).

**TOULOUSE (Radio-Toulouse) (France)**

913 kc/s (328.6 m.); 60 kW.  
11.40 a.m.—Ketelbey Music—Orchestra.  
11.48—Roman Catholic Address; Christus lag in Todesbänden (Bach).  
12.0 noon—News.  
12.30 p.m.—Film Songs.  
12.40—Light Music.  
12.45—Dance Band.  
1.15—Excerpts, "Les Cloches de Corneville" (Planquette).  
1.45—Opera Music. Excerpt, "The Song of Happiness" (Lehár). Potpourri (Misraki). Selection, "The Flower of Hawaii" (Abraham) and "O Papa" (Yvain).  
1.55—News.  
2.0-2.5—Protestant Address.  
4.30—English Concert.  
6.40—Chansonnettes.  
6.55—News; Sports.  
7.15—Refrains.  
7.45—Light Music.  
8.0—Songs.  
8.30—Variety.  
8.45—Salon Orchestra.  
9.15—Songs.

9.30—"Le Dancing de Teddy"—Fantasy.  
10.0—News.  
10.15—English Concert.  
11.15—Military Marches.  
11.35—Light Music.  
11.50-12.0 m't.—News.

**TURIN GROUP (Italy)**

Turin (No. 1), 1,140 kc/s (263.2 m.); 7 kW. Milan (No. 1), 814 kc/s (368.6 m.); Genoa (No. 1), and Trieste, 1,140 kc/s (263.2 m.); Bolzano, 536 kc/s (559.7 m.); Florence (No. 2), 1,258 kc/s (238.5 m.); and Rome (No. 2), 1,222 kc/s (245.5 m.).  
7.30-7.50 a.m.—News.  
8.30-10.0—See Rome.  
10.0—Mass from the Church of the Annunciation, Florence.  
11.0-11.15—Bible Reading.  
11.20—Sports.  
11.30—Request Music.  
12.0 noon—News.  
12.15 p.m.—Variety.



Photo: Paganini

A scene from "Andrea Chénier," which Turin is to broadcast at 8 p.m.

12.45-1.15—Records.  
2.30-8.0—See Rome.  
8.0—"Andrea Chénier" (Giordano). Conductor: Previtali. Chorus-Master: Costantini. Cast: Francesco Merli, Benvenuto Franci, Maria Pedrini, Agnese Dubbini, Edmea Limberti, Tito Gobbi, Piero Passerotti, Luigi Bernardi, Nino Mazziotti and Gino Conti. In the intervals, News (German), Talks and News.

**VIENNA (Austria)**

592 kc/s (506.8 m.); 100 kW. Relayed by Graz and Linz, 886 kc/s (338.6 m.); Innsbruck, 519 kc/s (578 m.); Klagenfurt and Vorarlberg, 1,294 kc/s (231.8 m.); and Salzburg, 1,348 kc/s (222.6 m.).  
Transmits at intervals from 6.45 a.m.  
7.10 a.m.—Gym.  
7.30—Weekly Hints.  
7.45—Records. Die Romantiker (Lanner). Wass kommt dort von der Höh? (Suppé-Lochmann). Fahr wohl, o Vögelein (Brahms). Spielerei (Stix). Odaliskentanz (Sendrey). Folk Song, Im grünen Wald, dort, wo die Drossel singt. Selection, "Der Prophet" (Meyerbeer). Waltz, España (Waldteufel). Waltz, Lippen schweigen (Lehár). Die Geige weint (Wismar). Selection, "Carmen" (Bizet). Minuet (Massenet). Song, Der Fremdenlegionär. Potpourri, Lustig und fidel (arr. Buchberger). Intermezzo, Struzzel (Siede).  
8.45—Mass (Wöss) from the Franciscan Church.  
10.0—For Farmers.

10.40—Time; Announcements.  
10.45—Symphony Concert. Vienna Chamber Orchestra. Conductor: Auerieth. Marianne Brünner (Pfte.). Sinfonia Concertante in D (Donizetti). Pfte. Concerto in B flat minor (Tchaikovsky). Symphony in G minor (Mozart).  
11.55—Winter Relief Fund Concert. Station Orchestra. Conductor: Sandauer. March, "The Bartered Bride" (Smetana). Waltz, "Der Rosenkavalier" (R. Strauss). Song, "The Gipsy Baron" (Joh. Strauss). Ländler, Grossmütterchen (Langer). Waltz, "Eva" (Lehár). Die Silbermyrthe (Stuhlmüller). Tango, Mädels verzeih' (Mahrer). Tango, Heisse Nächte (Riedlmaier). Waltz, Künstlerleben (Joh. Strauss). Erst wann's aus wird sein (von Frankowsky). Waltz, Ich möcht' vor dir ein Photo (Benes). March, Hoch Habsburg (Kral). March, Mein Oster-

(Sopranos). Walter Ernst and Dario Medina (Tenors). Hermann Baier (Baritone). Overture and Bacchanal from "Indigo" (Joh. Strauss). Tenor: Solang es Frauen gibt from "Venus in Seide" (Stolz). Excerpts, "The Gipsy Baron" (Joh. Strauss). Tenor Song from "The Blue Mazurka" (Lehár). Soprano and Tenor Duet, "The Gipsy Princess" (Kálmán). Hungarian Dances, "Wo die Lerche singt" (Lehár). Soprano and Choir: Du, mein Schönbrunn, from "Die Kaiserin" (Fall). Quartet, "A Night in Venice" (Joh. Strauss). Soprano and Tenor Duet from "Paganini" (Lehár). Excerpt, "Der Bettelstudent" (Millöcker). Overture, "The Mikado" (Sullivan). Tenor and Choir: Song from "The Cinema Queen" (Gilbert). Soprano Song from "Giuditta" (Lehár). Scene, "The Bayadère" (Kálmán). March, "Die Landstreicher" (Ziehrer). Songs, "The Little Dutch Girl" (Kálmán). Brüderlein und Schwesterlein, from "Die Fledermaus" (Joh. Strauss). Song from "Alt Wien" (Lanner-Stern). Gallop from "Orpheus in the Underworld" (Offenbach).

8.35—Records.

9.10—News.

9.30—Thiel Jazz Band.

9.55—Announcements.

10.0-10.30—Thiel Jazz Band.

**WARSAW (Poland)**

224 kc/s (1,339 m.); 120 kW. Relayed by Cracow, 1,022 kc/s (293.5 m.); Katowice, 758 kc/s (395.8 m.); Łódź, 1,339 kc/s (224 m.); Lwów, 795 kc/s (377.4 m.); Poznan, 868 kc/s (345.6 m.). Torun, 986 kc/s (304.3 m.); and Wilno, 536 kc/s (559.7 m.).

7.0 a.m.—News; For Farmers.

8.0 (from Łódź)—Mass; Records.

9.30—Building the "Basilica of the Sea" at Gdynia: Talk; Chóir; Naval Band.

10.0—Records; Topical.

11.3 (from Łódź)—Philharmonic Orchestra. Conductor: Pietruszka. Neumiller (Violin). Pieces (Svendsen): (a) Symphonic Poem, Zoro-haide, (b) Two Norwegian Melodies, (c) Romance. Pieces (Sibelius): (a) Valse triste, (b) Finlandia. Pieces (Järnefelt): (a) Berceuse, (b) Präludium. Two Norwegian Dances (Grieg).

12.0 noon—Review; Reading.

12.30 p.m. (from Lwów)—Seredynski Orchestra and Pfte. Duo.

1.45—For Country People.

2.45—For Children.

3.5—Rubinstein Music by Rabcewicz (Pfte.) and Lifan ('Cello). Pfte.: (a) Melody in B, (b) Valse allemande in F. 'Cello Sonata in G; Reading.

4.0—Station Orchestra, etc., from the Hotel Bristol. Conductor: Górzynski.

5.50—"Morning"—One-Act Play (Sarnecki).

6.35—Virtuoso Records.

7.35—Programme Notes; Politics.

7.50—News and Sports.

8.15—French Cabaret (arr Horowicz).

9.0 (from Cracow)—Concert. Salon Orchestra. Conductor: Nierychla. Zboinska - Ruszkowska (Soprano). Scherzo and Fugue (Zeisl). Eight Songs (Marx). Serenade (Larson). Sinfonietta (Bacewicz).

9.50-10.0—News.

reich (Suppé). Das ist mein Wien, die Stadt der Lieder (Hoffmann). March, Unter dem Doppeladler (Wagner).

1.20 p.m.—A Competition.

1.30—Programme Notes.

2.0—News; Book Review.

2.40—Chamber Music by the Kolbe Quartet. String Quartet in F minor (Beethoven). String Quartet in D (Haydn).

3.20—Talk: Bardo Thödol—the Tibetan Book about Death and Reincarnation.

3.45—Music from Fairyland. Station Orchestra. Conductor: Sandauer.

4.15—Talk: Mountaineering.

4.35—Franz Winkler reads. Introductory Talk by Bernhard Birk.

5.0—Viennese Characters Past and Present—Humorous Sequence (Bergauer).

5.25—Light Music. Anny Antl-Plakowitz (Accordion). Dorte Krauss (Songs). Hans Kremsberger (Saxophone and Clarinet). Julius Döthman (Pfte.).

5.50—Answers to Musical Riddles.

6.0—Time; Sports.

6.10—Weekly Review.

6.35—Karl Schwamberger ('Cello) and Cerné (Pfte.). Adagio and Allegro (Boccherini). Sonata (Valentini). Aria (Reger). Polonaise brillante (Chopin).

7.5—Operetta Concert. Station Orchestra and the Vienna Opera Choir. Conductor: Schönherr. Margit Bokor and Marianne Handl

# MONDAY Nov. 22

## NATIONAL

Time Signals (normally): Big Ben, 10.15 a.m., 5.15 p.m., 12 midnight, Greenwich, 10.30 a.m., 2.0, 6.0, 9.0, 11.30 p.m.

10.15 a.m. (D)—Service.  
 10.30 (D)—Weather Forecast.  
 10.45 (D)—Cinema Organ.  
 11.15 (D)—Records.  
 11.30 (D)—German for Schools.  
 11.45 (D)—Records.  
 12.0 (D)—Church History.  
 12.25 p.m. (D)—Orchestra.  
 1.0 (D)—In Defence of Unmodern Architecture: Peter Davies.  
 1.15 (D)—William H. Harris (Organ). 2.0 (D)—Herring Bulletin.  
 2.5 (D)—For Schools.  
 3.0 (D)—Geiger and his Orchestra.  
 3.30 (D)—German Schools.  
 4.0 (D)—Vest-pocket Vaudeville.  
 4.30 (D)—Records.  
 5.0—Alfredo Campoli Salon Orchestra: Max Goldberg (Trumpet).  
 6.0—The First News.  
 6.20—BBC Midland Orchestra, conducted by Leslie Heward.  
 7.0—Monday at Seven.  
 7.45—The Plums.  
 8.0—Design in Everyday Things.  
 8.30—Broadway Matinee: American Variety, with Freddy Rich and his Orchestra.  
 9.0—The Third News.  
 9.20—World Affairs.  
 9.35—"Words Upon the Window-pane," a play by W. B. Yeats.  
 10.5—Chamber Music: Menges String Sextet.  
 11.15—Maurice Winnick's Orchestra. 11.30-12.0—Dance Records.

## REGIONAL

Time Signals (normally): Big Ben, 10.15 a.m., 5.15 p.m., 12 midnight, Greenwich, 10.30 a.m., 7.0, 10.0, 11.30 p.m.

10.15-10.45 a.m. (ex. Western)—National.  
 10.45 (ex. Western, Scottish)—Orchestra: Jack Lewis (Tenor).  
 10.45 (Western, Scottish)—National.  
 11.45 (ex. Western, Scottish)—Hungarian Orchestra.  
 12.30 p.m. (ex. Western, Scottish)—Ballad Concert.  
 1.0 (ex. Western, Scottish)—Dance Records.  
 1.45 (ex. Western, Scottish)—Light Orchestra.  
 2.0 (Scottish)—For Schools.  
 2.30 (ex. Western, Scottish)—Norman Tucker (Pfte.).  
 3.0 (ex. Western, Scottish; Welsh 3.25)—Orchestra.  
 3.0 (Welsh)—For Schools in Wgles.  
 3.35 (Western, Scottish)—National.  
 4.0 (ex. Western, Scottish)—Norina Semino ('Cello); John Pauer (Pfte.). 4.30—Cinema Organ.  
 5.0 (ex. Western)—Children's Hour.  
 5.0 (Western)—National.  
 6.0 (ex. Midland, Welsh, Scottish)—The Little Orchestra.  
 6.0 (Midland)—"Moon Melodies."  
 6.0 (Welsh)—Welsh Regional Trio.  
 6.0 (Scottish)—Scottish Dances.  
 6.30 (ex. Western)—Reginald Foort (BBC Theatre Organ).  
 6.30 (Western)—Part Songs.  
 7.0—The Second News.  
 7.20—Regional Announcements.  
 7.30 (ex. Western)—Folk Songs of France. Dijon University Choir.  
 7.30 (Western)—Discussion.  
 8.0 (ex. Midland, Welsh)—Swing Music: Willie Lewis and his Orchestra, from Paris.  
 8.0 (Midland)—Billy Merrin and his Commanders.  
 8.0 (Welsh)—Frank Thomas (Violin).  
 8.30 (Regional, Midland, Western)—The Belavia Circle: The Kutcher String Quartet.  
 8.30 (Northern)—Chronicle of Speed.  
 8.30 (Welsh)—Mwycyn Gweld.  
 8.30 (N. Ireland)—"London Line."  
 8.30 (Scottish)—"Discovering Scotland;" Joe Corrie.  
 8.45 (Northern)—"A Rescue from the Sea;" talk.  
 8.45 (N. Ireland)—Records.  
 8.45 (Scottish)—R. C. Howells (Organ).  
 8.50 (N. Ireland)—Mrs. Rooney of Belfast.  
 9.0 (ex. Western)—Star-Gazing: Marie Burke.  
 9.0 (Western)—Light Orchestra.  
 10.0—News Summary.  
 10.25 (ex. Western)—Maurice Winnick's Orchestra.  
 11.30 (ex. Western)—Late News Summary. 11.40-12.0—Records.

Hours of Transmission in Greenwich Mean Time.

## ATHLONE (Ireland)

565 kc/s (531 m.); 100 kW. Dublin, etc. See Sunday.  
 1.30 p.m.—Records.  
 2.30-3.0—For Schools.  
 5.30—Among the Children.  
 6.0—"Where are you going to, my Pretty Maid?" by the Rev. Owen Dudley.  
 6.20—Records.  
 6.35—Irish News Feature.  
 6.45—News.  
 7.0—Sonatas (Beethoven), with Introductory Talk.  
 7.40—Favourite Italian Arias by the Irish Radio Orchestra and Mairé Dingle (Soprano). Overture, "The Thieving Magpie" (Rossini); Selection, "Manon Lescaut" (Puccini).  
 8.15—"The Vigil of the Holocaust"—A Manchester Martyrs Commemoration Programme.  
 9.0—Modern English Composers. No. 1—John Ireland Concert with Introductory Talk. Dina Copeman (Pfte.) and Frank Cowle (Baritone).  
 9.30—Variety. ✕  
 10.30—News.  
 11.0—National Anthem.

## BERLIN (Germany)

841 kc/s (356.7 m.); 100 kW. Transmits at intervals from 5.0 a.m. 11.0 a.m.—See Leipzig.  
 1.0 p.m.—News.  
 1.15—Kaiser Band. Riviera (Ailboud). Liebestraum (Bochmann). Marche militaire (Schubert). Romanesque (Winkler). Amphitryon-Walzer (Doelle). Der Weg zum Herzen (Lincke). Zauberklein (Meyer-Helmund). In deinen Armen (Böhme). Schreib' mir mal 'ne Karte (Kollo). Frauenherz (Strauss). Es kommt, wie es kommen muss (Carste). Alles tanzt Walzer (Ralph).  
 2.15—Exchange; Markets.  
 2.35-3.0—Records.  
 3.30—"Words describe Music"—Sequence (Klöden); Music by Sommerfeld.  
 4.0—Romantic Music. Bertha Gunderloh (Songs), Luise Gmeiner (Pfte.). Part I: Songs (Sobanski). O ihr Sommer, welche mir entschwinden. Wie steht der Mond so rot. Was ist für ein Gesänge. Part II: Pfte. Music. Ballad in D minor (Brahms). Scherzo in E flat minor (Brahms). In der Nacht (Schumann). Intermezzo (Schumann). 4.30—Mathias Wiemann talks about his film, "Das Unternehmen Michael."  
 5.0—Raatzke Quintet. Ein Walzer vom Rhein (Knümann). Intermezzo (De Micheli). Two Dances (Rust). Argentine Night (Krome). Tanzende Geisha (Zander). Elfän Dance (Heykens). Die lustige Schäferin (Wetzel). Juel-Frederiksen. Russian Night (Hippmann). Tarantella (Rossmann).  
 6.0—News.  
 6.10—Held Band, Angermann (Baritone). Schütz (Accordion).  
 7.0—Danzig-Berlin Exchange Programme. Danzig Police Band—Conductor: Stieberitz, from Danzig. Tresi Rudolph (Soprano). Schmitt-Walter (Baritone) and Berlin Station Orchestra—Conductor: Willy Steiner, from Berlin.  
 9.0—News; Sports.  
 9.30-11.0—See Deutschlandsender.

## BEROMÜNSTER (Switzerland)

556 kc/s (539.6 m.); 100 kW. Relayed by Basle and Berne, 1,375 kc/s (218.2 m.).  
 5.30-5.50 a.m.—Skiing Lesson.  
 9.20-9.50—For Schools.  
 11.0—Records.  
 11.29—News; Exchange.  
 11.40 a.m.-12.45 p.m.—Swiss Folk-Music.  
 3.0—For Women.  
 3.30—Dance and Light Music by the Canavesi Band. ✕  
 4.0—Gertrud Pfister (Soprano).  
 4.25—Pfte. Quartet in C minor (Fauré).  
 5.0—Porkert (Clarinet).  
 5.30—For Philatelists.  
 6.0—Records.  
 6.15—Talk.  
 6.45—Weather; News.  
 6.55—Mozart Concert.  
 8.0—Zürich Pictures.  
 8.10—Announcements.

8.15—Weekly Review for Swiss Abroad.  
 8.30-9.30—See Monte Ceneri.

## BRATISLAVA (Czechoslovakia)

1,004 kc/s (298.8 m.); 13.5 kW. Transmits at intervals from 5.15 a.m.  
 5.0 p.m.—Hungarian Talks.  
 5.45-6.15—See Prague.  
 6.15—Wireless Notes.  
 6.20—Vašica Jazz Band. ✕  
 6.45—Talk.  
 7.0—Blaho (Slovak Folk Songs).  
 7.15—"Wedding Clothes"—Play (Hurban-Vajansky).  
 8.25—Pfte. Trio in F (Saint-Saëns), by the Bratislava Trio.  
 9.0—See Prague.  
 9.15—News (Hungarian).  
 9.30-10.0—Records.

## BRESLAU (Germany)

950 kc/s (315.8 m.); 100 kW. Relayed by Gleiwitz and Görlitz, 1,231 kc/s (243.7 m.). Transmits at intervals from 4.30 a.m.  
 11.0 a.m.-1.0 p.m.—See Hamburg.  
 1.0—News; Exchange.  
 1.10-2.0—Cinema Organ and Records.  
 3.0—North Silesian Orchestra. Conductor: Anders. Overture, "Preciosa" (Weber). Air gai (Gluck). Accelerationen-Walzer (Strauss). Selection, "Halka" (Moniuszko). Intermezzo, Picnic (Siede). Ballet, "Die Puppenfee" (Bayer). Musette (Gluck). March, Mignon (Poldini). Indian Suite (Lüling). Waltz, Deutsche Mädels (Kochmann). Overture, "Die Irrfahrt ins Glück" (Suppe). Intermezzo (Rivelli). March (Rhode); at 4.0-4.10—Reading.  
 5.0—Talk: The Oberlausitz.  
 5.25—Beethoven Recital by Martha Bartling (Pfte.). Sonata in E flat. Bagatelles in C and D.  
 5.45—Talk: Germany's Recovery.  
 6.0—News; Markets.  
 6.10—"Appearance and Reality in Human Life"—"Blue Monday" in Words and Music (Sattler). Graumann (Tenor), Betty Sedlmayr (Soubrette), Station Dramatic Troupe and Dance Band.  
 8.0—Motto.  
 8.5—"Neisse, Upper Silesia"—a Town pictured in Sonnets (Alfred Jahn), by the Gleiwitz Station Players.  
 9.0—News.  
 9.20—"Copenhagen"—a Radio Picture.  
 9.30—Günther Bialas Songs by Claire Frühling (Soprano), the Composer at the Pfte. Wer du auch seist. Wir sind die Treibenden. Begrleute sind wir. Sterne fallen. Schneewittchen. Die sieben Zwerge. Triangel. Milder leuchten die Gestirne. Die Sirenen. Einmal vor manchem Jahr. Wiegenlied. Abendlied.  
 10.0-10.30—Karg-Elert Anniversary Concert by Wesemann (Harmonium). Ciaccona con variazioni. Air Träumerei. Deingedenken. Um Mitternacht.

## BRNO (Czechoslovakia)

922 kc/s (325.4 m.); 32 kW. Transmits at intervals from 5.15 a.m.  
 4.40 p.m.—German Talks.  
 5.15—News.  
 5.20—For Workers.  
 5.30—Morse.  
 5.45-6.20—See Prague.  
 6.20—Folk Songs.  
 6.35—Operetta Music by the Station Orchestra and Singers. Conductor: Plichta.  
 8.5—Talk.  
 8.25—Sonata (Juon) by Jenc (Viola) and Kalab (Pfte.).  
 9.0-10.0—See Prague.

## BRUSSELS (No. 1) (Belgium)

620 kc/s (483.9 m.); 15 kW.  
 6.30-9.5 a.m.—Records; Gym; News.  
 12.0 noon—Records: Light Music.  
 12.30 p.m.—Shipping; Salon Orchestra.  
 1.0-2.3—News; Salon Orchestra; Records; Art Notes.  
 4.55—News; Records; Talk.  
 5.30—Salon Orchestra, etc.; Talk.  
 6.0—"Roman de Chevalerie," by the Liege Marionettes.  
 6.30—Records: Old Music.  
 7.0—Hygiene and Sports Notes; Interview.  
 7.15—Records: Light Music.  
 7.30—News; Topical.  
 8.0—"Antony and Cleopatra"—Play (Shakespeare; trans. André Gide); Incidental Music by Florent Schmitt.  
 10.0—News; Record; Books.  
 10.30-11.0—Records: Light Music.

## BRUSSELS (No. 2) (Belgium)

932 kc/s (321.9 m.); 15 kW. Programme in Flemish.  
 6.30-9.5 a.m.—Records; Gym; News.  
 12.0 noon—Records: "The Pearl Fishers" (Bizet).  
 12.30 p.m.—Radio Orchestra. Conductor: Douliez.  
 1.0—News; Orchestra; Records.  
 2.0—Shipping.  
 4.55—News; Announcements.  
 5.0—Radio Orchestra. Conductor: Douliez, Delcroix (Saxophone).  
 5.45—For Children.  
 6.30—Hot Jazz Records of Louis Armstrong's Band.  
 6.45—Armand Franck (Songs).  
 7.0—Records: Light Music.  
 7.30—Theatre Review; Sports.  
 8.0—"Die Vielgeliebte" (Dostal). Conductor: Walpot. Talk in the interval.  
 10.0-11.0—News; Records of Light and Dance Music.

## BUCHAREST (Romania)

823 kc/s (364.5 m.); 12 kW. Relayed by Radio Romania, 160 kc/s (1,875 m.). Transmits at intervals from 4.30 p.m.  
 5.0 p.m.—Topical; Books; Review.  
 5.15—Serbanesco (Romanian Songs).  
 5.30—Quartet in A (Beethoven).  
 6.15—Records: Ballet Music.  
 7.0—Educational.  
 7.15—Old Music by the Radulesco Ensemble.  
 8.5—Hugo Wolf Songs by Naruja.  
 8.30—News; Sports.  
 8.45—Motoiu Orchestra.  
 9.45—News (French, German).

## BUDAPEST (No. 1) (Hungary)

546 kc/s (549.5 m.); 120 kW. Transmits at intervals from 5.45 a.m.  
 5.45 a.m.—Gym; Records; Menu.  
 6.0—News; Talks.  
 10.10—Water Level.  
 11.0—Chimes.  
 11.5—Sárközi Cigány Band; at 11.30—News.  
 12.30 p.m.—Police Band.  
 1.40—News.  
 3.15—For Schools.  
 4.0—Anita Kubelik (Violin).  
 4.30—Judit Beczassy.  
 5.0—Förrei Vocal Ensemble, Józsa Micsy and Margit Baumgarten (Songs), Szabados (Pfte.), Nagy (Harmonium), Rohmann (Harp).  
 5.45—"A Musical Journey up the Rhine"—Talk, with Records.  
 6.50—Literary Talk: Ady.  
 7.45—Segovia (Guitar), from the Academy of Music. Prelude and Gavotte (Scarlati). Pieces (Weiss): (a) Prelude, (b) Allemande, (c) Allegretto, (d) Gigue. Variations (Sor). Chaconne (Bach).  
 8.35—News.  
 9.0—Egressy and Dénes Cigány Band. Jenő Nádor (Songs).  
 9.45—Talk in French: The 1938 International Eucharistic Congress in Budapest.  
 10.0—News (German).  
 10.5—Jazz Band. ✕  
 11.5—News.

## BUDAPEST (No. 2) (Hungary)

359.5 kc/s (834.5 m.); 18 kW.  
 5.45 p.m.—German Lesson.  
 6.15—Dr. Tibor Dénes.  
 6.50—Records.

## COLOGNE (Germany)

658 kc/s (455.9 m.); 100 kW. Transmits at intervals from 5.0 a.m.  
 11.0 a.m.—Military Band.  
 12.0 noon—News; Greetings.  
 12.15 p.m.—See Hamburg.  
 1.0—News.  
 1.15—See Hamburg.  
 2.0-2.30—For Children.  
 2.45—Markets.  
 3.0—Variety.  
 4.10—See Deutschlandsender.  
 5.0—Poems (Ina Seidel).  
 5.15—Berger (Violin), Rummel (Pfte.).  
 5.50—What is your opinion?  
 6.0—News.  
 6.15—See Stuttgart.  
 8.0—Weekly Review.  
 8.40—Posthumous Songs of Hugo Wolf, by Mia Bishoff (Contralto).  
 9.0—News.  
 9.30-11.0—Serenade, Dance Music. Station Orchestra, Cologne Pfte. Duo, Aldo Ferraresi (Violin).

## DEUTSCHLANDSENDER (Germany)

191 kc/s (1,571 m.); 60 kW. Transmits at intervals at 5.0 a.m.  
 11.0 a.m.—See Hamburg.  
 11.55—Time; Greetings.  
 12.15 p.m.—See Hamburg.

## 12.50—News.

1.0—Music.  
 1.15—See Berlin.  
 2.0—Announcements; Records.  
 2.45—Literary Talk.  
 3.0—Joost Band.  
 4.0—Reading.  
 4.10—Band (contd.).  
 5.0—Concert by the Berlin Hitler Youth Mozart Choir.  
 5.25—Records of Frederick Hippmann.  
 5.40—Dr. Rickli describes his Film about X-Rays.  
 6.0—Motto; News.  
 6.10—"November Sunshine"—Sequence, with Music (Krug).  
 7.0—Variety Concert from Stuttgart.  
 7.45—Germany and Bolshevism—Addresses by Hagemeyer and Rosenberg.  
 9.0—News; Topical.  
 9.30-11.0—Serenade. Joost Band, Blacky Hübner and Paul Elbern (Two Pftes.).

## FRANKFURT (Germany)

1,195 kc/s (251 m.); 25 kW. Cassel, etc. See Sunday. Transmits at intervals from 5.0 a.m.  
 11.0 a.m.—See Hamburg.  
 12.0 noon—News; Weather.  
 12.15 p.m.—See Hamburg.  
 1.0—Time; News.  
 1.10—Records: Light Music.  
 2.0—Talk; Markets.  
 2.15-2.45—For Children.  
 3.0—Light Orchestral.  
 5.0—Topical Programme.  
 6.0—News; Weather.  
 6.15-8.0—See Stuttgart.  
 8.15—Station Orchestra. Conductor: Frickhoeffer. Pierre Fournier ('Cello). Cello Concerto (Couperin). Dances from Castor and Pollux (Rameau). 'Cello Concerto (Bocherini).  
 9.0—News; Sports.  
 9.30—See Cologne.  
 11.0-12.0 m't.—See Stuttgart.

## HAMBURG (Germany)

904 kc/s (331.9 m.); 100 kW. Bremen, etc. See Sunday. Transmits at intervals from 5.10 a.m. (from Hanover)—Hanover Castle Concert. Conductor: Secker. Anita Gura (Soprano), Toriff (Tenor).  
 12.0 noon—News.  
 12.15 p.m.—Concert (contd.).  
 1.0 p.m.—News.  
 1.15—Music.  
 2.0—Shipping; Markets.  
 2.25—Orchestral Records.  
 2.50—Ice Report.  
 3.0—Variety Concert. Station Dance Band, Marzel Salon Quintet, Gertrud Schnitzer (Soprano), Gregor (Organ). Talks in the intervals.  
 5.0—Theodor Blumer Chamber Music. Hamann (Violin), Eggers (Oboe), the Composer (Pfte.). Violin Sonata in D minor. Partita for Oboe and Pfte.  
 5.40—Talks.  
 5.50—Shipping.  
 6.0—News.  
 6.15—See Stuttgart.  
 8.0—"A Bachelor pours out his Heart."—A Glimpse of Life in Digs (Hippel).  
 9.0—News.  
 9.30-11.0—See Cologne.

## HILVERSUM (1,875 m.) (Holland)

160 kc/s; 10 kW until 2.40 p.m.; 150 kW from 2.40 p.m. NCRV Programme.  
 7.40 a.m.—Bible Reading; Meditation; Records; Sacred Music.  
 8.10—Records; at 9.10—Greetings.  
 8.10—Religious Programme.  
 10.40—Reading.  
 11.10—Records; at 11.40—News.  
 12.10 p.m.—Gray (Organ).  
 1.10—Records.  
 1.40-2.15—Educational.  
 2.15—Records.  
 2.40—Talk.  
 3.20—Records; Bible Reading.  
 4.25—Records; For Children.  
 5.25—Zondervan (Bass - Baritone) and Veelo (Pfte.).  
 6.10—Letter-box; News; Report.  
 7.40—News.  
 7.55 (approx.)—NCRV Orchestra. Conductor: v. d. Hurk.  
 8.40—Talk.  
 8.55—NCRV Orchestra (contd.).  
 9.40—News and Talk.  
 9.50—NCRV Orchestra (contd.).  
 10.25—Gym.  
 10.40-11.40—Records; Bible Reading.

## HILVERSUM (301.5 m.) (Holland)

995 kc/s; 15 kW until 6.10 p.m.; 60 kW from 6.10 p.m. VARA Programme.  
 7.40 a.m.—Records.

9.40—VPRO Religious Programme.  
 10.0—Recitation; Concert by the "Fantasia." Conductor: Wallis.  
 11.10—Steyn (Organ).  
 11.40—Records.  
 12.10 p.m.—VARA Orchestra. Conductor: de Groot.  
 12.55-1.25—Records.  
 1.40—Records.  
 2.40—Recitation.  
 3.0—Masha Polak (Violin).  
 3.40—Records.  
 4.10—For Children.  
 4.40—Records.  
 5.40—For Amateurs.  
 6.10—Music Talk; Records.  
 6.50—Talk.  
 7.10—"Prince Igor" (Borodin). Residentie Orchestra, Mixed Choir and Ballet. Conductor: Cooper; at 7.40—News.  
 8.55—Recitations.  
 9.20—Jong (Organ).  
 9.40—Press Review.  
 9.45—VARA Orchestra. Conductor: de Groot.  
 10.40—Dance Music by the Ramblers. Conductor: Masman.  
 11.10-11.40—Records.

**KALUNDBORG (Denmark)**

240 kc/s (1,250 m.); 60 kW. Relays Copenhagen, 1,176 kc/s (255.1 m.).

Transmits at intervals from 6.0 a.m.

11.0 a.m.—1.0 p.m.—Preil's Ensemble.

1.15—Gymnastica.  
 1.35—Radio Orchestra. Tuxen. Karen Matke (Pfte.). Overture, "Si j'étais roi" (Adam). Mazurka (Ganne). Excerpts, "Le Cid" (Massenet). Selection, "The Little Princess" (Rygaard). Waltz, "The Gipsy Princess" (Kalmán). March, "Wiener Frauen" (Lehár). Pfte.: (a) Prelude, Fugue and Variations (César Franck), (b) Six Preludes (Chopin). Overture, "Medea" (Cherubini). Waltz, "Faust" (Gounod). Selection, "Tales of Hoffmann" (Offenbach). Drommen efter Ballet (Lumbye). Gallop (O. Strauss); at 2.15 — For Women.  
 3.30—For Children.  
 3.50—Announcements.  
 4.0—Poems.  
 4.25—Weather.  
 4.40—Exchange; Markets.  
 4.50—Records.  
 5.15—Talk: Rasmus Rask the Philologist.  
 5.35—English Lesson.  
 6.0—News.  
 6.30—Talk: Denmark under an Absolute Monarchy.  
 7.0—Records.  
 7.15—Lange-Müller Concert—Radio Orchestra. Conductor: Grøndahl. Edith Schmidt (Songs). Fessel (Violin). Overture, "Vikingeblod." Songs. Suite from "Der var engang." Romance for Violin and Orchestra. Excerpts from the Suite in the Alhambra. Three Songs. Prelude, "Renaissance."  
 8.25—A Visit to a Wine Cellar.  
 8.55—News.  
 9.10—Weather.  
 9.15—Eighteenth Century Music. Hansen and Margrethe Kjaeldgaard (Violins), Leuse Møller (Cello), Jensen (Harpisichord). Sonata in D minor (Ph. E. Bach). Sonata in A minor (Sammartini).  
 9.40—Arne. Aase reads his own Poems.  
 10.0-11.15 — Louis Preil's Dance Band; at 11.0—Chimes.

**KÖNIGSBERG (Heilsberg) (Germany)**

1,031 kc/s (291 m.); 100 kW. Relayed by Danzig, 1,303 kc/s (230.2 m.).

Transmits at intervals from 5.0 a.m.

11.0 a.m.—See Hamburg.  
 12.0 noon—News.  
 12.15 p.m.—See Hamburg.  
 1.0—News; Anniversaries.  
 1.15—Music.  
 1.55-2.0—Exchange.  
 2.30—Fashion Hints.  
 2.40—Book Review.  
 3.0 (from Danzig)—Danzig State Orchestra. Conductor: Koschnick.  
 5.0—"Murmurs in the Sports Shed"—Humorous Programme.  
 5.20—Records.  
 5.35—Announcements.  
 5.45—See Breslau.  
 6.0—Weather; News.  
 6.10—A War Experience on the Syrian Front.  
 6.40—Topical Report.  
 7.0—A Rustic Evening — Peasant Band, Station Choir, etc.  
 9.0—News; Sports.  
 9.20—Reading.  
 9.35-11.0—Music from Cologne.

**LEIPZIG (Germany)**

785 kc/s (382.2 m.); 120 kW. Relayed by Dresden, 1,285 kc/s (233.5 m.).

Transmits at intervals from 5.0 a.m.

11.0 a.m.—Orchestra. Conductor: Hilmar Weber. Overture, "Die Zwillingbrüder" (Schubert). Ballet, "Idomeneo" (Mozart). Selection, "The Taming of the Shrew" (Goetz). Waltz, "Faust" (Gounod). Selection, "The Student Prince" (Mil-löcker). Norwegian Rhapsody in C (Svendsen). March (Schröder).  
 12.0 noon—Time; News.  
 12.15 p.m. (from Dresden) — Orchestra (contd.) Selection, "Die Drei Pintos" (Weber). Petite Suite (Debussy). Excerpts, "Der Rosenkavalier" (Strauss). Waltz (Chopin-Hilmar Weber). March (Dennert).

1.0—News; Exchange.  
 1.10—Operetta Records.  
 2.0—Talk.  
 2.20—Songs of Work by a Hitler Youth Choir.  
 2.50—Presents bring Pleasure.  
 3.0-5.0—See Deutschlandsender.  
 5.0—Talk: Creed and Politics.  
 5.20 (from Dresden)—Erna Richter (Soprano). Part I. Lönslieder (Graener). Bittersüßes Lied. Der König. Männertrou. Verspruch. Part II. Lieder vom Leben (Haas). Unterm Zeltdach. Kommt ein Kindlein. Gloria. Der Gänsehirt.  
 5.40—Book Review.  
 6.0—News.  
 6.10—Classical Records.  
 6.30—"Schwarzer Peter"—Opera (Norbert Schultze) from the State Opera, Dresden. Conductor: Striegler. Cast: Hanns Lange, Sven Nilsson, Helene Jung, Arno Schellenberg, etc.  
 9.15—News; Sports.  
 9.30-11.0—Light and Dance Music.

**LILLE (Radio PTT Nord) (France)**

1,213 kc/s (247.3 m.); 60 kW.

Transmits at intervals from 6.30 a.m.

7.0 p.m.—For English Listeners.  
 7.15—Mistinguett Songs.  
 7.30—News; Weather.  
 8.0—Rozanos Musette Ensemble.  
 8.20 (also Limoges (PTT) and Toulouse (PTT)) — Symphony Concert from Paris. National Orchestra. Conductor: Rosenthal. Claire Chalande (Songs), Yvonne Astruc (Violin). Concerto grosso (Vivaldi-Molinari). Second Symphony (Boyce). Songs (Lalo, Duparc, Wagner). Symphonic Movement (Weber). Waltz, "Der Rosenkavalier" (Strauss). Contrerimes (Delage). Concertino de Printemps (Milhaud). Suite (Rosenthal).  
 10.30 (approx.)—News; Weather.

**LYONS (PTT) (France)**

648 kc/s (463 m.); 100 kW.

Transmits at intervals from 6.30 a.m.

8.30 p.m.—Symphony Concert. Conductor: Waersegers. Bernac (Songs). Symphony, From the New World (Dvořák). Un Jardin sur L'Oronte (Bachelet). Songs.  
 10.30—News (French, German).

**MONTE CENERI (Switzerland)**

1,167 kc/s (257.1 m.); 15 kW.

11.0 a.m.—Records.

11.30—News.  
 11.40—Opera Records.  
 12.20-12.30 p.m.—Cookery Hints.  
 4.0-5.0—See Beromünster.  
 6.15—For Farmers.  
 6.30—Records.  
 6.45—News.  
 7.0—To be announced.  
 8.15—See Beromünster.  
 8.30-9.30—Engadine Evening from St. Moritz.

**MOSCOW (No. 1) (Russia)**

172 kc/s (1,744 m.); 500 kW.

4.45 p.m.—Concert.

5.30—Literary Programme.  
 6.0—Concert.  
 9.0—English Programme.  
 10.0—Hungarian Programme.  
 11.0-12.0 m.t.—Spanish Programme.

**MUNICH (Germany)**

740 kc/s (405.4 m.); 100 kW. Relayed by Nürnberg, 1,267 kc/s (236.8 m.).

Transmits at intervals from 5.0 a.m.

11.0 a.m.—Light Orchestral.  
 12.0 noon—News; Records.  
 1.0 p.m.—News; Exchange.  
 1.15—See Hamburg.  
 2.0-2.30—Ballads and Rhymes by a Girls' Choir.  
 3.0 (from Nürnberg) — "Musica Buffa"—Sequence (Meder), with Zilcher Music.

3.40—Book Review.  
 4.0—Weather; Markets.  
 4.15 (from Augsburg) — Swabia Yesterday and Today—Augsburg Orchestra and Topical Reports (Recorded).  
 5.45—Sports Talk.  
 6.0—Weather; News.  
 6.10—Dance Music and Light Music on Records, with Franz Humbach Verses.  
 8.0—Poems (Michelangelo; trans. Rainer Maria Rilke).  
 8.10—Augsburg Light Orchestra and Choir of the Augsburg Institute for the Blind. Piece (Rücker). East Prussian Song (Brust). Adagio (Rücker). Song: Des Sonntags in der Morgenstund (Schumann). Finale (Rücker). Song: Raucheret, ihr Eichen (Glück). Emperor Waltz (Strauss). Folk Song. Basque Dance (Heuser).  
 9.0—News; Sports.  
 9.20—Interlude.  
 9.30-11.0—See Cologne.

**NAPLES GROUP (Italy)**

Naples, 1,104 kc/s (271.7 m.); 10 kW. Florence (No. 1), etc. See Sunday.

6.0 p.m.—Light Music.  
 6.15—Topical.  
 6.25—Opera Records. Overture, "The Siege of Corinth" (Rossini). Aria, "Mignon" (Thomas). Excerpts, "Otello" (Verdi). Arias, "I Puritani" (Bellini) and "The Daughter of the Regiment" (Donizetti). Overture, "Figaro" (Mozart).  
 7.0—Time; News.  
 7.20—See Rome.  
 7.30—"La sagra degli osei" — Three-Act Play (Colantuoni).  
 8.50—Dance Music.  
 10.0—News.  
 10.15-10.55—Dance Music.

**OSLO (Norway)**

260 (1,153.8 m.); 60 kW. Fredrikstad, etc. See Sunday.

Transmits at intervals from 10.40 a.m.

4.0 p.m.—Variety Concert.  
 5.0—Talk.  
 5.20—Guitar, Saxophone, Banjo, etc.  
 5.50—News and Announcements.  
 6.30—Time; Report.  
 7.0—Symphony Concert. Conductor: Kramm. Alfhild Røsegg (Pfte.). Overture, Russian and Ludmilla (Glinka). Pfte. Concerto in C minor (Rachmaninoff). Ballet, "The Sleeping Beauty" (Tchaikovsky).  
 8.10—Foreign Affairs.  
 8.40—News.  
 9.0—Topical Talk.  
 9.15-10.0—Records: English Music.

**PARIS (Eiffel Tower) (France)**

1,456 kc/s (206 m.); 7 kW.

Transmits at intervals from 6.30 a.m.

8.0 p.m.—Lovano (Songs), Nicole Rollet (Pfte.).  
 8.30—See Lyons (PTT).  
 10.30—Records.  
 11.0-11.15—News; Weather.

**PARIS (Poste Parisien) (France)**

959 kc/s (312.8 m.); 60 kW.

Transmits at intervals from 7.10 a.m.

12.0 noon—Exchange; Records.  
 12.35 p.m.—Exchange; Records.  
 1.15—Amusements; Records.  
 2.0—Exchange.  
 3.45—Exchange.  
 4.35—Exchange.  
 5.0—News.  
 5.5—Cabaret.  
 6.0—Exchange; News; Records.  
 6.15—Radio Magazine.  
 6.30—Lery and Lacour Poems.  
 6.50—Records.  
 6.58—Racing.  
 7.0—Topical.  
 7.5—Talk; Sports.  
 7.17—Amusements; Song Records.  
 7.50—Lyné Clevers Successes, presented by Jean Loup.  
 8.0—News.  
 8.10—Old Records, with Germaine Sablon and Clément Doucet.  
 8.15—Programme with Reda Caire, presented by Jean Loup.  
 8.30—"Under the Lamp" (Diamant-Berger), with Mady Berry, Pierre Larquey and Robert Ozanne, etc.  
 8.45—La bonne histoire.  
 8.57—News.  
 9.0—Max Regnier and Company.  
 10.0—"La Croix Sonore," with

Marie Antoinette Aussenac Broglie, and Nicolas Obouhow. Commentator: Theodore Mathieu.  
 10.30-11.0—Cabaret.

**PARIS (PTT) (France)**

695 kc/s (431.7 m.); 120 kW.

Transmits at intervals from 6.30 a.m.

4.0 p.m.—Lanquetuit (Organ) from the Schola Cantorum; Reading.  
 4.45—Mady Hardy (Pfte.).  
 5.0—Talk; Poems; Records.  
 5.37—Announcements; Review.  
 6.0—Talk: Songs of Liberty and Work—the St. Simonians.  
 6.15—Talk: The U.S.A. Bank Rate.  
 6.30—Marguerite Girard (Songs); Lévy (Cello).  
 7.0—News; Topical.  
 8.0—Maurice Emmanuel Music by Doyen (Pfte.), Le Roy (Flute), Cahuzac (Clarinet), and Germaine Cernay (Songs). Pfte. Sonatina. Trio. Odelettes anacréontiques.  
 8.30—Bouillon Orchestra.  
 9.0—Paris Saxophone Quartet, Ida Perrin (Pfte.), Chastenet (Songs). Pfte. Sonata in C (Beethoven). Songs (Brahms, Fauré, Duparc). Saxophone Quartet: (a) Faunes et nymphes (Lefort), (b) Sévillanes (Vellones), (c) Chansons d'autrefois (Pierné). Two Songs (Rabey). Quartet (Français).  
 10.0—Bouillon Orchestra.  
 10.30—News; Weather.  
 10.45—Records: Scene, "Les plaideurs" (Racine) by Comédie-Française Players.



Exclusive "World-Radio" Picture Madame Renée Sénac, "Louise" in the Radio-Paris operetta at 8.30 p.m.

**PARIS (Radio-Paris) (France)**

182 kc/s (1,648 m.); 80 kW.

6.30 a.m.—Records.

6.40—Time; News; Gym; Records.  
 7.15—News; Time; Records.  
 8.0—News; Programmes; Records.  
 10.15—Mass of St. Stephen (Büsser) from St. Augustine's Church. Conductor: The Composer; Markets.  
 12.0 noon—Josse Orchestra.  
 1.0 p.m.—Time; News; Exchange.  
 1.30—Germaine Féraldy (Songs); Josse Orchestra; Programme Notes.  
 2.5—"Le Déménagement"—Sketch (Monnier).  
 2.30—Markets; Exchange.  
 2.45—Yvonne Bouchéze and Claire Candes (Songs); Women's Journals; Talk.  
 3.45—Exchange; Markets.  
 4.0—André Lévy (Cello).  
 4.30—Beauty Hints; Anniversaries.  
 4.50—Exchange; Markets.  
 5.0—Cantrelle Orchestra. Overture, "Figaro" (Mozart). Serenade (Haydn). Die Spinnerin (Mendelssohn). Two Preludes (Chopin). Divertissement (Rabaud). Une nuit à Lisbonne (Saint-Saëns). Norwegian Dances (Grieg). Spanish Dance (Fallá). Bridal March, "Lohengrin" (Wagner).  
 6.0—Educational; Art Reviews.  
 7.0—Educational; Books; Diets-etics.  
 7.55—Review by Paul Reboux.  
 8.0—Time; Foreign Affairs; Politics; Programme Notes.  
 8.17—Clarisse Dieterlen (Pfte.).  
 8.30—"Les Mousquetaires au Couvent" (Varney). In the interval — News; Press Review.  
 10.30—Records: Light Music.  
 10.45-11.0—Time; News.

**PRAGUE (Czechoslovakia)**

638 kc/s (470.2 m.); 120 kW.

Transmits at intervals from 5.15 a.m.

4.25 p.m.—For Children; Records.  
 4.50—Educational Talk.  
 5.0—For Farmers.  
 5.10 — German Transmission: Humorous Programme; Talk; For Beekeepers.  
 5.45—News (German); Record.  
 6.0—News; Topical; Record.  
 6.25—Talk on the following Programme.  
 6.35—"Johnny's Kingdom" (Ostrčil), from the German Theatre. Conductor: Fritz Zweig  
 9.0—News; Sports.  
 9.15—German Lesson; Record.  
 9.40-10.0—News (German).

**RADIO-NORMANDIE (France)**

1,113 kc/s (269.5 m.); 15 kW.

6.45 a.m.—Military Band.

7.0—Chansonnettes.  
 7.15—News.  
 7.45—Physical Exercises.  
 8.0—Light Music.  
 8.45—Jane and John; Records.  
 9.15—Light Music.  
 9.45—Hildegard.  
 10.0—Light Music.  
 11.0—Dance Music; Records.  
 11.30—Orchestra.  
 12.0 noon—Variety Concert.  
 12.45 p.m.—News.  
 1.0—Variety Concert.  
 2.0—Light Music.  
 3.0—Film Fantasy.  
 3.15—Military Band.  
 3.30—Light Music.  
 4.15—Accordion.  
 4.30—Light Music.  
 5.30—For Children; Records.  
 6.0—Markets.  
 6.5—Children's Corner.  
 6.45—Racing; News.  
 7.0—Chansonnettes.  
 7.25—News; Records.  
 8.0—Variety.  
 9.0—Variety Concert.  
 11.0—Cabaret.  
 11.45—News.  
 12.0 m.t.—Midnight Melodies.  
 12.30-1.0 a.m. (Tuesday) — Dance Music.

**REYKJAVIK (Iceland)**

208 kc/s (1,442 m.); 16 kW.

Transmits at intervals from 11.0 a.m.

8.10 p.m.—Weather (Icelandic, German, English).  
 8.20—Parliamentary Notes.  
 8.55—Announcements.  
 9.0—Time; News.  
 9.30—Talk.  
 9.55—Songs.  
 10.20—Popular Music—Radio Orchestra.  
 10.30—Trio in C (Brahms).

**ROME GROUP (Italy)**

Rome (No. 1), 713 kc/s (420.8 m.); 50 kW. Bari (No. 1), etc. See Sunday.

Transmits at intervals from 6.45 a.m.

4.0 p.m.—News.  
 4.15—De Angelis Tipicà Orchestra.  
 4.55-5.5—Poems.  
 5.50—Royal Geographical Society's Report.  
 6.0—Sports; Talk in French.  
 6.25—News (English, French).  
 7.0—Time; News.  
 7.20—Government Review.  
 7.30—Light Music.  
 8.0—Concert. Conductor: Tansini. Ebe Stignani (Mezzo-Soprano); Galeffi (Baritone). Symphony in C minor (Foroni). Arias, "La Gioconda" (Ponchielli), "Rigoletto" (Verdi), and "Cinq Mars" (Gounod). Prologue, "I Pagliacci" (Leoncavallo). In the Steppes of Central Asia (Borodin). Arias, "Le Roi de Lahore" (Massenet), "Samson and Delilah" (Saint-Saëns), and "A Masked Ball" (Verdi). Overture, "William Tell" (Rossini).  
 9.5—Film Review.  
 9.15—"La Signorina per bene"—Play (Camisior).  
 10.0—News.  
 10.15-10.50—Dance Music.

**SOTTENS (Switzerland)**

677 kc/s (443.1 m.); 100 kW.

Relayed by Geneva, 401 kc/s (748 m.).

11.29 a.m.—Time; News.  
 11.40 a.m.—12.45 p.m.—Records.  
 4.0-5.0—See Beromünster.  
 5.0-6.50—Programme from Geneva.  
 5.0—Records.  
 5.20—Esperanto Lesson.

MONDAY (November 22)

5.25—Interlude.
5.30—Bridge Lesson.
5.50—Talks.
6.15—Micro—Magazine.
6.50—News.
7.0—Hélène Teyssiere (Harpisichord) and Amparo Garrigoues (Viola d'amore).
7.20—Talk: The Atomic Theory.
7.40—Light Music by the Station String Quintet.
8.15—See Beromünster.
8.30—See Monte Ceneri.
9.30—League of Nations Report.

STOCKHOLM (Sweden).

704 kc/s (426.1 m.); 55 kW. Motala, etc. See Sunday. Transmits at intervals from 6.20 a.m.
4.5 p.m.—Folk Music.
4.30—Records.
5.30—French Lesson.
6.0—News.
6.30—Svea Life Guards Band. Conductor: Grundström. Wedding March (von Otter). Concert Overture (Söderman). Berceuse (Svendsen). Norwegian Artists Carnival (Svendsen). Finlandia (Sibelius).
7.15—Talk.
7.45—Radio Orchestra. Conductor: Grevillius. Erica Rokyta (Soprano). Overture, "The Magic Flute" (Mozart). Aria, Ah! Perfido (Beethoven). Overture (Schumann). Summer Music (Bax). Recitative and Aria, "Figaro" (Mozart). Aria, "Elijah" (Mendelssohn). Wedding March, "A Midsummer Night's Dream" (Mendelssohn).
8.45—News.
9.0-10.0—In Old Style—Light Music by Ingrid Kjellström (Harpisichord and Pfte.). Sällström (Songs), Björk (Violin) and Norrby ("Cello). Violin: (a) Adagio cantabile (Tartini), (b) Allegretto (Bocherini - Kreisler). Three Scottish Folk Songs (Haydn). Harpsichord: (a) Sarabande and Minuet (Handel), (b) Courante, Gavotte and Gigue (Kirnberger). Trio in G for Pfte., Violin and 'Cello (Haydn). Reading in the Interval.

STRASBOURG (France)

859 kc/s (349.2 m.); 100 kW. Transmits at intervals from 6.30 a.m.
5.15 p.m.—'Cello Sonata (Rachmaninoff).
5.45—Arab Songs (Perez), sung by Mme Forest.
6.0—Economics; Social Notes.
6.30—Orchestra from Limoges (PTT).
7.0—News; Topical.
7.30—Songs from Marseilles (PTT).
8.0—News (German, French).
8.30—Prize-winning Sketches for Young People: (a) "Un melon historique" (Mme Roger Favre); (b) "Sa première toile" (Fauconnier); (c) "Nocuds d'Alsace" (Marthe Hamel).
9.15—"Heures de Gloire"—Sequence (Bergeaud); Music by Paul Pierné.
10.30—News (French, German).

STUTT GART (Germany)

574 kc/s (522.6 m.); 100 kW. Transmits at intervals from 5.0 a.m.
11.0 a.m.—Request Concert.
12.0 noon—Weather; News.
12.15 p.m.—Concert (contd.).
1.0-2.0—Records.
3.0—Concert.
5.0—Müller (Baritone), Giesen (Pfte.).
5.30—Topical.
6.0—News.
6.15—Variety Concert. Station Orchestras. Conductors: Görlich and Bara. Annemarie Richartz (Soprano), Liebe (Trumpet).
8.0—"Andreas Hofer" (1767-1810)—Biographical Sequence (Tanneheimer).
9.0—News; Sports.
9.30—See Cologne.
11.0-12.0 m't.—Serenade (Recorded). Overture, "Armida" (Gluck). Sonata in D for Two Pftes. (Mozart). Sonata in F for Alto Flute and Harpsichord (Benda). Eine kleine Nachtmusik (Mozart).

TOULOUSE (Radio-Toulouse) (France)

913 kc/s (328.6 m.); 60 kW. Transmits at intervals from 8.0 a.m.
6.0 p.m.—Military Marches.

6.15—Opera Music, Excerpts, "Il Trovatore" (Verdi), "Thésée" (Lully), "Cavalleria rusticana" (Mascagni), "William Tell" (Rossini).
6.40—South American Orchestra.
6.55—News; Sports.
7.15—Interlude.
7.20—Film Music.
7.40—Light Music.
7.50—Variety.
8.0—Light Music.
9.15—"Un jour de congé"—Fantasy.
9.30—Operetta Music. Selection, "Les noces de Jeannette" (Masse), "The Gipsy Baron" (Strauss), "Schön ist die Welt" (Lehar), "Le petit Duc" (Lecocq).
10.0—News.
10.15—English Concert.
11.15—Salon Orchestra.
11.35—Light Music.
11.50-12.0 m't.—News.

TURIN GROUP (Italy)

Turin (No. 1), 1,140 kc/s (263.2 m.); 7 kW. Milan (No. 1), etc. See Sunday. Transmits at intervals from 6.45 a.m.
4.0 p.m.—News.
4.15—Irene Ferrari (Songs). Lithuanian Song (Chopin). Bacchanale (Chopin). Two Songs (Schumann): (a) Der Nussbaum, (b) Die Lotusblume. Le chant de ceux qui s'en vent sur mer (Galliera). Mandoline (Pick-Mangiagalli). Bergerette (Recl).
5.50—Royal Geographical Society's Report.
6.0—Light Music. Conductor: Dassetto.
6.40—News (French).
7.0—Time; News.
7.20—Government Review.
7.30—Light Music.

LAST NEWS BULLETINS (daily, but subject to slight alterations)

8.40 Oslo; 8.45, Stockholm; 9.0, German stations, Prague; 9.10, Vienna; 9.20, Beromünster; 9.45, Bucharest; 9.50, Warsaw; 10.0, Brussels, Italian stations; 10.30, Athlone, Paris (PTT); 10.45, Radio-Paris; 11.5, Budapest 1.

8.0—See Rome.
9.5—Topical.
9.15—Cetra Orchestra, Conductor: Barzizza.
10.0—News; Weather.
10.15-10.55—Radio Dance Band.

VIENNA (Austria)

592 kc/s (506.8 m.); 100 kW. Graz, etc. See Sunday. Transmits at intervals from 5.45 a.m.
11.0 a.m.—Chimes; Reading (Eichendorff).
11.20—Station Band. Concert Overture, Spring (Golwyn). Waltz, Rio (Tanterl). Excerpts, "La Falena" (Smareglia). Saxophones and Pfte.: Invention (Kubinsky). Waltz, Maskerade (Gebhardt). An der Donau ist meine Heimat (Perné-Bodach).
12.0 noon—Weather; News.
12.10 p.m.—Band (contd.). Overture, "Indigo" (Strauss). Donaulegenden (Lehar). Miniature Suite (Humperdinck). The Selfish Giant (Eric Coates). Foxrot, Lasciami danzare (Marks). Tango, Blaus Meer in Süden (Zalden). A G'selichtes, a Knödel, a Kraut (Engelhart). Marching Song (Buchbinder).
1.0—Records of Paul Knüpfer (Bass) and Julia Culp (Mezzo-Soprano), Der Kreuzzug (Schubert). Songs (Loewe): (a) Der gefangene Admiral, (b) Die Glocken von Speyer, (c) Der Nöck. Du bist wie eine Blume (Schumann). Der Nussbaum (Schumann). Feldeinsamkeit (Brahms). Verborgenheit (Wolf).
1.30—Announcements.
2.0—Exchange; Markets.
2.15—Talk and Reading.
2.40—For Women.
3.0—News; Markets.
3.5—Talk with Records: Viennese Music in Viennese Films.
2.50—Talk: Brahms' First Visit to Vienna.
4.10—Talk: The Viennese Song, Mei Muatterl war a Wienerin.
4.30—Harrard (Baritone). Rosenzeit (Reimers). Der Bettler (Reimers). Selige Nacht (Joseph Marx). Der Ton (Joseph Marx). Die Lotosblume (Pataky). Die Einsame (Pataky). Der Teich (Tlascal). Ankunft des Frühlings (Tlascal). Liebesqualen (Tlascal).

5.0—Talk. 5.25—English Lesson by Thomas MacCallum.
5.45—Patriotic Front Review; Talk: Winter Sports.
6.0—News; Weather.
6.10—Topical.
6.25—"The Barber of Seville" (Rossini) from the State Opera.
7.55—Talk on the present Production.
8.15—Act II, "The Barber of Seville."
9.10—News; Announcements.
9.20—Station Dance Band.
9.55—Announcements. 10.0-10.30—Station Dance Band.

WARSAW (Poland)

224 kc/s (1,339 m.); 120 kW. Cracow, etc. See Sunday. Transmits at intervals from 7.0 a.m.
10.57 a.m. (from Cracow)—Time; Fanfare.
11.3—To be announced.
11.20—News.
11.30 (approx.)-12.0 noon—To be announced.
2.30 p.m.—Economics.
2.45 (from Cracow)—Songs.
3.15—Orliowska-Czerwinska (Songs) and Roesler (Pfte.). Arias: (a) "Lohengrin" (Wagner). (b) Zygmunt August (Jotejko). Pfte.: (a) Rhapsody in G minor (Brahms), (b) Conte (Zaremski). Songs: (a) Maria Wiegienlied (Reger), (b) Songs my Mother taught me (Dvorak), (c) Erotiques (Karlowic), (d) Le cygne (Szymanowski). Pfte.: (a) Impromptu caprice (Zaremski), (b) Mazurka (Maciejewski).
3.50—Topical.
4.0—Medical Talk.
4.15—Echoes of Japan, with Music.
4.50—Sports.
5.10—Cigány Records.
5.30—Programme Notes.
5.35—For Country People.
6.30—Talks.
7.0 (from Poznan)—Station Orchestra. Conductor: Kowalik. Krzyzanowska - Zakowska (Soprano), The Revellers Ensemble, Kreglewski (Siffleur).
7.45—News; Topical.
8.0—Orchestra, etc. (contd.).
8.30—Book Review.
8.50—Symphonie fantastique (Berlioz), by the Station Orchestra. Conductor: Fitelberg.
9.50-10.0—News.
5.20—Reading (Mörke).
5.50—Programme Notes; Markets.
6.0—News.
6.10—Records.
6.40—Music.
7.0—"Der Erbe vom Schindlerhof"—Play (Schenke).
8.30—Motto.
8.35—Folk-Music by Upper Silesian Miners. Band, Choir, Schrammel Octet, Accordion.
9.0—News.
9.15—Political Press Review.
9.30-10.30—Folk Music (contd.).

BRNO (Czechoslovakia)

922 kc/s (325.4 m.); 32 kW. Transmits at intervals from 5.15 a.m.
4.40 p.m.—German Transmission: For Workers; For Farmers.
5.15—News.
5.20—Weekly Music Review.
5.30—Record; Social Notes.
5.45-9.15—See Prague.
9.15-10.0—Revue from Moravská-Ostrava (Recordings).

BRUSSELS (No. 1) (Belgium)

620 kc/s (483.9 m.); 15 kW.
6.30-9.5 a.m.—Records; Gym; News.
12.0 noon—Records.
12.30 p.m.—Weather; Shipping.
12.35—Light Orchestral.
1.0—Time; News.
1.10—Light Orchestral.
1.30—Cinema Organ Records.
1.45—Records of Ninon Vallin and Panzera.
2.0-2.45—Art Notes; For Schools.
4.55—News.
5.0—Records.
5.15—Bernadette Maire (Chromatic Harp).
5.30—For Children.
6.5—Poems.
6.15—Quintet for Oboe and String Quartet (Bax).
6.30—Musiques intimes (Florent Schmitt). Conductor: Souris.
7.0—Roman Catholic Review; For Workers; Film Review.
7.15—"Anna Pavlova et la Mort du Cygne" (Reynaldo Hahn) with Adam and Saint-Saëns Music.
7.30—News.
8.0—Gala Concert for the Festival of Youth, from the Royal Conservatoire. I.N.R. Symphony Or-

TUESDAY Nov. 23

NATIONAL

For Time Signals, see Monday.
10.15 a.m. (D)—Service.
10.30 (D)—Weather Forecast.
10.45 (D)—Housekeeping talk.
11.0 (D)—Records.
11.25 (D)—History for Schools.
11.45 (D)—Chamber Music.
12.15 p.m. (D)—Pageant of Radio.
1.0 (D)—Norman Andrew (Organ).
1.30 (D)—Records.
2.0 (D)—Herring Bulletin.
2.5 (D)—For Schools.
4.0 (D)—Talk.
4.15 (D)—Hungarian Gipsy Party.
5.0—Louis Prell and his Ensemble, from Copenhagen.
5.30—Charles Brill's Orchestra.
6.0—The First News.
6.25—The Belavie Circle: The Kutchur String Quartet.
7.0—BBC Military Band.
7.30—Clear Thinking: Talk.
8.0—"Star-Gazing," Marie Burke.
9.0—The Third News.
9.20—From the Four Corners.
9.40—Reginald Foot (BBC Theatre Organ).
10.0—BBC Orchestra (Section E), conducted by Warwick Braithwaite. Albert Voorsanger (Violin). 11.0—Poetry Will Out.
11.15—Harry Roy and his Band.
11.30-12.0—Dance Records.

REGIONAL

For Time Signals, see Monday.
10.15-10.45 a.m. (ex. Western)—National.
10.45 (ex. Western, Scottish)—Cinema Organ.
10.45 (Western, Scottish)—National.
11.15 (ex. Western, Scottish)—BBC Welsh Orchestra: Ifor Hughes (Bass). 12.0—Theatre Orchestra.
12.30 p.m. (ex. Western, Scottish)—Records. 12.55—Short Story.
1.15 (ex. Western, Scottish)—Concert. 2.0—Band.
2.0 (Scottish)—For Schools.
2.40 (ex. Western, Scottish)—The Harp Trio.

Hours of Transmission in Greenwich Mean Time.

ATHLONE (Ireland)

565 kc/s (531 m.); 100 kW. Dublin, etc. See Sunday.
1.30 p.m.—Records.
2.30-3.0—For Schools.
5.30—Choral and Solo Programme by the Children of St. Louis Convent, Kiltimagh, Co. Mayo.
6.0—Talk: Paris.
6.20—Leo Rowsome (Pipes).
6.35—Irish News Feature.
6.45—News.
7.0—"King John and the Mayor" (Edmund Downey)—Told by C. L. Keogh.
7.15—Declamatory Ballads (Schumann) by Sydney Russell with the Irish Radio Orchestra. Overture, Manfred. Schumann Potpourri (arr. Schreiner).
8.0—As I see it by Michael O'Murchu.
8.15—Manchester Martyrs Anniversary Concert from the Mansion House, Dublin.
9.15—Irish History through Ballads. No. 10.
9.30—Variety Programme.
10.30—News.
11.0—National Anthem.

BERLIN (Germany)

841 kc/s (356.7 m.); 100 kW. Transmits at intervals from 5.0 a.m.
11.0 a.m.—See Munich.
1.0 p.m.—News.
1.15—Berlin Opera Pre-view.
2.0-3.0—Raatzke Quintet; at 2.15—Exchange; Markets.
3.30—Orchestra from Königsberg.
4.30—Reading.
5.0—Operetta Records.
6.0—News; Topical.
6.10—Raatzke Quintet.
7.0—Evening Echoes.
7.15—Light Music by the Station Orchestra. Conductor: Willy Steiner.
8.0—Marches by an Airmen's Band.
9.0—News.
9.30-11.0—See Hamburg.

BEROMÜNSTER (Switzerland)

556 kc/s (539.6 m.); 100 kW. Relayd by Basle and Berne, 1,375 kc/s (218.2 m.).

5.30-5.50 a.m. (from Basle)—Gymnastics.
11.0—Records.
11.29—News; Exchange.
11.40 a.m.-12.45 p.m.—Records.
3.0 (from Berne)—Light Orchestral.
3.40 (from Berne)—Records of Caruso.
3.59—Time.
4.0-5.0—See Sottens.
5.0-6.25—Programme from Berne.
5.0—"A Book is born"—a Publisher and an Author interviewed.
5.20—Records.
5.30—Talk: The French Revolution of 1787.
6.0—Accordion Band.
6.20—Surprise.
6.25—League of Nations Report from Geneva.
6.40—Announcements.
6.55—Records.
7.5—Talk on the following Concert.
7.15—Symphony Concert from the Musiksal, Basle.
9.10 (approx.)—Reading.
9.25-9.30—News.

BRATISLAVA (Czechoslovakia)

1,004 kc/s (298.8 m.); 13.5 kW. Transmits at intervals from 5.15 a.m.
5.0 p.m.—Hungarian Transmission: Talk; Lily Kolosz (Songs), Arias, "Der Freischütz" (Smetana), "Bánk Bán" (Erkel).
5.45-7.10—See Prague.
7.10—"The Bottle Imp"—Play after Stevenson (Bochnickova), from Kosice.
7.55-9.15—See Prague.
9.15-10.0—To be announced.

BRESLAU (Germany)

950 kc/s (315.8 m.); 100 kW. Relayd by Gleiwitz and Görlitz, 1,231 kc/s (243.7 m.). Transmits at intervals from 4.30 a.m.
11.0 a.m.—See Munich; at 12.0 noon-12.15 p.m.—News.
1.0—News; Exchange.
1.10 (approx.)-2.0—See Deutschlandsender.
2.30—Play for Children.
3.0—Operetta Music—Station Dance Band. Conductor: Günther; at 4.0-4.10—Talk.
5.0—Discussion: Silesian Handwork.

chestra. Conductor: André. Monique de la Bruchollerie (Pfte.), Costy, Hosselet, Deneffe (Violins). Violin Concerto (Vieuxtemps). Pfte. Concerto in F (Saint-Saëns). Reading: "Le Jeune Homme" (François Mauriac). Symphonie espagnole (Lalo). Triple Concerto (Vivaldi).

10.0—News; Records.  
10.55-11.0—Christus vincit (Liszt).

**BRUSSELS (No. 2)**  
(Belgium)  
932 kc/s (321.9 m.); 15 kW.  
Programme in Flemish.  
6.30-9.5 a.m.—Records; Gym; News.  
12.0 noon—Records.  
12.30 p.m.—Salon Orchestra.



Willy Steiner and his Orchestra entertain listeners to Berlin at 7.15 p.m.

1.0—News; Brenders Dance Band.  
1.30—Records of Dajos Bela.  
2.0-2.45—Shipping; For Schools.  
4.55—News; Records.  
5.45—For Children.  
6.30—Harpichord and Harp Records.  
6.45—Foreign Affairs.  
7.0—Salon Orchestra.  
7.30—News; Interview with Senator Vos.  
8.0—Part I: "The Third Workers' Olympiad" — Descriptive Suite (Gleisner-De Man); Music by Douliez. Radio Orchestra. Conductor: The Composer.  
8.30—"Heroes of Liberty: Gracchus Babeuf"—Play after Ehrenburg (Van Daelen).  
9.15—Part II: "The Third Workers' Olympiad."  
10.0-11.0—News; Records.

**BUCHAREST (Romania)**  
823 kc/s (364.5 m.); 12 kW.  
Relayed by Radio-Romania, 160 kc/s (1,875 m.).  
Transmits at intervals from 4.30 a.m.  
4.15 p.m.—Schubert and Schumann Records.  
5.0—Art Review; Records.  
6.0—Romanian Songs by the Cotroceni Choral Sextet.  
6.30—Music on Two Pfes.  
7.0—Educational.  
7.15—Symphony Concert from the Athenaeum, Conductor: Scherchen. In the intervals, News; Sports.  
9.0—Records: Light Music.  
9.45—News (French, German).

**BUDAPEST (No. 1)**  
(Hungary)  
546 kc/s (549.5 m.); 120 kW.  
Transmits at intervals from 5.45 a.m.  
11.5 a.m.—Station Orchestra; at 11.30—News.  
12.40 p.m.—Tibor Szatmari (Pfte.).  
1.40—News.  
3.15—For Women.  
3.45—News.  
4.0—Opera Orchestra. Conductor: Rajter. Concerto for Strings (Lully). German Dances (Mozart). Hungarian Divertimento (Schubert-Kesztyer). Intermezzo, "A Village Romeo and Juliet" (Delius). Marching Song (Weiner).  
5.0—Sándor Györmey.  
5.30—Soetens (Violin). Sonata (Leclair). Printemps (Milhaud). Habanera (Ravel). Minstrels (Debussy).  
6.0—Talk: The Minorities after the War.  
6.30—Hungarian Songs by Margit Bodán and György Kubányi with the Gyula Csorba Cigány Band.  
7.30—"The Battle"—Play after Claude Farrere (Barsi) (Recorded).  
9.0—News.  
9.25—Roth String Quartet.  
10.30—Dance Records.  
11.5—News.

**BUDAPEST (No. 2)**  
(Hungary)  
359.5 kc/s (834.5 m.); 18 kW.  
5.30 p.m.—For Farmers.  
6.0—Organ Records.  
6.30—French Lessons.  
7.0—Talk.  
7.30—Records.

**COLOGNE (Germany)**  
658 kc/s (455.9 m.); 100 kW.  
Transmits at intervals from 5.0 a.m.  
11.0 a.m.—Workers' Band.  
12.0 noon—News; Greetings.  
12.15 p.m.—Orchestra from Munich.  
1.0—News; Riddles.  
1.45-2.0—Markets.  
2.45—Markets.  
3.0—See Deutschlandsender; at 4.0-4.10—Talk.  
5.0—Haass (Pfte.).  
5.30—German for Germans.  
5.50—Snapshots.  
6.0—News.  
6.10—Station Orchestra. Conductor: Kühn. Rhein (Violin). Four Ballet Pieces (Lully). Fantasia for Violin and Orchestra

(Schumann). Serenade (Reincke). Neue Unterhaltungsmusik (Rasch). Ballet, "The Sleeping Beauty" (Tchaikovsky). Bavarian Dances (Elgar). Hungarian Peasant Pictures (Bartók).  
8.0—See Deutschlandsender.  
8.15—Excerpts from Peter Hebbels "Rheinischer Hausfreund" (arr. Schaff); Music by Weismann.  
9.0—News.  
9.30—English Talk: Unknown London.  
9.50-11.0—Music from Hamburg.

**DEUTSCHLANDSENDER (Germany)**  
191 kc/s (1,571 m.); 60 kW.  
Transmits at intervals from 5.0 a.m.  
11.0 a.m.—See Stuttgart.  
12.50 p.m.—News.  
1.0—Olschewski Band.  
2.0—Announcements.  
2.15—Instrumental Records.  
2.45—Discussion for Mothers.  
3.0—Station Orchestra. Conductor: Dobrindt. Mikulicz (Pfte.); at 4.0-4.10—A Story.  
5.0—String Quartet in A (Pizzetti) by the Breronel Quartet.  
5.55—Genealogy.  
6.0—Motto; News.  
6.10—Station Orchestra. Conductor: Eigl. Symphony in C (Bizet). German Dances (Mozart). Comedy Overture (Blacher). Rameau Suite (Zilcher). Dances from Marosszek (Kodály). From the Fields and Groves of Bohemia (Smetana); at 7.0-7.10—Reading.  
8.0—Topical; Political Press Review.  
8.15—"Our Dumb Friends"—Musical Sequence for Animal Protection Day.  
9.0—News; Topical.  
9.30-9.45—Serenata on "Innsbruck, ich muss dich lassen" (Höffer) for Oboe, Violin, Viola, and Cello.  
10.0-11.0—Joost Band.

**FRANKFURT (Germany)**  
1,195 kc/s (251 m.); 25 kW.  
Cassel, etc. See Sunday.  
Transmits at intervals from 5.0 a.m.  
11.0 a.m.—Sec Munich; at 12.0 noon—News.  
1.0 p.m.—News.  
1.10—Records.  
2.0—Talk: Time; Markets.  
2.15-2.45—For Women.  
3.0—Hofmann (Pfte.). The Wanderer Fantasia (Schubert). Ballad in G minor (Brahms). Rhapsody in E flat (Brahms).  
3.30—Light Orchestra. Conductor: Körner.  
5.0—Topical.  
6.0—News.  
6.10—Chamber Music. Ludmilla Schirmer (Contralto), Elisabeth Dramer-Büche (Viola), Schröter (Pfte.), Schütze (Clarinet). Sonata for Viola and Pfte. (Kuhn). Songs for Contralto, Clarinet and Pfte. (Spohr). Sonata for Viola and Pfte. (Dittersdorf).  
7.0—Künneke—Gala Concert. Station Orchestra. Conductor: The Composer. Allmeroth and Seidenspinner (Tenors), Juliane Doederlein (Soprano), Hesse (Baritone). Introduction to "Glückliche Reise." Excerpts, "Der Vielgeliebte," "Der Tenor

der Herzogin," "Wenn Liebe erwacht." Intermezzo, "Tänzerische Suite." Excerpts, "Wenn Liebe erwacht." "Die lockende Flamme," "Der Vielgeliebte." Song, "Lady Hamilton." Finale from "Wenn Liebe erwacht." Overture, "The Ace of Hearts." Excerpts, "The Cousin from Nowhere," "Die lockende Flamme," "Das Blumenwunder." Barcarolle, "Zauberin Lola." Duet, "Little Dorrit." Excerpts, "Glückliche Reise," "Die grosse Sünderin," "Herz über Bord," "Zauberin Lola."  
9.0—News.  
9.30—See Hamburg.  
11.0-12.0 m't.—Serenade—German Festival Music (Recorded). Brandenburg Concerto (Bach). Egmont Overture (Beethoven). Festlicher Hymnus (Sieg). Homage March (Wagner). Olympische Festmusik (Egk).

**HAMBURG (Germany)**  
904 kc/s (331.9 m.); 100 kW.  
Bremen, etc. See Sunday.  
Transmits at intervals from 5.10 a.m.  
11.0 a.m.—Military Band.  
12.5 p.m.—Orchestra from Munich.  
1.0—News.  
1.15—Light Music.  
2.0—Shipping.  
2.15—Violin and Cello.  
2.50—Ice Report.  
3.0—Light Orchestra. Conductor: Secker. Rosl Seegers (Soprano). In the interval, Books.  
4.15—"Die Pechsträhne"—Radio Picture Book (Hilpert); Music by Ahl.  
5.0—"De Likedeler"—Pictures, Songs and Music about Klaus Störtebeker. Wind Band, Choir, Singer and Speakers.  
6.45—Harbour Notes.  
6.0—News.  
6.10—See Deutschlandsender.  
7.0—Topical.  
7.10—Variety (arr. Schaff); Music by Girmatis. Station Orchestra. Dance Band, Erna Kuhl-Lange (Soprano), Jaksthat, Mass-Baritone, etc. Conductor: Müller-Lampertz.  
9.0—News.  
9.30-11.0—Light and Dance Music —Heinemann Band. Balalaika Quintet and Pfte. Duo.

**HILVERSUM (1,875 m.) (Holland)**  
160 kc/s; 10 kW until 2.40 p.m.; 150 kW from 2.40 p.m.  
KRO Programme.  
7.40-8.55 a.m.—Records.  
9.40—Records.  
10.10—Joost van den Vondel Commemoration (Recorded).  
11.10—Religious Address; News.  
11.55—KRO Melodists. Conductor: Lustenhouwer. Klein (Refrains); at 12.40 p.m.—Records.  
1.40—For Women.  
2.45—Dressmaking Lesson.  
3.45—Records.  
3.55—KRO Chamber Orchestra. Conductor: Reinards.  
4.40—Records.  
4.55—KRO Orchestra. Conductor: Reinards.  
5.25—Greetings.  
5.40—KRO Melodists. Conductor: Lustenhouwer. Klein (Refrains).  
6.20—Esperanto Lesson; Announcements; Talks; News.  
7.55—Maastricht Municipal Orchestra. Conductor: Hermans. Maréchal (Cello).  
8.45—Records.  
9.10—KRO Orchestra. Conductor: Reinards, and Records.  
10.10—News.  
10.20—Kristel Dance Band.  
11.10-11.40—Records.

**HILVERSUM (301.5 m.) (Holland)**  
995 kc/s; 15 kW until 6.10 p.m.; 60 kW from 6.10 p.m.  
AVRO Programme.  
7.40 a.m.—Time; Records.  
9.40—Service.  
9.55—Records.  
10.10—Kovacs Lajos Orchestra.  
10.40—Cookery Talk.  
11.10—AVRO Orchestra. Conductor: Treep.  
12.10 p.m.—Records.  
12.40—Pierre Palla (Organ), Willy Wennink (Songs) and Boris Lensky (Violin).  
1.25—Records.  
1.40—AVRO Orchestra. Conductor: Treep.  
2.25—Dressmaking Lesson.  
3.25—Lya Trio.  
4.10—Children's Choir. Conductor: Hamel.  
4.40—For Children.  
5.10—Aolian Orchestra.  
6.10—Talk.  
6.40—For Children.  
6.45—AVRO Dance Band.

7.10—English Lesson.  
7.40—Time; News.  
7.55—Tuesday Night Special—Variety. Kovacs Lajos Orchestra, Mario Lorenzi (Harp), Anny Sains (Recitation), Lajos Szendi (Comedian), Pierre Palla (Organ) and Nina Dolce (Violin).  
8.55—Film Song Records of Marta Eggerth and Jan Kiepura.  
9.25—Tuesday Night Special (cont'd.).  
10.10—Records.  
10.25—Commentary on the Euwe v. Alekhine Chess Match.  
10.40—News.  
10.50—AVRO Dance Band.  
11.20-11.40—Records.

**KALUNDBORG (Denmark)**  
240 kc/s (1,250 m.); 60 kW.  
Relays Copenhagen, 1,176 kc/s (255.1 m.).  
Transmits at intervals from 6.0 a.m.  
11.0 a.m.—1.0 p.m.—Louis Preil's Ensemble.  
1.30—Radio Orchestra. Conductor: Grendahl. March, Hamburg bleibt Hamburg (Vollstedt). Overture, "Hansel and Gretel" (Humperdinck). Excerpts, "A Waltz Dream" (Strauss). Ave maris stella (Grieg). Polka (Ramsøe). Excerpts, "Il Trovatore" (Verdi). Fespilonaise (Oldenberg Poulsen). March, The Handicap (Rosey). Fantasia on Danish National Melodies (Grendahl). Theme Song from the Film "Klovnen" (Schroder). African Dance (Ganne). Ballet Suite (Poppy). Overture, "Le Caid" (Thomas); at 2.20—A Story (Rovsing).  
3.30—For Girls.  
3.50—Wireless Notes.  
4.0—Weather.  
4.15—Exchange; Markets.  
4.25—Louis Preil's Ensemble. Spanish Intermezzo (Borchert). Piece (Tegner). Habanera (Solazzi). Sektperlen (Kochmann-Schmidt). Ouvre tes yeux bleus (Massenet). Melody (Bentzen). Bolero, Murcia (Neago). Spanish March (Gyldmark). Illusions perdues (Gade). Excerpts from the Suite, "Amor and Psyche, 1937" (Kjaer). Invocation (Thomsen). Tango (Andersen). Jazz Rhapsody on a César Franck Theme (Rosenberg).  
5.35—German Lesson.  
6.0—News.  
6.30—A Film.  
6.40—Icelandic Music by the Reykjavik Male Voice Choir. Conductor: Thórdarson. Island (Thórdarson). I Skumringens Ro hun sover (Gudmundsson). Gronlandsviser (Eimansson). Ave Maria (Kaldalóns). Nomadernes Skarer (Runolfsson).  
7.0—Meeting of the Danish Women's National Advisory Council, from the Women's Institute. Discussion: Women and the Population Question.  
9.0—News; Weather.  
9.20—Danish Music. Radio Orchestra. Conductor: Taxen. Koppel (Pfte.). Overture, "Helios" (Nielsen). Dance from "Weylandt the Smith" (Henriques). Pfte. Concerto (Koppel). Jutland Rhapsody, Himmerland (Reesen).  
10.10—Records: Carmen (Bizet).  
10.30-11.30—Harry Roy's Band from London (Recorded).

**KÖNIGSBERG (Heilsberg) (Germany)**  
1,031 kc/s (291 m.); 100 kW.  
Relayed by Danzig, 1,303 kc/s (230.2 m.).  
Transmits at intervals from 5.0 a.m.  
11.0 a.m.—Sec Munich; at 12.0 noon—News.  
1.0 p.m.—News; Talk.  
1.15—Light Music.  
1.45—Exchange.  
2.30—Talk.  
2.40—Fairy Tales and Songs.  
3.0—Station Orchestra. Conductor: von Sosen. Spilcker (Baritone).  
5.0—"Without Knives and Forks"—Three Mediaeval Sketches (Greiser).  
5.40—Topical.  
6.0—News.  
6.10—Adelheid Armhold (Soprano), Pollack (Pfte.), Schupp (Tenor). Songs (Taubmann). Gavotte and Tocata (Vollerthum). Eight Songs (Kilpinen). Pfte. (Liszt); (a) Nocturne in A flat, (b) La Campanella.  
7.0—"Short Stories in Music"—Peter Arco and the Börschel Band, etc.  
8.10—"The First Cigar"—Sequence (Bartels).

**MUNICH (Germany)**  
740 kc/s (405.4 m.); 100 kW.  
Relayed by Nürnberg, 1,267 kc/s (236.8 m.).  
Transmits at intervals from 5.0 a.m.  
11.0 a.m.—Coburg Provincial Orchestra. Conductor: Tuebben.  
1.15 p.m.—Band from Deutschlandsender.  
2.0-2.30—For Children.  
3.5—Dumky Trio (Dvořák), by the Munich Pfte. Trio.  
3.40—Reading.  
4.0—Time; Weather; Markets.  
4.15—Light Orchestra. Conductor: Mihalovic. In the interval—Topical Talks.  
5.50—Anniversaries.  
6.0—News.  
6.10—To be announced.  
7.0—"Leonce und Lena"—Comedy (Büchner) with Music.  
8.0—Talk.  
8.5—Musical Kaleidoscope, with Hanna Rodegg and Schmid (Songs), Melanie Michaelis (Violin), Uhr (Cello), Arnold (Clarinet), Kusche and Schmidmeier (Pfte. Duo).  
9.0—News.  
9.20—To be announced.  
9.30-11.0—See Hamburg.

9.0—News.  
9.20—Political Press Review.  
9.35-11.0—Light Orchestral. Conductor: Wilken.

**LEIPZIG (Germany)**  
785 kc/s (382.2 m.); 120 kW.  
Relayed by Dresden, 1,285 kc/s (233.5 m.).  
Transmits at intervals from 5.0 a.m.  
11.0 a.m.—See Munich.  
1.0—News; Exchange.  
1.10—Records of the von Géczy Band.  
2.0—Talk: Town Criers, Night Watchmen and Postillions.  
2.30—Technical Talk: Volts and Amperes.  
2.50—Science.  
3.0—See Deutschlandsender; at 4.0-4.10—Time; Weather; Markets.  
5.0—Talk: Saxon Home Crafts.  
5.15—Paul Gerhardt Music—Härtel (Baritone), Schrepper (Violin), Gottschalk (Cello) and Burgert (Pfte.). Songs: (a) Es bricht dereinst ein Tag herein, (b) Abendlied. Abendmusik for Violin, Cello and Pfte. Songs: (a) Dulde, gedulde dich fein, (b) Ein geistliches Abendlied.  
5.50—Topical.  
6.0—News.  
6.10—KdF Variety Programme from Erfurt.  
7.0—"From Saxony to the Waterkant"—Scenes from the Good Old Days, with the Fricke Band, etc.  
9.0—News.  
9.30-11.0—See Hamburg.

**LILLE (Radio PTT Nord) (France)**  
1,213 kc/s (247.3 m.); 60 kW.  
Transmits at intervals from 6.30 a.m.  
8.0 p.m.—An Operetta.  
8.30—To be announced.  
10.30 (approx.)—News.

**MONTE CENERI (Switzerland)**  
1,167 kc/s (257.1 m.); 15 kW.  
11.0 a.m.—Records.  
11.29—Time; News.  
11.40 a.m.—12.30 p.m.—Records: Light Music.  
4.0-5.0—See Sottens.  
6.15—Talk: Ski-ing.  
6.30—Records.  
6.45—News.  
7.0—Records of Tito Schipa and Amelita Galli-Curci.  
7.15—Talk: Economics.  
7.30—String Orchestra. Conductors: Casella. Othmar Nussio (Flute). Flute Concerto in G (Vivaldi). Suite in B minor (Bach). Minuet, Musette and Gavotte (Handel; Martucci). Flute Sonata in F (Scarlatti). Prelude, Air and Fugue on "BACH" (Hofmeister). Arabesque, Nocturne and Improvisation (Nussio).  
8.30-9.0—Records: "Aida" (Verdi).

**MOSCOW (No. 1) (Russia)**  
172 kc/s (1,744 m.); 500 kW.  
4.30 p.m.—An Opera.  
9.0—Dutch Programme.  
10.0—Swedish Programme.  
11.0-12 m't.—Spanish Programme.

## TUESDAY (November 23)

## NAPLES GROUP (Italy)

Naples, 1,104 kc/s (271.7 m.); 10 kW. Florence (No. 1), etc. See Sunday.  
 6.0 p.m.—Light Music.  
 6.15—Topical.  
 6.25—Rinaldi Mandoline Ensemble. Conductor: Filippini.  
 7.0-7.30—See Rome.  
 7.30—Sound Film Music—Cetra Orchestra.  
 8.30—Topical.  
 8.50—Dance Music.  
 9.0—News.  
 10.15-10.55—Dance Music.

## OSLO (Norway)

260 kc/s (1,153.8 m.); 60 kW. Fredrikstad, etc. See Sunday. Transmits at intervals from 10.40 a.m.  
 4.0 p.m.—Bergen Radio Orchestra.  
 4.35—Literary Programme.  
 4.40—Amdahl Orchestra.  
 5.20—For Women.  
 5.50—News and Announcements.  
 6.30—Sonata in F (Strauss) by Karl Andersen (Cello) and Riefing (Pfte.).  
 7.0—Talk.  
 7.30—Variety Programme.  
 8.0—Theatre Notes.  
 8.20—Selection, "Boris Godunov" (Mussorgsky) by the Station Orchestra. Conductor: Kramm.  
 8.40—News.  
 9.0—Topical Talk.  
 9.15-10.0—Norwegian Music. Station Orchestra. Conductor: Kramm. Erling Carlsen (Clarinet). Overture (Reissiger). Suite Concerto (Fernström). Suite (Hurum). Saga og Fanitull (Olsen).

## PARIS (Eiffel Tower)

(France)  
 1,456 kc/s (206 m.); 7 kW. Transmits at intervals from 6.30 a.m.  
 8.0 p.m.—Jane Morlet (Songs) and Jeanne-Marie Darre (Pfte.). Pfte.: (a) The Bee's Wedding (Mendelssohn), (b) Toccata (Saint-Saëns). Songs (Chopin, Yvain). Pfte.: (a) Teddy Girl (Ibert), (b) Fox-trot (Marcheix). Songs (Spark, Hahn).  
 8.30—Symphony Concert. Choir and Orchestra. Conductor: Clergue. Doyen (Pfte.). Overture, Patrie (Bizet). Jeux d'enfants (Bizet). Pfte. Concerto in G minor (Saint-Saëns). Act II, "Proserpine" (Saint-Saëns). In the interval—Talk by M. Samazeuilh.  
 10.30—Records.  
 11.0—News.

## PARIS (Poste Parisien)

(France)  
 959 kc/s (312.8 m.); 60 kW. Transmits at intervals from 7.10 a.m.  
 12.0 noon—Exchange; Records.  
 12.35 p.m.—Exchange; Records.  
 1.15—Amusements; Records.  
 2.0—Exchange.  
 3.45—Exchange.  
 4.35—Exchange.  
 5.0—News.  
 5.5—Ray Ventura.  
 6.0—Exchange; News.  
 6.10—Religious Address.  
 6.20—Records: Quartet (Ravel).  
 6.40—Records (Liszt and Saint-Saëns).  
 6.55—Literary Review; Racing.  
 7.0—Topical; Sports; Amusements.  
 7.13—Film Talk; Record.  
 7.45—Tyrolean Ensemble, presented by Jean Loup.  
 8.0—News.  
 8.10—Humorous Programme by Claude Dauphin and Babyias.  
 8.15—Light Music.  
 8.30—"Edition speciale" (Diamant-Berger).  
 8.45—"La bonne histoire."  
 9.0—News.  
 9.10-11.0—"La Femme en blanc" Three-Act Play (Achard).

## PARIS (PTT) (France)

695 kc/s (431.7 m.); 120 kW. Transmits at intervals from 6.30 a.m.  
 5.0 p.m.—Jules Romain on his Life and Works—Report from the Palais des Arts.  
 6.0—Economics and Social Notes.  
 6.15—Talk.  
 6.30—Hélène Backer d'Isy (Pfte.). Part I: Brazilian Music (Villa-Lobos). Part II: Portuguese Music. (Da Silva, Coelho).  
 6.45—Mlle Lequien (Songs).  
 7.0—News.  
 8.0—Mlle Tant Mieux et M. Tant Pis.  
 8.30 (also for Alpes-Grenoble (PTT) and Marseilles (PTT))—"La

Fille de Madame Angot" (Lecocq). National Orchestra and Raugel Choir. Conductor: Inghelbrecht. Cast: Germaine Cernay, Mireille Berthon, Jane Morlet, Friant, Clérisseau, Balbon, Payen.  
 10.30—News; Weather.  
 10.45—Records: "Reflets d'Allemagne" (Florent Schmitt). Conductor: The Composer.

## PARIS (Radio-Paris)

(France)  
 182 kc/s (1,648 m.); 80 kW.  
 6.28 a.m.—Programme Notes; Records.  
 6.40—Time; News.  
 6.50—Gym; Records.  
 7.15—News; Records.  
 8.0—News; Programmes; Records.  
 10.15—Programme Notes; Records.  
 10.45—Reading; Records.  
 11.45—Markets.  
 12.0 noon—Jewish Talk.  
 12.20 p.m.—Giardino Orchestra.  
 1.0—Time; News; Exchange.  
 1.30—Germaine Cernay (Songs).  
 1.45—Giardino Orchestra.  
 2.0—Programme Notes; Talks.  
 2.30—Exchange; Markets.  
 2.45—Henriette Delanoy (Songs).  
 3.0—Henriette Roget (Pfte.).  
 3.15—Political Review; Talk.  
 3.45—Exchange.  
 4.0—Mlle. Servan (Songs).  
 4.15—Mlle. Armitz (Violin).  
 4.30—English Lesson.  
 4.50—Markets.  
 5.0—Locatelli Orchestra.  
 6.0—Educational; German Books.  
 6.45—Talk: The Cameroons.  
 7.0—Educational.  
 7.30—Talks; Reading.  
 8.0—Home Affairs.  
 8.5—Foreign Affairs.  
 8.15—Chamber Music — Doyen (Pfte.), Verroust (Songs) and the Calvet Quartet. Pfte.: Prelude and Fugue (de Bréville). Songs (de Bréville). Pfte.: (a) Sérénade (Samazeuilh), (b) Three Sketches (Beydts). Songs (Dupré). Quartet (Ropartz).  
 9.15—News.  
 9.30—"Les Hommes"—Five-Act Play (Paul Vialar) by the "Arts et Travail" Radio Group; at 10.45—Time; News.  
 11.30—Programme Notes.

## PRAGUE (Czechoslovakia)

638 kc/s (470.2 m.); 120 kW. Transmits at intervals from 5.15 a.m.  
 4.30 p.m.—Chopin Music by Dora Gussich-Feller (Pfte.). Nocturne. Two Mazurkas. Four Etudes.  
 5.0—For Farmers.  
 5.10—German Transmission. Talk: Oscar Strnad and his Work; Topical.  
 5.45—News and Review (German).  
 6.0—Time; News.  
 6.10—Orchestra and Songs from Moravská-Ostrava.  
 7.10—"A Blind Man and an Ugly Maiden"—Play (Lunzer-Wolf, Czech trans. by Mach).  
 7.55—Station Orchestra. Conductor: Kabelác. Berta Rixová (Pfte.). Variations on a Haydn Theme (Brahms). Music for Pfte., Winds and Two Harps (Hindemith). Venezia (Kálik).  
 8.55—Record.  
 9.0—Time; News.  
 9.15—Excerpts from the Prague Municipal Theatre Programmes.  
 9.35—Records.  
 10.0-10.15—News in English.

## RADIO-NORMANDIE

(France)  
 1,113 kc/s (269.5 m.); 15 kW.  
 6.45 a.m.—Band; Songs.  
 7.15—News.  
 7.45—Physical Culture; Records.  
 8.15—Jane and John.  
 8.30—"Contrasts"—A Fantasy.  
 8.45—Records.  
 9.15—Light Music.  
 10.45—Mandolines.  
 11.0—Records.  
 11.30—Chansonnettes.  
 12.0 noon—Records.  
 12.45 p.m.—News; Topical.  
 1.0—Variety Concert.  
 2.0—Records.  
 2.30—Light Music.  
 4.15—Records.  
 5.15—For Young People.  
 5.30—Records.  
 6.0—Children's Corner.  
 6.45—News Racing.  
 7.0—Chansonnettes.  
 7.25—News; Topical.  
 7.45—Records of the Livschakoff Band.  
 8.0—Records: Light Music.  
 8.40—Cornet Recitals.

9.0—Léon Raiter and his Music-comedians, with Pierrette Thourret.  
 11.0—Café Concert.  
 11.45—News.  
 12.0 m't.—Midnight Melodies.  
 12.30-1.0 a.m. (Wednesday) — Dance Music.

## REYKJAVIK (Iceland)

208 kc/s (1,442 m.); 16 kW. Transmits at intervals from 11.0 a.m.  
 8.10 p.m.—Weather (Icelandic, German, English).  
 8.20—Parliamentary Notes.  
 8.55—Announcements.  
 9.0—Time; News.  
 9.30—Talk.  
 10.0—Icelandic Folk Music.

## ROME GROUP (Italy)

Rome (No. 1), 713 kc/s (420.8 m.); 50 kW. Bari (No. 1), etc. See Sunday.  
 Transmits at intervals from 6.45 a.m.  
 4.15 p.m.—Lydia Fiorentini (Pfte.).  
 4.55-5.0—Morse Lesson.  
 5.50—Dopolavoro Notes.  
 6.0—Talk (English); Announcements.  
 6.25—News (English, French).  
 7.0—Time; News.  
 7.20—Talk; Light Music.  
 8.0—"Andrea Chénier" (Giordano). Conductor: Previtali. Chorus-Master: Costantini. Cast: Francesco Merli, Benvenuto Franci, Maria Pedrini, Agnese Dubbini, Edmea Liberti, Tito Gobbi, Piero Passerotti, Luigi Bernardi, Nino Mazziotti and Gino Conti. In the intervals, Talk; News.

## SOTTENS (Switzerland)

677 kc/s (443.1 m.). 100 kW. Relayed by Geneva, 401 kc/s (748 m.).  
 11.29 a.m.—Time; News; Records.  
 12.10 p.m.—Records.  
 12.35-12.45—Dance Records.  
 3.59—Time.  
 4.0—Radio Suisse romande Orchestra. Conductor: Haug. Overture, "La Princesse Jaune" (Saint-Saëns). Waltz, Longchamp fleuri (Waldeufel). Scènes alsaciennes (Massenet). Le Rouet d'Omphale (Saint-Saëns). Selection, "The Pearl Fishers" (Bizet).  
 5.0—Literary Programme.  
 5.20—French Light Music—Radio Suisse romande Orchestra. Conductor: Appia. Overture, "Gillette de Narbonne." La Farandole (Dubois). Deux propos (Février). Danse persane (Guiranel). Aubade et Scherzo (Lalo).  
 6.0—Sketches.  
 6.10—What History teaches us.  
 6.20—Medical Talk.  
 6.30—Music.  
 6.50—News; Weather.  
 7.0—The Beginning of Jazz — Lecture-Recital by St. Chaud.  
 7.30—"Le Voyage de Monsieur Perrichon" — Four-Act Play (Labiche-Martin) by the "Deux Masques" Players.  
 9.0-10.0—Mozart Concert—Radio Suisse romande Orchestra, Appia (Violin). Eine kleine Nachtmusik (Mozart). Violin Concerto in D. Symphony in A.

## STOCKHOLM (Sweden)

704 kc/s (426.1 m.); 55 kW. Motala, etc. See Sunday.  
 Transmits at intervals from 6.20 a.m.  
 11.25 a.m. (from Göteborg) — Light Orchestra.  
 11.50—Exchange; Markets.  
 12.0 noon — Light Orchestra (cont'd).  
 12.25 p.m.—Talk.  
 12.45—Anna Lisa Eriksson (Folk Songs).  
 1.0—Gymnastics.  
 1.15—Cabaret.  
 1.40-2.0—Talk with Reading: Gerhart Hauptmann.  
 4.5—For Children.  
 4.35—Reading (Westerlund).  
 5.0—Records.  
 6.0—News.  
 6.30 — Talk by Hr. Procopé: Scandinavian Co-operation and Competition.  
 7.5 (from Göteborg)—St. Cecilia Choir. Conductor: Carlsson. Kyrie from Missa brevis (Palestrina). Madrigal: Omnes amici mei (Palestrina). Jubilate (Banchieri). Kyrie (Bernabei). The Nightingale (Mendelssohn). Over stille Vandet (Kjerulf). Modersmaalet (Rung).  
 7.30—Literary Review.  
 8.0—Cabaret.  
 8.45—News.  
 9.0-10.0—Waldimir's Orchestra. Overture, "Maritana" (Wallace). Die Schönbrunner (Lanner). Berceuse (Jämfelt). Selection, "The

Bird Fancier" (Zeller). Spanish Gypsy Dance (Marquina). En sourdine (Tellam). Torch Dance (Rubinstein). Potpourri (Sandel). Le père la victoire (Ganne).

## STRASBOURG (France)

859 kc/s (349.2 m.); 100 kW. Transmits at intervals from 6.30 a.m.  
 5.15 p.m.—"Trio de France" Sonata (Leclair). Pfte. Trio (Ravel).  
 6.0—Educational.  
 6.30—Concert from Rennes-Bretagne.  
 7.0—News.  
 7.30—Concert from Limoges (PTT).  
 8.0—News (German, French).  
 8.30—Variety: "Optimists' Club" —Fantasy (Cor and Zins); Marie-Antoinette Pradier (Pfte.); "Les Dupont-Durand-Duval vont au spectacle" (Fontex).  
 10.30—News (French, German).

## STUTT GART (Germany)

574 kc/s (522.6 m.); 100 kW. Transmits at intervals from 5.0 a.m.  
 11.0 a.m.—Orchestra and Melo Trio.  
 12.0 noon—News.  
 12.15 p.m.—Orchestra (cont'd).  
 1.0-2.0—See Deutschlandsender.  
 3.0—Concert — Station Orchestra. Conductor: Bara, Trumpeter Corps, Stuttgart Folk Music Society, Hofele (Baritone).  
 5.0—Women at Work.  
 5.30—Topical; at 6.0—News.  
 6.15—"Masters of their Craft"—Records.  
 7.15—Microphone Visits to Places connected with Schiller's Youth.  
 8.15—"The Erl King's Daughter" (Gade), Station Choir and Orchestra. Conductor: Zimmermann. Irma Roster (Soprano), Emma Mayer (Contralto), Müller (Baritone).  
 9.0—News.  
 9.15—Political Press Review.  
 9.30—Records: Dance and Light Music.  
 11.0-12.0 m't.—See Frankfurt.

## TOULOUSE (Radio-

Toulouse) (France)  
 913 kc/s (328.6 m.); 60 kW. Transmits at intervals from 8.0 a.m.  
 6.0 p.m.—Musette Orchestra.  
 6.15—Songs.  
 6.40—Rumbas.  
 6.55—News; Sports.  
 7.15—Operetta Airs, "Deux sous de fleurs" (Benatzky), "Les cloches de Corneville" (Planquette), "The Duchess of Chicago" (Kálmán), "En super-folie" (Pipon), "Miami Nights" (Burke).  
 7.40—Light Music.  
 8.30—Request Programme.  
 8.45—Operetta Music. Excerpts, "A Waltz Dream" (O. Strauss), "Clo-clo" (Lehár), "Acqua cheta" (Pietri), "Eva" (Lehár). Melody (Pietri).  
 9.10—Light Music.  
 9.30 — Excerpts, "Véronique" (Messager).  
 10.0—News.  
 10.15—English Concert.  
 11.15—Musical Comedy Music.  
 11.35—Light Music.  
 11.50-12.0 m't.—News.

## TURIN GROUP (Italy)

Turin (No. 1), 1,140 kc/s (263.2 m.); 7 kW. Milan (No. 1), etc. See Sunday.  
 Transmits at intervals from 6.45 a.m.  
 4.0 p.m.—News.  
 4.15—Stella Calcina (Soprano), Zargani (Violin). Three Songs (Schubert). Sonata in D (Bach). Canzoncina (Previtali). Songs (Castelnuovo-Tedesco): (a) Lullaby, (b) Girotondo dei golosi. Intermezzo (Lalo).  
 5.50—Dopolavoro Notes.  
 6.0—Light Music. Conductor: Malatesta.  
 6.40—News (French).  
 7.0—Time; News.  
 7.20—Talk.  
 7.30—Light Music. Conductor: Salerno.  
 8.0 — From the Polonaise to the Rumba — Concert. Conductor: Petralia.  
 9.10—"La diva"—One-Act Play (Calzini).  
 9.40 (approx.)—Dance.  
 10.0—News; Weather.  
 10.15-10.55—Angelini Dance Band.

## VIENNA (Austria)

592 kc/s (506.8 m.); 100 kW. Graz, etc. See Sunday.  
 Transmits at intervals from 5.45 a.m.  
 11.0 a.m.—Chimes; Records. Die guten, alten Zeiten (Jos. Strauss). Ballet, "Undine" (Lortzing). Fandanguillo (Turina). Ein Lied geht um die Welt (May). Hör

mein Lied, Violetta (Klose-Lukesch). A Weana is net kränk (Dyczynski). Waltz in A (Dvořák-Prihoda). Ländler (Flemming). Lass mich schau'n, schau'n, schau'n (Eisenstein). Songs (Lehár): (a) Trinkt man auf du und du, (b) Song, "The Tsarevitch." Rubinstein's "Melody" in Jazz Style (Scott-Wood). Heimatklänge (Königs-hofer).  
 12.0 noon—Time; News.  
 12.10 p.m.—Opera Records. Overture, "Tsar and Carpenter" (Lortzing). Aria, "Der Freischütz" (Weger). Aria, "Hans Heiwig" (Marschner). Prelude, "The Flying Dutchman" (Wagner). March, "Die Rose vom Liebesgarten" (Pfitzner). Excerpts, "Der Rosenkavalier" (Strauss).

1.0—Records of Handel's Concerti grossi by the Boyd Neel String Orchestra.  
 1.30—Announcements.  
 2.0—Exchange; Markets.  
 2.15—Concert for Children.  
 2.40—Cookery.  
 3.0—News.  
 3.5—Station Orchestra. March (Hartlieb). Overture, "Bluebeard" (Offenbach). Pieces (Traduttore): (a) Was Blumen träumen, (b) Hochzeit in Liliput. Weaner Mad'ln (Ziehrer). Wiener Spaziergänge (Komzák). Im Mondenschein (Schneider). Ländler and Schuhplattler (Daxenberger). March (Pockberger).  
 4.0—Handwork.  
 4.25—Review.  
 4.35 — Margit Alenius-Theorecel (Harpischord). Chromatic Fantasy and Fugue in D minor (Bach). Suite in E (Scarlatti). Pieces (Couperin): (a) Le petit rien, (b) La Bourgeoise. Pieces (Rameau): (a) Two Minuets, (b) La Poule.  
 5.5—French Lesson.  
 5.25—The Anti-Waste Campaign.  
 5.35—Talk: Persia.  
 6.0—News.  
 6.10—The Film Industry.  
 6.40—"StadtPark"—Variety with the Station Band. Conductor: Sandauer.  
 7.40—Reading.  
 8.5—"Das Sternlied"—Radio Ballad about Jakob Stainer the Violin-Maker (Karrasch).  
 9.10—News.  
 9.20—Pauscher Jazz Band.  
 9.55—Announcements.  
 10.0-10.30—Jazz Band (cont'd).

## WARSAW (Poland)

224 kc/s (1,339 m.); 120 kW. Cracow, etc. See Sunday. Transmits at intervals from 5.15 a.m.  
 10.57 a.m. (from Cracow)—Time; Fanfare.  
 11.3—To be announced.  
 11.20—News.  
 11.30-12.0 noon—To be announced.  
 2.30 p.m.—Economics.  
 2.45 (from Poznań) — For Children.  
 3.5—Finance and Economics.  
 3.15—Station Salon Trio. Polish Suite (Walentyńowicz). Chanson triste (Tchaikovsky). Minuet (Boccherini). Gavotte (Gossec). Liebesleid (Kreisler). Two Waltzes (Brahms). Song (Mendelssohn). A toi (Czibulka). The Lark (Glińska).  
 3.50—Topical.  
 4.0—Talk: Bulgaria.  
 4.15 (from Lwów)—Sokol (Songs). Rudnicki (Pfte.). Pfte.: Miniatures (Scott). Old German Songs (Graener). Pfte.: (a) Danse lente (Frank), (b) Dance (Scott). Scottish Songs (Respighi).  
 4.50—Talk: Coursing.  
 5.0—Sports.  
 5.10—Technical Letter-box.  
 5.25—To be announced.  
 5.30—Programme Notes.  
 5.35—For Country People.  
 6.0 (from Lwów)—Reading from the Aeneid.  
 6.30 (from Lwów)—Niewiadomski and Gall Music for Choir and Soloists.  
 6.50—Topical.  
 7.0—Light Music and Dance Music—Station Orchestra. Conductor: Górzynski. Wronski (Songs).  
 7.45—News; Topical.  
 8.0—Symphony Orchestra. Conductor: Lewicki. Romanszko, Niemczewska and Dabrowska (Pftes.). Concert en style théâtral (Couperin). Concerto in F for Three Pftes. (Mozart). German Dances (Schubert). Overture, "The Barber of Seville" (Rossini).  
 9.0—Telmanyi (Violin).  
 9.50-10.30—News.



NATIONAL

For Time Signals, see Monday. 10.15 a.m. (D)—Service. 10.30 (D)—Weather Forecast. 10.45 (D)—Cinema Organ. 11.15 (D)—Records. 11.30 (D)—French for Schools. 11.45 (D)—BBC Midland Orchestra. 12.45 p.m. (D)—Band. 1.15 (D)—Alfred Salter (Baritone). 1.30 (D)—John MacArthur Quintet. 2.0 (D)—Herring Bulletin. 2.5 (D)—For Schools. 3.45 (D)—Talk on Children. 4.0 (D)—Evensong from St. Paul's Cathedral. 4.50 (D)—Records. 5.0—Big Bill Campbell and his Hill-Billy Band. 5.30—Records. 6.0—The First News. 6.20—Farming talk. 6.40—Leslie Howard in "Berkeley Square," by John L. Balderston. 7.40—Music from the Movies. 8.15—BBC Symphony Concert from Queen's Hall, London: Solomon (Pfte.); BBC Symphony Orchestra. Conductor, Sir Adrian Boult. 9.30—Third News. 9.50—BBC Symphony Concert (contd.). 10.40—News Revue. 11.15—Herman Darewski and his New Melody Rhythm Band. 11.30-12.0—Swing Time Records.

REGIONAL

For Time Signals, see Monday. 10.15-10.45 a.m. (ex. Western; Welsh 10.30)—National. 10.15 (Welsh)—Welsh Service. 10.45 (ex. Western, Scottish)—Mood and Movement. 10.45 (Western, Scottish)—National. 11.0 (ex. Western, Scottish; Welsh 11.25)—Cinema Orchestra. 11.5 (Welsh)—For Schools. 11.45 (ex. Western, Scottish)—Records. 12.20 p.m. (ex. Western, Scottish)—The Song Reporter, Ian Stewart; The Vagabond Lover. 12.50 (ex. Western, Scottish)—"Conquest of the Air;" talk. 1.15 (ex. Western, Scottish)—G. D. Cunningham (Organ). 2.0 (ex. Western, Scottish)—Theatre Orchestra. 2.0 (Scottish)—For Schools. 3.0 (ex. Western, Scottish)—"Far and Near," 3.15—Pfte. recital. 3.45 (ex. Western, Scottish)—BBC Northern Orchestra. 3.45 (Western, Scottish)—National. 4.30 (ex. Western, Scottish)—Light Orchestra. 5.0 (ex. Western)—Children's Hour. 5.0 (Western)—National. 6.0 (Regional, Western, N. Ireland)—BBC Northern Ireland Orchestra: A. V. Froggatt (Baritone). 6.0 (Midland)—Jack Venables (Pfte. syncopation). 6.0 (Northern, Scottish)—Orchestra. 6.0 (Welsh)—Welsh talk. 6.15 (Midland)—Quintet. 6.20 (Welsh)—Records. 6.30 (Welsh)—The A.B.C. Trio. 6.30 (Scottish)—Gaelic programme. 6.40 (Northern)—Morava (Violin). 6.45 (Scottish)—Willie Lindsay. 7.0—The Second News. 7.20—Regional Announcements. 7.30 (ex. Northern, Welsh, Scottish)—Tennis: Lord Aberdare v. R. Aird. 7.30 (Northern)—"Flippant Fingers." 7.30 (Welsh)—Welsh News. 7.30 (Scottish)—Scots Songs. 7.45 (ex. Western, Welsh)—"The World Goes By." 7.45 (Western)—Organ Recital. 7.45 (Welsh)—Discussion in Welsh. 8.5 (Welsh)—Pendryus Male Choir: Tom Williams (Baritone). 8.15 (Regional, Northern, Scottish)—Sextet. 8.15 (Midland)—"Melodies from the Comedies." 8.15 (Western)—Musicabaret. 8.15 (N. Ireland)—Bands; Male Voice Quartet. 8.45 (Scottish)—Discussion. 9.0 (ex. Northern, Western, Scottish)—"Bells over London." 9.0 (Northern)—"Men and Machines." 9.5 (Western)—"Ebb and Flow." 9.20 (ex. Welsh, N. Ireland; Scottish 9.30)—Variety. 9.20 (Welsh)—Ystalyfera Band: W. H. Thomas (Baritone). 9.20 (N. Ireland)—Male Voice Choir: George Beggs (Baritone); Lawrence McCann (Violin). 9.45 (N. Ireland)—Records. 10.0—News Summary. 10.25 (ex. Western; Midland, Scottish 10.45)—Herman Darewski New Melody Rhythm Band. 10.25 (Midland)—Reading. 10.30 (Scottish)—Evening Worship. 11.30 (ex. Western)—Late News. 11.40-12.0 (ex. Western)—Shepherd Munn (Pfte.).

Hours of Transmission in Greenwich Mean Time.

ATHLONE (Ireland)

565 kc/s (531 m.); 100 kW. Dublin, etc. See Sunday. 1.30 p.m.—Records. 2.30-3.0—For Schools. 5.30—Illustrated Talk by Eoghain O'Fairceallaigh: Bach. 6.0—Records: Famous Bands. 6.35—Irish News Feature. 6.45—News. 7.0—Strange Visitors to Ireland No. 4—Edna Fitzhenry. 7.15—New Talent with W. J. Watson as Comptre. 7.55—Dual Personalities No. 1—T. C. Murray, Schoolmaster. 8.15—Cathleen Rogers (Pfte.), Gretta Smith ('Cello) and Florence Byrne (Violin). 8.45—"Eamon an Chnuic"—Play (W. MacLysaght). 9.30—Variety Program. 10.30—News. 11.0—National Anthem.

BERLIN (Germany)

841 kc/s (356.7 m.); 100 kW. Transmits at intervals from 5.0 a.m. 11.0 a.m.-1.0 p.m.—See Stuttgart. 1.0—News. 1.15—Raatzke Band. 2.15—Exchange; Markets. 2.35—Raatzke Band (contd.). 3.30—Talk; Books. 4.0—Quintet in G minor (Mozart). 4.40—"The Brewer's Drayman"—Word Pictures. 5.0—Raatzke Quintet. 6.0—News; Announcements. 6.10—First Symphony (Bruckner) by the Station Orchestra and Leipzig Symphony Orchestra, Conductor: Weisbach. 7.5—Report on Forst, a Niederlausitz Textile Centre, followed by Concert from Forst—Berlin Station Orchestra, etc. Conductor: Willy Steiner. 8.0—Youth Programme. 8.30—Concert from Forst (contd.). 9.0—News. 9.30-11.0—See Breslau.

BEROMÜNSTER

(Switzerland) 556 kc/s (539.6 m.); 100 kW. Relayed by Basle and Berne, 1,375 kc/s (218.2 m.). 5.30-5.50 a.m.—Gymnastics. 11.0—Orchestra. 11.30—News. 11.40 a.m. - 12.45 p.m. — Zürich Radio Orchestra. 3.0—For Women. 3.20—Radio Orchestra. 4.0—Chamber Music for Children. 4.30—Duets by Dora Helen Zingg (Soprano) and Tina Müller-Marbach (Contralto). 4.45—Orchestral Records. 5.0—For Children. 5.30-6.55—From Basle. 5.30—Variety Music. 5.50—Talk in Dialect: Ducks. 6.0—Announcements. 6.15—Records. 6.35—See Vienna. 6.55—To be announced. 7.10 (approx.)—News. 7.20—Minnelieder (Heinrich von Morungen). 7.35—"Sichete i der Glungge"—Historical Picture after Gottlieb Lerch. 8.35—Orchestral Records. 8.40—Pierre Doriaan in his Repertoire. 9.0—Dance Records. 9.15—Tourist Report. 9.25-9.30—News.

BRATISLAVA

(Czechoslovakia) 1,004 kc/s (298.8 m.); 13.5 kW. Transmits at intervals from 5.15 a.m. 5.0 p.m.—Hungarian Transmission: Talk; Maria Roth (Pfte.). Fantasia in C minor (Bach). Sonetto del Petrarca (Liszt); Sports. 5.45-7.5—See Prague. 7.5—Talk. 7.30—See Prague. 8.30—Talk. 9.35-9.15—See Prague. 9.15—News (Hungarian). 9.30-10.0—Records.

BRESLAU (Germany)

950 kc/s (315.8 m.); 100 kW. Relayed by Gleiwitz and Görlitz, 1,231 kc/s (243.7 m.). Transmits at intervals from 4.30 a.m. 11.0 a.m.—Miners' Band. 1.0 p.m.—News. 1.15-2.0—Kern Band; Pfte. Duo. 2.30—For Children.

3.0—See Deutschlandsender. In the interval, Books. 5.0—Talk on Animals. 5.50—Programmes; Markets. 6.0—News. 6.10—"Twixt Dreaming and Waking"—Station Orchestra, Choir and Dance Band, Singers, Violin, etc. 7.40—Talk: India. 8.0—Motto; Sound News. 8.20—"Twixt Dreaming and Waking" (contd.). 9.0—News. 9.10—Political Review. 9.30-11.0—Light and Dance.

BRNO (Czechoslovakia)

922 kc/s (325.4 m.); 32 kW. Transmits at intervals from 5.15 a.m. 4.40 p.m.—German Transmission: Aich, Sigmund, and Kraus Songs by Edith Kraus (Soprano). 5.15—News. 5.20—Review of Russian Books. 5.35—For Workers. 5.45-6.25—See Prague. 6.25—Excerpts, "Uncle Vranáček's Troubles"—Folk Play (Robuš). 7.5-8.35—See Prague. 8.35—Polásek (Violin). Ciacona (Vitali). Rondo Vorisek. 9.0-10.0—See Prague.

BRUSSELS (No. 1)

(Belgium) 620 kc/s (483.9 m.); 15 kW. 6.30-9.5 a.m.—Records; Gym; News. 12.0 noon—Time; Variety Music. 12.30 p.m.—Weather; Shipping. 12.32 (approx.)—Salon Orchestra. 1.0—Time; News. 1.10—Orchestra (contd.). 1.30—Records. 2.0—Art Notes. 2.3-3.15—For Schools. 4.45—News. 5.0—Records: "Sword and Cloak" Music. 5.30—Talk: Walloon Literature. 5.40—Film Music. 6.0—Talk. 6.15—"Les Oliviers"—Poem (Signoret). 7.0—Reviews: (a) For Ex-Servicemen, (b) Periodicals, (c) Aviation. 7.15—Records; News. 8.0—Variety Concert. Brenders Jazz Band, Tity Quentin (Singers). 9.15—"1890"—A Radio Picture with the Salon Orchestra, etc. Conductor: Féron. 10.0—News. 10.10-11.0—Records. Overture, "Patrie (Bizet). Après un rêve (Faure). Waltz, "Faust" (Gounod). Chanson du Pêcheur (Faure) Excerpt, Manon Lescaut" (Auber). Ballet, "Le Cid" (Massenet). Waltz, "The Merry Widow" (Lehár). Intimité (Chopin). March (Warms).

BRUSSELS (No. 2)

(Belgium) 932 kc/s (321.9 m.); 15 kW. Programme in Flemish. 6.30-9.0 a.m.—Records; Gym; News. 12.0 noon—Records. 12.31 p.m.—Radio Orchestra. 1.0—News. 1.10—Orchestra (contd.). 1.30—Opera Records. 2.0-2.3—Shipping. 4.45—News. 5.0—For Children. 6.0—Radio Orchestra—Light Music. 6.15—Talk. 6.30—Orchestra (contd.). 7.0—Jewish Vocal Quartet. "Juval" Part I Synagogue Songs. Mizmour Schier Ganoekos (Kinstler). Weschomro (Heilman). Kol Doudi (Nowakowski). Part II Palestinian Folk-Songs (arr. Engel). Omrimjesna Erets. Lullaby, Noemi-Noemi. Bar Jochaj. Part III Yiddish Folk-Songs. Sloetsk (arr. Heilman). Gannale. Das Hemel. Katerina (arr. Slep). 7.30—Tourist Report. 8.0—Louvain Conservatoire Orchestra, Conductor: Soiron, Rose Delmar (Songs). La procession nocturne (Rabaud). Songs: (a) Aria from "La Clemenza di Tito" (Mozart), (b) Lied maritime (d'Indy), (c) Hungarian Folk-Songs (Pichler). Excerpts, "Deidamia" (Rasse). 8.45—Reading: The "Rubaiyat of Omar Khayyam." 9.0—Louvain Conservatoire Orchestra (contd.). Pathetic Symphony (Tchaikovsky). 10.0—News. 10.10—Poems. 10.30-11.0—Records: Symphony in B flat (Chausson).

WEDNESDAY Nov. 24

BUCHAREST (Romania)

823 kc/s (364.5 m.); 12 kW. Relayed by Radio-Romania, 160 kc/s (1,875 m.). Transmits at intervals from 4.30 a.m. 4.2 p.m.—Romanian Music by the Salomea Orchestra. 5.15—Lecture-Recital: Mediaeval Music. 6.5—Records of Famous Singers. 6.50—Educational. 7.5—Guslear Banjo Band. 7.35—Cello Sonata in A (Beethoven). 8.10—Anne Kleine (Songs). 8.30—News; Sports. 8.45—Radio Cabaret. 9.45—News (French, German).

BUDAPEST (No. 1)

(Hungary) 546 kc/s (549.5 m.); 120 kW. Transmits at intervals from 5.45 a.m. 11.5 a.m.—Hilda Saskó (Songs). 11.40—News. 12.0 noon—Misi Lakatos Cigány Band. 1.40 p.m.—News. 3.15—For Schools. 3.45—News. 4.0—Poems (István Vas). 5.0—Talk: Air Defence. 5.20—Records. 5.50—Marius Rabinovsky. 6.20—Station Orchestra. Excerpts, The Duchess of Chicago (Kálmán). Cradle Song (Perényi). Hindou Song (Rimsky-Korsakov); at 6.45—Foreign Affairs. 7.35—News. 8.0—Symphony in B flat (Bruckner) by the Opera Orchestra. Conductor: Rajter. 9.10—Dance and Film Records. 10.0—News (French, Italian). 10.10—Székely Jazz Band from the Café Szeffert. 11.5—News.

BUDAPEST (No. 2)

(Hungary) 359.5 kc/s (834.5 m.); 18 kW. 5.50 p.m.—Station Orchestra. 6.20—Italian Lesson. 7.5—Talk. 7.35—News. 8.0—Cigány Band. 9.5—Records.

COLOGNE (Germany)

658 kc/s (455.9 m.); 100 kW. Transmits at intervals from 5.0 a.m. 11.0 a.m.—Band. 12.0 noon—News. 12.15 p.m.—See Stuttgart. 1.0—News. 1.15—Schrammel Ensemble, etc. 2.0-2.30—For Children. 2.45—Industrial News. 3.0—Genealogy; Talk. 3.40—Music from Deutschlandsender. In the interval, Reading. 5.0—Topical Talks. 5.50—Visit to Cologne Zoo. 6.0—News. 6.10—Operetta, Film and Dance Records. 8.0—Talk. 8.10—Where are you, Comrade? 8.30—Violin Sonata in D (Beethoven). 9.0—News. 9.20—Political Review. 9.40-11.0—Music from Breslau.

DEUTSCHLANDSENDER (Germany)

191 kc/s (1,571 m.); 60 kW. Transmits at intervals from 5.0 a.m. 11.0 a.m.—Band from Danzig. 12.50 p.m.—News; Music. 1.15—See Berlin. 2.0—Exchange; Programmes. 2.15—Records: Light Music. 2.45—Report: Paper. 3.0—Krepela Sextet and Joost Band. 4.0—A Humorous Story. 4.0—Sextet, etc. (contd.). 5.0—Contemporary Choral Music. Station Chamber Choir, Conductor: Görner. 5.20—Erwin Wittstock reads. 5.40—Topical Report. 6.0—Motto; News. 6.10—Kaufmann Band, etc. 7.0—Joost Band. 8.0—Topical; Joost Band. 8.30—Violin Sonata in C minor (Beethoven). 9.0—News; Sports. 9.15—Melody and Rhythm. Station Orchestra, Bund Pflanzor, Brau (Saxophone), etc. 10.0-11.0—Joost Band.

FRANKFURT (Germany)

1,195 kc/s (251 m.); 25 kW. Cassel, etc. See Sunday. Transmits at intervals from 5.0 a.m. 11.0 a.m.—Band and Choir. 12.0 noon—News. 12.15 p.m.—See Stuttgart. 1.0—News; Records. 2.0—Talk. 3.0 (from Coblenz)—Contemporary Light Music—Trier Municipal Orchestra. Conductor: Creutzburg. In the interval, Anecdotes; Sports. 5.0—Topical Talks. 6.0—Time; News. 6.10—Operetta and Light Music. Station Orchestras, Conductors: Moritz and Hauck, Vocal Quintet, etc. 8.0—See Berlin. 8.30—"Our Four-footed Friends"—Sequence for Animal Protection Day, with Grieg, Haydn, Schubert and Tchaikovsky Music, and Readings from Löns, Kyber, Roegner, etc. 9.0—News; Report. 9.20—Where are you, Comrade? 9.30—Light and Dance Music. Conductor: Hauck, Tony Schantz (Soprano). 11.0-12.0 m.t.—See Stuttgart.

HAMBURG (Germany)

904 kc/s (331.9 m.); 100 kW. Bremen, etc. See Sunday. Transmits at intervals from 5.10 a.m. 11.0 a.m.—Band. Parademarsch der langen Kerls (Roland-Hackenberg). Overture, Fridericana (Zimmer-Hackenberg). Bataillon Garde (Zimmer-Hackenberg). Suite, Feuerwerksmusik (Handel-Schnitzler). Two Marches (Blumensaat). Sedan March (Lange-Hackenberg). Indra March (Neumann-Hackenberg). Overture, "Light Cavalry" (Suppe-Schröder). March on Carinthian Folk-Songs (Seifert-Hackenberg). Two Alsatian Folk-Dances (Merkling). March, In Treue fest (Teike). Kameradentreue (Bähre). 12.0 noon—Weather; Topical. 12.15 p.m.—See Stuttgart. 1.0—News; Music. 2.0—Shipping; Markets. 2.25—Station Orchestra, Conductor: Müller-Lampertz. Serenade (Schoeck). Excerpts, Pastoral Suite (Atterberg). Music for Chamber Orchestra (Gimatis). 2.50—Ice Report. 3.0—Café Concert. In the intervals, Talks. 5.0—War Reminiscences. 5.15—Pfte. Concerto in B flat (Beethoven) by Rosl Schmid and the Station Orchestra, Conductor: Krutge. 5.40—Talk; Shipping. 6.0—News. 6.10 (from Stettin)—Military Band and Chorus. Conductor: Möller, March (Jancovius). Overture, "William Tell" (Rossini). Song, Frisch gesungen (Silcher). Excerpts, "Aida" (Verdi). March (Meissner). Waltz, Dorfschwalben aus Oesterreich (Strauss). March (Schultz). March (Becker). 7.0 (from Kiel)—Kiel Orchestral Society, Conductor: Döring. Im Herbst (Grieg). L'auë sur l'eau (Gabriel-Marie). Tanz unter der Dorflinde (Reinecke). Spring Reverie (Palmgren). Friesenfahrt (Koch). Spiel der Wellen (Koch). Scandinavian Folk-Dance (Hartmann). 8.0—"Hamburg Harbour"—Word Pictures (Herbert-Esmarch). 9.0—News. 9.20—Political Review. 9.40-11.0—Music from Breslau.

HILVERSUM (1,875 m.) (Holland)

160 kc/s; 10 kW until 2.40 p.m.; 150 kW from 2.40 p.m. NCRV Programme. 7.40 a.m.—Bible Reading; Meditation; Records of Sacred Music. 8.10—Records. 9.10—Greetings; Records. 10.10—Service; Records. 10.55—Van der Horst Ensemble. 11.40—News; Records; Van der Horst Ensemble. 1.10 p.m.—Records. 1.40—van Rijn (Contralto); Mlle Münnichhoff (Pfte.). 2.40—Reading; Records. 3.25—Sacred Songs by de Heer, with Verver (Violin).

WEDNESDAY (November 24)

4.25-Greetings; For Children.
5.25-Records; Talks; News; Report.
7.40-News; Talks.
8.25-NCRV Choir. Conductor: Couvée.
9.15-Peters (Organ).
9.40-News; Peters (Organ).
10.25-Gym.
10.40-11.40-Records; Bible Reading.

HILVERSUM (301.5 m.) (Holland)

995 kc/s; 15 kW until 6.10 p.m.; 60 kW from 6.10 p.m.
VARA Programme.
7.40 a.m.-Records.
9.10-Talk.
9.40-VPRO Service.
10.0-Talk; Record.
11.10-For the Unemployed.
11.40-Records.
12.10 p.m.-VARA Orchestra. Conductor: De Groot. Hofman (Tenor).
12.55-1.25-Ramblers Dance Band.
1.40-Dressmaking Lesson.
2.10-For Women.
2.40-For Children.
5.10-Records.
5.40-The Lucky Birds. Conductor: Vogel. v. Dongen (Songs).
6.10-RVU Talk.
6.40-Tiggers (Songs).
7.10-VPRO Talk.
7.40-Announcements.
7.55-A Play.
9.10-Steyn Accordion Band.
9.40-Press Review; Records.
10.40-Talk.
11.0-11.40-Records.

KALUNDBORG (Denmark)

240 kc/s (1,250 m.); 60 kW. Relays Copenhagen, 1,176 kc/s (255.1 m.).
Transmits at intervals from 6.0 a.m.
11.0 a.m.-1.0 p.m.-Louis Preil's Ensemble.
1.30-Radio Orchestra, Conductor: Grøndahl. Overture, "The Bohemian Girl" (Balfe). Extase (Ganne). Slav Dances (Chabrier). Waltz (Gungl). My old Kentucky Home (art. Busch). Excerpts, "Katinka" (Friml). Overture, "Les Dragons de Villars" (Mailart). Waltz (Kálmán). Ballet Suite (Grétry). Franko. Romance in C for Strings (Sibelius). Excerpts, "Tosca" (Puccini). March (Fucik); at 2.20 - Henry Jensen (Violin).
3.30-For Children.
3.50-Wireless Notes.
4.0-For Farmers.
4.25-Weather.
4.40-Exchange; Markets.
4.50-Records.
4.55-Lili Horn (Songs).
5.15-Talk: Thorvaldsen's Museum.
5.35-French Lessons.
6.0-News.
6.30-Talk: Country and Town.
7.0-Chimes.
7.2-Dialogues.
7.10-"Wanted: An Announcer" - Play (Ungdary-Branner).
7.45-Radio Orchestra, Conductor: Grøndahl. Concert Overture, Michelangelo (Gade). Two Elegiac Melodies (Grieg). Prelude, "Saul and David" (Nielsen). Excerpts, Suite ancienne (Halvorsen). Symphonic Poem, Phaeton (Saint-Saëns). Waltz, "Der Rosenkavalier" (Strauss).
8.45-Visit to a Class for Commercial Travellers.
9.15-News.
9.35 - Hertha Björvig (Czech Songs).
9.55-Jazz on Two Pftes.
10.15-11.30-Preil's Dance Band.

KÖNIGSBERG (Heilsberg) (Germany)

1,031 kc/s (291 m.); 100 kW. Relayed by Danzig, 1,303 kc/s (230.2 m.).
Transmits at intervals from 5.0 a.m.
11.0 a.m.-1.0 p.m.-See Stuttgart.
1.0-News; Music.
1.55-Exchange.
2.30-Hints; Books.
3.0-Orchestra, Conductor: Wilcken. In the interval, Talk on Riding.
4.45-Topical.
5.0-"Safety First."
5.15-Operetta Records. Excerpts, "The Bird Fancier" (Zeller). "Die Fledermaus" (Strauss). "The Geisha" (Jones). "Der Obersteiger" (Zeller), and "Eva" (Lehár).
5.50-News; Weather.

6.10-"Before the Decision" - Play about Bismarck (Runge).
7.0-Station Orchestra, Conductor: Wöllner. Bärtich (Violin), Spengler and Pischel (Trumpets). March (Kletzky). Overture, "Gipsy Love" (Lehár). Suite (Geisler). Polka (Kling). Ballet Overture (Lincke). Concert Fantasia on Russian Themes (Rimsky-Korsakov). Bilder aus Osten (Schumann). Operetta Potpourri (Hruby). By the blue Hawaiian Waters (Ketelbey). In a Persian Market (Ketelbey). Waltz (Glessmer). Erinnerung an Wildbad (Frantz). March (Elbe).
9.0-News; Sports.
9.20-Political Review.
9.40-11.0-Music from Breslau.

LAHTI (Finland)

166 kc/s (1,807 m.); 150 kW. Relayed by Helsinki, 895 kc/s (335.2 m.).
Transmits at intervals from 6.45 a.m.
3.0 p.m. - Records: Norwegian Music.
3.50-For Children.
4.50-News (Finnish, Swedish).
5.15-For Mothers.
5.30-Folk Music (arr. Väisänen).
6.0-Talk.
6.20-Kalevan Laulajat Choir. Conductor: Krohn.
6.40-Talk.
7.0-Light Music.
7.45-News (Finnish, Swedish).
8.10-Records: Fifth Symphony in C minor (Beethoven) by the London Philharmonic. Conductor: Weingartner.
9.15-10.0-Light Music.

LEIPZIG (Germany)

785 kc/s (382.2 m.); 120 kW. Relayed by Dresden, 1,285 kc/s (233.5 m.).
Transmits at intervals from 5.0 a.m.
11.0 a.m.-Leipzig Symphony Orchestra, Conductor: Kretzschmar.
12.0 noon-Time; News.
12.15 p.m.-See Stuttgart.
1.0-News; Wagner Records.
2.10-Talk.
2.30-"Rhön Village Carvers" - Word Pictures.
3.0-See Deutschlandsender. In the interval, Announcements.
5.0-Talk: Animal Protection.
5.20-"Musical Fireworks"-Records. Foxtrot (Leux). Strahlender Stern der Liebe (Windt). Auf der Rutschbahn (Meyers). Auf der Lagune (Schimelpfennig). Akkordeon - Träume (Pörschmann). Karussell (Bräu). Kullerpfeifisch (Kalthof). Die Juliska aus Budapest (Raymond). Quickstep (Bochmann-Schultz-Gellen).
5.50-Topical; News.
6.10-"Alpine Pastures" - Bavarian Peasant Evening, with Nazi Eisele, Yodellers. Folk-Singers, Zither Players, Schrammel Ensembles and Dialect Humorists.
8.0-To be announced.
9.0-News; Sports.
9.30-11.0-See Frankfurt.

LILLE (Radio PTT Nord) (France)

1,213 kc/s (247.3 m.); 60 kW. Transmits at intervals from 6.30 a.m.
7.0 p.m.-Talk in English.
7.15-Massenet Records.
7.19-For Gardeners.
7.30-News.
8.0-One-Act Plays: (a) "Tante Arlette" (Keiler); (b) "Pendant l'Averse" (Timimory).
8.30 - Light Orchestra from Limoges (PTT).
10.30 (approx.)-Records; News.

MONTE CENERI (Switzerland)

1,167 kc/s (257.1 m.); 15 kW.
11.0 a.m.-Records.
11.29-Time; News.
11.40-Station Orchestra. Conductor: Herschel.
12.20-12.30 p.m.-Financial Notes.
3.59-Time.
4.0-5.0-See Beromünster.
6.15-Reading; Records.
6.45-News.
7.0-Virgilio Ranzato ('Cello) and Nino Herschel (Pfte.).
7.20-Talk: Tuberculosis.
7.35-'Cello and Pfte. (contd.).
8.5-9.0-See Vienna.

MOSCOW (No. 1) (Russia)

172 kc/s (1,744 m.); 500 kW.
3.30 p.m.-Literary Programme.
4.30-Concerts.
9.0-French Programme.
10.0-German Programme.
11.0-12.0 m't. - Spanish Programme.

MUNICH (Germany)

740 kc/s (405.4 m.); 100 kW. Relayed by Nürnberg, 1,267 kc/s (236.8 m.).
Transmits at intervals from 5.0 a.m.
11.0 a.m.-1.0 p.m.-See Stuttgart.
1.0-News; Exchange.
1.15-See Berlin.
2.0-2.30-Report: The Bavarac Glass Blowers.
3.0-Chamber Music. Sonata for Viola and Harpsichord (Ariosti). Sicilienne (Perkoles). Dances for Harpsichord (Handel, Couperin, Bach, Telemann). So wie die Taube (Handel). Sonata for Viola and Harpsichord (Marcello).
3.40-Political Review.
4.0-Time; Markets.
4.15 (from Nürnberg) - Light Music. Station Orchestra, etc. Conductor: Schwarz.
5.45-German for Germans.
6.0-Time; News.
6.10-Records of Marches.
7.0-"Animal Lovers"-Sequence for Animal Protection Day (Schröder - Justin). Station Schrammel Ensemble, Conductor: Cassimir; Singers and Speakers.
8.0-Political Review.
8.20-Pfte. Concerto in B flat (Brahms) by Hoehn and the Station Orchestra, Conductor: Winter.
9.0-News; Interlude.
9.30-11.0-See Breslau.

NAPLES GROUP (Italy)

Naples, 1,104 kc/s (271.7 m.); 10 kW. Florence (No. 1), etc. See Sunday.
6.0 p.m.-Light Music.
6.15-Topical.
6.25-Song Records.
7.0-7.30-See Rome.
7.30 - Three-Act Play (Rossato). Records in the interval.
9.0-Dance Music.
10.0-News.
10.15-10.55-Dance Music.

OSLO (Norway)

260 kc/s (1,153.8 m.); 60 kW. Fredrikstad, etc. See Sunday.
Transmits at intervals from 10.40 a.m.
4.0 p.m.-Opera and Operetta Records.
5.0-German Lesson.
5.25-For Boys.
5.50-News and Announcements.
6.30-Time; For Farmers.
6.40 - Records of Tito Schipa (Tenor). Ave Maria (Schipa). Princesita (Padilla). Arias, "Mignon" (Masseten) and "Lakmé" (Delibes).
6.55-Talk: Norwegian Emigrants.
7.15-Nordstjört (Songs). An die Musik (Schubert). Three Autumn Songs (Andersen, Sinding, Alnæs).
7.30-Talk from the University.
8.0-Station Orchestra. Conductor: Kramm.
8.40-News.
9.0-Topical Talk.
9.15-10.0-Station Orchestra. Conductor: Kramm. Suite on Seventeenth Century Melodies (Grossmann). Four Ways (Coates). Waltz, "Der Rosenkavalier" (R. Strauss).

PARIS (Eiffel Tower) (France)

1,456 kc/s (206 m.); 7 kW. Transmits at intervals from 6.30 a.m.
8.0 p.m. - Germaine Cernay (Songs), Pauline Gordon (Pfte.). Songs (Beysds). Pite.: (a) Preludes and Fugue (Bach), (b) Les Sauvages (Rameau), (c) Sonetto del Petrarco (Liszt).
8.30 (also Bordeaux-Lafayette, Montpellier (PTT) and Lyons (PTT)) - "Les Caprices de Marianne" - Two Act Play (de Musset) from the Théâtre Montparnasse.
10.30-Records.
11.0-11.15-News.

PARIS (Poste Parisien) (France)

959 kc/s (312.8 m.); 60 kW. Transmits at intervals from 7.10 a.m.
12.0 noon-Exchange.
12.35-Exchange; Song Records.
1.15-Amusement Guide.
1.17-Cuban Trio.
1.30-Song Records.
2.0-Exchange.
3.45-Exchange.
4.35-Exchange.
5.0-News.
5.5-Records: Symphony in E flat - The Eroica (Beethoven).
6.0-Exchange; News.
6.10-Jewish Programme.
6.20-Opera Records.
6.50-Talk: Electricity.
6.58-Racing.
7.0-Topical; Sports.

7.10-Thriller; Amusements.
7.18-Rouille, presented by Roger Francois.
7.45-Hahn Records.
8.0-News.
8.10-The Song of Songs-Damia.
8.15-"Simone."
8.45-Talk.
8.50-"La bonne histoire."
9.0-News.
9.10-Max Regnier and Company.
9.40-Records: "Le bal de Beatrice d'Este (Hahn)-Symphony Orchestra. Conductor: The Composer.
9.55-News.
10.10-Follow the Guide-Les Passages des Panoramas (Diamant-Berger), with Marguerite Moréno, Balder, Robert Ozanne, and Claude Dauphin, etc.
10.30-11.0-From the Shéhérazade.

PARIS (PTT) (France)

695 kc/s (431.7 m.); 120 kW. Transmits at intervals from 6.30 a.m.
2.30 p.m.-Concert for the Blind. In the interval, "Le grand Changement" - Play (Bauche) with Paul Castan, etc.
4.0-Reading (Créange).
4.15-Talk.
4.30-Julietta Stora (Songs).
4.45-Records.
4.50-Science Talk.
5.0-Simone Chauland (Violin).
5.15-Music Talk with Pfte. Illustrations.
5.30-Talks.
6.0-Programme by the Workers' Educational Centre.
6.30-Marguerite de Siebenthal (Songs).
7.0-Radio Journal; News.
8.0-"Le Pied de la Table vous parle" - Radio Fantasy (Clérouc).
8.30-To be announced.
10.30-News; Jazz Records.
11.0-U.S.A. Bulletin (Recorded).



Exclusive "World-Radio" Picture Madame Gabrielle Ristori, who takes part in "Les Ondes de Paris" (Radio-Paris, 9 p.m.)

PARIS (Radio-Paris) (France)

182 kc/s (1,648 m.); 80 kW.
6.28 a.m. - Programme Notes; Records.
6.40-Time; News.
6.50-Gym; Records.
7.15-News; Records.
8.0-News; Programme Notes.
8.35-For Women.
8.50-9.20-Records.
10.15-Programme Notes; Records.
10.45-Reading (Selma Lagerlöf).
11.0-Records.
11.45-Markets.
12.0 noon-Garde Républicaine Band.
1.0 p.m.-Time; News; Exchange.
1.30-Tubiana (Songs).
1.45-Band (contd.).
2.0 - Programme Notes; Music Talk by Wanda Landowska.
2.10-Talk: Exchange; Markets.
2.45-Ninon Guérald (Songs).
3.0-Arma (Pfte.).
3.15-Talks; Humorous Papers.
3.45-Exchange.
4.0-Mme. Grialys (Songs).
4.15-Sorel Nitzberg (Pfte.).
4.30-Books; November Almanac.
4.50-Exchange; Markets.
5.0-Bailly Orchestra.
6.0-Educational; Records.
7.30 - Pictures of the Second Empire.
7.45-Talk; Programme Notes.
8.0-Political Review.
8.15 - Talk for Young People: Student-Life in the U.S.A.
8.30-Mlle. Tavares (Songs) and Elisa de Souza Pedroso (Pfte.).
9.0-"Les Ondes de Paris"-Programme presented by Marie Clérouc, with Arnould, Paul Simon, Gabrielle Ristori, etc.; at 9.30-News; Review.
10.30-Dance Records.
10.45-Time; News.
11.0-Programme Notes.

PRAGUE (Czechoslovakia)

638 kc/s (470.2 m.); 120 kW. Transmits at intervals from 5.15 a.m.
4.10 p.m.-For Young People.
4.40-Industrial Review.
4.50-Record; For Workers.
5.5-German Transmission. Schwan Music. Lida Homma (Songs); The Composer (Pfte.). Songs: (a) In the Twilight, (b) Wandering Mood. Pfte.: Dance. Songs: (a) Dreamland, (b) Waiting; Talk; Announcements.
5.45-News (German); Record.
6.0-News.
6.10-Political Talk.
6.20-Local News.
6.25-Military Band. Conductor: Thier. March (Tichy). Wedding of the Winds (Hall). Selection, "Swan Lake" (Tchaikovsky). Dance (Smetana). Polonaise Kuchynka. Intermezzo (Oberthor). March (Vackar).
7.5-Discussion.
7.30-Opera Music. Station Orchestra. Conductor: Janota. Gleich (Tenor). Mandus (Bass). Overture and Arias, "The Seraglio" (Mozart). Selection, "Two Widows" (Smetana). Aria and Duet, "The Secret" (Smetana). Overture, Aria, and Dance, "Tsar and Carpenter" (Lortzing).
8.30-Poems.
8.35 - Sonata - Funeral March (Chopin) by Langer (Pfte.).
9.0-Time; News.
9.15-English Lesson.
9.35-Records.
10.0-10.15-News in French.

RADIO-NORMANDIE (France)

1,113 kc/s (269.5 m.); 15 kW.
6.45 a.m.-Band; Records.
7.15-News; Topical.
7.45-Physical Exercises.
8.0-Light Music.
9.30-Popular Music.
10.30-Scottish Music.
10.45-Light Music.
11.30-Symphony Music.
12.0 noon-Variety Concert.
12.45 p.m.-News; Variety Concert.
2.0-Records.
2.15-Light Music.
3.0-Film Fantasy; Records.
3.30-Light Music.
4.15-Italian Music.
4.30-Popular Music.
5.30-Light Music.
6.0-Children's Corner.
6.45-News; Racing.
7.0-Records.
7.25-News; Topical.
7.45-Cigány Music.
8.0-Vocal Duets.
8.20-Light Music.
8.40-"Normandy."
9.0-Variety Concert.
11.0-Café Concert.
11.45-News.
12.0 m't.-Midnight Melodies.
12.30-1.0 a.m. (Thursday)-Dance Music.

ROME GROUP (Italy)

Rome (No. 1), 713 kc/s (420.8 m.); 50 kW. Bari (No. 1), etc. See Sunday.
Transmits at intervals from 6.45 a.m.
4.0 p.m.-News.
4.15-4.50 - "Camerata Musicale Romana" Quartet. Quartet in A (Bocherini). Quartet in C (Gorini).
5.50-Motoring Notes.
6.0-Talk (German); Announcements.
6.25-News (English, French).
7.0-Time; News.
7.20-Government Notes.
7.30-Light Music.
8.0-Orchestra. Conductor: Ferro. Overture, "Figaro" (Mozart). Concerto grosso (Corelli-Toni). Andante (Geminiani-Marinuzzi). Air for 'Cello and Orchestra (Ferro). Pavane (Ravel). Overture, "Egmont" (Beethoven).
9.15 (approx.)-Variety Concert.
9.45 (approx.)-Dance Music.
10.0-News.
10.15-10.50-Dance Music.

SOTTENS (Switzerland)

677 kc/s (443.1 m.); 100 kW. Relayed by Geneva, 401 kc/s (748 m.).
9.10-9.50 a.m.-For Schools.
11.30-News.
11.40 (from Geneva)-Records.
12.0 noon-12.45 p.m. (from Geneva)-A Film.
4.0-5.0-See Beromünster.
5.0 till Close Down - From Geneva.
5.0-For Young People.
5.45-Interlude.
5.50 - Talk: Eighteenth Century Swiss Porcelain and Earthenware.

6.5—Interlude.
6.15—Micro-Magazine.
6.50—News.
7.0—Records.
7.15—Paul Chaponnière.
7.30—Radio Suisse Romande Orchestra, Conductor: Ansermet.
Milstein (Violin). Symphony in G (Haydn). Violin Concerto in E minor (Mendelssohn). Elegiac Symphony (Malipiero). Spanish Symphony for Violin and Orchestra (Lalo).
9.30—Weather.

STOCKHOLM (Sweden)
704 kc/s (426.1 m.); 55 kW.
Motala, etc. See Sunday.
Transmits at intervals from 6.20 a.m.
11.25 a.m.—Lind's Trio.
11.50—Exchange; Markets.
12.0 noon—For Schools.
12.30 p.m.—Martensson's Ensemble.
1.30—For Women.
1.45-2.0—Reading for Children.
4.5—Mandoline Music.
4.30—Talk.
5.0—Records.
6.0—News.
6.30—Operetta Music by the Göteborg Radio Orchestra. Conductor: Tor Mann. Overture, "Banditenstreiche" (Suppé). Intermezzo, "The Arabian Nights" (Strauss). March, "The Bird Fancier" (Zeller). Waltz, "The Count of Luxemburg" (Lehár). Selection, "Clivia" (Dostal).
7.15—A Play.
8.45—News.
9.0-10.0—Radio Dance Band.

STRASBOURG (France)
859 kc/s (349.2 m.); 100 kW.
Transmits at intervals from 6.30 a.m.
5.0 p.m.—Literary Talk by Georges Bernanos: Emile Hinezelin.
5.15—Excerpts, "Martha" (Flotow) by Jeanne Ward and Delancy.
6.0—Economic and Social Notes.
6.30—Dialect Talk.
7.0—News.
7.30—Concert from Rennes-Bretagne.
8.0—News (German, French).
8.30—Symphony Concert from the Palais des Fêtes. Municipal Orchestra. Conductor: von

Hoesslin. Overture, "Oberon" (Weber). The Unfinished Symphony (Schubert). Eroica Symphony (Beethoven).
10.30—News (French, German).

STUTT GART (Germany)
574 kc/s (522.6 m.); 100 kW.
Transmits at intervals from 5.0 a.m.
11.0 a.m.—Operetta Music. Station Orchestra, Jautz (Tenor).
12.0 noon—News.
12.15 p.m.—Light Music. Station Orchestra, Folk-Music Ensemble, etc.
1.0-2.0—Variety from Mannheim. Melo-Trio, 'Cello, and the Merry Five.
3.0—Variety Concert.
4.0—Reading; Variety Concert (cont'd.).
5.0—Talk: German Aviation.
5.30—Topical.
6.0—News; Topical.
6.15—Records: Operetta and Light Music.
7.15—Concert from Heidelberg. Heidelberg Municipal Orchestra, Conductor: Overhoff; Hedwig Erl (Soprano). Academic Festival Overture (Brahms). Excerpts, "Rosamunde" (Schubert). Aria, "The Barber of Seville" (Rossini). Tales from the Vienna Woods (Strauss). Excerpts from the Serenade (Overhoff).
8.15—Pozniak Trio. Trio in C (Cassado). Dumky Trio (Dvořák).
9.0—Time; News.
9.30—See Breslau.
11.0-12.0 m.t.—Concert on Records. Toccata and Fugue in D minor (Bach). Allegro for Organ (Handel). Larghetto (Nardini). Songs (Schumann): (a) Abendlied, (b) Der Nussbaum, (c) Mondnacht. Unfinished Symphony (Schubert).

TOULOUSE (Radio-Toulouse) (France)
913 kc/s (328.6 m.); 60 kW.
Transmits at intervals from 8.0 a.m.
6.0 p.m.—Orchestra.
6.15—Dance Songs.
6.40—Operetta Airs.
6.55—News; Sports.
7.15—Variety.
7.45—Ray Ventura and Collegians.

8.30—Revue with Pierre Ferrari and Romeo Carlés.
9.10—Light Music.
9.15—Maurice Saint-Paul Music by the Composer (Accordion).
10.0—News.
10.15—English Concert.
11.15—Songs.
11.35—Light Music.
11.50-12.0 m.t.—News.

TURIN GROUP (Italy)
Turin (No. 1), 1,140 kc/s (263.2 m.); 7 kW. Milan (No. 1), etc. See Sunday.
Transmits at intervals from 6.45 a.m.
4.0 p.m.—News.
4.15-4.50—Rita Stobbia (Soprano). Two Songs (Schumann). Der König von Thule (Schubert). Heidenröslein (Schubert). Wiegenlied (Brahms). Ballad (Goelwe). Three Lyrics (Labroca). Nocturne (Parelli). Chanson de Paques (Parelli).
5.30—Motoring Notes.
6.0—Light Music.
6.40—News (French).
7.0-7.30—See Rome.
7.30—Light Music.
8.0—Choir, Conductor: Somma.
9.0—Marcella Barzetti (Pfte.). Canzone (Frescobaldi). Sonatas in E and D (Scarlatti). Etude in F (Chopin). Theme with Variations in A minor (Liszt). General Lavine, eccentric (Debussy). Toccata (Casella).
10.0—News.
10.15-10.55—Dance Music.

VIENNA (Austria)
592 kc/s (506.8 m.); 100 kW.
Graz, etc. See Sunday.
Transmits at intervals from 5.45 a.m.
10.25 a.m.—Grete Halbwild (Pfte.), Maria Weinlinger (Soprano). Songs: (a) Das verlassene Mägdlein (Wolf), (b) Selige Nacht (Marx), (c) Unterwegs (Pahlen), (d) Klage (Heller), (e) Aria, "Manon Lescaut" (Puccini), (f) Aria, "Herodiade" (Massenet). Pfte.: (a) Prelude and Fugue in G minor (Bach), (b) Nocturne and Two Waltzes (Chopin).
10.55—Weather.
11.0—Station Band. Larysz (Violin). Overture, "Raymond" (Thomas). Waltz, Grüsse aus Oesterreich (Reinl). Excerpts,

WEDNESDAY (November 24)

"Cavalleria rusticana" (Mascagni). Violin: Romanza (Sidericudi). Alt-Wien (Drda). Slav Rhapsody (Friedemann). Viennese Suite (Pachemegg). Waltz, "Madame Pompadour" (Fall). Carpathian Dance (Smatek).
12.0 noon—News.
12.10 p.m.—Band (cont'd.). Fairy Overture, "König Drosselbart" (Hanel). Waltz, "Das Leben ist doch schön" (Strauss). Ballet, "Coppélia" (Delibes). Ja, das ist Wien (Goetz). Das Lied vom Godekratzen (Jäger). Dance Suite, "Maske in Blau" (Raymond).

1.0—Records of Erna Sack (Soprano).
1.30—Announcements.
2.0—Weather; Lottery Results; Exchange.
2.15—Games for Children.
2.40—Talk: Inventions.
3.0—News; Exchange.
3.5—Records: Symphony Music. Overture, Portsmouth Point (Walton). Pavane pour une Infante défunte (Ravel). Le martyre de S. Sebastien (Debussy). Norwegian Rhapsody (Lalo). March, "The Loves of the Three Oranges" (Prokofiev). Excerpts, "The Sleeping Beauty" (Tchaikovsky).
3.50—Art Notes.
4.5—For Teachers.
4.5—Contemporary Austrian Composers—Paumgartner and Scherber Concert.
5.20—Talk: Commercial Law.
5.40—Talk: Austrian Culture.
6.0—News; Weather.
6.10—Talk for the Nordbahn Railway Centenary.
6.30—Talk on the following Concert.
6.35—Third Subscription Concert of the "Gesellschaft der Musikfreunde," from the Musikvereinsaal. Vienna Symphony Orchestra, Conductor: Kabasta. Casadesus (Pfte.). Symphonic Poem, Penthesilea (Wolf). Pfte. Concerto in D (Mozart).
7.50—Talk on the Concert.

8.5—Concert (cont'd.). Third Symphony—the Eroica (Beethoven).
9.0—Military Band. March (Fucik). Waltz (Doelle).
9.10—News; Weather.
9.20—Band (cont'd.). Overture, "Pique Dame" (Suppé). Slav Dances (Dvořák). Hungarian Dances (Brahms). Aus dem Wiener Volksleben (Schück).
9.55—Announcements.
10.0-10.30—Band (cont'd.). March, Fesch voran! (Süsz). Paysages d'automne (Waldteufel). Schlagereolympiade (Schneider-Gaigg). March (Schmidt).

WARSAW (Poland)
224 kc/s (1,339 m.); 120 kW.
Cracow, etc. See Sunday.
Transmits at intervals from 5.15 a.m.
10.57 a.m.—Time; Fanfare.
11.3-12.0 noon—To be announced; at 11.20, News.
2.30 p.m.—Economics; For Children; Eloquution.
3.15—Lodz Salon Orchestra. Conductor: Ryder.
3.50—Topical; Talk.
4.15 (from Wilno)—Kinkulkin ('Cello). Sonata (Corelli). Adagio with Variations (Respighi). Arietta (Rogowski). Tarantella (Mahms-tröm).
4.50—Talk; Sports; Records.
5.30—Programmes; For Country People.
6.0—Reading (Parnicki).
6.20—Elvira Orlicz-Dreszer (Songs).
6.35—"All the World's a Stage"; Topical.
7.0—Records: Songs and Dance Songs.
7.45—News; Topical.
8.0—Chopin Pfte. Recital by Olga Iliwicka. Sonata in B minor. Mazurkas in F major and C minor. Nocturne in D flat. Preludes in C sharp minor, B major and G sharp minor. Scherzo in B flat minor.
8.45—Polish Poetry.
9.0—Station Orchestra. Conductor: Fiteiberg.
9.50-10.0—News.

NATIONAL

For Time Signals, see Monday.
10.15 a.m. (D)—Service.
10.30 (D)—Weather Forecast.
10.45 (D)—At Home Today.
11.5 (D)—Records.
11.25 (D)—For Schools.
11.45 (D)—Records.
12.30 p.m. (D)—Cinema Orchestra.
1.15 (D)—Records.
2.0 (D)—Herring Bulletin.
2.5 (D)—For Schools.
2.50 (D)—"Things I Cannot Explain"; talk. 3.5 (D)—Records.
3.15 (D)—Bournemouth Municipal Orchestra: Feuermann ('Cello).
4.45 (D)—"You and Your Clothes"; talk. 5.0—Dance Music.
6.0—First News. 6.20—Book talk.
6.40—Reginald Foort (BBC Theatre Organ). 7.0—Madrigals.
7.30—Jack Jackson and his Band.
8.0—Voices of Variety.
8.40—"Men Talking".
9.0—The Third News.
9.20—BBC Theatre Orchestra.
10.0—Short Mid-Week Service.
10.20—The Belavia Circle: The Kucher String Quartet.
10.55—Billy Cotton and his Band.
11.30-12.0—Dance Records.

REGIONAL

For Time Signals, see Monday.
10.15-10.45 a.m. (ex. Western)—National.
10.45 (ex. Western, Scottish)—Orchestra: Alex Rogers (Baritone).
10.45 (Western, Scottish)—National.
11.30 (ex. Western, Scottish)—Cinema Organ. 12.0—Quintet.
12.30 p.m. (ex. Northern, Western, Scottish)—BBC Singers (B).
12.30 (Northern)—Ballad Concert.
1.0 (ex. Western, Scottish)—"Horace Walpole"; Eric Gillett.
1.20 (ex. Western, Scottish)—Keith Falkner (Baritone); Frederick Stone (Pfte.). 2.0—Dance Records.
2.0 (Scottish)—For Schools.
2.30 (ex. Western, Scottish)—Light Classical Concert.
3.0 (Welsh)—For Schools in Wales.
3.15 (ex. Western, Scottish); Welsh 3.25—Royal Marines Band: Alexander Henderson (Bass).
3.30 (Scottish)—Mid-Week Service.
4.0 (Western, Scottish)—National.
4.15 (ex. Western, Scottish)—Bath Pump Room Orchestra.

Hours of Transmission in Greenwich Mean Time.

5.0—The Children's Hour.
6.0 (Regional)—Light Orchestra.
6.0 (Midland)—Band: Horace Lowe (Bass-Baritone).
6.0 (Northern)—Johnny Rosen and his Band.
6.0 (Western)—Organ music.
6.0 (Welsh)—"Cadw Gardd."
6.0 (N. Ireland)—Philip Whiteway Ensemble: Kathleen Daunt (Mezzo-Soprano).
6.0 (Scottish)—Band.
6.15 (Welsh)—Light Music.
6.30 (Welsh)—Festival of Praise.
6.30 (Scottish)—For Farmers.
6.40 (ex. Welsh)—"From the London Theatre."
7.0—The Second News.
7.20—Regional Announcements.
7.30 (Regional, Northern, Western)—The Hallé Orchestra conducted by Sir Thomas Beecham—Mozart, Beethoven.
7.30 (Midland)—"The Dream of Gerontius" (Elgar).
7.30 (Welsh)—Welsh News.
7.30 (N. Ireland)—"The Round Table," a comedy by Lennox Robinson.
7.30 (Scottish)—Students' Songs.
7.45 (Welsh)—Part Songs.
8.0 (Scottish)—"Scotland and the Empire."
8.15 (Welsh)—Lucy Winstanley (Oboe); Nancy Weir (Pfte.); Bangor University College String Orchestra.
8.20 (Scottish)—Songs and Sonnets.
8.30 (Regional, Northern)—BBC Military Band.
8.30 (Western)—Male Voice Choir: Muriel Kemp (Pfte.).
8.45 (N. Ireland)—Hymn Recital.
8.50 (Scottish)—Variety.
9.0 (Welsh)—Welsh talk.
9.5 (Regional, N. Ireland)—Darts: The Hanbury Arms v. The Caledonian Arms.
9.5 (Northern)—Murray and Mooney.
9.5 (Western)—For Farmers.
9.20 (ex. Western)—"Hadrian's Wall."
9.25 (Western)—Variety.
10.0—News Summary.
10.25 (ex. Western); N. Ireland 10.35—Billy Cotton's Band.
10.25 (N. Ireland)—Boxing: Eliminating Contest for Featherweight Championship of Great Britain.
11.30 (ex. Western)—Late News.
11.40-12.0 (ex. Western)—Eda Kersey (Violin).

ATHLONE (Ireland)

565 kc/s (531 m.); 100 kW.
Dublin, etc. See Sunday.
1.30 p.m.—Records.
2.30-3.0—For Schools.
5.30—Pfte. Music for Young Students by Lilian Conolly.
5.45—Talk for Women.
6.0—Irish Composers (Recorded).
6.35—Irish News Feature.
6.45—News.
7.0—Violin Concerto by Terry O'Connor and the Irish Radio Orchestra.
7.30—Debate in Irish.
7.50—Ida Starkie O'Reilly ('Cello).
8.5—Irish Radio Orchestra and Frank Ryan (Tenor). Overture, "Le Roi Pa dit" (Delibes).
8.45—"Sam Patterson's Party"—Humorous Northern Dialogue by Terence Rafferty.
9.0—Vocal Selections by the Good Companions.
9.30—Variety Program.
10.30—News.
11.0—National Anthem.

BERLIN (Germany)

841 kc/s (356.7 m.); 100 kW.
Transmits at intervals from 5.0 a.m.
11.0 a.m.—See Frankfurt.
12.0 noon—News.
12.15 p.m.—Music from Frankfurt.
1.0—News.
1.15—Band from Deutschlandsender.
2.15—Exchange; Markets.
2.35-3.0—Records.
3.30—"Under the Willow-Tree"—Fairy-tale after Hans Andersen (Fraenger).
4.0—Sonata in E flat (Richard Strauss), with Dünschede (Violin), and Laugs (Pfte.).
4.30—Old Songs.
5.0—Light Music by the Raatzke Quintet.
6.0—News.
6.10—Liebesliederwalzer and Hungarian Dances (Brahms).
7.0—Evening Echoes.
7.10—Dance Music and Kaiser Bands.
9.0—News; Sports.
9.30-11.0—See Stuttgart.

Nov. 25 THURSDAY

BEROMÜNSTER (Switzerland)

556 kc/s (539.6 m.); 100 kW.
Relayed by Basle and Berne, 1,375 kc/s (218.2 m.).
5.30-5.50—Gym.
9.20-9.50—For Schools.
11.0 (from Berne)—Goethe and Beethoven Records.
11.29—News.
11.40 a.m.—12.45 p.m. (from Berne)—Records.
3.0—For Invalids.
3.30—Records.
4.0-5.0—See Sottens.
5.0—Records.
5.30—Talk: Andrew Carnegie.
6.0—Traffic Notes.
6.10—Talk: Weather Forecasts.
6.25—Talk: New English Books.
6.45—News; Anniversaries.
7.0—"1812"—Historical Sequence about the Battle of the Beresina (Weiti).
8.5—Do you know?
8.15—Zürich Oratorio Choir.
9.25—News.

BRATISLAVA (Czechoslovakia)

1,004 kc/s (298.8 m.); 13.5 kW.
Transmits at intervals from 5.15 a.m.
5.0 p.m.—Hungarian Transmission: Talk; Giza Szabo (Songs) and Dusik (Pfte.); Talk.
5.45-6.30—See Prague.
6.30—Talk.
6.35—See Brno.
7.25—Play (Merimee).
8.20—Sacred Music from St. Martin's Cathedral. Male Voice Choir, etc. Kyrie (Schneider-Trnavsky). Motette (Mráz). Ave Maria (Kohn). Clamavi in toto corde (Drechsler). Libera nos (Liszt).
9.0-9.15—See Prague.
9.15—News (Hungarian).
9.30—Record.
9.35-10.5—See Prague.

BRESLAU (Germany)

950 kc/s (315.8 m.); 100 kW.
Relayed by Gleiwitz and Górlitz, 1,231 kc/s (243.7 m.).
Transmits at intervals from 4.30 a.m.
11.0 a.m.—Station Orchestra.
12.0 noon—News.
12.15 p.m.—Orchestra (cont'd.).
1.0—News.
1.15-2.0—Band from Deutschlandsender.
3.0—Orchestra; at 4.0-4.10—Sketch.
5.0—Books; Reading.
5.30—Topical; Announcements.
6.0—News.
6.10—Silesian Philharmonic. Conductor: Wüst. Organ Fantasia in F minor (Mozart). Five Minuets (Schubert). Cassation in G (Mozart). First Symphony (Bruckner).
8.0—Motto.
8.5 (from Gleiwitz)—Coal-Iron-Bread—An Upper Silesian Triad (Konietzny); Music by Heideuczek. Orchestra and Dramatic Troupe.
9.0—News; Topical.
9.30-10.30—See Stuttgart.

BRNO (Czechoslovakia)

922 kc/s (325.4 m.); 32 kW.
Transmits at intervals from 5.15 a.m.
4.40 p.m.—German Transmission: For Workers; Records; Talk.
5.15—News.
5.20—Theatre and Film Review.
5.30—Morse.
5.45-6.15—See Prague.
6.15—Discussion: Theatre Problems.
6.35—Station Orchestra. Conductor: Bakala. Haslik (Flute).
7.25-10.5—See Prague.

BRUSSELS (No. 1) (Belgium)

620 kc/s (483.9 m.); 15 kW.
6.30-9.5 a.m.—Records; Gym; News.
12.0 noon—Time; Records.
12.30 p.m.—Weather; Shipping.
12.35 (approx.)—Radio Orchestra. Conductor: Gason.

## THURSDAY (November 25)

1.0—Time; News; Records.  
 2.0—Art Notes.  
 4.55—News.  
 5.0—Time; Records: "Requiem" (Verdi).  
 5.30—For Children.  
 6.0—Talk: Everyday Life.  
 6.15—Light Orchestra.  
 7.0—For Workers.  
 7.15—Records: Negro Spirituals.  
 7.30—News.  
 8.0—Radio Orchestra. Conductor: Gason. Mlle Stradel (Songs). Suite caprice in G (Brusselms). Arias from: (a) "Le Roi d'Ys" (Lalo), (b) "Carmen" (Bizet). Petit Ballet (Candael). Arias from: (a) "Werther" (Massenet), (b) "Etienne Marcel" (Saint-Saëns). London Suite (Coates).  
 9.0—Talk: The Spanish Children's Santa Claus.  
 9.15—"Chabichou"—Play (Duvernois).  
 9.45—Records.  
 10.0—News.  
 10.10-11.0—Contemporary Music by Lydia Sariban (Songs) and Blochman (Pfte.). Pfte.: Two Mazurkas (Szymanowski). Songs (Woronoff): (a) The Paon, (b) How the Soul takes leave of the Body. Pfte.: Two Poems (Scriabin). Song: The Ugly Duckling (Prokofiev). Pfte.: (a) Three Improvisations (Poulenc), (b) Two Pieces (Espla).

## BRUSSELS (No. 2) (Belgium)

932 kc/s (321.9 m.); 15 kW. Programme in Flemish.  
 6.30-9.0 a.m.—Records; Gym; News.  
 12.00 noon—Records.  
 12.30 p.m.—Weather.  
 12.31—Kameli Segers (Tenor).  
 12.40—Salon Orchestra. Conductor: Féron.  
 1.0—News.  
 1.10—Brenders Dance Band.  
 1.30—Segers (Tenor).  
 1.40—Record.  
 2.0—Shipping.  
 4.55—News.  
 5.0—Salon Orchestra. Conductor: Féron. In the interval, Records.  
 5.45—Vondel Programme for Children.  
 6.30—Records: Songs (Benoit, Blockx).  
 6.45—Roman Catholic Address.  
 7.0—KVRO Notes; Film Review.  
 7.3—Records.  
 7.30—Art Review.  
 8.0—Brenders Dance Band and Records.  
 8.45—Talk: Lambert Swert.  
 9.0—"Hiawatha's Song" (Geszelle, Music by De Jong). I.N.R. Symphony Orchestra. Conductor: Dejoncker. Anton Van de Velde (Discour).  
 9.50—Pater noster (Wierzt).  
 10.10-11.0—Records: Songs of Many Lands. Vienna Boys' Choir: Ständchen (Schubert). Hofman Duo: Holland, zoo het weent en lacht (Fucson). Galli-Curci: Lo, here the gentle lark (Bishop). Maurice Chevalier: Le chapeau de Zozo (Borel-Clerc). Don Cossack Choir: Prince Oleg March (arr. Jaroff). Marita Grundgens: Das verständig du nicht (Hannes-Leux). Paul Robeson: Ol' Man River (Kern). Pills and Tabet: Pourquoï t'es tu teinté (Mireille). Chanteuses de la Colombière: Le vent (Boller). Marian Anderson: Tramping (arr. Boatner). Gigli: Salve, dimora, from "Faust" (Gounod). Mireille: Papa n'a pas voulu (Mireille). Toutenel: Van 't Kosterken (Ceulemans). Martha Eggerth: Frühlingsstimmen (Joh. Strauss). Meistersextett: Muss I denn zum Städle hinaus.

## BUCHAREST (Romania)

823 kc/s (364.5 m.); 12 kW. Relayed by Radio-Romania, 160 kc/s (1,875 m.).  
 Transmits at intervals from 4.30 a.m. to 5.55 p.m.—Dance Records.  
 5.55—Educational.  
 6.10—Sabine Nicolesco (Harp).  
 6.40—Lupesco (Songs). Talk.  
 7.15—Symphony Concert by the Radio Orchestra. Conductor: Alessandresco. Madeleine Cocorascu (Pfte.). Symphony in G (Cannabich). Symphony in D (Bocherini). Pfte. Concerto in E flat (Beethoven).  
 8.30—News; Sports.  
 8.45—Concert (contd.). Ballet (Jora).

9.10—Café Concert.  
 9.45—News (French, German).

## BUDAPEST (No. 1) (Hungary)

546 kc/s (549.5 m.); 120 kW. Transmits at intervals from 5.45 a.m. to 11.30 p.m.—Records; at 11.30—News.  
 12.30 p.m.—Endre Vocal Ensemble.  
 1.40—News.  
 3.15—Programme by Frau Stumpf.  
 3.45—News.  
 4.0—For Farmers.  
 4.30—Elek Mursi Cigány Band.  
 5.30—József Melly.  
 6.0—Karl Maria Schwammberger (Cello).  
 6.35—"The Black Tulip"—Play after Dumas (Szilágyi).  
 7.55—News.  
 8.20—Budapest Concert Orchestra. Conductor: Lajos Rajter. Hungarian Comedy Overture (Kardos). Ballet Scene (Nagy). Suite (Haydn).  
 9.5—Talk in German: Professor Szent-Györgyi der ungarische Nobelpreisträger.  
 9.20—Jenő Zeitinger (Pfte.).  
 10.0—Station Orchestra. Overture. "Ilka" (Doppler). Song. "Feenliebe" (Huszka). Slow Foxtrot, Budapest (Zakál). Suite, Werbentanz (Pongrácz). Selection. "The Merry Widow" (Lehár). Intermezzo (Nevin). Selection. "No, No, Nanette" (Youmans).  
 11.5—News.

## BUDAPEST (No. 2) (Hungary)

359.5 kc/s (834.5 m.); 18 kW.  
 4.0 p.m.—Dance Records.  
 6.0—English Lesson.  
 6.35—Records.  
 7.30—Budapest Concert Orchestra. Conductor: Rajter.  
 COLOGNE (Germany)  
 658 kc/s (455.9 m.); 100 kW. Transmits at intervals from 5.0 a.m. to 11.0 a.m.—Workers' Band.  
 12.0 noon—News; Greetings.  
 12.15 p.m.—See Frankfurt.  
 1.0—News.  
 1.15-2.0—Band from Deutschlandsender.  
 2.45—Markets.  
 3.0—See Deutschlandsender.  
 4.0—For Housewives.  
 4.10—See Deutschlandsender.  
 4.30—Mathias Wiemann discusses his Film, "Das Unternehmen Michael."  
 5.0—Light Music. Maria Mattheus (Contralto), Kastert (Violin), Grape (Pfte.).  
 5.30—Books; Snapshots.  
 6.0—News.  
 6.10—Light Music. Station Orchestra. Conductor: Eysoldt.  
 7.0—"Undine" (Lortzing). Station Orchestra and Choir. Conductor: Breuer. Cast: Erna Schlüter, Josef Witt, Felix Knäpper, Willi Schneider, Lotte Loos-Werther, Carla Spletter, Anton Germann, Philipp Gehly, Eduard Kandl.  
 9.0—News.  
 9.30-11.0—See Stuttgart.



Carla Spletter, "Undine" in Lortzing's opera at Cologne at 7 p.m.

## DEUTSCHLANDSENDER (Germany)

191 kc/s (1,571 m.); 60 kW. Transmits at intervals from 5.0 a.m. to 11.0 a.m.—See Breslau.  
 12.0 noon—Greetings.  
 12.15 p.m.—See Breslau.  
 12.50—News.

1.0—Malachowski Band.  
 2.0—Announcements.  
 2.15—Old German Chamber Music. Hanna Petersen (Soprano), Grehling (Violin), Döscher (Cello).  
 3.0—Light Orchestra.  
 4.0—Reading.  
 4.10—Light Orchestra (contd.).  
 5.0—Ornella Pulini Santoliquido (Pfte.), Mieczyslaw (Viola) (Recorded).  
 5.40—Report: Military Sports.  
 6.0—Motto; News.  
 6.10—Joost Band.  
 7.0—Light Music. Station Orchestra. Conductor: Richartz.  
 8.0—Monthly Review of World Politics.  
 8.20—Light Music (contd.).  
 9.0—News; Sports; Topical.  
 9.30-9.45—Dances—Serenade by Maria Dombrowski (Pfte.). German Dance (Fortner). Spanish Dance (Fallá). Old English Dance (Grainger). Polish Dance (Rodzycki).  
 10.0-11.0—Dance Music by the Joost Band.

## FRANKFURT (Germany)

1,195 kc/s (251 m.); 25 kW. Cassel, etc. See Sunday.  
 Transmits at intervals from 5.0 a.m. to 11.0 a.m.—1.0 p.m.—Orchestra.  
 1.0—News; Records.  
 2.0—Industrial News.  
 2.15-2.45 (from Freiburg)—For Children.  
 3.0—Orchestra. Conductor: Cujé.  
 5.0—Topical.  
 6.0—News.  
 6.10—"Instruments introduce themselves"—A Revue (Wippermann). Station Orchestra. Conductor: Hauck. Kullmann (Pfte.), The Vegas (Banjo Duo), Uhticke (Accordion) and Solo Instruments of the Station Orchestra.  
 7.15—Opera Music. Station Orchestra. Conductor: Moritz. Excerpts, "Alessandro Stradella" (Flotow), "Martha" (Flotow), "The Seraglio" (Mozart), "Undine" (Lortzing), "Der Waffenschmied" (Lortzing), and "The Bartered Bride" (Smetana).  
 8.15—"Father Litzmann"—Sequence about a Great General (Launer).  
 9.0—Time; News.  
 9.15—Christmas Books.  
 9.30—See Stuttgart.  
 10.12-12.0 m't.—French Music (Recorded). Istar (d'Indy), by the Paris Conservatoire Orchestra. Conductor: Coppola. Caruso: Les rameaux (Faure). Meditation, "Thais" (Massenet) by the Boston Symphony Orchestra. Gigli: Panis Angelicus (Franck). Two Movements from the Fantasia for Pfte. and Orchestra (Debussy) by Erdmann (Pfte.) and the Frankfurt Station Orchestra. Conductor: Rosbaud. Spanish Rhapsody (Ravel) by the Philadelphia Symphony Orchestra.

## HAMBURG (Germany)

904 kc/s (331.9 m.); 100 kW. Bremen, etc. See Sunday.  
 Transmits at intervals from 5.10 a.m. to 11.0 a.m.—Orchestra.  
 12.0 noon—Midday Review.  
 12.15 p.m.—Music from Frankfurt.  
 1.0—News; Music.  
 2.0—Shipping; Markets.  
 2.25—Schubert Songs by Oskar Jölll (Baritone).  
 2.50—Ice Report.  
 3.0—Light Music. In the interval, Talk.  
 4.15—"Walk up! Walk up! the performance will commence in five minutes"—Variety.  
 5.0—Chamber Music, by the Danish Quartet. Concerto in B minor for Flute, Violin, Cello and Pfte. (C. P. E. Bach). Divertimento in G (Haydn). Trio (Hye-Knudsen).  
 5.45—Shipping.  
 6.0—News.  
 6.10—Records.  
 7.0—Topical.  
 7.10 (from Hanover)—Gala Concert for the Reich Peasant Congress in Goslar.  
 9.0—News.  
 9.20—Orchestral Variety.  
 9.40-11.0—Serenade. Symphony Orchestra. Conductor: von Sosen.

## HILVERSUM (1,875 m.) (Holland)

160 kc/s; 10 kW until 2.40 p.m.; 150 kW from 2.40 p.m.  
 7.40-8.55 a.m.—KRO Programme: Records.  
 9.40-10.40—NCRV Programme. Records; Service; Records.  
 10.40 a.m.-1.40 p.m.—KRO Programme.

10.40—Records.  
 11.10—Religious Address; Announcements.  
 11.55—KRO Orchestra. Conductor: Reinards; at 12.40 p.m.—Records.  
 1.40 till Close—NCRV Programme.  
 1.40—Handiwork.  
 2.40—Records.  
 3.25—Bible Reading.  
 4.25—For Young People.  
 4.55—Records.  
 5.10—Armeh String Quartet.  
 5.55—Records; Talk; Announcements; Report.  
 7.40—Press Review; Records.  
 8.40—Talk.  
 9.10—Amsterdam Salon Orchestra. Conductor: Kiekens; at 9.40—Press Review.  
 10.25—Gymnastics.  
 10.40-11.40—Records; Bible Reading.

## HILVERSUM (301.5 m.) (Holland)

995 kc/s; 15 kW until 6.10 p.m.; 60 kW from 6.10 p.m.  
 AVRO Programme.  
 7.40 a.m.—Time; Records.  
 9.40—Service.  
 9.55—Records.  
 10.10—AVRO Orchestra. Conductor: Treep. In the interval, Reading by Corry Commering.  
 12.10 p.m.—Records.  
 12.25—Kovacs Lajos Orchestra.  
 1.40—For Women.  
 2.10—Fritz Braun (Songs).  
 2.40—Dressmaking Lesson.  
 3.25—Pierre Palla (Organ).  
 3.40—For Hospitals.  
 4.10—Records.  
 4.30—For Children.  
 5.10—AVRO Orchestra. Conductor: Treep.  
 6.10—Sports Talk.  
 6.40—For Children.  
 6.45—AVRO Dance Band.  
 7.10—English Lesson.  
 7.40—Time; Commentary on the Euwe v. Alekhine Chess Match.  
 7.55—Twilight Serenaders.  
 8.40—Women's Choir.  
 9.0—Commentary on the Euwe v. Alekhine Chess Match.  
 9.10—Symphonic fantastique (Berlioz), by the Concertgebouw Orchestra from the Concertgebouw, Amsterdam. Conductor: Mengelberg.  
 10.10—Records.  
 10.15—Commentary on the Euwe v. Alekhine Chess Match.  
 10.25—Records.  
 10.40—News.  
 10.50—AVRO Dance Band.  
 11.20-11.40—Pierre Palla (Organ).

## KALUNDBORG (Denmark)

240 kc/s (1,250 m.); 60 kW. Relays Copenhagen 1,176 kc/s (255.1 m.).  
 Transmits at intervals from 6.0 a.m. to 11.0 a.m.—1.0 p.m.—Louis Preill's Ensemble.  
 1.15—Gymnastics.  
 1.35—Aarhus Municipal Orchestra. Conductor: Jensen. March, "The Merry Widow" (Lehár). Salut d'amour (Elgar). Waltz, Amélie (Lumbye). Excerpts, "Peer Gynt" (Grieg). Serenade (Schrader). Norwegian Rhapsody (Svendson). Military March from the Algeria Suite (Saint-Saëns). Overture, "Mignon" (Thomas). Prelude in C sharp minor (Rachmaninoff). Excerpts, "Carmen" (Bizet). Madrigal (Simonetti). Potpourri (Poulsen); at 2.20—Reading (Benzon).  
 3.30—For Children.  
 3.50—Wireless Notes.  
 4.0—Religious Address.  
 4.25—Weather.  
 4.40—Exchange; Markets.  
 4.50—Records.  
 5.15—Talk.  
 5.35—English Lesson.  
 6.0—News.  
 6.20—Talk: Minority Problems.  
 6.50—Talk: Traffic Problems.  
 7.10—Tenth Thursday Concert. Symphony Orchestra. Conductor: Tuxen. Domgraf-Fassbender (Tenor). Overture, "Rübezahl" (Weber). Four Songs, "Lieder eines fahrenden Gesellen" (Mahler). Mathis der Maler (Hindemith). Ten Minutes Interval. Overture, "Benvenuto Cellini" (Berlioz). Cavatina, "The Barber of Seville" (Rossini). Spanish Rhapsody (Ravel).  
 9.0—News.  
 9.20—Scandinavian Poetry since 1870—Holger Drachmann. Songs to Drachmann Text and Recitations by Tavs Neijandam and Per Knudsen. Introductory Talk. Sakuntala. Hvi skal det være saa spejlglat alt? Improvisation ombord (Lange-Müller). Edith (Lange-Müller). I Skoven er det saa stille (Heise). Gurte (Heise). Du Klang, som en Gang vakt (Henriques). Den store Bjørns

Endeligt (Henriques). Den Spillemand snapped Fiolen (Miskow). Rhinskvin (Miskow). Gaa paa Landevejen ud (Henriques). Min Fredsby (Henriques). Havørn (Borresen).  
 10.0-11.15—Jutland Evening, with Prell's Dance Band.

## KÖNIGSBERG (Heilsberg) (Germany)

1,031 kc/s (291 m.); 100 kW. Relayed by Danzig, 1,303 kc/s (230.2 m.).  
 Transmits at intervals from 5.0 a.m. to 11.0 a.m.—1.0 p.m.—See Frankfurt.  
 1.0—News; Talk.  
 1.15—Variety.  
 1.55—Exchange.  
 2.30—Talk.  
 2.40—Readings and Music.  
 3.0 (from Danzig)—Orchestra. Conductor: Kallipke; at 4.0—Sports.  
 5.0—For Schools.  
 5.20—"Around the Farmhouse Table"—Sequence of Words and Music (S. Wagner).  
 5.50—Announcements.  
 6.0—News.  
 6.10—"Snow on the Summerhouse"—Sequence (Winkler-Lindberg).  
 6.45—Topical.  
 7.0—Light Music. Station Orchestra, Börschel Band.  
 9.0—News; Reading.  
 9.40-11.0—Music from Stuttgart.

## LEIPZIG (Germany)

1,285 kc/s (382.2 m.); 120 kW. Relayed by Dresden, 1,285 kc/s (233.5 m.).  
 Transmits at intervals from 5.0 a.m. to 11.0 a.m.—Military Band.  
 12.0 noon—News.  
 12.15 p.m.—See Frankfurt.  
 1.0—News.  
 1.15—Dresden Soloists' Ensemble.  
 2.25—Talk; Art Notes.  
 2.50—Talk from Rio de Janeiro.  
 3.0—Records.  
 4.0—Weather; Exchange.  
 4.10—Community Singing from Herzberg.  
 5.0—Books.  
 5.20 (from Dresden)—Italian Music by Margarete Aulhorn-Spetch (Soprano), Bauer (Violin), Elisabeth-Bauer-Thomas (Pfte.). Sonata in B flat (Tartini). Four Old Italian Songs. Chamber Sonata in A (Albinoni).  
 5.50—Evening Review.  
 6.0—News.  
 6.10—"Mein Egerland"—Sequence (Lohberger), with Songs to the Lute.  
 6.45—Parade Marches—Military Band. Conductor: Giltsch. Commentary by Georg Kandler.  
 8.0 (from Dresden)—"Modern German Songs of Combat"—Sequence (Linke) from the works of Bartels, Dahn, Fritsch, de Lagarde and v. Treitschke.  
 9.0—News; Sports.  
 9.30-11.0—Light and Dance Music by the Fricke Band.

## LILLE (Radio PTT Nord) (France)

1,213 kc/s (247.3 m.); 60 kW. Transmits at intervals from 6.30 a.m. to 7.30 p.m.—Orchestra, Songs.  
 7.30—News.  
 8.0—Dialect Programme.  
 8.30—Variety.

## MONTE CENERI (Switzerland)

1,167 kc/s (257.1 m.); 15 kW.  
 11.0 a.m.—Records.  
 11.29—Time; News.  
 11.40 a.m.-12.30 p.m.—Records.  
 4.0-5.0—See Sottens.  
 6.15—Records.  
 6.45—News.  
 7.0—Old Dances—Nino Herschel (Harpischord). Minuet (Muffat). Passacaglia (Gervais). Minuet and Passepied (Kimberger). Sarabande (Couperin). Minuet (Handel). Rigaudon (Desmarests). Passepied, L'Europe galante (Campra). Gigue (Locillet).  
 7.20—Book Talk.  
 7.30—Radio Orchestra. Conductor: Herschel. Overture, "Le prezioso ridicolo" (Lattuada). Danza aragonesa (Granados). Le petit berger (Debussy). Sérénade à la poupée (Debussy). Hungarian Rhapsody No. 12 (Liszt).  
 8.0-9.40—From Lugano Kursaal: Radio Artists at the Microphone. In the interval, Cinema Organ Records.

## MOSCOW (No. 1) (Russia)

172 kc/s (1,744 m.); 500 kW.  
 5.0 p.m.—Concert.  
 7.0—A Play.

8.15—Concert.  
9.0—French Programme.  
10.0-12.0 m't.—Spanish Programme.

**MUNICH (Germany)**

740 kc/s (405.4 m.); 100 kW.  
Relayed by Nürnberg, 1,267 kc/s (236.8 m.).  
Transmits at intervals from 5.0 a.m.  
11.0 a.m.—Orchestra.  
12.0 noon—News; Topical.  
12.15 p.m.—(from Nürnberg) — Gröschel Quintet.  
1.0—News; Exchange.  
1.15—Band from Deutschlandsender.  
2.0-2.30—Christmas Books for Children.  
3.0—Records.  
3.40—Reading.  
4.0—Weather; Markets.  
4.15—Variety Records. In the interval, Talk.  
5.45—Topical.  
6.0—News.  
6.10—"Extrablätter" (Dostal).  
8.0—Folk Music (Recorded).  
8.15—"The German Year"—XI Patriotic Sequence (Andreas Weinberger); Music by Beckerrath.  
9.0—Time; News; Sports.  
9.20—Interlude.  
9.30-11.0—See Stuttgart.

**NAPLES GROUP (Italy)**

Naples, 1,104 kc/s (271.7 m.); 10 kW. Florence (No. 1), etc. See Sunday.  
6.0 p.m.—Music; Topical.  
6.25—Folk Songs by the Florence Dopolavoro Choir.  
7.0—Time; News; Talk.  
7.30—Symphony Concert. Conductor: Pedrotti. Overture, "Le baruffe chiozzotte" (Sinigaglia). The Unfinished Symphony (Schubert). Los vecinos (Fallá). Miller's Dance. "The Three-cornered Hat" (Fallá). Overture, "Semi-ramide" (Rossini).  
9.30—Dance Music.  
10.0—News.  
10.30-10.55—Dance Music.

**OSLO (Norway)**

260 kc/s (1,153.8 m.); 60 kW. Fredrikstad, etc. See Sunday.  
Transmits at intervals from 10.40 a.m.  
4.0 p.m.—Café Concert.  
4.55—Reading.  
5.0—Service.  
5.25—Nina Bergh Williams (Songs) and Berge (Clarinet).  
5.50—News and Announcements.  
6.30—Time; Talk.  
7.0—Norwegian Music by Mme Hildur Overland (Songs), Gunnvaldsen (Violin), Kramm (Viola), and Vatn (Songs).  
8.40—Talk.  
8.45—Sandra Droucker (Pfte.).  
9.0—Topical Talk.  
9.15-10.0—Variety Programme.

**PARIS (Eiffel Tower)**

(France)  
1,456 kc/s (206 m.); 7 kW.  
Transmits at intervals from 6.30 a.m.  
3.45 p.m.—"Le Voile du Bonheur"—One-Act Play (Clemenceau), for the Anniversary of the Author's Death.  
5.0—Records.  
5.45—Warms Orchestra.  
6.30—Educational.  
7.0—Theatre Review.  
7.20—Records.  
8.0—Genio (Songs), Ginette Doyen (Pfte.). Songs. Improvmtu in A flat, Two Waltzes and Tarantella (Chopin). Improvisation (Fauré). Songs.  
8.30—"Le Sire de Vergy" (Terrasse).  
10.30—Records.  
11.0-11.15—News.

**PARIS (Poste Parisien)**

(France)  
959 kc/s (312.8 m.); 60 kW.  
Transmits at intervals from 7.10 a.m.  
12.0 noon—Exchange. Records.  
12.15 p.m.—For Children.  
12.35—Exchange. Variety.  
1.15—Amusements.  
1.50—Film Notes.  
2.0—Exchange; News.  
2.5—Amateurs' Programme presented by Jaboune.  
3.45—Exchange.  
4.35—Exchange.  
5.0—News.  
5.5—Cabaret.  
6.0—Exchange. News.  
6.10—For Children.  
6.25—Talk.  
6.30—For Children.  
6.58—Racing Results.  
7.0—Topical; Sports Notes.  
7.10—Talk; Amusements.  
7.16—Records.  
7.40—Legal Talk.

7.45—Paris Programme with Jean Clement, presented by Jean Loup.  
8.0—News.  
8.10—Les Frères Jacasse.  
8.15—"Plaisirs de Paris"—Variety Programme.  
8.45—Talk.  
8.50—"La bonne histoire."  
9.0—News.  
9.5—Coco Aslan and his Pals, w Ded Rysel.  
9.20—"En correctionnelle"—(Diamant-Berger).  
9.55—News.  
10.10—Records of Maria Müller.  
10.30-11.0—Dance Music.

**PARIS (PTT) (France)**

695 kc/s (431.7 m.); 120 kW.  
Transmits at intervals from 6.30 a.m.  
4.45 p.m.—The Jean Petit Cigany Band.  
5.45—Grammar Lesson.  
5.50—Talk: Art and Life.  
6.0—Talk.  
6.15—Talk: Cabanis (1757-1808).  
6.30—A Visit to the Church of Saint-Séverin, with Norbert Dufourcq. Dufuréf (Organ). Prelude in C (Saint-Saëns). La Vallée de Behorleguy (Bonnal). Variations on the "Veni Creator" (Durufé).  
7.0—News.  
8.0—Jean Lumière and Germaine Lix.  
8.30 (also Marseilles (PTT) and Alpes-Grenobles)—"Le Simoun"—Play (Lenormand), from the Comédie-Française.  
10.30—News.  
10.45—Concert Piece (Busser) by Lily Laskine (Harp) and Orchestra. Conductor: The Composer.  
11.0—Report by Alex Surchamp: St. Catherine's Day among the Gown-hands of Paris.  
11.30—Dance Music by the Xon Orchestra.

**PARIS (Radio-Paris)**

(France)  
182 kc/s (1,648 m.); 80 kW.  
6.28 a.m.—Announcements.  
6.30—Records.  
6.40—Time; News; Gym.  
7.0—Records; News.  
8.0—News; Announcements; For Youth; Records.  
9.0-9.20—Records.  
10.15—Announcements.  
10.20—Records; Reading.  
11.0—Records: Scandinavian Music.  
11.30—Records.  
11.45—Markets.  
12.0 noon—Protestant Address.  
12.20 p.m.—Cantrelle Orchestra.  
1.0—Time; News; Exchange.  
1.30—Lise Daniels (Songs).  
1.45—Cantrelle Orchestra.  
2.0—Announcements.  
2.5—Talk: Bohemians in Literature since Murger's "Vie de Bohème."  
2.15—Talk by Paul Rives illustrated by Lise Daniels: The Folk Song.  
2.30—Exchange.  
2.45—Instrumental Records.  
3.0—Aimée Mortimer (Songs).  
3.15—Talk: Old-time Café Concerts.  
3.25—Colonial Review.  
3.35—For Sportsmen.  
3.45—Markets.  
4.0—Diana Corke (Songs).  
4.15—Educational.  
4.45—Talk; Exchange; Markets.  
5.0—"Les Contens"—Five-Act Play (Odet de Turnèbe), by the Odeon Players.  
6.0—Educational.  
6.30—Talk: Sören Kierkegaard.  
6.45—Talk: Blood Transfusion.  
7.0—Educational.  
7.30—Julia Noach (Pfte.). Sonata in E flat (Beethoven). Ballad in D minor (Brahms). Rhapsody in G minor (Brahms).  
7.57—Time; Announcements.  
8.0—Foreign and Home Affairs.  
8.15—Operetta Records.  
8.30—Symphony Concert. National Orchestra. Conductor: Gaubert; Overture, "Carnaval romain" (Berlioz). Symphony in F (Gaubert). Suite. Mother Goose (Ravel). Iberia (Debussy). Bourrée fantasque (Chabrier); at 9.30—News; Review.  
10.30—Records.  
10.45—Time; News.

**PRAGUE (Czechoslovakia)**

638 kc/s (470.2 m.); 120 kW.  
Transmits at intervals from 5.15 a.m.  
4.5 p.m.—Pfte. Quintet (Bloch) by the Ondricek Quartet and Stepan (Pfte.).  
4.40—For Farmers.  
4.50—German Transmission. For Young People; Sports; For Farmers.  
5.45—News (German).  
6.0—News.  
6.15—Czechoslovak Songs (Recorded).

6.30—Reading.  
6.35—See Brno.  
7.25—"Tsarevitch Alexis"—Play (Merezkovsky, Czech trans. by Kricka).  
9.0—Time; News.  
9.15—Russian Lesson.  
9.35-10.5—Suzanne Suter-Sapin (Violin) and Schächter (Pfte.). Chaconne (Bach). Le tombeau (Leclair).  
**RADIO-NORMANDIE (France)**  
1,113 kc/s (269.5 m.); 15 kW.  
6.45 a.m.—Band; Records.  
7.15—News; Review.  
7.45—Physical Exercises.  
8.0—Popular Music.  
9.45—Hildegard.  
10.0—Popular Music.  
10.45—Cinema Organ.  
11.0—Dance Music; Records.  
11.30—Film Excerpts.  
12.0 noon—Records of Marek Weber's Orchestra.  
12.20 p.m.—Military Band.  
12.45—News; Topical.  
1.0—For Children.  
2.30—Light Music.  
4.0—Jane and John; Records.  
5.0—Hawaiian Music.  
5.15—For Children.  
5.30—Light Music.  
6.0—Markets.  
6.0—Orchestra.  
6.45—News; Racing.  
7.0—Chansonnettes.  
7.25—News; Topical.  
7.45—Records: Polydor Orchestra.  
8.0—Records: Bruno Clair.  
8.20—Operetta Music.  
8.40—Roger Vaysse.  
9.0—Request Concert.  
11.0—Café Concert.  
11.45—News.  
12.0 m't.—Records.  
12.30-1.0 a.m. (Friday)—Dance Music.

**ROME GROUP (Italy)**

Rome (No. 1), 713 kc/s (420.8 m.); 50 kW. Bari (No. 1), etc. See Sunday.  
Transmits at intervals from 6.45 a.m.  
4.0 p.m.—News.  
4.15—Ornella Puliti-Santoliquido (Pfte.).  
5.0-5.10—Talk.  
5.50—Dopolavoro Notes.  
6.0—Talk in Spanish; Sports.  
6.25—News in Foreign Languages.  
7.0—News; Talk; Music.  
8.0—"Julia Szendry"—Three Act Play (Herczeg).  
9.15—Lutz Quartet.  
10.0—News.  
10.15-10.50—Dance Music.

**SOTTENS (Switzerland)**

677 kc/s (443.1 m.); 100 kW.  
Relayed by Geneva, 401 kc/s (748 m.).  
11.29 a.m.—News; Records.  
12.30 p.m.—Records: Songs (Schumann) by Lotte Lehmann (Soprano).  
12.35-12.45—Records: Pfte. Concerto (Dall'Abaco).  
4.0—Dance Records.  
4.15—Flore Wend (Songs).  
4.35—String Quartet in E flat (Mendelssohn).  
5.0—Cookery; Records.  
6.0—For Farmers.  
6.10—Art Review.  
6.20—Talk: Radio Organisation, National and International.  
6.30—Musical Interlude.  
6.50—News; Weather.  
7.0—Soirée de Chansons, with Edith Burger, René Bersin and Company.  
8.5—Erik Satie Concert. Radio Suisse romande Orchestra. Conductor: Appia. Violette Andréossi (Songs). Talk by Mme Picabia. Ballet, "Mercury." Cinq grimaces. "Socrates."—Symphonic Drama.  
9.15—Records.  
9.30-10.0—Tourist Report: From Schaffhausen to St. Gall.

**STOCKHOLM (Sweden)**

704 kc/s (426.1 m.); 55 kW. Motala, etc. See Sunday.  
Transmits at intervals from 6.20 a.m.  
11.25 a.m.—Accordion Music.  
11.50—Exchange; Markets.  
12.0 noon—Report for Schools: A Visit to Copenhagen.  
12.30 p.m.—Trio. Bourrée and Sarabande (Handel). Gavotte (Lully). Rigaudon (Rameau). Duet (Schumann). Elegy (Henneberg). March (Christiansen).  
1.0—Reading.  
1.50-2.0—Records.  
4.5—Service from Göteborg.  
4.30—Bramme (Cello). Romance (Sitt). Nocturne (Chopin-Popper). Minuet (Debussy). Habanera (Ravel).  
4.50—Legal Review.  
5.15—Waldimir Orchestra. Waltz,

**THURSDAY (November 25)**

Tout Paris (Waldteufel). Russian Romance (Friml). Dance of the Hours (Ponchielli). Serenade (Fucik). Erotica (Grig). Selection, "The Tsarevitch" (Lehár). Sylphiden (Lincke). March (Blume).  
6.0—News.  
6.30—Talk: Swedish Emigrants in America.  
7.0—English Music. Radio Symphony Orchestra. Guest Conductor: Clarence Raybould. Cyril Smith (Pfte.). Overture, "The Wasps" (Vaughan-Williams). Rhapsody (Butterworth). Sinfonia concertante for Pfte. and Orchestra (Walton). Enigma Variations (Elgar).  
8.25—Microphone Visit.  
8.45—News.  
9.0-10.0—Cabaret (Record).

**STRASBOURG (France)**

859 kc/s (349.2 m.); 100 kW.  
Transmits at intervals from 6.30 a.m.  
6.30 p.m.—Wind Instruments. Suite (Delaunay). Octet (Lazzari).  
7.0—News.  
7.30—Marianne Ricklin (Soprano). Recitative and Aria, "Addio Corindo" (Cesti). Canzonetta (Pasquini). Recitative and Aria (Handel). Au temps des fées (Koechlin). Réponse d'une épouse sage (Roussel). Le Romarin (Silver). Résurrection (Février). Roses dans la nuit (Dupré).  
8.0—News (German, French).  
8.25—Introductory Talk.  
8.30-11.30 (Also Rennes-Bretagne and Nice-Côte d'Azur)—"Louise" (Charpentier), from the Opéra-Comique, Paris.  
11.30 (approx.)—News (French, German).

**STUTTGART (Germany)**

574 kc/s (522.6 m.); 100 kW.  
Transmits at intervals from 5.0 a.m.  
11.0 a.m.—See Frankfurt.  
12.0 noon—News.  
12.15 p.m.—Music from Frankfurt.  
1.0-2.0—See Berlin (Deutschlandsender).  
3.0—Orchestra. Conductor: Hollinger. Fühler (Flute), Schickel and Semmelbeck (Two Pfes.).  
5.0—Hitler Youth Programme.  
5.30—Topical.  
6.0—News.  
6.15—Song Records.  
7.0—"A Message from the Heart"—Play in the Minor Mode (Hofbauer-Schneider).  
8.0—String Quartet in G (Haydn) by the Mozarteum Quartet of Salzburg.  
8.30—"Students—Comrades"—Report from Heidelberg, Germany's Oldest University.  
9.0—Time; News.  
9.30—Folk Music and Light Music. Rehfeld Band, Stuttgart Folk Music Ensemble, Lore Schöfberger and Christin Hilsdorf (Song Duo), Ly Braun-Riethmüller (Harmonica).  
11.0-12.0 m't.—See Frankfurt.

**TOULOUSE (Radio-Toulouse) (France)**

913 kc/s (328.6 m.); 60 kW.  
Transmits at intervals from 8.0 a.m.  
6.0 p.m.—Jazz Band.  
6.15—For Children.  
6.40—Light Music.  
6.55—News; Sports.  
7.15—Orchestra.  
7.40—Light Music.  
7.55—Interlude.  
8.0—Light Music.  
8.30—Variety.  
8.45—Light Music.  
9.30—Excerpts, "La Mascotte" (Audran).  
10.0—News.  
10.15—English Concert.  
11.15—Military Marches.  
11.35—Light Music.  
11.50-12.0 m't.—News.

**TURIN GROUP (Italy)**

Turin (No. 1), 1,140 kc/s (263.2 m.); 7 kW. Milan (No. 1), etc. See Sunday.  
Transmits at intervals from 6.45 a.m.  
4.0 p.m.—News.  
4.15—Maria Negrelli Noé (Soprano).  
5.0-5.10—Talk.  
5.50—Dopolavoro Notes.  
6.0—Pieraldo Orchestra.  
6.40—News in Foreign Languages.  
7.0—News; Talk.  
7.30—Radio Orchestra.  
8.0—"Ginevra degli Almieri" (Peragallo). Conductor: Del Campo. Cast: Augusta Oldtrabella, Borgonovo, Venturini, Ilde Reggiani, Zambelli, Nessi, Ziliani,

Malatesta, Baracchi and Caselli. After the Opera, News.

**VIENNA (Austria)**

592 kc/s (506.8 m.); 100 kW. Graz, etc. See Sunday.  
Transmits at intervals from 5.45 a.m.  
11.0 a.m.—Chimes.  
11.2 (approx.)—Station Orchestra. Horak (Cello). Overture, "Sicilian Vespers" (Verdi). Transkationenwäzler (Strauss). Mozart Potpourri (Urbach). Nutcracker Suite (Tchaikovsky). Cello: Romance (Weiss). Granada (Albeniz). Waltz, "The Last Waltz" (Strauss). Selection, "Show Boat" (Kern).  
12.0 noon—Time; News.  
12.10 p.m.—Records: "Martha" (Flotow).  
1.0—Records: Segovia (Guitar).  
1.15—News.  
2.0—Announcements.  
2.15—For Children.  
2.40—For the Young Unemployed.  
3.0—News.  
3.5—Records: Light Music.  
4.0—Talk: The Dachstein Caves.  
4.20—Maria Schober (Soprano). Songs (Schubert): (a) Wohin?, (b) Ave Maria, (c) An die Nachtigall, (d) Die Forelle. Songs (Cornelius): (a) Untrue, (b) Veilchen, (c) Mondnacht. Songs (Schumann): (a) Aus den östlichen Rosen, (b) Du bist wie eine Blume, (c) Jasminstrauch, (d) Sandmann, (e) Röslein.  
4.50—Art Notes.  
4.55—Theatre Review.  
5.5—For Youth.  
5.50—Science Notes.  
6.0—News; Topical.  
6.25—A Homeland Evening from Braunau. Ländler and Folk Music Section of Braunau Municipal Orchestra; Folk Ensembles and Singers.  
7.25—Otto Berco at the Microphone.  
8.0—Vienna Symphony Orchestra. Conductor: Schönherr. Maria Dery-Spitzmüller (Soprano), Wernig (Tenor), Winkler (Cello). Abendmusik (Kattmigg). Soprano Songs (Marx): (a) Der bescheidene Schäfer, (b) Und gestern hat er mir Rosen gebracht. Tenor Songs (Richard Strauss): (a) Traum durch die Dämmerung, (b) Heimliche Aufforderung. Cello and Orchestra: Variations on a Rocooco Theme (Tchaikovsky). Soprano Songs (Marx): (a) Venezianisches Wiegenlied, (b) Hat dich die Liebe berührt. Tenor Songs (Richard Strauss): (a) Morgen, (b) Cäcilie. The Man from the Sea, from "The Three Men" (Coates).  
9.10—News.  
9.20—Report from Renz Circus: The World Championships in Cycle Polo and Stunt Cycling.  
9.40—Talk: Popular Education in Vienna.  
9.50-10.30—Station Dance Band.

**WARSAW (Poland)**

224 kc/s (1,339 m.); 120 kW. Cracow, etc. See Sunday.  
Transmits at intervals from 5.15 a.m.  
10.15 a.m. (from Lwów)—Sonatas—Maria Marco (Violin) and Steinberger (Pfte.) with Commentary. Pfte. Sonata (Scarlatti). Violin Sonata in E minor (Mozart). First Movement from the Pfte. Sonata in C minor (Beethoven).  
10.40—Records of Tito Schipa.  
10.57—Time; Fanfare.  
11.3-12.0 noon—To be announced; at 11.20—News.  
2.30 p.m.—Economics.  
2.45—Music Talk for Children.  
3.15 (from Torun)—Salon Orchestra.  
3.45—High School Anniversary.  
4.15 (from Poznań)—"St. Catherine's Day"—Folk Play (Czyzykowska).  
4.50—Sports; Letter-box.  
5.30—Programme Notes.  
5.35—For Country Youth.  
6.0 (from Lwów)—Play (Mayen).  
6.50—Topical Talk.  
7.0—Station Orchestra. Conductor: Górzyski. Dan Choit Szpilman and Zyński (Pfte. Duo); at 7.45—News; Topical Talk.  
8.45—Literary Programme.  
9.0—Chamber Music—Rosenbaum (Pfte.), Wojakowski (Flute), Sniecowski (Oboe), Szaleski (Viola), Halber (Cello) and Sliwinski (Double Bass). Adagio and Rondo (Mozart). Septet in D minor (Hummel).  
9.50-10.0—News.

# FRIDAY Nov. 26

## NATIONAL

For Time Signals, see Monday.  
 10.15 a.m. (D)—Service.  
 10.30 (D)—Weather Forecast.  
 10.45 (D)—Talk for Parents.  
 11.0 (D)—Music for Schools.  
 11.50 (D)—Janet Howe (Contralto); Aileen Brandson (Organ).  
 12.30 p.m. (D)—Henry Hall and his Dance Orchestra.  
 1.15 (D)—Birmingham Philharmonic String Orchestra.  
 2.0 (D)—Herring Bulletin.  
 2.5 (D)—For Schools.  
 4.0 (D)—Records.  
 4.30 (D)—"The Story of Southwark Cathedral," 5.0—Quintet.  
 5.40—Harold Child (Baritone).  
 6.0—The First News.  
 6.25—Deutsches Studenten Leben; Paul Britzner.  
 6.45—Dance Tunes of Yesterday.  
 7.15—"Music and the Ordinary Listener;" Sir Walford Davies.  
 7.45—Ord Hamilton (Songs at the pte.). 8.0—Kentucky Minstrels.  
 9.0—The Third News.  
 9.20—Coal: The Past.  
 10.0—BBC Orchestra (Section E); Redvers Llewellyn (Baritone).  
 11.0—Oscar Rabin Romany Dance Band. 11.30-12.0—Dance Records.

## REGIONAL

For Time Signals, see Monday.  
 10.15-10.45 a.m. (ex. Western)—National.  
 10.45 (ex. Western, Scottish)—Orchestra: John McAlpine (Baritone).  
 10.45 (Western, Scottish)—National.  
 11.50 (ex. Western, Scottish)—Octet. 12.30 p.m.—Margaret Maddison (Pfte.); The Foxhill Singers.  
 1.15 (ex. Western, Scottish)—Records.  
 1.45 (ex. Western, Scottish)—Reginald Foort (BBC Theatre Organ); Frank Titterton (Tenor).  
 2.0 (Scottish)—For Schools.  
 2.15 (ex. Western, Scottish)—BBC Empire Orchestra; Lance Dossor (Pfte.). 3.0—Military Band.  
 3.45 (ex. Western, Scottish)—BBC Midland Orchestra, conducted by Leslie Heward.  
 4.0 (Western, Scottish)—National.  
 5.0 (ex. Western)—Children's Hour.  
 5.0 (Western)—National.  
 6.0 (Regional, Midland, Welsh)—Reginald King's Orchestra.  
 6.0 (Northern)—"Anatomy of Music."  
 6.0 (Western)—Organ music.  
 6.0 (N. Ireland, Scottish)—Cinema Organ.  
 6.20 (Scottish)—"Next Week You'll Hear."  
 6.30 (N. Ireland)—For Farmers.  
 6.30 (Scottish)—Saturday Sport.  
 6.40 (Northern)—For Farmers.  
 6.40 (Scottish)—Army Piping Class.  
 6.45 (Regional, Western)—"Chronicles in Stone."  
 6.45 (Midland)—Poetry reading.  
 6.45 (Welsh)—"Wales at Westminster."  
 7.0—The Second News.  
 7.20—Regional Announcements.  
 7.30 (ex. Northern, Welsh, N. Ireland)—The Hawaiian Islanders.  
 7.30 (Northern)—School Choir.  
 7.30 (Welsh)—J. H. Johns (Baritone).  
 7.30 (N. Ireland)—"Ulster Place Names."  
 7.45 (Regional, N. Ireland)—Isobel Baillie (Soprano); Edward Reach (Tenor); Ronald Stear (Baritone); Belfast Philharmonic Chorus and Orchestra. Conductor, E. Godfrey Brown. "King Olaf" (Elgar).  
 7.45 (Midland)—Pfte. music.  
 7.45 (Western)—"Up to London."  
 7.45 (Welsh)—"Ar Nos Wener."  
 7.45 (Scottish)—"The Proper Place;" a play.  
 8.0 (Midland, Western)—BBC Midland Orchestra.  
 8.0 (Northern)—"Haunted Houses."  
 8.0 (Welsh)—"The House Under the Water."  
 8.15 (Northern)—String Players.  
 8.40 (Midland)—Shopping talk.  
 8.40 (Western)—"Music in the West;" Ronald Biggs.  
 8.45 (Northern)—"Domino." A radio play by R. P. Hughes.  
 9.0 (ex. Northern, Western; Scottish 9.10)—Jack Payne's Band.  
 9.0 (Western)—Penzance Orchestral Society; Bernard Fishwick (Baritone); John Simons (Pfte.).  
 10.0—News Summary.  
 10.25 (ex. Western)—Oscar Rabin and his Romany Dance Band.  
 11.30 (ex. Western)—Late News Summary. 11.40-12.0—Records.

Hours of Transmission in Greenwich Mean Time.

## ATHLONE (Ireland)

565 kc/s (531 m.); 100 kW. Dublin, etc. See Sunday.  
 1.30 p.m.—Records.  
 2.30-3.0—For Schools.  
 5.30—Schubert Programme (Recorded) with the Unfinished Symphony.  
 6.20—For Women.  
 6.35—Irish News Feature.  
 6.45—News.  
 7.0—"From Japan to Tunis," with Musical Illustrations, presented by Eamonn Stewart.  
 7.30—Debate in Irish: Beirt Deiseach.  
 7.50—Book Review by Dr. Dudley Edwards.  
 8.5—Felix Doran (Pipes) and E. Delaney (Fiddle).  
 8.30—Irish Radio Orchestra. Vera Nugent (Pfte.) and Kitty McDermott (Contralto). Overture, "Der Opernball" (Heuberger). Summer Night on the River (Delius). Three Dances (Cyril Scott).  
 9.30—Variety Programme.  
 10.30—News.  
 11.0—National Anthem.

## BERLIN (Germany)

841 kc/s (356.7 m.); 100 kW. Transmits at intervals from 5.0 a.m.  
 11.0 a.m.—Annual Congress of the Reich Chamber of Culture, and the Kraft durch Freude Organisation, from the German Opera House.  
 12.45 p.m.—Records.  
 1.0—News.  
 1.15—Egon Kaiser Band.  
 2.15—Exchange; Records.  
 3.30—Sports.  
 4.0—Chamber Music. Three Songs (von Hausegger). Excerpts, Lyric Suite (Grieg).  
 4.30—Tramping in the U.S.A.  
 5.0—Raatzke Quintet.  
 6.0—News.  
 6.10—Records of Favourite Melodies. Overture, "Das Nachtlager in Granada" (Kreutzer). Two Songs: (a) Dein gedenk ich Margarethe (Meyer-Helmund), (b) Grüsst mir das blonde Kind am Rhein (Heiser). Ballet Music, "Rosamunde" (Schubert). Wedding Day on Troldhaugen (Grieg). To Spring (Grieg). Two Hungarian Dances (Brahms). Der Vogel im Walde (Taubert). Lagunenwalzer (Strauss).  
 7.0—Evening Echoes.  
 7.15—Raatzke Quintet.  
 8.0—Records: Opera Music. Excerpts, "Alessandro Stradella" (Flotow). Ballet, "Prince Igor" (Borodin). Excerpts, "Otello" (Verdi). Intermezzo, "Suor Angelica" (Puccini). Finale, "Carmen" (Bizet).  
 9.0—News; Road Reports.  
 9.30-11.0—See Deutschlandsender.

## BEROMÜNSTER

(Switzerland)

556 kc/s (539.6 m.); 100 kW. Relayed by Basle and Berne, 1,375 kc/s (218.2 m.).  
 5.30-5.50 a.m.—Ski-ing Lesson.  
 11.0—Records.  
 11.29—News.  
 11.40—Schlusnus Records.  
 12.5-12.45 p.m.—Violin Concerto (Schumann) by Kuhlenskampff and the Berlin Philharmonic. Conductor: Böhm.  
 3.0—Records.  
 4.0—Programme from Zürich.  
 5.0—For Children.  
 5.35—Legal Talk.  
 5.45—Finnish Music by Konstantin v. Schoultz (Pfte.).  
 6.0—Announcements; Talk.  
 6.35—Waltz Records.  
 6.45—News.  
 6.55—Alban Berg Songs by Colette Wyss.  
 7.10—Radio Orchestra.  
 7.45—Talk: The Schnell Brothers.  
 8.5—Music of Women Composers.  
 8.30—Scene (Goetz).  
 8.45—Humorous Programme.  
 9.5—Berne Mandoline Society.  
 9.25-9.30 (approx.)—News.

## BRATISLAVA

(Czechoslovakia)

1,004 kc/s (298.8 m.); 13.5 kW. Transmits at intervals from 5.15 a.m.  
 5.0 p.m.—Hungarian Transmission: Topical; Discussion.  
 5.45-6.15—See Prague.  
 6.15—Light Music.

6.40—"The Duel"—Play (Kalytjuk), from Kosice.  
 7.15—Pfte. Suite, My Mother (Suk).  
 7.40—Talk.  
 7.55—See Brno.  
 8.55-9.15—See Prague.  
 9.15—News (Hungarian).  
 9.30-10.0—See Prague.

## BRESLAU (Germany)

950 kc/s (315.8 m.); 100 kW. Relayed by Gleiwitz and Görlitz, 1,231 kc/s (243.7 m.). Transmits at intervals from 4.30 a.m.  
 11.0 a.m.—See Berlin.  
 12.45 p.m.—Music.  
 1.0-2.0—News; Records.  
 3.0 (from Gleiwitz)—Light Orchestra. Conductor: Glielik. In the interval, Talk.  
 5.0—Talk: Famous Men of the Past.  
 5.20—Gym Report.  
 5.30—Baron von Gablenz, Director of Luftthansa, talks about his Flight over the Pamirs (Recorded); Household Hints.  
 6.0—News.  
 6.10—"No Thoroughfare!"—A Microphone Visit to the Unknown.  
 7.0—Talk. Rarely Heard Gramophone Records, with Illustrations.  
 8.0—Motto.  
 8.5 (from Gleiwitz)—"Poland"—Sequence for Germans abroad (Wiese).  
 9.0—News; Talk.  
 9.30-11.0—See Deutschlandsender.

## BRNO (Czechoslovakia)

922 kc/s (325.4 m.); 32 kW. Transmits at intervals from 5.15 a.m.  
 4.40 p.m.—German Transmission: For Women; Talk; Sports Notes.  
 5.15—News; Records. 5.35—Talk.  
 5.45-6.15—See Prague.  
 6.15—Records.  
 6.30—Musical Sketch (Dostál).  
 6.50-7.55—See Prague.  
 7.55—Station Orchestra.  
 8.55-10.0—See Prague.

## BRUSSELS (No. 1)

(Belgium)

620 kc/s (483.9 m.); 15 kW.  
 6.30-9.0 a.m.—Records; Gym; News.  
 12.0 noon—Records; Reading.  
 12.30 p.m.—Shipping; Records.  
 1.0—News; Records.  
 1.30—Isabelle Draye (Songs); Records.  
 2.0—Art Notes.  
 4.55—News; Accordion; Reading.  
 5.40—Bauwens (Cello). Sonata (Barrière). Cantabile (Locatelli). Melody (Glazunov). Spanish Serenade (Glazunov).  
 6.0—Talk; Records.  
 6.30—Moszkowski Music by Constant (Pfte.). Zephir. Tarantella. Concert Etude; Records.  
 7.0—Motoring Notes.  
 7.15—Bellemans (Songs).  
 7.30—News; Topical.  
 8.0—Military Benefit Concert—Military Band. Conductor: Spoel. La Brabançonne (Van Campenhout) Marches (Gilson, Degrez). "La Revue"—War Play with Songs (Charpentier). Excerpts, "Phédre" (Massenet).  
 9.0—Talk: For Soldiers.  
 9.20—Military Benefit Concert (contd.). Marchal (Cornet). Overture (E. Bach-Clabeck). Ballet, "Le Cid" (Massenet). Cornet: Memories of Ireland (Spoel). March (Spoel). Vers l'Avenir (Gevaert).  
 10.0—News; Topical.  
 10.10—Music-Hall on Records with Rolande Denef (Discuse).  
 11.0—La Brabançonne.

## BRUSSELS (No. 2)

(Belgium)

932 kc/s (321.9 m.); 15 kW. Programme in Flemish.  
 6.30-9.0 a.m.—Records; Gym; News.  
 12.0 noon—Records: "Manon Lescaut" (Puccini).  
 1.30 p.m.—Light Orchestral.  
 1.0—News; Light Orchestral.  
 1.30—Flemish Song Records.  
 2.0-3.15—Shipping; For Schools.  
 4.55—News; Announcements.  
 5.0—Light Orchestral. Conductor: Walpot. Derissen (Cello).  
 6.0—Talk on Morocco; Records; Topical Report.  
 7.0—Greek Folk Songs by Mme Massalska.  
 7.30—News; Topical.  
 8.0—Virtuoso Records.  
 8.30—"Balanstijd"—Play (Van der Linden); Records.  
 9.0—Requiem (Mozart)—Germaine Teugels (Soprano), Flor Moulart-Maes (Contralto), Segers (Tenor), Van Beveren (Bass), and the I.N.R. Choir and Symphony

Orchestra. Conductor: Franz André.  
 10.0—News; Topical.  
 10.10—Symphony—Le midi (Haydn) by the I.N.R. Symphony Orchestra. Conductor: Franz André.  
 10.30-11.0—Records: "Otello" (Verdi).

## BUCHAREST (Romania)

823 kc/s (364.5 m.); 12 kW. Relayed by Radio-Romania, 160 kc/s (1,875 m.).  
 Transmits at intervals from 4.30 a.m.  
 4.2 p.m.—Predesco Orchestra.  
 5.0—Arts and Science.  
 5.15—Orchestra; Educational.  
 6.0—Records of Polish Pianists.  
 6.35—From the Opera. In the intervals, Poems; News; Sports.  
 9.45—News (French, German).

## BUDAPEST (No. 1)

(Hungary)

546 kc/s (549.5 m.); 120 kW. Transmits at intervals from 5.45 a.m.  
 11.5 a.m.—Stepat Balalaika Orchestra.  
 11.30—News.  
 11.45—Stepat Balalaika Orchestra.  
 12.30 p.m.—Symphony Orchestra. Conductor: Melles.  
 1.40—News.  
 3.15—For Scholars.  
 3.45—News.  
 4.0—Station Orchestra.  
 4.25—Sports.  
 4.35—Station Orchestra.  
 5.0—Talk.  
 5.30—Nyilas Cigány Band.  
 6.30—From the Royal Opera.  
 9.30—Records: Waltzes and Marches.  
 10.0—News (English).  
 10.5—Wiedinger - Bohner Jazz Band.  
 11.5—News.

## BUDAPEST (No. 2)

(Hungary)

359.5 kc/s (834.5 m.); 18 kW.  
 5.50 p.m.—Shorthand.  
 6.30—Talk.  
 7.0—News.  
 7.25—Military Band.  
 8.50—Records of Lucienne Boyer and Tino Rossi.

## COLOGNE (Germany)

658 kc/s (455.9 m.); 100 kW. Transmits at intervals from 5.0 a.m.  
 11.0 a.m.—See Berlin.  
 12.45 p.m.—Records.  
 1.0—News.  
 1.15-2.0—See Hamburg.  
 2.45—Notes; Periodicals.  
 3.15—Music by Hitler Youth.  
 3.45—"Die Vogelmeiere"—Word Picture (Schnack).  
 4.0—Sextet, Althoff (Mandoline and Mandola); Kirst (Pfte.).  
 5.0—Quartet in E minor (Verdi) by the Station String Quartet.  
 5.30—Visit to a Ski Factory.  
 5.50—Snapshots.  
 6.0—News.  
 6.10—See Leipzig.  
 8.0—Talk: Eichendorff.  
 8.10—Cologne Chamber Trio for Old Music. Trio Sonata in D (Leclair). Arietto (Buxtehude). Sonata in G minor for Flute and Harpsichord (Bach). Trio Sonata (Quantz).  
 9.0—News.  
 9.20—U.S.A. Bulletin.  
 9.30-11.0—See Deutschlandsender.

## DEUTSCHLANDSENDER

(Germany)

191 kc/s (1,571 m.); 60 kW. Transmits at intervals from 5.0 a.m.  
 11.0 a.m.—See Berlin.  
 12.50 p.m.—News; Music.  
 1.15—See Berlin.  
 2.0—Exchange; Programmes.  
 2.15—Children's Choir.  
 2.35—"Der Aufsatz"—Play after Keller (Zöllner).  
 3.0—Station Orchestra. Conductor: Dobrindt, and the Joost Band. In the interval, Reading.  
 5.0—Records of the von Gecky Band; Talk.  
 5.40—The German Industrial Congress—Closing Address by Dr. Ley.  
 6.0—Motto; News.  
 6.10—"Die bunte Reihe"—Variety, with Hilde Seipp, Hermann Gees, Emmy and Thomas Thomassen (Pfte. Duo) and Records. Rudolf Platté (Compère).  
 7.0—Opera Music from Leipzig.  
 8.0—"Two Women and a Ship"—Ballad for Radio, after Elert (Schwarz), with Josef Pelz v. Felinau, Lotte Braun, etc.  
 9.0—News; Sports.  
 9.20—U.S.A. Bulletin.  
 9.30-11.0—Serenade—Joost Band. Rostock Instrumental Quintet and Tolsdorf (Pfte.).

## FRANKFURT (Germany)

1,195 kc/s (251 m.); 25 kW. Cassel, etc. See Sunday.  
 Transmits at intervals from 5.0 a.m.  
 11.0 a.m.—See Berlin.  
 12.45 p.m.—News.  
 1.0—Opera Records.  
 2.0-2.15—Industrial News.  
 3.0 (from Freiburg)—Autumn and Drinking Songs (Ernst Duis), after Poems by Claudius Meyer, Müller, Bellmann, Storm, etc.—Tenor, Lute, Violin, "Cello, Pfte.  
 3.45 (From Freiburg)—Light Orchestral. Conductor: Körner.  
 5.0—Topical.  
 6.0—Time; News.  
 6.10 (From Cassel)—Serenades and Barcarolles—Orchestra, Conductor: Dörrie, Mainzer Band and Sabel (Tenor). Overture, "Figaro" (Mozart). Minuet from the Serenade in D (Brahms). Waltz from the Serenade for Strings (Tchaikovsky). Serenade (Widor). Pizzicato, "Sylvia" (Delibes). Aria, "La Gioconda" (Ponchielli). Serenade (de Micheli). Barcarolle (Tchaikovsky). Serenade, "The Barber of Bagdad" (Cornelius). Salut d'amour (Elgar). Serenade pittoresque (Graener). Neapolitan Serenade (Winkler). Canzonetta (Nicodé). Serenade, "The Merry Wives of Windsor" (Nicolaï). Romance (Ohlschlager). Flute Serenade (Roland). Vergebliches Ständchen (Macbeth). Barcarolle (Sullivan). Serenade, Blau Nacht (Mainzer). Ständchen im Laubengang (Fischer). Barcarolle, "A Night in Venice" (Strauss). Serenata celebre (Tareghni). Serenade (Walter). Liebesgeföhler (Schessl).  
 8.15—Between the Vistula and the Memel—Sequence about Eastern Germany. "Rufendes Land."  
 9.0—News; Snow Report.  
 9.15—U.S.A. Bulletin.  
 9.30—Burkart Dance Band.  
 11.0-12.0 m't.—See Stuttgart.

## HAMBURG (Germany)

904 kc/s (331.9 m.); 100 kW. Bremen, etc. See Sunday.  
 Transmits at intervals from 5.10 a.m.  
 11.0 a.m.—See Berlin.  
 12.45 p.m.—Topical; News.  
 1.15—Music.  
 2.0—Shipping; Markets.  
 2.25—Records of Lauri - Volpi (Tenor).  
 2.50—Ice Report.  
 3.0—Variety Concert—Station Dance Band, Greta Keller, Peter Kreuzer, etc. In the intervals—Talks.  
 5.0—For Children.  
 5.10—Old Folk-Songs by the Station Vocal Ensemble.  
 5.40—Talk; Shipping.  
 6.0—News.  
 6.10—Opera, Operetta and Light Classical Music—Station Orchestra and Choir, Soprano and Violin. Conductor: Secker.  
 8.0—A Village Dance—Dialect Programme, with the Plön Village Musicians, Station Choir, Jakschat (Bass-Baritone) and Grothey (Fiddle).  
 9.0—News.  
 9.20—U.S.A. Bulletin.  
 9.30-11.0—See Deutschlandsender.

## HILVERSUM (1,875 m.)

(Holland)

160 kc/s; 10 kW until 2.40 p.m.; 150 kW from 2.40 p.m.  
 KRO Programme.  
 7.40-8.55 a.m.—Records.  
 9.40—Records.  
 11.10—Religious Address; News.  
 11.55—KRO Orchestra. Conductor: Reinards; at 12.40 p.m.—Records.  
 1.40—Haak (Organ).  
 2.45—KRO Chamber Orchestra. Conductor: Reinards.  
 3.40—Records.  
 3.55—KRO Melodists. Conductor: Lustenhouwer. Klein (Refrains); at 4.40—Records.  
 5.40—Talk.  
 5.55—KRO Melodists (contd.).  
 6.40—Announcements; Talk; Report; News; Records.  
 8.0—Haarlem Catholic Oratorio Society, Utrecht Municipal Orchestra, etc. Conductor: v. Beinum.  
 9.15—Recitation and Records.  
 9.40—Oratorio Society, etc. (contd.).  
 10.35—News.  
 10.45-11.40—Records.

## HILVERSUM (301.5 m.)

(Holland)

995 kc/s; 15 kW until 6.10 p.m.; 60 kW from 6.10 p.m.  
 7.40 a.m.—VARA Programme—Records.

9.40—VPRO Service.  
 10.0—VARA Programme: Recitations and Records.  
 11.40 a.m.—3.40 p.m.—AVRO Programme.  
 11.40—Kovacs Lajos Orchestra.  
 12.5—Violin Concerto (Schumann) by Kulenkampf and the Berlin Philharmonic. Conductor: Böhm.  
 12.45—Kovacs Lajos Orchestra.  
 1.40—Talk.  
 2.10—Louis van der Sande (Songs); Piet van Egmond (Organ).  
 2.55—AVRO Dance Band.  
 3.40—7.10—VARA Programme.  
 3.40—The Lucky Birds, Conductor: Vogel, and Records.  
 4.40—For Children.  
 5.10—Jong (Organ).  
 5.40—Amateurs.  
 6.10—Political Review.  
 6.30—Records and Talk.  
 7.10—8.40—VPRO Programme.  
 7.10—Announcements; Talk.  
 7.40—Corry Bijster (Soprano); de Nobel (Pfte.).  
 8.10—Literary Talk.  
 8.40—12.0—VARA Programme.  
 8.40—Records.  
 9.10—VARA Orchestra, Conductor: de Groot; VARA Theatre Ensemble.  
 9.40—Concert by Fantasia.  
 10.10—Announcements.  
 10.20—VPRO Service.  
 10.40—11.40—VARA Programme.  
 10.40—Couperus (Bass-Baritone).  
 11.10—11.40—Records.

**KALUNDBORG (Denmark)**

240 kc/s (1,250 m.); 60 kW. Relays Copenhagen, 1,176 kc/s (255.1 m.).  
 Transmits at intervals from 6.0 a.m.  
 11.0 a.m.—1.0 p.m.—Hussars Band. Conductor: Fjeldhoff, Per aspera ad astra (Urbach). Chant d'automne (Waldteufel). Scandinavian Folk Songs and Dances (Söderman). Song from "Der Evangelimann" (Kienzl). Russian Suite (Fjeldhoff). Shine, bright Sunshine (Lange-Müller). Amager Polka (Lumbye). March (Blon). March (Mollerius). Waltz, "Die geschiedene Frau" (Fall). Pizzicato, "Sylvia" (Delibes). Heise and Weyse Potpourri (Larsen). The Nigger's Birthday (Lincke). Elegy (Masset). Farbenspiele (Siede). March (Fjeldhoff); at 11.50—Mendelssohn and Schumann Music by Schwenger - Jensen ("Cello").  
 1.30—Young Musicians Association Ensemble. Conductor: Forchhammer. March, "Scipio" (Handel). Dance of the Butterflies from Pharaoh's Ring" (Rung). Romance (Enna). Morgenblätter (Strauss). Passetje (Delibes). Resignation (Schroder). Selection, "Carmen" (Bizet). Miniature Overture (Mortensen). Romance (Thieleman). Nachspiel (Peterson-Berger). Minuet (Clemmensens). Potpourri, Old Acquaintances (Larsen). Serenata (Fiehn). Romanesco (Jacob Gade). Berceuse (Agerby). To reader and andalous (Rubinstein); at 2.15—For Women.  
 3.30—For Children.  
 3.50—Wireless Notes.  
 4.0—Impressions of Cracow.  
 4.25—Weather; Exchange; Markets.  
 4.50—Hasselgreen and Overgaard-Nielsen (Accordion Duo). Per aspera ad astra (Urbach). Les soirées parisiennes (Métrá). Potpourri (Hasselgreen). Cocktail (Gyldmark). Tango (Elmelunde).  
 5.15—Talk.  
 5.35—German Lessons.  
 6.0—Time; News.  
 6.30—Scandinavian Review.  
 7.0—Weekly Review by Per Knutzon.  
 7.10—"Und Pippa tänzt"—Four-Act Play (Hauptmann, trans. Friis-Møller); Incidental Music by AgerSnap.  
 9.0—News; Weather.  
 9.20—10.30—Light Music. Taaning (Banjo), Banner Jansen (Saxophone), Lulu Ziegler (Songs). Part I, Banjo, Part II, Saxophone, Part III, Songs.

**KÖNIGSBERG (Heilsberg) (Germany)**  
 1,031 kc/s (291 m.); 100 kW. Relayed by Danzig, 1,303 kc/s (230.2 m.).  
 Transmits at intervals from 5.0 a.m.  
 11.0 a.m.—See Berlin.  
 12.45 p.m.—Music.  
 1.0—News; Music.  
 1.55—Exchange.  
 2.30—Talk.  
 2.40—Dances for Violin.

3.0—Slav Music and Light Music —Station Orchestra. Conductor: Wilken.  
 4.40—"Feierabend bei Wichmanns"—Word Picture (Bannert).  
 5.0—Report: The Nation's Food.  
 5.10—Station Choir and Oertel (Organ). Toccata in A minor (Schroder). Songs for Choir. Toccata and Fugue in D minor (Förster). Songs for Choir.  
 5.50—News; Topical.  
 6.10—"Farmyard Voices"—Peter Arco and Records.  
 6.45—Topical.  
 7.0—"Fidelio" (Beethoven), from the German Opera, Berlin.  
 9.0—News; Periodicals.  
 9.35-11.0—Light Orchestral. Conductor: Wilken.

**LEIPZIG (Germany)**

785 kc/s (382.2 m.); 120 kW. Relayed by Dresden, 1,285 kc/s (233.5 m.).  
 Transmits at intervals from 5.0 a.m.  
 11.0 a.m.—See Berlin.  
 12.45 p.m.—Music.  
 1.0—News; Records.  
 2.25—Books; Talk.  
 3.0—Kretschmar (Songs to the Lute) and the Fricke Band.  
 4.0—Weather; Industrial News.  
 4.10—Songs and Band (contd.).  
 4.50—Talk.  
 5.10—Chamber Music from Weimar; Books.  
 6.0—News.  
 6.10 (from Dresden)—Opera Music —Dresden Philharmonic and Solo Voices. Conductor: Blumer. Excerpts, "Cosi fan tutte" (Mozart), "Don Giovanni" (Mozart), "Figaro" (Mozart), "The Magic Flute" (Mozart), "Der Wildschütz" (Lortzing), "Das Nachtlager in Granada" (Kreutzer), "Alessandro Stradella" (Flotow), "Tsar and Carpenter" (Lortzing), "Der Waffenschmied" (Lortzing), "The Merry Wives of Windsor" (Nicolaï).  
 8.0—Thrillers: (a) "Riveria-Express" (Vollmer), (b) "Blondine, welche" (Hahnwald), (c) "The Blind Passenger" (Pruggel).  
 9.0—News; Sports.  
 9.30-11.0—See Deutschlandsender.

**LILLE (Radio PTT Nord) (France)**

1,213 kc/s (247.3 m.); 60 kW. Transmits at intervals from 6.30 a.m.  
 8.0 p.m.—Bour (Variety Items).  
 8.30—Station Orchestra. Conductor: Soret. Mme Fagnen (Songs). Overture, "Alphonse and Estrellae" (Schubert). Fifth Symphony (Beethoven). Recitative and Aria, "Der Freischütz" (Weber). Suite, "A Midsummer Night's Dream" (Mendelssohn). Six Pieces brèves (Tomasi). Recitative and Aria, "L'enfant prodigue" (Debussy). Pfte. Pieces. Excerpt from Rédemption (Franck). Suite in G (Tchaikovsky). Joyeuse marche (Chabrier). After the Concert—News.

**MONTE CENERI (Switzerland)**

1,167 kc/s (257.1 m.); 15 kW.  
 11.0 a.m.—Records.  
 11.29—Time; News.  
 11.40—Radio Orchestra. Conductor: Herschel. Overture, "Abu Hassan" (Weber). Selection, "Madam Butterfly" (Puccini). Waltz (Drigo). Intermezzo, Juanita (Boulanger). Kiss Serenade (de Micheli). Villanueva (Escobar).  
 12.15-12.30 p.m.—Weekly Review.  
 2.0-2.30 (approx.)—For Schools.  
 4.0-5.0—See Beromünster.  
 6.15—Talks; Records.  
 6.45—News.  
 7.0-9.0—To be announced.

**MOSCOW (No. 1) (Russia)**

172 kc/s (1,744 m.); 500 kW.  
 4.45 p.m.—Concert.  
 5.30—Literary Programme.  
 6.0—Concert.  
 9.0—English Programme.  
 10.0—French Programme.  
 11.0-12.0 m't.—Spanish Programme.  
**MUNICH (Germany)**  
 740 kc/s (405.4 m.); 100 kW. Relayed by Nürnberg, 1,267 kc/s (236.8 m.).  
 Transmits at intervals from 5.0 a.m.  
 11.0 a.m.—See Berlin.  
 12.45 p.m.—Music.  
 1.0—News; Exchange.  
 1.15—See Hamburg.  
 2.0-2.15—Sketch.  
 3.0—Peter Raabe Birthday Programme, with Records, Introduc-

tory Talk. Scherzo, Seventh Symphony (Beethoven), Conductor: Peter Raabe. Reading. Pfte. Concerto in A (Liszt), Conductor: Peter Raabe.  
 3.40—Talk: Aviation.  
 4.0—Markets.  
 4.15—"Hausmannskost"—Variety, with Records.  
 5.45—To be announced.  
 6.0—Time; News.  
 6.10—Station Orchestra, Conductor: Winter, Andersen (Tenor), Stuhlfauth (Violin), Schoen and Grosch (Pftes.). Symphonic Prologue to Sophocles' "Oedipus Rex" (von Schillings). Aria, "Banadietrich" (Siegfried Wagner) Excerpts, Serenade in E flat (Dräseke). Violin Concerto in D minor (Bruch). Two Pftes.: Excerpts, Suite in Old Style (Kau). March (Mauke). Songs (Strauss).  
 8.0—Winter Relief Fund Concert.  
 9.0—News; Sports.  
 9.30—For Ski-ers.  
 9.30-11.0—See Deutschlandsender.

**NAPLES GROUP (Italy)**

Naples, 1,104 kc/s (271.7 m.); 10 kW. Florence (No. 1), etc. See Sunday.  
 6.0 p.m.—Light Music.  
 6.15—Topical.  
 6.25—Records.  
 7.0—Time; News.  
 7.20—Government Notes.  
 7.30—"Il sabato del villaggio"—One-Act Play (Falconi-Biancoli).  
 8.10—Bormioli-Sempri Pfte. Duo. Music by Zipoli, Saint-Saëns, Schubert, Liszt, Bormioli and Albéniz.  
 8.40—"At the White Cat"—Radio-Bar Orchestra, Conductor: Filipini.  
 9.0—Dance Music.  
 10.0—News.  
 10.15-10.55—Dance Music.

**OSLO (Norway)**

260 kc/s (1,153.8 m.); 60 kW. Fredrikstad, etc. See Sunday.  
 Transmits at intervals from 10.40 a.m.  
 4.0 p.m.—Concert. Conductor: Kielland. Suite, Falstaff (Elgar). Holberg Suite (Grieg).  
 5.0—Report.  
 5.25—Light Music by the Harlem Ensemble.  
 5.25—News and Announcements.  
 6.30—Time; For Farmers.  
 6.45—Glaser (Violin), La Folia (Corelli-Leonard). Romance in G (Beethoven). Rondo (Mozart-Kreisler). Cancion (Falla). Nana (Falla). Turkey in the Straw (Manén).  
 7.20—Literary Review.  
 7.35—Sketch.  
 8.0—Sonata in E minor (Grieg) by Stangland (Pfte.).  
 8.25—Illustrated Music Talk.  
 8.40—News.  
 9.0—Topical Talk.  
 9.15-10.0—Bergen Radio Orchestra.

**PARIS (Eiffel Tower) (France)**

1,456 kc/s (206 m.); 7 kW. Transmits at intervals from 6.30 a.m.  
 7.0 p.m.—Peyron (Songs) and Jeanne Leleu (Pfte.). Vergebliches Ständchen (Brahms). Song: En sourdine (Fauré). Pfte. Pieces (Schumann): (a) Aufschwung, (b) Warum? La pastorale des cochons roses (Chabrier). Pâquerette (Gibert).  
 7.30—News.  
 8.0—Poetry Lecture-Recital by Robert Honnert and Madeleine Milhaud.  
 8.30—Dramatic Variety: (a) "Saint-Saëns visits Lebourg," (b) "La quinzaine sonore"—Fantasy (Constantin-Brive).  
 10.30—Records.  
 11.0-11.15—News.

**PARIS (Poste Parisien) (France)**

959 kc/s (312.8 m.); 60 kW. Transmits at intervals from 7.10 a.m.  
 12.0 noon—Exchange; Records.  
 12.35—Exchange; Records.  
 1.15—Amusements; Records.  
 2.0—Exchange.  
 3.45—Exchange.  
 4.35—Exchange.  
 5.0—News.  
 5.5—Cabaret.  
 6.0—Exchange; News.  
 6.10—Record; Talk.  
 6.15—Records: Contemporary Music.  
 6.58—Racing Results.  
 7.0—Topical; Sports.  
 7.10—Amusements; Talk.  
 7.18—Records.  
 8.0—News; Records: Trios.  
 8.25—"Si je gagnais les trois mil-

FRIDAY (November 26)

lions!"—Programme with Jean Tranchant, presented by Jérôme Arnaud.  
 8.40—"La bonne histoire."  
 8.55-12.0 m't.—"Famille"—Play (Denys Amiel-Amiel Pétry).

**PARIS (PTT) (France)**

695 kc/s (431.7 m.); 120 kW. Transmits at intervals from 6.30 a.m.  
 2.30 p.m.—"Jouez-moi un rêve"—Three-Act Play (Sauveplane-Fauré-Frémiat).  
 4.0—Mme de Terras (Songs).  
 4.15—Madame de Maintenon's Letters.  
 4.30—Singing Lesson.  
 5.0—Light Orchestral.  
 6.0—Educational.  
 6.30—Schubert and Wagner Songs by Marie Simon.  
 6.45—Gentil (Pfte.). Vöiles (Debussy). Les collines d'Anacapri (Milhaud). Saudades do Brasil (Rhythmic (Harsanyi). Spanish Dance (Granados).  
 7.0—News.  
 8.0—Talk: Old Paris Theatres—Operetta Theatres.  
 8.30—Concert. Orchestra and Choirs. Conductor: Wolff, Germaine Corney and Lovano (Songs). Overture, "Masaniello" (Auber). Solo Voices and Choirs: Excerpts, "Le Moissonneur" (Casadesu). Prelude, "Naïs Micoulin" (Bruneau). Ballet, "Le roi s'amuse" (Delibes). Suite funambulesque (Messager).  
 10.30—News.  
 10.45—Dance Records.

**PARIS (Radio-Paris) (France)**

182 kc/s (1,648 m.); 80 kW.  
 6.28 a.m.—Programmes; Records; News; Gym.  
 7.5—Records; News.  
 7.30—Records.  
 8.0—News.  
 8.30—Programme Notes.  
 8.35—Records: Light Music.  
 9.0-9.20—Classical Records.  
 10.15—Programme Notes.  
 10.20—Dvořák and Smetana Records.  
 10.45—Reading.  
 11.0—Records: Light Music.  
 11.30—Planquette Operetta Records.  
 11.45—Markets.  
 12.0 noon—Pascal Orchestra.  
 1.0 p.m.—Time; News.  
 1.15—Exchange.  
 1.30—Pasdoc (Songs).  
 1.45—Pascal Orchestra.  
 2.0—Programmes; Talks.  
 2.30—Exchange.  
 2.45—Mlle Castang (Songs).  
 3.0—Germaine Borde and Brél (Violins). Sonata for Two Violins and Pfte. (Loicillet). Sonatina for Two Violins (Honcgger).  
 3.15—Talks; Reading.  
 3.45—Exchange; Records.  
 4.15—Françoise Holnay (Songs).  
 4.30—English Lesson.  
 5.0—Chamber Music—Quintet and Jeanne Manceau (Songs). Quintet in E flat (Mozart). Song: Addio (Mozart). Movement for Quintet (Ibert). Pastorale (Pierné). Four Songs (Ibert, Pierné). Divertissement for Quintet and Pfte. (Roussel).  
 6.0—Educational.  
 6.30—For Women.  
 7.0—Educational.  
 7.30—Talks.  
 7.58—Time; Programmes.  
 8.0—Political Review.  
 8.8—Foreign Affairs.  
 8.15—Pfte. Sonatina (Hahn) by Ninette Chassaing.  
 8.30—"L'échange"—Three-Act Play (Claudel) from the Théâtre des Mathurins.  
 9.30 (approx.)—News.  
 9.45 (approx.)—Play (contd.).  
 10.30—Records.  
 10.45—Time; News.  
 11.0—Concert. Conductor: René-Baton. Overture in D (Boccherini). Fantasia for Pfte., Choirs and Orchestra (Beethoven). Symphony in E flat (Lazzari).  
 12.45 a.m. (Saturday)—Programme Notes.

**PRAGUE (Czechoslovakia)**

638 kc/s (470.2 m.); 120 kW. Transmits at intervals from 5.15 a.m.  
 3.25 p.m.—Mildner Quartet. String Quartet in D (Mozart). String Quartet in F minor (Debussy).  
 4.10—Stories; Art Review.  
 4.35—Markets.  
 4.45—News in Russian.  
 5.0—For Workers.  
 5.10—German Transmission: Medi-

cal Talk; Soprano and Contralto Duet (Steffani); For Farmers.  
 5.45—News and Art Review in German.  
 6.0—News.  
 6.15—Records: Waltzes (Dvořák).  
 6.35—Talk.  
 6.50—Records of the FOC Orchestra.  
 7.10—"Eliška Krásnohorská and Bedřich Smetana"—Musical Sequence.  
 7.55-8.55—See Brno.  
 8.55—Record.  
 9.0—Time; News.  
 9.15—Records.  
 9.30-10.0—For Sokols.

**RADIO-NORMANDIE (France)**

1,113 kc/s (269.5 m.); 15 kW.  
 6.45 a.m.—Band; Songs.  
 7.15—News; Topical.  
 7.45—Physical Exercises.  
 8.0—Light Music.  
 8.15—Records.  
 8.30—Light Music.  
 8.45—Records.  
 9.0—Light Music.  
 9.30—Popular Music.  
 10.0—Records.  
 10.15—Light Music.  
 10.30—Records.  
 10.45—Popular Music.  
 11.15—Records.  
 11.30—Symphony Music.  
 12.0 noon—Variety Concert.  
 12.45 p.m.—News; Topical.  
 1.0—Variety Concert.  
 2.0—Records.  
 2.30—Light Music.  
 2.45—Popular Music.  
 3.0—Records.  
 3.30—Jane and John.  
 3.45—Light Music.  
 4.0—Current London Productions.  
 4.15—Records.  
 4.30—Light Music.  
 4.45—Records.  
 5.15—Light Music.  
 5.30—Variety.  
 6.0—Children's Corner.  
 6.45—News; Racing.  
 7.0—Records.  
 7.25—News; Topical.  
 7.45—Mandoline Records.  
 8.0—Records of Tino Rossi (Tenor).  
 8.20—Records of the Locatelli Orchestra.  
 8.40—Light Music.  
 9.0—Variety Concert.  
 10.0—"L'Escadron Blanc"—film, from the Cinéma Normandie, Rouen.  
 11.55—News.  
 12.0 m't.—Midnight Melodies.  
 12.30 a.m. (Saturday)—Dance Music.  
 1.30-2.0—Light Music.

**ROME GROUP (Italy)**

Rome (No. 1), 713 kc/s (420.8 m.); 50 kW. Bari (No. 1), etc. See Sunday.  
 Transmits at intervals from 6.45 a.m.  
 5.0 p.m.—Paris Quintet from the Academy of St. Cecilia. In the interval, News.  
 5.50—Music.  
 6.0—Talk in French; Announcements.  
 6.25—News (English, French).  
 7.0—Time; News.  
 7.20—Government Announcements.  
 7.30—Music.  
 8.0—"La Mascotte" (Audran). Conductor: Mancini. In the intervals, Talk; News.  
 10.0—News.  
 10.15-10.50—Dance Music.

**SOTTENS (Switzerland)**

677 kc/s (443.1 m.); 100 kW. Relayed by Geneva, 401 kc/s (748 m.).  
 11.29 a.m.—Time; News.  
 11.40 a.m.—12.45 p.m.—Records.  
 3.59—Time.  
 4.0-5.0—See Beromünster.  
 5.0—Interlude.  
 5.15 (from Geneva)—Talk; Sports Review.  
 5.40 (from Geneva)—For Alpinists.  
 5.50—Weekly Parliamentary Review.  
 6.5—Football Notes.  
 6.10—Interlude.  
 6.15 (from Geneva)—Micro-Magazine.  
 6.50—News.  
 7.0 (from Geneva)—Mandolinata Orchestra. Conductor: Panosetti.  
 7.25—Financial Review.  
 7.45—Excerpts from "Allume! Allume!"—Revue (Ruy-Blag), by the Casino Theatre Troupe.  
 8.45—League of Nations Report.  
 9.5—Records.  
 10.0—Weather.

FRIDAY (November 26)

STOCKHOLM (Sweden)

704 kc/s (426.1 m.); 55 kW. Motala, etc. See Sunday. Transmits at intervals from 6.20 a.m. 11.25 a.m.—Records. 11.50—Exchange; Markets. 12.00 noon—For Schools. 12.30 p.m.—Johanson (Organ) from the Church of St. Clare. Festival Prelude (F. Wagner). Pastoral (Rudnick). Vision (Rheinberger). Canzona (Karg-Elert). Prayer (Bossi). Réves (Saint-Saëns-Guilment). Festival March (Johanson). 1.0—Gymnastics. 1.15-2.0—Waldimir Orchestra. 4.5—For Young People. 4.40—Hamnstedt (Songs), Svensson and Cederberg (Accordion Duo). 5.10—Records. 6.0—News. 6.30—Radio Male Voice Choir, Conductor: Nylander. Humoresque (Düring). Dofta, dofta vitt syren (Wikander). Maj i Munga (Widén). German Students' Songs. Wiegenlied (Brahms). Two Songs (Kjerulff). Behagen (Heise). 7.0—Chopin Recital by Friedman, from the Academy of Music. Polish Fantasia, Six Etudes. Fantasia in F minor. Nocturne in E. Barcarolle. 7.50—Talk. 8.20—Sundqvist and Marianne Mörner (Songs to Strindberg Text). Och riddaren for ut Osterland (Aulin). Det var en fattig yngling (Aulin). Song, "Kronbruden" (Rangström). Songs (Peterson-Berger): (a) Mitt trollslott, (b) Sju rosor och sju eldar, (c) Semele, (d) Villemo. 8.45—News. 9.0-10.0—Septiman Orchestra. Overture, "Poet and Peasant" (Suppé). Walt, Sekterperlen (Kochmann-Schmidt). Slav Dance (Dvořák). Sunset (de Micheli). Excerpts, Suite No. 2 (Rangström). Three Pieces (Peterson-Berger). Concerten på Tre Bytter (Bellman-Sköld). Sang till Stockholm (Aifven).

STRASBOURG (France)

859 kc/s (349.2 m.); 100 kW. Transmits at intervals from 6.30 a.m. 5.0 p.m.—Talk: Talleyrand. 5.15—Nicole Rolet (Pfte.). Sonata in G minor (Schumann). Etude (Chopin). Rondo capriccioso (Mendelssohn). Pièce en forme de mazurka (Aubert). Jeux d'eau (Ravel). 6.0—Talks. 6.30—Concert from Rennes-Bretagne. 7.0—News. 7.30—Concert from Limoges (PTT). 8.0—News (German, French). 8.30—Concert from Rennes Bretagne. 10.30—News (French, German). 11.0 p.m.—12.45 a.m. (Saturday)—See Paris (Radio-Paris).

STUTTGART (Germany)

574 kc/s (522.6 m.); 100 kW. Transmits at intervals from 5.0 a.m. 11.0 a.m.—See Berlin. 12.45-2.0 p.m.—News; Records. 3.0—Records and Baden-Baden Orchestra. Conductor: Assmus. 5.0—Sequence about Land Work. 5.30—Topical. 6.0—News; Talk. 6.15—Variety from Mannheim. The Five Merry Singers, Schrammel Ensemble, Accordion and a Verse Speaking Choir. 7.0—Variety Concert. 8.0—"Von Eichendorff"—Biographical Sequence (Otto Sonnen), with Schumann Music. Bruno Müller (Baritone), a String Trio, and Otto Sonnen (Pfte.). 9.0—News; Sports. 9.20—U.S.A. Bulletin. 9.30—Records: Dance and Light Music. 11.0-12.0 m't.—Serenade on Records. Fantasia and Fugue for Organ (Bach). Sonata for 'Cello and Harpsichord (Bach). Second Symphony (Beethoven). De profundis for Choir, Orchestra and Organ (Gluck).

TOULOUSE (Radio-Toulouse) (France)

913 kc/s (328.6 m.); 60 kW. Transmits at intervals from 8.0 a.m. 6.0 p.m.—Tangos. 6.15—Chansonnettes. 6.40—Operetta Songs, "The Daughter of the Regiment" (Donizetti). "Poulidette" (Sellers). "The Flower of Hawaii" (Abraham). "La Poule" (Christine). 6.55—News; Sports. 7.15—Variety. 7.45—Light Music. 8.0—Jazz Music. 8.10—Talk. 8.30—Variety. 9.10—Light Music.

8.0—Symphony Concert. Orchestra. Conductor: Bruno Walter; a-cappella Choir. Conductor: Consoli. Part I: The Seasons (Vivaldi). Part II: Requiem in D minor (Mozart). In the interval, Talk. After the Concert, News; Dance Music.

VIENNA (Austria)

592 kc/s (506.8 m.); 100 kW. Graz, etc. See Sunday. Transmits at intervals from 5.45 a.m. 11.0 a.m.—Station Orchestra. Wanausek (Flute). Ouverture zu einem heiteren Spiel (Wichl). Waltz, Natursänger (Ziehrer). Strauss-Millocker-Suppe Potpourri (Ziehrer). Flute: Idyll and Allegretto (Godard). Song

Backhaus plays, with Abendroth conducting the orchestra, at Warsaw (7 p.m.)



9.30—Maurice Saint-Paul Music by the Composer (Accordion). 10.0—News. 10.15—English Concert. 11.15—Viennese Orchestra. 11.35—Light Music. 11.50-12.0 m't.—News.

TURIN GROUP (Italy)

Turin (No. 1), 1,140 kc/s (263.2 m.); 7 kW. Milan (No. 1), etc. See Sunday. Transmits at intervals from 6.45 a.m. 4.0 p.m.—News. 4.15-4.50—Dance Music. 5.50—Light Music—Orchestra. Conductor: Giuliani. 6.40—News in French. 7.0—News. 7.20—Government Notes. 7.30—Light Music.

and Czardas (Lehár). Marionetten-Brautzug (Noack). Overture, "Das Modell" (Suppé).

12.0 noon—News; Records. 1.0 p.m.—Ländliche Hochzeit (Goldmark) by the Vienna Philharmonic, Conductor: Heger (Records).

1.30—Announcements. 2.0—News; Exchange. 2.15—Stumpf (Viola). Concerto in B minor (Handel). Souvenir (Stumpf). Tarantella (Ritter). 2.40—For Women. 3.0—News; Records. 4.0—For Children. 4.20 (from Klagenfurt)—Pfte. Quintet in E minor (Kattng). 5.0—Sports and Tourist Talk; Austria. 5.25—German for Everybody.

5.50—Music Talk: The Burgkapelle. 6.0—News; Topical. 6.25—Unpublished Music. Station Band. Conductor: Sandauer. Dolly Lichtneckert and Karl Glaser (Songs). 7.0—Ballad: "Der Tod des Wu-Hang-Tsi" (von Scholz). 7.5—"Don Juan Tenorio"—Two-Act Play (Zorrilla, trans. Wölfel). 9.10—News; Programmes. 9.20—Violin Concerto (Schumann), by Kulenkampff and the Berlin Philharmonic, Conductor: Böhm (Recorded). 10.5—News; Road Report. 10.10—Talk: Franz Gruber, Composer of Stille Nacht.

WARSAW (Poland)

224 kc/s (1,339 m.); 120 kW. Cracow, etc. See Sunday. Transmits at intervals from 5.15 a.m. 10.57 a.m. (from Cracow)—Time; Fanfare. 11.3—To be announced; at 11.20 News. 2.30 p.m.—Economics. 2.45 (from Wilno)—For Children. 3.0 (from Lwów)—For Invalids. 3.15—Police Band, March (Berlioz). Mountain Songs and Dances (Karas). Mazurka, "Halka" (Moniuszko). Romance (Tchaikovsky). 3.50—Topical. 4.0—Talk. 4.15 (from Cracow)—Mikuszewski (Violin). Intrada (Desplanes). Sarabande et tambourin (Lecclair). Andante and Fugue (Mozart). Caprice in B flat (Paganini). Andante (Fauré). Dance (Scott). Le printemps (Milhaud). 4.50—Books; Sports. 5.10—Records of Fred Astaire. 5.30—Programme Notes. 5.35—For Country People. 6.0 (from Wilno)—A Play after Eliza Orzeszko. 6.30—Songs. 6.50—Topical. 7.0—Warsaw Philharmonic Orchestra. Conductor: Abendroth. Backhaus (Pfte.). 8.0—News; Topical. 8.15 (approx.)—Orchestra, Pfte. (contd.). 9.50-10.0—News.

SATURDAY Nov. 27

NATIONAL

For Time Signals, see Monday. 10.15 a.m. (D)—Service. 10.30 (D)—Weather Forecast. 10.45—"The Week in Westminster." 11.0—Records. 11.45—BBC Welsh Orchestra: Walter Glynn (Tenor). 12.30 p.m.—Dance Records. 1.0—The Dolce Singers. 1.50—Manchester November Handicap: running commentary. 2.5—Herring Bulletin. 2.10—Cecil Dixon (Pfte.). 2.30—Athletics: Oxford v. Cambridge, Inter-Varsity relay. 3.0—Records. 3.30—See 2.30. 3.45—BBC Scottish Orchestra. 4.40—Serial Reading. 5.0—Henry Hall's Dance Orchestra. 6.0—The First News. 6.30—BBC Northern Orchestra. 7.30—"In Town Tonight." 8.0—Variety. 9.0—The Third News. 9.20—American Commentary. 9.35—BBC Theatre Orchestra; Section of BBC Women's Chorus. 10.45—Poetry reading. 11.0—Ambrose and his Orchestra. 11.30—Late News Summary. 11.40-12.0—See 11.0.

REGIONAL

For Time Signals, see Monday. 10.15-10.45 a.m. (ex. Western)—National. 10.45—Cinema Organ. 10.45 (Western)—National. 11.15 (ex. Western)—Light Music. 11.45 (ex. Western)—Records. 12.15 p.m. (ex. Western)—Maurice Reeve (Pfte.). 12.45—Talk. 1.0 (ex. Western)—Theatre Orchestra. 2.0—Records. 2.45 (ex. Western)—Talk. 3.0 (ex. Western)—Cinema Organ. 3.30 (ex. Western)—Mantovani Tipica Orchestra. 4.0—Kentucky Minstrels. 5.0 (ex. Western)—Children's Hour. 5.0 (Western)—National. 6.0 (Regional, Western, N. Ireland)—Records. 6.0 (Midland)—Theatre Orchestra.

6.0 (Northern)—Cinema Organ. 6.0 (Welsh)—A Welsh farce. 6.0 (Scottish)—The First News. 6.15 app. (Scottish)—Radio Visitor's Book. 6.20 (N. Ireland)—Association Football: Cliftonville v. Coleraine. 6.30 (Regional, Western, N. Ireland)—Enfield Central Band: Herbert Thorpe (Tenor). 6.30 (Northern)—Recital. 6.30 (Welsh)—Records. 6.45 (Midland)—Records. 6.45 (Scottish)—Sports News. 6.50 (Welsh)—Stop Press for Sport. 7.0 (Northern)—Band. 7.5 (Midland)—"Sport." 7.5 (Scottish)—Alexander McGregor (Baritone). 7.20—Regional Announcements. 7.30 (ex. Midland, Welsh)—The Katcher String Quartet. 7.30 (Midland)—Massed Bands: Championship Contest. 7.30 (Welsh)—Welsh News. 7.45 (Welsh)—Around and About. 8.0 (ex. Western)—"Voluntary Social Service—Whither?" 8.0 (Western)—New English Trio. 8.45 (Regional, N. Ireland)—G. Thalben-Ball (Organ). 8.45 (Midland)—Arnold Matters (Baritone); Orchestra. 8.45 (Northern)—Racing. 8.45 (Welsh)—"Enid," a play. 8.45 (Scottish)—Scottish Dances. 8.55 (Northern)—Rees Orchestra: Lilian Cooper (Soprano). 9.0 (Western)—Regional Director. 9.15 (Regional, Western)—Claire Croiza (Mezzo-Soprano); Frank Mannheim (Pfte.). 9.15 (N. Ireland)—Night Shift. 9.15 (Scottish)—Variety. 9.30 (Midland)—Brahms; Singers. 9.40 (N. Ireland)—"Schools." 9.40 (Scottish)—The Week in Scotland. 9.50 (Northern)—Everton v. Stoke. 10.0—News Summary. 10.30 (ex. Western; Northern 10.35)—Ambrose Orchestra. 10.30 (Northern)—Table Tennis. 11.30 (ex. Western)—Late News Summary. 11.40-12.0—See 10.30.

Hours of Transmission in Greenwich Mean Time.

ATHLONE (Ireland)

565 kc/s (531 m.); 100 kW. Dublin, etc. See Sunday. 1.30-3.0 p.m.—Records. 5.30—Tea-time Music by the Roberts Trio and Afric McGinley (Mezzo-Soprano). 6.20—"Two Scots hae a Crack" Donald McLean Skiffington, Clydebank, and W. Morrison Milne, Dublin. 6.35—Irish News Feature. 6.45—News. 6.55—Dublin Scots celebrate St. Andrew's Day. Talk by the croupier of the Dublin Benevolent Society of St. Andrew. 7.0—The Clarinet and its Story—Comdt. Sauerzweig and the Irish Radio Orchestra. 7.30—Radio Diary presented by Eric Boden. 8.0—Melodious Memories from Offenbach to Lehár by the Irish Radio Orchestra. Overture; "Orpheus in the Underworld" (Offenbach). Offenbach Potpourri (arr. Finck). Lehár Potpourri (arr. Geiger). 8.40—Lord Dunsany reads. 8.50—Andrew W. Keane (Pipes) and Tadgh Small (Violin). 9.15—Review in English of Recent Gum Publications. 9.30—Variety Programme. 10.30—News. 11.0—National Anthem.

BERLIN (Germany)

841 kc/s (356.7 m.); 100 kW. 5.0 a.m.—Call; Weather. 5.10—Gym. 5.30-7.0—Heyden Band; at 6.0—News. 7.0—Gym; Pfte. 7.30—Saarbrücken Orchestra. 8.30—Records. 9.0—See Cologne. 9.30-9.45—Weather; Markets. 10.15—Records: Light Music. 10.40—Report: From Hunting Ground to Fashion Show—a Visit to the Furriers. 10.55—Weather. 11.0—See Breslau; at 12.0 noon-12.15 p.m.—Midday Echoes. 1.0—Weather; News. 1.15—Serenade from Deutschland-sender.

2.15—Exchange; Markets. 2.30—Hitler Youth Choir. 2.45—Behind the Scenes at the Races—Reports on Weighing-in, etc. 3.0—See Stuttgart. 5.0—Records. Overture, "Beatrice and Benedict" (Berlioz). Grun-deis: Scherzo (Chopin). Baron Neuhaus Suite (Melichar). Julius Patzak (Strauss Songs): (a) Cäcilie, (b) Ständchen. Jota Navarra (Sarasate). Rondo, La Campanella (Paganini). Delirien-Walzer (Joh. Strauss). 6.0—News. 6.10—Raatzke Quintet. 7.0—Evening Echoes. 7.15—City Rhythm—Station and Musette Orchestras. Conductor: Willy Steiner. Eberhard Glombig and Willy Normann (Pfte. Duo), Vossen and Korsek (Accordion and Guitar), the Nollen Village Sparrows, Marianne Mewes (Soprano) and Ludwig Bernauer. 9.0—News; Sports Notes. 9.30-12.0 m't.—Dance Music—Kaiser Band and the Raatzke Quintet.

BEROMÜNSTER (Switzerland)

556 kc/s (539.6 m.); 100 kW. Relyed by Basle and Berne, 1,375 kc/s (218.2 m.). 5.30-5.50 a.m.—Gym. 11.0—Records; English Music. 11.29—Time; News. 11.40—Records: Light Music. 12.30 p.m.—Weekly Parliamentary Review. 12.45—Records. 1.10-1.30—Book Talk. 3.0—Degen (Accordion). 3.30 (from Basle)—Talk: Monasteries. 4.0—See Monte Ceneri. 5.0—Weather; Talk: Pro Juventute. 5.20—Talk. 5.30 (from Basle)—Pfte. Duets. 6.0—Chimes from Zürich Churches. 6.15 (from Basle)—Time; Markets. 6.20 (from Basle)—Talk: Johann Jakob Bachofen. 6.45—News. 6.55-10.5 (approx.)—Popular Programme from Basle. 6.55—Popular Concert.

7.45—Variety. 9.0—Dance Music. 10.0-10.5—News.

BORDEAUX-LAFAYETTE (France)

1,077 kc/s (278.6 m.); 35 kW. Transmits at intervals from 6.30 a.m. 12.0 noon—Variety Concert by the Station Orchestra. 1.0 p.m.—News. 1.15—Interlude. 1.30—Station Orchestra. Conductor: Guitraud. Doll's March (Lecoca). Selection from The Student Prince (Romberg) and Les Erinnyes (Massenet). 2.0-2.45—See Paris (Radio-Paris). 2.45—Orchestral Concert from Montpellier (PTT). 4.0—See Paris (PTT). 4.15—To be announced. 4.50—See Paris (Radio-Paris). 5.0—Orchestral Concert from Alpes-Grenoble. 5.45—To be announced. 6.30—Interlude. 6.45—Film Notes. 7.0—See Paris (Radio-Paris). 7.30—Interlude. 7.40—English Lesson. 7.55—News; Programme Notes. 8.30-10.30—See Paris (Eiffel Tower). 10.30—See Paris (PTT).

BRATISLAVA (Czechoslovakia)

1,004 kc/s (298.8 m.); 13.5 kW. Transmits at intervals from 5.15 a.m. 12.30 p.m.—Literary Talk; Record. 12.50-1.0—See Prague. 1.0—News (German, Hungarian). 1.15-1.20—Record. 2.10—Film Notes. 2.20—Operetta Ensemble and Station Orchestra from Kosice. 3.50—Play for Children, from Kosice. 4.35—Topical; Record. 4.50—Cultural Review. 5.0—Play in Hungarian (Egri). 5.45-6.20—See Prague. 6.20—See Brno. 6.40-9.15—See Prague. 9.15-News (Hungarian). 9.30-10.30—See Prague.



**BRESLAU (Germany)**

950 kc/s (315.8 m.); 100 kW. Relayed by Gleiwitz and Görlitz, 1,231 kc/s (243.7 m.).

- 4.30 a.m.—Weather; Records.
- 5.0—Motto; Gym.
- 5.30-7.0—See Berlin.
- 7.30—Saarbrücken Orchestra.
- 8.30—Weather; Greetings.
- 8.35—For Children.
- 9.0-9.30—See Cologne.
- 10.30—Weather; Water Level.
- 10.45—For Housewives.
- 11.0—Orchestra. Conductor: Koschinsky. March (John). Overture, "Poet and Peasant" (Suppe). Ballet, "Sylvia" (Delibes). Waltz, "Der Rosenkavalier" (R. Strauss). Suite, Des Königs Musikanten (Koschinsky). March, Barataria (Komzak).
- 12.0—News; Greetings.
- 12.15—Orchestra (contd.). Overture, "Idomeneo" (Mozart). German Dances (Beethoven). Entr'acte from "Rosamunde" (Schubert). Serenade for Strings (Haydn). Selection, "La Traviata" (Verdi).
- 1.0—News; Exchange; Records.
- 2.0—Book Talk.
- 2.10—Erna Hanke (Pfte.). Three Ecossaises and Two Waltzes (Chopin). Gnomesreigen (Liszt).
- 2.30—Talk: Little-known German Handicrafts—Thuringian Forest Glass.
- 2.45—Across the Atlantic in the Smallest Sailing Boat—Discussion between Helmut Rabuske and a Hitler Youth (Recorded).
- 3.0—Winter Relief Concert. Station Orchestras. Conductors: Weisshaupt and Topitz. Station Choir. Conductor: Rietz. Station Dance Band. Conductor: Günther. Military Band. Conductor: Engel. Anderten, Hellhoff, Odda and Böhmer (Speakers).
- 5.0—"Intermezzo"—Scene with Music and Songs (Sonnabend).
- 5.30—Winter Relief Concert (contd.).
- 6.0—News.
- 6.10—Winter Relief Concert (contd.).
- 8.0—Motto; Sound News.
- 8.20—Winter Relief Concert (contd.).
- 9.0—News.
- 9.15—To be announced.
- 9.30-11.0—Winter Relief Concert (contd.).

**BRNO (Czechoslovakia)**

- 922 kc/s (325.4 m.); 32 kW. Transmits at intervals from 5.15 a.m.
- 12.30 p.m.—Industrial Review.
- 12.40—For Farmers; Record.
- 12.50-3.50—See Prague.
- 3.50—Play for Young People.
- 4.35—Record.
- 4.40—German Transmission: Talk; Play for Children.
- 5.15—News; Literary Review.
- 5.30—Cultural Review.
- 5.45-6.20—See Prague.
- 6.20—Singing Lesson.
- 6.40-10.30—See Prague.

**BRUSSELS (No. 1)**

- (Belgium)
- 620 kc/s (483.9 m.); 15 kW.
- 6.30-9.5 a.m.—Records; Gym; News.
- 12.0 noon—Records: Light Music.
- 12.30 p.m.—Weather; Shipping.
- 12.35 (approx.)—Radio Orchestra. Conductor: Gason. Overture, "La belle Hélène" (Offenbach). Midnight Reflections (Malneck). Selection, "Sweet Adeline" (Kern). Nocturne (Griselle). Cortège de Bacchus (Delibes).
- 1.0—News.
- 1.10—Orchestra (contd.). Selection, "Yes, Madam" (Waller-Tunbridge). Suite, Springtime (Coates).
- 1.30—Records: Light Music.
- 2.0—Art Notes: For Women.
- 3.0—Chamber Music—Germaine Dupont (Songs) and Goffard (Flute).
- 3.45—A Visit to Italy—Address; A Belgian looks at Italy; Overture, "The Secret Marriage" (Cimarosa); Prelude to "La Traviata" (Verdi); Poem; Aria, "The Barber of Seville" (Rossini); Organ Concerto in A minor (Bossi); Poem; La Giara (Casella).
- 4.45—Baeyens ('Cello). Concerto (Handel). Cantilène (De Boeck).
- 4.55—News.
- 5.0—League of Nations Talk.
- 5.15—Beethoven Records: Coriolanus Overture. Aria, "Fidelio."
- 5.30—Talk: A Walloon Farm.
- 5.40—Records: Violin Concerto

**BRUSSELS (No. 2)**

- (Belgium)
- 932 kc/s (321.9 m.); 15 kW. Programme in Flemish.
- 6.30-9.0 a.m.—Records; Gym; News.
- 12.0 noon—Song Records. Elizabeth Schumann: Songs (Beethoven): (a) Mit einem gemalten Bande, (b) Wonne der Wehmut. Schlussus: Songs (Beethoven): (a) In questa tomba oscura, (b) Ich liebe dich. Emmy Bettendorf: (a) To Spring (Grieg), (b) Rustie of Spring (Sinding). Marian Anderson: (a) He was despised (Handel), (b) Caro mio ben (Giordano). Tauber: Das Herz am Rhein (Hill).
- 12.31 p.m.—Salon Orchestra. Conductor: Féron. Viennese Waltzes (Benatzky). Aubade (Caludi). Major and Minor (Schreiner). Fedora (Neudo). Suite in Gipsy Style (Liamine).
- 1.0—News; Announcements.
- 1.10—Orchestra (contd.). Colombinella (Delabre). Pavlova (Meyer-Helmund). Le mendiant d'amour (Gavel). Loin du bal (Gillet). Ké-Sa-Ko (Chapuis).
- 1.30—Records: Concerto for Pfte. and Jazz Band (Gershwin). Selection, "Peggy Ann" (Rodgers).
- 2.0—Shipping.
- 2.5 (approx.)—Lecture-Recital by Marcel Boereboom: Three Centuries of Chamber Music, XV: Franck and Mussorgsky.
- 3.0—Light Music. Conductor: Walpot. March of the Marionettes (Hullebroeck). Selection, "Roses of Florida" (Fall). In a Persian Market (Ketelbey). Tea-Room Orchestra. Capricieuse (Van Doren). In Styria (Pachernegg).
- 3.45—Records: Pfte. Jazz.
- 4.0—Light Music (contd.). Excerpts, "Till" (Albert). Ballet, "Rosamunde" (Schubert). Serenade (De Maeght). Fantasia (Verhoeven). At the Circus (Armandola).
- 4.40—Announcements; Talk.
- 5.0—Salon Orchestra. Conductor: Féron. Parade bouffonne (Delmas). Hungarian Harvesters' Festival (Dohnányi). In the Castle Park (Siede). Eastern Magicians (Lindeman). Les clochettes d'amour (Herpin). City of Song (Hoffmann). Les nuits qui chantent (Coda).
- 5.30—For Women; Records.
- 6.15—Lina (Songs). Part I: Jensen. Lehn deine Wang an meine Wang. Frühlingnacht. Der Bote. Lose. Part II: Archibald Douglas. On Wings of Song (Mendelssohn). Part III: Robert Franz. Aus meinem grossen Schmerzen. Mädchen mit dem roten Mundchen. Weisst du noch? Du liebes Auge. Es hat die Rose sich beklagt. Vergessen.
- 6.45—Talk: Modern Intellectuals.

- (Paganini). Marche troyenne (Berlioz).
- 6.0—Topical Talk.
- 6.15—Salon Orchestra. Conductor: Féron (Violin). Lardanois (Songs). Kovacs (Cymbalom). Hungarian Rhapsody (Gaal). Extase d'amour (Dame). Missouri Waltz (Logan). Songs: (a) Arias, "Mirella" (Gounod), (b) Les vieilles de chez nous" (Levadé), (c) La clameur de Roland (Jodin). Violin: Czardas (Monti). Au crépuscule. Songs: (a) Serenade (Mozart), (b) Danse macabre (Saint-Saëns). Cymbalom: Hungarian Songs and Czardas (Dury). Songs fantasques (De Bourguignon).
- 7.0—Art and Music Reviews; Interview.
- 7.15—Records: Petite suite de concert (Coleridge-Taylor).
- 7.30—News.
- 8.0—Variety with the Radio Orchestra, Conductor: Gason.
- 8.30—Historical Dwellings—Van Lerberghe's House—Programme with L. P. Kamms (Reporter), the Radio Orchestra and I.N.R. Choirs.
- 9.30—Variety (contd.).
- 10.0—News.
- 10.10—Brenders Dance Band.
- 10.45-12.0 m.t.—At the Casino—Records. Overture, "Oberon" (Weber). Wine, Woman and Song (Joh. Strauss). Cydalise et le Chevre-pied (Pierne). Turkish March (Mozart). Le plus joli rêve (Arezzo). Neapolitan Nights (Zamecnik). Selection, "Rip" (Planquette). Songs, "The Drum-Major's Daughter" (Offenbach). Aria, "Don Giovanni" (Mozart). Les Préludes (Liszt).

- 7.0—Huybrechts (Pfte.). Prelude and Fugue in G (Beger). Andante and Presto (Mendelssohn). Impromptu (Schubert). Paysage (Liszt). Ballad in A flat (Chopin).
- 7.30—Report: Opening of a Swimming Pool at Antwerp.
- 8.0—Programme from the Royal Flemish Opera, Antwerp. Part I: "Pan" (Schoemaker). Part II: "Vikings" (Meulemans).
- 11.0-12.0 m.t.—Brenders Dance Band.

**BUCHAREST (Romania)**

- 823 kc/s (364.5 m.); 12 kW. Relayed by Radio-Romania 160 kc/s (1,875 m.).
- 4.30-5.30 a.m.—To be announced.
- 11.0—Time; News; Water Level.
- 11.10—Round the World on Records.
- 12.10 p.m.—News; Discour Records.
- 1.0—Topical; Wireless Notes.
- 3.0—For Young People.
- 4.0—Time; Weather; Music.
- 5.0—Tourist Talk.
- 5.15—Folk-Music of the Banat.
- 6.0—Records: Romanian Dance Music.
- 7.0—Letter-box.
- 7.15—Dances by the Radio Salon Orchestra. Conductor: Bobesco.
- 8.30—News; Sports.
- 8.45—Dimitrescu Orchestra.
- 9.45—News (French, German).



Franz Baumann, tenor in Cologne's light-hearted programme at 3 p.m.

**BUDAPEST (No. 1)**

- (Hungary)
- 546 kc/s (549.5 m.); 120 kW. Transmits at intervals from 5.45 a.m.
- 11.5 a.m.—Röbert (Songs) and Maria Kálmán (Violin).
- 11.30—News.
- 11.45—Songs and Violin (contd.).
- 12.30 p.m.—Records.
- 1.40—News.
- 3.15—For Children.
- 4.0—Report from a Factory.
- 4.30—Radice Cigány Band.
- 5.0—Greetings.
- 5.30—Ica Leidenfrost (Songs).
- 6.0—Talk.
- 6.30—Jazz by Adler and Fejér (Pfte.).
- 7.0—"B. Nagy Gergely"—Biographical Play (Vitéz).
- 9.0—News.
- 9.25—Military Band. Conductor: Seregi. March (Seregi). Hungarian Comedy Overture (Kéler-Béla). Excerpts, "The Circus Princess" (Kálmán). Old Hungarian Dance (Seregi). Hungarian Rhapsody (Liszt). March (Lehár).
- 10.30—Szabó Jazz Trio.
- 11.5—News.

**BUDAPEST (No. 2)**

- (Hungary)
- 359.5 kc/s (834.5 m.); 18 kW.
- 4.0 p.m.—Radice Cigány Band.
- 5.30—For Farmers.
- 6.0—Dance Records.
- 7.0—News.
- 7.25—Station Orchestra.

**COLOGNE (Germany)**

- 658 kc/s (455.9 m.); 100 kW.
- 5.0 a.m.—Hymn; For Farmers.
- 5.10—Gym.
- 5.30-7.0—See Berlin.
- 7.0—Announcements.
- 7.10—Gym for Women.
- 7.30—Saarbrücken Orchestra.
- 8.30—Gertrud Maria Kisselbach (Violin) and Grete Schmitz-Nonnenmühlen (Pfte.).
- 8.45—News.
- 9.0—"Richtofen"—Play (Grote).
- 9.30-10.0—For Children.
- 10.40—Talk: The Reich Peasants' Day in Goslar.
- 11.0—See Breslau.
- 12 noon—News; Greetings.
- 12.15 p.m.—See Breslau.
- 1.0—News.
- 1.15—Serenade from Deutschland-sender.

**SATURDAY (November 27)**

- 2.0—Bückmann Recital by Ilse Muhlen (Pfte.) and Grünkorn (Recorder). Romance. Reigen. Andante. Gavotte.
- 2.15—Report from a Domestic Science School at Geldern.
- 2.45—Markets.
- 3.0—Light Music (arr. Hoppe). Hagedstedt Orchestra, Meta Fischer (Soprano), Baumann (Tenor), Kirsch (Baritone), Sternberg (Violin), Küster and Kiermeier Pfte. Duo, Kreisel (Saxophone) and Flamm (Accordion).
- 5.0—Programme Notes.
- 5.5—Hühnerfurst (Bassoon), Zimmermann (Clarinet) and Haass (Pfte.). Bassoon and Pfte.: Adagio (Spohr). Pfte.: Die Vogelpredigt (Liszt). Clarinet and Pfte. Variations (Weber). In the interval, Animal Stories.
- 5.50—Snapshots.
- 6.0—News.
- 6.40—Records.
- 7.10—See Hamburg.
- 9.0—News.
- 9.20—Report from Düsseldorf Women's Swimming Competition—Germany v. Holland.
- 9.35-12.0 m.t.—Dance Music from Berlin.

- 9.30-9.45—For Housewives.
- 10.30—Announcements.
- 10.40—Local News.
- 10.45—For Farmers.
- 11.0—Concert—Station Orchestra. Conductor: Hauck. Coda Wackers (Soprano). Marsch der Flak (Kletzki). Overture, Bagatelle (Rixner). Czardas from "Die Fledermaus" (Joh. Strauss). Black Eyes (Ferraris). Waltz-Intermezzo, Verträumte Nacht (Lohr). Song, "Die Vielgeliebte" (Dostal). Slav Rhapsody (Friedemann). Waltz Song from "The Bird Fancier" (Zeller). Spanische Nächte (Zander). Potpourri, Wir bitten um Gehör (Borchert).
- 12.0 noon—Time; News.
- 12.15 p.m.—See Breslau.
- 1.0—Time; News; Records.
- 2.15—Talk; Markets.
- 2.30—KdF Review—Travel, Sport, Work, Culture.
- 3.0—Freiburg-Frankfurt-Coblenz-Cassel Exchange Programme. Part I (from Freiburg)—Folk Band and Quartet and Fritz Brossmer (Humorous Anecdotes). Part II (from Frankfurt)—KdF Girls' Choir, Village Band, Accordion, etc. Part III (from Coblenz). Folk Band and Mixed Choir. Accordion, etc. Part IV: (from Cassel)—KdF Choral Society, Mandoline Band, etc.
- 5.0—Topical Talks.
- 6.0—Time; News.
- 6.10 (from Freiburg). Military Band. Conductor: Reckmeyer. Hallorenmarsch (Kämpfert). Hunting Fantasia (Schmidt). Jubel-Ouverture (Flotow). Two Marches (Becker). Selection, "William Tell" (Rossini). Kaisermarsch (Wagner).
- 7.0—"An Orchestral Concert"—Humorous Scenes (Witt) with Music by Lothar. Station Orchestras, etc. Conductors: Caspar and Hauck, and Fritz Kullmann (Pfte.).
- 9.0—Time; News.
- 9.30—See Berlin.
- 11.0-12.0 m.t.—Records: Dance and Light Music.

**DEUTSCHLANDSENDER**

- (Germany)
- 191 kc/s (1,571 m.); 60 kW.
- 5.0 a.m.—Chimes; Call; Weather; Records.
- 5.30-7.0—See Berlin; at 6.0—News.
- 8.0-8.40—To be announced.
- 9.0—See Munich.
- 9.30-10.0—For Children.
- 10.15—Weather.
- 10.30—Records; Light Music; Weather.
- 11.0—See Königsberg; at 12.0 noon—Greetings.
- 12.50 p.m.—News.
- 1.0—Serenade by the Merry Musicians.
- 2.0—Weather; Exchange; Programme Notes.
- 2.10—Variety Records.
- 3.0—See Cologne.
- 5.0—Joost Band.
- 5.45—Sports Review.
- 6.0—Motto; News.
- 6.10—"Tea-time Reveries"—Variety. Station Chamber Choir, Chamber Quintet, Hans Harturg (Baritone), and Speakers.
- 7.0—Music and Humour—Variety. Station Orchestra and Choir. Conductor: Thierfelder. Kaiser Dance Band. Schültz and his Merry Village Musicians. Zarah Leander, Carla Spletter, Iska Geri, Jupp Hussels, Willi Schaeffers, Johann Decker, Peter Igelhoff and the Five Belcantos.
- 9.0—News; Sports Notes; Topical Events.
- 9.30—Sittard (Organ). Prelude in E minor (Pachelbel). Organ Choral (Scheidemann). Prelude and Fugue in G minor (Buxtehude).
- 9.45—Weather.
- 10.0-11.55—Dance Music from Berlin.

**FRANKFURT (Germany)**

- 1,195 kc/s (251 m.); 25 kW. Cassel, etc. See Sunday.
- "Kraft durch Freude" Workers' Day.
- 5.0 a.m.—Prelude in F (Bottighier); Motto; Gym.
- 5.30-7.0—See Berlin.
- 7.0—Water Level; Weather; Gym.
- 7.30-8.30—Military Band, Workers' Choir, Accordion.
- 9.0—See Munich.

**HAMBURG (Germany)**

- 904 kc/s (331.9 m.); 100 kW. Bremen, etc. See Sunday.
- 5.10 a.m.—Motto; Weather; Gym.
- 5.20—For Farmers.
- 5.30-7.0—See Berlin; at 6.0—News.
- 7.0-7.20—For Housewives.
- 9.0—See Cologne.
- 9.30—Military Band. In the interval, Talk.
- 10.40—Ice Report.
- 10.45—Shipping; Weather.
- 11.0—Concert for the Fourth Anniversary of the "Kraft durch Freude" Society. Station Orchestra. Conductor: Röder. Jakschat (Bass-Baritone). Overture, "Euryanthe" (Weber). Drinking Song from "Der Freischütz" (Weber). Entr'acte, "Rosamunde" (Schubert). Overture, "The Flying Dutchman" (Wagner). Aria, "The Mastersingers" (Wagner). Festival March (Lürman). Song: Kleiner Haushalt (Loewe). Aquarellen-Walzer (Jos. Strauss).
- 12.0 noon—Weather; Review.
- 12.15 p.m.—See Breslau.
- 1.0—News.
- 1.15—Music.
- 2.0—Shipping.
- 2.20—Gregor (Organ).
- 2.50—Ice Report.
- 3.0—See Cologne.
- 5.0—Ex-Servicemen's Meeting at Hildesheim.
- 5.25—Records: Naval Marches.
- 5.50—Weather; News.
- 6.10—Report: Rügen—the KdF Holiday Resort.
- 6.40—Records: Songs of Work.
- 6.55—Press Review.
- 7.10 (from Bremen)—Festival Concert for the Fourth Anniversary of the "Kraft durch Freude" Society, from Oldenburg. Station Dance Band. Conductor: Hoffmann. Oldenburg Orchestra. Conductor: Schweppe. Lea Pitti (Coloratura—Soprano). Groh (Tenor). Jakschat (Bass-Baritone). Grothey (Accordion). Overture, "Semiramis" (Rossini). Coloratura-Soprano: (a) Aria, "Lakmé" (Delibes), (b) Waltz, "Mirella" (Gounod). Selection, "The Cousin from Nowhere" (Künneke). Tenor Songs from "The Cousin from Nowhere" (Künneke), "Die Vielgeliebte" (Dostal) and

SATURDAY (November 27)

"Eine Nacht in Venedig" (Joh. Strauss). Overture, "Der Wildschütz" (Lortzing). Accordion: Czardas, Hejre Roszika (Grothey). Accordion and Dance Band: Spatzen-Polka (Grothey). Baritone and Orchestra: (a) Heinrich der Vogler (Loewe), (b) Aria, "Der Wildschütz" (Lortzing). Two Foxtrots. Tenor and Dance Band; (a) Nur du, Maria, from "Ave Maria" (de Curtis), (b) Für dich allein (Geehl), (c) Song from "Der Opernball" (Heuberger). Gallop, "Leichtes Blut" (Joh. Strauss). Perpetuum mobile (Joh. Strauss). Coloratura-Soprano and Orchestra: The Blue Danube (Joh. Strauss). Pasodoble: Don Quichote (Mohr). Foxtrot, Zu zwein (Kötscher). Baritone and Accordion: Songs of the Wasserkante. March (Mackeben).

HILVERSUM (1,875 m.) (Holland) 160 kc/s; 10 kW until 2.40 p.m.; 150 kW from 2.40 p.m. KRO Programme. 7.40-8.55 a.m.—Records. 9.40—Records. 11.10—Religious Address. 11.40—News. 11.55—KRO Orchestra, Conductor: van 't Woud. 12.40 p.m.—Records; KRO Orchestra (contd.). 1.40—For Young People. 2.10—KRO Orchestra (contd.). 2.45—For Children. 3.45—KRO Melodists, Conductor: Lustenhouwer, Klein (Refrains). 4.25—Records; KRO Melodists (contd.). 5.10—Records. 5.25—KRO Children's Choir. 5.55—Records; Press Review; News; Talk. 7.15—Review; News. 8.10—Programme by the Liberal Democratic Union. 9.40—Variety. 10.40—News; Sports; Review. 11.5-11.40—Records.

HILVERSUM (301.5 m.) (Holland) 995 kc/s; 15 kW until 6.10 p.m.; 60 kW from 6.10 p.m. VARA Programme. 7.40 a.m.—Records. 9.40—VPRO Religious Programme. 10.0—"Fantasia," Conductor: Walis; Records. 11.40 a.m.—1.25 p.m.—Records. 1.40—Talk. 2.10—Records. 2.25—Amateurs' Programme. 2.55—Educational. 3.10—Records. 4.25—Esperanto Programme. 4.40—Records. 5.10—Talk. 5.40—Steyn (Organ). 6.10—"De Wielewaal" Choir, Conductor: Tiggers. 6.40—A Film. 7.10—VPRO Talk. 7.40—News. 7.55—"Souvenirs" Orchestra. Conductor: de Groot, VARA Children's Choir; Dramatic Ensemble, etc.; Play. 8.55—"Ramblers," Conductor: Masman, Brookhouse McCarthy (Pfte.), etc. 10.10—News. 10.25—Block (Bass-Baritone) and Jong (Organ).

KALUNDBORG (Denmark) 240 kc/s (1,250 m.); 60 kW. Relays Copenhagen, 1,176 kc/s (255.1 m.). 6.0 a.m.—Gym. 7.30—Service from Copenhagen Cathedral. 9.58—Weather. 10.10—Fish Markets. 10.45—Gym. 11.0 a.m.—1.0 p.m.—Preil's Ensemble. 1.15—Gym. for Schools. 1.35—Radio Orchestra, Conductor: Tuxen. Hedvig Jensen (Songs). Excerpts, "A Night in Venice" (Strauss). Excerpts, "Faust" (Gounod). Paris March (Ganne). Songs (Lange-Müller, Heise). Overture, "La Princesse de Trébizonde" (Offenbach). Excerpts, "Viel Lärm um Nichts" (Korngold). Scandinavian Suite (Juel-Frederiksen). Excerpts, "The Circus Princess" (Kaiman). Ex-

cerpts, "Der arme Jonathan" (Millöcker). 3.30-3.50—For Children. 4.0—Talk. 4.25—Weather. 4.40—Exchange; Markets. 4.50—Records. 5.15—Talk. 5.35—French Lesson. 6.0—News. 6.30—Discussion: Meat Prices. 7.0—Prague String Quartet. Quartet (Janáček). Quartet in A flat (Dvořák). 7.45—Talk: Bananas. 8.15—Jutland Songs (Agerby) by Else Jena, the Composer at the Pfte. 8.35—"Africa Sings"—Clara Rosenberg (Negro Songs). Introduction by P. A. Rosenberg. Life (Dunbar). The Mask Bearers (Dunbar). Grass fingers (Grimké). Paradox (Grimké). The Negress' Tale (Johnson). April Day (Cotter). To my White Brother (Cotter). Arabesque (Horne). I am a Nigger (Hughes). Chance (Cullen). No Picture (Cuncy). The River (Weeden). 9.0—News. 9.20—Dance Music. Radio Orchestra, Conductor: Grondahl. Radezky March (Strauss). Waltz, Die Romantiker (Lanner). Polka (Waldteufel). Française. Waltz, Wo die Zitronen blüh'n (Strauss). Helga Mazurka (Lumbye). Quadrille, "The Gipsy Baron" (Strauss). Waltz and Gallop (Lumbye). 10.0—Preil's Dance Band. 11.15-12.0 m.t.—Kaiser Band and Raatzke Quintet from Berlin.

KÖNIGSBERG (Heilsberg) (Germany) 1,031 kc/s (291 m.); 100 kW. Relayed by Danzig, 1,303 kc/s (230.2 m.). 5.0 a.m.—Weather; Records; Gym. 5.30-7.0—See Berlin. 7.0—Prayers. 7.15—Gym. 7.30-8.30—Saarbrücken Orchestra. 9.0-9.30—See Cologne. 9.45—Weather. 10.35—Talk: Town and Country. 10.50—Markets; Weather. 11.0—Concert for the Fourth Anniversary of the "Kraft durch Freude" Workers' Society. Station Orchestra. Conductor: von Sosen, Irmgard Armgart (Soprano) and Roth (Bass). Overture, "Sicilian Vespers" (Verdi). Arias, "Don Carlos" (Verdi) and "La Bohème" (Puccini). Minuet (Bolzoni). Prelude to Act III, "A basso porto" (Spinelli). Viennese Suite (Pachernegg). Rhapsody (Dvořák). Ballet Suite, "La Source" (Delibes). Arias, "Tar and Carpenter" (Lortzing) and "Der Waffenschmid" (Lortzing). German Folk Song Fantasia (Blumer). Suite, Esmeralda (Drigo). Austrian Peasant March (Schönherr); at 12.0 noon—News. 1.0 p.m.—News; Anniversaries. 1.15—Tücki and Peter at the Cinema. 1.55-2.0—Exchange. 2.30—Technical Review. 2.45—Guessing Competition. 3.0—Concert for the Fourth Anniversary of the "Kraft durch Freude" Workers' Society. Station Orchestras. Conductors: Brückner and Wilken. Börschel and Freundorfer Bands. KdF Choral Society. Conductor: Groke. Hitler Youth Choir. 5.0—Talk: KdF Gymnastics. 5.15—French Opera Records. Overture, "Raymond" (Thomas). Aria, "Mignon" (Thomas). Excerpts, "Carmen" (Bizet). Overture, "The Hermit's Bell" (Maillart). Selection, "Fra Diavolo" (Auber). 5.50—Announcements; News. 6.10—Peter Arco and Records. 6.45—Topical Report. 7.0—"Weinreise auf dem Pegasus"—Sequence (Pempelfort) with the Station Orchestra. Conductor: Kaestner. 9.0—News; Sports Notes. 9.40-11.0—Dance Music from Munich.

LAHTI (Finland) 166 kc/s (1,807 m.); 150 kW. Relayed by Helsinki, 895 kc/s (335.2 m.). Transmits at intervals from 6.5 a.m. 3.0 p.m.—Records. 4.0—For Children. 4.20—Toivo Maninen (Accordion). 4.40—Recitation. 4.50—News (Finnish, Swedish). 5.15—Talk. 5.35—Kalle Acker (Clarinet). 5.55—Interview. 6.20—Concert—Radio Orchestra. Conductor: Linko. Popular Songs, etc. 7.45—News (Finnish, Swedish). 8.10-10.0—Dance Music.

LEIPZIG (Germany) 785 kc/s (382.2 m.); 120 kW. Relayed by Dresden, 1,285 kc/s (233.5 m.). 5.0-7.0 a.m.—See Berlin. 7.0—Gym. 7.20—Krämer (Violin) and Burger (Pfte.). 7.30-8.30—Saarbrücken Orchestra. 9.0—See Cologne. 9.30-9.45—Weather; Programme Notes. 10.15—Talk: Production and Consumption. 10.35—Anniversaries. 10.40—Report: The Reich Peasant Day in Goslar. 11.0—Magdeburg School of Aviation Band. 12.0 noon—News. 12.15 p.m.—See Breslau. 1.0—News; Exchange. 1.10—Concert—Fuchs Band, Elisabeth Meinel (Soprano), Göpelt (Baritone), Grundeis (Pfte.). 2.20—Christmas Gift Competition. 2.50—Weather; Markets. 3.0—See Cologne. 3.0—A Modern Dictionary. 5.15 (from Dresden)—Songs from the KdF Song Book by a Dresden KdF Choir. Wir sind des Werktags Soldaten (Buder). Horch, es klingt der Glocke Ton. Aus grauer Städte Mauern. Ein Jäger in dem grünen Wald. Im März der Bauer. Ei, wie töricht. Glück auf, Glück auf. Lustig ist das Hirtenleben. Wer will mit uns nach Island gehn. Wir tragen und bauen das Reich. 5.50—Evening Review. 6.0—News; Dance Records. 6.30—Report: The Christmas Exhibition of Erzgebirg Peasant Art at Schwarzenberg. 7.0—Concert for the Fourth Anniversary of the "Kraft durch Freude" Workers' Society. Part I: (from Weimar)—Military Bands and Chorus. Conductors: Teuber, Schröder and Lasch. Part II: (from Plauen)—Berlin and Dresden Opera Singers, Rhine Singers, Workers' Bands and Choirs, Folk Ensembles, etc. Part III: (from Halle)—Excerpts from the Festival Concert of November 26th. Municipal Orchestra, etc. Conductor: Kraus. 9.0—News. 9.30-11.0—Dance Music from Munich.

LILLE (Radio PTT Nord) (France) 1,213 kc/s (247.3 m.); 60 kW. Transmits at intervals from 6.30 a.m. 4.0 p.m.—Jazz by Dehette and Duchêne. 5.0—Records. Poème (Chausson) by Enesco (Violin). 5.15—Talk. 5.45—Demon (Tenor). 6.0—Talk: Photography. 6.7—Records. 6.20—For Housewives. 6.30—Records. 7.0—For English Listeners. 7.15—Record; Sports. 7.30—News. 8.0—Max Cléry. 8.30—"Le Favori"—Play (Piechaud) from the Odéon, Paris. After the Play, News.

LYONS (PTT) (France) 648 kc/s (463 m.); 100 kW. Transmits at intervals from 6.30 a.m. 7.0 p.m.—Records. 7.30—News. 8.0—Surprise Programme. 8.30-10.30—See Paris (Eiffel Tower). 10.30—News (French, German). 11.0—Dance Music.

MONTE CENERI (Switzerland) 1,167 kc/s (257.1 m.); 15 kW. 11.0 a.m.—Records. 11.29—Time; News. 11.40 a.m.—12.30 p.m.—Records: Light Music. 4.0—Serenades and Gavottes—Radio Orchestra. Conductor: Herschel. Serenade, Sotto le tue finestre (Catalani). Gavotta pizzicata (Cerrri). Catalan Serenade (Niemann). Aubade pizzicato (Schnéklud). Gavotte (Sgambati). Sérénade lointaine (Filippucci). 4.20—Francesco Chiesa reads his own Poems. 4.30—Enzo Fusco and Giglio (Folk

Duets to the Guitar). La Romanina (Micheli-Di Lazzaro). Nuttata 'e sentimento (Capolongo). Waltz Gioventù (Marf-Mascheroni). Maremaro senz'amore (Bonavolontà). Il valzer delle campagne (Rusconi). Maria Marl (Di Capua). Funiculi Funiculà (Denza). 5.0—For Children. 5.30—Carla Badaracco (Pfte.). Bourrée (Bach-Saint-Saëns). Plenilunio sulla laguna (Pozzoli). Death of Isolde (Wagner-Liszt). Seguidillas (Albeniz). 5.45—English Lesson. 6.0—Records. 6.45—News. 7.0—Records of Famous Guitar-Players. 7.15—Talk. 7.30—Anna Anzilotti and Aldo Masseglia (Songs). Barcarolle, Santa Lucia (Cottrau). Duet: Fili d'oro (Capurro-Buongiovanni). Ciriibirin (Pestalozza). Duet: Stormelli montagnoli (Gill-Mazzucchi). 7.45—Talk: Humour of Fifty Years ago. 7.55—Anna Anzilotti and Aldo Masseglia (Songs). Lasciami sognare (Bracchi-d'Anzi). Voglio cantar l'amore (Bracchi-d'Anzi). Non partir (d'Anzi). Place a te? (Bracchi-d'Anzi). Buona notte amore (Bertini-Kramer). 8.10—"An Unforgettable Train Journey"—Sketch (Lichtenberg). 8.30—Radio Orchestra. Conductor: Herschel. Burlesque Overture (Méhul). Dreamland (Rust). March (Sinding). Momento (Flament). Dance (Schmitt). 8.45-9.15—Dance Records.

MOSCOW (No. 1) (Russia) 172 kc/s (1,744 m.); 500 kW. 12.0 noon—Dutch Programme. 4.30 p.m.—Music. 5.0—Literary Programme. 5.30—Concerts. 9.0—French Programme. 10.0-12.0 m.t.—Spanish Programme.

MUNICH (Germany) 740 kc/s (405.4 m.); 100 kW. Relayed by Nürnberg, 1,267 kc/s (236.8 m.). 5.0 a.m.—Motto; Weather; Gym. 5.30-7.0—See Berlin. 7.0—Motto; Gym. 7.30-8.30—Light Orchestral. 9.0-9.30—"Munich"—Scenes (Schröder-Justin). 10.0—Markets; Rosenberger Quartet; Talk; News. 11.0 (from Nürnberg)—Concert. 12.0 noon—News. 12.15 p.m.—Records. Overture, "The Lovely Galathea" (Suppé); Selection, "Die Puppenfee" (Bayer). Ballet égyptien (Luigini). Ballszene (Helmesberger). Waltz, Die Schönbrunner (Lanner). Geschwindmarsch (Jos. Strauss). 1.0—News; Exchange. 1.15—Sports Notes. 1.25—Records: Light Music. 2.40—Reading. 3.0—See Cologne. 5.0—Time; Weather; Markets. 5.10—Heinrich Scherrer Commemoration Programme—Helga Thorn, Oskar Besemfelder and Erich Burger (Songs to the Lute). 5.45—Topical Talk. 6.0—News. 6.10—Concert—Station Schrammel Ensemble, Lale Wilke (Songs of the Waterkant), Fred Kurt (Songs), Laci and Tibi (Music Parodies), and Hans Löschner (Speaker). 7.0 (from Nürnberg)—Variety. 9.0—Time; News. 9.20-11.0—Dance Music—Station Dance Band. Conductor: Michalski. Kristin Hilsdorf and Lore Schoeberger (Songs), and Mischa Ignatjeff (Balalaika).

NAPLES GROUP (Italy) Naples, 1,104 kc/s (271.7 m.); 10 kW. Florence (No. 1), etc. See Sunday. 6.0 p.m.—Light Music. 6.15—Topical. 6.25—Accordion and Guitar Trio. 7.0—Time; News. 7.20—Talk. 7.30—"Colibri" (Montanari). 9.30—Dance Music. 10.0—News. 10.15-10.55—Dance Music.

OSLO (Norway) 260 kc/s (1,153.8 m.); 60 kW. Fredrikstad, etc. See Sunday. Transmits at intervals from 10.40 a.m. 3.0 p.m.—Records. 3.45—Reading. 3.50—Hauger Dance Band. 4.50—For Children. 5.30—Economics. 5.50—News and Announcements.

6.30—Marches and Waltzes by the Station Orchestra. Conductor: Kramm. 7.0—Talks. 7.40—Orchestra (contd.). 8.5—Reading. 8.20—Old Dance Music. 8.40—News. 9.0—Topical Talk. 9.15-10.0—Dance Records.

PARIS (Eiffel Tower) (France) 1,456 kc/s (206 m.); 7 kW. Transmits at intervals from 6.30 a.m. 8.0 p.m.—Lise Daniels (Songs): Hélène Pignari (Pfte.). 8.30—Acts III and IV, "L'Argent" (Emile Fabre) with Introducing Talk by Irène Nemirowski. 9.10—"France in Song." 9.50—Symphony Orchestra, Conductor: Tomasi. Ballet, "Le Cid" (Massenet). Phaëton (Saint-Saëns). Overture, "The Black Domino" (Auber). Ballet Music, "Le roi s'amuse" (Delibes). 10.30—Records. 11.0-11.15—News.

PARIS (Poste Parisien) (France) 959 kc/s (312.8 m.); 60 kW. 7.10 a.m.—Fanfare; Records. 7.30—News; Records. 8.10—Menus; Records. 8.30—News; Records. 9.0—Records. 12.0 noon—Exchange; Records. 1.15—Amusements; Records. 1.30—Exchange; Records. 1.50—Interlude. 1.55—News. 2.0—Records; Talk. 2.20—Bridge Lesson. 2.35—Records. 3.0—Music-Hall. 4.35—Exchange. 6.0—Exchange. 6.10—Roman Catholic Programme. 6.30—For Farmers. 6.31—For Children. 6.58—Racing Results. 7.0—Foreign Press Review. 7.10—Sports Notes. 7.15—Amusement; Records. 8.0—News; Record. 8.15—Max Regnier and his Company. 8.45—La bonne histoire. 9.0—News. 9.10—Aspects of France—Women—presented by Roger François. 9.25—Willie Lewis Orchestra. 9.55—News. 10.5—Dance Music. 10.30-11.0—Ray Ventura and his Orchestra.

PARIS (PTT) (France) 695 kc/s (431.7 m.); 120 kW. Transmits at intervals from 6.30 a.m. 11.45 a.m.—Goldy Orchestra; Jean Sorbier (Tenor). 12.45 p.m.—News. 1.0—Goldy Orchestra (contd.). 1.45—Tourist Review. 2.0—Theatre Review. 2.30—Concert for Hospitals. Raiter Orchestra, Boris Zadri (Pfte.), Mme Rose-Monde (Songs); Mme Berthe d'Yd, Mme Valnys, Mme Bonelli and Paul Castan. Pfte.: (a) Toccata (Ravel), (b) Au bord d'une source (Liszt). Three Songs, "Le Vilain et l'oiselet"—Fable. Orchestra. 3.30—Literary Talk. 3.50—Art Talk. 4.0—Talk: Aviation. 4.15—Lucienne Astruc (Songs). 4.30—Records. 5.0—Colonne Concert. Uninsky (Pfte.) Overture, "Manfred" (Schumann). Pfte. Concerto in A (Liszt). El amor brujo (Fallá). Eroica Symphony (Beethoven). 7.0—News. 7.0—Variety with Marie Bizet and Jean Rieux. 8.50-10.30—Soirée tournante. 8.30—Symphony Orchestra, Conductor: Tomasi. Overture, "Figaro" (Mozart). Suite, Namouna (Lalo). Izeyl (Pierné). Au Village (Mouquet). 9.10—Act III, "L'argent n'a pas d'odeur" (Bernard Shaw, French Translation by Augustin and Henriette Hamon). 9.50—"France in Song." 10.30—News. 10.45—Records. Ländler (Schubert). Lettre d'amour (Hahn). Le chien fidèle (Hahn). 11.0 p.m.—1.0 a.m. (Sunday)—Dance Music.

PARIS (Radio-Paris) (France) 182 kc/s (1,648 m.); 80 kW. 6.28 a.m.—Programme Notes; Records. 6.40—News; Press Review. 6.50—Gym; Records.

SATURDAY (November 27)

7.15—Weather; Records.  
8.0—News; Records.  
9.30—Conservatoire Concert, Symphony (Haydn). Pfte. Concerto (Mozart). Fête polonaise (Cherrier).  
11.30—Records.  
11.45—Markets.  
12.0 noon—Mlle Bailly-Talazac (Pfte.).  
12.15 p.m.—Giardino Orchestra.  
1.0—Time; News.  
1.15—Giardino Orchestra (contd.).  
1.30—Canadian Songs (Vuillemoz) by Lucien Verroust.  
1.45—Giardino Orchestra (contd.).  
1.52—Programme Notes.  
2.0—Educational Programme.  
2.30—Exchange; Markets.  
2.45—Talk: Cochon China.  
3.0—Louise Bury (Schumann, Balakirev, Beysids and Leroux Songs).  
3.15—Literary Review.  
3.30—Talk on Aviation.  
3.45—Songs of Auvergne by Nadia de Cléry.  
4.0—Talk; Reading.  
4.20—Talk: America.  
4.35—Talk: Cuckoo.  
4.50—Exchange; Markets.  
5.0—For Children.  
5.45—Song Records.  
6.0—Dramatic Programme.  
6.30—Review by Haurigot.  
6.40—Theatre Review; Racing.  
7.0—Educational Programme.  
7.30—Talk: Dancing Displays.  
7.40—Theatre Reminiscences.  
7.45—Literary Talk.  
7.53—Programme Notes.  
8.0—Political Review.  
8.15—Records (Liszt, Bazzini, Popper).  
8.30—"The Pearl Fishers" (Bizet), from the Opéra-Comique. In the intervals, News; Review.  
11.45 p.m.—1.0 a.m. (Sunday)—Bouillon Dance Band.

PRAGUE (Czechoslovakia)

638 kc/s (470.2 m.); 120 kW. Transmits at intervals from 5.15 a.m.  
12.30 p.m.—Industrial Review.  
12.40—Records.  
12.50—Exchange.  
12.55—Exchange (German).  
1.0-1.20—German Transmission: "Millionth Girl"—Play (Fuchs).  
2.20—Concert from Kosice.  
3.50—See Brno.  
4.35—For Farmers.  
4.45—For Workers.  
4.55—German Transmission: "Peasant War"—Play (Franz Hauptmann).  
5.45—News (German).  
6.0—News.  
6.20—See Brno.  
6.40—Talk: Etiquette.  
7.0—"Tsar and Carpenter" (Lortzing). Conductor: Parik.  
9.0—Time; News.  
9.15—Records.  
9.30-10.30—Dance Music by Dvorak and his Melody Boys from the Lucerna Café.

RADIO-MEDITERRANÉE (France)

1,276 kc/s (235.1 m.); 27 kW. Transmits at intervals from 12.15 p.m.  
7.0 p.m.—Talk.  
7.15—Variety.  
7.25—Amusement Guide.  
7.30—Request Programme.  
8.0—News; Exchange.  
8.15—Light Musical.  
8.25—Variety.  
8.40—Records: Light Music.  
9.0—Talk.  
9.10—Variety.  
10.0—News.  
10.15—Dance Music.

RADIO-NORMANDIE (France)

1,113 kc/s (269.5 m.); 15 kW.  
6.45 a.m.—Band; Records.  
7.15—News; Topical.  
8.0—Light Musical.  
9.30—Records.  
10.15—Light Musical.  
11.0—Records.  
11.30—Chansonnettes.  
12.0 noon—Artists of the Folies-Bergère, Le Havre.  
12.45 p.m.—News; Topical.  
1.0—Light Musical.  
1.40—Trailer of Next Week's Programmes.  
2.0—Records.  
2.45—Light Musical.  
3.15—Film Fantasy.  
3.30—Light Musical.  
4.0—Records.  
4.15—Light Musical.  
5.30—Records.  
6.0—Children's Corner.  
6.45—News; Racing.  
7.0—Lottery Results.  
7.25—News; Topical.  
7.45—Trailer of Next Week's Programmes.  
8.0—Records.  
8.20—Light Musical.

8.40—"Désabillez-vous" (Yvain) from the Théâtre Français, Rouen.  
11.55—News.  
12.0 m't.—Midnight Melodies.  
12.30 a.m. (Sunday)—Records.  
12.45—Light Music.  
1.0-2.0—Dance Music.

REYKJAVIK (Iceland)

208 kc/s (1,442 m.); 16 kW.  
11.0 a.m.—Weather (Icelandic, English, German).  
1.0 p.m.—Music and News.  
4.0—Weather.  
8.10—Weather (Icelandic, German, English).  
8.20—Parliamentary Notes.  
8.55—Announcements.  
9.0—Time; News.  
9.30—Dramatic.  
10.0—Choir.  
10.25—Radio Orchestra.  
11.0 p.m.—1.0 a.m. (Sunday)—Dance Music.

ROME GROUP (Italy)

Rome (No. 1), 713 kc/s (420.8 m.); 50 kW. Bari (No. 1), etc. See Sunday.  
6.45 a.m.—Gym.  
7.0-7.20—Time; News.  
9.30-10.0—For Schools.  
10.30—See Turin.  
11.30—Sports Notes.  
11.40—Light Music. Conductor: Mancini. Overture, "Le Cheval de bronze" (Auber). Japanese Dance (Goublier). Prelude, "I Ranzau" (Mascagni). Suite, "La figlia di Jorio" (Franchetti). Dance (Friml). Parole gaie (Allietti).  
12.0 noon—News.  
12.15 p.m.—"From A to Z"—Musical Encyclopaedia (Marchesi).  
12.40—A Film.  
12.50—Announcements.  
1.0—News.  
1.20-2.0—News; Violin; Talk.  
3.40—For Children.  
4.0—News.  
4.15—Dance Music.  
4.55—Talk for Workers.  
5.10—Rural Programme.  
5.50—Doplovarov Notes.  
6.0—Talk in Esperanto; Notes.  
6.25—News (English, French).  
7.0—News.  
7.20—Talk.  
7.30—Light Music.  
8.0—"Ginevra degli Almieri" (Perugino) from the Teatro Comunale, Bologna. Conductor: Del Campa. Cast: Augusta Oltrabella, Luigi Boronovo, Emilio Venturini, Ilde Reggiani, Corrado Zambelli, Giuseppe Nesi, Alessandro Ziliani, Domenico Malatesta, Aristide Baracchi, and Dario Caselli. In the intervals, Talk; Notes. After the Opera, News.

SOTTENS (Switzerland)

677 kc/s (443.1 m.); 100 kW. Relayed by Geneva, 401 kc/s (748 m.).  
11.29 a.m.—Time; News; Records.  
12.0 noon—Talk: Ski-ing.  
12.10 p.m.—Variety Records.  
12.30—Records of Yehudi Menuhin. Rigaudon (Monsigny). Allegro (Flocco). Perpetuum mobile (Novacek).  
12.40-1.0—Slav Rhapsody (Dvořák).  
3.50—Time.  
4.0-5.0—See Monte Cenri.  
5.0—Cathedral Chimes.  
5.10—For Children.  
5.40—Records.  
6.0—Talk: Albania.  
6.10—Anecdotes and Recitations.  
6.20—Topical Talk.  
6.30—Music.  
6.50—News.  
7.0—"Friends"—One-Act Play (Dorly) by the "Deux Masques" Players.  
7.45—Radio Suisse romande Orchestra. Conductor: Appia. Irène Hertig (Pfte.). Toccata in C (Bach-Weinert). Symphony in B flat (Haydn). Suite, "Pelléas et Mélisande" (Fauré). Quand l'éte dore la moisson (Dénéfraz). Pfte. and Orchestra: Ballad (Blanchet-Schelling).  
9.5-10.4—Weber Dance Band from the Casino de Montbenon.

STOCKHOLM (Sweden)

704 kc/s (426.1 m.); 55 kW. Motala, etc. See Sunday. Transmits at intervals from 6.20 a.m.  
11.25 a.m.—Einar Groth's Schrammel Quartet.  
11.50—Exchange; Markets.  
12.0 noon—Skoglöf Wind Band.  
1.0 p.m.—Reading.  
1.30—Osterberg Orchestra.  
2.25—For Children.

3.0 (from Göteborg)—Wolf (Violin), Helligren (Songs). Violin: Suite in E (Bach). Songs (Kilpinen, Rangström).  
3.30—Reading (Jules Verne).  
4.5—Records.  
5.0—Talk.  
5.30—Nonne Hall (Songs). Det var dans bort i vägen (Lambert). Min första flamma (Körling). Tess lördan (Richnau). Jeremias i Tröstlösa (Richnau). Cradle Song (Mozart). My curly-headed Baby (Clutsam).  
5.45—Sketch.  
6.0—News.  
6.30—Old Dances by Sköld's Band.  
7.0—Talk: Swedish Excavations in Greece.  
7.30—Records: Famous Tenors.  
7.55—Talk.  
8.15—Ship Ahoy!—Swedish Sailor Songs with Karin Juel, Brandelius, the Seven Singing Sailor Boys, an Accordion Band, etc. (Recorded).  
8.45—News.  
9.0-10.0 (from Göteborg)—Fagerlund Dance Band.

STRASBOURG (France)

859 kc/s (349.2 m.); 100 kW. Transmits at intervals from 6.30 a.m.  
1.0 p.m.—Light Orchestral. Conductor: Bour. Grégoire (Violin) and Roskam ("Cello").  
1.45—Economics and Social Notes.  
5.0—See Paris (PTT).  
7.0—News.  
7.30—Songs by the Petits chanteurs de Hochstatt.  
8.0—News (German).  
8.15—News; Sports.  
8.30—Concert from the Palais de Fêtes. Radio Orchestra. Conductor: de Villers, Concordia Argentina Choir, Louise Debonte (Contralto) and Doyen (Pfte.). Overture, "The Flying Dutchman" (Wagner). Choir: Tousse-saint (Pastor). Aria, "Titus" (Mozart). Pfte. and Orchestra: Symphonic Poem (Pierné). Choir and Orchestra: Les fantômes de la nuit (Noudier). Choir: Sérénade d'hiver (Saint-Saëns). Four French Ballads (Gaubert). Pfte. Concerto in F minor (Chopin). Chorale Fantasia, Malborough (Commattant). Fête polonaise (Chabrier).  
10.30—News (French, German).  
11.0—Dance Music.

The Beethoven House in the Eroica Gasse Vienna: the "Eroica" is to be played at Paris (PTT) at 5 p.m. to-day; Vienna gave it on Wednesday evening



STUTTART (Germany)

574 kc/s (522.6 m.); 100 kW.  
5.0 a.m.—Hymn; For Farmers; Gym.  
5.30-7.0—See Berlin.  
7.0-7.30—See Frankfurt.  
7.30-8.30—Music from Baden.  
9.0-9.30—See Cologne.  
10.30—Folk Music; For Farmers.  
11.0—Workers' Concert.  
12.0 noon—Time; News.  
12.15 p.m.—Concert.  
1.0—See Deutschlandsender.  
2.0—Light Music from Mannheim—Melo Trio and The Merry Five (Songs).  
3.0—Variety Concert for the Fourth Anniversary of the "Kraft durch Freude" Workers' Society. Station Orchestra, Conductor: Bara. Rehfeld and Peasant Bands, KdF Dramatic Ensembles, Else Wagner (Songs) and Sisy von Barany (Violin). Overture, Bagatelle (Rixner). Two Guitars (Ferraris). Ständchen (Krebs). Spanish Serenade (de Micheli). El Relicario (Padilla). Dramatic Programme. Humoresque (Krebs). Allotria (Mahr). March (Hermann). Polka, Neckerei (Thaler). "Eulenspiegelchen"—Two Scenes (Halm). March (Mönch). Black Forest Ländler (Hermann). March (Oscheit). Waltz, Am

Isarbrücklein (Frantzen). Songs: (a) Der alte Marabu (Ruch), (b) Der Jäger aus Kurpalz, (c) Katzenliebe (Wagner-Mannheim). Violin: (a) Czardas Scene (Hubay), (b) Hungarian Fantasia (Mikus-Gsakk), (c) Zigeunerweisen (Sarasate). Wir tanzen gerne Polka (Hermann). Folk Dance. Bäure hat d'Katz verlore (arr. Mönch). Folk Song, Allerhand aus dem Schwabenland (arr. Schneider). Schwäbisches Hutzlebrot—Cabaret (Mayer-Nass-Kienk). Swabian Dances (Urbach). March, Auf Wiederhören (Hermann).  
5.0—Sound News.  
6.0—News.  
6.10—See Hamburg.  
6.40—Talk: The KdF Workers' Trip to Italy.  
7.0—Stuttgart-Karlsruhe-Mannheim Exchange Programme.  
9.0—Time; News.  
9.30—Operetta, Film, Cabaret and Dance Records.  
11.0-12.0 m't.—See Frankfurt.

TOULOUSE (Radio-Toulouse) (France)

913 kc/s (328.6 m.); 60 kW. Transmits at intervals from 8.0 a.m.  
12.0 noon—News.  
12.30 p.m.—Salon Orchestra.  
12.45—Light Music.  
1.15—"Guitars"—Fantasy.  
1.45—Marches.  
2.0-2.5—News.  
4.30—English Concert.  
6.40—Orchestra.  
6.55—News; Sports.  
7.15—Light Musical.  
8.0—Songs.  
8.30—Excerpts, "Deux de la Légion" (Scotto).  
8.45—Operetta Music. Excerpts, "The Dance of the Dragonflies" (Lehar), "La Gran Via" (Valverde), "The Gipsy Princess" (Kálmán), "Ballo Sieba" (Marenco), "Cin-ci-la" (Ranzato).  
9.10—Light Musical.  
10.0—News.  
10.15—English Concert.  
11.15—Light Musical.  
11.50-12.0 m't.—News.

Célèbre valse lente (Chopin). Spanish Caprice (Rimsky-Korsakov). Waltz, Freudengrüsse (Jos. Strauss). Hawaiian Guitar: American Fantasia (Mikulas).  
12.0 noon—News.  
12.10 p.m.—Orchestra (contd.). Overture, Hella (Pauspert). Waltz, Kärntner Madln (Kreutzberger). Selection, "The Land of Smiles" (Lehar). Saxophone: Concert Polka. Barli tanzt (Mosheimer). Potpourri, Allerhand vom Donaustrand (Kemeter). Tango, Für dichsing ich das schönste Lied (Krimps). Vineta-Step (Kaempfer).  
1.0—Records of George Thill (Tenor). Arias, "The Damnation of Faust" (Berlioz), "Werther" (Massenet) and Hérodiade (Massenet). Ständchen (R. Strauss). Heimliche Aufforderung (R. Strauss). Song (Coates). Songs (Lehar): (a) Dein ist mein ganzes Herz, (b) Du bist meine Sonne. Wine, Woman and Song (Joh. Strauss).  
1.30—Announcements.  
2.0—Time; Weather; Lottery Results; Markets.  
2.15—Vienna Teachers' A-capella Choir. Choir master: Reinhold Schmid. Songs (Schubert): (a) Nur wer die Sehnsucht kennt, (b) Liebe, (c) Mondenschein. Der Tod im Schacht (Czajkner). Über den Feldweg (Förster). Der schwarze Reiter (Kössner). Glück auf (Miessner). O Diandl, tief drunt' im Tal (Herbeck). Mädle, ruckruck (Plätzneder). Lippitzbach (Herbeck). Morgen marschieren wir (Eggermann).  
3.0—News; Exchange.  
3.5—Talk in Italian: Costantino, Primo Cesare cristiano.  
3.25—Records.  
4.45—Reading (Aul).  
5.10—Talk: Old Vienna.  
5.20—Folk Songs and Chamber Music by Karl Klier and Viktor Korda from the Concert House.  
6.0—Time; News.  
6.10—Film Talk.  
6.30—"Eva" (Lehar) by the Station Orchestra and Mixed Choir, etc. Conductor: Holzer.  
8.45—Grieg Pfte. Recital by Cornelius Czarniawski. Ballad in G minor. Lyric Pieces: (a) Norwegian Peasant March, (b) Butterfly, (c) March of the Dwarfs, (d) Shepherd Boy. Peasant Dances.  
9.10—News.  
9.20—Pfeffer Band. Muzik (Bugle Horn). March (Jarosch). Waltz, Wiener Grazien (Freisler). Bugle-horn Fantasia: Mein Osterreich (Rosenkranz). Annen-Gavotte (Raab). March, Huldigungs-fest (Müller).  
9.55—Announcements.  
10.0-10.30—Pfeffer Orchestra (contd.). March, Freiherr von Hess (Massak). Overture, "Der Bajazzo" (Czibulka). Potpourri, A Musical Fashion Book (Rentzsch). March, Isonzo (Schreiber).

WARSAW (Poland)

224 kc/s (1,339 m.); 120 kW. Cracow, etc. See Sunday.  
5.15 a.m.—Hymn; Gymnastics.  
5.40—Records.  
6.0—News; Records.  
7.0-7.10—For Schools.  
10.15—For Schools.  
10.40—Records: Serenades.  
10.57 (from Cracow)—Time; Fanfare.  
11.3—To be announced; at 11.20—News.  
2.30 p.m.—Economics.  
2.45—For Children.  
3.15—Folk Ensemble.  
3.50—Topical Talk.  
4.0 (from Lwów)—Talk.  
4.15 (from Poznań)—Talk: The History of Opera.  
4.50—Programme Notes.  
5.0—Sports Notes; Talk.  
5.15—Records of Alfredo Campoli.  
5.30—Programme Notes.  
5.35—For Country People.  
6.0—For Poles Abroad.  
6.50—Topical Talk.  
7.0 (from Cracow)—Salon Quartet, Orska (Soprano), Szyfman (Bari-tone), Frank and Roman (Pfte. Duo); at 7.45—News; Topical.  
8.45 (from Lwów)—Sketch (Raort).  
9.0—Station Orchestra. Conductor: Fiteberg. Italian Caprice (Tchaikovsky). Solveig's Song (Grieg). Minuet (Boccherini). Chant d'amour (Paderewski). Scherzino (Paderewski). Emperor Waltz (Strauss). Andantino in F minor (Tchaikovsky). March (Tchaikovsky).  
9.50-10.0—News.

TURIN GROUP (Italy)

Turin (No. 1), 1,140 kc/s (263.2 m.); 7 kW. Milan (No. 1), etc. See Sunday.  
6.45 a.m.—Gym.  
7.0-7.20—Time; News.  
9.30-10.0—For Schools.  
10.30—Pieraldo Orchestra.  
11.30 a.m.—1.0 p.m.—See Rome.  
1.0-1.20—News.  
3.40—For Children.  
4.0-6.0—See Rome.  
6.0—Light Musical. Conductor: Ferruzzi.  
6.40—News in French.  
7.0—Time; News.  
7.20—Talk.  
7.30—Light Musical—Radio Orchestra. Conductor: Salerno.  
8.0—"Come prima, meglio di prima"—Three-Act Play (Pirandello).  
9.30 (approx.)—Orchestra. Conductor: Barzizza.  
10.0—News.  
10.15-10.55—Dance Music.

VIENNA (Austria)

592 kc/s (506.8 m.); 100 kW. Graz, etc. See Sunday. Transmits at intervals from 5.45 a.m.  
11.0 a.m.—Chimes; Station Orchestra. Mikulas (Hawaiian Guitar). Ballet Overture (Kremer). Waltz, Traumdeale (Fück). Verdi Potpourri (Weninger). Freundliche Vision (R. Strauss).

# STATIONS IN ORDER OF FREQUENCIES AND WAVELENGTHS

kc/s	m.	kW	Station	kc/s	m.	kW	Station	kc/s	m.	kW	Station
<i>Band No. 1. 150-300 kc/s.</i>											
152	1973.5	5	Ankara (Turkey)	731	410.4	0.1	Assiut (Egypt)	1131	265.3	10	Hörby (Sweden)
153	1961	7	Kaunas (Lithuania)			3	Madrid (EAJ2) (Spain)			7	Turin (No. 1) (Italy)
		150	Hilversum (No. 1) (Holland)			5.5	Seville (Spain)	1140	263.2	10	Genoa (No. 1) (Italy)
160	1875		(Power 10 kW only until 2.40 G.M.T.)	740	405.4	20	Tallinn (Estonia)			10	Trieste (Italy)
		150	Radio-Romania (Romania)	749	400.5	100	Munich (Germany)	1149	261.1	20	LONDON NATIONAL
166	1807	150	Lahti (Finland)	758	395.8	1	Marseilles (PTT) (France)			20	NORTH NATIONAL
172	1744	500	Moscow (No. 1) (U.S.S.R.)	767	391.1	60	Pori (Finland)			50	SCOTTISH NATIONAL
182	1648	80	Radio-Paris (France)			12	Katowice (Poland)	1158	259.1	10	Kosice (Czechoslovakia)
185	1622	5	Istanbul (Turkey)			60	BURGHEAD	1167	257.1	15	Monte Ceneri (Switzerland)
187.5	1600	20	Irkoutsk (U.S.S.R.)			70	SCOTTISH REGIONAL	1176	255.1	10	Copenhagen (Denmark)
191	1571	60	Deutschlandsender (Germany)	776	386.6	0.25	Sortavala (Finland)	1185	253.2	60	Nice-Côte d'Azur (France)
200	1500	150	DROITWICH			10	Stalino (U.S.S.R.)			0.5	Cassel (Germany)
208	1442	35	Minsk (U.S.S.R.)			120	Toulouse (PTT) (France)			2	Coblenz (Germany)
216	1389	16	Reykjavik (Iceland)	785	382.2	120	Leipzig (Germany)	1195	251	25	Frankfurt (Germany)
216	1389	150	Motala (Sweden)	795	377.4	7.5	Barcelona (EAJ1) (Spain)			5	Freiburg-im-Breisgau (Ger.)
217.5	1379	100	Novosibirsk (U.S.S.R.)			50	Lwów (Poland)			2	Trier (Germany)
224	1339	120	Warsaw (No. 1) (Poland)	804	373.1	5	PENMON (Anglesey)	1204	249.2	5	Prague (No. 2) (Czechoslovakia)
232	1293	150	Luxembourg	814	368.6	70	WELSH REGIONAL	1213	247.3	60	Lille (Radio PTT Nord) (France)
		100	Moscow (No. 2) (U.S.S.R.)	823	364.5	50	Milan (No. 1) (Italy)	1222	245.5	0.3	Narvik (Norway)
240	1250	60	Kalundborg (Denmark)			12	Bucharest (Romania)			60	Rome (No. 2) (Italy)
		0.5	Vienna Experimental (Austria)			1.5	Agen (France)	1231	243.7	5	Görlitz (Germany)
248	1209.6	100	Kiev (No. 1) (U.S.S.R.)	832	360.6	35	Kiev (No. 2) (U.S.S.R.)			5	Gleiwitz (Germany)
253	1186	10	Vigra (Aalesund) (Norway)			0.4	Rueil-Malmaison (Radio 37) (France)	1235	242.9	1	Cork (Irish Free State)
256.4	1170	25	Tashkent (U.S.S.R.)	841	356.7	100	Berlin (Germany)	1249	240.2	17	Saarbrücken (Germany)
260	1153.8	60	Oslo (Norway)			100	Sofia (Bulgaria)			1	Bilbao (EAJ8) (Spain)
271	1107	100	Leningrad (No. 1) (U.S.S.R.)	850	352.9	10	Bodö (Norway)	1258	238.5	15	Riga (Latvia)
282	1065	10	Tromsø (Norway)			1	Porsgrund (Norway)	1267	236.8	2	Nürnberg (Germany)
283	1060	35	Tiflis (U.S.S.R.)			10	Stavanger (Norway)	1276	235.1	27	Radio-Méditerranée (France)
						3	Valencia (Spain)			2	Varna (Bulgaria)
						10	Simferopol (U.S.S.R.)	1285	233.5	1	ABERDEEN
340	882.3	20	Saratov (U.S.S.R.)	859	349.2	100	Strasbourg (France)			0.25	Dresden (Germany)
347	864	10	Finmark (Norway)	868	345.6	16	Poznan (Poland)			5	Klagenfurt (Austria)
350	857.1	10	Archangel (U.S.S.R.)	877	342.1	70	LONDON REGIONAL	1294	231.8	5	Vorarlberg (Austria)
355	845.1	20	Rostov-on-Don (U.S.S.R.)	886	338.6	15	Graz (Austria)	1303	230.2	0.5	Danzig (Danzig Free City)
359.5	834.5	18	Budapest (No. 2) (Hungary)			15	Linz (Austria)			0.25	Karlstad (Sweden)
375	800	40	Sverdlovsk (U.S.S.R.)	895	335.2	10	Helsinki (Finland)	1312	228.7	2.5	Malmö (Sweden)
390	769	10	Voronezh (U.S.S.R.)			1.5	Limoges (PTT) (France)			0.25	Norrköping (Sweden)
		0.6	Boden (Sweden)	904	331.9	100	Hamburg (Germany)			0.25	Trollhättan (Sweden)
392	765	30	Banská-Bystrica (Czechoslovakia)			10	Dnepropetrovsk (U.S.S.R.)	1321	227.1	1.25	Magyarovár (Hungary)
		1.3	Geneva (Switzerland)	913	328.6	60	Toulouse (Radio-Toulouse) (France)			2	Bremen, Hanover, Kiel, Stettin (Germany)
401	748					32	Brno (Czechoslovakia)	1330	225.6	0.5	Magdeburg (Germany)
413.5	726	100	Moscow (No. 3) (U.S.S.R.)	922	325.4	15	Brussels (No. 2) (Belgium)			2	Łódź (Poland)
		0.6	Östersund (Sweden)	932	321.9	15	Algiers (North Africa)	1339	224	1.5	Montpellier (PTT) (France)
431	696	10	Oulu (Uleaborg) (Finland)	941	318.8	10	Göteborg (Sweden)			0.5	Cairo (No. 2) (Egypt)
<i>Band No. 3. 500-1,500 kc/s.</i>											
518	579	0.5	Tartu (Estonia)	950	315.8	100	Breslau (Germany)			0.5	Dublin (Irish Free State)
519	578	0.7	Hamar (Norway)	959	312.8	60	Poste Parisien (France)	1348	222.6	2	Königsberg (No. 2) (Germany)
		1	Innsbruck (Austria)	968	309.9	30	Bordeaux-Sud-Ouest (France)			0.15	Rjukan (Norway)
527	569.3	6.3	Ljubljana (Yugoslavia)	977	307.1	100	Odessa (U.S.S.R.)			2	Salzburg (Austria)
		10	Viipuri (Finland)			100	NORTHERN IRELAND REGIONAL			0.7	Tampere (Finland)
536	559.7	50	Bolzano (Italy)			50	Bologna (Radio - Marconi) (Italy)			2	Bari (No. 2) (Italy)
546	549.5	120	Budapest (No. 1) (Hungary)	986	304.3	24	Torun (Poland)	1357	221.1	1	Rome (No. 3) (Italy)
556	539.6	100	Beromünster (Switzerland)			60	Hilversum (No. 2) (Holland)			4	Milan (No. 2) (Italy)
		100	Athlone (Irish Free State)	995	301.5	60	(Power 15 kW only until 6.10 G.M.T.)	1366	219.6	2	L'Île de France (France)
565	531	10	Klaipeda (Lithuania)			13.5	Bratislava (Czechoslovakia)	1375	218.2	0.5	Basle (Switzerland)
		3	Palermo (Italy)	1004	298.8	4	Chernigov (U.S.S.R.)			0.5	Berne (Switzerland)
574	522.6	100	Stuttgart (Germany)	1013	296.2	70	MIDLAND REGIONAL	1384	216.6	7	Warsaw (No. 2) (Poland)
583	514.6	20	Alpes-Grenoble (PTT) (France)			3	Barcelona (EAJ15) (Spain)	1393	215.4	25	Radio-Lyons (France)
592	506.8	100	Vienna (Austria)	1022	293.5	2	Cracow (Poland)	1402	214	2	Stara-Zagora (Bulgaria)
601	499.2	25	Rabat (Morocco)			0.7	Oviedo (Spain)	1420	211.3	10	Vaasa (Finland)
610	491.8	10	Sundsvall (Sweden)			100	Königsberg (No. 1) (Heilsberg) (Germany)			0.5	Alexandria (No. 2) (Egypt)
610	491.8	15	Florence (No. 1) (Italy)	1031	291	5	Paredo (Portugal)	1429	209.9	2.5	Kaiserslautern (Germany)
620	483.9	20	Brussels (No. 1) (Belgium)			10	Leningrad (No. 2) (U.S.S.R.)			0.5	Turku (Finland)
625	480	..	Cairo (No. 1) (Egypt)	1040	288.5	120	Reims-Bretagne (France)	1438	208.6	1.25	Miskolc (Hungary)
		..	Samara (U.S.S.R.)	1050	285.7	50	W. OF ENGLAND REG.	1456	206	7	Eiffel Tower (Paris) (France)
629	476.9	15	Christiansand (Norway)	1059	283.3	20	Bari (No. 1) (Italy)			0.1	Antwerp (Belgium)
		15	Lisbon (Emissora Nacional) (Portugal)	1068	280.9	0.8	Radio-Cité (Paris) (France)	1465	204.8	0.1	Coutrai (Belgium)
		20	Trondelag (Norway)	1077	278.6	10	Tiraspol (U.S.S.R.)			1.25	Pécs (Hungary)
638	470.2	120	Prague (No. 1) (Czechoslovakia)	1086	276.2	35	Bordeaux-Lafayette (France)	1474	203.5	1	BOURNEMOUTH
648	463	100	Lyons (PTT) (France)			2	Falun (Sweden)	1487	201.7	0.3	PLYMOUTH
658	455.9	100	Petrozavodsk (U.S.S.R.)			0.7	Zagreb (Yugoslavia)			0.1	Binche (Belgium)
668	449.1	20	Cologne (Germany)	1095	274	5	Madrid (EAJ7) (Spain)	1492	201.1	0.2	Albacete (Spain)
		70	Jerusalem (Palestine)			..	Salamanca (Spain)			0.1	Chatelneau (Belgium)
677	443.1	100	NORTH REGIONAL			10	Vinnitsa (U.S.S.R.)			0.7	Nîmes (France)
686	437.3	20	Sottens (Switzerland)	1104	271.7	10	Kuldiga (Latvia)			0.5	Santiago (Spain)
686	437.3	20	Belgrade (Yugoslavia)			10	Naples (Italy)			0.1	Wallonia (Belgium)
695	431.7	120	Paris (PTT) (France)			11.2	Moravská-Ostrava (Czechoslovakia)	1500	200	0.25	Pietersaari (Finland)
704	426.1	55	Stockholm (Sweden)	1113	269.5	15	Radio-Normandie (Fécamp) (France)			0.2	Radio-Alcalá (Spain)
713	420.8	50	Rome (No. 1) (Italy)			0.5	Alexandria (No. 1) (Egypt)			0.1	Seraing, Verviers, Wallonia (Belgium)
		1	Bergen (Norway)	1122	267.4	60	STAGSHAW (Newcastle)	1530	196	0.2	Karlskrona (Sweden)
		17	Hilversum (Lopikerkapel) (Testing)			6.25	Nyiregyháza (Hungary)	1734	173	0.1	Liepāja (Latvia)
722	415.4		Kharkov (U.S.S.R.)								
		1	Fredrikstad (Norway)								

ALL ADVERTISEMENTS FOR "WORLD-RADIO" should be addressed to the Advertisement Director, BBC, 35, Marylebone High Street, W.1.—Telephone: Welbeck 4468. Coupons should be sent direct to the Advertiser.

Printed in England by WATERLOW & SONS LTD., Twyford Abbey Road, Park Royal, N.W.10, and published by the British Broadcasting Corporation at 35, Marylebone High Street, London, W.1, England—November 19, 1937.