

WIRELESS



INCORPORATING
WIRELESS WEEKLY



Vol. V.] AUGUST 28, 1926. [No. 2

HOW TO BUILD A SIMPLE 5-VALVE SUPERHETERODYNE

By JOHN UNDERDOWN.

A RIVAL TO RADIO?

By Captain H. J. ROUND, M.C., M.I.E.E.

OPERATING THE SPECIAL NEUTRODYNE RECEIVERS

Results of our "CARTOONIGRAFS"
COMPETITION.

[Registered at the G.P.O. as a Newspaper.]



Overcomes direct pick-up from your local station

A DIFFICULTY encountered in attempting distant reception in the near neighbourhood of the local station is direct pick-up. Even when using a tolerably selective circuit, it is found that interference continues to give trouble.

For this reason the selectivity of any ordinary receiver is somewhat limited. In "A Screened-Coil Single-Valve Set," described in the September issue of THE WIRELESS CONSTRUCTOR—now on sale—an attempt has been made to overcome the direct pick-up by the use of a screened coil for the actual tuning circuit. A self-contained wave-trap has also been included, with the result that some really selective results are possible with this receiver.

Helpful assistance in the successful building of this receiver may be obtained by using the FREE BLUE PRINT given in exchange for the Coupon contained in the same issue.



This back-of-panel photograph shows the placing of the various components, such as the Screened Coil, High-Frequency Choke and the Integral Wave-Trap. The design is one which will commend itself to many.

As you will see, by reading this list, the September issue of THE WIRELESS CONSTRUCTOR contains many other interesting articles:—

- A Three-Valve Set with One Control. By R. J. O'CONNELL
- Talks to Beginners—VI. By PERCY W. HARRIS, M.I.R.E., Editor
- A "Matchless" Crystal Set. By ROBERT H. TINGEY, M.I.R.E.
- Where the "X's" Come From. By J. H. REYNER, B.Sc. (Hons.), A.C.G.L., D.I.C., A.M.I.E.E.
- Points for the Short-Wave Operator. By A. V. D. HORT, B.A.
- A Screened-Coil Single-Valve Set. By W. H. FULLER
- Splendid News for the Home Constructor
- A Crystal Set for the Double Programmes. By A. S. CLARK
- Where Resistance Helps and Hinders. By C. P. ALLINSON, A.M.I.R.E.
- Professor Hazeltine and the "Elstree Six" Constructing a Receiver. By D. J. S. HARTT, B.Sc.
- Do You Use Grid Bias? By GEORGE T. KELSEY

The Wireless
Constructor
SEPTEMBER ISSUE
NOW ON SALE
PRICE SIXPENCE.

The Wireless Constructor is obtainable from all Newsagents, Bookstalls and Booksellers, or direct from the Publishers, Radio Press, Ltd., Bush House, Strand, London, W.C.2. Subscription Rates, 8/6 per annum United Kingdom, 7/6 per annum Canada and Newfoundland, and Other Countries 8/6 per annum. Lesser periods pro rata.

S.P. 18 RED SPOT
An excellent all-round-purpose Valve. Very effective as an L.F. amplifier, especially in last stage. Exceptionally good as a rectifier and very efficient as an H.F. amplifier. Fil. Volts: 16-18. Amps.: 0.3.

S.P. 18 GREEN SPOT
Specially designed for resistance-capacity and choke coupling. Also suitable for use in early stages of L.F. amplification. A very efficient H.F. Amplifier and even a better detector than Red Spot. Fil. Volts: 16-18. Amps.: 0.3.

S.P. 18 BLUE SPOT
Extra high amplification Valve. With L.F. resistance-capacity coupling gives as much amplification as most valves with transformer. With a transformer, tremendous amplification. As an H.F. amplifier in stabilised circuits gives far greater amplification than otherwise obtainable. Takes only a fraction of the H.T. current taken by other valves. Fil. Volts: 16-18. Amps.: 0.09.

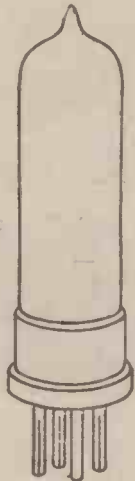

STAND No. 105
at the
NATIONAL RADIO
EXHIBITION.

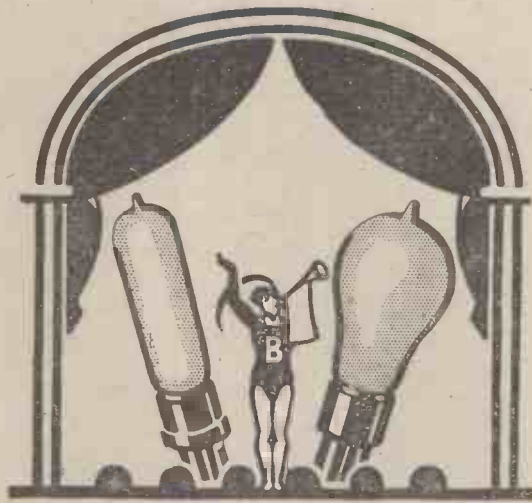

Making their bow

EVERYONE knows the name BENJAMIN—makers of the world-famous Valve Holder. This season BENJAMIN will be doubly in the public eye—for a complete range of BENJAMIN RADIO VALVES is now on the market. In these valves are combined every recent discovery and advance in valve manufacture.

Greater amplification, greater output, less distortion, exceptionally good rectification, and extremely low filament consumption are among their more important features. Better results can be obtained from any receiving set if BENJAMIN VALVES are fitted.

Ask your dealer about them—or send to us for leaflet giving full particulars.

BENJAMIN

SHORTPATH

RADIO VALVES

THE BENJAMIN ELECTRIC LTD.,
Brantwood Works, Tottenham, N. 17.
STAND No. 105 AT THE
NATIONAL RADIO EXHIBITION.

S.P. 55 RED SPOT
A perfect last-stage power Amplifier. Will handle an exceptional amount of power. Greater volume obtainable without distortion begins. Excellent in all stages with transformer or choke coupling. Also gives good results as H.F. amplifier or detector. Fil. Volts: 5.5. Amps.: 0.25.

S.P. 55 BLUE SPOT
An extra high amplification Valve with a moderate impedance. Designed specially for resistance and choke-coupled L.F. and for tuned anode H.F. Ideal for anode rectification. Fil. Volts: 5.5. Amps.: 0.09.

D.E. 55.
A very good general-purpose Valve for H.F., L.F., or detector work. Gives splendid results where the super-efficient SHORT-PATH Valves are not suitable because of their "liveliness." One of the most economical Valves with L.T. and H.T. current. Fil. Volts: 5.5. Amp.: 0.09.

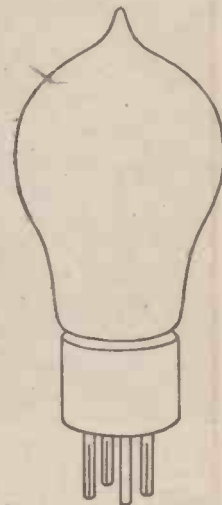

STAND No. 105
at the
NATIONAL RADIO
EXHIBITION.



Visit our Stand, No. 155, at the National Radio Exhibition, Olympia, September 4th—18th.



SIEMENS BROTHERS AND CO., LTD., WOOLWICH, S.E.18.

WIRELESS

INCORPORATING

WIRELESS WEEKLY

JOINT EDITORS

PERCY W. HARRIS

M.I.R.E.

J. H. REYNER

B.Sc. (Hons.), A.C.G.I., D.I.C., A.M.I.E.E.

ASSISTANT EDITOR

G. P. KENDALL

B.Sc.

TECHNICAL DIRECTOR

JOHN SCOTT-TAGGART

F. Inst. P., A.M.I.E.E.

THIS WEEK'S NOTES AND NEWS

The New Waves

THE date appointed for the great "re-shuffling" of European wavelengths is drawing near, and my readers would do well to look to their sets, and make sure that they will cover the whole range of the new waves. A set that is to receive all Europe on the shorter band must be capable of tuning from 201.3 metres to 588.2 metres in future. The lowest wave is occupied by Oviedo (Spain), and the top one is shared by Vienna, Linköping (Sweden) and Grenoble (France).

Bournemouth and the Ships

IT seems just possible that in future the great bulk of the shipping traffic will be conducted upon a fairly high wavelength of the order of 800 metres or so. Whether this comes off or not, it is morally certain that Bournemouth, on 306 metres, will be worth listening to if there are many 300-metre "sparkers" about.

International broadcasting co-operation will certainly have a very great effect upon the listening community. It has already done much to secure freedom from "land interference," and I have no doubt that it will soon begin to make its influence felt in the sphere of shipping.

Music Talks

THE B.B.C. is introducing a rather interesting novelty at the end of September. Weekly talks, lasting for about half an hour, will be broadcast on the subject of the musical items of interest which will be included in the following week's programme. These talks will be given by

celebrities in the musical world, and will be "illustrated" by means of the piano or gramophone records.

The New Director

IT is, by now, common knowledge that Mr. Dan Godfrey's successor as musical director of the London station is Mr. John Ansell. Probably there are not many, however, who realise that Mr. Ansell has composed several comic operas and written a

Belfast

MR. G. C. BEADLE, of the Durban, South Africa, station, has been appointed director of the Belfast station. Mr. Beadle was formerly on the B.B.C. staff, so that he is looking forward to "returning home."

Loud-Speakers Again

THE string of complaints about noisy loud-speakers, particularly in back gardens and on Sunday afternoons, still continues. Apparently there are many who do not yet realise that as soon as they force the volume of sound coming from their loud-speaker above the normal power of a man's speaking (not shouting) voice, the reproduction is bound to seem unnatural. The B.B.C. announcers do not bawl through megaphones!

Awkward!

A CORRESPONDENT in a daily paper is complaining about the hybrid word "television," and suggests as an alternative "teleopsis." The disadvantage of this would be that the only alternative to the word "televisor" would be "televope," which doesn't sound particularly nice!

Sets Wanted

THE National Institute for the Blind are still in need of discarded sets of any size, age and general description. Up to the present they have received 158 sets and 282 pairs of headphones, which certainly does not seem bad going.

(Continued on next page.)

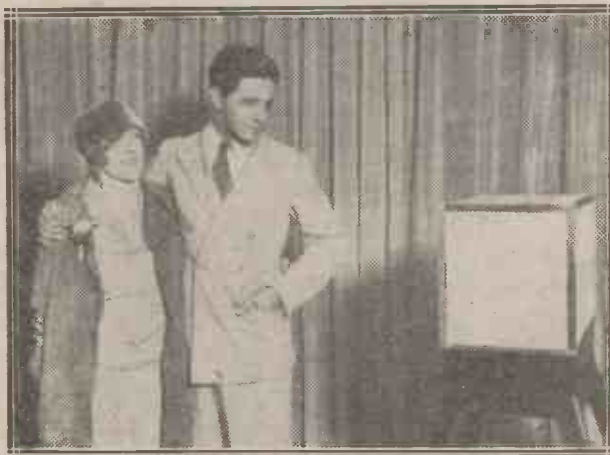

Before the microphone at 2LO. Miss Phyllis Monkman and Mr. Ivor Novello, who recently broadcast the last scene from "Down Hill" the play in which they are appearing.

large number of orchestral suites. I am sure that the London Wireless Orchestra will be in good hands!

More Power Abroad

NEARLY all the German stations are pushing up their powers during the next few months, so that it will soon be easier than ever to find them. The following stations will all use ten kilowatts:—Berlin, Hamburg, Koenigsberg, Frankfurt, Leipzig, Stuttgart, Nuremberg and Breslau.

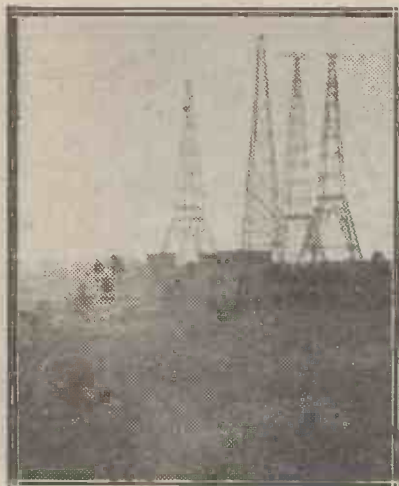

These giant masts, which support in all six aeriels, belong to the United States Navy Department. The station is situated at Arlington, U.S.A., and transmissions are carried out under the call sign of NAA.

A Suggestion

I MENTIONED last week the "fishing bulletins" broadcast by the Aberdeen station. Since then I have heard one or two complaints about them. Apparently foreign "pirates" have developed the unpleasant habit of picking them up, and arriving on the spot before our own trawlers. Practically all the foreign trawlers in the North Sea are fitted with wireless, and the bulletins tell them just where to make for the best results. Moral—Use the Scots dialect in broadcasting these bulletins. That will baffle 'em!

A Newcomer

THERE will probably be another large Spanish station "on the air" very shortly. The Union Radio Espanola has founded a high-powered station at Seville, and this is probably starting up very soon. Preliminary experiments are already under way.

Disappointing!

RATHER an amusing situation has cropped up in connection with the suggested "physical jerks" by radio. As one writer points out, the most thankless job would be that of the announcer. The Army "phiz-jerks" expert could derive consolation by making his squad writhe before his eyes, but the unfortunate "uncle" would be working hard in a cold studio, with his "squad" lying in bed laughing at him!

Microphone Drama

THE B.B.C. announces that a special course of training will shortly be instituted at the Academy

THIS WEEK'S NOTES AND NEWS

(Continued)

of Dramatic Art with a view to discovering talent that can be utilised for broadcasting. Microphones will be installed in some of the rooms, and will be connected to loud-speakers in others. Special examinations will be held at intervals, and the B.B.C. will award two prizes to the value of £10 each at the end of each half-yearly term.

The Future

"**M**ARGATE Night" is fixed for September 10, and will occupy the whole of the evening programme from 8 p.m. till midnight.

radio announcers. This number represents 93 per cent. of those who were asked for their opinion!

On Short Waves

I HEAR that the Department of Scientific and Industrial Research is shortly to commence a series of calibration waves which will be of special interest to short-wave enthusiasts. Hitherto their calibration signals have been transmitted on wavelengths between 833 and 5,000 metres only, but they are "coming down" very shortly. These transmissions will take place on alternate Tuesday afternoons, commencing on September 7.

Provisional Only

THE B.B.C. announce that their published figures on the new wavelengths are to be regarded as provisional at present. The first trials will, of course, show whether any alterations are necessary, and if they are they will, of course, be made with all speed. They also remind listeners that they will do all they can to help any whose receivers give them trouble as a result of these wavelength changes. Do not make any radical alterations in your receiver until the B.B.C.'s experiments enable definite statements as to the future wavelengths to be made. **CALL-SIGN.**



These giant loud-speakers were used in Madison Square, New York, to address over fifteen thousand people.

The "Romaine Four" are to appear at the Savoy Hotel in future, in place of the famous "Selma Four." The chief point about the "Romaine Four" is that they are five!

Coming Musical Events

THE Three Choirs Festival is to be broadcast from Worcester on September 8. Mr. Ivor Atkins, Mus. Doc., will direct, and Mr. Robert Radford and Miss Dorothy Silk will be among the vocalists. Mr. W. H. Read will conduct a performance of his own work, "Somersetshire Idylls."

Some Post!

MR. JACK HYLTON has written pointing out that the results of the "music-r-jazz" poll published recently left out 623 letters addressed personally to him. Perhaps Sir Landon Ronald has had a similar post-bag?

Another Illuminating Ballot

TEN thousand American listeners have come to the conclusion that women are not so suitable as men for



Some of the earlier American broadcasting stations used very simple aeriels. This one was at one time used for certain experimental transmissions by WJZ.

SIMPLIFYING THE SUPERHETERODYNE

A Five-Valve Set of Easy Construction

By JOHN UNDERDOWN

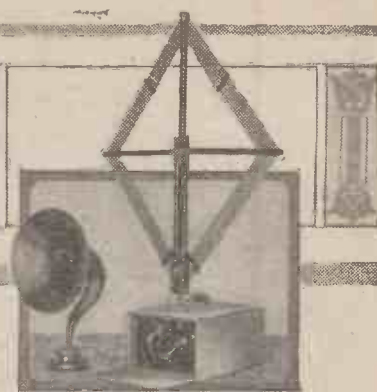

Constructors are apt to regard the superheterodyne as being necessarily an instrument of many valves and high cost. This set, however, is easy to build, employs only five valves, and is moderate in first cost and upkeep.



HERE is a fascination, entirely of its own, of working on a frame aerial, which makes an irresistible appeal to me. For this purpose the

supersonic heterodyne receiver, with its great simplification of tuning controls, is a particularly suitable type of circuit to employ.

An Early Test

In the early days of broadcasting in this country it was regarded by most experimenters as essential to employ eight or nine valves to obtain adequate range and volume, but upon making up a comparatively simple set with five valves I was enabled after dark to obtain a number of the main B.B.C. stations, and several Continentals, upon the loud-speaker. The actual receiver employed consisted of a very scratch arrangement, the "4-Valve Long-Range Neutrodyne," which I described in the January,

the arrangement was of two tuned H.F. transformers of ordinary type, followed by the other two valves mentioned. To the aerial coil in the set a further plug-in coil was coupled, and this acted as the primary of the filter transformer, and coupled a fifth valve,

good results that it was decided to describe it in full for the benefit of WIRELESS readers.

Preliminary Tests

When carrying out preliminary tests, London was the first station received, and adequate loud-speaking, which could be heard all over the house, was obtained. Hamburg, giving almost equal volume, was the next station heard, and subsequently all those British stations which happened not to be taking London's programme at the time were heard at fair loud-speaker strength, subject to fading in one or two cases. Of these latter stations, Manchester was obtained completely free from any interference from London, and Belfast, Dublin and Newcastle were heard.

Since these preliminary tests I have obtained, from time to time, 30 or 40 British and Continental stations, either at loud-speaker or good telephone strength, the tests being carried out in a neighbourhood of average receptive quality, approximately 12 miles south-east of 2LO.

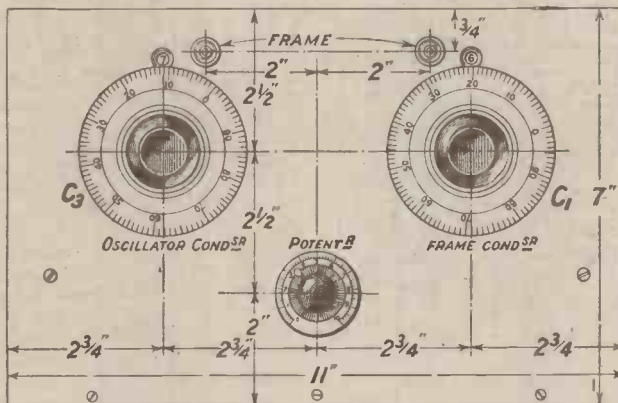

Fig. 1.—The panel layout is simple, and all dimensions may be taken from this drawing.

employing the well-known Tropadyne combined oscillator-detector arrangement, to the receiver.

Component Improvements

With improved components and more suitable valves than those I employed at the time above mentioned, it has been found that a much better set results, making a 5-valve supersonic heterodyne receiver a really practical and useful proposition.

The receiver about to be described was originally constructed as a semi-portable set, to be carried in my car, with a view to obtaining consistent loud-speaker reception from the nearest main station when touring, but on test it gave such

The Theoretical Circuit

Technical details of the circuit employed in the receiver will be appreciated from the simplified circuit diagram shown in Fig. 3. L_1 is a frame aerial, tuned by a .0005 variable condenser C_1 , and L_2 and L_3 are the grid and plate coils of the combined oscillator-detector valve, which employs a modified Tropadyne arrangement. The condenser C_2 is a special balancing condenser which allows the nodal point, or electrical centre, of the circuit to be determined with a degree of accuracy far greater than is possible by tapping the actual coil. A further benefit of this arrangement is that where desired the receiver can be rendered more sensitive by working slightly upon one side of the electrical centre.

(Continued on next page.)

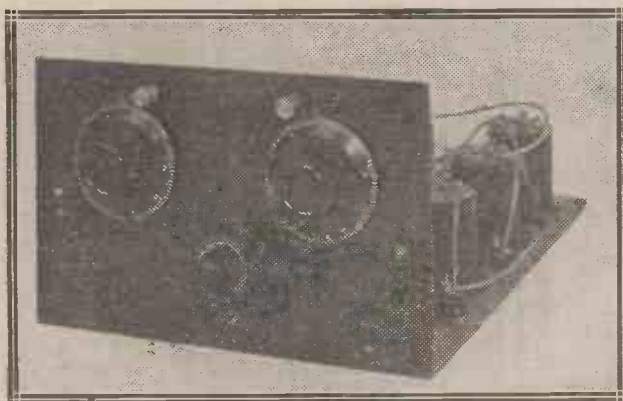

The use of baseboard mounting fixed resistors greatly simplifies the panel layout.

1925, issue of *Modern Wireless*, forming the long-wave side, the second detector and the note magnifier portion.

This set was altered slightly so that

carried in my car, with a view to obtaining consistent loud-speaker reception from the nearest main station when touring, but on test it gave such

**SIMPLIFYING
THE SUPERHETERODYNE**

(Continued from previous page)

It will be observed that, besides the plate coil of the oscillator, there is, in the plate circuit of the combined oscillator-detector valve V1—a further coil L4, across which C4 is connected. This is a primary coil of the "filter" which couples V1 to the first intermediate-frequency amplifying valve, V2. C4 is actually incorporated in the

WHAT YOU WILL NEED

One special oak case to take a base-board 11 in. wide by approximately 15 in. deep. This cabinet has a hinged lid and drop front. (Carrington Manufacturing Co., Ltd.)

One 3/16th in. thick black Radion panel, 11 in. by 7 in. (American Hard Rubber Co., Ltd.)

Two .0005 Collinson "Selector" geared condensers. (Collinson Precision Screw Co., Ltd.)

One 300 ohm potentiometer. (Lissen, Ltd.)

Two 4BA nickelled terminals. One filter transformer. Two intermediate transformers. Two small aluminium brackets. One ordinary-type valve holder. (Burne-Jones & Co., Ltd.)

Five Benjamin anti-vibratory valve holders. (Benjamin Electric Co.)

Four Temptrytes and bases. The resistances of the Temptrytes will have to be chosen to suit the valves used. I have used 5 ohm types throughout. (Sydney S. Bird & Sons.)

Four .015 fixed condensers, Type 610. One .0003 fixed condenser, Type 620. One .0005 fixed condenser, Type 620. (Dubilier Condenser Co. (1925), Ltd.)

One 2 megohm Dumetohm gridleak and holder. One 100,000 ohm anode resistance and base. (Dubilier Condenser Co. (1925), Ltd.)

One special Balancing Condenser. (Peto-Scott Co., Ltd.)

One type AF3 Ferranti transformer. (Ferranti, Ltd.)

One small piece of ebonite approximately 2 1/2 in. by 2 1/2 in. One single-circuit filament control Jack. (Bowler-Lowe Co., Ltd.)

One special plug-in oscillator-coupler. (Turn numbers and constructional details will be given in a future issue for those who prefer to construct their own oscillator-coupler.) (Peto-Scott Co., Ltd.)

A quantity of 20 gauge tinned copper wire and insulating sleeving rubber covered flex, and heavy twin flex.

Approximate cost—£14.

filter transformer itself, and therefore does not appear upon the wiring diagram.

The Intermediate Stages

V2 and V3 are the two intermediate frequency amplifiers, and are coupled by the intermediate transformers, L6, L7 and L8, L9. To control the tendency of the intermediate-frequency amplifying valves to oscillate, the potentiometer shown is incorporated,

(Continued on next page.)

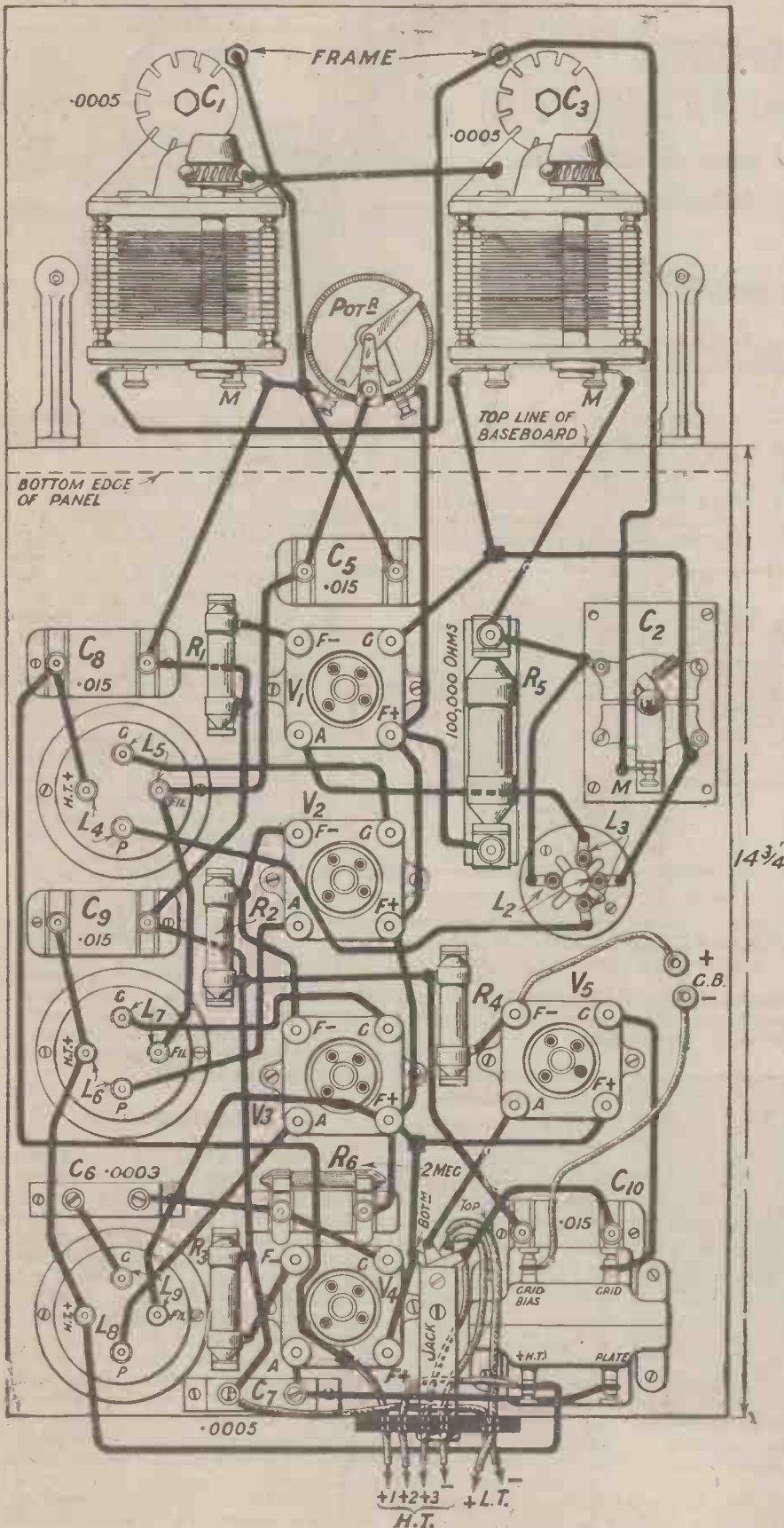

Fig. 2.—Take care to arrange your components on the baseboard as nearly as possible like the layout given in this wiring diagram.

An Easily Constructed Five-Valve Set

and by suitably adjusting the setting of this component the long-wave side may be worked in its most sensitive condition.

V4 is the second detector valve, and it will be observed that leaky grid rectification is utilised here. The last valve, V5, is a plain transformer-coupled note magnifier, and in its plate circuit a single-circuit filament

to be preferable. Filament control of the various valves is by means of fixed resistors, one being employed for each valve excepting in the case of the two intermediates, in which case one serves for both.

H.T. Tappings

A separate H.T. tapping has been provided for the oscillator-detector valve, and is shown as H.T. + 1, since experiment has shown that this valve

General Layout

The general design and layout of the receiver will be appreciated from the photographs, compactness and portability being the main features. The cabinet itself is arranged with a carrying handle, and I have also screwed on to the lid a base from a "Success" frame aerial, so that the frame is supported on the top of the case. The lid of the case lifts up and

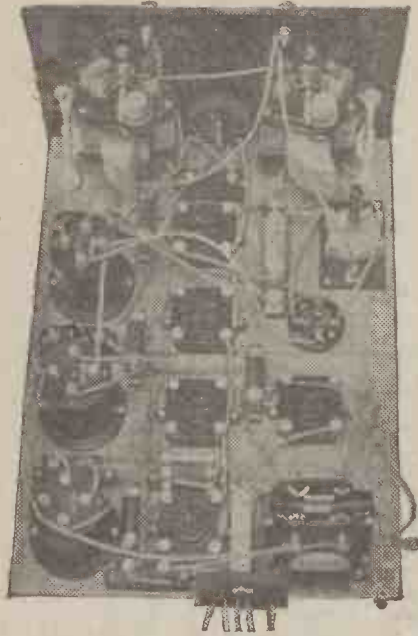

This rear view of the instrument will be helpful when the wiring stage is reached.

control jack is placed, all of the valves being lit when the loud-speaker or telephone plug is inserted therein. The three condensers seen to the right-hand side of the diagram are ordinary shunting condensers, which are arranged across both H.T. and L.T. batteries, since I find this arrangement

generally requires a higher voltage than the intermediate amplifiers and the second detector, for which the supply is from H.T. + 2. The note magnifier, again, has a separate tapping, allowing a higher voltage to be applied to its plate, which latter is particularly desirable when a loud-speaker is used.

the front is hinged so that it comes forward and exposes the tuning controls. All of these latter are located upon a comparatively small panel, the condenser knob on the left being that of the oscillator condenser, and that on the right the frame aerial tuning condenser. The two terminals for the

(Continued on page 71.)

WIRING INSTRUCTIONS

Join one "Frame" terminal to fixed plates of C1 and to moving plates of C2.

Join the other "Frame" terminal to the following points: metal screens of C1 and C3, moving plates of C1, one end of potentiometer, one end of R1, R2, R3 and R4, one side of C5, C8, C9, C10 and C7. From same side of C7 join flex lead for L.T.

Join remaining side of C5 to moving arm of potentiometer, to "Fil." terminals of L5 and L7.

Join remaining side of C8 to "H.T. + " terminal of L4 and to flex lead for H.T. + 1.

Join remaining side of C9 to "H.T. + " terminals of L6 and L8, to "H.T. + " terminal of L.F. transformer and to flex lead for H.T. + 2.

Join remaining side of C10 to top contact of jack and to flex lead for H.T. + 3.

Join remaining side of C7 to A of V4 and to "plate" terminal of L.F. transformer.

Join remaining side of potentiometer to F+ terminals of V1, V2, V3, V4, V5 and to bottom contact of jack.

Join remaining side of R1 to F- terminal of V1, remaining side of R2 to F- terminals of V2 and V3, remaining side of R3 to F- terminal of V4, and remaining side of R4 to F- terminal of V5, thence to flex lead for G.B. +.

Join moving plates of C3 to one side of R5 and to one set of fixed plates of C2, thence to "plate" leg of valve-holder taking L2 and L3.

Join other set of fixed plates of C2 to "grid" leg of valve-holder for L2, L3, also to G of V1 and to fixed plates of C3.

Join one filament leg of valve-holder for L2, L3 to A of V1, and remaining leg to "P" terminal of L4.

Join remaining side of R5 to F+ of V1.

Join "G" terminal of L5 to G of V2, "G" terminal of L7 to G of V3, "G" terminal of L9 to one side of C6.

Join remaining side of C6 to one side of R6 and to G of V4.

Join remaining side of R6 to F+ terminal of V3 to "Fil" terminal of L9.

Join "P" terminal of L6 to A of V2.

Join "P" terminal of L8 to A of V3.

Join G of V5 to "Grid" terminal of L.F. transformer, and attach flex lead for G.B. - to "grd Bias" terminal of L.F. transformer.

Join A of V5 to top contact but one of jack.

Join bottom contact but one of jack to two flex leads, for L.T. + and H.T. -.

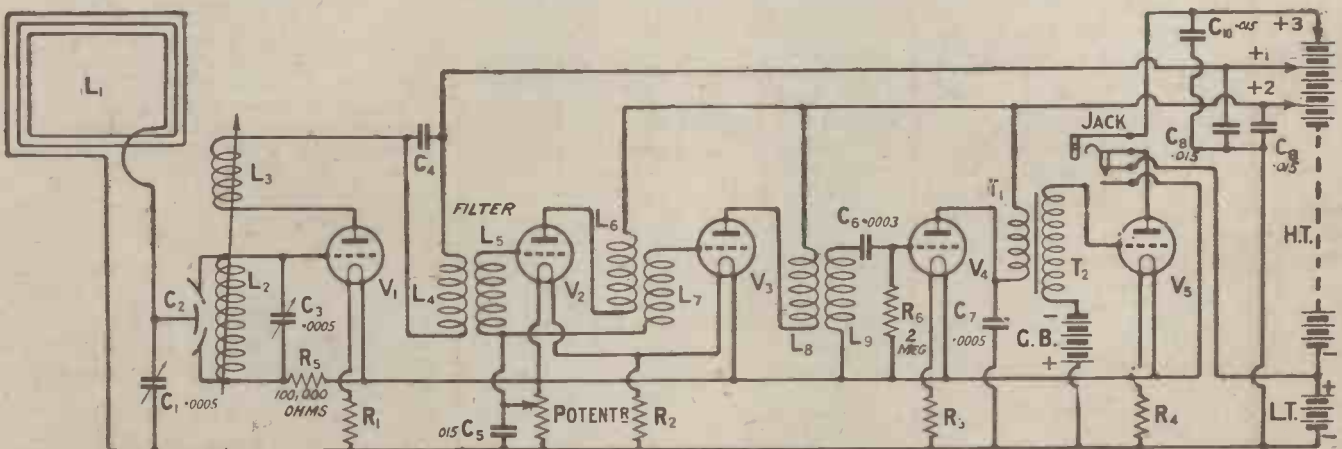

Fig. 3.—The insertion of the telephones or loud-speaker plug automatically lights the valves, the necessary connections being seen in this circuit diagram, which is slightly simplified for clearness.

MORE NEUTRODYNE FAULTS

By JOHN UNDERDOWN



Further helpful notes on some of the commoner faults in neutrodyne receivers.



CONTINUING my article upon "Faults in Neutrodyne Receivers," which appeared in last week's issue, it is intended to deal with other trouble experienced with "Elstree Six" and "Magic Five" type receivers. It has been indicated that lack of liveness may be due to cer-

tain faults in primary coils, or combined primary and neutralising coils, and here the direction of windings is important.

together instead of the arrangement previously indicated, the set will be lifeless, although it may appear to neutralise correctly.

Choice of Valves

magnifier. With most transformers it is best to use a valve with an average or low value of internal impedance, but if a good choke or an anode resistance is in the plate circuit of the detector, high-impedance types, giving maximum signal strength, may be used without loss of quality.

Detector Grid Bias

The employment of the correct grid

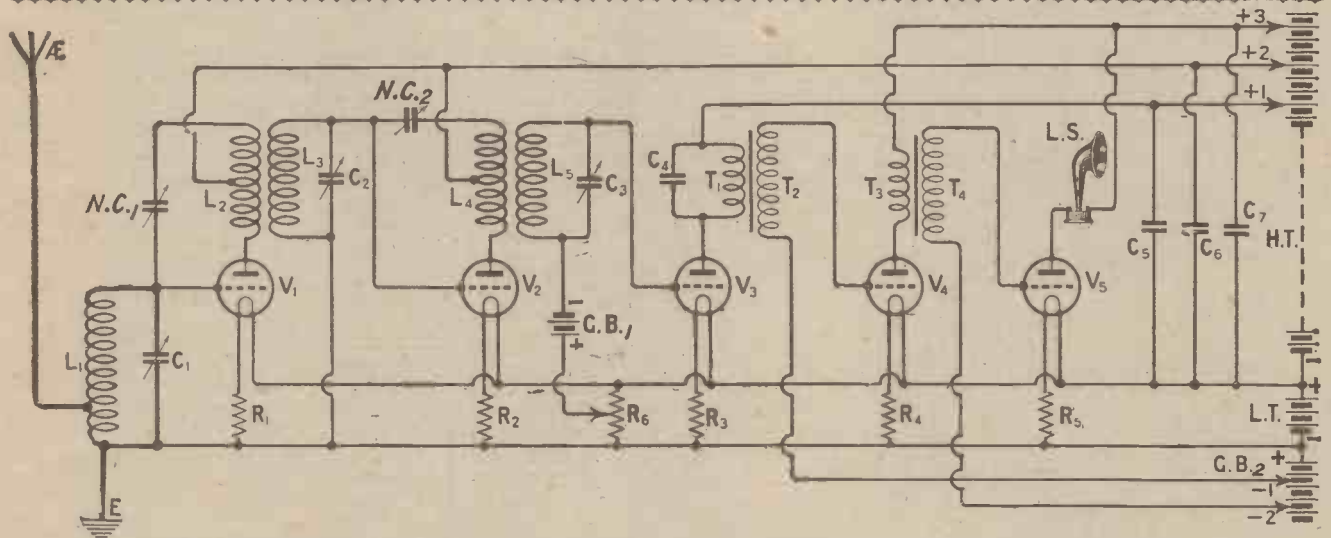

Fig. 3.—This circuit, which is of the "Magic Five" type, is repeated for reference. The Fig. 2 circuit which is referred to in the text is that which appeared in the previous article.

tain faults in primary coils, or combined primary and neutralising coils, and here the direction of windings is important.

Direction of Windings

With the Fig. 3 arrangement it is usual to wind the primary coils, that is, the lower halves of L2 and L4, over the neutralising windings, which are represented by the upper halves of these coils in the diagram. The windings should be connected in series; that is, when both windings are wound on in the same direction, which is the correct system to adopt, the finish of the neutralising winding should be taken to the start of the primary winding, this common point forming the position for the H.T. tapping. If the beginnings of the primary and neutralising windings are connected

should be employed. The "Elstree-Six" type set, that is the Fig. 2 arrangement, is less critical here than the Fig. 3 circuit and general purpose types, with an average value of impedance and amplification factor function satisfactorily, although the high-impedance types do give better selectivity and are to be preferred.

Lower-Bend Rectification

When lower-bend anode rectification is employed, resistance-capacity-type valves are generally advised for the detector, and will be found to give maximum signal strength, but in certain cases on the score of quality it may be found better to use a low-impedance valve here. Which type of valve is to be preferred largely depends upon the coupling employed between the detector and the first note

bias for the detector valve in the above-mentioned circuits has considerable bearing on the correct functioning of the receiver and on the stability of the L.F. side. With an incorrect grid-bias voltage here, a tendency for the L.F. side to be unstable may be noticed, generally a high-pitched whistle resulting. It is worth while to experiment carefully, both with the grid bias voltage and with the detector H.T. voltage to overcome this fault.

H.T. Battery Trouble

It should be realised that with modern neutrodyne receivers, in which several valves of the small power-type may be employed, the drain on the H.T. battery may be considerable. If ordinary small dry-cell types are
(Continued on page 68.)

A Filament

that is tough enough
to support four valves
without breaking

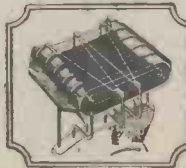

Every feature of the wonderful P.M. Filament has a superiority all its own.

In this case you can judge the high mechanical strength of the P.M. Filament, particularly when you realise that an ordinary filament will barely support a single valve compared to the four possible with the P.M. filament.

This great difference in the strength is due to the special core of rare metal in the P.M. Filament, which is so tough that it can be tied in knots after 1,000 hours' life, and cannot be broken except by the very roughest handling. The P.M. Filament is set around 5 strong resilient hooks in such a way that it is free from tension or sag and cannot become displaced during the long life of the valve.

The multi-coating on the P.M. Filament core is prepared from an alloy of precious metals that secures a copious and powerful stream of electrons at a temperature so low that no sign of glow can be discerned.

The low current consumption of the P.M. Filament, only one-tenth ampere, will make your accumulator charges last seven times as long, reducing your recharging costs and journeys to one-seventh. The emission of the P.M. Filament is completely within the field of the grid and anode, despite the fact that this emission is up to 50 times greater than that of an ordinary filament.

Finally, this vastly increased emission gives a wide range of power free from microphonic disturbances, and the P.M. Filament is so conservatively rated that it will stand a reasonable overload without fear of damage.

You will never really be satisfied until you have secured the valves with the P.M. Filament. There are many attempts to imitate its individual features, but all the advantages of the P.M. Filament can only be found in P.M. Valves:

ASK YOUR DEALER FOR P.M. VALVES. HE SELLS THEM BECAUSE THEY SATISFY.

NEW REDUCED PRICES

For 4-volt accumulator or 3 dry cells
THE P.M.3. (General Purpose)

0.1 amp. 14/-

THE P.M.4 (Power) 0.1 amp. 18/6

For 6-volt accumulator or 4 dry cells
THE P.M.5 (General Purpose)

0.1 amp. 18/6

THE P.M.6 (Power) 0.1 amp. 18/6

For 2-volt accumulator

THE P.M.1 H.F. 0.1 amp. 14/-

THE P.M.1 L.F. 0.1 amp. 14/-

THE P.M.2 (Power) 0.15 amp. 18/6

These prices do not apply in Irish Free State

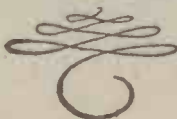

Mullard

THE MASTER VALVE

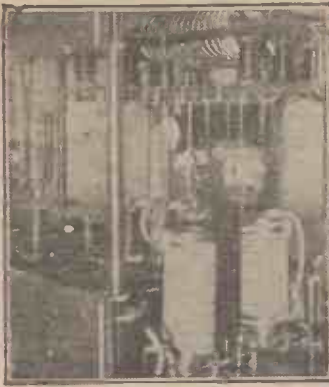

WHEN ARE WE GOING TO GET DOWN TO IT?

By J. H. REYNER, B.Sc. (Hons.), A.C.G.I., D.I.C., A.M.I.E.E.,
Joint Editor.

Mr. Reyner hails the new allocation of stations by Geneva on a "kilocycle" basis as an important step in the direction of a rationalised system.



OVER a year ago I wrote several articles dealing with the use of frequency rather than wavelength when referring to broadcasting. It is customary to-day to refer to the wavelength of the various broadcasting stations, and from the point of view of the general public the arrangement is reasonably satisfactory.

From a scientific point of view, however, this system of nomenclature leaves much to be desired. What happens in a broadcast transmitter is that we set up oscillating currents which flow backwards and forwards at a very rapid rate, the frequency or number of oscillations per second being of the order of more than 500,000.

"Tuning"

These currents are induced in the transmitting aerial, and the effect of the electric charges rushing up and down the aerial gives rise to certain strains in the ether which travel outwards in all directions like the ripples caused by a stone thrown in a pond. At the receiving end we erect a similar aerial which is so arranged that its natural rate of vibration is the same as that of the currents originally produced in the transmitting aerial.

Because of this coincidence of the two frequencies, or, in other words, the *tuning* of the two circuits, the receiving aerial will respond to very minute impulses, and will take no notice of other impulses to which it is not tuned unless they are exceedingly strong. In the latter case, of course, we have the condition of affairs known as jamming.

A Simple Analogy

The particular point is that it is the frequencies of the two systems which have to be tuned before we have obtained any response. A very simple mechanical analogy can be fixed up by anyone who is interested in half-an-

hour. In a wireless circuit we have electrical oscillating systems, and if we can replace these by suitable mechanical oscillating systems, then we can obtain a picture of what is happening.

A simple pendulum is a mechanical oscillating system, and will serve admirably for the purpose. Connect a length of cotton across two convenient points in a room about 10 ft. apart. From this cord suspend two pendulums made up of a length of three or four feet of cotton with a small weight at the end. These two pendulums should

and the second acts as a receiving aerial. Moreover, a little experiment will show that the second pendulum will only respond if it is exactly of the same length as the first, so that the natural frequencies of the two pendulums are equal.

The motion in this mechanical analogy is transmitted through the cord suspended across the room. The motion of the first pendulum will cause tiny ripples to be produced in this horizontal cord, and these will travel from one to the other, and will ultimately affect the second pendulum.

These ripples form a sort of wave on the wire similar to the waves on a sea shore or the ripples in a pond as a stone is thrown in the middle, and the distance between the top of the successive waves is called the *wavelength*.

The "Wavelength"

In an exactly similar manner we have a sort of wave motion in the ether around the transmitting station, which acts as a sort of invisible wire between the receiver and the transmitter, and the actual distance between the crests or points of maximum strength on this wave is termed the wavelength of the particular transmission.

As we have seen, however, what is important is that the natural frequencies of the transmitter and receiver shall be in harmony, and the wavelength has really nothing to do with the process. There is, of course, a definite relation between the frequency and the wavelength, and for this reason it is possible to design one's circuits if the wavelength of the station is known, and this is what has been happening for many years.

The Advantages

You will probably say "Why should this system be altered if it has proved satisfactory for many years? I am not interested in the scientific aspect of the question, so why should I worry?" There are, as a matter of



One of the difficulties in the way of the successful working of such a scheme as that initiated at Geneva is the maintenance of the exact allotted frequency by each station. "Wandering" has only been too common in the past.

be exactly equal in length, and should be suspended four or five feet apart.

Now the time of swing of a pendulum depends upon its length, so that if the two pendulums are of equal length as we have just made them, the time period or natural frequency will be the same.

What Happens

If one of these pendulums is set swinging, then it will be found that, after a very short time, the second pendulum will also commence to swing, and the two will swing to and fro together. In other words, the first pendulum acts as a transmitting aerial

When Are We Going to Get Down to It?—continued

fact, several advantages which become more apparent as one goes more and more deeply into the technicalities of the question.

Perhaps the one which principally appeals to the ordinary listener is the fact that the separation of the various broadcasting stations is determined not by their wavelengths but by their frequencies. If we have two frequencies close together, then they will interfere with each other, and will produce what is known as a beat note. The actual frequency of this beat note is equal to the difference between the frequencies of the two stations.

Frequencies up to 10,000 cycles per second are audible, and even frequencies above this limit can be heard by people who have sensitive ears. If, therefore, two stations are working closer than 10,000 cycles apart (or, as we should say, 10 kilocycles, one kilocycle being 1,000 cycles or oscillations per second), then interference will be produced between them, and we shall have an audible whistle present. This form of interference is unfortunately only too prevalent in Europe at the present time, where large numbers of stations heterodyne each other every evening, and no remedy is possible at the receiving end.

Necessary Separation

Now, without going into details, it can be stated that a frequency separation of 10 kilocycles on a wavelength of 300 metres would be equivalent to a wavelength separation of 3 metres only, while at 600 metres the same frequency separation would correspond to a wavelength separation of 6 metres. In other words, the wavelength separation of the stations varies continuously over the whole of the broadcast band, while the frequency separation remains constant.

This by itself is only a small point, but there are other similar advantages, all in themselves quite small, which would result in a simplification of calculations generally if the frequency system were adopted. The problem is very similar to that of the proverbial English coinage. If we would change to the decimal system calculations could be simplified considerably, and a great deal of time would be saved. The difficulties in the way of such a proceeding, however, are enormous, and this, coupled with the dislike for change which is characteristic of this country, has resulted in the present system being retained.

An Easy Change

The difficulties in the way of a change to kilocycles are nothing like so great, and the whole business could be done gradually if everyone attempted to use kilocycles and to speak in kilocycles. Yet when the suggestion was made a year ago it was either abused or treated as a choice piece of humour. In fact, any "kilocycle enthusiast" was, and is, still treated as a crank.

Undoubtedly the principal obstacle to a general move towards kilocycles is the fact that our own stations are still rated in wavelengths. American stations, on the other hand, definitely give their wavelength and their frequencies at the same time, and there

stations has been assigned a frequency and not a wavelength, the frequencies in each case being 610, 740, 780, and 830 kilocycles respectively. If, therefore, this plan is carried out to any degree of accuracy, it is going to be much simpler to remember the frequencies of the stations rather than the wavelength, and this will be the first step towards thinking in kilocycles.

Unexpected

I must admit that I did not expect such evidence of commonsense in choosing the new wavelengths, and only a few weeks ago I was somewhat deprecating the use of "SLF" condensers because we did not utilise a frequency separation in Europe. Now that we are going to do so, the "SLF" condenser becomes of some value, which is further evidence of the ludicrousness of continuing to think in wavelength.

If only the B.B.C. would pave the way by specifying the frequencies of their stations as well as the wavelength, they would be doing a great service to the science of radio in general. The principal scientific bodies, Government Departments, etc., have long realised the importance of frequencies, and if only the use of frequency could become popularised, a great service would be rendered to future generations. Are we going to take the opportunity?

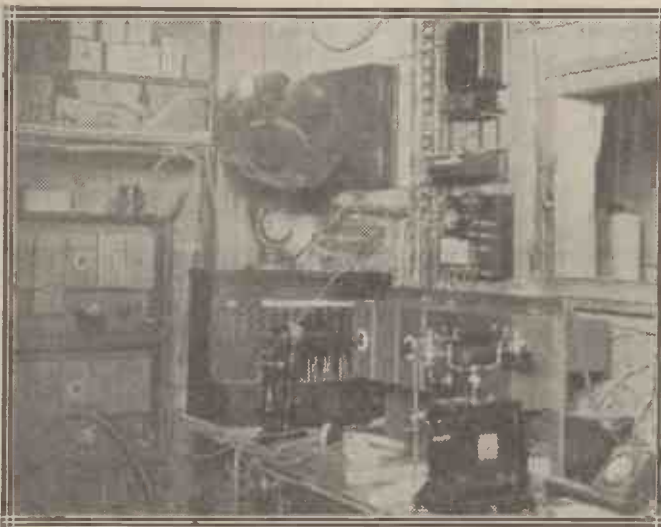

The exact control of frequencies and their immediate re-adjustment when trouble is reported in any particular district, will be rendered relatively easy in this country by the very complete intercommunication system of the B.B.C.

can be little doubt that in a few years' time the American stations will be rated in frequencies.

Action of Geneva

It is very interesting to find that the new Geneva plan for organising the broadcasting of Europe has adopted the only sensible method, and rated the various stations on a definite frequency basis. All the stations are separated by 10 kilocycles, and, what is more, they have been assigned frequencies which are whole numbers of kilocycles. This has given us a somewhat extraordinary system of wavelengths. One has only to look at the suggested wavelengths for this country. Birmingham is 491.8, Glasgow 405.4, Manchester 384.6, London 361.4, etc.

This use of decimals, which are fairly hard to remember, is necessitated by the fact that each of those

TAPPING A FRAME AERIAL

Many experimenters with frame-aerial circuits must have been faced with the difficulty of providing a centre-tap on the windings of these frames wound with braided insulated wire. To bare the insulation at approximately the centre-point will spoil the appearance of the aerial if such a spot proves unsatisfactory in use.

To obviate this difficulty, a stout brass pin may be pushed through the winding where desired. If the centre-point is not found at once, the pin may be tried in another place, no sign of the original pin-hole showing. When the centre-point has been located a permanent tap may be made if desired. The writer uses a Burndeft spring-clip for connection to the pin, and finds the arrangement very satisfactory in use.

A. P.

STANDARDISED SPEECH

From the Announcer's Viewpoint

By Capt. JACK FROST



An insight into some of the trials and difficulties of the announcer, and how he may be helped by the Pronunciation Committee.



MR. BROWN, an announcer at 210, had been allotted the privilege of a spell of late duty on the previous evening, and now, on this sunny morning was sleeping peacefully, making up for his late night. Into his dreams came a voice, the voice of authority, saying: "You must take great care with your pronunciation. Marseilles must be pronounced Mar-sails." He was not at all sure in his dream as to where Ma was due to sail, nor where she was sailing to, but he was content, still dreaming, to leave that in the lap of the gods and let her sail just where she liked.

Certainly Not!

Another voice came out of the mists—"Who said that Marseilles is pronounced Mar-sails? I say that it is Mar-seiy." Brown was troubled, deeply troubled, about this difference of opinion. Voices coming during sleep should surely speak correctly, they should tell him what to say and how to say it. Burr-burr, went the alarm, and Brown stirred, sat up in bed, yawned, rubbed his eyes, and settled down again for that other five minutes which he allowed himself the opportunity for reflecting upon today's events—to-day's difficulties.

How is Marseilles pronounced? Mar-sails or Mar-seiy? Why on earth is it that a fellow must be perpetually poised delicately between the Devil and the deep blue sea? Oh, hang, let's forget it.

The alarm ticked on, and Brown, deciding regretfully that it was time to get up, jumped, or rather rolled, out of bed, and proceeded with his toilet.

Mixed Feelings

When Brown arrived at Savoy Hill, on the tick of 10.30, another announcer, Smith, met him. On Smith's

face was a mingled look of mystery, hope and apprehension. "Brown," said Smith, "we are not without hope, yet we may be called to do those things which we have aforetime left undone. There is to be an Advisory Committee on Pronunciation. You, Brown, my lad, are about to be told how to speak the King's English."

Brown looked hopeful. "Well, Smith, I see it in this way. You and I have decided that when we have the News Bulletin to read, and when the said bulletin contains words which we

said Marseilles in one way, and the other half of the globe aver that it should be pronounced in another way. This Advisory Committee is going to be a jolly good thing for we fellows. They will meet every so often—we shall submit to them roneo'd sheets stating that we say 'cheese' just as it is written. Please, how should we say it? Some say 'chaise' and some say 'choize.' Then the Committee will say, 'In future all announcers shall say "cheese," as written. Anybody who complains will be informed accordingly.' Smith, it will take the onus from us and will settle all of our troubles."

Brown, concluding his speech, went into the office, closed the door, and glanced at the morning's post.

"Dear Sir," the first letter said—"Your announcer must be without any education, without sense, an empty-headed galoot, when he says the word 'Marseilles.' Why on earth does he not pronounce it as 'Marsie'? Who ever heard of it being called 'Marsails'? Perfectly ridiculous, and preposterous, I call it. What do I pay my ten shillings a year for? Certainly not to have mispronounced words shouted into my ear night by night!"

The Announcer's Day Begins

Brown sighed, and proceeded to draft a reply. "Dear Sir," he wrote—"It is regretted that you object to the way in which our announcer pronounced the word 'Marseilles.' Perhaps you are right. Any old how, the Advisory Committee now being set up to decide the right and the wrong way of pronouncing such words, will put us all right. The King's English is very confusing." Brown sucked the end of his pen, and wondered how he had best wind up his epistle, when it suddenly dawned upon him that Marseilles was the name of a place in the South of France—there-

(Continued on page 69.)



Many people, especially children, take unto themselves as correct the pronunciation of certain words used almost daily as they hear them spoken by the broadcast announcer.

think we know how to pronounce, we just give forth, consider that we have done right royally and well, and then we are met by a 'choking off' from someone who knows better than we do, or who can claim to know better than we do. They say that the word Marseilles is pronounced Mar-seiy and not Mar-sails.

Hope for Announcers

"Accordingly the very next time that Marseilles comes into the News Bulletin, we say Mar-seiy and leave the Studio with a feeling that duty well done is well worth doing. If a job is worth doing it is worth doing well—so say I. But when the post is opened in the morning, after our News Bulletin, we see that about half the world consider that we should have



A RIVAL TO RADIO?

By Captain H. J. ROUND

M.C., M.I.E.E.

Does the new and improved gramophone encroach on the field of radio? Captain Round believes that the two have quite separate and distinct spheres.



A POSSIBLE rival to broadcasting has arisen during the last year. That rejuvenated ancestor of radio, the gramophone, has become a very important figure in the world, so important, in fact, that when its rejuvenation is really discovered by the mass of people it will seriously alter their views on the functions of broadcasting.

The study of broadcasting has led to the revival of this old art, and thus to some extent has created its own rival. The story of what has happened is a very fascinating one, and the end of it has not yet been told. It is the story of the gradual replacement of blind trial and error engineering by accurate mathematical and experimental research work, aided by that greatest of modern weapons, the thermionic valve.

Microphone Developments

Our microphones consisted for many years of a cell of carbon granules fitted to a diaphragm. You and I have suffered with these things, and still suffer in our P.O. telephones. There was no thought or reason behind the theory, it just worked, and that was its excuse for existence. And then a great company, having made a gigantic fortune with this hit-and-miss device, decided to put aside a lot of money—perhaps as a kind of conscience money—for research work, and part of this research work was concentrated on the problems of, firstly, how this microphone worked, and, secondly, did it work properly?

Influence of the Valve

But for the valve, very little improvement could have been made, for previously the microphone maker had to keep strength in mind as the most important factor, quality being of almost secondary importance. When strength could be neglected and

quality only considered, enormous strides were at once rendered possible.

Rapidly, due to this research, came the development of an instrument which gave startlingly improved speech, but for the moment it was merely an object of intense interest in the laboratory.

Broadcasting

Radio broadcasting was then quite independently being developed, but it was suffering from all the defects of



Some of the numerous receiving centres which constitute the complex system at Radio-Electrique, Paris.

the old, empirical microphone, until it suddenly occurred to someone to use this experimental laboratory instrument to transmit the broadcasting. Such a perfect instrument could naturally transmit with accuracy much more complicated sounds, such as orchestras and choirs, and its use generally became imperative.

Other microphones with like properties sprung up, until now all radio broadcasting stations must necessarily, to maintain their prestige, be capable of sending out the most complex sounds. These microphones must be very perfect devices.

Gramophone Recording

While these developments have been taking place, some engineers have turned their minds to examine accurately that old and much reviled in-

strument, the gramophone, which, like the microphone, was the result of the old hit-and-miss engineering.

Have you ever seen any gramophone recording being done? The standard process used until recently was very simple. A long horn (curiously enough nearly always a conical one and not a logarithmic shape) was used to concentrate the sound to be recorded. This sound was forced to impinge on the diaphragm of a sound-box—very like the ordinary gramophone sound-box—

but instead of the ordinary needle a tiny little cutting tool with a V-shaped edge was forced to move by the sound. This cutting tool was dragged in a spiral groove over a flat wax slab, and any movement of the diaphragm was impressed on the wax along this spiral groove. From this wax records were made by duplicating the shellac records we buy.

Weaknesses

Considering the extreme simplicity of the arrangement it is wonderful that records could be made at all, and, providing the stuff to be recorded was simple enough the results were fairly good. But the end of a horn is not very big, and several performers required several horns, and you could not get enough horns to record a decent-sized orchestra. The horn was very necessary, because otherwise the impression on the wax would have been too weak.

On top of this the simple recording was defective in that very high notes and very low notes were hardly recorded at all because the horns and the diaphragm suffered with the same troubles as our loud-speakers.

Broadcasting, with its super microphones, was not troubled with these cramped conditions, and consequently could transmit almost anything.

Microphones for Recording

The obvious thing to do was to use a microphone for recording, and the last two years have seen the develop-

(Continued on next page.)

A Rival to Radio?—continued

ment of two or three methods of doing this, with a consequent production of much more perfect records, and, in addition, records of stuff previously unrecordable, such as large symphony orchestras and choirs playing and singing in vast halls and cathedrals.

The making of these records, even with the fine microphones obtainable, required the designing of quite intricate machinery. It is no easy problem to make the little cutting tool which cuts the wax behave at all frequencies and strengths just as is wanted, but it can be done, and it can be now assumed that what is on the modern gramophone record is very nearly the same quality as what is given from the broadcasting station.

There are, of course, some very obvious differences between the two, the chief of these differences being the shortness of an average record and its surface noise, which is, however, being reduced nowadays greatly, and records will probably be made to play a lot longer in the near future.

Records still lack in their true proportions the very high and very low notes—broadcasting can quite easily win out on these—but these points are not of immediate importance, although they will become so in the future.

The Gramophone

With the new records it was at once recognised that the ordinary gramophone did not do them justice, and a further scientific attack was made on the gramophone itself, and now we have gramophones which, while still wanting in some particulars, are really pleasing musical instruments and reproduce very fairly the original sounds.

The gramophone engineer had a far easier problem than the wireless man. If when you bought a record the cut on the record was so small that you had to use valves to amplify it up, then your difficulties would be the same as the difficulties of broadcast reception when the incoming signal is very weak. But the cut on the record is so large that with the aid of a clockwork motor it is able to make a sound louder than almost any ordinary broadcasting set, without the aid of any intervening amplifiers.

All the broadcasting man's batteries are replaced by a simple clockwork motor, which seldom requires any other attention than winding up. With the valve and battery link removed the gramophone engineer merely had to attach that part of the gramophone equivalent to the loud-speaker.

Loud-Speakers and Gramophones

In broadcasting reception we have the alternative of two types of loud-speaker—the horn type and the open-diaphragm type. Both can be used, but attempts so far to use the open



The radio compass aboard the s.s. "Leviathan," by which it is possible to obtain the exact location of the ship under all weather conditions.

diaphragm type with a gramophone have not been successful, and most efforts have been concentrated on the horn.

We have been too cheap in our

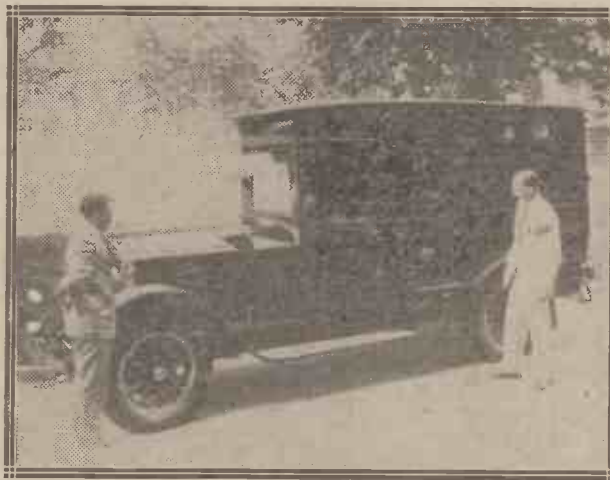

This newly built radio-equipped car has been designed for use by the Bureau of Standards at its field radio stations at Kensington and College Park, Maryland.

methods in wireless. Probably the cost of apparatus and batteries is so large that big sums are not left for a loud-speaker. The result has been that the horns of loud-speakers have been no better than the old gramophone horns, although the general

principles of a long horn have been known for a long time. Short horns can only give the high notes in their full volume.

Improvements in the Horns

A really good horn for low notes as well as high ones should be at least 6 ft. long, and the problem of making long horns and wrapping them up in a cabinet has been solved not by the wireless man, as it ought to have been, but by the gramophone man, because he had the money saved on expensive apparatus to put into that horn. He was aided also by the fact that the gramophone diaphragm has forces applied to it by the record groove much more nearly correct than the force applied by the magnet acting on the diaphragm of the loud-speaker, however correctly one's amplifier has been built.

The new gramophone records when played on these new machines with long horns are better in tonal quality than any broadcasting received in existing horn loud-speakers, and for the moment seriously rival broadcasting received on the open-diaphragm type of instrument, chiefly because of the expense of obtaining sufficient volume of sound with the open-diaphragm types.

However, the horn as we know it now in any practical size cannot really give us all we want in the way of the big low tones, and again, the record itself cannot give them in their full amount. Loud-speakers can, however, be constructed to give true value to all important tones, and the broadcasting itself can be exact, but the expense of batteries is rather serious if a volume equal to that given by a gramophone is required.

Until we have solved these financial and technical difficulties the gramophone in the field where it overlaps radio is definitely leading.

Where Rivalry may Occur

Live broadcasting, of course, can have no rival. No one wants to listen to a speech of a year ago, but music of all types is independent of date, and this surely refers to dance music more than to any other type of music. Each night I hear some dance band or other playing on my radio tunes which I can nearly always buy on a record, and play at any time I want—and that is the time I should want my dance music if I was addicted to the habit.

Perhaps I should never have bought the record but for hearing it on the radio, and that is true of almost all music; attention will be called to it

(Concluded on next page.)

by broadcasting, and then the record will be purchased for serious use.

Dance Programmes

At the present time there is really little need for anything like continuous dance programmes, as has been suggested may be sent from the alternative stations.

A set to use these programmes properly will cost a lot more than a gramophone for capital and maintenance, and the set of records added to by one each week will always be available to make up a really respectable dance programme for serious users of dance music.

Avoiding Rivalry

This field where radio is complementary to the gramophone must in the future be kept clearly in mind, and the two arts must not be allowed to seriously overlap, otherwise they will become rivals, and there is no need for it.

The glamour and adventure of broadcasting are too likely to leave as the organiser enters, and I am afraid that the new projects of multiple stations all

A RIVAL TO RADIO?

(Continued from previous page)

equally receivable and all grinding out standardised programmes, sounds very like a competition with a clock-work motor.

Items of Interest

We understand that a model of the Baird Televisor, a picture of which appears below, is shortly to be exhibited in the South Kensington Science Museum.

The principal manufacturers have decided on a considerable reduction in the price of valves. The price reductions, which include such valves as Mullard, Marconi, Osram, etc., will operate immediately.

TELEVISION



"Looking-in" at the receiving televisor at a scene taking place in the transmitting studio. The first station licensed for the transmission of pictures possesses the call-sign 2TV.

TINFOIL FOR USE AS SOLDER

It may not be generally known that tinfoil such as is to be found around packets of chocolates or cigarettes, etc., makes excellent soldering material. This may be easily prepared and formed into sticks of quite good solder by melting a quantity of this material in a ladle and pouring the liquid out into the cracks which are easily to be found between the tiles in the backyard. When the molten metal thus made is cool, it will be easy to lift it out in stick form ready for use for soldering purposes.

H. B.

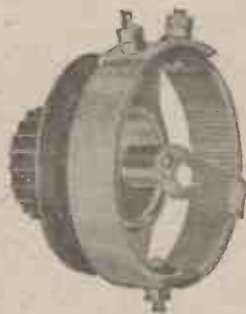

3/9 "PEERLESS" Dual Rheostat

TWO WINDINGS

Specially made for either dull or bright emitter valves. One winding has resistance of 6 ohms and continues on to a 30 ohm strip winding. Resistance wire wound on hard fibre strip under great tension and immune from damage. One hole fixing, terminals conveniently placed. Contact arm has smooth, silky action. All metal parts nickel plated. Complete with ebonite combined Knob and Dial 3/9

From all dealers or direct.

THE BEDFORD ELECTRICAL & RADIO CO., LTD.

22, Campbell Road, Bedford.

CHARGE YOUR ACCUMULATORS AT HOME

NO TECHNICAL KNOWLEDGE OR ATTENTION REQUIRED.

CLEAN, ECONOMICAL AND CONVENIENT



NEW EDITION of our large Illustrated Radio Catalogue, now ready. Free on request. Dealers should enclose Business Card for Trade Terms.

The "INDISPENSO" (Direct Current).

For High Tension Accumulators. Charges at no cost when light is in use. Simply plug-in to any convenient lampholder. Complete with Polarity Indicator, Flexible Cord, Adapter, and full instructions. Price 6/-

The "ALTERNO" (Alternating Current).

Charges the High Tension Accumulator at slight cost by simply plugging-in to any convenient lampholder. Complete with Cords, Adapter and full instructions. Price £1 : 1 : 0

The "PENDLETON" (Alternating Current).

Charges the Low Tension 2, 4 or 6 Volt Accumulator economically and effectively. No Valves or replacements. Connect to the most convenient lampholder. Charging rate approx. 2 amps. Price £2 : 12 : 6

Please state voltage when ordering.

Write direct for name of nearest stockist.



2 volt .3 amp. **Frelat is a Dull Emitter costing no more than a "Bright."**



The strongest recommendation a Valve can have comes from users in country districts who cannot easily replace. With Frelat they have no need to. It lasts longer, gives increased volume, and costs only 4s. 11d. It is the dependable valve. If your Dealer cannot supply send P.O. 4s. 11d. (post free), or request C.O.D. and send fd. in stamps.

THE CONTINENTAL RADIO IMPORT CO., LTD., 8, SPITAL SQUARE, LONDON, E.1

4/11





Correspondence

Lightning

SIR,—After reading through the pages of WIRELESS for August 14 I was very much interested in a paragraph in "The Week's Diary" of the possibility of a genuine case of an aerial being struck by lightning. I should like to say the case in question coincides almost in detail to an experience which occurred to my aerial. A month or two ago during a thunderstorm my aerial received a "direct hit" by a flash of lightning. The aerial was severed at each end, and both insulators were badly burned. The discharge travelled to earth by way of the wire pulley and thence down one of the stay wires (part of which I have enclosed), which I had fastened to a rain-water pipe which goes into the ground. The shock of the discharge at the moment of reaching the rain-water pipe sounded as though something had struck the wall of the house with a loud thud. A further proof of it being a "direct hit" was the fact that within a few feet of one of my aerial supports there are two other separate aerials. Neither of these received any damage whatever. I attribute this to the fact that my aerial was a few feet higher.

You will note on examining the enclosed piece of wire that in places the wire inside the insulation has entirely burnt out and disappeared altogether. Also you will note how brittle the wire has become. Another peculiar thing about it is the even way in which the discharge has burst through the insulation, viz., about every inch along the wire.

I should here like to say that my aerial was not earthed at the time. This accounts for the discharge finding another way to earth.

I must not close this narrative without expressing my entire satisfaction and interest I find in WIRELESS. Although not an actual builder of wireless sets, I find great pleasure and fascination in the numerous articles and reports which appear from time to time. I wish WIRELESS and its able staff the best of good luck.—I am, yours faithfully,

St. Albans.

S. ANDREWS.

[The piece of guy wire enclosed by our correspondent consisted of field telephone cable composed of a stranded tinned-steel wire core covered with vulcanised rubber and braiding.—ED.]

"The H.T. Tapping Myth"

SIR,—My experience of H.T. large-size units is that long before the majority of cells are worn out one or two go, sometimes very quickly. If a battery were made as you propose, finding a "dud" cell would be almost impossible, whereas

when the battery is tapped out every three volts it is easy to spot it, short it or dig it out and rewire.

While writing this my loud-speaker is working on a 100-volt and a 30-volt H.T. battery and going strong. There are four shorting strips in, and it has been like that for the last five weeks. The complete voltage is about 106.

Both of these would have been thrown away if made on your idea.

More tappings the better for H.T. dry batteries; saves money. Nuff said.

Wood Green.

A. C. GILBERT.

[EDITOR'S NOTE.—The author of the article in question states in reply that his experience of the more recent specimens of large H.T. units has been more fortunate than that of our correspondent. He reports that two 45-volt units have

volume, but this, of course, would be satisfactorily overcome by the provision of tappings at 72 and 84v. (as suggested for H. F.).

Best wishes to all Radio Press publications.—Yours faithfully,

New Barnet.

F. APPLETON.

P.S.—I should like to mention my appreciation of the section of WIRELESS devoted to "Transmitter Details," and of the prompt attention given to all communications.

How It Originated

SIR,—With regard to Mr. G. P. Kendall's article on "The H.T. Tapping Myth," may I be allowed to express my views on the subject? I think the whole business originated with the soft Dutch valves which used to be so popular as detectors, and which ionised at, say, 36 volts, while giving perfect results at 33 volts. The wireless amateur has an incurable habit of pushing things to the limit, and would probably have been far from satisfied in those days to be forced to work the said valve at 24 volts! Now, however, I think all we want is a tapping at every 20 or 25 volts, since valves are uniform in their behaviour, and, as Mr. Kendall says, the voltages are certainly not at all critical.—Yours faithfully,

J. R. BRENDAN.

Scarborough.

WHAT DO THEY THINK OF IT?



The Australians took an early opportunity of sampling British broadcasting. Four members of the team are here seen listening to 2LO.

A Critical Valve

SIR,—I beg to differ from the opinions of Mr. G. P. Kendall, expressed in "The H.T. Tapping Myth," recently published in WIRELESS. I find the adjustment of the high-tension for my detector valve very critical indeed, although I admit that almost anything will do for the H.F. and L.F. valves. I think tappings should be made at every 6 volts at least for good results.—Yours faithfully,

M. H. COLLINS.

Upper Tooting.

Forty-five Volt Units

SIR,—I am glad to see that the "H.T. Tapping Myth" has been exposed at last. In my opinion the ideal H.T. batteries are the large 45-volt units tapped at 22½ volts. For some time I have used two of these, employing 67½ volts on the H.F. valves, 45 volts on the detector, and the full 90 volts on the L.F. Nothing more convenient could be de-

sired. I hope Mr. Kendall's article will not fall on deaf ears.

Yours truly,

Hull.

M. R. WHITTAKER.

NEWS IN ADVERTISEMENTS

Messrs. Ward & Goldstone invite applications for their new and enlarged catalogue of radio accessories.

* * *

The Igranic Electric Co., Ltd., are advertising the Igranic-Pacnet Porcelain Rheostat, which is now made in resistances of 6, 10, 20, 30 and 50 ohms. A potentiometer of 400 ohms resistance is also supplied.

been in heavy use for five months, and still show 41 volts on test.]

A Saving.

SIR,—Re your interesting article in WIRELESS, dated August 7, "The H.T. Tapping Myth."

This has raised an old subject of "bad feeling" towards makers of H.T. batteries. I, personally, quite agree with your views as to tapping points and voltages, thereby effecting, for one thing, a cheaper battery and a saving of unnecessary labour and material. One wonders why makers of modern batteries have not given this point more interest before.

In only one instance have I found more than 45v. and H.T. on det. necessary, when using a W.1 type valve with 0-V.1 set; 80v. on same gives much greater

WHICH SHALL I TURN FIRST?

By PAUL WOODWARD

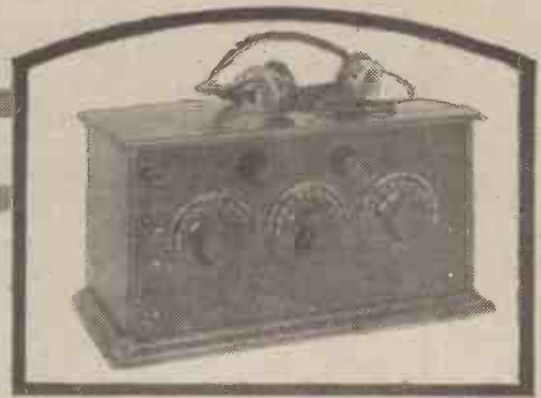

Can you operate a receiver with three tuning dials? If you are "at sea" when handling such a receiver, be sure to read this special article.



RECENTLY contributed an article to these pages under the title of "And Now To Try It," which appears to have proved of some use to readers. The article in question dealt only with fairly simple types of sets, and it is proposed to carry the idea a little further in these notes by dealing with receivers containing three tuned circuits, since special methods of operating are needed in a case like this.

A More Difficult Case

Let us assume, then, that we have just finished a receiver upon which there are three tuning dials, and wish to put it on test for the first time, and get some idea of its capabilities in the way of distant reception. Now, when a set has as many as three dials, which must all be set to the correct adjustment to pick up a distant station, the working of the instrument becomes somewhat difficult, and it is all the more important to go methodically through the various preliminary operations which are described in my last article. These included such matters as making sure the aerial and earth were connected correctly, battery leads properly arranged, loud-speaker or telephones connected to the right terminals, and so on, all little things which one is rather apt to assume have been correctly done without definitely running over the whole series of them to make absolutely certain.

The First Attempt

Assuming, then, that all those various points which have been mentioned, and the various others concerning the application of an approximately suitable H.T. voltage to the various valves, paying attention to their filament voltage, and so on, have been carried out, together with any special adjustments of neutralising

which this particular receiver may call for, we are ready to set about our first attempt at searching for distant stations with the instrument.

We can, for the moment, leave the question of the adjustment of reaction out of our considerations, because a set which has three tuned circuits will usually be of a fairly sensitive nature, and it is possible to pick up a number of distant stations without using reaction at all, even though it is provided. In some cases, of course, no

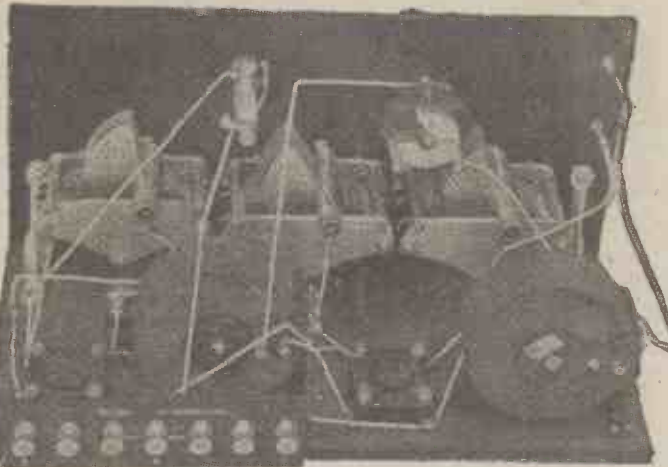

"In most receivers of modern design the readings of two of the condensers for a given wavelength will be approximately equal."

definite reaction will be provided, and the operations of searching and tuning in distant stations will be confined entirely to the manipulation of the three tuning dials. Where, however, a fourth control is provided which governs the reaction adjustment, this can be set at about its minimum position and left alone until we have experimented with the manipulation of the tuning dials.

Rules Wanted

Upon being confronted for the first time with three dials, all of which must be correctly adjusted before the desired station will be heard, the question "Which one shall I turn first?" is apt to be rather a dismaying one, and a good deal of time can be

wasted unless certain definite rules are followed as to the manipulation of those three dials, and we will now see if we can evolve something helpful to guide us in our first attempt at tuning.

Most receivers with three tuned circuits will be found to incorporate two high-frequency stages, and the first dial in such a case will be that of the condenser tuning either the aerial circuit or, more probably, a secondary circuit which is coupled to an aerial circuit of the kind usually called "aperiodic." The other two dials will be those on the condensers tuning the intervalve circuits, and in most receivers of more recent design the readings of these two condensers for a particular wavelength should be approximately equal. This fact renders searching very much easier, and, indeed, without it the process would be decidedly difficult.

The Easiest Case

We will, therefore, take first the easy case of a receiver in which the readings of the two intervalve dials are approximately matched, that is to say, within a degree or so. In a set like this the matter is not really a very difficult one, for all that one needs to do is to set the two intervalve condensers to their maximum reading, and then proceed to revolve the third condenser (usually the left-hand one) slowly throughout its whole scale. Probably nothing will be heard, and one's next step is to reduce the reading of the two matched dials by a couple of degrees and again slowly revolve the third condenser. By proceeding in this way, bringing down the readings of the two intervalve tuning dials by a couple of degrees at a time, a distant station will soon be picked up, and then final exact adjustments of all three dials can be made.

Matching

When you have tuned in a distant

(Continued on next page.)

Which Shall I Turn First? —continued

station note carefully the readings of the three dials. The left-hand one, which is usually that tuning the aerial or the secondary circuit, will probably be some little distance away from the other two, but the middle and the right-hand dial should read the same within a degree or so. Having noted the readings, it is worth considering whether it is not worth while to endeavour to match them more accurately by taking off the dial of one of the condensers and revolving it *without* the moving vanes until the readings agree more exactly, and then tightening it again. This is rather a crude method of matching readings, but it is more effective in practice than considerations of theory would lead us to believe. If this is done for some distant station which comes in somewhere in the middle of the scale, quite a useful degree of matching will hold over the rest of the tuning range.

A Mechanical Process

When such an adjustment has been made, and it is found that the two right-hand dials hold their matching fairly well over the scale, searching for distant stations becomes a fairly easy process, very little skill being needed. One simply moves the two matched dials, either one or two degrees at a time, and at each movement revolves the third condenser throughout its scale, or as much of its scale as experience shows to be necessary to cover the possible tuning point, and station after station is picked up with a fair degree of certainty. There is still some call for skill, of course, in making the final delicate adjustments which bring up the signals to such a surprising extent when carried out by the expert, but the actual process of searching becomes quite a simple one. The only point requiring any care concerns the speed at which the third or unmatched dial is turned. As I pointed out in my last article, the only way to pick up distant stations *quickly* is to *revolve the dials slowly*, which may sound paradoxical but will nevertheless be confirmed by any experienced operator.

The Third Dial

Attempts are sometimes made to match the third also to the readings of the other two, with a view to rendering searching still simpler, but it has never seemed to me to be worth taking very much trouble to achieve this result, since the ease of searching with the aid of two matched dials and a third unmatched one is really so great that nothing very much more is needed for the average operator. As a matter of fact, it is a decidedly difficult business to match the read-

ing of a secondary circuit which is coupled inductively to an aerial to the readings of two circuits which are not coupled to any other complex system like an aerial, because the readings in such a secondary are apt to be erratic under certain conditions.

Quite approximate matching can be given fairly simply, and it will often be found to exist in many sets made from Radio Press designs, such an approximate degree of matching being quite useful in simplifying the actual search operation, by limiting the amount over which this third dial needs to be swung,

LONDON—PARIS

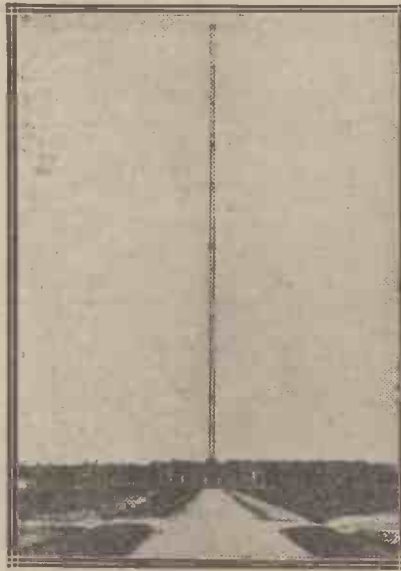

This mast is the one used at the Radio-Electrique centre for the London to Paris link.

but to go further than this is not a very easy business.

Unmatched Dials

We come now to the much more difficult case of a set with three separate tuned circuits, with little or no attempt at matching in any of them. In a case like this a good deal of patience is really called for, and one feels tempted to give the operator of such a set the rather discouraging advice that he would be better advised to build a more modern receiver than to spend a great deal of time in endeavouring to get good results from his present instrument. There are cases, however, to which such advice is not applicable, and perhaps a few words as to methods of overcoming this difficulty may be useful.

The method which should be adopted is one resembling that already detailed, but modified to allow for the fact that

it is not possible to set two of the dials backwards or forwards in unison with each other by equal amounts.

A Slow Proceeding

The method to be adopted must obviously be rather a laborious one, and it consists in setting any one of the dials to its full scale, or maximum, reading. Then set one of the others likewise to its maximum reading, and revolve the third one slowly throughout its full scale and back again. If nothing is heard, reduce the setting of No. 2 dial by 2 degrees, leaving No. 1 dial set as before at its maximum reading. Now revolve once again No. 3 dial throughout its scale and back again. If nothing is heard once more, reduce the reading of No. 2 dial by a further 2 degrees, leaving No. 1 alone as before, and once again swing dial No. 3 throughout its scale.

In this way proceed until all possible settings of dials 2 and 3 have been covered with No. 1 dial still set at its maximum position. If the desired station has not been picked up by the end of this process, reduce the setting of No. 1 dial by a suitable amount, say 2 degrees, and again search through all the possible combinations on dials 2 and 3.

Use a Log!

The process is slow, but it will only need to be carried out once with a new receiver, since when a good number of stations have been logged and their settings recorded, it will be discovered that only a certain portion of the various dials are actually used, and searching can be confined to those portions only henceforth. A good deal of time will be saved in this way, but the operation of such a receiver must always be a rather cumbersome affair; the only real help in such cases is to record the settings of as many stations as possible, so that when it is desired to pick up any given new station, whose wavelength is known, an approximate setting can be made of all three dials straight away by comparison with the settings for other stations of known wave. Just a little searching about on each dial will usually then result in picking up the desired station, especially if the methodical method of advancing certain of the dials in regular order while the others are swung is followed, within the narrow limits indicated by the previously obtained setting.

"MODERN WIRELESS"

1/6 THE SPECIAL AUTUMN DOUBLE NUMBER 1/6

will be published on September 1

ORDER EARLY

THE NEUTRODAPTER IN USE

By

G. P. KENDALL, B.Sc.

Assistant Editor

How to Use It

and

How To Get the Best from It



RESSURE upon space in the special number last week compelled me to cut my article describing the Neutrodapter rather short, but enough information was given to enable the instrument to be built, and it now remains to consider the various ways in which it may be used. First, however, there are one or two points connected with its arrangement and connections which require explanation.

Filament Control

First, there is the question of filament control. It will be observed that one of the limiting devices known as an Amperite is incorporated, and this is in place of a fixed resistor or a variable filament resistance. With these devices the filament current of a valve is automatically limited to the correct value, regardless of accumulator voltage within certain fairly wide limits. All that is necessary is to obtain the correct type of Amperite for the particular kind of valve which is going to be used, insert it in the clips, and give the matter no further thought. For example, the Amperite actually in the instrument when it was photographed was of the correct kind for a valve of the quarter-ampere filament type, running from a 6-volt accumulator.

Switching

It will further be noted that there is no separate on-and-off switch for the filament of the valve in the Neutrodapter, which brings up the question of the use of the double-pole change-over switch which is seen mounted upon the panel with its control lever projecting in front. This switch (which requires the use of a drill and a fretsaw, which can be of the hand variety, for cutting out the necessary slot in the panel) serves a dual purpose. One of its functions, and this is the main one, is to cut the Neutrodapter out of use altogether when it is not required, this effect being to

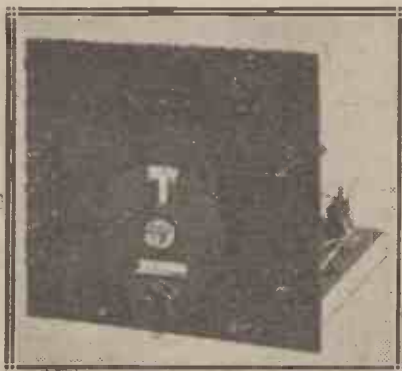

Full constructional details of the instrument were given last week.

transfer the aerial from the appropriate aerial circuit of the Neutrodapter across on to the output terminals of the instrument, whereby it is connected straight through to the existing receiving set, as though the Neutrodapter were not there. In this way one can work with the original set alone, or one can turn the switch over to the other side, whereupon the Neutrodapter comes into use, the

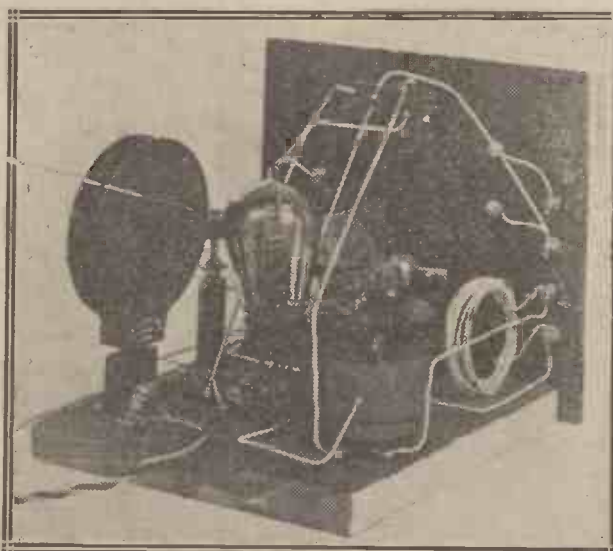

Apart from the degree of selectivity obtainable by using the Neutrodapter, with its use the present range of your receiver will be considerably increased.

other contact of the switch serving to close the filament circuit of the valve in the H.F. unit so that it lights up when required.

The Special Terminals

The next point requiring explanation is the use of the various aerial and earth terminals. A somewhat unusual scheme has been adopted here. Experimental work in the past has convinced me that the use of a single fixed coil in a so-called "aperiodic

aerial" circuit is not really adequate to cover the present broadcast band, if the best of results are desired, and some means of varying the aerial turns is usually desirable. This can be done by means of tappings, but since I have found that it is also often desirable to be able to include a fixed condenser in series with the aerial circuit, for the purpose of securing a higher degree of selectivity upon a certain wavelength or of achieving some other desired effect, it was decided to include a primary coupling coil of a fixed number of turns, this being provided upon the special ready-made coil which was incorporated in the unit, and in addition a small loading coil which could be included in circuit when desired, together with a fixed series condenser, which could also be brought into use by connecting the aerial to a suitable terminal.

How They are Used

The actual arrangement used is as follows. By connecting the aerial and earth to the two middle terminals upon the left of the panel, that is to say, to A₁ and E₁, the coupling coil is used alone, and this will be the correct arrangement for all the lower part of the broadcast band, say up to about 400 or 450 metres when only a normal degree of selectivity is desired. When a higher degree of selectivity is desired upon these waves, the aerial should be connected to the terminal A₂, the earth remaining upon E₁. The series condenser is thereby brought into operation and the desired effect

will be produced.

To secure a greater degree of signal strength upon the higher waves, say above 400 metres, the aerial should be connected to the terminal A₁, and the earth should be connected to the terminal E₂, thus bringing the loading coil into action. A third combination can be obtained by including both the loading coil and the series condenser in circuit, and this may also be found useful in some cases, experiment alone

(Continued on next page.)

The Neutrodapter in Use—continued

deciding which particular arrangement is best upon a given aerial. A sufficient number of combinations can be obtained, however, to cover the majority of likely situations.

Connecting Up

With this explanation of the use of the aerial and earth terminals, the method of connecting up the unit should become fairly clear. The terminals on the right, namely A_3 and E_3 , are for connecting across to the receiving set, A_3 being connected to the aerial terminal upon the receiver, and E_3 , of course, to the earth terminal. This applies to any type of existing receiving set, but a few words of explanation are desirable as to the connections of the aerial circuit in the set as regards series and parallel, C.A.T., and so on.

If the receiver is of the type with an ordinary tuned aerial circuit, care should be taken to see that the tuning condenser is in the parallel position, and if a C.A.T. terminal is provided this should not be used. The ordinary plain parallel tuning is what is required in such a set, while if the receiver incorporates any form of auto-coupled or "aperiodic aerial" circuit, no alteration will be needed of any sort, since it will function quite successfully by the mere connection across to the appropriate terminals.

Valves

Assuming that the method of connecting the Neutrodapter up to the various types of existing receivers is understood, we can proceed to the question of the choice of a valve and methods of making the preliminary neutralising adjustment.

A particularly suitable type of valve will be found in the variety specially produced for resistance-capacity low-frequency amplification, and in the special dull-emitting high-frequency amplifying valves which are now becoming popular. With these valves it will be found quite easy to obtain a suitable setting of the neutralising condenser, and good results will follow. About 90 volts H.T. is suggested, the filament voltage being, of course, adjusted to suit the particular type by using a battery of convenient voltage and inserting a suitable Amperite in the clips.

The First Test

Having connected the unit up to the receiving set, the first step to be carried out is to set the on and off

switch to the "off" position, and tune in the local station upon the receiver. Now turn the switch over to the "on" position, and remove the Amperite from the clips, leaving the valve in its socket in the Neutrodapter.

Leave the adjustments of the receiving set alone, and proceed to alter the tuning of the condenser in the Neutrodapter until the local station is heard at the best strength. Having done this, proceed to adjust the neutralising condenser until the point is found at which the local station's signals are reduced to the lowest possible value, and upon either side of which they begin to grow in strength once more. If you are not particularly close to the local station, you

where to look for any desired wavelength.

Final Adjustments

When you have picked up a distant station, you can proceed to make final delicate adjustments of the neutralising, and you will probably find that if you increase the capacity of the neutralising condenser slightly beyond the point at which you have set it in the first rough adjustment, signal strength will be materially improved. At the same time, you must be exceedingly careful not to go too far, or the first valve will break into oscillation and you will become a cause of offence to your neighbours.

On the other hand, if you are careful with the neutralising adjustment of the Neutrodapter, you can allow the succeeding receiving set to oscillate without any risk of causing interference, and the adjustment of reaction upon the set will therefore no longer be so dangerous a business.

COMING EVENTS

Sunday, August 29.

2LO Prize Band of Metropolitan Police Festival.

5SC Band of Grenadier Guards.

Monday, August 30.

2BD Dido and Aeneas.

2BE Variety Programme.

Tuesday, August 31.

6BM Municipal Military Band.

5NO Parry Jones, tenor.

Wednesday, September 1.

5WA "The Enchanted Land."

2EH Glimpses of Foreign Lands.

Thursday, September 2.

2LO "Nerves."

2ZY Blackpool Calling.

Friday, September 3.

5IT "What He Won."

Saturday, September 4.

6BM Louis Hertel.

5SC Irish Programme.

The latest product of the Radio Press Laboratories,

The "SOLODYNE,"

appears in the September Double Number of

"MODERN WIRELESS"

1/6 ON SALE SEPTEMBER 1st. 1/6

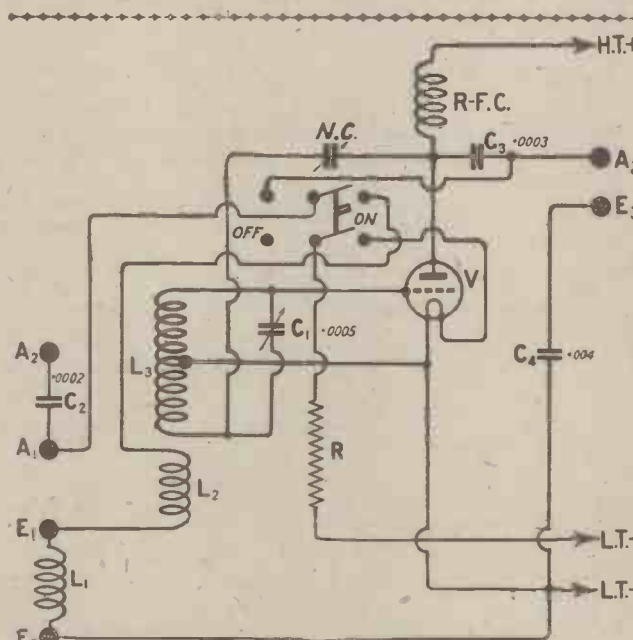

The purpose of the switch marked "on" and "off" is to cut the Neutrodapter out of circuit when not required

will probably find that it can be cut out altogether on this adjustment.

Searching

Now replace the Amperite in the clips, so that the filament of the valve lights up again, and with the switch of the Neutrodapter in the "on" position, you can proceed to search for distant stations with your new H.F. valve functioning. You will find that you now have an additional tuning control to operate, namely, the vernier dial of the condenser in the Neutrodapter, but you will soon get into the way of this, and once you have picked up a few distant stations, you will obtain an approximate calibration, so that you will soon discover

I HAVE BEEN ASKED . . .



I have a 3-valve set with a neutralised high-frequency stage, and in place of the neutrodyne unit I use a barrel-type H.F. transformer. I cannot, however, obtain stabilisation with any setting of the neutrodyne condenser, and should be glad if you could indicate to me where the fault is likely to be found.

The first point to receive attention should be the connections to the coupling unit, and here we would suggest that you reverse the connections to the neutralising coil. In practice it is generally best to employ the secondary winding of the H.F. transformer for the anode coil and the primary for the neutralising coil. If the reversal of the connections does not produce the desired effect, test through the neutralising circuit with telephones and a dry cell for continuity, paying special attention to connections between the leads to the plates of the neutrodyne condenser and the plates themselves, since if a screw which is too short is used it will account for the neutralising circuit being inoperative.

For the reception of 5XX the frame mentioned is not sufficiently large, and should either be loaded with a No. 200 coil, as indicated in Fig. 1, or a

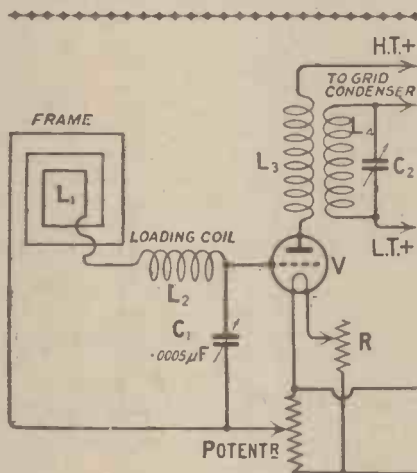

Fig. 1.—As an alternative to constructing a special frame aerial for 5XX, a loading coil may be used as shown with the existing frame.

larger frame should be constructed. For this latter we would suggest a 4-ft. square frame, with 25 to 30 turns spaced at $\frac{3}{16}$ in.

The famous bells at Croydon were recently broadcast, and a portion of the carillon may be seen in the left-hand picture. On the right M. Le Chevalier Jef Denyn is seen at the keyboard.



With my H.F. (transformer coupled) and detector receiver I can obtain good telephone strength from 2LO with a frame aerial consisting of 12 turns, but cannot receive 5XX, even though I employ an H.F. transformer of the 1,100 to 3,000 metre type. Can you explain this?

I am shortly going out to the Far East and intend to construct a receiver on the lines of Mr. Harris's "Anglo-American-Six," but with two further H.F. stages added, and with a plug and jack arrangement to cut out the extra H.F. stages which are not required. I should be glad if you would make any comments on the suitability of such a receiver.

In practice I do not think you will find the proposed set, with two H.F. stages added, at all satisfactory. Plug and jack switching on the H.F. side is almost bound to lead to instability, and it is very doubtful whether you will succeed in making the five H.F.

stages function correctly. There is also another aspect which you have not considered. This is the ratio of signal strength to outside or atmospheric interference. If atmospheric and other unwanted interference is stronger on the wavelength on which you desire to receive than the desired transmission, no receiver will allow you to obtain satisfactory signals. It is my considered opinion that you would do better to adhere to the arrangement of the "Anglo-American Six," as described by Mr. Harris, or, alternatively, to build such a set as the "Elstree Six," described in the June, 1926, issue of *Modern Wireless*.

I have a receiver consisting of a detector and one choke-coupled stage of note magnification, the set being switched by means of a jack so that I can listen on the detector only. My difficulty is that poor amplification is obtained from the note magnifier on the loud-speaker, and this only by keeping the telephones inserted into the jack.

It is likely that the winding of your choke has broken down, which would result in the detector valve receiving no H.T. supply when both valves are in circuit. By inserting the telephones the plate circuit of the detector valve is completed, and results are obtained, since the 'phones act as a rather inefficient choke.

How can I work out the fixed resistance required with any given valve, so that it may work on the correct filament voltage?

A very simple application of Ohm's law will give you the desired figure. This is obtained by dividing the volts to be dropped across the resistance by



the current taken by the valve when operating at its correct filament temperature. For example, when working a .06 ampere valve on a 4-volt accumulator the resistance required equals

$$\frac{4 - 3}{.06} = \frac{1}{.06} = 17 \text{ ohms approx.}$$

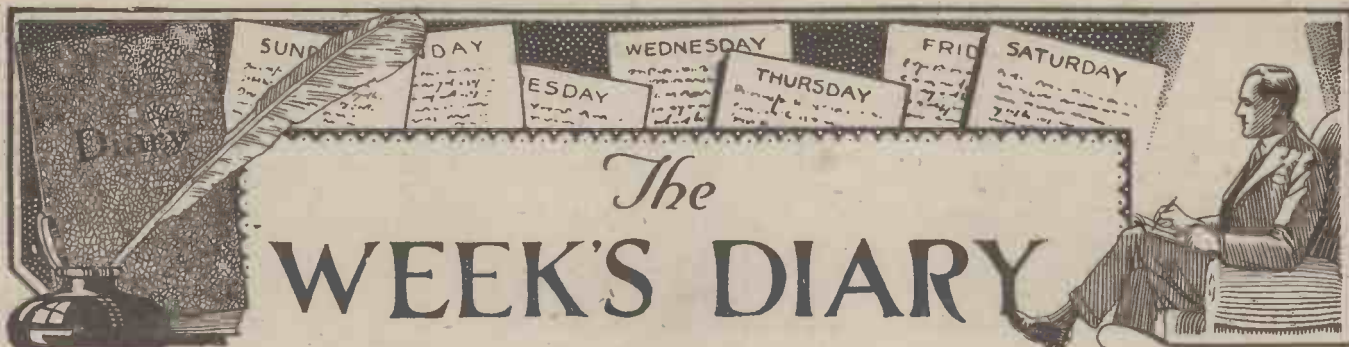

A WELL-KNOWN daily newspaper is suggesting that owing to the strong representations that have been made, marine traffic using Morse on the 300-metre wavelength will in future be conducted on a different wavelength—possibly about 800 metres. With the changes in wavelength about to be inaugurated, a number of important stations will be working round about the 300-metre mark, including, for example, Bournemouth, which itself is liable to Morse interference owing to the immediate proximity of shipping.

It would therefore appear that the benefit anticipated from the re-shuffle in wavelengths will be largely nullified if in shifting from a band where interference by broadcasting is taking place the station exchanges this trouble for irritating interference from Morse. At the same time we must remember that changes of this kind—eagerly discussed among broadcasting enthusiasts—can only be brought about by international agreement which is by no means easy to obtain, particularly when opposition is put up by interested parties, whose apparatus will become obsolete or whose pockets will be affected by the change.

* * *

SPEAKING of the wavelength changes, I find that the B.B.C. themselves are by no means certain that the proposed new wavelengths will all be successful, and indeed have officially stated that "listeners must be prepared for further changes if after a try-out a re-shuffle is found necessary." Certainly the experiment will be watched with great interest, but in my opinion the determining factor is whether or not the various organisations which have come to an agreement are technically in a position to obtain and maintain the accuracy of wavelength demanded. It is one thing to promise to keep to a certain figure and quite another to maintain it. I have no doubt that the British Broadcasting Co. will set an example which some of the smaller organisations will find it very difficult to copy.

* * *

I WISH all success to the *Daily News* scheme for the broadcasting of "Physical Jerks" each morning for a quarter of an hour. The reasons given why it cannot be done do not strike me as at all convincing, and if

the state of the British Broadcasting Co.'s finances is an obstacle, why not adopt the scheme which has proved so successful in America of obtaining a subsidy from the life insurance companies? The morning exercises broadcast simultaneously from a dozen or so American stations are undoubtedly a highly popular feature.

It is not very widely known that the whole cost of these talks by a physical drill instructor is borne by one of the largest life insurance companies in the United States, who,

THE NEW DIRECTOR



Mr. John Ansell who succeeds Mr. Dan Godfrey, Jr., as Musical Director at the London Station.

indeed, pay a very large sum to the American Telegraph and Telephone Co., who do the broadcasting, simply for the privilege of putting the drill "on the air." If an organisation as unsentimental as an insurance company considers that the health of its policy holders is improved sufficiently to warrant them spending a very large sum each year, surely there is every reason for supporting the scheme in the interests of public health.

I PREDICT that next year will see a much more continuous use of radio throughout the summer months than has been the case in the past. An American friend over here for his first holiday abroad for many years commented to me the other day on the almost ideal conditions, as he called them, connected with broadcasting in this country. "In the States," he said, "at least as far as some districts are concerned, it is almost hopeless to attempt to use your radio set during the summer months, as interference from static, or atmospheric, as you call them here, makes the loud-speaker reproduction resemble the sound of a load of gravel sliding down a corrugated iron roof. I have listened-in a great deal in England, and I find that even on days when there is summer lightning about and to all appearances it would be had for radio, perfectly satisfactory reproduction is obtained. I am also a great admirer of your broadcast programmes."

Of course, there have been some days when there has been a little interference, particularly with old-fashioned receivers, many of which seem to pick up interference far more than is technically necessary. A good modern type of set such as is now being turned out by Radio Press designers will give static-free reproduction when many of the older types make comfortable listening impossible.

* * *

SECRETARIES of Radio Societies are at present busily engaged in looking up their membership list, sending reminders and making all preparations for the coming autumn season, and many of the Societies are looking forward to excellent attendances and members intend to exhibit their new sets, such as the Elstree Six, which they have been building during the last few months. May I suggest to those who want a good feature that a "pure reproduction evening" be organised, at which members will vie with one another in giving demonstrations with the purest possible reproduction of the local station. Members and their friends will then be able to compare the relative merits of various schemes and many experimenters will learn with surprise how wonderfully pure reproduction can be obtained by methods which some of us think are "impossible."

The Week's Diary—continued

ONE of the simplest pure reproduction receivers to build is a permanent crystal detector followed by three stages of resistance-coupled note magnification, but unless suitable valves and adequate high-tension voltage be used, the results will not be of the best. With a really good low-frequency transformer it is possible to obtain practically identical results with the same crystal detector and two stages of transformer coupling, and it is no bad scheme to arrange a demonstration with a change-over switch of two such receivers, asking listeners to judge which is the transformer and which is the resistance coupling. Furthermore, a pure reproduction demonstration of this kind will do a great deal to remove the erroneous impression so widely formed that if you want really good music and speech you must use headphones.

IF I may add one further suggestion, it is that all members should be informed that no marks will be given for mere volume, as so many ardent beginners are under the impression that they have achieved the miraculous by making their reproduction far louder than comfortable for audition in the room in which the demonstration is being given.

WHILE radio control of apparatus at a distance crops up at regular intervals in connection with some spectacular "stunt," such as that shown on the cover of this week's issue, it must not be forgotten that a great deal of very serious work is going on behind the scenes in connection with the fighting services, in all countries. Our front cover shows two automobiles, the first containing receiving apparatus and means of operating the throttle and steering gear, and the car behind with the transmitting apparatus. Although it was possible to control the first car completely from the second, as a precautionary measure, and seeing that the two cars were proceeding through thick New York traffic, it was considered advisable that an assistant should stand on the running board ready to jump in and take control if for any reason the mechanism failed. Actually there was a slight collision with another accompanying car, due, it is said, to faulty mechanism of the steering wheel.

In America a great deal of experimental work has been tried in connection

with the wireless control of boats and torpedoes, but do not imagine that this country is behindhand in that respect. The difference between



The clock at the U.S. Naval Observatory, Washington, which is used for the exchange of time signals by radio with Australia.

methods on this side of the Atlantic and the other is that very often British work is of a "hush hush" nature. In other words, let the Americans do the talking!

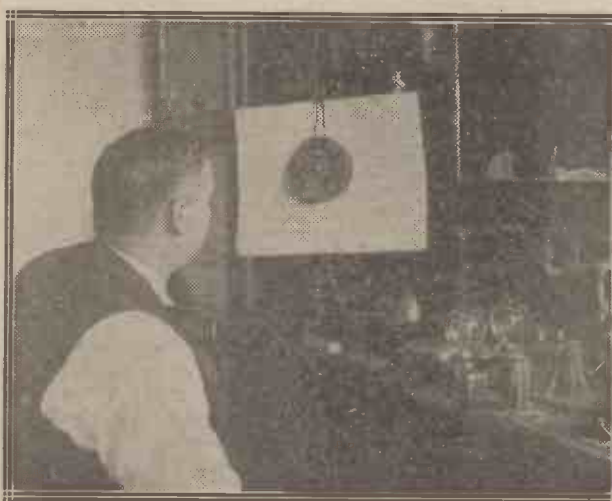

This new microphone, which is the invention of Dr. Phillips Thomas, of America, is claimed to record sounds too high for the human ear to hear.

READERS will, I know, be pleased to hear that not only will Radio Press, Ltd., be giving demonstrations of its remarkable new receivers in

London, but arrangements are being made for a provincial tour and lectures in all parts of the country, beginning with some of the centres named in the present issue. It is, however, impossible to go everywhere with the sets, but you can take my word that all of them will be well worth travelling many miles to hear.

Readers of these columns will know that I am not in the habit of exaggerating, and I am stating a fact when I say that the receivers produced by Radio Press, Ltd., for this autumn mark an entirely new era for the home constructor, not only in England, but in other countries as well.

IMPORTANT ANNOUNCEMENT

READERS of WIRELESS will be interested to hear that Radio Press, Ltd., the Proprietors of this journal and also of *Modern Wireless* and *The Wireless Constructor*, are proposing to arrange for a series of lectures up and down the country for the purpose of stimulating interest in the new developments which have originated in their Elstree Laboratories.

So strongly do they feel that entirely new fields are opened by this work that they propose to demonstrate how far advanced their new Star receivers are, compared to those produced by other designers, and sets which a few months ago were regarded as satisfactory.

A Fascinating Set

It is the immediate intention of Radio Press, Ltd., to demonstrate the truly fascinating set called the Solodyne, described in the Autumn Double Number of *Modern Wireless*. It is, of course, impossible to arrange for every reader to see and operate the Solodyne, but by giving lectures in different parts of the country, wireless enthusiasts will spread the news of the success of the instrument, and this will encourage the less enterprising to build what is undoubtedly the finest achievement of the Elstree Laboratories, taking into consideration simplicity and ingenuity, as well as signal strength, selectivity and range.

If you wish to attend one of these lectures you are requested to send a postcard addressed "Lecture Tour," RADIO PRESS, LTD., Bush House, Strand, W.C.2, stating your name and address and the maximum distance you are prepared to go to hear the demonstration.

HOW TO OBTAIN "DX ON THREE"

By L. H. THOMAS

Last week we published full constructional details of a screened-coil three-valve neutrodyne receiver. Below will be found some notes on how to obtain the best results from this set.

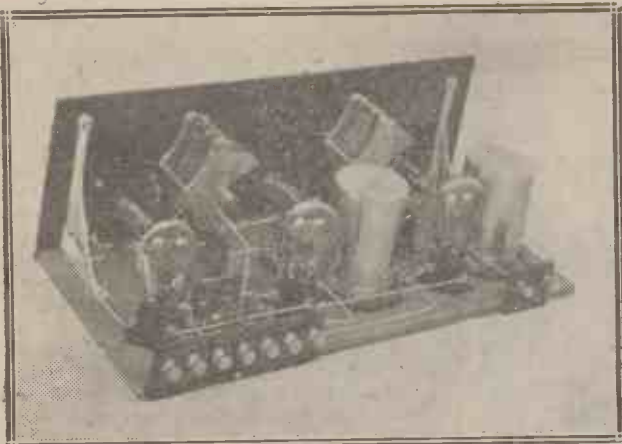

FURTHER tests of the three-valve screened-coil receiver described last week have revealed a few points that are probably of interest to those who have constructed it. Different valves as well as different H.T. voltages, etc., have been in use, and the receiver appears to function almost as well with general-purpose valves throughout as with valves of the types specified in the original article.

Voltages

It is certainly preferable to use a high-impedance type of valve as detector, since the following note-magnifier is choke-coupled. With two-volt valves in use, the H.T. voltages were: H.F. valve, 67½ volts; detector, 45 volts; note magnifier, 90 volts. With six-volt valves, slightly different values were found best, namely: H.F. valve, 50 volts; detector, 30-36 volts; and L.F. valve, 80-90 volts.

Neutralising Adjustment

Full details of the preliminary neutralisation of the high-frequency amplifier were given last week, but it should be remembered that the most sensitive adjustment of the set is obtained when the neutralising condenser

has been turned about a quarter of a turn *beyond* the position of correct neutralisation. If turned further still, the set may seem to be working very satisfactorily, but will most probably be found to oscillate at one point on the two main tuning controls. Remember, that it is not at all an efficient practice to work the set at this point, controlling oscilla-

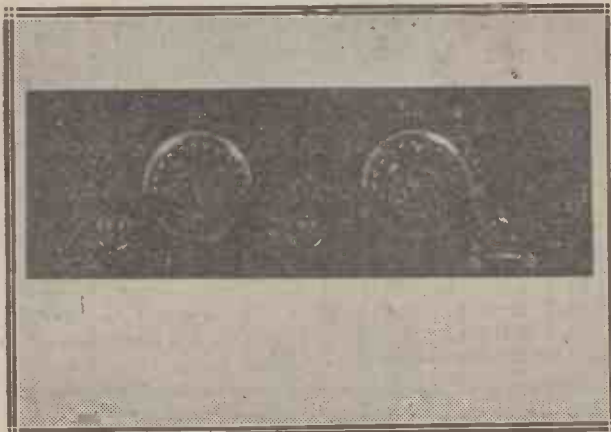

tion by deliberately de-tuning one of the circuits. Turn the neutralising condenser back until no trace of oscillation appears at any point at all.

The Screens

Trouble may possibly arise after a time through bad contact between the screens and the bases. Should mys-

terious scratching noises occur, it will be well to look to this point. The split portions of the screens themselves may be opened out slightly, and may also pay for an occasional rubbing with emery cloth.

Also, do not be alarmed if the set behaves in a very erratic manner when the screens are removed or handled in any way. One correspondent complained about another screened-coil receiver that he could "tune stations in by holding the screens in his hands and lowering them gradually over the coils." This is bound to occur, and also the receiver will very likely be found to burst into oscillation in certain circumstances when the screens are removed. Do not, however, regard this as an advantage and remove them permanently!

Turn Them Slowly

Lastly, rotate the two dials *slowly*. The tuning, especially on distant stations, is so sharp with this set

that it would be the easiest thing in the world to miss them altogether. The slight rushing noise (from external "mush," etc.) that can be heard when the two tuned circuits are accurately adjusted serves as a very useful guide in tuning, if the dials are kept "in step."

STATIONS HEARD ON THE "THREE-VALVE SCREENED-COIL RECEIVER"

- | | |
|---------------------------|---------------------|
| 297 m. Hanover (Relay). | 387 m. Bournemouth. |
| 300 m. Barcelona. | 404 m. Newcastle. |
| 306 m. Sheffield (Relay). | 410 m. Münster. |
| 335 m. Hull (Relay). | 425 m. Rome. |
| 340 m. Madrid. | 440 m. Belfast. |
| 353 m. Cardiff. | 479 m. Birmingham. |
| 365 m. London. | 487 m. Brussels. |
| 373 m. Madrid. | 495 m. Aberdeen. |
| 378 m. Manchester. | 531 m. Rosenhügel. |



PRACTICAL TOPICS

By G. P. KENDALL, B.Sc., Assistant Editor

Interesting Tests—A Panel Suggestion—Unsatisfactory Frame Aerials

IT may be remembered that some little time ago I mentioned in these columns that I have the opportunity of carrying out some quite interesting tests on the question of just how local were the really rather bad conditions under which I used to work at my old address in Wimbledon; my new position being not more than a quarter of a mile away from the old one, it was thought that some useful results could be obtained by carrying a portable receiver from one to the other upon several occasions and noting the results obtained at each place.

A Preliminary Test

As a preliminary to this, it seemed desirable to gain a general idea of what conditions were like at the new position, and with this end in view I have been listening during a series of evenings with a receiver with the performance of which I am very familiar, the set in question being a six-valve portable superheterodyne, which I constructed some five or six months ago, and which has been in more or less constant use ever since.

The results are certainly interesting as far as they have gone, as well as gratifying, because it appears that, as I had suspected, the bad conditions under which I used to work were very local indeed, the behaviour of the receiver for the last few evenings in the new situation suggesting that conditions are at least up to normal. For one thing, I am no longer troubled by interference from a certain tramway route which used at one time to make my existence rather a hard one, and, for another, signals from stations which were exceedingly difficult to receive at the old position now come in with great ease.

Dublin

For example, it used to be particularly difficult to receive any station in a general westerly direction, such as Cardiff, and, farther to the North, Dublin. This latter station was by no means easy to receive at my old address, being decidedly erratic, sometimes coming in quite well for perhaps half an hour at a time, but as a rule being weak and undependable.

For the last few evenings, however, during the tests in question, it has been perfectly easy to obtain at good strength, coming in with quite a "local station" effect, on the six-valve set. Last night, for example, I held this station for nearly an hour upon the loud-speaker perfectly steadily and with only one short spell of fading, the signals being at all times well above the general level of atmospherics and interference.

These tests have gone on for a period long enough to show that a

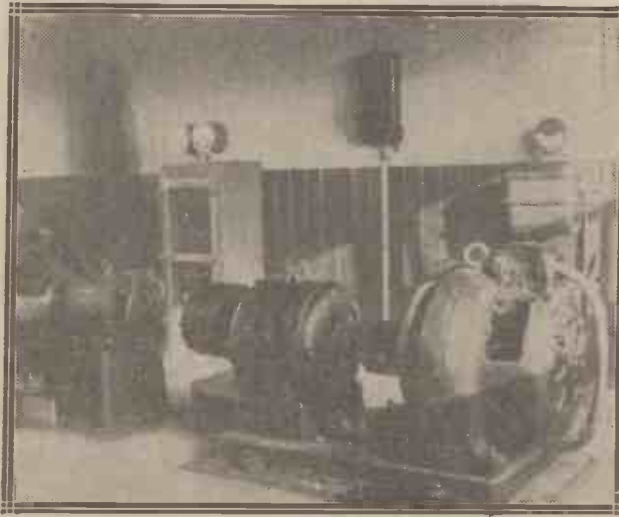

Mr. Kendall finds that the Dublin Station is one which reveals interesting differences in the reception condition he describes. The view shows the power plant at 2RN.

false impression has not been gained as a result of listening upon a few particularly good nights, and it will be interesting to see just how far they are confirmed by the more decisive experiment of carrying the receiver from one position to the other and back again upon the same evening.

A Pleasant Dream

Having occasion recently to drill a panel in something of a hurry, it occurred to me what a blessing it would be if some enterprising ebonite manufacturer were to start turning out his panels ready ruled upon the back with two sets of parallel lines, one set running lengthwise on the panel and the other set crosswise, the lines being perhaps 1 in. apart. Then, if the panel was properly cut so that its edges fell upon ruled lines the laying-out of the panel and

the fixing of the positions for the various components would be the easiest thing in the world. All that one would have to measure would be the fractions of an inch between the lines and the marking up of the various holes would become a matter of minutes only. A pleasant dream—if only a dream!

The Top-heavy Frame

The more I use frame aerials the more I wonder why it is that so few manufacturers seem to have gone to the trouble of designing and producing a frame which is not a thoroughly annoying and tiresome piece of apparatus to use. Almost every frame which I have ever used has suffered from two defects which could surely be removed without very much difficulty or expense. In the first place, they have all been more or less top-heavy, with a very inadequate base or stand, so that some modification was needed before they could be used safely, and, secondly, with only one or two exceptions they suffered from the drawback of trailing flex connections to a pair of terminals or sockets, which turned round with the frame when it was revolved, so that the leads were constantly winding up and unwinding in a very messy fashion.

Untidy Appearance

One has to use leads of excessive length to allow for this winding-up process, and the result is a very untidy appearance. The length of the leads can be kept down a little, of course, by always remembering to rotate the frame first half a revolution in one direction and then half a revolution in the other, but it should not surely be too difficult to devise some other means of making connection

which should be sound electrically and satisfactory mechanically.

An American Method

In America it has been quite a common practice to mount the frame aerial upon a telephone plug, and to insert this in one of the ordinary telephone jacks, fixed in the lid of the cabinet of the receiver with which the frame is to be used. Such a scheme does not appeal to me very much, because the average telephone plug and jack is a rather "high-loss" piece of apparatus when made to carry high-frequency currents. Possibly something could be devised on the lines of the devices used for making connection to the moving spindle of variable condensers, which would be satisfactory when made upon a larger scale and fitted to the base of a frame aerial.

THE LAST STRAW!

MORE TALKS !!



AH! JONES - I JUST WANT TO GIVE YOU A GOOD TALKING TO -



HELLO - THAT YOU MR JONES - I WANT TO TALK TO YOU ABOUT OUR ACCOUNT



OH! I MUST TELL YOU ABOUT MY YOUNGSTER - YOU NEVER SAW SUCH A CLEVER LITTLE RASCAL -



GLADYS WANTS SOME NEW SHOES AND CYRIL BROKE A WINDOW TO-DAY - A BILL FOR THE RATES CAME - OH YES AND -



"YOU ARE NOW TO HEAR A TALK ON -"

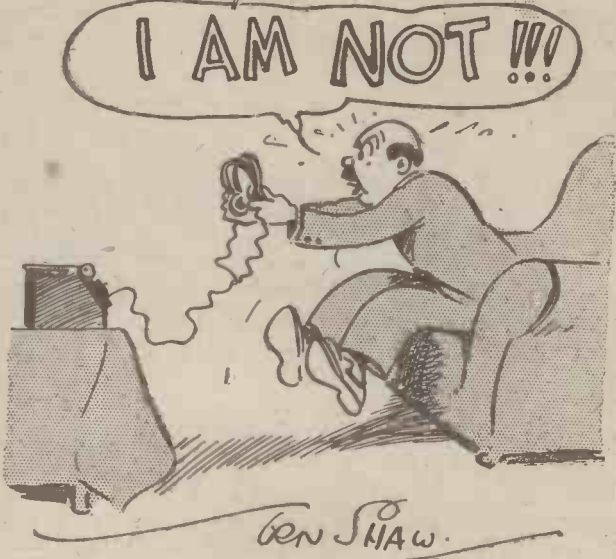

I AM NOT !!!

Ben Shaw.

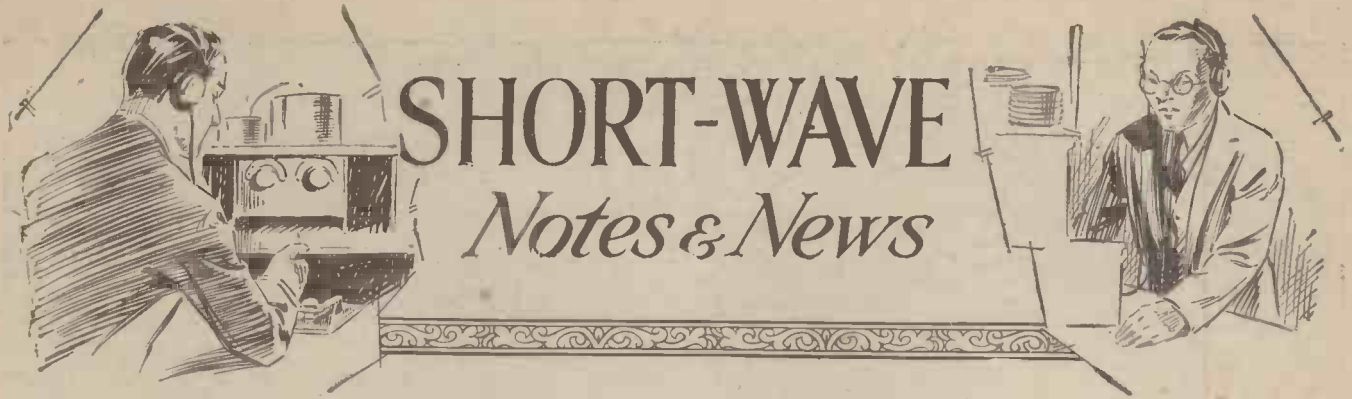

SHORT-WAVE

Notes & News



THE past fortnight has been decidedly quiet compared with the previous few weeks, no doubt on account of the large number of amateur transmitters taking a well-earned rest from the key at well-known seaside resorts! No doubt the end of September and the beginning of October will see a greater number of stations working on short waves than ever before. It is rather remarkable that the Brazilian stations should come through quite consistently throughout the year, while the United States amateurs can hardly be depended upon from one day to another. The latter can rarely be heard before 1 a.m., no matter what the conditions for receiving Brazil are like just before midnight. The only indication of what the "U's" will be like is the strength of WIZ, the high-power automatic station, who generally commences to come through before the lower-powered amateurs make themselves heard.

Some American Records

Our short-wave stations will certainly have to look to their laurels, if they wish to keep up their reputation, however much good work they may have done up to the present. What seems to be wanted is a real "star" station that will work every country in the world with a power of .5 watt or so! U-8GZ has recently worked to Australia, South Africa, and New Zealand with inputs all below .57 watt (this including the input to the filament as well).

The set used was perfectly "straight" in every way, and the secret of success was almost certainly the fine D.C. note that may be obtained so easily when the power is kept down and nothing is overloaded. He states that several of the stations he worked asked him if he was using crystal control. The aerial in use was a "Hertz," 70 feet high, and clear of screening, so that it seems that with a good radiating system a well-thought out set, and a reasonable amount of common-sense, anything is possible.

Crystal Control

Crystal - controlled stations in America seem fairly numerous, but this system does not seem quite as popular as it might be over here. Whether this is on account of the difficulty of obtaining crystals or of the extra complications that arises from the addition of another valve or valves is rather doubtful. Obviously if a crystal with

it seems that powers up to 8 or 10 watts may easily be controlled in this manner. The trouble is that crystals with such a short natural wavelength are not only very difficult to obtain, but are so very fragile that the risk of accidental breakage is very great.

Master Oscillators

The master-oscillator system, though not capable of producing such a wonderfully steady and pure note as that obtained by crystal control, is well worth while, especially where the operator of a transmitter is in such a position that he cannot keep his aerial dead steady, or is affected by swaying on the part of neighbouring aerials.

The chief difficulty to be overcome when using this system on short waves of the order of 45 metres is that the power amplifier often has to be neutralised to prevent it from oscillating on its own. If it does this, of course, the so-called "master-oscillator" need not be in use at all! Research on this subject is being carried out by several well-known experimenters at the present time, and probably some definite data will soon be available.

Receiver-Transmitters

The use of receivers as transmitters seems to be very successful on the shorter waves, particularly upon the 23-metre band. The writer heard the receiver howl of a station 235 miles distant recently, when both stations were listening to some signals from across the Atlantic. Communication was carried out between the two receivers by tapping upon the aerial terminals! This was a freak, however, as several attempts to repeat the performance have all proved unsuccessful.

Communication over ten miles or so has also been established with a heterodyne wavemeter with an anode potential of 24 volts only. The power in this case was not measurable, but was probably of the order of .001 watt! Though the "miles-per-watt" record is quite high, it may easily be broken yet by such "stunts" as this.

"3LO"

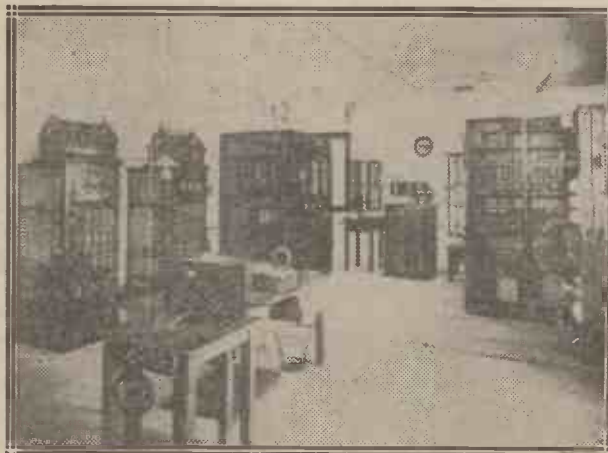

The transmitting plant at the Melbourne Station, Australia, follows very closely upon the lines of those in use at B.B.C. Stations, as may be seen from this interesting photograph.

a fundamental wavelength of 90 metres is used, an amplifier will be needed, and this may be arranged as a "frequency-doubler" to enable the crystal to be used for controlling at 45 metres.

For low powers it is, of course, preferable where possible to use a crystal with a fundamental of 45 metres, and from the results of recent experiments

QRA QUERIES

Cur QRA department deals with all queries relating to call signs, addresses, etc., of amateur transmitting stations.

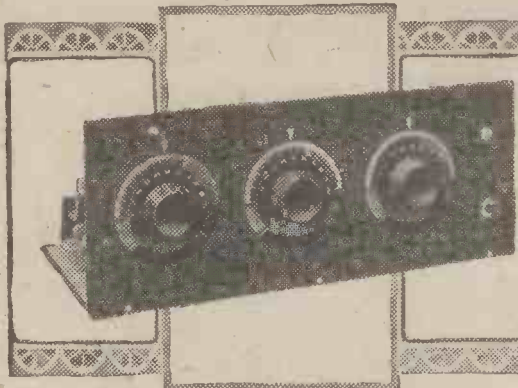

OPERATING THE TEN-GUINEA NEUTRODYNE RECEIVER

By A. JOHNSON-RANDALL

Those readers who have constructed the Ten-guinea Four-valve Neutrodyne Receiver, of which full constructional details were given in our last issue, will find these notes helpful in getting the best from the set.

IN my article in the last issue of WIRELESS I described the construction of a simple "Ten-Guinea Neutrodyne Receiver," and in these notes I intend giving a few hints upon the operation of the set.

An Important Point

One of the most important factors in the successful working of the receiver lies in the spacing of the Neutroformers themselves.

As stated in the article last week, it is essential that the makers' template should be followed in this respect, since any deviation in the angles between the coils and the horizontal or the distances between the centres will seriously affect the neutralisation, and poor results will be obtained. The makers of the Fada Kit state that an error of one degree will be detrimental to the correct functioning of the set, hence the importance of drilling the panel correctly.

The 'Neutrodon's'

Provided the spacing of the Neutroformers is correct, the receiver can be neutralised with valves of all types. This is rendered possible by the design of the "neutrodon's" or small neutrodyne condensers, shown as N.C.₁ and N.C.₂ in the Fig. 3 wiring diagram given on page 10 in the last issue of this journal. For the purposes of explanation, this wiring diagram is reproduced. It will be seen that there are three terminals to which connections may be made. A number of capacity variations are pos-

sible, since by connecting the two leads to the end terminals the minimum capacity is obtained, but by changing one lead to the centre terminal further variations in the capacity range become available. In addition to this, if one joins a small piece of wire between the centre terminal and one of the end terminals, one obtains the maximum capacity variation possible. This should make it an easy matter to

the effect of connecting a small capacity across the primary winding, but its value is not critical, and anything between .0003 and .001 will probably be found quite satisfactory. In practice, the use of this small condenser may increase the tendency of the set to oscillate. Those constructors who have any trouble from oscillation should try the effect of disconnecting the condenser altogether.

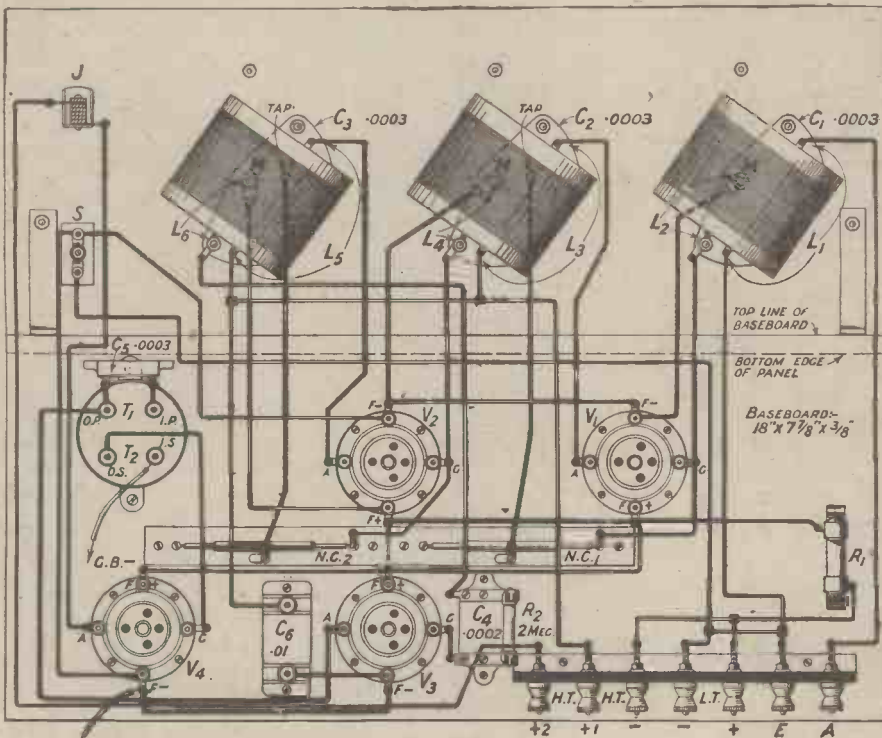

It is possible to neutralise the receiver with all types of valves by employing suitably the two small condensers N.C.1 and N.C.2.

neutralise any of the commercial types of valves.

The By-pass Condenser

The next point concerns the small by-pass condenser, shown connected between O.P. and I.P. on the L.F. transformer. This is not absolutely necessary, and the set may be found to be more stable with this condenser omitted. However, it is well to try

same. Having neutralised the receiver, all that is necessary to tune-in a station is, assuming that the aerial and earth have been connected, to rotate the three dials together one or two degrees at a time until signals are heard. The adjustment of the C.3 may be slightly different to that of the other two dials. This, however, should not make the operation of the receiver difficult.

H.T. Voltages

With regard to the H.T. values, I have found that the following for valves of the small-power type are quite satisfactory: For V.4, that is, the L.F. valve, 100-120 volts, with about 7½ volts grid bias, is usually correct. The rectifying valve usually requires a much lower voltage, and 30 volts will in most cases be ample. The two H.F. valves, V.1 and V.2, will require anything from 60-90 volts, the correct values being found by experiment.

Tuning

Although the three dials must be adjusted, tuning is simplicity itself, since the readings on the dials are approximately the same.

From my Armchair

BY EARL RUSSELL

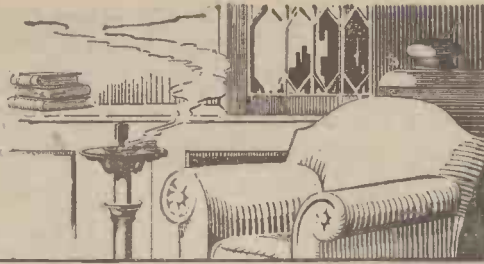

In these columns Lord Russell expresses each week his own personal views on matters of interest to "Wireless" readers.

Loud-Speakers a Nuisance

I can imagine nothing more maddening to a person with a sensitive ear, or one of studious habits, than to have a raucous and distorted loud-speaker braying in an adjacent garden on a summer night. Personally, I should be inclined to think the night spoilt, even if it was not distorted. This inconsiderate and selfish usage has now apparently become so frequent that Reading has passed a bye-law about it.

The legal difficulties in the way of anything of this sort are always very great, as the numerous old cases about the crowing of cocks, the bark-

had a birthday, so shall treat myself to a set of them.

Too Easy

Stations are so powerful now, and receiving sets are so good, that I am very much afraid the vast majority of ordinary listeners with valve sets will take no interest in the art. Of course, from the manufacturers' point of view, one desires to supply the public with a fool-proof article which will work if they only let it alone, but, from a scientific point of view, it means an experimenter lost. However, no doubt enough will survive, especially among the young, who, by

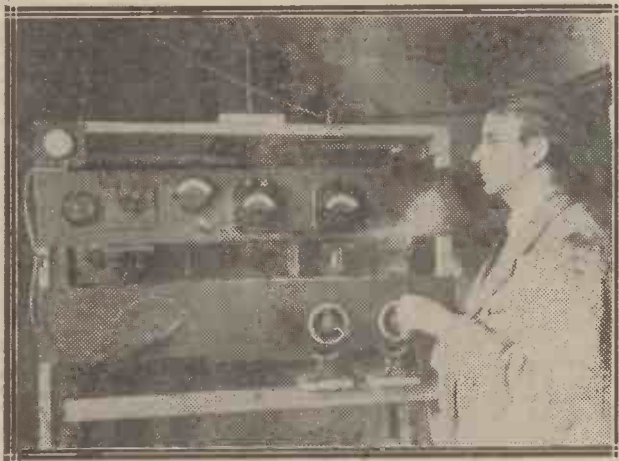

The P.M.G. has recently issued the first licence for television transmission. Our picture shows the inventor, Mr. J. L. Baird, standing by some of the apparatus.

ing of dogs, and the noise of machinery show. The theoretical legal view is that an amount of noise which is fairly continuous and in excess of that which a reasonable person might be expected to endure in a town may constitute a nuisance, but who on earth is to interpret the word "reasonable" in such a definition? I sympathise with the framers of the bye-law, but I see difficulties in its enforcement.

Panel Meters

I have seen some very attractive little instruments for the face of the panel that are just what I have been looking for. They are neat in appearance and small in size, while the name of the maker is a guarantee of sufficient accuracy for what is, after all, only an indicator; and, to sum up, the prices are reasonable. Milliameters, for instance, are 10s. 6d., and I have never been able to get one for less than 25s. before. I have just

wanting to get better and better results, will continue to develop the art and practice of wireless reception, and invite theory to catch them up if it can. I am moved to these reflections by a four-valve set I saw, very dirty, with an encrusted accumulator and a rag-bag H.T. battery, connected to an aerial not twenty feet high, with very poor insulation, but which, nevertheless, was receiving 5XX quite well.

British Association

I have just virtuously spent a week of my holiday in attending the British Association, but practically the only lecture on wireless was the public one given by Captain Eckersley in the Town Hall. From the severe things I heard mathematicians and professors of pure physics saying about each other's theories, I gathered that it was not only in the science of wireless that there are acute differences of opinion among the more eminent exponents.

It will Pay You to see this Exhibit!

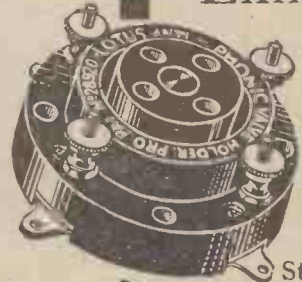

Visit Stand No. 84 at the National Radio Exhibition—see the "Lotus" Valve Holders and learn just how and why they excel in absorbing shock, protecting the valves and eliminating all microphonic noises.

Valve sockets and springs locked together by a mechanical process, making a definite and permanent connection. Bakelite mouldings nickel silver springs and phosphor bronze valve sockets, nickel plate.

2/6 With terminals

2/3 Without terminals

Rigorous tests at the factory ensure that "Lotus" Valve Holders will give entire satisfaction under any conditions. That is why you should insist on them for your set.

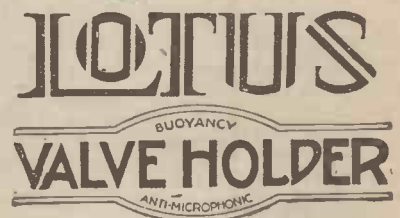

Made by the makers of the famous Lotus Vernier Coil Holder. GARNETT WHITELEY & CO., LTD., Lotus Works, Broadgreen Road, LIVERPOOL.



AN OBSOLETE COMPONENT

By "PROGRESS"

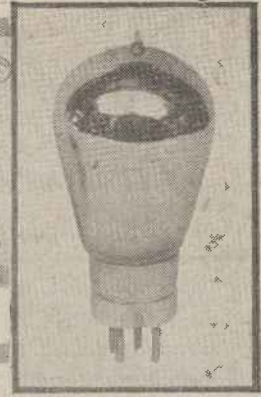

Our contributor expresses very forcibly his views on the question of the use of variable filament resistances. The question is one indicative of a change in general practice, and every designer now considers whether fixed resistors or barretters will serve his purpose in any given receiver. While we do not necessarily associate ourselves with the extreme views of "Progress," it is obvious that the point is one deserving full consideration.



I HAVE no doubt that many of you who read these lines think your sets are the very last word, and yet I have no doubt that amongst those very fine sets of yours I should find that a very large proportion contain a component which was obsolete a year ago, and ought now to be regarded as a relic of the middle ages, speaking in the wireless sense. To which component do I refer? Why, to the filament rheostat, of course, that survival of days when we used to use weird valves and funny circuits, and an operator spent half his time trying to persuade his valve to behave the same way as it did yesterday.

New Conditions

Times have changed. Modern valves (and by modern valves I mean the newer dull emitters, of course) are no longer in the least bit critical about their filament current, when used in any plain and straightforward circuit, and all that one has to do is to see that they get the ration recommended by their makers, and one can be quite sure that any further fiddling will not be of the least use.

The filament rheostat is dead. Why not bury it? To provide a row of rheostats upon a panel is simply setting a trap for the unfortunate beginner, who proceeds to twiddle all the little knobs with great assiduity, finds that for the most part they make very little difference, and ends up by turning two of them at once, with the result that he probably dims one valve much below the correct point, turns the other up so brightly that its life is liable to be shortened, and then having got himself thoroughly mixed up, proceeds to play with the reaction control instead for a while, and wonders why the set is no longer so easy to control as it was before he started upon his operations on the rheostats.

Not Critical

Any modern valve worthy of the name (of course, I am not speaking

of bright emitters; they are dead likewise, or very soon will be) requires only the roughest of adjustment of filament voltage and most emphatically does not require readjustment for different purposes. If its makers recommend that it be given 5 volts, at which pressure it will take a quarter of an ampere, arrange to give it those 5 volts, and you will find that it will take fairly accurately the current at

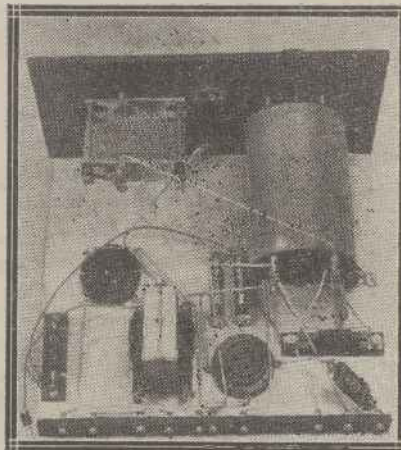

Here is an example of a set without rheostats: the two control devices may be seen near the centre of the base-board.

which it is rated, and will function perfectly happily for as long as you care to ask it to do so. What is more, variations on either side of the recommended voltage will have little effect on signals; increases will merely shorten the life of the valve, while a reduction below a certain figure will certainly lead to a falling off in efficiency in any ordinary circuit.

Why Vary It?

When our valves are of such an accommodating nature, requiring merely a certain definite filament current, what in the name of common-sense is the use of providing a means of varying the current? Not merely is a variable resistance useless, but it

is a positive danger in the case of a comparatively inexperienced user, because it substitutes the method of trial and error for what should be a perfectly definite and exact proceeding. The proper way to get a definite current through the valve is to connect in series with it a certain definite value of resistance, which can be calculated by the simplest of arithmetic. If you do this, you know that your valve is getting just the correct voltage, enough to make it function correctly, and not enough to do it any harm.

Risky Methods

With a variable resistance, on the other hand, you have two methods of adjusting the current correctly, and neither of them are particularly satisfactory, in my opinion. The first way is to turn up the valve fairly full, and then proceed to turn it down until you find the point at which signals begin to suffer. You then turn it up a little and hope for the best. The other method is to turn the valve up to what you have previously found to be the correct degree of brilliance, estimating its temperature by eye, a rather dangerous method. Either of these methods may be fairly effective in the hands of an experienced valve user, but what about the poor beginner? He is often told as the first step in getting his new set into operation to "turn the valves up to the correct degree of brilliance." If he has never seen a valve of that type in use before, how on earth is he going to do it? No wonder that one sometimes hears beginners complain that "dull-emitters are no good, they lose their emission in a few hours"!

Simple!

To my mind, there is only one proper course to adopt, when you are going to use a certain type of valve upon a battery of known voltage, and that is to insert in series with each valve a fixed resistor of the appropriate value. Possibly the reason why some people incorporate variable filament rheostats in new sets is because they think they may want to use all sorts of different types of valves at various times,

AN OBSOLETE COMPONENT

(Continued from previous page)

always, in all probability, with the same six-volt accumulator. If they would but realise it, however, a fixed resistor of the interchangeable variety is still the correct solution, and once they have discovered how easy it is to calculate the value of the required resistance, and to slip it in place, I am confident that they would never go back to the primitive and dangerous method of the use of a rheostat.

Not Expensive

It may be objected to the use of fixed resistors that it is expensive to keep a stock of them to cover all the various possible types of valves, but as a matter of fact this is not so. Three or four fixed resistors will cover the likely changes of valves, and their cost is not heavier than that of a good type of filament rheostat, and the matter would become simpler still if British valve manufacturers would come to their senses and stop bringing out new types of filament every other week.

"MODERN WIRELESS"

1/6 Special Double Number, 1/6
On Sale September 1st.

A HANDY GADGET

A handy little component for the amateur is the adjustable aluminium spark-gap used on the trench spark-transmitters during the war. These can be obtained very cheaply from some of the large Government surplus



Spark-gaps like this can be picked up for a few pence and used as neutralising condensers.

stores. They make excellent base-board-mounting neutralising condensers for some of the latest circuits, as they are already mounted on a small ebonite base. Furthermore, they are adjustable within wide limits, so that a capacity sufficient for neutralising is obtainable. Their appearance is very neat, not much baseboard space is required (4 1/2 in. by 1 in.), and they are simply screwed into position by two wood screws.

Such a spark-gap is shown in the illustration. It has the advantage that when the correct neutralising adjustment has been found, it may be locked in position by means of the screws on each aluminium pillar.

To remove any risk of shorting, a small piece of mica may be stuck upon one of the electrodes with shellac varnish. A. P.

"Classics versus Jazz"

SIR,—I should be glad if you would allow me to correct an unfair and misleading statement issued recently by the British Broadcasting Co. following the broadcasted debate "Classics versus Jazz" between Sir Landon Ronald and myself.

According to the B.B.C., the "actual voting (by letter) was for Classical 568, for Jazz 172, indefinite 88. Consequently classical music is much more favoured than jazz."

Now aside from the inconclusiveness of a poll of a few hundred out of a possible poll of some hundreds of thousands, the B.B.C.'s figures did not take into consideration the 623 letters which I personally received. Of these, 545 were definitely in favour of so-called popular music, and 78 were either incoherently indefinite or violently abusive of me. Allowing, therefore, the 78 violently minded people who presumably prefer the gentler classics to what they wrongly call jazz to be counted with "opposition," the amended poll is 717 for popular music and 646 for the "classics."—Yours faithfully,
London, W.C.2. JACK HYLTON.

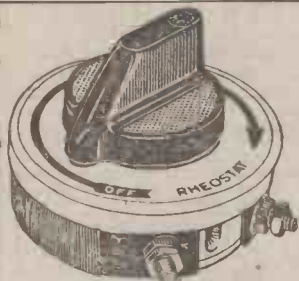

VALUE!

THE Igranic-Pacent Porcelain Rheostat is only 2s. 6d., but the action is smooth and silent and the contact thoroughly reliable and constant.

The method of mounting is particularly simple and preserves the original accuracy of adjustment.

Each rheostat is supplied with an attractive bakelite knob and silvered dial, which forms a pleasing contrast to the panel when mounted.

2/6

Made with resistances of 6, 10, 20, 30 and 50 ohms, and as a potentiometer with a resistance of 400 ohms.

SEND FOR LIST No. S 26.

BE SURE TO VISIT THE
IGRANIC STANDS, Nos. 72 & 73

NATIONAL RADIO EXHIBITION
OLYMPIA—SEPT. 4th—18th

IGRANIC ELECTRIC CO LTD

149, Queen Victoria Street, LONDON. Works: BEDFORD.

DESIGNED SPECIFICALLY FOR BUILDERS OF THE "ELSTREE SIX"

So that the countless experimenters who invariably prefer to use J.B. Condensers in all their receivers may incorporate them in the "Elstree Six," we announce the introduction of .0005 J.B. lowloss twin condenser.

The design adheres to the type here illustrated (.02 ohms loss at a million cycles certified by the M.P.C.) in addition to the other essential features which characterise the J.B. to give the utmost tuning efficiency.

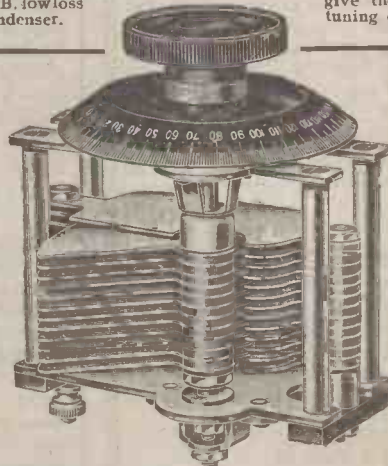

J. B. LOW LOSS GEARED VERNIER (50 to 1).

.001	- 17/6
.0075	- 10/3
.0015	- 15/-
.003	- 13/6
.0025	- 13/3
.002	- 12/-
.001	- 12/-

[Pat. No. 246009].

J. B. LOW LOSS.

.001	- 18/-
.0075	- 11/0
.0015	- 10/0
.003	- 9/-
.0025	- 8/0
.002	- 8/0
.001	- 8/3

Pat. Nos. 241803 and 246009

J.B. low loss Twin Condenser for the "Elstree Six" .0005 mfd. 21/- each; £4 for the set of four.

JACKSON BROS
8, POLAND ST- OXFORD ST
LONDON - W.1. Telephone: GERARD 7444
(First Floor)

Agents for Holland: Radio Beurs, Papestraat 8, Sgavenhage, Hague, Holland.

Stand 84, Olympia Radio Exhibition

The name 'LOTUS' is your guarantee of sound results and solid satisfaction

The 'LOTUS' JACK

Designed to take up the least space, the depth back of panel being 1½ in. Made from best Bakelite mouldings, with nickel silver springs and pure silver contacts. One-hole fixing. Soldering contacts can be brought into any position.

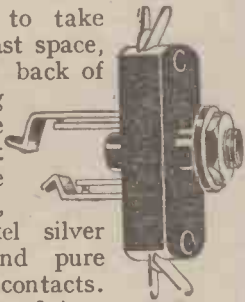

Prices
No. 3, as illustrated 2/6
others from 2/- to 3/-

The 'LOTUS' JACK SWITCHES

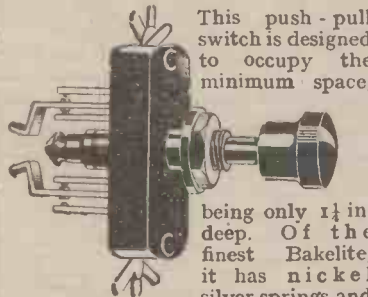

This push-pull switch is designed to occupy the minimum space,

Prices

No. 9, as illustrated 4/-
others from 2/9

being only 1½ in. deep. Of the finest Bakelite, it has nickel silver springs and contacts of pure silver. Soldering contacts can be made to suit any wiring.

The 'LOTUS' JACK PLUG



Designed for use with Lotus Jacks. Made from best Bakelite mouldings and nickel plated brass. To fix, the wires are placed in slots and gripped in position by a turn of the screw cams.

Price
2/-

Made by the makers of the famed 'LOTUS' Vernier Coil Holders and 'LOTUS' Buoyancy Valve Holders

Garnett, Whiteley & Co., Ltd.,
LOTUS Works
Broadgreen Road, Liverpool

MORE NEUTRODYNE FAULTS

(Continued from page 44)

employed these may fairly soon develop a high internal resistance which will tend to make the set unstable unless the H.T.appings are shunted with suitable by-pass condensers.

Defective Anode Resistances

Failure to neutralise an "Elstree Six" type receiver (Fig. 2 arrangement) I have found to be due, in one case, to a defect in an anode resistance, for example R4, R5 or R6, and some indication of the symptoms which are present when such a fault occurs will be of interest. I have tried deliberately replacing each resistance in turn by a defective anode resistance, which on the megger gave an infinity reading, and the symptoms have been particularly varied. In some cases, a high-pitched whistle—which no adjustment of the neutralising condensers would alter, and which was still present when the 'phones were placed in the plate circuit of the detector valve, showing the trouble to be on the H.F. side—occurred, whilst in others signal strength was slightly weaker than normal and slight distortion was present. On the other hand, the usual bubble, bubble, bubble noise, often obtained with a break in a grid circuit may be heard. A "short" in an anode resistance, on the other hand, may make little noticeable difference in results.

Some indication as to whether an anode resistance is correct may be obtained by applying the well-known telephones and dry cell test across the resistance, when if the component is not defective very loud clicks should be heard. Although this test does not give a particularly good indication of the actual resistance, for its purpose, sufficiently accurate for most purposes. When no clicks are heard, upon thus testing, replacement is necessary.

Grid Battery Trouble

It occasionally happens, though not often, that an internal break occurs in a detector grid-bias battery, that is, a connection between two cells becomes discontinuous. When this occurs with a set of the "Elstree Six" or "Magic Five" type, a roar or a pop, pop, pop type of noise superimposed on a continuous oscillation or whistle is generally heard. Such a defect in a grid-bias battery will be easily located by connecting a voltmeter across the whole battery, when no reading will be obtained. The first step in this case is to test between each adjacent pair of tapping sockets with a voltmeter, when it will probably be found that no reading is obtained between a particular pair. These two sockets, if located, should be shorted, when the battery will give further useful service.

WIRELESS.—Capable, trustworthy men with spare time who wish to substantially increase income required where we are not fully represented. Applicants must have practical knowledge of installation of Set and Aerial, be a householder or live with parents, and be able to give references; state age and experience. Address: Dept. 38, GENERAL RADIO COMPANY, LIMITED, Radio House, Regent Street, London, W.1.

Build Your Own LOUDSPEAKER

WITH A LISSENOLA OR BROWN A and our COMPONENTS. You can construct yourself a handsome CONE type, or FLEATED PAPER type LOUDSPEAKER in half an hour for less than it would cost you for the ordinary cheap horn type Loudspeaker. You will obtain VOLUME, CLARITY, and unsurpassed tonal quality. Prices, particulars and Diagrams for stamp. TRADE inquiries invited. Tell your dealer **Goodman's, 27, Farringdon St., E.C.4**
Also obtainable from Spencer's Stores, 4-5, Mason's Ave., E.C.2

WET H.T. BATTERIES

British made round or square Leclanche Glass Jars, 2½ x 1½ x 1½, for wet H.T. Units. Waxed, 1/3 doz.; plain, 1/- doz. Carriage and packing extra. 'Phones and Loudspeakers reconditioned, 4/6 & 5/-. The H.R.F. Co., 1, Cottrill Road, nr. Hackney Downs Station, London, E.8.

LITTLE WIRELESS GADGETS



MAP Co., 246, Gt. Lister St., Birmingham.

EARTH FAULTS ENDED

Entirely new method of Earth-system efficiency. 20 per cent. to 200 per cent. increase guaranteed. Vastly superior to all metal sulphates. Ideal for all outdoor Earths. 2/6 complete, post 6d. Cash on delivery if desired. Particulars free. **J. W. MILLER, 68, Farringdon St., E.C.4.**
Phone: Central 1950. Approved by Radio Association.

PICKETTS CABINETS

For every Wireless Constructor.
Send for Cabinet Designs and Lists free.
Picketts (W.L.) Cabinet Works, Bexley-Heath.

Valves Repaired

AS GOOD AS NEW!!

HALF PRICE
(Except Weco, S.P.'s and low capacity types.) Minimum D.S. Current 0.15 amps when repaired. ALL BRIGHT & DULL EMITTERS. Minimum charge - 3/-.
VALCO LTD., Dept. W., Tabor Grove, Wimbledon, S.W.

Sterling Receivers

Sensational Offer!

Having purchased a large number of Sterling 2-Valve Loud-Speaker Sets, we are offering them to the Public on unprecedented terms. A genuine Sterling 2-Valve Loud-Speaker Set complete, ready for immediate use with D.R. '06 Valves, H.T. & L.P. Accumulator Aerial Equipment, and one of our World-Famed De Luxe Excellence Loud Speakers. Price £15 15 0. Royalties paid. Terms—15/- Deposits and 15 monthly payments of 20/-. Send for one of these Superb sets at once as the number for sale is limited and, when sold, cannot be repeated under double the price.

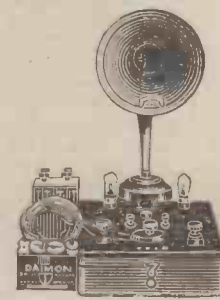

Free Catalogue on Application.

The Wireless Distributing Co., Ltd. (Dept. W.),
WIRELESS HOUSE, STOKE NEWINGTON, N.16

COUPON.

QUESTIONS AND ANSWERS.

This coupon must be accompanied by a P.O. for 2/6 for each question, and a stamped addressed envelope when sending queries to the Radio Press Information Dept. for a postal reply.

"WIRELESS." Vol. V. No. 2.

COMPONENTS WE HAVE TRIED

Conducted by the "Wireless" Laboratories, Elstree.

"All-Wave" Tuner

MESSRS. C. S. Dunham have submitted to us for test and report one of their "All-Wave" tuners.

This instrument consists of a composition tube $3\frac{1}{2}$ in. in diameter and $5\frac{1}{2}$ in. long, which carries two windings, one of thick and one of thin wire.

Tappings are provided so that the various amounts of inductance may be used, while a small rotor revolving within the tube carries a winding by means of which reaction may be applied. Terminals are provided for making connection to the reaction coil, the spindle of which carries a graduated dial and knob for controlling the amount of reaction.

Laboratory Tests.—When tested in the aerial circuit for tuning a three-valve set employing a .0005 variable condenser, the range of this instrument was found to be from 250 to about 2,800 metres.

A satisfactory degree of overlap was obtained on each of the tappings. Several main B.B.C. stations, ships' transmissions on 600 metres, Daventry and Koenigswusterhausen were received, while no appreciable loss of efficiency was observed owing to any dead-end effect.

H.F. Vario-Transformers

MESSRS. The Metrovick Supplies have sent us a "Cosmos" H.F. vario-transformer for test and report. This instrument consists of a double variometer,

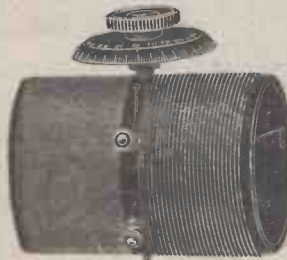

The "All-Wave" tuner, manufactured by C. S. Dunham.

of which one winding acts as the primary and the other as the secondary of an H.F. transformer. Thus, as the rotor is rotated, the inductance of both primary and secondary is varied simultaneously. What appears to be a small balancing condenser is mounted on the side of this

instrument. For connecting the instrument in circuit four insulated leads are provided.

The Test.—The component is marked as having a range of 350 to 500 metres, and when placed on test this range was exceeded, it being found to be actually in the neighbourhood of 280 to 600 metres. When correctly connected a very satisfactory degree of stability was obtained, while the degree of H.F. amplification obtainable was in every way up to standard. A number of distant stations were tuned in in daylight, using two valves, H.F. and detector, while the addition of a stage of L.F. amplification brought some of them in at a weak loud-speaker strength. The selectivity obtained with this component was up to standard, and the overall efficiency was of a satisfactory order.

A knob and pointer are provided, which, together with a scale graduated in ten divisions, enabled the setting of any station to be logged. Both the construction and finish of this component are satisfactory, and it can be recommended for use.

A Reaction Coil.—A further component submitted by Messrs. Metrovick Supplies for use with the vario-transformer is a swinging reaction coil, by means of which reaction may be applied to the component previously tested. This consists of a small ebonite ring just over 2 in. in diameter, slotted to carry the reaction winding, two flexible leads being provided for making connection to it. This reaction coil is mounted on the end of a metal arm, the other of which is fastened to a spindle passing through a bush, the bush being screwed for mounting on the panel.

STANDARDISED SPEECH

(Continued from page 48)

fore a French geographical word—therefore not King's English at all. Nonplussed, he tore up his draft and marked the difficult letter, for "Mr. Smith's attention, please," and covertly slipped it into Smith's "post-in" tray.

The electric clock upon the wall said five to eleven. The Daventry concert was due to start at eleven, and he was announcing. So Brown sprinted for the door, into the corridor, and along it into the Studio, just as Big Ben sounded the eleven "booms" through the headphones which he hastily donned. The Radio Quartette were awaiting his arrival. Brown pushed the button in the wall, the red light above the door gleamed into life with a series of preliminary flickers. Brown, wondering whether he could make any mistake in the opening announcement, marched to the microphone.

"Daventry calling. Good morning, everybody. Our morning concert will commence with ——— played by the

Radio quartette." Another day had commenced.

A Standard

This is an insight into the worries of a broadcast announcer, and incidentally an introduction to the way in which the newly-formed Advisory

to, and take unto themselves as correct, the pronunciation of certain words used almost daily, as they hear them spoken by the broadcast announcer. It is surely imperative that every word broadcast by the B.B.C. is correctly pronounced.

It hardly requires the assistance of a vivid imagination to realise the enormous influence which broadcasting may have upon the language as spoken by us, throughout the length and breadth of our land, and perhaps, in the not very distant future, of our Empire also. People of the North Country, the West land, and the East land, not forgetting the folk of the Downlands, each with their own tongue, have been, as it were, localised in dialects, each to their own particular county or district. With the ever-growing interest in broadcasting, correct speech, as administered by those under the guidance of a Committee of authorities, might well influence the dialect of these districts, gradually bringing them nearer to one standard of speech—King's English.

What lovers of dialect, who regard it as something to be preserved, will say to all this, however, is doubtful!

A MARCONI STATION



The masts and aerial equipment of the Marconi Station at Newfoundland. The reception of this station used to be one of the great feats of crystal days.

Committee on pronunciation will make themselves useful. Many people, especially children in schools, listen-in

A USEFUL POLISH

It may not be commonly known that floor polish (Mansion) may be put to good use by the wireless constructor. A polished ebonite panel which has become dull with use, or smeared with finger marks, etc., may be made to look even better than a new one. All that it is necessary to do to achieve this is to remove the panel components and apply a very small quantity of polish, then rub off with a clean rag, and give a final polish with a piece of silk. The result will be surprising and is well worth the trouble expended.

For Nickel

In addition to this it has undoubtedly often been found that nickel parts are apt to lose their polish if allowed to lie idle for any period of time, especially when in a room which is liable to be somewhat damp, or where there is a damp atmosphere. It is not an easy matter actually to polish such small parts as terminals, and other external fittings. The polish mentioned may therefore be put to another useful purpose. Apply in the first instance a light coating of polish, and finish as before mentioned. By doing this, the nickel parts are covered over with a thin coat of polish which hardens with time, and it will be found that parts so treated are not affected in any way by atmospheric conditions and they will not even require polishing from time to time.

H. B.

**"THE WIRELESS
CONSTRUCTOR."**
6d. SEPTEMBER ISSUE 6d.
NOW ON SALE

RESULTS OF "CARTOONIGRAFS" COMPETITION

No. 8.—**JOHN HENRY**

FIRST PRIZE: "Hello! Everybody!" he'll say,
In his humorous broad Yorkshire way,
"You know it's all wrong!
Blossom says before long
Well—no matter—Ah've got to obey."

ALFRED MEE, 1, Summer Road, East Molesey.

SECOND PRIZE: *She will neutralise most of my pay."*

WM. I. KINNAIRD, 5, Lavernshields Terrace, Nitshill, Glasgow.

THIRD PRIZE: *You'll hear bridegrooms consent to obey."*

JAMES JEWELL, 7, Ranelagh Gardens, Ilford, Essex.

CONSOLATION PRIZES:—The following fifty competitors have each been awarded a Consolation Prize, consisting of three Radio Press Handbooks or Envelopes, each book or envelope not exceeding 2s. 6d. in price. Will those readers whose names appear below, please communicate their choice by letter to the Editor, WIRELESS, Radio Press, Ltd., Bush House, London, W.C.2, marking the envelope "Consolation Prize"? Lists of Radio Press Handbooks and Envelopes will be found on page 72.

George Chiverton, 17, West End Terrace, Newport, Isle of Wight. John M. Brooks, 259A, Edward Street, Nuneaton, Warwickshire. Francis Stromborg, 28, Rodney Street (Flat 3), Finsbury, N.1, London. G. Du Meaume, "Hillcrest, Fairfield, Farnham, Surrey. C. N. McKerrow, 106, Boulevard, Anlaby Road, Hull. W. E. China, 106, Albert Palace Mansions, Battersea Park, S.W.11. F. T. Rayner, 395, Stanforth Road, Sheffield. Arthur Lampitt, 24, Wilson Street, Rainbow Hill, Worcester. Frederick Davis, 57, Hart Street, Southport, Lancs. E. Wainwright, 208, West Parade, Lincoln. R. Lane, The Firmings, West Bergholt, Colchester. E. J. Doxat, Spur Cottage, Madresfield Road, Great Malvern, Worcs. F. Goodall, 37B, Vera Road, Fulham, S.W.6. A. H. Easterford, 4, Campsbourne Road, Hornsey, N.8, London. Nelly Mills, 84, Churchgate, Stockport, Cheshire. W. Harbutt, 69, Cecil Avenue, Bradford, Yorks. William Marshall, 78, Shambles Street, Barnsley, Yorkshire. A. Newall, 53, Bevenden Street, East Road, London, N.1. A. W. Harvey, 38, Elgin Road, Seven Kings, Essex. Robt. J. Heaves, 28, Bennett

Street, Lewisham, S.E.13. J. Lewis, 11, Alexandra Street, Stapleford, Nottingham. J. H. Hollier, 27, Queen Square, Bath. A. Ansell, 3, Osman Road, South Tottenham, N.15. M. Crump, The Cottage, Brownmoor Lane, Great Crosby. Harold R. Moore, 21, Blackhall, Kendal, Westmorland. A. E. Osborne, 53, Granville Park, Lewisham, S.E.13. M. Heathcote, Jesus Hospital, Bray, Berks. Neville Mather, 47, Thornville Road, Cardigan Road, Leeds. C. Daniel, 3, Overy Street, Dartford, Kent. A. J. Peck, 21, Geere Road, West Ham, E.15. C. B. Melton, 41, Bolton Road, London, N.W.8. Richard Naylor, 2, Ivy Grove, Highfield, Farnworth, Nr. Bolton, Lancashire. R. W. Tully, "Selworthy," Cranley Gardens, London, N.10. N. Prosser, 13, Ceflog Road, Townhill, Swansea. Robert Young, West End, Lower Largo, Fife. Geo. R. Maddison, 4, Poplar Grove, Dipton, S.O., Newcastle-on-Tyne. C. Thomas, 59, Cannon Street, Wisbech, Cambs. J. Healey, 64, Muswell Avenue, Muswell Hill, London, N.10. C. Lancaster, 20, Dalryell Road, Stockwell, London, S.W.9. S. Hobson, 88, Prospect Road, Scarborough. A. M. Barnes, 4, Talbot Square, Bayswater, London, W.2. Wm. Clark, 1A, Grosvenor Road, South Cliff, Scarborough, Yorkshire. C. E. Eaglestone, 54, Church Road, Tovil, Maidstone, Kent. Arthur Ferris, 559, Barking Road, Plalstow, E.13. F. W. Sheppard, 108, Murrillo Road, Lee, S.E.13. Frank Mason, 280, Loxley Road, Malin Bridge, Sheffield. John Newman, 46, Gerald Street, Derby. James Fowles, 27, New Street, Sutton Oak, St. Helens. A. Hudson, Ashmore, Lan Wood, Pontypridd. W. N. Craig, 35, Stonard Road, N.13.

No. 44.

"Safety First!"



**SIMPLIFYING
THE SUPERHETERODYNE**

(Continued from page 43)

frame are located near the top edge of the panel, and lower down, on the centre line, is the potentiometer.

Behind-Panel Layout

The behind-panel layout is comparatively simple and should present no difficulty in construction, even to the beginner. Looking at the set from the back, it will be observed that the two intermediate transformers are placed upon the left-hand side, whilst upon the right is the L.F. transformer, the valve socket which takes the oscillator-coupler, which is of plug-in type, and also the balancing condenser. This latter is not mounted upon the panel, since when once suitably set little, if any, alteration is required. The first four valve-holders are placed upon the centre line of the baseboard, whilst that for the note magnifier is placed between the

wood screws upon the baseboard, excepting in the case of the jack, which is mounted on the small ebonite panel at the back. None of this work should present any difficulty, but the spacing should be followed as nearly as possible.

The Wiring

Since the receiver is of semi-portable type, and is likely to be carried over rough roads, fairly fine wire, covered with insulated sleeving, has been employed, and a large number of the joints are made by screwing wires under terminals. I, personally, have found this system of wiring preferable to that of using rigid wires and all soldered joints, since it is quite easy to tighten a terminal head if one works loose, whereas with soldered joints a soldering outfit would be required. Where soldered joints have been used wires have been taken through holes, in order that a sound job, unlikely to be affected by vibration, results.

Valves

In the tests which I have carried out the valves employed have been

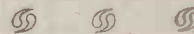
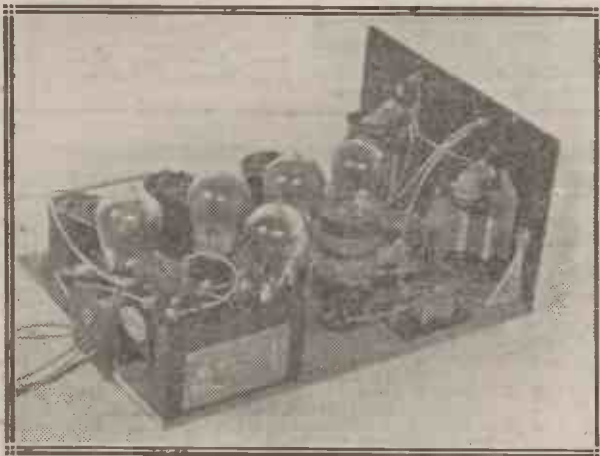

The grid-bias battery stands upon the baseboard beside the L.F. transformer.

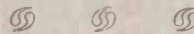

L.F. transformer and the oscillator-coupler. The anode resistance, seen below the oscillator tuning condenser, is of 100,000 ohms, and acts as the grid-leak for the combined oscillator-detector valve. In this position I originally employed a very high value of grid-leak, but squealing was noticed upon the lower dial settings of the oscillator condenser, and the anode resistance has been found to give better control here and also to give greater signal strength.

The small ebonite panel at the back of the baseboard takes the filament control jack and through four holes near the baseboard the battery leads are brought out.

Constructional Work

The constructional work has been reduced to a minimum, only three components being mounted upon the main panel, and these are all of one-hole fixing type. The remainder of the components are mounted by means of

V1, an Electron SS6, V2 and V3, two Marconi D.E.8H.F., V4 a further SS6, and V5 a D.E.5. Suitable H.T. voltages are 80 volts for H.T. + 1, 60 volts for H.T. + 2, and 100 to 120 volts for H.T. + 3, with 6 or 7½ volts grid bias. This latter battery stands by the side of the L.F. transformer, as seen in the photographs. Many other valves can, of course, be used, and this point will be dealt with when further details for operating the set are given next week.

**“THE WIRELESS
CONSTRUCTOR”**



SEPTEMBER ISSUE.



NOW ON SALE - - Price 6d.

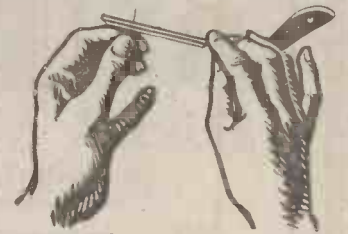

**Make your
tuning
razor-sharp.**

With Lissenstat control your valve is made sensitive to a touch—responsive to every fractional turn of a knob. Electronic emission—that vital force in the correct working of a valve—is accurately controlled. You open the way to fine detection—signals from farther away are brought in stronger, sharper than ever before—through a background of dead silence.

Let the “Lissenstat” play its part in your search for distant stations—put an edge on your tuning that will add valuable range to your receiver.



Sold in three models:

Lissenstat Major 7/6

Lissenstat Minor 3/6

Lissenstat Universal 10/6

LISSEN

LISSEN LIMITED,
18-22, Friars Lane,
Richmond, Surrey

Managing Director: Thomas N. Cole.

The NEW BURNDEPT SUPER VALVES for 1926-27

incorporate the biggest advance ever effected in a season's research and improvement. These new Valves definitely supersede many other Valves made to-day and will be the talk of the Exhibition.

★ BETTER VALVES—REDUCED PRICES ★

The new discoveries by our Research Department give longer life, higher efficiency, still further improved reproduction and shock proof filaments. Burndept valves are now more than ever essential for best possible results. They are a revelation.

For 2 Volt Accumulators		For 4 Volt Accumulators		For 6 Volt Accumulators		
H.L. 213 Dull Emitter Impedance 23,000 ohms Consumption 0.13 amps. 14/-	H.L. 310 Dull Emitter Impedance 20,000 ohms Consumption 0.1 amps. 14/-	H.L. 425 - Dull Emitter Impedance 10,000 ohms Consumption 0.25 amps. 14/-	L.L. 525 Super Power Valve Impedance 3,000 ohms Consumption 0.25 amps. 22/6	L. 525 Power Valve Impedance 6,500 ohms Consumption 0.25 amps. 18/6	H.L. 512 Dull Emitter Impedance 10,000 ohms Consumption 0.12 amps. 18/6	

NOTE: H.L. = General Purpose. H. = H.F. L. = Power. L.L. = Super Power.
Publication No. 293 contains particulars and characteristics of the complete range of Burndept Super Valves.

**OLYMPIA
STANDS**
140, 141, 142
& 209 Gallery



Agents and Branches everywhere

Head Office and Factory:
Blackheath, London,
S.E.3. Phone: Lee Green
2100. Telegrams: Burna-
coil Phone London. London
Offices and Showrooms:
Bedford Street, Strand,
W.C.2. Phone: Gerrard
9072. Telegrams: Burn-
dept Westrand London.

RH

Contributing to
the success of
the famous
"Elstree Six"

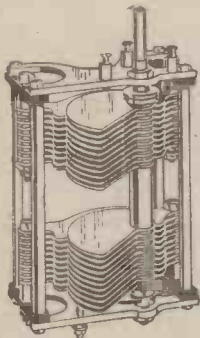

CYLDON .0005 SQUARE LAW DUAL CONDENSERS

Price 27/6 each; set of four £5 10/-
.0003 Mfds. 25/- each.

COMPLETE WITH 4 IN. KNOB DIAL

THE CYLDON DUAL CONDENSER comprises two .0005 mfd. Condensers mounted in one frame with special Grounded Rotor (on a common spindle) giving surprising smoothness and ease of action.

Other Cyldon Condensers.

Square Law.		S.L.F.	
Capacity.	Price.	Capacity.	Price.
.001 Mfds.	21/-	.0005 Mfds.	15/6
.0005 "	17/6	.00035 "	15/-
.0003 "	16/6	.00025 "	14/6
.00025 "	16/-	.0002 "	15/6
.0002 "	15/6		

With 4 in. Knob Dial. 4 in. Knob Dial 2/- extra.



CYLDON CONDENSERS from your dealer or post free from makers.

SYDNEY S. BIRD & SONS

"Cyldon" Works, Sarnesfield Road, Enfield Town, Middlesex
Telephone: Enfield 0672.

Choose Your "Cartoonigraphs" Prize from the following Lists

BOOKS

No.		Price.	Post Free.
1	Wireless for All By JOHN SCOTT-TAGGART, F.Inst.P., A.M.I.E.E.	9d.	11d.
2	Simplified Wireless By JOHN SCOTT-TAGGART, F.Inst.P., A.M.I.E.E.	1/-	1/2
4	How to Erect Your Wireless Aerial By B. MITTELL, A.M.I.E.E.	1/-	1/2
5	The Construction of Wireless Receiving Apparatus By P. D. TYERS.	1/6	1/8
6	The Construction of Crystal Receivers By ALAN L. M. DOUGLAS.	1/6	1/8
8	Pictorial Wireless Circuits By OSWALD J. RANKIN.	1/6	1/8
9	Wireless Valves Simply Explained By JOHN SCOTT-TAGGART, F.Inst.P., A.M.I.E.E.	2/8	2/8
12	Radio Valves and How to Use Them By JOHN SCOTT-TAGGART, F.Inst.P., A.M.I.E.E.	2/6	2/8
13	500 Wireless Questions Answered By G. P. KENDALL, B.Sc., and E. REDPATH.	2/8	2/8
16	Home-Built Wireless Components	2/6	2/8
18	Tuning Coils and How to Wind Them By G. P. KENDALL, B.Sc.	1/6	1/8
22	Switches in Wireless Circuits By OSWALD J. RANKIN.	1/6	1/8
24	Wireless Faults and How to Find Them By R. W. HALLOWS, M.A.	1/6	1/8

ENVELOPES

No.		Price.	Post Free.
6	How to Build the ABC Wave Trap By G. P. KENDALL, B.Sc.	1/6	1/8
7	How to Build a 2-Valve Amplifier de Luxe By HERBERT K. SIMPSON.	1/6	1/8
8	How to Make a 1-Valve Reflex Receiver By HERBERT K. SIMPSON.	1/6	1/8
9	How to Build an Efficient Single-Valve Set By HERBERT K. SIMPSON.	1/6	1/8
11	An Adaptable Crystal Set By PERCY W. HARRIS, M.I.R.E.	1/6	1/8

All the above can be obtained from Wireless dealers, booksellers, bookstalls, or direct from Dept. S.

RADIO PRESS, LTD. BUSH HOUSE, STRAND, LONDON, W.C.2.



Exhibition Time is spending time

THE wide experience of Mr. PERCY W. HARRIS in analysing the mind of the buying public is placed at the disposal of the readers of "THE DEALER," in an enlightening article under the title "Who Spends the Money?" He gives some interesting facts which cannot but be of great interest and value to every member of the Industry whose business it is to sell radio apparatus.

Published prior to the Exhibition, this article, which appears in the August issue, when read in conjunction with other permanent features of "THE DEALER," is alone worth the full year's subscription.

Selection of Contents from August issue :

Who Spends the Money?
 Professor Hazeltine and the Elstree Six.
 Can we Standardise Valves?

Impressions of Radio in America.
 The British Broadcasting Corporation.
 What the Wireless Journals are doing.

SUBSCRIPTION RATES

7/6 per annum (abroad 10/-). Available to the Trade only. Trade card or business heading should accompany every subscription to the SALE'S MANAGER, Radio Press, Ltd., Bush House, Strand, London, W.C.2.

Do not forget to renew your subscription for the season 1926-1927. Published on September 4—the opening day of the Olympia Exhibition—the September issue of THE DEALER will contain all the advance news of the exhibits. By sending your cheque now you will begin the new season well.

VISIT THE DEALER STAND—No. 57

The Wireless Dealer

AND MANUFACTURER



If it's a question of easier tuning

You'll find what you want in the R.I. Retroactive Tuner. Simple tuning over the range of wave-lengths from 175-4,000 metres. All in one unit, not a multitude of coils to choose from. Cheaper, too, than a set of coils with coil holder to cover the same range.

Former wound with a single layer of double silk covered wire, proved to be more efficient than multi-layer winding.

R.I. Workmanship—R.I. Results. Altogether the right unit to tune in the station you're after, easily and quickly.

Whatever future changes in wavelength the B.B.C. adopt they will be well inside the range of the R.I. Retroactive Tuner. It is a safe investment.

Price 39/6

Write for the R.I. Blue and Gold Catalogue.



THE MARK



OF BETTER RADIO

Advt. R.I. Ltd., 12, Hyde Street, New Oxford Street, London, W.C.1.

P.C. 36

Published by RADIO PRESS, LTD., Bush House, Strand, London, W.C.2, on Tuesday of each week, and printed for them by THE AVENUE PRESS (L. Upcott Gill & Son, Ltd.), 55-57, Drury Lane, W.C.2. Address for Subscriptions and Editorial Communications:—Bush House, Strand, London, W.C.2. Address for Advertisements:—Advertisement Manager, WIRELESS, Bush House, Strand, London, W.C.2. Registered as a newspaper and for transmission by Canadian Magazine Post. Subscription rates:—13s. per annum, 6s. 6d. for six months, post free. Sole Agents for Australasia:—Gordon & Gorch (Australasia), Ltd. For Canada:—IMPERIAL NEWS, LTD. For South Africa:—CENTRAL NEWS AGENCY, LTD.