

# WIRELESS

# 2<sup>D</sup>

## THE ONE-WORD WEEKLY

Technical Director:  
**JOHN SCOTT-TAGGART,**  
F.Inst.P., A.M.I.E.E.

EDITOR:  
**PERCY W. HARRIS, M.I.R.E.**

Research Editor:  
**MAJOR JAMES ROBINSON,**  
D.Sc., Ph.D., F.Inst.P.

SATURDAY, SEPTEMBER 19, 1925.

### THE WEEK'S NEWS AND NOTES

#### SHORT WAVES.

EVERY few weeks I have to alter my short-wave receiving apparatus. Just as I am congratulating myself on being able to receive 15 metres comfortably, out comes Marconi with his wireless lighthouse using a 6 metre wavelength! The trouble in these regions is that it is difficult to distinguish between wireless signals and the radiation from the ignition system of the nearest Ford car!

#### A NEW THRILL!

I hear that the Germans are having some success with their experiments in "plastic" or "stereoscopic" broadcasting. Captain Round, the famous Marconi expert, is telling us all about stereoscopic broadcasting in the next issue of WIRELESS.

#### EDITOR TO BROADCAST.

Listen on Friday evening, September 18, for Mr. Harris' broadcast talk. He will relate some of his American experiences, full details of which are to appear in the special articles he is writing for WIRELESS.

#### A NEW STATION.

I have recently been given to understand that detailed plans are being worked out for a new station to the south-east of London, and that as soon as a practical scheme is developed, it will be submitted to the Postmaster-General for approval. If the new station goes up, many thousands of crystal users who feel they have been badly hit will be relieved.

#### DAVENTRY CHALLENGED.

It looks as if Daventry will not remain very long the most powerful broadcasting station in the world. WGY, the Schenectady station of the General Electric Company of America, is already fitted with a power plant capable of supplying more than the Daventry power, and on a very similar wavelength (1,660 metres). What will Captain Eckersley say if they put 5XX in the second place?

#### A VALVE CHANGE.

It will come as a surprise to most wireless enthusiasts to learn that Marconi-Osram valves will in future be marketed separately as Marconi valves and Osram valves, each having their own types and models.

#### AERIAL BYE-LAWS.

The new Ministry of Health Bill, which has just come into force, permits certain local authorities to pass bye-laws regulating the erection of aerials. I know there are often many pompous busy-bodies on local councils who would, if they could, abolish everything new. You may rest assured that WIRELESS will watch these people carefully.



MAJOR JAMES ROBINSON, D.Sc., Ph.D., F.Inst.P., who writes upon Death Ray Secrets in this issue.

Lord Gainford (Chairman of the British Broadcasting Co., Ltd.):—

"Best Wishes for the Success of your New Journal."

### DEATH RAY SECRETS REVEALED.

By MAJOR JAMES ROBINSON,  
D.Sc., Ph.D., F.Inst.P.

SEE PAGE 3.

### THE NEW ST100 RECEIVER.

By JOHN SCOTT-TAGGART,  
F.Inst.P., A.M.I.E.E.

SEE PAGE 26.

### The "Centodyne."

You oughtn't to miss any of the Editor's accounts of American developments. I understand his articles will appear weekly for the next six weeks. Mr. Harris, as you may know, is a very prominent designer of sets for the home constructor. He saw everything and everyone worth while, and he has come back with the impression that we shall have to pull our socks up—and if I know him at all he's going to show us how. His "Centodyne" receiver, by the way, which is appearing in next week's issue, should interest one-validators. Sounds promising, anyway!



Broadcasting from 5IT during the International Broadcasting Tests.

### B.B.C. Wavelengths.

What do you think of the extraordinary B.B.C. wavelength figures given in this issue? I saw them some time ago and they explained many mysteries to me. I shall have to apologise to the people who sold me my wavemeter. It certainly has not the wonderful accuracy of the quartz resonator, but I noted my wavemeter was "inaccurate" on several stations. Now I know it's the station wavelengths that are wrong. Anyway, a laboratory has its points, hasn't it?

### Special "Coastal" Sets.

Our technical director was down at Broadstairs for the week-end, and from his account of the jamming it is extremely likely that we shall see some special "coastal area" sets of high selectivity described soon in our "one-word" weekly.

CALL-SIGN.

# About Ourselves

By JOHN SCOTT-TAGGART, M.C., F.Inst.P., A.M.I.E.E.,

Technical and Managing Director of Radio Press, Ltd.

**T**ENS of thousands of those who have bought this first number of WIRELESS—the one-word weekly—have probably never read a wireless paper before.

In view of the very large number of new readers, I would like to explain who the owners of this paper are, what they have done, and what they are going to do.

### Exclusively Wireless.

We are the only exclusively wireless publishing firm in this country. Whereas, with some, wireless publishing is a side-line, we ourselves have devoted every ounce of our energy to giving the wireless public the most reliable, interesting, and original literature on the subject.

### Five Periodicals.

We now publish five wireless periodicals, *Modern Wireless* (1s. monthly), *Wireless Weekly* (6d. weekly), *The Wireless Constructor* (6d. monthly), and *The Wireless Dealer*. The third, an ideal monthly for readers of WIRELESS, has net sales of 253,180 per month. This figure is greater than the sales of all the wireless papers by other British publishers put together!

It is because we own five successful papers that we can give what no other publishers can give. Let me give you a few facts, which, perhaps, you do not know. Our technical staff is the most highly paid in this country. I have gathered round me some of the most able radio experts available. The average income of the first six technical men of the Radio Press is over £1,700 per annum. The average income of the first four is over £2,000 per annum! The most highly-paid engineer in the company (my own position is excluded) derives from the Radio Press an income far in excess of that of any engineer of the B.B.C., any technical member of the staff of any wireless firm and more than double (and probably treble) that of any outside editor or official engaged exclusively on wireless.

### About your Editor.

Mr. Percy W. Harris, M.I.R.E., the editor of this new paper, has been in wireless journalism for very many years. His brilliant editorship of *The Wireless Constructor* has greatly contributed to its record-breaking success. His great reputation as a wireless designer is known amongst all that vast number of enthusiasts who build their own sets.

Since last winter a very great enter-

prise has been launched by us. We have purchased the freehold of seven acres of land at Elstree, twelve miles north of London, and we have commenced to build a series of laboratories exclusively to serve WIRELESS and the other Radio Press publications. We estimate that it will take three years to complete the scheme, the initial cost being in the neighbourhood of £20,000, while the annual expenditure will be about £10,000. Even at the start the salaries alone are accounting for £7,000 per annum. Two buildings are already erected.

### Readers and Our Laboratories.

These laboratories will carry out practical research work, and will develop new ideas, new circuits, and new designs. This will ensure in the years to come that WIRELESS will be completely up to date, and will give its readers the latest inventions developed at the laboratories.

A further function of the Laboratories is to test and, if desired, put right any sets made in accordance with the design of any sets published in WIRELESS; a very small fee is charged.

We are justifiably proud of our set designs, which are given exhaustive tests before publication. If you ever fail to get results with a set built from Radio Press designs you can bring it to us and we shall show you where the fault lies and put it right. Many sets published in wireless papers are taken on trust, and if readers fail to get proper results there is no satisfaction which they can obtain. In our case, however, every single set is examined exhaustively and tested by ourselves; the drawings, blue-prints and photographs are made and taken in our own offices. And behind all this, our new Elstree Laboratories, which supplant our test department, loom large in the background ready at any instant to prove technical data and designs published in WIRELESS.

### The Director of Research.

The importance of the new Laboratories may be gauged from the fact that I advertised the post of director for research and chief engineer, the basic salary being £2,500, which, with royalties, fees for publications, rights in writing, etc., will probably be brought up to £4,000 per annum. The choice fell on Major James Robinson, D.Sc., Ph.D., F.Inst.P., M.B.E., Council P.S.L., etc., who was the tech-

(Continued on page 11.)



**O**N the first rumour that another Death Ray has been discovered—a real one this time—the whole world is roused to excitement, and it is not to be wondered at. There have been so many marvels of science in the last thirty years that the public mind is ready to believe that science can achieve practically anything, almost even the impossible. It is quite a profitable occupation to allow one's mind to wander over the discoveries of the last few years. The oldest of us remember when the electric light and the telephone were introduced, and marvelled at them. The younger people now accept them as a matter of course.

#### Earlier Miracles.

Many of us, however, can go back to the last few years of the nineteenth century, when X-rays were discovered, a perfectly marvellous, almost miraculous achievement, enabling one to see through thick walls. Then there was the gramophone, and shortly afterwards wireless telegraphy, probably the most marvellous of all. Then followed in rapid succession the motor-car, airships, flight of heavy bodies in the form of aeroplanes, wireless telephony, wired and wireless photography, and the promise of television at no distant date. In other realms of science the discoveries have been no less marvellous; for instance, in the medical field there is the recent discovery of the cause of cancer, and rumours that a theory of life and death has been put forward which will lead to a great possible prolongation of life.

#### A New Thrill.

No wonder, then, that the first whisper of the words Death Ray stirs the population. It immediately brings to our minds some new and wonderful ray possibly manoeuvred like a searchlight, but absolutely invisible, which will wither us all up in an instant. Or perhaps others think of it in some other form. In fact, its existence is in our imagination, and in this form it is no single thing at all, but just what each one of us likes to have it.

It arises forcibly from time to time, sometimes in fiction and other times by the claims of inventors, but still we remain unconvinced of any practical results. Will it come, and if so will it be in our time! There will be no one with courage enough to say

"No," but there will be many of great eminence who will say "Most probably not."

What a dreadful thing it would be, and the leaders of our Defence Forces cannot afford to ignore any suggestion, in case one of the many suggestions may have some useful germ in it. But they are given much worry and labour in examining impossible Death Rays.

#### What We Do Know.

Looked at from the point of view of an invisible set such as a beam of some dark radiation, we know nowadays something about every form of radiation from the shortest wave length, that of very hard X-rays, to the longest wireless waves, and scientists have not discovered that any form of radiation would kill a single person instantly at a distance of a mile. Naturally, some forms of radiation have harmful effects, X-rays, for instance, cause such trouble to the human frame that after continuous application for days, arms or legs are withered. This does not fit in with our ideas of a Death Ray. Again, ultra-violet rays have a harmful effect on the eyes. Such rays can be obtained from a mercury arc lamp in a quartz tube, or from an open arc lamp of any form. The ordinary mercury arc in a glass tube is much less harmful. Here again the particular form of ultra-violet radiation which damages the eye will not travel far through the atmosphere, and it is necessary to be within 20 ft. of the arc to feel any ill-effects. This harmful property on the eyes was actually proposed during the Great War as a means of damaging the eyes of the enemy and so blinding them. Even this is impossible, and again the whole thing is far removed from our ideas of the Death Ray.

#### A Remote Possibility.

We do not know everything about every form of radiation, so that there is still the remote possibility of a discovery that will change our ideas completely, but from this aspect there is no scientist of any distinction who will be stirred from his ordinary path by the rumour of a Death Ray consisting of radiations of any form. Any discovery of new forms of radiations or of new properties of known forms have so many other interesting phases that in all probability Death Ray applications would come as an afterthought.

One other form of the imagination is that the atom might be disintegrated suddenly, and that this might occur by some form of ray. This is a horrible thought, but scientists at present consider that there is no possibility of atoms being completely disintegrated.

#### Types of Inventor.

What type of person is it who suggests the Death Ray? All of them are possessed of some form of acute imagination. Every inventor must possess this valuable characteristic, but the ordinary successful inventor has imagination backed up by knowledge and experience. There is another form of imagination which has no such backing, but which is of an emotional type, and thus has the reason clouded over. This type of Death Ray inventor very often does not try out his experiment himself, but tells the story in a hushed voice, and in fact does not tell the public anything more than the words Death Ray. He tries to persuade some Government Department to try the experiment for him.

There is another type, unfortunately, who do try experiments, and give demonstrations up to a point.

#### The Ulivi Ray.

There is one famous example of a Death Ray which was to be used for blowing up battleships. The name associated with it is that of Signor Ulivi. A claim of this nature could not possibly be completely ignored by



our Admiralty, to whom the suggestion was put forward. Signor Ulivi actually did arrange tests where everything was under his own control, even the ship to be blown up. No test of this kind is of any convincing nature, for if a battleship is to be blown up

## DEATH RAY SECRETS REVEALED—continued.

our Admiralty could not possibly induce the enemy to place the battleship at its disposal for preparation. Thus the test was put to Signor Ulivi that he would be allowed only to control the Death Ray and the Admiralty would provide a ship to be destroyed. This test apparently proved too severe for the Italian, for it was never carried out, and he quietly disappeared from this country. This was not the end of him, however, for he next tried to give some form of demonstration to the Italian Navy. The Admiral in charge of the tests there apparently imposed similar severe conditions of test, with promise of great reward if successful, but penalties if unsuccessful. Again Signor Ulivi disappeared. Whether there was really anything in the Italian claims must remain a matter of doubt, but as he refrained from accepting the conditions for a satisfactory test we cannot be far wrong in concluding that his Death Ray existed only in his imagination.

There was a different type of case during the war in which the claimant actually did accept the conditions of test, and succeeded in killing a dog.

### A Cruel Test.

In this case the inventor prepared his Death Ray, which involved a considerable amount of power of the order of 50 horse-power. He arranged the source of his ray near the focus of a huge concave reflecting mirror, the diameter being about 10 ft. At a distance of about 20 ft. the poor unfortunate dog was held in chains, so that the energy of the Death Ray was concentrated on him. After a considerable time—about an hour—the dog was dead. This is easy to understand, supposing merely an ordinary searchlight were used, for the amount of heat radiated is very large indeed, and if the rays are concentrated at a particular point there is sufficient heat to perform quite a large number of feats. Water can be boiled, matches can be set alight, paper can be burned, and many other interesting experiments can be done. These experiments can also be performed with the sun's rays and a lens or mirror. In fact, because of this well-known fact, a lens is often called a burning glass. Obviously, by having a powerful enough searchlight

with a large enough mirror sufficient heat can be concentrated to make a dog, or any other animal, or, in fact, any of us; feel very uncomfortable. If we are foolish enough to stay in such a spot long enough, or if we are held there, then obviously death must result.

### A Means of Attack.

But again this fails as the Death Ray of our conception. We think of it as being of such terrible powers that the first application will produce death or total incapacitation. We could not conceive of the enemy consenting to remain at a spot where he was uncomfortable long enough to allow himself to be killed. So again there is no need for us to worry about the consequences of a ray of the nature just described.

### Recent Rays.

Most recently the character of the supposed Death Rays has changed, and

inventor in the neighbourhood practising his art.

The principal suggested method is to stop the magneto from functioning. In some way energy is to be directed to the aeroplane or motor-car in the form of electro-magnetic waves, or wireless waves. If sufficient energy is directed, and if it is in the correct form, it is quite conceivable that a magneto can be stopped. The factors required are a sufficient amount of energy directed in the correct way, a short enough distance, a sufficiently long time of application, and again the all-important condition that the enemy will allow it to be done.

### A Possible Way.

One possible way is to use ordinary electro-magnetic induction, which will produce such large induced voltages and currents in the magneto circuits that the magneto coils will be burnt up. With ordinary powers of a few kilowatts it might be possible to achieve this result over 4 or 5 ft., so that there is not much hope along these lines. Another method is the wireless method, by assuming that there is a tuned circuit in the magneto. As a matter of fact, this usually does occur, and the circuit from the spark gap to the distributor has a frequency corresponding to a

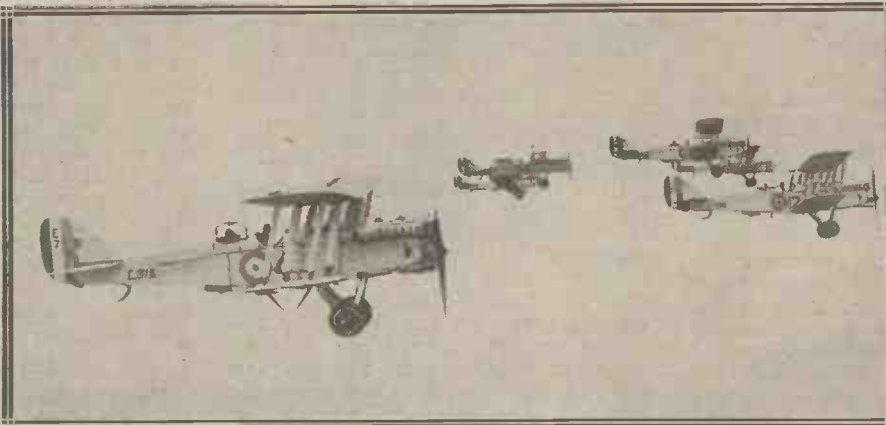

*Our airmen still laugh at death rays!*

they have been suggested as a means of defence against attacking aeroplanes. This is a very laudable field of endeavour, and will obtain even the sanction of our peace-lovers, who are always so bitterly opposed to the use of science for developing death-dealing weapons. The most frequent suggestion put forward is to stop the engines of the aeroplanes, and thus put the aeroplane completely out of action.

### Affecting Magnetos.

It is certainly comparatively easy to experiment on such lines, for the engines of motor-cars operate on the same principle as aircraft engines, being internal-combustion engines, with some form of spark ignition, usually from a magneto. How often have we heard of cars stopping mysteriously at a certain spot, and of aeroplanes having forced landings always in the same district. Under these circumstances there is always supposed to be some mysterious in-

wavelength of from 5 to 30 metres, depending on the length of the leads. Thus if we have a transmitter whose wavelength can be varied, we might find the correct wavelength for one of the spark gap circuits. Again, if there is sufficient energy transmitted we might make this circuit absorb so much energy that the spark takes place constantly instead of at the correct instant, and thus cause the engine to cease functioning. Here again the conditions are very severe, for in order to get any distance the waves should be concentrated, and as an aeroplane travels very rapidly it would be necessary to keep any such beam of radiation on the aeroplane.

### *Concluding Article Next Week:*

THE INNER HISTORY  
OF THE  
GRINDELL - MATTHEWS  
DEATH RAY.

## B.B.C. WAVELENGTH DISCLOSURES

*Some facts regarding serious discrepancies*

**T**HERE has been considerable uneasiness in certain technical quarters regarding the wavelengths on which the B.B.C. stations have been working.

It was therefore regarded that one of the first duties of the laboratory staff was to check and investigate the position. The results of the test show some surprising discrepancies between the official and published wavelengths of the B.B.C. stations and those actually measured.

Extraordinary care was taken in making the measurements, and the apparatus actually used consisted of the very latest type of "Quartz Resonator" wavemeter, the calibration of which is guaranteed to within 1 part in 10,000. The figures given in the table are accurate to one place of decimals.

### Figures and Facts.

The figures we give in the table show the official B.B.C. wavelengths and also our measurement of the same stations. If the B.B.C. have the slightest doubt regarding the accuracy of our figures, we suggest that they invite the National Physical Labora-

tory to give them information regarding to what extent the broadcasting stations have been "off" their wavelengths almost from the start.

Week after week, in their official organ, the B.B.C. have stated the wavelength of their stations, and as late as the Radio Supplement of August 28, a high official of the Broadcasting Co. gave a list of the standard wavelengths and also the recent experimental wavelengths. The actual statement reads as follows: "Below is tabulated an official list of the stations with their new and old wavelengths." This statement is a very important technical document, because the variations of wavelength between standard

Station.	Official.	Actual.	Discrepancy.
	Metres.	Metres.	Metres.
London .. ..	365	357.7	7.3
Manchester ..	378	372.1	5.9
Daventry .. .	1,600	1,607	7
Glasgow .. .	422	424.6	2.6
Bournemouth ..	386	383.6	2.4
Swansea .. .	482	484	2
Newcastle .. .	403	401.5	1.5
Birmingham ..	479	477.6	1.4
Cardiff .. .	353	351.8	1.2
Stoke-on-Trent ..	306	305.5	0.5

Our own measurements were taken on July 31st and August 6th.

and experimental amount, in some cases, to only half a metre.

The only conclusion to be arrived at is either that the B.B.C. are obtaining entirely inaccurate results from their wavemeters or that they are deliberately withholding from the public the real wavelengths on which their stations are working. We are very much inclined to believe that in some cases the first explanation is the real one, while in others the wavelength discrepancies can only indicate that the public is misinformed, e.g., in the case of 2LO.

From the table it will be seen that London is 7.3 metres off its wavelength. Cardiff 1.2, Manchester is widely out by 5.9 metres, Bournemouth by 2.4, Glasgow by 2.6, while Daventry is 7 metres out. These figures explain several difficulties experimenters experience. For example, the difficulty of separating London and Cardiff is notorious. The B.B.C. say that there is 12 metres between these stations, whereas our own investigations show that there are only 5.9 metres difference.

### An Unjust Accusation.

Another mystery cleared up is that commercial wavemeters, as supplied to the broadcast listener, have been unjustly accused of inaccuracy, whereas the real truth is that the B.B.C. wavelengths have been inaccurate.

*(Continued on page 38.)*

## Will the Outside Aerial Disappear?

*Indoor Alternatives Discussed*

*By D. J. S. HARTT, B.Sc.*

**"W**HY do you want an aerial?" and "Can't you do without a large aerial like that?" are questions one often hears asked, and naturally so, by those ignorant of the more technical aspects of wireless. In this short article I propose to discuss the pros and cons of the matter, and to indicate, as far as it is possible at the present, the answer to the question asked in the heading.

### Comparative Results.

Let us consider first the average results which can be obtained with various types of sets on different aërials. During summer conditions most small or single-valve sets on a large outdoor aerial will bring in little else except a local broadcasting station, and under the same conditions a powerful valve set has its limitations, for even if distant telephony or music is received, the background noises, due to atmospherics and general "mush," are generally sufficient to mar reception completely. When better conditions prevail in the winter each type of set, of course, shows a marked improvement.

On indoor aërials the volume of re-

ception suffers in all cases when compared with results on an outdoor



*No one can say the outdoor aerial is a thing of beauty.*

aerial, and more sensitive receivers are called for; this may not hold good in all cases, since on an indoor aerial the ratio of the signal strength to the background "noises" may be increased, and the signals will sound all the louder.

Again, on a frame aerial, a still more sensitive receiver is required to secure any measure of useful reception, and very little can be done with less than four or six valves, unless special precautions are taken, or some special circuit is employed. In the latter case the difficulty of tuning is such as to prohibit the use of such sets to all except the experienced experimenters,

### Super-heterodynes.

The super-heterodyne receiver solves the problem of reception on a frame aerial, and remarkable selectivity and volume can be obtained with only a small loop. With our present circuits, however, the number of valves and amount of apparatus required prohibits the use of the super-heterodyne by the vast majority of listeners. Future developments, however, give promise of more hope in this direction in abolishing the large outdoor aerial than in any other. Indeed, as Dr. Robinson, Director of Research to Radio Press, Ltd., disclosed in his article on "Forthcoming Developments in Radio," in the September Double Number of *Modern Wireless*, Mr.

*(Continued on page 38.)*

# Should Parliament be Broadcast?

By EARL RUSSELL.

*As a Member of the House of Lords, and a keen wireless experimenter, the writer speaks with authority.*



**I**N considering whether the broadcasting of Parliament is desirable or advantageous, I am assuming that the financial side has satisfied the B.B.C., although if they do broadcast Parliament, I can hardly imagine its being other than a public obligation on their part, rather than a remunerative enterprise. I am assuming also that the technical difficulties have been got over, and this is a pretty large assumption. Ministers, ex-Ministers and the Speaker are more or less closely grouped round the table, but other Members speak from all parts of the House, and in voices of very varying strength. If the House is at all talkative, as it sometimes is, I can speak personally—as to the difficulty of hearing exactly what is being said, even from so advantageous a position as the Peers' Gallery.

## The House and the Nation.

The House of Commons is truly a reflex of what the nation as a whole is thinking and saying, and Members are very much in touch with their constituencies; but, except in the case of very special discussions, this microcosm of the country is more apparent in the Lobbies and the smoking rooms than in the formal debates, though it sometimes finds an echo in Questions. Take, for instance, the weeks that are devoted to the Estimates, containing speeches on finance in general by Front Benchers, and special points on almost every conceivable subject, often very minute, raised by the Members who are interested in them, or expert criticism on various small details.

## Debates.

Taken as a whole, these debates are interminably dull, and it is almost inconceivable that any listeners should wish to listen to them. Certainly the Members of the House of Commons do

not. On the other hand, the proceedings in both Houses of Parliament are so infamously reported by every newspaper, with the single exception of "The Times," that the average citizen who derives his information from these papers has a completely false picture of what Parliament is really like and what really takes place there.

## Events of National Interest.

On the other hand, there are momentous debates of the tensest interest in which almost every word spoken is of value in forming a judgment, such as the Maurice Debate in the Lloyd George administration, the debate which turned Baldwin out, and the corresponding debate which turned out Ramsay MacDonald, and there are often utterances by Ministers, of the first importance to everyone in the country, such as Mr. Churchill's momentous and unexpected pronouncement just before the House adjourned, to the effect that we must expect £800,000,000 Budgets indefinitely. These debates involve great issues which affect the life of everyone in the country, though probably not one-tenth of the number that are eagerly watching Hobbs's centuries, attach importance to them.

## A Personal View.

I take a very strong view that it is desirable that as many of the public as possible should have a reasonably clear idea as to how Parliament functions, and an unbiased idea, such as they do not now get from so-called descriptive reports. Since they cannot get this idea from the newspapers as now conducted, broadcasting seems almost the only way.

## Mob Law.

If we desire to retain democratic representative government and parliamentary institutions, as opposed to

mob law, newspaper dictation, direct action, or anarchy, it is imperative that the machine by which the will of the people is constitutionally expressed should be understood and its actions appreciated. For this purpose there are some debates in the House of Lords which ought also to be broadcast. Since the object is to educate the people and to tell them the truth it is essential, if there is any broadcasting done, that there should be no picking and choosing, but that the entire sitting of the House should be broadcast. I think broadcasting of Parliament would do real harm instead of good if it were limited to scenes and great occasions, because then it would resemble the newspapers in giving a false picture.

## The Listener.

And then comes the human difficulty; you can take a horse to the water, but you can't make him drink; you can supply the listener with the debate, but you can't make him listen. I very much doubt whether at first more than one per cent., if so many, of the present listeners would listen at all regularly to the proceedings in Parliament; but political secretaries, working-men who took a real interest in politics, and other earnestly minded persons might do so to begin with, and it is possible that their example might spread, though, quite frankly, I doubt whether the number who would listen would ever reach five per cent., except on the occasion of very special debates.

## Special Wavelengths.

The proceedings should, in my opinion, be broadcast upon a special wavelength, so that no person need receive them unless he definitely desires to do so. This would leave existing listeners no ground for complaint, and given that, I can see no disadvantages whatever in the broadcasting of Parliament, apart from the financial disadvantage.

## Unpractical Dreamers.

If the public realised better the conditions of parliamentary government, less of a shock would be caused to unpractical dreamers when success at the polls fails immediately to translate ideals and dreams into laws and government action. And it might save us from the sort of irresponsible person I met at a club the other day, who suggested that the obvious method of retrenchment was to cut down £200,000,000 on Education!



## HOW TO MAKE A CRYSTAL SET IN HALF AN HOUR

By  
**PERCY W. HARRIS, MIRE.**  
Editor

A junior member of the staff tries the receiver.

IT is quite a mistake to imagine that a crystal set to be efficient must necessarily be elaborate. Take the crystal set I am about to describe. Everything to make it with will be found in the average house, with the exception possibly of the crystal and its cat-whisker, which you can buy reclining together in a neat little box on a piece of cotton wool, from the nearest wireless shop, for eighteenpence. You do not need any special tools to make the set, and the whole receiver can be completed in about half-an-hour by anyone who likes to try it. -Let us see how we set about it.

### Materials required.

First of all collect your material. You will need a piece of board, the dimensions of which may be almost



First steps in winding the coil.

anything convenient; as a matter of fact, in the actual instrument photographed, this board is a piece 9 in. x 6 in. x  $\frac{1}{2}$  in. Obtain some thick cotton-covered wire (old bell wire will do if you have nothing else on hand, or, if you have to buy some, get half a pound of No. 19 d.c.c. wire), four ordinary wire staples, some odd bits of thinner wire, some small pieces of tin (I obtained mine from an old cocoa tin), and two small wood screws, complete the outfit. You will also need a tumbler upon which to wind the coil,

and a wireless crystal with cat-whisker complete. Any of the well-known makes will do, and I have used the crystal known as Neutron.

Winding the coil is simplicity itself, and the number of turns you will need depends upon where you are situated. If you are near a broadcasting station, whose wavelength is below 400

*Somebody once said that if the Editor of this paper were wrecked on a desert island with nothing more than a keg of nails and a few empty biscuit boxes, he would establish wireless communication with a passing ship within a day! Be this as it may, you will find that with the crystal set described on this page, you will get far better results than with many much more pretentious pieces of apparatus. Try it and see!*

metres, wind 35 turns of wire around the wider end of the tumbler as shown. If your station is on a wavelength above 400 metres, make it 50 turns. When you have wound the coil, hold the turns together and slip the whole coil from the glass by pushing it down towards the smaller end. Having done this, wrap the two ends tightly round as shown, and set the coil aside until you have completed the other parts of the apparatus.



Removing the coil from the tumbler.

To make the crystal detector stand, you will now need the two pieces of tin. The drawings show you the rough dimensions and method of cutting, while the photographs show you the final result. The piece of tin, which is made into a kind of cup, is pierced at one end with a hole to take the wood screw, while the other end is bent upwards and pinched together to hold the crystal, which is first of all wrapped in some tin-foil to make good contact. The other piece of tin is given two slits at one end, and in these slits, in the manner shown, the cat-whisker is secured. The other end of the second piece of tin is also pierced, as is the first, to take a wood screw.

### Securing the coil.

Now drill four holes to take the string which secures the coil to the board, place the coil in position, and



Securing the ends.

tie it tightly in place with string, as shown in the photographs. Now bare each of the ends and secure the bare ends tightly to the board by means of two wire staples.

Having done this take a short length of thin wire, bare one end, and twist this round the staple and the end of the thick wire of the coil till a good joint is made. This connection can be soldered if you are skilful in such work, but a soldered joint is not necessary if the wire is pulled tight. Now bare the other end of this same wire

and place it underneath the piece of tin which forms the cat-whisker support, holding the tin and the wire underneath firmly in position by a wood screw, which can now be passed into the board.

**The Crystal Holder.**

A short lead of wire is similarly secured from the piece of tin used as the crystal holder, and passed to the left-hand front staple, which in this case is not driven right into the board but only a sufficient distance to allow of one telephone tag being tucked underneath the staple without being too loose. The second telephone-staple on the front (the right hand front staple) is similarly secured to the board, and from this a piece of wire is taken to the right-hand back staple, which, as you will see, secures the other end of the thick wire coil. For neatness this

long wire may be held in position in one or two places by a dab of sealing wax.

You have now completed your receiver. To connect the aerial, tuck the end of the aerial wire underneath the left bared end of the coil, and make the earth connection by similarly tucking the earth wire under the other end of the thick wire coil. Secure the catwhisker to the clip by the simple expedient of pushing the cat-whisker wire between the strips and bend the tin downwards so that the cat-whisker

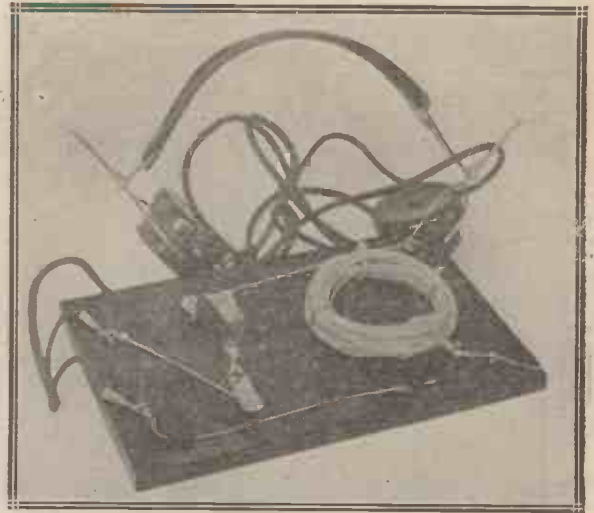

The finished receiver is quite compact.

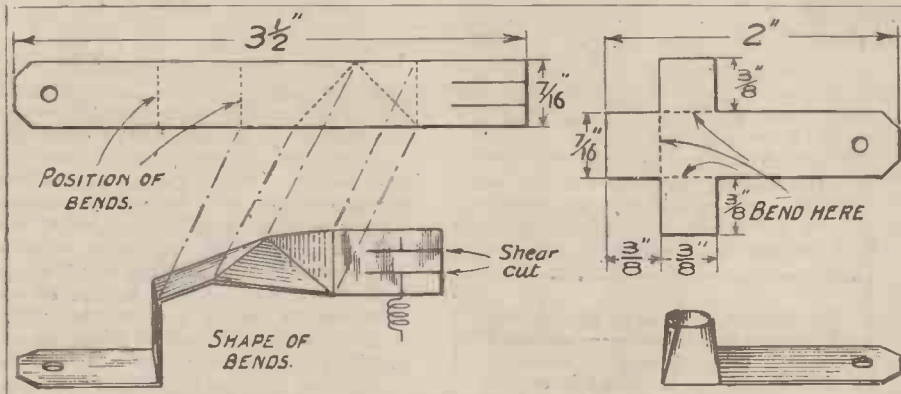

Above: Practical details of the strips for holding cat-whisker and crystal respectively. On the left: a plan view of the completed set.

point makes contact with the crystal surface. Take a good pair of high-resistance 'phones, push the two ends under the front staples and listen. Probably you will hear signals at once, if not move the cat-whisker about lightly on the crystal surface until you get good results.

On an indoor aerial at Wimbledon, this set gives good clear signals from 2LO, while on the outside aerial, signals can be heard several feet from the 'phones in a quiet room, being almost too loud for head-phone work when the earpieces are clamped over the ears. If you have doubts about this receiver being able to work well, try it. I am prepared to say that it gives much better signals than many crystal receivers for which the owners have paid a pound or more. Let us hear about your results when this set works well in your locality. A postcard will do.

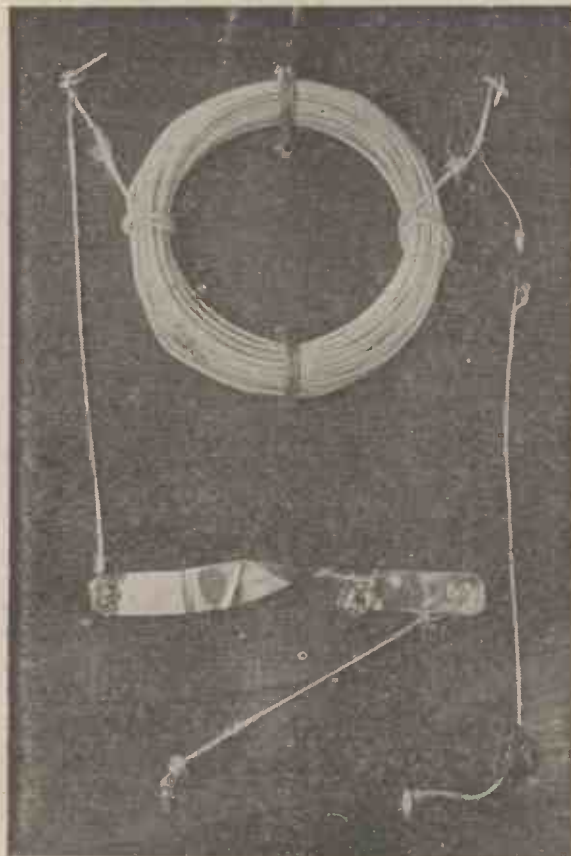

<p><b>NEXT WEEK'S ISSUE,</b> SPECIAL FEATURES.</p> <p>STEREOSCOPIC BROADCASTING. By Capt. H. J. Round, M.C.</p> <p>THE "CENTODYNE": A new single valve receiver. By Percy W. Harris, M.I.R.E.</p> <p>THE GRINDELL-MATTHEWS RAY By Major James Robinson, D.Sc., Ph.D.</p> <p>Animals as Broadcast Artists. By Capt. West of the B.B.C.</p> <p>Circuits you will use this Winter, No. 2. By John Scott-Taggart, F.Inst.P.</p> <p>More about the new ST100 Receiver. Beginning: A Weekly series of Talks by Earl Russell.</p>	<p><b>THE MEN BEHIND "WIRELESS"</b></p> <p>Editor: Percy W. Harris, M.I.R.E.</p> <p>Technical Director: John Scott-Taggart, F.Inst.P., A.M.I.E.E.</p> <p>Director of Research: Major James Robinson, D.Sc., Ph.D., F.Inst.P.</p> <p>Deputy Director of Research: Captain H. R. Crowther, M.Sc.</p> <p>Senior Technical Staff: H. J. Barton-Chapple, B.Sc.(Hons.) A.C.G.I., D.I.C. E. H. Chapman, M.A., D.Sc. A. D. Cowper, M.Sc. R. W. Hallows, M.A. G. P. Kendall, B.Sc. A. Johnson-Randall. Stanley G. Rattee, M.I.R.E. J. H. Reyner, B.Sc. (Hons.) A.C.G.I., D.I.C.</p>
--	--





# CLIMAX

## RADIO

# UP-TO-DATE

Yesterday—to-day—and to-morrow. The experiences of yesterday in the light of the knowledge of to-day point clearly to the practices of to-morrow.— See the "Climax Magazine Catalogue."

**THE CLIMAX RADIO EARTH.** (Prov. Pat. 17653).—The low loss direct tubular earth. Far better than the old-fashioned water-pipe or gas-pipe earth. Provided with flanges which break up the earth around the tube, thereby preventing any rocking of the tube in the ground. In addition, the surface projections provide water courses, making perfect electrical contact. Ready for use. Easily fitted. Maximum efficiency. Length approx. 30 ins. Price, 5/-.  
Climax Insulated Low Loss Earth Lead, 20 ft. Price, 1/8.

**THE NEW CLIMAX AERIAL INSULATOR** (Regd. Design No. 708718)—Stands four times the flush over voltage. Far less capacity to earth. Will stand a direct pull of hundreds of pounds. Entirely non-hygroscopic. Cannot absorb moisture even if fractured. Insulates perfectly during rainfall. Self-cleaning on all surfaces.  
Price per pair 1/-.

**THE CLIMAX INSULATED SHOCK ABSORBER SET.**—Comprising set of four Climax low-loss aerial insulators and two Climax aerial shock-absorbers, 3/- per box.

If you believe in metal—and who does not?—use exclusively Climax Rheostats and Potentiometers. They are wire wound on metal cooling cores with vitreous enamel insulation.

Price—Climax Rheostats, 6 ohm pattern for one, two or three bright valves 3/- each  
Climax Rheostats, 30 ohm pattern, Universal pattern for D.E. or Bright Valves, 4/- each  
Climax Potentiometers, 300 ohm pattern 5/- each

**CLIMAX RESISTANCE CAPACITY UNIT FOR L.F. AMPLIFICATION.**

—A new convenient design of Resistance Capacity coupling unit embodying the Climax fixed Mica Condenser, the Climax Wire Wound Anode Resistance and the Climax New System Grid Leak. Each item is readily replaceable and interchangeable so that the discriminating user has complete freedom of control. Price 12/6

**THE CLIMAX ANTI-MICROPHONIC VALVE SOCKETS.**

—No larger than the old-fashioned solid sockets. Readily fitted to any existing panel. They fit flush with the panel and give a particularly attractive appearance, and protect the valve from accidental damage. Fitted with the Climax patented hour-glass spring contacts. The valve floats on metal springs. Perfect electrical contact. Set of four Climax Anti-microphonic Valve Sockets, per box 2/-.

**CLIMAX FIXED MICA CONDENSERS.**

—Manufactured of the finest mica, having extremely high insulation resistance and the lowest possible dielectric losses. Fitted with substantial terminals and mounted in vitreous porcelain containers of the highest grade. Guaranteed accurate within 5 per cent.

Price :  
.0001 mfd. to .0009 mfd. 2/- ea.  
.001 mfd. to .006 mfd. 2/6 ea.

**THE CLIMAX POPULAR L.F. TRANSFORMER.**

—A highly efficient transformer for general low frequency amplification. Specially designed to give uniform amplification over the widest possible range of frequencies. Reproduction of speech and musical notes is therefore exceptionally good and pure. Price 17/6



Prof. A. M. Low on "THE POSSIBILITY OF TELEVISION."

W. B. Mediam, B.Sc., A.M.I.E.E. on "Building a Superheterodyne."

Articles on "Building a Wireless Set," "Upkeep of a Crystal Set," "Those Microphonic Noises," "Dodging the Aerial," and many others.

Full details of all the new CLIMAX RADIO COMPONENTS & SETS.



INSIST ON THE NAME "CLIMAX," REFUSE SUBSTITUTES. If substitutes are offered, send your order direct to us together with P.O. and we will send the goods by return.

## CLIMAX RADIO ELECTRIC LIMITED

Head Office and Works : QUILL WORKS, PUTNEY, LONDON, S.W.15. Telephone—Putney 2599  
All Communications to Head Office

Showrooms - - - 275, HIGH HOLBORN, LONDON, W.C.1. Telephone—Holborn 2538

LISSENIUM

# SELECTIVITY—

*an ever growing need*

LISSENAGON X COILS

No. 50	...	...	6/-
60	...	...	6/4
75	...	...	6/4
250	...	...	9/9

*Readers of this magazine are invited to send for interesting leaflet describing the uses of Lissenagon X Coils. Copy of the LISSEN TEXT BOOK will be sent also.*

In practically all modern circuits, selectivity plays an important part, and the non-selective set is considered by many as out of date. Since the re-arrangement of wave-lengths at the Geneva Conference, many stations are separated by only a few metres and a receiver capable of long distance reception is wasted if it is not selective, owing to the interference experienced.

If you are building a new receiver or are not satisfied with the tuning on your present set, the most simple means of obtaining selectivity is the use of LISSENAGON X COILS.

Single or multi-valve receivers—straight or reflex—there are few circuits using plug-in coils in which the selectivity cannot be increased by the substitution of LISSENAGON X COILS.

LISSENAGON X COILS can be used for aerial or anode tuning, Reinartz, Neutrodyne and wave-trap circuits, and their use makes possible many interesting experiments.

LISSENAGON X COILS are interchangeable with and can be used as standard coils. They possess all the characteristics and high efficiency which have made standard LISSENAGON COILS famous. In many receivers LISSENAGON X COILS can be used without alteration to wiring: often in others it is only a matter of reversing two wires.

LISSENAGON X COIL No. 60 covers the broadcast wavelengths, but in order to obtain the best coil combinations for all conditions of reception, LISSENAGON X COILS No. 50 and 75 are recommended for the lower and higher broadcast wavelengths, respectively. LISSENAGON X COIL No. 250 covers the Daventry and Radio-Paris wavelengths.

*The experimenter usually buys the complete set.*

# LISSEN LIMITED

LISSENIUM WORKS, 18-22, FRIARS LANE, RICHMOND, SURREY.

Phone: RICHMOND 2285 (4 lines).

Grams: "LISSENIUM, LONDON."

*There is a LISSEN PART for every vital place in a receiver*

**ABOUT OURSELVES**

*(Concluded from page 2.)*

nical wireless head of the Royal Air Force, and who had under his charge the great wireless laboratories of the Air Force at Farnborough. He has had long and unrivalled experience of every phase of modern radio.

**Deputy Director of Research.**

When Dr. Robinson handed in his resignation, we advertised the post of Deputy Director of Research, which post carries a minimum basic salary of £1,700 per annum, with further rights and remuneration which will probably bring the salary up to £2,500 per annum. The appointment has just been filled by Capt. H. L. Crowther, M.Sc., who, curiously enough, had been appointed to Dr. Robinson's post when the latter resigned. We thus have secured two successive wireless heads of one of the great Fighting Services.

It is easy to produce a weekly wireless paper on less sound lines which to the superficial reader might have much the same general appearance as WIRELESS. The beginner finds it difficult to tell the difference between a good paper and a poor one, between sound advice and inaccurate counsel, between a set design which is guaranteed to work, and one which looks as though it would. All he can do is to ask his experienced friend. We will abide by his decision.

I have often been told that we are simply wasting thousands of pounds in employing highly-paid experts, erecting very costly laboratories, and so forth. I am told that the wide public, the average man, the beginners, do not care about these things and are satisfied without them, provided their wireless paper is readable and superficially satisfactory.

**Radio Press Staff.**

I refuse to believe it. I cannot think that once a reader has the advantages of our organisation pointed out to him, he will regard the existing papers as all "much-of-a-muchness." The great prestige of the Radio Press has been achieved by the principle that the finest organisation and the greatest experts are not too good for the veriest novice. The staff I have chosen are men of high reputation and great ability. They have been chosen not only for their distinctions and practical experience, but for their very broad interest in and experience of the troubles, difficulties and needs of the beginner.

I have in this introduction not indulged in opinions, but in facts—facts which can be justified up to the hilt. And I have sufficient faith in those I am addressing to believe that these facts will influence them in their future choice of a weekly wireless paper.

JOHN SCOTT-TAGGART.

**Broadcasting Street Noises from WRNY**

*Street noises were recently broadcast by the Radio News station WRNY with*

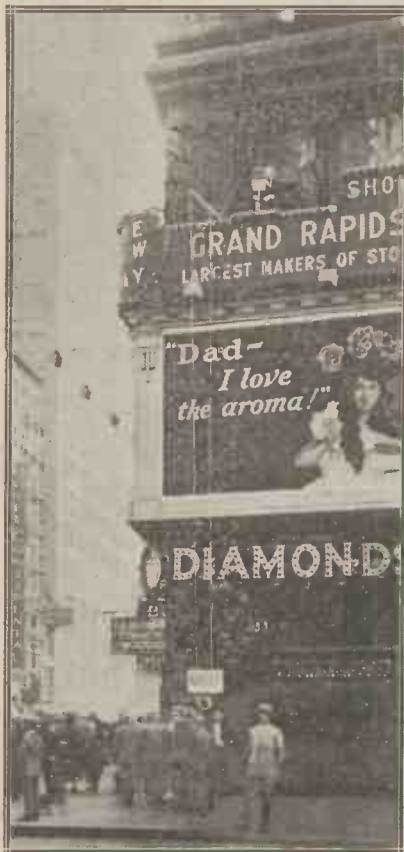

*great success. Two microphones were used, one hanging about eight feet above the pavement as shown in the first photograph, while a platform was built on the second floor of the building, from which the announcer advised the listeners of what was going on.*



*The announcers and microphone on the platform which may be seen in miniature in the first photograph.*

**Counting the Turns**

*By R. W. HALLOWS, M.A.*

ONE of the most finicky businesses when one is engaged in winding coils or transformers is that of counting the number of turns put on. If some kind of winder is in use one may be able to keep a tally of the revolutions of the crank, but one is always liable to lose count should an interruption occur at an inopportune moment.

**Single Layer Inductances.**

When single-layer inductances are being made one can generally work by measuring the length of the windings, provided that the turns are put on closely. As double cotton-covered wire is almost universally employed, the following little table showing the number of turns made to the inch by swg. d.c.c. wires of various gauges may be found useful:—

swg.	Turns per inch.
16	13
18	18.5
20	21
22	26
24	31
26	36
28	40
30	44
32	55
34	70.4
36	64
38	74

When winding low-frequency transformers it is often convenient to work by a combination of weight and measurement in the following way:—

Before starting to wind on the primary, weigh the former and make a note of its exact weight.

Measure the precise width between the cheeks of the former and discover from the table given above the number of turns that each layer will contain. It is now necessary only to count the number of layers. A convenient way of doing this is to make a stroke on a piece of paper as each is finished. Having finished the primary, weigh the former once more. The difference between its original weight and the one which is now obtained will give you the weight of the wire used in the primary windings.

**NO. 3 OF "WIRELESS" WILL CONTAIN AN IMPORTANT ARTICLE BY MAJOR JAMES ROBINSON ON "GETTING THE MOST FROM REACTION"**

# CLEANING UP THE ETHER

By A. D. COWPER, M.Sc.

*How a Radio Press expert studied wireless conditions during the recent International tests.*



*The studio at the Radio-Belge station which is received so well in this country.*

ON the nights of August 31-September 1 and September 2-September 3 respectively, and on certain subsequent nights, nearly every broadcast station in Europe that was able to, took part in a two-hour rehearsal between the hours of midnight and 2 a.m., B.S.T. It may interest those who did not have an opportunity of listening to this gigantic experiment on either of these occasions to follow the writer awhile in a tour round the stations, as it fell to his lot to make it via a sensitive receiver and an unusually effective high aerial in N.W. London on the first two nights of the test.

## The First Night.

On the first night, Radio Belge immediately led off at moderate loud-speaker strength (i.e., audible at 10 ft. from the L.S. without removing the head-phones from the ears after switching over). Bradford, Stoke, Nottingham and Leeds came in on their new (temporary and provisional) wavelengths at excellent telephone strength, with Liverpool, Dundee, Hull and Plymouth at just audible L.S. to moderate L.S. strength. Sheffield had apparently got entangled with a loud German station, and was well off the advertised new short wavelength. Some of the announcers had not quite realised that other than their immediate local listeners were trying to recognise their stations. Radio Lyon and Radio Toulouse left no shadow of doubt as to whom one was listening to, although they had not much to be proud of as to purity of reproduction: all were using maximum modulation. Some selfish amateur transmitters with flat-tuned trivial telephony did their best, in the London district, to spoil the international test, as far as the lower end of the belt was concerned.

## Waves from Spain.

A Spanish station contributed some horribly over modulated music, whilst another one, apparently Barcelona,

displayed a prowess with a mandolin which was a pleasant relief for a few seconds. Elberfeld was very anxious to tell the world that he was exactly "auf Welle 267 $\frac{1}{2}$ "; whilst another German between Liverpool and Edinburgh relayed market news from Hamburg relating to the shortage of



*The studio at Zurich, one of the Continental stations participating in the tests.*

bananas. A terrible heterodyne on around 300 m. wavelength (999 kc.), and another on 350 m. (857 kc.), which superimposed a steady wail on top of unintelligible speech, were all that was worthy of record in this region. Later a Spaniard gave loud music badly heterodyned on about 355 m. (843 kc.).

On the second night, the upper wavebelt was explored. Vienna started with a band which vied with a loud spark for supremacy; Zurich's contribution was faint telephony, on this much poorer night for reception.

Even Aberdeen could do no more than faint far-off music. Birmingham came in at loud strength, comfortably audible when switched over to the loud-speaker, with a faint heterodyne whistle in the background, and some spark Morse. A faint heterodyne whistle suggested Swansea in trouble, probably with Munich.

## German Stations.

Frankfort was at fair 'phone strength; Koenigsberg gave music and guttural speech; the Ecole appeared to be on holidays. A horrible bubbly wave with no intelligible modulation marked Stuttgart's wavelength—or was it a contribution from Moscow to the amenities of international broadcasting? Passing an idle wave, Belfast came in at excellent 'phone strength, and free from his usual unwelcome companions: terrible spark and other Morse jamming quite wiped out Rome, though he was evidently striving nobly in the background to get past it. Radio Toulouse jumped in here with clear French speech, but accompanied by bad C. W. Morse; then a slight whistle brought one suddenly on a tremendous low-pitched heterodyne moan which marked the clashing of Glasgow and Breslau, through which the Scotch station sometimes would attain to L.S. strength.

## Bilbao.

Just after the test the new Spanish station Bilbao came in here with a courteous good-night: at this moment a loud high-pitched whistle suggested a difference with either Munster or Breslau. Newcastle then came on the scene with an L.S. voice; faint music and a fainter wave below, plus spark Morse (probably Hamburg and Madrid or Gotenberg: proximity to London is beginning to tell on ease of reception): then Bournemouth on the L.S. with a talk about John Wesley, and Manchester (hard to separate from London at 12 miles) at good 'phone strength. A jump down to Cardiff brought in his call at fair 'phone strength in an interval of London, without wave-trap removed; some garbled speech just above him spells Spanish heterodynes, and good English speech from a relay, through the same 350 m. (857 kc.) heterodyne wail as on the previous evening, finishes up our present tour.

## Equipment.

The equipment for this trip was a one-control single-valve receiver of ultra-low-loss type with unusually sensitive reaction. The valve was a DE3B. the H.T. 40 volts, and the grid-leak 4 megohms. A series acceptor trap cut out London except on waves very close to him.

# STRANGE DETECTORS

By J. H. REYNER, B.Sc. (Hons.), A.C.G.I., D.I.C.

Potatoes, sugar, flame—all kinds of weird arrangements will receive wireless signals. This article tells you how.



This potato will act as a detector for wireless signals.

WIRELESS waves are peculiar in many respects. One of these is that they will at times demand from you the most complicated circuits in order to receive and detect them, while at others they will permit themselves to be detected and rendered perfectly audible by methods which are little short of ludicrous.

For example, we have on the one hand a variety of manufacturers experimenting to find a super-sensitive crystal, while on the other hand the enthusiastic "fan," having no crystal handy at the moment, inserts a piece of coke in his crystal cup and immediately obtains a perfectly good concert.

#### Sugar as a Detector.

There are no end of unorthodox detectors of this type. Even a lump of sugar, tickled with a cat-whisker, has been induced to respond to the witching waves and give readable signals. Such signals, of course, are not nearly as strong as those obtained with an orthodox detector, but the fact remains that they are audible, and that the sugar is undoubtedly acting as a detector.

#### A New Use for Potatoes.

Another substance which can be made to act as a detector is the humble potato. If a steel knife and a silver (or plated) fork are stuck into a potato, the arrangement acts as a detector and can be substituted for a crystal.

This action is due to the slight voltages set up by the two dissimilar metals, the arrangement behaving as a species of battery.

#### A Flame Detector.

A very simple detector can be rigged up with the aid of a gas flame. The flame should preferably be of the

bunsen type, giving a blue flame. If two wires are inserted in the flame and the arrangement is connected in circuit, signals will be distinctly audible.

The hot gases produced by the flame are in a state of ionisation, i.e., contain electricity in a more or less free state.

The gases are thus conducting, but the conductivity depends upon the direction of the applied voltage, so that the flame conducts better in one direction than the other, similar to a crystal.

#### An Improvised Detector.

There is a story of a wireless fan who was stranded with his car in the mountains, and concocted an improvised transmitting and receiving set from materials actually on the car.

## Making a Start in Wireless

By A. JOHNSON-RANDALL.

Timely hints to the new recruit.

ARE you just starting wireless? If so, a few hints on how to begin this popular hobby will not be out of place. As even the veriest beginner is no doubt aware of, some form of energy collector must be employed, and this, in the majority of cases, will be an outside aerial. The maximum size of this is laid down by the General Post Office, which states that the length of the horizontal portion plus that of the down lead shall not exceed 100 ft., and bearing this in mind you must now decide what type of aerial to erect.

#### Aerial Length.

Whether you can utilise the full length allowed will depend upon the space at your disposal, but assuming this to be adequate, probably the most suitable type of aerial for all-round results will be one with an average height of from 30 to 35 ft., and with a horizontal portion about 60 ft. in length. A single wire of 7/22 gauge hard-drawn copper, well insulated with two good insulators at each end, and with the down lead kept well away from the house, will give excellent results. Those who are not in a position to erect a good outside aerial can still obtain good reception, provided they are situated at a reasonable distance from a broad-

casting station, by stretching two or three parallel wires across a room at a distance of a foot or so from the ceiling.



Not galena, but sugar with a cat-whisker? Even this gives signals.

As regards the set to be used on the aerial, readers will find the Radio Press Envelope instructions ideal guides. Those new to radio will find the following two books by John Scott-Taggart, F.Inst.P., A.M.I.E.E., very helpful:—

- (1) "Wireless for All" (9d. net).
  - (2) "Simplified Wireless" (1s. net)
- the sequel.

# A Revelation in Radio Reproduction

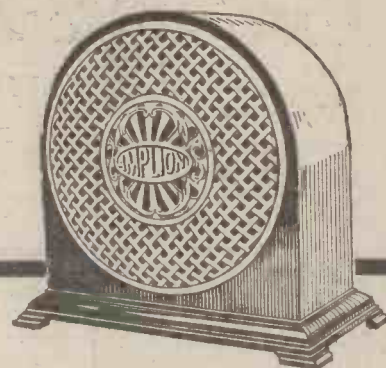

## The AMPLION Radiolux Series

of hornless Loud Speakers introduced the nearest approach to the ever present ideal—perfect reproduction of Radio Broadcast.

This new masterpiece blends the art of furniture design with the science of electro-acoustics.

Here the living voice and true perspective in musical reproduction are within the immediate reach of all interested in Radio. Sensitive to a degree, loud in its fullest measure, with unequalled brilliance and clarity, *real music* at last enters the home upon the trial of the Wireless Wave providing an AMPLION is there to voice its accents.

The Radiolux series of cabinet styles is available in several alternative forms of varying capacity at "utmost value" prices ranging from £4 10 0.

For those who may still wish to procure the hitherto standard horn models, available in the junior variety at even lower costs, the manufacturers continue to offer the famous "Dragon" range, a series known in every quarter of the globe.

It is a business principle of the House of Graham that every AMPLION user shall secure the best possible results and an unconditional guarantee of satisfaction while the advantage of free service is extended to every purchaser of a genuine

The  
World's  
Standard

# AMPLION

Wireless  
Loud  
Speaker

## FOR BETTER RADIO REPRODUCTION

*Patentees and Manufacturers*

ALFRED GRAHAM & COMPANY (E. A. GRAHAM)  
ST. ANDREW'S WORKS - - CROFTON PARK, LONDON, S.E.4

*Demonstrations gladly given during business hours at the Graham Showrooms:*

25-26, SAVILE ROW, REGENT STREET, W.1; 79-82, HIGH STREET, CLAPHAM, S.W.4.;  
and at the recently opened Scottish Depot, 101, ST. VINCENT STREET, GLASGOW.

## SEE THEM AT THE RADIO EXHIBITION

ROYAL ALBERT HALL, SEPT. 12th—23rd. AMPLION Stand No. 40, Main Hall.

Demonstrations will be given continuously during the Exhibition period at The AMPLION Suite, Kensington Palace Mansions, 3, De Vere Gardens (a few hundred yards from the Albert Hall).

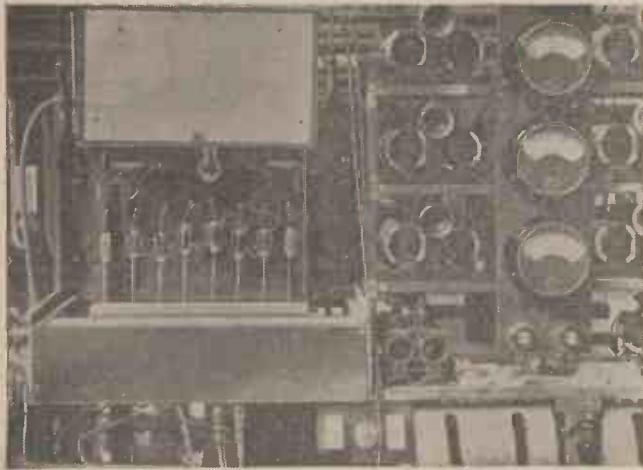

*Pump tables with eddy current heating equipment for dull-emitter valves.*

# Dull - Emitter Valves

*By Captain H. R. CROWTHER, M.Sc.,  
Deputy Director of Research of our Elstree Laboratories.*

*This article tells of many little known facts regarding popular valves.*

**T**HERE are two types of dull-emitter valve on the market at the present time. In one, the filament, which is usually of platinum, is coated with a thin layer of material consisting of the oxides of the rare earths. This type of filament has been known since the early days of valves, but it is only recently that methods have been devised for coating very thin filaments, such as that contained in the well-known Pea-nut tube developed by the Western Electric Co. of America.

The other type of valve contains a filament consisting of a homogeneous mixture of tungsten and thorium, and it is only this type of valve which will be considered below.

### The Thoriated Tungsten Filament.

Although thorium is usually contained in the bright-emitter filament, it is only in comparatively small quantities compared with the percentage of thorium in the dull-emitter filament. At normal bright temperatures the highly thoriated filament behaves in practically the same way as the ordinary tungsten filament. After suitable treatment, however, the highly thoriated filament is capable of giving a high emission at a very much lower temperature, and one at which the emission from an ordinary filament would be negligible.

This high emission property of a thoriated tungsten filament not only depends on the actual composition of the filament, but also to a large extent on the degree of vacuum in the valve itself. Valves in which the vacuum is very slightly defective cannot be treated or "activated" so as to give this abnormal emission at low temperatures. Minute traces of water vapour and other impurities are fatal to the production of a dull-emitter.

### How the Vacuum is Obtained.

The evacuation of a valve cannot be dealt with in detail here, but one or two of the general principles will be mentioned. The main pump used

for valve work is usually of the mercury vapour type.

As all the metal parts of the valve contain a considerable amount of occluded gas, the latter has to be driven off during evacuation by heating the electrodes to a bright red heat. This can be carried out by two methods, as follows:—

(a) *Electron bombardment* by connecting a high tension supply between the grid and anode connected together and the filament.

(b) *Induction heating* carried out by placing the entire valve in a coil of a few turns of thick wire through which a high-frequency current of 10 to 20 amps is passed. This high-frequency current can be provided by means of a valve oscillator or arc:

This method is particularly suitable for fine filaments, as these are liable to become deteriorated if method (a) is used.

In order to reduce the time required for the elimination of the last traces of gas, what is known as the Getter process is generally used. This consists in coating the anode with some material which volatilises when the anode becomes hot and absorbs the last traces of gas in the valve. Phosphorus and magnesium have been extensively used for this purpose. The silvery coating on the glass of so many modern valves consists of this magnesium which has volatilised and been deposited on the walls of the bulb.

### Dull- and Bright-Emitter Valves Compared.

The chief advantages of the dull emitter is, of course, the long life of the filament, which may be many times that of the ordinary filament, and also the small heating power required.

Although the life of the actual fila-

ment of the dull-emitter may be many thousands of hours, there is a tendency for the electron emission to fall off, especially if the valve is misused. It is, therefore, possible to have a valve which appears perfectly good, but which is quite useless for operation in a receiver under its ordinary conditions. Another objection to dull-emitter valves is their tendency to produce what is known as microphonic noise. Some valves, particularly those with very fine filaments, will produce serious ringing noises in the 'phones or loud-speaker, with the least vibration or external noise. In many cases the valves are so susceptible to external noise that the sound from the loud-speaker itself will often cause the set to give a continuous howl.

### Renovation of Dull-Emitting Valves.

Do not throw away dull-emitting valves which fail to give signals. In many cases the failure is simply due to loss of emission caused by too much high tension or too high a filament voltage. If the valve is a good one in other respects, the emission can generally be recovered by the following simple treatment. The faulty

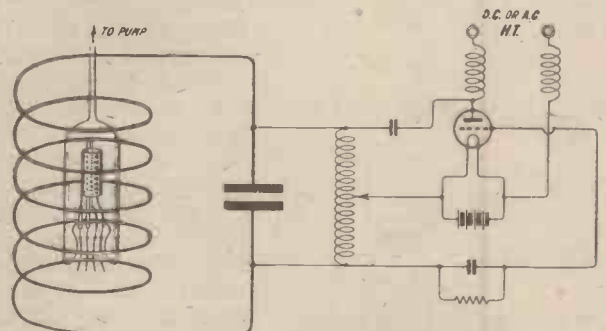

*The circuit used for induction heating of the metal parts of a valve.*

valve is first of all "flashed" by applying across its filament terminals a voltage about three and a-half times its normal working voltage, e.g., a 2-volt valve should be flashed at between 7 and 8 volts. This should only be kept on for a few seconds, otherwise the filament will burn out. No H.T. should be connected to the anode during this process. This treatment has the effect of cleaning up the surface of the filament and makes it suitable for activation.



## Like wine, the Wuncell improves with age—

IT is a remarkable fact that the Wuncell—alone among Dull Emitters—actually improves with age. Whereas in most dull emitters the filament loses much of its emission through course of time, that used in the Wuncell actually gains in productivity of electrons.

The Wuncell filament is unique. It is built up layer upon layer under an entirely new process. As a result it is exceptionally robust. When next you get the opportunity to examine a Wuncell compare its filament with that used in any other dull emitter—or even in any bright emitter. You will be amazed at its thickness. It is practically as stout as that used in the average

bright emitter. Yet its wonderful economy of current will enable a six-volt accumulator (with its cells re-connected in parallel to give 2 volts) to give 70 hours' use where it gave but 9 before.

Couple that exceptional economy with the fact that the filament never gets hotter than a very dull red and you will readily realise that even if Wuncells cost twice as much they would be much cheaper in the long run than any bright emitter.

Eventually you'll use Wuncells—why not begin now? Buy them one by one as your present valves become useless. If they will save you money in a month's time, they will save you money now.



The Wuncell Dull Emitter,

Voltage 1.8 volts. Consumption 3 amp.  
 W1 for Detector and L.F. 14/-  
 W2 for H.F. amplification 14/-  
 W3 Cossor Loud Speaker Valve  
 Voltage 1.8 volts. Consumption 5 amp.  
 Price 18/6

# Cossor



# THE WIRELESS SPY MENACE

By WM. LE QUEUX

*The Famous Novelist and Student of Espionage Methods.*

THE modern spy system, an intricate network of which is spread over Europe, would at first sight not be efficient without the use of wireless. As one who had something to do with contra-espionage in Great Britain before and during the war, I happen to have knowledge of certain facts which have never hitherto been published.

## Seizure of Amateur Sets.

When in August, 1914, the Postmaster-General gave orders for the seizure of all amateur sets and made it a penal offence to possess one, every loyal Englishman dismantled his apparatus, took down his aerial, and handed everything over to the polite post office officials who called for it. In the course of the next few weeks post office linesmen noticed in the outskirts of London, and at several places on the east and south coasts, aerials still up. On investigation they found the house shut up and deserted, and attached to the aerial a neat and very effective little German set, a compact spark transmitter and receiver. But the German spy had taken fright and flown, probably escaped back to Germany just before the open door had closed. These sets were never claimed when, in due course, amateurs received back their apparatus, and their owners, who were known to their neighbours as honest persons, never suspected of being spies, have never since been seen.

## "Fixed Posts."

Those German agents, known in the world of espionage as "fixed posts," had been sent here in preparation for the intended invasion so that the enemy could obtain intelligence from within our camp, but their outdoor aerials had given them away. If war again breaks out—and in the course of the last few months spent in Germany and German-Switzerland I have formed the conclusion that such a disaster is extremely likely—the same conditions will not arise. Experiments are just now being conducted with secret "aerials," namely, those buried in the ground and concealed in such a manner that their existence would never be suspected.

## The Apparatus

The secret aerial consists of No. 12 heavy rubber-covered copper wire 100 feet long, enclosed in a length of rubber garden hose. A trench is then dug a foot or two feet deep, and the wire laid in it in a straight line.

Now the laying of such an aerial might attract the attention of neighbours or others, so there must be camouflage. This is easy. It is quite in the ordinary course to lay a line of

drain-pipes through a garden, therefore when the line is laid the aerial can be pushed through it, the end of the pipe sealed with a plate, and the ground filled in without exciting the least suspicion.

With such a secret aerial it is possible to tune the transmitter from 50 to 120 metres, but the most efficient seems from 80 to 95 metres. Of course, it is strongly directional—



Mr. William Le Queux

another point in its favour for the purposes of espionage on the transmission of confidential intelligence.

## What the War Taught Us.

Now it is one thing to possess a secret wireless set, but in these days of direction-finders and highly sensitive listening apparatus it is quite another thing to use it. Many lessons were learnt both by ourselves and the Germans in the World War, and not the least was the importance of wireless, in which, be it said, Britain held all the honours in the game. As Lord Fisher declares in his memoirs: "Wireless telegraphy is the strong man's weapon; rightly used, dangerous for the enemy; but carelessly used, more dangerous for one's self." We recognised this fact, but not so the Germans; hence the British wireless organisation became entirely different from that of the Germans.

The transmitters of the latter buzzed merrily along with miles of code messages, the enemy little dreaming that when the German cruiser *Magdeburg* was stranded near Odensholm an iron safe was found in the sea near by which, on being opened by the Russians, was found to contain not

only the signal books, but a key to the code! In consequence, a special listening bureau was established, with a number of receivers, to each of which was assigned a different wave-length, so that not a single message should be missed. Everything received was sent direct to the Admiralty, and there decoded. By thus paying attention to everything received we soon became masters of the German code, and were able to send out messages which were intended to deceive, and which certainly did so. As the war proceeded, directional stations were established at suitable points on the coast, and there the directions of every German ship transmitting were taken. At the Admiralty these were collated, and by that means it was usually discovered who was the sender. Thus German warships and scouts at sea almost invariably betrayed themselves, so that we generally knew exactly where the enemy's ships were.

## Secret Agents.

That Germany's secret agents are again among us in Britain is undoubted, but the authorities who deal with such matters are not so blind as many people think. The majority of these persons are known, and their movements noted, so that hands could be placed upon them at the sudden outbreak of hostilities. The people we term spies are technically not spies, for it is laid down by the Hague Convention that a spy is a person who is acting within the war-zone. But whether in a war-zone or out of it, a secret agent of the enemy would think twice before giving himself away by sending a wireless message. Therefore I think it is quite safe to assume that however great the advantages of wireless may be, they are useless to the spy. He must find other and more secret means of communication.

## A Prophecy.

Though wireless sets with secret aerials may be a menace in the hands of spies, I do not think that they will be used to any extent in the next war on account of our improved apparatus for detecting enemy messages. It would indeed be a bold enemy agent who would dare nowadays to communicate with his paymasters by wireless. In the last war our supremacy in radio and our eventual radio silence proved the key to victory. The Germans are now aware of it. I happen to know that they have designed a very compact transmitter and receiver to be used with a secret aerial, for I actually saw one in Hanover a month ago. It is an ideal set for spy work, but I think the danger is more imaginary than real.

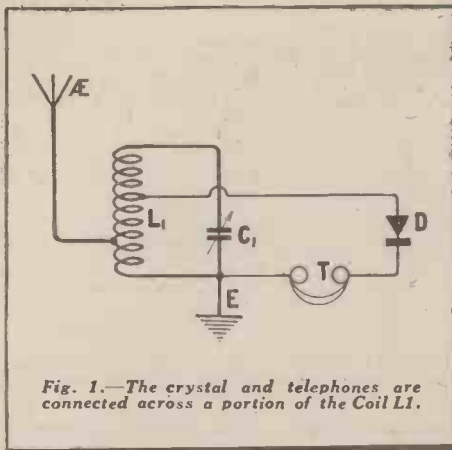

Fig. 1.—The crystal and telephones are connected across a portion of the Coil L1.

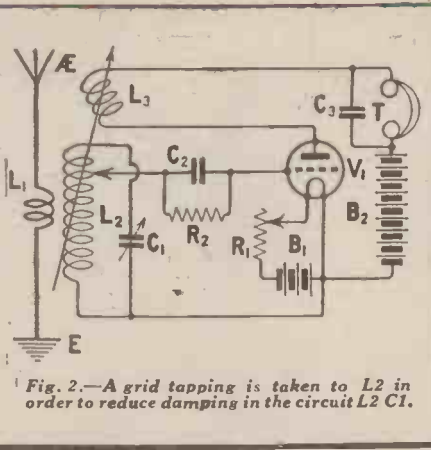

Fig. 2.—A grid tapping is taken to L2 in order to reduce damping in the circuit L2 C1.

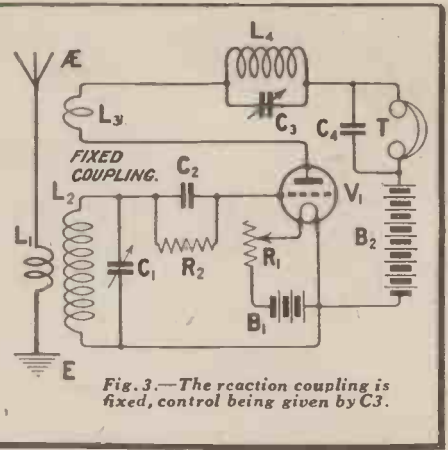

Fig. 3.—The reaction coupling is fixed, control being given by C3.

THIS winter will see a considerable change in both the types of circuits used and the general design of the apparatus itself.

As regards the design, there will undoubtedly be an extension of the idea of having all the components behind the panel with simply the controls at the front.

It is a fact that many home constructors find this method of construction more difficult than the older method of construction, but, curiously enough, the fashion in connecting the apparatus on a baseboard behind the panel has a distinct bearing on the type of circuit used.

## Circuits You Will Use this Winter

By JOHN SCOTT-TAGGART, M.C., F.Inst.P., A.M.I.E.E.

No. 1.

ideas as to what is likely to become popular in the way of circuits. The list here is the first of a series and some of the circuits will be new to many readers.

All the circuits are shown pictorially as well as in the ordinary manner, so that even the novice can follow them out with ease.

Fig. 1.

Fig. 1 is a crystal circuit which employs auto-coupling. In this case the crystal detector and telephones are connected across only a portion of

Fig. 2 employs a type of aerial-coupling known as the "aperiodic" aerial arrangement, in which a relatively few number of turns are closely coupled to a larger coil. This arrangement is shown in use in most of the circuits, and as it gives great selectivity and makes the tuning of the secondary circuit almost entirely independent of the nature of the aerial, the method will probably become standard in most sets. It will be noticed in Fig. 2 that a variable tapping of the coil L2 goes to the grid of the valve, and this reduces the damping in the circuit L2 C1. Mr. Cowper, M.Sc., has drawn special attention to the effect of grid-circuit damping in the case of a rectifier valve. Reaction is introduced in the usual way by coupling the reaction coil L3 in a variable manner to L2.

Fig. 3.

Fig. 3 is a somewhat similar circuit to Fig. 2, except that the ordinary grid connection is taken, while the reaction coil L3 is actually fixed and may be wound as a number of turns on the same low-loss former as the inductance L2, while L1 may be wound at the other side of L2, each of the three coils, of course, being wound quite separately on the same former. These low-loss formers, incidentally, will achieve great popularity, and plug-in coils will suffer accordingly. On the other hand, the

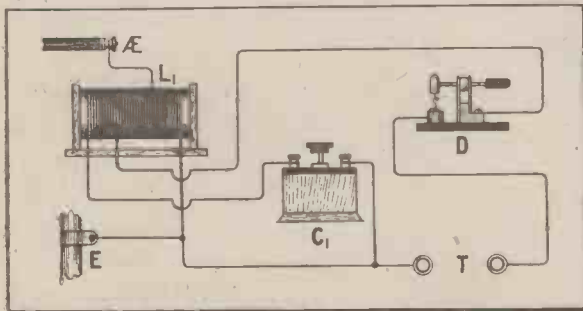

Fig. 1a.—The Fig. 1 circuit in pictorial form.

Components available to the public also affect the type of circuit which can be used. For example, with the ordinary plug-in coil it is impossible to employ certain types of circuits at all, and consequently there will be a market for specially wound coils.

Undoubtedly the introduction of new components will encourage the production of new circuits, while new circuits developed at our Elstree Laboratories will necessitate new components. This winter will therefore be a particularly interesting one for those interested in new designs and receiver circuits.

It is, of course, always dangerous to prophesy, but I propose in the next few issues of this paper to give my

the inductance coil, while the aerial is tapped to another point on the coil. This circuit possesses nearly all the advantages of Fig. 4, although only one inductance coil is used.

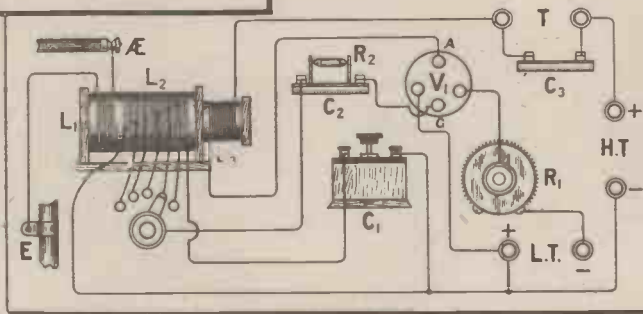

Fig. 2a.—A pictorial representation of Fig. 2.

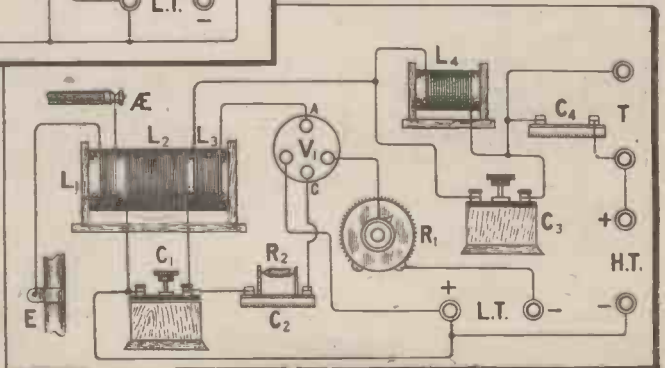

Fig. 3a.—The same arrangement as Fig. 3.

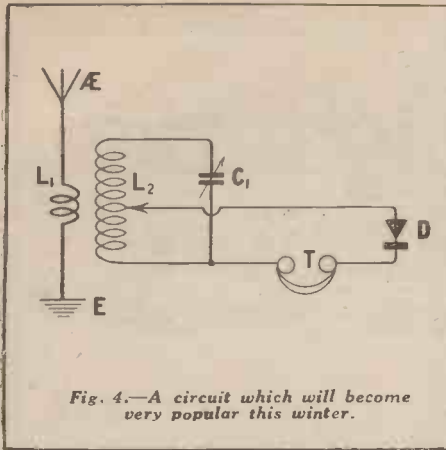

Fig. 4.—A circuit which will become very popular this winter.

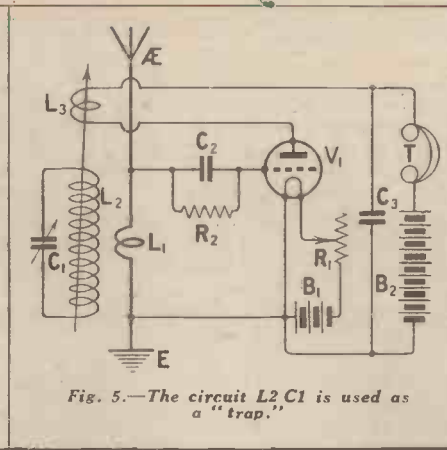

Fig. 5.—The circuit L2 C1 is used as a "trap."

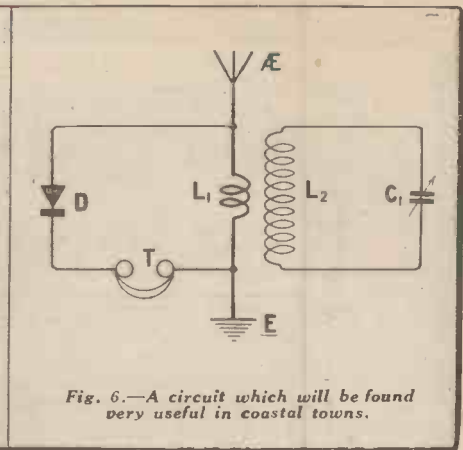

Fig. 6.—A circuit which will be found very useful in coastal towns.

low-loss coil is not very adaptable for receiving 5XX. Although the circuits given here are primarily for low-loss coils, yet they will work quite well on ordinary plug-in coils and a two- or three-coil holder, in which case, of course, 5XX or the ordinary B.B.C. stations may be received at will.

In Fig. 3, the reaction coil being fixed, it is necessary to vary the reaction in some other way, and this may be done by connecting a choke coil L4, which may be a 200 plug-in coil in the anode circuit of the valve. The coil L4 is shunted by a variable condenser C3, which will vary the amount of reaction and give a very smooth control. This circuit is excellent for reaching down to the very shortest wavelengths, and this, and other methods of obtaining very smooth reaction, will undoubtedly become very popular. The usual two-coil holder is by no means the last word in variable reaction devices.

Fig. 4.

Fig. 4 is a crystal circuit which is bound to become very popular. It is highly selective, and the tapping taken off the coil L2 ensures not merely greater selectivity, but generally also greater signal strength due to the general reduction in the damping.

Fig. 5.

Fig. 5 uses a trap circuit, and is a single valve set suit-

able for cases where there is a very large amount of interference. It will be noticed that a coil L1 of only a few turns is in the aerial circuit, while coupled to it is another coil L2 shunted by a variable condenser C1. A reaction coil L3 is variably coupled to L2. This circuit is one of the most selective it is possible to arrange, and the condenser C1 requires vernier adjustment. Signal strength is only a little less than that obtained with the most efficient

will be noticed that instead of connecting the crystal and telephones across L2 C1, they are connected across the small inductance L1. This curious type of circuit is extraordinarily selective, and is of great value to those working in coastal towns.

C3 in Fig. 2, C4 in Fig. 3, and condenser C3 in Fig. 5 are all of .002  $\mu$ F capacity, while all the variable condensers are of .0005  $\mu$ F, or, where a shorter wave band is required, .0003  $\mu$ F capacity. The sign " $\mu$ F," of course, is the official standard abbreviation for "microfarad,"

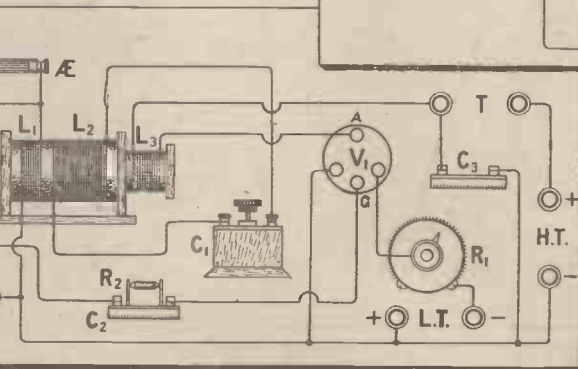

Fig. 5a.—The coils L1 and L2 may be wound upon the same former.

ordinary single valve circuit.

Fig. 6.

Fig. 6 is another trap circuit which has a tuned oscillatory circuit marked L2 C1, with its inductance L2 coupled to the aerial inductance L1. It

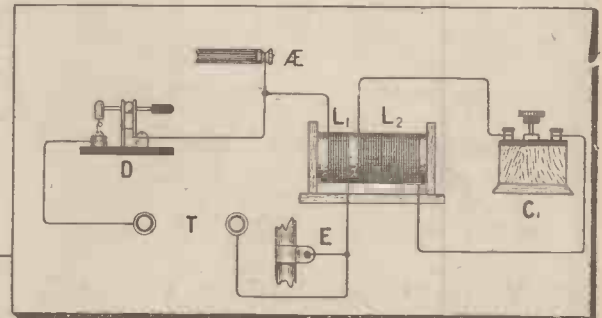

Fig. 6a.—As in the Fig. 5 circuit L1 and L2 may be supported upon the same former.

which is often incorrectly shortened to "mfd."

Next week I propose to give one or two more circuits, and will continue to do so weekly for some time.

**SPECIAL NOTICE.**

The next issue of "Wireless" will contain a description of the "Centodyne," a remarkable single valve receiver.

By PERCY W. HARRIS, M.I.R.E.

YOU can make it.

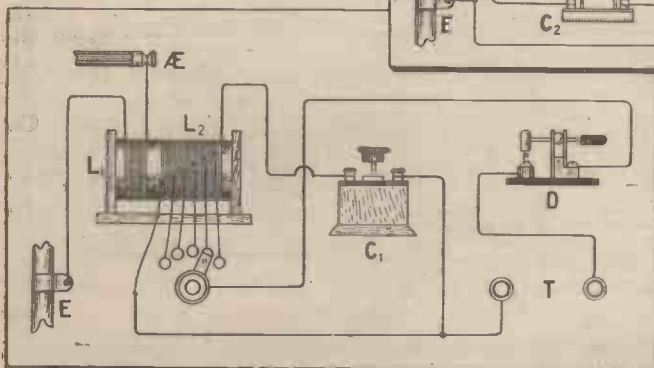

Fig. 4a.—The components necessary for the Fig. 4 circuit will be easily recognised.

# The First-Fruits of Gigantic Research Collaboration-



THE combined forces of the Philips and Mullard Technical Research Organizations have achieved the first of many wonderful developments in the perfection of radio valves.

The P.M.4 Master Loudspeaker Valve stands triumphantly alone above the accepted standard in valves for loudspeaker reception.

It is the NEW "N" FILAMENT VALVE! This filament is prepared by an entirely new process, whereby the special coating is obtained in an extremely adherent condition, making it capable of giving considerable electron emission at very low temperatures.

There are four supports to this unique "N" filament. It is absolutely non-microphonic. The low current consumption of only 100 milli-amperes means vastly increased valve life and longer battery service without re-charging.

Only a 4-volt accumulator or three dry cells are required for the P.M.4 Master Valve.

Try one in your set to-night and note the wonderful purity of tone and volume you will obtain from your loudspeaker.

PRICE 22/6 each

Ask for Leaflet V.R. 28

A giant model of this wonderful P.M.4 Valve will be shown at Stand No. 10—All British Wireless Exhibition. September 12—23, 1925

# Mullard

THE MASTER VALVE

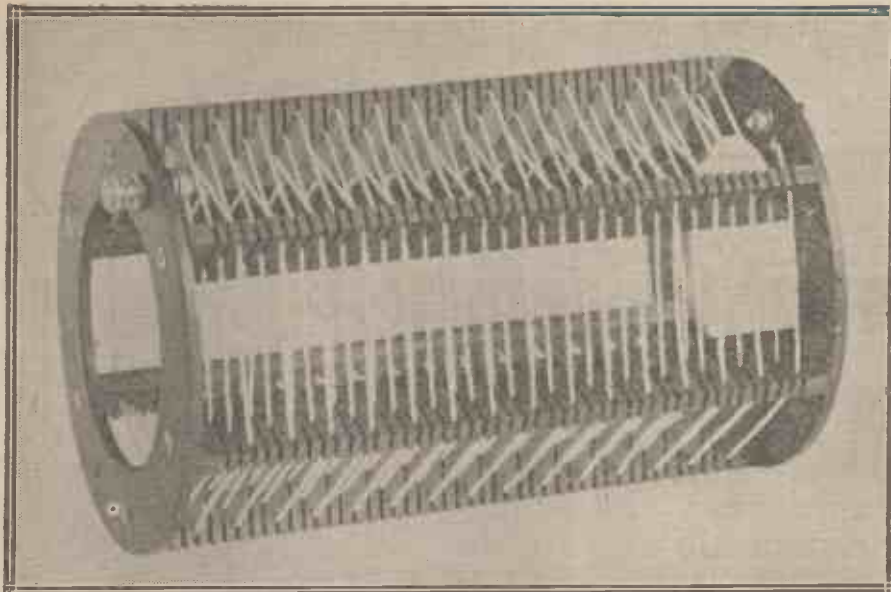

The completed "Three-step" coil has a distinctive appearance.

ONE feels a certain hesitancy in putting forward yet another low-loss coil. However, the latest investigations all go to confirm the belief that the tuning inductance represents one of the most important sources of loss in tuned circuits, and there can be no doubt that improvements in coil design present an extremely fruitful field for experiment.

**Added Efficiency.**

Improvements here, moreover, really do lead to perceptible increases in the efficiency of one's equipment, provided always that it is remembered that the aerial circuit forms something of an exception to the rule as to the tuning coil being the main source of loss. In the aerial circuit there are so many other factors, such as the resistance of the earth connection, that when the coil has been improved up to a certain point further increases in its efficiency do not seem to give very much improvement in results, simply because the other sources of loss swamp the effects of the coil.

**Distinctive Features.**

The inductance described in this article I find to be of decidedly high efficiency, in that it compares very favourably with every type of low-loss inductance which I have yet tested. It presents the usual features of well separated turns, air spaced and supported upon a skeleton former, enamel covered, or bare, wire of a fairly robust gauge being used.

The turns are supported in a series of saw cuts which are made in the six side strips of the skeleton former, the saw cuts being made to varying depths to produce the desired formation of the winding. As will be seen in the photograph, the strips forming the skeleton arrangement are mounted between two ebonite end rings, and the resulting framework is quite a rigid one.

The saw cuts are arranged in sets of three, each cut of the three being to a different depth in the former, which point will be readily understood from one of the drawings accom-

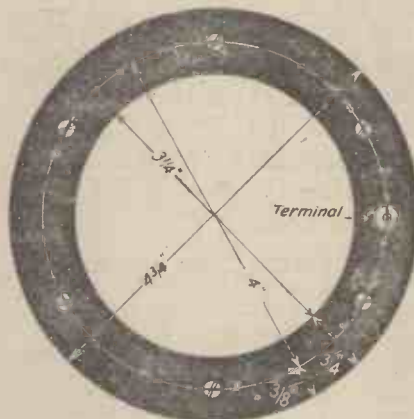

Ebonite Disc 1/8" Thick  
End-disc details.

panying this article, and it will be seen that the result is to produce quite a wide spacing between the turns of the coil without making the whole inductance extremely bulky. The necessary dimensions for making

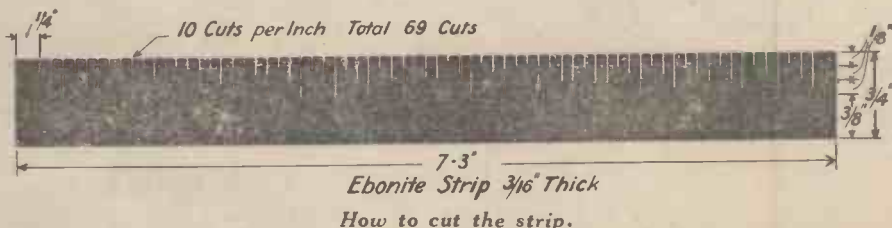

How to cut the strip.

all the parts of one of these formers are given in the diagrams, and the only point requiring mention is one concerning the making of the saw cuts.

The  
"Three - Step"  
—A New Home-  
Made Low Loss  
Coil

By G. P. KENDALL, B.Sc.

Mr. Kendall's work on low-loss coils is well known to all experimenters. In this article he describes a new coil specially designed for "Wireless" readers.

**Cutting the Slots.**

It is only necessary to mark out one of the ebonite strips, as a guide to the sawing, and then all the strips can be clamped together in a vice, and all the sawing can be done at once. The end rings are attached to the ebonite strips by means of small screws fastened in tapped holes in the strips, but those who do not feel equal to the job of making these small tapped holes can perform the necessary attachment by means of angle pieces made from brass strip.

**Formers Available.**

Those who do not wish to spend time on the making of these formers can obtain them complete and ready for winding from a number of manufacturers. The one illustrated in the photographs was made by Messrs. Burne-Jones & Co., Ltd.

The winding of the coil is very simple and easy, and is best done with No. 20 or 22 enamelled wire.

To prevent the side strips being forced inwards by the tension on the wire, a small ring of ebonite is slipped inside the former, and this can be cut from an ebonite tube of a suitable size, the one required with the dimensions given being 3/4 in.

The dimensions given in the diagram and the number of saw cuts therein illustrated will, if followed, result in a coil of suitable size for use in a

tuned anode circuit, or a secondary circuit coupled to one of the aperiodic aerial arrangements which are now becoming so popular. It will also be correct for use in a Reinartz circuit.

## The Seal of Excellence

On every Igranitic Radio Device appears the distinctive Igranitic Trade Mark—the seal of excellence—which is a guarantee of highest efficiency and the finest materials, workmanship and finish.

It is a sign that the device is the result of exhaustive research and experiment, developed by experienced radio engineers—manufactured by precision methods, by workers long skilled in the production of delicate electrical devices in a factory which has produced electrical control gear for well over a quarter of a century.

With the Igranitic Trade Mark goes the liberal Igranitic Guarantee under which any Igranitic Radio Device is repaired or replaced free of charge, should the user fail to derive that complete satisfaction in performance which Igranitic Radio Devices are consistently giving to thousands of radio enthusiasts throughout the world.

Write for interesting new booklet Z708 and leaflets showing the latest Igranitic Radio Devices, to IGRANIC ELECTRIC CO., LTD., 149, Queen Victoria Street, London, or to the works at Bedford.

*Branches at Birmingham, Cardiff, Glasgow, Leeds, Manchester and Newcastle.*

**IGRANIC RADIO DEVICES INCLUDE:—**

Honeycomb Duolateral Coils; Variable Condensers; Fixed Condensers; Filament Rheostats; Intervalve Transformers; Variable Grid-Leaks; Variometers; Vario-couplers; Coil Holders; Potentiometers; Vernier Tuning Devices; Switches, etc., etc.  
All carry the IGRANIC guarantee.



# When we Broadcast Movies by Wireless

By Captain P. P. ECKERSLEY

An article in characteristic vein by the genial Chief Engineer of the British Broadcasting Company.

IN the latter middle of last century James Clerk Maxwell showed that wireless communication was a theoretical possibility. Later, Hertz did "wireless" of a sort over short distances—his experiments were laboratory demonstrations on very short waves. About 1900 Marconi invented a practical system, and it was even then realised that the voice might be transmitted from place to place without wires. It was in 1906, roughly, that the sounds of the human voice were intelligibly transmitted by wireless waves over practical distances. About 1914 the germ of a practical wireless telephone set was evolved. Broadcasting—probably delayed by the war—came into its own about 1920. The war saw very little really satisfactory wireless telephone work.

## A Quarter of a Century.

Between 1900 and 1925 then we see the development of wireless telephony. It has taken a quarter of a century to evolve a practical system from a theoretical possibility.

It is a theoretical possibility even now to send movies by wireless. A combination of selenium cells, many channels of communication, modulators of several carrier waves, each controlling the intensity of a patch of



New Ambassador lands at New York.

light in your drawing-room—why not? But it is not very practical yet, is it?

The early wireless telephone relied for its success upon a microphone, which had intrinsically to control the whole of the power in the aerial. To give a rough idea of quantities, the ordinary microphone you use when you want Hop 101 passes .2 or .3 amps. A practical wireless telephone, relying as it then did upon crystal receivers—the valve was not then invented—required for a 20-mile range perhaps 10 amperes in the aerial, the microphone had to control 10 amps. I well know that amps. are not power, but I find people appreciate them more. In terms

of watts, the ordinary microphone handles at maximum 2 watts (usually much less); the wireless telephone microphone might for a 20-mile communication have to handle 1,000 watts. The system thus relied upon all sorts of weird arrangements, as a search among the patents of the day will reveal. It was the valve, in giving us the means of amplification to increase the power of the simple microphone and also increasing our powers of reception, that brought a practical system within our reach.

So it must be with television. I give the brave inventors 10, 15 or 20 years before you with simple apparatus in your homes will be able to see and hear plays. I hope I shall live to be shown up as a pessimist and a false prophet.

## The Present Problems.

As I see the problems at present, from a fundamental point of view the great difficulty would appear to be to get a practical number of channels for transmitting the picture, seeing that every graduation of light must be transmitted simultaneously. Pick up your illustrated paper. You will notice that the picture is given reality in terms of a number of dots of different shades.

## Dots and Pictures.

A cheap paper relies upon a general impression by using few dots. The better the reproduction the greater the number of dots. I have counted up the dots in a picture before me now. It is still visible as a picture at about a yard. It has 40,000 dots. It relies for its appearance as a picture upon the different intensity of the 40,000 dots. If we are to transmit a moving picture these dots will each have to be controlled from moment to moment in sympathy with the variations of the object we are attempting to convey by television to a receiver. 40,000 channels! If in terms of sound we are to send various frequencies each controlling a dot's intensity we



Captain Eckersley with his favourite Crystal Set.

shall need some fairly adequate acoustical selectivity in our receiver. This is the fundamental problem. Never mind the methods taken to solve the little problems of technology involved. By using few dots a crude image can be transmitted, just as about 1906 recognisable sounds could be conveyed. It is so different making the thing practical and simple.

The Editor will be getting annoyed! He told me to write on *when* we send movies by wireless. What a time for the programme people, what a lot of extra embarrassments! No more conducting in a sweater and shorts, no more coats, collars and ties off for the operatic tenors, no more falling in love with voices. And think what may happen if someone oscillates. The fair form of the radio star, the world's sweetheart in voice, figure and face, is distorted beyond recognition. Think of the fury of the "looker-in."



The effect of an oscillator.

I suppose, though, in a hundred years we actually shall be auditors and spectators of the world's happenings.

## Seeing the News.

"1st General News.—'New British Ambassador lands at New York,' says a voice in our room. We are aware immediately of the hum of propellers and on the wall of our living room a great shape, the world's largest Transatlantic Airship glides into view. We can see the crowd waving handkerchiefs. A cheer breaks out. 'Clank! She is moored.' Down comes the caisson from the mooring mast, the Ambassador steps out, we hear him,

## When we Broadcast Movies by Wireless—*continued.*

'I am glad to have arrived. We did a record trip in 24 hours 3 mins. 19 secs. . . . My policy, . . . etc., etc.' We are glad he has arrived, too, and he's looking very well, better than when he was in South Africa that time he spoke on the inauguration of the half-day service to London."

We see no barrier to the linking of the world by broadcasting theoretically to-day. Where broadcasting can percolate, so, assuming a practical system, will television. We dream, and the dreams of to-day are the facts of to-

morrow, but let no one expect tomorrow to dawn before the earth's necessary revolutions. Science and Technology have accomplished many wonders. Do not let us in imagination try to force a pace that is logically determined by our advances not in this section or that, but, as they said in the war, "on a wide front." When we send movies by wireless, much water will have passed under the bridges. In the meanwhile, let us face present problems, which are plentiful enough, and not be too (tele)visionary.

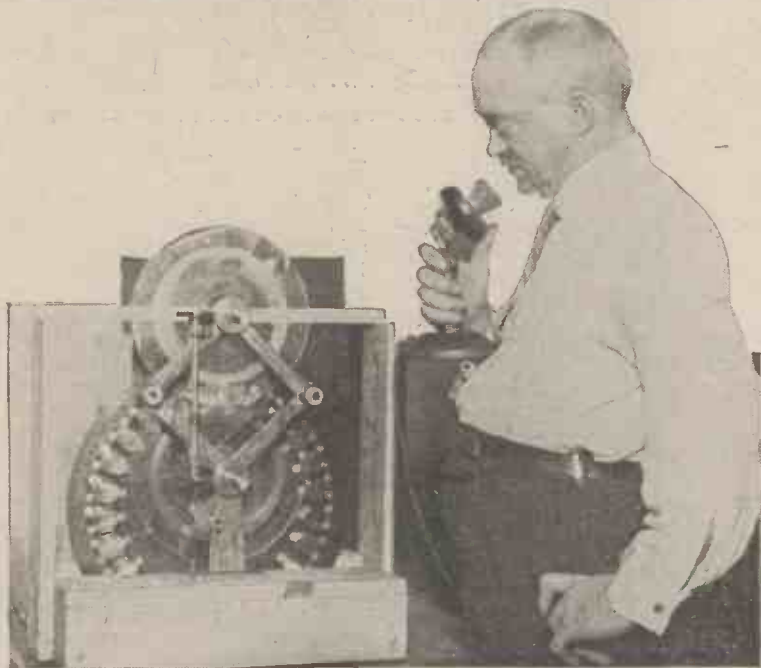

Mr. C. Francis Jenkins, Washington, D.C., who has succeeded in receiving a moving picture and a verbal description of the picture at the same time in tests recently completed by him.

## Where the Crystal User Scores

By **STANLEY G. RATTEE, M.I.R.E.**

WHEN the owner of a crystal receiver is asked why he does not use a valve set, it is not unusual for one's question to be answered by the words "I can't be bothered with accumulators, valves that burn out, and all the other paraphernalia that go to make the valve set a worry!" Probably, this reason of the "self-maintenance" of a crystal receiver is why so many people favour the simple crystal set, but undoubtedly, there are many other features which account for public favour.

### Questions of Cost.

Both valve and crystal users will admit that the question of cost is easily in favour of the crystal set, and further, after the initial cost is considered, the maintenance expenses are negligible; with the valves set,

however, charging the accumulator, replacing valves and H.T. batteries are all too frequent causes for expenditure.

### The Local Station.

If one lives in the vicinity of a broadcasting station then it is not by any means unusual for one's listening hours to be spent exclusively in the enjoyment of that station's programmes; and since, in the majority of cases a crystal set fills the requirements, in the large cities and centres where the B.B.C. have stations, sets of this type go to make the greater number. It is true that the same enjoyment may be given by a valve set, but since in the large centres the question of oscillation is often a serious one, the crystal user claims the advantage that with his less sensi-

tive receiver much of the resulting interference is beyond his range; the same remarks apply also to morse interference.

### Simplicity.

Another advantage which the crystal set possesses is the simplicity with which it may be operated by old and young people alike. In many cases the valve set presents many fears to the uninitiated members of the household, with the result that many of the day-time transmissions are not listened to, though the desire to do so may be very keen. With the crystal receiver, the position is somewhat different, and even children feel confident when tuning, and further, tune with success to the local station or 5XX as local conditions demand.

### A Point of Doubt.

Among the advantages of crystal reception many people will no doubt claim that the crystal gives a much clearer reproduction than the valve detector. On the other hand, many valve users will deny the claim. The decision seems to be largely a matter of opinion, and though I, personally, am inclined to believe that the crystal rectifier gives a clearer result than the valve, there are many people who think there is little in it.

The term "crystal purity" has become a sort of standard. Theoretically the crystal gives greater purity than the "grid condenser" rectifying valve.

### Reliability.

One of the most commonly admitted advantages of the crystal receiver is its reliability. Whereas with the valve set the accumulator may just be run down when one particularly wanted to hear a certain programme, the crystal receiver never fails to do what is required of it, and now that the permanent and semi-permanent detectors are becoming so popular the set can be so constructed that its tuning adjustment may also be fixed for the best results. In this way, all that is necessary to do to hear the local or other desired and possible station, is to place the telephones on the head—less work than winding a gramophone.

### HAVE YOU BOUGHT YOUR COPY?

The Autumn Double Number of  
**MODERN WIRELESS**  
NOW ON SALE. Price 1/6

A Selection from the Contents:  
**Forthcoming Developments in Radio**  
By Major James Robinson, D.Sc., Ph.D., F.Inst.P.

**Anode-Input Circuits**  
By John Scott-Taggart, F.Inst.P., A.M.I.E.E.,  
A Listener in New York

By Percy W. Harris, M.I.R.E.  
**How to Make: A Simple Eight-Valve  
Supersonic Receiver** By W. H. Fuller.

**The "Harmony Four" Receiver**  
By Percy W. Harris, M.I.R.E.

**The "America Three" Receiver**  
By Stanley G. Raltee, M.I.R.E.,  
A Single-Valve Reflex Set

By A. Johnson-Randall,  
etc., etc.

**OBTAINABLE EVERYWHERE.**



*It's here!*

**THE NEW SUPER FULSTOP CONDENSER—  
the greatest advance in variable condenser constructions since the introduction of wireless.**

Fifteen months ago the Fulstop Variable Condenser superseded all other condensers. It possessed two entirely new features—it was geared and it abolished absolutely hand-capacity effects. The New Super Fulstop Condenser is as far in advance of the old Fulstop as that was in advance of ordinary variable condensers. This is why.

The new Super Fulstop Condenser is fitted with dual gearing. It has two operating knobs. One has a gear ratio of 2 to 1 and is used for first adjustment. The second—a small vernier knob—is geared 125 to 1—and is used for final critical tuning.

The dial is graduated round the whole circumference from 0 to 100. These graduations are again divided, giving 200 actual readings. Each reading is capable of an infinite number of adjustments by means of the vernier gearing.

The clockwork multigear is made by watchmakers for the sake of accuracy and is quite free from backlash. It is a no-loss condenser, is perfectly square law and has brass vanes.

It is the superlative condenser and is positively unapproached by any other variable condenser made.

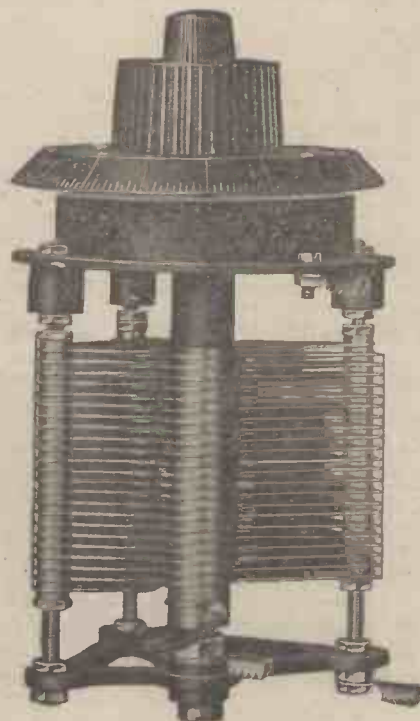

**Guaranteed to Abolish Hand-Capacity Effects**

Made in 3 Models.  
**SUPER FULSTOP.**

*00025	...	...	...	...	...	25/6
*0005	...	...	...	...	...	28/6
*001	...	...	...	...	...	30/6

*The Standard Fulstop, geared 2 to 1, is still in great demand.*

**PRICES.**

STANDARD FULSTOP.		PLAIN FULSTOP. (No gears)	
*0002	... 9/6	...	... 8/3
*0003	... 10/3	...	... 8/6
*0005	... 11/3	...	... 9/6
*001	... 13/6	...	... 11/6

*Send for full descriptive leaflet free. There are 3 models and all are guaranteed for 12 months.*

**PROTECTED THROUGHOUT THE WORLD.**



*If you have the slightest difficulty in obtaining Fulstop, send direct to address below.*

**J. H. NAYLOR, LTD.**

**WIGAN.**

## 1926 MODEL.

IT is now over two years since the ST100 receiver was first produced. It introduced almost an era of reflex broadcast sets, and something like 80,000 Radio Press Envelopes giving full instructions for building the set have been sold. The actual number built is probably far in excess of this figure.

Since the Envelope design was first produced there have, however, been many changes in ideas regarding selectivity, ease of control of reaction, adaptability of sets to any aerials,

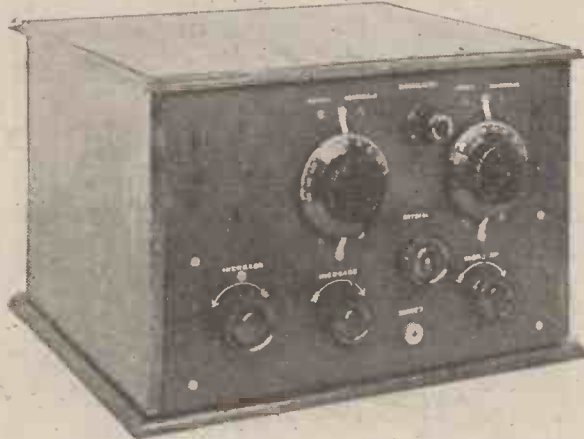

The receiver is totally enclosed in the American fashion of set design.

vernier adjustment of condensers, the introduction of square law condensers, and other features of design.

The introduction of these new aspects have made it at length necessary to issue a new ST100 receiver which, while embodying the main features of the original set, is more up-to-date in certain directions.

I am quite certain that there will be large numbers who do not get as good results as with their existing set. There will be an equal number who will get the same results, while there will be a very large number who will get better results. This is always our experience in publishing new designs.

I can only say that I am very satisfied indeed with the present design, which has been carried out by our laboratory staff under my general supervision, the final work, of course, being carried out personally by myself.

### Advantages.

The new receiver possesses the following advantages:—

1. Signal strength on the local station is fully maintained, while the range of the receiver is somewhat extended, although the ST100 has never been regarded by myself as a "distance getter," in spite of the extraordinarily successful test reports from builders of the set.

2. An automatic crystal receiver is employed which, while giving great sensitiveness, can be operated by any member of the family without any "fiddling."

3. The selectivity of the set is very greatly enhanced, due to the use of a tapped aerial coil and by the splitting up of the anode coil into two separate coils, the crystal detector and phones being connected across one of the coils only. The selectivity advantages over the original ST100 are very marked,

and that is one reason why special low-loss variable condensers are used giving a vernier adjustment.

4. The reaction adjustment so vitally important when receiving over long ranges is much better than in the original ST100. This is largely because the reaction coupling coil can remain the same whatever the wavelength to be received may be (within limits). Moreover, the ST100 would tend to oscillate even when the reaction coil was reversed, due to the big capacity between the aerial and reaction coils. By using a smaller reaction coil and having a large portion of the anode inductance quite separate, it is possible to avoid this trouble which worried many readers.

5. The set will work equally well, relatively, on different kinds of aerials, and a change of aerial makes little difference to the tuning of either circuits.

## THE NEW S

By JOHN SCOTT-TA

The popularity of the ST100 ci achieve still greater popularity above those

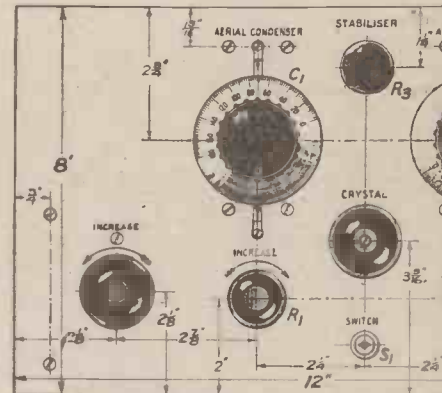

The layout of the panel is particularly ne No. W.2001a. Price 1s. 6d., po

6. The components and valves of the set are mounted behind the front panel, on the front of which are the simple controls. The aerial, earth, battery and loud-speaker terminals are at the back of the cabinet, and a switch appears on the front of the cabinet which enables the set to be put into operation readily, so that any member of the family may, by inserting the key, receive signals. The ingenious key arrangement incidentally prevents the set being used by anyone not authorised to do so.

Next week further details will be given of the constructional features and the circuit diagram. Operational notes and the types of valves recommended will also be given in this paper, and much fuller information will be given on obtaining the best results out of the set than was done when the ST100 was originally placed before the public.

### Components.

Those who have built the original ST100 receiver will note that many of the original components are not used. I would like to make it quite clear that this is no reflection on the original components. Anti-vibration valve holders have been introduced, and these were not originally employed as they were not available. The set is ideal for certain dull emitter valves, of which details will be given. It is, of course, safer to use the components actually described, and our definite guarantee, of course, only applies if this is so. Neverthe-

# ST100 RECEIVER.

GART, M.C., F.Inst.P., A.M.I.E.E.

Circuit is beyond question. This new ST100 will as it possesses a number of advantages over and found in the original receiver.



less, I have no reason to doubt that many of the components could readily be changed without in any way affecting the operation of the set. It must be remembered that while all the components used in this new set are of distinct merit, yet there are equally good components of other makes. If any substitution of components is made, due regard must be paid to the dimensions of the panel, etc. A lack of appreciation of this fact may result in a reader building the set and finding that there is no room for certain different components.

The set, of course, like all other sets described in WIRELESS, is guaranteed by our Elstree Labora-

Blueprint. Blueprint free.

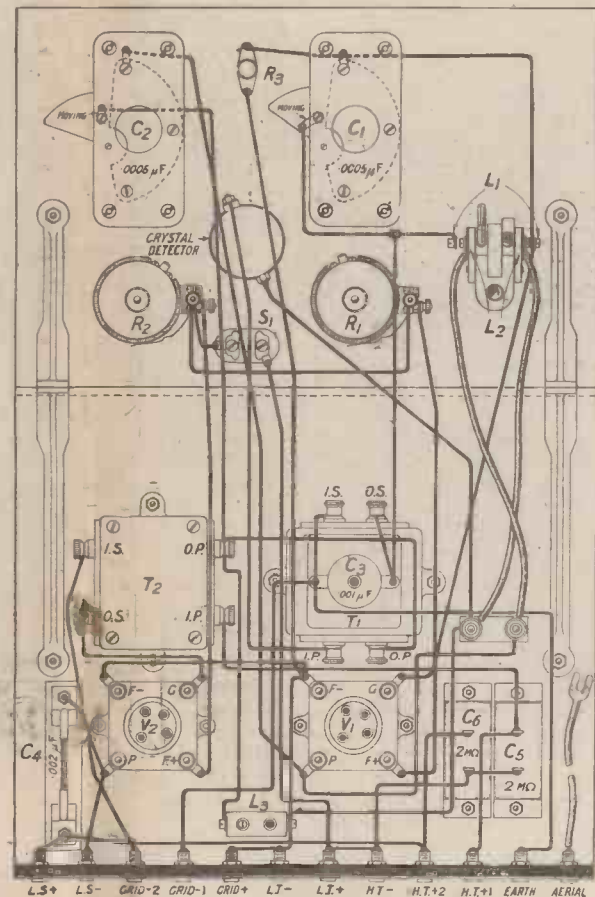

The wiring of the receiver with the baseboard and panel shown in the same plane for simplicity. Blueprint No. W.2001b. Price 1s. 6d., post free.

ories, and anyone failing to get the results stated can have their set tested and put right if necessary at a small fee.

- 1 Lissen X coil.
- 2 plug-in coils (any good make).
- 2 variable square law condensers, each of .0005  $\mu$ F (Success, Beard & Fitch, Ltd.).
- 1 fixed condenser .001  $\mu$ F (Watmel).
- 1 fixed condenser .002  $\mu$ F (McMichael interchangeable), on base with clips. This condenser may be varied at will, and some readers may find that they prefer the results obtainable with slightly different values. Normally, however, the .002  $\mu$ F will be found satisfactory.
- 2 fixed condensers 2  $\mu$ F (T.C.C.).
- 1 crystal detector (Wilkins & Wright).

## The Ideal Family Receiver.

- 1 cabinet to take the panel indicated ("Cameo").
- 1 baseboard. (This is provided with the cabinet).
- 12 multi contacts (Belling & Lee).
- 1 ebonite strip 12 in.  $\times$   $\frac{7}{8}$  in.  $\times$   $\frac{1}{4}$  in.
- 1 ebonite strip 1 1/2 in.  $\times$   $\frac{1}{2}$  in.  $\times$   $\frac{1}{4}$  in.
- Radio Press panel transfers.
- 20 ft. Glazite insulated wire.
- Begin work by preparing the panel

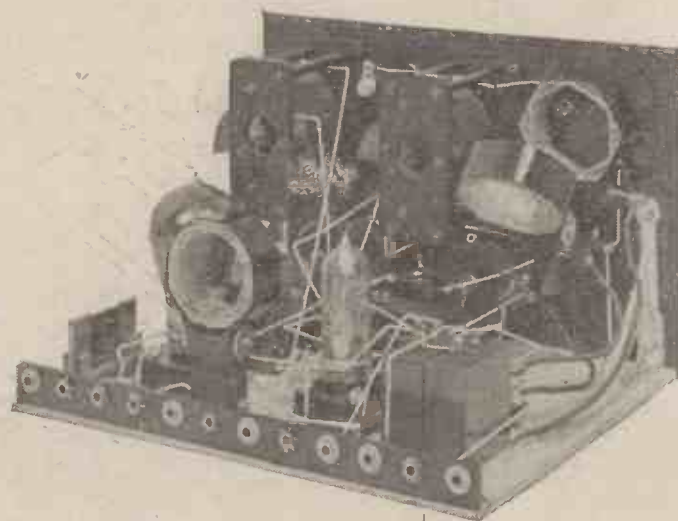

The battery and other connections are all made at the back of the receiver.

- 1 variable anode resistance (Bretwood).
- 2 filament resistances to suit the valve used (Polar interchangeable bobbin).
- 1 low frequency transformer (C.A.V. All-Purpose). This transformer has been found to suit the particular circuit excellently.
- 2 terminals.
- 1 second-stage transformer (Gambrell).
- 2 valve holders (Benjamin).
- 1 two-coil holder (Goswell Engineering Co.).
- 1 single plug for plug-in coil (Goswell Engineering Co.).
- 1 key switch (Igranic).
- 1 panel 8 in.  $\times$  12 in.  $\times$   $\frac{1}{4}$  in. (Peto-Scott "Pilot").
- 2 brackets to support panel and baseboard (Magnum).

to the dimensions given. The drawings and illustrations will show you just where to space the various parts, and a full-size blue print of the front panel and the back of panel wiring can be obtained, price 1s. 6d. each, from Radio Press, Ltd. You will find it advisable to leave the mounting of the variable condensers until after you have done most of the wiring, as these condensers partially cover some of the other wiring. You should, however, drill the holes for the condensers at the time of making the other holes. Do not vary the layout of this receiver if you want to obtain identical results. Some readers vary the design very greatly, but our guarantee does not then apply.

NOTE.—Fuller building instructions, circuit diagram, etc., will appear next week.

# Brandes Audio Transformer

successful engineering research achieves  
greater volume and clearer tone

Brandes Engineers have long been engaged in a close study of radio acoustics. There can be no angle of thought or experiment which has not been investigated in their efforts to obtain perfect reproduction of voice or music. Consequently, all Brandes radio equipment for bringing the receiver to life has unique constructional principles which mean vast improvements. Acoustics is the science of sound. *Radio* acoustics is the science of transforming electrical impulse into audible sound, and with the knowledge of seventeen years' research in this direction Brandes have come near to perfection in the reproduction of radio transmission of sound. The new *Audio Transformer* as a step to purity and greater volume is a definite achievement.

Any good Dealer stocks Brandes.

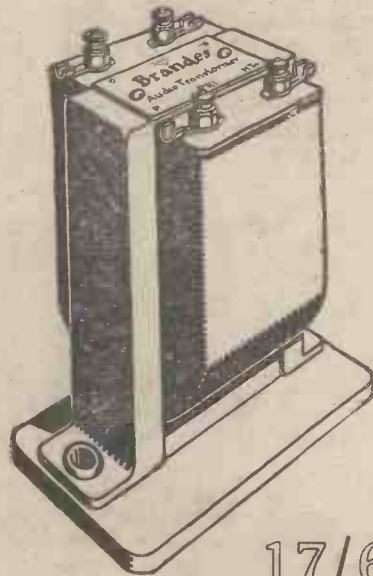

The Brandes *Audio Transformer* has been developed along sound engineering lines, the main objects in view being a high amplification of applied voltage, together with a straight line amplification-frequency curve. That is to say, for a given input voltage, the amplification is constant over a wide band of frequencies, and thus resonance eliminated. Comparative tests have authentically established a greater and more uniform relative amplification as against existing transformers. The Unit is well protected mechanically and the shielding is such that the Transformers may be placed close together without any interaction. It is an ideal first stage Transformer and is very satisfactory for second stage work.

Ask your Dealer for Brandes.

## Brandes

Experts in radio acoustics since 1908

Brandes Limited, 296, Regent St., W.1 Works: Slough, Bucks.

### Three other famous Brandes products.

#### THE TABLE-TALKER

Re-designed goose-neck horn which produces clear, more rounded and mellow tones. Constructed of special material which defeats any suggestion of harshness or metallic resonance. The adjustment lever, located at the rear of the base, controls the volume and sensitivity. 18 ins high, diameter of bell 10 ins. Strongly built and attractive in appearance. Splendid value at moderate price **30/-**



#### MATCHED TONE HEADPHONES.

Every pair of Brandes 'phones is matched in tone by a special apparatus so that the two receivers produce exactly the same sound at the same instant. Comfortable and light in weight with clutch on headband giving perfect adjustment to any head. Included in the leading types of completely equipped receiving sets ... .. **20/-**



#### THE BRANDOLA

Special constructional features ensure greatest volume with minimum current input and exceptional clarity over full frequency range. Adjustable semi-goose-neck horn of patent non-resonant material, electroplated fittings and polished walnut plinth. 28 ins. high 12 in. bell **90/-**



## WHERE AMERICAN RECEIVERS ARE BETTER THAN OURS

By Percy W. Harris, M.I.R.E. Editor.



**JUST** as I sailed for America in the s.s. *Berengaria* last May, I received a letter from a man who holds a very high position in the radio industry. "Dear Mr. Harris," it said, "I am very glad to hear of your forthcoming visit to America. Now we shall be able to have some really unbiased information as to whether American sets are really as selective as is claimed, and why it is that when these sets are brought to England they do not seem to work so well.

### An Extensive Trip.

The purpose of this article is to give answers to these questions, and if in so doing I give offence to some of the British wireless manufacturers, I am afraid it cannot be helped. I am not out to praise or blame anyone unduly, but merely to present the facts.

If you have spent, as I have done, some couple of months in an extensive investigation and study of radio conditions in the States—a study which embraced visits to the leading broadcasting stations, such well-known radio centres as the Bureau of Standards, Washington, The United States Naval Laboratories, at Anacostia, D.C., the famous Westinghouse Station KDKA, at East Pittsburgh, The General Electric Co.'s research laboratories, at Schenectady, and their station WGY, research laboratories in Chicago, New York and other centres, as well as visits to factories in various parts of the United States, interspersed with long evenings listening-in on all kinds of sets—you would get something like a fair idea of radio conditions in that great country.

### Tests in England.

Furthermore, I have now in my laboratory at home several high-grade American sets which I picked as representative of the really up-to-

date American receiver, and I have tested them on small and large aerials here in this country. You will naturally ask what conclusions I have come to. Let us see!

### Plain Talk.

First of all there is not a single wireless receiver sold in England to-day that would have a ghost of a chance in the United States in competition with any ordinary American receiver. There



*The interior of the American receiver shown in operation above.*

is not a single commercial receiver in this country (exclusive of one or two super heterodynes), which would give a fraction of the selectivity required in a New York suburb, if satisfactory broadcast reception is to be carried out. All the American commercial sets are, of course, not good—some are poor—but the leading makes unquestionably are well fitted for the purpose for which they are designed.

### A Typical Set.

Take, for example, the receiver which the photograph at the heading of this article shows me operating. It is a 5-valve set which sells in

America for about £30 or £35. It has three dials, a single-filament control, and a knob for what is called volume control. The filament control acts upon all valves at once and also serves as an on-and-off switch, while the volume control gives an excellent means of varying the strength when, as is often the case with such a receiver, the volume is too great to be comfortable in the loud speaker. To pick up a station you have to tune it in on the three dials, but as all three read exactly the same for a given station, the tuning process is quite simple. It cannot possibly radiate and thus cause howling, however you mismanage it, and its sensitivity and selectivity are representative of perhaps half a dozen leading makes in America. The controls, too, are representative of modern American practice.

### An Evening's Test Work.

I have at Wimbledon a large outside aerial some 50 ft. high by about 35 or 40 ft. long. I also have a small indoor aerial consisting of a length of wire passing out of my laboratory into the roof where it is hooked round the rafters. Its highest point is not more than 10 ft. above the instrument and its total length is perhaps 30 ft. I have not yet used telephones for this receiver and have done all my experiments on a loud speaker. The first night I used it I picked up a copy of the *Times*, which publishes the radio programmes each morning in rather full detail, and, starting with Aberdeen, picked up one station after another, in the order in which they appeared in the paper. On this indoor aerial I had no difficulty whatever in tuning in to Manchester at full loud-speaker strength without the slightest trace of interference from London. The 2LO station, by the way, is only 6 or 7 miles from Wimbledon, and hitherto I have never been

able to obtain this degree of selectivity with any but a super-heterodyne. Such relay stations as Hull, Plymouth, Edinburgh and Stoke-on-Trent were picked up in a few minutes, while Continental stations were too strong for comfort and had to be cut down by means of the "volume control." On the big outdoor aerial the selectivity was not so high, owing to the overpowering strength of London at this short distance, but on Bournemouth there was not the slightest suspicion of interference from London, and Manchester could be understood with London in the background. Cardiff I failed to separate from London with either the indoor or the outdoor aerial, due to the fact that the Cardiff and London wavelengths are very close to one another—much closer than the nominal figures indicate.

#### The Reason Why.

So much for the set. . . . What are the reasons for this remarkable superiority? The circuit consists of two stages of high-frequency amplification, a detector and two stages of note magnification. The detector and note magnifier call for no special comments, indeed, on the audio-frequency side American sets are not particularly brilliant, while in the detector there is nothing novel. The secret lies in the exceedingly clever design of the receiver as a whole, so far as the wiring is concerned and the particular form of high-frequency coupling used. There is no question that in the modern American receiver, high-frequency amplification has been developed in an exceedingly clever way, largely aided by the fact that in America they have no worry about a long wave high-power station, all of the work being done on about 250 to 550 metres. It is thus possible to design a single high-frequency transformer to cover the whole broadcast band, and by the use of special coils which have a practically negligible exterior field, and which do not interact with one another for this reason, by the exceedingly careful arrangement of the wires—the result of many months of experimenting—and by the use of neutralising methods, these results have been achieved.

As I have said, the receiver, as described, is but one of a number of excellent receivers. There are others as good, and I picked this one as typical of the best practice.

#### Popular Five-Valve Sets.

Let us generalise a little and see what the main difference between our sets and the American sets is. Owing to the fact that there are a large number of stations in each popular centre in simultaneous operation, crystal sets are practically dead, for they are far

too flat in their tuning to be of any real value. Nearly everyone wants to work a loud speaker, and most people like to listen to distant stations at times. A detector and two note magnifiers are essential for volume, while to obtain both selectivity and distance, two stages of high-frequency amplification must be added. The wonderful selectivity comes mainly through the use of these two stages of high-frequency amplification, carefully designed, so that

*Mr. Harris has only recently completed an extensive tour of the United States, during which, on behalf of Radio Press, Ltd., he has made very thorough investigations of all aspects of radio in America. The results of this trip will be embodied in a special series of articles for "Wireless," of which this is the first.*

practically all the popular receivers in use in the United States (excluding a few very cheap sets) are of the 5-valve variety with two stages of high-frequency, a detector and two note magnifiers. With very few exceptions the sets do not use reaction in a direct form, and none of the better sets can be made to radiate, for which reason there is almost a complete absence of howling at night, a boon and a blessing of incalculable benefit to the industry as a whole. I listened-in for some five hours one evening in the suburbs of New York and during which time I heard not a single howl. On another occasion I spent about three or four hours listening-in at Chicago with the same result. Can you imagine this state of affairs in England? Practically every one of the commercial receivers sold in England can be made to radiate with the slightest mishandling, and many people make their sets howl the whole evening without apparently realising the fact.

#### Selective and Sensitive.

Yes, American sets are selective and are sensitive. In addition to this, the ether conditions in America are

for some unexplained reason superior to those which hold in this area. The ether on this side of the Atlantic seems "dead" when you are listening-in, so that I am not at all surprised that very frequently American sets, particularly of the older type, which have now passed out of use, proved unsatisfactory when used in England. The newer type, using high-frequency amplification, shows up much better, and it is incumbent upon the British manufacturer to make sets not only equal to the American standard, but superior to it.

#### Components.

I do not hold a very high opinion of American components. In such details as filament rheostats, low-frequency transformers and the like, the average British product is distinctly superior. Variable condensers, too, with a few exceptions, are not so good as those sold here. This may come as a surprise to many, but it must be remembered that the American condensers we have seen in England are by no means representative of the great bulk of the examples sold in the United States. Knowing the British radio industry as I do, I am convinced that in a very short time we can turn out receivers which will not only be as good as, but considerably better than, the best of the American, but we must tackle the problem in the right way and do some hard thinking and sound experimental work. A year or two ago American receivers were of the straight regenerative type and were in many cases decidedly inferior to those used here, but radio practice has developed to a far greater extent in America than it has here, and, though I hate to say it, we have fallen behind. British manufacturers should eliminate many of the controls, and should devote time to really sound designing, not merely the assembling of a few components in convenient places in a cabinet.

Just one word in conclusion. Ebonite panels for the front of radio instruments are no longer used in America. The American manufacturers realised some time ago that ebonite, whatever its electrical insulating qualities may be, discolours readily and looks dirty, green and shabby after very short exposure to the sun and air. Practically every manufacturer has standardised on either bakelite panels or panels of a material containing bakelite, such as Formica. These panels are strong mechanically, take a high polish, and keep both polish and colour. It is no argument to say that the electrical insulating qualities of bakelite are inferior to those of ebonite, for the sets are now designed in such a way that the front panel serves only as a mechanical support.

Next week I will tell you some more interesting facts about American receivers.



An interesting American portable set—the Radiola Superheterodyne.

# B.T.H. RADIO APPARATUS & VALVES



Bijou Crystal Set



New Type 2 Valve Set



Type C8 Loud Speaker



Table Lamp Loud Speaker



Type D Loud Speaker



Valve Crystal Set



2 Valve Power Amplifier



Head Telephone Selector Switch



Gramophone Attachment



Type C2 Loud Speaker



Type C1 Loud Speaker



3 Valve Super Het Portable Set



New Type 1 Valve Amplifier



2 Valve Set

See them all at

STAND No. 1

and Boxes 59 & 60

at the

N. A. R. M. A. T. WIRELESS EXHIBITION

Albert Hall, London.

Sept. 12th to Sept. 23rd, 1925.

Advert of The British

Thomson Houston Co. Ltd.



1 Valve Unit Amplifier



L.F Transformer (Ratios 4:1 & 2:1)



"Model A" Crystal Set



3 Valve Cabinet Set with enclosed Loud-Speaker



Head Telephones



B3



B5

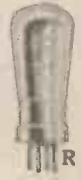

R

General Purpose Valves



Portable Loud Speaker and Amplifier



6 Valve Super Het Cabinet with enclosed Loud Speaker

Variable Condensers (.001, .0005, .00025)



Standard Vernier Square Law



B4



B6



B7

Power Amplifying Valves

2388.

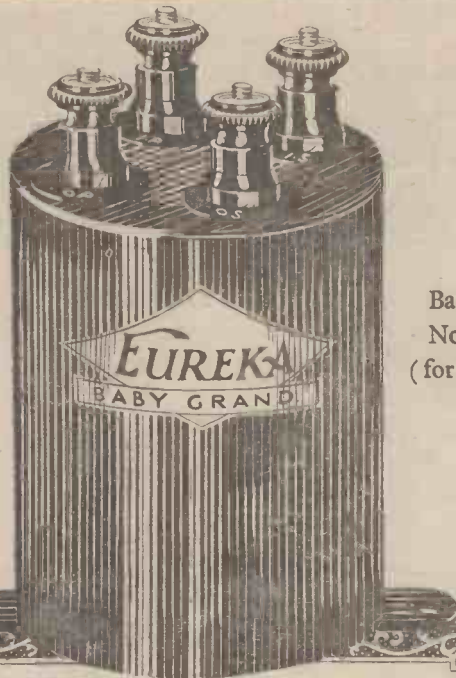

Baby Grand  
No. 1 15/-  
(for 1st stage)

Baby Grand  
No. 2 15/-  
(for 2nd stage)

## A real Eureka for 15/-

**H**ERE'S a real Eureka Transformer guaranteed to contain all the essential features of construction of the larger Concert Grand at a price within the reach of all. The same non-laminated core—the same exclusive method of winding—the same hermetical sealing to protect the contents from the action of the atmosphere—the same coppered steel case to prevent interaction—in every respect identical in design with the famous Eureka Concert Grand long ago accepted as the country's standard for volume and even amplification at all frequencies.

The manufacture of Eureka Transformers is a whole-time all-the-year-round job. It is directed by a group of engineers whose experience in the design of low-frequency transformers is absolutely unrivalled. When they say that the new Baby Grand is worthy of the name Eureka, you can rely on their judgment.

Don't judge the Eureka Baby Grand on its price—there is no transformer at anywhere near its price which can approach it for volume or mellowness of tone.

Other Eureka Transformers:  
Concert Grand 25/- No. 2 (for 2nd stage) 21/-  
Eureka Reflex (for all reflex circuits) - - 15/-

Portable Utilities Co. Ltd.  
Eureka House, Fisher St., London, W.C.2

# EUREKA

## Six Sixty

The Best Dull Emmitter.

The  
VALVE

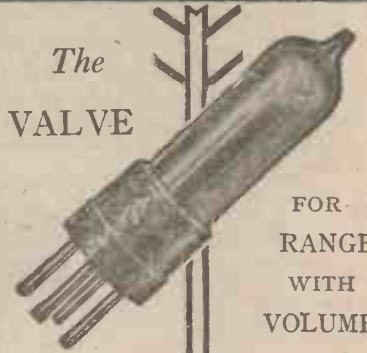

FOR  
RANGE  
WITH  
VOLUME

Its unique feature  
100% Efficient  
Electron Emitting  
Filament.

**MOLYBDENUM  
THORIUM COVERED**

The proof of  
performance  
is here.

Grangetown, Yorks.  
I wanted a good Valve as  
Detector. I purchased the  
"Six Sixty" Valve, and when  
I put it on the Set as a de-  
tector I got MANCHESTER,  
LONDON, ABERDEEN and  
NEWCASTLE, all on the  
LOUD SPEAKER, a thing I  
never have had before. NEW-  
CASTLE was deafening on  
the Loud Speaker, and a great  
many stations came swarm-  
ing in on the 'phones.—J.C.M.

Our free folders give many more  
users' testimonials of recent "Six  
Sixty" achievements as well as a  
description of the remarkable  
Molybdenum Filament. They await  
your request.

FILAMENT VOLTS 1.5 2  
FILAMENT CURRENT  
3 AMP'S BRITISH MADE  
B.B.C. STAMPED.

14/-

If you have any difficulty in  
obtaining from your local  
dealer send direct to us.  
Please give dealer's name  
and address.

THE  
**Electron**  
CO., LTD.

TRIUMPH HOUSE  
189 REGENT STREET,  
LONDON, W.1

'Phone: Regent 5336



**“WHAT** is the best whisker to use?” This question has been addressed to me, countless times, by friends who possess crystal sets, and who are for ever trying to get signals, “just a little bit louder.”

**What is the Crystal?**

In the first place, different crystals require different forms of whisker contact; tellurium crystal, for instance, works best in conjunction with a gold point, while carborundum requires a heavy contact, usually made by a piece of steel spring, with a fairly heavy pressure. In general, however, with the most common form of crystal in use for broadcast receiving sets, a fine wire contact is desirable, since the various forms of “ite” in use demand a fairly light contact. Too often one sees a man vainly hunting over the surface of a crystal for a sensitive spot, and upon investigation it is found that the “whisker” consists of a fat piece of wire sticking out toward the crystal in a most threatening attitude, more resembling a man with a bayonet than the fairy touch that is called for. A light coiled spring type of whisker should thus be employed, and should be of such a length that it can be completely lifted out of contact with the crystal, in order that it may be moved over the whole surface.

**Choice of Metals.**

As regards the metal of which the wire contact is composed, either brass or copper will be found to give satisfac-

**CATWHISKERS GOOD and BAD**

By  
**C. P. ALLINSON.**

tory results, while a silver contact is favoured by many, and certainly gives excellent results with the modern forms of treated galena, of which most of the “ites” are composed.

In any case the point of the whisker must be kept clean, and to this end

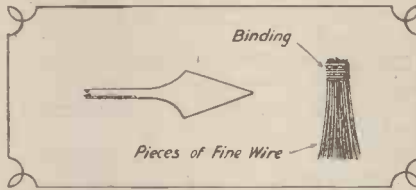

**Two unusual “Whiskers.”**

should receive periodical attention. Contact with a crystal of the heated galena type will soon cause the bright tip of the contact wire to become tarnished. When signals, then, are noticed to have weakened considerably, before scraping the crystal the effect should be tried of snipping a tiny fragment off the end of the cat-whisker.

There are many forms of whisker in common use, and we may feel a little undecided at first as to which is the best to use in a crystal detector of conventional type. The simple spiral type of whisker has already received attention. It is suitable for most forms of crystal requiring a light contact. Next there is the “spear-point” type, which is essentially the same as the spiral type, with the single exception that the business end is slightly flattened out and filed to a point, thus giving a finer point of contact with the crystal. This may be used in all cases where the spiral type is employed. Then there is the “whisker,” already referred to, which consists of a piece of stiff copper wire, sometimes without the end being flattened or pointed in any way. *Don't use it!*

**The Brush.**

Another type one sees occasionally may be designated the “brush” type. This consists, as its name implies, of a bunch of fine wires, all of which are intended to make contact with the crystal. Cases have come to the writer's notice in which this has given good results, but often the opposite is the case, and my experience has decided me against such a contact.

To sum up, for nearly all crystals a fine wire catwhisker is to be preferred, coiled in such a way as to give a springy effect. Avoid stiff and coarse wires, which injure the crystal and prevent a good, sensitive spot being found.

**After all,  
the  
Transformer  
is the thing!**  
“**POWQUIP**”  
GUARANTEED  
**TRANSFORMERS**



*Price 14/6 each*

Owing to recent improvements in the design of this “Powquip” model, the amplification and tone have benefited to the extent of 20%.

*The*  
**POWER EQUIPMENT  
COMPANY LIMITED**

**KINGSBURY WORKS, THE HYDE, HENDON, N.W.9.**

- Height .. . . . 31”
- Width .. . . . 21”
- Depth .. . . . 17”
- Ratios .. . . . 5:1 to 1:1

**ACCEPTOR.**—A circuit consisting of inductance and capacity in series which has the property of offering low resistance to currents of the frequency to which it is tuned.

**Aerial Resistance.**—If a current is set up in a wireless aerial there is a certain loss, due partly to the actual resistance of the condenser and partly to radiation of waves from the aerial. The whole of this effect can be measured as a simple resistance which is termed the "aerial resistance."

**Attenuation.**—The strength of wireless waves decreases as they travel further and further away from the transmitting station. That part of the reduction in strength which is due to absorption or similar effects is called attenuation.

**Auto-transformer.**—One in which the primary winding is a tapping from the secondary or vice versa.

**Bakelite.**—A solid insulation made in various forms. One form consists of a vegetable fibre impregnated with a phenol compound. It possesses excellent insulating properties at high frequencies.

**Blocking Condenser.**—A condenser placed in a wireless circuit in such a position that use is made of its property of stopping steady current but allowing oscillatory currents to pass.

**Choke Coil.**—A coil of low resistance, the main purpose of which is to keep down, by its inductance, the alternating current in the circuit. For low frequency currents the choke coil has

## Some Technical Terms and their Meanings

By E. H. CHAPMAN, M.A., D.Sc.

A Useful Guide for the Student.

an iron core. For high frequency currents it usually has an air core.

**Continuous Waves.**—A term applied to those wireless waves whose amplitude remains constant all the time the radiation is in progress.

**Damped Oscillations.**—Owing to unavoidable losses an oscillation set up in an oscillatory circuit gradually decreases in amplitude unless energy is continually supplied to the circuit. Such decreasing oscillations are called "damped oscillations."

**Distortion.**—A term signifying the deterioration in clearness which speech or music may undergo when being transmitted and received by wireless apparatus.

**Eddy Currents.**—Stray currents set up in a conductor which is under the influence of a varying magnetic field.

**Frequency.**—The current in a wireless circuit flows first in one direction and then in the other. The number of

complete reversals accomplished in one second is termed the frequency of the oscillation.

**Hydrometer.**—An instrument used for measuring the density of liquid. In particular it is used for measuring the specific gravity of the acid in accumulators.

**Litzendraht Wire.**—Stranded wire made up of many strands of fine enamelled copper wire. The resistance of ordinary solid copper increases rapidly at high frequency, but Litzendraht wire has very nearly the same resistance at high frequency as for direct current.

**Modulation.**—The term "modulation" is used to express the effect of varying the amplitude of radio frequency current set up by wireless transmitters in accordance with variations of the voice or music.

### ARE YOU A READER OF "THE WIRELESS CONSTRUCTOR" ?

The best monthly magazine for the beginner in wireless.

October issue now on Sale, price 6d.

A Selection of the Contents:—  
WHY WE BUILT DAVENTRY.

By Capt. P. P. Eckersley.

IS SECRET BROADCASTING POSSIBLE?

By Major James Robinson D.Sc., F.Inst.P., etc.

RECEIVING IN DEAD SPOTS—A sensitive 2-valve Set.

By Percy W. Harris, M.I.R.E.

A NOVEL SINGLE-VALVE RECEIVER.

By C. P. Allinson.

A SIMPLE VARIOMETER CRYSTAL SET.

By Percy W. Harris, M.I.R.E.

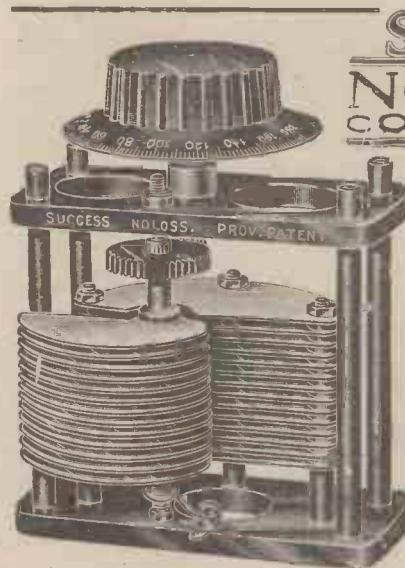

**SUCCESS NOLOSS CONDENSER**

**AERIAL CONDENSER:**  
Approx. Maximum Capacity '0005.  
RETAIL PRICE:  
Black Ebonite - 27/6  
Mahoganite - 30/-  
With knob and dial, 1/6 ex.

**ANODE CONDENSER:**  
Approx. Maximum Capacity '0003.  
RETAIL PRICE:  
Black Ebonite - 25/-  
Mahoganite - 27/6  
With knob and dial, 1/6 ex.  
List No. 112

### A QUALITY CONDENSER —mechanically and electrically perfect

THE Success No Loss Condenser is the first variable condenser of British manufacture rightly designated NO LOSS. Its construction departs from customary practice in skeleton design and in skeleton end-plates. Has a 4 to 1 gear which, besides making a vernier unnecessary, also removes all hand capacity effects, since the hand has no electrical contact with the moving vanes.

As used in the NEW S.T.100 described in this issue by JOHN SCOTT-TAGGART, F.Inst.P., A.M.I.E.E.

BEARD & FITCH, Ltd., 34 Aylesbury St., Clerkenwell, E.C.1

## A 100% INVESTMENT THE WONDERFUL



# BRONEL

### Permanent Crystal Detector.

**5/- POST FREE**

**EACH BRONEL CARRIES A WRITTEN GUARANTEE FOR FIVE YEARS!**

The BRONEL has been incorporated in four circuits in Radio Press Publications.

By Mr. E. J. MARRIOTT,  
In "Modern Wireless," June 25, Page 557.

By Mr. PERCY W. HARRIS,  
In "The Wireless Constructor," July 25, Page 829.

By Mr. JOHN W. BARBER,  
In "The Wireless Constructor," August 25, Page 898.

By Mr. EDWARD F. BURNETT,  
In "Modern Wireless," August 25, Page 790.

**A Wonderful Detector.**

ASK YOUR DEALER OR WRITE TO—  
**WILLIAM R. BOWMAN, Ltd., 47, Mark Lane, London, E.C.3.**  
Phone: ROYAL 4484.

# K. RAYMOND

## 7, GRAPE STREET, SHAFTSBURY AVENUE - W.C.2.

NEW OXFORD STREET END.

NOTE: Grape Street is between Prince's Theatre and Muddie's Library.

See the **K. RAYMOND** NAME

1 minute Tottenham Court Road Tube.  
3 minutes Holborn Tube.  
2 minutes Palace Theatre.

### Hours of Business

Daily 9 a.m. to 8 p.m.  
Sundays, 11 to 1.

Open all day Saturday.

Two shops, one always open.

Telephone (private line) Gerrard 2821.

Customers purchasing £5 worth of our OWN goods presented with a first class pair of HEADPHONES, 4000 ohms. Particulars free.

OR, alternatively, if you buy 25/- worth of our OWN goods you can purchase a good Pair of PHONES for 4/- extra.

OR have your PANEL DRILLED FREE.

This offer is limited to one offer per order.

ALL PRICES SUBJECT TO ALTERATIONS WITHOUT NOTICE.

**BOWYER LOWE PARTS.**—H.F. Transformers, 7/-; Anti. Pong V.H., 3/-; Var. Condensers, with V. .0003, 19/-; .0003, 20/-; Low Loss Coil Former, 6/-

**BURNEDEPT PARTS.**—Rheostats, 5/-; Dual, 7/6; Detector, 4/-; L.F., 24/-; Potentiometer, 7/8; Anti-Phonic, 5/-; Coils from 3/-

**CRYSTALS (Best).**—Neutron 1/8; Listeron, 1/6; Uralium, 1/3; Shaw's Genuine Hertzite (Sealed), 1/-; Silverex, 2/8; Collinsons Colvern X Selector Low Loss Geared Variable, .0003, 20/-; .0005, 21/-; Vernier, 2/6; Neutrodyne, 3/6.

**DUBILIER CONDENSERS.**— .0001 to .0005, each 2/8; .001 to .006, 3/- each; Grid Leaks, 2/6 each; Type 610, fixed, 3/-, 3/6, 4/-, 4/8; Anode, 7/0, 100,000; each, 5/6 on stand. Mansbridge Variometer, 300/1,800, 12/8.

**DORWOOD FIXED.**— .001 to .008, 3/- each; .001, 3/6; .0003 (with grid leak clip), 2/6.

**EUREKA TRANSFORMERS.**—Concert Grand, 25/-; 2nd Stage, 21/-; Baby Grand, 18/-; Gravity Detector, 6/6

**ENERGO H.F. TRANSFORMERS.**—B.B.C., 3/11; Daventry, 4/8. Other sizes stocked. L.F. Transformer, 15/-

**EDISON BELT PARTS.**—Ser. Far. Variometer for B.B.C. or 5XX, 16/8; Old Model, 10/-; Fixed Condenser, .001, .0001 to .0005, each, 1/3; .002 to .006, each, 2/6; Shaped Plug, 2 for 2/-; Loud Speaker, 42/-; Dulcevox, 42/-.

**GOSWELL (QUALITY RADIO).**—Coils, mounted 25, 1/6; 35, 1/8; 50, 2/-; 75, 2/3; 100, 2/8; 150, 3/-; 175, 3/6; 200, 3/9; 250, 5/3; 300, 5/-; Valve Holders, Legics, 1/3; Sub-Panel, 1/3. 4-Valve Sockets, 1/-; Coil Stands Panel—2-way, 3/-; 3-way, 5/-; Cam operated—3-way, 9/-; 3-way, 12/8. Low Loss Coil Former, 3/6.

**GAMBRELL PARTS.**—L.F. 1st or 2nd. Stage, 27/6 each. 2-way Anti Cap Switch, 7/-; 4-way, 8/6; Neutrodyne Condenser, 7/9. Coils all sizes.

**H.T.C. VALVE HOLDERS.**—“A” or “B” 1/3; C 1/6

**H.T. BATTERIES.**—B.B.C., 36/-; 6/3; 60v., 8/8; Extra Large B.B.C., 10/4; Eveready 66v., 12/6; 108v., 20/-; 60v., best made, 8/11; 4.5, 5/6, 6/- dozen.

**HEADPHONES, BRITISH** 4,000 OHMS.—B. T. H., Brown, Brande, 20/- pair; Sterling, English Ericsson, 22/6 pair. Boverman's Super Phones, 12/8 pair.

**IGRANIC PARTS.**—L.F., 1st Stage, 21/-; 2nd Stage, 19/6; Coils, Ultrinic, 9/-; Unitune, Major, 9/-; Minor, 7/6; Honeycomb, 25, 35, 4/3; 50, 4/8; 75, 4/10; 100, 6/9; 150, 7/-; 200, 8/-; 250, 8/6; 300, 9/-; 400, 10/-; 500, 10/3; 600, 11/-; 750, 12/6; 1,250, 15/8; 1,500, 17/8. Rheostats, 3/8, 5/6. Variometers, 10/-, 12/6. Potentiometer, 5/8. H.R. Variometer, 8/6. Variable Grid Leak, 8/6. New Square Law Variable Condensers, .001, 27/6; .0003, 24/-; .0003, 21/-.

**“KAY RAY” DETECTORS.**—Enclosed nickel fittings, trigger movement, 2/6; Permanent, 2/-; Do., one-hole fixing, 2/6.

**LOUD-SPEAKERS (Various)**—Sterling, 50/-; 55/-; Dinkie, 30/-; Primax, 155/-; Amplifon Dragon Fly, 25/-; Junior 27/6; A.R. 111, 50/-; A.R. 114, 65/-; A.R. 44, 105/-; Browns, all models, Ultra, 27/8; G.A.V., 27/8, 30/-; And all new models makers' prices.

**LOTUS (GEARED)**—2-way, 7/-; 3-way, 10/6.

**LISSEN PARTS.**—Anode or Variable Grid Leak, 2/6 each; L.F. or H.F. Choke, 10/-; Switches, D.P.D.T., 5 point Reversing, 4/- each. 2-way series Far, 2/9 each. Minor, 3/8; Major, 7/6. Universal, 10/6. Potentiometer or Wire Rheostat, 4/- each. Neutrodyne Condenser, 4/8. Coils 25, 35, 4/10 each; 50, 5/-; 60, 7/5, 5/4 each; 100; 6/9; 150, 7/-; 200, 8/5; Lissen X 50, 8/-; 60, 6/4; 75, 6/5; 250, 9/8. Tuner, 2/8. Mark III. Var., 17/6

**MARCONIPHONE.**—Potentiometer, 11/-; Ideal L.F. Transformers, 6, 1, 4, 1, 2, 7, 1, 35/- each. Automatic Detector, 6/-.

**McMICHAEL PARTS.**—Rheostat, 5/8; D.E., 6/8; Dual, 7/6; Triple, 22/6; Potentiometer, 7/8; H.F. Transformers, 10/- each. Supersonic AT 12/6. Fixed and clips, .001 to .001, 1/9 each; .002 to .001, 2/3 each. Grid Leaks, 2/-; Anode, 7/0, 80, 100,000, ohms, 2/8. L.F.T., 21/-

**MAGNUM (BURNE JONES).**—H.F. Transformers, 7/- each. Coil Holders, 2-way, 9/6; 3-way, 12/6. Valve Holders, 2/8. Vibro, 5/-; T.A.T. Tapp. Coil, 8/6. Neut. Cond., 4/8. All parts stocked.

**POLAR (RADIO COMM. CO.)**—R.C.R. Unit, 15/-; Condensers, Micro, 6/8; Neut., 5/6. Variable, .001, .0005, .0003, 10/8 each. Coil Stands, Cam, V., 2-way, 6/-; 3-way, 9/6. Polar Sets stocked.

**R. I. RADIO INSTRUMENTS.**—L.F. in sealed box, 25/-; Anode Choke, 10/-; Permanent Detectors, 9/-; 7/8. New Var. Air Condensers and V., .0003, 22/6; .0005, 24/-.

**REFLEX RADIO COILS** (Made under Burndept License)—35, 8d.; 50, 9d.; 75, 1/-; 100, 1/2; 150, 1/8; 200, 2/9; 250, 3/3. Post 2d. each. Mounts, 1/- each extra.

**STERLING PARTS.**— .00025 Square Law and V., 23 6; .0005, 25/8. Non Pong Valve Holder, 1/3.

**T.C.G. (MANSBRIDGE).**—2 Mid., 4/8; 1 Mid., 3/10; .25, 3/-.

**ACCESS (BEARD & FITCH).**—L.F., all black Super, 21/-; Choke, 10/- etc., etc.

**SHIPTON.**—Rheostats, 7, 30, 60 ohms, 3/6 each. Potentiometer, 600 ohms, 4/6.

**TRANSFORMERS (L. F.)**—Ferranti, 17/6; Pyc, 23/6; Silvertown, 21/-; Ormond 14/-; Royal, 20/-; Lissen T1, 30/-; T.2, 25/-; T.3, 18/8; Popquip, 14/6; Shrouded, 10/8; Croix, 9/8; Wates Supra, 12/6. Brunet Shrouded 5-1 or 3-1 13/8 each.

**UTILITY (WILKINS & WRIGHT).**—Coil Changing Unit, 7/6. Variable Condensers, .0003, 8/9; .0005, 10/8 (Vernier 2/6 extra). Switches, Knob, 2-way 4/-; 4-way, 6/-; 6-way, 8/-; Lever, 5/-; 7/6, 10/-; Nickel, 9d. extra.

**UNIDYNE (THORPE K. 4).**—Bower Electric Genuine only Thorpe K.4 5-Pin Valve, 14/-; 5-Pin Holders, 1/3. Sets of parts, one Valve, 48/8; two Valve, 68/8 (excluding box and panel, but including valves) List sent post free.

**VALVES (ALL MAKES).**—Mullard, Cosor, Ediswan Marconi, B.T.H., 8/-; 14/-, 16/8, 18/8, 22/8, etc.

**COSMOS (MET. VICKERS).**—DE 11, 12/6; A. 45, 7/6.

**WATMEL.**—Variable Grid Leak, 2/8. Anode, 3/8. Green Knob, 3/6. Fixed Condensers, 2/8, 3/6 (all sizes).

**WOODHALL PARTS.**—L.F. Transformer, 23/6. Vernier Rheostat 7 ohms, 2/8; 30, 3/8.

**“WONDER” AERIAL.**—Multi 49 Strand, Phosphor Bronze, Indoor, Outdoor, Frame Aerial, 10/6 text, 3/3.

**SUNDRIES—COIL STANDS**—2-way Standard, 2/8. Cam, V., 4/8; Geared, 5/8, 6/-; 3-way Standard, 5/-; Cam, 6/8; Geared, 7/11.

**COIL PLUGS (Ebonite).**—Fitted Fibre, 1/6 pair. Shaped, Brass sides, 1/8 pair. Standard, 1/- pair. Panel Mfg., 1/6 pair.

**TERMINALS.** Complete, per Dozen.—Ormond, W.O. and Pillar, generous size, 2/-; Standard, 1/3. Nickel, 8d. dozen extra. Phone, 1/1. Screw Pins or Spades, 1/-; Do., Red or Black, 1/6. Nickelless Tags, 6d. Brass Tags (3 dozen) 6d. Flush Panel Sockets, 1/- dozen.

**RHEOSTATS.**—Raymond, 1/3. Extra quality with Dial, 2/6. Peerless, 6 or 30 ohms, 2/6 each. “Kay Ray,” 30 ohms, 22/6; 6 or 30 ohms wound on china former, 2/- each. Ormond, 2/-; Most makes stocked.

**AERIAL WIRE (100 feet).**—Heavy, 7/22, 2/6. Ribbon (Tape), 2/8. Insulators, egg, sent with wire only, 6 for 1/-.

**FLEX (Twin), etc.** (any length cut)—Red and Black, 12 yds. 1/6. Miniature Silk, 12 yds., 1/8. Rubber Lead in 10 yds., 1/8. Extra heavy, 4/- doz. Insulating Hooks, 1/8 doz. Empire Tape, 1, 12 yds. 1/-.

**TOOLS.**—Soldering Irons, 1/-; Set of high-class drills, 1/8; 4 Taps, 0, 2, 4, 6, BA, 2/6 set. Cutting Pliers, 1/6.

**VARIOMETERS.**—Standard, 2/6. Ebonite, 3/11. Ball Rotar, 4/8. Inside Wound, 6/11. All fine valve.

**PANEL SWITCHES.**—NICKEL.—SPDT, 1/-; DPDT, 1/3.

**PHONE CORDS.**—etc.—6 ft. Rubber Insulated, 1/1; 7 feet do, 2/6. Loud Speaker, do, 12 ft., 2/0; 20 ft., 3/6. Beautifully made and finished.

**HEADPHONES GENUINE** 4,000 ohms.—Dr. Nesper Adjustable, 12/11; Telefunken Adjustable, 16/8; N and K Stamped on back, 14/11; Brunet, new model, 14/11.

**COIL WINDERS (Homeycomb).**—Westminster, 4/-; “Kay Ray,” well made, 46 spokes, handle, cannot be equalled, 2/-.

**EBONITE (due quality)**—Cut to size, id. per square inch, 3/16, id. for id. Post extra.

**ACCUMULATORS, NEW.**—2v. 40 amp., 9/8, 10/8; 2v. 60 amp., 11/8, 12/8; 4v. 40 amp., 15/11, 16/8; 4v. 60 amp., 19/8, 21/-; 4v. 80 amp., 24/8, 25/6; 6v. 60 amp., 28/8; 6v. 80 amp., 35/8.

**ATHOL VALVE HOLDERS** 1/3; Aeronomic, 1/6. A.B.C. Wavetrap former, 3/6.

## RAYMOND Variable Condensers

### SQUARE LAW LOW LOSS.

One hole fixing. Ebonite Ends. With Vernier Without Vernier  
.001 .. 8/6 .. .001 .. 7/6  
.0005 .. 7/6 .. .0005 .. 5/9  
.0003 .. 7/- .. .0003 .. 5/3

Including Knob and dial. Post 3d.

### ORMOND LOW LOSS AMERICAN.

Skeleton Ends, Knob and Dial.  
.001 .. 9/- .. .0005 .. 8/-  
.0003 .. 7/6 .. .00025 .. 6/6  
(With Vernier, 1/6 each extra)

### “J.B.” (Jackson Bros.)

Square Law Standard  
.001 .. 9/6 .. .001 .. 8/6  
.0005 .. 8/- .. .0003 .. 5/-  
.0003 .. 6/9 .. .0005 .. 7/-  
.0002 .. 6/6 .. .0002 .. 5/-

Square Law with Vernier  
.001 .. 13/6 .. .0005 .. 12/6  
.. .0003 .. 11/6  
All sizes stocked. Knob & dial free.

### SECOND-HAND GOODS.

#### PATRONISE THE LIVE FIRM!

I will accept in part payment for new goods (or purchase if so desired) any articles you have no use for. This is a stunning offer, so don't forget to take advantage of it. Make out your list of what you have to sell, and I will offer you best prices. This applies to post or callers. Bring your goods.

**WEST-END LEADING STOCKIST FOR** Edison Bell, Jackson's (J.B.), Polar, Igranic, Peerless, Eureka, Magnum, Burndept, Lotus, Dublier, Marconi, Dorwood, Sterling, Success, B.T.H., McMichael, Lissen, Woodhall, Utility, R.I., Bowyer-Lowe, Amplion, Formos, Brunet, Ormond, parts, etc.

IMPOSSIBLE to advertise all lines here. Send name and address (postcard, please), for illustrated folder. Special offers not obtainable elsewhere.

IF WANTING ANY GOODS MAKE OUT LIST AND I WILL QUOTE LOWEST INCLUSIVE PRICES.

**VALVES.** To encourage you to use British Valves I am willing to purchase one burnt-out valve for each valve you purchase. Prices given range from 1/3 to 4/- according to valve you buy.

Delivery given at the earliest possible moment, but no responsibility accepted for manufacturers' delays, lock-outs, strikes, or any cause over which I have no control. All orders accepted on condition place of payment, 7, Grape Street, W.C.2.

## COLUMN FOR CALLERS ONLY

## SPECIAL LIST NOW READY

**H.T. BATTERIES.**—60 volt Crown, 6/11; long life, 65v. Ever Ready, 12/8, 108v., 20/-; 60v., B.B.C., 8/11. 36v., 5/8. 6v. (grid bias), 2/-

**ACCUMULATORS.**—(Well-known makes): 2v. 40s., 7/8, 8/6. 4v. 40s., 13/11, 15/11. 4v. 60s., 17/6, 18/3. 4v. 80s., 22/6, 23/8. 6v. 60s., 25/11, 27/6. 6v. 80s., 33/-; Flash lamp, 4v., 4d. each. Terminals, 1d. Valve holder, 9d. Ditto, sockets, 1d. Coil plugs, 4d. Shaped, 8d. Battery clips, 5 for 2d. Spade tags, 6 for 1d. Screw spades, 2 for 1d. Pin spades, 2 for 1d. Switch arms, 6d., 9d. Cannot possibly quote all goods in limited space allotted.

**EBONITE.**—Stock sizes, 3/16th, 6 x 6 — 7 x 6, each 1/2. 8 x 6 — 9 x 6, each 1/10. 10 x 8 — 12 x 6, 3/-; 12 x 8, 4/3, 5/-; 12 x 12, 5/8. 14 x 10, 5/6. 1-in. also stocked.

**COME ALONG AND SEE OUR SECONDHAND DEPARTMENT.**

For full lists of callers' lines, see *Wireless Constructor*, *Modern Wires*, and all weekly periodicals. Better still, ask here for callers' list. It will pay you.

## CALLERS—We stock everything you require.

**S**EPTEMBER 12 marked the opening of the annual exhibition of the N.A.R.M.A.T. at the Royal Albert Hall, London, where a large number of new components and accessories are now on view.

**List of Exhibitors.**

A complete list of the exhibitors and their stand numbers, which are marked on the plan, is given below.

The "Loggia Boxes" encircle the ground floor. "Stands" are in the middle.

Radio Press, Ltd. (publishers of "WIRELESS") occupy Loggia 51, 52 and 73. Do not miss these exhibits. They have much to interest YOU.

Loggia.	Name.	Stand.
41 & 76	Auto Sundries, Ltd.	10
	Autoveyors, Ltd.	
	Beard & Fitch, Ltd.	23
	Bowyer Lowe Co., Ltd.	14
	British Ebonite Co., Ltd.	15
72	British L. M. Ericsson Mfg. Co.	9
47	British Radio Corporation, Ltd.	

# GUIDE TO THE WIRELESS EXHIBITION

Loggia.	Name.	Stand.	Loggia.	Name.	Stand.
59 & 60	British Thomson-Houston Co.	1	50	Dubilier Condenser (1925) Co., Ltd.	28
61	Broadcaster.			Eagle Engineering Co.	22
	Brown Bros., Ltd.	G. 1 & 2		Eastick & Sons, J. J.	21
	Brown, Ltd., S. G.	3		East London Rubber Co.	G. 28 & 29
74 & 75	Burndept Wireless, Ltd.	11 & 12		Edison Swan Electric Co., Ltd.	26
	Cables & Electrical Supplies.	2		Falk, Stadelmann & Co., Ltd.	34
70	Cable Printing and Publishing Co., Ltd.			Galliers, H. J.	G. 6
55 & 54	Cassell & Co., Ltd.			Game & Co., Ltd., A. W.	39
	Chloride Electric Storage Co., Ltd.	38	42	General Electric Co., Ltd.	17, 18, 19
	Climax Radio Electric, Ltd.	35		Gent & Co., Ltd.	7
64	Colonial Technical Press, Ltd.			Graham & Co., Alfred.	40
48	Cossor, Ltd., A. C.	25	62 & 63	Hart Accumulator Co., Ltd.	
	Day & Co., Ltd., Bertram.		53	Hirst Bros. & Co., Ltd.	
	Dew & Co., A. J.	G. 32 & 33		Hobday Bros., Ltd.	G. 24 & 25
				Houghtons, Ltd.	G. 30 & 31
			44 & 45	Iliffe & Sons, Ltd. (Wireless World).	
			71	Kenmac Radio, Ltd.	
			69	London & Provincial Radio Co. McMichael, Ltd.	6
				Marconiphone Co., Ltd.	30 & 31
				Metro Vick Supplies, Ltd.	8
				M.O. Valve Co., Ltd.	4
				Mullard Radio Valve Co., Ltd.	16
			56 & 57	National Wireless Elec. Co.	
				Neutron, Ltd.	20
			49	Pell, Cahill & Co., Ltd.	27
				Quartermaine, Esq., Henry, J.P.	G. 8
				Radiax, Ltd.	21a
				Radio Association	G. 18
			67	Radio Communication Co., Ltd.	5
				Radio Instruments, Ltd.	36
			51, 52 & 73	Radio Press, Ltd. Radio Society of Great Britain.	G. 9
			65 & 66	Radio Times (Geo. Newnes, Ltd.)	
				Selfridge & Co., Ltd	G. 3 & 5
				Smith & Sons, Ltd., M. A.	24
				Sterling Telephone & Elec. Co.	29 & 32
			46	Stevens & Co., (1914) Ltd., A. J.	37
				Sun Electrical Co., Ltd.	G. 26 & 27
				Sylvex, Ltd.	G. 7
			43	Trader Pub. Co., Ltd. (Wireless Trader).	
			58	Vandervell & Co., Ltd., C. A.	33
			68	Wireless Times.	
				Wootton, Ltd., F. E.	13

## PLAN OF THE EXHIBITION

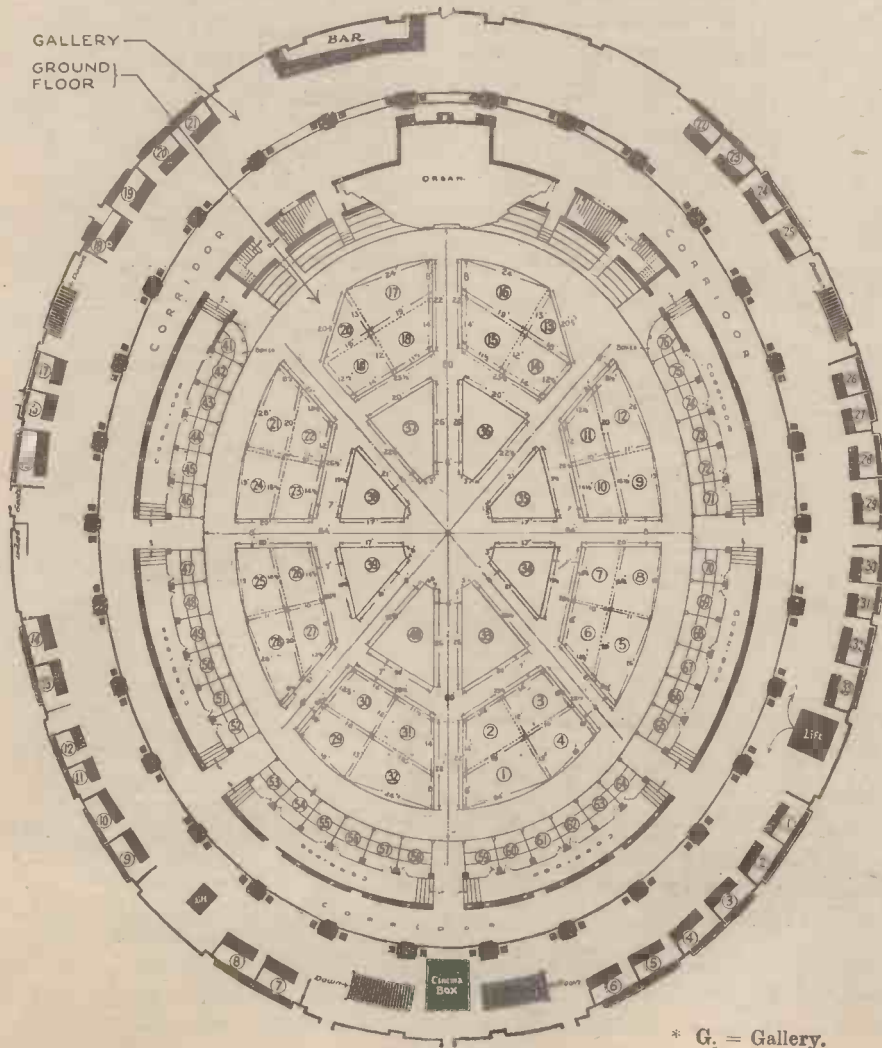

\* G. = Gallery.



## Our Business.

Because we value our reputation, and because we take a genuine pride in our manufactures apart from their function as profit-makers, we are always exerting ourselves to the utmost to maintain the high standard that it has always been our aim to achieve. For this reason, therefore, the two words—"Specify Dubilier"—are buttressed by all the moral weight and all the material resources of the world's largest Condenser Manufacturing Firm. A Dubilier Guarantee is a genuine guarantee, and a Dubilier Product is the best of its kind.

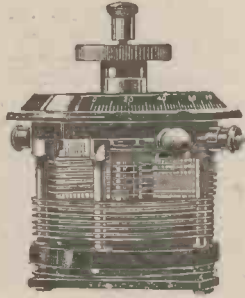

**The Double Vanicon.**

A Dubilier Variable Condenser giving simultaneous control of two tuned anode circuits. This is a very useful condenser to the experimenter. Capacity of each side 0.00025 mfd. complete with balancing plate

Price 25/6



**The Ducon.**

An aerial adaptor made by Dubilier, it is inserted in an electric lamp socket and connected to your set, thus converting your wiring system into an aerial and doing away with outside aerials.

Price 10/-



**The Dubrescon.**

A new Dubilier device that protects valves from being burnt out by insertion in the holder the wrong way round. Connected in an H.T. lead it is a permanent protection, and is not a fuse.

Price 6/-



**The Minicap.**

A Dubilier Anti-Capacity Switch for use in all types of receiving circuits for switching in and out Valves, Transformers, Series-parallel switching, etc. Soundedly made and thoroughly reliable, it is strongly recommended.

Price 8/-



**Anode Resistances and Grid Leaks.**

These Dubilier resistances are very carefully made and graded; they can be relied upon to maintain their values indefinitely and are tested on 200 volts D.C. and 100 volts D.C. respectively.

*N.B.—They must not be tested at higher voltages.*

Anode Resistances, 20,000—100,000 ohms.

Complete with holder 5/6  
Grid Leaks 0.5—5 megohms 2/6



**Type 577 Mica Condensers.**

A very good quality condenser for use everywhere in wireless receiving sets. This condenser is supplied in a polished metal case, and is provided with tags for soldering. It can also be supplied with flexible wire leads if required. All capacities from 0.0001 mfd. to 0.01 mfd.

Price 7/6

The Dubilier Condenser Company (1925) Ltd. manufactures:—

Fixed Mica Condensers—Types 577, 600, 600a, 610 and 620.

Vanicon Variable Condensers—the Vanicon, the Double Vanicon, the Duwatcon and the Vanicon Square Law.

Anode Resistances and Grid Leaks, the Ducon, the Minicap Switch, the Mansbridge Variometer and the Dubrescon.

**Specify Dubilier.**

We are exhibiting at the N.A.R.M.A.T. Wireless Exhibition, Royal Albert Hall, Sept. 12th to 23rd.

Stands Nos. 28 and 50.

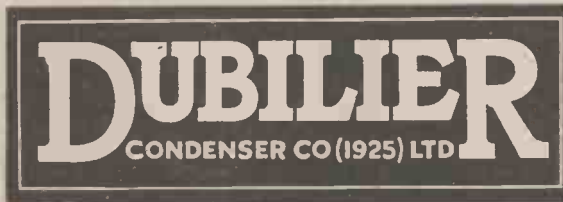
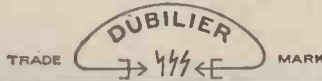

Scott-Taggart has already evolved a circuit on the super-heterodyne principle, embodying special methods of multiple reflexing, which saves several valves.

Another type of aerial which allows one to dispense with an outdoor arrangement is the "capacity" aerial, which may consist of two large metal plates placed parallel to each other at a certain distance apart, but the "pick-up" value of this type is small and a powerful receiver is necessary even for the reception of a nearby station.

**Earth Lead Reception.**

We may dispense with an aerial of the conventional type in yet another way, but, again, at the expense of signal strength. This method consists in the use of the earth lead alone, and a set employing this principle, was described by Mr. Kendall in the May 16, 1923, issue of *Wireless Weekly*.

**Electric Light Wires.**

Even if any of these methods fail, there is still another arrangement which gives promising results, and that is to use the wires of the house lighting system as the aerial. This is accomplished by fitting an ordinary plug-in connector with a flex lead from one contact only into any electric light socket, and connecting a small condenser (about .001  $\mu$ F) in this lead, which is then taken to the aerial terminal of the set.

**Will the Outside Aerial Disappear?**  
(Concluded from page 5).

We can, of course, still receive signals of sorts without either aerial or earth connections, but the manipulation of a set under these conditions calls for a fair degree of skill.

There are several means available, therefore, for dispensing with a large outdoor aerial, but we have seen that in all cases this is done only at the expense of signal strength, and we must compensate for this by using more sensitive and powerful receivers.

**Ultra-short Waves.**

There is one aspect of the subject which I have not so far considered, and that is the use of the ultra-short waves. The carrying powers of transmissions at these high frequencies is well known, and only a small aerial suffices for picking up transmissions from great distances. The fact is that any metal objects in the vicinity of the receiver, such as electric lighting wires, etc., may serve as aerials, and transfer sufficient energy to the receiver even though only a loose coupling exists. Such metal objects may, of course, also cause absorption of the waves under some circumstances.

Nevertheless, the use of shorter wavelengths for broadcasting would seem in some measure a solution of the problem of abolishing the aerial, but here, again, there are many practical difficulties to be overcome.

**Changing by Degrees.**

We have seen above what are the disadvantages of large outdoor aerials, and as the science of radio progresses our sets will tend to become more sensitive, and will certainly have to be more selective.

**B.B.C. Wavelength Disclosures**  
(Concluded from page 5.)

The wavelengths given in the table are merely examples we have taken at random, but the results show that it is high time that the B.B.C., after these many months, took the public into their confidence and stopped the present state of affairs. Very recent tests we have made indicate great accuracy in the case of the new experimental wavelengths, and in future it is the intention of the Elstree Laboratories serving this Journal to keep a friendly but close watch on the wavelengths of the B.B.C. stations to ensure an equal degree of accuracy being maintained. Meanwhile the B.B.C. are continuing to publish inaccurate figures. What are they going to do about it?

**On being SURE**

The average experimenter has not time to investigate the claims made for every component on the market, nevertheless he is anxious that his receivers shall reach the high standard of efficiency which only the best parts can give. Bowyer-Lowe Component Service solves his difficulty. Every part is tested by engineers before it leaves the factory and is then guaranteed "up to the hilt" for twelve months and will be replaced without question if it fails to give completely efficient service.

*Be safe—say "Bowyer-Lowe" to your dealer.*

**BOWYER - LOWE CO., LTD.,**  
RADIO WORKS, LETCHWORTH.  
N.A.R.M.A.T. Exhibition, Albert Hall, Sept. 12 to 23, Stand 14.



**"ANTIPONG" LOW LOSS VALVE HOLDER.**

Low loss, anti-capacity, shock absorbing. Prevents all microphonic noises in Dull Emitters and reduces inter-electrode capacity to a minimum. Valve legs are surrounded by air & attached by Phosphor Bronze springs to a non-inflammable bakelite ring. Universal fitting, complete with screws. Price 3/-



**VOLTMETERS.**

Reasonably priced instruments for Panel Mounting. Specially made for sets using Dull Emitter Valves. Current consumption at 3 volts, only .045 amps. Instrument fits hole 2 1/4 in. diameter. Beautifully finished. Price 14/-

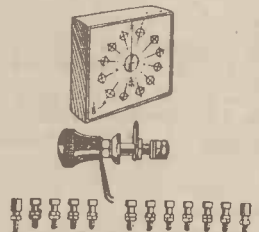

**STUD SWITCHES.**

All parts necessary for building series parallel or stud switches; including switch arms and knobs, studs and stops, screws, nuts, drilling templates and instructions. Stud Switch Parts make any switch from 2 to 10 way. Series or parallel switch is useful for every purpose where a double pole change over is needed. Stud Switch, 2 to 10 way. Price 2/3 Series Parallel Switch Price 4/-



**COIL PLUG & SOCKET.**

Three types made. One for baseboard mounting with top connection; another mounted on circular ebonite flange for use on wood panels and cabinets; a third consisting of plug and socket only for panel mounting. Baseboard or flange type, 2/6. Panel mounting type, 9d.



**MATCHED H.F. TRANSFORMERS.**

Every Bowyer-Lowe Transformer is individually matched against standards, so that every one of a range is precisely like every other. No special selection for H.F. Stages is necessary. All ranges from 150 to 2,000 metres and up, and special Neurodyne Unit, 300 to 600 metres, at uniform price. ALL RANGES

**7/- EACH.**



**SHORT CIRCUITING & TRANSFER PLUGS.**

These components are very useful where it is desired to short circuit a reaction coil or to transfer connections from a coil holder to some other part of a circuit. Made of best ebonite, highly polished; and solid brass. Short Circuiting Plug 1/6 Transfer Plug 2/-

**TESTED EBONITE.**

All Bowyer-Lowe Ebonite is guaranteed Grade A and may safely be used without rubbing down. Sold in Semi Matt Sheets, cut to any size at 1d. per sq. inch. Drilled, engraved and polished for any set of which full size drawings or blueprints are available; 1 1/2d. per sq. inch.

**BOWYER - LOWE CO., LTD., LETCHWORTH.**

Please send your **SPECIAL SHOW CATALOGUE.**

NAME.....

ADDRESS.....

**Bowyer-Lowe Tested Components**

# Build your Set the Labour-Saving Way



THE Polar Blok System simplifies the building of Wireless Sets in just the same way as the use of steel framework, interlocking parts and standardised sections have simplified the building of works, of houses and of motor-cars.

The Polar Blok Method reduces the labour and time required for *assembling*, and leaves you more time for actual experimenting—for the testing of a thousand and one circuits, the adjusting of values and the developing of your set to full efficiency.

There is no workshop practice needed with Polar Blok; no sawing, drilling, filing or soldering. An interlocking metal framework is used, on which standard, ready-assembled panels are mounted in any sequence or combination you please. Insulated wire is provided, which readily permits the angular

method of wiring, giving the set the desirable neatness beneath panel, in addition to the excellent appearance of the exterior. You can extend your set at will with the Polar Blok System, making it perfectly practicable to add any number of improvements or further valves without "scrapping" any previous parts.

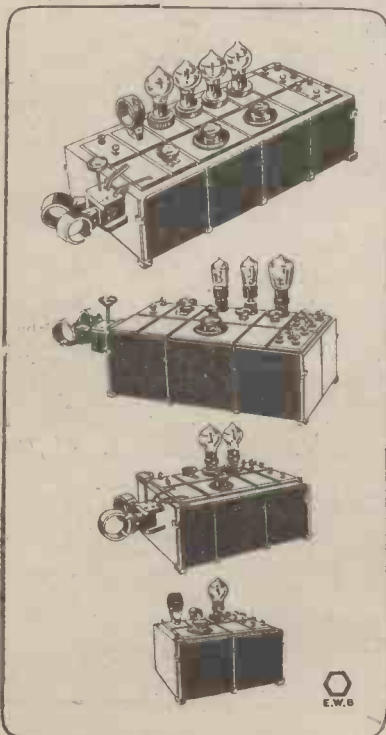

## POLAR BLOK



For real Experimenting—without workshop, litter or labour.

Pliers and Screw-driver the only tools needed.

*Polar Blok Parts are sold by all good-class Radio Dealers.*

Write for 16-page Polar Blok Booklet, 7d. post free, giving full details of six complete sets, incorporating resistance-capacity coupling, with wiring diagrams, lists of components, and prices.

**RadioCommunication Co. Ltd.** 34-35, Norfolk Street, Strand, London, W.C.2

# Eavesdropping by Wireless

By JOHN W. BARBER

**H**AVE you ever, during a slight pause in the programme, heard small voices and strange sounds that you have been unable to account for? Possibly you have remarked, "Oh, that is the announcer talking quietly to other people in the studio." Maybe you were right; but has it ever struck you that the sounds may have originated in your next-door neighbour's house, where there is also a crystal set installed? No? Well, listen to this.

### A Remarkable Experience.

Very soon after broadcasting came into being my next-door neighbour made a crystal set, and one evening, whilst listening-in, I distinctly heard a voice that I knew quite well giving instructions and talking to my friend, the owner of the crystal set. Upon remarking to my friend about this, he confirmed what I had heard, and we decided to try and get into touch with each other again by the same means. This was easily accomplished during the next pause in the programme by alternately listening and speaking into the telephone receivers, speech being clearly audible. Since then I have

heard, upon different aerials, many scraps of conversation from neighbouring houses, the speakers being, of course, totally unaware that anyone outside their house could hear what was going on.

How is it done? you may ask. As you speak into the telephone receiver the diaphragm moves toward and away



A shell used as a loud-speaker.

from the magnets in sympathy with the sounds you make. This causes a minute current to be produced, which tries to flow through the crystal, thus varying the contact between the crystal and catwhisker. This in turn varies the amount of "resistance" which is across the tuned circuit

(aerial coil and condenser, and vario-meter), causing the steady carrier wave from the broadcasting station to be feebly modulated in accordance with your speech.

### How it Happens.

The crystal set next door, by reason of the proximity of the aerials, is able to pick up these feeble currents, and the result is that you hear what your neighbours are talking about.

### How to Avoid Trouble.

What an alarming prospect—shall we never know now who is hearing our private conversations? Perhaps our most cherished secrets may quite easily become general knowledge, and all because we have a seemingly harmless crystal receiver in the room. But things are not really so serious as that—all that is necessary is to lay the 'phones face downwards upon a cushion or other soft object, and the danger will be minimised, if not altogether got rid of. To be absolutely certain that you will not be overheard, however, it is best to disconnect the aerial lead, earth lead, or telephones. Failing this, the catwhisker may be lifted from the crystal, and there is then no possibility of eavesdropping with a crystal set taking place.

400,000 COPIES OF THIS ISSUE PRINTED!

## Quality RADIO CAM-VERNIER COIL HOLDER.

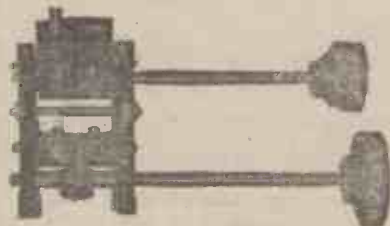

This is the last word in accurate tuning devices. Similar to our standard coil holder, but the usual fixed socket has a very slow movement giving a micrometer adjustment in both directions through 10°. This is effected by a cam operated by a separate knob.

PRICE.—2-way 9/-

PAT. NO. 231, 251.

## Quality RADIO BOX SPANNERS FOR B.A. NUTS.

Indispensable for quick work to the constructor, experimenter, and professional assembler. Made of solid steel in four sizes, 2, 4, 5 and 6 B.A., size marked on each by rings. Price (all sizes) 1/- each; postage 3d. each. Nickel plated, 6d. each extra.



## Quality RADIO SET CLEANER.

Dust is the great enemy of wireless and a fruitful source of leakage, weak signals, and noises. The brush keeps the panel free and the looped cleaner clears the dust from between the condenser plates and from the otherwise unaccessible places between valve legs and terminals. Price 6d. each; postage, 2d.



If your dealer cannot supply, we send post free if you mention his name and address. 30 page, fully illustrated new list now ready, post free.

**GOSWELL ENGINEERING CO., LTD.,**  
95, 96, 97, 98, WHITE LION STREET, LONDON. N.1

## THE PANEL DE LUXE



**A RADION PANEL**—with its sleek polished surface—is a joy to behold. But the wireless enthusiast knows that its advantages are more than "skin deep." Its superior insulation qualities are even more important than its handsome appearance. In every way it proves itself the "panel de luxe."

Radion is available in 22 different sizes in black and mahogany. Radion can also be supplied in any special size. Black rd. per square inch, mahogany 1 1/4d. per square inch.

# RADION Trade Mark

**American Hard Rubber Company (Britain) Ltd.**

Head Office: 13a Fore Street, London, E.C. 2  
Depots: 120 Wellington Street, Glasgow. 116 Snow Hill, Birmingham.  
Irish Agents: 8, Corporation Street, Belfast.



# A wonderful achievement



## The new Brown A 'phones now at a price within the reach of all

IT is doubtful if there is a single wireless enthusiast who has not heard of Brown A-type Headphones. Not everyone, however, who has coveted them has been able to buy them—in fact, owing to their comparative high price, only a small proportion have been able to enjoy their advantages.

Brown A-type—with their famous super-sensitive tuned reed mechanism—have always been acknowledged to be the world's best headphones and in a class apart from competition. Governments, shipping and telegraph companies have all paid tribute to their wonderful efficiency and have taken the bulk of the available supplies.

But the insistent demand for a cheaper instrument compelled us to consider the production of a modified A-type Headphone suitable for mass production on a large scale.

Twelve months have been spent in designing the new Brown A-type. We can now guarantee that they contain all the essential details of the famous tuned reed mechanism—that in sensitiveness they are still without equal—that the same superb Brown standard of workmanship is maintained. That in short, although produced in huge quantities by the aid of the most elaborate and costly machinery, they are in every way comparable to the world-renowned standard Brown A-type.

Their production at the amazing price of 30/- is a truly remarkable achievement—one of the greatest, perhaps, in the whole wireless industry during 1925. The demand for them will be immense—order a pair from your Dealer at once.

### TO THE TRADE

We want you to have adequate stocks of these Headphones and all the new Brown Loud Speakers. In case of difficulty write us immediately and we will see that you are supplied.

**S. G. BROWN, LTD**  
 Head Office & Works :  
 Victoria Rd., N. Acton,  
 W.3

Retail Showrooms:  
 19 Mortimer St., W.1  
 15 Moorfields, Liverpool  
 67 High St., Southampton

# Brown

Headphones and Loud Speakers.

All the new Brown Loud Speakers may be seen, heard and bought at the Works or at our Show-rooms.

Depots (Wholesale only):  
 13 Bushy Park, Bristol  
 Cross House, Westgate Road, Newcastle



# HOW TO MAKE YOUR OWN PERMANENT DETECTOR

By  
A. V. D. HORT, P. A.

In designing this detector, a crystal requiring a light contact for efficient reception was avoided, a "Perikon" combination of two crystals being used, the pair chosen being Zincite and Bornite. Zincite and Copper Pyrites will be found to function equally well.

### Firm Pressure.

Quite firm pressure can, with advantage, be maintained between the crystals, which is all to the good, since thus the setting is more likely to be undisturbed by vibration.

Many of the parts required will probably be to hand already, while others are readily obtainable. The materials used are:—A piece of glass tubing, not more than 1 in. long, with an internal diameter of about 7/16 in.

Two fine grained soft corks to fit tightly into the ends of the tube.

One strip of stiff brass 1 1/4 in. x 1/4 in.

One strip of springy brass 1 1/4 in. x 1/4 in.

Two 3/8 in. 6 B.A. esk. head bolts with nuts.

Two 6 B.A. terminals—these may quite well be 6 B.A. bolts with ordinary hexagon nuts.

Two eyelet soldering tags.

4 ins. of thin flex.

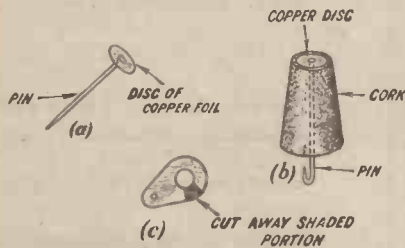

Fig. 1.—Constructional details.

Ebonite strip, 3 ins. x 1 in. x 3/16 in. (unless the detector is to be mounted direct on a panel).

Two ordinary pins and a small piece of copper foil.

One Zincite and one Bornite (or Copper Pyrites) crystal.

The first operation is to make the metal contacts for the crystals. Two discs are cut from the copper foil, of

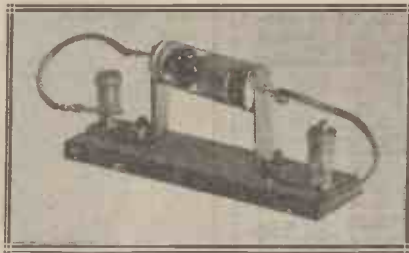

Fig. 2.—All ready for connecting up.

a diameter to fit easily inside the tube. A pin is pushed through the centre of each disc as far as its head (Fig. 1 (a)). The disc is then soldered in this position by holding the pin by its point in a pair of pliers, smearing a little flux on the foil, and touching it on a well-



Fig. 3.—The brass strip.

tinned, hot soldering iron. The pins with their discs on are now pushed through the corks lengthways, the discs finally resting on the narrow ends of the corks (Fig. 1 (b)). One cork may be cut down with a sharp knife to a thickness of 1/4 in.; the other should be left about 1/2 in. long. The points of the pins are bent over and a 2-in. length of flex is soldered to each. To the other ends of the flex leads are soldered the two tags, each of which has a slot cut in one side, as shown in Fig. 1 (c).

### How to Make the Strips.

The brass strips for mounting the tube may next be prepared. The dimensions for drilling them are shown in Fig. 3, both strips being treated in the same way. The strips are bent at right angles, 3/4 in. from one end.

The stiff brass strip may now be mounted on the ebonite strip, or the receiver panel, the two holes in it being used as a guide for marking the positions of the holes in the ebonite. The dimensions of the strip are given in Fig. 4, the end hole for the stiff strip being located 3/16 in. from one end.

### Finishing Off.

Now push the short cork into one end of the tube, drop in the two crystals, holding them with a pair of tweezers and not in the fingers, and close the other end with the long cork, pushing it in as far as it will go without actually crushing the crystals. Shake the tube; if the crystals rattle, tighten the long cork a bit more, till they are firmly wedged.

The pin in the short cork is now slipped, via the slot, into the hole in the stiff brass strip, and the springy strip is slipped in a similar way on to the other pin. When the holes have

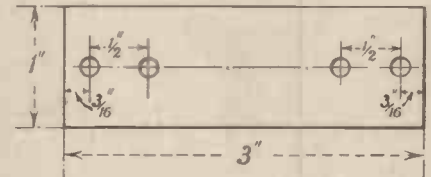

Fig. 4.—Drilling plan of the ebonite strip.

been drilled in the ebonite, this strip can be mounted, and the tube fitted in position. It only remains to secure the tags on the end bolts or terminals, when the detector may be connected in circuit.

If the setting of the crystals is not satisfactory on trial, turning the glass tube slightly while holding the long cork may effect the necessary improvement.



This is to introduce Hector of "Wireless" and his wife Buttercup. Their radio adventures will form a weekly feature in this journal.



## COMPONENTS



**MH MICA  
FIXED CONDENSER**

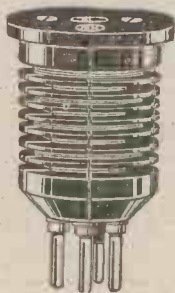

**MH  
H.F. TRANSFORMER**

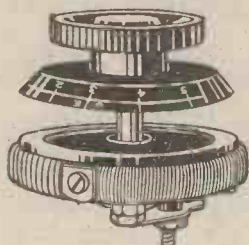

**MH  
FILAMENT RHEOSTAT**



**MH GRID LEAK**

Let your choice of components always be **MH** and ensure best possible results at all times.

**MH MICA**

**FIXED CONDENSERS**

Are of the permanent capacity engraved thereon. Are instantly interchangeable.

**PRICES.**

each  
0.0001 μF to 0.001 μF (030) 1/9  
0.015 μF to 0.01 μF (031) 2/3  
0.015 μF to 0.03 μF (034) 2/6  
(Two clips are supplied with each condenser.)

Above mounted on ebonite base, with terminals, any value, 1/- extra.

**MH**

**H.F. TRANSFORMERS**

"The Transformer that made H.F. Amplification popular."

Supplied in six ranges of wavelengths, covering 80 to 7,000 metres. Price 10/- each. Special "M.H." Neutrodyne Units and Super-heterodyne Couplers also supplied. No extra charge for matching, if stated when ordering.

**MH**

**FILAMENT RHEOSTATS**

The "M.H." Filament Rheostat has been designed for either Dull emitter or Bright emitter valves. A Double Type enables either Bright or Dull emitter valves to be used with safety. Fixing is the simplest possible, three clear holes in the panel being all that is required.

**PRICES.**

each  
Bright Emitters ... 5/6  
Dull Emitters ... 6/6  
Double, Bright and Dull Emitters ... 7/6  
Triple Rheostat ... 22/6

**MH GRID LEAKS**

Can be obtained mounted (as illustrated) or unmounted (with two clips).

**PRICES.**

each  
Grid Leak, all values ... 2/-  
Anode Resistance, all values ... 2/6  
(Each supplied with two clips.)

Mounted on ebonite base with terminals extra 1/-

**"M.H." COMBINED GRID LEAK AND CONDENSER**

Price ... 4/- each

# EFESCA

## Regenerative

# AERIAL TUNER



The Efesca Regenerative Aerial Tuner is the natural development of the extremely convenient series of

Efesca One-Hole Fixing Tapped Coils. It is a specially designed form of Tapped Aerial Coil incorporating Aerial Reaction in a self-contained unit. Reaction is effected by means of a rotor revolving in a separately wound section of the Aerial Coil, thereby effecting maximum and uniform reaction over the whole wave band covered by the coil. Wavelength range 150 to 2,600 metres in conjunction with a .0005 Variable Condenser in parallel. Price complete with Knob, Pointer and Scale 32/-

Other components in the Efesca Series of One-Hole Fixing Tapped Coils are the H.F. Transformer and Anode Tuner, Aerial Tuner and the H.F. Reactance Coil.

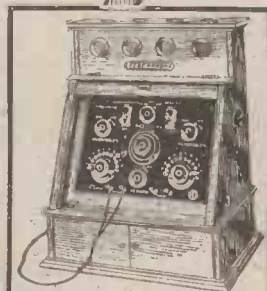

**EFESCAPHONE RECEIVING SETS**

There are Efescaphone Receiving Sets at prices ranging from £2 5s. od. for the simple crystal set, complete with aerial outfit and headphones, to the 4-valve set with artistic cabinet incorporating the Puravox Loud Speaker at £59. The model illustrated is the Nelson 4-Valve Grand Efescaphone, price complete, except valves, £35 15s. Royalties, 50s. net extra.

# EFESCA COMPONENTS

Write for Catalogue No. 559 describing and illustrating EFESCA Components and EFESCAPHONE Receiving Sets Wholesale only.

## FALK STADELMANN & CO., LTD.

EFESCA ELECTRICAL WORKS,  
83/93, FARRINGDON ROAD, LONDON, E.C.1.  
Also at Glasgow, Manchester and Birmingham.

VISIT THE **MH** STAND No. 6 AT THE N.A.R.M.A.T. EXHIBITION, ROYAL ALBERT HALL, Sept. 12th to 23rd, 1925.

# L.M. MICHAEL LTD

Manufacturers of Wireless and Scientific Apparatus,  
HASTINGS HOUSE, NORFOLK STREET, STRAND, LONDON, W.C.2.

EVERYONE knows the main features of Switzerland. It is a country of high mountains upon whose snow-capped peaks stand picturesquely garbed natives yodelling tunefully to one another across the valley; it is a country inhabited largely by cows who wear bells round their necks and produce condensed milk; it is also a country where the hardy mountaineer has little to fear if he is caught in a snowdrift, since he has only to whistle



"... Natives yodelling tunefully."

when he finds himself in difficulties, and up gallops a St. Bernard dog wearing a kind of saddle affair, upon one side of which is a packet of sandwiches, whilst upon the other is a flask of brandy. If the snowed-up traveller is an American, he whistles through his nose to make the fact known, whereupon the sagacious hound substitutes waffles or pumpkin pie for the sandwiches and iced water for the brandy. Switzerland is also the land of avalanches and moraines. Do you remember the schoolboy's definition of a

## WIRELESS IN SWITZERLAND

By our Irresponsible Correspondent.

moraine? "A moraine is caused by a glazier slipping down a mountain." If you have ever seen a Swiss glazier who carries his outfit in a wooden rack strapped to his back you will appreciate the beauty of this. Switzerland is also the playground of Europe, where the gentle Hun gambols upon the hills, quenches his thirst with mighty draughts of champagne, and eats enough to satisfy the needs of any six normal human beings. A few English and Americans also manage to squeeze their way in at times.

### Wires!

Switzerland is all these things, but it is not a country of wireless, mainly because it is a country of wires. When you pay your first visit to Switzerland you imagine that your eye is going to be struck at every turn by snowy peaks and azure lakes and picturesque chalets and so on. It is not. It is struck by wires and wires and wires

and wires. They stretch across the plains upon high poles, they swing airily across the valleys, they climb the mountains. Wherever you go they extend maze-like in all directions. Swiss laws are not half so grandmotherly as our own. If ever you wished to send current at a voltage of a paltry 5,000 or so from place to place in this country heaven alone knows what sort of regulations you would have to comply with. Your



"... mighty draughts of Champagne..."

Swiss merely rigs up a line of poles decorated with insulators, slings to them power cables with a 60,000 voltage, sticks up a little notice, "Danger de mort," and leaves it at that.

### A Problem.

All this leaves the would-be wireless man in Switzerland in a very difficult position. Everyone knows that in order to avoid interference from power cables, tramways, electric railways and so on you must stick your

# TUNGSTALITE

## THE SUPER CRYSTAL

*Proved 99.5% efficient in recent tests.*

From all over the world come enthusiastic reports of successes achieved with TUNGSTALITE.

Obtainable of all dealers or direct from:—

**TUNGSTALITE Ltd.**  
47, Farringdon Rd., London, E.C.1.

Phone: Holborn 2557  
41, Call Lane, Leeds.

BLUE  
**1/6**  
LABEL

GOLD  
**2/-**  
LABEL

**BUY YOUR SPECIMEN TO-DAY.**

## The Home Constructor

We specialize in and supply components for all apparatus described in *Wireless, Modern Wireless, Wireless Constructor*, and all Radio Press publications.

**The New S.T. 100**  
as described in this issue.

	£	s.	d.
2 Magnum Aluminium Angle Brackets .. .. .	0	3	0
1 Utility Crystal Detector .. .. .	0	7	6
1 Bretwood Anode Resistance .. .. .	0	3	0
2 T.C.C. Fixed Condensers 2 mfd. .. .. .	0	9	4
2 Benjamin Valve Holders .. .. .	0	5	6
1 C.A.V. L.F. Transformer .. .. .	0	15	0
1 Gambrell L.F. Transformer .. .. .	1	7	6
1 Ebonite Strip 12" x 1" x 1/4", with 12 sockets .. .. .	0	4	0
2 Success Variable Geared Condensers .0005, with Microtune .. .. .	3	8	0
2 Polar Rheostats .. .. .	0	11	0
1 Walmel Fixed Condenser .001 .. .. .	0	2	6
1 Magnum Single Coil Holder .. .. .	0	1	9
1 McMichael Fixed Condenser and Clips .002 .. .. .	0	2	3
1 Terminal Strip and 2 Terminals .. .. .	0	0	9
1 Igranite Key Switch .. .. .	0	3	0
1 Goswell Geared 2-coil Holder .. .. .	0	10	6
1 Set Radio Press Transfers .. .. .	0	0	6
1 Coil Glazite .. .. .	0	1	2
	£8	16	3
1 Ebonite panel 12" x 8" x 1/4" Drilled .. .. .	10	0	0
1 Baseboard 12" x 10 1/2" .. .. .	2	0	0
1 Cabinet as described .. .. .	1	5	0

NOTE.—Where a complete set of components is purchased together, a Marconi royalty of 12s. 6d. per valve holder is payable.

Send stamp for lists dealing with components for Radio Press circuits, also the Wonderful Magnadyne Super-Het.

---

**BURNE-JONES & CO., Ltd.,** Magnum House:

296, BOROUGH HIGH ST., LONDON, S.E.1

Telephone: Hop 6257. Telegrams: "Burjomag, Sedist, London."

Cables: "Burjomag, London."

TRADE ENQUIRIES INVITED.

aerial at right-angles to the source of the trouble. To do this in most places in Switzerland would be a problem in the fifth or sixth dimension, which is rather beyond even a Swiss. For a small country Switzerland is well provided with broadcasting stations, remarkable chiefly for the fact that they do not broadcast. If you pick up a newspaper and turn to the radio programmes you will find something like this:—

- Lausanne: No transmission.
- Geneva: 5.50 to 6.10. Talk on Child Welfare.
- Zürich: No transmission.

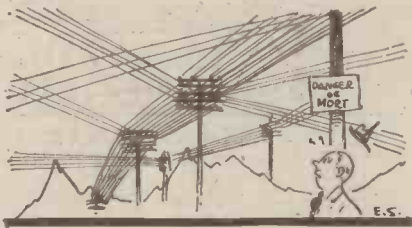

Not wireless, but wires

Most of the broadcast catching accomplished is done upon English and French stations, atmospherics, power lines, tramways and railways permitting.

**How to Catch Trains.**

Do not imagine, though, that wireless does not exist in Switzerland, or

that great use is not made of it. Hundreds of folk who used to miss their trains or who had in the old days to perform mighty feats of sprinting in order to catch them now find their travelling problems immensely simplified by installing wireless sets. If, for example, you wish to catch the eleven o'clock train at Lausanne, you merely switch on your set at about 10.45. A continuous booming noise lets you know that the train is on the way. The practised ear can tell at once by the intensity of sound how far away it is. When a cessation occurs you either say, "Ah, it has just stopped at St. Maurice," and fill another pipe, or else you know that it has reached Vevey, in which case you seize your impedimenta and make for the station.

**A Peculiar Effect.**

One of the best stations for reception in Switzerland is 5XX. Owing,

however, to the frequent occurrence of thunderstorms, a peculiar kind of selectivity is often met with. Thus from Daventry it is at times possible to receive only the X's and not the 5, whilst from London L comes through shorn of both 2 and O.

**A Felt Want.**

What is really wanted in Switzerland is an ingenious appliance which will enable the electric trains to play tunes as they go along instead of sending out, as at present, a mixture of



Professor Schnitzelwurst is now actively engaged

booms, fizzes, crackles, bangs and other strong but unwanted signals. I understand that Professor Schnitzelwurst is now actively engaged upon this problem, and that as the result of his efforts it is likely that the ether of Central Europe will shortly be filled with music.

**SPECIAL NOTICE.**

**"WIRELESS"**

IS ON SALE

**EVERY TUESDAY**

AT ALL NEWSAGENTS AND BOOKSTALLS.

**PETO-SCOTT**



**Super-Het Builders**

You need this

Before building your Super-Het be sure to send 2d. for a copy of our latest Folder: "The Keystone Super-Heterodyne and how to build it." All Keystone Super-Het parts are British made of the highest quality and specially matched for use with British Valves.

For all your components you cannot do better than go to Peto-Scott's—one of the oldest firms in the radio industry. Whatever your requirements we can supply them, and at a most reasonable price. All components and finished instruments carry our full guarantee. Orders despatched per return of post.

**CATALOGUE:**

Experimenters should always keep a copy of Peto-Scott's Catalogue, 48 pages fully illustrated. You save money by buying from Peto-Scott's.

Post free - - 3d.

**PETO-SCOTT CO., Ltd.**

Registered Offices, Mail Order and Showroom:

**77, City Rd., London, E.C.1.**

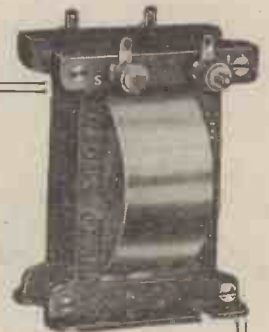

**H.F. Transformers.**

A Transformer of the highest grade. Very selective, with a high amplification factor. These transformers can be supplied matched for two or three stages of high frequency amplification without extra charge.

No.	200—600	500—900	900—1500	1200—2300	2200—7000
No. 1.	10 0	10 0	10 0	10 0	10 0
No. 2.	10 0	10 0	10 0	10 0	10 0
No. 3.	10 0	10 0	10 0	10 0	10 0
No. 4.	10 0	10 0	10 0	10 0	10 0
No. 5.	10 0	10 0	10 0	10 0	10 0

These wavelengths are reached with a variable condenser of the value of .0003 mfd.

**Slow Motion Coil Holders.**

To carry three coils as illustration. Friction drive by means of rubber-faced spindle and milled ebonite pinion. Smooth movement without backlash ... **15/6**

Ditto, but carrying two coils only **10/6**

Ditto, but arranged to carry coils at back of panel and fitted with an indicator wheel to show position of moving coil. One Hole fixing ... **12/6**



Branches:—  
LONDON—82, High Holborn, W.C.1.  
WALTHAMSTOW  
230, Wood St.  
PLYMOUTH—  
4, Bank of England Place.  
LIVERPOOL—  
4, Manchester St.

**The famous Max-Amp.**

One of the first high-grade Transformers to be placed on the market and still without equal for distortionless amplification. A soundly designed transformer, well made from the finest materials. Fully shielded in die-cast metal case to prevent interaction. Windings tested to 500 volts for insulation. Clamping screws do not go through laminations. In two ratios: First stage and general use (blue band) 19/6. Second stage (black band) 19/6

**Reflex Type.**

For use with reflex circuits we have designed a special Max-Amp which will give even better results than a standard Max-Amp. Supplied in the familiar metal case used for all Max-Amps, but identified by a red band. All Max-Amps are fully guaranteed ... **19/6**

*There's life in the family now!*



*Introducing Miss Mellovox. Merry Miss Mellovox has been chosen to identify in the advertising the merits of the Mellovox Loud Speaker. We shall see her making life generally a little brighter—in papers, in windows, at dances, here, there and everywhere.*

What a difference broadcast music, song and interest makes to family life. Greater still will become the added pleasures of radio now that the Sterling Mellovox is here. A loud speaker supremely perfect in performance, gracefully artistic in design and offered at a price that makes the luxury of its reproduction and appearance available to every radioist.

Hear it to-day at your radio dealers.

**STERLING  
MELLOVOX**  
Loud Speaker.



THE STERLING MELLOVOX is artistically finished in brown, blue or purple, with floral designs on the diaphragm. 2,000 ohms resistance.  
PRICE. - 48/-

An ideal combination with the famous MARCONIPHONE V.3a (illustrated below), complete with all accessories.  
PRICE £33.18.8 inclusive  
At your dealers

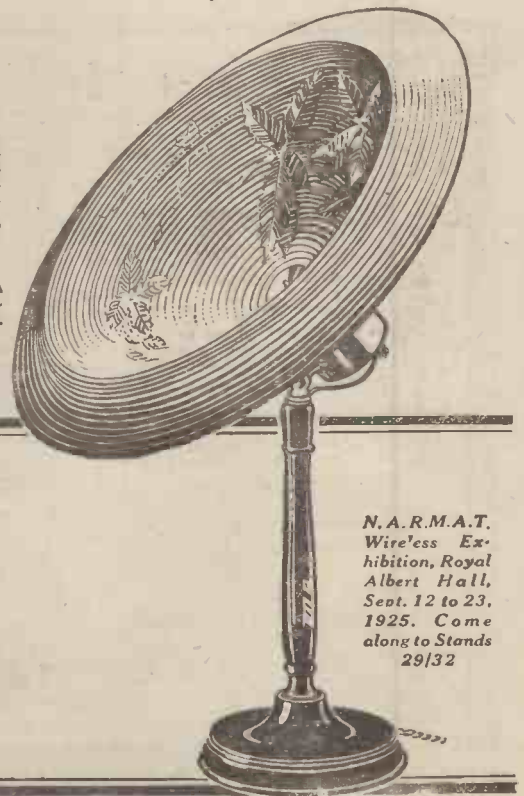

N. A. R. M. A. T.  
Wireless Exhibition, Royal Albert Hall, Sept. 12 to 23, 1925. Come along to Stands 29/32

**Marconiphone V.3a.**

Sole Agents:—THE MARCONIPHONE COMPANY, LIMITED, 210-212, Tottenham Court Road, London, W.1

**Internal Metal Chuck to grip 14 to 44 gauge wire or flex.**  
**Price: Plug 4d. Socket 2d. Indicating Ring 1d.**



**PATENTED**

## BELLING-LEE INDICATING TERMINALS & "MULTY-CONTACT" PLUGS & SOCKETS

(Handles and dome-shaped Indicating Rings in Red or Black) Stocked in the following indications:

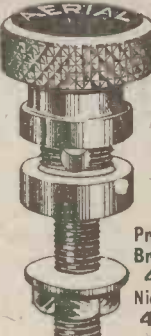

**Price: Brass 4d. Nickel 4½d.**

**PATENTED**

**DIAL INDICATORS**



**Solid cast metal, with raised, polished letters showing white on a black background. Single hole fixing, complete with nut. Stocked in Tuner, Filament, Reaction, Aerial, Anode, H. F. Tuner, Secondary, Rejector.**  
**Price - 6d. each.**

**Aerial, Earth, Phones+, Phones-, I.T. +, L.T. -, H.T. +, H.T. -, Input +, Input -, Output +, Output -, L.S. +, L.S. -, Grid +, Grid -, A.T.I., Reaction, Ap. Aerial, H.T. Medium, and Blanks.**

Every high-class dealer stocks them, but in case of difficulty send to **BELLING & LEE, Ltd. Queensway Works, Ponder's End, Midx.**

**SUB-CONNECTORS**

Eliminate Soldering.



Perfect connection; lowest possible self-capacity; low resistance; connection changed in an instant. Tapped to screw on to 2, 4, 5 and 6 B.A. threads; also T connectors for joining wires.

**Price 1d. each.**



# Think this over carefully

If your progress in wireless has stopped at the building of a simple Crystal Set you are denying yourself one of the real thrills of Radio. The thrill of long-distance reception. Why not decide to build a good Valve Set now? Valves are cheap, and the upkeep costs of a really good Set are very low.

A good Valve Set built the Pilot way is wonderfully economical to make. Every Pilot Set is based on a proved Radio Press design—the Panel is drilled and engraved—the components fit snugly together—every part is supplied down to the last screw—the special diagram renders the wiring a simple operation of an hour or two. Everything, in fact, which human ingenuity can contrive to make Set-building easy has been done under the Pilot Service.

When completed, the Set is one of which you can be justly proud. In appearance it will possess all the characteristics of the professionally built Set, yet its entire cost is no more than the bare price of the components.

The following are a few of the well-known Sets available under the Pilot Service: The ST100, All Concert de Luxe, Harmony Four, Transatlantic V, Anglo-American Six, and many others of proved efficiency. Send 3d. for a copy of the Pilot Chart and see how little it costs to build a really good Set—fully guaranteed to give you excellent results and backed by our Service department.

**PETO - SCOTT Co., Ltd.**  
**Head Office & Mail Order: 77 City Road, E.C.1**  
 Branches: LONDON—62 High Holborn, W.C.1.  
 WALTHAMSTOW—230 Wood Street.  
 PLYMOUTH—4 Bank of England Place.  
 LIVERPOOL—4 Manchester Street.

# PILOT RECEIVERS

Gilbert Ad. 3475



## I am still here

after 25 years of hard work AND SUCCESS. Why? Because I have helped thousands of people to better their positions socially and financially. I am assisted by a large and expert staff and the advice we give is sound. If we cannot help you we will say so; if we can, we will tell you how.

We have booklets setting out the possibilities in connection with each of the subjects shown in the lists; send for the one in which you are interested, or ask for **MY PRIVATE ADVICE**, which is free. You incur no obligation.

**Have You ANY Ambition?**

The Bennett College specialises in all Exams. in the following subjects, and guarantees tuition until successful. No extra fees.

**WE TEACH BY POST**

**COMMERCIAL.**

- Accountancy
- Advert Writing
- Salesmanship
- Auditing
- Banking
- Book-keeping
- Commercial Arithmetic
- Commercial Law
- Company Law
- Costing
- Economics
- English and French
- Exercitorship Law
- Foreign Exchange
- Modern Business Methods
- Secretaryship
- Workshop Organisation

**Engineering Dictionary. Part One. Free. To extend the name of the Bennett College we are publishing an illustrated Encyclopaedic Dictionary of Engineering. Civil, Motor, Elect. Mech., etc. You may have Part I FREE. Send for Part I to-day; you are under no obligation.**

**EXPERT TUTORS FOR EVERY DEPARTMENT.**

**TECHNICAL.**

- Architectural Drawing
- Building Construction
- Clerk of Works' Duties
- Boiler Engineering
- Boiler Making
- Chemistry
- Civil Engineering
- Concrete and Steel
- Draughtsmanship
- Electricity
- Engineering
- Foundry Work
- Internal Combustion Engines
- Marine Engineering

**TECHNICAL.—Cont.**

- Mathematics
- Metallurgy
- Mining
- Mine Surveying
- Motor Engineering
- Naval Architecture
- Pattern Making
- Sanitation
- Shipbuilding
- Structural Engineering
- Surveying and Levelling
- Telegraphy & Telephony
- Wireless Telegraphy
- Works Managers' Course

**WRITE FOR FREE BOOKLET**

to The Bennett College, Dept. 111, Sheffield, naming the subject you are interested in. Parents should seek our advice for their sons. Please state your age. Courses specially combined to meet all requirements. Why stay in the rut?



**THE BENNETT COLLEGE**  
**SHEFFIELD**

Dept. 111.



# "UTILITY" WIRELESS PRODUCTS

## The "UTILITY" Automatic Crystal Detector



No. W.152.

As used in the new ST100 Receiver, described in this issue, it is entirely automatic, and by turning the Knob, the Cat's Whisker is withdrawn from the Crystal surface, a new point is found on the Crystal, and the whisker pressure adjusted to a nicety—three operations in one. Tediousness usually experienced with the ordinary type is entirely eliminated, and the Detector is fool proof, shock proof, and dust proof. It is made in two patterns. W.151 for mounting beneath the panel, and W.152 for mounting on the panel surface. The prices are as follows:—

No. W.151 7/6 each. No. W.152 8/- each.

Manufactured by

# WILKINS & WRIGHT,

"Utility" Works, Kenyon Street,  
BIRMINGHAM.

Send for our Illustrated Catalogue, sent post free on request.

## The New Radiax Loud Speaker

WILL handle faint signals with surprising results, and large volume without loss of tone, due to the non-resonating horn and other features. The exceptionally permanent characteristics of the specially shaped cobalt steel magnets permit our permanent guarantee.

The standard Model is a medium size for average needs. The Minor is a wonderful bargain for those who wish to spend less money.

Standard 19" high 45/-  
Minor 12 1/2" " 22/6

Ask for Special Folder.



## RADIAX H.E. LOW LOSS COILS

These wonderful coils are tremendously and deservedly popular. They improve tuning, volume and selectivity, and make the most of weak signals. They are beautifully made and of appealing appearance, rigid and strong, packed in individual containers. Due to improved construction they are not unwieldy in the large sizes.

Insist on Radiax Coils from your dealer. See that our Trade Mark appears on the mount. If he cannot supply send to us.

No. 25 .... 1/6	No. 150 .... 3/-
No. 35 .... 1/9	No. 200 .... 4/3
No. 50 .... 2/-	No. 250 .... 4/9
No. 75 .... 2/3	No. 300 .... 5/3
No. 100 .... 2/9	Set of 9 .... 26/6

**RADIAX LTD.** 14, RADIO HOUSE  
Tottenham Court Rd. LONDON, W.1

**RADIAX**  
WE SATISFY YOU

**All Post Free At Callers Prices**

Orders 5/6 value, carriage paid. Under 5/6, 2d. per 1/- for packing, etc.

<p><b>Ebonite Panels.</b></p> <p>Matt. 1" 3/16"</p> <p>9" x 6" 2/2 1/10</p> <p>12" x 9" 4/6 3/9</p> <p>12" x 12" 6/9 5/-</p> <p>15" x 9" 5/6 4/9</p> <p>15" x 12" 7/6 5/8</p> <p>4" x 4" 8d. 6d.</p> <p>7" x 5" 1/6 1/2</p> <p>6" x 6" 4" 10d.</p> <p>Any size cut.</p> <p>Sq. in 4", 1d., 4", 1d.</p>	<p><b>Square Law Var. Condensers</b></p> <p>with knob and Dial.</p> <p>.001 panel type 6/6</p> <p>.0005 " " 5/-</p> <p>.0003 " " 4/6</p> <p>Vernier Blade extra 1/4</p> <p>" J.B." Ormond 1/4</p> <p>" "Utility" usual prices</p> <p>Vernier, no dial 2/6</p> <p>5 vane, 3/3; 7 3/6</p> <p>Polar types 10/6</p>
--	---

**SEND FOR NEW FREE Comprehensive Price List. TRADE ENQUIRIES INVITED Generous Terms - Prompt Service.**

<p><b>Aerial Wire</b> 7/22's Bright</p> <p>100' 3.3 2/8</p> <p>" Electron 1/8</p> <p>" Mars 9/6</p> <p>Lead-in 4d. yd.</p>	<p><b>1,000-ohm. ex-Gvt. Choke Coils</b> 9d.</p> <p><b>Coll Plugs</b></p> <p>Ebonite 10d.</p> <p>Superior 1/8</p> <p>Narrow 5d.</p> <p>Basket 11d.</p> <p>"Athol" Ebonite 1/3</p> <p>Do. Porcelain 1/-</p> <p>Horned Coll Plugs 9d.</p> <p>Basket Coll Sets, 6-1/8, 4-1/8</p>	<p><b>H. T. Batteries.</b></p> <p>With Wander Plugs 60v. 8/- 36v. 4/10</p> <p>30v. 4/- 15v. 2/-</p> <p>4v. F.L. Btry. 5d.</p> <p>66v. Ever-Edy. 13/6</p> <p>36v. 8/- 16v. 3/6</p>	<p><b>Transformers L.F.</b></p> <p>Radio Inst. (new) 25/-</p> <p>Silvertown 21/-</p> <p>Igranite 21/- &amp; 20/-</p> <p>Burndept (new) 24/-</p> <p>Reliability 10/- &amp; 12/6</p> <p>Perranti 17/6</p> <p>Tangent 18/6 &amp; 14/6</p> <p>Royal 20/-</p> <p>R.A.F. Modulation, or Telephone type 8/-</p> <p>H.F. Tangent 5/6</p> <p>McMichael's 10/-</p> <p>Oajah 900 5/6</p>
--	---	---	---

<p><b>Insulators</b></p> <p>Shell, 2 1/2" x 3d.</p> <p>Crystal type 9d.</p> <p>Lead-in 4d.</p> <p>4" &amp; 8" 9d.</p> <p>9" 1/-, 12" &amp; 15" 1/3</p>	<p><b>British Wires.</b></p> <p>avg. dec. sec. disc.</p> <p>18 1/11 2/11 3/8</p> <p>20 2/2 3/4 4/2</p> <p>22 2/6 3/9 4/7</p> <p>24 2/11 3/10 5/-</p> <p>26 3/4 4/2 5/9</p> <p>28 3/9 4/9 6/6</p> <p>30 4/10 5/4 7/6</p> <p>32 5/6 6/- 8/9</p> <p>36 8/- 8/8 12/-</p> <p>40 17/- 14/8 20/-</p>	<p><b>New Jacks 4-Contact.</b></p> <p>One hole fixing 1/3</p> <p>Standard Plus 1/3</p> <p>Potentiometer 300 ohms ex-Govt. 5/-</p> <p>Microphones 2/-</p> <p>Alum. H'bands. 2/6</p> <p>Ex-Govt. Dewar Switches 12-contact 2/6</p>	<p><b>Pil Resistances.</b></p> <p>Good quality 1/6</p> <p>Igranite 4/6</p> <p>Vernier type 7/-</p> <p>Ormond 2/- Ajax 4/-</p> <p>Burndept 5/-</p> <p>T.C.B. 4/ &amp; 5/-</p> <p>Microstat 2/9</p> <p>Peerless Jr. 2/6</p>
--	---	--	---

<p><b>Valve Holders.</b></p> <p>Type A 7d., Polar 1/3</p> <p>Screwed 8 nuts 3d.</p> <p>Ebonite 10d.</p> <p>Do. Open Type 6d.</p> <p>"Security" Valve Holder 1/-</p>	<p><b>Condensers.</b></p> <p>Dubilier 32</p> <p>Mullard (Usual Edison-Bell prices) 36</p> <p>New Mansbridge, 2 mfd., 3/6, 1 mfd. 2/6</p>	<p><b>Variable Leaks.</b></p> <p>Filltron 0-7 meg. 3/-</p> <p>Watmel 0-5 meg. 2/6</p> <p>Lissen type 2/6</p> <p>" Resistances 2/6</p>	<p><b>Coll Holders.</b></p> <p>Ashley fixed 2/6</p> <p>" moving 3/6</p> <p>Igranite 3 set 8/6</p> <p>Ebonite 3 Coll 2/6</p> <p>" 2 coll 2/6</p>
---	--	---	---

**J.H. TAYLOR & Co**

11 RADIO HOUSE  
MACAULAY ST. HUDDERSFIELD  
Tel. 541 Grams THOROUGH HUDDERSFIELD.

## THE ACME OF EBOHITE PANELS

**DISTINCTIVE**

By no means the least important feature is the uniform ebony black, fine grain, dead matt surface so distinctive of and exclusive to

**PARAGON EBOHITE PANELS**

"The Best Made."

Radio Quality Post Office Specification.

All Radio Press Panels supplied from Stock at 3d. per sq. in. Prices for drilling and engraving upon request.

Sold everywhere in Sealed Cartons only stamped Paragon.

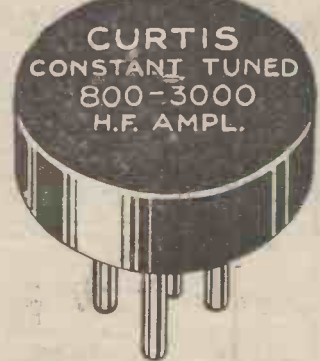

## Aperiodic Tuning — no condenser required

The Curtis "Constant-Tuned" High-Frequency Amplifier is the only automatic high-frequency amplifier which guarantees high efficiency for two stages or more of radio frequency amplification on any wavelengths between 300 and 3,000 metres.

Circuit diagrams supplied free with every amplifier.

Type A, 900 to 800 metres. Price 15/-

Type B, 800 to 3,000 metres. Price 17/6 Postage 6d.

**CURTIS VARIABLE MICA CONDENSER**

ELIMINATES THE MANY DEFECTS IN THE EXISTING TYPE OF CONDENSER. This Condenser gives a Square Law Reading. In operation there is no backlash, since its precision gives "dead beat" action. Essential for the perfect reception in all circuits; indispensable for Super Heterodynes.

.001 Mfd.: .0005 Mfd.: .00025 Mfd.

PRICE 12/6

**PETER CURTIS, LTD. 75, CAMDEN RD., N.W.1**

**—the new  
Watmel Product**

**A LOW LOSS, HIGH GRADE  
FIXED CONDENSER.**

MONTHS of exhaustive research in the Watmel Laboratories has resulted in the production of a fixed condenser that can truly be called perfect.

There is no wax whatever used in the construction of the Watmel Condenser. For this reason you will appreciate this immunity from temperature changes and consequent dielectric loss. And its ease of ebonite with its polished contacts adds as greatly to the appearance of any set as the construction does to its efficiency. It sets a new standard in fixed condenser design.

*As used in the New S.T.100.*

**WATMEL WIRELESS CO., LTD.**  
332a, GOSWELL ROAD, LONDON, E.C.1.



**PRICES:**  
Capacities for Standard Grid Condensers.  
.0005 to .0005 ... 2/6 each  
Standard Fixed Condensers.  
.002 to .001 ... 2/6 each  
.0025 to .006 ... 3/6 each  
Combined Grid Leak and Condenser 3/- each.

Agent for Lancashire and Cheshire—  
Mr. J. B. LEVEE, 23, Hartley Street,  
Levenshulme, MANCHESTER.

*Barclays Ad.*

**That ELUSIVE STATION**

which you got and missed again last night! THE PELICAN UNIVERNIER gets it for you again—and holds it! The PELICAN UNIVERNIER makes accurate tuning dead easy. You can fit it in a few minutes to your existing condenser without altering the set or drilling the panel.

**BUY ONE TO-DAY AND LOSE YOUR TUNING TROUBLES.**

**THE PELICAN UNIVERNIER 6/-**  
AT YOUR DEALER or post paid on receipt of P.O.

**PELL CAHILL & COMPANY, LTD.,**  
MANUFACTURERS OF RADIO APPARATUS,  
64, NEWMAN STREET, W.1.  
Phone: Museum 9236. Telegrams: Pelcarad, Weado, London.



SEE US AT THE SHOW,  
STAND 27.

**“Scientific”  
NON-METALLIC HORNS  
FOR EFFICIENCY AND ELEGANCE.**

A few of our latest Models—	No.	Ht.	Flare	Approx. PRICE	Post
	508	24"	14"	15/6	1/9
	517	—	14"	15/6	1/9
	537	30"	18"	25/6	2/6
	539	25"	14"	25/6	2/0

No. 517 is designed for Amplicon “Juniors” and similar bases. Model 539 is specially suitable for Gramophone Attachments.

**TRADE INQUIRIES INVITED.**

**SCIENTIFIC SUPPLY STORES**  
126, NEWINGTON CAUSEWAY, LONDON, S.E.1.  
Phone: HOP 4177.

Branches:  
80, Newington Causeway, S.E.1. 7, St. George's Circus, S.E.1. 16, Manette St., Charing Cross Rd., W.1. 291, Edgware Rd., W.2. 84, Church Rd., Upper Norwood, S.E.23.



**FINSTON COMPONENTS for PERMANENT RELIABILITY**

**FINSTON SQUARE LAW CONDENSERS**—Aluminium top and bottom plates, high-grade ebonite composition knob and dial, cleanly engraved 0-180. Vanes 98 per cent. pure aluminium. PRICES. .001 ... 9/-, .0003 ... 7/6, .00075 ... 8/6, .0001 ... 6/6, .0005 ... 8/-, .00005 ... 6/-.

**FINSTON STANDARD VARIOMETER.**—Another trustworthy Finston component. Ebonite stator, high-grade ebonite moulding rotator, engraved dial and knob. PRICE **5/6**

**FINSTON ONE-HOLE FIXED CONDENSERS**

**FEATURES** Reliability of Capacity. Finest grade Mica Dielectric Highest possible quality Copper Foil. Adapted for Terminal or soldered connections.

**CAPACITIES** .0001 to .002, price 2/- each. .003 to .006, price 2/6 each.

**FINSTON MFG. CO.,**  
45 Horseferry Rd., Westminster, S.W.1.



**The Power is there**

**Do you get it HERE**



BROADCASTING is transmitted at enormous strength! There can be only one reason why YOU are not receiving it—the first and vital part of your equipment—the AERIAL is inefficient. ABBEY STEEL AERIAL MASTS offer the only correct method of suspending the Aerial. Save in valves and batteries! Equip with an “ABBIEY” NOW, and get greater range and more volume.

From 10ft. to 70ft. high. 50/-  
30ft. with all accessories.

Catalogue W and Prices sent free.

**ABBIEY ENGINEERING WORKS**  
WATTON, NORFOLK.

**ABBIEY AERIAL Steel MAST**





From **15/-** deposit and easy payment terms.

**DUNHAM famous WIRELESS RECEIVERS** may now be purchased on the easiest of easy payment terms, and you would be well advised to send two penny stamps for twelve-page illustrated catalogue. Established since the advent of broadcasting, and members of the B.B.C. since its inauguration, Dunham receivers are world renowned for their great efficiency.

The set illustrated is the three-valve cabinet receiver with loud-speaker range of from 350 to 450 miles, and there are (thirteen other sets to choose from at all prices to suit YOUR pocket.

**C. S. DUNHAM,** Radio Engineer  
(Late of Marconi Sc. Inst. Co.),  
Enquiry B Dept.  
234-5 BRIXTON HILL, LONDON, S.W.2



**AT LAST !!**

“Listen in—while tuning in!”

**DETECTIKON**

The only Always Permanent Detector.  
A Low Impedance Parallel Detector.

**PRICE 4/6**  
from every dealer.



Patentees and Manufacturers: **The DETECTIKON Co.,** 43, GRAFTON STREET, W.1. Trade supplied through wholesale houses only.

**Radcom**

**CHEAP VARIOMETERS**

No.	1 Terminal, 3/6	No.	3. 2 Terminals, 4/-
2. 1	4/-	4. 2	4/6

Wave-length to cover B.B.C. Short Wave Stations. Ebonite formers—Grooved windings.

Write for loose leaf catalogue of Radcom Radio Components.

**Radio COMPONENTS, LTD.**  
19, Rathbone Place, Oxford Street, London, W.1  
Phone: Museum 3485. Grams: Radponent, Westcent, London.



# Burndept Coils

(1924-25 Pattern)

## REDUCED IN PRICE

**D**UE to mass production methods and the constant demand for Burndept Coils it has been possible to effect considerable reductions in their prices.

### REDUCED PRICES of BURNDEPT COILS (1924-25 Pattern).

Number of Coil.	Reduced to	Number of Coil.	Reduced to
A	3/-	150	4/6
B	3/-	200	5/6
C	3/-	300	6/-
S1	3/-	400	6/6
S2	3/-	500	7/6
S3	3/-	750	9/-
S4	3/-	1000	11/-
S5	3/-	1500	13/-
100	3/6		

Set of four Extra Short Wave Coils (80-150 metres), 12/-

Set of four Concert. Coils (150-800 metres), 12/-

Set of nine Coils, S5 to 1000 (750-20,000 metres), £2 16 6

Although these Coils are reduced in price, their well-known efficiency remains the same. A special feature of



Burndept Single Layer Coil (1924-25 Pattern).

the multi-layer type is that their construction allows plenty of air space between each layer, thus reducing the distributed capacity to a minimum. Burndept old pattern Coils cover all wavelengths from 80 to 25,000 metres. Write for particulars of the latest pattern Burndept Coils which cover all waves from 20 to 22,000 metres.



The Ethovox Standard Loud Speaker.

## Burndept Ethovox Standard Loud Speaker

### REDUCED IN PRICE

**T**HE Burndept Ethovox Loud Speaker is another Burndept product which has been reduced in price, while a new model with special mahogany flair has been introduced.

The Ethovox is renowned throughout the world for its excellent reproduction of broadcast speech and music, and will give great volume without distortion. The Ethovox stands 26 inches high and is coloured a rich mahogany shade. The diaphragm is adjustable.

Ethovox Standard Loud Speaker, either 120 or 2000 ohms resistance ... .. £4 10 0

Ethovox Loud Speaker (new model, wooden horn), either 120 or 2000 ohms resistance £5 5 0

A new device which simplifies fine tuning.

### The Super-Vernier Dial.

**T**HE Burndept Super-Vernier Dial is a special device designed to give very fine adjustment of condensers, vario-couplers, etc.

The mechanism of the Super-Vernier Dial consists of a novel friction-driven epicyclic gear which gives a reduction of about 7:1. This friction gear is absolutely noiseless and completely free from backlash.

There is nothing whatever to go wrong in the mechanism, and all moving parts are self-compensating for wear. The Super-Vernier Dial can be easily fitted to practically all existing receivers.



This simple mechanism—

—is concealed beneath the dial.

Burndept Super-Vernier Dial, Model A, for ¼-inch spindles (not for one-hole fixing condensers), complete with knob and instructions ... .. 7s. 6d.

Model B, for 3/16 and ½-inch spindles (one-hole fixing condensers, etc.), complete with distance ring, knob and instructions ... .. 8s. 6d.

Visit our Stands, 11 & 12 at the N.A.R.M.A.T. Wireless Exhibition at the Royal Albert Hall, September 12th to 23rd.

HEAD OFFICE:  
Aldine House, Bedford Street, Strand, London, W.C.2.  
Telephone: Gerrard 9072.  
Telegrams: Burndept, Westrand, London.

# BURNDEPT

## WIRELESS LIMITED

BRANCHES at Birmingham, Brighton, Bristol, Cardiff, Exeter, Glasgow, Leeds, Liverpool, Newcastle, Manchester, Northampton, and Nottingham.

# WHY THE **RI** CURVE IS RIGHT

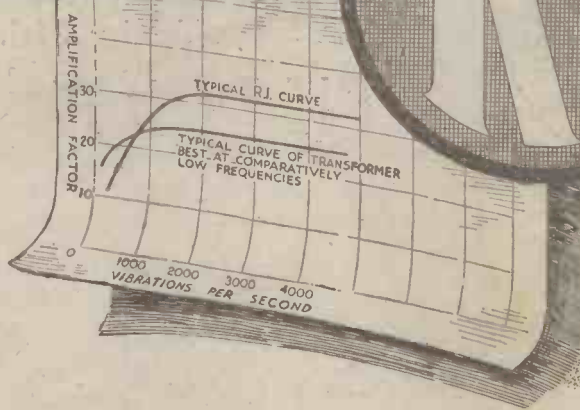

## *The Amplification that Preserves the Overtones*

The real personality of any artist lies in the overtones that are additional to the fundamental note waves. These overtones vary in frequency from one thousand to several thousand cycles per second, whereas the frequency of the fundamental notes generally varies between 250-1,200 per second.

A transformer that is designed to amplify the fundamental frequencies only, gives characterless reproduction resulting from the elimination of the smaller but nevertheless all-important overtone frequencies. The increased amplification necessary to bring out these minute vibrations is shown by the curve of the R.I. Transformer.



**25/-**

Write for R.I. Catalogue, free on application.

Visit our STAND No. 36 at the All-British Wireless Exhibition, Albert Hall, September 12th.—September 23rd

The immediate increase above the frequency of 1,000 is the reason why the R.I. curve is right.

The problem of the overtones has called for extensive and thorough research and the solution that maintains lifelike character in reproduction is the World's Transformer.

### THE R.I. TRANSFORMER



Advt. R.I. Ltd., 12, Hyde Street, New Oxford Street, London, W.C.1

P.C.I.

Printed for the Proprietors, RADIO PRESS, LTD., of Bush House, Strand, W.C.2, by THE AVENUE PRESS (L. Upcott Gill & Son, Ltd.), 55-57, Drury Lane, W.C.2, and Published by the Proprietors, RADIO PRESS, LTD., at Bush House, Strand, W.C.2, on Tuesday of each week. Address for Subscriptions and Editorial Communications:—Bush House, Strand, London, W.C. Advertisement Managers:—BARCLAYS ADVERTISING, LTD., Bush House, Strand, London, W.C.2. Registered as a newspaper and for transmission by Canadian Magazine Post. Subscription rates:—13s. per annum, 6s. 6d. for six months, post free. Sole Agents for Australasia:—GORDON & GOTCH (Australasia), LTD. For Canada:—IMPERIAL NEWS, LTD. For South Africa:—CENTRAL NEWS AGENCY, LTD.