

**WW COMPUTER: SYSTEM DESIGN**

SEPTEMBER 1967  
Three Shillings

# Wireless World

**ELECTRONICS • TELEVISION • RADIO • AUDIO**

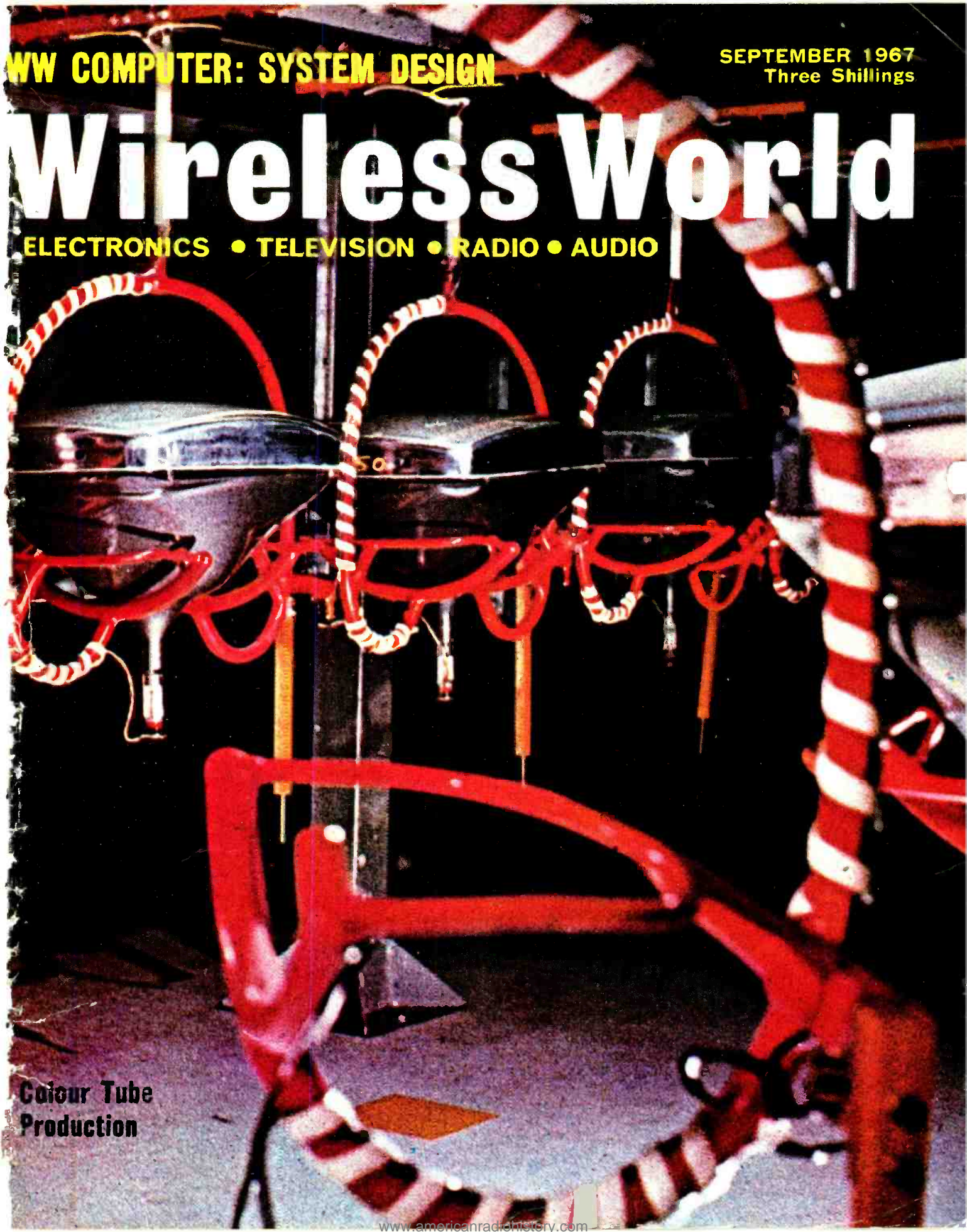

**Colour Tube  
Production**

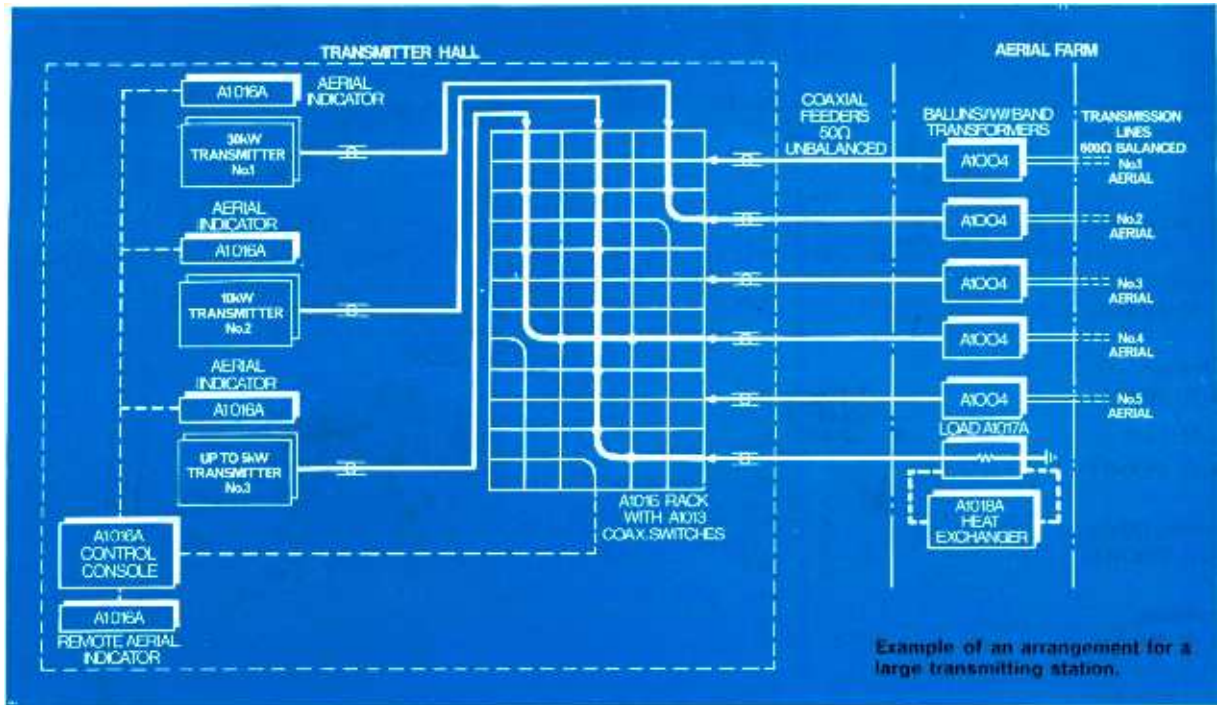

Example of an arrangement for a large transmitting station.

## Aerial ancillaries for STANFAST\* transmitter systems

STANFAST automatic tuning and supervisory techniques enable the modern transmitting station to be operated with a minimum of attendance. The aerial systems for use with these stations must, of necessity, embody components designed specifically for this form of operation. STC can supply a complete range of aerial ancillaries for this purpose.

- 5kW and 10kW wideband aerial matching transformers A.1003 and A.1012
- 20/30kW baluns A.1004
- Co-axial crossbar switch A.1013

- 2 and 4-way co-axial switches A.1014-A and A.1015-A
- Crossbar aerial exchange A.1016-A comprising switching rack, crossbar switches, control console and lamp indicators.

**STANFAST\*** The STC concept of automated radio stations.

\*Registered Trade Mark.

For further details, write, phone or telex Standard Telephones and Cables Limited, Radio Division, Oakleigh Road, New Southgate, London N.11. Telephone: ENTerprise 1234. Telex: 261912.

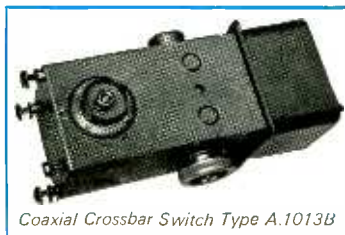

Coaxial Crossbar Switch Type A.1013B



Wideband Matching Unit (Balun) Type A.1004

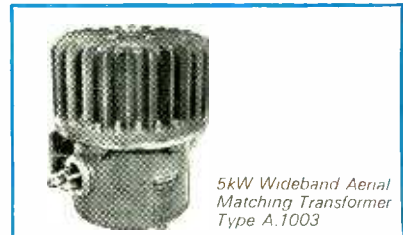

5kW Wideband Aerial Matching Transformer Type A.1003

# STC

world-wide telecommunications and electronics

WW-001 FOR FURTHER DETAILS

# Wireless World

ELECTRONICS, TELEVISION, RADIO, AUDIO

SEPTEMBER 1967

- 415 Is Measurement a Science?  
416 *Wireless World* Digital Computer—2  
424 Colour Tube Production  
433 Tape Pre-amplifier using F.E.T. *by P. F. Ridler*  
435 Getting the Best Signals into your Receiver *by T. D. Towers*  
440 Speed Control for D.C. Model Motors *by H. M. Butterworth*  
443 Standard Frequency Transmissions *by J. McA. Steele*

## SHORT ITEMS

- 423 Marconi Airborne Computer  
428 New Receiving Licences and Penalties  
432 New Approach to Thin-film Circuits  
432 Electrochemical A.C. Time Switch  
432 Germanium for I.Cs

## REGULAR FEATURES

- |                                 |  |
|---------------------------------|--|
| 415 Editorial Comment           | 451 Letters to the Editor                    |
| 428 World of Wireless           | 454 Literature Received                      |
| 430 Personalities               | 454 H.F. Predictions                         |
| 432 Technical Notebook          | 455 World of Amateur Radio                   |
| 434 Books Received              | 456 New Products                             |
| 449 News from Industry          | 462 Real and Imaginary<br><i>by "Vector"</i> |
| 450 Conferences and Exhibitions |  |

### Editor-in-chief:

W. T. COCKING, F.I.E.E.

### Editor:

H. W. BARNARD

### Technical Editor:

T. E. IVALL

### Editorial:

B. S. CRANK

F. MILLS

G. B. SHORTER, B.Sc.

### Drawing Office:

H. J. COOKE

### Production:

D. R. BRAY

### Advertisements:

G. BENTON ROWELL  
(Manager)

J. R. EYTON-JONES

Iliffe Technical Publications Ltd.,  
Managing Director: Kenneth Tett  
Dorset House, Stamford Street,  
London, S.E.1

Subscribers are requested to notify a change of address four weeks in advance and to return wrapper bearing previous address

© Iliffe Technical Publications Ltd., 1967. Permission in writing from the Editor must first be obtained before letterpress or illustrations are reproduced from this journal. Brief extracts or comments are allowed provided acknowledgement to the journal is given.

VOLUME 73 No. 9

PRICE: 3s.

FIFTY-SEVENTH YEAR  
OF PUBLICATION

PUBLISHED MONTHLY (3rd Monday of preceding month). Telephone: 01-928 3333 (70 lines). Telegrams/Telex: Wiworld Iliffepres 25137 London. Cables: "Ethaworld, London, S.E.1." Annual Subscriptions: Home; £2 6s 0d. Overseas; £2 15s 0d. Canada and U.S.A.: \$8.00. Second-Class mail privileges authorised at New York N.Y. BRANCH OFFICES: BIRMINGHAM: 401, Lynton House, Walsall Road, 22b. Telephone: Birchfields 4838. BRISTOL: 11 Marsh Street, 1. Telephone: Bristol 21491/2. COVENTRY: 8-10, Corporation Street. Telephone: Coventry 25210. GLASGOW: 123, Hope Street, C.2. Telephone: Central 1265-6. MANCHESTER: 260, Deansgate, 3. Telephone: Blackfriars 4412. NEW YORK OFFICE U.S.A.: 300 East 42nd Street, New York 10017. Telephone: 867-3900

# The Capacitor Crescendo by Mullard

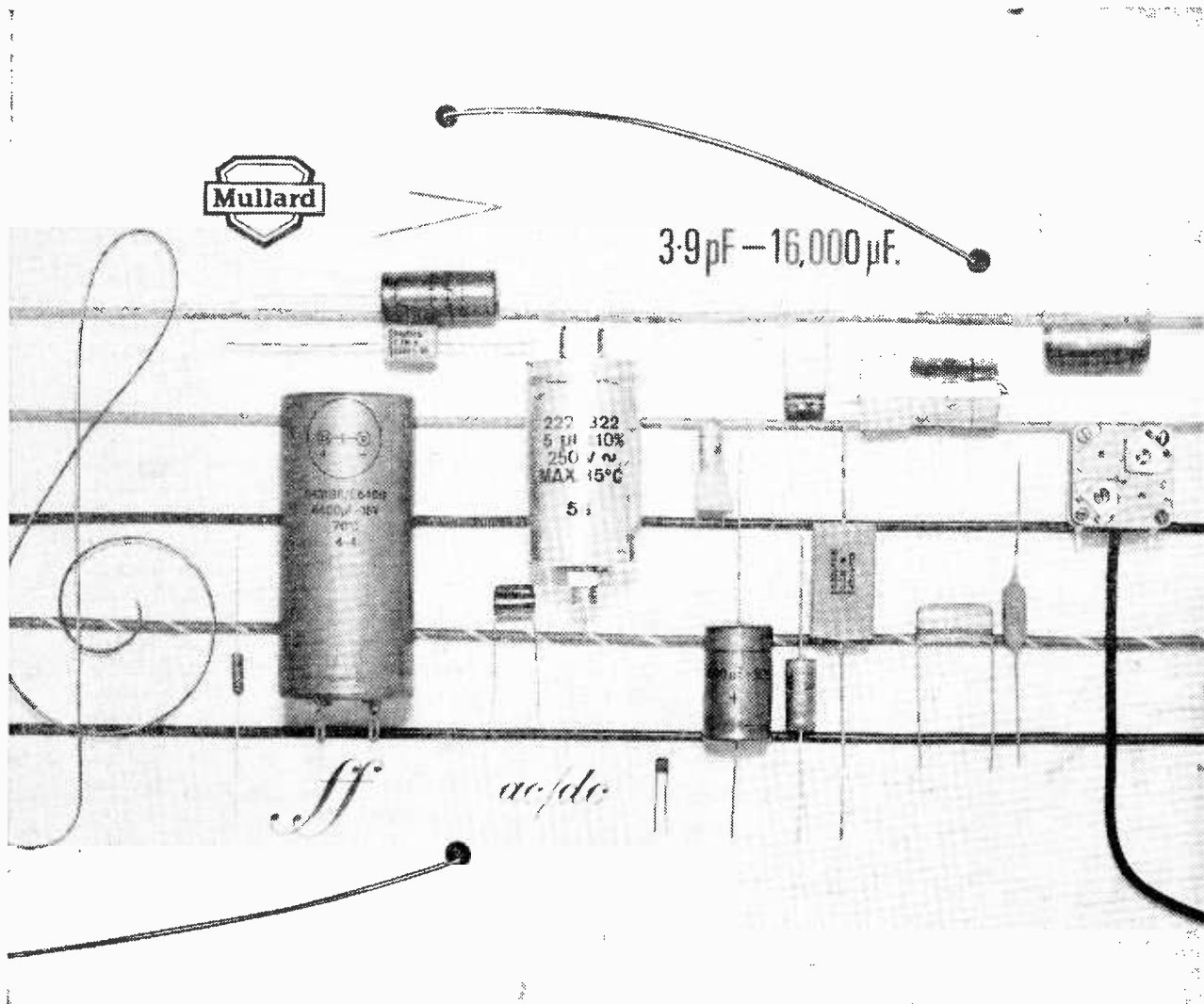

Ex-stock delivery, competitive prices—music to any radio and TV setmaker's ears. But when you add Mullard quality and Mullard reliability you can see we're adding up to something big. It's the old problem. How do you keep a competitive edge on your products without the price creeping up? Improve quality and reliability without cutting the profits?

You choose from the eleven Mullard ranges which cover 3.9pF to 16,000µF. Or tell us your requirements. You buy in bulk—just name the quantities. And you get them ex-stock.

NT1038

The usual ranges are available in:—

Foil/Film; Metallised Polyester Foil; Metallised Polycarbonate Foil; Aluminium Electrolytic; Tantalum Electrolytic; Plate Ceramic and Solid Dielectric Tuning for AM or AM/FM.

Send for information to Mullard Limited, Consumer Electronics Division, Mullard House, Torrington Place, London WC1. Or Telephone 01-580 6633.

## Mullard

END 15R

WW—096 FOR FURTHER DETAILS

# Wireless World

ELECTRONICS, TELEVISION, RADIO, AUDIO

## Is Measurement a Science?

SOME unexpectedly heated discussions at the recent Fourth International Measurement Congress in Warsaw raised the question of whether the process of measurement has in it something unique and intrinsic which entitles it to be considered as a science in its own right. In short, can measurement be isolated from what is measured?

Electronics engineers, although constantly engaged in making measurements, probably never bother to think about it because their interests are centred in a specialized field—the measurement of electrical variables. But when electronic instruments are used to measure other physical variables, such as pressure or temperature, the question does become relevant to our sphere of engineering.

According to Professor P. K. Stein (U.S.A.), who outlined at Warsaw a unified approach to measurement engineering forming the basis of a course at Arizona State University, “measurement is a respectable science in its own right” and provides a unified body of knowledge which can be exploited for engineering purposes. To judge from his lecture, and a paper he distributed at the Congress, the unified approach is largely a matter of forming generalizations and classifications from existing techniques in specialized fields and applying to them new general-purpose names. For example, he speaks of “primary quantities” (those which carry desired information) and “secondary quantities” (the necessarily co-existing physical quantities). Transducers are divided into “self-generating or active” and “non self-generating or passive” types, and in the last-mentioned case there is a “major input” (containing the information to be transmitted) and a “minor input” (providing biasing, a supply, a carrier, etc.). Also, transducers are classified by means of a “transducer space,” a three-dimensional diagram. The terms “acceptance ratio,” “transfer ratio” and “emission ratio” describe relationships between the primary and secondary quantities. Generalized dicta are of the type: “It is not necessary that the method of carrying the information be the same at the input as at the output of a transducer. Indeed, the function of certain devices is precisely to alter the method of information transfer.”

Several of the participants at Warsaw (including ourselves) were very dubious about the value of this approach. It seems to us that in attempting to be truly general, to extract the quintessence of measurement from the dross of what is measured, one is being forced to use terms that are so abstract as to have lost all useful meaning for engineering purposes. The last quotation, for example, may seem highly significant to somebody who has never met a transducer, but what does it tell him that is really useful? Also, it is very easy to fall into the trap of thinking that by writing down names one is explaining real things. “Measurement,” for example, is nothing more than an abstract noun which *can* conjure up a mental concept if one has actually experienced the making of particular measurements. There is no real link between, say, the measurement of strain in human bone and the measurement of voltage ratios in an inductive divider (both of which were the subjects of papers at Warsaw) beyond this purely verbal one.

One of the most sensible remarks made at the Congress was that “the only real way to learn about measurement is to make some measurements.” So electronics engineers, in their narrow specialization, need not feel that they are lacking in some greater wisdom which lies beyond their normal horizons.

VOL 73 NO 9  
SEPTEMBER  
1967

# WIRELESS WORLD DIGITAL COMPUTER

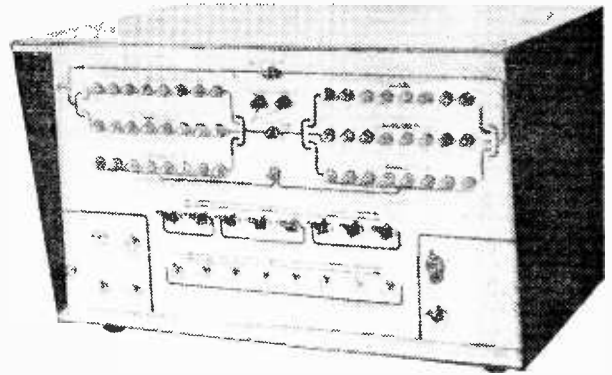

## 2—System design : the arithmetic unit and store : how information is transferred from one part of the computer to another

**T**HE heart of the “arithmetic unit” shown in our simplified schematic Fig. 1 last month is a unit called the adder/subtractor. The function of the adder/subtractor is to either add or subtract two binary numbers. The digits to be dealt with are fed into the circuit a pair at a time, starting with the  $2^0$  column, proceeding to the  $2^1$  column, and so on. At this point we can define six input lines to the adder/subtractor: control signals to tell the unit to add or subtract, and data signals representing the digits to be manipulated, which we shall call A and B that require the four input lines, A,  $\bar{A}$ , B,  $\bar{B}$ .

If, as a result of an arithmetic operation, say in the  $2^0$  column, a “carry” is generated, this carry must be stored until the  $2^1$  digits appear at the input. Some form of storage is obviously called for, the output of the store being delayed one “digit time” and fed back to the input of the adder/subtractor. This store is called the “carry store” and its outputs are C and  $\bar{C}$ . The output of the adder/subtractor, the result of the arithmetic operation, will be called the SUM output and this, for reasons to be seen later, will be negated to form, in addition to the SUM output, a NOT sum output ( $\bar{SUM}$ ).

The carry store is called upon to store only one digit at a time, so this function may be performed by a bistable. As a bistable assumes an indeterminate state at switch-on, a means must be available to reset it; therefore a carry-store reset line is another required input to the adder/subtractor. In the section on binary arithmetic last month it was stated that in order to form the 1s complement of a number it was added to a series of 1s and any carry

generated was ignored. This calls for another input, an “inhibit carry” line. Yet another input needed is a “shift pulse”, and the reason for this will be explained later. The black box representing the adder/subtractor is shown in Fig. 13.

To add and subtract, the adder/subtractor must produce outputs which obey the rules given in the tables on page 368 last month. First we will consider the addition table, in which the two binary digits to be added are in columns A and B, while column C is the carry from the last operation. Taking the second line down,  $1 + 0 + 0 = 1 \rightarrow 0$ , this could be rewritten as  $A\bar{B}\bar{C} = SUM \rightarrow \text{carry } 0$ , and the line  $1 + 1 + 0 = 0 \rightarrow 1$  could be rewritten  $AB\bar{C} = \bar{SUM}$  and set 1 in carry store to be used in next most significant position. All it has been necessary to do is to write A when a 1 appears in column A and to write  $\bar{A}$  when an 0 appears in column A.

Using this method and writing the Boolean equation for a sum output we get:

(1)  $A\bar{B}\bar{C} + \bar{A}B\bar{C} + \bar{A}\bar{B}C + ABC = SUM$  (remember + means OR) and the equation for a carry to be generated is

(2)  $AB\bar{C} + \bar{A}BC + \bar{A}BC + ABC = \text{carry}$ .

Referring to the subtraction on p.368 last month the equations are:

(3)  $A\bar{B}\bar{C} + \bar{A}B\bar{C} + \bar{A}\bar{B}C = ABC + SUM$

and

(4)  $\bar{A}B\bar{C} + \bar{A}BC + \bar{A}BC + ABC = \text{CARRY}$ .

Comparing these equations, we find that the equations for a SUM output for adding and subtracting (1) and (3) are identical, and, furthermore, that the carry equations (2) and (4) contain two common terms,  $\bar{A}BC$  and  $ABC$ . Bearing this in mind, we can rewrite equations (1) to (4) and also take into account our add and subtract control signals:

add ( $A\bar{B}\bar{C} + \bar{A}B\bar{C} + \bar{A}\bar{B}C + ABC$ )  
 + subtract ( $\bar{A}B\bar{C} + \bar{A}BC + \bar{A}BC + ABC$ ) = SUM.  
 add ( $A\bar{B}\bar{C} + \bar{A}B\bar{C}$ ) + subtract ( $\bar{A}B\bar{C} + \bar{A}BC$ ) +  $\bar{A}BC$   
 +  $ABC = \text{carry}$ .

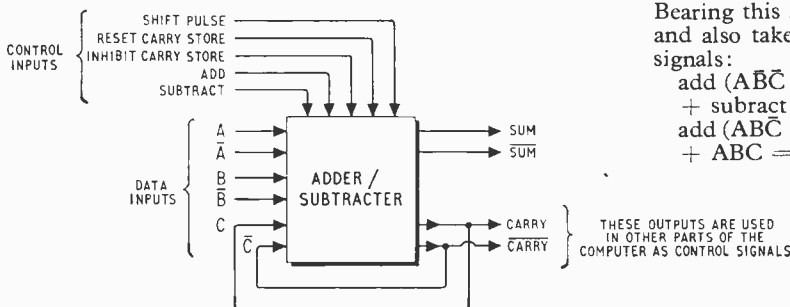

Fig. 13. Black box representation of adder/subtractor, showing inputs and outputs.

The words "add" and "subtract" in these equations are the control signals. It will be noticed that the term ABC is common to both the above equations. From this we can design the adder/subtractor circuit to conform to the equations.

Fig. 14 shows the logical diagram of the adder/subtractor. It can be seen that it is roughly divided into two sections, one for the sum and one for the carry. AND gates 4, 7, 8, 9 provide outputs corresponding to the SUM equation. These are OR gated by OR gate 2 and applied to NOT gate 3. The output of NOT gate 3 is the SUM output. This is applied to NOT 4 to provide the SUM output. When input conditions are such that the SUM and gates 4, 7, 8, 9 outputs are "down," the output of OR 2 can be considered to be an open circuit, the output of NOT 3 will be "up", providing a SUM output, and the output of NOT 4 will be "down". When the inputs change and a SUM output is required, an AND gate opens and the conditions at the outputs of NOTS 3 and 4 reverse.

Up to bistable 1 the operation of the carry section of the circuit is identical. It will be noticed that AND 4 is common to both the sum and carry circuits (the common term ABC in the sum and carry equations). The terms of the add and subtract equations are AND gated with the "add" and "subtract" control signals. We can now state that each pair of digits (A and B) are presented to the adder/subtractor under the controlling influence of the shift pulse mentioned above. The output of the generator that provides this pulse can normally be considered to be "down". At a given time the output of this generator goes "up" (negative-going), and stays "up" for the length of the pulse, and then goes "down," forming the trailing edge of the shift pulse (positive-going). On this positive-going trailing edge the next pair of digits appear at the adder/subtractor input and the SUM output of the adder/subtractor is stored.

Bearing this in mind, we will proceed with the description of the carry circuits. We will assume that input conditions are such as to open one of the carry AND gates. The output of NOT 2 will be "up" and NOT 1 "down". As a result bistable 1 will be set and its output will be "up" (NOT output "down"). Bistable 2 is of the shift-register variety. Reference to Fig. 11 (d) last month will show that the outputs of bistable 1 will provide bias for the input steering diodes D1 and D2. Now the trailing edge of the shift pulse is applied to the S.P. (shift pulse) input of bistable 2. During this trailing edge period three things happen: firstly, this positive change is applied to the switched-on transistor of bistable 2 by the steering diodes to turn it off (setting bistable 2); secondly, a new set of digits appear at the adder/subtractor input; thirdly, the output of the SUM circuit is stored. Bistable 2 (the carry store) is now set so C appears at the adder/subtractor input. If this new set input condition is such as not to require the generation of a carry, all the carry AND gates will be closed, bistable 1 will reset as the output of NOT 1 will be "up", so on the trailing edge of the next shift

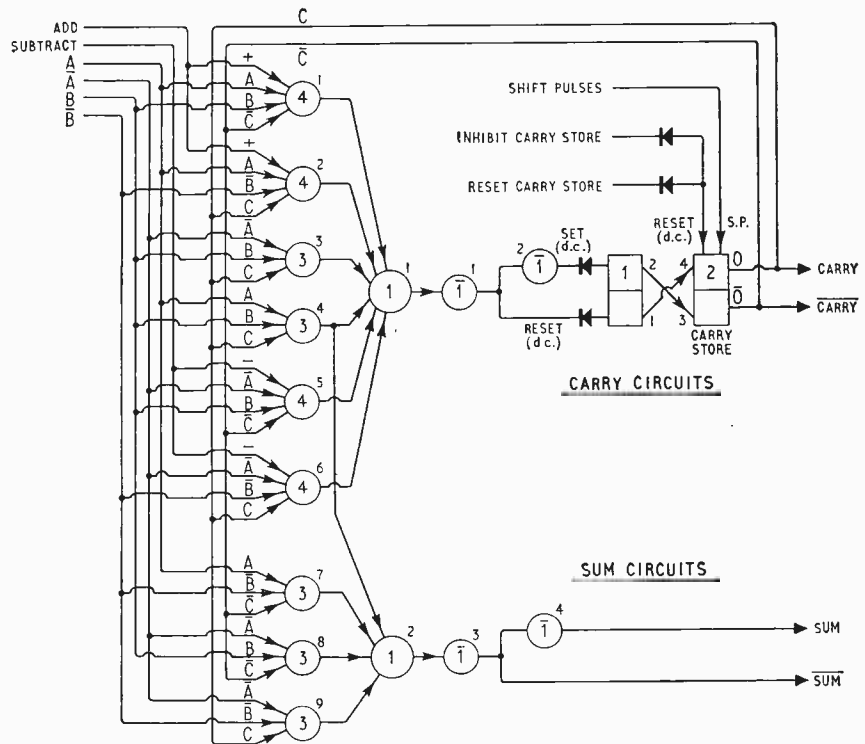

Fig. 14. Logical diagram of adder/subtractor.

pulse bistable 2 will reset, and the CARRY output goes down. This sequence of operations is illustrated in Fig. 15. The reset carry store provides a means of putting the carry store in the reset condition before operations commence. The inhibit carry store input is held up to ensure the carry store can never set during the formation of the 1s complement of a number.

The numbers to be operated on by the adder/subtractor must, as has previously been shown, be applied to the input a pair at a time starting with the least significant position (2<sup>0</sup>), and the SUM output must be stored. These functions are carried out by shift registers.

A shift register is capable of storing a binary word, and so the shift registers used in this computer must be capable of holding eight bits. Imagine an oblong block divided into eight separate compartments, each of which will hold one binary digit. This is shown pictorially in Fig. 16. In (a) the shift register compartments all contain 0, and "queued up" at left hand side is a word that is to be placed in the register. The 1 in the 2<sup>0</sup> position of this word is already presented to the input of the register.

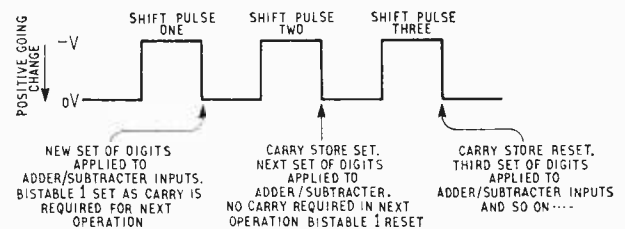

Fig. 15. Showing how, if a carry is generated, it is delayed by one shift-pulse time.

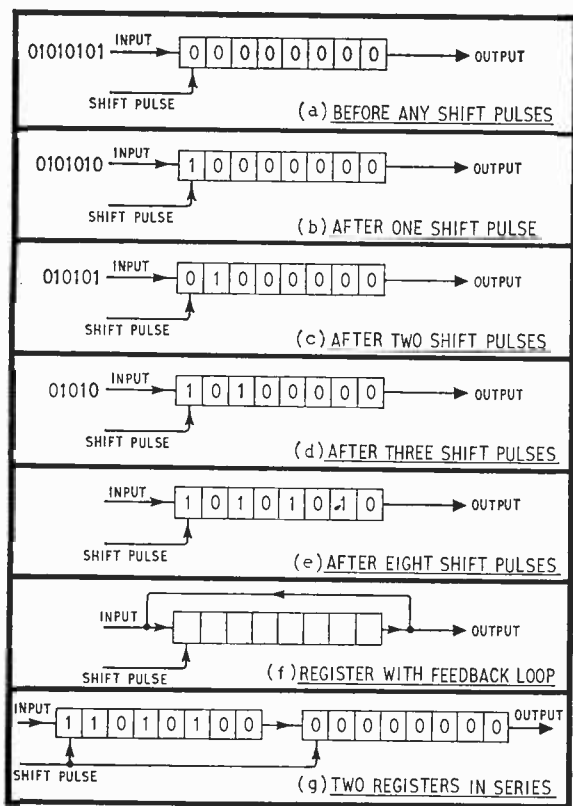

Fig. 16. Principle of shift register operation.

If now a pulse is applied to the S.P. input, the 1 in the  $2^0$  position will enter the extreme left-hand compartment, as shown in (b). Another shift pulse will move in the word one further position, (c) and so on. After eight pulses have been applied the register holds the complete word, (e).

If further pulses were applied each digit would appear at the output in turn, starting with the  $2^0$  position. This is precisely what we require to feed the adder/subtractor. After eight pulses the register would be "empty". If a register containing a word is connected as shown in Fig. 16 (f) and eight pulses are applied, each digit appears as before, but now the output is connected back to the input, so the word re-enters the register, returning to its original position. Proceeding further, if two registers were connected as in (g) and eight shift pulses were applied to both registers simultaneously, the word held in the left-hand register would end up in the right-hand register.

Having now dealt with the register as a black box, we can consider the logical diagram of the device, Fig. 17. As can be seen, the shift register consists of eight bistables of the type depicted in Fig. 11 (d) last month, each bistable forming one of the compartments shown in Fig. 16. When a bistable is set, its output is "up" and it can be considered to contain a binary 1. When it is reset, its NOT output is "up", corresponding to a binary 0 being stored. The state of each bistable determines which of the steering diodes in the bistable next in line is biased on or biased off. In this way shift pulses are steered to the appropriate transistor in each bistable so that on the trailing edge of a shift pulse each bistable will assume the state of the bistable immediately on its left.

Five shift registers are used in the basic computer. Two of these require a common reset line that is d.c. coupled to each bistable (Fig. 11). When this line goes negative the register is "cleared", that is, all bistables are reset and the register contains eight 0s. A "set d.c." facility has to be provided for each bistable in the other three registers. This allows individual bistables to be set to enter a word into the register in parallel (all digits simultaneously). To avoid confusion all the inputs and outputs that each black box requires will not be shown in future explanatory diagrams—only those relevant to the points under discussion will be shown.

Fig. 18 depicts the adder/subtractor connected to two shift registers. One of these registers has been called the accumulator, because it not only holds the word that will provide the A and  $\bar{A}$  inputs to the adder/subtractor but also accumulates the result of each operation performed by the adder/subtractor. The second register is simply called a register. This holds the B and  $\bar{B}$  inputs to be fed to the adder/subtractor. It has a regenerative loop, as shown, and this means that each digit the register holds is sequentially fed to the adder/subtractor and is also fed back to the input of the register. Any word held by the register will therefore circulate. The C and  $\bar{C}$  inputs to the adder/subtractor are internal to this unit and are provided by the output of the carry store as previously described. Though it is not quite so obvious, the accumulator also has a regenerative loop. This is completed by the connection of the SUM output of the adder/subtractor to the input of the accumulator.

We now have a working unit, and it would be helpful to use this to analyse in detail the addition of two binary words. During this analysis the reader is asked to refer

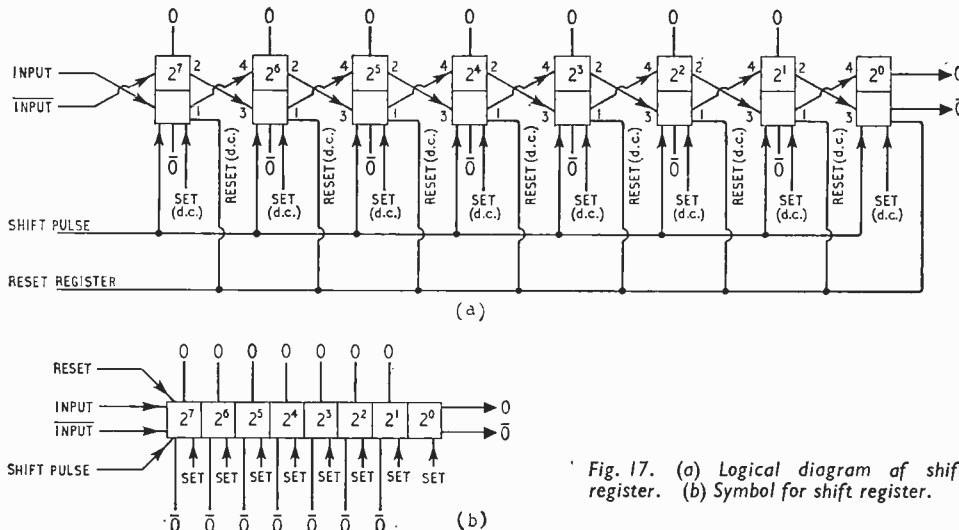

Fig. 17. (a) Logical diagram of shift register. (b) Symbol for shift register.



We have not yet discussed division. Although this does not introduce any real difficulty, the explanation is best left until later on. At present our computer consists of two divorced units with no method of inter-connection. These are the skeleton arithmetic unit shown in Fig. 18 and the counter/comparator/store 1 assembly in Fig. 21. It is necessary now to integrate these two units, and to do this some extra gating and a further two storage registers will be introduced. These storage registers are used to hold words for future use by the arithmetic unit of the computer or to store the results of calculations. Fig. 22 shows the new logical diagram of the computer. It is a more complete representation of how the machine is organized, and the reader is advised to become well acquainted with this diagram. A number of the inputs and outputs to various parts of the computer do not appear to be connected to anything at all. All these connections either go to or come from the order decoder

Two other units are necessary for the multiplication process. These are a store (labelled Store 1) and a comparator. Store 1 is a standard shift register; it does not require a common reset line but individual d.c. set inputs have to be provided for each bistable. The comparator must be able to determine when the word held in store 1 is the same as that held in the counter. It has two outputs which are called EQUAL and EQUAL. To achieve this it is necessary to compare the output and the NOT output of each bistable in store 1 with the output and the NOT output of the corresponding bistable in the counter. Eight comparator gates (Fig. 9 last month), three AND gates and one NOT gate are required. The logical circuit is shown in Fig. 20. For the EQUAL output to be able to go "up", AND 12 must go "up". For AND 12 to go "up", both AND 10 and AND 11 must be "up". For AND gates 10 and 11 to be "up", all the comparator gates must be "up". Finally, for all the comparator gates to be "up", the bistables in the counter and store 1

must be in identical conditions. For any other condition the EQUAL output will be "up". Fig. 21 shows how the interconnection of the counter, comparator and store 1 are drawn symbolically, the "16" interposed in the single wires to the comparator showing that there are in fact 16 wires.

The counter used in this multiplication process consists of a chain of bistables, as shown in Fig. 19, one word-length long. They are of the counter type depicted in Fig. 11(c). The output of each bistable is connected to the "complement" terminal of the next. Each stage will divide by two and the counter will count according to the rules of natural binary as shown on p.367 last month. Bear in mind that each input pulse to this type of bistable will reverse its condition and that this will only happen on a positive-going edge, i.e. the preceding bistable's output going from "up" to "down". It will also be noticed that a common reset line is provided to ensure that the counter starts at 0. It is left as an exercise for the reader to work out the condition of the various bistables in the counter for each successive input pulse. This should conform to the table given last month. As eight places are involved the final count will be 255<sup>(10)</sup> or 11111111<sup>(2)</sup>. After this the next pulse will return the counter to all 0s and the counter will start again.

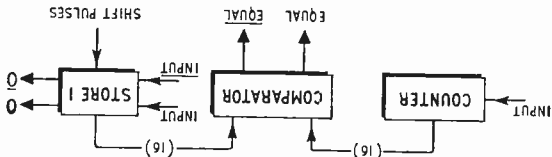

Fig. 21. Showing method of comparing the contents of the counter and the store.

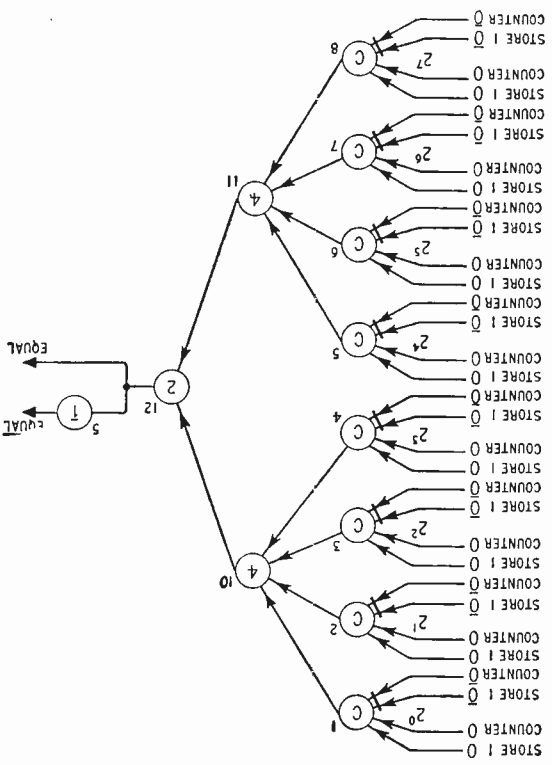

Fig. 20. Comparator logical diagram.

multiplied 7 by 4. However, this is a rather cumbersome method of multiplying, especially if the multiplier is, say, 50, requiring that the button be pressed 50 times. So, in order to multiply, what is required is some method of performing addition the number of times specified by the multiplier. This is achieved by storing the multiplier in a shift register, which will be called store 1. The multiplicand, which is held in the register, is continuously added to the contents of the accumulator, each addition being counted on a counter. The contents of the counter are continuously compared with the contents of store 1 (the multiplier) and when these two numbers are equal the additions are stopped. The multiplicand will have then been added to the accumulator the number of times specified by the multiplier.

The counter used in this multiplication process consists of a chain of bistables, as shown in Fig. 19, one word-length long. They are of the counter type depicted in Fig. 11(c). The output of each bistable is connected to the "complement" terminal of the next. Each stage will divide by two and the counter will count according to the rules of natural binary as shown on p.367 last month. Bear in mind that each input pulse to this type of bistable will reverse its condition and that this will only happen on a positive-going edge, i.e. the preceding bistable's output going from "up" to "down". It will also be noticed that a common reset line is provided to ensure that the counter starts at 0. It is left as an exercise for the reader to work out the condition of the various bistables in the counter for each successive input pulse. This should conform to the table given last month. As eight places are involved the final count will be 255<sup>(10)</sup> or 11111111<sup>(2)</sup>. After this the next pulse will return the counter to all 0s and the counter will start again.

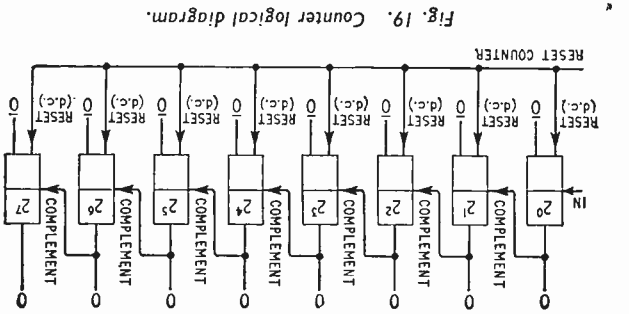

Fig. 19. Counter logical diagram.

**On trailing edge of fifth shift pulse.**—SUM output now holds ( $2^7=1, 2^8=0, 2^5=1, 2^4=0, 2^3=1, 2^2=0$ ), written in the  $2^7$  position of the accumulator, which

**Before fifth shift pulse  $2^4$ .**—Inputs to adder/subtractor are now ABC, AND 9 opens, SUM output goes "up," Bistable 1 resets as no carry AND gates are open.

**On trailing edge of fourth shift pulse.**—An 0 is written in  $2^7$  in the accumulator because of the SUM output. The accumulator now holds ( $2^7=0, 2^6=1, 2^5=0, 2^4=1$ ). Carry store remains set.

**Before fourth shift pulse  $2^3$ .**—Inputs to adder/subtractor are now ABC, SUM output "down," bistable 1 set as AND 2 is open.

**On trailing edge of third shift pulse.**—Accumulator and register shift one place to right. SUM output sets  $2^7$  in accumulator (accumulator contents are now  $2^7=1, 2^6=0, 2^5=1$ ). Carry store remains set as bistable 1 was set.

**Before third shift pulse  $2^2$ .**—Inputs to the adder/subtractor are now ABC (as carry store is now set) AND gate 4 opens, dictating a SUM and carry output. As a result, bistable 1 is held set.

**On trailing edge of second shift pulse.**—Contents of accumulator and register shift one place to the right. The SUM output of the  $2^2$  operation moves to the  $2^6$  position of the accumulator and the SUM output of the  $2^1$  operation writes an 0 in the  $2^7$  position. The 1 in the  $2^1$  position is written in the  $2^7$  position of the register. Because bistable 1 was set the carry store also sets.

**Before second shift pulse  $2^1$ .**—Inputs to the adder/subtractor are now ABC. All sum AND gates are closed, so the SUM output is "down." Carry AND gate 1 opens to set bistable 1 (bistable 2 will not set at this stage).

**On trailing edge of first shift pulse.**—The SUM output sets the  $2^7$  bistable in the accumulator (which is vacant as the contents of the register and accumulator have simultaneously moved one place to the right). Also by virtue of the register regenerative loop the 0 that was in the  $2^2$  position of the register is now written in the  $2^7$  position.

**Before first shift pulse  $2^0$ .**—The inputs of the adder/subtractor are ABC, and gate 7 is open. The SUM output is "up" as is the input to the accumulator.

**On trailing edge of first shift pulse.**—The SUM output sets the  $2^7$  bistable in the accumulator (which is vacant as the contents of the register and accumulator have simultaneously moved one place to the right). Also by virtue of the register regenerative loop the 0 that was in the  $2^2$  position of the register is now written in the  $2^7$  position.

**Before first shift pulse  $2^0$ .**—The inputs of the adder/subtractor are ABC, and gate 7 is open. The SUM output is "up" as is the input to the accumulator.

**On trailing edge of first shift pulse.**—The SUM output sets the  $2^7$  bistable in the accumulator (which is vacant as the contents of the register and accumulator have simultaneously moved one place to the right). Also by virtue of the register regenerative loop the 0 that was in the  $2^2$  position of the register is now written in the  $2^7$  position.

**Before first shift pulse  $2^0$ .**—The inputs of the adder/subtractor are ABC, and gate 7 is open. The SUM output is "up" as is the input to the accumulator.

**On trailing edge of first shift pulse.**—The SUM output sets the  $2^7$  bistable in the accumulator (which is vacant as the contents of the register and accumulator have simultaneously moved one place to the right). Also by virtue of the register regenerative loop the 0 that was in the  $2^2$  position of the register is now written in the  $2^7$  position.

**Before first shift pulse  $2^0$ .**—The inputs of the adder/subtractor are ABC, and gate 7 is open. The SUM output is "up" as is the input to the accumulator.

**On trailing edge of first shift pulse.**—The SUM output sets the  $2^7$  bistable in the accumulator (which is vacant as the contents of the register and accumulator have simultaneously moved one place to the right). Also by virtue of the register regenerative loop the 0 that was in the  $2^2$  position of the register is now written in the  $2^7$  position.

**Before first shift pulse  $2^0$ .**—The inputs of the adder/subtractor are ABC, and gate 7 is open. The SUM output is "up" as is the input to the accumulator.

If we had a button that when pressed provided eight shift pulses to the register, accumulator and adder/subtractor, then, with the circuit of Fig. 18 we could add, subtract and complement with the press of a button. If we put the binary equivalent of decimal 7 in the register, selected "add," and pressed the button four times, the result in the accumulator would be  $7+7+7+7$

i.e.  $1+0=1$  and  $1+1=0$  ignore carry. Applied, as was shown in the binary arithmetic section, the word in the accumulator will be complemented. If under these conditions eight shift pulses are applied, the word in the accumulator will be complemented. This has the same effect as setting all the bistables in the input of the adder/subtractor for the entire operation.

The  $2^0$  bistable cannot reset and therefore B is "up" at the input of the complete operation. This means that stay "up" for the complete operation. This means that "down," input of the  $2^0$  bistable in the register is made to provide the series of 1s, all that is done is that the "set" necessity of setting all the bistables in the register to avoid the adder/subtractor can never go "up". To avoid the

that the carry store cannot set so the C input to the adder/subtractor can never go "up". To avoid the "down," and inhibit carry store is "up" (this means applied, as follows. "Add" is "up," "subtract" is "down," and inhibit carry store is "up" (this means

generated. The word to be complemented is placed in a series of 1s and preventing any carries from being complemented of a number was performed by adding it to the formation of the 1s

It will be remembered that the formation of the 1s only and not B-A. contents of the accumulator and not vice versa, i.e. A-B

possible to subtract the contents of the register from the contents of the accumulator and not vice versa, i.e. A-B only limitation of the circuit now emerges. It is only 0 0 0 1 1 1 at the end of the operation.

accumulator should contain its original number the word that we have just added, and therefore the further shift pulses were applied. This is subtracting

happen if the "subtract" input of the adder/subtractor were "up" and the "add" input "down" and eight

The reader is now invited to analyse what would because of the regenerative loop, will hold 0 0 0 0 1 1 0. which is the result of the addition, and the register, of the operation the accumulator will hold 0 0 1 0 1 0 1, accumulator and register a place to the right, at the end

additional shift pulse will move the contents of the and no sum or carries will be propagated. However, each subtracter will be ABC, so all AND gates will be closed. For all the further shift pulses the input to the adder/subtracter are required in all to complete the operation. Eight shift

store now also resets. Because bistable 1 was reset the carry

Fig. 18. "Skeleton" of the arithmetic unit.

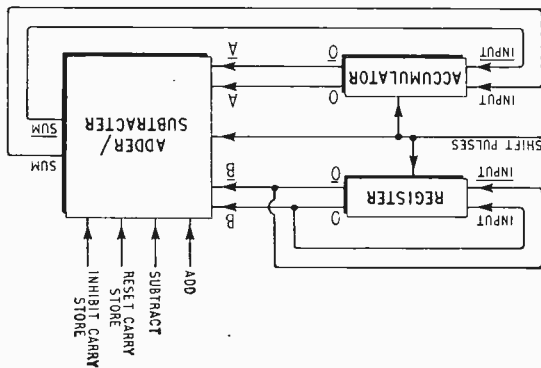

to Fig. 14 (adder/subtractor logical diagram) and Fig. 18 arithmetic section last month to demonstrate binary addition. These, when extended to eight bits, are:—

First we will reset all bistables in the unit and then place 0 0 0 1 1 1 in the accumulator and 0 0 0 1 1 0 in the register.

Assume that the S.P. inputs of the adder/subtractor, accumulator and register are connected together to ensure that all will receive simultaneous shift pulses, and that the "add" input of the adder/subtractor is "up" and the "subtract" input down.

**Before first shift pulse  $2^7$ .**—The inputs of the adder/subtractor are ABC, and gate 7 is open. The SUM output is "up" as is the input to the accumulator.

**On trailing edge of first shift pulse.**—The SUM output sets the  $2^7$  bistable in the accumulator (which is vacant as the contents of the register and accumulator have simultaneously moved one place to the right). Also by virtue of the register regenerative loop the 0 that was in the  $2^2$  position of the register is now written in the  $2^7$  position.

**Before second shift pulse  $2^6$ .**—Inputs to the adder/subtractor are now ABC. All sum AND gates are closed, so the SUM output is "down." Carry AND gate 1 opens to set bistable 1 (bistable 2 will not set at this stage).

**On trailing edge of second shift pulse.**—Contents of accumulator and register shift one place to the right. The SUM output of the  $2^2$  operation moves to the  $2^6$  position of the accumulator and the SUM output of the  $2^1$  operation writes an 0 in the  $2^7$  position. The 1 in the  $2^1$  position is written in the  $2^7$  position of the register. Because bistable 1 was set the carry store also sets.

**Before third shift pulse  $2^5$ .**—Inputs to the adder/subtractor are now ABC (as carry store is now set) AND gate 4 opens, dictating a SUM and carry output. As a result, bistable 1 is held set.

**On trailing edge of third shift pulse.**—Accumulator and register shift one place to right. SUM output sets  $2^7$  in accumulator (accumulator contents are now  $2^7=1, 2^6=0, 2^5=1$ ). Carry store remains set as bistable 1 was set.

**Before fourth shift pulse  $2^4$ .**—Inputs to adder/subtractor are now ABC, SUM output "down," bistable 1 set as AND 2 is open.

**On trailing edge of fourth shift pulse.**—An 0 is written in  $2^7$  in the accumulator because of the SUM output. The accumulator now holds ( $2^7=0, 2^6=1, 2^5=0, 2^4=1$ ). Carry store remains set.

**Before fifth shift pulse  $2^3$ .**—Inputs to adder/subtractor are now ABC, AND 9 opens, SUM output goes "up," Bistable 1 resets as no carry AND gates are open.

**On trailing edge of fifth shift pulse.**—SUM output now holds ( $2^7=1, 2^8=0, 2^5=1, 2^4=0, 2^3=1, 2^2=0$ ), written in the  $2^7$  position of the accumulator, which

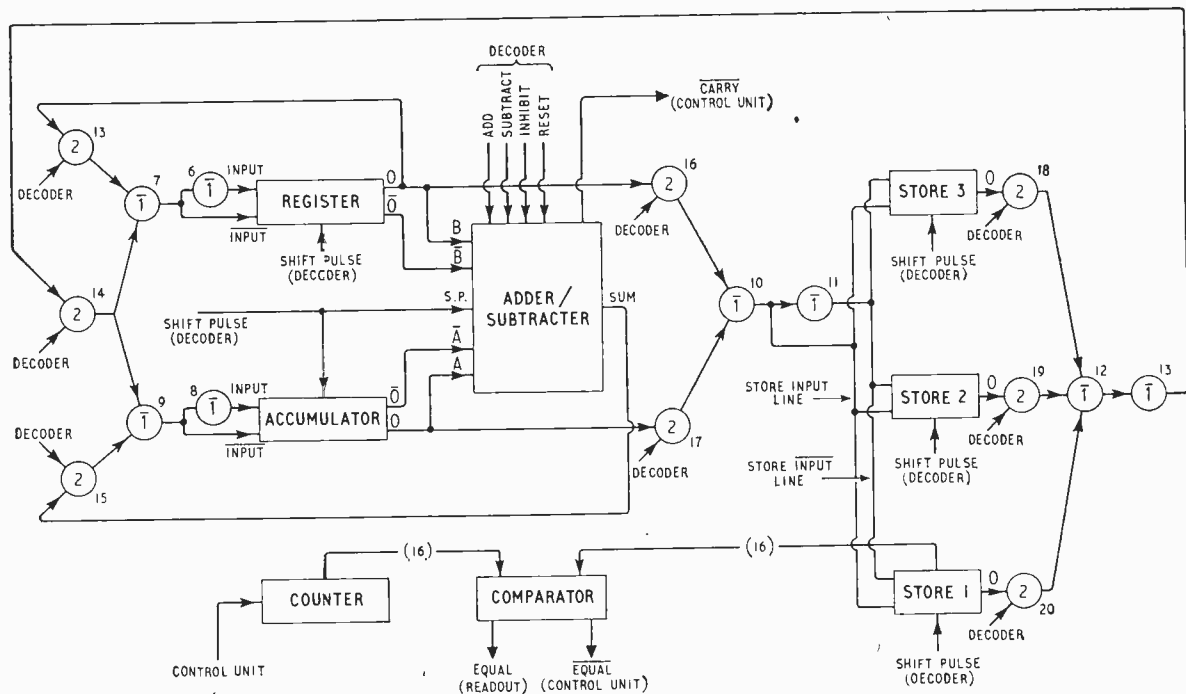

Fig. 22. A more complete logical diagram of the computer showing interconnections of the arithmetic unit and the store.

or the control unit and are marked either DECODER or CONTROL UNIT to indicate this.

It is necessary to be able to move words (data) about the computer from the stores to the register or accumulator and vice versa. Most of the extra gating shown in Fig. 22 is included for this purpose.

When it is desired to perform an arithmetic operation the outputs from the order decoder close all the AND gates of Fig. 22 with the exception of AND 13 and AND 15; these complete the feedback loop of the register and con-

nect the SUM output of the adder/subtractor to the input of the accumulator. This loop is similar to that depicted in Fig. 18 with one important difference; the NOT output of the register and the SUM output of the adder/subtractor are not fed back as was done before. Instead, the NOT outputs are reformed by negating the outputs at the inputs of the register and accumulator by the NOR gates 6 and 7, and 8 and 9, respectively. This results in an economy of components as control gating has only to be applied to the outputs and not to the NOT outputs.

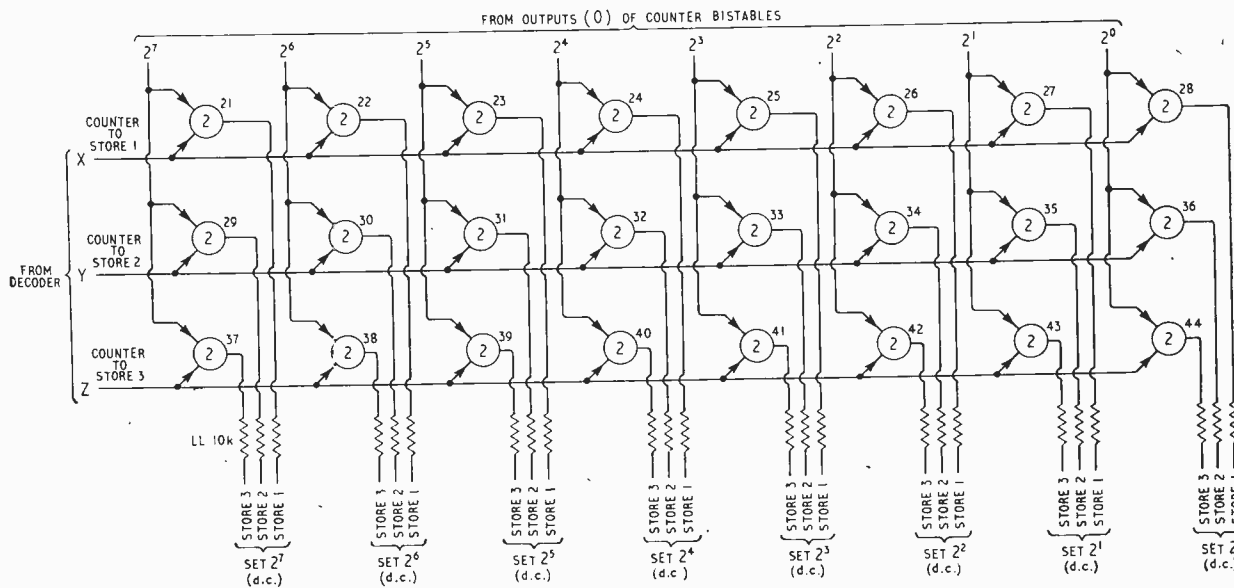

Fig. 23. The counter transfer gating unit logical diagram; note the 10k resistors in series with the outputs.

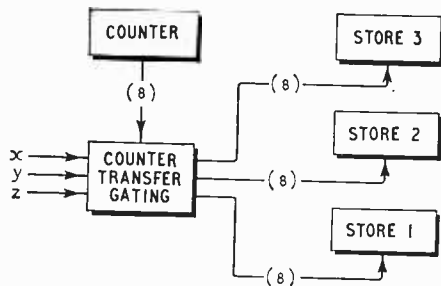

Fig. 24. Showing how data held in the counter is transferred to the store. (The numbers on the interconnections indicate number of wires.)

If it is desired to add or subtract, the appropriate instruction is given to the adder/subtractor by the decoder, which also applies 8 shift pulses to the register and accumulator. When it is wished to multiply, the multiplier is put in store 1, by a method to be described, and the multiplicand is put in the register. The order decoder tells the adder/subtractor to add and tells the control unit that multiplication is to take place. At the start of each addition the control unit provides an input pulse to the counter which advances by 1. At the end of the addition, which has resulted in a pulse to the counter that makes the contents of the counter equal to the contents of store 1, the EQUAL output of the comparator is "down." This informs the control unit that multiplication is complete and no further additions take place.

Division is performed by continuous subtraction, as was shown in the binary arithmetic section. If, for instance we wish to divide 16 by 4, we could subtract 4 four times to get our answer. So 16 could be put in the accumulator and 4 in the register (A-B) and the counter could be fed from the control unit in such a way as to count each subtraction. The control unit could be told to stop the subtractions when the accumulator was reduced to 0. This

would work well if the divisor were a factor, as in our example  $(16 \div 4)$ . What would happen if the divisor were not a factor, say  $17 \div 4$ ? The contents of the accumulator after each subtraction would be as follows: 17, 13, 9, 5, 1, -3, -7 . . . , etc. In other words, the accumulator contents would not be reduced to zero at the end of a subtraction and the computer would not stop. In view of this the computer is told to subtract until the accumulator contents go negative. This may be conveniently detected by the carry store being set at the end of a subtraction. From our example it can be seen that this occurs when the accumulator holds -3, but to achieve this we have performed five subtractions and the counter will hold five as an answer, which is obviously incorrect. So this procedure is again modified. When the control unit is instructed by the decoder that division is to take place it provides one output pulse to the counter for every subtraction except the last one, so the counter will hold the number of subtractions -1 at the end of the operation. In our example  $17 \div 4$ , the counter will hold 4, which is correct. The accumulator holds -3 and the register holds the divisor which was 4. If we now add, the accumulator will hold  $-3 + 4 = 1$  which is the remainder. After division and the subsequent addition the counter holds the quotient and the accumulator holds the remainder.

Now suppose we want to keep this remainder for a further operation and before we need it we have to perform another arithmetic operation which will require the use of the accumulator. We will therefore have to transfer the 1 in the accumulator to a store, say store 3. So the order decoder will be instructed to transfer the contents of the accumulator to store 3. Gate 15 will close. Closing the accumulator feedback loop, gate 17 will open, providing the accumulator output access to the store. It will be noticed that only the output is used, the NOT output being reformed by NOR gates 10 and 11. The inputs to the storage registers are connected in parallel, the actual selection of the particular store to be used being carried out by apply-

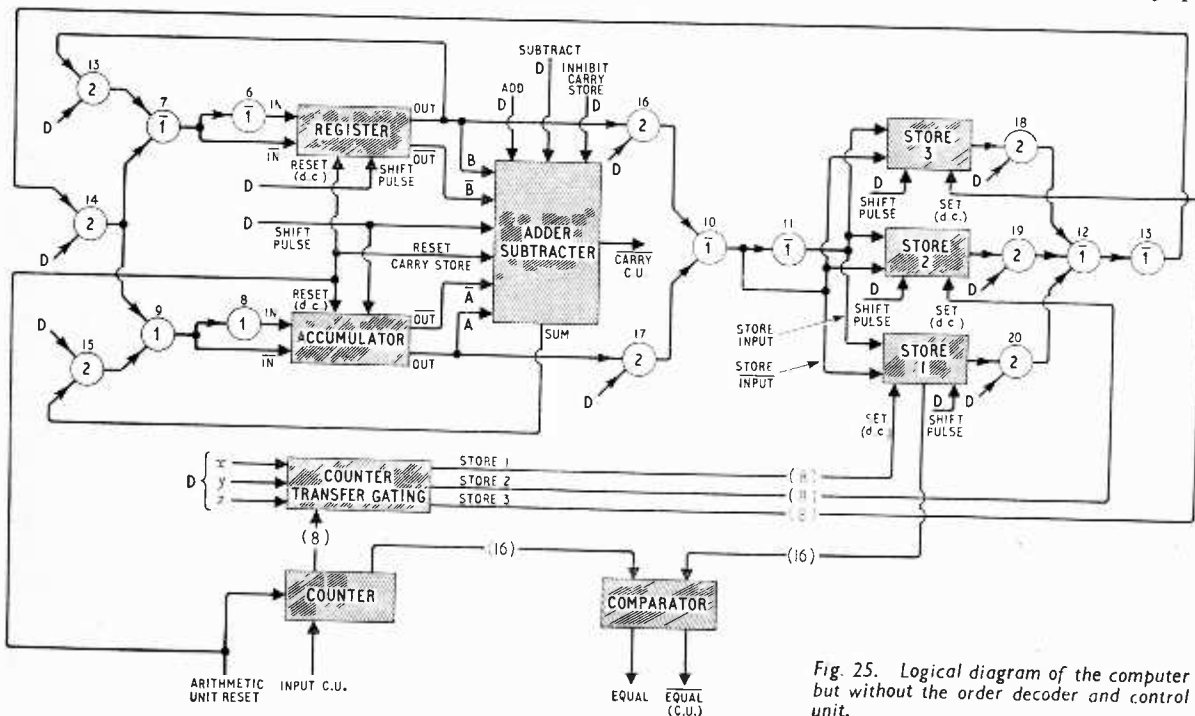

Fig. 25. Logical diagram of the computer but without the order decoder and control unit.

ing shift pulses to the required store only. So with AND 15 closed and AND 17 open, eight shift pulses are applied to the accumulator and store 3. The word that was in the accumulator will now be in store 3.

When this word in store 3 is again required, say in the register, an order is given to the decoder to transfer store 3 to the register. AND gate 13 is closed, closing the register feedback loop, AND gates 14 and 20 are opened and eight shift pulses are applied to the register and store 3. The transfer will have then been carried out.

We have only described two of a possible twelve transfer functions that may be carried out, i.e., the contents of either the register or the accumulator can be transferred to any store, and the contents of any store can be transferred to either the register or the accumulator. As soon as any transfer instruction is ordered both AND gates 13 and 15 close, and not just one of them as was suggested in the two examples given.

It was previously seen that the result of a division is held in the counter. Some means of transferring information from the counter must obviously be introduced. This transfer cannot be a serial one as with a shift register it will therefore have to be a parallel transfer. This means that the contents of the counter will be "copied" into a register. It is arranged that the contents of the counter can be copied into any of the three stores by the network of AND gates shown in Fig. 23. Altogether 24 AND gates are used, divided into three banks of eight. One control line from the decoder (X, Y and Z) is common to each bank of eight. There is one AND gate for each binary position for each store, so the output of each bistable in the counter is connected to three AND gates. When a control line goes "up" the output of each AND gate, associated with that control line, will go "up" if

it is connected to a bistable in the counter that holds a binary 1. If the counter held 0 0 0 0 0 1 1 and line Y went "up" then the outputs of AND gates 35 and 36 would go "up" to set the 2<sup>1</sup> and 2<sup>0</sup> bistables in store 2. Now store 2 will hold 0 0 0 0 0 1 1. Fig. 24 shows the counter transfer gating interconnections. Figures have been used to represent the number of wires to simplify the drawing.

Fig. 25 shows the computer as so far described. All that is required to complete the design is the addition of the order decoder and the control unit. An arithmetic unit reset facility has been added as can be seen from the diagram. This enables the register, accumulator, counter and carry store to be reset on switch on.

(Next month: design of the control system, by which instructions are given to the computer.)

## POINTS ARISING FROM READERS' ENQUIRIES

The computer has been designed primarily as a teaching aid for use in schools and colleges and is not intended as an operational computer.

If it is desired the word length can be extended to 16 bits by adding extra bistables, no circuit modifications being necessary.

The choice of the term flip-flop was perhaps not a good one: in this series flip-flop refers to a monostable.

The bar over the word output in the fourth line of left hand column, page 371, should be deleted.

The bar across the inputs of the comparator gate (Fig. 8) does not imply that negation takes place within the gate as is confirmed in the circuit of Fig. 9.

# MARCONI AIRBORNE COMPUTER

A LARGE number of equipments have in the past been developed for determining the position of an aircraft in flight and for automatically keeping this information up to date. Such equipments have to take into account a large number of variables—wind speed, wind direction, drift, heading, track, air speed, ground speed, etc. If the information is to be presented in terms of latitude and longitude then the equipment must know that the lines of longitude converge towards the polar regions and due allowance made. Another way of presenting information is by means of an imaginary linear grid, the equipment indicating nautical miles flown North/South and East/West of a starting position. Another system sometimes used is known as the along and across track (A/A) method. Here the equipment indicates, as the name suggests, the number of nautical miles flown along a predetermined track and at right angles (across) to that track.

Up until a few years ago, all equipments that performed this task were analogue and the vast majority were almost completely mechanical. The latest generation of machines are digital employing integrated circuits to ensure the reliability and small size essential in airborne equipments, one such equipment, shown for the first time at this year's Paris Air Show, is the Marconi type AD 670 Airborne Computer.

As with all such devices the AD670 computes the aircraft's track (the true direction in which the aircraft is travelling) from the aircraft's compass heading and the drift angle, which in turn depends on wind speed and wind direction. Heading can be obtained from either the aircraft's compass system or from an inertial navigator. Drift is usually obtained from a doppler radar system. This information, together with ground speed, obtained from doppler or the inertial navigator is fed into the computer which in turn drives the output display and, if required, provides guidance information for the automatic pilot.

This task could easily be carried out using a "general purpose" computer which would be more flexible and allow complete reprogramming during flight. Marconi's feel that this facility is seldom required and developed the AD670 which uses only 18% of the storage capacity and 50% of the logic circuitry of a comparable general purpose machine; resulting in increased reliability and a reduction in size, weight and cost.

A converter unit provides the necessary interfaces between the various aircraft equipments and the computer. Up to 32 input/output channels are available. These can be increased if desired by using time sharing techniques on certain channels.

The equipment will provide navigational information in any one of the previously mentioned modes, lat./long., grid, A/A track. In addition it will provide guidance information, either visually or automatically via the automatic pilot, to any predetermined position once the course and distance have been specified. The predetermined position is set in to the computer by punched cards. In all twelve switch-selected, easily replaced cards can be accommodated corresponding to twelve destinations. The equipment will also provide the reference signals (earth and vehicle rates) to correct an inertial platform or a master reference gyro.

The computer may also be used for general flight management monitoring such parameters as fuel flow, engine r.p.m., and temperature, etc. In the event of a power failure an automatic shutdown procedure is initiated, the calculation in hand is completed and all relevant information stored. When the power supply is restored the computer goes through a self check sub-routine and if successful carries on with calculations using information stored before the power failure. It will then be necessary for the human navigator to manually "tell" the equipment the aircraft's new position.

# Colour Tube Production

## Deposition and processing of the tri-colour phosphor screens; Assembly and testing of Mazda shadow-mask tubes

UNTIL recently the shadow-mask cathode-ray tubes\* used in British colour television receivers were all imported types or laboratory-made samples. Now, with the B.B.C. well into its "colour launching period," British production lines are beginning to roll. The first colour tube plant to be seen in operation by *Wireless World* is a factory of Thorn-AEI Radio Valves and Tubes Ltd. at Brimsdown, North London. Here the company are producing Mazda 25-inch rectangular shadow-mask tubes, type CTA2550 (A63-11X). The capacity of this plant is over 1,000 tubes per week, but Thorn-AEI point out that it is, in fact, quite a small manufacturing unit as tube factories go. When the demand for colour tubes builds up they will have to open a bigger production plant. At present no 19-inch tubes are being made at Brimsdown, but the company say they are ready to start on this size when there is sufficient demand from the set makers.

First impressions of the Brimsdown factory are that it is largely an assembly plant, since the main components of the product are all bought-in items (actually imported from America). But it soon becomes evident that the most characteristic, and difficult, technique in the production of the colour tube—the laying of the tri-colour fluorescent screen—is a manufacturing process in the full sense of the word, using equipment specially developed by the company and backed by their own R & D effort.

\* For a detailed description of this type of tube, see "A million spots before your eyes," Colour Receiver Techniques Part 3, *Wireless World*, March 1967, p. 106.

By comparison with this the other operations seem relatively straightforward, and in fact, are rather similar to those familiar in the production of monochrome tubes.

In preparation for screen laying the glass faceplates are washed (in hydrofluoric acid, tap water, and demineralized water), while the steel shadow-masks, which are of flat open-box structure, are cleaned to remove dirt from the perforations and checked for surface uniformity. Since, in the finished tube, the accurate registration of the electron-beam rays with the appropriate phosphor dots depends critically on the screen/shadow-mask geometry, the shadow-mask destined to be sealed into a particular tube must itself be used to determine the positioning of the phosphor dots on the faceplate of that tube. Consequently the faceplate and shadow-mask of a particular tube have to be kept together right through the manufacturing process. The shadow-mask fits inside the faceplate and is secured by springs on its rim which clip on to lugs formed in the glass of the inner surface of the faceplate rim.

Screen laying takes place in a dust-free room with its temperature controlled to  $\pm 1^\circ\text{F}$  and its humidity to within 2%. Daylight is excluded since the process is a photo-mechanical one, and the room is lit by fluorescent safelights. Deposition of the phosphor materials on the faceplate is done by three rotary multiple-position machines (one for red, one for green, one for blue), while the photomechanical formation of the dot mosaic takes place on an associated group of photo-exposing machines called "light-houses." First the faceplate is washed with

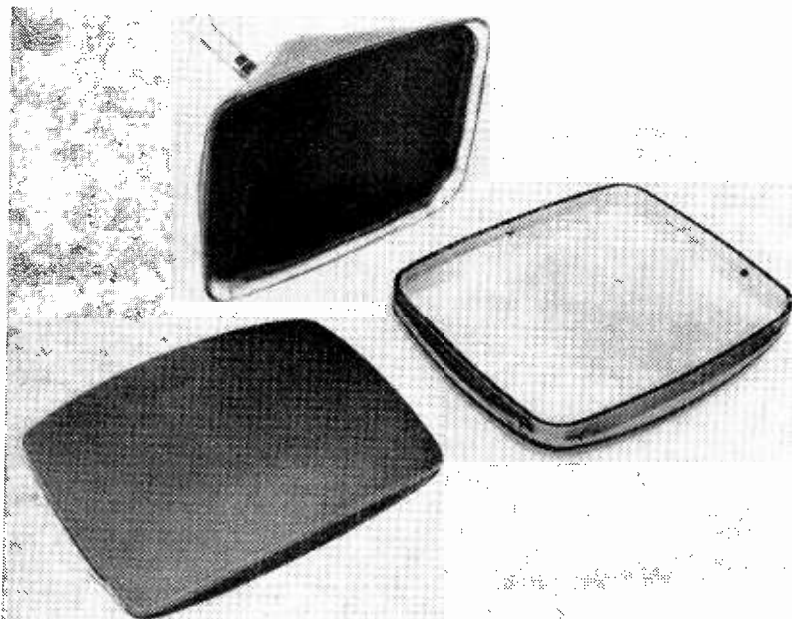

The two major glass components—cone and faceplate—and (left) the blackened steel shadow-mask. One of the three locating springs, which clip on to lugs in the inner surface of the faceplate, can be seen on the rim of the shadow-mask.

One of the rotary machines, designed by Thorn-AEI, for the deposition of the three phosphors and subsequent "developing" of the sets of dots after the phosphors have been exposed in the "light-houses."

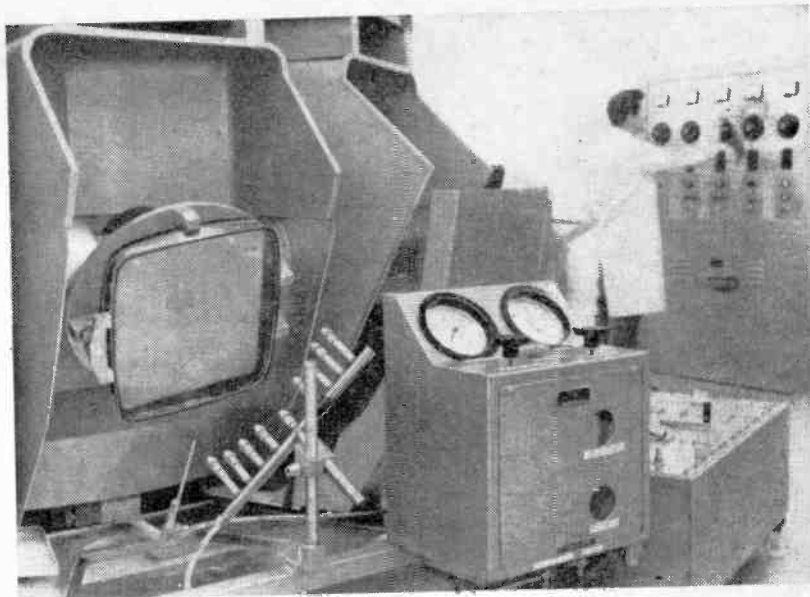

hot water to bring it to the required temperature, then it is mounted in the first of the multiple-position machines, for application of the green phosphor. A measured quantity of the green phosphor material (cadmium zinc sulphide), suspended in a mixture of polyvinyl alcohol, ammonium dichromate and distilled water to form a slurry, is poured into the centre of the faceplate. Then the machine moves the faceplate in a smooth, programmed cycle of tilting and rotation until the whole of the inside surface of the glass is evenly covered. At the next position of the rotary machine the surplus slurry is spun off, and at subsequent positions the deposited layer is dried and cooled for controlled periods. The screen is now ready for the process of forming the green phosphor dots out of the, at present, continuous layer of green phosphor.

First the shadow-mask is fitted into the faceplate, then the assembly is placed on top of one of the "light-houses." At the bottom of the light-house is a 1-kW ultra-violet lamp, the rays from which are directed through a quartz rod shaped to form a small source of u.v. From this small source the u.v. rays pass upwards through the holes in the shadow-mask, which act as pin-hole lenses so that a pattern of u.v. round spots (images of the small source) is thrown on to the phosphor layer. By displacing the u.v. source slightly from the optical centre line of the light-house, and by use of a specially shaped refracting plate interposed in the u.v. path, the u.v. rays are made to simulate exactly the electron rays from the green electron gun in the finished tube. (The only difference being, of course, that the light-house is providing continuous, all-over illumination of the shadow-mask, whereas in an operating tube the electron beam progressively scans its surface. The refraction plate corrects for the effects of all the electron-optical changes that occur during scanning—for example at wide scanning angles.)

Where the green phosphor material is thus exposed to the u.v., the radiant energy polymerizes the polyvinyl alcohol (which has been made sensitive to u.v. by the ammonium dichromate) and so hardens the phosphor material in these exposed areas, leaving the remainder of the material unaffected and soft. After an exposure of several minutes the faceplate is removed from the

light-house, the shadow-mask is detached from it and the exposed phosphor is then "developed." This means, in fact, that the screen is washed with demineralized water at a fixed temperature in the multi-position machine. As a result the soft, unexposed areas of phosphor are washed away while the exposed, hardened round spots of green phosphor are left on the screen.

After drying, the whole process is repeated to lay the blue phosphor dots (again basically zinc sulphide), then the red phosphor dots (basically yttrium vanadate). In



Some of the Thorn-AEI designed "light-houses" in which the faceplate, through its shadow-mask, is exposed to ultra-violet light to form the dots on the phosphor.

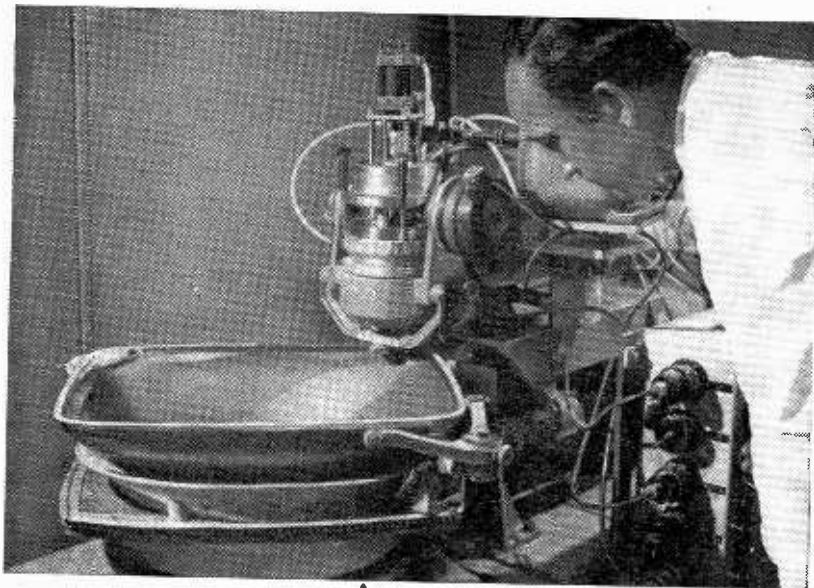

*Automatic application of the sealing compound to the rim of the cone preparatory to the fitting of the faceplate.*

each case; of course, the u.v. source in the light-house is suitably displaced from the optical centre-line so that it simulates the appropriate electron gun in the finished tube. Examination of the finished screen under a magnifier, using u.v. to activate the phosphors, shows that the red-green-blue triads are laid extremely accurately, with the sharply defined edges of the circular spots just contiguous and with small uncoated areas of glass between the circles.

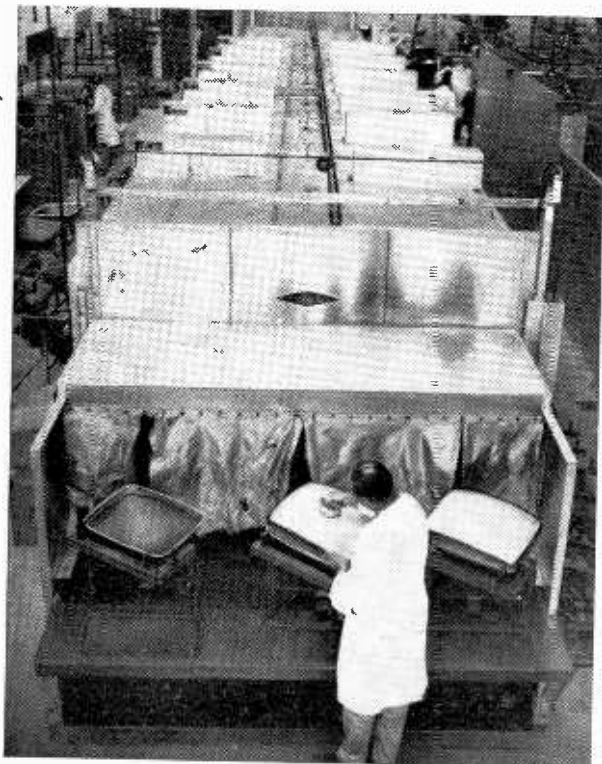

*The faceplate, which with its shadow-mask weighs about 23 lb, is aligned with the cone in a jig ready for passing through an oven for heat sealing.*

The red phosphor is an exceptionally expensive material and the quantity actually deposited on one screen (forgetting the surplus removed during processing, which is by far the greater part) costs approximately £3. For this reason great care is taken to recover unused material—the normal surplus and other residues from the screen-laying process—and a good deal of plant and R & D apparatus is devoted to this purpose.

The finished screen is taken to another room where it is coated with cellulose and aluminized (the purpose of the cellulose being to provide a good surface for the aluminizing). Next the shadow-mask is fitted back into the faceplate, for the last time, and the gaps between the periphery of the mask and the rim of the faceplate are blocked with thin metal shields attached to the shadow-mask frame. The purpose of these shields is to prevent stray electrons from passing round the outside of the shadow-mask to randomly activate the screen and so cause colour dilution. Spring contacts are welded on to the assembly to connect the screen and shadow-mask to the internal graphite coating of the cone and thence to the e.h.t. stud on the cone.

Meanwhile the cone has been prepared for joining to the faceplate. After being washed it has had an internal coating of graphite applied by spraying and dried by hot air. Next the jointing edge of the cone is chemically cleaned and the cone is placed in a machine which automatically extrudes on to this edge a ribbon of sealing material in paste form. Conventional glass welding cannot be used for joining the cone and faceplate because the high temperatures required might well damage the screen or shadow-mask, so a low-temperature technique using a thermal setting solder (basically lead oxide) is employed for sealing. When this material is heated it forms into a ceramic which bonds with the two glass edges.

For this jointing operation cone and faceplate are put together in specially made jigs. On the rim of the faceplate are three studs formed in the glass which bear on to adjusting screws in the jig, and by means of these screws the faceplate can be accurately positioned on the cone. The now assembled bulbs are passed through an oven on a moving belt, a journey taking some four hours. During this the tubes are heated to 450°C, at which they remain for about an hour, then allowed to cool



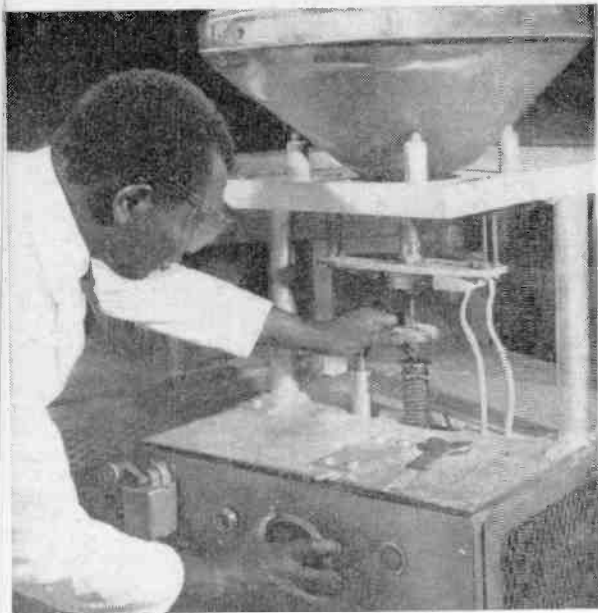

A 25-in tube, complete with electron gun, being connected to a vacuum pump.

slowly. The ceramic seals so formed are tested by applying a p.d. of 50 kV across them, from the inside to the outside of the tube, and measuring the leakage current, which indicates the existence of any discharges through the material.

Next the triple electron gun is sealed into the neck and the tubes are evacuated and sealed off. These techniques follow conventional practice with monochrome tubes, but a much higher standard of positional accuracy is

required to ensure that the three electron guns are correctly aligned with respect to the shadow-mask/screen assembly.

The finishing and testing of the tube is a most comprehensive and exhaustive procedure. First the d.c. characteristics of the electron guns are checked—a procedure which is also used for testing the vacuum by measuring the ion current to one of the tube electrodes. Then, the tubes are placed on an overhead conveyor which passes them through a whole series of basic electrical tests and processes, such as heater testing, “spot-knocking” by applying 50 kV to the anode to break down any sharp points on the internal structures likely to cause flash-overs, and ageing and conditioning. Each tube is then taken separately to a console, where deflection and convergence coils are fitted to it and a series of tests on its performance as a colour display device are carried out. These include examination of cross-hatch patterns to check the alignment of the electron-gun/shadow-mask/screen assembly.

A small sample of the tubes produced is put on a life test of 4,000 to 8,000 hours at the maximum voltages and currents that will be met in practice and with scanning applied. During this life test they are switched on and off 12 times a day, the “off” periods being long enough to allow the tubes to cool down completely.

After seeing all the manufacturing processes at Brimsdown—many of which have not been mentioned in this article—one can fully appreciate why colour cathode-ray tubes are so expensive. In fact the retail price of the Mazda 25-inch tube will be “in the region of £90-£100,” though, of course, the price to set-makers will be somewhat less than this. Everybody enquires when the price is likely to come down, but there does not seem to be any immediate prospect of this. No doubt we will have to wait until there has been a long run of production at several million tubes a year and all the capital investment and development costs for manufacturing this highly complex new product have been paid off.

Completed tubes in cradles passing through the automatic high-voltage testing plant. The illustration on our front cover shows tubes in another section of the testing chamber.

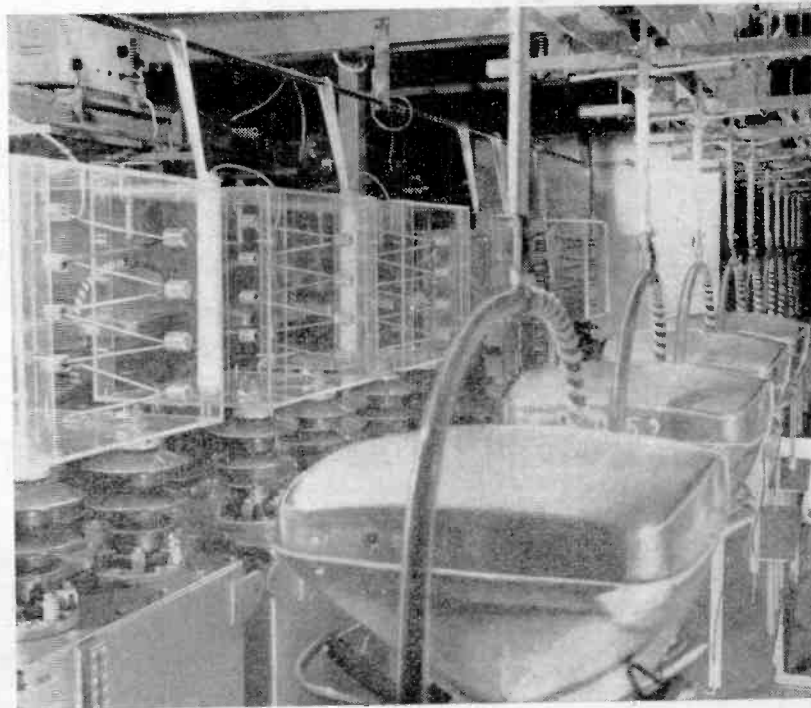

# WORLD OF WIRELESS

## New Receiving Licences and Penalties

THE COST of a receiving licence to cover sound radio, colour and monochrome television will be £10 starting on January 1st. This includes a supplementary licence fee of £5 for the reception of colour television. This supplementary licence has been made available since "It is the Government's view, that the cost of colour programmes which are likely at the outset to be available only to a small minority of viewers because of the cost of receivers, should not fall upon viewers in general" (White Paper on Broadcasting December 1966). A special licence for radio and television dealers known as a demonstration licence will cost five shillings, and will be valid for seven years. These licences are restricted to dealers' showrooms only.

Under the Wireless Telegraphy Act 1967—now given Royal Assent—maximum penalties for television licence evasion are raised from £10 to £50 for a first offence and from £50 to £100 for a subsequent offence. By the same Act, the Post Office will require dealers to provide names and addresses of everyone who purchases or rents a television set, new or secondhand, for cash or credit. Dealers may also be asked for names and addresses of those already renting sets. It is stated that last year the loss of revenue due to licence evasion rose to £10M per year.

## Anglo-Japanese Electronics Symposium

"A FIRST-CLASS opportunity for an exchange of ideas with Japanese experts at the highest level." These are the words of Sir Robert Watson-Watt, F.R.S., who will lead the British delegation to the three-day electronics symposium in Kyoto, Japan. Of the sixteen papers to be read at this symposium (September 21st-23rd) sponsored by the Electronics Engineering Association and B.N.E.C. Asia, eight will be presented by British companies. Titles will include "Automatic landing, autopilots, flight control systems and navigational aids" from the Aviation Division of Smith's Industries; "Trends and development in maritime radio communications" from Marconi International Marine Co. and "Laser range finder" from G. & E. Bradley. Other companies presenting papers are S.T.C., Elliot Flight Automation, British Aircraft Corporation, Marconi Company, G.E.C. Road Signals, and Decca Radar. The themes chosen for two joint discussions are language communications systems and integrated circuits. The symposium will be followed by the Japanese Electronics Show in Osaka (September 28th to October 4th) which is being organized by the British Embassy.

## Computer Languages for Laymen

A PROGRAMME of research into suitable languages for information retrieval from computers has been promoted by the Ministry of Technology. A team working in the mathematics laboratory at the Royal Radar Establishment have undertaken to design computer programmes that allow a wide range of users to communicate directly with their computers without necessarily being skilled programmers. At Malvern, one approach being made to this problem is that of designing programmes which analyse sentences or questions by referring to a pre-arranged vocabulary and a set of grammatical rules. As well as increasing flexibility it allows the user to extend both vocabulary and grammar. Other vocabularies and grammars can be substituted at will, depending upon the particular application. Disc stores will be employed to ensure a rapid response.

## CCTV Network for Schools

ANOTHER education authority is planning a large scale educational television scheme. The borough of Hillingdon in Middlesex is to start experimental transmissions over coaxial links to nine local schools. This is the first stage in the development of a network, which, when completed, will distribute programme material to over 100 schools and to adult education centres in the borough. The studio, equipped with five E.M.I. cameras, will be at the Brunel University, London, W.3. Full sound and vision mixing/switching facilities will also be employed. The university itself will also employ television as a visual teaching aid, and programmes will be relayed to a suite of six lecture theatres. In the May issue it was reported that the Inner London Education Authority are training teachers in television production techniques at the Authority's television centre at Islington; this being the first place in a plan to eventually link 1300 schools and colleges in a television network.

## Manx Radio

NOW that the Marine Broadcast Offences Act has been brought into operation we have been asked by the general manager/chief engineer of the Isle of Man Broadcasting Company to clear up any doubts readers may have regarding the legality of its station, especially as it is erroneously listed as "at sea" in our book "Guide to Broadcasting Stations." Operating under the call sign of Manx Radio, this station is licensed by the Postmaster General and operates under a concession agreement with the Isle of Man government.

*The aerial array shown here helped the owner R. A. Ham of Storrington, Sussex, to win several contests for logging amateur radio stations. There is an eight element, 2-metre beam at the top of the tower, a three-element four-metre beam and a J-beam X10 which is aligned on the Pole star for radio astronomy work.*

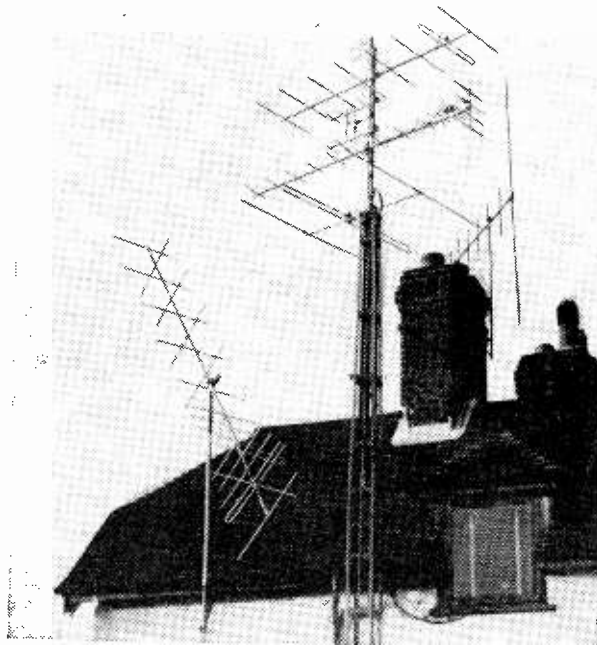

Operating frequencies are 1,295 and 1,594 kc/s in the medium-waveband and 89 Mc/s in Band II. Manx Radio is the only local commercial radio station in the United Kingdom. The medium-wave transmitters are at Foxdale, near the centre of the Island, and the v.h.f. transmitters on the top of Snaefell mountain (2,030 ft above sea level).

**London Components Show to be International?**—The opinion having been expressed in some quarters (including *Wireless World*) that the doors of the R.E.C.M.F. biennial components show should be opened to overseas exhibitors, the Federation is taking a poll among members and exhibitors. The alternatives are (a) restriction, as at present, to U.K. manufacturers or (b) admitting foreign exhibitors and products. Even if proposition (a) is accepted members can state whether or not the present regulations should be relaxed slightly to enable U.K. exhibitors "to display a limited range of foreign products which they offer for sale or intend to manufacture in the U.K."

**U.H.F. transmitters for 25 stations** have been ordered by the I.T.A. These will be employed in the Authority's duplicated 625-line service, and for maximum reliability the transmitters will be installed in pairs, connected in parallel, and automatically controlled. Installation will begin in January 1969, and the first three stations to be equipped under this contract will start monochrome transmissions in the late summer of 1969, going over to colour as soon as possible. The remaining 22 stations will be brought into service successively up to the end of 1971. All the equipment will be used for the transmission of the I.T.A. colour service which is planned to open early in 1970. A contract worth over £2M has been placed with Pye TVT Ltd. of Cambridge for the supply of twelve pairs of 25kW, ten pairs of 10kW, and three pairs of 6.25kW transmitters.

Development of an **East African School of Aviation** has been agreed upon by the United Nations Development Programme's Special Fund and the three governments of Kenya, Uganda and Tanzania. The executive agency will be the International Civil Aviation Organization. Courses to I.C.A.O. standards will be for air traffic control officers, aeronautical telecommunications operations officers and telecommunications engineering officers. Annual total of students is expected to be about 140 to 180 and these students will include those from neighbouring countries as well as holders of I.C.A.O. scholarships.

The first edition of the list of **Space and Radio Astronomy Service Stations** has just been published by the International Telecommunication Union (I.T.U.). Particulars of land, space, and radio astronomy stations are provided in French, English and Spanish in one 70-page volume. The price is 26 Fr. (Swiss) inclusive of surface mail postage, and supplements. Copies are obtainable from the I.T.U., Place des Nations, 1211-Geneva-20, Switzerland.

**Silicon transistor tape recorder.**—Following publication of the general-purpose class D oscillator design in the August issue (p. 394) the U.K. agents for Bogen heads (Cole Electronics Ltd, Lansdowne Road, Croydon CR92HB) have pointed out that the three heads listed have been superseded. The new types are UL197, UL290 and UL296 which respectively replace UL117, BL210 and BL216. The relation between erase voltage and turns was incorrectly given in the text, and should be  $n=V/1.3$ .

**Low-distortion RC Oscillator.**—In the article by P. F. Ridler in the August issue the component designations in Fig. 5, the printed board layout, do not correspond with those of Figs. 3 and 4. For correspondence, the subscripts of resistors  $R_1$  to  $R_{13}$  should be reduced by one,  $R_1$  should be taken as  $VR_2$ ,  $R_{23}$  as  $VR_1$ ,  $R_{26}$  as  $R_{23}$ ,  $C_6$  as  $R_3$ , and  $R$  as  $R_1$ . Resistors  $R_1$ ,  $R_2$ , and  $R_3$  are unaffected.

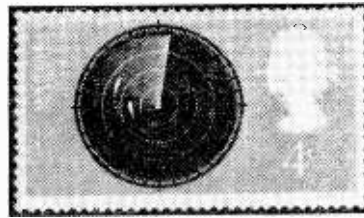

Two stamps from a set of four with the theme *British Discovery* to be issued on September 19th. The 1s 9d shows Baird's television apparatus and a modern television camera and the 4d a radar screen.

## Courses

A bulletin of special courses in **higher technology, management studies and commerce** has been published by the London and Home Counties Advisory Council for Technological Education. This bulletin gives details of special advanced courses during 1967/8 which do not regularly appear in college calendars or prospectuses as part of a grouped course, or as subjects offered for endorsement on Higher National Certificates. Copies of the bulletin at 8s 6d may be obtained from the Secretary, Regional Advisory Council, Tavistock House South, Tavistock Square, London, W.C.1.

**Post-graduate evening courses** starting in the autumn, in the department of electrical engineering, West Ham College of Technology, Romford Road, London, E.15, include integrated circuit application theory, silicon transistor and i.c. technology, semiconductor device theory, and linear circuit theory. There is also a specialist evening course on medical electronics which is open to all working in the medical or biological field, and who require advice and guidance in the use of electronic instrumentation. This course will be conducted at the Medical College of the London Hospital.

Enrolment for part-time day and evening classes at the **Twickenham College of Technology** will take place on the 14th, 15th and 18th September for the 1967/68 year. Full details of fees, and college calendar are included in the prospectus "Department of Engineering 1967/68." Ordinary and Higher National Certificate courses are conducted by the department and among these are electrical engineering, electronic engineering, I.E.R.E., and I.E.E. courses. This prospectus is available from the college at Egerton Road, Twickenham, Middlesex.

Two prospectuses have been received from **Norwood Technical College** for 1967-1968. One is issued by the department of telecommunications and electronics, and includes details of both telecommunications and marine radio courses. The other prospectus is from the science departments and it deals with degree courses and also courses leading to membership of various institutes. Norwood Technical College, Knight's Hill, London, S.E.27.

Computing techniques for industrial application, transistor and transistor circuit design, thyristor applications, and colour television are some of the titles of **short courses** to be conducted during the coming session in the electrical engineering department at Hendon College of Technology, The Burroughs, London, N.W.4.

Details of an evening course for the **L.Inst.P.** can be obtained from the Head of Science Department, Croydon Technical College, Fairfield, Croydon, Surrey. Three subjects, mathematics, applied physical electronics, and non-destructive testing, each an endorsement to H.N.C. in applied physics, have to be passed within two years.

# PERSONALITIES

**F. N. Sutherland, C.B.E., F.I.E.E.**, chairman of The Marconi Company, has been elected chairman of the Conference of the Electronics Industry in succession to the founder chairman, **O. W. Humphreys, C.B.E., B.Sc., F.I.E.E., F.Inst.P.** The Conference (known by the initials C.L.I. to avoid confusion with the Council of Engineering Institutions) was formed in the latter part of 1963 to provide a single, and fully representative organization for the industry. It consists of representatives of the nine principal trade associations representing the various sectional interests of the industry, together with a number of high-level executives from major electronics companies. Mr. Sutherland has been the chief executive of The Marconi Company since 1948. He is currently a member of the N.E.D.C. for the Electronics Industry, and of the Postmaster General's Television Advisory Committee, and was president of the Electronic Engineering Association for 1964-65 and of the Royal Television Society for 1965 and 1966.

**J. H. H. Merriman, O.B.E., M.Sc., A.Inst.P., F.I.E.E.**, senior director of engineering in the Post Office, has been elected chairman of the board of the Electronics Division of the I.E.E. Mr. Merriman, who is a physics graduate of King's College, London, obtained his M.Sc. for work on non-linear oscillations. He joined the Post Office Research Station at Dollis Hill in 1936 and was closely associated with the steerable aerial system—M.U.S.A. At the outbreak of the second war he set up and ran radio laboratories at Castleton, near Cardiff. He was appointed an assistant engineer-in-chief in 1963. Mr. Merriman, who is 52, was appointed senior director of engineering (the new Post Office title for engineer-in-chief) a few months ago.

**B. H. Venning, B.Sc.(Eng.), Ph.D., M.I.E.E.**, senior lecturer in the department of electronic engineering at the University of Southampton since 1963, is to be head of the department of electrical & electronic engineering at the Brighton College of Technology. Dr. Venning graduated at the City & Guilds Engineering College (after service in Royal Signals during World War II) and from 1949-52 was at the Admiralty Underwater Weapons Division. He then spent three years as lecturer in electronics at the Manchester College of Technology before joining the staff of the University in 1955.

**W. E. Miller, M.A., M.I.E.R.E.**, has retired after 42 years' association with *Electronic & Electrical Trader* (formerly *Wireless Trader*). After graduating at Peterhouse, Cambridge, and spending a few months with the Cambridge Instrument Company he joined the editorial staff of the *Trader* in 1925. He became technical editor the following year and editor in 1940. In 1962 he succeeded **Hugh S. Pocock** as managing director of Iliffe Electrical Publications Ltd. (which is now Iliffe Technical Publications Ltd.) and for the past few months has been chairman of the company.

**E. Eastwood, C.B.E., Ph.D., M.Sc., F.I.E.E.**, the new chairman of the Control & Automation Division of the I.E.E., has been director of research for the English Electric group of companies since 1962. Dr. Eastwood, who is 57, joined English Electric at the Nelson Research Laboratory, Stafford, where he was in charge of radiation studies, in 1946. He was appointed deputy chief of research with Marconi (a member of the E.E. Group) at Chelmsford in 1948 and subsequently became director of research.



Dr. E. Laverick

**Elizabeth Laverick, B.Sc., Ph.D., A.Inst.P., F.I.E.E.**, head of the Radar Research Laboratory, Elliott Automation Radar Systems Ltd., since 1959, is the first woman to be appointed to a divisional board of the I.E.E. She is among nine ordinary members elected to the Electronics Division board. Dr. Laverick, whose particular field of interest is microwaves and radar, worked for a year at the Radio Research Station, Slough, before going to Durham University in 1943 where she studied physics and radio. She obtained her Ph.D. in 1950 and joined Elliott Brothers (London) Ltd. in 1953. Dr. Laverick is senior vice-president of the Women's Engineering Society.

**Colonel Donald McMillan, C.B., O.B.E., B.Sc.(Eng.), F.I.E.E.**, who is shortly retiring from the Post Office, has been appointed chairman of Cable & Wireless Ltd., and associated companies. Col. McMillan, who is 60, joined the Post Office Radio Section after general engineering training, and in 1931 was posted to the Research Branch, where he concentrated on electro-acoustical problems. In 1952 he took charge of the Engineering Branch and the following year became deputy



F. N. Sutherland



J. H. H. Merriman



Dr. E. Eastwood



Col. D. McMillan

director of the External Telecommunications Executive. Since 1955 he has been director of the Executive and U.K. member of the Commonwealth Telecommunications Board.

**Geoffrey G. Gouriet, F.I.E.E.**, head of the B.B.C. research department, has been elected an ordinary member of the council of the I.E.E. for three years and has also been appointed vice-chairman of the Royal Television Society Council for 1967-8. Mr. Gouriet was head of the Television Group, B.B.C. Research Department from 1950-58. He then joined Wayne Kerr Company as technical director but in 1964 returned to the Corporation to take up his present position.

**Alan T. Watts** has joined SGS-Fairchild Ltd. as applications engineering manager at their head office at Planar House, Aylesbury. He succeeds **Gordon C. Padwick**, who has joined Fairchild Instrumentation, Mountain View, California, as applications manager. For the past 18 months Mr. Watts has been applications manager in Plessey's semiconductor division. Prior to this he was



A. T. Watts

for 14 years with Mullard Ltd., of which eight years were spent at the Research Laboratories at Salfords and six years at Mitcham, during which period he became manager of thin film development.

**C. H. Robertson**, recently appointed by the Marconi International Marine Company as deputy manager, north sea area, served for a time at the Royal Navy Signal School, Devonport, before joining the company as a seagoing radio officer in 1940. He was appointed to the shore staff in 1947 as a technical assistant. In 1959 he became an inspector and since 1964 has been the company's representative at Lowestoft.

**E. Newland-Smith** has joined the Wyndor Recording Company as general manager. For the past 10 years he has been with Elizabethan Electronics.

**T. M. B. Wright, B.Sc.**, has joined Cossor Electronics Ltd. as marketing manager of the surface equipment division. After graduating in physics at Reading University in 1950 he joined the scientific branch of the Ministry of



T. M. B. Wright

Supply (Aviation). For most of his ten years in Government service he was at the Royal Radar Establishment but was for two years on the Air Ministry staff in Washington. Mr. Wright, who is 39, was until recently head of systems planning in the satellite communications department of the Plessey Company.

**David N. T. Scott, B.A.**, who joined Rank Bush Murphy Ltd. as marketing manager in 1965, has been appointed a director of the company. A graduate of Trinity College, Cambridge, Mr. Scott, who is 37, was previously with Philips Electrical.

**A. S. Banks**, formerly works manager of H. W. Sullivan Ltd., has joined Alma Components Ltd. of Diss, Norfolk, as chief engineer. He was with Sullivan for 18 months prior to which he was for nine years with H. Tinsley & Company as general manager. For nine years prior to 1957 Mr. Banks was with Sperry Gyroscope Company as standards engineer on the Blue Streak project.



A. S. Banks

The Société d'Encouragement pour la Recherche et l'Invention recently presented its Ordre du Mérite pour la Recherche et l'Invention to five members of the Institution of Electronic and Radio Engineers. **Earl Mountbatten of Burma, K.G., F.R.S.**, president of the I.E.R.E. and chairman of the National Electronics Council received the Grande Médaille d'Or in recognition of his support for research. **Leslie H. Bedford, C.B.E.**, director of engineering, guided weapons division, B.A.C. (Operating) Ltd. (a past president of the Institution) received the Médaille d'Or "in recognition of his original researches and direction of work in television, radar and guided weapons." Medals were also received by **Graham D. Clifford, C.M.G.**, secretary of the I.E.R.E., **Wing Commander Gerald E. Trevains**, of the British Embassy in Paris, and **Paul J. C. Prevost**, secretary of the committee of the Institution's French Section.

**B. J. Hadley, B.Sc.(Eng.)**, who joined International Rectifier Company (Great Britain) in 1962 as production manager, and subsequently became director of production and deputy managing director, has been appointed managing



B. J. Hadley

director. After completing national service with the Royal Air Force, Mr. Hadley, who is 39, studied at Birmingham College of Technology (now the University of Aston) and obtained a London University degree in engineering, specialising in electronics. In 1953 he joined A.E.I. as a graduate apprentice and from 1958-62 was with Texas Instruments latterly as superintendent of planning.

**A. G. Emmerton, A.M.I.E.R.E.**, has been appointed manager of Sierra Leone External Telecommunications Ltd., on secondment from Cable & Wireless Ltd. He began his career in telecommunications with Cable & Wireless in 1943 when he joined the London Training School, and later went to Marconi College. Between 1952 and 1960 he was responsible, as project engineer, for setting up radio stations in Ikoyi (Nigeria), Sitra (Bahrain) and Hiswa (Aden).

# TECHNICAL NOTEBOOK

## New Approach to Thin-film Circuits

ONE of the major upheavals that integrated circuits are causing is the transference of circuit design from the small equipment manufacturer to integrated circuit manufacturer. This is because expensive capital equipment and complex processes are involved. The screen printing process, though, used for thick film manufacture has a wider appeal but the technique is still involved and will no doubt deter the smaller would-be circuit producers. This situation can be eased by a technique which allows selective etching of multi-layer thin films. The method, which has been developed by the Scientific Instrument Research Association (S.I.R.A.) at Chislehurst, allows the processes of deposition and pattern making to be completely divorced.

Films are produced with one pumping operation by sequential deposition in a vacuum plant and a typical film order might be: resistor material (Ni-Cr), conductor material

(Au), capacitor base plates, bonding layer (Ni-Cr), capacitor dielectric (SiO), bonding layer (Ni-Cr), capacitor top plate (Al). The multilayer film can then be supplied to the user who uses etchants for removing unwanted parts. The layers are photolithographically processed, starting with aluminium, to produce the required pattern on each film. Layers are coated with a photoresist material which is dried, exposed through an appropriate negative, developed and hardened. Unwanted parts of the film are then dissolved with an etchant which dissolves that particular film. After washing, the remaining photoresist is stripped chemically and the process repeated with further films. Various film materials may be used provided, of course, that suitable etchants can be made.

The process is at present used commercially by a number of firms but so far only for two-layer films (resistor and conductor).

## Electrochemical A.C. Time Switch

AN electrochemical timing device has been developed which can turn off alternating currents after a prescribed time. The switch depends on transference of a metal through a solution from one electrode to another in much the same way as in electrochemical elapsed time indicators in which mercury is transferred from anode to cathode. The figure shows a simple demonstration set-up in which the cell is formed with 12% copper

sulphate solution, two tantalum electrodes and a copper control electrode. The tantalum electrodes are treated by heating to a high temperature (670°C) in order to form an oxide film. With a circuit along the lines of that illustrated and with the control electrode open circuit only a small "leakage" current will flow through the cell. With the control electrode in circuit and at a positive potential copper is transferred to electrode B for positive half cycles and to electrode A for negative half cycles. With this deposition the cell resistance decreases and passes alter-

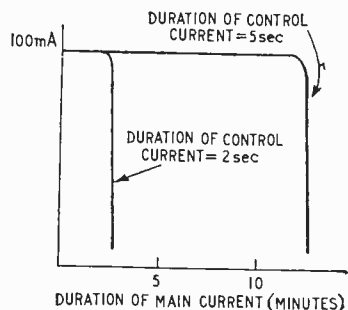
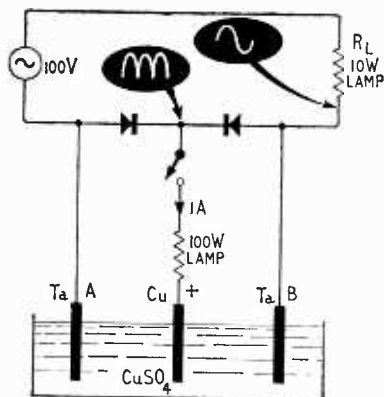

nating current to the load. The feature of the cell is that if now the control current is switched off, the main current will continue to flow until the copper has been transferred back to the control electrode. The time required for the copper to be returned depends on the amount deposited, which in turn depends on the control electrode current and its duration. The graph shows that for a control current of about 1 A lasting for 5 s, the current through the load (a 10 W lamp) is maintained for about 12 min.

This time switch was developed by Yamaguchi and Ogawa of Yamaguchi University, Japan, and is reported briefly in *Nature* 213 p. 216 (1967).

## Germanium for I.C.s

ALTHOUGH mention of integrated circuits almost exclusively implies the use of silicon for active devices, recent work has shown that germanium devices can be developed which enable switching to take place faster than with the present silicon microcircuits. Switching delays of the order of 300 ps have been obtained at the I.B.M. research laboratories.

The circuits are in fact hybrid types, using a ceramic or passive substrate, with thin film nichrome resistors and germanium chip transistors. The transistors, which are only experimental types, are reported to exhibit a cut-off frequency of 6.5 Gc/s and a 5 ps base-collector time constant (base resistance  $\times$  intrinsic collector capacitance). Low time-constant is given by reducing base resistance, this being more amenable to manipulation than collector capacitance which is usually fixed by device area and operating voltage.

Such circuits have been experimentally developed in the past for linear applications in the microwave region. Texas Instruments, for example, developed a hybrid integrated circuit with germanium chips some time ago. Bell Telephone produced a hybrid 4 Gc/s balanced amplifier also some time ago, this using silicon transistors. Last year, a monolithic microwave circuit was announced by Texas, which was described as a 9 Gc/s transmit-receive switching circuit. The chip measured  $0.1 \times 0.1$  in by 0.01 in thick.

Maximum operating frequency of such devices is, of course, limited by the active devices but so far the limits of 9 Gc/s for silicon and 11 Gc/s for germanium (August 1965 issue, p. 417) do not seem to have been exceeded.

# INTERNATIONAL BROADCASTING CONVENTION

SEPTEMBER 20th to SEPTEMBER 22nd, 1967

ROYAL LANCASTER HOTEL,  
LONDON, W.8.

## BRITAIN'S PREMIER BROADCASTING EVENT

**This Convention combines a high-level Conference of wide and practical scope with an Exhibition, covering some 10,000 sq. ft., of the latest broadcasting and supporting equipment by leading manufacturers.**

● **Convention papers include:**

**On Colour Television:** Colour studio operations practice (United States); Colour film equipment (United Kingdom); Colour production techniques (United States); 4-tube colour cameras (United Kingdom); Colour TV mobile units (United States); Colour recording techniques (United Kingdom).

**Other Papers:** Planning a TV installation in a developing society (Singapore); Electronic conversion between European and North American television standards (United Kingdom); The design and operation of a complete wired television service (Hongkong); High power UHF television transmitters (United Kingdom); Television presentation suite and its practical experience (Austria); UHF Aerials (United Kingdom); EBU video pre-emphasis standard for television tape recording (Italy); An automated television network switching centre (United States); An electronic system for the control of stage and studio lighting (United Kingdom).

● **An attractive social programme, including a Convention Dinner, a cocktail party and an itinerary of tours and visits of special interest to ladies.**

**Convention organised by the Electronic Engineering Association and the Royal Television Society, supported by the I.E.E.E. (U.K. and Republic of Ireland section).**

POST THIS SOON FOR FULL DETAILS AND REGISTRATION FORMS

The Convention Secretary, International Broadcasting Convention, Royal Television Society,  
166 Shaftesbury Avenue, London, W.C.2.

Please send me full details and registration forms.

NAME .....

Organisation .....

ADDRESS .....

.....

# HELASHRINK TUBING HELASHRINK END CAPS HELASHRINK SLEEVES HELASHRINK MARKERS

## AND NOW

# HELASHRINK\* TAPE

Heat shrinking, multi-purpose insulating tape provides inexpensive airtight and waterproof sealing.

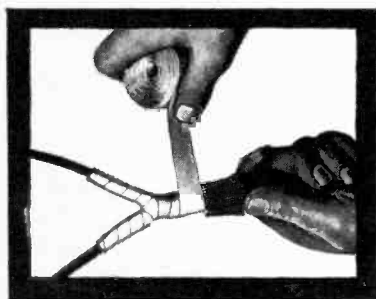

$\frac{3}{4}$ " wide tape in 108 ft. rolls (Part No. HTP x  $\frac{3}{4}$ "). Adhesive backing "holds" dual thickness tape prior to heating

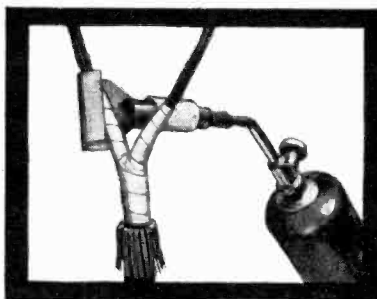

Heat for a few seconds with a Hellermann Heat Gun—the new Gas Gun is shown here—and the result is instant sealing

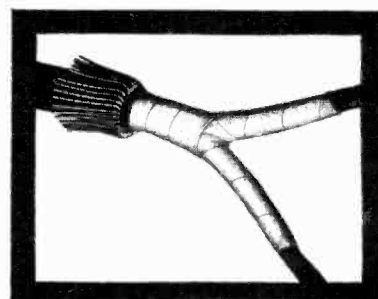

Helashrink Tape eliminates the need for expensive "shapes". There is now a Helashrink material to cover all applications

Write or phone for leaflet and samples

## HELLERMANN ELECTRIC LTD.

World Leaders in Cable Accessories

\* Registered Trade Name



GATWICK ROAD · CRAWLEY · SUSSEX · TELEPHONE: 28888

A member of the Bowthorpe Holdings, Ltd. group of companies

WW—096 FOR FURTHER DETAILS



# Tape Pre-amplifier using F.E.T.

Design to eliminate head magnetization and reduce tape noise

By P. F. RIDLER, B.E., M.I.E.E.

**T**WO main types of transistor tape recorder pre-amplifier have been used in the past. The high-impedance type<sup>1</sup> amplifies the voltage signal from the head and uses feedback to make the input impedance of the amplifier much greater than the impedance of the reproducing head. Equalization may be incorporated into the feedback network or alternatively a flat frequency response amplifier may be followed by a passive equalizer circuit. The low-impedance type of pre-amplifier<sup>2</sup> uses as an input the current output of the head and automatically equalizes the low frequency range, while feedback, or some other means, is used for the high frequency range.

Both types of pre-amplifier have one outstanding disadvantage in that each must feed the signal to the input stage through a blocking capacitor, in order to isolate the bias voltage of the input transistor from the tape head. Under steady state conditions this is easily achieved, but when the amplifier is switched on or off the resulting changes in the bias voltage create a transient current surge through the blocking capacitor which may amount to several hundreds of microamperes, leaving a considerable degree of residual magnetization in the reproducing head.

Any constant magnetization of a reproducing head will not be removed by high frequency bias currents as it would be in a recording head and will cause a serious degradation of the reproduced signal. As the residual magnetization is asymmetrical, (blank) tape noise will no longer average out and there will be a considerable increase in the background noise level, which may be thought of as modulation noise on the zero-frequency signal stored in the tape head. The same asymmetry will also cause distortion of the reproduced signal.

The second effect of head magnetization may be even more serious if the tapes are irreplaceable. The magnetized reproducing head acts as a weak erase head, gradually reducing the higher frequencies recorded on the tape and introducing frequency distortion.

It has been suggested in the past<sup>3</sup> that a direct current which may be adjusted to minimize the noise output from a fully erased tape by demagnetizing the reproducing head is a useful feature of a reproducing system, and in fact this will simultaneously minimize distortion of the

signal. The author considers that this facility should be built into any high quality system.

However, it is no use periodically demagnetizing the heads if every time the equipment is switched on or off they are heavily remagnetized, so accordingly a pre-amplifier has been designed which eliminates the blocking capacitor at the input and thus does not magnetize the heads. This simply cannot be done using bipolar transistors as the base of the input transistor requires a bias current and this, because it must not be allowed to flow through the tape head, renders the use of a blocking capacitor mandatory. The field effect transistor, on the other hand, requires only a bias voltage, the gate current being of the order of nanoamperes, and this magnitude of current will not significantly magnetize a tape head. The bias voltage may be obtained from a source resistor in the same way as it would be if a triode valve were being used with a cathode resistor for automatic self bias. This type of biasing system allows both ends of the head to be at (zero frequency) earth potential.

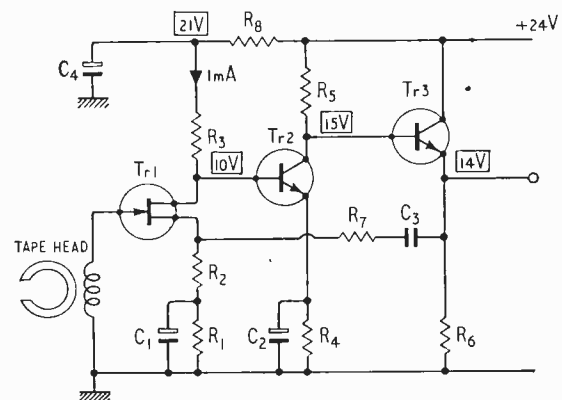

Fig. 1. Circuit of complete pre-amplifier using f.e.t. to avoid head magnetization.

The circuit diagram of the pre-amplifier is shown in Fig. 1, and consists of a 2N3819 f.e.t. (common source mode) feeding a common-emitter connected bipolar transistor. The output is taken from a common collector stage to isolate the amplifier from load variations and also to provide a low-impedance source for the feedback network. The f.e.t. is self biased by means of the by-passed resistor  $R_1$  and the value of this resistor may need some adjusting to bring the drain voltage to within a volt or so of the specified 10 V, as current production low-priced f.e.t.s have a fairly wide spread in their characteristics.

The feedback network,  $C_3R_3$  and  $R_1$ , gives 100 $\mu$ s C.C.I.R. equalization and the high frequency (3kHz) gain of the amplifier is 50 times more than sufficient to load

## COMPONENTS

$R_1$	330 $\Omega$ (see text) 5% high stability	$C_1$	100 $\mu$ F 25 V electrolytic
$R_2$	100 $\Omega$ 5% high stability	$C_2$	50 $\mu$ F 25 V electrolytic
$R_3$	12k $\Omega$ 5% high stability	$C_3$	0.02 $\mu$ F 2% polyester
$R_4, R_5$	5.6 k $\Omega$ 10% composition	$C_4, C_6$	100 $\mu$ F 25 V electrolytic
$R_6$	3.3 k $\Omega$ 10% composition	$C_5, C_7$	50 $\mu$ F 15 V electrolytic
$R_7$	5 k $\Omega$ 2% high stability	$Tr_1$	2N3819 (Texas)
$R_8$	2.7 k $\Omega$ 10% composition	$Tr_2, Tr_3$	2N3707 (Texas)
$R_9$	100 k $\Omega$ linear pot.		
$R_{10}, R_{11}$	10 k $\Omega$ 10% composition		
$R_{12}$	1 M $\Omega$ 10% composition		
	All resistors $\frac{1}{4}$ watt.		

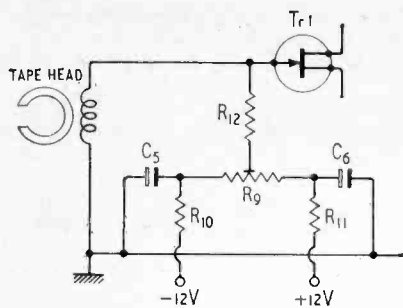

Fig. 2. Suggested circuit for d.c. demagnetizing bias to reduce noise output.

fully the high impedance input of most main amplifiers. When the amplifier is used with a medium impedance reproducing head, the noise level is more than 60dB below a 3% distortion tape signal, and considerably below that of bulk-erased tape. At no time does the direct surge current through the head reach  $1\mu\text{A}$  and it is probably considerably less than this: it will not magnetize the heads to the extent that the noise level is increased.

Fig. 2 suggests a circuit which will provide a current of between plus and minus  $12\mu\text{A}$  through the head for noise reduction: this is well worth trying for very high quality reproduction. The current should be adjusted with a bulk-erased tape running through the machine until the tape noise is a minimum. Care should be taken that the two power supplies to the potentiometer turn on at the same rate or it will be necessary to re-adjust the current every time the equipment is switched on. A few trials will show if any alteration is necessary after switching the mains supply on and off once or twice, and if this is so, slight alterations to the filter capacitors  $C_5$  and  $C_6$  will rectify the situation.

#### REFERENCES

1. High Quality Tape Pre-amplifier, P. F. Ridler. *Wireless World* Feb. 1962.
2. Transistor Tape Pre-amplifier, P. F. Ridler. *Wireless World* Dec. 1958.
3. Adjustments for Obtaining Optimum Performance in Magnetic Recording, A. W. Friend. *R.C.A. Review* Mar. 1950.

## BOOKS RECEIVED

**How to Build Speaker Enclosures**, by Alexis Badmaieff and Don Davis, describes the practical and theoretical "hows" and "whys" of high-performance speaker cabinets. It contains constructional information on the infinite baffle, bass reflex and horn projector types of enclosures and various combinations of these. The book also discusses the advantages and disadvantages of each enclosure type, loudspeakers in general, crossover networks and test methods. Pp. 144. Price 25s. W. Foulsham & Co., Yeovil Rd., Slough, Bucks.

**Topology and Matrices in the Solutions of Networks**, by F. E. Rogers. This book sets out to explain the principles of systematic methods of solving linear networks; these are based on the fact that the pattern of the Kirchhoff law equations for a linear network is governed solely by its geometric pattern, in the sense conveyed by a topological graph. This is not a text book, but one that seeks to show how to apply these approaches in practice. Pp. 204. Price 27s 6d. Iliffe Books Ltd., Dorset House, Stamford Street, London, S.E.1.

**Electrical Noise**, by Robert King. This book discusses the mechanisms that are responsible for noise in electronic circuits together with associated mathematical techniques. After developing expressions for the magnitude of the principle sources of noise generated in thermionic and semiconductor devices, the processing of input noise and the effects of internally generated noise are described. The application of the preceding work in communications is next illustrated and the book ends with a chapter on measuring methods and the facilities available for noise generation. Pp. 195. Price 35s. Chapman and Hall Ltd., 11 New Fetter Lane, London, E.C.4.

**Spread-F and its effects upon radiowave propagation and communications**, compiled by The Advisory Group for Aerospace Research and Development (AGARD). Initiated in 1961 as part of NATO, it is the function of AGARD to sponsor technical meetings and symposia and the publication of technical papers. The meeting on spread-F irregularities was successful in assembling a large number of specialists in the field and in obtaining a cross-section on classical and new aspects which form the subject matter of this book. The work is divided into four sections which are headed, Spread-F, Scintillation and radio wave propagation, Movements of irregularities and Production of F region irregularities. Pp. 617. Price 105s. Technivision Ltd., Braywick House, Nr. Maidenhead, Berks.

**Understanding Telemetry Circuits**, by John D. Lenk, provides a non-mathematical introduction to telemetry for intending service technicians. The first chapter discusses the four basic techniques in common use—f.m./f.m., p.a.m., p.d.m., and p.c.m. In the remaining chapters these methods are dealt with in more detail, the various circuits being built up into basic building blocks and the blocks into systems, concluding with a glossary of terms related to telemetry. Although originally intended for the American market a chapter is included for the benefit of the English reader. Pp. 160. Price 25s. W. Foulsham & Co., Yeovil Road, Slough, Bucks.

**Proceedings of the Second Lecture Course, Oxford 1966.** The series of Oxford Lecture Courses, held annually, is designed to keep engineers abreast with the rapid advances in technology that are taking place in their own and other fields. This book contains nineteen papers on such diverse subjects as microwave generation in solids, electronics in the automobile, semiconductor lasers, advanced computer systems and thermionic power generation. Pp. 142. Price 70s. United Trade Press Ltd., 9 Gough Sq., Fleet Street, London, E.C.4.

**Outline of Electronic Circuit Analysis** by Andrew R. Cohen. (Pp. 314.)

**Outline of Pulse Circuits** by Constantine H. Houpis & Jerzy Lubefeld. (Pp. 319.)

**Outline of Electromagnetic Theory** by Mathew Zuret. (Pp. 317.)

**Outline of Atomic Physics** by Solomon E. Liverhunt. (Pp. 315.)

**Outline of Fourier Analysis** by Hwei P. Hsu. (Pp. 344.)

**Outline of Transistor Circuit Analysis** by Alfred Gronner. (Pp. 383.)

**Outline of Linear Circuits and Systems** by Andrew R. Cohen. (Pp. 320.)

**Outline of Servo-Mechanisms** by Sidney A. Davis. (Pp. 320.)

This series of paper-backed books is of American origin under the Unitech Outline heading. Throughout the series the text covers both well known and new techniques, each subject being approached through basic principles and illustrative step by step worked problems. A good working knowledge of mathematics is assumed. Price 30s each. Distributed by Iliffe Books Ltd., Dorset House, Stamford Street, London, S.E.1.

# Getting the Best Signals into Your Receiver

By T. D. TOWERS,\* M.B.E

The design requirements of aerials for colour TV reception and the practical problems of selecting and installing the most suitable type

IN considering what aerial provision to make for a colour television set, the thoughtful engineer will note first that colour transmissions are radiated on the same u.h.f. channels as BEC-2 monochrome (and ultimately also as BBC-1 and ITV when these are duplicated on 625 lines in u.h.f.). In these channels, moreover, the technical requirements for colour and black-and-white are exactly the same. Why, therefore, should not a standard "BBC-2" u.h.f. aerial deal with colour as effectively as black-and-white? The answer is that it will, provided it is correctly selected, designed and installed. The rub is that colour reception is much less tolerant of aerial inefficiencies than black-and-white. This is so true that in some areas an aerial could give an acceptable picture on black-and-white transmission, but when the transmitter switched over to colour the picture would become unusable. That is why the design and installation of aerials for colour television merit special attention.

## COLOUR TELEVISION SIGNALS

Sixty-four main stations, with effective radiated powers from 100 to 1,000 kW, will provide colour transmissions in the U.K. in the u.h.f. bands. The table below gives the locations of the first twenty-eight of these u.h.f. television stations with the dates of coming into operation. There will also be low and medium power

Locations of u.h.f. stations in United Kingdom with dates of coming into operation. (See also August issue p. 378).

COUNTY	LOCATION	DATE
Anglesey .. .. .	Llandona	1967
Angus .. .. .	Balcaik	1969
Bedfordshire .. .. .	Sandy Heath	1968
Cornwall, East .. .. .	Caradon Hill	1968
Durham .. .. .	Pontop Pike	1966
East Lothian .. .. .	Craigkelly	1968
Flintshire .. .. .	Moel-Y-Parc'y	1968
Hampshire, North .. .. .	—	1969
Ireland, North East .. .. .	Divis	1967
Ireland, North West .. .. .	Londonderry	1968
Isle of Wight .. .. .	Rowridge	1966
Kent .. .. .	Dover	1967
Kincardineshire .. .. .	Durriss	1967
Lanarkshire .. .. .	Black Hill	1966
Lancashire .. .. .	Winter Hill	1965
Leicestershire .. .. .	Waltham	1967
Lincolnshire, East .. .. .	Belmont	1966
London .. .. .	Crystal Palace	1964
Norfolk .. .. .	Talcolneston	1967
Oxfordshire .. .. .	Oxford	1967
Somerset .. .. .	Mendip Forest	1968
Staffordshire .. .. .	—	1969
Suffolk .. .. .	Sudbury	1967
Sussex .. .. .	—	1969
Wales, South .. .. .	Wenvoe	1965
Warwickshire .. .. .	Sutton Coldfield	1965
Yorkshire, North .. .. .	Bilsdale West Moor	1968
Yorkshire, South .. .. .	Winter Hill	1966

relay stations associated with the main transmitters to deal with poor reception in "shadow areas."

The u.h.f. frequency range used for television lies in two bands between 470 and 854 Mc/s; Band IV=470-582 Mc/s and Band V=614-854 Mc/s. Band IV has 14 channels, numbered 21 to 34, and Band V has 30 channels, numbered 39 to 68. The missing channels 35 to 38 are reserved for non-television purposes. Each station has four channels assigned to it; one for BBC-2 and the other three for other programmes such as the duplication of Band I/III (BBC-1 and ITV) programmes on Band IV/V. As a rule, the station channels are spaced out evenly over an 11-channel-wide spectrum of 88 Mc/s.

Transmission on u.h.f. in Bands IV/V uses 8 Mc/s-bandwidth, 625-line, negative-going vision modulation, with f.m. sound carrier spaced 6 Mc/s from the vision carrier. V.H.F. on Band I/III uses 5 Mc/s-bandwidth, 405-line, positive-going vision modulation, with a.m. sound carrier at 3.5 Mc/s from the vision carrier. This means, of course, that TV receivers and aerials for Band IV/V differ materially from those used for Band I/III.

**Band IV/V signal propagation characteristics.**—Signal propagation characteristics at u.h.f. differ in some important respects from v.h.f. Firstly, the u.h.f. signal strength at any point is much less predictable. Shifting a u.h.f. aerial a matter of a few inches can produce a large change in signal pick-up, something not common with v.h.f.

The u.h.f. television signal strength tends to fall off with distance beyond the primary service area more rapidly than with a v.h.f. signal of the same field strength. Also, u.h.f. signals tend to be less influenced by the troposphere and ionosphere than v.h.f. Ultra-fringe u.h.f. reception is thus not so common. This, of course, has the advantage that the u.h.f. service areas are much more clearly defined, and you seldom experience in Bands IV/V the summer-time interference between geographically distant stations that occurs regularly on the lower Band-I v.h.f. channels.

Because of their shorter wavelengths, u.h.f. signals are more easily blocked by large buildings, hills, etc., so that "shadow areas" of poor signal strength are more common than in Band I/III. Also u.h.f. signals are reflected more easily than v.h.f. so that double-pictures or "ghosts" are more common. Finally because of the short wavelength, u.h.f. reception is more prone to proximity effects from the chimney or wall on which the aerial is mounted.

\*Newmarket Transistors Ltd.

Signal reflection at u.h.f. is not as troublesome as might appear, however, because highly directional aerial arrays are normally used, and in addition reflected u.h.f. signals attenuate more rapidly than v.h.f. before they reach the aerial. Even so, it will still be found that multipath interference tends to be more troublesome in Band IV/V.

If the normal "line-of-sight" computations are carried out, it would seem that u.h.f. reception would be unusual beyond 30-40 miles from the transmitter. However, in Cambridge, at 60 miles from London, I have been able to pick up adequate BBC-2 signals from there as a matter of course.

### UHF AERIAL TYPES

The tuned half-wavelength aerial commonly used in television receivers is referred to as a "half-wave" dipole, and in its simplest form takes the shape shown in Fig. 1(a). This elemental dipole, when orientated vertically, responds equally to vertically polarized signals arriving from all directions, and is said to be "omni-directional."

To increase the signal pick-up from any particular direction, a reflector can be attached behind and parallel to the dipole. This leads to the now familiar "H" type aerial commonly used for Band I reception, and is shown diagrammatically in Fig. 1(b) for the vertical polarization common in that band.

In Band III, where the signals may be horizontally or vertically polarized, the aerial elements are much smaller, and parasitic "director" elements are usually attached in front of the dipole (as well as the reflector behind) as

shown in Fig. 1(c) for horizontal polarization. This multi-element array is known as a "Yagi" beam.

In Bands IV and V, the dipole and its parasitic elements are even smaller and the number of directors is usually much greater than in Band III. In addition, the dipole is frequently folded back on itself to make it easier to match the down-lead impedance. A typical u.h.f. aerial is shown diagrammatically in Fig. 1(d), for the horizontal polarization standards in Band IV/V.

As to the actual size of the aerial elements, at the lower frequency end of Band V, the dipole is about  $9\frac{1}{2}$  in long and the first director about  $8\frac{1}{2}$  in with subsequent directors slightly smaller. The reflector is usually spaced between 0.125 and 0.25 of a wavelength behind the dipole, i.e., a distance of anything from a quarter to a half the full aerial dipole length.

**Aerial signal pick-up.**—The tuned dipole itself can be as long as  $10\frac{1}{2}$  ft in Band I or as short as 7 in in Band V. But for the same pick-up, the total length of all the elements in a television aerial added together tends to be the same in Bands I, III, IV and V. Even so, u.h.f. aerials, although containing about the same amount of metal as v.h.f. aerials, are much more compact and place less strain on their mounting arrangements.

This rule of "equal ironmongery" in all bands is a wide generalization, of course. In applying it you must remember that generally the signal-to-noise ratio of the television sets themselves tends to get worse as the frequency rises. Experience to far has been that on Channel 33, Crystal Palace, around 570 Mc/s, the noise factor of a standard valve tuner over the 8 Mc/s channel width is about  $2\frac{1}{2}$  times (8dB) worse than around 45Mc/s over the 5 Mc/s bandwidth used in Channel 1. With new-generation tuners, which use special u.h.f. transistors, however, the noise performance in Band IV/V is not nearly so much worse than in Band I/III.

Another factor affecting pick-up at u.h.f. is that the signal attenuation in the average length of lead between the aerial and the set is usually about 8dB worse than at v.h.f. for the same cable.

The general conclusion is that, other things equal, more attention must be paid to the aerial in the u.h.f. bands, whether colour or black-and-white is being received, than was necessary in Band I and III.

**Polar diagrams.**—In Fig. 1 you will also see displayed the polar diagrams of the various aerial types. These indicate how the pick-up of the aerials varies with the direction from which signal is received.

We noted earlier that the simple dipole of Fig. 1(a) is omnidirectional and this gives a circular polar diagram. The addition of the reflector in Fig. 1(b) produces a cardioid, "heart shaped," polar diagram, in which the pick-up from the front is about two times (+3dB) the pick-up from a simple dipole. The pick-up as compared with a simple dipole is usually referred to as the "forward gain" and expressed in dB. Also, as the response from the rear of the aerial is reduced by parasitic elements, the term "front-to-back-ratio" is used as an indication of the maximum-to-minimum response of the aerial. With a dipole-plus-reflector H aerial, a front-to-back ratio of 10dB is typical.

The addition of director elements, as in Figs 1(c) and (d), increases the forward gain, in some designs up to 15dB total. Similarly, front-to-back ratios can be increased to 25dB. As the number of parasitic elements in the aerial increases, the "directivity" also increases, this is usually specified by an acceptance angle between the two directions at which the forward gain drops to

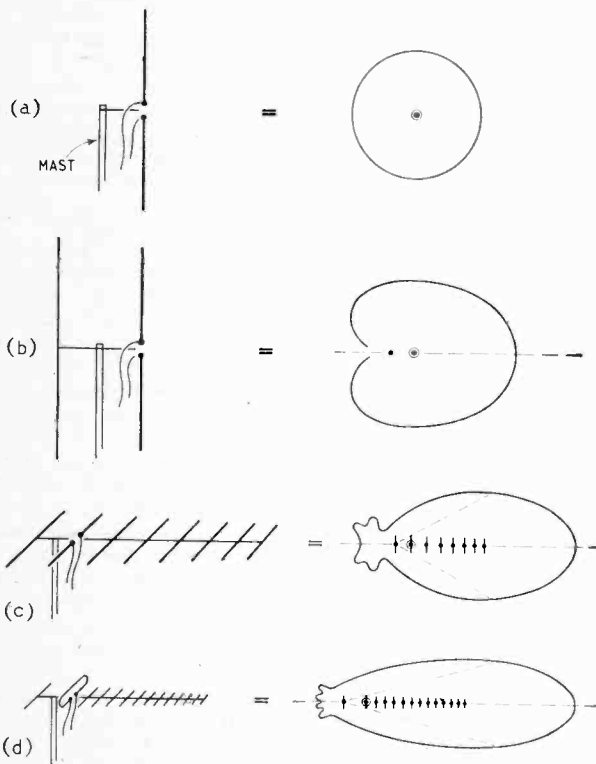

Fig. 1. Various common types of television aerials shown in simplified diagram form with their polar diagrams: (a) simple Band-I dipole, (b) Band-I dipole + reflector, (c) Band-III dipole + reflector + 6 directors, (d) Band IV/V folded dipole + reflector + 12 directors.

half the gain along the axis. Acceptance angles as low as 30° are not uncommon in multi-element arrays.

**Aerial characteristics.**—To simplify comparison of aerials of different makes, manufacturers of u.h.f. aerials have agreed that, whatever form the reflector takes, it should count only as one element, to avoid confusion when stating the number of elements. Some aerials have quite complex multi-rod or net reflectors, which count as only one reflector element. Thus an 18-element u.h.f. aerial comprises a dipole, 16 directors, and 1 reflector, even though the reflector may in fact consist of, say, four separate rods.

The specification of u.h.f. aerials is always made in terms of the three primary parameters: forward gain, directivity and front/back ratio. The forward gain specifies the amount of signal induced across the dipole terminals in a given signal field as compared with the signal that would be induced across the dipole on its own, stripped of the reflector and directors. The directivity expressed as an "acceptance angle" relates to the ability of the aerial to reject signals arriving off-centre. The front/back gain ratio indicates how well the aerial will reject pick-up from the rear, but it also indicates the ability of the aerial to avoid interference from standing waves and proximity effects resulting from the mounting arrangements.

**Aerial choice.**—The choice of aerial type depends very much on where the receiver is located with reference to the transmitter. A rule of thumb is that the number of elements should not be less than half the distance in miles from the transmitter. In ultra-fringe areas this calls for aerials "stacked," i.e., mounted side by side in parallel. (When two aerials are stacked, about 3dB extra forward gain results.)

I recently carried out a survey of u.h.f. aerials, and, among the eighteen firms in this field, found the greatest number of elements offered in a single u.h.f. aerial was 20.

Aerials now come in three colours: Red=Chs 21-34 (Band IV), Yellow=Chs 39-51 (Band V), Green=Chs 50-66 (Band V), so that the channel group for which the aerial is designed can be immediately seen from the colour code.

In colour television receiver work, the best advice is to use the highest-gain, most efficient aerial practicable in your location. The better the signal you put into the set input terminal, the better will the colour reception be.

#### UHF AERIAL CONNECTION

Later we will consider the problem of actual aerial installation, but first we will take a look at the factors involved in efficient coupling of the aerial to the receiver.

The signal to be fed to the set is normally taken off from the inner ends of the two halves of the dipole element. Now the dipole possesses impedance, and for maximum transfer of signal from the aerial to the set the down leads should present a good impedance match to the aerial. Mismatch will result in signals being reflected back and forth along the feeder line until lost. Also, part of the incoming signal may be reflected up the feeder from the receiver back to the aerial and down again to arrive after the original signal, giving rise to a fainter displaced image. Finally, the mismatch of the aerial to the feeder may promote a mismatch of the feeder to the television set and lead to u.h.f. tuner instability.

In the past, two forms of feeders have been used for

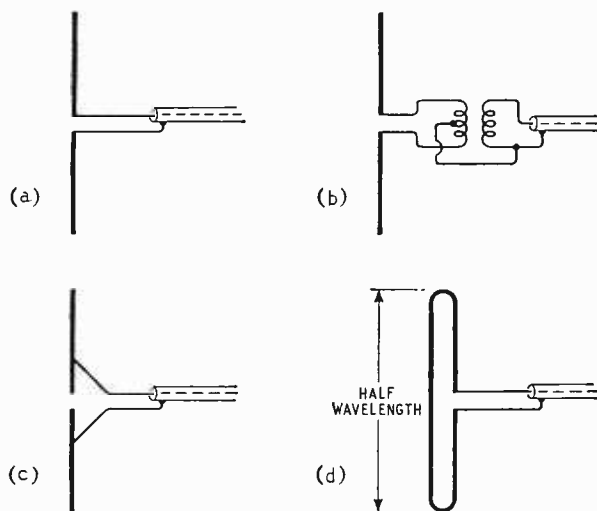

Fig. 2. Connecting a u.h.f. TV aerial dipole to feeder cable: (a) simple dipole unbalanced direct connection to coax lead, (b) "balun" (= balance-to-unbalance) transformer, (c) "delta" match, (d) folded-dipole direct connection.

connecting aerials to sets: the coaxial cable ("coax") and the twin feeder. The twin feeder has almost dropped out of use, and nowadays a coaxial cable with a characteristic impedance of about 75 ohms is standard.

The half-wave dipole is basically symmetrical, and, to preserve this balance, a twin feeder should theoretically be used, with a balanced input arrangement at the receiver. Experience has shown, however, that even at u.h.f. little trouble is caused by connecting a fundamentally unbalanced coaxial cable direct to a balanced dipole, joining the coaxial centre conductor to one half of the dipole and the earthed outer conducting sheath to the other, as shown diagrammatically in Fig. 2(a).

Coaxial cables cannot be perfectly lossless. The losses that occur in them are measured in dB per 100ft at some specified frequency. Very approximately coax losses increase as the square root of the frequency. Thus a cable with an attenuation of 1.5 dB per 100ft at 45 Mc/s in Channel 1 would probably have an attenuation of 6 dB per 100ft at 720 Mc/s in Channel 52. Therefore a good-quality, low-loss feeder should always be used for a u.h.f. aerial. In fringe and ultra-fringe areas only the best of extra-low-loss coax is advisable.

The output impedance of a simple half-wave dipole in free air is of the order of 75 ohms and admirably matches a 75-ohm coax (if terminated in a 75-ohm characteristic impedance at the set). The addition of directors and a reflector progressively reduces the aerial output impedance until it can fall as low as 10 ohms, which clearly does not make a satisfactory match to 75 ohms. One way of matching the aerial to the feeder is to use a "balun" transformer at the masthead, as shown in Fig. 2(b). This transformer converts from the balanced dipole to the unbalanced coax, and at the same time can convert the impedance appropriately. Another arrangement that has been used is the "delta" match, (Fig. 2(c)) which taps the take-off points on the dipole rods away from the centre, since the impedance rises from a minimum across the centre to a maximum across the ends.

However, by far the commonest way to match a dipole, where its impedance has been unacceptably

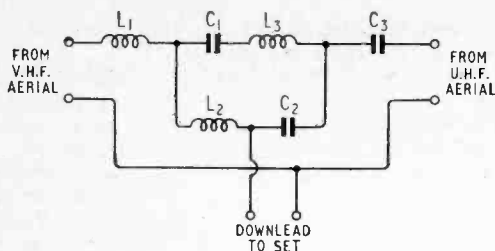

Fig. 3. Combining-unit using low- and high-pass filters to enable u.h.f. and v.h.f. aeri- als to be fed into common downlead.

lowered by parasitic elements, is to use the "folded" dipole arrangement of Fig. 2(d) feeding directly into the coax feeder. The folding of a full-wave-length aerial to give the same overall half-wave length dipole results in the centre impedance increasing four times in isolation to  $4 \times 75 = 300$  ohms. When directors and reflector are then added, the dipole impedance falls, and finally furnishes a good match to the 75-ohm feeder. The folding of a full-wave aerial into a dipole does not materially increase the signal pick-up as compared with the simple half-wave dipole.

**Separate u.h.f. and v.h.f. aeri- als.**—In areas where the u.h.f. signal is strong, and a separate u.h.f. aerial is added to the existing v.h.f. aerial array, it is sometimes possible to use the existing v.h.f. feeder to carry the u.h.f. signal as well. A combining unit ("diplexer" or "cross-over unit") is then necessary to enable the two aeri- als to be fed into the one coax without interfering with each other. Fig. 3 shows a basic circuit of a double-filter network that can be used. If you analyse it, you will see that it represents a low-pass filter accepting the v.h.f. signals from the left and a high-pass filter accepting the u.h.f. signals from the right. At the same time, it presents an all-band rejector network isolating the two aerial inputs. Commercial combining units for this purpose are readily available.

Where the u.h.f. transmissions come in from a station different from the v.h.f. station, a separate differently orientated u.h.f. aerial is normally employed. Ultimately it will be possible in many areas to receive BBC-1, ITV and BBC-2 transmitted from the same site, in which case combined v.h.f./u.h.f. aeri- als will be usable. Dual-standard sets tend to have separate u.h.f. and v.h.f. input coaxial sockets at present so that separate downleads can be used from the separate u.h.f. and v.h.f. aeri- als.

**Booster amplifiers.**—In fringe and ultra-fringe areas, it is commonly necessary to boost the signal with some form of u.h.f. preamplifier. Use of such a "booster" amplifier can give an improvement of signal-to-noise ratio up to 10 dB or so, if the amplifier is mounted at the masthead. However, to avoid the cost of adding the booster amplifier at the masthead on an existing aerial, it is possible to fit it at the bottom of the down lead. This has the disadvantage that spurious signal pick-up in the lead may be amplified. If the booster is masthead mounted, it receives its power along the coax centre lead, with isolating filters to separate the signal and power paths at both ends of the feeder. Booster amplifiers are now usually transistorized, and give a very worthwhile improvement in signal-to-noise ratio. However, they are subject to cross-modulation distortion from two signals arriving together, and it has been found difficult to protect the transistor from failure due to transient voltage "spikes" in thunderstorms.

## UHF AERIAL INSTALLATION

Because of the short wavelengths involved in u.h.f. television (from 26 in to 14 in) and because of the high reflectivity of the signals, more care must be exercised in locating the aerial than at v.h.f. U.h.f. aeri- als must be as high as possible on the chimney or house wall; the higher the aerial, the better the chance of picking up a good signal. It should be located as far as possible from other aeri- als which may upset its impedance and possibly lead to an apparent change in bandwidth. A common practice is to shift the v.h.f. aerial system into an attic and leave the u.h.f. one clear outside on its own.

Moving a u.h.f. aerial up or down a little, or sideways can lead to very pronounced changes in pick-up; as little as a few inches change can double the signal pick-up.

U.h.f. aeri- als are more highly directive than v.h.f. and require more careful orientation for optimum signal pick-up and rejection of interference and signal reflections. With v.h.f. receivers, it was often possible to site the array for the best picture quality using the receiver itself as a monitor. With u.h.f. colour, some form of signal strength meter is usually necessary because of the often low signal level and the need to site the aerial for a flat 88 Mc/s bandpass. Good u.h.f. field-strength meters are now readily available commercially.

The problem of optimising aerial arrays in ultra-fringe regions is complex. In Cambridge, where I carried out my experimental work on colour, I used the aerial set-up pictured in Fig. 4, which shows a Labgear U-18 18-element u.h.f. aerial, (15 dB forward gain, 25 dB front/back ratio, 30° acceptance angle) with a Labgear E-5122 u.h.f. masthead transistor amplifier (14 dB gain) all mounted on a Channel-Master "Compass Tenna-Liner" aerial rotator. The assembly was mast-mounted above the roof and clear of all other aeri- als on my three-storey house. As a result I was able to receive Crystal Palace, Channel 33, from the South at 60 miles and Belmont,



Fig. 4. Author's ultra-fringe, high-gain, rotatable, u.h.f. aerial system (Labgear U-18 aerial and E-5122 booster amplifier, mounted on Channel-Master "Tenna-Liner" rotator).

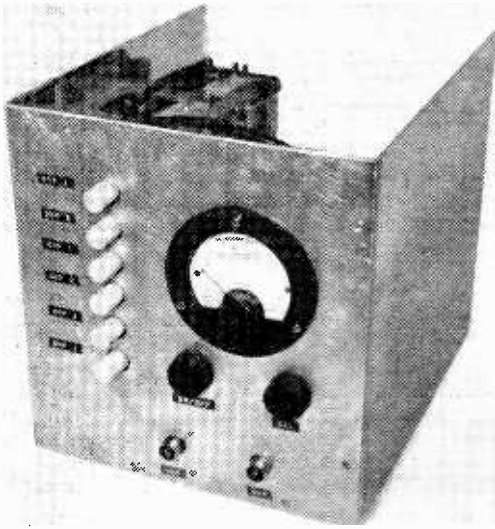

Fig. 5. Field-strength meter assembled by author to ensure optimum aerial location and orientation.

Channel 28, from the North at 80 miles with satisfactory signal strength.

In lining up the aerial system, I used the "do-it-yourself" signal strength meter shown in Fig. 5 which I built around a Pye dual-standard transistorized integrated tuner (just visible on the left in the illustration inside the case). The tuner plus a small mains power pack, a meter and a few bits and pieces gave me an instrument that enabled me to line up my aerial at will on both London and Lincoln.

**Alternatives to rooftop Yagi.** Although an adequate rooftop assembly must be the first choice for colour television reception, nowadays many housing authorities prevent the use of them. In these circumstances, the viewer may be able to "latch" into one of the efficient communal aerial systems that are being developed to pipe high-quality sound and vision signals to individual dwellings in new housing developments. Where this is not possible, he will have to make do with the best substitute he can find. Near to the transmitter, he can use one of the commercial "set-top" indoor u.h.f. aerials now available. These have the drawback that they require very careful positioning, and the signal pick-up can be affected by people moving nearby. Set-top aerials with inbuilt transistor booster amplifiers are also available, but farther from the transmitter probably the best answer is one of the loft-mounting versions of the standard u.h.f. aerials which are now available.

Loft aerials have the disadvantage that, particularly when the roof is wet, attenuation on the u.h.f. bands may be excessive, and may markedly impair the signal-to-noise ratio of received signals. My experiments with loft-mounted broadside arrays of double 18-element u.h.f. aerials (with a supporting booster amplifier) in an ultra-fringe area suggests that loft-mounted aerials, particularly if amplifier boosted, are usable well beyond the transmitter primary service area.

#### SUMMARY

Good aerial performance is of vital importance for colour reception on u.h.f. Except close to the trans-

mitter, an outside aerial should be used if possible, to ensure consistently good reception.

A good u.h.f. aerial must have satisfactory forward gain to provide the receiver with adequate signal-to-noise ratio signals to give a good picture at all times. It must also have excellent directivity and front-to-back gain ratio to eliminate unwanted signals and interference from other directions. It must have a bandwidth large enough to receive the four widely separate channels allocated to a transmitter. It must be correctly matched to the downlead for the receiver to reproduce all the signal content fed in by the aerial. Also, it must be mechanically stable so that no trouble in reception can arise from small movements of the aerial as a whole or of the individual elements within the aerial.

Apart from being sufficiently wideband to encompass the four channels spread over 88 Mc/s, the aerial must have constant characteristics across the band, mainly in forward gain, directivity and matching.

The aerial must be mounted in as high and unobstructed position as possible and only the best quality low-loss coax feeder cable should be used to connect it to the set.

There can be no doubt that the aerial is an essential factor in ensuring the benefit of 625 lines and colour available on u.h.f. are fully realized in the television receiver.

#### CORRECTIONS

**"D.C. Power Supplies."**—Mullard Ltd. have written to say that in their circuit, reproduced as Fig. 7 in the August issue (p. 377), the 1 k $\Omega$  resistor in the cathode of the PD500 performs the function of current monitoring. The feedback for taking care of valve spreads and ageing effects is provided by the circuit configuration. The potential applied to the control grid is determined by the mean load current flowing through the resistor to the stabilized boost potential. Hence the shunt stabilizer maintains a constant load current and the v.d.r. stabilization tends to maintain a constant peak voltage.

**"Sorting out the Colour Signals."**—The misplacing of a line made nonsense of two sentences in Part 7 of the series (July issue). The top line in the first column of p. 335 should be transferred to the same position on p. 334.

#### READERS' COMMENTS

In Part 6 (June issue) of his admirable series of articles on colour receiver techniques, Mr. Towers has unfortunately omitted one vital word and may have given rise to misconceptions in the minds of some of his readers.

We refer to the first paragraph on p. 285 in which it is stated "This error signal is applied to the reactance control stage, D, which in turn varies the local oscillator frequency to bring it into step with the *colour burst phase*" (our italics). This, as it stands, is incorrect; the function of the reactance control being to lock the local oscillator frequency to the *mean* colour burst phase.

Confusion is worse confounded by the paragraph on p. 286 entitled "Colour burst phase detector" which not only suffers from the same omission but also introduces the novel concepts of "unidirectional a.c." and "the phase of d.c."

H. L. BAKER and W. B. SMITH

Northwood Hills,  
Middx.

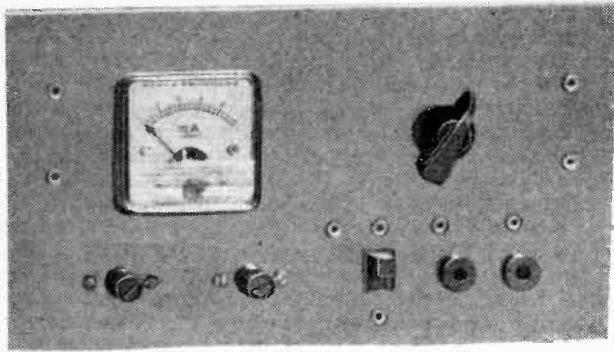

*Bridge circuit senses motor back-e.m.f. to give closed loop control for model locomotives. The method gives improved performance at low speeds and also enables an indication of armature speed to be given. Unit can be used for any small d.c. motor consuming up to 1A average at up to 12V over a speed range of 40:1.*

# Speed Control for D.C. Model Motors

By H. M. BUTTERWORTH, B.Sc., L.Inst.P.

ALTHOUGH low impedance control units (see the panel) are a great improvement over a simple rheostat for d.c. motor control, they are limited in that they do nothing about winding resistance. When the writer first looked at model power supplies, it appeared that this point was accepted, and that attempts to get round it involved feeding sufficient a.c. to the motor in the hope of rattling the armature over rough spots. This was accomplished either by injecting raw 50c/s a.c. into the drive signal, or by running a switching device at a low enough p.r.f. for some of the a.c. components of the drive signal to get through.

But if we are to really get at the root of the problem, we must get round the winding resistance. One way of doing this is to use an auxiliary circuit which can analyse the voltage appearing at the motor terminals, and develop a voltage which is proportional to the back e.m.f. This voltage can then be compared with a voltage produced by the setting of a potentiometer, and the difference used to drive an amplifier which will drive the motor in such a way as to make the difference small. This, of course, is essentially a servo-control system, which in

H. Butterworth graduated in physics at the University of Bristol in 1961. He then spent three years with a group where he was concerned with the design of high-power industrial ultrasonic equipment and is now designing high-speed electro-mechanical systems.

except that of the armature itself, has a reasonable performance when working with most motors in the power range for which it is intended.

**Bridge circuit.** Consider the circuit of Fig. 1. Here the motor is shown as a resistance  $R_W$  in series with a voltage  $V_R$ , representing the winding resistance and the back e.m.f. respectively. Then if the supply voltage is  $V_S$ , the voltage at A is  $V_S R_1 / (R_1 + R_2)$  and the voltage at B is  $(V_S - V_R) R_3 / (R_3 + R_W)$  so the difference between the two is

$$V_1 = V_S \left( \frac{R_1}{R_1 + R_2} - \frac{R_3}{R_3 + R_W} \right) + \frac{V_R R_3}{R_3 + R_W} \dots (1)$$

If things are arranged so that the bridge is balanced (i.e.  $V_1 = 0$ ) when the motor is stalled ( $V_R = 0$ ) we have

$$\frac{R_1}{R_1 + R_2} - \frac{R_3}{R_3 + R_W} = 0 \dots (2)$$

in which case (1) reduces to

$$V_1 = V_R \frac{R_3}{R_3 + R_W} \dots (3)$$

Equation 3 is independent of  $V_S$  and  $V_1$  is shown to be proportional to  $V_R$ , which is exactly what we were looking for. But first we must balance the bridge, and there are two ways in which this can be done. We may either measure the winding resistance and choose suitable values for  $R_1$ ,  $R_2$  and  $R_3$ , or we may make one of these resistors variable and adjust it to make  $V_1$  zero while the armature is held still. This latter arrangement is the

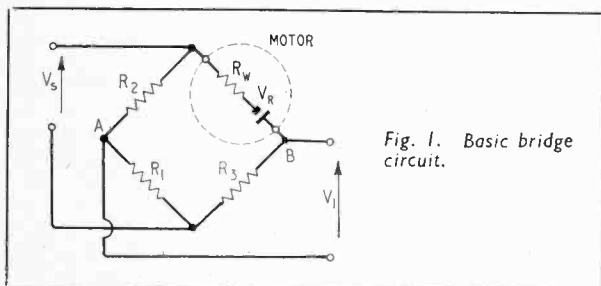

Fig. 1. Basic bridge circuit.

common with all feedback systems is liable to go into oscillation on its own account. Strictly speaking, any such device should be carefully matched to a particular motor, but an arrangement has been devised which, by keeping loop gain low and eliminating all time constants



more satisfactory, since the bridge is then readily adapted for any motor.

**Tachometer.** A voltmeter is needed to detect balance. Once this is established equation 2 is satisfied, and equation 3 holds. The voltmeter then measures a voltage which is proportional to  $V_R$ , as shown by equation 3. Since  $V_R$  to within a few per cent, is proportional to the speed of the motor, the meter may be calibrated in rev/min or mile/h. So the voltmeter can be built into the unit and used both to set up the bridge and as a speedometer.

We now have a system which, after a simple adjustment has been made, develops a voltage proportional to  $V_R$ . The next step is to compare this with a voltage set up on a potentiometer (which will become the speed control), and to use the error voltage to control the supply to the bridge, and therefore to the motor itself.

**Comparator.** The voltage  $V_1$  is developed across the bridge, and therefore has no relationship with the supply rails. For the purposes of the motor drive circuit it is

necessary to use a comparator so that a voltage can be developed which is proportional to  $V_1$  and which does take its reference from one of the supply rails. This can be achieved with a long-tailed pair circuit. Strictly speaking, we should now use a second similar circuit to compare this voltage with the reference voltage generated by the potentiometer. For present purposes, however, the arrangement shown in Fig. 2 has been found to be adequate, and involves rather fewer components. The reference voltage is developed in  $RV_3$ , and for small values it is proportional to the setting of  $RV_3$ , which therefore gives us accurate control of motor speed when it is low. For high settings,  $RV_3$  behaves rather like an accelerator control which gives a rather more "realistic feel" for model control, and incidentally reduces the risk of hunting.

The diode D1 and the resistor from the base of Tr1 to the positive rail are introduced to ensure that Tr1 can be switched off and thus prevent "inching" of the motor.

The long-tailed pair has quite sufficient voltage gain

## BACKGROUND ON D.C. MOTOR CONTROL

A voltage impressed across the brushes of a small d.c. permanent magnet motor causes a current to flow in the windings, the value of which we may derive by Ohm's Law from the applied voltage and the resistance of the armature winding. If the armature is allowed to rotate, the wires cut the magnetic field, and a voltage (often known as the back e.m.f.) is developed which opposes the applied e.m.f. This means that the voltage across the resistance of the winding must have dropped by the same amount, and so the current flowing must also drop. Since torque developed is proportional to current, the torque is correspondingly reduced. If friction is absent and the motor is entirely unloaded, its speed will rise until eventually the impressed e.m.f. and the back e.m.f. are equal, and the current has fallen to zero.

Any load on the armature causes its speed to fall, so that again current flows. The product of current and back e.m.f. represents the power available to the load, and the motor speed will fall until this power is sufficient to drive the load at a steady speed (assuming, of course, that the load is not excessive). The remainder of the power drawn from the supply is given by the product of the current and the voltage drop across the resistance of the winding and is lost as heat.

We thus can represent such a motor as a resistance in series with a voltage proportional to armature speed (Fig. A). Now, with the motor lightly loaded, the armature speed is such that the applied and back e.m.f.s are similar, and so the applied e.m.f. is a good representation

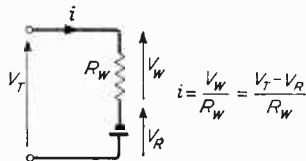

Fig. A. Equivalent circuit of motor showing how armature current is related to applied voltage  $V_T$  and induced voltage (back e.m.f.)  $V_R$ .

of armature speed. But at low armature speeds or with the armature stalled as when starting from rest, the picture is different. The back e.m.f. is small compared to the voltage across the winding resistance, and so the current flowing changes very little as the armature speed changes. This in turn means that the developed torque remains essentially constant, but the load on the motor under these conditions is usually mainly frictional and liable

to vary rapidly over a very wide range. Armature speed, therefore, is controlled by the instantaneous value of frictional resistance to motion, and has no direct relationship with applied voltage.

The "nigger in the woodpile" is, of course, the resistance of the windings, and any increase in circuit resistance contributed by the power supply just makes matters worse. So the usual approach is to drive the motor from a source whose output impedance is low compared to the winding resistance. In general there are two ways of doing this, and both have their advantages.

The first method is to use a compound emitter follower arrangement (Fig. B) containing enough transistors to

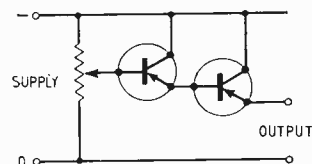

Fig. B. Compound emitter follower. Further transistors may be added if greater impedance transformation is required.

enable a sufficiently low output impedance to be obtained whilst using a high enough value for the resistance of the potentiometer to bring its wattage rating down to a convenient value. Adequate heat sinks must be provided, but excessive currents due to overload or short circuit can be avoided simply by building in sufficient resistance to the primary d.c. source.

In the second type one motor terminal is grounded, and the other is switched between ground and a supply rail by a device whose mark-space ratio can be varied over a wide range. The signal fed to the motor may then be considered as having a d.c. component dependent on the mark-space ratio, and an a.c. component which takes the form of a harmonic series all of whose components have frequencies equal to or greater than the oscillator frequency. This frequency is chosen to be high enough for the reactance of the winding inductance plus the inductance which is the reflection into the circuit of the armature inertia to be large compared to the winding resistance. The part of the equivalent circuit of the armature which involves power (the series combination of winding resistance and back e.m.f.) then merely sees the d.c. component of the drive signal. An example of a design using transistors was given in October 1966 issue of *W.W.*

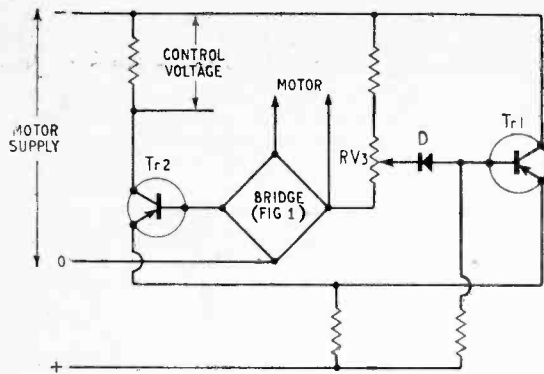

Fig. 2. Comparator circuit using long-tailed pair to compare  $V_1$  with reference voltage from  $RV_3$ .

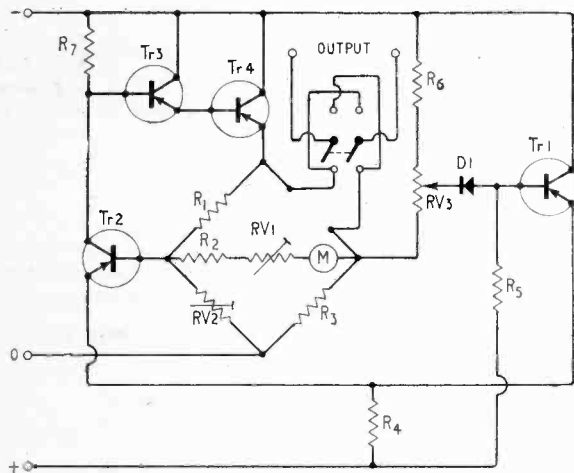
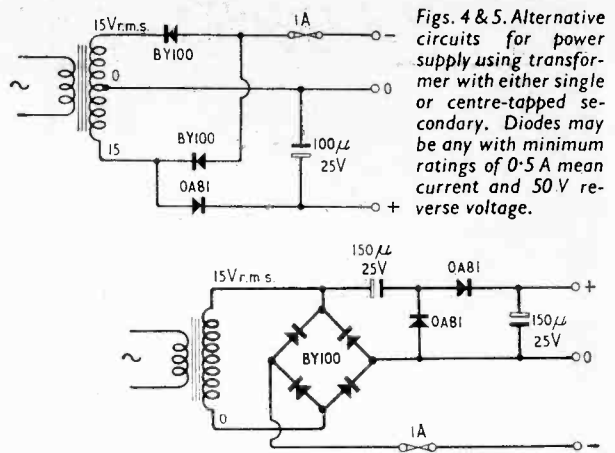

Fig. 3. Final circuit of control unit, less power supply.

for present purposes. We now need an impedance converter to couple its output to the bridge and hence drive the motor. This could be done with a switching amplifier, but it is necessary to be quite sure that none of the a.c. signal gets back into the input of the converter, and this must be accomplished without introducing phase shift into the control loop. Since for small motors there is no great heat dissipation problem for series transistors working in the amplifying mode, there seems little point in using anything other than an emitter follower. A pair of transistors is needed to obtain a high enough impedance transformation, and the circuit, now complete, is as shown in Fig. 3. The transistors may all be OC84 (with Tr3 held in a clip to the chassis as heat sink) except Tr4, which may be any member of the OC28 series, although it should be in reasonable condition, for if it leaks too much when hot it may cause Tr3 to overheat. It should be mounted on a heatsink at least 4in square by  $\frac{1}{4}$ in thick (aluminium) around which cool air must be able to circulate freely.

**Power supply.** Suitable power supplies are indicated in Figs. 4 and 5. If a split-phase transformer is available, full wave rectification is accomplished by two diodes such as BY100. A 12 V r.m.s., 1.5 A transformer can be converted for 15 V split phase by re-winding the secondary with the appropriate number of turns (30/12 of the original number, centre tapped) of wire of diameter



Figs. 4 & 5. Alternative circuits for power supply using transformer with either single or centre-tapped secondary. Diodes may be any with minimum ratings of 0.5 A mean current and 50 V reverse voltage.

0.56 of that of the original. The positive voltage for the tail of the differential pair is then developed by an OA81 and a 100 μF, 25 V capacitor. This is shown in Fig. 4. If the transformer cannot be modified a bridge circuit must be used, as in Fig. 5. The rather elaborate circuit necessary to develop the positive supply voltage will be noted.

Some power is lost, as with all transistor power supplies, in the control circuits, and so a 15 V r.m.s. transformer is needed where a 12 V one might have been used with a rheostat. However, as most models manage a scale 150 mile/h or so when driven this way, a 12 V r.m.s. transformer may be found adequate.

It has been found that in practice the omission of smoothing from the negative supply is evident as a somewhat rougher running of the motor at low speeds, but that this is more than compensated for by the effect on friction of the a.c. component at very low speeds. It also saves on expensive components.

A fuse is incorporated in the circuit diagram. Actually, the circuit will stand occasional short circuit without damage, but Tr4 is liable to get excessively hot if the unit is left with its output short circuited for any length of time. The meter goes hard over under these conditions, and if it is sure to be noticed and the trouble remedied within a reasonable time, the fuse may be discarded.

**Setting up.** The setting up procedure is as follows. The motor is held so that it cannot rotate, and the speed control advanced sufficiently to enable the meter to be brought to zero using  $RV_2$ , which is very quickly done. With three-pole motors it is a good idea to let the armature rotate a little and check the reading in case the brushes had found a rough spot on the commutator. Calibration of the meter, which is adjusted by  $RV_1$ , must be carried out by estimating the scale speed of the model and setting  $RV_1$  accordingly. Both these controls must, of course, be set for each motor.

#### COMPONENTS

$R_1$	120 $\Omega$	1W	$RV_1$	2.5 k $\Omega$	1in. carbon
$R_2$	1.2 k $\Omega$	$\frac{1}{2}$ W	$RV_2$	100 $\Omega$	w.w. 1W
$R_3$	4.7 $\Omega$	5W	$RV_3$	2.5 k $\Omega$	1in. carbon
$R_4$	2.2 k $\Omega$	$\frac{1}{2}$ W	Tr1, 2, 3	OC84	
$R_5$	22 k $\Omega$	$\frac{1}{2}$ W	Tr4	OC28, OC29, OC35,	
$R_6$	2.2 k $\Omega$	$\frac{1}{2}$ W		OC36,	
$R_7$	2.7 k $\Omega$	$\frac{1}{2}$ W	D1	OA81	

All resistors  $\pm 10\%$  tolerance.



# Marconi is advanced space communication

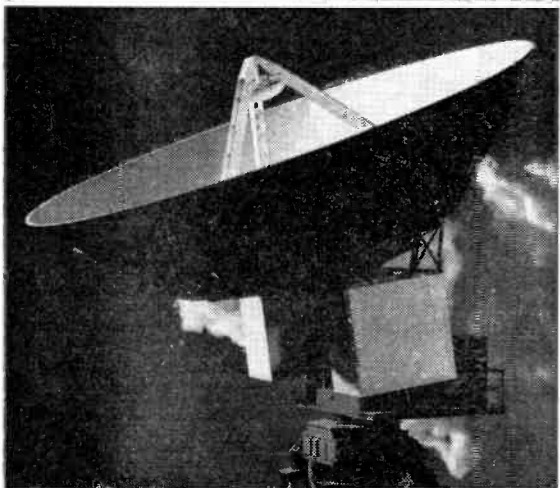
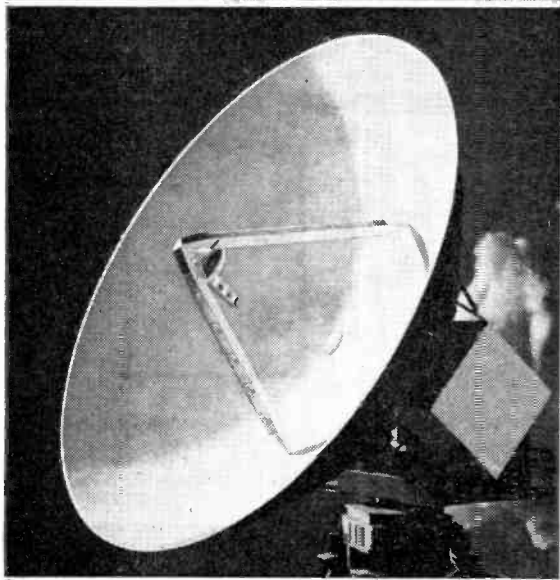
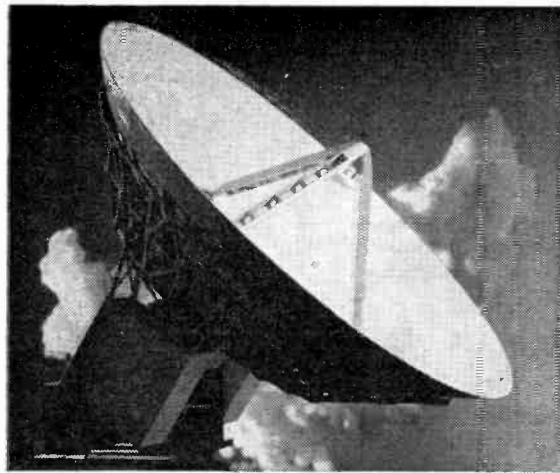

Britain's first overseas civil satellite communication ground station has been built by Marconi on Ascension Island for Cable and Wireless Limited. Marconi has also supplied Britain's first three military space communication stations.

Marconi space capability is based on long experience in all the elements required by communication systems via synchronous and random orbit satellites—computers for traffic handling and aerial direction, highly accurate aerial and servo control systems, ultra high frequency transmitters and extremely sensitive receivers. Marconi has a lifelong experience in planning, designing, manufacturing, installing and commissioning complete operational systems anywhere in the world.

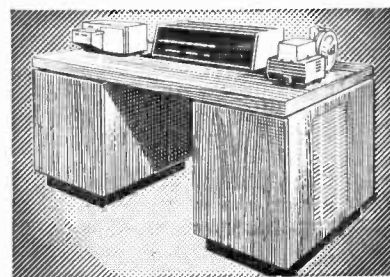

Marconi Myriad computer—a vital part of many Marconi space communication systems.

## Marconi space communications systems

AN 'ENGLISH ELECTRIC' COMPANY

The Marconi Company Limited, Space Communication Division, Chelmsford, Essex, England

LTD/P51

WW-099 FOR FURTHER DETAILS

# The Lilliput Series

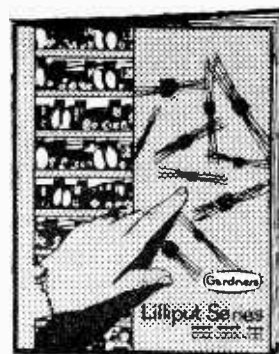

ULTRA MINIATURE, INVERTER, WIDE BAND, CARRIER MATCHING, DRIVER AND PULSE TRANSFORMERS, A.F. AND SMOOTHING INDUCTORS

Gardners Lilliput series of Ultra Miniature transformers has been specifically developed for compatibility with other wired-in modules used on printed circuit boards. Exceptional performance has been achieved by a unique form of construction incorporating extremely thin (down to 3.2 microns) high permeability core materials and a very short length of coil turn. Transformers in this new series are particularly suitable for pulse and switching circuits with rise times of 10 nanoseconds or less

GT 12A. Describes the Lilliput series of Ultra Miniature transformers and gives useful information and data on their application in transistor converter/inverter, wide band communication and high speed pulse circuits.

# The Alpha Series

FILTERS, DELAY LINES, TRANSFORMERS, MODULATORS, HIGH STABILITY INDUCTORS, TUNED CIRCUITS, OSCILLATORS

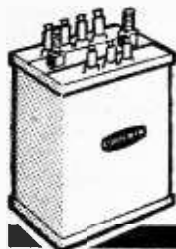

A range of custom built components from simple or hybrid transformers and modulators to highly complex multi-section filters or complete active networks of exceptional stability hermetically sealed to DEF. 5214 Humidity Class H1.

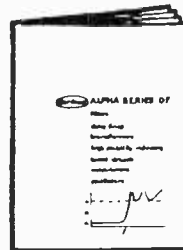

GT 16. Gives a general description of the Alpha series assemblies and describes their suitability for wound components where a high degree of stability is required.

# Low Voltage Isolating and Auto Transformers

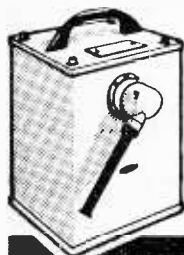

A comprehensive range of conventional double wound and auto transformers for applications in industry and in the home. Nearly 200 types are available in six different styles and with outputs from 6 volts to 240 volts and from 5VA rating to 2 kilowatts. All types are normally held in stock in reasonable quantities for immediate delivery.



GT 17. Everyone in the electronics industry uses low voltage, isolating and auto transformers at some time or other and this booklet describes the complete Gardner range of this type of transformer in a convenient and presentable form.

Complete coupon and post indicating publication(s) required



Gardners Transformers Ltd., Christchurch, Hampshire  
Telephone: Christchurch 1734 Telex 41276

Lilliput Series  Alpha Series   
 Low Voltage Isolating, Auto Transformers   
 Name .....  
 Designation .....  
 Company .....  
 Address .....

WW-100 FOR FURTHER DETAILS

# Standard Frequency Transmissions

## Survey of Characteristics of Standard Frequency and Time Signal Stations

By J. McA. STEELE,\* B.Sc.(Eng.)

SINCE the publication of the article in *Wireless World* in April 1962 summarizing the characteristics of standard frequency and time signal emissions, the requirements for greater accuracy in frequency determination have resulted in a decided shift in emphasis away from the high frequencies towards the use of low- and very-low frequencies where propagation is sufficiently stable and reproducible to permit frequency comparisons of the highest precision. At v.l.f. a comparison accuracy of one or two parts in  $10^{11}$  can be achieved over 24 hours at ranges up to 10,000 km, using frequencies in the range 15 to 25 kHz. At shorter ranges the l.f. band is being increasingly used for the dissemination of both time and frequency and does not suffer from the limitations of mutual interference and varying propagation which beset high frequencies. There are now stations in operation on 40, 50, 60, 75, 77.5 and 80 kHz and in addition two European broadcasting stations—Allouis (164 kHz) and Motala (191 kHz)—following the example of Droitwich (200 kHz), now operate with precisely controlled carrier frequencies.

It is encouraging that many of the stations in the l.f. band radiate frequencies adjusted to nominal in the atomic scale and without the fractional frequency offset which is applied to all controlled emissions at v.l.f. The question of the offset is considered in more detail later but briefly it accommodates the present difference between the scale of atomic time and the scale of Universal Time (UT2) based on the Earth's period of axial rotation. The extent of the offset is subject to annual review and in the past changes in the offset have been a source of inconvenience to users of the standard frequency services. Atomic frequency standards are now available commercially from several sources and a number of the stations listed in Table 1 are controlled either directly or indirectly by reference to an atomic generator. This is particularly appropriate at l.f. and v.l.f. and also at very high frequencies where the stability of propagation is well matched to the frequency stability of the controlling standard.

### HIGH-FREQUENCY EMISSIONS

In the h.f. band the frequencies of 2.5, 5, 10, 15, 20 and 25 MHz are allocated internationally to the standard frequency services. They may also be used by the radio astronomy service and in addition the bands 10.003-10.005 and 19.990-20.000 MHz are available on a secondary basis to the space and earth-space services for research purposes. Despite the extension of controlled frequency emissions to both higher (v.h.f.) and lower (l.f. and v.l.f.) frequencies, the h.f. band continues to provide a widely used service of time and frequency reference. It is true to say that with the increasing standard of

accuracy required in industry and research the h.f. carrier frequencies are now less useful since the signal is usually received after reflection in the ionosphere and Doppler effects restrict the stability to, at best, one or two parts in  $10^8$ , while variations ten times as great may be experienced at sunrise and sunset. Where the local frequency source can be operated as a clock the use of the time signals enables the diurnal and Doppler effects to be largely eliminated by extending measurements over 24 hours. The limiting accuracy in time setting is then governed by other factors such as multi-path propagation and selective fading of the sidebands of the modulated signals. The h.f. stations will continue to provide a satisfactory service of time signal dissemination to an accuracy of a few tenths of a millisecond although in the absence of firm time or frequency sharing arrangements the usefulness of the service will still be impaired in certain areas by mutual interference between stations.

In Table 1 are given the characteristics of 15 stations, operating either with single or multiple emissions on the allocated frequencies in the range 2.5 to 25 MHz. Also included by reason of their general usefulness are the stations CHU (Ottawa) and DIZ (Nauen) both of which provide a continuous emission of time signals at intermediate frequencies. The Table is confined to those stations operating with stabilized carrier frequencies which are coherent with the time signals or, at least, remain in a known relationship with the phase of the time signals. There are many other time signal emissions with unstabilized carrier frequencies which this article does not attempt to cover. For the schedules of these emissions the appropriate publications of the Bureau International de l'Heure (B.I.H.) or the International Telecommunication Union (I.T.U.) should be consulted. It will be noted in Table 1 that the majority of stations operate with an aerial power of a few kilowatts and it is an advantage of h.f. propagation that such modest powers provide wide coverage. It should be noticed also that WWV is now located at Fort Collins, Colorado, and that reception in Europe is likely to be less certain than when the transmitters are operating from Beltsville, Maryland.

The information in Table 1 is supplemented by details of the hourly modulation schedule, presented in schematic form in Fig. 1 and showing the sequence of alternating periods of tone or pulse modulation. The form and content of the station announcements and the type of time signal modulation are also described. One of the past recommendations of the International Radio Consultative Committee (C.C.I.R.) was that modulated time signals should take the form of  $m$  cycles of 200  $m$  Hz ("where  $m$  is an integral number limited by the bandwidths allotted for standard-frequency transmissions and time signals") thereby producing a pulse of constant

\* National Physical Laboratory, Teddington

TABLE 1  
Schedule of standard frequency and time signal stations in the h.f. band at June 1967

Call sign and approximate location	ATA Kalkaji, Delhi, India	BPV Shanghai, China	CHU Ottawa, Canada	DIZ Nauen, German D. Rep.	FFH Cher- vannes, France	IAM Rome, Italy	IBF Turin, Italy	JJY Tokyo, Japan	LOL Buenos Aires, Argentina	MSF Rugby, U.K.	OMA Liblice, Czecho- slovakia	RWML- RAT Moscow, U.S.S.R.	WWV Ft. Collins, U.S.A.	WWVH Hawaii, U.S.A.	ZLFS Lower Hutt, N. Zealand	ZUO Oifants- fontein, S. Africa	ZUO Johannes- burg, S. Africa
Latitude	28° 34' N	31° 12' N	45° 18' N	52° 39' N	48° 32' N	41° 52' N	45° 02' N	35° 42' N	34° 37' N	52° 22' N	50° 04' N	55° 45' N	40° 41' N	20° 46' N	41° 14' S	25° 58' S	26° 11' S
Longitude	77° 19' E	121° 26' E	75° 55' W	12° 55' E	2° 27' E	12° 27' E	7° 43' E	139° 31' E	58° 21' W	1° 11' W	14° 53' E	37° 18' E	105° 02' W	156° 28' W	174° 55' E	28° 14' E	28° 04' E
Carrier power to aerial (kW)	2	—	0.3, 3, 5	5	5	1	5	2	2	0.5	1	20	2.5, 10	2	0.3	4	0.25
Carrier (MHz)	10	5, 10, 15	3, 330, 7, 335, 14, 670	4, 525	2.5	5	5	2.5, 5, 10, 15	5, 10, 15	2.5, 5, 10	2.5	2.5, 5, 10, 15	2.5, 5, 10, 15	2.5, 5, 10, 15	2.5	5	10
Frequencies used	1, 1000	1, 1000	1	1, 1000	1, 1000	1, 1000	1	1, 1000	1, 440, 1000	1	1, 1000	1, 1000	1, 440, 600	1, 440, 600	Nil	1	1
Days of operation	Mon.-Fri.	7	7	Mon.-Fri.	Mon.-Fri.	Mon.-Sat.	7	7	Mon.-Sat.	7	7	7	7	7	Tues.	7	7
Hours per day	05.30-07.30	24	24	08.00-16.25	08.00-16.25	07.30-08.30	†	24	§	24	24	‡	24	24	01.00-04.00	24	24
Accuracy of frequency and time intervals* (parts in 10 <sup>10</sup> )	±200	—	±1	±50	±2	±1	†	±1	±10	±1	±10	±50	±0.5	±1	±10	±1	not offset

TABLE 2  
Schedule of standard frequency and time signal stations in the i.f. and v.l.f. bands at June 1967 (excluding navigational stations)

Call sign and approximate location	GBR Rugby U.K.	NAA Cutler Maine U.S.A.	NCK/NPG Jim Washing- ton U.S.A.	WWV Ft. Collins Colorado U.S.A.	NSS Annapolis Maryland U.S.A.	NPM Lualaba Hawaii U.S.A.	NBA Balboa C.Z. U.S.A.	JJM/6/ IG2AS Kamigawa Japan	OMA Liblice Czecho- slovakia	MSF Rugby U.K.	WWVB Ft. Collins Colorado U.S.A.	HGB Prangins Switzer- land	DFC77 Main- flingen G.F. Rep.	CYZ40 Ottawa Canada	RES Moscow U.S.S.R.	Allouis France	Motala Sweden	Droit- wich U.K.
Latitude	52° 22' N	44° 39' N	48° 12' N	40° 41' N	38° 59' N	21° 25' N	09° 04' N	35° 38' N	50° 04' N	52° 22' N	40° 41' N	46° 24' N	50° 01' N	45° 21' N	55° 45' N	47° 10' N	58° 26' N	52° 18' N
Longitude	01° 11' W	67° 17' W	121° 55' W	105° 03' W	76° 27' W	158° 09' W	79° 39' W	140° 04' E	14° 53' E	01° 11' W	105° 03' W	06° 15' E	09° 00' E	75° 53' W	57° 18' E	02° 12' E	14° 12' E	02° 06' W
Carrier power to aerial (kW)	60	1000	250	1.7	85	300	150	10	5	10	7	25	12	20	500	500	600	400
Carrier (kHz)	16.0 (15.95)	17.8	18.6	20.0-19.9	21.4	23.4	24.0	40	50	60	60	75	77.5	80	100	164	191	200
Frequencies used	1	nil	nil	nil	1	nil	1	nil	1	1	1	1	1	1	1	A3 broadcast	1	1
Days of operation	7	7	7	7	7	7	7	7	7	7	7	7	Mon.-Sat.	7	7	7	7	7
Hours per day	24	24	24	24	24	24	24	24	24	24	24	24	5½	24	24	24	24	22
Duration of time signal emission (minutes)	4 x 5 (2)	nil	nil	nil	55-60 in each hour	nil	55-60 in each hour (3)	nil	23 hours per day (4)	cont.	cont.	cont.	(5)	nil	55-60 in each hour (6)	nil	nil	nil
Accuracy of (1) frequency and time intervals* (parts in 10 <sup>10</sup> )	±1	±0.5	±0.5	±0.2	±0.5	±0.5	±0.5	±0.5	±10	±1	±0.2	±0.2	±5	±1	±50	±0.5	±2	±5

**FOOTNOTES TO TABLE 1**

\* All times are G.M.T. The hourly modulation schedule is given in schematic form, where appropriate, in Fig. 1.

† IBF operates from 06:45-07:00 and for 15 minutes preceding the hours 09:00, 10:00, 11:00, etc., until 18:00.

‡ LOL transmits for one hour at 11:00, 14:00, 17:00, 20:00 and 23:00.

§ RWM-RAT follows a variable schedule on one or other of the frequencies indicated; examples of the programme are given in the text.

\* All the stations in the Table, with the exception of BPV and RWM-RAT, attempt to maintain their time signals in agreement to within about 1 ms with the international co-ordinated time scale U.T.C. The rate of the time signals differs from that of a clock keeping atomic time by the amount of the frequency offset which is announced for each year by the Bureau International de l'Heure (B.I.H.). For 1967 the offset is 300 parts in 10<sup>11</sup>, equivalent to 2.592 ms per day. The carrier frequencies of nearly all h.f. stations are offset from nominal by this amount and the figures for accuracy given in the Table are therefore with respect to the offset value. The exceptions to this practice are IBF,† and ZUO; these emissions operate with the carrier frequencies adjusted to nominal in the atomic scale and zero offset. The time signals, however, continue to adhere to the co-ordinated system, U.T.C.; a suitable time scale conversion being introduced at the transmitter between the carrier and time signal generators.

**FOOTNOTES TO TABLE 2**

(1) The same distinctions in regard to accuracy apply as detailed in footnote \* to Table 1. Nearly all stations attempt to maintain their time signals in agreement to within about 1 ms with the international co-ordinated time scale U.T.C. The exceptions are WWVB, DCF77 and RES. No offset is applied to either the carrier frequency or the time signals of WWVB and DCF77. These two stations co-ordinate the times of emission of their signals to within 1 ms and adjustments are made simultaneously, when necessary, in steps of 200 mc. These are the only stations at present transmitting seconds pulses; in all other emissions the interval between seconds pulses is greater than one second by the amount of the offset.

(2) Time signals are radiated for 5 minutes preceding the hours 03:00, 09:00, 15:00 and 21:00 U.T.

(3) Except 23:55 to 24:00 U.T.

(4) Unmodulated carrier between 10:00 and 11:00 U.T. except for the call sign OMA at the beginning of each quarter hour.

(5) (Atomic) seconds pulses controlled by the Physikalisch-Technische Bundesanstalt (PTB) from 07:45-07:59, 08:30-10:59, 11:30-11:35, 20:11-20:29, 20:41-20:59 and then at 57:59 minutes in each hour until 00:57-00:59 (November to February) or 02:57-02:59 (March to October). 440 Hz modulation at 08:11-08:29 and 200 Hz modulation from 11:11-11:29.

(6) (U.T.C.) seconds controlled by the Deutsche Hydrographische Institut (DHI) from 08:00-08:10, 11:00-11:10, 20:00-20:10, 20:31-20:40, 21:00-21:10 and then at minutes 00-10 in each hour until 01:00-10:10 or 13:00-13:10.

length equal to 5 cycles. In practice, as Fig. 1 shows, a pulse consisting of 5 cycles of 1,000 Hz is used by the majority of emissions. However, the system constitutes a useful method of discriminating between potentially interfering emissions and finds satisfactory application in the Pacific area where WWVH makes use of a signal consisting of 6 cycles of 1,200 Hz tone while JJY uses a signal consisting of 8 cycles of 1,600 Hz. Pulses departing from the C.C.I.R. formula are radiated by stations BPV, CHU, DIZ and RWM-RAT, all of which make use of considerably longer signals. The seconds pulses of CHU last for 200 cycles of 1,000 Hz, extended to 500 cycles at the minutes and to 1,000 cycles at the hours. Each minute pulse is preceded by a voice announcement of the time in minutes and hours. Further time identification is provided by omitting the pulse at minute 29 and from minutes 51 to 59; the pulses from minutes 1 to 10 in each hour are also suppressed. Station DIZ emits telegraphy signals lasting 100 ms at the seconds and about 600 ms at the minutes. The emissions of RWM-RAT also make use of telegraphy signals and include short periods when rhythmic (61/minute) seconds are broadcast as well as standard 1 Hz and 10 Hz pulses. The rhythmic seconds are radiated in minutes 0-6 after each even hour (U.T.). Seconds signals, 100 ms long, are emitted in minutes 20-25, 30-35 and 50-55 in each hour, the minute pulse being lengthened to about 500 ms. Seconds pulses are also radiated in minutes 25-30, 35-40 and 55-60 in each hour. In these periods the minute is not identified and each seconds pulse is followed 200 ms later by a train of 8 pulses, 20 ms long and spaced 100 ms apart. In the intervals between pulse transmissions there are periods of unmodulated carrier, the carrier frequencies in use throughout the day being chosen to ensure the most favourable propagation.

The same basic schedule of pulse transmission of RMW-RAT is followed by other Russian stations operating either at the same carrier frequencies or at frequencies staggered 4 kHz above and below the nominal values. The details are as follows:

Call sign and location	RCH-RIM Tashkent	RTA Novosibirsk	RKM-RID Irkutsk
Latitude .. ..	41° 19' N	55° 04' N	52° 18' N
Longitude .. ..	69° 15' E	82° 58' E	104° 18' E
Frequencies (MHz)	2.5, 5, 10, 15	4.996 9.996 14.996	5.004 10.004 15.004

It will be seen from Fig. 1 that WWV and to a lesser extent WWVH provide information in their announcement periods additional to that required of a simple standard frequency and time signals service. WWV radiates radio propagation forecasts every 5 minutes. These consist of a letter and number code: N=normal, U=unsettled and W=disturbed, while the numbers run from 1 to 9 and indicate a gradation from useless (1) through fair (5) to excellent (9). Time information giving the second, minute, hour and day of the year is emitted in binary coded decimal (b.c.d.) form ten times per hour, i.e. in each 5-minute period except the first and the tenth. The code consists of nine b.c.d. groups, two each for the seconds, minutes and hours and three for the day of year. Code weighting is 1-2-4-8 and a complete time frame occupies 1 second. The code is synchronous with the frequency and time signals, a binary "zero" consisting of 2 cycles of 1,000 Hz and a binary "one" of 6 cycles of 1,000 Hz. The leading edge of the time code pulse coincides with the

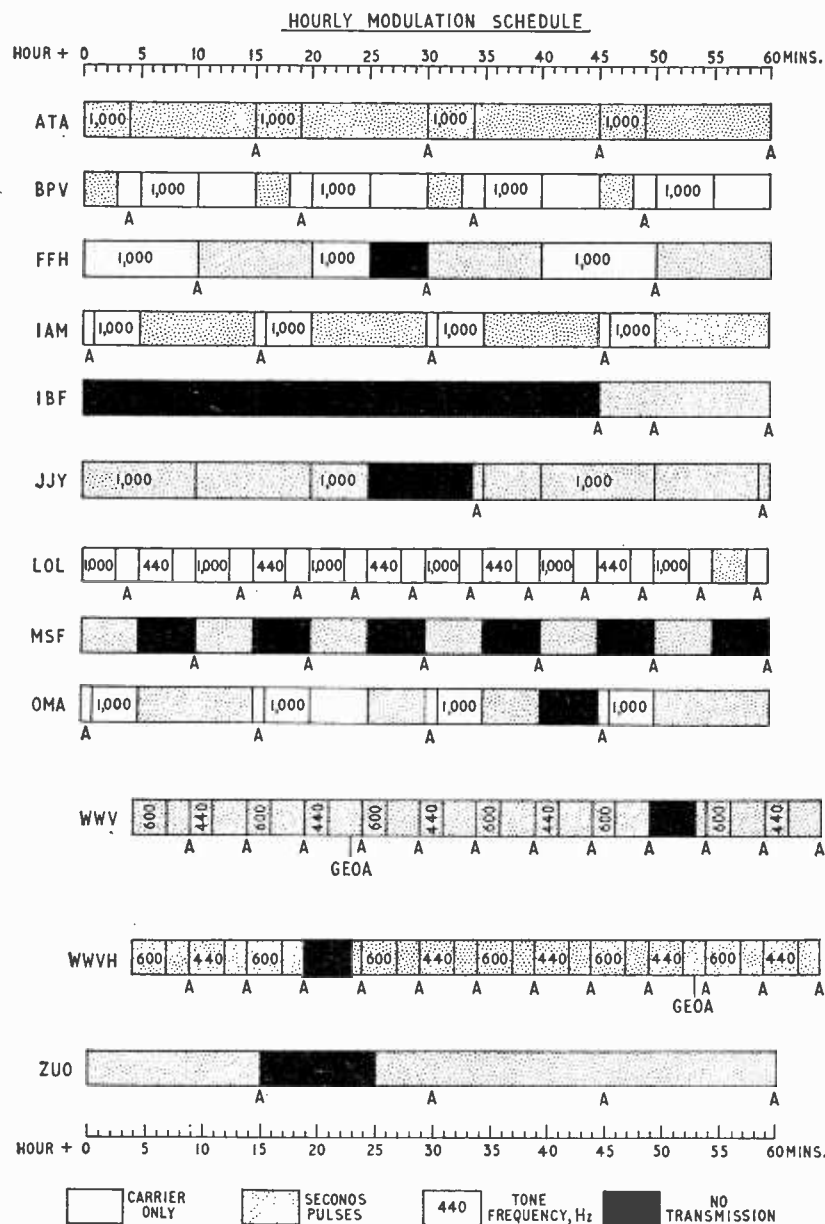

**FORM OF SECOND AND MINUTE SIGNALS, MORSE AND VOICE ANNOUNCEMENTS (A)**

Pulse of 5 cycles of 1,000 Hz tone lengthened to 100 ms at the minute. Call sign and time (U.T.) in morse and voice.

Pulse of 100 cycles of 1,000 Hz tone; no identification of minute. Call sign in morse repeated during two minutes.

Pulse of 5 cycles of 1,000 Hz tone; minute pulse followed by 500 Hz tone for 500 ms. Call sign in morse and voice announcement.

Pulse of 5 cycles of 1,000 Hz tone, repeated 4 times at the minute. Call sign in morse and voice identification.

Pulse of 5 cycles of 1,000 Hz tone, repeated 7 times at the minute. Call sign and time (U.T.) in morse; voice identification at beginning and end of emission.

Pulse of 8 cycles of 1,600 Hz tone, minute pulse preceded by 600 Hz tone for 655 ms. Call sign and time (JST) in morse and voice. Radio propagation warnings in letter code: N (normal), U (unstable) and W (disturbed).

Pulse of 5 cycles of 1,000 Hz tone, 59th pulse omitted. Call sign in morse, identification and time (U.T.-3h) in voice. Tone modulation lasts for 3 minutes in each 5-minute period.

Pulse of 5 cycles of 1,000 Hz tone, lengthened to 100 ms at the minute. Call sign in morse.

Pulse of 5 cycles of 1,000 Hz tone, 100 ms pulse at minute and 500 ms pulse every 5th minute. Last 5 pulses in each quarter hour 100 ms long. From minute 55-60 in every 3rd hour 100 ms pulses lengthened to 500 ms. Call sign in morse. 1,000 Hz tone suppressed from 18.00 to 06.00 U.T.

Pulse of 5 cycles of 1,000 Hz tone, 59th pulse omitted and minute pulse repeated 100 ms later. Call sign and time (U.T.) in morse and voice. Radio propagation forecasts in letter and number code. Time code (second, minute, hour and day of year) ten times per hour. Frequency offset in morse on hour. Geophysical alerts (GEOA) in first half of 19th minute; in second half UT2 time correction.

Pulse of 6 cycles of 1,200 Hz tone, 59th pulse omitted and minute pulse repeated 100 ms later. Frequency offset in morse on the hour. Geophysical alerts (GEOA) in first half of the 49th minute; in second half UT2 time correction. Call sign and time (U.T.) in morse and voice.

Pulse of 5 cycles of 1,000 Hz tone, lengthened to about 500 ms at the minute.

positive-going crossing of the 1,000 Hz modulation so that millisecond time resolution is readily obtained.

**FREQUENCY OFFSET AND TIME CO-ORDINATION**

Reference has already been made in the footnotes to Table 1 to the different bases of accuracy for the standard frequency emissions. Two distinct aspects are involved here—time co-ordination and the use of offset or non-offset frequencies. As indicated, co-ordination of time signals now embraces nearly all emissions and is clearly a great convenience to the user who may thus make use of co-ordinated stations interchangeably, knowing that they are adjusted to the common time scale U.T.C. and taking care only to apply the propagation delay appropriate to each station. Until recently all co-ordinated h.f. emissions operated with the offset applied

uniformly to the carrier frequency and the time signal pulses. This system has the advantage that coherence between carrier and time signals is maintained, the interval between successive time pulses being an exact multiple of the carrier period, e.g. 5,000,000 periods at 5 MHz. The disadvantages are twofold. First, it is undesirable in principle to radiate a "standard frequency" which is, in fact, offset from the internationally agreed standard by several parts in 10<sup>8</sup>. Also, the interval between "seconds" pulses is no longer 1 second but differs from the international unit of time interval by the amount of the offset. In consequence the interval between corresponding pulses on successive days, at present, exceeds 86,400 seconds by 2.592 ms. The second objection lies in the application of the system. The offset is designed to harmonize the variable time scale (UT2) based on the Earth's mean rate of rotation on



its axis and the invariant time scale realized by atomic standards. The Earth is subject to unpredictable variations in rate and these are reflected in the yearly adjustments to the value of the offset. In the past these have been as large as 150 parts in  $10^{10}$ , and changes of such magnitude have been disturbing to many users. Where local atomic standards are in use these have to be provided with auxiliary equipment to generate the changing offset if comparisons with received emissions are to continue on the same basis from year to year.

Although several stations have been operating in the l.f. band for some years with non-offset carrier frequencies it was only in 1966 at the C.C.I.R. Plenary Assembly in Oslo that the regulations affecting the h.f. emissions were relaxed to permit the use of non-coherent carriers and time signals. As a result there are now three stations, IBF, MSF and ZUO, as shown in Table 1, where the carrier is no longer offset. The advantages of time co-ordination are so great that the offset for the time signals has been maintained, a time scale converter at the transmitter developing the necessary offset for the time signal generator. In the case of MSF this takes the form of an electro-mechanical phase-shifter which can be readily adjusted in steps of  $\pm 50$  parts in  $10^{10}$  to operate at any value of the offset in the range  $\pm 500$  parts in  $10^{10}$ . The phase jitter from the device is less than  $0.1 \mu\text{s}$ . Since the 2nd June, 1967, all the MSF carrier frequencies, including MSF 60 kHz, have been derived from a rubidium gas cell standard at Rugby. This also supplies the (offset) drive for GBR 16 kHz. Atomic frequency control is also used for the emissions of WWV and ZUO.

#### VERY-HIGH FREQUENCIES

The range of v.h.f. emissions is necessarily limited to line-of-sight distances or slightly beyond and it seems appropriate to consider separately the three standard frequency and time signal stations operating in Band 8 (30-300 MHz). The characteristics of the stations are as follows:

Call sign and location	SAZ Enköping Sweden	SAJ Stockholm Sweden	ZUO Johannesburg S. Africa
Latitude .. ..	59° 35' N	59° 20' N	26° 11' S
Longitude .. ..	17° 08' E	18° 03' W	28° 04' E
Frequency (MHz) ..	100	150	100

The Swedish stations have zero offset for the carrier frequency and in the case of SAJ, which radiates time signals during its limited period of operation (09:30-11:30 U.T. each Friday) these are coherent with the carrier frequency. SAZ provides a continuous unmodulated carrier. ZUO also radiates continuously a non-offset carrier derived from the atomic standard controlling the lower frequency ZUO emissions, the carrier being modulated with 100 kHz and 1 Hz signals.

#### LOW AND VERY LOW FREQUENCY EMISSIONS

When the first experimental service from MSF was begun in 1950 it was recognized that the h.f. transmissions would be subject to frequency variations induced in propagation. To provide a more stable reference frequency, therefore, the programme was enlarged to include a short period of transmission on 60 kHz. This ensured ground wave coverage of the British Isles and western Europe: in fact the transmission was also received on the east coast of the United States and following the successful phase measurements there on 60 kHz it was

suggested that the MSF oscillator should be used to control the frequency of the Rugby long-wave transmitter, GBR, operating on 16 kHz. This was done in 1954 and enabled the MSF standard to be distributed virtually world-wide by means of the favourable propagation at v.l.f. Much of the pioneer work on the stability of v.l.f. propagation was carried out using the GBR transmission and the results led to the extension of precise frequency control to other v.l.f. stations, particularly those operated by the U.S. Navy. The value of v.l.f. emissions for precise frequency (and phase) distribution was recognized by allocating a band of  $\pm 50$  Hz centred on 20 kHz to the standard frequency service. At present it is occupied by one of the emissions from station WWVL of the National Bureau of Standards. In addition the International Radio Regulations allow all stations with allocations in the range 14-70 kHz to emit standard frequencies and time signals. The characteristics of stations operating in this band are given in Table 2, the stations being listed in ascending order of frequency from 16 kHz and including the upper part of the l.f. band as far as 200 kHz. The stable propagation which is such a desirable feature of the v.l.f. band makes it a natural choice for the operation of radio navigational systems. There are now many stations established both at l.f. and v.l.f. and emitting highly stable frequencies. By reason of their number and the relative complexity of their schedules these are not included in Table 2 but will be considered separately, later.

Perhaps the most striking feature of the Table is contained in the last row where the figures for the accuracy of frequency control are given. For the majority of the stations listed these are 1 part in  $10^{10}$ , or less. The stable and reproducible nature of propagation in these bands enables a frequency reference to be distributed over distances of the order of 10,000 km with an uncertainty of only one or two parts in  $10^{11}$ , corresponding to a phase stability over 24 hours of 1 or  $2 \mu\text{s}$ . To exploit fully this stability it is desirable that frequency control at the transmitter should be based on an atomic source. Many of the stations in the Table now operate with atomic control. Caesium beam standards are installed at NAA, NLK/NPG, and NSS; rubidium gas cell standards at GBR (and MSF), JJM-6/G2AS, HBG, CYZ40 and Allouis. The emissions of WWVL and WWVB are controlled relative to the master clock at the N.B.S. Boulder Laboratories which in turn is measured daily in terms of the N.B.S. caesium standard. The decline in the use of the frequency offset is most marked for stations in the l.f. band and it is to be hoped that ultimately all stations in this band will operate at nominal frequency in the atomic scale. So far as the broadcast stations are concerned there is, indeed, no requirement for offset since they do not radiate time signals derived from the carrier frequency. As the notes indicate WWVB and DCF77 have discontinued the offset not only for the carrier frequency but also for the time signals which they now emit in agreement with each other, to within 1 ms.

Previously all the v.l.f. transmitters made use of simple on-off keying and this method is still employed to some extent. However, in order to increase communication capabilities the tendency now is to make use of frequency-shift keying. This system is already in use by stations NAA, NBA and NPM, for part of the total operating time. The American practice is to switch between the assigned frequency and a frequency 50 Hz higher, the lower frequency being a space and the upper a mark. The latter frequency e.g. 24.05 kHz for NBA, may not

be phase stable but the lower or assigned frequency as given in Table 2, is at present phase stable. It should be noted, however, that the U.S. Navy has announced its intention of making use in the future of minimum shift keying (m.s.k.) on its communication transmitters. In this mode ambiguities in phase of  $180^\circ$  will exist on both mark and space frequencies and suitably adapted receivers will be required to realise a stable frequency reference. GBR will adopt f.s.k. in the future but here the mark frequency will be 15.95 kHz, 50 Hz below the assigned value. The present accuracy of the 16 kHz carrier will be retained and measures taken to prevent a phase shift when the aerial is returned from on-off to frequency-shift keying, and vice versa. The phase of each carrier will remain coherent throughout the transmission and there will be a smooth transition from one frequency to another lasting about 8 ms, this being the time constant of the GBR aerial. WWVL also makes use of two frequencies, separated by 100 Hz, the carrier being radiated on 20.0 and 19.9 kHz in alternate seconds.

Looking in more detail at the stations in the l.f. band the carrier frequency of the Japanese coast radio station on 40 kHz is now obtained from a rubidium atomic standard the emitted frequency being continuously monitored at the Radio Research Laboratories, Koganei, Tokyo. Telegraph signals are used both for communication as JJM-6 and for standard frequency broadcasts as JG2AS: in the latter case the mark and space signals each last for about 0.5 s. Europe is now particularly well served by standard frequency and time signal transmissions in this band with stations in continuous operation at frequencies of 50, 60 and 75 kHz and for a limited period each day on 77.5 kHz. In addition, standard frequencies only are provided by the three broadcasting transmitters operating at 164, 191 and 200 kHz. It is foreseen that the carrier frequencies of other broadcasting stations, e.g. Brasov (155 kHz) and Warsaw (227 kHz), will be stabilized in the future. The seconds time signals radiated by HBG and MSF are of the same form, consisting of an interruption of the carrier lasting 100 ms, the time reference being the start of the break. On HBG the minute is marked by two successive carrier breaks and the hour by three: the minute pulse on MSF is lengthened to about 500 ms. Similar carrier interruptions, lasting about 50 ms, are used for the time signals on an atomic scale radiated by DCF77, the minute being identified by suppressing the 59th pulse. In the case of WWVB, time information is transmitted continuously in the form of a b.c.d. code, using a 10 dB shift in carrier level to generate a series of seconds markers. Depending on the coding these markers last for 0.2 s for a binary 'zero', 0.5 s for a binary 'one' and 0.8 s for the 10 s markers. The code embraces minute, hour and day of year information and also the difference in milliseconds between the time as emitted and the current estimate of UT2.

#### NAVIGATIONAL STATIONS

**Loran-C.**—The development of a long-range radio navigation system is authorized in the band 90-110 kHz. This relatively wide band is clearly suitable for a pulsed system and pulses of length about  $30 \mu\text{s}$  are used in the Loran-C hyperbolic navigational aid, all stations of which operate at a carrier frequency of 100 kHz. Chains of between 3 and 5 stations are operational in the general areas of the East Coast of the United States, North Atlantic, Norwegian Sea, Mediterranean, N.W. Pacific, Hawaii and the Aleutians. Each station radiates a group of 8 pulses (9 for the master station in each chain) spaced 1 ms apart, the pulses being sufficiently short to allow separation of

the ground wave from the first sky wave at distances in excess of 2,000 km. Chains are distinguished by differing intervals between pulse groups. The Loran-C stations are only useful for timing purposes when this interval is a sub-multiple of T seconds, T being a small integer. This condition is not satisfied for most of the chains but for the U.S. East Coast chain the group period is 100 ms and in addition this chain is precisely controlled in time relative to the time standard of the U.S. Naval Observatory. The master station is located at Cape Fear, N. Carolina ( $34^\circ 04'N$ ,  $77^\circ 55'W$ ) and the first pulse of one of the groups is emitted at 0 s U.T.C. To resolve the time ambiguity resulting from the 100 ms group period a 1 s pulse is added to the Cape Fear emissions and emitted 2 ms ahead of the 0 s U.T.C. pulse. The other stations of the chain do not transmit this 1 s marker but their emission delays relative to the master are published by the U.S. Naval Observatory.

**Omega.**—The previously unused part of the v.l.f. band in the region 10-14 kHz is now being exploited by the Omega navigational system. In its final form eight stations, emitting several frequencies on a time-sharing basis, will provide a world-wide hyperbolic phase-comparison system which should enable position fixing with an r.m.s. error of about 1 km during the day and about 2 km at night. There are now four stations operating as part of the research and development programme on frequencies between 10.2 and 13.6 kHz. Their main characteristics are as follows:

Location	Aldra Norway	Forestport New York	Haiku Hawaii	Trinidad
Latitude .. ..	$66^\circ 25'N$	$43^\circ 27'N$	$21^\circ 24'N$	$10^\circ 42'N$
Longitude .. ..	$13^\circ 09'E$	$75^\circ 05'W$	$157^\circ 50'W$	$61^\circ 38'W$
Frequencies (kHz)	10.2, 13.6	10.2, 11.33, 12.4, 12.5, 13.6	10.2, 13.6	10.2, 11.33, 12.0, 13.6

When the Omega system receives full approval it is likely that the above stations, with the exception of Forestport, will become operational stations and will be joined by others located in the United States, South America, the Indian Ocean, Australasia and the Philippines-Okinawa area. Each of the experimental stations is equipped with three caesium atomic beam standards, one of which controls the emission. The latter consists of a series of frequencies transmitted in successive 1-second intervals, the sequence repeating after 10 seconds. The first segment starts at 0 s U.T.C.: all times are synchronized with the time standard of the U.S. Naval Observatory and all frequencies are offset. The frequencies of 10.2, 11.33 and 13.6 kHz are common to all stations although emitted at different segments of the 10-second sequence for each station. To receive these frequencies, therefore, a commutator is necessary at the receiver, synchronized with the emission pattern and phased to isolate the appropriate 1-second segment of the desired station. In addition each station will radiate a unique frequency which can be received without using a commutator although some form of gating may still be desirable to improve the signal-to-noise ratio. At present Trinidad is transmitting a unique frequency of 12.0 kHz while Forestport is operating experimentally on 12.4 and 12.5 kHz.

Thanks are due to the many organizations which have made available details of their standard frequency emissions. This survey has been prepared at the National Physical Laboratory as part of the information programme for the standard frequency services.

# NEWS FROM INDUSTRY

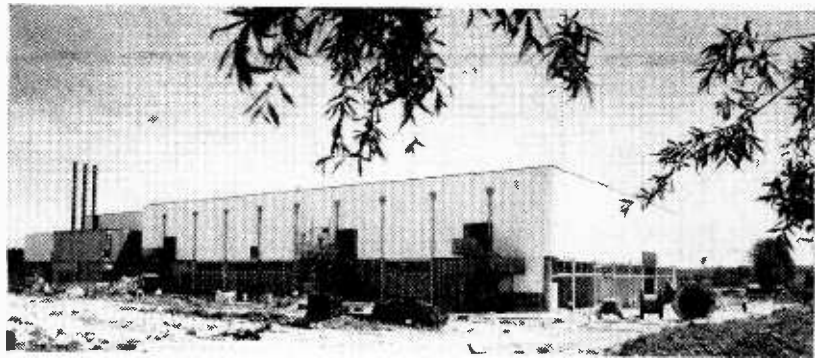

*"The largest microelectronics manufacturing plant in Europe" is the claim of the Marconi Company for this project at Witham, Essex, soon to be ready for the production of integrated circuits. The company has invested £3M in the project.*

G.E.C. (Telecommunications) Ltd. are to supply over £8M worth of equipment and services towards the next £13M phase of the Nigerian national telecommunications plan. The company will provide a 2,500-mile long microwave and v.h.f. radio network that will be integrated with the country's existing telecommunications system. G.E.C. will be responsible for all aspects of the project from surveying the route to bringing the equipment into operation and training engineers.

The Data Equipment Division of Plessey Automation have announced a new range of incremental magnetic tape recorders that have been developed in conjunction with the National Research Development Corporation. The recorders feature a new stepping mechanism that replaces the usual stepping motor. Modular construction allows several different versions to be built up from the basic unit and facilitates servicing. Prices start at £1,000.

The Electro-Mechanical Division of Standard Telephones and Cables Ltd. have formed a sub-system design department enabling non-electronic companies to have electronic logic control systems designed, built and fitted to their machinery or products without the need to employ a permanent electronics staff. The department is known as EMD (Logic Control Sub-systems), and is housed at West Road, Harlow, Essex.

Twenty-four manufacturers of fractional horse-power motors have combined to form the British Fractional H.P. Manufacturers' Association with headquarters at 8, Leicester Street, London, W.C.2. Technical co-operation between members is being encouraged, although all firms will remain independent and in competition with each other.

The Soviet Ministry of Communications have placed a £200,000 order with Marconi Ltd. for self-tuning receiving equipment which will consist of a number of solid state double diversity independent sideband receivers together with associated equipment.

The West German Defence Ministry have ordered a year's supply of kalam batteries at a cost of £44,000 from Vidor Ltd., Royston. The batteries will be used for the air-sea rescue beacons carried by the West German Air Force.

R.C.A. Colour Tubes Ltd. started production at their new factory at Skelmersdale, Lancashire, on July 17th. It is planned that by the end of 1967 a total of 10,000 colour television tubes will have been distributed to the trade and it is expected to more than double this figure in 1968. R.C.A. Colour Tubes Ltd. was set up last year by the Radio Corporation of America and Radio Rentals (see "News from Industry" October, 1966).

Marconi International Marine Co. Ltd., intend to withdraw from the business of installing land-based sound systems although existing installations will continue to be serviced in accordance with contractual obligations. This move will enable the company to concentrate its resources on its shipping interests and this will involve a gradual run-down and ultimate closure of the Electra Sound Systems division.

The Automation Group of the Plessey Company, Poole, Dorset, is to receive the support of the National Research Development Corporation in the development of a digital sequence control machine employing integrated circuits. The machine will be employed in low-cost process control applications that do not justify using a general purpose computer. The development programme is scheduled to run for 2½ years by which time the first production models should be available.

Standard Telephones and Cables Ltd. have started to install the first of London's p.c.m. telephone equipment. Work is progressing on two routes, the first of these serves Redhill and Caterham and the second Sunbury, Ashford, Staines, Walton, Weybridge and Esher. Existing telephone circuit capacity will be increased by 48 or 96 circuits depending on requirements. In this first phase of the scheme S.T.C. are providing 40 p.c.m. systems necessitating the installation of some 960 repeaters in existing manholes and footway boxes.

G. & E. Bradley Ltd., of Neasden Lane, London, have been appointed exclusive U.K. agents for a range of electronic instruments manufactured by Monsanto Electronics Technical Center, of West Caldwell, New Jersey, U.S.A. The range includes a frequency synthesizer, counter/timers and digital voltmeters which all utilize integrated circuits.

Siliconix Agents.—The Micro Electronics Division of Ultra Electronics (Components) Ltd., Park Royal Road, London, N.W.10, have been appointed sole distributors in the U.K. of semiconductor devices manufactured by Siliconix Inc., California.

WEL Components Ltd., Reading, Berks., have been appointed sole U.K. agents for the Greomar Manufacturing Company, Wakefield, Massachusetts, who manufacture a range of coaxial plugs, sockets and adaptors.

I.C.T.'s Computing Services Division is to be re-formed as a wholly owned subsidiary of the I.C.T. group of companies under the title International Computing Services Ltd.

Arrow Electric Switches Ltd., of Southall, Middlesex, have opened a new office and stores at 13 Murray Place, Stirling, to cope with the increasing demand of the expanding Scottish electrical and electronics industries.

Technical Representation Ltd. have been appointed sole U.K. agents for the Exellon Industries of California, who manufacture a range of drilling machines for printed circuits.

Joseph Lucas (Electrical) Ltd., have announced price cuts of up to 30% on their range of semiconductors.

The Cambridge Instrument Company Ltd. reports for 1966 a profit before tax of £495,000 compared with £499,000 last year.

# SEPTEMBER CONFERENCES & EXHIBITIONS

Further details can be obtained from the addresses in parentheses

## LONDON

Sept. 11-15 Olympia  
**Industrial Photographic and Television Exhibition**  
 (Industrial and Trade Fairs, Commonwealth House, New Oxford St., W.C.1)

Sept. 11-15 Olympia  
**Engineering Materials and Design Show and Conference**  
 (Industrial and Trade Fairs, Commonwealth House, New Oxford St., W.C.1)

Sept. 13-14 I.E.E. Savoy Pl.  
**High Voltage Insulation in Vacuum**  
 (I.P.P.S., 47 Belgrave Sq., S.W.1)

Sept. 20-22 Royal Lancaster Hotel  
**International Broadcasting Convention**  
 (I.B.C. Secretariat, Royal Television Soc., 166 Shaftesbury Ave., W.C.2)

Sept. 20-22 University College  
**Stress Analysis in Bio-engineering**  
 (I.P.P.S., 47 Belgrave Sq., S.W.1)

Sept. 26-28 Savoy Pl.  
**Magnetic Materials and Their Applications**  
 (I.E.E., Savoy Place, W.C.2)

Sept. 27-30 R.H.S. New Hall  
**R.S.G.B. Radio Engineering & Communications Exhibition**  
 (P. A. Thorogood, 35 Gibbs Green, Edgware, Middx.)

## BIRMINGHAM

Sept. 19-21 The University  
**Individual Responsibility for Quality & Reliability**  
 (Inst. Engineering Inspection, 616 Grand Bldgs., Trafalgar Sq., London, W.C.2)

## CULHAM

Sept. 11-13 U.K.A.E. Laboratory  
**Waves in Plasma**  
 (I.P.P.S., 47 Belgrave Sq., London, S.W.1)

## LEATHERHEAD

Sept. 21-22 Cent. Elec. Research Labs.  
**Electrodeless Breakdown of Gases**  
 (I.P.P.S., 47 Belgrave Sq., London, S.W.1)

## MANCHESTER

Sept. 5-7 The University  
**Physics of Quasars**  
 (I.P.P.S., 47 Belgrave Sq., London, S.W.1)

Sept. 5-8 The University  
**Solid State Devices**  
 (I.P.P.S., 47 Belgrave Sq., London, S.W.1)

Sept. 26-30 Belle Vue  
**Electronics, Instruments, Controls & Components Show**  
 (Institution of Electronics, Pennine House, Shaw Rd., Rochdale, Lancs.)

## ST. ANDREWS

Sept. 19-21 The University  
**Electron Optics, Instrumentation and Quantitative Electron Microscopy**  
 (I.P.P.S., 47 Belgrave Sq., London, S.W.1)

## SUTTON COLDFIELD

Sept. 19-20 Town Hall  
**Components, Instruments & Control Gear**  
 (Hawnt & Co., 112/114 Pritchard St., Birmingham 6)

## SWANSEA

Sept. 11-15 University Col.  
**Radio Receiver Systems**  
 (Dr. R. C. V. Macario, Electrical Engineering Dept., University College, Swansea, Glam.)

## OVERSEAS

Sept. 1-10 Paris  
**International Radio & Television Show**  
 (Federation Nationale des Industries Electroniques, 16 rue de Presles, 75 Paris 15)

Sept. 4-6 Balatonszeplak  
**Industrial Electronic Measuring & Control Symposium**  
 (Federation of Hungarian Scientific Societies, c/o Hungarian Embassy, 35 Eaton Pl., London, S.W.1)

Sept. 4-8 Vienna  
**I.F.A.C. Symposium on Automatic Control in Space**  
 (Austrian Productivity Centre, Committee on Automation, POB 131, A-1014 Vienna)

Sept. 4-10 Mexico City  
**S.I.M.A. Exhibition of Measuring Instruments**  
 (Scientific Instrument Mfrs' Assoc., 20 Peel St., London, W.8)

Sept. 4-11 Leipzig  
**Autumn Fair**  
 (Lex Hornsby & Partners Ltd., 125/130 Strand, London, W.C.2)

Sept. 6-8 Chicago  
**Computer Conference**  
 (I.E.E.E. 345 E.47th St., New York, N.Y. 10017)

Sept. 9-17 Milan  
**Italian Radio & Television Show**  
 (Mostra Nazionale della Radio et Televisione, Via Luciana Manara 1, Milan)

Sept. 10-19 Brno  
**International Trade Fair**  
 (Fairs & Exhibitions Ltd., 14 New Burlington St., London, W.1)

Sept. 11-14 Haifa  
**I.F.A.C. Automatic Control Symposium**  
 (Israel Committee for Automatic Control, Technicon City, Haifa)

Sept. 11-15 Athens  
**Information Theory Symposium**  
 (I.E.E.E. 345 E.47th St., New York, N.Y. 10017)

Sept. 16-22 Boston  
**Eurofair U.S.A.**  
 (Eurofair U.S.A. 94 Gerrit va der Veenstraat, Amsterdam-Z, Netherlands)

Sept. 17-22 Chicago  
**S.M.P.T.E. Exhibition & Conference**  
 (Society of Motion Picture & Television Engineers, 9 E.41st St., New York, N.Y. 10017)

Sept. 21-22 Detroit  
**Electronics in Vehicle Safety and Traffic Control**  
 (I.E.E.E., 345 E.47th St., New York, N.Y. 10017)

Sept. 21-23 Washington  
**Broadcast Symposium**  
 (I.E.E.E., 345 E.47th St., New York, N.Y. 10017)

Sept. 21-23 Kyoto  
**Anglo-Japanese Electronics Symposium**  
 (B.N.E.C. Asia, 6-14 Dean Farrar St., London, S.W.1)

Sept. 21-Oct. 1 Amsterdam  
**Firato Electronics Show**  
 (R.A.I. Gebouw N.V., 8 Europaplein, Amsterdam)

Sept. 25-27 Toronto  
**International Electronics Conference**  
 (I.E.E.E. 1819 Yonge St., Toronto 7)

Sept. 28-Oct. 4 Osaka  
**Electronics Show**  
 (British Embassy, Tokyo)

Sept. 29-Oct. 7 Brussels  
**British Week**  
 (BNEC Export Council for Europe, 27 Northumberland Ave., London, W.C.2)

# Vortexion quality equipment

## TYPE C.B.L. TAPE RECORDER

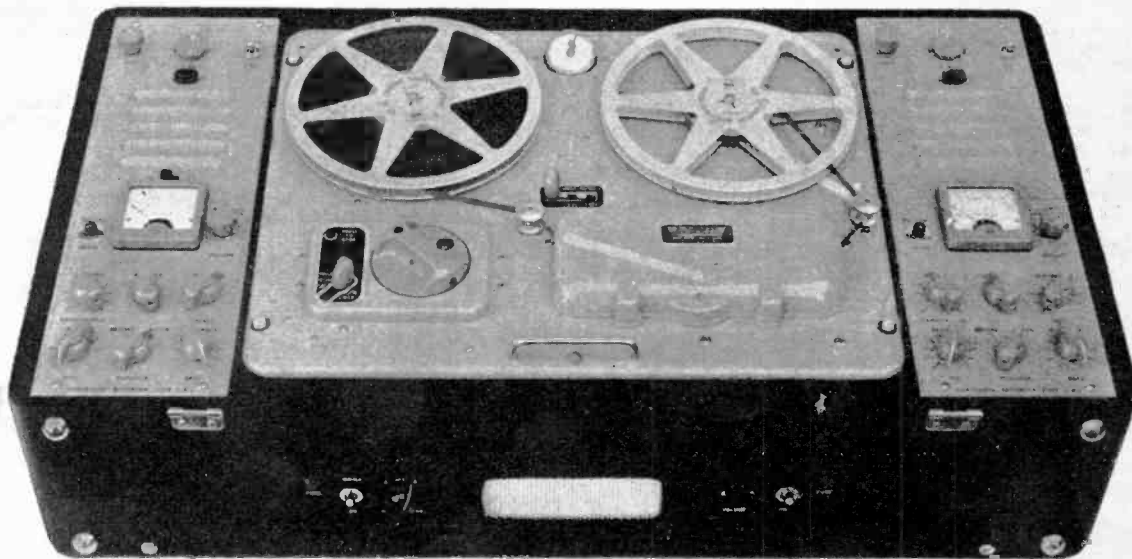

Here is a versatile stereophonic recorder which has no equal in its price group.

IT CAN record monaurally or stereophonically with its own mixed inputs from Gram, Radio or other sources and from high grade low impedance balanced line microphones. With good microphones, etc., the result is a suitable master for disc manufacturers. "Before and After" monitoring is provided together with adjustable metered bias for perfection.

IT CAN also make a recording on one track and then transfer it to the other track while measuring and listening to it and adding one or two more signals also metered. A special PPM type meter is now used.

IT CAN repeat the process and transfer this combined signal to the first track with one or two more signals. Composers use it for this purpose. One track may have music or commentary and the other cueing signals or commentary and either may be altered without the other.

IT CAN playback stereophonically or monaurally with its own amplifiers of  $3\frac{1}{2}$  watts each.

Speeds  $1\frac{7}{8}/3\frac{3}{4}/7\frac{1}{2}$  i.p.s. Price **£172 0s. 0d.**

Speeds  $3\frac{3}{4}/7\frac{1}{2}/15$  i.p.s. Price **£180 0s. 0d.**

The Vortexion W.V.B. is a high quality monaural machine with "Before and After" monitoring. The recording inputs are a high sensitivity socket for moving coil or ribbon microphone and a high impedance socket for radio, etc., either of which can be selected by a switch. Superimposing and echo work can be done and the playback has reserve gain for abnormal requirements. This model cannot be converted for stereo playback, but it is a thoroughly reliable machine for the engineer specialising on monaural work.

Speeds  $1\frac{7}{8}/3\frac{3}{4}/7\frac{1}{2}$  i.p.s. Price **£115 10s. 0d.**

Speeds  $3\frac{3}{4}/7\frac{1}{2}/15$  i.p.s. Price **£128 0s. 0d.**

The Vortexion W.V.A. is a monaural machine which has a performance equal in sound quality to the other models. It possesses all the features of the W.V.B. except for "Before and After" monitoring, Dubbing and Echoes. The recording being made can be heard on the internal loudspeaker as in the W.V.B. and C.B.L. The controls are uncomplicated.

Speeds  $1\frac{7}{8}/3\frac{3}{4}/7\frac{1}{2}$  i.p.s. Price **£96 7s. 0d.**

Speeds  $3\frac{3}{4}/7\frac{1}{2}/15$  i.p.s. Price **£107 3s. 0d.**

All tape recorders have adjustable bias controls, low impedance mic. inputs for unlimited lengths of cable, highly accurate position indicators and meters to measure recording level and bias.

**VORTEXION LIMITED, 257-263 The Broadway, Wimbledon, S.W.19**

Telephone: 01-542-2814 and 01-542-6242/3/4

Telegrams: "Vortexion London S.W.19"

WW-101 FOR FURTHER DETAILS

**Radio towers**

Fixed, portable and  
telescopic masts

Co-axial and open-wire  
feeders

Aerials (LF to HF): rhombics,  
log periodics, dipoles,  
quadrants, 'T'-aerials,  
wide-band aerials

Aerials (VHF to microwave):  
yagis, ground plane, helices,  
dipoles, dishes

Filters

Aerial switches

Lead-in panels

Earth systems

Air-cooled transmitter loads  
up to 20kW

Termination networks

Propagation surveys

Site layouts and installation

# Coubro & Scrutton

## a complete aerial service

(LF to Microwaves)

**INSTALLATIONS  
IN OVER  
200 COUNTRIES**

**BROADCASTING  
POINT TO POINT  
GROUND TO AIR  
NAVIGATIONAL AIDS  
MARINE AERIALS**

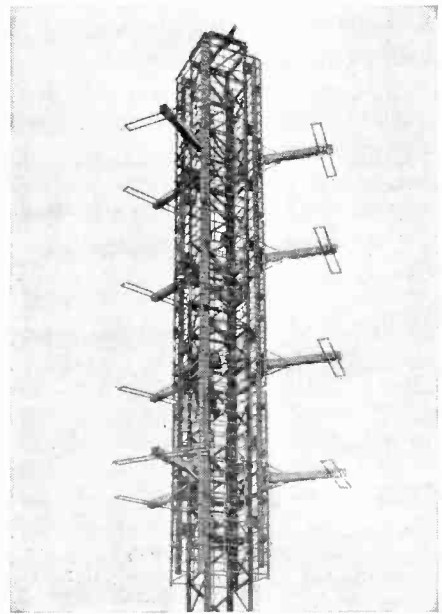
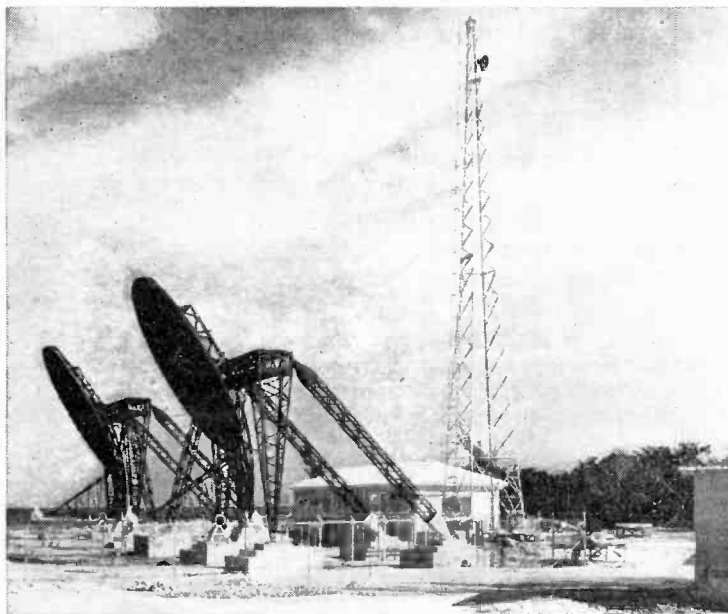

### The Coubro & Scrutton Companies

LF, MF and HF: Coubro & Scrutton Ltd.

VHF and UHF: Associated Aerials Ltd.

Microwaves: Precision Metal Spinings Ltd.

Business Radio: R. T. Masts Ltd.

Telescopic Masts: A. N. Clark (Engineers) Ltd.

**COUBRO & SCRUTTON LTD.**

Group Sales Office, 430 Barking Road,

London E13 Tel: 01-476-4477

Telex 25850 Cables: Coubro London E13

**WW-102 FOR FURTHER DETAILS**

CS10

# LETTERS TO THE EDITOR

The Editor does not necessarily endorse the opinions expressed by his correspondents

## Noise Figure Measurement

IN his article on noise figure measurement in the August issue Mr. Matthews does the usual trick of doubling the output power reading, the first reading being noise power only and the second noise plus signal generator. The signal generator setting during the initial phase is described as "set so that the amplifier is operating at the lower limit of normal working conditions". Since this is the first of two settings from which the noise figure is derived it seems to require more accurate definition.

Later he says "the ratio of the new signal to the old is  $S_2/S_1$ ". Surely if the "old" is  $N_i$ , the "new" is

$S_2 + N_i$ ? The ratio is then  $\frac{S_2 + N_i}{N_i}$ .

But since the noise figure is then taken as the difference of readings, and since we are speaking of 8 dB, or about 6:1, the first reading is one sixth of the second, and obviously cannot be negligible. A true version of the

ratio is therefore:  $\frac{S_2 + N_i}{S_1 + N_i}$  where  $S_2$  and  $S_1$  are two attenuated signal levels. The apparent noise figure quoted by Mr. Matthews is then  $S_2/S_1$  (not  $S_2/N_i$ ). But ignore the signal-to-noise equation for a moment and let us see what we have got. If the noise figure is  $F$ , and the power gain  $G$ , then the output at phase one is  $G(FN_i + S_1)$ . Later, when we have increased the signal, the output is  $G(FN_i + S_2)$ . The second is made to double the first, so:  $G(FN_i + S_2) = 2G(FN_i + S_1)$ , whence:—

$F = \frac{S_2 - 2S_1}{N_i}$  which goes towards Mr. Matthews' expres-

sion only if  $S_1$  goes to zero. For  $F$  to equal  $F_{apparent}$ ,

therefore,  $\frac{S_2}{S_1} = \frac{S_2 - 2S_1}{N_i}$

giving  $N_i = S_1(1 - 2F_{apparent})$ .

If  $F_{app}$  is 6.3:1, this gives  $S_1 = 1.46N_i$ , a very specific value indeed. An examination of Mr. Matthews' table shows that in fact the Magnetic AB measurements differ from the others by about unity when taken as numerical ratios. This would suggest:

$$\frac{S_2}{S_1} - 1 = \frac{S_2 - 2S_1}{N_i}$$

## Energy Storage in Smoothing Systems

THE energy storage concept discussed by Mr. Arguimbau in the May 1967 issue offers advantages which make further exploration profitable. It may first be noted that if a choke is roughly one-half iron, one-half copper, a figure of 0.1 watt-sec/lb, corresponding to about 0.025 watt-sec/in<sup>3</sup>, is about equivalent to a working point of 0.1 HA<sup>2</sup>/in<sup>3</sup> on the Hanna curves. Although for C-cores the published curves extend up to 0.2 HA<sup>2</sup>/in<sup>3</sup> we can rarely obtain a satisfactory design at this level.

In most design problems the amount of ripple is fixed.

This gives:  $F_{app} - 1 = \frac{S_1}{N_i}(F_{app} - 2)$  or  $S_1 = \frac{N_i(F_{app} - 1)}{F_{app} - 2}$   
or about  $1.2N_i$ .

It becomes clear that for the measurements to have any meaning, the first signal level must have some definite relation to the amplifier noise level. If it does not, we know nothing about  $N$  at all beyond the fact that if one can just "see" the signal on the meter it is within a few dB of  $N$ . The true expression for  $F$  includes  $S_2$ ,  $S_1$ , and  $N_i$ . The attenuator readings only give  $S_2$  and  $S_1$ . They tell us nothing accurate about  $N_i$ . ( $S_2/S_1$  does not equal  $S_2/N_i$ . Even if it did it could not then be ignored in phase one, for  $S_1$  would equal  $N_i$ .)

F. V. BALE & M. J. S. QUIGLEY

Slough, Bucks.

The author replies:

I WOULD like to thank Messrs. Bale and Quigley for their interest.

The point that they seem to have missed is that we cannot measure noise and signal separately and must therefore deal in terms of changes rather than in absolute values. This can be confusing when we consider the input side. The new signal  $S_1$ , is  $S_r + N_i$ , where  $N_i$  is the initial signal and  $S_r$  is the amount by which it was increased.  $N_i$  corresponds to the cold termination noise of the calibrated source used in conventional noise figure measurement,  $S_i$  is this noise plus the noise generated in the source. The dB relationship between hot and cold noise is of course the excess noise of the source. In a gas discharge source we can control this excess noise by using an attenuator, in a temperature limited diode by varying the filament voltage. In neither do we make an absolute measurement of either hot or cold noise. All that we need is the dB change in noise input to the device under test.

A signal generator used in the manner described simulates a noise source except that it provides a single frequency instead of the wide-band signal provided by a conventional source. Since the output is still the amplified input plus internally generated noise this does not invalidate the usefulness of a signal generator for making quick, approximate noise figure checks.

C. N. G. MATTHEWS

Feltham, Middx.

If we rearrange the equation for ripple in the form

$$W_L W_C = \frac{P^2}{135\pi^2 f^2} \frac{E}{E_{ripple}} = K,$$

and we take the storage density of a capacitor as  $r$  times that of a choke, we can easily find that the minimum volume smoothing system will be obtained if

$$W_L = \sqrt{K/r} \text{ and } W_C = \sqrt{Kr}$$

A typical value of  $r$  is about 10. This result can also be obtained to secure a minimum cost solution, if we now take  $r$  as the ratio of the watt-sec/shilling. Here a random

catalogue choice gives 120 shillings per watt-sec for a choke and 6 shillings per watt-sec for a capacitor, so that  $r = 20$ .

When an optimum choke is sought for the 15 V, 1 W, 60  $\mu$ V ripple example discussed by Arguimbau we find that the solution is a choke of such high resistance that the open-circuit voltage would be intolerable in many transistor applications. To estimate the useful region we can proceed in the following way. For any particular mechanical size of choke we have  $R_L = K_1 L$ , and thus the voltage drop in the choke can be written

$$IR_L = 2K_1 W_L / I.$$

If we now fix a limiting value of  $IR_L/V$  for the safe fractional rise of voltage under open-circuit conditions (or, more strictly, light load) we have

$$\frac{IR_L}{V} = \frac{2K_1 W_L}{P}.$$

In the minimum volume case the ratio  $W_L/P$  depends only on the ripple ratio and making further bold, or rash, assumptions we reach, as a design limit guide, a ripple ratio of 1/1000. This is rarely likely to be a troublesome limit: very quiet power supplies are nowadays usually required to be well-regulated, and the regulator will deal easily with this level of ripple.

We now note that

$$\frac{W_L W_C}{P^2} = \frac{r W_L^2}{P^2} = \frac{E}{E_{ripple}} \frac{1}{135 \pi^2 \epsilon^2}.$$

For  $E/E_{ripple} = 1000$ ,  $f = 50$  Hz and  $r = 10$ , this leads to the simple result,

$$W_L = P/180 \text{ and } W_C = P/18.$$

Reducing the smoothing to give  $E/E_{ripple} = 100$ , we have

$$W_L = P/570 \text{ and } W_C = P/57.$$

We can now go on to estimate the actual volume of the smoothing circuit, and we find that for the ripple ratio of 1000 it is about  $P/2$ , while for the ripple ratio of 100 it is about  $P/6$ . Chokes and capacitors being the shapes they are, it is unprofitable to calculate with any precision.

As an example let us take a 12 V 10 A supply with 120 mV ripple. The volume will be about 20 in<sup>3</sup>. A 25,000  $\mu$ F capacitor (15 V wkg) is a cylinder of volume 12 in<sup>3</sup>. A choke with a core of 5 in<sup>3</sup> volume will have a weight of 1.35 lb, which corresponds to a double-loop C-core ref. HWR 40/16/13. At 120 AT/in we find we need 84 turns, or 68 T/in<sup>2</sup> of winding area. A winding of 11 s.w.g., rated at 10.57 A, gives 68.5 T/in<sup>2</sup>. This is rather near the knuckle, to put it mildly, and rather than move to a higher storage density we can use a single loop of HWR/50/14/13.

From the energy storage/power expressions we obtain values of  $L$  and  $C$  as 4 mH and 28,000  $\mu$ F. Our core weighs 1.56 lb, so that we can get about 6 mH, while our capacitor has a 15 V rating, which accounts for the short-fall.

This example was a quite genuine random choice and there have been no painful reappraisals on separate scraps of paper. The 96 turns on the choke will mean a winding density of 57 T/in<sup>2</sup>, a reasonable margin. The resistance of this winding, which gives a drop of only 0.5 V, indicates that our first guess would have done had we accepted a wire rating of 1500 A/in<sup>2</sup>.

It would appear that we can design smoothing circuits using the energy-storage concept so that we demand, for a smoothing ratio of 100, a capacitor having  $V$  wkg volts and a volume of  $P/12$  in<sup>3</sup>, and a choke for  $I$  amps of weight  $P/50$  lb. on a core weighing  $P/100$  lb.

I must confess to some surprise at the apparent strength of this method as a short-cut to an approximate design.

THOMAS RODDAM

London, W.8.

## Radio Interference from Motor Speed Regulators

THE article by K. C. Johnson in the July issue on thyristor circuits for controlling the speed of appliances containing small motors will undoubtedly arouse considerable interest. The method is simple, effective and capable of much wider application. There are, however, certain aspects which do not appear to have received much attention and one of these is the problem of radio interference. Several circuits have been examined by the E.R.A. and all have shown r.f. terminal voltage levels considerably in excess of the limits specified for domestic appliances in B.S.800. Typical values at 200 kHz for circuits without suppression are in the range 100-120 dB/1  $\mu$ V. These values are so far in excess of the specified limits that widespread interference may be caused and failing effective voluntary suppression it would seem likely that some form of statutory control might have to be imposed. If the speed control circuit is installed in an electric drill or similar appliance, suppression components can also be installed and reduction of the interference to below the specified limit can be achieved without recourse to a complex filter. If, however, the control circuit is a separate unit which may be located some distance from the appliance, then suppression will generally be necessary at both input and output. Since the levels of interference are high in the long and medium wave bands capacitive suppression alone is inadequate and it is necessary to install inductors. Inevitably transient surges are generated which may cause damage to the thyristor. The use of thyristors rated at 400 volts is recommended to withstand peak mains voltage but this rating may be inadequate to withstand additional transient voltages. Currently specified radio interference measuring techniques involve the use of a mains isolating network containing inductances of several millihenries and here again the transient voltages may cause damage. These aspects of the problem including the development of a satisfactory measuring technique are currently being examined at the E.R.A.

G. A. JACKSON

Electrical Research Assoc.,  
Leatherhead, Surrey.

## Transistor Curve Tracing

THE article by G. B. Clayton on transistor curve tracing in the June issue interests me, for the circuit shown is similar to one that I have been using for some time. Two simple improvements may be of interest.

Mr. Clayton's oscilloscope photographs show a bright spot at the zero point of the trace. This is caused by the use of a half-wave rectified collector supply—the spot rests for half a mains cycle at the zero point and makes one voltage excursion for the remaining half cycle. The trace brilliance must be adjusted for a satisfactory curve point and this results in an excessively bright zero-point bright spot that may damage the screen. The use of a full-wave rectified collector supply eliminates this bright spot for the curves are now painted twice per mains cycle. A bridge rectifier is satisfactory in this application.

Mr. Clayton limits his collector voltage to about 17 V (peak). This is usually too low to exhibit the breakdown characteristics of transistors. The curve tracer is an ideal instrument for investigating breakdown ratings because the average power dissipation in the sample is kept within acceptable limits while doing so. To restrict the tracer to a limit of only 17 V at most is, in my opinion,



to get only half the value from the unit. A simple expedient to almost double the collector voltage is to put a capacitor in series with the transformer primary. This increases the primary current and hence the secondary voltage. I have found that a  $1\ \mu\text{F}$  500 V paper capacitor to be satisfactory with the transformer I have in use (12 V domestic bell transformer with 230 V primary). A normally closed press-to-open microswitch in parallel with the capacitor ensures normal operation—pressing the microswitch brings the capacitor into circuit and increases the collector voltage to display the breakdown characteristic. If the transformer has loose laminations, the additional current produces a buzz to audibly warn that the unit is operating on its high voltage range. This method may seem to be extremely crude but it is most effective. No damage to the transformer or any transistor has occurred through the use of this arrangement. Consideration of the mains input power factor (etc.) shows that no ratings are exceeded. The use of a press switch ensures that operation in the high voltage range must be intentional.

These two improvements are shown on the diagram below.

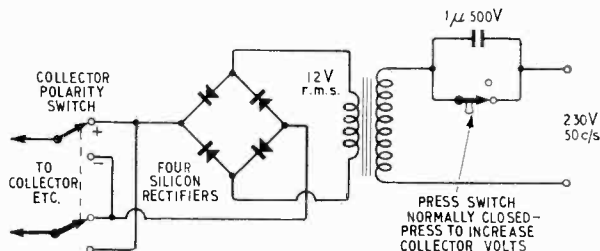

I congratulate Mr. Clayton on producing an interesting article and concur with his remarks about the value of semiconductor curve tracers. His circuit is confined to common-emitter characteristics. By suitably reconnecting the sample, the characteristics in common-base and common-collector can be displayed. I have used my tracer to display characteristics of thyristors, diodes, Zeners, uni-junction transistors, p-n-p and n-p-n transistors, and p-channel and n-channel f.e.t.s. It is a most useful device educationally.

J. F. C. JOHNSON

Central Inst. of Technology,  
Petone, New Zealand.

## High-efficiency Voltage Regulation

AFTER reading the letters of Mr. Pasch and Mr. Williams (May and June respectively) concerning high efficiency voltage regulations, I feel that a circuit which I developed some time ago may be of interest. The circuit was originally designed for supplying an output of 12 volts at 500mA.

The Zener current is held reasonably constant since it is fed from the stabilized output side of the supply

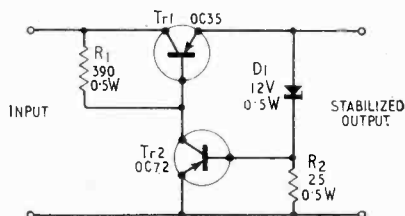

(provided the quiescent Zener current is substantially greater than the leakage current of Tr1 and the base current of Tr2).

The circuit also offers the additional advantage of clamping very fast pulses which could not normally be followed by the regulator, since the e-b junction of Tr2 appears effectively in series with D.

MALCOLM BARETTE

Portland,  
Dorset.

## Using Integrated Circuits

I WAS pleased with the interest shown by readers in my recent article on an i.c. stereo mixer, as evidenced by the letters in the August issue. On the rather minor economic point, I would query whether Mr. Short's "cheaper" discrete component circuit would "do the same job." His input transistors are in the common-emitter mode, less suitable for use from high-impedance sources. In turn, the CD 2200 follows the common-collector inputs with a 3-stage amplifier, in which heavy negative feedback to maintain the signal/noise ratio is applied. I would maintain that, to achieve comparable performance, at least twelve transistors, plus several resistors would be required to replace the i.c., even with the most economical design. The i.c. therefore at least breaks even, and from the viewpoint of sophistication and convenience, is superior. "The millennium has arrived."

A. J. MCEVOY

Larne, Co. Antrim.

## Honorifics

THE Editorial in the June issue and letters in July regarding professional engineers and technicians is all very interesting but omits one vital point.

A scan through the situations vacant advertisements is sufficient proof that employers consider the holder of a Higher National Certificate to be a professional engineer, not a technician. Many advertisements ask for qualifications of B.Sc., H.N.C., etc., presumably because these employers consider these two qualifications roughly equivalent.

Consequently, if the holder of an H.N.C. joins a body with the word technician in its title, he is lowering his status.

There is another body known as the Society of Engineers which accepts the H.N.C. as a requirement for membership and I suggest that this is the professional society that H.N.C. holders should join.

JEFFREY RENDALL

Port Stanley,  
Falkland Islands.

IT was with interest that I read your June editorial and the letters in the July issue dealing with the qualifications required for membership of professional bodies. It is, however, worth noting that the most prized professional honorific, i.e., F.R.S., is not obtained by written examination but by selection, with reference to the importance of the work done.

JOHN D. BENSON

Bedford.

The last line of Mr. Oakenfull's letter in the July issue should have read:—"I have ignored the effect of the increase in  $I'_{co}$ "

# LITERATURE RECEIVED

Revised and expanded editions of **Logic Handbook** and **Small Computer Handbook** are available not only to professional users, but also for schools and industrial training programmes. The former publication of over 400 pages includes an educational primer discussing digital logic, and analogue-to-digital conversion, and a section on the logic laboratory. Other sections contain detailed specifications of Digital's Flip Chip modules. The latter publication includes a primer on the use of a digital computer and sections on products by Digital Equipment Corporation (U.K.) Ltd., 3 Arkwright Road, Reading, Berks.  
**WW 333 for further details**

A comprehensive 224-page **Welwyn component catalogue** describes all the company's film resistors and power and special resistor products including potentiometers. A special section covering integrated circuits includes hybrid (passive and active circuits), attenuators and precision resistor networks. There is a general information section giving cross references to Welwyn products against National/International, Post Office and Defence specifications, as well as details of resistor preferred values and resistor markings. Welwyn Electric Ltd., Bedlington, Northumberland.  
**WW 334 for further details**

Both Electronic Services-STC and Electroniques are to extend distributing activities into the field of **technical books**. Five publishers of technical and reference books (Iliffe Books, Foulsham Sams, R.S.G.B., Editors & Engineers and David Rayner Associates) will have books selected from their current title lists and these will be marketed by the above-named services. About 170 titles are involved and a 40-page booklet giving details of them—publication MG22S2—can be obtained from Electronic Services-STC, Edinburgh Way, Harlow, Essex.  
**WW 335 for further details**

A leaflet on the probability slide rule by the Rolatape Corporation, U.S.A., is available from the U.K. importers Entwistle Thorpe & Co. Ltd., 86-88 Pentonville Road, London, N.1. Of value and interest to those concerned with the **measurement and analysis of random data**, this rule permits direct reading of probability values for Gaussian, Rayleigh and Maxwell distributions on one side. The other side is used to compute the probability of no successes or at least one success in a given number of independent trials.  
**WW 336 for further details**

**High- and low-melting point solders** for special applications, and where melting points outside the normal tin/lead range are necessary, are listed in the leaflet **Technical Memorandum No. 3, Soft Solders for Special Service** received from Enthoven Solders Ltd., Dominion Buildings, South Place, London, E.C.2.  
**WW 337 for further details**

**Professional Cathode Ray Tubes** contains 13 pages of technical data on c.r.t.s for applications ranging from automation and avionics, through medical electronics to ultrasonics. Two pages are allocated to a tabular description of tube phosphors and nomenclature. The M-O Valve Co. Ltd., Brook Green Works, Hammersmith, London, W.6.  
**WW 338 for further details**

Fourth edition of the **Handlist of Basic Reference Material** for Librarians an Information Officers in Electrical and Electronic Engineering has been received from the ASLIB Electronics Group, London. This 40-page publication lists encyclopaedias and dictionaries, handbooks and year books, trade directories, book lists, periodical lists, and subject bibliographies. Other guides to sources of information are included. Available (price 15s) from R. S. Lawrie, ASLIB Electronics Group, c/o Sperry Gyroscope Division, Sperry Rand Ltd., Downshire Way, Bracknell, Berks.

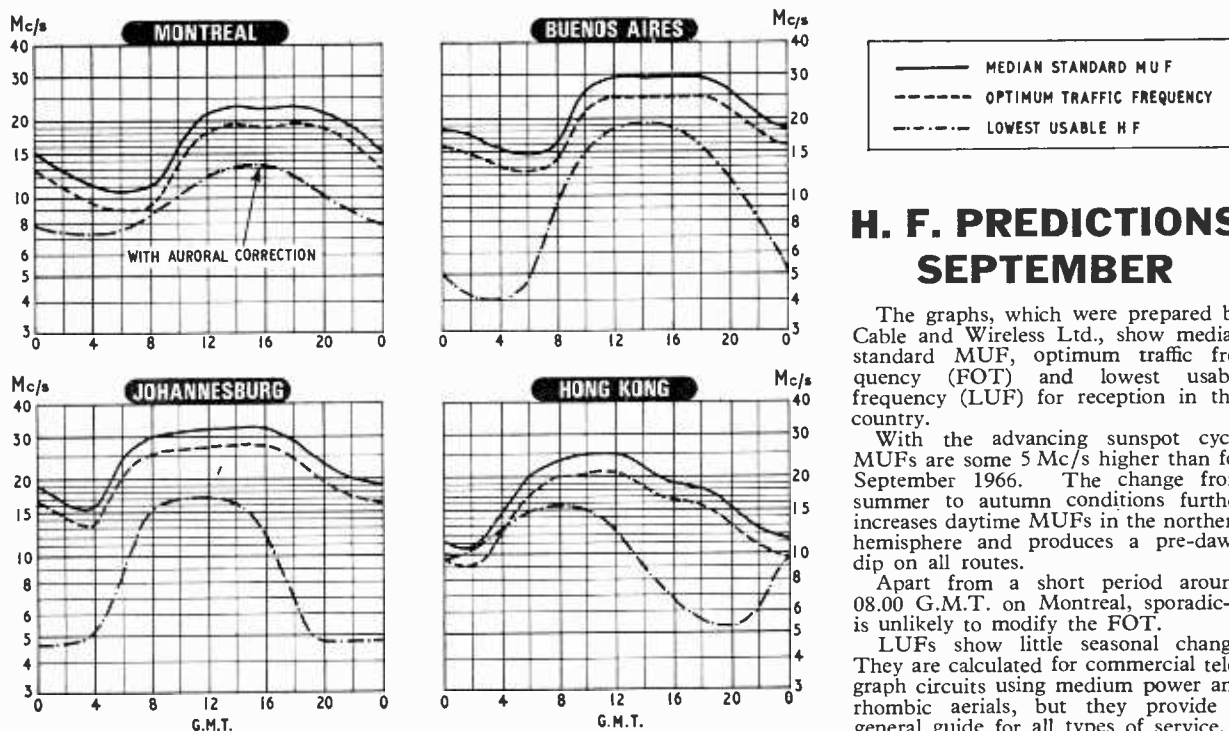

## H. F. PREDICTIONS SEPTEMBER

The graphs, which were prepared by Cable and Wireless Ltd., show median standard MUF, optimum traffic frequency (FOT) and lowest usable frequency (LUF) for reception in this country.

With the advancing sunspot cycle MUFs are some 5 Mc/s higher than for September 1966. The change from summer to autumn conditions further increases daytime MUFs in the northern hemisphere and produces a pre-dawn dip on all routes.

Apart from a short period around 08.00 G.M.T. on Montreal, sporadic-E is unlikely to modify the FOT.

LUFs show little seasonal change. They are calculated for commercial telegraph circuits using medium power and rhombic aerials, but they provide a general guide for all types of service.

# WORLD OF AMATEUR RADIO

## More Transmitting Licences

DURING the year ended June 30th the number of amateur transmitting licences in the U.K. increased by 964, reaching a total of 15,398. Of this number 14,610 (compared with 13,854 a year earlier) were Type A sound licences of which 2,302 (2,110) were for mobile operation. Type B sound licences, permitting operation on telephony only on 420 Mc/s and above, totalled 605 (compared with 402) of which 15 (5) were mobile. Television licences at the end of June were 183, an increase of five during the year.

Another class of licence in which there has been considerable growth during the past few years is for the radio control of models. The June 30th figure was 11,621 compared with 9,653 at the same date last year and 8,141 a year earlier.

## V.H.F./U.H.F. Beacon Station in Rhodesia

INSTALLED at a site 50 miles north west of Salisbury, Rhodesia, on a mountain peak 5,600 feet above sea level, a new v.h.f./u.h.f. 100 W beacon—known as the Steve Wright Memorial station—has come into operation using the call sign ZE1JZA. The main purposes of the beacon are to (a) provide transmissions for a propagation survey to be carried out by radio amateurs in Rhodesia and possibly South Africa by recording signal levels on the two operating frequencies of 144.016 and 432.048 Mc/s separately or simultaneously, and (b) enable v.h.f./u.h.f. enthusiasts to set-up and adjust their equipment for optimum results.

Although the likelihood of the beacon being consistently heard in Europe is remote, meteor scatter, tropospheric bending and other forms of freak conditions make reception at great distances possible.

The original concept of the beacon came from the Council of the Radio Society of Rhodesia who were aware that a sum of money had been donated by Mr. Peter Lowth, ZE7JX, for the purpose of establishing a memorial to the late Steve Wright, ZE1JZ, of Bulawayo who, until his death a few years ago, had been an active v.h.f./u.h.f. worker. The construction of the beacon transmitter and aerials has been the task of many members of the Society. Modulation is by f.s.k.  $\times 300$  c/s on 144 Mc/s and  $\times 900$  c/s on 432 Mc/s. Reception reports should be sent to ZE1JZA, c/o Radio Society of Rhodesia, P.O. Box 2377, Salisbury, Rhodesia.

**Finland's 50th Anniversary of Independence.**—This year Finland celebrates the 50th anniversary of its independence as a nation and to mark the occasion the country's 52 recognized amateur radio club stations will be authorized to use the special country prefix OF (instead of OH) during the 50-day period from October 18th to December 6th. Club stations using OF calls will issue special QSL cards (embracing the symbols of the Golden Jubilee year) to confirm contacts and reception reports. The OF activity will commence at 00.01 local time on October 18th and end at 24.00 local time on December 6th—Independence Day. Local time in Finland is two hours ahead of G.M.T.

**Norway Leads the Way.**—Norway is the first Scandinavian country to enter into reciprocal licensing agreements with other administrations. The first agreement was signed with the United States and negotiations are continuing with Belgium, Denmark, Finland, France, Spain, West Germany and the United Kingdom. In advance of formal agreements being signed, amateurs from Denmark, Sweden and West Germany have been authorized to operate from Norwegian territory and a British subject permanently resident in that country has been issued with a transmitting licence and the call LAØAA.

**I.A.R.C. Convention.**—The Annual Convention of the International Amateur Radio Club opens on September 22nd in the I.T.U. Building, Geneva. The programme will include a visit to the Club station 4U1ITU, a session devoted to the reception of reports from national amateur radio society representatives and a technical session during which the Director of the C.C.I.R. (Jack Herbstreit, WØIIN-HB9AJI) is due to speak. Other speakers will discuss earth-moon-earth (moonbounce) amateur communication, amateur communication via satellite and amateur teleprinting developments. Guests from abroad will include the assistant general manager of the A.R.R.L. (Richard Baldwin, W1IKE) and representatives of the American Project OSCAR Association. The registration fee has been fixed at 20 Sw. Fr (\$5 U.S.) and forms are available from I.A.R.C., P.O. Box 6, CH-1211, Geneva 20.

**Scandinavian Activity Contest 1967.**—The telegraphy section of this annual contest will start at 15.00 G.M.T. September 16th and end at 18.00 the next day with the telephony section following a week later at the same hours. Non-Scandinavians will attempt to work with as many Scandinavian stations as possible, one contact only being permitted to count for points on each band (3, 5, 7, 14, 21, 28 Mc/s). Responsibility for organizing the 1967 Contest is being undertaken by the Finnish National Amateur Radio Society, S.R.A.L. P.O. Box 10306, Helsinki, 6, from which address full details can be obtained. Completed log sheets must be mailed before October 15th. The prefixes considered to be in Scandinavia for the purposes of this contest are LA (Norway), JW (Svalbard), JX (Jan Mayen), OH (Finland), OHØ (Aland Islands), OX (Greenland), OY (Faroes Islands), OZ (Denmark) and SM/SL (Sweden).

**European OSCAR Satellite.**—According to the Project OSCAR Association of America tests and evaluation of the European OSCAR satellite are proceeding slowly because work has been delayed by the time required to exchange correspondence with the German amateur responsible for the initial construction. For this reason a launch is not yet imminent.

**Amateur Radio in Bulgaria.**—The Central Radio Club of Bulgaria has about 3,600 members, 640 of whom are licensed and three classes of licences are available to anyone over the age of 18 years. The distinction between licence classes is Morse code speed and maximum input power. Class A requires 20 w.p.m. and allows the use of 1 kW, Class B requires 16 w.p.m. and permits 250 W, Class C requires 12 w.p.m. and allows only 50 W. For all classes of licensee operation on all Region I amateur bands from 3.5 to 144 Mc/s is permitted except that in the first named band operation is restricted to the segment 3.5-3.65 Mc/s.

**New I.A.R.U. Member Societies.**—The Faroese Amateur Radio Society and the Malta Amateur Radio Society have been elected to membership of the International Amateur Radio Union. F.R.A. has about 80 and M.A.R.S. about 50 members, half the members of both societies being licensed radio amateurs.

**First England-Denmark Contact on 23 cm.**—The first two-way amateur contact on 23 cm (1,300 Mc/s) between England and Denmark took place on June 16th, between Peter Blair (G3LTF), of Galleywood, Chelmsford, Essex, and P. M. Varming (OZ7SP), near Copenhagen. Reports were 599 in both directions with rapid fading.

**Beacon Station in the Faroes.**—A new beacon station (OY3VHF) operating from the Faroes on 145.26 Mc/s has been heard as far south as The Netherlands (PAØLB) at up to 3 dB above the noise level.

JOHN CLARRICOATS, G6CL

# NEW PRODUCTS

## Network Analyser System

SWEEP tests for gain, phase, impedance, admittance and attenuation from 110 Mc/s to 12.4 Gc/s can be carried out with the Hewlett Packard network analyser system. Magnitude and phase of all network parameters can be presented in any one of three forms: (a) phase and amplitude relation may be read directly by meter, (b) swept phase and amplitude responses simultaneously versus frequency on a conventional oscilloscope, and (c) on a c.r.t. plug-in for swept polar displays of phase and amplitude. Smith chart overlays are provided for direct impedance or admittance read-out on the polar display unit. This system samples

the signals to be compared, produces 20 Mc/s replicas and measures their amplitude and phase relationships. The sampling principle used for heterodyning, with high-gain i.f. amplifier, results in high sensitivity. Two essential tests for complete performance characterisation are (a) transmission and (b) reflection. The transmission tests define the effect which the whole device (component, circuit element or whole circuit) will have on the signal passed. Reflection tests reveal matching and interfacing relations within and surrounding the device. Hewlett Packard Ltd., 224 Bath Road, Slough, Bucks.

WW 301 for further details

## PATTERN GENERATOR

OPERATING on six U2 batteries, and weighing only 6½ lb, the Labgear E5180 pattern generator is intended for use in the adjustment of colour television receivers. This solid state instrument will not only provide the necessary crosshatch pattern for convergence checking, but it will also provide facilities for centralization, width, height, and linearity adjustments of picture before convergence checks are made. The four controls on the front panel are: 405/625 line standard selector; pattern selector for crosshatch or dot pattern, vertical or horizontal lines; pattern stability control; and adjustment of r.f. carrier frequency. Tunable

channels are 6 to 13, and 26 to 52. Power consumption is 1.1 W. Price £75. Labgear Ltd., Cromwell Road, Cambridge.

WW 302 for further details

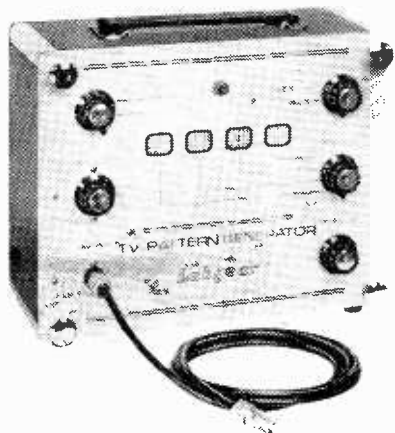

456

## Six-gang Potentiometer

A RANGE of single-turn potentiometers by Ether Ltd., known as the 4004 series, are able to accommodate up to six gangs with an accuracy of alignment between gangs of  $\pm 1\%$ . Resistance range available is from  $1\Omega$  to  $100\text{ k}\Omega$ . Resistance accuracy is  $\pm 3\%$ ,

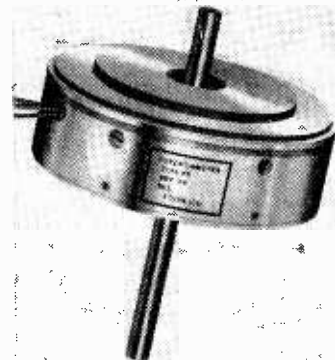

and independent linearity is said to be as high as 0.05%. Typical resolution for  $1\text{ k}\Omega$  is 1,500 turns and for  $5\text{ k}\Omega$  it is 3,000 turns. This range of potentiometers will operate in ambient temperatures up to  $100^\circ\text{C}$ . General Products Division, Ether Ltd., Caxton Way, Stevenage, Herts.

WW 303 for further details

## Solid State Relay

NO moving parts, no maintenance or adjustment, no distortion caused by contact bounce, bias or transit time, are some of the negative, but outstanding features of the fully solid state relay TER10 developed by the Data Handling Division of the Plessey Automation Group. It is intended to replace the Carpenter relay used in the company's telegraph equipment. However, it can also be used for electronic conversion of voltage levels, and as a general replacement for orthodox relays under specific input and local conditions. The actual switching elements are two thyristors which are switched sequentially by the input pulses. An auto transformer sends a reverse voltage pulse to switch off one thyristor as the other is switched on. Should both thyristors be turned on together they are switched off, leaving

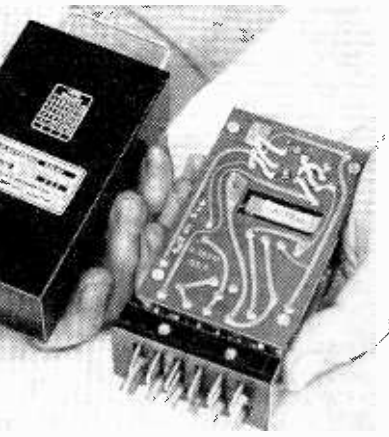

the output to line, open circuit, then the next input transition restores correct signalling to the line. Isolation of input and output is provided by an output transformer. TER10 will operate with supplies of 75 to 100 V. Plessey Automation, Poole, Dorset.

WW 304 for further details

WIRELESS WORLD, SEPTEMBER 1967

## DIGITAL MODULE KITS

TWO series of digital module kits have been introduced by Digital Equipment Corporation (U.K.) Ltd. These are intended to provide easily assembled common logic functions such as up-down counting, decoding, digital-to-analogue and analogue-to-digital conversions, and computer interfaces. The two series will be Octaid (containing up to eight standard flip-chip modules) and Panelaid (containing up to 64 modules). Each kit contains modules, connectors and printed circuit back panel wiring. Input/Output buffer kits are available to act as interfaces between Octaid kits or specially designed systems. Digital Equipment Corporation (U.K.) Ltd., 3 Arkwright Road, Reading, Berks.

WW 305 for further details

## Ferrite Core Store

MOUNTED on a single printed circuit card, and measuring  $12 \times 12 \times \frac{3}{8}$  in is the Trend Electronics 1024-bit ferrite core matrix, complete with address decoders, read/write drive circuits, and a sense amplifier. Access is random, and the logic levels are "1" 0 to  $-0.750$  V, and "0" is greater than  $-6$  V from  $1.5$  k $\Omega$ . Address selection for both X and Y is 5 bits (10 wire normal and inverse). Read/write cycle time  $4 \mu$ s. Operating temperature range 0 to  $55^\circ$ C. Supply requirements are 12 V positive at 1.5 A peak, and 12 V negative at 10 mA. For integrated circuit version, 5 V positive is required. The price is £150. Trend Electronics Ltd., St. John's Works, Tylers Green, Nr. High Wycombe, Bucks.

WW 306 for further details

## Radar Sheet

FOR use in microwave aerials, this material known as radar sheet is constructed from a large number of parallel wires (0.010 in diameter soft, high-conductivity copper wire) with 0.080 in wire spacing. The backing material can be glass cloth 0.005 in thick, polystyrene foam, polyester non-woven tissue 0.003 in thick or polyurethane foam. The polystyrene foam backing is 3 mm and 5 mm thick. These backings are easily cut and shaped and experiments are still being carried out using different wire spacings and other backing materials. Maximum width of sheets presently available is 36 in and in lengths of 4 ft and 8 ft. National-Standard Co. Ltd., Stourport Road, Kidderminster, Worcs.

WW 307 for further details

## Tape Cassette Mechanism

CASSETTE player mechanisms operating at a speed of  $1\frac{7}{8}$  in/s are to be manufactured by Garrard Engineering Ltd. When a cassette is inserted into the slot of the player mechanism, it triggers a sequence of events, switching on unit, playing the tape, stopping motor, ejecting cassette and switching off. The electronic stop and eject system prevents cassette ejection before the motor stops and all the tape is released from capstan and pinch rollers. Apart from normal automatic operation, the unit can be stopped, and the cassette rejected immediately, by a manual control. The mechanism works vertically or horizontally, and it is driven from 110/220 V 50/60 c/s mains voltage or from the batteries specified for players using either silicon or germanium devices. Wow and flutter are said to be better than 0.5% and the speed with a battery motor is kept within 3% of nominal at room temperature. The basic unit is also being developed for use as a cassette auto-

changer, whereby cassettes may be added to the stack or the playing order altered without affecting the tape being played. Garrard Engineering Ltd., Newcastle Street, Swindon, Wilts.

WW 308 for further details

## Tachometer

FOR the measurement of linear and rotary speeds, a range of industrial tachometers is being manufactured by Sapphire Research and Electronics Ltd., Ferndale, Rhondda, Glam., Wales. This range of instruments—the 500 series—is available with either electromagnetic or photo-electric transducers. Transducers may also be used for control or display purposes in converting signals of alternating nature to d.c. voltage or current. The units with associated meters can be calibrated for use as frequency meters, or rate of flow meters.

WW 309 for further details

## TRANSMITTER ANALYSER

THE TG-2400 is a transmitter output analyser by Green Electronics & Communications Equipment Ltd, 79-81

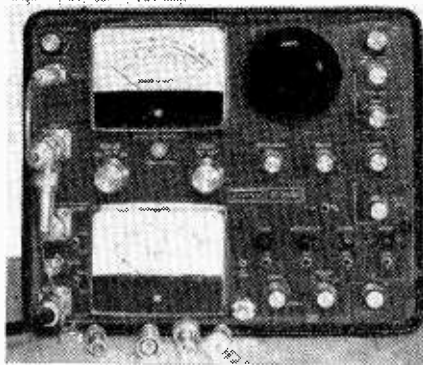

Braemar Road, London, N.15. The following functions can be carried out over a wide range of r.f. power and frequencies; transmitter output power dummy load wattmeter; v.s.w.r. indicator (with frequency range of 1.8 to 3.5 Mc/s) accuracy  $\pm 15\%$ ; two-tone oscillator, transmitter output envelope display monitor and oscilloscope. The frequency range is 2 to 500 Mc/s, which can be extended to 2 Gc/s, and the maximum power rating 1 kW peak. The wattmeter has an accuracy of  $\pm 5\%$  from 2 to 150 Mc/s and  $\pm 10\%$  from 150 to 500 Mc/s. Output impedance is 10 k $\Omega$  and input impedance 52  $\Omega$ . The price is £290.

WW 310 for further details

## Miniature Battery Charger

ORIGINALLY designed to recharge the batteries in an ultrasonic torch for the blind, is a miniature ( $4 \times 1\frac{1}{2} \times 2\frac{1}{2}$  in.) battery charger by Stoneleigh Electronics Ltd., Romford, Essex. A constant-current charger, it has a solid-state stabilized circuit and will charge (without switching) one or two 9 V nickel cadmium batteries at a constant current of 15 mA  $\pm 0.5$  mA with a  $\pm 50$  V swing on the input or any variations in the battery voltage. It has a mains transformer isolated input circuit.

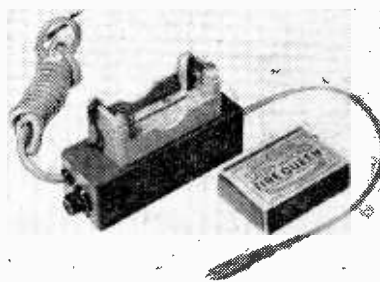

WW 311 for further details

## Potentiometer Recorder

ALL the major component parts of the Jaquet potentiometer recorder are available in plug-in or clip-on form, so that they can be exchanged either in one instrument or between different instruments. These major parts include chart magazine, chart speed gears, amplifier and measuring circuit unit, range cards, range and channel distribution unit. The measuring circuitry permits the instrument to record from various types of input. This allows recording of mixed inputs simultaneously with up to six channels. The recording chart width is 100 mm and the accuracy is  $\pm 0.5\%$  f.s.d. The response is one second

f.s.d. (maximum). Input impedance is 20 k $\Omega$ . Radiotron, 7 Sheen Park, Richmond, Surrey.

WW 312 for further details

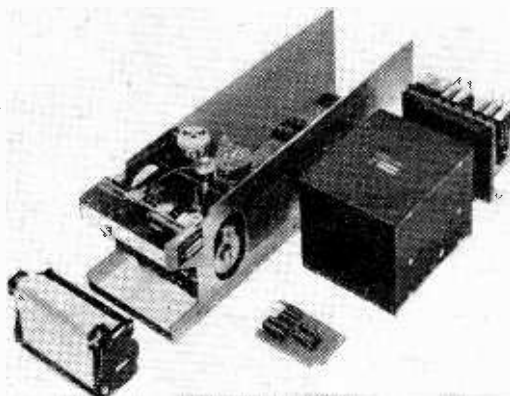

## High Sensitivity Television Camera

A NEW television camera system Type OA.1705 by Marconi Instruments Ltd., employs a highly sensitive camera tube, the Isocon (developed by the English Electric Valve Co. Ltd.), to present details, which because of the low incident light are difficult or impossible to perceive with the human eye. The information can be reproduced on television monitors for direct viewing or recording. Apart from its obvious applications in the military and industrial fields, this system—which is the result of extended development of a medical image intensifier—has been used in astronomy to

record on cinefilm, details of the Milky Way. The OA.1705 consists of three units. An image detection unit (including the Isocon tube), which feeds into a master control unit, where the information is processed into a complete video signal conforming to C.C.I.R. standards. The output from this unit is then passed to a monitor which normally possesses a raster with 1:1 ratio. Cine and still-photo recording units are available as well as video tape facilities. Marconi Instruments Ltd., St. Albans, Herts.

WW 313 for further details

## Single Function Meters

MOVING-COIL meters designed to operate as single-function multi-range instruments are available from Anders Electronics Ltd. Uncluttered scales,

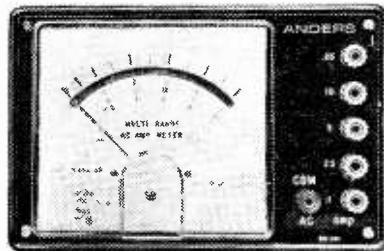

simple circuitry and switching, reliability, and reasonable prices are said to make this SM range of instruments desirable for educational and other

institutions. All meters have a 3.5in mirror scale. The instruments in the range include a.c. and d.c. milliammeters, ammeters and voltmeters and a d.c. microammeter. The microammeter (SM-301) covers 50 to 1000  $\mu$ A in five ranges selected by rotary switch. The a.c. ammeter (SM-361) covers 1 to 25A in five ranges selected by terminals, and it incorporates a current transformer. Accuracy on d.c. models is within 1.5% of f.s.d., and on a.c. models it is within 2.5% of f.s.d. With the exception of the two ammeters, all models are fitted with a varistor protection device permitting 50% overload on the movement. Prices range from £8 to £9 15s. Anders Electronics Ltd., 103 Hampstead Road, London, N.W.1.

WW 314 for further details

## Thermoplastic Hinge

ONE-PIECE extruded piano type hinge which can be cut to any length and attached by nailing, screwing, stapling or other mechanical means, and known as Polyhinge, is available in white, blue, black, or metallic grey. It is resistant to acids, oils, and grease and is also weatherproof, watertight, and non-conductive. Available—with pre-punched holes or slats—in continuous lengths or pre-cut to any specific size, and in a variety of profiles. Herzbi Ltd., 16 Northwold Road, London, N.16.

WW 315 for further details

## MATRIX DRIVERS

PLANAR epitaxial transistors BSX60 and BSX61 by Mullard have primary applications as drivers for one and two microsecond computer stores. Both transistors have a  $V_{CB0}$  of 70 V, an  $I_{CM}$  of 1 A, and a  $P_{tot}$  (at 25°C) of 800mW. The switching-on time for the BSX60 is 40 ns and for the BSX61 it is 50 ns. The  $f_T$  minimum in both cases is 250 Mc/s. It is stated that they are suitable for use with the largest ferrites now in use in matrix stores. Mullard Ltd., Mullard House, Torrington Place, W.C.1.

WW 316 for further details

## Microwave Power Meter

FOR monitoring microwave power over the band 10 Mc/s to 12.4 Gc/s, a miniature microwave power meter with amplifiers has been produced by the General Microwave Corporation, U.S.A. Model 462 offers a choice of three power heads, with seven full-scale ranges covering from 100  $\mu$ W to 100 mW with an accuracy of  $\pm 2\%$  on the low range and  $1 \pm \%$  on medium and high ranges. Instrument Division, Livingston Laboratories Ltd., Greycaine Road, North Watford, Herts.

WW 317 for further details

## S.S.B. Crystal Filter

FOR use in a.m. communication equipment the FC-17-U crystal filter is said to possess carrier and adjacent sideband suppression to a degree not generally attainable. Carrier attenuation is stated to be 50 dB minimum while suppression of unwanted sideband is 65 dB minimum from -200 c/s to -75 kc/s. The carrier frequency of the unit is 1.65 Mc/s, and the passband at 3 dB is  $+300$  c/s to  $+3$  kc/s. Nominal impedance is 12 k $\Omega$ . Transatron Electronic Ltd., Gardner Road, Maidenhead, Berkshire.

WW 318 for further details

## Firing Angle Meter

THE Westinghouse CTS1 meter for measuring the firing angle of thyristor gate drive circuits is said to provide a more convenient and direct method of obtaining a steady state indication than by examination with an oscilloscope. Included in the instrument is a stabilized d.c. supply which is intended to be used as a variable control voltage input to firing circuits, to determine the overall transfer characteristic. The CTS1 may be fed with the outputs of up to three firing circuits, thus easing the testing of three-phase units. Supply voltage is 240 V (+10%, -15%), and supply frequency should be 50 c/s  $\pm 10\%$ . Input pulse signal (pulse or train) 3 to 20 V. Minimum pulse duration is 5  $\mu$ s. The firing angle range is 2° to 178° and absolute accuracy is 3°. Westinghouse Brake and Signal Co., Ltd., Semiconductor Division, 82 York Way, King's Cross, London, N.1.

WW 319 for further details

## Wow and Flutter Meters

TWO Miniflux wow and flutter meters manufactured by Tech.-Phys, Munich, Germany, are available from the U.K. distributors, Lennard Developments Ltd., 7 Slades Hill, Enfield, Middlesex. The ME 102A, superseding the ME 102, has a higher sensitivity of the drift indicator ( $\pm 2\frac{1}{2}\%$ ), and wow and flutter indications are 0.15 and 0.75% full scale respectively. The ME 103, for use with a wide range of turntables has a drift indicator  $\pm 4.5\%$ , while wow and flutter meter ranges are 0.3, 1.0, and 3%. Both instruments operate on 3,150 c/s and have "flat" or "weighted" characteristics in accordance with C.C.I.R. specifications. The frequency oscillator and the measuring circuits can however, be adjusted to 3 kc/s.

WW 320 for further details

## Recycling Timer

THE Actan timer is intended for applications where only d.c. supplies are available. With a d.c. motor fitted, the currents consumed for the operating volt-

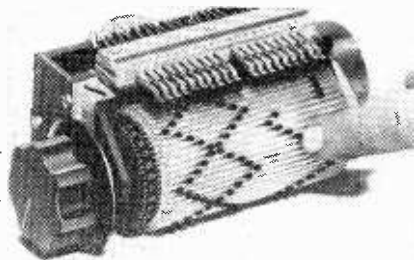

## POSITIONING TOOLS

LOCATING small screws, nuts and other small components in places difficult to reach, can now be expedited with the kit of five positioning tools from Henri Picard & Frère Ltd., 34/35, Furnival Street, London, E.C.4. A screw positioner has a split blade, each half of which twists out of alignment to grip the walls of the screw slot. There are two positioners for nuts, bolts and washers up to 4BA sizes, and two other tools for holding leads during soldering or threading them through awkward holes. Each tool is 180 mm (7 in) long with a shank of 100 mm (4 in). The price of the kit, including plastic wallet, is 62s 8d.

WW 321 for further details

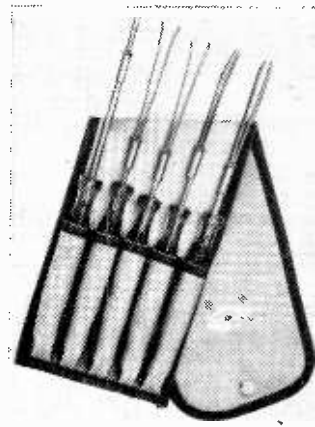

## Programmable Power Supplies

SILICON devices are employed in the Belix RS power supply units. Employed in the testing of integrated circuits where a fast switching time is imperative, two of these units have a rise time of 0 to 30 V in 30  $\mu$ s and the three units cover 1, 2, and 5 A at up to 30 V. Their m.t.b.f. of 10<sup>4</sup> hours at +70°C is stated to make them particularly suitable for these applications. The out-

puts are fully programmable, voltage being a function of resistance and current of conductance. Input voltages are 100, 120, 220, 230, 240 V r.m.s. with permissible variation of +15%, -10% about any nominal at frequencies between 45 to 66 c/s, single phase. The Belix Company Ltd, 47 Victoria Road, Surbiton, Surrey.

WW 322 for further details

## SERIES REGULATOR

WITH a regulation of 0.01% from zero to full load, the Startronic plug-in series regulator module M147 is designed to operate from a suitable rough d.c. supply. Primarily intended for use with i.c.s, the maximum input voltage is 25 V d.c., minimum input voltage is 2 V more than required output. These limits include ripple. The output is 9 to 15 V d.c., 0 to 1A. Output current is

limited at 1.2A to protect the module against overload and short circuit.

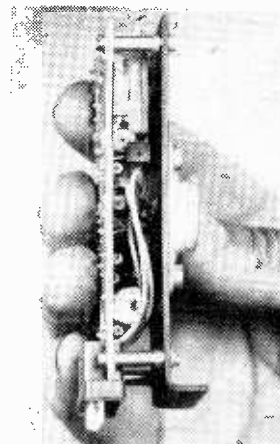

Maximum dissipation is 10 W at 40°C, and stability is 0.01% for  $\pm 10\%$  change of input. The M147 is 3  $\frac{1}{2}$  in high excluding pins. Startronic Ltd., 117a-119a Malden Road, New Malden, Surrey.

WW 324 for further details

ages of 6, 12 or 24 V d.c. are 500 mA, 250 mA and 125mA respectively. Models with motor speeds of one or two r.p.m. are available, while both models can be supplied with on/off cam segments installed in increments of 0.5 seconds. Timing accuracy is  $\pm 10\%$  of the nominal. Ten or 19 independent circuits can be controlled, with contacts rated at 2 A (resistive). Both units can be provided with a programmed stop at the end of a complete cycle or for continuous recycling operation. Sealectro Ltd., Farlington, Portsmouth, Hants.

WW 323 for further details

## Modular Chassis

SYSTEM J modular chassis for high density packaging of circuits based on a card size of  $4.750 \times 2.530$  in have been designed by Imhofs. This card size can be used with 16-way  $\times 0.15$  in pitch edge connectors. Two types of frame are available: (a) an open rack framework (in two sizes) accepting cards from the front, one 19 in wide and  $3\frac{1}{2}$  in high accommodating 32 cards, the other  $22\frac{1}{2}$  in wide  $\times 3\frac{1}{2}$  in high, accepting up to 38

cards; (b) the alternative type of frame accepts plug-in modules and is available in one size 19 in wide  $\times 17\frac{1}{2}$  in high. However, this frame will accept three different size plug-in modules, all of which accept cards from the top, and up to 88 cards can be accommodated in one frame. Alfred Imhof Ltd., Ashley Works, Cowley Mill Road, Uxbridge, Middlesex.

WW 325 for further details

## E.H.T. Measurement

TWO high-voltage probes for the measurement of e.h.t. voltages on monochrome and colour television sets are available from Salford Electrical Instruments Ltd., Peel Works, Barton Lane, Eccles, Manchester. These models P.25 and P.30 are intended to extend the range of the Minitest and

Selectest Super 50, or any other make of  $20 \text{ k}\Omega/\text{V}$  multirange test instrument to 25 kV or 30 kV d.c. Maximum power consumption at full voltage on the 30 kV resistor will be 1.5 W, the unit is rated at 9 W. The probes are  $13\frac{1}{2}$ -in long, plus 36 in lead, and the barrel is  $\frac{1}{2}$  in in diameter with a guard  $1\frac{1}{2}$  in diameter.

The price of the probes is £5 3s each for the P.25 (25 kV d.c.) and P.30 (30 kV d.c.).

WW 326 for further details

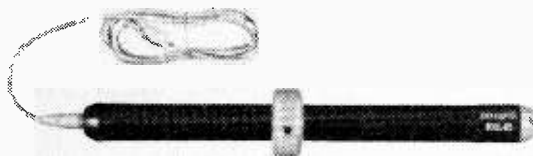

## Differential Voltmeter

AS a differential voltmeter, the Model 1000 instrument by Honeywell Controls Ltd., of Brentford, Middlesex, provides  $\pm 0.0025\%$  accurate measurement of d.c. signals with six digits of numerical readout. A seventh digit of resolution can be provided by the 10% over-range on the one- and ten-volt ranges. Potentiometric input impedances are said to provide errorless measurement of signals with high source impedances. As a decade voltage divider, the six decade Kelvin-Varley divider network is utilized, and accurate voltage level divisions can be made within  $\pm 0.001\%$ . Operating as a ratiometer, it provides measurements within  $\pm 0.001\%$ , while the external reference signal level may range up to  $\pm 100$  V d.c. Calibrated voltage levels of six-digit resolution are obtainable when the Model 1000 is used as a precision calibrated reference source, and this operation uses the precision Zener reference and voltage divider. The output levels are selected by dialling the desired voltage on the controls. The levels ranging from 0 to 11 V d.c. are accurate to  $\pm 0.0025\%$  and are used for the calibration of

potentiometric instruments. The electronic null detector facilities possess drift-free operation and maximum reliability, due, it is said, to the use of silicon f.e.t.s. Input changes as small as 10 V can be detected.

WW 327 for further details

## Ni-Cd Cell Charger

A PORTABLE, universal charger for nickel cadmium cells and batteries is available from Cadmium Nickel Bat-

## Tape Head Maintenance Kit

INTENDED for cleaning tape heads, and other units of the tape path, of reel and cassette tape recorders, the Bib tape head maintenance kit is available from Multicore Solders Ltd., Multicore Works, Marylands Avenue, Hemel Hempstead, Herts. The kit is made up of tape head applicator tools, two tape head polisher tools, ten applicator and polisher sticks, one double ended brush, one bottle of instrument cleaner, one pocket of cleaning tissues and a five-page instruction folder. The price is 12s 6d, and replacements for different items in the kit are available.

WW 328 for further details

## VHF Direction Finder

DEVELOPED for small airports, the portable direction finder Type NP8 by Rohde and Schwarz is a solid-state table set weighing about 66 lb. It is a wide aperture set operating on the Doppler principle, and, by using a suitable control crystal, it is possible to set frequencies in the range 117.5 to 135.5 Mc/s. Bearing accuracy of  $\pm 1^\circ$  places this finder in Class A of C.C.I.R. recommendations for bearing accuracy and position specifications. The circular aerial reference plane is segmented, enabling simple, speedy assembly. Once the operating frequency is set the system operates automatically. Three digital indicator tubes indicate true bearing and direction is shown by 36 indicator lamps. A built-in speaker permits monitoring of the tuned-in transmitter without extraneous noise. Rohde and Schwarz, Pressereferat 8000 München 8, Mühldorfstrasse 15, Germany.

WW 329 for further details

teries Ltd., Spedant Works, Park Royal Road, London, N.W.10. Three models of the Voltabloc CC are offered with

the respective output ranges of 10 to 20 mA, 10 to 750 mA and 100 to 1000 mA, while the output remains constant irrespective of input or load variations. The three units can be connected to an input of 90-130 V or 200-250 V, 50/60 c/s. A light will indicate wrongly connected cells, or a short circuit.

WW 330 for further details





## Edge-operated Switch

REQUIRING a panel cut-out of only  $0.96 \times 0.5$  in, the "Miniswitch" is a single-pole eight- or ten-way unit, operated by an edgewise thumbwheel.



Offered by Digitizer Techniques Ltd., Banner Works, Rock-a-Nore Road, Hastings, Sussex, it will also be available in binary coded decimal form at a later date. Mounting accessories available are end cheeks to complete a bank of switches (see illustration) and to permit panel mounting. Output connections can be either wires soldered to the printed circuit board, or by means of a 0.75in pitch printed circuit edge connector.

WW 331 for further details

## Electromagnetic Brakes and Clutches

VARLEY miniature brakes and clutches manufactured by Oliver Pell Control Ltd., have a rated static torque of 2 lb/in. The diameter of both the electromagnetic brake MB7 and clutch MC7 is less than 1 in. Brakes and clutches possess a stationary coil housing which magnetically attracts an armature sliding on a square section of the shaft to be coupled or controlled. The clutch also

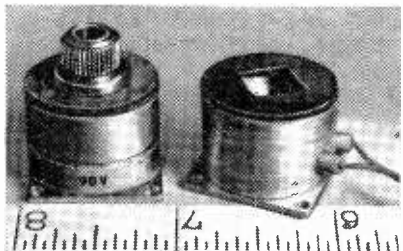

has a rotor. Coils are rated at 3.5 W at 28 or 90 V but designs for up to 100 V can be produced. Coils are epoxy resin encapsulated. Oliver Pell Control Ltd., Cambridge Row, Woolwich, London, S.E.18.

WW 332 for further details

The U.K. agents (Guest Electronics Ltd.) for the S.6A multimeter (p. 409, August issue) state that the price of this instrument is now £10 5s.

WIRELESS WORLD, SEPTEMBER 1967



THE HOUSE OF BULGIN  
AT YOUR SERVICE

## PLUGS & SOCKETS ALL ORIGINAL DESIGNS



**List No. P.73**  
Three-pole 250V. ~. 5A. polarized connector, also available as a two-pole  
List No. P.74.



**List No. P.J60/SE**  
Miniature three-pole connector rated 250V. ~ 1.5A. with side cable entry to socket.



**List No. P.485 + P.486**  
Single-pole screw locking connector, 250V. ~ 5A. available red or black.

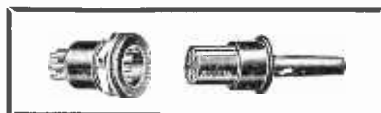

**List No. P.194**  
Miniature six-pole, polarized connector rated 250V. ~ 1.5A. Companion model to P.360.

## FOUR NEW MODELS



**List No. P.46 (Plug) + P.543 (Socket)**  
New single-pole connector with 4 mm.  $\phi$  pin and socket, rated 250V. ~ 5A. available in red or black.

**List No. P.542**  
New single-pole socket specially developed for use in "Patch Plug Programming Systems" accepts  $\frac{1}{8}$ "  $\phi$  spl.t pins.

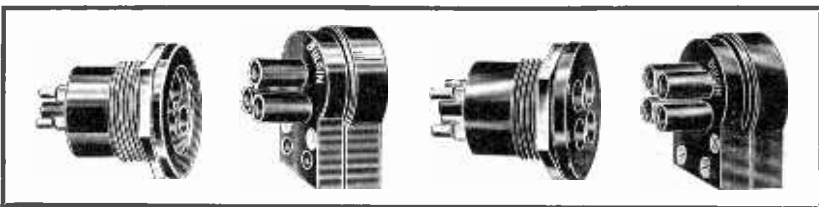

**List No. P.561**  
Three-pole fully shrouded and polarized connector miniature but rated 250V. ~ 2A. side cable entry.

**List No. P.560**  
Four-pole version of model on left, both produced from shatter resisting material.

SEND FOR OUR NEW PUBLISHED LEAFLET No. 1506/C.

**A. F. BULGIN & CO. LTD.,**  
Bye Pass Rd., Barking, Essex.  
Tel: R1Ppleway 5588 (12 lines)

MANUFACTURERS AND SUPPLIERS OF RADIO AND ELECTRONIC COMPONENTS TO

ADMIRALTY	MINISTRY OF WORKS	B.S.C.
WAR OFFICE	MINISTRY OF AVIATION	C.P.O.
AIR MINISTRY	MINISTRY OF SUPPLY	I.T.A.
HOME OFFICE	RESEARCH ESTABLISHMENTS	N.P.L.
CROWN AGENTS	U.K.A.E.A.	D.S.I.R.

WW-103 FOR FURTHER DETAILS

## Thoughts from a Lay-by

A COUPLE of miles back along the road there is a trailer caravan, upside down and crumpled almost beyond recognition, lying beside a jumble of metal that was once a family car. On the grass verge, huddled in blankets, sit two small children, miraculously unhurt, staring numbed into a future that no longer includes their parents.

This isn't fiction; it's cold sober fact. But while (I hope) accepting it as such, no doubt you are legitimately wondering what on earth it's got to do with electronics. And that, sir, is precisely my point. It hasn't, but it ought to have.

Stand back and take a hard look at the human race in a strong light and you will surely find all the symptoms of mass lunacy. We make it virtually impossible for an ordinary citizen to own a revolver but we blandly permit almost anyone to use that equally lethal weapon the motor vehicle. We would consider it lunacy to permit engine drivers to career up and down the railway lines at their own sweet will, but we don't bat an eyelid at the sight of hundreds of thousands of car drivers doing precisely that on the roads.

### Electronic control

Let's consider just one aspect of road accidents, the inter-vehicle collision, which, in spite of all road improvements, continues to keep the undertaking profession in affluent business. Here, I suggest, electronics could do a really powerful job if it were given the chance to get at the core of the trouble instead of being permitted only to dabble around on the perimeter with things like speed traps.

But before it can begin to do so we motorists must face up to some unpalatable truths which we have been sidestepping for far too long. One is that the motor vehicle is a projectile which is being controlled by its individual (and largely asynchronous) computer, namely, the human brain: another is that although, in other respects, the brain is the computer *par excellence* it simply is not designed for car driving. It is much too sensitive to far too many stimuli (and thereby to distractions) to be good at it, and the human servo-mechanisms are too sluggish to respond adequately to emergencies of the character encountered. For example, the meek little man who has just had his ears beaten off by the boss can all too easily find an emotional safety(?) valve by climbing into his jalopy and doing a Jack Brabham down the by-pass.

If we are big enough to accept this blow to our ego we are well on the way to the acceptance of better control systems; better, because they are simpler. Harness the electron to road vehicle control and it will do what it is told; no more and no less. Electronics, unlike the human computers at present on our motorways, are insensitive to bullying bosses; they have no in-law problems; and do not have to worry about where the next lot of school fees is coming from.

Is there anything so fantastic about an electronically controlled M1? If we can make electronic toys which can steer a course across the floor, dodging obstacles and homing on to a power plug when the battery needs re-charging, surely we could progress lines of vehicles up and down a straight road? If we can design an aircraft blind-landing system which exercises control in three dimensions, what can be so difficult about controlling a car in two planes only?

The buried cable is one obvious approach, having thoroughly proved itself on robot trucks and was in fact successfully tried out on a highway many years ago. Entry to the motorway might be computer-controlled, with automatic assignment to a given speed lane according to the category and condition of the vehicle. *En route*, speed and steering control would be taken over by electronics and a safe distance maintained between vehicles by the same means; should a mechanical defect occur, a "panic button" could serve to bring all cars behind to a halt until the defective vehicle was shunted to a lay-by, using the manual steering control.

By such means the traffic-bearing capacity of a motorway could be utilized to the full and it could operate equally well in fog, with no multiple crashes such as are all too common an instance today. Overtaking, that prolific cause of fatal accidents, would be eliminated.

Naturally in any such scheme, considerations of cost, and the bulk of equipment which would have to be carried, raise their ugly heads. It is here, perhaps, that microcircuits could find a mass market; the quantity of standard units should cheapen the price while the small size would solve the stowage problem. The decision-making pulses coming along the cable (or whatever means is best) would, of course, be generated in static roadside units.

### Electric propulsion

Real emancipation will come when the electric motor ousts the noisome internal combustion engine. This is more in the court of our cousins in electric traction, but if the railways can make successful use of overhead conduction I don't see why it should be impossible on the road. It would make possible the use of powerful motors and thus turn electric vehicle design away from the milk-float trend.

On the other hand, self-contained power units may still hold their own. Is it, I wonder, absolutely out of the question to scale-down nuclear propulsion units as used in submarines to road vehicle requirements? Can some timely help come from new developments in fuel cells? One hears talk also of more efficient "conventional" cells than the lead-acid type (which was used by our grandfathers and is still standard on today's cars). Given a somewhat higher capacity and a high charge rate might it not be feasible to construct charging avenues at reasonably frequent intervals along a highway through which vehicles could pass at speed, picking up energy *en route*, rather like the old express steam locomotives used to pick up water.

These are only the ramblings of an amateur or weekend driver whose only interest in road vehicles is as a means of getting from A to B in safety, comfort and in reasonable time. They will only arouse fury in the breasts of hot rod enthusiasts, but I respectfully submit that for all such, special areas should be provided (a kind of poor man's Brands Hatch?) where their talents could be exercised at no risk to anyone except their peers.

Accept then, that the suggestions made are from an ignoramus, put forward only in the hope that they may stimulate readers to produce infinitely better ones.



## SPECIALIST MANUFACTURERS OF THE MOST MODERN UP-TO-DATE SOLDERING EQUIPMENT IN THE WORLD

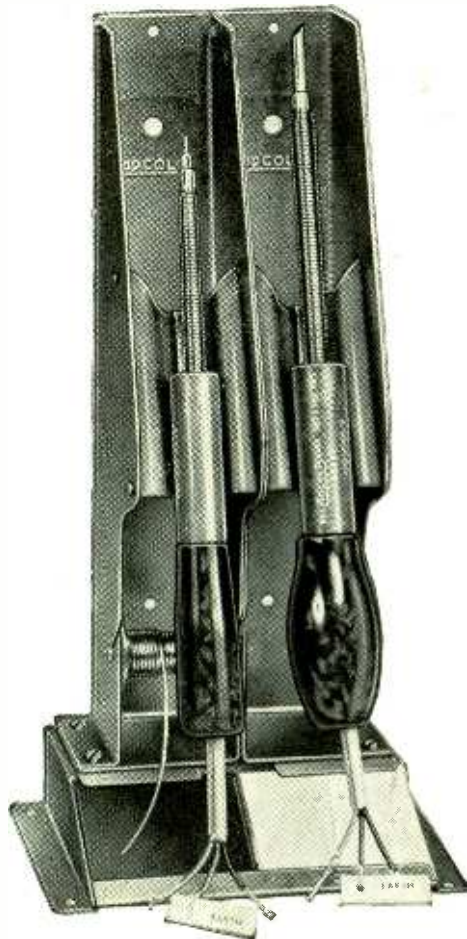

OVER A DOZEN DIFFERENT MODELS OF SOLDERING INSTRUMENTS AVAILABLE, WITH A CHOICE OF 54 DIFFERENT BITS RANGING IN SIZE FROM  $\frac{1}{32}$ " TO  $\frac{3}{4}$ ", IN TEMPERATURES OF 250°C TO 500°C TO SUIT ANY VOLTAGE SUPPLY, AND WITH LONG LIFE BITS IF REQUIRED.

SPECIAL SOLDERING INSTRUMENT BITS MANUFACTURED TO CUSTOMERS' REQUIREMENTS.

FULL AFTER SALES SERVICE, INCLUDING TECHNICAL ADVICE, AVAILABLE ON ALL EQUIPMENT.

HAND PYROMETERS, HAND & BENCH THERMAL CABLE STRIPPERS, TRANSFORMERS, BENCH MOUNTED SOLDERING INSTRUMENTS, AN ANTI-SEIZING COMPOUND FOR SOLDERING INSTRUMENT BITS, PROTECTIVE SHIELDS, ARE ALL PART OF THE ADCOLA RANGE OF HIGH EFFICIENCY SOLDERING EQUIPMENT.

Send for details to

HEAD OFFICE SALES & SERVICE

**ADCOLA PRODUCTS LTD**  
**ADCOLA HOUSE, GAUDEN ROAD,**  
**LONDON, S.W. 4.**

Telephones: 01-622-0291-3

Telegrams: SOLJOINT, LONDON, S.W. 4

AUSTRALIAN ASSOCIATES: ADCOLA PRODUCTS PTY. LTD., 673 WHITEHORSE ROAD, MONT ALBERT, MELBOURNE  
 AGENTS IN ALL LEADING COUNTRIES

for repetition soldering processes use  
precision made



**solder pellets**

Precision made solder pellets should reduce materially the cost of automatic soldering processes where a very small precise weight of solder is required for each joint. Previously preforms of solder by the use of discs or spheres have often been employed for this purpose which have also proved comparatively expensive to make owing to accumulation of scrap during production.

After a considerable amount of research it has now been made possible to manufacture cylindrical pellets which can be cut to an accuracy of  $\cdot 001$ " from drawn wire which eliminates the production of any scrap.

These Multicore pellets are now available in tin/lead alloys to British and U.S.A. Specifications. The pellets can be supplied either without flux or containing up to 5 cores of non-corrosive Ersin flux. Virtually any combination of length

and diameter pellet is available, also pieces of solder tape square or rectangular in shape.

Please contact us for free advice, samples and literature if you think you have a use for Solder Pellets, tape, rings or any other solder application.

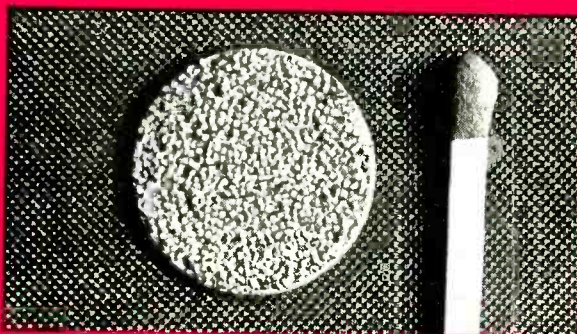

*The illustration above shows 1000 Pellets Diameter  $\cdot 022$ " with a length of  $\cdot 024$ ", laid over a 6d. The match head serves to illustrate the comparison in size.*

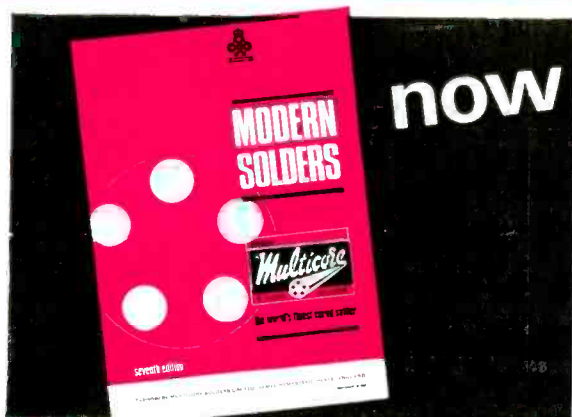

**now available!**

## 7th edition of Modern Solders

Engineers and technicians are invited to write on their Company's letterheading for the new comprehensive A4 size 7th edition of Modern Solders containing complete information on the full range of Ersin Multicore Solders, Printed Circuit Materials, Solderability Test Machine and Automatic Soldering Equipment.

### Multicore Solders Ltd

Hemel Hempstead, Herts.

Telephone: Hemel Hempstead 3636 Telex: 82363



WW-002 FOR FURTHER DETAILS