

SIMPLE CONTROLLED POWER SUPPLY

Wireless World

ELECTRONICS • TELEVISION • RADIO • AUDIO

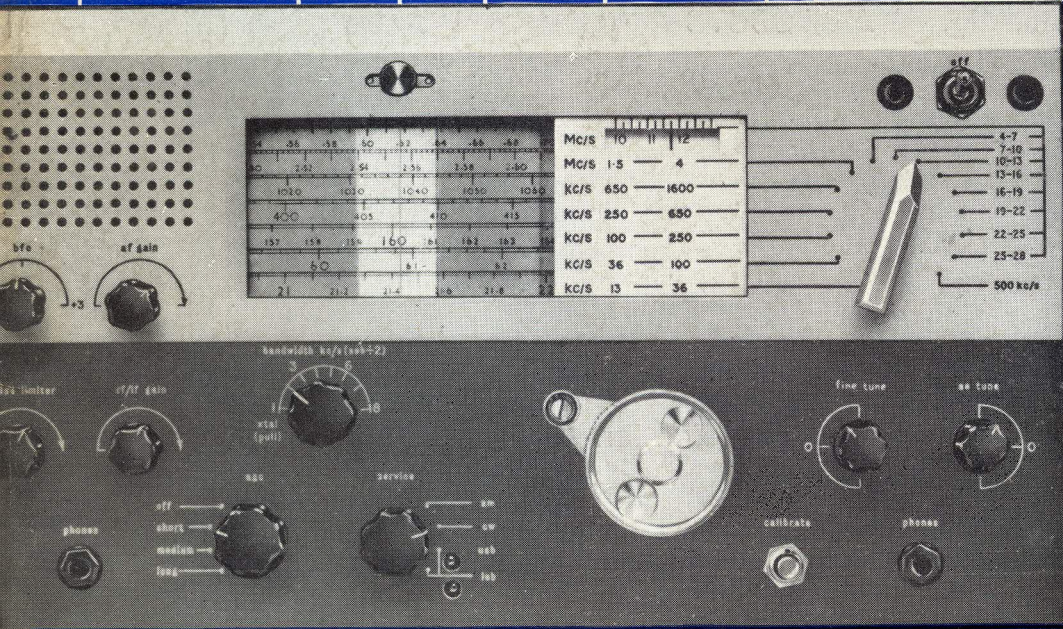
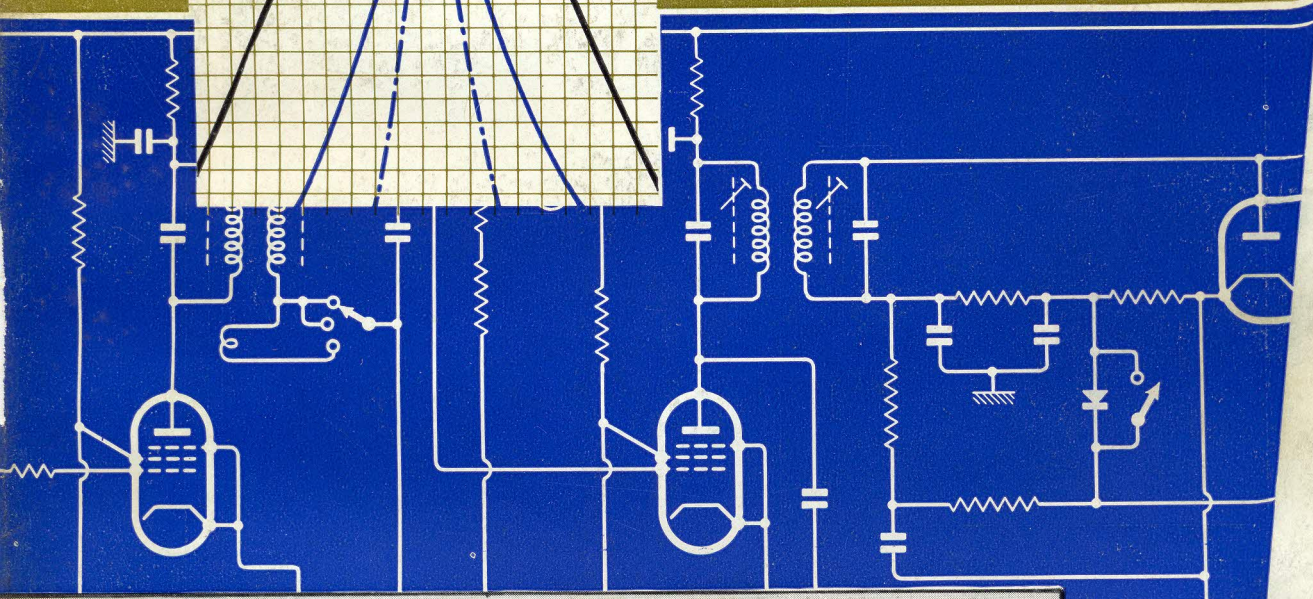
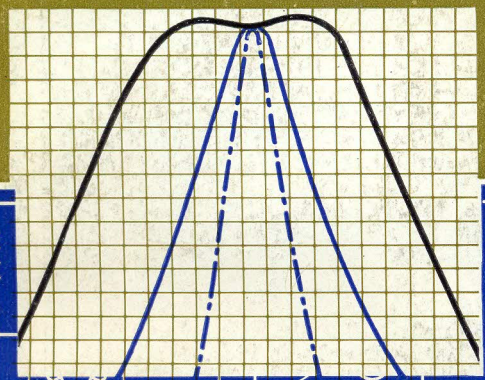

Survey of
Communication
Receivers

Wireless World

ELECTRONICS, TELEVISION, RADIO, AUDIO

APRIL 1966

- 153 "Information Explosion": Can it be Controlled?
154 Simple Thyristor-protected Power Supply *by J. S. Taylor*
157 Communications Receiver Survey
166 You Can Begin to Design with F.E.Ts Now *by T. D. Towers*
171 Danish Electronics
178 Audio Fair Preview
185 Attenuation in Coaxial Cables *by A. I. H. Wade*
190 Curve-fitting, Covariance and Correlation *by D. A. Bell*
200 Voltage-controlled Amplifier—2 *by M. Bronzite*

SHORT ITEMS

- 170 Normal Pitch Recordings at Double Speed
173 Reciprocal Amateur Licensing
173 Colour Television Decision?
173 Local Broadcasting Proposals
194 Optical Waveguides
199 Oscillating Diode used for Short-range Transmission
199 Transistor Feedback Capacitance Reduced
295 Physics Exhibition—List of Exhibitors

REGULAR FEATURES

- | | |
|---------------------------|---|
| 153 Editorial Comment | 204 Month's Conferences and Exhibitions |
| 173 World of Wireless | 205 H.F. Predictions—April |
| 175 Personalities | 206 New Products |
| 177 News from Industry | 212 April Meetings |
| 195 Letters to the Editor | |

PUBLISHED MONTHLY (3rd Monday of preceding month). Telephone: Waterloo 3333 (70 lines). Telegrams/Telex: Wiworld Iiffepres 25137 London. Cables: "Ethaworld, London, S.E.1." Annual Subscriptions: Home £2 6s 0d. Overseas: £2 15s 0d. Canada and U.S.A. \$8.00. Second-class mail privileges authorised at New York N.Y. BRANCH OFFICES: BIRMINGHAM: 401, Lynton House, Walsall Road, 22b. Telephone: Birchfield 4838. BRISTOL: 11, Marsh Street, 1. Telephone: Bristol 21491/2. COVENTRY: 8-10 Corporation Street, Telephone: Coventry 25210. GLASGOW: 123, Hope Street, C.2. Telephone: Central 1265-6. MANCHESTER: 260, Deansgate, 3. Telephone: Blackfriars 4412. NEW YORK OFFICE U.S.A. 111 Broadway, 6. Telephone: Digby 9-1197.

"Wireless World"
Iiffe Electrical Publications Ltd.,
Dorset House, Stamford Street,
London, S.E.1

Managing Director:
W. E. MILLER, M.A., M.I.E.R.E.

Editor-in-Chief:
W. T. COCKING, M.I.E.E.

Editor:
H. W. BARNARD

Technical Editor:
T. E. IVALL

Editorial:
B. L. SEXTON, Grad. I.E.R.E.
G. B. SHORTER, B.Sc.

Drawing Office:
H. J. COOKE

Production:
D. R. BRAY

Advertisements:
G. BENTON ROWELL
(Manager)

J. R. EYTON-JONES

© Iiffe Electrical Publications Ltd., 1966. Permission in writing from the Editor must first be obtained before letterpress or illustrations are reproduced from this journal. Brief extracts or comments are allowed provided acknowledgement to the journal is given.

VOLUME 72 No.4
PRICE: 3s.

FIFTY-SIXTH YEAR
OF PUBLICATION

Wireless World

ELECTRONICS, TELEVISION, RADIO, AUDIO

"Information Explosion": Can it be Controlled?

THIS much used phrase "information explosion" was the subject of two recent London meetings—one at the Royal Institution, addressed by the Earl Mountbatten of Burma, and the other a discussion at the I.E.E. That there is an explosion (complete with paper "fall-out"), few will deny. It has been estimated that there were about 100 scientific journals and periodicals at the beginning of the 19th century, by 1850 the number had grown to 1,000, by 1900 it had reached 10,000 and today it may be as high as 100,000. Every week the Patent Office Library, Britain's main technical open-access reference library, handles over 7,000 new items—books, periodicals and patent specifications. It has been suggested that one reason for the explosion is the "publish or perish" attitude of would-be Ph.Ds; another is that companies anxious to project their image go to great lengths to encourage their professional writers to propagate the ideas of their engineers.

How much, or how little, one might ask, of the published material is technically new or significant? So often one finds that the author has put in a tremendous amount of time writing up background information against which to present his new technique and, if it is published in its entirety (as so often happens) the reader similarly spends a lot of time sifting the wheat from the chaff. It was suggested by Mr. J. A. Ratcliffe (until recently director of the Radio and Space Research Station, Slough), when he opened the I.E.E. discussion, that some published information is so specialized and goes into such precise detail that it is a waste of time publishing it in a journal; it should, he said, be deposited in the library of one of the learned societies and maybe a few copies circulated privately to the specialists working in that particular field.

Even if the volume of published material does not grow beyond the present limits there still remains the problem of information retrieval. The National Electronics Research Council is conducting a pilot scheme for the selective dissemination of information (S.D.I.) to 1,000 research workers in an endeavour to find a solution to the problem and the I.E.E. is seeking Government aid to run for a trial period a computer-aided information service for physicists. Both are using electronic means, but there are others looking to microfilming to provide the answer.

It is perhaps significant that several of the larger American electronics organizations are acquiring, or obtaining interests in, publishing companies to gain an entry into the public market for information. We may well see in the not-too-distant future print giving way to electronic means of communication; a magnetic store from which "readers" can see an up-to-date record of developments in a particular field.

There is, of course, the other side of the coin. Many of us read journals for the pleasure we get from them—we hope this might be true of some readers of *Wireless World*. There is a parallel in the way we provide nourishment for our bodies. It could be done—and with much less waste of time—by swallowing a few pills or capsules every so often, but what a lot of pleasure would be taken out of life!

This dissertation in the pages of a public journal whose very existence has depended, and will continue to depend, on its ability to disseminate technical information may seem out of place but in fact it is very relevant. We must continually be asking ourselves what should be included and what excluded from the contents of *Wireless World*. As we see it the function of a public journal, which people buy presumably because they enjoy reading it, must be one of interpretation, leaving the learned societies as the main vehicles for the dissemination of information of a highly specialized nature.

VOL 72 NO 4
APRIL 1966

A Simple Thyristor-protected Power Supply

By J. S. TAYLOR, * Grad. I.E.E.

ALTERNATIVE CIRCUITS FOR VARIABLE REGULATED SUPPLIES

A USEFUL transistor power supply is described which is both practical and economical. The output resistance is not very low (approximately 1 ohm) but should be suitable for driving most "bread board" circuits. The power supply is equipped with a thyristor operated overcurrent trip which is sensitive enough to protect the power supply under conditions of short circuit and the load under conditions of thermal runaway. The basic design features of each stage are considered so that either alternative components can be chosen or the specification can be altered to suit requirements.

Throughout the article the design is illustrated by the parameters of the author's own power supply (quoted in brackets in the article) which are as follows:—

- Voltage: Variable 0-16 V.
- Current: 0-500 mA.
- Overcurrent trip: 20 mA-500 mA, variable.
- Output resistance: 1Ω approximately.

Design procedure

The unstabilised supply consists of a 20 V r.m.s supply, rectified by means of two OA210 silicon diodes and roughly smoothed by a 1,000 μF capacitor; this gives

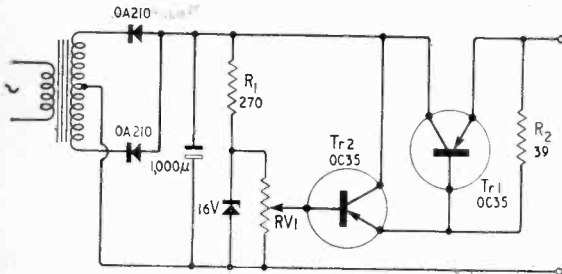

Fig. 1. Circuit of the basic power supply without overload trip.

approximately 26 V on open circuit and 20 V with a load of 500 mA.

The initial stabilised voltage source is obtained from a 16 V, 1.5 Zener diode. R1 is chosen for approximately 30 mA from 26 V. A 5 kΩ potentiometer is used for RV1—a lower value will give a lower final output resistance. If a lower value is used R1 should be adjusted to leave 25-30 mA through the Zener diode.

The output transistor must have a $V_{CE\ max}$ greater than 26 V and an $I_{C\ ave}$ greater than 0.5 A. The maximum dissipation in the series transistor occurs when the power supply is supplying full load current at low voltage.

Taking extreme values of 500 mA @ 1 V, the dissipation in the output transistor is:

$$0.5 \times 25 = 12.5 \text{ W.}$$

The equation for maximum permissible dissipation of a transistor on a heat sink is:

$$P_{tot} = \frac{I_{jmax} - I_{amb}}{\theta_m + \theta_j + \theta_h} \dots \dots \dots 1$$

Where I_{jmax} is the maximum permissible junction temperature (90°C for OC35),

I_{amb} is ambient temperature (say 30°C max.)

θ represents the thermal resistances in °C per watt as θ_m : junction to case (1.5°C/watt for OC35)

θ_j : case to heat sink (0.5°C/watt with mica washer)

θ_h : heat sink to ambient ($\approx 2.2^\circ\text{C/watt}$ for $7 \times 7 \times \frac{1}{8}$ in aluminium)

The thermal resistances quoted are taken from published data. Substituting in equation 1:

$$P_{tot} = \frac{90 - 30}{4.2} = 14 \text{ W.}$$

Absolute maximum values for an OC35 are $V_{CE} = 32 \text{ V}$, $I_E = 6.0 \text{ A}$, and total dissipation = 30 W. It can be seen that an OC35 is suitable for use as the output transistor. Should the unit be used in a higher ambient temperature or supply a greater current than 500 mA, a larger heat sink may be required. After the supply has been constructed a final check on the output transistor is that the temperature of the heat sink should be less than $(90 - 2P)^\circ\text{C}$, where P is the power dissipated in the transistor.

The OC35 is connected as an emitter follower but the base drive required is greater than can be supplied by the Zener stabilised supply. Therefore a further transistor is used to form a compound emitter follower.

The driver transistor must have a $V_{CE\ max}$ greater than 26 V and be able to supply the base current required by the OC35 when supplying a load of 0.5A. The base drive required by the OC35 will be between 6 and 10 mA depending upon the particular transistor and the load voltage. The maximum dissipation in the driver transistor occurs when the output transistor is at maximum

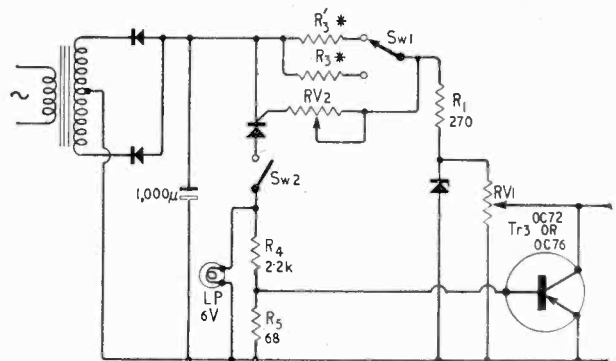
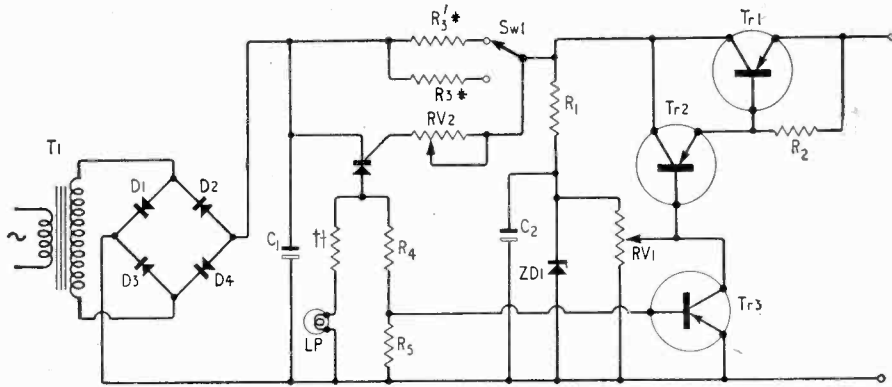

Fig. 2. Overload trip circuit. The indicator lamp lights when the trip is operated. Resistors marked * are adjusted on test—see text.

* Development engineer, I.C.I. Plastics Division, Dumfries.

Fig. 3. Complete circuit of protected power supply (Mk. I). Resistors marked * are adjusted on test—see test. Resistor marked † to suit lamp.



dissipation, and under these conditions is $10 \times 25 \times 10^{-3} = 250 \text{ mW}$. An OC76 has been successfully used as the driver transistor by utilising a $\frac{1}{2} \times 1\frac{1}{2} \times 2\frac{1}{2}$ in heat sink. However, if possible, a second OC35 should be used as the driver transistor which can be mounted on a small heat sink ($2 \times 2 \times \frac{1}{16}$ in).

The unit, as shown in Fig. 1, is the basic power supply and should work well on test. If the temperature of the output transistor is raised, by operating under conditions of high dissipation, it will be found impossible to control

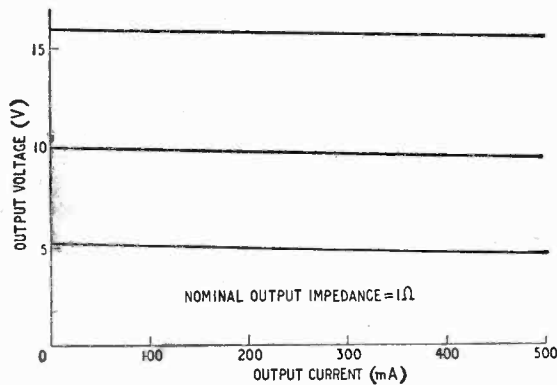
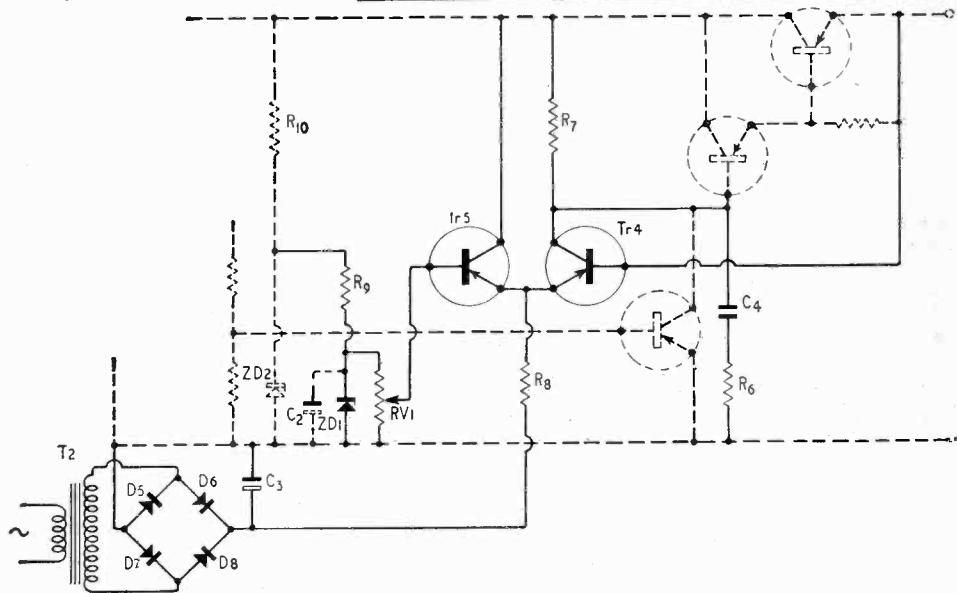

Fig. 4. Output characteristics of Mk. I power supply.

Fig. 5. Modified circuit of power supply to give better regulation (Mk. II).



Components for Fig. 3

Resistors

- R1 680Ω 1W
- R2 39Ω 1W
- R3 } adjusted as per text
- R3 } adjusted as per text
- R4 2.2kΩ 1W
- R5 68Ω 1W
- RV1 5kΩ 2W
- RV2 500Ω 2W

Capacitors

- C1 1,000μF 70 V
- C2 50μF

Semiconductor devices

- D1-D4 OA210
- ZD1 16 V Zener $\frac{1}{4}$ W
- Tr1 OC35
- Tr2 OC35 or OC76
- Tr3 OC76 or OC72
- Transistor: suitable type available from B.W.
- Cu: sons for 22/6.

Miscellaneous

- LP 6 V indicator lamp
- T1 240 V primary 24 V, secondary (20VA)
- S1 s.p.s.t. switch

Additional components for Fig. 5

Resistors

- R6 1kΩ 1W
- R7 33kΩ 1W
- R8 6.8kΩ 1W
- R9 220Ω 1W
- R10 470Ω 1W

Capacitors

- C3 10μF 16 V
- C4 0.1μF

Semiconductor devices

- D5-D8 OA81
- Tr4-5 OC203
- ZD2 20V Zener $\frac{1}{4}$ W

Miscellaneous

- T2 240 V primary 8 V secondary (e.g. bell transformer)

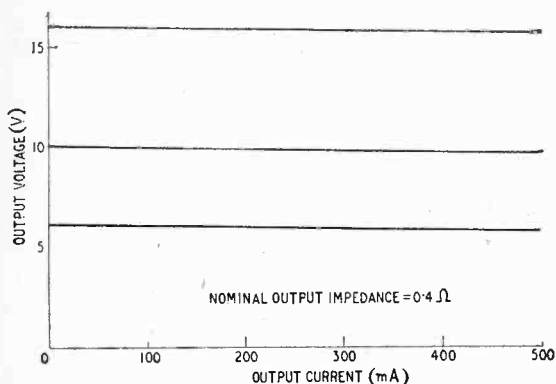

Fig. 6. Output characteristics of Mk. II power supply.

the output voltage to zero under open circuit, or light load conditions. This is due to the base being effectively open circuited when the output is set to zero and consequently I'_{CO} flows in the emitter circuit. Since I'_{CO} is extremely temperature dependent the higher the temperature the higher the minimum possible voltage on open circuit. The trouble is cured by the addition of R_2 , causing base current to flow which tends to turn off the transistor, the leakage current which remains is nearer to I_{CO} (grounded base leakage current). Since $I_{CO} = I'_{CO}/\alpha$, much better control over the output voltage under light load conditions is obtained, even under elevated temperature conditions. The addition of R_2 increases the emitter current and therefore the dissipation of the driver transistor, because under operating conditions the current through R_2 is supplied by Tr2.

Trip circuit

The trip circuit reduces the output voltage to zero in the event of the load current exceeding a predetermined limit.

The load current produces a voltage across R_3 which provides the trigger current for the thyristor. When the thyristor fires the transistor Tr3, which was previously turned off, is fully bottomed by suitable choice of R_4 and R_5 , and the base of Tr2 is clamped at the positive rail potential. Actually the potential of Tr2 will be slightly negative due to the bottoming voltage across Tr3. When the supply is operating normally and Tr3 is turned off very little collector current will flow in Tr3 due to the negative feedback between emitter and base through R_5 .

In designing the trip circuit the minimum desired trip current must first be decided (20 mA). A potentiometer is used in place of R_3 and set to minimum value and the load is set to 20 mA. The thyristor is wired up with its lamp load only and the potentiometer resistance increased until the thyristor fires. The potentiometer is replaced by a resistor equal to its final value and capable of carrying 500 mA. A high resistance potentiometer is then wired in place of R_3 and set to maximum value. With the load set to 500 mA, the potentiometer resistance is reduced until the thyristor fires. The potentiometer is then replaced by R_3 , its value being the nearest standard size larger than the final value of the original potentiometer.

The maximum dissipation of Tr3 occurs during switching just as the current through the Zener diode reaches the Zener breakdown potential and is about $25 \times 10^{-3} \times 16 = 400$ mW. This dissipation only occurs for a limited time during switching and the

transistor is not operating at high dissipation in either of its stable states. Tr3 is therefore chosen for its ability to withstand a V_{CE} of 16 V and to carry 65 mA collector current; an OC72 or OC76 are suitable for use as Tr3.

The base voltage required to bottom Tr3 can be determined by wiring the collector to the base of Tr2 and the emitter to the positive rail, with the base wired to the wiper of a potentiometer connected across the unsmoothed supply the voltage required to bottom can be determined. By suitable choice of R_4 and R_5 this voltage can be arranged to appear at the base of Tr3 when the thyristor fires. The voltage drop across R_3 is found to be excessive at high load currents, a resistor, R_3 , is therefore chosen in the same way as R_3 was chosen, except that a load current of approximately 150 mA is used instead of the 20 mA used in the choice of R_3 .

APPENDIX

The original circuit has deliberately been kept as simple as possible compatible with reasonable regulation and protected output, in the interests of economy. Should better regulation be required the following modifications can be included in the original circuit, as shown in the Mk. II circuit.

The Zener diode circuit is responsible for a fair proportion of the output voltage drop and cascading the Zener diode circuit, as shown, provides a more stable output voltage.

The output resistance of the cascaded emitter follower is equal to the resistance presented to the base of the first transistor divided by the current gain product of both transistors in the Darlington pair. The voltage drop across the series transistor can be compensated by applying negative feedback across the compound emitter follower. The second transistor in the long tailed pair provides the gain in the negative feedback loop whilst the first acts as an emitter follower and also acts to keep the current in the emitter resistor constant (and therefore the common emitter potential constant) when the bias point of the second transistor changes to compensate for the voltage drop across the output transistor.

For best output voltage stability the power supply should not be operated above 150 mA with the toggle switch in the high resistance position.

The series RC circuit on the base of the cascaded emitter follower is to reduce the loop gain at frequencies at which 180° phase shift may occur.

ELECTRONIC ORGANS AND PICKUP TRACKING

Among the articles in the May issue of *Wireless World*, which will be published on April 18th, is the first of a series on electronic organs culminating in a design for home construction; the first of two articles on correct pickup tracking; and a review of some of the more outstanding items at the Physics Exhibition (Alexandra Palace, London, March 28-31). The issue will also include all the usual regular features.

Communications Receiver Survey

GENERAL DETAILS OF SOME OF THE CURRENT RECEIVERS

THIS survey is based on the response from U.K. manufacturers and marketing companies to a specially prepared questionnaire. In size these firms ranged from small wholesalers to large manufacturing organizations. Early appraisal of the response disclosed that a wide range of equipment is available. Some replies contained details of synthesizers, quadruple superhets and complex diversity reception installations containing several hundred transistors and equipment of this nature, although interesting from a technical point of view, was considered to be beyond the scope of the survey which is intended to strike a balance between the requirements of the serious amateur and the professional operator.

After a careful analysis of the returned questionnaires



The RA217 is the latest receiver from Racal Ltd. It is 11in wide, 12in deep and 6½in high.

it was decided to limit the survey to receivers which could be continuously tuned through their frequency range. This decision deleted receivers designed for reception on crystal-controlled "spot" frequencies and here acknowledgement is made to firms who returned questionnaires with details of such equipment.

The characteristics and features presented in the table were requested on the basis that they would provide the maximum amount of general information in the space permissible for the table. In some parts of the table blanks appear due to information being unobtainable.

Where possible, prices have been given, but some manufacturers have indicated that this is not always practical, especially when receivers are sold abroad and are subject to export duty and shipping charges. When quoted, prices are for home market sales.

In the space available it has not been possible to discuss all the receivers listed or to give circuit details. However, brief details of three of the latest receivers from different manufacturers are given as being of general interest.

Just coming off the assembly line and featured on our front cover, the Redifon 408 receiver has some particularly interesting features. Basically, the design was evolved to meet the requirements of a G.P.O. specifica-

tion for a marine receiver, but the final design is also suitable for a general purpose communications receiver. The first fully transistor receiver to be given Post Office approval for use as a ship's main receiver, the R408 incorporates a possible trend-setting feature of continuously variable bandwidth, a special (patented) a.g.c. system for s.s.b. reception and an aerial protection circuit which gives "front-end" protection of about 30 V across 50 Ω.

An important advantage of continuously variable bandwidth (from ±800 c/s to ±8 kc/s, in the R408) is that an optimum setting for maximum intelligibility with minimum interference can always be found to suit different reception conditions whereas with preset switch-selected bandwidths an optimum balance condition is not always possible. For s.s.b. operation, the frequency variation of bandwidth is divided by two and is available for the upper or lower sidebands. On s.s.b. the facility has been found to be particularly useful where experiments have shown that narrowing of bandwidth to reduce adjacent-channel interference or switching from one sideband to the other does not necessitate readjustment of tuning. In practice, during reception of i.s.b. transmissions containing teleprinter information in one sideband and audio information in the other, use of the sideband switching facility to listen to audio has completely eliminated any break through from the teleprinter intelligence, and vice versa.

At the minimum bandwidth setting a crystal filter can be switched in circuit by a "pull out" action applied to the control. Bandwidth is then decreased to 80 c/s and the gain of the receiver is increased by 6 dB.

The a.g.c. system has been designed to overcome the disadvantage of noise pulses occurring during fast a.g.c. attack times on s.s.b. Due to the fast attack time required for rapid response of the a.g.c. and the long delay times required for noise suppression, a short burst of noise can normally paralyse a receiver for the duration of the a.g.c. recovery time but the a.g.c. circuitry has been designed to prevent this and differentiates against noise pulse interference with a 5 ms attack and a 10 s decay time.

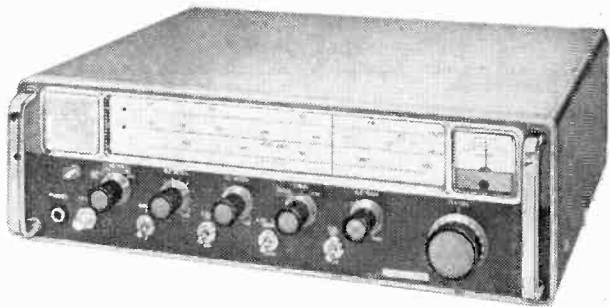

The Eddystone 990S can be used in conjunction with an EP17R panoramic display unit for visual monitoring of received signals.

The RA217 is the latest receiver from Racal Ltd. which utilizes the Wadley frequency changing system originally employed in the RA17. (*Wireless World*, Aug. 1957, p. 388). Transistor circuitry is used throughout and the performance with regard to characteristics such as a.g.c., cross-modulation, inter-modulation and stability is claimed to be better than that of a valve-circuit receiver. Linearity is not affected by operation of the a.g.c., thus the level of an interfering signal at which cross modulation would occur increases as the level of the wanted signal increases.

The basis of the design of the receiver is founded on the Wadley drift-cancelling loop which can be considered as an arrangement for drift-free conversion of a 0 to 30 Mc/s frequency spectrum to that of 2 to 3 Mc/s. The frequency reference for the loop is a 1Mc/s crystal standard which can also be used as a reference for an external frequency synthesizer such as the Racal MA.350 series. Tuning is indicated by a five digit

frequency read-out scale which can be read to within 200 c/s.

Four different switch selected bandwidths are available on the RA217 and these are determined by different crystal filters to provide bandwidths within limits of approximately ± 100 c/s to ± 6.5 kc/s. The dynamic range of receiver noise to maximum interfering signal is 85 dB and protection against high input level signal ranges from many volts sine wave to impulses of 10 kV.

Modular construction is used to allow both ease of access for maintenance and versatility for conversion of the receiver to customer-special requirements. A wide range of adapters and converters is available to allow the receiver to be used for all normal types of transmissions.

A new receiver from Eddystone is the 990S which, in addition to covering the 420 to 450 Mc/s amateur band, can be used for reception of television transmissions and the investigation and measurement of interference.

Trade Name and Model	Country of Origin	Type of Circuit	Frequency Bands	Receiving Modes	Input and Output Impedance	Sensitivity and $-(S+N)/N$	Selectivity
AVELEY ELECTRIC LTD. Rhode & Schwarz EK07 (Price on request)	Germany	Superhet Double superhet	0.5-1.1 Mc/s 1.1-2.1 Mc/s 2.1-3.1 Mc/s 3.1-6.1 Mc/s 6.1-30 Mc/s (in 3 Mc/s steps)		50-75 Ω (I/P) 15,600, 2k Ω (O/P)	Bandwidth setting μ V dB ± 0.3 kc/s 0.4 20 ± 0.3 kc/s 1.3 30 ± 0.3 kc/s 5.5 40 ± 6 kc/s 4 20 ± 6 kc/s 15 30 ± 6 kc/s 100 40	Bandwidth (kc/s) setting 20dB 60dB ± 0.3 <0.55 <1.5 ± 6 <1.7 <6 * \pm kc/s off bandwidth setting
Rhode & Schwarz ESG £2,681	Germany	Superhet Double superhet	30-40 Mc/s 40-60 Mc/s 60-80 Mc/s 80-100 Mc/s 100-120 Mc/s 120-300 Mc/s (in 20 Mc/s steps) 300-330 Mc/s	F.M. A.M. pulse	60 Ω (I/P) 30 Ω (O/P)	2 μ V >20dB (F.M.) 5 μ V >20dB (A.M.)	12.5* 90dB >50+ 75* { 60dB >300+ 60dB >400+ *Bandwidth setting in kc/s †kc/s off tune from centre frequency
Rhode & Schwarz ESM180 ¹ £719 8s	Germany	Double superhet	30-42.5 Mc/s 42.5-61 Mc/s 61-87.5 Mc/s 87.5-126 Mc/s 126-180 Mc/s	F.M. A.M.	60 Ω (I/P) O/P 60 Ω (i.f.) 2k Ω (phone)	Below 126 Mc/s <2.5 μ V 10dB Above 126 Mc/s <5 μ V 10dB	
COASTAL RADIO LTD. Caravel 361 £65	U.K.	Superhet	170-425 kc/s 600-1500 kc/s 1.6-3.8 Mc/s	A.M.	3 Ω (O/P)	31 μ V 30dB	± 3 kc/s @ 6dB ± 20 kc/s @ 60dB
COURIER COMMUNICATIONS Hallicrafters SX-117 £178	U.S.A.	Triple superhet	3.5-4 Mc/s 7-7.5 Mc/s 9.5-10 Mc/s 14-14.5 Mc/s 21-21.5 Mc/s 28-30* Mc/s *In 4 bands of 0.5 Mc/s	A.M. S.S.B. I.C.W.	50-70 Ω (I/P) 3-2 Ω 500 Ω 50 to 2k Ω } (O/P)	1 μ V 10dB (a.m. 30% mod.) <0.5 μ V 10dB (S.S.B., I.C.W.)	500 c/s @ 6dB or 2.5 kc/s @ 6dB or 5 kc/s @ 6dB
Hallicrafters SX-122 £136 10s	U.S.A.	Double superhet	0.54-1.6 Mc/s 1.75-4.9 Mc/s 4.8-12.6 Mc/s 12.5-3.4 Mc/s (1)	A.M. S.S.B. I.C.W.	50-600 Ω } (I/P) 3.2 Ω 50 to 50k Ω } (O/P)		500 c/s @ 6dB 2.5 kc/s @ 6dB 5 kc/s @ 6dB
Hallicrafters SX146 £118	U.S.A.	Superhet	3.5-4 Mc/s 7-7.5 Mc/s 14-14.5 Mc/s 21-21.5 Mc/s 28-30 Mc/s (In four 0.5 Mc/s bands)	A.M. S.S.B. I.C.W.	50-70 Ω (I/P) 3.2 Ω and phones } O/P	<1 μ V 20dB	1500 c/s 15 kc/s 2.1 kc/s
DAYSTROM LTD. Heachkit RG1 £39 16s (kit) £53 (Assembled)	U.K.	Superhet	600 kc-s-1.5 Mc/s 1.7-4 Mc/s 3.9-8 Mc/s 7.9-14 Mc/s 13.9-22 Mc/s 21.9-32 Mc/s	A.M. S.S.B. C.W.	600 Ω (I/P) 3 Ω 600 Ω } (O/P)	3 μ V 10dB	2.4 kc/s @ 6dB 9.8 kc/s @ 40dB

Continued on page 160.

Frequency coverage is 230 to 870 Mc/s and signals are received by two separate r.f. trough-line tuned heads (incorporating minute Lecher lines for the r.f. and oscillator circuits), one for the 230-510 Mc/s range and one for the 470-870 Mc/s range. Separate aerial connections are made to each head, and the heads are energized by switching a common supply voltage to the required head. Each head contains three stages, r.f. amplifier, combined mixer and oscillator, and i.f. amplifier; the main function of the i.f. amplifiers is to correctly load either of the head outputs which are fed to a common main 36.5 Mc/s i.f. amplifier via one of two switch selected bandpass filters. Provision is also made to feed the output from an external convertor to the main i.f. amplifier. The bandwidths of the two filters are 1 Mc/s and 6 Mc/s and both are available for a.m. reception, but on f.m. the bandwidth is fixed to 1 Mc/s to suit the discriminator deviation acceptance of 250 kc/s. Six i.f. stages are used for amplification of a.m. signals. In

addition to a signal detector two a.g.c. detectors derive voltages from the a.m. signals for i.f. and r.f. gain control; to preserve optimum signal-to-noise ratios the level of drive to the a.g.c. detector for the i.f. amplifier is greater than that to the a.g.c. rectifier for r.f. Both a.g.c. voltages are amplified and the a.g.c. voltage for r.f. is applied to both head circuits.

Frequency modulated signals are taken from the fifth i.f. amplifier stage via an emitter follower, amplified and, after two limiter stages, applied to a Foster Seeley type of discriminator.

Two two-stage video amplifiers are used to amplify the a.m. and f.m. signals and in normal circumstances the two amplifiers can be used simultaneously. Output from each channel is approximately 2.5 V peak-to-peak into a 1 k Ω load. Audio output from each channel is taken from the first stage of each video amplifier and switched to two independent a.f. gain controls feeding two separate a.f. amplifiers.

Image Rejection		Local Oscillator	(a) Xtal Filter (b) B.F.O. (c) A.N.L. (d) Xtal Calibrator (e) Loudspeaker (f) Power Unit	Gain Controls	Valves and/or Semi-conductors	Additional Information
Single superhet operation >70dB	300 kc/s	1st (v.f.o.)	b, d, f	A.F. R.F.	27 valves	A.G.C. characteristic: <3dB variation of O/P voltage for an i.f. voltage variation between 0.7 μ V and 100mV. A.G.C. time constants: 0.1, 1, 10s. "S" meter.
Double superhet operation >80dB	1st 3.3 Mc/s 2nd 300 kc/s	0.8-33.4 Mc/s 2nd 3 Mc/s (xtal)				
Single superhet operation 80dB Double superhet operation >100dB	15.7 Mc/s		b, c, d, f	A.F. I.F. R.F.	44 valves 15 semi-conductors	Recorder O/P Z=1M.
Below 126 Mc/s >80dB Above 126 Mc/s >60dB	1st 21.4 Mc/s 2nd 3.4 Mc/s		c, d, e, f	A.F. R.F.	19 valves	¹ Also available as ESM300 (85-300 Mc/s), £719-8s
60dB (at 2.2 Mc/s)	470 kc/s	V.F.O.	b, e	A.F. R.F.	13 semi-conductors	
50dB	1st 6.5-6 Mc/s 2nd 1.65 Mc/s 3rd 50-75 kc/s	1st 6.5 Mc/s above lowest frequency tuned 2nd 4.85-4.35 Mc/s 3rd 1.6 Mc/s for l.s.b. 1.7 Mc/s for u.s.b.	b, c, d, f	A.F. R.F.	13 valves 4 semi-conductors	Provision for l.f. tuner 85 kc/s-3 Mc/s. Variable "T" notch filter. Controls: 12.
	1st 1,650 kc/s 2nd 50 kc/s	2nd 1,700 kc/s (xtal controlled)	b, c, f d ²	A.F. R.F.	11 valves 1 semi-conductor	¹ Bandspread on amateur bands. ² Plug in module available. Controls: 11.
	9 Mc/s		a ¹ , b, c, d ² , f	A.F. R.F.	9 valves	¹ Shape factor better than 1.8 : 1 ² Plug in module available. Controls: 10.
40dB	1,621 kc/s		a, b, f, d ¹	A.F. R.F.	8 valves 2 semi-conductors	¹ Optional extra. A.G.C. time constant: 0.1s. "S" meter.

Trade Name and Model	Country of Origin	Type of Circuit	Frequency Bands	Receiving Modes	Input and Output Impedance	Sensitivity and (S+N)/N	Selectivity
DAYSTROM LTD. (continued) RAI £39 6s 6d (kit) £52 10s (Assembled)	U.K.	Superhet	1.7-2 Mc/s 3.5-4 Mc/s 7-7.3 Mc/s 14-14.45 Mc/s 21-21.5 Mc/s 28-30 Mc/s	A.M. S.S.B. C.W.	75Ω (I/P) 3Ω } (O/P) 600Ω	2μV 10dB	2.4 kc/s @ 6dB 9.8 kc/s @ 40dB
SB300E £139 (kit) £169 (Assembled)	U.S.A.	Double superhet	3.5-4 Mc/s 7-7.5 Mc/s 14-14.5 Mc/s 21-21.5 Mc/s 28-28.5 Mc/s 28.5-29 Mc/s 29-29.5 Mc/s 29.5-30 Mc/s	D.S.B. S.S.B. C.W.	50Ω (I/P) 8Ω } (O/P) + phones	1μV 15dB	S.S.B. 2.1 kc/s @ 6 dB 5 kc/s @ 60 dB C.W. 400 c/s @ 6 dB
GR64E £22 10s 0d (kit) £27 10s 0d (Assembled)	U.S.A.	Superhet	550 kc/s-1.5 Mc/s 1.5-4 Mc/s 4-10.5 Mc/s 9.5-30 Mc/s	A.M. C.W.		5μV 10 dB	
GREEN ELECTRONIC & COMMUNICATION EQUIPMENT LTD. TMR5 (Basic receiver) £35 Also available with Mk. 5 converters	U.K.	Single Double Triple Superhet (depending on Band in use)	1-1,000 Mc/s (to order)	A.M. C.W.	72Ω (I/P) 4Ω (O/P)	1μV	
K. W. ELECTRONICS LTD. HQ180A £161	U.S.A.	Double Superhet Triple Superhet	1.8-2 Mc/s 3.5-4 Mc/s 7-7.3 Mc/s 14-14.4 Mc/s 21-21.6 Mc/s 28-30 Mc/s 50-54 Mc/s				—All other details—
Hammarlund HE180A7 £193	U.S.A.	Double Superhet Triple Superhet	540 kc/s-7.85 Mc/s 7.85-30 Mc/s Bandspread (3.5-30 Mc/s)	A.M. S.S.B. C.W.	(I/P) 52-600Ω (O/P) 3Ω 500Ω	1.5μV for 10:1 S/N (D.S.B.) 0.7μV for 10:1 S/N (s.s.b. and c.w.)	At -6dB u.s.b. 1, 2, 3 kc/s l.s.b. 1, 2, 3 kc/s a.m. 0.5, 2, 4, 6 kc/s
SP6001X £520	U.S.A.	Single Superhet Double Superhet	540 kc/s-1.35 Mc/s 1.35-3.45 Mc/s 3.45-7.4 Mc/s 7.4-14.8 Mc/s 14.8-29.7 Mc/s 29.7-54 Mc/s	A.M. S.S.B. C.W.	100Ω (I/P) 600Ω (O/P)	0.75-1μV 10dB (c.w.) 1.5-2.3μV 10dB (a.m.)	At -6dB Six positions between 200 c/s and 13 kc/s
KW201 (Price to be announced)	U.K.	Double Superhet	1.8-30 Mc/s (Amateur bands only)	A.M. S.S.B. C.W.	(I/P) 50-75Ω 3Ω (O/P)	1μV 30dB	3 kc/s @ 6dB <6 kc/s @ 60dB
MARCONI COMPANY LTD. H2301 (Price on request)	U.K.	Double Superhet	0.5-30.5 Mc/s (in 30 ranges each covering 1 Mc/s plus small overlap)	A.M. S.S.B. C.W.	75Ω (I/P) 2.5Ω } (O/P) 600Ω	3μV 15dB (above 1.5 Mc/s) 5μV 15dB (below 1.5 Mc/s)	Overall bandwidth -6dB -60dB 14 kc/s 36 kc/s 7 kc/s 27 kc/s 3 kc/s 15.5 kc/s 3 kc/s 11.5 kc/s 1.2 kc/s 9 kc/s 0.4 kc/s 7.5 kc/s
PLESSEY RADIO SYSTEMS DIVISION PRI55 (Price on request)	U.K.	Triple Superhet	0.1-30.1 Mc/s (covered by 30 one Mc/s ranges with 0.1 Mc/s overlap at each end of the range)	A.M. S.S.B. I.S.B. F.S.K. C.W.	75Ω (I/P) 60Ω } (O/P) 600Ω	<0.5μV for 9dB noise factor	8 300 c/s (c.w.) 6 kc/s a.m. 3 kc/s s.s.b.

Continued on page 162

Image Rejection	I.F.	Local Oscillator	(a) Xtal Filter (b) B.F.O. (c) A.N.L. (d) Xtal Calibrator (e) Loudspeaker (f) Power Unit	Gain Controls	Valves and/or Semi-conductors	Additional Information
40dB	1,621 kc/s		a, b, d ¹ , f	A.F. R.F.	8 valves 2 semi-conductors	¹ Optional extra. A.G.C. time constant: 0.1s. "S" meter. Aerial trimmer.
50dB	1st 8.5 Mc/s (xtal controlled) 2nd 3.395 Mc/s	1st xtal controlled 2nd 5-5.5 Mc/s	a, b, d, f	A.F. R.F.	10 valves	A.G.C. time constants 0.05 and f.c.
	465 kc/s		b, c, e, f	A.F.	4 valves	¹ Bandspread on all bands.
	33 Mc/s 1.8-3.8 Mc/s 465 kc/s		a ¹ , b, c, d ² , e, f	A.F. R.F.	20 semi-conductors	¹ Bandpass, xtal, mechanical to order. ² To order.
as for HQ180A						→
>55dB	1st 3,035 kc/s 2nd 455 kc/s 3rd 60 kc/s	1st Tunable 2nd 2,580 kc/s (xtal) 3rd 395 kc/s	a, b, c, d, f	A.F. R.F.	18 valves 2 semi-conductors	¹ Also available as HQ 180AX (£213) which has 11 additional preset frequencies. "S" meter. Controls: 14. Matching speaker available in separate case.
>72dB	1st 3,955 kc/s 2nd 455 kc/s	1st Tunable or 6 xtal controlled frequencies 2nd 3.5 Mc/s	a, b, c, d, f	A.F. R.F.	20 valves	A.G.C. characteristic: 12dB variation of o/p for input variation of 80dB. "S" meter. Controls: 12.
60dB	1st 5 Mc/s 2nd 455 kc/s		b, c, d ¹ , f	A.F. R.F.		¹ Optional. A.G.C. time constant: 20 ms charge, 300 ms discharge. Switching for u.s.b. and l.s.b. "S" meter. Controls: 8. Mechanical filter.
90dB (1.5-15 Mc/s) 60dB (above 15 Mc/s)	1st (2.5-3.5 Mc/s) or (3.5-4.5 Mc/s) 2nd 500 kc/s		a, b, c, d, e, f	A.F. I.F. R.F.	24 valves	A.G.C. characteristic: 6dB variation of o/p for input variation of 100dB. A.G.C. time constant: 0.05, 0.5, 10s. Aerial trimmer.
80dB	1st 37 Mc/s 2nd 10.7 Mc/s 3rd 0.1 Mc/s	1st 37.3-67.3 Mc/s Other l.o. from internal xtal	a, b, c ¹ , d, e, f	I.F. A.F.	128 semi-conductors	¹ Available. A.G.C. time constant: Rise time 20 ms, hang time 1s, decay time 200 ms. "S" meter. Standby switch. Controls: 12.

Trade Name and Model	Country of Origin	Type of Circuit	Frequency Bands	Receiving Modes	Input and Output Impedance	Sensitivity and (S+N)/N	Selectivity
PLESSEY (Continued) PRI52 (Price on request)	U.K.	Double Superhet	0.55-1.5 Mc/s 1.65-4 Mc/s 4-10 Mc/s 10-17 Mc/s 17-24 Mc/s 24-30 Mc/s	A.M. M.C.W. C.W.	75Ω (I/P) 600Ω (O/P)	6μV 15dB (below 24 Mc/s) 10μV 15dB (above 24 Mc/s)	±3 kc/s @ 6dB ±10 kc/s @ 60dB with a.f. filter ±100 c/s @ 6dB ±300 c/s @ 20dB
RACAL LTD. RA17L (Price on request)	U.K.	Wadley system of frequency-changing and mixing	0.5-1 Mc/s 1-30 Mc/s (In 29 one Mc/s ranges)	A.M. C.W. M.C.W.	75Ω (I/P) 75Ω } (O/P) 75Ω } 100 kc/s 600Ω } 3 mW 600Ω } (O/P) 600Ω } 600Ω } 10 mW 3Ω } 50 mW	C.W. 1μV (Bandwidth 18 dB 3 kc/s) M.C.W. 3μV A.M. 18 dB Bandwidth 3 kc/s 30% mod.	6 dB* 66 dB 13 kc/s 35 kc/s 6.5 kc/s 22 kc/s 3 kc/s 15 kc/s 1.2 kc/s 8 kc/s †0.3 kc/s < 2 kc/s †0.1 kc/s < 1.5 kc/s *Bandwidth settings †Xtal lattice filter
RA117 (Price on request)	U.K.	Wadley system of frequency changing and mixing	As for RA17L except for 0.5-1 Mc/s range	As for RA17L	As for RA17L except 3Ω O/P is rated at 1 W	As for RA17L	As for RA17L
RA217 (Price on request)	U.K.	Wadley system of frequency changing and mixing	As for RA117	A.M. M.C.W. C.W. S.S.B.	75Ω (I/P) O/P 75Ω (1.6 Mc/s) 75Ω (100 or 445 kc/s) 600Ω (1 mW) 600Ω (10 mW) 600Ω (phone)	3 kc/s Bandwidth C.W. } 1μV 15 dB S.S.B. } A.M. } 3μV 15 dB M.C.W. } (30% mod)	3 dB* 60 dB †13 kc/s 40kc/s †3 kc/s 15 kc/s †1 kc/s 4 kc/s †0.2 kc/s 2 kc/s *Bandwidth setting †Xtal lattice filter
RADIO COMMUNICATIONS CO. Telecomm. VCRA £120	U.K.	Superhet	66-125 Mc/s (1 band)	A.M	75Ω (I/P)	25-μV 10 dB	±300 kc/s @ 40 dB
Telecomm VCRB £120	U.K.	Superhet	78-176 Mc/s (1 band)	A.M.	75Ω (I/P)	2-5μV 10 dB	±300 kc/s @ 40 dB
Telecomm VCRC £120	U.K.	Superhet	96-220 Mc/s (1 band)	A.M.	75Ω (I/P)	2-5μV 10 dB	±300 kc/s @ 40 dB
REDIFON LTD. R408 (Price on request)	U.K.	Seperhet and Double superhet	13-36 kc/s 36-100 kc/s 100-250 kc/s 250-650 kc/s 650-1600 kc/s 1.5-4 Mc/s 7-28* *In seven 3 Mc/s bands	A.M. S.S.B. I.C.W. I.S.B.	72Ω (I/P) 3Ω } (O/P) 600Ω }	<1μV 10 dB (Above 650 kc/s)	Bandwidth < 6 dB > 60 dB setting 0.08† 1.2† Xtal 0.5† 3† 1* 1.5† 4† 3* 4† 6.5† 8* kc/s *Bandwidth †± kc/s off band limit
R402 (Price on request)	U.K.	Superhet plus adaptor	2-3.65 Mc/s 3.65-6.5 Mc/s 6.5-11.4 Mc/s 11.4-18.5 Mc/s 18.5-27.5 Mc/s 1.75-2.7 Mc/s 2.7-4 Mc/s	A.M. S.S.B. I.S.B.	72Ω (I/P) 2.5Ω } (O/P) 600Ω }	10μV 15 dB	7.5 kc/s @ 1 dB 17 kc/s @ 20 dB
STRATTON & CO. LTD. (Eddystone) 880/2 (Price on request)	U.K.	Double superhet	0.5 to 30.5 Mc/s in 30 bands each of 1 Mc/s coverage	A.M. S.S.B. C.W.	75Ω (I/P) 2-5Ω } (O/P) 600Ω }	D.S.B. 3μV 15 dB (above 1.5 Mc/s) 5μV 15 dB (below 1.5 Mc/s) C.W. 1μV 15 dB	(†)

Continued on page 164

Image Rejection	I.F.	Local Oscillator	(a) Xtal Filter (b) B.F.O. (c) A.N.L. (d) Xtal Calibrator (e) Loudspeaker (f) Power Unit	Gain Controls	Valves and/or Semi-conductors	Additional Information
> 50dB (below 17 Mc/s) > 30dB (above 17 Mc/s)	1st 1.575 Mc/s 2nd 465 kc/s (xtal controlled)	1st Variable 1.575 Mc/s above signal frequency 2nd 1.11 Mc/s (xtal controlled)	b, d, e, f	A.F. R.F.	23 semi-conductors	A.G.C. characteristic: 6dB variation of o/p for 60dB variation of i/p above 5 μ V. Aerial trimmer. Controls: 10.
> 60 dB	1st 40 Mc/s 2nd 2-3 Mc/s 3rd 100 kc/s	1st 40.5-69.5 Mc/s 2nd 2.1-3.1 Mc/s	a, b, c ¹ , d, e, f	A.F. I.F.		¹ Switched noise limiter. A.G.C. characteristic: <7 dB variation of o/p for 100 dB variation of I/P above 1 μ V. A.G.C. time constant: charge 25 ms, discharge 200 ms; charge 200 ms, discharge 1 s. ² 'S' meter on North American version RA17C12. Controls: 18. Carrier level meter arbitrarily calibrated.
80 dB	1st 40 Mc/s 2nd 2-3 Mc/s 3rd 1.6 Mc/s 4th 0.1 Mc/s	1st 41.5-69.5 Mc/s 2nd 3.6-4.6 Mc/s 3rd 1.7 Mc/s	a, b, c ¹ , d, e, f	A.F. I.F.		¹ Switched noise limiter. A.G.C. characteristic: <7 dB variation of O/P for 100 dB variation of I/P above 1 μ V. A.G.C. time constants: charge 25 ms, discharge 200 ms; charge 200 ms, discharge 1 s. Suitable for diversity reception. ² 'S' meter. Controls: 19. Provision for connection of external frequency synthesiser.
80 dB	1st 40 Mc/s 2nd 2-3 Mc/s 3rd 1.6 Mc/s 4th either 100 kc/s or 445 kc/s	1st 41.5-69.5 Mc/s 2nd 3.6-4.6 Mc/s 3rd 1.5 Mc/s (for 100 kc/s i.f.) or 1.45 Mc/s (for 445 kc/s i.f.)	a, b, d, f	A.F. I.F.		A.G.C. time constant: charge 15 ms, discharge 15 ms; charge 25 ms, discharge 1 s; charge 50 ms, discharge 4 s. ² 'S' meter. Controls: 11. Provision for connection of external frequency synthesiser. Suitable for diversity reception.
40 dB	30 Mc/s		c, e, f	A.F.	10 semi-conductors	A.G.C. characteristic: 6 dB variation of O/P for I/P variation of 60 dB above 10 μ V. Standby switch.
40 dB	30 Mc/s		c, e, f	A.F.	10 semi-conductors	A.G.C. characteristic: 6 dB variation of O/P for I/P variation of 60 dB above 10 μ V. Standby switch.
40 dB	30 Mc/s		c, e, f	A.F.	10 semi-conductors	A.G.C. characteristic: 6 dB variation of O/P for I/P variation of 60 dB above 10 μ V. Standby switch.
90 dB (at 3 Mc/s and below) 70 dB (above 3 Mc/s)	1st 470 kc/s 1.5 Mc/s 4.5 Mc/s 2nd 80 kc/s	1.58 Mc/s 4.58 Mc/s 550 kc/s	a, b, d, e, f	A.F. I.F. R.F.	87 semi-conductors	A.G.C. characteristic: 2 dB variation of O/P for 110 dB variation of I/P above a.g.c. threshold. A.G.C. time constant: 10 ms attack, 1 s decay; 5 ms attack, 5 s decay; 5 ms attack, 10 s decay Controls: 13.
> 65 dB (at 12 Mc/s) > 40 dB (at 20 Mc/s)	455 kc/s	V.F.O. or Xtal control	b, c, e, f	A.F. R.F.	18 valves 57 semi-conductors	A.G.C. characteristic: 4 dB variation of O/P for 80 dB variation of I/P above 2 μ V. A.G.C. time constant: 0.1, 1, 3 s. Controls: 10.
> 60dB (above 15 Mc/s) > 90 dB (below 15 Mc/s except for 0.5 to 1.5 Mc/s which is 60 dB)	1st 2.5-3.5 Mc/s or 3.5-4.5 Mc/s 2nd 500 kc/s	1st xtal controlled 2nd 3-4 Mc/s (nominal)	a, b, c ² , d, e, f	A.F. I.F. R.F.	23 valves 5 semi-conductors	¹ Selectivity is variable and optional xtal filters are available. ² Switched noise limiter. A.G.C. characteristic: <6 dB variation of O/P for I/P variation of 100 dB above 3 μ V A.G.C. time constant: 0.05, 0.5, 10s (S.S.B.).

Trade Name and Model	Country of Origin	Type of Circuit	Frequency Bands	Receiving Modes	Input and Output Impedance	Sensitivity and (S+N)/N	Selectivity
STRATTON (Continued) 940 (Price on request)	U.K.	Superhet	480-1030 kc/s 1.03-2.4 Mc/s 2.4-5.4 Mc/s 5.4-12.7 Mc/s 12.7-30 Mc/s	A.M. S.S.B. C.W.	75Ω (I/P) 2.5Ω } (O/P) 600Ω }	<3μV 15 dB	Overall bandwidth variable 6 dB 40 dB min 10 kc/s 22 kc/s max 4 kc/s 12 kc/s xtal 0.4 kc/s 3.5 kc/s
840C (Price on request)	U.K.	Superhet	480-1150 kc/s 1.12-2.58 Mc/s 2.5-6.1 Mc/s 5.2-12.9 Mc/s 12.4-30 Mc/s	S.S.B. C.W.		<10μV 15 dB	±10 kc/s @ 30 dB
EA12 (Price on request)	U.K.	Double Superhet	1.8-2.4 Mc/s 3.4-4 Mc/s 6.9-7.5 Mc/s 13.9-14.5 Mc/s 20.9-21.5 Mc/s 27.9-28.5 Mc/s 28.4-29 Mc/s 28.9-29.5 Mc/s 29.4-30 Mc/s	A.M. S.S.B. C.W.	75Ω (I/P) 2.5Ω } (O/P) 600Ω }	<2μV 10 dB	Overall bandwidth variable 6 dB 50 dB A.M. 6 kc/s 12 kc/s S.S.B. 3 kc/s 8 kc/s C.W. 1.3 kc/s 5 kc/s
770R Mk II (Price on request)	U.K.	Superhet	19-27 Mc/s 27-39 Mc/s 39-54 Mc/s 54-78 Mc/s 78-114 Mc/s 114-165 Mc/s	A.M. C.W. F.M.	75Ω (I/P) 2.5Ω } (O/P) 600Ω }	<5μV 15 dB	Note: Discriminator is designed for 15 kc/s (narrow) and 75 kc/s deviation A.M. 50 kc/s @ 40 dB F.M. 175 kc/s @ 40 dB F.M. 80 kc/s @ 40 dB (narrow)
770U Mk II (Price on request)	U.K.	Double Superhet	150-180 Mc/s 180-220 Mc/s 220-270 Mc/s 270-330 Mc/s 330-400 Mc/s 400-500 Mc/s	A.M. F.M.	75Ω } (I/P) 2.5Ω } (O/P) 600Ω }	<10μV 15 dB	Overall i.f. response ±20 kc/s @ 6 dB ±50 kc/s @ 20 dB
990S (Price on request)	U.K.	Superhet	230-510 Mc/s 470-870 Mc/s	A.M. F.M.	75Ω } (I/P) 3Ω } (O/P) 600Ω }	Noise factor 10-16 dB (230-510 Mc/s) 8-12 dB (470-870 Mc/s)	
850/4 (Price on request)	U.K.	Superhet	10-20 kc/s 19-40 kc/s 40-85 kc/s 80-160 kc/s 150-310 kc/s 300-600 kc/s	A.M. C.W.	75Ω } (I/P) 300Ω } 2.5Ω } (O/P) 600Ω }	A.M. 5μV 15 dB (above 100 kc/s) C.W. <5μV 15 dB (throughout entire band)	Bandwidth variable 6 dB 40 dB 400 c/s 6 kc/s 1.5 kc/s 6 kc/s 6 kc/s 15 kc/s An audio filter can be switched in to give a bandwidth of 120 c/s @ 6 dB 400 c/s @ 30 dB
830/7 (Price on request)	U.K.	Double Superhet	300-520 kc/s 480-860 kc/s 860-1,500 kc/s 1.5-2.5 Mc/s 2.5-4 Mc/s 4-6.7 Mc/s 6.7-11 Mc/s 11-18 Mc/s 18-30 Mc/s	A.M. S.S.B. C.W.	75Ω (I/P) 2.5Ω } (O/P) 600Ω }	<3μV 15dB (at 3 kc/s i.f. bandwidth)	Bandwidth variable 6dB 50dB A.M. 6 kc/s 12 kc/s S.S.B. 3 kc/s 8 kc/s C.W. 1.3 kc/s 5 kc/s XTAL 50 c/s 2 kc/s
EC10 (Price on request)	U.K.	Superhet	550-1,500 kc/s 1.5-3.5 Mc/s 3.5-8.5 Mc/s 8.5-18 Mc/s 18-30 Mc/s	A.M. C.W.	75Ω (I/P) (below 18 Mc/s). 400Ω I/P (above 18 Mc/s)	<5μV 15dB (below 18 Mc/s) 15μV 15dB (above 18 Mc/s)	5 kc/s @ 6dB 25 kc/s @ 40dB
WINTER TRADING CO. LTD. TR10 9R59 £34 13s.	Japan	Superhet	540-1605 kc/s 1.6-4.8 Mc/s 4.8-14.5 Mc/s 10.5-30 Mc/s	A.M. S.S.B. I.C.W.		10μV, 20 dB (at 10 Mc/s)	
TR10 JR60 £61 19s.	Japan	Superhet	0.54-1.605 Mc/s 1.6-4.8 Mc/s 4.8-14.5 Mc/s 10.5-30 Mc/s 14.2-148 Mc/s (1)	A.M. S.S.B. C.W.		3μV 10 dB (at 10 Mc/s)	Without Q multiplier over 65 dB for 10 kc/s With Q multiplier Variable from -74 dB to -95 dB for ±10 kc/s

Image Rejection	I.F.	Local Oscillator	(a) Xtal Filter (b) B.F.O. (c) A.N.L. (d) Xtal Calibrator (e) Loudspeaker (f) Power Unit	Gain Controls	Valves and/or Semi-conductors	Additional Information
90 dB (at 1 Mc/s) 40 dB (at 20 Mc/s)	450 kc/s		a, b, c ¹ , f	A.F. R.F.	13 valves 1 Semi-conductor	¹ Switched noise limiter. A.G.C. characteristic: <9 dB variation of O/P for input variation of 100 dB above 5 μ V.
> 15 dB (at 30 Mc/s)	450 kc/s		b, e, f	A.F. R.F.	8 valves	A.G.C. characteristic < 15 dB variation of O/P for input variation of 30 dB above 10 μ V.
> 50 dB (at 30 Mc/s)	1st 1.1-1.7 Mc/s 2nd 100 kc/s		a, b, c ¹ , d, e, f	A.F. I.F. R.F.	13 valves 5 semi-conductors	¹ Switched noise limiter. A.G.C. characteristic: <9 dB variation of O/P for I/P variation of 90 dB above 5 μ V A.G.C. time constant: 0.15, 4.5s.
> 20 dB (at 165 Mc/s)	5.2 Mc/s		b, c ¹ , d, f	A.F. I.F.	20 valves 2 semi-conductors	¹ Switched noise limiter. A.G.C. characteristic: < 12 dB variation of O/P for I/P variation of 70 dB above 5 μ V.
40 dB (at 200 Mc/s) 25 dB (at 400 Mc/s)	1st 50 Mc/s 2nd 5.2 Mc/s	2nd 44.8 Mc/s	c ¹ , d, f	A.F. I.F.	19 valves 5 semi-conductors	¹ Switched noise limiter. A.G.C. characteristic: < 12 dB variation of O/P for I/P variation of 60 dB above 10 μ V.
50 dB	36.5 Mc/s		d, e, f	A.F. I.F. R.F.		A.G.C. characteristic: < 12 dB variation of O/P for input variation of 70 dB above 10 μ V.
> 75 dB (at 600 kc/s)	720 kc/s	Eight xtal controlled frequencies are available	a, b, c ¹ , f	A.F. I.F. R.F.	11 valves	¹ Switched noise limiter. A.G.C. characteristic: < 10 dB variation of O/P for I/P variation of 80 dB above 10 μ V.
> 50dB	1st 1,350 kc/s \pm 100 kc/s 2nd 100 kc/s	1st and/or 2nd I.o. can be xtal controlled	a, b, c ¹ , d, f	A.F. I.F. R.F.	15 valves 4 semi-conductors	¹ Switched noise limiter. A.G.C. characteristic: < 9dB variation of o/p for input variation of 90dB above 3 μ V. A.G.C. time constant: 0.15, 10s.
50dB (at 2 Mc/s) 20dB (at 18 Mc/s)	465 kc/s		b, e	A.F. R.F.	13 semi-conductors	A.G.C. characteristic: < 15dB variation of o/p for input variation of 80dB above 6 μ V.
			b, c, f	A.F. I.F.	9 valves	Bandspread on 10, 15, 20, 40 & 80 m. 'S' meter. Aerial trimmer.
	455 kc/s		b, c, f	A.F. R.F.	15 valves	¹ Bandspread on amateur bands. 'S' meter. Standby switch. Aerial trimmer

You Can Begin to Design with F.E.Ts Now

A STATE-OF-THE-ART SURVEY BY A SEMICONDUCTOR ENGINEER

By T. D. TOWERS, M.B.E.

J. B. Franklin argued in the February, 1966, issue ("What is holding back the F.E.T.??") that the field effect transistor is a dilettante device destined to occupy in the end, like the tunnel diode, only a tiny plot on the margin of the wide field of semiconductor applications. One has even heard the f.e.t. roundly dismissed as a mountain pregnant with promise but doomed to bring forth the proverbial mouse! But many people do not agree. In this article the author gives reasons why he believes that the f.e.t. will become at least as important as the transistor and may eventually supplant it

FOR those just coming in, it might be well to recap. The field effect transistor is a new semiconductor amplifying device in which the output current is controlled by the input *voltage*, rather than—as in the case of the "ordinary transistor"—by the input current. The f.e.t. depends for its action on only one kind of current carrier (electron or hole). It is therefore sometimes called "unipolar" to distinguish it from the ordinary transistor which uses two types of current carriers and is called "bipolar."

F.E.T. encapsulations

You would find it impossible to tell the difference between f.e.t.s and transistors by their external appearance, because both use the same sort of encapsulation. A caution is necessary here. With transistors, most people now recognize the standard lead orientation with common (=emitter), input (=base) and output (=collector) leads normally going clock-wise round the base. Unfortunately, the internal construction of the f.e.t. is such that manufacturers sometimes arrange their leads, i.e. common (=source), input (=gate) and output (=drain), in a different way from the transistor. Before you use an f.e.t. it is prudent to check the lead orientation from the data sheet.

Biasing

To familiarize the new reader with the f.e.t. terms "source," "gate" and "drain," we can use Fig. 1, which illustrates that some f.e.t.s have to be biased off to work like a valve, and others on like a transistor. In the depletion-type f.e.t. (and the valve), considerable drain (anode) current flows if the gate (grid) is at the same potential as the source (cathode); such a device has to

have the input reverse-biased to reduce the output current to a suitable operating bias value by an arrangement such as the self-biasing of Fig. 1(a) by means of the source resistor. With the enhancement-type f.e.t. (and the transistor), virtually no drain (collector) current flows when the gate (base) is at the same potential as the source (emitter), and the device has to be forward-biased by some arrangement such as Fig. 1(b). This possibility of using either enhancement or depletion type f.e.t.s adds another degree of freedom to circuit design—over and above the p-n-p/n-p-n, complementary-symmetry advantage which the transistor already had over the valve.

Transfer characteristics

To d.c.-bias an f.e.t., you must know how the source-to-drain current varies with the gate-source voltage. Now, as Fig. 2(a) illustrates, the output (drain) current of an f.e.t. plotted vertically varies as the square of the input (gate) voltage plotted horizontally. This means that the f.e.t. has a true "square-law" characteristic, i.e. its drain current versus gate voltage characteristic is a parabola. A bipolar transistor, by contrast, has an exponential transfer characteristic as shown in Fig. 2(b), where the output (collector) current varies as the exponential of the input (base) voltage. The importance of this is that cross-modulation distortion can be made much less in the f.e.t., a square-law device, than in the bipolar transistor, an exponential-law one.

But it is not only the d.c. biasing of the f.e.t. that is governed by its forward transconductance. In the f.e.t. (as the valve), gain is normally specified by this transconductance, g_m , i.e. the rate of change of output current with input voltage. (In bipolar transistors, however, gain is usually specified as *current gain*, h_{fe} , i.e. the change of output current with input current.) Typically the f.e.t. has about the same g_m as the valve, i.e. about 0.5 to 5.0mA/V, which is small compared with the transistor.

Not only is the g_m of the f.e.t. much lower than the

T. D. Towers, M.B.E., M.A. (Glasgow), M.A. (Cantab.), B.Sc. (Econ.) A.M.I.E.E., A.M.I.E.R.E., who will be well known to readers of *Wireless World* for his series of articles on "elements of transistor pulse circuits" (now available as a book) and others, is chief applications and measurements engineer with Newmarket Transistors Ltd. A wrangler and double-first in mathematics and physics at Cambridge, he entered the Colonial Audit Service in 1940 and served in nine overseas territories before joining Newmarket in 1958.



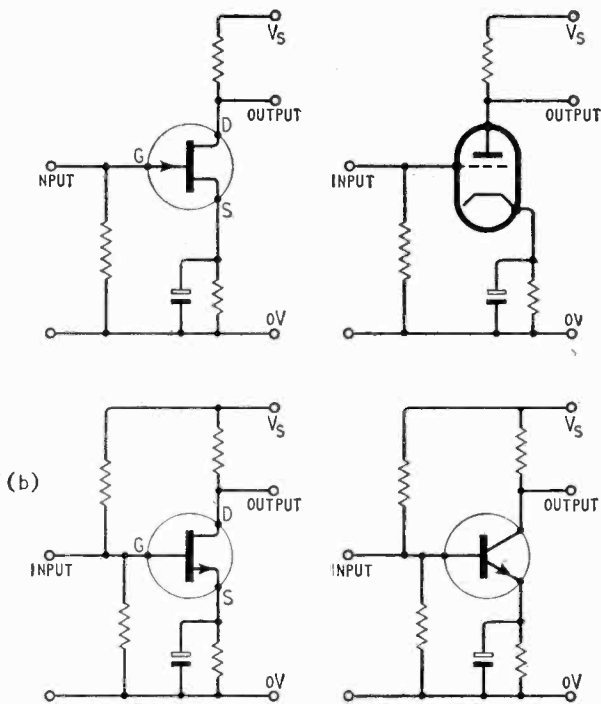

Fig. 1. Biasing of f.e.t.s of different types: (a) depletion type—compared with valve; (b) enhancement type—compared with transistor.

transistor's, but it varies with bias in a different way. In the f.e.t., the g_m varies directly with the square root of the output current. In the bipolar transistor, g_m varies directly with the output current.

Output and input characteristics

The output impedance of an f.e.t. looks somewhat like that of a transistor—for example, a typical f.e.t., the Semitron C94, has a low-frequency drain resistance of about 100k Ω at a drain current of 3mA.

The f.e.t. input characteristics, on the other hand, are quite different from a transistor. At low frequency, the gate-source impedance can look like anything from 100 to 100,000 megohms shunted by a capacitance of from 1 to 10pF or so. The transistor base input, on the other hand, often looks more like 1k Ω shunted by about 50pF. This clearly means that changing over from transistors to f.e.t.s calls for new circuitry.

PROS & CONS OF THE F.E.T.

After this look at some of the characteristics of the f.e.t. let us examine some of the arguments put up by people who do not consider it much of a contender for the transistor title.

Slow acceptance of f.e.t.s

Some engineers feel that the f.e.t. has been around long enough to establish itself. That it has not done so yet is regarded as proof that it "will never come to anything."

Admittedly the f.e.t. is not a new device. In 1933, J. E. Lilienfeld took out a patent for what can be regarded as the progenitor of the f.e.t., in that the conductivity between two electrodes was modulated by a potential applied to a third electrode, close to, yet insulated from

a semiconductor layer. Nothing came of this at the time but in November, 1952, W. Shockley revealed details of a practical f.e.t. in which the control electrode called the "gate" formed a reverse-biased p-n junction with the semiconductor substrate. Many such junction gate f.e.t.s (or "JUGFETs" in the phraseology of Mr. Franklin in the article in the February issue) are now commercially available.

In June, 1961, P. K. Weiner described another f.e.t. fabrication: the first practical insulated-gate field-effect transistor (IGFET) in the form of the thin-film-transistor (t.f.t.). In this, a thin film of semiconductor was deposited on an insulating substrate such as glass, and connections were made to the end of it. Current flowing through the semiconductor was varied by applying a control voltage to a metal gate electrode deposited over it, but separated from it by a thin layer of insulation. In September, 1963, S. R. Hofstein and F. P. Heiman described the MOSFET, another type of IGFET, which was to be the first of the modern family of IGFETS. This version is formed on the surface of a single crystal of silicon, the gate (as with the t.f.t.) being isolated from the semiconductor by an insulating layer.

Although the f.e.t. has been around in theory and practice for several decades, commercial development has been slow because of the critical processing required. This calls for ultra-precise control of geometrical dimensions and impurity distributions to produce satisfactory devices with narrow spreads of characteristics, high gain and low noise. It is only within the last few years that oxide masking, diffusion, and photoresist techniques, spilled over from silicon transistor technology, have suddenly made the f.e.t. a commercial proposition.

Gate breakdown

Some f.e.t.s (of the insulated gate type) have proved difficult to use in production because static charges developed in ordinary handling can cause permanent catastrophic damage to the device. Voltages accumulated, for example, by walking in rubber-soled shoes on a dry day can be sufficient to rupture permanently the silicon dioxide layer between the gate metal and semiconductor chip. This weakness of some types of f.e.t.s has been widely publicized and people tend to overlook that it refers only to IGFETs as fabricated at present. Manufacturers have already taken steps to deal with this. Some include a protective diode in the gate circuit. Others are considering silicon nitride gate insulation with a higher breakdown voltage than the silicon dioxide

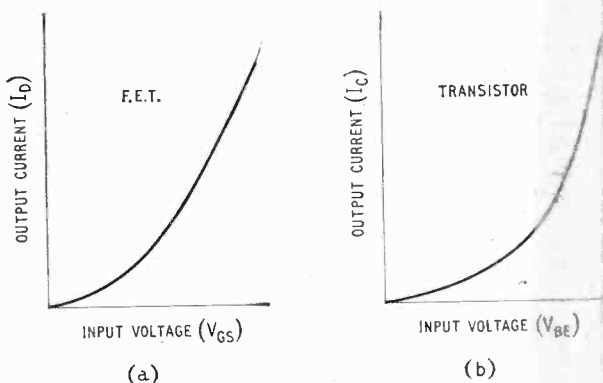

Fig. 2. Variation of output current with input voltage: (a) f.e.t. parabolic ("square-law"); (b) bipolar transistor: exponential.



Fig. 3. Author carrying out point-to-point plotting of f.e.t. d.c. characteristics on ordinary laboratory equipment.

hitherto used. Gate breakdown *can* be avoided by reasonable care in assembling equipment. And, when you think of it, the limited (2-3V) rating of the emitter-base junction of some modern silicon transistors has not impeded their wide use.

Stability of f.e.t. characteristics

One criticism that has been levelled at f.e.t.s is that they are very subject to drift in electrical characteristics with time. This, too, is not true of all types. It has been reported primarily in connection with insulated-gate f.e.t.s. When you look more closely into it, you find that the drift was observed when devices were tested continuously at very high temperatures with full applied bias voltages, i.e. under conditions that they would meet only exceptionally. Under less extreme conditions (i.e. for ordinary applications), the IGFET characteristics do not exhibit substantially greater drift than bipolar transistors.

Again, silicon nitride, as the gate insulator, appears to remove much of the drift associated with silicon oxide.

Parameter spreads

Although f.e.t.s have in general achieved satisfactory stability of parameters with time, the spread of characteristics between devices of the same type number is still unduly large. (This is true for the transistor as well.) But it looks as though the f.e.t. will eventually achieve narrower parameter spreads than the transistor. This is because the characteristics of the f.e.t. depend on only one "junction", but in the transistor two independent junctions are involved.

The biasing of f.e.t.s

Because of the wide production spread of f.e.t. characteristics, engineers often find it difficult to set up an f.e.t. amplifier stage without a variable bias preset or a pre-selection of the f.e.t.s. Now you can learn much about biasing f.e.t.s from textbooks and articles, but there is no

substitute for getting the feel of it with actual bench work. You can do this quite easily with standard multimeters and power supplies. Provided you use only low voltages, it is almost impossible to damage the f.e.t. The sort of thing you can do with ordinary laboratory equipment is illustrated in Fig. 3 which shows the author carrying out point-to-point plotting of f.e.t. static characteristics to verify how closely they agree with the values expected from theoretical considerations.

The transconductance, g_m , of an f.e.t. increases with I_D , the drain current. Therefore, other things equal, quiescent bias current should be set as high as possible. For power economy, however, I_D should be kept low; also a low I_D permits large-value bias resistors with low rail voltages.

As a practical illustration of the problem of optimizing bias conditions, consider the RC-coupled audio amplifier shown in Fig. 4. The voltage gain of this stage is given by

$$A_v = g_m R_L R_d / (R_L + R_d)$$

Now g_m is proportion to $(I_D)^{1/2}$ and R_d to $1/I_D$. For any given load resistance, R_L , the voltage gain will rise as the drain current falls. For highest voltage gain in Fig. 4, the IGFET may have to be starved to below 0.5mA. For a specific example, take an IGFET with $g_m = 2.0\text{mmho}$, and an $R_d = 25\text{k}\Omega$ at 1mA drain current, used in a circuit with $R_L = 56\text{k}\Omega$. At 1mA drain current, the voltage gain works out at about 34, and at 0.45mA, despite the fall of g_m from 2.0mmho to 1.33mmho, the voltage gain has increased to 37.

Frequency limitations of f.e.t.s

Field effect transistors currently available tend to have a limited frequency response. A useful figure-of-merit for the high-frequency performance of an f.e.t. is the gain-bandwidth product, GBW . This relates to the voltage gain-times-bandwidth of a single-stage common-source amplifier and is given by

$$GBW = g_m / (2\pi C_{in})$$

where C_{in} is the sum of the capacitances between the input (gate) and the other terminals (source and drain). For a typical r.f. f.e.t. with $g_m = 1.5\text{mmho}$ and $C_{in} = 12\text{pF}$, GBW works out approximately at 18 Mc/s. This would represent a gain of 18 at 1Mc/s, for example. The present frequency restriction can be regarded as temporary. Although the bipolar transistor is nearing the limit of its frequency capabilities, the f.e.t. is a long way from this. There is no technical reason why ultimately f.e.t.s should not become readily available for frequencies well beyond the present transistor limits.

Noise performance of f.e.t.s

A general feature of noise in an f.e.t. is that with very large values of source resistance, it can be very small compared with a transistor. For example, the noise characteristics of a typical JUGFET, the Toshiba 2SJ11, shown in Fig. 5

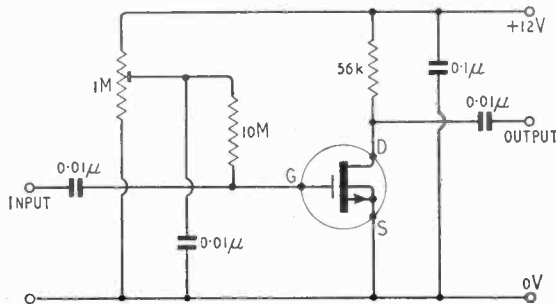

Fig. 4. Illustration of biasing component values for typical f.e.t. audio amplifier stage.

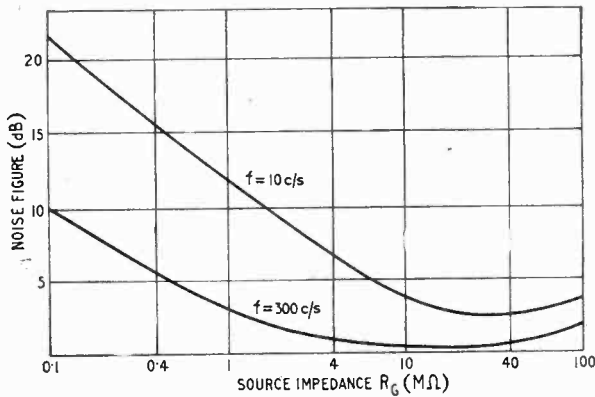

Fig. 5. Variation of spot noise figure (at 300 c/s and 10 c/s) of junction-gate f.e.t. with source impedance characteristics.

exhibit variation with source resistance and frequency, which suggest that the f.e.t. will be peculiarly suited for low-noise applications with high impedance input transducers, such as capacitor or crystal pickups. On the other hand, for low impedance sources, such as dynamic pickups, the bipolar transistor would still seem to be the first choice.

The characteristics displayed in Fig. 5 are for a JUGFET, and it must be conceded that the noise performance of IGFETs with silicon dioxide gate insulating layers are much poorer. However, devices with silicon nitride insulant offer possibilities of better noise performance.

Power limitations

There is nothing fundamental in the f.e.t. that limits its power handling capabilities. At present (just as with any modern diffused silicon transistor) power dissipation is limited by fabrication technology. However, there is every reason to suppose that higher power devices, be they f.e.t.s or transistors, will eventually become available.

Radiation sensitivity of some types

Bipolar transistors, depending for their action primarily on minority carriers in the presence of majority carriers have always been sensitive to nuclear radiation. Field effect transistors, as majority carrier devices, were expected to be more resistant to nuclear radiation. This has proved so for the JUGFET, but not for the IGFET. For normal applications this is unimportant; the poor radiation resistance of bipolar transistors has not handicapped them unduly to date.

Costs

The prices of f.e.t.s are falling fast under the drive of new manufacturing techniques, wider demand and inter-company competition. There is quite a way to go, but with devices such as the Semitron C94 already around the 50s mark in one-off quantities, experimenters are now in a position to "buy and try." The important point is that, whatever the present position, the f.e.t. (with one junction) is ultimately fundamentally cheaper to manufacture than the transistor (with two junctions). On this basis alone it must replace the transistor in the end, provided of course it does the job equally well.

Supplies

Semitron, mentioned earlier, are only one of the manufacturers who have f.e.t.s on the U.K. market. For those

who would like to find out more about what is available, a list is given on the following page.

JUGFETS V. IGFETS

At present, both junction and insulated-gate f.e.t.s are widely marketed. It is desirable to bring into focus the essential differences between the two types to see how both compare with the transistor. For this, Fig. 6 illustrates the two f.e.t. constructions: The diagrams, not to scale, are deliberately simplified to highlight the main features. Fig. 6 (a) shows the JUGFETs in n-channel form. Notice how the n-type channel joining the source and drain leads is constricted by a p-type gate region which forms a p-n junction with the channel. When a gate-source voltage is applied to reverse-bias this junction, the junction depletion layer spreads down into the channel, constricts it, and controls the electron current that passes through the channel from the source to the drain.

In Fig. 6 (b) you will find the diagram of an n-channel IGFET. Here again we have an n-type channel between source and drain, but the gate electrode this time is isolated from the channel by an insulating layer. The basic mechanism of control by the gate is different from the JUGFET case, but the end result is the same. A voltage applied between gate and source will vary the conductivity of the channel and thus control the electron current from source to drain.

As present IGFETs tend to be worse than JUGFETs in signal-to-noise ratio, JUGFETs are preferred for r.f.

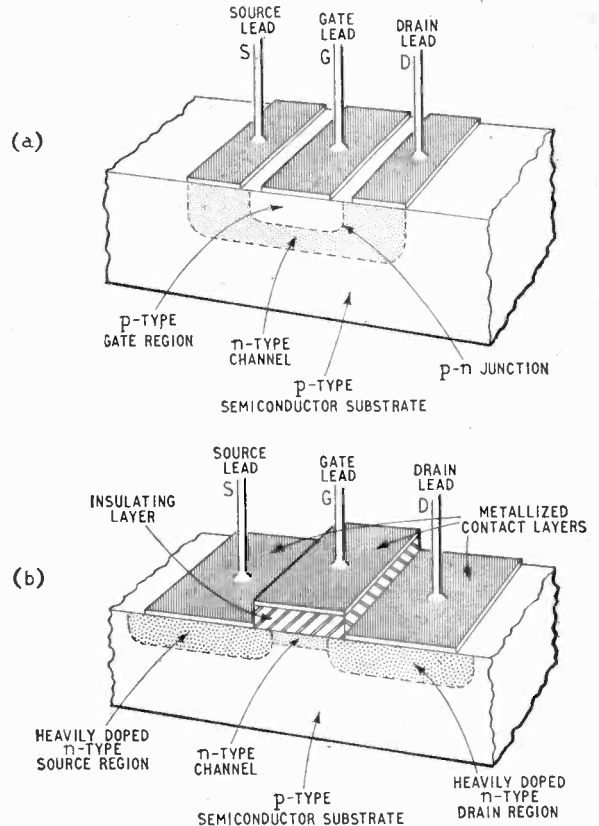

Fig. 6. Illustration of basic construction of f.e.t.s: (a) junction-gate type (JUGFET); (b) insulated-gate type (IGFET).

SUPPLIERS OF F.E.Ts IN THE U.K.

Ferranti, Ltd., Gem Mill, Chadderton, Oldham, Lancs.

Mullard, Ltd., Mullard House, Torrington Place, London, W.C.1.

Semiconductors, Ltd. (Plessey), Cheney Manor, Swindon, Wilts.

Semitron Ltd., Cricklade, Wiltshire.

Siliconix, Walmore Electronics, Ltd., 11-15 Betterton St., Drury Lane, W.C.2.

SGS-Fairchild, Ltd., 23 Stonefield Way, Ruislip, Middx.

Texas Instruments, Ltd., Dallas Road, Bedford, Beds.

Toshiba, Mitsui Ltd., 117/119 Denmark Road, Camberwell Trading Estate, S.E.5.

TRW, M.C.P. Electronics, Ltd., Station Wharf, Alperton, Middx.

and a.f. linear amplifier applications, and for low-level digital and "chopper" work. IGFETs find more place in high-level switching.

Lack of published information on circuits

Engineers considering f.e.t.s complain that it is difficult to find suitable circuits. This is rapidly being put right. Already there are at least two good practical textbooks: "Field Effect Transistor Applications" by W. Gosling (Heywood 1964) and "Field Effect Transistors" by L. J. Sevin (McGraw Hill 1965). I know also of at least one new one coming out this year.

Symbolology confusion

Many differing f.e.t. symbols are current and complaints of confusion are justified. However, f.e.t. symbol standardization is apparently to be discussed by the global standards body, the I.E.C., in Israel in October 1966, and it is hoped this will lead to an accepted common set of symbols. Meanwhile, the engineer actually experienced in handling f.e.t.s in design work will be surprised how little trouble he finds with the variety of competing f.e.t. symbols.

Commercial use of f.e.t.s

Device manufacturers have been pouring much money and effort into f.e.t. technology. The outcome is just beginning to make itself apparent in the commercial field at user level. In the instrument field, quite a number of f.e.t. operational amplifiers are now on the market, and already Hewlett-Packard, for example, have brought out an f.e.t. valve voltmeter. In the field of high-quality amplifiers again, the American manufacturer, H. H. Scott, has started to use JUGFETs in the front end of the new Scott f.m. tuner.

POINTS OVERLOOKED BY F.E.T. CRITICS

Engineers seem to divide themselves into two armed camps over f.e.t.s. You are "for" or "against," but seldom neutral. And, oddly, when I look round my friends, the prejudice against the device does not always lie with the old hands. Part of the trouble is that with so little practical experience of the device, many have had to form judgments on secondhand evidence.

Compatibility with transistors

Many engineers I find are not aware that the f.e.t. runs happily in harness in hybrid circuits with the bipolar transistor. Much of the circuitry in existence suggests that they make a useful partnership to bring out the best

of both devices. Neither the tunnel diode nor the valve formed convenient running mates with the transistor.

Voltage supply rails

One of the reasons for the rapid rise of the transistor was its ability to work with low supply voltages in the 1.5V to 12V range. Earlier f.e.t.s had characteristics which prevented their use as amplifiers at low supply voltages. More recently, f.e.t.s for low voltage applications have become readily available.

Utilizing thermal dependence parameters

The variation of some f.e.t. parameters with temperature can be made positive, or negative, or zero, by adjusting the d.c. biases on the device. In particular, the output current for a given input bias arrangement can be kept constant over a wide temperature range, a property which obviously is most valuable in d.c. amplifier designs.

Excellent switching properties

As a switch, the f.e.t. presents a very high "off" resistance (1,000M Ω upwards), but also its "on" resistance (100-1,000 Ω) is high compared with the bipolar transistor. Its off-to-on resistance ratio is, however, much higher than in the case of the transistor, which makes it a useful switch in high impedance circuits. The intrinsic switching times of the f.e.t. are so short (in the nanoseconds region) that actual switching times are governed mainly by the parasitic capacitances of the device.

Summing up

In summary, the f.e.t. is better than the transistor because it has a higher input impedance, a lower noise figure, freedom from hole storage delay, absence of offset voltage, freedom from thermal runaway, no reduction of efficiency at low temperatures, high resistance to radiation, and potential low cost. On the other hand present f.e.t.s are admitted to have the disadvantages of low power capacity, relatively high "on" resistance and relatively poor frequency characteristics, although there is nothing in the physics of the f.e.t. to suggest that these are other than only temporary defects.

As a device, the f.e.t. has the virtues of both the thermionic valve and the transistor—and few of the vices of either. The main reason it has failed so far to oust the others is simply cost. But there are indications that the f.e.t. could eventually be the cheapest to produce, and is likely therefore to become in the end the premier amplifying device.

Normal-pitch recordings at double speed

EQUIPMENT which enables tape recordings to be played at twice the recorded speed but at normal voice pitch is being developed by the American Foundation for the Blind as a mean of increasing the rate at which information can be taken in by blind persons. A speech rate of 300-400 word/minute (equivalent to fast reading) can be achieved.

The principle involved, harmonic compression, is not new—the original idea was to reduce speech bandwidth by one half by frequency dividing the individual harmonic components of the speech signal. In the present application, where bandwidth compression is not the aim, frequency multiplication is provided by a tape recorder running at twice the normal recording speed. Normal speech is fed to a bank of 36 bandpass filters: each of the filters feeding a frequency divider providing narrow-band signals at half the original frequency. By playing back a recording at twice the recording speed, an output is obtained which is at twice the normal speech rate but at the correct pitch. The scheme was developed by Schroeder and Golden of Bell Telephone Laboratories.

DANISH ELECTRONICS

KØBENHAVN MESSE FOR ELEKTRONIK. AUTOMATION. INSTRUMENTER

THE first electronics fair to be held in Denmark, as opposed to the earlier domestic radio shows, was well supported both by the country's indigenous industry and by overseas manufacturers. The catalogue lists some 800 manufacturers but most of these were overseas companies (from 16 countries) represented at the show by their Danish agents. There were in fact about 150 stands and on some of them the products of as many as 20 or so overseas manufacturers—many of them British—were exhibited. There were only two British-manned stands; one occupied by B.E.A.M.A., which was primarily an information centre, and the other by Graseby Instruments Ltd. of Tolworth, Surrey, who were showing their range of transducers, accelerometers, read-out equipment and vibrational test gear.

While the exhibition in general was interesting, much of the equipment is to be seen at similar exhibitions in this country and elsewhere on the Continent. Our visit to Copenhagen did, however, afford an opportunity to see

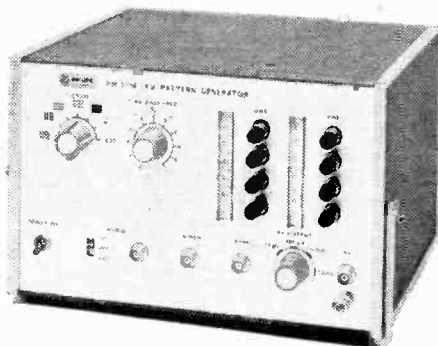

Four separately tunable, push-button controlled, output frequencies in the u.h.f. band are provided in the Philips television signal generator PM5525.

the Danish electronics industry, or at least part of it, in action. We propose, therefore, to confine ourselves to discuss equipment produced in Denmark.

Although it is still true, of course, that Denmark is basically an agricultural country, the output of the manufacturing industries has, or is about to, overtake the agricultural output. The electronics industry is small but virile, indeed it has to be as it must live by its exports, for the national demand for electronic equipment is on the whole small. Export figures quoted by exhibitors varied from 85% to as much as 98% of their outputs.

Although closely linked with the parent Philips organization in Eindhoven the Danish Philips company is a separate entity and has done some very original work some of which was to be seen at the exhibition. The latest composite piece of equipment is a television pattern generator. The basic u.h.f. signal generator (PM 5525), which employs transistors throughout, is designed to accept modulation by monochrome or encoded colour signals and gives an output on one of four push-button pre-selected channels in Bands IV or V. Three versions

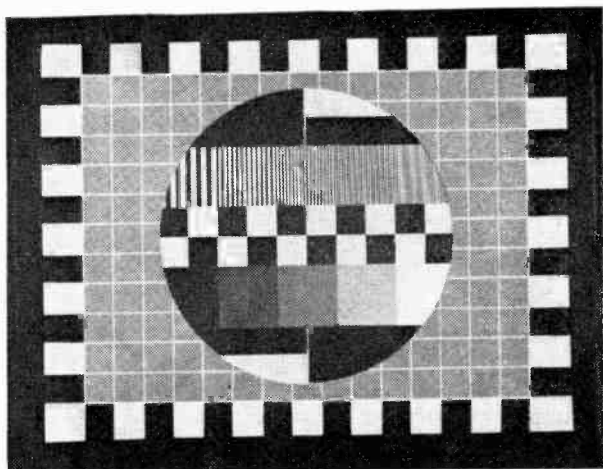

Composite monochrome test pattern produced by the Philips PM5540.

are available covering the American, European or British standards. The associated pattern generator (PM5540) provides a composite electronic test pattern, which includes an extremely stable circle generated by digital techniques using some 20 high-speed flip-flops operating in conjunction with a ferrite core memory. The test pattern is composed from three basic generators—one for frame information, another for line information and the third for the circle. These three sources of picture information can be combined to generate, individually or as composite (see illustration), information to provide a cross-hatch pattern, black-white steps, grey scale, definition lines, saw tooth, vertical bars, etc.

In the same series of pattern generators there is one

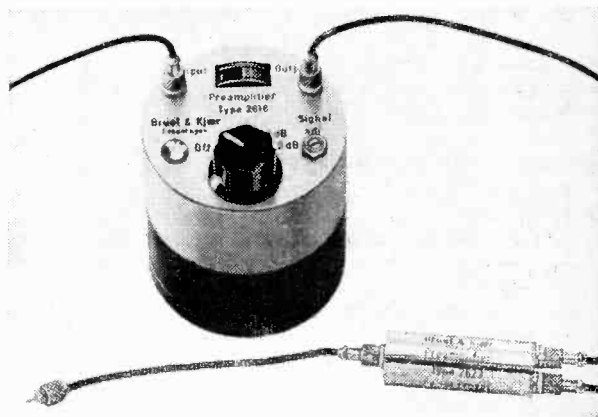

Two new B. & K. pre-amplifiers (types 2610 above and 2623 below) which employ f.e.t.s in their input stages.

supplying basic colour bars and a composite colour pattern for display on an RGB monitor or for encoding with an N.T.S.C. or Pal encoder. The colour test pattern comprises seven equal horizontal bars consisting of (1) signal with subcarrier in I-phase, (2) signal with subcarrier in Q-phase, (3) fine step linear staircase with black/white and black/white transient, (4) colour bar consisting of primary and secondary colours plus white and black, (5) sawtooth with superimposed carrier with the red phase, (6) signal with subcarrier in R-Y phase, and (7) signal with the B-Y phase. By means of push-buttons it is also possible to display only signals 3, 4 or 5 to fill the whole screen.

The Danish electronics industry includes several companies specializing in test and measuring equipment. Among those showing at the exhibition were Brüel and Kjaer, Radiometer, and Danbridge. Brüel and Kjaer, whose U.K. agents are B. & K. Laboratories, have specialized in acoustical and vibrational research tools since their formation in 1945. The company, which now employs over 900 people, exports 98% of its production. Its latest project, not yet on the market, is a tape-recorder (Type 7001) designed as a two-channel recorder for frequency analysis. The tape speeds of 1.5, 6, 15 and 60 in/sec provide a frequency range from 0-20 kc/s. Two new accelerometers have been added to the range available from B. & K. The type 4336 miniature

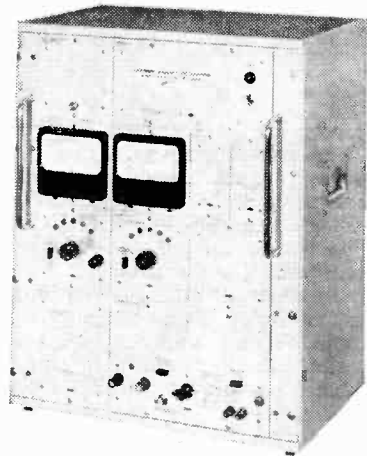

Component linearity test equipment (CLT1) produced by Radiometer which employs the "third harmonic index" system of measurement.

accelerometer weighs only 2 grammes, making it particularly suitable for measurements on light structures. Its frequency response is flat up to at least 25 kc/s for 2% accuracy and, with one of the latest B. & K. pre-amplifiers of high input impedance, its lower limit is 0.5 c/s. Field effect transistors are used in the input stage of these latest accelerometer pre-amplifiers giving an input impedance of 2000 M Ω (type 2623) and 1200 M Ω (type 2616).

Radiometer, who are represented in the U.K. by Livingston Laboratories, featured a component linearity tester (CLT1) which is designed for investigating non-linearity in nominally linear components such as resistors and capacitors. Basically it operates by the selective measurement of the 3rd harmonic generated in the component under test when a pure sinusoidal 10 kc/s voltage is applied to it (see *W.W.* July 1965, p. 340). It is, of course, intended for production testing of components

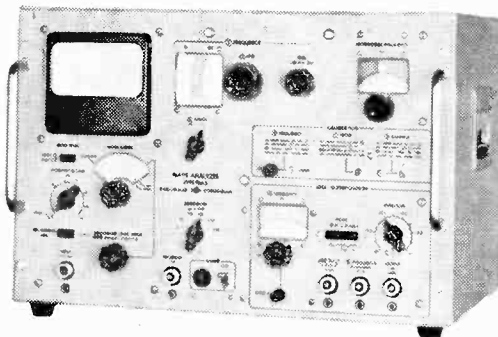

Wave analyser for measuring the individual frequency components of a periodic a.f. signal (Radiometer).

to detect defects in manufacturing processes. Radiometer were also showing a new wave analyser (FRA3). It employs the superheterodyne principle with double conversion and has a linear frequency scale from 10 c/s to 60 kc/s with a scale division for every 10 c/s. It features a backlash-free fly-wheel on the main tuning capacitor which permits the complete frequency range to be scanned in a few seconds by one twist of the operating knob.

Danbridge, whose U.K. agents are Dawe Instruments, have introduced the RCL Component Tester (Type CFT2) which measures impedance deviation and phase-angle deviation on two separate meters. The RC oscillator provides frequencies of 100 c/s, 1 kc/s, 10 kc/s and 100 kc/s to the bridge circuit via a transformer with closely coupled balanced output windings which provide identical thermistor controlled voltages to the unknown and the standard. Two sets of test terminals are provided: the 0.3 V range having an impedance range of 3 Ω to 5 M Ω and the 3 V range 100 Ω to 50 M Ω .

The Copenhagen exhibition presented an excellent cross section of the Danish electronics industry which includes, of course, component manufacturers, such as Vitrohm the resistor specialists, and the well-known v.h.f. communications equipment manufacturers Storno. Through their British subsidiary of the same name Storno have supplied about 500 pocket transceivers to the Metropolitan Police Force. The latest innovation is the incorporation of a numerical identification system for mobile radio communication. When a car makes a call to the base station an individual tone code is transmitted which appears in digital form.

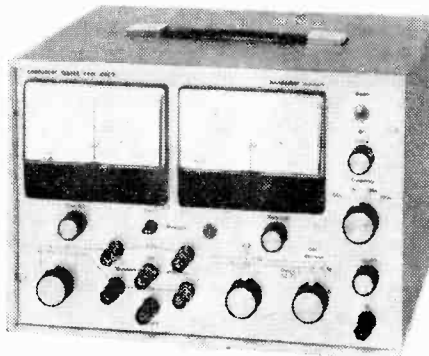

Danbridge RCL component tester for the measurement of impedance and phase-angle deviation.

WORLD OF WIRELESS

Reciprocal Amateur Licensing

ON March 16th last year, in answer to a question in the House of Commons, the Postmaster-General announced that, subject to certain conditions being met, he would, in future, grant licences to engage in amateur transmissions in the United Kingdom to licensed amateurs who are nationals of countries which are prepared to grant reciprocal facilities to this country's radio amateurs.

Last December a reciprocal agreement was signed between the U.K. and the U.S.A. Similar agreements have been signed with other administrations.

The Post Office has now produced a pamphlet (available from the Radio Services Department, Radio Branch, G.P.O., St. Martin's-le-Grand, London, E.C.1) which explains the conditions under which the new licences are granted. These conditions are:

1. There must be a reciprocal agreement in force between the U.K. and the administration of the alien's country.
2. The alien's licence must be currently in force and a photostat copy must be forwarded with the application.
3. The alien's licence must be of a type for which the applicant was required to demonstrate that he had reached a level of technical and Morse proficiency comparable to that which the U.K. requires of British amateurs.

Four types of licences are being offered:

Amateur (Sound), Type C (Fixed) for 1 year (£2).

Amateur (Sound Mobile), Type C for 1 year (£1).

Amateur (Sound), Type D (Fixed) for 3 months (£2).

Amateur (Sound Mobile), Type D, for 3 months (£1).

British amateurs cannot hold a mobile station licence unless they already hold a fixed station licence, but an alien may apply for a mobile station licence without having to hold a fixed station licence.

Call signs will be assigned in strict alphabetical order from a new United Kingdom series G5AAA, G5AAB, G5AAC . . . G5ZZZ, to which will be added an oblique stroke, followed by the call sign assigned to the amateur in his own country. In mobile station work the double call sign will also be followed by the suffix /M.

If an alien visiting the U.K. does not wish to apply for a personal licence, a British licensed amateur may apply to the G.P.O. for permission for his station to be operated under his direct supervision by the visiting amateur.

Local Broadcasting Proposals

B.B.C.'s plans for local broadcasting are outlined in a 15-page booklet "Local Radio in the Public Interest" issued by the Corporation. It suggests an initial scheme of 80 to 90 v.h.f. stations with a possibility of more at a later stage. To finance these stations, which at today's prices would each cost between £30,000 and £35,000 and about £1,000 per week to run, the B.B.C. suggests an extra 5s on each broadcasting licence bringing in nearly £4M a year. The B.B.C. has offered to launch up to nine local stations as a pilot scheme (without additional finance) to give "local broadcasting on community service lines a trial run and to test its acceptability and usefulness."

The P.M.G. recently stated in the House that there are three main candidates or alternatives for local broadcasting and these were being considered by the Government. They are: first the B.B.C. Second, commercial radio companies "not pirates ashore." This he said raised the question of the local press. "Some felt that it would be destroyed unless it could run the stations. This in turn could have implications for a monopoly of local communications." The third group were the advocates of genuine community stations—"local authorities, educationists and those who wanted to give a new lease of life to local arts, drama and music."

Colour Television Decision?

ALTHOUGH the Postmaster-General stated in the House of Commons on March 3rd that the Government had decided to accept the advice of the Television Advisory Committee and "opt for PAL" the situation is really not as simple as the headlines in the lay press lead one to believe. The P.M.G. also stated that "if the Oslo conference was to show another system had general acceptance, the Government would take this into account."

The Oslo meeting of the C.C.I.R. to which he was referring will be held in June and it remains to be seen whether the Franco-Russian alliance will make a definite proposal for the adoption of the N.I.R./SECAM system. Tests conducted in this country show that the N.I.R. colour system is an improvement on both PAL and N.T.S.C in certain respects but not overwhelmingly so. If therefore the Franco-Russian system is officially considered at Oslo it would undoubtedly delay still further a final decision on a European standard. It remains to be seen whether the Government will go ahead with its plans to introduce colour on BBC2 in 1967.

\$250 Station Receives Weather Pictures

RADIO amateurs may have improvised with many items in the past but surely an argon electric light bulb, a rolling pin and an elastic band used by an American amateur to receive satellite weather pictures, said to be comparable in quality with those received by \$30,000 commercial stations, must take full honours. The amateur, Wendell Anderson, an engineer with R.C.A. has built a ground station for \$250 in the basement of his home in Moorestown, N.J. and used it to obtain weather pictures from the NIMBUS satellite. The equipment for the station supplements the basic receiver,



Mr. J. Colbert, a 70-year-old radio amateur of Braintree, Essex using a receiver he built himself, made a chance contact with a Mr. T. Easterwood, of Lusaka, Zambia, who subsequently wrote and offered him an expenses paid holiday in Zambia, which he has accepted. Mr. Colbert, who passed the Radio Amateurs' Examination only last year, is shown in the illustration operating his station G3TZY.

a 1938 model. For the aerial an ordinary twin-lead cable commonly used for television aerials is stretched across the roof, and to record signals from the satellite a small domestic tape recorder is used. Signals are filmed by means of a microscope and argon electric light bulb, which is arranged to scan an 8×10in sheet of film wrapped around a rotating cylinder made from a rolling pin and cushioned, to ensure smooth rotation, by an elastic band. Scanning is effected by two small electric motors, one rotates the rolling pin while the other moves it slowly horizontally so that the microscope can register the numerous lines that make up the picture. Finally the film is developed and printed. The NIMBUS satellite was launched in September 1964.

American Subscription Television.—The Kaiser Broadcasting Corporation recently signed an agreement for an option on the Los Angeles franchise for the Zenith system of broadcast subscription television. Future development by Kaiser is contingent on the decision of the Federal Communications Commission on the outcome of litigation concerning the legality of subscription television in California. The petition seeks authorization of nation-wide subscription television and is based on the three-year experimental operation of the Hartford, Connecticut, station.

Under the Science Research Council's **Industrial Fellowship Scheme** awards are made to a scientist or technologist to allow a period of post-graduate training to assist his future career in industry, and the cost is shared between the S.R.C. and the employer concerned. Among the latest recipients are A. P. Clarke, two years at Imperial College of Science and Technology, London for research into the application of random access discrete address systems; D. R. Clouting, up to three years at Southampton University to work on digital communications systems; and T. M. McKeon, two years at Leeds University to work on optimisation of reactor design with on line computer control.

The course on "**Semiconductor Switching**" is to be repeated by the Engineering Department of Slough College during a one week residential course from May 16th-20th. The fee is 18gn and application forms which must be returned by April 6th are available from the College, William Street, Slough, Bucks.

A **quality-component postal service** for the home constructor was started on March 1st by Elmbridge Instruments Ltd., Elmbridge Works, Island Farm Avenue, West Molesey Trading Estate, East Molesey, Surrey. Small quantity packs of professional electronic components (including carbon film resistors, polyester capacitors, rechargeable nickel-calcium cells and push button switches) which in the past have been difficult for the home-constructor to obtain are now available.

Institution of Electronics Exhibition, or to give it its full title International Electronics, Instruments, Controls and Components Exhibition and Convention, will be held at Belle Vue, Manchester, from September 27th to October 1st. Further details are obtainable from the Institution's general secretary, W. Birtwistle, 78 Shaw Road, Rochdale, Lancs.

The 12th **international v.h.f. convention** organized by the Radio Society of Great Britain will be held on April 2nd at the Kingsley Hotel, London, W.C.1. The lecture session commences at 2 p.m. and a dinner will be held in the evening. Admission is 4s 6d for the afternoon session or 32s for the afternoon session and dinner. Remittances should be sent to the Convention Secretary 48 Borough Way, Potters Bar, Herts.

The applications of **m.o.s. transistors** will be discussed by speakers from various industrial and research establishments during a one-day symposium to be held on April 4th at the Borough Polytechnic, Borough Road, London, S.E.1. Further details are available from the Secretary.

PAL Transmission Characteristics.—The colour sub-carrier frequency for the PAL transmission was originally agreed by the European Broadcasting Union as 4.43361875 Mc/s and this frequency was used by the B.B.C. At the request of the E.B.U. this frequency was altered in 1964 to 4.4296875 Mc/s with a line period of 64.056789 μs and a field frequency of 49.9556 c/s to assist German manufacturers who were experimenting with receivers which would accept both PAL and N.T.S.C. systems. However, at a meeting in January of representatives of the E.B.U., the subcarrier frequency, line period and field frequency were again changed and are given below, together with other characteristics of the PAL transmission system.

Line Standard	625-line Standard "I"
Luminance Bandwidth	5.5 Mc/s
Subcarrier Frequency	4.43361875 Mc/s
Line Period	64.00 μs
R-Y Bandwidth	1.6 Mc/s
B-Y Bandwidth	1.6 Mc/s
Burst Amplitude	0.3 V peak-to-peak
Burst Phase	45° clockwise from the -(B-Y) axis for +(R-Y). 45° anti-clockwise from the -(B-Y) axis for -(R-Y).
Burst position	As for N.T.S.C. (back porch)
Field frequency	50 c/s
Switched phase line-by-line	R-Y axis.

Descriptions of the PAL system have been given in *Wireless World*, December 1963, p. 584, and December 1965, p. 595.

Colour Television Test Film.—The Society of Motion Picture and Television Engineers recently announced the availability of a test film, produced in 16mm and 35mm and a set of eight 2×2 in transparencies as test material for the evaluation of such factors as colour balance and contrast range in colour television transmission systems. Further information is obtainable from S.M.P.T.E. Test Films, 9 East 41st Street, New York City.

A **new television and v.h.f. sound relay station** serving Cambridge was brought into service on March 7th. Transmissions, which are horizontally polarized, relay BBC-1 television on channel 2 (sound 41.5 Mc/s vision 45 Mc/s) and three v.h.f. sound programmes, 88.9, 91.1 and 93.3 Mc/s. The station is one of a large number of low-power relay stations being built by the B.B.C. to extend the coverage of its television and v.h.f. services. B.B.C. television programmes are now available to 99.45% of the total population of the U.K. and v.h.f. sound programmes are available to 98.7%. These are the highest percentages for any country in the world.

A **new mast and aerial** for the I.T.A. Winter Hill station (channel 9, sound 216.25 Mc/s, vision 219.75 Mc/s) went into full operational service on February 28th. The new mast is 1,015ft tall and replaces the old 450ft tower which has been used by I.T.A. since May 1956.

Integrated Circuits.—A three-day symposium on "The use of integrated circuits in electronic equipment" is to be held at Brunel College, Acton, London, W.3, from June 6th.

"Integrated Circuits Flood Into Europe."—The SA.20 integrated amplifier mentioned on p. 120 of the March issue was incorrectly attributed to Philco. It is, in fact, made by Sylvania Electric Products Inc., for which the U.K. agents are Thorn-AEI Radio Valves and Tubes Ltd.

"Inexpensive Tape Recording Amplifier."—In this article in the March issue (p. 144) the sentence 14 lines from the bottom of the third column beginning "C₃ may be omitted . . ." should read "C₃ should be omitted. . . ."

"Silicon Transistor Millivoltmeter."—In Fig. 4 on p. 113 of D. E. O'N. Waddington's article in the March issue the component designations R5 and R6 should be interchanged.

PERSONALITIES

Howard Steele, A.C.G.I., B.Sc.(Eng), A.M.I.E.E., chief engineer of ABC Television since 1961, has been appointed chief engineer of the Independent Television Authority in succession to **P. A. T. Bevan, C.B.E., B.Sc., M.I.E.E.**, who has asked to be released from the position but is remaining in the full-time service of the Authority as consultant engineer. Mr. Bevan joined the I.T.A. in 1954 as its first chief engineer. Previously he was for 20 years with the B.B.C. before which he was for three years graduate apprentice at the B.T.H. Rugby works after graduating at Cardiff University. Mr. Steele graduated at Imperial College in 1952 and went to Marconi's as a graduate apprentice. When he left in 1957 he was head of the established designs group in the Television Development Department. In 1957 he joined Alpha Television Services in Birmingham and a year later joined ABC Television as head of the Planning and Installation Department.



Howard Steele

ABC Television Ltd. has done considerable work on the study and evaluation of the various colour systems which have been the centre of controversy throughout Europe. This work is now to be taken over by the Independent Television Authority, and Mr. Steele has therefore been released by ABC from his contract to join I.T.A.

G. Boris Townsend, Ph.D., B.Sc., A.K.C., F.Inst.P., M.I.E.E., has joined ABC Television at Teddington as head of research and development (electronics). Dr. Townsend, who is 46, has been with the Rank Organisation since 1963 and has latterly been manager responsible for development, production, marketing and service in the product group of Rank Cintel Television. Before joining Rank he was for 23 years in the G.E.C. Research Laboratories where he was for some time

responsible for the research work on colour television. He is joint author, with P. S. Carnt, of the Iliffe book "Colour television: the N.T.S.C. system, principles and practice." A few



Dr. Boris Townsend

months ago he received his doctorate from the University of London; his thesis was on "the influence of the design of colour television systems and apparatus on the reproduced colour and the colour responses of viewers."

Percy Wilson, M.A., who recently severed his 40-year association with *The Gramophone*, has set up an audio consultancy—Percy Wilson & Partners, of 56 Staunton Road, Headington, Oxford. His associates are **G. E. Horn** and **P. G. Tandy** (partners in Horns the audio and radio dealers of Oxford), who were both trained as Post Office engineers. **G. L. Wilson** (Professor of Acoustics in the Ordnance Dept. of Penn State University) and **R. Wilson** (Professor of Physics at Harvard University), sons of P.W., are acting as American correspondents for the organization. Mr. Percy Wilson, who is 69, was technical adviser to *The Gramophone* from 1924 to 1938 and since 1953 had been technical editor.

Walter C. Marshall, B.Sc., Ph.D., F.Inst.P., head of the theoretical physics division of the Atomic Energy Research Establishment, Harwell, since 1960, has been appointed deputy director of the Establishment. Dr. Marshall, who is 34, graduated in mathematical physics at the University of Birmingham in 1952 and received his doctorate two years later. He joined A.E.R.E. in 1954 and for two years from 1957 was at Berkeley and Harvard Universities in the U.S.A.

D. C. Greenhalgh, B.Sc., A.M.I.E.E., A.M.I.E.R.E., a member of the technical sales staff of the Marconi International Marine Company, is on a three-month demonstration and training tour of the company's Asian depots. Mr. Greenhalgh, who was educated at Leys School, Cambridge, and the Manchester College of Technology, served in the R.A.F. as a technical officer (radar) from 1942 to 1947 and then joined the Diplomatic Wireless Service for three years. In 1950 he joined the Marconi College as a radar lecturer. For the past year he has been with Marconi Marine as a technical sales engineer.

K. Hoselitz, Ph.D., F.Inst.P., has been appointed to the first Visiting Professorship of Battersea College of Technology, which is planned to become the University of Surrey. Dr. Hoselitz, who will retain his position as deputy director of Mullard Research Laboratories, will be associated with the work of the College's Solid State Physics Group which recently received a grant of £25,000 from the Science Research Council for investigating the structure and chemical properties of crystalline polymers. Dr. Hoselitz, who is already a Visiting Reader in the Department of



Dr. K. Hoselitz

Physics, gained his doctorate in the University of Bristol after studying in Vienna and Bristol. In 1952 he joined Mullard Research Laboratories where he helped to establish the Solid State Physics Division.

M. E. Kelsey, B.Sc.(Eng.), A.M.I.E.E., who has been appointed works manager of Marconi Instruments Ltd., St. Albans, at the age of 30, graduated in electrical engineering at Kings College, University of London, in 1957, and joined Marconi Instruments the same year. Fol-

lowing a two-year graduate apprenticeship, Mr. Kelsey served for nearly three years in the design and development department. In 1961 he transferred to the production department, where he



M. E. Kelsey

operated a training section for some eighteen months. This was followed by a Churchill College Management Course at Cambridge University. Since his return, Mr. Kelsey has been Special Products Manager.

Marc A. de Ferranti has joined the Plessey Company as group director of Plessey Telecommunications in succession to F. Limb, O.B.E., who retires at the end of June. Mr. Limb, who joined Ericsson Telephones Ltd.—now part of Plessey—40 years ago, delayed his normal retirement in 1964 in order to assist in the Company's major reorganization implemented last year. Mr. de Fer-



M. A. de Ferranti

ranti was born in Brussels, and taken at the age of two to Australia. While apprenticed he completed the Electrical Engineering Diploma Course at the Sydney Technical College, following which he was a student engineer with B.T.H., Rugby. He later went to the General Electric Company, U.S.A., and became an American citizen in 1937.

He was at one time president and general manager of ITT Europe Inc., and just prior to joining Plessey was with Standard Pressed Steel, Pennsylvania.

L. D. Hadfield, B.Sc., B.E., A.M.I.E.E., has been appointed general manager of Plessey's Microwave and Transmission Divisions. Mr. Hadfield, who was born in Sydney, served as a radar officer with the Australian Imperial Forces during the war after which he worked in Britain for three years on television research. He then went to Woomera for three years on the development of guided missiles and long-range weapons. This was followed by five years as technical director of the



L. D. Hadfield

Australian Broadcasting Corporation and for the past four years he has been general manager of Automatic Electric Telephones Pty, in Sydney.

C. Leo Philps, M.I.E.R.E., has become manager of the North Eastern regional office of Standard Telephones and Cables Ltd. in succession to R. S. Proudlock, manager for the last three years, who is emigrating to the U.S.A.



C. Leo Philps

Mr. Philps joined S.T.C. in 1960 at Enfield, Middlesex, as commercial manager responsible for instrumentation and control equipment. He moved to Harlow, Essex, in mid-1963 as marketing manager for rectifier equipments. Before he joined S.T.C. he was managing director of Atkins, Robertson & Whiteford Ltd., electronic engineers of Glasgow.

J. Sykes, M.I.E.E., M.I.E.R.E., consultant, who recently moved from Stalbridge, Dorset, to Orkney, is planning the formation of a small manufacturing company under the name Orkney Electronics. His address is "The Old Manse," Rusness, Sanday, Orkney.

OBITUARY

Edward E. Rosen, founder in 1920 of the company which is now the Ultra Group, died on March 6th at the age of 68. He relinquished the chairmanship of the holding company and its subsidiary Ultra Electronics just over a year ago. A year earlier he relinquished his full-time executive responsibility with the Group. After serving with the Royal Flying Corps in the First World War Mr. Rosen, who was trained at Marconi's, started his own company (Edward E. Rosen & Co.) for the manufacture of headphones and loudspeakers and three years later the name was changed to Ultra Electric Ltd. He had represented the radio industry on various government committees and was for several years, until 1961, chairman of the Radio Industry Council.

Professor Reginald Otto Kapp, B.Sc., M.I.E.E., who died on February 20th aged 80, was incumbent of the Pender Chair of Electrical Engineering at University College, London, from 1935 until he retired as emeritus professor in 1950. He was subsequently a consultant to Kennedy and Donkin with whom he had been associated before entering the academic world. Professor Kapp's extra-mural interests included the formation of the Technical Information Group of which he was president, and he was chairman of several committees in such organizations as the British Standards Institution, the International Standards Organization and the International Electrotechnical Commission.

Herbert George Starling, the Cambridge Instrument Company's resident engineer in Nottingham for over 17 years, died on January 5th aged 61. He joined the company in 1919 and in the early 1930s, after a successful period of outside servicing on all types of instruments, he was transferred to the head office in London, where he helped to start a mobile instrument demonstration service.

NEWS FROM INDUSTRY

SATELLITE-TRACKING AERIAL

A 40ft dia. tracking aerial and station is to be erected at a satellite ground station at the Signals Research and Development Establishment at Christchurch, Hants. The station will be one of three British-built stations in the U.S. Initial Defence Communications Satellite Project. The location of the other two stations has not been disclosed.

The three stations are currently being built and tested by the Marconi Company, for delivery this spring. An important feature of the stations is that they are capable of being transported by air. The data handling equipment will include the Marconi Myriad microelectronic computer, which will co-ordinate reception as a satellite passes below the horizon and another comes into range.



University of Glasgow O.B. television unit, supplied by The Marconi Company. The unit will be used primarily to record lectures on the helical-scan video tape recorder and relay lectures to a number of lecture theatres.

HELP FOR EXPORTERS

THE British Standards Institution is increasing its efforts to help British exporters to meet the technical requirements of overseas markets and to this end is extending its information and certification services. From next month part of the Hemel Hempstead Testing and Approvals Centre will be enlarged to provide a fuller service to exporters, mainly in the electrical field, both as regards the details of overseas approvals schemes, the technical interpretation of specifications and arrangements for testing and approval. It is hoped to negotiate arrangements with overseas test stations and approval authorities which will simplify the task of exporters in getting their equipment accepted.

For 15 years, B.S.I. has operated the U.K. end of an approvals scheme for electrical goods for the Canadian market. In that time, electrical goods worth about £100M have been exported to Canada.

Philips colour TV camera using Plumbicon tubes. Over 200 orders have been placed for the camera, now available in the U.K. through Peto Scott Ltd. In contrast to the Marconi camera (see February issue) three Plumbicon tubes are used and a three prism colour-splitting arrangement. This has eliminated the need for auxiliary or "relay" lenses. Acceptable colour pictures can be obtained down to 25 ft-candles.

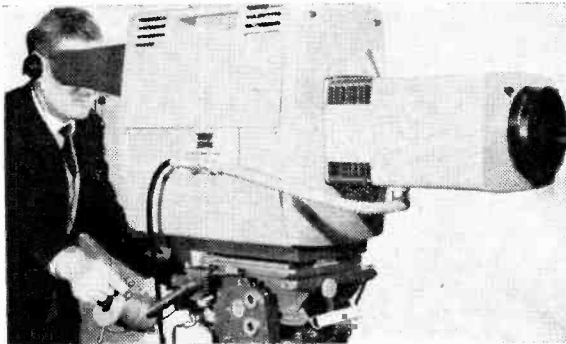

EDUCATIONAL O.B. VAN

THE University of Glasgow has received the first television outside broadcast unit designed for an educational establishment in the U.K. The equipment includes four vidicon cameras, five 8½in monitors, sound and vision mixers, distribution amplifiers providing five outputs, video recording equipment, communication facilities for crews and, of course, linked lecture theatres. The complete unit (illustrated) was supplied for about £16,000 by the Marconi Co.

Three of the light-weight vidicon cameras are fitted with electronic viewfinders, two have four-lens turrets and the other has a zoom lens. The fourth camera is a caption camera.

Marconi International Marine announce that export sales for 1965 were over £1.5M. This represents an increase of 77% on the 1964 total.

Defense Electronics, of Maryland, U.S.A., have appointed Aveley Electric Ltd. as sole U.K. concessionaires for their range of telemetry systems.

C.B.S. International, of New York, announce the appointment of Denham and Morley of 173 Cleveland Street, London W.1, as U.K. distributors of their range of magnetic tapes.

Fi-Cord International have changed their address to Charlwoods Road, East Grinstead, Sussex. Fi-Cord are the U.K. agents for Beyer microphones. An agreement is being completed with Braun for the distribution of their sound reproducing equipment. The previous distributors for Braun were Argelane Ltd., but the arrangement was terminated last November when the last-mentioned company went into liquidation.

Audio Engineering Ltd, of 33 Endell Street, London, W.C.2, have been appointed the sole representatives in Great Britain for Sennheiser Electronic of Hanover. Sennheiser manufacture microphones of all types; also headphones and other studio equipment. The previous agents were Impectron Ltd.

The U.K. agents for Dual (record players and turntables) are now Dual Electronics Ltd. of Radnor House, London Road, Norbury, London, S.W.16. (Previously Dual equipment had been handled by Celsa Electric Ltd.)

Since passing for press K.L. Distributors' advertisement (p. 105 in this issue) an error has been noticed. The steel gauge referred to under "professional arc welders" should be ⅜in.

AUDIO FAIR PREVIEW

GUIDE TO NEW EQUIPMENT ON SHOW AT HOTEL RUSSELL

THE 1966 International Audio Festival and Fair is being held at the Hotel Russell, London, W.C.1, from Thursday 14th to Sunday 17th April. The following preview has been compiled with the help of those exhibitors who were able to give us advance information on their products in time for our press day. In the June issue we plan to publish a review of the latest developments in audio techniques seen at the Fair.

The short reports are arranged alphabetically under trade names or abbreviated company titles. Where, however, the trade name bears no resemblance to the exhibitor's name it is given in brackets after the firm's name in the list of exhibitors below. At the end of each report is a code

number intended to facilitate further enquiry about the products mentioned through our information service for professional readers (see card facing advertisement page 16).

A special service of stereo broadcasting for the Fair, using a local v.h.f. transmitter working on the pilot-tone system will be provided by the B.B.C. for the use of exhibitors with stereo decoding equipment. The B.B.C. will also have their own stereo demonstration room and an information bureau.

The Fair will open each day at 11 a.m. and close at 9 p.m. (Sunday 8 p.m.). Admission on the first day until 4 p.m. is restricted to invited guests. Tickets, each admitting two, are available from exhibitors, dealers or the editorial office of *Wireless World* (but please send an s.a.e.).

AKG

The complete range of microphones and accessories will be exhibited, together with four new types. The new **miniature condenser microphone** (C61) uses a Nuvistor pre-amplifier and both circular and cardioid directional patterns are provided. The power unit is provided with a switched bass-frequency attenuator. The D202 **dynamic microphone** (illustrated) has two capsules and a cross-over network to give a cardioid characteristic independent of frequency. A variable bass cut control is provided. Other new models are the D150 omnidirectional type and the D109, the first dynamic lavalier microphone from AKG. [324]

Agents: *Politechna (London) Ltd.*, 182 Campden Hill Road, London W.8.

ACOUSTICAL MFG. CO.

[see Quad]

ARMSTRONG

The complete range of **tuners, amplifiers and tuner-amplifiers** will be exhibited. It is hoped to demonstrate a **stereo decoder** intended for use with the tuners.

The decoder uses six transistors and includes a pilot carrier indicator. Channel separation is better than 30 dB up to 15 kc/s. Some of the older tuner models may be used for stereo reception, these being the Stereo 12 Mk. 1 and 2, the Stereo 55 tuner-amplifier and the ST3 Mk. 1 and 2 and T4. [325]

Armstrong Audio Ltd., *Walters Road*, London N.7.

AUDIO & DESIGN

This company concentrates mainly on equipment design and its scope includes pickup arms, loudspeakers, professional recording equipment and, in the near future, p.a.

Of particular interest is a **pickup arm** which has immeasurably low pivot friction, due mainly to the abolition of the lead-out wires. The pivot arrangement is interesting in that the arm is attached to a ball which rests on five other balls, around which damping fluid may be placed if required. Electrical connection is made through baths of mercury, so that the arm may be *lifted off* its pivot. The adjustable bias arrangement is provided magnetically.

Other items shown are enclosures with modified Jordan-Watts modules, a completely new drive unit designed by

E. J. Jordan, formerly with Jordan-Watts, a transistor limiter amplifier for professional use, and a $\frac{1}{2}$ in tape transport with four-channel heads. [326]

Audio & Design Ltd., 40 *Queen Street*, Maidenhead, Berks.

BASF

A demonstration is being staged at which visitors will be able to listen to a selection of short tape-recorded items. They will also be able to record selections of these items and take them away on a sample of BASF tape on a message

LIST OF EXHIBITORS

AKG	Ferranti	Peto-Scott
Acoustical Manufacturing [Quad]	Ferroglyph Co.	Philips Electrical
Agfa	Fi-Cord International	Pioneer Electronics Corp.
Amateur Tape Recording	Field [Record Housing]	Pullin Photographic
Ampex	Fisher Radio	Pye
Arena-Hede-Nielsen	G.K.D.	Radford Electronics
Armstrong Audio	Garrard Engineering	Rectavox Company
Audio & Design	Goldring Manufacturing Co.	Records & Recording
Audio & Record Review	Goodmans Industries	Revox-Studer
BASF	Gramplan Reproducers	Richard Allan
BSR	Gramophone	Rogers Developments
Beyer Elektrotechnische	Hammond, C. E. & Co.	SME
Boosey & Hawkes [Jordan-Watts]	Hi-Fi News	Saba-Werke
Braun	High Fidelity Magazine	Sennheiser Electronics
Brenell Engineering	KEF Electronics	Shure Electronics
Brown, S. G.	Kodak	Standard Telephones & Cables
Butoba	Leak, H. J. & Co.	Sugden, A. R. & Co. [Connoisseur]
Celestion	Living Sound	Tannoy Products
Decca Radio & Television	Loewe-Opta	Tape Recorder
Decca-Kelly	Lowther Manufacturing	Tape Recorder Maintenance
Design Furniture	Lustraphone	Tape Recording Magazine
Dual Electronics	Mallory Batteries	Telefunken
E.M.I.	MB Electronic	Technical Ceramics [Sonotone]
Elcom	Metrosound Manufacturing Co.	Thorens
Electrical & Electronic Trader	Minnesota Mining & Manufacturing Co. [Scotch]	Truvox
Elizabethan Electronics	Mullard	Vortexion
Elstone Electronics [Tandberg]	Ortofon A/S	Wharfedale
Fane Acoustics		Whiteley Electrical
Farnell, A. C.		Willman, K. H. & Co.
		Wilmax
		Wireless World
		Worden
		Wyndson Recording Co.

spool. The full range of tapes and accessories will be displayed, including an improved library box. Engineers will be available (in Room 304) to discuss special problems. [327]

BASF Chemicals Ltd., 5a Gillespie Road, London N.5.

BSR

New to the Fair this year, BSR will show the latest version of their **Superslim record changer**. The restyled model is UA15SS5G (illustrated) and incorporates a low mass tubular pickup arm.

A new record changer, the UA70, will be on view. A calibrated stylus pressure control is provided permitting tracking down to 2 gm. An automatic lock secures the pickup arm to its rest when the (last) disc has been played. Turntable diameter is 11 in. Other equipments to be shown are the UA50 Mini-changer, the C1 ceramic cartridge and the TD10 tape deck. [328]

BSR Ltd., Old Hill, Staffs.

BEYER

Two **microphones**, the M55 and M80, having output impedances of both 200 Ω and 80 k Ω , can also be supplied with matching transformers for the 50 k Ω input impedance of many European tape recorders (e.g. Grundig, Philips, Telefunken).

Other microphones are the M110 and the M610 with bass attenuation switch. The M610 is suitable for p.a. work, being available with a balanced 37.5 Ω output impedance.

Among the **headsets** are the DT 48 (5 Ω or 25 Ω impedance), the DT 96 and the DT 508. [329]

Agents: Fi-Cord International.

BRAUN

Equipment, previously handled by Argelane, will be seen and includes **amplifiers, tuners, loudspeakers and tape recorders**. Full details were not known at the time of going to press. [330]

Agents: Fi-Cord International.

BRENELL

The most recent addition to the range is a **tape link**, designed to match a three-head stereo deck to any amplifier. It contains two recording amplifiers with equalization circuits for four tape speeds, a push-pull oscillator, and two replay pre-amplifiers. All valves are d.c. heated to reduce hum injection.

The **Mark 5 Series 3** tape equipment, shown last year, is featured and includes a tape deck, amplifier, complete recorder, and the type M twin head and amplifier model. The Mark 510 large-spool deck and the STB 2/5/2 stereo unit will also be exhibited. [331]

Brenell Engineering Co. Ltd., 231 Liverpool Road, London N.1.

S. G. BROWN

A moving coil **headset**, suitable for both stereo and mono operation, is featured. This is designated the 3C.1100/1 and



Latest version of the BSR Superslim record changer (UA15SS5G).

has an impedance at 1 kc/s of 8 Ω . It requires an input of 1 mW for normal listening level, and distortion at this level is less than 1%.

Also shown is the **handphone** 11C 200 and 201 series, for use in listening cubicles, churches and so on. Impedance is 4 k Ω at 1 kc/s and the input required for normal listening levels is 1 mW. Frequency response is down 5 dB at 3.5 kc/s. [332]

S. G. Brown Ltd., King Georges Avenue, West Watford, Herts.

BUTOBA

The MT5 and MT22 **tape recorders**, shown on previous occasions, are the attractions. The transistor model MT22, now in full production, is notable in that no mechanical switch links are used, switching being accomplished with relays. The recorder may be operated from dry batteries, a car battery, dry accumulators or from the mains. [333]

Agents: Denham & Morley Ltd., 173 Cleveland Street, London W.1.

CELESTION

The Ditton 10 compact enclosure introduced at the 1965 Audio Fair will be demonstrated with the two 12 in co-axial **loudspeakers** CX1512 and CX2012. These loudspeakers will be installed in new 2½ ft³ reflex enclosures manufactured by Record Housing. The first two digits of the type number refer to the power handling capacity in watts.

The manufacturers announce price increases of their 12 in units and enclosures of between 8s and £1. [334]

Celestion Ltd., Perry Works, Thames Ditton, Surrey.

CONNOISSEUR

The turntable assembly shown last year—the Classic—is notable in that two separate motors are used for the two speeds. The Craftsman two- and three-speed **turntables** will also be on view. These turntables are also available mounted on a plinth with pickup arm and transparent cover. The pickup arm and shell (SAU-1) and the SCU1 stereo ceramic cartridge are available and are



AKG D202 cardioid characteristic microphone with two capsules and a cross-over network.

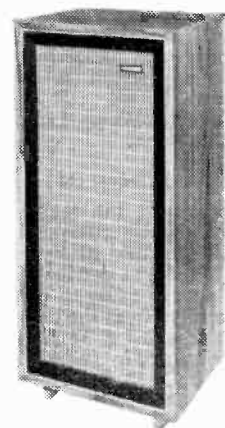

New Decca-Kelly loudspeaker system incorporating the Kelly acoustic lens to give wide h.f. dispersion.

used with the Craftsman turntables in the above assemblies.

Two **loudspeaker enclosures**, in the Craftsman series, are column types and give 360° radiation. [335]

A. R. Sugden & Co. (Engineers), Ltd., Market Street, Brighouse, Yorks.

DECCA

A new Decca-Kelly **loudspeaker system**—the Kelly Kardiod—will be introduced. Good high frequency dispersion is the main attraction of this system, resulting in a wider stereo listening area. The system incorporates the Decca-Kelly DK1 12 in bass unit and the Kelly Mk. II ribbon loudspeaker. The wide-angle dispersion is due to the mounting of the Kelly **acoustic lens**, introduced last year, in front of the ribbon loudspeaker. At 15 kc/s the dispersion is 150° (± 3 dB). [336]

Decca Record Co. Ltd., Ingate Place, Queenstown Road, London S.W.8.

DESIGN FURNITURE

Two **equipment cabinets** will be shown for the first time. The RC192 is a record storage cabinet on castors with space for nearly 200 records. The

EQC17 is a hand-carved reproduction cabinet suitable for most types of equipment.

It is likely that other cabinets will be shown including prize-winning designs from a recent competition. [337

Design Furniture Ltd., Calthorpe Manor, Banbury, Oxon.

E.M.I.

Two tape recorders for professional use are to be exhibited—the BTR4, announced last year, and the L4, shown at the Fair last year. The battery-operated L4 is a portable two-speed model suitable for remote operation, and with provision for a fourth head for sync purposes. [338

E.M.I. Electronics Ltd., Hayes, Middlesex.

ELCOM

Equipment to be demonstrated will be taken from the company's range of sound mixers, amplifiers, multi-channel consoles, faders and complete systems.

Components relevant to the audio field will be exhibited. [339

Elcom (Northampton) Ltd., Weedon Road, Northampton.

ELIZABETHAN

In accordance with the company's new name, Elizabethan Electronics Ltd., new items outside the field of tape recorders will be exhibited—no details being available at the time of going to press.

Tape recorders from the current range will be shown, the LZ 32 and 34, with a front-facing 10 in elliptical loudspeaker, the L 2102 four-track transistor model and the stereo 711. The Pop-20 portable stereo record player will also be on view. [340

Elizabethan Electronics Ltd., Crow Lane, Romford, Essex.

FANE

A wide range of loudspeakers will be on view and, of course, the Ionofane units. These units are similar to the Ionophone loudspeaker, having no moving parts and using ionised air as the radiator. The principle has been described previously in *Wireless World* (e.g., see June 1965 issue pp. 29, 30). [341

Fane Acoustics Ltd., Hick Lane, Batley, Yorks.

FERRANTI

Applications of silicon planar transistors in audio equipment will be the theme of the display. Equipment shown will include a 7-watt amplifier, AMP100 (two of which will be included in a stereo demonstration); a 15-watt amplifier, AMP105; a pre-amplifier, PA20; a capacitor microphone pre-amplifier (using an f.e.t.); and an f.m. tuner using a gallium phosphide light source in its tuning indicator.

The 7-watt amplifier and pre-amplifier are based on the design used in the Grundy and Collins silicon transistor tape recorder (*W.W.* July/August 1965), a model of which will be on show. [389

Ferranti Ltd., Electronics Dept., Gem Mill, Chadderton, Oldham, Lancs.

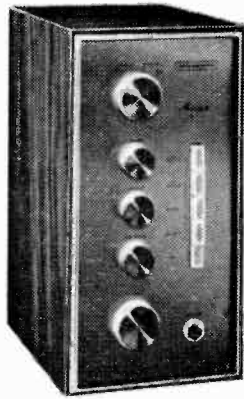

A new venture for Goodmans—the Maxamp 30 using silicon transistors.



One of the latest cabinets from Design Furniture (EQC17).

FERROGRAPH

The Series 6 tape recorders, introduced last year, will be augmented this year by the **Connoisseur 633**. This single channel instrument incorporates all the features of the Series 6 and in addition has separate record and playback heads enabling direct comparison of the incoming and recorded programme. (Echo effects can also be introduced.)

The signal level meter functions on both recording and playback, hence providing a silent monitoring facility. An equalized input socket is provided for magnetic pickups. Further, a spot erasure feature is provided. [342

Ferroglyph Co. Ltd., 84 Blackfriars Road, London S.E.1.

FI-CORD

The 202A battery operated tape recorder shown last year will be seen again. This may be operated from a 12 V car battery or the mains supply.

Fi-Cord's own range of microphones will be shown and includes three types, the FC 801, 901 and 1100. Two Headsets are also featured, types FC 1500 and 1501, with impedances of 200 Ω. [343

Fi-Cord International Ltd., Charlwoods Road, East Grinstead, Sussex.

GARRARD

The now well-known 401 and Lab 80 turntable units are the major attractions here. Both of these units have anti-static turntable mats and an interesting feature of the Lab 80 is the auto-trip mechanism which is actuated magnetically.

Other well known Garrard units on display are the A70 automatic, the AT60 automatic, the SP25 automatic single player and the model 3000. [344

Garrard Engineering Ltd., Swindon, Wilts.

GOLDRING

A new turntable, the G99, will be on view for the first time. The unit is

designed for use with any pickup arm and has a variable speed adjustment and an illuminated stroboscope. The turntable is non-ferrous and weighs 8 lb.

Another new item is the GL 68 turntable and pickup arm, again with variable speed control, and fitted with the new G.65 pickup arm (illustrated). The low mass tubular arm is fitted with a stylus pressure adjustment.

A new ceramic cartridge is introduced (CS.91/E) for stereo operation with an elliptical diamond stylus. [345

Goldring Mfg. Co. Ltd., 486 High Road, London E.11.

GOODMANS

The recently introduced Mezzo loudspeaker will be on show. This 15 W loudspeaker is designed to fit almost any bookshelf and the size falls between that of the Maxim and the Magnum-K.

Since last year's Audio Festival Goodmans have announced their entry into the amplifier field and have produced a silicon transistor amplifier rated at 15 W per channel. The amplifier (the Maxamp 30) incorporates a pre-amplifier with low and high pass filter and measures 10½ × 5½ × 7¼ in—about the size of the Maxim. [346

Goodmans Industries Ltd., Axiom Works, Lancelot Road, Wembley, Middx.

GRAMPIAN

Various microphones and accessories such as windshields, reflectors and stands, are displayed. Two pre-amplifier mixers are newly introduced. One is a "semi-professional" type with low noise level available for battery and mains operation.

Another new item is the ambiphonic unit (type 666), developed from the reverberation unit (636). This is intended for increasing the reverberation time of rooms and halls. Loud-

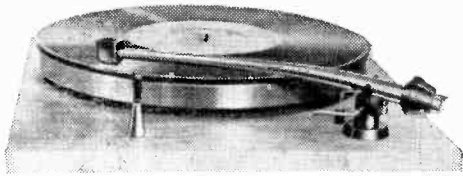

Leak stereo pickup arm and variable reluctance cartridge with elliptical stylus.

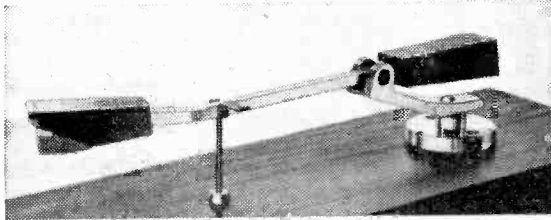

Model G.65 pickup arm from Goldring. This arm is fitted to the GL.68 turntable unit.

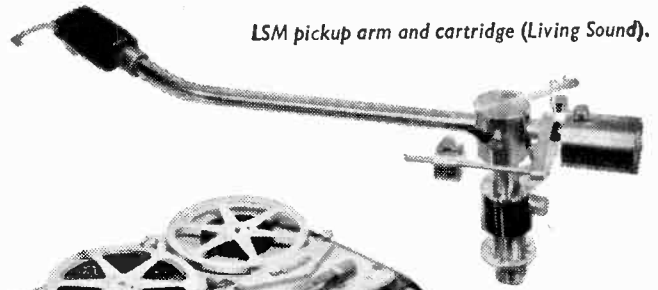

LSM pickup arm and cartridge (Living Sound).

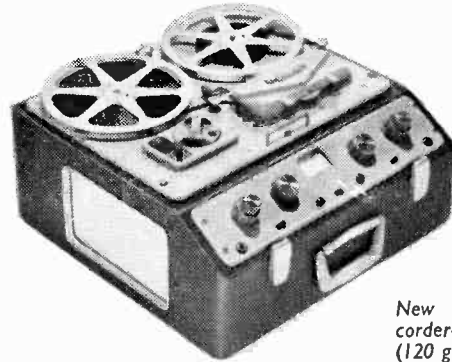

New Ferrograph tape recorder—the Connoisseur 633 (120 gn).

speakers and amplifiers for p.a. work are also shown. [347]
Gramplan Reproducers Ltd., Hanworth Trading Estate, Feltham, Middx.

HAMMOND

A new condenser microphone, the M-100, using a miniature capsule with an unbreakable diaphragm, is introduced. Two versions are available—stereo and mono—and although both units are supplied with a mains operated power supply, a battery power unit is being developed for use in the field. Output impedance is 60 Ω and up to 200 ft of cable can be used from the microphone. [348]

C. E. Hammond & Co., Ltd., 90 High Street, Eton, Windsor, Bucks.

KEF

Aside from current loudspeakers, two new models will be shown for the first time, details of which were not forthcoming in time for press. [349]

KEF Electronics Ltd., Tovil, Maidstone, Kent.

JORDAN-WATTS

Six new items will be shown—two of them, the Juno and Jumbo enclosures, have been recently announced in *W.W.* The Gemini is a reflex enclosure fitted with two Jordan-Watts modules, giving a power handling capability of 25 W. The better-quality Jupiter, also with a power rating of 25 W is stated to give a good power down to 20 c/s.

A resistive reflex enclosure (the Jason) designed for the modules, and rated at 12 W will be shown. For low output impedance amplifiers a 3-5 Ω version of the modular drive unit is available, which can be incorporated into any of the enclosures. [350]

Distributors: Boosey & Hawkes (Sales) Ltd., Sonorous Works, Deansbrook Road, Enfield, Middx.

KODAK

A 5 min slide-music demonstration will be given, the slides being controlled from a six-track recorder. The full range of recording tapes available to amateurs and professionals will be seen. The most notable tape, perhaps, is the Quadruple play P400 tape. Such tape on a 3 $\frac{1}{2}$ in reel would give a 5 $\frac{1}{2}$ hr playing time (800 ft). [351]

Kodak Ltd., Kodak House, Kingsway, London W.C.2.

LEAK

A stereo pickup arm with cartridge and a Mini-Sandwich loudspeaker are introduced. The pickup arm has a single pivot bearing with light viscous damping which is at record level to reduce wow from warped records to a minimum (see illustration). The cartridge is a variable reluctance type with an elliptical stylus. Playing weight is pre-set at 2 gm.

The Mini-Sandwich loudspeaker unit is a smaller version of the Sandwich, with dimensions 18 $\frac{1}{2}$ \times 11 \times 7 in, the performance differing only in the lowest octave. [352]

H. J. Leak & Co. Ltd., Brunel Road, London W.3.

LIVING SOUND

Newcomers to the show, Living Sound offer mainly a hi-fi supply and installation service. However, a pickup arm and cartridge, manufactured by Micro Seki of Tokyo, will be shown.

The arm was announced last September and since then the overall weight has been reduced. The arm is known as the Living Sound Micro tone arm and is shown in the illustration. [353]

Living Sound, 11 Essex House, Croydon, Surrey.

LOWTHER

A direct replacement for the P.M.6 drive unit, the P.M.7 will be introduced; it

is claimed to give an improved performance from the Acousta and similar horn loading enclosures. Efficiency is increased and the new gap flux is 19,650 gauss. The corner Acousta enclosure is superseded by a dual-purpose Acousta, which may be used in a corner or at any side wall position.

The LL 15 and LL 15S amplifiers are superseded by the L 18 using the EL 506 output pentode and giving 18 W per channel with the distributed load configuration.

Valve and transistor f.m. tuners and control units are also shown. [354]
Lowther Mfg. Co. Ltd., St. Mark's Road, Bromley, Kent.

LUSTRAPHONE

A complete range of microphones based on a sub-miniature lightweight ribbon unit, type VR70/1 is introduced. Ceramic magnets are used in this unit and available models are VR/75, with built-in pre-amplifier (illustrated), VR70/HS headset, VR/270 noise-cancelling microphone, VR70/L lavalier type and the VR70/1/2 suspended in an anti-vibration mounting.

The Radiomic systems and other well-known lines will be on view. [355]
Lustraphone Ltd., St. George's Works, Regent's Park Road, London N.W.1.

MB ELECTRONIC

The German firm of Mikrofonbau-Vertrieb G.m.b.H., formed about three years ago by the chief designer of Beyer, is represented in the U.K. by Denham and Morley. A range of moving-coil microphones for both amateur and professional use is featured and an aluminium ribbon type is also available. The company also manufacture dynamic type headsets for both mono or stereo operation. The headbands of the sets

are made from plastic-coated steel to avoid risk of shock. [356]

Agents: *Dennam & Morley Ltd.*, 173 *Cleveland Street, London W.1.*

MALLORY

The ability of the company's alkaline batteries to deliver a steady voltage over a long period will be the main theme of this year's display. These batteries have a low internal impedance and are produced in five standard sizes. A variety of miniature mercury batteries will also be on show. [357]

Mallory Batteries Ltd., *Crawley, Sussex.*

METROSOUND

The manufacturing side of this organization is showing a range of accessories for tape and record reproduction, including a tape speed checking device, tape and head cleaning kits, a tape splicer, a stylus cleaning kit, an anti-static turntable mat and diamond and sapphire replacement styli. [358]

Metrosound Manufacturing Co. Ltd., *Bridge Works, Wallace Road, London N.1.*

ORTOFON

In addition to the well known SPU stereo moving-coil pickup cartridge (and type SPU-T with transformer) a range of transcription pickup arms with adjustable counterweights is on show, together with the Hi-Jack remote control lever for raising, cueing and powering of these arms. The Hi-Jack can be fitted to any turntable, and on the Thorens TD-124 no drilling is required. Also shown are elliptical styli, the SPU/GTE, mounted for all Ortofon pickup arms, and the SPU/TE, unmounted for use in other arms. [359]

Agents: *Metrosound (Sales) Ltd.*, *Bridge Works, Wallace Road, London N.1.*

PETO SCOTT

Microphones for both the domestic and professional market are featured, and two new microphones are introduced.

The new professional 50 W amplifier from Quad.



The Philips Hi-Q microphone (EL.6033) includes a switch to change the polar characteristic. The EL.7500 is supplied in kit form and can be used as a hand microphone, with a desk stand, or neck lung.

Also on display will be the video tape recorder, p.a. equipment, a multi-channel recorder, and studio equipment. [360]

Peto Scott Ltd., *Addlestone Road, Weybridge, Surrey.*

PHILIPS

The current range of seven tape recorders will be demonstrated. A wide range of accessories is provided, including a new continuous tape cassette. [361]

Philips Electrical Ltd., *Century House, Shaftesbury Avenue, London W.C.2.*

PYE

The Brahms series of equipment and the Peri Hi-Fi Ensemble will be shown this year. The transistor amplifier (HFS30T) provides a 15 W per channel and incorporates a loudness control giving a 10 dB accentuation at 100 c/s.

The nine-transistor a.m./f.m. tuner (HFT300) has switched a.f.c. and an inter-station noise muting circuit. Sensitivity of the f.m. section is 3 μ V for a 20 dB s/n ratio. The compact loudspeaker enclosure (HF3BS) measures 21½ × 12 × 6½ in and is sealed, housing a 10 × 6 in twin-cone loudspeaker and a 4 in tweeter.

The Peri Ensemble (HF1000), based on the above, includes a Goldring GL70 deck, but the two loudspeakers measure about 12 × 12½ × 6½ in. [362]

Pye High Fidelity Division, St. Peters Road, Maidenhead, Berks.

QUAD

A 50 W transistor amplifier intended primarily for professional and industrial use is introduced this year. Harmonic distortion (at 700 c/s) is quoted to be only 0.25% at 50 W output. The output can be either for 4, 9 or 16 Ω loads or for 50 or 100 V lines, and damping factor

is 10. At the 1 W level, the response extend to 30 kc/s (-3 dB), and down to 17 c/s (-3 dB) for 50 W into a resistive load. Hum level is -83 dB relative to 50 W.

The other item of transistor equipment is the multiplex decoder, the amplifier and control unit remaining valved. [363]

Acoustical Mfg. Co. Ltd., *Humington.*

RADFORD

A new f.m. tuner will be shown—the FMT2M. Silicon transistors are used and the front end has a four-gang tuning capacitor, two being used before the first transistor. Sensitivity for full limiting is given as 3 μ V. A multiplex stereo decoder is available with automatic stereo/mono switching. A twin-T circuit is used to attenuate the re-inserted 38 kc/s sub-carrier.

Other Radford equipment present will be the Series 3 power amplifiers—the phase splitter of which was described in *Wireless World* September 1962, the SC22 pre-amplifier and control unit shown last year, and the range of loudspeaker units, some similar in principle to that described in *Wireless World*, October, 1965. [364]

Radford Electronics Ltd., *Ashton Vale Road, Bristol 3.*

RECORD HOUSING

New items are the Acoustex loudspeaker system and turntable unit, and the Mobile and Playview equipment cabinets. These cabinets have transparent lids, which have been gaining popularity recently.

Also to be exhibited are the Hi-Flex group of matching units and associated metal frames (Hi-Raks). The Hi-Flex loudspeaker enclosure has been modified with co-operation from Celestion and will be demonstrated with the CX1512 unit.

There are new 25 different cabinets in the Record Housing range. [365]

N. & S. B. Field & Co., *Brook Road, London N.22.*

RECTAVOX

First time exhibitors, Rectavox will show the Omni Mk. II loudspeaker enclosure. This unit includes a K.E.F. B 139 and a K.E.F. T 15 tweeter. Power handling capacity is 15 W. The interesting feature of this enclosure is its shape, the top being front-facing and inclined at 45°. This is claimed to improve the bass response by about 3 dB over a conventionally shaped enclosure of the same volume. [366]

The Rectavox Co., *Central Buildings, Wallsend, Northumberland.*

REVOX-STUDER

The Revox 736 stereo tape recorder, shown in previous years, is again demonstrated. This machine accepts 10½ in spools, includes a 6 W amplifier and uses relays for switching.

(Continued on page 183)

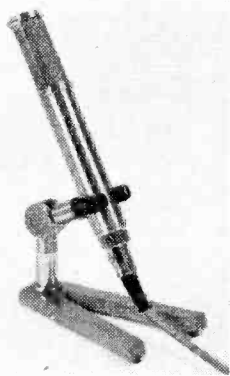

Miniature Lustraphone ribbon microphone with built in transistor pre-amplifier and using ceramic magnet.

Studer professional tape recorders include the A62 and C37. The C37 is used by many broadcasting organizations, including the B.B.C. The new model (A62) is a transistor recorder with plug-in printed board modules for the two amplifiers and oscillator. Large spools (up to 10 in) can be accommodated. Equalization for both NAB and CCIR standards is included. [367]

Revox agents: C. E. Hammond.

Studer agents: F. W. O. Bauch Ltd.

RICHARD ALLAN

A loudspeaker module, incorporating a 5 in bass unit and a 4 in tweeter integrally constructed on a panel and designed for small "bookshelf" enclosures, is featured in the Minette enclosure. This has been described previously in *Wireless World*. Two new enclosures are to be exhibited, one based on an 8 in bass unit plus tweeter and the other on a 12 in bass unit, mid-range unit and tweeter.

Two high-frequency loudspeakers, one a 4 in unit (CB4) with ceramic magnet and the other a horn loaded type which is claimed to include several new features, will also be shown. The illustration shows the 5 in bass loudspeaker intended for bookshelf enclosures. [368]

Richard Allan Radio Ltd., Bradford Road, Gomersall, Leeds, Yorks.

ROGERS

Three stereo amplifiers with control units are included in the display. Two Mk. III f.m. tuners are also presented, one with switched and one with variable tuning. The variable model with decoder and amplifier will be demonstrated in conjunction with two alternative loudspeaker systems (the Wafer Ultra-slim and the 88 system).

The 88 is a new design based on two models, the standard and the studio, the latter incorporating the French Orthophase loudspeaker for the range 500 c/s-25 kc/s. [369]

Rogers Developments (Electronic) Ltd., 4 Barneston Road, London S.E.6.

SME

The Series II pickup arms and accessories will be shown. The arms have not undergone any significant changes, although a revised balance system was introduced some time ago. The accessory weights were dispensed with, allowing cartridges from 3-17 gm to be balanced. [370]

SME Ltd., Steyning, Sussex.

SABA

Two transistor tuner-amplifiers exhibited are the Studio 11A (12 W per channel) and the Freiberg (30 W per channel) fitted with remote control. An amplifier is also on show, the telewatt TS100, giving 25W per channel (35W music power).

Two loudspeaker enclosures are presented, totally enclosed types of 1 ft³ and 1.8 ft³ with music power ratings of 25 and 35W respectively. A plinth has



Slim Audio Metric domestic enclosure introduced by Tannoy.

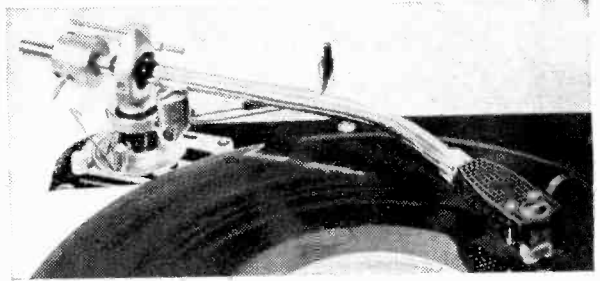

An SME series II pickup arm fitted with a Shure cartridge.

5 in dia. bass unit with neoprene surround manufactured by Richard Allan Radio



been produced to accompany the Saba tape recorder—the Sobofon 300S. [371]

Agents: Saba Electronics Ltd., Eden Grove, London N.7.

SCOTCH (3M)

A low-noise magnetic tape is newly introduced and is known as Dynarange Scotch tape. It is claimed to have a signal-to-noise ratio better than that of conventional tapes by 3-5 dB. Frequency response is also said to be improved. Bias requirements are somewhat greater than Scotch tape type 111 and the recording signal should be greater by 2 dB. Equalization may be altered to take advantage of the better h.f. response. [372]

3M Company Ltd., 3M House, Wigmore Street, London W.1.

SENNHEISER

This German company, of Hanover, manufacture microphones of all types and among those exhibited will be condenser and sub-miniature microphones. R.F. condenser types for which no polarizing voltage is required are shown and one model, a "gun" microphone, has highly directional characteristics. Another r.f. transistor type has a frequency response covering 17½ octaves—0.1 c/s to 20 kc/s (MKH 110).

A professional stereo reproducer, the Philharmonick, incorporates many refinements. A remote control unit, a three-channel stereo mixer and equalizers to compensate for the position of loudspeakers in the room are some of its features. [373]

Agents: Audio Engineering Ltd., 33 Endell Street, Shaftesbury Avenue, London W.C.2.

SHURE

Two cartridges are introduced, models M80E and M80E-D designed specifically for use with Garrard Lab 80 and Dual 1009 turntables respectively.

Transistor stereo pre-amplifiers (M61 Series) are featured and are for use with cartridge and tape heads where the amplifier does not have the necessary input facilities. A transistor amplifier (SA-2E) for use with stereo headphones is also available.

The range of microphones for both amateur and professional use has been augmented with models 581, S33, and the new SM series. [374]

Shure Electronics Ltd., 84 Blackfriars Road, London S.E.1.

SONOTONE

The established 9TA ceramic cartridge will be shown again. Recommended loading is 2 MΩ and 100 pF, giving a response of 30-15 kc/s ± 3 dB. Output is about 100 mV per cm/sec. Channel separation is 27 dB at 1 kc/s, falling to 15 dB at 5 kc/s. [375]

Agents: Metro-Sound Manufacturing Co. Ltd.

S.T.C.

Comparative playback sessions will be held hourly of stereophonic tape recordings (of a string quartet) made with four different types of microphones: the 4113 ribbon, the 4105 moving coil, the 4038 high quality ribbon and the 4126 capacitor type (using an f.e.t. circuit). In a lobby adjoining the demonstration room there will be a comprehensive display of microphones, headsets and accessories. [376]

Standayd Telephones and Cables Ltd., S.T.C. House, 190 Strand, London W.C.2.

TANNOY

A new item to be demonstrated is the Audio Metric loudspeaker enclosure. The slim enclosure incorporates a 12 in bass loudspeaker and an h.f. unit. Power handling capacity is 15 W and distortion is said to be low. Recommended price of this enclosure is £27 10s.

The Lancaster enclosures introduced last year, will be shown, together with the complete range of dual concentric types. [377]

Tannoy Products Ltd., Norwood Road, London S.E.27.



Telefunken Magnetophon 204E stereo tape recorder.

Left: The new Wyndor Vanguard four-track tape recorder.

TAPE RECORDER MAINTENANCE

The well-known range of tape recorder spares will be on show, with many new lines. The range includes drive bands and 38 basic connecting lead terminations. [378]

Tape Recorder Maintenance Ltd., 323 Kennington Road, London S.E.11.

TELEFUNKEN

The Magnetophon 204E four-track transistor stereo tape recorder is the first Telefunken mains model to permit vertical as well as horizontal operation. Providing a high sound output of 6 watts per channel, the recorder incorporates the power amplifiers and loudspeakers in the main cabinet and has separate level controls and VU meters for each channel.

Cassette loading is now introduced by Telefunken in their Magnetophon 401 half-track tape recorder for monophonic operation. The DC System International cassettes provide playing times, at 2 i.p.s., of 2×45 minutes or 2×60 minutes. [379]

AEG (Great Britain) Ltd., Lonsdale Chambers, 27 Chancery Lane, London W.C.2.

THORENS

The TD150 transcription turntable has a low-speed (375 r.p.m.) double synchronous motor and a simple belt drive with a speed change mechanism which shifts the belt to give 33½ r.p.m. or 45 r.p.m. Speed change and on-off switch are combined in a single-knob control. Type TD150A is supplied with a professional pickup arm, TD150B with a wooden plinth and TD150AB with both. Also shown is the four-speed TD124 turntable in a new version (Series II) incorporating improvements to switching and motor suspension. [380]

Agents: Metrosound (Sales) Ltd., Bridge Works, Wallace Road, London N.1.

TRUVOX

The Series 100 of transistor tape recorders and tape units, introduced last year, will be shown and demonstrated together with their new tuner. The recent Series 40 will also be on display.

A new loudspeaker enclosure is introduced to match the Series 100 and is known as the LS102. Two Celestion drive units are used in the enclosure, which is only 13×8×7 in. [381]

Truvox Ltd., Neasden Lane, London N.W.10.

VORTEXION

Current professional tape recorders are the CBL/6, the WVB/6 and WVA/6. Also offered are established amplifiers, mixers and mixer-amplifiers.

Many features are included in the CBL model, including monitoring of both original and recorded sound. [382]

Vortexion Ltd., 257 The Broadway, London S.W.19.

WHARFEDALE

The complete range of products will be on display and demonstrations of the Linton, Dalesman, Dovedale and Aire-dale enclosures will be given. This array of enclosures covers a dimensional range from 19×10×10 in to 39×27×14 in, power handling capacities from 10 to 20 W and a price range from about £19 to £70.

A new 12 in loudspeaker with a Flexiprene roll surround and priced at about £12 will be shown. [383]

Rank Wharfedale Ltd., Idle, Bradford.

WHITELEY

Latest addition to the range of loudspeaker systems is the type LC92. This uses a 9-inch drive unit with a graded cone giving extended frequency response. It is mounted in a reduced depth acoustic labyrinth enclosure and is claimed to give a balanced response throughout the audio spectrum. A small system suitable for stereophonic use or for mounting in bookshelves is the Clumber Compact loudspeaker. Also on show are ready-to-assemble bass reflex cabinets and the Stentorian range of loudspeakers. [384]

Whiteley Electrical Radio Co. Ltd., Radio Works, Victoria Street, Mansfield, Notts.

WILLIMAN

This company are concerned specifically with exporting and the equipment

handled includes tuners, amplifiers and loudspeaker systems. Williman are exclusive agents for Armstrong, Kelly, Rogers and Jordan-Watts.

Overseas visitors interested in British audio equipment are invited to discuss export availability. [385]

K. H. Williman & Co. Ltd., Blackford House, Sutton, Surrey.

WILMEX

As an export house, Wilmex are exhibiting some of their lines available to overseas visitors; in particular, the new Ferrograph Connoisseur 633 (and also the Series 6 machines), the Wyndor Vanguard tape recorder and the Rectavox loudspeakers. [386]

Wilmex Ltd., Compton House, Malden Road, New Malden, Surrey.

WORDEN

A new transistor amplifier, in addition to an articulated pickup arm and the Panasonic reproducer, is shown. The last-mentioned loudspeaker system uses the horn loading principle and three models will be demonstrated, which can be supplied with either Wharfedale or Lowther drive units.

The pickup arm is well established and the manufacturers make the point that tracking error is low—which has become more important with the advent of elliptical styli. [387]

Worden Audio Developments Ltd., 54 Chepstow Road, London W.2.

WYNDSOR

The new Vanguard tape recorder will be shown in addition to the 707II, 707IV and Sabre II. The Vanguard (59 gn) is a four-track, three-speed machine providing most facilities. Track-to-track recording and monitoring from either the incoming or the recorded signal are possible with the separate record and playback amplifiers. An 8 in loudspeaker is fitted in the detachable lid and the output stage (ECL86) provides 4 W at 15 Ω. The recording indicator (a meter movement) is illuminated by a red light on recording and green on playback. [388]

Wyndor Recording Co. Ltd., 2 Bellevue Road, London N.11

Attenuation in Coaxial Cables

WITH PARTICULAR REFERENCE TO THE MEASUREMENT OF ATTENUATION AT AMATEUR STATIONS

By A. I. H. WADE,* B.Sc., D.L.C., Grad.I.E.E., G3NWR

COST and attenuation are the two prime factors governing the choice of coaxial cable for use in amateur stations, especially if it is used as feeder at v.h.f. Low cost and low attenuation are conflicting requirements, but, whilst little can be done about the cost, a basic knowledge of the attenuating properties of cables is essential when choosing a particular type.

This article shows how the attenuation of a cable is related to its construction, and also to operating and environmental conditions. There follows a discussion of the effects of losses on the standing wave ratio (s.w.r.), and a simple method of measuring attenuation, using an s.w.r. bridge, is described in detail.

Attenuation requirements

The purpose of a transmission line is to transfer r.f. energy from one end to the other, ideally without losses of any kind. In practice, however, losses do occur, and whether or not they are acceptable depends on the conditions of operation. At frequencies up to 30 Mc/s most types of cables present an attenuation of less than 1 dB/100ft, but as the frequency rises into the v.h.f. and u.h.f. regions the attenuation increases rapidly. Low attenuation is important if low power equipment is being used, as it is required to get as much energy into the aerial as possible. At the other end of the power scale, excessive attenuation may result in undesirable heating of the dielectric.

Similarly, when the cable is being used to transfer signals from the aerial to the receiver, the losses should be kept to a minimum. The noise figure of a receiver is governed principally by the noise contribution of the first stage; thus, in order to achieve a good signal-to-noise ratio, the cable should have low attenuation to enable as large a signal as possible to reach the receiver.

Characteristic impedance

The characteristic impedance of a coaxial cable is given by the equation

$$Z_0 = \frac{138}{\sqrt{\epsilon}} \log_{10} \frac{D}{d} \text{ ohms} \quad \dots \quad (1)$$

where ϵ is the average dielectric constant of the medium between the two conductors,

D is the inner diameter of the outer conductor, and d is the outer diameter of the inner conductor.

From this equation it would seem that by varying the dimensions of the inner and outer conductors it is possible to produce any required value of Z_0 . In practice, however, cables are usually produced with an impedance in the range 20 Ω to 300 Ω , with 50 Ω and 75 Ω as "standard" values.

Attenuation constant

A measure of the losses in a transmission line is given by the attenuation constant α . It can be shown¹ that at radio frequencies α is given closely by

$$\alpha = \frac{1}{2} \left(\frac{R}{Z_0} + GZ_0 \right) \text{ Neper/unit length} \quad \dots \quad (2)$$

$$\text{or } \alpha = \frac{1}{2} \left(\frac{R}{Z_0} + GZ_0 \right) \times 8.686 \text{ dB/unit length} \quad \dots \quad (3)$$

where R is the resistance of the cable/unit length, Z_0 is the characteristic impedance of the cable, and G is the conductance of the cable/unit length. The usual practice is for the loss to be quoted in dB/100ft.

The first conclusion that can be drawn from these equations is that the voltage is attenuated in a logarithmic manner as it progresses along the cable. To illustrate this by an example, consider a cable which has an attenuation constant of 3 dB/100ft. If the input voltage is, say, 1,000 V, it will be attenuated to 707 V after 100 ft; i.e. a power loss of 3 dB. After a further 100 ft, the voltage is reduced to 500 V, again a loss of 3 dB.

Frequency and the attenuation constant

The resistance and conductance of a cable are not constant, but vary with frequency as follows:—

Resistance. The resistance R is not the d.c. resistance of the conductors, but the effective resistance to r.f. At very low frequencies R is low in value because the current flows through most of the cross-section of each conductor. However, as the frequency rises the skin effect predominates, resulting in the r.f. current penetrating only a small depth into the conductors. Hence the effective resistance is much higher; it is in fact proportional to the square root of the frequency.

Conductance. The conductance of a cable represents the losses in the dielectric, and is proportional both to the power factor and to the operating frequency. Hence the conductance should be kept to a minimum, and this is achieved by using as little dielectric as possible.

The power factor of polythene in good condition is typically of the order of 0.0004 (at 1 Mc/s), but this value can be increased significantly by the presence of moisture. It is possible for moisture to permeate throughout the whole length of a cable, particularly in semi-air-spaced types, and many leakage paths, all of which are effectively in parallel, are thus created. In some cables the power factor, and hence the conductance, can be doubled within ten minutes of exposure to the atmosphere. For this reason it is imperative that the ends of the cable be sealed to prevent the ingress of moisture.²

It has already been shown in eq. 1 that the characteristic impedance of a cable depends largely on its

* Chelmsford, Essex.

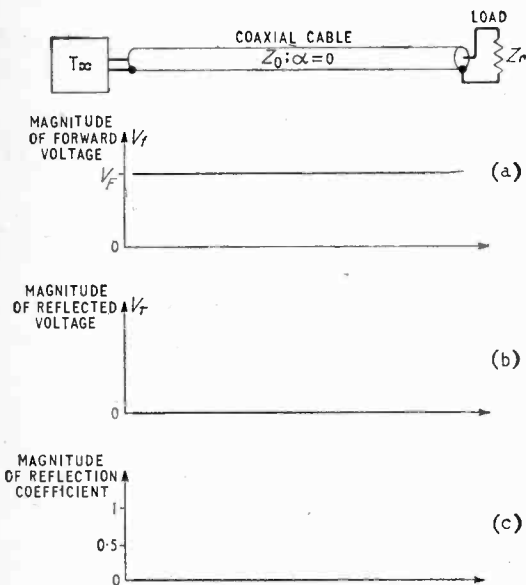

Fig. 1. Voltage distribution with matched load (lossless cable).

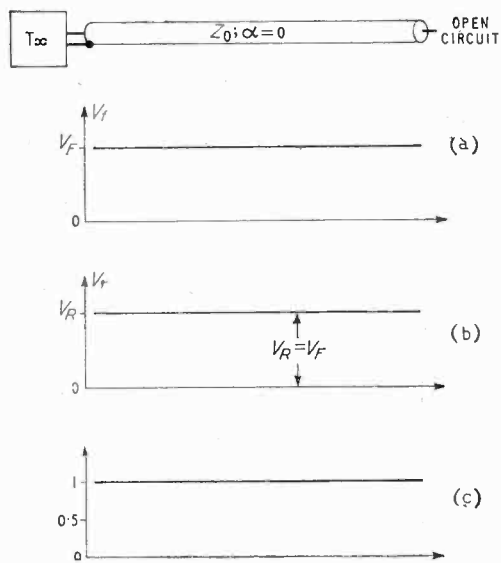

Fig. 2. Voltage distribution with open-circuit termination (lossless cable).

physical dimensions. From that equation it is not easy to deduce how Z_0 varies with frequency, so an alternative expression involving electrical quantities only is now introduced. At radio frequencies, Z_0 is given approximately by

$$Z_0 = \sqrt{\frac{L}{C}} \quad \dots \quad (4)$$

where L and C are the inductance and capacitance respectively of the cable/unit length.

L and C are sensibly constant with frequency, so that the characteristic impedance also remains constant with frequency.

Returning to eq. 2 and 3, it will now be seen that as the frequency increases so will the attenuation constant, because of the increases in R and G as described above. (Furthermore, the attenuation will be higher still if moisture is present). This illustrates the importance of stating the frequency of operation when discussing cable attenuation.

Attenuation figures for several types of coaxial cable most likely to be found in amateur stations are shown in Table I, for three of the v.h.f. bands. Clearly, the losses will be smaller on the h.f. bands. Comprehensive details

of the mechanical and electrical properties of these cables and many others are to be found in reference 3.

Voltage distribution on a lossless line

Before describing how the attenuation constant of a given length of cable may be measured, it is instructive to examine the voltage distribution along it. To simplify matters, let us assume first of all that the cable has no losses, and that it is terminated by its characteristic impedance Z_0 (Fig. 1). Referring to Fig. 1a, the forward voltage is the same at all points along the line because there is no attenuation. At the load all the power is absorbed, which means that the reflected voltage is zero. (Fig. 1b.)

The reflection coefficient at any point k , is defined as

$$k = \frac{V_r}{V_f} \quad \dots \quad (5)$$

Thus $k=0$ at all points on the line (Fig. 1c). By knowing the value of k we can calculate the s.w.r. ρ by substitution in the equation

$$\rho = \frac{1+k}{1-k} \quad \dots \quad (6)$$

In this case, the s.w.r. is unity throughout the whole length of the line.

If the load is now removed, leaving the end open-circuited, we obtain the conditions shown in Fig. 2. As before, the forward voltage is constant in magnitude at V_f as it progresses down the line (Fig. 2a), but because there is no load, all the power is reflected back to the transmitter. Therefore the reflected voltage V_r is equal in magnitude to the forward voltage (Fig. 2b). The reflection coefficient is now unity (Fig. 2c), and the s.w.r. is infinity at all points along the line.

If the end of the line is short-circuited, a similar argument will show that the s.w.r. is again infinity at all points (the difference being that the forward and reflected currents are considered instead).

By now it will have become apparent that one particular

TABLE I

Attenuation of Uniradio coaxial cables †					
U.R. No.	Z_0 (ohms)	Dielectric (Polythene)	Attenuation (dB/100ft)		
			70 Mc/s	144 Mc/s	450 Mc/s
17	71	Solid	0.9	1.35	3.15
39	69	Solid	2.05	3.25	6.5
43	52	Solid	3.4	5.6	11.5
57	75	Solid	1.5	2.3	4.45
63	75	Air	0.45	0.65	1.15
65	75	Solid	1.5	2.3	4.45
67	50	Solid	1.7	2.5	4.75
70	72	Solid	3.8	5.75	11.2
74	51	Solid	0.85	1.2	2.45
77	75	Solid	0.85	1.2	2.45
79	50	Air	0.5	0.7	1.25
83	50	Air	0.75	1.05	1.95
85	75	Air	0.65	0.95	1.7

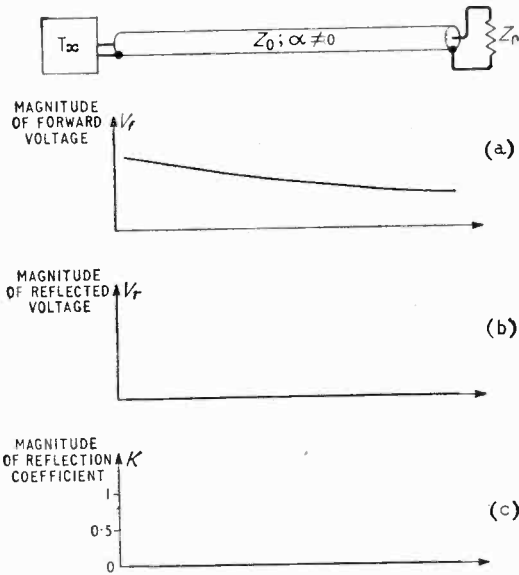

Fig. 3. Voltage distribution with matched load (lossy cable).

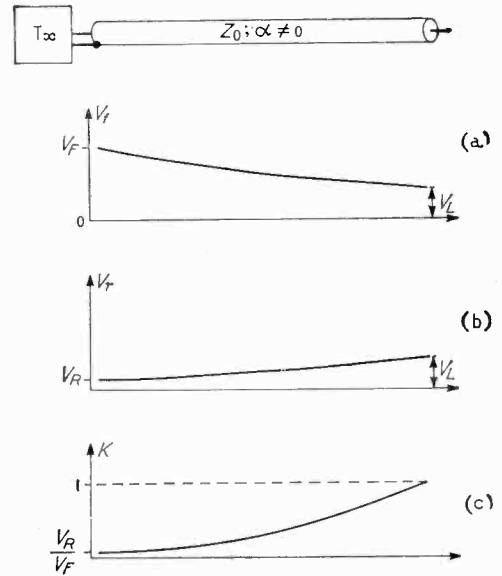

Fig. 4. Voltage distribution with open-circuit termination (lossy cable). Similar current curves are obtained when the cable is terminated in a short-circuit.

detail has been stressed several times, i.e. in a lossless line the reflection coefficient and the s.w.r. are constant in magnitude at all points, regardless of the attenuation. Except for one special case, this is not true when the line is lossy. Accordingly, let us now discuss how the voltage distribution is affected by the presence of attenuation.

Voltage distribution on a lossy line

With a lossy line terminated in its characteristic impedance Z_0 , the curves shown in Fig. 3 are obtained. Owing to the attenuation the forward voltage decreases in magnitude as the load is approached (Fig. 3a). All the power which reaches the load is absorbed, and none is reflected. The reflected voltage and the reflection coefficient are thus zero (Figs. 3b and 3c). As with a lossless line, an s.w.r. bridge will indicate unity at all points. This is the special case mentioned above.

Once again the load is removed. Referring to Fig. 4a, the forward wave is attenuated to a value V_L at the open end. This voltage is completely reflected, and then further attenuated on its return to the transmitter, where its magnitude is V_R (Fig. 4b). The reflection coefficient is not now constant, but decreases from unity at the open end to V_R/V_F at the transmitter (Fig. 4c). As before, an analogous situation exists when the line is terminated in a short-circuit.

Hence although the s.w.r. is infinite at an open- or short-circuit termination, it does have a finite value at all other points. It would therefore be reasonable to assume that there is a definite relationship between the reflection coefficient, measured at the transmitter, and the cable attenuation¹. This is shown graphically in Fig. 5.

Practical measurement of attenuation

To measure the attenuation of a length of coaxial cable, the set-up is as shown in Fig. 6. The far end of the cable is short-circuited. The transmitter is switched on, and the power amplifier tuned to resonance. Then, using the

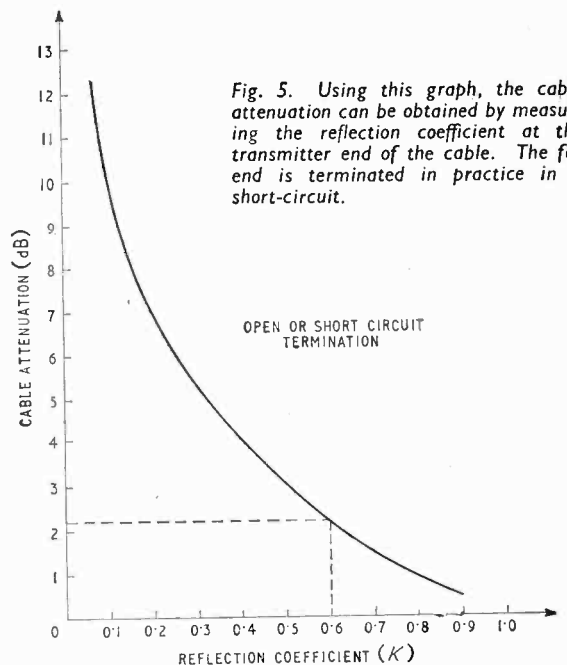

Fig. 5. Using this graph, the cable attenuation can be obtained by measuring the reflection coefficient at the transmitter end of the cable. The far end is terminated in practice in a short-circuit.

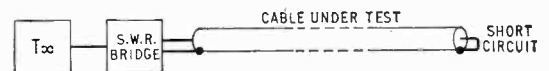

Fig. 6. Practical arrangement for measuring cable attenuation. Only low transmitter power should be used. The short-circuit is made effective by cutting the cable cleanly, folding the braid over the exposed end and soldering it to the inner conductor.

s.w.r. bridge, the reflection coefficient is obtained in the usual way. The attenuation is then obtained from Fig. 5. As an example, suppose that for a particular sample of cable the "forward" reading is 100 units, and the "reflected" reading is 60 units. The reflection coefficient k is therefore $60/100 = 0.6$. Referring to the graph, the attenuation of the cable is 2.2 dB.

If the bridge indicates the s.w.r. directly, the reflection coefficient can be calculated from the equation

$$k = \frac{\rho - 1}{\rho + 1} \dots \dots \dots (7)$$

Hence in the above example a direct-reading bridge would indicate an s.w.r. of 4. Substituting in eq. 7 we

$$\text{obtain } k = \frac{4 - 1}{4 + 1}, \text{ again equal to } 0.6.$$

Experimental details

Dealing first with the transmitter, the most important point is that only low power should be used, in the region of ten watts input. The reason for this will be appreciated by considering what happens to the power which is reflected at the short-circuit termination. On its return journey to the transmitter it must be dissipated in

- (a) the cable dielectric,
- (b) the s.w.r. bridge,
- (c) the final tuned circuit of the transmitter,
- and (d) the p.a. valve or transistor.

If the cable is of low loss, little power will be dissipated in the dielectric, the dissipation in the s.w.r. bridge is negligible, so that most of the power will be dissipated in the tuned circuit and the p.a. Hence, if the power level is too high, the p.a. dissipation may exceed its rated maximum. Alternatively, if the cable has high losses, most of the power will be absorbed by the dielectric which may soften if too high a power is used.

Another reason for using low power is that because of the standing wave set up on the line, the outer may no longer act as a screen, but as a radiator. As well as radiating power at the transmitter frequency, the harmonics generated by the diodes in the s.w.r. bridge could also be radiated. Therefore low power should be used to keep such radiation to a minimum.

Turning now to the s.w.r. bridge, the type used depends on the frequency at which tests are to be carried out. The reader is referred to the literature for descriptions of several types of instrument suitable for use from top-band

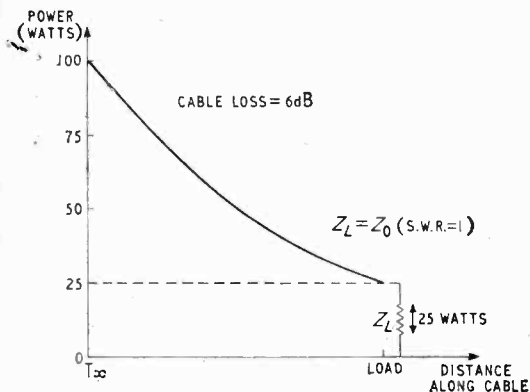

Fig. 7. Forward power distribution in a lossy cable. Because the cable is accurately matched there is no reflected power, and the total loss is that of the cable.

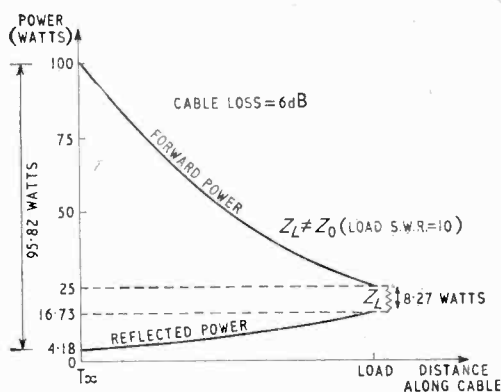

Fig. 8. Power distribution in a lossy cable with mismatched load. When considering the net transmitter output power and the net power dissipated in the load, the total attenuation of the system is greater than that of the cable alone, by an amount depending on the degree of mismatch.

to v.h.f. ^{5, 6, 7, 8}. At most amateur stations the facilities for accurate calibration of the bridge are not available, but it should at least be checked that it is working as a bridge. The method of doing this will vary from type to type, but usually involves some or all of the following checks:—

- (a) When the output is terminated by a dummy load equal in value to the characteristic impedance of the line, there should be little or no indication with the bridge switched to the "reflected" position.
- (b) With the output terminated either by an open- or short-circuit (which of these depends on whether the bridge samples the line voltage or current), the forward and reflected readings should be equal.
- (c) With the bridge reversed (i.e. input becoming output), the above checks are repeated to ensure symmetry of the circuit in each direction.

The question may be asked: why not terminate the cable in an open-circuit, as it has been shown earlier that the attenuation can be measured with either a short- or open-circuit load? The answer is that it is impossible to obtain a true open-circuit with a lossy cable. The term "open-circuit" means that no current flows between the inner and outer conductors at the open end; a condition difficult to realise because of end effects which give the appearance of the cable being terminated in a finite impedance.

A short-circuit termination must therefore be used. In turn, this implies that the voltage between the two conductors at the end of the line is zero. A true short-circuit may be achieved in practice by cutting the cable cleanly, folding the braid over the exposed end and soldering it to the inner conductor. If the connection is not made as short as possible, the resulting loop will exhibit inductance, and a voltage will be developed across it. At v.h.f. the inductive reactance of the loop can amount to a sizeable fraction of Z_0 , especially if low impedance cables are used, and so it is particularly important that the short-circuit is effective.

Accuracy

The accuracy of results is determined primarily by the s.w.r. bridge. Whilst it is beyond the scope of this article to discuss in detail the factors governing bridge accuracy, a few brief notes are not out of place.

The presence of the bridge should not disturb the

voltage or current distribution in the cable. This means that the coupling to the sampling line should be as small as possible. To avoid absorbing too much power, and to reduce the loading effect of the diodes, the resistance of the meter circuit should be as high as possible, consistent with reasonable sensitivity.

The bridge should not be used at a frequency higher than for which it was designed. If too high a frequency is used, the length of the sampling line becomes comparable to the wavelength of the signal, so that the voltage induced on to the line varies significantly from point to point along it. This introduces errors because the meter indication is proportional to the average voltage on the sampling line. At low frequencies the line is so short compared with the wavelength that the voltage is approximately constant at all points.

The construction of the bridge should be such that the coupling between the forward and reflected halves is minimal. Any unwanted stray coupling will unbalance the symmetry of the bridge.

There should be no harmonics in the transmitter output. Power at the harmonic frequencies will not be in phase with the power at the fundamental frequency, so that the resulting complex waveform sampled by the bridge will give rise to misleading readings.

Total attenuation

The total attenuation between the transmitter and the aerial in a practical system is not necessarily only that of the feeder cable. If the aerial does not match the cable, additional attenuation is introduced. This may best be clarified by a numerical example.

Suppose that a transmitter is connected to a length of cable, whose attenuation has already been measured in the manner described above, and the far end of the cable is perfectly matched. If the transmitter produces an output of 100 W, say, and the cable presents an attenuation of 6 dB over its length, the distribution of power will be as shown in Fig. 7. By the time the forward wave reaches the far end of the cable it will have been attenuated by 6 dB, so that the power dissipated in the load is 25 W.

Because the load matches the line, no power is reflected. Thus the overall attenuation from transmitter to load is 6 dB.

Consider now what happens when the load does not match the characteristic impedance of the cable, but presents an s.w.r. of 10, say (Fig. 8). As before, the forward wave is attenuated by 6 dB to 25 W at the load. The s.w.r. at the load is 10, so that the reflection coefficient is $(10 - 1)/(10 + 1) = 9/11$, and the power reflected is therefore 81/121 of 25 W, i.e. 16.73 W. This power is attenuated on its return to the transmitter, again by 6 dB, to 4.18 W.

The net power output of the transmitter is therefore $100 - 4.18 = 95.82$ W, and the net power dissipated in the load is $25 - 16.73 = 8.27$ W. The overall attenuation between transmitter and load is now $10 \log_{10}(95.82/8.27) = 10.6$ dB compared with only 6 dB when the load was matched. In other words, the mismatch has introduced an additional attenuation of 4.6 dB.

The additional attenuation introduced by mismatching is shown graphically in Fig. 9. To use the graph, the s.w.r. at the load and the cable attenuation must be known. Returning to the example, with a load s.w.r. of 10 and a cable attenuation of 6 dB, the additional attenuation is read off as 4.6 dB, as calculated above. In practice, cable losses would be much less than 6 dB, so that the additional attenuation would be small, even when the load is badly mismatched.

Final comments

What then is the maximum loss which can be tolerated in an aerial feeder system? Obviously the losses must be as small as possible, but the expense and size of good quality cable have to be taken into consideration, particularly with long runs at v.h.f. A suggested tolerable maximum for cable attenuation is 1 dB over the whole run. With such a loss, the additional attenuation due to any mismatch will be negligible, and the reduction in signal strength small.

Many samples of coaxial cable have been measured at G3NRW for attenuation on frequencies between 1.8 Mc/s and 70 Mc/s. On the h.f. bands, sw.r. bridges similar to that described by G30OU⁷ were used, with a copy of the v.h.f. bridge by G3GPN⁸ on 4 meters. Although instruments have not been calibrated to laboratory standards, they passed the simple tests described earlier, and it is thought that the errors were small. Even though errors are bound to be present, this method of measuring the attenuation has much to commend it from the point of view of speed and simplicity, using a piece of test equipment which is (or should be) found in every shack.

REFERENCES

1. Wires and RF Cables, G. W. A. Dummer and W. T. Blackband (Pitman) p. 109.
2. Amateur Radio Handbook (R.S.G.B.) p. 394.
3. Wires and RF Cables, G. W. A. Dummer and W. T. Blackband (Pitman).
4. VHF Line Techniques, C. S. Gledhill (Arnold) pp. 14-17.
5. Simple SWR Indicator, V. Scott, R.S.G.B. Bulletin, September, 1958.
6. A Reflectometer for 145 Mc/s, R. C. Hills, R.S.G.B. Bulletin, September, 1965.
7. Top Band Z-Match, R. F. Burns, R.S.G.B. Bulletin, September, 1961.
8. Standing Wave Ratio Meters, P. Harris, R.S.G.B. Bulletin, May, 1964.

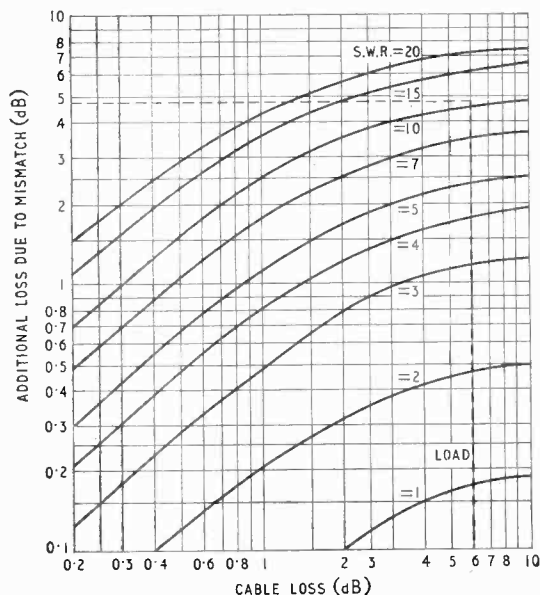

Fig. 9. Additional attenuation due to load mismatch.

4—Curve-fitting, Covariance and Correlation

By D. A. BELL,* M.A., B.Sc., Ph.D., M.I.E.E., F.Inst.P

ONE purpose of statistics is to suppress irrelevant detail so that significant characteristics can be seen more clearly; but one must always remember that any quantity or formula created by statistics, such as a mean value or the equation of a curve fitted to a set of experimental points, is only a hypothesis and has no independent significance apart from the experimental facts on which it is founded. It must also be emphasised that the existence of correlation between two quantities is not evidence of a causative or other direct connection between them: logicians have long recognised the fallacy of suggesting that because *A* follows *B*, therefore *A* is necessarily caused by *B*.

Let us then consider the problem of fitting the best straight line through a set of *k* points in a two-variable system, e.g. the problem of determining the mean rate of a clock from a set of readings of clock errors *y* on successive days, numbered on the *x* axis. We assume here that positions along the *x* axis are all exact, the errors and random variations being all in the *y* quantity, so the desired line is that known to statisticians as the regression line of *y* on *x*. (With *y* values known exactly and fluctuations in *x* one determines the regression line of *x* on *y*.) This is a straight line which passes through the mean values \bar{x} and \bar{y} and has the equation $y - \bar{y} = m(x - \bar{x})$ where:

$$m = \frac{\sum_{i=1}^k (x_i - \bar{x})(y_i - \bar{y})}{\sum_{i=1}^k (x_i - \bar{x})^2} \quad \dots \dots \dots (1)$$

Fig. 1 shows the process applied to the hypothetical data tabulated in the appendix. This is the straight line which has the "best" fit in the sense of minimising the sum of the squares of the errors in the *y* direction. The least-squared-error criterion is widely used (another common application of this criterion is in assessing the accuracy of an automatic-control system) and is mathematically convenient. The squaring increases the weight given to large errors, so that a least-squared error criterion tends to minimise large errors particularly but to leave a large number of small errors; such an arrangement accords with the expected distribution of errors, e.g. in a Gaussian distribution where there are many small errors but few exceeding several times the standard deviation. This introduces the idea of "maximum likelihood" estimates which are of importance in communication theory. If one knows that a received signal pulse is contaminated with Gaussian noise, the maximum-likelihood estimate of the pulse amplitude is that value which, with the addition of the noise, is more likely than

any other pulse amplitude to have produced the observed signal.

If the data obviously do not fit a straight line, the most practical procedure is to re-plot them to some non-linear scale, e.g. on log/linear, log/log or "arithmetic probability" graph paper, which does give a straight line. In theory one can always fit a polynomial to a non-linear distribution by the "method of moments," but a good deal of labour is involved if the polynomial has more than three or four terms, and it is dangerous to use the polynomial for extrapolation beyond the range of the given data. However, if it must be done the "method of moments" for fitting a polynomial to a set of points is as follows.

Let $y = a_0 + a_1 x + \dots + a_n x^n \dots \dots \dots (2)$ be the equation of the polynomial which gives the best fit to the set of *k* experimental points, in the sense of minimising the squares of the discrepancies in the *y* direction, and write down the following set of equations:

$$\begin{aligned} \sum y_i &= ka_0 + a_1 \sum x_i + \dots + a_n \sum x_i^n \\ \sum x_i y_i &= a_0 \sum x_i + a_1 \sum x_i^2 + \dots + a_n \sum x_i^{n+1} \\ &\vdots \end{aligned}$$

$\sum x_i^n y_i = a_0 \sum x_i^n + a_1 \sum x_i^{n+1} + \dots + a_n \sum x_i^{2n} (3)$ In the first of the *n* + 1 equations (3) we have written out equation (2) for each pair of *x_i*, *y_i* from *y* = 1 to *k* and summed these *k* equations; in the second line of (3) we have multiplied (2) by *x* on both sides before performing a similar operation; and so on down to the last line which is (2) multiplied by *xⁿ* and then summed over all values of *i* from 1 to *k*. Each of these is a legitimate operation, so we now have the *n* + 1 equations (3) to

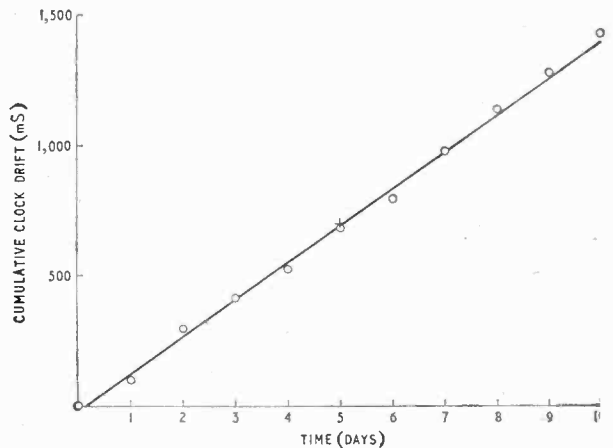

Fig. 1. Regression formula used to determine line of best (least-squares) fit.

* University of Hull

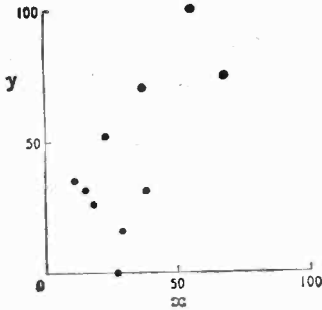

Fig. 2. Apparent correlation between random values of x and y .

solve for the $n + 1$ unknown coefficients a_0, a_1, \dots, a_n in terms of the summations of powers of x and of y times powers of x . The process is known as the method of moments because $\sum x_i^n$ is the n th moment of the distribution of x . The formal solution may be written.

$$a_r = \frac{\Delta_r}{\Delta_0} \quad \dots \quad \dots \quad \dots \quad (4)$$

where Δ_0 is the determinant made up from the right-hand side of the set of equations (3) with all the a 's deleted and Δ_r is obtained from Δ_0 by removing the column corresponding to a_r and substituting the column consisting of the left-hand sides of the equations. The evaluation of (4) is obviously a job for a computer if n is more than three or four.

It is interesting to note also that when a curve is approximated by a Fourier series, the Fourier coefficients are such as to give a fit which minimises the sum of squares of errors for the given number of terms in the Fourier series.

The denominator of equation (1) is k times the variance, but what of the numerator? It can be seen qualitatively that if $y - \bar{y}$ is positive whenever $x - \bar{x}$ is positive and both are negative together, all terms in the summation will be positive and the summation will have a large positive value; that if the variables have always opposite signs, the sum will be large and negative; and that if they have sometimes the same sign and sometimes opposite, the sum of some positive and some negative terms will be small. The magnitude and sign of the sum of cross-products therefore gives an indication whether the variables move together or in opposition or independently, i.e. how they are correlated. However, the magnitude of the sum depends on the number and size of the terms. To enable comparison to be made between different cases the measure must be normalised; and the correlation coefficient r , which varies between $+1$ and -1 for perfect in-phase or anti-phase correlation, passing through 0 for independence, is given by

$$r = \frac{\sum_{i=1}^k (x_i - \bar{x})(y_i - \bar{y})}{\sqrt{\left\{ \sum (x_i - \bar{x})^2 \cdot \sum (y_i - \bar{y})^2 \right\}}}$$

$$= \frac{1/k \sum_{i=1}^k (x_i - \bar{x})(y_i - \bar{y})}{\sqrt{\{\sigma_x^2 \cdot \sigma_y^2\}}} \quad (5)$$

The numerator of (5) is known as the covariance of x and y by analogy with the (self) variance $\sigma_x^2 = (1/k) \sum (x - \bar{x})^2$. Then it may be said that the correlation coefficient be-

tween x and y is obtained by taking the covariance of x and y and normalising it by dividing by the geometric mean of the individual variances of x and y . Fig. 2 shows a plot of ten points of which the x and y co-ordinates are in each case pairs of numbers taken from a table of random numbers. There should then be no correlation between x and y , but application of formula (5) yields a value of $r = 0.697$. With a small number of points the positive and negative contributions to the sum of cross-products are unlikely to balance out exactly, so that r is not zero although the two variables are known to be uncorrelated; and with small samples it is therefore unwise to attribute significance to a correlation coefficient below, say, 0.8 .

The relation between covariance and correlation coefficient has been expressly stated because in another field one finds the two terms autocorrelation and autocovariance used equivalently by different writers. The field in question is the determination of the power spectrum of a random waveform or a random series of pulses. The Fourier series representation of a single specified waveform involves both sine and cosine terms, or else the amplitude and phase of each harmonic; and corresponding to the preservation of phase of each harmonic is the fact that an infinite number of different series representations of a single waveform can be produced by varying the origin of time. This phase information is superfluous if one only wants to know the frequencies involved, e.g. in order to find the bandwidth needed in a communication channel, and can be eliminated by taking $\cos^2 + \sin^2$ for each frequency component and ignoring phase. But if we multiply by $\frac{1}{2}$, to convert squared amplitude of a sinusoid to mean-square, the squared values will represent mean power in the signal (e.g. volts-squared in a one-ohm circuit). The power in each harmonic is independent of the sharing between sine and cosine component, and independent of the origin of time used in the harmonic analysis. When the spectrum represents a random series of pulses, instead of a single specified waveform, it will be found to be continuous; and it is then possible to set up a continuous function $W(f)$ known as a power spectrum, such that $W(f)df$



Fig. 3. Random sequence of telegraphic characters.

represents the power in the frequency band between f and $f + df$.

We shall therefore seek a means of obtaining the power spectrum without first finding sine and cosine components.

The "random telegraph signal" provides a very practical example of the problem of finding the bandwidth required for a random sequence of pulses. Each letter in the teleprinter alphabet consists of a combination of five equal elements of time, some being mark elements and some space. Ignoring the question of synchronising elements, a succession of letters would then consist of a stream of pulses all of equal length but with varying intervals (varying numbers of space elements) between them; and the problem is to find the bandwidth occupied by such a signal as Fig. 3 which is the 5-unit code representation of the random sequence of letters D N O E A N (without synchronising pulses).

The Fourier spectrum of a group of pulses, representing a particular letter, is not the same as that of a single pulse. In attempting to find the spectrum of a random

sequence of letters by Fourier series techniques one would first have to find the Fourier representations of all 31 possible combinations of 5 units and average them; but one would in addition have to consider the effects of combinations of adjacent letters in a long sequence. The question is therefore whether there is a method of deriving the power spectrum which does not require individual sine and cosine representations and which is applicable to statistically specified distributions.

In fact there is, and it forms part of what may be called *generalised Fourier analysis*. In Fourier-series analysis one multiplies the waveform under examination by a sinusoid and integrates over a fixed period such as a half cycle of the fundamental frequency, e.g.

$$a_n = \int_0^{\pi/\omega_0} f(t) \sin n \omega_0 t \cdot dt \quad (6)$$

If $f(t)$ included some random noise and repeated cyclically one could average over m half cycles by writing

$$a_n = \frac{1}{m} \int_0^{m\pi/\omega_0} f(t) \sin n \omega_0 t \cdot dt \quad (7)$$

But a sinusoid is not the only possible multiplying factor or weighting function under the integration. For example, the arithmetic is simplified if $f(t)$ is multiplied by a square wave which alternates between +1 and -1. This picks out any component having the same periodicity as the square-wave, plus a weighted average of its odd harmonics, since a square wave may be represented by

$$\sum_{m=0}^{\infty} \frac{1}{2m+1} \sin(2m+1)\omega_0 t$$

The general formula, replacing the sinusoid or square wave by an arbitrary weighting function $g(k, t)$, is

$$\alpha_k = \frac{1}{T} \int_0^T f(t) g(k, t) \cdot dt \quad (8)$$

where the k which is a suffix of the coefficient α must also be a parameter of the weighting function; but k is not limited to being a multiple of some fundamental frequency and T is a time interval which is long enough to give a good average but otherwise arbitrary. Now the special device is to let the function g be merely the function f delayed in time by an amount τ . Since τ is continuous the coefficient α_k is replaced by a continuous function $\psi(\tau)$; and the best possible averaging will be obtained if we take the integral over all time from $-\infty$ to $+\infty$:

$$\psi(\tau) = \text{Limit}_{T \rightarrow \infty} \frac{1}{2T} \int_{-T}^{+T} f(t) f(t-\tau) dt \quad (9)$$

Referring back to the numerator of (5) for a definition of covariance, it can be seen that if the sets of k discrete values of x, y are replaced by the continuous functions $f(t)$ and $f(t-\tau)$ respectively and the summation over k is replaced by integration over time, then $\psi(\tau)$ is the covariance of $f(t)$ and $f(t-\tau)$: this is the *autocovariance* of $f(t)$ with lag τ . It has often been called the autocorrelation function, but this name should properly be reserved for the normalised function obtained by dividing the autocovariance by the mean-square value of $f(t)$. Note that as $T \rightarrow \infty$ the integral of $[f(t)]^2$ must be the same as that of $[f(t-\tau)]^2$ so that the normalising factor is just the mean-square value of the function instead of being the geometric mean of two variances as in the correlation

coefficient. It also follows from the infinite range of integration that the exact origin of time is of no significance and on shifting the origin by amount τ one has

$$\psi(\tau) = \text{Limit}_{T \rightarrow \infty} \frac{1}{2T} \int_{-T}^{+T} f(t+\tau) f(t) \cdot dt \quad \dots \quad (10)$$

But the order of the two factors under the integral is of no significance, so comparison of formulae (9) and (10) shows that

$$\psi(\tau) \equiv \psi(-\tau)$$

Unfortunately $\psi(\tau)$ does not directly represent a spectrum. A further mathematical transformation is needed (the Wiener-Khinchine transform) which may be written as

$$W(f) = 4 \int_0^{\infty} \psi(\tau) \cos 2\pi f\tau \cdot d\tau \quad \dots \quad (11)$$

where $W(f)$ is the power spectrum described above. The process thus uses two stages: (i) obtain $\psi(\tau)$ for a wide range of values of τ by means of formula (10); and then (ii) take the cosine Fourier transform of $\psi(\tau)$, as indicated in (11), in order to obtain the power spectrum. Since the Fourier transform will give the (amplitude) spectrum of any well-behaved waveform, what is gained by inserting the intermediate step of finding $\psi(\tau)$? Firstly $W(f)$ is a power spectrum, independent of phase and therefore independent of any particular choice of origin of time: the direct determination of the amplitude spectrum from a specific waveform would require two Fourier transforms, sine and cosine. Secondly, we are no longer tied to finding the spectrum of a specific waveform, but can find the power spectrum of any random train of pulses or noise waveform, provided only that its statistical properties (mean value, mean-square, etc.) do not vary with time. A sequence of events with such constant statistical properties is known as a *stationary time series*; and an important feature of proceeding via the autocovariance is that all the averaging required is carried out by formula (10).

As an example, consider the determination of the spectrum of the approximation to a random telegraph signal which consists of a rectangular wave with reversals between $+E$ and $-E$ occurring uniformly at random, i.e. a Poisson distribution of the number of reversals in any given time interval. Take this waveform as $f(t)$. Starting from any point and shifting along by an interval τ , the probability of $f(t) \times f(t-\tau)$ having the value $+E^2$ is the probability of an even number of reversals having occurred in time τ while the probability of the product having the value $-E^2$ is the probability of an odd number of reversals having occurred. Note that by working in probabilities we have already performed the averaging

represented by $\frac{1}{2T} \int_{-T}^{+T} dt$, so the autocovariance (which

in this case is E^2 times the autocorrelation because the mean-square value is E^2) is

$$\psi(\tau) = E^2 \{ P(0) - P(1) + P(2) - P(3) + \dots \} \quad (12)$$

where the P 's are the probabilities of the specified number of reversals happening in time τ . But if the reversals occur at an average rate μ per second and the P 's are Poisson terms, then

$$\begin{aligned} P(0) &= e^{-\mu\tau} & P(1) &= \mu\tau e^{-\mu\tau} \\ P(2) &= (\mu^2\tau^2/2!)e^{-\mu\tau} & P(3) &= (\mu^3\tau^3/3!)e^{-\mu\tau} \\ && & \text{etc.} \end{aligned}$$

Inserting these values of P in (12) and taking out the common factor $e^{-\mu\tau}$

$$\psi(\tau) = E^2 e^{-\mu\tau} (1 - \mu\tau + \mu^2\tau^2/2! - \mu^3\tau^3/3! + \dots) \quad (13)$$

(continued on p. 93)

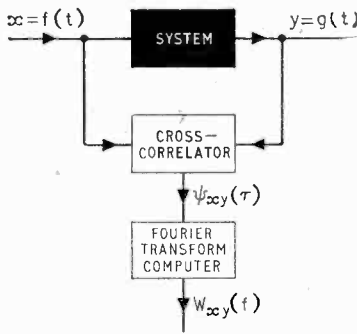

Fig. 4. Determination of transfer function of a system or process via cross-correlation.

But the brackets in (13) enclose a series expansion for $e^{-\mu\tau}$, so that

$$\psi(\tau) = E^2 e^{-2\mu\tau} \dots \dots \dots (14)$$

Now combining (14) with (11) the power spectrum is found to be

$$W(f) = 4 E^2 \int_0^{\infty} e^{-2\mu\tau} \cos 2\pi f \tau \cdot d\tau$$

$$= 4 E^2 \frac{2\mu}{(2\pi f)^2 + (2\mu)^2} \dots \dots \dots (15)$$

Writing ω for $2\pi f$ and T (a time-constant) for $1/2\mu$, the spectrum becomes

$$W(f) = \frac{4E^2 T}{\omega^2 T^2 + 1}$$

which is the same shape as would be obtained by passing white noise through a single-stage RC filter with time-constant equal to half the average pulse width. (Since μ is the average rate of occurrence of reversals, $1/\mu$ is the average interval between reversals, i.e. the average pulse width.)

If the two functions under the integral in formula (10) are different,

$$\psi_{xy}(\tau) = \text{Limit}_{T \rightarrow \infty} \frac{1}{2T} \int_{-T}^{+T} f(t) g(t-\tau) dt \dots \dots (16)$$

the resulting quantity is the covariance of the two functions, or when normalised is the cross-correlation. Since in this case the two functions are not interchangeable, $\psi_{xy}(\tau) \neq \psi_{yx}(-\tau)$. The cross-correlation can be used in the determination of the transfer function of an unknown system. If one correlates the input and the output of a device, as sketched in Fig. 4, $\psi_{xy}(\tau)$ will be a maximum for the value of τ which is equal to the delay of the signal in passing through the system. In fact one can go further and say that the frequency characteristic $Y(f)$ of the system can be completely specified if the input and cross-power spectra $W_{xx}(f)$ and $W_{xy}(f)$ are known and represent random processes:

$$W_{xy}(f) = Y(f) \cdot W_{xx}(f) \dots \dots \dots (17)$$

The cross-power spectrum $W_{xy}(f)$ is a complex quantity; so if it is written in terms of amplitude and phase, $W_{xy}(f) = A(f)e^{j\theta(f)}$ while the system transfer function is written $Y(f) = |Y(f)|e^{j\theta(f)}$, it can be shown that

$$|Y(f)| = \frac{A(f)}{W_{xx}(f)}$$

$$\theta(f) = B(f)$$

Formula (17) does not make very explicit the importance of the form of the test signal. But it is intuitively obvious that in order to provide information about the whole of the frequency response of the device the input

signal must cover a corresponding range of frequencies. White noise seems an obvious choice of test signal, but suffers from the disadvantage that a truly random signal includes components down to zero frequency. This means that when one observes over a finite time one includes only part of a cycle of the very low frequencies and the final value will be different from the initial value, which looks like zero-drift. Therefore it is preferred to use a pseudo-random sequence of pulses which in fact repeats exactly after a sufficiently long time. The lowest frequency in this test signal corresponds to the repetition period of the whole sequence of pulses, while the highest frequency depends on the width of the individual pulse, so the number of octaves (or decades) of frequency effectively covered by the spectrum of the signal depends on the number of pulses in the train. (The use of such pseudo-random sequences was discussed at two conferences which were reported in *Wireless World*, August 1965, vol. 71, p.384.)

The role of statistics in this technique is two-fold. Firstly it is through statistics that the ideas of autocovariance and autocorrelation were developed; and secondly the process provides an average over many samples. In the ordinary way the purpose of this averaging would be to distinguish between signal and noise, but in this instance something like noise was deliberately introduced as a test signal! The reason for this choice is that it provides simultaneously a large range of test frequencies: the same is true of a single sharp pulse used as a test signal, but it is often impossible to get sufficient energy into a single narrow pulse without making its amplitude so great as to risk exceeding the linear range of the system under test.

The accuracy obtained with a noise test signal depends on the duration of the signal in relation to the number of different frequency points which are to be determined in the power spectrum, the duration of the signal determining the magnitude of the limits of integration $+T$ and $-T$ in formulae (10) and (16). If a truly random noise generator is used, it can be left on as long as desired; if a pseudo-random series is used, there is no advantage in repeating the series unless a significant amount of spurious noise is also present, which may well happen in practice. The danger is that repetition of the whole sequence of length T_0 will give a spurious peak in $\psi(\tau)$ in the neighbourhood of $\tau = T_0$; but one could not work with τ comparable with the duration T of the signal, because (as sketched in Fig. 5) the useful integration time is $T-\tau$, rather than T_0 . Since the lag τ must be comparable with the period of the lowest frequency of interest, the duration T must in fact be considerably greater than the period of the lowest frequency to be recorded; and the frequency spread of the signal must accordingly be greater than the frequency spread of the response of the device under test, by the factor T/τ .

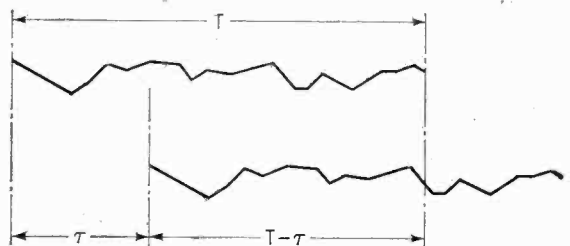

Fig. 5. When a function is limited to length T , correlation with lag τ can be carried out only over an interval $T - \tau$.

If t is the pulse width, then it is pointless to make observations much closer together than t since they would not be independent. The approximate number of sample measurements which can be made in one test run is therefore $(T-\tau)/t$. If n is the number of points in the frequency spectrum which it is desired to determine, then in effect $(T-\tau)/nt$ measurements can be allocated to the determination of each frequency point; and the variance of all but the end points in the power spectrum will be less than the variance of each measurement by this factor. (The first and last points in the spectrum gain only half this advantage.)

APPENDIX

Construction of Figs. 1 and 2.

The hypothetical clock drift in Fig. 1 was set up by postulating a constant component of 100 ms per day and a random variation represented by successive entries in a table of 2-digit random numbers. Since these numbers range from 00 to 99 the average of the random component over a sufficiently long time should be 49.5 ms/day, giving a total average drift of 149.5 ms/day. However, the random numbers actually used (from the first column of the table in Brownlee's "Industrial Experimentation") were as shown in the table at the top of the next column.

Day	0	1	2	3	4	5	6	7	8	9	10
Random No.	—	03	97	16	12	55	16	84	63	33	57
Cumulative drift	0	103	300	416	528	683	799	983	1146	1279	1436

The total drift over 10 days is 1436 ms, giving an average of 143.6 ms/day.

Fig. 2 was constructed by taking successive pairs of random numbers for the x, y values, and the numbers drawn from the same table as used for Fig. 1 were:—

x	18	23	37	56	16	68	27	29	11	38
y	26	52	70	99	31	74	00	16	35	31

These lead to the following statistical parameters: $\bar{x} = 32.3$; $\bar{y} = 43.4$; $\Sigma(x-\bar{x})(y-\bar{y}) = 3336$; $\Sigma(x-\bar{x})^2 = 2959$; $\Sigma(y-\bar{y})^2 = 8152$; $\rho = 0.696$.

It would have seemed very natural, both from the graph and from the tabulated figures and correlation coefficient, to say that these points were not randomly distributed; but the explanation is that one would have to take a large number of random points to obtain uniform coverage of the area, and in fact the distribution would have to be systematic, rather than random, to get a small number of points uniformly distributed.

OPTICAL WAVEGUIDES

SINGLE-MODE PROPAGATION IN OPTICAL FIBRES AND FILMS

SINCE the advent of the laser much effort has been and is being expended in the field of optoelectronics. The information-carrying capacity of monochromatic coherent optical radiation is, of course, the attraction, but the limitations associated with long-range transmission through the atmosphere are severe. Some attention, therefore, has been paid to transmission *via* light guides, and work involving gas-filled light

pipes has been briefly reported in *W.W.* Waveguides using the hair-like optical fibres are also under investigation and some work has recently been announced by Dr. C. K. Kao of Standard Telecommunication Laboratories, Harlow.

Propagation is by optical surface waves along the interface of two media; optical surface waves being essentially no different from other kinds of surface wave. However, the waveguide structures, dimensions and materials used are peculiar to this region of the spectrum.

Dielectric waveguides in the form of fibres (as used in fibre optics) and films are examples of surface wave guiding structures. A fibre waveguide developed by S.T.L. consists of a glass core 3-4 μm dia. of refractive index n clad with a coaxial layer of another glass with a value of n 1% lower than that of the core. The total diameter is about 300-400 μm or twice the thickness of a human hair. Some of the advantages of this sort of transmission line are that the permitted bending radius of 1000 λ makes the structure almost completely flexible, and also, up to 1 mW of power can be transmitted by this means. A major limiting factor is that with presently available materials, the loss is about 1 dB/m, but it is foreseen that materials will become available with losses much less than this figure.

Thin-film guides

In order to circumvent this limitation thin film guides have been developed. A very thin film is supported on a U-shaped channel about 1 cm across. The wave is then propagated along the interface between the film and surrounding air. By making the film sufficiently thin, the distribution of the guided energy can be made so that only a small fraction is within the dielectric. With a film thickness of 0.1 λ only 1% of the energy is within the material, thus reducing the effective loss to about 1% of the bulk loss. For a 1 μm wavelength the film thickness required is 0.1 μm or 1000 \AA . Films of this thickness are already available for some materials.



An optical bench at S.T.L. for investigating optical waveguides. A He-Ne laser (left) is used as a light source and the light is launched on to the waveguide through an oil-immersion microscope objective and a crystal of potassium dihydrogen phosphate used for modulation. A photomultiplier is used as a receiver. The fibre guide, although present, cannot be seen since this is less than 400 μm dia.

LETTERS TO THE EDITOR

The Editor does not necessarily endorse opinions expressed by his correspondents

Matrix Algebra

READING and re-reading through the two articles on Matrix Algebra by G. H. Olsen in the March and April issues of last year, like Byron of BBC3 fame, I am "shaken to fragments" when I read "by similar reasoning we may build the following table." (Top of page 121, March issue.) "By similar reasoning" has much in common with "it may be shown." Both these phrases being distant cousins of "q.c.d." which has a trite and superior flavour.

To come to the point, it just so happens that I and my fellow students are doing a study on three- and four-leg phase shift oscillators, advance and retard phase configuration. We have been undecided as to the best method of dealing with the mathematical solutions of the oscillators. Grandiloquently, we have discarded Kirchoff and Cramer's rule for determinants and have seized upon the matrix method for obtaining the gain and frequency, etc., this being the neatest method. BUT, after going through Hatfield and Stevenage libraries' electronics sections, we did not come up with any textbook giving a clear exposition of the logic of matrix algebra as applied to circuitry. G. H. Olsen gives us a tempting nibble, bottom of page 120, March issue, "let us exploit this rule by *first finding the matrix elements*" (my italics). F. A. Benson takes a gentle stab in his book "Problems in Electronics with Solutions," page 75, but he says "hence, show, etc." We, perspiring aspirants in the H.N.C. (Electronics) race, having sat so many times in those over-quiet examination halls surrounded by all those genius types writing like bombs, and we sitting there tensely mute, transfixed by the word "hence," we ask that it be erased from the dictionary.

M. E. van Valkenburg in his "Network Analysis" gives the academic approach; it makes beautiful reading and we suspect the only correct method, but one gets lost. Somewhere, somewhere, we feel there is a slim volume entitled, "How to get your H.N.C. standing on one hand." Possibly written by a latter day Sylvanus P. Thompson. Even Terman, the electronics engineer's bible, dismisses matrix algebra in a few lines on p. 501.

We feel that someone of the stature of "Cathode Ray" could tear the whole subject apart in three eloquent pages.

Stevenage-new-Town,
Herts.

H. HINA

Integrated Circuits

IN his letter published in the March issue, Mr. Boswell presented the theory that the long-term future of integrated circuits can be expected to be based on film technology. To substantiate this theory he presented some statements which are not in agreement with published facts.

Mr. Boswell quoted as evidence for his theory the statement that "the 1965 sales value of film circuits in the U.S.A. was double that of Mr. Padwick's little pellets." On the basis that I sold no "little pellets" in the U.S. in 1965 this statement may well be true. If

Mr. Boswell was referring to the total number of monolithic integrated circuits sold in the U.S.A. I would like to refer him to the Electronic Industries Association report, which estimates that the total value of monolithic integrated circuits sold in the U.S.A. during 1965 was \$75 M and that the total value of film circuits sold in the same period was \$11 M. In terms of units it has been estimated that 90% of all integrated circuits sold in the U.S.A. during 1965 were monolithics. (*Electronic Products*, January 1966, page 26.)

As a further piece of evidence, Mr. Boswell states that the largest computer manufacturer in the world is using large quantities of film circuits. Again this is true. What Mr. Boswell does not say is that I.B.M. regards the film circuit as a passing phase. In a recent statement Thomas J. Watson, I.B.M. Chairman, stated that "Despite a massive use of thin film microcircuits, International Business Machines Corporation is convinced most computers will be built of monolithic integrated circuits eventually" (*Electronics News*, November 8th, 1965, page 1). In support of this intention I.B.M. has recently negotiated an agreement with the Fairchild Camera and Instrument Corporation which entitles I.B.M. to use the patented planar processes by which all monolithic integrated circuits are manufactured.

From his letter it is clear that Mr. Boswell's interests are mainly in the field of linear circuits. It is only in the last year that monolithic integrated circuits have become important in this field. This is because semiconductor manufacturers had previously been consolidating their position in the digital field. Mr. Boswell emphasizes many of the limitations of semiconductor passive components but omits to draw attention to the advantages of semiconductor technology in this area. For example, the inherent very close matching between transistors and between resistors in a monolithic integrated circuit enable very low drift d.c. amplifiers to be made without any component selection or elaborate circuit techniques. By basing circuit design techniques on monolithic technology instead of attempting to make in monolithic form a circuit based on discrete component ideas, in many areas the monolithic circuit can give better performance at a lower cost than can be achieved in discrete component or film circuit form.

It is for economic reasons that the monolithic circuit dominates, and will continue to dominate, integrated circuit usage. By the planar manufacturing processes a very large number of complete circuits are manufactured simultaneously. At present more than 1,000 circuits are diffused on a single wafer of silicon. Typically 25 wafers are diffused simultaneously. Even if one accepts Mr. Boswell's grossly pessimistic yield figure of 15% this gives a batch of 3,750 circuits. The reader can interpret for himself the implications of this on the manufacturing cost of each circuit.

In comparison very many fewer film circuits can be manufactured simultaneously. Even if film circuits could be manufactured in such large quantity, the film circuit is merely an array of interconnected passive components. Transistors and diodes have to be connected individually to each circuit. Consequently the manufacturing cost

of complete film circuits must always be greater than that of monolithics.

The "reddest herring" of Mr. Boswell's letter is his statement that silicon costs about 8s per gram. As each monolithic circuit consists of between 0.2 and 0.3 milligrams of silicon this is not really a very significant part of the manufacturing cost.

Despite the greater importance of monolithic integrated circuits there is an important place for the film circuit. In circumstances where small size is an imperative and small quantities of a special circuit are required the film circuit may be more attractive due to its lower tooling cost. Despite the advanced circuit design techniques that enable very high performance to be achieved with monolithic circuits, there will always be some cases where passive components of low temperature coefficient or small tolerance are necessary. In circumstances like these the film circuit has, and will continue to have, a place.

The monolithic circuit has already established itself as the form of integrated circuit in greatest demand. The high performance and low manufacturing cost of this type of device indicates that it will continue to meet the bulk of the industry's needs for the foreseeable future.

SGS-Fairchild Ltd.,
Ruislip, Middx.

GORDON C. PADWICK
(Applications Manager)

Collision Avoidance System for Aircraft

IN controlled airspace over land, the problem of avoiding collisions between aircraft is probably best solved by ground based surveillance radar, with v.h.f. communication to pilots. Secondary radar, using replies from aircraft coded with height and heading information is also of use. On transoceanic routes, however, neither of these methods can be used, because of the limited range of the radars concerned. On the other hand, the secondary radar transponders will still be carried, and information regarding altitude and heading will still be available in coded form for use with the flight recorder. It is therefore proposed that this information could be interchanged between aircraft on transoceanic routes by means of a simple modification to the secondary radar transponders. Relative velocity information also could be interchanged, and thus potentially hazardous conditions assessed.

Imagine several aircraft in range of the transponder of a given aircraft, P. The exchange of information starts by aircraft P transmitting its own identity and height in digitally coded form. If any of the other aircraft are at the same height they reply, on the same frequency, with their identity and height; otherwise, they remain silent. If an aircraft is changing, or is about to change its height, the height codes appropriate to the range of heights through which it will pass are transmitted, and similarly, if an interrogated aircraft is changing its height it will reply if its future height coincides with that of the interrogating aircraft. During any transmission, the transmitters of all other aircraft within range are temporarily disabled. Should however, two aircraft, say S and T, be at the same height as the interrogating aircraft P, and at the same range (although on different bearings), the initial replies from S and T will be simultaneously received at P, thus resulting in a garbled signal. Should this condition occur, P reinterrogates, random delays in S and T preventing a recurrence of the garbling. The next stage of the interchange of information, provided that P has received a valid reply from, say, air-

craft S, is for P to transmit the identity of S, followed by about 0.5sec of unmodulated carrier. The master oscillator in S, and also in other aircraft at the same height, is then adjusted into synchronism with the received carrier from P. When P's transmission ends, S replies with a burst of carrier at the frequency as received from P. This burst is received by P, and is compared with the frequency of P's master oscillator, thus giving a Doppler signal representing the relative velocities between P and S. If f_p and f_s are the frequency transmitted by P to S and the frequency received from S, $f_s - f_p$ positive will represent a closing velocity and vice versa. If the velocity is opening no further action needs to be taken. If the velocity is closing, an interchange of heading information, taken in conjunction with the relative velocity information, will indicate the probability of a collision hazard. The range between P and S can also be determined from the propagation delay during the interchange of signals. Only if a collision hazard exists will the attention of the pilot be directed to the information. He can then call the other aircraft, whose identity is known, on a normal v.h.f. channel and discuss avoiding action.

If very stable master oscillators (with stabilities of the order of 1 in 10^7) are carried, the synchronization of the remote aircraft's master oscillator can be avoided. However, with information bit rates of about 1 Mc/s, the initial interchange, including propagation delays will not take longer than a few milliseconds, and as it is unlikely that more than four aircraft will be at the same altitude and also within range, thus, even with a synchronizing period, the complete interchange between these four aircraft would not take longer than 2sec. The channel would then be free for another aircraft to start its interrogation. Every aircraft would interrogate once per minute, so that about 30 aircraft (with four on each altitude level) could be handled by the system. In practice, the present despatching techniques limit the number of aircraft in a given flight level to less than four (assuming a range of about 100 miles) and therefore a greater number of aircraft could use the system, for it is the passing of velocity information only that takes an appreciable time.

EMI Electronics Ltd.,
Wells, Somerset.

W. D. GILMOUR

The F.E.T.

MR. FRANKLIN'S article "What is holding back the F.E.T.?" (February issue) will, I think, be filed in a future museum along with writings such as those who thought there was no future in the work of Marconi and that the transmission of information without wires was interesting, but of little practical value.

I can agree with Mr. Franklin regarding cost but then silicon transistors were as much as £20 each only a few years ago. I think there is a good parallel here because at the time when silicon transistors were high priced they were also made by several processes—alloy, grown, mesa, alloy diffused, etc., etc., as f.e.t.s have been, but now the price is well down, as the majority are made by those processes found to be suited to both mass production and quality—the planar and epitaxial planar processes.

The field effect devices are I believe at the point of break-through to quantity application, since their production by repeatable cheap processes is now an achieved fact.

I feel the first large-scale application will occur in digital integrated circuitry because of the low power requirement and the fact that "fan-in" and "fan-out"

is limited only by the loss of speed due to capacitance loading. For this field of application the enhancement mode f.e.t. will I think be paramount.

Running a close second will be r.f. applications where the superior cross modulation characteristics and ease of application of a.g.c., together with, I believe simpler circuit design will soon bring the f.e.t. into more common use.

For space applications particularly in digital circuitry the f.e.t.'s low power requirements and relatively high resistance to radiation damage must make it a serious contender with the transistor.

The electrostatic breakdown difficulties experienced with the insulated gate f.e.t. will I believe be overcome by means of processes already in use in integrated circuit manufacture—for instance the building in of protective diodes integral with the silicon slice of the f.e.t. Such a device is already in existence (see p. 96 of *Electronics* 15th November, 1965).

I find it difficult to believe that this device is a non-starter as implied by Mr. Franklin, when I look at the vast amount of work and effort being expended by so many manufacturers both large and small. They surely are not all doing the work just for the fun of it. I do not pretend it will displace the transistor, but it certainly will rank alongside.

Lastly, is Mr. Franklin serious in his statement on p. 77 that the f.e.t. "is the only amplifier device that it has been possible, so far, to fabricate as an integral part of the structure of an integrated circuit?"

Brentwood.
Essex.

L. NELSON-JONES

The author replies:—

I must thank Mr. Nelson-Jones for pointing out in the last paragraph of his letter a bit of loose writing on my part. My only excuse is that my fingers may be more used to the screwdriver than to the fountain pen. What I had meant to say is that f.e.t.s appear to bid fair to becoming the prime commercial integrated circuit active device, since, for example, only one diffusion is required for a MOSFET compared with at least four for double-diffused integrated circuits. (*Electronics*, January 18th, 1966, p. 22.)

I don't quite know what to say on the rest of Mr. Nelson-Jones' letter. His statements seem to me just carbon copies of the f.e.t. wishful thinking that has brightened the sometimes pallid pages of electronic technical journals for years now.

I have no first-hand experience in micropower, high-fan-out, picosecond, digital integrated circuitry, but I have tried with a soldering iron (not a coffee cup) in my hand to use the vaunted a.g.c. characteristics of the f.e.t. in the first stage of a transistor television i.f. strip . . . but without much success, I fear. I had a little better luck with an f.e.t. used as a voltage controlled resistor for remote volume control applications, but not really a substantial improvement on a cheap ORP12 arrangement.

Looking at it again in retrospect, I am still sure that the tunnel diode never really "got anywhere" because commercially it could not be engineered into a domestic radio or television receiver. Whatever the "paper" advantages of the f.e.t., it too will not get anywhere until cheap f.e.t. radio receivers are flowing down the production lines. When that will be, Mr. Nelson-Jones' guess is as good as mine.

Glasgow.

J. B. FRANKLIN

"The Field-effect Transistor at V.H.F."

I WAS very interested to read the article on field effect transistors at v.h.f. by U L. Rohde which appeared in the January 1966 issue, but I regret I am unable to agree on some of the author's opinions.

On page two the author states that "the transconductance of the f.e.t. is . . . a constant," and attempts to justify this in his appendix. This is not true—if it were, the f.e.t. would be useless as a mixer for it would be a perfectly linear device. The characteristic of a diffused junction f.e.t. is approximately given by:—

$$I_D = I_{DSS} \left(1 - \frac{V_{GS}}{V_P}\right)^2 \quad (0 \leq V_{GS} \leq V_P)$$

Differentiation of this gives:—

$$g_m = \frac{dI_D}{dV_{GS}} = -2I_{DSS} \left(1 - \frac{V_{GS}}{V_P}\right) \frac{1}{V_P}$$

hence at $V_{GS} = 0$

$$g_m = -\frac{2I_{DSS}}{V_P}$$

and at $V_{GS} = V_P$

$$g_m = 0$$

Also, from equation two it can be seen that for $0 \leq V_{GS} \leq V_P$, g_m varies linearly with the gate voltage, thus giving an ideal mixing characteristic.

Mr. Rohde also seems to confuse the junction field effect transistor (JUGFET) with the metal oxide semiconductor field effect transistor (MOSFET). The 2N3822/3 f.e.t.s used by the author are JUGFETs, and his analysis is based on this type of f.e.t. However, in paragraph 1 and other places he refers to the MOSFET. (The symbols of Fig. 8 are also for a MOSFET and not a JUGFET.)

The analysis of the MOSFET is much more involved. In Ref. 1 it is shown that the MOSFET has a characteristic that lies somewhere between the forms:—

$$\begin{aligned} I_D &\propto V_{GS} & (g_m \text{ constant}) \\ I_D &\propto (V_{GS})^2 & (g_m \propto (V_{GS})^2) \end{aligned}$$

Many manufacturers try to make their devices with a "square-law" characteristic, but higher order terms are always present and at high and low Drain currents the MOSFET departs from this ideal characteristic.

At v.h.f. the main difference between the JUGFET and the MOSFET is that the capacitances of the latter can be made much smaller; however, slightly higher noise figures are typical, and the cross-modulation performance is slightly inferior.

Mr. Rohde's analysis of the f.e.t. amplifier is interesting, but he fails to justify his lengthy method compared with the more conventional result:—

$$\text{Stability factor} = \frac{1}{\text{loop gain}} = \frac{(y_L + y_{22})(y_9 + y_{11})}{y_{12} y_{21}}$$

Essentially the result is the same (see equation 6, page 2) but Mr. Rohde fails to show how it can be used to design an amplifier of prescribed stability. (In fact I calculate his circuit to have a stability factor of 1.7 which is not very good.)

Mr. Rohde also says very little about cross-modulation distortion, whereas the f.e.t.'s superiority in this respect is the main reason for preferring f.e.t.s to transistors at v.h.f. The cross-modulation performance of transistors has been fully analysed (Ref. 2) and at all frequencies up to about $(f_r/5)$ an interfering input of 2.6mV r.m.s. is required to produce 1% cross-modulation (-40dB c.m.). Above this frequency the performance improves due to the base resistance attenuating the interfering voltage. To produce the same level of cross-modulation the

KMC Corporation quote 30mV for a MOSFET (K1201) and Texas Instruments quote 45mV for a JUGFET (2N3823). However, it should be remembered that the input resistance of the f.e.t. is about one hundred times that of the transistor. Thus if matched to, say, 75Ω, the f.e.t. would be only slightly better than the transistor.

Furthermore because the MOSFET input resistance rises more rapidly as the frequency is reduced, there will be a frequency below which the transistor is superior. Thus generally speaking, the MOSFET should only be considered for the v.h.f. and u.h.f. bands unless high input resistance is the prime requirement.

I should also like to point out some minor errors:—

Table 1: Re Y_{22} should be 0.3mmhos to agree with Mr. Rohde's calculations. However, even this does not agree with the maker's data, although a different Drain current may be the explanation.

Fig. 8: The substrates of f.e.t.s should be earthed or connected to the source as they are an integral part of the device and could be used as a second gate.

Ilford, Essex. R. S. MARSHALL

The author replies:—

I am very grateful to Mr. Marshall for pointing out that the differentiation was given incorrectly.

The samples of the 2N3822 transistor (not 2N3823) I used were obtained during the early period of production and were sent to me from Dallas without a data sheet. My initial work was to measure the admittance parameters and find the capabilities of the devices. From remarks made to me I was under the impression that the devices were MOSFETs, but subsequently, after publication of the article, I learned that they were JUGFETs.

As is evident from eq. 13, parameters were used for a given stability of 1, not 1.7 as in the approximation used by Mr. Marshall. I did not intend to consider common stability problems, as in the literature he refers to, but just give a small demonstration of the f.e.t.'s capabilities. Mr. Marshall must have failed to recognize this, as he asks for cross-modulation data. Fig. 9 gives interesting information on this subject and all voltages are given at 60Ω and must not be transformed as Mr. Marshall suggests.

Although I made no comments on the question of whether f.e.t.s should be used at u.h.f. or not, I can only confirm Mr. Marshall's statement, as far as the MOSFETs he mentions are concerned.

The ReY_{22} should, in fact, be 0.3 mmho, and the substrate might be grounded but this can be seen by reading the article.

In a forthcoming article on new circuitry for germanium planar transistors, I will be using a method similar to that suggested by Mr. Marshall to analyse stability, but without the need for approximations.

Darmstadt, Germany. U. L. ROHDE

1. C. D. Root & L. Vadasz, "Design Calculations for MOS Field-Effect Transistors," *I.E.E.E. Transactions on Electron Devices*, June 1964, pp. 294-299.
2. A. H. J. Nieveen van Dijkum & J. J. Sips, "Cross-Modulation and Modulation Distortion in AM Receivers equipped with Transistors," *Electronic Applications*, Vol. 20, No. 3, pp. 107-127.

"Flip-flop" a Misnomer?

WHAT do you understand by the type of multivibrator designated "flip-flop"?

I think it is true to say that a certain amount of confusion exists about the precise meaning. Try saying "flip-flop" to an engineer in the computing field and the

bistable multivibrator* will immediately come to his mind, whereas to any hobbyist in electronics the reasoning seems to be towards a monostable multivibrator*.

My own personal view on the matter is that flip-flop, as used by computer men is a misnomer, and the term ought to be applied to a two-state device which is flipped into one state, then, after a suitable time period, flops back into the original state, remaining there until flipped once more. This is the action, surely, of a monostable device, and working along these thoughts, why not call a bistable a "flip-flop" and an astable a "flop-flop," the latter on account of its ability to "flop" from one state to another repeatedly without the injection of any triggering signal?

Dept. of Electrical Eng'g,
The University,
Newcastle upon Tyne.

R. S. PINDER

* See references 32042/3, B.S. 204: 1960—Ed.

Headphone Listening

IT is known that curious spatial sound effects can be produced by reversing the phase of one earphone whilst listening to a monophonic or stereophonic channel with two earphones.

When listening to stereophonic music on headphones (i.e. an earphone on each ear) connected in phase, using a system designed to reproduce sound from two loudspeakers spaced in a domestic environment, the effect is very different from loudspeaker listening, given of course that the earphones have a wide frequency response without marked resonances. This is due to the fact that each ear hears each channel directly, whereas with loudspeaker listening, local acoustics, inter-channel intensity, and inter-aural time differences⁽¹⁾ play their part. Proposals have been made⁽²⁾ to improve headphone listening by interposing a network between the earphones and the stereophonic channels in order to produce (by cross coupling) an improvement by introducing some of the effects present with loudspeaker listening.

If the phase of an earphone is reversed a different effect is produced, but realism is not improved.

When listening to a monophonic channel with two earphones certain effects have been reported. The cases of interest are speech communication in the presence of noise, and listening to speech, music, or pure tones.

In the case of earphone listening in the presence of loud noise (119 dB re 0.0002 dyne/cm²), out-of-phase earphones resulted in slightly better speech intelligibility for low and medium level speech, but slightly worse intelligibility for loud speech, as compared with in-phase earphone listening⁽³⁾.

For music listening, improvements in spatial effect have been claimed⁽⁴⁾ by introducing between the monophonic channel and the earphones a phase splitter followed by a cross-coupling network. Experiments have been carried out using loudspeakers as earphones⁽⁵⁾ for music listening, when changes in spatial effects were noticed when the phase of one loudspeaker was reversed.

The writer has carried out a short experiment using a monophonic channel, several subjects of normal hearing,

¹ D. M. Leaky, "Further thoughts on stereophonic sound systems," *Wireless World*, April, 1960, p. 154.

² B. B. Bauer, "Improving headphone listening comfort," *J. Audio Eng. Soc.*, October 1965, p. 300.

³ D. Greenberg and H. O. Benecke, "Study of intelligibility improvement with out-of-phase connections of headphones," *J. Ac. Soc. Amer.*, June 1961, p. 851.

⁴ B. B. Bauer, op. cit.

⁵ F. B. Johnson, "Loudspeaker polarity," *Wireless World*, Oct. 1964, p. 523.

(Continued on page 199)

and speech, music, and pure tones as sound sources.

High-quality moving-coil earphones of two types were used—one type in a conventional headphone, the frequency response being smooth, but cutting off fairly sharply at about 7 kc/s, the other using earphones mounted in circumaural headphones with earshell resonances well damped, and a frequency response extending to well over 15 kc/s. The subjective impressions to be described were not appreciably affected when one or other of these headphones was used.

For speech, the consensus of opinion was that for earphones in phase, the sound was localized in the middle of the head, whereas for out-of-phase listening a well

diffused, and pleasanter sound was heard. For music, the effect was similar, but less marked. For pure tones, regardless of the frequency, intensity, or earphone phasing, the spatial sensation remained the same.

The matter is of some interest at the present time because of the widespread use of headphones with a monophonic speech channel in language laboratories.

It would be interesting to know whether any of your readers have experimented with in-phase or out-of-phase earphones in respect of subjective judgement, fatigue, etc.

Amplivox Ltd.,
Wembley, Middlesex.

A. E. CAWKELL

OSCILLATING DIODE USED FOR SHORT-RANGE TRANSMISSION

AN experimental, light-weight microwave system capable of short-range transmission of television signals has been developed by the Semiconductor Division of Sylvania Electric Products, Inc., in the U.S.A. The low-power microwave beam is generated by a gallium arsenide oscillator diode energized by d.c. from a standard 30-volt battery.

Sylvania state that the experimental equipment represents a first step towards the development of low-cost, closed-

to cable in the transmission of television signals from a remote receiving station to a master aerial in a community television distribution system.

The GaAs oscillator diode,* designated D-5540, is biased in the avalanche breakdown region of its characteristic (breakdown voltage 20-40V at $-10\mu\text{A}$) and in this mode will generate at least 1mW of r.f. power in the frequency range 12-14 Gc/s, with an efficiency of 0.2-2%. Maximum power dissipation is 300mW and maximum reverse current 10mA. Total capacitance across the diode is 0.4-1.5pF at zero volts bias.

*See also "Microwave Semiconductor 'Transit-time' Devices," *Wireless World*, February, 1965, p. 61.

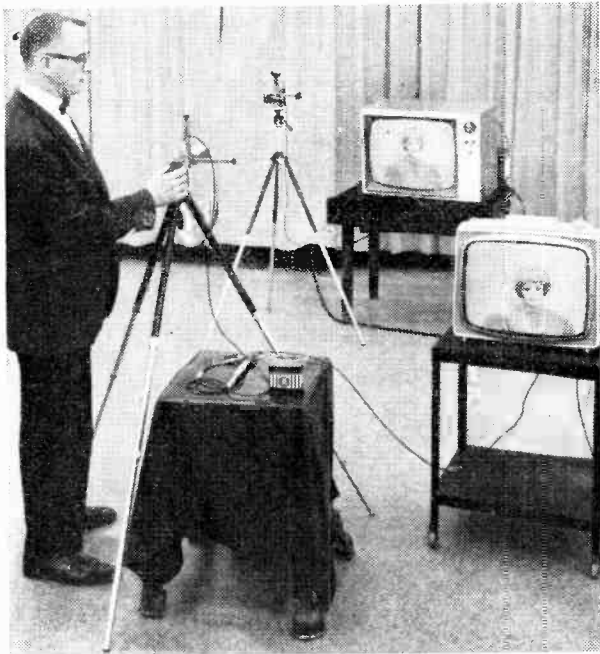

The experimental microwave transmission equipment, using horn aerials. The transmitted and received television pictures are displayed on receivers for comparison.

circuit television systems which could provide direct communication between schools, hospitals and other establishments. (The company is a subsidiary of General Telephone and Electronics Inc.) Other suggested applications include television transmissions between manned orbiting satellites, aircraft tracking during landing approaches, car collision avoidance and marine navigation. Another possibility is that the equipment could be utilized as an economical alternative

TRANSISTOR FEEDBACK CAPACITANCE REDUCED

ELIMINATION of neutralising circuits in transistor i.f. amplifiers is made possible by a new "integrated circuit" technique in the manufacture of n-p-n silicon planar transistors. An inherent problem in the use of planar transistors is the high collector-to-base feedback capacitance, due partly to the base connection bonding area and partly to the normal junction capacitance, and this demands the use of neutralising techniques in r.f. circuits. In the BF167 transistor just introduced by Mullard for television i.f. applications, this capacitance is stated to be reduced to 0.15 pF—less than a quarter of that of conventional planar transistors. In another transistor, the BF173, the capacitance is reduced to 0.23 pF. The new technique in their manufacture consists of diffusing a thin screening layer of p-type material into the n-type collector surface under the base connection bonding area. The junction between this p-type screening layer and the n-type collector acts, in effect, as a reverse-biased diode.

Owing to the presence of the screen the base connection bonding area capacitance is transformed into additional capacitance at the input and output of the transistor stage. In i.f. amplifiers, however, these capacitances do not cause any serious problems because they become part of the tuning capacitances of the bandpass filters.

The transistors are intended for grounded-emitter operation, and the lead-out arrangement from the TO-18 encapsulation is designed to give minimum capacitance for this type of circuit. The BF167 ($f_T = 350$ Mc/s) is intended for use as an i.f. amplifier with forward gain control, while the BF173 ($f_T = 550$ Mc/s) is a higher dissipation type (200 mW) intended for the final stage of an i.f. amplifier

Voltage-controlled Amplifier - 2

USING MODULATED PULSES TO GIVE VARIABLE GAIN A.F. AMPLIFICATION

Last month an amplifier using pulse-ratio modulation to enable the gain to be controlled by an external voltage was described. This month the author describes numerous possible applications of the amplifier, which include a.f. amplification, a.g.c., audio sweep generation, voltage-controlled impedances, and analogue multiplication.

M. BRONZITE,
B.Sc.

IN the first part of the article an audio amplifier was described where a d.c. control voltage varied the amplitude of the output signal. This may be represented symbolically by Fig. 11, where the "black box" represents the modulator and all its associated circuitry. The gain of the amplifier is given by the expression

$$v_o = v_{in}(R_2/R_1) \cdot n,$$

where $n = \frac{1}{2}(a + 1)$ and a denotes the ratio of control input level to the maximum permitted level and can vary between +1 and -1. It is intended to conclude the article with discussion of various applications of the amplifier which illustrate its different modes of operation.

Automatic gain control

The most obvious use for the amplifier would be as some form of automatic gain control, and this has been achieved by the circuit shown in Fig. 12. The output from the amplifier is amplified by transistor Tr2 (with a gain equal to R_4/R_5), d.c. restored by components C_3 and D1, rectified and smoothed by D2 and C_4 , and fed back to the control voltage input. The gain of the control voltage amplifier had been modified to give a full range of operation with $\pm \frac{1}{2}$ V input. Emitter followers Tr1 and Tr3 merely act to isolate one stage from the next. Appendix 3 shows that, to a first order approximation, the output voltage is independent of the input and is

TABLE I
Results obtained from the a.g.c. circuit with a 1 kc/s input signal.

v_{in} (V, r.m.s.)	v_o (V, pk-pk)	Feedback voltage (V)
0.1	0.65	+0.54
0.2	1.05	0.44
0.3	1.04	0.08
0.4	1.04	-0.10
0.5	1.06	0.20
0.7	1.06	0.33
0.9	1.08	0.41
1.0	1.08	0.43
1.5	1.08	0.51
2.0	1.08	0.57
2.5	1.08	0.62
3.0	1.08	0.65

equal to V/G , where V is the voltage to which the d.c. restorer is linked, and G equals the gain of the amplifier stage. With the circuit shown in Fig. 12, $V = 20$, and $G = 20$, so the output will be fixed approximately at 1 V. It will be evident that this can be changed at will by suitable choice of V and G . The change in the output amplitude over the operating range is given by the ratio of maximum control swing to the value of V . In this case, the control input can be varied over 1 V and $V = 20$, thus giving the overall change of output amplitude of 5%. This can also be varied at will by choice of operating

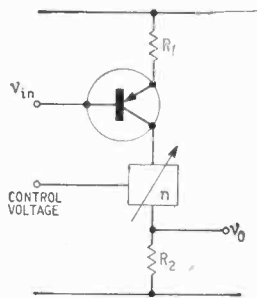

Above:—Fig. 11. Symbolic representation of the amplifier.

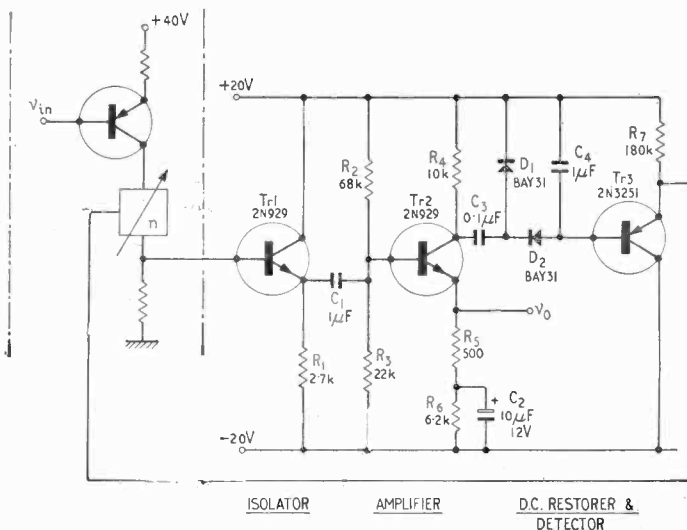

Right:—Fig. 12. Circuit for automatic gain control.

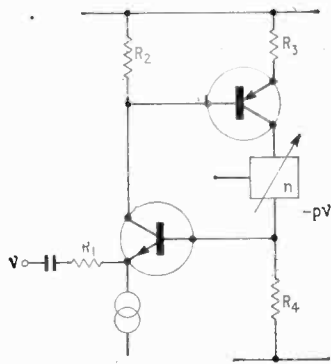

Fig. 13. Circuit for voltage-controlled resistance.

conditions. The above figures are substantiated by the results shown in Table 1, where the input varies by more than 20 dB, and the output varies by about 5%. If a larger band of operation is required then cascaded variable gain amplifiers could be used, when the overall gain would be given by the expression

$$v_o = v_{in} \cdot (R_2/R_1 \cdot n)^2.$$

In this case the current switch and filter would be duplicated, but the modulator could be common to both. Some care must be taken with the selection of the parameters discussed above, since the system shows a tendency to spurious oscillation. This is overcome by using a larger value of capacitance for C_4 than is usual ($1\mu\text{F}$), and "slugging" the output resistors of the control-voltage amplifier with $5\mu\text{F}$ capacitors. As the control input range is made smaller, the ripple developed across C_4 becomes more important which means that more attention must be paid to the filtering if a smaller output amplitude variation is required.

It might be suggested by the more caustic members of our profession that a circuit that used 11 transistors and associated components represents a poor exchange for one modest thermistor! However, it is felt that adequate recompense is given for the complexity, since the performance is completely designable without recourse to trimmers, and all the operating parameters are known prior to construction. Further, all the active elements are non-critical, and temperature has only a second-order effect.

Variable resistors and attenuators

It is sometimes desirable to control the current taken from a voltage source, and the circuit shown in Fig. 13 achieves this aim. The circuit relies on controlled positive feedback, and the analysis is given in Appendix 4. If the input resistor R_1 is broken down into R_a and R_b , then, with an output taken at the junction of the two resistors, the attenuation may be varied in a similar manner. However, it is of interest to note that, with the given circuit configuration, the change in attenuation may be made as large as desired by the selection of appropriate values for R_a and R_b . The practical disadvantage, though, of designing for a ratio of change of attenuation greater than say 20, is that all components of the system must be stable and accurately known.

Variable impedance

The circuit shown in Fig. 14 will alter the effective impedance of a capacitor or inductor, again by positive feedback, such that:—

$$Z_{eff} = Z/(1-n)$$

It was found expedient to use a complementary emitter

follower (Tr2 and Tr3) with a capacitive load to ensure a low impedance to all parts of the input waveform, and the diodes D1 and D2 are inserted to remove cross-over distortion. The potentiometer R_1 is adjusted such that the output across R_6 is equal to $\frac{1}{2}v_{in}$ when $n = 0.5$. To illustrate the variation of impedance with control voltage, the Z of Fig. 14 was made part of a non-saturating LC oscillator¹³ which is shown in Fig. 15. Thus, altering the control voltage will alter the frequency of oscillation. The control amplifier was driven by a conventional p-n-p-n ramp generator shown in Fig. 16. R_4 is adjusted to give adequate range of operation, and then R_{10} is adjusted to provided sync. with the incoming a.f. signal. (The control amplifier was biased to -0.7V and the ramp signal varied from zero to -1.4V .) The unwanted ramp signal at the output of the whole amplifier is compensated by means of the current generator Tr6.

Thus, with just the ramp generator and an a.f. signal, the output signal appears as shown in Fig. 17(a), where

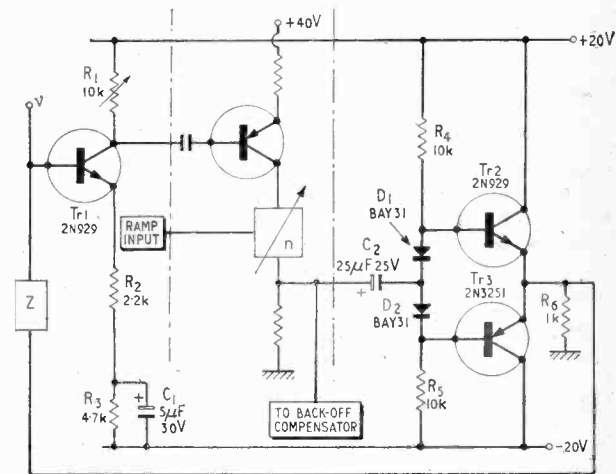

Fig. 14. Arrangement for a voltage-controlled impedance.

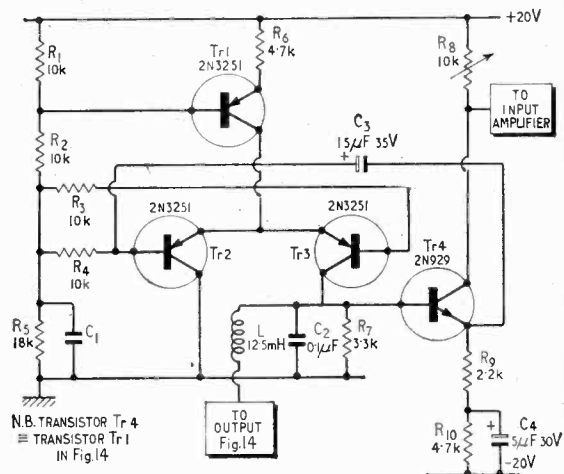

Fig. 15. A non-saturating LC oscillator which was used as Z in Fig. 14. With this arrangement, the frequency of the oscillator was varied by the control voltage, derived from ramp generator shown in Fig. 16.

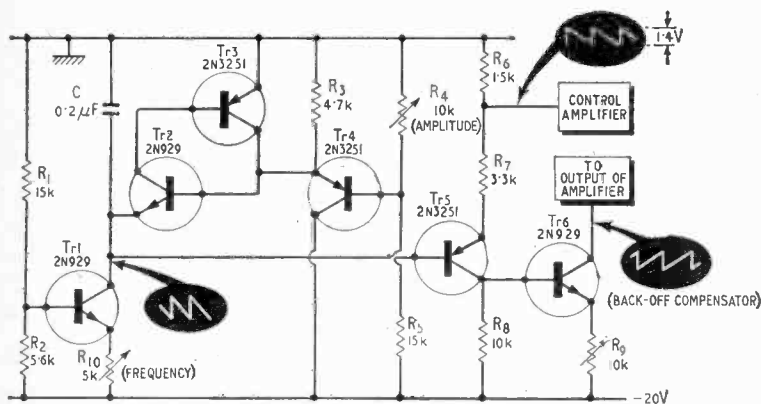

Fig. 16. Ramp generator used in conjunction with Figs. 14 and 15 to provide a voltage-controlled impedance.

the lower trace is the input to the control amplifier. Connecting the oscillator to the system provided the rather dubious output shown in Fig. 17(b). The loss in amplitude and increase in distortion is probably due to the changing Q of the inductor, since simply changing the capacitor to lower the frequency causes a drop in amplitude. However, in principle, the frequency did

change and this can only be due to a change in the effective impedance of the inductor.

Sweep generator and filter

Considering an extension of the circuit that produced the sad trace of Fig. 17(b), it does not seem unreasonable that a true audio sweep generator covering four octaves could be constructed. If one takes, for example, the familiar Wien bridge oscillator, a 3:1 range of frequency could be obtained by varying one component over a 10:1 band (since $f = 1/2\pi\sqrt{C_1C_2R_1R_2}$). If however, while say a resistor is being varied by an in-phase signal, a capacitor is varied by an equal amplitude out-of-phase signal, then a 10:1 frequency range would result. A disadvantage of this method would lie in the variation of attenuation that the network gives with change of components. (If R_2C_2 are the parallel components, and if $R_2 = kR_1$, and $C_2 = kC_1$ then the gain required by the subsequent amplifier is equal to $(k^2 + k + 1)/k$. Thus for a 10:1 change in components, $k = 10$ and the required gain varied from 3 to 11.) This in turn requires the use of a good a.g.c. system (a thermistor?), but this should give little trouble. Some form of digital circuit would be required to give decade switching and this could be accomplished by a count-of-four circuit applied to f.e.t. switches which are series connected to additional components. A block diagram of the system is given in Fig. 18, and while the overall system may use many transistors and components, the advent of cheap plastic-encapsulated active elements may yet make it a practical circuit.

Variable filter.—Working on a similar basis to the above it should be possible to obtain almost any form of filter with a variable “turnover” point controlled by a d.c. input. The easiest forms to simulate are obviously those with a single control already existing^{14, 15} but others should be capable of suitable modification. Of particular interest are the filters incorporating Miller integrators^{16, 17} since the input current for the integrators could come straight from the variable-gain amplifier, and the change in current would directly affect the RC time constant.

Analogue multiplication

In order to achieve true multiplication the circuit shown in Fig. 19 may be used. The modulated signal appearing at the output of the amplifier will be out-of-phase to the input, and by algebraically adding the two by means of

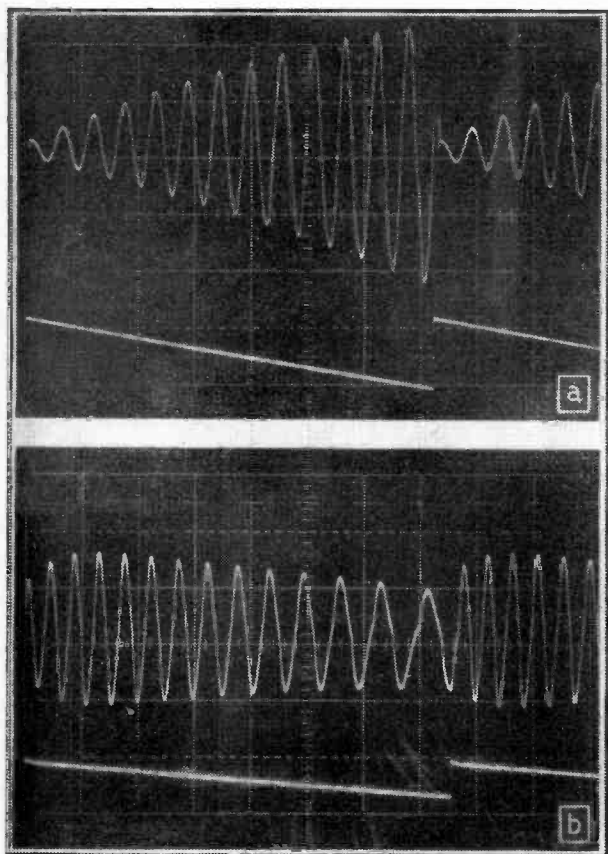

Fig. 17. (a) Output of amplifier with ramp signal (from Fig. 16) applied to control amplifier. (b) Output of amplifier with oscillator of Fig. 15 connected to the system, showing variation of frequency. The loss in amplitude and increase in distortion are probably due to the changing of the inductor.

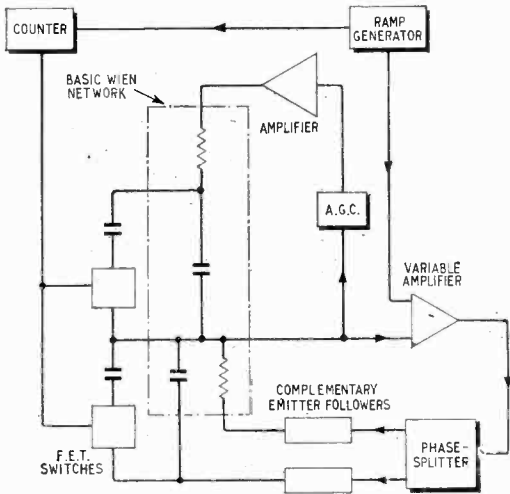

Fig. 18. A possible block diagram for an audio sweep generator.

a unity-gain summing amplifier the true product of the two inputs is obtained. By making the two inputs the same the circuit will produce the output equal to the square of the input. If higher powers are required then amplifiers may be cascaded. Thus for a cubic function, the square of the input is obtained, and this is multiplied by the input in a second amplifier. By an inverse process square roots can be obtained. A possible method would be to inject a ramp signal, compare the output with a fixed level, and when the two are equal stop the ramp. The instantaneous level of the ramp would be proportional to the square root of the fixed level.

Audio amplification

Having started the article with a discussion of a circuit that was used for an audio amplifier, it is only fitting that one should finish in a similar manner. In other

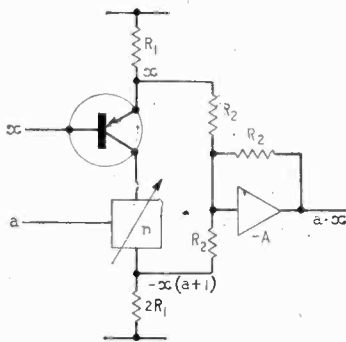

Fig. 19. Illustrating analogue multiplication.

words—can this modulator be used in an audio amplifier? The answer, as usual, is that it all depends. If the control amplifier input consists of an audio signal then the output of the modulator will have a duty ratio that exactly follows the signal, but it must be remembered that this will be a 2 V amplitude signal which will require subsequent power amplification before it can be applied to the loudspeaker. It is precisely in the pulse power amplifier that the problems of class D systems exist.

It transpires that for a low output, two d.c. supplies of 20 V must supply a peak current of about 1A, via the two saturating output transistors, to the loudspeaker. (If the switching transistors are not saturated then the main advantage of the switching mode of operation is lost, i.e. low dissipation in the output transistors.) Now, for good linearity, i.e. good pulse shape, the rise and fall times of the transistors should be less than 100 ns, and to achieve this with 1A signals constitutes something of a problem. A more serious difficulty lies in ensuring that one transistor is off when the other is on. If care is not taken in this matter, then two "on" transistors are connected in series directly across the power supply. The author has managed to destroy more than a dozen transistors in a series of unsuccessful efforts to overcome this problem.

To summarise: while the modulator may certainly be used as a converter stage, possibly with advantage over the other forms available, it is felt that it will in no way affect the main problem of class D amplifiers—that of a reliable output stage.

Summing up

In the first part of this article an amplifier was discussed in which the output amplitude could be reliably controlled by means of an applied d.c. level. It was shown that there was good linearity between applied d.c. and output amplitude, and that this was largely unaffected by component, temperature, and d.c. supply variations.

In the second part an effort is made to show some of the possible applications of the system in several differing fields of electronics, and to show that its utility should extend to many more. The circuits shown were constructed purely on an *ad hoc* basis, and no claim is made that they represent an optimum design.

At this stage, it must be pointed out that the work was carried out as a personal investigation, and no company can be held responsible for any circuits shown, or opinions expressed.

APPENDIX 3

Analysis of AGC circuit

With symbols as shown in Fig. 20,

$$v_2 = 2xn = x(a+1)$$

where x is the pk-pk value of the input signal.

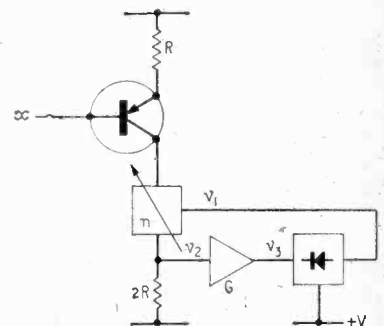

Fig. 20. Block diagram for analysis of a.g.c. (see Appendix 3).

Now total range of input signal is $\pm \frac{1}{2}$ V, therefore:—

$$a = v_1 / \frac{1}{2} = 2v_1$$

$$\therefore v_2 = x(2v_1 + 1) \dots \dots \dots (1)$$

and, if the gain of the amplifier stage is G

$$v_3 = Gx(2v_1 + 1)$$

After rectification, the d.c. level produced is equal to the pk-pk value of v_3 .

$$\therefore v_1 = \frac{V - Gx(2v_1 + 1)}{V - Gx}$$

i.e.
$$v_1 = \frac{V}{2Gx + 1}$$

and from equation 1,

$$v_2 = \frac{x(2V + 1)}{2Gx + 1} \dots \dots \dots (2)$$

Since $2V \gg 1$ and $2Gx \gg 1$ if $x \approx 1$,

$$v_2 \approx V/G \dots \dots \dots (3)$$

APPENDIX 4

Variable resistance and attenuator

With notation as shown in Fig. 13

$$i_{R_1} = v(1+p)/R_1$$

$$v_{R_2} = v(1+p)R_2/R_1$$

$$i_{R_3} = v(1+p)R_2R_3/R_1$$

$$\therefore v_{R_4} = -v(1+p) \frac{R_2}{R_1} \cdot \frac{R_3}{R_4} \cdot n$$

If $R_2 = R_1$ and $R_3 = R_4$, then

$$-pv = -v(1+p)n$$

i.e.
$$p = n/(1-n)$$

$$\therefore i_{R_1} = v/R_1(1-n)$$

Now $R_{eff} = v/i_{R_1}$

$$\therefore R_{eff} = R_1(1-n)$$

If R_1 consists of two resistors in series and the output is taken from the midpoint, then the system acts as an attenuator. Let the two resistors be R_a and R_b . Then

$$i_{R_a} = \frac{(1+p)v}{R_a + R_b}$$

$$\therefore v_o = v - \frac{(1+p)v.R_a}{R_a + R_b}$$

and attenuation (A) is

$$A = \frac{(R_a + R_b) - (1+p)R_a}{R_a + R_b}$$

and, since $p = \frac{n}{(1-n)}$,

$$A = \frac{R_b - \frac{n}{(1-n)} \cdot R_a}{R_a + R_b}$$

Now, put $R_b = bR_a$ then

$$A = \frac{b - n/(1-n)}{(1+b)}$$

If $0.1 < n < 0.9$, then when $n = 0.1$

$$A_1 = \frac{b - 0.11}{1 + b} \approx b/(1+b)$$

and when $n = 0.9$

$$A_2 = \frac{b - 9}{b + 1}$$

If the required ratio of change in attenuation is M , then

$$M = A_1/A_2 = \frac{b}{b - 9}$$

$$\therefore b = \frac{9M}{M - 1}$$

With an initial known value of R_1 , this uniquely determines the value of R_a and R_b .

REFERENCES

13. "LC Oscillator Design", R. C. Foss and M. F. Sizmur, *Wireless World* November 1962, p. 535.
14. "A Simple Null Filter with Variable Notch Frequency", J. L. Douce and K. H. Edwards, *Electronic Engineering* July 1964, p. 478.
15. "Two-Transistor-Operated Frequency-Selective Amplifier", S. Harkness, *Electronic Engineering* September 1964, p. 622.
16. "A Two-Phase Low Frequency Oscillator", E. F. Good, *Electronic Engineering* April 1957, p. 164.
17. "Tunable Filter for Low Frequencies Using Operational Amplifiers", H. Sutcliffe, *Electronic Engineering* June 1964, p. 399.

THE MONTH'S CONFERENCES AND EXHIBITIONS

Further details are obtainable from the addresses in parentheses

- LONDON**
 Apr. 14-17 Hotel Russell
Audio Festival & Fair
 (C. Rex-Hassan, 42 Manchester St., W.1)
 Apr. 19-21 Imperial College
Environmental Engineering & Its Role in Society
 (Soc. of Environmental Eng'g, Radnor House, London Rd., S.W.16)
 Apr. 25-May 4 Earls Court & Olympia
Engineering & Marine Exhibition
 (F. W. Bridges & Sons, 1-19 New Oxford St., W.C.1)

- BIRKENHEAD**
 Apr. 19-21 Technical College
Scientific & Technical Books & Visual Aids
 (Birkenhead Tech. College, Borough Rd., Birkenhead)

- GLASGOW**
 Apr. 12-15 University of Strathclyde
Electronics & Shipping (I.E.E./I.E.R.E.)
 (K. A. Murphy, 50 Holburn Rd., Newlands, Glasgow, S.3)

- SHEFFIELD**
 Apr. 15-17 The University
Integration of Physics and Chemistry Teaching
 (Inst. of Physics & Phys. Soc., 47 Belgrave Sq., London, S.W.1)

- YORK**
 Apr. 4-7 The University
Scattering, Non-linear Optics & Electro Magneto-Optics
 (Inst. of Physics & Phys. Soc., 47 Belgrave Sq., London, S.W.1)

- OVERSEAS**
 Apr. 12-14 New York
Symposium on Generalized Networks
 (Polytechnic Institute of Brooklyn, 333 Jay St., Brooklyn, N.Y.)
 Apr. 12-15 Phoenix
Quantum Electronics Conference
 (I.E.E.E., 345 E. 47th St., New York)
 Apr. 19-21 Atlantic City
Frequency Control Symposium
 (Electronic Component Lab., U.S. Army Electronics Command, AMSEL-KL-ST, Fort Monmouth, N.J.)
 Apr. 19-22 Budapest
Colloquium on Microwave Communication
 (Valkó Péterné, Budapest V, Szabadsag ter 17, Hungary)
 Apr. 20-22 Stuttgart
Conference on Magnetism
 (Dr. K. Sixtus, AEG, Goldsteinstrasse 235, 6 Frankfurt/M)
 Apr. 30-May 8 Hanover
Hanover Fair
 (Schenkers, 13 Finsbury Sq., London, E.C.2)

PHYSICS EXHIBITION

FOR the first time the annual exhibition of scientific instruments and apparatus organized by the Institute of Physics & Physical Society is to be held at Alexandra Palace, North London. This year's exhibition, the 50th since the series started in 1905, opens on March 28th for four days. It will open at 10 a.m. each day (but on the first day admission until 1 p.m. will be restricted to members and invited guests) and will close at 6 p.m. on the first two days, 8.30 on the 30th and 5 on the last day. Admission is by ticket, obtainable free from the Exhibitions Officer at 47 Belgrave Square, London, S.W.1. Applicants are asked to send a stamped addressed envelope.

We give below a list of the exhibitors, and in our next issue will report on some of the more outstanding exhibits.

Airmec
 Associated Electrical Industries
 Associated Engineering
 Baldwin Instrument Co.
 Bendix Electronics
 Bir-Vac
 Bradley, G. & E.
 British Oxygen, Co.
 Chandos Products (Scientific)
 C.N.S. Instruments
 Cussons, G.
 Data Laboratories
 Deakin Phillips Electronics,
 Decca Radar
 Dynamco Instruments
 Edwards High Vacuum
 Electrical Remote Control, Co.
 Electro Mechanisms
 Electronic Instruments
 Elga Products
 Elliott Automation Radar Systems
 Elliott Brothers (London)
 EMI Electronics
 Epsylon Industries
 Ether Langham Thompson
 Fenlow Electronics

Flann Microwave Instruments
 Frigistor Laboratories
 G.E.C. (Electronics)
 General Electric Co.
 Genevac
 Hilger & Watts
 Imperial Chemical Industries
 Dyestuffs Division
 Nobel Division
 Plastics Division
 International Research & Dev. Co.
 International Computers & Tabulators
 Instron
 Isotope Developments
 Johnson Matthey & Co.
 Labgear
 Lan-Electronics
 Marconi Co.
 Mechatronics (London)
 Mercury Electronics (Scotland)
 Metals Research
 Meter-Flow
 Microscal Ltd.
 Microwave Instruments
 Mining & Chemical Products
 Montford Instruments

Morganite Research & Development
 Muirhead & Co.
 Mullard
 Newport Instruments
 N.G.N.
 Nuclear Enterprises
 Optical Works
 Oxford Instrument Co.
 Panax Equipment
 Paton Hawksley Electronics
 Perkin-Elmer
 Planer, G. V.
 Plessey
 Pye, W. G., & Co.
 Pye Printed Motors
 Rank Nucleonics & Controls
 Rank Taylor Hobson
 Rosemount Engineering Co.
 Research & Industrial Instruments
 Scientifica
 S.E. Laboratories (Engineering)
 "Shell" Research
 Smiths Medical Equipment Co.
 Southern Analytical
 South London Electrical Equipment
 Sperry Gyroscope Co.
 Standard Telephones & Cables
 Swift, J. & Son
 Techrne
 Telechrics
 Telcon Metals
 Tequipment
 Telford Products
 Tensometer
 Thermal Syndicate
 20th Century Electronics
 Vacuum Generators
 Veeco Instruments
 Venner Electronics
 Wallace, H. W., & Co.
 Wareham E. M. (Measuring Systems)
 Watson, W., & Sons
 Wayne Kerr Laboratories
 Wolfendale, Peter
 Wray (Optical Works)

Government & Industrial Research Establishments
 Atomic Energy Estab. (Winfrith)
 Atomic Weapons Research Estab.
 Reactor Engineering Laboratory
 British Coal Utilisation Res. Assoc.
 British Railways Chem. Res. Div.
 British Scientific Inst. Res. Assoc.
 Central Electricity Generating Board
 Chemical Defence Exp. Res. Estab.
 Chemical Inspectorate (Army)
 Culham Laboratory (U.K.A.E.A.)
 Medical Research Council
 Ministry of Aviation
 Ministry of Defence (Navy)
 National Committee for High Speed Photography (A.W.R.E.)
 National Engineering Laboratory
 National Physical Laboratory
 National Research Development Corp.
 Reactor Eng'g Lab. (Risley)
 Rutherford High Energy Lab.
 Safety in Mines Res. Estab.
 Warren Spring Laboratory

Universities and Colleges
 Battersea College of Technology
 College of Aeronautics
 Imperial College of Science & Technology
 Middlesex Hosp. Medical School
 Powered Prosthetic Unit, Princess Margaret Rose Orthopaedic Hosp.
 Royal Military College of Science
 Royal College of Advanced Technology (Salford)
 St. Andrews University
 Sir John Cass College
 University College of North Wales
 University of Aston
 University of Birmingham
 University of Cambridge
 University of Hull
 University of Lancaster
 University of Newcastle upon Tyne
 University of Nottingham

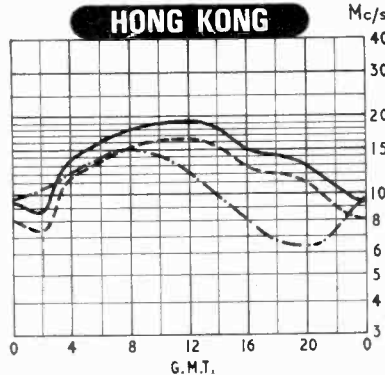
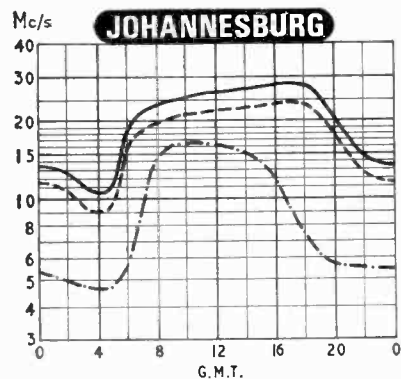
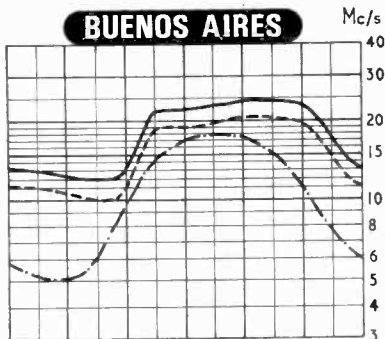
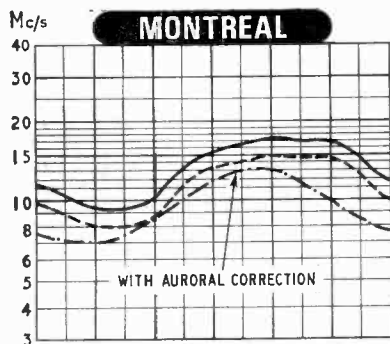

H. F. PREDICTIONS APRIL



The predictions for this month are beginning to show the flatter shape, characteristic of the approach of summer. This should permit the use of higher frequencies for a longer period each day. Circuit working will still prove difficult, notably on the relatively short Montreal-London route, and little advantage can be expected due to Sporadic-E ionization. The reverse path London-Montreal might prove somewhat easier, due to lower LUF.

The curves show the median standard MUF, optimum traffic frequency and the lowest usable frequency (LUF) for reception in this country. Unlike the standard MUF, the LUF is closely dependent upon such factors as transmitter power, aerials, and the type of modulation. The LUF curves shown were drawn by Cable and Wireless Ltd. for commercial telegraphy and assume the use of transmitter power of several kilowatts and rhombic type aerials.

NEW PRODUCTS

equipment systems components

1Gc/s SAMPLING VOLTMETER

A VOLTMETER (type 3406A), for reading alternating voltages from 10 kc/s to 1Gc/s and using a sampling technique, is introduced by Hewlett Packard. The instrument's ranges are from 1mV to 3V, and differences of 50 μ V can be read.

Random sampling of the input provides a train of pulses, of a.f. repetition

frequency, with the same average, peak or r.m.s. values as the input signal. The absolute average value of an input signal is read (in terms of the r.m.s. value of a sine wave) regardless of the waveform shape. True r.m.s. values can be measured from the available a.f. output by use of a separate low frequency true r.m.s. meter.

The probe contains a push-button switch which causes the meter to retain its reading until released. Push-buttons are also used for range switching.

The input impedance of the voltmeter is 100 k Ω in parallel with 2 pF at 100 kc/s. The accuracy is $\pm 3\%$ up to 100 Mc/s, $\pm 5\%$ for 100 Mc/s-800 Mc/s, and $\pm 8\%$ up to 1Gc/s. The price is about £250 and a range of accessories is available.

WW 301 for further details

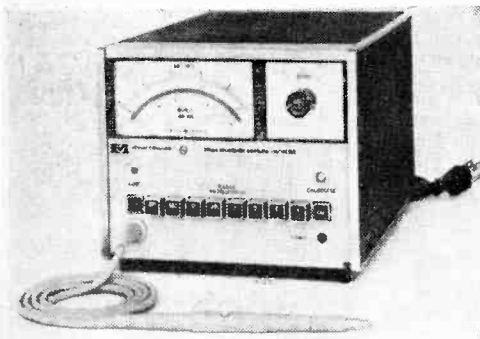

Transistor Phase Meter

A NEW instrument from Dawe Instruments is intended for the measurement of phase shift and gain in feedback and other complex systems, and for demonstrating the principle of phase shift. Designated type 632, it permits comparison between symmetrical input signals over the frequency range 50 c/s to 100 kc/s. Input attenuators permit a large range of signal levels from 10 mV to 10 V (60 dB); these can be measured by a panel voltmeter. There are no frequency sensitive controls.

The phase meter scale is designed to give f.s.d. for each quadrant range, for maximum resolution. Direct indications of phase differences are read from four quadrant ranges 0°-90°, 90°-180°, 180°-270° and 270°-360°. There are two auxiliary ranges of 0°-360°, and 180°-0°-180°.

Input impedance per channel is 1M Ω paralleled with approximately 40 pF. Phase measurement accuracy over the whole frequency range is $\pm 1.5^\circ$ for 50 c/s to 25 kc/s, and $\pm 5^\circ$ for

25 kc/s to 100 kc/s. Voltage measurement accuracy is ± 5 per cent of f.s.d.

Operation is from 200-250 V 50 c/s, or 110 V 60 c/s. Dimensions: 8 $\frac{1}{4}$ x 13 x 12 $\frac{1}{2}$ in high. Weight: 14 lb. Provisional price £180 from Dawe Instruments Ltd., Western Avenue, London W.3.

WW 302 for further details

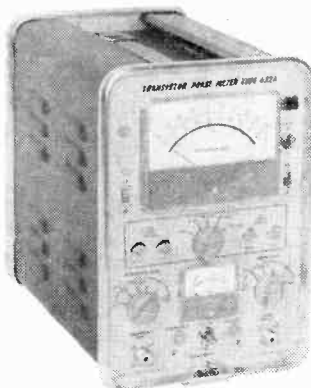

DIGITAL CLOCK

DESIGNED for use in industrial process control and data logging applications or as a 24-hour "time-of-day" indicator, the Type SA.7100 Digital Clock System from Racal Electronics Ltd., Western Road, Bracknell, Berks., provides digital indication of time in hours, minutes and seconds on a 6-digit columnar or in-line display. Different versions are available; for example as regards accuracy, the Type SA.7100A is referenced to the 50 c/s mains whereas the SA.7100C is referenced to a precision quartz crystal oscillator which affords a system accuracy of better than 2 parts in 10⁹ per day. An external standard may be used for greater accuracy.

General facilities include synchronization of the display in steps of 0.01, 0.1 and 1s and provision for operation of a digital recorder. The clock has all transistor circuitry and is designed for operation within an ambient temperature range of 0-45°C. Power supply requirements are 115, 230 V, 50 c/s or 115 V, 400 c/s or external batteries.

WW 303 for further details

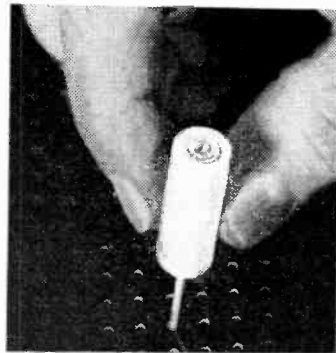

Matrix Board Component Holder

SEALLECTO board is a matrix constructed of contact strips disposed at right-angles to each other, and electrically isolated. A new device for use with it is a component holder, RDP-6, containing a miniature trimming potentiometer and diode in series. It is suitable for matrix applications where unidirectional current flow is required. The trimming potentiometer permits adjustment of current flow at each intersection.

RDP-6 may be used with two-tier Seallecto boards and half-inch centre intersections.

From Seallecto Limited, Walton Road, Farlington, Portsmouth, Hants.

WW 304 for further details



MINIATURE CIRCUIT BREAKER

DESIGNED for integrated control systems and for instantaneous fault indication in equipment, a miniature circuit breaker introduced by E.T.A. is available in standard current ratings of 50 mA to 10 A in fixed steps, although intermediate ratings can be obtained.

The 3600-Si is a single pole plug-in unit for 240 V a.c. or 65 V d.c. supplies with auxiliary signal contacts continuously rated for 1 A at 240 V d.c. Operation is thermal on small overloads, and magnetic on high overloads or short circuits. Maximum rupturing capacity is 200 A, and although trip time is dependent upon percentage overload, the 3600-Si can operate faster than 20 ms. Techra (Sales) Ltd., 47 Whitehall, S.W.1.

WW 305 for further details

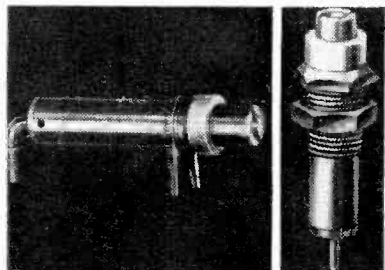

25 pF Printed Circuit Trimmer

TWO VERSIONS of a tubular trimmer capacitor are announced by Oxley Developments Co. Ltd. of Priory Park, Ulverston, Lancs. The type shown horizontally is intended for printed circuit mounting and the other for chassis mounting.

The new trimmers have a p.t.f.c. dielectric and are available with capacitances up to 25 pF and the temperature coefficient of both is 50 p.p.m./°C. Insulation is $10^9 \text{ M}\Omega$ and the power factor is 0.0005 at 10 kc/s.

WW 306 for further details

D.V.M. à la mode

INTERESTING features of the Venus digital voltmeter made by the French Schneider company are its small size (12 in \times 7 in \times 4 in), modish styling, with piano keys for range and calibration selection, and modular construction—using modules which can be purchased separately by people wishing to build their own equipment. Accuracy is claimed to be 0.1%. Available from Kynmore Engineering at a basic price of £250, the Venus 123 model has three d.c. measuring ranges: -9.99V to +9.99V, -99.9V to +99.9V and -999V to +999V. Automatic decimal point and polarity indications are provided. Another model, the 124, has a single additional digit to give overload indication. The maximum readings in the three ranges are thus 10 V, 100 V and 1000 V respectively, but higher values are indicated. For both models input impedance is 20 M Ω minimum, with an optional 1,000 M Ω on

the 10 V range. Allowable overload is about 25% except on the 1000 V range.

Optional facilities include a printer output, and either model will operate with a Schneider printer or with an ancillary Schneider instrument which converts it into a digital multimeter (providing two lower d.c. ranges down to 100 mV f.s.d., four a.c. ranges from 300 mV to 300 V f.s.d., as well as resistance ranges). The address of Kynmore Engineering Co. Ltd. is 19 Buckingham Street, London W.C.2.

WW 307 for further details



Miniature Ceramic Trimmers

THREE types of ceramic disc trimmer capacitors have been added to the range of trimmers manufactured by Steatite Insulations Ltd. The two types shown below are the type 7S-TriKo 03 (right) and the sub-miniature type 5S-TriKo (left) and are available in the following ranges:—

	Type 7	Type 5
P 100	2 —3.5 pF	1.5—2.5 pF
N 033	2.5—6 pF	2.5—6 pF
N 075	3 —10 pF	3 —8 pF
N 470	3.5—13 pF	3.5—11 pF
N 750	4.5—20 pF	4.5—15 pF
N 1500	7 —35 pF	6 —22 pF

The trimmers have been designed to meet military and professional require-

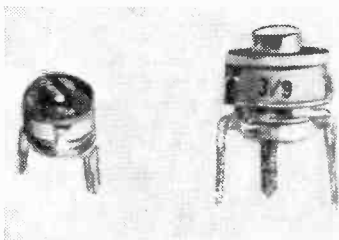

ments. The insulation resistance and temperature range of both types is $10^9 \text{ M}\Omega$ and -40, +85°C respectively. The rated voltages of the capacitors are 63 V and 160 V for types 5 and 7 respectively.

The 1250b screw-type trimmer, above, is designed for more general application. This type is available with two capacitance ranges, 2-19 pF and 2-20 pF and the capacitance law is linear over six 360° turns. Power factor at 1 Mc/s is 0.002 with a working voltage of 250 V. All types are designed for printed board mounting.

The address of Steatite Insulations Ltd. is Hagley House, Hagley Road, Birmingham 16.

WW 308 for further details

R.F. MILLIVOLTMETER

A TRANSISTOR millivoltmeter, type TF2603, with a frequency range of 50 kc/s to 1.5 Gc/s is announced by Marconi Instruments Ltd., of St. Albans, Herts. The instrument will

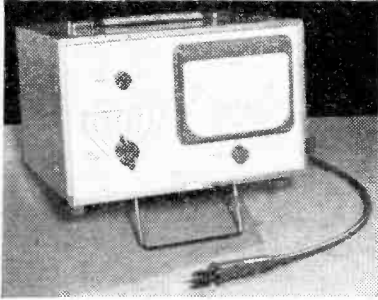

measure from 300 μ V to 3 V and up to 300 V with addition of a 100:1 multiplier, available as an accessory. The input impedance is about 200 k Ω at 1 Mc/s (with an input of 1 V r.m.s.) in parallel with 2 pF. Accuracy within the range 200 kc/s-50 Mc/s is $\pm 3\%$ f.s.d. on all ranges except the 3 mV and 1 mV ranges, where accuracy is $\pm 5\%$.

The wide frequency range results from the use of the rectifier-d.c. amplifier-indicator arrangement. The probe unit uses a pair of germanium gold-bonded diodes in a full-wave rectifier circuit, whose output is then passed to an electro-mechanical chopper via a balanced attenuator, the balanced arrangement giving low 1/f noise. A heater, which operates at temperatures below 32°C, is incorporated into the probe to minimize changes in output

with ambient temperature. A spring-loaded earth spike, designed to accommodate differences between live and earth planes is also supplied, and can be seen in the accompanying photograph. The probe responds to true r.m.s. for inputs less than 30 mV and from 0.5 V to 3 V it responds to peak-to-peak values.

The amplifier-indicator section incorporates a phase-sensitive detector, with the advantage that the meter electrical zero coincides with the scale zero, noise producing no standing reading. The virtually linear scale is achieved by means of a silicon diode shaping circuit which progressively shunts the meter as f.s.d. is approached.

A range of five accessories is available singly or as a kit and the instrument may be operated from a battery, if required.

WW 309 for further details

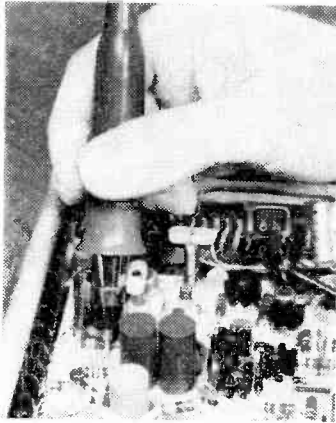

Miniature Relay

NOW available from T.M.C. Components Division is a new miniature relay, type 300. Features are a low-loss core to yoke junction which improves the magnetic efficiency, a fully bridged mounting frame that prevents base distortion, and a three-point location for cover retention.

A small-frame version possesses one changeover, two changeover light duty

(1 amp d.c.) and one make/one break heavy duty (3 amp d.c.) contacts.

The large frame version offers four changeovers, six makes or six breaks light duty (1 amp d.c.) or two changeover heavy duty (3 amp d.c.) spring sets. The material for the spring sets complies with BSS.267, and carries gold flashed silver contact units.

Overall dimensions are 1.2in \times 1in \times 0.75 in, and standard coil voltages of 6, 12 and 24 volts are available. Coils for other voltages are available.

Socket mountings will interchange with similar U.K. and Continental relays. The address is Roper Road, Canterbury, Kent.

WW 310 for further details



FOUR-LAMP PUSH BUTTON SWITCH-INDICATORS

FOUR miniature incandescent lamps project their light through either a single coloured screen or four separate colour filters in the Plessey-Licon Type 44 switch. The device saves space by combining the one to four colour indicator with a multi-pole switch control, in a compact circular housing 3 in deep and 1 in diameter.

When the display screen is pressed, the force is transmitted through the light module centre to operate one or more sub-miniature switches. Normal operation involves two lamps, one each in opposite quadrants to project a single colour; alternatively, each of the four quadrants may display a different colour or legend.

Type 44 switches are offered with one- or two-pole momentary or maintained contact, and solenoid held arrangements.

Individual mounting requires a hole 1.14 in (2.9 mm) diameter, while permitting use of panels from 1/16 in (1.6 mm) to 1/8 in (3.2 mm) thick. Projection from rear of panel is 3 1/8 in (80 mm). From the Electromechanical Division of the Plessey Components Group, New Lane, Havant, Hants.

WW 311 for further details

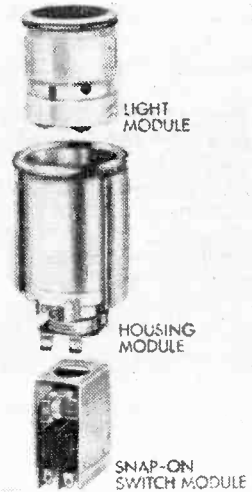

Low Voltage Ceramic Capacitors

CERAMIC disc capacitors, rated at 50 V, are available from Centralab Ltd. Capacitance values are 0.01, 0.02 and 0.05 μ F with tolerances of either +80% -20% or $\pm 20\%$. Disc diameters are approximately 0.3, 0.36 and 0.52 in respectively.

Cost varies between 1.15d and 1.9d per capacitor in quantity.

WW 312 for further details

Printed Circuit Trimmer

DESIGNED specifically for mounting on 0.1 in module printed wiring boards is the Wingrove & Rogers Ltd. air dielectric trimmer capacitor C.31-51/6, which is constructed on a ceramic base. The base measures 0.65 in \times 0.925 in and the distance between stator and rotor contacts is 0.9 in. The method of stator

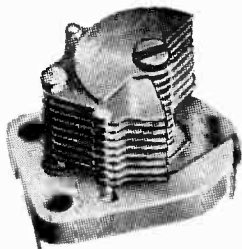

support and design of the rotor contact are claimed to give high mechanical and electrical stability. Minimum capacitance is 4 pF and capacitance swing is up to 57.5 pF. The capacitor will withstand voltages up to 500 V peak at 50 c/s

WW 313 for further details

Photo-detectors for 2-25 μ m Waveband

TWO new fast-response photo-detectors sensitive to pulsed or modulation radiation in the 2 to 25 μ m waveband will be of particular interest to physicists and spectroscopists. The detectors, types RPY37 and RPY40 from Mullard Ltd., are cooled to 4.2 $^{\circ}$ K in cryostats filled with liquid helium; once filled they require no further attention for at least seven hours. The intrinsic response time of the sensitive element in both devices is less than 1 μ s, which is a most important feature in the study of transient phenomena. The RPY37 has a sensitive area of 6 mm \times 1 mm and provides the spectroscopist with a means of obtaining high resolution at wavelengths up to 25 μ m, whereas the RPY40, which has a larger sensitive area, is suitable for examination of transient phenomena such as pulsed or modulated emission from long-wavelength gas and solid-state lasers where there may be only a few milli-seconds during which a particular effect can be observed.

Other applications for these detectors will be the examination of radiation phenomena encountered in shock tube studies, plasma studies and solid-state research. Both types of detectors are priced at just under \pounds 1,000.

WW 314 for further details

DE-SOLDERING INSTRUMENT

A SOLDERING iron designated M 207 and whose primary use is the removal of solder from tags, components and printed boards, is announced by the well-known firm of Adcola. The instrument is manufactured by Adcola Products Pty. Ltd., of Melbourne, and is available through Soldering Instrument Components Ltd. of Adcola House, Gauden Road, London S.W.4, a subsidiary of Adcola Products Ltd.

The instrument is provided with a hollow stainless-steel-lined tip, which can be used for normal soldering as well as for de-soldering, or alternatively, solid bits can be inserted. The bulb protruding from the handle, which enables operation with the forefinger, draws solder through the tip and a gauze filter situated at the other end of the bit collects the solder, which may then be blown out by pressing the bulb. The gauze filter may be removed from the filter chamber for cleaning, as shown in the illustration.

A range of 12 tips are available for use with the M 207, six hollow for de-soldering and six solid. The range includes tips with face diameters of $\frac{1}{16}$, $\frac{3}{32}$, $\frac{1}{8}$, $\frac{3}{16}$, $\frac{1}{4}$ and $\frac{1}{2}$ in, the hollow $\frac{1}{8}$ in tip being included as a standard fitting. The tips are iron plated to prevent seizure in the barrel and to prolong the life of the face.

Heater elements, de-soldering and soldering bits, filters and filter chambers are stocked by Soldering Instrument Components, who also provide servicing facilities for the U.K. Instruments can be supplied for any voltage range between 6 and 250 V. The price is \pounds 5 4s 4d.

WW 315 for further details

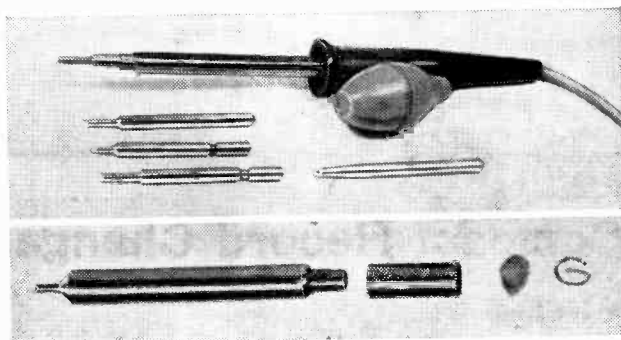

BIT LUBRICANT

SEIZURE OF BITS in soldering irons is a frustrating occurrence but one which can be avoided by the use of a bit lubricant introduced by Light Soldering Developments Ltd. (28 Sydenham Road, Croydon, Surrey), manufacturers of Litesold and Adamin soldering irons.

The lubricant, Bitloos, is an organo-metallic compound incorporating silica derivatives and high melting point polymers and as a consequence can withstand temperatures in excess of 800 $^{\circ}$ C. The compound is applied to the appro-

appropriate portion of the bit before insertion and can be left for long periods. Bitloos will no doubt find application in other instances where high temperature causes corrosion and seizure of metal parts. The compound exhibits good water and corrosion resistance.

Tubes of the compound cost 14s 6d (2 oz) which should be sufficient for 1,000 applications. The compound will in future be used on all the Litesold and Adamin soldering irons.

WW 316 for further details

Miniature 50 Ω Coax

MINIATURE polythene coaxial cable manufactured by Filotex S.A. (of France) is available in the U.K. from Lectropon Ltd. at Kinbex House, Wellington Street, Slough, Bucks. Attenuation at 200 Mc/s is 0.4 dB/m and at 400 Mc/s it is 0.56 dB/m. Capacitance is 10 pF/m and the impedance 50 Ω .

WW 317 for further details

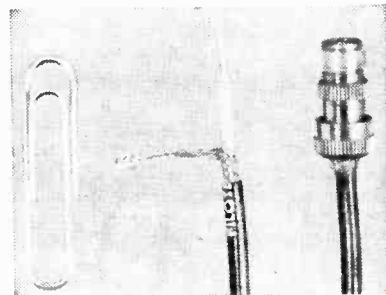

AUDIO PRODUCTS

Grouped on this page for the convenience of readers interested in the Audio Fair Preview (page 178)

HIGH-POWER AUDIO AMPLIFIER

A SILICON transistor amplifier and pre-amplifier is announced by Sherwood of Chicago. Power output is quoted as 160 W (I.H.F.M. music power rating) and 120 W continuous sine wave, but since maximum power consumption is stated to be 150 W, this would represent an efficiency of 80% (not obtainable with a class B stage), and consequently the rating will no doubt be a peak rating, giving 30 W r.m.s. per channel. At 30 W, distortion is less than 0.3%, 46 dB of feedback being used. The output transistors are thermostatically protected.

The amplifier, designated S-9000a, is

suitable for operation with electrostatic loudspeakers. Twenty-three silicon transistors are used in the amplifier.

A silicon transistor stereo f.m. tuner is also announced (model S-3300) with a sensitivity of $1.6 \mu\text{V}$ (I.H.F.M.). Sherwood Electronic Laboratories Inc., 4300 North California Avenue, Chicago 18, Illinois, U.S.A.

WW 318 for further details

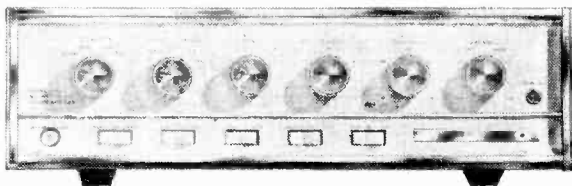

Compact Record Changer

A COMPACT record changer that is fully automatic, the UA50 MINICHANGER, has been developed by BSR Ltd., Monarch Works, Old Hill,

Staffordshire, England. Weighing only $4\frac{1}{2}$ lb, and measuring $11\frac{1}{8}$ in \times $8\frac{3}{8}$ in \times 5 in deep, it is claimed that the UA50 is 40% lighter and 35% smaller than other similar record changers. The four speed unit can operate from battery or mains supply, and provision is made for both monaural and stereo cartridges.

Six records of 7 in, 10 in, or 12 in can be loaded at once, while 10 in, and 12 in records of the same speed may be mixed. Shut-off is automatic.

WW 319 for further details



LOUDSPEAKER UNIT

A 12-in full range (25-16,000 c/s) speaker with an impedance of 15/16 Ω has been announced by Adastra Electronics Ltd, 167 Finchley Road, N.W.3. Called the Silver Voice 15 and priced at 9 $\frac{1}{2}$ gn, it is intended for use in audio systems either as a single full-range unit, or with mid-range and high frequency units.

Increased high frequency performance and improved response are claimed as results of the SilverDisk h.f. diffuser, which is elastically coupled to the 1 $\frac{1}{2}$ -in diameter voice coil. With a power rating of 15 W r.m.s. (30 W peak), this unit has a bass resonance of 35 c/s.

The chassis is cast aluminium in silver

finish, while the suspension is plastic foam. Weight is 6 $\frac{1}{2}$ lb.

WW 320 for further details

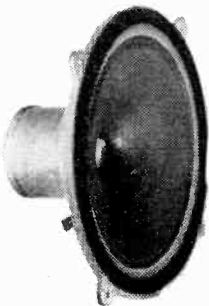

A.M./F.M. PORTABLE

A 14-TRANSISTOR a.m./f.m. portable receiver is available from Roberts Radio Co. Ltd., of Molesey Avenue, West Molesey, Surrey. A 7 \times 4 in loudspeaker is included and output is about 1 W from the complementary push-pull output stage. A rotatable telescopic rod aerial is fitted for v.h.f. reception, the rod being hinged. The receiver can also be rotated on a turntable, a common feature of Roberts receivers.

An interesting deviation from normal practice is that the f.m. and a.m. sections are completely separate, the i.f. stages being normally common. A broadband grounded-base input stage is used in the f.m. section. The tone control circuits in the a.m. stages are similar to the well-known Baxandall circuit. The receiver costs 29 gn and a carrying cover is available for 37s 6d.

MICROPHONE/RECEIVER

A HAND microphone which will operate as a two-way unit is announced by Amplivox. The microphone is known as the Telemike and a single electromagnetic transducer is used for both reception and transmission.

The sensitivity is -70 dB relative to 1 V per dyne/cm² (10 mV for close speech) and as an earphone +46 dB relative to 1 dyne/cm²/mW (at 1 kc/s). Impedance is 300 Ω at 1 kc/s and frequency coverage is 200 c/s-5 kc/s.

A "drop in" holder is also available for use with the Telemike. Typical applications include mobile radio, dictating machines and portable transceivers.

Amplivox Ltd., Beresford Avenue, Wembley, Middx.

WW 321 for further details



Picture Tube Reinforcement

THE new Mazda CME 1201 Rimband 12 in picture tube, like the Rimguard tube, is proofed against implosion by reinforcement of the join between the face and back. The simplified construction technique for Rimband, however, is dissimilar to those techniques previously employed.

The Rimband bulb has been formed to obtain correct distribution of stress;

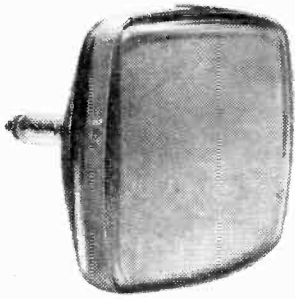

this, combined with a high-tensile steel band that is accurately positioned and tensioned during application, gives the CME 1201 its high strength.

This technique used by the manufacturers (Thorn-AEI Radio Valves & Tubes Ltd.) has considerable weight advantages, since elimination of safety glass, twin panel or metal frame and filler are achieved. Net weight of the tube, which has 110° deflection, is 6 lb. Another advantage is that maximum picture area is obtained.

WW 322 for further details

DARK TRACE C.R.T.

REPLACEMENT of the type AS 17-21 dark-trace c.r.t. with type AS 17-21A is announced by Standard Telephones and Cables Ltd. The main improvement in the new tube is an increase in operating life, which has been extended by a factor of five. For intermittent operation, the life of the new tube is approximately 40,000 write/erase cycles; if continual erasing is necessary a life expectancy of more than 3,500 hours is probable. The tube is particularly suitable in circumstances where the graphic presentation has a duration greater than 20-30s and where a complete series of a large number of successive transients at long intervals must be recorded. The type of oscillographic equipment for which the tube is suitable is that used for mechanical, aerodynamic, hydromechanical, thermal, chemical and low frequency electrical applications.

WW 323 for further details

WIRELESS WORLD, APRIL 1966



THE HOUSE OF BULGIN AT YOUR SERVICE

ENGRAVED SIGNAL LAMPS

Pioneers of Engraved Signal Lamps in Great Britain and still leading the field. These illustrations show only a small selection from our vast range of over 280 types. Legends can be permanently visible or secret-until-lit.

- ★ ONE MESSAGE OR MORE
- ★ IN ANY COLOUR
- ★ MAINS OR LOW VOLTAGE
- ★ IN ANY LANGUAGE
- ★ ENGRAVED TO ORDER
- ★ STAINLESS STEEL BEZELS

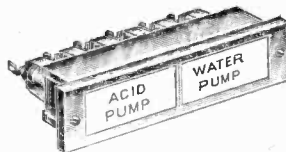

List No. D.870/2
Length 5 1/4", width 2 7/32", height 1 1/2"

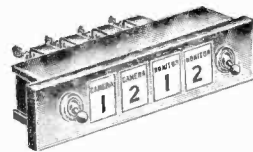

List No. D.872/2S/2L
Length 5 1/4", width 3 3/8", height 1 1/2"



List No. D.901/
M/SS
Length 5 7/64",
width 1 1/64",
height 4 7/64"

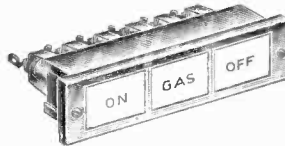

List No. D.870/3
Length 5 3/8", width 2 7/32", height 1 1/2"

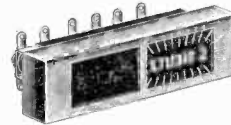

List No. D.902/M/SS/2
Length 2 47/64", width
1 1/64", height 4 7/64"



List No. D.610
1 13/16" Ø, 3" depth

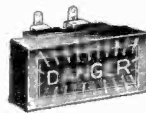

List No. D.720/M/SS
Length 1 49/64", width
2 11/64", height 4 7/64"

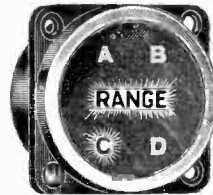

List No. D.830
Length 1 3/8", width 1 1/4",
height 1 3/8"

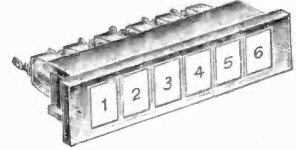

List No. D.870/6
Length 5 1/4", width 2 7/32",
height 1 1/2"

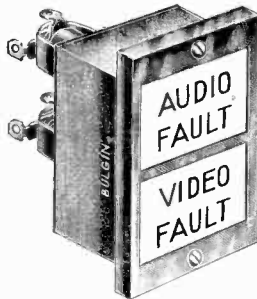

List No. D.871/2/VERT
Length 1 11/16", width 2 39/64",
height 2 11/16"

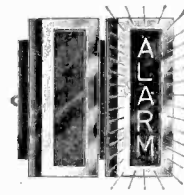

List No. D.720/M/SS
Length 4 7/64", width
2 11/64", height 1 49/64"

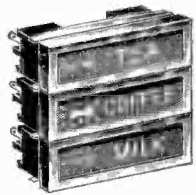

List No. D.920/M/SS
Length 1 29/32", width
1 1/16", height 1 9/32"

SEND FOR LEAFLET 1512/C

A. F. BULGIN & CO. LTD.,
Bye Pass Rd., Barking, Essex.
Tel: RIPpleway 5588 (12 lines)

MANUFACTURERS AND SUPPLIERS OF RADIO
AND ELECTRONIC COMPONENTS TO

ADMIRALTY	MINISTRY OF WORKS	B.B.C.
WAR OFFICE	MINISTRY OF AVIATION	G.P.O.
AIR MINISTRY	MINISTRY OF SUPPLY	(T.A.)
HOME OFFICE	RESEARCH ESTABLISHMENTS	N.P.L.
CROWN AGENTS	U.K.A.E.A.	D.S.I.R.

WW-126 FOR FURTHER DETAILS.

APRIL MEETINGS

Tickets are required for some meetings: readers are advised, therefore, to communicate with the secretary of the society concerned

LONDON

4th. I.E.E.—“Measurements on semi-conducting material” by Dr. G. A. Allen at 5.30 at Savoy Pl., W.C.2.

4th. I.E.E.T.E.—“Microelectronics” by G. W. A. Dummer at 6.0 at Savoy Pl., W.C.2.

5th. I.E.E.—“Teaching by television” by B. R. Webster at 5.30 at Savoy Pl., W.C.2.

14th. I.E.E.—Discussion on “Non-optical transmissions” at 5.30 at Savoy Pl., W.C.2.

14th. S.E.R.T.—“An introduction to the logical operation of digital computers” by B. Godfrey at 7.0 at London School of Hygiene and Tropical Medicine, Keppel St., W.C.1.

15th. I.E.E.—“Equilibrium coding for pulse code modulation” by A. H. Reeves at 5.30 at Savoy Pl., W.C.2.

15th. Inst. of Navigation—“Land navigation” by Col. J. Kelsey and D. N. Bisgood at 5.30 at the Royal Instn. of Naval Architects, 10 Upper Belgrave St., S.W.1.

15th. Television Soc.—“Domestic video recording” by W. Silvie at 7.0 at the I.T.A., 70 Brompton Rd., S.W.3.

18th. I.E.E. & I.E.R.E.—Discussion on “Computer bulk storage” at 5.30 at Savoy Pl., W.C.2.

19th. I.E.E.—“A high input impedance clip-on a.c. voltmeter” by G. F. Turnbull and B. E. Jones and “Automatic corona loss measuring equipment” by E. Rawlinson, P. H. King and P. K. Richardson at 5.30 at Savoy Pl., W.C.2.

20th. I.E.E.—“Automatic landing” by B. D. Armstrong at 6.0 at Savoy Pl., W.C.2.

20th. I.E.R.E.—“Low distortion transistor audio amplifiers—some important design characteristics” by P. J. Baxandall at 6.0 at I.E.R.E., 9 Bedford Sq., W.C.1.

20th. Radar & Electronics Assoc.—“A survey of video tape recording to date” by C. E. Urban at 7.0 at the R.S.A., John Adam St., W.C.2.

21st. I.E.E. Grads.—“Satellite communication” by D. Wray at 6.30 at Savoy Pl., W.C.2.

21st. Television Soc.—Fleming Memorial Lecture “The implications for television of modern thinking on the visual process” by Prof. W. D. Wright at 7.0 at the Royal Institution, Albemarle St., W.1.

26th. I.E.E.—Discussion on “Problems in the design and installation of surge-proof transistorized control equipment” at 5.30 at Savoy Pl., W.C.2.

27th. I.E.R.E.—Two papers on the U.K.3 satellite:—“Data handling and telemetry equipment” by W. M. Lovell and “The satellite and its ground checkout equipment” by F. P. Campbell at 6.0 at the London School of Hygiene and Tropical Medicine, Keppel St., W.C.1.

27th. I.E.R.E. & I.E.E.—Discussion on “Physiological and Psychological hazards of high intensity sound and light” at 6.0 at I.E.R.E., 9 Bedford Sq., W.C.1.

28th. I.E.E.—Fifty-seventh Kelvin Lecture “Scientific research in space” by Sir Harrie Massey at 5.30 at Savoy Pl., W.C.2.

29th. I.E.E.—“Distribution of mechanical forces in magnetized material” by Prof. G. W. Carter, “A note on the distri-

bution of mechanical forces in magnetized material” by C. J. Carpenter and “Evaluation of magnetized energy density in magnetized matter” by B. D. Popovic at 5.30 at Savoy Pl., W.C.2.

BASILDON

19th. I.E.R.E.—“Digital magnetic recording” by J. H. Streeter at 6.30 at Barmstable Grammar and Technical School.

BIRMINGHAM

19th. I.E.R.E. & I.E.E.—Symposium on “Communication in Industry” at 9.30 a.m. in Dept. of Electronic and Electrical Engineering, the University.

20th. Television Soc.—“The Post Office Television Switching Centre” by F. Salter at 7.0 at Broadcasting House, Carpenter Rd., Edgbaston.

BRISTOL

5th. I.E.E.T.E.—“Future development in television” by F. C. McLean at 6.30 at the Council House, College Green.

12th. Television Soc.—“Radiophysics” by F. C. Brooker at 7.30 at the Royal Hotel, College Green.

CHELMSFORD

18th. I.E.E.—“Microelectronics” by J. G. Cressell at 6.30 at the Lion and Lamb Hotel.

FARNBOROUGH

5th. I.E.E. & I.E.R.E.—“Ultrasound in medicine” by P. N. T. Wells at 6.30 at the Technical College, Boundary Rd.

GLASGOW

6th. I.E.E.—“The industrial designer in electrical engineering” by P. E. M. Sharp at 6.0 at the Inst. of Engineers and Shipbuilders, 39 Elmbank Crescent, C.2.

20th. I.E.E.T.E.—“The future of telecommunications” by D. A. Barron at 6.30 (venue undecided).

LEEDS

7th. I.E.R.E.—“D.C. stabilized power supplies” by T. F. Cryer at 7.0 at Dept. of Electrical Engineering, the University.

20th. S.E.R.T.—“Television studio control equipment” by P. R. Berkley at 7.30 at Branch College of Engineering, Cookridge Street.

LEICESTER

26th. Television Soc.—“The G.P.O. Museum Tower” by J. R. Mackie at 7.15 at Vaughan College, St. Nicholas St.

LIVERPOOL

20th. I.E.R.E.—Annual General meeting of the Merseyside Section at 6.30 followed by “Colour television by wire” by E. J. Gargini at the Walker Art Gallery, William Brown St.

NEWCASTLE-UPON-TYNE

6th. S.E.R.T.—“Microwave techniques” by J. Bilbrough at 7.15 at Charles Trevelyan Technical College, Maple Terrace.

13th. I.E.R.E.—“Instrument colour matching” by J. Hambleton at 6.0 at Inst.

of Mining and Mechanical Engrs. Neville Hall, Westgate Rd.

OXFORD

19th. I.E.R.E.—“Hybrid analogue/digital computers” by Dr. C. H. Vincent at 7.30 at Clarendon Laboratory, Parks Rd.

PLYMOUTH

6th. Television Soc.—“Sound in television” by D. J. Basinger at 7.30 at Westward Television Studios.

PORTSMOUTH

19th. I.E.E. Grads.—“The design of high quality audio amplifiers” by J. Dinsdale at 7.0 at the College of Technology, Anglesea Rd.

PRESTON

20th. I.E.E.—“The Radiophonic Workshop of the B.B.C.” by F. C. Brooker at 7.30 at Harris College, Corporation St.

SOUTHAMPTON

28th. S.E.R.T.—“Video tape recording” at 7.30 at the College of Technology, East Park Terrace.

TORQUAY

28th. I.E.E.—“The Radiophonic Workshop of the B.B.C.” by F. C. Brooker at 2.30 at Electric Hall, Union St.

YORK

5th. I.E.E.—“Research and development in control engineering” by Prof. J. H. Westcott at 7.0 at the Royal Station Hotel.

LATE MARCH MEETINGS

LONDON

25th. I.E.E.—“Propagation measurements at 11 Gc/s for line-of-sight communication” by D. Turner, B. J. Easterbrook and J. E. Golding; “Measurement of multipath propagation over a line-of-sight radio link at 4 Gc/s using frequency-sweep techniques” by R. W. Meadows, R. E. Lindgren and J. C. Samuel; and “The determination of the total reflection of a 3-6cm wavelength radiation passing through the atmosphere” by D. E. T. Nicholls at 5.30 at Savoy Pl., W.C.2.

25th. I.E.E.—Discussion on “Semi-conduction in organic and other weakly conducting materials” at 5.30 at Savoy Pl., W.C.2.

28th. I.E.E., I.E.R.E. & Television Soc.—“Semiconductors in television receivers” by R. Bridger, K. E. Martin and P. L. Mothersole at 5.30 at Savoy Pl., W.C.2.

29th. I.E.R.E. & I.E.E.—Symposium on “Computer control in industry: equipment design and application engineering” at 10.30 at the London School of Hygiene and Tropical Medicine, Keppel St., W.C.1.

29th. I.E.E.—Discussion on “Gun-effect devices” at 5.30 at Savoy Pl., W.C.2.

31st. I.E.R.E.—A symposium on “Monitoring of ground and airborne I.L.S. equipment for automatic landing” at 2.30 at the London School of Hygiene and Tropical Medicine, Keppel St., W.C.1.