

## Fair of the Air

THIS year the National Radio Show reflects the atmosphere of expectancy which for some time now has surrounded the workings of the Pilkington Committee. In many cases expectancy has been followed by active anticipation and sets have been produced to receive the u.h.f. bands and dual line standards which many people think the Committee may propose and the Postmaster General may or may not approve. The B.B.C., too, will be showing what they could do in colour if only they were given the green light.

Some people will stigmatize these moves as tendentious, an attempt to force the hand of the Pilkington Committee; others will point to the inconsistency of manufacturers who collectively, through their associations, advocate the retention of 405 lines, but who will be demonstrating 625-line receivers at Earls Court on signals provided by Radio Exhibitions Ltd., an off-shoot of B.R.E.M.A. As we see it there is nothing inconsistent in advocating and hoping for stability, but at the same time hedging against inflation—whether it be of monetary values or of line standards. In any case many of the 625-line sets will be ostensibly for export only.

The demonstrations of colour will be a great success and will give many members of the public who have so far only read about it the pleasure of seeing the technical excellence of the pictures which can be transmitted—and received in areas of good signal strength.

Comparative demonstrations of 405- and 625-line standards will, we think, provide plenty of good clean fun. It will be amusing to try to guess, from the size of screens used and any differences in the degree of interlace, into which camp any particular manufacturer has wittingly or unwittingly placed himself. Seriously, we think the differences in picture quality will be marginal and we would suggest that if demonstrations on the floor of the hall are inconclusive a visit to the gallery and a glance at the monitor screens through the windows of the R.I.E. control room might help to give the casting vote. Many of the 625-line receivers on show will be export models and so the signals distributed to the stands will be on one or other of the Continental 625-line standards. It should not be forgotten, however, that the Television Advisory Committee in its 1960 report recommended modifications to those standards in the event of the adoption of 625 lines in the U.K. The improvements may be "marginal but definite" and we only mention them here to underline our main point, that the demonstrations

which will be put on for our enjoyment at the Show should not be used at this stage to form hard prejudices.

The general public, for whom the Show is primarily intended, will be unaware of and therefore not unduly perplexed by these considerations and will tend to see these things metaphorically in black and white (and literally, too, for the line structure will not be so apparent in colour). They are likely to be more confused by the association of famous names—hitherto rivals for their custom—on the stands of some of the new and even larger company groups. At one time these associations were kept as quiet as possible, on the principle that if a customer gave a bad name to brand X you still had the chance of selling him virtually the same set under brand Y. These days are past, largely due to the motor manufacturers who make no secret of selling the same car under different names. But the customer still has the choice of a different radiator grille, and knows that the initial price and the cost of service and spares would probably be much higher but for the rationalization of basic production.

Last year we deplored the fact that the Pye Group had decided to hold their own Show outside Earls Court and we are glad to see them once again in the main exhibition. This year it is the turn of G.E.C. (with Sobell and McMichael) to invite us to make the journey to another part of London in order to see their products and their own demonstration of colour television. Once again we think it a pity that last minute differences between the organizers and some of their principal exhibitors cannot be resolved in time to make a national show truly representative of all that this country has to offer in television and sound broadcasting.

## Brit.I.R.E.

BY an Order in Council dated 2nd August Her Majesty the Queen has granted a Royal Charter to the British Institution of Radio Engineers. Since it was founded in 1925 the technical standard of its meetings and published papers has not only reached but has been sustained at the highest level. It has drawn the support of many eminent figures in radio and electronic engineering and has formed a focal point for workers in these professions throughout the Commonwealth. We offer congratulations to the members and administrative body of the Institution on this authoritative recognition of their efforts and achievements.

# Listening in the Next Room

WHY THERE IS AN APPARENT IMPROVEMENT IN SOUND QUALITY

By J. MOIR, M.I.E.E.

**M**ANY people have noted that "my loudspeaker sounds better when I listen in the next room", and have wondered why this should be so. Clearly a difficult question to answer when we do not understand all the factors that result in one loudspeaker "sounding better" than another one, though the reasons for the gross differences are, of course, well understood.

Whether a loudspeaker does sound better in an adjacent room is clearly a matter of opinion. In most instances the judgement has been the result of a casual observation rather than a laboratory experiment, but the view has been independently expressed so frequently that it probably has some significance. I have also noted the same phenomena, and, in consequence, decided to explore the objective performance of a loudspeaker playing in an adjacent room to see if there is any reasonable explanation of the reported improvement.

In every instance sound quality was reported to improve only when orchestral music was being played. Comment about speech reproduction

resulting from listening in the adjacent room. These suggestions will be examined in turn.

The frequency response as measured at a remote listening position may differ radically from that measured nearer the loudspeaker, particularly if the rooms have widely different furnishings. As the measuring microphone is moved away from the loudspeaker the contribution of the direct sound from the loudspeaker to the total acoustic intensity at the measuring position becomes less significant. The indirect sound, the result of room reverberation, then constitutes the major part of the total acoustic power at the listener's ears. Now the energy spectrum of a complex sound wave is modified at each reflection from a boundary surface, the general effect being a reduction in the high-frequency content, for most wall finishes and furnishings are more effective absorbants at the high audio frequencies than they are at the low-frequency end of the spectrum. Thus the measured frequency response will generally exhibit a progressive reduction at the high-frequency end as the microphone is moved away from the loudspeaker. This is illustrated by Fig. 1 which shows the result of some measurements on a Quad electrostatic loudspeaker in a well-furnished room.

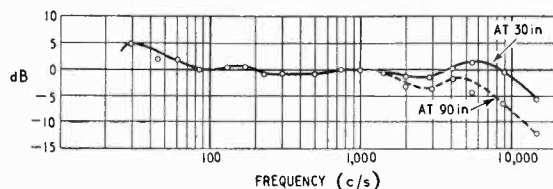

Fig. 1. Effect of microphone/loudspeaker spacing on frequency response.

varied, but in no instance was any significant improvement noted when the listener moved into the adjacent room. Under these conditions, speech required more concentration (i.e. intelligibility was lower) but there was some comment that "speech sounds very natural". In every instance the communicating door between the two rooms had to be wide open to achieve an improvement in sound quality, all those questioned being in agreement that with the door closed or even slightly open the top response suffered. Again, all were in agreement that sound quality was adversely affected when judged in the room above that in which the loudspeaker was playing.

"Sounding better" is a rather nebulous description of a change in sound quality. An improvement in quality may result from a modification in the effective frequency response at the listening position, or from some reduction in the intrinsic distortions produced by the loudspeaker. As a third alternative the sound may be improved by some advantageous change in the acoustic environment

## Coupling Between Rooms

There is a second effect that may also introduce some frequency discrimination. An opening between two rooms does not transmit sounds of all frequencies with equal efficiency. At low frequencies the standard door opening (6ft 6in by 2ft 6in) is a fraction of a wavelength and thus gives a relatively inefficient coupling between two rooms. The actual coupling efficiency is a function not only of the area of the opening, but also of the size and shape of the two rooms and the position of the communicating opening in the common wall. At the top end of an audio spectrum a standard door opening is many wavelengths wide and is likely to give efficient coupling between the rooms.

The increase in coupling efficiency at the higher audio frequencies tends to offset the increase in room absorption in the same part of the audio spectrum, and thus the frequency response as measured in the second room may not differ widely from that found in the loudspeaker room. A calculation of the overall result is difficult and probably pointless in view of the many variables, but Fig. 2 illustrates the results of measurement in two rooms in the writer's house.

The curve was obtained by driving the loudspeaker (not the speaker used to obtain the data for Fig. 1) from a white-noise source and measuring the sound pressure level in bands one-third of an octave wide between 50 c/s and 10 kc/s. The measurements were carried out in two adjacent

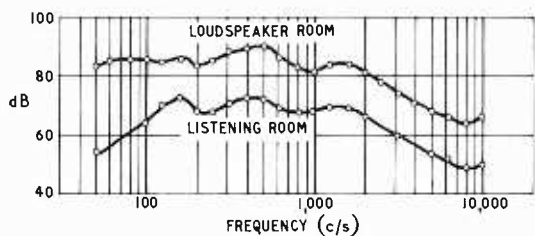

Fig. 2. Speaker frequency response in loudspeaker and listening rooms.

rooms. In this particular instance the top response is not appreciably attenuated in the second room, but the bass response below about 160 c/s shows an increasing loss. Unless further tests showed this to be typical it would not appear to be very significant.

There seems no reason to expect that the intrinsic distortions introduced by the speaker will be reduced by the presence of the second room, but they may become less noticeable when heard in an adjacent room. A non-linear relation between electrical input and the resultant sound pressure implies the appearance of harmonically related tones and, when a complex wave is being reproduced, the introduction of inharmonically related intermodulation products. Harmonics do not result in any very significant subjective annoyance, but the accompanying intermodulation products introduce roughness, and create "blurr", and this is extremely annoying. Listening in the adjacent room may well reduce the high-frequency response, and this will reduce the amplitude of the higher harmonics, but it will do little to modify the intermodulation distortion products, for being difference tones many of these will be close in frequency to the primary tones. Thus there is no very good reason for expecting that any improvement in sound quality due to listening in the adjacent room is the result of a reduction in non-linear distortion.

Doppler distortion, the introduction of frequency modulation products as a result of the use of a single diaphragm sound radiator, may well be slightly reduced by listening in an adjacent room. These distortion products are concentrated in the direct sound on the speaker axis and do not exist in the plane of the diaphragm. Any change in the acoustic environment that results in a decrease in the ratio of direct to reverberant sound will reduce the annoyance created by this form of distortion. Normally it does not make a very significant contribution to the total distortion, so it is unlikely that any reduction due to adjacent room listening will result in any very noticeable improvement in overall sound quality.

Significant annoyance can be created by the presence of lightly damped, mechanically resonant elements in a loudspeaker cone or chassis. Such elements continue to "ring" after the driving impulse ceases and thus colour the reproduction to an extent quite out of proportion to their effect on the steady-state response curve. Their subjective effect is likely to be reduced by listening in an adjacent room merely because any room introduces ringing of the same general kind and two rooms introduce twice as much distortion of this type as one room. An increased amount of room ringing might

dilute similar distortion introduced by the speaker itself, but while it is impossible to be dogmatic, reduction of the effect of speaker ringing is not thought to make a significant contribution to any improvement in sound quality that results from listening in an adjacent room.

The sound transmission loss introduced by a standard wooden door or the usual board-on-joint ceiling is so frequency-dependent that it might be expected to result in unacceptable sound quality in an adjacent room or in a room above. A typical plywood door will introduce a loss at 10 kc/s (relative to the loss at 1 kc/s) of about 10-12 dB, while a plasterboard joist and board ceiling will result in a relative loss of 25 dB. Average values for doors and ceilings are shown in Fig. 3, but the sound insulation value of a door is critically dependent upon the leakage through cracks round the jamb.

Measurement of the attenuation introduced and observations on the sound quality that results from listening in an adjacent room under "door closed" conditions are at least in fair agreement.

### Reverberation Change

On reviewing the previous discussion it seems reasonable to suggest that none of the factors mentioned is likely to account for the reported improvement in sound quality due to listening in an adjacent room. The effect on frequency response should, from the conventional viewpoint, only result in a deterioration in sound quality, but in this particular instance the change is probably too small to be significant. However, let us look at some of the more predominantly acoustic factors that affect the quality of reproduction.

An aesthetically satisfying orchestral performance is only secured when the direct sound reaching the ears without any reflection is softened and rounded by the presence of a proportion of reverberant sound. The ratio of direct to reverberant sound is generally adjusted at the studio either by placing the microphone at a suitable distance from the orchestra or

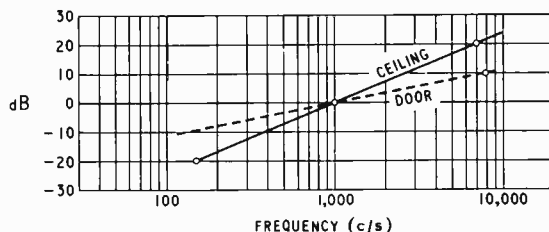

Fig. 3. Average transmission loss due to doors and ceilings.

by mixing into the output of a microphone close to the orchestra a suitable amount of sound from some more remotely placed microphones. There is some evidence that even when the optimum spacing of microphone and orchestra for a monophonic transmission is achieved, the result is less satisfying than that obtainable from a two-channel transmission.

At the receiving end, the amount of reverberant sound can be increased by moving away from the loudspeaker, though a limit to the effect is set by the reverberation time of the listening room. Any further addition can only be achieved by moving out of the room and into the adjacent room. The imme-

diate result will be to produce a listening space of increased volume and having (possibly) a longer reverberation time.

There is no simple method of calculating the combined reverberation time of two rooms coupled by a communicating opening, for the combined value is a function of the area and position of the communicating opening, and of the relative positions of loudspeaker and microphone. As a simplification that applies when two typical domestic-sized rooms of roughly equal size and similar furnishing are coupled by a standard door, it can be said that the reverberation time of the combined volume is roughly  $\sqrt{2}$  times that of either room. This would not hold if the reverberation time of the individual rooms differed appreciably.

Thus both the physical and acoustic size of the listening environment is increased by moving into an adjacent room. This is thought to be a significant advantage. As a result of listening tests carried out some years ago, the author came to the conclusion that good sound quality could not be secured in a room having a volume less than (roughly) 1,600 cubic feet and that between rooms of about 1,000 cubic feet and 1,600 cubic feet there was a very rapid improvement in sound quality with increase in room volume. Above about 2,500 cubic feet the rate of change of quality with further increase in volume decreased, though the quality continued to improve with increase in room size.

It may well be that in most of the instances of improvement that have been reported, the volume change produced by adding the second room happened to fall on the steep portion of the sound quality/room volume relation suggested above.

### Room Resonances

However, in my own personal experience, the subjective effect of listening in an adjacent room is that one is in a room very much larger than a single room having the volume of the combined rooms. The change is one of character rather than quantity of reverberation. This may be due to the following properties of coupled rooms.

Any room exhibits a series of room resonances (eigentones is the fashionable word) the frequencies of which are determined by the room dimensions. Resonance occurs at each of the frequencies at which the length, width and height are half a wavelength, and at harmonics of these frequencies. Thus there are three independent series of resonances, one for each of the three axes of the room. In addition there are other series of resonances corresponding to the combination of the three axial dimensions, though there is some evidence that these are not particularly important in determining the acoustic character of a room.

Rayleigh deduced an equation relating room dimensions and resonance frequencies

$$f = \frac{V}{2L} \sqrt{\frac{A^2}{L^2} + \frac{B^2}{W^2} + \frac{C^2}{H^2}}$$

where L is the length, W the width, H the height, V the velocity of sound and A, B, C independently any of the integers 0, 1, 2, 3, 4, etc. For a typical room (15.3ft by 11ft by 8.2ft), Fig. 4 shows the first 10 resonant frequencies. This room is perhaps larger than the average listening room, but it will be seen that all the resonances fall in the lower part of

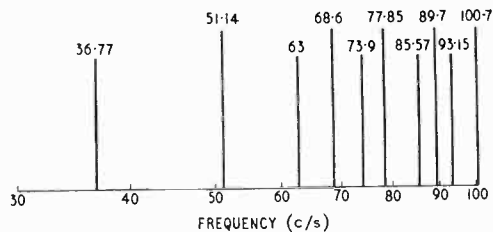

Fig. 4. Typical eigentone spectrum for a small room.

the audio band. For a smaller room the resonance frequencies would appear at correspondingly higher frequencies and their effect would be subjectively more obvious.

It will be noted from Fig. 4 that the resonances in the lower end of the range are well spaced apart, the spacing decreasing with increase in frequency. Apart from changing the shape of the room, nothing can be done to modify the spacing of the resonances or to decrease the gaps between the individual resonance frequencies. However, if one listens in an adjacent room coupled by a relatively small opening, the eigentones corresponding to each room exist separately. When the dimensions of the listening room differ from that of the loudspeaker room, the eigentone spectra of the two rooms will interlace and tend to reduce the gaps that exist in the resonance spectrum of any single room.

All the eigentones corresponding to the sum of those characteristics of the separate rooms will not exist in the coupled rooms, for the coupling between rooms will be weak for those modes of resonance in which the air particles are moving parallel to the door opening. Nevertheless, in a typical example the number of modes that are excited will be much greater than that of either room considered alone, or in a single room having a volume equal to that of the combined rooms. Thus the overall acoustic performance of two coupled rooms is considerably smoother than that of any single room unless the single room is so large that the first ten (approximately) resonance frequencies are approaching the sub-audible, and thus have no very significant effect on the sound quality.

The acoustic performance of a small (domestic size) room is determined almost entirely by the eigentone spectrum and particularly that part of the spectrum below about 200 c/s. Any smoothing of the spectrum should make the small room performance approach that of a much larger room; it should in fact convert a domestic sized room into the domestic equivalent of a small hall.

Finally, there is the possible effect of the size of the sound source. When listening in an adjacent room the effective source of sound tends to be the door opening and not the loudspeaker. This increases the source size by a large factor, an area increase in the region of two hundred times taking the example of a 12-in speaker and a standard 6ft 6in by 2ft 6in door. Not all critics are in agreement on this point but I believe that a large sound source results in a softness and lack of irritation in listening that cannot be achieved with a small source. The reason for this is not particularly clear and in the situation being discussed it may not be particularly important, but at least the change in size is a change in the direction of improving the sound quality.

A number of possible explanations for the improvement in sound quality have been discussed, and there may be others, but it is impossible to be sure which, if any, of the suggested mechanisms of improvement is really significant. The coupling between a room and the loudspeaker is so poor that the intrinsic performance of a speaker is unlikely to be affected by the relatively small change produced by opening a door into a second room. This suggests that it is the acoustic environment of the listener that is significantly changed when he moves into an adjacent room. Of the explanations discussed, smoothing of the eigentone spectrum appears most likely to result in an improvement in sound quality, but the apparent lengthening of the reverberation time (using the conventional definition) may also contribute. Both these effects are characteristic of a small hall and this agrees with the subjective assessment of the effects produced by moving into an adjacent room.

The absence of any suggestion that speech "sounds better" and the comment that "speech

sounds very natural" is qualitatively consistent with the improvement on music being due to smoothing of the eigentone pattern rather than to any increase in reverberation time.

The only experimental observations that may be at variance with the suggested explanation of "eigentone spectrum smoothing" is that I have never met an example where sound quality was improved by opening a door into a second room while listening in the first room. In my experience this almost invariably results in a degradation in sound quality though I have no other observers' comments on this listening condition.

Any well-founded conclusion would require an extensive investigation first to decide whether there really is an improvement in sound quality when listening in a room adjacent to that containing the speaker system. If this was confirmed then a fairly large number of specific examples would have to be examined in detail to see whether there were any common factors. An interesting but unremunerative project.

## SCOUT SATELLITE EQUIPMENT

THE photograph on the right shows an e.h.t. generator producing 1.6kV for the counter tubes used to detect X-radiation in the Scout research satellite, UK Scout 1. Designed by Bristol Aircraft for the Space Research Group at University College, London, the generator will have to supply power for as long as a year and maintain the voltage stable in the face of a variation of supply of  $\pm 15\%$ .

A single-transistor 8-kc/s oscillator, drawing 80mW at 6.5V, has its output stepped up by a transformer and quadrupler rectifier. The high voltage is then smoothed to contain less than 0.005% ripple and stabilized by a corona stabilizer tube to within 1.5V at 1.6kV.

The completed unit is  $5\frac{1}{2}$ -in in diameter and the components are coated with polysulphide rubber and "potted" in foamed synthetic resin. This will prevent discharges during the reduced air-pressure phase encountered as the Skylark rocket lifts UK Scout 1 into orbit.

The photograph below shows an eight-channel capacitor data storage unit for electron density measurements made in the same satellite. This unit has been developed by G. & E. Bradley Ltd., for the Electron Physics Department of Birmingham University.

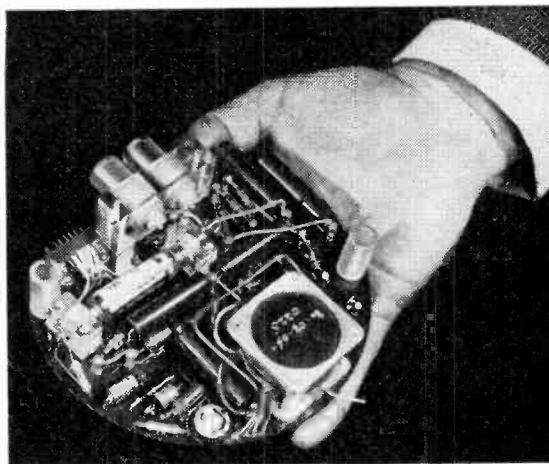

*E.h.t. generator.*



*Data store.*

Information on the maximum electron density in the first ten seconds of each sixty-one second period is gated into the store. It is read out towards the end of this period either to the telemetry system for immediate transmission to earth or to magnetic tape for subsequent transmission at a more convenient time. The sequence of operations is erase, gate, read in, store and read out, the timing being obtained from the satellite master clock.

This unit contains 180 components (mostly silicon diodes and transistors) in a space  $1\frac{1}{4}$ in by  $5\frac{1}{4}$ in diameter. It weighs about 8oz, unencapsulated.

**Radio Valve Data:** A.E.I. have asked us to point out that the address of their Electronic Apparatus Division was omitted from p.123 of the seventh edition of *Wireless World* "Radio Valve Data." All enquiries concerning semiconductor products listed as "A.E.I." should be sent to Associated Electrical Industries, Ltd., Electronic Apparatus Division, Carholme Road, Lincoln.

# Transistor V.H.F. Amplifier

FRINGE AREA F.M. RECEPTION

By F. BUTLER

UNTIL recently the high cost of v.h.f. transistors has discouraged their use in domestic broadcast receivers, although a study of the characteristics of such types as the Philco/Semiconductors 2N502 and Texas Instruments 2G101 or 2G102 shows that they should perform well in the 80-100 Mc/s frequency range. Data sheets<sup>1</sup> have in fact been produced by Texas Instruments giving designs suitable for use at 100 Mc/s and also at 200 Mc/s.

In the autumn of 1960, Semiconductors Ltd. released technical data on a range of inexpensive transistors, including one, Type T 1832, having a maximum frequency of oscillation around 1,300 Mc/s. Substantial price reductions of the Texas transistors have also been made. Samples of all these units have been tested by the writer in a simple 2-stage tuned amplifier designed to form the front end of a conventional f.m. tuner (Eddystone Type 820), in order to increase the sensitivity sufficiently for use in fringe areas with a simple indoor dipole aerial.

With minor modifications this unit has been in continuous use for some months and has made a worth-while improvement in the performance of the tuner, particularly during periods of poor v.h.f. wave propagation.

A single-stage tuned amplifier using a good transistor in the common-emitter connection will give a gain of 15-20 dB and will have a noise figure around 5-7 dB. For stability with this high gain the amplifier must be neutralized or unilateralized. Extra components are required and the adjustments become tedious unless a fair amount of test equipment is available. If very high Q coils are used the bandwidth may be inadequate for high quality f.m. reception while the use of broad-band lossy circuits will cause a substantial decrease in gain. An alternative is to use two low-gain broadband stages in

tandem. Under favourable conditions one can then dispense with the neutralizing components. Experience shows that with purely resistive terminations it is easy to construct a stable high gain amplifier using two grounded base transistors in cascade but that when an aerial is connected to the input through a transmission line, and when the amplifier output is connected to a receiver instead of a pure resistance load, a rather drastic gain reduction may be required to maintain stability. The judicious use of damping resistors backed by a careful choice of component values will normally result in stable operation over a wide range of temperature and supply voltage changes.

A recent paper<sup>2</sup> on the measurement of transistor power gain and noise figure at frequencies up to 100 Mc/s contains much information of value to the circuit designer and indicates the performance which can be achieved using currently available transistors. With some types an increase of emitter current results in a substantial increase in gain, accompanied by a reduced noise figure. With all types there is a progressive reduction in gain as the operating frequency is raised from 30 to around 100 Mc/s. Gain and noise figure are not the only factors which must be considered in designing a transistor amplifier. It will be found that in respect of cross modulation the performance of transistors is much inferior to that of conventional valve amplifiers. Too much gain will also bring in a number of unwanted continental v.h.f. transmissions and unless the first oscillator and mixer stages are very well designed there may be some pulling or f.m. of the oscillator frequency. There may also be a degradation of the receiver performance in respect of a.m. suppression and in the degree of reduction of impulsive interference.

Before considering a practical amplifier circuit it

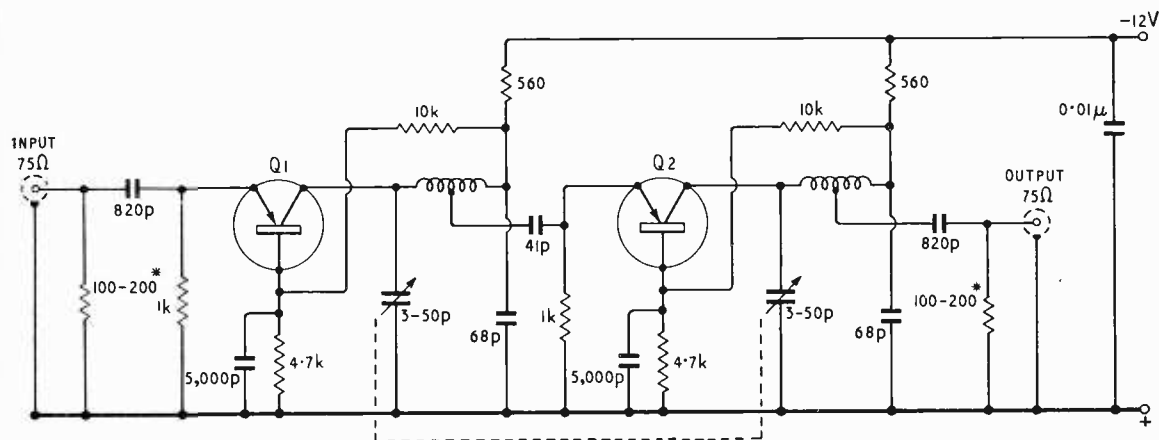
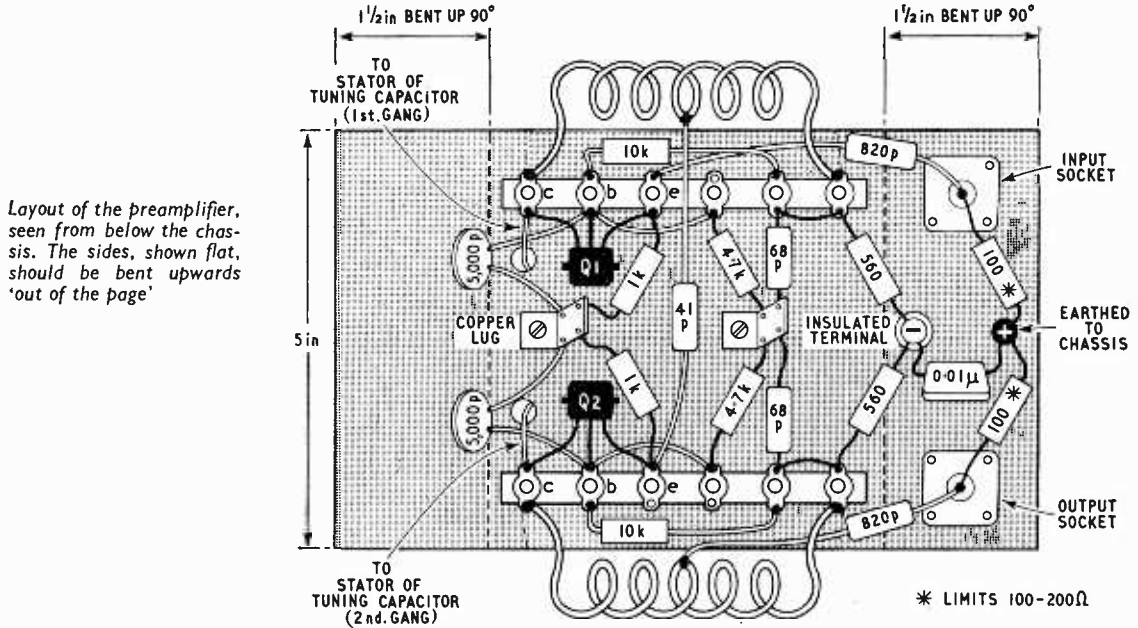

Fig. 1 Circuit diagram of v.h.f. preamplifier. The transistors can be Semiconductors T1832 or 2N502, or Texas Instruments 2G101 or 2G102

CHASSIS PLATE 5in x 6 1/2in 18 s.w.g.



Layout of the preamplifier, seen from below the chassis. The sides, shown flat, should be bent upwards 'out of the page'

is worth comparing the merits of tunable versus broadband amplifiers. The tunable version is clearly acceptable if it forms an integral part of a complete receiver, since its tuning mechanism can be ganged to the oscillator control. It is a nuisance if it is used with a separate receiver because tuning then calls for the manipulation of two controls. Against this, cross-modulation is likely to be worse with the broad-band amplifier and, for transistors with a limited gain—bandwidth product, the gain is necessarily lower than for a narrow band amplifier. On balance, it may be advisable to accept the necessity for additional controls when a fairly high gain with a reasonably low noise figure are the prime requirements.

### Practical Amplifier Circuit

The complete circuit diagram of an experimental amplifier is shown in Fig. 1. The arrangement is entirely conventional and calls for little comment. Both amplifier transistors are operated in the earthed base mode and the bias network components are chosen to ensure thermal stability over a wide temperature range. The input impedance of Q<sub>1</sub> is rather higher than the characteristic impedance of the 75-ohm coaxial cable from the aerial, but the mismatch is not so serious as to warrant the inclusion of a broadband transformer. Instead, a supplementary resistance may be used to terminate the cable. Its value should be in the range of 100-200 ohms.

The aim to be achieved in the design of the inter-stage and output circuits is to get the maximum possible gain consistent with stability and at the same time to ensure that the loaded Q of the circuits is low enough to give the necessary bandwidth for distortionless f.m. reception.

The coupling network between the two transistors is required to match the output impedance of the first stage to the input impedance of the second. For use at a single frequency a pi-network consist-

ing of a coil and two capacitors is convenient for this purpose. Design data for such networks can be found in Terman, "Radio Engineers' Handbook," 1st Edition, p.p. 208-214. The simple pi-network is less suitable for use in an amplifier which is required to be tunable over a range of frequencies by variation of a single capacitor. A satisfactory compromise is to use a hybrid coupling system in the form of a pi-section with a variable capacitor only at the input end and to secure an impedance match by connecting the load to a suitable tap on the tuning coil. The transistor standing collector-current is fed through a 560-ohm resistance into the network at a low-impedance point without serious reduction of the unloaded Q of this circuit.

The output tuned circuit provides an impedance match between the second transistor and the input impedance of the f.m. tuner connected to the output end. Except for one coupling capacitor (820 pF instead of 41 pF), the components in both networks are identical. Each circuit is tuned by one element of a 2-gang, 3-50 pF tuning capacitor which in fact covers a frequency range well in excess of the f.m. band 85-100 Mc/s. This allows considerable latitude in the construction of the associated tuning coils. If desired, smaller variable capacitors may be used in conjunction with some fixed parallel capacitance so that the desired band is just covered by the full range of capacitance change.

The choice of tapping points on the tuning coils is not at all critical and a centre tap is actually used. This gives sufficient damping to guarantee stability and the bandwidth is well in excess of the f.m. requirement. Higher gain, with a correspondingly smaller bandwidth, requires the tapping point to be brought nearer to the output end of the network. Lower gain (and less risk of instability) will result if the tap is made nearer to the input (collector) end of the tuned circuit.

The remaining components on the diagram in-



clude coupling capacitors, decoupling components and filtering elements. The values of these are not particularly critical although it is possible that more precise matching could be achieved by a more careful choice of coupling capacitors.

### Construction and Alignment

The amplifier is assembled on a small aluminium chassis  $5\text{in} \times 3\frac{1}{2}\text{in} \times 1\frac{1}{2}\text{in}$  deep, the ends being left open for easy access when wiring. The 2-gang tuning capacitor is mounted on the flat top and the rear panel carries the battery terminals and the coaxial input and output sockets.

Two 6-way ceramic insulated tag strips serve to support most of the components, ground connections being made to low-inductance copper straps bolted to the metal chassis.

The two tuning coils are self-supporting and each consists of six turns of 18 S.W.G. enamelled copper wire wound on a  $\frac{5}{16}\text{in}$  round former  $1\frac{1}{4}$  inches long. Before winding, the enamel covering should be scraped from the middle of each length of wire and the cleaned portion carefully tinned to simplify the subsequent connection of a centre tap. The point-to-point wiring diagram in Fig. 2 is self-explanatory. For clarity the folded sides of the chassis are shown developed flat. They are actually bent through a right angle along the dotted lines.

Alignment consists simply of tuning to a programme nearest to the high frequency end of the range and squeezing or expanding turns on the tuning coils until the maximum signal is received, re-tuning the capacitor after each operation on the

coils. Tracking will then be found to hold over the remainder of the range.

### Performance

At 90 Mc/s the power gain between 75-ohm resistive terminations is at least 30 dB and the amplifier remains quite stable. This gain figure is an artificial one and must be regarded with caution if the amplifier is used between a reactive source and load. Under some conditions the use of an excessively high collector voltage will provoke instability at frequencies around the maximum of 100 Mc/s. Even with reactive terminations, stability can always be achieved at one selected frequency by conjugate matching at both input and output of the amplifier. In principle this is a simple operation, calling for equal resistances and equal but opposite reactances on both sides of the matching terminals. In practice, the adjustment required is a function of frequency and is difficult to maintain over a wide range of frequencies. Except in the case of gross mismatching of impedances, a moderate reduction in collector voltage and current is sufficient to ensure unconditional stability.

### REFERENCES

1. Texas Instruments, Ltd. Application Note No. 2: "Operation of V.H.F. Transistors with Collectors Earthed." Application Note No. 4: "V.H.F. Amplifiers Using Diffused-base Mesa Transistors."
2. Transistor Measurements: Power Gain and Noise Figure at Frequencies up to 100 Mc/s. B. N. Harden and R. W. Smith, *Electronic Technology*, February 1961, p. 58.

## S.B.A.C. EXHIBITORS

WHEN one considers that some 20% of the capital cost of "military" aircraft such as the Buccaneer is for its electronic and radio equipment, it is not surprising that this aspect of aeronautics will be well represented at the Farnborough Air Show (4th-10th Sept.), organized by the Society of British Aircraft Constructors. Almost 40% of the exhibitors in the static exhibition are showing electronic or radio equipment (see list below). As already announced, we hope to include in our next issue a survey of the trends in aeronautical electronics as seen at the show.

A.E.I.  
Airmed  
Aircrew Co. & Jicwood  
Amalgamated Wireless (Aust.)  
Amphenol-Borg  
Amplivox

B.I. Callender's Cables  
Bakelite  
Bell Precision Engg. Co.  
Belling & Lee  
Beme Telecommunications  
British Aircraft Corp.  
British Communications Corp.  
British Mfd. Bearings Co.  
Brown, S. G.  
Bryans Aeroequipment  
Burgess Products Co.  
Burndept

Canadian Marconi Co.  
Cementation (Muffelite)  
Chloride Batteries  
Ciba (A.R.L.)  
Cole, E. K.  
Cossor, A. C.

Cossor Radar & Electronics  
Curran, John

Decca Navigator Co.  
Decca Radar  
Delaney Gallay  
"Diamond H" Switches

Ekco Electronics  
Elliott Brothers (London)  
English Electric Co.

Ferranti  
Fibreglass  
Formica

G.E.C.  
General Precision Systems  
Girdlestone Pumps  
Godfrey, Sir George  
Goodmans Industries  
Graseby Instruments  
Grundy & Partners

Hawker Siddeley Aviation  
Hellerman  
Hendrey Relays  
Honeywell Controls

Imhof, Alfred  
Integral

K.L.G. Sparking Plugs  
Kelvin & Hughes  
Ketay

Lucas, Joseph  
Lucas Gas Turbine Equip.

M.L. Aviation Co.  
Marconi Instruments  
Marconi's W/T Co.  
Marston Excelsior  
Micanite & Insulators Co.  
Microcell  
Ministry of Aviation  
Murphy Radio

Negretti & Zambra  
Newmark, Louis  
Newton Brothers (Derby)

Optical Measuring Tools

Plannair  
Plessey  
Pullin, R. B., & Co.  
Pye  
Rank Cintel  
Redifon  
Rotax  
Royston Industries

Salford Electrical Instruments  
Sanders, W. H. (Electronics)  
Sangamo Weston  
Savage, W. Bryan  
Semiconductors  
Short Brothers & Harland  
Simmonds Aeroceramics  
Smart & Brown (Machine Tools)  
Smiths Aircraft Instruments  
Solartron  
Solus-Schall  
Southern Instruments  
Sperry Gyroscope Co.  
Standard Telephones & Cables  
Stone, J. & Co. (Deptford)

Taylor, Taylor & Hobson  
Tecalmit  
Technograph Electronic Prods.  
Thermionic Products  
Thorn Electrical Industries  
Tucker Eyelet Co.

Ultra Electronics

Vactric (Control Equipment)  
Venner

W.S. Electronics  
Ward, Brooke & Co.  
Waymouth Gauges & Instruments  
Western Manufacturing  
Westinghouse Brake & Signal Co.  
Westland Aircraft  
Whiteley Electrical Radio Co.  
Wireless Telephone Co.

### CHANGE OF PRICE

AS from this issue the price of *Wireless World* is increased to 2s 6d. The U.K. and sterling area subscription rate will in future be £2 p.a., and for the U.S.A. and Canada \$5.50.



## AIR-TRAFFIC CONTROL AID

BEARINGS given by ground-based direction finders working from an aircraft's v.h.f. radio contacts can, by triangulation, indicate position and identity of an aircraft. Manual methods, though, are too slow for use in a modern air-traffic control organization and resort is made to automatic triangulation of the bearings from several stations, the results from distant points being transmitted by land line to the central a.t.c. point.

Last year S.T.C. demonstrated an automatic triangulation apparatus at the S.B.A.C. exhibition at Farnborough; this relied upon the optical combination of maps and of bearing lines displayed on a bank of c.r.t.s, and the resultant composite picture was distributed by closed-circuit television.

Recently a further development of the principle was demonstrated at the Ministry of Aviation's Experimental Unit at London Airport; here the system was used to identify surveillance-radar paints on the p.p.i.-display tube.

A marker blip, which can be controlled in position by a "joystick", is fed into the auto-triangulation apparatus where it appears on one of the c.r.t.s whose displays are combined; this marker is also fed into the radar-display system. The joystick operator watches a television display of the triangulation and he lines up the marker with the intersection of the bearings, the marker on the p.p.i. tube moves correspondingly and so identifies the aircraft paint.

This system thus provides identification for aircraft

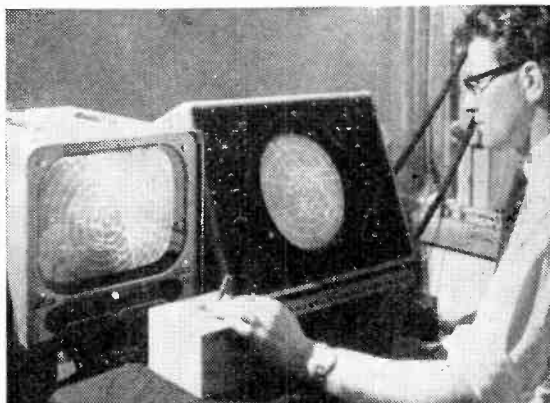

*Auto v.h.f. direction-finding triangulation coupled to primary surveillance radar as demonstrated by S.T.C. On left is TV screen displaying triangulation; right-hand tube is primary radar screen on which identifying marker appears.*

carrying the minimum of radio equipment required by law—a v.h.f. R/T set—and, although it takes advantage of co-operation of the aircraft, it does not demand anything other than the ordinary procedural use of R/T.

## FLYING TV CLASSROOM

EDUCATIONAL television in the U.S.A. took a further step forward (or should we say upward?) recently when a regular airborne schools TV service covering six States in the Mid-West was introduced. Videotape recorded lessons are radiated on two channels (72

and 76) in the 818 to 848Mc/s band. The "stations", flying at a height of 23,000ft in the vicinity of Montpelier, Indiana, are said to give an effective coverage to an area of up to 200 miles radius—approximately sixteen times the area covered by a ground station. The Western Electric's "Stratovision" system is employed in the two planes equipped for the service which is intended to provide instruction for various grades of schools and colleges in Indiana, Illinois, Michigan, Ohio, Wisconsin and Kentucky. A relatively small number of aircraft could provide a coast-to-coast service in the U.S.A. In this country three "stations" would probably suffice for a national service.

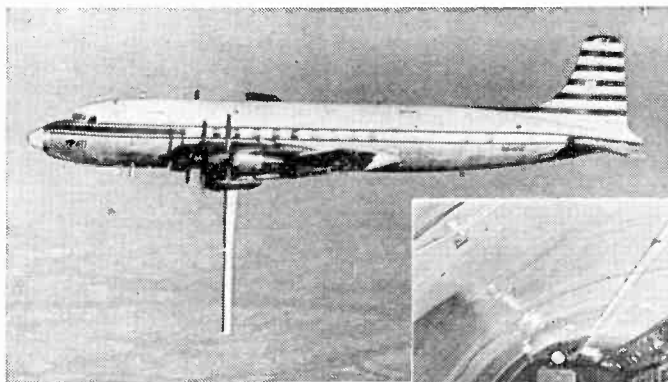

*The retractable 24-foot aerial on a DC-6 used for the airborne television station is stabilized to keep it vertical to the earth even when the plane is banking at angles of up to 20°. (Right) The airborne transmitter, which radiates on two channels in the u.h.f. band, and video tape equipment.*



# TECHNICAL NOTEBOOK

**Cold-cathode Thyratrons** which do not contain mercury and thus can be used for high currents without a run-in period for mercury vaporization have been developed by Cerberus A.G. of Switzerland (agents in the U.K.—Walmore Electronics Ltd.). Known as "Arcotrons," these valves are gas filled at relatively high pressure. Near the cathode is an auxiliary anode consisting of a perforated disc: between this and the cathode a small arc discharge is struck and maintained with an arc drop of some 25V. The grid is another perforated plate and viewed from this point the cathode-cum-auxiliary-anode structure appears as an electron-emitting cathode. With the grid negative, a space charge is built up in the manner of an ordinary valve; but, when the grid potential is positive with relation to the real cathode, the anode-voltage field can extend through the grid and electrons are accelerated into the anode region, causing ionization and breakdown. Arcotrons are available for mean currents of up to 6A and working voltages up to 700 (direct) and 500 (alternating).

**Power Rheostat.**—The illustration shows a printed-circuit step-variable resistor developed by Mills & Rockley in association with Lucas. The resistance element itself is of  $10^{-3}$ -in thick cupro-nickel, having a total resistance of  $15\Omega$ . The element is bonded to epoxy-resin cum glass-fabric insulator which in turn is bonded to the  $\frac{3}{2}$ -in thick aluminium

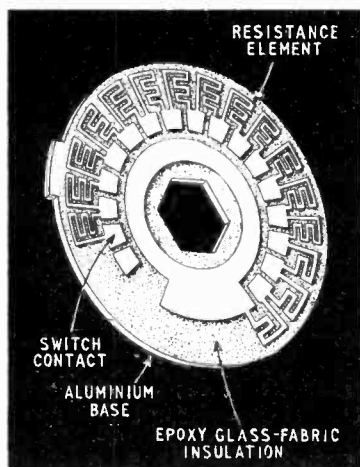

base, which increases the dissipation of heat and can be fixed to a larger surface. This method of construction is, of course, applicable to fixed

resistors also and the power rating of the component shown (about 1-in across) is 15W. The address of Mills and Rockley's printed-circuit division is Swan Lane, Coventry.

**Increased TV-Aerial Bandwidth** is useful when several transmitters on different channels are available. A technique known as "double-driving" has recently been employed by Antiference to increase the bandwidth of a Band-III Yagi array designed primarily for the export market. Double driving involves the use of two folded-dipoles spaced some  $\lambda/4$  along the boom, connected in parallel by a length of open line formed by two parallel tubes. An ordinary Yagi design can be used usually on adjacent channels only, whereas the double-driven array is claimed to cover a major part of Band III.

**Beam-Width Modulation** devices are discussed in an article by H. Lashinsky in the May, 1961, issue of the *I.R.E. Transactions on Electron Devices* (p. 185). Referring to the diagram (based on Fig. 1 of this article) the voltage on the perturbing apertured grid just beyond the cathode gives the beam electrons a transverse velocity. Due to the longitudinal magnetic field this results in the beam taking up a scalloped aspect in which the scallop amplitude is determined by the magnetic field and the perturbing voltage and the scallop wavelength is determined by the magnetic field and the cathode-anode accelerating voltage. An apertured anode is used so that the intercepted beam current depends on the longitudinal position of this anode relative to the scallops. If then the anode voltage is modulated, the scallops move longitudinally relative to the aperture so that an a.c. component is produced in the intercepted beam current. Such a device can be used as a frequency multiplier by modulating the anode voltage so deeply that an integral number of scallops swing back and forth through the anode aperture. Two advantages of this type of multiplier are that the power is concentrated mainly in a single harmonic and that the harmonic number can be altered simply by altering the anode modulating voltage. Unfortunately, it can be shown that any harmonic frequencies obtained in this way must be less than the frequency of cyclotron motion of the electrons in the magnetic field. If the anode is square-wave modulated, a number of current pulses are

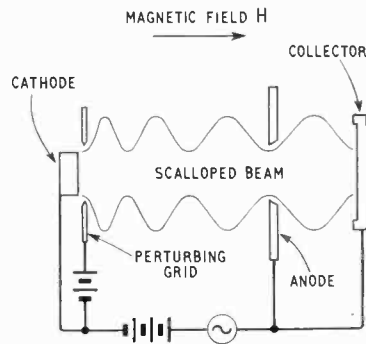

produced depending on the square-wave amplitude. This arrangement thus provides analog-to-digital conversion. Mixing of two frequencies is possible by applying one to the anode and the other to the perturbing grid. One general disadvantage of this type of modulation is that its efficiency is low. This is because most of the anode current must produce heat, it being essentially the loss current which is modulated. Transit time conductance effects can be shown to be minimized because the grid current is small, the electron motion being mainly at right angles to the field between the grid and cathode. The deflection sensitivity decreases at high frequencies because the electrons remain in the grid field for an appreciable fraction of a modulating cycle. This effect can be reduced both by moving the grid close to the anode aperture and by shielding the grid so that the transverse field is applied only over a very short part of the electrons' path.

**"Frictionless" Bearing** obtained by magnetic "levitation" is discussed in an article by F. T. Backers in Vol. 22 No. 7 of *Philips Technical Review* (p. 232). The bearing shaft has a number of magnetic rings on it (made, for example, of Ferroxdure): these rings are radially magnetized alternately inwards and outwards. Inside the bearing housing is a similar set of oppositely magnetized rings: the repulsion between the housing and bearing rings keeping the shaft suspended in radial equilibrium. Unfortunately this system does not in itself produce axial equilibrium, and this was obtained by fitting Ferroxcube magnetic disks to the ends of the shaft and using any unbalance between the self inductance of two coils in the housing opposite these disks to energize electromagnets at the ends of the shaft so as to correct any axial displacement.

# DOUBLE-BASE-DIODE OSCILLATOR

By P. LLOYD\*

SIMPLE CIRCUIT USING CAPACITOR, RESISTOR AND SEMICONDUCTOR

**T**HIS oscillator was demonstrated at a recent exhibition† and uses a General Electric 2N489 double-base-diode semiconductor device in conjunction with a metal-film resistor and a newly developed tantalum capacitor of the dry oxide-film type‡.

A general view of the oscillator is shown in photograph. With a supply voltage of 4.5V, the output is 350mV at a frequency of 300 kc/s. As can be seen from the circuit diagram given in Fig. 1(a)

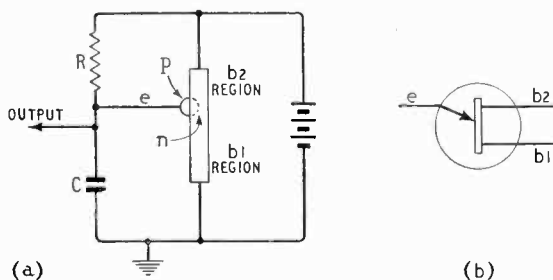

Fig. 1 (a) Oscillator circuit, using pictorial representation of the unijunction. (b) Symbol that has been used for double-base diode

use of the double-base diode, or unijunction transistor as it is sometimes called, makes possible the construction of an oscillatory circuit using the minimum of components.

Physically, the double-base diode consists of a bar of n-type semiconductor with two ohmic contacts, bases 1 and 2, made at the ends and at an intermediate position a third contact, the emitter, forming a p-n junction with the bar. The operation of this device when used in the circuit of Fig 1(a) is analogous to that of a thyatron relaxation oscillator and can be described as follows:—

The capacitor C is charged from the supply through resistor R; when the emitter potential reaches a sufficiently high value the p-n junction starts to inject minority carriers into the bar, causing the resistance in the base 1 region to become negative. This action, which is cumulative, results in a rapid discharge of the capacitor through base 1. When the discharge is complete the emitter potential has returned to the cut-off condition and the cycle recommences<sup>1, 2</sup>.

In the oscillator described above the capacitive element consists of a very thin film of tantalum oxide as the dielectric, sandwiched between two

aluminium electrodes. The aluminium and oxide layers are deposited, under vacuum, upon an insulating substrate; the former by evaporation and the latter by a process known as “reactive sputtering”<sup>3</sup>. This process is an extension of the technique of cathodic sputtering, whereby metal is deposited from its parent cathode under the influence of an ionizing discharge occurring under vacuum. Now if oxygen is leaked into the vacuum chamber there is a chemical “reaction” and the sputtered deposit forms as an oxide of the cathode metal. The effect has been employed in optical applications such as lens-blooming; but is a new development in the electronic components field.

Reactively sputtered tantalum-oxide capacitors of the type used in the double-base-diode relaxation oscillator have a capacitance of 0.01 uF and a  $\tan \delta < 0.01$  at 10 kc/s. The dimensions of the two aluminium electrodes are  $\frac{1}{8} \times \frac{1}{8}$  in and the total thickness of the capacitor element, excluding the substrate, is only 0.00002 in.

Micro-miniaturization of electronic circuitry, especially for transistor applications is being advanced further by the development of com-

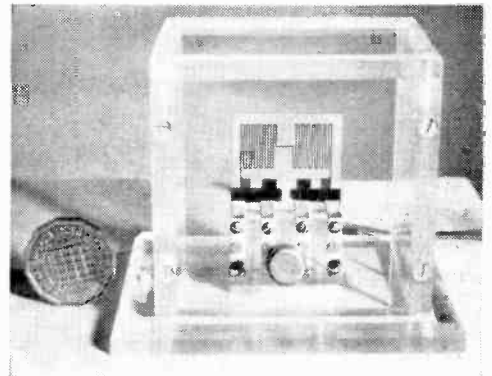

(Crown Copyright)

Double-base-diode relaxation oscillator.

ponents such as these, and it will be appreciated from the sizes given that the circuit elements employed are virtually two-dimensional.

## References

1. General Electric Transistor Manual—G.E. Co., New York, 1959.
2. Double Base Expands Diode Applications by J. J. Suran, *Electronics*, March 1955, p. 198.
3. Reactive Sputtering and Associated Plant Design by L. Holland and G. Siddall, *Vacuum*, 3, 1953, p. 245.

\* Royal Radar Establishment.

† Physical Society Exhibition—January, 1961.

‡ U.K. Patent Application No. 42094/60.

# WORLD OF WIRELESS

## *I.E.E. and Electronics*

BECAUSE of "the increasing importance of electronics in electrical engineering, and the part being played by electronics engineers in the work of the Institution" the I.E.E., at a meeting on June 22nd, decided on a major reorganization to "demonstrate unequivocally the significance of electronics in the Institution's affairs." In place of the existing four specialized sections (Electronics & Communications, Measurement & Control, Supply, and Utilization) there will be three Divisions representing "electronics," "power," and "general," the latter covering activities of common interest to all electrical engineers, such as basic measurement and technological education.

Each of the divisions will comprise a number of technical groups designed to cover specializations within its field.

It is planned to bring the new scheme into operation in October next year.

## *G.E.C., Sobell, McMichael*

A SEPARATE exhibition of the G.E.C. group of companies is being held from August 19th to 24th inclusive at the New Horticultural Hall, Westminster, when the full ranges of radio and television receivers will be shown.

In addition there will be live and film shows of colour television demonstrating the 405-line N.T.S.C. receivers developed by G.E.C. and also the SECAM system (on 625 lines) developed in conjunction with the French company, Compagnie Générale de T.S.F. and its associate Compagnie Française de Télévision.

Other demonstrations will enable the public to compare monochrome pictures on 405- and 625-line standards, and there will be supporting displays illustrating the wide activities of G.E.C. in engineering, atomic energy, telecommunications, etc.

**Brit.I.R.E. Graduates.**—The rise in the number of candidates entering for the Graduateship Examination of the Brit.I.R.E. in May was not reflected, however, in the number of passes. Of the 210 candidates who sat section A 94 were successful and of the 170 sitting section B (all of whom had previously passed section A) only 42 passed. In view of this it is interesting that the Institution is holding a whole-day symposium on the subject of its new graduateship syllabus on September 27th at University College, London. The morning session (10.30 to 1.0) will be devoted to the syllabus itself and the afternoon session (2.30 to 5.30) to the Institution's recommendations for practical training.

**B.E.A.M.A. Electronics Board.**—The British Electrical and Allied Manufacturers' Association, which recently formed an Industrial Electronics Equipment Section, has now established an Electronics Board "to represent that part of the B.E.A.M.A. membership directly concerned with electronic engineering." The initial membership of the Board is:—L. Bagrit (Elliott Bros.)—chairman, O. W. Humphreys (G.E.C.)—vice-

chairman, E. B. Banks (English Electric), W. S. Steel (A.E.I.), S. Z. de Ferranti (Ferranti), C. Metcalfe (E.M.I.), and W. Gregson (Ferranti)—chairman of the Industrial Electronic Equipment Section. The plan is designed "to provide within the framework of the B.E.A.M.A. an organization to safeguard the interests of British manufacturers concerned with electronic engineering, but it is not intended to assume on behalf of BEAMA members responsibility for other sectors of the electronic engineering industry, e.g., telecommunications and components which are already dealt with by existing Associations."

**S.I.M.A. Officers.**—The new president of the Scientific Instrument Manufacturers' Association is A. W. Jones (Fleming Radio), with R. E. Burnett (Marconi Instruments) as vice-president and president-elect; G. C. Ottway (W. Ottway & Co.) vice-president; Major Wm. Logan (Avo) hon. secretary; and G. S. Sturrock (Kelvin and Hughes) hon. treasurer. The newly elected members of the Council are: J. E. C. Bailey (Baird & Tatlock), A. G. Peacock (Mervyn Instruments), L. B. Lambert (Negretti & Zambra), J. E. T. Haile (Rank Precision Industries), I. C. M. Worsfold (W. H. Sanders Electronics), H. Wyn Griffith (Shirley Developments), and A. Richardson (Stanhope-Seta).

**Scientific Instrument Makers.**—The new master of the Company of Scientific Instrument Makers is A. E. Evans, managing director of Evans Electro-Selenium. The senior and junior wardens elected for 1961/62 are respectively Paul Goudime, managing director of Electronic Instruments, and F. W. Dawe, managing director of Dawe Instruments.

**Standards and Measurements.**—The third in a series of biennial conferences on Standards and Electronic Measurements will be held next August (14-16) at the Boulder, Colorado, laboratories of the National Bureau of Standards, which is one of the sponsors. Further information is obtainable from: Dr. John M. Richardson, Chief, Radio Standards Laboratory, National Bureau of Standards, Boulder, Colorado.

**Lugton's,** the well-known London wholesalers, are celebrating their Diamond Jubilee this year. As part of their celebration they are holding an exhibition at the Café Royal, London, W.1, from August 22nd to 24th and 28th to 31st. It will be open daily from 9.30 a.m. until 9 p.m.

**Rockets.**—Paul Adorian, managing director of Associated Rediffusion, has had a paper reprinted on the technique of rocket propulsion which he read in January, 1929, before the Engineering Society of the City and Guilds (Engineering) College, where he was then a student. In the Introduction he says: "While there is little original matter in the paper, it is thought that it may be interesting to read this particular approach to rocket propulsion as presented more than thirty years ago." The proceeds from the sale of the reprint, which is available from the author at 21 Denmark Street, London, W.C.2, price 8s, will be given to the Henry Tizard Memorial Fund.

**Soviet production** of TV sets during the first half of this year totalled 934,000, which was a 17% increase on the same period last year. Sound radio and radiogramophone reproduction totalled 2.1M (a 3% increase).

**Another V.H.F. Station.**—The B.B.C.'s 21st v.h.f. sound broadcasting station which serves the south-east corner of England was brought into operation on August 8th. The Dover station which is of the translator type operates unattended and re-radiates the Wrotham transmissions on different frequencies but without demodulation. The station operates on 90.0, 92.4 and 94.4Mc/s with an e.r.p. of 3.5 kW. It is on the same site as the Dover television station.

**Industrial Research Fellowships.**—A scheme of research fellowships "which may contribute to furthering the collaboration between Universities and industry" has been introduced by J. Langham Thompson Ltd. The research workers appointed to the fellowships, normally on a two-year tenure, will follow "their own line of research" at the company's laboratories at Watford, Herts.

**"Mathematics—Friend or Foe?"** is the title of the first annual lecture of the British Conference on Automation and Computation (B.C.A.C.) which is to be given by Dr. D. G. Christopherson on September 27th at 5.30 at the Institution of Electrical Engineers, Savoy Place, London, W.C.2. Tickets are obtainable free from the Hon. Secretary, B.C.A.C., c/o the I.E.E.

**Colour Television.**—A refresher course of lectures on colour television will be given on the six consecutive Monday evenings from September 18th in the Lecture Theatre at the London School of Hygiene and Tropical Medicine, Keppel Street, W.C.1. The lecturers will be S. N. Watson (B.B.C. Designs Dept.) and G. B. Townsend and P. Carnt of the G.E.C. Hirst Research Centre. The course is organized by the Television Society (166 Shaftesbury Avenue, London, W.C.2) from which enrolment forms are obtainable. Fee for non-members is 2gn.

Three conferences or symposia have been arranged by the Institute of Physics and the Physical Society for September. The first, on "some aspects of the physics of space research," will be from the 20th to 22nd at the Royal Military College of Science, Shrivenham, Wilts. The second, at the University College of North Wales, Bangor, on 21st and 22nd, is on "radiospectroscopy of solids," and is being organized jointly with the British Radio Spectroscopy Group. During the conference, Dr. D. Shoenberg, F.R.S., will deliver the Guthrie lecture on "The de Haas-van Alphen effect and the electronic structure of metals." The third is on the 28th and 29th at the Town Hall, Leamington Spa, and is entitled "the physics of gas discharge devices." The Institute and Society is also holding a one-day symposium on "some aspects of vacuum science and technology" at Imperial College of Science and Technology, London, on January 5th. Further details are obtainable from 47 Belgrave Square, London, S.W.1.

**The Transit Navigation Satellite System** will be discussed at a whole-day meeting to be held jointly by the Institute of Navigation and the Electronic Engineering Association on September 26th from 10 a.m. The meeting, which is open and for which there is no fee, will be held at the Royal Geographical Society, 1, Kensington Gore, London, S.W.7.

**Stereophonic concerts** are to be given in the Cripple-gate Theatre, Golden Lane, London, E.C.1, each Monday evening from September 18th to December 18th. New records will be used for each of the concerts which begin at 6.30 and will last about two hours. Admission will cost 2s.

Tabulated lists of colleges in Manchester and district showing the types of courses they provide are given in the booklet "Engineering Education" published by the Manchester and District Advisory Council For Further Education, Deansgate, Manchester 3.

**Radio Hobbies Exhibition,** which is sponsored by the Radio Society of Great Britain, will be held at the Royal Horticultural Hall, Vincent Square, London, S.W.1, from November 22nd to 25th.

**Receiving Licences.**—The June figure for combined TV/sound receiving licences in the United Kingdom of 11,440,884 shows an increase of nearly three-quarters of a million in the past twelve months. Sound-only licences, including 488,759 for sets fitted in cars, totalled 3,856,884—a decrease of over half a million, during the same period.

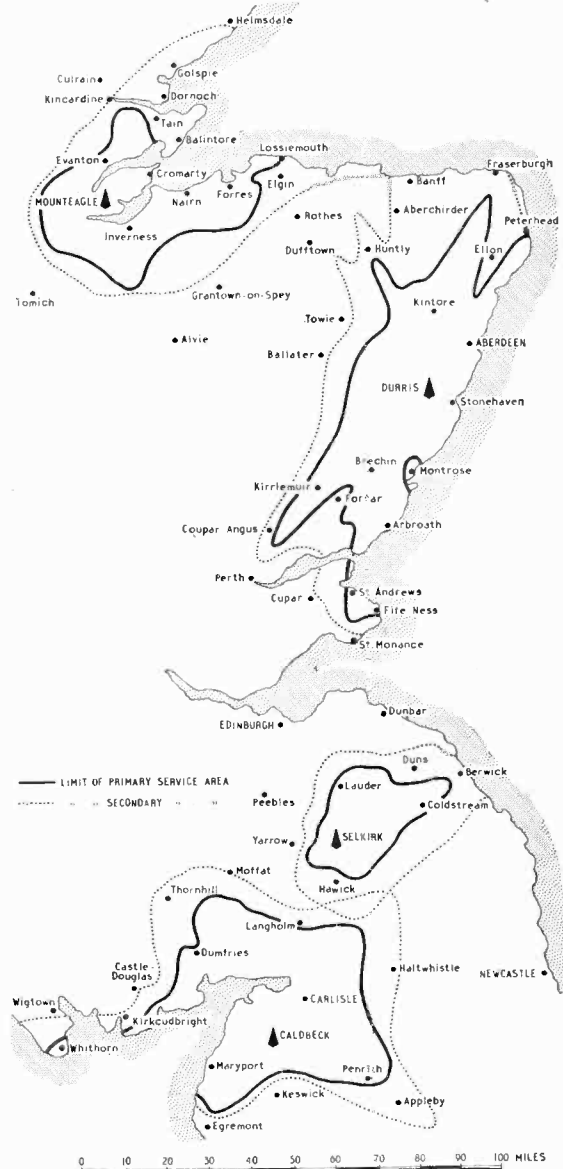

SERVICE AREAS of the I.T.A.'s "Border" stations at Caldbeck, which begins regular transmission in Channel 11 on September 1st, and its unattended satellite transmitter near Selkirk, which is planned to be brought into service in Channel 13 at the end of the year. Also shown are the service areas of the Authority's N.E. Scotland stations at Durriss (Channel 9), to be opened on September 30th, and Mountheadle (Channel 12)

# Personalities

**Sir Hamish MacLaren**, K.B.E., C.B., D.F.C., until recently Director of Electrical Engineering at the Admiralty, has been appointed a consultant to Associated Electrical Industries Ltd. After graduating at Edinburgh University in 1921 he joined British Thomson Houston Co., Rugby, as a student apprentice. Under a B.T.H. Fellowship he spent one year (1923-24) with the G.E. Company of Schenectady, U.S.A., and joined the Admiralty as assistant electrical engineer in 1926. Sir Hamish is the 1960/61 president of the I.E.E.

**C. F. Bareford**, Ph.D., M.Sc., A.M.I.E.E., who joined Vickers Ltd. in 1956 as head of electronic research and has been managing director of Vickers Research Ltd. since its formation in January 1959, has been appointed Controller of Research of Vickers Ltd., and will retain his present position. Dr. Bareford was for 10 years at the Admiralty Signal Establishment before joining Mullards as head of their research laboratory at Sal-fords, Surrey, in 1946. From 1953 until he joined Vickers he was chief superintendent of the Long Range Weapons Establishment at Woomera, South Australia.

**J. A. Saxton**, deputy director of the D.S.I.R. Radio Research Station, Slough, is going to the United States in September, where he has accepted a year's visiting professorship at the University of Texas Radio Research Establishment. Dr. Saxton, who has been in the scientific civil service since 1938, has twice served in the U.K. Scientific Mission in Washington.



Dr. J. A. Saxton



A. W. Jones

**A. W. Jones**, recently installed as president of the Scientific Instrument Manufacturers' Association of Great Britain, is managing director of Fleming Radio (Developments) Ltd., which he formed in 1945. He joined Orr Radio (now Invicta Radio) as an inspector, in 1933 at the age of 19 becoming ultimately technical manager. During the war he was working on radar research and development with Pye who acquired Invicta in 1938. Mr. Jones was vice-president of S.I.M.A. for 1960-61 and was also chairman of the Electronics, Telecommunications and Electrical Instruments Section to which 70 S.I.M.A. members belong. He is a founder member of the Livery Company of Scientific Instruments Makers.

**Grp. Capt. A. Foden**, C.B.E., Command Signals Officer, R.A.F., Germany, since last September, has become Director of Telecommunications, Air Ministry. He has been a signals specialist throughout his Service career, which began in 1939. He is 47.

**T. H. A. Llewellyn**, A.F.C., M.A., has been appointed chief executive, and **L. S. White**, technical adviser, of British Telemeter Home Viewing Ltd. These are the first executive appointments made by the company which was formed last year jointly by a number of companies, including Granada TV Network and British Lion Films, to operate subscription television. Mr. Llewellyn, who is 51 and a graduate of Trinity College, Oxford, has been adviser to a number of companies in the fields of engineering and applied physics and was at one time chief executive of Taylor, Taylor & Hobson. Mr. White has for the past six years been with Redifusion, for most of the time as chief engineer of one of its operating companies. For seven years before joining Redifusion he was with Standard Telephones and Cables Pty., Australia, prior to which he was for six years in the Anti-submarine Warfare Division of the Royal Navy. He is 48.

**Trevor C. Standeven**, who left Radio & Allied Industries in 1958 to join Ultra and was appointed managing director of Ultra Radio & Television Ltd. when it was acquired earlier this year by Thorn Electrical Industries, has resigned and joined G.E.C. (Radio & Television) Ltd. as managing director. In his new position he will again be associated with Radio & Allied Industries which recently became a subsidiary of the General Electric Company.

**Hugh S. Pocock**, M.I.E.E., managing editor of *Wireless World* and managing director of our publishers Iliffe Electrical Publications Ltd., has been appointed a director of Associated Iliffe Press Ltd. Mr. Pocock, who has been with W.W. since 1913, is also managing editor of our sister journals *Electronic Technology* and *Electrical Review*.

**S. N. Ray**, M.Sc., B.Sc.(Eng.), M.I.E.E., F.Inst.P., has been appointed principal lecturer (applied electronics) in the Department of Electrical Engineering and Physics, Borough Polytechnic, London, which he joined in 1939 and where he has been senior lecturer in radio engineering. Born in Calcutta in 1902, Mr. Ray came to this country after receiving his M.Sc. degree from Calcutta University in 1925 and continued his studies for his B.Sc. (London) and the Diploma of Faraday House. For 11 years from 1928 he was in the radio industry, for the major part of the time with Dubilier and subsequently as chief engineer of the Magnavox Division of Benjamin Electric.

**L. H. Griffiths**, M.A., B.Sc., A.M.I.E.E., who joined the B.B.C. in 1951, has been appointed head of the Film Unit, Television Studio Section, Planning and Installation Department. Mr. Griffiths has been largely responsible for the design and planning of the central telerecording area at the London Television Centre. He is co-inventor with **F. W. Nicholls** of an improved photographic telerecording system, which has been incorporated in the design of 35-mm rapid pull-down telerecording equipment used by the B.B.C.

**A. H. Campbell**, M.A., M.I.E.E., who has been a director of Hilger & Watts since 1951 and general manager since 1954, has been appointed joint managing director with **G. A. Whipple**, M.A., M.I.E.E., F.Inst.P. Mr. Campbell was for some time before the last war with the Cambridge Instrument Company. During the war he was with the Royal Corps of Signals, finally as Lieutenant-Colonel commanding 8 Corps Signals.



## OUR AUTHORS

**J. M. Briggs, M.A., A.M.I.E.E.**, the new Director of Electronics, Research and Development (civil aviation) at the Ministry of Aviation, has been superintendent in the Ground Radar Department of R.R.E. since 1955. He graduated at St. John's College, Cambridge in 1935 and spent 18 months in the G.E.C. carrier communications development laboratory before joining the Government service at the Royal Aircraft Establishment. He transferred to T.R.E. in 1940 and was closely associated with the development of A.S.V. For a period after the war he was chairman of the Inter-Services Radio Measurement Committee.

**J. R. Mills**, recently appointed head of the Radio Department at the Royal Aircraft Establishment, Farnborough, was from 1954 to 1960 superintendent in the Airborne Radar Department at the R.R.E., Malvern. For a few months prior to his present appointment he was the assistant director at the Ministry of Aviation concerned with electronic problems of civil aviation. Mr. Mills has been in the scientific civil service since 1940. He was a member of the team set up in 1946 at T.R.E. to develop electronic systems for civil aviation, his particular interest being D.M.E.

**A. Robert Enshaw** has been appointed executive director in charge of the Government Contracts Department of Plessey. He joined the company in 1946 and was, until his present appointment, manager of the Telephone Apparatus Department. Plessey also recently announced the following appointments:—**A. A. Farrell** becomes director and general manager of Plessey Ireland Ltd., and also a director of Plessey Sales Ltd., Dublin; **A. W. Henderson, Ph.D., B.Sc.**, previously with CIBA (A.R.L.) and Ferranti, is now Plessey's chief chemist-metallurgist; and **L. Walker** is appointed chief inspector of the Plessey group of companies.

**R. J. Keir, O.B.E., B.Sc., A.M.I.E.E.**, has been appointed engineer-in-charge of the B.B.C.'s External Services short-wave transmitting station at Skelton, Cumberland. He joined the Corporation in 1937 and from 1956 until early this year was resident engineer of the B.B.C.'s Far Eastern Broadcasting Service at Tebrau, Singapore. Since his return to this country he has been asst. e.-in-c. at Skelton where he succeeds **H. F. Bowden, Assoc.I.E.E.**, who is retiring after 36 years' service. Mr. Bowden has served at a number of stations including the television station at Alexandra Palace and has been at Skelton since 1945.

**Peter Frost, Dip.Tech., Grad.I.E.E.**, personal assistant to the manager of the capacitor division at the G.E.C. Telephone Works, Coventry, has been awarded a £90 travel scholarship from the Department of Electrical Engineering at the Birmingham College of Advanced Technology. He joined G.E.C. in 1955 as a student apprentice and received his Dip. Tech. after a sandwich training course. He hopes to use the scholarship to study the manufacture of electronic components, management organization and technical education in Europe.

**G. A. Graham, A.M.Brit.I.R.E.**, has been appointed to succeed the late **W. J. Chalk** as engineer (frequency allocations) in the B.B.C.'s Engineering Information Department. He has been with the Corporation since 1947 and had been assistant to Mr. Chalk since 1958. He was a member of the U.K. delegation to the recent V.H.F./U.H.F. Broadcasting Conference in Stockholm.

**Aubrey Harris, A.M.I.E.E., A.M.Brit.I.R.E.**, who has been associated with the Ampex Corporation of Redwood City, California, since November, 1958, has joined Ampex Electronics, Ltd., in Reading, Berkshire, as senior engineer. He started his career at the Post Office Research Station, Dollis Hill, later spending over five years with Marconi's on research and advanced development of television equipment. In 1957 he went to Bermuda as chief engineer of television station ZBM-TV.

**A. T. Ferguson**, who describes in this issue an instructional radio receiver, is lecturer at the South Shields Marine and Technical College, where he started his teaching career in 1947. From 1937 he was for eight years a marine wireless operator with Marconi's and from 1945 he spent two years in the Post Office Radio Service.

**J. M. Winwood, M.A.**, author of the article on page 491, is in charge of the group concerned with travelling-wave devices at the Mullard Research Laboratories, which he joined in 1955. After graduating at Cambridge in 1952 he worked for two years on the production of magnetrons and travelling-wave tubes at the English Electric Valve Company in Chelmsford.

**Peter Lloyd, Grad.I.E.E.**, who describes a double-base-diode oscillator in this issue, has been at what is now the Royal Radar Establishment, Malvern, since 1945. He has been in the technical services department of the Establishment since 1956 and for the past three years has been concerned with capacitor development. Mr. Lloyd, who was a student apprentice with E.M.I. at Hayes for four years before going to Malvern, is a member of the Inter-Services Radio Component Research & Development Committee for Fixed Capacitors.

## OBITUARY

**H. V. Slade, O.B.E., J.P.**, chairman of the Garrard Engineering & Manufacturing Co., died on July 19th at the age of 72. He founded the Garrard Company, of which his sons Hector and Kenneth are respectively managing director and sales director, 46 years ago and although the company's productions have been very varied, his main interest had always been the gramophone.

**R. W. Hall**, chief sales executive of the Aerial Division of Antiference which he joined in 1952, died on July 21st aged 47.

# News from Industry

**British Space Development Company.**—Two more companies, making eleven in all, have joined this consortium of aircraft and electronics companies. They are Elliott-Automation Ltd. and C. A. Parsons & Co., who are represented on the company's technical committee by **W. R. Thomas, B.Sc., M.I.E.E.**, and **H. M. Finnis-ton, Ph.D., B.Sc.**, respectively.

**Elliott-Automation, Ltd.**—The 1960 gross profit of the group, of which Elliott Brothers (London), Ltd. is now the largest subsidiary, was £1,776,510. Of this sum the Rheostatic Company, acquired during the year, contributed over £0.5M. Excluding this figure the E-A profit increased by nearly 24%. Taxation took £816,863.

**Ferranti's** accounts for the year ended March 31st show a group net profit of £1,661,023 compared with £2,123,390 the year before. Taxation charged in arriving at the 1960/61 figure was £1,740,000. The company recently opened a Northern Computing Service in Manchester based on a Pegasus general purpose digital computer. Clients wishing to use the service may prepare their own programmes or leave the programming to the computing staff.



**Associated Electrical Industries** are terminating semiconductor development, production and sales by their Radio and Electronic Components Division. Thus Ediswan-Mazda semiconductors will cease to be available, but A.E.I. will honour existing commitments and orders and will be able to supply devices for a short time from stock. Semiconductor devices produced by A.E.I.'s Electronic Apparatus Division at Carholme Road, Lincoln, are not affected by this announcement. Exact electrical equivalents to some Ediswan-Mazda devices are available from R.C.A. Great Britain, Ltd., and also Ferranti, Ltd., who are to produce some types of R.C.A. transistors under licence from the Radio Corporation of America.

**Thorn.**—Group trading profits of Thorn Electrical Industries Ltd. for the year ended March 31st amounted to £4,113,907, compared with £3,916,990 the previous year. After deducting all charges the net profit is £1,548,769 (£1,525,988).

**Thorn-A.E.I. Radio Valves & Tubes, Ltd.**, is the name of the company formed as a result of the merger of the Thorn and A.E.I. interests in the manufacture and sale of c.r. tubes and valves "for the entertainment industry" announced on p. 406 last month. Thorn Electrical Industries Ltd. is responsible for management.

**A.T.V.**—The profit of the Associated Television Group for the year ended on April 30th, before making provision for taxation, was £6,411,899 compared with £5,388,330 for the previous year.

**Radio and Television Trust, Ltd.**, of which Airmec and British Communications Corp. are operating subsidiaries, announce a consolidated profit for the year to 31st March of £265,782 compared with £118,060 for the previous nine months. The charge for taxation is £127,266, leaving a net profit of £138,516. D. D. Prens is chairman and managing director of the Trust and chairman of the two operating companies, and Dr. J. C. Simmonds is managing director of Airmec and of B.C.C., and is deputy managing director of R.T.T.

**Cossor and Raytheon.**—A cash offer has been made by the Raytheon Company, of Lexington, Mass., for the issued share capital of A. C. Cossor, Ltd. The prices offered for the shares puts the overall purchase price at over £2M.

**Pye-Ling Ltd.** has been formed jointly by Pye Ltd., and Ling Temco Electronics Inc., of Dallas, U.S.A. It will embrace what was the Vibration Division of W. Bryan Savage Ltd., a member of the Pye group, and its products will include both the Savage and Ling ranges of vibration test equipment.

**Amalgamated Electric Services, Ltd.** has been formed as a subsidiary of Philips Electrical Industries to take over the service activities at the Central Service Departments of Cossor Radio & TV, Philips Electrical and Stella Radio & TV at Waddon, Surrey. In addition, the new company will be service agents for Peto Scott Electrical Instruments and Ajax Domestic Appliance Co. The address is Waddon Factory Estate, Croydon, Surrey (Tel.: Croydon 7722).

**Hilger & Watts, Ltd.** have acquired the whole of the issued share capital of Microwave Instruments, Ltd., well known for their wave-guide components and microwave test equipment. J. Bilbrough, A.M.Brit.I.R.E., will continue as managing director of Microwave Instruments whose factory is at North Shields, Northumberland.

**Bradmatic, Ltd.**, makers of tape recording equipment, of Witton Lane, Aston, Birmingham, wish to make it clear that the acquisition by Birmingham Sound Reproducers of their former associate company Bradmatic Productions, Ltd. (now Tape Heads, Ltd.) does not affect them. They still operate independently.

**U.K.-U.S.A. Telemetry Tie-Up.**—S.E. Laboratories (Engineering) Ltd., of Feltham, Middlesex, are to represent Electro-Mechanical Research Inc., of Sarasota, Florida, in the U.K. The American company's main activities are in the field of frequency and time-division multiplexing equipment, for use in telemetry and data acquisition and processing applications for both airborne and ground-based use.

**Aga Dictating Machine Co.**, of 146, New Cavendish Street, London, W.1, have been appointed distributors in the U.K. and certain Commonwealth countries, of Aga domestic sound receivers and radio-grams manufactured by Svenska AB Gasaccumulator, of Stockholm-Lidingö, Sweden. They are also sole distributors for Agavox dictating machines.

**Walmore Electronics Ltd.**, who are agents for several American companies including Eitel-McCullough, National Electronics and Vacap, have been appointed U.K. distributors for the products of Motorola Semiconductor Products Inc. Walmore Electronics are now at 11-15 Betterton Street, Drury Lane, London, W.C.2 (Tel.: Temple Bar 0201).

**Aveley Electric Ltd.** have been appointed sole U.K. agents for the Hudson Tool & Die Co. Inc., of Newark, New Jersey, makers of drawn and pressed metal enclosures for electronic components.

**Ortofon.**—Metro-Sound Manufacturing Co., of 19A Buckingham Road, London, N.1, have been appointed sole U.K. agents for the Danish company Ortofon S.A. They are setting up a service department for the fitting of diamond and sapphire styli.

## NEW ADDRESSES

**Mallory Batteries Ltd.** have transferred their works from Dagenham, Essex, to Gatwick Road, Crawley, Sussex.

**Lexor Electronics Ltd.** have moved their head office and production unit from 25 to 31 Allesley Old Road, Coventry (Tel.: Coventry 72614). The laboratories are remaining at the old address.

**Ferroglyph.**—The London offices, showrooms and service department of The Ferroglyph Company, British Ferroglyph Recorder Company, Rendar Instruments and Wright & Weaire have been moved from Horseferry Road, S.W.1, to 84 Blackfriars Road, London, S.E.1 (Tel.: Waterloo 1981).

**J. & S. Sieger Ltd.**, previously known as I.E.C.—Sieger Ltd., manufacturers of amplifiers, electronic gas detectors and other electronic equipment, have moved from Bournemouth to Stanley Green Road, Poole, Dorset (Tel.: Poole 1130).

**Mullard's** Government and Industrial Valve Division is now at 80 New Oxford Street, London, W.C.1 (Tel.: Langham 5522).

**Jason Electronic Designs Ltd.** have moved from the West End to Kimberley Gardens, Harringay, London, N.4 (Tel.: Stamford Hill 5477).

**Magnavox.**—The head office of Magnavox Electronics Ltd. has been transferred from 129 Mount Street, London, W.1, to Magnavox House, Alfred's Way, Barking, Essex (Tel.: Rippleway 5533).

**Cossor Radio & TV Ltd.** have moved from 71 Endell Street, London, W.C.2, to 233 Tottenham Court Road, W.1. The telephone number is unchanged—Gerrard 2931. The showroom in Kingsway has been closed.

**Lasky's Radio**, the well-known retailers, have moved from 42 to 33 Tottenham Court Road, London, W.1, and have also added a demonstration studio to their premises at 207 Edgware Road, W.2.

# Impedance-Magnitude Measurement

PRECAUTIONS WHEN USING THE SUBSTITUTION METHOD

By R. C. WHITEHEAD, A.M.I.E.E.

**T**HE measurement of the *magnitude* of an impedance is a very common laboratory requirement, and although the simple method which follows is apparently very obvious, it remains a fact that many techniques which are more complex and less satisfactory are commonly employed.

Fig. 1 shows the basic circuit. A signal generator drives a current through two impedances  $Z_u$  and  $Z_s$  in series.  $Z_u$  is the impedance the magnitude of which is to be measured and  $Z_s$  is a calibrated adjustable standard. It is only necessary to adjust  $Z_s$  until the high-impedance voltmeter V (usually a valve-voltmeter) gives the same reading in both positions of the switch, then to read, on the calibrated scale of  $Z_s$ , the magnitude of the impedance of  $Z_u$ .

This is simple enough if all or most of the components are effectively earth-free. Fig. 1 shows alternative earthing points A and B to be used according to whether the signal generator or the voltmeter is earthed. Either of these conditions will cope with  $Z_u$  being earthed.

In the event of both the generator and the voltmeter being earthed then we can only cope with a

effects of the voltmeter impedance. If this is very high in comparison with the magnitude of the impedance of  $Z_u$  (say 100 times as great) then its loading effect may usually be ignored, irrespective of the relative *phase-angles* of  $Z_u$  and  $Z_s$ .

But is this very high ratio of impedances always necessary? A moment's consideration will show that if finally the magnitudes and *phase-angles* of  $Z_u$  and  $Z_s$  are identical, then the voltmeter loading should not materially affect the final result.

If the voltmeter impedance is purely *resistive* then it will have *similar* loading effects in turn upon  $Z_u$  and  $Z_s$  providing that these have the same *magnitudes* of phase angles, irrespective of their *signs*. E.g., if  $Z_u$  is an inductor and  $Z_s$  is a capacitor they will be loaded similarly by a resistive voltmeter. This is a condition which might apply at frequencies below 100 kc/s using a rectifier and moving-coil meter.

If, as is usually the case at high frequencies, the input impedance of the voltmeter is predominantly capacitive, then impedances  $Z_u$  and  $Z_s$  will be loaded differently if their phase-angles are different either in magnitude or sign. Thus a capacitor is best

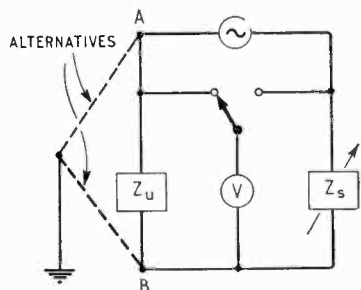

Fig. 1. The basic measuring circuit. The earthing point may be either A or B, depending on whether the signal generator or valve voltmeter is earthed.

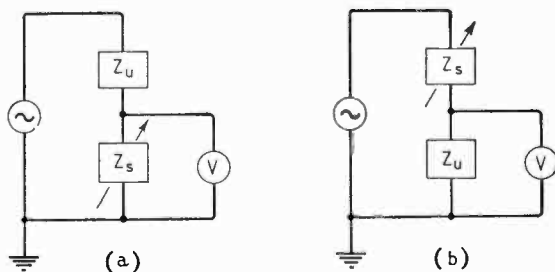

Fig. 2. The circuit used when both signal generator and valve voltmeter are earthed.

$Z_u$  which is not earthed and Fig. 2 shows the basic idea of the new arrangement. If the voltmeter gives similar deflections when the circuit is arranged as at (a) and at (b) then once again the two impedances will have similar magnitudes.

Fig. 3 shows the practical circuit with  $Z_u$  and  $Z_s$  connected to a double-pole double-throw switch which produces in its two positions the two circuits of Fig. 2. Again the testing procedure consists of adjusting  $Z_s$  until there is no change in the meter-reading when the switch is operated. Then the *magnitude* of the impedance of  $Z_u$  may be read on the calibrated dials of  $Z_s$ .

Now we must consider the possible loading

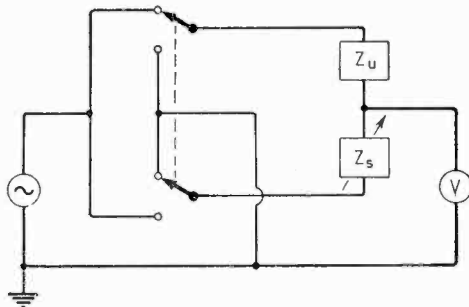

Fig. 3. The practical arrangement of Fig. 2.

balanced against a capacitor, an inductor against an inductor and a resistor against a resistor. If, however, the input impedance can be kept really high, then the magnitude of the error can be kept small.

Finally a little care in the operating procedure will expedite the measurement.

Consider first the case where  $Z_u$  and  $Z_s$  are both resistive or both reactive. The switch should first be set to produce the circuit of Fig. 2b, i.e.  $Z_s$  should be connected to the live side of the generator.

The magnitude of  $Z_s$  should now be reduced to zero and the voltmeter reading noted. The magnitude of  $Z_s$  should then be raised until the voltmeter reading is halved. Finally the switch should be operated simultaneously with fine adjustment of  $Z_s$  to produce identical readings in the two positions.

Where one of the impedances is resistive and one reactive, then the value of  $Z_s$  should be adjusted until the voltmeter reads about  $1/\sqrt{2}=0.7$ , not half, of its original setting.

## LETTERS TO THE EDITOR

*The Editor does not necessarily endorse the opinions expressed by his correspondents*

### Transistor Parameters

SQN. LDR. de Visme (in your June issue) is worried over the complications arising from his three sets of transistor parameters. These three (Hybrid, T, and Mullard) date back to the period when transistors were in the main low-frequency devices, and recent work, naturally directed towards higher frequencies, has produced a further crop of parameters.

Moreover, though his equations may look numerous and involved enough, they are simplicity itself when compared to the full expressions, including the transistor capacities (up to six in all) which must be used in all serious work other than at audio frequencies.

Let him produce the complete expressions relating his three sets of parameters (including capacities) with each other, and with the two circuits currently most in use—the Y parameter circuit and the Hybrid  $-\pi$  equivalent circuit. This must, of course, be performed in triplicate (for emitter, base and collector grounded). For good measure, he could include also the  $\pi$  equivalent and the Z parameters, and he should take into account the effects of lead inductance which are important at v.h.f.

In addition, he should include a list of equivalent symbols (e.g.  $r'_{11}$  is also written  $r_{11}$ ,  $R_{11}$ ,  $r_{1s}$ ,  $r_{ins}$ ,  $r_{te}$ , etc., with or without primes), and should write many of his equations in two forms, one in terms of  $\alpha$ , and the other of  $Y_m$ .

Then he will know what *real* worry is!  
Southend-on-Sea. M. V. CALLENDAR

*The author replies:*

Had the whole of the June issue been at my disposal, instead of only two or three pages of it, I might have been able to satisfy Mr. Callendar's demands!

I am afraid I contented myself by saying that in general the  $h$ -parameters must be considered as complex functions of frequency, one of those rather vague statements which are true but not ever so useful. All the  $r$ 's and  $a$ 's expressed in terms of these parameters therefore likewise become complex functions of frequency.

Mr. Callendar has shown, far better than I could have done, the extreme difficulty of formulating circuits consisting of well-behaved elements which shall be equivalent, over a useful range of frequency, to a fragment of impure semiconductor. I wish him well in his efforts.

G. de VISME

### Testing Tunnel Diodes

THE circuit of Fig. 1 is useful for quick checks of tunnel diodes. It can be used to make reasonably accurate measurements of the quantities indicated in Fig. 2;

i.e., the peak and valley currents  $I_p$ ,  $I_v$ , and the corresponding voltages  $V_p$ ,  $V_v$ .

Unless  $R_1$  and  $R_2$  are very small (a few ohms), and unless care is taken to keep the circuit inductance low, the circuit will be unstable when the operating point lies in the negative-resistance region BC. For routine checks, it is not worth while trying to preserve stability, because the required quantities can be measured without doing so.

The measuring technique is as follows. Start with the slider of  $R_1$  at the negative end and turn the control slowly so as to increase the diode current. The operating point now moves from A towards B. Almost as soon as it has passed B the circuit becomes unstable, and the operating point jumps to somewhere on the negative

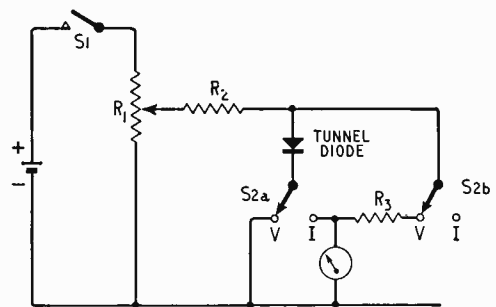

Fig. 1.

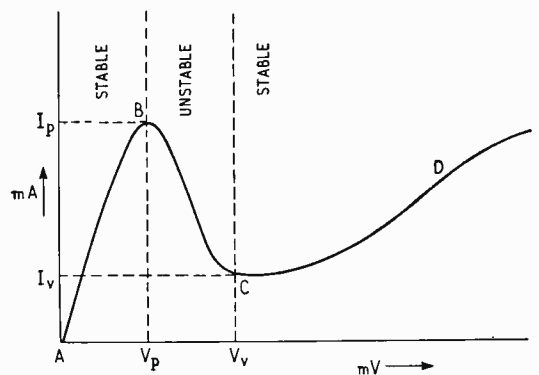

Fig. 2.



# National Radio Show Guide

COLOUR television on 405 lines and monochrome 625-line television are being featured at the 28th National Radio and Television Show which opens at Earls Court, London, on August 23rd with a preview for overseas visitors and invited guests the day before. The colour demonstration is being given by the B.B.C.

Of the 24 television set manufacturers exhibiting 21 of them are demonstrating 625-line receivers. The signal is being distributed to the stands on channel 11, and for those exhibitors with u.h.f. receivers converters are provided raising the frequency to 495 Mc/s (channel 17).

Signals for 405-line monochrome receivers are distributed on channel 4.

For the demonstration of broadcast receivers there is a Band II f.m. sound service distributed to stands and also a long-wave induction system.

A feature of the Audio Avenue on the first floor is the E.M.I. display "Milestones in Recording," stand 409, which traces the history of sound recording from 1888.

The usual training and servicing feature in which a number of manufacturers are participating is on stand 316 on the first floor.

## ALPHABETICAL LIST OF EXHIBITORS

<b>A.E.I. Sound</b>	412	Belling & Lee	51	Direct TV Replacements	316*
Admiralty	304	Brimar	64, X17	Domain	113a
Advance Components	316*	British Radio Corp.	23, 41, X11, X12, X28	Dynatron	27
Aerialite	6				
Air Ministry	305	Bulgin	316*	<b>E.A.R.</b>	56
Alba	9	Bush	38, X25	E.M.I. Records	62, X19
Alberice	204	<b>Clarke &amp; Smith</b>	406, 414	Easco	417
Antiference	59, X21	Cossor	52	Econasign	114
Astley Vulcan Finance	25	<b>Dansette</b>	39	Ekco	33, X6
Audix	402	Decca	22, 418, X29	Electronic Technology	42
<b>B.B.C.</b>	301, 302, 303	Defiant	2	Elizabethan	3
Barclays Bank	19	Design Furniture	30	Ember Records	116
				Encyclopaedia Britannica	48

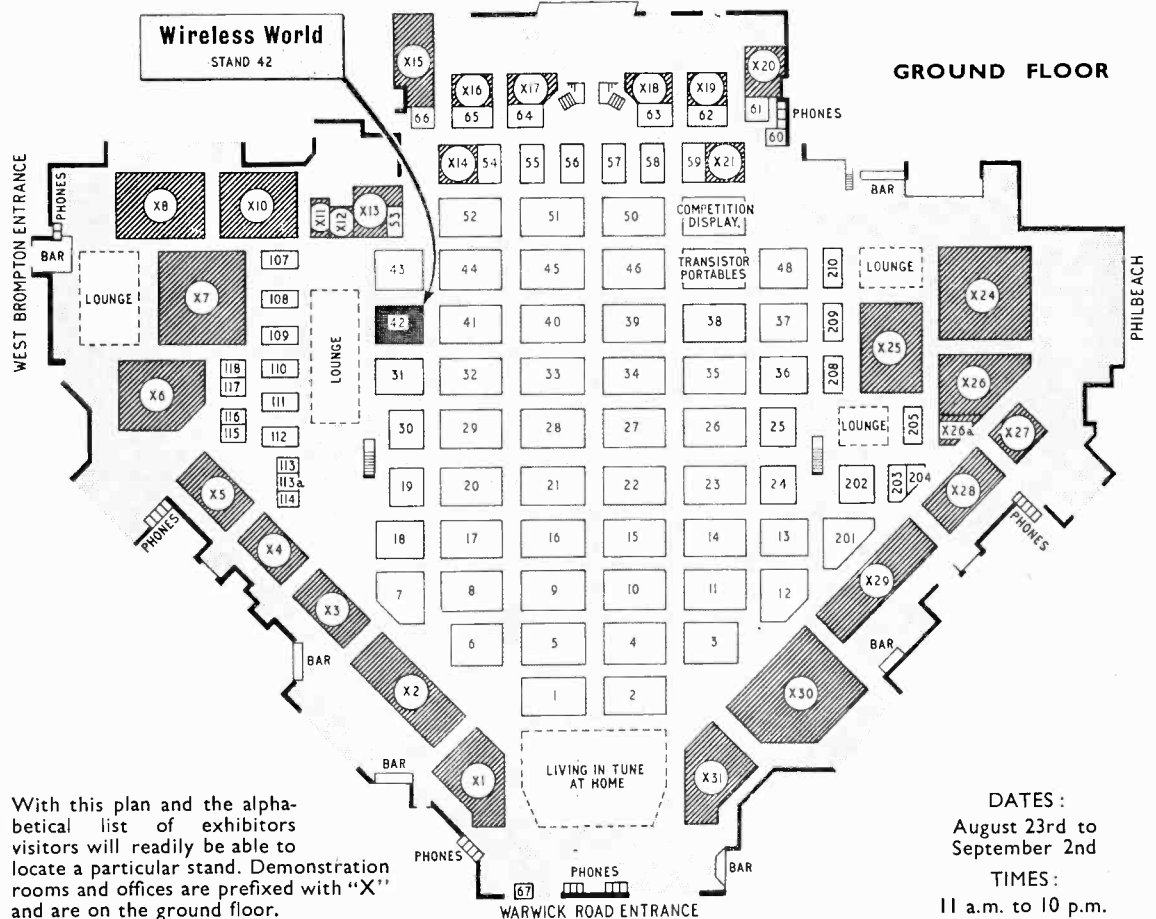

Ever Ready	28, X4	Markovits	113	<b>S.T.C.</b>	410
<b>Ferguson</b>	20, X5	Martins Bank	201	Saga Records	118
Ferranti	14, X2	Mercantile Credit	57	Simon	117
Fidelity	8	Metropolitan Police	308	Slingsby	24
Fountain Press	115, 316*	Midland Bank	11	Southgate Tubular Products	205
Fund for the Blind	312	Mullard	46, 316*, X24, X26, X26a	Stella	40
<b>G.P.O.</b>	306	Multicore	65, X16		
Garrard	36	Murphy	16, X1	<b>T.C.C.</b>	54, X14
Gramophone Co.	408	<b>N.E.V.</b>	109	Tape Recorders	405
<b>Hacker Radio</b>	55	National Provincial Bank	7	Taylor Electrical	110
Heathkit	111	Newnes	112	Teleng	107
His Master's Voice	23, X28	<b>Odhams Press</b>	208	Telegroup	316*
Hobday	53, X13	<b>Pam</b>	21, X3	Telection	34
<b>Invicta</b>	17	Pamphonic	58	Telesurance	5
<b>J-Beam</b>	18	Perdio	1	Territorial Army	317
Jason	411	Peto Scott	26	Texpe	314
<b>K.B.</b>	50	Philco	35, X27	Thorn-A.E.I.	29, X8
Keith Prowse	67	Philips	10, 15, 316*, 401, X30	Tricity Finance	31
Kerry's	43	Pitrie	108	<b>Ultra</b>	4, X31
<b>Lee Products</b>	415	Plessey	61, X20	<b>Westminster Bank</b>	13
Linguaphone	209	Portogram	416	Whiteley Electrical	66, X15
Lloyds Bank	12	Publishers' Association	316*	Williams Deacon's Bank	203
Lowther	413	Pye	32, X7	Wireless & Electrical Trader	42
<b>Marconi Instruments</b>	316*	<b>R.G.D.</b>	44, X10	Wireless for the Bedridden	60
Marconiphone	41	R.S.G.B.	315	Wireless World	42
		R.T.R.A.	202, 316*	Wolsey	37
		Radio and TV Services	316*	<b>Zonal</b>	404
		Regentone	45		
		Rehabilitation of Disabled	313		
		Roberts	63, X18		
		Rola Celestion	210		

\* Composite stand; see "Trade Technical Section" in Show Guide.

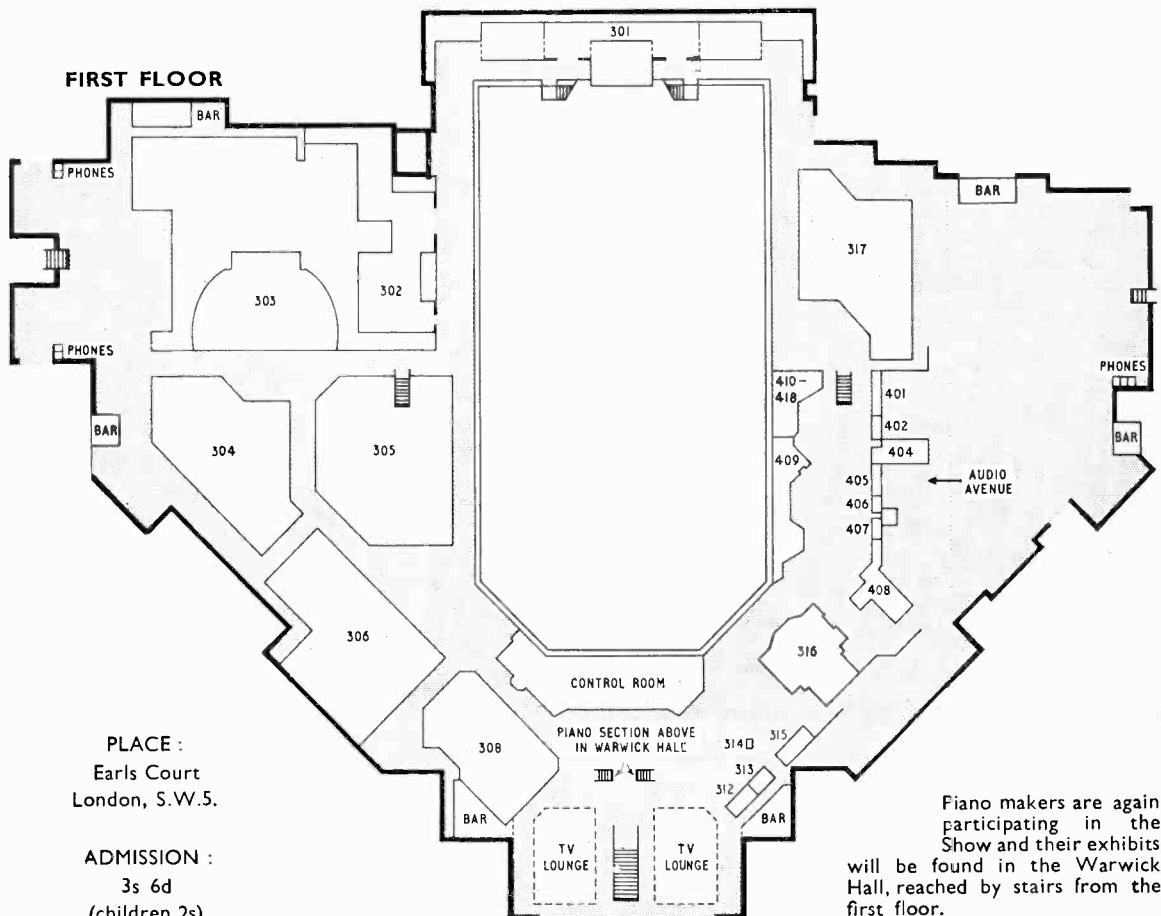

# NATIONAL RADIO SHOW

## Guide to the Stands

### A.E.I. SOUND (412)

The main emphasis on this stand will be on sound reproduction equipment for industrial and club use. This includes a pre-amplifier, 30-watt amplifier and two 18-watt 12-in loudspeakers in three portable cabinets, a 5-ft line-source loudspeaker and a table model record player and amplifier.

Also shown are a stereo control unit and 2 x 10 watt amplifier and the DC12 dual-concentric loudspeaker with its horn-loaded h.f. diaphragm.

*A.E.I. Sound Equipment Ltd., Crown House, Aldwych, London, W.C.2.*

### ADMIRALTY (304)

The communications network used by a Royal Marine Commando Force establishing a beach-head is the main feature on this stand, where there will also be found examples of modern Naval communications and navigation equipment.

*Admiralty, Whitehall, London, S.W.1.*

### AERIALITE (6)

Coaxial cables, using a longitudinal foil screen, especially designed for relay working are a feature of the display of communal-aerial equipment on this stand. A new coaxial cable particularly suitable for car-radio-aerial use has a capacitance of only 9.5pF/ft.

Another feature of the display is, of course, a wide range of aerials for indoor and outdoor mounting for reception of television, f.m. and medium- and long-wave broadcasting.

Aerials and fittings for overseas markets are shown.

*Aerialite Ltd., Aerial and Electronics Division, Hargreaves Works, Congleton, Cheshire.*

### AIR MINISTRY (305)

The central feature of the Royal Air Force stand, which occupies over 7,000 square feet, is a display comprising two air traffic control rooms typical of those employed at an R.A.F. airfield. A radar simulator with remote control facilities is employed to show the uses of search and precision approach radars. Other exhibits include a simulated representation of airborne interception radar.

*Air Ministry, Whitehall, London, S.W.1.*

### ALBA (9)

Incorporated in the new range of 19-in and 23-in television receivers is the "Concord" remote control unit. The device gives the viewer full control over programme selection, volume, contrast and mains on/off and when not in use, is held in place magnetically on the side of the set. All the television receivers on display employ plug-in modules for ease of servicing. Also exhibited is a range of transistor radio receivers, record players and radio-grams, some of which offer reproduction of stereophonic records.

*Alba (Radio & Television) Ltd., 52-70, Tabernacle Street, London, E.C.2.*

### ALBERICE (204)

Slot meters for "pay-as-you-view" television are the feature on this stand. Both fixed-tariff (6d/hour) and variable-tariff types are shown and are available both to the trade and the public (for saving towards a replacement receiver, for instance).

*Alberice Meter Co., 87-89 Sterte Avenue, Poole, Dorset.*

### ANTIFERRE (59, X21)

The whole of Stand 59 is this year devoted to a display of television, f.m. and medium- and long-wave aerials and aerial equipment for both the home and export markets (trade visitors are welcomed at the adjoining Demonstration Room X21). The aerial display includes some new models, the established ranges of aerials and a wide assortment of accessories: of particular interest are car-radio aerials.

*Antiferre Ltd., Television & Radio Aerial Division, Bicester Road, Aylesbury, Bucks.*

### AUDIX (402)

This company is showing a wide range of public address and club sound reproducing equipment. This includes combined receivers and amplifiers, a five-channel mixer, 15-watt transistorized amplifiers, and valve amplifiers (with ratings ranging up to 60 watts) which incorporate four-input-channel mixer/pre-amplifiers and also level indicators. Also displayed are column, re-entrant horn and cabinet loud speakers, and moving-coil and ribbon microphones.

*Audix B.B. Ltd., Bentfield End, Stansted, Essex.*

### B.B.C. (301, 302, 303)

Closed-circuit colour television is featured by the B.B.C. on stands 301 and 302 where transmissions from a glass-sided studio are displayed on six 21-in monitors. Each colour monitor has a 21-in monochrome monitor beside it to demonstrate compatibility. The system employed is the 405-line Anglicized version of the American N.T.S.C., the principles of which are shown graphically on the stand. The Corporation is featuring the growth of its sound and television services with maps of the coverages and another map shows the 2,000-mile route taken for the first direct TV transmission from the U.S.S.R. via Eurovision.

*British Broadcasting Corporation, Broadcasting House, London, W.1.*

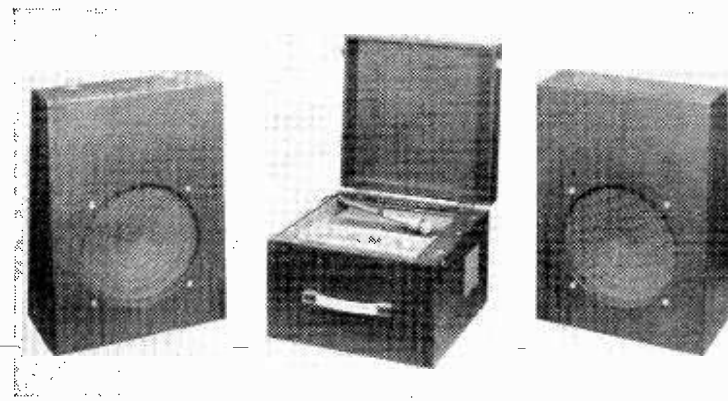

*A.E.I. Sound portable 30-watt amplifier/pre-amplifier and two 18-watt 12-in loudspeakers.*



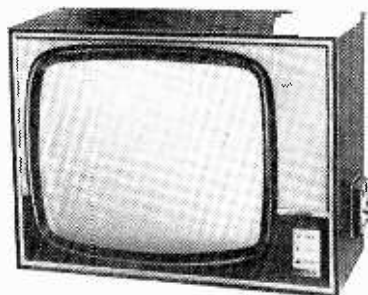

Alba T877 19-in television receiver, with its remote control unit in its stowage on the side.



"Monitor" push-button-tuned television aerial (Belling-Lee).

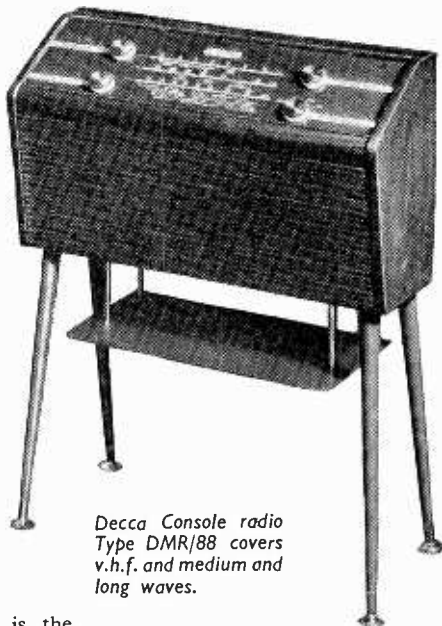

Decca Console radio Type DMR/88 covers v.h.f. and medium and long waves.



Bush TP.50 tape-recorder. The single-speed deck incorporates a digital counter.

#### BELLING-LEE (51)

Well-known for their already wide range of decorative in-the-room television and f.m. aerials for strong- and not-so-strong signal areas, this company introduce a new model called the "Monitor." This has provision for u.h.f. reception and pre-set push-button tuning to realize maximum signal. Other new types include the "Envoy"—claimed to be a descendant of the popular "Doorod" aerial—and a range of folding aerials for loft mounting. Many types of outdoor aerials are exhibited.

Communal-aerial and relay equipment of advanced design is on show, as is a wide range of accessories.

*Belling and Lee Ltd., Great Cambridge Road, Enfield, Middlesex.*

#### BRIMAR (64, X17)

Valves and cathode-ray tubes are displayed on this stand, the cathode-ray tubes including twin-panel types with bonded safety shields made from Diakon, anti-reflection coated glass and plain glass. A working demonstration emphasizes the advantages of these types of c.r.t.

New valves on show include the EMM802 double "magic eye" designed for f.m.-set tuning and for stereo tape recorders.

*Brimar, Ltd., Footscray, Sidcup, Kent.*

#### BUSH (38, X25)

A new departure for Bush is the introduction of a tape-recorder—the TP50. This uses a 4-track, single-speed deck, playing at  $3\frac{3}{4}$ -in/sec; simple controls are provided. Another new introduction is the VTR103 nine-transistor portable radio, which operates on f.m. and a.m. and has a telescopic aerial for use at v.h.f. The VHF91 is a valve receiver covering three wavebands. Two speakers are used and separate bass and treble controls are provided. New television sets, the TV105c and T102c, use 19-in and 23-in tubes respectively.

*Bush Radio Limited, Power Road, London, W.4.*

#### CLARKE & SMITH (406, 414)

H.M.V. high-fidelity equipment displayed includes an a.m./f.m. tuner and separate and combined stereo pre-amplifiers and amplifiers. An unusual feature of two of these—the 556 comprehensive pre-amplifier and the 555 combined pre-amplifier and  $2 \times 10$ -watt amplifier—is the provision of a c.r.t. level indicator for indicating correct balance or checking the frequency response using a frequency test record. Another unusual feature of the 556 is the provision of a signal (obtained by mixing both stereo channels and approximately 16dB down on each) for feeding a central loudspeaker to reduce "hole in the middle" effects.

*Clarke & Smith Manufacturing Co., Ltd., Melbourne Works, Wallington, Surrey.*

#### COSSOR (52)

The CR1501A stereo radio-gram incorporates two double-cone 8-in speakers with a balance control. The Philips 4-speed autochanger is button-controlled, and the amplifier is

equipped for use with a tape-recorder. The name "Melody Maker" is again used, this time for an a.m./f.m. radio. Built-in aerials are provided for both transmissions and external aerials may be used. A portable 4-speed stereo record-player, the CR1800A, has detachable speakers and the pickup contains a turnover stereo head with two sapphire styli.

*Cossor Radio & Television, Ltd., 233, Tottenham Court Road, London, W.1.*

#### DANSETTE (39)

Several portable transistor receivers and a very wide range of fifteen mains and battery (transistorized) mono record reproducers and portable radio-grams will be on show. An unusual feature of one of these—the TRG/45—is that the radio is automatically switched off when the record player is started. Also exhibited is the stereo A35 record reproducer with its separate second loudspeaker.

*Dansette Products Ltd., 112/116 Old Street, London, E.C.1.*

#### DECCA (22, 418, X29)

The wide range of gramophones and radio and television receiving equipment shown here culminates in the stereo Decola. New stereo radio-grams Types 550 and 650, together with the 700 are of particular interest: push-pull amplifiers are used in the 650 and 700. Television receivers use 19- and 23-in tubes and the new DR29/C has tambour doors over the c.r.t. New radio receivers include a mains "consolette" (DMR/88) of unusual design and a 6-transistor m.w. and 1.w. set, the Debonette.

In the Audio Avenue is shown the

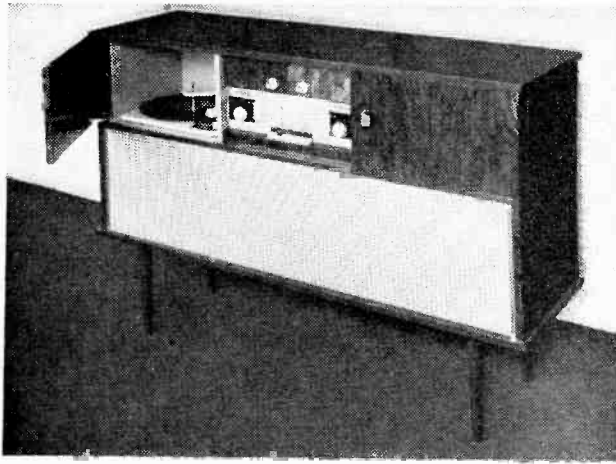

New Ekco "radiostereogramophone" SRG 395 has high-quality 8-in loudspeakers and affords reception of f.m. and a.m. transmissions.

new SRG700 a.m./f.m. stereo radiogram. The three four-inch middle and upper frequency (crossover frequency  $\approx 350\text{c/s}$ ) loudspeakers for each stereo channel are internally mounted on two baffles and—an unusual feature—each baffle can be rotated about a vertical axis through up to  $55^\circ$ . This allows adjustments to be made to the apparent width and direction of the sound field.

Decca Radio and Television Ltd., 15-17 Ingate Place, Queenstown Road, London, S.W.8.

#### DEFIANT (2)

A range of sound reproducers includes the HF3 automatic player, which has three speakers and covers  $50\text{c/s}$ - $15\text{Kc/s}$  at  $3\frac{1}{2}\text{W}$ . The T12 tape recorder is a  $3\frac{1}{2}$ -in/sec model with a frequency response of  $100\text{c/s}$ - $8\text{kc/s}$  at  $3\text{W}$  output and has superimpose facilities. Automatic stabilization of picture height is provided in the 9A35 19in television receiver, which has a forward-tilted screen to reduce reflections.

Co-operative Wholesale Society, Ltd., Radio & Television Dept., Alma Park, Warley Street, Upminster, Essex.

#### DESIGN FURNITURE (30)

Exhibited on this stand is a range of equipment, record storage and loudspeaker cabinets, and also television tables. New introductions include two loudspeaker cabinets which have been tested and approved for use with their speakers by Goodmans, and a combined cocktail/record cabinet.

Design Furniture, Ltd., Carnwath Road, London, S.W.6.

#### DOMAIN (113A)

A range of display stands for television receivers, tape recorders, etc., include free-standing and peg-board

shelves, and a special trolley for the Mullard valve tester. A lettering and pricing system for peg-board displays is also exhibited. New to the range is the BUK display stand, which can take many forms, the frames being joined by means of plastic "push-on" connectors.

Domain Products, Ltd., Domain Works, Barnby Street, London, N.W.1.

#### DYNATRON (27)

Shown is the attractively styled new "Planet" range of television receivers, features of which are their adaptability to 625-line or u.h.f. transmissions, should these be provided. Available for this range is a "wire-less" remote control unit for channel-selection, volume and brightness. Other new introductions include valve and transistor a.m./f.m. receivers. A feature of the valve model—the Pathfinder—is that it gives continuous coverage from medium waves down to the 12-metre band (as well as covering long waves). Among notable stereo radiograms is the Queen Anne—which also incorporates a tape recorder. Also shown are mains and battery (transistor) record reproducers and the Cordova three-speed tape recorder.

Dynatron Radio Ltd., St. Peter's Road, Furze Platt, Maidenhead, Berks.

#### E.A.R. (56)

The main emphasis on this stand is on the recently-introduced range of "1000-M" one-watt output battery (cordless) transistor units. Included in this range are the Astor receiver (which also features a relatively-large (5-in) loudspeaker and slow-motion tuning) and the Auto-Bat automatic four-speed transistor record reproducer (also available with radio included). Also shown are mains record players and repro-

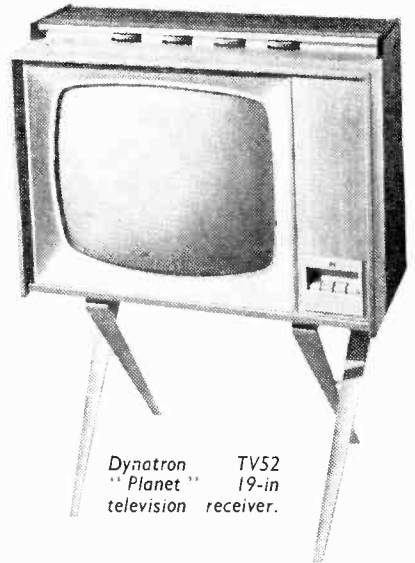

Dynatron TV52 "Planet" 19-in television receiver.

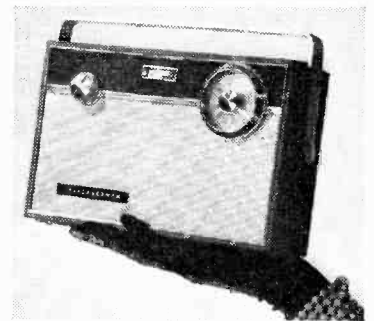

Elizabethan "Corsair" a.m. transistor receiver.

ducers in the MusicMaker, Bantam and Triple-Four (4 controls, 4 speeds, 4 loudspeakers) series. Stereo and mono record listening booths for shops are also displayed.

Electric Audio Reproducers Ltd., The Square, Isleworth, Middlesex.

#### E.M.I. RECORDS (62, X19)

Shown on this stand are  $33\frac{1}{3}$  r.p.m. 10 and 12in, and 45 r.p.m. 7in microgroove records under the labels of Capitol, Columbia, H.M.V., M.G.M., Mercury, Parlophone and Top Rank. A record query answering service will also be operated.

E.M.I. Records, Ltd., E.M.I. House, 20 Manchester Square, London, W.1.

#### EASCO (417)

On show will be a selection of this company's specialized audio equipment. For marine use this includes a 10-watt loudhailer, talkback intercom panels, a transistorized combined talkback and telephone system, amplifiers for sound relay applications, and an amplifier capable of operating from 110V d.c. (giving eight watts

(Continued on page 465)

output). Another specialized item is a talkback intercom system for fire engine ladders.

*Easco Electrical (Holdings), Ltd., 6 and 8 Brighton Terrace, Brixton, London, S.W.9.*

#### EKCO (33, X6)

Television receivers in the three main "styles"—traditional, contemporary and Continental—are one of the features on this stand. All television receivers have provision for internal fitting of an add-on unit to cater for a change of standards, should this come about: four new models have motor-driven tuning. Radio and gramophone equipment of particular interest is a transistor a.m./f.m. portable receiver with a tape recorder outlet and a new "radio-stereogramophone". Also on show are car radios, a tape recorder and range of record players and radio receivers.

*E. K. Cole, Ltd., Ekco Works, Southend-on-Sea, Essex.*

#### ELIZABETHAN (3)

This company has recently entered the transistor receiver and (valve) record reproducer market and a second record reproducer is introduced at this show. A four-track version of the inexpensive single-speed (3 $\frac{1}{2}$ in/sec) Popular de Luxe and a two-track version of the three-speed F.T.3 are additions to this company's wide range of tape recorders. This range also includes two- and four-track versions of the "Major" recorder with its special features of six-watts push-pull out-

put, bass and treble loudspeaker system and meter level indicator.

*Elizabethan Tape Recorders Ltd., Bridge Close, Oldchurch Road, Romford, Essex.*

#### EMBER (116)

Shown on this stand are a range of inexpensive single-channel, 12-in 33 $\frac{1}{2}$  r.p.m. and 7-in 45 r.p.m. micro-groove popular and jazz records. This company holds the licence to produce in this country all records and film sound tracks of the American 20th Fox Record Corporation.

*Ember Records (International) Ltd., Central House, 12 Great Newport Street, London, W.C.2.*

#### EVER READY (28, X4)

The full range of Ever Ready and Berec portable and table model transistor receivers will be on show. Also displayed is the recently-introduced dual purpose portable and car radio. This, on being plugged into its special screen container in the car, is automatically connected to the car aerial, car battery (which supplies a higher voltage and thus increases the power output), and an 8in  $\times$  5in loudspeaker in place of the corresponding internal units. Also exhibited are ranges of batteries for various purposes.

*Ever Ready Co. (Great Britain) Ltd., Hercules Place, London, N.7.*

#### FERGUSON (20, X5)

With one exception (a 7-valve a.m./f.m. set), all Ferguson's radio receivers are transistorized, but valves are used in the radiogramophones,

two of which (660RG, 661RG) have headphone sockets for personal binaural listening. All new television receivers contain switching for conversion to 625-line u.h.f. reception, should the occasion arise: additional components required will include a sub-chassis and u.h.f. tuner.

Other new items include two tape recorders and a personal portable radio.

*Ferguson Radio Corporation, Ltd., Thorn House, Upper St. Martin's Lane, London, W.C.2.*

#### FERRANTI (14, X2)

New television receivers on show use the square-cornered 19- and 23-in c.r.t.s. and this company's first 23-in table model features remote control. For radio reception the PT.1065 is of interest. This is a 9-transistor portable receiver covering v.h.f./f.m., and medium and long waves. A telescopic aerial is fitted and the carrying handle can be detached so that the set presents a neat appearance as a table model.

The 19-in "Homemaker" television receiver is claimed to be suitable for conversion to 625-line reception should the need arise.

*Ferranti Radio & Television Ltd., 41-47 Old Street, London, E.C.1.*

#### FIDELITY (8)

Half of the range of auto and non-auto record players, transistor receivers and Argyll two- and four-track tape recorders on show are new models. Also exhibited are the inexpensive Coronet transistor receiver (featuring a 90mW push-

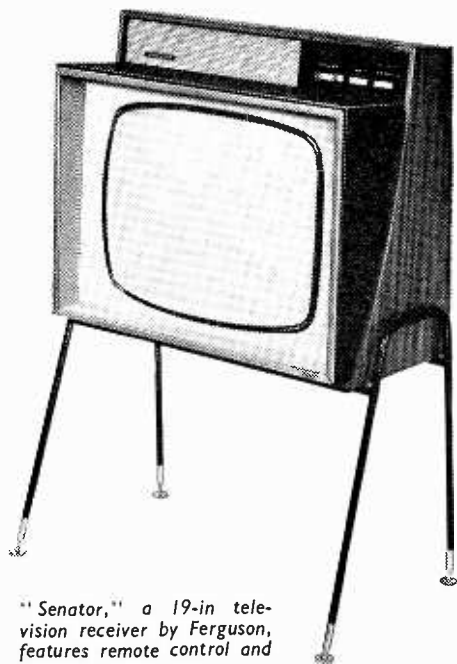

"Senator," a 19-in television receiver by Ferguson, features remote control and unusual styling.

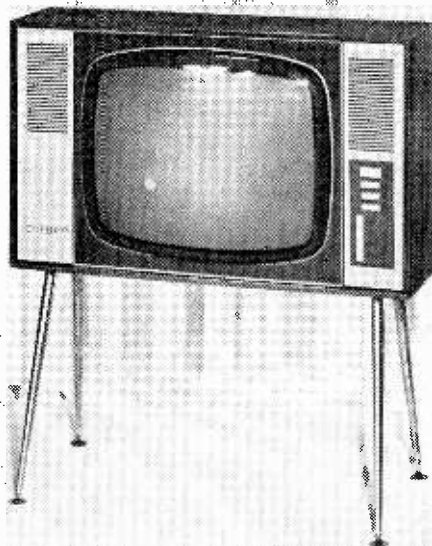

19-in Ferranti "Homemaker" television receiver has push-button tuning and a front-mounted loudspeaker.

pull output, two i.f. stages and a socket for private earphone listening or tape recording) and the RG-26 a.m./f.m. radio-gram (which features a four-watt output).

*Fidelity Radio, Ltd., 11-13 Blechynnden Street, London, W.11.*

#### FUND FOR THE BLIND (312)

Equipment and appliances designed or modified to help blind people to overcome their handicap are displayed on the stand which features the service of installing and maintaining radio sets for the blind. The Fund helps the civilian blind of Greater London by collecting and distributing money to fourteen institutions and associations.

*Greater London Fund for the Blind, 2 Wyndham Place, London, W.1.*

#### G.P.O. (306)

A feature of the telecommunications display mounted by the Post Office is the part the 500-ft tower to be erected near Tottenham Court Road, London, will play in the future development of micro-wave radio links for the telephone service. A look still further into the future is provided by a display depicting the use of earth satellites in international telephone links.

*General Post Office, Headquarters Building, St. Martins-le-Grand, London, E.C.1.*

#### GARRARD (36)

Recent introductions by this company include the Autoslim and Autoslim-de-luxe record changers, which have been specially designed to occupy minimum height, and the Laboratory Series automatic record player type A with its unusual sandwich constructed turntable and weight-counterbalanced pickup arm. Also shown are the well-known magazine loading single-speed (3 $\frac{1}{2}$ in/sec) two- and four-track tape decks, SPG3 stylus pressure gauge, TPA12 pickup arm and 301 adjustable-speed transcription record turntable. A range of crystal and ceramic stereo and mono pickups is also available.

*Garrard Engineering & Manufacturing Co., Ltd., Newcastle Street, Swindon, Wilts.*

#### GRAMOPHONE COMPANY (408)

Shown on this stand is the latest version of the E.M.I. "Voicemaster" tape recorder—the 65A. The use of four tracks and separate record and replay heads and amplifiers allows (with extra switching) re-recording to be carried out (from one track to another)—a facility normally only possible with two tape recorders. Also displayed is the E.M.I. EPU100 variable-reluctance stereo pickup and arm with its special features of sideways and longitudinal balance about the single viscous-damped pivot and very low

effective stylus tip mass (approximately 1mgm).

Also exhibited are a range of E.M.I. record reproducers, the Glyndebourn IV a.m./f.m. stereo radio-gram with suitable external loudspeaker systems and, for the home constructor, the 985 record turntable (available in mains or battery versions and with pickup and arm) and DLSU bass and treble loudspeaker systems.

*Gramophone Co., Ltd., Blyth Road, Hayes, Middlesex.*

#### HACKER (55)

Newly introduced by this company is an f.m.-only receiver which features three i.f. stages, a seven-watt push-pull output, and adjustable local station markers on the tuning scale. Also shown are transistor portable receivers, record reproducers and radio-grams which feature one-watt push-pull outputs and large (8 × 5in) resistive-slot loaded loudspeakers. The receiver—the Herald—is also unusual in incorporating a treble tone control and 2000-ohm input for a microphone (to provide a baby alarm) or pickup.

*Hacker Radio Ltd., Norreys Drive, Cox Green, Maidenhead, Berks.*

#### HEATHKIT (111)

The full range of Heathkit high-fidelity, test gear and radio kits is shown, with several additions. The GC-1U transistorized communications receiver covers the range 550kc/s to 30Mc/s and over most of the range gives better than 10dB signal-to-noise with 2 $\mu$ V input. An inexpensive 1.f. oscillator—the AO-1U—works from 20c/s-150kc/s in four ranges at an output of up to 10V r.m.s. The square wave output is 20c/s-50kc/s at a maximum output of 80Vp-p. The 200-400V stabilized power supply—HSP-1—has an output impedance of less than 0.5 $\Omega$  at 500kc/s and a total noise of less than 1 mV. Single-sideband adaptor SB-10 covers 10-80 metres and requires less than 3W r.f. input for 10W peak envelope power.

*Daystrom Ltd., Bristol Road, Gloucester.*

#### HIS MASTER'S VOICE (23, X28)

Incorporating a socket for car-radio aerial and another for output to a tape recorder, the Model 1424 receiver—a medium- and long-wave portable—employs seven transistors, three of which are the diffused-alloy type giving high gain. A mains a.m./f.m. table model, the 1379, has two 8 × 5in loudspeakers, one on either side of the dial.

A new a.m./f.m. radio-cum-stereogramophone (Model 1644) incorporates a "spring" reverberation unit and on radio and "mono" the two stereo channels are operated in push-pull.

In the range of television receivers the 1922 is of particular interest as it employs a motorized tuner (which is adaptable for u.h.f.) with only one push-button for control. The field, as well as the line, time-base is stabilized.

*British Radio Corporation Ltd., 21 Cavendish Place, Cavendish Square, London, W.1.*

#### HOBDAY (53, X13)

In association with Ultimate Television Rentals this company is illustrating a rental scheme for Alba television receivers. An information counter on Stand 53 enables members of the public to obtain full details of this scheme. As wholesalers, Hobday exhibit a wide range of radio and television receiving equipment and sound-reproducing apparatus distributed by them to the retail trade.

*Christopher Hobday Ltd., Hobday House, Southchurch Road, Southend-on-Sea, Essex.*

#### INVICTA (17)

New 19-in and 23-in television receivers on show incorporate motor-driven, push-button tuning and remote-control units available give control of volume, brightness and channel selection. Several new transistor portable radios are displayed.

*Invicta Radio Ltd., 100 Great Portland Street, London, W.1.*

#### J-BEAM (18)

For use with a portable receiver the C.R.P.6 aerial is of interest: this has two p.v.c. suckers which enable it to be attached to any suitable surface, such as the bodywork of a car. Television and f.m. aerials are on show, including arrays using J-Beam's specialities, the end-fed Band-I dipole and the Band-III skeleton slot. From the company's associates, Radio Telephone Aerial Systems, come communications aerials proofed against adverse weather conditions by an epoxy-resin enamel.

*J-Beam Aerials Ltd., Westonia, Weston Favell, Northampton.*

#### JASON (411)

Newly introduced by this company for use with tape recorders are a two-channel unit with separate record amplifiers and playback pre-amplifiers, erase and bias (available ready built or in kit form) and also, in kit form only, a tunable transistor a.m. tuner. The range of f.m. tuner kits on show includes fringe and a.f.c. models.

Ready-built units displayed include stereo and mono combined comprehensive pre-amplifiers and 10-watt amplifiers and also tuners covering f.m. and TV sound (switched tuning) or f.m. only (variable tuning).

*Jason Motor & Electronic Co., Kimberley Gardens, Harringay, London, N.4.*

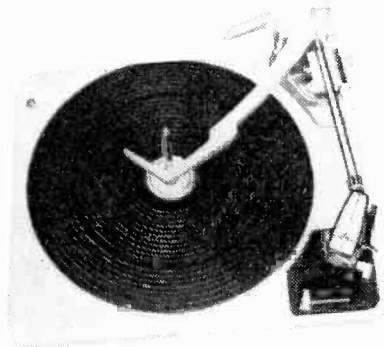

Above: Garrard "Autoslim-de-Luxe" record changer.

Right: Murphy "Astra" television receiver with v.h.f./f.m. features push-button tuning of Home, Light and Third programmes on the "Compass" tuner.

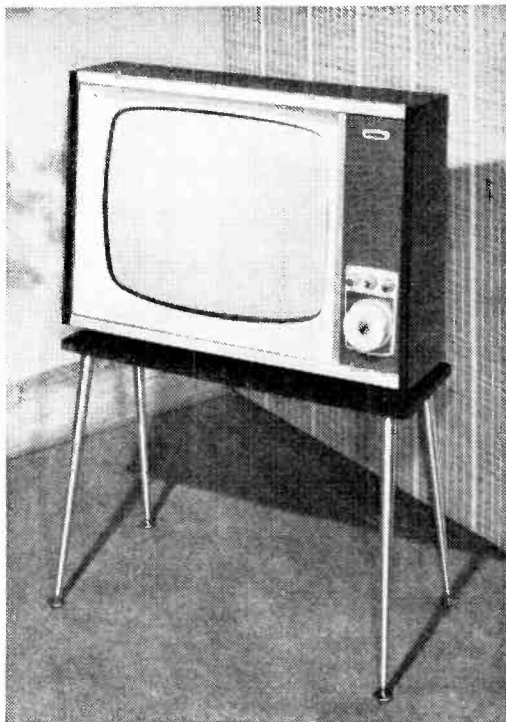

His Master's Voice battery portable receiver Model 1424 has socket for tape-recording.

#### K.B. (50)

An addition to the range of transistor portables is the "Cavalier," which is a 7-transistor set with sockets for car-aerial, tape-recording and baby alarm. Three new transistor record players are shown and the "Nocturne" small stereo radio-gram is on view. A full range of television receivers from 19-in to 24-in is displayed and a newcomer is the 4-track, 3 $\frac{1}{2}$ -in/sec tape recorder.

*Kolster-Brandes Ltd., Footscray, Sidcup, Kent.*

#### KERRY'S (43)

This wholesaler will display a comprehensive range of television and radio receivers, radio-grams, record players, record storage cabinets and television tables from Alba, Berec, Dansette, E.A.R., Elizabethan, Ever Ready, Fidelity, Marconi, Perdio, Philips, Regentone and W.B.

*Kerry's (Great Britain) Ltd., Warton Road, Stratford, London, E.15.*

#### LEE PRODUCTS (415)

This company's standard range of equipment includes two and four-track tape recorders using the single-speed (3 $\frac{1}{2}$ -in/sec) B.S.R. "Monar-deck", valve and transistor four-speed record reproducers (the latter with a 1-watt, push-pull output), an a.m./f.m. radio-gram chassis and a 10-watt amplifier. It is also hoped to introduce a new range of audio equipment which includes a.m./f.m. and f.m.

tuners and stereo and mono amplifiers and pre-amplifiers.

*Lee Products (Great Britain) Ltd., Elpico House, Longford Street, London, N.W.1.*

#### LINGUAPHONE (209)

Recorded language courses in 38 languages, many of them now on 45 r.p.m. discs, are available from the Institute. For technical students the Institute provides supplementary printed courses after the basic language has been mastered.

*Linguaphone Institute, Ltd., Linguaphone House, 207-209 Regent Street, London, W.1.*

#### LOWTHER (413)

Horn-loaded loudspeaker systems shown include the well-known TP1 and Acousta mono units and also the stereo Acousta-Twin—which features variable reflectors for positioning the apparent sound sources. General features of the loudspeaker drive units exhibited are their high-flux magnets and the use of a fixed central "stabilizer" to load the inner of the two cones and to reduce interference between sound radiated from its various parts. Also shown are a comprehensive control unit and two power amplifiers—the latter including feedback to an unusual point in the output valves (their suppressor grids).

*Lowther Manufacturing Co. Ltd., Lowther House, St. Mark's Road, Bromley, Kent.*

#### MARCONIPHONE (41)

Called their "Diamond Jubilee Range" (as it was in 1901 that Guglielmo Marconi succeeded in spanning the Atlantic by wireless), Marconiphone are showing many new models. Among these are the VT170 television receiver with a 19-in c.r.t. and preset fine tuning, the T98B transistor table model a.m. receiver and the RG95 six-valve a.m./f.m. radiogramophone.

The T84 is an a.m./f.m. table model mains receiver tuning over long and medium waves and Band II.

*British Radio Corporation Ltd., 21 Cavendish Place, Cavendish Square, London, W.1.*

#### MARKOVITS (113)

The exhibit comprises a selection of die-cast, electroplated nameplates and emblems for the radio and electrical industry. Also on view is a new type of metal nameplate with a decorative plastic insert.

*I. Markovits Ltd., Premier House, 8 Golden Square, London, W.1.*

#### METROPOLITAN POLICE (308)

A variety of equipment used by the Police is shown on the stand on which are featured mobile equipment and headquarters radio operating positions. The recently introduced "specially equipped traffic accident car" (SETAC), which on show, is fitted with a 7-channel transmitter-

receiver which has a transmitter output of 10 watts.

*Metropolitan Police, New Scotland Yard, London, S.W.1.*

#### MULLARD (46, 316, X24, X26, X26A)

As last year, the main stand (46) comprises a cinema. This year two films are shown simultaneously illustrating the advantages accruing from the possession of a "second" set; also featured are recent developments in Mullard valves, c.r.t.s and components employed in domestic apparatus.

The always popular "Home Constructor Centre" is this year at X26A, where the full range of Mullard technical publications is available, as is technical advice on Mullard designs and the use of Mullard valves, semiconductors and c.r.t.s.

Other Mullard stands are X24 (for remakers) and X26, "Dealer Rendezvous."

*Mullard Ltd., Mullard House, Torrington Place, London, W.C.1.*

#### MULTICORE (65, X16)

Shown for the first time are solder rings, washers and pellets in several alloys, with or without flux, for automatic assembly of computers and sub-units. New alloys containing silver are shown and additions to the range of tin/lead alloys are specially low and high melting-point solders. Several new packs of solder are shown, and the range of Bib tape-recording accessories is exhibited, including the popular Bib splicer.

*Multicore Solders, Ltd., Maylands Avenue, Hemel Hempstead, Herts.*

#### MURPHY (16, X1)

This company, which was the first to introduce tunable television receivers with a preset fine-tuner control, this year present their "Astra" range which, when fitted with v.h.f. radio facilities, provide push-button tuning of Home, Light and Third programmes. The new 19- and 23-in c.r.t.s are used and the receivers are claimed to be capable of conversion from 405 to 625 line transmissions should the need arise at some time in the future.

For radio reception new sets include a pocket-size personal portable tuning over m.w. and v.h.f./f.m. and a transistor table model whose back repeats the front design, thus ensuring neat appearance from any angle.

*Murphy Radio Ltd., Welwyn Garden City, Herts.*

#### N.E.V. (109)

The "Nev Mini-Eye Transistor"—a transistorized closed-circuit television camera—is being demonstrated. This camera has no external controls and is available for export in 525- and 625-line versions.

Also on show is the "Nev Eye" low-cost camera, and the company's range of cathode-ray tube repair and manufacturing plant will be displayed.

*Nottingham Electronic Valve Co., Ltd., Main Street, East Bridgford, Notts.*

#### PAM (21, X3)

The complete range of radio and television receivers and sound equipment is on view. A range of transistor radio receivers includes the TB77, a table model using seven transistors on a printed circuit. The range of television receivers incorporates transistor synchronization and remote-control units, and all the types shown can be converted to operate on 625 lines. Stereophonic reproduction is provided by the RG630 radio-gram, which incorporates a four-speed auto-changer and medium wave/v.h.f. radio receiver.

*Pam (Radio and Television) Ltd., 295 Regent Street, London, W.1.*

#### PAMPHONIC (58)

The Domestic Natural Sound division are showing an advance model of their "Slim Line" stereo radio-gram designed to operate with the new Pillar speakers. This speaker is a tuned column containing two cones, one covering the range 45c/s-12kc/s and the other 1kc/s upwards. The Reflectograph tape recorder is now manufactured by Pamphonic and is on view. The Beamed Sound division exhibit kits from which can be assembled sound reinforcement systems for halls, churches, etc. A 4-ft. indoor line source loud-speaker is shown.

*Pamphonic Reproducers, Ltd., 17 Stratton Street, London, W.1.*

#### PERDIO (1)

The range of transistor receivers made by this company includes the Mini-Six—features of which are its small size (4½ in by 2½ in by 1½ in), light weight (8oz) and 200mW push-pull output, and the Multi-Band 102—which is unusual in that it gives



Portogram "Varsity Model B" record reproducer.

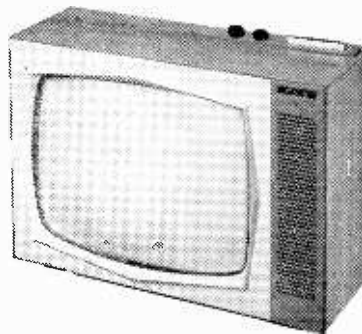

"Diadem," Model 619 by R.G.D., has push-buttons at top to avoid movement of set when operating controls.

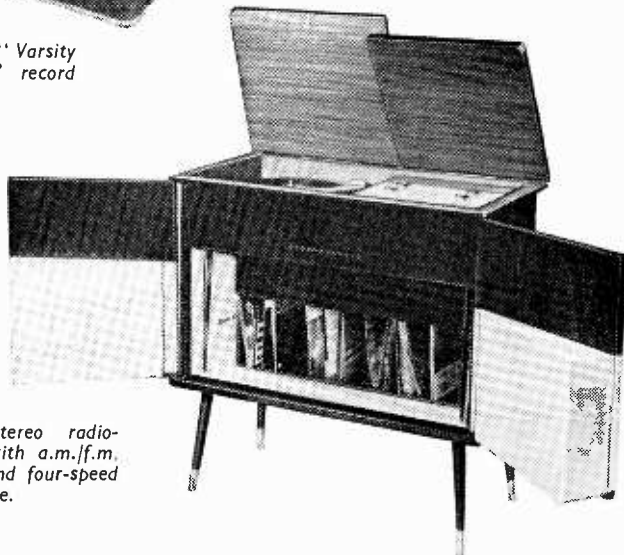

Pam stereo radio-gram with a.m./f.m. radio and four-speed turntable.



continuous coverage from medium waves to the 11-metre band (as well as covering the long-wave band) and that it uses amplified a.g.c. General features of this company's range are the provision of sockets for car aerial and for private earphone listening or tape recording.

*Perdio Ltd., Perdio House, Bonhill Street, London, E.C.2.*

#### PETO SCOTT (26)

Motorized tuning and automatic contrast control are features of new television receivers. The ARG71 stereo radio-gram uses nine valves and will play both mono and stereo records; an a.m./f.m. radio receiver is incorporated. A 4-track, single-speed tape recorder and a transistor portable are shown.

*Peto Scott Electrical Instruments Ltd., Addlestone Road, Weybridge, Surrey.*

#### PHILCO (35, X27)

"Selectafash" is the name given Philco's latest remote control system for television. This uses an ordinary hand torch as the controlling device, the beam being directed to either of two sensitive spots on the set. The receivers also incorporate switching for conversion to 625-line working, should the need arise.

Other new items include radio receivers, three radiogramophones, record players and a portable tape recorder.

*Philco (Gt. Britain) Ltd., 21 Cavendish Place, London, W.1.*

#### PHILIPS (10, 15, 316, 401, X30)

Television receivers on view include the 19TG108U 19-in model with side-mounted controls and hinged chassis, and the 23-in, 23TG107U which has automatic fine tuning. Several transistor portable radio receivers are shown, including the 303T medium- and long-wave model. The speaker is 5-in diameter and the handle folds for indoor use, while a socket is provided for use with a car aerial. A range of sound equipment is on display.

In the Audio Avenue the exhibit comprises mono and stereo record-players and radio-grams, including the full range of "Disc Jockey" players.

*Philips Electrical, Ltd., Century House, Shaftesbury Avenue, London, W.C.2.*

#### PITRIE (108)

As in previous years, Pitrie are welcoming trade visitors to discuss their range of replacement cathode-ray tubes. Also shown is a range of components.

*Pitrie Ltd., 21 Noel Street, London, W.1.*

#### PORTOGRAM (416)

Shown on this stand are tape recorders (incorporating the Collaro "Studio" three-speed and B.S.R.

"Monardeck" single-speed decks) and a range of record players and reproducers. Prominent among the latter is the "Varsity" Model B which features the continuously-variable speed Lenco turntable, Collaro Studio pickup, an automatic device for lowering the pickup on to or raising it from the record, and a six-watt push-pull amplifier. An unusual feature of the AutoGram is the "Panoramic" tone control which allows treble boost with bass cut or bass boost with treble cut.

*Portogram Radio Electrical Industries Ltd., Audio Works, Paxton Road, Tottenham, London, N.17.*

#### PYE (32, X7)

A full range of 19-in and 23-in television receivers are shown, which incorporate push-button automatic tuning and, as an accessory, remote control. All receivers in the range use transistors in the time-base synchronizing circuits, hence the name, the "Transista Range." Also on view are portable radio receivers and a range of car radios includes the TCR 3000/E, which covers 1600kc/s to 17.4Mc/s in nine wavebands.

*Pye, Ltd., Cambridge.*

#### R.G.D. (44, X10)

The "Diadem" range of television receivers, which have an octagonal mask claimed to reduce eyestrain, and a leather-cased transistor portable receiver tuning over medium and long waves, are among the new models shown on this stand. Also on show is a wide range of radio receivers, radiogramophones and record players. Another new set is a 7-valve mains a.m./f.m. set with sockets for connection of a tape recorder (Model 37). This set has a plastics-moulded case and a 7 x 4-in loudspeaker.

*Radio Gramophone Development Co., Ltd., Eastern Avenue West, Romford, Essex.*

#### R.S.G.B. (315)

Exhibits of both home-constructed and commercial gear for the amateur transmitter and short-wave listener are shown on this stand. There will also be found the latest editions of the books and pamphlets issued by the Society, including "Amateur Radio Call Book" and "Radio Amateurs' Examination Manual".

*Radio Society of Great Britain, New Ruskin House, Little Russell Street, London, W.C.1.*

#### R.T.R.A. (202, 316)

In addition to the information bureau for both the trade and the public on its main stand R.T.R.A. is featuring its apprenticeship scheme in the Trade Technical Section on the first floor.

*Radio and Television Retailers' Association, 15-17 Goodge Street, London, W.1.*

#### REGENTONE (45)

Shown on this stand is a wide range of television and radio receivers, record players and radiogramophones. New items include the TV191 and 192 19-in television receivers, the 191 having turret tuning and the 192 push button. Two new transistor radio receivers are the BT16 and BT18, the BT18 being a "pocket" personal set having a linear tuning scale.

*Regentone Radio & Television, Ltd., Eastern Avenue West, Romford, Essex.*

#### REHABILITATION OF DISABLED (313)

Details are available on this stand of the work of the Council for Rehabilitation of the Disabled whose primary function is, through training courses, to facilitate the return to work of injured and disabled people. Among the courses provided by the Council is one covering radio maintenance.

*British Council for Rehabilitation of the Disabled, Tavistock House (South), Tavistock Square, London, W.C.1.*

#### ROBERTS (63, X18)

Transistor receivers shown on this stand include the R200 and RT7. Features of the RT7 are its large (8 x 5-in) loudspeaker, one-watt push-pull output and treble tone control. Features of the R200 are its ½-watt push-pull output and relatively-large (5-in) loudspeaker. Protective carrying cases are available for both these receivers.

*Roberts' Radio Co., Ltd., Creek Road, East Molesey, Surrey.*

#### ROLA CELESTION (210)

The main feature of this stand is the Colaudio II loudspeaker system. The 12-in bass unit in this is unusual in having a "solid" rather than a hollow cone. This is made of "exploded" polystyrene to achieve a high stiffness-to-weight ratio. This loudspeaker also has a very low free-air fundamental resonance (about 10c/s) so that although the cabinet volume is only 1.8cu ft, this resonance is not raised to more than about 40c/s. A 2¼-in pressure-driven tweeter crossing over around 2 kc/s is also used.

Also displayed are domestic loudspeakers with diameters ranging from 2½ in to 15 in. Among commercial loudspeakers will be shown new bowl diffusers.

*Rola Celestion Ltd., Ferry Works, Thames Ditton, Surrey.*

#### S.T.C. (410)

This company is showing its range of high-quality microphones. These include moving-coil units with cardioid or, in the case of the well-known "ball and biscuit" 4021, omni-



directional polar responses. Ribbon microphones include the 4038 as well as the 4104 close-talking noise-discriminating unit. A combined ribbon and moving-coil microphone which can be switched to give alternative figure-of-eight, omnidirectional or cardioid polar responses, the 4033-A, is also displayed.

*Standard Telephones & Cables, Ltd., Connaught House, 63 Aldwych, London, W.C.2.*

#### SAGA RECORDS (118)

Recordings shown by this company include mono microgroove 33 $\frac{1}{2}$  r.p.m. 12in and 45 r.p.m. 7in records (the latter including the Dandy series for children), mono 3 $\frac{1}{2}$ in/sec and stereo and mono 7 $\frac{1}{2}$ in/sec pre-recorded tapes.

*Saga Records Ltd., 127 Kensal Road, London, W.10.*

#### SIMON (117)

An addition to the range of tape recorders is the high quality SP5 twin track, two speed instrument, which is sold in either mono or stereo versions, with easy conversion. The deck operates at 7 $\frac{1}{2}$ in/sec or 3 $\frac{1}{2}$ in/sec and at the former speed, the frequency response is 30c/s-20kc/s. The recorded signal, which may be monitored through the internal speaker, or by earphones, can be transferred from one track to the other, and mixing, fade and pause controls are incorporated. A 2.5-in meter indicates the record level, and this can also be switched to read the bias level.

*Simon Equipment Ltd., 46-48 George Street, Portman Square, London, W.1.*

#### SLINGSBY (24)

Trucks and trolleys designed for the easy and safe moving of heavy apparatus are manufactured by this company.

*H. C. Slingsby, Ltd., 89, 95 & 97 Kingsway, London, W.C.2.*

#### SOUTHGATE TUBULAR PRODUCTS (205)

Shop display equipment shown includes a new battery-powered turntable, which is 6-in diameter and carries a load of four pounds; four weeks' continuous operation is obtained from two U.2 batteries. Several new fittings for the Unipole display stand are on view.

*Southgate Tubular Products, 148 Chase Side, Southgate, London, N.14.*

#### STELLA (40)

Valve and transistor radio receivers, television receivers and sound reproducers are shown. The ST243U mains radio is a 6 valve a.m./f.m. receiver with a hank aerial for v.h.f. reception and a loop aerial for medium and long waves. A special balance control is used for stereo balance in the ST314A radio-gram,

which uses the Philips 4-speed automatic changer and push-button function switch. A v.h.f. radio is incorporated. Mono and stereo record-players are on view and the ST562A employs a high-fidelity stereo pickup.

*Stella Radio and Television Co. Ltd., Astra House, 121-123 Shaftesbury Avenue, London, W.C.2.*

#### T.C.C. (54, X14)

A very wide range of capacitors is on view, among the new additions being ranges of wet and dry solid sintered capacitors for operation in extremes of temperature. Vertical mounting is adopted in the Elkomold range of miniature electrolytics and mounting feet are moulded into the case. Tubular capacitors shown work in the range -40°C to 100°C and comply with H.I requirements; a considerable size reduction is achieved. Printed-circuit boards displayed contain plated-through holes, and flush-bonded panels in silver and rhodium are available.

*Telegraph Condenser Co., Ltd., Wales Farm Road, North Acton, London, W.3.*

#### TAPE RECORDERS (405)

New tape recorders introduced include two and four-track single and three-speed models using the B.S.R. "Monardeck" and Collaro "Studio" decks respectively. Also shown are the Connoisseur with its built-in four-speaker system, and the four-track, three-speed Soundmaster with its special features of push-pull erase oscillator, level indication by recording meter, separate record and play back amplifiers, low-noise transistor play back pre-amplifier and 10-watt "low loaded" push-pull output stage.

Also shown is the Sonocolor range of magnetic tapes and associated equipment.

*Tape Recorders (Electronics) Ltd., 784-788 High Road, Tottenham, London, N.17.*

#### TAYLOR (110)

The full range of test equipment is displayed, with several recent additions. For the dealer, Sweep Oscillator 92B covers the frequency range 4-210Mc/s on fundamentals and has a maximum output of 300mV. The 45C Valve Tester is capable of testing over 5,000 valve types, and will check 12V car radio valves. A range of multimeters and valve voltmeters is shown, and the display of panel meters includes miniature edgewise mounting types.

*Taylor Electrical Instruments, Montrose Avenue, Trading Estate, Slough, Bucks.*

#### TELENG (107)

Specialists in the field of wired television and v.h.f./f.m. relay and communal-aerial systems, this com-

pany is showing a wide range of equipment for these applications. New items include a repeater with a novel a.g.c. system, which is claimed to avoid the picture degradation inherent in the use of mean-level a.g.c. Another item of interest is a ferrite-cored directional transformer for the splitting of one coaxial feed into two. Whilst the forward loss is only 3.5dB, the reverse loss is at least 14dB.

*Teleng Ltd., Teleng Works, Church Road, Harold Wood, Romford, Essex.*

#### TELERECTION (34)

A wide range of television and f.m. aerials catering for conditions ranging from swamp signal to extreme fringe is shown together with new combined arrays and a spring-assembly feature for Band-III elements. The name "FM Clipper" is given to Band-II attachments for v.h.f./f.m. use.

*Telecton Ltd., Antenna Works, Lynch Lane, Weymouth, Dorset.*

#### TELESURANCE (5)

In addition to providing details of its maintenance-insurance scheme Telesurance has organized a composite display of television receivers.

*Telesurance Ltd., 14 Windmill Street, London, W.1.*

#### TERRITORIAL ARMY (317)

The 65th Signal Regiment (T.A.), formerly No. 1 Special Communications Regt., is showing some of the equipment used for training in such trades as W/T operator, radio mechanic and line mechanic in this signals unit.

*Territorial Army (65th Signal Regt.), 79-85 Worship Street, London, E.C.2.*

#### TEXPEX (314)

This firm offers a specification-writing service to the radio and electronics industry. The stand functions as an enquiry office.

*Texpex, Ltd., 110 Kennington Road, London, S.E.11.*

#### THORN-A.E.I. (29, X8)

Mazda valves and cathode-ray tubes are displayed on this stand. Notable are the new 19- and 23-in twin-panel television c.r.t.s which have the safety glass bonded to the tube face.

Preferred ranges of valves for a.m./f.m. sets are shown and another feature is the illustration with typical circuits of the use of valves and c.r.t.s.

*Thorn-A.E.I. Radio Valves and Tubes, Ltd., 155 Charing Cross Road, London, W.C.2.*

#### TRADE TECHNICAL SECTION (316)

A number of firms and associations are showing equipment and services provided for the serviceman. On this stand is also shown the winning entries and runners up in the com-

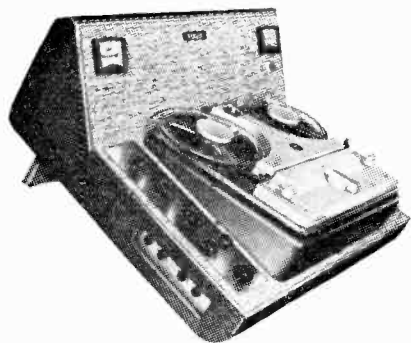

Above: Simon SP5 twin-track tape recorder. The record-level meter may be switched to read bias level.

Pilot (on the Ultra stand) "Coffee Table" radiogram, tuning over medium and long waves, is about 3ft 6in long.

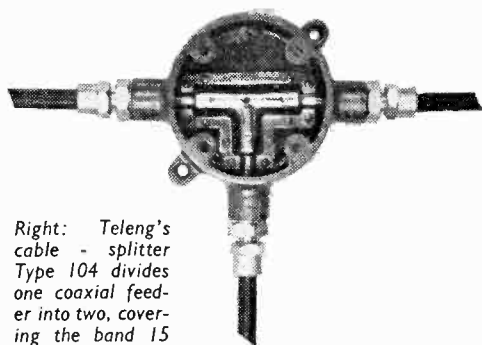
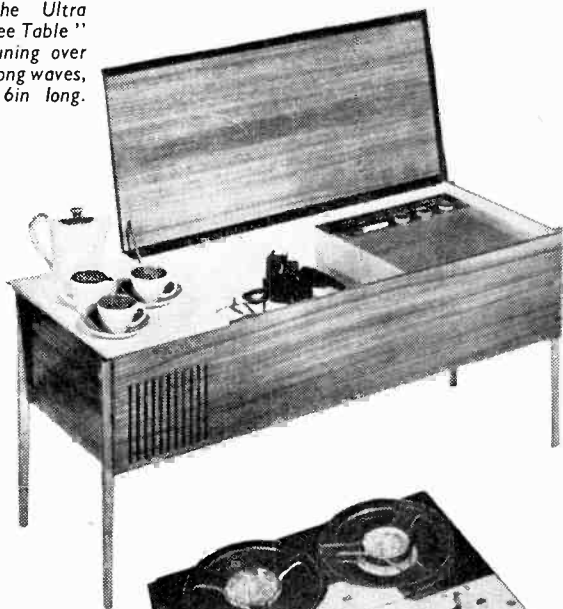

Right: Teleng's cable - splitter Type 104 divides one coaxial feeder into two, covering the band 15 to 230 Mc/s.

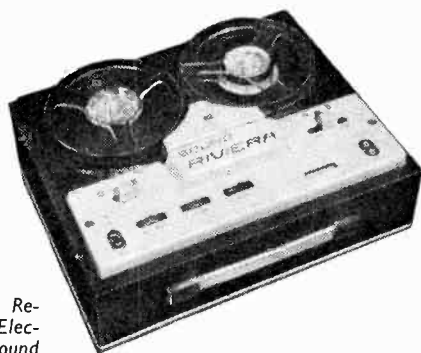

Right: Tape Recorders (Electronics) "Sound Riviera" recorder.

petition for servicing ideas sponsored jointly by our sister journal *Wireless & Electrical Trader* and the exhibition organizers.

*Radio Industry Exhibitions Ltd.*, 59 Russell Square, London, W.C.1.

#### ULTRA (4, X31)

Most visitors to the show will know that the Ultra TR70 transistor radio won the Duke of Edinburgh's Prize for Elegant Design: this set and many other radio and television receivers and gramophones are on show. Two new 23-in TV sets are claimed to be capable of conversion to 625-line reception, should this be necessary. New Pilot models include a "coffee-table" style medium- and long-wave radiogramophone which has a bass-reflex mounting chamber for the loudspeaker.

*Ultra Radio and Television Ltd.*, Television House, Field End Road, Eastcote, Ruiship, Middlesex.

#### WHITELEY (66, X15)

A prominent feature of the display on this stand is the wide range of Stentorian high-fidelity equipment. This includes loudspeakers available to suit a wide variety of requirements in cone construction, magnet strength, speech-coil impedance and size (from

1½ to 18in in diameter), loudspeaker enclosures (including the "Break-down" range for home constructors) and matching equipment cabinets, stereo and single-channel amplifiers and an f.m. tuner. Some loudspeaker cabinets will be shown with Perspex fronts so that their internal construction can be examined. A recently-introduced compact bass-reflex loudspeaker system is the "Clumber".

Also displayed are industrial sound reproducing equipment, and ranges of transformers and chokes.

*Whiteley Electrical Radio Co., Ltd.*, Radio Works, Victoria Street, Mansfield, Notts.

#### WIRELESS FOR THE BEDRIDDEN (60)

Space for the stand of the "Wireless for the Bedridden" Society, which exists to provide free radio facilities to needy bedridden, housebound and aged invalids, has been given by the exhibition organizers. The Society has so far provided and maintains over 8,000 receivers and relay facilities and it is now also providing television receivers to Voluntary Old Peoples' Homes, etc.

"Wireless for the Bedridden" Society, 20 Wimpole Street, London, W.1.

#### WOLSEY (37)

The wide range of radio and television aerials and accessories on show includes several new aerials of improved performance and a new pre-assembled lashing bracket of very strong construction.

A new "in-the-room" television aerial, called the Hermes, is designed to give increased "gain" so increasing the range at which this type of aerial can be used.

Communal-aerial and relay network equipment and accessories are on show.

*Wolsey Electronics Ltd.*, Cray Avenue, St. Mary Cray, Orpington, Kent.

#### ZONAL (404)

This company is showing the Zonatape range of standard and long-playing magnetic recording tapes, a feature of which is the incorporation of a coating lubricant for reducing head wear. Bases used in this range are diacetate, p.v.c., or polyester. Also displayed is the Zonastripe range of magnetically-stripped films. A fluid which toughens film by replacing the moisture in the emulsion by organic compounds—Permafilm—is also exhibited.

*Zonal Film (Magnetic Coatings) Ltd.*, The Tower, Hammersmith Broadway, London, W.6.

# JAPANESE VIDEO RECORDER

TELEVISION picture recording on tape, until recently, seemed to have stabilized on the system developed by Ampex. However, a different approach on the part of workers at the Tokyo Shibaura Electric Company Ltd. has resulted in the appearance of another system, which was described recently\* in the Journal of the Society of Motion Picture and Television Engineers.

The Toshiba system uses only a single head rotating in a cylindrical guide drum round which the tape is wrapped, forming one turn of a helix (Fig. 1). Thus rotation of the head with the tape stationary will result in a track being drawn out by the head, slantwise from one edge of the tape to the other, at an angle of about 4° to the edge of the tape (Fig. 2). This track is 26.5 inches long by just under one-hundredth of an inch wide and contains one whole field (frame) of the picture starting and finishing in the sync period: the effective tape-speed past the head is consequently about 1,600in/sec and the head-disk speed is 3,600 r.p.m.

To synchronize the sweep of the head with a track

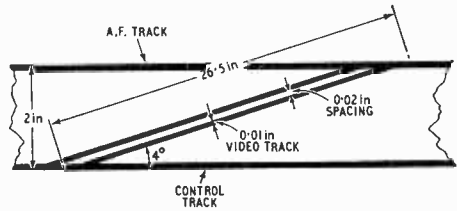

Fig. 2. Layout of tracks on tape. Measurements given are approximate and, for clarity, only two scans of the rotating video head are shown. (Based on diagrams in the original paper.)

entirely, the tape can be kept stationary for editing purposes.

Other important advantages are that, as a "picture" is complete in one track, scalloping of vertical lines cannot occur; head switching is not required, thus there is no danger of switching transients imposing themselves on the picture and the replaying of registered colour signals is made easier.

The sound channel and a control track are recorded directly in the usual way along the edges of the tape with the head gaps at right angles to the tape motion. Now on the tape at these points is a part of the video signal; but, because the heads are not in line with the video tracks and an f.m.-carrier system is used for the picture, no mutual interference is apparent. The a.f. signal-to-noise ratio on the prototype machine was given as 45dB—in the region of that which one would expect from an ordinary professional machine—and this has since been improved slightly.

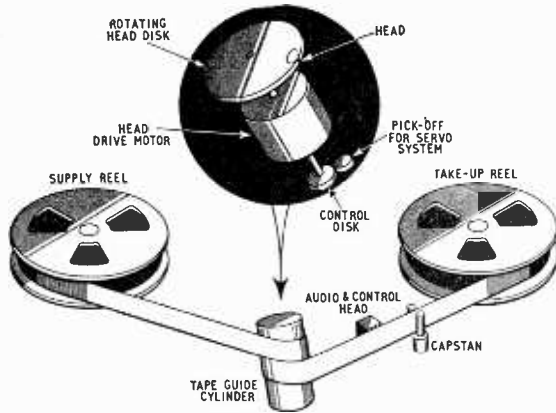

Fig. 1. Simplified diagram of tape-transport and (inset) head arrangements. Tape wraps round cylindrical guide containing rotating head disk so that head crosses between start and finish of spiral where top and bottom edges of tape are adjacent. (Based on diagrams in the original paper.)

on the tape, a position-indicating pulse is produced from the head drive by the passage past a coil of a piece of magnetic material on the spindle. This pulse is "compared" with the field sync pulse and the error signal is used to control the angular position of the head disk, which is driven from a supply derived from the sync pulses. On playback, the field-sync pulses from the head are fed into the phase comparator. Naturally, "cleaning-up" of the sync pulses is carried out and this removes noise generated during the short period when the head is crossing the slight gap between the two tape edges. Compressed air is blown through holes in the cylinder to reduce tape wear.

So far, no mention has been made of reel-to-reel, or lateral, tape speed—in fact, for a still picture it is not necessary to move the tape. As described above, the recorder can record one field and then reproduce it until the tape wears out. The normal tape speed is 15in/sec; but this obviously can be varied to give "slow-" or "fast-motion" effects and, most conveni-

## Tape Recorder "Replacements"?

NOT the least of the problems confronting the long-suffering tape recorder service engineer is the number of foreign bodies which find their way into machines, often deliberately introduced as "replacements". Some "museum pieces" which have been extracted from Grundig tape recorders returned to them for further service are, reading from left to right in the photograph, screw fitted in place of a fuse, fuse with a rating one hundred times too high, two gadgets for connecting knobs to their spindles, record and erase heads worn right through to the plastic behind, two broken belts mended with thread and, in the second row, the charred remains of a family of cockroaches and three improvised drive belts, the first of unknown origin, the second a bottle closure and the third from a vacuum cleaner.

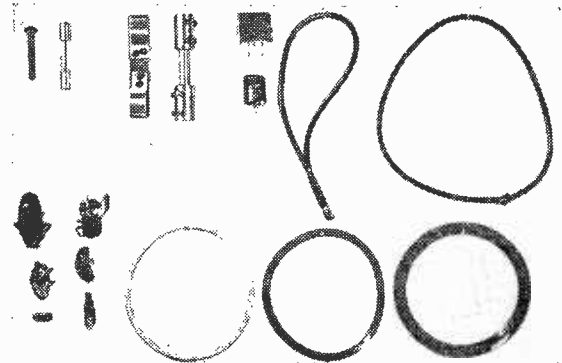

\* J.S.M.P.T.E. Vol. 69, No. 12, p. 868, A New Video-Tape Recording System, by Norikazu Sawazaki, Motoi Yagi, Masahiro Iwasaki, Genya Inada and Takuma Tamaoki.

# THE MARK IV CAMERA CHAIN

## ***EXPERIENCE COUNTS***

Marconi's pioneered the use of the 4½ inch Image Orthicon Camera using the tube developed by their associates, the English Electric Valve Company. Marconi's have amassed more 'know-how' on the use of the 4½ inch Image Orthicon than any other manufacturer.

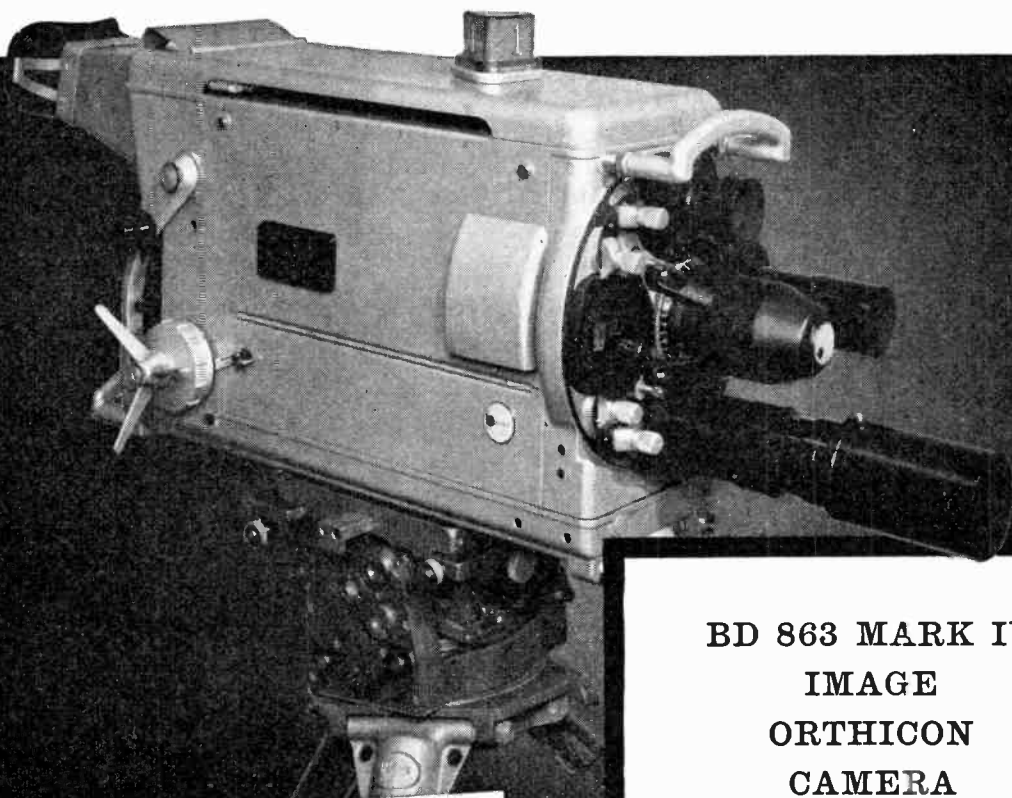

**OVER 500 MARCONI IMAGE  
ORTHICON CAMERA CHAINS  
HAVE BEEN SOLD  
THROUGHOUT THE WORLD**

### **BD 863 MARK IV IMAGE ORTHICON CAMERA**

**EXTREME STABILITY**

Novel circuit design and careful choice of components give such a high degree of stability that operational controls have been removed from the camera.

**FIRST CLASS PICTURE QUALITY**

The 4½ inch Image Orthicon tube gives a picture quality substantially better than any other type or size.

**LIGHT AND COMPACT**

By reducing and simplifying the camera electronics its weight has been held below 100 lb. and its size made correspondingly small.

# **MARCONI**

**COMPLETE SOUND AND TELEVISION SYSTEMS**



A  
new  
military  
packset  
—the  
**HF  
156**

JH&amp;P

## Now approved for the British Army

THE HF156 manpack transmitter/receiver is a thoroughly reliable, robust, fully sealed and entirely self-contained portable set for active service in extreme climatic conditions. Six crystal-controlled channels, extreme simplicity of operation and exceptional range on voice and CW are some of the many features that stood out during extensive user trials in the Far East. The military-type one-man canvas pack in the picture above contains the combined transmitter/receiver and power supply and the aerial loading unit. A pocket contains handset, morse key and headset with boom microphone when they are not in use. A sectional rod aerial and its flexible base are also carried. Dipole and end-fed aeriels, in a separate haversack, need be carried only when required. Provision is also made for vehicle-borne operation and for the use of non-spillable lead/acid accumulators or dry batteries, greatly increasing the versatility of this latest set in the BCC HF15 series.

Ask for a leaflet describing the HF156 and the additional facilities for vehicle-borne operation and for power supply from lead/acid accumulators or dry batteries.

BCC also design, engineer, instal and service complete communications systems. Our advisory service would be glad to have the opportunity of helping you.



\*

**BRITISH COMMUNICATIONS CORPORATION LIMITED**

HIGH WYCOMBE BUCKS Tel: HIGH WYCOMBE 2501  
GRAMS: BEECEEE HIGH WYCOMBE AND AT WEMBLEY



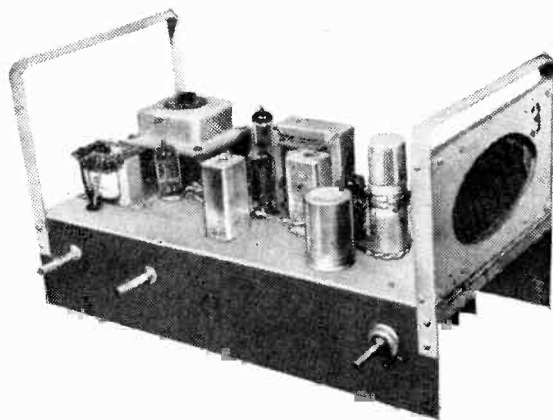

## AN AID TO THE TRAINING OF SERVICE TECHNICIANS

By A. T. FERGUSON\*

# INSTRUCTIONAL RADIO RECEIVER

**W**HEN a particular task has to be performed it is done with the tools available but if the task has to be done many times it is often worth while to produce a new tool or instrument that will make the work easier. The subject of this article is a radio receiver that has been designed to help with the training of apprentices who are studying for the Radio Trades Examination Board examinations in radio and television servicing.

The need for a receiver of this type became apparent when preparatory work for practical sessions of a training course was considered in detail. During a practical instruction period, two and a half or three hours, the student has to locate and clear faults on a receiver and it is obviously desirable that he should work by himself and not in a group of two or three persons. In this way he will get the maximum amount of practice and, through this, confidence in his work. However, even if there are classes of only fifteen students, each with his own receiver, there would be a considerable amount of time occupied in placing two or three faults on each receiver. The situation becomes more complex if these receivers are required for a different group of students the next day, which is quite likely if there are part-time day classes and evening classes being held for the same year of a course. It is not unreasonable to expect that any one radio receiver may have ten different faults put on and removed in any one week. A way of reducing the amount of preparation has been introduced into the practical examination itself; this method consists of putting one fault on a receiver and making the students diagnose the trouble, in turn and in a given time. This is a helpful idea and it gives practice in fault diagnosis; it does not however, give the student the satisfaction of clearing a fault after he has located it. The new R.T.E.B. practical examination may use fault simulator cards and this, perhaps, makes it more important than ever to see that students receive adequate time training on actual equipment. The cards are a clever and

useful substitute when equipment is not readily available but it should be the aim of training establishments to provide equipment first.

The circuit diagram, Fig. 1, illustrates the type of the receiver. The medium frequency broadcast band only is covered. With the exception of the valves and loudspeaker all the components are readily available from two well-known suppliers; the chassis, tuning condenser, reduction drive coils from one and the remainder of the components from the other. Additionally, mild steel strip is required for the chassis brackets and plywood and perforated metal for the speaker. The total cost of all the parts for each receiver can be kept to about £8. The use of separate loudspeakers and power supplies was considered and rejected; although satisfactory for some equipment the idea was not considered practicable from the point of view of handling, storing and issue. As far as possible each component has been mounted between a separate pair of tags, which have slots, rather than holes, and the connecting wires of the components are touched in with solder without being wrapped around the tag; this enables components to be replaced in a matter of seconds. Criticism about this method of fastening components could be made but this is a receiver for training and its utility would be greatly impaired if connections were made in the usual fashion. Separate instruction in soldering methods ensures that the student has a proper knowledge of the correct way to wire in components. The connecting leads from tag to tag are fastened by wrapping and soldering in the usual fashion.

Little difficulty was experienced with the construction of the receivers. Additional capacitors, 56pf, had to be added to the intermediate frequency transformers to tune them to 470 kc/s, and these are mounted inside the screening cans. A tendency to "motorboat" with maximum volume was removed by inserting a little fixed resistance into the tone control circuit. The values of capacity associated with the output stage were selected by considering the performance with the type of output transformer

\*Lecturer, South Shields Marine and Technical College.

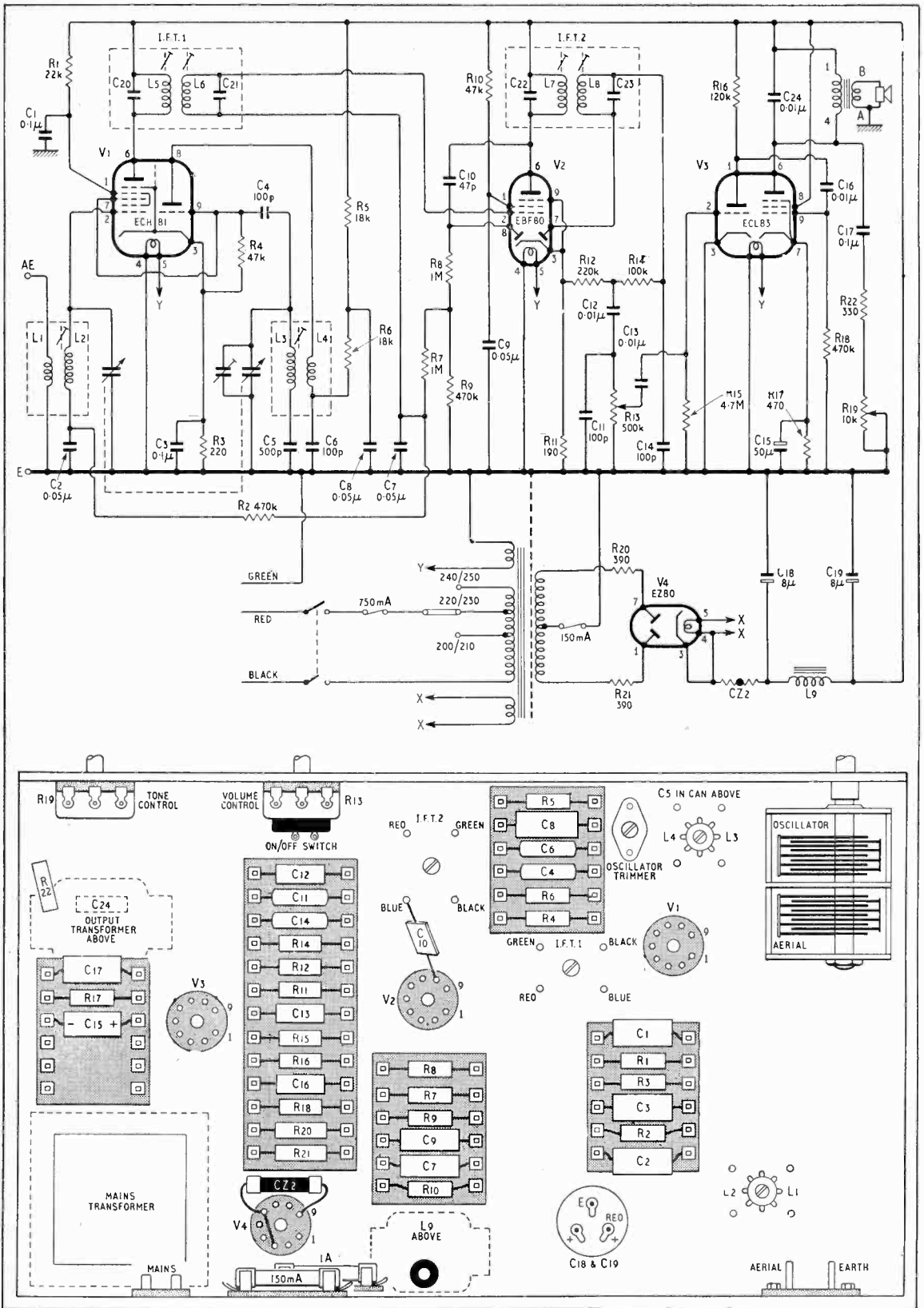
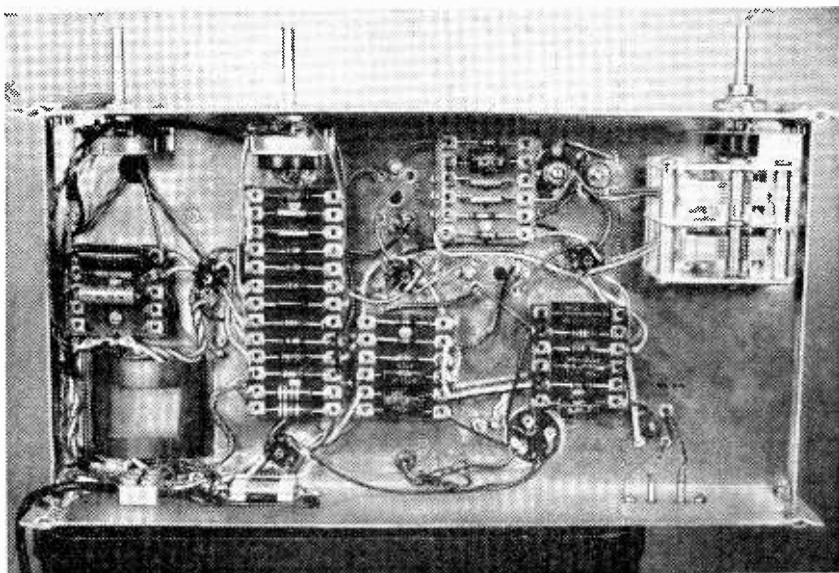

Fig. 1. Circuit diagram of the receiver and component layout



Bottom view of the chassis. Ease of access and component replacement is evident.



used. The leads to the volume control are screened. A cardboard washer should be inserted between the perforated zinc speaker fret and the wooden mounting to prevent vibration of the metal.

In practice the application of these receivers has more than justified the small amount of time taken to design and construct them; they are ideal for demonstration purposes on account of the accessibility of every component and the ease with which its value may be altered; many basic experiments can be performed with them. All essential voltages can be measured with a 0-250 V, single range D.C. instrument without there being any risk of damage to either the meter or the receiver. The accuracy of the readings is sufficient on a single range meter if it has, at least, a two and a half inch scale.

Faults are put on the receiver by replacing a good component with a defective one which blends with its surroundings and looks normal. The student has to locate this, replace the defective component and then check the performance of the receiver. The provision of defective components requires a considerable amount of effort; various manufacturers have been asked if they could supply dummy or defective parts but their polite and understandable reply was to the effect that it is not in their nature to produce such articles. One firm that produces resistors has, however, been kind enough to supply unmarked resistors; these are painted to indicate the value of the resistor which they will represent in the circuit. Painting the colour code on by hand needs a little practice at first, thereafter it can be done quickly and expertly. Small tins of enamel paint, such as those obtainable from handicraft centres, are used. The supply of open circuit dummy capacitors is the most difficult to provide; the markings on the dummy must be identical with those of the original, otherwise the student will quickly see the fault without having to test for it. An estimate of the number of students training for the R.T.E.B. examinations is about ten thousand and as each of these will require dummy components in the course of their training, perhaps some far-sighted organization will see its way to provide for the demand; this does not, of course, rule out the R.T.E.B.

The circuit diagram of the receiver should be duplicated on foolscap paper and then pasted on to pieces of thin hardboard cut to a size just smaller than the foolscap, the paper projecting at each edge. After drying the edges are sandpapered off. The surface of the paper is then given two coats of cellulose paste to seal it and, after drying, two coats of transparent lacquer. Diagrams protected in this way will be serviceable for many years and are immune from the effect produced by the momentary application of a hot soldering iron.

## Commercial Literature

**Pencil Tubes**—valves designed to provide low capacitances, low inductances and close element spacings—made by RCA are suitable for efficient u.h.f. use. A coaxial electrode construction is employed and most types are little bigger than the familiar B7G miniature valves. Further details from (in U.K.) RCA Great Britain, Ltd., Lincoln Way, Windmill Road, Sunbury-on-Thames, Middlesex, or Radio Corporation of America, Electron Tube Division, Harrison, N.J., U.S.A.

**Toroidal Suppression Inductors**, as their leakage field is very small, offer valuable advantages in closely packed equipment or near sensitive apparatus. Technical Data Sheet MM/102 from Standard Telephones and Cables Ltd., Connaught House, Aldwych, London, W.C.2.

**Communal Aerial** equipment for up to 40 outlet points is described in Rainbow Radio's "Major Dumec" leaflet. Four-stage amplifiers are used for Band-I and -III TV and f.m., each with separate gain control. Rainbow Radio (Blackburn) Ltd., Mincing Lane, Blackburn, Lancs.

**110° C.r.t. Deflection** techniques are described by B. Eastwood in a reprint of his Television Society paper. In the reprint deflector-coil, line-output stage and frame timebase design are considered: copies may be obtained from Associated Electrical Industries Ltd., Radio and Electronic Components Division, 155 Charing Cross Road, London, W.C.2.

**Instruments made** by Dawe Instruments Ltd., Harlequin Avenue, Great West Road, Brentford, Middlesex, and marketed in France by Promesur, 19 rue Eugene Carriere, Paris 18e, are described in French in an abridged catalogue.

**Attenuators** suitable for motor drive or manual operation are dealt with in a leaflet from Hatfield Instruments Ltd., Burrington Way, Plymouth, Devon. Maximum frequency is 500Mc/s in power ratings of 0.5 and 5.0W: 50- and 75-Ω types are available in 1 and 10dB steps.

# Single-Transistor Receivers

SOME CIRCUITS FOR USE WITH HEADPHONES

By S. W. AMOS\* B.Sc.(Hons.), A.M.I.E.E.

THE advent of transistors has made possible the construction of small receivers with low power requirements. For example a multi-transistor a.m. receiver driving a miniature loudspeaker and operating from a 9-volt battery can fit into a jacket pocket. Several designs for home-constructed super-heterodyne receivers of this type have appeared in the technical press.

Not so much attention has, however, been paid to much simpler receivers employing a single transistor and intended to drive headphones. Such a receiver can give excellent reception of a number of medium-wave signals and can be constructed very simply. Moreover, its power requirements are so modest that battery life is more easily expressed in years than in months. The construction of such a receiver provides excellent practice for those seeking experience with transistors and associated circuitry. For example such a receiver is well within the abilities of a teen-age schoolboy to construct and the performance of the finished receiver is quite satisfying. Moreover, if the receiver stimulates enthusiasm, an a.f. stage can be added to make loudspeaker operation possible and later an r.f. stage can be added to improve sensitivity and selectivity.

This article is, however, confined to single-transistor receivers and suggests a number of circuits which can be used, itemising their advantages and disadvantages. Perhaps the most obvious method of using a transistor in a receiver is to employ it as an a.f. amplifier, following a diode detector. A suitable circuit is given in Fig. 1.  $R_1$  is the diode

load and the a.f. signal developed across this is amplified by the transistor.  $C_1$  is a d.c.-blocking capacitor and  $R_2$  provides base bias current for TR1. The headphones may have an impedance of, say, 10 kilohm and the conditions in the collector circuit of TR1 should be adjusted for an optimum load of this value. For example, if the collector supply voltage is 4.5 volts, then the collector current should be  $4.5/10,000$  A, i.e. 0.45 mA. A collector current swing of 0.45 mA is then accompanied by a voltage swing of 4.5 volts and the transistor characteristics are used to maximum efficiency. If the  $\alpha'$  (sometimes called  $\beta$ ) of the transistor is 50, the quiescent base current will be  $0.45/50$ , i.e. 0.009 mA. The base potential of a transistor is very nearly equal to the emitter potential and the voltage across  $R_2$  is thus 4.5 giving the required value of  $R_2$  as  $4.5/(9 \times 10^{-6})$ , i.e. 0.5 megohm. As the  $\alpha'$  of the transistor used is not likely to be known with accuracy it is best to adjust the value of  $R_2$  empirically to give the required 0.45 mA collector current.

Purists may object to the simple biasing circuit advocated for the transistor on the grounds that it provides no protection against thermal runaway. If, however, the d.c. resistance of the headphones is 4,000 ohms (as is common), then the collector current cannot appreciably exceed 1 mA under any conditions. However, if a more stable operating condition is required, it can be obtained by biasing the transistor by the potential-divider method described later.

Such a receiver has the advantage that TR1 can be an a.f. transistor but there are the following disadvantages:

1. The diode detector cannot operate under good conditions. The input resistance of the a.f. stage is of the order of 2 kilohm and this puts an upper limit on the value of  $R_1$ . To minimise peak clipping  $R_1$  should be small compared with the input resistance but such a low value would lead to inefficient detection and to very heavy damping of the tuned circuit. With a value of  $R_1$  of 4.7 kilohm, as suggested in the circuit diagram, diode damping is still high and the diode should be tapped down the tuned circuit as shown to provide adequate selectivity.
2. A good aerial is essential to provide good results and an earth connection is also desirable.

A natural development of the diode plus triode circuit is to eliminate the diode and to use the base-emitter junction of an r.f. transistor for detection. This leads to a circuit of the type shown in Fig. 2, which could be described as that of a leaky grid transistor detector. The performance of this detector is unsatisfactory in practice and it is instruc-

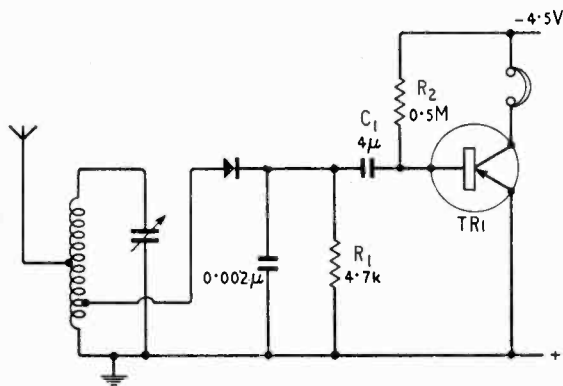

Fig. 1. Circuit employing a diode detector followed by a single-transistor a.f. amplifier.

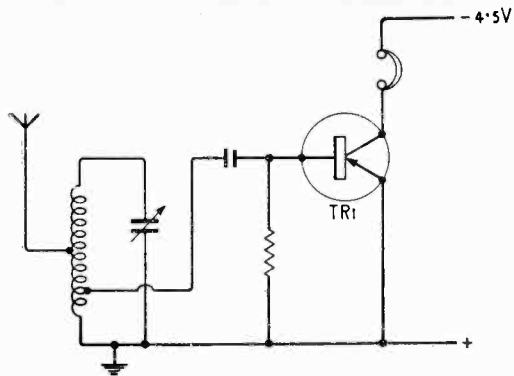

Fig. 2. Circuit of a leaky-grid transistor detector deduced by analogy with its valve counterpart: the performance is unsatisfactory.

tive to consider the reasons. In a valve leaky-grid detector the grid-cathode structure operates as a diode and a negative potential, proportional to the carrier amplitude, is developed on the grid. The valve is required to operate as an audio amplifier and for this purpose a negative grid bias voltage is required. The value of this bias is not critical because the a.f. signal generated on the grid is normally small compared with the grid base. Thus the detector can function well in spite of variations in input-signal amplitude.

Now consider the performance of a transistor as a leaky-grid detector. As a result of detection in the base-emitter junction, the base is driven positive to an extent proportional to the input carrier amplitude. A transistor, however, does not require a positive base bias. As shown in Fig. 3(b) a npn transistor is cut off by a positive base-emitter voltage: for satisfactory operation a negative base-emitter voltage is required. Thus leaky-grid operation is not satisfactory with transistors. Nevertheless the circuit illustrated in Fig. 2 does produce results although admittedly not very good ones. Moreover, the collector current of the transistor behaves in an unexpected manner when a signal is tuned in. For a leaky-grid detector the anode or collector current should fall on receipt of a signal: in Fig. 2 the current increases! The reason for this is not difficult to explain. An increase in current is a characteristic of an anode-bend detector and it is clear from Fig. 3(b) that the  $I_c-V_b$  curve for a transistor inevitably gives rise to this type of detection. Thus in the circuit of Fig. 2 leaky-grid and anode-bend detection occur simultaneously and as one mode of action tends to increase the collector current and the other tends to decrease it, the poor performance is not surprising. Examination of the transistor characteristic in Fig. 3(b) shows that it has no linear portion comparable with that of a valve. The transistor curve is, in fact, closely exponential in form and anode-bend detection therefore occurs at any point on the characteristic. If the transistor is forward-biased, the efficiency of anode-bend detection is increased and a suitable circuit for a detector working on these principles is illustrated in Fig. 4. This gives results comparable with those obtainable from the circuit of Fig. 1 but the anode-bend circuit is

simpler and does not require a diode: moreover the anode-bend circuit lends itself very simply to the application of reaction and this produces a great improvement in performance. On the other hand the anode-bend circuit does require the use of an r.f. type of transistor and this should preferably be of the type recommended for use as frequency changer in super-heterodyne a.m. receivers.

In the circuit of Fig. 4 the collector current is stabilised against thermal runaway by the potential divider method.  $R_1$  and  $R_2$  form a potential divider which applies a negative potential, say 1 volt, to the base of the transistor. There is normally very little difference in the potentials on base and emitter of a transistor and the emitter also takes up a potential of  $-1$  volt. Thus a potential difference of 1 volt is established across the emitter resistor  $R_3$ . By choosing the value of  $R_3$  appropriately we can make the emitter current almost any desired value: for example if  $R_3$  is made 1 kilohm, the emitter current is 1 mA. Moreover the emitter current—and hence the collector current—remain at the determined values in spite of variations in collector leakage current due to temperature changes. To avoid loss of amplification as a result of negative feedback  $R_3$  must be decoupled and a large-value electrolytic capacitor is connected across  $R_3$ .

One refinement—and a most valuable one—can be added to the circuit of Fig. 4. This is reaction or controlled positive feedback and is achieved by returning r.f. energy from the collector to the base circuit. This improves sensitivity and selectivity

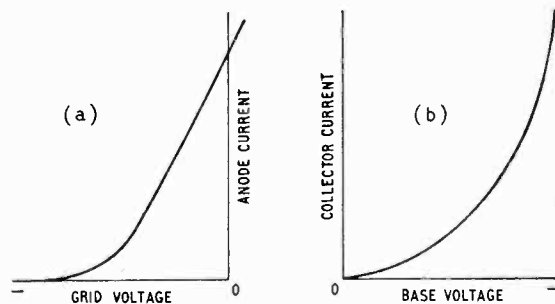

Fig. 3. Input voltage-output current characteristic of (a) a valve and (b) a transistor.

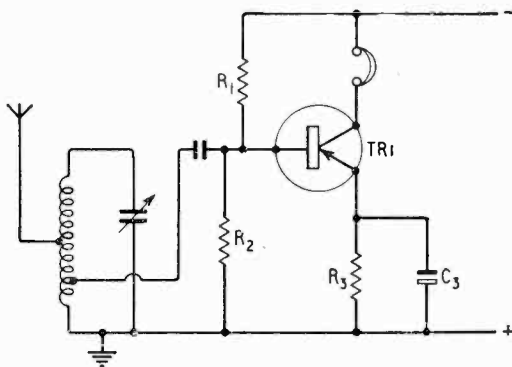

Fig. 4. Basic circuit for an anode-bend transistor detector.

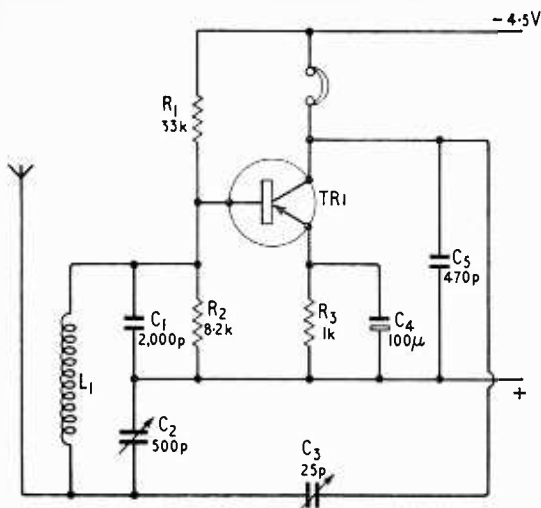

Fig. 5. Circuit for complete receiver using the detector of Fig. 4 with reaction.

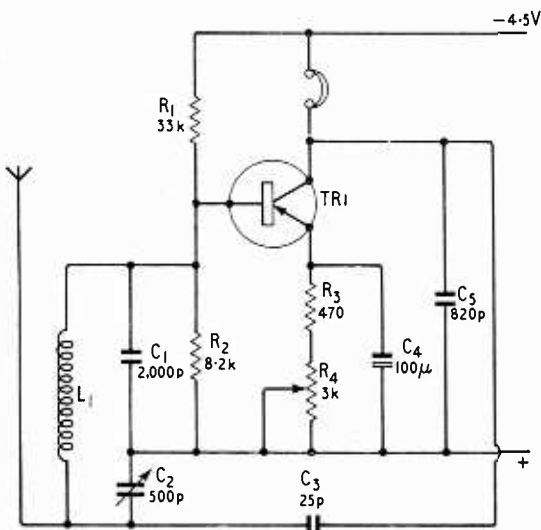

Fig. 6. Improved version of the circuit of Fig. 5 with better control of reaction.

considerably. Many of the circuits advocated for reaction require an additional coil coupled to the tuning inductor or tappings on the tuning inductor but it is possible to avoid both by using a circuit based on that of the Colpitts oscillator and described by the author\* some years ago. A detector circuit using an anode-bend detector and reaction of this type is illustrated in Fig. 5. The equivalent of a tapping point on the tuning inductor is achieved by use of the two capacitors  $C_1$  and  $C_2$  connected in series across it. The transistor is connected across  $C_1$ , the larger capacitor, and reaction is obtained by use of the variable capacitor  $C_3$  connected between the collector

and the high-potential end of the inductor. For an OC44 transistor a suitable value of collector current is 0.6 mA and the values of  $R_1$ ,  $R_2$ ,  $R_3$  and battery voltage given in the diagram give approximately this value of current.

The effective maximum tuning capacitance in parallel with the tuning inductor is less than 500 pF and if a standard medium-wave inductor of approximately 160  $\mu$ H is used, there is some curtailment at the low-frequency end of the band, the minimum frequency receivable being about 600 kc/s (500 metres). For many applications this reduced coverage may not matter but if it is desired to tune to 550 kc/s an inductor of 200  $\mu$ H is required. A number of commercial medium-wave inductors have adjustable magnetic cores which enable this value of inductance to be reached: one suitable coil is Teletron type BA2.

Satisfactory results can be achieved using an aerial consisting of a few feet of vertical wire connected to the high-potential end of the tuning inductor as shown in Fig. 5. An earth connection, though helpful, is not essential. Naturally results are better if a longer aerial is used: such an aerial is better connected to the low-potential end of the tuning inductor or alternatively can be connected to the high-potential end via a small fixed capacitor of say 20 pF capacitance.

The tuning inductor can be replaced by a winding on a ferrite rod, and, in fact, a standard ferrite-rod aerial (for use with a tuning capacitor of 500-pF maximum capacitance) can be employed with some restriction in coverage at the low-frequency end of the band. By increasing the number of turns on the ferrite rod it is, of course, possible to achieve complete medium-wave coverage. However, the receiver is not so sensitive with a ferrite rod aerial as with a vertical aerial.

One slight disadvantage of the circuit of Fig. 5 is that adjustment of the reaction capacitor  $C_3$  causes slight mistuning. This arises because  $C_3$  is effectively in parallel with the tuning capacitor  $C_2$ , the mistuning is hence most marked at low settings of  $C_2$ , i.e. at the high-frequency end of the band. This causes difficulty in tuning particularly for a weak signal which requires a considerable degree of reaction, but it is of little consequence if the receiver is used only to receive strong signals. The mistuning effect can be virtually eliminated by using a fixed capacitor for  $C_3$  and by controlling reaction by adjustment of the mutual conductance of the transistor. The mutual conductance is measured by the slope of the  $I_c - V_b$  characteristic and the exponential slope of this curve illustrated in Fig. 3(b) shows that the conductance is proportional to the collector current. Thus by adjusting the collector current we can control the conductance. A convenient way of doing this is to make the emitter resistor variable as shown in Fig. 6. A 470-ohm fixed resistor is included to give an upper limiting value of approximately 1.2 mA to the collector current and a 3-kilohm variable resistor is included to enable the current to be reduced to about 0.25 mA. This arrangement gives smooth control of reaction with very little disturbance of tuning.

The values of  $C_3$  and  $C_5$  given on Fig. 6 give good control over reaction over the whole of the medium waveband for the particular specimen of OC44 used by the author—and the transistor was not specially

\*"Miniature Bedside Receiver." *Wireless World* November 1954

(Continued on page 479)

selected. Other OC44s may have higher or lower values of  $\alpha'$  and alpha cut-off frequency: thus reaction may be too fierce or too weak. If control of reaction is not satisfactory, it may be desirable to depart from the values of  $C_3$  and  $C_5$  specified.

This receiver can be used to cover the long waveband by using a suitably-large tuning inductor for  $L_1$  and one advantage of the circuit is that this is the only change necessary:  $C_1$  and  $C_2$  ensure that reaction is available on the new waveband. If, however, the receiver is required to operate on the short wavebands, then a number of changes are advisable:

1. Firstly a different type of transistor is necessary,

for the OC44 is not intended to operate at such high frequencies. A transistor such as the OC170 is suitable for use on short waves and, of course, this transistor is quite satisfactory at medium and long waves also.

2. It is desirable to reduce the values of  $C_1$  and  $C_2$  for use in a short wave receiver in order to keep a high dynamic resistance. Some experimenting with the ratio of  $C_1$  and  $C_2$  might be desirable to obtain smooth control of reaction.
3. The tuning inductor should be chosen, in conjunction with the net capacitance of  $C_1$  and  $C_2$  to tune over the frequency band required.

# Low-voltage Stabilizer Using Semiconductors

By D. E. O'N. WADDINGTON\*, Grad.Brit.I.R.E. and M. R. AINLEY\*, B.Sc., Grad.I.E.E.

WITH the advent of transistorized equipment, the need for stabilized low-voltage power supplies has become very apparent. This is so because batteries, the most obvious power source, are not stable over their useful life and it is thus necessary to check equipment designed for battery operation over the range of voltages likely to be encountered under operational conditions. A further case in which a stabilized supply is essential is where the equipment will not function efficiently unless fed from a constant-voltage source.

## Definition of Characteristics

Before discussing stabilizers it is necessary to define certain characteristics of power supplies. The first consideration is the *stabilization characteristic* or *stabilization factor* which may be defined as the ratio between the percentage change in input voltage and the corresponding percentage change in output voltage. Thus a supply having a stabilization factor of 50 will produce a 0.4% change in output voltage for a 20% change in supply voltage. The other consideration is the *load characteristic* or the *incremental slope resistance* of the supply and this may be defined as the ratio between the change in output voltage and the corresponding change in load current. By having a knowledge of these two factors together with the output voltage and current,

it is possible to assess whether a circuit is suitable for the application envisaged.

The simplest shunt stabilizer for low-voltage work is, of course, the Zener diode in Fig. 1. Its advantages are that it is compact, efficient and easy

\*Marconi Instruments, Ltd

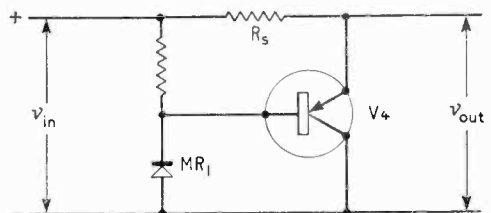

Fig. 2. Stabilizer performance is improved and power-handling capacity raised by transistor fed from Zener-diode reference.

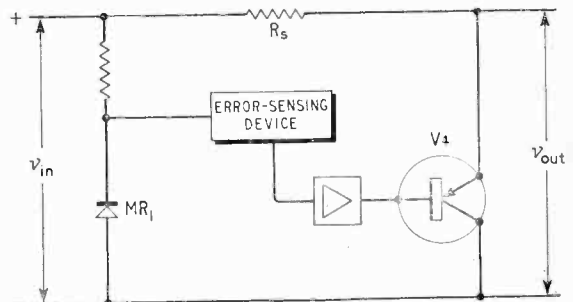

Fig. 3. Further improvements in stabilization factor and incremental slope resistance are provided by error-sensing circuit and error-signal amplifier.

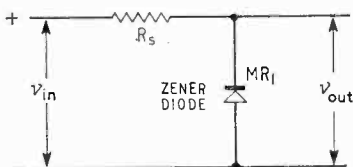

Fig. 1. Simple semiconductor stabilizer using Zener diode.

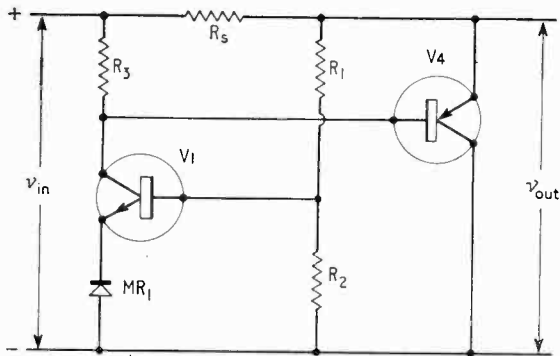

Fig. 4. Circuit incorporating provisions of Fig. 3. Note npn transistor ( $V_1$ ) error-sensing and amplifying stage.

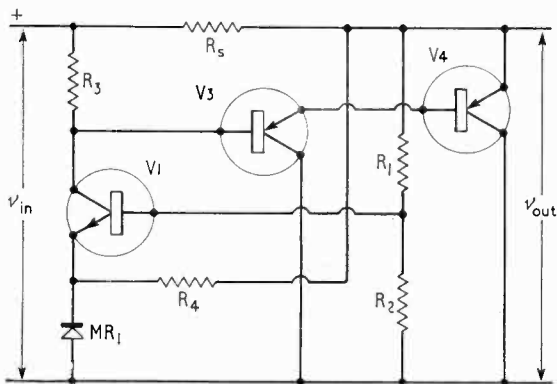

Fig. 5. Emitter follower ( $V_3$ ) isolates  $V_1$  from loading of  $V_4$  and resistor  $R_4$  feeds Zener diode from stabilized supply to improve stabilization factor.

to use. However it has several shortcomings which make it unsuitable for use in many applications. Not the least of these is the fact that the output voltage is fixed by the diode's characteristics, with the result that the user wishing to change the output voltage can only do so by replacing the diode with another one having the desired voltage rating. The designing of supplies using Zener diodes has been well covered (see, for instance, Ref. 1). The follow-

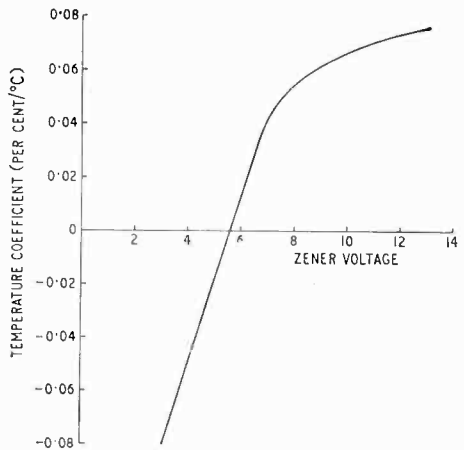

Fig. 6. Variation of temperature coefficient of Zener diodes against Zener-voltage rating.

ing are typical figures measured on supplies tested in the laboratory:—

Stabilization Factor 20-40.

Incremental Slope Resistance  $1\Omega$ - $20\Omega$  (depending on diode used).

In order to improve the incremental slope resistance and the power handling capacity of the stabilized supply a transistor may be added to the circuit as shown in Fig. 2. Here the diode acts as a reference source which keeps the base at a constant potential with respect to the collector. As the emitter-to-base voltage is of the order of 0.15V and relatively independent of the current through the transistor, the voltage between the collector and emitter of the transistor will remain constant. This circuit produces little or no improvement in the stabilization factor but the incremental slope resistance is improved. In a practical circuit this is of the order of  $0.6\Omega$ . Like the straight-forward Zener diode circuit, this type of stabilizer does not give an easily adjustable output voltage.

### Use of Error-sensing Circuit

Further improvements in the stabilization factor and incremental slope resistance can be made by

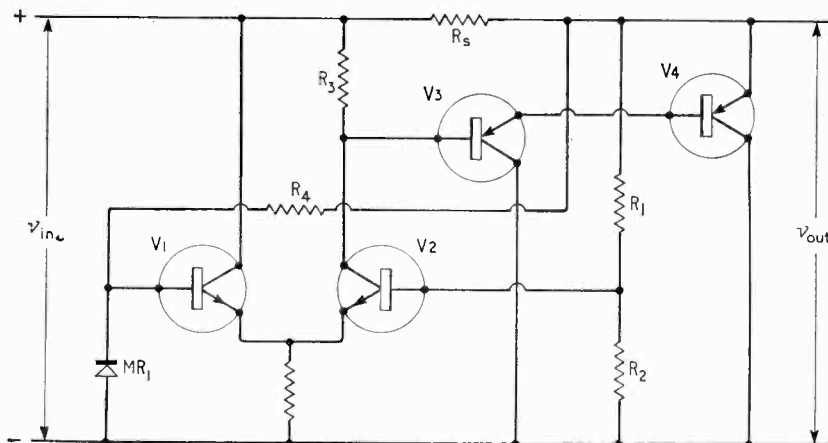
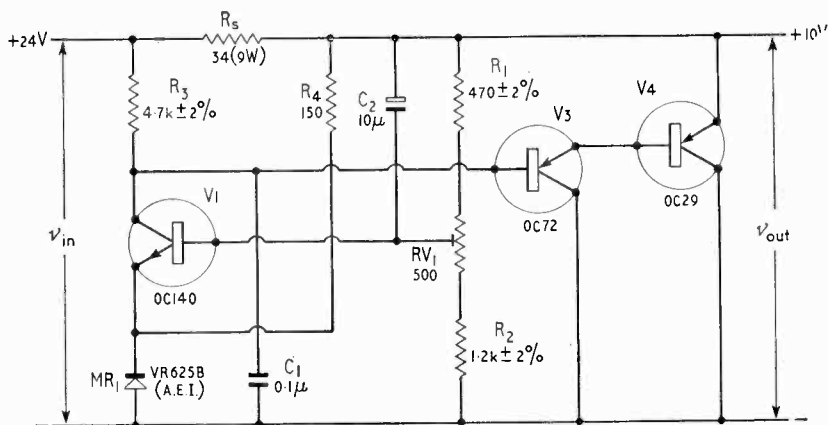

Fig. 7. Circuit arranged to overcome temperature variation problems.  $V_1$  and  $V_2$  form "long-tailed pair" error-sensing circuit and Zener diode of zero temperature coefficient is used.



Left. Fig. 8. Circuit of final stabilizer design. Here temperature coefficients of sensing transistor and Zener diode are equal but of opposite sign, so minimizing temperature effects.

building a stabilizer of the form shown in Fig. 3. In this an error-sensing device compares the output voltage with the reference voltage. The "error" is then amplified and applied to the shunt transistor in such a sense as to reduce the error. A circuit in which this is done is shown in Fig. 4. The n-p-n transistor V1 acts as the error-sensing device as it compares the voltage at the junction of  $R_1$  and  $R_2$  with the reference voltage developed across the Zener diode connected in series with the transistor's emitter. The values of  $R_1$  and  $R_2$  will be chosen such that

$$v_{ref} = v_{out} \times \frac{R_2}{R_1 + R_2} - v_{be}$$

Thus any reduction of the output voltage will appear as an error voltage at the base of V1: this will reduce the current flowing through the resistor  $R_1$  and hence increase the voltage at the base of V4, so increasing the output voltage. An increase in the output voltage will have the reverse effect. Thus it is seen that this feedback system has had the effect of reducing the incremental slope resistance considerably.

As the circuit stands it still has two main disadvantages. The first lies in the fact that, as the load current is decreased, the current through V4 increases thus increasing its base current and hence the loading on V1. In order to overcome this, an emitter follower is included between V1 and V4 (see Fig. 5). So far no action has been taken about improving the stabilization factor of the supply but we now include the resistor  $R_1$ . This provides the main feed for the Zener diode from a stabilized source which improves the stabilization factor two or three times.

### Temperature Changes

Up to now we have regarded the Zener diode as a reference element whose characteristics do not change with temperature. In practice, however, we find

Right. Fig. 9(a). Change in output voltage (mV) plotted against load current for stabilizer shown in Fig. 8. (b) Change of output voltage (mV) plotted against change in input voltage, expressed as a percentage, for the same stabilizer. (c) Effect of temperature variation.

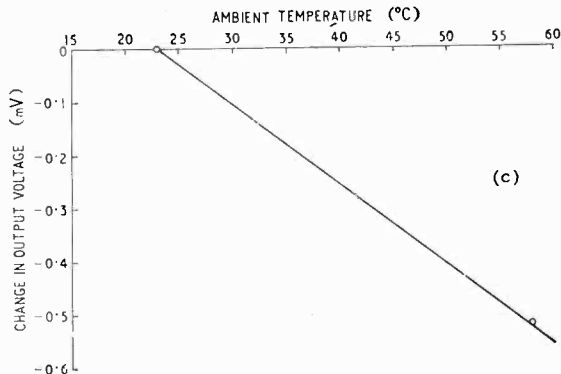
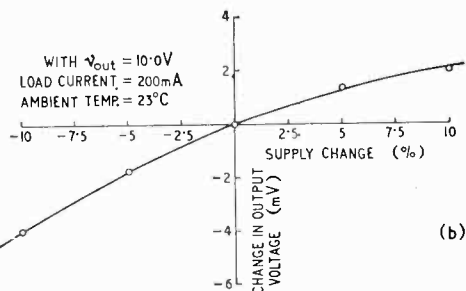
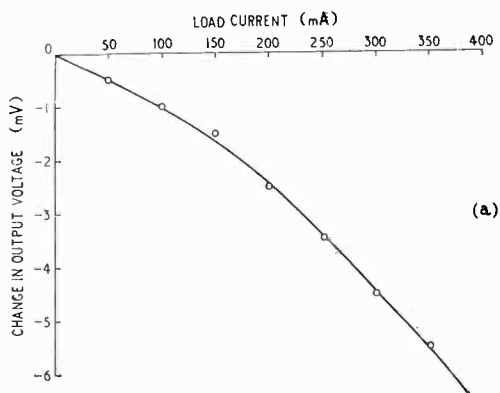



that the diode voltage changes with temperature and that the temperature coefficient is a function of the voltage rating of the diode (see Fig. 6). The effect of this variation will be to make the output voltage change with temperature variations. The temperature problem is further aggravated by the fact that the base-to-emitter voltage of a germanium transistor reduces at the rate of approximately 2 mV/°C.

There are two ways of reducing these errors. The first is to make the circuit more complicated (see Fig. 7) and use a balanced system for the error-sensing device. The effect of this is to make changes in the emitter-to-base potentials of V1 and V2 cancel each other out. Temperature stability is then achieved by using a zero-temperature-coefficient Zener diode which may be either a single diode or two diodes with opposing temperature coefficients connected in series.

The second method of overcoming the temperature drift is to make use of a Zener diode which has a temperature coefficient which exactly cancels the temperature effects in the base-to-emitter voltage of the error-sensing transistor, i.e., to use a Zener diode whose reference voltage increases at a rate of 2 mV/°C. Examination of the characteristics of Zener diodes shows that diodes having a voltage of approximately 6.2 volts satisfy this requirement. As a result the practical circuit shown in Fig. 8 was evolved. The graphs of Fig. 9 show the performance characteristics of this circuit.

### Practical Details

It will be seen that the practical circuit includes three extra components which have not been discussed so far. Their functions are as follows: C<sub>1</sub> is included to prevent the circuit from oscillating at high frequencies, a trouble which often occurs in voltage stabilizers. C<sub>2</sub> increases the a.c. feedback in the circuit with the result that any ripple on the supply is reduced by the stabilizer action. The function of the variable resistor RV<sub>1</sub> is to enable the user to set the output voltage to the required level. This

is necessary because there is nearly always a tolerance of 5% on the actual voltage of the Zener diode.

In a practical stabilizer circuit it may be necessary to provide some form of cooling for the shunt transistor so that it is not damaged by over-heating. The dimensions of the heat sink required will depend on the power dissipated in the transistor<sup>2</sup>, the ratings of the transistor and the maximum ambient temperature in which the supply is to be operated. In the circuit shown the power dissipated in the transistor under "off-load" conditions is of the order of 5W. From the manufacturer's information it may be shown that, in this case, it is not essential to mount the transistor on a heat sink for the normal range of ambient temperatures. However, it is both convenient and desirable to mount the transistor on a rigid metal bracket.

The 24-V supply for the stabilizer may readily be obtained from a centre-tapped transformer having a secondary rating of 20-0-20V r.m.s. feeding two semiconductor diodes in push-pull (bi-phase or "full-wave" circuit). Smoothing is conveniently provided by a single capacitor (1,000 $\mu$ F, 50V working) connected across the output.

Readers may wonder why the authors have chosen the shunt regulator in preference to the series regulator. Much thought was given to this decision before work was started and they came to the conclusion that it must be possible to short circuit the supply without damaging the circuit. If a series regulator had been used some form of protection device would, of necessity, have had to be included; but with a shunt stabilizer, the series resistor R<sub>s</sub> may be rated to withstand the dissipation when the output is subjected to a short circuit.

### References

- 1 "Stabilization by Zener Diodes," by J. Pereli; *Wireless World*, p. 537, vol. 64 (November, 1958).
- 2 "Heat Sink Design," by O. J. Edwards; *Mullard Technical Communications*, p. 258, vol. 3, No. 29 (March, 1958).

## SHORT-WAVE CONDITIONS

Prediction for September

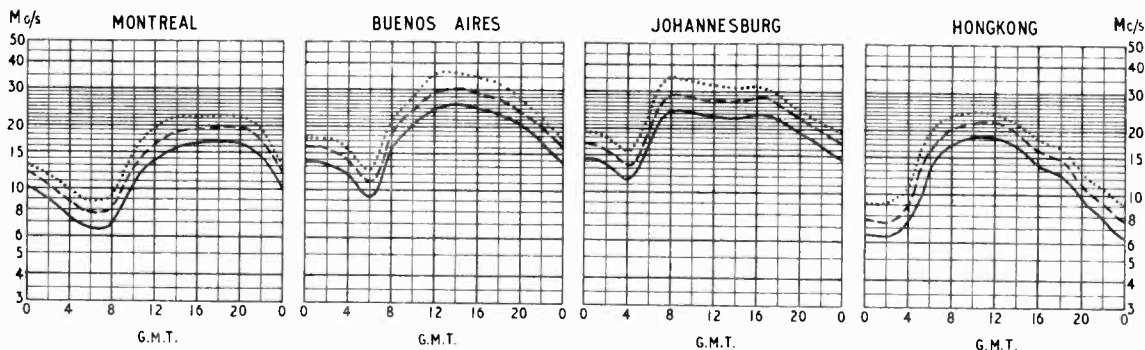

THE full-line curves indicate the highest frequencies likely to be usable at any time of the day or night for reliable communications over four long-distance paths from this country during September.

Broken-line curves gives the highest frequencies that will sustain a partial service throughout the same period.

- ..... FREQUENCY BELOW WHICH COMMUNICATION SHOULD BE POSSIBLE FOR 25% OF THE TOTAL TIME
- PREDICTED MEDIAN STANDARD MAXIMUM USABLE FREQUENCY
- FREQUENCY BELOW WHICH COMMUNICATION SHOULD BE POSSIBLE ON ALL UNDISTURBED DAYS

# ELECTRONIC MUSIC

By F. C. JUDD

## SOUND SOURCES AND TREATMENT

THE methods of producing Electronic Music and its closely allied Musique Concrète are similar, it is only the source of the sound which differs. In purely Electronic Music almost all the sounds are obtained from tone generators used in conjunction with electronic circuits. In Musique Concrète the sounds are derived mainly from those picked up by a microphone; sounds such as machinery noise and bell chimes, or those produced by traditional musical instruments and the human voice. Composers can and do sometimes combine electronically-produced tones with sounds picked up by a microphone. There is in fact no real dividing line between these

cision quite beyond that of a human musician. The replay direction of magnetic tape can of course be reversed so that recorded sounds end on the attack.

By using additional replay heads as shown in Fig. 2, recorded signals can be returned to the tape via the recording amplifier for the production of artificial reverberation. Echoes and pre-echoes obtained by this method sound hard and somewhat unreal; their intensity can be controlled by means of volume controls in the return circuits.

**Sound Sources and Treatment.**—Of the electronic sound sources, the sinewave generator is most used because it provides the composer with pure tones covering a wide range of frequencies and with variable amplitude. Its lack of harmonics gives a sine wave a rather unearthly sound. With continuously variable control over frequency almost any desired scale can be used.

The multivibrator is a device familiar to electronic engineers and since it generates harmonics up to about the 31st, the tones have a rich sound when reproduced via a loudspeaker. Its output can of course be integrated or differentiated by simple R-C networks in order to produce still further varieties of tone colours.

The white noise generator is a source of sound which is distinctive because of its continuous spectrum. Owing to its constant energy distribution with frequency, its sound is, musically, somewhat uninteresting. Used in conjunction with filters, however, sounds with definable pitch can be produced.

There is also a rather mixed group of "electronic" sound sources which generate tones by electro-mechanical methods although these can only be reproduced electro-acoustically. Two sources belonging to this group were used by H. Badings in the production of his "Cain and Abel" electronic ballet music. These were the electronic drums and an electronic clavichord. In one of the drums the drum

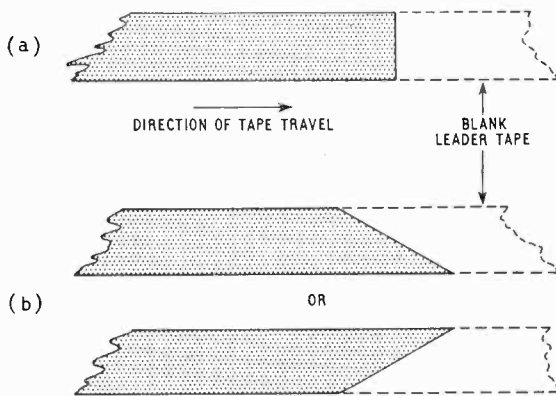

Fig. 1. Controlled attack by tape cutting.

two forms of new music. Electronic Music, sometimes called "Radiophysics", should not be confused with conventional music performed on "electronic" instruments such as the Hammond organ, or the Aetherophone developed by Leon Theremin.

**Magnetic Tape Manipulation.**—Magnetic tape provides the composer of Electronic Music and Musique Concrète with a foundation on which to present his work and is an aid to special forms of transformation that cannot be carried out electronically. For example, he can remove the portion of tape on which the "attack" of a sound is recorded. Sounds can also be given a new degree of attack (or decay) by cutting the tape at certain angles. For example a hard attack is produced by a straight cut as in Fig. 1a; a softer degree of attack can be produced by cutting at a steep angle as in Fig. 1b. This particular cutting technique is only practicable with full-track recording.

Other transformations are obtained by using different recording and playback speeds. This alters the pitch of a sound without changing the relative strength of its harmonics. Continuous variation of tape speed can produce unusual gliding-tone effects and allow the production of arpeggios with a pre-

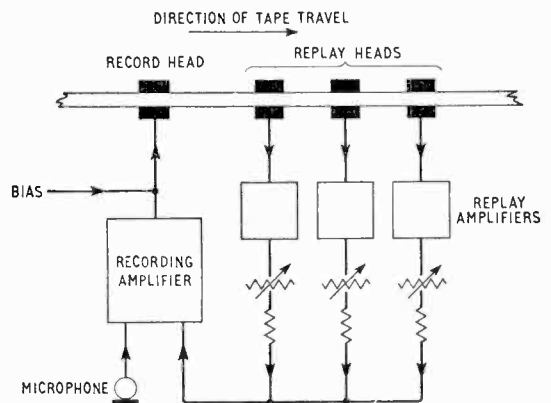

Fig. 2. Method of obtaining artificial reverberation.



Fig. 3. H. Badings and J. W. De Bruyn operating the Optical Siren used in the production of electronic music for the "Cain and Abel" ballet. (Photograph by courtesy of N. V. Philips, Gloeilampenfabrieken, Eindhoven, Netherlands, Technical and Scientific Literature Department.)

diaphragm was simply used also as the diaphragm of a condenser microphone.

An equally unusual sound source used by Badings was a so called "Optical Siren" (Fig. 3). The tones produced by this apparatus depended on the speed of a slotted rotating plate which was used to scan a pattern of oscillations drawn on paper. The scan was translated into electrical oscillation by means of a light beam and photo-electric cell (Ref. 1).

A few conventional electronic circuits have also been adopted for the treatment of sounds used in electronic music. The ring modulator (Fig. 4) is commonly used, the difference tone which it provides being the favoured one for composers. When a tone and white noise are passed through a ring modulator "hard" sounds are produced which are also used by composers. The "gating" principle has been adopted and a circuit such as Fig. 5 provides a considerable degree of control over the attack and decay of signals fed into it. The circuit requires no critical adjustment and any medium-impedance triode valve will operate successfully. The diode can be a crystal type such as the GEX 34. Varying degrees of attack and decay can be produced by different settings of VR1 and VR2. A tone is only allowed through the gate when the key S1 is quickly closed and opened again. Various kinds of R-C and L-C filters are also used in conjunction with tone sources, or with the amplifiers associated with recording and re-recording processes, to eliminate harmonics to filter off unwanted sound.

The stereophonic effect is frequently used to simulate movement of sound in such a manner that a listener's acoustical impression is made to differ from any natural visual impression. This technique alone has contributed something new to the development of both electronic and traditional music and was used in Le Corbusier's Poème Electronique at the 1958 Brussels Exhibition.

Various devices have been invented for electronic music creation and of these the "Phonogene" which was produced by Pierre Schaeffer and Jacques Paulin in 1951 is interesting. It employed a number of record/playback heads and could transpose the pitch

of sounds automatically in the chromatic scale. It was in fact coupled to a keyboard from which the pitch could be selected in the same way as notes on a pianoforte.

**Electronic Music Composition.**—The composer's equipment, his new orchestra, consists of audio sig-

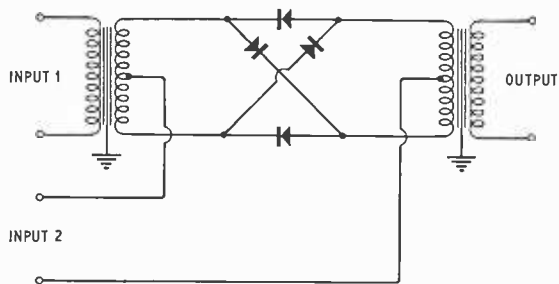

Fig. 4. Ring modulator (see Radio Engineering by E. K. Sandeman, Vol. 1, p. 542 (Chapman & Hall)).

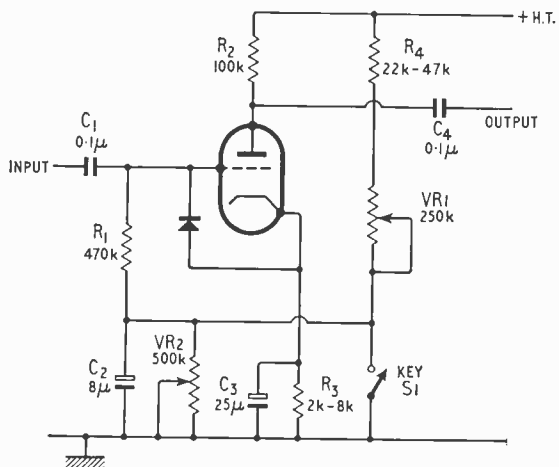

Fig. 5. Gating Circuit for controlling attack and decay.

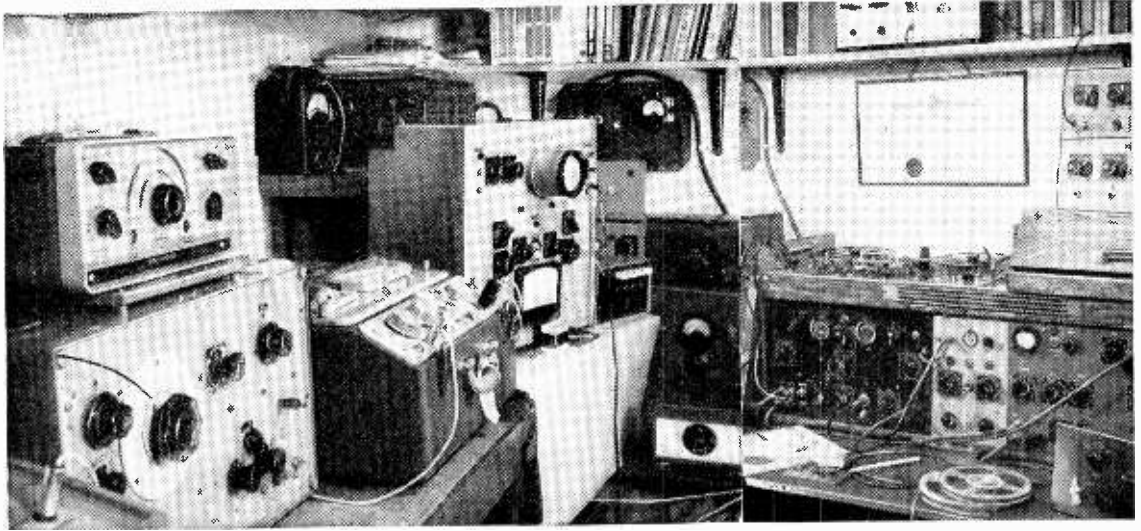

Fig. 6. Audio equipmen. used by the writer for producing electronic music.

nal generators, tape recorders, loudspeakers and other electronic equipment (Fig. 6). From these he produces his music and determines each note by its pitch, duration and intensity. He no longer has only 70 to 80 different intervals, intensities from pianissimo to fortissimo, and time values in terms of crochets and quavers. The entire audio range of frequencies is at his disposal with possibly 60 controlled dynamic levels and an infinite range of duration values, which are measured in terms of centimetres of tape.

Composers of electronic music are well aware of the tremendous possibilities that these factors afford. They can think in terms of what they call "micro-structures" which are exceedingly small differences in pitch, intensity and time, not possible with musical instruments. For example, between the note of A natural at 440 c/s and the next whole tone of B natural at 492 c/s there are 50 other frequencies (441, 442, 443 c/s and so on) which can be utilized. From these approximately every fourth step is an audible and therefore new interval.

The complex forms and range of electronically produced sounds cannot be notated as in a traditional music score and therefore have to be presented in the form of an "acoustical diagram" (Fig. 7). A score for electronic music is written in terms of frequency (cycles per second) intensity (measured in decibels) and time (centimetres of tape).

Although experiments with electrically produced music began almost with the invention of the radio valve, its full potentialities only became possible with the introduction of magnetic tape recording. Most of the earlier work with tape was carried out by Herbert Eimert and Karlheinz Stockhausen of the Cologne studios of the West German Radio. Electronic music studios have since been established in other European countries and in the U.S.A. In this country there is, of course, the B.B.C. Radiophonics workshop, but this is only available to composers by invitation.

A few "concerts" of electronic music have been given in the U.K. and in the United States there are "Vortex Music" concerts, most of which are broad-

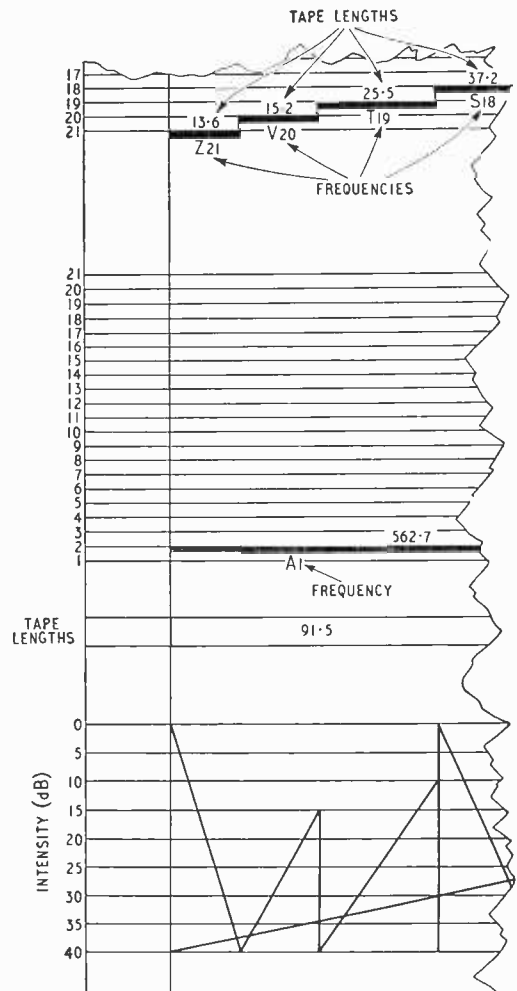

Fig. 7. Opening of "Incontri di Fasce Sonore", a score for electronic music by Franco Evangelisti (by kind permission of Universal Edition).

cast over the radio networks. Recordings of electronic music, many of which originate from the European countries, are available in the U.K. (Ref. 6). Readers particularly interested in the æsthetics and composition of electronic music, or in the more practical application of the electronic elements, are referred to the two publications given as Refs. 2 and 3 respectively.

### References

<sup>1</sup> Electronic Music by H. Badings and J. W. de Bruyn, *Philips Technical Review* Vol. 19 (1957-58), No. 6 (issued with a 45 r.p.m. disc containing examples of Electronic Music).

<sup>2</sup> die Reihe—Electronic Music—by H. Eimert and K. Stockhausen, Universal Edition.

<sup>3</sup> Electronic Music and Musique Concrète by F. C. Judd, A.Inst.E., to be published shortly by Neville Spearman Ltd.

<sup>4</sup> *Musica ex Machina* by F. K. Prieberg (survey of the studios of electronic music), Allstein Verlag.

<sup>5</sup> Scores of Electronic Music:—Essay by G. M. Koenig, *Incontri di Fasce Sonore* by Franco Evangelisti and *Studie 2* by K. Stockhausen, all Universal Edition.

<sup>6</sup> Records of Electronic Music:—LP16132—Introductory talk (in German) with examples and elementary composition by H. Eimert, LP16133—Pieces by K. Stockhausen, LP16134—Pieces by E. Krenek and G. M. Koenig (all Deutsche Grammophon), and Philips abel10073—Cain and Abel (electronic music for ballet) by H. Badings.

<sup>7</sup> Pre-recorded Tapes of Electronic Music:—Bi-Tapes ATR134 (3¼ i.p.s.)—Power of Music by F. C. Judd (based on a poem by John Dryden) and Bi-Tapes ATR135 (3¼ i.p.s.)—Experiment in Sound by F. C. Judd, (contains examples of electronic music and demonstrates the techniques employed).

<sup>8</sup> Electronic Music Instruction:—Dartington Summer School of Music, Dartington Hall, Nr. Totnes, Devonshire and the Rose Bruford College of Speech and Drama, Lamorby Park, Sidcup, Kent.

## “COLOUR TELEVISION”

TEXTBOOK OF PRINCIPLES AND PRACTICE APPLICABLE TO ALL LINE STANDARDS

FOR a long time in this country people have been talking about the system chosen by the America's National Television Systems Committee for colour television; but apart from widely scattered articles in the technical press and papers presented to learned institutions and societies, there has been no British reference book. However, Mr. Carnit and Mr. Townsend, in their book “Colour Television,” have not only remedied this situation but they have done so in an eminently readable and interesting way.

The reader with a knowledge of television but no priming on colour will find little that is not explained clearly, whilst to the man already “in the field,” whether by interest or profession, the book should be of immense value for the full treatment and as a ready reference source. To these ends the authors have introduced each chapter by exposing clearly the problem and explaining it in general terms; they then proceed to detailed analysis and the means for carrying out the desired function at the transmitter or receiver with practical illustrations from equipment of proven design.

After dealing with such principles of colour as are necessary to the understanding of colour TV, giving a brief *résumé* of various display methods and means of providing basic colour-television signals, the authors progress logically through the system. Chapters on transmitter encoding and specification of colours in the N.T.S.C. system are followed by consideration of receiver design, with particular emphasis on de-coding and reference-frequency generators. An example of the authors' complete treatment (which, incidentally, extends to 525- and 625-line systems as well as 405) is given by the chapters on test equipment, receiver installation and fault finding, whilst the last two chapters deal with monochrome reception of the colour signal and an analysis of the shortcomings of the N.T.S.C. system. They are, for instance, to be congratulated on explaining clearly why a positive-modulation, a.m.-sound television system is preferable to the negative-modulation f.m.-sound type for the transmission of N.T.S.C. colour and also on their gathering together of mathematical treatment in appendices; thus the book can be read without the need for the immediate de-coding of mathematics! A comprehensive bibliography and index complete the book which has also 14 coloured photographs including “off-the-screen” pictures.

“Colour Television, The N.T.S.C. System, Principles and Practice,” by P. S. Carnit, B.Sc. (Eng.), A.C.G.I., A.M.I.E.E., and G. B. Townsend, B.Sc., F.Inst.P., M.I.E.E., A.K.C., is published by Iliffe Books Ltd. for *Wireless World* and costs 85s.

### Transistor Radar Simulator

RADAR simulators have not, in the past, been notable for their compactness—at least one 6ft, 19-in rack or its equivalent was used to house the equipment and often, for a complex installation, the space occupied was very much greater, and power consumption was such that fan-cooling was necessary.

Solartron, however, have produced a simulator which, for a six-target installation, takes up no more space than an ordinary office desk. The key to this reduction in size and power consumption, for each target unit consumes only 20W, is the use of transistors. Designed for easy servicing, all the plug-in printed-circuit boards are colour coded and fully labelled with test points and provision has been made for the addition of units to simulate all the “gadgets” available and effects seen on the most modern radars.



# Voltage or Current Operated?

By "CATHODE RAY"

**T**HERE has been a lot of discussion lately about how we should regard transistors. One question is whether any of the three basic circuit configurations is more fundamental than the others, and if so which. It seems to have been satisfactorily established that there can be no preference on purely theoretical grounds, but I am glad to be able to report general agreement on the proposition that for practical purposes there are advantages in regarding the common-emitter configuration as the normal one.

Being analogy-minded, and therefore inevitably looking on the transistor as a new kind of valve, I have never been able to think of any other as the normal; and that is why it makes me so cross that people allocated the primary transistor symbols— $\alpha$ , etc.—to the common-base configuration. They might have had some excuse in the short-lived era of the point-contact transistor, but no excuse whatsoever for persisting in the error to this day, thereby creating a wholly unnecessary difficulty and complication for every student of electronics, including generations yet unborn, unless those who made a false start on the common-base track exert the slight mental effort of getting on to the right one again. Oddly enough, I find it is the comparatively young engineers who are most apt to justify ill-conceived conventions by the plea that "it's too late to change", thereby showing themselves less progressive and mentally adaptable than their elders who altered the firmly-established "resistance" into "resistor" for the sake of terminological tidiness, even though it was less practically important than the basic transistor symbols.

And as for the crypto-Americans among us who persist in favouring what they call the "grounded-base" configuration (and even the true Britons who call it "earthed-base") Fig. 1 should be sufficient comment.

But (to get back to the subject) I was referring to those who are busy announcing their discovery that a transistor is rather like a valve and should be taught as such. I am naturally among the most enthusiastic in welcoming them, belated though their conversion is. However, an occupational hazard of new converts is allowing enthusiasm to get the better of them. At least one of them<sup>1</sup> might be thought to have done just that when he urged that it would be helpful to consider as the important parameters of the transistor the mutual conductance ( $g_m$ ) and the input admittance ( $y_{in}$ ) and strongly challenged the common view that the transistor is current operated, in contrast to the valve, which is voltage operated. He argues that the situation is like that of a capacitor shunted by a resistor, in which the force between the plates is proportional to the current supplied but is not caused by that current. And about six years ago no less an authority than Dr. Shockley<sup>2</sup> said "the [voltage] bias across

the emitter junction controls the electron flow into the base region. In effect, the emitter junction acts like the region between the cathode and grid in a vacuum tube."

The "common view" is expressed in a well known manual<sup>3</sup>: "The base current . . . is important because it controls the current in the emitter-collector circuit. A similar controlling function is exercised in the valve by the control-grid voltage."

So here is a contradiction: some say transistors are current operated; others, that they are voltage operated. Which are right?

The first thing is to decide what exactly is meant by "current operated" and "voltage operated".

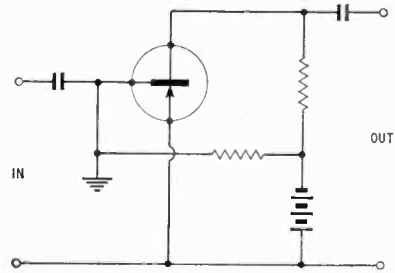

Fig. 1. Here the base is earthed. So, with the most elementary and irrefutable logic, it could be called an earthed-base circuit. But would it not be disowned as such by those who use that term? Many who, for some reason that has never been satisfactorily explained, refer to "grounded-base" circuits, would in addition disown themselves as Americans, logical though that conclusion is. The only unconfusing term for this circuit is "common-emitter".

These descriptions were used long before transistors were thought of. So, like the lawyers when they want to settle the meanings of terms, we might look up the precedents.

When I first began to study electricity I was told that instruments for measuring current were wound with a few turns of thick wire, whereas instruments for measuring potential difference, called voltmeters, had a great many turns of fine wire. That seemed to be the only difference, and I was a good deal puzzled how it could be that instruments for measuring two fundamentally different quantities were identical in principle, differing only in degree. If one gradually varied the turns and gauge of wire, at what precise point did an ammeter turn into a voltmeter?

Such being the textbooks and lecturers of the period, it was left to me to work out for myself that the so-called voltmeters were really current meters, and that the voltage was deduced thereby from the current flowing through a known resistance. And that the only true voltmeter was the electrostatic variety.

<sup>1</sup> H. L. Armstrong, *Electronic Technology*, June 1961, p.229.  
<sup>2</sup> *Proc. I.E.E.*, January 1956, p.35.

<sup>3</sup> *Mullard Reference Manual of Transistor Circuits*, p.13.



But in common thought a moving-coil voltmeter responds to volts (the current taken by it being an unavoidable evil) and so may almost by definition be regarded as voltage operated, in contrast to ammeters and milliammeters which are current operated. The inquiring student appears pedantic for objecting that there is really no difference in principle.

The distinction, unscientific though it may be, is of even greater practical significance when we come to adapt our moving-coil instrument for a.c. The metal rectifiers used for the purpose vary widely in their resistance, both with the current flowing and the temperature and with the particular sample chosen. This being so, the rectifier resistance, or the voltage required to pass a given current through it, would be a most unpractical parameter to put first in instrument design. Certainly it is of some interest, to the extent that one wants it to be as little as possible, but its precise value is altogether unimportant. It wouldn't do at all to give a rectifier-type milliammeter higher ranges by shunting it, as one would a d.c. instrument, for the readings would then depend on the uncertain and variable rectifier resistance. Instead, one uses a current transformer.

So although the first cause in making the pointer move is undoubtedly the e.m.f. that drives current through the rectifier and meter coil, this voltage is only of minor concern to the meter designer, who for practical purposes regards the contraption as current operated. When he connects in series a sufficiently high known resistance to render the rectifier resistance negligible by comparison, then he has produced a voltmeter and only then do practical people describe it as voltage operated.

And so one might go on with relays, microphones, and many other devices. Whatever may be the first cause and whatever may be the direct cause of the perceived result, voltage operated devices are normally understood to be those having a relatively high input impedance and/or a simple relationship between result and input voltage; and correspondingly for current operated devices.

Let us now try, like a jury, to forget what every man in the street thinks he knows about the case and apply strictly judicial minds to it. In particular,

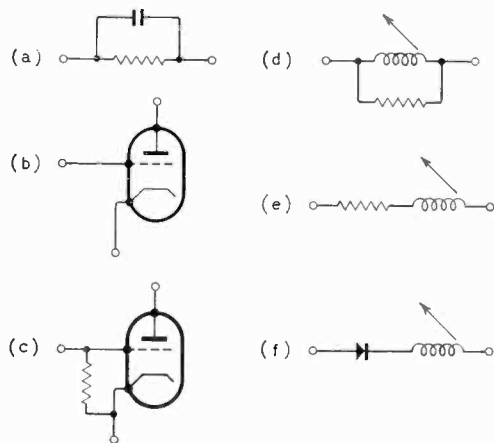

Fig. 2. Are these voltage operated or current operated, and why? (The coil and pointer denote a moving-coil meter.)

let us look more closely at the capacitor analogy, Fig. 2(a). To make the thing a little more practical, we can suppose the capacitor to be an electrostatic voltmeter, in which the force between the plates produces a visible result. Then of course we would all have to agree that this result was due to the potential difference between the plates. But might it not also be permissible to regard that p.d. in turn as due to the current through the shunt? The combination could, in fact, be scaled in milliamps. When we find a high pressure at the point where we connect the garden hose to the tap, may we not think of it as due to the current of water, in combination with the resistance of the hose? This seems to be a question of point of view rather than absolute right or wrong.

Example (b) shows a valve, in which the anode current is controlled by grid-to-cathode p.d., without appreciable current flow. This can hardly be described as other than voltage operated or controlled. Connecting a resistor between grid and cathode (c) creates essentially the same situation as in (a). Some may say it opens up a new branch circuit but makes no difference in principle to (b), others that this branch current controls the p.d. (depending on the resistance of the source) and thereby controls the anode current. Example (d) shows our ammeter. Here the deflection is produced by a magnetic field, which is caused by the current through the coil. But some may point out that the current is driven by an applied e.m.f., so as regards first causes it is voltage-operated. The same applies to the voltmeter (e) but this time there may be more who regard voltage as the operative quantity.

In all these except (b) there is a current and a voltage, and as they are directly proportional to one another there is liable to be dispute as to which is the cause. But look at (f), in which the deflection is directly caused by the current, and the current is—or can be argued to be—caused by the applied e.m.f., but is *not* proportional to it.

Legal cases in which the true cause has to be established are often troublesome, and the jury needs careful direction by the judge. May I suggest that the safest policy throughout Fig. 2 is to discard all "causes" which in principle are not essential. In (a) a current is not essential to the production of a force between the plates; they could be completely insulated and static. The same goes for (b) and (c). In (d) and (f) the current is the operative quantity; voltage could be dispensed with altogether by making the wire of a suitable metal cooled to a temperature at which it is superconductive. The rectifier could be a mechanical one with the same treatment. The only room for doubt would seem to be concerning (e), in which current is essential, but also resistance, and therefore voltage is essential for producing the current. The verdict in that case would probably rest on whether the instrument was considered as a whole or as a "movement" (by comparison, say, with the electrostatic type).

If we apply to the transistor this principle of what is essential, we can hardly avoid the conclusion that it is voltage operated. The base current, it seems to me, is an incidental and unavoidable evil, the amount of which (other things being equal) depends on the thickness of the base, the proportions of  $p$  and  $n$  impurities, etc. A valve would not,



presumably, cease to be voltage operated if it happened to be used with a positive grid, in which circumstances its similarity to a transistor is very close<sup>1</sup>.

But while this may be all very convincing, it seems to me quite academic. I am sure that when so many people say transistors are current operated they are not thinking of theoretical physics or deciding on first or direct or essential causes. What I believe they are thinking about can be illustrated by some characteristic curves I plotted for a fairly typical transistor I happened to have around—the OC45. Incidentally, they turned out to be very similar to the published "average" curves.

The output of a transistor is most appropriately expressed in terms of collector current,  $I_c$ . In Fig. 3 this is plotted against the input or base current,  $I_b$ , and also against the input voltage,  $V_b$ . The collector voltage was of course kept constant.

Comparing these, we see that the  $I_c/I_b$  curve is remarkably straight, right from the origin, whereas the  $I_c/V_b$  curve, after a late start (not shown) is thoroughly curved all the way. It is in fact (as can be shown by plotting  $\log I_c$  against  $V_b$ ) almost exactly logarithmic. There are theoretical reasons why this should be so.

If for some special purpose we desired to make the logarithm of the transistor output proportional to the input, then we would obviously make the input the input voltage. But for nearly all practical purposes we want the output to be directly proportional to the input, and this relationship is clearly far better fulfilled by the  $I_c/I_b$  curve, in which the input is current.

The effectiveness of a transistor as an amplifier is expressed by the slopes of these curves, the slope of the  $I_c/V_b$  curve being  $g_m$ , and that of the  $I_c/I_b$  curve,  $\alpha$ . The curves tell us at a glance that, right from zero,  $\alpha$  is fairly constant, whereas  $g_m$  varies widely all the way. So whatever bias voltage was applied, the output current would be a very distorted version of the input voltage.

It may be argued that such a transistor would usually be used for signals of a very small amplitude, over which even the  $I_c/V_b$  curve is reasonably straight. But even if the potentialities of the transistor were restricted in that way, the amplification—indicated by the slope of the curve—would vary enormously with the voltage bias applied. And although it would not be difficult to decide on a bias suitable for this particular OC45 transistor, that bias would probably be quite unsuitable for another OC45 transistor. The point at which the  $I_c/V_b$  curve reaches, say, 0.5mA, varies greatly from one sample to another. This is not a feature peculiar to that type of transistor or its maker; it is common to all types and makes sold at reasonable prices.

It has been pointed out that if the  $I_c/V_b$  curve is continued beyond about 0.25V it tends to straighten out. Yes; but one of the main ideas of using transistors is to economize in current, so most often they are used below the part that could reasonably be described as straight.

So however the theoretical physicists look at it, in common practice transistor bias is related to current. And nearly always the input signal is applied as current. That is what I think designers have in mind when they say transistors are current operated.

Another thing I think they have in mind when

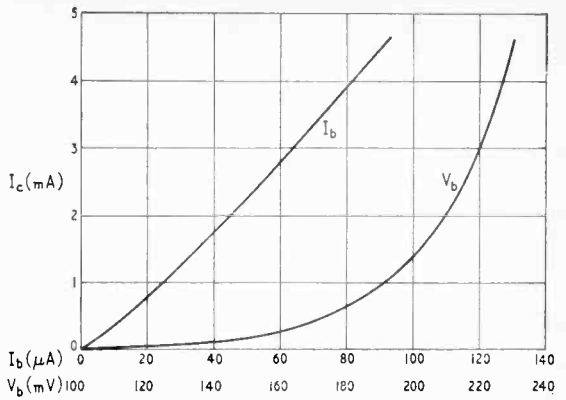

Fig. 3. Showing the relationship of collector current  $I_c$  (at a constant collector voltage  $-3V$ ) to base voltage,  $V_b$ , and base current,  $I_b$ . Note the "false zero" for the  $V_b$  scale. Transistor: OC45.

comparing transistors with valves is their low input resistance, contrasted with the almost infinite input resistance of a valve (at low frequencies). While emphasizing the close analogy between transistors and valves, Mr. Armstrong nevertheless recommends as the second most important transistor parameter—not its voltage amplification factor, or even its equivalent of  $r_{a1}$ , but its input admittance. This is the reciprocal of its impedance, and is quite large, in contrast to the valve's which is almost nil.

Not only so, but like  $g_m$  it is extremely non-linear, as can be deduced from Fig. 3. Using it, a curve of  $I_b$  against  $V_b$  (or vice versa) can be constructed; Fig. 4. The input admittance (or actually conductance, since no account is taken of reactance) is shown by the slope of this curve, which varies just about as much as  $g_m$ . So it too is rather an awkward thing to have to fill into design formulae.

Though I would hate to discourage anyone from teaching valves and transistors by comparison, that being what I do myself, the best policies can be spoiled by pressing them too far. To ignore the contrasts between valves and transistors is an example.

For any who may prefer figures to curves—the popular choice is, no doubt, both combined—here tabulated are the vital statistics of my OC45.\*

1 $V_b$ (V)	2 $I_c$ (mA)	3 $g_m$ (mA/V)	4 $g_{in}$ (m $\Omega$ )	5 $r_{in}$ (k $\Omega$ )	6 $\mu$	7 $\alpha$
0.150	0.18	7.2	0.25	4.0	2000	37
0.175	0.50	20	0.50	2.0	1650	40
0.200	1.4	56	1.08	0.93	850	48
0.225	3.7	148	3.0	0.34	430	56
Ratio, max min		20.6	12	12	4.7	1.5

\* I am aware that some of these symbols are used elsewhere with different meanings, but if people choose to use for transistors the same symbols as for valves but with different meanings, responsibility for resulting confusion is entirely theirs. I adhere to the meanings that have been universally understood for the last 35 years or so. And I refuse to make the common-emitter  $\alpha$  wear a ' still less degenerate into a  $\beta$ ; if you insist that all three configurations are on an equal footing, let their  $\alpha$ s be  $\alpha_1$ ,  $\alpha_2$ , and  $\alpha_3$ , the subscript indicating which electrode is common to input and output. The latest British Standard on the subject (BS.3363: 1961) apparently sets out to discourage the use of  $\alpha$  altogether, mentioning it only in an inconspicuous footnote as a possible alternative to  $-h_{fe}$ ;  $\alpha'$  is entirely ignored, and  $\beta$  is to be  $h_{fe}$ . The only thing about this that gives me any joy is the official use, at last, of the single subscript to indicate configuration.

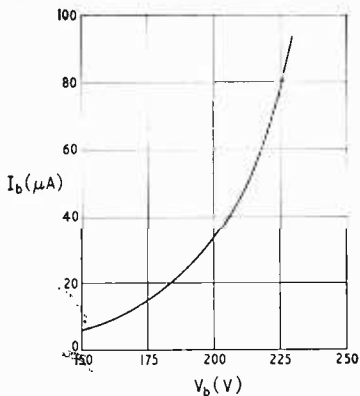

Fig. 4. Input characteristic ( $I_b$  against  $V_b$ ) for OC45. Again,  $V_c = -3V$ .

Column 3 is what has been recommended as the most important transistor parameter, and that varies the most widely of the lot. Coupled with it was  $g_{in}$ , column 4 (shown alternatively in 5 as resistance), and that comes next in variability. Column 6 shows the strangely overlooked  $\mu$ , which by comparison is tolerably constant (I had, of course, to do some  $I_c/V_c$  measurements to find it). But far more constant is  $\alpha$ , column 7.

I will concede that in some transistors, especially

the high-power kinds,  $\alpha$  varies more and  $g_m$  varies less than in the OC45; on the other hand, there are some of which the opposite is true and  $\alpha$  is almost perfectly constant. All this reminds one strongly of  $\mu$  in valves.

Personally, then, I am not disposed to quarrel with people who call transistors either current operated or voltage operated, provided they do so in the right context. It seems to me misguided to prove by theoretical physics that the Mullard handbook and all suchlike are wrong in saying that transistors are current operated; and it would be equally wrong to quote the arguments I have just been using, against Dr. Shockley.

Readers with long memories (Mr. Clay?)† may recall, however, that there is one related situation in which a perfectly definite answer is forced on us. I refer to negative resistance, all of which appears on a current/voltage graph as a downwards-to-the-right slope. In spite of that, experiment reveals two distinct types of behaviour; the difference, as I showed in the February 1957 issue, is due to some negative resistance being voltage operated (or controlled) and some current operated.

It would save a lot of acrimonious breath and ink if we were always careful to observe the distinction between questions that are decided for us by Nature and those that are matters of convention or point of view.

† The allusion is to correspondence which appeared in this journal between April and September 1960.—Ed.

## BOOKS RECEIVED

**F.M. Simplified** by Milton S. Kiner. The third, completely revised edition of a non-mathematical treatise on the whole subject of frequency-modulation. The author describes the fundamentals of transmission and reception, including aerials and audio amplifiers in the first ten chapters. Several chapters are then devoted to the alignment and servicing of receivers, with reference to commercial equipment, followed by a section on the principles of f.m. transmitters and commercial transmitting equipment. A fault-finding chart is included and there is a bibliography. Pp. 376; Fig. 306. D. Van Nostrand Company Ltd., 358 Kensington High Street, London, W.14. Price 45s.

**Transistor Circuits and Servicing**, by B. R. A. Bettridge. (2nd edition.) Explains, in a practical manner, the nature of transistors, their applications in radio circuits and recommended methods to adopt when servicing transistor equipment. Written for the service engineer. Pp. 227; figs. 12. Iliffe Books Ltd., Dorset House, Stamford Street, London, S.E.1. Price 3s.

**A First Course In Wireless**, by "Decibel." The fourth, revised edition of a well-known elementary textbook of radio theory. Ranging from a chapter entitled "What is Electricity" to a description of superheterodyne technique and audio amplifiers, the book is completely non-mathematical and very readable. A chapter has been included on semiconductors. Pp. 247; Figs. 98. Sir Isaac Pitman and Sons, Ltd., Pitman House, Parker Street, Kingsway, London, W.C.2. Price 12s 6d.

**Linear Graphs and Electrical Networks**, by S. Seshu and M. B. Reed. An introduction to the use of linear graphs in electrical engineering network problems. The treatment is at post-graduate level, and Laplace transforms, the theory of functions and Boolean algebra are used extensively. The major part of the book is devoted

to the application of the linear graph. A comprehensive bibliography is included. Pp. 315. Addison-Wesley Publishing Company, Inc., 10-15, Chitty Street, London, W.1. Price 74s.

**Industrial Electronics Apparatus** by P. van der Ploeg. Concerned with reliability in industrial electronics the book discusses the electrical and mechanical design, and installation of equipment from this viewpoint. The second part of the book deals with maintenance, detailing essential equipment and proposing methods of fault-finding and repair. Data on valve operating characteristics is contained in a supplement. Pp. 116; Figs. 22; plates 33. Cleaver Hume Press Ltd., 31 Wright's Lane, London, W.8. Price 9s 6d.

**Radio Waves in the Ionosphere**, by K. G. Budden. A mathematical treatise on the propagation of radio waves in the ionosphere, and on their reflection from its boundaries. Intended both as a reference book for engineers and a textbook for students. It is assumed that the reader is familiar with the operators div, curl and grad., and electro-magnetic theory. Pp. 542. Cambridge University Press, Bentley House, 200, Euston Road, London, N.W.1. Price 95s.

**La Modulation de Fréquence** by J. Marcus. A mathematical treatise on the subject of frequency-modulation. Each chapter presents the theory of the phenomenon under discussion before going on to the more practical aspect. The more highly-mathematical calculations are contained in appendices. After having dealt with definitions and fundamentals, the author proceeds to describe the generation and detection of frequency-modulated signals, and devotes a chapter to the problem of noise. Multiplexing is discussed and examples are given of commercial f.m. equipment. Pp. 320; Figs. 175. Editions Eyrolles, 61 Boulevard Saint-Germain, Paris, 5<sup>e</sup>, France. Price 43.65 NF (by post).

## Magnetically-Focused

# Travelling-Wave Tubes

By J. M. WINWOOD\*

### USE OF REVERSED-FIELD PERMANENT MAGNETS

**T**RAVELLING-WAVE tubes and some other microwave valves depend for their operation on the interaction between an r.f. field and a long, straight electron beam. In most cases, because of the mutual repulsion between electrons, this beam would expand too rapidly unless constrained by immersion in a suitable magnetic field or by other means. Such a focusing field may be provided by a long solenoid, but when possible it is obviously advantageous to replace electromagnets and their power supplies with lightweight permanent magnets.

It is possible to design a uniform field magnet to replace almost any solenoid (although there is a limit to the straightness of field obtainable with permanent magnet circuits, the errors can be made comparable with ordinary mechanical tolerances in coils) but the resultant permanent magnet will usually be very heavy and stray fields may extend over a large area.

Suppose that a certain axial field  $H_0$  is required to focus a given beam. The weight of a magnet designed to give this magnetic field is proportional to the cube of the length of uniform field  $H_0$  required since magnets with similar shapes but varying sizes all give the same field. However, although the field must be parallel with the axis of the electron beam,

the polarity of the magnet is immaterial. Thus, in order to decrease the weight of the focusing assembly for a given valve, it may be possible to use an assembly of several short magnets, each of which separately is capable of giving the desired field. For example, if we use a combination of two magnets each half the length of the original magnets, their weights will each be  $\frac{1}{8}$  of the original. The total weight of the focusing system would then be only  $\frac{1}{4}$  of the original. It will be necessary to reverse the direction of the fields of adjacent magnets so that the stray field of any magnet (which is oppositely directed to its wanted field) does not reduce the useful field of its neighbours. The stray field of the assembly will then be much lower than that of an equivalent uniform field magnet.

One application of this principle is in *periodic focusing*. Clogston and Heffner<sup>1</sup> and others<sup>2</sup> have shown that it would be possible to replace a uniform magnetic field with a sinusoidal field having a similar r.m.s. value (and suitable period). Fig. 1 shows a typical periodic permanent magnet circuit together with its associated travelling-wave tube and Fig. 2 shows a plot of the magnetic field. The weight of the magnetic material is about 2 lb. This should be compared with about 40 lb for the equivalent uniform-field magnet.

Present low-noise travelling-wave tubes require a high magnetic field near the cathode (at least 500 and perhaps 1500 Oersteds) and it is also important that there should be no interception current in the early part of the slow-wave structure. A solenoid to give this field over the whole length of the valve may require from 0.2 to 2kW and with the higher powers will probably require water cooling, while the equivalent uniform-field permanent magnet may weigh more than 100 lb. One effective solution for low-noise travelling-wave tubes would appear to be the com-

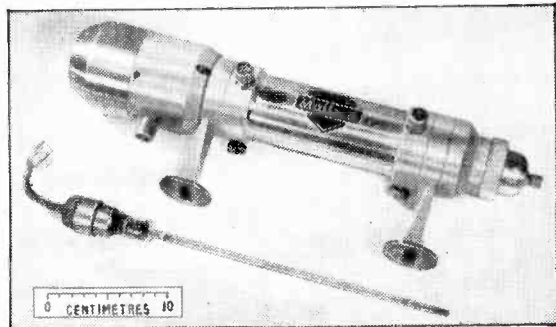

Fig. 1. Periodic permanent magnet circuit and (below) travelling-wave tube.

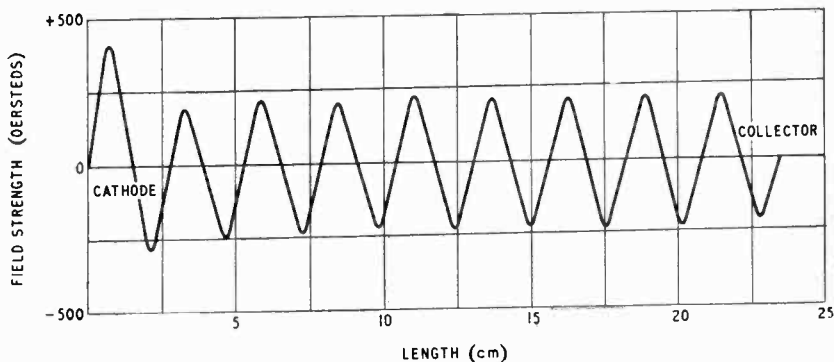

Fig. 2. Plot of typical periodic focusing field.

\* Mullard Research Laboratories, Redhill.

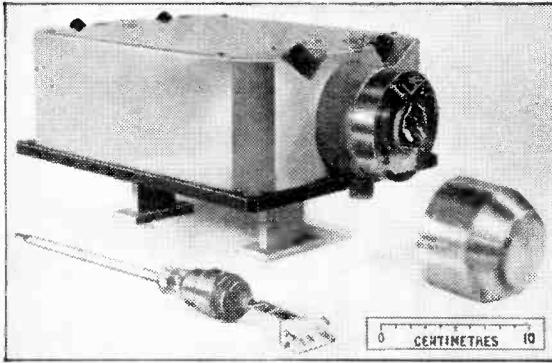

Fig. 3. Reversing-field permanent-magnet circuit and travelling-wave tube.

combination of a short permanent magnet giving a suitably high uniform field in the cathode region, together with a periodic focusing system. If the field at the cathode is large, one finds that good focusing is only obtained if the peaks of the periodic field are also high. Unfortunately a criterion for satisfactory periodic focusing is that the period ( $L$ ) is given by

$$L < \sqrt{\frac{400V}{\eta B^2}}$$

where  $V$  is the beam voltage,  $B$  the peak flux density

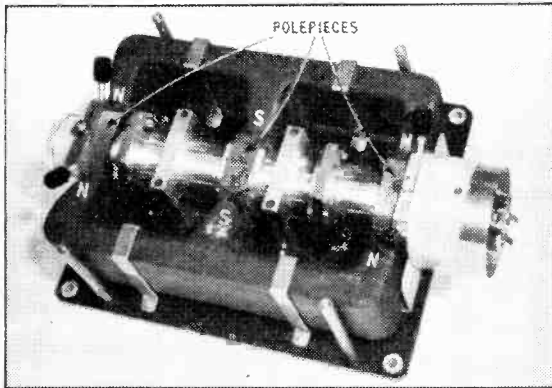

Fig. 4. Magnet assembly of reversing-field circuit of Fig. 3.

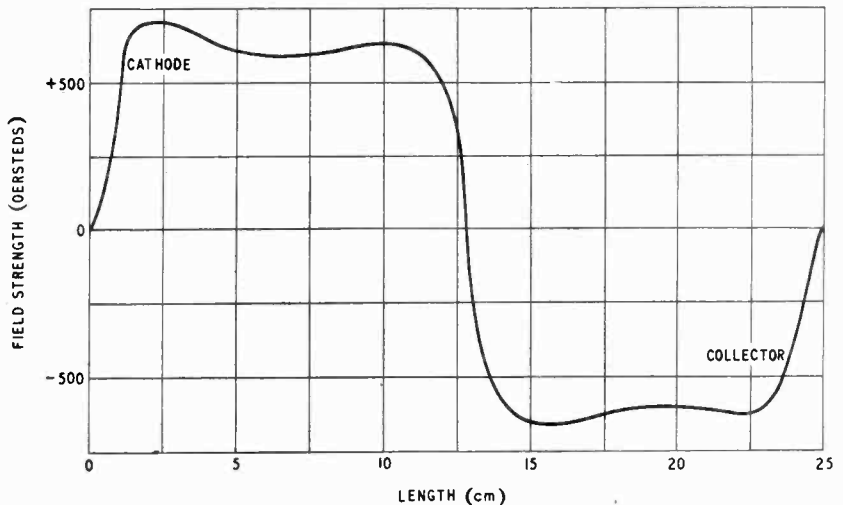

Fig. 5. Plot of typical reversing - focusing field.

and  $\eta$  the ratio of the charge to mass of an electron, all in m.k.s. units. Because of the limitations of available magnetic material, this is not easily satisfied for the high peak fields required.

Recently, therefore, some theoretical and experimental work has been devoted to the possibility of using only a small number of abrupt reversals of field in order to reduce the weight of magnetic material in certain particular applications where periodic focusing is not possible. Such a system, with comparatively long periods, has been called *reversing-field focusing*. If it were possible to make very sudden reversals of magnetic field, the number and position of the reversals would be immaterial. In practice it is not possible to achieve perfectly sharp reversals, and it is found that the correct positions depend on both the amplitude of the magnetic field and on the beam voltage. This method of focusing has been found advantageous not only for low-noise travelling-wave tubes, but also for high-power klystrons where periodic focusing of the beam would be possible if the position and size of the cavities did not interfere with normal periodic permanent magnets. The weight-saving factor when a reversing-field system with  $n$  units of equal length replaces a unidirectional field is better than  $n^2$ . However, if the weight of the pole-pieces and r.f. circuitry is taken into account, there is little point in using more than one or two reversals.

The use of reversing field focusing has been discussed for the case of magnetically shielded cathodes by Murphy<sup>3</sup> and the case of immersed cathodes will be the subject of a paper which will be published later<sup>4</sup>.

Systems with one reversal have been shown to work well for a range of low-noise t.w.t. amplifiers operating at frequencies covering from 3,000 to 10,000 Mc/s. An example of a typical amplifier for the 6,000 Mc/s communications band is illustrated in Figs. 3 and 4. The magnetization of the magnet system is also indicated in Fig. 4 and the axial magnetic field is plotted in Fig. 5. The direction of the field on the axis of the circuit is controlled by assemblies of soft ferro-magnetic rings (known as field straighteners) between the pole-pieces and is not dependent on the symmetry of magnetization of the magnets. Thus the performance of the travelling-

wave tube is not affected by the presence of small transverse stray fields from other sources. The weight of the magnet is 20 lb, compared with about 100 lb for the equivalent uniform-field magnet.

The noise factor and gain of a t.w.t. are similar to those obtained in an equivalent solenoid, but the extra weight and fault liability of the solenoid power supply are eliminated. In addition there will be no danger of r.f. modulation induced by insufficient smoothing or poor stabilization of the power supply, or by pick-up in the solenoid coils. Perhaps, however, the greatest advantage of the reversing-field system is that whereas the solenoid takes a long time to reach thermal equilibrium and may also require special cooling, particularly in enclosed equipment, the permanent magnets waste no power and remain cold so

that consistent life and performance should be obtained from the valve.

#### References

<sup>1</sup> "Focusing an Electron Beam by Periodic Fields", by A. M. Clogston and H. Heffner. (*J. App. Phys.*, Vol. 25, p. 436 (1954).)

<sup>2</sup> "Electron-beam Focusing with Periodic Permanent Magnet Fields", by J. T. Mendel, C. F. Quate and W. H. Yocom. (*Proc. I.R.E.*, Vol. 42, p. 800 (1954).)

<sup>3</sup> "A Method of Focusing Electron Beams", by B. T. Murphy. (*Proc. I.E.E.*, Pt. B., Supp. 12, Vol. 105, p. 1033 (1958).)

<sup>4</sup> "Reversing-field Focusing", by B. T. Murphy and J. Kelly. (Paper presented at the International Conference on Microwave Valves, Munich 1960.)

## 1,000-FT RADIO TELESCOPE

### USE OF NATURAL BOWL-SHAPED VALLEY

By R. J. SLATER, B.Sc., A.M.I.C.E

NOW under construction at Arecibo, Puerto Rico, and expected to be completed shortly, is a 1,000-ft diameter radio telescope. When completed, this new telescope will dwarf the 250-ft diameter Jodrell Bank telescope and 600-ft diameter radio telescope now being built at Sugar Grove, West Virginia. It will not however be as flexible in operation as either of these two telescopes.

When completed the telescope is to be used for investigations into the nature of the ionosphere.

The Arecibo radio telescope will have an aerial area of 18 acres, and will be able to detect a reflector only 3ft square at a distance of 22,000 miles.

In contrast to conventional radio telescopes the aerial will be only a short distance above the ground in a large bowl-shaped valley. Instead of the parabolic antenna normally used with radio telescopes, the antenna at Arecibo will be made hemispherical so that it can scan a larger segment of the sky (up to 40°). To compen-

sate for spherical aberration a specially designed line feed is thus necessary. This will be suspended 435ft above the wire mesh reflector. By movement of the line feed it will be possible to detect incoming waves and to direct radar signals within a cone of 40 degrees.

Levinthal Electronics Products are building the transmitter. This will permit initial operation of the telescope as a radar at 430Mc/s with a beam-width of  $\frac{1}{2}$  degree and a maximum power of  $2\frac{1}{2}$ MW. Cornell University have designed the receiver. This will have two channels, a spectrum analyser and a gated radio-meter for pulse integration.

Advantages of the Puerto Rican location as a site for this telescope are the natural bowl-like configuration of the valley in which it is situated, absence of radio noise in the area, and the latitude. This last is within  $23\frac{1}{2}^\circ$  of the equator, thus permitting planetary observations with  $20^\circ$  of beam span.

Impression of how the 1,000-ft Arecibo radio telescope will look on completion.

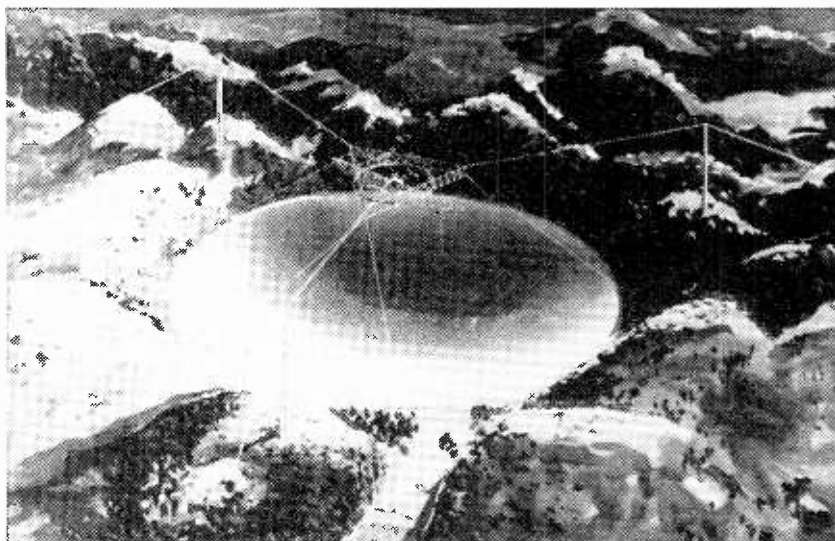

# RANDOM RADIATIONS

By "DIALLIST"

## Reliability Wanted

NO ONE could agree more heartily than I with Earl Mountbatten of Burma in the plea for greater reliability in electronic apparatus which he made in his presidential address to the British Institution of Radio Engineers. If you have no need to keep an eye on production costs, a very good standard of reliability can be attained. I'm thinking of the apparatus shot up into space in exploring rockets: price there is no particular object and the gear seems to survive pretty well such rough treatment as terrific acceleration, and big temperature changes. I feel, though, that the increased freedom from breakdown is needed chiefly in the moderately priced gear which the man in the street buys in most of the world's countries to-day. Where I'd like to see greater reliability is in such things as domestic sound radio and television sets. You can't look through a radio magazine published in any country without finding descriptions of faults and fault finding in such sets.

## Shocks Are Warnings

WHAT wickedly dangerous things connections to the electric mains by two-pin plugs and sockets and lamp-holder adaptors are. It's an even

chance with either whether or not you connect the metal parts of any apparatus to the neutral or the phase wire. If I'd anything to do with it, I'd make it illegal to fit any but properly earthed three-pin sockets or to sell electrical goods provided with two-pin plugs or lampholder adaptors. Not long ago a man who was actually a skilled electrician was killed by a shock from his electric guitar. The unfortunate fellow had had shocks from it previously, but took no notice of them. A shock, however slight, from any piece of electrical gear is a warning: it shows that there is something wrong and action should be taken at once. If you move into a new house, it's always as well to run over the three-pin sockets with a neon pole-finder. I've several times found many of those in friends' houses wrongly wired, so that switching off merely broke the neutral and left the phase socket alive.

## TV Gets Going in France

IT has been officially announced that the number of licensed television receivers in France passed the two million mark at the end of March, when 2,131,305 were in use. Between the end of March 1960 and the same date in 1961 over 600,000 new TV sets were installed. In this country

and in the United States it seems as if the saturation point has almost been reached—it can never quite be reached because of the number of new houses that become occupied. France has still a long way to go before anything of the sort happens there. It's believed that there'll be another big jump forward when the second programme with 625-line definition gets going.

## Exploring Caves in the "Med"

WHAT an interesting time the members of the Cambridge University Underwater Exploration Group will have in the Mediterranean. Equipped with a formidable array of electronic gadgets, they have set out from this country in the 138-ton yacht *Titanica* and will spend four months on their task, which is to make a fresh set of readings in the level of this sea since the early days of the Ice Age. All the fifteen members of the expedition are experienced divers. Navigation to and from the "Med" is being done largely by means of Marconi radar and two Ferrograph echometers. There is also a portable echometer for use in mapping underwater caves. Once located, the caves are to be explored by divers, equipped with underwater intercommunication apparatus. Nearly 50 underwater caves are known and from these the team hope to collect evidences of human occupation in the old days. They will also search for specimens of organic matter, which, after testing the radioactive carbon 14, may date the time when the caves were above the surface.

## Underwater Television

NEW uses for underwater television are continually being found. One of the latest is of Australian origin. The catching of sea crayfish is an important industry off Australian coasts; but it's not always easy to find them, for they move about from reef to reef. The idea is to equip a control boat with a TV camera and to send her over successive reefs. If crayfish are there, they show up well on the screen. Once found this boat would put out a radio marker buoy, transmitting a v.h.f. signal to guide fishing boats to the scene of action.

## "WIRELESS WORLD" PUBLICATIONS

	Net Price	By Post
<b>PRINCIPLES OF SEMICONDUCTORS</b> M. G. Scroggie, B.Sc., M.I.E.E.	21/-	21/11
<b>COLOUR TELEVISION: N.T.S.C. System, Principles and Practice.</b> P. S. Carnot, B.Sc. (Eng.), A.C.G.I., A.M.I.E.E. and G. B. Townsend, B.Sc., F.Inst.P., M.I.E.E., A.K.C.	85/-	86/9
<b>PRINCIPLES OF FREQUENCY MODULATION</b> B. S. Camies	21/-	21/10
<b>RADIO VALVE DATA</b> Compiled by the staff of "Wireless World." 7th Edition	6/-	6/10
<b>ELECTRONIC COMPUTERS. Principles and Applications.</b> T. E. Ivall. 2nd Edition	25/-	26/-
<b>INTRODUCTION TO LAPLACE TRANSFORMS for radio and electronic engineers.</b> W. D. Day, Grad.I.E.E., A.M.Brit.I.R.E.	32/6	33/6
<b>BASIC MATHEMATICS FOR RADIO AND ELECTRONICS</b> F. M. Colebrook, B.Sc., D.I.C., A.C.G.I. Revised by J. W. Head, M.A. (Cantab.). 3rd Edition	17/6	18/5
<b>PRINCIPLES OF TRANSISTOR CIRCUITS</b> S. W. Amos, B.Sc.(Hons.), A.M.I.E.E. 2nd Edition	21/-	22/-
<b>SOUND AND TELEVISION BROADCASTING. General Principles.</b> K. R. Sturley, Ph.D., B.Sc., M.I.E.E.	45/-	46/4

A complete list of books is available on application.

Obtainable from all leading booksellers or from

ILIFFE BOOKS LTD., Dorset House, Stamford Street, London, S.E.1.



Other jobs for underwater TV are being found in the Suez Canal. There, it will locate submerged debris, which now causes much damage to the cutting teeth of dredgers. It will also enable engineers to examine ships damaged below the water line and to direct repair operations. It is hoped that means will soon be found of fitting cameras to the keels of ships passing through the canal. On monitor screens it will then be possible to keep a constant watch ahead on their clearance of the bottom and this should prevent any possibility of their running aground.

## Further Education

HERE is a selection from the many prospectuses and syllabuses of both part-time and full-time courses we have received from colleges and further education establishments.

**Twickenham Technical College.**—The first of three four-week full-time courses begins on October 2nd. It covers "Electronic Circuit Design." The second, "Transistor Theory and Applications," starts on November 6th, and the third, "Principles of Automatic Control," on January 15th. On Friday evenings from September 22nd the college is providing a 12-lecture course on printed circuit techniques and on Thursday evenings from September 28th a 23-lecture course on pulse circuit design.

**South-East London T.C.**—An evening course of about 25 lectures on electric circuit and field theory commences on October 17th.

**Norwood T.C.**—In addition to full-time courses for C. & G. certificates in telecommunications engineering and the P.M.G.'s certificate for marine radio officers, there are short courses of 6-12 weeks' duration in such subjects as electronic computers, transistors, parametric amplifiers and medical electronics. A six-lecture evening course on masers and parametric amplifiers starts on October 3rd.

**Northern Polytechnic.**—A five-year part-time day or evening course for the recently introduced Electronic Servicing Certificate is provided. The college's three-year course for its diploma in telecommunications fully meets the requirements for the graduation examination of the Brit. I.R.E.

**Radio Amateur's Exam.**—Classes in preparation for the P.M.G.'s examination are again being held at the Wembley (Middx.) Evening Institute (Mondays from Sept. 18th); Allan Glen's School, Glasgow (Tuesdays from Sept. 12th) with a general radio theory class on Thursdays (from Sept. 14th); Brentford (Middx.) Evening Institute (Wednesdays from Sept. 20th) with a radio servicing course on Tuesdays and a mathematics course on Thursdays; and Ilford (Essex) Literary Institute an eight-month course on Wednesdays (from Sept. 20th) and a two-year course on Thursdays, both courses being organized by the East London R.S.G.B. Group.



# NEW LINES

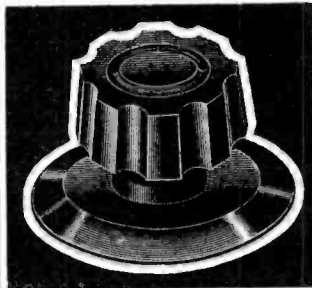

Its transparency is the feature of this new knob, which is for push fit and firm grip to "D" shape spindles. The legend plate is fixed under the front surface thus being kept clean and always readable. List No. K.436.

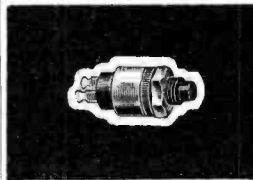

This really sub-MINIATURE meter push List No. M.P.16 requires only a 1/4 in. panel hole, in panels up to 9/64 in. thick. Single pole action, push to make.

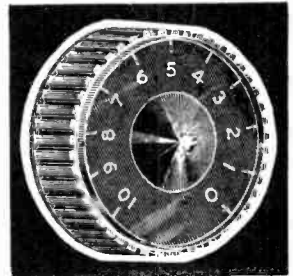

A neat, new knob and dial with a "nest" type escutcheon on which the white filled pointer line is engraved. The silver legended dial is printed to order. List Nos. K.400 + K.450 + K.449.

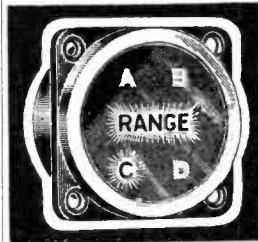

Our new Multi Legend Signal Lamp List No. D.829-831 is a versatile component incorporating a number of LES. (B.S. 98/E5) lamp sockets and adjustable light barriers, which allow many different types of legending for successive or together lighting.

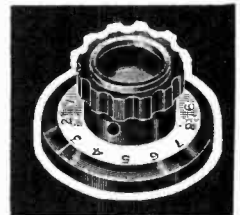

A revolutionary new development from BULGIN is this Neon Signal Fuse-holder List No. D.F. 826. Manufactured to our usual high standards, it takes 200-250 V. fuse links (up to 7A.) to B.S. 2950 1 1/4 in. x 1/4 in. It glows if the fuse Blows.

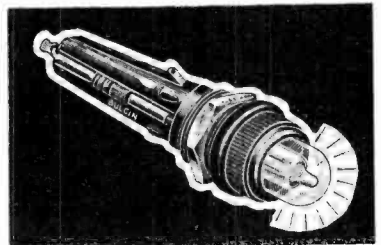

**A. F. BULGIN & CO. LTD., BYE-PASS RD.  
BARKING, ESSEX. TEL: RIP 5588**



By "FREE GRID"

## Transistorized Tintinnabulations

DURING this summer there have been many references in the press to the nuisance caused at our seaside resorts by the tiny and sometimes tinny portables which add their transistorized tintinnabulations to the already existing pandemonium caused by bawling babies and barking dogs. I cannot say this addition to normal beach noises distresses me a lot as, being blessed with a clear conscience, I never find any difficulty in taking a quiet nap on the beach while Mrs. Free Grid tans her torso.

However, one day earlier in the summer I did have a somewhat unusual experience which may be of help to our seaside authorities in giving them an idea as to how it would be possible to tackle this new nuisance. I was having my normal nap on the sands when I received a sharp dig in the ribs from Mrs. Free Grid who wanted to know why all the portables on the beach seemed to be bellowing morse at full blast.

When I had collected my senses, and my false teeth which I always remove when sleeping, I was astonished to realize that all the portables on the beach were churning out my initials, while their owners were frantically but unsuccessfully trying to recapture the B.B.C.'s drowned-out daily drool. My initials were soon followed by the morse signal "de" (from) and then by the initials of one of the little grid leaks of the third generation. Then followed a message urgently requesting my presence at the car, which was parked on the sea front.

Wending my way thither I found

the boy standing by the open bonnet of the car. It appeared that he had forgotten exactly whereabouts on the beach he had left me, and so he had displayed his initiative by connecting the rod aerial of the car radio receiver to one of the sparking plugs and using two pieces of wire connected in the primary circuit as an improvised morse key. The urgent demand for my presence arose because he needed money for ice-cream.

It was this incident which made me think what an excellent thing it would be if seaside corporations could equip a car with a low-power spark transmitter to trundle up and down the promenade every now and again. With a direct-coupled spark transmitter, of course, the tuning is so broad that it would break through on any of the wavelengths to which the beach sets would be tuned.

The trouble is that it would cause interference to people who were using sets in nearby houses, and the Postmaster General's minions would then intervene. What is obviously wanted is some form of selective or directional jamming. W.W. does not dabble in politics otherwise I might be able to suggest the name of a foreign power which could advise in this matter.

## Forestalled Inventions

SPEAKING as one who has always regarded Hertz as giving the first practical demonstration of Clerk-Maxwell's theory of electromagnetic waves, I was rather surprised to read recently that Edison forestalled him by several years.

In the issue of the *Scientific American*, dated December 25th, 1875, Edison gave a full description of his apparatus for generating and detecting the presence of e.m. waves. There is nothing very startling in that, of course, for after what Clerk-Maxwell had to say, it was obviously open to any competent person to seek experimental proof of his theory. The only part that interested me was that Edison was several years in advance of Hertz\*, who is always the one mentioned whenever reference is made to the first practical demonstration based on Clerk-Maxwell's work.

It was Edison also who, in 1883, first stuck a metal plate in an electric lamp and measured the current passing across the gap between it and the filament. In one sense this constituted the invention of the diode which Fleming patented twenty-one years later. But the difference is that Edison had no idea of using it as a rectifier for the detection of wireless signals and he did not patent it, whereas Fleming had and did.

I suppose there must be many instances of that sort of thing not only in the matter of radio inventions but of others also. Thus Edison first had the idea of recording sound in 1876 and in the following year he patented the cylinder-instrument which we know as the phonograph. But Leon Scott recorded sound on his "phonograph" twenty years earlier, in 1857, but he did not pursue the matter.

Coming to modern times, articles dealing with the experiments of Lossev (a Russian engineer) and others with what were called oscillating crystals appeared in W.W. during 1924, and the matter was not new even then. Yet nearly twenty-five years had to pass before these devices, in greatly improved form, made their bow under the name of transistors.

Many of the things which I myself invented in pre-war years, such, for instance, as radio-controlled traffic lights for emergency operation by fire engines and ambulances (2.12.37) have not yet been put into use. When they are I feel quite sure I shall not be the one to receive the credit of the "marvellous new invention" as it will be called by the lay press.

\* Among other even earlier anticipations of e.m. wave phenomena (as distinct from induction effects) may be cited the words of Joseph Henry in a communication to the Smithsonian Institution in 1842: "It would appear that a single spark is sufficient to disturb perceptibly the electricity of space throughout at least a cube of 400,000 feet of capacity, and it may be further inferred that the diffusion of motion in this case is almost comparable with that of a spark from flint and steel in the case of light." But it was Hertz whose scientific work verified hypothesis.—Ed.

## Lexical Ectopism

CAN anybody tell me why it is that when we went all classical by adopting the word "anode" in place of the more homely "plate," we still continued to use the plebeian word "grid" to describe the electrode which acts as the door or gateway which regulates the anode current by the degree to which it is open or shut?

Why didn't we call it a thyrode or pylode? The mundane word "grid," used to describe an electrode which is sandwiched between such lordly-sounding things as an anode and a cathode has always struck me as a very strange ectopism.

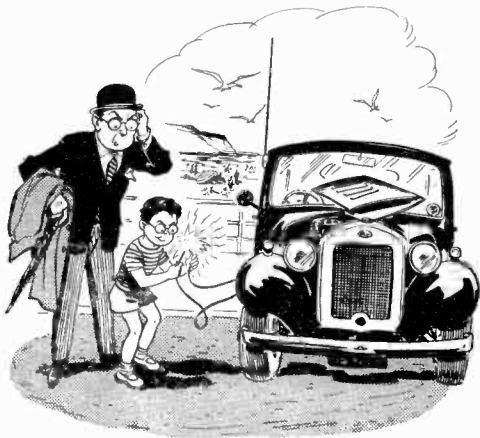

Junior Sparks.