

Wireless World

APRIL 1952

VOL. LVIII. No. 4

Harbour Radiophones

IT is a chastening thought that in one respect at least passengers in modern ocean liners are worse served than were their ancestors who voyaged in sailing ships. So long as they are on the high seas present-day travellers are remarkably well catered for by radio-telegraphy and often by radio-telephony as well, but, in the interval between arriving in a British harbour and actually landing, their only way of communicating with the shore is by hiring a waterman to take a message. And we gather that watermen are not so plentiful nowadays as in the days of sail! Normal radio communication is suspended on the ship's entering harbour limits, and there is apparently a real need for a last-minute telephone service. A short-range v.h.f. system for use in harbours and their approaches seems to be an amenity which may reasonably be expected to-day.

Provision of such a service is predominantly an economic and administrative problem. Multi-channel v.h.f. working of the kind likely to be necessary is practicable by the use of known and tried techniques, though the task would be somewhat complicated by the intermittent and highly concentrated nature of the load. Traffic would also be largely unpredictable; obviously, if a ship suffers an unexpected delay in docking, many passengers will want to make last-minute changes in their arrangements.

Up to a point the Thames Radio Service, introduced by the Post Office a year or two ago, paved the way for a radiophone system such as that under consideration, though it was intended rather more for small craft—tugs and the like—than for passenger ships. It was devised to put vessels navigating the waterways of the entire Port of London into connection, *via* v.h.f. radio, with the telephone system of the country. A service for liners in or approaching harbours would obviously involve more complex problems; the most difficult of these would fall on the G.P.O., which would be responsible for the shore terminal equipment.

As the port of Southampton handles by far the greatest number of passengers, it is the obvious choice for an initial experimental service.

It is not only in the shipping world that com-

munications must keep abreast of public demand. Operators of aircraft are constantly reminding us that the ever-increasing speeds of flight call for commensurate increases in the speed of radio for both communications and navigational aids. Of course, we cannot do anything about the velocity of radio wave propagation, but, subject to that single limitation, we can, on the whole, flatter ourselves that this particular challenge has been met fairly satisfactorily. Such weaknesses as may at the moment exist are, more often than not, brought about by organizational rather than technical shortcomings.

Telegraph Tempo

Apart from the question of operational communications, the growth of passenger flying has brought about a need for quicker handling of ordinary inland and overseas telegrams.

Perhaps our own particular cross-section of experience is unfortunate, but we have gained the impression that there has of recent years been no increase in the speed of transit of telegrams; in fact, rather the reverse. Be that as it may, it seems to be a not entirely unknown experience for an air passenger to arrive at his destination ahead of a telegram announcing his departure.

Radio and wire telegraphy are now so closely integrated that for many purposes they must be treated as one, and in any case almost all radio-telegrams pass over the inland system to their destination. Radio is sometimes unjustly blamed for delays.

We suggest that in the telegraph world the well-known business axiom "the customer is always right" should be modified to "the customer is always in a hurry," and that this slogan should be inculcated into the minds of all concerned. Quite recently, on the occasion of the Queen's dramatic return flight from Africa, we saw what could be done in the way of rapid communication by wireless linked with wire. The communication achievements of the Ministry of Civil Aviation on that abnormal occasion might well be taken as setting a standard for more humdrum traffic.

Orchestral Studio Design

Recent Modifications to the B.B.C. Maida Vale Studio

By T. SOMERVILLE,* B.Sc., M.I.E.E., F.Inst.P., and H. R. HUMPHREYS,* A.R.I.B.A.

THE principal B.B.C. concert studio was built in 1935 at Maida Vale, when it became necessary to have a studio big enough to accommodate an orchestra of 100 and a large choir. The acoustic treatment was based on ideas current at that time and consisted mainly of building board on the walls and a floor carpeted except on the area occupied by the orchestra. Some additional absorption was obtained from an audience of about 150 seated in a balcony at the far end of the studio. The reverberation/time characteristic of this studio is shown in Fig. 1(a) and the shape is consistent with the boominess of the studio and its extreme deadness at high frequencies. At a later date an organ and orchestral platform were added, resulting in the reverberation/time charac-

* British Broadcasting Corporation.

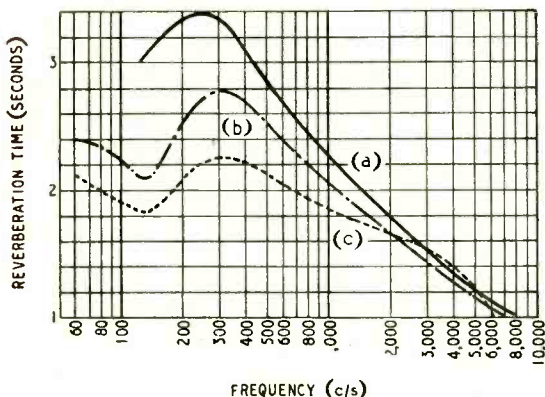

Fig. 1. Reverberation characteristics of Maida Vale No. 1 studio, (a) in original condition, (b) with organ and orchestral platform added, (c) with Cabot's quilt and extended wood block apron (1947).

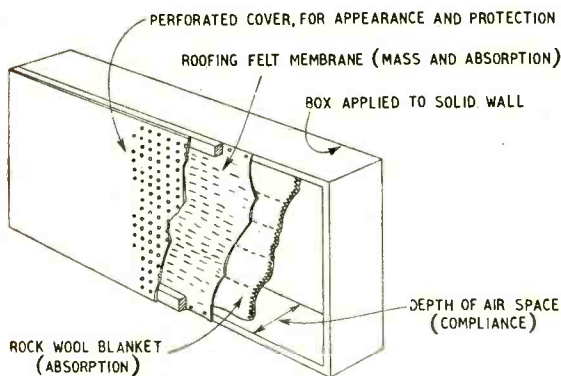

Fig. 2. Construction of membrane absorption units.

teristic shown in Fig. 1(b). The greater absorption at low frequencies reduced the boominess of the studio but there was little change at high frequencies. Although pleasing broadcasts could be obtained, the studio was never entirely satisfactory, and it was realized that improvements could be made. Consequently, after the war a treatment, using Cabot's quilt hanging loosely from the ceiling and on the rear wall, was introduced to improve the acoustics until a complete re-design could be undertaken. To increase the upper frequency response the walls were distempered and the wood block apron for the orchestra was extended, resulting in the curve of Fig. 1(c). The studio remained in this condition until the modernization which has been recently completed.

Since the end of the war the B.B.C. has been carrying out an intensive programme of research into the various problems of acoustics, and investigations have been carried out in broadcasting studios and concert halls on the Continent in addition to those in Britain. As a result of these investigations the conclusion has been reached that to obtain good "tone" and "definition" it is necessary to have efficient diffusion in a large concert hall or studio, so that the sound reaches the listener or the microphone by many diverse paths, instead of after only a few reflections. The opinion was also formed that the best tone was obtained in those halls in which a rectangular form of ornamentation, known in architectural circles as coffering, was employed. This opinion has been confirmed by experimental work.¹ It was further observed that good acoustic conditions for orchestra and audience seem to occur in those halls in which there is a choir or audience placed behind the orchestra.

In the light of these opinions it was therefore decided when re-treating the large concert studio to rebuild the orchestral platform to accommodate permanent absorbent choir seats behind the orchestra, and to use a rectangular form of ornamentation on the walls.

Membrane Absorbers

A rectangular form of ornamentation is convenient for another reason. One of the principal faults of this studio was its boominess, so that some form of bass absorption was necessary as part of the new treatment. The B.B.C. has been experimenting for some time with a type of absorber called a membrane absorber, which consists of a rectangular cavity sealed in front by a flexible membrane consisting of bituminous roofing material. A sketch of such a unit is shown in Fig. 2. It is essential that the membrane material should have high internal friction to provide resistance to motion and is responsible for most of the absorp-

¹ T. Somerville & F. L. Ward, "Investigation of Sound Diffusion in Rooms by Means of a Model." *Acustica*, Vol. 1, 1951, p. 40.

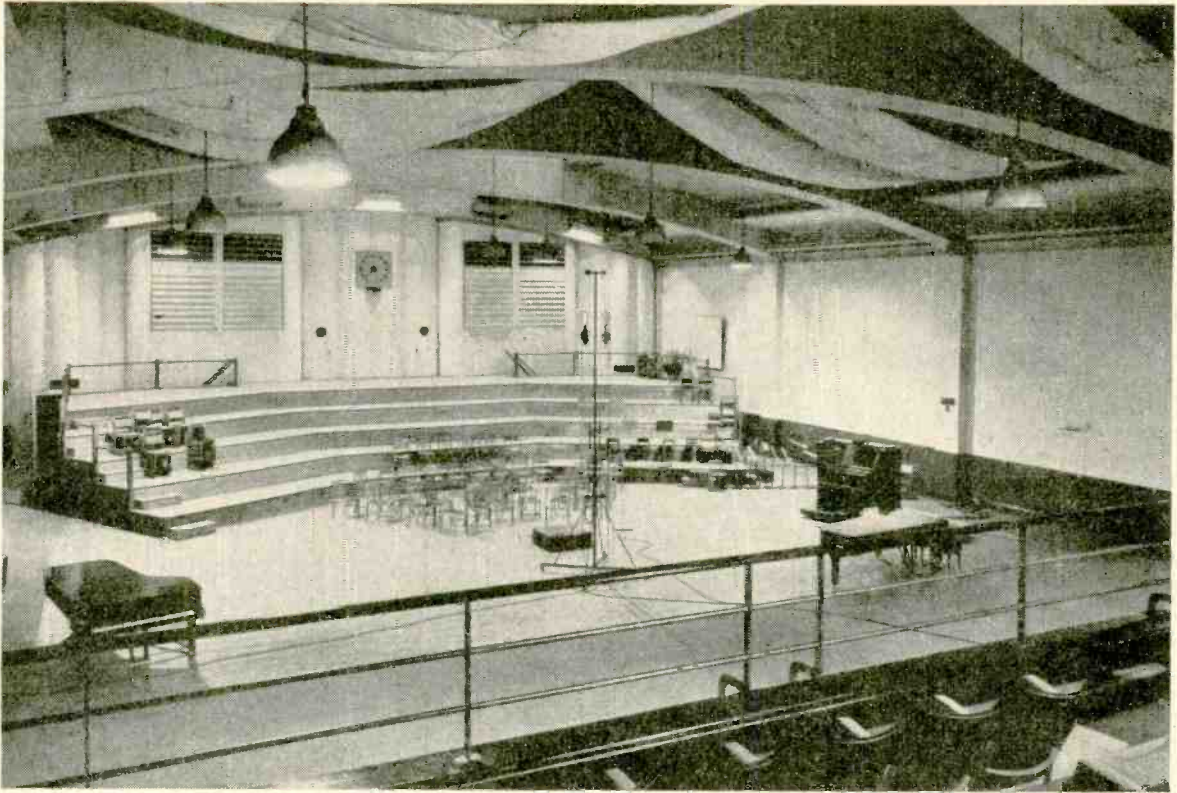

Maida Vale Studio No. 1 before re-treatment. Below : After acoustic re-treatment, showing orchestra platforms and choir seating.

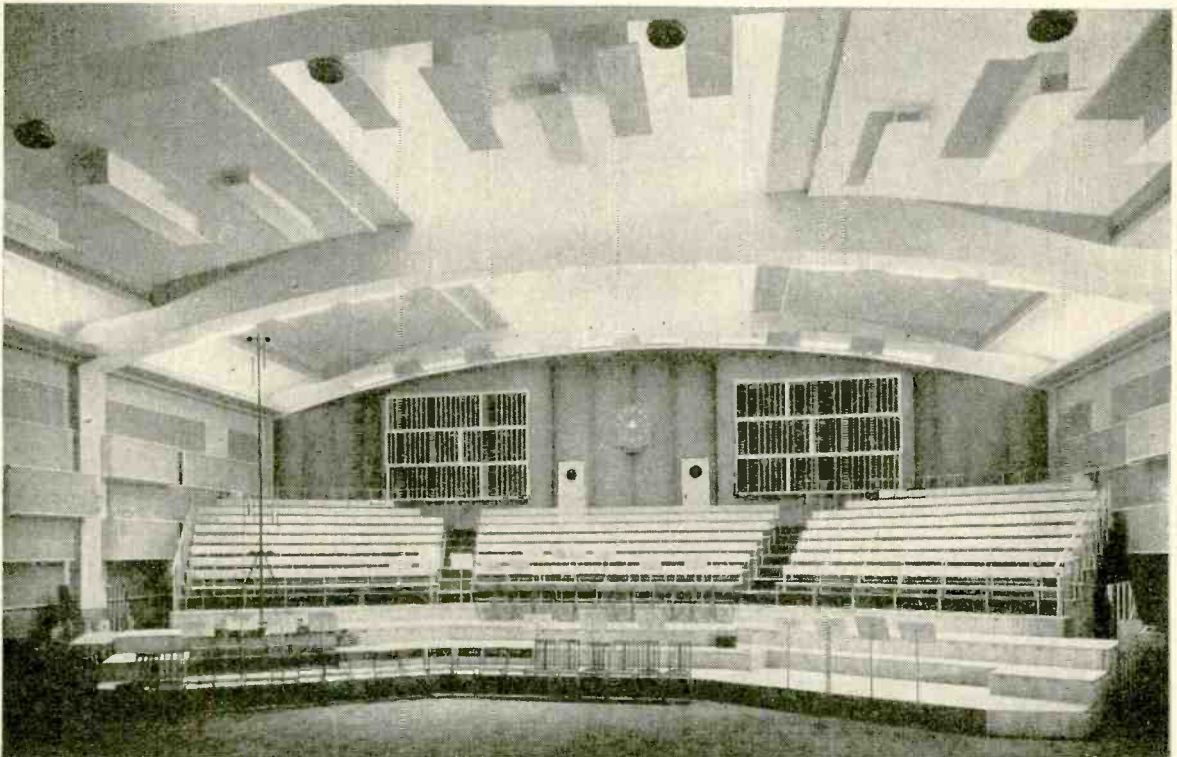

tion. The frequency of resonance, at which the greatest absorption occurs, is a function of the mass of the membrane, and the stiffness of the air which is inversely proportional to the depth of the box. The formula for these absorbers is

$$f_r = \frac{1}{2\pi} \sqrt{\frac{1}{MK_A}}$$

where f_r is the frequency of vibration, M is the mass per unit area of the membrane, and K_A is the compliance per unit area of the air space, acting on the equivalent piston.

It is essential to avoid transverse vibration of the air contained in the box, and the units are therefore divided by partitions so that the divisions are small compared with the wavelength. To flatten the resonance curve and increase the band over which the absorber is effective, a blanket can be placed in the cavity as shown in Fig. 2.

These absorbers are most conveniently made rectangular and can either be recessed into the walls or mounted as boxes on the surface. In the present case surface mounting of the absorbers seemed to be the obvious choice since it is easiest to carry out and provides the necessary diffusion.

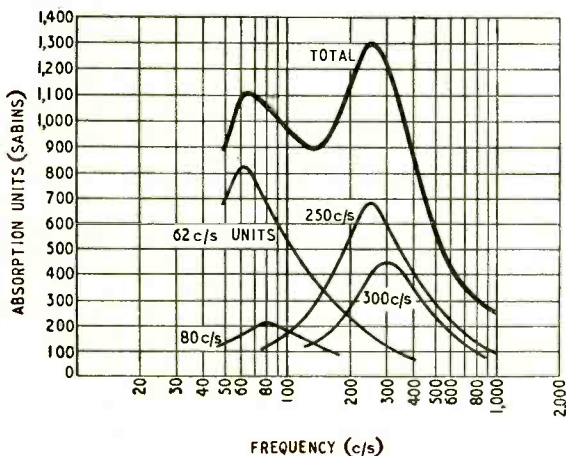

Fig. 3. Absorption curves of different groups of membrane units and total absorption curve for the range 50-1,000 c/s.

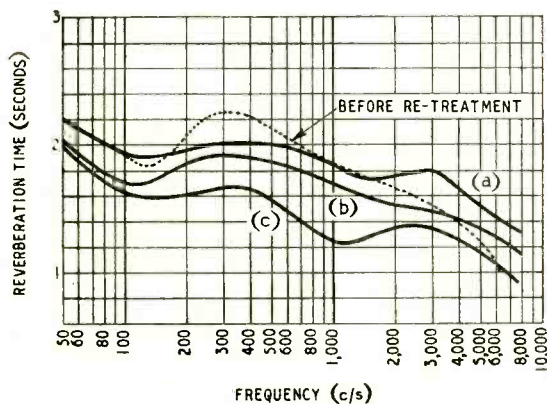

Fig. 4. Reverberation characteristics after re-treatment (a) empty, (b) with orchestra, (c) with orchestra and choir of about 200.

The first step in designing the new absorption treatment was to assess from the measured data, and from details given by laboratory measurements, what amount of absorption was provided by the existing surfaces of the studio and the hanging drapes of Cabot's quilt. Unfortunately, it is not always possible to rely on published figures of absorption coefficients, either because of differences in the mounting of materials, compared with the method used in the reverberation test chamber, or because no such data is available. This assessment showed that considerable extra absorption would be needed in the frequency range from 50 to 1,000 c/s, and that absorption should be reduced at frequencies above 1,000 c/s. Moreover, it would be necessary to grade the amount of absorption in order to smooth out the reverberation time curve into the desired shape. For example, considerably more absorption would be required at 60 c/s than at 125 c/s, and even more at 250 c/s.

Absorption Synthesis

It is possible, by selecting the frequency and total area of the membrane-type absorbers, to achieve any desired pattern of extra absorption, and at the same time the choice of these elements can be influenced by architectural considerations as to what arrangement would look pleasing when assembled in the studio. In this case four different resonant frequencies were chosen, namely, 62, 80, 250 and 300 c/s, and the amount of absorption provided by the different areas of these units is given in Fig. 3, together with the sum of the total absorption, which is seen to conform with the requirements outlined above.

At the same time it was desired or necessary to introduce other absorbent surfaces into the studio, and the extra absorption supplied by these had, of course, to be added to the totals. For example, it was decided to panel the whole of the dado, part of the rear wall and the sides of the orchestral rostrum with veneered wood panelling. Such panelling applied to battens over an air space in which is inserted a porous damping material (such as glass wool) provides a moderately efficient low-frequency absorbent of resonant type with a fairly wide frequency band. There is a theory (possibly fallacious) that wood enhances in some way the acoustical quality of an auditorium. However that may be, it is very practical and a satisfactory material aesthetically.

As already stated, it was also desired to add upholstered seating for the choir on the orchestral rostrum. This consists of long form-like seats with back rests upholstered with "Dunlopillo" padding. In order to ensure that the porous rubber padding could serve as a useful sound absorbent the covering chosen was a woven plastic fabric having a high degree of porosity. The material wears very well, is at the same time water-resistant, and can be easily cleaned by sponging.

The area of the wood block floor was increased, and the carpeted area correspondingly reduced both in order to lower the high-frequency absorption and to provide more space for orchestral players when unconventional layouts are required.

Special care was taken with the absorbent treatment of the rear wall above the balcony. This wall is sufficiently far from the normal microphone position to be liable to cause echo at the microphone. A double treatment was provided consisting of shallow depth (250 c/s) membrane units mounted on the wall, and in front of these a spaced-out treatment of 2in of rock wool covered by a perforated facing. This rock

Fig. 5. Pulsed gliding tone reverberation patterns of Maida Vale No. 1 Studio taken (a) before (Feb. 1951) and (b) after re-treatment (Oct. 1951). At these low frequencies the decay curves after re-treatment are steeper, smoother and have a more uniform average slope.

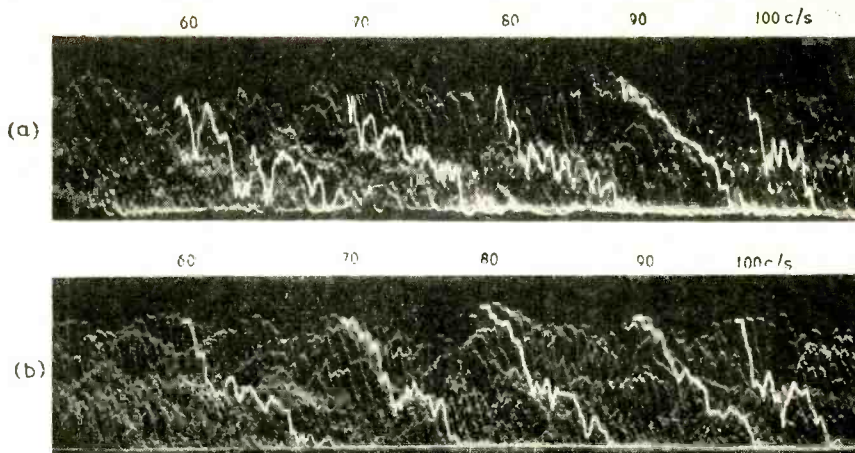

wool treatment is most efficient in the mid-frequency region and, owing to the low percentage perforation of the facing, the efficiency falls off fairly rapidly above 1,000 c/s. This is done to avoid lowering the reverberation time at these high frequencies, but the danger remained that some high-frequency reflections might be sent back to the microphone. The treatment was therefore mounted in a saw-tooth manner so that any reflections would be of a scattered nature.

Although the ceiling profile consists of flat planes these are set out approximately in the form of an arc, and it had been noted that some unwanted focusing of sounds resulted from this. Large projecting boxlike devices of varying sizes were, therefore, attached to the ceiling in a decorative pattern in order to break up any reflections from the ceiling.

Appearance

The membrane units are applied to the side walls of the studio in rows so that the horizontal lines are emphasized. This was done in order to break up the vertical lines caused by the roof-supporting piers which originally had the effect of making the orchestra appear very remote when seen from the gallery. At the same time the various amounts of projection of the units were mingled together to provide a maximum number of angle reflectors, thereby greatly increasing the diffusion.

The front part of the orchestral rostrum is constructed on a concrete slab over which is applied wood boarding with hardwood ply finish. In order to allow the wood to resonate—a requirement for such instruments as cellos and double basses where sound energy is believed to excite the floor through the spike of the instrument—a layer of corrugated cardboard was interposed between the boards and the concrete. The primary object of having a concrete foundation is to prevent reinforcement of heavy bass notes by boominess when, for example, tympani are sited on the rostrum. In order to ensure compact orchestral layouts, an important requirement both for concerted playing and best acoustical effect, the risers were reduced in width and the waste of space normally occasioned by the music stand bases was avoided by employing specially designed music stands which can be dropped into any of a large number of sockets mounted on the front of the risers. The back part of the rostrum for the choir is constructed on a tubular steel scaffolding frame, and the dimensions are arranged so that the chorus is as compact as possible consistent with rea-

sonable comfort. The seating, which is undivided by arm rests to allow flexibility in layout, will accommodate choruses of up to 300. On the rare occasions when even larger choirs are used, extra seating can be installed at the rear of the rostrum or on portable rostra.

The results of recent reverberation measurements are shown in Fig. 4. It will be seen that the curves are now reasonably level and a marked improvement on the previous condition.

A new technique, already described,^{2,3} has also been used to compare the old and new conditions. This new method consists of radiating pulses of tone of slowly rising frequency into the studio, rectifying logarithmically the output from a microphone, and displaying it on a cathode-ray oscilloscope. Only the decay is shown on the oscilloscope. A series of reverberation curves is, therefore, obtained and photographed on a slowly moving film, giving the result shown in Fig. 5.

If these displays are carefully examined it will be observed that the decays in the modified condition are smoother than before. Furthermore, the long reverberation in the region below 100 c/s in the original condition no longer exists.

Aural Assessments

The measurements indicate a considerable improvement in the acoustics of the studio and this has been confirmed by its use in service. Considering the difficulties of acoustic design, criticisms have been surprisingly few. Most performers and conductors have considered it to be excellent, and the audiences who have heard it have also given it praise. The old boominess has disappeared. The low frequencies are now very clean, probably due to the type of bass absorption employed. Most musicians have been surprised at the "brightness," compared with the majority of concert halls, and the performers in an orchestra can hear each other well. In loud passages there is very little confusion, and even the wood-wind instruments succeed in making themselves heard. The broadcast results are very good because the studio has a clarity and spaciousness usually associated only with the best concert halls.

² T. Somerville. "Acoustics in Broadcasting." *Proceedings of the Building Research Congress*, 1951, Division 3, Part I, p. 53.

³ "Studio Acoustics—New Technique of Measurement used by the B.B.C." *Wireless World*, October, 1951, p. 435.

1400-Mc/s RADIOPHONE

Novel Application for Master and Slave System of Frequency Control

By J. B. LOVELL FOOT,* A.M.I.E.E.

APART from their suitability for multi-channel wide-band systems, decimetre waves confer some benefits for simple point-to-point communication over an optical path. For example, as compared with the longer wavelengths, they allow the use of a reflector of simple construction and less than 2 ft in any dimension to beam the transmission. This reflector can be inexpensive and requires only a light mast for its support. The narrower beaming that is possible on the shorter wavelengths has several obvious advantages; for example, the equipment is less likely to pick up interference or to produce interference with other services. A higher degree of privacy is also obtained. Further, the r.f. power of the transmitter can be very small owing to the higher aerial gain obtainable.

The decimetre-wave system to be described is designed around the DET23 disc-seal triode valve which is operated to give an output of about 1 watt. This gives a range of up to 30 miles between suitable sites with a signal-to-noise ratio of about 20 db. Normally the frequency drift of a triode oscillator necessitates the use of either a wide-band receiver with a correspondingly poor signal-to-noise ratio, or a complicated system of frequency control of the local oscillators for both the transmitter and the receiver at both ends of the system. Direct crystal control of frequency is out of the question for a simple equipment, since it would be necessary either to pick out a high-order harmonic from the crystal oscillator and

amplify it at very high frequency, or to use a large number of multiplier stages keeping a high level throughout the chain. Both techniques present serious difficulties.

The system adopted to provide an experimental link employs a "master and slave" principle. Two single decimetre-wave oscillators are employed, one at each end of the link. These were designed to give a good frequency stability by a rigid construction and light loading. The oscillator at the "slave" terminal is controlled in frequency by signals received from the "master" so as to keep the frequency difference between the two stations constant. In addition to providing the carrier, these oscillators also supply the voltage necessary for frequency conversion to the first i.f. in a double superheterodyne receiver.

The system imposes several important limitations:—(a) The frequency stability of the whole system is entirely dependent on the stability of one uncontrolled oscillator. (b) The frequency of the "go" and "return" carriers must have a difference equal to the first i.f. of the receivers. (c) Modulation at either terminal produces an audio signal in both receivers.

As an illustration of the first limitation (a), Fig. 1 shows a typical curve of frequency variations of the master oscillator over a period of 24 hours. The slow drift that takes place during warming up shows that the thermal capacity of the oscillator block is large. This has the effect of flattening out variations due to rapid changes of ambient temperature and, if the initial warming-up period is disregarded, a good stability is obtainable.

Limitations (b) and (c) may be regarded as advantages for certain applications. In the case of the former, since the transmitter and receiver local oscil-

* G.E.C. Research Laboratories, Wembley.

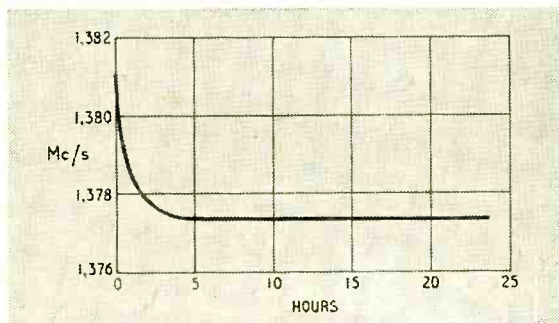
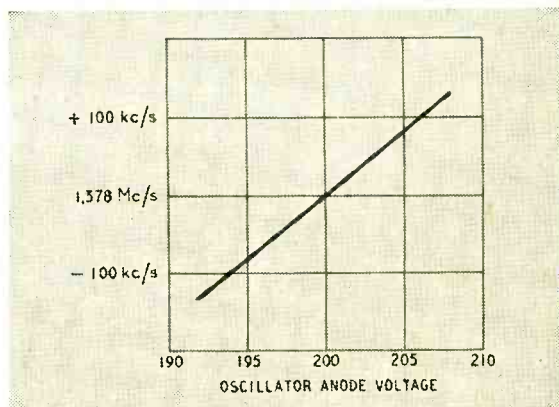

Fig. 1. Graph showing the variation of oscillator frequency over a period of 24 hours

(Right) Fig. 2. Graph showing the variation of oscillator frequency with change of anode voltage



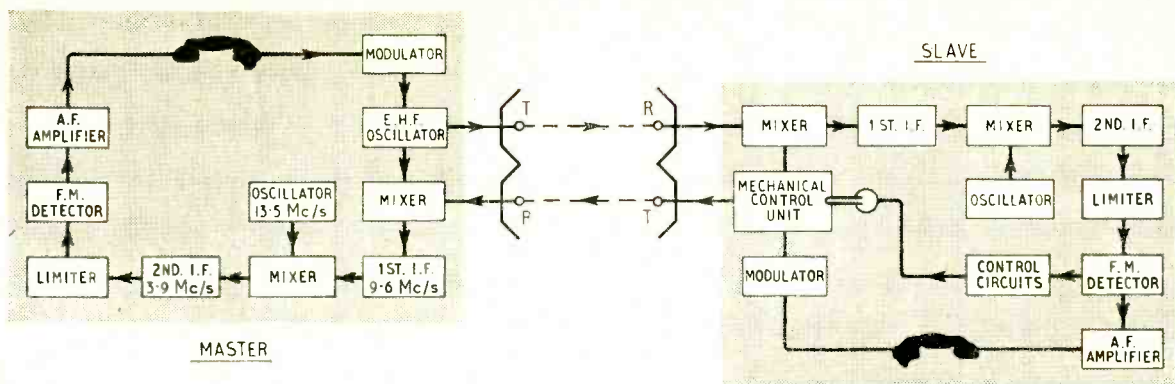

Fig. 3. Block diagram showing the arrangement of the master and slave stations

lator functions are performed by one oscillator, it becomes unnecessary for the aerials to be elaborately shielded to prevent the local transmitter from blocking the receiver. The only precaution required is to prevent excessive current in the crystal employed as first mixer of the receiver.

As for (c) the reception of the modulation of the local transmitter provides side-tone and also proves that the distant transmitter carrier is being received, thus giving a check on both "go" and "return" radio signals. In cases where side-tone is undesirable, however, it can be balanced out by a special circuit combining the audio in the modulator with the audio from the receiver.

Method of Modulation.—When the anode voltage of a free-running oscillator is varied, an amplitude modulation and also a frequency modulation of the r.f. output is obtained. The latter is due to changes of the capacitance of the valve with changing space current. For a lower frequency oscillator, where the valve provides only a part of the capacity tuning the circuit, a considerable change of anode voltage would be needed to provide sufficient frequency deviation for an f.m. system. Since there are better ways of obtaining this frequency deviation without the disadvantages of simultaneously producing amplitude modulation the method is not normally used. In a decimetre-wave system, the case is different; a reactance modulator is very difficult to apply to the oscillator. On the other hand, because the capacitance tuning the circuit consists mainly of valve capacitance, sufficient deviation can be obtained by variation of the h.t. voltage without introducing a very large amplitude modulation. Fig. 2 shows the variation of frequency obtainable with change of anode voltage at these frequencies. A deviation of ± 100 kc/s was chosen as the condition for full modulation and the receiver was designed accordingly. Amplitude modulation is eliminated at the receiving end by the use of limiters.

A block diagram of the complete system is given in Fig. 3. Two aerials constructed with corner-type reflectors forming one unit are employed at each terminal. These are connected by concentric cables to an oscillator of the tuned-grid tuned-cathode type and the receiver respectively. The master station receiver on the left of the diagram comprises a chain of stages normally employed in a double superheterodyne.

The first mixer is a silicon crystal which is mounted in a cavity attached to the oscillator block, as shown in Fig. 4 and this is followed by an i.f. amplifier of 9.6 Mc/s. The i.f. is then changed to 3.9 Mc/s by mixing with the output from a 13.5-Mc/s oscillator. This second frequency change simplifies the amplifier as regards shielding, since the use of a high-gain amplifier, having the same frequency throughout, is avoided. The frequency stability requirement of the second oscillator does not call for any special precautions. The 3.9-Mc/s i.f. amplifier is followed by a limiter and an f.m. detector. Finally a single-stage a.f. amplifier feeds the hand-telephone set.

In the transmitting chain, the hand-set microphone output is applied to the input of the modulator. This consists of a double-triode valve, one half of which operates as an amplifier and the other half as a cathode follower. The cathode follower is suitably matched to modulate the anode voltage of the deci-

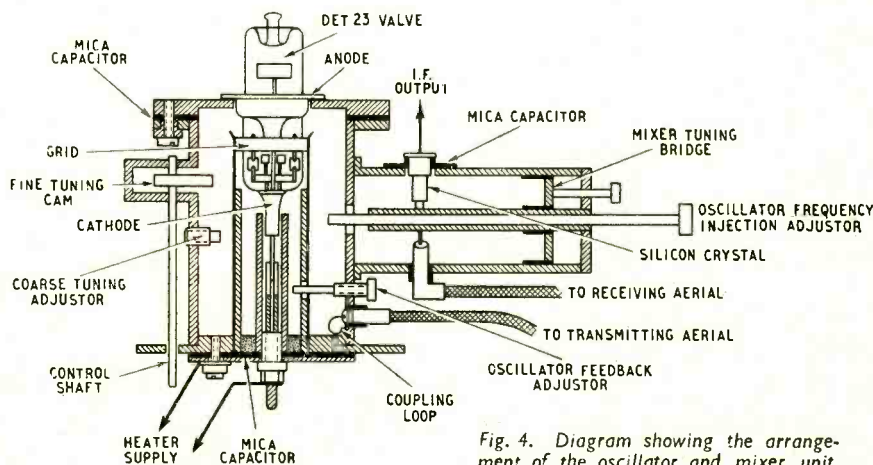

Fig. 4. Diagram showing the arrangement of the oscillator and mixer unit.

metre-wave oscillator without the use of a modulation transformer.

The Frequency Control System.—The "slave" station on the right of the block diagram (Fig. 3) follows the same arrangement as the "master" station, but has the addition of a frequency control circuit shown in greater detail in Fig. 5. Use is made of the d.c. component derived from the f.m. detector of the receiver. When the local oscillator frequency is accurately tuned to produce the correct intermediate frequency after combining with the incoming signal, the detector is balanced and the d.c. potentials produced by the detector diodes at points A and B (Fig. 5) are equal. If, however, the local oscillator

frequency is too high, or too low, the potentials at these points will change in a push-pull manner, the polarity depending on whether the mean intermediate frequency produced is too high or too low, and the voltage depending on the extent of the "error."

The following electro-mechanical method interprets these voltage changes into a rotation of a tuning control on the "slave" oscillator in the direction to correct the frequency. Two independent RC oscillators V_1 and V_2 (Fig. 5) of stable design and similar characteristics operate at a frequency of 56 c/s. Each drives an amplifier which supplies power to a slow-running, clock-type synchronous motor. One of the resistance elements in the feedback circuit of each oscillator is replaced by a valve (V_3 or V_4) whose resistance is controlled by the d.c. voltage produced at the detector. At the balance point V_1 and V_2 are adjusted to have exactly the same frequency, but if the balance is upset owing to a change of frequency of the master oscillator, one 56-c/s oscillator increases in frequency and the other decreases in frequency, resulting in a difference between the speeds of the two motors. This difference in speed is transmitted, via a reduction gear, to a shaft on the slave oscillator unit. The shaft carries a frequency controlling cam which rotates until the correct intermediate frequency has been restored. The tuning cam is made of a low-loss insulating material and avoids interference due to intermittent metallic contacts. It is so mounted in the cavity of the oscillator unit as to affect the capacity distribution and produce a nearly linear frequency change of 10 Mc/s for 180 deg rotation. The master oscillator is of similar construction but here the cam is arranged to provide a manual adjustment of the frequency and is controlled from the front panel.

If, for any reason, the slave oscillator frequency lies outside the output range of the f.m. detector; for example when the sets are first switched on, a frequency search is brought into operation in the following manner. The valve V_5 (Fig. 5) in parallel with the feedback resistance R is normally biased beyond cut-off by a potential developed by the limiter when a signal is being received. In this condition, the frequency of V_1 is unaffected. If, however, the signal is removed, V_5 assumes a conducting state, reducing the resistance across R, and causing the frequency of V_1 to change. Continual rotation of the tuning cam then takes place until the signal is again picked up and V_5 is restored to its normal condition. It will be seen that, for one revolution of the tuning cam, the slave oscillator frequency will rise to a maximum and then fall to a minimum. Owing to the reversal in the direction of this frequency change, there would normally be a reversal in the direction in which the frequency correction is applied for each 180 deg rotation of the cam. This difficulty was overcome by reversing the polarity of the d.c. input from the detector to the control circuit in step with the reversal of frequency change. This is carried out by the contacts S_1 and S_2 of the relay S/2. A contact, X, fitted to the cam shaft and arranged to open and close for each half revolution, controls the current to the relay, this ensures that the correct direction of control is always applied.

Aerials.—One of the illustrations shows an aerial unit. This consists of two centre-fed half-wave dipoles, each placed in a corner reflector made of sheet aluminium and measuring 20 in \times 10 in across the opening. The transmitting and receiving pair are alike and are mounted side by side in a "W"

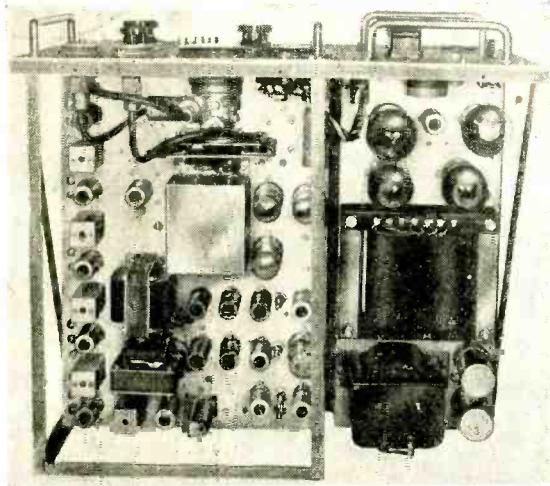

Internal view of slave equipment, showing on left-hand chassis oscillator unit and gear box. Power unit on right

Receiving and transmitting aerials are arranged as a single unit giving vertical polarization

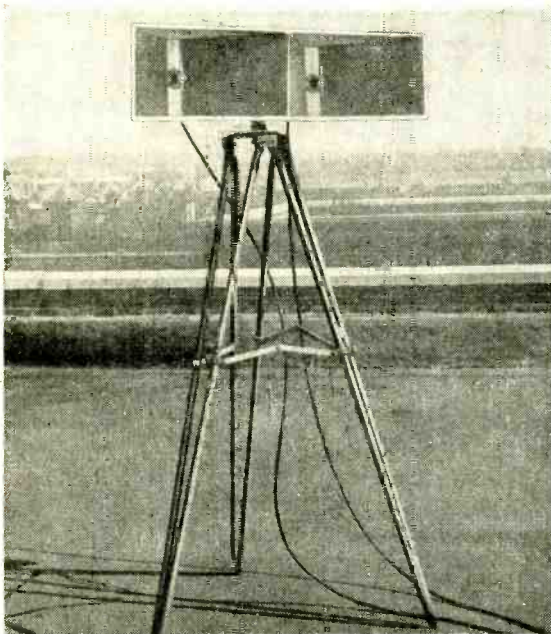
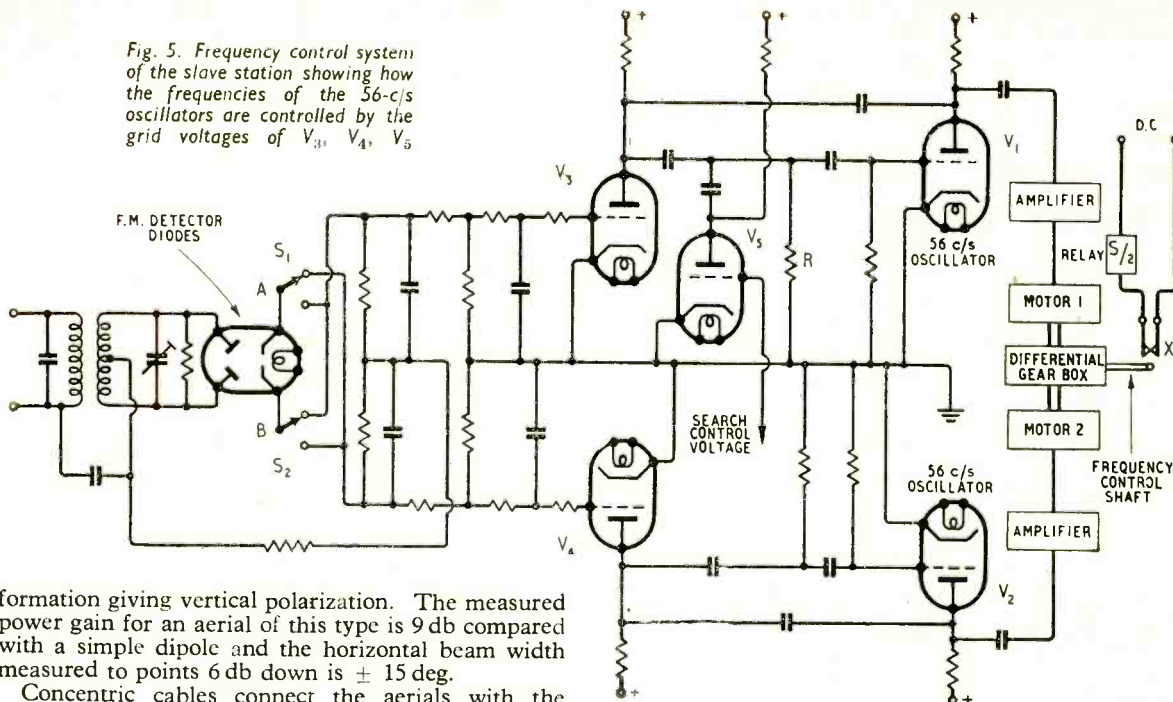

Fig. 5. Frequency control system of the slave station showing how the frequencies of the 56-c/s oscillators are controlled by the grid voltages of V_3 , V_4 , V_5



formation giving vertical polarization. The measured power gain for an aerial of this type is 9 db compared with a simple dipole and the horizontal beam width measured to points 6 db down is ± 15 deg.

Concentric cables connect the aerials with the equipment. Since most concentric cables have a high loss at the frequencies used in this equipment, (for a typical $\frac{1}{2}$ -in diameter polythene cable it is 0.4 db per yard) it is important to situate the equipment as near as possible to the aerial. By careful adjustment of the aerial length a standing-wave ratio of better than 1.2 was obtained. This adjustment was carried out using a line of variable length between the oscillator and the aerial, measuring the aerial output at a fixed point a few yards away. The aerial was then adjusted so that the least variation in power occurred for a change of a quarter of a wavelength in the length of the cable.

The Power Supply.—A stable oscillator frequency is obtainable only if the h.t. voltage supply is also stable. To achieve this the output voltage of the a.c. supply unit included in the equipment is held in a fixed relationship with a voltage developed across a neon stabilizer by the use of an amplifier controlling the resistance of a pair of series-connected tetrodes. This arrangement not only provides a d.c. potential almost independent of change of a.c. input voltage over a wide range, but makes also the effective internal resistance of the power supply very low. This is important in order to avoid frequency pulling between the two 56-c/s oscillators. Experiments showed that the heater voltage stability was less important than the h.t. stability and no special precautions were taken.

Purpose of the Equipment.—The equipment was constructed as part of an experimental project to test the potentialities of such a simple system and to obtain information on the propagation of e.h.f. radio waves under special conditions. One example of its special uses has been in tests made on transmission through railway tunnels.¹

Further tests were carried out over several point-to-point optical paths. The greatest range tried was between Hanger Hill, Middlesex and Woodcote Hill,

near Reading, a distance of nearly 34 miles. Over this path communication was satisfactory, but the frequency control was operating at the limit of reliable locking. For shorter ranges the control operates well and is particularly free from overshoot and the generation of noises common to many mechanical control systems.

GRAMOPHONE MOTORS

Recent Trends in Design and Manufacture

SOME insight into precision engineering processes involved in the production of domestic gramophone motors and record changers was given by E. Mortimer (Garrard Engineering Co.) in opening the discussion at the January meeting of the British Recording Association.

Nowadays the governor-controlled motor has given place, except for special applications, to the constant speed induction motor, with a friction drive to the rim of the turntable. This lends itself to the design of simple change-speed mechanisms with interchangeable friction wheels for 78, 45 or $33\frac{1}{3}$ r.p.m. Although simple in principle, careful design and manufacture are necessary to ensure steady running in this type of mechanism. A heavy turntable is ruled out in the interest of the life of the friction surfaces, and the motor is run in the saturated condition with constant slip at 1,340 r.p.m. up to a torque of 25gm-cm. A shaded four-pole stator is used and laminations for both stator and rotor are cut simultaneously and kept together to allow for variations in the composition of the raw material.

Turntable spindles are form-ground in one operation on special machines to ensure concentricity of the different diameters and tapers. Rotor spindles

¹ *Wireless World*, December, 1950, pp. 456-458.

are lapped as well as ground since surface finish, as well as clearance, is a vital factor in smooth running. Particular care is paid to the thrust bearing of the main spindle which is usually the primary source of low-frequency "rumble."

All rotors are electro-dynamically balanced before assembly, and the complete unit is given a 6-hour over-voltage test at 270V, followed immediately, while hot, by an insulation test. Speed and torque are checked stroboscopically with an air-brake load. A final listening test on the electrical output from the pickup is made for "wow," "flutter" or "rumble."

In the discussion which followed there was general agreement that any improvement upon the performance of the mass-produced motor would inevitably involve a substantial increase of cost. To the many speakers who asked for a unit intermediate in quality and price between the domestic types and "professional" models costing £20 or more. Mr. Mortimer explained that designs had been developed, but that at the present time all available materials were needed to supply the overseas demand for British domestic gramophone motors which found a ready sale in the face of strong foreign competition.

"SPORADIC E" CLOUDS

Abnormal Propagation Due to Patches of Intense Ionization

By D. W. HEIGHTMAN, M. Brit.I.R.E.

SINCE the end of the late war and the resumption of amateur radio activities, a great deal of interest has been aroused by the abnormal behaviour at times of v.h.f. signals due to sporadic E propagation. Radio amateurs in many parts of the world have experienced these phenomenal conditions which have been encountered on the 6-, 5- and 2-metre wavebands.

For several years now I have kept careful observation on the E layer's characteristics, including the drift of the patches, or clouds, of abnormally dense ionization over Europe and which were mentioned in a recent article in *Wireless World*.^{*} Some of this work is referred to in my paper "Propagation of Metric Waves Beyond Optical Range" published in the October, 1950, *Journal of the British Institution of Radio Engineers*.

For these observations reliance was placed on signals from various known stations in Europe, reflected at oblique incidence, in the 30- to 60-Mc/s band. It was assumed that the point of reflection was mid-way (as has been done in the large-scale American amateur tests controlled by O. P. Ferrell).

Some of these results have yet to be analysed but in general the conclusions have been similar to those resulting from the American tests. Speeds of drift of "clouds" can vary over wide limits as can the direction of motion and area of clouds—so much so that at present it is not possible to see any regular behaviour of the phenomenon.

Ionosphere sounding stations may be too widely separated to allow accurate tracking of the E clouds. The intense centres often appear to be only a mile or so across, particularly at the commencement, thereafter spreading over a wider area, but with reduced density.

Some tests carried out with a Belgian amateur in 1949 indicated that these E clouds were the source of (or diverted) a noise radiation, similar to solar radiation (reception was in the 100-Mc/s region). This gave the interesting possibility of using beam aerials to track the source, though here complication by direct pickup from the sun would at times result.

As will be seen from my paper, I obtained good

correlation between times of occurrence (on a local time basis) provided fairly wide areas were considered.

I am inclined to think of these clouds as being due to two or more variables, which would account for their random and largely unpredictable nature:— (1) a condition of the upper atmosphere which may be related to upper weather. (2) solar radiation (temperature zone type "E").

There seems in another case to be some connection between weather and ionosphere conditions, inasmuch as fast moving depressions (and severe gales) have frequently been observed to follow ionosphere storms by a day or two.

My observations show that higher frequencies were reflected at the last sunspot maximum, as would be expected, but that the actual number of occurrences on the lower frequencies is not necessarily less at the sunspot maximum.

Further useful information on the subject generally could be contributed by systematic observations on a fairly large scale by radio amateurs. Unfortunately in this country we do not have a Government-sponsored scheme for collection and analysis of the reports as in the U.S.A.

Siting Direction-Finding Stations

MODERN radio direction finders are capable of extremely high precision and in most cases the accuracy of the bearings is limited only by the imperfections of the station site. There is much valuable information available on the effects of buildings, railways, trees and other topographical features, but it is widely scattered throughout the literature.

Radio Research Special Report No. 22, "The Siting of Direction Finding Stations" presents the available information on the subject in a single publication. The types of direction finders dealt with are mainly those with loop or Adcock aerials covering frequencies of from 100 kc/s to 300 Mc/s. The report is published by Her Majesty's Stationery Office for the Department of Scientific and Industrial Research and the price is 1s 6d (1s 7½d by post).

^{*} "Propagation of V.H.F. via Sporadic E" by T. W. Bennington. *Wireless World*, January 1952, pp. 5-9.

Physiological Feedbacks

A Radio Man's Introduction to Cybernetics

By T. E. IVALL

THE animal brain and nervous system would never be able to control the body as precisely as they do if they simply relied on sending "blind" instructions to the muscles. What actually happens can be seen from Fig. 1. The brain knows what it wants done (desired result) and begins to send the appropriate control signals. While the muscles are performing, their progress is continually being reported back to the brain (muscle feedbacks) and compared with the desired result; then, according to the amount of discrepancy, the brain operates them so that the actual result approaches the desired result until finally the discrepancy is reduced to zero. In picking up a pencil, for example, the muscular action of the arm and fingers is regulated by a continual feedback of information on the amount by which the pencil is "not yet picked up," so to speak.

All this may look very complicated, but those who read the article on servo-mechanisms in the January issue will realize that it is, in fact, nothing more than

a description of servo operation. Others, seeing Fig. 1, will probably infer negative feedback, which, of course (as Mr. Taylor pointed out), is virtually the same thing. All the mechanisms of the animal body are controlled on this principal and the negative feedback loops are provided by the circuitry of the nervous system. The natural function of these "servo systems" is to give stable operation and make the body adaptable to changes in the outside world—just as negative feedback stabilizes an amplifier against "environmental" changes in load, supply voltage, and so on. Without them we should not last for very long. The feedbacks which control the muscles of the limbs are necessary for mechanical stability in getting about the world, for avoiding danger and so on, but there are also comparatively slow-acting ones which do things like maintaining the body temperature against cold and adjusting the aperture of the eye pupils according to light intensity. On some we exercise voluntary control (picking up the pencil for example), while others are purely automatic and we are not conscious of them till they go wrong. A good many of the feedback loops are contained entirely within the body, but some are completed through the outside world *via* the sense organs; for example, when the eyes are brought into play to feed back "error-information" on what the hands are doing (the visual feedback loop in Fig. 1). Animals with these obviously have a great advantage over others. There are also loops which regulate the processes of the brain itself, feeding back from each stage to the previous one.

Sir Charles Sherrington began to make a really systematic study of physiological feedbacks as long

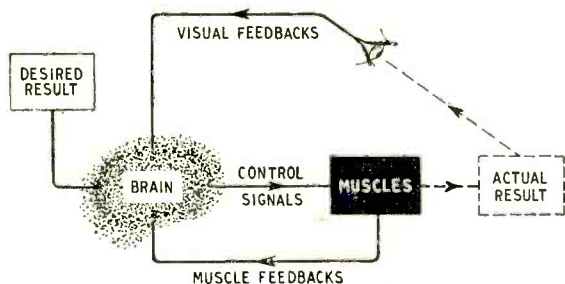
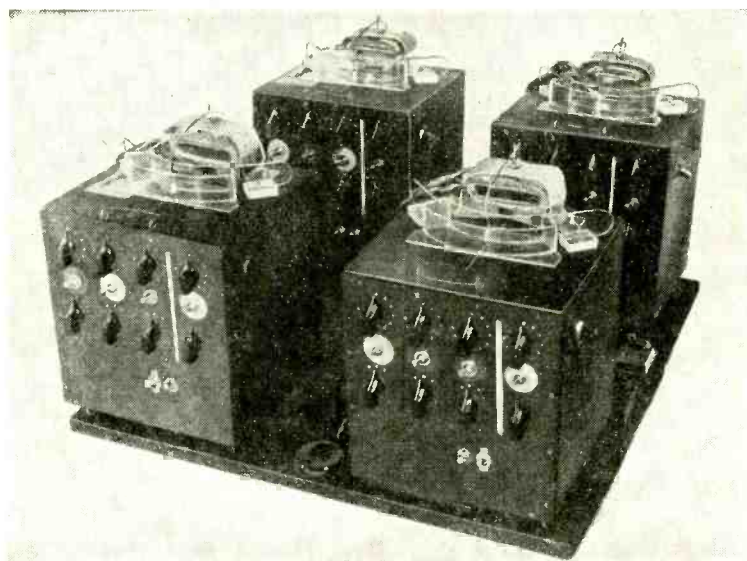

Fig. 1. Simplified block schematic showing how negative feedbacks in the nervous system are arranged for giving a self-stabilizing control action.

Right: Behaviour of interacting feedbacks in the brain is simulated by this machine—the "homeostat"—designed by W. R. Ashby. On top of the units are swinging magnets whose movements affect each other and produce complex patterns of behaviour. Each magnet is swung by magnetic fields from four coils energized by the outputs of the four units; the movements are converted into corresponding electrical variations by a liquid potentiometer and these are amplified to drive the coils. Stability is attained when all four magnets are central. The machine adapts itself to any "environment" (i.e. arbitrary hand settings) by automatically altering its own wiring until it finds an arrangement of feedbacks that produces this stable condition.



ago as 1893, but it is only recently that servo and feedback technique has developed into a complete subject of its own and provided the physiologist with a set of cut-and-dried theories and concepts. By thinking about the animal mechanisms in this engineering language he is now greatly improving his understanding of them. Likewise, the engineer is learning a lot by studying natural systems, particularly in the vast communications network of the nervous system. Neurophysiology and communications engineering, in fact, are becoming part of each other.

This idea of the biological and engineering sciences drawing analogies from each other is not by any means new, and in the past has been responsible for some of the greatest scientific achievements. In the days when engineering was concerned only with purely mechanical devices, the analogies were necessarily restricted to the mechanical systems of the body. William Harvey discovered the circulation of the blood, for example, because he was interested in the work on air-pumps that was being done at the time. Now, in what is perhaps the heyday of electronics and communications engineering, the analogies are all electrical. A new kind of machine has arisen, often having no moving parts, but nevertheless approaching much nearer to the animal machine in complexity. We have pick-up devices like microphones, photocells, thermistors, with obvious counterparts in the animal sense organs, and actuating devices like motors and solenoids comparable with the electrically operated muscles. Circuitry and communication channels clearly serve the same purpose as the nervous system—transmission of information—while automatic telephone exchanges and computers are, in a sense, “brains.” Moreover, the behaviour of some of the electronic homing devices used in air navigation can be remarkably like instinctive animal behaviour.

All these analogies—many of which are really homologies because of the electrical properties of the animal body—have prepared the ground very effectively for the modern ideas which revolve around the central theme of feedback. What might be described as the bible of this modern movement is the book “Cybernetics” by Norbert Wiener, an American mathematician. Wiener uses this strange word cybernetics, an Anglicized version of the French *cybernétique*,* as a name for the general field given

by his sub-title as “control and communication in the animal and the machine.” The subject links control and communication engineering together into a common mode of thought that can be applied to any organized system—man-made machine, animal or human physiology, society in general. Modern Information Theory puts the “communication” side on a quantitative basis, while servo and feedback theory does the same for the “control” side. Many different fields are touched upon in the book, but the thread linking them all together is this idea of communication of information for the production of a self-stabilizing control action.

Nerve Communications

Now what about the circuitry of these feedback loops? How exactly does the nervous system transmit its information? The nervous system is a vast network of interconnected nerve cells spreading to all parts of the body, and it conveys the control signals as electrical impulses. Large groups of the nerve cells are massed inside the spinal chord, and there is a particularly large conglomeration in a bulb at the top of it—that is, the brain. External stimuli cause the sense organs to generate signals which travel inwards to the brain, and the brain uses this input of information about the outside world for deciding the appropriate control signals to send out to the muscles.

A single nerve cell, or one link in the feedback chain, looks something like Fig. 2. At one end (the input) there are some pick-up “roots” called dendrites, while the other end (the output) tails off into a long fibre. Anything up to a thousand output fibres of other cells connect on to the receiving dendrites. The cell is electrically polarized, with the outside maintained at about 0.1V positive with respect to the inside. In response to a certain patterned sequence of impulses from the other cells, the cell is triggered and fires a new impulse. This is transmitted down the length of the fibre as a kind of “travelling discharge” of the polarizing voltage, with a speed of anything between 1 and 150 yards per second. After the discharge has passed, each part of the broken cell wall automatically repairs itself, but it takes a certain amount of time to do so and this sets a limit to the number of impulses that can be transmitted per second; the cell does, in fact, cut off like a filter, at a repetition frequency somewhere in the region of 500-1,000 pulses per sec. The impulses are of more or less constant amplitude and it is their repetition frequency which indicates the strength of a signal (see Fig. 3), the system being something in the nature of a combination of p.c.m. and p.p.m. Like ordinary f.m., this has a great advantage in the presence of noise. Moreover, at every nerve cell the pulses are regenerated—as in a pulse-code telephony repeater—so that their sharpness is preserved no matter how long the transmission circuit.

Broadly speaking, then, the nerve cell is a kind of relay device, though its action is much more complex. As such it can be compared with a relay in any kind of communications system, but there is one system in which the comparison is particularly significant—that of the modern digital computer. Why? Because it immediately suggests a parallel between the com-

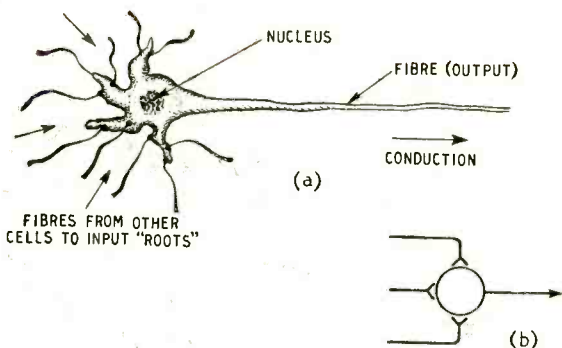

Fig. 2. (a) Sketch of a nerve cell, with inputs from other cells. The biggest nerve cells have a bulb diameter of about 0.002in, dendrites 0.1in long, and a fibre 0.0001in thick and 6ft long. (b) Type of graphical symbol used by physiologists to represent a nerve cell.

* Coined by Ampere to mean “the science of government” and derived from the Greek *κυβερνήτης* meaning “steersman.”

plex circuitry of relays in the computer and the mass of interconnected nerve cells constituting the brain. It suggests, in fact, that the brain calculates its outgoing control signals from the incoming "monitoring" signals by a process akin to digital computing. But how far is this true?

Digital computers use relays (electromagnetic or electronic) because they are robust and uncritical in operation. Although they have only two electrical states, open and closed, on and off, and consequently have to work on a scale of two (binary code) instead of the more familiar decimal scale, this is an advantage because there are no doubtful intermediate states to introduce error. These relays are arranged as a network of "gates," which determine the path through the computer of digit pulses from a central generator. Each relay makes a logical decision consisting of a simple choice between two alternatives: it either says "yes" and allows a pulse through, or "no" and stops it.

Obviously there is a certain similarity between the "yes-no" action of these relays and the action of the nerve cell, which also has only two states—pulse and no-pulse. Moreover, some of the computer "gates" are coincidence devices (Fig. 4 for example), and only open when triggered by a certain pattern of impulses from several inputs—again the same kind of behaviour as the nerve cell. Although the nerve cell is triggered by a time-sequential pattern, as distinct from the simultaneous pattern in Fig. 4, the logical operation is the same. (Note that the respective graphical symbols (Figs. 2 and 4) are similar, too.) It is possible, in fact, to analyse a network of nerve cells by logical algebra just as straightforwardly as a computer network. Thus it can be shown by physical examination that the network of cells in the brain has the right equipment for doing logical operations—and, of course, we know for a fact that the brain can think logically.

Storage and Timing

There are two other rather interesting points of resemblance in this brain-computer analogy. The first is the memory, or storage of information. One system of storing digit pulses in the computer is to keep them circulating in an ultrasonic delay line, regenerating them every time round to preserve their amplitude and shape—just as a juggler "stores" more balls than he can actually hold by keeping them circulating in the air. The fact that storage can be achieved in this way by an electronic device has prompted neurophysiologists to think in similar terms about the brain, and they are now almost certain that part of our memory system consists of long and tortuous loops of nerve cells in which the brain signals are kept circulating by regenerative action. Memories can be eradicated simply by cutting the loops.

The other point of resemblance is the "clock," or system for providing a time scale. In the computer this is usually a crystal-controlled oscillator, to which the digit pulses throughout the machine are locked

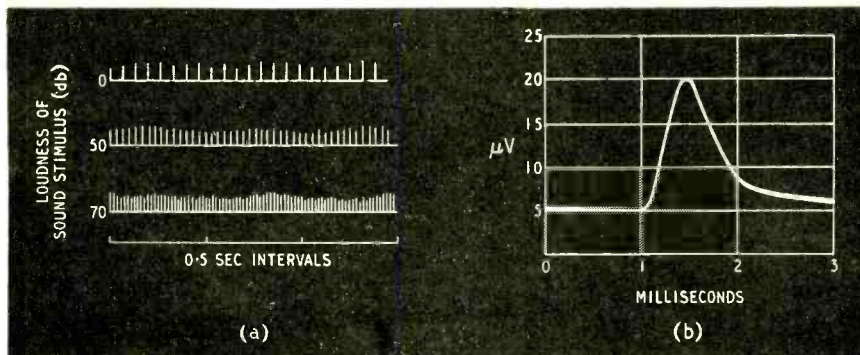

Fig. 3. (a) Record of impulses from a single fibre in an auditory nerve, showing how the p.r.f. increases as the sound stimulus to the ear gets stronger. (b) Single impulse recorded from a point on a nerve fibre, the "travelling discharge" taking nearly a millisecond to pass by.

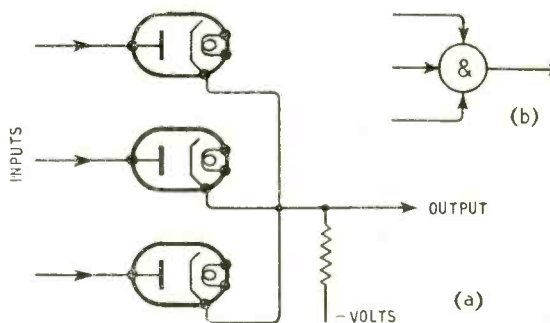

Fig. 4. (a) Coincidence gating circuit that will only give out a signal when negative impulses are applied simultaneously to all three inputs. (b) Symbol for (a) used in logical circuit diagrams of digital computers.

so that they have a time-position corresponding to a space-position on paper. Drawing an analogy from this, neurophysiologists have suggested that in the brain a similar function is performed by the 10-c/s electrical waveform known to electro-encephalographers as the alpha rhythm.* It is probably responsible for our sense of time and its regularity may have something to do with our ability to associate things into patterns and, indeed, our ability to reason. At any rate, the notion that the alpha rhythm is a timing oscillator, to which all the control signals of the body are locked, has been largely corroborated by experiment. A person is asked to press a bell-push haphazardly, whenever and as often as he likes, and the impulses obtained from it are displayed against his alpha rhythm, which is being recorded at the same time. Despite the random nature of the impulses, they show that the instants he presses the bell-push all bear the same fixed phase relationship to the alpha rhythm.

It seems likely that this timing waveform in the brain also serves as a kind of scanning mechanism. In television, scanning is used to convert a spatial electrical pattern, which would require an impossibly wide bandwidth to transmit all at once, into time-sequential signals that can be handled by a channel of practicable bandwidth. A similar thing happens

* "Studying Brain Waves," February 1952, p. 72.

in animal vision. The spatial image focused on the retina of the eye has to be converted into time-sequential signals so that it can be conveyed by a nerve channel of normal "bandwidth" to the exchange and computing parts of the brain. To do this, a "wide bandwidth" optic nerve channel, containing about a million parallel fibres, transmits the picture complete to the visual cortex, where it is reproduced, undistorted, as a spatial electrical pattern and then scanned. (Note that the familiar time-bandwidth dependence holds good in both television and physiological scanning.) Although this is only a tentative theory, it is nevertheless supported by the experimental evidence that we cannot read printed characters faster than 10 per second—the frequency of the alpha rhythm scanning waveform.

This spatial electrical image on the visual cortex plays an important part in the physiological feedback by which the eyes centre themselves on an object and follow it about if it is moving—say a bird in flight. (A good example, incidentally, of a feedback loop completed through the outside world.) The nerve cells on the visual cortex compute an electrical vector from the existing central line of gaze to the visual centre of the bird. This is relayed to the cells which control the eye muscles, which move the eyes so as to reduce the vector, until finally, by this process, the vector is brought to zero and the eyes are centred on the bird. If four electrodes are placed on the skull to pick up the electrical vector and the voltages from them are amplified and applied to a corresponding arrangement of deflector plates on a c.r.o. (two X plates and two Y plates), the spot of the c.r.o. follows the movement of the eyes exactly. This feedback mechanism is analogous to the automatic lock-and-follow searchlight and radar devices used in war for keeping the search beam trained on a moving target. Similarly, the feedbacks by which the eye guides the hand to grasp a moving object are analogous to radar-guided missiles.

Feedback Faults

Animal mechanisms and servo systems often exhibit the same kind of behaviour when they go wrong. Certain nervous diseases produce tremors of the limbs, for example, which are remarkably like the oscillatory effect known as "hunting" in servo-mechanisms, although there is no real evidence to show that the same kind of fault is responsible. Again, the brains of neurotic or epileptic people contain certain feedback loops which should give negative feedback but have changed round to positive feedback. They are unstable in the same way as an amplifier with spurious positive feedback loops is unstable, and with an epileptic it only requires a small triggering impulse to set the whole brain into a violent "motor-boating" oscillation and so cause a fit.

Since man is a microcosm of the society in which he lives, what has been said about control and communication in the animal body can also be applied to society in general. Communication by speech, writing, the press, films, radio, television, and so on, is essential to organized communities, and it tends to exercise the same kind of self-stabilizing control action as a negative feedback system. Without such communication, society would be in chaos, as would the body without a nervous system. Thus, people like historians, sociologists and economists, who study

large-scale trends in society, are particularly interested in the notions about feedback, and, like the biologists, are turning to communications engineering for help in solving their problems. Economists, in particular, think that cybernetics will make the study of recurring booms and slumps into a really exact science. The present inflationary trend, for example, with wages and prices driving each other up, might be examined as a feedback which should be negative (giving stability) but has gone positive and produced regenerative action.

All this may seem to have come a long way from radio, but the whole point is that the theories from which biologists, economists, psychologists, sociologists and the like are deriving most benefit just now—Information Theory, for example—were originally devised by engineers to solve practical problems in communications. Moreover, it is from the practical techniques of radio, television and electronics that most of the really fruitful analogies are being drawn.

ELECTRIC WIRING REGULATIONS

ALL concerned in the installation of radio and television sets should know something of the regulations governing the electric wiring of dwelling houses if only in order to avoid some of the more serious pitfalls. For example, there are regulations governing the use of water pipes for earthing electrical equipment connected to the supply mains. Few will require the full regulations governing all types of installation, but there is now available a pocket-size abridged edition of some 80 pages which contains all the essential regulations for small dwelling houses.

Copies can be obtained from The Institution of Electrical Engineers, Savoy Place, London, W.C.2, and the price is 2s 6d. The full regulations, revised in 1950, are available also from the same address, price 5s with a paper cover and 7s 6d with cloth. Postage is included.

Educational Filmstrip

"THE Story of Television" is the title of a new filmstrip recently produced by Mullard in conjunction with the National Committee for Visual Aids in Education. Designed for students in the 11-16 age group, it traces the history and development of television from the first attempts to transmit pictures by wire to the latest developments utilized by the B.B.C. Television Service, and explains in simple terms how a programme is produced, transmitted and reproduced. The actual process of radio transmission between the studio and the receiving apparatus is not described at length as this is already covered in a companion filmstrip "The Story of Radio."

The filmstrip has 34 frames in black and white and costs 10s. It is available, with lecture notes, from the distributors, Unicorn Head Visual Aids, Ltd., at Broadway Chambers, 40, Broadway, Westminster, S.W.1.

Booklet Received

The B.B.C. Type "B" Disc Recording Feedback Cutterhead.—Technical and service data on this component and descriptions of associated amplifiers including circuit diagram and transformer winding details. Useful formulae for disc recording. Pp.29+V; Figs. 16. Gramplan Reproducers, Ltd., Hanworth Trading Estate, Feltham, Middlesex. Price 5s or \$1.00 including postage.

F.M. IN GERMANY

V.H.F. Broadcasting Network : Recommended Receivers

WHILE the medium-wave broadcasting situation in this country is far from satisfactory, that obtaining in Germany is far worse. Under the Lucerne Plan (1934) the area now known as Western Germany had available five good channels, four fairly good and one bad, whereas, under the present Copenhagen Plan, it was allocated only three mediocre channels and four bad ones. It has, therefore, been decided by the broadcasting authorities in each of the Zones in Western Germany to introduce v.h.f. networks to supplement the existing stations.

In view of the discussions which will take place preparatory to the granting of the new Charter to the B.B.C.—in which the question of the introduction of a v.h.f. service is bound to loom large—some of the factors which have influenced the introduction of frequency-modulated v.h.f. in Western Germany are summarized in this article.

Dr. Werner Nestel, Technical Director of Nordwestdeutscher Rundfunk (N.W.D.R.), has contributed an informative article on the subject in the *Bulletin* of the European Broadcasting Union. He states that N.W.D.R., which serves the British Zone, has at its disposal only one mediocre m.w. channel and two bad channels. It is impossible even with the most careful use of these to cover even reasonably well the area which extends from the Danish frontier to Bonn in the south and Berlin the east. In fact, Dr. Nestel states the situation is so bad that the minimum field strength for an effective service can no longer be regarded as 2 mV/m but 4 mV/m and, in the case of

the international common frequencies, some five times greater.

Before choosing an alternative system, preliminary tests were made with the following:—

- (a) R.F. distribution over telephone circuits;
- (b) R.F. distribution over electricity mains;
- (c) a combination of methods (a) and (b);
- (d) low-power shared-wavelength broadcasting (a very large number of very low-power transmitters on each frequency);
- (e) short-wave broadcasting;
- (f) amplitude-modulated v.h.f.;
- (g) frequency-modulated v.h.f.;

The Technical Director of N.W.D.R. states that the preliminary tests established without doubt the far-reaching superiority of frequency-modulated v.h.f. The decision was therefore taken to build up as quickly as possible a network of v.h.f. transmitters with the object of giving complete coverage of the area served.

The fact that v.h.f. can result in improved quality of reception was not a deciding factor; the main reasons were: it permits the coverage of areas which cannot be served on medium waves and provides a service which can be complementary to the single programme necessitated by the synchronization of m.w. transmitters.

Amplitude modulation was given very serious consideration, but the decision in favour of f.m. is stated to have been based on the following reasons:—

1. Simple f.m. receivers are no more expensive

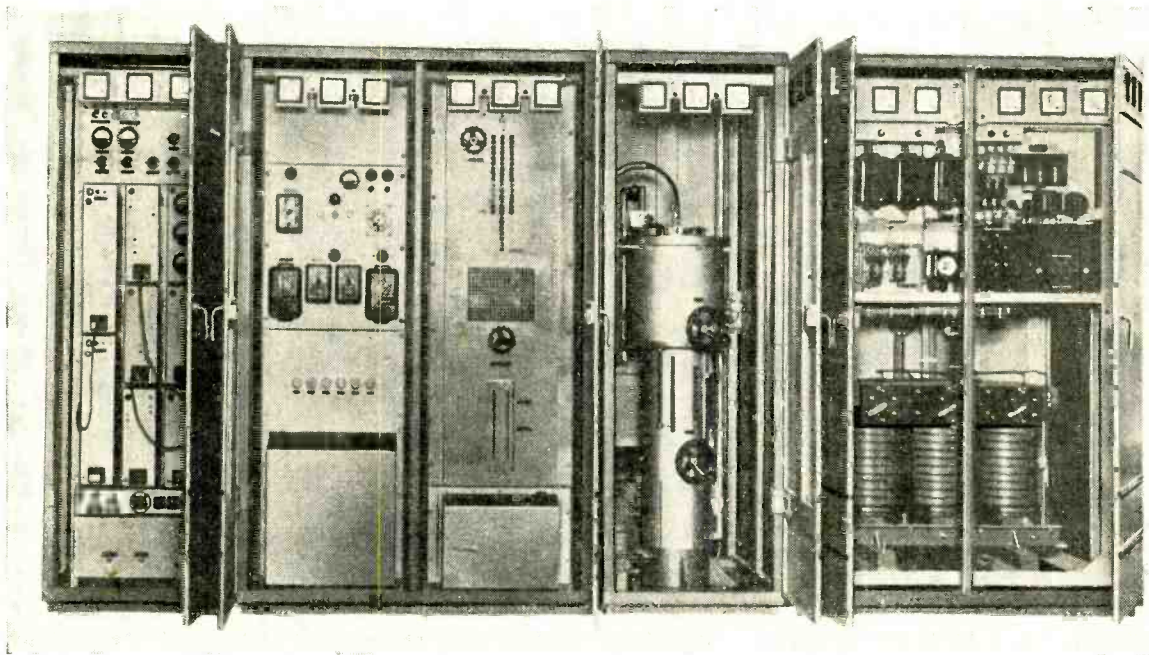

Standardized 10-kW frequency-modulated v.h.f. transmitter used by N.W.D.R. The fourth unit from the left is the output stage.

than those for a.m. (according to the German radio industry they are cheaper).

2. High-quality f.m. receivers are not more expensive than those for a.m., and they offer, in addition, the possibility of improved reproduction through the elimination of interference.

3. In addition to the area reliably covered by an a.m. transmitter of the same power, f.m. makes available a zone in which good reception is possible with

the aid of high-quality receivers equipped with limiters. In this zone satisfactory reception is quite impossible with a.m.

4. A European v.h.f. plan is practicable only if f.m. is adopted, since f.m. reception is possible with a signal-to-interference ratio of 5:1, whereas for a.m. reception a ratio of as high as 100:1 is required.

Of the two bands available (41-68 and 87.5-100 Mc/s), the higher was chosen despite the fact that it

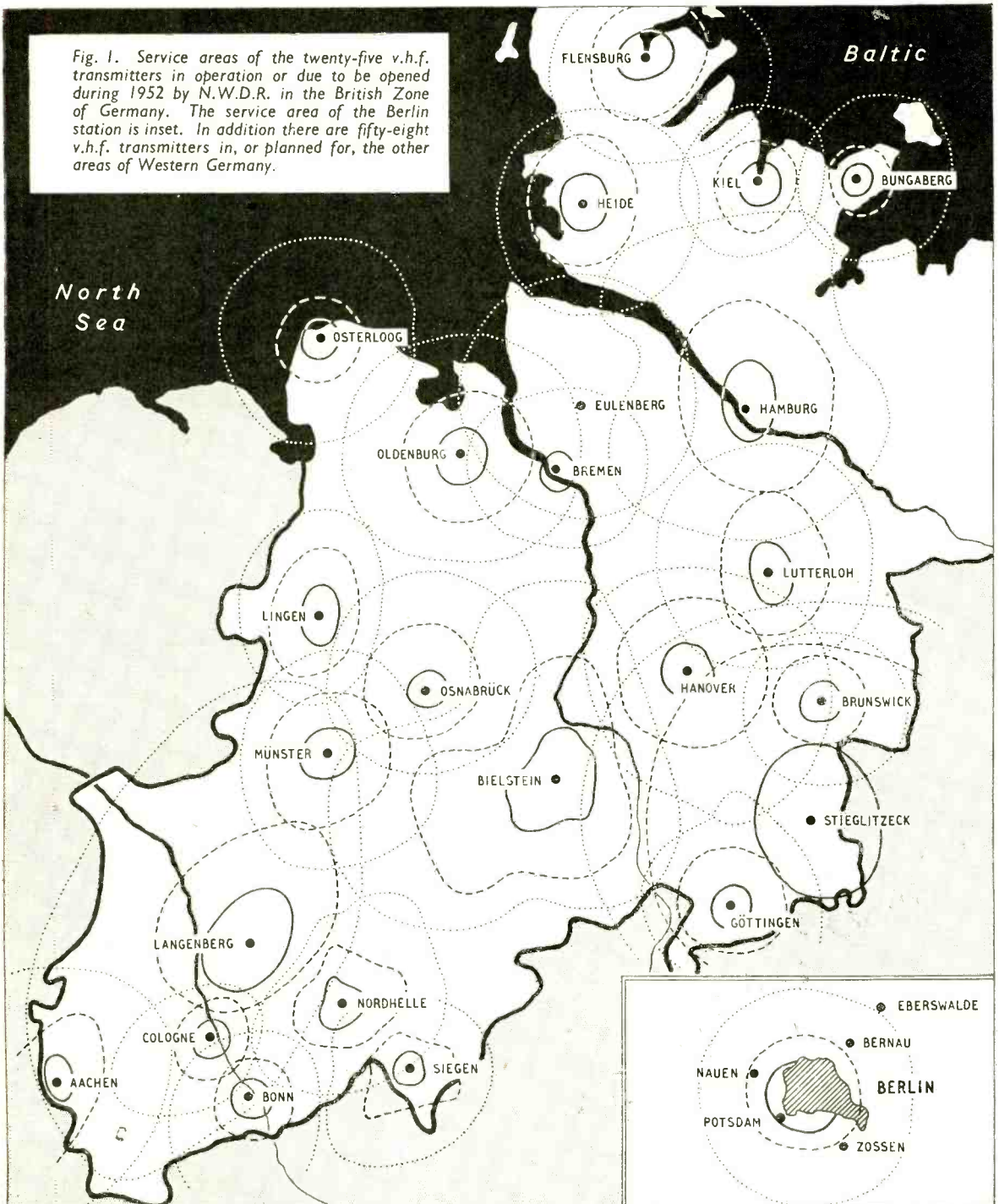

Fig. 1. Service areas of the twenty-five v.h.f. transmitters in operation or due to be opened during 1952 by N.W.D.R. in the British Zone of Germany. The service area of the Berlin station is inset. In addition there are fifty-eight v.h.f. transmitters in, or planned for, the other areas of Western Germany.

provides fewer channels. On the question of channel separation, Dr. Nestel points out that the receiver stability, which cannot be improved very much, and the selectivity, which is not very great in the cheap receivers, as well as the bandwidth essential for f.m., prescribe a minimum separation between channels of 0.4 Mc/s. The channel separation of only 0.2 Mc/s customary in America would have led to more expensive receivers, and was not chosen for that reason. However, a separation of 0.4 Mc/s does not preclude the adoption of the American figure at a later date, when more selective receivers may be available. Only 31 channels are therefore available in the chosen band, necessitating a very careful allocation of frequencies for good coverage over a large area while allowing for subsequent complete coverage with a second, and perhaps even a third, programme. Dr. Nestel contends that the number of channels available, if carefully exploited, is quite adequate to solve any broadcasting coverage problems that could possibly arise in Europe. Careful consideration was also given to the question of possible interference from powerful transmitters in neighbouring countries.

Horizontal polarization has been chosen mainly because it provides better propagation in built-up areas and is less susceptible to motor-ignition interference.

Standardized Transmitters

The disposition of the transmitters in the area served by N.W.D.R. is shown in Fig. 1. It is anticipated that the entire network of twenty-five stations will be operating by the middle of this year. On this sketch map is shown the measured or estimated field-strength contours in three reception zones:— A, more than 50 mV/m (permitting the use of cheap receivers with indoor aerials); B, 5-50 mV/m; and C, 1-5 mV/m necessitating the use of both a good receiver and good aerial. On the question of aerials, it is interesting to note (Fig. 2) how the field-strength varies with the position of the dipole in different parts of a building; incidentally, the N.W.D.R. recommends the use of a folded dipole fixed to the window-sill.

So far as transmitters are concerned, it has been found, contrary to previously held views, that it is possible to obtain an output efficiency of well over 50 per cent. By taking into account the additional power fed to the aerial circuit from the penultimate stage by the earthed-grid amplifier, an apparent efficiency of 65 per cent may be attained, which is comparable with the efficiency of transmitters in other frequency bands. Modern 10-kw v.h.f. transmitters require for the entire transmitter a power intake of only 22.5 kW. For the first transmitters, the American example was followed and stage outputs of 0.25, 1, 3 and 10 kW were chosen. It was, however, soon found that this was unnecessary, and more recent transmitters have a smaller number of stages, the requisite higher power amplification for each stage being achieved without difficulty.

N.W.D.R. has standardized 10-kw transmitters for the network, which, with an aerial gain of 8, gives an effective radiated power of more than 50 kW. This gives a field strength of 1 mV/m (according to the international definition, at 10 m above the ground) at a range which, for reasons of wave propagation, may still be regarded as within the fading-free service area. Such field-strengths are regarded as adequate for the use of cheap aerials and cheap receivers. A further increase of the transmitter output and the field-

strength at the receiver would have led to difficulties in the allocation of channels on account of the extra range which must be expected as a result of tropospheric propagation.

The high-efficiency 10-kw transmitters incorporat-

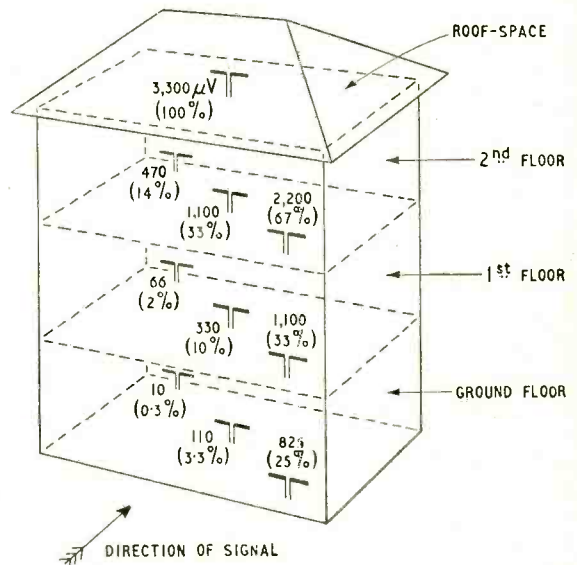
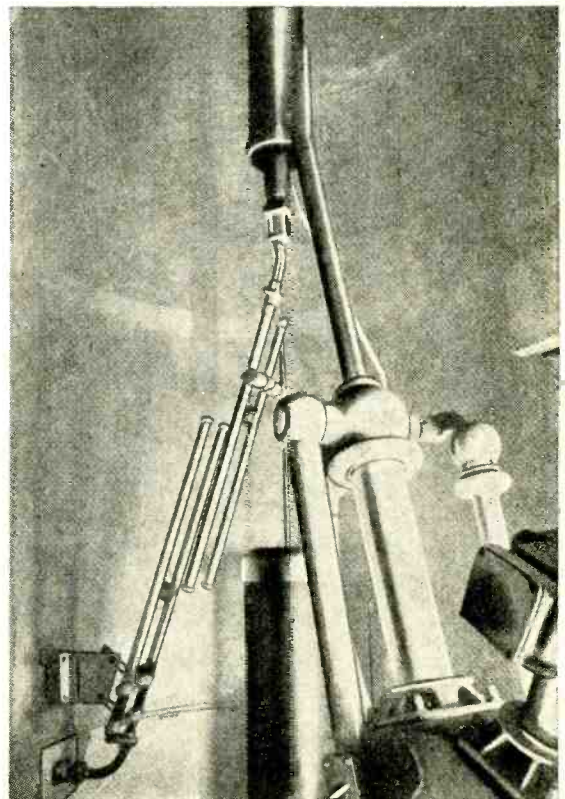

Fig. 2. Representative relative signal-strengths measured in different parts of a building. The figures in parentheses give the signal strength as a percentage of that in the roof.

Coupling device for feeding 10 kW at v.h.f. to an aerial atop a mast radiating medium waves at 100 kW.



ing few stages which were developed as a result of these considerations have become so straightforward and small and consist of so few parts (no coils, no capacitors, only quite simple cylindrical circuits not liable to failure) that they are now very much cheaper than the equivalent a.m. transmitters for other bands.

It is noteworthy that the v.h.f. aerials have in some instances been erected at the top of existing medium-wave mast radiators. The coupling device for feeding 10 kW at v.h.f. to an aerial on a 100-kW m.w. mast radiator is illustrated.

Dr. Nestel points out that the real key to the success of a v.h.f. broadcasting system is the provision of inexpensive receivers. The German radio industry was initially against the introduction of v.h.f. broadcasting because of the supposed high cost of producing adaptors and complete receivers. It was, however, shown that the provision of limiters and discriminators, which permit of reception with an input of only a few microvolts but necessitate a considerable outlay in valves and components, although orthodox, were generally unnecessary with the signal provided by N.W.D.R. This deviation from what has become general practice in America made available two very simple receiving circuits which, it is stated, do not require one single component more than a.m. circuits:—

1. The super-regenerative circuit, and,
2. Frequency-discrimination by means of a diode using the slope of the selectivity characteristic.

The cheapest receivers and adaptors use super-regeneration for which the Post Office and the broadcasting authorities jointly have made stringent regulations requiring that the interference produced in the super-regenerator must not get into the aerial circuit. Adaptors, costing between DM 27 and DM 50, which can be added to any existing receiver, employ a recently developed triode-pentode. The pentode has an untuned grid circuit and merely serves as a separator between the aerial and the actual receiving valve. It thus suppresses radiation and

ensures that the main tuning circuit is unaffected by the aerial circuit. The actual receiving circuit, then, consists of an ordinary triode acting as a super-regenerator. The production of the quenching frequency is completely controlled, even during fluctuations in the mains voltage. Following the super-regenerative stage is an audio-frequency filter-equalizer, consisting of a capacitor and resistor. The output of this one-valve circuit is adequate for direct coupling to the audio-frequency stage of an existing receiver. The sensitivity of such simple circuits is about 0.1 mV.

The use of the second type of circuit recommended (diode discrimination using the slope of the selectivity characteristic) permits the production of a four-valve superhet receiver providing for f.m. reception, as well as the usual three a.m. wave-ranges. It employs an i.f. of 10.7 Mc/s in addition to the normal 468 kc/s (see Fig. 3). Some 80 per cent of the receivers now produced by the German radio industry cover the v.h.f. band. The difference in cost between a three-band superhet and one also covering the v.h.f. band is about DM 10. According to the latest available figures, the number of v.h.f. sets in use exceeds two million.

It must not be thought from the foregoing that only cheap receivers are being produced. Higher-priced receivers, incorporating all the refinements considered necessary to do full justice to f.m., are also being made.

In order to do full justice to the improved quality provided by v.h.f. broadcasting the German broadcasting authorities have extended the response of their studio equipment from the existing 10 kc/s to 15 kc/s, this extension covering all stages of the installation.

In the opinion of the author, the only solution of the wavelength problem in Europe lies in the adoption in all countries of v.h.f. broadcasting for all requirements beyond a single programme. This will, of course, mean an improved service on long and medium waves, as the majority of the m.w. channels could then be used exclusively and the separation extended from the present 9 kc/s to, say, 10 kc/s.

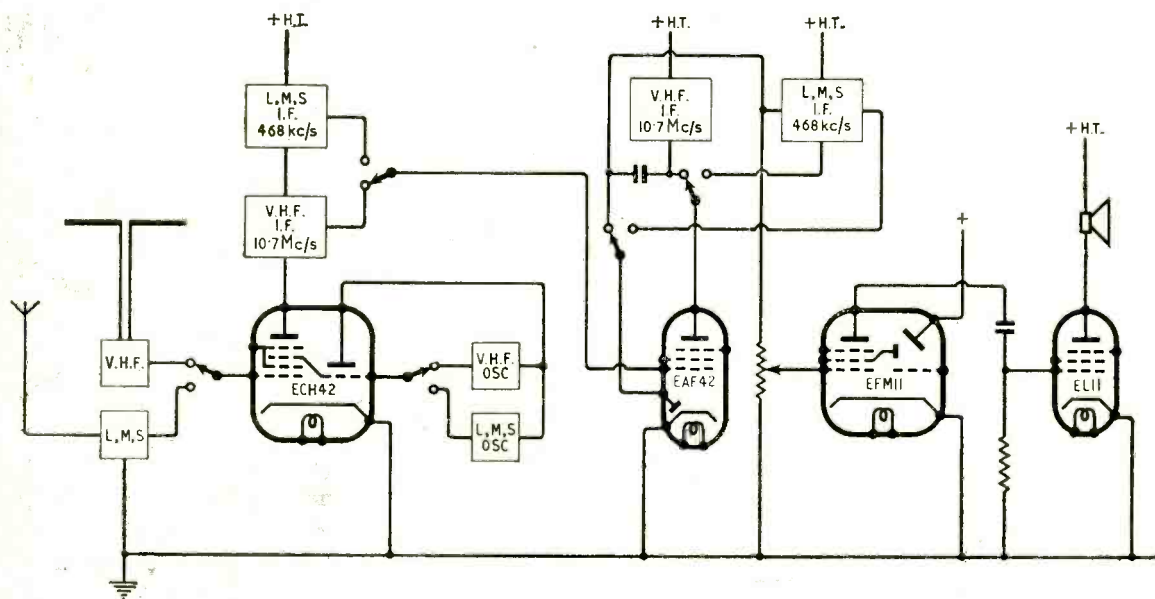

Fig. 3. Block schematic of a typical superheterodyne receiver providing v.h.f./f.m. reception in addition to covering the normal long (L), medium (M) and short (S) wavebands.

LETTERS TO THE EDITOR

The Editor does not necessarily endorse the opinions expressed by his correspondents

"Standardizing Television I.F."

WE have noted with considerable interest the editorial on this subject in your February issue, and feel that, on behalf of the television receiver manufacturers, we should comment, if only to let your readers know what the industry has been doing.

It is no secret that in 1949 a special Committee of this Association investigated the technical aspect of this particular subject of television i.f.s, and that from this investigation emanated the theoretical case for the use of the 34-38-Mc/s band. Equally, there is nothing secret in the knowledge that at that time only one of the intended transmitting stations of the British five-channel system was in operation, so that actual experience of operating conditions in such a system was largely conjectural.

There has been, since, a transformation in both transmission and reception; three stations are operating, a fourth is due to be opened in less than a month; and the five-channel receiver has come to be typical of current design for the normal domestic television receiver. This has meant that industry has been able to gain considerable practical experience which was not available to it in 1949. Broadly, the position today is that there are two schools—those of the "low" i.f. and those of the "high" i.f., and it is at this point that B.R.E.M.A. has deemed it opportune to resuscitate its special Committee and to set it the task of making a practical re-examination of the advantages and disadvantages of intermediate frequencies which can be employed. This practical re-examination must obviously take into consideration not only technical aspects (of which statistics form as important and accepted part as any) but also those economic factors without which any technical solution would be reduced to one of academic value only.

It may thus be adjudged that a quick decision is not likely to be as readily available as your article suggests; there is, moreover, a danger that a quick decision which neglects the allocation of a correctly proportioned weighting to all relevant factors may aggravate rather than ease the situation. The story of the development of sound broadcast and television systems throughout the world contains an adequate quota of the wrong decisions at the wrong time, pointers which should be accepted as of fundamental significance in attempting to solve this problem of television receiver intermediate frequencies with the sweet reasonableness and rationality which we, as you, are confident will be applied.

S. E. ALLCHURCH, Secretary,
British Radio Equipment Manufacturers' Association.

"Hot Stylus Technique"

YOUR report (February issue) on M. C. Philip's short address at the B.S.R.A. meeting on 21st December is of considerable interest as it directs attention to a disc recording topic that has received scant attention in the British technical papers.

The method appears to be due to Columbia Records Inc., of New York, in whose laboratories development work was undertaken early in 1948 by William S. Bachman and his colleagues and described in the issue of *Audio Engineering* for June, 1950.

Equipment for commercial use of the technique has been available in the U.S.A. from such well-known companies as Fairchild and Presto for years, but it is gratifying to be able to mention that significant research in the method has been done in this country by Arnold Sugden, of A. R. Sugden and Co. (Engineers), Ltd., Yorkshire. Suitable attachments for hot stylus recording have been incorporated in Mr. Sugden's microgroove apparatus for some time.

I am not sure that your note makes it clear that many

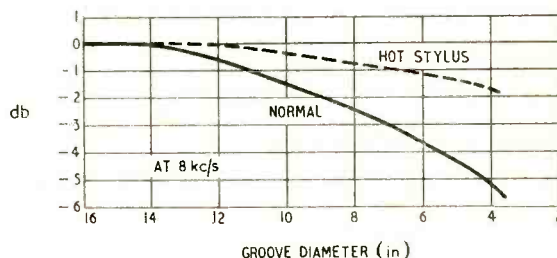

experimenters (including myself) prefer to wind the coil directly on the sapphire tip near the junction of the jewel and the dural shank proper for maximum heat transference. Currents of the order of 0.4-0.5A may be employed and the stylus temperature does not seem to be critical for good results. Some workers claim a reduction in surface noise of as much as 20db and the accompanying curves show relative frequency-response losses of normal and hot stylus recordings at various groove diameters (78 r.p.m. and standard pitch).

Torquay, Devon. DONALD W. ALDOUS.

"Television Ghosts"

I HAVE read with great interest the article by J. A. Hutton in your March issue and would like to mention that an improved performance

can be obtained from the double H if folded dipole elements are used. In addition, by a careful choice of broadside and reflector spacings it is possible to arrange the array feed impedance to match into a standard 75-ohm feeder cable.

The closer broadside spacing of 0.4λ in the aerial shown in the accompanying photo results in a lower forward gain, although the front/back, front/side ratios remain substantially the same.

Commercial double H aerials are manufactured by Wolsey Tele-

vision, Ltd. (Model B/AH) and Aerialite, Ltd. (Model 69).
Edison Swan Electric Company, K. W. KING.
London, W.C.2.

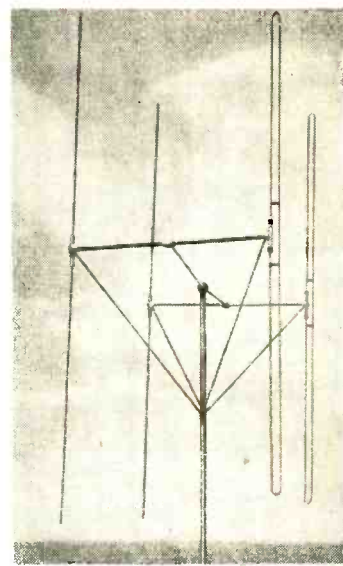

I HAVE read J. A. Hutton's very interesting article (your March issue) and, as a result of independent investigations carried out by my company, would like to confirm his findings, and to emphasize some important conclusions that, I think, may be drawn from them.

It is obvious that an anti-ghosting aerial (in the present state of the art) cannot be sold "over the counter." The article thus serves a useful additional purpose as a warning against extravagant claims for a "general purpose" anti-ghosting aerial, unless a new and proven technique

is evolved. It also brings to mind the possibility of similar problems arising, locally, within the service areas of the Scottish and Welsh transmitters.

Considerable thought should be exercised before buying, or selling, television installations in anticipation of the transmission, if the site possesses the contour features described by Mr. Hutton. F. R. W. STRAFFORD.

Belling & Lee, Ltd., Enfield, Middx.

"Valve Voltmeter Without Calibration Drift"

SINCE the publication of my article in the January issue, my attention has been drawn to Patent No. 636,212 granted to C. Morton. This patent is in respect of push-pull amplifiers in which the ratio of negative feedback to the two halves is critically variable, with the objects: (1) of compensating for any differences in the characteristics of the two halves and so balancing out residual zero instability; and (2) varying the performance by varying the load resistance.

Although my objects in devising the valve voltmeter circuit shown in my Fig. 4 were quite different (viz., to use so much negative feedback as to swamp zero instability without the need for an adjustment, and to make the output voltage equal to the input, regardless of load resistance), this circuit is formally very similar to one of those shown in Mr. Morton's specification.

The main difference between the two circuits is that in mine R_1 and R_2 are provided for eliminating any residual inequality between input and output voltages. Although these are not included in Mr. Morton's specification, by a suitable choice of values and by suitably varying their ratio, it would be possible to use them for the purpose that forms the main claim in the patent, which would then appear to cover the circuit I described. Provided, however, that there is no provision for varying the feedback ratio so as to obtain a critical balancing-out of zero instability, the valve voltmeter does not appear to come within the scope of the patent.

Before completing my article I made a lengthy search of valve voltmeter circuits, including the comprehensive compilation of American practice in the recent 2nd edition of Rider's "Vacuum-Tube Voltmeters," and found nothing similar to mine, until notified of Mr. Morton's patent. I understand, however, that a pH meter embodying the circuit in question (though operating in a substantially different manner from my valve voltmeter) is now manufactured by the Cambridge Instrument Company under this patent.

Bromley, Kent.

M. G. SCROGGIE.

Aerial Propaganda

RECENT letters have been critical of suggested commercial advertising on British broadcasting. It seems possible, however, that the listening public would benefit if one example of Radio Luxembourg were followed by the B.B.C. Those who wish to hear that station properly are advised over the air to put up good outdoor aerials as a means of improving reception!

Longsight, Manchester.

A. G. CLARKE.

"Why 47?"

REGARDING "Cathode Ray's" article on preferred values (February issue), I trust you will bear with me, but as I see it, if this system is established exactly as is described it can hardly be reliable.

If, for example, I require a resistor of 50 ohms $\pm 20\%$ and obtain instead one of 47 ohms $\pm 20\%$, then any actual value from 37.6 to 40 ohms, which this nominal 47 may well be, is beyond the tolerance permitted by my desired value. The possibility of such an error must surely exist for any desired value to a greater or lesser extent—unless,

of course, this value corresponds to a preferred value. It would appear, therefore, that for satisfaction at $\pm 20\%$ I must obtain the nearest preferred value at $\pm 10\%$.

London, W.11.

F. M. SPEECHLEY.

Pulse Testing

READERS of M. V. Callendar's article (your February issue) may be interested to know that "pulse" testing of television receivers was introduced as a production line test in this factory in 1949 when the first vestigial sideband receivers were produced. Since then this has been a standard production test for all television receivers.

I strongly support Mr. Callendar's assertion that a test of this nature can control the large variations in picture quality inevitable with normal alignment methods and ensure a far greater consistency in the performance of receivers.

I demonstrated equipment for pulse testing at the Television Society Exhibitions of 1949 and 1950 and at the lecture referred to in the article. E. A. F. MOSS.

Bush Radio, Ltd., London, W.4.

Radio Indiscipline

I SUPPOSE it is a sign of the times in which we live, in which we are motivated largely by "me first and blow you" sentiments, but I must confess that as one of the old hands going back to coherer days I am shocked at the indiscipline of present-day radio operators.

Recently, during a distress call off the East coast, the indiscriminate jamming by unnecessary calling was awful, but was far exceeded on Sunday, December 9, when there were three distresses at the same time in the North Sea and coast stations spent most of their time trying to enforce silence; most of their efforts were ignored. Two operators, after repeated warnings, were told "report for you" and several more were threatened.

I should hesitate to pick out any nationality worse than others on these occasions mentioned, for candidly there was little to choose, but it is to be hoped that some drastic action will be taken when the "reports" go in—they were deserved in every case. Wm. A. RICHARDSON.

Ashford, Kent.

"Trustworthy Valves"

WHEN a valve is no longer an expendable accessory but a component no more liable to failure than other components, and wired into position like any other components; then, surely, the last vestige of excuse for purchase tax would disappear.

ROBERT C. BELL.

Ambleside, Westmorland.

Broadcasting Coverage

AS one of the unfortunate persons unable to receive an interference-free Home Service programme, may I plead for some action by the B.B.C. The "relay" stations at St. Leonards, and elsewhere, are no solution, except for those living within two miles' range of the stations.

I was under the impression that a re-allocation of frequencies within the United Kingdom was being considered and suggest that if the Brookman's Park and Start Point transmitters change frequencies a marked improvement would result. At the moment the West of England Home Service transmission fades too heavily to be of any programme value in East Sussex, and nothing can remove the 2-kc/s whistle from the Home Service transmission.

Meanwhile, I hope the Postmaster-General has not forgotten that we still await his decision on a.m./f.m., and ask that in the near future the Wrotham transmitters be operated for the benefit of the general public.

Sedlescombe, Sussex.

P. A. COOMBES.

WORLD OF WIRELESS

This Year's Exhibitions ♦ Experimental Television for Schools ♦
International Standards ♦ Marconi Memorial

Shows

THE date of the nineteenth National Radio Exhibition has been announced by the R.I. Council—August 26th to September 6th at Earls Court. Details are not yet available, but it is planned to organize it on similar lines to last year's show.

On April 7th the components show, organized by the Radio & Electronic Component Manufacturers' Federation, opens at Grosvenor House, Park Lane, London, W.1. The exhibition, to which admission is restricted to those who have a professional, industrial or trade interest in components, will be open from 11 to 6 on the 7th, 10 to 6 on the 8th and 10 to 5 on the 9th. Tickets are obtainable from the R.E.C.M.F., 22, Surrey Street, London, W.C.2.

A list of the fifty or so exhibitors at the Northern Radio Show, which opens at the City Hall, Manchester, at noon on April 23rd, is given elsewhere in this issue. The normal hours of the show, which closes on May 3rd, will be 11-10.

As was the case last year, the Physical Society's exhibition of scientific instruments and apparatus will overlap the R.E.C.M.F. Show; it will be held from April 3rd to 8th at the Imperial College of Science and the Huxley Building, South Kensington. Tickets, valid for specified days, are obtainable from the Society, 1, Lowther Gardens, Prince Consort Road, London, S.W.7. The exhibition opens daily at 10 a.m., but on the first day admission will be limited to members and the Press until 6. It closes at 9 on the 3rd, 4th and 7th and at 5 on the 5th and 8th.

New Television Stations

AS in the case of the Scottish station which opened on March 14th, the Welsh transmitter at Wenvoe (Cardiff) will initially operate on low power. The Asst. P.M.G. stated that it was hoped to open the station—using the standby vision (5-kW) and sound (2-kW) transmitters—in August. He said that it was too early to announce when the high-power transmitter would be completed. The station will operate in channel five (63.25 Mc/s sound, 66.75 Mc/s vision).

The 50-kW E.M.I. main transmitters for both the Kirk o' Shotts and Wenvoe stations employ low-level modulation. The main advantages of this principle are that it re-

duces the number of stages and the size of the transmitter, yet giving a substantial increase in its overall efficiency. The 12-kW sound transmitters for these stations are provided by Standard Telephones & Cables. The Wenvoe transmitter will be linked with the London studios by cable.

International Television

THE recent decision of the Belgian Government to adopt two standards of television, 819-lines (French) and 625 (Flemish), to facilitate the exchange of programmes with neighbouring countries, emphasizes the need—if it required emphasizing—for the adoption of an international standard.

Whilst it seems almost impossible to reach agreement internationally on the number of lines to be used—the latest figure suggested is 729!—it is noteworthy that the representatives at a recent meeting of the International Television Committee voiced their preference for standardizing the bandwidth at 7 Mc/s. The countries represented were Belgium, France, Germany, Italy, Netherlands, the U.K. and the Arab States. The U.K. representative on this committee, set up in 1947 to encourage international collaboration in the field of television techniques, was Dr. R. C. G. Williams, chief engineer, Philips Electrical.

Anglo-U.S. Scholarships

WITH the object of contributing to industrial productivity in this country, 75 scholarships are to be awarded this year by the Ministry of Education for the study of production in the United States.

Thirty-five of the awards will be tenable for one year (from September) for the study of production technology and will be open to students who hold good honours degrees in either pure science or technology. Applicants must have had at least two years' industrial experience and be at present working in industry or research associations or teaching. Applications must be received by April 16th. The remaining forty awards, open to persons between the ages of 23 and 35, are for the study of management, for which the closing date is April 30th.

Return passages to the United States will be met from public funds. Full details may be obtained from the Ministry of Education (F.E. Division 1), Curzon Street, London, W.1.

School Television

SIX schools in North London have been chosen to participate in the experimental transmission of television programmes for schools for four weeks beginning on May 5th. The vision signal will be radiated by one of the O.B. transmitters set up at Alexandra Palace using a frequency between 180 and 200 Mc/s. It will be necessary, therefore, for schools to be equipped with frequency converters, which will be provided by the B.B.C., to enable standard receivers to be used. To avoid the possibility of interference from the London station, receivers will operate on the Kirk o' Shotts' frequency (56.75 Mc/s). Sound will be conveyed to the schools by P.O. land line.

The choice of schools has been governed largely by the radiation pattern of the O.B. aerial to be used.

Standard Frequencies

THE American National Bureau of Standards wishes to have reports from users of the standard frequency transmission services conducted by stations WWV (Washington) and WWVH (Hawaii). Users are asked to complete a questionnaire from which it is hoped to obtain information helpful in increasing the usefulness of the service and to assist the C.C.I.R. in the study of the possibilities of providing a world-wide standard frequency and time signal service.

Dr. R. L. Smith-Rose, director of the Radio Research Station, Ditton Park, Slough, Bucks, is collecting reports originating in this country and copies of the questionnaire are obtainable from him.

Television Convention

CONTRARY to the usual practice of the I.E.E., attendance at the Convention on the British Contribution to Television (April 28th-May 3rd) is not confined to members of the Institution. The registration fee for the ten 2-hour technical sessions, which will cover the whole field of television "from studio to viewer" is 30s. A number of visits of technical interest have been arranged.

Radio Plaques

AS was anticipated, the London County Council has decided to waive its ruling not to erect a plaque until at least twenty years after the death of the celebrity they wish to honour in the case of Marconi, as they did recently for Baird. Within

the next few weeks a plaque with the wording "Guglielmo Marconi, 1874-1937, the pioneer of wireless communication, lived here in 1896-7" is to be erected on 71, Hereford Road, W.2.

Among the 200 or more already erected are plaques to Faraday (48, Blandford Street, W.1), Clerk Maxwell (16, Palace Gardens Terrace, W.8), and Baird (22, Frith Street, W.1).

A.P.A.E. Show

THE annual exhibition organized by the Association of Public Address Engineers will be held at the Horseshoe Hotel, Tottenham Court Road, London, W.1, on May 29th from 10 to 8. In addition to the exhibits of a number of manufacturers of sound recording and reproducing equipment, there will be a display of "ideas" used by members in their P.A. work for which prizes will be awarded.

Readers of *Wireless World* may obtain tickets gratis from the Secretary, Alex. J. Walker, 394, Northolt Road, South Harrow, Middx.

PERSONALITIES

Sir Ernest Fisk, who has been with Electric and Musical Industries, Ltd., since he came to this country from Australia in 1944, has resigned from the managing directorship of the company and the various offices he held in companies within the E.M.I. Group. For four years prior to going to the antipodes in 1910 he was with Marconi's. In 1913 he assisted in the formation of Amalgamated Wireless (Australasia), Ltd. (A.W.A.), of which he became chairman in 1937, the year he was knighted. Sir Ernest played a prominent part in antipodean radio and received the first direct transmission from this country to Australia in 1918.

Peter E. M. Sharp, A.C.G.I., B.Sc. (Eng.), A.M.I.E.E., who, since 1949, has been Industrial Officer (electronic equipment) with the Council of Industrial Design where he was responsible for the selection and organization of communications and electronic exhibits at the Festival of Britain, has joined the Commercial Department of the Telegraph Construction and Maintenance Co., Ltd. (Telcon), where he is specializing in communications cables and systems. Prior to joining the Council of Industrial Design he was responsible for the production of technical publications issued by Standard Telephones & Cables.

T. C. Macnamara, who on leaving the B.B.C. Planning & Installation Dept. (of which he was in charge) in 1950 joined the Board of Scophony-Baird, has resigned from the Board in order that he can devote himself exclusively to development work with High Definition Films, Ltd., of which he has been technical director since its formation last year, with the backing of Pye, Ltd., the J. Arthur Rank Organization and British Lion Films.

John Kier, who has been with Marconi's since 1915, when he joined the Company as a sea-going wireless operator, has been appointed assistant general manager of the marine group of companies—M.I.M.C. Co., Radio Com-

munication Co., and Marconi Sounding Device Co. After serving as an instructor at Marconi House he held various head office appointments and in 1929 went to Brazil as managing director of the Companhia Nacional de Comunicacoes Sem Fio, which later became



JOHN KEIR

the Companhia Marconi Brasileira. He returned to this country in 1946 and in 1951 became manager of the Service Division, for which he will still be responsible in his new post.

E. B. Rogers, manager of the Service Department of Mullard's Valve Division, recently completed his twenty-fifth year with the Company, and, to mark the occasion, he was presented with an inscribed clock and a cheque. He joined the Company as service manager and throughout has been responsible for testing and reporting on all returned valves and electron tubes. Mr. Rogers took a first-class P.M.G.'s Certificate in 1915, joined Siemens Brothers as a wireless operator and in 1918 became a wireless instructor at the Royal Naval Barracks, Chatham. He was an amateur transmitter (2WY) in 1919.

H. L. Oura, M.B.E., B.Sc., who has been appointed managing director of Acoustic Products, Ltd., of South Ruislip, Middx., joined E. K. Cole, Ltd., in 1946 to take charge of their Western Development Unit at Malmesbury, Wilts. Prior to that he was for many years with the Gramophone Company and was a director of E.M.I. Engineering & Development, Ltd.

C. A. Ingram, M.A. (Cantab.), who has been secretary of the Radio Section of the I.E.E. since 1947, has resigned to go to the Stanmore Research Laboratories of the G.E.C. He joined the I.E.E. editorial staff in 1946, prior to which he was a Naval radar officer.

D. M. Sheil-Small, general manager of Alfred Imhoi, Ltd., has been appointed a director of the company. For the last ten years he has been concerned with the development of the company's engineering interests.

C. H. Davis, Assoc. I.E.E., who recently became sales manager of the Electronic Engineering Dept. of Hallam, Sleigh & Cheston, Ltd. (Birmingham), will operate from the company's new London office at 299, New King's Road, Fulham, S.W.6. He has been sales agent for the company since 1946, prior to which he was, for three years, employed as a technical officer in the Admiralty Signal Establishment.

G. Darnley-Smith, who is managing director of Bush Radio, Ltd., and Cinema-Television, Ltd., has been elected chairman of the Radio Industry Council in succession to J. W. Ridgeway, director of Edison Swan, Ltd., and manager of the company's Radio Division. Mr. Darnley-Smith was chairman of the R.I.C. in 1947 and was vice-chairman last year. He has been chairman of the Industry Television Policy Committee since its formation in 1948.

G. A. Marriott, B.A., is the new vice-chairman of the R.I. Council. He is manager of the valves and electronic devices department of the G.E.C. and a director of the Marconi-Osram Valve Co. He is also chairman of the British Radio Valve Manufacturers' Association (B.V.A.).

P. H. Spagnoletti, B.A., M.I.E.E., who is director and general manager of Kolster-Brandes, Ltd., and manager of the Brimar Valve Works of Standard Telephones & Cables and E. K. Balcombe, managing director of A. J. Balcombe, Ltd., were re-elected chairman and vice-chairman respectively of the British Radio Equipment Manufacturers' Association (B.R.E.M.A.).

K. S. Davies, B.Sc., A.M.I.E.E., this year's chairman of the Radio Communication and Electronic Engineering Association (R.C.E.E.A.), was recently appointed to the new executive post of director of engineering created by Murphy Radio "to bring into closer relationship all the radio engineering and production activities" of the company. He joined Murphy's in 1933 and since the war has been general manager of the electronics division. He was previously with Standard Telephones and Cables.

C. G. White, director and general manager of the marine division of Kelvin and Hughes, is the new vice-chairman of R.C.E.E.A.

T. Somerville, co-author of the article "Orchestral Studio Design" in this issue, graduated from Glasgow University and joined the B.B.C. in 1929. From that date till 1942 he was concerned with field strength and propagation measurements, becoming head of the section devoted to this in 1936. In 1942 he transferred to the Design and Installation Department of the Corporation, where he stayed for a year with the recording section. He was then put in charge of the recording section of the Research Department. The a.f. and acoustics sections also subsequently came under his charge.

H. R. Humphreys, who, with T. Somerville, contributes the article "Orchestral Studio Design," joined the B.B.C. in 1949 as architect concerned with all acoustic design and treatment of studios. He was doing research work on acoustics and sound insulation at the Building Research Station of D.S.I.R. for four years prior to joining the B.B.C. and from 1931 until 1945 was with E.M.I. as a technical writer.

J. B. Lovell Foot, contributor of the article "1400 Mc/s Radiophone" in this issue, joined the Radio Group of the G.E.C. Research Laboratories in 1928, after completing a course in electrical engineering at University College, Southampton. Before the 1939-45 war, he was engaged in the early work on v.h.f. equipment, and has had a wide experience in the development of radio transmitters and receivers.

Prof. E. W. Marchant, who writes on "Pre-Heaviside Propagation Theories" in this issue, has been at Liverpool University, of which he is now Emeritus Professor of Electrical Engineering, since 1901. He graduated B.Sc. from London University with honours in physics and mathematics. Prior to going to Liverpool, Dr. Marchant was chief assistant at the Finsbury Technical College under the late Prof. Sylvanus P. Thompson. He was closely associated with Duddell in the development of the oscillograph.

John A. Howie, who contributes the article on Indian radio manufacture in this issue, graduated B.Sc. (Hons.) in chemistry and physics from University College, Southampton, in 1933. He joined E.M.I. in 1936 and was engaged on the selection, specification and processing of all the materials used in radio manufacture. For three years prior to leaving E.M.I. in 1943 he was Assembly Factory manager. Mr. Howie joined E. K. Cole, Ltd., in 1943 to assist in the re-occupation of the Company's Southend factory which had been partially closed since 1940. In 1946 he took charge of the shadow factory at Rutherglen, Lanarkshire, and converted it for the production of car sets and electrical equipment. From 1949 until January this year he has been resident director and general manager of National-Ekco, Bombay.

OBITUARY

Lord Marley, who died on February 29th at the age of 67, made wireless telegraphy his speciality during his Naval career. Dudley Aman, who was created a baron in 1930, was at one time on the staff of the late Admiral Sir Henry Jackson, and, before retiring from the Service, was attached to the Royal Signal School, Portsmouth.

Edmund T. Flewelling, inventor of the super-regenerative circuit bearing his name (sometimes spelt Flewellyn), died in Massachusetts on December 30th. His single-valve super-regenerator obtains its quenching action by the choice of grid resistor and capacitor and by tightening the reaction coupling to cause squegging. In recent years Mr. Flewelling turned his attention to electro-acoustics, on which he contributed a number of articles to the American Press.

IN BRIEF

Television Tasting of scenes for films is in use at the Elstree studios of Associated British Pictures, where, with the aid of Marconi equipment, film executives and technicians will now be able to see on large screens rehearsals taking place in adjacent studios and more readily assess the value of a production.

Silver Jubilee of the Television Society, founded in 1927 "for the furtherance of study and research in television and allied problems," will be marked by a dinner at the Waldorf Hotel, Aldwych, London, on April 25th.

American Marconi Memorial.—A bust of Marconi was unveiled by Marchesa Marconi in the studios of KDKA, Pittsburgh, at the conclusion of a series of broadcasts commemorating the first transatlantic transmission.

Australian Amateur Activities.—During the Jubilee Royal Adelaide Exhibition, being held from March to May, the South Australian Division of the Wireless Institute of Australia will maintain a transmitter on the 7- and 14-Mc/s bands. Special commemorative QSL cards are being used to acknowledge reports.

V.H.F. for the "Queens"?—Anthony Fell, M.P., chairman of Rees Mace, announced recently that his company (the marine offshoot of Pye) had put up a scheme to install a v.h.f. radio-telephone system for the use of passengers on the *Queen Mary* and *Queen Elizabeth* when the ships were approaching Southampton. Mr. Fell stated that, largely because the Post Office had as yet done nothing about suitable v.h.f. shore stations, it was not possible for this offer to be taken up.

Electronics Summer School.—A series of lectures intended to show "both the designer and the user of electronic equipment how far engineering problems are circumscribed by physical laws", has been arranged for the Summer School on Electronics organized by the Dept. of Electrical Engineering, Birmingham University. The tuition fee for the course (July 14th—19th), which is intended for engineers and others of university degree or similar standing in electrical technology, is £2.

Television is among the fifteen specialist subjects covered by courses to be held in this country for overseas students under the auspices of the British Council. The course, which will be run from September 21st to October 4th, is designed for senior radio engineers. Details are obtainable from the British Council's offices in this country and overseas.

E.M.I. Employees' Successes.—Two junior employees of E.M.I. Engineering Development have achieved distinction in the Higher National Certificate examination in Electrical Engineering. The Page Prize, awarded by the I.E.E. to the best candidate in the country who obtains distinctions in all the compulsory subjects of the final year of the Higher National Certificate in Electrical Engineering, has been given to E. R. Robson, who is engaged on transformer design work. D. H. Pentelow, who is concerned with the design of test gear, has been awarded an Institution Prize by the I.E.E. for outstanding merit in the H.N.C. final year.

British Marine Radar equipment is fitted in over 800 foreign ships in addition to 1,400 or more British ships. Some 200 of the latter are still using the ex-Naval Type 268 set.

B.S.R.A. has accepted the invitation to become an "institution in union" with the Royal Society of Arts which has power to extend such invitations "provided that the primary object of such learned bodies is the promotion of arts, manufactures or commerce." The annual dinner, convention and exhibition of the Association will be held at the Waldorf Hotel, Aldwych, London, W.C.2, during the week-end May 16th-18th.

Information Theory in the field of telecommunications is the subject of a symposium which it is planned to hold at the Institution of Electrical Engineers in September. Offers of papers from both this country and abroad will be welcomed by Professor Willis Jackson, Electrical Engineering Dept., Imperial College, London, S.W.1, from whom copies of the preliminary programme may be obtained.

Electronics in Atomic Research.—Physicists and engineers who wish to obtain specialized knowledge of electronic instruments used in nuclear physics, radiochemistry and work with radioisotopes, are being offered a week's course at the Atomic Energy Research Establishment, Harwell (May 19th-23rd). Applications for admission to the course, for which the fee is 12 gns. plus 6gns for meals, accommodation and transport, should be made to the Electronics Division, A.E.R.E., Harwell, Didcot, Berks.

Soviet Standard Sets.—All broadcast receivers produced in the U.S.S.R. after January 1st will conform to the specification of the State Standard Receiver issued by the Council of Ministers of the U.S.S.R. It is learned from the *Bulletin* of the International Broadcasting Organization that there are four categories of receiver graded, so far as mains sets are concerned, according to the maximum undistorted power output.

Radio Facilities.—A new edition of the Radio Facility Charts has been issued by the Ministry of Civil Aviation showing the full Airways System for the U.K. including the radio navigational aids. Each of the eight sheets costs 3d.

Mechanical Handling.—The third exhibition and convention devoted to mechanical handling is to be held at Olympia from June 4th to 14th. Tickets

BUSINESS RADIO.

Interior of one of the mobile stations used by Marconi's to carry out a survey for prospective users of v.h.f. business radio. The equipment shown in this "head-quarters station" includes five- and ten-watt transmitter receivers on the bench and a rack-mounted fifty-watt transmitter.

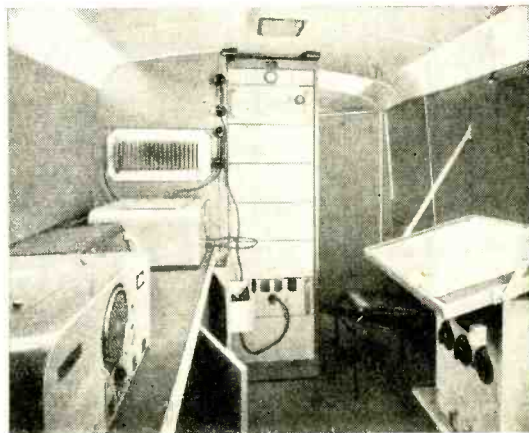

for the exhibition are obtainable from the organizers, the Associated Iliffe Press, Dorset House, Stamford Street, London, S.E.1. Tickets for the convention will be obtainable at the exhibition only.

INDUSTRIAL NEWS

B.R.E.M.A.—At the annual general meeting of the British Radio Equipment Manufacturers' Association the following member firms were elected to the Council (the representative's name is in brackets):—A. J. Balcombe (E. K. Balcombe), Bush Radio (G. Darnley-Smith), E. K. Cole (G. W. Godfrey), A. C. Cossor (J. H. Williams), G.E.C. (M. M. Macqueen), Gramophone Co. (F. W. Perks), Kolster-Brandes (P. H. Spagnoletti), McMichael Radio (C. G. Allen), Philips (A. L. Sutherland), Pilot Radio (H. L. Levy), Pye (C. A. W. Harmer) and Ultra Electric (E. E. Rosen).

A Record number of receivers and chassis (590,000) were exported from this country last year, it was stated at the annual meeting of B.R.E.M.A.

Emitron Valves and cathode-ray tubes are now recognized as officially branded B.V.A. products. The makers, Electronic Tubes, Ltd., have just issued a list which shows several complete receiving ranges and gives characteristics, base connections and prices.

Radar Scanners.—It is announced in the annual report of Marconi's W.T. Co. that the company has acquired Scanners, Ltd., of Gateshead-on-Tyne, who are engaged on the design and manufacture of radar scanning equipment.

Pye in Italy.—An agreement has been completed between Pye, Ltd., of Cambridge and Radio Minerva, of Milan, for the manufacture of Pye television receivers under licence in Italy.

Racal, Ltd., formed just over a year ago to provide an aeronautical and radio consulting service, with offices at 41, Kingsway, London, W.C.2, have issued a duplicated news sheet, "Racal Review." In it details are given of the parent company and the subsidiaries, Racal Engineering, Ltd., Canadian Aviation Electronics (Overseas), Ltd., and Racal (Canada), Ltd. The chief engineer of Racal Engineering, which has a factory at 274, Worton Road, Isleworth, Middx, is D. A. Webb, who was, until recently, with the Ministry of Civil Aviation.

H. J. Enthoven & Sons hope to have the new section of their "Superspeed" resin-cored solder factory at Croydon open early this month. The new plant will provide for the production of cored ribbon solder, coloured-cored solder and various fluxes as well as the normal resin-cored wire solder.

Marconi's are to supply two 100-kW air-cooled transmitters, with paralleling equipment providing an output of 200 kW, for installation at Kalundborg for the Danish broadcasting service. The company is also equipping the Omdurman (Khartoum) broadcasting station with a 50-kW transmitter.

Plessey Co. announce that H. T. Parker is undertaking a detailed marketing survey for the Plessey group in Australasia and will return via Canada and the U.S.A. He left on February 20th and will be away about six months.

Rees Mace, the marine subsidiary of Pye, are to fit three of the Tate and Lyle sugar ships with Pye PTC 115 radio-telephone sets in order that the crews can avail themselves of the G.P.O. Thames radio-telephone service.

A. H. Hunt (Capacitors), Ltd., have reorganized their sales section. R. C. W. Clarke is now responsible for Government contracts, O. G. Cox and E. A. Benwell (hitherto technical sales representatives in the Radio, Electronic and Industrial Division) become joint sales managers of the division, while John Moor continues as sales manager of the section dealing with the wholesale and retail service trade.

Taylor Electrical Instruments announce the reintroduction of their Model 130A insulation tester, which has two ranges, 200k Ω -1,000M Ω (500V max) and 20 Ω -100k Ω (50mV max).

Multicore.—All correspondence for Multicore Solders, Ltd., should now be sent to the company's new premises, Multicore Works, Maylands Avenue, Hemel Hempstead, Herts (Tel.: Boxmoor 3636). The office at Mellier House, Albemarle Street, London, W.1 (Tel.: Regent 1411), is being retained for executive purposes only.

Radio Heaters, Ltd., of Wokingham, Berks, manufacturers of Radyne industrial radio heating equipment, have opened a London office at 46, Gray's Inn Road, London, W.C.1 (Tel.: Chancery 8354).

Kolster-Brandes have opened a distribution and service depot at 87, McAlpine Street, Glasgow, C.3 (Tel.: Central 1779). Although both television and broadcast receivers are stocked, only television sets will be serviced.

MEETINGS

Institution of Electrical Engineers

Radio Section.—Symposium of papers on micro-wave links at 5.30 on April 9th.

Convention on "The British Contribution to Television" from April 28th to May 3rd.

The above will be held at the I.E.E., Savoy Place, London, W.C.2.

Cambridge Radio Group.—"Radio Astronomy" by K. E. Machin, M.A., at 8.15 on April 1st at the Cavendish Laboratory, Cambridge.

Mersey & North Wales Centre.—Discussion on "Should Broadcasting be Superseded by Wire Distribution?"; opener, P. P. Eckersley, at 6.30 on April 3rd at the Liverpool Royal Institution, Colquitt Street, Liverpool.

North Midland Centre.—"The Sutton Coldfield Television Broadcasting Station" by P. A. T. Bevan, B.Sc., and H. Page, M.Sc., at 6.30 on April 1st at 1, Whitehall Road, Leeds, 1.

North-Western Radio Group.—"High-Gain D.C. Amplifiers" by W. Kandiah and D. E. Brown at 6.15 on April 2nd at the Engineers' Club, Albert Square, Manchester.

Scottish Centre.—Faraday Lecture on "Sound Recording—Home, Professional, Industrial, and Scientific Applications" by G. F. Dutton, Ph.D., B.Sc. (Eng.), at 7.0 on April 22nd at the Royal Technical College, Glasgow.

North-East Scotland Sub-Centre.—Faraday Lecture (see above) at 7.30 on April 24th at the Music Hall, Aberdeen.

South Midland Centre.—Discussion on "The Position of the Cathode Ray

Oscillograph in Electrical Engineering"; opener, W. Wilson, D.Sc., B.Eng., at 6.30 on April 7th at the James Watt Memorial Institute, Birmingham.

South Midland Radio Group.—"Radar Sonde" by F. E. Jones, Ph.D., B.Sc., at 6.0 on April 28th at the James Watt Memorial Institute, Great Charles Street, Birmingham.

Southern Centre.—Faraday Lecture on "Sound Recording" by G. F. Dutton, Ph.D., B.Sc. (Eng.), at 6.30 on April 7th at the Guildhall, Southampton.

British Institution of Radio Engineers

London Section.—Discussion on "V.H.F. and U.H.F. Broadcasting"; opener, P. Adorian (president), on April 3rd.

"Current Radio Interference Problems" by E. M. Lee, B.Sc., on April 16th.

Both meetings will be held at 6.30 at the London School of Hygiene and Tropical Medicine, Keppel Street, Gower Street, London, W.C.1.

North Eastern Section.—"V.H.F. Broadcasting: the Case for Amplitude Modulation" by J. R. Brinkley at 6.0 on April 9th at Neville Hall, Westgate Street, Newcastle-upon-Tyne.

South Midlands Section.—"Acoustics and the Radio Engineer" by E. G. Richardson, B.A., Ph.D., D.Sc., at 7.15 on April 16th at the Winter Gardens, Malvern; also at 7.15 on April 17th at the Exhibition Galleries, Public Library, Rugby.

North Western Section.—"V.H.F. Broadcasting: the Case for Amplitude Modulation" by J. R. Brinkley at 7.15 on April 30th at Reynolds Hall, College of Technology, Manchester.

British Sound Recording Association

London.—Discussion "Fact and Fancy" with particular reference to present-day gramophone records" at 7.0 on April 18th at the Royal Society of Arts, Adelphi, London, W.C.2.

Manchester.—Inaugural meeting of the Manchester Centre at 6.0 on April 24th at the Engineers' Club, Albert Square, Manchester, 2.

Institution of Electronics

North-Western Branch.—Lecture on "Pumps and Vacuum Technique" by D. Latham, B.Sc. (W. Edwards & Co.), at 7.0 on April 18th at the College of Technology, Manchester.

Television Society

London.—"A New Television Recording Camera" by W. D. Kemp, B.Sc. (B.B.C.), at 6.45 on April 2nd at Film House, Wardour Street, London, W.1. (Joint meeting with the British Kinematograph Society.)

Radar Association

"Projection Television Receivers for 4ft x 3ft Screen" by V. Valchera (Valradio) at 8.0 on April 1st at the Bedford Corner Hotel, Tottenham Court Road, London, W.C.1.

Society of Relay Engineers

"Cable for Television Relay Systems" by H. J. Dixon and J. D. S. Hinchcliffe (B. I. Callender's) at 2.30 on April 29th at 21, Bloomsbury Street, London, W.C.1.

Institute of Practical Radio Engineers

Thames Valley Branch.—Discussion on service problems at 8.0 on April 1st at the Wheatsheaf Hotel, Kingston Market Place, Kingston-on-Thames, Surrey.

Pre-Heaviside Propagation Theories

By E. W. MARCHANT, D.Sc., F.C.C.I., Hon.M.I.E.E.

Early Attempts to Explain Long-Distance Transmission

WHEN Marconi made his classic transatlantic experiment in December 1901 and received on a kite aerial in Newfoundland the "S's" sent out by the 12-kW transmitter at Poldhu in Cornwall, a good many scientific people were very sceptical about the signals having actually come through. They knew that there was a mountain of water 160 miles high between the transmitter and the receiver and could not believe that, since wireless waves travel in straight lines like light, they could have climbed over the top of this mountain.

At that time I had the good fortune to see a good deal of Lord Kelvin, and even he was among the sceptics. Marconi was regarded with considerable suspicion by many professional physicists, because he tried experiments which seemed bound to fail. Today everyone agrees that it was his persistence in the face of much criticism that led to the rapid development of wireless. He was convinced that it would be possible to send signals by wireless all over the world, though he did not know how it would be done. He did not bother about theory but made his transatlantic tests to show that he was right.

As soon as long-distance wireless had been demonstrated, scientists began to work out theories to explain it. The strength of signal that was to be expected if diffraction was responsible was worked out very completely by Professor Watson, a pure mathematician at Birmingham University. He showed that this could not be the explanation, as the signals were many times as strong as they were calculated to be on this theory.

It had been found in the South African war that wireless was very limited in its range over the dry and arid soil of many parts of South Africa. The signals received from a transmitter in South Africa were much weaker than those received at the same distance from the same transmitter in England, and very much weaker than those received over the same distance over sea. The use of aeriels that were not conspicuous, but arranged in troughs cut in the ground, had been studied intensively in Germany just before the outbreak of the 1914-18 war, and Sommerfeld had worked out a theory of transmission by earth currents, but this also had been shown to provide a very inadequate explanation of the effects observed.

In a paper to the Royal Society W. Eccles had calculated the effect of ionization on the velocity of transmission of electromagnetic waves through a medium, and had shown that the velocity was greater in such a medium than in one that was not ionized. If ionization increased with increasing height above the earth's surface, this phenomenon would explain the bending or refraction of the waves round the curvature of the earth. From 1912 to 1914 a number of measurements were made in Liverpool of signals sent out from the

Eiffel Tower through the kindness of General Ferrié, who was in charge of the wireless transmitting station. These were described in a paper before the Institution of Electrical Engineers in London and a very interesting discussion was provoked. The suggestion that some of the variations were due to reflection from clouds of ionized atmosphere was made and the effects described were explainable on this theory.

It is difficult to determine the first published suggestion that there existed a layer of ionized atmosphere in the upper regions, now known as the Heaviside Layer. Oliver Heaviside had a brother who was in the Post Office Telegraph service and there is no doubt that they must often have discussed the transatlantic transmissions that were of absorbing interest to all at work on the transmission of telegraph messages, and it is very fitting that the name of Heaviside should have been given to the layer which is now generally accepted as the explanation of long-range wireless.

In about 1916 I wrote a paper for the Radio Society of America showing how multiple reflection from the earth and the Heaviside layer could explain transmission over very long distances, and that the waves were more likely to be transmitted better over sea than land. It was Appleton, however, who determined the actual height of the layer from which the reflection came, by varying the wavelength of the transmitter and measuring the corresponding change in the strength of the signals received at a place sixty or seventy miles away. At such a distance the waves will travel directly, and also by reflection from the Heaviside Layer. The received signal is made up of the combination of the two. If these two waves arrive in phase the signal will be strong, if 180° out of phase, they will be weak. The difference in the lengths of the two paths can thus be easily calculated from the wavelengths corresponding to maximum and minimum strength, and the height of the reflecting layer estimated. It was by measurements of this kind that Appleton discovered the Appleton Layer above the Heaviside Layer. There may be other layers which have different effects on waves of different wavelengths.

EDUCATIONAL MATERIAL

TEACHERS and instructors in electronics will welcome the introduction of an educational service by Mullard providing a regular supply of information on recent developments in, and applications of, electronics enabling them to relate theory to practice. The recently instituted Mullard Educational Service provides registered teachers with technical publications, film strips, wall charts, assistance to individual instructors, and instructional and work sheets for class use.

Particulars are obtainable from the Technical Publications Dept., Century House, Shaftesbury Avenue, London, W.C.2.

DUALS

By "CATHODE RAY"

Two Formulas for the Price of One

NO; it is not a misprint, nor am I proposing to order pistols for two. Duals are not duels, though both are two-party relationships. The punctilious gentleman of chivalry wouldn't have a clue when it came to a dual. For it is really a mathematical concept, and the reason I have raised the matter now is to warn you that what has until recently been a rather highbrow preserve is likely to be all over the place before very much longer.

It is because of transistors. These, as most readers probably know by now, are germanium crystal triodes. Germanium diodes have been in commercial production for some time; most current television models contain several, replacing thermionic diodes. They need no heater supply or valve holder, they are smaller and lighter and less breakable, and their capacitance is exceptionally low. In due course, just as De Forest vastly extended the usefulness of the Fleming diode by putting a third electrode into it to make a triode, so two Bell Telephone research workers did the same with a germanium crystal and (presumably after a lot of messing about) found that it worked. We have heard about transistors from time to time, and seen them in scientific exhibitions, and have been warned that they are not suddenly going to supersede thermionic valves and that it may be a long time before they can be used commercially. But while it is wise for a firm hand to be kept on the information brake in case some lay journalist gets out of control, and although it is true that any transistor one has heard about yet is far behind thermionic valves as regards noise (to mention one thing), some of the recent disclosures indicate that transistors are going to make quite a hit, and probably earlier than the remote future. In particular, the junction type, in which the contacts are between whole layers of germanium having different impurities, instead of the point-contact arrangement reminiscent of the old crystal and cat-whisker, really deserves the description "sensational." Some while ago Dr. W. Shockley (who might be called the father of the transistor) demonstrated a complete oscillator no larger than a lump of sugar, drawing so little power that the watt-hour capacity of an ordinary l.t. accumulator cell would be enough to run it continuously for about 500 years!

Although transistors resemble thermionic valves in many ways, including their ability to amplify and oscillate, in some respects they are different and even opposite. For one thing, instead of having a very high input resistance and low output resistance, the input is lower than the output. Instead of having grid bias voltage they have grid bias current—except that the "grid" is called the emitter. All this is very frustrating for people who have been brought up on valves. They—we—I have become so used to

the way valves work and the kinds of circuits that get the best out of them that it is difficult to turn all this technique upside down and inside out—worse than having to draw a pattern while looking at it in a mirror. It was reassuring to find that it is not only dopes like me who experience this difficulty with transistors; even the bright research boys were not getting on too well with it until they thought of duality.

It would be possible, of course, to work out the principles of transistor circuit design from the start, as a fresh subject, just as was done with valves. But look at all the years that has taken. And even if it is agreed that designers have had their wits sharpened a good deal since then, and that many more of them are on the job, you must set against that this upsetting effect of trained habit. The more practised one is in valve circuit design, the greater the mental effort needed to change over to transistors.

That is where duality comes in. Like other mathematical devices, it doesn't create new knowledge. But it does reduce the effort required to dig knowledge out from the facts one has. Duality is really a systematic analogy. You know how analogies are often used to try to make things clearer. Sometimes they only make confusion worse confounded. But most learners do feel a little comforted when an invisible and rather abstract idea like electrical potential

is presented to them with the aid of an analogy—height above sea level. Seeing and knowing the effects of height above sea level on the flow of liquids through pipes, they can visualize better what electric currents do. The danger of analogies such as this is that they are not perfect. They break down in places. For example, resistance to the flow of water in a pipe is not inversely proportional to its cross-section area, as is the resistance to the flow of electricity in a conductor.

In duality the analogy is perfect. Knowing it to be perfect, and knowing the relationships between one set of things, we can find the relationships between the other set of things—their duals—merely by substituting the appropriate symbols. For instance, there is duality between certain mechanical and electrical systems; the dual of electrical resistance is mechanical resistance, that of inductance is mass, that of capacitance is the reciprocal of elasticity, that of current is velocity; and so on. And the very people who, as students, probably gained their first ideas of electricity from what they already knew about springs and flywheels often make so much progress with electrical laws and relationships that they carry some of it back into mechanics. The behaviour of electrical circuit arrangements has been so thoroughly studied and worked out into equations that it is sometimes easiest to tell how a given mechanical system will behave by translating its measurements into mechanical ohms, henries, etc., and then applying the known

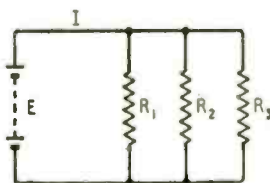

Fig. 1. In parallel circuits such as this the dual form of Ohm's Law—with conductances instead of resistances, and current and voltage interchanged—is more convenient.

electrical equations and methods of analysis and calculation. This is particularly useful in mechanical systems that are closely interlinked with electrical systems, such as loud speakers and gramophone pickups.

But there are duals within the electrical camp itself. Here are some of them in parallel columns :

Current, I	Voltage, V or E
Resistance, R	Conductance, G (=1/R)
Inductance, L	Capacitance, C
Reactance, X	Susceptance, B
Impedance, Z	Admittance, Y
Series Connection	Parallel connection

For every relationship established between any of these, a dual relationship can be discovered by substituting the symbols in the other column. The most obvious example is Ohm's Law, which can be expressed in symbols as :

$$E = IR$$

Substituting the symbols in the opposite column we get :

$$I = EG$$

which is also true, and is sometimes more useful ; for example, with parallel circuits. Ohm's Law in its usual form is not at all well adapted for finding the current I in the Fig. 1 circuit. The extension $I = E/(R_1 + R_2 + R_3)$ is no good, because it applies only to resistances in series. But since the dual of a series connection is a parallel connection, the dual equation can be adapted directly as $I = E(G_1 + G_2 + G_3)$. To find the total current one just adds up the conductances of the parallel branches and multiplies them by the applied voltage.

And so with inductance and capacitance. Suppose one has got the length of finding that the voltage across an inductance can be calculated from :

$$E = 2\pi fLI$$

Then there would be no need to start from the beginning to find the corresponding equation for capacitance. Making use of dualism converts the inductance formula into :

$$I = 2\pi fCE$$

I suggest that this dualism is a useful tip for aiding the memory, and for checking formulae against one another. But in the more elaborate circuits a little care is needed.

Fig. 2 is a slight advance in complexity. If E in (a) is kept constant while its frequency is varied through resonance, I increases to infinity at the peak of resonance and then descends on the other side. Correspondingly, in (b), if I is kept constant, E at resonance must be infinitely great. We can fill in the analogy in detail. The total reactance in (a) is :

$$X = 2\pi fL - \frac{1}{2\pi fC} = \omega L - \frac{1}{\omega C}$$

Because inductive and capacitive reactances work in opposition, the total is the *difference*, not the sum. That is a fact of Nature. But to pick on capacitive reactance as the negative one is merely a convention. However, having done so, we must stick to it through thick and thin.

The dual of the above reactance equation is the susceptance equation for the dual circuit arrangement (b) :

$$B = \omega C - \frac{1}{\omega L}$$

Because inductance is the dual of capacitance, the convention that capacitive reactance is negative leads to inductive susceptance being negative and capacitive

susceptance positive. Dualland is upside-down in other ways. To see how, consider both of these circuits when the frequency is, say, *above* resonance. That makes ωL greater than $1/\omega C$, so the net reactance in (a) is inductive, or positive ; and as regards phase the voltage leads the current. But in (b) the fact that the inductive reactance is the greater means that its effectiveness as a current path—its susceptance—is less, and its current is more than cancelled out in the main circuit by what goes through C. So the circuit as a whole is capacitive and the current leads the voltage.

This Fig. 2 circuit with its infinite current or voltage is of course quite unreal, but it can be elaborated into something resembling a practical tuned circuit (Fig. 3(a)) by inserting resistance R in series with C and L.

The formula for series impedance :

$$Z = \sqrt{R^2 + \left(\omega L - \frac{1}{\omega C}\right)^2}$$

can at once be converted by dualism into the one for parallel admittance (b) :

$$Y = \sqrt{G^2 + \left(\omega C - \frac{1}{\omega L}\right)^2}$$

And of course the dual of $E = IZ$ is $I = EY$. At resonance, Fig. 3(a) behaves as if C and L were

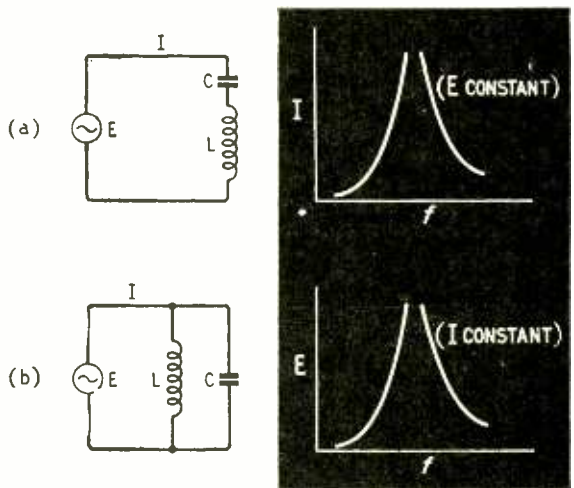

Fig. 2. The dual of (a) — a series circuit, shown with its current resonance curve — is (b), a parallel resonant circuit with a voltage resonance curve.

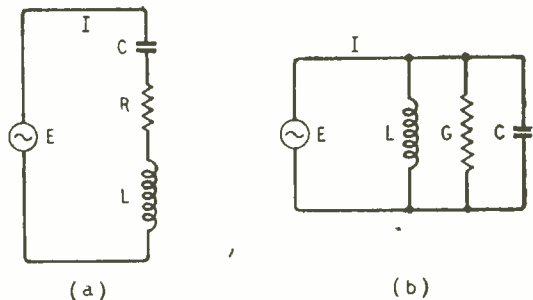

Fig. 3. More practical tuned circuits, with resistance in (a) and conductance in (b) to represent the losses.

short circuited, leaving only R ; and the dual of a short circuit is an open circuit, so (b) behaves as if L and C were removed, leaving G , which is the reciprocal of the dynamic resistance.

Duals and Equivalent Circuits

It is necessary to guard against a possible misunderstanding. The symbols I have used are simply to distinguish one circuit parameter from another—inductance from resistance, and so on. They are *not* intended to mean that L in Fig. 3(b) necessarily has the same value as L in Fig. 3(a); still less that G in (b) is $1/R$ in (a). The risk of confusion might exist if one happened to have in mind the fact that it is possible to find values for L , C and G in (b) which at any one frequency would make this circuit behave towards the generator exactly the same as (a); but these values are not the same as those in (a). In other words, this duality device, which enables a formula for one type of circuit to be derived at once from that for the dually related one, must be kept quite distinct in the mind from the equivalent-circuit device, which enables one circuit arrangement to be

substituted for another without affecting whatever it is connected to, provided that suitable component values are chosen for each frequency.

The next example is one I have discussed before,* and the fact that it was in connection with circuit equivalents does not really contradict what I have just said, because any circuit has equivalents. Fig. 4(a) is the well known "valve equivalent circuit" or "equivalent generator," and (b) is a generally less well-known variety. But that is by the way; the feature I want to point out just now is that they are duals of one another. (a) is a constant-voltage generator, with the anode resistance of the valve in series. (b) is a constant-current generator, with the anode conductance ($1/r_a$, or g_m/μ) in parallel. Representing this constant-current generator by the same symbol as the generator in (a) would tend to suggest that its internal resistance was zero and might make one wonder how there could be any voltage across it, whereas actually one has to imagine that its resistance is infinite. To overcome this difficulty, the dotted arrow symbol has been suggested in America.

Either (a) or (b) can be used to calculate what one gets out of a valve when a given load is connected to the output terminals; but (a) is particularly suitable for finding the current through a given load impedance connected to a triode and (b) the voltage across a load admittance connected to a pentode (for a pentode with its very high internal resistance is nearly a constant-current generator). In the first arrangement r_a must be added to the load impedance to find the total impedance through which E drives the current, and in the second g_a must be added to the load admittance to find the total admittance across which I sets up the voltage. If (as is usual in an r.f. pentode) g_a is very small compared with the load admittance it can be neglected.

Before we get on to transistors there is another duality about circuit arrangement that ought to be noted. Usually, when students have taken in Ohm's Law, they go on to Kirchhoff's Laws. The interesting thing just now is that there are two of them, duals of one another. The first—or is it the second? I can never remember—says that when a number of currents meet at a point, such as in Fig. 5(a), the sum of them, reckoned all towards or all away from the point, is always zero. And the other law says the corresponding thing about voltages round a loop, as at (b). The lines here are not meant to be short-circuits; each can include as many as you like of anything—impedances, valves, generators, etc. If these same two dual circuit structures are drawn slightly differently, and some typical components shown (Fig. 6), we see the two general types of filter, T and π . These are, in fact, duals. Series L is replaced by parallel C , and vice versa. So it is not necessary to work out the equations for both types of filter; when one has been done, those for the other can be derived by duality substitution.

And now for transistors. It was obvious all along that crystal triodes were analogous to thermionic valve triodes, but it soon became clear that the analogy was upside down. And that suggested applying duality to the valve circuits to find the corresponding circuits for the transistors. I have already mentioned that where a valve uses negative voltage bias a transistor uses positive current bias. Severe distortion takes place in a valve if the voltage bias is removed

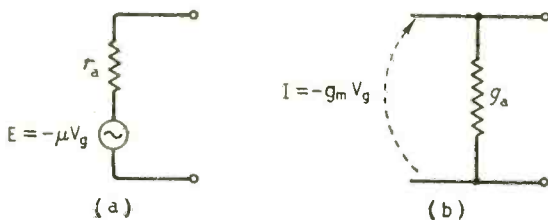

Fig. 4. Generator circuits equivalent to a valve; (a) constant voltage; (b) constant current.

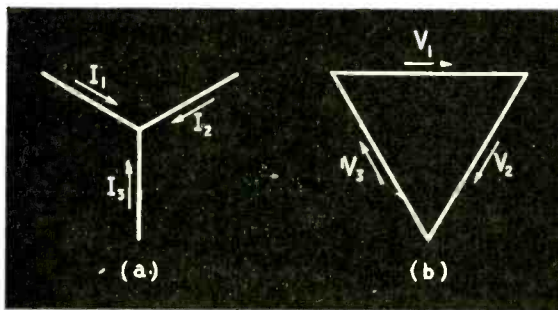

Fig. 5. These two arrangements, illustrating Kirchhoff's two laws, are duals of one another.

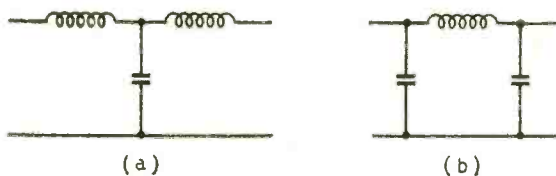

Fig. 6. These two main types of filter circuit, T and π are particular examples of Fig. 5.

* "That Other Valve Equivalent" April 1951, p. 152.

and grid current flows; correspondingly there is distortion in the transistor if the current bias is removed and voltage builds up across the input (emitter to base).

On the output side, we have already noted (in connection with Fig. 4) that a pentode is approximately in dual relation to a low-resistance triode, as regards circuit arrangement at least. But the dualism extends to the interchanging of current and voltage. This is not very well brought out by published characteristic curves, because those for pentodes are always plotted as current against voltage, just the same as for triodes—compare Fig. 7(b) with (a). But if the pentode curves (b) are replotted as voltage against current (c) the likeness to (a) is obvious.

The types of transistor for which data have been published have output characteristics of pentode shape (Fig. 8). The main practical difference is that the "h.t." voltage applied to the collector (corresponding to the valve anode) is negative.

But unlike the pentode the transistor's dual relationship to the thermionic triode includes the input as well as the output. In fact, one could say that transistors are rather like low-power output pentodes worked under grid-current conditions, requiring slightly positive grid bias voltage.

Amplification Duality

Apart from the transistor "h.t." being negative, the weakest thing about this comparison is that in the pentode the output voltage is not mainly controlled by grid current as such, but only in so far as the variation of grid current means that the grid voltage is varying; whereas in the transistor it is the emitter current that controls the collector output current.

So it is natural that μ , which is the ratio of anode voltage change to grid voltage change (at constant anode current), should have as its transistor analogue (α) the ratio of collector current change to emitter current change (at constant emitter voltage).

The only thing that radically spoils the dualism between the thermionic triode and crystal triode is the collector voltage and current being negative. Whereas there is the well known reversal of sign between input and output when a valve is working in an earthed-cathode circuit, there is no such reversal when a transistor is working in a corresponding (earthed-base) circuit. So in deriving the dual of a valve circuit, one has to remember to add to the normal procedure a sign reversal.

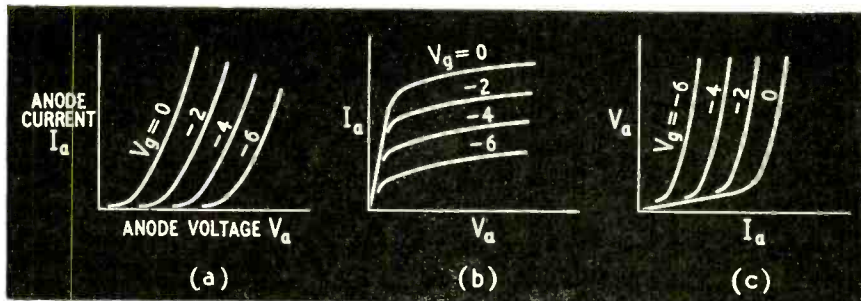

Above: Fig. 7. (a) shows the characteristic curve shape for a triode and (b) for a pentode. If (b) is replotted with current and voltage interchanged the result (c) is very similar to (a).

Right: Fig. 8. Typical transistor curves, being similar to Fig. 7 (a) with current and voltage interchanged, indicate an approximate dual relationship to the thermionic triode.

Below: Fig. 9. Basic tuned-anode tuned-grid valve oscillator circuit (a) compared with corresponding (dual) transistor oscillator circuit (b).

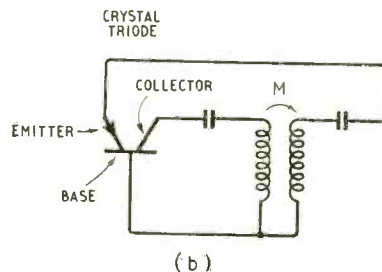
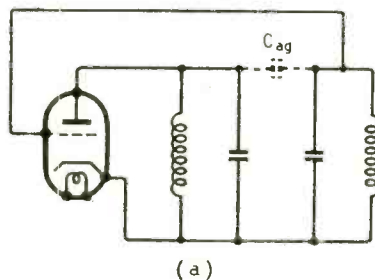
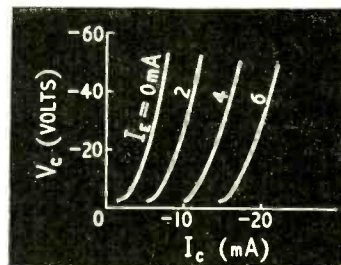

Although designers seem to find dualism a great help, as a means of applying the vast accumulation of experience of valve circuits, it is not altogether plain sailing. It is one thing to arrive at the appropriate set of equations, and even the theoretically best circuit; but in practice it is rather disconcerting when the grid bias battery (or other source of constant voltage) is found to have given place to a constant-current generator. However there is a way out, for a constant-current generator in series with an input or output coupling impedance can be replaced by a parallel-fed constant-voltage generator.

In fact, the outstanding effects of the dual transformation are to interchange series with parallel and capacitance with inductance. Perhaps the simplest and most obvious example is to compare the tuned-anode tuned-grid oscillator circuit with its transistor counterpart, Fig. 9(b), which needs no explanation. So as not to obscure the issue, all feed supplies have been left out. If I were to follow up what readers may have already found to be rather a tough meal with full details of transistor circuit design, the risk of indigestion would be considerably increased. After all, we are not likely to be able to buy transistors in the shops for some while yet, so a wealth of detail would be rather premature. But I do believe they may be near enough for the mentally alert to be glad of a little advance warning of the sort of technique that is being used. And even if practical transistors fail to come our way, it may be helpful in other directions to be aware of duality.

RADAR REFLECTORS

WITH the increasing use of radar as a marine navigational aid (some 1,400 British Commonwealth merchant ships are now equipped) there is a growing need for navigational buoys to be readily distinguishable on the p.p.i. A symbol appearing with increasing frequency upon charts is "Ra. Refl.," indicating that a buoy or beacon is fitted with a radar reflector. More than fifty of these "raflacs," as they are colloquially known, are now in use around the coasts of the United Kingdom, while it is understood they are in greater use off the east coast of N. America.

Fundamentally, the best reflector is a flat metal plate, but this would only be effective were the radar beam always directed at right-angles to it, which is, of course, impracticable.

A review in a recent issue of *The Scanner* (house journal of Decca Radar, Ltd.) compares figures for dihedral and polyhedral reflectors on both stationary and moving objects. While the response from a reflector with two surfaces (4ft high by 1½ft wide), forming a right-angle, is stated to have increased the detection range of a specified lighthouse from 8 to 18 miles, it is necessary to add a third surface—forming a cone—when using a reflector on a buoy to compensate for the vertical tilt. These corner reflectors are normally used in clusters forming a multi-trihedral reflector as illustrated.

Tests show that a 12-in corner reflector 6ft above the water is detectable 5.4 miles away with a scanner 50ft above sea level; this is decreased to 4.6 miles in a rough sea. The intensity of reflections from a reflector buoy passed at 3.75 miles using Decca marine radar Type 159 is given in Fig. 1.

The use of reflectors is not confined to navigational marks, and it has been found that a collapsible reflector, which can be readily assembled and run up to



Pentagonal cluster of corner reflectors used in "raflac" trials by the National Research Council of Canada.

Fig. 1. Intensity of reflections from a radar reflector buoy passed at 3.75 miles. The vertical scale gives the number of times the echo was received in ten revolutions of the scanner.

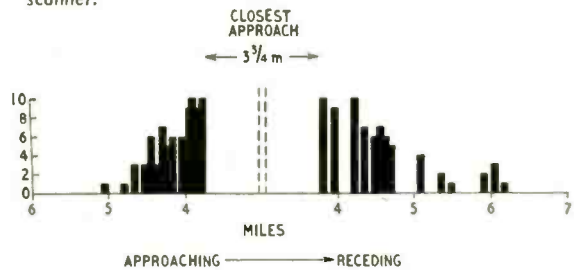

the masthead of a ship's lifeboat, increased the detection range of such a craft from less than 2 miles to about 4.5 miles.

NEWS FROM THE CLUBS

Birkenhead.—Meetings of the Wirral Amateur Radio Society, which now has nearly thirty licensed amateurs among its members, meets on alternate Wednesdays at 7.30 at the Y.M.C.A., Whetstone Lane, Birkenhead. The April meetings will be held on the 9th and 23rd. Sec.: A. H. Watts, 14, Grange Crescent, Hooton, Cheshire.

Birmingham.—At the April 25th meeting of the Slade Radio Society, R. Ledger, of the G.E.C., will talk on "Electric Traction." Meetings are held at 7.45 at the Parochial Hall, Broomfield Road, Erdington. Sec.: C. N. Smart, 110, Woolmore Road, Erdington, Birmingham.

Coventry.—The next meeting of the Coventry Amateur Radio Society will be held on April 28th when there will be a lecture on communication receivers. Meetings are held on alternate Mondays at 7.30 at the Y.W.C.A., Queen's Road, Coventry. Sec.: K. G. Lines, 142, Shorncliffe Road, Coventry.

East Grinstead.—Readers in the East Grinstead (Sussex) district who are interested in the formation of a radio society, are invited by Frank Glynn (G3GVZ) to communicate with him at The Mount, 13, Station Road, East Grinstead, Sussex.

Ilford.—Lectures on capacitors, valves and technical

literature are scheduled for the month's meetings of the Ilford & District Radio Society. On the 3rd H. J. Cozens, of T.C.C., will talk on capacitors; 10th, "Radio Valves: Manufacture and History," by G. P. Thwaites (S.T.C.); and 17th, "Technical Articles and Books," by Geoffrey Parr (Chapman & Hall). Meetings, to which visitors are welcome, are held every Thursday at 8 at St. Albans Church Hall, Albert Road, Ilford. Sec.: C. E. Larget, 44, Trelawney Road, Barkingside, Ilford, Essex.

Leicester.—"Tuned Circuits: with special reference to the 144 Mc/s band" is the subject to be dealt with by R. Weston at the meeting of the Leicester Radio Society at 7.30 on April 7th at the Holly Bush Hotel, Belgrave Gate, Leicester. Sec.: A. L. Milnthorpe, 3, Winsters Drive, Thurmaston, Nr. Leicester.

Southend.—By the death of Henry H. Burrows, O.B.E., the Southend and District Radio Society has lost its president, who was also a founder member of the society. We are advised by the club's temporary secretary (T. W. Hudson) that the judging of entries for the Pocock and Hudson cups (for home-built gear) will take place on April 4th. Sec. (*pro tem*): T. W. Hudson, 27, Park Road, Southend-on-Sea, Essex.

RADIO HEATING

Typical Installations in Two Modern Industries



ALTHOUGH the two basic methods of radio heating—dielectric heating and induction heating—are now very well known, there is always some fresh interest to be found in the new methods of application which are constantly arising. Take, for instance, two of the latest installations by Radio Heaters, Ltd.—a dielectric heater for a plastics factory and an induction heater for a motor works.

The dielectric heater, installed for British Moulded Plastics Ltd., should be of particular interest to radio people because it plays a vital part in the manufacture of the unusually large moulded plastic cabinet of the Sobell "Stargazer" console television set. Normally, a plastic moulding is made by applying heat and pressure to the raw material—blocks of compressed powder—until it flows into the required shape. This, however, would have been unsuitable for commercial-scale production of the "Stargazer" cabinet as it would have taken too long and required an inconveniently large press. It was therefore decided that the 32 lb of powder blocks should be "pre-heated"

Dielectric heater for pre-heating the compressed powder blocks used in the manufacture of the plastic television cabinet shown below. Closing down the lid automatically switches on the power and a process timer switches it off.

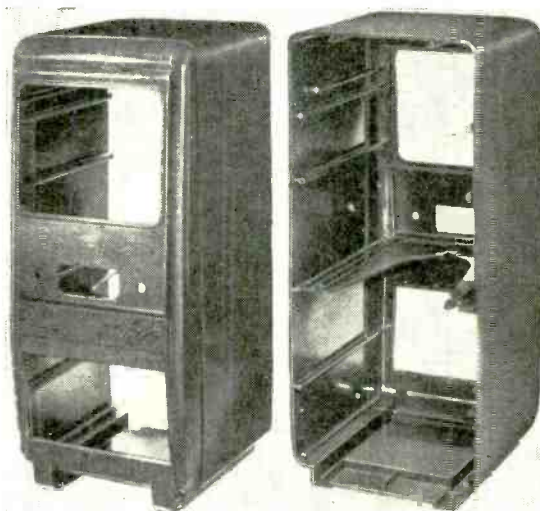

Below: The threaded sections of these pins are being annealed by heating in the long coil on the left. Below, right: Using a different rotating table, the tappet pads on the rocker arms are being hardened by heating in the small coil (right) and quenching in the two oil jets.

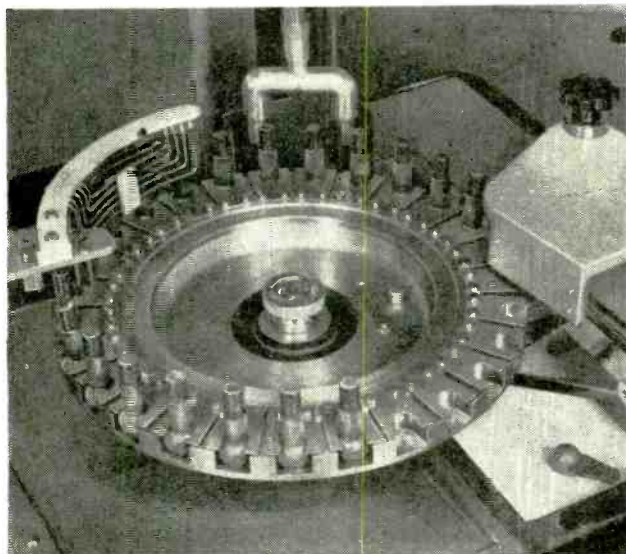

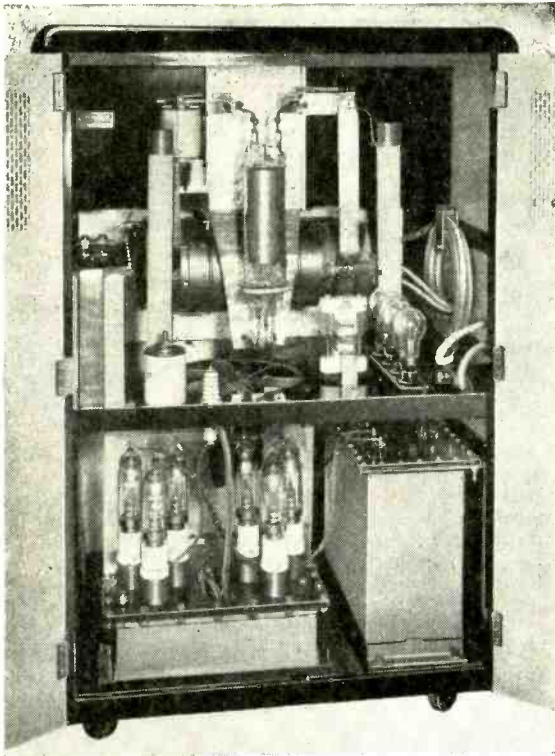

Back view of induction heater, showing the oscillator valve in the top section and the power unit below.

into a near-plastic condition first, so that less time would be needed for "curing" and the easier flow of plastic would make possible the use of a reasonable size of press.

Ordinary methods of heating are not altogether satisfactory as the powder has poor thermal conductivity and does not get heated uniformly throughout. Radio heating, however, gives uniform distribution of heat in a very short time, so a radio dielectric heater was chosen to do the job. In this, the powder blocks are placed between two metal plates and the capacitor so formed is included in an oscillator circuit working at about 19 Mc/s. The equipment delivers 6 kW of r.f. power into the blocks and the dielectric loss effect raises their temperature to 70-80 deg C in 8 minutes. As a result of this treatment the curing time of the plastic is reduced by 30-40 per cent and only about half of the normal pressure is required to produce the moulding.

The induction heater, installed at the Ford Motor Company's Dagenham Works for treating small metal parts, exemplifies well the special ability of this type of equipment for giving very localized heating. It has three work coils, which can be connected in turn to an r.f. oscillator, and these heat the parts by the well-known eddy-current and hysteresis effects. The first coil is for hardening, to a depth of $\frac{1}{8}$ in, the side wearing surfaces of a ball on the end of a steering arm. The ball is placed inside it and an operator switches on the r.f. power; then, at the end of 27 seconds, a process timer switches off and turns on a water supply to quench the hot metal. The second coil is for annealing steel pins over their threaded length only. A number of them are loaded on to a rotating table, and

as this is indexed round the threaded sections pass through the coil. Each pin remains in it for 30 seconds, then cools down for a while before being ploughed off down a chute. The third coil is for hardening the tappet pads on rocker arms. Again a rotating table is used, but this time each tappet pad remains in the coil for 10 seconds then is indexed straight into a quenching jet of oil.

The r.f. oscillator for this installation uses a single valve in a Colpitts circuit working at about 400 kc/s, and the 8-kW output goes to the work coil via an r.f. transformer. A point of special interest is that the grid leak is formed by a number of lamps connected in series. This is often done in r.f. heating equipment as it greatly reduces the grid current variations which occur when the load on the oscillator is altered.

SPINNING PARABOLIC REFLECTORS

MAKING parabolic reflectors for electric lamps and heaters is more or less a bread-and-butter job for the metal spinner, but turning out the giant versions used in c.h.f. radio stations is an altogether different matter. The one in the picture, for instance, is 8ft 6in across, and had to be made out of several pieces of aluminium welded together because no rolling mill could supply a one-piece sheet big enough for the job. Spinning these jointed sections is a considerable feat of skill, for the metal has to be made to "flow" smoothly into the required shape and this is not easy when there are any irregularities, such as these welds, in its crystalline structure. The makers, Precision Metal Spinings of Stratford-on-Avon, tell us that they are hoping to produce even larger spinings—up to 12ft in diameter—by the same method.

Work in progress on one of the reflectors.

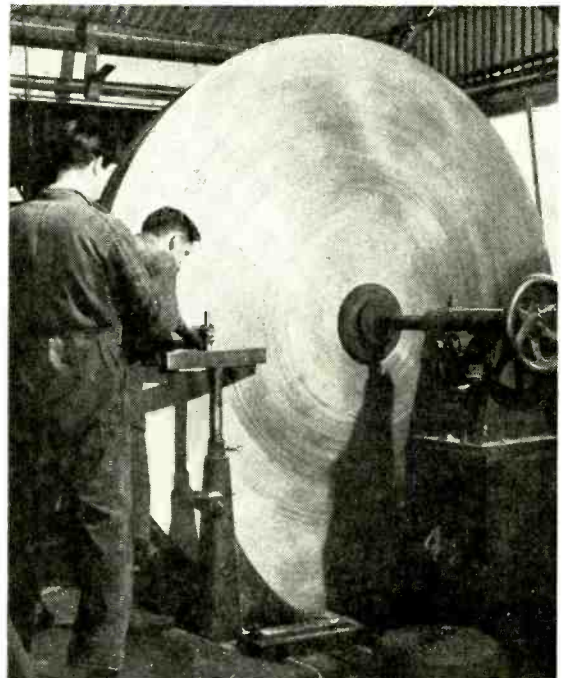

Radio Manufacture in India

Production Problems of Indigenous Industry

By JOHN A. HOWIE, B.Sc. (Hons.)*

IN 1947 the Indian Congress Government found itself faced with the gigantic task of organizing a population of some 350,000,000 multi-lingual and largely illiterate peoples into a coherent nation. They inherited the All-India Radio broadcasting service which had been organized more or less on the lines of the B.B.C., but its transmitters covered only a very small proportion of the country and, in any case, less than one in a thousand of the population owned a radio receiver. A Ministry of Communications and Broadcasting was therefore set up to expand A.I.R., promote the Rural Broadcasting Service (which installs and maintains community receivers in the villages and broadcasts special programmes to them) and encourage the formation of an indigenous radio industry.

Two companies had already been formed to manufacture radio receivers in India: the National Radio and Engineering Company of Bombay, a subsidiary of the Tata group of industries, and the Radio & Electrical Manufacturing Company of Bangalore, owned by the Government of Mysore State and operating at that time in association with the Philco Company of Great Britain. The National Radio Company commenced production in 1947 of a small three-valve t.r.f. mains receiver, preset to one m.w. station and known as "The People's Set." This was designed and made entirely by Indians, all the components, with the exception of valves and loudspeakers, were manufactured in Bombay. Although it was offered at a list price of only Rs.95 (£7 3s)—less than half the price of the cheapest imported receiver—it proved unpopular and production ceased in 1948. The principal reason for this was the short transmitting periods and unattractive programmes of the local A.I.R. stations which were the only broadcasts receivable on the People's Set, because of its limited range. The company, therefore, decided to associate with a foreign manufacturer and a new joint company called the National Ekco Radio and Engineering Co., Ltd., was formed in association with E. K. Cole, Ltd.

The Radio & Electrical Company of Bangalore, under the technical guidance of the British Philco Company, constructed and equipped a large factory designed to produce 100,000 receivers per annum, including all components, but in 1948 their association with Philco was dissolved, and in the following year they commenced assembly of kits imported from the International General Electric Company, Inc., of America.

The promise of Government support encouraged a large number of small concerns to produce battery

receivers, mostly of rather odd design, made largely from war surplus valves and components left behind by the British and American armies. There are now about sixty of these small concerns with an average individual output of less than 500 sets per annum.

In 1948 Murphy Radio (India), Limited, was set up in Bombay to assemble kits imported from the parent company, and Philips and H.M.V. at Calcutta began to change over to partial local assembly.

The most recent additions have been Tesla (India), Limited, assembling kits imported, apparently at very low prices, from the State-owned Tesla Company of Czechoslovakia and the Birla Bros., subsidiary Indian Plastics, Limited, set up

under the technical guidance of Leland Instruments, Ltd., of London. The Government of India restricted imports of complete receivers from 1948 but granted special "blanket" licences to indigenous manufacturers for the import of necessary components and materials.

Thus the foundations have been laid for a new industry in which British, Continental, American and unaided Indian interests are all represented.

The potential market is, however, limited, for less than five per cent of the population can hope to own anything as expensive as a domestic radio receiver. Even so, this provides a potential demand of about three million receivers. The number of licence holders is still only slightly more than six hundred thousand.

The total annual sales is at present less than one hundred thousand, of which about thirty per cent are imported receivers, another thirty per cent are made by the small Indian assemblers, and the remainder are manufactured by the larger companies mentioned above. Last year the National Ekco company alone produced more than twenty thousand receivers.

The remaining 95 per cent of the population (totaling over 300,000,000) are potential customers only for community receivers, and so far only about 3,000 of these receivers have been installed. Elaborate plans have, however, been made by Central, Provincial and State Governments for the equipment of all the 700,000 Indian villages, but the necessary finance has yet to be found.

The design, manufacture and use of village community receivers in India is a separate story which cannot be adequately dealt with in the compass of this article but it is probable that these highly specialized receivers will play an increasingly important part in the Indian radio industry during the next few years.

Meanwhile the domestic market should continue to

The author, who has had practical experience of setting up a radio factory in India, outlines some of the problems which have been solved in the process of manufacturing many thousands of high-quality receivers each year using Indian labour with British co-operation and technical guidance.

* Formerly National Ekco Radio and Engineering Co., Bombay.

take about 100,000 receivers per annum unless a general business depression sets in. If and when the ambitious plans for progress of the Indian Government, including a higher standard of living for the middle classes and great expansion of electrification of homes, mature, the demand should increase substantially—probably to 300,000 per annum—but it is too early yet to estimate the probability of these plans proving economically possible. Vast sums of money are already being spent on new hydro-electric projects and the expansion of industry, but, simultaneously the population is increasing at the rate of 5,000,000 per annum and maintenance of even the present standard of living is proving increasingly difficult.

Listener Requirements

The Indian listening public divides sharply into two categories, one being the rural population, almost unchanged in outlook and habit from their forebears of earlier centuries, and the other the inhabitants of the larger cities who have acquired many "westernized" tastes and interests. All-India Radio is attempting to meet these diverse requirements by operating a comparatively large number (27) of low-powered m.w. transmitters in the cities, combined with 15 higher-powered s.w. transmitters, chiefly from Delhi, to provide more general coverage. Financial stringency prevents their operating these transmitters for more than a few hours each day, and even these limited periods have to be shared out among broadcasts in a number of different languages. A fairly close parallel would be the planning of programmes to suit all the peoples of Europe on a budget equal to

a tenth of that of the B.B.C.—the number of different languages and the overall area to be covered both being of the same order.

The Government of India still refuses to sanction commercial broadcasting, but recently two commercial s.w. transmitters, one in the small Portuguese territory of Goa on the West coast, and the other in Ceylon, have gone into service and have become very popular. Radio Ceylon in particular broadcasts continuously each day from a 75-kW transmitter and has probably become the most important single factor in stimulating the sales of domestic receivers in India. Overseas broadcasts, especially those from British, American and Australian stations, are listened to regularly.

It follows, therefore, that the Indian market demands really adequate s.w. reception, which is a very different thing from the novelty value s.w. performance usually provided for the British or Continental markets. Moreover, the climate and the prevalence of dust and insects quickly destroys both the receivers and the reputation of the manufacturers unless thoroughly reliable and fully proofed components are used.

Tropic-proofing

Many reputable manufacturers have spent a great deal of their own and Government's money studying tropicalization for the past ten years, but too much reliance has been placed on extreme, accelerated tests, such as the Inter-Service K110 test and, since 1946, tropic-proofing specifications have tended to be diluted by price considerations.

Any manufacturer who sincerely wishes to determine the performance of his products under tropical conditions is recommended to expose complete receivers to a temperature of 95° F and a relative humidity of 95 per cent continuously for one month preferably in the presence of some of the more virulent moulds which flourish under these conditions, and then examine the appearance and measure the performance of the receivers while still in that atmosphere. The results are apt to be discouraging, but these conditions are only little more severe than those experienced regularly during a large part of each year in the homes of his potential customers and, more significantly, in the shops of his Indian dealers, where his products may lie for several months before sale.

Because so many of the urban listeners live in flats, they are unable to fit efficient aerials and earths. Interference from lifts, fans, refrigerators, etc., is heavy and the mains voltage fluctuates widely due to overload. Under these unfavourable conditions and the prevailing high humidity, sensitivities of less than 50 microvolts for 500 milliwatts output, correspondingly high selectivity and signal/noise ratio and an output at not more than 10 per cent distortion of at least 1.5 watts are really essential for reception of distant s.w. broadcasts at enjoyable quality and volume in the cities.

For battery receivers, the reduced background noise and interference and the better aerial facilities usually available in rural districts make sensitivity of the order of 100 microvolts for 50 milliwatts output and peak outputs of 250 milliwatts adequate.

Bandspreading, frequency stability and a visual tuning indicator are desirable. The use of textiles for speaker grilles is inadvisable because of the



The author checking a tool-shaping machine. Piecparts and components are produced in the National Ekco Radio and Engineering Company's factory in Bombay.

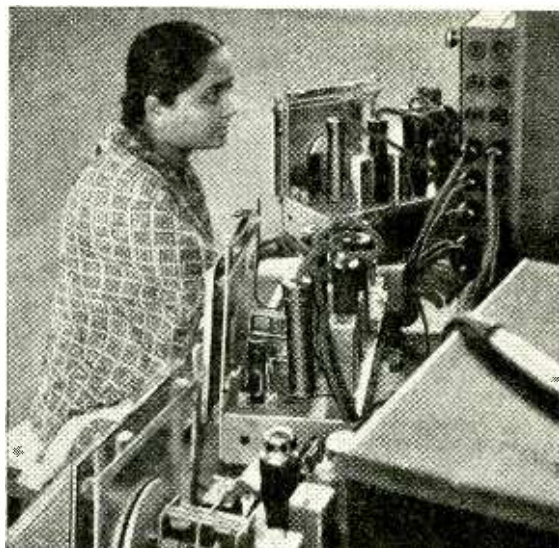
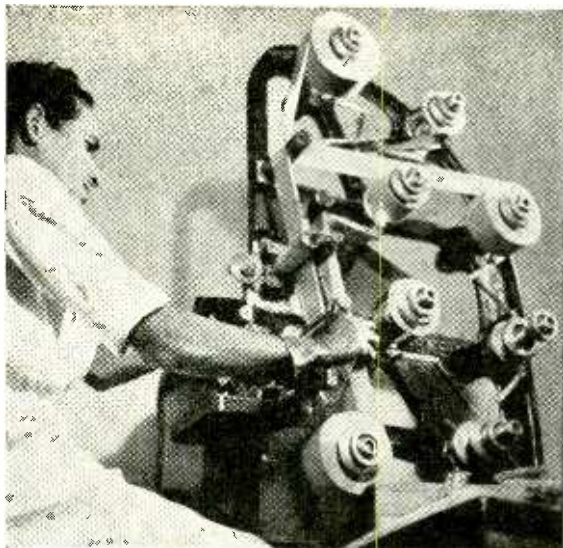

Left: Winding paper capacitors for which air conditioning is essential. Right: Receiver chassis at the circuit comparator test bench.

ravages of cockroaches, and completely waterproof cabinet construction and finishing are essential. At the same time, prices must be kept within limits. A receiver which would sell at £16 plus purchase tax in this country costs at least £30 in India because of the imposition of 44 per cent duty on C.I.F. value and the high distribution expenses. The "Official" list retail price is, moreover, increased by about 25 per cent because nearly all Indian customers expect to receive a large discount off the list price as a result of a prolonged haggle with the dealer.

Production Problems

The radio manufacturer in India starts off with a number of difficult administrative and technical problems to overcome. The large-scale mass production of receivers is probably one of the most efficient industries in this country, but no one who has attempted to compete with these large producers on a comparatively small scale will claim that it is easy. The production of tropicalized all-wave receivers in a hot, humid and industrially backward country is infinitely more difficult, especially when they must be competitive with imported receivers. There is little future in importing kits and confining manufacture merely to assembly and test because the landed cost of a complete kit is not sufficiently less than that of the corresponding finished receiver.

The comparatively low Indian labour rates must be utilized by making a large proportion of the piec-parts and components and thus saving the import duty charged on these items. To do this without excessive capital expenditure or overhead charges demands a fair amount of ingenuity in scaling down the elaborate organization, machines and tools commonly employed by the big producers. For example, the use of a 100-ton power press and an elaborate tool to blank and pierce chassis in one operation is efficient when large numbers are required and labour costs are high, but three or four cheaper tools set up successively in a smaller press can be made to produce quite a range of different chassis with appropriate withdrawal or addition of punches.

Similarly, the use of mechanized assembly lines looks impressive to visitors and earns its keep at high outputs, but ordinary benches are cheaper and more flexible for smaller rates of production. On the other hand, no relaxation in accuracy or quality can be permitted because "trouble-shooting" and component replacements on the assembly lines are just as expensive in any country and a "renovated" chassis always looks what it is.

The Indian universities and technical institutes annually turn out hundreds of matriculates and engineering graduates who are intelligent and enthusiastic but sadly lacking in practical experience and initiative. With patient training and firm leadership they can be turned into reliable production staff, but very few of them have executive capacity. Nevertheless, the National Ekco Company and two other manufacturing companies are each staffed by Indians with a British manager.

Many types of working-class Indians also make good "raw material" for radio production, but the lack of industrial background demands much more extensive training and a greater degree of supervision. Indian girl assembly workers are intelligent and dexterous but, even after training, cannot achieve more than about 60 per cent of the output of British girls because of their inferior physique and the enervating climate. This is also true of the men but, as a good Indian factory worker does not cost more than 30s per week (which is appreciably higher than the average wage paid in other industries), labour costs per receiver are lower than in this country.

Practically all materials, with the exception of certain types of steel, mica, shellac and varnishes, have to be imported, although locally made non-ferrous sheets, rods and fabricated parts produced from imported ingots are available in suitable qualities and at competitive prices. The National Ekco Company manufactures all types of radio transformers, chokes and coils, together with paper and mica capacitors, and sells them to other assemblers, but at present there is little other component manufacture in India. All materials have to be very carefully stored and protected against corrosion due to the high humidity and contamination by dust and insects.

This also applies to machine tools and plant, which must be cleaned and oiled daily.

A State radio factory was projected for the production of all Services requirements, including valves and components, but this proposal appears to have been dropped because of its prohibitive cost. When the Indian radio industry has developed further it is probable that contracts will be issued to it for the development and manufacture of most types of communication gear, receivers and components.

The numerous police forces are also using considerable numbers of mobile transceivers and public-address equipment, and the large Indian Posts and Telegraph factory at Bangalore is buying some of its components from commercial radio manufacturers. Recently an Atomic Energy Commission has been set up to exploit India's resources of radio-active minerals and already small quantities of electronic apparatus have been designed and made in India for this Commission. It is noteworthy that the Government of India has included radio manufacture in a list of fourteen strategic industries selected for special encouragement and would apparently welcome the investment of further British capital in this industry, particularly if the production of valves and components were undertaken.

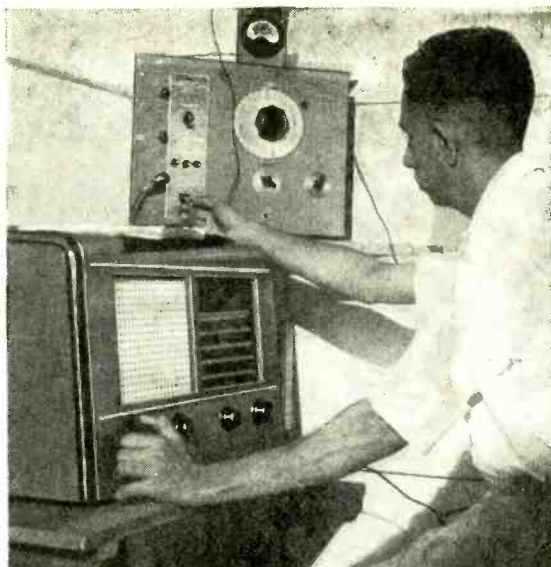

Completed receiver undergoing the final test.

Simplified Aerodrome Approach Aid

Combination of 3-cm Radar and Metre-wave Direction Finder

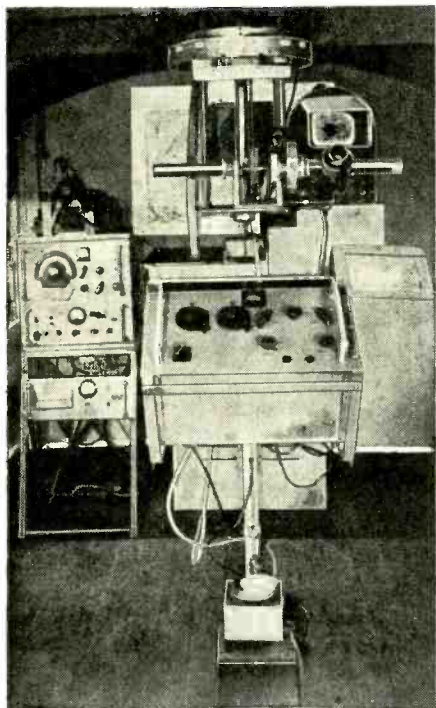

EkcO prototype 3-cm radar approach aid combined with a v.h.f. direction-finding receiver.

MANY aerodromes do not handle a density of traffic sufficient to justify the high cost of full GCA (ground-controlled approach) equipment. However, there is generally still need for a radio aid to landing in poor visibility, and, to meet such a need, a simplified and cheaper type of equipment has been developed by E. K. Cole, Ltd. The apparatus, which was recently demonstrated experimentally at Southend Municipal Airport, consists of a 3-cm radar installation producing a narrow pencil-like beam of radiation combined with a metre-wave direction-finding receiver (116-132Mc/s). The radar beam does not scan in the usual way but the "dish" aerial is mounted on the rotatable shaft which carries the v.h.f. aerial, and is arranged so that the axis of the radar beam coincides with the null position of the d.f. aerial. The radar dish is controllable independently in elevation but not in azimuth.

The radar display tube is calibrated in nautical miles and scales show the elevation angle of the radar beam and the azimuth angle of the d.f. aerial. Adjustable contacts on the scale-drives illuminate lamps which indicate when the aircraft is within certain prescribed limits of the desired course, when it deviates, and whether the deviation is in azimuth or in elevation.

The necessary changes in course, and in altitude, are conveyed to the aircraft by radio-telephone.

In the illustration can be seen two horizontal hand-grips and above the right-hand one is the c.r.t. indicator, while clamped to the hand-grip is the microphone. Above are the scales.

The operator uses the horizontal hand-grips to rotate the radar dish and d.f. aerial (azimuth search), while for elevation search the grips are twisted about their axis. The v.h.f. direction finder and radar approach aid can be operated by one man.

An improved model is in course of development in which the operator can be seated and operate the azimuth control by a hand wheel and elevation control by foot pedals.

High-Tension Delay Circuit

Relay-Operated Protective Device

By D. CLEMENTS

THE arrangement to be described is applicable to mains-driven power units where a capacitance input filter is used. It provides a delay in applying the full h.t. voltage to capacitors and other components until the load is of sufficient magnitude to prevent the voltage rising to a dangerous level. In the event of the load failing, the voltage is immediately reduced to its former safe level.

The circuit has several advantages over the conventional thermal delay system, and calls for fewer components; one relay is the only extra component required. The delay is only as long as that needed for the load to present itself, and, if the load is not forthcoming, the device does not switch and the voltage remains at a safe level. If the load fails the circuit reverts to its original condition and the voltage is reduced. Relay contacts do not have to make or break any excessive voltages or currents.

Fig. 1 shows the circuit before power is switched on. C_1 , which is normally the reservoir capacitor, is switched in parallel with the first smoothing capacitor C_2 by relay contacts A_1 , the relay coil $A/1$ being in series with the smoothing choke L_1 . When power is first switched on, the smoothing circuit L_1, C_1 and C_2 is connected as a choke-input filter and, providing there is a small h.t. drain, the voltage across the capacitors does not rise above the effective value of the alternating voltage applied to the rectifier. Since there is no appreciable load current the relay $A/1$ does not operate.

When the load current has increased to a value that will keep the final voltage down to a safe level (i.e., when the heaters have warmed up) the relay operates and the capacitor C_1 is switched to its conventional position in the circuit as a reservoir capacitance. The h.t. voltage now rises to its normal "on load" value.

Until the operation of the relay, C_1 is charged to the voltage across C_2 so that the contacts, on switching, do not have to "make" any excessive voltage. The only current carried by the relay contacts is that of the ripple current in C_1 .

If, when power is switched on, the heaters are already hot and current flows, the relay will immediately operate and there will be no delay. Conversely, if the load should fail during operation, the relay immediately becomes de-energized and the

circuit reverts to its original condition to give reduced h.t. voltage as previously explained.

The load which is required initially to limit the h.t. voltage to a given safe level is almost entirely dependent on the value of the inductance L_1 . If the maximum permitted level of this voltage is the effective value of the applied a.c. (0.9 of r.m.s. value), then the load resistance R_L must satisfy the expression,

$$R_L < \omega L_1 \frac{E_0}{E_1}$$

where $\omega = 2\pi \times$ lowest ripple frequency

$$\frac{E_0}{E_1} = \frac{\text{Output voltage}}{\text{Lowest-frequency ripple component}}$$

In the case of full-wave single-phase rectification

$\frac{E_0}{E_1} = 1.5$ and if the supply frequency is 50 c/s then,

approximately, $R_L (\text{max}) = 10^3 \times L_1$. In the above expressions the value given for R_L includes the resistance of the inductance plus the equivalent valve and transformer resistances.

If the maximum permitted direct voltage is higher than that quoted above, and if electrolytic capacitors of the surge-limiting type are used, the load resistance may be considerably higher. Occasionally it can be omitted altogether, as when the leakage current of the electrolytics is sufficient to limit the voltage. It is usually best to find the resistance of R_L empirically using a meter to indicate the voltage across the capacitors (the relay is best made inoperative by means of a short circuit during this operation).

The relay $A/1$ may be of any type that will operate when the h.t. current rises to the appropriate value which, in the absence of more accurate information, may usually be taken as being approximately 75 per cent of the final h.t. drain. If a relay of greater sensitivity than necessary is used, it may conveniently be modified by a resistor R_1 in parallel. The value of this resistor is best found by wiring a variable resistance set to zero ohms, across the relay and, after switching on and allowing a suitable period for heaters to warm up, slowly increasing the resistance until the relay operates. A fixed resistor of appropriate value may now be substituted.

If a standard 3,000-type relay, fitted with one

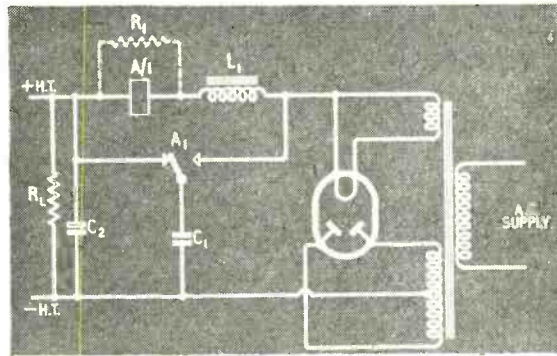

Fig. 1. Circuit of h.t. supply fitted with a relay to reduce the output voltage while the valve heaters are warming up.

change-over contact, is used, then approximately 75 ampere-turns are required to operate it. If the full winding space of the relay is used, T^2 approximately equals 250,000R where T is number of turns and R resistance in ohms. This gives rise to the following expression which may be of use to ascertain the suitability of a given relay when the resistance is known:—

$$\text{Minimum operating current in amperes} \approx \frac{1}{6.5 \sqrt{R}}$$

TECHNOLOGISTS IN MEDICAL WORK

Young Professional Association

MOST electro-medical technologists are in the work for sheer love of it; for they get very little out of it in prestige or monetary reward. Nevertheless they are expected to know a lot about medicine as well as nearly everything about electronics, to be extremely adaptable, and to make silk purses out of sows' ears—hospitals being notoriously reluctant to part with money for new equipment. Many of them are practised in the art of designing unusual and specialized apparatus for medical people who refuse to entertain the idea of more than one control knob—and sometimes the result is such a good engineering job that it is taken up and developed commercially.

Two years ago an association was formed to look after the interests of these workers (there are fewer than 200 in this country) and make possible an interchange of technical information on the somewhat unusual work. It is called The Electro Physiological Technologists' Association (E.P.T.A. for short) and at the moment has about 50 members. The first issue of its official journal, *Proc. E.P.T.A.*, gives the objects of the Association as: (a) To exercise professional supervision over its members and to provide for them such definite status and recognition as may assist in the discharge of their duties provided that these activities do not in any way cause the Association to act as a trade union. (b) To devise means of testing the qualifications of candidates for admission to membership by examinations in theory and practice and to grant certificates and diplomas of qualifications to successful candidates. (c) To hold meetings and conferences for the discussion of scientific and technical matters and to co-operate with other learned bodies.

The president is Professor F. L. Golla of the Burden Neurological Institute, while the present Hon. Secretary is G. Johnson of Hurstwood Park Hospital, Haywards Heath, Sussex.

EXHIBITORS AT MANCHESTER

THE Northern Radio Show, organized by the Radio Industry Council, opens at the City Hall, Manchester, at 12 noon on April 23 for ten days. As will be seen from the appended list, the majority of the major receiver manufacturers are among the fifty exhibitors, but it is not confined to domestic radio. Although smaller than the National Radio Show, it will be representative of the radio industry in general. In addition to the receivers operating in the Television Avenue, exhibitors will be permitted to operate sets on their stands which will be fed from the exhibition control room. The television sound channel

will be employed for public address. The price of admission to the show is 2s (children 1s).

Name	Stand No.	Name	Stand No.
Aerialite	22	J.B. Mfg.	2
Alba	15	Kemsley Newspapers	48
Ambassador	20	Kolster-Brandes	18
Antiference	3	McMichael	19
Argosy Radiovision	37	Marconiophone	23
B.B.C.	49	Mullard	26
Belling & Lee	44	Multicore	39
British Radio & Television	35	Murphy	13
Bush	33	Peto Scott	34
Cossor	32	Philips	11 & 12
Decca	29	Pilot	28
Defiant (Co-op)	9 & 45	Practical Wireless	1
Dubilier	4	Pye	10
Ediswan	43	Regentone	27
Ekco	24	S.R.M. Television	51
English Electric	42	Stella	46
Ferguson	25	Telcon	38
Ferranti	30 & 40	Ultra	14
G.E.C.	31	Vidor	16
Goodmans	47	Wireless Trader	21
H.M.V.	17	Wolsey	36
Hobday Bros.	5		
Hunt	50		
Invicta	41		

Short-wave Conditions

Predictions for April

THE full-line curves given here indicate the highest frequencies likely to be usable at any time of the day or night for reliable communications over four long-distance paths from this country during April.

Broken-line curves give the highest frequencies that will sustain a partial service throughout the same period.

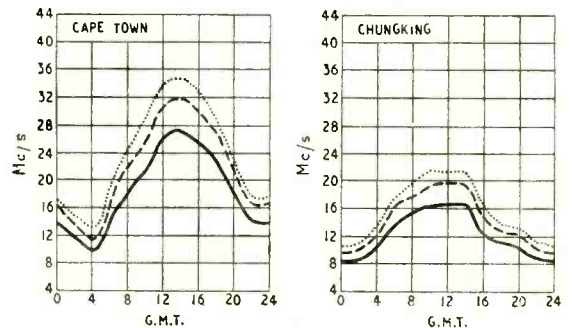
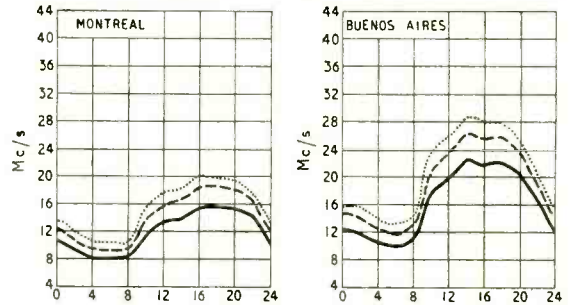

— FREQUENCY BELOW WHICH COMMUNICATION SHOULD BE POSSIBLE ON ALL UNDISTURBED DAYS
 - - - PREDICTED AVERAGE MAXIMUM USABLE FREQUENCY
 FREQUENCY BELOW WHICH COMMUNICATION SHOULD BE POSSIBLE FOR 25% OF THE TOTAL TIME

Manufacturers' Products

NEW EQUIPMENT AND ACCESSORIES FOR RADIO AND ELECTRONICS

Miniature Earphone

LARGE and uncomfortable headphones are on the way out, thanks to the enterprise of hearing-aid manufacturers who are now adapting their miniature earphone design technique for general use. A recent example of this particular kind of miniaturization is the Amplivox

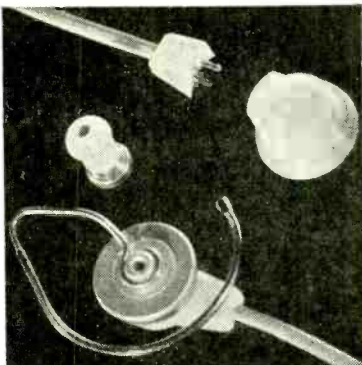

Amplivox miniature earphone.

E5 earphone, which is little bigger than a sixpence in diameter and weighs only $\frac{1}{2}$ oz. It is held in position by a flexible ear attachment (see picture)—although a stethoscope headset is available if required—and can be fitted with a plastic ear tip to close the ear canal against extraneous noise. The construction is robust and the plug and cord are designed to withstand the various strains caused by movement. The earphone is available in d.c. resistances of 2 to 2,000 ohms and it has a frequency response of 100c/s-4kc/s. The address of the makers is 2, Bentinck Street, London, W.1.

Signal Strength Meter

B.B.C. television transmissions are among others in the 40-70Mc/s band whose aerial signal strengths can be measured by an instrument recently put on the market by E.M.I. Sales & Service Ltd. Actually, it consists of three instruments in the one case—superhet receiver, signal generator and valve voltmeter—which it uses for the substitution method of measurement. Signals

E.M.I. signal strength meter.

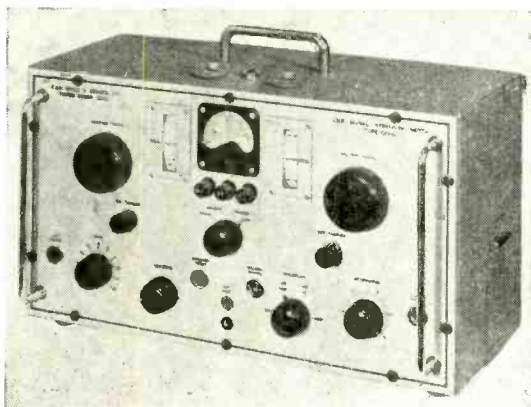

from the aerial are tuned in by the receiver and measured on the valve voltmeter, then the signal generator is substituted for the receiver and adjusted to give the same meter reading; the aerial signal strength—represented by the output of the generator—being read off from a calibrated attenuator. The instrument is completely portable, having its own vibrator power supply working from an internal 2-V accumulator. An a.c. mains charging unit is also incorporated to enable the accumulator to be charged when necessary.

The signal strength meter is obtainable from the Dealers' Service Development Division of E.M.I. Sales & Service Ltd. at Blyth Road, Hayes, Middlesex, and costs £75.

Two-speed Reduction Drive

THE new "Microdual" reduction drive produced by Transradio Ltd., 138A, Cromwell Road, London, S.W.7, is notable for the fact that it provides two gear ratios from a single control knob—you push in the knob for one (coarse adjustment) and pull it out for the other (fine adjustment). With the coarse adjustment (for searching rapidly over the dial) the drive from the knob goes direct to the pointer through a single reduction gear, but with the fine adjustment (for accurate setting) it goes via a layshaft which introduces additional reduction—this is brought into play by pulling out the knob and is held in place by spring-loading. The arrangement is claimed to have no observable backlash and there is a friction clutch which obviates overdriving. Several models of the reduction drive are available with different kinds of dials and scales and the gear ratios available are 1:8 with 1:100 and 1:15 with 1:200.

New
TRIX

Quality

SOUND EQUIPMENT

MAINS
& BATTERY
AMPLIFIER

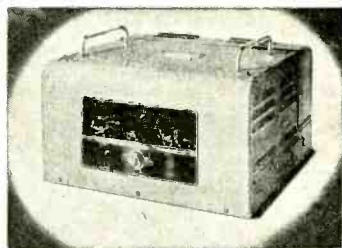

Model T620.

This 20 watt amplifier model T620 can be operated from batteries as well as from AC mains by the addition of a plug-in adaptor unit for 6 volts, thus adding, considerably to the variety of applications for which this amplifier is suitable.

This new model is similar in general design to the well-known 30 watt type T633B, and is fitted with the same controls, push-pull output with negative feed-back, high and low impedance outputs, etc.



HIGH FIDELITY
MICROPHONE

Model G7808, moving coil type. New design, neat and unobtrusive, with die-cast alloy grille. Fitted with switch and plug and socket connection.

Send for latest catalogue and price lists of the Trix range of Sound Equipment.

THE TRIx ELECTRICAL CO. LTD.
1-5 Maple Place, Tottenham Court Road,
London, W.1. 'Phone: MUSEUM 5817
'Grams & Cables: "Trixdio, Wesdo, London"

AMPLIFIERS * MICROPHONES * LOUDSPEAKERS

RANDOM RADIATIONS

By "DIALLIST"

Resistors

QUITE A NUMBER of readers tell me that they have found unreliable resistors just as great a nuisance as I have. I'm not sure, though, that every resistor which shows a value differing wildly from that indicated by its colours is altogether to blame for the discrepancy. A good many, I believe, are "fried" during the process of soldering them into their places. A large (and permanent) change in their value may be brought about by overheating. Resistors are not the only components that can be injured in this way and one of the soundest of all rules for the constructor of electrical apparatus is: Make your soldered joints quickly. The four chief causes of slowness in soldering are: solder too hard for the job, flux not active enough, metal parts not properly cleaned, and iron not sufficiently hot. For radio work you can't beat a good cored solder of 60/40 grade—the 60 is the percentage of tin and the 40 that of lead. I like to have my bit so hot that if it is pressed on to a piece of newspaper for 4 or 5 seconds it leaves a slight singe mark. Then joints are so quickly made that components don't have time to get warmed up.

Scopes, Graphs and Grams

THE EDITOR of *W.W.* has the very sound plan of so standardizing the technical terms used by those who write in this journal that, so far as possible, each is always used with one meaning and one meaning only. A case in point is the cathode-ray oscilloscope, which to some is merely an alternative name for the c.r. oscillograph. In *W.W.* the words are not interchangeable: the oscilloscope means one kind of instrument; the oscillograph, another. The -scope part of oscilloscope actually signifies "look at"; hence the term oscilloscope is used to mean an instrument designed to enable you to look at voltage waveforms on the screen of a cathode-ray tube. But -graph means "write" or "record"; and so the oscillograph is an instrument containing a built-in camera, or other device, enabling a permanent record—an oscillogram—to be made of the effects appearing on the screen of the tube. A pity that all our technical

names with Greek derivations have not been subjected to equally sensible rules. A photograph, for example, should be an instrument which records by means of light; and a photogram, the record it makes.

Is the Valve Doomed?

WONDERFUL though its performances undoubtedly are, the thermionic receiving valve has never seemed to me to be more than a temporary makeshift, likely to remain in use only until something better could be found. It has a whole heap of weak points, amongst which are its fragility, its comparatively high cost, the instability of its characteristics (which change as it ages with use), its poor input-output efficiency ratio, its proneness to distort the signal which it transmits and its short working life. By input-output ratio I do not mean just the gain, or the anode efficiency; I am thinking of the average domestic receiver's consumption of 40 or more watts from the mains for an output of one or two watts to the loudspeaker. A year or two ago the transistor made its appearance as a possible rival; and now comes the news of the development in the laboratory of the dielectric amplifier. Whether either of these will eventually provide the answer, one cannot yet say. I hardly think that either

of them will, though one or other (or both) of them may set some genius thinking and experimenting along the lines which lead to the super-efficient amplifiers of the future. The time will undoubtedly come when the receiving valve will be as much of a museum piece as is the coherer to-day.

A Queer Fault

A WELLINGBOROUGH reader is kind enough to send me an account of a particularly baffling fault which he encountered in a broadcast receiver. The set worked normally for about 10 minutes after it had been switched on; then the volume fell to about half what it had been. Switch off for a minute or two and when it was switched on the same thing happened again. After a long and fruitless search for the cause of the trouble, he gave the semi-silent set an angry jab with his screwdriver to show what he thought of it. To his amazement, there was an instant return to full volume. Investigation showed that his screwdriver had administered a good sharp rap to a resistor. When the drop in volume again occurred, he gave the resistor another knock and once more all was well for some minutes. Replacement of the resistor cured the trouble—but what was wrong with the resistor itself! Taking it to pieces, he found that the resistive element, housed in a ceramic tube, was cracked in two near its middle. Tests showed that during the warming up period, after switching on the set, a carbon deposit formed and bridged the gap. This carbon burned off after some 10 minutes when the set was at work. The



"WIRELESS WORLD" PUBLICATIONS

	Net Price	By post
MICROPHONES. By the Staff of the Engineering Training Dept. B.B.C.	15/-	15/5
FOUNDATIONS OF WIRELESS. M. G. Scroggie, B.Sc., M.I.E.E. Fifth Edition	12/6	13/-
RADIO VALVE DATA: Characteristics of 2,000 Valves and C.R. Tubes. 2nd Edition	3/6	3/9
TELEVISION RECEIVING EQUIPMENT. W. T. Cocking, M.I.E.E. 3rd Edition	18/-	18/8
SHORT-WAVE RADIO AND THE IONOSPHERE. T. W. Bennington. 2nd Edition	10/6	10/10
WIRELESS SERVICING MANUAL. W. T. Cocking, M.I.E.E. 8th Edition	12/6	12/11
RADIO LABORATORY HANDBOOK. M. G. Scroggie, B.Sc., M.I.E.E. 5th Edition	15/-	15/5
WILLIAMSON AMPLIFIER: Articles on Design of a High-quality Amplifier. By D. T. N. Williamson	3/6	3/9
GUIDE TO BROADCASTING STATIONS. Compiled by "Wireless World." 6th Edition	2/-	2/2

A complete list of books is available on application.

Obtainable from all leading booksellers or from
ILIFFE & SONS LTD., Dorset House, Stamford Street, London, S.E.1.

result of his assault on the resistor was presumably to shake off bits of the resistive element into the gap.

Mains Voltages

IN THE DAYS before the war the electricity authority placed a very definite limit on the amount by which the voltage of one's mains supply might vary from its stated value. If I remember aright, the maximum permissible variation was something like $\pm 2-3$ per cent. This is, of course, a dead letter to-day, when we are lucky if on a very cold day, a "cut" does not bring about a -100 per cent change! Being the proud possessor of a very accurate 0-300V meter for a.c., I take the voltage of my alleged 200-V, 50-c/s supply fairly frequently. In the past few months the lowest reading (outside "cuts," of course) has been 182V and the highest 208V, which means a variation of from -9 per cent to $+4$ per cent of the rated voltage. I am not grousing, for I realize that this kind of thing is just one of the minor horrors that the victors in a modern war must expect—and endure indefinitely. But such big upward or downward swings cannot be too good for the health of some electronic gear. The 6.3V heaters of valves, for instance, may have anything from about 5.75 to 6.5 volts applied to them. It says a lot for the reliability of our domestic radio and television receivers that they work as well as they do with these ups and downs in supply voltage and frequency.

Fame Indeed!

THE GREATEST HONOUR that can be conferred on a man of science is, I suppose, the adoption of his surname as a technical term. Unfortunately it is nearly always a posthumous honour, for comparatively few men, or women, live to bask in such glory. Madame Curie is one of those I can think of who have done so. Another honour accorded to but few men is the adoption of their names to form new words in a foreign language. The latest to achieve this is D. T. N. Williamson of amplifier renown. In the February issue of *Toute la Radio* I read on page 58: *Notre correspondant a construit son Williamson . . . dans un unique coffret*—"our correspondent has built his Williamson in a single cabinet." Williamson has not yet reached the summit of fame indicated by the spelling of his name with a small w, but one day we may see it recorded in print that some French enthusiast has built *un magnifique williamson!*

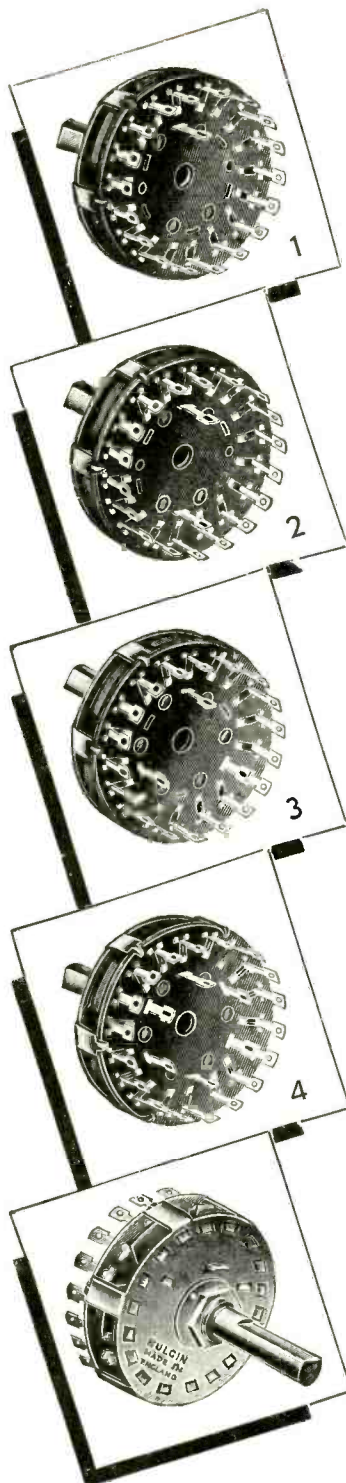

ROTARY SELECTOR SWITCHES

THESE efficient complete-Unit Rotary Selector Switches are specially suitable for meter-switching, tone-control, wave-change, etc. Manufactured to the usual high Bulgin Standards of quality and workmanship.

OVERALL dimensions are reasonable for all types of equipment; $1\frac{1}{2}$ in. ϕ , rear-projection $\frac{3}{8}$ in. Incremental Angle of movement, 20° . Shaft ϕ , " $\frac{1}{4}$ in." (0.247 in. - 0.249 in., for all $\frac{1}{4}$ in. - bore knobs). Normal shaft-protrusion from bush, $1\frac{1}{8}$ in. Bush, $\frac{3}{8}$ in. ϕ \times $\frac{1}{4}$ in. \times 26 t.p.i. Panel locator for hole $\frac{3}{8}$ in. ϕ at $\frac{3}{8}$ in. crs. from bush hole.

MADE with heavily Ag-plated Contacts with integral tags, for easy and reliable soldering of connections. Insulation of highest grade Synthetic sheet, average I.R. $< 100M\Omega$ at 500V. (max. test-V.) dry; good 'recovery' characteristics. Extremely low C.R., average 0.01Ω (10 m Ω) even under adverse conditions. Reliable and positive location-index mechanism. Type-tested for $< 50,000$ ops. at 16 c.p.m.

MADE with Break-before-Make or Make-before-Break contacting, moving contacts having an adequate factor of reserve-resiliency. These switches are used in the highest grades of instruments and equipment all over the world, because of their unflinching accuracy, consistency, and long life.

MAKE-BEFORE-BREAK TYPES

Illus. No.	List No.	Poles	Ways	Total angle of Movement
1	S.205	1	18	360°
2	S.206	2	9	160°
3	S.207	3	6	100°
4	S.208	6	3	40°
1	S.249	1	5	80°

(S. 249 is an "adding" switch, with 5 rotor contacts)

BREAK-BEFORE-MAKE TYPES

Illus. No.	List No.	Poles	Ways	Total angle of Movement
1	S.435	1	18	360°
2	S.436	2	9	160°
3	S.437	3	6	100°
4	S.438	6	3	40°

SEND FOR CATALOGUE

No. 190/WW

PRICE 1/- POST FREE

MANUFACTURERS OF RADIO AND ELECTRONIC COMPONENTS



A. F. BULGIN & CO. LTD
BYE-PASS ROAD BARKING
 TELEPHONE Rippleway 3474 (5 lines)

Contracting Out

THE Post Office van for detecting television pirates, described in the March issue, is of considerable interest, but I cannot agree with the *Wireless World* reporter when he states that, in addition to its primary object, the van could, by a rapid cruise round a given area, determine how many sets were in use at a given time.

The only figures which such a cruise would arrive at would be the number of television sets in operation which were owned by people so lacking in public spirit that they had not taken steps, by carefully screening the walls, floor and ceiling of their television viewing room with ferrous metal, to prevent interference to the ordinary anophthalmic listening of their immediate neighbours. Surely there cannot be any reader of *W.W.* with soul so dead to decency that he did not take immediate action on reading the article by M. G. Scroggie published two years ago this month and to which the writer of the recent note on the detecting van drew attention.

Talking of pirates, is it not time that the present system of licensing was abandoned in favour of a more realistic one?

In the case of ordinary sound broadcasting, there can hardly be a family in the country which does not own a receiver. Should not the demand for the £1 fee be sent automatically by the Income Tax inspector to the head of every family or taken into account when his P.A.Y.E. coding number is calculated. The Trade Union political levy example could be followed and the onus of contracting out placed on the shoulders of non-listeners who would subsequently be visited by a G.P.O. inspector to make sure that they really and truly did not possess a set; those who satisfied him as to this would be required to visit a hospital so that an investigation into their mental state could be made by electro-encephalography and other means.

Television licensing could, of course, be brought into line after the B.B.C. had completed its present constructional programme when some 80 per cent of the population will be within the television service area.

The Radiogramphonicon

IN the February issue I pointed out the need for an improved type of television set which would be provided with "pickup" terminals to enable you to enjoy visual recordings on the c.r.t. in the same manner as

you can now enjoy sound recordings on the loudspeaker by using the ordinary pickup terminals of your set. I further suggested that eventually a complete home-entertainment instrument, including a radiogramophone, a television receiver and a visual reproducing unit, would be marketed.

As a result of this, a reader, who is also an inventor, has written to the Editor to draw attention to a brain child of his called the videograph, a prototype of which was illustrated and briefly described in the July, 1950, issue of *Electronic Engineering*. The videograph is an all-embracing home-entertainment instrument, not altogether unlike the one I had in mind. To quote the words of the article describing this new wonder it is "... a normal television receiver with the addition of a simple mechanism for running 16-mm talkie film in front of a small electrostatic c.r.t. which scans through it on to a photoelectric cell and electron multiplier, the output of which can be switched into the video output of the receiver. . . ."

In his letter he states that I have shown myself not only unbiased but also unread. He evidently thinks he has forestalled me by eighteen months in describing an all-embracing radio plus video-cum-audio (*pace* Latin scholars) reproducing instrument, but I would point out that I first drew attention to a device of this nature nigh on a quarter of a century ago. At the same time, I mentioned that it was to be called by the none-too-euphonious name of radiogramoscope; presumably the issue of *Wireless World* for December 31st, 1930, escaped the attention of the videograph inventor.

It is true that the videograph of 1950 is a vast improvement on the old radiogramoscope of 1930, but, surely, this is no more than one would expect after twenty years, for after all, "this 'ere progress does go on." As Gibbon says in his "Decline and Fall," "All that is human must retrograde if it does not advance." But even the videograph, marvellous as it is, does not fulfil all I prophesied, as the visual recordings are just cine films and nothing more, whereas I envisaged recordings on film, disc or magnetic tape of the type Baird pioneered on discs long years ago. That I was not talking through my bowler may be seen by referring to the January, 1952, issue of the American journal *Tele-Tech* where we are told that television recording on magnetic tape is already practicable; in fact a recording unit was illustrated.

The correspondent makes the further point that videograph is a more

elegant word than radiogramoscope. I would reply that the beautiful old English colloquialism "an't" (usually mis-spelt ain't) is also elegant but it ain't used in the pages of *Wireless World* because the Editor maintains that, despite its elegance, it ain't correct and proper like. The same criticism applies to the word radiogramoscope and I did not conceal my dislike of it when originally writing about it in *Wireless World* over twenty years ago.

The most appropriate name for an all-embracing instrument like that visualized would be "radiogramophonicon" or, if we make it a truly panhellenic word, "actinogramophonicon." Long words, but Lilliputian compared with the 58 letters of the longest Welsh name or the 169 of the longest Greek word. I would, however, suggest as abbreviations "ragron" and "akron," respectively.

Radiæsthesia

MY recent request for a definition of radiæsthesia and teleradiæsthesia (January issue) brought in such a wealth of information from all and sundry that I am quite unable to reply individually, and I hope that all who wrote will accept my grateful thanks.



"Information from all and sundry."

I was misled by the use of the prefixes "radi" and "tele" into thinking that it had something to do with ordinary and long-distance wireless communication and even with television. Actually, radiæsthesia is something which I have always known as rhabdomancy or, in plain English, dowsing. But don't think that teleradiæsthesia is just dowsing at a distance, for it is much more than that. It seems to be closely akin to, if not identical with, what is sometimes known as psychometry.