

# The Wireless World

THE  
PRACTICAL RADIO  
JOURNAL  
27<sup>th</sup> Year of Publication

No. 949.

THURSDAY, NOVEMBER 4TH, 1937.

VOL. XLI. No. 19.

Proprietors: ILIFFE & SONS LTD.

Editor:  
HUGH S. POCOCC.

Editorial,  
Advertising and Publishing Offices:  
DORSET HOUSE, STAMFORD STREET,  
LONDON, S.E.1.

Telephone: Waterloo 3333 (50 lines).  
Telegrams: "Ethaworld, Sedist, London."

COVENTRY: Hertford Street.  
Telegrams: "Autocar, Coventry." Telephone: 5210 Coventry.

BIRMINGHAM:  
Guildhall Buildings, Navigation Street, 2.  
Telegrams: "Autopress, Birmingham." Telephone: 2971 Midland (4 lines).

MANCHESTER: 260, Deansgate, 3.  
Telegrams: "Iliffe, Manchester." Telephone: Blackfriars 4412 (4 lines).

GLASGOW: 26B, Renfield Street, C.2.  
Telegrams: "Iliffe, Glasgow." Telephone: Central 4857.

PUBLISHED WEEKLY. ENTERED AS SECOND-CLASS MATTER AT NEW YORK, N.Y.

Subscription Rates:  
Home, £1 1s. 8d.; Canada, £1 1s. 8d.; other countries, £1 3s. 10d. per annum.

*As many of the circuits and apparatus described in these pages are covered by patents, readers are advised, before making use of them, to satisfy themselves that they would not be infringing patents.*

## CONTENTS

	Page
Editorial Comment .. ..	437
Small Quality Amplifier .. ..	438
Bigger and Better Aerials .. ..	442
The Modern Broadcast Set .. ..	445
Listeners' Guide .. ..	447
Broadcast Brevities .. ..	448
High-Quality Reproduction .. ..	449
Useful Facts and Figures .. ..	453
Short-Wave Reception .. ..	454
Symbols Used in Circuit Diagrams .. ..	455
Cossor All-wave AC Superhet .. ..	456
Tracing Faults .. ..	458
From Studio to Screen .. ..	460
Avoiding Ganging Errors .. ..	463
Unbiased .. ..	465
Random Radiations .. ..	466
Letters to the Editor .. ..	468
Recent Inventions .. ..	470

## EDITORIAL COMMENT

### New Readers

#### The Aim of this Issue

FROM time to time we endeavour to bring *The Wireless World* to the notice of a wider circle, with the object of increasing our readership, and we make this the occasion to publish what we describe as a "New Readers' Number." With this issue we increase the normal number of pages and include a considerable amount of matter of special interest to those who may be prospective new readers, or who, having neglected wireless during the summer months, return to find themselves somewhat rusty in their knowledge of recent developments.

Our aim on this occasion has been to include articles to bring the knowledge of lapsed readers up to date and to show those who we hope may become new regular readers the kind of matter they may expect to find in *The Wireless World*.

May we ask all those who take this issue to endeavour to interest others in it, and so help us to attain our object of an increased readership?

### Empire Broadcasting

#### Use of Foreign Languages

A DEFINITE statement has now been made by the Postmaster-General that the Government has decided to use languages other than English for broadcasting, and it is understood these transmissions will begin almost at once. We are gratified to know that the Postmaster-General emphasises that foreign languages must be used for the transmission of "straight" news and not for anything in the nature of propaganda such as

that sent out by some foreign countries at the present time.

These other language broadcasts will, no doubt, be directed primarily for the consumption of listeners in areas over which we have no control, but at the same time they will prove useful for disseminating accurate news throughout the territories of the British Empire where many languages other than English are spoken, and where often these are the only languages understood.

#### Reception Facilities

It will be a very long time indeed before individual wireless receivers will be in the hands of a sufficiently large number of these people for the Empire news transmissions to take full effect. This brings us to the point that we would urge the establishment, wherever convenient and desirable, of loud-speaker "disseminating posts" on the public address system. In the bazaars of the East and Middle East, or wherever large numbers of persons congregate, loud-speaker equipment could be in operation, to give the news in the local tongue at specified hours. With proper supervision this equipment could also be used, as required, for local announcements and would, in this way, we believe, do much to tranquillise countries which at present are beset with rumours, mostly started as a result of unfriendly propaganda from foreign countries.

To carry out transmissions by the Empire service in foreign languages is a valuable move, but at present the service will be handicapped by lack of facilities for reception, except by the more educated type of person, who stands least in need of information to guide him on current events.

# Small Quality A

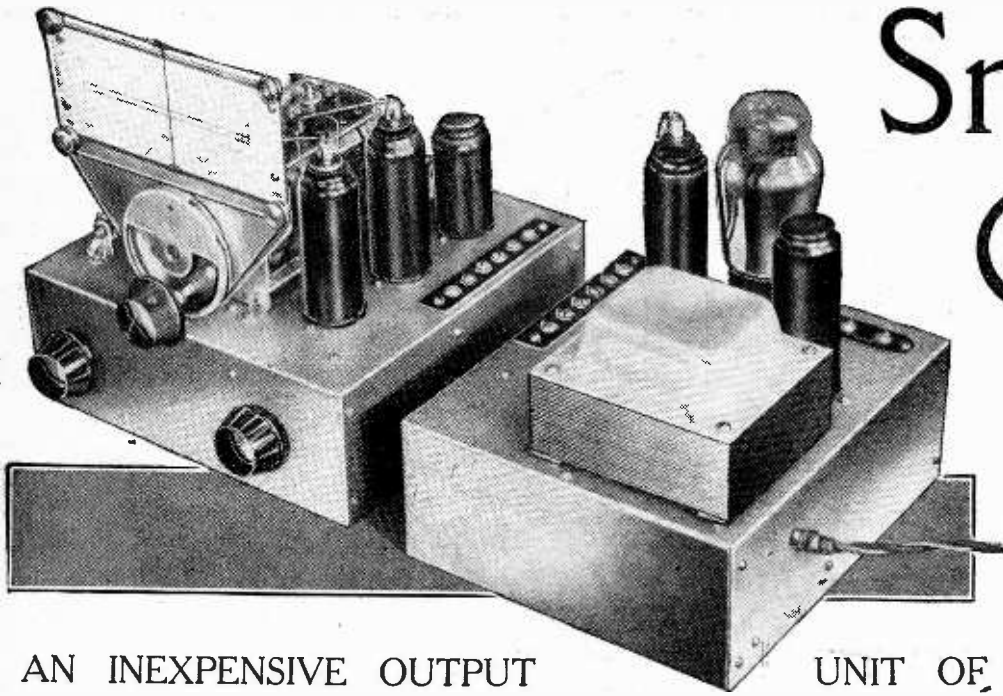

AN INEXPENSIVE OUTPUT UNIT OF HIGH PERFORMANCE

**H**IGH-QUALITY reproduction at good volume does not necessarily involve the use of expensive apparatus, and the amplifier described in this article gives an output of 3.5 watts with a low level of distortion. The frequency response is also good, the variation over the range of 20 c/s to 10,000 c/s being only  $\pm 2.5$  db.

**I**N spite of the widely held opinion that outputs of 10 watts or more are needed for the highest quality of reproduction, most people feel, and rightly so, that a smaller output will meet their requirements. Actually, an output of more than 6 watts or so cannot be tolerated when an efficient modern loud speaker is used in the usual small room in which 90 per cent. of listeners spend their time. The use of a greater output, in fact, makes one a certain nuisance to one's neighbours.

Most people probably operate an amplifier with a peak output of 3-4 watts, some at an even lower level. It is clear, then, that an amplifier of this output will serve most domestic purposes adequately.

This does not mean, of course, that a greater output is never necessary; when listening is done in a large room greater volume is naturally required, and a large output stage becomes essential as soon as one adopts volume expansion or operates several loud speakers in different rooms, or even uses an inefficient type of loud speaker.

When one considers the various possible ways of obtaining an output of 3-4 watts, one has at the outset to decide between the use of a single output valve or two in push-pull, and then to choose between the triode and the pentode. The questions are ones which must be settled on a basis of quality and cost. There is no doubt that push-pull has much in its

favour, but most of its advantages appear when a considerable output is needed. Thus, if we have a valve giving an output of 3 watts, two such valves in parallel will give 6 watts, but in push-pull they will give about 8-9 watts—in each case for the same degree of distortion.

For fairly large output, two valves in push-pull are definitely advantageous from the economic standpoint; 3-watt output valves need about 250 volts only for their anodes, but a single valve to give over 6 watts must have at least 400 volts. The higher voltage HT supply precludes the use of electrolytic condensers in a part at least of the smoothing equipment, and

Fig. 1.—The complete circuit diagram of the amplifier is shown here. A triode output valve is used and preceded by a high-gain triode stage.

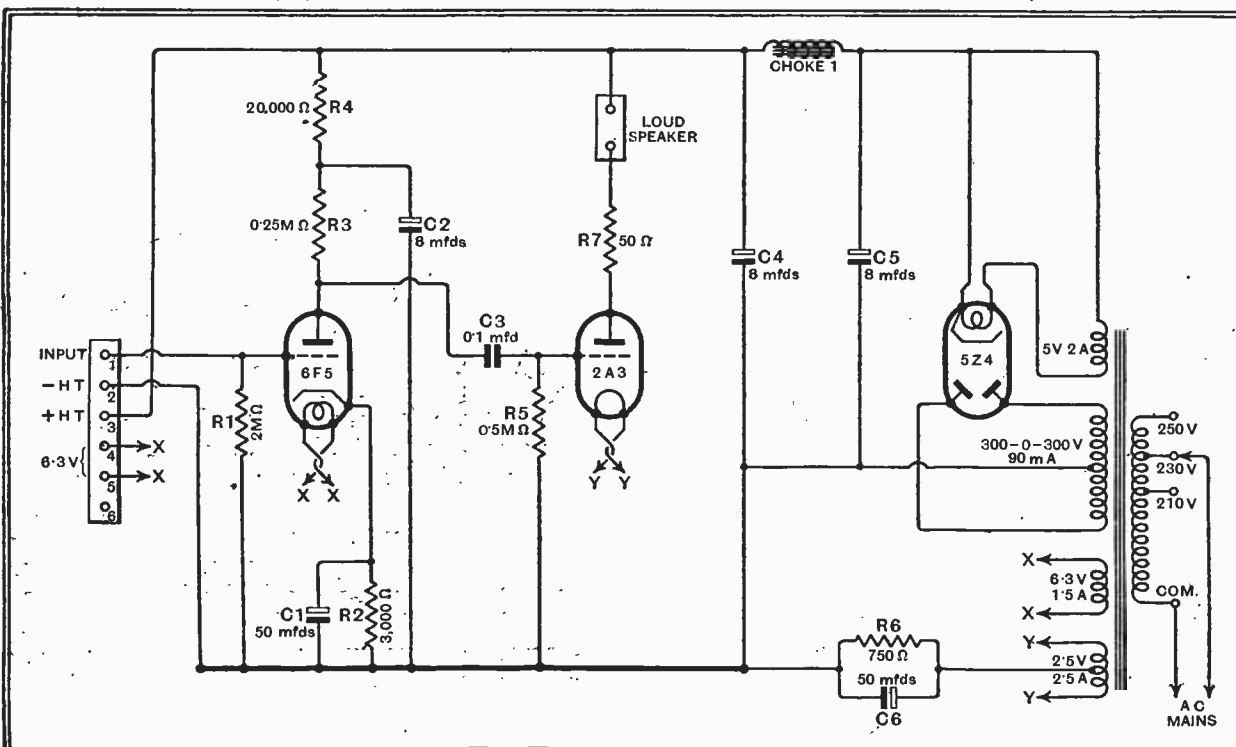

the cost of the mains equipment is consequently considerably greater. In general, the use of push-pull is economical when the alternative means an increase in the mains transformer winding above 350 volts.

Now when we need an output of the order of 3 watts only, push-pull offers less advantage, for we can obtain the required output from a single valve without the anode supply exceeding 250 volts. This voltage is

usually needed for the early stages of an amplifier or receiver, so that there is no saving to be effected by using a lower voltage for the output stage. It would, of course, be possible to use push-pull

# mplifier

with two smaller valves, but this course would have little technical advantage and would certainly cost more on the principle that two valves are dearer than one. One cannot carry this principle too far, however, for it is necessary to consider the cost of components as well, and the use of an extra valve sometimes enables such a

tive feed-back. Unfortunately, by the time that the distortion and damping are reduced to the same level as with a triode the sensitivity has also fallen to the same level and the only advantage which the pentode then retains is its power efficiency.

In cases where power efficiency is important — battery sets, AC/DC equipment, and very large output stages — the pentode with negative feed-back is probably to be preferred to the triode, but it seems to offer no advantage over the triode in the type of apparatus which we are considering. Indeed, a pentode with feed-back would probably cost more.

We can, therefore, decide that our amplifier shall have a single output triode, and we have now to consider in principle the preceding stage or stages. An amplifier of the type we are considering will be used chiefly with a gramophone pick-up or following the detector of a receiver. In either case, it is usually sufficient if the full output can be secured with an input of 1 volt RMS. With the exception of the needle-armature types, modern pick-ups give an output of this order and some much

more. With a suitable valve it should be possible to obtain sufficient amplification from a single stage before the output valve, even with resistance coupling. This type of coupling is the best to use, for it is the cheapest and also introduces the least distortion.

Coming now to the choice of valves, the Octal-base types have much to commend them. The 6.3-volt 0.3-ampere heater rating makes for convenience in wiring, since heavy conductors become unnecessary in all but the largest sets, and the cost of the mains transformer is probably reduced slightly owing to the greater ease of winding with lighter gauge wire. More important, the valves are of smaller physical dimensions and this is of the greatest advantage in RF stages, and the Octal-base with its

keyway makes the insertion of valves easier.

Octal-base valves are really American types and have been standard in that country for some time. Those of American

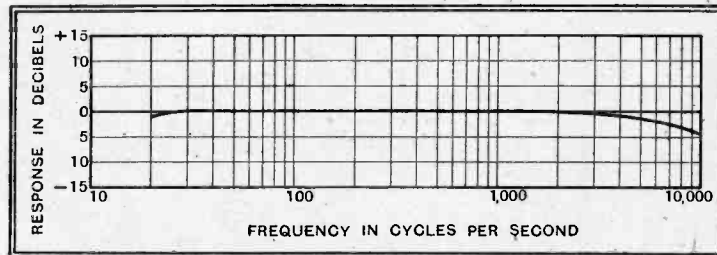

Fig. 3.—The frequency response curve is given here.

manufacture are available in three types—the metal, metal-glass, and glass valves.

The British-made ones are only of the glass type. The metal valves have no glass bulb, and are of exceedingly small dimensions; the metal-glass types are built with the conventional glass bulb, but this has a metal case over it. Save that its dimensions are somewhat greater, it looks like a metal valve and, since the metal case can be earthed, it has the same advantage of being self-screened as the metal type. The glass valves are conventional and unmetallised; except in AF circuits, they require a valve screen. The type numbers of these valves are the same, but the metal-glass construction is indicated by the suffix MG and the glass by G. We thus have among the triodes the 6F5, 6F5MG, and 6F5G; these all have the same characteristics, but the first is a metal valve, the second a metal-glass, and the third a glass type.

### The Output Stage

The metal and metal-glass types are particularly advantageous for the RF stages, for they make valve screens unnecessary. As the metal case extends over the valve-base, the screening is more effective than metallising, which covers the bulb only. If we decide to use these types, we shall have to use American valves, for the British equivalents are only made with glass bulbs, and we might as well use American types throughout.

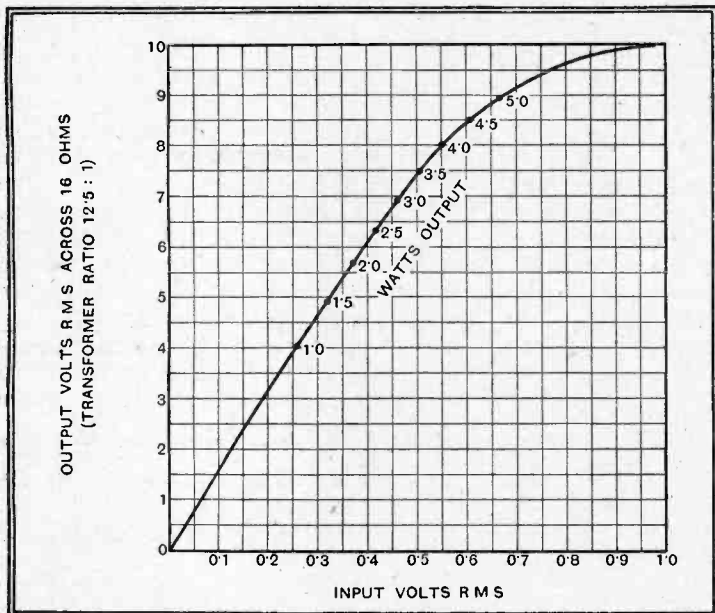
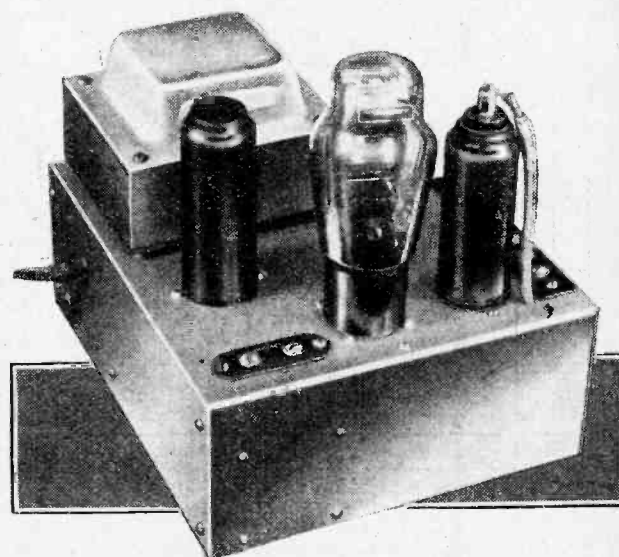

Fig. 2.—The input-output curve shows good linearity for outputs up to 3.5 watts.

saving in components to be made that it is more than paid for.

It will be clear that for an output of the order of 3 watts a single output valve will do all that we need, and we now have to consider the relative merits of the triode and pentode. The power efficiency of the pentode is better than that of the triode; that is, the ratio of power output to anode dissipation is greater. This is not of much consequence with small mains-operated stages, however, but it is important in battery equipment and in very large power stages. For an output of 3 watts, the use of a pentode will give us no appreciable reduction in the cost of the mains equipment.

The pentode is considerably more sensitive than the triode in that it will provide the same output from a smaller signal input. It does, however, tend to introduce more distortion than the triode, and owing to its high AC resistance the loud speaker is not properly damped, which is again deleterious to quality. These two defects are serious, but can be reduced very greatly by the use of nega-



A view of the complete amplifier.

**Small Quality Amplifier—**

There is, in any case, no suitable output triode in the Octal-base range, and our choice of output valve lies between the 4-volt PX4, the 2-volt PA20, and the 2.5-volt 2A3 types. These valves all require an anode supply of 250 volts, and they need respectively -34 volts, -27.5 volts, and -45 volts grid bias and consume 48 mA, 50 mA, and 60 mA. Their optimum loads are 3,200 ohms, 2,750 ohms, and 2,500 ohms, while their outputs are 2.5 watts, 2.75 watts, and 3.5 watts. The PA20 has the greatest sensitivity and the 2A3 the least, but the 2A3 gives the greatest output. The PX4 can be used to give 3.5 watts output, but it then needs 300 volts anode supply. The fact that the 2A3 gives the greatest output for a 250-volt anode supply is largely because the anode dissipation is the highest, but it is also partly due to the straighter characteristics resulting from the lower mutual conductance which is also responsible for the lower sensitivity.

Since we need an output of 3-4 watts, the 2A3 is obviously the one to use. It needs an input of 45 volts peak, so that the previous stage must give a gain of  $45 \times 0.707 = 31.8$  times if full output is to be secured with an input of 1 volt RMS. This gain is easily secured from a triode of the 6F5 type; actually, a considerably

greater amplification can be secured. Our amplifier now begins to take shape, and we have a 6F5 triode as an input valve resistance-capacity coupled to a 2A3 output valve, and we shall naturally have, in addition, a rectifier. The complete

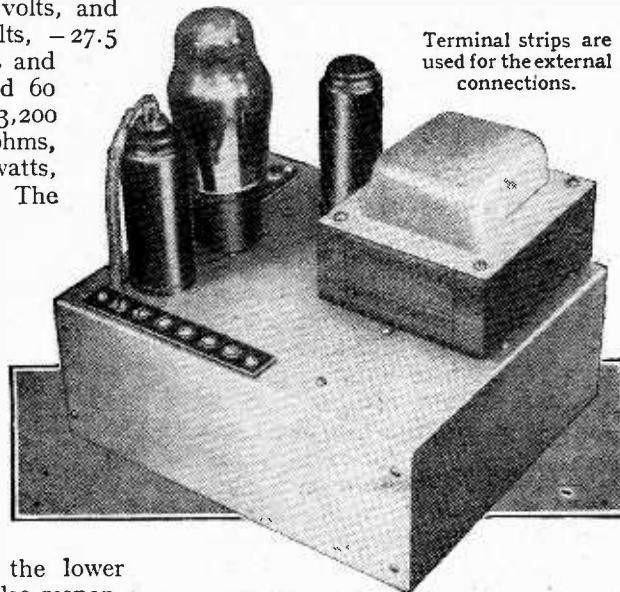

circuit diagram is shown in Fig. 1, and the 2.0 megohm resistance R1 is included to prevent the grid circuit from being accidentally left open if the amplifier is operated with nothing connected to the input terminals. When following another valve with resistance coupling it serves as the grid leak.

The 6F5 amplifier has a coupling

resistance R3 of 0.25 megohm and decoupling is provided by the 20,000-ohm resistance R4 in conjunction with the 8-mfd. condenser C2. Bias is obtained by the voltage drop along the cathode resistance R2 of 3,000 ohms; in order to prevent loss of gain through the feed-back of voltages developed across this resistance it is shunted by the 50-mfd. condenser C1. The coupling to the output valve is completed by the 0.1 mfd. condenser C3 and the 0.5-megohm resistance R5. With these values the calculated stage gain is 71 times.

The output valve itself is run from a separate winding on the mains transformer and is biased by the voltage drop along R6 of 750 ohms; this resistance is shunted by a 50-mfd. condenser C6. A resistance R7 of 50 ohms is included in the anode circuit to prevent parasitic oscillation.

**The Mains Equipment**

The HT<sub>1</sub> supply is derived from the 300-0-300 volts winding on the mains transformer with the aid of the 5Z4 indirectly heated full-wave rectifier. The reservoir condenser C5 has a capacity of 8 mfd. and smoothing is effected by the choke Ch1 in conjunction with the 8-mfd. condenser C4.

A smoothed output of some 330 volts is obtained at the current consumed by the amplifier alone, some 61 mA, and about 310 volts at the full rating of the transformer when an additional 15 mA or so is drawn for operating a receiver. The

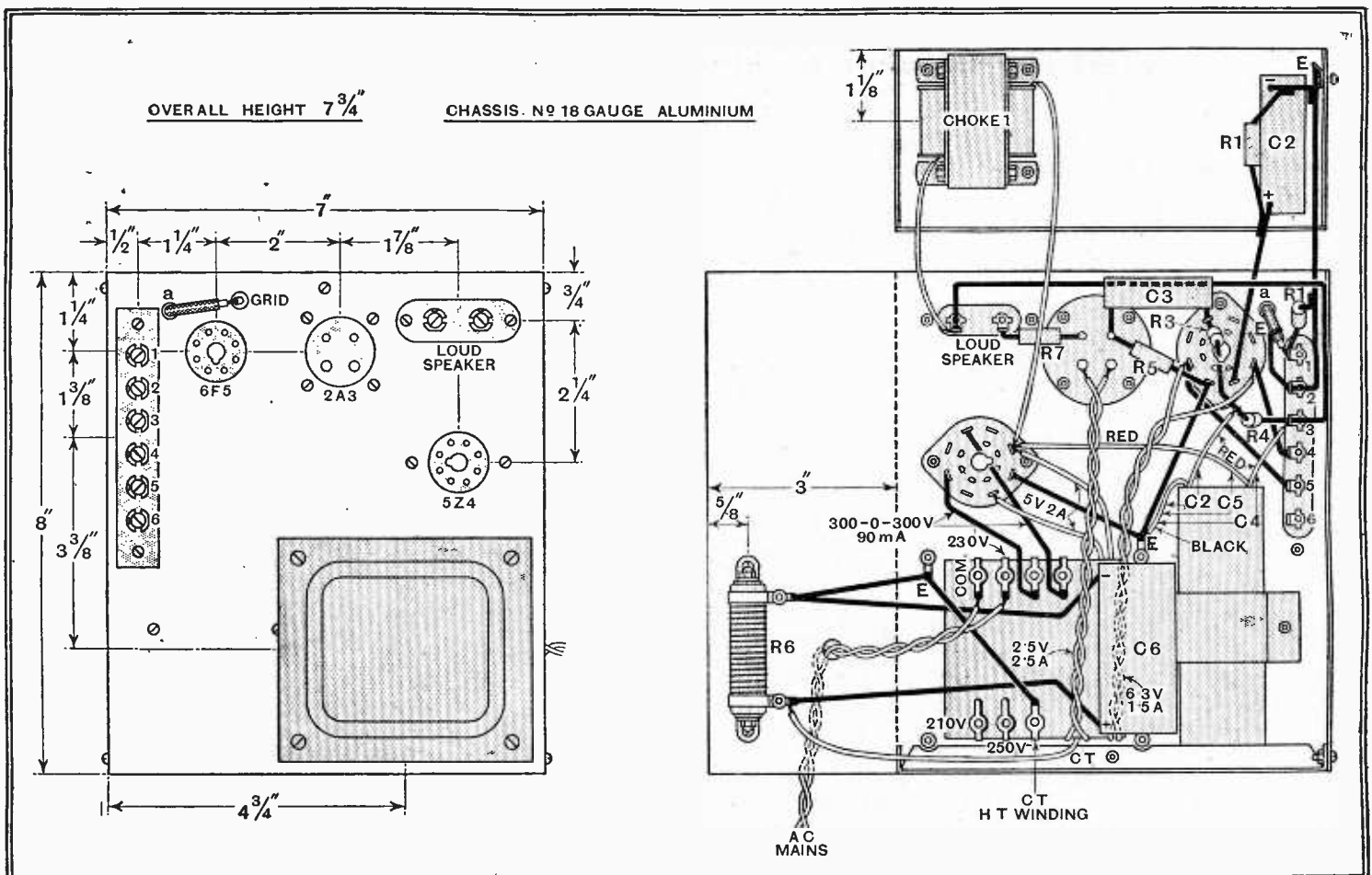

Complete constructional and wiring details are given in these drawings.



**Small Quality Amplifier—**

output valve requires 298 volts made up of 45 volts grid bias, 250 volts anode supply, and 3 volts drop in R7. The difference of 12-32 volts is allowed for the drop in the output transformer primary. The 6F5 valve passes an anode current of about 0.5 mA and is consequently biased to -1.5 volts. The LT winding on the transformer is rated at 1.5 ampere, so that up to four valves can be operated in addition to the 6F5.

No provision is made for energising a loud speaker field, since the increase in the mains transformer rating would entail an appreciably greater cost. In view of the high performance of modern types, it is suggested that a permanent magnet model be used.

The output volts developed across a 16-ohm resistance on the secondary of the output transformer of ratio 12.5-1 (actually, the Universal Output Transformer<sup>1</sup>) are shown in Fig. 2 plotted against input volts. It will be seen that the curve is very nearly

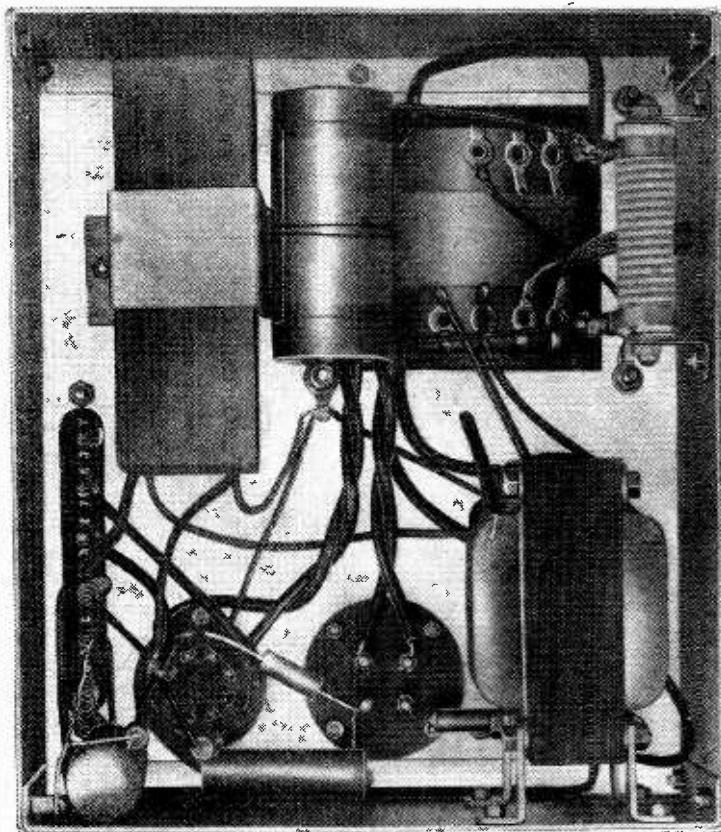

The underside of the chassis.

straight up to 7.5 volts, corresponding to 3.5 watts output, so that the distortion up to this output is exceedingly small.

For 3.5 watts output an input of only 0.5 volt RMS is needed, so that we have actually obtained rather more gain than we set out to do. Fig. 3 shows the frequency response; at 20 c/s it is -1.0 db. and at 10,000 c/s it is 4.5 db. This is a

very good performance for such simple equipment.

Constructionally, the amplifier has been made on the simplest lines and there is consequently nothing which should cause any difficulty. Care should be taken to scrape the paint off the chassis beneath fixing bolts which are also used for connections, and the smoothing choke must be left off until the rest of the wiring is

may be of interest. The 6F5 can be metal, metal-glass, or glass without affecting the performance. Under the type numbers of 6F5, 6F5MG, and 6F5G it is available from importers of American valves, and British made as the H63 glass valve in the Marconi and Osram ranges. The 5Z4 rectifier is also generally obtainable and is listed by Tungram as the 5Z4g; there is no exact equivalent in the Marconi and Osram ranges, but the U50 directly heated rectifier can be used without alteration. The American equivalent of this is the 5Y3.

Those who wish to use a British output valve can adopt the Mazda PA20; the bias resistance R20 must be changed to 550 ohms and a resistance of 0.125 ohms inserted in each filament lead. Alternatively, the mains transformer can be obtained with a 2.0 volt winding. The PX4 valve or its equivalent can be used if a mains transformer with a winding of 4 volts 1 amp. is obtained.

In a forthcoming issue it is hoped to describe a small receiver designed especially for use with this amplifier and which will enable high-quality local reception to be obtained as well as possessing sufficient sensitivity and selectivity to enable reception of a number of the more powerful Continental transmissions.

<sup>1</sup> The Wireless World, Dec., 1 1933.

**The H.M.V. Record-player**

THIS instrument forms a logical complement to the better class of table model receivers, in which provision for the attachment of a gramophone pick-up is made nowadays as a matter of course. With it one obtains all the scope of a radio-gramophone with this important advantage, that the record-player can be conveniently operated from an armchair at some distance from the set.



H.M.V. Model 119 record-player.

The pick-up provided is of the same high-fidelity type as is used in H.M.V. radio-gramophones, and the AC turntable motor is controlled by a master switch incorporated with the pick-up volume control at the side of the walnut case. A speed regulator and hand-operated and automatic brakes are also fitted. The specification is completed by a tone-arm rest, needle-box clip for the H.M.V. High Fidelity needles recommended, and a used-needle receptacle, and the price is £3 19s. 6d.

**THE LIST OF PARTS REQUIRED.**

Certain components of other makes but of similar characteristics may be used as alternatives to those in the following list.

- 1 Mains transformer, Primary: 200/250 volts, 50 c/s. **Sound Sales US/300**
- Secondaries: 300-0-300 volts, 90 mA.; 2.5 volts, 2.5 amps. CT; 5 volts, 2 amps.; 6.3 volts, 1.5 amps.
- 1 Smoothing choke, 20 H., 60 mA., 700 ohms Ch1. **Bulgin LF14S**
- Resistances:
  - 1 50 ohms, ½ watt, R7 **Erie**
  - 1 3,000 ohms, ½ watt, R2 **Erie**
  - 1 20,000 ohms, ½ watt, R4 **Erie**
  - 1 250,000 ohms, ½ watt, R3 **Erie**
  - 1 500,000 ohms, ½ watt, R5 **Erie**
  - 1 2 megohm, ½ watt, R1 **Erie**
  - 1 750 ohms, 20 watts, R6 **Bulgin PR4**
- Condensers:
  - 1 0.1 mfd., 350 volts, tubular, C3 **Dubilier 4423/S**
  - 1 50 mfd., 12 volts, electrolytic, C1 **Dubilier 3016**

completed. The choke connections must be made before the component is actually screwed down, for it has to be moved out of position somewhat to enable the connecting points to be reached.

No volume control is included, for this is usually more conveniently placed in the receiver, and if the amplifier is only used with a pick-up it can always be connected externally.

Before concluding, a word as to valves

- 1 50 mfd., 50 volts, electrolytic, C6 **Dubilier 3004**
- 1 8-8-8 mfd., 500 volts, electrolytic, C2, C4, C5 **Dubilier 312**
- 1 Valve holder, 4-pin, American type **Premier Supply Stores**
- 2 Valve holders, Octal type **Premier Supply Stores**
- 1 Skeleton captive screw strip, 2-way, "speaker" **Bulgin T10**
- 1 Skeleton captive screw strip, 6-way **Bulgin T12**
- 1 Valve top clip, octal type **Bulgin T96**
- Chassis, with clip **B.T.S.**
- Miscellaneous: **Peto-Scott**
  - 2 lengths systoflex; small quantity No. 20 tinned copper wire, etc. Screws: 26 ¼in. 6 BA R/hd.; 4 ¼in. 4 BA R/hd., all with nuts and washers.
- Valves:
  - 1 2A3, 1 6F5MG, 1 5Z4MG **Premier Supply Stores**

# Bigger and Better Aerials



## A Common Fallacy Exposed

By "CATHODE RAY"

**T**HERE are people who think that a small aerial is more selective than a large one. Still more people, apparently, suppose that if a small aerial gets all the stations they want there is no sense in having a bigger one. If any readers hold either or both of these views they are invited to look into the matter a little more closely.

The objections raised against a large aerial are: (1) it is unsightly and conspicuous; (2) it is a fag to put up or to find anybody to do it (this objection is not always actually mentioned). With these two prejudices in the mind, very flimsy technical evidence is accepted to back them up, but (3) it may have been found by actual trial that a large aerial causes a powerful local station to interfere. Although this experience may be regarded by some as an unanswerable argument, a large aerial no more necessarily provokes interference than a large stock of food in the house necessarily provokes over-eating. Admittedly, a receiver that takes all that the aerial can give it is liable to be inselective, just as a person who insists on consuming the whole of the contents of an ample larder is liable to be indisposed. If a large aerial is connected to the aerial terminal of a receiver designed for a small one, and there exists in the neighbourhood a powerful station (which perhaps was not thought of when the keel of the set was laid down), then interference is more than likely to occur, and it can be reduced by shortening the aerial. I don't dispute that. What I do dispute is that this is the best way of reducing it.

The disadvantages are (a) that the wanted station, which presumably is weak compared with the interfering station, is less strongly received by the shortened aerial, and if there are reserves of amplification to open up for correcting this the interference tends to come back too. An exception is when there is a reaction control to improve the true selectivity, but the ability to bring up reaction is more usefully gained by cutting down on the volume control than by scrambling up

trees or housetops to shorten the aerial. (b) An aerial consists roughly of two parts—the upper portion, which is chiefly effective in reception and is usually the least to blame for picking up local electrical noises, and the lower or lead-in portion, which is generally too badly mixed up among trees and walls to be effective for distant station reception, but is liable to bring in the noises generated by equipment in one's own and neighbouring premises. (See Fig. 1.) Now, as it is quite obvious that any shortening of an aerial cannot be done at the receiver end, it is the end most effective for reception that suffers, while the noise-producing end remains. In an anti-interference aerial system this end is completely screened and freed from noise, but at the same time is rendered entirely useless for reception. So with this type of aerial, as to a less extent with others, the upper part must be relied upon for reception, and the larger it is the more can be received. Even when, by virtue of extreme sensitivity, the receiver can get all the available programmes on the traditional wire-round-the-picture-rail, such high amplification is associated with internally generated noise.

For a given strength of wanted programme, then, a small aerial gives more receiver noise, more chance of local noise, and (assuming all *station* reception is re-

duced in the same proportion), *the same* station interference. Actually, the small aerial introduces less resistance into the tuned circuit to which it is coupled; the true selectivity is therefore better, and a small reduction in relative interference results. That is the sole benefit.

### Coupling and Damping

We have now got to the root of the matter—aerial coupling. Even a small aerial is too much to connect straight to the grid of the first valve. There is some looseness of coupling, obtained by tapping across only a portion of the aerial coil, or by connecting the aerial to a separate coil which may have only a few turns, or by putting a condenser in series as shown in Fig. 2. There are many variations and combinations of these, but they all have the following effects: (1) the resistance, loss, damping, or whatever you like to call it, on the first tuned circuit is reduced and its selectivity improved; (2) less of the signal voltage picked up by the aerial is passed on to the receiver; (3) the portion of the aerial capacity thrown into this circuit is reduced, and it is easier to gang it with others.

(1) and (2) are to some extent conflicting in their results—in this way, that if the aerial is plonked straight on to the grid of the valve it yields a maximum of its signal for amplification, but the damping down of the tuned circuit is also a maximum, so that its response is blunted. When the coupling is nil the tuned circuit is in its sharpest and most responsive condition (and likewise the most selective) but, unfortunately, there is no signal for it to respond to. Precisely what happens at intermediate adjustments depends on the nature of the aerial and of the tuned circuit; thus, if the aerial is very large and the circuit by itself very selective, the result of close coupling is at its unhappiest; but Fig. 3 illustrates typical conditions. Here it can be seen that with the closest coupling the damping due to the aerial prevails over the more complete transfer of signal, and not only is selectivity at its worst, but even on grounds of strength of reception there is no argument for this degree of coupling, and it is, in fact, never used. At an intermediate coupling, which, judged by usual practice, is generally rather close, reception is at a maximum, but selectivity is a good deal

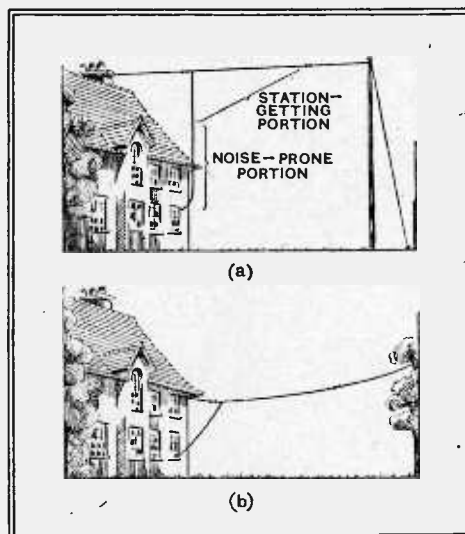

Fig. 1.—Although there is no clearly defined division, an aerial consists roughly of two portions (a). In a small low aerial (diagram (b)) the most useful part is the one that is chiefly lacking.

**Bigger and Better Aerials—**

less than its best; to be precise, just a half. The adjustment of looser couplings is much more critical, for reception falls off more and more sharply, and although it is practically always worth sacrificing *some* signal in the interests of selectivity, there comes a point where the loss of signal is so rapid as to be disproportionate to the slight corresponding improvement in selectivity. At the risk of being tedious I want to emphasise that what is happening towards the zero coupling end is that the programme to which the set is tuned diminishes, as shown by the "Sensitivity" curve, while an interfering programme on another wavelength is reduced rather more rapidly. It is much the same sort of problem as the size of the aerial—is it worth sacrificing a large amount of wanted signal for a slight gain in selectivity?

The inquiring mind naturally asks: "Is it better to have a large aerial loosely coupled, or a small aerial closely coupled?" Some time ago, when the

"That may be all very well," says the owner of a modern sealed box-of-mystery, with the nature of the coupling unknown and unknowable; "I have to take things as they are or lose my guarantee. The aerial is the only part under my control." It is quite true that any attempt to modify the coils inside the riveted-up cans is likely to lead to an unremunerative conclusion unless the attempter knows his job much too well to waste his time reading what "Cathode Ray" has to say about it. But it is possible to experiment with external coupling circuits if it is suspected that those provided are too close to enable the benefits of a really good aerial to be obtained. I admit that as some of the aerial circuits in modern receivers are of very high impedance, and others are very low, one may have to do quite a lot of experimenting; that, however, is part of the fun, and if one doesn't like the result there is no difficulty in reverting to normal connections. In any case, the modern inaccessible type of receiver is not likely to

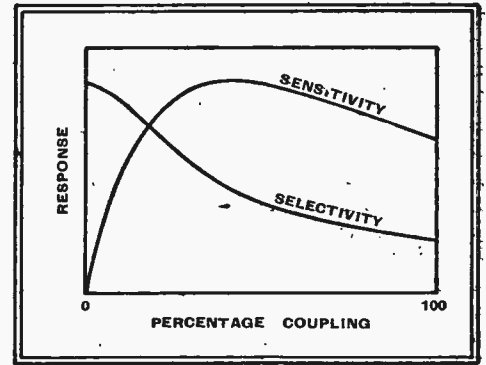

Fig. 3.—The effect on sensitivity and selectivity of differing degrees of coupling depends on the nature of aerial and circuits, but the results shown here are typical.

ling *must* be kept low to avoid upsetting the ganging.

And it also makes it important to find out whether the *method* of coupling affects this side of the problem. It does. If in each method the capacity thrown into the tuned circuit by the aerial is restricted to a small amount, as is compulsory in a gang-tuned set, the inductive coupling shown in Fig. 2 (a) and possibly also (b) gets far more signal across than the capacity method (c). Fig. 4 shows the result of an actual measurement of the voltage across a typical tuned circuit due to London Regional. Suppose the mistuning capacity is to be restricted to 5  $\mu\mu\text{F}$ , inductive coupling gives over 0.75 volt, and capacity coupling barely 0.15!

Another advantage of the tapped coil coupling is that the impedance of the tuning circuit between aerial and earth circuits is low, and, as I pointed out some time ago (February 28th, 1936), this makes it possible to use a screened anti-interference aerial without a special matching transformer at the lower end, or to run the aerial wire around the house to extension sockets without excessive loss. Unfortunately, it is the capacity

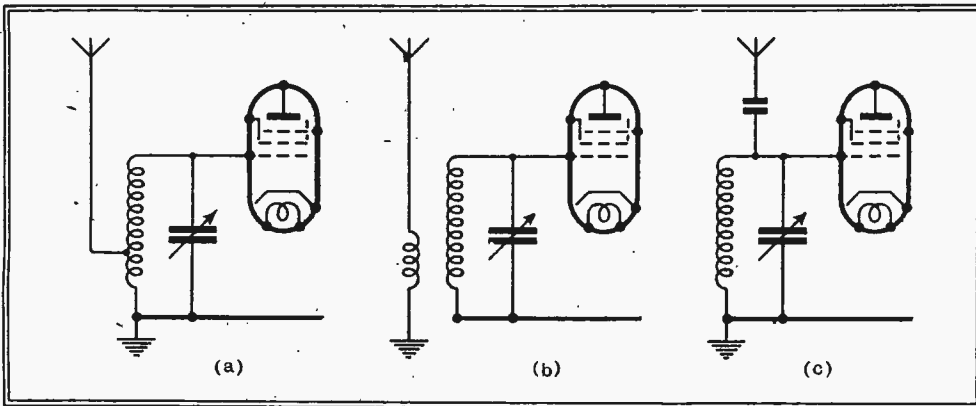

Fig. 2.—Alternative methods of coupling an aerial to the tuned circuit.

high-power Régional stations were springing up and it was the regular practice of the B.B.C. to advise those suffering from the new interference to shorten their aerials, I went into this question rather carefully. More recently the Editor has remarked that people are tending to put up (and put up with) smaller and smaller aerials, so some of these findings may have a topical value. I am not inflicting the mass of detail on the patient reader, but go right on to state that it showed quite definitely that if the coupling is adjusted in each case to give a specified degree of selectivity, a large aerial, even if of rather high capacity, gives better signal transfer than a small, inefficient aerial; or, alternatively, if the couplings are adjusted to a given signal efficiency, the large aerial is the more selective *and that these results take no account of the differing amounts of signal actually picked up*. As the large aerial picks up far more, the coupling can be made looser than that just indicated and still better selectivity obtained. Furthermore, it is the highly efficient, easily damped tuned circuit that benefits most from the large aerial. But, of course, all this hinges on the coupling being right, and a large aerial and sharp circuit call for very loose coupling.

be too closely coupled or to lack selectivity; the owner has just no excuse at all for his lazy aerial. It is the older sort of set which may need adjustment in order to stand a good aerial under modern conditions.

That brings us again to actual methods of coupling. But before looking at them there is the third influence of aerial size, which has rather escaped attention so far, and now requires it—the shift in tuning due to the addition of the aerial capacity. So long as the tuning of each circuit was separately controlled, this used not to cause much trouble—one merely tuned in a station with less tuning condenser capacity—but, now that practically all sets are gang-controlled, it is essential that the disturbing effect of the aerial capacity be kept very small.

**Aerial Capacity**

The capacity of an aerial may be several hundred micro-microfarads, but even 10  $\mu\mu\text{F}$  added to the tuned circuit may appreciably reduce the selectivity of the set as a whole. The looser the coupling the less capacity is effectively added to the tuned circuit. That is why I said there is less fear of excessive coupling in a modern set than in an old one; the coup-

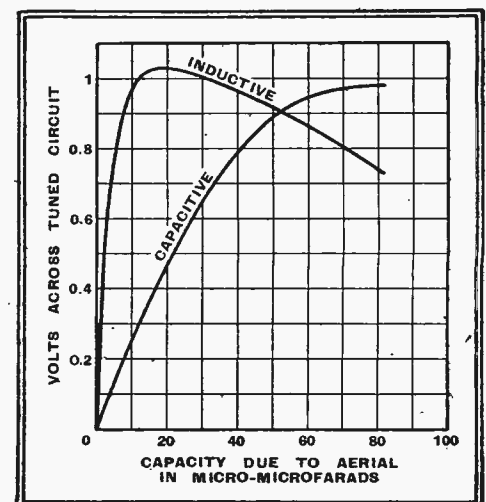

Fig. 4.—Measured results showing how inductive coupling gives stronger reception for a given transference of aerial capacity to the tuned circuit. The difference would be even more marked if this capacity had been allowed to exert its mistuning effect; actually the circuit was retuned each time the coupling was altered.

**Bigger and Better. Aerials—**

system that is easy to add and adjust external to the receiver; to tap the coil one must be able to get at it. Just what can be done depends on the exact nature of the coupling system already in use; any detailed instruction I might give would be as likely to mislead as to help. It is quite common nowadays to have Fig. 2 (b) with a "high-peaked" primary coil—one resonating at a longer wavelength than any in the band covered—to help keep the sensitivity level over the waveband; but this does not necessarily make a large aerial undesirable.

I am sorry if this aerial exposition has turned out to be rather rambling; there are so many interlocking considerations. But the main conclusions can be summed up quite briefly:—

(1) A large, well-arranged aerial, properly coupled, gives better selectivity, stronger reception, and less noise and

interference (what more can you want?) than a small one.

(2) The "better" (i.e., lower loss) the aerial, tuning circuit and the larger the aerial the looser the optimum coupling and the better the results.

(3) As regards method of coupling, the tapped-down coil has the important advantages over the series condenser method of causing less de-ganging for a given signal transfer efficiency and of lending itself to low-impedance aerial lead-in systems.

(4) Old sets, the most likely to suffer in selectivity through the direct connection of an unusually large aerial, are generally accessible for alteration of coupling; modern sets, though inaccessible, are obliged by the exigencies of ganging to have loose enough coupling to stand large aerials, and some are provided with a trimmer for adjustment to any individual aerial.

The Italian authorities are certainly not "crystal-minded" or "three-valve-minded." They realise that with a respectable modern set the service areas of stations are very large. Hence they don't hesitate to establish three groups of transmitters for the evening programmes. Would that our own B.B.C. might become similarly enlightened! With our array of 17 stations—11 of 50-150 kilowatts, two of 20 kilowatts, and four of 5 kilowatts or less—we should be able to run at least three programmes after the first news.

The Canadian 50-kilowatt stations at Montreal and Toronto that I referred to in my last notes are, I learn, to be opened next year and not this. But they will work on the medium waves and not on the long, as I have seen stated elsewhere. Long-wave broadcasting is out of the question in Canada or the United States, partly because nearly every available channel is in use by a commercial station and partly because very few of the receiving sets in use in either land tune higher than about 575 metres.

D. EXER.

# Distant Reception Notes

## THREE NEW HIGH-POWERED STATIONS

SOME interesting newcomers are at work now on the medium waves. Hilversum, Loperikapel (power not stated), is shown in the official lists as testing. On Sunday, October 24th, the station was in full operation when I tuned it in at about 9 p.m. The wavelength used is 415.4 metres, a channel shared by Bergen, Fredrikstad and Kharkov. The Dutch transmission, however, came through without any interference, and I should judge its output power to be considerable—certainly not less than 50 kilowatts.

The new 100-kilowatt Sofia turns out to be of little use to listeners in this country in the ordinary way. Though none of its wavelength partners (Bodö, Porsgrund, Stavanger and Valencia) is rated at more than 10 kilowatts, the big station does not succeed in shouting them down, and all that one hears is a jumble of noise.

Rome No. 2, now at work with 60 kilowatts on 245.5 metres, is more fortunate. The only sharer of its channel is the 0.3-kilowatt Narvik, of which nothing is to be heard. Rome No. 2 dominates the wavelength and comes in clearly and strongly, provided that the set is selective enough to separate it clearly from Lille, P.T.T., on the next-door channel.

Another newcomer, Genoa No. 2, is at work on the Italian common-wave channel on 221.1 metres. Here, I'm afraid, you'll find nothing but "common-wave hash," for with 5 kilowatts Genoa No. 2 is not powerful enough to outvoice the rest.

From Italy it is reported that that country now has for the main evening programmes three groups of stations, relaying, respectively, Rome, Turin and Naples, instead of the former two groups which relayed Rome and Turin. Rome No. 1 is now the key station of the Rome group; Rome No. 2 relays Naples and Rome No. 3 Turin. A large portion of Italy will thus have the choice of three programmes from dusk till bedtime.

One wonders if this fresh arrangement will have any effect on the apathy of Italians as a whole towards broadcasting.

For a long time they have had one of the best broadcasting services in Europe, but the percentage of receiving licences to the total population of the country has ever been the lowest in any important country. Italy has now 18 stations, of which four are rated at 50 kilowatts or more, two at 20 kilowatts, six at between 5 and 10 kilowatts, and six at something below 5 kilowatts.

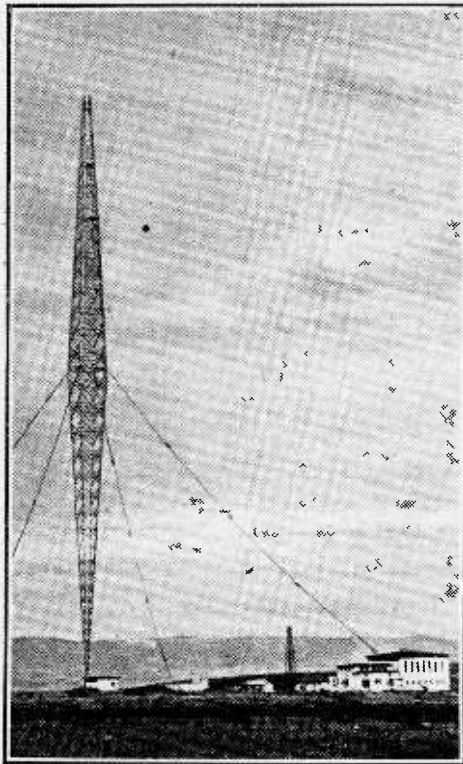

ON TEST. There has been some delay in the official opening of the new 100 kW Bulgarian station shown here. The transmitter has been built at Vakarel, near Sofia and employs a non-fading aerial similar to those now used by the B.B.C. The station works on a wavelength of 352.9 metres.

## Television Programmes

Vision 45 Mc/s. Sound 41.5 Mc/s.

THURSDAY, NOVEMBER 4th.

3, Fashion Parade. 3.15, Cartoon Film. 3.20, Kuda Bax: the Man with the X-ray Eyes. 3.30, Gaumont-British News. 3.40, Nelson Keys in "Intimate Cabaret."

9, Fashion Parade. 9.15, The Mozart Boys' Choir of Vienna. 9.25, British Movietonews. 9.35, Experiments in Science—3. Tests devised to investigate intelligence and vocational aptitude. 9.50, "Close-up": a little show.

FRIDAY, NOVEMBER 5th.

3, Stanelli with his Hornchestra. 3.10, Preview: Highlights of the Week. 3.15, Bridge Experiment No. 4. Hubert Phillips and four players. 3.25, British Movietonews. 3.35, Powder and Pipe-clay: a revue of old Army Songs.

9, "Red Peppers": an interlude with music by Noel Coward. 9.35, Gaumont-British News. 9.45, Family likenesses in a royal line: illustrated by portraits from the National Portrait Gallery. 9.55, Preview.

SATURDAY, NOVEMBER 6th.

3, In Our Garden: C. H. Middleton on planting roses. 3.10, Puppet Show. 3.20, Gaumont-British News. 3.30, Three Epic Dramas by Stephen Leacock.

9, Nelson Keys in "Intimate Cabaret." 9.20, British Movietonews. 9.30, "The Importance of Being Earnest": Oscar Wilde's comedy.

MONDAY, NOVEMBER 8th.

3, Black and White Boxing: demonstration by instructors from the Army School of Physical Training. 3.15, Gaumont-British News. 3.25, Turkey in the Straw: a truly rural cabaret.

9, Black and White Boxing. 9.15, British Movietonews. 9.25, Turkey in the Straw.

TUESDAY, NOVEMBER 9th.

2-2.30, The Lord Mayor's Show televised on its return journey along Northumberland Avenue.

3, "Rush Hour": a revue by Herbert Farjeon. 3.50, British Movietonews.

9, Speaking Personally—6: James Agate. 9.10, Cartoon Film. 9.15, Clothes-line—4. Hats and Headgear. 9.30, Gaumont-British News. 9.40, Cabaret.

WEDNESDAY, NOVEMBER 10th.

3, A little Show. 3.20, Gaumont-British News. 3.30, Ninety-third edition of "Picture Page."

9, A little Show. 9.20, British Movietonews. 9.30, Ninety-fourth edition of "Picture Page."



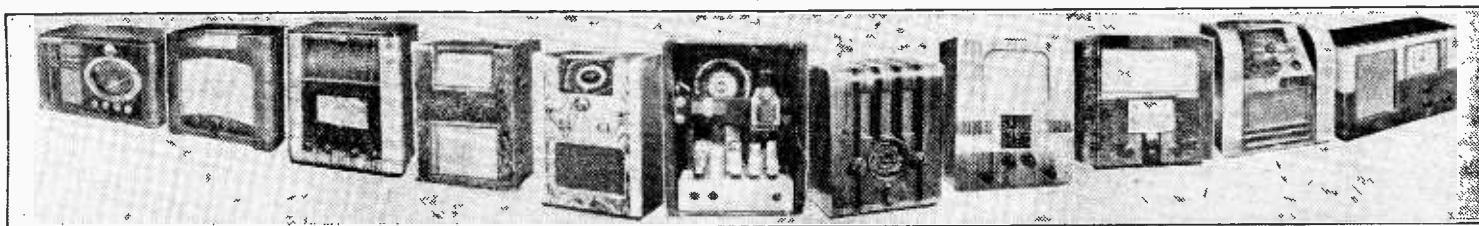

# THE MODERN BROADCAST SET

## Salient Features and Their Relative Importance to the User

**M**OST readers of this journal will have had the experience of being asked, "Which is the best set to buy these days?" and of discovering after a minute or two's tongue-tied silence that this question is literally unanswerable. Inevitably a series of counter questions must be posed. "Do you want good-quality reproduction?" "Are you keen on foreign stations?" "Is the set to be handled by someone who will be mystified by a large number of controls?" etc. But what if your enquirer answers with a comprehensive Yes? Well, if you come to think of it you are much in the same position as the manufacturer who has had to decide the type of set which will satisfy the greatest number of customers.

Many of their requirements, notably quality of reproduction and selectivity, are mutually irreconcilable, so that we find the majority of sets to be examples of skilful compromise in design. The type of receiver which best lends itself to compromises of this kind is the superheterodyne, and the simple four-valve (five valves with rectifier) table model superheterodyne would seem to provide the best answer when price also has to be taken into consideration.

Nowadays a short-wave range is included as a matter of course, but it was the requirements of reception on the medium and long waves which produced a decisive verdict in favour of the superheterodyne when the "superheterodyne v. straight set" controversy was at its height. As it happens, that verdict is likely to be upheld for short-wave reception, for selectivity with a capital S is the first consideration in any set required for general listening in the present congested state of the ether.

In order to achieve the required degree of selectivity a large number of tuned circuits is required, and if these are all to be variably tuned to the frequency of the incoming signal a formidable problem is presented which, if not incapable of solution, is yet far too troublesome and expensive to be of real commercial value. The essential feature of a superheterodyne is that it reduces all signals to a single wavelength or frequency. For this reason any number of tuned circuits and valves can be arranged to give suitable amplifi-

cation and selectivity which, when once adjusted, require no further attention. The signals which are thus, so to speak, passed through the eye of a needle are subsequently treated in exactly the same way as they would be in the simplest straight receiver; that is to say, they are rectified to separate the music or speech from the new "carrier" frequency and subsequently amplified to bring them up to a suitable volume for passing to the loud speaker.

All modern superheterodynes are based on this simple principle, but they vary considerably in the degree of complexity of their circuits. "Improvements" of one kind or another are continually being evolved by designers and manufacturers, and it is often difficult to decide between the relative claims of such features as variable selectivity, automatic selectivity control, automatic noise suppression, etc.,

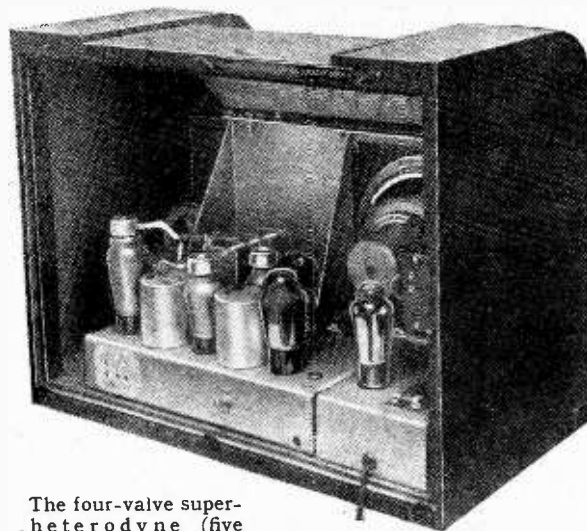

The four-valve superheterodyne (five valves with rectifier) provides the best compromise between selectivity, quality of reproduction, range and price. Note the off-set loud speaker which often improves the quality of reproduction in a table model.

when setting out to pay a little more than the price of the bread-and-butter sets which constitute the foundation of the industry. These new developments are continually being described and discussed in the pages of this journal, and it may be instructive to review some of the more recent refinements of the superheterodyne

circuit stage by stage. For the benefit of those who may wish to go more deeply into the theory than is possible in this article references to important contributions on the various subjects will be found at the end of this article.

Aerial circuits these days are beginning to look complicated. Even if only one circuit is actually tuned to the incoming signal the aerial arrangement will often have the appearance of a band-pass filter on account of the addition of high-impedance primary coupling coils,<sup>1</sup> image rejector couplings,<sup>2</sup> and built-in anti-interference aerial transformers.<sup>3</sup>

If an RF amplifier is provided the valve will be a variable-mu pentode; variable-mu to give freedom from distortion at small inputs when the valve is biased back by AVC and the pentode to give stability and freedom from overload distortion at the high inputs which may be expected from the local station.

The frequency-changer is the crucial stage in superheterodynes. Here, if anywhere, we shall find the seat of unwanted whistles and lack of tuning stability under the influence of AVC. Automatic devices have been evolved for controlling the oscillator frequency, so making the set self-tuning,<sup>4</sup> but sets of this type are expensive to build and generally the manufacturer must be able to rely on an inherently stable frequency-changer valve. In the earliest superheterodynes the frequency-changer stage consisted of two triodes, but by a process of evolution we have arrived finally at the triode hexode, which is now the most generally adopted type.<sup>5</sup>

The IF amplifier usually consists of a single stage employing a variable-mu pentode of the same type as that used in the RF stage. Associated with it are band-pass input and output circuits containing four tuned circuits. Ample selectivity for reception under present-day conditions is available with this arrangement, and it is usual to adjust the filters to give a fixed compromise between quality of reproduction and selectivity. The compromise usually gives freedom from interference outside one or two channels on either side of the local station and a cut-off on high-note reproduction somewhere between 4,000 and 6,000 cycles.

In the more expensive sets selectivity is variable.<sup>6,7</sup> The variation may be

**The Modern Broadcast Set—**

effected either by altering the coupling between the filter coils mechanically or by electrical means. In the latter case it is usual to employ two stages of IF amplification. It is also possible to arrange that the selectivity is controlled automatically by the strength of the incoming signal so that a wider audio-frequency response is provided for local reception.<sup>8</sup>

**Second Channel Interference**

The choice of the intermediate frequency is important and 465 kc/s or a frequency of that order is now generally adopted on account of the help which it gives in reducing second channel or image interference.

Detection or, as it is often called, demodulation is now invariably effected by a diode. There are often two diodes, and one takes part of the IF output and supplies rectified bias to control the amplification of the preceding stages in the set. Usually the action of the automatic volume control is delayed by applying an appropriate initial bias in order that the full amplification of the set may be available for weak signals up to a predetermined strength. An extension of this arrangement has been devised to give quiet tuning between stations.<sup>10, 11</sup> There are, however, possibilities of distortion here, but this can be overcome by careful design.<sup>12</sup>

Only in the cheapest sets is the output from the diode fed directly to the output stage and usually a triode amplifier is incorporated in the same glass envelope as the diode rectifiers. Some manufacturers favour a separate intermediate audio-frequency amplifying stage, and when this is done there is the possibility of introducing what is termed volume expansion.<sup>13, 14</sup> For various reasons it is necessary to compress the range of volumes which are passed to the modulation stages of the transmitter; thus *pianissimo* passages in music are louder than they should be and the *fortissimo* effects are reduced in strength. The object of volume expansion in the receiver is to restore the relative strengths at the extremes of the volume range, but for the scheme to work satisfactorily the "compression" at the transmitting end and the expansion at the receiving end should be made to follow the same law. In practice this is not the case, as the degree of compression is decided by the control-room engineers and is varied to suit different types of transmission. Nevertheless, volume expansion works extremely well in certain circumstances, and it is particularly valued for the reproduction of gramophone records.

Coming finally to the output stage, there is little doubt that triode valves in push-pull<sup>15</sup> give the best results, but they are only to be found in the more expensive sets. Where price is a consideration manufacturers cannot afford to ignore the efficiency of the pentode type of output valve. Valves of similar characteristic are now being produced with only four elec-

trodes, as it is found that the fifth electrode could be dispensed with, either by critical spacing of the anode or by introducing earthed deflector plates to direct the electron stream in the form of a beam.

Negative feed-back<sup>16, 17</sup> has recently been widely adopted with benefit in all types of output stage, and its advantages are particularly noticeable in the case of single pentode and tetrode valves. By taking a small proportion of the output and returning it in the appropriate phase to the input circuit of the valve considerable improvement is obtained both from the point of view of frequency and amplitude distortion. It is true that there is a loss of over-all amplification when this method is employed, but with modern valves this is not a serious drawback. On the other hand, the system produces a change in the effective output impedance of the valve which can be very useful.

The HT supply circuits of the modern AC set generally make use of a full-wave valve rectifier, and in the better class of

emission from valve filaments, which is not a continuous flow as many people suppose, but shows irregularities under high amplification.<sup>18, 19</sup>

There can be no doubt that a single RF stage is well worth the extra cost, and two IF amplifiers are useful, particularly when variable selectivity is included. Not more than one AF stage is necessary between the detector and output valves, and in the output stage push-pull is a system which is well worth paying good money for.

Features involving auxiliary valves, which may be regarded as branches of the main line of amplification through the set, can be indulged in without fear of detriment to the performance from the point of view of increased valve noise. Most people would agree that the order of usefulness of auxiliaries of this kind would be as follows: Cathode-ray tuning indicator, separate amplified AVC system, volume expansion, automatic tuning control, automatic selectivity control.

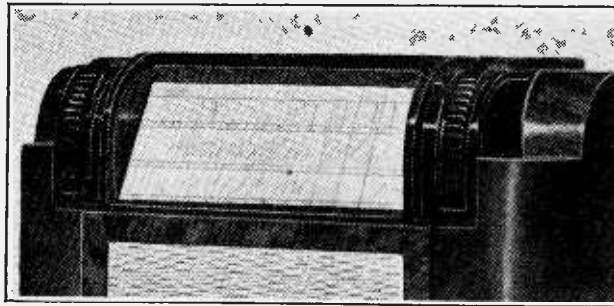

"Flywheel" or "spin-wheel" tuning control meets the requirements of both SW and ordinary broadcast listening.

On the mechanical side the industry has many attractive gadgets to offer, and here the choice is largely a matter of personal taste. Efforts to crowd too many station names on a dial are hardly worth the

cost they involve, for not only is the scale difficult to read but one should really have the set re-ganged at frequent intervals to ensure that the printed scale registers accurately with the various positions of the pointer. When short-wave reception is a primary interest, however, it is worth while to pay a little extra, if necessary, for a set which has a really well designed slow-motion control. The recently introduced flywheel or spin-tuning devices satisfy these requirements.

In conclusion, a word about cabinets. Rigid construction and careful attention to the placing of the loud speaker have done much to improve the quality obtainable from table-model sets, but for those for whom good quality of reproduction is the first consideration a well-designed console undoubtedly justifies its extra cost.

**REFERENCES**

1. Avoiding Gauging Errors (page 463, current issue).
2. Suppressing Second Channel Interference (January 17th, 1936).
3. Screened Aerial Losses (May 21st, 1937).
4. Automatic Tuning Control (January 10th, 1936).
5. Why the Triode Hexode (May 7th, 14th, 1937).
6. Variable Selectivity (July 5th, 1935).
7. Variable Selectivity Developments (July 3rd, 1936).
8. ASC Circuits (March 26th, 1937).
9. Choosing the Intermediate Frequency (July 12th, 1935).
10. Practical QAVC Circuits (September 27th, 1935).
11. Delayed Detector Operation (QAVC) (April 10th, 1936).
12. Distortionless AVC Systems (June 12th, 1936).
13. Contrast Amplification (December 18th, 1936).
14. Is Volume Expansion Worth While? (October 2nd, 1936).
15. About Push Pull (April 9th, 23rd, 30th, 1937).
16. Negative Feed-back Amplifiers (November 6th, December 25th, 1936).
17. Negative Feed-back (October 15th, 1937).
18. How Sensitive Need a Set Be? (December 13th, 1935).
19. Inherent Receiver Noise (October 9th, 16th, 1937).
20. Anti-Interference Filters (May 7, 1937).

**How Many Valves ?**

Those who are wise will give attention first to what may be termed the backbone of the set; that is to say, the valves in the direct line of amplification from the aerial to the loud speaker. There is a limit to the number of stages of amplification which can be usefully employed in this chain, and the high performance which can undoubtedly be obtained by two or more RF stages and a similar number of IF valves is almost certain to be offset by the increase in background noise. This is inherent in the conducting wires of the circuit and in the

# Listeners' Guide for the Week

## Outstanding Broadcasts at Home and Abroad



A WORD PICTURE of the scene at the Lord Mayor's Banquet will be painted for National listeners by Mrs. Olga Collett.

hear the Prime Minister reply to the toast of "His Majesty's Ministers." The reply has traditionally come to be regarded as an opportunity for the speaker to explain the Government's policy, which will this year in particular be eagerly awaited and followed by millions of listeners.

### STORIES IN STONE

THE Director of Religion, the Rev. F. A. Iremonger, has had the idea of giving a series of feature programmes at irregular intervals on Sundays, which will dramatically narrate the history of our famous abbeys, cathedrals, and churches. It is fitting, especially in this Coronation year, that the series should open with Westminster Abbey, where for centuries our Kings have come to their anointing and where many of them lie buried. The first record of a church being built on the site where the Abbey now stands is during the reign of Edward the Confessor. When, after the Great War, the Abbey was chosen as the resting place of the Unknown Soldier, it became the focal point in the lives of millions.

### PAGEANTRY

AGAIN this year listeners will hear from a commentator stationed on the roof of the Mansion House a description of the scene as on Tuesday the new Lord Mayor sets out on his journey through the City, with traditional pageantry, to show himself to the people of London. This commentary will be radiated Nationally.

Viewers will be given the opportunity of seeing the procession during the afternoon as it returns from the Law Courts to the Mansion House.

For the first time a commentary on the scene at the commencement of the Lord Mayor's Banquet at the Guildhall on Tuesday will be given to National listeners. The task has been given to Mrs. Collett, a daughter-in-law of Sir Charles Collett, who was Lord Mayor in 1934. In June she broadcast a description of the fashionable scene at Ascot. From a vantage point she will look down upon the scene as the new Lord Mayor enters, heralded by a fanfare of trumpets, at the head of his retinue. The party then proceeds round the Banqueting Hall, the Lord Mayor greeting the guests assembled to do him honour. The broadcast will conclude with "Grace," said by the Lord Mayor's Chaplain.

Listeners will later (9.20) be taken back to the Guildhall to

### SPORTS COMMENTARIES

A VARIETY of sports will provide commentaries for listeners during this week. On Friday at 8.40 (Nat.) C. L. de Beaumont, who was captain of the British fencing team at the Olympic Games, 1936, will give a commentary on the final stages of the contest for the Alfred Hutton Memorial Cup in the Ladies' International Fencing Contest at the Salle Bertrand. For a few minutes prior to de Beaumont's commentary Emrys Lloyd, who was also a member of the British Olympic team, will enlighten the uninitiated on the technical terms used in fencing. On Saturday at 4 (Reg.) de Beaumont will describe the international match between England and Denmark.

From the Empire Pool and Sports Arena, Wembley, listeners will, on Saturday at 9.35 (Reg.), hear a commentary on the last period of the Ice Hockey match between Wembley Lions and Streatham.

Tommy Woodrooffe will describe some of the bouts in the Amateur Boxing Contest between the Imperial Services and the Police at the Albert Hall on Tuesday at 9.50. This is the first of a series of such broadcasts planned for the Winter months by the O.B. Director.

Zimmermann" (Tsar and Carpenter) will be relayed from the Berlin State Opera. As doubtless you know, this tells the story of Peter the Great, who worked as a shipwright in order to gain knowledge for his onerous task as King. The scene is laid at a wharf at Zaardam, Holland.

The second opera relay comes from Sadler's Wells on Saturday at 8 (Reg.), when the first act of Beethoven's "Fidelio," which will be preceded by the "Leonora Overture No. 3," will be heard.

The programmes from abroad include an exceedingly interesting triple bill which is promised by Milan for Friday at 8. Malipiero, whose "Festino" and "San Francesco" are being given, is a most versatile and intellectual musician, whose name, curiously enough, is better known in intellectual musical circles outside Italy than in his own country. Refice, whose opera, "La Samaritana," closes the programme, is a priest who teaches in the Papal Academy of Sacred Music. As a composer he confines himself to sacred themes. The present work follows the Gospel story of the Samaritan woman at Jacob's Well.

At 7.15 on Friday Poste - Parisien will give excerpts from Kurt

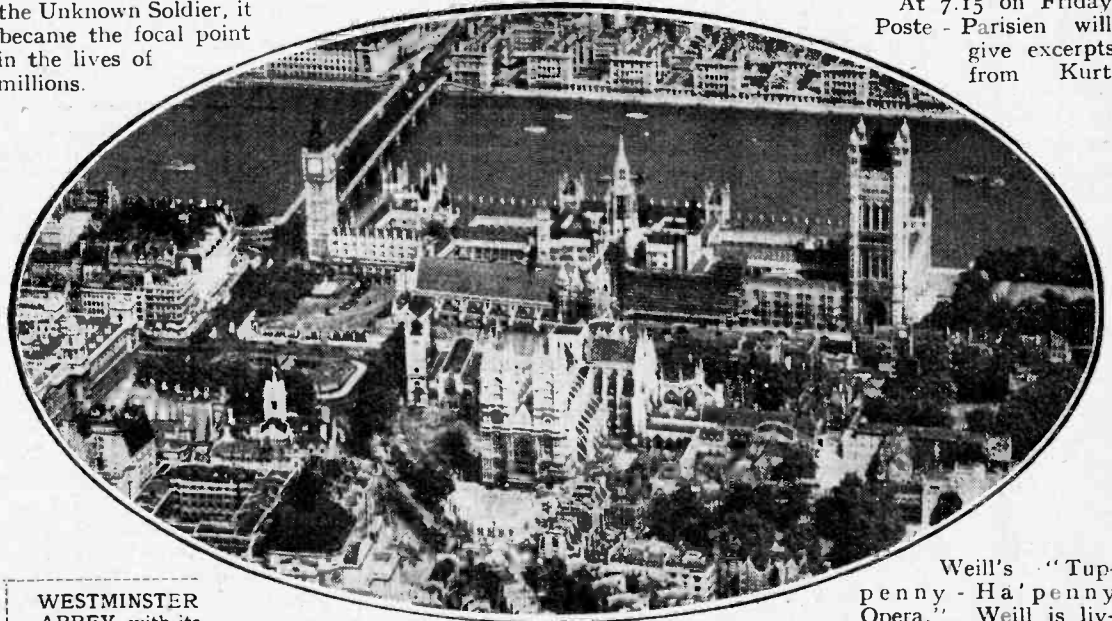

### WESTMINSTER ABBEY, with its

Coronation annexe, and the Houses of Parliament seen from the air. The history of the Abbey will be traced in a feature programme on Sunday.

This programme, the material for which has been supplied by Mr. L. E. Tanner, the Abbey Librarian, will be heard Nationally on Sunday at 9.5.

### OPERA

Two opera broadcasts come into the home programmes this week. On Friday at 7 (Nat.) Act I of Lortzing's "Zar und

Weill's "Tuppenny - Ha'penny Opera." Weill is living in banishment, for his opera, though really but the German version of the "Beggar's Opera," is an authentic expression of that post-War Berlin impressionism which was certainly more Semitic than German.

The Italo-German exchange of compliments continues, and



**Listeners' Guide—**

is reflected in the promising concert, "Verdi-Puccini-Giordano—three masters of Italian opera," which Cologne offers on Sunday evening at 7.0. The same evening brings yet another international exchange of compliments in the shape of a Wagner Festival concert from Radio-

Paris from 5.0 to 7.0, which is one of the monthly series of Franco-German exchanges.

A French comic opera, "La Poupée," by Audran, comes from Radio-Paris on Monday. Audran, who died in 1901, attained a very wide popularity with his *opéras-bouffe*, especially "La Mascotte," which reached

17,000 performances in Paris.

On Tuesday Rennes presents two comic operas at 8.30, "Vent du soir," by Offenbach, and Manuel de Falla's "Vida breve," the work which laid the foundation of its author's world-wide fame and which is, indeed, his only real opera.

THE AUDITOR.

troller of Engineering, is to take Empire listeners into his confidence at the end of the month by participating in a broadcast "Visit to Daventry."

The "Chief," as he is called at Broadcasting House, will chat with the engineers in earshot of the microphone, discussing the aerial system, the switching arrangements and the generator hall.

Miraculously enough, Empire listeners will hear the station switched on and the sounds of "warming up." Obviously this is only possible because the programme is being recorded in advance.

**Now for Droitwich and Tatsfield**

Why not a "visit to Droitwich" for incorporation in the National programme? A large percentage of listeners would relish a vivid, first-hand description of the station which serves them so faithfully.

Or, if not Droitwich, why not an hour at Tatsfield? This would teach the many owners of all-wave sets how a world-beating receiver *should* be handled.

# Broadcast Brevities

## NEWS FROM PORTLAND PLACE

**A Good Job**

AN ideal job for a keen wireless man would be that of official observer to the B.B.C. Empire Service, touring the world to gauge the relative strengths of Daventry and foreign propaganda stations at different spots on the earth's surface.

Unfortunately, no such job has been advertised.

**Roaming the Americas**

Actually, duties of this kind are being carried out to a limited extent by Felix Greene, the B.B.C.'s New York representative, who has been ranging North and South America for material for relays to the home country. In the course of his travels Mr. Greene reports on the reception of Daventry.

Latest report from Buenos Aires shows that Daventry beats Zeesen by a short head over there when the two stations are working on comparable wavelengths.

**B.H. in New York**

Felix Greene, by the way, is the Corporation's only representative overseas. His office on the third floor of the British Empire Building in Rockefeller Centre, New York, is a home from home—a miniature Broadcasting House.

On all sides are evidences of the link with headquarters.

"Internal" memo, forms (which cross the Atlantic), B.B.C. notepaper and envelopes and Miss Annette Ebson, secretary, all remind the visitor that B.H. is a mere 3,000 miles away. Dominating all is a large portrait of the Director-General. So near and yet so far.

**The Radio Link**

An eight-valve superhet completes the office equipment, enabling Mr. Greene to keep a check on most of the transmissions from Daventry.

**More Radio Ambassadors Needed**

One day the Corporation may send representatives to the Dominion capitals to establish personal liaison with the other

broadcasting organisations of the Empire and facilitate relay exchanges. Indeed, if all countries were to have "radio ambassadors" of this kind, world peace would be brought nearer.

**Listener Reaction**

ONLY water-tight method of assessing Listener Reaction, which the B.B.C. is now so strenuously pursuing, would be by means of a special relay system to perhaps 10,000 representative homes. Ammeter readings at relay exchanges have always provided a reliable guide as to the popularity of particular items. But, of course, this method would be too costly.

**If You Win a Cross-Word . . .**

The B.B.C., therefore, will probably resort to a postal referendum early in the New Year. Names and addresses will be selected at random from telephone directories, Debrett's "Peerage," lists of cross-word winners and similar sources, and to each address a short questionnaire will be sent.

Return postage will be prepaid, whether or not the address is in Scotland.

**Up the Smiths!**

A more popular appeal, with a greater certainty of response, could be directed at family pride. Let all the Smiths worthy of the name be invited to vote; if the Smiths did not hearken to their country's call in sufficient numbers, let the Joneses and Robinsons be asked, too.

**No Birthday Cake**

NOVEMBER 14th will mark the fifteenth anniversary of the start of British broadcasting from 2LO, London, yet, according to present arrangements, the date will go unrecorded in the broadcast programmes.

**Five Years Ago**

Actually it is five years since the Corporation broadcast a birthday programme. On that occasion—November 14th, 1932—the Duke of Windsor, then Prince of

Wales, witnessed part of a studio variety programme in celebration of the tenth anniversary.

**Ten Year Complex?**

It seems that the B.B.C. has a "ten-year" complex. Members of the staff who have served for that period receive a handshake from the D.G. and a cash bonus.

**Sir Noel Visits Daventry**

HOME listeners with any technical leanings may well envy their cousins overseas, for Sir Noel Ashbridge, B.B.C. Con-

**HIGHLIGHTS OF THE WEEK'S PROGRAMMES****THURSDAY, NOVEMBER 4th.**

Nat., 7.55, The Two Leslies present another "Radio Pie." 10.20, Light Music through the ages—3: The Dance.

Reg., 8, The Microphone at Large: S. P. B. Mais visits Rockingham. 9, Agatha Christie's "The Yellow Iris."

**Abroad.**

Frankfurt, 7, Radio Day, Coblenz-Trier Culture Week: concert from the Festhalle, Coblenz.

**FRIDAY, NOVEMBER 5th.**

Nat., 7, Relay of Act I of "Zar und Zimmermann" from Berlin. 8.40, Commentary on the Ladies' International Fencing Championship Contest from the Salle Bertrand.

Reg., 6, Recital for two pianos. 8.10, "Family Tree": revival of Philip Wade's radio play. 9.25, Variety from the Winter Gardens, Morecambe.

**Abroad.**

Oslo, 7.15, Leoncavallo's two-act Opera "I Pagliacci."

**SATURDAY, NOVEMBER 6th.**

Nat., 5, Roy Fox and his band. 7.30, In Town To-night. 8, Music Hall. 10, An historical and poetical programme on Wine.

Reg., 4, Ladies' fencing: commentary on the England v. Denmark match. 4.15, "Radio Pie." 8, Act I of Beethoven's "Fidelio" from Sadler's Wells. 9.30, Ice Hockey: Wembley Lions and Streatham.

**Abroad.**

Paris PTT, 8.30, Weber concert from the Conservatoire.

**SUNDAY, NOVEMBER 7th.**

Nat., 3.30, Jewish ex-Servicemen's National Remembrance Service on the Horse Guards Parade. 7, Three Victorian Plays by Laurence Housman. 9.5, Stories in Stone: Westminster Abbey.

**(Sunday, November 7th—continued)**

Reg., 3.30, The Walford Hyden Magyar Orchestra. 6.30, Fourth Sunday Orchestral Concert.

**Abroad.**

Brussels 1, 8.30, Artistes' Benefit Concert from the Palais des Beaux-Arts.

**MONDAY, NOVEMBER 8th.**

Nat., 7, Monday at Seven. 8.30, Broadway Matinee. 10, "The Camel of Compassion": a comedy from the Arabian Nights.

Reg., 8, Two Pianos in harmony. 8.20, Organ recital: Joseph Donnet. 9, Revival of "Puccini: the Man and His Music."

**Abroad.**

Cologne, 8.40, Recital of songs left by Hugo Wolf.

**TUESDAY, NOVEMBER 9th.**

Nat., 5, Relay from abroad. 7.20, The Lord Mayor's Banquet: a description of the scene. 8, "Puccini: the Man and His Music." 9.20, The Premier's Speech at the Lord Mayor's Banquet.

Reg., 6.25, Harry Roy and his band. 7.45, The Royal Philharmonic Society's concert from Liverpool.

**Abroad.**

Brussels 1, 9, Twenty Years of Jazz Hits (1917-37).

**WEDNESDAY, NOVEMBER 10th.**

Nat., 7.45, Dance music from America: relay from the Roosevelt Hotel, New York. 8.15, Fourth Symphony Concert from the Queen's Hall.

Reg., 4, Wee Georgie Wood's variety programme arranged for the Lest We Forget Association (Kingston Empire). 8.15, Carroll Lewis and his discoveries.

**Abroad.**

Deutschlandsender, 8.15, Organ recital from the Garrisonkirche (Garrison Church), Potsdam.



# High - Quality

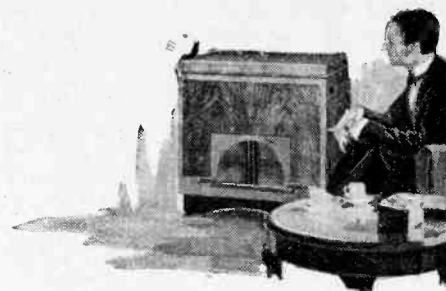

# Reproduction

**T**HE quality of reproduction obtainable is always limited by the weakest link in the chain of apparatus stretching from the microphone and studio on the one hand to the loud speaker and "auditorium" on the other. It so happens that a much closer approach to perfection is obtainable in the purely electrical links than in the acoustic or electro-acoustic; but the known imperfections of the latter are no excuse for neglecting to strive after perfection on the electrical side. Distortion is accumulative, and a reduction in any part of the chain improves the reproduction.

The electrical apparatus can introduce three main types of distortion: frequency distortion, phase distortion, and amplitude distortion. By frequency distortion we mean that different frequencies within the audible range are unequally dealt with by the apparatus; that is, the amplification is a function of frequency. Phase distortion is really a convenient way of expressing a time-delay, and when it is present notes of different frequencies take different times to pass through the apparatus. Amplitude distortion is present when the output is not proportional to the input; it introduces harmonics and combination tones. Frequency and phase distortion are closely interlinked, and it is very rare for one to occur without the other.

It is also generally agreed that the ear is incapable of detecting phase distortion except when it is present to a gross degree. It can, therefore, be taken for granted that when frequency distortion is satisfactorily low, phase distortion is quite negligible. Consequently, we need not further consider this type of distortion.

The frequency response is a matter of considerable importance, however, in spite of the fact that the ear is capable of tolerating quite large departures from perfection. The full range of audibility is about 16 c/s to 30,000 c/s, but many people cannot hear anything approaching the full range. It has been established by practical tests that in the reproduction of music the presence of frequencies from 30 c/s to 10,000 c/s gives 95 per cent.

perfection. For the natural reproduction of noise, such as the jingling of coins, the response should extend up to 20,000 c/s.

There is in practice no difficulty whatever in building an amplifier which discriminates to a negligible degree between different frequencies in the range 30 c/s to 20,000 c/s, or indeed, a much wider range. It will, however, cost more than one which is effective over a narrower range. It is, however, only possible to make full use of a wide frequency response under exceptional circumstances. Apart from difficulties in the loud speaker, frequencies above some 8,000 c/s are not present in the ordinary gramophone record and frequencies above about 13,000 c/s are not normally broadcast.

A response up to 13,000 c/s in the receiving equipment is thus sufficient to deal with the most exacting of present requirements. Even this can be utilised, however, only in the reception of the local station, and even then only when the station really is local and is distant by five miles at the most. As broadcasting stations have their operating frequencies spaced by 9,000 c/s only, a whistle of this frequency is produced; the strength of this whistle depends on the strength of the adjacent channel station relative to

the sidebands of the interfering station and the carrier of the wanted one, and also between the two sets of sidebands themselves. The resulting interference is commonly known as sideband-splash or monkey-chatter. Like the beat note between the carriers of adjacent stations, its magnitude depends on the relative strength of the stations involved, and it is only negligible in truly local reception.

## Factors in the Receiver which Affect Fidelity

For the avoidance of sideband-splash under all conditions, the high-frequency response of the receiver cannot be permitted to extend above some 3,000 c/s, and with such a response the quality of reproduction is very poor indeed. In general, a compromise is made and the response is maintained up to about 5,000 c/s with a considerable improvement in quality and sideband-splash is kept low on all but the very weakest stations. The utility of the receiver is restricted, however, for the quality is poorer than it need be on some stations and the selectivity is lower than it should be on others.

Methods of achieving variable selectivity<sup>1</sup> are consequently being adopted so that the operator can adjust the receiver to suit the particular station he wishes to listen to. He can then always get the best quality that the interference conditions permit.

The general tendency in the overall frequency response of an amplifier or receiver is for there to be a falling off at low and high frequencies. The drop in response at low frequencies is due almost entirely to the interval couplings in the audio-frequency amplifier, but the drop at high frequencies is caused by practically every stage in the apparatus. The tuned circuits in the RF and IF amplifiers all contribute towards reducing the high-frequency response and it is the charac-

***T**HE performance of receiving equipment from the point of view of quality of reproduction depends on many factors in both receiver and loud speaker. These factors are discussed in this article and the limitations set by modern broadcasting conditions are explained*

that of the wanted one and with a good high-frequency response in the receiver it is only inaudible if one is listening at short range to the local station.

This is not all, however, for the sidebands of the station on an adjacent channel overlap those of the wanted station. As a result, beats occur between

**High-Quality Reproduction—**

characteristics of these which are modified for variable selectivity.

It is generally considered good practice to design each individual stage to give an even response over the desired range of frequencies, but sometimes the characteristic of one stage is deliberately made uneven in order to compensate for an inverse characteristic in another stage. Thus, the sideband cutting of tuned circuits is sometimes corrected by designing the AF amplifier so that its response increases with frequency. In this way a flat overall characteristic can be secured in spite of all the defects of the individual stages. Tone-correction requires great care in its application, however, and skilful design is necessary if excessive amplitude distortion is to be avoided<sup>2</sup> and proper reproduction of transients secured. Applied in a mild degree, tone-correction can be very useful, but it is not a scheme to be adopted indiscriminately.

The possibility of transient distortion is not always realised. It occurs when the tone-corrector includes a tuned circuit, for any sudden impulse may kick this into oscillation at its natural frequency. Instead of retaining more or less its natural shape, the pulse then has a damped oscillation of perhaps 5,000 c/s superimposed upon it. The effect can be avoided by suitably damping any tuned circuit employed in the AF amplifier.

The general aim in AF amplifier design is to obtain a flat response curve for each stage and the most widely used type of coupling is resistance-capacity.<sup>3,4</sup> One reason for its wide use is that it is the cheapest coupling, but it is also the best in most cases from the point of view of quality. The gain per stage is always less than the amplification factor of the valve, but with modern types gains of 10-70 per stage are easily realised. At high frequencies the response is limited by the valve and stray circuit capacities, the true limiting factor being these capacities in relation to the valve and circuit resistances. At low frequencies, the response is limited by the grid leak and coupling condenser and also by the cathode bias circuit.

**The Penultimate Stage**

Now that the design considerations are fully understood, however, no difficulty is experienced in building amplifiers with a response so flat that the ear cannot detect any variation over the range of 20 c/s to 20,000 c/s. Such variations as there are can only be found by careful measurement.

The maximum output which can be secured from a resistance-coupled stage without amplitude distortion is always less than one-half the HT voltage, and is usually about one-third the HT voltage. When a large output stage is used, therefore, it cannot always be fully driven from a resistance-coupled penultimate stage, and transformer coupling is then adopted. When a resistance-fed transformer is used the maximum output is equal to that of a resistance-capacity

coupled stage multiplied by the transformer ratio. When the transformer is directly fed, the output is roughly doubled. As the usual transformer has a ratio of 1:2 to 1:4, it can be seen that a much greater output can be obtained than with resistance coupling.

Transformer coupling is also used before an output stage which has a low input impedance, or an input impedance which varies with the input voltage; the ratio adopted is then usually step-down and the penultimate valve is of the small power type. Sometimes, also, valve makers place a low limit to the resistance which must be included in the grid circuit of an output valve. A common value is 50,000 ohms and as this is really too low for the grid leak of a resistance-coupled stage, transformer coupling is again adopted.

It is more difficult to secure a good frequency response with transformer coupling than with resistance, but the gain per stage is higher. The response at low frequencies is determined by the primary inductance in relation to the valve resistance. In general, it is easier to secure a good bass response with the resistance-coupled transformer than with the directly-fed, for the absence of the steady anode current through the winding enables high permeability core material to be used and a high inductance can be secured with a small core and relatively few turns.

At high frequencies, the matter is much more complicated and the response depends on the leakage inductance, the circuit capacities, and the damping. Resonance occurs between the leakage inductance and circuit capacities and tends to give a peaked response at high frequencies; in practice, this peak is smoothed out by the adoption of suitable damping. This may take the form of core losses, and winding resistance, but it is now becoming usual to connect a resistance across the secondary.

A transformer is almost invariably employed for coupling the output stage and loud speaker.<sup>5</sup> Owing to the loaded secondary, the capacities are unimportant and the responses at low and high frequencies are governed by the primary and leakage inductances in relation to the circuit resistances. A low leakage inductance is secured by winding the primary and secondary in interleaved sections and a large primary inductance by using many turns and a large core. Unfortunately, the leakage and primary inductances increase together and some compromise is often needed, especially in inexpensive designs. It is, however, quite possible to produce a component with a high inductance primary and a low enough leakage inductance for the response to be maintained up to 20,000 c/s.

In spite of the need of avoiding frequency distortion it is actually much less important than amplitude distortion for the ear can tolerate it to a much greater degree. If perfection cannot be achieved it is better to aim at a very low degree of amplitude distortion than to try and maintain a perfect frequency response.

Any non-linear device introduces amplitude distortion in some degree, consequently all valves introduce some distortion. The amount of distortion, however, depends very largely upon the amplitude of the signal and is naturally greatest in the output stage where the signal level is greatest. An adequate output stage is thus the first essential for high quality reproduction. The power output needed depends on the volume level required and upon the efficiency of the loud speaker, but for average domestic purposes 4 watts is usually sufficient. Where rooms are unusually large or the speaker efficiency exceptionally low 12 watts may be needed. For halls and PA work generally, of course, still more output is necessary, and 30 watts is a common output for such work.

**Push-Pull Operation**

The non-linearity of valves results in the introduction of harmonics of a single input frequency and of the production of beat tones between the different frequencies when the input has more than one frequency. The distortion is generally assessed by the relative amplitudes of the fundamental and harmonics for a single input frequency.

When a single triode output valve is used the harmonics introduced rapidly decrease in intensity with their order and the second harmonic so greatly predominates that the distortion is reckoned for this alone. Power output figures are usually quoted for 5 per cent. second harmonic distortion, since this figure is considered just tolerable for high quality.

With two triodes in push-pull,<sup>6</sup> the even order harmonics are balanced out and the limit to power output is set by the third harmonic. A considerably greater output is possible with a push-pull stage and it is consequently becoming widely used in high-quality apparatus.<sup>7</sup> At the present time there is no entirely satisfactory method of rating output stages. It is the general practice to express the power output for a given percentage harmonic distortion; this is satisfactory as long as the relative magnitudes of the different harmonics are much the same, but fails when they are not. It has, for instance, been fairly well established that 5 per cent. second harmonic is tolerable, but that 0.1 per cent. of the 11th harmonic is not! In general, the higher the order of the harmonic the smaller is the percentage that the ear can tolerate.

Push-pull scores over a single output triode mainly because all harmonics are kept at a very low level until the maximum output is approached, when the distortion rises rapidly. With a single valve there is much more distortion at low volume. In general, when an output of some 2-3 watts at high quality is sufficient, a single triode is used, but for greater output push-pull is adopted.

The foregoing refers to Class A operation; that is the valves are biased to the mid-points of their characteristics and grid current is not permitted. When large output is needed Class AB operation is

**High-Quality Reproduction—**

often adopted. Two valves in push-pull are used and biased much more negatively than with Class A operation<sup>8</sup>; a higher anode voltage is used, for the higher grid bias enables this to be done without exceeding the maker's rating for anode dissipation, and the anode current fluctuates with the signal input. This necessitates a low resistance HT supply system and a fixed-voltage source of grid bias if the full output is to be secured. This in turn usually means that the resistance in the grid circuit must be kept fairly low, so that transformer coupling to the output stage is adopted.

The output of a properly adjusted Class AB amplifier is about twice that of the same two valves run under Class A conditions. There is a greater risk of distortion occurring, however, and all valves are not suitable. The system is rarely used for outputs of less than 10 watts.

For very large output Class B output is adopted. This is essentially the same as Class AB, but a large signal is applied so that the valves are driven into grid current on the positive peaks of the signal. This results in the input impedance of the output stage varying during the cycle of the signal with the result that the gain of the previous stage varies in sympathy with consequent distortion. In order to reduce this to a minimum the penultimate stage is of the small power type and a step-down transformer is used for the coupling to the output stage.<sup>9</sup> In this way it is readily possible to keep the total harmonics introduced below 5 per cent. and to obtain very large output. This type of amplifier, however, suffers from the defect that unless it is very carefully designed and adjusted small percentages of very high harmonics are introduced and cause serious distortion on certain musical instruments, notably the piano. Moreover, the distortion does not fall off much at low outputs, as with other types of output stage.

**The Pentode Output Valve**

The pentode is probably the output valve most commonly used. Unlike the triode it introduces both second and third harmonics in about equal degree.<sup>10</sup> Consequently the use of two valves in push-pull under Class A conditions does not offer the same advantages as with triodes for although it removes the second harmonic distortion it leaves the more important third harmonic unaffected.

The great advantage of the pentode is its high efficiency; for a given output it requires a smaller anode dissipation and a smaller signal input. This is the reason why it is so widely used. It has the disadvantage of a very high AC resistance which leaves the loud speaker undamped by any external source. With a triode, the speaker is heavily damped by the low resistance of the valve, with the result that bass resonances are less pronounced than with the pentode.

The disadvantages of the pentode can be removed by the use of negative feed-

back in suitable form.<sup>11, 12, 13</sup> With this a portion of the output voltage is fed back in opposite phase to the input. Harmonics are reduced and the effective AC resistance of the valve is also lowered and the frequency response is improved. Negative feed-back can, in fact, give triode characteristics to a pentode and enables a considerable improvement in quality to be obtained. Its use, however, means that the high sensitivity of the pentode is lost, but the power efficiency remains.

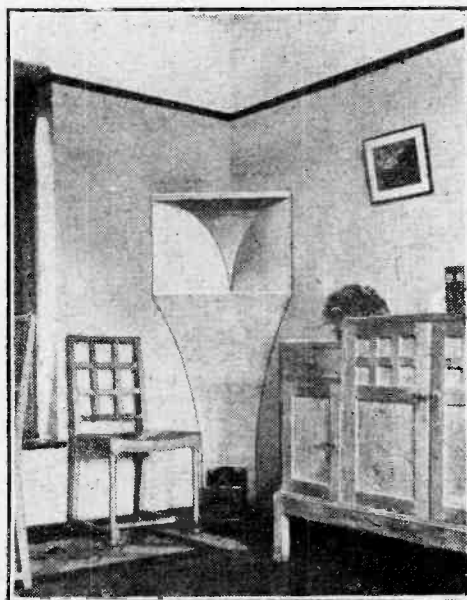

A corner horn affords one of the best known methods of loading a loud speaker for high quality domestic reception.

Pentodes, or nowadays more commonly, tetrodes<sup>14</sup> can be used in Class AB and Class B with or without negative feedback, and their high power efficiency makes them particularly useful for large outputs. Thus a Class A stage giving 5 watts output with a single valve will give 10-15 watts with two in push-pull. Under Class AB conditions, the pair will give 25-30 watts,<sup>15</sup> and under Class B conditions 50-60 watts.

Where the very highest standard of quality is desired, a pair of triodes in Class A push-pull cannot be bettered, but in spite of the importance of the output stage the earlier part of the equipment must not be overlooked. The penultimate stage must deliver sufficient output to load the output stage without itself introducing distortion and it is sometimes advantageous to use push-pull here also. Unless tone-correction schemes are introduced, there is little risk of amplitude distortion in still earlier AF stages, for the signal levels are normally very small.

The detector must be given careful consideration, however. A diode<sup>16</sup> is usually adopted, but it is no better than a grid or anode-bend detector if the signal input is small. With a large input, however, it can be nearly distortionless, but if the input is too large serious difficulty arises in the RF or IF stage preceding it. Moreover, especially with a large input, the impedance of the load circuit at modulation frequencies must be

as nearly as possible equal to its DC resistance, otherwise distortion occurs when the modulation depth exceeds a certain amount. Quite recently negative-feed-back has been applied to the detector.<sup>17</sup>

In the writer's experience the distortion introduced through using too small a detector input is much less noticeable to the ear than that caused by overloading the last IF valve through trying to obtain a large detector input. Small-input detector distortion is chiefly second harmonic and the probability is that the usual forms of distortion met with when using a large detector input introduce higher harmonics of which the ear is less tolerant.

Of more importance than all these, however, is the distortion caused by delayed diode automatic volume control.<sup>18, 19</sup> At certain signal levels this can be very serious and is of the same nature as that introduced by a Class B output stage. It is particularly distressing to the ear if the AF amplifier has a good high-frequency response. It comes about because the application of a delay voltage to the AVC detector causes it to have an input impedance which varies throughout the cycle of modulation and this in turn makes the impedance of the intervalve coupling between the IF valve and detector a variable quantity. The poorer the tuned circuit used and the lower the input impedance of the detector, the less effect the AVC circuit has on quality, and this is the reason why this type of distortion has become more noticeable recently, for better quality coils are now used.

**The Loud Speaker**

Even when all forms of distortion are reduced to the practicable minimum, there are still things to do in the interests of quality. Traces of a heterodyne whistle, for instance, can often be removed by a suitable filter<sup>20</sup> without affecting quality to any noticeable degree. Another fitting which is of especial use in the reproduction of gramophone records is a volume expander.<sup>21</sup> In recording, the volume range of music is necessarily reduced, because the full intensity cannot be recorded. A piece of apparatus which produces appropriate expansion of the volume range in the reproduction is, therefore, desirable. Volume expansion is not without its pitfalls, however, for many systems introduce too much amplitude distortion to be entirely satisfactory. It is probably this difficulty which has prevented its general adoption.

It will be fairly obvious, however, that with the knowledge at present at our disposal it is not difficult to ensure an electrical input to the loud speaker which is a reasonably faithful replica of the modulation impressed on the carrier wave at the broadcast transmitter. The translation of electrical into acoustic energy is a much more difficult task and one which still depends a good deal on empirical methods. Much has been done recently to establish the principles of



**High-Quality Reproduction—**

loud speaker design on a sound scientific basis and it is possible to circumscribe most of the qualities which go to the making of a good reproducer.

It goes without saying that a frequency range at least as wide as that catered for in the receiver and amplifier must be provided. At present this is beyond the scope of a single diaphragm, for if this is given an area sufficient for adequate radiation in the bass, the high frequency response suffers not only on account of the appreciable mass of the diaphragm, but because it is difficult to prevent the large area of the diaphragm from breaking up into a series of subsidiary resonances in the upper middle register. The use of two or more loud speakers of different sizes afforded a temporary solution of the difficulty, but the methods most in favour at the present time involve the use of a single diaphragm system of composite structure. Equally good results are obtained by the twin diaphragm form of construction in which a small subsidiary cone is rigidly attached to the voice coil with a partially flexible joint between the main diaphragm, and the "Duode" form of construction in which a light metal former, separated from the main voice coil by a layer of resilient material, acts as a single turn voice coil of light weight at high frequencies.

A wide frequency range is, by itself, of little value unless the response is smooth and free from prominent resonances. The poor quality given by cheap moving-coil loud speakers is attributable to two causes: a series of violent "break up" resonances in the region from 2,000-5,000 c/s. and an undamped fundamental resonance at a frequency just over a 100 c/s which encroaches on the band of frequencies occurring in speech. The former trouble can be cleared up by the choice of suitable diaphragm material and the latter is controlled by the restoring force and the mass of the diaphragm as a whole, and by the damping. In good quality loud speakers the fundamental resonance occurs at about 40 c/s and in the best makes does not show at all, as the damping renders the diaphragm movement practically dead-beat. Critical damping is also an important factor in transient response<sup>22</sup> and there is no doubt that a loud speaker with good damping and a reduced frequency range is much to be preferred to one in which the order of these qualities is reversed.

**Amplitude Distortion in Speakers**

Harmonic distortion in loud speakers is due to two main causes. Either the diaphragm surround may be too tight or the speech coil may travel outside the area of uniform magnetic flux when the diaphragm is developing the large amplitudes necessary for adequate radiation of extremely low frequencies. There are two simple expedients for overcoming this latter trouble. Either the coil may be made long compared with the depth of the air gap or *vice versa*. The first-mentioned of these two alternatives is usually

adopted as it involves a less expensive field magnet.

Given a wide-range diaphragm system free from resonances and harmonic distortion and of low inertia with critical damping, there still remains the problem of useful air loading and radiation efficiency. At high frequencies this can safely be allowed to take care of itself; any troubles which may be experienced will be confined to the lower half of the musical scale. A properly designed horn provides the best solution since it acts as an acoustic transformer between the diaphragm and the surrounding air.

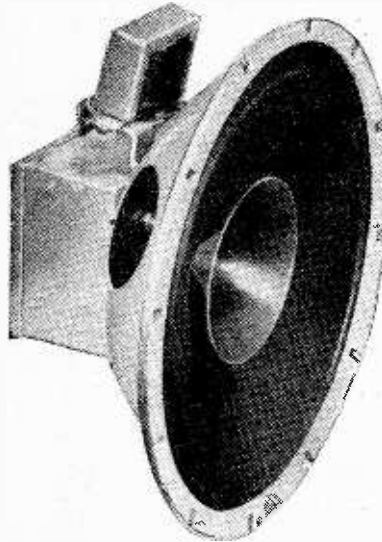

Twin cones are often employed to extend the frequency range of a loud speaker.

Another advantage of horn loading is that it calls for much smaller diaphragm amplitudes at low frequencies with a consequent reduction in amplitude distortion. On the other hand, if a small throat is used and very high powers are radiated there is a possibility of overloading the air itself in the constricted space near the diaphragm.<sup>23</sup>

The lowest frequency which can be radiated without loss from a horn loud speaker is determined by the area of the flare and for uniform radiation down to 30 c/s it would not be possible to get the horn into the average room. The same limitation applies to loud speakers designed for use on a plane baffle, but in either case no difficulty will be found in arranging for effective radiation down to 70 c/s, which most people find to be sufficiently low for the artistic appreciation of music. In the case of a horn loud speaker an effective extension of the bass response is obtained by building the horn into the corner of the room when the walls act as an extension of the flare.

If a plane baffle is used the loud speaker should not be placed exactly in the middle, otherwise peaks and troughs due to interference between the back and front radiation may be noticeable when listening on the axis.<sup>24</sup> Incidentally, it is necessary in most cases to arrange that the listener's chair is placed somewhere near the axis of the loud speaker in order to obtain the full benefit of the high-frequency radiation. This does not apply in the case of

horn-type loud speakers and attention has recently been given to the solution of the problem in the case of baffle loud speakers by the use of elliptical diaphragms and diffusion cones.

The adaptation of high quality radiation from a loud speaker to the acoustic characteristics of the listening room is more a matter for personal judgment, as the investigation of a single room by scientific methods might involve months of work. The principal factor is the ratio of direct to reflected sound from the walls, etc., and the simplest and most effective solution is to find by experiment a position for listening in which a satisfactory balance is obtained. The volume level at which the loud speaker is worked will also have a definite effect on the apparent quality<sup>25</sup> but most people with the natural ability to appreciate good quality of reproduction will subconsciously adjust the volume to the correct level.

**REFERENCES**

1. Variable-Selectivity Developments, July 3rd and 10th 1936.
2. Amplifier Correction and Waveform, June 25th, 1937.
3. Resistance Coupled Amplifiers, Oct. 30th, Nov. 6th, 13th, 27th, Dec. 18th and 25th, 1936.
4. RC Coupled Pentodes, Sept. 24th, 1937.
5. Loaded Transformers, June 21st, 1935.
6. About Push-Pull, April 9th, 1937.
7. The Push-Pull Quality Amplifier (issue out of print—reprint available), May 11th and 18th, 1934.
8. About Push-Pull, April 23rd, 1937.
9. Distortionless Driver, April 30th, 1937.
10. Pentodes and Loud Speakers, Dec. 18th, 1936.
11. Negative Feed-Back Amplifier, Nov. 6th, 1936.
12. Negative Feed-Back Amplification, Dec. 25th, 1936.
13. Degeneration, March 5th, 1937.
14. The Bean Power Tube, Jan. 1st, 1937.
15. 30-Watt PA Amplifier Sept. 10th and 17th, 1937.
16. The Detector, Sept. 11th, 1936.
17. New Detector Circuit, Jan. 1st, 1937.
18. Distortionless AVC Systems, June 12th, 1936.
19. Is Automatic Volume Control Worth While? May 22nd 1936.
20. Rejecting Whistles, Dec. 4th 1936.
21. Simplified Volume Expansion, April 24th, 1936.
22. Transient Response, July 30th, 1937.
23. Acoustic Distortion at High Amplitudes, May 15th, 1936.
24. Loud Speaker Baffles, May 22nd, 1936.
25. Scale Distortion, Sept. 24th, 1937.

**G.E.C. Anti-interference Aerial**

THE introduction of a new anti-interference aerial system that is adaptable to any make of all-wave receiver is announced by the General Electric Co., Ltd., Magnet House, Kingsway, London, W.C.2.

This aerial is designed to be an efficient collector on all wavelengths from 10 to 2,000 metres, and special attention has been given to reduce to a minimum signal loss in the various matching transformers and in the transmission line.

Another feature of considerable importance is that this new G.E.C. aerial is not appreciably directional on the short waves, so that it has a virtually uniform response to signals arriving from all points of the compass.

The collector portion of the aerial consists of a "double V" arrangement of wires, and this must be erected outside the field of interference for it to be efficacious as a noise-reducing system. A transmission line with matching transformers is used to join the aerial to the receiver.

There is no waveband switching in the system, as the transformers have been designed to provide automatically the correct coupling on the short-, medium-, and long-wavebands.

The complete kit, which consists of aerial wire, insulators, transformers, and 60ft. of transmission line, costs 5s. 6d.



# Useful Facts and Figures

THE information given on this page has been chosen to meet the needs of the new reader. Valve base diagrams, which might properly have been included, will appear shortly, complete with the latest additions made since the publication of our last list.

## CURRENT, VOLTAGE AND RESISTANCE CALCULATIONS

ONE can go a long way in amateur radio without any mathematical knowledge, and, indeed, many of those who are content to tread the stereotyped paths seem to get on remarkably well without even making the simplest arithmetical calculations. Sooner or later, however, one is bound to encounter the need for delving into the precise relationship between Amperes, Volts and Ohms. Fortunately, the necessary calculations for ascertaining these relationships are of the easiest; Ohm's Law tells us that current (in amperes) is equal to potential difference (in Volts) divided by Resistance (in Ohms), or—

$$I = \frac{E}{R}$$

*Example:* What current will flow through a 1,000-ohm resistor when a 100-volt battery is connected across it?

$$I = \frac{100}{1,000} = 0.1 \text{ amp. (=100 milliamperes).}$$

Another application of the same Law tells us what voltage will be developed across a given value of resistance when a known value of current is passing through it. The formulæ is  $E=IR$ .

*Example:* What voltage will be absorbed by a 1,000-ohm resistance when the current flowing through it is 0.1 amp.?

$$E = 0.1 \times 1,000 = 100 \text{ volts.}$$

Lastly comes what is perhaps the most useful application of the Law:—

$$R = \frac{E}{I}$$

*Example:* It is required temporarily to work a 2-volt battery consuming 0.1 amp. from a 6-volt battery; what value of "breaking-down" resistance must be inserted in the circuit to absorb the surplus 4 volts and thus to prevent overrunning the valve?

$$R = \frac{4}{0.1} = 40 \text{ ohms.}$$

## RESISTOR COLOUR CODE

THE ohmic value of many makes of resistor is indicated by means of three distinctive colours. The colour of the body represents the first figure, while that of the tip or end-band represents the second figure. Lastly, the colour of a spot or centre-band indicates the number of ciphers that follow the first two figures.

Figure	Colour	Figure	Colour
0	Black	5	Green
1	Brown	6	Blue
2	Red	7	Violet
3	Orange	8	Grey
4	Yellow	9	White

*Example:* A resistor with red body, green tip and yellow spot has a value of 250,000 ohms.

It should be noted that when no spot (or centre-band) is apparent on the resistor it is to be assumed that the spot is of the same colour as the body. This system of identification and the other codes that follow are

as recommended by the Radio Component Manufacturers' Federation.

## FIXED CONDENSER COLOUR CODE

CERTAIN condensers have their capacity values indicated by a code that is inherently similar to that given above for resistors. Capacity is expressed in micro-microfarads (symbol  $\mu\mu F$ ). One micro-microfarad is equal to 0.00001 microfarad, while 100  $\mu\mu F$  equals 0.0001 mfd.

Three coloured dots which appear on the trademark side of the condenser case are read from left to right; the first dot represents the first figure, the second dot the second figure, and the third dot the number of ciphers, all being in accordance with the key given for resistances.

*Example:* Red, black and brown dots (in that order) stand for 200  $\mu\mu F$ , or 0.0002 mfd.

## WANDER PLUG COLOUR CODE

Highest positive HT ... ..	Red
2nd highest positive HT ... ..	Yellow
3rd highest positive HT ... ..	Green
4th highest positive HT ... ..	Blue
LT positive ... ..	Pink
Negative (—LT, —HT, +GB) ... ..	Black
Maximum GB negative ... ..	Brown
2nd GB negative ... ..	Grey
3rd GB negative ... ..	White

Any additional battery lead is Violet and any centre-tap White.

## COLOUR CODING OF FUSES

60 mA Black	1 Amp. Dark Blue
100 mA Grey	1.5 Amp. Light Blue
150 mA Red	2 Amp. Purple
250 mA Brown	3 Amp. White
500 mA Yellow	5 Amp. Black and White.
750 mA Green	

## RULES OF THUMB

THE wireless art is not so fortunate as some others in having easily remembered rules of thumb, by the help of which long calculations or the consultation of reference books may be avoided. There are, however, at least two such rules which, if not scientifically accurate, have at least stood the test of time, and generally yield results sufficiently close to the truth to be really useful.

"The number of turns of wire in a tuning coil is proportional to wavelength." The method of winding and the mean diameter of the coils must be sensibly unchanged.

*Example:* A short-wave set with interchangeable coils tunes comfortably to 80 metres with a 25-turn coil (the largest available). It is desired to improvise a coil for reception of amateur transmissions on 160 metres. As the wavelength is twice as long,

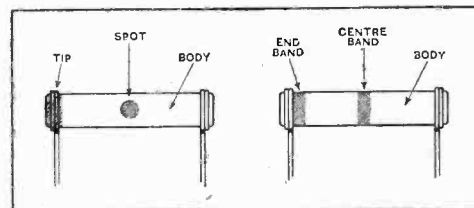

Ohmic values of fixed resistors are indicated by coloured markings.

a coil with twice the number of turns would be about right.

Frame aerial windings: Assuming that the frame is of a fairly conventional type, a winding consisting of 75ft. of wire will be about right for the medium broadcast wave-band, while 250ft. will be needed for the corresponding long-wave winding. It will generally be found that the inductance of frames wound to this rough rule is on the high side, but that is a fault in the right direction, as it is easier to remove any surplus turns by trial and error than to add them.

## AMATEUR WAVEBANDS

BY international agreement the following bands of frequencies have been allotted for amateur use:—

Frequency in megacycles per second.	Equivalent wavelength (approx.) in metres.
1.715—2.000	174.635—150
3.500—4.000	85.714—75
7.000—7.300	42.857—41.095
14.000—14.400	21.428—20.833
28.000—30.000	10.714—10
56.000—60.000	5.357—5

These bands are popularly known as the 160-, 80-, 40-, 20-, 10- and 5-metre bands.

## WAVELENGTH-FREQUENCY CONVERSION

TO ascertain the wavelength (in metres) of a station of which the frequency is known, divide 300,000 by the frequency (in kilocycles per second).

Similarly, to convert wavelength into frequency, divide 300,000 by the wavelength.

## GENERAL HINTS

NO output valve—and, to be on the safe side, no amplifying valve—should ever be operated without proper grid bias, or it is likely to be damaged by the resultant excess anode current. Consequently, special attention should be paid to the soundness of all grid-circuit connections, and care should be taken that the continuity of such circuits is never interrupted even momentarily.

Always measure the voltage of a battery while it is "on load," i.e., while it is feeding the valves of the receiver. "Open-circuit" readings are nearly always misleading.

The modern set depends greatly on the accuracy of alignment of its tuned circuits, and this accuracy is almost certain to be impaired if the ganged tuning condenser is roughly handled. Above all, beware of bending or in any way displacing the fragile moving vanes.

Alignment of the ganged tuning system of the present-day receiver is an operation calling for considerable skill and knowledge; never disturb the trimming condensers, etc., unless you are quite sure that you know the correct procedure and have the necessary apparatus to do the job properly.

An exception to the foregoing rule is to be found in the aerial input circuits of many receivers. Quite often it is possible to improve sensitivity quite appreciably by adjusting the trimmer associated with this circuit, which may not be accurately matched to the constants of the aerial with which it is being used. In any case, there is little possibility of doing harm, provided the other trimmers are not disturbed.

# Short-Wave Reception

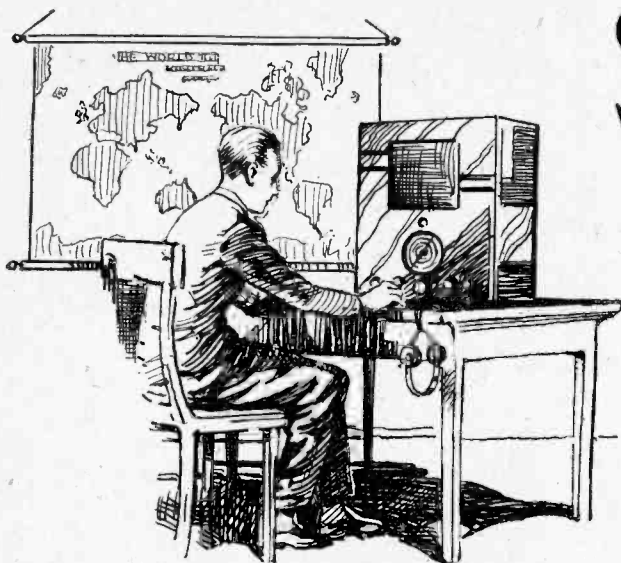

## Stations to Look For and Best Times to Listen

Pittsburg, on 11.87 Mc/s (25.27 metres), W1XAL, Boston, on 11.79 Mc/s (25.45 metres), and W2XAF, Schenectady, on 9.53 kc/s (31.48 metres), will probably provide the best signals from the U.S.A. In the 9 Mc/s band W1XK and W3XAU are also available.

As the majority of the new season's receivers are of the all-wave type, that is to say, they include one or more short-wave ranges, it is only natural that readers having no previous acquaintance with the short waves would want to know what form of wireless entertainment can be expected and whether this waveband can provide anything of greater interest than is to be found on the familiar bands.

Well, in the first case, there is broadcasting not only from European countries but from such distant places as America and from even farther afield, for stations in the Antipodes can be heard in this country on the short waves.

Time plays an important part in short-wave listening for many of the regularly operating broadcast stations are transmitting programmes for the benefit of their own listeners and the times of transmitting are regulated accordingly. It is obviously useless trying to tune-in a station on the other side of the world during the evening if in that country it is early morning.

There are seven main broadcasting bands in the short waves, and these are in the vicinity of 26, 21, 18, 15, 12, 9.5 and 6 Mc/s—11, 14, 17, 20, 25, 31 and 49 metres respectively.

Occasionally telephony signals on higher and also on lower frequencies are to be heard, some are broadcasts, others are of an experimental nature.

If 30 Mc/s (10 metres) is the highest

frequency to which the set will tune, one can look for amateur transmissions round about 30 Mc/s, and possibly some of the American high-fidelity broadcasting stations which operate between 33 Mc/s and 26 Mc/s (9.1 and 11.5 metres). Saturday and Sunday afternoons are the best times to look for amateur transmissions on 10 metres. The U.S.A. amateurs are usually very strong and of good quality. Signals reach their zenith in the afternoon at this time of the year and remain audible until after sunset. Usually they fade out about two hours after dark.

### Daylight Frequencies

During the daytime this year, and for the next two or three years, W2XE, at Wayne, U.S.A., on 21.52 Mc/s, is certainly worth while looking for, and in the afternoon will probably be better to try for than W3XAL, Bound Brook, on 17.78 Mc/s, or W2XAD, Schenectady, on 15.53 Mc/s, although both the latter may also be good.

As the day progresses the higher radio frequencies tend to fade out and the lower to come in, but on most days the 18 and 15 Mc/s bands will usually be productive of signals until quite late at night. A new transmitter on 18 Mc/s is TGWA, Guatemala City, on 17.80 Mc/s.

Late in the evening a shift to still lower frequencies is desirable, and W8XK,

The main reasons why one can usually look to the U.S.A. for short-wave programmes is that in that country there are a comparatively large number of quite powerful stations in regular operation, their times are favourably related to our own; Eastern Standard Time, for example, is five hours earlier than GMT, and last but not least the language is the same.

### Local Reception

European short-wave stations can be heard at most hours of the day, though only the nearer and more powerful ones are likely to be heard regularly. Between 6.02 and about 21.0 Mc/s (49.83 metres and lower) there are ten or more stations, most of which are rated at 50 kW, operating from Zeesen, in Germany. All have call signs commencing with DJ, such as DJA, DJB, etc.

The Italian short-wave stations are also well received in this country, the principal ones being the two Rome transmitters, 12RO4, on 11.81 Mc/s (25.4 metres), and 12RO3, on 9.635 Mc/s (31.15 metres), and the Vatican transmitter, HVJ, now being rebuilt.

So far as the B.B.C.'s Empire stations at Daventry are concerned, GSH, on 21.47 Mc/s (13.97 metres), is usually good in the south, while GSJ, also in the 21 Mc/s band, has an aerial directed eastwards and gives good signals on the east coast.

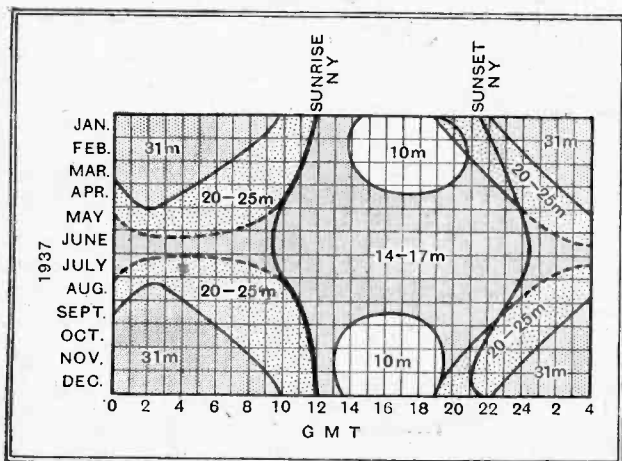

From Fig. 1 (left) it is possible to ascertain the optimum wavelength for best reception of American stations at any time of the day. These curves relate to the propagation of short waves during sunspot maximum years.

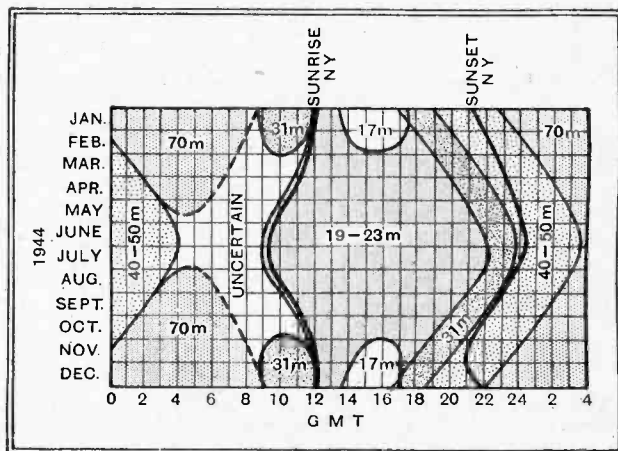

Fig. 2 (right) shows what conditions will prevail during the sunspot minimum years of 1944-45.

**Short-Wave Reception—**

Amateur transmissions are also to be found in the vicinity of 14 Mc/s (21 metres), 7 Mc/s (42 metres), and if one has a set with a particularly wide short-wave coverage, on about 80 and 160 metres also.

During the evening it should be possible to hear Moscow, U.S.S.R., RNE, on 12.06 Mc/s (25.0 metres); Rio de Janeiro, Brazil, PRF5, on 9.5 Mc/s (31.58 metres), and Prague or Podebrady, Czechoslovakia, OLR2A, on 6.01 Mc/s (49.92 metres), and other frequencies in the 11 and 15 Mc/s band. A new and powerful Danish transmitter, OZF, on 9.52 Mc/s, is also very well heard.

If one desires to span the globe there are stations in Australia that can be received in this country. The time of listening is important, for as a rule Sydney, VK2ME, on 9.59 Mc/s (31.28 metres)—the most powerful of the Australian short-wave stations—is generally only received here well in the afternoon.

**Optimum Wavelengths**

The curves shown in Fig. 1 and Fig. 2 represent an attempt to forecast general short-wave reception conditions "three-dimensionally" for the England-North American services.

The figures, one for the sunspot maximum years of 1937-38-39 and the other for the sunspot minimum years of 1944-45, show the twelve months of the year vertically and the time of day, in GMT, horizontally. On the horizontal time scale it will be seen that a small "overlap" in time is provided.

The various shadings then represent the optimum wavelengths for reception (or transmission) between this country and North America.

For example, it will be seen that in the midsummer period of 1938 it will be possible to receive continuously on 17 metres throughout the twenty-four hours, although during the midday period a 14-metre wave might be somewhat superior.

The dotted portion of the curves in this particular case show that on a few nights it might be necessary to use the next longest wave.

On some occasions, even during the "maximum" years, it may be necessary to consult the second "sunspot minimum" chart (Fig. 2), since during the so-called magnetic-storm periods ionisation levels seem to become abnormally low and reception conditions often approximate to the normal conditions of Fig. 2. When this is the case the optimum band of wavelengths for reception from America in the evening will be quite narrow and well defined, with only moderate strength signals, in distinct contrast to the conditions depicted in Fig. 1.

Normally the optimum wave, as indicated in Fig. 1, will be only the best wave of quite a broad band of useful frequencies centred about it.

It will be seen, finally, that the general trend of short-wave reception conditions follows the New York sunrise and sunset lines quite closely.

**SYMBOLS USED IN CIRCUIT DIAGRAMS**

FOR the benefit of new readers, we give below a selection of the graphical symbols most commonly used in circuit diagrams published in *The Wireless World*. As the schematic circuit diagram is such an invaluable aid to the illustration and explanation of wireless principles and practice, all readers would find it worth while to memorise these symbols and to acquire the comparatively simple art of reading the diagrams in which they are used.

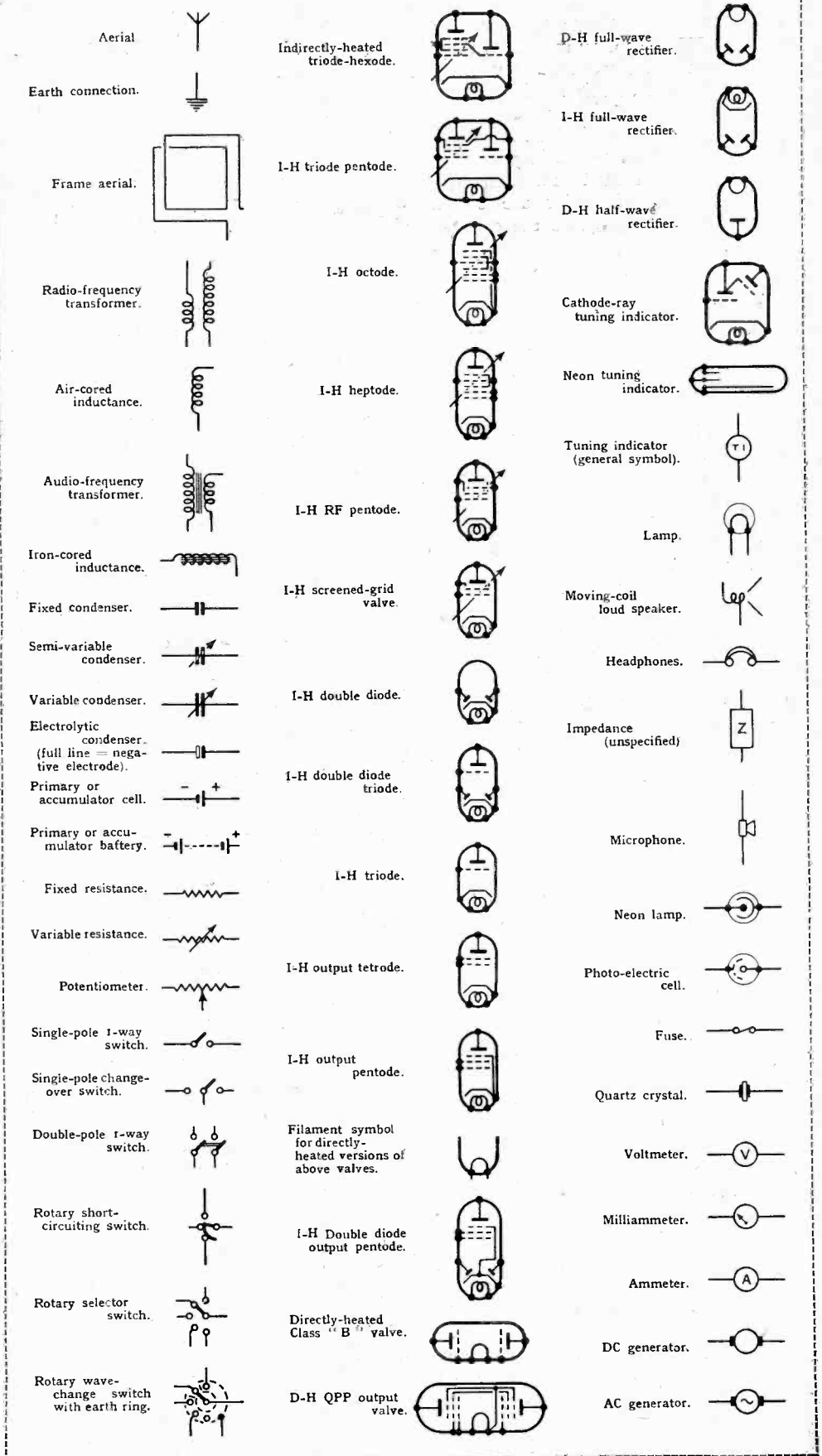

# Cossor MODEL 584

AN ALL-WAVE AC SUPERHETERODYNE  
WITH VARIABLE SELECTIVITY

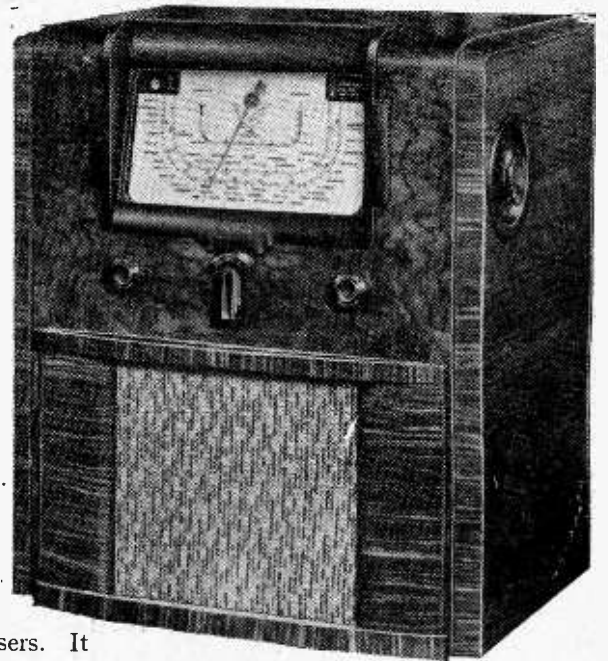

**T**HERE are many ingenious ideas, both in the electrical and mechanical design of this receiver, which come as a refreshing change from the stereotyped form which the four-valve superheterodyne has taken in the hands of the majority of manufacturers. The tuned circuits in particular are of unusually efficient design, and the coils are assembled in a small separate chassis which is rubber-mounted in the centre of the main chassis. On top of this is the three-gang tuning condenser with ceramic insulation, and this in turn is rubber-insulated from the coil assembly.

More than usual attention has been given to the design of the aerial circuit. On the short-wave range a single tuned circuit with loose coupling is employed, and the aerial terminals are arranged so that a doublet can be used if desired. On the medium and long waves the coils are iron-cored and are wound with stranded Litz wire. A resonant type of high-impedance primary with mixed coupling is employed, which overcomes many of the ganging troubles which are experienced with the simpler forms of coupling.

A triode-hexode frequency-changer converts the incoming signal to 405 kc/s, and this is amplified by a variable- $\mu$  pentode coupled by iron-cored and Litz-wound IF transformers in which permeability adjustment of tuning has been adopted in preference to the more usual

**FEATURES.** *Circuit.*—Triode-hexode frequency-changer — var. $\mu$ . pentode IF amplifier—double-diode-triode second detector—tetrode output valve. *Full-wave valve rectifier.* **Controls.**—(1) Tuning. (2) Volume. (3) Selectivity and tone. (4) Waverange. (5) Mains on-off switch. **Price.**—13 guineas. **Makers.**—A. C. Cossor Ltd., Highbury Grove, London, N.5

method of using trimming condensers. It is claimed that this is not only more accurate, but gives increased stability over a long period.

The coupling of the coils in the first IF transformer is varied to give a wide band width for local station reception, and the coupling mechanism is controlled from the tone-control knob by means of a flexible cord passing along the underside of the chassis.

The anode current of the IF valve is also used to control the magnetisation of a small subsidiary transformer supplying AC to the pilot lamp which serves as tuning indicator. This method has often been employed in sets previously, but we have not so far come across a system which gives as sensitive a control as is obtain-

able with the Cossor interpretation of the principle.

A double-diode-triode follows the IF stage and supplies delayed AVC to the two previous valves. The tone control is connected across the anode circuit of the triode amplifier in order that the loading of the tetrode output valve may be kept constant.

The tuning control is particularly sweet in action, and is operated from a knob at the side of the cabinet giving a 30:1 reduction ratio. A finger-tip control is provided to facilitate rapid movement from one part of the dial to another. A key-type waverange switch occupies the middle of the tuning-dial escutcheon, and

The aerial couplings on medium and long waves are designed to reduce ganging errors. Another interesting feature of the circuit is the use of permeability tuning in the IF couplings.

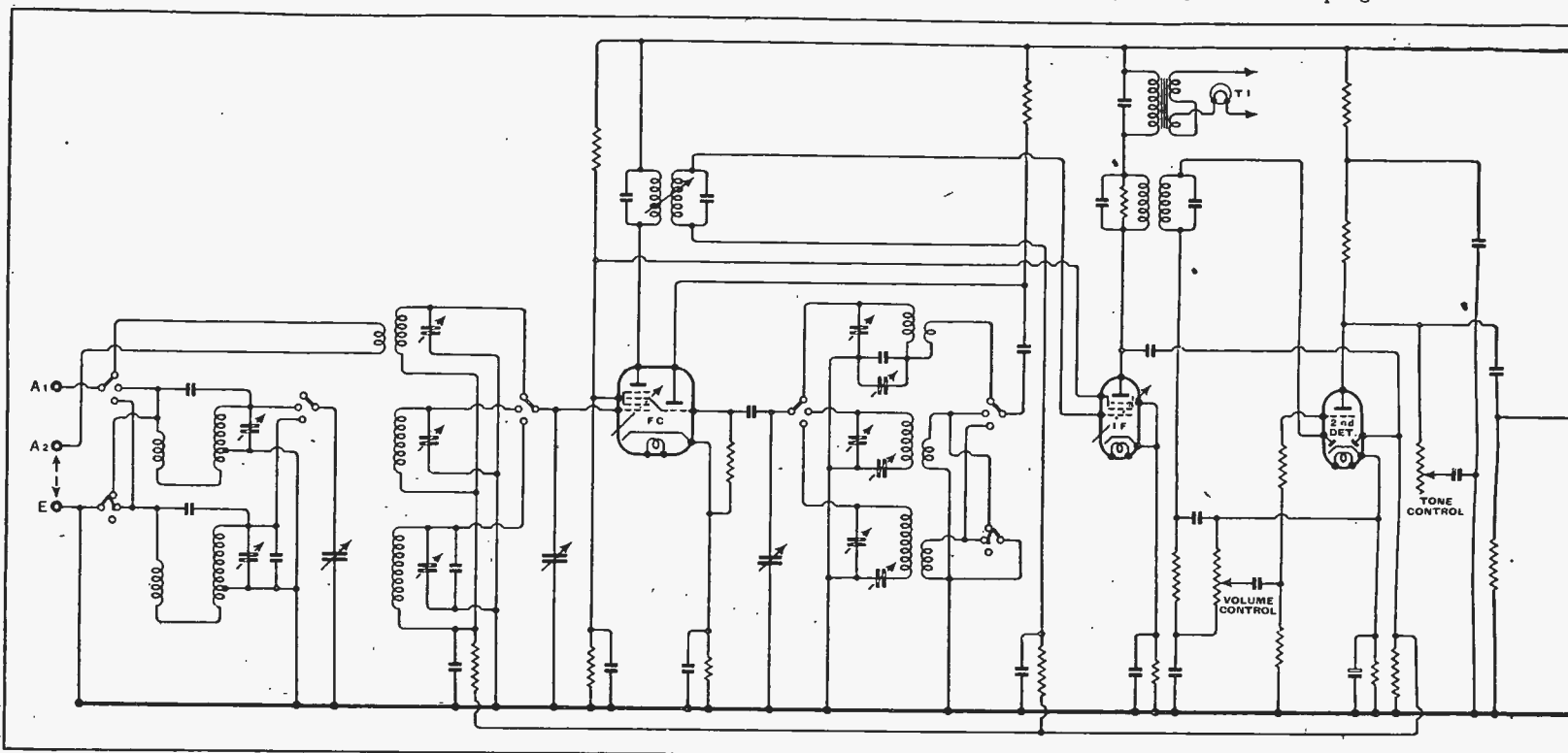



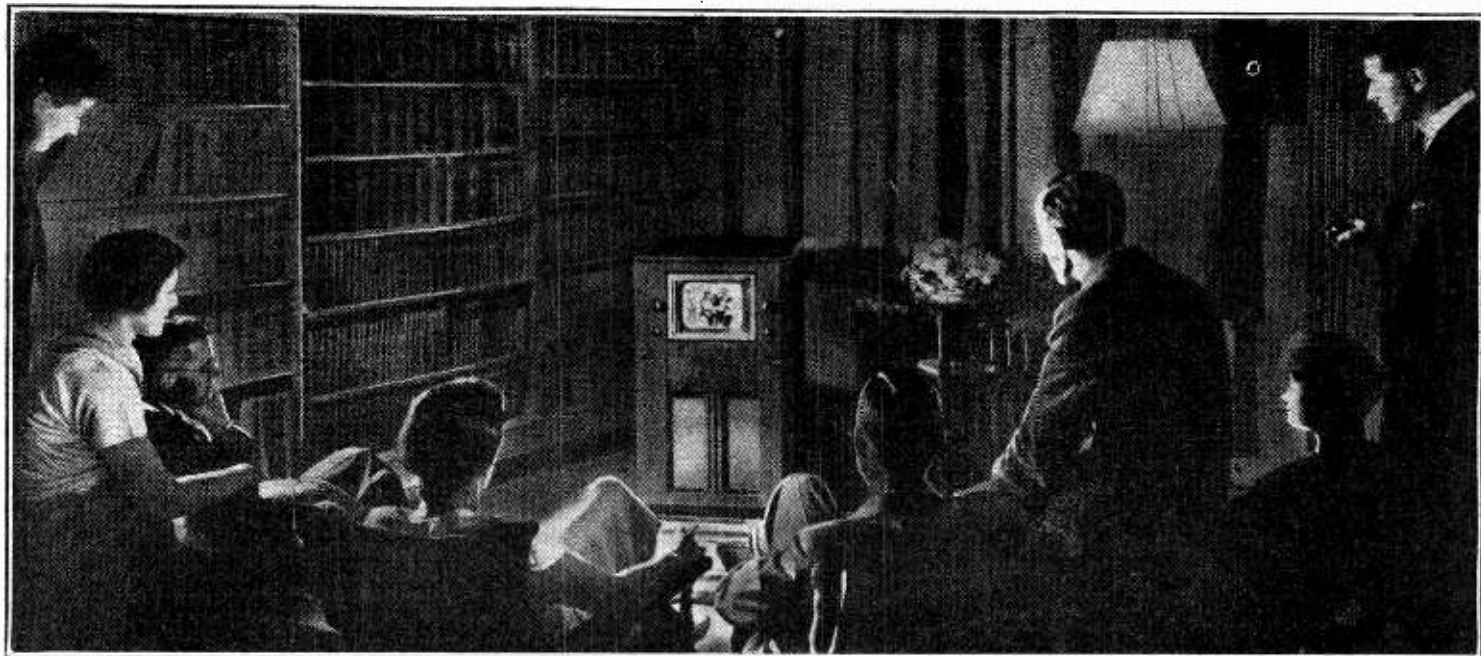

Photo by courtesy of the G.E.C.

# From Studio to Screen

**S**INCE the introduction of broadcasting, the most spectacular innovation in wireless is television. The idea of transmitting pictures is especially attractive, and attempts have been made for well over fifty years. It is only comparatively recently, however, that these attempts have been successful and the development of television as we know it to-day has taken place in the last decade.

Many different systems of television have been proposed and some of them have proved successful. The great rivalry has lain between electrical and mechanical methods, and in spite of the fact that the former now predominate in regularly operating services, it is too early to say that we have seen the last of mechanical systems.

It is obviously impracticable to discuss all television methods in one article, and we shall consequently deal chiefly with the electrical system now used in the transmission and reception of the programmes from the Alexandra Palace. Although in its details and in the circuits employed television can be quite complicated, it is simple in its essentials.

The first step in television is to convert the scene to be transmitted into variations in an electric current, and this is done by means of the Emitron camera. This camera consists essentially of a cathode-ray tube in which is mounted an inclined plate upon which the scene to be transmitted is focused by a lens mounted outside the tube. In the actual camera

## TELEVISION AND HOW IT IS DONE

two lenses are used: one to focus the picture on to the tube screen and the other to give an image on a ground-glass screen. The operator thus sees the picture on this ground-glass screen and can focus and swing the camera to obtain a sharp image of the desired subject without any difficulty.

The tube screen consists of a sheet of mica with a metal backing plate and a deposit of photo-electric material on its face.

This photo-electric material is so deposited that it is in the form of a mosaic of tiny globules each of which forms a tiny photo-cell. Each of these miniature cells has a small capacity to the metal backing-plate, so that, in effect, the screen consists of a mosaic of thousands of photo-cells each joined to a common point, the backing-plate, through a minute condenser.

Now when a picture is focused on the screen each cell emits electrons proportionately to the amount of light falling upon it. These electrons charge the condenser formed by the capacity of the cell to the backing-plate, and the voltage to which each condenser is charged depends on the number of electrons emitted by each cell, and hence upon the light falling on each cell. We thus obtain a "picture in voltages" on the thousands of minute condensers. In other words, we have

converted the variations in light intensity of the picture falling on to the screen into variations in the voltage to which thousands of little condensers are charged.

The screen alone has converted the light energy into electrical energy. The next step is to change the, at present latent, electrical energy into a suitable form for transmission. The whole picture cannot be transmitted simultaneously, and it is necessary to break it up into little bits and transmit these in sequence. This complicated process is done by the scanning system.<sup>1</sup>

The process is probably most easily understood with the aid of a simple type of picture consisting of alternate black and white squares as shown in Fig. 1. Here there are nine squares; now suppose that the mosaic of photo-cells has nine similarly disposed cells so that the light corresponding to each square falls on its own individual cell. The corresponding condensers become charged to different voltages, one representing black and the other white.

Now suppose that we discharge each of these condensers in turn, starting with

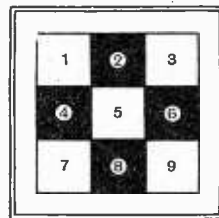

Fig. 1.—One of the simplest forms of "picture" consists of alternate black and white squares.

No. 1, we shall obtain from each condenser a current the magnitude of which depends on the voltage to which it was charged. The picture which is actually present the whole time is thus converted into a sequence of currents which correspond to the elements. No normal picture could be transmitted with so few

*MODERN television differs greatly from the old experimental systems, and its practice is quite different from that of sound broadcasting. In this article the essential details of the system now used at Alexandra Palace are simply explained, emphasis being laid throughout upon "how it works."*

# PROCEDURE IN CUMSTANCES

wards from the output end of the set, and to apply the short-circuits across points A to H in that order. Many of these are alternatives; the primary of a transformer may be more accessible than its secondary, or vice versa.

To illustrate this method of testing, let us imagine that crackling noises are actually due to an intermittent fault in the transformer used as a coupling between V<sub>2</sub> and V<sub>3</sub>. Noises due to this fault will be stopped by short-circuits at points A, B, C, D, but will reappear when the short-circuiting wire is transferred to point E. The trouble is thus localised in the valve V<sub>2</sub> or its anode circuit.

Another method of stage-by-stage testing involves the opposite practice—that of starting from the aerial or input end of the set and “jumping over” one or more stages. This system, though less useful now than in the days of the “straight” set, still has its uses. If, for example, the signal-frequency stage of a superhet is completely inoperative, the fault will be clearly localised if signals—even weak ones—are obtained on transferring the aerial connection to the grid circuit of the next valve in the chain, which will be the frequency changer. A very small condenser should be interposed in the aerial circuit when making tests of this kind.

## Testing the IF Amplifier

In superhets having an IF amplifier of 465 kc/s, a useful test can be made by connecting the aerial to the anode of the frequency changer, and thus, in effect, to the input of the IF amplifier. If a set that was previously dumb produces a welter of morse signals with this alteration, we can assume that the fault lies in the frequency changer or in the circuits preceding it.

Incidentally, having located a burnt-out component, it is hardly wise to assume that after replacing it all will probably be well. No part of a wireless circuit is independent of other parts, and there is a possibility that at least one other fault exists. Take the very common case shown diagrammatically in Fig. 2 (a), where the decoupling resistance is found to be burnt out. It is highly probable that the excessive current causing the burn-out was due to a breakdown in the associated decoupling condenser C. Similarly, if the primary of the AF transformer shown in Fig. 2 (b) has suffered the same fate, it is well to look for a partial or complete short-circuit between the points indicated by the dotted line.

Although it will be admitted that much

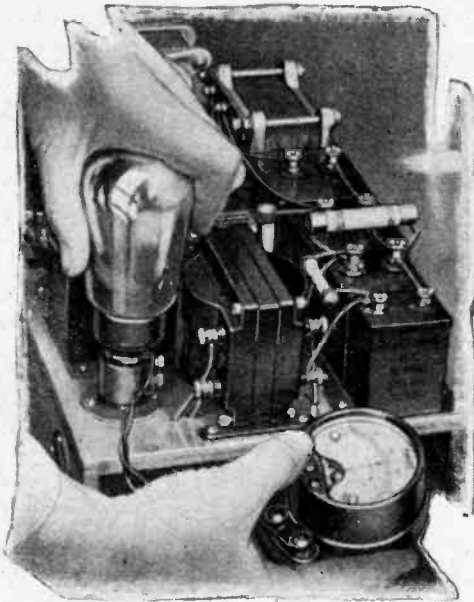

Measurement of anode current is generally more informative than any other single test.

can be done without equipment, it would be wrong to suggest that one can get very far in the art of fault-finding without proper measuring instruments. As pointed out in *The Wireless World* “Servicing Manual,” which deals with the whole subject very comprehensively, 90 per cent. of faults are revealed at once by properly made measurements of current, voltage, and resistance.

Most amateur fault-finders will prefer a multi-range instrument (it is certainly much cheaper than separate meters) with which all three quantities can be measured. The resistance of the voltmeter

tions, but current measurements are not so important.

It would be impossible within the scope of this article even to cover sketchily the method of making measurements, and still less to deal with the deductions that can logically be made so easily from these measurements—when one knows how. For full information on these matters the reader is referred to the book already mentioned. It should be pointed out, however, with regard to voltage measurements the presence of high resistances in the receiver will sometimes impair accuracy, but if one is on one’s guard against such errors the readings will still be useful.

## Using a Milliammeter

Current readings, particularly those of the anode currents of individual valves, are particularly useful, and the only “snag” is that instability may be provoked in RF or IF circuits if the meter is connected to the anode of the valve (which often happens to be the easiest place) or to any high-potential part of the circuit.

If one is fortunate enough to have a good ohmmeter included in the meter, tests of resistance may often help to show up faults more quickly than any other method. Not only will the instrument serve for checking the values of resistors, but it will be useful as an indicator of continuity between various points and different components. It is also a useful indicator of the functioning of such components as wave-change switches. Referring to Fig. 2 (c), if the meter be connected from point A to earth the resistance

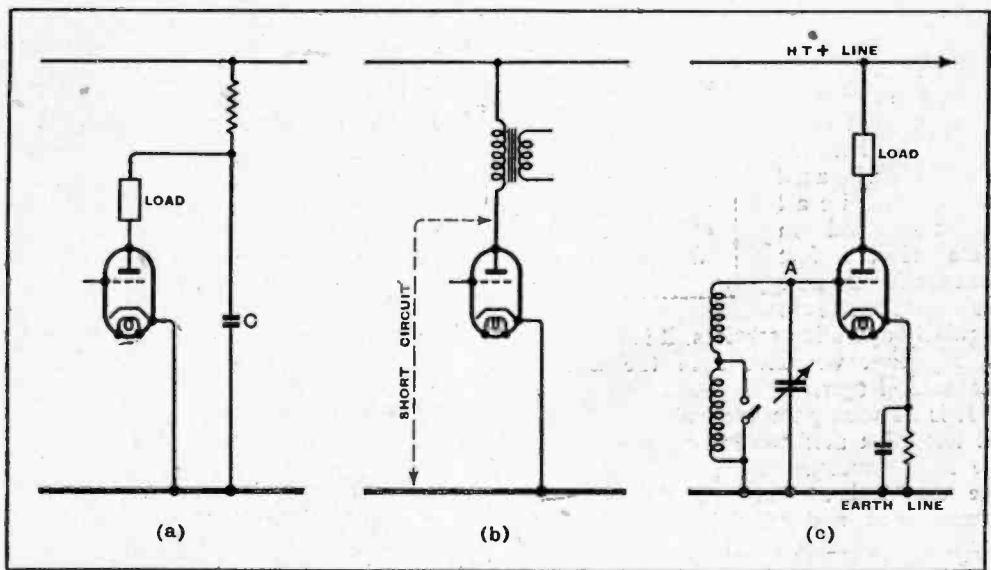

Fig. 2.—Diagrams (a) and (b) illustrate the fact that the breakdown of one component is probably due to a fault in another. Diagram (c) shows how a wave-change switch may be tested.

section should be high, preferably in the region of 1,000 ohms per volt. Cheap moving-iron meters are generally worse than useless. It is desirable to be able to read DC volts from 1 to 500 or 600, and current from 0.5 mA to 500 mA or even more. AC voltage ranges covering between 2 and 1,000 volts are desirable addi-

should be greatly reduced by setting the switch to “medium wave” and thus short-circuiting the long-wave section. If this effect is not noticeable, the switch is probably failing to close. On the other hand, if there is no change of indicated resistance value, the contacts are probably not opening properly.

# Tracing Faults

## COURSES OF VARIOUS CL

WHEN a broadcast receiver refuses to work, the difficulty is not, in nine cases out of ten, the actual repairing of the fault, but the finding of it. Comparatively seldom is real manual dexterity required; more often than not it is simply a matter of remaking a joint, tightening a screw connection, or, most frequently of all, replacing a faulty component with a new one. It is seldom worth while, even when possible, trying to repair a component that has well and truly broken down.

Having thus attempted to justify the title of this article, we will consider the matter first from the point of view of those who are only just beginning to take an interest in the means whereby wireless signals come to them; in other words, from the point of view of the typical new reader to whom this issue of *The Wireless World* is dedicated. For the present no real knowledge of the receiver will be assumed.

When a mains-driven set begins to function intermittently, or else becomes entirely dumb, the first thing to do is to assure oneself that there is no interruption of the source of electrical supply. If the pilot light glows steadily there is at least presumptive evidence that all is well here. If the pilot lamp itself has failed (it often does) then very much the same kind of evidence can be obtained by momentarily connecting a portable lamp, electric heater, etc., to the mains outlet from which the set is fed.



A tester for low-resistance circuits may be improvised from a dry cell and flashlamp

Having explored the possibility of a power failure with negative results, a general look-over may very possibly reveal some obvious fault; before beginning, switch off and withdraw the power plug. Are all the valves firmly seated in their socket? Is one of the valve-cap connectors

displaced? Has the aerial connector been knocked off? Are any of the accessible terminals loose?

If there is superficially nothing wrong, one may go a step farther and make sure that all the valves are making good contacts with their sockets. Many modern valves have so-called "banana" pins, the slots of which may be slightly opened up very gently and carefully with the point of a knife-blade; the necessary knack is easily acquired.

### Burnt-out Resistors

Unless spare valves are available for trial, there is little more that can be done externally, but it may be worth while to remove the chassis in order to make a superficial examination of its underside,

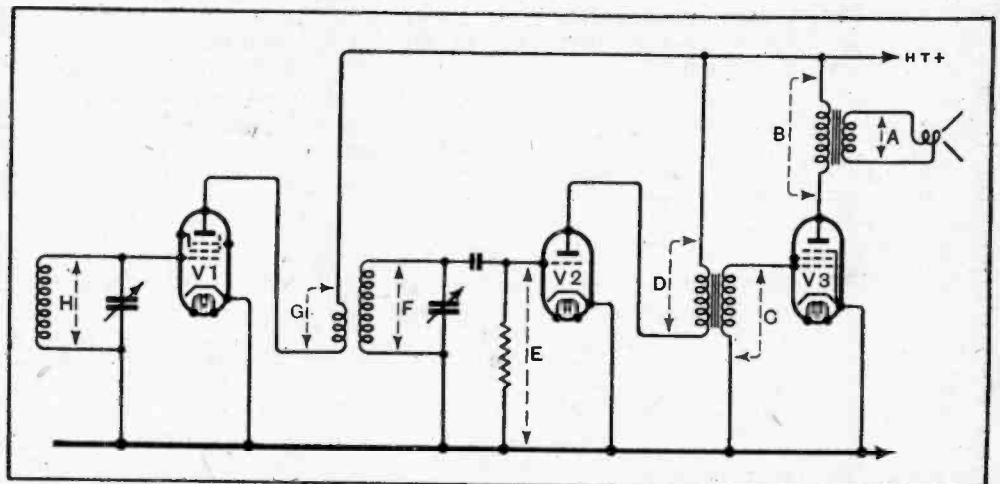

Fig. 1.—When making stage-by-stage tests by the method of short-circuiting, it is usual to work backwards from the loud-speaker end of the set.

which can be carried out very much on the lines already suggested. One should keep a good look-out for discoloured resistors; the kind of discoloration caused by overheating is obvious, and there is at least a good chance that the replacement of a resistor that shows such outward signs of damage may put matters right.

When everything else fails, there is at least some satisfaction in localising the source of trouble. If, for instance, the set works normally with a gramophone pick-up, it can be assumed that the fault lies in the circuits preceding the audio-frequency amplifier. In the absence of a pick-up, a test can be made with the help of a dry cell; on connecting it across the pick-up terminals (with the change-over switch in the "gram" position) a click should be heard.

It has so far been assumed that no testing equipment is available. Still on that assumption, but allowing a certain amount of knowledge on the part of the tester, we will see what can be done without any proper measuring or indicating instruments whatever. A contributor to these

pages has shown<sup>1</sup> most ingeniously that one need not be at a loss in such circumstances, but some of the methods suggested were perhaps too heroic for the beginner. However, the article showed that it is generally possible to improvise the means for testing either from articles to be found in the average household or from sections of the receiver itself. For instance, the continuity of a valve heater or filament may be tested with the help of a dry cell, a flashlamp bulb, and a short length of wire. The pilot lamp bulb of the receiver, in conjunction with a spare flashlamp battery, may possibly be made to serve the purpose.

Again, it is possible to prove the presence, or otherwise, of high voltages at the appropriate points with the help of a low-wattage bulb in an ordinary domestic portable lamp after removing the connector, but such tests should be made with great care, and contacts should only be momentary.

### Stage-by-Stage Tests

Apart from the question of equipment—or the lack of it—valuable information can often be gleaned from the behaviour of the set when various parts of it are momentarily short-circuited. In particular, the cause of intermittent reception or crackling noises can often be localised in this way. The circuit diagram of Fig. 1, though not truly representative of a modern receiver, is chosen for its simplicity to illustrate the usual course of procedure. The rule is always to work back-

<sup>1</sup> "Testing Without Equipment," *The Wireless World*, March 8th, 1935.



the tone and volume controls are mounted to left and right respectively. The mains on-off switch is situated in a recessed plate at the opposite side of the cabinet to the tuning control.

The amplification and range on all three wavebands is well matched, and the uni-

selectivity control was tried out on the London Regional transmitter when working the set in Central London, and it was found that with the maximum selectivity only one channel was lost through the spread of this station. Turning the control to the minimum selectivity posi-

## Rothermel "Hushatone"

*Bedtime Listening without the Discomfort of Headphones*

THIS new product of R. A. Rothermel, Ltd., is a special type of reproducer designed to transmit sound through a pillow or cushion. The sound radiated to the surrounding air is negligible, but when the head is placed on the pillow reproduction of excellent quality and volume is heard. It should, therefore, prove of special value in hospital installations, in which case not the least advantage is the elimination of the discomfort inseparable from the wearing of headphones over long periods.

The vibrating element in the "Hushatone," the price of which is 35s., is a piezo-electric crystal which is housed in a sealed bakelite case with thin walls. Flexible rubber leads 9ft. in length are provided, and the unit can conveniently be connected across the primary of the output transformer in the set. The power required is only of the order of 50 milliwatts so that a number of units can be operated from a single broadcast receiver of conventional design.

In free air the response of the "Hushatone" rises steeply with increasing frequency, but as the absorption of a cushion is greatest for the higher frequencies an approximately level response is obtained. If

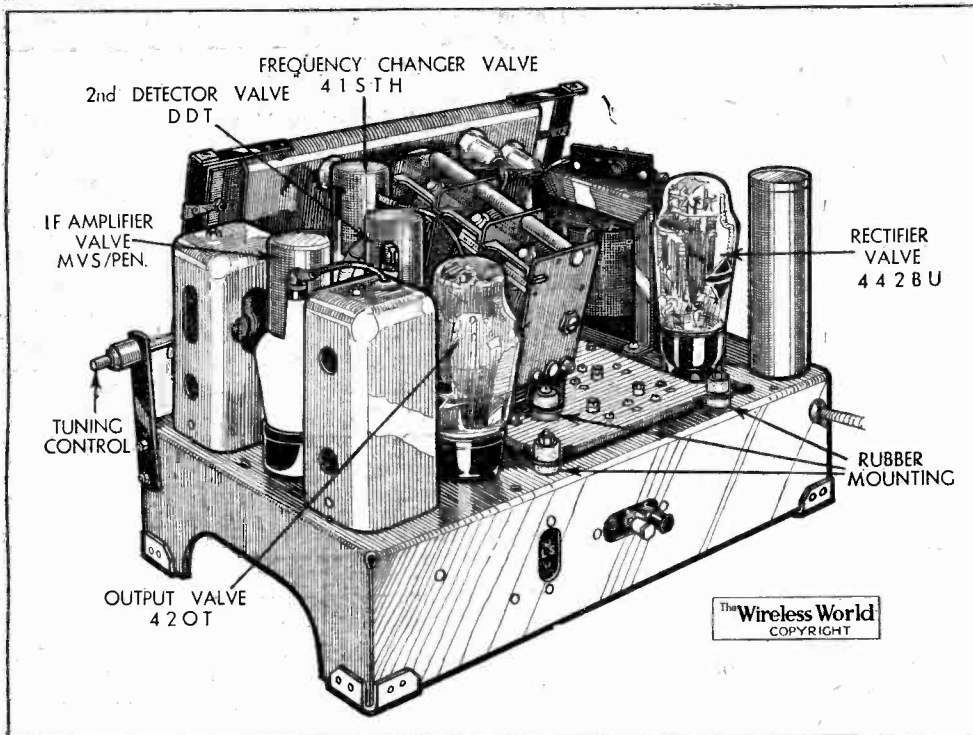

More care than usual has been given to the mechanical isolation of the tuning condensers and coils in the Cossor "584" chassis.

formity of sensitivity and ganging even at the extreme ends of the tuning scale is conspicuously good by comparison with the majority of sets. Noise between stations is also low, particularly on the short-wave range, and there is no trace of any self-generated whistles on any of the three wavebands. The variable

tion appeared to have only a slightly detrimental effect on the selectivity from the point of view of the spreading of interference, but there was a marked improvement in the quality of reproduction through the extension of the high-frequency response.

In view of the trouble which the makers have taken to isolate the tuned circuits from mechanical vibration, it is with regret that we have to record that microphonic howl set a limit to the volume which could be obtained from many of the principal European broadcasts on short waves. This trouble is only experienced when the carrier wave is exceptionally strong, so that the volume obtainable before the acoustic oscillation is established is generally more than is required. It is not advisable, however, to approach the critical volume point too closely or the reproduction will be coloured by the approach of oscillation.

On the medium-wave band the bass reproduction has a curious reverberant quality which is not unpleasant on certain types of transmission, but on speech it is inclined to be obtrusive if the volume is too high. In the middle and upper registers, however, the quality of reproduction is full and clear, and the high-note response in particular is quite free from the groups of resonances which are frequently associated with this region.

The set is provided with terminals for the addition of an extension loudspeaker, but there is no provision for gramophone reproduction.

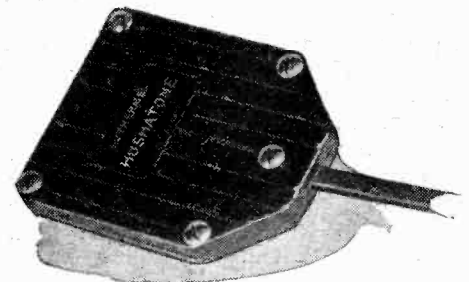

The Rothermel "Hushatone" has a rising characteristic to compensate for absorption in the pillow under which it is placed.

desired, a further increase in the relative bass response can be obtained, at some slight cost in sensitivity, by inserting a resistance of about 10,000 ohms in series with the unit.

### TRANSFORMER REPAIRS

IT may not generally be known that faulty mains transformers can be rewound and that if the work is carried out by experts the repaired article is every bit as good as a new model.

Occasionally, rewinding can be resorted to in order to obtain an increase in HT volts, or, again, new LT windings giving, for example, 6.3 volts in place of the 4 volts may be required.

A firm that specialises in this class of repair is Gardner's Radio, Ltd., West Southbourne, Bournemouth, Hants, a specimen of whose work has been sent to us for examination.

This transformer has the appearance of a new model, for, not only has it been rewound, but all metal parts have been cleaned.

The repair has been executed in a perfectly satisfactory manner, and the workmanship is of a very high standard.

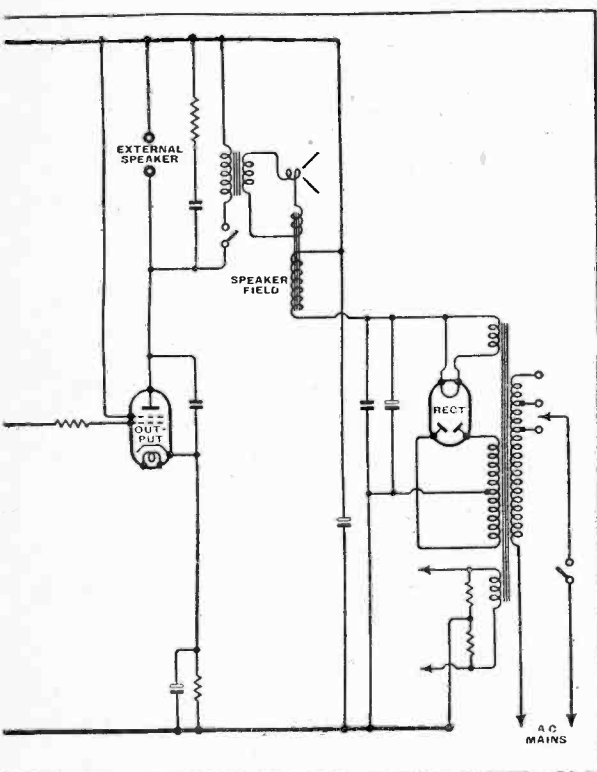



**From Studio to Screen—**

cells as in Fig. 1, but it is easy to see that, if we had a sufficient number, many thousands quite complex pictures could be dealt with.

This is what happens in the television camera, for the screen is scanned by a beam of electrons. A beam of electrons is focused into a very small spot on the screen and is arranged so that the spot travels steadily across the screen in a straight line. Having reached the far side of the screen, it flies back very rapidly to a point immediately beneath its previous start and then begins to trace out another line. In this way it gradually covers the whole of the screen.

Although the beam falls on the photo-cells it does not directly influence them, but as they form part of the minute condensers which carry the picture in voltage, these condensers receive electrons from the beam which neutralise their charges. The number of electrons entering any given condenser at any instant depends on the charge on that condenser, and hence on the light value of the corresponding portion of the picture. The varying number of electrons leaving the beam as it sweeps across the screen constitutes a varying current superimposed upon the beam, and it can consequently set up voltage variations across an external impedance. In effect, the scanning beam is used as a conducting beam to discharge the condensers.

**Definition**

The screen in the tube can be regarded as converting the picture in light variations, which we can see, into a picture in voltage variations, which we cannot see. These voltage variations all occur simultaneously and have position just as in the original image. The scanning process converts these voltage variations over an area into current variations in sequence.

The necessity for scanning reduces the definition of the picture obtainable in the reproduction at the receiver, but the amount of the reduction depends upon the number of lines which the scanning beam traces out. Early transmissions had only 30 lines and gave but little detail to the picture. Nowadays, 405 lines are used and a very high standard of definition is possible.

The picture has a width-height ratio of 4 : 3 and 405 scanning lines, which means that the system could just deal with a chessboard pattern such as that of Fig. 1, having a total of  $405^2 \times 4/3 = 218,700$  squares. Quite good detail can thus be secured.

This process naturally gives one picture only, and it must be continually repeated to obtain a moving picture. To preserve the appearance of smooth motion something like 15 complete pictures, or frames as they are usually called, must be transmitted every second. For the avoidance of flicker, however, something like 50 frames a second are needed. The use of such a high repetition rate is wasteful, for it greatly increases the space occupied in the ether by the transmission, and it

greatly increases the cost of both transmitter and receiver.

In the Alexandra Palace transmissions, therefore, interlaced scanning is adopted, and this enables 25 pictures a second to be used without flicker. Instead of scanning the picture in the way shown in Fig. 2 (a), it is done in the manner of Fig. 2 (b). The spot starts at (A) and scans the line (AB); it then flies back, not to a point immediately below (A) as in sequential scanning, but to a point one line below this and then traces out the line (CD). In this first coverage only alternate lines are scanned. The picture is then gone over again, the spot covering the lines missed in the first scan.

With the ordinary scanning there is one frame to every picture, but with interlaced scanning there are two frames to every picture, and as the flicker depends on the number of frames rather than the number of pictures the eye is cheated into believing that there are more pictures than there are. In this way flicker is avoided while retaining a reasonable number of pictures a second.

The idea of frequency response<sup>2</sup> is one which comes to us from sound apparatus where we are, in fact, dealing directly with frequency. In television it has not quite the same meaning, and it is more fundamental to speak of the rate of change of current or voltage. This can, however, be converted into terms of frequency, and it is usually convenient to do so. The lowest frequency present in television is zero, corresponding to the mean illumination of the scene to be transmitted. The highest is really infinity, but is usually

taken in practice as equal to one-half the number of elements multiplied by the number of frames per second; this gives us  $109,350 \times 25 = 2,733,750$  c/s. The importance of this figure will be evident later when we consider the actual transmission.

Reverting to the camera, we have seen how the picture is converted into variations in an electron current by means of the mosaic of photo-cells and the electron

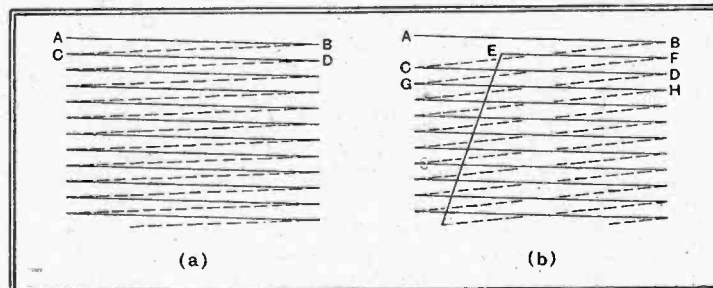
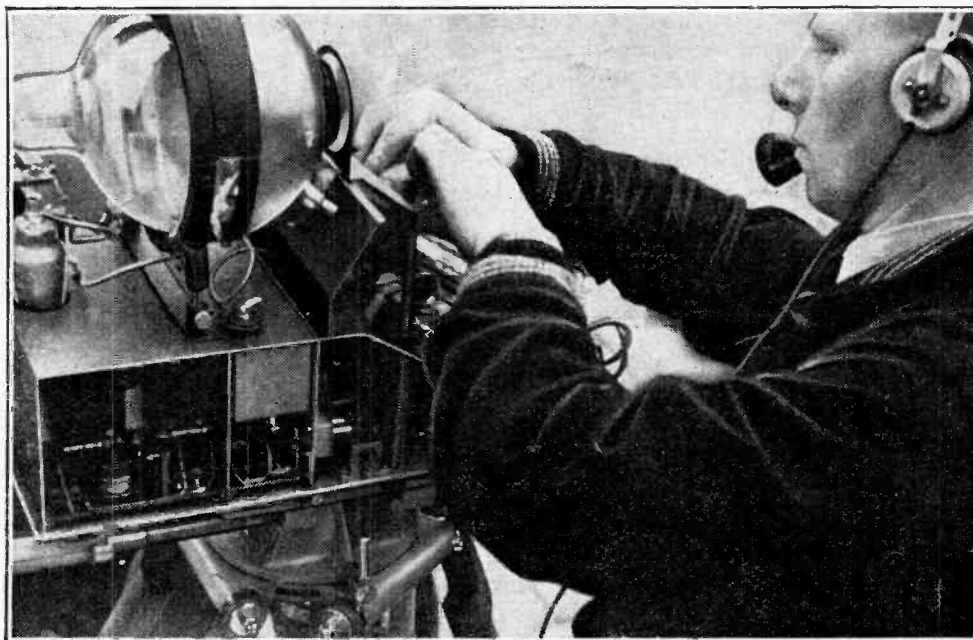

Fig. 2.—Sequential scanning is illustrated at (a) and interlaced at (b). With the latter, alternate lines are scanned in the first frame and those missed are covered in the second frame.

scanning beam; we have not yet considered how this beam is produced, however, nor how it is made to scan the screen. This part of the camera is really a cathode-ray tube, and in its essentials is like the receiving tube. The electrode assembly is contained in the neck of the evacuated glass envelope in which the mosaic screen is placed, and the assembly consists of cathode, grid and anode. The cathode is surrounded by the grid and emits electrons. The grid regulates the number of electrons which can travel down the tube and constrains their path to a beam, while the anode, at a high potential, accelerates their velocity.

The beam is focused<sup>3</sup> on to the screen by a magnetic field produced by passing current through a coil wound around the neck of the tube. The effect is analogous to that of a lens on a light beam, and the combination of anode and magnetic field is often spoken of as an electron lens.



The external shape of the "Emitron" television camera is by now quite a familiar sight, but few have had the opportunity of looking at the works.

**From Studio to Screen—**

Pairs of coils placed alongside the neck of the tube after the focusing coil enable the beam to be deflected.<sup>4</sup> Currents of suitable waveform are passed through these coils; for the horizontal or line deflection the current varies 10,125 times a second, and for the vertical or frame deflection it varies 50 times a second. The combined action of the electromagnetic fields produced by these currents causes the beam to traverse the screen in a series of parallel lines in the manner already described.

Now having obtained signal currents of frequencies up to some 2.7 Mc/s, they are amplified in the usual way, combined with the sync pulses, of which more anon, and used to modulate the carrier in fundamentally the same way as in a sound transmitter. It is here, however, that we see the reason why television must be carried out on ultra-short wavelengths.

**The Side-band Spread**

In the first place, the carrier frequency must be higher than the highest modulation frequency, so that the lowest possible carrier frequency for modern television is about 2.8 Mc/s, or 107 metres. If such a frequency were used, the station would occupy the band of 0.1 Mc/s to 5.3 Mc/s, or 3,000 metres to 56.6 metres. Thus all present medium- and long-wave broadcasting stations would have to close down, as well as many long-wave telegraph stations, air stations, shipping, trawler services, some amateur bands, and some SW broadcast stations. All this to make room for one television station!

There is actually no room in the ether for television except on ultra-short waves, and a frequency of 45.0 Mc/s is consequently used. An entirely separate transmitter on 41.5 Mc/s is used for sound, but this need not be described since it follows normal practice in its essentials.

We now come to the receiver<sup>5</sup>, and here standard practice is followed in its fundamentals. The wide frequency band, however, necessitates careful design, and as only a low gain per stage is possible, more valves are needed than in a sound receiver. After detection one vision-frequency stage is usually employed, and as the cathode-ray tube is a voltage-operated device, unlike a loud speaker which requires power, this need not be of the power type.<sup>6</sup>

The vision-signal is fed, sometimes directly and sometimes through a resistance-capacity coupling, to the grid of the cathode-ray tube upon which the picture is reconstructed. This tube is essentially similar to that employed in the transmitting camera, but instead of a mosaic of photo-cells the end of the tube carries a fluorescent screen. Various materials are used for this screen, but all have the property of fluorescing under the stimulus of high-velocity electrons and so giving a spot of light at the point at which the beam strikes the screen. By making the beam perform identical evolutions to that in the transmitting camera, and varying

its intensity in accordance with the current variations in the output of the camera, the intensity of fluorescence is varied appropriately and the picture reconstituted on the end of the tube.

**Cathode-ray Tubes**

Receiving cathode-ray tubes are of two types: electromagnetic and electrostatic. The former is similar in its essentials to the transmitting tube, but the latter depends on electrostatic fields for focusing<sup>7</sup> and deflection instead of on electromagnetic fields produced by currents flowing through external coils. In addition to the cathode and grid, three anodes are included. The first anode is operated at about 300 volts and provides the initial acceleration of the electrons, the second anode works at some 1,000 volts, and the electrostatic field produced by it largely controls the focusing of the beam on the screen. The third anode is operated at 3,000-6,000 volts and provides the final acceleration. All electrodes, of course, have their effect upon the focusing, but in practice this is carried out by varying the second anode voltage.

After the third anode two pairs of plates are mounted at right angles and voltages of saw-tooth waveform applied to these enable the beam to be deflected. These voltages are generated in the receiver by

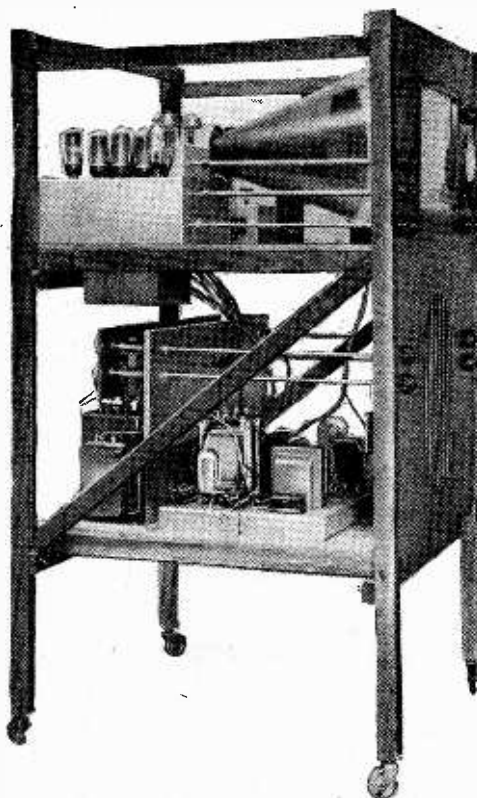

"The Wireless World" television receiver designed and built in our own laboratory. The equipment consists of five separate units, making use of seventeen valves and four rectifiers, linked up and mounted in a conveniently accessible form of framework.

the time-base.<sup>8</sup> This usually contains two saw-tooth oscillators, one of 50 c/s for the frame scan and one of 10,125 c/s for the line scan, and their amplifiers. For

electrostatic deflection, each amplifier usually consists of two triodes in the paraphase connection and operating with an HT supply of 1,000 volts. For electromagnetic deflection, however, the amplifier is usually a single pentode operating at comparatively low voltage.

The saw-tooth oscillator can be of many types; one of the simplest is a gas-filled triode, but ordinary valves are often employed in special circuits.<sup>9</sup> It derives its name from the kind of waveform which it produces, for this has the appearance of a saw-tooth. The voltage output actually rises linearly with time to produce the line, or frame, deflection, and then drops rapidly to zero for the fly-back to the start of the next line or frame.

However well these oscillators work they must be synchronised<sup>10,11</sup> with those in the transmitter if a stable picture is to be obtained. Synchronising signals<sup>12</sup> are included in the transmission, therefore, and in the receiver are separated from the picture signals by a filter and used to control the time-base oscillators.

We thus see that in the receiver the time-base enables the beam in the CR tube to perform exactly the same evolutions as that in the transmitting camera, and this beam falling on the fluorescent screen causes it to fluoresce and become visible. At any instant the spot of light on the screen of the receiving tube is in exactly the same relative position as the scanning beam on the mosaic screen in the transmitting tube. The picture is then built up by applying the picture signal to the grid of the tube so it regulates the density of the electron beam and varies the degree of fluorescence of each point on the screen to give the necessary light and shade.

**REFERENCES**

1. Scanning in Television, Jan. 8, 1937.
2. Frequency Response in Television Amplifiers, Oct. 8, 1937.
3. Magnetic Focusing, April 2, 1937.
4. Magnetic Deflection, Feb. 19, 1937.
5. The Television Receiver, Feb. 12, 19, 26, March 5, 12, April 9, 16, 30, May 14, 28, June 11, 1937.
6. The Wireless World Television Receiver, July 2, 9, 16, 23, 30, 1937.
7. Electrostatic Focusing April 2, 1937.
8. The Time-base in Television, Jan. 15, 1937.
9. Hard-Valve Time-bases, April 2, 1937.
10. Synchronising in Television, Jan. 22, 1937.
11. Synchronising Problems in Television, Jan. 29, 1937.
12. Television Transmission, Oct. 4, 1935.

**"Wireless World" Great Circle Projection Map**

THIS map has been prepared especially for short-wave listeners and amateur experimenters so that the true distance and direction from London of any place in the world may be found in a simple and straightforward manner. It is centred on London, whilst round the periphery is a protractor marked in degrees.

The scale is 1,000 miles to the inch, and a foot rule with the inches divided decimally will give both distance and direction simultaneously. It thus provides the essential information needed for the erection of a directional aerial either for experimental short-wave transmissions or for the best reception of foreign broadcast stations.

The price is 2s., post free, and it is obtainable from *The Wireless World*, Dorset House, Stamford Street, London, S.E.1.

# Avoiding Ganging Errors

## THE USE OF "LARGE-PRIMARY" TRANSFORMERS

By W. T. COCKING

WHETHER the receiver be straight set or superheterodyne, signal-frequency tuning is necessary to provide the maximum sensitivity and signal-noise ratio, and to give selectivity with the straight set and freedom from whistles with the superheterodyne. The use of such circuits is so commonplace that they often do not receive the attention they deserve. It is by no means uncommon to find that quite good coils are spoilt by the manner in which they are used, and more mistakes are probably made in the coupling of the aerial to the first tuned circuit than in any other part of the receiver.

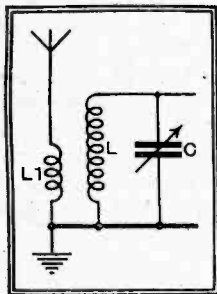

Fig. 1.—The usual aerial circuit connections are shown here; L1 is the primary and LC forms the tuned secondary.

Probably the commonest arrangement is that shown in Fig. 1, although it is sometimes varied by tapping the aerial down the coil L instead of using the coupling coil L1. There is an optimum degree of coupling between the two coils which gives the highest efficiency, and with this coupling the selectivity of the circuit is one-half of that of the tuned circuit alone.

This is not all, however, for the optimum coupling is not a constant but varies over the waveband. Unless continuously variable coupling is used, therefore, it must be sub-optimum over a portion of the band.

In addition to this, the tuning of the secondary is affected by the primary. If we start with very loose coupling and gradually tighten it we find that we have to reduce the value of the secondary tuning condenser C to maintain resonance. This is because the impedance of the aerial-earth system is reactive; the coupling causes its impedance to be reflected into the secondary in some degree, and we have to change the secondary reactance, that is, alter the setting of the tuning condenser, to compensate for it.

On the ordinary broadcast bands the aerial can be represented by the series combination of inductance La, capacity

Ca, and resistance Ra as shown to the left of the dotted line in Fig. 2. Here the generator e1 represents the voltage induced in the aerial by the signal. The secondary circuit consists of L, C, and R in series, and the voltage e2 across C is the voltage we use and apply to the first valve of our receiver.

Now it will be observed that the primary circuit alone has a resonance frequency. It will resonate at a frequency  $f = 1/6.28\sqrt{C(La + L1)}$ . It is the general practice to make L1 of small inductance so that this resonance frequency is higher than any to which the receiver will tune; for the medium waveband this aerial circuit resonance is often about 1,600 kc/s.

With fixed coupling and the usual tuned circuit having a dynamic resistance, increasing with frequency, the ratio of e2 to e1 increases with frequency and the selectivity falls off. The variation in selectivity is largely due to the tuned circuit alone, but it is accentuated by the aerial circuit. In the transference of energy from one circuit to another, it is not the coupling alone which is of importance, but the coupling in relation to the circuit impedances. Both primary and secondary impedances vary with frequency, and if

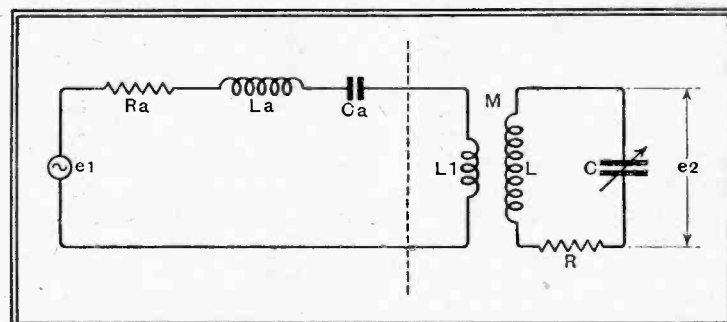

Fig. 2.—The equivalent circuit of Fig. 1 is illustrated here, the components to the left of the dotted line representing the aerial.

the coupling is fixed the transference of energy consequently varies.

The most serious defect of this circuit lies in its effect on the tuning of the

secondary. In these days of ganged tuning it is essential that all circuits should be tuned to the same frequency within quite close limits, and this is achieved in practice by assigning identical values of inductance and capacity to all circuits. In the case of an intervalve coupling of normal type, the reactance of the tuned circuit is not affected to any appreciable extent by the primary, for the primary circuit is closed through the AC resistance of a valve, and this is of very high value. Resonance in the primary circuit can only be between the primary inductance and its self-capacity plus the output capacity of the valve. Normally, this resonance is at much too high a frequency to have any appreciable effect.

### The Effect of the Primary

Now in the aerial circuit the conditions are different, and the effective secondary inductance is increased by the presence of the primary circuit and by an amount which is not constant but which varies with the frequency.

The amount of the change of secondary inductance is

$$\frac{\omega^2 M^2 Ca}{1 - \omega^2 Ca(L1 + La)}$$

When resonance in the primary circuit is much higher than any frequency within the tuning range this becomes very nearly  $\omega^2 M^2 Ca$ , and it is clear that the effect of the primary is to change the secondary inductance by

an amount which is proportional to the square of the frequency. The units employed are, of course, the usual ones of henrys and farads for inductance and

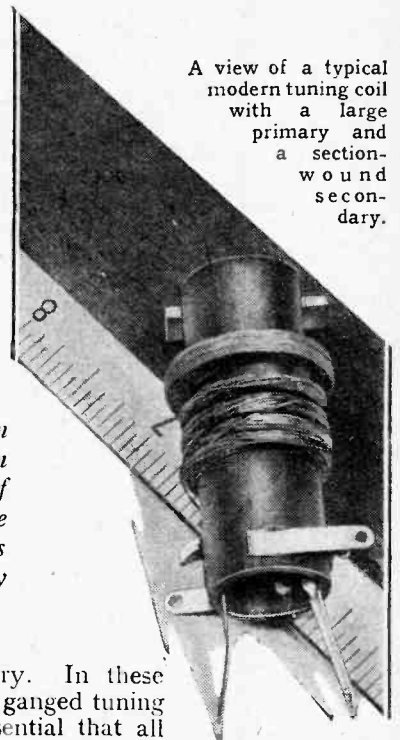

A view of a typical modern tuning coil with a large primary and a section-wound secondary.

**Avoiding Ganging Errors—**

capacity respectively;  $M$  is the mutual inductance between  $L_1$  and  $L$  and  $\omega = 6.28 \times$  frequency in c/s. Since the secondary inductance change is not constant, compensation by altering the secondary inductance or the secondary trimmer capacity is obviously impossible, for it will hold only for one frequency. Correct ganging thus cannot be secured.

When the coupling is anywhere near optimum the effect is quite marked, and it is consequently the general practice to use loose aerial coupling. This reduces the ganging errors greatly, and also improves selectivity, but has the disadvantage of reducing efficiency and making for a poorer signal-noise ratio. With loose enough coupling, of course, the ganging errors can be made smaller than the normal errors due to mismatching of components, and hence, negligible.

**The Large Primary**

Now if instead of using the usual small coil  $L_1$  we use a large value of inductance at this point, the conditions are quite different. If we make  $L_1$  so large that the primary resonance is at a much lower frequency than any within the tuning

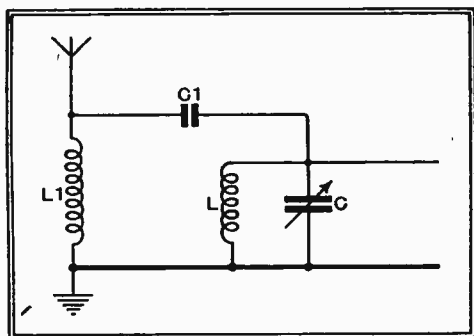

Fig. 3.—A form of coupling which can give many of the benefits of a large primary and which is easy to fit to an existing set.

range, then the effect of the primary on the secondary is to *reduce the secondary inductance by a fixed amount*. This can be corrected by an alteration of the secondary inductance, and, theoretically, perfect ganging is possible.

This is easily seen from the above expression for the change of secondary inductance, for when the primary resonance is much lower than any frequency within the tuning range, the change of inductance becomes very nearly  $-M^2/(L_1 + L_a)$ .

It will be seen that this does not contain  $C_a$ ; consequently, the secondary is unaffected by the aerial capacity. Moreover, in all normal circumstances  $L_1$  is much greater than  $L_a$ . These two factors render the secondary tuning substantially independent of the characteristics of the particular aerial employed. It is a commonplace that with a small primary the first tuned circuit must be trimmed to suit the particular aerial employed, but this is not so with a large primary. The trimming can be carried out once and for all, and is hardly affected by any change in aerial.

In practice, however, it does not pay to make the primary resonance at too low a frequency, and the best results are secured when it occurs at a frequency only a little lower than any within the band. The full theoretical perfection of ganging

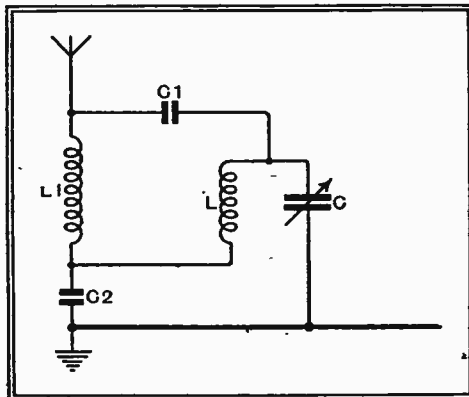

Fig. 4.—A better arrangement than that of Fig. 3 is shown here. It cannot always be used, however, for  $C_2$  restricts the tuning range.

is not then obtained, but the errors occur at the low-frequency end of the range where they are best tolerated owing to the higher selectivity of the circuits. By choosing such a resonance frequency for the primary circuit the energy transference at low frequencies is increased, as is also the damping effect of the primary on the secondary. This tends to offset the natural characteristics of the tuned secondary, and so makes the efficiency and selectivity more uniform over the tuning range.

**Interval Transformers**

This same principle can be, and sometimes is, applied to circuits used for interval coupling, and very high inductance primaries are then used since they must resonate with their own self-capacity plus the output capacity of the valve. Such primaries introduce an inductance change in their secondaries, and by careful design it is possible to make the changes in all circuits, including the aerial, alike so that the conditions for perfect ganging can be met.

In general, however, the principle is most useful in the aerial circuit, and it is not too much to say that the performance of many of the older receivers could be improved by using a high inductance primary for the aerial circuit. It is not always an easy matter to alter a receiver so that such a primary can be used, however, since the precise form of primary winding will depend upon the dimensions of the existing secondary coil.

**Modifying an Existing Circuit**

Where possible, however, a coil should be wound of the correct inductance and inserted inside the tuned coil, its position being adjusted for the best signal strength. The coil should be of small dimensions and preferably of the lattice-wound type; where this is not possible, however, the

wire can be run on anyhow into a single slot in a light former. The inductance should be about  $500 \mu\text{H}$ . for the medium waveband and some  $6,000 \mu\text{H}$ . for the long.

Another arrangement, shown in Fig. 3, which is extremely easy to apply and which gives a similar performance is available. Here the primary winding  $L_1$  is not coupled to the tuning coil  $L$  by their proximity, but by the small condenser  $C_1$ . The coil  $L_1$  should have an inductance such that with the average aerial resonance occurs at about  $450\text{--}500 \text{ kc/s}$  for the medium waveband and about  $140 \text{ kc/s}$  for the long waveband. This means an inductance of about  $500 \mu\text{H}$ . for the medium and  $6,000 \mu\text{H}$ . for the long waveband. The value of the condenser  $C_1$  depends upon the efficiency of the secondary circuit, and with a highly efficient circuit will be smaller than with a poor one. It will usually be of the order of  $10 \mu\text{F}$ ., however. With this circuit the effect of the primary is to increase the secondary capacity by an amount nearly equal to the capacity of  $C_1$ .

**The Superheterodyne**

This type of circuit finds its greatest application in the straight set, for in a superheterodyne having an intermediate frequency of  $465 \text{ kc/s}$  or thereabouts it greatly increases the liability to interference by the break-through of signals on the intermediate frequency. In such superheterodynes, therefore, it must be used cautiously.

Where only one signal-frequency tuned circuit is adopted, therefore, the circuit of Fig. 2 or 3 is retained, but the inductance of  $L_1$  is reduced in value so that the primary resonance occurs in the middle of the band. Quite loose coupling must then be used to avoid excessive damping of the tuned circuit and excessive variations of the secondary inductance, but this is tolerable in view of the higher resonance frequency. In general, however, a double coupling is advisable in the manner shown in Fig. 4. The top-end condenser  $C_1$  is reduced to about  $2\text{--}3 \mu\text{F}$ . only and is effective at the high-frequency end of the band. The bottom-end condenser  $C_2$  has a capacity of some  $0.005 \mu\text{F}$ . and is effective at the low-frequency end of the band.

The use of  $C_2$  restricts the tuning range for it is in series with the tuning condenser and so reduces its maximum capacity. Consequently, a smaller value than  $0.005 \mu\text{F}$ . is hardly permissible, and a larger value gives too loose coupling. This particular arrangement can also be used in a straight set with a value of  $L_1$  resonating around  $450 \text{ kc/s}$ ; if it is, however, all the tuned circuits must have a condenser included in them of the same capacity as  $C_2$ , otherwise ganging will be impossible.

Some experiments along these lines will often enable a considerable improvement to be made in the performance of the older receivers, especially in the case of those in which the aerial circuit ganging is unsatisfactory.



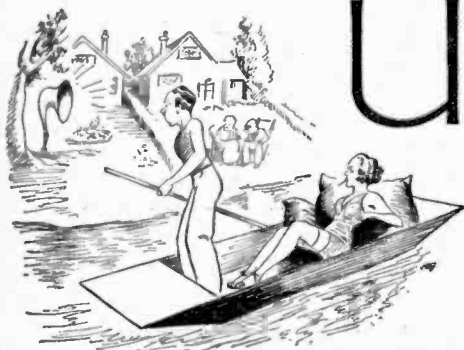

Complaints from the neighbours.

## A Question of Morals

ALTHOUGH I intend to spend the next few minutes of your time discussing the moral law, there is no need to send the children out of the room. I merely wish to know your opinion as to what course a right-thinking man should take when confronted with a conflict between the moral law and the law of the land.

The problem is, of course, a wireless one and concerns the predicament of a riverside dweller who spends a great deal of his time afloat. Actually, his garden runs down to the river, and this, to some extent, accounts for his morbid craving for hanging round backwaters in a punt. Quite often when on the water only a relatively short distance from home, friends have called, and, receiving no answer to their knockings on the front door, have gone away. Although, of course, in most cases this is a highly satisfactory state of affairs, there are occasions when somebody calls whom he would particularly like to see.

In order, therefore, to enable the knockings of callers to be heard he built *The Wireless World* 30-watt amplifier, and, by means of a microphone fixed to the front door, enabled the sound of the knocker to be transferred in greatly amplified form to a large "five-mile" PA type loud speaker in the garden. Owing to the high power of *The Wireless World* amplifier he was able to hear the hammerings on his front door when over a mile away, but unfortunately it led to complaints from his neighbours, since naturally the noise from the loud speaker when anybody knocked at the front door was reminiscent of an artillery barrage.

Since the individual whom we are discussing is of the increasingly rare and curious type who bothers about his neighbours' feelings, he was naturally considerably upset when he learnt that he was annoying them. Fortunately, the constructional details of a 5-metre transmitter which appeared recently in *The Wireless World* provided him with the solution to his problem, since all he did was to build it and thus radiate the sound of his door-knocker silently to his distant punt, where it is picked up by a 5-metre receiver, converted into sound once more and passed to a small, inoffensive type of loud speaker in the punt. Thus, he has preserved the peace with his neighbours and at the same

# UNBIASED

By  
FREE GRID

time has benefited himself, since he can now go much farther afield in his boat without getting out of range of his door-knocker than he could when employing the giant loud speaker method.

But—and there is always a but in these cases—there is one fly in the ointment, namely, that he is infringing the law of the land by establishing a transmitter without a licence. He asserts that he is perfectly well aware of this, but that, on the principle of the old proverb about what the eye doesn't see the heart doesn't grieve over, it is much better to let the P.M.G. sleep away in blissful ignorance than to harass him unduly by making useless application for a licence which he feels sure the G.P.O. chief would not grant him.

He furthermore maintains that although he is breaking the law of the land, he is harming nobody and not even causing interference to broadcasting or other transmissions and that his conduct is therefore morally correct, whereas under the old system, where he was within the law, he was causing unwarranted distress to his neighbours, which was an undoubted infringement of the moral law. I fear that the problem is far too involved for me, and I must therefore leave it to you moralists to wrangle over at the next meeting of your local debating society.

## Women and Television

I WONDER if any of you fellows who happen, like myself, to be students of human nature, and who visited the television exhibition at the Science Museum, noticed what an extremely high tribute was paid to television by the women visitors to the show? Personally I visited the exhibition on several days specially to watch the reactions of the women to the demonstrations, as I knew that from them I should obtain an absolutely unbiased judgment as to its merits or otherwise.

Naturally, most people like myself whose lives are bound up in scientific matters are, in their enthusiasm, apt to over-estimate the degree of perfection to which any development has reached, just as, for instance, the inhabitants of South-end are apt to give an unduly high place to winkles and whelks as table delicacies.

It was for this reason that I sought an outside judgment on the merits of television, and the reason why I chose to listen to the comments of the women visitors rather than to those of the men was that women will, when it suits them, speak the truth regardless of hurting anybody's feelings, whereas men in similar circumstances, moved by mistaken feelings of kindness, will make their criticisms utterly

valueless by meaningless and fatuous dissimulation.

At the demonstrations, as was the case at Radiolympia, the greater part of the visitors were men, but a fair sprinkling of them were dragging along with them one or two bored-looking women just as they do at the wireless exhibition. It was remarkable, however, how quickly the bored look disappeared from the women's faces as soon as they saw the television pictures, and it was obvious that they imagined themselves in their favourite cinema. This in itself was a tribute to the entertainment value of television, but it was not until they began to express annoyance that they gave their real verdict in favour of it.

This apparent paradox is explained by the particular nature of the programme, which consisted for the most of snippity bits. It so happened that a portion of film was being shown featuring some star or other who was a particular favourite of the women. This item ceased abruptly, and we passed on to something quite different, namely, a topical talk on Egyptian mummies or some such subject.

In a somewhat lengthy life I have, I think, seldom heard such an outburst of annoyance which came from the lips of the women at being so suddenly deprived of their favourite mental pabulum. It was obvious that in their absorption in the programme the machine had completely been forgotten, which is, I think, the highest tribute which can be paid to any scientific device for providing entertain-



I listened to the comments of the women.

ment, be it wireless set, cinema or television. It was not only on one day, but on several, that this unconscious tribute was paid to television. Yet another unconscious tribute to television's entertainment value was the fact that several of the women turned up as though clad for Covent Garden.

# Random Radiations

By

"DIALLIST"

## Radio Newspapers

IN America they're trying the experiment of publishing what we may call broadcast news sheets. Broadcasting concerns operating in three different States are lending to selected listeners apparatus which can be attached to an ordinary receiving set and produces facsimiles of printed matter. The idea, apparently, is to test what would be called over there the reactions of the public. So far as one can see, the apparatus is not unlike the old Fultograph, which a good many of you will remember. It produces its facsimiles in the same way by means of a metal stylus travelling over the surface of a piece of sensitised paper. Myself, I can't see any particular usefulness for the broadcast newspaper in the home—the spoken bulletins are so much more quickly transmitted. The facsimile apparatus brings in printed matter at the rate of an inch, or say, 50 words a minute. The average announcer speaks between 100 and 150 words in the same time. Hence the facsimile bulletin must either take much longer to transmit, or be very much more brief.

## Will It Catch On ?

Whether the broadcast newspaper will catch on in the United States one can't say, though I should hardly think that it would. The Fultograph, though the B.B.C. gave still-picture transmissions over a long period, and I have picked them up successfully from Vienna as well as from London, had no great success in this country. One reason for this is possibly that pictures sent out by the B.B.C. were so restricted in scope that only with rare exceptions was anything sent out that wasn't of the dull-est kind. The only topical transmission that I can remember was of pictures of the Boat Race within a few hours of its being rowed. One objection that people had to the Fultograph was that reception demanded a certain amount of preparation. You had to pour a solution into a photographer's developing dish, to dip your paper into it, to drain it and to wrap it round a drum before each picture began. Then the building-up of the picture took four minutes, which is rather a long time. Possibly, the American people have managed to evolve a sensitised paper which does not require treatment in a developing dish, and there may be other improvements as well.

## The Approach of Winter

CURIOUS, isn't it, to notice how quickly we find ourselves working under winter conditions once B.S.T. has given place to G.M.T.? In the early part of October the 19-metre stations were often going strong till midnight, for it was still daylight in the United States until then. You had to wait till the small hours before the 31-metre and the 49-metre bands were of much use. Now the 19-metre stations are apt to "flutter" by about ten o'clock and you can hear those on the higher wavelengths without sitting up into unconscionable hours. The only fly in the ointment is that the entertainment value of the programmes that you hear on the 19-metre band doesn't get any better as we advance into the darker

months. You hear earlier and earlier afternoon programmes and unless there is something exciting, such as a baseball game or a football match, the broadcast items are apt to be chock-a-block with the kind of advertising matter that makes you (or me, at any rate) want to scream.

## Fun with the Propagandists

YOU can spend an amusing hour when you feel like it by tuning-in on the short-wave range of your set the propaganda broadcasts which various foreign countries send out in English. However venomous they may sound—and, my hat, they do sometimes—one can feel pretty sure that they don't do much harm in this country, for whose consumption they are principally intended. There are three things about the British which the foreign propagandists hardly realise. The first is that we don't like being talked at through our loud speakers; the second, that we don't like political talks; the third, that we don't very much like any talks unless they are brief, interesting and to the point. Most of the propaganda stuff that you hear is exactly what is calculated to make the average Briton either turn to another station or switch off altogether. Yet the speakers go to untold trouble in getting out masses of statistics of the deadliest and dullest kind and in marshalling facts which aren't of the faintest interest to us. A consoling thought for those who are worried over the question of foreign impropropaganda is that there's safety in numbers . . . of words.

## Hitting Back

IT is reported that it is quite likely that before long the B.B.C. may be sending out news bulletins on the short waves in Arabic, and possibly in one or two other foreign languages. The idea is that there shouldn't be anything of a propaganda nature about them, but that they should be just plain unvarnished statements of facts. Possibly they'll be confined to translations

of the news bulletins ordinarily broadcast in English. Whilst I am strongly against propaganda, I can't help thinking that we really ought to speak up for ourselves in a calm and dignified way. In the past we allowed the most amazing attacks on us to go completely unanswered, and however fantastic the statements may be that are broadcast about us from foreign countries, they are bound to be believed if we don't let people know the truth of the matter. There's a good deal in the Irish saying, "In throwing mud some of it sticks, even if none does." I hope we'll be careful not to indulge in any other wrangles, for that sort of thing won't do at all and might intensify foreign propaganda.

## Lord Mayor's Nests

ONCE more the poor old B.B.C. has been putting its collective foot into it and raising the storms that follow as a natural consequence. This time the foot has been planted firmly in a brace of Mayors' nests—and not merely Mayors' nests but Lord Mayors' nests. The first planting of the aforesaid foot took place at the opening of Stagshaw and the nest was that of the Lord Mayor of Newcastle, who complained bitterly of the queer way in which he was treated at the opening of the new station. The second Lord Mayor to suffer within a day or two was the Lord Mayor of Stoke-on-Trent, who has taken grave offence at Mr. Geoffrey Boumphrey's talk about his tour in the Potteries. Mr. Boumphrey's description of what he saw was certainly not flattering to Stoke, and the Lord Mayor complains that it is nothing but a travesty of the truth. I know nothing of Stoke save what I have seen when passing through it in the train, so can't say who is right. At the same time, both these instances seem to show that the B.B.C. people don't quite realise how strong

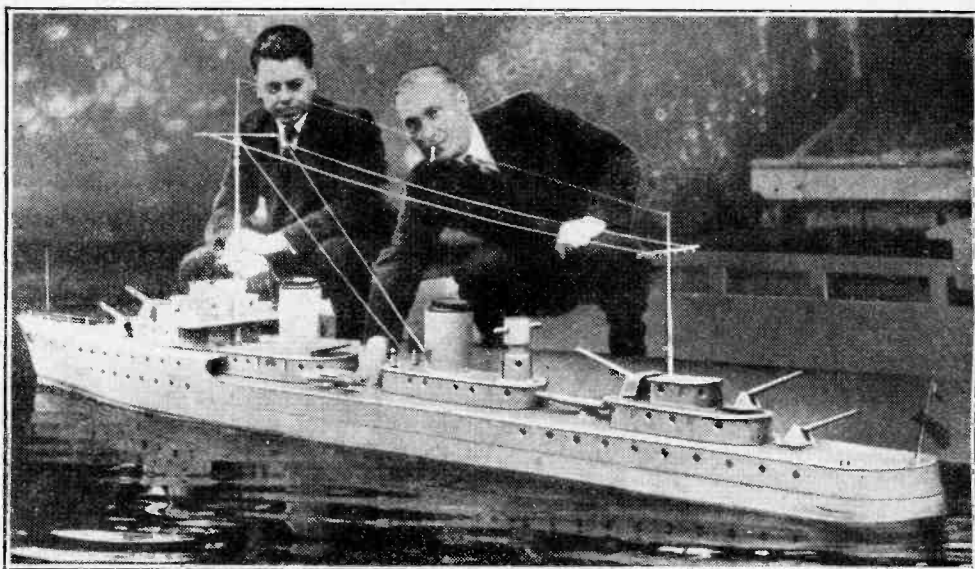

TELEARCHICS FRANÇAISE.—The guns and torpedoes, as well as all movements, of this 12-foot model of the French destroyer "Terrible" are controlled by SW wireless.

a thing local pride is. And it's a very fine thing, too. These bricks just shouldn't have been dropped.

**Diplomacy Needed**

Nothing is so likely to cause hard feelings in a locality as the slighting of its civic dignitaries, or the broadcasting to the world of criticisms that are felt to be entirely unjustifiable. I haven't the least doubt that Mr. Boumphrey described quite honestly what he saw. But is there a town in this country, or any other for that matter, of which you couldn't paint a pretty grim picture if you confined yourself to visiting and describing its meanest quarters? I would suggest that if those responsible for talks receive a manuscript that is likely to hurt local feelings, they would do well before passing it for broadcasting to ascertain that the man about to deliver it has not harped overmuch on just one side of the picture.

**A Short-Wave Grouse**

THOUGH our manufacturers have managed to turn out low-priced "all-wave" receiving sets of a sensitiveness on the short-wave range that is quite surprising, all things considered, there is one point to which I feel that a good deal more attention deserves to be paid. This is the question of crowded tuning scales. Probably the 19-metre band is the most popular of all those on the short waves among ordinary listeners, the reason being that American stations can be heard on it at convenient hours in the early evening. On one set that I have handled (not a very cheap one, either) the entire 19-metre band, which contains about a score of important stations, occupies exactly one-fifth of an inch. Put three pennies together, look at them edge-wise and you realise what this means. Where the short waves from, say, 16.5 to 50 metres are covered in one sweep of the tuning pointer it's not at all unusual to find the 19-metre band occupying a good deal less than half an inch on the scale.

**Not Too Easy**

Even if you have a good deal of experience in short-wave work and have developed that delicacy of touch that is needed for making fine adjustments, tuning is not a very simple business when the scale is as cramped as this. Also, it is quite impossible to do anything in the way of calibration, and almost impossible to record the setting of a particular station for future reference. It seems to me that the only way of making short-wave listening really popular is to ensure that tuning is not too fiddling a business for the ordinary man to undertake without putting a severe strain on his skill and his patience. I know well enough that band-spreading adds considerably to the production cost of a set; but don't you think that the man in the street would rather pay an extra guinea for a set that he can tune easily than buy a cheaper one whose adjustment on the short wave is a very ticklish business? At any rate, I have come across quite a few people who, after investing in "all-wave" sets, have given up the short-wave range as something quite beyond them. It isn't that their sets won't bring in short-wave stations; they will, if they are properly handled. If band-spreading in the cheaper sets is impossible owing to its cost, mightn't it be better to make the portion of the short waves covered extend only from, say, 19 to 32 metres?

**News from the Clubs**

**International Short-wave Club**

Hon. Sec.: Mr. A. E. Bear, 100, Adams Gardens Estate, London, S.E.16.

The above Society ask us to announce the following: The London Chapter meets at 8 p.m. every Friday at 80, Theobald's Road, London, W.C.1. The Brighton Chapter meet at 8 p.m. every Wednesday at the Seafield Dance Hall, Kingsway, Hove, and the Guernsey meets at 8 p.m. every Tuesday at 5, Well Road, St. Peter Port, Guernsey, Channel Islands. A free copy of the Club's "News Letter" containing full details of coming features will be sent to all readers who send a postcard.

**Bradford Short-Wave Club**

Hon. Secretary: Mr. S. Fischer, "Edenbank," 10, Highfield Avenue, Idle, Bradford, Yorks.

A very interesting and instructive evening was spent recently when Mr. T. M. Wood, of Messrs. Stratton & Co., Ltd., demonstrated two ultra-short-wave radiotelephone installations similar to those used in the 1936 Mount Everest Expedition.

**Surrey Radio Contact Club**

Hon. Secretary: Mr. A. B. Wilshire, 14, Lytton Gardens, Wallington.

An exceptionally interesting talk was given at the October 19th meeting by Mr. Miles (G2NK), who brought along with him his three commercially made American "amateur band" receivers, two having a crystal gate filter. The sensitivity of all three sets when tested on a 6-ft. aerial was exceptionally good. The crystal gate on two of the sets provided a very high degree of selectivity although tuning was easy owing to the use of the band-spread principle. In the case of one set the arrangements made for interference elimination excited very favourable comment, especially in the case of car ignition.

**Cambridge Television Society**

Meetings: Wednesday evenings.  
Hon. Secretary: Mr. W. Jones, 115, Milton Road, Cambridge.

This Society, which has just been formed, held its first meeting on October 18th, when there was an attendance of over forty. A Committee was elected and after the official business had been transacted the members were invited to witness a television demonstration which was made possible by the courtesy of the well-known Pye Company. Reception was remarkably good in spite of the fact that the transmitter is some fifty miles distant.

**Exeter and District Wireless Society**

Headquarters: Y.W.C.A., 3, Dix's Field, Southernhay, Exeter.

Meetings: Mondays at 8 p.m.  
Hon. Secretary: Mr. W. Ching, 9, Sivell Place, Heavitree, Exeter.

Great interest was aroused by the recent lecture on direction finding by Mr. R. C. Lawes. The lecturer has had experience in installing DF gear on a number of ocean-going yachts, and he himself took part in this year's Fastnet Yacht Race. On the 200 miles crossing from the Fastnet Rock to the Scilly Isles no celestial observations were obtained, but the DF apparatus enabled a perfect landfall to be made.

On November 8th Dr. D. R. Barber will give an illustrated lecture on the Ionosphere.

**Southend and District Radio and Scientific Society**

Hon. Secretary: Mr. F. S. Adams, 27, Eastern Avenue, Southend-on-Sea.

The final DF contest of the 1937 season has been arranged for next Sunday (November 7th). Intending competitors should assemble by 1.30 p.m. outside the Crown Hotel, Rayleigh, and should bring along with them the 1s. entrance fee and the 1s. 3d. for tea, which will be collected before a start is made. Sealed envelopes will be handed to competitors giving the location of the transmitter and the tea rendezvous. The transmitter (G5QPK) will use telephony on a wavelength of 155.8 metres. Test transmissions will be made to-night (November 4th) from 11 to 11.30 p.m., and on Sunday at 9 to 9.15 a.m.



and  
**T.C.C.**

FOR over 30 years T.C.C. have bitten deeply into every condenser problem—biting hard yet never biting more than could be chewed. Still biting deeply into today's—into tomorrow's problems, T.C.C. are meeting every possible condenser need of the radio industry. No demand of radio technician, of setmaker, of amateur but what can be fulfilled from the T.C.C. range. That's why, through three decades, T.C.C. have maintained unquestioned leadership. Whatever your need consult T.C.C. first!

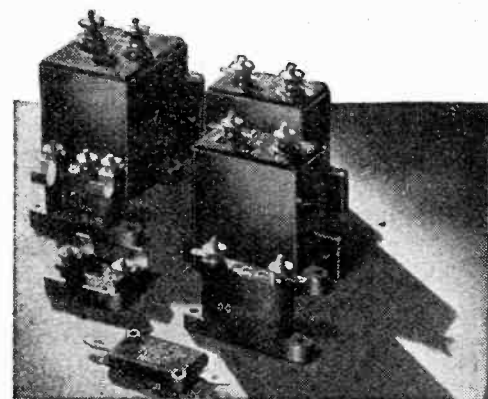

**T.C.C.**  
ALL-BRITISH  
**CONDENSERS**

THE TELEGRAPH CONDENSER CO. LTD.  
WALES FARM ROAD, N. ACTON W.3



# Letters to the Editor

The Editor does not hold himself responsible for the opinions of his correspondents

## "Earth Resistance"

"MAINSMAN'S" article seems to call for a certain amount of criticism when viewed from a purely wireless standpoint.

In the first place, earthing systems as used by the "Grid" and/or to connect lightning arresters to earth are designed primarily to be able to carry very large currents, and their technique does not apply to domestic wireless installations.

In the second place, the simple method of measurement described is not so simple as would at first appear. After all, only an approximation is obtained, especially so far as "RF resistance" is concerned. It would seem better, therefore, to adhere to an older method which, while also using two additional earth rods, has at least the advantage that tests can be made instantaneously and without fuss. The final result is in no way effected by a large difference in the resistance of each separate connection. The method referred to employs the three "earths": A, the one the resistance of which has to be ascertained, and B and C, the two temporary ones. With only one instrument, such as an ohmmeter, a bridge or a suitable volt- or amp-meter and battery, three resistance readings are obtained with A and B, A and C, and B and C in series. From these three results it is a simple matter to deduce the value of the resistance of A alone. The electrolytic effect which creeps into most methods can be largely overcome by taking a second series of reading with the battery polarity reversed. Then, taking a mean of the two values for A, a nearer approximation will be found.

A further interesting point, which is only too often overlooked by the serious experimenter, is that it is well worth while to install the two additional "earths" permanently and to join the three sets of wires to form one "earth," since the total resistance of three resistances in parallel is always smaller than that of one only. When these three earth connections are joined indoors at some convenient place, it is an easy matter to separate them from time to time, in order to take comparative readings under various weather conditions or to ascertain whether any one or more of them has deteriorated.

In the third place, the earthing rod suggested in the article may be excellent in every respect, when used to earth all manner of gear, with the notable exception of wireless apparatus. Since two dissimilar metals are used in close proximity, a potential difference between these will exist and may be constantly varying. Especially in damp soil, when the arrangement is not far short of constituting a primary battery (the damp soil being the electrolyte between two electrodes), the reception from a wireless receiver using such an earthing rod will be far from pleasant to listen to.

In the fourth and last place, the use of chemicals, such as salt, can only have a detrimental effect in the long run on any earthing system. The so-called "chemical earths" which appeared on the market a few years ago, have proved that and their success, or otherwise, by their conspicuous absence to-day.

EARTHMAN,

Chiswick.

## Paraphase v. Transformer Push-pull Coupling in Audio Frequency Amplifier

FOR some two or three years it has been fashionable to regard resistance capacity paraphase coupling as being superior in every respect to transformer coupling; indeed, the intervalve transformer has become very much of a "black sheep" in the beliefs of many people.

To recapitulate the advantages claimed for RC paraphase it is convenient to tabulate thus:—

- (a) Less phase distortion.
- (b) Decrease in waveform distortion.
- (c) Freedom from hum and extraneous field pick-up.
- (d) Increased frequency range, especially at higher frequencies.

However, from recent investigations, the writer is not convinced that all the above items can be justifiably placed to the credit of RC paraphase when compared with transformer coupling.

Setting the limits of useful audio frequency response at 20-15,000 c/s, the writer claims that a suitable transformer working between known impedances is the equal of RC paraphase on all counts from (a)-(d), and, in addition, will handle peaks with an amount of distortion considerably less than RC paraphase.

This brings the methods of testing amplifiers into account.

The writer contends the normal audio frequency test, using a beat frequency oscillator as the source with a cathode-ray oscillograph and recording camera in the output circuit, is not a true test, since it does not show the behaviour of the amplifier on "peaks" such as encountered from, say, a tympani. Thus the writer modified the above test scheme and took oscillographic recordings of (1) a RC paraphase amplifier, (2) a properly designed transformer coupled amplifier. The signal source was a common programme from Droitwich. By comparing the two recordings it is quite obvious the RC paraphase is defective—indeed, it distorts badly—on peaks.

It is not desired at the moment to prolong this letter unduly, but as many tests and measurements are being made on the two systems, it may be interesting to learn the view-points of other readers in the interim.

Portsmouth. "NAUTICUS."

## Scale Distortion

MR. J. L. MONTAGUE claims to have discovered "the real catch (which has apparently escaped 'Cathode Ray')" in the alleged phenomenon of scale distortion. I have read his letter several times, but I regret to say that it continues to escape me. I cannot find anywhere that Mr. Montague denies the truth of any statement he quotes, to the effect that, unless the original intensity of sound is reproduced, the reproduction is a distorted version of the original. Instead, he winds up by saying: "The proper application of the flexible tone control is under the conditions where the sound intensity of the ear in the home listening

room is below that in a reasonably good position in the concert hall," etc. Quite. Exactly what I was trying to explain in my article. Except that I do not see why he restricts this statement to sound intensities lower than the original, since apparently he agrees that the bass is super-normal where the intensity is greater than that of the original.

Incidentally, it appears that he is in the habit of listening to concerts reproduced more loudly than the original—"a symphony orchestra, for instance, would seem much louder in the home listening room than it does to the conductor of the orchestra in a large concert hall where the absorption effect is very much higher indeed." As a matter of fact, unless the home is very barely furnished, its absorption may well be higher than that of a concert hall; but I take it that Mr. Montague includes the reduction in reflected sound owing to the greater size of the hall. But (quoting Terman's "Radio Engineering") "the power involved in musical sounds is often very large, and in the case of large orchestras may reach peak values approaching 100 watts." Bearing in mind that, allowing for the usual generous rating of receivers and the low acoustical efficiency of good-quality domestic loud speakers, this is equivalent to an electrical power output of one or two kilowatts, Mr. Montague must have an exceptionally powerful set if he hears the orchestra "much louder" than the conductor close up to it, even assuming infinite absorption—i.e., an open-air performance; and he probably enjoys it like that more than his neighbours do. But it is hardly fair to take this as the standard that the composer of the music (probably dead for a century) had in mind and then deduce from my statements that the conductor and *a fortiori* the audience are getting a distorted version!

"CATHODE RAY."

## Droitwich Quality

AS a high quality enthusiast I was interested to read the divergent opinions expressed by Mr. Dougharty and Mr. Cotterell in letters published in your issue of October 22nd. I would like to add my voice to Mr. Dougharty's and point out, by way of emphasis, that the Wednesday Symphony Concerts are available at high quality only to those listeners in the night-time service area of the London National transmitter.

Mr. Dougharty is, however, I think, wrong when he criticises the Droitwich transmitter itself. In a reply which I recently received from them, the B.B.C. state it to be flat to 10 kc/s, though they freely admit that this is "substantially modified" by land line losses.

Mr. Cotterell's defence of Droitwich is, therefore, a little difficult to understand. If he is referring to the transmitter itself he is justified for the reasons given above. His only measure of its qualities, however, will be the programmes originating from the Birmingham studios, which do not often figure in the National programme. On the other hand, it is difficult to see how he can defend the bulk of Droitwich transmissions, originating, as they do, from London. And can he have failed to notice the superiority of the medium-wave programmes originating from the local studios as compared with those coming from London by land line? At least, the converse difference is observed quite easily on the London Regional transmissions when a Voigt speaker is used.



## Letters to the Editor—

In the letter already referred to, the B.B.C. point out that the top loss on Droitwich is often made to appear much worse than it really is by the sideband cutting in the receiver. I agree with Mr. Cotterell and the B.B.C. that sideband cutting presents a problem, and I certainly hold no brief for the receivers mentioned by "Diallist" if they are of the normal commercial variety, but surely most complaints, such, at least, as are published in *The Wireless World* correspondence columns, come from writers who are fully alive to this difficulty. See, for example, a letter from Mr. Voigt published as long ago as April 3rd, 1936.

The greatest advance which could be made on the present system of programme distribution would be, from my own point of view, to install high-quality land lines between London and Droitwich. I fully sympathise with the views of those who lament the partial loss of the London National, but as I am outside the service area of that station—at night at least—I must go elsewhere for the National programme. I should probably not benefit either from an ultra-short-wave service. A land line capable of doing justice to the Droitwich transmitter would provide a high quality for listeners outside the London area, such as could only be achieved otherwise by linking up all the medium-wave National transmitters by high-quality land lines. As they already have some good transmissions from their local studios in the Regional programmes, there would then be quite a fair choice of material to do justice to a good loud speaker.

We quality enthusiasts are not crying for the moon. In the whirl of change which constitutes "progress" there is seldom a visible goal, but in the matter of frequency range, at least, transmissions including frequencies up to 20 kc/s would constitute perfection. Surely, therefore, it is not unreasonable to ask the Post Office to let us have lines capable of transmitting these frequencies, particularly in these days of television cables.

Finally, lest Mr. Cotterell thinks I bear him a grudge, let me say that his recent letter has by no means damped the fellow-feeling he aroused in me with his previous letter, written during the horn-loading controversy, earlier in the year.

Maidenhead, Berks. W. J. CLUFF.

I AM very pleased to see the letter from Mr. A. H. Bridges, of Brighton, pleading for a "hands-off" policy with regard to Droitwich National. As I have myself remarked on divers occasions, the reception on the South Coast of Regional transmitters, including London Regional, is far from satisfactory even with powerful sets, and Droitwich is the only satisfactory and reliable home station to be received there. I consider that in raising the power of London Regional will not materially improve matters, and I also have my doubts concerning Start Point from the point of view of Sussex coast listeners. I find Droitwich of excellent quality except in thundery weather.

T. J. E. WARBURTON.

DROITWICH is certainly not nearly so black as she is painted, and I find myself in agreement with most of Mr. Cotterell's letter on the subject. Land lines can be bad, and the usual B.B.C. outside broadcast is so much inferior to a studio broadcast that I can tell instantly on entering my room which

kind is coming over. And I do not possess hyper-sensitive ears—only first-class receiving equipment.

The land line to Droitwich, however, must be quite a different matter. There is certainly some lack of top, and, if conditions allow, it is preferable to receive the programme from the medium-wave station, but the difference is not so great as disgruntled listeners make out. I agree with Mr. Cotterell that where there is a considerable degree of high note attenuation a good portion of the trouble is attributable to the RF tuning circuits in the receiver.

In the summer I use a 2 RF set (4 tuned circuits), and if I merely switch over for the reception of Droitwich, quality is poor. If, however, I am energetic enough to open up the set and clip the aerial on to the grid of the second RF valve, quality, if not of the very highest standard, is at least acceptable, and "acceptable" quality, when judged by Voigt standards, is better than the casual reader might realise. I forgot to mention that my speaker is a Voigt domestic horn.

To all those readers living outside the swamp area of Droitwich, might I suggest that they are not competent to discuss the merits or otherwise of that station until their reception of it has been accompanied by a noticeable 9 kc/s whistle?

Leicester.

W. WINDER.

### Autumn 1937 Edition Radio Amateur Call Book

THE autumn edition for 1937 of the *Radio Amateur Call Book Magazine* is now available and copies can be obtained from F. L. Postlethwaite, 41, Kinfauns Road, Goodmayes, Ilford, Essex, at the price of 6s., post free.

One of the most useful publications available to the amateur, it contains the call signs, names and addresses of all amateur stations throughout the world. There is a list of short-wave commercial stations and data relative to those stations that regularly transmit Press and weather reports. The "Q," "R" and "T" codes are included, also a very useful two-page map of the world marked with the international amateur prefixes.

### I.E.E. Wireless Section

On November 23rd at 6.30 p.m. there will be an informal meeting of the Wireless Section of the Institution of Electrical Engineers at which Mr. H. L. Kirke will open a discussion on electrical gramophone reproduction.

## The Radio Industry

A PARTY of Indian radio engineering students from the Bombay Technical Institute are undergoing a course of instruction in radio servicing, car radio, anti-interference aerial installation, etc., at the works of the National Radio and Television Service Company.

The new Dagenham factory of British Belmont Radio, Ltd., is now in full swing, and it is safe to say that the only part of the receiver which is still of American origin is the circuit.

Technical particulars of the new Ferranti Model 1037 all-wave AC superheterodyne and its AC/DC equivalent are contained in list RA122, which we have just received.

A new battery superheterodyne is announced by the G.E.C. To be known as the "Battery All-Wave QPP4," this set, which is designed for reception on three wavebands, has an economical push-pull output stage and is priced at 11½ guineas.

# ROLAMATIC

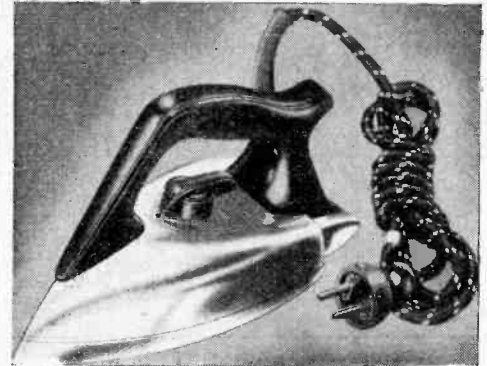

## The "G.12" of ELECTRIC IRONS

Probably you're not a bit interested in Electric Irons. We didn't expect you would be. But we rather felt that as a radio connoisseur who has experienced the quality of the Rola G.12 speaker you would be interested in a new Rola product that is to other Electric Irons what the Rola G.12 is to ordinary speakers. Of one thing there is no doubt at all—your wife will be interested in the ROLAMATIC Electric Iron from the moment she sets eyes upon its fine streamlining and gleaming untarnishable chromium plating, feels its perfect balance and notes the finger-tip controlled switch, marked in terms of materials, that sets the iron to exactly the correct degree of heat for any fabric. There is no electric iron made that possesses so many important exclusive features as the ROLAMATIC—you will appreciate that and also its technical excellence and soundness of construction if you will ask your dealer for a demonstration. Alternatively, write to-day for folder "RA."

**5/-** for Your Old  
Electric Iron

Just get hold of the wife's old electric iron and take it along to your dealer. Whatever its condition, he'll take it in part exchange for a brand new ROLAMATIC and make you a 5/- allowance, which means that you get a 35/- iron for only 30/-.

**THE BRITISH ROLA CO., LTD.**  
MINERVA ROAD, PARK ROYAL, N.W.10.  
PHONE: WILLESDEN 4322-3-4-5-6.

# Recent Inventions

## PROJECTING TELEVISION PICTURES

THE image of the picture is formed on a screen S as the latter is heated to various degrees of incandescence by the impact of a stream of electrons from the cathode C. The screen is made of a very thin sheet of tantalum or tungsten, and the electron stream is focused into a sharp pencil so as to intensify its effect by an

*Brief descriptions of the more interesting radio devices and improvements issued as patents will be included in this section.*

encloses most of the space between the plates P and P1. In operation a stream of electrons from the cathode C of an auxiliary tube enters an aperture N in the side of one of the plates

ing-plates of a cathode-ray receiver by the circuit arrangement shown in the drawing.

The main condenser C is charged up through a resistance R and is periodically discharged through a gas-filled valve V. One terminal P of the deflecting-plates is connected via a condenser C1 to what is, in effect, the cathode of the valve V, whilst the terminal P1 feeding the other deflecting-plates is connected via a condenser C2 to the anode of an amplifier V1. The grid of the latter is connected to the main condenser C through a potentiometer R1, R2, both arms of which have the same time-constant.

aerials are arranged symmetrically on a circle so that they can be rotated simultaneously in parallel planes. The frames are all coupled up to a central radiogoniometer, and are found to give an accurate "zero" indication when orientated on a distant beacon station. The pick-up from a separate vertical aerial may be added to the output from the frames, so as to eliminate the 180 deg. ambiguity in the directional "sense" of the distant beacon.

*Convention date (Germany) October 19th, 1935. Telefunken Ges. für drahtlose Telegraphie m.b.H. No. 467785.*

## ULTRA-SHORT-WAVE SYSTEMS

HIGH-FREQUENCY energy is propagated in the form of "displacement waves" through a "dielectric guide." The waves are of the order of a few centimetres long, the wavelength being a function of the diameter of the guideline. Under proper conditions transmission is effected with small attenuation, and with no external

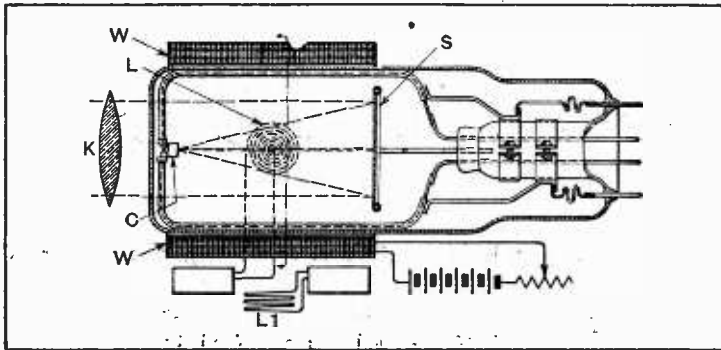

Cathode-ray tube for projecting television pictures.

external magnetic winding W. The scanning movement is controlled by a pair of deflecting coils L, L1. The incandescent image is projected by a lens K on to a viewing-screen located outside the tube.

One advantage of the arrangement is that the light is collected directly from the "face" of the screen S that receives the direct bombardment of the electrons. It is, therefore, of high intensity, particularly as compared with a fluorescent screen, where the picture is viewed after much of the light has been lost in passing from the front to the rear face of the screen.

*Farnworth Television, Inc. Convention date (U.S.A.) February 6th, 1935. No. 468795.*

P, and is then thrown in zig-zag fashion from one plate to the other. At each impact, secondary emission occurs, until the amplified stream is finally collected by the anode A.

Obviously the extent of amplification will depend upon the number of impacts made by the stream against the plates P, P1 before it reaches the output electrode A. This in turn depends upon the angle at which the stream passes through the aperture N, which, in fact, is controlled by the voltage applied from a source Or to a pair of deflecting plates K, K1. For instance, if the stream passes centrally through the aperture N, as shown in full lines, it will make four impacts, while if it passes

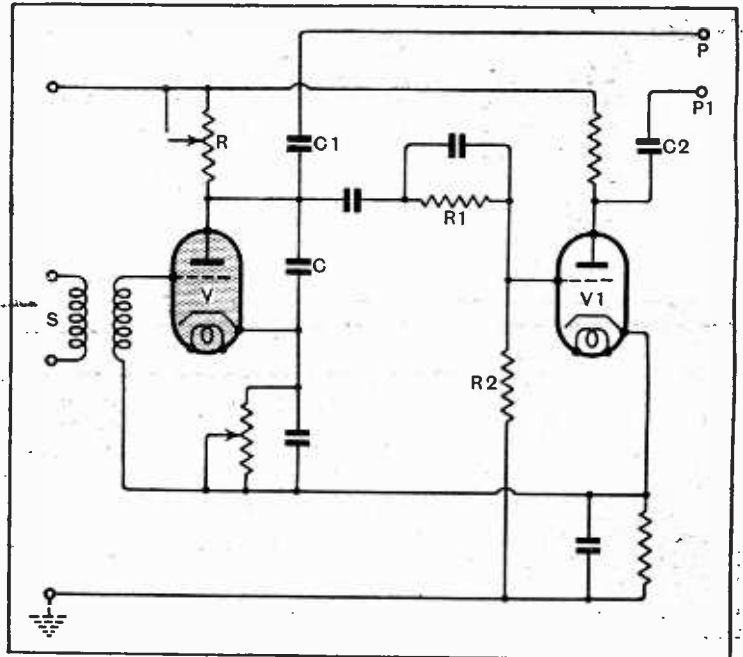

Time-base circuit arranged for push-pull operation.

The result is that whilst the mean potential of the deflecting-plates is kept at the same datum level, one plate varies about this potential with the cathode of the valve V and the other plate with the anode of valve V1.

*The General Electric Co., Ltd. and D. C. Espley. Application date January 14th, 1936. No. 468394.*

field, the energy travelling forward as a true wave and not as a "go and return" current.

The displacement waves are classified into various types, according to whether the magnetic or electric component is parallel to the direction of travel, and the invention is concerned with different forms of terminal couplings for transferring or converting the waves from one of these types to another.

*Standard Telephones and Cables, Ltd. (communicated by Western Electric Co., Inc.). Application date September 25th, 1936. No. 468548.*

## DIRECTION FINDING

IN order to get rid of the so-called "night effect," which vitiates the accuracy of direction finding, three or more frame

The British abstracts published here are prepared with the permission of the Controller of H.M. Stationery Office, from Specifications obtainable at the Patent Office, 25, Southampton Buildings, London, W.C.2, price 1/- each. A selection of patents issued in U.S.A. is also included.

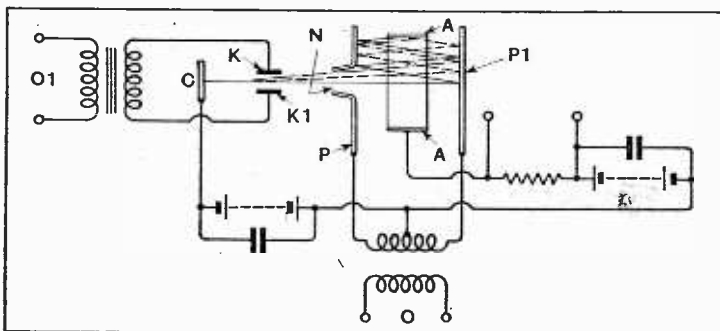

Electron multiplier in which the amplification can be controlled externally.

## ELECTRON MULTIPLIERS

AN electron-multiplier is so arranged that the effective amplification of the electron stream is controlled from outside the tube. As shown, the "multiplier" consists of two parallel "target" electrodes P, P1, which are biased by an alternating voltage from a source O. The output or collecting anode A is in the form of an open cylinder which

at other angles, shown by the two dotted lines, the impacts are reduced to three and two respectively.

*J. E. Keyston. Application date November 8th, 1935. No. 468623.*

## TIME-BASE CIRCUITS

THE saw-toothed voltages used for scanning in television are applied in push-pull to the deflect-

# The Wireless World

THE  
PRACTICAL RADIO  
JOURNAL  
27<sup>th</sup> Year of Publication

No. 950.

THURSDAY, NOVEMBER 11TH, 1937.

VOL. XLI. No. 20.

Proprietors: ILIFFE & SONS LTD.

Editor:  
HUGH S. POCOCK.

Editorial,  
Advertising and Publishing Offices:  
DORSET HOUSE, STAMFORD STREET,  
LONDON, S.E.1.

Telephone: Waterloo 3333 (50 lines).  
Telegrams: "Ethaworld, Sedist, London."

COVENTRY: Hertford Street.  
Telegrams: "Autocar, Coventry." Telephone: 5210 Coventry.

BIRMINGHAM:  
Guildhall Buildings, Navigation Street, 2.  
Telegrams: "Autopress, Birmingham." Telephone: 2971 Midland (4 lines).

MANCHESTER: 260, Deansgate, 3.  
Telegrams: "Iliffe, Manchester." Telephone: Blackfriars 4412 (4 lines).

GLASGOW: 26B, Renfield Street, C.2.  
Telegrams: "Iliffe, Glasgow." Telephone: Central 4857.

PUBLISHED WEEKLY. ENTERED AS SECOND-  
CLASS MATTER AT NEW YORK, N.Y.

Subscription Rates:  
Home, £1 1s. 8d.; Canada, £1 1s. 8d.; other  
countries, £1 3s. 10d. per annum.

As many of the circuits and apparatus described in these  
pages are covered by patents, readers are advised, before  
making use of them, to satisfy themselves that they would  
not be infringing patents.

## CONTENTS

	Page
Editorial Comment .. .. .	471
Ohmmeters .. .. .	472
Short-Wave Technique .. .. .	475
Listeners' Guide .. .. .	478
Broadcast Brevities .. .. .	479
Auditorium Acoustics, Part III ..	480
"Q" A Useful Measure of "Goodness" .. .. .	483
Television Programmes .. .. .	484
Unbiased .. .. .	485
The Mains Transformer .. .. .	486
News of the Week .. .. .	487
Random Radiations .. .. .	488
On the Short Waves .. .. .	489
Letters to the Editor .. .. .	490
New Apparatus Reviewed .. .. .	490
Recent Inventions .. .. .	492

## EDITORIAL COMMENT

### Wire or Wireless?

#### What Does the P.O. Mean?

**B**ROADCAST relay services were started in this country as private enterprises and the first was set up a good many years ago. The Post Office monopoly on communications required that these relay exchanges should only be worked under licence from the P.M.G., and the licences issued were temporary and were of such a nature that the P.M.G. could take over these exchanges on favourable terms at any time that the licence expired, in lieu of renewing the licence, if he so desired.

In 1936 the Ullswater Committee on broadcasting recommended that any technical development of relay exchanges and their control should be undertaken by the Post Office and the supply of programmes be controlled by the B.B.C.

Broadcast relay licences which have been expiring recently have generally been renewed by the P.M.G. until December, 1939, so that the various concerns at present working them will continue to do so to that date. What will happen after 1939 has, so far, not been disclosed. Quite a lot of people would like to know the answer and are, we think, entitled to know because interests are affected in a good many branches of industry in this country. The general public, too, will be directly concerned.

#### Views of the "Engineer-in-Chief"

When the Ullswater Committee recommended that the relay services should come under the complete control of the Post Office, the impression got about that the intention was to close

down the relays gradually, or at least discourage their growth.

A recent address to the Institution of Electrical Engineers by the Chairman, Sir George Lee, who is also engineer-in-chief of the Post Office, contained some statements which seemed to us to have some special significance in connection with wired relay services. For he put forward the suggestion that the distribution of television by wire to subscribers might prove to be the means of simplifying and cheapening television broadcast reception so as to make it as popular as sound broadcast reception is to-day.

Previous remarks by the engineer-in-chief had impressed upon his listeners the large scale on which the Post Office was prepared to carry out a job when once it set its hand to it.

#### Revolutionary Changes

If the Post Office takes on the task of developing the sound broadcast relay system on a wholesale scale and throws in television reception as well, the whole technique of broadcast reception, and probably transmission, too, in this country will be changed. The industry which has been built up on broadcasting would largely disappear and be replaced by an industry depending upon P.O. contracts for the supply of terminal apparatus, much on the lines as the Post Office telephone service is now conducted.

We feel that Sir George Lee owes it to the scientific workers, of which he is so prominent a representative, to the public, and to the wireless and electrical industry, to make it quite clear what is the future policy of the Post Office in this matter and whether there is any intention of developing the relay services on a "Post Office scale."

# Ohmmeters

## ADAPTING A MILLIAMMETER FOR RESISTANCE MEASUREMENTS

THE conversion of a low-range milliammeter into a multi-range instrument for measuring voltages and currents is reasonably straightforward and the procedure is well known. The position with regard to the adaptation of a similar unit to the measurement of resistance values is not so satisfactory, and the limitations of the simple ohmmeter circuit shown in Fig. 1 are not always fully appreciated.

Referring to the diagram, it is obvious that the sum of  $R_F$ ,  $R_V$  and the internal resistance of the meter  $R_m$  must be such that with AB short-circuited the current flowing is limited to the value required for full-scale deflection of M. One or more dry-cells usually form the battery E, and owing to the well-known variation of voltage with age and load characteristic of this form of cell, variation of the resistance  $R_V$  is necessary to maintain full scale deflection over the working voltage limits of the battery. The possible extent of the error with this circuit is indicated in the following specific case.

With an 0.1 milliammeter having a resistance of 100 ohms, the combined value of  $R_V$  and  $R_F$  would be 1,400 ohms when the battery voltage is 1.5. It is apparent that insertion of a resistance between A and B equal to the sum of  $R_F$ ,  $R_V$  and  $R_m$ , i.e., 1,500 ohms, would give half-scale deflection of M. When the battery voltage has fallen to 1.2 volts, however, the total resistance in circuit would have to be reduced to 1,200 ohms in order to obtain the 1 mA necessary for the zero ohms setting. Half-scale deflection of M would now correspond to 1,200 ohms. Assuming calibration of the ohms scale had been made for a battery voltage

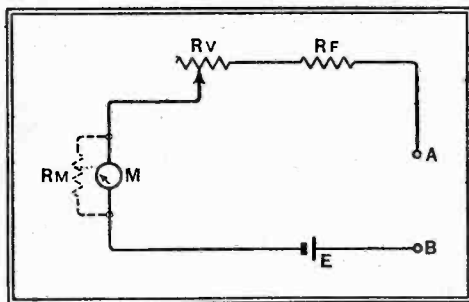

Fig. 1.—Simple ohmmeter circuit:  $R_F$  is a fixed limiting resistance while  $R_V$  serves as a zero adjuster.

of 1.5 the possible error from this source alone would amount to 20 per cent. when the battery voltage had dropped to 1.2. If calibration had been carried out with a battery voltage of 1.35 the possible error would be reduced to  $\pm 10$  per cent., but this is unnecessarily high.

Provided it is suitably proportioned the circuit shown in Fig. 2 is capable of much greater accuracy. The main essential is that  $R_F$  should be considerably greater than the equivalent resistance of  $R_m$  in

*ALTHOUGH a milliammeter can be converted into an ohmmeter quite easily, the simplest and most obvious arrangement suffers from the disability that accuracy is seriously affected by changes in battery voltage. The author of the present article discusses means for reducing errors due to this cause, and shows how various types of meter may be adapted for resistance measurements covering a wide range.*

By T. S. DUTTON

parallel with  $R_V + R_L$ . The higher this ratio the better, but quite reasonable accuracy is obtainable with a ratio as low as 10:1. It may be of interest to find the possible error with this circuit. With an 0.1 milliammeter of internal resistance 100 ohms as before, suitable values are as follows:  $R_F = 925$  ohms,  $R_V = 0.300$  ohms,  $R_L = 200$  ohms. When the battery voltage is 1.5, the resistance, looking into the circuit from the terminals AB, equals 1,008.3 ohms, but drops to 991.6 with a battery voltage of 1.2. Therefore, half-scale deflection would be obtained with from 1,008.3-991.6 ohms as the battery falls from 1.5-1.2 volts. This meter reading would be calibrated as 1,000 ohms, consequently the error is less than  $\pm 1$  per cent., i.e., less than  $\frac{1}{10}$ th the error using the circuit shown in Fig. 1. In this case  $R_F$  is approximately 12 times the equivalent resistance of  $R_m$  and  $R_V + R_L$  in parallel.

### Calculating Resistance Values

The manner in which the values of  $R_F$ ,  $R_V$  and  $R_L$  are arrived at will be indicated by finding the values for a typical 0.1 milliammeter, but the procedure and data will be found applicable to any other similar type meter. An 0.1 milliammeter usually has a resistance less than 100 ohms, but in the following calculations 100 ohms has been used in order that the values to be obtained may serve a wider field. The useful working range of a battery is from 1.5-1.2 volts. Below 1.2 volts battery internal resistance rises, and voltage is liable to drop under load. Both these features being undesirable, and possible causes of error, it is advisable to arrange for the lower limit to be automatically indicated by inability to set to zero.

The first step is to decide upon the value of the total series resistance of the

circuit. This resistance must be low enough to allow a current at least 20 per cent. more than that required for full-scale deflection of M to flow when the cell voltage or voltages have dropped to 1.2 each, terminals AB being shorted. As it will correspond to the half-scale reading of the ohmmeter it is advisable to make it a convenient number, such as one from the series 2,000, 1,000, 500, etc. Suitable values with various battery voltages and meters are indicated in Table 1. A suitable value for the 100-ohm meter under discussion would be 1,000 ohms with a single 1.5V cell. With this value the current flowing would drop from 1.5 to 1.2 mA over the battery range from 1.5 to 1.2 volts.

This leads to the second step, determination of the resistance values of  $R_V$  and  $R_L$  collectively referred to as  $R_S$  (shunt). Between the battery limits just mentioned  $R_S$  has to pass the current in excess of the

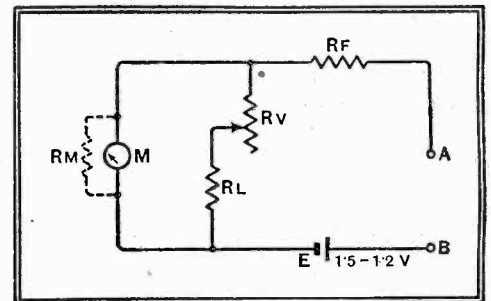

Fig. 2.—Reducing inaccuracies due to changing battery voltage.

1 mA required for full-scale deflection. This varies from 0.5-0.2 mA., and remembering that the currents through two resistances in parallel are in inverse ratio to their value in ohms the respective values to by-pass (i) 0.5 and (ii) 0.2 mA are given by:—

$$\frac{R_m}{R_s} = \frac{I \text{ (shunt)}}{I_m}$$

$$\text{Therefore } R_s = \frac{R_m I_m}{I \text{ (shunt)}}$$

$$(i) R_s = \frac{100 \times 1}{0.5} = 200 \text{ ohms.}$$

$$(ii) R_s = \frac{100 \times 1}{.2} = 500 \text{ ohms.}$$

As it is not desired to work the battery below 1.2 volts, it is essential that the maximum value of the shunt must not exceed 500 ohms. With this condition satisfied, inability to reach zero indicates that the battery needs replacement. Suitable values for  $R_V$  and  $R_L$  would therefore be  $R_V = 0.300$  ohms, and  $R_L = 200$  ohms.

The next point is to ascertain the equivalent resistance values of the 100-ohm meter in parallel with the two limit-



**Ohmmeters—**

ing values of shunt resistance, just found to be 200 and 500 ohms respectively. From the usual formulae for resistances in parallel these two values are found to be 66.6 and 83.3 ohms. The mean figure of 75 ohms is therefore taken to minimise error.

Having decided upon 1,000 ohms as the total series resistance of the circuit in the first step above, the value of  $R_F$  is now obviously  $1,000 - 75 = 925$  ohms.

such a value that the resistance looking from A, B (Fig. 3;  $R_1$ ) is 100 ohms will now mean that half-scale deflection corresponds to 100 ohms. Similarly for 10 ohms half-scale ( $R_2$ ). The two values of shunt resistances required to give half-scale deflection on 100 and 10 ohms respectively can be found by the usual formulae for resistances in parallel. It is only necessary to find what two resistances in parallel with 1,000 ohms will give equivalent resistance values of 100 and 10

TABLE I.  
FUNDAMENTAL CIRCUIT VALUES (Fig. 2).

Meter Type.	$R_m$ : Meter Resistance (Internal).†	Battery Voltage.	Total Internal Series Resistance.*	$R_F$	$R_V$	$R_L$
0-500 $\mu$ A	200 ohms	1.5 V	2,000 ohms	1,850 ohms	0-600 ohms	400
0-1 mA	100 ohms	1.5 V	1,000 ohms	925 ohms	0-300 ohms	200
0-2 mA	50 ohms	3.0 V	1,000 ohms	962.5 ohms	0-150 ohms	100
0-5 mA	50 ohms	7.5 V	1,000 ohms	962.5 ohms	0-150 ohms	100

† If under this value, bring up to value specified by suitable series resistance.  
\* This corresponds to the fundamental half-scale reading.

Provided the above sequence is observed no difficulty should be encountered in finding values for any other similar type meter. Of course, the values just found and shown in Fig. 2 hold good for any 0-1 millimeter having a resistance of 100 ohms. A 0-1 millimeter having less resistance than this can obviously be used if an additional resistance is connected in series with the meter to bring the combined value to 100 ohms.

**Multi-range Ohmmeter**

The circuit of Fig. 2 can easily be provided with further ranges using the same scale by connecting shunts as shown in

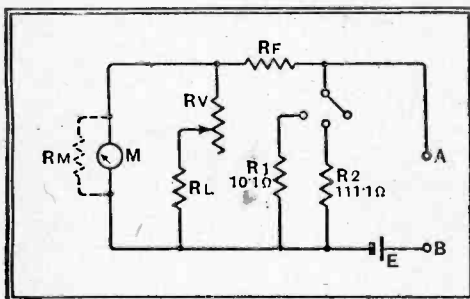

Fig. 3.—Adapting the basic arrangement of Fig. 2 to a multi-range ohmmeter.

Fig. 3. As the most accurate reading range of an ohmmeter is from 0.33 to 3.33 times the half-scale reading, it is advisable to make further ranges fall in the sequence  $\frac{1}{10}$ th,  $\frac{1}{100}$ th, of the fundamental range.

Taking the values shown in Fig. 2 for the 0-1 millimeter (resistance 100 ohms) under discussion, it has been shown that as the total internal resistance of the circuit is 1,000 ohms to better than  $\pm 1$  per cent., a resistance of 1,000 ohms connected between A and B will give half-scale deflection. Consequently, insertion of a shunt across the complete circuit of Fig. 2 of

ohms respectively. Values for this case are found to be 111.1 and 10.1 ohms.

The current drain on the battery is, of course, greater when working on these lower ranges, being 15-12 mA (maximum) on the 100-ohm range, and 150-120 mA (maximum) on the 10-ohm range. It is hardly practicable, therefore, to go lower than the 10-ohm half-scale range, and important to use the largest current capacity cell possible. For this reason care must be exercised when using the 10-ohm range to make the measurement as short as possible, and an immediate check made to see that the zero has not wandered during measurement. When the zero has been set on the 1,000-ohm range, it should still hold good to a fraction of an ohm on the two lower ranges. In the case of the 100-ohm range, the departure from zero is hardly discernible, but it is quite appreciable on the 10-ohm range. This need cause no error, however, being due mainly to the internal resistance of the battery, the resistance of the leads to AB playing a very small part. These should therefore be of large gauge copper wire. The switch used should also be a good pattern having low contact resistance. Readings on the 10-ohm scale should be taken as follows: Set the ohms zero on the 1,000-ohm range, switch over to the 10-ohm range, and without touching the zero adjuster ( $R_V$ ) note the residual circuit resistance. This should then be subtracted from any reading obtained on this range.

The circuit of Fig. 4 shows a four-range ohmmeter with values shown for the 100-ohm 0-1 millimeter discussed throughout. The 10-, 100- and 1,000-ohm half-scale ranges corresponding to the switch positions 1, 2 and 3 have already been dealt with, but the fourth range reading 10,000 ohms half-scale is arrived at as follows: It is known that the internal resistance of the circuit will have to be 10,000 ohms in order to obtain half-scale

deflection on 10,000 ohms connected externally. As the internal resistance of the circuit is already 1,000 ohms it is obvious that an additional 9,000 ohms series resistance is called for. Furthermore, as the circuit resistance has been increased ten times it is now necessary to use ten times the battery voltage. A separate 15V. battery is therefore switched in on this range. This only supplies 1.5 mA (max.) when in use, and can therefore use standard or midget-type cells if desired.

With an ohmmeter constituted as in Fig. 4 it is possible to measure from  $3\frac{1}{2}$ -33,000 ohms with a high degree of accuracy, from 2-100,000 ohms with fair accuracy, whilst the indicating range is from a fraction of an ohm to one megohm, and continuity is shown on resistances of 2 megohms and over. It will be noticed that no actual percentage accuracy figure has been mentioned. The order of accuracy of the completed instrument is dependent on a number of factors. These include accuracy of the meter itself, accuracy of the calibration, possible parallax errors, accuracy of the shunts, and correct setting of the zero. Provided the meter conforms to B.S.I. specification, the resistance values are correct, and the reading within  $\frac{1}{3}$ rd to 3.3 times the half-scale reading of the range in use, then (assuming correct calibration, and zero setting) the greatest possible error is of the

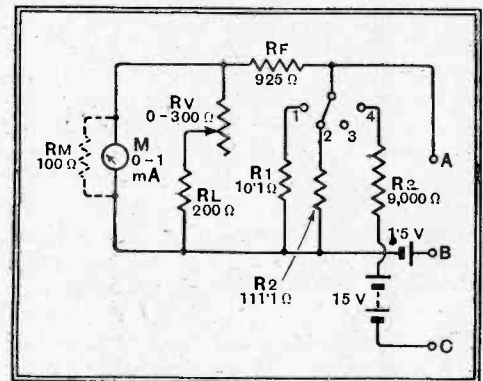

Fig. 4.—A practical 4-range ohmmeter with a working range of from 2 to 100,000 ohms. Values shown are for an 0-1 mA meter as discussed in the text.

order  $\pm 3$  per cent. on the 10,000-, 1,000- and 100-ohm ranges. In the case of the 10-ohm range, however, the resistance variation of the battery with load is another possible contributory factor to error, but with a triple capacity, or preferably larger cell, figures better than  $\pm 6$  per cent. should be obtained. These values are based, however, on maximum possible errors being of the same sign (positive or negative), but in actual practice accuracies better than these should be obtained. It is important to use the correct range as there is overlap of indicating range. The most accurate measuring limits of the several ranges are as follows: 10-ohm range,  $3\frac{1}{2}$ -33 ohms; 100-ohm range,  $33\frac{1}{3}$ rd-333 ohms; 1,000-ohm range, 333-3,333 ohms; and 10,000-ohm range, 3,333-33,333 ohms. When using the instrument on the 10,000-ohm range terminals B and C are used, terminals A and B being used on the other ranges.

**Ohmmeters—**

It is, of course, necessary for the resistances used in the instrument itself to be as accurate as possible, with  $\pm$  per cent. regarded as the maximum permissible error. If means are available for check-

would be well advised to leave the meter alone and tolerate the inconvenience of taking resistance readings from a graph or logged values in terms of the existing calibration.

Values are given in Table I and Table II

TABLE II.  
SHUNT VALUES FOR EXTRA RANGES.  
(Wing fundamental circuit values given in Table I.)

Meter Type.	R <sub>1</sub>	R <sub>2</sub>	R <sub>3</sub>	Additional Battery req. for R <sub>3</sub> Range.
0-500 $\mu$ A	20 ohms half-scale 20.2 ohms	200 ohms half-scale 222.2 ohms	20,000 $\Omega$ half-scale 18,000 ohms	15.0 V
0-1 mA	10 ohms half-scale 10.1 ohms	100 ohms half-scale 111.1 ohms	10,000 $\Omega$ half-scale 9,000 ohms	15.0 V
0-2 mA	Ditto	Ditto	Ditto	30.0 V
0-5 mA	Not practicable (See text)	Ditto	Not practicable (See text)	—

ing resistances to this accuracy, they can be easily made from Eureka resistance wire of convenient gauge, wound on midget hard wood bobbins or other suitable formers.

Calibration can be made by calculation if desired, but more accurate results will be obtained by actually calibrating against resistances which are known to close limits. A decade resistance box is, of course, invaluable for this purpose. It is only necessary to calibrate one range, preferably the fundamental 1,000- or 2,000-ohm range, readings on other ranges being  $\times 10$ ,  $\times \frac{1}{10}$ ,  $\times \frac{1}{100}$ , as the case may be. Slightly greater accuracy (approx. 0.5 per cent.) will result if the battery used for calibrating has fallen to 1.35 volts per cell.

**Direct Readings**

The simplest and most accurate method of making and fitting an ohmmeter scale is as follows: After setting the ohms zero control for exactly full-scale deflection on the existing scale, insert the known resistances, and note what the readings are in terms of this scale. When sufficient resistance values have been logged remove the meter movement from the case, and remove the scale, being careful not to damage the pointer. The meter movement, less scale, should be temporarily replaced in the case for safety. A piece of thin Bristol-board or ordinary postcard should then be cut so that it covers the upper part of the existing scale with a curved edge running parallel and flush with the upper curve of the existing scale. Before sticking in position with "Durofix" or similar adhesive, care should be taken to see that the pointer will not foul. When firmly stuck in position, the resistance readings in terms of the existing meter calibration can be easily and accurately marked with the aid of a mapping pen on the immediately adjacent blank ohms scale. It should be pointed out, however, that this operation calls for extremely delicate handling, and if any qualms are felt the reader

for four low-range milliammeters, and the meter resistance values given will usually be found greater than that of the model to hand. If this is the case, a resistance of suitable value should be connected in

series with the meter so that the combined resistance is equal to the value specified. All necessary values can then be read from Tables I and II. If any difficulty is experienced in obtaining the correct value rheostat for R<sub>v</sub> it is possible to use a component of greater value, and reduce the value of R<sub>L</sub> correspondingly. This will mean that the zero adjustment will not be spread over all this control for battery voltages from 1.5-1.2, and consequently the adjustment will be a little coarser. Alternatively, and preferably, a smaller control may be used, the value of R<sub>L</sub> being unchanged. In this case it will not be possible to work the battery down to 1.2 volts per cell, as inability to set to zero will be experienced before the voltage has dropped to this figure.

No shunt value is given for a 10-ohm range with the 0-5 mA meter as it would not be practicable to fit this range on account of the current drain being too great (0.75 amp. max.). As the 10,000-ohm range would require a voltage of 75, this has also been omitted. The current drawn on the 10-ohm range with the 2 mA meter is also high (0.3 amp. max.), and if it is not desired to use large cells capable of supplying this value the range should be omitted.

## Ferranti Model 1737

### A Superheterodyne with an Extended Audio-Frequency Range

SO far as the fundamental circuit of this receiver is concerned it is essentially the same as that of the "Arcadia" receiver reviewed in our issue of January 1st, 1937. In that report we commented on the extension of the bass response resulting from improvements in the low-frequency circuit and the employment of a freely suspended cone in the loud speaker.

In the new receiver a corresponding extension of the high tones has been effected, and the makers' claim of a  $2\frac{1}{2}$ -octave increase over that of the average set is, we think, a fair one.

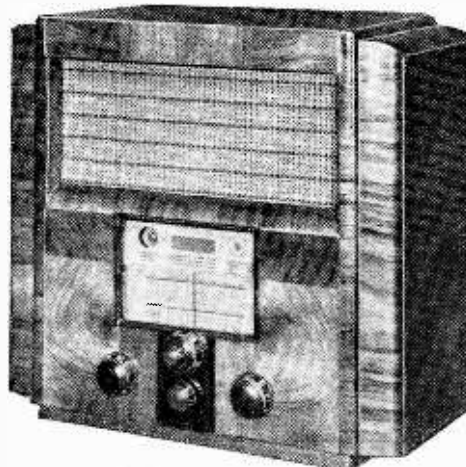

Many modifications directed to the improvement of quality reproduction are included in the new Ferranti Model 1737.

As in the "Arcadia" receiver variable selectivity is included, and while the high performance in the position of maximum

selectivity is maintained it is evident that an extension of the range of the control in the direction of wider audio-frequency response has been effected. Previously it was noted the change in quality resulting from manipulation of the "tone control" was more apparent on distant regional stations than on the local, but now the full range of the control is obtained on all stations irrespective of the strength of the incoming signal.

Other modifications which have been made in the receiver design are of a minor character, and include the substitution of a cathode-ray tuning indicator for the meter type used in the "Arcadia" receiver, AVC volts taken from the primary instead of the secondary of the output IF transformer, the elimination of the noise-suppression control at the back of the set, and the addition of a switch for cutting out the internal loud speaker if desired.

An improved form of "Magnascope" tuning dial is now fitted, and a colour-code type of waveband indicator takes the place of the pointer used in the "Arcadia" receiver. The new cabinet is sturdily reinforced inside, and has a horizontal loud-speaker grille behind which the loud speaker is offset. The price is 17 guineas, and a console model is available at 20 guineas.

### SMALL QUALITY AMPLIFIER

IT is regretted that an error occurred in the practical wiring diagram of this amplifier on page 440 of *The Wireless World* for November 4th, 1937. In this diagram the connections are shown correctly, but the bias resistance and its by-pass condenser for the 6F5 valve were lettered R<sub>1</sub>, C<sub>2</sub>, instead of R<sub>2</sub>, C<sub>1</sub>.

# Short-Wave Technique

## Transmissions on the Higher Frequencies and How to Receive Them

**B**EFORE attempting to discuss the various technical aspects of short-wave reception perhaps it would be advisable to fix our ideas as to what actually constitutes the useful portion of the short-wave band,<sup>1</sup> for in the broader sense it can be said to take in all wavelengths from 10 to about 200 metres.

Regarded in terms of frequency—for the short-wave listener and experimenter should cultivate the practice of thinking in frequency rather than in wavelength—this short-wave band is over twenty times wider than the medium and long broadcast wavebands put together.

Actually, broadcasting services occupy only a small portion of the short waves, and the principal stations are confined to a region bordered by 27 Mc/s and 6 Mc/s—11 metres and 50 metres respectively. This region is shared with many other services, but there are certain exclusive bands reserved solely for broadcasting. Nevertheless there is quite a lot of interesting short-wave transmissions to be found outside the limits mentioned, and in the design of a short-wave set consideration will have to be given to the actual requirements of the individual listener. If, for instance, broadcasting only is wanted, a set covering 6 to 27 Mc/s only would suffice. A coverage of 39 metres does not at first sight appear to be much and many might think that a single range would serve the purpose.

This, however, is a case where wavelengths can be misleading, for in frequency this represents a coverage of 21,000 kc/s, whereas on the medium broadcast waveband the frequency coverage is only 950 kc/s. Thus with a tuning scale divided into 100 divisions each would represent 9.5 kc/s change on the medium-wave band, but on the short-wave band it would represent 210 kc/s. Obviously, tuning would be extremely critical, for short-wave broadcasting stations are often separated by only 10 kc/s.

### Choosing Ranges

It would require twenty ranges to give the same "openness" of scale. As this is quite impractical a compromise must be found and in practice it is usual to fix the upper and lower limits of each short-wave range on the basis of a 1.5 or a 2 to 1 frequency ratio. Thus, the short-wave broadcasting band could be conveniently covered in three ranges, viz., 27 to 15 Mc/s, 16 to 8.9 Mc/s and 9 to 5 Mc/s—11 to 20, 18.7 to 33.8 and 33.4 to 60 metres respectively.

In a set intended to cover the whole band from 10 to 200 metres a slightly wider coverage might be tolerated, and with a

2.2 to 1 frequency ratio four ranges would carry the tuning from 30 Mc/s to 1.45 Mc/s, i.e., 10 metres to 206 metres.

A question that often arises in connection with short-wave reception is the relative merits of straight, or tuned radio frequency, and superheterodyne sets.

In the writer's opinion the usefulness of the TRF set is very limited, for while quite good sensitivity can be obtained it lacks the required selectivity to cope with the conditions prevailing now on the short waves. Selectivity quite comparable with that of the better-class broadcast receivers is now almost indispensable, and this cannot be achieved in the TRF set unless a very large number of tuned circuits is employed.

The selectivity question also enters into the design of the IF amplifier of a superheterodyne. High selectivity can be obtained with little complication at low radio frequencies, such as 110 kc/s, for example. On the other hand, it is advisable to choose a fairly high intermediate frequency in order to avoid "pulling" or

interaction between the oscillator and the signal circuits.

The frequency that provides the best compromise is probably 465 kc/s. It serves equally well for the short, the medium and the long waves, and so it has been standardised in the now popular all-wave type of set.

Six or eight tuned IF circuits are often used, yet the selectivity does not seem to be unduly high for short-wave reception though it generally entails some sacrifice in quality. Variable selectivity is thus a desirable feature in sets of this kind.

### Frequency Changers

The next point that arises concerns the frequency-changer. Before the triode hexode reached its present stage of development a two-valve frequency-changer comprising a mixing valve and a separate oscillator was the common practice on the short waves, but now there seems little to choose between the two schemes, since both are used in commercial sets and it is largely a question of cost versus convenience in layout.

The design of the oscillator circuit presents an interesting problem, for that which serves best on the short waves is not readily applicable on the ordinary broadcast wavelengths, nor can it be used with a standard-pattern gang condenser.

This is the Colpitts circuit shown in Fig. 1 (a) with a modified version in Fig. 1 (b). It is an efficient oscillator for all wavelengths down to and even below 5 metres, and the stray capacity across the oscillator circuit is exceptionally small. Its drawback is that ganging oscillator and signal circuits cannot be undertaken unless separate condensers are employed.

In an amateur experimenter's set there should not be any objection to the use of two tuning controls, one for the oscillator and one for all the signal circuits, though in an all-wave set intended for general use this idea would probably not meet with approval.

The familiar reaction-type oscillator such as is shown in Fig. 2 makes for easier ganging but the stray capacity across the tuned coil is rather high. With this circuit it is rarely possible to reduce the minimum capacity much below 70 m-mfds. On the higher frequencies the coil inductance becomes very small and the frequency coverage is restricted unless comparatively large tuning condensers are employed. Nevertheless, it is the circuit that finds favour in most of the commercial all-wave sets.

The experimenter contemplating building a set covering the short waves only might be well advised to consider the

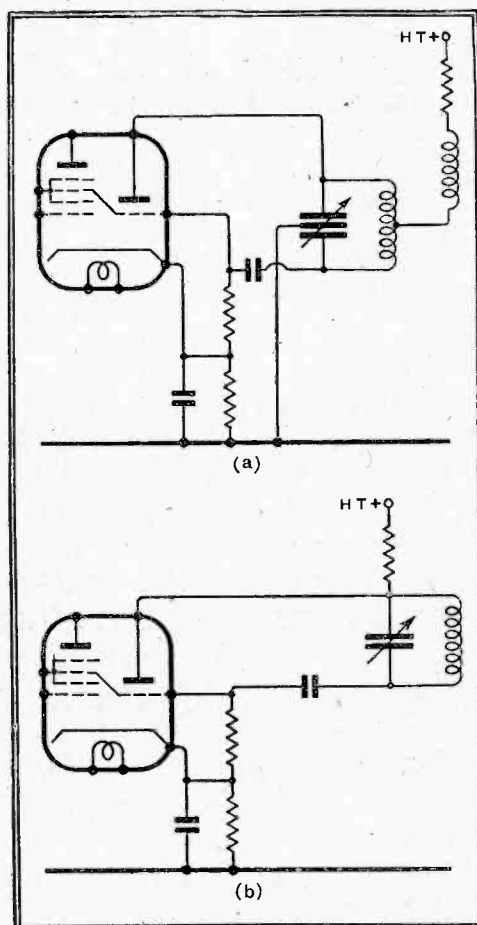

Fig. 1.—Typical short-wave oscillator circuit for frequency-changing. (a) Is the Colpitts circuit, whilst (b) is a modification that functions satisfactorily on wavelengths from 5 to about 100 metres.

**Short-Wave Technique—**

merits of the modified Colpitts oscillator of Fig. 1 (b). It permits the use of condensers of about 100 m-mfds, which is a convenient size for the short waves, and this size condenser is readily obtainable in single units with provision for ganging.

Though at times very good results are obtained from a set in which the input is applied to the frequency-changer, when conditions are such that very high sensitivity is needed the background noise may

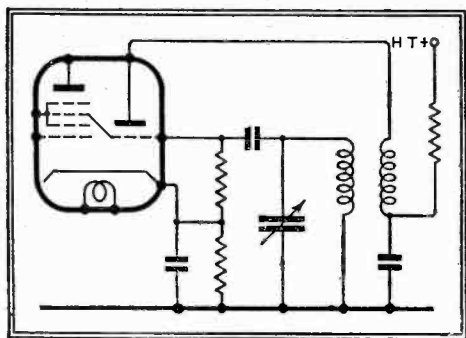

Fig. 2.—Conventional oscillator circuit for a frequency changer; it is generally adopted for all-wave sets.

become very obtrusive.<sup>3</sup> The frequency-changer is often responsible for a large percentage of the noise and one way of obtaining a better signal-to-noise ratio is to add a signal frequency RF stage and reduce the gain of the IF amplifier with or without a corresponding reduction in the audio amplification.

In order to prevent overloading the frequency-changer on very strong signals an RF volume control should be fitted and one for the IF amplifier is also desirable.

Signal frequency amplification serves also another useful purpose since it acts as a barrier to image signals and so reduces the number of repeat points at which any one station can be received.

This phenomenon is rarely encountered on the ordinary broadcast wavelengths, for if we take the case of a station on 250 metres—1,200 kc/s—and assume ganged circuits with the oscillator on the higher frequency beat, then an image signal could be produced by a station operating on 2,130 kc/s, i.e., twice the intermediate frequency away. This represents 77.5 per cent. off resonance.

**Image Signal Rejection**

Now, in the case of the short waves a 25-metre signal—12,000 kc/s would acquire an image signal on it from a station also 930 kc/s away, i.e., on 12,930 kc/s. But the percentage off tune is now only 7.75 as compared with 77.5 on the medium waveband.

As on the short waves a single tuned circuit connected to a valve in the orthodox way is not sufficiently selective to serve as an efficient barrier to a signal this amount off tune, it is obvious that on still higher frequencies—shorter wavelengths—where the percentage difference is actually smaller image signal interference may be very troublesome indeed.

The inclusion of an RF stage, which, of course, presupposes one more tuned circuit, therefore helps materially in suppressing this form of interference.

Too much stress cannot be placed on the need for a really good condenser drive on sets of this kind. It is, perhaps, of even more importance in the case of the all-wave set, which in the form it now takes is essentially a broadcast set with the addition of one or more short-wave ranges. Tuning condensers of the order of 0.0005 mfd. are often used so that short-wave tuning is naturally rather critical.

Various means have been evolved to simplify the tuning on the short waves, one such being described as band-spread. In its simplest form it consists of a small variable condenser joined in parallel with the main tuning condenser and provided with a separate scale. Sometimes condensers of the same capacity are used and the band-spread member joined across a portion only of the coil, the two arrangements being shown in Fig. 3.

A scheme that possesses unusual features is to incorporate a separate short-wave frequency-changer in a standard broadcast superheterodyne, but instead of tuning its circuits in the usual way its frequency is changed in steps and the normal tuning control on the broadcast portion of the receiver is then used to tune in the short-wave stations.

**Short Wave Converters**

The majority of the short-wave broadcast stations likely to be received on the average set are confined to seven principal sub-bands between 11 and 50 metres, and in the region of 11, 14, 17, 20, 25, 31 and 49 metres respectively, though there are, of course, others outside these areas. None of the sub-bands are much wider than about 500 kc/s and most are smaller. If the medium broadcast waveband is used as the tuning medium for, say, seven spot positions on the short-wave frequency-changer the necessary frequency coverage for each broadcast band is available without noticeable falling off in efficiency, and the tuning scale is, of course, much more "open" than with normal methods of tuning.

This idea is actually a variation of the well-known practice of adding a short-wave converter to an existing broadcast set.<sup>3</sup>

A unit of this kind is merely a short-wave frequency-changer and the broadcast set becomes its IF amplifier and audio stage. Sometimes they are made as self-contained units—that is to say, the power pack is also included. Converters can be used with any type of broadcast set, though in the case of straight, or TRF, sets at least one RF stage must be available.

With superheterodynes the addition of a converter necessitates a double change in frequency, first from the short waves to the frequency to which the input circuit of the broadcast set is tuned and then to that of the IF amplifier. Thus two oscillators are in operation and care has to be exer-

cised that these two do not produce beats. Beats can be produced not only between the fundamental frequencies of the two oscillators, but between their harmonics, and also between the harmonics of one and the fundamental of the other.

The last-mentioned is the most likely cause of trouble when a short-wave converter is employed.

Obviously, their frequencies should be as widely separated as possible, but other factors have also to be taken into account. Space does not permit a detailed treatment of this subject here and it must suffice to say that unless very special precautions are taken the input circuit of the broadcast set should not be tuned to a higher frequency than about 550 kc/s, i.e., 550 metres approximately.

**Communication Receivers**

Broadcasting is but one of the interests to be found on the short waves, the other is amateur experimental transmissions. Whilst a good all-wave set, or broadcast set plus converter, will provide the means for receiving amateur telephony transmission, the short-wave listener who proposes to take more than a passing interest in this aspect of radio will soon find that such sets, admirable as they are for short-wave reception, lack the refinements and flexibility required for this class of listening.

Amateur experimenters are permitted to operate transmitters on six wavebands at approximately 5, 10, 20, 40, 80 and 160 metre ones, which are the most used, wavebands and consequently are very crowded, especially the 20- and the 40-metre ones, which are the most used, though for long-distance communication during the winter months 10 metres is becoming a popular band.

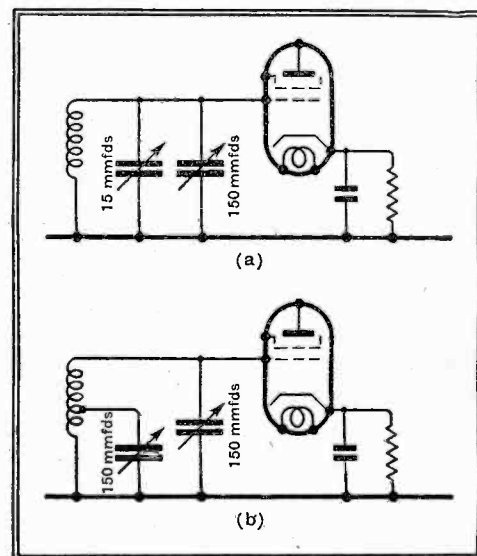

Fig. 3—Two systems of band-spread tuning. In (a) a small condenser is joined in parallel with the main tuning condenser, while in (b) condensers of the same capacity can be used and the band-spread member tapped across a few turns of the coil.

Of course, for telephony reception the degree of selectivity that can be employed is governed by the requirements of good intelligibility, but for CW work there is



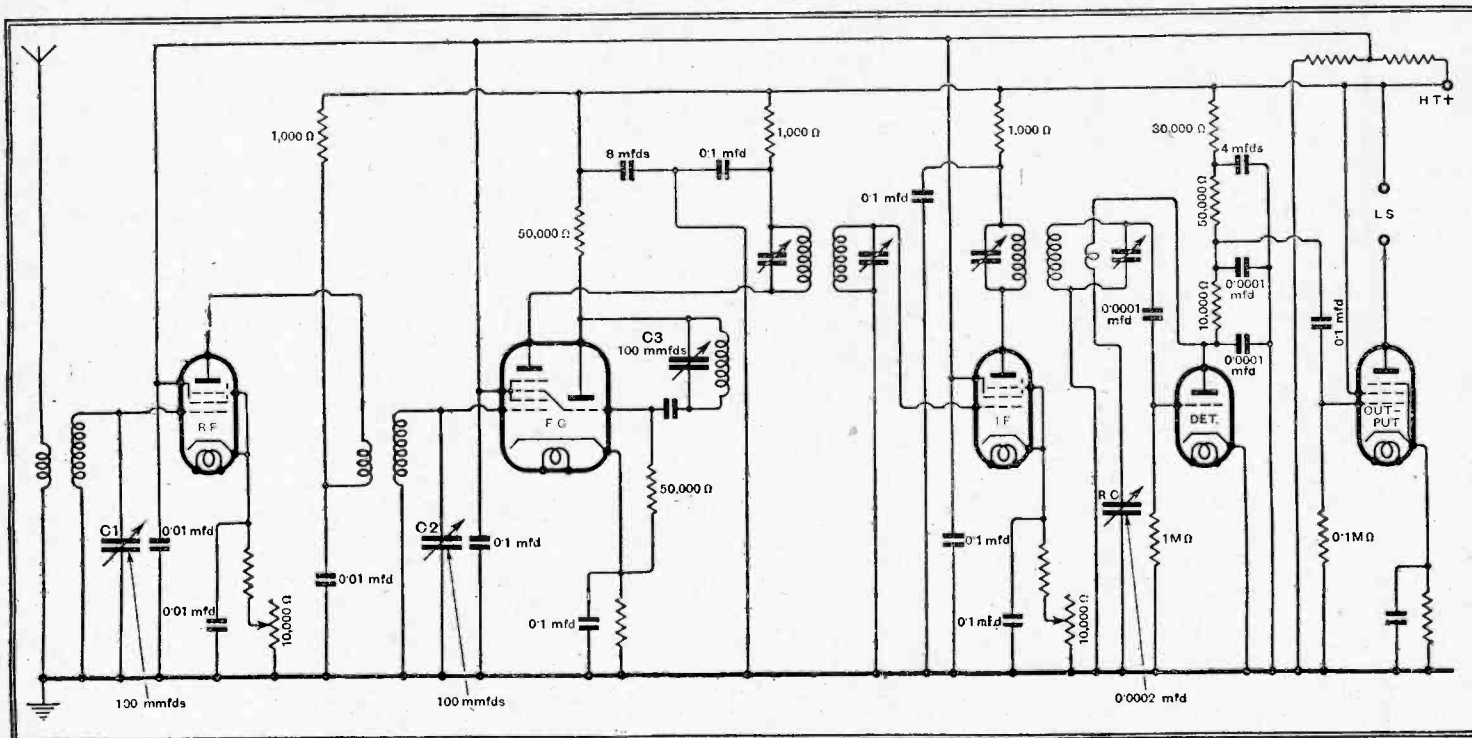

Fig. 4.—This circuit represents the simplest form of communication receiver likely to be of real use to the beginner. If space is allowed when building it a separate IF beat oscillator can be added later, also AVC might be included.

really no limit and a selectivity such that all frequencies higher than about 1,000 c/s are highly attenuated is quite permissible and indeed often employed by amateur workers. Sets embodying this feature are sometimes referred to as "single signal" receivers.

Another description met with in this class of work is "communication" receiver, and it may or may not be of the super-high selectivity kind—it merely signifies that the set is of the special type designed for communication work rather than for broadcast reception, though it will usually serve admirably for the latter purpose.

The main features of a communication set are high selectivity, generally controllable so that telephony or CW can be received with the minimum of interference, wide waverange usually extending up to 200 metres and sometimes including the medium broadcast band as well, a heterodyne beat oscillator, optional AVC, crystal gate giving very high selectivity for CW reception and, in some of the more up-to-date sets, a calibrated signal strength indicator which is described either as an "R" or as an "S" meter.

It is not unusual to find in this style of set the system of band-spread tuning mentioned in the earlier part of this article.

Whilst a set with this specification might be regarded as approaching the ideal for short-wave use it would be expensive to build and by no means easy to line up and adjust for correct operation on all wavebands. Many of the features can, however, be dispensed with, yet retaining the general idea of the communication receiver. For example, the circuit of Fig. 4 shows a comparatively simple arrangement that will serve quite well for general purpose use on the short waves.

Five valves only are used and it includes an RF stage. It will have moderately high selectivity despite the inclusion of only four IF circuits, for the provision of reaction will considerably sharpen the tuning. By increasing reaction until the second detector oscillates CW can be received.

Condensers C1 and C2, which tune the signal frequency circuits, can be ganged and small padding condensers joined across one or both of the circuits to equalise the stray capacities. The beginner would be well advised to use plug-in coils for a set of this kind as it simplifies the construction, and is, incidentally, cheaper. Any padding condensers neces-

sary can then be mounted on the coil formers.

It is also recommended that a separate tuning control be used for the oscillator, since correctly tracking this stage for single control on all wavebands is a tedious business. Plug-in coils and separate oscillator tuning makes the set far more flexible and enables slight modification to be introduced from time to time and new ideas tried out with the minimum of alteration.

REFERENCES

1. Which are the Short Waves?—*Wireless World*, Oct. 30th, 1936.
2. Inherent Receiver Noise.—*Wireless World*, Oct. 9th and 16th, 1936.
3. AC Short Wave Converter.—*Wireless World*, April 9th and 16th, 1937.

News from the Clubs

Southall Radio Society

Headquarters: Southall Library, Osterley Park Road, Southall.  
 Meetings: Tuesdays at 8.15 p.m.  
 Hon. Secretary: Mr. H. F. Reeve, 26, Green Drive, Southall.

A considerable number of members exhibited apparatus at a recent meeting which was devoted to a display of 56-megacycle gear.

Highlights among forthcoming lectures are "The Manufacture of Thermionic Valves," which will be given on November 30th by Mr. W. G. J. Nixon, of the Ostram Valve Technical Department, and "The Suppression of Electrical Interference with Radio Reception," which Mr. H. J. Walters, of the Belling & Lee technical staff will give on December 14th.

Croydon Radio Society

Headquarters: St. Peter's Hall, Ledbury Road, South Croydon.  
 Meetings: Tuesdays at 8 p.m.  
 Hon. Pub. Secretary: Mr. E. L. Cumbers, 14, Campden Road, South Croydon.

The recent pick-up night was a great success. Many of the models tested were commercial instruments which had been specially modified by their owners. After exhaustive tests first place was won by a crystal-type pick-up which had been designed regardless of cost,

and gave 98.5 per cent. correct tracking. Members are looking forward with keen interest to November 16th, when they will bring along their loud speakers for test and comparison.

Dollis Hill Radio Communication Society

Headquarters: Braintcroft Schools, Warren Road, London, N.W.2.  
 Meetings: Alternate Tuesdays at 8 p.m.  
 Hon. Sec.: Mr. J. R. Houghkyns, 102, Crest Road, Cricklewood, N.W.2.

The Society has now grown to such an extent that recently it was deemed advisable to hold a re-election of officers and committee. There are now between forty and fifty members. On November 23rd Mr. S. C. Ash (G6OV) will give a lantern lecture on X-rays and their uses.

Edgware Short-wave Society

Headquarters: 40, Raeburn Road, Edgware.  
 Meetings: Sundays at 11 a.m. and Wednesdays at 8 p.m.  
 Hon. Sec.: Mr. G. Yale, 40, Raeburn Road, Edgware.

Several field days have been arranged for the winter months, at which visitors will be welcomed. The club's meetings are being very well attended and the morse class is making good progress.

# Listeners' Guide for the Week

**R**EMEMBRANCE Day is again this year fittingly commemorated in the broadcast programmes, outstanding among the arrangements is the fact that for the first time the British Legion Festival of Empire and Remembrance is to be broadcast in its entirety.

In the morning, from 10.25, the music played by the Massed Guards' Bands and the Service at the Cenotaph, including the observance of the two minutes' silence, will be broadcast on all wavelengths. Howard Marshall will, from a room in the Ministry of Labour, describe the scene for listeners.

From 7.55 until 9.50, the British Legion Festival at the Albert Hall will be broadcast Nationally. The task of describing the almost indescribable scenes at this annual act of remembrance has been entrusted to F. H. Grisewood. The programme follows very much the lines of previous years, the first part ending with the singing of war-time choruses and "Land of Hope and Glory."

During the second part, which is of a more serious nature, that of remembrance, Major-General Sir Frederick Maurice, K.C.M.G., C.B., President of the British Legion, will read from Lawrence Binyon's "To the Fallen."

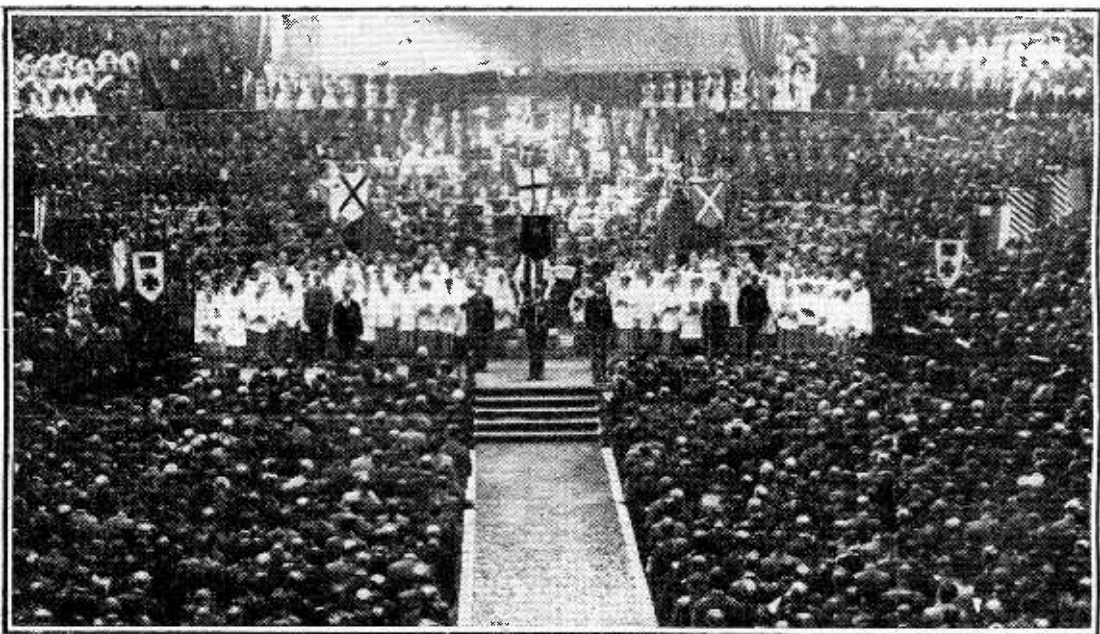

"WE SHALL REMEMBER THEM." The scene in the Albert Hall at the British Legion Festival immediately after the 1,104,890 poppy petals have been released from the roof. Each petal represents the life of a member of the British forces laid down in the Great War. The festival will be broadcast from 7.55

There is an alternative commemorative programme, to be radiated Regionally, from 8 till 8.50, compiled by E. A. Harding and Val Gielgud. It is a chronicle of events from the summer of 1914 to autumn, 1918.

All transmitters will close down at 10.20.

## BY ROYAL COMMAND

THE high spot of the winter's variety programmes comes to National listeners on Monday when the Royal Com-

mand Variety Performance to be given at the Palladium will be broadcast in its entirety from 8.5 to 10.50.

It is not since 1934 that even a part of a Command Performance has been broadcast, and permission has this year been granted on the B.B.C.'s payment to the Variety Artists' Benevolent Association of a sum variously estimated between £500-1,000.

For five minutes prior to the opening of the programme Thomas Woodroffe from a

position opposite the Royal Box will describe the scene in the crowded auditorium. As the bell rings to announce that Their Majesties are about to enter the theatre the switch will go over to a microphone on the staircase in the foyer where Mrs. Olga Collett will picture the entry of the Royal Party. As the King and Queen pass from her view Mr. Woodroffe will again take up the story until the playing of the National Anthem proclaims the presence of Their Majesties in the Royal Box.

John Watt, B.B.C. Director of Variety, will himself announce the acts from the wings. As the time between acts is, on an average, 12 seconds, only the briefest possible explanations of points which he may think need elucidating will be given.

## HAMPSTEAD HEATH

ALL the fun of the fair to be found on Hampstead Heath on a Bank Holiday is to form the setting of Archie Campbell's new Cockney revue, "Merry-Go-Round," which he will produce in the National programme on Friday at 8, and again Regionally on Saturday at 4. The cast includes Ronnie Hill and Billie Houston, John Rorke, Tessa Deane, Leon Cortez and Doreen Costello.

### THURSDAY, NOVEMBER 11th.

Nat., 10.25 a.m., Service of Remembrance from the Cenotaph. 7.55, Festival of Empire and Remembrance.

Reg., 6, Havana Nights: a Cuban "Cafe Collette." 8, In Memorium: a Chronicle of 1914-18.

#### Abroad.

Paris PTT, 8.30, "La Grand Voyage": French version of R. C. Sherriff's "Journey's End."

### FRIDAY, NOVEMBER 12th.

Nat., 6.45, Music from the Movies. 8, "Merry-Go-Round."

Reg., 6.40, From the London Theatre: extracts from "Wanted for Murder." 8, Discussion on Safety in Industry.

#### Abroad.

Prague, 6.30, "Mignon": Thomas' three-act opera.

### SATURDAY, NOVEMBER 13th.

Nat., 8, "Palace of Varieties." 9.35 Massed Guards' Bands from Alexandra Palace.

### HIGHLIGHTS OF THE WEEK

Reg., 4, "Merry-Go-Round." 7.30, Act I of "La Boheme" from the Empire Theatre, Liverpool.

#### Abroad.

Paris PTT, 8.45, Dukas' three-act opera, "Ariane et Barbe-Bleue."

### SUNDAY, NOVEMBER 14th.

Nat., 3, Eastbourne Municipal Orchestra. 6.30, World Theatre No. 2.

Reg., 6, The Military Band and Walter Widdop. 7, Orchestre Raymonde and Lilli Heinemann: opera music.

#### Abroad.

Brussels II, 8, Johann Strauss' operetta, "Die Fleidermaus."

### MONDAY, NOVEMBER 15th.

Nat., 9.5-10.50, Royal Command Performance. Reg., 8, Town and Country Planning. 9.30, "La Paloma": the story of the tragic life of the last Emperor of Mexico.

#### Abroad.

Radio Paris, 8.30, Gluck Festival, relayed from the Conservatoire.

### TUESDAY, NOVEMBER 16th.

Nat., 5, Relay from Amsterdam: the A.V.R.O. Light Orchestra.

7, Relay from Stockholm: "Ship Ahoy"—songs, shanties and waltzes. 9.20, From the Four Corners: the Solomon Islands.

Reg., 6.25, Pianoforte Recital: Stefan Askenase. 8.4, Edward German's opera, "Tom Jones."

#### Abroad.

Brussels I, 8, Purcell's three-act opera, "Dido and Aeneas."

### WEDNESDAY, NOVEMBER 17th

Nat., 7, Edward German's "Tom Jones." 8.15, Fifth Symphony

Concert from the Queen's Hall. Reg., 8.15, Excerpt from "Crazy Days." 9, Relay from the Lyceum Theatre, Sheffield.

#### Abroad.

Strasbourg, 8.30, The Evolution of Jazz: from the Quadrille to the Rumba.

**"SPLINTERS"**

THIS week's production of Palace of Varieties on Saturday at 8 (Nat.) fittingly includes the famous war-time entertainers, "Splinters" (Les Rouges et Noirs), presented by Lew Lake, Junior, with Hal Jones, one of the original members of the party, in the cast.

**"DEATH OF A FIRST MATE"**

THE play of this title which will be heard Regionally on Saturday at 9 is an account of the highly sensational happenings aboard a coastal steamer, on a round trip from Sunderland to Cork and back. It is adapted by J. Inglis from Charles Barry's novel, and in spite of its highly melodramatic nature, the plot has an air of perfect authenticity which may be explained by the fact that the author of the novel has travelled extensively.

**OPERA FROM ABOARD**

OSLO announces Boieldieu's "White Lady" (La dame blanche) for its 7.30 transmission—an opera particularly pleasing to English and Scottish audiences, as the scene is laid in Scotland. The composer has incorporated "Robin Adair" in the overture. Prague, in its relay of the State Opera programme at 6.30 the same evening, gives a French opera, Thomas' "Mignon," instead of the almost invariably national theme one hears from this station.

So many important performances will be heard on the air on Saturday that it will be difficult for the listener of taste to make a choice. Hilversum I and Paris PTT both relay public performances. The Dutch station at 6.50 gives Richard Strauss' "Rosenkavalier" from the Municipal

Theatre, Amsterdam, where the Wagner Association and the Concertgebouw Orchestra are responsible for the more solid part of the production. The French station at 8.45 gives us the pleasure of hearing again Dukas' "Ariane et Barbe-Bleue" (Ariadne and Bluebeard) from the Opéra.

Works of the great German composer Christoph Willibald Ritter von Gluck will be heard from many European stations in commemoration of the 150th anniversary of his death. On Monday (Nov. 15th) the actual anniversary, Deutschlandsender will broadcast Wagner's adaptation of his opera "Iphigenie in Aulis" at 7. His works will also be heard on the same evening from Hamburg at 7, Stuttgart and Frankfurt at 8.15—the latter giving excerpts from "Orpheus and Eurydice"—and Radio Paris at 8.30. THE AUDITOR.

which was chronicled in these columns a few weeks ago.

Fletcher and his opposite numbers in Germany found that they shared many problems. More recording is carried out in the Fatherland than here, and for this very reason, perhaps, the Germans have found high-speed cutting methods less necessary than the B.B.C.

**Record Exchanges**

Both the Deutschland Rundfunk and the B.B.C. are anxious to build up record libraries designed to present a cross-section of contemporary life. Officials in Berlin are now hunting up records of occasions like Herr Hitler's first broadcast to present to the B.B.C. in exchange for Coronation recordings and similar high spots.

Other countries are interested in the idea, and if they can not all exchange records, a European Recordings Exchange may be formed—run perhaps by the International Broadcasting Union—which would enable any country to obtain at short notice other countries' important broadcasts of the past.

# Broadcast Brevities

**NEWS FROM PORTLAND PLACE****B.B.C. Reception in Europe**

**"EXILED"** English listeners on the Continent, although not contributing to the B.B.C. coffers, are not forgotten in Portland Place.

Recently the engineers have been assessing the possibilities of good reception of British programmes in Western Europe.

Main deduction is that beyond about 400 miles from Droitwich it is far, far better to try for Daventry short-wave. Within that distance entertainment value should be got from the long-wave National and from one or more of the medium-wave Regionals, always assuming a good modern receiver is available with a reasonable aerial system.

**After Dark**

Daventry can be a real solace to the homesick in places like Cologne and Luxembourg and beyond, especially after tea-time, when Transmission 4 begins. Before then the Daventry wavelengths are rather short for European reception.

Assuming absence of local interference and a low noise level, Droitwich can be heard satisfactorily in daytime up to a distance of 700 miles with a high aerial.

After dark, on lucky nights with little static, Droitwich is audible up to 1,000 miles.

Daytime reception of the medium waves can be reckoned on up to 200 or more miles.

B.B.C. engineers contend that

the medium waves are more dependable than the long after dark and that the average amount of interference is less, though at times a little more slow fading must be tolerated.

So much for European reception. When Daventry begins its "foreign" service next year, a more general survey may be necessary, which would involve mapping the whole world on a signal-strength basis.

A score of "Tatsfields" dotted about the earth's surface would ensure that there were no unsuspected blind spots.

**Return of the Native**

**RECORDINGS**, as well as broadcast programmes, may soon be exchanged by the countries of Europe. This is the view of H. L. Fletcher, Recorded Programmes Executive of the B.B.C., who has just returned from his Berlin visit,

**All Dressed Up . . .**

THE people most deserving of sympathy when the television station breaks down—and this happens surprisingly seldom, all things considered—are the artistes, all dressed up and nothing to do. And they are likewise all keyed up, but have to relax while the minutes tick by. Not even the thought that they suffer in no wise financially, and that they will be given another "date," quite atones for the disappointment.

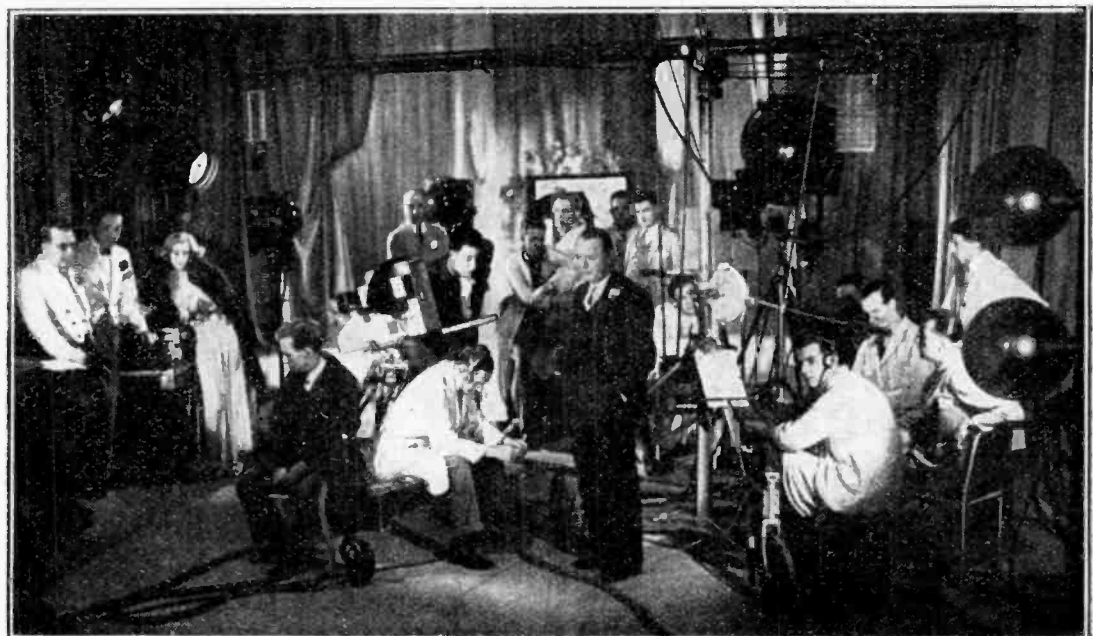

**BREAKDOWN AT A.P.** Artistes, producers and cameramen standing around, during a recent breakdown of the vision apparatus, patiently waiting for the "all clear." The fault, however, was not traced and the afternoon's programme was included with that for the evening. In the centre of the picture is Hyam Greenbaum, the conductor of the Television Orchestra.

# Auditorium Acoustics

## PART III.—THE MEASUREMENT OF REVERBERATION TIME

**R**EVERBERATION time, as described previously, is the time a sound in an auditorium takes to decay to one millionth of its original value. This may alternatively be expressed as a decay of 60 db, i.e., from average loudness to inaudibility. Although a certain amount of guidance as to the reverberation time may be obtained by calculation, as stated in the previous article, it is always highly desirable to take practical measurements of the reverberation time in the auditorium itself. These practical measurements are usually variations of one of the three following methods: (a) blown organ pipe and stopwatch, (b) chronograph reverberation meter, and (c) oscillograph reverberation meter.

The first method is of a rough and ready nature, and consists usually of blowing by mouth a miniature organ pipe held in the hand, then suddenly stopping the supply of air whilst simultaneously starting a stopwatch. As the air is stopped the sound from the organ pipe ceases and the sound remaining in the auditorium decays according to its absorptive characteristics. When the sound becomes just inaudible the stopwatch is stopped and the recorded time is taken as the reverberation time. The method suffers from several disadvantages, including the fact that the original loudness varies with the size of auditorium and the point of audibility varies according to the amount of background noise present.

W. C. Sabine, the father of modern acoustics, used this method in his classic experiments, but he used a constant pressure of air to blow the organ pipes.

*THE calculation of reverberation time was dealt with in the previous article in this series, and the author now describes practical methods of measurement and the interpretation of the results obtained.*

By D. B. FOSTER, M.Sc., Ph.D.

The miniature organ pipe and stopwatch method is very portable and quick, but most serious work nowadays is carried out with electrical reverberation meters. Organ pipe measurements can be carried out up to 2,000 c/s, but reverberation meters enable this top limit to be extended up to 10,000 c/s, and any exact intermediate frequency can be explored if it is suspected that resonances are influencing the acoustics at such intermediate points.

### The Spark Chronograph

Electrical reverberation meters are of two kinds, depending on whether the results are expressed directly in terms of the reverberation time or whether in the form of the decay waveform from which the reverberation time may be deduced. Of the two methods the latter has the advantage that the waveform enables other acoustical factors such as echo and flutter to be studied.

There are several variations of the chronograph method, and the essential layout of one, known as the spark chronograph method, is shown in Fig. 9.

A loud speaker LS is located in the auditorium in the normal position of the speaker or orchestra and is supplied with a single frequency pure tone from an oscillator O. A recording drum D driven from a constant speed motor M possesses a cam which closes a pair of contacts S1

in the oscillator circuit. When the cam rotates so that the contacts open, the loud speaker is cut off and the sound in the auditorium begins to decay. Also located in the auditorium, in the position of a typical listener, is a microphone mounted at the end of a long rotating arm to reduce standing wave effects, and this is fed to an amplifier A, potentiometer P and rectifier R. The output of the rectifier passes through the coil of a sensitive relay G whose contacts S2 operate a spark discharge circuit consisting of the battery B, condenser C and ignition coil L. The spark gap of this circuit is between the needle point N and the recording drum which is fitted with a sheet of sensitised paper to leave a mark when a spark passes through it. Consequently, when the sound in the auditorium falls below a certain level the rectified current from the microphone is insufficient to hold the relay contacts apart and they close, causing a spark to be recorded on the rotating drum.

The procedure for the measurement of reverberation time is as follows: With the recording drum stopped with the cam contacts together the sound from the loud speaker is adjusted to the maximum free from harmonics. The potentiometer in the microphone circuit is reduced until the relay is just at its closing point where it would cause a spark to record. The potentiometer is then increased by 60 db so that the current through the relay would have to fall by 60 db to cause a spark on the recording drum. The drum is then set in motion, and when the spark point is opposite the zero time line the cam-operated contacts open and the loud speaker is cut off. The sound in the auditorium begins to decay and eventually reaches an intensity 60 db below the original intensity. The microphone current falls by a like amount so that the relay contacts close and a spark is recorded on the drum. The time represented by the travel of the drum from the zero time line to the spark mark is the reverberation time.

In practice it is not usual to measure the reverberation time as a single 60 db drop, but to take a series of measurements every 6 db, from 6 db. to 60 db. by corresponding settings of the microphone circuit potentiometer. The spark point is moved across the drum as the steps are

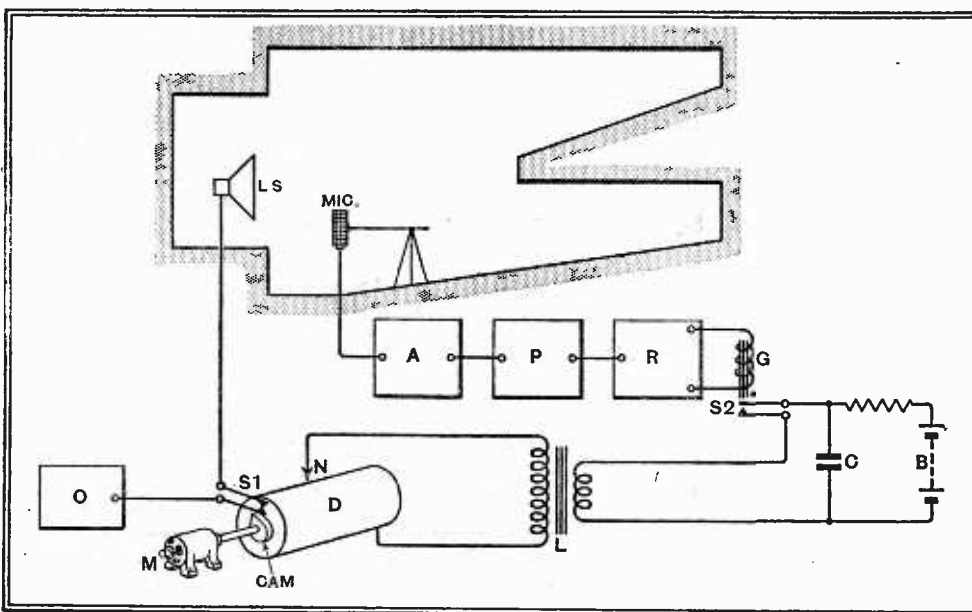

Fig. 9.—Schematic layout of spark chronograph method of measuring reverberation time.



**Auditorium Acoustics—**

varied and a typical record is as shown in Fig. 10. It is usual to take 10 to 20 recordings at the same decay setting, and a certain amount of spread occurs partly

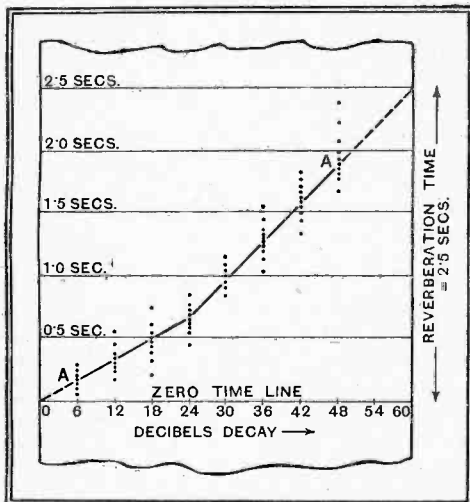

Fig. 10.—Sample record from the spark chronograph.

due to standing wave variations as the loud speaker is cut off at a different phase in the cycle. In order to determine the nominal reverberation time a mean line is drawn through the spread of points as AA in Fig. 10. Due to considerations of background noise it is often difficult to obtain reliable measurements with



Western Electric spark chronograph reverberation meter.

greater decays than 40-50 db., and so the curve has to be extrapolated as the dotted line in Fig. 10 until it intersects the 60 db. axis.

Instead of employing a microphone rotating on about a 12ft. diameter to reduce standing wave interference effects, use may be made of a stationary microphone and the wave pattern may be varied by "warbling" the oscillator by means of a small rotating condenser in parallel with the main tuning condenser. This method is inferior as it prevents measurements being made at exact frequencies.

period to the point where the record crosses the 60 db. axis. In the record shown the sound actually rises after its first decay showing the presence of echo, since the time exceeds 0.06 seconds.

As with the chronograph method, successive records will vary to a certain extent, and it is necessary to average the results or the oscillo-

The alternative method of measuring reverberation time is that using oscillograph records. The sound is again produced by a loud speaker fed from an oscillator and it is picked up by a rotating microphone which feeds a logarithmic amplifier, rectifier and recording oscillograph. The purpose of the logarithmic amplifier is to provide a linear intensity scale in decibels. Contacts are so arranged that the time base of the recording oscillograph cuts off the loud speaker and the decay characteristics of the sound may be photographically recorded.

**Oscillographic Methods**

The ideal decay characteristics of an auditorium according to the reverberation mathematics would be logarithmic as shown in Fig. 11(a), but a typical result obtained in practice would be more like Fig. 11(b). From this latter figure it will be seen that for a short time the sound does not decay at all and this sustained period is due to the time taken for the remainder of the direct ray to reach the microphone from the loud speaker after the cut-off. The reverberation time should be measured from the end of this

graph can be arranged for continuous superimposed recording from which to strike a graphical mean.

Having obtained the reverberation characteristics with either chronograph or oscillograph method with one particular placing of the microphone, other placings must be tried, and it is customary to find wide variations in reverberation time. In order to overcome this difficulty as many as six microphones have been distributed over an auditorium and used simultaneously to obtain an average figure. It is, however, difficult to see any great advantage to be gained in producing an average figure when, in fact, the reverberation time value for an auditorium is not a very uniform figure except when related to one particular arrangement of speaking and listening.

Two other typical decay curves obtained by recording reverberation meters are shown in Figs. 11(c) and (d). In the first diagram it will be seen that the decay commences slowly and then suddenly speeds up, whilst in the next diagram the reverse takes place. Both these characteristics are known as double decay rates, and the majority of decay recordings are of this nature and are due to uneven distribution of absorption over the surfaces of the auditorium. The first type occurs when the microphone is located in a relatively live or reverberant part of the auditorium, since the local sound takes a long time to decay, but when it has done so the second part of the decay is rapid, since very little sound comes in to sustain the decay from the dead parts of the auditorium, where a more rapid initial decay has taken place.

In the second case the microphone is located in the relatively dead part of the auditorium and the local sound first decays rapidly, but is later reinforced by sound arriving from the overhang in the live part of the auditorium. These two types of double decay exist simultaneously in such an auditorium and the

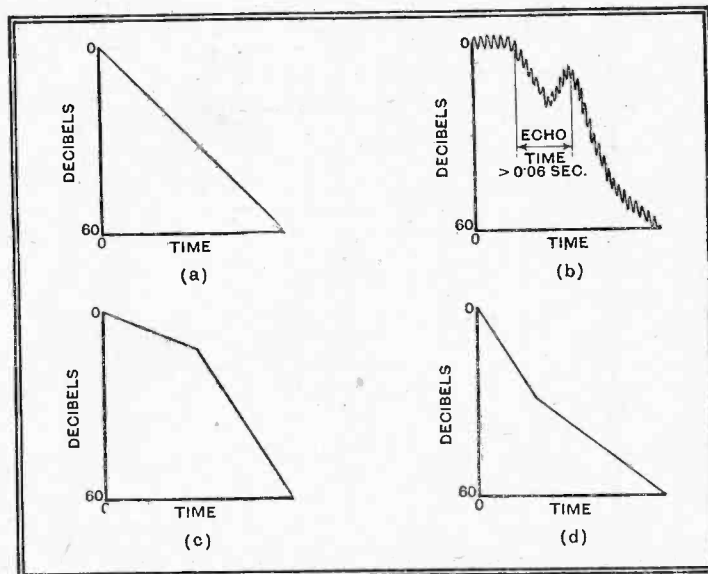

Fig. 11.—Typical oscillograph records of auditorium sound decay characteristics. (a) Ideal logarithmic decay; (b) Record showing presence of echo; (c) and (d) double decay rates due to the uneven distribution of absorption over the surfaces of the auditorium.

**Auditorium Acoustics—**

microphone placing will determine the one which will be obtained.

It is interesting to note that the reverberation time of the Queen's Hall can be measured by means of a radio set during an actual B.B.C. broadcast with the aid of a little extra apparatus. The output of a radio set, after passing through a rectifier, should operate a logarithmic recording oscillograph which should be set in operation just before a single sharp

piano chord is expected from a knowledge of the musical score. The sound decay would thus be recorded and the reverberation time could be scaled off. The reverberation time could be obtained on a frequency basis by the use of suitable electrical filter circuits. It would be important, of course, to select an isolated chord of damped characteristics so that the vibration decay of the musical instrument was short compared with the reverberation time of the auditorium.

—In Next Week's Issue—

## Two-RF Straight Set

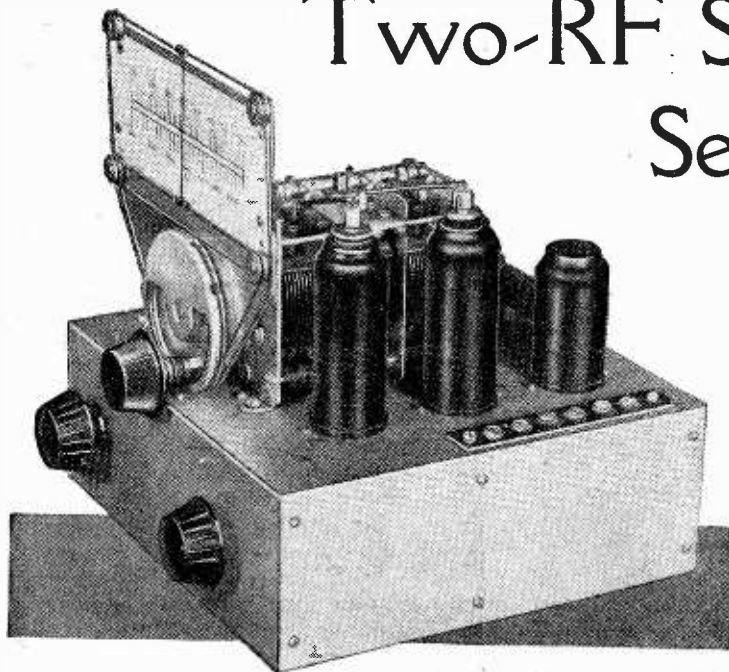

A  
Receiver  
for the  
Small  
Quality  
Amplifier

**M**OST people employ a receiver chiefly for local reception, but wish to be able to receive a number of the more powerful Continental transmissions when the local programmes are not to their taste. The performance necessary for this is not particularly exacting, and a moderate degree of sensitivity and selectivity will suffice.

The receiver to be described next week is designed for use with the Small Quality Amplifier and includes Octal-base type valves. There are two RF stages with three tuned circuits and a diode detector which also provides AVC. The medium and long wavebands are covered and provision is made for the use of a gramophone pick-up.

### LIST OF PARTS

Certain components of other makes but of similar characteristics may be used as alternatives to those given in the following list.

- |   |                           |
|---|---------------------------|
| 1 Variable condenser, 3-gang, 0.0005 mfd. | Polar Bar Type            |
| 1 Dial                                    | Polar VP Horizontal Drive |
| Fixed Condensers:                         |                           |
| 1 0.0001 mfd., mica                       | T.C.C. "M"                |
| 1 0.0005 mfd., mica                       | T.C.C. "M"                |
| 1 0.01 mfd., tubular                      | T.C.C. 250                |
| 1 0.05 mfd., tubular                      | T.C.C. 250                |
| 4 0.1 mfd., tubular                       | T.C.C. 250                |

### Resistances:

- |   |  |
|---|--|
| 1 250 ohms, $\frac{1}{2}$ watt                            | Erie   |
| 1 1,200 ohms, $\frac{1}{2}$ watt                          | Erie   |
| 1 20,000 ohms, $\frac{1}{2}$ watt                         | Erie   |
| 1 2 megohms, $\frac{1}{2}$ watt                           | Erie   |
| 1 3,000 ohms, 20 watts                                    | Bulgin PR8   |
| 1 7,500 ohms, 20 watts                                    | Bulgin PR10  |
| 1 10,000 ohms, 20 watts                                   | Bulgin PR11  |
| 1 Volume control, tapered, 0.25 megohm                    | Ferranti PG  |
| 2 RF transformers, MW                                     | Wearite PHF?   |
| 2 RF transformers, LW                                     | Wearite PHF1   |
| 1 Aerial coil, MW   | Wearite PA3  |
| 1 Aerial coil, LW   | Wearite PA1  |
| 1 Switch assembly, 4-pole, 3-way                          | B.T.S. C423  |
| 1 Coupler for $\frac{1}{4}$ in shafts                     | Bulgin   |
| 1 Length rod, 7 in. $\times$ $\frac{1}{4}$ in. dia.       | Bulgin   |
| 1 Panel bush, $\frac{1}{4}$ in.                           | Bulgin 1048  |
| 3 Valve holders, octal type                               | Premier Supply Stores  |
| 1 Skeleton captive screw strip, 2-way, "PU"               | Bulgin T10   |
| 1 Skeleton captive screw strip, 2-way, "AE"               | Bulgin T10   |
| 1 Skeleton captive screw strip, 6-way                     | Bulgin T12   |
| 2 Valve top clips, octal type                             | Bulgin T96   |
| 2 Knobs   | Bulgin K.24  |
| Chassis   | B.T.S.   |
| Miscellaneous:  | Peto-Scott   |
| 3 lengths systoflex; 2oz. No. 20 tinned copper wire, etc. | Screws: 40 $\frac{1}{4}$ in. 6 BA R/hd.; 6 $\frac{1}{2}$ in. 4 BA R/hd.; 4 in. 4 BA R/hd.; 4 $\frac{1}{2}$ in. 4 BA R/hd. all with nuts and washers. |
| Valves:   | 1 6K7MG, 1 6J7MG, 1 6H6MG.   |

Premier Supply Stores

## Communication Receivers

Sets Designed Especially for Amateur Experimenters

**A**MATEUR experimenters in search of a good communication receiver may be interested to learn that Webb's Radio, 14, Soho Street, Oxford Street, London, W.1, have a representative selection of some of the better-known American sets of this kind.

Prices vary according to the specification, and they range from £9 to about £60.

The majority of the sets costing more than £25 are equipped with crystal gate filters giving super-high selectivity for CW reception.

The cheaper models do not, as a rule, cover the 10-metre amateur band, the Halli-crafter Sky Chief, for example, which is a seven-valve superhet and costs £12 10s., has a tuning range of 18 to 550 metres. It includes an RF stage, a beat oscillator, AVC and a signal-strength meter among other features.

The Sky Challenger made by the same firm, on the other hand, gives continuous tuning from 7.5 metres to 560 metres. A large dial directly calibrated in kc/s. is fitted, iron-cored coils are used, band-spread is included, and it can be supplied with or without a crystal gate. With the last-mentioned refinement the price is £25.

One of the most interesting of the sets is, perhaps, the RME 69, an eight-valve single-signal superhet embodying an RF stage, a separate oscillator, two IF stages, beat-frequency oscillator, signal-strength meter and many other valuable features. A crystal gate in the IF amplifier can be switched in or out as required.

This set has six ranges giving continuous tuning from 9 to 550 metres. Electrical band-spread with separate calibrated dial is included, and the price is £39 15s., or fitted with a noise silencer £43 10s. There is available for use with this receiver a two-stage RF amplifier which is designed to feed into the main set at the optimum input impedance. With this unit connected to the set five tuned circuits at signal frequency and three RF stages are available, giving a signal-to-image ratio of about 20,000 to 1.

The additional signal amplification is in the region of 20 db. It includes its own power supply unit, and is described as the DB-20 Signal Intensifier. It costs £12 10s.

**Sound Recording for Films.** By W. F. Elliott. Pp. 134. 3 diagrams and 11 plates. Published by Sir Isaac Pitman and Sons, Ltd., 39, Parker Street, London, W.C.2. Price 10s. 6d.

**A**FTER an introductory chapter on the history of photographic sound recording and another on the principal characteristics of the variable density and variable area systems, the author reaches the main purpose of his work, which is to outline the duties and responsibilities of the "recorder" in the studio. Starting with the sound script the whole range of production technique—microphone placing, orchestral balance, level continuity, perspective, etc.—is exhaustively treated, and there is much to stimulate thought and to show that sound is an integral part and not a mere accompaniment of the modern film. The book is well illustrated by "stills" taken from recent documentary and dramatic films.

# “Q” A USEFUL MEASURE OF “GOODNESS”

By “CATHODE RAY”

**I**F you were to ask the next person you met what idea “Q” conveyed to him he would probably say “queer.” That may be the sole or main impression created by the appearance of this letter standing on its lonesome in technical literature. I have no idea who first used it in connection with wireless components, or how it started. It has yet to be admitted to the official list of symbols of the British Standards Institution, which probably regards it as a vulgar Americanism. But it is accepted by all the most reputable authorities over there, and by many of them here; and it is fully justified by its usefulness. So, as it is likely to make increasingly frequent appearances in technical advertisements, catalogues, books and articles, a few words on the subject may help to remove some of the queerness.

To eliminate a possible misunderstanding at the start, I must mention that this Q has nothing to do with the “Q” that is an abbreviation of an abbreviation<sup>1</sup> of “Quiet Automatic Volume Control,” and is used colloquially to refer to any muting or background-silencing system in receivers; but is a symbol, like R for resistance or I for current (historically derived from “Intensity”). The thing it stands for really ought to have been represented by a Greek letter in accordance with recommended practice, because it is not a quantity on its own as the two just mentioned, but, like  $\mu$  or  $\pi$ , is the ratio of two quantities. It is too late to think about that now, however.

Q is the ratio of reactance to resistance. That statement may or may not arouse enthusiasm in the breast of the reader. Probably not. It is more interestingly described as a measure of the “goodness”

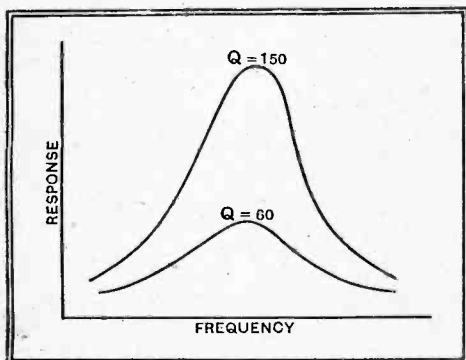

Fig. 1.—Q is a measure of the height and sharpness of a tuning response curve.

of certain components. Even some who know quite a lot about it would have said “coils” instead of “certain components.” But I have deliberately refrained from tying it down exclusively to coils, for one

<sup>1</sup> “Q.A.V.C.”

misses a large part of the advantage of the idea by doing so. However, now that is clear, let us consider a coil as a particular example.

What are the possible ways of comparing a coil offered by Messrs. A., Ltd., with something of the sort by Messrs. B., Ltd.? The size, shape and the number of turns are the more obvious attributes, but the single quantity *inductance* (L) sums up the more directly useful result of these various dimensions. But of the many possible different coils having the same L and therefore serving to tune to a given frequency, which is the best?

### Basis of Comparison

The radio-frequency resistance  $r$  may be said to decide this. The lower the resistance the more selective is the tuned circuit of which the coil forms a part, and the greater the amplification obtainable when in tune. Generally, we want as much as possible of both of these quantities, so would choose the coil with the lowest  $r$ ; but for some purposes—e.g., television—there is such a thing as too much selectivity, and then it is necessary to work out the right  $r$  for the particular job.

This specification may seem quite a good one, but what about coils that do not happen to be of the same inductance? It is not necessary for them to be, even for tuning to the same frequency; the capacity can be adjusted to do that. And what about coils intended for quite different frequencies? Is a 20-ohm coil a good one or a bad one? I don't know. Nor does anybody else, unless he happens to know both the inductance and the frequency (or wavelength). Depending on these, 20 ohms might represent an extremely flat, unselective coil, or an exceptionally efficient one. To decide which it is necessary to know  $r$ , L and  $f$ . Now, which is the more selective coil, No. 1 of 20 ohms and 800 microhenrys at 600 kc/s (500 metres) or No. 2 of 15 ohms and 95 microhenrys at 1,500 kc/s (200 metres)? Even a competent radio engineer, unless he is also a lightning calculator fit for any music-hall stage, must do a bit of slide-rule shoving before he can say with confidence that No. 1 (with the higher resistance, please note) is just  $2\frac{1}{2}$  times as good as No. 2, goodness being reckoned in selectivity and sensitivity (Fig. 1).

The drawbacks of the foregoing system of specification are that *three* quantities must be quoted for each item; that until calculation of a rather more than mental order has been carried out one is not very much farther towards making a quick comparison; and—another snag—the quantity  $r$  does not stay put, but alters very largely according to  $f$ . Still another

disadvantage is that the quantities mentioned cover only one element—the coil—of those that go to make up a tuned circuit.

What the man with the slide-rule does with the above data is to work out  $\frac{2\pi fL}{r}$ .

The top part of this expression is the reactance of the coil at that particular frequency, so the whole thing is the ratio of reactance to resistance, or what we now know as Q. What is more to the point is that this is the number of volts (or microvolts, etc.) that are developed across the coil at resonance when one volt (or microvolt, etc.) is injected into it (Fig. 2). For this reason it is often called the *magnification* of the coil. But again, it must not be forgotten that there are other things that go to make up a tuned circuit and have some say in the result.

Suppose our coil is used in connection with a tuning condenser and valve which themselves contribute no losses, and that a signal of 200 microvolts arrives from an aerial. No. 1 coil, just specified, has a

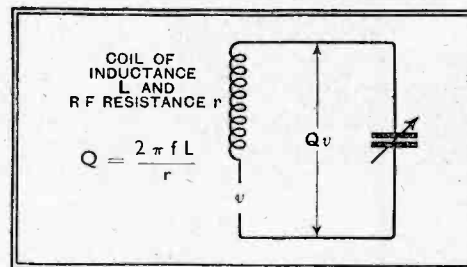

Fig. 2.—If a certain signal voltage  $v$  is injected or induced into a circuit that is exactly tuned to it, the voltage appearing across the circuit is Q times  $v$ .

Q of 150 and the voltage developed across the coil and available for passing on to the valve is therefore  $150 \times 200$ , or 30,000 microvolts. No. 2 coil, which has a Q of 60, yields only 12,000 microvolts. So Q is a direct measure of sensitivity. And as  $r$ , within the limits of frequency for which any coil is likely to be used, is usually roughly proportional to  $f$ , the Q measured at one frequency holds fairly well for other frequencies.

### Response Off-Tune

What about selectivity? The percentage off-tune required to reduce the response by a given proportion is also measured by Q. The coil with the Q of 60 would have to be detuned  $\frac{150}{60}$ , or  $2\frac{1}{2}$  times as much as the coil with a Q of 150 in order to reduce the response to any specified fraction—say a tenth, or 20 db—of what it is at exact resonance.

**"Q" A Useful Measure of "Goodness"—**

Actually one is not so very much interested in the *percentage* off-tune because the sidebands of a station are not in proportion to the frequency of the carrier wave. The side-bands of Droitwich on 200 kc/s extend to about 4 per cent. each side, but as Welsh Regional transmits on a carrier wave of four times the frequency, its sidebands are only about 1 per cent.;

for comparing selectivities. In fact, a single selectivity curve can be drawn for all coils, if the "frequency off-tune" scale is multiplied by  $\frac{Q}{f}$  (Fig. 3).

I have been rather labouring the point that this Q business is not exclusive to coils. If the coil whose Q is 150 (which is quite good for small commercial types) is tuned by a sufficiently bad condenser,

they were in series, so the same formulæ do not apply. But any parallel resistance R can be converted into the equivalent series resistance,  $r$ , by  $r = \frac{(2\pi fL)^2}{R}$ . Or, if  $Q_1$  is the magnification of the coil by itself, when R is shunted across it, the total effective Q becomes

$$\frac{RQ_1}{2\pi fLQ_1 + R}$$

Finally, if the magnification and the capacities of a number of items in parallel with the tuned circuit are denoted by numbered letters such as  $Q_1, C_1$ , etc., and the figures for the whole combination are denoted by Q and C, then

$$\frac{I}{Q} = \frac{C_1}{Q_1C} + \frac{C_2}{Q_2C} + \frac{C_3}{Q_3C}, \text{ etc.}$$

The contribution of each item in the circuit to the loss of magnification and selectivity can thus be estimated.

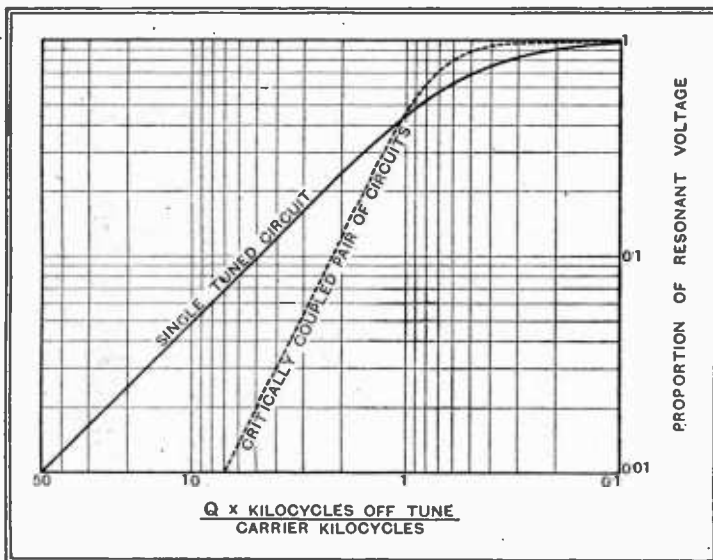

Fig. 3.— Universal resonance curves for a single tuned circuit and a pair of similar tuned circuits, each with a magnification Q and critically coupled. By multiplying the horizontal scale by the frequency of the signal in kc/s and dividing by Q, it reads directly the kc/s off tune. For instance, if Q is 100 and the frequency is 1,000 kc/s (wavelength 300 metres), 0.9 on the scale represents 9 kc/s and the adjacent-channel response can be seen to be 0.48 for a single circuit and 0.53 for a coupled pair. Note the much more level response of the latter to sidebands and the greater selectivity when further detuned. The resonant response has been brought to 1 in each case for comparison; actually if the single circuit is regarded as 1, the coupled pair starts at 0.5.

and to give the same working selectivity the Q ought to be four times as great. So for comparison of the selectivity of coils under conditions in which stations are spaced at intervals of equal frequency (instead of intervals proportional to the carrier wave frequencies) the proper measure to use is  $\frac{Q}{f}$ . This seems rather silly, dividing Q by f when we have already multiplied something by f in order to arrive at Q. In fact, it is quite correct to take  $\frac{L}{r}$  as a measure of selectivity. Personally, I prefer  $\frac{Q}{f}$ , because one wants to know Q anyway, for the reasons already given; and f, the frequency of any station in which one is interested is, of course, known; whereas r is something that is not known apart from f. Again, there is the objection against  $\frac{L}{r}$ , that it applies only to coils, whereas  $\frac{Q}{f}$  is quite general.

To sum up so far, then, Q is something that can either be measured directly (say, by applying a small signal voltage in series with the coil and measuring the multiplied voltage across it) or calculated from the inductance and RF resistance at some working frequency; and it is a figure by which the responsiveness of coils can be compared. Divided by the frequency to which the coil is tuned, it is a figure

it may be degraded to the level of a 60 Q coil tuned by a good condenser. In fact, the higher the Q the more liable it is to be spoilt by losses due to condenser, valve, wiring, insulating material, etc.

According to the definition of Q as the voltage magnification of the tuned circuit (see Fig. 2 again), it is clearly quite natural to apply it to the whole tuned circuit. There are instruments known as Q-meters for measuring the Q of the whole or any part of a circuit, and they show up any suspected or unsuspected item that may be ruining the performance of otherwise good components. But such meters are expensive, so it may be necessary to calculate Q from other data. The formula  $\frac{2\pi fL}{r}$  is no good for condensers or valve holders. But remember that  $2\pi fL$  is reactance, and the condensers and things do have reactance. It is  $\frac{I}{2\pi fC}$ . So, for

anything that has capacity,  $Q = \frac{I}{2\pi fCr}$  where r is the RF resistance apparently in series with the capacity. Generally the Q of a tuning condenser is very much higher than that of even a good coil. Suppose our old friend coil No. 1 is tuned by a condenser with a Q of 850. Then the Q of the whole tuned circuit, conveniently neglecting all else such as the self-capacity of the coil and capacity of wiring, etc., is  $\frac{850 \times 150}{850 + 150} = 127.5$ . (In case it is not clear

what has been done here it is  $\frac{I}{Q} = \frac{I}{Q_1} + \frac{I}{Q_2}$ ).

Suppose there is a resistance, R ohms, shunted across the tuned circuit; it may be the resistance of a valve. The resistances of the coil, etc., are reckoned as if

## Television Programmes

An hour's special film transmission intended for the Industry only will be given from 11 a.m. to 12 daily.

Vision, 45 Mc/s. Sound, 41.5 Mc/s.

THURSDAY, NOVEMBER 11th.

10.30 a.m., O.B. of Service of Remembrance from the Cenotaph, Whitehall.

3, "November 11th": a document of war and peace. 3.15, O.B. from the Cenotaph with a descriptive commentary by Thomas Woodrooffe. 3.30, British Movietonews. 3.40, Thelma Riess (cello) and the Fleet Street Choir.

9-10, R. C. Sherriff's "Journey's End." The scene is a dug-out in the British trenches before St. Quentin, March, 1918.

FRIDAY, NOVEMBER 12th.

3, Marcel Boulestin demonstrates the making of a game dish. 3.15, Preview Highlights of the Week. 3.20, Gaumont-British News. 3.30, The White Coons Concert Party.

9, Marcel Boulestin. 9.15, Preview. 9.20, British Movietonews. 9.30, The White Coons.

SATURDAY, NOVEMBER 13th.

3, The Clowes Marionettes. 3.10, Starlight. 3.20, British Movietonews. 3.30, Jack Jackson and his Band.

9, "Rush Hour": a revue by Herbert Farjeon. 9.50, Gaumont-British News.

MONDAY, NOVEMBER 15th.

3, Nat Gonella and his Georgians. 3.15, British Movietonews. 3.25, Marie Ney in Esmé Church's production of Henrik Ibsen's "Ghosts," from the Vaudeville Theatre.

9-10, R. C. Sherriff's "Journey's End."

TUESDAY, NOVEMBER 16th.

3, Song and Dance No. 3: a little show presented by Dallas Bower. 3.20, How a life mask is made. 3.35, Gaumont-British News. 3.45, A New Ballet: "A Stained Glass Window."

9, Starlight. 9.10, Body-line No. 4: The Work of Men's Clubs. 9.25, British Movietonews. 9.35, "Thomas and Sally, or The Sailor's Return": a dramatic pastoral by Dr. Arne.

WEDNESDAY, NOVEMBER 17th.

3, A little show. 3.20, British Movietonews. 3.30, Ninety-fifth edition of Picture Page.

9, A little show. 9.20, Gaumont-British News. 9.30, Ninety-sixth edition of Picture Page.



# UNBIASED

By FREE GRID

## An Amazing Discovery

**I**N spite of the fact that winter is now on our doorstep and we have already had a goodly dosage of autumn fogs and mists, many of my friends have been commenting on my extremely bronzed and healthy look. For some time I put this down as merely another of the hopeless conversational futilities to which people give utterance when meeting each other. It was said so consistently, however, by all sorts of different people that I began to think there must be something in it, and tried to call to mind what I must have been unknowingly doing to produce this healthy tan.

I am aware, of course, that, as the advertisements used to tell us, "Handsome men are slightly sunburnt," but fortunately I have never needed any of these adventitious aids to popularity among the fair sex, and I had a clear conscience in this respect. I must honestly confess, however, that I did feel in glowing health. I was utterly at a loss to account for it, because in recent weeks, instead of getting out in the afternoon to indulge in healthy exercise, I have been so entranced by the B.B.C.'s programmes from the Alexandra Palace that I have been glued to my television set.

Eventually I sought the advice of a doctor on the matter, as I felt and looked so well that I began to think there must

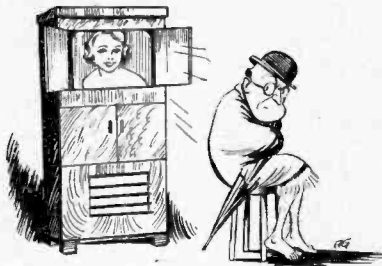

Reluctant to expose my back

be something seriously the matter with me. To my amazement, he was puzzled by the same phenomenon in his own case, and in our subsequent talk we found that the one common factor in our lives of late was close attention to the television programmes, and herein lay the solution of the problem. As the result of a brainwave, born simultaneously in our minds, the doctor and I began a series of spectroscopic experiments which amply confirmed our suspicions.

As everybody knows, the effect of the electronic bombardment of the fluorescent material at the end of the cathode-ray tube is to produce light. Different makes of cathode-ray tubes employ different

materials to produce fluorescence and, with certain of them, not only is light produced, but ultra-violet radiation also, and as our particular tubes were of this type, the effect on our health has been the same as though we had been basking every afternoon in Mediterranean sunshine.

This discovery should, needless to say, be invaluable to the manufacturers of television receivers and, indeed, to the popularising of television generally, since it obviously provides another and extremely forceful selling point. There is only one snag, and that is a psychological one. Although my face has, of course, been constantly exposed to the health-giving rays, my back has not, and I, in common with other men, feel a natural reluctance to removing my coat and collar and exposing my back to the gaze of the B.B.C.'s female television announcers. Obviously the announcers cannot see their audience, but all the same, it is a very real difficulty, and I look to psychologists to assist me and other men by recommending some suitable auto-suggestive process to us.

## An Unjust Accusation

**I** AM, as many of you know, always ready to uphold my fellow wireless experimenters and listeners against the many base and malicious attacks which are made upon them from time to time by non-wireless sections of the public, such as chamber music addicts and jealous adherents of other hobbies, such as stamp collecting and other puerile pastimes. There are far more of these attacks made than the average experimenter or listener is aware of, and I spend a good deal of my time in quiet and unobtrusive de-calumniating work. An innuendo of a more than ordinary degree of malice and offensiveness has lately been made to me, however, by a certain correspondent, and I do not feel that I am justified on this occasion in keeping it to myself.

The innuendo in question vitally concerns the honesty and integrity of almost every listener, and is really more than an innuendo as it is practically a direct accusation that every user of a mains receiver is wilfully and knowingly engaged in depriving the electric light companies of part of their lawful revenue. It is alleged, in fact, that nearly all of you are operating not only your wireless sets proper, but the dial light also, from a power point instead of a lighting socket. Needless to say, such a thing would be very improper since, in the case of this

device, it is actually used to produce light. It is not as though the light were an unwanted by-product, as in the case of that coming from valve filaments.

I must confess that when I installed my first dial light on a mains set, I did, in a moment of forgetfulness, connect it to the other wiring of the set, thus dishonestly operating it from the power socket. It was, in fact, owing to Mrs. Free Grid doing the same thing with the built-in light on her electric sewing machine that I realised the error of my ways, since she was brought up with a round turn by an unexpected visit from an inspector of the local electric lighting company one evening when she happened to be repairing a rent in my trousers.

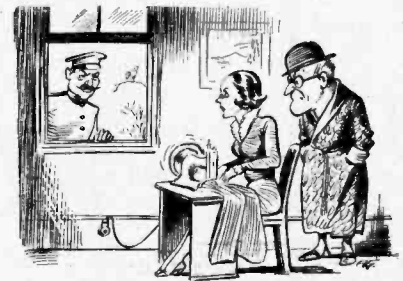

While repairing a rent in my trousers

Needless to say, I at once salved my conscience by providing a separate connection for my dial light and, at the same time, forwarded a written confession and a cheque to the company which I had unwittingly defrauded. I feel sure that if any of you are guilty of the misdemeanour of which my correspondent so maliciously accuses you, you are merely offending in ignorance, and the appearance of this note will have the desired effect of inducing you to follow my example.

In order to refute a base and cynical remark which Mrs. Free Grid has just made to the effect that this ought to be a busy week-end among my readers, I should esteem it a favour if those of you who, owing to ignorance or absentmindedness, have hitherto not used a separate dial light connection, would drop me a brief line.

## The Lost Chord

**I** WONDER how many of you observed the little news item in your daily rag the other morning telling how certain of our great wireless manufacturers have dug up an old idea and have installed PA apparatus in their factories in order to influence the work of the operatives according to requirements. Highly selective portable receivers, it appears, are produced to the appropriate strains of "The Lost Chord," while radiograms are turned out to the more stately measure of the Tannhauser overture. I have long advocated a similar scheme to the Editor for use in *The Wireless World* office in order to speed things up with a view to bringing out a daily edition of *W.W.*, but, so far, I have been merely knocking my head up against a brick wall.

# The Mains Transformer

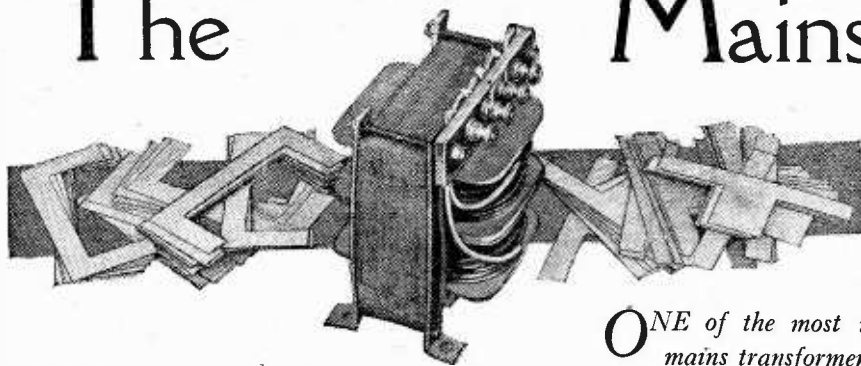

## ENGINEERING CHECKS OF DESIGN AND PERFORMANCE

By "TEST ENGINEER"

ONE of the most important components in a receiving set is the mains transformer. In this article some insight is given into the precautions which are taken to ensure its efficiency and reliability.

THE mass production methods in vogue to-day do not afford much opportunity for quantitative research on any one component. Therefore, to keep a check on the output of the multiple test jig it has become the practice to institute a thorough investigation on manufactured parts taken at random from the assembly lines.

In the case of mains transformers the assembly process follows a routine common to most factories. At some strategic point in the transformer assembly line each bobbin has undergone tests for resistance and short-circuited turns, in addition to a purely mechanical inspection. With some firms it is usual to "count" the turns in a bobbin by clamping it over a separately excited iron core, and measuring the induced volts, but this type of test requires frequent attention, and is of doubtful value from a production standpoint.

The magnetic characteristics of the transformer iron is a matter which may confidently be left to the Research Department, the usual practice being to test a representative sample from each batch of laminations as received from the manufacturers.

On the assembly lines the laminations are gauged for quantity and assembled with the bobbins. The "T" and "U" pieces are interleaved alternately, but they may be interlocked 3 and 3 without much detriment to transformer performance. The "ironed-up" assembly is

clamped in a vice to reduce air gaps in the iron circuit, the end plates bolted up and the leads connected to the terminal plates according to specification. The complete unit then passes to the test section.

Let us assume that a specimen transformer from the test jig is to be examined quantitatively as a cross-check on production. According to B.E.S.A. specification, the transformer is subjected to a breakdown test from windings to core and from windings to windings at a test pressure of 1,000 volts plus twice the working voltage.

In some cases a "flash test" is employed, i.e., the pressure is applied suddenly, but the practice has a tendency to impair the insulation, and it is more usual to increase the voltage gradually to the required figure and to reduce it in the same way.

An alternative procedure is to excite the primary winding with an increasing voltage (Fig. 1) until the induced secondary voltage reaches the test value. To avoid saturation of the core, a higher frequency is used than that for which the transformer is designed.

The windings are then given a "Megger" test at 500 volts DC as a check on the insulating medium. Incomplete drying-out after impregnation may cause a leak of a few megohms, resulting in subsequent electrolytic action and possible failure in service. An insulation resistance of the order of 20 megohms is regarded as a satisfactory minimum.

After the insulation test the transformer is connected as in Fig. 2 and the following data determined.

The magnetising current, which is given by the ammeter A in series with the primary winding, will show the losses due to hysteresis and eddy currents in the iron circuit, and is a valuable test for short-circuiting turns, particularly if a higher frequency is used than the de-

signed value. In the ideal case this current lagging by 90 degrees on the primary voltage will be "wattless," but iron losses account for a small wastage in the practical case.

The magnetising current decided, the next check is made on voltage regulation. Considering the case of a transformer rated to give the following outputs:—

- Secondary 1. 60 mA at 250/0/250v.
- Secondary 2. 3 A at 4v.
- Secondary 3. 2 A at 4v.

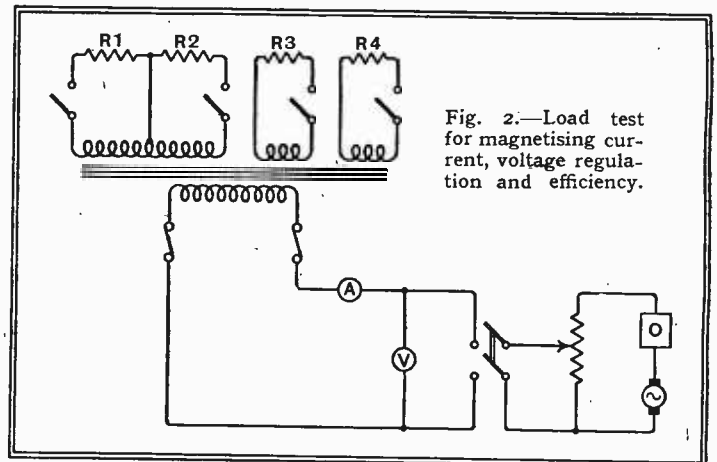

Fig. 2.—Load test for magnetising current, voltage regulation and efficiency.

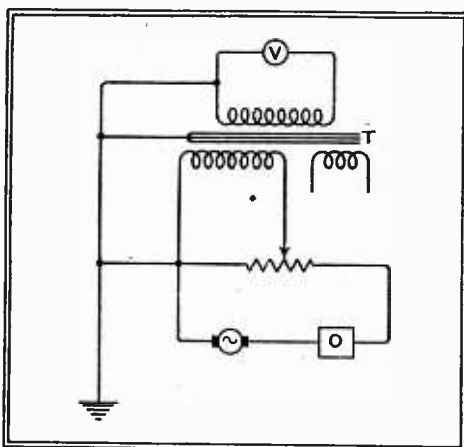

Fig. 1.—Circuit diagram of insulation breakdown test. V is an electrostatic voltmeter, T the transformer under test and O an overload release to protect the generator in case of breakdown.

with a primary input of 200v. at 50 cycles per second, the various loads are regarded as purely resistive, and suitable ohmic values are apportioned to R1, R2, R3 and R4 (Fig. 2).

The loading switches are opened and the terminal voltage of any winding is measured with a high resistance voltmeter of the order of 1,000 ohms per volt. Call this voltage  $V_1$ . The load switches are then closed and a second reading  $= V_2$  is taken. The percentage regulation is then determined from the formula

$$\frac{100 (V_1 - V_2)}{V_2}$$

While the transformer is on load the efficiency is calculated from the formula

$$\frac{\text{(Total secondary watts) } 100}{\text{Primary watts}}$$

The secondary watts are determined from the voltmeter readings  $W = \frac{E^2}{R}$ , assuming a pure resistive load, while the primary watts are given by the voltmeter

**The Mains Transformer—**  
and ammeter in the primary circuits,  
 $W = E \times I$ .

The efficiency figure should be in the neighbourhood of 90 per cent. Efficiencies of power transformers of 100 kW rating have been recorded as 98 per cent., showing that the transformer is an extremely efficient machine when properly designed and constructed.

The losses in transformation may be briefly remarked in passing. Iron losses, due to hysteresis and eddy currents, cause heating of the iron circuit and result in waste of energy, and hence low efficiency. On the other hand, losses due to indifferent design and/or construction will lead to leakage flux, i.e., the primary magnetic flux will not link fully with the secondary windings. This will result in bad regulation.

High resistance windings caused by excessive turns or a small size conductor give rise to "copper loss," and also result in poor regulation. The copper loss can be calculated from the following:  $Watts\ loss = I_p^2 R_p + I_s^2 R_s$ , where  $I_p$  and  $I_s$  are the primary and secondary currents, and  $R_p$  and  $R_s$  the primary and secondary resistances respectively. To keep the copper loss reasonably low, the current density in the windings should approximate to 900 to 1,500 amperes per square inch of conductor. Higher values than these will result in better regulation, but overheating may occur with detriment to the insulation.

In the case of power transformers a heat run under full load conditions usually follows the efficiency test, but in dealing with mass production components, such runs are rarely necessary.

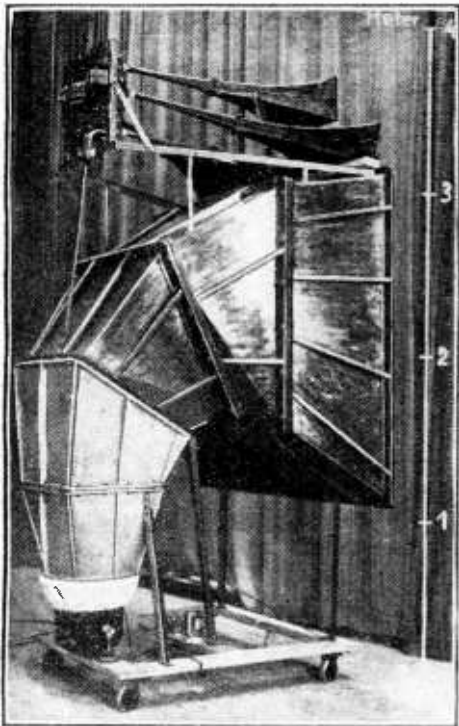

**SOUND SOUND.** Five horn-type units are employed in the latest "Klangfilm" talkie equipment recently installed in a Berlin cinema. Two units are for high notes, two for the middle register and the low-frequency horn has a 7ft. flare.

## NEWS OF THE WEEK

### New Suez W/T Station

A WIRELESS station is to be built by the Egyptian Government on the western side of the Gulf of Suez. The building of this station has been decided upon mainly for military reasons.

### Tribute to British Wireless Workers

GIVING evidence at the Ministry of Labour before the Committee set up by the Government to investigate the question of holidays with pay for factory workers, Sir Louis Sterling, managing director of E.M.I., Ltd., said that he had opened factories all over the world, and had found that, with certain reservations, the workers of this country were the best of the lot. At present, he said, the radio industry did not pay workers for bank holidays, but he would like to see this done.

### I.P.A.E. Appointment

THE Institution of Public Address Engineers, the headquarters of which are at 83, Cannon Street, London, E.C.4, has appointed Mr. C. S. Grace, B.Sc., F.I.C., as secretary. Full information concerning membership can be obtained from him at 22, Spencer Road, Chiswick, London, W.4.

### Indian Broadcasting

A SPECIAL set for Indian listeners has been produced by Professor K. Screenivasan, who is in charge of the Communications Engineering Course in the Indian Institute of Science. If the set is produced on a large scale it is stated that it ought not to cost more than about £3.

It is expected that the projected short-wave 10 kW station at Delhi will begin testing this month, while the stations at Lahore and Lucknow will probably be first heard at the end of this year and some time early next year respectively. The transmitting equipment for all three of these stations has already been delivered. In the case of the Lucknow station the transmitter building is not yet completed.

The erection of the station buildings at Bombay and Madras is now in hand, whilst similar work in connection with the projected Trichinopoly and Dacca stations is to begin shortly. Bombay will be the second of the SW transmitters to commence operations, and the apparatus is expected to arrive during the present month.

### Television at Sea

ALTHOUGH the normal range of the Alexandra Palace transmitter is estimated at twenty-five to thirty miles, successful reception was obtained recently on a Marconiphone receiver installed on the Cunard White Star liner, *Britannic*. The ship was, at the time, in the English Channel en route for Le Havre and New York, and the direct-line distance from the transmitting station was about 100 miles. This is believed to be the first time that high-definition television has been received at sea.

### Wartime Operators' Reunion

THERE was a record attendance at the Eighth Annual Reunion dinner of the R.F.C. Wireless Operators' Old Comrades' Association, held recently in London. Among other representatives of the broadcast wireless industry present were Messrs. Frank Murphy, D. Dobie and A. E. Trehearne. The Association's headquarters are at 56, Regency Street, London, S.W.1.



## 6-valve all-wave Superhet with Radio Frequency Stage

8 stages.  
8 tuned circuits.  
3 wavebands.

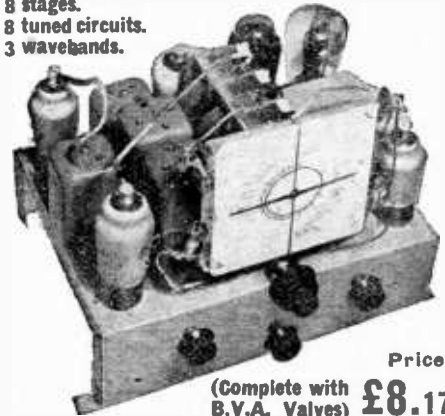

Price  
(Complete with B.V.A. Valves) **£8.17.6**

Performance (made possible by use of multi-electrode valves) equal to that of many receivers employing 8 valves or more. Brief specification includes: Large "Airplane" dial, with different coloured lights automatically switched on for each wave-range. Micro-vernier 2-speed drive. 4-point wave-change and gramophone switch. Volume control and variable tone control also operative on gramophone. Reinforced heavy-gauge steel chassis. Covers 19-2,000 metres.

Circuit comprises: Pre-selector circuit, radio frequency amplifier (operative on all 3 wavebands), triode-hexode frequency changer, double band-pass I.F.T. coupled I.F. amplifier, double diode detector and L.F. amplifier. D.A.V.C. applied to 2 preceding valves. 3-watt pentode output.

## 9 VALVE FOUR-WAVE SUPERHET DE LUXE

**14 GNS.**

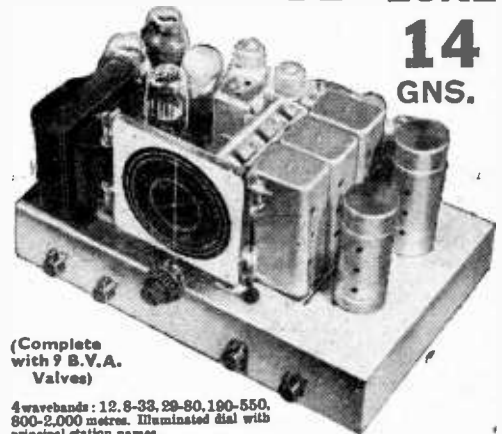

(Complete with 9 B.V.A. Valves)

4 wavebands: 12, 8-33, 29-80, 190-550, 800-2,000 metres. Illuminated dial with principal station names.

Controls.—A feature of the receiver is the number of independent controls fitted, making it extremely interesting to operate. These include sensitivity control (varying bias on R/F stage), or Q.A.V.C. with manual muting control for inter station noise suppression. 5-position wave-change and gramophone switch. Progressive variable tone control operative on radio and gram. Circuit in Brief—Aerial input to pre-selector circuit, radio frequency amplifier, latest type triode-hexode frequency changer, 2 band-pass I.F.T. coupled I.F. amplifiers, double diode detector, triode L.F. amplifier, separate triode phase-changer capacity coupled to 2 large pentodes in push-pull. Heavy 16-gauge steel chassis. Finest components and workmanship throughout. Harries tetrodes in place of output pentodes if desired.

STANDARD MODEL 12 GNS. As above, but with triode push-pull output, and fewer controls fitted,

**DEFERRED TERMS**  
on application or through our City Agents  
**LONDON RADIO SUPPLIES LTD.**  
11, OAT LANE, E.C.2.  
Demonstrations Daily.

All McCarthy receivers supplied complete with valves, knobs, pilot lamps, leads, mains cable and plug. 12 months' guarantee. (Valves 3 months.)

The prices at which McCarthy receivers are advertised include Marconi Royalties.

Cash with order on 7 days' approval. Also write for illustrated catalogue of complete range of all McCarthy receivers.

**MCCARTHY RADIO LTD.**  
44a, Westbourne Grove, London, W.2

Telephone: Baywater 3201/2.



# RANDOM RADIATIONS

By "DIALLIST"

## Not All Giants

A CANADIAN correspondent, to whom my best thanks, sends me some interesting information about the radio sets of to-day in Canada and the United States. He seems to think that most people in this country have the idea that every set on the other side of the Atlantic is a monster containing a double-figure array of tubes. I never laboured under such a delusion myself, though one runs across any amount of people who won't believe you when you say that the receiving set most commonly seen in Canada and the United States has a six-valve or an eight-valve circuit. Those are the sets which correspond to our models selling at prices between, say, £15 and £25. In Canada the cost of a table model of this kind works out at from £14 to £20, whilst consoles run up to about £30. Larger models with 10 or 12 valves are priced at from £40 to £50, and some of the 16-valve and bigger sets sell at from £60 to well over £100.

## For All Tastes

The great point of difference between the wireless market in North America and in this country is that whilst our makers have hitherto catered hardly at all for the luxury market, except to some extent with radio-grams, theirs have for years offered both moderately priced sets of reasonable performance and high-class hand-built sets intended for the people who want the very best in wireless and are quite willing to pay for it. The luxury market has proved to be a pretty big one in America, and I see that one of their manufacturers, who will shortly be making receivers over here, estimates that there are half a million homes in this country in which the first-class set costing quite a lot of money can hope to find a place. I had hardly thought that the number was as big as that, but it must be a pretty considerable one all the same. What America has, and what we need, is a range of receiving sets to suit all tastes and all pockets.

## Transatlantic Eyewash

My correspondent, who is head of a big wireless servicing concern, sends me some amusing examples of the eyewash that is used now and then in the make-up of sets and in those glowing descriptions wherewith some Transatlantic manufacturers seek to lure the purchaser.

"In some of the big set designs," he writes, "the main object is to impress the prospective buyer by sheer numbers of tubes. Actually the first question usually asked of the dealer is: 'How many tubes has it?'" One model that recently passed through his hands is classed as a 12-tube receiver. One of these turns out to be the cathode-ray tuning indicator and four half-wave rectifiers are used, though one heavy-duty valve would easily do the work, just to bring up the numbers. But the gem is perhaps a form of telephone-dial tuning, glowingly described as the greatest advance in radio made in recent years, the thrill of a lifetime and something far beyond all other forms of automatic tuning—any one of 10 stations brought in instantly by the flip of a finger. My correspondent's caustic comment is: "i.e., pre-set mica condensers and a multi-point switch!"

## Still Going Up

THE increase in the licence figures for September was simply amazing. During that month the number grew by no fewer than 49,152. This brings the total to the end of September to 8,329,539, which is 542,619 greater than on September 30th, 1936. Few, I think, would have been bold enough to have prophesied that with the number of wireless licences standing at over seven and three-quarter millions at the end of September last year there would be an increase of well over half a million in the following twelve months. But there it is, and it seems that there is quite a good chance that the eight and a half million mark may be reached early next year. England naturally showed far the biggest increase for last September, the figure being 39,706. Scotland's addition of 6,347 shows that Bournemouth is pulling its weight, whilst Penmon and the Welsh Regional station no doubt helped Welsh licences to grow by 2,399. Northern Ireland still lags behind, with an increase of only 700 for the month and a total of 106,269. What is rather hard to understand is that there should be quite substantial decreases in certain English and Scottish districts. Leighton Buzzard, for example, is down by 95, Deal by 56, Uxbridge by 75 and Edinburgh by 55.

## G.P.O. Relays

It is reported that the G.P.O. is likely to choose Southampton as the centre for its first relay service, which will be brought into action to see how far it is possible for the authorities to adopt the recommendations of the Ullswater report by taking over the whole of the relay services. It is wise to start with one experimental area before coming to a decision affecting the whole country. Southampton should be a good place for this trial, since it is not too well served for direct reception of the home stations, and it contains a pretty large number of licence holders.

## Our Foreign Trade

I HAVE just been looking through the import and export figures for September and whilst they make a better showing than they did a year ago, they still leave, to my mind, a good deal to be desired. The balance in our favour for the month was £28,554, as against £16,120 for September 1936. But this favourable balance does little more than wipe out the adverse balance for last August, which amounted to £24,286. It is pretty evident that we are buying a great deal too much from abroad and selling too little in foreign countries, especially in the Empire. At first sight the figure for radio sales to the Empire looks quite imposing at £55,773. When you look again you see that this includes sales to the Irish Free State and the Channel Islands which between them bought radio goods to the value of £25,354 from us in September. These are really parts of the British Isles, so that the total value of what we sold to the Empire boils down to £30,419. I haven't the American or the Dutch figures by me, but I am open to wager that they reaped a much bigger harvest in our own Empire than we did, which is all wrong. Germany is now re-entering the export field and if we don't look to our laurels she, too, will take trade that could be ours.

## Throwing Chances Away

IT is really time that our manufacturers awakened to the possibilities of trade with the Empire. One would think that with the number of licences here approaching (though it may be slowly) the saturation point, and with growing competition from the American firms that are setting up factories in this country, they would be striving to make the most of every outlet abroad for their wares. But they just aren't. About a score of our set making concerns list export models—but listing is about all as far as many of them seem to get. Take India, which is the part of the Empire of which my knowledge is greatest—or perhaps I should say, my ignorance is least. There is a country of over 360,000,000 people with a broadcasting service in being and rapidly expanding. The list of overseas radio agencies recently published by *The Wireless Trader* shows that in the whole of India only seven British set making firms are represented, in addition to five valve manufacturing companies and but eleven which make batteries, loud speakers, and so on. It's a pathetic business, but no one can help those who won't help themselves.

## A True Story

AND now I'll tell you a story for the truth of which I can vouch. I know a man who about two years ago had an inspiration that there should be a big market in India, the Straits Settlements, Hong Kong and several other places for small valve sets and crystal sets, which could be very cheap to make. Local broadcasting had then just begun in many densely populated centres, in some of which over a million people lived within a few miles of the transmitter. As all broadcasting was done on the medium waves there was no need in these little sets that he had in mind for any kind of wave-change arrangement. Selectivity, again, was a matter of no importance since the local station was the only one within hundreds of miles. You will see that there wasn't much difficulty about turning out at minute cost crystal sets and one-valve or two-valve sets, which would give a good account of themselves. He prepared designs; he approached various manufacturers. Did they jump at the idea? They did not. Did they so much as nibble at the bait? Only two firms went so far as that, and they were so half-hearted about it and so disinclined to risk even the smallest amount in exploring a huge potential market that our designer friend gave it up in disgust. Where, oh where are those Merchant Adventurers who made British trade in years gone by?

## The Radio Industry

NO fewer than 150 Benjamin Model 66 loudspeakers are used for the PA installation in the new Earls Court exhibition buildings. The amplifiers were supplied by the G.E.C., while the installation was carried out by the Brighton and Preston Relay Station, Ltd.

An importing firm in Rhodesia wishes to obtain a sole agency for a British-made broadcast receiver covering short wavelengths from at least 13 metres upwards in addition to the medium band. The importance of a good performance on short waves is stressed. Letters will be forwarded.

# On the Short Waves

CONDITIONS during October, on the whole, were very poor, and no doubt many owners of new all-wave receivers were quite disappointed with their reception on the short waves during the past month. Fortunately, the particular group of sun-spots which appears to have been responsible for these very poor conditions has now entirely disappeared, and a smaller group of similar characteristics which appeared a little later than the main group has also dispersed.

These two groups were notable for their complex structure and large number of closely packed nuclei, and, perhaps, most significantly, they were both located almost on the sun's equator; these points serve to distinguish them from nearly all the previous spots of the present cycle.

That they were apparently responsible for the worst short-wave conditions (at least after sunset) for many months is therefore of more than passing interest; recent solar activity has been of a more favourable kind, and on November 2nd, in particular, conditions were very good, signals from America being strong over a broad band of frequencies extending from 18 to almost 6 Mc/s.

During the afternoons reception of the U.S. 28 Mc/s amateurs and the various police and high-fidelity transmitters has also been excellent. One has often been surprised by the disproportionately good performance of the Boston police transmitter, W1XAO, considering its very high frequency of 35.6 Mc/s (8.43 metres), which can only be accounted for if it possesses either a very good aerial system or site, or both.

It is most amusing to hear the replies from police cars via the loud speaker and microphone at W1XAO, and a friend of mine from Cambridge, Mass., just across the way from Boston, was most intrigued by this experience when visiting me recently. Another U.S. high-frequency station, W1COO, an amateur in the 28-Mc/s band whom I have mentioned before, also gives remarkably good results, which one attributes in this case to the use of a rhombic aerial at the transmitting end. The diamond aerial at W1COO is of the non-terminated variety, has (four) sides each  $3\frac{1}{2}$  wavelength long (on 10 metres) at one wavelength above the ground, a very important point; the "tilt angle," that is the half-angle formed between two sides at the centre of the aerial, has been adjusted to project the signals at an angle of 10 deg. to the ground.

He is shortly proposing to terminate the horizontal rhombic correctly with a 700-800-ohm resistance, and it will be interesting to see if this change makes any difference in the performance of the array; the power used is 150 watts.

More and more evidence is being gathered pointing to 10 deg. being the mean correct projection angle for distant transmission on these high frequencies.

In the October issue of the "Proceedings of the Institute of Radio Engineers" there is a very interesting paper dealing with reception of the Alexandra Palace sound and vision signals in the U.S.A. This paper states that the mean downcoming angle of these transmissions is 7.5 deg., and in addition a table giving the downcoming angles of the signals from a number of U.S. 28 Mc/s amateur stations.

There are, in general, three types of transmitting aerial which the amateur can construct which will give projection (and con-

versely reception) angles of between 10 deg. and 12 deg.; these are, of course, the horizontal rhombic aerial used by W1COO and others (see QST for May, 1937), the long-wire harmonic type (see QST, November, 1936), and, finally, the stacked horizontal type.

A suitable long-wire aerial would be one 66ft. long erected 35 deg. off the bearing on which it is desired to transmit or receive. An aerial of this type has four major and four minor lobes, which makes it behave almost as a non-directional aerial, less than a quarter of the energy being useful from the directional point of view. For best results the aerial should be erected at least 33ft. above the ground, and may be fed in the centre with an open wire feeder made an odd quarter-wave long for ease of coupling to the transmitter or receiver. In this case the aerial is not strictly a two-wave but two full-waves in phase, and the pattern will be different from that shown in QST for the first case.

Finally, a stacked dipole aerial may be constructed, of which the popular two half-waves in phase is the simplest case (one stack).

To obtain a projection angle of 10 deg. with this type of aerial two stacks, one a half-wave above the other, with the lower a wavelength above earth, or a three stacks, the lower stack half a wavelength above earth will be required. Both the structures require masts about 50ft. high.

The feeder line must be "twisted" through 180 deg. between the stacks; if "twisted flex" is used for aerials only one half-wave wide, then "red" goes to the left-hand half of one dipole and "black" to the left-hand half of the one above it.

The three-stack aerial gives a slightly lower angle and somewhat more gain. The argument is, of course, based on the perhaps unproven but logical assumption that the angle of projection is (roughly) equal to the angle of reception.

For the benefit of listeners W1XAL Boston is now regularly working on 15.25 Mc/s between 7.15 p.m. and 9 p.m., and should be a good signal when this channel is not being used by R1M Tashkent.

The signal could be located by reference to GSI Daventry on 15.26 Mc/s, which is also radiating at this time.

ETHACOMBER.

## New KB Receivers

AN interesting battery receiver and a new radiogramophone are announced by Kolster-Brandes, Ltd. The battery receiver is a three-valve "straight" set with four waveranges. The two lower ranges cover 18-52 and 85-220 metres and the set is specially suited for the reception of messages to trawlers and other vessels. Housed in a walnut and sycamore cabinet the KB 620T is equally suitable for service ashore or afloat. The price, complete with batteries, is £9.

In the KB 670 all-wave AC mains radiogramophone at 31 guineas three waveranges are provided, the short-wave range covering 16.5-50 metres. A four-valve superheterodyne is employed and the power output is 3 watts into the 8in. moving-coil loud speaker. The gramophone reproducing equipment is a self-contained unit making use of an induction type motor suitably insulated mechanically to obviate microphonic troubles.

## ACHIEVEMENT



OBSTACLES ARE OVERCOME — THE HEIGHTS ATTAINED — ONLY THROUGH HIGH INTENT, TENACITY OF PURPOSE AND A STEADFAST WILL TO ACHIEVE



THROUGH more than 28 years T.C.C. have always had but a single goal—the attainment of perfection in the manufacture of condensers. From that original intent—to concentrate on the one product alone, T.C.C. have never deviated. Passing time has brought it problems, demands have varied and T.C.C. have invariably been the first to solve the difficulty. A case in point is the T.C.C. Wet Electrolytics. Introduced to this country by T.C.C. these voltage regulators have played the biggest possible part in making the A.C. Receiver a DEPENDABLE instrument. The inherent SURGE VOLT danger to components has been eliminated. For safety sake—use these T.C.C. Wets in your A.C. Receiver.

### FOUR STANDARD TYPES

Type	Capacity	Continuous Working Volts
802	16 mfd.	440 volts Peak
602	8 mfd.	440 volts Peak
805	8 mfd.	500 volts Peak
809	32 mfd.	320 volts Peak

Special types are available to meet the stringent conditions found in A.C./D.C. Receivers. Write for full details.

# T.C.C.

## SURGE-PROOF

## WET ELECTROLYTICS

THE TELEGRAPH CONDENSER CO., LTD., WALES FARM ROAD, NORTH ACTON, W.3.

# Letters to the Editor

## Advantages of Negative Feed-back

I FEEL someone ought to thank you for the series of articles on "Negative Feed-back" as I think it the best recent contribution for the quality enthusiasts. I had for some time been looking for an output valve which, with an available voltage of around 250 and reasonable anode current, would give an almost undistorted output of 3.5 watts. I have found a genuine 3.5 watts with an efficient speaker as much as I dare inflict on the locality. You can guess how delighted I am to find that my existing AC<sub>2</sub>/Pen., with negative feed-back, has provided the solution.

After trying feeding back from the OT secondary (alternatively trying the speaker winding and a separate winding) to the AF cathode network with good results, I then tried feeding back from the output anode to the same point with better results and less apparent phase shift, although there still seemed a good deal of "positive" feed-back at what seemed intermediate frequencies (approx. 120 kc/s) causing instability, particularly if the set earth were removed.

This has now been completely cured by the possibly original method of coupling a small condenser (in my case 0.0002 mfd. with 5,000-ohm "grid-stopper") from the AF grid to cathode, thus, presumably, both further filtering the input and eliminating feed-back at very high frequencies. There is no deterioration in the "top" output, rather it is much improved, and extends possibly farther than it did.

I may say that in arranging the feed-back network I allowed for the usual 20 per cent., the actual feed-back being 1/125, allowing an amplification factor for the AF valve of 25 (a Mullard 354V).

The results now are wonderful (I nearly said perfect). Again thanking you.

Wembley.

W. CROFT.

## "Direct Current" or "Zero Frequency."

BECAUSE such objections to my "ZF" suggestion as have appeared seem to arise from misunderstandings of my proposal, I should like an opportunity of replying to them.

In the first place it was certainly not my intention that the term "DC" should be supplanted entirely. I agree with Mr. D'Arcy Ford that in the majority of places where "DC" is written there is no need to alter it. I agree, too, that omission of the term altogether, where the meaning is clear without it, is best of all.

Although "direct" is not an ideal adjective for describing what is meant, it is not bad enough to abolish altogether, seeing that most of the alternatives are worse. But on the other hand there are a good many occasions when the use of "DC" is definitely wrong. "DC current" is a self-evident illiteracy, but I am fairly sure people will never be persuaded to use the correct "D. current" (except, perhaps, in moments of stress following a severe electric shock!). "DC voltage" is contradictory in those cases where the voltage is unaccompanied by any current at all.

But if it were merely a matter of correctness of language, I agree with Mr. Ledward that the advantages of "ZF" are not so

The Editor does not hold himself responsible for the opinions of his correspondents

very obvious, and I will grant him that comparison with the metric system is not quite apt. But he goes on, presumably unconsciously, to support my argument. "It is questionable whether the term 'current' is correct as applied to an alternating quantity." I would like to concentrate attention on my suggestion—or a better one if it can be found—for the purpose of filling a serious gap in technical language. For ordinary electrical engineering purposes, "AC" and "DC" are quite adequate. But we are only at the beginning of an enormously expanding thing to which it is difficult to put a name, but it included broadcasting; sound recording, transmission and reproduction; electro-acoustics; sound films; picture telegraphy; and television. It is only when one has to try to write or talk clearly about these things that one realises how badly off we are for language. That is why Lt.-Comdr. Harper, as a practical instructor, is whole-hearted in his approval of my attempt to fill one of the gaps.

Mr. Ledward asks, "How are we to deal with pulsating DC, which has a definite frequency of pulsation?" Exactly; how? The term "DC" fails to make clear whether it does or does not apply to this. "Pulsating" is the officially approved term, and if one wants to go into details the most concise way of doing so is to describe it as a ripple of so many volts and c/s, on a ZF bias of so many volts.

I would like to ask any who are doubtful of the advantages of some such term as "ZF," and think "DC" is good enough, how they would describe a device—part of some television apparatus, let us say—designed to respond to light corresponding to "DC" and reject that part of the light corresponding to "AC." I would say it responds only to the ZF component of the light. Can anybody improve on that?

"DC" applies to current, so can hardly be used for light intensity. When a corresponding sort of magnetism is meant, one has to use the word "polarising" (no abbreviation known). When light or sound intensity is meant, heaven knows what word one is supposed to use. Personally, until somebody improves on it, I am going to use "ZF," which briefly and correctly applies to the whole lot, and to as many more as may be discovered or invented.

The time has passed when men could work in one little corner with electricity, and in another with sound, and in another with light. Already there are in everyday use appliances in which effects pass through several of these media. The time is surely due, then, for using terms that are correctly applicable to all, instead of only to one part of one of them? M. G. SCROGGIE.

Bromley, Kent.

## Invention

THE letter you publish in your issue of October 29th from Mr. Shoenberg would seem to indicate that television may well lead us through technical or commercial nationalism to another controversy on the lines of the Fleming diode v. De Forest triode discussion of some years back.

It is hardly fair to Zworykin or Farnsworth to suggest that British television results from the logical developments of the ideas of early British pioneers. Just as the valve would never have become the basis of all wireless practice without De Forest's grid, so would television never have reached its present perfection in England without the mosaic anode and electron image cameras, both originated in America.

It is an undeniable fact that nearly every great step forward in wireless invention and technique has originated in the United States. Yet many technical men in this country constantly deprecate America's contribution to this branch of applied science. A short list of American-originated developments would include the three-electrode valve, regeneration, super-regeneration, the superheterodyne, neutralisation, the screened-grid valve, the moving-coil loud speaker, electronic coupling, electronic cameras, grid-controlled ionisation tubes and the electron multiplier. What can we offer in reply to this list? I can only think of the diode, the Franklin array and the copper-oxide rectifier. Let us give credit where it is due and frankly acknowledge our debt to America.

The recent adoption of the latest American types of valves as a short cut out of the British valve impasse was a great compliment to American practice. But this step was taken in no straightforward manner. The American types made or assembled in England are described as "international types." When I asked a representative of one of our valve manufacturers at Olympia why the same type numbers were not used as in America, he replied: "Because the British-made international range valves are so much more efficient than their American equivalents." This remark is typical of the technical nationalism which is not calculated to lead to the best of feeling between wireless engineers here and in America.

"HEPTODE."

## New Apparatus Reviewed

### M.R. Minor Microphone

THE Minor, which is the latest addition to the range of microphones made by M.R. Supplies, 11, New Oxford Street, London, W.C.1, is a transverse current carbon model assembled in a moulded bakelite case.

As the electrical portion of the microphone is thoroughly insulated this model is recommended for use with amplifiers which have provision for obtaining the microphone polarisation from the HT line. High insulation is particularly desirable also when the amplifier is of the universal AC/DC kind.

The specimen submitted for test has a much higher resistance than is usual for this type of microphone, as it is of the order of 2,000 ohms. Consequently with six volts, and this seems quite sufficient for most purposes, the current through the microphone is only 3 mA. One advantage of being able to operate the microphone with such a small current is that the background noise is exceptionally low.

For our tests with this microphone we used the transformer Type MR/221 which is designed for their transverse current micro-



phones, and which has a primary inductance of approximately 0.9 henry.

Aural tests revealed that the microphone and transformer gave very good reproduction at the higher frequencies, but while no noticeable resonance could be detected the introduction of a little high-note attenuation was not undesirable for the reproduction of speech. On music, however, advantage can be taken of the wide frequency range of the

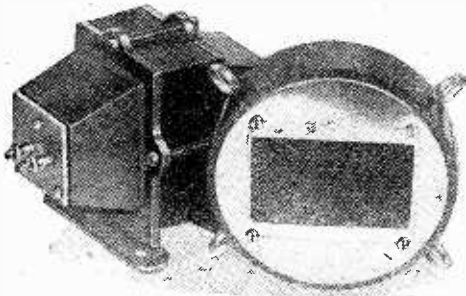

M.R. Minor transverse current microphone and type MR221 transformer.

microphone, and the amplifier operated with virtually a flat characteristic.

The Minor microphone has a very attractive appearance as the case is a polished black moulding with plated suspension hooks and front cover. It measures 3 3/4 in. in diameter, and is 1 1/2 in. deep overall.

It costs 37s. 6d., and the price of the MR/221 transformer is 11s. 6d.

#### McELROY MORSE PRACTICE SET

THIS Morse practice set is a combination of two individual parts, and although assembled in a convenient form for learning the code the two parts can be used separately when the need for a practice set has passed.

It consists of a straight key designed and made by T. R. McElroy, of Boston, Massachusetts, U.S.A., the world's champion radio telegraphist, and a Hummer which is a combined telephone and microphone producing a perfectly clean note at about 1,000 c/s. The note compares very favourably indeed with that obtained from a well-designed valve oscillator, and is not only easy to read but it also bears a close resemblance to what one actually hears when listening to CW signals.

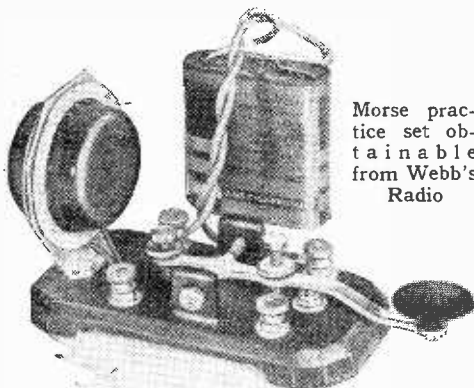

Morse practice set obtainable from Webb's Radio

Two terminals are provided on the key for attaching a pair of headphones, but they are not essential as the tone generated by the Hummer is quite loud enough to read without them.

The key has a very smooth action, is exceptionally well balanced and comfortable to operate. Being assembled on a heavy cast base it does not require screwing to the table, for it remains where it is placed with-

out creeping about as some lighter keys are inclined to do.

When its usefulness as a learner's set has passed the key can become part of a transmitting station's equipment, while the Hummer could be used for tone modulating ultra-short-wave transmitters.

In view of these applications the two parts are available separately and each costs 10s. As a complete Morse practice set the price is £1. A small 4 1/2-volt flash-lamp battery is required to operate the Hummer.

The separate items or the complete outfit is obtainable from Webb's Radio, 14, Soho Street, Oxford Street, London, W.1.

#### G.E.C. HEADPHONES

THE GENERAL ELECTRIC CO., LTD., Magnet House, Kingsway, London, W.C.2, have introduced a new pattern headphone in which high sensitivity coupled with a very wide frequency range are the predominating features.

Headphones still find many applications in wireless reception, for they are used extensively in hospitals and other institutions where radio is relayed throughout the building. They are indispensable for



New G.E.C. light-weight headphones, Type BC. 88.

amateur experimental work, particularly for use with frequency monitors and such-like test apparatus, while often 'phones have to be employed for short- and ultra-short-wave reception when it is inconvenient to use a loud speaker. These new G.E.C. headphones are designed so that when connected across the extension loud speaker terminals of the set they provide normal volume for individual listening and would consequently be of great assistance in the case of deafness. When, however, a much greater volume is needed it can be obtained with a matching transformer, and when used in conjunction with a potentiometer the volume can be adjusted to suit individual requirements. Special attention has been given to the design of the head-band, and as the total weight is only a few ounces the headphones can be worn for hours at a time without discomfort.

Two models are available, one the BC 88, which is the standard or general-purpose type, is of 4,000 ohms impedance, whilst the other is of 120 ohms and is described as the BC 89. The price is 17s. 6d. in each case. A matching transformer to suit the type BC 88 when joined to the extension loud speaker terminals has the type No. BC 714 and it costs 5s.

## POINTS OF IMPORTANCE in the Rola G.12

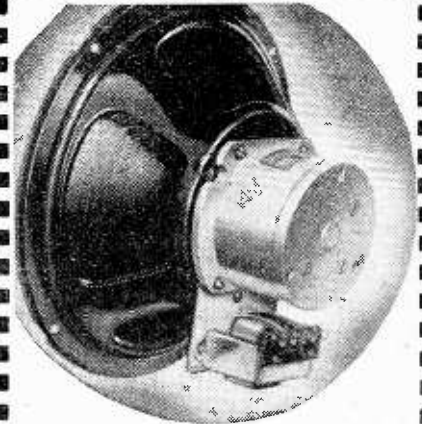

### THE STANDARD GALLON

Just a hollow cylinder of brass... a very ordinary object with nothing about it that would make anyone pause to look a second time. Yet it is the standard by which all measures of capacity are judged—the Imperial Gallon, constructed in 1824. Just so, in looking at a Rola G.12 you would probably fail to realise that there was anything exceptional about its construction, yet the G.12 also sets a standard, a standard of performance. For brilliance of tone, fidelity of reproduction and high power handling capacity this 12in. diameter speaker is generally acknowledged to stand alone. Ask your dealer to demonstrate the G.12 or a set in which this speaker has been installed.

G.12 P.M. (as illustrated) with Transformer	25 5 0
G.12 P.M. less Transformer	24 16 0
G.12 D.C. Complete with Transformer, Mounting Stand, Handle and Base	55 5 0
G.12 D.C. with Mounting Stand, Handle and Base, but without Transformer	24 16 0
G.12 D.C. Stripped but with Transformer	24 4 0
G.12 D.C. Stripped and without Transformer	23 15 0

(When ordering please state Field Resistance and Impedance of Transformer required.)

For Public Address work both the P.M. and Energised Models can be supplied with a 15 ohm Voice Coil at an additional charge of 3/-.

Write for Folder A.

OVER 8 MILLION IN USE

# ROLA

The World's Finest Reproducers

THE BRITISH ROLA CO., LTD.  
MINERVA ROAD, PARK ROYAL, N.W.10.  
PHONE: WILLES DEN 4322-3-4-5-6.



# Recent Inventions

**Brief descriptions of the more interesting radio devices and improvements issued as patents will be included in this section.**

## MODULATORS

THE output from an oscillator valve V is modulated by a variable-absorption circuit containing two opposed rectifiers R and R<sub>1</sub>. The arrangement is stated to require less power for a given high-frequency output, and to be free from frequency drift. So long as the microphone M is

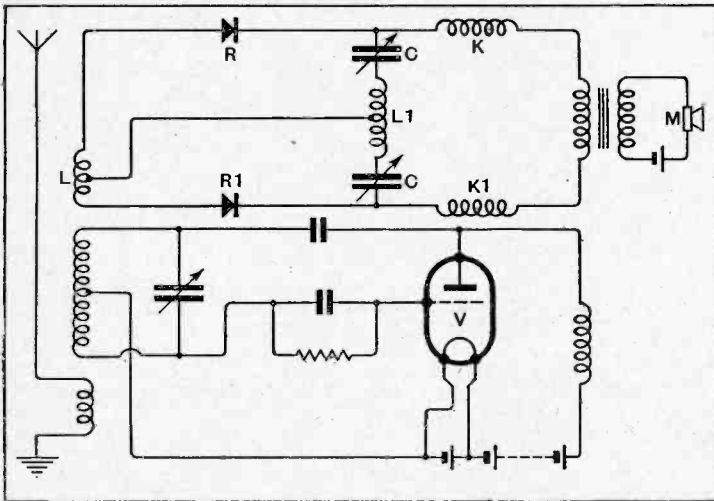

Method of modulating an RF oscillator by an absorption circuit.

out of action, maximum energy is transferred from the valve V through the coupling L to the tuned acceptor-circuit LiC, where it is absorbed by the rectifiers R, R<sub>1</sub>, leaving minimum power to be radiated from the aerial. The effect of speaking into the microphone is to apply AF biasing voltages through the choke coils K, K<sub>1</sub> to the rectifiers, so that their conductivity is reduced to a greater or less degree. This lessens the amount of absorption, and at the same time causes the high-frequency currents in the aerial to vary in amplitude.

As maximum radiation only takes place when the microphone is being used, there is less interference with other transmitters working on neighbouring wavelengths.

F. G. Frost and Sterling Works (Dagenham), Ltd. Application date January 1st, 1936. No. 468289.

## TELEVISION RECEIVERS

THE invention relates to the disposition of the various control knobs of a television receiver. The front of the panel is fitted with two knobs only. The first switches on the set, and, as it is further rotated, regulates the light intensity. The second knob, which serves to tune the circuits, is also

geared to an indicator scale which shows the appropriate settings for sound reception only, picture reception only, or for both picture and sound.

The rest of the controls are mounted at the back of the panel. One controls the synchronizing signals, and there are others for regulating amplification, the sharpness and size of the picture, and the line and image frequency.

Radio-Akt. D. S. Loewe. Convention date (Germany) December 4th, 1934. No. 468437.

## TELEVISION SYSTEMS

THE picture to be televised is scanned simultaneously, but over separate areas, by the ordin-

ary and extraordinary rays derived from a doubly-refracting prism. The method may be used, for in-

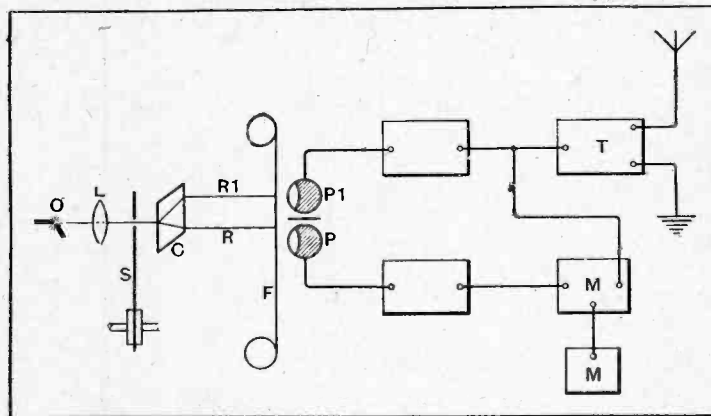

Schematic arrangement of television transmitter to produce stereoscopic effects.

stance, to produce stereoscopic effects, or a two-colour picture.

As shown in the drawing, light from a source O is focused by a lens L upon a scanning-disc S. It is then passed through a calcite prism C, which produces an ordinary ray R and an extraordinary ray R<sub>1</sub>. These fall upon different parts of the cinema film F to be projected, and are collected by two photo-electric cells P, P<sub>1</sub>.

Both the resulting signals may be transmitted over a common channel or line T by stepping-up the frequencies of one set of signals by a local heterodyne M, so that they do not overlay the frequency-band of the other set of signals. At the receiving end, the original frequencies are restored, and are then applied separately to modulate the two rays from a similar doubly-refracting prism.

Baird Television, Ltd., and G. E. G. Graham. Application date January 13th, 1936. No. 468837.

## PRODUCING INFRA-RED WAVES

PHOTO-ELECTRIC cells of the caesium-silver type produce maximum current when energised by infra-red light. Such light is therefore suitable for use in certain systems of television.

According to the invention an electric discharge lamp for producing infra-red rays is made by filling a bulb with a mixture of neon gas and caesium vapour at a specified pressure.

The General Electric Co., Ltd. (communicated by Patent-Treuhand Ges). Application date March 24th, 1936. No. 468805.

## MAGNETRON VALVES

THE Figure shows a section through the electrode system of a magnetron valve. Four anodes A are placed, along the sides of a square, around the central cathode C, the arrangement being such that, under the influence of the externally applied magnetic field, the electrons flow along a circular path, tangential to the anodes, as shown in dotted lines.

Auxiliary electrodes K are located at the corners of the square, where they lie outside the

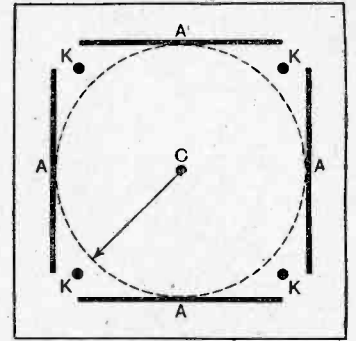

Section through electrode assembly of magnetron valve designed to have high sensitivity.

applicable for the generation, amplification, or reception of high-frequency oscillations. It is highly sensitive and requires only a small input control for modulation.

Telefunken ges. für drahtlose Telegraphie m.b.h. Convention date (Germany) October 16th, 1935. No. 468596.

## AUTOMATIC TUNING CONTROL

IN the known method of automatic tuning, which depends upon the operation of two circuits, one tuned a little above and the other a little below the fixed intermediate frequency, there is a tendency for a strong interfering signal to "pull" the receiver out of resonance with the desired signal.

According to the invention, this tendency is prevented by combining the control exercised by a pair of broadly-tuned circuits with a second or auxiliary control exercised by two more sharply-tuned circuits, such as a pair of piezo-electric crystals. The two control voltages are applied, in opposition, to a variable-impedance device—or to a motor—which then serves to keep the tuning in step with the desired signal.

J. Robinson. Application date January 10th, 1936. No. 469077.

## COMMON-WAVE BROADCASTING

WHEN transmitting the same broadcast programme from several stations simultaneously, on the same wavelength, it is necessary to supervise the several stations as regards synchronism, so as to avoid distortion due to phase differences in the overlapping waves at any given point of reception.

According to the invention this object is achieved by means of a Wheatstone Bridge circuit, which measures any phase deviation and automatically applies the necessary correction. The correcting device is characterised by the fact that, after each operation, it is brought back to normal, without the use of springs or similar restoring devices.

R. J. Berry (communicated by C. Lorenz Akt.). Application date May 1st, 1936. No. 468724.

The British abstracts published here are prepared with the permission of the Controller of H.M. Stationery Office, from Specifications obtainable at the Patent Office, 25, Southampton Buildings, London, W.C.2, price 1/- each. A selection of patents issued in U.S.A. is also included.

# The Wireless World

THE  
PRACTICAL RADIO  
JOURNAL  
27<sup>th</sup> Year of Publication

No. 951.

THURSDAY, NOVEMBER 18TH, 1937.

VOL. XLI. No. 21.

Proprietors: ILIFFE & SONS LTD.

Editor:  
HUGH S. POCOCK.

Editorial,  
Advertising and Publishing Offices:  
DORSET HOUSE, STAMFORD STREET,  
LONDON, S.E.1.

Telephone: Waterloo 3333 (50 lines).  
Telegrams: "Ethaworld, Sedist, Loudou."

COVENTRY: Hertford Street.

Telegrams: "Autocar, Coventry." Telephone: 5210 Coventry.

BIRMINGHAM:

Guildhall Buildings, Navigation Street, 2.  
Telegrams: "Autopress, Birmingham." Telephone: 2971 Midland (4 lines).

MANCHESTER: 260, Deansgate, 3.

Telegrams: "Iliffe, Manchester." Telephone: Blackfriars 4412 (4 lines).

GLASGOW: 26B, Renfield Street, C.2.

Telegrams: "Iliffe, Glasgow." Telephone: Central 4857.

PUBLISHED WEEKLY. ENTERED AS SECOND-  
CLASS MATTER AT NEW YORK, N.Y.

Subscription Rates:

Home, £1 1s. 8d.; Canada, £1 1s. 8d.; other  
countries, £1 3s. 10d. per annum.

*As many of the circuits and apparatus described in these  
pages are covered by patents, readers are advised, before  
making use of them, to satisfy themselves that they would  
not be infringing patents.*

## CONTENTS

	Page
Editorial Comment .. .. .	493
2-RF Straight Set .. .. .	494
The Super-Emitron Camera .. .. .	497
Unbiased .. .. .	499
Philips' 787AX Receiver .. .. .	500
Current Topics .. .. .	502
"U.S. Patent" .. .. .	503
Listeners' Guide for the Week .. .. .	504
Broadcast Brevities .. .. .	505
Principal Broadcasting Stations .. .. .	506
Auditorium Acoustics, Part IV .. .. .	508
Letters to the Editor .. .. .	510
Random Radiations .. .. .	512
Recent Inventions .. .. .	514

## EDITORIAL COMMENT

### Second-hand Sets

#### Bargains Available

**T**HERE are many people who continue to use the same receiver they have had for years, simply because there is at present no convenient method of disposing of it."

This comment was made on this page just over two years ago, when we stressed the importance of a satisfactory second-hand market for receivers as a means of enabling better sets to get into the hands of those of limited means and maintaining a healthy state of receptivity for new sets amongst the public generally.

To-day the second-hand set market should be regarded as even more important than it was two years ago, for the reason that we are very nearly reaching saturation point as far as acquiring wireless in homes in this country is concerned, and nearly all the sales of new sets now are to homes where a receiver is already in use.

The sale of sets to-day is to a replacement market, but what facilities are offered the public for disposing of the set they already have? They can in many cases do a deal with the local shop and get an allowance on the old set, but at the current allowance figures no member of the public would be ready to change a set until he has had almost the last ounce of use out of his existing one. There seems to be a conspiracy in the industry to create the impression that second-hand sets ought not to exist and are of practically no value. But the industry seems to forget that the public will hesitate to buy an article if the second-hand value is practically nil after a few months use.

#### A Problem to Solve

The local shop probably cannot be expected to give a better allowance on the old set and would much prefer not to have to take it over at all, yet there undoubtedly is a market for second-hand sets in good condition, and plenty of buyers

available. One outstanding difficulty lies in the cost of replenishing a set with new valves. Valves, like the sparking plugs of a car, require replacement from time to time during the life of a set, but we should be astonished if a new set of plugs cost us a sum approaching the value of the car, yet this is the position when we come to renewing valves in a receiver to-day.

The problem of creating a proper second-hand market has remained far too long unsolved, but solved it must be, unless sets are to remain in the same ownership year after year indefinitely.

### Super-Emitron

#### New Television Camera

**T**HE Super-Emitron camera, which is a very recent product of the E.M.I. Laboratories at Hayes, was brought into use by the B.B.C. for their television broadcasts of the Lord Mayor's Show, and a day or two later for the Cenotaph ceremony on Remembrance Day.

The new camera, a technical description of which is included elsewhere in this issue, constitutes a very striking improvement. It has overcome some of the greatest difficulties which those responsible for programme production came up against with the earlier, though still highly efficient, camera.

The new camera has a sensitivity many times greater than the old, so that in ordinary lighting a brighter image can be obtained, or a smaller aperture lens used to increase depth of focus. With the old camera full lens aperture was necessary on nearly all occasions, with a consequent shallowness of focus which hampered production efforts. The use of tele-photo lenses has also been made possible with the new camera, and outstandingly good results were obtained with such lenses in the recent broadcasts, which will have been recognised as constituting a new milestone in television history.

# 2-RF Straight Set

## Receiver Unit for Two-valve Quality Amplifier

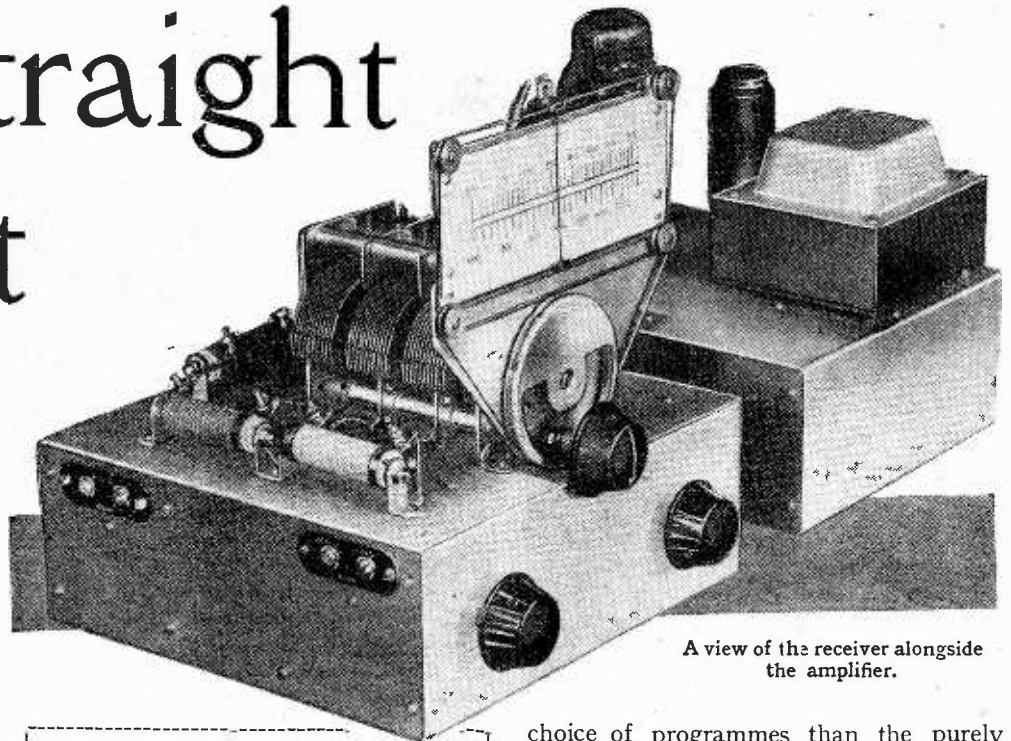

A view of the receiver alongside the amplifier.

**I**N a recent issue of *The Wireless World*<sup>1</sup> an inexpensive amplifier was described which is capable of giving really high quality of reproduction. The amplifier has two stages, the first being a high-gain triode and the second a low-resistance output triode. Resistance-capacity coupling is used, and an output of 3.5 watts obtained for an input of some 0.5 volt RMS. The mains equipment included is of sufficiently liberal design to enable a modest receiver to be operated from it as well as the amplifier, and a special receiver has been designed and is described in this article.

When considering the design of a receiver the starting point is always the performance which will be expected of it, and on this point people differ greatly. Some only want to receive the local stations at ultra-high quality, and are fortunate enough to live within a few miles of those stations; others chiefly desire to be able to receive distant stations, and need very high sensitivity and selectivity. The requirements of the majority come between these two extremes.

Most receivers are tuned to the local station for the greater part of their operating time, and it consequently seems unnecessary for such sets to be extremely sensitive and selective. Since the local

*DESIGNED for use with the 3½-watt Quality Amplifier recently described in "The Wireless World," this receiver has two RF stages and a diode detector. Three tuned circuits are employed and the first valve is controlled for AVC purposes. In the interests of quality of reproduction, AVC is not delayed.*

station may be anything up to, perhaps, 50 miles distant, however, these qualities must be present in good measure, but they need not be there to overflowing. A receiver which will give high-quality reproduction from the local station, but which is yet both sensitive and selective enough to enable a number of distant stations to be received with a reasonable aerial system, would seem to meet the requirements of the majority. Without great expense it enables them to secure a really high standard of reproduction, and at the same time it gives them a greater

choice of programmes than the purely local-station set.

The aim in designing this new receiver has thus been to produce a receiver, with a performance of the type described, in the least expensive manner. The straight set has been chosen in preference to the superheterodyne because it is much easier for the unskilled to adjust, and because it is quite free from self-generated whistles. Experience shows that at least three tuned circuits are necessary to obtain adequate selectivity, and there are two ways of arranging them. The most widely adopted scheme is to use a coupled pair for the input tuning system with a single RF valve, and the third circuit acting as the coupling to a reacting detector. This arrangement has several disadvantages; in the first place it is difficult to secure the proper waveband coverage because the intervalve circuit has across it the rather large input capacity of a grid detector; secondly, good ganging is difficult to secure because the reaction circuit affects the tuning of the intervalve coupling; thirdly, AVC cannot readily be obtained on account of the necessarily small detector input; and fourthly, the reaction con-

<sup>1</sup> *The Wireless World*, November 4th, 1937.

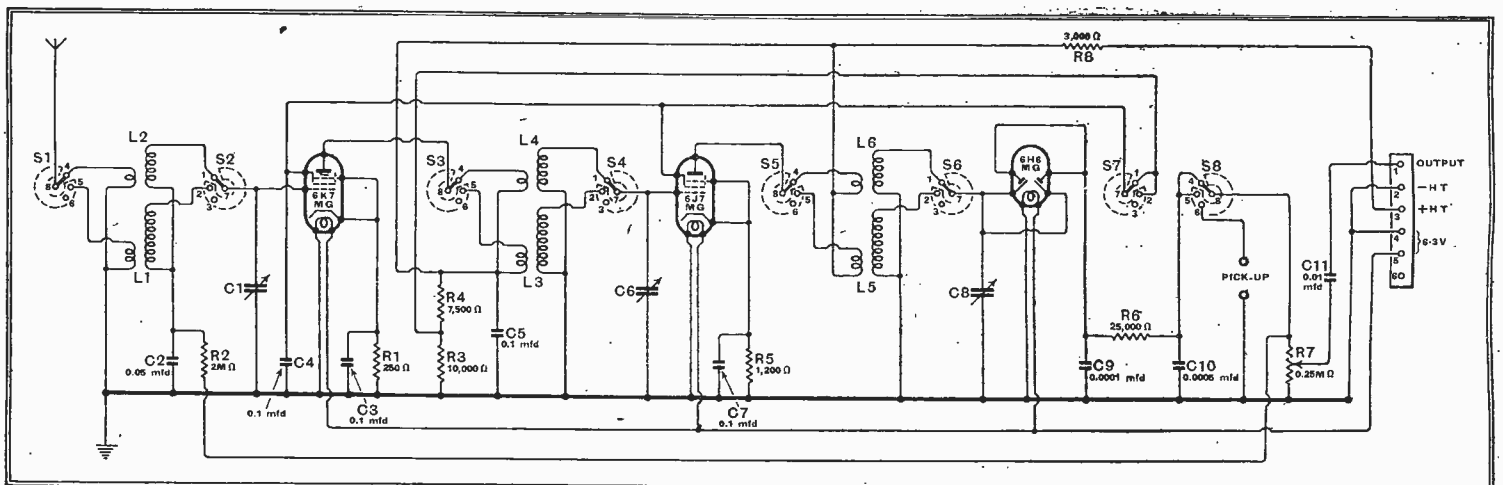

Fig. 1.—The complete circuit diagram is shown here. The tuned circuits all have high-inductance primaries.



**2-RF Straight Set—**

trol increases the difficulties of operation.

The alternative way of arranging three tuned circuits is to use them as inter-valve couplings; this necessitates two RF stages, but enables a diode detector to be used so that it is quite easy to obtain AVC, and reaction is unnecessary. If a simple form of construction is to be obtained no attempt should be made to secure the highest possible amplification from the valves. High gain demands very thorough screening if stability is to be obtained, and, moreover, it would not be balanced by the selectivity of three tuned circuits. If we are content with amplification proportionate to the selectivity, we shall find that quite a modest amount of screening will be satisfactory.

In view of these points it was decided that a receiver with three tuned circuits, two RF stages and a diode detector, would give the desired performance. The circuit diagram appears in Fig. 1, and it will be seen that the general arrangement is extremely simple. RF transformers are used for all couplings, and the primaries are resonant at a frequency lower than any within the tuning range,<sup>2</sup> thus enabling more nearly constant sensitivity and selectivity, and better ganging, to be secured than if the more usual small primary transformers were used.

For clarity the individual switches are

<sup>2</sup> *The Wireless World*, November 4th, 1937.

shown separately on the diagram. Actually, there is a pair of switches on each of the four switch-plates; thus S1 and S2 form a single switch-plate. The first valve is a 6K7MG, a variable-mu valve of the low mutual conductance type, and it is controlled for AVC purposes, the AVC bias being applied through the filter R2 C2. The initial bias is provided by the cathode resistance R1 of 250 ohms, which is by-passed by the 0.1  $\mu$ F. condenser C3.

**The RF Amplifier**

The second stage is a 6J7MG, an RF pentode of the non-variable-mu type. This valve takes quite a small anode current, and an unusually high value of bias resistance is consequently needed to develop the normal bias of 3 volts. This resistance is R5, and it has a value of 1,200 ohms; it is by-passed by the 0.1  $\mu$ F. condenser C7.

The 6H6MG diode consists actually of two separate diodes built in the same envelope. As only a single diode is needed, the anodes and cathodes are joined together in the manner shown on the diagram. The usual RF filter circuit, comprising R6, C9, and C10, is included, and the load resistance takes the form of a volume control potentiometer, and has a value of 0.25 M $\Omega$ .

The anode and screen supplies at about 250 volts and 100 volts are taken from

the voltage divider built up of R8, R4 and R3. A point which many may find surprising is the absence of decoupling in the RF stages. Actually, experiment proved that a single by-pass condenser C5 for the anode, and another C4 for the screen, supplies is adequate. The receiver was originally built with full decoupling in all circuits, and when it was found to be com-

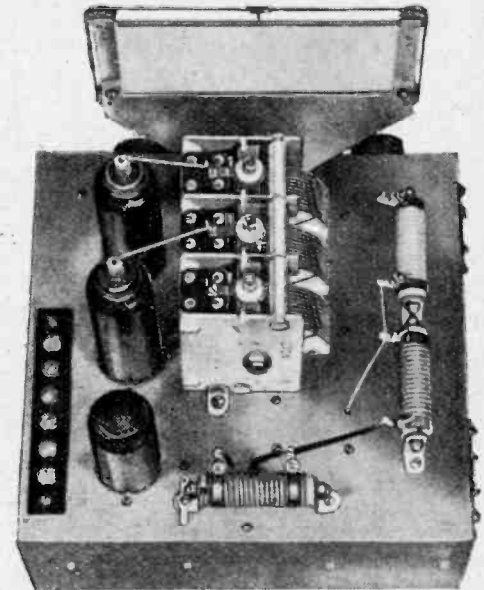

The voltage-divider is mounted on the top of the chassis to permit good ventilation.

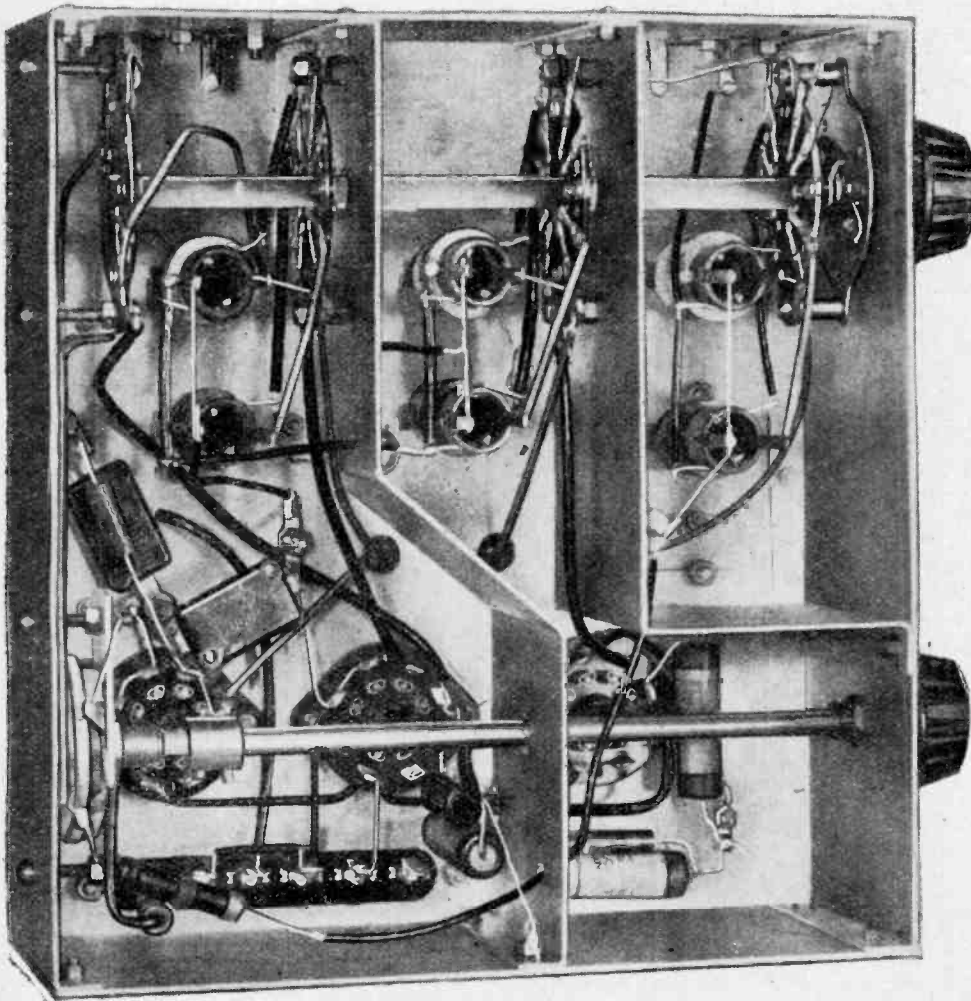

An under view of the receiver showing the layout of components and wiring.

pletely stable the decoupling components were removed one at a time until the present condition of only two by-pass condensers was reached. The receiver was still quite stable, and the reduction in components not only simplified the wiring, but reduced the cost of the apparatus.

Provision is made for the use of a gramophone pick-up, and the volume control R7 operates on both radio and gramophone. The change-over is effected by S8, and S7 breaks the screen circuit of the RF valves on gramophone to prevent any interference. Actually all switches are operated by the same control knob, and for clockwise rotation the three positions are: Long Wave, Medium Wave, Gramophone.

**The Construction**

The construction of the receiver calls for little comment, but the wiring of the switch plates should be carried out before the switch rod, which with its locator plate is mounted on the detachable front of the chassis, is inserted. Wires should also be attached to the S7 and S8 switch plate before the chassis front is placed in position, as the soldering tags are afterwards inaccessible.

When wiring the valve-holders, care should be taken to identify the sockets by their position relative to the keyway and not by the mounting holes. The relative position of the keyway and mounting holes differs in different makes of holder.

The valves actually used in the original model were American metal-glass types, but metal types can be used without



**2-RF Straight Set—**

alteration. If glass valves are used, either American or British, valve screens must be fitted, and the valve-holder spacing is sufficient to permit their use. In most British types, and in the American, the glass valves bear the type numbers 6K7G, 6J7G, and 6H6G. In the

Marconi and Osram ranges, however, the valves are listed as W63, Z63, and D63.

The receiver is so designed that it can be placed alongside the amplifier and the input and output terminals cross-connected. If desired, however, the units may be separated and a 5-way cable used for their connection. The heater leads

should be of generous size, but need not be exceptionally heavy for cable lengths up to one yard, for the current is only 0.9 ampere.

**Satisfactory Performance**

The initial adjustments are confined to the three trimmers on the gang condenser, which should be adjusted at the lower end of the medium waveband for maximum signal strength. Owing to the action of AVC it is a good plan to connect a voltmeter across R1 to serve as an indicator, and the adjustments should be carried out for minimum reading of the meter.

On test in London the receiver proved capable of giving quite a large number of Continental stations, such as Fécamp, Paris, Cologne, and Brussels on the medium waveband, and Luxembourg, Paris and Huizen on the long. At night many more could be obtained, and the selectivity proved sufficiently high to permit satisfactory reception of the stronger distant stations. The "spread" of the locals is, of course, greater than with a superheterodyne, but to counter-balance this there are no whistles. Actually, in daylight, Fécamp could be well received clear of the London National transmission.

Quality of reproduction proved exceedingly good, and the signal/noise ratio, as one might expect, very high.

**LIST OF PARTS REQUIRED**

*Certain components of other makes but of similar characteristics may be used as alternatives to those given in the following list*

- 1 Variable condenser, 3-gang, 0.0005 mfd. C1, C6, C8 Polar Bar Type
- 1 Dial Polar VP Horizontal Drive
- Fixed Condensers:
  - 1 0.0001 mfd., mica, C9 T.C.C. "M"
  - 1 0.0005 mfd., mica, C10 T.C.C. "M"
  - 1 0.01 mfd., tubular, C11 T.C.C. 451
  - 1 0.05 mfd., tubular, C2 T.C.C. 341
  - 4 0.1 mfd., tubular, C3, C4, C5, C7 T.C.C. 341
- Resistances:
  - 1 250 ohms, 1/2 watt, R1 Erie
  - 1 1,200 ohms, 1/2 watt, R5 Erie
  - 1 25,000 ohms, 1/2 watt, R6 Erie
  - 1 2 megohms, 1/2 watt, R2 Erie
  - 1 3,000 ohms, 20 watts, R8 Bulgin PR8
  - 1 7,500 ohms, 20 watts, R4 Bulgin PR10
  - 1 10,000 ohms, 20 watts, R3 Bulgin PR11
- 1 Volume control, tapered, 0.25 megohm, R7 Ferranti PG
- 2 RF transformers, MW, L3, L5 Wearite PHF2
- 2 RF transformers, LW, L4, L6 Wearite PHF1
- 1 Aerial coil, MW, L1 Wearite PA2
- 1 Aerial coil, LW, L2 Wearite PA1
- 1 Switch assembly, 4-plate, 3-way B.T.S. C423
- 1 Coupler for 1/4 in shafts Bulgin
- 1 Length rod, 7 in. x 1/4 in. dia. Bulgin
- 1 Panel bush, 1/4 in. Bulgin 1048
- 3 Valve holders, octal type Premier Supply Stores
- 1 Skeleton captive screw strip, 2-way, "PU" Bulgin T10
- 1 Skeleton captive screw strip, 2-way, "AE" Bulgin T10
- 1 Skeleton captive screw strip, 6-way Bulgin T12
- 2 Valve top clips, octal type Bulgin T96
- 2 Knobs Bulgin K.24
- Chassis B.T.S.
- Miscellaneous: Peto-Scott
  - 3 lengths systoflex; 2oz. No. 20 tinned copper wire, etc. Screws: 40 1/4 in. 6 BA R/hd.; 6 1/4 in. 4 BA R/hd.; 4 1 in. 4 BA R/hd.; 4 1/2 in. 4 BA R/hd. all with nuts and washers.
- Valves:
  - 1 6K7MG, 1 6J7MG, 1 6H6MG. Premier Supply Stores

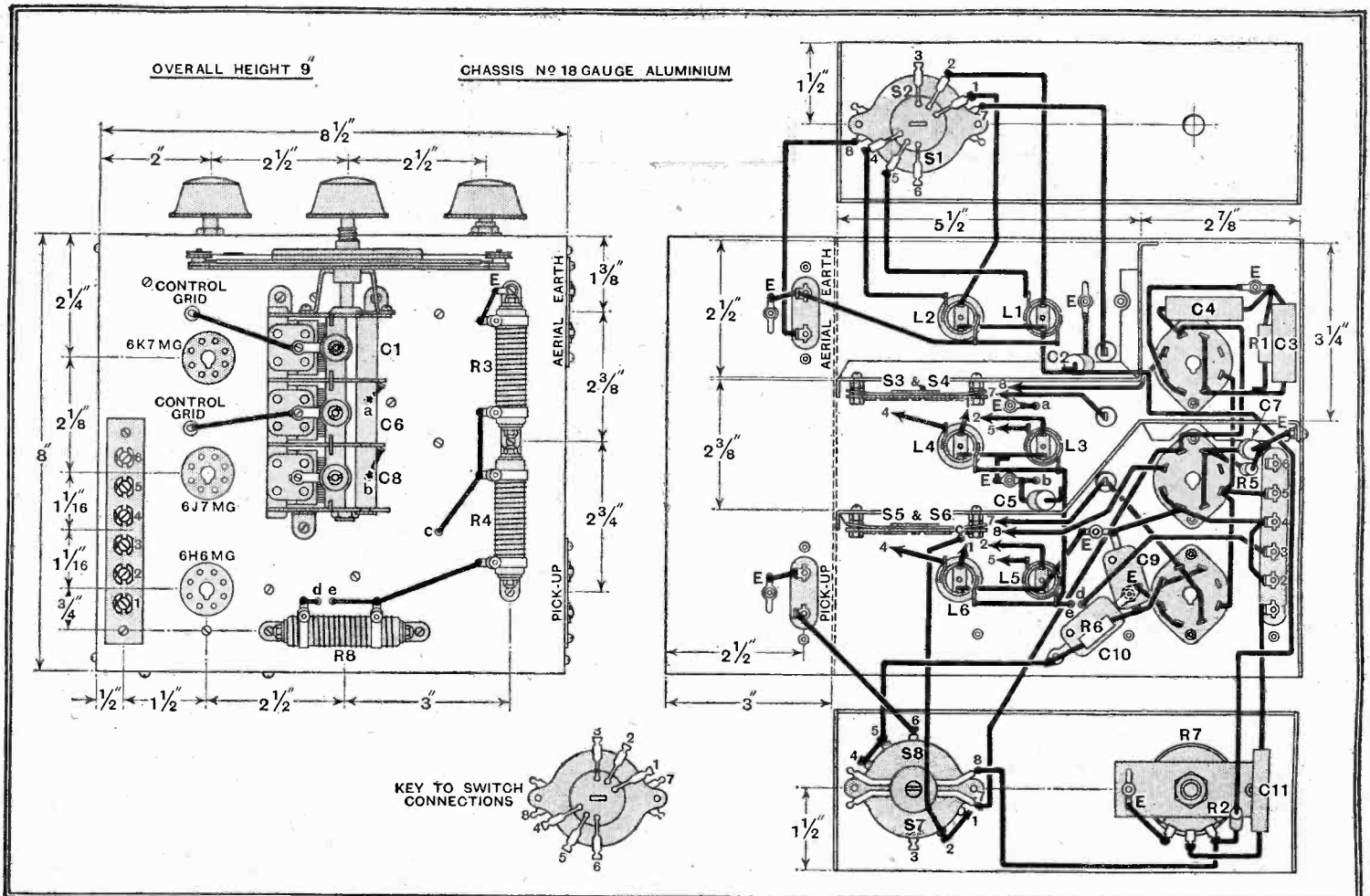

Full constructional details appear in these drawings, which also fully show the wiring. The connections to two of the switch-plates are indicated by numbers and must be joined to the correspondingly numbered tags on these plates.

# Super-Emitron Camera

NEW TELEVISION EQUIPMENT FIRST USED FOR THE LORD MAYOR'S SHOW AND CENOTAPH BROADCASTS

THE principles of operation of the Emitron camera used in present-day television by the London Television Station have been previously described,<sup>1</sup> and its performance over a considerable period has been proved excellent as all viewers can testify. The camera is, in fact, highly sensitive, as is evidenced by the good outdoor broadcasts which have occurred from time to time. The attainment of this high sensitivity, however, necessitates the use of a large aperture lens with a correspondingly low depth of focus. This means that objects at different distances from the camera cannot be sharply focused simultaneously, and even small movements of the object are sufficient to throw out the focus. This can often be observed in a close-up of a singer, at one moment he is sharply focused, at the next he moves towards the camera and is blurred until the operator refocuses.

A new Emitron of higher sensitivity and much wider scope has now been developed by E.M.I. This camera, which has been named the "Super-Emitron," operates on different lines from the older type of Emitron. In the old type camera the picture is focused upon a mosaic of photo-cells which become charged due to the liberation of photo-electrons, the stored up charges being then discharged by the scanning electron beam. The Super-Emitron also has a mosaic which is scanned by an electron beam, but the

mosaic need not be photo-electric, since an entirely separate photo-surface is provided. This separation of the photo-surface from the mosaic is fundamental to the operation of the tube and brings very important advantages.

There are several forms which the construction of the new Emitron can take, and one of the simplest is shown in Fig. 1, which is taken from British Patent Specification No. 442,666. An evacuated glass container has a photo-electric screen mounted at one end and a mosaic screen at the other, while an electron gun is mounted in a tube which is let into the side of the main body at an angle, so that the cathode-ray beam can scan the mosaic screen. Between the two screens is a metallic cylinder of large diameter which

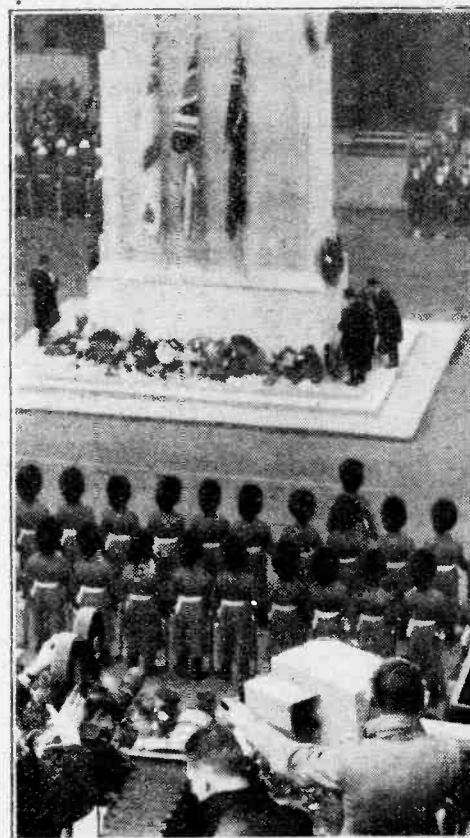

Occupying a position of advantage, shared with the news-reel teams, practically opposite the Cenotaph, the new television camera is seen in action during the transmission.

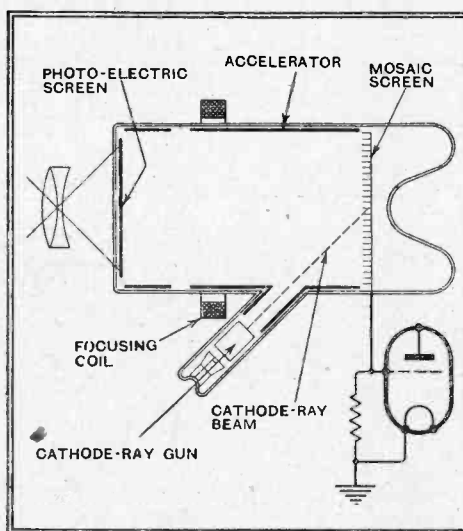

Fig. 1. The main details in the construction of the Super-Emitron camera are shown in this drawing.

made of a secondary emissive material which is deposited upon a sheet of mica, the mica forming the dielectric between the elements of the mosaic and a continuous metal backing plate. Each element of the mosaic thus has a given capacity to the backing plate. (In some cases it is found that the mica sheet can itself serve as a mosaic, no additional secondary emissive material being necessary.)

Referring to Fig. 1, the scene to be televised is focused on the photo-electric screen by means of a suitable optical lens system. Each point on the screen then emits electrons in proportion to the amount of light falling on that point. These electrons are accelerated towards the mosaic screen by the positive accelerating electrode and are focused to produce a sharp electron image thereon by the magnetic field set up by the external focusing coil, through which a suitable direct current is passed.

### Secondary Emission

Owing to the secondary emissive properties of the mosaic screen material, each photo electron which strikes this screen liberates on an average several secondary electrons. These secondary electrons are attracted to the positive accelerator. The net loss of electrons causes each element of the mosaic to become more positive relative to the backing plate, so that each minute condenser formed by the capacity of each element to the backing plate becomes charged. This charge is proportional to the difference between the number

is maintained at a positive potential with respect to the photo-electric screen, and which is known as the accelerator. A coil is mounted outside the tube for producing a magnetic field which focuses the electron image on to the mosaic.

The elements of the electron gun are conventional and, consequently, need not be explained here. The usual deflecting coils for the scanning process are mounted around the narrow neck of the tube.

The photo-electric screen can be deposited on a transparent plate mounted internally, or it can be deposited on the inside surface of the glass end-wall of the tube. In either case it can consist of a layer of silver with a silver-oxide surface upon which is deposited a layer of caesium, the whole coating being so thin that it is semi-transparent. The mosaic is

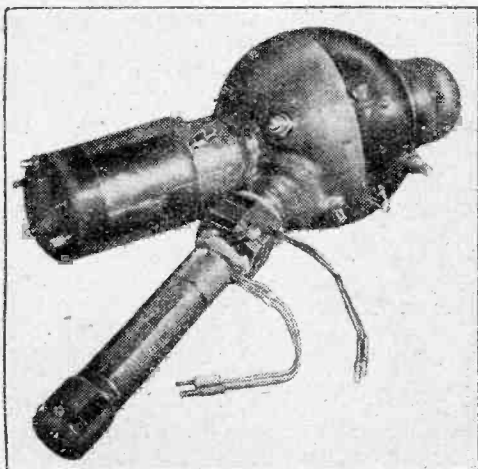

A view of the tube used in the Super-Emitron camera. The deflecting coils can be seen around the neck of the lower cylinder containing the cathode-ray gun.

<sup>1</sup> Wireless World, Nov. 4th, 1937.

**Super-Emitron Camera—**

of secondary electrons leaving each element, and the number of primary electrons reaching it from the corresponding point on the photo-electric screen during one frame period. In turn, the number of primary electrons is proportional to the amount of light falling upon that part of the screen. The charge of each minute condenser is thus proportional to the light on the corresponding part of the picture.

The mosaic screen is scanned by the cathode-ray beam, and as each element has a positive charge, owing to its net loss of electrons, it receives electrons from the beam in sufficient quantity to neutralise its charge. As the beam sweeps over the elements composing the mosaic it delivers electrons to the elements in varying quantities which depend upon the magnitudes of their charges, and this varying loss of electrons constitutes a varying current which produces a varying voltage across a resistance in the external circuit. This voltage is applied to a valve and amplified in the usual way.

In the ordinary Emitron the picture is focused on the mosaic screen, which is made of photo-electric material, and the charging of the minute capacities takes place because the photo-electric material loses electrons under the influence of light. In the Super-Emitron the photo-electric and mosaic screens are separate and the electrons lost by the former under the influence of light are made to eject a greater number of electrons from the latter by means of secondary emission.

It is easy to see that the separation of

the photo-surface from the mosaic brings advantages. The photo-surface may be made transparent so that the limitations placed upon the optical projection system by the geometry of the present Emitron are removed, and lenses of shorter focal length and wider angle of view or telephoto lenses may be used. Further, by making the mosaic from substances having high secondary emission considerable electron multiplication is obtained, thus giving additional sensitivity. Again, the sacrifice of photo sensitiv-

The standard television camera is seen overlooking the Super-Emitron at work on close-ups during the Lord Mayor's Show.

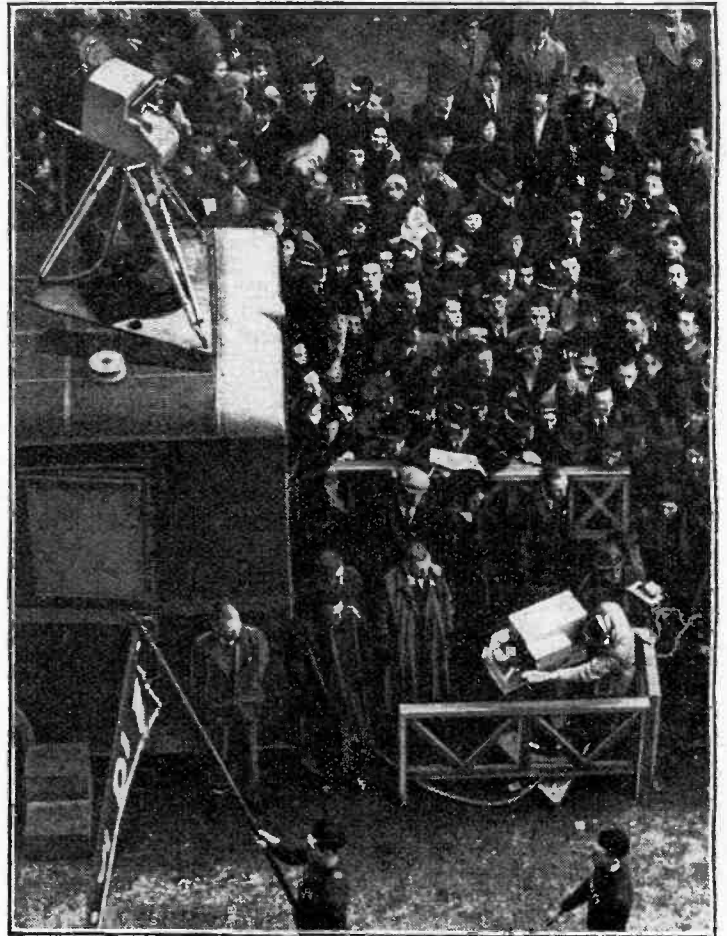

ity necessitated by the requirement of inter-element insulation in the case of the photo-electric mosaic used in the old Emitron no longer remains, and full photo-

sensitivity can be readily obtained.

The result is that the Super-Emitron is considerably more sensitive than the old Emitron. Because of this, less illumination of the subject is necessary for the attainment of a good picture if the normal aperture lens system is retained. This is especially valuable in outdoor broadcasts on dull days, or when using a telephoto lens for the reproduction of distant scenes. If the normal illumination is retained, however, the aperture of the lens can be reduced, with a consequent gain in focal depth. For studio work this is the more important aspect, and should lead to a great improvement.

### Next Week's Issue

## VALVE DATA NUMBER

THE appearance of the issue of *The Wireless World* with pages particularly devoted to the subject of valves is now looked forward to as an important annual event. A specially prepared

### VALVE DATA SUPPLEMENT

will be included in this enlarged number, in which will be given a full list of over 900 valves now on the market, including American types, with tabulated details of their characteristics.

The issue will also contain pages devoted to articles and regular features covering the normal field of the journal.

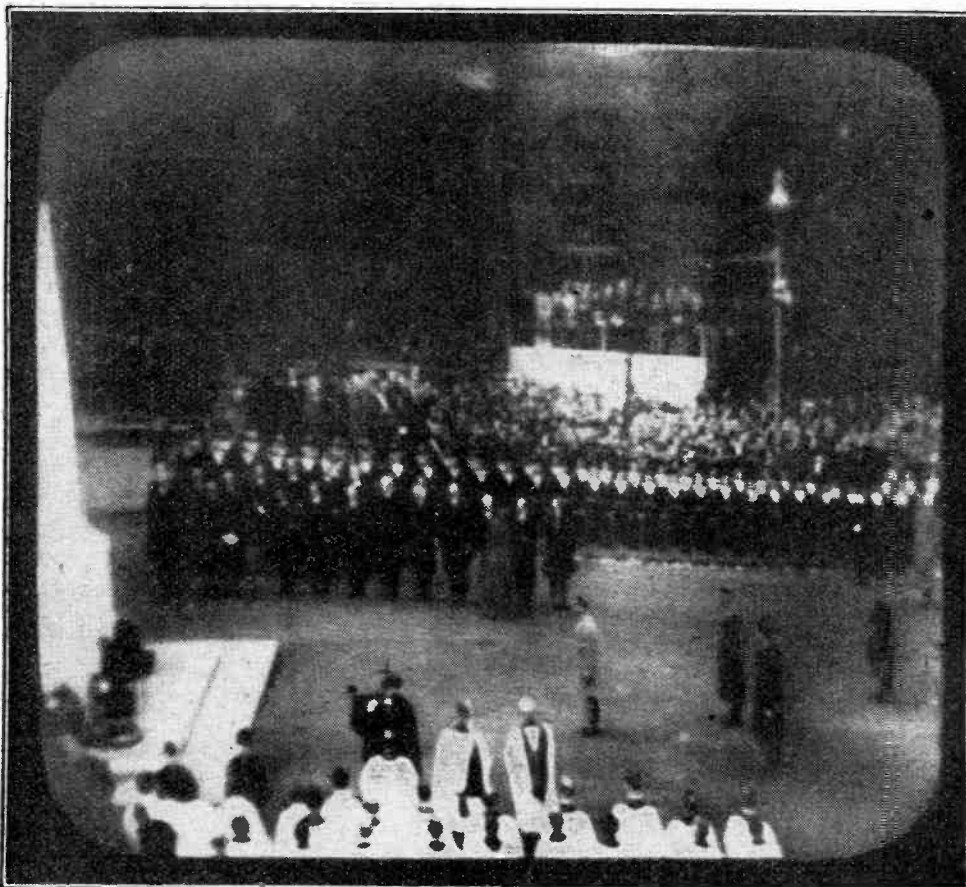

The benefit of the new camera to viewers was most marked: a greatly improved picture resulted. The reproduction above was made from an untouched photograph of the television screen.



# UNBIASED

By FREE GRID

## True Television or Not?

OWING to my having a somewhat sensitive and refined nature I have, throughout my life, always fought shy of the rather coarse and ultra-Bohemian atmosphere of the average public-house. But I must confess that, of late, I have been a fairly regular customer at one of these houses of refreshment. In order to prevent any misapprehension arising in your minds, I may say at once that my regular attendance at this drinking den has been dictated solely by a sense of duty towards you which demands that I investigate to the full anything new which comes along in the world of wireless, no matter if in so doing I am compelled to drain to its dregs the cup of personal inconvenience and aversion.

As many of you know, several London pubs have installed television receivers, and the vested interests of the brewers, which we hear so much about, have been used to compel the B.B.C. to put on the thirst-provoking television programmes which they do.

Now, ordinary television in an ordinary pub would certainly not attract me, but it came to my ears that in a certain one a projection-type of television receiver had been installed; and, as this type is still more or less in the laboratory stage and unlikely to be available commercially for quite a long time to come, I was naturally interested. I found that the television gear itself was in a room adjoining the saloon bar, the screen, about the size of the average home cinema one, showing through a hole in the wall.

All went well until the other evening when, without any warning, the local power station played into the hands of Mr. Therm once more by letting London down and plunging the whole place into darkness. It was not until long after the television hour had passed that the light came on again. To my astonishment the television show came on again, too, and continued from the exact point at which it had been broken off. It went on for the best part of a minute, and then abruptly ceased again.

As soon as I had recovered my self-possession I expressed myself somewhat forcibly to the effect that there must be dirty work at the cross-roads somewhere and that we hadn't been seeing television at all. The other denizens of the bar immediately rounded on me warmly for what they termed my unworthy suspicions, and I momentarily expected personal violence. Furthermore, my technical knowledge was called into question, as one scruffy-looking little bar-lounger pointed out that I probably didn't know enough about television to realise what was the explanation of



Draining to its dregs.

what had happened; this irritated me rather severely, for, after all, it was more or less true.

Fortunately, the pub owner came to my rescue, and, furthermore, he showed me the apparatus, which turned out to be the latest attempt to solve the large-screen television problem. The picture came from a very small cathode tube, and was projected through a lens directly on to a film of a specially made sub-standard home-talkie camera. The exposed film passed straight through first a processing bath and then a home-talkie projector, and in this manner a large picture got on to the screen. It was, in fact, nothing more or less than the "delayed-film" system of television applied rather ingeniously to the receiver instead of to the transmitter end.

## Not Guilty

AS a result of my recent protest against the over-loud loud speaker (22.10.37) I have been receiving a large number of letters accusing me of heresy and attempted schism. Most of you seem to think that I was basely attacking certain technical arguments that have recently appeared in this journal, and, in particular, the article on Scale Distortion by my old friend Cathode Ray, which came out on September 24th. What is worse still, some of you seem to think that I have been guilty of the old political trick of maliciously insinuating that the article in question was advancing the obviously absurd argument that first-class reproduction is impossible unless the sound output from the loud speaker is the same as that of the original signal.

## An Example for the P.M.G.

I HAVE received a very interesting letter from one of my Continental readers in connection with a recent paragraph I wrote concerning unsolved murders. I suggested that the solution of the many apparently motiveless murders with which the police are confronted from time to time lay in the annoyance caused by certain thoughtless listeners who exasperate their neighbours by operating their loud speakers at unnecessarily large volume. Such conduct can only have one end, and that is the quiet removal of the offender from this troubled world by the outraged neighbour.

Judging by a letter I have received,

this country is by no means the only one where this loud speaker nuisance exists, but in my correspondent's country the Government has apparently been doing something about it instead of indulging in the apathetic attitude of the authorities over here. The Government Department concerned with broadcasting in my reader's enlightened land has apparently been quietly investigating the matter and searching for the true reason why certain wireless listeners operate their loud speakers at excessive volume. It has been found that it is mainly due to a total lack of musical appreciation. Real music-lovers never overrun their loud speakers, for the simple reason that the resultant bellowing distortion causes distress to their sensitive nature.

In view of the result of this enquiry the Government in question is preparing something in the nature of a bombshell for broadcast listeners. Although it is being kept dark at present, I am informed that everybody who wishes to take out or to renew their licences after a certain date will have to pass a special tuning test, just as a would-be motorist has to pass a driving test over in this country.

Owing to the fact that my correspondent holds an important Government position in his native land, he is able to let me have these advance details which he has given me permission to pass on to you, provided, of course, that I do not disclose the name of the country until the whole thing is made public. He tells me that not only will there be careful tests to see

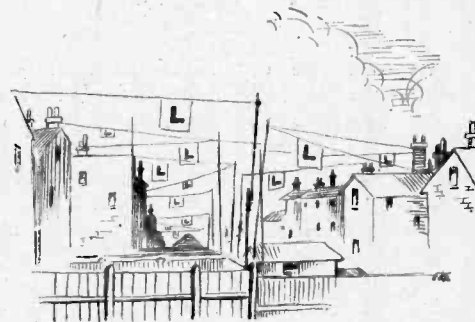

Learning to listen.

that would-be listeners know how to tune a set properly without being spoon-fed by automatic tuning and other trouble-saving devices of this decadent age, but they will have to undergo a very rigid examination as to their knowledge and appreciation of good music.

By this means, my informant states, the Government hopes not only to eradicate the loud-speaker nuisance, but to raise the whole cultural standard of the country, since everybody will naturally set himself to study, and learn to appreciate the best in music, as he will realise that unless he passes the test it will mean the end of his listening. Provisional licences will be granted to listeners in order to give them a chance to learn, and, following the example of embryo motorists over here, every holder of a temporary licence will have to have a large letter "L" hanging from his aerial.



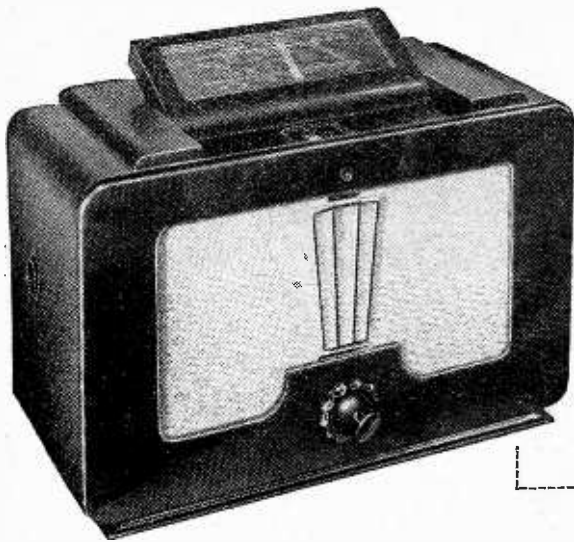

# Philips TYPE 787AX

**FEATURES.**—*Circuit.*—Triode hexode frequency-changer—var.-mu pentode IF amplifier—double-diode-triode signal rectifier and gramo. amplifier—double-diode-triode AVC rectifier and first AF amplifier—two pentode output valves in parallel. Full-wave valve rectifier. *Controls.*—(1) "Mono-knob" incorporating tuning, volume, tone, selectivity and waverange. (2) Contrast amplification switch. (3) Bass control switch. (4) Internal loud speaker switch. (5) Mains aerial switch. (6) Mains on-off switch. **Price.**—19½ guineas. **Makers.**—Philips Lamps Ltd., 145, Charing Cross Road, London, W.C.2.

## Fine Quality and Volume from a Circuit of Unusual Technical Interest

**I**N repose this receiver has an air of simplicity which belies its true character, for not only is the design an outstanding example of the strides which have recently been made in modern research, but the performance from every point of view is one which is calculated to arrest the attention even of the hardened professional radio engineer, who is often too ready to indulge in cynicism at the expense of the mass-produced broadcast set.

First and foremost there is the quality of reproduction, which will cause many of us to revise our ideas of what we thought to be the limitations of table-model receivers in this respect. Two pentode output valves in parallel, each capable of an undistorted output of between 3 and 4 watts, give some idea of the volume level available. This is accompanied by an extraordinarily low level of harmonic distortion, with the result that in the middle and top registers the reproduction is crystal clear without the usual confusion of sound in concerted music. But it is the bass response which chiefly draws our admiration, for it is no mere make-weight to balance the middle and upper registers, but a solid foundation, mobile and uncoloured by any obvious resonance. A switch is provided to cut down the low-frequency response for some types of broadcasting such as speech, but our feeling was that the full bass response is without any adverse effect even on the male voice, and in our opinion this, more than anything else, is proof of the skill with which the frequency range has been extended in the low-frequency range.

The design of the cabinet, particularly from the point of view of rigidity, must take some share of the credit for the good quality of reproduction, and it is interesting to note once again the use of the off-set loud speaker. On the electrical side the special negative feed-back circuit adopted makes the most important con-

tribution. A portion of the output from the loud speaker transformer secondary is fed back through high-frequency and low-frequency AF filters to the input circuit of the first AF stage. Included in the high-frequency filter circuit is an arrangement for introducing a sharp trough at 9,000 c/s, the most common frequency for heterodyne whistles between stations. Advantage is also taken of the negative feed-back circuit to provide contrast amplification by means of a special pilot lamp, the resistance of which alters under

the influence of the feed-back speech currents. The practical advantage of this feature is not obvious at low-volume levels, but above, say, 1½ watts there can be no doubt of its value on orchestral items where the range of volume levels is wider than that which can be conveniently handled by the transmitter. On gramophone records the effect of switching in the contrast volume expansion is even more marked.

Distortion in the AVC circuits, which is a prevalent source of increased harmonic content, has been considerably reduced in the Philips set by the use of a separate diode for signal rectification and two diodes for AVC supply. One of these diodes is employed in the usual way to provide the control bias and the other provides the delay by acting as a

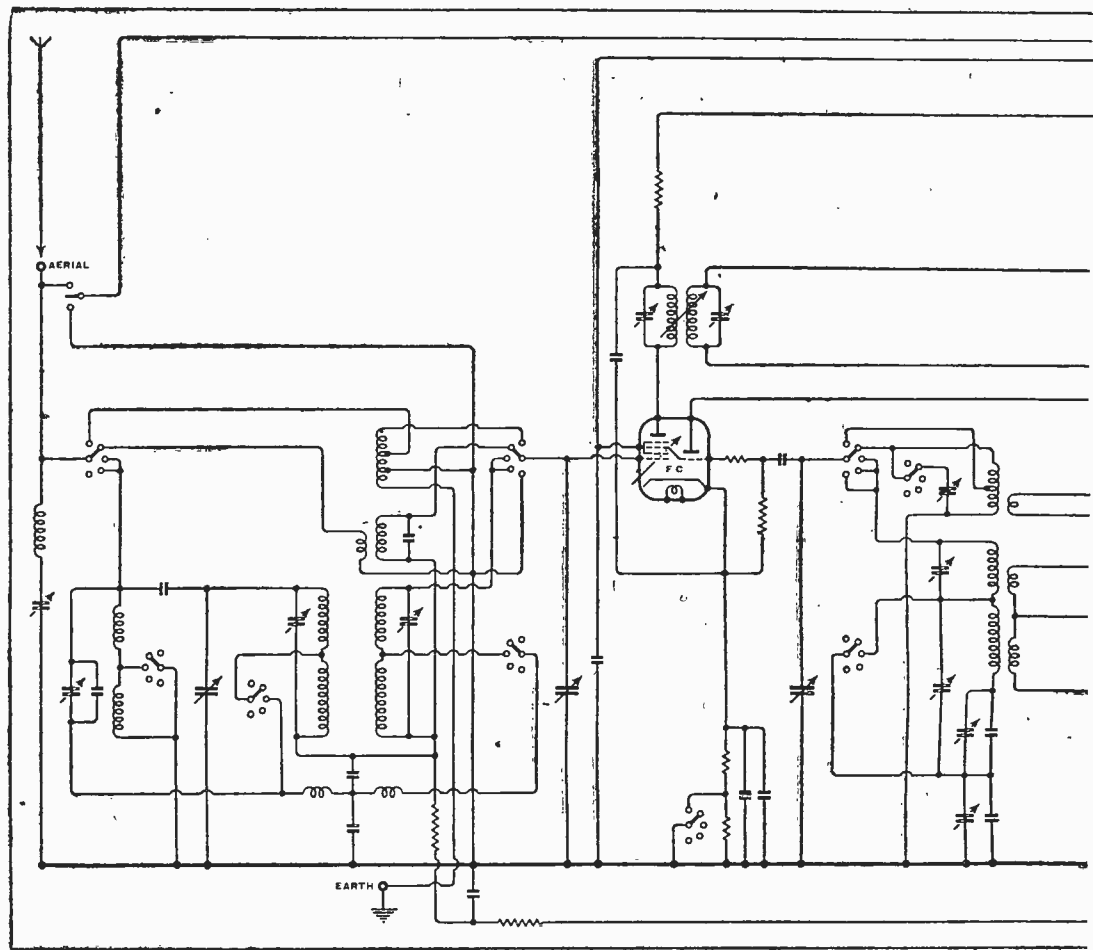

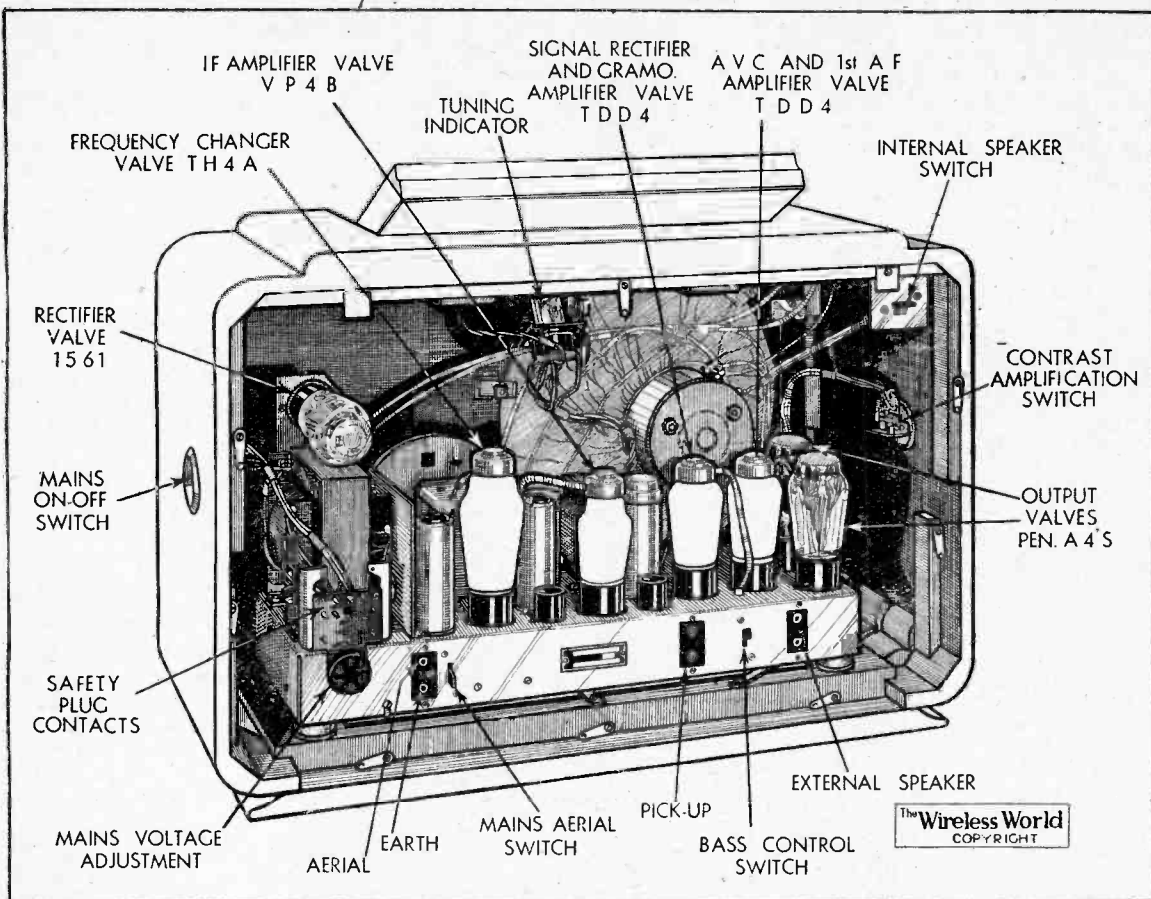

temporary shunt until the signal input reaches a pre-determined value. Two double-diode-triode valves are employed, but only the triode amplifying part of the second valve is used for amplifying the rectified signal from radio transmissions. The first triode is added for gramophone reproduction in order that adequate amplification may be retained while still using the negative feed-back circuits.

As might be expected in a set of this calibre, variable selectivity has been provided, and ganged with the variable selectivity control is a combined tone control which reduces bass as well as treble response, while increasing the output in the middle register in the position of highest selectivity.

All these various controls are concentrated in the unique Philips "Mono-knob" control in which rotation of the knob adjusts the tuning, movement in a vertical plane the volume, and in a horizontal plane the tone and selectivity. An annular ring surrounding the knob actuates the waverange switch.

To those accustomed to the ordinary system of receiver controls this feature may at first prove puzzling, but one soon

General view of interior of cabinet showing auxiliary switches. The safety plug is provided with two positions in order that the set may be operated directly from AC mains or from DC mains through a vibratory converter unit.

The circuit diagram shows many breaks with convention. Separate valves are used for signal rectification and AVC supply and an additional stage of AF amplification is provided in order that the benefits of negative feed-back may be retained for gramophone reproduction.

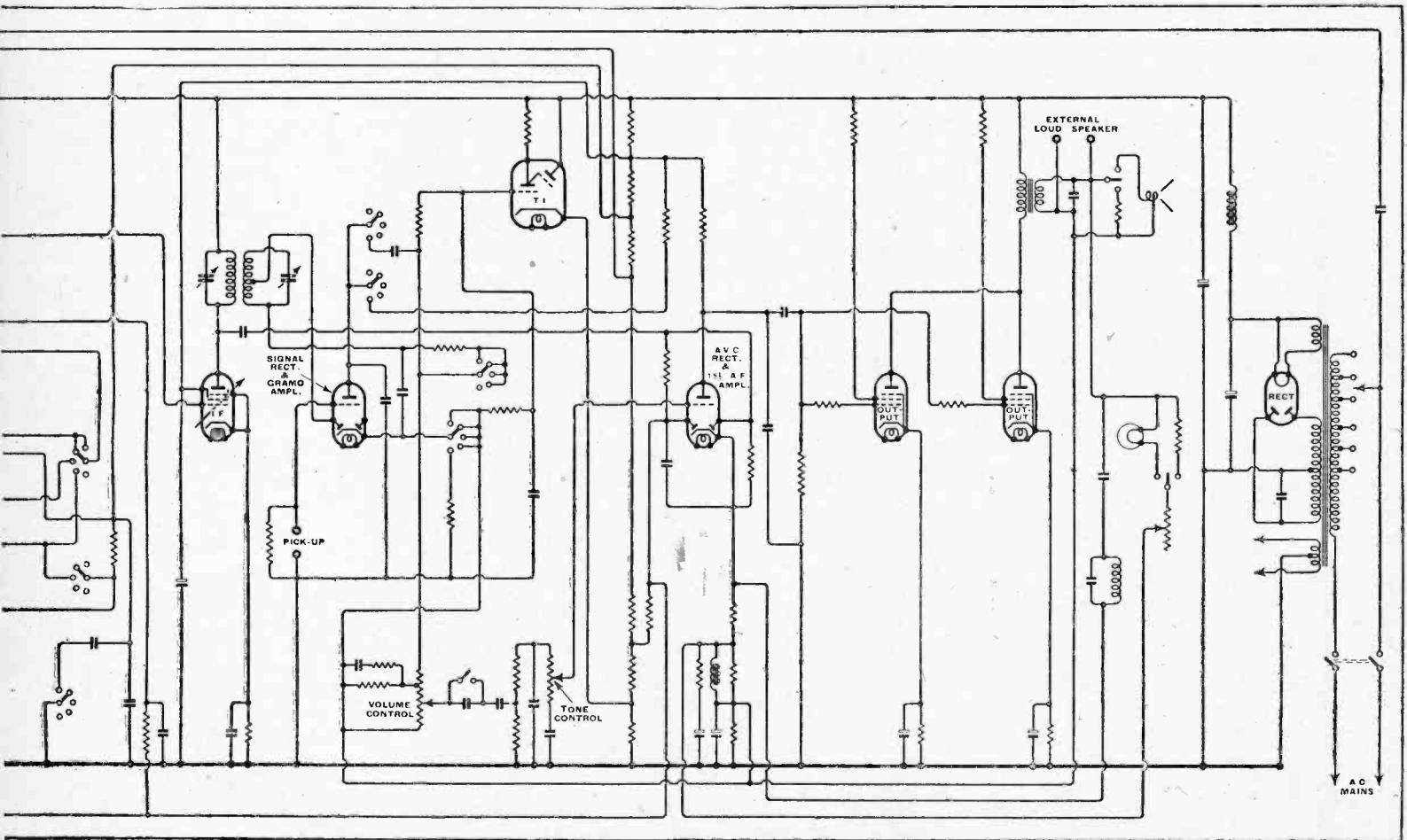

**Philips Type 787AX—**

gets the feel of the thing and avoids the only possible pitfall of accidentally rotating the tuning knob when altering volume or tone. Incidentally, the "Mono-Knob" has now been in use in Philips sets for more than a year, and its continuance may be taken as proof of its success in the hands of the public.

Coming now to the performance of the set in the matter of range and selectivity, we were most impressed by the liveliness of the set on medium- and long-wavelengths, and by the high sensitivity below 200 metres and above 500, where the majority of sets show some falling off. With the control set for maximum selectivity adjacent channel separation on distant stations is easy, and in the presence of a strong signal from the local Regional station, not more than one channel is lost on either side of the medium wavebands. On long waves we have seldom heard the Deutschlandsender with less sideband interference from the adjacent British and French stations, or with such a reserve of volume. The set is remarkably free from whistles of every kind, and altogether is just the kind of set one would choose for systematic long-distance reception of Continental stations.

On the short-wave band there is plenty of punch down to the 16-metre broadcast band, though in the short length of scale which remains below this band the sensi-

tivity falls off fairly rapidly. Three American broadcast stations were received without any difficulty, but it was found advisable not to rely on the tuning pointer for final adjustment, as a small amount of backlash, which passed unnoticed on the medium-wave band, became apparent under the more exacting requirements of short-wave reception. There is, however, no backlash between the tuning control knob and the condenser vanes, so that whether one tunes by ear or by the electron tuning indicator no difficulty is experienced. The ultra short-wave band has a much higher sensitivity than the majority of sets in which there is provision for reception of the television sound transmission, and several interesting amateur transmissions were logged on the 10-metre band. In the absence of an RF stage with its extra preselection circuit and with a 128 kc/s IF stage, well-marked repeat tuning points are only to be expected in the two short-wave ranges.

**Mechanical Features**

From the mechanical point of view the design is as full of innovations as the circuit. The rectangular tuning scale is in the form of a hinged flange which disappears flush with the top of the cabinet when the set is not in use. Not only is the tuning indicator, with its own pilot light, actuated through the single hinge,

but there is a shutter control bringing into operation illuminated arrows pointing to the particular tuning scale in use, and also general indirect illumination for the station names and wavelength calibrations.

The tuning indicator is conveniently placed below the tuning scale, and is covered by it when the set is closed up. In addition to the bass control there are two other auxiliary switches at the back of the set, namely, a silencing switch for the internal loud speaker and a switch to change over from external to an internally-connected mains aerial. The simple Philips rotating mains voltage adjustment is again provided, and a multiple-contact safety plug is arranged to adapt the set by a single movement of the plug for operation from DC mains in conjunction with the converter unit which will shortly be available.

With all the ingenuity which has been given to detail refinements the simpler requirements of installation and maintenance have not been overlooked, and in support of this it is only necessary to point to the arrangement of all the valves in a row at the back of the chassis.

This is a set which reflects great credit on the research organisation which gave it birth, and is one which we can unhesitatingly recommend, particularly for its outstandingly good performance from the point of view of quality of reproduction.

**Questions in the House**

THE B.B.C. had spent a total of £458,000 on television up to September 30th, according to a reply given by the P.M.G. to a question asked in the House of Commons. £112,000 of this was capital expenditure and £346,000 was working expenditure, which, of course, includes programme, engineering and staff expenses. In reply to a further question, the P.M.G. stated that in the near future the proportion of licence revenue payable to the Corporation will be reviewed in order to take account of their expenditure on television and also on the proposed broadcasts in foreign languages.

The question of relay exchanges was also raised, and it was officially stated that the G.P.O. were considering the question of operating an experimental relay service at Southampton.

**A Popular Job**

THERE were over 1,300 applicants for a recent vacancy for a broadcast announcer in South Africa. There were several candidates over 50 years of age, one being 71.

**Physical Jerks**

EARLY morning music is now broadcast at 6.30 a.m. by certain Belgian stations. This is followed by a weather bulletin and a gymnastic lesson.

# Notes and News

**Another High-powered Station**

THE new 100-kW transmitter, which is intended to radiate programmes in their native tongue for the benefit of the German-speaking people of Czechoslovakia, will probably be put into commission next January. The transmitter site is at Melnik, forty miles north of Prague, but the station will probably be known as Prague No. 2, the present station of that name closing down entirely. At present the Prague No. 1 transmitter radiates a special programme for the German-speaking part of the population. The new station is planned so that it can very quickly be changed over to the wavelength of Prague No. 1 in order to be in a position to take over the programmes of that station should it be put out of action at any time.

**Hungarian Enterprise**

AT the new Information Bureau opened by the Hungarian Post Office in Budapest not only are demonstrations given of man-made static and its cure, but the proper method of erecting aeriels is explained. In addition, valve-testing apparatus has been installed, and arrangements have been made to reply to technical queries.

**Women Prefer Listening**

ACCORDING to a survey recently completed by an American journal, listening to broadcasting is the most popular home recreation among women. In the case of men, reading is given first place, but listening is a close second.

**Static-Maker Fined**

THAT the French authorities mean business in their war on electrical interference to broadcasting is shown by a case recently brought against a garage owner in Dieppe. The defendant was charged with interfering with reception on the 1,400-metre wavelength and taking no steps to reduce such interference. The evidence revealed that he had made no attempt to affix suppressors to his neon sign and other electrical apparatus under his control. He was convicted and fined.

**Progress in France**

THE energetic measures which have been pursued by the French authorities in order to increase the popularity of broadcasting during the past month have been rewarded, as the number of new licences issued is in the neighbourhood of a million. This compares with an increase of roughly half a

million in this country during the same period. There are now rather more than 4 million licences issued in France.

Figures have also been published concerning the number of listeners in the French North African Colonies. There are, in round figures, 85,000 receivers in use in Tunisia, 70,000 in Algeria, and 32,000 in the French part of Morocco.

**An Interesting Scheme**

GREAT care is being exercised in the designing of the Great Assembly Hall of the new Palace of the Soviets in Moscow to ensure that there is perfect audibility in every one of the twenty thousand seats.

As is well known, a large number of languages is spoken in the Soviet Union, and when a delegate is speaking his words will be conveyed by microphone to interpreters who will repeat the speech in the other languages of the Union. The interpreted speeches will be carried by suitable PA apparatus to headphone receivers so that non-Russian-speaking delegates may hear them in their own tongue. It is reported that this latter link will not be by ordinary AF circuits, but that RF carriers will be employed in order to deal with the various languages, each delegate's seat being provided with tuning apparatus so that the appropriate language may be selected.

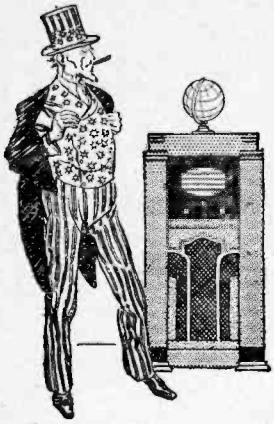

# "U.S. Patent"

(BUT OUR VALVES ARE WONDERFUL)

By  
"CATHODE  
RAY"

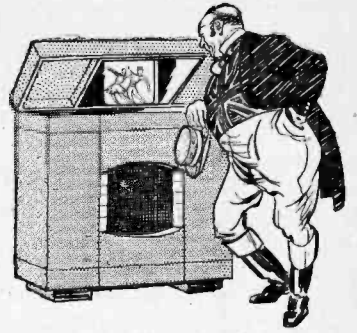

ONE of the advantages the radio industry in this country enjoys is that it can find out what it will be doing next year, or the year after, merely by watching America. This saves a lot of brain-fag.

Somebody in one of our wireless trade papers recently remarked that "our much-vaunted 1937 receivers are technically on a par with those sold by them (i.e., Americans) five years ago." Personally, I think that is an example of the gentle art of hyperbole; in other words, taking care to lose nothing in the telling, save, perhaps, a little accuracy. Still, the general idea is not so very far wrong. There are very few receiver developments one can name that did not appear on American sets before ours.

So long as one has not a middle-European temperament, obsessed by national pride, this may be considered to be quite a happy arrangement. The pioneers get all the hard work, the copycats draw the profits. That is how it looks to me, anyway. (I am not a copycat.) Those who are not financially interested either way may be troubled in soul about such a condition of affairs. Why must *everything* in radio come from America? Including the language, as "Diallist" bitterly reflects on being confronted with the word "video," of which even I may not be altogether guiltless. Actually, there *are* a few details in which we lead the States, and for the small crumb of consolation it may afford here are some examples. There are probably others.

A certain American technical editor has been at pains during the last year or so to let his readers know that the television progress rumoured from time to time to be taking place in Europe is just re-discovery of American television. Unfortunately for him, his contemporary, *Electronics*, in the October, 1937, issue rather gives the show away by presenting a very detailed study of British television made on the spot, in which occurs the statement: "That these British standards constitute a major improvement over present American practices is an inescapable conclusion, because television is technically successful and an accomplished fact in England," and "Unless changes are made in the type of signal which is now being used for experimental transmitters, American receivers will be more expensive, more difficult to service,

and will give performance inferior to British receivers."

To be quite fair, I must emphasise that these remarks do not apply to television technique as a whole, but to the positive modulation system of signals adopted as standard by the B.B.C. We owe at least a share of the credit to American laboratories for the most triumphantly successful appliance used in television—the electron camera or iconoscope.

The issue of *Electronics* just quoted seems to have been a particularly gracious one, for elsewhere in it occurs the remarks, "The only fundamental improvement in pick-up arms to appear in a long while is the use of the bent arm. This has been standard practice in England for some time," and "Try . . . a record with very heavy bass . . . (Columbia 6844D or preferably the corresponding British pressing, which is quieter)." The latter is not very significant, only amusing; the former refers to the shaping of gramophone pick-up arms so that the needle lies accurately in line with the record groove from beginning to end of the record, instead of dragging sideways. An article appeared in *The Wireless World* of March 26th, 1930, on the science of this, with an apology for dealing with such a well-worn subject, but it is just being discovered in U.S.A. in 1937.

The same American journals have recently been carrying advertisements pointing out that complete cabinets can be moulded in bakelite. Of course, that is quite old here; some might even say it is outmoded. At least, there seem to be fewer bakelite cabinets than there were years ago.

If there is any sort of set for which a bakelite cabinet is suitable it is the midget. That is undoubtedly an American speciality. There is, however, a British speciality to match it—the portable. It is curious how each of these types of receiver has been a virtual monopoly of the respective country. Just as we have been intrigued by the tiny all-mains set (until it has set the carpet on fire), so our transatlantic relatives have sure found the nifty suitcase mighty cute (until the batteries have run down).

## Unknown in U.S.A.

Valves. They are a tender subject. Of course, our valves are marvellous. So far as mutual conductances are concerned, the five-year lead I quoted at the start is surely reversed. And look at the neat metal coatings—apparently quite unknown in U.S.A., where the set manufacturer has to provide a "form-fitting tube shield." To this day, as far as I am aware, the old pentagrid is still more or less standard in

America, and the triode-hexode unheard of. But the rub comes when price is discussed. What is the advantage of stupendous conductances if three or four American "toobs" can be bought, duty paid, for the same money as one of ours? As a matter of fact, the American valve industry is not quite as steady as it used to be. At one time they kept clear of our thirst for new types, and an ordinary brain could remember the names and characteristics of all those on the list. But in recent years this feat has demanded a Pelman on both sides of the Atlantic. They made matters worse over there by going in for metal tubes in a big way, and are now retreating from them in as dignified a manner as the situation allows.

I remember the time when American receivers were quite innocent of grid bias. The "C battery" was a comparatively recent refinement for high-quality amplifiers. That reproach can no longer be upheld, but I have an impression that to this day our sets, on the whole, type for type, sound rather better. Theirs have led the way to quantity rather than quality. I am afraid I have not heard very many recent American models, so am open to be converted on this score.

There is no doubt that they are more highly developed as regards facilities and general performance. It will be interesting to see if the manufacture in this country of the Scott luxury receivers will have a gently stimulating action on our industry's policy.

## Club News

### Bradford Radio Society

Headquarters: Cambridge House, 66, Little Horton Lane, Bradford.

Meetings: Tuesdays at 8 p.m.

Hon. Sec.: Mr. S. Hartley, 7, Blakehill Avenue, Fagley, Bradford.

On November 23rd Mr. S. Noble, of Hartley-Turner's, is giving a lecture and demonstration of certain of his firm's products. The meeting is being thrown open to the public.

### Slade Radio

Headquarters: Broomfield Road, Slade Road, Erdington.

Meetings: Alternate Thursdays at 8 p.m.

Hon. Sec.: Mr. G. C. Simmonds, 28, Rabone Lane, Smethwick.

Members recently proceeded to the Aston Technical College for a lecture on light rays by Mr. Wynne. The lecturer gave numerous demonstrations and explanations of the properties of this part of the spectrum, and members eagerly inspected the apparatus on view. A Morse class has been started.

### Southall Radio Society

Headquarters: Southall Library, Osterley Park Road, Southall.

Meetings: Tuesdays at 8.15 p.m.

Hon. Sec.: Mr. H. F. Reeve, 28, Green Drive, Southall.

The visit of Mr. P. G. A. H. Voigt to demonstrate his well-known domestic-type loud speaker proved very popular, there being sixty members present.



# Listeners' Guide for the

## Outstanding Broadcasts at Home and Abroad

**W**HAT would undoubtedly be the most interesting, as far as *Wireless World* readers are concerned, of the week's programmes is to be given in the National programme at an hour when but a small percentage of readers will be able to listen in, *i.e.*, 12.15 on Tuesday.

Howard Rose, the Empire Drama Director, will produce, for Empire listeners as well as National listeners, a programme featuring the high spots in the history of radio. The story opens with the voices of such pioneers as Alexander Graham Bell, Thomas Edison, Oliver Lodge, Ambrose Fleming, and Lee De Forest. Then follows the story, in dramatic form, of how Guglielmo Marconi is struck with an idea inspired by Hertz's experiments.

The success of his experiments at home; his coming to England; at the G.P.O.; signalling across the English Channel; at the War Office, Admiralty, and the Board of Trade are all rapidly linked into a continuous story, following which comes the building of the Poldhu station and ultimately the successful reception, by Marconi and his assistants, of the now famous "esses" at St. John's, Newfoundland.

The practical application of radio is brought in—the arrest of Dr. Crippen and the drama of the sinking of the *Titanic*, and so, on to broadcasting with Capt. P. P. Eckersley introducing Dame Nellie Melba in the first British Wireless Concert which was broadcast from Chelmsford.

It is to be hoped the powers that be at Broadcasting House will see fit to rebroadcast this programme at an hour when the great majority of listeners can hear it.

### CAMPANOLOGY

"Bells Over London" is the title given to a programme which will be heard Regionally on Wednesday at 8.15. Bellingering was born in England some three centuries ago, when William, Lord Brereton, founded a band of bell-ringers

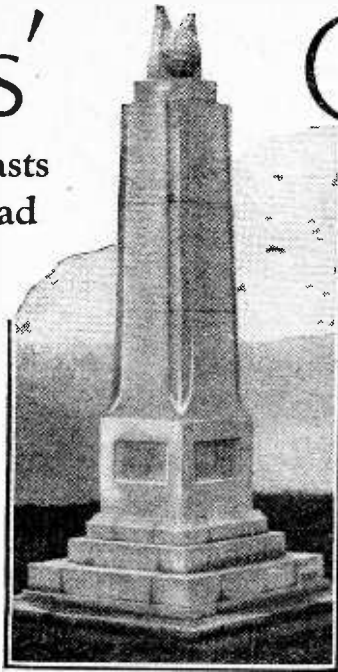

**THIRTY-SIX YEARS AGO** the first wireless signal to be received on the other side of the Atlantic was transmitted from the Poldhu wireless station the site of which, on the cliffs of Cornwall, is marked by this memorial. It is to be inaugurated in a week or two and is to commemorate the work done there by many radio pioneers, including Marconi, in the service of Marconi's Wireless Telegraph Company.

who became known as the Society of College Youths. This society is still flourishing, and from its ranks are drawn the official ringers for St. Paul's and Westminster Abbey.

Many eminent campanologists will take part in this programme, among them being W. T. Cockerill, who was secretary of the society for forty-six years and as the official conductor of the St. Paul's Cathedral Band has rung there on Sunday mornings for nearly fifty years. The intricacies of the art will be discussed and demonstrations with hand bells of some of the changes, among them being "Whittingtons" and "Grand-sire Caters," will be given.

### CONTINENTAL RELAYS

CONTINUING the elaborate schedule of relays from abroad, the B.B.C. are providing us with three programmes from the Continent this week. Two of these will be heard Regionally on Monday, one from Dijon, at 7.30, and the other from Paris, at 8. That from Dijon will be a programme of French folk songs sung by the choir of Dijon University. This is an enthusiastic body of choristers who have devoted themselves largely to making known old melodies of Burgundy. The programme will be given in the Municipal Theatre, and the Mayor, Robert Jardillier, who was Minister of Postes and Telegraphes in a recent Govern-

ment, and is choirmaster, has arranged for an explanation to be given in English.

The relay from Paris will consist of swing music played by Willie Lewis and his Dance Orchestra. This famous coloured swing band, which will be playing from Chez Florence, has previously been heard in the English programmes.

Copenhagen provides the third relay of the week, which will be given at 5 on Tuesday. This will consist of popular Danish dance music played by Louis Preil and the Danish Radio Dance Band. This band, which consists of fourteen members, is responsible for supplying nearly all the dance music broadcast from the Danish stations since the ban was imposed on relays from restaurants.

### EXPERIMENTAL

THE second experimental hour arranged by the Drama Department will be given on Monday at 9.35 (Nat.) and will consist of "The Words Upon the Window-pane," by W. B. Yeats. This play, which was written in 1934, and has been adapted for broadcasting and television by Eric Crozier, was seen by viewers a few weeks ago. The scene is laid in a house in Dublin which was once occupied by

# Week

Swift, and the story revolves round a spiritualistic seance which is being held there.

### FILM BALL

THE Film Ball which will be held at the Royal Albert Hall on Friday and at which so many famous stars and artistes gather will provide a thirty-minute broadcast for those who are not between the sheets at 11.30. Billy Cotton and his Band are to provide the music, and Charles Brewer, Assistant Director of Variety, will be compère, and it is hoped will be able to introduce to National listeners a number of the guests.

### OPERA

HUBAY, the composer, who died this year at the age of seventy-nine, was primarily a violin virtuoso. Nearly all the great Hungarian violinists of the present day—Jelly d'Aranyi, Szigeti, Vecsey, etc.—were his pupils. His operas number but two—"Anna Karenina" (after Tolstoy) and the two-act opera, "The Violin-Maker of Cremona," which Budapest No. 1

### HIGHLIGHTS OF THE WEEK

#### THURSDAY, NOVEMBER 18th.

Nat., 8, Songs You Might Never Have Heard—4. 9.20, Jack Hylton and his Band.

Reg., 6.20, "The Fox's Mask," by Dennis Constanduros. 8.15, The Royal Philharmonic Society's Concert from the Queen's Hall.

#### Abroad.

Vienna, 6.30, Strauss Festival Concert from the Musikvereinsaal.

#### FRIDAY, NOVEMBER 19th.

Nat., 7.30, Folk Songs by Engel Lund (soprano). 7.55, Conversation in a Train—3. "What is best worth having in life?"

Reg., 7.30, Organestra: the Theatre Organ and Variety Orchestra. 9, Variety from the New Theatre, Northampton.

#### Abroad.

Brussels II, 8, Ibsen's drama, "Peer Gynt."

#### SATURDAY, NOVEMBER 20th.

Nat., 2.30, Rugby: Oxford v. Harlequins and Cambridge v. Blackheath. 8, Music Hall.

Reg., 8, The Trial and Death of Mary, Queen of Scots. 9.40, International Table Tennis.

#### Abroad.

Naples, 7.30, Kalmán's operetta, "The Little Dutch Girl."

#### SUNDAY, NOVEMBER 21st.

Nat., 6.50, Songs and Duets from famous operettas. 9.5, "Daisy Miller": adaptation from the story by Henry James.

#### Sunday, November 21st (continued)

Reg., 6.5, Students' Songs. 6.30, Pau Casals conducts the Sixth Sunday Orchestral Concert.

#### Abroad.

Vienna, 7.5, Viennese Operettas Old and New.

#### MONDAY, NOVEMBER 22nd.

Nat., 8.30, Broadway Matinée. 9.35, "The Words Upon the Window-pane."

Reg., 7.30, Folk Songs of France, relayed from Dijon. 9, Star Gazing: Marie Burke.

#### Abroad.

Königsberg, 7, Musical evening in an East Prussian village.

#### TUESDAY, NOVEMBER 23rd.

Nat., 5, Louis Preil and the Danish Radio Dance Band. 8, Star Gazing: Marie Burke.

Reg., 8.20, Bruckner's Mass No. 2. 9, "Aunt Jeannie," a play for broadcasting by Aimée Stuart.

#### Abroad.

Radio Toulouse, 9.30, Selection from Messenger's "Veronique."

#### WEDNESDAY, NOVEMBER 24th

Nat., 6.40, "Aunt Jeannie." 8.15, Solomon at the Sixth Symphony Concert.

Reg., 8.15, "Bells Over London." 9.20, Variety from the Victoria Theatre, Burnley.

#### Abroad.

Leipzig, 8, Bruckner's First Symphony in its original form.

**Listeners' Guide—**

relays from the State Opera on Friday at 6.30 and which was first produced in Budapest in 1894. Needless to say, it is the epic story of Stradivarius. The only other opera choice of Friday evening is "I quattro rusteghi" (The Four Rustics), by the half-German Venetian, Wolf-Ferrari, which Warsaw gives at 7.5. It was first produced in Munich in 1906.

Those who love Gounod have an opportunity of hearing his seldom-given "Mirella" from Radio-Paris on Saturday evening at 8.30, relayed from the Opéra-Comique. The same evening brings Boito's "Mefistofele," relayed from Bologna at 8.0 by the Rome group. It was first produced at La Scala in 1868, when the amazing Boito was but, twenty-six years old. Boito, musician, poet, and artist, who died in 1918, was one of the most extraordinary characters in modern music.

Giordano's "Andrea Chénier" is the main Italian Opera event of the week. It is being given by the Milan Group on Sunday and by Rome on Tuesday, at 8 on both occasions. First produced in 1896 at La Scala, it came to London (in English) in 1903. The poet victim of the French Revolution is one of the many historical characters whose lives have been turned into fiction by the librettists.

THE AUDITOR.

# Broadcast Brevities

## NEWS FROM PORTLAND PLACE

### The New Microphone

TWO new pieces of apparatus made their B.B.C. debut last week.

At the Lord Mayor's Guild-hall banquet Mrs. Collett, the commentator, used for the first time the new hand microphone to which exclusive reference was made in these columns three weeks ago.

### No Extraneous Noises

Did you notice any difference in tonal quality? Probably not, except that extraneous noises were missing. But Mrs. Collett proved that the new mike was ideal for the job.

### Super-Emitron Camera

The other technical innovation was the use of one of the new Super-Emitron cameras for televising the Lord Mayor's Show and the Cenotaph ceremony. It was brought into circuit for close-up shots of the Lord Mayor's coach and again when the King placed his wreath at the foot of the Cenotaph. The principle of the new camera is described elsewhere in this issue.

### B.B.C. and N.B.C.

GENTLEMANLY pride is registered on the faces of the Music Department in Broadcasting House at news of formation of the new N.B.C. Symphony Orchestra. For this much-bruited American orchestra has only 92 players as compared with the 119 of the B.B.C. Symphony Orchestra.

### World Combed

A fine cosmopolitan flavour distinguishes the N.B.C. orchestra. First ten names are Antek, Barenblat, Birkenholz, Frank, Galindo, Gingold, Koutzen, Rabinowitz, Silverman, Schulman. One name will be familiar to all B.B.C. listeners—that of William Primrose, formerly member of the London String Quartet and now at the viola desk of the N.B.C. Orchestra.

### No Binaural Transmissions

BINAURAL sound tests by the Bell Telephone Laboratories in U.S.A. are being watched with interest by the B.B.C. engineers, who recall binaural transmission experi-

ments carried out at Savoy Hill several years ago.

Unfortunately, the research staff at Nightingale Square, much as they would like to continue the good work, realise the impracticability of binaural transmission for the ordinary listener.

### A Question of Wavelengths

To obtain this "third dimension in sound," as it is called, two wave channels are necessary, i.e., two wavelengths for each programme and two receivers. The present difficulty is to find enough wavelengths for normal broadcasting.

### Extending the Daventry Service

EXTENSION of the Daventry short-wave service to include transmissions in foreign languages will involve considerable additions to staff.

Two sub-editors will be needed, two translators, two publicity officers, and at least 30 office staff and typists.

### Mid-Wales in Trouble

MID-WALES is now registering a plea for a small relay station. The burden of complaints is that a "No-Man's-Land" has been created in the centre of the country since the 5-kW relay station at Penmon came into operation in February.

### Synchronisation the Cause?

Strangely enough, owners of obsolete sets are not worried. Modern ultra-sensitive receivers, it appears, are troubled by the synchronisation of Penmon and Washford Cross.

Research Department is now busy on the problem.

It is fair to the B.B.C. Engineering staff to say that they foresaw that Penmon would not please everybody. Sir Noel Ashbridge, the Chief Engineer, said in a talk broadcast from Penmon at the opening ceremony: "This station cannot give an entirely satisfactory service to the whole of North Wales—and this is mainly due to the mountains—but it will certainly improve reception enormously for at least a quarter of a million people."

### Penmon's Power

One thing is certain. The power of Penmon cannot be increased without the installation of a new transmitter. And if this were done, one wonders whether the stronger signal might accentuate the troubles brought about by synchronisation with Washford.

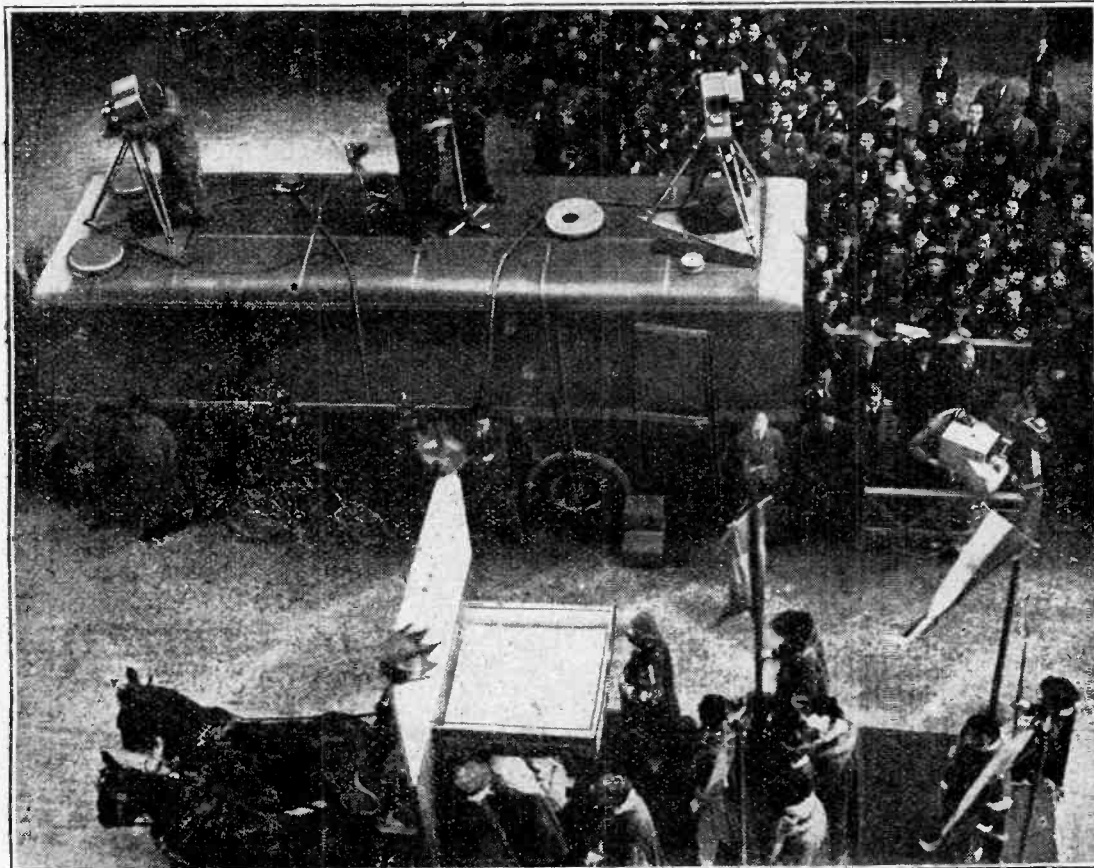

**CAMERAS AND COMMENTATOR.** The three cameras, the one on the ground being the new Super-Emitron, and F. H. Grisewood, at the microphone on the top of the television van, during the televising of the Lord Mayor's Show last week. The transmission as far as vision was concerned was excellent, but the commentator, being unable to see the monitoring tubes, was frequently talking about things that were not at the time visible to viewers.

# PRINCIPAL BROADCASTING STATIONS OF EUROPE

Arranged in Order of Frequency and Wavelength

Stations with an Aerial Power of 50 kW. and above in heavy type

Station.	kc/s.	Tuning Positions.	Metres.	kW.	Station.	kc/s.	Tuning Positions.	Metres.	kW.
Ankara (Turkey)	152		1973.5	5	Leipzig (Germany)	785		382.2	120
Kaunas (Lithuania)	153		1961	7	Barcelona, EAJ1 (Spain)	795		377.4	7.5
Radio Romania (Brasov) Romania	160		1875	150	Lwow (Poland)	795		377.4	50
Hilversum, No. 1 (Holland) (10 kW. till 2040)	160		1875	150	Welsh Regional (Penmon) (Anglesey)	804		373.1	5
Lahti (Finland)	166		1807	150	Welsh Regional (Washford)	804		373.1	70
Moscow, No. 1, RW1 (Komintern) (U.S.S.R.)	172		1744	500	Milan, No. 1 (Italy)	814		368.6	50
Paris (Radio Paris) (France)	182		1648	80	Bucharest (Romania)	823		364.5	12
Istanbul (Turkey)	185		1622	5	Kiev, No. 2, RW9 (U.S.S.R.)	832		360.6	35
Irkutsk (U.S.S.R.)	187.5		1600	20	Agen (France)	832		360.6	1.5
Deutschlandsender (Germany)	191		1571	60	Berlin (Germany)	841		356.7	100
National (Droitwich)	200		1500	150	So. a (Bulgaria)	850		352.9	100
Minsk, RW10 (U.S.S.R.)	208		1442	35	Norwegian Relay Stations	850		352.9	—
Reykjavik (Iceland)	208		1442	16	Valencia (Spain)	850		352.9	3
Motala (Sweden)	216		1389	150	Simferopol, RW52 (U.S.S.R.)	859		349.2	10
Novosibirsk, RW76 (U.S.S.R.)	217.5		1379	100	Strasbourg (France)	859		349.2	100
Warsaw, No. 1 (Poland)	224		1339	120	Poznan (Poland)	868		345.6	16
Luxembourg	232		1293	150	London Regional (Brookmans Park)	877		342.1	70
Moscow, No. 2, RW49 (Stchelkovo) (U.S.S.R.)	232		1293	100	Linz (Austria)	886		338.6	15
Kalundborg (Denmark)	240		1250	60	Graz (Austria)	886		338.6	15
Vienna, No. 2 (Austria)	240		1250	0.5	Helsinki (Finland)	895		335.2	10
Kiev, No. 1 (U.S.S.R.)	248		1209.6	100	Limoges, P.T.T. (France)	895		335.2	1.5
Vigra (Aalesund) (Norway)	253		1186	10	Hamburg (Germany)	904		331.9	100
Tashkent, RW11 (U.S.S.R.)	256.4		1170	25	Dnepropetrovsk (U.S.S.R.)	913		328.6	10
Oslo (Norway)	260		1153.8	60	Toulouse (Radio Toulouse) (France)	913		328.6	60
Leningrad, No. 1 RW53 (Kolpino) (U.S.S.R.)	271		1107	100	Brno (Czechoslovakia)	922		325.4	32
Tromsø (Norway)	282		1065	10	Brussels, No. 2 (Belgium)	932		321.9	15
Tiflis, RW7 (U.S.S.R.)	283		1060	35	Algiers (Algeria)	941		318.8	12
Saratov (U.S.S.R.)	340		882.3	20	Göteborg (Sweden)	941		318.8	10
Finmark (Norway)	347		864	10	Breslau (Germany)	950		315.8	100
Archangel (U.S.S.R.)	350		857.1	10	Paris (Poste Parisien) (France)	959		312.8	60
Rostov-on-Don, RW12 (U.S.S.R.)	355		845.1	20	Bordeaux-Sud-Ouest (France)	968		309.9	30
Budapest, No. 2 (Hungary)	359.5		834.5	18	Odessa (U.S.S.R.)	968		309.9	10
Sverdlovsk, RW5 (U.S.S.R.)	375		800	40	Northern Ireland Regional (Lisnagarvey)	977		307.1	100
Voroneje, RW25 (U.S.S.R.)	390		769	10	Bologna (Radio Marconi) (Italy)	936		304.3	50
Boden (Sweden)	392		765	0.6	Torun (Poland)	986		304.3	24
Banska-Bystrica (Czechoslovakia) (15 kW. after 1800)	392		765	30	Hilversum No. 2 (Holland) (15 kW. till 2040)	995		301.5	60
Geneva (Switzerland)	401		748	1.3	Bratislava (Czechoslovakia)	1004		298.8	13.5
Moscow, No. 3 (RCZ) (U.S.S.R.)	413.5		726	100	Midland Regional (Droitwich)	1013		296.2	70
Ostersund (Sweden)	413.5		726	0.6	Chernigov (U.S.S.R.)	1013		296.2	4
Oulu (Finland)	431		696	10	Barcelona, EAJ15 (Spain)	1022		293.5	3
Tartu (Estonia)	511		587.1	0.5	Cracow (Poland)	1022		293.5	2
Hamar (Norway)	519		578	0.7	Oviedo (Spain)	1022		293.5	0.7
Innsbruck (Austria)	519		578	1	Königsberg, No. 1 (Heilsberg) (Germany)	1031		291	100
Ljubljana (Yugoslavia)	527		569.3	6.3	Pareda (Portugal)	1031		291	5
Viipuri (Finland)	527		569.3	10	Leningrad, No. 2, RW70 (U.S.S.R.)	1040		288.5	10
Bolzano (Italy)	536		559.7	10	Rennes-Bretagne (France)	1040		288.5	120
Wilno (Poland)	536		559.7	50	West of England Regional (Washford)	1050		285.7	50
Budapest, No. 1 (Hungary)	546		549.5	120	Bari No. 1 (Italy)	1059		283.3	20
Beromünster (Switzerland)	556		539.6	100	Paris (Radio Cité) (France)	1068		280.9	0.8
Athlone (Irish Free State)	565		531	100	Tiraspol, RW57 (U.S.S.R.)	1068		280.9	10
Klaipeda (Lithuania)	565		531	10	Bordeaux-Lafayette (France)	1077		278.6	35
Palermo (Italy)	565		531	3	Zagreb (Yugoslavia)	1086		276.2	0.7
Stuttgart (Germany)	574		522.6	100	Falun (Sweden)	1086		276.2	2
Alpes-Grenoble, P.T.T. (France)	583		514.6	20	Madrid, EAJ7 (Spain)	1095		274	5
Madona (Latvia)	583		514.6	50	Vinnitsa (U.S.S.R.)	1095		274	10
Vienna, No. 1 (Austria)	592		506.8	100	Kuldiga (Latvia)	1104		271.7	10
Rabat (Morocco)	601		499.2	25	Naples (Italy)	1104		271.7	10
Sundsvall (Sweden)	601		499.2	10	Moravska-Ostrava (Czechoslovakia)	1113		269.5	11.2
Florence (Italy)	610		491.8	20	Radio Normandie (Fécamp) (France)	1113		269.5	15
Cairo, No. 1 (Egypt)	620		483.9	20	Alexandria, No. 1 (Egypt)	1122		267.4	0.5
Brussels, No. 1 (Belgium)	620		483.9	15	For East Regional (Stagshaw)	1122		267.4	60
Lisbon (Portugal)	629		476.9	15	Nyiregyhaza (Hungary)	1122		267.4	6.25
Trøndelag (Norway)	629		476.9	20	Hörby (Sweden)	1131		265.3	10
Christiansand (Norway)	629		476.9	20	Turin, No. 1 (Italy)	1140		263.2	7
Prague, No. 1 (Czechoslovakia)	638		470.2	120	Genoa (Italy)	1140		263.2	10
Lyons, P.T.T. (France)	648		463	100	Trieste (Italy)	1140		263.2	10
Petrozavodsk (U.S.S.R.)	648		463	10	London National (Brookmans Park)	1149		261.1	20
Cologne (Germany)	658		455.9	100	North National (Slaithwaite)	1149		261.1	20
North Regional (Slaithwaite)	668		449.1	70	Scottish National (Westerziden)	1149		261.1	50
Jerusalem (Palestine)	668		449.1	20	Kosice (Czechoslovakia)	1158		259.1	10
Sottens (Switzerland)	677		443.1	100	Monte Ceneri (Switzerland)	1167		257.1	15
Belgrade (Yugoslavia)	686		437.3	20	Copenhagen (Denmark)	1176		255.1	10
Paris, P.T.T. (France)	695		431.7	120	Nice-Corse (France)	1185		253.2	60
Stockholm (Sweden)	704		426.1	55	Frankfurt (and Relays) (Germany)	1195		251	25
Rome, No. 1 (Italy)	713		420.8	50	Prague, No. 2 (Czechoslovakia)	1204		249.2	5
Hilversum, No. 3 (Holland) (Testing)	722		415.4	—	Lille, P.T.T. (France)	1213		247.3	60
Kharkov, No. 1, RW20 (U.S.S.R.)	722		415.4	10	Rome, No. 2 (Italy) (Testing)	1222		245.5	60
Fredrikstad (Norway)	722		415.4	1	Gleiwitz (Germany)	1231		243.7	5
Tallinn (Estonia)	731		410.4	1	Cork (Irish Free State)	1235		242.9	1
Madrid, EAJ2 (Spain)	731		410.4	30	Saarbrücken (Germany)	1249		240.2	17
Seville (Spain)	731		410.4	5.5	Riga (Latvia)	1258		238.5	15
Munich (Germany)	740		405.4	100	Rome, No. 3 (Italy)	1258		238.5	1
Marseilles, P.T.T. (France)	749		400.5	100	Bilbao, EAJ8 (Spain)	1258		238.5	1
Fori (Finland)	749		400.5	1	Nürnberg (Germany)	1267		236.8	2
Katowice (Poland)	758		395.8	12	Radio Méditerranée (Juan-les-Pins) (France)	1276		235.1	27
Scottish Regional (Westerzlen)	767		391.1	70	Dresden (Germany)	1285		233.5	0.25
Scottish Regional (Burghead)	767		391.1	60	Aberdeen	1285		233.5	1
Stalino (U.S.S.R.)	776		386.6	10	Klagenfurt (Austria)	1294		231.8	5
Toulouse, P.T.T. (France)	776		386.6	120	Vorarlberg (Austria)	1294		231.8	5
					Danzig	1303		230.2	0.5



Station.	kc/s.	Tuning Positions.	Metres.	kW.	Station.	kc/s.	Tuning Positions.	Metres.	kW.
Swedish Relay Stations	1312		228.7	—	Vaasa-Vasa (Finland)	1420		211.3	10
Magyarovar (Hungary)	1321		227.1	1.25	Alexandria, No. 2 (Egypt)	1429		209.9	0.5
German Relay Stations	1330		225.6	—	Turku (Finland)	1429		209.9	0.5
Montpellier, P.T.T. (France)	1339		224	1.5	Miskole (Hungary)	1438		208.6	1.25
Lodz (Poland)	1339		224	2	Paris (Eiffel Tower) (France)	1456		208	7
Dublin (Irish Free State)	1348		222.6	0.5	Pees (Hungary)	1465		204.8	1.25
Rjukan (Norway)	1348		222.6	0.15	Belgian Relay Stations	1465		204.8	0.1
Salzburg (Austria)	1348		222.6	2	Bournemouth	1474		203.5	1
Tampere (Finland)	1348		222.6	0.7	Plymouth	1474		203.5	0.3
Cairo No. 2 (Egypt)	1348		222.6	0.5	Binche (Belgium)	1487		201.7	0.1
Königsberg (Germany)	1348		222.6	2	Belgian Relay Stations	1492		201.1	0.1
Nottoden (Norway)	1357		221.1	0.15	Nimes (France)	1492		201.1	0.7
Italian Relay Stations	1357		221.1	—	Albacete (Spain)	1492		201.1	0.2
L'le de France (France)	1366		219.6	2	Santiago (Spain)	1492		201.1	0.5
Basle (Switzerland)	1375		218.2	0.5	Belgian Relay Stations	1500		200	0.1
Berne (Switzerland)	1375		218.2	0.5	Pietarsaari (Finland)	1500		200	0.25
Warsaw, No. 2 (Poland)	1384		216.8	7	Radio Alcalá (Spain)	1500		200	0.2
Lyons (Radio Lyons) (France)	1393		215.4	25	Karlskrona (Sweden)	1530		193	0.2
Stara-Zagora (Bulgaria)	1402		214	2	Liepāja (Latvia)	1734		173	0.1

## SHORT-WAVE STATIONS OF THE WORLD

Station.	Call Sign.	kc/s.	Tuning Positions.	Metres.	kW.	Station.	Call Sign.	kc/s.	Tuning Positions.	Metres.	kW.
Batavia (Java)	YDA	3,040		98.88	10	Madrid (Spain)	EAQ	9,860		30.43	20
Vancouver (Canada)	VE9BK	4,750		62.63	—	Lisbon (Portugal)	CSW	9,940		30.18	5
Kharbarovsk (U.S.S.R.)	RV15	4,273		70.20	12	Bandoeng (Java)	PMN	10,260		29.24	5
Caracas (Venezuela)	YV5RC	5,800		51.72	1	Ruyselede (Belgium)	ORK	10,330		29.04	9
San Jose (Costa Rica)	TIGPH	5,820		51.52	0.5	Buenos Aires (Argentina)	LSX	10,350		28.99	12
Vatican City (Vatican State)	HVJ	5,970		50.26	10	Teneriffe (Canary Isles)	EAJ43	10,350		28.99	4
Mexico City (Mexico)	XEBT	6,000		50.00	1	Bandoeng (Java)	PLP	11,010		27.25	3
Montreal (Canada)	CFUX	6,005		49.96	—	Lisbon (Portugal)	CSW	11,040		27.17	5
Havana (Cuba)	COCO	6,010		49.92	2.5	Motala (Sweden)	SBG	11,700		25.63	1
Prague (Podebrady) (Czechoslovakia)	OLR2A	6,010		49.92	30	Winnipeg (Canada)	CJRX	11,720		25.60	2
Bogota (Colombia)	HJ3ABH	6,010		49.92	1	Paris (Radio-Colonial) (France)	TPA4	11,720		25.60	12
Zeesen (Germany)	DJC	6,020		49.83	50	Daventry (Gt. Britain)	GSD	11,750		25.53	10-50
Boston (U.S.A.)	W1XAL	6,040		49.67	20	Zeesen (Germany)	DJD	11,770		25.49	50
Miami (U.S.A.)	W4XB	6,040		49.67	2.5	Boston (U.S.A.)	W1XAL	11,790		25.45	20
Daventry (Gt. Britain)	GSA	6,050		49.59	10-50	Tokio (Japan)	JZJ	11,800		25.42	20
Cincinnati (U.S.A.)	W8XAL	6,060		49.50	10	Vienna (Austria)	OER2	11,800		25.42	1.5
Philadelphia (U.S.A.)	W3XAU	6,060		49.50	10	Rome (Italy)	I2RO4	11,810		25.40	25
Skamleback (Denmark)	ONY	6,060		49.50	0.5	Daventry (Gt. Britain)	GSN	11,820		25.38	10-50
Motala (Sweden)	SBG	6,060		49.50	1	Wayne (U.S.A.)	W2XE	11,830		25.36	10
Chicago (U.S.A.)	W9XAA	6,080		49.34	0.5	Lisbon (Portugal)	CTIAA	11,830		25.36	2
Nairobi (Kenya)	VQ7LO	6,083		49.31	0.5	Prague (Podebrady) (Czechoslovakia)	OLR	11,840		25.34	30
Toronto (Bowmanville) (Canada)	CRCX	6,090		49.26	0.5	Zeesen (Germany)	DJP	11,850		25.31	50
Hong Kong (China)	ZBW2	6,090		49.26	2	Daventry (Gt. Britain)	GSE	11,860		25.29	10-50
Johannesburg (South Africa)	ZTJ	6,100		49.20	5	Pittsburgh (U.S.A.)	W8XK	11,870		25.27	40
Bound Brook (U.S.A.)	W3XAL	6,100		49.18	35	Paris (Radio-Colonial) (France)	TPA3	11,880		25.23	12
Chicago (U.S.A.)	W9XF	6,100		49.18	10	Moscow (U.S.S.R.)	RNE	12,000		25.00	20
Belgrade (Yugoslavia)	YUA	6,100		49.18	1	Lisbon (Portugal)	CTICT	12,082		24.83	0.5
Manizales (Colombia)	HJ4ABB	6,105		49.12	1	Reykjavik (Iceland)	TFJ	12,235		24.52	7.5
Daventry (Gt. Britain)	GSL	6,110		49.10	10-50	Paredo (Portugal)	CTIGO	12,400		24.20	0.35
Calcutta (India)	VUC	6,110		49.10	0.5	Warsaw (Poland)	SPW	13,635		22.00	10
Pittsburgh (U.S.A.)	W8XK	6,140		48.86	40	Amateurs		14,000		21.42	0.01
Winnipeg (Canada)	CJRO	6,150		48.78	2			to		to	
Lisbon (Portugal)	CSL	6,150		48.78	0.5			14,400		20.84	
Paredo (Portugal)	CTIGO	6,200		48.40	5	Sofia (Bulgaria)	LZA	14,970		20.04	1.5
San Jose (Costa Rica)	TIPG	6,410		45.80	0.5	Moscow (U.S.S.R.)	RKI	15,040		19.95	25
Valencia (Colombia)	YV4RV	6,520		46.00	0.5	Zeesen (Germany)	DJL	15,111		19.85	50
Riobamba (Ecuador)	PRADO	6,620		45.31	2	Vatican City (Vatican State)	HVJ	15,123		19.84	10
Amateurs		7,000		42.86	0.01	Daventry (Gt. Britain)	GSF	15,140		19.82	10-50
		to		to		Bandoeng (Java)	YDC	15,160		19.80	3
		7,300		41.10		Tokio (Japan)	JZK	15,160		19.80	20
Prangins (Radio-Nations) (Switz'l'd)	HBP	7,780		38.48	20	Daventry (Gt. Britain)	GSO	15,180		19.76	10
Budapest (Hungary)	HAT4	9,125		32.88	5	Hongkong (China)	ZBW4	15,190		19.75	2
Bangkok (Siam)	H88PJ	9,350		32.09	20	Zeesen (Germany)	DJB	15,200		19.74	50
Madrid (Spain)	EAQ2	9,480		31.65	20	Pittsburgh (U.S.A.)	W8XK	15,210		19.72	40
Rio de Janeiro (Brazil)	PRF5	9,500		31.58	12	Huizen (Holland)	PCJ	15,220		19.71	20
Daventry (Gt. Britain)	GSB	9,510		31.55	10-50	Prague (Podebrady) (Czechoslovakia)	OLR5A	15,230		19.70	30
Melbourne (Australia)	VK3ME	9,510		31.55	1.5	Paris (Radio-Colonial) (France)	TPA2	15,243		19.63	12
Hongkong (China)	ZBW3	9,520		31.49	2	Boston (U.S.A.)	W1XAL	15,250		19.67	20
Jeløy (Norway)	LKJ1	9,520		31.49	1	Daventry (Gt. Britain)	GSI	15,260		19.66	10-50
Schenectady (U.S.A.)	W2XAF	9,530		31.48	25	Wayne (U.S.A.)	W2XE	15,270		19.65	10
Zeesen (Germany)	DJN	9,540		31.45	50	Zeesen (Germany)	DJQ	15,280		19.63	50
Suva (Fiji)	VPD2	9,540		31.45	3	Buenos Aires (Argentina)	LRU	15,290		19.62	5
Prague (Podebrady) (Czechoslovakia)	OLR3A	9,550		31.41	30	Daventry (Gt. Britain)	GSP	15,310		19.60	10-50
Zeesen (Germany)	DJA	9,560		31.38	5-50	Schenectady (U.S.A.)	W2XAD	15,330		19.57	18
Lima (Peru)	OAX4T	9,560		31.33	10	Zeesen (Germany)	DJR	15,340		19.53	50
Lima (Peru)	OAX4Z	9,565		31.36	15	Budapest (Szekesfehervar) (Hungary)	HAS3	15,370		19.52	20
Bombay (India)	VUB	9,565		31.36	4.5	Hongkong (China)	ZBW5	17,750		16.90	2
Millis (U.S.A.)	W1XK	9,570		31.35	10	Zeesen (Germany)	DJE	17,760		16.89	50
Daventry (Gt. Britain)	GSC	9,580		31.32	10-50	Wayne (U.S.A.)	W2XE	17,760		16.89	10
Lyndhurst (Australia)	VK3LR	9,580		31.32	1	Huizen (Holland)	PHI	17,770		16.88	23
Philadelphia (U.S.A.)	W3XAU	9,590		31.28	10	Bound Brook (U.S.A.)	W3XAL	17,780		16.87	40
Sydney (Australia)	VK2ME	9,590		31.28	20	Daventry (Gt. Britain)	GSG	17,790		16.86	10-50
Huizen (Holland)	PCJ	9,590		31.28	20	Bandoeng (Java)	PLE	18,830		15.93	60
Prangins (Radio-Nations) (Switz'l'd)	HBL	9,595		31.27	20	Bangkok (Siam)	H88PJ	19,020		15.77	20
Moscow (U.S.S.R.)	RW96	9,600		31.25	20	Bandoeng (Java)	PMA	19,350		15.50	60
Rome (Italy)	I2RO3	9,635		31.13	25	Daventry (Gt. Britain)	GSH	21,470		13.97	10-50
Sourabaya (Java)	YDB	9,640		31.11	1	Wayne (U.S.A.)	W2XE	21,520		13.94	10
Lisbon (Portugal)	CTIAA	9,655		31.09	2	Daventry (Gt. Britain)	GSJ	21,530		13.93	10-50
Buenos Aires (Argentina)	LRX	9,660		31.06	5	Pittsburgh (U.S.A.)	W8XK	21,540		13.93	40
Lisbon (Portugal)	CTICT	9,680		31.00	0.5	Daventry (Gt. Britain)	GST	21,550		13.92	10-50

# Auditorium

By D. B. FOSTER, M.Sc., Ph.D.

## PART IV.—OPTIMUM ACOUSTICS FOR SPEECH AND MUSIC

# Acoustics

**I**N earlier articles it was pointed out that reverberation time is the outstanding factor controlling the acoustics of an auditorium of given seating capacity and the best or optimum reverberation time can be considered from two viewpoints, (a) the production of the greatest intelligibility and loudness for a given sound source, usually referring to speech reproduction, or (b) the production of the most pleasing and artistic effect, usually referring to musical reproduction.

For a given auditorium, the conception of optimum reverberation time in terms of (a) above will be one definite value which is a compromise between the minimum reverberation required for adequate loudness and the maximum reverberation permissible for intelligibility. The second conception of optimum reverberation time in terms of (b) above depends on the judgment of competent observers such as musicians (both performers and audience), and this optimum value will vary somewhat according to personal tastes and previous experience.

Since these two conceptions of reverberation time have little in common, it is clear that it is possible to design an auditorium which is suitable for speech purposes, which may be quite unsuitable for musical purposes, and vice versa. Generally speaking, it is permissible to have a much longer reverberation time in a music auditorium than in a speech auditorium.

Considering first the optimum reverberation time for speech purposes, it is almost always the rule that the average loudness could be increased with advantage, and it is usual to allow the maximum reverberation to lean towards an increase of loudness consistent with ade-

quate intelligibility. In deciding intelligibility, use may be made of an articulation test similar to that employed by telephone engineers. A speaker with good enunciation would stand in the normal speaking position in the auditorium and call out in turn 1,000 meaningless syllables at the customary rate of speaking. If the observers in the auditorium heard 850 correctly out of the 1,000 the auditorium would be said to have 85 per cent. articulation and the intelligibility would be good. In practice it is desirable to attain an intelligibility of 80 per cent. or more, and Fig. 12 shows an experimental curve of optimum reverberation time for adequate loudness and intelligibility.

It will be noticed that the permissible reverberation time increases with size of the auditorium, and this is necessary to

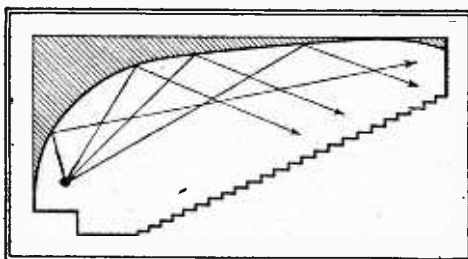

Fig. 13.—Cross-section of ideal auditorium for speech showing saving of volume with sloping ceiling.

preserve the best balance between loudness and intelligibility, although both are being progressively reduced. At a certain size of auditorium it will be clear from the corresponding reverberation times that both the loudness and the intelligibility will become unsatisfactory, and at this size, which is about 150,000 cu. ft., it becomes desirable to employ an artificial aid in the shape of a public-address system.

With regard to the best distribution of the absorption giving the optimum reverberation time, it is desirable that the surfaces close to the speaker should be highly reflecting so that all the voice power is directed towards the audience and so that the speaker has that confidence of making himself heard which comes from hearing his own voice. This latter effect is, of course, analogous to the surprisingly satisfactory effect when singing in one's bathroom.

From the considerations of optimum reverberation time, loudness and intelligibility it will be seen that the volume of an auditorium for a given seating capacity should be as small as possible, and advan-

*THE previous article dealt with the methods used for measuring reverberation time and in this part the application of the results to the design of auditoriums for speech and music is discussed.*

tage may then be taken of reflections from the consequent low ceiling height to ensure that the sound is adequately distributed to the most distant listeners. A cross-section of an auditorium for good reception of speech is shown in Fig. 13, and the shaded area represents the saving in volume from the more conventional arrangement. The benefits of low reverberation time and better distribution are enhanced by probable freedom from echo from the low ceiling.

It should be emphasised that those other acoustical defects due to shape, mentioned in the first article, such as focusing from curved surfaces, flutter due to extensive parallel walls, etc., should be carefully avoided.

### Music Auditoriums

The requirements governing the acoustics of music as distinct from speech auditoriums depend upon the type of performance for which they will be used, but in this case the optimum reverberation time will be decided on subjective artistic judgment. Furthermore, for many types of performance the size of auditorium need not be limited on the score of inadequate loudness, since the sound powers available from musical instruments are much greater than from the unaided human voice. A curve of optimum reverberation time for music auditoriums based on artistic judgments and due to F. R. Watson is shown in Fig. 12. Certain departures from this curve will be desirable, since, for example, shorter times are suited to the delicate nature of chamber music and longer times to the heavier type of rendering such as a church organ. This optimum reverberation time is given for a frequency of 512 c/s. The optimum time varies with frequency, and McNair suggested that all frequencies, if of the same initial loudness, should decay to reach inaudibility simultaneously so that the same loudness balance should persist throughout the decay. Readers may remember in a recent article\* that it was

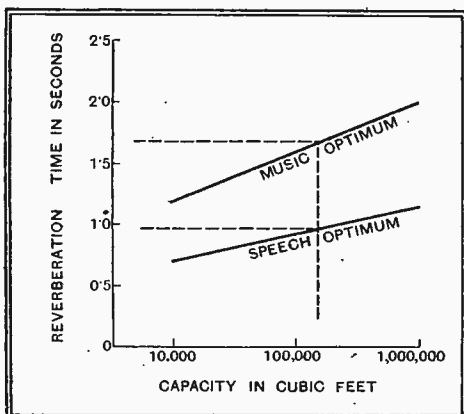

Fig. 12.—Optimum reverberation times for speech and music in auditoriums of various capacities.

\* "The Evolution of the Phon," *The Wireless World*, July 9th, 1937.

**Auditorium Acoustics—**

shown that it requires a smaller sound intensity change to produce a given loudness change at low frequencies than at high frequencies. This means that if the reverberation time were constant with frequency the low frequency sounds would appear to die away before the high frequency sounds, and in order to overcome this effect it is necessary to have longer reverberation times at low frequencies as shown in Fig. 14. The problem of distribution of absorption and of shape is also different for a music auditorium, since the stage or playing area must be acoustically

Considering the acoustics of a music auditorium from the aspect of the audience, it is clear that they should hear the rendering as played and approved by the performers, and there would appear to be little artistic need for the audience section to contribute to the overall reverberation time. This does not mean that the audience section should be completely absorbent or dead, but it need only be sufficiently live to give good distribution to all parts. Again, as with the playing area, focal points from concave surfaces and flutter between parallel surfaces should be avoided, and delayed reflections from distant surfaces will give rise to echo if the reflected sound travels 60 feet farther than the direct sound. As with speech auditoriums, a lowish ceiling can be arranged to give good distribution, freedom from delayed reflections and a suitable reverberation time.

The acoustics of music auditoriums may, therefore, be summarised as follows:

(a) The playing area should be compact with good distribution and should contain all the reverberation and resonance characteristics required by the performers for optimum musical expression.

(b) The audience area should be dead *relative* to the playing area and the shape and amount of reverberation should be designed from the aspect of good distribution.

This arrangement has the advantage that the acoustics of the playing area are largely unaffected by the amount of absorption introduced by the audience and so the acoustics can be satisfactory under empty conditions at rehearsals.

It will be seen that, due to the uneven distribution of absorption between playing area and audience area, such an auditorium will tend to have a double decay rate in its reverberation characteristics as explained in the previous article. In this consideration of the acoustics of speech and music auditoriums no mention has been made of permissible extraneous noise levels, but it is a natural conclusion that these should be as low as possible and should not exceed about 15 phons with no audience present. Under these circumstances the audience will normally be responsible for all the noise that is likely to be disturbing.

The next and concluding article will deal with the acoustics of talking picture cinemas and studios, broadcast studios and rooms for broadcast reception.

**"W.W." Straight Six**

AS a result of an unexpectedly large demand for coils for the above set, a delay in production by the manufacturer has occurred, but all outstanding orders are expected to be met this week, and no further delays should occur.

**"Ohmmeters": A Correction**

THE battery voltages given in the last column of Table II should read:—  
 0.500  $\mu$ A ..... 13.5 V.  
 0.1 mA ..... 13.5 V.  
 0.2 mA ..... 27.0 V.  
 In Fig. 4, the battery shown as 15.0 V should be 13.5 V.

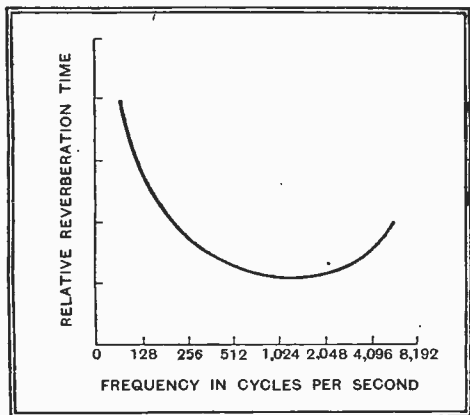

Fig. 14.—Curve, due to McNair, of relative reverberation time with change of frequency required for best results.

correct to a high degree so that the conductor and performers can give their best interpretation. The custom in the past, in fact, has often been to attend to the acoustics from the performers' aspect and let the acoustics from the audience's aspect take care of themselves. The most essential acoustical requirements of the "playing area" are that the reverberation time shall be satisfactory, as exemplified by such an optimum curve as that of Fig. 12, and that the distribution shall be uniform. This latter is very necessary so that each performer shall be able to sense the proper balance of the musical rendering and thus relieve the conductor of excessive control. That the conductor's place, in particular, shall be quite free from acoustical defects of distribution is of the greatest importance. A further point in preserving the correct balance is to keep the playing area compact so that a performer does not receive too great a proportion of sound from those other performers in his immediate vicinity.

The surfaces surrounding the playing area should therefore be fairly reflecting to give adequate reverberation time and should be irregular without parallel or concave surfaces to facilitate even distribution. With regard to the actual materials from which these surfaces should be constructed there is a preference among musicians for thin wood panels which are capable of sympathetic resonance rather than hard plaster walls, and although there may be little quantitative data on the virtues of such a construction it appears to have the advantage, at least, of making the performers feel in tune with a traditional atmosphere.



**6-valve all-wave Superhet with Radio Frequency Stage**

8 stages.  
 8 tuned circuits.  
 3 wavebands.

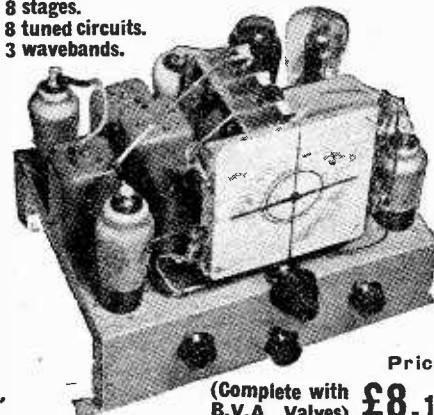

Price  
 (Complete with B.V.A. Valves) **£8.17.6.**

Performance (made possible by use of multi-electrode valves) equal to that of many receivers employing 8 valves or more. Brief specification includes: Large "Airplane" dial, with different coloured lights automatically switched on for each wave-range. Micro-vernier 2-speed drive. 4-point wave-change and gramophone switch. Volume control and variable tone control also operative on gramophone. Reinforced heavy-gauge steel chassis. Covers 19-2,000 metres. Circuit comprises: Preselector circuit, radio frequency amplifier (operative on all 3 wavebands), triode-hexode frequency changer, double band-pass I.F.T. coupled I.F. amplifier, double diode-triode detector and L.F. amplifier. D.A.V.C. applied to 3 preceding valves. 3-watt pentode output.

**9 VALVE FOUR-WAVE SUPERHET DE LUXE**

**14 GNS.**

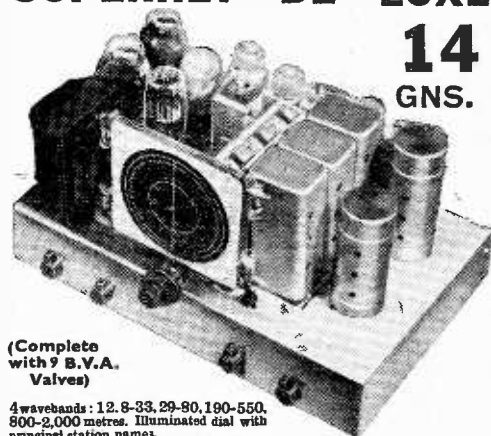

(Complete with 9 B.V.A. Valves)

4 wavebands: 12.8-33.29-80.190-550. 800-2,000 metres. Illuminated dial with principal station names.

**Controls.**—A feature of the receiver is the number of independent controls fitted, making it extremely interesting to operate. These include sensitivity control (varying bias on R/F stage), or Q.A.V.C. with manual muting control for inter-station noise suppression. 5-position wave-change and gramophone switch. Progressive variable tone control operative on radio and gram. **Circuit in Brief.**—Aerial input to pre-selector circuit, radio frequency amplifier, latest type triode-hexode frequency changer, 2 band-pass I.F.T. coupled I.F. amplifiers, double diode detector, triode L.F. amplifier, separate triode phase-changer capacity coupled to 2 large pentodes in push-pull. Heavy 16-gauge steel chassis. Finest components and workmanship throughout. Harries tetrodes in place of output pentodes if desired.

**STANDARD MODEL 12 GNS.** As above, but with triode push-pull output, and fewer controls fitted.

**DEFERRED TERMS** on application or through our City Agents  
**LONDON RADIO SUPPLIES LTD.**  
 11, OAT LANE, E.C.2.  
 Demonstrations Daily.

All McCarthy receivers supplied complete with valves, knobs pilot lamps, leads, mains cable and plug. 12 months' guarantee. (Valves 3 months.)  
 The prices at which McCarthy receivers are advertised include Marconi Royalties.  
 Cash with order on 7 days' approval. Also write for illustrated catalogue at complete range of all McCarthy receivers.

**MCCARTHY RADIO LTD.**

44a, Westbourne Grove, London, W.2

Telephone: Bayswater 3201/2.



# Letters to the Editor

The Editor does not hold himself responsible for the opinions of his correspondents

## Start Point Transmitter

IN reply to Mr. T. J. E. Warburton I would like to mention certain points which will likely be of interest to him, in view of his criticism of the proposed Regional transmitter at Start Point. The B.B.C. inform me that "the new transmitter will supply a power of no less than 100 kW to an aerial system of the most modern 'mast-radiator' type which has been designed to increase as far as possible the minimum range at which fading phenomena becomes troublesome, and this aerial system will be directional towards the east. In view of this, and since the line of propagation towards Sussex is almost entirely over water, over which the wave is submitted to only about one-hundredth of the attenuation which would occur over land, it has been predicted (to continue in the words of the B.B.C.) that the new station will be able to provide a very much more reliable service of a Regional programme along the south coast than at present exists." I might add that during recent evenings Droitwich, for short periods, has been fading (accompanied by the usual distortion) in this district.

A. A. SHANNON.

Bexhill-on-Sea.

## British and American Inventors

IT is not easy to trace any technical development down to its first origins, even when it is covered by a so-called "pioneer" patent and is earning huge royalties. Small wonder, then, that disputes and controversies constantly arise both between individuals and from what "Heptode" calls "technical or commercial nationalism."

No one wants to disparage the many contributions made by our American friends to the advancement of the wireless art, including, of course, television, but in his efforts to do them justice "Heptode" seems anxious to hand over more bouquets than the facts warrant.

After all, in the letter to which "Heptode" takes exception, Mr. Shoenberg simply points out that much has been done in our own laboratories, and by our own engineers, to develop television along lines which are radically different from, and give better practical results than, those favoured across the Atlantic. And he quotes chapter and verse from a well-known American technical journal by way of corroboration.

Mr. Shoenberg does not even go so far as to deny Mr. Sarnoff's assertion that our work is "fundamentally based" upon the system of television developed in the R.C.A. Laboratories in America, though I fancy he would be prepared to do so if put to the point.

Campbell Swinton, for instance, started experimenting with cathode-ray (Braun) tubes in 1903, and in 1908 published the first definite proposal to use them for both the transmission and reception of moving pictures. In 1911 he suggested the use of a fine "mosaic" screen of photo-electric cells to generate the signalling currents in the transmitter tube. All this ante-dated the work of the R.C.A., and of Zworykin, by many years.

The cathode-ray tube itself was introduced in 1897 by Braun, of Germany, but

the number of inventors who have since made this improvement, and that in order to promote its use in television, is legion, and their nationality is as much British and German as American. Time-basis circuits and saw-toothed oscillators, too, are of widespread origin, though the early British oscillator due to Kipping was one of the first specially designed for television work.

But the "fundamental basis" of television dates back beyond the cathode-ray tube, back, I would say, to the birth of the idea of "scanning" the picture in order to break it up into elemental areas, each of which can be transmitted as a separate signal, and then reassembled in proper sequence at a distant receiver.

Surely the name of Baird has some significance in this connection, and for his later work in the development of modern high-speed television. Nipkow secured a German patent covering the use of a scanning-disc for transmitting motion pictures over wires as early as 1884, and I believe there is a still earlier disclosure of the same general idea in a French technical journal, the name of which has escaped me for the moment. Who, in face of all this, can claim credit for the "fundamental basis" of television?

It is unnecessary, perhaps, to dot the i's and cross the t's too heavily. But one may be allowed to point out that the American Courts decided, in effect, that if Fleming had not first produced the two-electrode valve, de Forest would not have been able to put his "grid" into it. And "Heptode" should remember that Franklin, here, and Meissner, in Germany, have claims on reaction; Bolitho, from this country, on super-regeneration; Levy, of France, on the superhet; whilst Sir Oliver Lodge protected the first moving-coil speaker.

Is it fair, too, to overlook Sir Oliver's pioneer work on aerial tuning, and on the Lecher-wire circuits which are now proving so useful in ultra-high-frequency work? Again, in the last-mentioned field, Gill and Morrell share credit with Barkhausen and Kurz for the discovery of a new method of valve operation which has revolutionised the generation and reception of micro waves.

In direction-finding, the Adcock aerial is a British invention of established worth, whilst the name of Appleton carries weight everywhere for his work on the constitution and location of the Upper Reflecting Layers—even after giving full credit to Heaviside.

Finally, "Heptode" seems to have forgotten names like Round, Willans, Robinson, and quite a number of others who have left their mark on the records of British wireless enterprise.

"OCTODE."

## Reception Conditions

I HAVE built the W.W. Straight Six. This is really a wonderful receiver for quality combined with sensitivity. I have built in turn every one of the W.W. superhet series, starting with the band-pass superhet and thence the Monodial and Quality series, finishing with the QA Super I, but in my opinion this Straight Six has even the QA Super I easily beaten.

A point I consider wants stressing in *The Wireless World* is a request to all readers

suffering electrical interference to fill in and post the necessary form to the G.P.O. I understand that all S.E. Essex is suffering from a new type of this interference. It takes the form of a rhythmic crackle all over the medium waveband and is on all 24 hours day in, day out. It emanates, I understand, from some form of electrically charged plates fixed 'on top of a cement factory chimney at Purfleet. This chimney is some hundreds of feet high, and the plates have something to do with collecting dust from the smoke. Here in Upminster the interference is sufficient to be audible in the background in daylight on London National. What it must be like for people in a nearer radius to the factory I can't imagine.

Upminster, Essex. J. CHANDLER.

## "Scale Distortion"

ON several occasions "Cathode Ray" has mentioned the fact that the man with the straight-line amplifier is getting only a travesty of the truth when listening to a large orchestra owing to the fact that the reproduction is nothing near the volume of the original.

A moment's reflection will show the fallacy of his reasoning: he is confusing sound (as an absolute quantity)—see his notes on the 100-watt orchestra this week—with *sound intensity*.

It is possible to hear this "100-watt" orchestra *louder* than the original with an output of only 100 milliwatts—using moving-coil headphones!

The reason is quite simple: the *sound intensity* is greater in the aural cavity (approximately 10 c.c.) than it is in the concert hall of possibly many thousands of cubic feet capacity.

Looking at it from the quality enthusiast's point of view, let us imagine a room 20 x 20 x 10ft.—4,000 cubic ft. It should be obvious to "Cathode Ray" that several watts fed into a good speaker will produce at least as much intensity of sound as Toscanini and his minions in the Queen's Hall.

The frequency response of the human ear is a simple matter if it is regarded as pressure-operated, and it makes no difference if a large source of pressure at a distance (the orchestra in the concert hall) or a nearer and smaller source (the loud speaker) is responsible provided the pressure is the same.

I hope "Cathode Ray's" theory will be decently buried with full musical honours (with peak volumes of  $x$  kilowatts).

QUALITY ENTHUSIAST.

[This letter has been shown to "Cathode Ray," whose reply is printed below.—ED.]

## "Cathode Ray" Replies

I AM glad that "Quality Enthusiast" has given me another excuse for returning to this subject, because I have had an uneasy feeling that he and J. L. Montague and "Free Grid" are not the only ones who think I do not know the difference between sound power and sound intensity. When I say sound intensity (e.g., in my reply to J. L. Montague) I mean sound intensity as so excellently explained by "Quality Enthusiast." That being so, if "Cathode Ray's theory" (wrongly so called) is to be buried with full musical honours, so must the work of Harvey Fletcher and all the accepted authorities on acoustics who were responsible for the loudness/sound-intensity curves I caused to be reproduced as

Letters to the Editor—

Fig. 1 in my article. And as these curves are the averages of actual tests on actual people's ears . . . ! For what I said—that when the level of sound is altered, as by a volume control, the distribution of loudness over the frequency scale as judged by ear is also altered—is shown plainly and numerically by those curves. There is no theory about it at all; it is simply experimental fact!

The "Cathode Ray theory" to which "Quality Enthusiast" objects, then, must be that the listener in the home cannot hear the orchestra at the same intensity as he would if he were sitting in the concert hall. I have never said such a thing, because I agree with "Quality Enthusiast" on this point. What I did say in replying to J. L. Montague was that I thought it unlikely that anybody like him, who makes a habit of causing the sound in his room to be "much louder" than the 100-watt orchestra itself at a distance of a few feet, would succeed very long in escaping the wrath of his neighbours. Mr. Montague evidently does not get over the difficulty as suggested by "Quality Enthusiast" by using phones, for he refers to the absorption due to his room.

My impression is that unless one is making a special occasion of listening to some programme (and not always then), reproduction of very loud programmes at their original sound intensity is not tolerated by most of the persons inside or immediately outside the home. Furthermore, "scale distortion" is inevitable if a number of items of widely differing original intensity (e.g., bands and news bulletins) are listened to without considerable adjustment of the volume control.

The misunderstanding must have arisen from my comparison of the orchestra's 100 watts with the average home loud speaker's few acoustical milliwatts. To avoid any such misunderstanding I tried to calculate the probable corresponding sound intensities (which I have reason to believe would still be considerably unequal in most circumstances) from published formulæ, but found the available data insufficient. By way of apologising for the defocusing of the "Cathode Ray" on this occasion, I propose to carry out actual tests of sound intensity in public buildings and homes, and, with the permission of the Editor, to report them on some future occasion. If it turns out that they are, in certain cases, approximately equal, so much the better; "scale distortion" will be absent in such cases. But I repeat that, in the measure in which the original and reproduced intensities differ, "scale distortion" is present; and if anybody (including "Free Grid") disagrees with that, let him now speak or henceforth for ever hold his peace.

"CATHODE RAY."

Recording

IN his article on "High-Quality Home Recording," Mr. John R. Ord-Jolly has given some useful information. (October 29th issue.) As author of the "Simplat" booklet, issued by the V. G. Manufacturing Co., Ltd., Gorst Road, Park Royal, I am naturally interested in his remarks on this blank, but I think it advisable to correct one slip. In the sixth line of the second column "50 deg. C." should be Fahrenheit and not Centigrade.

I would add that experiments have shown that the optimum temperature for storing the "Simplat" blank is from 50 to 68 deg.

F. and the latter figure should never be exceeded. The moisture content of the atmosphere should be between 60 and 70 per cent., with around 70 per cent. as the optimum condition. This relative humidity should, however, never be greater than 80 per cent. For storage the blanks should be in their paper covers and cardboard boxes and be placed vertically.

Ilford, DONALD W. ALDOUS.  
Essex.

D.C. or Z.F.

WILL Mr. Scroggie agree that "D.C." differs from "A.C." in not having a life cycle of growth and decay?

But if a thing has no life cycle it must be a dead thing!

Well then, if it is dead, why not call it "D.C."? A. Y. B.

Television Programmes

An hour's special film transmission intended for the Industry only will be given from 11 a.m. to 12 daily.

Vision	Sound
45 Mc/s.	41.5 Mc/s.

THURSDAY, November 18th.

3, The Western Brothers. 3.10, Gaumont-British News. 3.20, "Fifteen Minutes." 3.35, "Thomas and Sally or the Sailor's Return." A dramatic pastoral by Arne.

9, Gillie Potter. 9.10, Cartoon film. 9.15, Experiments in Science, No. 4—Economising Effort. 9.30, British Movietonews. 9.40, Song and Dance No. 3.

FRIDAY, NOVEMBER 19th.

3, Starlight. 3.10, British Movietonews. 3.20, The Habima Theatre in scenes from "The Dybbuk" with members of the company from Tel-Aviv. 3.55, Pre-view: highlights of the week.

9, Dancing lesson. 9.15, Pre-view. 9.20, Artists and their Work, No. 1—John Graham, convict. 9.35, Gaumont-British News. 9.45, "Quid pro quo": a little foul play in one act.

SATURDAY, NOVEMBER 20th.

3, Gardening: a talk on fruit. 3.15, Gaumont-British News. 3.25, "Pride of the Green": a very Grand Opera by Rae Elrick.

9, Cabaret commèred by Sheila Douglas Penant. 9.25, "The Butterfly": a Hans Andersen story. 9.35, British Movietonews. 9.45, "Fifteen Minutes."

MONDAY, NOVEMBER 22nd.

3, Entertainer. 3.10, Gaumont-British News. 3.20, Characters from "Bleak House" by Hugh Miller. 3.30, Jack Hylton and his Band.

9, "Quartet," with Irene Prador, Wendy Tove, Russell Swann and Cyril Fletcher. 9.30, British Movietonews. 9.40, A. P. Herbert's one-act opera, "The Policeman's Serenade."

TUESDAY, NOVEMBER 23rd.

3, Round the Film Studios, No. 3—O.B. from Elstree. 3.15, Fashion Forecast. 3.30, British Movietonews. 3.40, Comic Strip, No. 2—a programme of American Humour.

9, O.B. from Elstree. 9.15, Speaking Personally, No. 6—W. D. H. McCullough. 9.25, Gaumont-British News. 9.35, Fashion Forecast. 9.50, Starlight.

WEDNESDAY, NOVEMBER 24th.

3, O.B. from Elstree. Tour to be conducted by Diana Churchill. 3.14, Gillie Potter. 3.25, Gaumont-British News. 3.35, Ninety-seventh edition of Picture Page.

9, O.B. from Elstree. 9.15, Nauton Wayne. 9.20, British Movietonews. 9.30, Ninety-eighth edition of Picture Page.

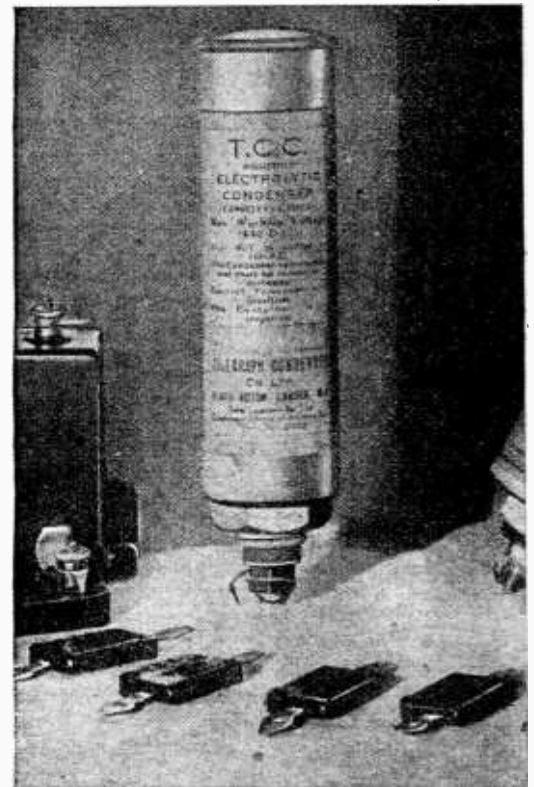

Here Familiarity Breeds Respect!

Setmakers and designers must know condensers . . . know that they will work within specified limits . . . will stand up to the hundred and one different conditions. Only through years of continuous contact with these condensers . . . being really familiar with their performance can the designer make sure. For over 30 years, T.C.C. Condensers have been the almost invariable choice of they who know. T.C.C. have earned their respect.

That's why these T.C.C. Condensers are specified for the

"W.W. TWO R.F. STRAIGHT SET"

- one T.C.C. .0001 mfd Mica 'M' - - 9d.
- one T.C.C. .0005 mfd Mica 'M' - - 9d.
- one T.C.C. .01 mfd Tubular '451' - - 1s. 0d.
- one T.C.C. .05 mfd Tubular '341' - - 1s. 3d.
- four T.C.C. .1 mfd Tubular '341' each 1s. 4d.

T.C.C. ALL-BRITISH CONDENSERS

The Telegraph Condenser Co. Ltd., Wales Farm Rd., N. Acton, W.3

# RANDOM RADIATIONS

## Power from the Air

**O**FTEN I've wondered why we don't make more use of wind power for running our wireless receivers. Those who live in towns don't need to do so, for if they haven't electric lighting supplies they can always get batteries charged without much trouble. But it's very different for the country dweller, who often has no electric light and is miles from the nearest charging station. For many years now American radio manufacturers have catered for people who are so situated. Battery sets using the "air cell" for filament heating and a big dry HTB have long been available. And at least one firm markets a generator driven by a small windmill which charges a 6-volt accumulator of the kind that is always found on American cars. By means of a converter it is possible to run a standard AC mains set from the accumulator—and there you are: you operate your wireless set at no cost except that of installing and maintaining the wind-driven generator and the battery.

## Should be Simple

I can't help thinking that something of the kind might be very popular in this country. One advantage that we have is that the standard car-starting battery is a 12-volt accumulator, which should be much better able to undertake the supply of current than a six. The drain on a six-volt battery must be considerable. Take it that the set requires 50 watts and that the converter is 60 per cent. efficient; then the battery would have to supply nearly 84 watts, which means a current of 14 amperes from a 6-volt battery. With a 12-volt battery the discharge rate is, of course, just half, and should be well within the powers of a good multiple-plate accumulator of, say, 60 ampere-hour capacity. There are also several alternative methods of using a wind-driven generator. It could, for instance, be used for charging 4-volt accumulators which would serve a battery set designed on the Ekco "No HT" principle. Or, again, it could be employed to charge the LT accumulator of a receiving set and a nickel-cadmium HT accumulator, such as the Milnes, either directly, if the voltage were suitable, or indirectly *via* three 2-volt cells. One American apparatus whose picture and description I have seen is both simple and inexpensive. The supports of the windmill are so designed that they can be bolted to the roof of a shed, and the mill with generator costs 17 dollars 50 cents, which is about £3 10s.

## News Bulletins Galore

**T**HERE'S a minor battle going on just now in France over the question of news bulletins. And really I don't wonder, for the amount of news poured out during the day by the French broadcasting stations is simply immense. Take Radio-Paris alone: on one typical day this station started with a news bulletin at 6.40 a.m. and gave another at 8 o'clock. Market and exchange reports were given five times between 11.45 a.m. and 4.50 p.m., and news again at 1 p.m. and 11 p.m., with a review of foreign affairs and politics at 8 o'clock and a press review at 9.30. The programmes of the Poste Parisien begin at 7.10 a.m., but details are not published in our

## By "DIALLIST"

papers for the hours before 12 noon. From that time onwards on a recent day this station had five exchange reports and two news bulletins. The reason for the battle is that some of the newspapers claim that they are suffering because the public can get news for nothing at almost any time of the day by merely switching on the wireless set. But, curiously enough, some of the private stations which are owned by newspapers are amongst the most prolific in the news bulletins that they pour out.

## Would You Like This?

On the whole I think you'll agree that our stations do us quite well enough in the matter of news. But there's just one extra news bulletin that I'd like to see put on, and I rather think that you'll agree. On Good Friday, Christmas Day and Boxing Day no papers are published, in England, at any rate; and on those days I do feel it rather a trial to have to wait until the evening to hear what has been taking place in the world. It couldn't possibly injure the newspapers and it would, I believe, be greatly appreciated by listeners at large if we could have news bulletins or news summaries at, say, 10 o'clock on the mornings of such days. It wouldn't be necessary to send them from all stations; probably Droitwich alone could cope with the task. Or, if 10 o'clock is thought to be too early an hour, why shouldn't we have them at midday, when all stations are at work?

## This Year's Sets

**H**OW many models of wireless receivers and radiograms do you think there are on our market at the present time, counting only those which are made in this country? I should have guessed about 300, but in a recent issue the *Wireless Trader* published details of nearly six hundred current models. These range from three-valve battery sets, of which there are 39 different kinds, to a twenty-valve radiogram. Amongst battery superhets the most used number of valves is four, though the five-valve set is a good second. Out of 54 models, 24 have four valves and 20 five. The numbers are made up by one three-valve set, eight with six valves, and one with seven valves. In mains superhets four valves is again the most popular number, this being the make-up of 113 out of 277 AC receivers and radiograms, and 62 out of 110 AC/DC models. The combination of five valves is found in 73 AC receivers and radiograms, and 19 of those designed for AC/DC working. It is rather surprising to find that of a total of 387 mains superhets of one kind or another, only 109 have tuning indicators. Straight sets of the bigger type are more in evidence than I had thought. There are 2 five-valve models, 2 with eight valves, and 4 with eleven valves.

## Books of the Words

**A**S a rule the instruction books which accompany wireless sets are pretty lucid in the directions that they give for installing and running them. Occasionally, though, one comes across some astonishing omissions. One set that I have been trying out recently has four knobs at the front of the cabinet as well as two at the back. None of the front knobs has anything on it to show its purpose, and only to two of them is any reference made in the book of the words. One discovered by trying it which was the main tuning knob. The other must therefore be the wave-change switch, but there was no mention of its various positions. The tuning dial is rather a complicated affair at first sight, though perfectly straightforward once you had examined it and got the hang of it.

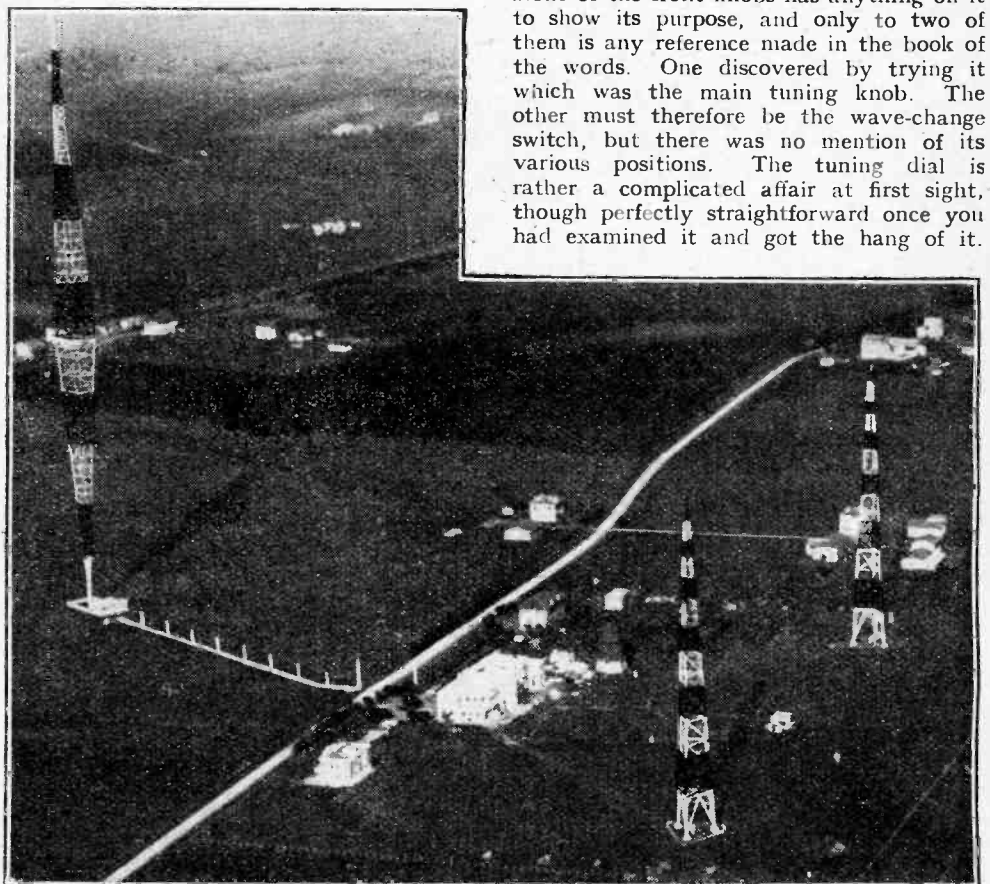

**HAVE YOU HEARD** the new Rome No. 1 transmitter? Situated at Santa Paloma, twelve miles outside the city, the new transmitter uses a modern mast type of aerial radiator and is reported to be working with 120 kW. The older station used an aerial slung between the masts seen on the right.



**Random Radiations—**

However, you have to find out for yourself what it's all about, for the instruction book gives no help.

**What is Needed**

Some makers possibly don't realise that many of those who buy and use wireless sets know nothing whatever about wireless, and are quite unable to find out for themselves how a set should be operated. It is essential, therefore, for the instruction books to be written in the clearest and most detailed way, the purpose of every control being thoroughly explained. I have come across several instances of the way in which some people are utterly at sea with a wireless set, however simple it may be, whose working isn't explained to them almost in words of one syllable. One old lady who lives in the London service area had been receiving the Regional programme for months from Midland because on first turning the tuning knob she had found the programme coming in at that setting and concluded that it must be the right one. In another case a straight set was being operated with the volume control nearly in the minimum position and reaction used almost to the limit—with disastrous results to quality. The average man and the average woman are probably fairly knowledgeable about the wireless sets of to-day; but it must be remembered that every year there are tens of thousands who are graduating from the small straight set to the superhet, and tens of thousands more whose understanding of, to them, such a complicated thing as a wireless receiver is more than limited. For all of these the fullest and clearest working instructions are essential.

**Can't We Standardise Controls?**

A GOOD many years ago I was staying with a friend who had broken his arm only a day or two before I arrived, and, therefore, couldn't drive his own car. I had come down by train, and it was broken to me that I must act as chauffeur on our expeditions afield by motor. When I came to examine the car I found that the only control which was in the same place or worked in the same way as in my own was the screen-wiper switch. The gear-lever gate was "inside-out," as compared with mine; the foot brake, the hand brake, the accelerator pedal, the horn button, the self-starter switch and the lighting switch were all in different places. However, car controls are in general more or less standardised nowadays, though there are still a few makers who like to show their independence by being "contrary." Why shouldn't wireless controls be standardised in the same kind of way? It would be a boon and a blessing if they were. The man in the street could take on a new set without having to apply a wet towel to his brow and the expert wouldn't lose quite so much kudos as he does now, when he is asked by friends to show them how such-and-such a set (which he has never seen in his life before) should be worked and has to enquire before he starts which knob does what.

**K.B. 670 Radiogramophone****A Correction**

IN our notice of this new Kolster Brandes instrument in last week's issue the price was given in error as 31 guineas. The correct figure is, of course, 21 guineas.

**Distant Reception Notes**

TO the secretary of the Sydney branch of the Australian D-X Club I am grateful for a long and interesting letter about distant reception notes in his country. He tells me that he'll be happy to answer letters from British D-Xers, so if you have a query here's the man to write to:—

V. E. Deadman, 17, Railway Street, Rockdale, New South Wales, Australia.

It is rather surprising to learn that the British medium-wave Regional stations are easily logged in Australia in the spring and autumn. I can well believe that, as he puts it, the medium-wave Nationals are difficult. However, he tells me that they are received on occasion. The distant stations best received in Australia are those of Japan, China, India and the western parts of the U.S.A. South Africa is the most difficult country to receive, with South America next in order. The D-X season is a short one, since atmospherics make anything but local listening next to impossible for six months in the year.

There are no fewer than 120 broadcasting stations in Australia and New Zealand, two of them operating right round the clock for twenty-four hours each day.

Writing of 24-hour stations reminds me that WJBO of Baton Rouge, Louisiana, U.S.A., has now increased its power, and should therefore be receivable in this country under favourable conditions. Its wavelength of 267.7 metres (1,120 kilocycles) is shared by over a dozen Canadian and U.S.A. stations, but as WJBO is the only one to work continuously both day and night there must be considerable periods when it is alone in its glory. Probably about seven o'clock on a dark winter morning would be as good a time as any for those with the requisite enthusiasm to try for it.

Listeners in France have at last passed the four-million mark. It's curious that though that country was the cradle of broadcasting (old hands will remember the time when the Eiffel Tower's afternoon concerts were the only regular broadcasts), and though it is very well served by its numerous stations, both Government-controlled and privately owned, the French as a nation have been rather slow in taking up wireless as a hobby. French stations have always been so well received in this country that I shouldn't be surprised if a few years ago their transmissions were tuned in by almost as large an audience here as in France.

For nearly two years now work has been in progress on the 100-kilowatt station at Melnik, in Czechoslovakia. It is now completed, and tests will probably be under way about the time that you read these notes. The station, which is to be devoted mainly to programmes for German-speaking inhabitants of the country, is to work on 269.5 metres. Displaced from this wavelength, Moravska-Ostrava will move to 249.2 metres. Prague No. 2, whose wavelength this now is, will close down for the time being, but I am told that its 5-kilowatt transmitter is to be moved to Budejovice, where it will work as a relay for the Melnik station.

When Melnik is in full operation Czechoslovakia will have a first-rate broadcasting service with Prague No. 1 (120 kw.), Melnik (100 kw.), Brno (32 kw.), Banska-Bystrica (20 kw.), Bratislava (13.5 kw.), Moravska-Ostrava (11.2 kw.) and Kosice (10 kw.).

D. EXER.

# NOTABLE FEATURES of the *New* ROLA F 742-PM

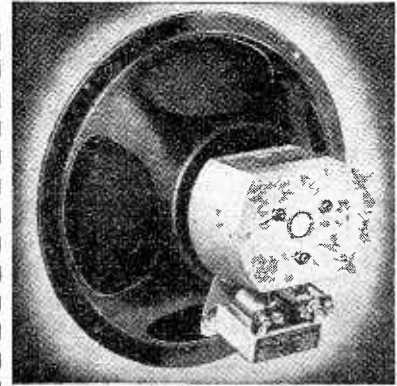

## "EFFICIENCY IS EXTREMELY GOOD"

says "The Gramophone"

Read these extracts from "The Gramophone" test report on the Rola F 742-PM — "Efficiency, judged aurally, is extremely good. Relatively small inputs produce good volume, and what is more important the quality of the reproduction does not fall off at low volume to any appreciable degree. On the other hand inputs up to about four or five watts do not seem to disturb the equanimity of the speaker. The feature we liked best about the reproduction was the crispness and definition almost throughout the range. And this is maintained in all classes of music." This report refers to a 9½in. speaker selling at the extremely moderate price of 49/6. Its performance is equal to that of much larger and more expensive units and has to be heard to be fully appreciated. Ask your dealer to demonstrate the Rola F 742-PM or write to-day for folder A.

Model  
F 742-  
PM 49/6

WITHOUT TRANSFORMER 42/-

OVER 8 MILLION IN USE

# ROLA

The World's Finest Reproducers

THE BRITISH ROLA CO. LTD.  
MINERVA ROAD, PARK ROYAL, N.W.10.  
PHONE WILLESDEN 4322-3-4-5-6.

# Recent Inventions

The British abstracts published here are prepared with the permission of the Controller of H.M. Stationery Office, from Specifications obtainable at the Patent Office, 25, Southampton Buildings, London, W.C.2, price 1/- each. A selection of patents issued in U.S.A. is also included.

## ELECTRON MULTIPLIERS

IN a device of the kind in which an electron stream is forced to strike in succession against a series of "target" electrodes, and in which amplification occurs at each impact owing to secondary emission, only the first "target" is sensitised, the others being made of pure metal.

For instance, the first "target" may be of silver coated with caesium, whilst the others are of pure uncoated silver. This is stated to increase the stability of the multiplier, and also to improve the ratio of signal intensity to noise.

W. E. Williams. Application date January 18th, 1936. No. 469111.

## TELEVISION SYSTEMS

THE object is to obtain, for scanning purposes, a flat beam of light which is smaller in one direction than the original source of light. The beam is used in conjunction with a light valve of the kind in which a "lag effect" is secured by the application of mechanical vibrations from a piezo-electric crystal.

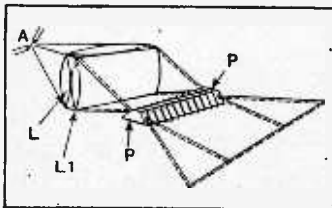

Method of obtaining a flat beam of light for scanning purposes in television receivers.

As shown in the Figure, light from a source A is passed through a spherical lens L and a cylindrical lens L1, and emerges as a convergent beam. The narrow end of the beam is then passed through a series of right-angled prisms P, which have the effect of rotating the beam through 90 deg. In its

**Brief descriptions of the more interesting radio devices and improvements issued as patents will be included in this section.**

## SELECTIVITY CONTROL

WHEN working on the short-wave side of an all-wave superhet set there is a tendency for the carrier-wave of the incoming signal to be displaced from the centre of the transmission band of the intermediate-frequency stages. This is due in some cases to fluctuations in the frequency radiated by the transmitter, and in others to variations in the frequency of the local-oscillator valve in the receiver; but the result in each case is to produce a certain amount of distortion, and, in the limit, to make the reception of certain stations impossible.

According to the invention, the difficulty is overcome by "ganging" the wave-change switch to a device which automatically reduces the selectivity (or, in other words, widens the acceptance band of the IF stages as the set is switched over to the shorter wavebands. For instance, a loading condenser may be inserted in the band-pass filter circuit on the short-wave setting. Fluctuations in carrier-wave frequency are thus given a greater "tolerance" and do not lead to distortion.

E. K. Cole, Ltd. Convention date (Sweden) July 4th, 1936. No. 469380.

## CAR RADIO SETS

INTERFERENCE from the ignition system of a motor car is prevented by a method of balancing-out, as distinct from the use of suppressors or other devices likely to impair the running efficiency of the car. The invention is based on the fact that any radiation which is likely to cause interference will also set up standing waves on the chassis or other metallic parts of the car, and that such waves can

picked up is fed to a coil L1, which is reversely coupled to the coil L, and then earthed.

The two coils L, L1 are made as flattened helices, as shown in Fig.

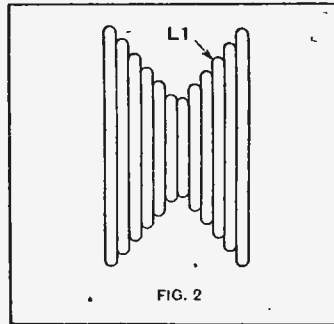

Construction of coils used in aerial filter.

2, and the coil L1 is mounted on a screw-threaded support so that it can be adjusted relatively to the aerial coil L with a suitable setting of the two coils, the interference component (which is common to both coils) will be cancelled out, and the broadcast signal received on the aerial A will alone pass through to the receiver.

Galvin Manufacturing Corp. (assignees of R. E. Wood and R. S. Yoder). Convention date (U.S.A.) January 10th, 1935. No. 468763.

## LIGHT VALVES

THE invention relates to means for generating mechanical waves of supersonic frequency, by means of a piezo-electric crystal, for application to a light valve used in television.

Between the crystal and the material to be set into vibration, there is interposed a layer—one half-wave thick—of a third substance. This is separated from the crystal by a space filled with a further substance, such as wax, which is one quarter-wave thick and has an "acoustic refractive index" less than that of the crystal, but not less than that of the crystal assembly.

Scophony, Ltd. and J. H. Jeffrey. Application date January 14th, 1936. No. 469018.

## PERMEABILITY-TUNING

TWO high-frequency circuits, which are ganged together, are tuned by the insertion or withdrawal of two powdered-iron cores. The arrangement is such that the coefficient of coupling is increased as the frequency is lowered. The coils themselves are designed to have a constant inductance-to-resistance ratio, but any small deviation from this condition can also be compensated by an initial adjustment of the moving cores.

Johnson Laboratories Inc. Convention date (U.S.A.) June 26th, 1935. No. 468675.

## TIME-BASE CIRCUITS

A TIME-BASE circuit having coupling components of low time-constant, although suitable for "straight" scanning, may cause serious loss of the lower signal frequencies when applied to an "interlaced" system of scanning.

According to the invention this is avoided by loading the coupling elements so that they have a time-constant greater than the framing frequency. The correcting impedances consist of condensers, which are arranged both in series and in parallel with the coupling-resistances between the saw-toothed oscillator, the succeeding amplifier, and the terminals of the deflecting-plates of the cathode-ray tube.

Radio-Akt. D. S. Loewe. Convention date (Germany) May 16th, 1935. No. 468808.

## SCANNING SYSTEMS

IN television transmitters of the cathode-ray or Iconoscope type, it is found that the definition of the outlying parts of the picture is less satisfactory than at the centre. This is due to the fact that the current collected from the electron beam by each cell of the "mosaic" screen depends very markedly upon the angle at which the beam strikes against it.

According to the invention, a ring-shaped "lens" electrode L is inserted in the path of the electron beam from the cathode C, for the

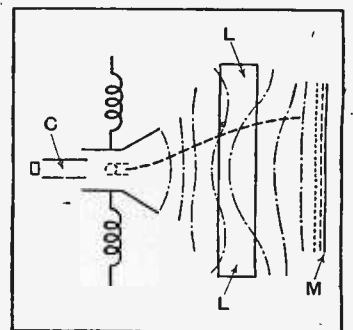

Method of improving definition in television transmitting equipment of the Iconoscope type.

purpose of deflecting it in the way shown in dotted lines, so that it falls substantially vertically upon the marginal parts, as well as upon the centre of the mosaic-cell screen M.

H. G. Lubszynski. Application date January 15th, 1936. No. 468965.

ONE rotating disc is formed with a slot which starts at the centre of rotation of a second rotating disc. The latter is formed with a series of scanning apertures which follow the track of the slots in the first. The arrangement provides a system of interlaced scanning in which the centre of the picture is reproduced with a higher degree of definition than the general background.

J. G. S. Arathoon. Application date January 21st, 1936. No. 468294.

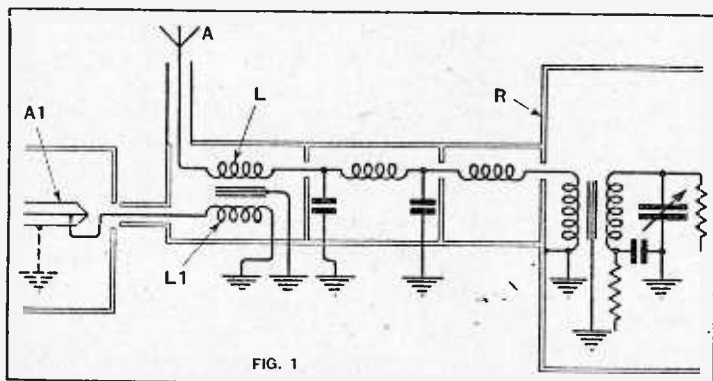

Screened filter aerial circuit to cut out car ignition interference.

final "flattened" form the beam is passed through a light valve (not shown), where it is subjected to supersonic vibrations from a quartz crystal, as it is modulated by incoming television signals. Scophony, Ltd. and J. H. Jeffrey. Application date January 25th, 1936. No. 469427.

be used to counterbalance the interference picked up by the aerial.

As shown in Fig. 1 the aerial A is coupled through a screened filter circuit, comprising a coil L, to the receiver R. A connection is also made to a convenient part of the chassis, such as A1, and the "standing wave" voltage there

# The Wireless World

THE PRACTICAL RADIO JOURNAL  
27<sup>th</sup> Year of Publication

No. 952.

THURSDAY, NOVEMBER 25TH, 1937.

VOL. XLI. No. 22.

Proprietors: ILIFFE & SONS LTD.

Editor:  
HUGH S. POCOCK.

Editorial,  
Advertising and Publishing Offices:  
DORSET HOUSE, STAMFORD STREET,  
LONDON, S.E.1.

Telephone: Waterloo 3333 (50 lines).  
Telegrams: "Ethaworld, Sedist, London."

COVENTRY: Hertford Street.

Telegrams: "Autocar, Coventry."  
Telephone: 5210 Coventry.

BIRMINGHAM:

Guildhall Buildings, Navigation Street, 2.  
Telegrams: "Autopress, Birmingham."  
Telephone: 2971 Midland (4 lines).

MANCHESTER: 260, Deansgate, 3.

Telegrams: "Iliffe, Manchester."  
Telephone: Blackfriars 4412 (4 lines).

GLASGOW: 26B, Renfield Street, C.2.

Telegrams: "Iliffe, Glasgow." Telephone: Central 4357.

PUBLISHED WEEKLY. ENTERED AS SECOND-  
CLASS MATTER AT NEW YORK, N.Y.

Subscription Rates:

Home, £1 1s. 8d.; Canada, £1 1s. 8d.; other  
countries, £1 3s. 10d. per annum.

*As many of the circuits and apparatus described in these  
pages are covered by patents, readers are advised, before  
making use of them, to satisfy themselves that they would  
not be infringing patents.*

## CONTENTS

	Page
Editorial Comment .. ..	515
Screened Aerials .. ..	516
New Valves? .. ..	519
Automatic Input Control ..	521
Camouflaged P.A. .. ..	522
When the Tuning Dial Slips..	523
Listeners' Guide for the Week ..	524
Broadcast Brevities .. ..	525
Current Topics .. ..	526
Wireless World Valve Data Supple- ment .. ..	527
Unbiased .. ..	551
Random Radiations .. ..	552
Letters to the Editor .. ..	554

## EDITORIAL COMMENT

### Valve Data

1927—1937

**I**N this issue we present for the eleventh year in succession *The Wireless World* Valve Data Supplement in which characteristics are given in tabular form of all current valve types, both British and American. To look through the supplements of successive years reveals in a striking manner not only the growth in the number of valves which are available but also the increasing amount of information which we need about a valve in order to select a suitable type for our purpose.

The supplement to *The Wireless World* for April 6th, 1927, contained details of 333 valves, whereas this year's gives data for over 900 types. At first sight this increase is not very great, but it must be remembered that the original supplement included 4-volt and 6-volt battery valves as well as the now universal 2-volt type. Not a single indirectly heated valve, a type which now makes up the bulk of the tables, was listed, and every valve was a triode. At that time, the screen-grid valve, the RF pentode, the output tetrodes and pentode, the frequency-changer, had yet to make their appearance. Rectifiers also were not in common use in the days when almost every set was battery-operated.

#### Increased Demand for Data

In this early supplement it was thought sufficient to give only the filament voltage and current, the AC resistance and the amplification factor of a valve. Nowadays much more information is needed and varies according to the types of valve. A knowledge

of the anode, screen and grid voltages for normal operation, together with the anode and screen currents is an essential to the correct choice of a valve, and with the advent of short-wave apparatus and television receivers data on the inter-electrode capacities are also needed. For output valves we must know the power output of the valve and the load impedance into which it will deliver that power.

#### Growth of the Supplement

The increase in number of valves and the growth of the necessary data have made the supplement correspondingly larger. In 1927, a single sheet, corresponding in area to about three pages of *The Wireless World*, sufficed; now nineteen are needed! In addition to the electrical data, two pages giving details of the valve-base connections are included.

We have often expressed the opinion that the number of valves is unnecessarily large and we feel this most strongly when we are preparing the supplement! We thought this in 1927, and in the editorial for April 6th said, "Looking through this formidable list one is almost forced to the conclusion that there are too many valve types made by nearly every manufacturer," and "One final plea, which must not be overlooked, is that for a standard method of nomenclature which is surely many-years overdue." It is now ten more years overdue!

Our thoughts in 1927 are still our thoughts in 1937, especially with regard to the standardisation of type numbers. However, if standardisation could not be achieved ten years ago with the relatively few valves then available, it seems too much to hope for it now.



# Screened Aerials

## DISCRIMINATION BETWEEN WANTED SIGNAL AND UNWANTED INTERFERENCE

By F. R. W. STRAFFORD  
(Research Dept. Belling and Lee, Ltd.)

*A DISCUSSION of the general principles of anti-interference aerials, with a clear exposition of the conditions under which such devices can satisfactorily discriminate between signal and interference. The author also throws new light on the way in which the typical screened aerial system performs its function.*

**P**ROBABLY every technically minded listener in this country is now aware that it is a practical certainty that within a year legislation will be directed against all forms of electrical interference with wireless broadcast and telegraph reception.

The listener is probably not so fully aware of the tremendous amount of committee and laboratory work which has been necessary to formulate the basic requirements upon which legislation may be framed. This has occupied a great deal of time, spread over the last three years, of many committees with expert representation of communicating, standardising, engineering and research organisation, not only of this country but of others in Europe.

Out of the mass of statistical and technical evidence accumulated by the combined efforts of these organisations a British Standard Specification will shortly be issued laying down the permissible limits of interference from electrical appliances, and when legislation is enacted these limits will presumably form the legal boundary beyond which interference must not encroach.

It is obvious upon mature reflection that some limit must be imposed. Theoretically, an infinite reduction of interfering electric currents by means of filter networks cannot be obtained, and, furthermore, the cost of suppression filters rises very much more rapidly than their effectiveness if attempts to reach a high degree of suppression are made. It would not, again, be fair to impose the whole of the cost of suppression upon the manufacturer in order to improve wireless reception for even 100 per cent. of the listeners of this country.

We thus envisage partial suppression of these interfering appliances or devices by the manufacturer or user, and suppression of the residuum by the listener. This is not only economical, but it appears to be logically fair.

### Ineffective Aerials

There exists an interesting B.B.C. publication entitled "Receiving Aerials and Electrical Interference," which gives the results of an international survey which was carried out on existing aerial systems and sources of interference in various

European countries. The results show that existing aerials are, on the whole, so inefficient and closely coupled to electric wiring that appliances would have to be suppressed to an extent sufficient to attenuate the interfering voltages at their terminals to the extremely low level of 35 microvolts to cater for outdoor aerials. An even lower figure of 10 microvolts is estimated for indoor aerials. With this degree of suppression only 75 per cent. of the existing installation would be free from interference. Even in Germany, where portable appliances are all unearthed and, therefore, produce less interference than many British earthed appliances, it was estimated that the interference would have to be reduced to 100 microvolts at

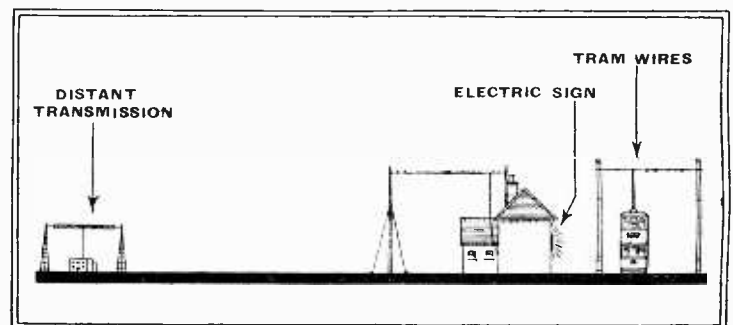

Fig. 1.—Diagrammatic representation of conditions under which a screened aerial may prove effective.

the machine terminals before even half of the existing receiving installations obtained full relief.

Such a low level of interference as envisaged in the B.B.C. publication would entail expensive filtration of appliances, and for this reason such a low limit cannot be enforced. It may be logically expected, therefore, that the limit will probably be of the order of a few hundred microvolts.

Fig. 2.—A practical example of the conditions shown in Fig. 1.



Thus, although considerable amelioration of present interference troubles is to be expected, the listener with a poor external aerial possessing a lengthy down-

lead trailing close to the building, or with a picture-rail or attic aerial, may find himself practically unaffected by these changes unless he is prepared to contribute in some measure to a general reduction of interference at his own residence.

This contribution may be effected, in the case of mains-borne interference, by the use of mains filters at the input socket to the receiver,\* or by the use of an efficient anti-interference aerial system if the interference is of the radiated form. It is the purpose of this article to expound at some length upon the general principles involved in order to clarify some of the general misunderstanding which appears to exist among many listeners and quite a few technicians.

### Discriminating Powers of Aerials

The fundamental requirement is that such an aerial system must be capable of efficiently collecting the desired signal to the exclusion of the unwanted electrical interference.

Before investigating in what manner this desirable discrimination may be obtained, it is essential to investigate the nature of the electric field in the neighbourhood of an aerial both from the desired signal and the electrical interference.

For this purpose refer to Fig. 1. Here is depicted a remote transmitting station T, say 10 miles distant, an inverted L receiving aerial A, and a nearby source of interference, I. It is not difficult to show mathematically that the electric field due to the desired signal is substantially uniform in intensity over any portion of the aerial A. On the other hand the field surrounding the aerial due to the interference radiated from I is by no means uniform and is much more intense along the vertical portion V, which is close to I, than along the horizontal portion H.

It is not difficult to visualise this state of affairs by crude analogy. Imagine that T is emitting a wide beam of light instead of broadcasting waves. The illumination at all points around A will be

substantially equal providing its dimensions are quite small compared with the distance from T (e.g., small compared

\* See "Anti-Interference Filters," by F. R. W. Strafford; *The Wireless World*, May 7th and May 14th, 1937.

**Screened Aerials—**

with 10 miles). On the other hand, if the source of light is located at I, the illumination over A falls off rapidly as one moves along the horizontal portion.

Now the conditions of Fig. 1 are duplicated very closely in most practical domestic broadcast installations, of which Fig. 2 depicts a representative case. Here the interference emanates by radiation from the house wiring or appliances connected thereto, and is also produced by passing trams or by flashing or neon signs located on the walls of the building. It will be evident that the greatest field intensity will exist in the vicinity of the down-lead from the aerial.

It may now be laid down as quite axiomatic that the distribution of signals and interfering fields respectively must be similar to that which has been already outlined before any anti-interference aerial can function.

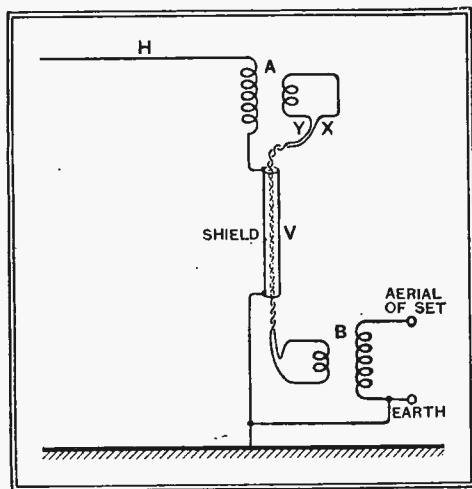

Fig. 3.—Typical anti-interference aerial with the down-lead arranged as a screened transmission line.

*No anti-interference aerial at present in existence is capable of suppressing atmospherics or the electrical interference radiated from points at a considerable distance from the aerial.*

Such disturbances, when remote from the aerial, merely produce a uniform field around the aerial in the same manner as a normal broadcast transmission, and no aerial system can discriminate between the two.

Now that the general facts concerning the nature of the field of both the desired signals and the unwanted interference have (it is hoped) been elucidated, it is necessary to consider their action upon a normal inverted L aerial. A rigid analysis of this problem requires a background of mathematical physics rather beyond the scope of the present article, and the reader is asked to accept the postulations that follow.

A typical receiving inverted L aerial consists of a horizontal span 60ft. in length and 25ft. above ground level, the down-lead being, say, 30ft. in length. It is assumed that the whole of this aerial is located in a substantially uniform field when considering the action of a distant broadcast transmitter.

From an interference viewpoint it is only those parts of the aerial which are closest to the interfering field, i.e., the down-lead and lead-in wire, which are most affected. It therefore appears logical to screen the down-lead or somehow to arrange matters so that the interfering field is unable to induce any EMF in it.

This procedure would appear to be so delightfully simple as to require no further theoretical consideration. The construction of a suitable system based upon our existing knowledge of transmission lines and filters does, in fact, prove to be highly effective, giving real amelioration in many severe cases of electrical interference of the radiated form.

Fig. 3 is the circuit diagram of such a system wherein the down-lead is replaced by a screened transmission line, the base of which is earthed. The horizontal portion of the aerial is connected through the primary of a suitable step-down transformer A designed to match the end impedance of the aerial to the characteristic impedance of the transmission line. At the termination of this line a further step-up transformer B matches (as nearly as possible) the input impedance of the receiver with which it is to be used.

The design of these transformers calls upon the ingenuity of the engineer, for it is impossible to obtain an optimum transfer of signals at all wavelengths, since both the aerial and receiver impedances vary with frequency.

Compromises must, therefore, be effected, and circuits are designed with band-pass characteristics to give a good average transfer over the whole wave-range of the receiver. These compromises express themselves in many cunning artifices to be found in the various existing makes of equipment, but these artifices do not alter the general problem, which is that of screening the down-lead against the action of the concentrated interfering fields in its vicinity.

**Revised Theory of Operation**

Several months ago Dr. L. Smith-Rose, of the National Physical Laboratory, pointed out to the writer that such systems could not work if considered in the light of the earlier delightfully simple reasoning adopted by every previous writer on the subject.

It was pointed out that these reasonings were fallacious because the vertical portion of the aerial is theoretically the only portion which collects an EMF from the uniform field of a vertically polarised electro-magnetic wave (the desired broadcast signal). The horizontal portion is, however, indispensable because it increases the effectiveness of the vertical portion without actually collecting any further EMF from the signal field.

Consider this action as applied to the aerial system of Fig. 3. Due to the vertically polarised field of the desired signal, currents are induced in the shield of the screened down-lead and flow through the primary of the aerial transformer A. The resultant EMF's are thus transferred by

the transmission line X and Y to the receiver transformer B where they are stepped up again and applied to the receiver.

Now there does not appear to be any reason why the currents induced in the

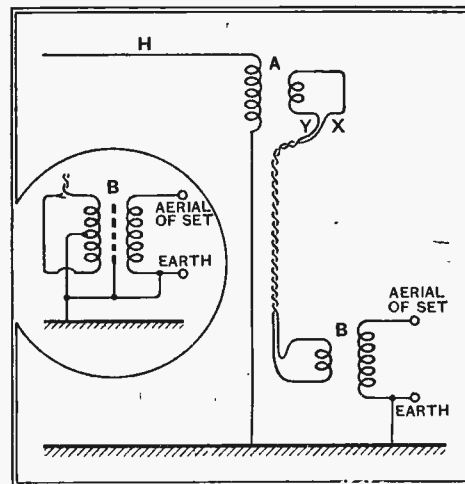

Fig. 4.—Similar arrangement to that of Fig. 3, but with the down-lead screen replaced by an earthed wire. Inset: a balanced centre-tapped transformer.

same shield by a non-uniform interfering field located in close proximity to the screened down-lead should not do precisely the same thing.

With the aid of some earlier mathematical work on aerials by Mr. F. M. Colebrook,† of the National Physical Laboratory, the analysis has been extended by the writer and his colleagues to embrace this particular problem, and the results are very illuminating.

It would appear that the requirements of screening are not essential, and that the problem must be reinvestigated upon the following lines: Consider Fig. 4: the only physical difference between this and Fig. 3 is that the screen surrounding the twin transmission line X and Y has been removed and replaced by a simple earthed vertical wire. If we could assume that X and Y are not influenced by any field in their neighbourhood the arrangement must work in precisely the same manner as the circuit of Fig. 3.

The lines X and Y, though devoid of a shield, may be rendered entirely immune from a field in their vicinity by the simple process of centre-tapping to earth the primary winding of transformer B with the addition also of an earthed electrostatic shield between primary and secondary windings. Current produced in X and Y as the result of the action of any field (signal or interference) along their lengths must flow in the same direction towards earth and thus cancel out in the transformer primary. Any electrostatic coupling is also avoided by the use of the screen between the windings. Any current which flows in the aerial (whether due to signal or interference fields in the vicinity of the vertical or horizontal portions (or in both)), must in consequence

† An Experimental and Analytical Investigation of Earthed Receiving Aerials. *Journal I.E.E.* Vol. 71 No. 427, July 1932.

**Screened Aerials—**

flow through the primary of the aerial transformer A. The resultant induced currents in X and Y are now circulatory and do not balance in the receiver transformer B. They are thus transferred to the receiver without hindrance.

Summarising briefly at this point, it is shown that whether or not the transmission line is enclosed in a shield it may be

portions of the vertical wire nearest the ground.

There is no reason why the screen should be omitted from future systems, since it is a simpler matter to render the transmission line unaffected by either signals or interference by enclosing it in a shield, then balancing it with respect to ground. (Inset Fig. 4.)

Although the problem is not yet com-

reception is mainly limited to what little effective EMF is induced into the horizontal portion as a result of slight departures of the arriving waves from precise perpendicularity of polarisation.

On short waves, say 30 metres, a very different state of affairs exists. First, the waves mainly arrive by reflection from the upper ionosphere, and their polarisation is a mixture of horizontal and vertical components. On an average, a vertical aerial thus develops the same EMF as a horizontal one. Secondly, the distributed inductance and capacity of the horizontal portion is such that the aerial resonates somewhat broadly like a rather inferior tuned circuit.

An aerial of 40ft. in horizontal length will resonate at approximately 25 metres, providing an excellent transfer of signals at this wavelength and a fair performance at the extremes of 10 and 40 metres. By placing the horizontal portion well clear of interfering fields, the arrangement is also capable of discriminating between signal and interference to the advantage of the former, but it must be remembered that at these high frequencies perfect screening is impossible, and it becomes increasingly difficult to balance feeders with respect to earth (wherever that may be at high frequencies).

Finally, by further skilful circuit arrangements, engineers have evolved anti-interference aerials suitable for use over short, medium, and long waves, by combining the arrangement of a doublet for short waves, and a T aerial for medium and long waves.

In this way maximum transfer is obtained on all bands. Aerials of this type with twin balanced transmission lines which are unshielded will not give adequate transfer on long waves unless the transmission line is partly unbalanced to

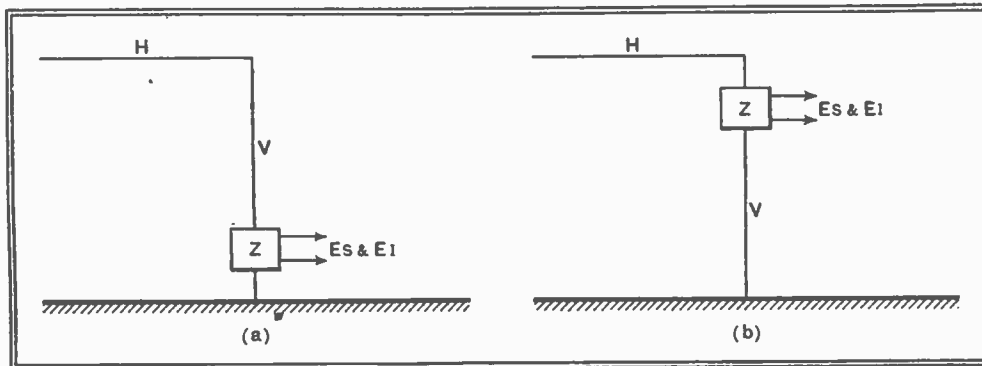

Fig. 5.—Showing how a screened aerial discriminates between wanted signal and unwanted interference.

rendered ineffective to fields acting upon its length, but this is secondary to the main problem, which consists of explaining why the vertical portion of Fig. 4 discriminates between signals and interference, always remembering that its use is essential for collecting signals.

The problem analytically resolves itself into the diagrammatic forms of Figs. 5 a and b.

Both the aerials depicted in these diagrams are of equal dimensions, the only difference in arrangement being that the impedance  $Z$  (the input to the broadcast receiver) is located at the base of the vertical portion in (a) and at the top in (b). Fig. 5a clearly represents the normal inverted L aerial with the receiver connected between the base of the down-lead and earth, while Fig. 5b is the equivalent circuit for the anti-interference arrangement of Figs. 3 and 4, since it is permissible to transfer all the transmission line, transformer and receiver constants into a lumped impedance  $Z$ .

One now assumes a certain field strength of signal which is distributed in a uniform manner over the aerial and derives an expression for the EMF thereby generated across the impedance  $Z$ . A further expression for the EMF generated across  $Z$  by a non-uniform interfering field is then derived. These derivations are obtained for the arrangements (a) and (b) of Fig. 5 respectively.

**Signal/Interference Ratios**

It is found that the ratio of signal to interference is greater for the arrangement depicted in Fig. 5b than for Fig. 5a, which is in confirmation of the results experimentally obtained.

For a given field intensity the ratio of signal to interference is greater as the impedance  $Z$  is increased in distance from the ground. The ratio is also greatest when the interference is concentrated on those

pletely solved, we do know what part the screen plays, and why the vertical portion is capable of discriminating between the wanted uniform signal field and the unwanted non-uniform interfering field.

**Short-wave System**

As the wavelengths of the desired signals more closely approach the dimensions of the receiving aerial certain transitions occur, and theories which are applicable on medium and long waves no longer apply on the short waves.

For example, a horizontal wire 40ft. in length, split in the centre and connected to a receiver via a screened or unshielded

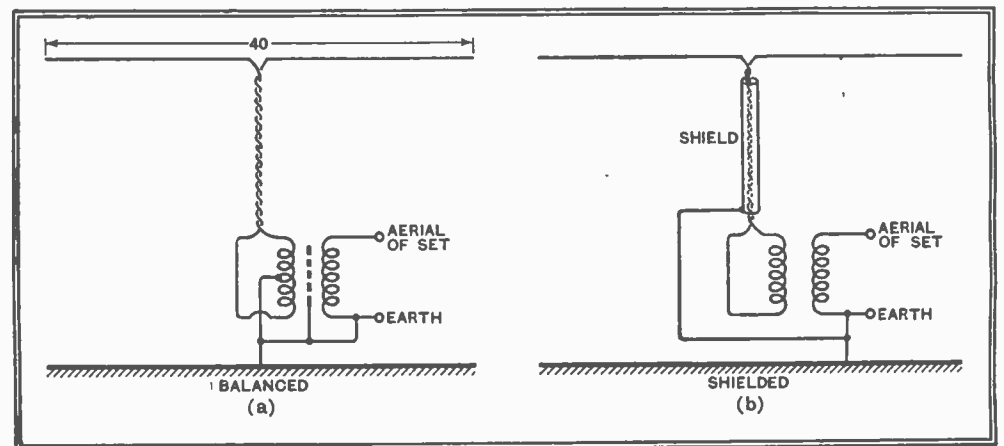

Fig. 6.—Balanced and shielded anti-interference aerials for short-wave reception.

transmission line (Fig. 6a and b), is a very poor collector on medium and long waves, particularly the latter. This is mainly due to the fact that the electromagnetic waves representing the signal are substantially vertically polarised, and as such can only influence the vertical portion of the aerial. Now in Fig. 6a and b one has the equivalent effect of balancing the line X and Y as in Fig. 4. Hence

make the system act as a T aerial. In these circumstances the arrangement has virtually no anti-interference properties on long waves.

In conclusion, the writer would like to acknowledge the interest and encouragement of Dr. Smith-Rose and Mr. F. M. Colebrook in this interesting problem, the general solution of which is by no means completed.



# New Valves? WHEN REPLACEMENT IS DUE

THE attitudes of set-owners towards valves differ considerably. Some people suspect them of being at the bottom of any disease the receiver may develop, and allow them to be removed, like a bodily appendix, on the slightest professional encouragement. Others work them till they drop dead in their tracks, and complain bitterly if this occurs in the first three years or so.

Their similarity to electric lamps may be responsible for the prevalent idea that the time to replace is when they fail to "light." In my experience that hardly ever happens with AC-heated valves. With battery valves it quite often happens, from three chief causes—dropping on the floor, genuine old age, or accidental contact with the HT battery. However it occurs, or to whatever type, the need for replacement is too obvious for further comment except to call attention to the wisdom of making quite sure that apparent deadness of the valve is not due to failure of the heater current to reach it; in particular, bad socket contacts should be suspected.

There are a few other faults—such as grid touching cathode—that put a valve right out of action and leave no choice about replacement. But most valves deteriorate less drastically, and sometimes the balance between continuing to tolerate the symptoms and discontinuing to possess the price of a new valve is very even. It may not always be realised how far below normal performance valve deterioration has brought the set. Even the more apparent faults, such as rattles, may perhaps not be traced to valves, and the less obvious falling-off in range, volume or quality, may go unsuspected altogether. These represent two classes of trouble that include most non-fatal valve ailments—noisiness and loss of emission.

## Hums, Groans or Rattles

If a valve becomes noisy at all it is quite likely to do so at an early stage in its life; so much the better if it is within the guarantee period. Sometimes the noise is purely mechanical, produced by movement of one of its parts; if it buzzes continuously the source of the sound is fairly easy to locate, but if it rattles only when shaken up by the vibration from the loud speaker it may be very difficult to trace the trouble to valves at all, let alone to any individual valve. When the loose part controls the characteristics of the valve in any way the mechanical rattle is usually swallowed up in the much louder noise that it causes from the loud speaker. The variety of types of sound that can be produced in this way is remarkable, from shrill tinkles to deep groans or hums, and they may be continuous or intermittent. The latter are sometimes very elusive,

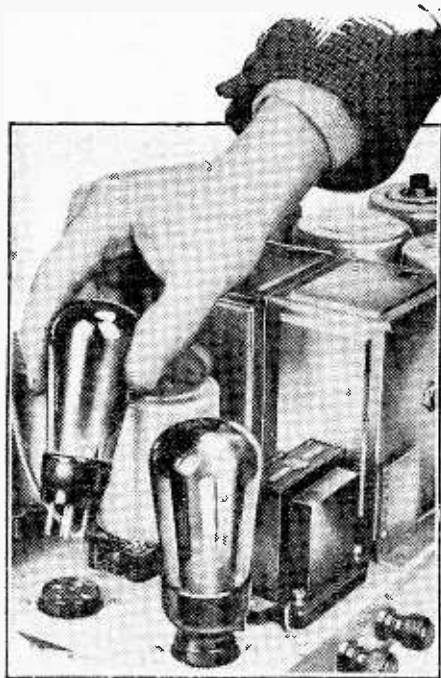

especially when the effect is more of the nature of an obscure type of distortion than of a distinguishable noise. Then there are various crackles, rustlings and hissings due to such electrical faults as leakage between electrodes. It is also possible—and quite common—for the normal slight hum from a set to be increased to offensive proportions as a result of valve faults.

Now I am not going to be drawn into a lengthy treatise on fault location—that can be studied elsewhere\*—for the continuous types of noise are straightforward examples of it. As for the sound-excited noises, once they have been clearly spotted—and often only certain musical notes make them apparent—the procedure of tapping each valve in turn generally shows up the offender. But it should be noted that it may be necessary to make the test with a silent carrier wave tuned in.

Noisiness, even although it has its obscurer and more exasperating forms, is a positive sort of thing; and, as it takes away a lot of the pleasure of listening, the valve responsible should be replaced without delay. But *loss of emission* usually comes on so gradually that it is difficult to say when the results justify a new valve or valves. The set-owner himself may be the last to realise that there is anything wrong at all, though a quick change-over to the original standard would leave no doubt about it. The output valve is the most likely to deteriorate in this way, and the result is, of course, a reduction in undistorted output. If it is far gone, there may be serious distortion at all volumes. It is possible for distortion to follow re-

duced emission in the other stages, but it is more usual for the first results to be reduced sensitivity, and perhaps total interruption over part of the tuning range (when the frequency-changer stops oscillating).

By "CATHODE RAY"

Now (except for the non-oscillation) without laboratory equipment it is very difficult to tie this down to any particular valve; or even to prove that it is a valve at all. Unless there are definite grounds for suspecting something else, however, it is fairly safe to start by checking the valves. The question is, *how* to check them. Assuming the possession of a multi-range test-set of reliable quality, it resolves itself into systematic use of this instrument (again, I refuse to sit down and write a book on this subject when there is a perfectly good one by Cocking); but as the majority even of *The Wireless World* readers probably are devoid of such equipment the problem remains.

## Dealers' Valve Testers

A few years ago it would just have had to keep on remaining, but in these enlightened days every radio dealer worthy of the name owns a valve tester or set analyser, and he has every reason to encourage people to come and check their valves on it. Although the indication of a valve tester may mean anything or nothing, the scope for faking is actually rather limited, for, although it is to the dealer's advantage for valves brought in by the potential customer to register an uncompromising "BAD" when applied to the instrument, it is essential to his reputation that new valves off the shelf should escape this condemnation, or even the intermediate "POOR," and come safely within the "GOOD" zone. Not all valve testers are marked in this outspoken fashion, though non-technical customers are suspicious (and perhaps rightly so) of the sort that reads only in figures and can the more easily be explained away by a resourceful salesman. But to those who know something about radio (and who does not after reading "Cathode Ray" weekly?) the figures are much more informative, always assuming that the instrument is a reliable one. Practically all such valve checkers read one of two things—*anode current* when certain voltages are applied or *mutual conductance*. The latter reading fails to distinguish between valves of very different types, but does give some idea of the condition of a valve, even without any other information. An *anode-current* reading is quite useless on its own

\* See "Tracing Faults," *The Wireless World*, Nov. 4th, 1937.

**New Valves ?—**

—what is "good" for one type of valve may be "very bad" for another—but when compared with a table showing what the readings ought to be when tested under those particular conditions it is more informative than the mutual conductance test. Preferably *both* readings should be available; but instruments intended for counter demonstrations are not usually so technical as this. The knowing customer will ask the dealer to produce his service gear.

Having so far treated the dealer with unconcealed suspicion, I must now join him on his side of the counter to point out to the exacting customer that he must not be too strict in demanding that a new valve should give precisely the reading specified as normal. Valves are allowed to pass out from the manufacturer with readings differing as much as 30 per cent. or even 50 per cent. from normal; and except for push-pull purposes there is

seldom much point in insisting on limits of 5 or 10 per cent. Similarly, a used valve may depart quite largely from the normal for that type without necessarily being due for replacement. But if the comparison is made with the readings given *by that same individual valve when new*, a change of as little as 20 per cent. is likely to mean that it is no longer capable of doing its job properly. For that reason one is recommended to scratch a note of the readings on all valves when new. I have never actually done this myself, but I am sure it is excellent advice.

Of course, a reasonable amount of common sense must be exercised, so that readings are not taken one time with batteries that are well up and next time with them run down; nor must it be forgotten that when the readings are taken with the valves in position in the set any one reading depends on the other valves working normally.

## Call-Bell Police Wireless

### ADAPTING POCKET RECEIVERS FOR SHORT-WAVES

AS long ago as September 9th, 1932, we printed the first published description of the pocket-size receivers used by the Brighton police; further technical details of the circuit arrangement appeared in *The Wireless World* of June 14th, 1935. The receivers, more or less in their original form, have apparently been in fairly constant use by police officers on their beats since they were first introduced.

According to a speech recently delivered by Capt. W. J. Hutchinson, the Chief Constable of Brighton, before the local Rotary Club, the confidence placed in the wireless communication scheme at its inception has been amply justified. "Having regard to the size of the pocket set, the tiny aerial which picks up the signals and the unfavourable conditions which sometimes arise through screening, it is remarkable that it has attained such a high degree of efficiency." After describing some of the occasions on which wireless communication has been of value, he entered a plea for the co-operation of the public.

Capt. Hutchinson would also appreciate help in



The Brighton police receiver employs a super-regenerative circuit, and embodies a call-bell (mounted in the ear-phone handle) whereby the attention of the policeman on his beat is attracted.

another direction which more closely concerns our readers; he asks for suggestions as to the adaptation of the sets for working on short and ultra-short wavelengths. Correspondence on this matter should be addressed to the Chief Constable, Town Hall, Brighton.

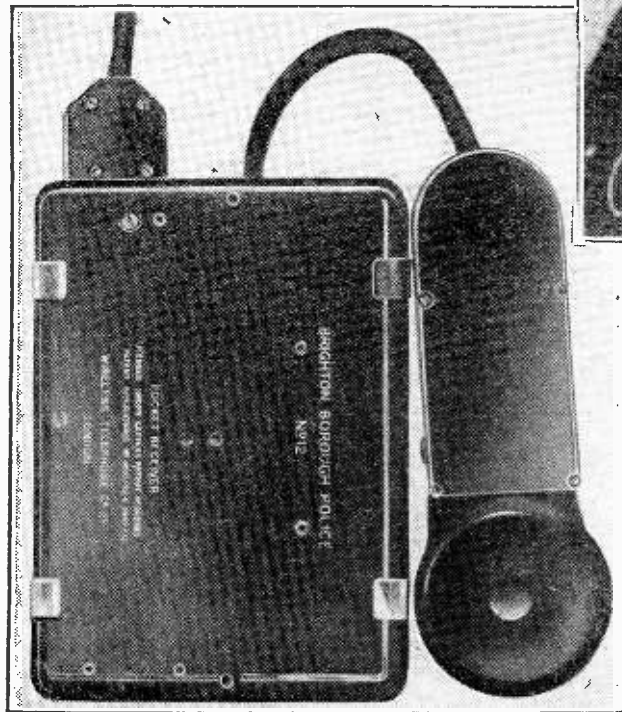

## Television Programmes

An hour's special film transmission intended for the industry only will be given from 11 a.m. to 12 daily.

Vision  
45 Mc/s.

Sound  
41.5 Mc/s.

THURSDAY, NOVEMBER 25th.

3, O.B. from Elstree. 3.15, British Movietonews. 3.25, The Habima Theatre in scenes from "Uriel Acosta."

9, O.B. from Elstree. 9.15, Clothes-line No. 5—Influences at work. 9.30, Gaumont-British News. 9.40, Television Follies.

FRIDAY, NOVEMBER 26th.

3, O.B. from Elstree. 3.15, Gaumont-British News. 3.25, Friends from the Zoo. 3.40, Cartoon Film. 3.45, Preview: highlights of the week. 3.50, Starlight: Charles Heslop.

9, Final O.B. from Elstree. 9.15, Friends from the Zoo. 9.25, British Movietonews. 9.35, Russell Thorndike in "Eight o'clock": a play by Reginald Berkeley.

SATURDAY, NOVEMBER 27th.

3, "The Policeman's Serenade": an opera in one act by A. P. Herbert. 3.20, British Movietonews. 3.30, Cabaret Cartoons.

9, "Pride of the Green": a very grand opera by Rae Elrick. 9.35, Gaumont-British News. 9.45, Sigurd Rascher (saxophone) with the Television Orchestra.

MONDAY, NOVEMBER 29th.

3, Television Follies. 3.20, British Movietonews. 3.30, Scenes from "Cymbeline" at the Embassy Theatre.

9, Comic Strip, No. 2—a programme of American Humour. 9.20, Gaumont-British News. 9.30, Scenes from "Cymbeline."

TUESDAY, NOVEMBER 30th.

3, Variety with Jock McKay, Pamela Randall and Stetson. 3.20, Gaumont-British News. 3.30, "Stands Scotland . . . ?" an essay in contrast for St. Andrew's Day.

9, Sports Review, No. 5 (November), Howard Marshall interviews some distinguished people in the world of sport. 9.10, Cartoon Film. 9.15, Bodyline No. 5—Demonstration by Students of the Margaret Morris Movement. 9.30, British Movietonews. 9.40, "Stands Scotland . . . ?"

WEDNESDAY, DECEMBER 1st.

3, Second edition of André Charlot's cabaret "Spirit of Midnight" from the New Bristol. 3.20, British Movietonews. 3.30, Ninety-ninth edition of Picture Page.

9, Cabaret "Spirit of Midnight." 9.20, Gaumont-British News. 9.30, One hundredth edition of Picture Page.

## Railway PA

A LARGE-SCALE public address installation has just been completed by Grampian Reproducers, Ltd., at Cardiff Central Station, G.W.R.

The installation is in three parts, with two announcing points. A switching and light signalling circuit is so arranged that, although an announcer can speak through any combination of the three sections, he cannot break into a circuit already in use by the other announcer.

Grampian PVH projector speakers, with the diaphragms modified to give extra high-note response for high intelligibility, are used on the platforms.

## BOOK RECEIVED

Television. By J. H. Reyner, B.Sc. 2nd edition. Pp. 224+xi. Published by Chapman and Hall, Ltd., 11, Henrietta Street, London, W.C.2. Price 12s. 6d.

# Automatic Input Control

## AVOIDING DISTORTION DUE TO OVERLOADING

By A. LANDMANN

**T**OO little attention is still paid to the harmful effects of RF distortion, and only in a few specialised "high-fidelity" receivers are serious efforts made to reduce it. It is evident that when applying AVC voltage to the control grid of the first amplifier valve of the receiver, which is nearly always an RF pentode with variable mu characteristics, nothing is done to reduce the amplitude of the incoming signal which may be too high for the type of valve used. The automatic volume control, which might be better called automatic gain control, applies a DC voltage to the grid and thus increases the negative bias, lowers the conductance and reduces the amplification, but cannot prevent the overloading of the valve by a strong signal. Such a strong signal causes distortion due to change of modulation depth, cross talk, and (if the receiver is a superheterodyne) unwanted responses.

A variable mu valve is necessarily a compromise, because its curved (exponential) characteristic, which allows the gain to be controlled by variation of grid bias, introduces a constant amount of third harmonic for a constant amplitude at any working point of the characteristic. There is only one theoretical way; to combine the advantage of a straight portion of characteristic long enough to digest a big input (say, one volt) and the general possi-

straight portion to the centre of the neighbouring one; such a solution is evidently impossible in practice.

Bearing in mind that many transmitters modulate their carriers up to 100 per cent., the maximum input voltage on the

land Regional). Thus an additional control of the aerial input voltage seems to be necessary in the case of a quality receiver.

An additional and independent manual control is contradictory to the principle of one single adjustment of volume and the ganging of both volume controls (input signal and AF voltage) would reduce the automatic gain control efficiency and deteriorate the signal/noise ratio generally. Therefore a device for automatic regula-

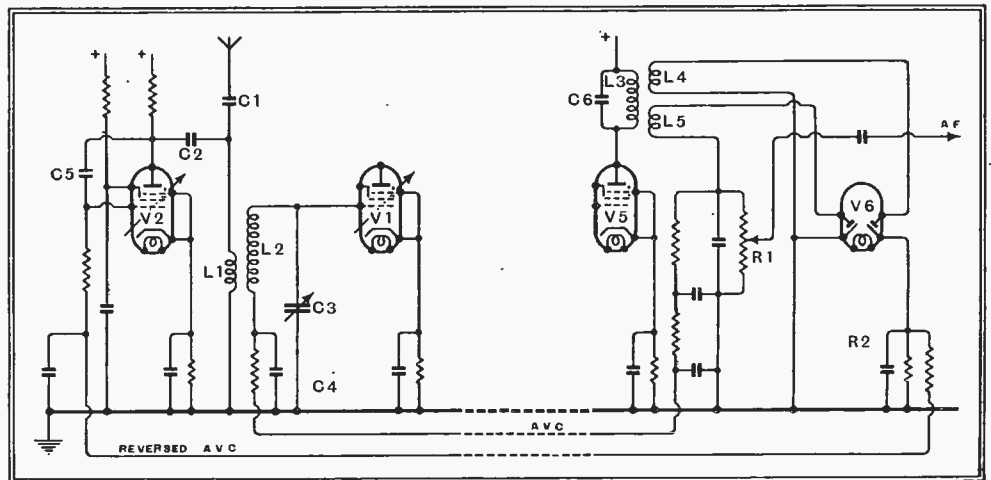

Fig. 2.—A practical arrangement for input regulation; a strong signal reduces the negative bias of the "potentiometer" valve V2.

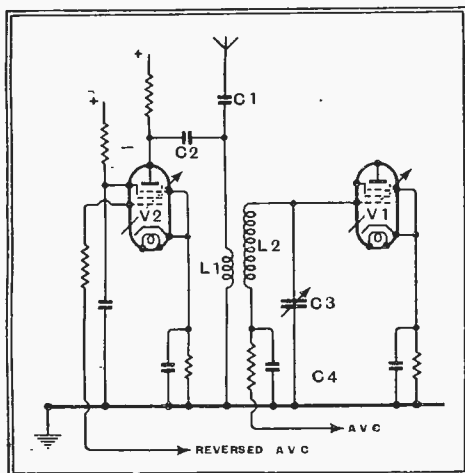

Fig. 1.—The auxiliary valve V2 forms one limb of a potentiometer, through which the signal applied to the input valve V1 is automatically regulated.

bility of conductance control by bias variation. The ingenious suggestion has been made that the characteristic should be built up from linear portions, each having constant slope, and the operating point should be switched from the centre of one

grid of the first valve in a high-fidelity set should not exceed 1 volt, which figure is, contrary to a popular opinion, nearly constant for every grid bias between -30 and -8 volts; in other words, it is wrong to think that a valve is able to digest much higher input voltage when a large negative bias is applied. Under normal operating conditions a modern RF pentode may accept 0.5 volt, which value increases to 1.0 volt when applying bias over -8 volts. Such a signal involves a noticeable change of the modulation depth, and with regard to further sources of RF distortion, especially in the detector circuit, this voltage cannot be regarded as too small for a quality receiver. Apart from the cross-talk factor, which is proportional to the third harmonic content, modulation hum and unwanted responses would rapidly increase for higher input signals. Assuming that the average step-up from the aerial input to the grid is about 1:5, which is rather a low figure, we come to the conclusion that the aerial input voltage must be kept below 0.2 volt. The antenna voltages are of such an order near powerful transmitters in a radius of more than ten miles, and it can be said that approximately one-third of the Greater London area and a Midland district with a population of two million people are in the vicinity of such signals, considering two transmitters only (London Regional and Mid-

tion of the input signal in a high-quality receiver is considered to be necessary. A suitable device is a capacitive voltage divider in the aerial circuit, one branch of which is built up by a capacity and a valve-impedance in series. By applying a control bias to the grid of this auxiliary valve its impedance can be varied over a wide range and thereby the ratio of the two arms of the potentiometer varied.

### Valve-controlled Potentiometer

Fig. 1 may illustrate the method in principle: C1 is the one arm of the potentiometer and C2 in series with the impedance of V2 forms the second arm. L1 is the aerial coupler, and L2, C3 and C4 compose the tuned grid circuit of the first amplifier valve V1. The auxiliary valve V2 is normally biased to ensure a high impedance, so that C2 plus V2 presents a very high impedance and the full signal gets through to L1. When the bias of V2 is so far reduced that, due to the voltage drop across the anode load resistance, the anode voltage sinks below the screen voltage, the impedance decreases to such an extent that C2 plus V2 appears as a capacity of the same order as C1 and a signal input regulation is effected. Thus for strong inputs a smaller grid bias must be applied to V2, involving a reversal of the normal AVC voltage. A practical circuit



**Automatic Input Control—**

is shown in Fig. 2.  $V_5$  is the last IF amplifier,  $L_3$  and  $C_6$  form the last tuned IF circuit,  $L_3$  is coupled to  $L_4$  and  $L_5$ ,  $L_5$  feeds the signal diode, and the load  $R_1$  supplies AF voltage and AVC voltage for the amplifier valves.  $L_4$  feeds the second diode which is connected in such a way that the voltage across the load  $R_2$  gets more positive with increasing IF signal. Thus reversed AVC voltage is obtained

# Camouflaged PA

## Installation at a New Open-air Theatre

**G**ERMANY'S frequent mass meetings and the nation-wide addresses by the Führer have given the radio industry the opportunity for the extensive development of public-address equip-

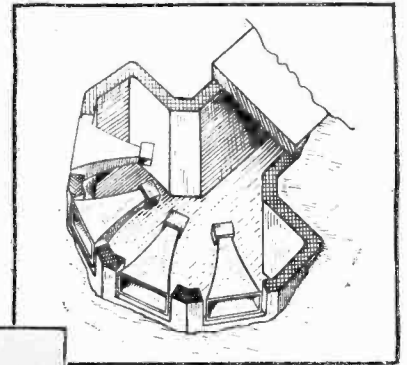

The loud speaker dug-outs, the layout of which is shown in the above sketch, can be seen in the white circles during their construction. In the finished "set" these are camouflaged in the layout of the gardens.

In the picture below the operator is at the control desk, on which can be seen the volume controls for each microphone and loud speaker group set in their respective positions on a diagram of the scene.

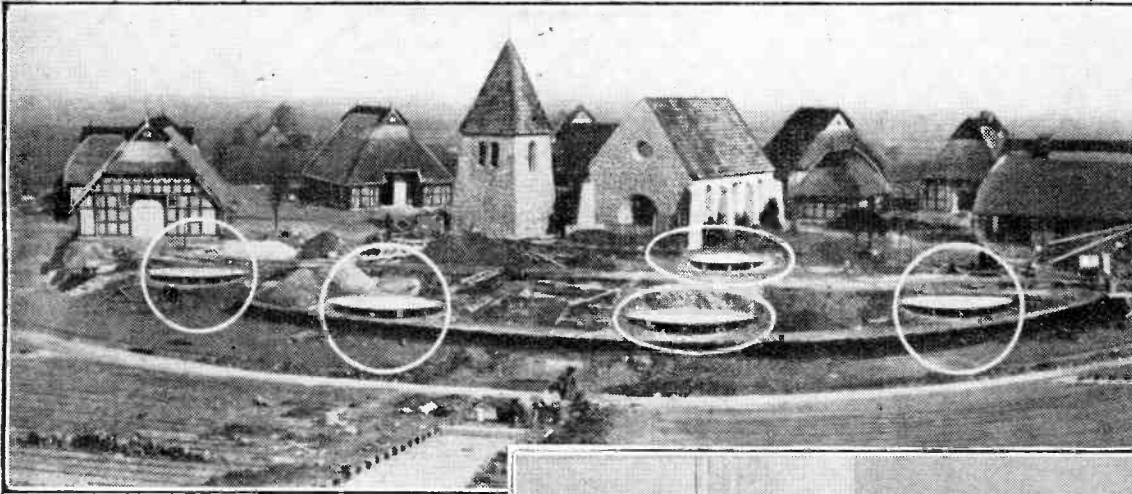

and applied to the grid of  $V_2$ . The condenser  $C_5$ , connected from anode to grid of  $V_2$ , causes degeneration in  $V_2$  and, by reducing the valve impedance, accelerates the control.

Without degeneration the input signal is reduced to half the value by a grid bias change of 4.5 volts; with degeneration and for the same bias change the signal is attenuated to a quarter. The control action may be regulated by adjustment of the screen grid voltage of  $V_2$ .

The author is indebted to The Gramophone Company for permission to publish this account of work which was carried out in its laboratories.



## The Radio Industry

**A** NEW record-changer designed by Mr. R. Wilkinson, 1, Southdown Crescent, Cheadle Hulme, Cheshire, awaits commercial development. In addition to the usual facilities for playing one or both sides of records of different diameters, it is possible to repeat both sides of individual records or even isolated passages of music or language phrases. Operating intervals are as follows: changing record, 9 seconds; turning record, 6 seconds; repeating one side, 3 seconds; repeating short section,  $\frac{3}{4}$  sec. The dimensions of the unit are  $26\frac{1}{2}$  in. wide, 20 in. high, and 17 in. deep, and the magazine holds 12 records.

In the New Times Sales Company's advertisement in last week's issue, the price of the 8 $\frac{1}{2}$  in. PM speaker was omitted; these speakers are priced at 13s. 6d.

Resistances for use in converting milliammeters into ohmmeters, in the manner described in our issue of November 11th, may be obtained from H. V. Bothamley, 23, Westdown Road, London, S.E.6. A series of resistance units of the various values required are wound on an insulating strip; values are stated to be accurate to better than 0.5 per cent. The cost is 2s. 6d. for each resistance unit.

ment. Frequent reference has been made in the pages of *The Wireless World* to the progress in PA loud speaker design and to its various applications.

The many open-air theatres and ceremonial meeting places which are being built throughout the country present difficulties which are not easily overcome. Microphones and loud speakers must be concealed; audiences up to 20,000 must be able to hear even stage whispers, and, moreover, directional sound must be maintained—that is, an actor must be heard from the position he is occupying and not from banks of loud speakers.

### A Natural "Stage"

At one of Germany's new open-air assembly grounds for ceremonial meetings and dramatic productions, at Stedingsehre-Bookholzberg, west of Bremen, Körting's of Leipzig have provided complete PA equipment to enable 14,000 people to hear the progress of a play on a natural "stage" which represents a small moated village. There are twelve groups of loud speakers, totalling 30 in all, and no fewer than 50 condenser microphones, all of which are

carefully hidden in the scenery, with fifteen high-quality 20-watt amplifiers.

Some of the loud speakers are concealed in roofs of houses and a church, whilst the main LS positions are dug-outs, each containing four speakers, which are connected by underground galleries. Each section of the stage has its own set of microphones, amplifiers and speakers. This grouping is an automatic check for the operator, who is thus prevented from inadvertently switching microphones in one part of the "set" into circuit with speakers in another. The output from the twelve loud speaker groups can, of course, be mixed or faded in at will.

The controller is stationed in an elevated box at the back of the audience, and from the window he has a clear view of the entire stage. Before him he has a control panel on which is outlined the whole scene. On this scene are set the volume controls, switches and signal lights for each microphone and speaker group, thus enabling the controller to locate immediately the stage position of those in use. Apparatus is provided in the control room for monitoring the output of each individual amplifier and for general checking purposes. A. A. G.

# When the Tuning Drive Slips

## THE ART OF MECHANICAL ADJUSTMENT

By R. C. RICKARD

**A** LOT of people seem to fight shy of tackling broadcast receiver faults of the purely mechanical kind, and yet often think nothing of adjusting a brake on a motor car, even without a scrap of previous experience or advice. There is a general impression apparently that a fault like a slipping drive is due either to wear, unfortunate but inevitable, in the case of an old set, or faulty manufacture in the case of a new one. In actual fact, however, in nearly every case it is just a matter for slight readjustment, which the owner is probably quite capable of carrying out himself.

The majority of present-day sets, certainly of those which have the greatest tendency to drive troubles, are fitted with some kind of cord drive similar to that shown in Fig. 1, which depicts an all-wave chassis having a gear-driven direct drive and a concentric friction-driven vernier. The mechanical arrangement shown, although not illustrative of any actual receiver model, is fairly representative of its type, and is intended to show as clearly as possible the likely causes of most drive troubles.

### First Find the Cause

Before tackling any particular set it is useful to realise that all of these possible causes fall under two main headings—not enough friction where it is wanted, e.g., in the friction drive, or too much friction where it is *not* wanted. Much time and trouble can be saved at the beginning by finding out which of these two main faults appears to be causing the trouble. It is not always possible to tell definitely, but a good plan is to rotate the main knob independently of the vernier and test it for

free movement. If it seems at all stiff, or tightens up at any point, the slipping is sure to be due to excessive unwanted friction, which must be located and removed—usually with an oil-can. If, on the other hand, the knob spins quite freely and smoothly throughout its travel, then it is a fairly safe bet that the vernier is not gripping sufficiently; i.e., it requires more friction pressure.

### Classification of Common Troubles

A list of likely faults is tabulated below, and it will be at once obvious that some of these could never develop in service. They are, however, very liable to be present in a new set, perhaps through rough handling in transit, and are sometimes of so slight a nature that it hardly seems worth while pointing them out to the dealer. It should, perhaps, be mentioned that the slipping here refers

Causes of Drive Slip.	Cure.
(1) Lack of oil ...	Obvious.
(2) Slide sticking ...	Rub down guide with fine emery.
(3) Spring too strong	Mark pointer-setting at bottom of scale, stretch spring, then readjust pointer to mark.
(4) Pulley or bearing seized.	Apply penetrating oil and ease backwards and forwards.
(5) Vernier too slack	Adjust if possible (see below).
(6) Vernier incorrectly adjusted	Adjust mounting bolts (B in Fig. 2).
(7) Pointer fouling scale ...	Obvious.

Fig. 2 illustrates one type of self-contained vernier in fairly common use, bolted directly on to a gang condenser. The mechanism is entirely enclosed, the only adjustment being by four screws

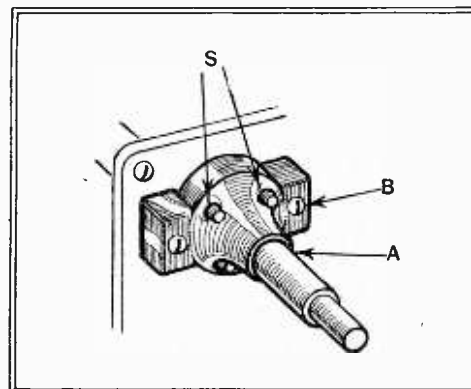

Fig. 2.—Self-contained vernier control. A = main spindle; B = mounting bolts; S = projecting screws.

whose heads are not accessible without removing the complete drive from the gang. This is most inadvisable, as the calibration, as well as another delicate adjustment, would be badly upset by doing so. The only other possible way of taking up wear in this type of vernier is to grasp the projecting ends of the screws S with a good pair of fine pointed-nosed pliers and give each one half a turn in an anti-clockwise direction.

### Other Faults

A *rough* drive, if not due to any of the previously mentioned faults, may often be cured by putting a spot of oil on the main spindle (A in Fig. 2) so that it runs in between it and the hollow aluminium housing.

Should the gang condenser itself appear to be on the stiff side, on no account try to adjust its bearings, as the calibration would be hopelessly upset by so doing.

*Backlash* is due to the same causes as vernier slip—excessive friction or spring tension.

*Pointer wobble* is caused by the slide which carries the pointer being too loose a fit on its guide rail; remedy—reduce the amount of play, but not so much as to cause it to stick at any point.

When a plain drive of the friction disc type slips it can usually be cured by cleaning the driven edge of the disc thoroughly, or perhaps by means of the adjustment provided. If no means of adjustment is provided, it should be possible, with the help of a little ingenuity, to find a way of increasing the pressure of the small wheel on the disc.

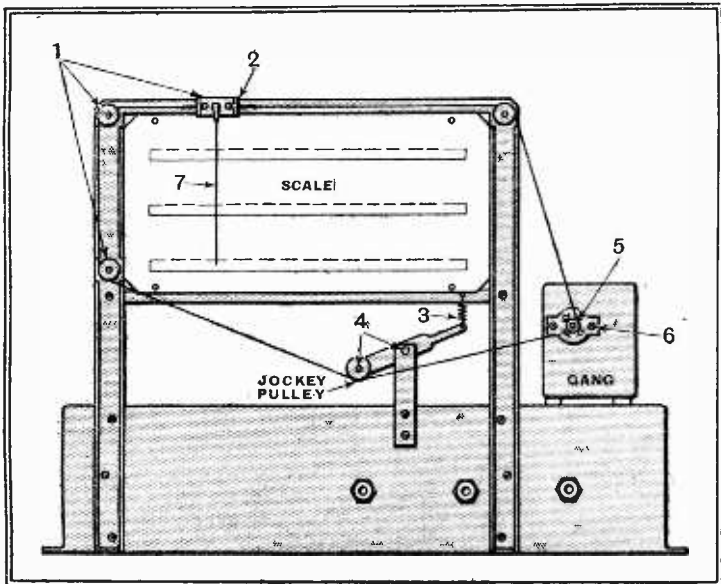

Fig. 1.—Representative scale and drive mechanism. The numbers serve to identify the parts listed in the table.

only to the vernier or slow-motion drive, and not to the main drive, which, in this case, is positive and cannot slip.

This table is intended to be used in connection with Fig. 1, the numbers corresponding to the key numbers on the diagram.

# Listeners' Guide for the Week

## Outstanding Broadcasts at Home and Abroad

**A**LMOST every region of Scotland will be represented at the microphone during the most comprehensive of programmes which has been arranged for St. Andrew's Day, Tuesday, by George Blake, the well-known Scottish novelist and commentator. This programme, to be heard at 9.40 (Nat.), will consist of a lightning tour of Scotland, and will present a striking picture of the diversity of life in this comparatively small country.

Some of those taking part in the programme will have to make long journeys to Edinburgh, the one from Orkney being away from home three days.

### FOLK SONGS

REGIONAL listeners will, on Monday, hear two programmes devoted to folk songs. The first, at 6, will emanate from Poland, and will consist of folk music from the regions of Podhale and Cracow. There will be a mountaineers' band from Podhale, a folk musicians' band from Cracow, and a choir of four pipers.

Later in the evening, at 8.30, comes a programme featuring the life and work of Cecil Sharp, the well-known authority on folk songs. The inscription on his memorial in London, the Cecil Sharp House, rightly states that he "restored to the English people the songs and dances of their country." His researches took him to the Appalachian mountains of America, and some of the music he discovered there will be heard during this broadcast.



JOY BOUGHTON, the daughter of the well-known composer Rutland Boughton, who will play an oboe concerto, specially written for her by her father, during the concert by the Boyd Neel String Orchestra on Tuesday at 8.30 (Reg.).

### FALSE ALARM

THE next broadcast in the "Night Shift" series of programmes, which is designed to portray the work which goes on when most Londoners have finished their day, comes from the new headquarters of the London Fire Brigade on the Albert

outbreak of the Civil Wars in England and ends in the year 1657, will portray among other characters Cromwell, Milton and Admiral Van Tromp.

Blake, who is generally acknowledged to rank next to Nelson in the list of great English admirals, was the son of a



POLISH HIGHLANDERS gathering outside an old church in the Cracow district. Polish folk music from Warsaw will be relayed by the Regional transmitter on Monday at 6.

Embankment, Lambeth. A description of the premises, which were opened by His Majesty in July, and the modern fire-fighting equipment will be followed by a sound impression of the activities of the men on duty.

Listeners will be switched over to a close-by street where they will hear the breaking of the glass in an alarm and will then be switched back to the station, where in less than thirty seconds from the sounding of the alarm bell the engines and escapes will be leaving for the scene of the "fire."

Regional listeners will hear this programme at 9.40 on Wednesday.

### "GOD'S ADMIRAL"

THE title of this broadcast which will be heard Regionally on Wednesday at 7.30, expresses the spirit of the play which has for its central figure Robert Blake, who regarded every war as a holy war, believing that he was fighting not only for the Commonwealth, but for the Lord God of Battles. This "sequence for radio" which opens with the

Bridgwater merchant. It was not until middle life that Cromwell appointed him Admiral and General-at-Sea, and although he had little knowledge of the Navy, for he was a soldier, he soon made his presence felt, and did more than any other to gain for his country supremacy of the seas.

### A RADIO SQUIB

Two years ago Francis Dillon, at that time an income-tax official in the Midlands, submitted a radio script of Hans Andersen's fairy tale, "The Nightingale." It was immediately apparent that in broadcast drama he had found the ideal medium for his undoubted talent, and he is now a feature producer in the West of England Region. His latest play, "The Shirt," which will be heard on Sunday at 9.5 (Nat.), is described as a radio squib on an old folk tale.

The tale itself is the hoary one of the king who, in spite of the most desperate efforts on the part of his jesters, found it impossible to be amused. A new twist is given to it by the

### HIGHLIGHTS OF THE WEEK

THURSDAY, NOVEMBER 25th  
Nat., 7.30, Jack Jackson and his band. 8, Vaudeville from the Granada, Clapham Junction.

Reg., 7.30, The Hallé Society's concert from Manchester. 9.5, Commentary on darts match from the Hanbury Arms, Islington.

#### Abroad.

Stuttgart, 8.30, Programme from Germany's oldest university, Heidelberg.

FRIDAY, NOVEMBER 26th.

Nat., 8, The Kentucky Minstrels. 9.20, Coal—11: The Past.

Reg., 7.45, The Belfast Philharmonic Society's concert. 9, Jack Payne with his band and guest artistes.

#### Abroad.

Warsaw, 7, Backhaus (piano) with the Warsaw Philharmonic.

SATURDAY, NOVEMBER 27th.

Nat., 1.50, The Manchester November Handicap. 2.30 and 3.30, Inter-Varsity Relays. 8, Palace of Varieties.

Reg., 8, Discussion: Voluntary Social Service—Whither? 8.45, Organ recital: G. Thalben-Ball.

#### Abroad.

Radio Paris, 8.30, "The Pearl Fishers" (Bizet) from the Opéra-Comique.

SUNDAY, NOVEMBER 28th.

Nat., 9.5, "The Shirt": a radio fantasy on an old folk tale. 9.40, Callender's Senior Band.

Reg., 6.15, Eugene Pini and his Tango Orchestra. 9.5, Seventh Sunday Orchestral Concert.

#### Abroad.

Strasbourg, 5, Concert from the Conservatoire, soloist, Alice Ehlers (harpsichord).

MONDAY, NOVEMBER 29th.

Nat., 7, "Monday at Seven" (Scottish). 8.30, Broadway Matinée.

Reg., 6, Folk Music relayed from Warsaw. 8.30, The life and work of Cecil Sharp.

#### Abroad.

Deutschlandsender, 7, Philharmonic concert relayed from the Philharmonic, Berlin.

TUESDAY, NOVEMBER 30th.

Nat., 5, Relay from Prague. 8, "Kybosh of Kedgerree": a comic opera. 9.40, For St. Andrew's Day: a salute from Scotland.

Reg., 8.30, The Boyd Neel String Orchestra. 9.20, Eddie Carroll and his music.

#### Abroad.

Brussels 11, 8, Symphony Concert from the Théâtre Français, Ghent.

WEDNESDAY, DECEMBER 1st.

Nat., 6.40, Herman Darewski and his new Melody Rhythm Band. 8.15, Queen's Hall Symphony Concert. 11.5, Revue: "Ad Lib."

Reg., 3.15, International Football match between England and Czechoslovakia. 7.30, Programme about Robert Blake. 9.10, Variety from the Hippodrome, Boscombe. 9.40, Night Shift: the London Fire Brigade.

#### Abroad.

Lille PIT, 8.30, Puccini festival concert.

**Listeners' Guide—**

presence at Court of a gentleman called Master Buckram, the Purveyor of the People's Amusements, who is asked to stage a variety performance, which resulted in deeper and more abysmal gloom. Finally, a physician informs the king that the only cure for his complaint is that he should wear the shirt of a really happy man. The claimant to complete earthly bliss is found to be a beggar, but he lacks the one thing the king wants—a shirt.



**FROM SWEDEN**

Two celebrated British musicians will be heard from the Swedish stations during a special concert of works by Elgar, Walton, Butterworth, and Vaughan Williams which will be broadcast

at 7 to-night (Thursday). Clarence Raybould will conduct the Swedish Wireless Symphony Orchestra, and Cyril Smith will be at the piano during Walton's "Sinfonia Concertante."



**OPERA FROM ABROAD**

It will be remembered that the B.B.C. planned a relay of the first act of Lortzing's "Tsar and Carpenter" a week or two ago. Unfortunately, this had to be cancelled at the eleventh hour. Listeners will, however, have the opportunity of hearing the complete opera from Prague on Saturday at 7. The same composer's romantic opera, "Undine," is billed by Cologne for 7 this evening (Thursday).

The three-act work of Mario Peragallo, "Ginevra degli

Almieri," will be relayed from the Teatro Comunale, Bologna, by Milan at 8 this evening. The composer is as yet practically unknown outside his own country.

Königsberg promises an excellent performance of Beethoven's "Fidelio" for Friday at 7, when that station relays the Berlin Opera House production.

Saturday's 8 o'clock programme from Brussels 2 consists of a relay from the Royal Flemish Opera, Antwerp. The "bag" is mixed, with "Pan," a ballet by that Flemish modern, Schoemaker, who is already beginning to be recognised as a front-rank composer, as a curtain raiser. "Vikings," Meulemans' newest opera, is the *pièce de résistance*.

THE AUDITOR.

structions. Obituary talks, for instance, should always be given in person. Records must not be employed on O.B.s, however great the temptation to improve the dramatic or realistic nature of the occasion.

Finally, it is laid down that artistes must not be led to imagine that they can record their act in advance, so as to be free for another appointment or bridge party. In exceptional circumstances a speaker may record his talk if public engagements make it impossible for him to be in the studio at the time of the broadcast.



**More Television ?**

ONE of the blots on the television service at present is the absence of a Sunday programme. To have about the house a sixty-guinea contraption which declines to function on the Sabbath is enough to make any viewer impatient, no matter how great his faith in television.

It is expected that the introduction of Sunday programmes will be one of the first reforms introduced at Alexandra Palace in the New Year.



**Physical Jerks Soon**

BREAKFAST broadcasting is still under discussion. Since the B.B.C. pleaded poverty as an excuse for not initiating "physical jerks" transmissions, powerful forces have been at work.

It is understood that a well-known athlete, aided by a committee, has strongly impressed the National Fitness Council with the necessity of co-opting broadcasting for spreading the gospel of national health.

A Treasury grant of £20,000 would cover all the expense involved, including an extra shift of engineers and the starting up of the Droitwich transmitter at 7.30 a.m.

# Broadcast Brevities

## NEWS FROM PORTLAND PLACE

**Start Point Starts**

START POINT, from now on, takes its place in broadcasting history. Last week the Building and By-laws Committee of the Devon County Council passed the plans for the new station which the B.B.C. hopes to have ready by midsummer, 1939.

Opposition has been overcome which once threatened to stop the whole project of this much-needed transmitter.

**Station Almost Invisible**

Council for the Preservation of Rural England registered a strong protest last spring, but, in a spirit of sweet reasonableness, it was agreed that Mr. W. Hardy Thompson, F.R.I.B.A., should submit plans for a building which would blend with the surroundings.

Mr. Thompson's suggested building, which appeals to all concerned, blends so well with the surroundings that it will be almost invisible; in fact, expeditions may be sent out to find it.

**500ft. Masts**

It will be built on a ground plan 200ft. by 100ft. about a mile from the Point. Two 500ft. masts, not so easily camouflaged, should do justice to a station which is intended to serve at least three million people.

Service area is to take in all Cornwall and Devon and parts of Dorset, Hampshire and the Isle of Wight.

The station will operate on a wavelength of 285.7 metres, taking over the West Regional

programme from Washford Cross.

**Another Relay for Hampshire ?**

Isle of Wight will still be badly served as regards the National programme, and it is probable that a 5kW relay on the Penmon pattern will soon be erected on the Hampshire coast, possibly near Calshot.



**B.B.C. and Recorded Programmes**

B.B.C.'s recent exchange of views with the German broadcasting authorities on the subject of recordings has raised doubts as to whether recording can be overdone. Are tape and discs supplanting "live" material? The Corporation would answer with an emphatic "No." Strict rules have been laid down for the guidance of producers and announcers.

Briefly, recordings are permissible in the following circumstances:—

They may be used

**TAPE RECORDING ROOM No. 2 at Maida Vale showing one of the Marconi-Stille magnetic recorders in use. The rules governing the use of recordings in programmes as laid down by the B.B.C. are given on this page.**

when the timing of an event is inconvenient to the majority of listeners; when an O.B. is impossible from place at which the event occurs, and in feature programmes of the reminiscent type, such as the "Scrapbooks."

Records are also permitted when an original programme is to be repeated, and on certain occasions when a recorded programme is announced as such.

Again, records may be used in the case of technical breakdowns and also to "fill in" when bad reception during features of the "Round the Empire" type is liable to spoil continuity.

**When Records Are Banned**

Cases in which records must not be used are cited in the in-

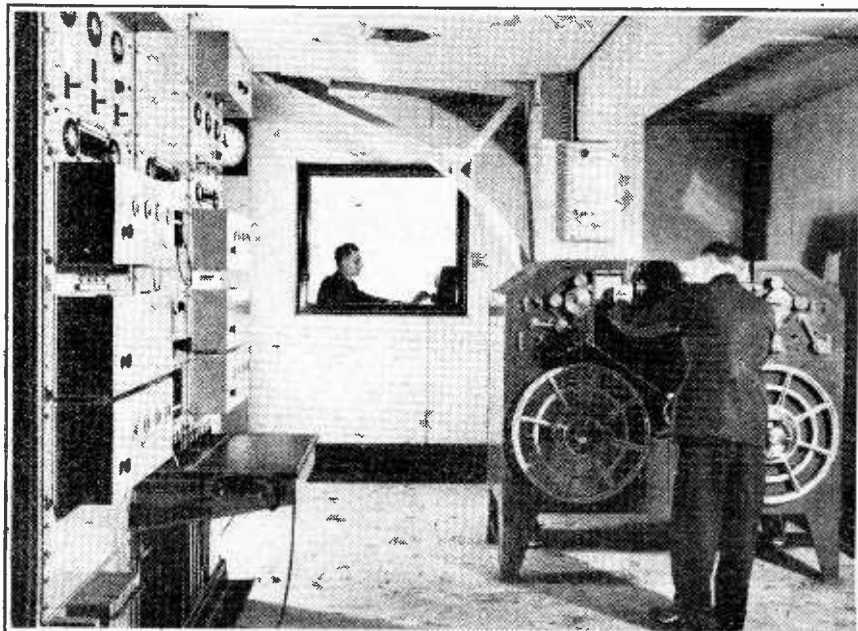



# Current Topics

## EVENTS OF THE WEEK IN BRIEF REVIEW

### Burma Assigned Separate Prefix

THE prefix XZ has been allotted to amateur stations in Burma. Hitherto they have used VU, which belongs to India; a call-sign of their own has been allotted owing to their governmental separation from India.

### New Marconi Laboratory

THE projected new laboratory to be erected by Marconi's Wireless Telegraph Co. at their Chelmsford Works will have an area of over 80,000 square feet. It is stated that the Marconi Co. are to proceed with the building of it forthwith.

### The Orkneys on the 'Phone

A HILLTOP has been acquired by the Post Office near Kirkwall for the erection of an ultra-short-wave telephone station for linking the Orkney Islands with the mainland. It is proposed that the station should also link up with the Shetland Islands.

### German Television

SPEAKING recently on the subject of television, Herr Kriegler, who is head of the broadcasting department in the German Ministry of Propaganda, declared that when the three television transmitters now in course of erection were put into service there would be sixteen million potential viewers. At first, he said, only a few thousand television receivers would be

manufactured, but this would pave the way for the development of a low-priced mass-produced instrument.

Dr. Banneitz, head of the German Post Office Television Research Institute, has stated that the 441-line transmitter for Berlin would be ready by Easter of next year. He also said that the work of installation would shortly begin on the Brocken and the Feldberg sites.

Dr. Banneitz stressed the fact that, owing to the peculiarities of ultra-short waves and the large band-width required, it would not be possible to provide the entire country with a television service. The ultra-short-wave transmitters will have to be supplemented by distribution along wires. Tests, he said, had proved that this was possible on the ordinary telephone circuits up to distances of about a mile and a half without special amplifiers. For greater distances amplifiers and high-quality cables could, and would, be provided.

### ZD9AB Calling

PERMISSION has been granted by the Colonial Office for a wireless transmitting station to be erected on Tristan da Cunha. The wireless station will be set up and operated by the Norwegian Expedition, which is leaving Cape Town this month under the leadership of Dr. Erling Christophersen. The station will use the call-sign ZD9AB for general transmissions and ZOE for communication with shipping.

### Broadcast Morse Practice

AN instructional course for would-be wireless operators "covering the whole field of sending and receiving" is now being radiated from Rome I, Milan I, Turin II, Genoa II, Florence II, Naples II, and Bari II. The lessons, which begin with Morse code instruction, are sponsored by the Italian Ministry of War and are transmitted from 3 to 3.30 p.m. G.M.T. on Mondays, Tuesdays, Wednesdays, and Thursdays.

### Verda Stacio

To celebrate the tenth anniversary of the first Esperanto talk broadcast from Brno, the Czechoslovakian authorities have issued a special publication in Esperanto dealing with the national broadcasting system. Broadcasts in this international language are now a regular feature of the Brno programmes, and the station is known among Esperantists as Verda Stacio.

### Telegraphic Difficulties in China

THE science of phototelegraphy (not to be confused with telephotography) whereby photographs are transmitted by land-line or wireless is reported to be making great strides in China. It is said that the Chinese Government regularly communicates with its various legations by this means, as the international morse code is obviously an unsuitable medium for Chinese script, which, unlike Greek or Russian, for instance, cannot readily be rendered in the Roman alphabet. It was in



NEW MICROPHONE, developed by the B.B.C. Research Department to exclude extraneous noises, being used by Mrs. Olga Collett when describing the arrival of the King and Queen at the Palladium for the Royal Command Variety Performance.

China that M. Belin, the French inventor, made the first commercial phototelegraphic installation using his system.

### 2-RF Straight Set

WE are informed that the manufacture of the metal-glass type of American valve has been discontinued. As explained in last week's constructional article, the glass type is suitable provided valve screens are fitted. The glass valves for this receiver are 6K7G, 6J7G, and 6H6G.

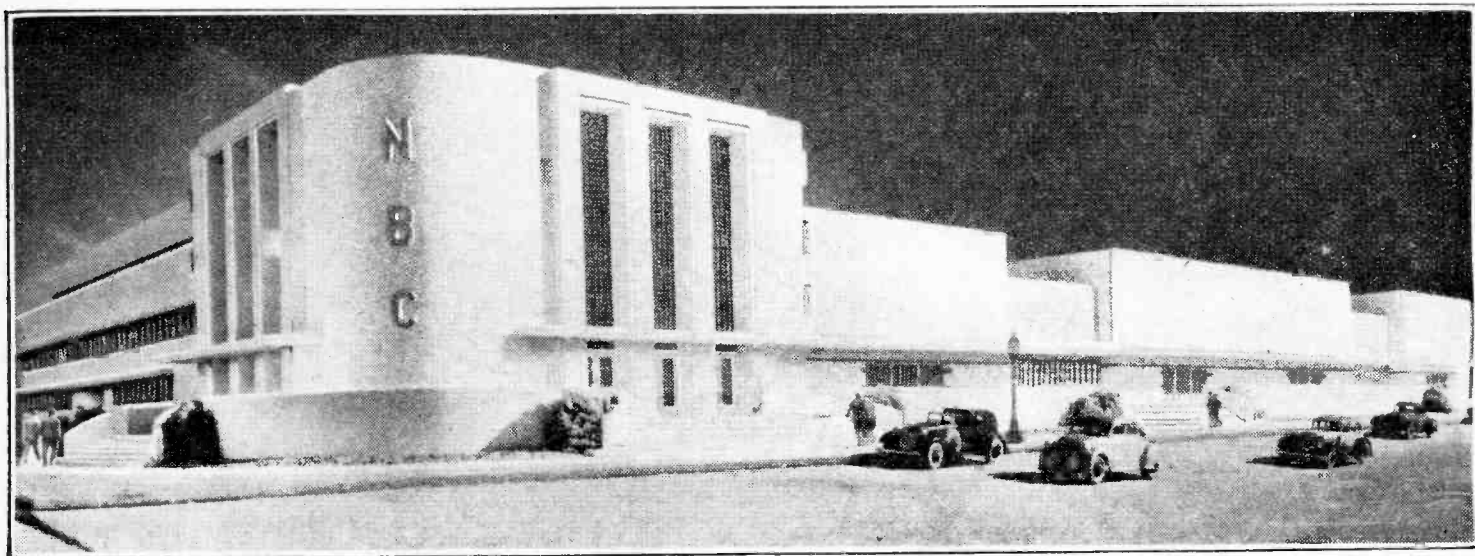

WORLD'S LARGEST STUDIO BUILDING? From Hollywood comes the report and the above architects sketch of the proposed N.B.C. radio centre in that city. The scheme provides for eight studios, four of which are designed to accommodate several hundred onlookers to the broadcast performances.

# The Wireless World

## VALVE DATA SUPPLEMENT

**T**HE number of valves increases steadily each year, and *The Wireless World* Valve Data Supplement, which presents in compact form detailed information on all current specimens, grows proportionately in size. This year both British and American valves are included, together with their base connections.

The data is divided into sections for the types of radically different construction or use, and in each section the valves are arranged in order of filament or heater voltage. Battery types are rated at 2 volts, naturally enough, since most people use a single-cell accumulator. The indirectly-heated types, however, require from 2.5 to 40 volts. The extension of voltages has been brought about by the car set and the AC/DC receiver. In the latter all valves must consume the same current, for they are connected in series; the voltages of the heaters consequently vary in the different types just as the currents taken by the heaters vary in constant voltage valves. The 13-volt range, which overlaps greatly with the AC/DC range, has been brought into being for car radio, and the valves are intended for operation from the usual 12-volt accumulator. The 6.3 volt range has also been developed for the same purpose, but for cars which have only a 6-volt accumulator. In America, few, if any, cars have a 12-volt battery, and so the valves are of the 6.3-volt type. Although originally developed for car radio and AC/DC sets, they are now almost universally employed in AC receivers, and the older 2.5-volt types, although still widely used, have been superseded in the newer receivers. The 6.3-volt type has recently been introduced in this country, and these valves are fitted with the Octal base.

### Frequency-changers

Among the sections into which the valves are divided, the first is headed Frequency-Changers. In this fall those valves which have been developed to perform this essential function to the superheterodyne. There are four types:—the heptode, the octode, the triode-pentode, and the triode-hexode; among the Octal-base valves is one which is a type in itself, of which more anon. The valves perform two functions and consist really of two more or less independent sections. Each contains in essentials a triode oscillator and a multi-electrode mixer.

In the case of the heptode, the cathode is surrounded by two grids which form the grid and anode of a conventional triode oscillator. This assembly is surrounded by a screen-grid, and then comes the control-grid of a screen-grid type valve, followed by another screen grid and an anode. This type of valve is thus analogous to a triode oscillator and a screen-grid valve in series. The octode is similar, but has a suppressor grid between the outer screen-grid and the

## Facts and Figures on the 1937-1938 Types

anode, and is analogous to a triode and an RF pentode in series.

The triode-pentode is quite different, for the two electrode assemblies are entirely distinct save that they operate on a common cathode. No internal interconnection exists and the valve is exactly equivalent to the two-valve frequency changer built up of an RF pentode mixer and a triode oscillator. External coupling between the two sections must be provided.

The triode-hexode is now widely used. It contains two separate electrode assemblies with a common cathode. One is a triode and functions as an oscillator, while the other is a hexode which serves as a mixing valve. In the construction the cathode is surrounded by the control grid, and this in turn by two concentric screen-grids between which is the injector grid which is internally connected to the grid of the triode assembly. The anode comes outside the outer screen grid.

Apart from the ordinary frequency-changers, one unusual valve will be found among the Octal-base types. This is the 6L7 and its equivalents; it contains only the electrodes of a mixing valve and requires a separate oscillator. The electrode arrangement is similar to that of a hexode, but there is an extra grid between the outer screen-grid and the anode which functions as a suppressor-grid.

In general characteristics the heptode and octode are very similar, but the latter generally has a higher AC resistance and so damps the first IF tuned circuit to a lower degree. The triode-pentode also has a high AC resistance and generally a high conversion conductance, but has the disadvantage of requiring external oscillator coupling. The triode-hexode has a high AC resistance and a conversion conductance comparable with that of other types; internal coupling is obtained by electronic means and the mutual conductance of the oscillator section of the valve is higher than is generally found with heptodes and octodes. Consequently, it oscillates more readily and can be used at shorter wavelengths. There is also greater freedom from interaction between the signal- and

oscillator-frequency circuits with this valve, and this is particularly valuable in short- and ultra-short-wave reception.

### Screen-grid Valves

The ordinary screen-grid tetrodes and pentodes are now rarely used for RF and IF amplification, having been superseded by the variable- $\mu$  types. There are signs, however, of a revival of interest in this class for television purposes. Several makers have recently produced pentodes with very high values of mutual conductance in order to permit reasonable stage gain with the enormous band-width required in a television amplifier. The tetrodes also find application as dynatron oscillators and in the separation of the synchronising impulses in television receivers. This class thus cannot be considered as even approaching obsolescence.

When used as an amplifier the stage gain can readily be calculated by multiplying the mutual conductance of the valve (mA/V) by the parallel value of the dynamic resistance of the tuned circuit and the valve's own AC resistance and dividing by 1,000. When the valve resistance is very high compared with the dynamic resistance, the gain is nearly equal to the product of mutual conductance and dynamic resistance divided by 1,000. Expressed algebraically,

$$\text{Gain} = \frac{g R_a R_p}{R_a + R_p} \approx g R_p \text{ when } R_a \gg R_p.$$

This same equation is accurate also for other valves. In the case of frequency-changers, conversion conductance must be substituted for mutual conductance, and with resistance-coupled amplifiers  $R_p$  becomes the value of the coupling resistance in parallel with the grid leak of the following valve. The equation is exact for all classes of amplifiers in which resistance, or a resonant tuned-circuit coupling is used. It does not apply when the coupling is largely reactive.

In the past, it has been customary to use the simplified equation (for  $R_a \gg R_p$ ) for all calculations with tetrodes and pentodes and to retain the exact expression only for triodes. This is not always justifiable, however, for recent advances in coil design have made possible high values of dynamic resistance, and the simpler equation may lead one seriously astray when dealing with tetrodes and frequency-changers, although it is still reasonably accurate in most cases with pentodes, on account of their higher resistance.

### Variable- $\mu$ Valves

In broadcast receivers the variable- $\mu$  valve is now almost universally employed for RF and IF amplification. The stage gain is calculated in the same way as with screen-grid valves of the sharp cut-off type.

The difference between the ordinary screen-grid and the variable- $\mu$  valve, in

**"Wireless World" Valve Data Supplement—**

fact, is merely that with the former the mutual conductance tends to remain constant as the grid bias is increased and then rapidly falls to zero, whereas with the variable-mu valve the mutual conductance falls continuously and gradually as the bias is applied. In practice, of course, the mutual conductance with both types falls on increasing the bias, but the change is much more gradual and a much higher bias voltage is needed to obtain the same minimum value with the variable-mu valve.

The practical result is that it is possible to control the amplification within wide limits by varying the grid bias of variable-mu valves without distortion or cross modulation being introduced. This statement must be taken conservatively, of course, for there is naturally a limit to the conditions under which freedom from distortion occurs, and even with variable-mu types trouble will be experienced if the input exceeds a certain figure.

**Inter-electrode Capacities**

With all valves the inter-electrode capacities are important, but they are especially so in the case of types which are used for RF and IF amplifiers. The input and output capacities usually occur in parallel with the tuned circuits and are only important in that they increase the minimum capacity of these circuits and so restrict the tuning range. The effect is most noticeable in short-wave reception, but it must be remembered that a receiver will require re-trimming if a valve is replaced by one having different capacities.

The grid-anode capacity, however, is important in that it very greatly affects the stability; it does, in fact, place a definite limit to the possible stable gain even with all other couplings eliminated. With a single stage of amplification having identical grid and anode circuits, the limit of amplification is  $A = 2/\omega C_{gr} R_D$  when the valve resistance is high compared with the dynamic resistance. With two stages the number 2 in the above equation should be replaced by 1, with three stages by 0.76, and with four stages by 0.67. With  $R_D$  in ohms and  $C_{gr}$  in microfarads,  $\omega = 6.28$  times frequency in Mc/s.

Diode valves are used chiefly as detectors and for AVC purposes. The majority contain two anodes and a common cathode and can provide detection and delayed AVC. In general, they can be safely operated at a much larger signal input than the diodes fitted to the multiple diode class of valve and they often have a lower resistance. Westectors are included in this section since they fulfil the same functions as diodes of the thermionic type.

**Multiple Diode Types**

Valves which include one or more diodes in addition to another type of electrode assembly are listed in the section appropriate to the major elements. Thus, the duo-diode-triode appears under the heading of "Triodes," while a duo-diode-RF pentode is listed among "Screen-grid" or "Variable-Mu" valves according to whether the pentode section has straight or variable-mu characteristics. Valves of this nature are very widely used, and in general one diode acts as a detector while the other provides delayed AVC. In the case of a duo-diode-triode the triode section generally functions as an AF amplifier, but with a duo-diode-

RF pentode the pentode section is normally the last IF amplifier. These valves also find application in amplified AVC circuits.

**Triodes**

Triodes are divided into two categories: those with a resistance greater than 7,000 ohms and those with a resistance less than 7,000 ohms. The former are now used chiefly as AF amplifiers, grid detectors, and oscillators, while the latter are output or driver valves.

For a grid detector or AF amplifier a valve with a resistance of 7,000-10,000 ohms is usually the best from the point of view of quality, but where high amplification is important a higher resistance can be selected. The deterioration in quality will usually be small and in some cases non-existent, depending very largely upon the circuit conditions.

In calculating the amplification from the formula already given it is important to remember that the mutual conductance and AC resistance both depend on the operating voltages. The figures given in the tables are for zero grid bias and 100 volts HT, following the standard practice. The actual values at maximum HT and the optimum negative grid bias are not widely different, but when using resistance coupling it is a wise plan to take the resistance as being about 25 per cent. greater than the figure given and the mutual conductance as about 25 per cent. less.

Valves having resistances below 7,000 ohms are chiefly of the output type and the power output obtainable is undoubtedly the most important characteristic. Unless an adequate output is obtained it is impossible to secure good quality reproduction. The output necessary depends on the loud speaker efficiency and on the volume required. Experience shows that 2,000 milliwatts are needed for ordinary room strength, but that where the very best quality is desired, and particularly when the high and low frequency responses are unusually well maintained, some 4,000 milliwatts should be allowed.

The output figures given are obtained only when the valve is operated into the correct load impedance, figures for which also appear in the tables. The speech coil of the loud speaker rarely has the correct impedance so that an output transformer is necessary, and the ratio is readily calculated by dividing the optimum load impedance by the speech-coil impedance and taking the square root of the result. When the speech-coil impedance is less than the optimum load impedance, the transformer ratio is step-down.

**Tetrodes and Output Pentodes**

The pentode as an output valve has the advantages of higher sensitivity and efficiency. It is more sensitive in the sense that it requires a smaller signal voltage on the grid for the same power output, and it is more efficient in the sense that it will give the same power output with a smaller consumption of power from the HT supply. In some cases, however, these advantages are more than offset by the high AC resistance of the valve, which leaves the loud speaker undamped, by the necessity for accurate matching of valve and loud speaker, and by the comparatively large amount of third harmonic distortion introduced.

The result is that from the point of view

of quality the triode is to be preferred, especially if two can be used in push-pull. Good results can be secured from pentodes, however, particularly if the sacrifice in sensitivity involved in the application of negative feed-back can be tolerated. It should be noted that the optimum load impedance for a pair of pentodes in push-pull is not twice the value for one valve, as it usually is with triodes. The optimum load for two valves is of the same order as that for one, because second harmonics are largely balanced out by the push-pull connection, whereas third harmonics are not, and both are present to an appreciable extent with pentodes.

There is now a tendency for the output pentode to be replaced by the tetrode and it is claimed that this type introduces less distortion and is more nearly the equal of the triode in quality. The high AC resistance remains, however, but can be reduced by negative feed-back.

**Quiescent Output Valves**

The British valves listed in this section are chiefly battery types. The Class "B" valve consists of two triodes mounted in a single glass envelope and operated in push-pull. Zero, or only a small negative bias, is used, with the result that grid current flows during a large part of the cycle of input voltage.

The valve characteristics are similar to those of pentodes, so that careful matching to the loud speaker is necessary. It is especially important that the output transformer should have a low DC primary resistance and that the leakage inductance should be small. The valve has a low input impedance and requires a power rather than a voltage input. It *must* be fed from a push-pull transformer having a secondary of low DC resistance and the preceding, or driver valve, *must* be capable of an adequate power output. The driver transformer usually has a step-down ratio which can be calculated by dividing the optimum load of the driver valve by the input impedance of the Class "B" valve and taking the square root of the result.

Class "B" stages have now been largely superseded by QPP so far as battery sets are concerned. The QPP valve is really a double pentode and a large grid bias is used so that the standing anode current is very small. Grid current does not flow, so that no difficulties arise in the input circuit as they do with the Class "B" stage. The output circuit is treated exactly as any other.

Among the American valves will be found many indirectly heated Class "B" types. These are intended primarily for considerable output in mains-driven equipment, but they are often operated as amplifiers under Class "A" conditions. A single valve will then operate as a complete push-pull stage giving a compact and economical assembly.

**Rectifiers**

Few remarks are necessary on rectifiers, but it is as well to point out that the figures for output assume a 4-mfd. reservoir condenser. This condenser must be rated for working at not less than 1.4 times the RMS AC input to the rectifier. Thus, the reservoir condenser used for a full-wave rectifier with an input of 500-0-500 volts must be rated for working at not less than 700 volts.

There are two general types of rectifier  
(Continued on page 550.)

FREQUENCY-CHANGERS

Type.	Heater.		Volts.			Current (mA.).		AC Resistance (Mil.)	Conversion Conductance (mA/V.).	Opt. Osc. Volts (Peak).	Capacities (mmfds.).		Base.	Price.
	Volts.	Amps.	Anode.	Screen.	Grid.	Anode.	Screen.				Input.	Output.		
<b>BRIMAR</b> .. 15 A 2 (H)	4.0	0.65	250	100	- 3.0	3.5	2.0	0.3	0.6	10.0	8.0	9.0	7 B	15/-
.. osc.			200						0.75					
.. tet.	13.0	0.2	250	100	- 3.0	3.5	2.0	0.3	0.6	10.0	8.0	9.0	7 B	15/-
.. osc.			200						0.75					
<b>COSSOR</b> .. 210 PG (H)	2.0*	0.1	150	65	0				0.45	7.0			7 A	14/-
.. osc.			150											
.. tet.	2.0*	0.1	150	80	0								7 A	14/-
.. osc.			150											
.. tet.	4.0	1.0	250	100	- 1.5	2.5	3.0		1.5	8.5			7 B	15/-
.. osc.			100			3.0								
.. tet.	4.0	1.15	250	100	- 1.5	3.0	4.0		0.6	12.0			7 B	15/-
.. osc.			100			2.0								
.. tet.	13.0	0.2	250	65	- 1.5	1.0	3.0		0.75	8.5			7 B	15/-
.. osc.			200			6.0								
.. tet.	20.0	0.2	200	100	- 1.5	2.5	3.0		1.5	8.5			7 B	15/-
.. osc.			100			3.0								
.. tet.	20.0	0.2	250	100	- 1.5	3.0	4.0		0.6	12.0			7 B	15/-
.. osc.			100			2.0								
<b>DARIO</b> .. RK 22 (O)	2.0*	0.14	135	45	0	0.6	2.5		0.25	11.3	9.1	14.3	7 A	12/6
.. pent.			250	70	- 1.5	1.3	3.0			11.3	9.0	12.5	7 B	14/-
.. tet.	4.0	0.65	200	70	- 1.5	0.8	3.0		0.6	11.3	9.0	12.5	7 B	14/-
.. pent.			200						0.6					
<b>EVER-READY</b> .. K 80 A (O)	2.0*	0.1	150	70	0	0.8	0.75		0.2	13.0	9.9	14.5	7 A	14/-
.. osc.			130								7.0	6.4		
.. pent.	2.0*	0.12	135	45	- 0.5	0.7	0.7		0.27	8.5			7 A	14/-
.. osc.			250	90	- 1.5	1.6	3.8		0.6	12.0	9.0	12.5	7 B	15/-
.. tet.	4.0	0.65	200	90	- 1.5	2.0	2.0			12.0	9.4	6.1		
.. pent.			90											
.. tet.	4.0	1.0	250	70	- 1.5	4.0	6.0		1.0	20.0	7.4	14.3	7 B	15/-
.. hex.			150			6.0					2.8	1.8		
.. osc.			150								8.0	14.5		
.. tet.	4.0	1.45	250	100	- 2.0	3.5	7.5		0.75	8.0	8.0		7 B	15/-
.. osc.			150			7.0			5.5					
.. pent.	13.0	0.2	200	70	- 1.5	1.6	3.8		0.6	12.0	9.0	12.5	7 B	15/-
.. osc.			90			2.0					9.4	6.1		
.. tet.	21.0	0.2	250	100	- 2.0	3.5	7.5		0.75	8.0	8.0		7 B	15/-
.. hex.			150			7.0			5.5					
.. osc.														
<b>FERRANTI</b> .. VHT 4 (H)	4.0	1.0	250	100	- 3.0	2.6	5.1		0.7	16.0	15.0	16.0	7 B	15/-
.. osc.			100			1.2					11.0	9.0		
.. tet.	2.0*	0.3	150	70	0	4.3	0.8		0.325	3.5	9.1	9.7	9 A	14/-
.. osc.			60			0.9					1.3	1.8		

**REFERENCES.**

\* Directly heated filament.  
 HW Half-wave.  
 FW Full-wave.  
 VD Voltage-doubler.  
 MV Mercury Vapour.  
 (B) Class "B" valve.  
 (O) QPP valve.  
 (D) Driver valve.  
 (T) Tetrode.  
 † Per pair in push-pull.  
 ‡ Under operating conditions quoted.  
 (SA) Split-anode.  
 (SD) Single-diode.  
 (DD) Duo-diode.  
 (TD) Triple-diode.

(T) BF Pentode.  
 (H) Heptode.  
 (O) Octode.  
 (TP) Triode-Pentode.  
 (TH) Triode-Hexode.  
 \*\* The mains transformer secondary should be tapped for these rectifiers, as with some specimens a lower voltage is needed to obtain the rated output.  
 \*\*\* Also available with bayonet type base.  
 †† Special double-triode.  
 ††† Double-pentode  
 § Each filament  
 §§ Self-rectifying



FREQUENCY-CHANGERS—(Continued)

Type	Heater		Volts			Current (mA.)		AG Resistance (MΩ)	Conversion Conductance (mA/V)	Opt. Osc. Volts (Peak)	Capacities (mmfds.)		Base	Price
	Volts	Amps.	Anode	Screen	Grid	Anode	Screen				Input	Output		
<b>MARCONI and OSRAM.</b>														
X 22 (H) ..	2.0*	0.15	150	70	0	1.0	2.7	1.0	0.35	10-20	12.7	23.7	7 A	14/-
"	4.0	1.0	110	80	- 3.0	5.5	2.0	0.5	—	—	8.5	6.85	7 B	15/-
"	4.0	0.6	150	100	- 3.0	2.1	2.53	—	—	—	7.0	4.0	7 B	15/-
"	4.0	1.2	250	80	- 1.5	3.65	2.8	0.75	0.64	12.0	7.0	21.5	7 B	15/-
"	6.3	0.3	150	100	- 3.0	2.2	4.4	3.0	0.225	10.0	17.0	8.5	A 8 A	15/-
"	13.0	0.3	150	80	- 1.5	4.6	2.8	0.75	0.64	12.0	10.4	5.5	7 B	15/-
"	13.0	0.3	250	80	- 3.0	2.2	2.0	0.2	0.8	10.0	17.0	8.5	7 B	15/-
"	2.0*	0.25	150	60	- 1.5	1.2	0.4	1.6	0.5	3.0	9.0	10.0	J A	14/-
TP 22 (TP) ..	2.0*	0.25	100	60	- 1.5	0.8	1.0	0.024	0.25	8.0	4.5	6.5	7 A	14/-
TP 23 (TP) ..	4.0	1.25	80	200	- 5.0	2.5	2.5	0.0095	0.7	3.0	13.5	9.0	9 B	15/-
ACTP (TP) ..	4.0	1.3	150	100	- 3.0	1.5	6.0	0.0215	0.75	9.0	8.0	4.5	7 B	15/-
ACTH 1 (TH) ..	13.0	0.4	100	200	- 5.0	4.0	2.5	0.003	0.7	3.0	10.25	4.0	9 B	15/-
TP 1340 (TP) ..	26.0	0.2	250	200	- 5.0	6.5	2.5	0.0215	0.7	3.0	8.0	4.5	9 B	15/-
TP 2620 (TP) ..	26.0	0.2	150	100	- 3.0	1.5	6.0	0.0215	0.75	9.0	5.75	4.5	7 B	15/-
TH 2620 (TP) ..	2.0*	0.12	135	45	- 0.5	0.7	0.7	2.5	0.27	12.3	9.1	13.6	7 A	14/-
FC 2 A (O) ..	2.0*	0.1	150	70	0	2.1	0.75	—	—	—	6.6	8.5	7 A	14/-
FC 2 (O) ..	4.0	0.65	250	90	- 1.5	1.6	3.8	1.6	0.5	12.0	9.9	14.5	7 B	15/-
TH 4 (TH) ..	4.0	1.0	90	70	- 1.5	4.0	6.0	1.5	1.0	20.0	9.4	6.1	7 B	15/-
TH 4 A (TH) ..	4.0	1.45	150	100	- 2.0	6.0	7.5	2.0	0.75	8.0	7.4	14.3	7 B	15/-
FC 13 C (O) ..	13.0	0.2	200	90	- 1.5	7.0	3.8	1.6	5.5	12.0	13.0	2.3	7 B	15/-
TH 13 C (TH) ..	13.0	0.31	90	70	- 1.5	2.0	6.0	1.5	1.0	20.0	9.4	6.1	7 B	15/-
TH 21 C (TH) ..	21.0	0.2	250	70	- 1.5	4.0	6.0	1.5	1.2	20.0	7.4	2.8	7 B	15/-
"	100/250	0.024	250	60	- 1.7	2.5	3.0	1.5	0.6	8.0	3.0	15.0	C 7 A	17/6
<b>OSTAR-GANZ.</b>														
G 5 (H) ..	4.0	1.0	250	80	0	7.0	—	—	—	—	—	—	7 B	15/-
<b>TRIOTRON</b>														
O 202 (O) ..	2.0*	0.14	135	45	0	0.6	2.5	2.5	0.25	11.3	9.1	14.3	7 A	11/6
O 406 (O) ..	4.0	0.65	250	70	- 1.5	1.3	3.0	1.5	0.6	11.3	9.0	12.5	7 B	12/-
O 1307 (O) ..	13.0	0.2	200	70	- 1.5	0.8	3.0	1.5	0.6	11.3	9.0	12.5	7 B & Ct 8 A	12/-
<b>TUNGSRAM</b>														
VO 2 (O) ..	2.0*	0.13	135	45	0	0.7	0.6	2.5	0.27	11.0	9.1	14.3	7 A	14/-
VO 4 (O) ..	4.0	0.63	250	70	- 1.5	1.3	3.8	1.0	0.6	12.0	9.0	12.5	7 B	15/-
TX 4 (TH) ..	4.0	1.0	300	80	- 1.5	5.5	6.0	1.5	1.0	17.0	9.4	6.1	7 B	15/-
"	2.0*	0.13	150	45	- 1.5	4.0	—	—	1.2	—	—	3.7	7 B	15/-

FREQUENCY-CHANGERS—(Continued)

Type	Heater		Volts		Current (mA.)		AC Resistance (MΩ)	Conversion Conductance (mA/V.)	Opt. Osc. Volts (Peak)	Capacities (mmfds.)		Base	Price
	Volts	Amps.	Anode	Screen	Anode	Screen				Input	Output		
<b>TUNGSRAM</b> — contd.													
VO 6 S (O)	6.3	0.2	250	60	1.1	1.0	2.0	0.45	12.0	8.4	11.3	Ct. 8 A	18/-
VX 6 S	6.3	0.2	250	100	1.85	3.8	2.0	4.0	19.0	—	—	Ct. 8 J	—
6 TH 8 (TH)	6.3	0.6	300	80	5.5	6.0	1.0	1.0	12.0	6.2	13.0	A 8 A	15/-
VO 13 (O)	13.0	0.2	250	70	1.8	3.5	1.0	0.6	12.0	9.0	3.7	7 B	15/-
TX 21 (TH)	21.0	0.2	250	80	5.5	6.0	1.5	1.0	17.0	9.1	13.0	7 B	15/-
			150	—	4.0	—	—	1.2	—	—	2.9	—	—
<b>AMERICAN</b>													
{ 1 A 6 (H)	2.0*	0.06	180	67.5	1.3	2.4	0.5	0.3	—	10.5	9.0	{ A 6 A	—
{ 1 D 7 G	2.0*	0.12	135	67.5	2.3	—	—	0.495	—	5.0	6.0	{ A 8 Q	—
{ 1 C 6 (H)	2.0*	0.12	180	67.5	1.5	2.0	0.75	0.325	—	10.0	10.0	{ A 6 A	—
{ 1 C 7 G	2.5	0.8	135	100	3.3	—	—	1.0	—	6.0	6.0	{ A 8 Q	—
2 A 7 (H)	6.3	0.3	200	100	4.0	2.2	0.36	0.52	—	7.0	5.5	A 7 A	—
6 A 7 (H)	6.3	0.3	250	100	3.5	2.2	0.36	0.52	—	8.5	9.0	A 7 A	—
6 A 8 (H)	6.3	0.3	250	100	4.0	—	—	—	—	7.0	5.5	A 8 A	—
6 F 7 (TF)	6.3	0.3	250	100	3.3	3.2	0.36	0.5	—	12.5	12.5	A 8 A	—
6 L 7	6.3	0.3	250	150	2.8	0.6	2.0	0.3	7.0	3.2	12.5	A 7 A	—
6 D 8 G (H)	6.3	0.15	250	100	3.3	8.3	1.0	0.45	18.0	2.5	3.0	A 8 B	—
			250	—	—	—	0.32	0.35	—	8.0	11.0	A 8 A	—
			250	—	—	—	—	1.0	—	6.0	5.5	—	—

SCREEN-GRID VALVES

Type	Heater		Volts		Current (mA.)		AC Resistance (MΩ)	Mutual Conductance (mA/V.)	Input	Output	Grid-Anode	Base	Price
	Volts	Amps.	Anode	Screen	Anode	Screen							
<b>BRIMAR</b>													
8 A 1 (P)	4.0	1.0	250	100	3.5	1.2	0.6	4.0	—	—	—	5 B & 7 D	12/6
8 D 2 (P)	13.0	0.2	250	100	2.5	0.5	1.5	1.25	4.0	10.0	0.005	7 D	12/6
<b>COSSOR</b>													
215 SG	2.0*	0.15	150	60	2.5	0.5	0.3	1.1	8.3	5.2	0.001	4 B	11/-
220 SG	2.0*	0.2	150	60	3.1	0.6	0.2	1.6	—	—	—	4 B	11/-
210 SPT (P)	2.0*	0.1	150	60	2.95	0.75	0.6	1.3	8.0	6.4	0.005	7 C	11/-
MSHA	4.0	1.0	200	80	2.05	—	0.5	2.0	—	—	—	5 B	12/6
41 MSG	4.0	1.0	150	60	0.8	—	—	—	—	—	—	5 B	17/6
MSGLA	4.0	1.0	200	80	5.25	—	0.2	3.75	—	—	—	5 B	12/6
MSPen & MS Pen B (P)	4.0	1.0	200	100	4.8	1.3	0.8	2.8	10.0	8.0	0.003	7 D & 7 E	12/6
MSPen A (P)	4.0	1.0	200	150	9.0	5.0	0.09	4.0	—	—	—	7 D	12/6
41 MPT (P)	4.0	1.0	200	100	12.0	2.0	0.2	4.2	—	—	—	7 D	15/-
42 MPT (P)	4.0	2.0	200	200	34.0	6.5	0.1	8.5	—	—	—	7 V	15/-
41 MTS (SA)	4.0	1.0	250	100	—	—	—	1.6	—	—	—	7 V	20/-
13 SPA (P)	13.0	0.2	200	100	2.3	0.6	1.0	1.25	5.2	9.1	0.003	7 D	12/6
<b>DARIO</b>													
PF 462 (P)	2.0*	0.18	150	150	3.0	1.0	0.55	1.85	5.2	5.6	0.003	7 C	10/-
TB 622	2.0*	0.18	150	150	2.0	0.5	0.35	1.4	—	—	0.008	4 B	9/6
TE 424	4.0	1.0	200	100	1.5	0.6	0.8	0.9	9.0	6.0	0.002	5 B	11/6
TE 524	4.0	1.0	200	100	3.0	1.0	0.45	2.0	12.0	7.0	0.002	5 B	11/6
TE 464 (P)	4.0	1.1	200	100	3.5	1.5	1.45	3.0	11.0	10.0	0.001	7 D & 5 B	11/6
TE 444 (SD)	4.0	1.1	200	33	0.35	0.25	3.0	3.0	11.0	7.0	0.003	C 7	13/6
TP 713 (P)	13.0	0.2	200	100	3.0	1.1	2.0	2.4	6.6	7.7	0.003	7 E	11/6

SCREEN-GRID VALVES—(Continued)

Type.	Heater.		Volts.			Current (mA.).			AC Resistance (MΩ).	Mutual Conductance (mA/V.).	Capacities (mmfds.).		Base.	Price.
	Volts.	Amps.	Anode.	Screen.	Grid.	Anode.	Screen.	Output.			Grid-Anode.	Input.		
<b>EVER-READY</b> ..	2.0*	0.18	135	75	—	2.0	0.4	0.33	1.5	—	—	4 B	11/-	
A 50 A (P) ..	4.0	1.0	200	100	—	3.0	1.2	2.2	2.3	—	—	5 B	12/6	
A 50 B (P) ..	4.0	0.65	250	250	-2.4	4.0	1.5	—	3.4	6.9	7.8	7 E	12/6	
C 50 B (P) ..	13.0	0.2	200	200	-2.2	2.5	2.0	—	2.5	6.9	8.1	7 E	12/6	
<b>GRAHAM-FARISH</b> ..	2.0*	0.15	150	80	0	2.0	0.75	0.25	1.0	7.9	9.2	4 B	11/-	
SX 2 ..	2.0*	0.2	150	80	0	2.25	0.6	0.33	1.5	9.0	9.4	4 B	11/-	
SWG 5 ..	2.0*	0.2	150	80	0	2.25	0.6	0.33	1.5	—	—	4 C	13/6	
HP 2 (P) ..	2.0*	0.15	150	70	0	1.5	0.3	0.5	1.2	8.4	8.0	7 C	11/-	
AC/SG ..	4.0	1.0	200	80	-1.5	2.4	0.3	0.225	3.3	11.2	7.0	5 B	17/6	
AC/HG ..	4.0	1.0	200	80	-1.5	4.5	0.5	0.8	3.5	11.6	7.0	5 B	12/6	
AC/HP (P) ..	4.0	1.0	200	100	-1.5	3.0	1.0	0.85	3.2	12.9	9.3	7 D	17/6	
<b>HIVAC</b> ..	2.0*	0.065	120	60	0	2.2	0.5	0.5	0.75	1.7	2.7	Sm. 4 B***	15/6	
SG 215 ..	2.0*	0.15	150	75	-1.5	2.7	0.8	0.25	1.0	7.9	9.2	4 B	9/6	
SG 220 ..	2.0*	0.2	150	70	-1.5	2.4	0.9	0.33	1.5	9.0	9.4	4 B	9/6	
SG 220 SV ..	2.0*	0.2	150	70	-1.5	2.4	0.9	0.33	1.5	5.4	9.9	4 C	12/6	
HP 215 (P) ..	2.0*	0.15	150	70	-1.5	1.5	0.3	0.5	1.2	8.4	8.0	4 B & 7 C	10/6	
AC/SL ..	4.0	1.0	200	80	-1.0	3.8	0.4	0.225	3.3	11.2	7.0	5 B	10/6	
AC/SH ..	4.0	1.0	200	80	-1.5	7.4	0.5	0.5	3.5	11.6	7.0	5 B	10/6	
AC/HP (P) ..	4.0	1.0	200	100	-2.0	4.2	1.4	0.35	3.2	12.9	9.3	5 B & 7 D	10/6	
<b>LISSEN</b> ..	2.0*	0.15	150	80	—	3.0	0.25	0.9	1.1	—	—	4 B	11/-	
ACSG ..	4.0	1.0	200	80	-1.5	7.0	0.5	0.34	4.0	—	—	5 B	12/6	
<b>MARGONI and OSRAM</b> ..	2.0*	0.1	150	70	0	1.4	0.8	0.3	1.1	8.35	9.0	4 B	11/-	
S 23 ..	2.0*	0.15	150	70	0	1.4	0.8	0.3	1.1	9.3	8.9	4 B	11/-	
S 24 ..	2.0*	0.1	150	70	0	1.4	0.8	0.3	1.1	9.3	8.9	4 B	11/-	
MS 4 B ..	4.0	1.0	200	70	-1.5	2.4	0.3	0.5	1.1	9.9	4.8	5 B	12/6	
MSP 4 (P) ..	4.0	1.0	200	80	-1.0	3.4	1.2	0.35	3.2	12.7	5.6	5 B	12/6	
MSP 41 (L) ..	4.0	1.0	250	100	-1.75	3.0	1.0	1.0	4.0	14.0	10.0	7 D & 5 B	12/6	
ZY 1 (Acorn) (P) ..	4.0	0.25	250	240	-4.0	8.5	3.2	—	3.2	14.0	10.0	7 D & 5 B	15/-	
<b>MAZDA</b> ..	2.0*	0.15	150	60	0	2.0	1.7	—	1.1	3.0	3.0	—	60/-	
S 215 A ..	2.0*	0.15	150	60	0	1.9	0.3	0.72	1.1	8.5	12.5	4 B	11/-	
SP 215 (P) ..	2.0*	0.15	150	80	-1.5	2.1	0.7	0.8	1.6	10.0	8.5	7 C	11/-	
SP 210 (P) ..	2.0*	0.1	120	120	0.1	1.1	0.33	2.0	1.2	10.0	11.25	7 C	11/-	
ACSG ..	4.0	1.0	200	60	-1.5	4.5	0.8	0.805	1.9	10.0	10.0	5 B	12/6	
ACS 2 ..	4.0	1.0	200	80	-1.5	7.9	0.8	0.6	4.5	12.0	10.0	5 B	12/6	
ACS 2 Pen (P) ..	4.0	1.0	250	100	-1.5	6.5	2.2	1.0	4.0	13.5	8.0	7 D	12/6	
ACSP 1 (L) ..	4.0	1.0	250	200	-3.0	4.9	4.1	—	2.6	13.0	8.75	7 D	12/6	
ACSP 3 (P) ..	4.0	1.0	250	100	-1.5	9.2	3.0	0.47	7.5	14.5	11.0	7 E	15/-	
SP 2220 (P) ..	20.0	0.2	250	200	-3.0	4.9	4.1	—	2.6	13.0	8.75	7 D	12/6	
<b>MULLARD</b> ..	2.0*	0.18	135	90	0	2.0	0.4	0.33	1.3	—	—	4 B	11/-	
PM 12 A ..	2.0*	0.15	135	75	0	4.0	1.0	0.18	1.1	—	—	4 B	11/-	
PM 12 ..	2.0*	0.15	135	75	0	4.0	1.0	0.18	1.1	—	—	7 C	11/-	
SP 2 (P) ..	2.0*	0.18	135	135	0	3.0	1.25	0.7	1.8	—	—	7 C	11/-	
S 4 VA ..	4.0	1.0	200	110	-1.5	2.75	0.7	0.5	2.0	—	—	5 B	12/6	
S 4 VB ..	4.0	1.0	200	110	-1.5	4.6	1.05	0.3	2.5	—	—	5 B	12/6	
SP 4 (P) ..	4.0	1.0	200	100	-2.0	3.0	1.2	2.2	2.3	6.9	8.1	5 B & 7 D	12/6	
SP 4 B (P) ..	4.0	0.65	250	250	-2.4	4.0	1.5	2.0	3.5	9.6	7.5	7 E	17/6	
TSP 4 (P) ..	4.0	1.3	200	200	-2.5	8.0	1.5	—	4.73	3.0	2.7	7 E	17/6	
AP 4 (Acorn) (P) ..	4.0	0.2	250	100	-3.0	2.0	0.7	3.5	1.4	3.0	3.0	—	60/-	
SP 13 C (P) ..	13.0	0.2	200	200	-2.2	2.5	0.9	2.5	2.8	6.9	8.1	7 E	12/6	
<b>OSTAR-GANZ</b> ..	100/250	0.024	250	100	-2.0	4.0	0.4	0.25	3.8	—	—	7 B	15/6	
S 100 ..	100/250	0.024	250	100	-1.0	1.0	0.2	1.0	3.5	—	—	7 B	15/6	
H 3 (P) ..	100/250	0.024	250	100	-2.0	1.6	0.6	3.5	3.5	11.0	12.0	7 C	15/9	
<b>PIX</b> ..	2.0*	0.15	150	75	—	2.5	0.5	0.23	1.0	—	—	4 B	8/6	
450 AC ..	4.0	1.0	200	100	—	3.5	0.75	0.2	3.0	—	—	5 B	10/6	

SCREEN-GRID VALVES—(Continued)

Type.	Heater.		Volts.		Currents (mA.).		AC Resist- ance (MΩ).	Mutual Conduc- tance (mA/V.).	Capacities (mmfds.).		Base.	Price.
	Volts.	Amps.	Anode.	Screen.	Anode.	Screen.			Input.	Output.		
362 ..	2.0*	0.2	150	80	1.5	1.0	0.4	1.5	—	0.01	4 B	7/6
..	4.0	1.0	250	80	0.4	1.0	0.4	2.5	—	0.009	5 B	10/6
..	4.0	1.0	350	150	0.2	4.0	0.2	2.5	—	0.012	5 B	13/-
..	4.0	1.0	250	150	0.1	2.0	0.1	2.5	—	—	7 Z	13/-
..	4.0	1.0	400	250	—	12.0	—	4.0	10.0	0.01	5 K & 7 D	18/6
•												
TRITRON ..	2.0*	0.18	150	150	0.55	1.0	0.55	1.85	5.3	0.002	7 C	8/6
..	2.0*	0.15	120	100	0.33	0.25	0.33	1.5	—	0.05	4 B	8/6
..	4.0	1.1	200	100	1.45	0.5	1.45	3.5	12.0	0.002	7 D & 5 B	10/-
..	4.0	1.0	200	100	0.4	0.5	0.4	1.0	9.0	0.02	5 B	10/-
..	4.0	1.0	200	60	3.3	0.25	3.3	3.0	11.0	0.003	C 7	13/6
..	4.0	1.0	200	33	2.0	1.0	2.0	2.4	6.6	0.003	7 E	10/-
..	13.0	0.2	250	100	1.5	1.0	1.5	3.0	8.0	0.002	Ct. 8 B	10/-
..	13.0	0.2	200	100	1.5	0.25	1.5	3.5	12.0	0.002	5 B	10/-
..	20.0	0.18	200	100	1.45	0.25	1.45	3.5	—	—	—	—
•												
TUNGSRAM ..	2.0*	0.12	150	75	1.5	0.1	1.5	1.4	9.0	0.003	4 B	10/-
..	2.0*	0.12	150	150	0.7	0.1	0.7	1.9	9.0	0.003	7 C	11/-
..	2.0*	0.05	135	135	0.8	1.0	0.8	0.8	5.3	0.006	7 N	11/-
..	4.0	1.0	200	100	2.0	0.6	2.0	3.5	—	0.002	7 D	12/6
..	4.0	0.65	250	250	2.0	0.8	2.0	4.0	6.4	0.003	7 E	12/6
..	6.3	0.2	250	100	1.75	1.0	1.75	2.0	4.7	0.003	Ct. 8 B	16/-
..	13.0	0.2	250	100	1.5	1.5	1.5	3.5	6.4	0.003	7 E	12/6
..	13.0	0.2	200	200	1.5	1.5	1.5	3.5	6.4	0.003	7 E	12/6
•												
AMERICAN ..	2.0*	0.06	135	67.5	0.95	0.4	0.95	0.64	5.3	0.015	A 4 B	—
..	2.0*	0.06	180	67.5	1.2	0.4	1.2	0.65	4.6	0.007	A 4 B & A 8 R	—
..	2.5	1.75	250	90	0.6	1.7	0.6	1.05	5.3	0.007	A 5 B	—
..	2.5	1.0	250	100	1.5	2.0	1.5	1.225	5.0	0.007	A 6 B	—
..	3.3*	0.132	135	67.5	0.5	1.3	0.5	0.5	3.5	0.02	A 4 B	—
..	6.3	0.3	250	100	1.5	0.5	1.5	1.25	4.7	0.007	A 0 B	—
..	6.3	0.3	250	90	0.55	1.7	0.55	1.08	9.2	0.007	A 5 B	—
..	6.3	0.3	250	100	1.5	0.5	1.5	1.225	5.0	0.01	A 6 B	—
..	6.3	0.3	250	100	1.5	0.5	1.5	1.225	7.0	0.005	A 8 C	—
•												

VARIABLE-MU VALVES

Type.	Heater.		Volts.		Current (mA.).		AC Resist- ance (MΩ).	Mutual Conduc- tance (mA/V.).	Capacities (mmfds.).		Base.	Price.
	Volts.	Amps.	Anode.	Screen.	Anode.	Screen.			Input.	Output.		
BRIMAR ..	4.0	1.0	250	100	1.5	2.0	0.6	4.25	—	—	5 B & 7 D	12/6
..	13.0	0.2	250	125	-2.0	3.0	0.6	1.8	4.0	10.0	7 E	12/6
•												
COSSOR ..	2.0*	0.2	150	60	0.4	0.9	0.4	1.6	—	—	4 B	11/-
..	2.0*	0.2	150	60	0.11	0.7	0.11	1.6	—	—	4 B	11/-
..	2.0*	0.1	150	60	0.6	0.75	0.6	1.1	8.2	6.7	7 C	11/-
..	4.0	1.0	200	80	0.2	0.75	0.2	2.5	—	—	5 B	12/6
..	4.0	1.0	200	100	0.6	1.3	0.6	2.2	9.2	8.5	7 D & 7 E	12/6
..	13.0	0.2	200	100	0.8	1.7	0.8	1.5	5.2	9.0	7 D	12/6
•												
DARIO ..	2.0*	0.18	150	150	0.5	0.5	0.5	1.7	5.7	5.1	7 C	10/-
..	2.0*	0.15	150	75	1.5	0.4	1.5	0.35	—	—	4 B	9/6
..	4.0	1.1	200	100	1.0	2.0	1.0	3.5	12.0	10.0	7 D & 5 B	11/6
..	4.0	1.0	200	100	0.3	1.0	0.3	3.0	11.0	8.0	5 B	11/6
..	13.0	0.2	200	100	1.0	2.6	1.0	2.8	3.0	7.5	7 E	11/6
•												



VARIABLE-MU VALVES—(Continued)

Type.	Heater.		Volts.			Current (mA.).		AC Resistance (MΩ).	Mutual Conductance (mA/V.).	Capacities (mmfds.).		Base.	Price.
	Volts.	Amps.	Anode.	Screen.	Grid.	Anode.	Screen.			Input.	Output.		
			0	0	0	0	0	0	0	0	0	0	0
<b>EVER-READY</b> ..	2.0*	0.18	150	90	0	2.5	0.5	—	1.4	—	—	4 B	11/-
K 50 M (P) ..	2.0*	0.18	150	150	0	3.75	0.5	0.75	1.7	—	—	7 C	11/-
A 50 N (P) ..	2.0*	0.18	150	100	0	3.75	0.5	—	3.27	—	—	7 D	12/6
A 50 P (P) ..	4.0	1.2	200	100	-1.5	5.0	1.8	—	5.0	—	—	7 E	12/6
A 40 M ..	4.0	0.65	250	250	-3.0	11.5	4.23	—	2.0	8.05	—	5 B	12/6
A 40 N ..	4.0	1.0	200	110	-1.5	6.0	0.8	—	2.5	—	—	7 D	12/6
A 50 M (P) ..	4.0	1.0	200	100	-2.0	4.5	2.1	—	2.3	12.4	10.0	7 E	12/6
C 50 N (P) ..	13.0	0.2	200	200	-2.0	9.0	3.6	—	2.2	6.1	8.0	7 E	12/6
<b>FERRANTI</b> ..	4.0	1.0	250	100	-3.0	5.5	3.0	1.0	2.0	8.8	8.4	5 B	12/6
<b>GRAHAM-FARISH</b> ..	2.0*	0.15	150	75	0	6.0	1.5	0.11	1.0	7.8	9.2	4 B	11/-
VP 2 (P) ..	2.0*	0.15	150	70	0	3.75	0.75	0.11	1.0	8.4	8.0	7 C	11/-
AC/VG ..	4.0	1.0	200	80	-1.5	4.4	0.6	0.225	3.0	11.2	7.4	5 B	17/6
AC/VN ..	4.0	1.0	200	80	0	5.0	0.7	0.45	3.3	11.5	7.5	5 B	17/6
AC/VP (P) ..	4.0	1.0	200	100	0	6.0	2.0	—	3.0	12.9	9.4	7 D	17/6
<b>HIVAC</b> ..	2.0*	0.15	150	75	0	6.0	1.7	0.11	1.0	7.8	9.2	4 B	9/6
VP 215 (P) ..	2.0*	0.15	150	70	0	3.75	0.75	—	1.25	8.4	8.0	4 B & 7 C	9/6
AC/VN ..	4.0	1.0	200	80	-1.5	4.4	0.6	0.225	3.0	11.2	7.4	5 B	10/6
AC/VH ..	4.0	1.0	200	80	-1.5	9.3	1.6	0.45	3.3	11.5	7.4	5 B	10/6
AC/VP (P) ..	4.0	1.0	200	100	-1.5	5.7	2.3	—	3.0	12.9	9.4	5 B & 7 D	10/6
VP 13 (P) ..	13.0	0.3	200	100	-1.5	6.3	2.0	—	3.0	12.6	9.3	7 D	10/6
<b>LISSEN</b> ..	2.0*	0.15	150	80	0	4.0	0.25	0.4	1.2	—	—	4 B	11/-
SG 2 V ..	4.0	1.0	200	80	-1.5	6.0	0.5	0.3	3.25	—	—	5 B	12/6
ACSGV ..	2.0*	0.15	150	75	0	4.4	0.3	0.25	1.5	9.2	8.73	4 B	11/-
<b>MARCONI and OSRAM</b> ..	2.0*	0.1	150	60	0	2.8	0.7	1.0	1.1	11.5	9.0	7 C	11/-
VP 21 (P) ..	4.0	1.0	200	80	-0.5	12.0	2.0	0.25	2.2	9.9	4.8	5 B	12/6
VMS 4 B ..	4.0	1.0	200	80	-0.5	6.7	1.3	0.25	2.9	9.9	4.8	5 B	12/6
VMP 4 G (P) ..	4.0	1.0	250	100	-2.0	8.0	5.0	1.0	2.7	14.0	8.7	7 D	12/6
W 42 (P) ..	4.0	0.6	250	100	-3.0	7.6	1.85	—	1.5	—	—	7 E	12/6
W 30 (P) ..	13.0	0.3	250	250	-1.0	12.0	6.0	—	4.0	5.7	10.0	7 D	15/-
W 31 (P) ..	13.0	0.3	250	100	-2.0	8.0	5.0	1.0	2.7	14.0	8.7	7 D	12/6
<b>MAZDA</b> ..	2.0*	0.15	150	80	-1.5	2.5	0.8	0.8	1.25	10.0	8.5	7 C	11/-
VP 210 (P) ..	2.0*	0.15	150	70	-1.5	1.8	0.63	0.89	1.1	8.75	11.0	7 C	11/-
ACVP 1 (P) ..	4.0	0.65	250	250	-4.0	8.8	2.2	0.85	2.0	10.0	8.0	7 D	12/6
ACVP 2 (P) ..	4.0	0.65	250	250	-4.0	8.8	2.2	0.85	2.0	6.3	9.25	7 E	12/6
VP 1321 (P) ..	13.0	0.2	250	250	-4.0	8.8	2.2	0.85	2.0	10.0	7.75	7 D	12/6
VP 1322 (P) ..	13.0	0.2	250	250	-4.0	8.8	2.2	0.85	2.0	6.5	9.25	7 E	12/6
<b>MULLARD</b> ..	2.0*	0.18	135	90	0	1.8	0.4	0.4	1.4	—	—	4 B	11/-
VP 2 (P) ..	4.0	1.0	200	135	0	3.0	1.25	—	1.5	10.7	6.3	7 C	11/-
MA 4 V ..	4.0	1.0	200	110	-1.5	6.0	0.8	—	2.5	—	—	5 B	12/6
VM 4 V ..	4.0	1.0	200	100	-1.5	8.5	1.0	—	1.2	—	—	5 B	17/6
VP 4 (P) ..	4.0	1.0	200	100	-2.0	4.5	2.4	1.0	2.3	12.4	10.0	7 D & 5 B	12/6
VP 4 A (P) ..	4.0	1.2	200	100	-2.0	4.25	1.8	1.4	2.5	12.5	10.2	7 D & 5 B	12/6
VP 4 B (P) ..	4.0	0.65	250	250	-3.0	11.5	4.25	—	2.0	5.35	8.05	7 E	12/6
VP 13 C (P) ..	13.0	0.2	200	200	-2.0	9.0	3.6	—	2.2	6.1	8.0	7 E	12/6
VP 13 A (P) ..	13.0	0.2	200	100	-2.0	4.0	1.14	1.0	2.2	—	—	Cl. 8 B	17/6
<b>OSTAR-GANZ</b> ..	100/250	0.024	250	100	-2.0	5.0	4.0	0.5	3.0	—	—	7 B	15/6
V 3 (P) ..	100/250	0.024	250	100	-2.0	3.5	1.5	3.2	2.5	11.0	12.0	7 C	15/9
<b>362</b> ..	2.0*	0.2	150	80	0	5.0	1.0	0.5	1.2	—	—	4 B	7/6
VP 2 C (P) ..	4.0	1.0	250	75	-1.0	6.0	2.0	0.4	2.0	—	—	7 C	9/-
ACVS 4 ..	4.0	1.0	250	150	-1.0	6.0	2.0	0.4	3.0	—	—	5 B	12/6
ACVP 4 (P) ..	2.0*	0.18	150	150	-0.5	2.5	0.5	0.5	1.7	5.7	5.1	7 C	8/6
<b>TRIOTRON</b> ..	2.0*	0.18	150	90	-0.5	3.0	0.3	0.3	1.3	—	—	4 B	8/6
S 217 (P) ..	4.0	1.1	200	100	-2.0	5.5	0.01	1.0	3.5	12.0	10.0	7 D & 5 B	10/-
S 434 N (P) ..	4.0	1.1	200	100	-2.0	6.0	1.0	0.3	2.8	11.0	8.0	5 B	10/-
S 415 N ..	13.0	0.2	200	100	-3.0	8.0	2.6	1.0	2.8	8.0	7.5	7 E & Cl. 8 B	10/-
S 1323 (P) ..	20.0	0.18	200	100	-2.0	5.5	0.01	0.6	3.5	12.0	10.0	5 B	10/-
S 2034 N (P) ..	20.0	0.18	200	100	-2.0	5.5	0.01	0.6	3.5	12.0	10.0	5 B	10/-

VARIABLE-MU VALVES—(Continued)

Type.	Heater.		Volts.		Current (mA.).		AC Resistance (MΩ).	Mutual Conductance (mA/V.).	Capacities (mmfds.).		Base.	Price.
	Volts.	Amps.	Anode.	Screen.	Anode.	Screen.			Input.	Output.		
<b>TUNGSRAM</b>												
HP 211 (P) ..	2.0*	0.12	150	150	-0.9	2.6	2.0	1.7	—	—	7 C	11/-
SE 211 ..	2.0*	0.12	150	75	-0.9	1.0	1.5	1.3	—	—	4 B	10/-
VP 2 B (P) ..	2.0*	0.05	135	135	-0.5	2.5	2.0	0.65	5.7	5.1	7 N	11/-
HP 4100 (P) ..	4.0	1.0	200	100	-2.0	5.0	1.2	3.5	—	—	7 D	12/6
HP 4115 (P) ..	4.0	1.0	200	100	-2.0	4.5	1.25	3.2	—	—	7 D	12/6
VP 4 B (P) ..	4.0	1.0	250	250	-1.0	10.0	1.0	4.0	6.4	7.6	7 E	12/6
VP 6 S (P) ..	6.3	0.2	250	100	-3.0	8.0	1.2	1.7	4.7	7.3	Cc. 8 B	15/-
VP 13 (P) ..	13.0	0.2	250	100	-1.0	8.0	1.0	2.8	6.4	7.6	7 E	12/6
HP 13 (P) ..	13.0	0.2	250	100	-1.0	8.0	1.0	3.5	—	—	7 E	12/6
VP 13 B ..	13.0	0.2	200	200	-1.0	10.0	1.0	3.5	6.4	7.6	7 E	12/6
<b>AMERICAN</b>												
54 (P) ..	2.0*	0.06	135	67.5	-3.0	2.8	0.6	0.6	6.0	11.5	A 4 B	—
1 A 4 & 1 D 5 G ..	2.0*	0.06	180	67.5	-3.0	2.3	0.96	0.75	4.6	11.0	A 4 B & A 8 R	—
1 F 6 & 1 F 7 G (P) (DD) ..	2.0*	0.06	180	67.5	-1.5	2.0	1.0	0.65	—	—	A 6 K & A 8 T	—
35 ..	2.5	1.75	250	90	-3.0	6.5	0.4	1.05	5.3	10.5	A 5 B	—
58 (P) ..	2.5	1.0	250	100	-3.0	8.2	0.8	1.6	4.7	6.5	A 6 B	—
2 B 7 (P) (DD) ..	2.5	0.8	250	125	-3.0	9.0	0.65	1.125	3.5	9.5	A 7 B	—
39, 44 (P) ..	6.3	0.3	250	90	-3.0	5.8	1.4	1.05	3.5	10.0	A 5 B	—
78 (P) ..	6.3	0.3	250	125	-3.0	10.5	0.6	1.65	4.5	11.0	A 6 B	—
6 B 7 (P) (DD) ..	6.3	0.3	250	125	-3.0	9.0	0.65	1.125	3.5	9.5	A 7 B	—
6 K 7 (P) ..	6.3	0.3	250	125	-3.0	10.5	0.6	1.65	7.0	12.0	A 8 C	—
6 D 6 (P) ..	6.3	0.3	250	100	-3.0	8.2	0.8	1.6	4.7	6.5	A 6 B	—
6 S 7 (P) ..	6.3	0.15	250	100	-3.0	8.5	0.63	1.75	4.6	7.8	A 8 C	—
6 B 8 (P) (DD) ..	6.3	0.3	250	125	-3.0	9.0	0.65	1.125	—	—	A 8 S	—
6 U 7 (P) ..	6.3	0.3	250	100	-3.0	8.2	0.8	1.6	4.7	6.5	A 8 C	—

DIODES

Type.	Heater.		Maximum Rating.		No. of Diodes.	Capacities (mmfds.).			Base.	Price.
	Volts.	Amps.	Input Volts RMS.	Rect. Current (mA.).		Anode 1 to Cathode.	Anode 2 to Cathode.	Anode 1 to Anode 2.		
<b>BRIMAR</b>										
.. .. 10 D 1 ..	13.0	0.2	50	1.0	2	—	—	—	5 C	5/6
<b>COSSOR</b>										
.. .. 200 DD ..	2.0	0.2	—	—	2	3.5	3.5	0.7	5 C	5/6
DD 4 ..	4.0	0.75	—	—	2	3.7	3.7	0.7	5 C	5/6
DDL 4 ..	4.0	0.75	20	10.0	2	—	—	—	5 C	5/6
<b>DARIO</b>										
.. .. TB 24 ..	4.0	0.65	200	0.8	2	4.0	4.0	0.3	5 C	4/6
<b>EVER-READY</b>										
.. .. A 20 B ..	4.0	0.65	200	0.8	2	4.5	4.5	0.5	5 C	5/6
.. .. C 20 C ..	13.0	0.2	200	0.8	2	4.5	4.5	0.3	5 C	5/6
<b>HIVAC</b>										
.. .. AC/DD ..	4.0	1.0	—	—	2	3.0	2.4	0.4	5 C	4/6
<b>MARCONI and OSRAM</b>										
.. .. D 41 ..	4.0	0.3	25	0.13	2	3.5	2.5	0.5	5 C	5/6
.. .. D 42 ..	4.0	0.6	75	15.0	1	4.0	—	—	4 H	10/-
<b>MAZDA</b>										
.. .. DD 207 ..	2.0*	0.075	—	—	2	3.5	2.8	0.5	4 E	5/6
.. .. V 914 ..	4.0	0.3	—	1.0	2	3.5	3.0	0.25	5 C	5/6
.. .. D 1 ..	4.0	0.2	—	20.0	1	1.4	—	—	—	10/6
.. .. DD 620 ..	6.0	0.2	—	1.0	2	3.5	3.0	0.25	5 C	5/6

DIODES—(Continued)

Type.	Heater.		Maximum Rating.		No. of Diodes.	Capacities (mmfds.).			Base.	Price.
	Volts.	Amps.	Input RMS.	Rect. Current (mA.).		Anode 1 to Cathode.	Anode 2 to Anode 2.			
							Anode 1 to Cathode.	Output.		
MULLARD	2.0	0.09	87.5	0.5	2	2.8	2.8	0.5	5C	5/6
2 D 2	4.0	0.65	140	0.8	2	4.5	4.5	0.5	5C	5/6
2 D 4 A	4.0	0.35	140	0.8	2	3.8	3.9	0.07	7W	5/6
2 D 4 B	13.0	0.2	140	0.5	2	4.5	4.5	0.5	5C	5/6
2 D 13 C	100/250	0.024	200	15.0	2	—	—	—	U 7 D	9/6
OSTAR-GANZ	4.0	0.65	200	0.8	2	4.0	4.0	0.3	5C	4/6
TRIOTRON	13.0	0.2	200	0.8	2	4.0	4.2	0.3	5C	4/6
TUNGSRAM	4.0	0.18	100	1.5	1	—	—	—	4K	4/-
DD 4	4.0	0.65	200	0.8	2	4.0	4.0	0.5	5C	4/6
DD 6 DS	6.3	0.2	200	0.8	2	3.5	3.5	0.5	5C	5/6
DD 13	13.0	0.2	200	0.8	2	4.0	4.0	0.5	5C	4/6
DD 13 S	13.0	0.2	200	0.8	2	4.0	4.0	0.5	5C	4/6
WESTINGHOUSE	—	—	24.0	0.25	1	—	—	—	—	5/-
W 4 (M)	—	—	36.0	0.28	1	—	—	—	—	5/-
W 6 (M)	—	—	24.0	0.5	2	—	—	—	—	10/-
WM 24 (M)	—	—	24.0	0.5	2	—	—	—	—	10/-
WM 26 (M)	—	—	36.0	0.5	2	—	—	—	—	10/-
WX 6 (M)	—	—	36.0	0.12	1	—	—	—	—	5/-
AMERICAN	6.3	0.3	100	4.0	2	4.6	4.6	0.02	A 8 D	—

TRIODE VALVES (AC Resistance greater than 7,000 ohms.)

Type.	Heater.		Volts.		AC Resistance (ohms).	Anode Current (mA.).	Mutual Conductance (mA/V.).	Capacities (mmfds.).		Base.	Price.	
	Volts.	Amps.	Anode.	Grid.				Input.	Output.			Grid-Anode.
HLA 2	4.0	1.0	200	—	18,000	2.8	—	—	—	7G	12/6	
4 D 1	13.0	0.2	250	—	10,000	4.0	—	—	—	7F	9/6	
11 D 3 (DD)	13.0	0.2	250	—	84,000	1.2	1.7	3.5	1.5	7G	12/6	
COSSOR	2.0*	0.1	150	—	50,000	0.8	—	—	—	4A	4/9	
210 RC	2.0*	0.1	150	—	22,000	1.1	7.0	7.0	4.0	4A	4/9	
210 HL	2.0*	0.1	150	—	15,800	1.5	—	—	—	4A	4/9	
210 HF	2.0*	0.1	150	—	13,000	1.1	—	—	—	4A	4/9	
210 DET	2.0*	0.1	150	—	10,000	1.4	—	—	—	4A	4/9	
210 LF	2.0*	0.1	150	—	19,500	2.6	—	—	—	5A	14/-	
41 MRC	4.0	1.0	200	—	18,000	4.0	12.0	11.0	5.0	5A	9/6	
41 MRH	4.0	1.0	200	—	14,500	2.8	—	—	—	5A	14/-	
41 MHF	4.0	1.0	200	—	11,500	4.5	12.0	10.5	5.5	5A	9/6	
41 MHL	4.0	1.0	200	—	7,950	1.9	—	—	—	5A	14/-	
41 MLF	4.0	1.0	180	—	17,000	2.4	—	—	—	7G	12/6	
DDT (DD)	4.0	1.0	200	—	83,300	1.5	—	—	—	7G	12/6	
13 DHA (DD)	13.0	0.2	250	—	17,000	2.4	—	—	—	7G	12/6	
202 DDT (DD)	20.0	0.2	500	—	30,000	4.0	—	—	—	7G	12/6	
DARIO	2.0*	0.1	150	—	22,000	1.3	—	—	—	4A	3/6	
TB 982	2.0*	0.1	150	—	12,000	1.4	—	—	—	4A	3/6	
TB 172	2.0*	0.1	150	—	8,000	1.25	—	—	—	4A	3/6	
TB 102	2.0*	0.14	135	—	10,500	1.5	—	—	—	5E	6/6	
BBC 12 (DD)	4.0	1.0	200	—	10,000	2.4	6.0	7.0	2.0	5A	8/6	
TBE 244	4.0	0.65	250	—	7,500	3.6	4.3	3.1	1.7	7G	11/-	
TBC 14	4.0	1.0	200	—	25,000	4.0	7.0	5.0	1.5	5A	8/6	
TBE 994	4.0	1.0	200	—	25,000	1.5	6.0	6.0	3.0	5A	8/6	
TE 384	13.0	0.2	200	—	7,500	3.6	4.3	3.1	1.7	7G	11/-	
TBC 113	20.0	0.18	200	—	30,000	4.0	7.0	5.0	1.5	5A	8/6	

TRIODE VALVES—(Continued) (AC Resistance greater than 7,000 ohms.)

Type.	Heater		Volts.		Anode Current (mA.)	AC Resistance (ohms)	Mutual Conductance (mA/V.)	Capacities (mmfds.)		Base.	Price.
	Volts.	Amps.	Anode.	Grid.				Input.	Output.		
<b>EVER-READY</b>											
K 30 C	2.0*	0.1	135	— 1.5	2.2	21,500	1.4	3.6	4.0	4 A	4/9
K 30 D and K 30 E	2.0*	0.1	135	— 4.5	2.0	12,000	1.5	3.5	4.0	4 A	4/9
K 23 B (DD)	2.0*	0.12	135	— 1.5	1.95	25,000	1.2	2.5	7.6	5 E	9/-
K 23 A (DD)	2.0*	0.11	135	— 4.5	2.5	12,000	1.4	—	—	5 E	9/-
A 30 B	4.0	0.05	200	— 2.0	2.0	36,000	2.0	8.8	7.8	5 A	9/6
A 30 D	4.0	0.05	250	— 4.5	6.5	11,500	3.5	5.3	4.2	5 A	9/6
A 23 A (DD)	4.0	0.05	200	— 3.5	7.0	10,300	2.9	4.3	3.1	7 G	12/6
C 30 B.	13.0	0.2	500	— 3.7	5.0	12,000	3.3	3.9	4.5	7 F	9/6
<b>FERRANT</b>											
D 4	4.0	1.0	200	— 3.0	4.0	17,300†	2.5†	8.0	9.8	5 A	9/6
H 4 D (DD)	4.0	1.0	200	— 3.0	4.5	16,000†	2.3†	5.2	7.9	7 G	12/6
<b>GRAHAM-FARISH</b>											
DX 2	2.0*	0.1	150	— 3.0	2.5	12,000	1.4	4.0	4.5	4 A	4/9
LF 2	2.0*	0.1	150	— 6.0	2.5	7,500	1.6	—	—	4 A	4/9
AC/DX	4.0	1.0	200	— 3.0	5.0	10,000	3.5	6.8	7.0	5 A	9/6
AC/LP	4.0	1.0	200	— 14.0	18.0	2,350	4.25	7.0	7.2	5 A	14/-
<b>HIVAC</b>											
XD	2.0*	0.066	100	— 1.5	1.1	23,000	0.75	1.3	1.5	Sm. 4 A	10/6
XL	2.0*	0.066	100	— 3.0	2.5	14,000	0.85	1.4	1.6	Sm. 4 A	10/6
H 210	2.0*	0.1	150	— 3.0	1.1	22,000	1.15	4.3	4.5	4 A	3/9
DDT 215 (DD)	2.0*	0.15	150	— 3.0	3.0	12,500	1.6	3.8	3.9	5 E	7/-
D 210	2.0*	0.1	150	— 4.5	2.4	12,000	1.35	4.4	4.0	4 A	3/9
D 210 SW	2.0*	0.1	150	— 4.5	2.4	12,000	1.35	2.1	4.5	4 A	5/6
L 210	2.0*	0.1	150	— 6.0	4.2	7,500	1.6	—	—	4 A	3/9
AC/DDT (DD)	4.0	1.0	200	— 4.0	5.0	15,000	2.3	2.4	5.1	7 G	10/6
AC/HL	4.0	1.0	200	— 2.75	6.0	10,000	3.5	6.8	7.0	5 A	8/6
DDT 13 (DD)	13.0	0.3	200	— 4.0	5.0	15,000	2.5	2.4	5.1	7 G	10/6
HL 13	13.0	0.3	200	— 2.75	6.0	10,000	3.5	6.5	6.9	7 F	8/6
<b>LISSEN</b>											
H 2	2.0*	0.1	150	— 1.5	1.0	45,000	1.1	—	—	4 A	4/9
HL 2	2.0*	0.1	150	— 3.0	1.5	22,000	1.6	—	—	4 A	4/9
L 2	2.0*	0.1	150	— 4.5	2.0	10,000	2.0	—	—	4 A	4/9
L 2 D (SD)	2.0*	0.1	150	— 4.5	2.0	12,000	1.5	—	—	—	4/9
<b>MARCONI and OSRAM</b>											
H 11	1.0*	0.1	100	— 2.0	0.6	50,000	0.5	2.6	3.25	Ct. 4 A	15/-
L 11	1.0*	0.1	100	— 12.0	2.8	12,500	0.4	2.0	3.9	Ct. 4 A	15/-
HL 2	2.0*	0.1	150	— 3.0	1.8	18,000	1.5	5.2	3.5	4 A	4/9
L 21	2.0*	0.1	150	— 6.0	2.2	8,900	1.8	—	—	4 A	4/9
HD 22 (DD)	2.0*	0.2	200	— 3.0	2.0	18,000	1.5	1.8	15.0	5 E	9/-
MH 4	4.0	1.0	200	— 3.0	4.5	11,000	3.6	7.1	4.4	5 A	9/6
MH 41	4.0	1.0	200	— 1.5	5.0	13,300	6.0	8.1	4.3	5 A	9/6
MHL 4	4.0	1.0	300	— 6.0	7.0	8,000	2.5	4.27	1.8	5 A	13/6
MHD 4 (DD)	4.0	1.0	200	— 3.0	3.0	18,200	2.2	2.5	5.2	7 G	12/6
H 42	4.0	0.6	250	— 2.0	1.0	66,000	1.7	—	—	7 F	9/6
DH 42 (DD)	4.0	0.6	250	— 3.0	1.1	58,000	1.2	—	—	7 G	12/6
A 537	4.0	0.4	150	— 6.0	3.3	10,000	1.53	1.4	1.5	—	50/-
MH 40	4.0	1.0	200	— 3.0	2.7	18,750	2.4	—	—	Special Side Ct.	50/-
HA 1 (Accorn)	4.0	0.25	180	— 4.5	4.0	11,800	1.7	—	—	5 A	50/-
H 30	13.0	0.3	250	— 1.7	5.5	13,300	6.0	5.2	8.4	7 F	9/6
DH 30 (DD)	13.0	0.3	200	— 1.7	3.8	18,000	4.5	4.9	11.8	7 G	12/6



OUTPUT TETRODE AND PENTODE VALVES—(Continued)

Type	Heater		Volts.			Current (mA.)		Optimum Load (ohms).	Power Output (mW.)	Bias Resistance (ohms).	Capacities (mmfds.)		Base.	Price.	
	Volts.	Amps.	Anode.	Screen.	Grid.	Anode.	Screen.				Input.	Output.			Grid-Anode.
<b>COSSOR</b> ..	2.0*	0.2	150	150	-4.5	9.5	2.0	20,000	500	—	8.0	4.0	1.0	11/-	
230 PT	2.0*	0.3	150	150	-15.0	14.0	3.0	10,000	1,000	—	—	—	—	16/6	
220 HPT	2.0*	0.2	150	150	-9.0	19.0	4.0	7,500	1,000	—	—	—	—	13/6	
MP Pen	4.0	1.0	250	250	-16.0	8.0	1.5	17,000	500	—	10.5	11.0	—	11/-	
42 MP Pen	4.0	2.0	250	250	-16.0	30.0	6.0	10,000	3,500	450	14.0	12.0	—	13/6	
PT 41 ..	4.0*	1.0	250	250	-5.5	32.0	6.0	8,000	3,100	300	15.5	12.0	1.3	13/6	
PT 41 B ..	4.0*	1.0	400	300	-12.5	30.0	6.0	8,000	2,600	350	—	—	—	13/6	
42 OTDD (T) (DD)	4.0	2.0	250	250	-5.5	34.0	7.0	6,500	3,100	1,900	—	—	—	22/6	
42 OT (T)	4.0	2.0	250	250	-5.5	34.0	7.0	6,500	3,100	1,900	—	—	—	16/-	
40 PPA	40.0	0.2	200	200	-6.7	40.0	7.8	6,500	2,500	130	15.5	5.0	1.3	13/6	
40 PPA	40.0	0.2	150	150	-25.0	36.0	6.0	5,500	2,500	140	11.5	6.0	0.7	13/6	
402 Pen	40.0	0.2	200	200	-6.7	40.0	7.5	4,500	2,500	570	—	—	—	12/6	
<b>DARIO</b> ..	2.0*	0.2	150	150	-4.5	9.5	2.0	15,000	420	—	—	—	—	10/-	
TE 434	4.0*	1.1	250	250	-14.0	36.0	7.0	8,000	3,400	325	9.0	14.0	1.1	5 F	
TE 534	4.0	1.1	250	250	-15.0	24.0	7.0	10,000	2,500	500	7.0	7.0	1.2	5 F	
TE 634	4.0	1.35	250	250	-22.0	36.0	9.0	8,000	3,400	500	8.0	9.0	1.0	5 G & 7 O	
TL 44 ..	4.0	1.5	200	200	-6.0	32.0	3.0	8,000	3,500	175	—	—	—	7 O	
TL 4320	20.2	0.2	200	100	-19.0	40.0	5.0	7,000	3,500	400	—	—	—	7 O	
TL 413	33.0	0.2	250	250	-13.0	36.0	4.5	4,500	4,000	320	—	—	—	Ok. 8 D	
<b>EVER-READY</b> ..	2.0*	0.15	135	135	-4.5	5.6	2.5	20,000	340	—	8.5	13.0	1.0	5 F	
K 70 B	4.0	1.95	250	250	-5.8	36.0	5.0	8,000	3,800	145	11.0	11.0	1.15	5 F	
A 70 C ..	4.0	1.5	250	250	-22.0	32.0	5.0	6,000	3,800	500	—	—	—	11/-	
A 70 B	4.0	1.95	250	250	-5.8	36.0	5.0	8,000	3,800	145	11.5	9.7	1.0	13/6	
A 70 D	4.0	2.25	250	250	-14.0	36.0	5.0	7,000	4,300	145	13.0	13.0	0.5	7 J	
A 27 D	4.0	2.1	250	275	-9.0	40.0	7.0	3,500	8,800	175	14.0	11.0	1.0	16/-	
A 70 E	35.0	0.2	200	200	-6.0	32.5	7.0	6,500	3,100	165	14.3	10.7	1.2	7 J	
<b>FERRANTI</b> ..	4.0	2.0	250	250	-6.0	32.5	7.0	6,500	3,500	150	12.0	18.0	0.7	7 I	
<b>GRAHAM-FARISH</b>	2.0*	0.2	150	150	-4.5	10.0	1.8	12,000	500	—	6.3	3.8	0.9	5 F	
PP 2 ..	4.0	1.0	250	250	-10.0	32.0	4.3	7,500	3,400	230	6.1	3.8	0.8	6 F	
AC/PT ..	4.0	2.0	250	250	-5.5	32.0	4.3	6,800	3,200	150	10.2	5.0	1.5	7 J	
<b>HIVAC</b> ..	2.0*	0.14	100	100	-6.0	5.5	1.1	15,000	—	—	—	—	—	15/6	
Y 220 (T)	2.0*	0.2	150	150	-4.5	10.5	1.3	11,500	500	—	6.3	3.8	0.9	Sm. 5 A	
Z 220 (T)	2.0*	0.2	150	150	-6.0	18.0	2.1	7,500	1,000	—	6.1	3.8	0.8	4 G or 5 J	
AC/Y (T)	4.0	1.0	250	250	-10.0	32.0	4.3	6,500	3,000	300	7.9	4.8	1.6	4 G or 5 J	
AC/Y (T)	4.0	2.0	250	250	-10.0	68.0	10.0	3,000	5,000	140	9.5	6.0	1.9	5 G or 7 J	
AC/Z (T)	4.0	2.0	250	250	-5.5	32.0	4.3	6,500	3,000	160	10.2	5.0	1.5	7 J	
AC/ZDD (T) (DD)	4.0	2.0	250	250	-5.5	32.0	4.3	6,500	3,000	160	9.9	4.3	0.8	5 G or 7 J	
XY	4.0*	1.0	250	250	-10.0	32.0	6.0	6,000	3,000	370	7.5	4.8	1.5	7 I	
AC/Q (T)	13.0	0.3	250	250	-22.0	35.0	2.5	4,000	11,500	550	7.5	4.8	1.5	5 J	
Y 13	26.0	0.3	250	250	-11.0	38.0	6.0	4,000	3,000	250	7.5	4.8	1.5	7 J	
Z 26 ..	2.0*	0.2	200	200	-10.5	16.0	3.0	12,500	1,000	—	—	—	—	11/6	
<b>LISSEN</b> ..	2.0*	0.2	150	150	-6.0	8.0	2.0	18,700	400	—	—	—	—	11/-	
PT 240	2.0*	0.2	150	150	-10.5	18.0	3.0	8,500	1,400	—	—	—	—	4 G or 5 F	
PT 225	4.0	1.25	250	200	-8.0	31.0	4.0	7,500	3,000	240	—	—	—	4 G or 5 F	
PT 2 A	2.0*	0.2	150	150	-6.0	8.0	2.0	18,700	400	—	—	—	—	11/-	
ACPT ..	4.0	1.25	250	200	-8.0	31.0	4.0	7,500	3,000	240	—	—	—	13/6	
<b>MARCONI and OSRAM</b>	2.0*	0.2	150	150	-4.5	9.5	1.9	20,000	500	—	—	—	—	11/-	
KT 2 (T)	2.0*	0.3	150	120	-2.5	5.3	1.1	19,000	460	—	—	—	—	13/6	
KT 21 (T)	4.0	1.0	250	200	-11.0	32.0	5.0	8,000	2,800	300	—	—	—	5 F	
MKT 4 (T)	4.0	2.0	250	250	-4.4	40.0	8.0	7,800	4,500	90	19.5	12.5	2.0	7 J	
KT 41 (T)	4.0	2.0	250	250	-16.5	34.0	5.5	7,000	3,250	420	—	—	—	13/6	
KT 42 (T)	4.0	2.0	250	250	-4.4	40.0	10.0	7,800	4,500	90	15.5	16.5	0.3	7 J	
N 43 ..	4.0	2.3	250	400	-16.0	62.5	12.5	7,800	4,500	90	18.5	15.7	0.75	7 Q	
DN 41 (DD)	4.0*	2.0	400	400	-16.0	62.5	12.5	7,800	4,500	250	—	—	—	25/-	
PT 25 H	13.0	0.3	250	250	-12.0	40.0	7.0	7,500	2,700	260	—	—	—	16/-	
KT 30 (T) and N 30 G	13.0	0.6	200	180	-4.4	40.0	10.6	5,500	2,500	87	19.0	11.0	0.7	5 F	
KT 31 (T)	26.0	0.3	200	180	-4.4	40.0	10.6	5,500	2,500	87	19.0	11.0	0.7	7 T	

TRIODE VALVES—(Continued) (AC Resistance greater than 7,000 ohms.)

Type.	Heater.		Volts.		Anode Current (mA.)	AC Resistance (ohms.)	Mutual Conductance (mA/V.)	Capacities (mmfds.).			Base.	Price.
	Volts.	Amps.	Anode.	Grid.				Input.	Output.	Grid-Anode.		
AMERICAN												
30 & 1 H 4 G ..	2.0*	0.06	135	- 9.0	3.0	10,300	0.9	2.1	6.0	A 4 A & A 8 V		
1 B 5 & 1 H 6 G (DD)	2.0*	0.06	135	- 3.0	0.8	35,000	0.575	1.6	3.6	A 6 C & A 8 U		
27 ..	2.5	1.75	250	- 21.0	5.2	9,250	0.975	3.1	2.3	A 5 A		
55 (DD) ..	2.5	1.0	250	- 20.0	8.0	7,500	1.1	1.5	4.3	A 6 D		
56 ..	2.5	1.0	250	- 13.5	5.0	9,500	1.45	3.2	2.2	A 5 A		
2 A 6 (DD) ..	2.5	0.8	250	- 2.0	0.4	91,000	1.1	1.7	3.8	A 6 D		
37 ..	6.3	0.3	250	- 18.0	7.5	8,400	1.1	2.9	2.0	A 5 A		
75 & 6 B 6 G (DD) ..	6.3	0.3	250	- 2.0	0.4	91,000	1.1	1.7	3.8	A 6 D & A 8 E		
76 ..	6.3	0.3	250	- 13.5	5.0	9,500	1.45	3.5	2.8	A 5 A		
85 (DD) ..	6.3	0.3	250	- 20.0	8.0	7,500	1.1	1.5	4.3	A 6 D		
6 C 5 ..	6.3	0.3	250	- 8.0	8.0	10,000	2.0	4.0	13.0	A 8 G		
6 F 5 ..	6.3	0.3	250	- 2.0	0.9	66,000	1.5	6.0	12.0	A 8 F		
6 Q 7 (DD) ..	6.3	0.3	250	- 3.0	1.1	58,000	1.2	4.4	1.4	A 8 E		
6 R 7 (DD) ..	6.3	0.3	250	- 9.0	9.5	8,500	1.9	4.8	4.0	A 8 E		
6 Q 6 (SD) ..	6.3	0.15	250	- 3.0	1.2	62,000	1.05	—	—	A 8 O		
6 L 5 ..	6.3	0.15	250	- 3.0	8.0	9,000	1.9	3.0	5.0	A 8 G		
6 J 5 ..	6.3	0.3	250	- 3.0	9.0	7,700	2.6	3.8	3.3	A 8 G		
6 K 5 ..	6.3	0.3	250	- 3.0	1.1	50,000	1.4	2.4	2.0	A 8 M		
6 C 8 G ..	6.3	0.3	250	- 4.5	3.1	26,000	1.45	3.4	3.5	A 8 A A		

TRIODE VALVES (AC Resistance less than 7,000 ohms.)

Type.	Heater.		Volts.		Anode Current (mA.)	AC Resistance (ohms.)	Mutual Conductance (mA/V.)	Optimum Load (ohms.)	Power Output (mW.)	Bias Resistance (ohms.)	Capacities (mmfds.).			Base.	Price.
	Volts.	Amps.	Anode.	Grid.							Input.	Output.	Grid-Anode.		
BRIMAR															
PA 1 ..	4.0	1.0	200	- 10.5	40.0	1,050	12.0	4,000	1,250	260	—	—	—	5 A	12/6
COSSOR															
215 P ..	2.0*	0.15	150	- 7.5	10.0	4,000	2.25	9,000	150	—	9.0	9.0	0.0	4 A	6/-
220 P ..	2.0*	0.2	150	- 7.5	11.0	4,000	2.25	9,000	180	—	9.0	8.0	5.5	4 A	6/-
220 PA ..	2.0*	0.2	150	- 4.5	10.0	4,000	4.0	9,000	180	—	—	—	—	4 A	6/-
230 XP ..	2.0*	0.3	150	- 18.0	22.0	3,000	3.0	3,500	450	—	—	—	—	4 A	10/-
41 MP ..	4.0	1.0	200	- 7.5	24.0	2,500	7.5	3,000	1,250	320	10.0	11.5	6.5	5 A	10/-
41 MXP ..	4.0	1.0	200	- 12.5	40.0	1,500	7.5	2,500	2,000	300	—	—	—	5 A	12/6
4 XP ..	4.0*	1.0	250	- 28.5	48.0	900	1.1	3,000	3,000	600	20.0	14.0	12.0	4 A	12/6
680 XP ..	6.0*	0.8	400	- 125.0	25.0	2,750	1.1	6,700	2,500	5,000	—	—	—	4 A	25/-
620 T ..	6.0*	2.0	400	- 95.0	62.5	1,300	2.3	4,000	5,000	1,500	—	—	—	4 A	30/-
660 T ..	6.0*	4.5	500	- 120.0	120.0	900	2.3	2,400	11,000	1,000	—	—	—	4 A	105/-
402 P ..	4.0	0.2	200	- 17.5	40.0	1,330	7.5	2,500	200	300	—	—	—	7 F	—
DARIO															
TB 062 ..	2.0*	0.33	150	- 10.5	13.0	3,000	2.0	8,000	550	—	—	—	—	4 A	4/6
TB 122 ..	2.0*	0.2	150	- 4.5	6.0	3,600	3.5	7,000	150	—	—	—	—	4 A	4/6
TB 052 ..	2.0*	0.15	150	- 15.0	7.0	2,000	1.2	10,000	200	—	—	—	—	4 A	4/6
TB 032 ..	2.0*	0.20	150	- 30.0	12.0	2,000	1.5	6,000	500	—	—	—	—	4 A	4/6
TE 094 ..	4.0	1.0	200	- 16.0	12.0	7,000	1.3	3,000	600	850	7.0	5.0	1.5	5 A	8/6
EVER-READY															
S 30 C ..	4.0*	1.0	250	- 29.0	48.0	950	6.8	2,500	2,700	600	8.75	4.95	13.95	4 A	12/6
S 30 D ..	4.0*	1.0	250	- 29.0	48.0	1,200	5.0	2,500	2,700	600	8.75	4.95	13.95	4 A	12/6
FERRANTI															
LP 4 ..	4.0*	1.0	250	- 36.0	48.0	980†	5.5†	2,500	2,800	730	17.6	13.5	9.4	4 A	12/6
GRAHAM-FARISH															
LP 2 ..	2.0*	0.15	150	- 12.0	8.0	3,600	2.2	10,000	150	—	—	—	—	4 A	6/-
MP 2 ..	2.0*	0.2	150	- 12.0	12.5	2,300	3.0	5,000	250	—	—	—	—	4 A	10/-
XP 2 ..	2.0*	0.3	150	- 15.0	17.5	1,850	3.5	4,000	450	—	—	—	—	4 A	10/-

TRIODE VALVES—(Continued) (AC Resistance less than 7,000 ohms.)

Type	Heater		Volts		Anode Current (mA.)	AC Resistance (ohms)	Mutual Conductance (mA/V.)	Optimum Load (ohms)	Power Output (mW.)	Bias Resistance (ohms)	Capacities (mmfds.)		Base	Price
	Volts	Amps.	Anode	Grid							Input	Output		
<b>HIVAC</b> ..	2.0*	0.066	100	—	4.5	5,000	1.0	10,000	—	—	1.4	1.5	Sm, 4 A	12/6
P 215 ..	2.0*	0.15	150	—	8.0	3,600	2.2	10,000	150	—	—	—	4 A	4/9
P 220 ..	2.0*	0.2	150	—	6.0	4,700	3.0	9,000	250	—	—	—	4 A	5/6
PP 220 ..	2.0*	0.2	150	—	12.5	2,300	3.0	5,000	450	—	—	—	4 A	6/6
PX 230 ..	2.0*	0.3	150	—	17.5	1,850	3.5	4,000	450	—	—	—	4 A	7/6
PX 230 SW ..	2.0*	0.3	150	—	17.5	1,850	3.5	4,000	450	—	—	—	4 A	12/—
AC/L ..	4.0	1.0	200	—	17.0	2,350	4.25	6,300	675	760	4.3	11.5	4 A	8/6
PX 41 ..	4.0*	1.0	250	—	40.0	830	6.0	3,500	2,500	830	7.0	7.2	5 A	12/6
PX 5 ..	4.0*	2.0	400	—	62.5	1,480	6.5	3,000	5,750	530	—	—	4 A	20/—
<b>LISSEN</b> ..	2.0*	0.2	150	—	7.6	4,000	1.75	10,000	160	—	—	—	4 A	6/—
PX 240 ..	2.0*	0.4	200	—	25.0	1,500	3.0	5,000	800	—	—	—	4 A	10/—
<b>MARCONI and OSRAM</b> ..	2.0*	0.2	150	—	11.5	3,900	3.85	7,000	150	—	—	—	4 A	6/—
P 2 ..	2.0*	0.2	150	—	19.0	2,150	3.5	4,500	300	—	—	—	4 A	10/—
ML 4 ..	4.0	1.0	200	—	20.0	2,860	4.2	7,000	500	400	—	—	5 A	10/—
PX 4 ..	4.0*	1.0	300	—	42.0	830	6.0	4,000	3,500	400	—	—	4 A	12/6
PX 25 ..	4.0*	2.0	400	—	62.5	1,265	7.5	3,200	5,500	530	—	—	4 A	25/—
PX 25 A ..	4.0*	2.0	400	—	62.5	580	6.9	8,400	32,000†	1,000	—	—	4 A	25/—
DA 30 ..	4.0*	2.0	500	—	60.0	580	6.9	3,400†	44,000†	—	—	—	4 A	30/—
DA 60 ..	6.0*	4.0	500	—	120.0	835	3.0	3,000	10,000	1,150	—	—	1g, 4 A	110/—
DA 100 ..	6.0*	2.7	1,000	—	100.0	1,410	3.9	6,700	—	1,490	—	—	Lg, 4 A	210/—
<b>MAZDA</b> ..	2.0*	0.2	150	—	5.5	3,700	3.4	10,000	160	—	—	—	4 A	6/—
P 220 A ..	2.0*	0.2	150	—	15.0	1,850	3.5	4,100	350	—	—	—	4 A	10/—
PA 30 ..	2.0*	0.2	300	—	48.0	1,000	6.5	3,000	4,200	750	—	—	4 A	12/6
ACP ..	4.0	1.0	200	—	17.0	2,650	3.75	6,000	650	800	—	—	5 A	10/—
ACP 1 ..	4.0	1.0	200	—	24.0	1,450	3.7	5,000	1,000	1,200	—	—	5 A	12/6
ACP 4 ..	4.0	1.0	600	—	—	2,850	7.0	—	—	—	—	—	5 K	17/6
PP 3/250 ..	4.0*	1.0	300	—	48.0	1,000	6.5	3,000	4,200	775	—	—	4 A	12/6
PP 5/400 ..	4.0*	2.0	400	—	62.5	1,500	6.0	2,700	5,900	510	—	—	4 A	25/—
PP 3521 ..	35.0	0.2	200	—	70.0	600	10.0	2,000	2,300	360	—	—	7 L	12/6
<b>MULLARD</b> ..	2.0*	0.2	135	—	6.0	4,400	1.7	9,000	150	—	—	—	4 A	6/—
PM 2 A ..	2.0*	0.2	135	—	5.0	6,000	2.0	7,000	150	—	6.3	3.3	4 A	6/—
PM 202 ..	2.0*	0.2	135	—	14.0	2,000	3.5	3,700	350	—	—	—	4 A	10/—
AC 042 ..	2.0*	2.0	250	—	48.0	1,200	5.0	2,500	2,700	600	8.75	4.95	4 A	12/6
TT 4 ..	4.0	1.0	250	—	20.0	3,300	3.2	10,000	500	800	7.0	3.7	5 A	10/—
164 V ..	4.0	1.65	200	—	12.0	4,700	3.4	—	—	750	8.6	8.4	5 A	14/—
AC 044 ..	4.0*	1.0	250	—	48.0	1,200	5.0	2,500	2,700	600	8.75	4.95	4 A	12/6
DO 24 ..	4.0*	2.0	400	—	63.0	2,500	4.0	2,500	5,900	540	—	—	4 A	25/—
DO 26 ..	4.0*	2.0	400	—	63.0	950	3.8	3,000	7,500	1,500	—	—	4 A	25/—
DO 25 ..	6.0*	1.1	400	—	63.0	1,780	3.75	4,000	7,000	1,780	—	—	4 A	30/—
MZ 05-60 ..	6.0*	1.7	500	—	120.0	940	3.2	2,000	11,000	790	—	—	4 A	30/—
MZ 1-75 ..	10.0*	1.1	1,000	—	75.0	2,500	4.0	7,500	20,000	1,050	—	—	Lg, 4 A	110/—
<b>OSTAR-GANZ</b> ..	100/250	0.024	200	—	7.0	3,700	3.0	10,000	750	1,000	—	—	5 A	13/6
L 1525 ..	100/250	0.024	200	—	20.0	1,850	3.0	5,000	900	1,000	—	—	5 A	13/9
K 3560 ..	100/250	0.024	200	—	60.0	500	6.0	1,200	2,500	800	—	—	5 A	19/6
K 2050 ..	100/250	0.024	200	—	40.0	1,000	5.0	2,700	2,500	800	—	—	5 A	19/6
<b>PIX</b> ..	2.0*	0.15	150	—	5.0	4,600	1.2	8,000	150	—	—	—	4 A	4/6
120 ..	2.0*	0.2	150	—	12.0	3,900	1.8	6,000	200	—	—	—	4 A	6/6

TRIODE VALVES—(Continued) (AC Resistance less than 7,000 ohms.)

Type	Heater		Volts		Anode Current (mA.)	AC Resistance (ohms)	Mutual Conductance (mA/V.)	Optimum Load (ohms)	Power Output (mW.)	Bias Resistance (ohms)	Capacities (mmfds.)		Base	Price	
	Volts	Amps.	Anode	Grid							Input	Output			Grid-Anode
362 ..	2.0*	0.3	200	—	10.0	—	3.0	—	—	—	4.0	6.0	4 A	5/-	
..	2.0*	0.2	200	—	9.0	5,000	3.0	10,000	500	—	—	—	4 A	4/-	
..	2.0*	0.2	200	—	13.0	3,000	3.0	6,000	1,000	—	—	—	4 A	4/6	
..	4.0	1.0	250	—	20.0	—	4.0	—	—	1,000	8.0	12.0	5 A	10/-	
..	4.0	1.0	250	—	30.0	2,000	4.0	3,000	2,500	600	—	—	5 A	9/-	
..	4.0*	1.0	250	—	50.0	1,200	5.0	3,000	3,000	800	—	—	4 A	9/-	
..	4.0*	1.0	250	—	65.0	1,000	6.0	3,000	7,000	800	—	—	4 A	20/-	
..	6.0*	2.0	500	—	100.0	800	5.0	7,500	13,000	790	—	—	1g. 4 A	30/-	
..	6.0*	3.0	1,000	—	100.0	1,200	5.0	7,000	35,000	1,400	—	—	1g. 4 A	100/-	
TRITRON ..	2.0*	0.22	150	—	12.0	4,500	2.0	10,000	350	—	—	—	4 A	4/6	
..	2.0*	0.15	150	—	15.0	5,000	1.0	13,000	150	—	—	—	4 A	4/6	
..	2.0*	0.22	150	—	15.0	2,700	2.0	5,000	500	—	—	—	4 A	4/6	
..	2.0*	0.33	200	—	18.0	3,000	3.0	8,000	550	—	—	—	4 A	4/6	
..	4.0	1.0	200	—	15.0	3,000	3.0	10,000	350	1,000	7.0	5.0	5 A	7/6	
..	4.0*	0.65	250	—	40.0	1,000	3.5	1,500	2,500	1,000	5.0	6.0	4 A	10/-	
..	4.0*	2.0	550	—	35.0	1,250	8.0	3,500	5,000	900	7.1	4.4	4 A	20/-	
TUNGSRAM ..	2.0*	0.15	150	—	12.0	3,300	1.5	7,000	260	—	—	—	4 A	4/9	
..	2.0*	0.2	150	—	14.0	2,200	3.0	6,700	360	—	—	—	4 A	4/9	
..	2.0*	0.2	150	—	5.0	3,900	3.5	7,500	290	—	—	—	4 A	4/9	
..	4.0*	1.0	250	—	48.0	3,300	6.0	3,200	2,750	700	—	—	4 A	12/6	
..	4.0*	1.0	250	—	60.0	670	6.0	2,500	4,200	750	—	—	4 A	12/6	
..	4.0*	1.0	250	—	40.0	1,800	4.5	6,000	3,500	900	—	—	4 A	12/6	
..	4.0*	1.0	500	—	37.0	530	7.0	5,000	6,300	1,600	—	—	4 A	20/-	
..	4.0*	2.0	500	—	62.5	1,050	8.5	5,000	5,000	500	—	—	4 A	20/-	
..	4.0*	2.0	500	—	31.0	750	4.0	2,500	6,000	2,500	—	—	4 A	25/-	
..	4.0*	2.0	500	—	65.0	1,000	3.0	4,500	5,000	1,600	—	—	4 A	20/-	
..	7.5*	1.25	600	—	84.0	1,900	2.1	4,300	8,000	1,000	—	—	4 A	20/-	
..	7.5*	1.25	750	—	50.0	3,700	2.2	2,800	8,000	1,000	—	—	4 A	25/-	
..	6.0*	4.0	600	—	130.0	1,000	3.5	2,600	15,000	1,000	—	—	1g. 4 A	88/-	
..	6.0*	2.7	1,000	—	100.0	1,400	4.0	6,700	30,000	1,500	—	—	1g. 4 A	168/-	
AMERICAN ..	2.0*	0.13	135	—	8.0	4,100	0.925	7,000	185	—	3.5	2.7	5.7	A 4 A	—
..	2.5*	1.5	275	—	36.0	1,700	2.05	4,600	2,000	1,550	4.0	3.0	7.0	A 4 A	—
..	2.5*	2.5	250	—	60.0	800	5.25	2,500	3,500	750	9.0	4.0	13.0	A 4 A	—
..	2.5*	2.25	250	—	40.0	5,150	3.5	5,000	4,000	600	—	—	—	A 7 D	—
..	6.3	0.7	375	—	31.0	2,250	2.1	7,000	1,400	1,300	—	—	—	A 8 F	—
..	6.3	0.8	300	—	45.0	—	—	7,000	4,000	—	—	—	—	A 6 E & A 8 W	—
..	6.3*	1.0	250	—	60.0	800	5.25	2,500	3,200	—	—	—	—	A 4 V & A 8 V	—
..	6.3	0.6	250	—	18.0	3,500	1.7	14,000	1,500	—	—	—	—	A 7 E	—

OUTPUT TETRODE AND PENTODE VALVES

Type	Heater		Volts			Current (mA.)		Optimum Load (ohms)	Power Output (mW.)	Bias Resistance (ohms)	Capacities (mmfds.)		Base	Price
	Volts	Amps.	Anode	Screen	Grid	Anode	Screen				Input	Output		
BRIMAR ..	2.0*	0.2	150	150	—	8.1	1.8	18,000	500	—	—	—	5 F	11/-
..	4.0*	1.0	250	250	—	32.0	7.0	8,000	2,850	450	—	—	5 G	13/6
..	4.0	1.2	250	250	—	32.0	8.0	8,000	3,200	330	—	—	7 J	13/6
..	4.0	2.0	250	250	—	32.0	8.0	8,500	4,000	140	—	—	7 J	13/6
..	13.0	0.2	250	250	—	32.0	8.0	8,500	4,000	140	—	—	7 J	13/6
..	40.0	0.2	250	250	—	32.0	8.0	8,500	4,000	140	—	—	7 J	13/6
..	40.0	0.2	150	150	—	40.0	10.0	3,750	2,500	400	—	—	7 J	13/6



OUTPUT TETRODE AND PENTODE VALVES—(Continued)

Type.	Heater.		Volts.			Current (mA.).		Power Output (mW.).	Bias Resistance (ohms).	Capacities (mmfds.).		Base.	Price.	
	Volts.	Amps.	Anode.	Screen.	Grid.	Anode.	Screen.			Input.	Output.			Grid-Anode.
<b>COSSOR</b> ..	2.0*	0.2	150	150	-4.5	9.5	2.0	20,000	—	8.0	4.0	5 F	11/-	
230 PT	2.0*	0.3	150	150	-15.0	14.0	3.0	10,000	—	—	—	5 F	16/6	
220 PT	2.0*	0.2	150	150	-9.0	19.0	4.0	7,500	—	—	—	5 F	13/6	
220 HPT	2.0*	0.2	150	150	-4.5	8.0	1.5	17,000	—	10.5	11.0	5 F	11/-	
MP Pen	4.0	1.0	250	250	-16.0	30.0	6.0	10,000	450	14.0	12.0	7 J	13/6	
42 MP Pen	4.0	2.0	250	250	-5.5	32.0	6.0	8,000	130	13.5	12.0	7 J	13/6	
PT 41 ..	4.0*	1.0	250	250	-12.5	30.0	6.0	8,000	350	—	—	5 F	13/6	
PT 41 B ..	4.0*	1.0	400	300	-40.0	30.0	6.0	8,000	1,200	—	—	5 F	22/6	
42 OTDD (T) (DD)	4.0	2.0	250	250	-5.5	34.0	7.0	6,500	130	15.5	5.0	7 J	16/-	
42 OT (T)	4.0	2.0	250	250	-5.5	34.0	7.0	6,500	130	15.5	5.0	7 J	13/6	
4020 T (T)	40.0	0.2	200	200	-6.7	40.0	7.8	5,500	140	11.5	6.0	7 Q	13/6	
40 PPA	40.0	0.2	150	150	-25.0	36.0	6.0	4,000	570	—	—	7 J	13/6	
402 Pen	40.0	0.2	200	200	-6.7	40.0	7.5	5,500	140	—	—	7 Q	12/6	
<b>DARIO</b> ..	2.0*	0.2	150	150	-4.5	9.5	2.0	15,000	—	—	—	4 G & 5 F	10/-	
TE 434	4.0*	1.1	250	250	-14.0	36.0	7.0	8,000	325	9.0	14.0	5 F	12/6	
TE 534	4.0	1.1	250	250	-15.0	21.0	7.0	10,000	500	7.0	7.0	5 G & 7 O	12/6	
TE 634	4.0	1.35	250	250	-22.0	36.0	9.0	8,000	500	8.0	9.0	7 O	-12/6	
TL 44 ..	4.0	1.5	200	200	-6.0	32.0	3.0	8,000	3,500	—	—	7 O	12/6	
TE 4320	20.2	0.2	200	100	-19.0	40.0	5.0	7,000	400	—	—	Cl. 8 D	12/6	
TL 413	33.0	0.2	250	250	-13.0	36.0	4.5	4,500	320	—	—	7 O	12/6	
<b>EVER-READY</b> ..	2.0*	0.15	135	135	-4.5	5.6	2.5	20,000	—	8.5	13.0	5 F	11/-	
K 70 B	2.0*	0.3	135	135	-2.4	5.0	0.8	24,000	—	11.0	11.0	5 F	11/-	
A 70 C ..	4.0	1.35	250	250	-5.8	36.0	5.0	8,000	145	11.5	9.7	7 J	13/6	
A 70 B	4.0	1.5	250	250	-22.0	32.0	5.0	6,000	500	11.5	9.7	7 J	13/6	
A 70 D	4.0	1.95	250	250	-5.8	36.0	5.0	8,000	145	11.5	9.7	7 J	13/6	
A 27 D	4.0	2.25	250	250	-6.0	36.0	5.0	7,000	145	13.0	9.5	7 X	16/-	
A 70 E	4.0	2.1	250	275	-14.0	72.0	7.0	3,500	175	14.0	11.0	7 J	18/6	
G 70 D	35.0	0.2	200	200	-9.0	40.0	6.0	4,000	165	14.9	10.7	7 J	13/6	
<b>FERRANTI</b> ..	4.0	2.0	250	250	-6.0	32.5	7.0	6,500	150	12.0	18.0	7 I	16/-	
<b>GRAHAM-FARISH</b>	2.0*	0.2	150	150	-4.5	10.0	1.8	12,000	—	6.3	3.8	5 F	11/-	
PP 2 ..	2.0*	0.2	150	150	-9.0	18.0	4.0	7,500	—	7.9	4.8	5 F	11/-	
AC/PT ..	4.0	1.0	250	250	-10.0	32.0	4.3	7,500	230	10.2	5.0	7 J	16/6	
AC/PP ..	4.0	2.0	250	250	-5.5	32.0	4.3	6,800	150	—	—	7 J	18/6	
<b>HIVAC</b> ..	2.0*	0.14	100	100	-6.0	5.5	1.1	15,000	—	—	—	Sm. 5 A	15/6	
Y 220 (T)	2.0*	0.2	150	150	-4.5	10.5	1.3	11,500	—	6.3	3.8	4 G or 5 J	9/6	
Z 220 (T)	2.0*	0.2	150	150	-6.0	18.0	2.1	7,500	—	6.1	3.8	4 G or 5 J	9/6	
AC/Y (T)	4.0	1.0	250	250	-10.0	32.0	4.3	6,500	300	7.9	4.8	5 G or 7 J	11/6	
AC/YX (T)	4.0	2.0	250	250	-10.0	68.0	10.0	3,000	140	9.5	6.0	7 J	25/-	
AC/Z (T)	4.0	2.0	250	250	-5.5	32.0	4.3	6,500	160	10.2	5.0	5 G or 7 J	11/6	
AC/ZDD (T) (DD)	4.0	2.0	250	250	-5.5	32.0	4.3	6,500	160	9.9	4.3	7 J	14/-	
TY ..	4.0*	1.0	250	250	-10.0	32.0	6.0	6,000	250	7.6	4.8	5 J	11/6	
AC/Q (T)	4.0	1.35	375	250	-22.0	57.0	2.5	4,000	370	7.5	4.8	7 J	18/6	
X 13 ..	13.0	0.3	250	250	-11.0	38.0	4.5	3,000	550	—	—	7 J	11/6	
Z 26 ..	26.0	0.3	250	250	-11.0	38.0	6.0	4,000	250	9.8	4.9	7 J	11/6	
<b>LISSEN</b> ..	2.0*	0.4	200	150	-10.5	16.0	3.0	12,500	—	—	—	5 F	11/-	
PT 225	2.0*	0.2	150	150	-6.0	8.0	2.0	18,700	—	—	—	4 G or 5 F	11/-	
PT 2 A	2.0*	0.2	150	150	-10.5	18.0	3.0	8,500	—	—	—	4 G or 5 F	11/-	
ACPT ..	4.0	1.25	250	200	-8.0	31.0	4.0	7,500	240	—	—	5 G	13/6	
<b>MARCONI and OSRAM</b>	2.0*	0.2	150	150	-4.5	9.5	1.9	20,000	—	—	—	5 F	11/-	
KT 2 (T)	2.0*	0.3	150	150	-2.5	5.3	1.1	19,000	—	—	—	5 F	13/6	
MKT 4 (T)	4.0	1.0	250	200	-11.0	32.0	5.0	8,000	300	—	—	7 J	13/6	
KT 41 (T)	4.0	2.0	250	250	-4.4	40.0	8.0	7,800	90	19.5	12.5	7 J	13/6	
KT 42 (T)	4.0	1.0	250	250	-16.5	34.0	5.5	7,000	420	—	—	7 J	13/6	
N 43 ..	4.0	2.0	250	250	-4.4	40.0	10.0	7,800	50	15.5	16.5	7 Q	25/-	
DN 41 (DD)	4.0	2.3	250	250	-4.4	40.0	8.0	7,800	90	18.5	15.7	7 I	16/-	
PT 25 H	4.0*	2.0	400	400	-12.0	62.5	12.5	5,000	250	—	—	5 F	45/-	
KT 30 (T) and N 30 G	13.0	0.3	250	250	-16.0	40.0	7.0	7,500	280	—	—	7 J	13/6	
KT 31 (T)	{ 13.0 26.0 } 0.6	0.3	200	180	-4.4	40.0	10.6	5,500	87	19.0	11.0	7 T	13/6	

OUTPUT TETRODE AND PENTODE VALVES—(Continued)

Type.	Heater.		Volts.			Current (mA.).		Optimum Load (ohms).	Power Output (mW.).	Bias Resistance (ohms).	Capacities (mmfds.).		Base.	Price.
	Volts.	Amps.	Anode.	Screen.	Grid.	Anode.	Screen.				Input.	Output.		
<b>MAZDA</b>	2.0*	0.2	150	150	4.5	9.0	1.6	14,000	600	—	—	—	5 F	11/-
Pen 220 A	2.0*	0.2	150	150	—	18.0	3.0	6,000	1,100	—	—	—	5 F	13/6
Pen 231	2.0*	0.3	120	120	2.5	5.0	1.0	19,000	370	—	—	—	5 F	13/6
AC/Pen	4.0	1.0	250	250	13.5	32.0	6.0	7,500	3,400	400	—	—	7 J	13/6
AC 2/Pen	4.0	1.75	250	250	5.3	32.0	6.0	6,700	3,500	140	—	—	7 J	16/-
AC 2/Pen DD (DD)	4.0	2.0	250	250	5.3	32.0	6.0	6,700	3,500	140	—	—	7 J	16/-
AC 4/Pen (I)	4.0	1.75	250	250	8.8	64.0	13.0	7,000	4,000	114	—	—	7 J	18/6
Pen 1340	13.0	0.4	240	240	—	41.0	8.0	5,500	4,900	185	—	—	7 J	13/6
Pen DD 1360 (DD)	13.0	0.6	260	260	5.3	32.0	6.0	6,700	3,300	140	—	—	7 J	16/-
Pen 3529	35.0	0.2	250	250	11.8	40.0	8.0	5,500	3,700	250	—	—	7 J	13/6
Pen DD 4020 (DD)	40.0	0.2	250	250	8.0	40.0	8.0	5,300	3,800	165	—	—	7 J	16/-
Pen DD 4021 (DD)	40.0	0.2	175	175	—	65.0	13.0	2,700	4,400	115	—	—	7 J	16/-
<b>MULLARD</b>	2.0*	0.15	135	135	4.5	5.6	1.35	10,000	310	—	—	—	5 F & 4 G	11/-
PM 22 A	2.0*	0.3	135	135	—	13.0	3.5	8,000	600	—	—	—	5 F & 4 G	16/6
PM 22	2.0*	0.3	135	135	16.0	23.0	—	5,000	1,450	—	—	—	5 F	13/6
PM 22 C	2.0*	0.3	135	135	2.4	5.0	0.8	24,000	300	—	—	—	5 F	13/6
PM 22 D	2.0*	0.3	135	135	—	36.0	3.0	6,000	3,800	500	—	—	7 J & 5 G	13/6
Pen 4 VA	4.0	1.35	250	250	22.0	36.0	5.0	8,000	3,800	145	—	—	5 F	13/6
Pen A 4 & Pen 4 VB	4.0	1.95	250	250	5.8	30.0	5.6	7,000	2,800	480	—	—	5 F	45/-
Pen 24 M	4.0*	1.1	250	250	17.0	30.0	9.0	10,000	10,000	750	—	—	5 F	13/6
PM 24 E	4.0*	2.0	500	500	35.0	72.0	7.0	3,500	8,800	145	—	—	7 J	18/6
Pen B 4	4.0	2.1	250	250	6.0	36.0	5.0	7,000	4,300	165	—	—	7 J	25/-
Pen 4 DD (DD)	4.0	2.25	250	250	—	48.0	5.0	6,500	28,000	165	—	—	7 J	25/-
Pen 428	4.0	2.1	375	375	—	40.0	5.0	3,000	3,000	420	—	—	7 J	18/6
Pen 26	24.0	0.2	200	200	19.0	40.0	6.0	4,000	3,100	165	—	—	7 J	18/6
Pen 36 C	36.0	0.2	200	200	9.0	40.0	6.0	7,000	2,000	500	—	—	7 J	13/6
<b>OSTAR-GANZ</b>	100/250	0.024	250	250	16.0	26.0	5.0	1,000	2,000	500	—	—	7 J	16/9
PT 3	100/250	0.037	250	250	26.0	40.0	4.0	5,000	3,500	500	—	—	7 J	17/6
M 43	100/250	0.037	200	200	7.5	40.0	5.0	3,000	3,000	160	—	—	7 J	17/6
<b>362</b>	2.0*	0.2	200	200	12.0	13.0	4.0	7,000	1,000	—	—	—	4 G	10/-
ME 2 A	4.0	1.0	250	250	16.0	95.0	12.0	5,000	3,000	400	—	—	5 G	10/6
ACME 4	4.0*	1.0	250	250	22.0	42.0	12.0	3,000	3,500	500	—	—	5 F	10/6
ACME 4 B	4.0*	2.0	400	400	40.0	60.0	18.0	6,000	9,000	700	—	—	5 F	30/-
<b>TRIOTRON</b>	2.0*	0.2	150	150	4.5	8.0	2.0	15,000	500	—	—	—	4 G & 5 F	8/6
P 225	2.0*	0.25	150	150	15.0	16.0	2.0	10,000	600	—	—	—	3 G & 5 F	8/6
P 215	4.0*	1.1	250	250	15.0	45.0	5.0	7,000	2,800	400	—	—	5 F	11/-
P 435	4.0*	2.0	550	550	40.0	45.0	10.0	7,000	7,000	730	—	—	5 F	30/-
P 460	4.0	1.1	250	250	15.0	24.0	5.0	7,500	2,000	600	—	—	5 G & 7 O	11/-
P 440 N	4.0	1.1	250	250	22.0	36.0	3.2	9,000	2,800	540	—	—	7 O	11/-
P 441 N	4.0	1.35	250	250	6.0	32.0	3.0	8,000	2,500	175	—	—	7 O	11/-
P 435	4.0	1.5	250	250	19.0	40.0	5.0	7,500	3,500	400	—	—	5 G	11/-
P 2450	24.0	0.18	200	200	19.0	40.0	5.0	7,000	3,500	400	—	—	5 G	11/-
P 2060	24.0	0.2	200	200	13.0	36.0	4.5	4,500	4,000	320	—	—	7 O	12/6
P 3580	35.0	0.2	250	250	6.0	9.0	2.0	14,000	600	—	—	—	5 F	10/-
<b>TUNGSRAM</b>	2.0*	0.265	135	135	12.0	18.0	2.0	6,000	1,000	—	—	—	5 F	11/-
PT 225	2.0*	0.14	135	135	5.0	7.0	1.0	19,000	440	—	—	—	—	13/6
PT 2	4.0*	1.1	250	250	15.0	36.0	6.0	7,500	2,800	400	—	—	5 F	13/6
APP 4 A	4.0	1.2	250	250	16.5	38.0	6.0	7,000	3,500	400	—	—	7 J	13/6
APP 4 B	4.0	2.0	250	250	5.0	36.0	4.0	6,500	3,400	150	—	—	7 J	13/6
APP 4 C	4.0	2.0	250	250	5.0	36.0	4.0	7,000	3,600	150	—	—	7 O	13/6
APP 4 E	4.0	2.0	275	275	13.5	72.0	8.0	8,800	8,800	175	—	—	7 O	16/6
APP 4 G	4.0	2.0	250	250	6.0	36.0	4.0	7,000	3,600	150	—	—	7 E	16/6
DDPP 4 B (DD)	4.0	2.0	250	250	5.0	45.0	6.0	4,400	3,200	170	—	—	7 X	16/-
DDPP 39 (DD)	35.0	0.2	200	200	8.0	45.0	5.0	4,400	3,200	170	—	—	7 X	16/-
PP 35	35.0	0.2	200	200	6.5	45.0	5.0	4,400	3,200	170	—	—	7 J	13/6
PP 36	35.0	0.2	200	200	6.5	45.0	5.0	5,000	3,200	170	—	—	7 O	13/6
<b>AMERICAN</b>	2.0*	0.26	135	135	13.5	14.5	3.0	7,000	700	—	—	—	A 5 C	—
1 F 4 & 1 F 5 G	2.0*	0.12	135	135	4.5	8.0	2.6	16,000	840	—	—	—	A 5 C & A 8 Y	—
950	2.0*	0.12	135	135	16.5	7.0	2.0	13,500	450	—	—	—	A 5 C	—
1 E 7 G	2.0*	0.34	135	135	7.5	6.5	2.0	24,000	650	—	—	—	A 8 Z	—
1 G 5 G	2.0*	0.12	90	90	6.0	8.5	2.7	8,500	300	—	—	—	A 8 Y	—
47	2.5	1.75	250	250	16.5	31.0	6.0	2,700	2,700	450	—	—	A 5 C	—
59	2.5	2.0	250	250	18.0	35.0	9.0	6,000	3,000	400	—	—	A 7 F	—
2 A 5	2.5	1.75	250	250	16.5	34.0	6.5	7,000	3,000	400	—	—	A 6 H	—

OUTPUT TETRODE AND PENTODE VALVES—(Continued)

Type	Heater		Volts.			Current (mA.)		Optimum Load (ohms)	Power Output (mW.)	Bias Resistance (ohms)	Capacities (mmfds.)		Base	Price
	Volts.	Amps.	Anode.	Screen.	Grid.	Anode.	Screen.				Input.	Output.		
AMERICAN—contd.														
38	6.3	0.3	250	250	-25.0	22.0	3.8	10,000	2,500	1,000	3.5	7.5	0.3	A 5 E
41	6.3	0.4	250	250	-18.0	32.0	5.5	7,000	3,400	475	—	—	—	A 6 H
42	6.3	0.7	250	250	-16.5	34.0	6.5	7,000	3,000	400	—	—	—	A 6 H
89	6.3	0.4	250	250	-25.0	32.0	5.5	6,750	3,400	650	—	—	—	A 6 L
6 A 4 and LA	6.3*	0.3	180	180	-12.0	22.0	3.3	8,000	1,400	465	—	—	—	A 3 C
6 F 6	6.3	0.7	315	315	-22.0	42.0	8.0	7,000	5,000	440	—	—	—	A 8 H
6 L 6 (L)	6.3	0.9	375	375	-20.0	24.0	0.6	14,000	4,200	380	—	—	—	A 8 H
12 A 5	12.6	0.3	180	180	-27.0	40.0	9.0	4,500	2,800	550	—	—	—	A 7 C
12 A 7	12.6	0.3	135	135	-13.5	9.0	2.5	13,500	350	—	—	—	—	A 7 C
43	25.0	0.3	135	135	-20.0	34.0	7.0	4,000	2,000	500	—	—	—	A 6 H
25 A 6	25.0	0.3	180	135	-20.0	40.0	8.0	5,000	2,750	400	—	—	—	A 8 H
25 B 6	25.0	0.3	95	95	-18.0	45.0	4.0	2,000	1,750	300	—	—	—	A 8 H
48	30.0	0.4	125	100	-20.0	56.0	9.5	1,500	2,500	300	—	—	—	A 6 H
25 L 6 G	26.0	0.3	110	110	-7.0	50.0	3.5	2,000	—	130	—	—	—	A 8 H

QUIESCENT OUTPUT VALVES

Type	Heater		Volts.			Current (mA.)			Input Impedance (ohms)	Optimum Load (ohms)	Power Output (mW.)	Base	Price
	Volts.	Amps.	Anode.	Screen.	Grid.	No-signal		Average.					
						Anode.	Screen.						
COSSOR													
220 B (B)	2.0*	0.2	120	—	—	0	2.5	—	12,000	1,100	7 K	11/-	
240 B (B)	2.0*	0.4	120	—	—	0	3.0	—	8,000	2,000	7 K	11/-	
240 QP (QPP)	2.0*	0.4	120	150	-12.0	—	3.0	0.7	24,000	1,250	7 L	—	
TB 402 (B)	2.0*	0.2	150	—	—	0	3.0	—	14,500	1,500	7 K	9/6	
K 77 A (Q)	2.0*	0.45	135	135	-10.5	—	2.5	—	16,000	1,400	9 D	17/6	
K 83 A (B)	2.0*	0.2	150	—	—	0	3.0	—	3,000	1,250	14,000	11/-	
K 83 B (B)	2.0*	0.2	150	—	—	-4.5	3.0	—	3,000	1,450	7 K	11/-	
QP 2 (Q)	2.0*	0.4	150	150	-18.0	—	8.0	1.2	14,500	1,400	7 L	19/6	
HIVAC													
B 230 (B)	2.0*	0.3	150	—	—	0	2.5	—	4,000	1,250	7 K	9/6	
DB 240 (B)	2.0*	0.4	120	—	—	0	2.5	—	4,000	1,250	7 P	15/6	
(B + D) (D)	2.0*	0.4	120	—	—	-4.5	3.0	—	—	—	—	—	—
QP 240 (Q)	2.0*	0.4	150	150	-18.0	—	8.0	1.2	14,500	1,400	7 L	17/6	
LISSEN													
BB 240 A (B)	2.0*	0.4	150	—	—	-3.0	5.0	—	8,000	3,500	7 K	11/-	
B 2	2.0*	0.1	120	—	—	—	2.0†	—	—	1,200†	4 A	4/9	
B 21 (B)	2.0*	0.2	150	—	—	-6.0	2.2	—	30,000	2,000	7 K	12/6	
QP 21 (Q)	2.0*	0.4	150	150	-9.0	—	3.0	—	12,000	1,200	7 L	17/6	
MARCONI and OSRAM													
PD 220 (B)	2.0*	0.2	150	—	—	-1.15	0.8	—	11,500	2,850	7 K	11/-	
PD 220 A (B)	2.0*	0.2	150	—	—	-6.0	2.5	—	10,000	2,900	7 K	11/-	
QP 240 (Q)	2.0*	0.4	150	130	-11.5	—	4.0	0.9	15,000	2,250	9 D	17/6	
QP 230 (Q)	2.0*	0.3	120	120	-9.6	—	4.05	1.15	—	830	7 L	17/6	
PA 40 (Q)	4.0*	2.0	450	—	—	-96.5	110.0†	—	—	43,000†	4 A	30/-	
MULLARD													
PM 2 B (B)	2.0*	0.2	135	—	—	0	3.0	—	4,000	1,250	7 K	11/-	
PM 2 BA (B)	2.0*	0.2	135	—	—	-4.5	3.0	—	4,000	1,450	7 K	11/-	
QP 22 A (Q)	2.0*	0.45	135	135	-10.5	—	2.5	—	—	1,400	9 D	17/6	
BA 2 (B)	2.0*	0.2	150	—	—	0	1.5	—	10,000	1,500	7 K	9/-	
BX 2 (B)	2.0*	0.4	180	—	—	—	2.5	—	6,000	3,000	7 K	9/-	
TRIOTRON													
F 220 B (B)	2.0*	0.3	150	—	—	0	3.0	—	18,000	1,350	7 K	9/6	
CB 220 (B)	2.0*	0.2	150	—	—	0	2.5	—	10,000	2,000	7 K	11/-	
CB 215 (B)	2.0*	0.22	135	—	—	0	2.0	—	10,000	1,700	7 K	11/-	
TUNGSRAM													
19 (B)	2.0*	0.26	135	—	—	0	5.0	—	—	2,100	A 6 G	—	
49 (B) (T)	2.0*	0.12	180	—	—	0	4.0†	—	10,000	3,500†	A 5 D	—	
53 (B)	2.0	2.0	300	—	—	0	35.0	—	10,000	10,000	A 7 E	—	
46 (B) (T)	6.3*	1.75	400	—	—	0	12.0†	—	5,800†	20,000†	A 5 D	—	
79 (B)	6.3	0.6	250	—	—	0	10.5	—	14,000	8,000	A 6 F	—	
6 A 6 (B)	6.3	0.8	300	—	—	0	35.0	—	10,000	10,000	{ A 7 E } { A 8 N }	—	

RECTIFYING VALVES

Type.	Filament		Type of Rectification.	Max. Anode Volts (RMS).	Max. Rect. Current (mA.).	Unsmoothed Rect. Volts at		Base.	Price.
	Volts.	Amps.				Full-current.	Half-current.		
<b>BRIMAR</b> ..	4.0	1.0	FW	250-0-250	60	260	280	4 E	10/6
R 1	4.0	2.5	FW	350-0-350	120	360	410	4 E	10/6
R 2	4.0	2.5	FW	500-0-500	120	610	610	4 E	15/-
R 3	4.0	0.2	HW	250	75	265	300	5 I	10/6
<b>COSSOR</b> ..	4.0*	1.0	FW	250-0-250	60	330	270	4 E	10/6
506 BU	4.0*	2.5	FW	350-0-350	120	350	400	4 E	10/6
442 BU	4.0*	2.5	FW	500-0-500	120	520	600	4 E	18/-
480 BU	4.0*	0.2	HW	250	75	210	280	5 I	10/6
40 SVA	4.0	2.5	FW	350-0-350	120	360	400	4 E	10/6
43 IU	4.0	2.5	FW	500-0-500	120	560	610	4 E	15/-
44 IU	4.0	2.5	FW	500-0-500	200	540	590	4 E	20/-
4/100 BU	4.0*	5.0	VD	1,500-0-1,500	20	1,720	1,800	4 E	20/-
405 BU	4.0*	0.58	VD	750	20	2,000	—	7 Y	20/-
225 DU	2.0*	1.0	HW	5,000	2	5,500	6,030	4 F	20/-
SU 2130	2.0	1.15	HW	5,000	2	5,500	6,030	4 F	20/-
SU 2150	2.0	1.15	HW	5,000	2	5,500	6,030	4 F	20/-
<b>DARIO</b> ..	4.0*	1.0	HW	400	60	400	450	4 D	6/6
SW 1	4.0*	1.0	FW	250-0-250	60	245	280	4 E	7/6
FW 1	4.0*	1.0	FW	350-0-350	120	320	370	4 E	9/6
FW 2	4.0*	2.0	FW	500-0-500	120	500	570	4 E	10/6
FW 3	4.0*	2.0	FW	500-0-500	120	500	570	4 E	10/6
1 FW 1	4.0	0.2	HW	250	80	250	270	5 I	9/6
TW 1	20.0	0.2	HW	250	120	250	270	5 I	9/6
TW 2	30.0	0.2	HW	125-0-125	120	125	150	5 H	10/6
<b>EVER-READY</b> ..	4.0	2.4	FW	350-0-350	120	395	418	4 E	10/6
111 A	4.0	1.0	FW	250-0-250	60	250	275	4 E	10/6
111 A	4.0	2.4	FW	500-0-500	120	550	600	4 E	15/-
111 C	4.0	2.0	FW	350-0-350	120	380	430	4 E	10/6
111 D	4.0	2.0	FW	350-0-350	120	380	420	4 E	10/6
S 11 D	4.0	0.2	HW	250	75	210	265	5 I	10/6
C 10 B	20.0	0.2	HW	250	75	210	265	5 I	10/6
<b>FERRANTI</b> ..	4.0*	2.5	FW	350-0-350	120	275	330	4 E	10/6
R 4	4.0*	2.5	FW	500-0-500	120	475	550	4 E	16/-
R 4 A	4.0*	3.0	FW, MV	350-0-350	350	330	380	4 E	25/-
GR 4	4.0*	1.0	HW	5,000	3.0	5,800	6,200	4 F	20/-
ER 4	4.0	1.0	HW	5,000	3.0	5,800	6,200	4 F	20/-
<b>GRAHAM-FARISH.</b>	4.0	1.25	FW	300-0-300	75	310	355	4 E	12/6
UU 60/250	4.0	2.5	FW	350-0-350	120	325	380	4 E	15/-
UU 120/350	4.0	1.25	FW	300-0-300	75	310	360	4 E	8/6
UU 60/250	4.0	2.5	FW	350-0-350	120	345	395	4 E	10/6
UU 120/350	4.0	2.5	FW	500-0-500	120	530	595	4 E	12/6
UU 120/500	4.0*	3.0	HW	1,000	250	1,100	1,220	4 D	20/-
MR 1	4.0*	0.6	HW	250	75	175	240	7 M	12/6
U 26	13.0 or 26.0	0.3	VD	250-0-250	120	230	270	7 M	12/6
<b>LISSEN</b> ..	6.0*	0.5	HW	300	40	500	500	4 D	10/6
<b>MARCONI and OSRAM</b>	4.0*	1.0	FW	250-0-250	60	260	300	4 E	10/6
U 10	4.0*	2.5	FW	350-0-350	120	325	380	4 E	10/6
U 12	4.0*	2.5	FW	500-0-500	120	340	410	4 E	10/6
MU 12	4.0*	2.5	FW	500-0-500	120	540	620	4 E	15/-
U 14	4.0*	2.5	FW	500-0-500	120	540	620	4 E	15/-
MU 14	4.0*	3.75	FW	500-0-500	250	520	600	4 E	25/-
U 18	4.0*	0.25	HW	5,000	2	6,800	7,000	4 F	20/-
U 16	2.0*	1.0	HW	2,600	30	2,950	3,050	4 F	20/-
U 17	4.0*	3.0	HW, MV	1,000	250	1,100	1,150	4 D	25/-
GU 1	4.0*	3.0	HW, MV	1,500	250	1,270	1,300	4 F	25/-
GU 5	4.0*	0.3	{ HW, VD	180	120	136	175	7 M	15/-
U 30	26.0	0.3	{ VD	220	75	425	480	7 M	15/-
U 31	26.0	0.3	HW	250	120	270	310	A 8 AG	10/6
<b>MAZDA</b> ..	4.0	2.2	FW	350-0-350	120	370	415	4 E	10/6
UU 4	4.0	2.5	FW	500-0-500	120	465	600	4 E	15/-
UU 5	4.0	0.2	HW	250	75	265	300	5 I	10/6
U 4020	4.0*	2.5	HW, MV	4,500	5	—	—	4 F	20/-
MU 2	2.0*	1.65	HW	4,500	5	—	—	4 F	20/-
U 21	2.0	1.15	FW, VD	550	35	1,150	1,275	7 AA	20/-
UD 41	4.0	1.15	FW, VD	550	35	1,150	1,275	7 AA	20/-



RECTIFYING VALVES—(Continued)

Type	Filament		Type of Rectification	Max. Anode Volts (RMS)	Max. Rect. Current (mA.)	Unsmoothed Rect. Volts at		Base	Price
	Volts.	Amps.				Full-Current	Half-Current		
<b>MULLARD</b>									
1 W 2	4.0	1.2	FW	250-0-250	60	220	260	4 E	10/6
DW 2	4.0*	1.0	FW	250-0-250	60	250	275	4 E	10/6
1 W 3	4.0	2.4	FW	350-0-350	120	350	418	4 E	10/6
DW 3	4.0*	2.0	FW	350-0-350	120	350	375	4 E	10/6
1 W 4	4.0	2.4	FW	500-0-500	120	550	600	4 E	15-
1 W 4/350	4.0	2.0	FW	350-0-350	120	380	430	4 E	10/6
DW 4/350	4.0*	2.0	FW	350-0-350	120	385	425	4 E	10/6
RZ L-150	4.0*	0.3	FW	1,000-0-1,000	160	1,100	1,200	4 E	60/-
HVR 1	2.0*	0.3	HW	6,000	5	5,400	6,900	4 F	20/-
HVR 2	4.0	0.65	HW	6,000	3	6,200	7,500	4 F	20/-
UR 1 C	20.0	0.2	HW	250	75	210	265	5 I	10/6
UR 3	30.0	0.2	FW	250-0-250	120	270	310	Ct. 8 F	15/-
<b>OSTAR-GANZ</b>									
EG 50	100/250	0.024	HW	300	60	250	300	5 I	9/6
EG 100	100/250	0.024	HW	300	120	300	300	5 I	12/9
NG 100	100/250	0.044	2 x HW	300	2 x 100	200	300	C 7 G	17/6
<b>PHILIPS</b>									
1821	4.0*	1.0	FW	250-0-250	60	250	280	4 E	10/6
1881	4.0	1.2	FW	250-0-250	60	250	285	4 E	10/6
1807	4.0*	2.0	FW	350-0-350	120	350	390	4 E	10/6
1867	4.0	2.4	FW	350-0-350	120	350	395	4 E	10/6
1561	4.0*	2.0	FW	500-0-500	120	585	585	4 E	15/-
1861	4.0	2.4	FW	500-0-500	120	500	590	4 E	15/-
<b>FIX</b>									
60/250	4.0*	0.6	FW	250-0-250	40	230	260	4 E	2/6
120/350	4.0	2.0	FW	350-0-350	120	350	370	4 E	3/6
120/500	4.0*	2.0	FW	500-0-500	120	500	570	4 E	4/6
<b>362</b>									
RB 350/80	4.0*	1.5	FW	350-0-350	80	350	380	4 E	7/6
RE 500/120	4.0*	2.0	FW	500-0-500	120	500	550	4 E	10/-
RE 650/250	4.0*	4.0	FW	650-0-650	250	650	710	4 E	15/-
<b>TRIOTRON</b>									
G 429	4.0*	0.3	HW	250	30	250	280	4 D	6/-
G 470	4.0*	1.0	FW	300-0-300	75	300	350	4 E	7/6
G 4120	4.0*	2.0	FW	500-0-500	120	584	584	4 E	9/6
G 4120 N	4.0*	2.5	FW	500-0-300	130	500	580	4 E	9/6
G 2080	20.0	0.2	HW	250	80	270	270	5 I & Ct. 8 E	9/6
G 3080	30.0	0.2	2 x HW	125	120	125	150	Ct. 8 F	10/6
G 3412	33.0	0.18	2 x HW	125	120	125	150	7 M	10/6
<b>TUNGSRAM</b>									
APV 4	4.0	2.0	FW	400-0-400	120	425	467	4 E	10/-
PV 4201	4.0*	2.0	FW	600-0-600	180	575	660	4 E	15/-
PV 4	4.0*	2.0	FW	350-0-350	120	350	390	4 E	10/-
PV 4200	4.0*	2.0	FW	500-0-500	120	500	600	4 E	15/-
V 30	30.0	0.2	HW	275	120	265	285	5 I	10/-
<b>AMERICAN</b>									
80	5.0*	2.0	FW	400-0-400	110	400	450	A 4 C	—
81	7.5*	1.25	HW	700	85	—	—	A 4 C	—
82	2.5*	3.0	FW, MV	500-0-500	125	—	—	A 4 C	—
83	5.0*	3.0	FW, MV	500-0-600	250	—	—	A 4 C	—
83-V	5.0	2.0	FW	400-0-400	200	440	495	A 4 C	—
84	6.3	0.5	FW	350-0-350	50	430	450	A 5 F	—
5 Z 3	5.0*	3.0	FW	500-0-500	250	480	530	A 4 C	—
5 Z 4	5.0*	2.0	FW	400-0-400	125	450	510	A 8 I	—
12 Z 3	12.6	0.3	HW	250	60	250	280	A 4 E	—
25 Z 5	25.0	0.3	VD	125	100	—	—	A 6 J	—
5 Y 3	5.0*	2.0	FW	400-0-400	110	—	—	A 8 I	—
6 X 5	6.3	0.6	FW	350-0-350	75	—	—	A 8 K	—
25 Z 6	25.0	0.3	VD	125	85	—	—	A 8 J	—
5 W 4	5.0*	1.5	FW	350-0-350	110	—	—	A 8 I	—
1-V	6.3	0.3	HW	360	60	380	440	A 4 E	—
6 W 5 G	6.3	0.9	FW	350-0-350	100	—	—	A 8 K	—

METAL RECTIFIERS

Type.	Capacity (mfd.) of Voltage Doubling or Reservoir Condenser. 50 c/s Mains.	Peak Voltage Rating of Condensers (Working).	Type of Rectifier.	Max. Input (RMS).	Max. Input Current (mA.).	Normal Rect. Current (mA.).	Unsmoothed Rect. Volts at		Price.
							Full-current.	Half-current.	
WESTINGHOUSE									
HT 14	4 + 4	200	{ VD HV	80	60	20	140	170	10/-
HT 16	4 + 4	400	{ HV VD	135 30	90	60	330	515	13/-
HT 17	8 + 8	250	{ VD HV	400 240	300	100	225	350	15/-
2 x HT 17	6 + 6	500	{ HV VD	150 250	180	120	530	620	—
HT 15	4 + 4	200	{ VD HV	300 250	140	30	230	315	12/6
H 1	100	12	{ HV HV	3.5	15	10	3.6	4	4/2
H 10	10	50	{ HV HV	35	15	10	36	40	4/6
H 50	2	250	{ HV HV	175	15	10	180	205	7/10
H 100	1	500	{ HV HV	350	15	10	360	410	12/4
H 176	0.5	1,100	{ HV HV	620	15	10	650	750	20/-
J 10	10	250	{ HV HV	80	3	2	80	—	4/6
J 50	2	650	{ HV HV	400	3	2	400	—	7/10
J 100	1	1,250	{ HV HV	800	3	2	800	—	12/4
J 176	0.5	2,000	{ HV HV	1,400	3	2	1,400	—	20/-
Two H 120	0.5 + 0.5	700	{ VD VD	480	30	10	870	1,000	—
Two H 176	0.25 + 0.25	1,000	{ VD VD	720	30	10	1,300	1,500	—
Ten H 176	0.05 + 0.05	5,000	{ VD VD	3,600	30	10	6,500	7,500	—
Two J 10	10 + 10	250	{ VD VD	80	6	2	170	—	—
Two J 50	2 + 2	650	{ VD VD	400	6	2	850	—	—
Two J 100	1 + 1	1,250	{ VD VD	800	6	2	1,700	—	—
Two J 176	0.5 + 0.5	2,000	{ VD VD	1,400	6	2	3,000	—	—
Ten J 176	0.1 + 0.1	12,000	{ VD VD	7,000	6	2	15,000	—	—

VIBRATORS

Type.	Input.		Output.		Base.	Price.
	Volts.	Amps.	Volts.	Current (mA.).		
BULGIN						
HTV 1 & HTV 588	6.0	3.75	250	60	5 & A 5	20/-
HTV 2	—	—	—	—	5	17/6
HTV 388	4.0	—	—	—	5	20/-
HTV 488	12.0	—	—	—	5	20/-
HTV 6	6.0	3.5	250	60	A 5	17/6
HTV 788	4.0	4.5	250	60	A 5	20/-
HTV 888	12.0	1.75	250	60	A 5	20/-
ROCKE						
475	6.0	—	—	—	A 4	—
480	6.0	—	—	—	A 4	—
73588	6.0	—	—	—	A 5	—
425	6.0	—	—	—	A 6	—
72188	6.0	—	—	—	A 5	—
83588	4.0	—	—	—	A 5	—
93588	2.0	—	—	—	A 5	—
33588	12.0	—	—	—	A 5	—
325	12.0	—	—	—	A 6	—
32688	12.0	—	—	—	A 6	—
3240	32.0	—	—	—	A 6	—
11028	110.0	—	—	—	A 6	—
11034	110.0	—	—	—	A 6	—
ROTHERMEL-MALLORY						
4988	6.0	2.5	250	130	7	20/-
9488	6.0	2.5	250	130	7	18/6
G 49	12.0	3.7	250	130	A 4	25/-
G 94	12.0	3.5	250	130	A 4	20/-
SIMMONDS						
NR 2	2.0	3.0	—	—	—	12/6
NR 4	4.0	2.0	—	—	—	12/6

BARRETTERS

Type.	Normal Current (Amps.).	Range of Volts dropped across Barretter.	Base.	Price.
MARCONI and OSRAM				
202	0.2	120-200	4 J	8/6
301	0.3	138-221	Edison Screw	8/6
302	0.3	112-195	Edison Screw	8/6
303	0.3	86-129	Edison Screw	8/6
304	0.3	95-165	Edison Screw	8/6
OSRAM	0.2	120-300	4 J	8/6
PHILIPS				
1904	0.1	40-70	4 J	12/6
1933	0.1	50-160	4 J	15/-
1927	0.18	60-120	4 J	12/6
1928	0.18	100-310	4 J	15/-
C 2	0.2	40-100	4 J or Ct. 8 H	12/6
C 1	0.2	90-230	4 J or Ct. 8 H	10/-
1920	0.25	40-70	4 J	12/6
1934	0.25	85-195	4 J	15/-
1941	0.3	100-240	4 J	15/-

REFERENCES.

\* Directly heated filament.  
 HV Half-wave.  
 FV Full-wave.  
 VD Voltage-doubler.  
 MV Mercury Vapour.  
 (B) Class "B" valve.  
 (O) QPP valve.  
 (D) Driver valve.  
 (T) Tetrode.  
 † Per pair in push-pull.

‡ Under operating conditions quoted.  
 (SD) Single-diode.  
 (DD) Duo-diode.  
 (TD) Triple-diode.  
 (P) RF Pentode.  
 (H) Heptode.  
 (O) Octode.  
 (TP) Triode-Pentode.  
 (TH) Triode-Hexode.

\*\* The mains transformer secondary should be tapped for these rectifiers, as with some specimens a lower voltage is needed to obtain the rated output.  
 \*\*\* Also available with bayonet type base.  
 †† Special double-triode.  
 ††† Self-rectifying.

# A Guide to Valve Bases : BRITISH

**M**ODERN valve development has led to an increase in the number of external connections to a valve, with the result that many different types of bases are now used. The connections for both British and American valve bases are given in these pages, and it is particularly important to note that the view is of the valve base itself or the underside of the valve holder

## ABBREVIATIONS USED IN THE TABLES

A = Anode.	M = Metallising and metal-shield.
B = Class B	OA = Oscillator Anode.
C = Cathode.	OG = Oscillator Grid.
DA = Diode Anode.	R = Resistance.
DC = Diode Cathode.	SG = Screen-grid.
Dr = Driver.	Sup. = Suppressor-Grid.
G = Grid.	TA = Triode Anode.
H = Heater.	Tar. = Target.
HCT = Heater Centre-Tap.	TC = Top-cap.
IG = Injector Grid.	TG = Triode Grid.

NOTES.—Numerical subscripts indicate in multi-electrode valves the order of assembly of the grids, G1 being the grid nearest the cathode, and in multiple valves they distinguish the different electrode assemblies. In one or two cases the now rarely found side-terminal on a valve is included under the column headed TC.

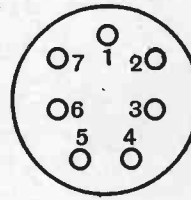

7 PIN

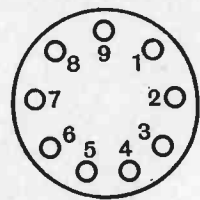

9 PIN

## 7-PIN BASE CONNECTIONS

Type of Valve	Base	TC	1	2	3	4	5	6	7
DH Frequency-changer	7A	G	OA	OG	SG	F	F	M	A
IH Frequency-changer	7B	G	OA	OG	SG	H	H	C	A
DH Screened Pentode.	7C	A	M	G	Sup.	F	F	—	SG
IH Screened Pentode..	7D	A	M	G	Sup.	F	H	C	SG
IH Screened Pentode..	7E	G	M	A	Sup.	H	H	C	SG
IH Triode .....	7F	G	M	—	—	H	H	C	A
IH Duo-diode-triode..	7G	G	DA	M	DA	H	H	C	A
IH Single-diode-tetrode	7H	A	—	G	SG	H	H	C	DA
IH Duo-diode-output pentode .. ..	7I	G	DA	A	DA	H	H	C	SG
IH Pentode .. ..	7J	—	—	G	SG	H	H	C	A
DH Class " B " ..	7K	—	G2	G1	A1	F	F	—	A2
DH QPP .. ..	7L	—	G2	G1	A1	F	F	SG	A2
IH Rectifier, FW or VD	7M	—	HCT	A1	C1	H	H	C2	A2
DH Screened Pentode.	7N	G	M	A	Sup.	F	F	—	SG
IH Pentode .. ..	7O	—	Sup.	G	SG	H	H	C	A
DH Driver and Class B	7P	Dr.A	BG2	BG1	BA1	F	F	Dr. G	BA2
IH Pentode .. ..	7Q	G	—	—	SG	H	H	C	A
IH Triode .. ..	7R	—	—	G	—	H	H	C	A
IH Double-triode ..	7S	—	—	G1	A1	H	H	C	A2
IH Pentode .. ..	7T	G	HCT	—	SG	H	H	C	A
CR Tuning Indicator...	7U	—	—	TG	Tar.	H	H	C	TA
IH Split-anode Pentode	7V	—	A	G	SG	H	H	C	A
IH Duo-diode... ..	7W	—	M	DA2	C2	H	H	C1	DA1
IH Duo-diode-output pentode .. ..	7X	G	DA	C	DA	H	H	A	SG
VD Rectifier .. ..	7Y	—	—	A1	F1	F1	F2	F2	A2
IH Split-anode-tetrode	7Z	G	M	A	A	H	H	C	SG
VD Rectifier .. ..	7AA	—	—	—	H1, H2	H1	H2	H2,C2, A1	A2

## THE BRITISH TYPES

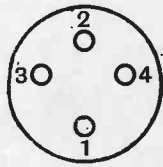

4 PIN

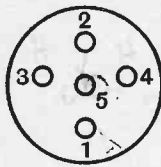

5 PIN

## 4-PIN BASE CONNECTIONS

Type of Valve	Base	TC	1	2	3	4
DH Triode .. ..	4A	—	A	G	— F	+ F
DH Screen-grid .. ..	4B	A	SG	G	— F	+ F
DH Screen-grid .. ..	4C	G	A	SG	— F	+ F
DH Rectifier HW .. ..	4D	—	A	—	F	F
DH or IH Rectifier FW ..	4E	—	A	A	F	F
DH or IH Rectifier HW (High Voltage) .. ..	4F	A	—	—	F	F
DH Output Pentode .. ..	4G	SG	A	G	— F	+ F
IH Diode .. ..	4H	—	A	C	H	H
DH Triode .. ..	4I	G	A	—	— F	+ F
Barretter .. ..	4J	—	—	—	R	R
IH Diode .. ..	4K	DA	C	—	H	H

## 5-PIN BASE CONNECTIONS

Type of Valve	Base	TC	1	2	3	4	5
IH Triode .. ..	5A	—	A	G	H	H	C
IH Screen-grid .. ..	5B	A	SG	G	H	H	C
IH Duo-diode .. ..	5C	—	DA	DA	H	H	C
IH Duo-diode .. ..	5D	DA	DA	M	H	H	C
DH Duo-diode-triode ..	5E	G	A	AVC DA	— F	+ F	Det. DA
DH Pentode .. ..	5F	—	A	G	— F	+ F	SG
IH Pentode .. ..	5G	SG	A	G	H	H	C
IH Rectifier FW .. ..	5H	—	A	A	H	H	C
IH Rectifier HW .. ..	5I	—	A	—	H	H	C
DH Tetrode .. ..	5J	—	A	G1	F	F	G2
IH Pentode .. ..	5K	A	SG	H	G	H, C	Sup.

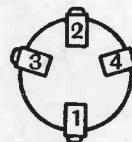

Ct. 4

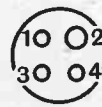

Sm. 4

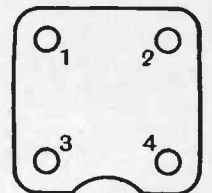

Lg. 4

## VARIOUS 4-PIN AND 4-CONTACT TYPES

Type of Valve	Base	TC	1	2	3	4
DH Midget Triode .. ..	Sm. 4A	—	A	G	F	F
DH Midget Screen-grid ..	Sm. 4B	A	SG	G	F	F
DH Large Output Triode ..	Lg. 4A	—	A	F	F	G
DH Midget Triode .. ..	Ct. 4A	—	A	G	— F	+ F

# INDIAN AMERICAN TYPES

## VARIOUS 5-PIN AND 5-CONTACT TYPES

Type of Valve	Base	TC	1	2	3	4	5
DH Midget Pentode ..	Sm. 5A	—	A	G	F	F	SG
IH Duo-diode ..	Ct. 5A	—	DA	H	H	C	DA
IH Duo-diode ..	Ct. 5B	DA	M	H	H	C	DA

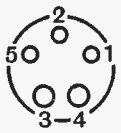

Sm. 5

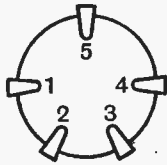

Ct. 5

## 8-CONTACT TYPES

Type of Valve	Base	TC	1	2	3	4	5	6	7	8
Frequency-changer	Ct. 8A	G	M	H	H	C	OA	OG	SG	A
RF Pentode ..	Ct. 8B	G	M	H	H	C	Sup.	—	SG	A
Triode ..	Ct. 8C	G	M	H	H	C	—	—	—	A
Output Pentode ..	Ct. 8D	G	—	H	H	C	—	—	SG	A
HW Rectifier ..	Ct. 8E	—	—	H	H	C	—	—	—	A
FW Rectifier ..	Ct. 8F	—	C1	H	H	C2	A1	—	—	A2
Duo-diode-triode ..	Ct. 8G	G	M	H	H	C	DA	DA	—	A
Barretter ..	Ct. 8H	—	—	—	—	—	R	—	—	R
CR Tuning Indicator	Ct. 8I	—	—	H	H	C	—	TG	Tar.	TA
Hexode ..	Ct. 8J	G1	M	H	H	C	G3	G4	G2	A
Duo-diode ..	Ct. 8K	—	M	H	H	C1	DA1	—	DA2	C2

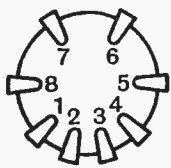

Ct. 8

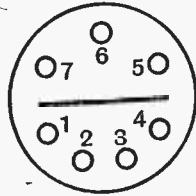

C7 PIN

## OSTAR-GANZ BASE CONNECTIONS

Type of Valve	Base	TC	1	2	3	4	5	6	7
IH Frequency-changer	C7A	G	C	H	H	SG	OG	OA	A
IH Screen-grid ..	C7B	A	C	H	H	SG	G	—	—
IH RF Pentode ..	C7C	G	C	H	H	SG	Sup.	M	A
IH Duo-diode ..	C7D	DA	C	H	H	M	—	—	DA
IH Triode ..	C7E	—	C	H	H	—	G	—	A
IH Pentode ..	C7F	—	C	H	H	SG	G	Sup.	A
IH Rectifier ..	C7G	—	C1	H	H	C2	A2	—	A1

## THE AMERICAN TYPES

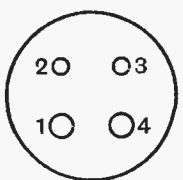

4 PIN

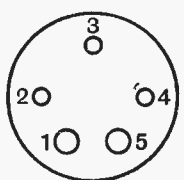

5 PIN

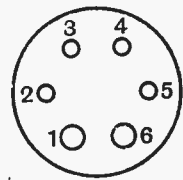

6 PIN

## 4-PIN BASE CONNECTIONS

Type of Valve	Base	TC	1	2	3	4
DH Triode ..	A4A	—	F	A	G	F
DH Screen-grid ..	A4B	G	F	A	SG	F
DH Rectifier FW ..	A4C	—	F	A	A	F
DH Rectifier HW ..	A4D	—	F	A	—	F
IH Rectifier HW ..	A4E	—	H	A	C	H

## 5-PIN BASE CONNECTIONS

Type of Valve	Base	TC	1	2	3	4	5
IH Triode ..	A5A	—	H	A	G	C	H
IH Screen-grid ..	A5B	G	H	A	SG	C	H
DH Pentode ..	A5C	—	F	A	G	SG	F
DH Tetrode ..	A5D	—	F	A	G1	G2	F
IH Pentode ..	A5E	G	H	A	SG	C	H
IH Rectifier FW ..	A5F	—	H	A	A	C	H

## 6-PIN BASE CONNECTIONS

Type of Valve	Base	TC	1	2	3	4	5	6
DH Frequency-changer ..	A6A	G	F	A	OA	OG	SG	F
IH RF Pentode ..	A6B	G	H	A	SG	Sup.	C	H
DH Duo-diode-triode ..	A6C	—	F	A	DA	DA	G	F
IH Duo-diode-triode ..	A6D	G	H	A	DA	DA	C	H
IH Duo-triode ..	A6E	—	H	A2	A1	G1	C2	H
IH Duo-triode ..	A6F	G1	H	A2	G2	C	A1	H
DH Duo-triode ..	A6G	—	F	A2	SG	G1	A1	F
IH Pentode ..	A6H	—	H	A	SG	G	C	H
IH Pentode ..	A6I	G1	H	A	G2	G3	C	H
IH Rectifier, FW ..	A6J	—	H	A1	C1	C2	A2	H
DH Duo-diode-pentode ..	A6K	G	F	A	SG	DA	DA	F

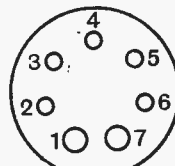

7 PIN

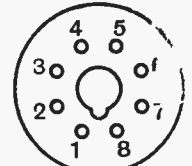

8 PIN (OCTAL)

## 7-PIN BASE CONNECTIONS

Type of Valve	Base	TC	1	2	3	4	5	6	7
IH Frequency-changer	A7A	G	H	A	SG	OA	OG	C	H
IH Duo-diode-pentode	A7B	G	H	A	SG	DA	DA	C	H
IH Single-diode-pentode	A7C	G	H	A	SG	DC	DA	C	H
IH Duo-triode ..	A7D	—	H	A2	A1	G1	G2, C1	C2	H
IH Duo-triode ..	A7E	—	H	A2	G2	C	G1	A1	H
IH Pentode ..	A7F	—	H	A	G2	G1	G3	C	H
IH Pentode ..	A7G	—	H	A	SG	G	C	HCT	H

## 8-PIN BASE (OCTAL) CONNECTIONS

Type of Valve	Base	TC	1	2	3	4	5	6	7	8
IH Frequency-changer	A8A	G	M	H	A	SG	OG	OA	H	C
IH Mixer ..	A8B	G	M	H	A	SG	IG	—	H	C
IH RF Pentode ..	A8C	G	M	H	A	SG	Sup.	—	H	C
IH Duo-diode ..	A8D	—	M	H	DA2	C2	DA1	—	H	C1
IH Duo-diode-triode	A8E	G	M	H	A	DA	DA	—	H	C
IH Triode ..	A8F	G	M	H	—	A	—	—	H	C
IH Triode ..	A8G	—	M	H	A	—	G	—	H	C
IH Pentode ..	A8H	—	M	H	A	SG	G	—	H	C
IH Rectifier FW ..	A8I	—	M	H	—	A	—	A	—	H & C
IH Rectifier FW ..	A8J	—	—	M	H	A2	C2	A1	—	H & C1
IH Rectifier FW ..	A8K	—	M	H	A	—	A	—	H	C
Gaseous Rectifier FW	A8L	—	M	—	A	—	A	—	—	C
IH Triode ..	A8M	G	M	H	A	—	—	—	H	C
IH Duo-triode ..	A8N	—	M	H	A1	G1	G2	A2	H	C
IH Single diode-triode	A8O	G	—	H	A	—	DA	—	H	C
IH Tetrode... ..	A8P	—	—	H	A	SG	G	—	H	C
DH Frequency-changer	A8Q	G	—	+ F	A	SG	OG	OA	— F	—
DH RF Tetrode ..	A8R	G	—	+ F	A	SG	—	—	— F	—
IH Duo-diode-pen.	A8S	G	M	H	A	DA	DA	SG	H	C
DH Duo-diode-pen.	A8T	G	—	+ F	A	DA	DA	SG	— F	—
DH Duo-diode-triode	A8U	—	—	+ F	A	DA	DA	G	— F	—
DH Triode ...	A8V	—	—	+ F	A	—	G	—	— F	—
IH Double-triode ...	A8W	—	M	H	A2	A1	G1	—	H	C
DH Double-triode...	A8X	—	—	+ F	A1	G1	G2	A2	— F	—
DH Pentode ..	A8Y	—	—	+ F	A	SG	G	—	— F	—
DH Double Pentode	A8Z	—	—	+ F	A1	G1	G2	A2	— F	SG
IH Double-triode ...	A8AA	G1	M	H	A1	C1	G2	A2	H	C2
IH Tuning Indicator	A8AB	—	—	H	TA	Tar.	TG	—	H	C
DH Rectifier HW ..	A8AC	—	—	F	—	—	A	—	F	C
IH All-stage ..	A8AD	G1	H	C	A	G5	G4	G3	G2	H



# HIVAC-HARRIES ALL-STAGE VALVE

Heater volts = 15.0. Heater current = 0.3 A.

Anode volts = 400 max. Screen volts = 300 max.

Base = A8AD. Price 13/6.

### OPERATING CONDITIONS.

Frequency-changer.	
Anode	200/250 volts
G5 = Screen	90 volts
G4 = AVC grid	—
G3 = Signal grid	-6 volts
G2 = Osc. anode	90 volts
G1 = Osc. grid	—
AC resistance	1 M Ω
Conversion conductance	0.48 mA/V.
Opt. osc. volts	10/20 volts peak
Anode current	2.0 mA.
Screen current	8.5 mA.

### Detector-Amplifier.

Anode = Diode anode	—
G5 and G2 = Screen	40 volts
G4	-11 volts
G3 = Signal anode	130 volts
G1 = Signal grid	-4 volts
Anode current	3 mA.
Screen current	2 mA.

### RF Amplifier (1).

Anode	200/250 volts
G5 and G2 = Screen grids	90 volts
G4 and G3 = AVC grids	—
G1 = Signal grid	-6 volts
Anode current	5 mA.
Screen current	2.7 mA.
AC resistance	0.75 M Ω
Mutual conductance	1.2 mA/V.
Anode-grid capacity	0.001 μμF.

### RF Amplifier (2).

Anode	250 volts
G5, G4 and G2 = Screen	60 volts
G3 = AVC grid	—
G1 = Signal grid	-3 volts
Anode current	5 mA.
Screen current	1.5 mA.
AC resistance	1.2 M Ω
Mutual conductance	2.0 mA/V.
Anode-grid capacity	0.001 μμF.

### Output.

Class A.	
Anode	400 volts
G5 = Screen	150 volts
G4 = Screen	0
G3, G2 = Screen	250 volts
G1 = Signal grid	-14 volts
Anode current	34 mA.
G5, screen current	4 mA.
G3, G2, screen current	18 mA.
Optimum load	7,000 Ω
Power output	5,300 mW.

### Push-Pull Output.

Class A.	
Optimum load	12,000 Ω
Power Output	12,000 mW.

### Push-Pull Output.

Class AB.	
Optimum load	12,000 Ω
Power output	17,500 mW.
Grid circuit driving power	500 mW.

Continued from page 528

—directly heated and indirectly heated. With the former, the valve functions a few seconds after the set is switched on, so that if the receiving valves are indirectly heated most of the condensers connected, even remotely, to the HT line are charged nearly to the peak value of the AC supply to the rectifier. Consequently, to avoid breakdown, all condensers should have the same voltage rating as the reservoir condenser.

This is avoided with the indirectly heated type, however, for the rectifier does not be-

come operative until the other valves have warmed up and are ready to draw current. Condensers thus need be rated only for the normal working voltages.

A number of rectifiers rated for very high voltages is to be found. These are of the half-wave type and are intended for providing the very small current taken by a cathode-ray tube. They are primarily television valves. The reservoir condenser with these is usually 0.1 mfd.

The data for metal rectifiers is essentially the same as for valves. The capacities of

voltage-doubler condensers, however, depend on the mains frequency, the values given being for 50 c/s. With 100 c/s mains the capacities must be one-half the listed figures and with 25 c/s supplies double.

Each valve has its base connections definitely identified. In every case the figure opposite a valve in the "Base" column denotes the number of pins in the base, while the following letter denotes the connections for that number of pins. A preceding letter is used to distinguish between different arrangements of the same number of pins. Thus, a conventional 4-pin triode is listed as Base 4A, while a 4-pin screen-grid valve has Base 4B. The Midget valves have different pin arrangements and a triode is listed as Sm.4A, being an abbreviation for "small 4-pin base, A connections." Similarly, an American valve base has the prefix A, and Continental types the prefix C. Side-contact types are distinguished by Ct.

The code is an arbitrary one, but is easy to remember, for the numeral and any preceding letters show at a glance the number of pins in the base and the type of base, while the following letter refers to the connections for the particular valve.

In connection with the small 4-pin base for Midget valves, this is used by at least two valve makers, and it should be pointed out that the different makes are not interchangeable. The bases appear the same at a glance and the connections are the same. Actually, however, the pin spacing is slightly different in the Hivac valves from that adopted by Mullard.

### BRITISH COUNTERPARTS OF AMERICAN VALVES

(for characteristics, see American Types).

American Type.	Brimar.	Hivac.	Marconi and Osram.	Tungram.
<b>FREQUENCY CHANGERS.</b>	6 A 7	6 A 7	—	6 A 7
	6 A 8	6 A 8 G	—	6 A 8 G
	6 L 7	6 L 7 G	X 63	14/-
			X 64	12/6
<b>SCREEN-GRID VALVES.</b>	77	—	—	77
	6 C 6	6 C 6	—	6 C 6
	6 J 7	6 J 7 G	Z 63 (P) & KT 63 (T)	6 J 7 G
<b>VARIABLE-MU VALVES.</b>	57	—	—	57
	58	—	—	58
	78	12/6	—	78
	6 B 7	6 B 7	—	6 B 7
	6 B 8	6 B 8 G	—	6 B 8 G
	6 D 6	6 D 6	—	6 D 6
	6 K 7	—	W 63 (P) & KTW 63 (T)	6 K 7 G
	6 U 7	6 U 7 G	—	6 U 7 G
<b>DIODES ..</b>	6 H 6	6 H 6 G	D 63	6 H 6 G
<b>TRIODES (greater than 7,000 ohms).</b>	75	75	—	75
	6 C 5	6 C 5 G	—	6 C 5 G
	6 F 5	—	H 63	—
	6 J 5	—	—	6 J 5 G
	6 Q 7	6 Q 7 G	DH 63	6 Q 7 G
<b>TRIODES (less than 7,000 ohms).</b>	6 B 5	6 B 5	—	—
	6 N 6 G	6 N 6 G	—	—
<b>OUTPUT PEN-TODES AND TETRODES.</b>	2 A 5	—	—	2 A 5
	42	42	—	42
	43	43	—	43
	6 F 6	6 F 6 G	KT 63 (T)	6 F 6 G
	6 L 6	—	KT 66	6 L 6 G
	25 A 6	25 A 6 G	—	25 A 6 G
	25 L 6	—	KT 32	—
<b>RECTIFIERS ..</b>	80	80 S†††	—	80
	5 Y 3	—	U 50	5 Y 3 G
	5 Z 4	5 Z 4 G	—	5 Z 4 G
	25 Y 5	—	—	25 Y 5
	25 Z 5	25 Z 5	—	25 Z 5
	25 Z 6	25 Z 6 G	—	25 Z 6 G

††† Indirectly heated.

### SUPPLIERS OF AMERICAN TYPE VALVES

#### BRITISH AGENTS.

- Amerad.**—Amerad (G.B.), Ltd., Epoch House, 101-105, Goswell Road, London, E.C.1.
- Arcturus.**—U.S. Radio, Ltd., 138, Southwark Street, London, S.E.1.
- Philco.**—Philco Radio and Television Corporation of G.B., Ltd., Aintree Road, Perivale, Middlesex.
- National Union.**—Universal Radio Distributors, Ltd., 24, Fitzroy Square, London, W.1.
- Sylvania.**—Claude Lyons, Ltd., 76, Oldhall Street, Liverpool, 3, Lancs.
- Triad.**—Premier Supply Stores, 20/22, High Street, Clapham, London, S.W.4.

# UNBIASED

By FREE GRID

## Technical Highbrows Indicted

WE hear a lot about the official mind and its mysterious workings, but it is really nothing to the lack of simplicity possessed by the mind of the technical highbrow. I well recollect on one occasion during the war one of these gentry giving me a long-winded discourse on the use of what he termed hydrostatic valves in connection with mine-sweeping gear. I utterly failed to grasp his meaning until I suddenly realised that he was talking about what vulgar people like you and me would, in our ignorance, call washers.

The most recent instance of the highbrow's lack of simplicity which has been thrust before my notice, however, concerns the working of a friend's wireless set. This friend has lived for many years in a charming house on the outskirts of a country town which is served by a very antique and truly rural electric power station. Recently the power station changed over to AC, but as the engineer in charge, who was appointed to his position in 1889, doesn't hold with new-fangled things like AC, he has made the change very reluctantly and gradually, and has compromised by keeping the old voltage of 110 and using 25 cycles instead of 50, this being, I am told, because 25-cycle generators can be obtained very cheaply from the Caledonian Market and similar great centres of commerce.

Now, the voltage maintained by this power station was always terribly erratic even in its DC days, and the consequent fluctuations of the lights led, I recollect, to my friend and several of his neighbours



Appointed in 1889.

being arrested during the war and charged with signalling to enemy aircraft. If anything, the change to AC has made it worse, and my friend, who has recently installed an all-mains set, has soon had trouble.

He very foolishly consulted a particularly rabid technical highbrow about it, and the other evening he called me in to show me the results of the expert's handiwork. I was simply amazed at the complexity of the apparatus which has been installed to deal with what should have been a comparatively simple problem. The highbrow consultant has installed a large

motor which starts up and operates a hefty compensating rheostat, which is in series with the mains, immediately the voltage starts to fluctuate. The whole thing is, in fact, a system of AVC, the V,



Impossible to hear yourself speak.

in this case, standing not for "volume" but for "voltage." While the theory of the thing compels my admiration, the method of putting it into practice certainly does not.

In spite of the fact that the lights are now more or less steady and the wireless set functions normally, it is utterly impossible to hear yourself speak in the house owing to the pandemonium due to the continual stopping and starting of the motor. I can only suppose that the highbrow consultant disdained the remedy which, since AC was available, is so obvious to simple folk like you and me. Possibly, of course, his mind was too complex to think of it.

## Television Sets and Honesty

I AM rather shocked at the large number of letters and post cards that I have received from readers in reply to my recent request asking if any of them had been guilty of defrauding the electric light company by operating the dial light as well as the actual wireless set from a power socket. A very small percentage of them appear to have provided a separate connection on their mains receivers for operating the small dial lamp from a lighting socket as strict honesty demands.

What perturbs me more, however, is to learn that people are actually operating television receivers from a power socket. This seems to me very wrong indeed. It cannot possibly be argued that the function of television sets is any other than to produce certain variations of light; after all, the production of patterns in light and shade—or, in other words, in varying strengths of light—is the whole essence of television.

It may be argued that the only part of a television receiver which is directly concerned with the production of light is the cathode-ray tube, and that therefore the dictates of conscience may be met by operating only this from the lighting mains, but for this type of quibbling I have no use whatever. The whole of the auxiliary apparatus, including valves, power pack and time-base units, is directed towards one ultimate end, namely, to cause variations in light according to a certain time-schedule. It is not like the case of an ordinary receiver, when the ultimate aim of all the auxiliary apparatus is to cause variations in sound.



## 6-valve all-wave Superhet with Radio Frequency Stage

8 stages.  
8 tuned circuits.  
3 wavebands.

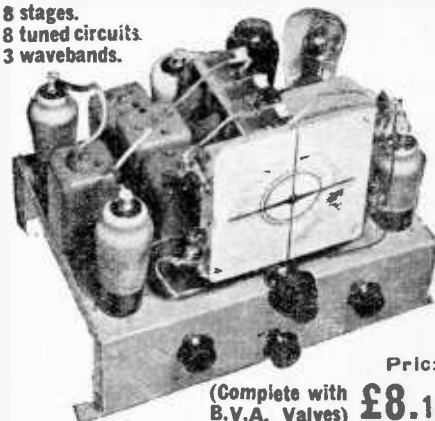

Price  
(Complete with B.V.A. Valves) £8.17.6

Performance (made possible by use of multi-electrode valves) equal to that of many receivers employing 8 valves or more. Brief specification includes: Large "Airplane" dial, with different coloured lights automatically switched on for each wave-range. Micro-vernier 2-speed drive. 4-point wave-change and gramophone switch. Volume control and variable tone control also operative on gramophone. Reinforced heavy-gauge steel chassis. Covers 19-2,000 metres.

Circuit comprises: Pre-selector circuit, radio frequency amplifier (operative on all 3 wavebands), triode-hexode frequency changer, double band-pass I.F.T., coupled I.F. amplifier, double diode-triode detector and L.F. amplifier. D.A.V.C. applied to 3 preceding valves. 3-watt pentode output.

## 9 VALVE FOUR-WAVE SUPERHET DE LUXE

14  
GNS.

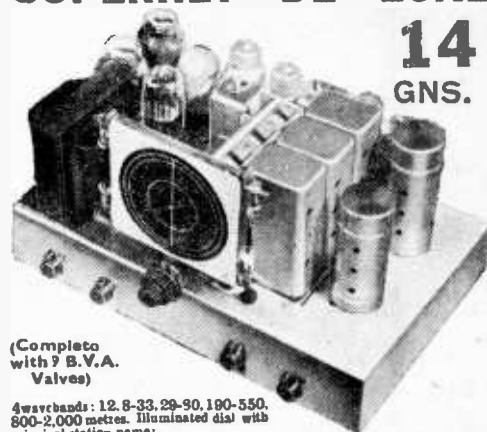

(Complete with 9 B.V.A. Valves)

4 wavebands: 12.8-33.29-90.190-550. 800-2,000 metres. Illuminated dial with principal station names.

Controls.—A feature of the receiver is the number of independent controls fitted, making it extremely interesting to operate. These include sensitivity control (varying bias on R/F stage), or Q.A.V.C. with manual muting control for inter-station noise suppression. 5-position wave-change and gramophone switch. Progressive variable tone control operative on radio and gramophone. Circuit in Brief.—Aerial input to pre-selector circuit, radio frequency amplifier, latest type triode-hexode frequency changer, 2 band-pass I.F.T., coupled I.F. amplifiers, double diode detector, triode L.F. amplifier, separate triode phase-change capacity coupled to 2 large pentodes in push-pull. Heavy 16-gauge steel chassis. Finest components and workmanship throughout. Harries tetrols in place of output pentodes if desired.

STANDARD MODEL 12 GNS. As above, but with triode push-pull output, and fewer controls fitted.

**DEFERRED TERMS**  
on application or through our City Agents  
**LONDON RADIO SUPPLIES LTD.**  
11, OAT LANE, E.C.2.  
Demonstrations Daily.

All McCarthy receivers supplied complete with valves, knobs, pilot lamps, leads, mains cable and plug 12 months' guarantee. (Valves 3 months.)  
The prices at which McCarthy receivers are advertised include Marconi Royalties.  
Cash with order on 7 days' approval. Also write for illustrated catalogue of complete range of all McCarthy receivers.

**MCCARTHY RADIO LTD.**

44a, Westbourne Grove, London, W.2

Telephone: Bayswater 3201/2.

# Random Radiations

## Readers Everywhere

WHEN I began writing these notes I hoped that I'd receive letters from readers in a good many far-away parts of the world, but I had no idea then how wide was the circle of *Wireless World* readers. In Europe alone I have had letters from France, Belgium, Holland, Spain, Denmark, Sweden, Germany, Italy, Czechoslovakia, Poland and Lithuania. But besides Europe all the other continents have produced letters in considerable numbers. They've come, in fact, from Egypt, Kenya, and South Africa; from Australia and New Zealand; from many places in India, from Singapore, from Hong Kong and from Tokio; from Canada, from the United States, and from several of the South American countries. Then there are the ships' wireless operators, quite a few of whom have written to me whilst on the high seas, posting their letters at the next port of call. *Wireless World* readers, I gather, are not just here and there, but everywhere—which is as it should be.

## "Creaking-hinge" Interference

FROM Belling and Lee, who specialise in anti-interference devices, I have just heard of a nasty wireless noise which is a new one to me. A reader's letter in last week's issue also drew attention to this particular disturbance. It is described as sounding like a creaking hinge or a squeaking door, and in districts affected it just goes on, and on and on. The Post Office engineers have investigated a good many complaints in Essex and in parts of Kent. They found that this poisonous kind of interference, from which some readers may be suffering, was due to the working of a precipitation plant. One of these, installed at a cement works, has been giving listeners over a wide area a great deal of trouble. I don't know whether the same plant is responsible, but the creaking-hinge interference has been worrying people at Tilbury, Upminster, Romford, Purfleet, and other places. Luckily the interference can be suppressed at the receiving end by the use of an anti-static aerial and a special filter, which is connected to the socket from which the receiver takes its power supply. It is, though, a shame that it should still be legal for manufacturing concerns to install and use apparatus which interferes with the reception of thousands of wireless listeners when the trouble could be cured at the one source.

## Delays, Delays, Delays

HOW long it is since the committee on interference with wireless reception made its report I can't remember off-hand, but a good deal of water has flowed beneath the bridges since it did. Meantime the authorities still haven't given us the much-needed legislation which will make it a punishable offence to radiate interference. The longer we delay the more difficult it is going to be to take effective steps. The G.P.O. engineers have been doing everything in their power. Those who call in their services invariably find them willing to take any amount of trouble in tracking down interference to its source. But once

## By "DIALLIST"

they have located the source the utmost that they can do is to exercise tactful persuasion on the offender. If he refuses point blank to do anything, as so often he does, no further steps can be taken. Motor cars which radiate interference on the short waves and the ultra-short waves are still going on to the roads in considerable numbers and few will deny that on all wavelengths interference is increasing rather than decreasing. It is said that the Government intends to bring in an entirely new wireless telegraphy Bill which will cover the interference question. That's all very well. What we need is drastic action now.

## Comparative Testing

THE letters on the subject of comparative testing of receiving sets which have appeared in *The Wireless World* were particularly interesting to me, because I have to make such tests quite frequently. What one wants is a means whereby one can change over from set A to set B instantly, making sure at the same time that each set is given a proper chance of doing its best. A method that I usually find quite satisfactory is to have a common earth connection for the two sets and to connect the lead-in from the aerial to the middle point of a single-pole change-over switch. The aerial terminals of the sets are connected to the clip contacts of the switch. With this the change over can be made so quickly that you can go from one set to the other in the middle of a bar of music. An alternative, though slightly slower method, is to connect the aerial lead-in to a "telephone" terminal mounted on a board placed between the two sets. A short piece of stout bare wire is inserted into the terminal and screwed tight down. To the aerial terminal of each set is connected a piece of flex with a crocodile clip at its far end. It doesn't take long to detach one crocodile from the wire held by the telephone terminal and to snap the other on. Some sets, by the way, may bring in nearby stations with the earth lead only in use. In such cases the use of a double-pole change-over switch dealing with both aerial and earth leads simplifies matters.

## Break-through

LATELY I have been rather surprised to find in one or two up-to-date sets that I have been testing out a break-through of medium-wave local stations on to the lower part of the long-wave band. If such break-through is present it occurs as a rule in the neighbourhood of 750 to 800 metres for the two London stations; hence you find it only in sets which tune down rather low on their long-wave range. Where break-through from North Regional is found, when it occurs I don't quite know, but I should guess it would be between 800 and 900 metres and might interfere with the reception of airport and aircraft transmissions. That from the London stations is most annoying, since it spoils one's chance of bringing in some of the seldom-heard stations on the intermediate-wave band.

Break-through is a thing which should not occur nowadays, and set makers would be well advised to satisfy themselves that their products are guiltless.

## A Big Noise

LEICESTER had a new experience the other day when the air raid warning apparatus that has been developed for the city was tested for the first time. A good deal of experimental work has been done in different parts of the country with the object of discovering whether a modified form of public address equipment could be devised for the giving of air raid warnings over considerable areas. The Government experts, however, were not satisfied with the results, and when the Leicester authorities expressed the desire to have something really efficient the firm of Parmeko settled down to see what could be done. Their apparatus, which was tested only at half-power, is described as a rotating sound beacon. A three-note chord is used, each of the three notes having a pitch suitable for certain weather conditions. During the tests it was found that the ordinary traffic noises of the city were overcome by the beacon and that its sound—described as a low, mellow note—was heard not only in the streets but also in the interiors of buildings. The sound is said to be so persistent that it forces itself upon people's attention, but it is not an unpleasant or nerve-shattering noise.

## News from the Clubs

### Wirral Amateur Transmitting and Short-wave Club

Headquarters: Beechcroft Settlement, Whetstone Lane, Birkenhead.

Meetings: Second and last Wednesday evenings in each month.

Hon. Sec.: J. R. Williamson, 49, Neville Road, Bromborough, Birkenhead.

Each transmitting amateur present at a recent meeting of the Club was called upon to give a five-minute talk on some subject of amateur interest. Subjects ranged from keying methods to stabilised grid-bias supplies.

### Edgware Short-wave Society

Headquarters: 40, Raeburn Road, Edgware.  
Meetings: Sundays at 11 a.m. and Wednesdays at 8 p.m.  
Hon. Sec.: Mr. G. Yale, 40, Raeburn Road, Edgware.

This Society is giving wireless sets to blind people in Edgware for Christmas, and would be grateful of any set which people may care to give the Society for distribution in this manner.

### Iford and District Radio Society

Headquarters: St. Alban's Church Room, Albert Road, Iford.

Meetings: Thursdays at 8 p.m.

Hon. Sec.: Mr. C. E. Largen, 44, Trelawney Road, Barkingside, Iford.

A monthly bulletin has been started by this Society, a copy of the first number having been sent to us. Apart from the usual notices concerning forthcoming events, the publication also contains useful technical information. It is circulated privately to members, the subscription being 1s. per annum. Interest in amateur radio is well maintained in the Iford district, and several new members have joined. Tonight (November 25th) there will be a Junk Sale, and on December 2nd there will be a talk and loud speaker demonstration by Mr. H. A. Hartley.

### Croydon Radio Society

Headquarters: St. Peter's Hall, Ledbury Road, South Croydon.

Meetings: Tuesdays at 8 p.m.

Hon. Pub. Sec.: Mr. E. L. Cumbers, 14, Campden Road, South Croydon.

At a lecture on sound film reproduction the chairman, Mr. W. J. Bird, went very fully into the functioning of the sound head in

**News from the Clubs—**

addition to the method of controlling the tone and volume of the amplifier.

A later talk, entitled "Some Stepping Stones in Loud Speaker Progress," given by Mr. G. S. Taylor, proved very interesting. The lecturer traced the development of the moving-coil loud speaker during the last ten years, and concluded with a demonstration of the Planoflex in conjunction with Mr. P. G. Clarke's *Wireless World* Quality Amplifier.

On November 30th a lecture on Avo instruments is to be given by the Automatic Coil Winder and Electrical Equipment Co., Ltd.

**Southall Radio Society**

**Headquarters:** Southall Library, Osterley Park Road, Southall.

**Meetings:** Tuesdays at 8.15 p.m.

**Hon. Sec.:** Mr. H. F. Reeve, 25, Green Drive, Southall.

The demonstration recently given by Mr. Douglas Walters, the Society's President, on the Hammarlund Super Pro receiver proved very popular. Mr. Walters also gave a short talk on the principles of the crystal gate.

**Golders Green and Hendon Radio Scientific Society**

**Headquarters:** 60, Pattison Road, Hampstead, London, N.W.2.

**Hon. Sec.:** Mr. A. G. Griffiths, "Hornbeams," Priory Drive, Stammore, Middlesex.

To-night (November 25th) the R.S.G.B. film, showing several well-known amateur transmitting stations, will be exhibited. On December 9th a talk, entitled "An Outline of Electron Optics," will be given by Mr. S. Rodda, B.Sc.

**Glasgow Short-wave Society**

**Headquarters:** Masonic Hall, 73, Berkeley Street, Glasgow, C.3.

**Meetings:** Thursdays.

**Hon. Sec.:** Mr. J. Neilson, 14, Bolivar Terrace, Glasgow, S.2.

Members recently paid a visit to the police radio department and were shown the silence room and the large map on which were marked the position of the police cars and vans. They

then proceeded to the Pinkston Power Station three miles distant in order to inspect the remotely controlled transmitter. Members wish to thank Lieutenant E. W. Eagers for the visit and also Sergeant J. Cooper for his explanatory description of the apparatus.

The president, Mr. A. Chaplin, who recently described two artificial-aerial transmitters to the society, has arranged to give a series of lectures for beginners.

**Exeter and District Wireless Society**

**Headquarters:** 3, Dix's Field, Exeter.

**Meetings:** Mondays at 8 p.m.

**Hon. Sec.:** Mr. W. J. Ching, 9, Sivell Place, Heavitree, Exeter.

At his recent talk on radio on moving vehicles Mr. F. S. Rumball demonstrated several makes of car radio, and dealt at length with the question of interference.

Mr. Barber's lantern lecture on the Ionosphere was considered one of the best this season. The lecturer dealt thoroughly with each layer, including those which are designated D1 and D2. These, he explained, were only discovered two years ago. Members are asked to note that the visit to the Exeter City Power Station has been altered from November 29th to November 30th.

**Radio Society of Northern Ireland**

**Headquarters:** Y.M.C.A. Radio Club, Wellington Place, Belfast.

**Meetings:** The first Wednesday of each month.

**Hon. Sec.:** Mr. C. Taylor, 2, York Crescent, Shore Road, Belfast.

At the last monthly meeting it was announced that the services of a professional wireless operator had been secured to help members to learn the Morse Code in a proper manner. The recent visit to the short-wave telephony station at Ballygomartin was very much appreciated. This visit was made possible by the kindness of Mr. M. C. Cooper, who welcomed the party. Mr. G. Edwards, the engineer-in-charge, and his two assistants made the visit a very successful one, owing to their detailed technical explanations.

## PILOT Model 475

Unusually Good Signal-to-Noise Ratio on Short Waves

WE have recently received for test this example from the wide range of sets comprising the 1938 Pilot range. A preliminary examination shows the chassis exterior to be very similar to that of the Model U650 reviewed in our issue of October 9th, 1936, and the circuit is in fact basically the same. The valves have been changed throughout, however, and are of the latest octal base type. In the RF stage, which is tuned on each of the four wave-

channel being lost on either side of the local Regional as against 1½ channels in the earlier set. On long waves, however, it is still difficult to get the Deutschlandsender clear of Droitwich and Radio-Paris, though there is no fault to find with the sensitivity on this or the medium-wave band.

Once again we are able to record the very high standard of performance on short waves which has always been a feature of Pilot products. It is not the sensitivity alone which distinguishes this set, but also the remarkably high signal-to-noise ratio. Background noise on the short-wave ranges is extremely low even for a receiver with an RF stage, and under these conditions reception of American broadcasting assumes the role of a regular service rather than an occasional novelty.

As regards quality of reproduction there is no suggestion of an excessive bass response, and microphonic feed-back on the lowest wavelengths is negligible. The upper register is free

from harshness, and as a result of the low background noise the tone control can be set to give the full high-frequency response even on short waves.

The price of the Model 475, which is for AC mains operation, is 17 guineas, and the makers are Pilot Radio, Ltd., 87, Park Royal Road, London, N.W.10.

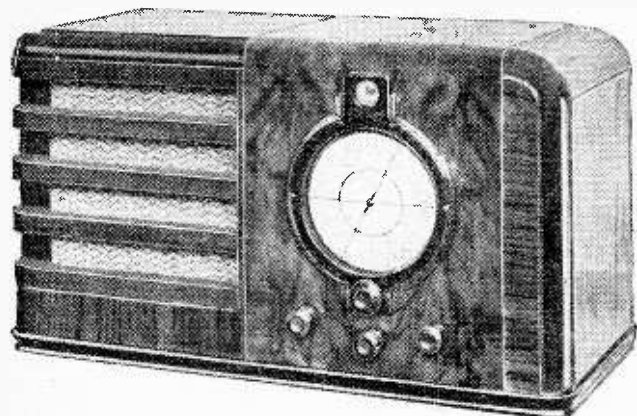

bands, and the IF amplifier the 6U7G pentode valve is used. The frequency-changer is a 6A8G, the double-diode-triode second detector a 6Q7G and the pentode output valve a 6F6G.

The same type of triple-tuned IF transformers are used as in the Model U650, but if anything the selectivity is better, only one

## Inferior condensers deceive only the people who trust them

EVERY set designer and serious experimenter knows that some people take almost anything for granted . . . expect all condensers to live "up to specification" . . . and fail to appreciate that to-day's reliable condenser didn't "just happen" — that it is the result of much research.

And, when a receiver suddenly "goes dead" when, after hours of careful set construction, nothing happens—yet another has learned his expensive lesson.

How little need there is for buying such costly experience—T.C.C. have made and designed condensers for 30 years — done nothing else — for three decades T.C.C. have spent lavishly on research, have employed the finest technicians—the most skilled workers, in order that "T.C.C." should be the symbol of dependability, so that none may come and say "You have let me down."

Fortunately for the industry the number of those who trust the inferior condenser grows less each year. Setmakers to-day put all their confidence in T.C.C. Designers of repute invariably insist on T.C.C. — and to-day's receivers are remarkably dependable.

Remember this, whatever condenser you need, don't deceive yourself, it pays to get condensers from the condenser specialists—from T.C.C.

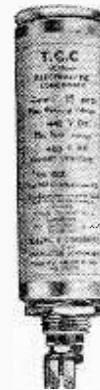

# T.C.C.

ALL-BRITISH

## CONDENSERS

THE TELEGRAPH CONDENSER CO. LTD.,  
WALES, FARM ROAD, NORTH ACTON, W.3.



# POINTS OF IMPORTANCE in the Rola G.12



## THE TROY POUND

As long ago as 1758 a standard of weight, the Troy Pound, was constructed by order of Parliament and lodged with the Clerk of the House of Commons. The Troy Pound was lost when the Houses of Parliament were destroyed by fire in 1834 but a fresh standard took its place for always there must be some measure of weight by which others are judged. So with loudspeakers, the connoisseur instinctively takes the best producer he knows as a standard upon which to base his judgments.

Nowadays, it is the Rola G.12, a 12in. diameter unit of remarkable fidelity and high power handling capacity. If you have not already heard it be sure to ask your dealer to demonstrate a G.12, or a set in which a G.12 has been installed. It is an experience no radio enthusiast should miss.

G.12 P.M. (as illustrated) less Transformer	£4 16 0
G.12 P.M. with Transformer	£5 5 0
G.12 D.C. Complete with Transformer, Mounting Stand, Handle and Base	£5 5 0
G.12 D.C. with Mounting Stand, Handle and Base, but without Transformer	£4 16 0
G.12 D.C. Stripped, but with Transformer	£4 4 0
G.12 D.C. Stripped and without Transformer	£3 15 0

(When ordering please state Field Resistance and Impedance of Transformer required.)

For Public Address work both the P.M. and Energised Models can be supplied with a 15 ohm Voice Coil at an additional charge of 3/-.

Write for Folder A.

OVER 8 MILLION IN USE

# ROLA

The World's Finest Reproducers

THE BRITISH ROLA CO., LTD.  
MINERVA ROAD, PARK ROYAL, N.W.10.  
PHONE: WILLESDEN 4322-3-4-5-6.

## Letters to the Editor

The Editor does not hold himself responsible for the opinions of his correspondents

### Synchronising Sound and Picture

I AM grateful to Mr. D. Roe for his reply (September 24th issue) to my letter (July 30th), in which he refers to a German method of electrically synchronising film and disc described in "Funktechnische Monatshefte" for November 1936. (Anyone who would like to consult the original article for its illustrations can examine this periodical in The Patent Office Library, Chancery Lane, W.C.2.)

A method of electrically synchronising the film projector and disc play-back turntable has recently been published in the *Amateur Cine World* (September and October issues), and through the courtesy of its Editor I am able to reproduce the accompanying photograph. For the benefit of interested persons I now add an outline description of Mr. W. Hugh McNeile's method.

The projector motor and disc play-back motor are both operated from AC mains and the basic principle is to arrange for the disc motor to control the projector motor so that if the speed of the projector tends to increase it is automatically decreased, and actually this increase is predetermined by running the projector slightly fast. As soon as the projector has caught up with the disc turntable a resistance is included in the circuit with the projector motor, which, of course, slows it down. When the projector lags behind the disc turntable the resistance is short-circuited and the projector speed increases sufficiently to overtake the turntable, and then the cycle re-commences.

In practice two variable resistances are used and pre-set to run the projector at the desired speed, *i.e.*, number of frames per second. Two home-made commutators,

The turntable of Mr. McNeile's sound-on-disc system is synchronised with the projector by a simple electro-mechanical device.

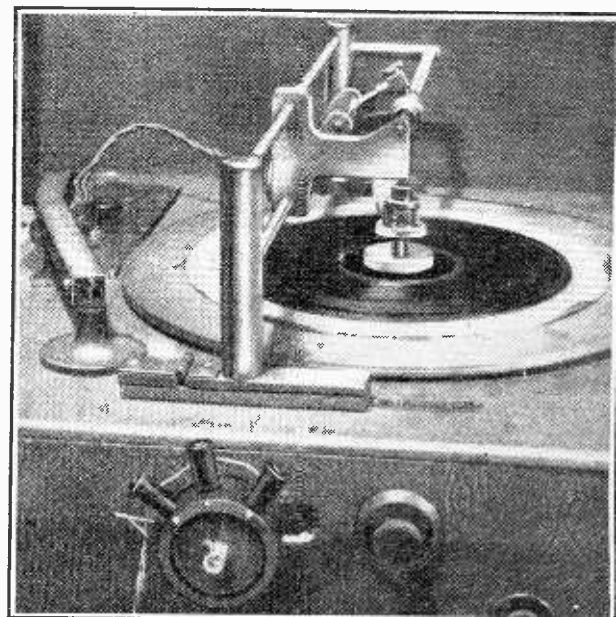

consisting of ebonite with two brass sectors, a brass ring in contact with the sectors, and the carbon brushes, are connected mechanically to the projector and the turntable, and their function is to short-circuit the resistances.

The advantages claimed are (1) easy correction, while both motors are running, of the relationship of film to disc, (2) possibility of using two turntables with only one projector, thus extending the SOD film running time with economy and (3) remote operation possible, *i.e.*, no necessity for the projector to be adjacent to the turntable.

I must now refer to an important contribution to this subject, namely, a sub-standard SOD system developed by the aforementioned Mr. Roe in his capacity as sound engineer to Sonodisc Film Productions, an amateur film society.

Briefly, the system is as follows: two separate films are used, one for the picture and the other for the sound-track, the two being electrically synchronised. Usually, a

9.5 mm. film stock is employed for taking the picture, but any gauge can be used. The sound-track is recorded on both edges of a 16 mm. positive film which is split down the centre after developing. This 8 mm. sound-film is run at 32 frames per second (9 inches per second) to enable the recording to be of good quality. In "shooting," the picture camera is coupled to the sound recording camera by a special method of electrical synchronisation, and ordinary clapper boards (two wooden sticks hinged at one end and brought together with a smart snap in front of the camera) indicate on the sound-track the frame required for subsequent synchronisation. Alternatively, an electrically operated marker light can be used to "fog" the sound-track and so permit the mute (picture) and sound-track to be aligned. For projection, a sound-head is directly linked to a standard projector, the latter with a suitable picture gate for the film size employed.

The merits of this system include (1) initial outlay is not great, as ordinary camera and projector can be used, (2) flexibility in editing and cutting the complete

film and (3) cheapness, *e.g.*, a 100 ft. reel provides 200 ft. of sound-track and to put sound to 50 ft. of film costs only 4s. 6d.

Dr. L. E. C. Hughes informs me that the now defunct Riverside Film Fans society used a system of separate projectors for sound-track and picture, which were electrically synchronised, about six years ago and excellent results were obtained.

Ilford, DONALD W. ALDOUS.

### SOUND EFFECTS

IN the recently issued "Mood Music Catalogue" the Central Record Information Bureau, "His Master's Voice," 363, Oxford Street, London, W.1, provides a useful guide to those responsible for the incidental music to plays, amateur cinema shows, etc. Suitable musical recordings are classified under about fifty headings, and in addition there is a comprehensive list of special "effect" records which have recently been reviewed and brought up to date.