

# The Wireless World

AND  
RADIO REVIEW  
(19<sup>th</sup> Year of Publication)

No. 653.

WEDNESDAY, MARCH 2ND, 1932.

VOL. XXX. No. 9.

Editor: HUGH S. POCOCK.

Editorial Offices: 116-117, FLEET STREET, LONDON, E.C.4.

Editorial Telephone: City 9472 (5 lines).

Advertising and Publishing Offices: DORSET HOUSE, TUDOR STREET, LONDON, E.C.4.

Telephone: City 2846 (15 lines).

Telegrams: "Ethaworld, Fleet, London."

COVENTRY: Hertford St.

BIRMINGHAM: Guildhall Bldgs, Navigation St.

MANCHESTER: 260, Deansgate

GLASGOW: 26B, Renfield Street, C.2.

Telegrams: "Cyclist, Coventry."  
Telephone: 5210 Coventry.

Telegrams: "Autopress, Birmingham."  
Telephone: 2970 Midland (3 lines).

Telegrams: "Liffie, Manchester."  
Telephone: Blackfriars 4413 (4 lines).

Telegrams: "Liffie, Glasgow."  
Telephone: Central 4857.

PUBLISHED WEEKLY.

ENTERED AS SECOND CLASS MATTER AT NEW YORK, N.Y.

Subscription Rates: Home, £1 1s. 8d.; Canada, £1 1s. 8d.; other countries abroad, £1 3s. 10d. per annum.

*As many of the circuits and apparatus described in these pages are covered by patents, readers are advised, before making use of them, to satisfy themselves that they would not be infringing patents.*

## A STATEMENT OF POLICY.

**T**O those who have been regular readers of *The Wireless World* for a number of years, it may seem unnecessary for the paper to make any public statement of its policy, for the reason that over so long a period the policy must have made itself clear to them by the general conduct of the paper and its contents. We have to bear in mind, however, that with an ever-growing circle of readers there are many who have not had this experience. It seems to us, therefore, that the present moment is opportune to indicate what are the guiding principles of policy on which *The Wireless World* is conducted.

First and foremost, we believe that the editorial policy should be guided by the consideration of service to the reader, and, in order to give this service, strict impartiality of the editorial policy is essential.

It can be no secret to our readers that a paper of the character of *The Wireless World* depends for its financial success on the revenue which it derives from its advertisement pages. On this account the temptations may be strong to depart from a policy of editorial impartiality and make promises of special attention in the editorial pages in return for advertisements.

The view which *The Wireless World* has always adopted is that every commercial product referred to, and every component recommended in connection with receivers described, is included without consideration of whether advertising revenue will result or not; there must, in fact, be no "bargain" with the advertisers, so that products mentioned in the editorial pages are dealt with entirely upon their merits. Any system whereby consideration of advertisement revenue is allowed to control the degree of editorial attention paid to the products advertised must inevitably have the effect of leaving the reader in the predicament that he is unable to estimate how much or how little value to attach to the editorial comment. The reader, the paper,

and eventually, we believe, the advertiser, would all suffer if such a policy were tolerated.

Complete independence of the editorial from advertising considerations does not, however, in itself ensure that the impartiality of the paper can be depended upon by the readers. It is necessary to go farther and to guarantee, both by the choice of members of the editorial staff and by the conditions imposed upon them, that they remain individually independent of any commercial wireless interests.

No member of *The Wireless World* editorial staff, therefore, is permitted, at any time during his service, to be employed by another wireless concern, on the staff or as a consultant, whether for a salary or a fee.

### We Value Your Confidence.

Arrangements with advertisers to give them *individually* special attention and editorial support would, we know, result in an increase in revenue to our proprietors, but they, with us, believe that service and a square deal to the reader should be put above all other considerations, and that in so acting we are, in addition, serving the wireless industry in the right spirit by benefiting the industry *as a whole*.

There are, of course, many aspects of this question, and one in particular relates to the design of constructional receivers described in *The Wireless World*. All such receivers as are described in *The Wireless World*, unless in the nature of reviews of commercial sets, are built by the technical staff of the paper.

We believe that in maintaining this policy we earn the confidence of our readers and of the wireless industry as a whole. Moreover, merely carrying out this policy in silence without stating it would be unfair to ourselves, whilst, in our view, it is also highly desirable that both our readers and the industry generally should be acquainted with these matters.

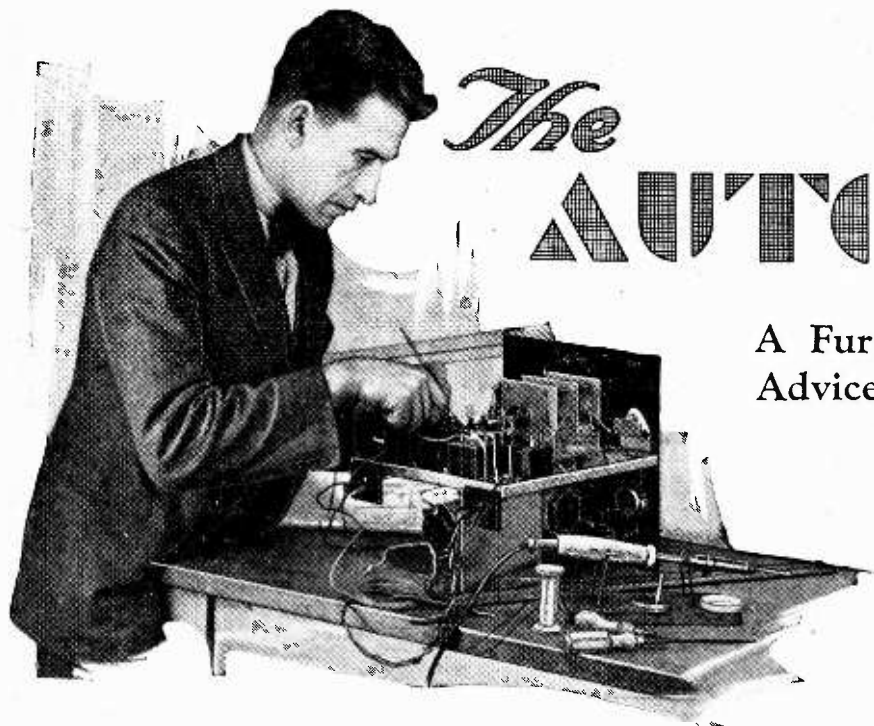

# The AUTOTONE

## A Further Article Giving Advice on Construction and Wiring.

By F. L. DEVEREUX, B.Sc.,  
and H. F. SMITH.

Fig. 6, and it will be noticed that the 6B.A. supporting rod is used also to secure the L.F. transformer and valve holder in each

**I**N designing the layout of the chassis every care has been taken to simplify constructional work while still retaining the electrical efficiency of the circuit. The chassis is built up of three members—a horizontal aluminium baseplate, a vertical screening partition and an  $\frac{1}{8}$ -inch paxolin front panel. It is hardly necessary to give drilling details of the baseplate and screen, as these components will be available ready pierced in commercial form. The same remarks apply to the paxolin front panel, except that in some cases it may be necessary to mark off and drill the fixing holes for the vertical screen after first bolting together the two aluminium members. The latter are held together with 4B.A. screws, the nuts being fixed underneath, except in the case of the hole nearest the back edge of the chassis, which must be fitted with a countersunk screw inserted from the bottom in order to clear the two mfd. condensers  $C_{15}$  and  $C_{16}$ .

Having assembled the baseplate, screen, and front panel, all the components should be fixed in position, with the exception of the primary coil and the gang condenser. The layout can be easily followed from the wiring diagrams, but it should be noted that the resistances  $R_5$  and  $R_9$ ,  $R_7$  and  $R_8$  have been displaced in these drawings in order to show more clearly the connections of the two L.F. transformers. The method of mounting these resistances is shown in

case. Spacing washers should be inserted between the resistances to give clearance for the soldering tags. Since there is a common junction between each pair of resistances, the tags should be arranged so that a single wire can be taken from the junction in each case. The correct arrangement is for  $R_9$  to be assembled over  $R_5$ , and  $R_7$  over  $R_8$ .

Before fitting the main gang condenser, it is necessary to pass the two wires from the secondary coil to the wave-range switch through holes 4, 5, 6, and 7, and to solder them to the appropriate terminals. These wires lie between the condenser base and the chassis, and are effectively screened from the primary coil. It will simplify the subsequent wiring of the coupling condenser  $C_2$  if the lead from K on the secondary coil is taken to the upper contact on one side of the wave-range switch. Similarly, the lead from D on the primary coil should go to the corresponding contact on the opposite side of the switch. Incidentally, a simple modification to the Telsen four-point switch will be required; a soldering tag should be fitted

under the nut on the end of the switch spindle and connected by a short flexible lead to the chassis.

The next step is to screw down the gang condenser, having first removed the cover, and to couple up the reaction compensating condenser. Accurate alignment of the two spindles is essential in order that friction may

*THE "Autotone" embodies a new principle of reception which gives critical selectivity without in any way impairing quality of reproduction or increasing the difficulty of tuning.*

*Last week's issue contained a detailed description of the circuit and full particulars of special components such as the tone correction choke and tuning coils. The present article deals with the assembly and wiring of the chassis and the concluding instalment will contain full instructions for balancing the circuit and hints on tuning.*

THE "AUTOTONE" VIEWED IN PLAN.

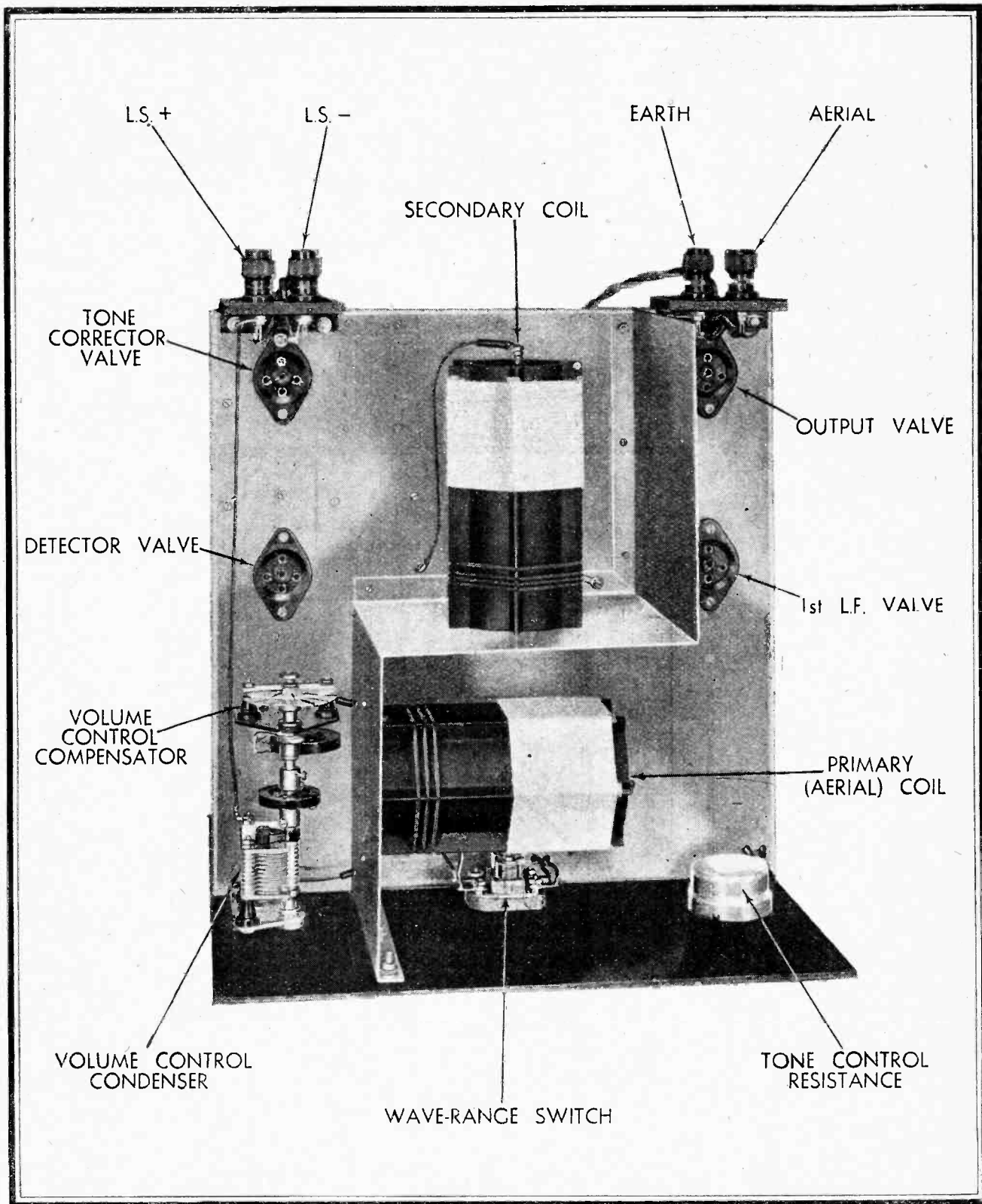

A clean layout on the top of the chassis contributes to the efficiency of the tuning coils.

THE "AUTOTONE" CHASSIS

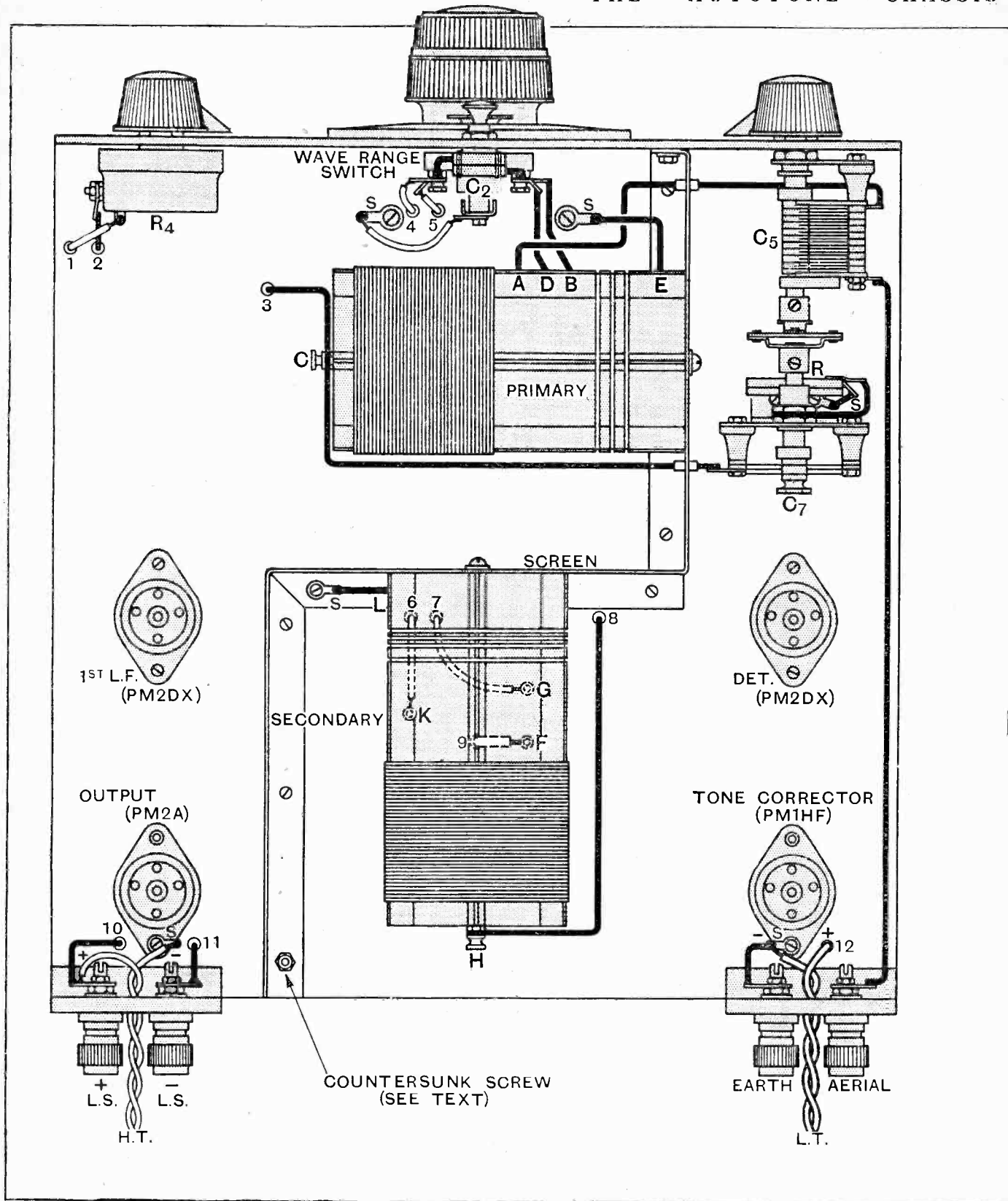

Layout of components and complete wiring diagram of the "Autotone" receive

SCALE HALF - SIZE.

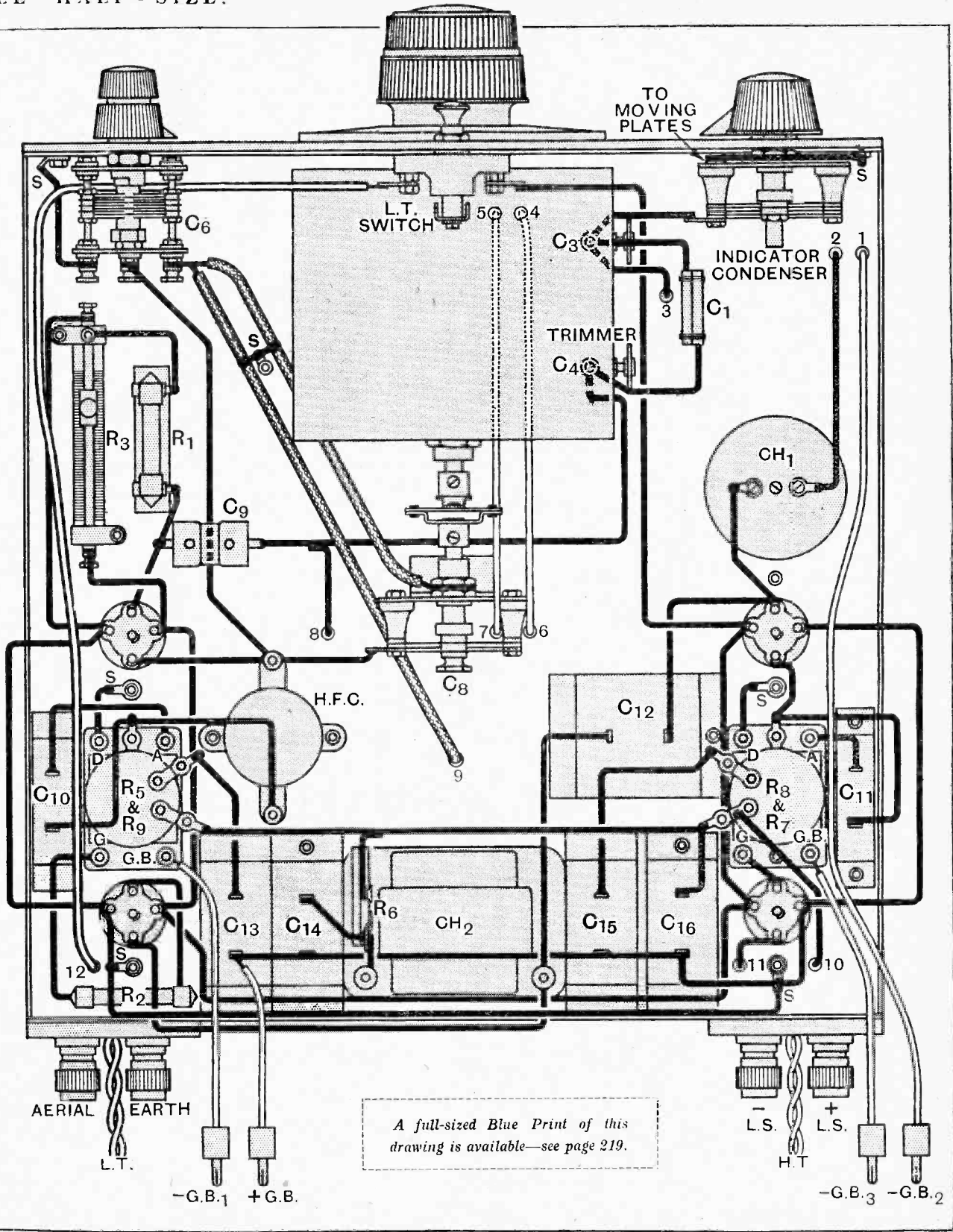

A full-sized Blue Print of this drawing is available—see page 219.

connection to the metal chassis is made at all points marked S.

## UNDERSIDE VIEW OF "AUTOTONE" CHASSIS.

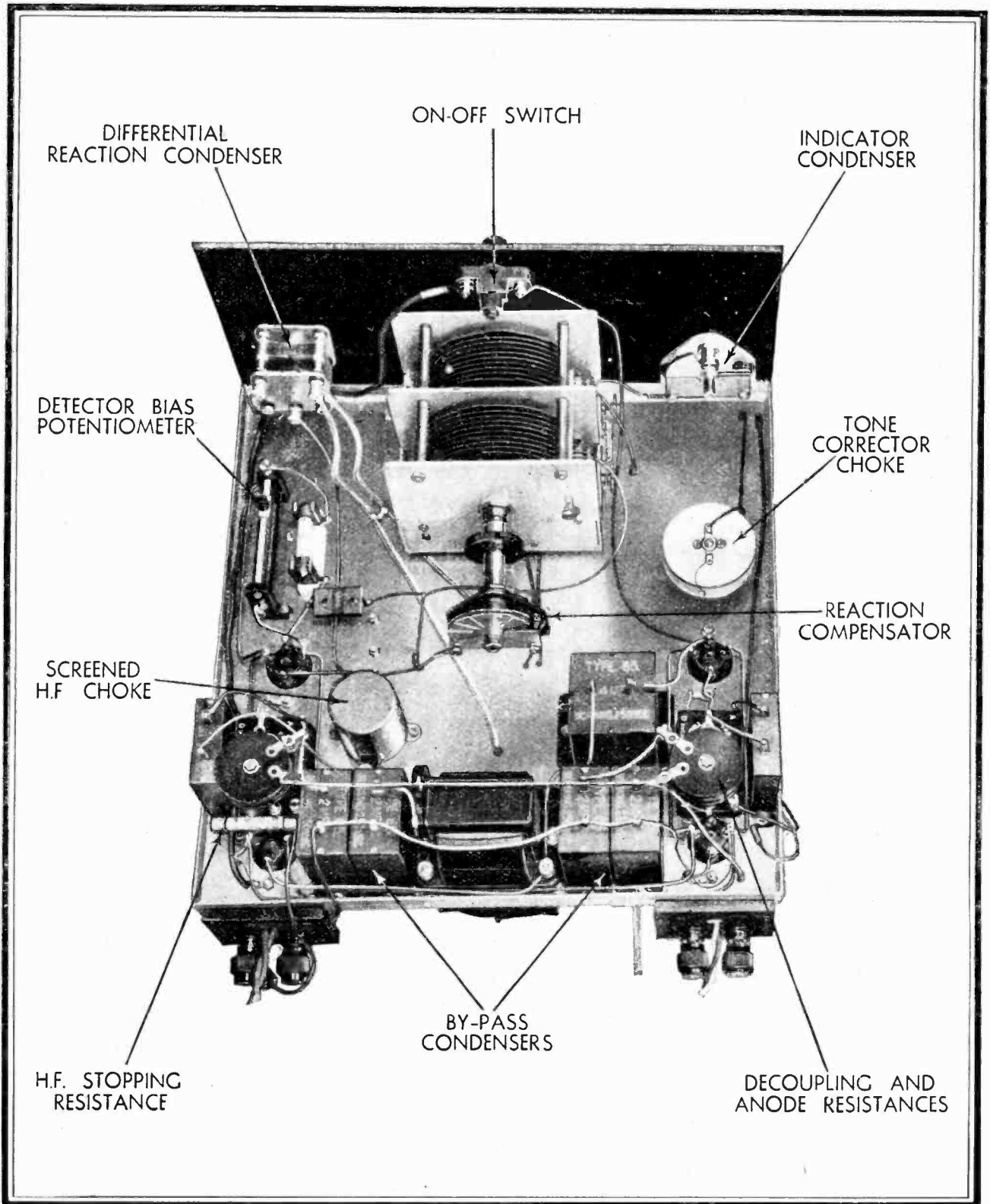

The chassis is easily supported in this position by the coil screen while carrying out the wiring and final adjustments.

**The Autotone.—**

be reduced to the minimum. If, after taking all possible precautions in this direction, it is found that the slow-motion dial slips at any point on the scale, the slow-motion knob should be removed and the knurled screw tightened to increase the pressure on the friction drive (see Fig. 7). The gang condenser cover can be left off until the final adjustment of the set has been completed, when it can be replaced, if desired, after first removing the L.T. switch.

It is now necessary only to fit the primary coil to complete the assembly, and wiring can be completed

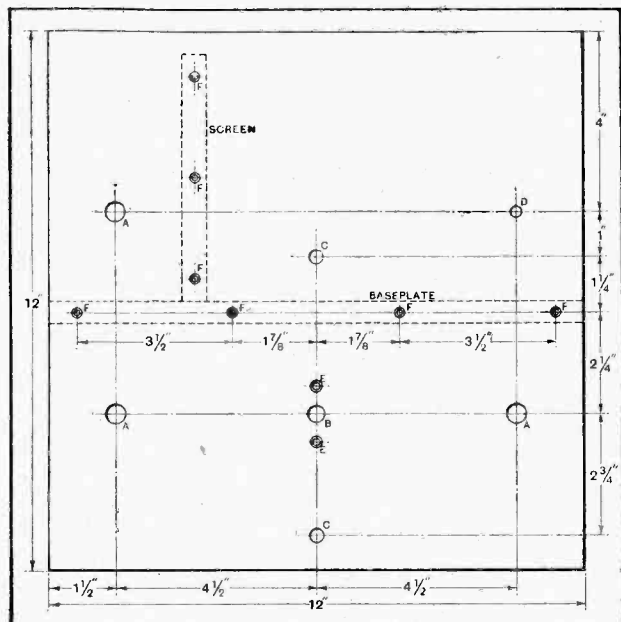

Fig. 5.—Drilling details of the 1/8 in. paxolin front panel. A, 7/16 in. dia.; B, 3/8 in. dia.; C, 5/16 in. dia.; D, 1/4 in. dia.; E, 5/32 in. dia., countersunk for 4B.A. screws; F, 1/8 in. dia., countersunk for 6B.A. screws.

in a perfectly straightforward manner. Sistoflex sleeving or one of the special covered wires of about 20 S.W.G. will be quite suitable. The wire actually used in the original design is a new product of the Gutta Percha Co., Ltd., Wharf Road, London, N.1., known as "Telconite." Some of the lighter components, such as the resistances  $R$  and  $R_0$ , and the condenser  $C_9$ , are suspended in the wiring, and the condensers  $C_1$  and  $C_2$ , which consist of two short wires tied together, are self-supporting. Further details of these condensers will be given in next week's issue. It is important, having regard to the small capacity of  $C_1$ , that the leads going to  $C_3$  and  $C_4$  should be kept well separated. Another important lead which should be kept equidistant from adjacent leads and components is the grid wire joining  $C_4$  and  $C_9$ . Actually this wire runs *above* the two screened leads to the reaction condenser  $C_0$ . It has been shown underneath to avoid

the appearance of being connected to the braiding, which is earthed to the chassis by a tag under one of the screen bolts at S. Any of the well-known braided wires, such as "Lewcos," "Harbros," or "Goltone," will be suitable for the reaction leads.

The variable resistance  $R_1$ , if obtained in potentiometer form, will be provided with three terminals. In this case one of the two connections should be made to the centre terminal, and the other to that terminal which gives a *decrease* of resistance when the knob is turned in a clockwise direction.

It is intended that twin flexible leads should be used for the H.T. and L.T. supplies, and it will be found that holes are provided in the terminal blocks through which these may be conveniently passed. The L.T. leads should be kept short to reduce their resistance, or, alternatively, thicker flex may be used.

The grid-bias battery should be secured to the base of the cabinet just inside near the hinged door, with the sockets facing towards the back and the positive socket on the right when viewed from the back. If the PM2A valve is used with a battery H.T. supply, a 9-volt grid-bias battery will suffice, but a 15- or 16½-volt battery will be necessary if the PM202 is used in conjunction with an eliminator. The set is inserted in the cabinet from the front, and is supported by narrow fillets running along the inside of the cabinet.

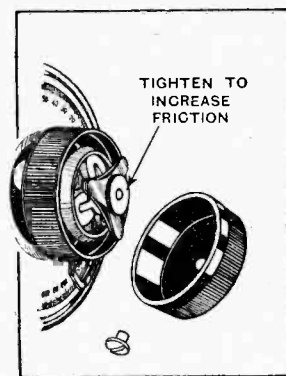

Fig. 7.—Friction adjustment in the "Utility" slow-motion dial.

marking the settings of the condensers while making the initial adjustments of the compensating condensers. (To be concluded.)

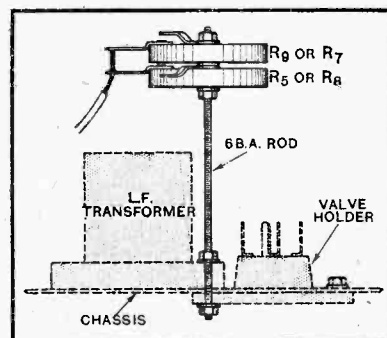

Fig. 6.—Method of supporting "Berco" coupling and decoupling resistances.

is supported by narrow fillets running along the inside of the cabinet.

Next week full details for adjusting the condenser vanes and the small coupling condensers  $C_1$  and  $C_2$  will be given, together with some notes on the performance of the set. In the meantime small paper disc scales should be temporarily attached to the front panel underneath the reaction and indicator condenser knobs. These scales will be found useful for

For the convenience of readers constructing the "Autotone" receiver, full-sized blue prints of the complete wiring diagram, pages 216-217, are available from the publishers at 1s. 6d. post free.

# Unbiased

by *Tree Grid*

## In the Lions' Den.

THE other night a friend who had, somehow or other, secured possession of a ticket to admit two, took me along to a song and dance by the B.B.C. Symphony Orchestra. Ignoring the seats of the mighty, which took the form of comfortable divans placed near the conductor, we humbly acquired places in the north-west corner of the studio. Now, I have previously confessed in these columns that my appreciation of good music is sadly deficient, and a preliminary glance at the programme caused me to take along my "Vest Pocket" Portable, which, as I have already remarked in this journal, invariably accompanies me to the Boat Race, Cup Final, Derby, and similar functions.

The overture was quite pleasing to my depraved musical tastes, but later on, when we arrived at the sixth movement of a nine-spasm suite, I quietly slipped on the phones and was soon carried away with the lilt of a waltz from Radio Paris. I suppose that in my enthusiasm I must have unconsciously commenced to beat time with my foot, as, on looking up, I found several members of the audience gazing at me in horror, and a befurred female on my right dug me sharply in the ribs.

Fortunately, I had the presence of mind to fix her with a withering glance, and, taking advantage of a sudden paroxysm on the part of the cymbals, informed her that she would be removed forcibly if she persisted in obstructing me or any other B.B.C. engineer in the course

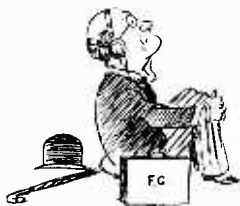

Slipped on the phones—

of his duties in checking wavelength and modulation. This, happily, caused her and her friends to subside like punctured balloons. Later I tuned in London Regional, and found that the voice of the announcer, who was mumbling away at the back of the conductor, came to me far more clearly over twenty-four miles of land-line and ether than across the studio.

Even though good quality can scarcely be expected from headphones, I was sadly enlightened as to the deficiencies of my receiver in this respect, as I was able to make an instantaneous comparison with the actual orchestra. In the course of my experiments I had the misfortune to oscillate, and I daresay that those listeners who were within my range would have been considerably surprised to have learned that the oscillation was, metaphorically speaking, made in the lions' den, although, of course, the lions themselves were in total ignorance of it.

## Hatfield or Halifax?

I FEEL that it is high time that a protest was made concerning the utter uselessness of test reports of receivers published by some daily journals. I happened to pick up a copy of a certain London evening newspaper the other night and was gravely presented with the information that "London National was cut out within 15 degrees." There was not the slightest indication whether the set accomplished this performance in Hatfield or Halifax; if it was the former place, which is only about half a dozen wavelengths away from the London transmitter, the

performance was meritorious, but if the latter the less said about it the better. Matters were made much worse by the fact that the review came from the pen of one of the leading lights in radio.

## Help for the Deaf.

I HAVE received a letter from a reader who has the misfortune to be somewhat hard of hearing, and he appeals to me to recommend to him a really satisfactory microphone and amplifying device to enable him to enter into ordinary conversation with ease and comfort. He explains that he has tried out several devices,

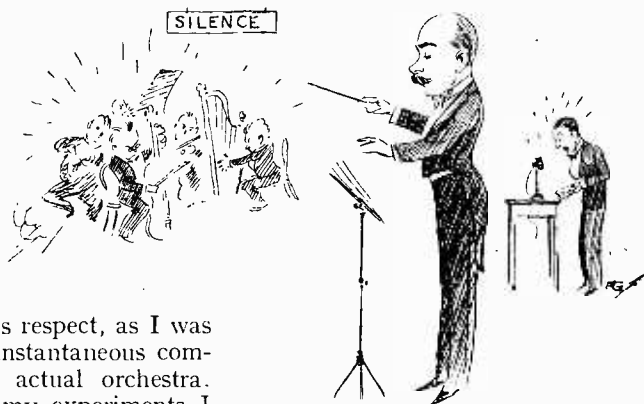

—at the sixth spasm.

but all of them have proved unsatisfactory for one reason or another, the principal trouble being distortion—which is even worse than that of a Post Office telephone—and extraneous noises.

In his letter he stresses the fact that improvements in microphone and amplifier design have been so enormous owing to the impetus given by broadcasting that surely I must know something which would be suitable for him. Expense, he says, is no object. It would be easy enough for me to help him if bulk and weight were also no object, but, unfortunately, I gather from his letter that he wants an ultra-portable apparatus which must have none of the defects usually associated with such devices. I have replied regretting my inability to help him, but, at the same time, have promised to see if any of my readers know of a suitable device, and so, if you have any useful suggestions to offer, I will gladly pass them on to him.





# AUTOTONE PILOT AUTHOR KIT EXACT TO SPECIFICATION

**FREE** FULL SIZE BLUE PRINT WITH EVERY PILOT AUTHOR KIT



## THIS IS THE KIT THE AUTHOR USED

Any parts supplied separately. If value over 10/- sent carriage paid, or C.O.D. post charges paid.

Aluminium Chassis and Coil Screen	10 0
1 Wearite Paxolin Panel, 12in. x 12in. x 1/8in. Thick	5 0
Ready Drilled	12 6
1 Wearite Primary Tuning Coil	1 6
1 Wearite Secondary Tuning Coil	1 0
1 Telsen Four-Point Push Pull Switch	1 6
1 Telsen Two-Point Push Pull Switch	1 0
1 Utility Dual Screened Gang Condenser, 0.0005 mfd. (Special "Experimenter's Model.")	12 10
1 Utility Condenser Dial High Ratio, W.181	
2 Utility Flexible Couplings (insulated)	
2 Utility Universal Compensating Condensers with Brackets	
1 Utility Special Indicator Condenser, 50 mufds.	
1 Utility Special Variable Condenser, 0.0003 mfd. "Mite" with Spindle Extension and Knob	
1 Polar Slow Motion Differential Reaction Condenser, 0.0003 mfd.	6 6
1 Wearite Variable Resistance, 5,000 ohms	2 6
1 R.I. Special Choke Coil, 0.3 henry	3 6
4 W.B. Valve Holders, Skeleton Type	2 0
2 R.I. "Parafeed" Inter-valve Transformers	17 0
1 Ferranti L.F. Choke, B.S.	7 0
1 "Kinva" H.F. Choke	2 9
4 T.C.C. Fixed Condensers, 2 mfd., Type 65	12 0
2 T.C.C. Fixed Condensers, 1 mfd., Type 65	4 6
1 T.C.C. Fixed Condenser, 4 mfd., Type 65	5 0
1 Graham-Farish Fixed Condenser, 0.0001 mfd., mica	0 6
4 Berco Fixed Resistances, 30,000 ohms	5 6
1 Berco Fixed Resistance, 50,000 ohms	1 6
1 Berco Fixed Resistance, 30 ohms	0 9
1 Ediswan Grid Leak, 0.25 megohm	1 6
1 Dubilier Metallised Resistance, 50,000 ohms, 1 watt	1 0
1 Bulgin Resistance Holder Porcelain	0 6
1 Ready Radio Potentiometer, 400 ohms	2 9
2 Junit Terminal Panels	1 4
4 Belling-Lee Terminals	2 0
1 Ever Ready Grid Bias Battery, 10 volts	1 9
4 Glix Grid Bias Wander Plugs, "Vicegrip"	0 8
Connecting Wire, Screws, etc., etc.	Gratis
<b>Kit "A," Cash or C.O.D.</b>	<b>£8 2 0</b>
Set of Mullard Valves (2) PM2DX (1) PM1HF (1) PM202	£1 19 0
Set of Mullard Valves (2) PM2DX (1) PM1HF (1) PM2A	£1 16 0

## DOMINATING FEATURES OF PILOT AUTHOR KITS

- Chosen and first specified by "Wireless World" Experts.
- Officially approved therefore by a world-famous technical authority you can trust implicitly.
- Backed by Peto-Scott—ALWAYS FIRST—ESTABLISHED IN 1919.
- The only kit of parts that guarantees strict adherence to the Author's first specified component.
- Enables the Author's published set to be duplicated exactly in every respect.
- Panels Ready Drilled.

## KIT-BITS Cash or C.O.D.

You pay the Postman we pay all Post charges on orders over 10/-

1 Wearite Primary Tuning Coil	} 12 6
1 Wearite Secondary Tuning Coil	
1 Utility Dual Screened Gang Condenser 0.0005 mfd. (Special "Experimenter's Model.")	} 12 10
1 Utility Condenser Dial High Ratio, W.181	
2 Utility Flexible Couplings (insulated)	} 12 10
2 Utility Universal Compensating Condensers with Brackets	
1 Utility Special Indicator Condenser, 50 mufds.	} £2 10
1 Utility Special Variable Condenser, 0.0003 mfd. "Mite" with Spindle Extension and Knob	

**KIT "A"** Author's Kit less valves and cabinet

**CASH or C.O.D. £8.2.0**

or 12 monthly payments of **14/10**

**IMMEDIATE DELIVERY—CASH, C.O.D. or H.P.**



**CO. LTD.**  
77, CITY ROAD, LONDON, E.C.1. Telephone: Clerkenwell 9406-7-9  
62, HIGH HOLBORN, LONDON, W.C.1. Telephone: Chancery 8266

**ALWAYS FIRST—ESTABLISHED 1919**

Messrs. PETO-SCOTT CO. LTD., 77, CITY ROAD, LONDON, E.C.1.  
Please send me C.O.D./CASH/H.P.

"AUTOTONE" KIT .....

for which I enclose £      s.      d. CASH/H.P. Deposit.

NAME .....

ADDRESS .....

W.W. 2/3/32

# REASONS WHY YOU SHOULD USE MAZDA INDIRECTLY HEATED RECTIFIERS

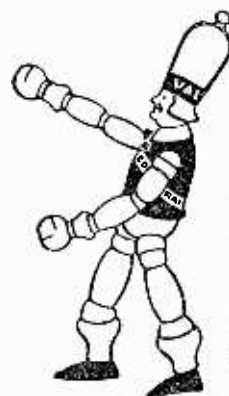

**LOOK FOR  
"EDDY" IN  
YOUR  
DEALER'S  
WINDOW**

**MAZDA INDIRECTLY HEATED RECTIFIERS**

TYPE	PRICE
<b>Full wave</b>	
UU.30/250 - - -	12/6
UU.2 - - -	15/-
UU.60/250 - - -	15/-

**THE AMAZING**

**MAZDA  
THE  
BRITISH  
VALVES**

THE EDISON SWAN ELECTRIC CO. LTD.  
RADIO DIVISION:  
155 CHARING CROSS ROAD, LONDON, W. C. 2



If you are using rectifying valves in your A.C. mains receiver there is a definite advantage to be gained by using **Mazda indirectly heated Rectifying Valves**. You are safeguarding the condensers, chokes and valves of your receiver. When you switch on an ordinary rectifying valve, operating temperature is reached considerably before that of the receiving valves. A surge is caused and damage is frequently done.

Mazda indirectly heated Rectifiers heat up with the receiving valves, and so afford you absolute protection. Mazda valves are 100% British made and designed by British engineers.

**EDISWAN RADIO**

V136

*Mention of "The Wireless World," when writing to advertisers, will ensure prompt attention.*

A20

# TELSEN NON-INDUCTIVE BLOCK CONDENSERS (MANSBRIDGE TYPE)

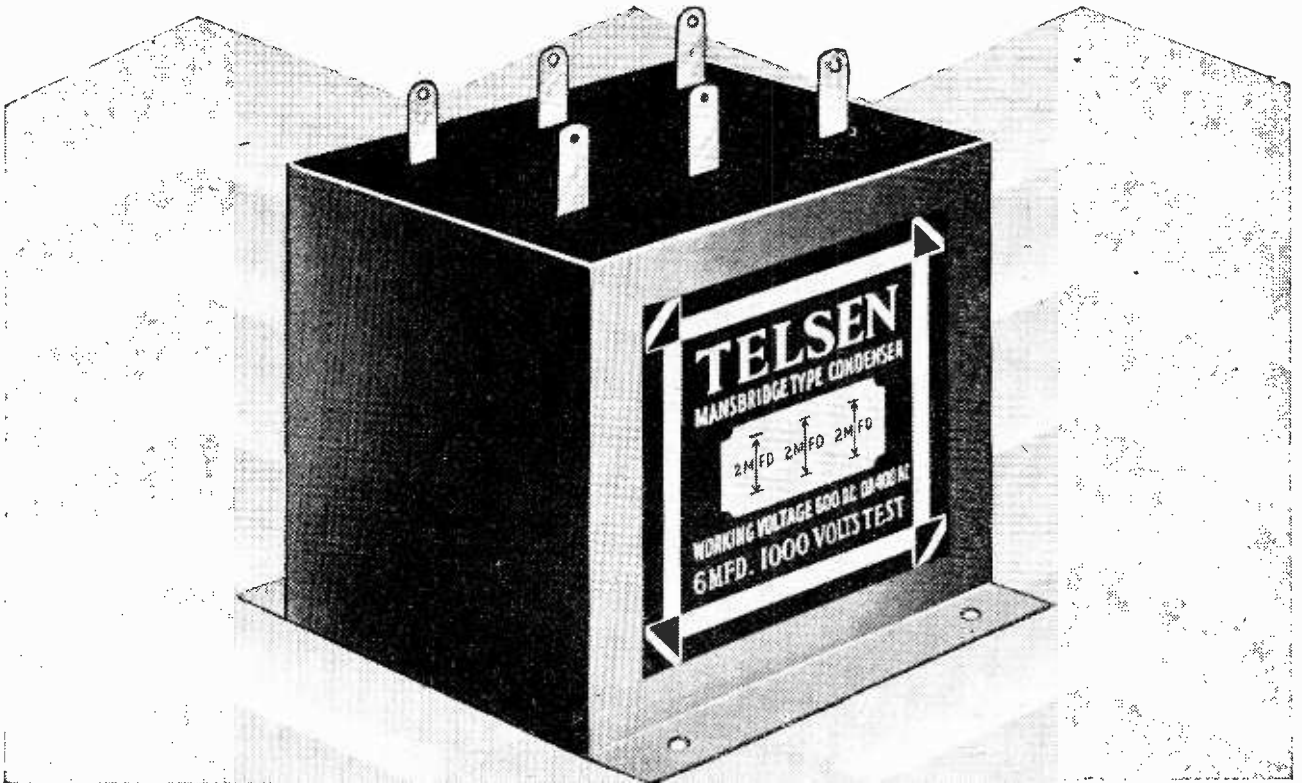

## TELSEN NON-INDUCTIVE BLOCK CONDENSERS (MANSBRIDGE TYPE)

These are made by the most advanced processes from the finest materials it is possible to obtain, and subjected during manufacture to a series of stringent tests under laboratory conditions. They are of the true Mansbridge type, self-sealing, non-inductive and hermetically sealed.

Cap.	500 volt test	1,000 volt test
4-mfd. .. ..	5/6	9/6
6-mfd. .. ..	8/-	14/6
8-mfd. .. ..	10/6	



*The Telsen Short-wave Coil adds the Short Waves without coil changing*

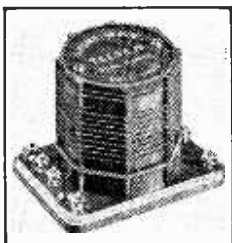

# TELSEN TRIPLE THREE

**LONG, MEDIUM AND SHORT WAVE RECEPTION ON ONE DIAL**

Advt. of The Telsen Electric Co., Ltd., Aston, Birmingham.

CVS-176

A2c

*Elementary Principles of Wireless Telegraphy and Telephony. (Third Edition.) By post, 11/-*

Here is the  
**MICA  
BRIDGE**  
which ensures



**EFFICIENCY and CONSISTENCY**



Cossor Valves for  
"W.W." Sets

2nd March.—"The Autotone," 210 LF,  
210 HL, 210 LF, 220 P-A.

27th Jan.—"Power Radiogram," \*41 MHL,  
41 MP, 460 BU.

9th Dec., 1931.—"Single Dial Super," \*215 SG,  
\*215 SG, \*210 HF, \*210 HF, 230 PT.

25th Nov., 1931.—"Variable-Mu Three,"  
\*MVSG, \*MVSG, MP/Pen, 442BU.

\*METALLISED.

THE Cossor Mica Bridge principle is to-day accepted as a notable contribution to the radio industry. By its use a much higher standard of valve efficiency is attained. Better radio is now available for all who fit Cossor Valves to their Receivers.

In the assembly of every Cossor Valve, the elements are rigidly secured in

absolute life-long alignment by the mica bridge as shown above. In some types, four, and in others, two bridges are used. No variation is possible—either during or after manufacture. Therefore a remarkably consistent performance is ensured throughout the life of the valve.

A copy of the 72 page Cossor Wireless Book B11 will be sent you free on application to A. C. Cossor Ltd., Melody Dept., Highbury Grove, London, N.5.

Get one of the new Cossor Station Charts price 2d. Ask your dealer for a copy of this useful novelty or write to us enclosing 2d. stamp.

**COSSOR**  
ALL-BRITISH  
**VALVES**

A. C. Cossor Ltd., Highbury Grove, London, N.5. Depots at Birmingham, Bristol, Glasgow, Leeds, Liverpool, Manchester, Newcastle, Sheffield and Dublin. 45 ♥ 9886

Mention of "The Wireless World," when writing to advertisers, will ensure prompt attention.

A30

# Practical

# Hints & Tips

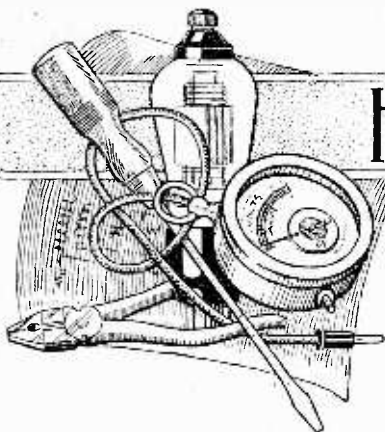

AFTER reading a recent note in the "Hints and Tips" section regarding modification of existing sets for the reception of 833-metre aerodrome transmissions, a reader writes to remind us of another very simple method of making the necessary alterations to a portable set of the "aperiodic" type, in which there is only one tuned circuit.

Briefly, this consists of nothing more complicated than the connection,

**INDUCTANCES  
IN PARALLEL**

in parallel with the long-wave frame aerial, of an ordinary commercial

coil of suitable inductance. It is stated that a No. 150 coil gave a tuning range of from 800 to 1,150 metres when added to a certain commercial receiver.

This arrangement is equally applicable to "open aerial" sets of the single-circuit type; or, for that matter, to sets with more than one tuned circuit, provided that a suitable shunt coil can be connected across each inductance.

THIS section of *The Wireless World* is intended to assist the amateur in solving his purely practical problems, and matters of purely theoretical and academic interest are rigorously barred. But this is not sufficient reason for ignoring a theoretical problem that becomes an intensely practical one when assembling a mains-operated receiver; this is with regard to the connections of a rectifying valve.

**RECTIFYING  
VALVE  
CONNECTION.**

We have always accepted as an article of faith that the anode of a thermionic valve must be made positive with respect to its cathode in order that it may function, and at first sight there seems to be something wrong when the circuit diagram of a valve rectifier, as used in

## Simplified Aids to Better Reception.

H.T. supply circuits, shows that the positive output is invariably taken from the filament and not from the plate.

The confusion which exists on this subject probably arises from the conventional method of representing a rectifier circuit, and the matter will probably become clear, even to those who have but a nodding acquaintance with valve theory, if a half-wave rectifier circuit is redrawn as in Fig. 1. This shows at a glance that the rectifier action does not conflict with accepted ideas, and

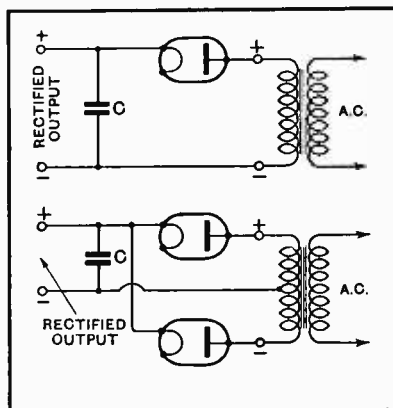

Fig. 1.—Polarity of rectified current. Simplified diagrams showing why the positive output is taken from the filament terminal of a rectifying valve.

that it is quite obvious that the positive output should be taken from the filament terminal.

Still referring to the diagram, it should be realised that the valve can only pass current at the instant when a positive voltage exists at the

terminal of the power transformer secondary which is in connection with the anode. This means that the other end of the transformer must be negative, and so the polarity of the rectified output is at once obvious.

To understand the operation of full-wave rectification by means of a double-anode valve, it is perhaps easiest to divide the functions of the separate anodes by redrawing the circuits as if two independent valves were employed (Fig. 1). Here, each valve in turn passes a pulse of current as its anode becomes positive, and the centre tap of the transformer secondary will always be negative in relation to the anode of the valve that is working at the moment.

WE are all inclined to be unduly pessimistic with regard to the possibilities of simple detector-L.F. sets in the matter of selectivity. Although it is generally agreed that this arrangement, in its ordinary form, is quite out of date for serious and consistent long-range reception, it still has—and probably will have for some time to come—a very real field of usefulness for high-quality reception of a local station, or even

**SHORT-RANGE  
SETS**

of twin stations that are fairly well separated in wave-length.

Unfortunately, in the immediate neighbourhood of a twin-station transmitter, it may become necessary to sharpen up tuning by using rather more reaction than is strictly desirable from the point of view of quality. This is the reason why the "Power Radio-Gram," recently described in this journal, was fitted with a simple form of input band-pass filter, which confers quite enough selectivity for the purpose for which the set was designed.

Those who are favourably situated, from the point of view of

interference, may be interested to know that it would be permissible to simplify this set by the omission of the extra tuned circuit, but it would be a pity to impair its performance by doing so in a case where there is any doubt as to the suitability of a simpler arrangement than that described.

FROM the amateur point of view, one of the advantages of tone-corrected reception is that an interesting test of the principle may be made without elaborate or expensive apparatus. Lay-out of components is a matter of comparatively small importance, and provided that a det.-L.F. set with an L.F. amplifier giving plenty of magnification and having a reasonably "straight-line" characteristic is available, or

can be improvised, it is easy enough to make the modifications necessary to

**ALTERNATIVE TONE-CORRECTION CIRCUIT**

try this interesting system. Readers may be reminded that it is not absolutely essential to copy

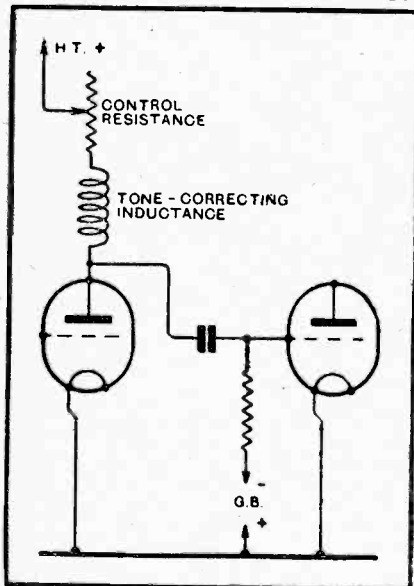

Fig. 2.—An air-cored tone-correction choke may be inserted directly in the anode circuit.

faithfully the tone-correcting stage of the "Autotone" receiver, although this represents what is probably the best arrangement. When the necessary components are not available, the tone-correcting inductance, in series with the neces-

sary control resistance, may be inserted directly in series with the anode of the valve, as shown in Fig. 2. Coupling to the next valve

be obtained that the resulting reproduction was so lamentably lacking in high notes that speech became unintelligible, and as for music, half

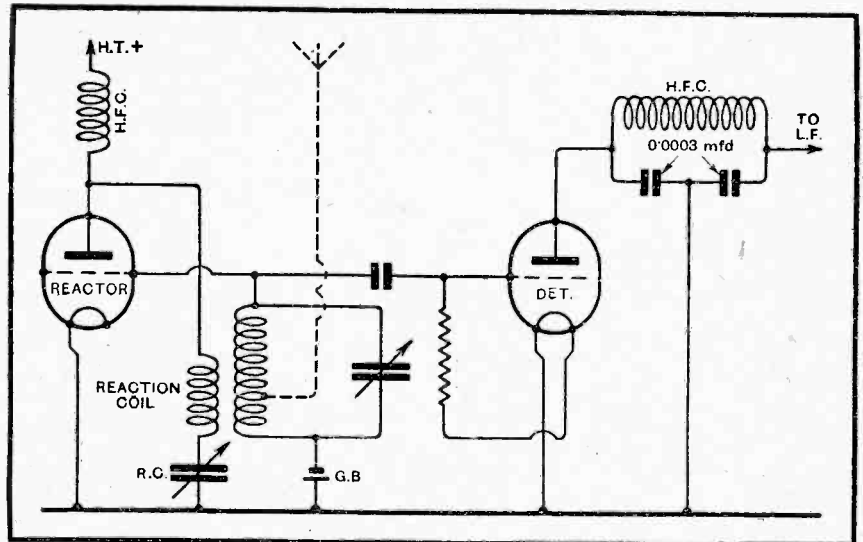

Fig. 3.—Connections of a reactor valve: the grid circuit is in parallel with that of the detector.

is effected by means of the usual condenser-grid leak combination; these components should have the values customarily employed in a high-quality L.F. amplifier where consideration has been given to the passage of the lower frequencies.

DUE to the great amount of interest shown in the system of reception in which highly selective circuits in conjunction with tone correction are employed, attention is again being directed to the problem of obtaining smooth and critical control of reaction. By careful design, the functions of detection and regeneration can be combined in an unexceptional manner in a single valve, but it is safe to say that

**THE REACTOR VALVE**

equivalent, or even better, results are more easily obtained when separate valves can be allotted for each operation.

The use of a separate "reactor" valve was suggested some years ago, but this refinement—for such it undoubtedly is—never attained any wide popularity. Perhaps it was rather too successful; such critical control of regeneration could easily

the instruments in the orchestra became almost inaudible.

That was before we appreciated the fact that a proper "proportional" tone-correcting system could easily be designed. Now that this problem has been solved satisfactorily, deliberate "side-band cutting" can be carried to great lengths without any loss of brilliancy in reproduction, and so the reactor valve may well be given a new lease of life.

As to the actual type of valve employed, for this purpose requirements are by no means critical, and it is hardly an exaggeration to say that almost anything will do, but a good general-purpose valve is a safe choice. For the benefit of those who are interested in arrangements of this sort, the basic connections of a reactor valve to a conventional grid detector are shown in Fig. 3. It should be noted that although an H.F. choke is no longer required in series with the detector anode as a deflector for the purpose of reaction control some form of H.F. filter should be included.

By arranging the circuit in the manner indicated, it is possible to apply negative bias to the reactor valve without upsetting the operations of the detector.

# Running Records

Germany's Sound-reporting Service.

By A CORRESPONDENT.

**A** NEW method of conducting "running commentaries" is now used by the Nordische Rundfunk A.G., popularly known as the "Norag," which controls broadcasting in Northern Germany.

The service depends upon the fact that important events are rebroadcast, not at the moment of their happening, but at the first convenient opportunity after they have been recorded on ordinary wax records. By such means it is found possible to include many items which, owing to the clashing of times, inconvenient hours, etc., could not otherwise be broadcast.

The recording process is carried out in the motor van seen in the first picture. Sometimes an event worthy of broadcasting would consume more time than could be devoted to it, but by first recording the event it is possible to select the best records, the joins between records being smoothed over by brief commentaries at the microphone. In this way the long and tedious waits which so often occur in direct outside broadcasts are eliminated, and the broadcast, when transmitted, gives the listener a concentrated essence of the events, which includes all the high lights and none of the dull spots. A good example of such an event was the recent outside broadcast from Hagenbeck's Zoo. The "stars" were naturally inclined to be temperamental, and could not be relied upon to perform on the spot. But, with the use of a selection of records taken at the times when the

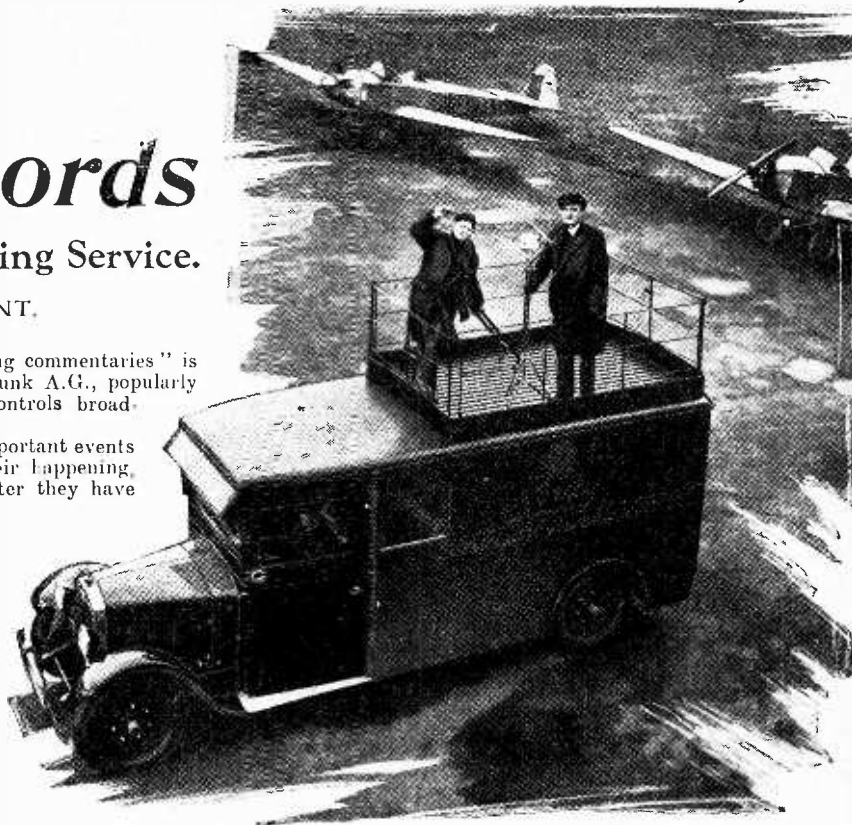

The "Norag" reporting van captures the sounds at an aerodrome for subsequent broadcasting.

animals were most vocal the sound service van was able to provide an excellent broadcast.

Sometimes the records are made in conjunction with a special short-wave transmitting plant used for relaying events at a distance, or from a reporting launch at regattas or other aquatic festivals. Another activity which is contemplated for the sound service is the interviewing of distinguished persons. Unrehearsed remarks and spontaneous expressions of opinion are always relished by the radio audience, though celebrities differ in their response to the microphone. It is hoped that, with the co-operation of hotels, consulates, and others, the sound service reporters may be able, at a moment's notice, to meet and interview the leading lights as they land at the ports of Hamburg and Bremen. The service should also be useful in securing realistic sound effects for radio plays. It can either make records from life which can be used directly in producing the play, or—in certain cases where artificial "effects" are even better than the real thing—it can help in the development of these by providing records for comparison. Another "internal" use of the service is in connection with the work-up of an elaborate feature; it can provide records of rehearsals over which the various big guns can "go into a huddle," as the Americans say. And its function as a more or less permanent recorder of the fleeting word from the broadcasting aerial is obvious. How often (certain cynics will say how seldom) does it seem little less than a crime that some broadcast performance should die away into eternal nothingness.

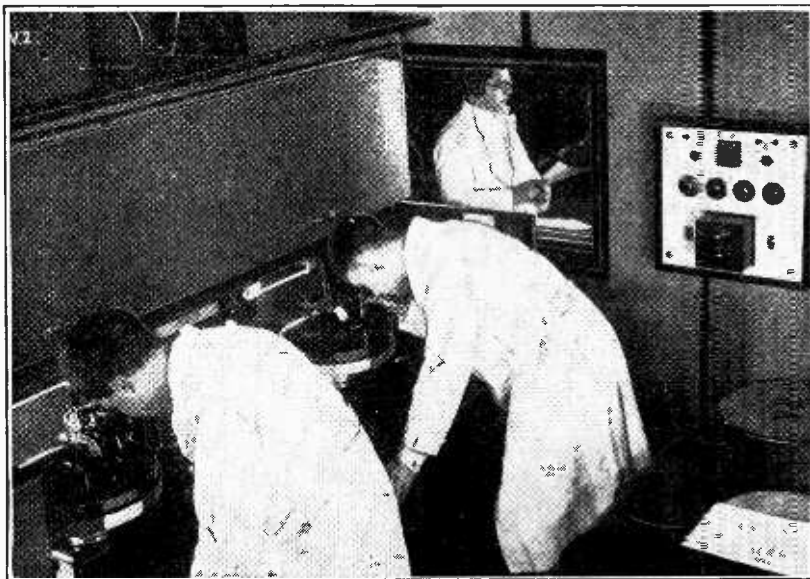

The interior of the reporting van showing sound recording in progress. Through the window in the background the Sound Director can be seen giving the running commentary.



# CORRESPONDENCE

The Editor does not hold himself responsible for the opinions of his correspondents.

Correspondence should be addressed to the Editor, "The Wireless World," Dorset House, Tudor Street, E.C.4, and must be accompanied by the writer's name and address.

## Working Voltages or Test Voltages?

WITH regard to a letter by Mr. T. Lebbon in your issue of February 17th, the state of affairs with regard to condensers seems to be brought about largely by the disappearance of foreign condensers from the British markets, due, no doubt, to the present economic situation. We, as transformer manufacturers, naturally attach great importance to the quality of the condenser used in any smoothing circuit working in conjunction with our transformers. The very small percentage of service trouble we have had has been traced, in practically every case, to breakdown of condensers, and the customer has often written stating that the condenser was marked with quite a reassuring test voltage. To further protect our products and maintain our reputation, our own "Sound" condensers were put on the market with the working voltage only stated. Our 500 working condenser has shown negligible leakage when tested at 1,500 volts by a well-known technical paper, and the user might be encouraged to use such a condenser on anything up to 750 volts. Indeed, if condensers are to be sold purely on test voltage, we have a letter from a scientific customer, who tested one of the 500-volt condensers to destruction; the breakdown voltage proved to be no less than 8,000 volts. What should we charge for a condenser with such a test voltage?

The 500-volt working condenser is priced at 11s., and this compares favourably with the prices of the best-known makes. The policy of my company is not to compete in a price market without considering the quality of the product offered.

SOUND SALES, LTD.

R. N. WELLINGTON, Managing Director.

London, N.19.

IN your issue of February 17th we notice a letter from your correspondent, Mr. T. Lebbon, in reply to another letter by Mr. Norman P. Slade, which appeared in your issue of January 27th.

The subject of performance of radio components has now narrowed down to condensers as exemplified by the capacity 4 mfd. 1,500 volt D.C. test. This is a matter to which we have given attention for some years, which can be verified by referring to our advertisements in the wireless journals during November and December, 1930, where we make the following statement under the heading, "Working Voltages or Test Voltages?":—

"At the present time there is some confusion regarding the most suitable method of indicating condenser voltages. Some manufacturers, including ourselves, mark their condensers with their actual *working* voltages. Others adopt the more spectacular method of indicating *test* voltages.

"Because test voltages are obviously much higher than actual working voltages, the condenser buyer may be led to believe that the higher voltage indicates a more efficient and better insulated condenser. This is not necessarily the case.

"In the past it has been fairly safe to assume that the continuous working voltage of a condenser was half of its stated test voltage. Unfortunately, this method of grading condensers can no longer be universally relied upon, since it has been found that condensers of similar capacity and size have been sold stamped with varying test voltages, but with no indication as to the working voltage. (This formed the subject of a statement issued by us earlier this year in reference to condensers of foreign manufacture.)

"We therefore recommend all users in their own interests to see that the condensers they purchase are definitely marked with their maximum working voltage. This will always be found on 'T.C.C.' condensers."

It will be seen from this that we make a feature of specifying working voltages. This policy has been continued, and reference to our advertisement in your January 27th issue will show that our 1,500 volts D.C. test condenser is to work up to 800 volts D.C. The price is 19s. 4d., which represents the high limit referred to by your correspondent.

The great difference between the higher-priced and the lower-priced condensers will, we suggest, be explained by a comparison of their volume. The case dimensions of our 4 mfd. 800 volts D.C. working type 101 condenser are 5in. x 6in. x 1½in., neglecting feet and terminals. The cheapest condenser we should expect to be of foreign manufacture, and contained in a case having the following dimensions: 2in. x 1½in. x 1½in., neglecting terminals and fixing feet. It may be taken that both condensers are reasonably filled with the condenser elements, and consequently the dielectric or thickness of insulation in the larger one must be greater than that of the smaller one. It is, therefore, a question of factors of safety relative to the working conditions which are involved, and we think it will be found that the maximum continuous D.C. peak working voltage of the smaller condenser will be substantially under the 800 volts, which is our standard.

We should like to suggest that:—

(a) *The Wireless World*, in specifying condensers, should specify the working voltage of the components used, which would help forward our second suggestion.

(b) That the home constructor should always specify the working voltage for the condenser he requires.

Should any reader be in difficulty on these matters, our technical department will be glad to give every assistance.

THE TELEGRAPH CONDENSER CO., LTD.

H. W. COLE, Assistant Manager.

London, W.3.

[We fully endorse the suggestion that working voltages and not test voltages should be specified.—Ed.]

## Selectivity and Tone Correction.

WE are interested to see that you are actively continuing your policy with regard to high selectivity and tone correction in receivers, and that you are describing details of a receiver which can be constructed by your readers.

It is very probable that by means of reaction and correction (such as is used in the "Autotone" receiver) it will be possible to obtain selectivity and quality of a type which has hitherto been thought impossible.

Your readers may wonder whether a receiver of this nature is a "Stenode" receiver, and we can inform them that, if the "Autotone" or any other receiver is capable of receiving telephony without appreciable interference from another station whose audio-frequency side-bands overlap the required side-bands of the wanted signals, it is an infringement of our patent No. 344,869.

As the prospect of infringing our patent may deter some amateurs from carrying out experiments in this field, and as we are most anxious that developments on these lines should not be handicapped, we are prepared to consider the granting of free licences to *bona fide* amateurs to use this patent.

BRITISH RADIOSTATION CORPORATION, LTD.

F. G. Philpott, London Secretary.

London, W.1.

[Special interest attaches to the above letter as paragraph three appears to us to be the first attempt to define the "Stenode" in concise language. We would, however, like to see a further definition to decide what constitutes "appreciable interference."—Ed.]



# Broadcast Brevities.

By Our Special  
Correspondent.

## The New 5XX.

AS I was able to announce last week, 5XX is to leave Daventry. The mobile transmitter is now casting its net in the Droitwich area, which is some seventeen miles south-west of Birmingham.

## In No Hurry.

West countrymen can conserve their exclamations of delight until 1935 at the earliest, for I learn that it is very unlikely that constructional work at Droitwich will even be started upon until the Regional scheme is completed.

## Spa Waters for Engineers.

The move to Droitwich will banish the reproach that B.B.C. engineers must of necessity lead unhealthy lives. In a few years' time it will doubtless be the rule when an engineer falls sick to "send him up to Droitwich." A course of the spa waters between shifts should soon cure control engineer's cramp, though it may fail to correct that distressing disfigurement known as "phone ear."

## Influenza.

I AM sorry to hear that Sir John Reith has himself fallen a victim to the influenza epidemic which is now attacking the Savoy Hill staff. The "D.G." is very rarely absent from his post, and it is worth recording that, even in this case, he has been one of the last to go, having been preceded by quite a number of departmental heads.

## Dance Band Talkie.

THERE is to be some shooting (*vide Dallas Bower*) at Broadcasting House before Henry Hall and his dance orchestra take the ether on March 15th. I hear that a talkie of the new orchestra, with Henry Hall conducting, will be released on the day of the first broadcast.

## Film-making at Portland Place.

The filming is to take place in a few days' time in Studio 8A at Portland Place. This studio is on the seventh floor, but the sound-recording equipment will remain at ground level, necessitating the use of an unusually long cable, which will probably be taken up one of the lift shafts.

## Why Not More B.B.C. Talkies?

This venture reveals the true spirit of showmanship, and one wonders why the talkies have not been used more extensively in the interests of broadcasting. Why not a talkie of a typical B.B.C. vaudeville programme? Numbers of listeners who, considering the length of the waiting list, would have to wait till their dotage before joining the studio audience, would welcome a film showing their vaudeville favourites at the microphone.

## A Microphone Baffle.

AT first sight it seemed to those of us in No. 10 Studio last week that the B.B.C. was to regale us with loud-speaker selections from some other transmitter. An experimental condenser "mike" housed in a huge baffle looked,



ROYALTY IN THE STUDIO. King Carol of Rumania inaugurating the "grand" studio at the new Bucharest station. The buildings include gramophone and music libraries, together with an experimental laboratory.

from a distance, exactly like a moving-coil speaker. In front of it dangled an ordinary Reisz microphone.

## Comparative Tests.

The explanation was that the B.B.C. are now testing with condenser microphones which can be substituted for the ordinary type at a moment's notice by means of switches operated by the control engineer.

The use of microphone baffles is, I believe, an entirely new departure so far as the B.B.C. are concerned. The results are reported to be excellent in the case of large orchestras, and reception from No. 10 studio seems to prove this.

## Jack Payne's Farewell.

JACK PAYNE'S farewell to listeners under the title of "Jack Payne and His B.B.C. Dance Orchestra," takes place on March 11th, when he and his "boys" link items in a vaudeville programme which contains the names of Harry Hemsley, Peggy Cochrane, and other favourite artistes.

## Vaudeville Stage in "Studio Ten."

BROADCAST vaudeville will go a big step nearer than ever before to the music-hall type of programme on March 26th, when, in Studio Ten, ("warehouse"), a full "bill" will be given from a specially erected stage, with the B.B.C. Theatre Orchestra below and behind the footlights, and an audience of some hundreds occupying the body of the studio.

The microphones will be suspended in mid-air and artistes, visible audience, and listeners alike, will get an impression of expansiveness without the drawbacks attaching to many of the relays from an actual music-hall or theatre, particularly on the acoustics side. The more intimate style of broadcast, in which artistes with bent heads whisper or sing their pieces into the microphone, will continue to be given in the usual vaudeville shows.

## B.B.C. Take Up Flag Signalling.

THE B.B.C. has done (or will do) most things; but I confess that it gave me a thrill to learn last week that this great radio organisation will, on March 19th, revert to a method of human communication which was used with great success in the days of the Spanish Armada and again at the Battle of Trafalgar.

## A Sticky Problem.

The Corporation is justifiably anxious that nothing shall mar the excellence of the Oxford and Cambridge Boat Race relay. The first requirement is that the short-wave signals from the launch "Magician," which will follow the crews, shall be picked up satisfactorily on the official receiver installed on the roof of Harrod's Depository, Hammer-smith. The problem is how to indicate to the engineers in the boat whether the signals are coming over well.

## On the Roof.

A set of flags has been purchased and the engineers are now devising a code with which they will be able to signal to the launch crew while the boats are proceeding along the straight mile before reaching the bend at Hammer-smith.

Shade of Hertz, be still!

## Low Wavelength.

As a friend of the B.B.C. points out, the engineers will still be using the ether as their communication medium. It is understood that the wavelength will be of the order of 0.0000005 metres, provided that the flags are yellow.

They certainly will be if the fog is heavy.

## The Lone Commentator.

Another innovation—what a race!—will be the employment of only one commentator. Mr. J. W. M. Snagge, who has had useful experience, is undertaking to describe the whole affair "off his own bat." It seems a heavy responsibility, and I can imagine Mr. Snagge wishing that Holt Marvell or some other inspired personage could breathe a little poetry into the business as the race nears the Mortlake brewery.

# Laboratory Tests

## ON NEW RADIO PRODUCTS.

### SPECIAL DEMONSTRATION MODEL E.D.C.C. ROTARY CONVERTER.

The special portable cabinet model D.C. to A.C. rotary converter made by the Electro Dynamic Construction Co., Ltd., Devonshire Grove, London, S.E.15, has been developed for use in dealers' showrooms where it is necessary to demonstrate all types of A.C. receivers, but where the electric supply is of the direct-current form.

The special equipment consists of a 200-watt machine, a filter unit, a voltage regulating rheostat and an A.C. voltmeter. The inclusion of the two last-mentioned items enable the output voltage to be adjusted to any value between 200 and 250 volts on all loads up to 200 watts.

The machine is supported on sponge rubber; the lid of the cabinet being bedded down also on this material. The method of mounting, coupled with a well-balanced armature, results in perfect silence when the machine is running;

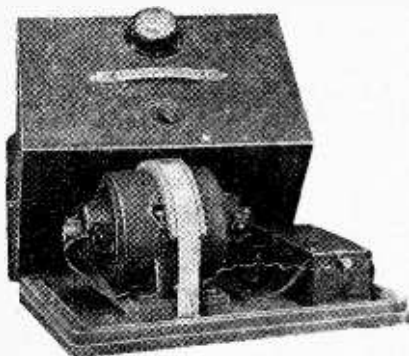

Electro Dynamic D.C. to A.C. converter intended for demonstration purposes.

indeed, without the aid of the voltmeter it would be difficult to say whether the machine was in operation or not if the observer was at a greater distance than five feet.

We had occasion recently to run a specimen model for eight hours continuously on a load of about 100 watts, and at the end of this period the machine was only comfortably warm. The temperature inside the silence cabinet was very little higher than that which a machine of this type would attain when running in the open.

It is as satisfactory electrically as it is mechanically; the special filter unit discharges its function admirably, and the A.C. output is entirely free from D.C. ripple.

The price of this special demonstration model is £24, complete in silence cabinet, and it should prove a great asset to those supplied with D.C. but who have occasion to demonstrate A.C. receivers either in retail showrooms or elsewhere.

### "PEAK" CONDENSERS.

We have been asked if the "Peak" condensers reviewed in our last issue are suitable for use in *The Wireless World* "Power Radio-Gram," for which purpose high-voltage-test condensers are specified. The query is, perhaps, understandable in view of the small physical size of the condensers, despite the fact that they are rated as coming within the 1,500-volt D.C. test category.

Some specimens have been subjected to a pressure of 1,500 volts D.C., and in every case the condenser stood up to the voltage with negligible leakage. As a general rule the normal working voltage of condensers of this type is about half the D.C. test voltage, so that "Peak" condensers are quite suitable for use in all circuits where the steady potential does not exceed, normally, 750 volts D.C.

In the "Power Radio-Gram" the highest voltage attained is across the 4-mfd. condenser feeding the loud speaker, which has to deal with the signal voltage in addition to the steady D.C. on the anode of the valve. "Peak" condensers will withstand the full voltage at this point.

Supplies are obtainable from Wilburn and Co., 23, Bride Lane, London, E.C.4.

### "MAGNADENSER."

This is a new "Magnum" variable condenser of the solid dielectric type, and as it is tested to withstand 500 volts A.C. it would seem to be an ideal component for us in reaction circuits. The moving vanes are anchored to a stiff brass arm fixed to the back extension of the spindle, and contact is made by a spring pigtail.

The movement is perfectly smooth, and there is no trace of backlash. The "Magnadenser" is made in three sizes,

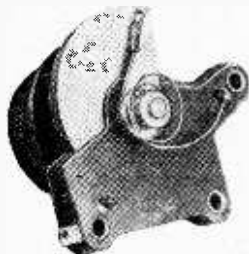

For reaction circuits; the "Magnadenser"

viz., 0.0002 mfd., 0.0003 mfd., and 0.0005 mfd., the price being 2s. 6d. in each case.

The makers are Burne-Jones and Co., Ltd., Magnum House, 296, Borough High Street, London, S.E.1.

### WATES UNIVERSAL TEST METER.

This is the smallest and most comprehensive test instrument we have examined so far, having regard to the fact that its price is 12s. 6d. The overall dimensions are 3x2x2½ in., yet it provides facilities for measuring I.T. up to 6 volts; H.T. up to 150 volts; H.T. current up to 30

milliamps.; resistances up to 2,000 ohms, and, in addition, can be employed as an indicator of continuity.

The nucleus of the instrument consists of a magnetically damped moving-iron movement taking 30 mA. for a full-scale deflection on both voltage scales. Fitted in the back of the case is a small 4½-volt dry-cell, which is brought into use when making measurements on the resistance scale and when utilising the instrument as a continuity tester.

The various ranges are selected by inserting the two wander leads into the appropriate sockets, located on the front of the case and immediately below the meter. Our tests reveal an extraordinarily high order of accuracy for a meter of



Wates Universal test meter for voltage, current and resistance measurements.

this price; the average error on the 6-volt and 150-volt ranges being no greater than the thickness of the pointer, and governed only by the limitations imposed by the length of the scale. With the exercise of a little care in reading the scale it is possible to measure voltages to within 2 per cent., and the same order of accuracy can be assured on the milli-ampere scale.

Measurements of resistance cannot be achieved with the same degree of accuracy; for one reason, the scale is very short and the thickness of the pointer accounts for a much larger error than that obtaining on the longer scale. However, a reasonably good approximation of resistance can be obtained. A useful purpose to which this range can be applied is for test of continuity of accessories and components. It can be used, also, to ascertain whether the insulation of a condenser is sound or has broken down, and resulting in an internal short-circuit.

The functions of the voltage and milli-amp. ranges are, of course, obvious, and with the additional facilities for test available this small, versatile instrument should prove exceedingly useful to all home constructors.

The makers are the Standard Battery Co., 184-188, Shaftesbury Avenue, London, W.C.2.

# READERS' PROBLEMS

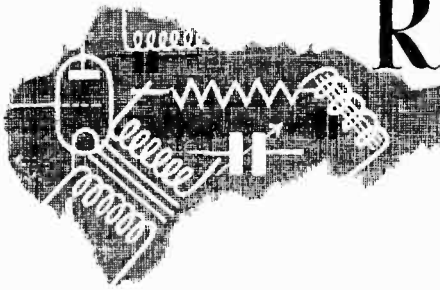

## Cathode Circuit Biasing.

A READER who proposes to carry out some experiments in automatic volume control asks whether it would not be possible to bias a battery valve by inserting a resistance in the filament lead in the manner customarily adopted when dealing with indirectly heated A.C. valves.

We think that our correspondent has overlooked the fact that a bias resistance will always have such a high value that it is quite impossible to insert it in series with the filament of even the most economical type of valve. True, it is possible to obtain automatic bias from a filament circuit resistor when a surplus L.T. voltage is available, but in this case we assume that a change in bias brought about by changes in anode current is required for the purpose of our querist's experiments.

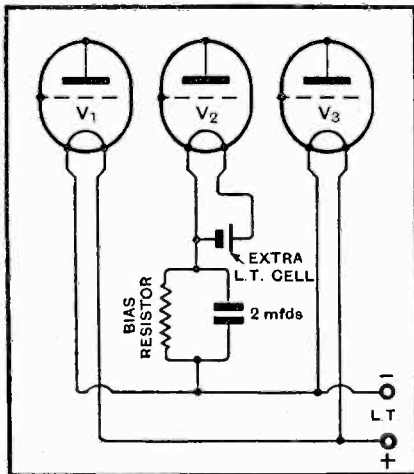

Fig. 1.—A separate source of L.T. current is essential when an individual valve ( $V_2$ ) is to be biased by the flow of its own anode current through a cathode-circuit resistor.

If the matter is considered carefully, it will be appreciated that a single-valve set could be biased by means of a resistor interposed between the L.T. negative and H.T. negative terminals, but with more than one valve it would be impossible to arrange for each valve to receive bias from its own cathode circuit resistor, unless an entirely separate L.T. battery were used for each valve.

Therefore the scheme would be im-

possible with conventionally wired filament circuits, but L.T. cells are now so cheap that it would be quite practicable to arrange for one valve of a multi-stage battery set to be biased by means of its own cathode circuit resistor by providing an extra L.T. cell for that valve. The appropriate connections are shown in Fig. 1.

## Condenser Test Voltages.

THERE seems to be some uncertainty regarding the substitution of condensers of lower test-voltage rating than those specified for the "Power Radio-Gran." It should be made quite clear that it is distinctly unwise to exercise undue economy in this matter, and the margin of safety allowed in the design should be regarded as the irreducible minimum.

Thanks to the use of a delay-action H.T. switch, it has been possible to use, in certain positions, condensers of low test voltage. If this protective device is omitted, it is desirable that the condensers  $C_0$ ,  $C_{12}$ , and  $C_{13}$  should be of the "1,500-volt test" type, in spite of the fact that they are in series with voltage-absorbing resistances.

It was pointed out in the article that 100-milliamp. fuses may be inserted in the leads between the H.T. transformer secondaries and each rectified anode terminal. The observance of this extra precaution does not, strictly speaking, allow the use of low test condensers, but it does make the consequences of a breakdown very much less serious.

## A Frame-Aerial "Autotone."

IN the skeleton diagram of the new "Autotone" receiver, given in the preliminary announcement which appeared in our issue of January 27th, a two-circuit aerial tuner was shown, and it was stated that an arrangement of this sort is necessary if the full measure of selectivity, of which the principle of reception embodied in the new set is capable, is to be attained. A querist asks whether, if one were willing to sacrifice a good deal of selectivity, a satisfactory medium-range set could be made with a single tuned input circuit. He intends to make provision for very loose coupling between this circuit and the aerial, in order to avoid interference.

Although the receiver modified in this way would function satisfactorily enough, and would confer the advantages of tone correction, we do not consider that it would be altogether attractive. So much of the available aerial input would have to be abandoned in order to attain reasonable selectivity that the set would be distinctly lacking in range—at any rate when compared with the "official" version which is described elsewhere in this issue.

THESE columns are reserved for the publication of matter of general interest arising out of problems submitted by our readers.

Readers requiring an individual reply to their technical questions by post are referred to "The Wireless World" Information Bureau, of which full particulars, with the fee charged, are to be found elsewhere in this issue.

Another query of a similar nature deals with the use of a frame aerial for this circuit. The main object in this case is to receive the nearest station at a distance of about forty miles, in a situation where locally generated interference is so bad that an external aerial is useless. Our correspondent's experience shows that almost all this interference can be avoided by the use of a frame.

There need be no doubt as to whether the "Autotone" will have sufficient sensitivity when used under these conditions, even if the frame aerial be a small one. Indeed, it should be possible to devise a highly satisfactory set by embodying the principles of critical reaction with tone correction in a frame aerial receiver; such a set should be very much simpler than one having an H.F. stage.

## Choosing H.F. Valves.

SEVERAL readers seem to be uncertain regarding the choice of screen-grid H.F. valves. This is a subject on which much might be written, as it is far from simple, but there are one or two simple rules that can be put forward with the assurance that they will not be misleading. For instance:—

In sets with one H.F. stage, the high-impedance, high-efficiency type of valve should be chosen, but in situations where interference is troublesome, and where no form of pre-selection or input band-pass filter is included in the set, a valve of lower impedance will generally be more satisfactory, and it is certainly safer to use in cases where no great amount of amplification is required.

In multi-stage H.F. amplifiers, it is generally a matter of real difficulty to coax high-efficiency, high-impedance valves to work entirely satisfactorily, and so the less ambitious types are generally to be recommended. This is particularly true of mains-operated sets.

### A D.C. "Wireless World Three."

REQUESTS have been received for information as to how the A.C. model of the "Wireless World Three" could be modified for operation with indirectly heated D.C. valves. At first sight this might seem to be a fairly simple procedure, as the D.C. valves have similar characteristics to those of their A.C. counterparts. But the position is complicated by the fact that the maximum voltage delivered by D.C. mains is almost invariably much less than that obtainable from the rectifying equipment specified for the "Wireless World Three"; and consequently a number of alterations would be necessary in order satisfactorily to modify the set for D.C. operation. Those who propose to do so would be well advised to wait for a "D.C." version of the set, which is to be described in the near future.

### Uncontrollable Reaction.

THE latest and most efficient modern valves are sometimes too good—if the expression be permitted—for sets designed a few years ago. This seems to

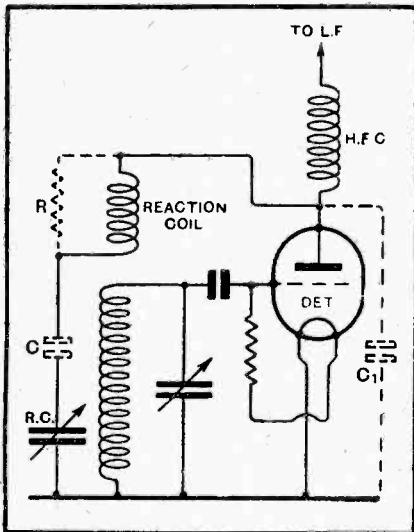

Fig. 2.—Curbing excessively "fierce" reaction control.

be at the root of the trouble encountered by a querist, who has been overhauling an admittedly out-of-date det.-L.F. set; new valves have been fitted, and it is now found that over a part of the tuning scale uncontrollable H.F. oscillation takes place, even when the reaction control condenser is set at minimum.

It is realised that the trouble could probably be overcome by removing turns from the reaction winding, but it so happens that this winding is not accessible. We are asked if there are any other means of producing an effect similar to that brought about by the removal of reaction turns.

In such cases it is usual to recommend the connection of a damping resistance across the reaction coil; some thousand

ohms or so will generally do the trick, but the right value is really only to be determined by trial and error. We suggest the use of a variable resistance of 5,000 ohms.

A still simpler cure that is often effective lies in the connection of a small fixed condenser—of about 0.0003 mfd.—across the anode and negative filament terminals of the detector valve. This plan, however, is liable to fail if the reaction control condenser has an excessively high minimum capacity; sometimes this deficiency can be put right by inserting a fixed condenser of 0.0001 mfd. in series with the reaction circuit, but this addition may render the control inoperative at the upper end of the wavelength scale.

All these alterations are illustrated diagrammatically in Fig. 2, where the suggested additions are shown in dotted lines.

### The Power Radio-Gram.

THE "Power Radio-Gram" is essentially a short-range receiver, which means that it is capable of operating satisfactorily up to distances of 20 or 30 miles from a receiving station under practically any conditions. Where conditions are good, this range may be extended up to 40 or 50 miles.

The "radio" section of the receiver is most distinctly not of the type which is suitable for consistent reception of Continental stations, or for use in remote parts of the country. Of course, an H.F. stage could be added quite simply, but this is another story.

Another question with regard to the same set deals with the use of paper condensers in the grid bias circuits, in place of those of the electrolytic type, which were employed in the original model. These condensers have the advantage of extreme compactness, and are capable of withstanding a considerably higher working voltage than they are required to deal with; but paper condensers are equally satisfactory from the electrical point of view.

### Loading an Eliminator.

IT is well known that the voltages marked on the output terminals of an eliminator will only be obtained exactly when a certain definite load is imposed on the instrument. When a small amount of current is drawn, there will be a more or less serious tendency for voltage to rise. This matter is perhaps not so serious as it would seem, but it is often an advantage to know with some exactitude what voltage may be expected.

A case in point. A reader has a commercial eliminator which is rated to give 28 milliamps. at 150 volts; this is the maximum pressure he requires for his receiver which, however, takes only 15 milliamps. He asks whether it would be practicable to ensure that voltage did not rise beyond this figure by the addition of an artificial load in the form of a resistance; in the event of this being possible, he asks how to calculate the value of the resistance required.

In this case, the surplus current to be absorbed is 13 milliamps. (0.013 amp.), and the required value of loading resistance is readily ascertained by dividing this figure into 150 (the maximum output volts). This gives 11,533 ohms as the resistance required to absorb the surplus output, and a resistor of the nearest value that is commercially available should be used. This scheme is quite a practical one, but it is generally best to connect the loading resistance directly across the rectifier output rather than across the external output terminals.

### "The Wireless World" INFORMATION BUREAU.

#### Conditions of the New Service.

(1) THE service is intended primarily for readers meeting with difficulties in the construction, adjustment, operation, or maintenance of wireless receivers described in *The Wireless World*, or those of commercial design which from time to time are reviewed in the pages of *The Wireless World*. Every endeavour will be made to deal with queries on all wireless matters, provided that they are of such a nature that they can be dealt with satisfactorily in a letter.

(2) Communications should be addressed to *The Wireless World* Information Bureau, Dorset House, Tudor Street, E.C.4, and must be accompanied by a remittance of 5s. to cover the cost of the service. The enquirer's name and address should be written in block letters at the top of all communications.

(3) The fee of 5s. covers the reply to any wireless technical difficulty, but in special cases, where the enquiry may involve a considerable amount of investigation, an increased fee may be necessary. In such cases a special quotation will be made.

(4) Questions should be clearly written and concisely worded in order to avoid delay. Where enquiries relate to trouble experienced in receivers built to specifications in *The Wireless World* a complete account should be given of the trouble, and especially the symptoms.

(5) Where reference is made to published articles or descriptions of apparatus, the title of the article, the date of publication in *The Wireless World*, and the page reference number should be given, in order to facilitate reply.

(6) Full circuit diagrams, constructional details of apparatus, or values of components for home-designed receivers cannot normally be supplied, but circuit diagrams sent in with queries will be checked and criticised.

(7) Particular makes of components cannot, in general, be recommended, but advice will be given as to the suitability of an individual component for a particular purpose specified by the enquirer.

# The Wireless World

AND  
RADIO REVIEW  
(21st Year of Publication)

No. 654.

WEDNESDAY, MARCH 9TH, 1932.

VOL. XXX. No. 10

Editor: HUGH S. POCKOCK.

Editorial Offices: 116-117, FLEET STREET, LONDON, E.C.4.

Editorial Telephone: City 9472 (5 lines).

Advertising and Publishing Offices: DORSET HOUSE, TUDOR STREET, LONDON, E.C.4.

Telephone: City 2846 (15 lines).

Telegrams: "Ethaworld, Fleet, London."

COVENTRY: Hertford St. BIRMINGHAM: Guildhall Bldgs., Navigation St.

MANCHESTER: 260, Deansgate

GLASGOW: 26B, Renfield Street, C.2.

Telegram: "Cyclist, Coventry."  
Telephone: 5210 Coventry.

Telegrams: "Autopress, Birmingham."  
Telephone: 2970 Midland (3 lines)

Telegrams: "Hiffe, Manchester."  
Telephone: Blackfriars 4412 (4 lines).

Telegrams: "Hiffe, Glasgow."  
Telephone: Central 4857.

PUBLISHED WEEKLY.

ENTERED AS SECOND CLASS MATTER AT NEW YORK, N.Y.

Subscription Rates: Home, £1 1s. 8d.; Canada, £1 1s. 8d.; other countries abroad, £1 3s. 10d. per annum.

*As many of the circuits and apparatus described in these pages are covered by patents, readers are advised, before making use of them, to satisfy themselves that they would not be infringing patents.*

## EDITORIAL COMMENT.

### Wireless Earths.

**T**HE water pipe has been the wireless user's best friend for many a long year, and, despite many attempts to persuade the public to adopt the ideal of efficiency in the shape of a specially constructed earth buried in the garden, the vast majority of listeners still adhere to the original expedient of making the earth connection to the water pipe. No book of instructions on the installation of a set has been complete without the advice that, if a buried earth is impracticable, then a clean connection to the water pipe should be as a very satisfactory alternative.

After all these years of quiet enjoyment of the facilities which the water pipe offers it will come as a shock to learn that an attempt is being made to divorce wireless sets from water pipes on the grounds that the practice "is likely, in course of time, to cause serious deterioration of the water pipes and mains, leading to subsequent leakage of water."

The first instance of objection to come to our notice originates with the Portsmouth Water Company, and it seems likely that, if their view is accepted, other water-supply authorities will also take steps to prevent the use of their water pipes for wireless earthing purposes. It is difficult to estimate the inconvenience to wireless users which would be caused if they were deprived of this means of earthing, and we therefore feel that a scare in regard to the damage which might be caused to the water pipes ought not to be started unless there is ample and unchallengeable evidence that damage does actually result. Up to the present we cannot recollect having seen any evidence published of damage resulting from this practice, and we would like to be referred to any reliable source of information on this subject or records of experiments which have

been carried out. Surely this subject must have been fully investigated long ago, and the reason that no action has been taken is that there is no justification for it.

Whilst recognising that if damage to water pipes does occur, then water-supply companies have every right to protect their property, yet we feel very strongly that when the use of the water pipe for this purpose has been so universally adopted over many years no restrictions ought to be imposed on frivolous or ill-founded evidence.

### Voltage Fluctuations.

**I**T is interesting that, just after we have been discussing in our columns the question of fluctuation in the voltage at consumers' mains, a case should have been brought up at the Exmouth Petty Sessions, where a local Electric Light and Power Company has been fined for selling electricity at a voltage lower than that declared by the company and required by the regulations.

It appears that many complaints were received in this case in regard to the variation in supply; the voltage at consumers' terminals should have been 220, subject to a possible variation not exceeding 4 per cent. above or below. Voltages as low as 196 were recorded by an inspector, and proceedings were taken against the supply company after a number of investigations had been made.

In imposing the fine of £10, the Chairman of the Bench remarked that the actual liability of the company was some £95. It is to be hoped that the wide publicity which this case appears to have received may have the effect of reminding other supply authorities of their responsibilities, so that they take greater precautions to maintain voltages within the prescribed limits.

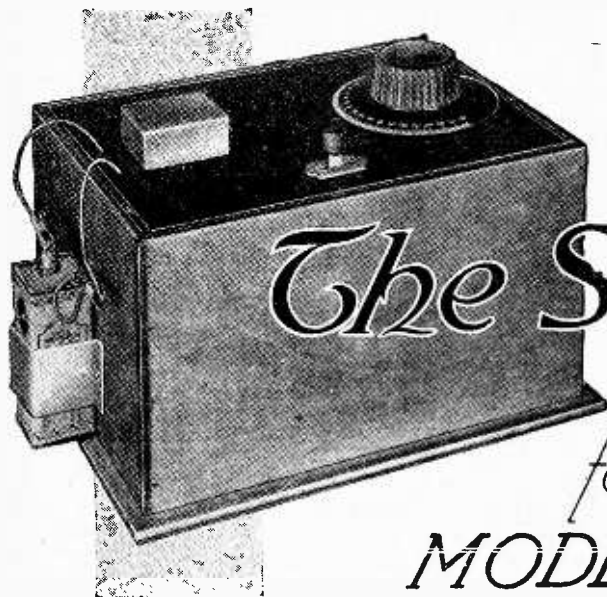

# The STATION FINDER for MODERN CONDITIONS

An Accurate Buzzer Wavemeter for the Medium and Long Wavebands.

By A. L. M. SOWERBY, M.Sc.

**T**HERE can be no question that the heterodyne wavemeter, in which an oscillating valve is used as the source of calibrated signals, is more accurate than any buzzer wavemeter can ever hope to be. But; on the other hand, there can also be no doubt that the extra batteries and equipment necessary before a valve wavemeter can be set going are a source of extra expense and extra trouble. One, therefore, is inclined to see how far the accuracy of the buzzer wavemeter can be improved, and whether, when all possible improvements have been made, the resulting instrument is accurate enough for ordinary practical work.

In the hands of the average listener a wavemeter has only one object in life—it is used in conjunction with a receiving set to enable its owner to identify a station already tuned in, or to pick out, from the bewildering welter of stations that come in on any powerful set, that particular one whose programme it is desired to hear. For this purpose, as distinct from the many laboratory uses to which a wavemeter of absolute accuracy can be put, it is necessary only to distinguish with certainty between one channel and the next. For example, loud music may be heard when the receiver is tuned to a wavelength just about that of Midland Regional. Is it Midland Regional that is being heard, or is it the powerful Swiss station Söttnens. These are adjacent transmitters, separated by nine kilocycles, and working on wavelengths of 398.9 and 403 metres respectively. To determine which of the two stations is being heard, it is only necessary for

the wavemeter to indicate the narrow band 398 to 400 metres for the one station, or 402 to 404 metres for the other; exact determination of the wavelength to the nearest tenth of a metre is not necessary.

### Sharp Tuning.

With care it is possible to make the simple buzzer wavemeter fulfil this condition over most of the normal tuning range, so that it becomes an instrument of high enough accuracy for really certain identification of stations. To obtain this accuracy it is found necessary

to reduce the output of the wavemeter until the buzz is quite faint, though it remains loud enough for any set having high enough amplification to be a reasonably good distance-getter. The sharpening of the tuning and the reduction of the output are brought about by using a tuned circuit of low losses, and then coupling the buzzer to it with extreme looseness.

In the wavemeter described in this article the buzzer current does not pass through the tuned coil itself, but through a primary winding of only a few turns placed

in proximity to one end of the tuned coil. This mode of coupling, apart from being found to give the sharpest tuning for a given loudness of buzz, has as an additional advantage in the fact that any user or constructor of the wavemeter can adjust the number of turns in the primary to provide himself with the compromise between sharpness of tuning and loudness that happens best to suit his own particular receiver.

*AS a means of identifying a transmission from the welter of stations that now can be received with almost any set, an accurate wavemeter is almost an essential equipment for the experimenter. The sharply tuned buzzer wavemeter here described constructionally can be relied upon to give certain identification. Simple design and low cost are points in its favour.*



**The Station Finder for Modern Conditions.—**

be locked as firmly as possible to the spindle of the condenser. The buzzer coil must be shunted by a 6-ohm resistance which can conveniently be made up of 13

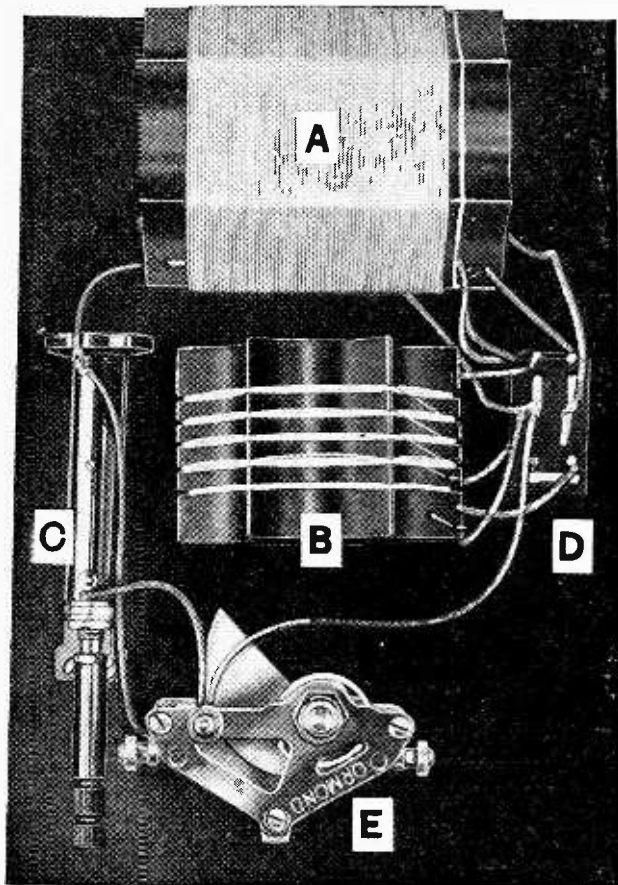

Details of the components under the panel are as follows :  
**A**, short-wave inductance of 66 turns of No. 22 D.C.C. wire on 6-ribbed, 3in. ebonite former ; winding length, 2.5in. ; primary 4 turns 34 D.S.C. 1/8in away from end of winding.  
**B**, long-wave inductance on same size of former ; winding consists of 38 turns No. 34 D.S.C. in each of 4 slots, fifth slot contains primary of 12 turns No. 34 D.S.C. Slots are 1.8in. deep and 3/16in. apart. **C**, neutralising condenser.  
**D**, switch. **E**, variable condenser, 0.0005 mfd. log law.

inches of No. 36 Eureka wire wound on a piece of 5/16 in. ebonite rod.

**Calibration.**

The calibration, rather than the construction, is likely to prove a stumbling-block to those who have no access to a standard wavemeter. It is best carried out with the aid of a receiving set capable of bringing in a moderate selection of foreign stations, allowing those few which can be recognised to act as finger-posts to others whose identity is less certain. Besides the set and the wavemeter itself a few sheets of squared paper, a well-sharpened soft pencil, and an up-to-date list of stations and their wavelengths will be needed. Armed with these the process will be somewhat as follows.

**LIST OF PARTS.**

- 1 Variable condenser, 0.0005 mfd. log law.....(Ormond R/483)
  - 1 Dial for above, 4ins. diameter.
  - 1 Neutralising condenser, 2 to 38  $\mu\mu\text{F}$ ....(Gambrell, Neutrovernia)
  - 1 Townsend buzzer, high note.....(Electradix Radios)
  - 1 Switch, two-way, lever pattern.....(Wearite I.12)
  - 1 Ebonite former, 3ins. diameter overall, 6ins. length, 6 ribs  
(Redfern type J "WW")
  - 1 Bakelised panel, 10  $\times$  7  $\times$  3/16 ins.
  - 18ins. No. 36 gauge Eureka resistance wire.
  - Wood for cabinet, aluminium for buzzer dust cover, wire, ebonite for coil supports, screws, etc.
- Approximate cost 25s.

First, a station is tuned in on the receiver, the one chosen preferably being the lowest in wavelength which can be identified with certainty. The wavelength of this station, taken from the list, must, of course, be known. The wavemeter is set buzzing, and the dial is turned until the buzz is heard in the loud speaker superimposed on the programme. Until the sound of the buzz is so well known as to be easily picked out, it will be well to wait until there is an interval in the programme, or at least speech or a soft passage of music. The reading of the wavemeter dial is then compared with that given as appropriate for the wavelength of the station on the calibration curve reproduced.

**Plotting the Curves.**

The wavemeter may have a dial reading higher than that shown. The Neutrovernia condenser is then to be screwed in (higher capacity) until on further trials the reading given by the meter is as nearly as possible the same as that shown on the curve. When this has been done, the minimum capacity will be the same as that of the original instrument. Since, in addition, the coils and tuning condenser are identical, the home-made instrument should follow with fair exactness the calibration-curve of the original wavemeter over the whole of both wave-ranges.

The next step is to make an exact copy of the two curves on two of the sheets of squared paper. This done, tune in on the set, one after another, all the stations whose identity is known beyond doubt, and find, for each one, the setting of the wavemeter that brings in the buzz at its loudest on top of the programme. Comparing these readings with the curve will soon show just how close a copy of the original the wavemeter being calibrated really is; the readings may be entered as dots on the squared paper, when it will be found that they

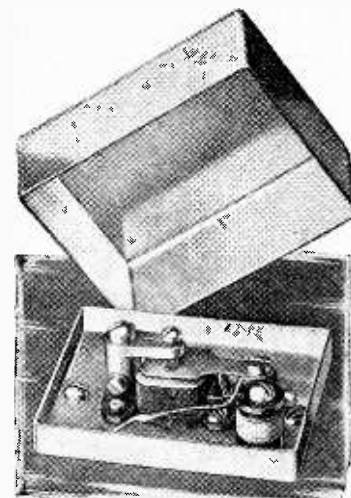

The buzzer across the coil of which is shunted a 6-ohm resistance.



**The Station Finder for Modern Conditions.—**

outline a new curve, close to the original one, but almost certainly not quite identical with it. Any dots that do not fall on the new curve should be ignored; they represent a mistake of some kind or other, for wavemeter curves do not develop sudden kinks and wavers at any point of their length.

Taking the original curve as a guide, the new curve should now be drawn through the points determined as described. It can then be checked by setting the wavemeter to the wavelength of some station that it is desired to hear, tuning in the buzz on the set, and switching off the wavemeter, whereupon the required station should be heard without altering the tuning dials at all. If such an alteration is found to be needed, the wavemeter curve should be suitably revised. When fully assured that the curve is right, it may finally be transferred to a new sheet of paper.

The same procedure can now be carried out on the long-wave range; the Neurovernia must not, of course, be altered.

So far nothing has been said of the way in which the wavemeter is to be coupled to the set. When receiving a distant station, with the set amplifying to its utmost, it will probably be found necessary to turn the wavemeter round until the buzz as heard in the loud speaker is at its faintest, the wavemeter being kept well away from the set all the time. For a more powerful station, where the set is working well within its powers, it will be enough to stand the wavemeter somewhere near the set, while for the local station it will probably be impossible to hear the wavemeter at all unless it is brought right up to the aerial coil, or the aerial lead is looped round the wavemeter to provide very close coupling. If the set is too powerful for the wavemeter, so that the latter has to be kept

at a great distance always to prevent the buzz from being heard all the time, whatever the setting of the wavemeter dial, the number of turns in the primary through which the buzzer-current passes should be reduced. With super-heterodyne receivers making use of a frame aerial this will probably be found necessary. If, on the other hand, the set is not sensitive enough to suit the wavemeter, so that it is almost impossible to hear more than the faintest buzz at any time, the number of

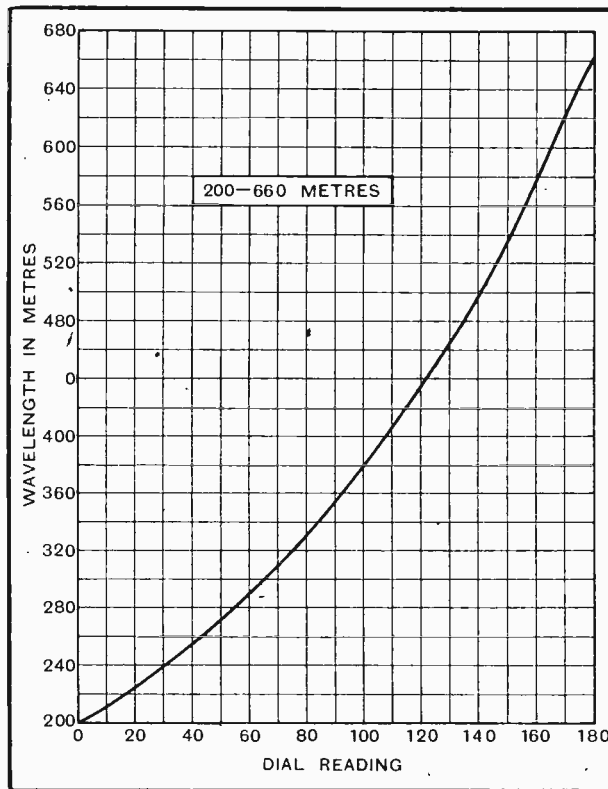

Calibration curves of the buzzer wavemeter for both short and long waves. The wavemeter is sharp enough in tuning to meet modern conditions.

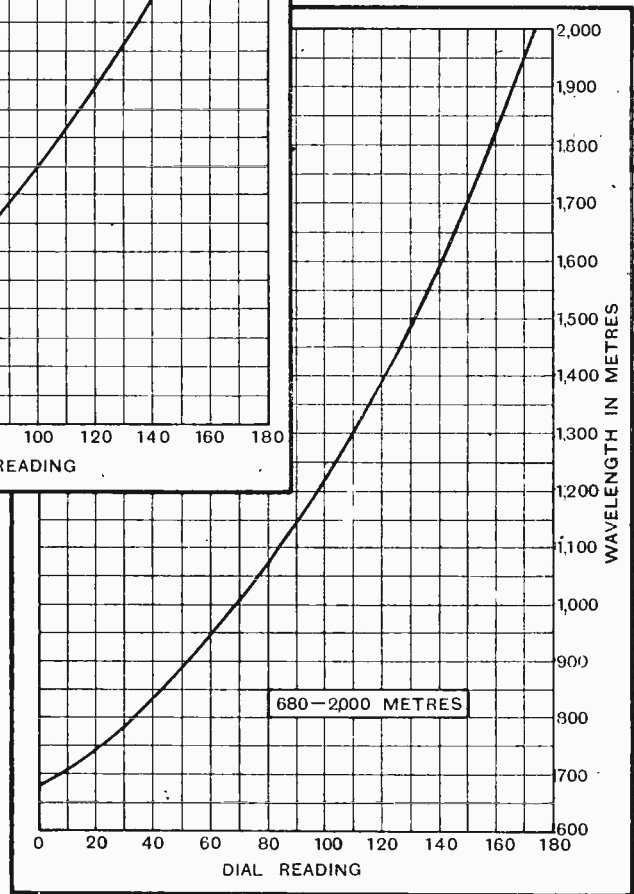

turns in the primary should be increased. As described, the output of the wavemeter is about suitable for the average two-screen-grid receiver of commercial design.

*THE WIRELESS ENGINEER. Principal Contents for March, 1932.*

*The Field in the Neighbourhood of a Transmitter—Influence of Valve Resistance in Oscillation Generators—Mutual Interference (an important article dealing with new aspects of selectivity)—Equivalent Mass of Loud Speaker Cones—Abstracts of the World's Wireless Literature.*

# Unbiased — "FREE/GRID" — by

## Ocean Waves.

RADIO Paris still seems to be as popular as ever as a medium through which various commercial undertakings, not excluding journals, can put across their welcome Sunday programmes. In these days of "Buy British," however, it seems a pity that so much good money should have to go out of the country for the hire of the station, and I hear that, in spite of



If the sea were rough.

the B.B.C.'s monopoly, it is not unlikely that we shall soon be hearing these programmes radiated from what is technically British soil.

According to an acquaintance in shipping circles, a well-known financial house contemplates the purchase of one of the many liners which are at present laid up around our coasts, with the object of fitting it up as a high-power broadcasting station. When one thinks of the relative smallness of the wireless room on even the largest liner, it is at first a little difficult to see how a station with reasonably high power could be accommodated, until one remembers that there would be a very large amount of space, usually devoted to goods or passengers, available for the transmitting apparatus and studios.

The idea is that the vessel shall pick up its artists or gramophone records at some convenient spot and then go out beyond the three-mile limit and cruise about while transmission is in progress. There is no information as to which part of the coast the ship would use as its base, but I do not suppose the inhabitants

of the neighbouring coast towns would be too pleased about it, unless they had Autotones, or at least superhets; but still, there are plenty of lonely stretches of coast, and in case of complaints the ship could get several miles farther out.

I am told that if the P.M.G. raised any objection, the vessel would use as its base a near-by Continental port, the artists being conveyed thither by aeroplane. The question which at once springs to my mind is what would happen if the day were rough and the artists were seasick.

## My Autotone.

IT is a funny thing that all the greatest brains in radio, including my own, have been unable to devise a better method of matching condensers than by means of segmented end vanes. The method looks crude, but nevertheless it works well—as the hangman said to his doubting client—and that's all that matters. This principle of fine adjustment by vane-bending is, of course, carried to its logical conclusions in the Autotone, where, I suppose, more accurate ganging has been achieved than ever before. I have, by the way, been finding the initial adjustment of this set uncannily fascinating; the set is almost foolproof—no nasty remarks, please—and yet it comes as a welcome relief amid the welter of "factory-hand" designs which make no appeal to the pukka amateur.

## Cackle Control.

I HAVE so often complained of the annoyance caused by the sycophantic studio audience who give such roars of applause at the conclusion of every item, whether good or bad, that I am only too glad to admit that I have done them an injustice and to apologise accordingly. I have had my suspicions for a long time, and so the other night, when I happened to be a member of the audience in Studio

No. 10, I took special notice of the fact that the red lamp went out—thus indicating that the microphone was dead—immediately the various items finished, and therefore our faint-hearted efforts at polite approval were not broadcast.

The applause which is invariably broadcast is usually so hearty that I concluded at once that my worst suspicions were confirmed. My presumption, however, that the B.B.C. kept a couple of dozen professional applauders in a spare studio, continuously clapping and emitting other noises of approval, and that their efforts were duly "mixed-in" in the control room, proved to be quite wrong. I am told on reliable authority that the B.B.C. are far too economical in man power to do this, and that although there is actually an applause studio, it contains a number of Blattnerphones continuously operating records of hand clapping, feet stamping, laughter and apprehensive gasps, each of which is "faded-in" according to taste.

I wonder, however, how it is that in the *middle* of an item we get the inane cackles of laughter which so often mercifully prevent us from hearing some of the chesnuts which are broadcast. I can only think that the B.B.C. must have an expert psychologist in an ante-room constantly watching the faces of the

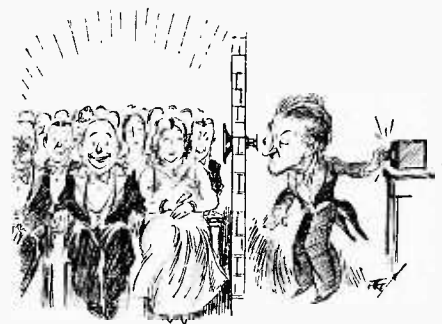

Anticipating a boo.

audience through a peep-hole so that he can intelligently anticipate a boo, and with a quick turn of the "mixer-control" replace it with laughter. When television is perfected, and we can see the audience, I suppose that the B.B.C. will arrange at critical moments for a quick fade-in of a talkie film of a Coliseum audience listening to George Robey.

# Greater selectivity No cross modulation Independent volume control

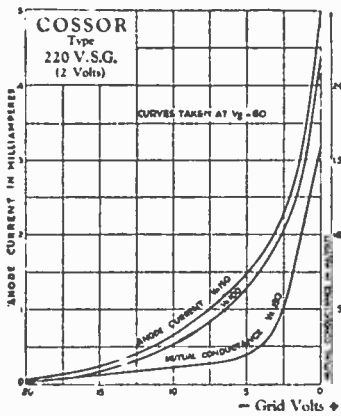

### COSSOR 220 V.S.G.

(for battery operation)

Filament volts 2; Filament amps. 0.2; Impedance 110,000 ohms and Mutual Conductance 1.6 m.a./v at V<sub>a</sub> 150, V<sub>g</sub> 60, V<sub>g</sub> 0; Grid Bias Variable for one stage 0.9, for two stages 0.15; Normal Anode Volts 120; Positive Voltage on Screen 60-80. Price **20/-**

Available with either plain or metallised bulb.

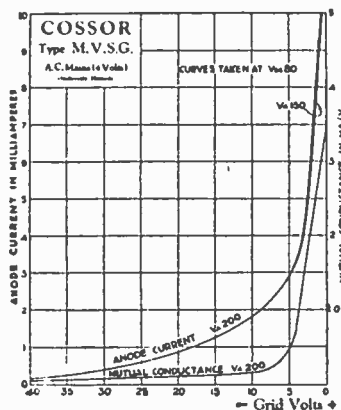

### COSSOR M.V.S.G.

(Indirectly heated A.C. Mains Valve)

Heater Volts 4; Heater amps. 1; Impedance 200,000 ohms and Mutual Conductance 2.5 m.a./v at V<sub>a</sub> 200, V<sub>g</sub> 80, V<sub>g</sub> 1.5; Grid Bias 36-1.5v; Normal Anode Volts 200; Positive Voltage on Screen 80-100. Price **22/6**

Available with metallised bulb only.

COSSOR Variable-Mu Valves provide a ready solution to the difficulty of preventing cross modulation and high frequency distortion. By variation in grid bias, the actual grid acceptance in Cossor Variable-Mu Valves can be directly controlled, so giving complete freedom from cross modulation. Further, the variable bias acts as a volume control which functions entirely independently and does not affect quality or tuning.

Send for full technical details of Cossor Variable-Mu Valves, both Battery and A.C. Mains operation.

Have you got your Cossor Station Chart? Ask your Dealer for a copy of this useful novelty, price 2d., or write to us enclosing 2d. stamp.

# COSSOR VARIABLE-Mu VALVES

British made by A. C. Cossor Ltd., Highbury Grove, London, N.5. Depots at Birmingham, Bristol, Glasgow, Leeds, Liverpool, Manchester, Newcastle, Sheffield and Dublin.

♡ 9939.



A SPEAKER  
IS NO BETTER  
THAN ITS MAGNET

BEHIND EVERY  
DARWIN MAGNET  
STANDS THE  
LARGEST MAGNET  
FACTORY IN THE  
BRITISH EMPIRE

**Darwins Ltd**  
**CORRECT MAGNET DESIGN**

HEAD OFFICE: FITZWILLIAM WORKS, SHEFFIELD.

LONDON: 29-31, REGENT STREET, S.W.1

All who prefer  
Quality in  
Cigarettes

Say  
**Player's  
Please**



N.C.C.86



**PIVASPRING  
PARK ROYAL  
INSTRUMENTS**

Tested on a special "dithering" machine, which shakes and bumps the instrument continuously. A drastic test proving that the quality of material used and the workmanship is of the best.

Regd.  
Des. No.  
759295

**100% BRITISH  
ALWAYS ACCURATE**

**SPECIFICATION.**

High-grade Cobalt Steel Magnet, accurately machined, giving excellent damping and accuracy. First quality Sapphire Jewel bearings. Will withstand heavy overloads without injury.

Zero correctors fitted to all instruments.

Each instrument separately calibrated and scaled.

Park Royal "Fivaspring" Instruments are used by Government Departments.

*Full catalogue sent on request.*

Type 1 1/2" M.C.F.	List Price each.
VOLTMETERS 0-300	1,000 ohms per volt - - - 33/9
MILLI-AMMETERS	- - - 30/-

**PARK ROYAL**

**ENGINEERING CO. LTD.,  
CUMBERLAND AVENUE, PARK ROYAL, N.W.10.**

Mention of "The Wireless World," when writing to advertisers, will ensure prompt attention.

A18

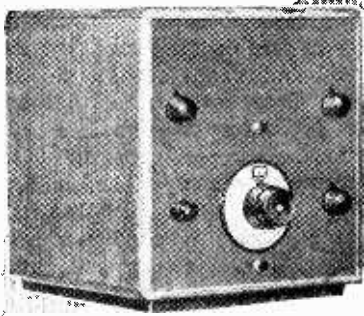

# The AUTOTONE

## Final Adjustments and Hints on Tuning.

By F. L. DEVEREUX, B.Sc., and H. F. SMITH.

**A**SSUMING that the construction and wiring of the chassis have been carried out in accordance with the drawings and instructions published in our last issue, the next step is to fit the two small coupling condensers ( $C_1$  and  $C_2$  in the wiring diagram, pages 216 and 217 of the March 2nd issue).

The capacity of the coupling condensers is so small that it is impracticable to use any of the numerous trimming and neutralising condensers on the market. The majority of these were measured with a view to their possible suitability for the circuit, but it was found that their *minimum* capacity was either equal

to or higher than the values required. In the circumstances, there is no alternative but to call upon the reader to make these couplings for himself. They can be constructed from material in the hands of every experimenter, they take up very little space in the set, and their cost is practically nil.

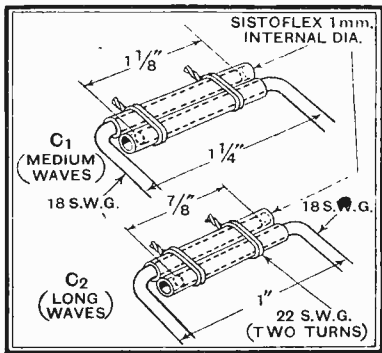

Fig. 8.—Constructional details of the coupling condensers.  $C_1$ , 2.5 micro-mfd.;  $C_2$ , 2.0 micro-mfd.

to specification,  $C_1$  should have a capacity of 2.5 micro-mfd. and  $C_2$ , 2 micro-mfd. These are the capacities of the two condensers in Fig. 8. SistoFlex sleeving is quite suitable for the insulation, and should be a sliding fit on the 18 s.w.g. wire forming the conductors (1mm. was the size actually used). It is important that the sleeving should be clean and free from flux, and a piece that has not been previously used is to be preferred. Make sure that the parallel wires overlap by the correct distance (this can be inspected by holding to a strong light) and that the sleeving extends a short distance beyond the end of each wire. Then bind in two places with two turns of copper wire of 22 s.w.g.—just sufficiently tightly to prevent the wire inside the sleeving from slipping out of position—no more.

If the general design of the set is altered, different values for  $C_1$  and  $C_2$  may be required. In this case the capacity can conveniently be increased by putting on more turns to bind the two elements of the condenser together; on the other hand, if a lower capacity is required, the length of overlap must be reduced. The optimum coupling can be found experimentally, and the method will be dealt with later for the benefit of those readers who may wish to satisfy themselves that the degree of coupling in their set is correct.

### Preliminary Tests.

With the coupling condensers  $C_1$  and  $C_2$  connected across the appropriate points in the circuit, as described in last week's issue, the set is ready for test. A high-tension voltage of 120 to 150 volts is recommended, and the following grid-bias values will be approximately correct for this range: G.B.1, 1½ volts; G.B.2, 3 volts; G.B.3, 6 volts for PM2A or 12 to 15 volts for PM202. The low-tension current, of course, is supplied from a 2-volt accumulator.

Since the majority of the components requiring adjustment are on the underside of the chassis, it is most convenient to invert the chassis, resting it carefully on

If the set has been built exactly

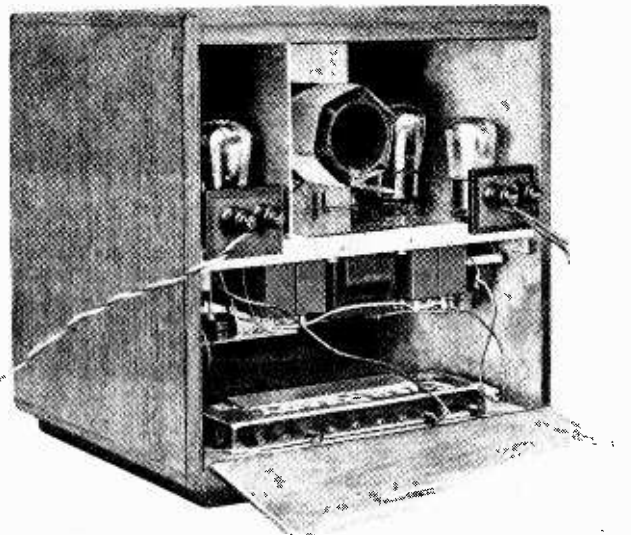

Back view of chassis in cabinet showing mounting of grid bias battery.

**The Autotone.—**

the edge of the vertical coil screen. The set will then present the view shown on page 218 of the previous issue, and all the essential components will be readily accessible.

At this stage it is possible to make a preliminary trial on the local station with reaction first at minimum in order to make sure that connections are correct and that the L.F. stages are functioning properly. During this test the detector bias potentiometer should be adjusted to give the best compromise between smoothness of reaction and detector efficiency. To facilitate the process of ganging it may be as well to err on the side of smoothness of reaction, and to achieve this the slider will probably have to be moved towards the extreme negative end of the potentiometer. The final setting for best reception will be about a quarter of the length of the potentiometer winding from the negative end.

In the "Autotone" the ganging can be carried out without the aid of any external instruments, since the relative tuning of the circuits at any point in the wave-range will be reflected in the setting of the

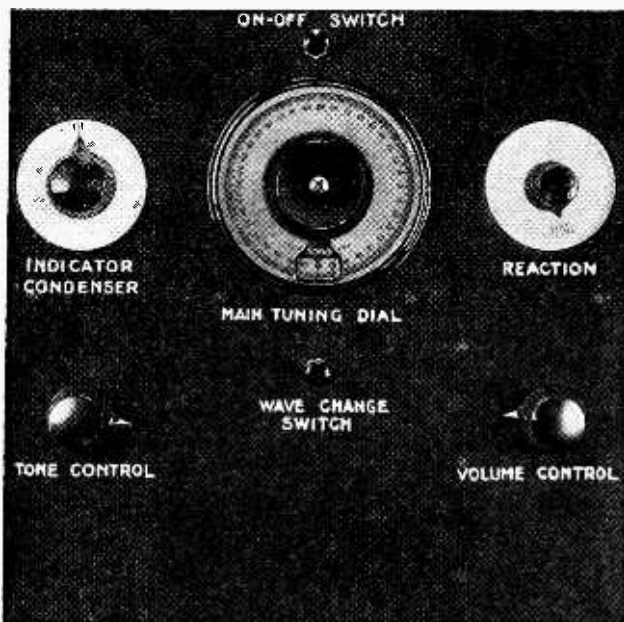

Appearance of controls with chassis inverted for initial adjustments. Note temporary scales and markings on the indicator and reaction controls. For convenience the indicator knob is reversed; a fresh zero mark on the opposite side of the scale should be made when the set is fitted in the cabinet.

indicator condenser. It is important, therefore, at the outset to gain a thorough understanding of the function of this condenser in order that its settings may be accurately interpreted. Essentially it is a trimming condenser in parallel with the primary circuit of the coupled tuner, and if no provision in the form of slotted end vanes had been made for matching the two sections of the gang condenser it would still be possible to tune-in stations using the indicator as an auxiliary

control for bringing the two circuits into step at any point in either the medium or long wave-range. However, since the main condensers are adjustable, an arbitrary zero can be marked on the indicator condenser scale, and the slotted end vanes can be so adjusted that in the final state there is no need to touch the indicator condenser in order to maintain accurate ganging.

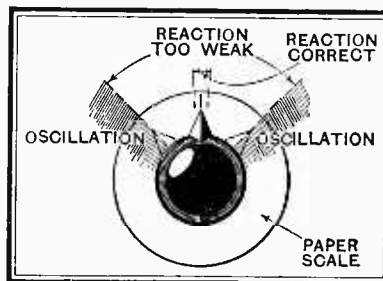

Fig. 9.—Illustrating the method of adjusting the indicator condenser.

is absorbed from the secondary circuit and more reaction is required to bring the circuit to the point of oscillation. This effect will be readily observed if reaction is increased until the set is just oscillating and the indicator condenser is slowly turned from minimum to maximum. It will then be found that over a certain angular movement of the indicator knob the set ceases to oscillate. At first the "angle of absorption" will be fairly wide, and reaction must then be increased until it is narrowed down to a  $\frac{1}{4}$  in. movement of the pointer. By marking with a pencil on the paper scale the two boundaries of oscillation and then making a third mark midway between these two lines the setting at which the circuits are exactly in resonance will be accurately determined—far more accurately, in fact, than would be the case had the adjustment been made by the more usual method of employing an external wavemeter. A few exercises in locating and narrowing down the angle of absorption on the indicator condenser for different settings of the main tuning dial will soon familiarise the reader with the function of this control, and he may then safely proceed to the final adjustment of the circuits.

While making the initial adjustments the reaction compensating condenser  $C_8$  should be set at minimum and disconnected mechanically from the main drive by releasing one of the grub screws in the flexible coupling. The coils are so designed that reaction is practically constant over the whole of the medium waveband, and the setting of the compensating condenser  $C_8$  is a refinement which can be well left until some of the more important adjustments have been made.

### Matching the Main Condenser.

The ganging of the main condenser must be carried out with the trimmer  $C_7$  at minimum and the volume-control condenser  $C_5$  at maximum. The first step is to mark an arbitrary zero on the indicator condenser scale with vanes half-engaged, and then to adjust the trimmers of  $C_3$  and  $C_4$  so that the middle of the

**The Autotone.—**

absorption band coincides with the zero mark already chosen. Since the indicator is in parallel with  $C_3$ , the trimmer associated with this section of the gang condenser should be reduced to its minimum in order that

**Correct Sequence of Adjustments.**

- (1) Set grid bias potentiometer for smooth reaction.
- (2) Adjust main gang condenser.
- (3) Check coupling condensers  $C_1$  and  $C_2$  if necessary.
- (4) Adjust reaction compensating condenser  $C_3$ .
- (5) Adjust volume control compensating condenser  $C_7$ .
- (6) Reset grid bias potentiometer for best compromise between smoothness of reaction and detector efficiency.

the capacity of the indicator can take its place in the circuit. The trimmer of  $C_1$  should then be adjusted until the two circuits come into resonance with the indicator zero mark. The adjustment of the trimmers is, of course, made with the main condenser at minimum.

Now engage the first section of the slotted end vanes on the main condenser and note the shift of the indicator condenser setting required to bring the two circuits into tune (if necessary, readjust reaction to keep the angle of absorption practically constant). If the movement of the indicator knob is equivalent to a decrease of capacity in that condenser it will be necessary to open *outwards* the vanes on  $C_3$  in order that the indicator condenser may be returned to zero. The slotted end vanes have been made specially soft for this purpose, and two, or, at the most, three, tests will be sufficient to effect the necessary adjustment. In some cases it may be found that adjustment of  $C_3$  alone is not suffi-

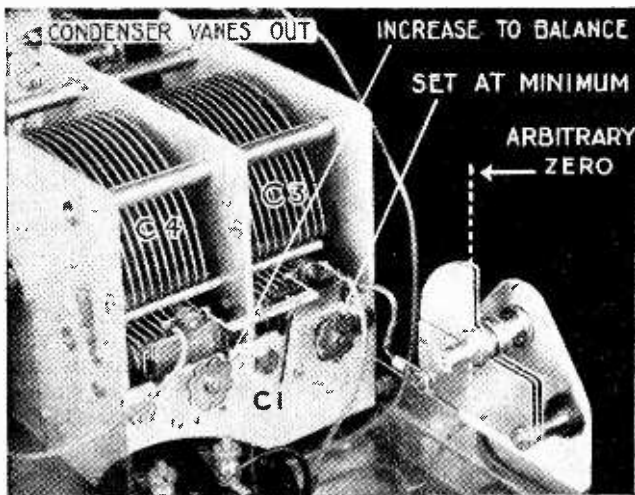

Fig. 10.—Adjustment of gang condenser trimmers to bring indicator condenser to suitable arbitrary zero (vanes half engaged).

cient to bring the indicator back to zero. In this event the corresponding sections of the end vanes on  $C_1$  would have to be bent slightly *inwards*. Now move the main condenser until the second section is engaged, and let us assume, for the sake of example, that the indicator condenser now shows an *increase* for resonance. To bring the indicator back to zero it will be necessary to

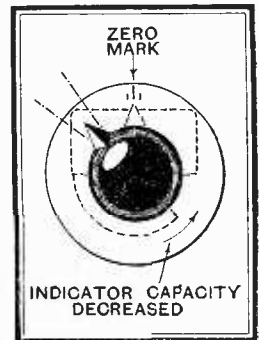
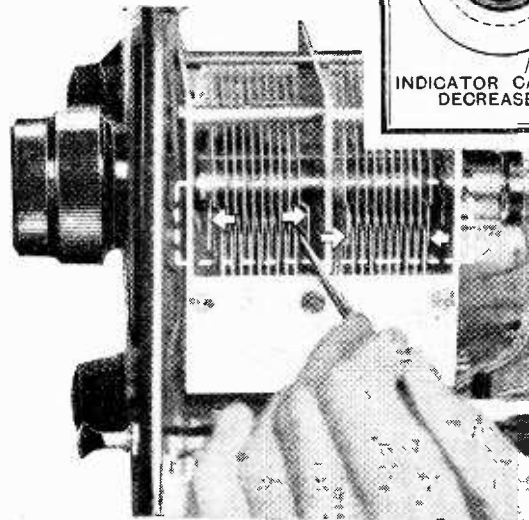

Fig. 11.—Adjustment of slotted end vanes in main gang condenser to restore indicator condenser to zero.



reverse the process indicated in the first example, and the segments of  $C_3$  will have to be pressed *inwards*, or, alternatively, those of  $C_1$  pulled *outwards*. Repeat the adjustment progressively for each remaining section of the main condenser, taking the utmost care not to disturb the positions of the vanes already adjusted. It is worth while spending a little time and trouble over the adjustment of the main condenser, as accurate ganging is essential if the subsequent adjustment of the reaction compensator is to be successful. This will be obvious when it is appreciated that only a small difference of tuning between the two circuits may call for a large change in the reaction setting required to bring the set to the point of oscillation.

**Adjusting the Tuned Circuit Coupling.**

Another important factor influencing the degree of reaction required is the coupling between the primary and secondary of the tuned input circuit. Any adjustments of the coupling condensers  $C_1$  and  $C_2$  should, therefore, be made at this stage before turning attention to the reaction circuit. Provided that the set has been built exactly to specification the condensers specified in Fig. 8 will not require checking, but if the layout of parts or the wiring of the tuned circuits have been altered in any way it may be advisable to adjust the coupling condensers from first principles. Starting with a coupling capacity which is obviously less than that which will be finally required, set the main tuning

**The Autotone.—**

condenser to maximum (i.e., the upper extremity of the wave-range in each case) and gradually increase the coupling capacity until it is just possible to detect absorption between the two circuits on the indicator condenser. Care must be taken not to exceed the minimum coupling capacity required to give absorption at the top of the tuning scale; too tight a coupling will result in "double hump" tuning at the bottom of the scale, and accurate tone compensation will not be possible.

The next step is to adjust the reaction compensator. First of all, before coupling up the compensating condenser  $C_8$  it may be advisable to take a note of the settings of the main reaction condenser  $C_4$  required to give critical reaction at, say, every 10 degrees on the main tuning scale. For this purpose a temporary paper scale with suitable marking may be attached to the panel under the reaction condenser knob. From an examination of the reaction settings obtained in this way it will be possible not only to ascertain the best method of coupling  $C_8$ , but also the probable degree of bending of the vanes which will be required. Thus, if an increase of reaction is required as the wavelength is increased, the compensator should start with the moving vanes at minimum when the main condenser is at zero. This is the form which the reaction will take with the coils specified. The degree of reaction compensation required will depend to a certain extent on the characteristics of the individual detector valve employed, and in some circumstances it may be found that the capacity range of the condenser is more than is required. In this case it is a simple matter to remove one of the slotted moving vanes—preferably the one farthest from the main bearing of the condenser. Care should be taken to avoid short-circuiting between the fixed and moving vanes of  $C_8$ , and an insulated point should be used when bending the sections.

**Volume Control Adjustment.**

Finally, we come to the adjustment of the volume-control compensator. This must be coupled to the main volume-control condenser in such a way that its capacity is at maximum when the condenser  $C_7$  is at minimum. The slotted vanes of  $C_7$  must be adjusted in such a way that the setting of the indicator condenser is not disturbed as the volume control is moved from maximum to minimum. The reason for fitting a com-

pensator to the volume control is to add capacity to the primary circuit as the capacity load of the aerial is reduced by the series aerial condenser  $C_3$ .

The set is now ready for service, but before settling down to log stations it is worth while to revert to the grid-bias potentiometer and to make a few experiments to find the best compromise between detector efficiency and smoothness of reaction. (It will be remembered that the latter quality has been given preference while carrying out the preliminary adjustments.)

The success of the set as a "single dial" receiver will depend upon the skill with which the various condenser adjustments have been made, for these will determine the closeness with which critical reaction may be approached without actually breaking through into oscillation at one or more points on the dial. Any local patches of oscillation on the main tuning scale (generally caused by inaccurate ganging of the main condenser) will limit the degree of reaction that can be usefully employed with "single dial" tuning.

This brings out an important advantage of the "Autotone" design. The special compensating condensers, while contributing to the ease of control of the receiver in its final form, are in no way essential to the electrical efficiency of the circuit. Whatever the degree of success attained in the matter of ganging, it will always be possible to obtain the maximum range and selectivity of which the circuit is capable on any given station by slight readjustment of the indicator and reaction controls. On the long waves independent adjustment of the subsidiary controls must, in any case, be relied upon to a greater extent than on the medium band, since it is difficult to arrange for accurate ganging on both long and medium wave-ranges. When making the

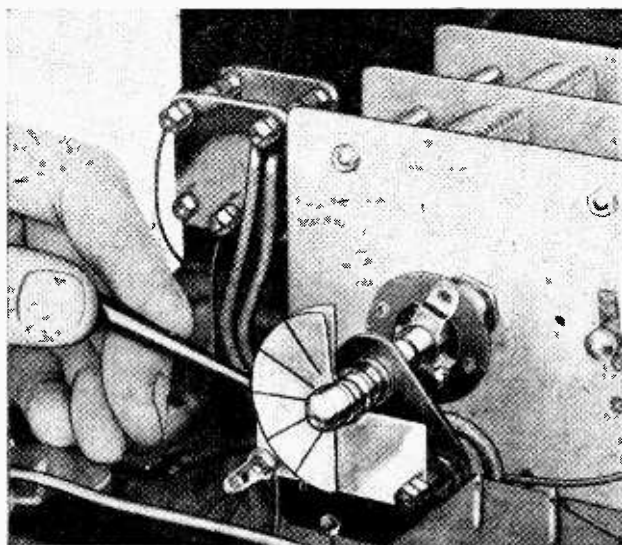

Adjustment of the reaction compensating condenser should be made with a pointer of insulating material to avoid short circuits.

final adjustment on a station on either wave-band, the correct procedure is to increase reaction until the boundaries of oscillation as shown by the indicator condenser nearly coalesce, and then to set the indicator pointer mid-way between the two boundaries. A slight readjustment of the main tuning control may be necessary as a result of the alterations of the indicator and reaction settings in order to bring the station exactly into tune. Precise resonance with the carrier of the station is very important, for if the receiver is only very slightly off tune certain of the side-band frequencies will be over-accentuated and the characteristics of the tone corrector will not be able to cope with the consequent distortion.

Without tone compensation the sharpness of tuning under these conditions would produce intolerable distortion. One has only to turn the tone control to the



**The Autotone.—**

limit in an anti-clockwise direction (increasing resistance) to appreciate the truth of this statement. Speech is unintelligible, and music is swamped by a preponderance of bass, which also overloads the output valve. Starting with the minimum of correction, the control should be turned in a clockwise direction (decreasing resistance) until speech is clear and a correct balance between bass and treble in music is restored. The correct setting will depend on the degree of reaction employed, and care should be taken not to over-correct, as this not only results in over-emphasis of the higher frequencies, but causes an apparent decrease of volume.

**Range and Selectivity.**

As an indication of the performance which may reasonably be expected from the "Autotone" the following results obtained with the original set may be cited. In Central London the selectivity on a 15ft. indoor aerial was sufficient to enable Mühlacker to be received clear of London Regional. On a 50ft. outdoor aerial, at a distance of five miles from Brookmans Park, seven stations could be tuned in between the London National and Regional transmitters. Under "single dial" conditions of tuning twenty-nine foreign stations came in at good loud speaker strength on the medium wave-band (with careful adjustment of the subsidiary controls this number was increased to 36). The long waves provided eleven stations, and, as might be expected, the selectivity was even better than on medium waves. In consequence of this it is necessary to use a slightly higher degree of tone correction on long waves.

The "Autotone" is a receiver which we put forward with confidence, not merely because of the advanced nature of the fundamental principles underlying its design, but because we know that it is capable of a performance, in the matter of range and selectivity, which will overshadow that of the majority of H.F.-detector-pentode receivers, and is streets ahead of anything that has so far been achieved with detector-L.F. circuits. Further, while it affords the experimenter ample scope for the exercise of skill in adjustment and manipulation, it is a set which can be used with perfect safety as a "single dial" broadcast receiver by the non-technical members of the household.

NOTE.—Since the receiver was first planned, the Ediswan 0.25 megohm grid leak, which was used in the original model, has been withdrawn from the market. Any of the makes of resistors specified as alternatives (Dubilier, Graham Farish, or Loewe) may be used. It should be noted that of the various kinds of Loewe resistances available, the type F.Z.128 is the most convenient for use in this set.

Also, in the plan view of the "Autotone" chassis on page 215 of the previous issue, the aerial circuit and loud speaker terminals should be transposed. The correct arrangement is as shown in the wiring diagrams.

The original receiver is available for inspection at the Editorial Offices, 116, Fleet Street, London, E.C.4.

**MILLIAMMETER SHUNT VALUE**

**A Refractory "Nut"**

**A** CERTAIN number of readers appear to have had some difficulty in solving Problem No. 10 of "Nuts to Crack," the solution of which appeared in the issue of January 27th. It will be remembered that the question referred to a milliammeter of 5 ohms resistance which it was desired to use with a shunt resistance such that the effective resistance of the combination should be 0.5 ohm.

It would appear that the presence of the milliammeter led some readers to attribute a greater difficulty to the question than it really possesses. So far as we are here concerned, the milliammeter acts simply as a resistance of 5 ohms, and there is no question at all of measuring currents. The connections of milliammeter and shunt may be illustrated as in Fig. (a), which may be replaced by the symbolic Fig. (b), which, in turn, is equivalent to the single equivalent resistance of 0.5 ohm shown in Fig. (c).

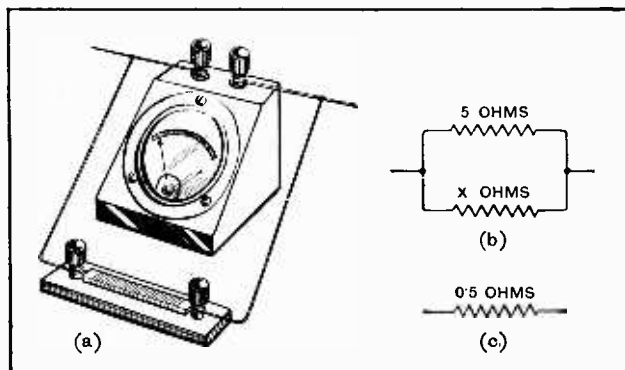

Schematic drawings simplifying the calculation of meter shunt resistances

The formula for the equivalent resistance of a parallel combination of resistances had been already given in the solution to Problem No. 9; for reasons of space, it was omitted in discussing No. 10. If  $R_1$  and  $R_2$  are the constituent resistances, the equivalent single resistance  $R$  of the parallel combination is given by

$$\frac{1}{R} = \frac{1}{R_1} + \frac{1}{R_2}$$

In this case one of the constituents, viz., the shunt, is unknown, and has to be found. We therefore call it  $x$ , and, substituting the known values for the other two symbols in the above equation, we have

$$\frac{1}{0.5} = \frac{1}{x} + \frac{1}{5}$$

This equation is that given in the text. It is a simple algebraical equation which has, as mathematicians say, to be "solved for  $x$ ." The steps of the solution were given in detail in the text, and it is hoped that the above explanation of how the equation was arrived at will have helped to clear away any lingering difficulties.

NUTCRACKER.

# PRACTICAL HINTS AND TIPS.

## SIMPLIFIED AIDS TO BETTER RECEPTION.

WHEN a receiver is fed with H.T. current from the mains, there is no particular need to be niggardly in the matter of consumption; a few milliamps. here or there make practically no difference to the cost of upkeep. But it is a different matter when dry batteries are employed; in this case, all possible sources of waste should be rigorously avoided, and it may be helpful to enumerate some of the more com-

mon causes of excessively high anode current.

As often as not, a valve

takes more anode current than it should because an insufficient amount of negative bias is applied to its grid. Of course, the same thing happens if the grid is totally unbiased, but then an audible indication that something is wrong is generally given. Further, it is not enough that merely the bias battery itself should be in order, and where there are grounds for suspicion, it is advisable to test the entire circuit for continuity to make sure that a negative voltage is actually impressed on the grid.

A "soft" valve will generally pass a high anode current; if this defect is not made obvious by the presence of a blue glow around the electrodes of the valve, it may generally be detected fairly easily by short-circuiting the grid circuit resistance, and noticing whether this brings about an appreciable change in anode current. If it does, the valve will definitely be "soft." It should be remembered that if there is not already a resistance of sufficiently high value in the grid circuit, this test will not be conclusive, but a resistance may be temporarily inserted.

Other faults that may occasionally be responsible for excessive anode current consumption in battery-operated sets are short-circuited anode feed resistances, or leakages, or more or less complete "shorts" in the anode circuits; the by-pass condensers may be suspected.

USERS of D.C. mains supplies are always handicapped by the fact that the H.T. voltage available is inevitably fixed at a considerably lower value than that obtainable from the majority of A.C. rectifiers. This limitation is particularly annoying when one is trying to devise means for supplying a power grid detector with sufficient anode pressure; even if initial difficulties are overcome the detector decoupling

must always be designed on almost parsimonious lines. Even if a actual "motor-boating" is not present, there is always an uneasy feeling that too much stray L.F. reaction for really good quality is taking place. The final result is that we generally arrive at a compromise—something like a "semi-power

February 3rd suffers from none of these limitations, and, apart from providing almost perfect detection, has the additional advantage that it does not impose any serious damping on the tuned circuit which immediately precedes it. The arrangement, therefore, is one that should be particularly attractive to D.C. mains users, who may accordingly be interested in the skeleton circuit diagram given in Fig. 1. This shows the nucleus of a diode-2 L.F. set suitable for high-quality reproduction of local broadcasting, and in which indirectly heated D.C. valves are used throughout. Where greater range is necessary, an H.F. stage may be added in the usual way.

In the suggested circuit diagram a pentode output valve is shown, but, of course, there is no reason why this should not be replaced by a triode, or where large outputs are

required, by a pair of triodes in push-pull.

A set on these lines, with an H.F. amplifier, is definitely capable of long-distance reception, and there is always the possibility of improved sensitivity by using the diode anode—which in the simpler form of circuit is unemployed—for purposes of reaction in the manner suggested in *The Wireless World* of June 10th, 1931.

**CONSERVING H.T. CURRENT.**

**THE D.C. DIODE.**

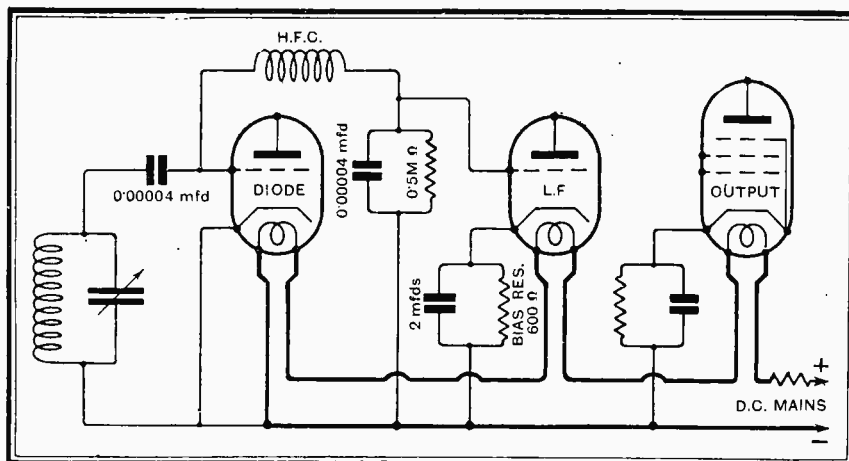

Fig. 1.—Diode detector for a D.C. mains set; the main heater circuit is shown in heavy lines.

grid" detector, in which the usual anode circuit limitations may possibly become evident, due to insufficient H.T. voltage. At the best, we can hardly hope to use, as a coupling between the detector and succeeding L.F. valve, an arrangement which will produce anything approaching the maximum attainable magnification.

The type of diode detector discussed in *The Wireless World* of

**Thirty-six Studios.**

DETAILS are emerging concerning the projected "radio palace" in Moscow, upon which work is to start this year. The palace will occupy a large site in the Place Mioussky, and will contain thirty-six studios serving thirteen transmitters. According to a correspondent, five specialists have already left Moscow on a world tour to examine the broadcasting buildings of London, New York, Berlin, and other capitals. The Russians have evidently learnt the value of proceeding slowly and profiting by other people's mistakes.

**New Time Signals.**

HAVE you heard the new German time signals? The broadcasting stations have now abandoned the old and rather complicated transmission from Nauen, and the new signal consists of an automatic gong stroke operated in conjunction with a chronometer. The announcer gives listeners the fortieth and fiftieth second of the sixtieth minute of the hour. The signal is at present broadcast at 7 a.m., 12 noon, and 10 p.m. (Central European Time).

**Still More Power.**

GERMANY'S new giant transmitter, built by Lorenz, of Berlin, has left the factory, and is being fitted at Pegau, 18 km. south-south-west of Leipzig. The station, which will go by the name Leipzig, is the most powerful in Germany, and has an aerial output of 120 kW., with 70 per cent. modulation, or, according to the older rating, 150 kW. We learn that the station will start testing towards the end of April.

A whole group of high-power stations is to be opened in Germany this year, beginning with Breslau, which will be followed by Leipzig, Munich, and Hamburg, the last two with powers of 60 kilowatts.

**Ferrié Statue at Eiffel Tower?**

OUR Paris correspondent reports that a fund is about to be opened for the erection of a permanent memorial to the late General Ferrié at the foot of the Eiffel Tower, which was the scene of his greatest radio triumphs. Following the usual French custom, it is also probable that a street or boulevard will be given the name of Ferrié in the near future.

**Cheers in the Control Room.**

BROADCASTING engineers in America are heaving a sigh of relief over the abolition of the rule requiring a continuous watch for S O S messages from ships at sea.

The listening watch on 500 metres, the distress wavelength, was required as an additional safeguard to navigation, each station having an extra receiver tuned to that wave at all hours. In many cases stations were required to close down immediately an S O S call was heard. Lately such calls have been picked up from far-away places, to the great inconvenience of stations and their audiences. The coasts, it is believed, are now adequately safeguarded without any watch by broadcasters.

# Current Topics.

## Events of the Week in Brief Review.

**£100 for an Essay.**

A KNOWLEDGE of wireless may be of considerable help to those competing for the £100 prize offered by the Royal Society of Arts for an essay on the following subject —

"The rescue, by another vessel, of passengers and crew of a sinking vessel, (a) when they are still on the vessel and while it is still afloat, (b) when they have taken to the boats. Particular attention should be given to improvements which might be effected in life-saving appliances, and to the navigation and manœuvring of the rescuing vessel under varying weather conditions."

Competitors must send in their essays not later than December 31st, 1932, to the Secretary, Royal Society of Arts, John Street, Adelphi, London, W.C.2.

Competitors must be past or present

**Manchester's Lead.**

MANCHESTER will be the first city in Britain to have its own airport equipped with a radio-telegraph and radio-telephone station possessing direction-finding apparatus. According to our aviation correspondent, sites for the stations have already been chosen at the Manchester Municipal Aerodrome, and constructional work will begin almost immediately.

**Why German Programmes Suffer.**

GERMANY'S broadcasting budget for 1932 shows a total of 88.8 million marks. Of this huge sum, three million go to the German Treasury, a further ten million will be used by the Post Office to cover deficits in other departments, in addition to 10 per cent. deducted for the cost of collection, so that broadcasting will actually absorb 68 million marks. On the same financial reckoning, British broadcasting absorbed only 24 million marks in 1930. German broadcasting costs are treble those in this country, which serves to show why German listeners pay approximately 25s. for their licences. Perhaps the fact that Germany has ten broadcasting companies and three independent broadcast research laboratories, apart from those of the big firms, explains why Germans can spend only 17 million on programmes!

**"Small Ads" at Easter.**

WITH the approach of the Easter holidays slight alterations become necessary in our printing arrangements. The latest dates on which small advertisements can be accepted for our issues of March 23rd and 30th are respectively Wednesday, March 16th, and Tuesday, March 22nd.

**A Fishy Question.**

THE recent award of 50,000 francs by the Paris Tribunal of Commerce to a wireless trader whose set demonstrations were spoiled by a neighbour's luminous sign, and the order to have the source of the evil removed, have unleashed some angry protests. *Excelsior*, a daily, asks whether the wireless amateurs will obtain the right "to suppress all of the magnetos of the universe."

The *Petit Bleu*, another daily, considers the judgment "odious," and puts forward this argument: "If the plaintiff had been a fish dealer and the defendant a perfumer, could the former have been able to prevent the latter installing fragrant essences and pomades on his frontage, on the ground that the odour of the perfumes would have overwhelmed that of the cod and other fish on the neighbour's stalls?"

We suggest a practical test.



A RADIO CITY. Excavations have now begun in earnest on the site of New York's "Radio City" between Fifth and Sixth Avenues. The plans include a roof terrace and a sunk garden.

members of the seafaring profession, a designation which includes ships' wireless operators.

**The Pirates' Tribute.**

FINES amounting to £1,933, in addition to costs totalling £240, were obtained during 1931 in 1,042 prosecutions against unlicensed wireless listeners. In the House of Commons last week, Sir Kingsley Wood, the Postmaster-General, stated that licences had risen by about 544,000 since September 30th last, and he considered that the greater part of this increase might be fairly attributed to the Post Office campaign.

# Nuts to Crack

## Instructive Problems and their Solution.

**T**HE present series has been started by *The Wireless World* for the benefit of readers who like to work out little problems for themselves and be sure that the results they obtain are correct. From time to time certain wireless problems are presented, and in the following instalment the answers are given with the methods of working them out, and hints on possible points of difficulty. Previously Questions 19 to 21 were given, and below the answers appear, whilst another set of problems is included this week for treatment in the next instalment.

**QUESTION 19.—Under working conditions a certain triode has an anode A.C. resistance of 20,000 ohms and a mutual conductance of 1.8 milliamperes per volt. What is its magnification factor?**

*Answer—36.*

It is very important to distinguish clearly between the D.C. and the A.C. resistances of a valve to the electronic current which passes through the space between the filament and the anode. If the grid potential is held at a constant value, we can use Ohm's Law to find the D.C. resistance by simply dividing the P.D. between anode and filament (or plate voltage) by the current passing between them. Apart, however, from its effect on the actual anode power dissipation, the D.C. resistance has very little significance indeed. Practically, we are always much more interested in the amount of opposition which the anode-filament path will offer to alternating currents fluctuating about a mean value. If the grid potential be still assumed to be held constant, we can express the A.C. resistance as the ratio between any increase in plate volts to the corresponding increase in anode current. Since this plate current is usually given in milliamperes, we can write

$$R_0 = \frac{\text{Increase in plate volts}}{\text{Increase in milliamperes}}$$

where  $R_0$  is the anode A.C. resistance expressed in thousands of ohms.

Again, a greater plate voltage will result in the passage of more current through the valve, but a slightly greater value of negative grid bias will bring the current back to its original value. The ratio between the increase of plate volts and the extra grid volts necessary to counteract it defines the magnification factor,  $\mu$ .

$$\text{Thus } \mu = \frac{\text{Increase of plate volts}}{\text{Increase of grid bias volts}}$$

(for same anode current).

The mutual conductance,  $g$ , of a valve is equivalent to the ratio of the magnification factor  $\mu$  to the A.C. resistance  $R_0$ . Conductance, of course, is the inverse of resistance, and is properly expressed in "amperes

per volt." In quoting the mutual conductance of a valve, the figures are usually given in "milliamperes per volt," and this will be the case if the value of  $R_0$  in the above ratio is taken as expressing "thousands of ohms." With this proviso we may write,  $g = \mu/R_0$ . In the present case  $g$  is given as 1.8 mA. per volt;  $R_0$  is 20, while  $\mu$  is unknown. We have, therefore,  $1.8 = \mu/20$ , which gives  $\mu = 20 \times 1.8 = 36$ .

**QUESTION 20.—A 50-turn coil has an inductance of 200  $\mu$ H. What is its approximate reactance at a wavelength of 314 metres? If its resistance is 500 ohms, what is the impedance of the coil at this wavelength?**

*Answer—1,200 ohms; 1,300 ohms.*

The simple formula for finding the reactance of a coil is

$$X = 2\pi fL$$

in which  $f$  represents the frequency of the current oscillations in the coil in cycles per second,  $L$  is the inductance of the coil expressed in henrys, and  $\pi$  is the well-known constant, 3.14.  $X$  is then the corresponding value of reactive ohms set up by the inductive action of the coil.

The first thing to be done here is, evidently, to find the frequency corresponding to the wavelength of 314 metres. Now, any wavelength  $\lambda$  is related to the frequency  $f$  of the corresponding oscillations by the equation

$$\lambda \times f = 300 \times 10^6.$$

(This number is a constant, and represents the speed in metres per second with which the wireless waves radiate outwards from the source. Since  $\lambda$  represents "metres" and  $f$  represents "times per second," the interpretation of the constant as a velocity should be apparent.) Transposing, therefore, we may write  $f = 300 \times 10^6 / 314$ . In the next place, the value of  $L$  which was given in  $\mu$ H must be brought to henrys. This is done by dividing by  $10^6$ , i.e., by multiplying  $10^{-6}$ , thus

$$L = 200 \times 10^{-6} \text{ henrys.}$$

Substituting for  $f$  and  $L$  the two values thus found, our formula becomes

$$X = 2 \times 3.14 \times \frac{300 \times 10^6}{314} \times 200 \times 10^{-6}$$

which will be easily found to cancel down to give  $X = 1,200$  reactive ohms.

In most cases, unfortunately, the calculation does not "pan out" as simply as this, and much gruelling arithmetic may be necessary. Happily, however, this can be avoided by using *The Wireless World* Abacs, which will always yield the required answer at sight.

We have been careful to express the value of  $X$  as found above in "reactive" ohms, to emphasise the

**Nuts to Crack.—**

difference between these and the true ohmic resistance  $R$ , which in this case amounts to 500 ohms. The total impedance or opposition of the coil to alternating current is not, of course, obtained by adding  $X$  and  $R$ . The impedance of the coil at the specified frequency is denoted by the symbol  $Z$ , and is given in ohms by the equation  $Z = \sqrt{X^2 + R^2}$ .

Putting in the ascertained values for  $X$  and  $R$ ,  $Z = \sqrt{1,200^2 + 500^2}$ , which equals  $\sqrt{1,690,000} = 1,300$  ohms.

It should be noticed that the ohms of impedance, likewise, are not true "resistive" ohms. The impedance depends in part on  $X$ , which in turn depends on  $f$ ; hence impedance should always be cited as relative to the frequency which is being considered.

**QUESTION 21.—**The filaments of two valves are connected in parallel, and current is supplied from a 4-volt accumulator. If the resistances of the two filaments are 10 ohms and 12 ohms, what is the total filament current taken?

Answer—0.733 ampere.

Nothing is said here regarding the working voltages of the filaments. We can, therefore, assume that we are dealing with 4-volt filament valves, across each of which the full voltage of the accumulator may be applied. The currents drawn by the two filaments will accordingly be  $4/10$  and  $4/12$  ampere, i.e., 0.4 and 0.333 ampere, making a total current of 0.733 ampere.

**NEXT SERIES OF PROBLEMS.**

**QUESTION 22.—**A coil of 1,266  $\mu$ H. and a condenser of 0.0005 mfd. are placed in series. What is the wavelength to which they are resonant? What would be the resonant wavelength if they were placed in parallel?

**QUESTION 23.—**The frequency of a certain sound wave is 200 cycles per second. What is the frequency of its third harmonic?

**QUESTION 24.—**In a stage of resistance-capacity coupled L.F. amplification the valve has a magnification factor of 32 and an anode A.C. resistance of 270,000 ohms when the working voltages are applied to the circuit. If the anode resistance employed is 500,000 ohms, what is the actual voltage amplification obtained by the stage?

NUTCRACKER.

# Letters to the Editor.

The Editor does not hold himself responsible for the opinions of his correspondents.

Correspondence should be addressed to the Editor, "The Wireless World," Dorset House, Tudor Street, E.C.4, and must be accompanied by the writer's name and address.

**INFORMATIVE ADVERTISING.**

**M**AY I add a few words concerning "Informative Advertising"?

Mr. Watkins-Pitchford's letter is like some advertisements, just jargon! The pleas of "divulging of details of manufacture" and "variants outside the manufacturer's control" hold no water, as the "details" can always be found out by those wanting them; and if constructors used their parts as specified by the manufacturers or professional set designers there would be no variants.

We who read *The Wireless World* do so because we appreciate and understand what it tells us. We therefore expect to find that "So-and-so's" valve has a certain impedance, voltage, consumption, and mutual conductance, and do not care about physical details. It is not at all likely that we should use a pentode for a screen-grid circuit or *vice versa*.

Loud speakers should be quoted with their D.C. resistance, so that a transformer can be chosen to match it with the valve used in the output holder.

Give us information every time; those who have commercial receivers either call in the local "expert," who in turn returns it to the manufacturer for repairs when necessary. So, whether technical or otherwise, the advertisements are of no interest to them.

Mr. Slade—in his letter in your issue of January 27th—just hit the nail right on the head when he says it is exasperating to read all the journalistic extravaganza; believe me, it is—and more!  
Bournemouth. E. J. B. CURTIS.

**DIODE DETECTION.**

**"Softness of Tone."**

**I** NOTICE in *The Wireless World* for February 24th a letter from Mr. Hunt, which refers to the softness of tone associated with diode rectification. This softness of tone may be from one of two causes; due to the high impedance of the diode circuit the tuned circuit preceding it may be only very lightly damped, and a considerable loss of the higher modulation fre-

quencies may be experienced due to this cause. On the other hand, softness of tone may be due to linearity of the detector, which undoubtedly gives softness of tone when compared with a non-linear type of detector.

I have often heard these two causes of so-called softness of tone confused with one another. Very careful listening and comparison should, however, tell which of the two is the real cause.

My feeling about the whole question of rectification is that people pay a great deal of attention to distortionless amplification, and do not in general pay sufficient attention to distortionless detection; they are of equal importance. It is my experience that it definitely pays, from the quality point of view, to go all out for linear detection, and my recent article on diodes was meant to point out that linear detection with a diode, which is, I think, unquestionably the safest and surest method of obtaining linear detection, can be obtained without the enormous sacrifice in efficiency that is usually associated with this type of detection.

A writer in one of your previous numbers (which I regret I am unable at the moment to refer to) hinted that 2 volts input was not sufficient to operate a diode. This is not my opinion, nor my experience. Where a grid leak detector will work a diode will work—with probably better results. This is, of course, assuming that reaction is not employed, or at any rate only to a very limited extent, in the case of the grid leak detector.

From the point of view of quality I strongly recommend, where the field strength is greater than 10 mV-metre, a good aerial and earth; some form of coupled circuit, preferably one in which it is not possible to distort the incoming wave by having two peaks one on each side of the carrier, one much higher than the other; this followed by a diode and two L.F. valves in suitably designed circuits. H. L. KIRKE.  
London, S.W.4.

**Adapting the Diode to Existing Sets.**

**T**HE publication of Mr. H. L. Kirke's article in your issue of February 3rd and the letters from Messrs. N. Bonavia-Hunt and E. H. Sumner in the issue of February 24th should



# Tracing

By M. G. SCROGGIE,  
B.Sc., A.M.I.E.E.

# Troubles

## No. 5.—Mains Receivers and Superheterodynes.

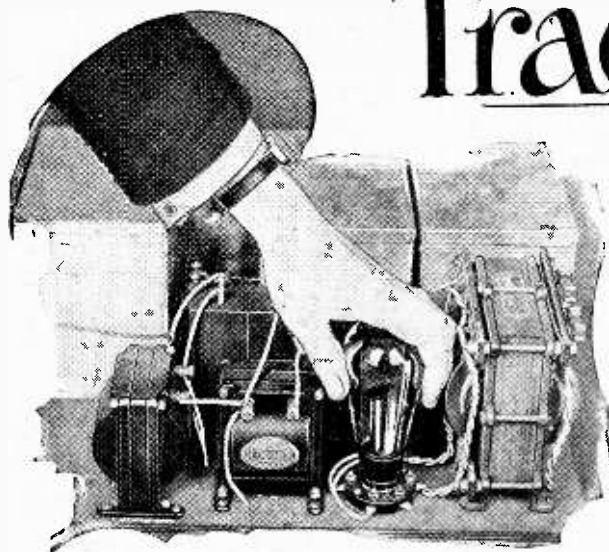

**T**HE remarks in the previous articles of this series, which assumed a battery-driven receiver, apply with a few obvious exceptions to apparatus which derives its power directly from an A.C. or D.C. public electricity supply. In addition, there are some faults and methods of testing which apply only to the latter class of receiver, and these will now be considered.

The extra components in an A.C. set, i.e., power transformer, rectifier, and smoothing circuit, will be referred to as the power unit, whether it actually takes the form of a separate unit or is built into the receiver proper.

If the receiver ceases to function properly, all haste should be made to switch off pending further investigation, otherwise the trouble of locating the fault may be avoided by the power transformer going up in smoke. The first thing to do (having switched off at the main) invariably is to feel the transformer for any abnormal heating. Blood-heat is a reasonable average temperature for normal running. It does not follow that because the transformer is cool there is no fault that would overheat it if kept on. Assuming, however, that the transformer is hotter than usual, the next thing is to feel around for other components which are unduly warm—rectifier valve, chokes, resistors—for this may give the clue. In the case of the rectifier valve one may also note if it is unduly cool, for that would indicate a short circuit in the transformer itself, whereas an excessively hot rectifier valve is very likely to be due to a broken-down filter condenser. If the short-circuit is in the receiver itself or in the smoothing condenser on the output side, the smoothing chokes are likely to warm up noticeably. Unless the transformer has been so badly cocked that it has approached

the burning-out stage, the next test can be cautiously embarked upon. Switch on and *very rapidly* take voltmeter readings between earth (negative) and various positive points, beginning nearest the rectifier. Thus, in Fig. 1, which represents a typical power unit with valve rectifier, the negative side of the voltmeter would be connected to E (which is usually accessible in the form of the earth terminal on the receiver) and the positive terminal in turn on A, H.T.2, and H.T.1. Absence of volts at all these places would signify a short-circuit of condenser  $C_1$ ,  $C_1C_1$  (if fitted), a deceased rectifier valve, or a break in one or more of the transformer windings or leads.

### Using a Neon Lamp.

A total short-circuit of the transformer may almost be left out of consideration, for it would be practically certain to blow the house fuse, even if one were not provided on the power unit. A short-circuit is usually announced by an audible kick from the transformer at the moment of switching on, and most transformers also hum angrily when their secondaries are shorted. Some clue to the other main type of fault, an open-circuit, may be given by an unnatural stillness and coldness. Do not forget to take account of the possibility of a bad valve-holder contact. The functioning of the valve filament circuit can usually be inspected visibly, though it may be necessary to do so in the dark or twist the neck into an awkward position to find a tolerably unobscured part of the glass through which to see the filament or heater.

If no A.C. voltmeter is available, a neon lamp of the type sold for use on lighting circuits, and which is fitted with an internal resistor, makes a good substitute for checking the existence of voltage at the transformer H.T. secondary, but be careful to put it across only one half

*SPECIAL treatment may be necessary in the case of a faulty mains receiver—A.C. or D.C.—when attempting to diagnose troubles. One of the most frequent causes of annoyance is hum, and its elimination is accordingly dealt with at some length. Notes are given at the conclusion of this article on locating faults in superheterodyne sets.*

**Tracing Troubles.**—

at a time of a centre-tapped winding; even one half may be rated at 300 to 450 volts in these days, so a momentary application is all that is desirable. The 4-volt L.T. windings may be checked by a flash-lamp bulb of appropriate voltage, which may also be used to confirm the continued soundness of centre-tapping of a L.T. circuit by connecting from centre to each side in turn. Some designs take connections from centre taps of L.T. windings (including the one for rectifier valve), and some take them from one side; it is often necessary to know which in interpreting the results of tests.

**Locating Hum.**

If condenser  $C_2$  has shorted, or any similarly connected component in the receiver, there will, of course, be an absence of voltage across it, but a reduced reading will exist at A; similarly for a short in H.T. circuit. Accurate readings are, of course, not essential for the foregoing tests, but when they are it is quite necessary for the voltmeter to have a high resistance; 1,000 ohms per volt is perhaps the highest practicable in a reasonably priced robust instrument, though even then there is a perceptible error.

We have considered the case of a total cut-off of H.T. voltage; if the principal symptom is a *reduced* voltage it may be caused by some receiver fault leading to excessive current drain, for which refer to the articles on battery-drive sets, or there may be some reduction in efficiency inside the power unit. A total short-circuit of one or other of the windings would result in a considerable reduction in all the other voltages; it is easy to detect the winding which is shorted, however, for it is the only one which is giving no volts at all. But when the short-circuit is partial, such as a layer or a few turns, all the output voltages are reduced, and it is by no means easy to decide which winding is faulty.

heater current being rather heavy, a very slight extra resistance, such as a poor joint, is sufficient to cool the heaters below the point of efficiency.

The procedure with a metal rectifier power unit is much the same, but it is particularly desirable to clear a short-circuit immediately, otherwise the rectifier will be of no further use. A pea-lamp fuse in the rectifier output is a wise safeguard; it must be of enough current-carrying capacity to pass the surges which are often set up at the time of switching on and off.

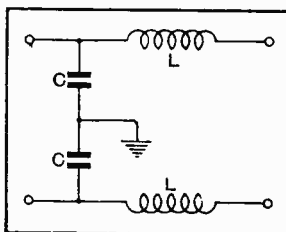

Fig. 2.—Filter for reducing mains interference when condensers  $C_2, C_3$  (Fig. 1) are not adequate. The mains can be connected at either end. The coils LL can consist of 26 gauge wire and should possess an inductance of about 5,000 microhenrys.

The condensers  $C_1, C_4$ , useful in preventing hum of the type which is only in evidence when a carrier wave is tuned in, must be of very high test voltage—ten times the working voltage is not too high—because they have to withstand rather severe potentials, and their breakdown does not do the rectifier and transformer any good. Condensers  $C_2, C_3$  are sometimes fitted to conduct machine interference away to earth instead of to the receiver. Their failure would blow the house fuses.

In dealing with hum it is important to distinguish between that which issues from the loud speaker and that which does not, for perhaps the commonest sort is caused by vibration of the power transformer or choke core stampings or of iron in the neighbourhood (Fig. 3). The former is cured by several applications of varnish, allowed to fill up the cracks between stampings, and the latter by packing with strips of rubber or other suitable material, or by more rigid clamping.

True loud speaker hum may be accompanied by other effects which help in deciding the cause. For example, if the voltage from E to H.T.2 (Fig. 1) is found to be the same as that across EA, it is quite obvious that the choke between is short-circuited. An open-circuited filter condenser naturally causes hum, and if it is the first condenser after the rectifier it causes a noticeably reduced output voltage also. The method of test is to take a condenser of about 2 mfd. and connect it across each filter condenser in turn. The effect should be small unless the one it is connected across has retired from business.

To locate a hum fault in the receiver follow the method advocated for tracing the cause of noises; little need be added on that subject. Of course, a cause of hum, such as inadequate smoothing, which is entirely inoffensive if in connection with the power valve, may be very bad if acting on an earlier valve, and particularly the detector. For this reason most

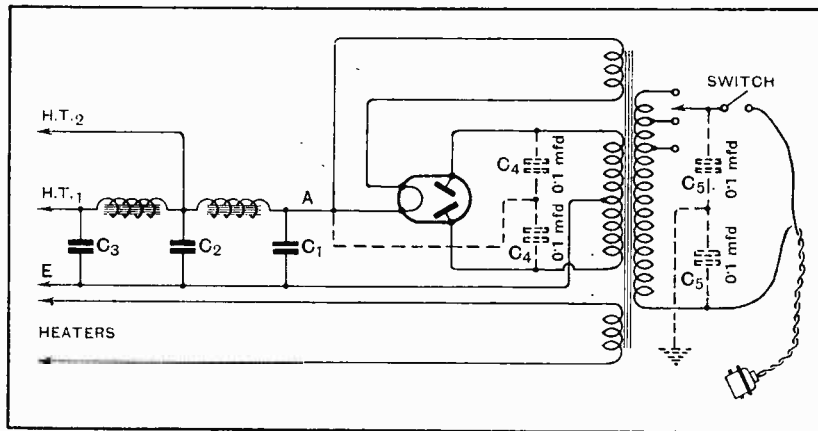

Fig. 1.—Typical mains equipment in a modern A.C. receiver. The points at which voltage readings should be taken are indicated.

A reduction in voltage *and* current, when the transformer is in order, can hardly be anything else than a senile rectifier valve, not omitting the possibility of half-waving due either to the valve or its holder. If the heater circuit fails, causing the current to the valves to be cut off, the H.T. voltage is *greater* than normal. The



**Tracing Troubles.—**

designs provide progressive smoothing as the feed moves along from the power-valve anode. It would be very extravagant and unnecessary to pass the anode current to all the valves through all the smoothing filter, for not only would the amount of smoothing necessary for the detector valve be many times as great as need be for the power valve, but the presence of the heavy current to the latter would make chokes which would be good enough for the former extremely large and expensive.

Indirectly heated A.C. valves sometimes develop hum through internal faults, and are more likely to display this if the grid circuit is completed through a leak and not through a tuning coil or other low-resistance circuit. Hum due to H.F. valves or their adjuncts may only be heard in the presence of a carrier wave, but the same type of hum may be caused by a power rectifier (valve or metal) or by some form of H.F. disturbance conveyed along the mains, as noted when referring to the buffer condensers across the transformer H.T. winding. The same channel is liable to convey all sorts of interference, for which reason it is frequently inadvisable to make use of a "mains aerial," but, on the contrary, to take steps that the mains shall *not* act as an aerial, either by the rudimentary filter shown dotted in Fig. 1 (condensers  $C_5, C_3$ ), or by a more elaborate arrangement with chokes in series, as in Fig. 2. In any case, one can hardly avoid clicks when lights are switched off in the vicinity, and vacuum cleaners—but the subject is too painful to go over again.

**Mains Sets.**

In turning to D.C. apparatus the principal point to be observed is extreme care, because the whole affair is more or less "live," and, whereas a momentary short is practically harmless in an A.C. set, a really undesirable display of fireworks—and probably something worse—may be the result of such a slip when probing a D.C. set. The awkward thing is that there are two "earths"; the parts which are of low potential from the point of view of reception (the cathodes of valves, "earthy" ends of tuning coils, negative H.T., etc.), and the parts which are of low potential with respect to the user, such as accessible metal parts, which should be connected to true earth. In other types of apparatus the two systems are one and the same, but with D.C. the full supply voltage may exist between them, a fact which must be carried in the foreground of one's mind when working with the lids off and the current on. It is quite advisable to have fuses incorporated, chosen

to blow at comparatively little more than the normal current, as a lot of damage may be done before a heavy house fuse cuts out. Another point is that, in switching off, reliance should not be placed on the ordinary single-pole lighting switch. It is not unknown for this to be in the low-potential line, leaving the "live" side connected all the time. A two-pole switch should be used, or else the plug disconnected entirely when working inside the set (Fig. 4).

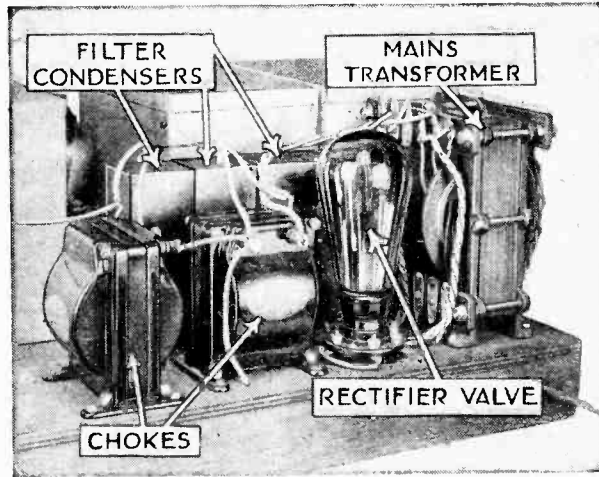

The principal components of the mains equipment in a modern all-A.C. receiver.

The main peculiarity of D.C. is that, the filaments or heaters being all in series (in practically all designs), the failure of one cuts off the current to all. To find which one contains the fault, test across each pair of filament sockets in turn, all valves being in position and the current on, with a voltmeter scaled up to the full mains voltage; the one with the open-circuited valve will be the only one to show a reading, unless the position is complicated by shunt circuits, in which case it will

probably show considerably the largest reading. An ordinary lamp makes a good substitute for a high-reading voltmeter. For the same reason it is obviously impossible to test individual valve anode currents by pulling all the others out, and the valve adaptor must be resorted to.

The remarks on mains interference apply with greater force to D.C., because motors connected elsewhere on the system are necessarily of the commutator type and therefore most likely to interfere noisily. Unfortunately the current taken by D.C. sets is usually rather heavy and makes the design of effective H.F. filter chokes

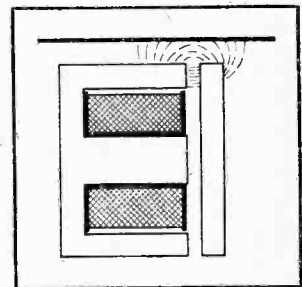

Fig. 3.—The leakage flux at the gap of an iron-core choke may pass through adjacent iron sheet and cause it to vibrate. This is sometimes the cause of hum.

less easy than could be desired. The actual faults that are likely to occur are similar to those already dealt with, as far as applicable.

A few words may well be devoted to the case of the superheterodyne, now that its voice is heard once more in the land. This series will have failed in its object if it has led to reliance on a catalogue of tests rather than on principles of testing, and the latter are applicable in the main to all types of circuit. Thus, if a superhet. fails to work, first find out if it is sound from the second detector onwards, which section may

**Tracing Troubles.**—

be treated in an identical manner to that already described. If it is, follow the same principle of adding to the sound part of the body until the injured organ betrays its identity by a twinge of pain or lifelessness, as the case may be. Use the initial signal frequency stage, if any, and connect it through to the second detector, skipping the I.F. amplifier and leaving a "straight" circuit. If this works, then it is the frequency changer or I.F. amplifier that is sick and must be looked to. Failure to obtain wild squeals on rotating the oscillator tuning control, the other parts being modified in connection as just suggested, would narrow the search down to the oscillator, for if it were working it would heterodyne with the carriers of stations to give audible notes. In examining the I.F. part, cut out each stage in turn.

One must, of course, be always on guard to avoid introducing complications and to interpret the tests aright. This is where due regard must be paid to the individual peculiarities of the design concerned.

The art of tracing troubles becomes a matter almost

of intuition when one has gained experience, but until that stage is reached it is wise to follow sound methodical principles rather than blindly to try one thing and then another.

Much exasperation may be caused by drawing a plausible but unjustifiable inference. An experimental receiver developed a fault, and, suspecting that the A.C. power unit was responsible, a battery was temporarily substituted, and stood on top of the receiver, which was enclosed in a metal cover for screening purposes. Results with the battery being perfectly satisfactory, it seemed not unreasonable to place the fault in the power unit and not in the receiver, the more so as reconnecting the former brought back the fault. It was some time before it was found that the weight of the battery shifted a short-circuit to the screen, which closed up again when the battery

was removed from the top of the receiver.

Finally, never give up attempting to understand an effect which appears contrary to known principles. Most great discoveries have been the result of not taking apparent contradictions for granted.

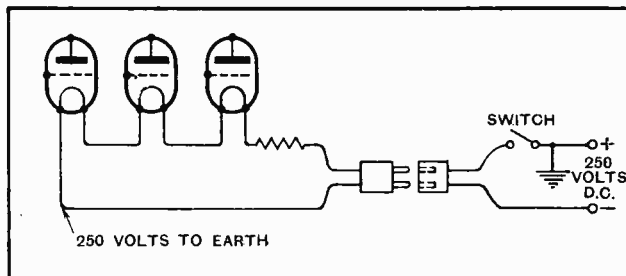

Fig. 4.—Sometimes the house switch controlling a D.C. supply is connected in error in the low-potential side causing the filaments and other parts to be fully live to earth in those cases where the positive main is earthed at the power station. It is wise to pull the plug out entirely.

## MORE HOWLERS FROM FRENCH PROGRAMMES.

*Our Correspondent sends another Selection of Misprints taken from the Announcements of Broadcast Items in the French Press.*

THE good work still continues; and, as ever, one's most frequent reaction to the howlers is the wish that pieces *did* exist with these names.

For example, "Soffy as in a morning sunrise"; one knows that "soffy" feeling in the early morning so well, and it only remains for a composer to do it justice. Or, "When the white hlies blow again," suggesting a March for the reopening of Parliament. Or, "The little thigs of life," such as a cold in the head in this case, obviously (hear it on the muted saxophones, with the violins sneezing). And "Sin ginging the Rain," evidently the incidental music for the Somerset Maugham play. And "You can't stop me from lowing you," a pastoral idyll of calf-love. And will someone please write the "Overture de Haendel et Gretel"?

Then "Rubble and Squeak" is the ideal motto for the jerry-built house; well, isn't it? And as a name for the nice sort of old-fashioned pub, what about "The Mery Windows"?

Comment is perhaps better omitted in regard to "Swett Mama," though "Bitter Swett" suggests the curse of Eden. And "The Moincible Eagle" obviously comes from the same Lear book as the "runcible spoon." "Yoll want me Bach," not very clear but an improvement in musical taste is indicated. "When its S Sprinting the Rockies," possibly the ultimate form of Marathon Race? "Mal Kung with Susie," yellow

peril? And another thoroughly nice name, with an Oriental suggestion also, is "Kathlee Mavonnkeen," arranged for gongs and Chinese flutes, I think.

"Je suis un Rameur (Mendelssohn)," retranslate, "I'm a Rower." And the next item *was* the Voga Boatsong.

Two good doubles: "On top of the word olone" and "On top of the wold alve," and "Deep Nigh" with "Dreep Nisaht." The word "night" seems to worry the printer: "To Naygt you belong" suggests that he has been listening to certain of the B.B.C. announcers. Without comment: "Waht dy a say?" "Righ in wing," "I'm reeping compagy," "When I take my sugard to teao," "Shine of harvest moon," "Luke a breath," "The Maon I love," "The Surinse" (early morning feeling again!), "In la little fide aawy," "Indian Love Sall" (in our Alley?), "Tea fort two," "The voice of the Southiand" (Scotch term of contempt, equivalent to Sassenach), "Silent Night, Doly Night," "Sfay out of the South" (Somerset?), "You re in my hear," "Dixies Shaves," "Your driving me grazi," "Motor Rid," "The Golligog's Cakewalk."

Just to show that English is not unduly favoured: "Kennst Du dao gefilth?" described, incidentally, as "Valse Anglaise."

In fact, as one of the titles says, the contributions recently are "Bidger and Bether than ever." R. R.-II.

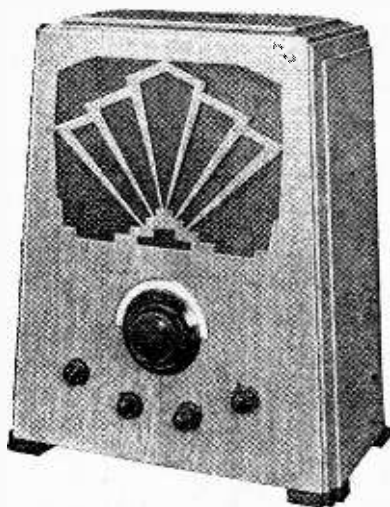

# Wireless World D.C. THREE

In response to a large number of requests a D.C. mains version of "The Wireless World A.C. Three" has been designed, and will be described in next week's issue.

Very large areas of the country are likely to remain dependent upon D.C. supply for some years to come, and, even should a change be made, this receiver would be easily adaptable, most of the parts, including the chassis and cabinet, being interchangeable with the A.C. model described in *The Wireless World* some time ago.

### Features of the Set.

- Band-pass tuning with inductive link coupling.*
- Tuned anode intervalve coupling with reaction.*
- Power grid detection with auto-transformer linked to pentode.*
- Built-in moving-coil loud speaker.*
- Single-tuning control of three tuned circuits.*
- Volume control using single potentiometer for H.F. grid bias variation combined with change of signal input.*
- Radio-gramophone and wave-change switch.*
- Indirectly heated 16-volt 0.25 amp. valves.*

### LIST OF PARTS.

After the particular make of component used in the original model, suitable alternative products are given in some instances.

- 1 Three-gang condenser with fixing screws (British Radiophone)
- 3 Five-pin valve-holders (W.B. large-type base)
- 1 L.F. transformer (R.I. "Parafed")
- 1 Slow-motion condenser, 0.0002 mfd. (Ormond Midget R/149)
- 1 H.F. choke (McMichael Binocular Junior)
- 1 Pre-set condenser, 0.0001 mfd. (Polar)
- 1 Valve screen (Colvern)
- 1 Wire-wound potentiometer, 50,000 ohms. (Colvern)
- 1 Ethovernier dial and log (Henry E. Taylor, Ltd., 51-53, Church Street, Greenwich, S.E.10)
- 1 Length of flexible metallic screened sleeving (Lewcos). (Goitone)
- 1 Set of coils complete with A.C. chassis (Colvern WW3)
- Strip resistances as under (Colvern)
- 1 x 250 ohms 1 x 15,000 ohms
- 1 x 300 " 1 x 20,000 "
- 1 x 1,000 " 1 x 30,000 "
- 1 x 10,000 " (Dubilier 1-watt type).
- 8 Fixed condensers, 1 mfd. (T.C.C., Type 65)
- 1 Fixed condenser, 4 mfd. (Dubilier, Peak, Formo, Sound Sales, Ferranti, Lissen, Hydra, Loewe). (T.C.C., Type 65)
- 1 Fixed condenser, 0.0001 mfd. (T.C.C., Type M)
- 1 Fixed condenser, 0.0002 mfd. (Dubilier, Type No. 665). (T.C.C., Type M)
- 1 Fixed condenser, 0.005 mfd. (Dubilier, Type No. 670). (T.C.C., Type M)
- 1 Metallised resistance, 250,000 ohms, 1 watt. (Dubilier)
- 1 Switch (Claude Lyons, B.A.T. 151)
- 1 L.F. choke (R.I. Hypercore)

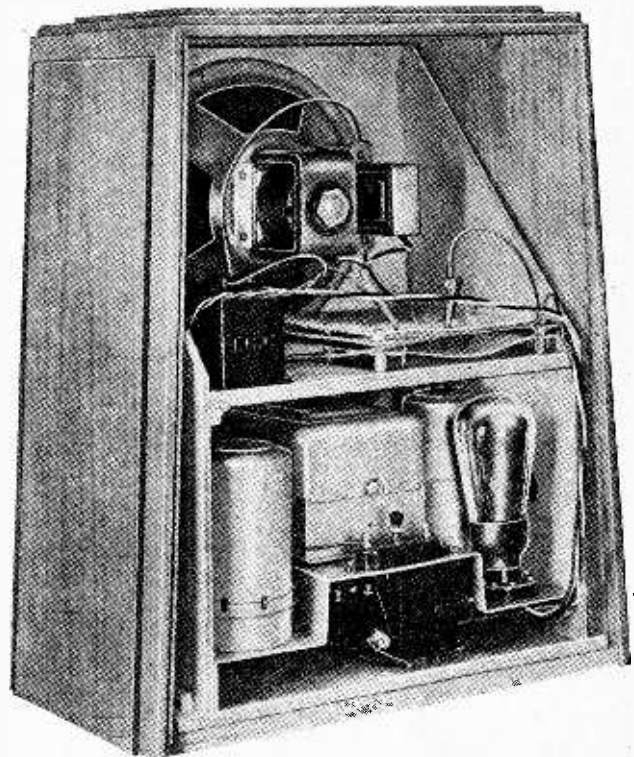

- 1 Resistance mat, 225 ohms, tapped (Cressall, Type S.R. 35)
- 1 Resistance mat, 400 ohms, 65 watts (Cressall, Type E.R.J.)
- 1 Resistance mat, 200 ohms, 65 watts (Cressall, Type E.R.F.) (Bulgin Mains Resistance).
- 1 D.C. Minor moving-coil speaker chassis, with pentode transformer (Ultra)
- Valves: D.S., D.H., and D.P.T. (Marconi)
- (O-ram).
- Systoflex, wire, screws, etc.
- 1 Cabinet with interior chassis (Clarion, Type S.C. 3)

# LABORATORY TESTS ON NEW RADIO PRODUCTS.

## AUSTIN MAINS FILTER.

Small electric motors, motor generators and kindred types of electrical machinery are often responsible for considerable interference where a sensitive broadcast receiver is in use; the commutator type of motors such as are employed on D.C. supplies being the worst offenders in this respect as a rule. With a view to rendering wireless reception possible under such conditions Austin Mills, 3, St. Albans Avenue, Heaton Chapel, Stockport, has introduced an interference filter unit, which when inserted in the wiring to the offending machine has proved very effective in eliminating interference.

Tests were carried out with one of these units fitted to a small electric motor which was responsible for considerable interference, and proved very effective indeed. Good reception on a sensitive receiver was possible with the unit in circuit where otherwise it was badly marred by the motor. The unit was located close to the machine, and inserted in the two mains leads; the lead to the starter was not included in the smoothing circuit since the unit will deal with two lines only. The metal case of the unit was earthed.

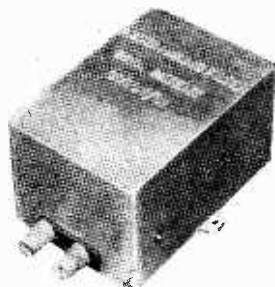

Austin Mills interference filter for fitting to a small electric motor.

A further test was made with a D.C. to A.C. converter, also a bad offender when not fitted with filtering equipment, and although the interference was reduced to quite a low level it was necessary to include simple filtering in the A.C. output circuit to eliminate all interference, as these leads passed close to the receiver. With the A.C. leads disconnected from the converter the Austin Mills filter, only, sufficed to silence the machine. The unit was inserted in one line lead and the lead from the starter to the armature terminal on the motor.

From the tests made we feel confident that the Austin Mills filters will successfully eliminate the interference so often caused by electric motors, and make possible good wireless reception of both local and distant programmes.

A popular size of filter carrying up to two amps. costs about 21s., but larger sizes are available also to order. It is necessary to notify the makers when placing an order of the nature of the electric supply on which the filter will be used.

## LEWCOS L.F.T.6 TRANSFORMER.

Made by the London Electric Wire Co., and Smith's, Ltd., Church Road, Leyton, London, E.10, this inter-valve L.F. transformer is intended for use when a high-ratio step-up is desirable, such as in the case where only one L.F. valve follows the detector. It is wound on a bi-metal core of high permeability, and has a step-up ratio of 1:6. Since quite small amounts of D.C. flowing through the primary cause a considerable drop in its inductance, the transformer should, for preference, be used with a parallel feed circuit; an anode coupling resistance of about 30,000 ohms and a 1 mfd. feed condenser being suitable values for the associated components.

With no D.C. flowing, the measured primary inductance was 28 henrys, and this fell to 10.8 henrys when 2 mA. of D.C. were passed through the winding. The best results will be obtained with a detector valve of comparatively low A.C. resistance, but the transformer is quite suitable for use after valves whose A.C. resistance is of the order of 14,000 ohms.

Tested in a circuit with a valve having an amplification factor of 19, and an A.C. resistance of 10,000 ohms, and employing the parallel feed system, a voltage amplification of over 60 times was obtained from the single stage between 300 cycles and 4,000 cycles, while at 50 cycles and at 7,000 cycles the amplification was about half this value.

In view of the high amplification

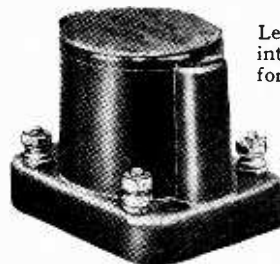

Lewcos 1:6 ratio interval transformer; Model L.F.T.6.

afforded by the model L.F.T.6, this transformer is particularly well suited for use in a two-valve set consisting of a detector and pentode. The price is 10s. 6d.

## "KINVA" HETERODYNE WHISTLE FILTER.

Of the many forms of interference met with at the present time on the medium broadcast waveband the most irritating is undoubtedly the continuous heterodyne whistle which mars so many of the foreign programmes. If the selectivity of the re-

ceiving circuits is improved to such an extent that this type of interference disappears, then the quality of reception is seriously impaired, and it would seem that the most satisfactory method so far suggested to combat this trouble is to include a low-pass filter which cuts off fairly steeply above 3,500 cycles. If a good response is maintained up to this point on the audible scale the quality of reproduction will be acceptable, and most of the heterodyne whistles will disappear. Without a filter, reception in certain districts might be intolerable.

Postlethwaite Bros., Church Hill, Kinver, Stourbridge, have developed a range of filters to achieve this end, and reference was first made to the filter in an article published in *The Wireless World* dated November 4th last. Some new

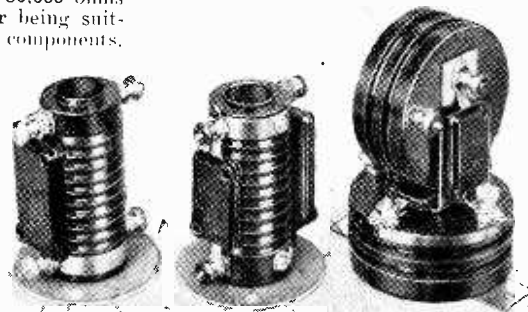

Range of Postlethwaite "Kinva" Heterodyne whistle filters.

models have since been introduced, styled the types "B" and "BI," respectively. The first-mentioned is a single-stage low-pass filter for use in the anode circuit of the detector after the H.F. choke, if reaction is used, and consists of a high inductance provided with an adjustable nickel-iron alloy core and two by-pass condensers. The cut-off frequency is raised as the core is extracted.

The "BI" model differs from the type "B" in that it can be used in place of the H.F. choke, but the filtering effect is sensibly the same. Tests show that the cut-off is quite steep above 3,500 cycles, and that when inserted in the anode circuit of a detector all heterodyne whistles above 3,500 cycles are entirely suppressed. If the receiver is fitted with two L.F. stages it would be best to use the type "A" filter, which is a two-stage unit costing 15s., and intended to be connected in the anode circuit of the penultimate valve. The prices of the models "B" and "BI" are 7s. 6d. and 7s. respectively.

## EDDYSTONE SUPERHET SHORT-WAVE CONVERTER.

This unit is intended for use in conjunction with a broadcast receiver fitted with at least one H.F. stage. It functions on the superheterodyne principle, but embodies one valve only—a Mullard P.M.2DX.—which serves the dual purpose of local oscillator and first detector, or frequency changer.

The unit is entirely self-contained, the H.T. and L.T. batteries being housed in the cabinet. As a consequence, it is suit-

able for use with all types of receivers whether they be battery operated or mains driven. An aerial is a necessity, and the usual broadcast type is quite satisfactory. The converter covers a wave range

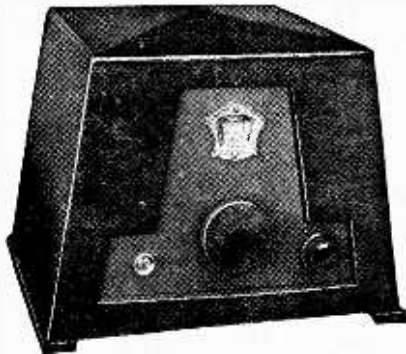

Eddystone converter for short-wave reception with a broadcast set.

between about 15 metres and 65 metres in two steps. A tapped coil is fitted which embodies a wave-change switch, the control for which is located at the back of the unit. The two ranges are 15 to 32 metres and 29 to 55 metres respectively.

According to the makers' recommendation, the broadcast set should be adjusted to a wavelength between 1,800 and 2,000 metres, but we obtained excellent results with a set tuned to any wavelength, from 1,000 metres upwards. The wave range of the converter is affected slightly by working with a low I.F. wavelength.

With a poor aerial and using a receiver fitted with an efficient H.F. stage, exceptionally good results were obtained. To receive C.W. signals the broadcast set must be just oscillating.

The makers are Stratton and Co., Ltd., Balmoral Works, Bromsgrove Street, Birmingham, and the price of the converter is £4 17s. 6d. complete with valve and batteries, or £4 5s. without batteries.

**WATES A.D. LOW TENSION CELLS.**

The discharge test to which mention was made in the first review of these batteries

it has been necessary, of course, to accelerate the process of discharge to enable this to be completed within a reasonable time. The specimen cell has been discharged intermittently at the rate of 0.5 amp. for periods of four hours at a time, with similar periods for rest and recuperation.

Under normal conditions of use the rest periods would be of much longer duration, for in all probability the battery would be in use for about four hours per day. Despite this, the tests just completed give a very fair indication of the performance as it will be seen from the curve here reproduced that some 900 hours actual working time has been achieved.

A point of interest is that after passing the 900-hour mark the voltage fell rapidly, and although two days were allowed for rest and recuperation the voltage did not again attain, on load, the same level as formerly.

Assuming the cells are in use for four hours per day, 900 hours will represent some 32 weeks' use, but it is more than probable that with the longer rest periods allowed in normal use the life of these cells will be of the order of 1,000 hours.

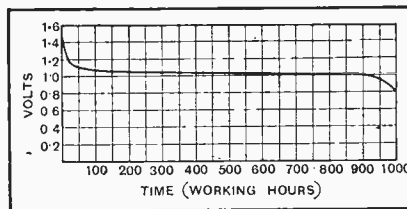

Discharge curve of Wates A.D. cell at 0.5 amp.

During this time the only attention required is occasional "topping up" with water to replace that lost by evaporation.

Recharging is a simple process. The used electrolyte is poured out, the zinc discarded, and after flushing out the cells with clean water a new zinc and fresh solution is added. The zinc elements cost 8s. each, while the sal-ammoniac crystals cost 3s. for each cell.

A.D. cells are made by the Le Carbon organisation and marketed by the Stan-

**ANOTHER CABINET FOR "THE AUTOTONE."**

The cabinet illustrated here has been submitted by Smith's Cabinets, Ltd., 18-20, Hertford Road, London, N.1. It has been designed specially to house the Auto-

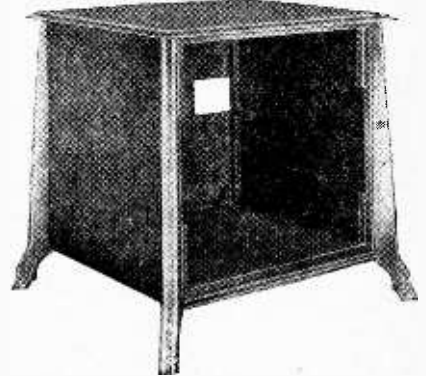

tone. It is neat in appearance and well finished, and sells at the price of 21s. 6d.

**TRIPLE DECOUPLING CONDENSER.**

It is often a matter of importance that high-potential connections to by-pass condensers used in H.F. decoupling circuits should be short and direct.



Savage condenser block, comprising three 1-mfd. non-inductive units.

In the case of a screen-grid H.F. valve it may be necessary to decouple the grid, anode, and screening-grid circuits, and for this purpose a new type of triple condenser made by W. Bryan Savage, of 292, Bishopsgate, London, E.C.2, should be highly satisfactory. It comprises three separate sections of 1 mfd. each, contained in a single container, and is non-inductive, thus making it suitable for use in H.F. circuits. Designed for operation at voltages up to 500, the condenser block costs 4s. 6d. The arrangement of the tags at the side is particularly good, allowing for short connections.

Another use is for decoupling grid and anode circuits of a detector valve which operates also as a gramophone amplifier; two of the 1-mfd. elements may be "paralleled" and used for anode decoupling, the remaining element serving as a by-pass for the grid circuit.

**MAJESTIC MIDGET SUPERHETERODYNE.**

The review of this receiver is unavoidably held over until next week.

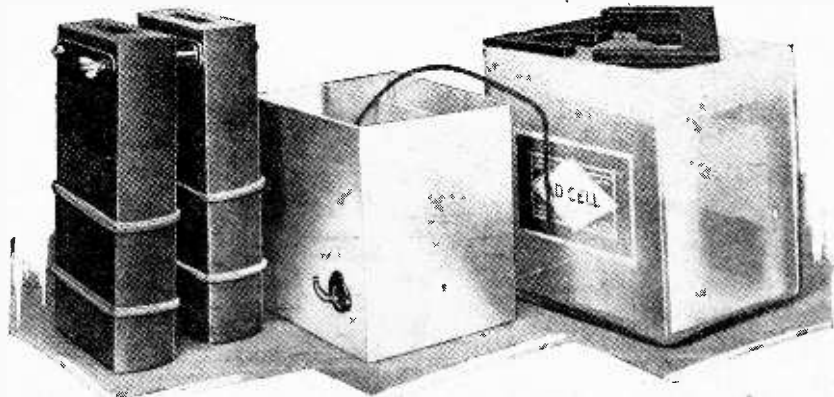

Component parts of Wates A.D. low tension cell.

published in our issue dated December 23rd last, has now been completed, but

ard Battery Co., 184-188, Shaftesbury Avenue, London, W.C.2. The price is £2 complete.

# Broadcast Brevities

By Our  
Special Correspondent.



Signor Gastone Coffa, the only male announcer at Esane, was a London banker for nine years before the War. The obsolete "meat-safe" on the right houses a modern R.C.A. microphone.

those who feared that his programmes would be of a very restricted kind.

"A lot of fuss has been made," he said, "over a chance remark of mine last January that I favoured 'sweet' music. It appears to have been interpreted as meaning that I intended to exclude other forms of dance music such as ultra-syncoated 'hot' jazz and the vaudeville type."

## A Varied Repertoire.

"This is quite wrong," explained Mr. Hall. "While my mandate is to provide dance music, listeners will probably find that there is no form of music played in the past by dance orchestras that the B.B.C. band will exclude from its repertoire."

## That Oboe.

Talking of dance bands, many readers have reproved me more or less gently for daring to assert a fortnight ago that Henry Hall's would be the first dance band to include an oboe. Apparently oboes have been pressed into service since 1923 or thereabouts, and I must apologise to all concerned.

And one reader suggests that the artiste whom I mentioned would feel far more flattered if referred to as a vocalist rather than as a singer. I had no idea that dance vocalists were so modest.

## A Gangster and Others.

STILL determined to make our flesh creep (and I am glad of it) the B.B.C. will begin in May a Saturday night series of talks, under the general title of "Hazard," in which notable adventurers will give us first-hand descriptions of their experiences. The subject seems as promising as "Escapes," which provided such an engrossing collection of true yarns a few months ago.

The contributors will be famous sailors, soldiers, flying men, an Arctic explorer, and, also, if it can be arranged, a real gangster. I assume he will be on the retired list.

## England v. Scotland Rigger.

A RUNNING commentary on the England v. Scotland Rugby International match will be given by Captain H. B. T. Wakelam on March 19th, and relayed from Twickenham.

## Where are the Oscillators?

ONLY 6,910 letters of complaint regarding local oscillation reached the B.B.C. during 1931, as compared with 7,023 in 1930.

This is not a big drop, but it is significant of the fact that oscillators are a slowly dying race. I hold no brief for the squealers, but there is always something sad in the decline of a popular movement. Steps might be taken to ensure the survival of a few specimens, perhaps by the founding of a national reservation similar to those which accommodate the Red Indians in America. The few remaining squealers and their squaws could then re-radiate to their hearts' content.

## Misgivings at Savoy Hill.

"THE B.B.C. staff must fight their own battles," remarked a genial listener to whom I had said that nearly everybody in Savoy Hill is dreading the day of removal to Broadcasting House. He added that staff discomforts, although regrettable, do not really concern the general public.

## Poor Accommodation at "B.H."

Most readers will probably agree that he is wrong. A discontented staff is not likely to be efficient, and inefficiency on the staff side is bound, sooner or later, to affect the programmes and, consequently, listeners' enjoyment.

So that, looking at the question from a purely selfish angle, I am sorry to find that the grumbles are growing at Savoy Hill over the pitiful shortage of accommodation in the new building.

## On Board the Lugger.

Months ago, when people were making jocular allusions to the ship-like appearance of Broadcasting House, it was hinted that space would be at a premium, and now that the stage has been reached when rooms are being allocated to the various departments, it is becoming only too evident that the ship idea has been carried through to the bitter end.

## Cubicles.

At "Broadcasting House" rooms measuring 8ft. x 6ft. are being coveted by the many people who will be condemned to labour in cubicles 7ft. x 5ft.

The Civil Engineer himself, who helped to design and erect the building, works in a compartment in which, as the American said, "You couldn't cuss a cat without getting hair on your teeth."

## A Mistake.

To put it candidly, the B.B.C. have made a mistake in attempting to cram into Broadcasting House all those extra departments which were formerly "farmed out" in various odd buildings in the neighbourhood of the Strand. The next move, I suppose, will be the demolition of the houses adjoining the new building to provide for the construction of annexes.

## Plenty of Echo.

It is at least comforting to know that there has been no cheeseparing in regard to studio space. Indeed, the size of most of the studios is such that very little use will be made of the auxiliary echo rooms. In most cases the engineers have found it necessary to introduce damping to cut down resonance effects, and Mr. Ashbridge promises that the general effect of transmission from the new studios will show a great improvement over those from Savoy Hill.

## Guessing Game.

The change-over begins on March 15th with the first broadcast of Henry Hall and the B.B.C. Dance Orchestra from Studio 8a, and thereafter the new studios will come into use one by one.

There is material here for a good guessing game if the B.B.C. could be persuaded to tell us at the end of each programme whether the studio used was new or old.

## Henry Hall Explains.

MR. HENRY HALL, the new B.B.C. dance band conductor, made a statement last Friday which should reassure

# READERS' PROBLEMS

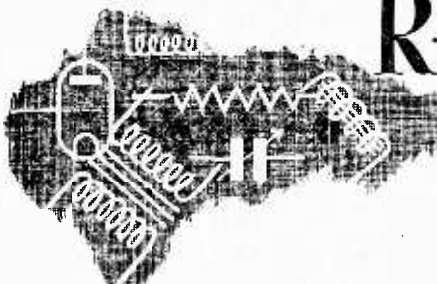

## Checking Anode Current.

IT would seem that a number of readers have obtained misleading results when measuring the anode current of individual valves, because some of the other valves in a receiver have been removed from their sockets while the operation has been carried out. This applies almost exclusively to mains-operated sets.

It should be realised that the voltage output of every type of eliminator is dependent to a greater or lesser extent on the amount of current drawn from it. It is no exaggeration to say that if we remove the output valve from its socket the voltage on the anodes of the remaining valves may possibly rise by as much as 50 per cent. above its normal value. A reading of anode current taken while this excessively high voltage is applied will obviously be more or less misleading; but, as a matter of fact, when free bias is employed the increase in current will not be so great as might be expected.

## Variable-mu Valves and Economy.

AFTER reading a recent note on the subject of variable-mu valves for battery feed, a querist, who proposes to use these valves in a two-stage H.F. amplifier, asks whether it would be practicable to effect an economy in H.T. battery current by making provision for switching out one of the H.F. stages while transmissions from his nearest stations are being received. He knows by experience that a single H.F. stage gives more than enough amplification for this purpose.

We cannot help feeling that it is a great pity to complicate a receiver by making provision for eliminating one of the stages. Indeed, it would probably be most difficult to do so without introducing instability, or, at any rate, an appreciable loss of efficiency.

Even if these disadvantages could be overcome, we cannot see that any great advantage would be gained. Although the variable-mu valve consumes a fairly heavy anode current when operating under the conditions giving maximum sensitivity, it should not be forgotten that when sensitivity is reduced by over-biasing—the normal method—this consumption of current is greatly reduced, and in the case of our correspondent, who, we see, lives about forty-five miles from Brookmans Park, we should imagine that

so much negative bias would be necessary that anode and screening current would be practically negligible.

This is an important point in favour of variable-mu battery valves; except when extreme sensitivity is required, it is generally possible to operate them with so much negative bias that the normal maximum anode current consumption is at least halved.

## “Power Radio-Gram” Output Circuit.

REQUESTS have been received for information as to how the output circuit of the “Power Radio-Gram” should be modified in cases where an existing moving-coil loud speaker of the permanent-magnet type or with a separately energised field is to be used.

When this alteration is made it will be obvious that the loud speaker field winding can no longer be connected in series with the anode of the output valve. Two alternatives are open to us; the primary winding of an output transformer in series with a suitable value of voltage-absorbing resistance may be inserted in the output anode circuit, or a choke with a similar resistance may be employed, the output transformer being

*THESE columns are reserved for the publication of matter of general interest arising out of problems submitted by our readers.*

*Readers requiring an individual reply to their technical questions by post are referred to “The Wireless World” Information Bureau, of which full particulars, with the fee charged, are to be found on the next page.*

parallel-fed through a large condenser.

Of these two plans the second is the better, and the connections will be as shown in Fig. 1. In order that the valve may not be overrun it is necessary that the total resistance in the anode circuit should not be less than 1,500 ohms; if the choke is of 500 ohms the series resistance must have a value of at least 1,000 ohms. This is on the assumption that it is desired to operate the PP5/400 valve at its maximum rating, but if it is to be slightly underrun, as in the original design, the choke and resistance may have a total value of 2,500 ohms.

## Triode Output for the Single-dial Superheterodyne.

A READER asks whether good results could be expected from the “Single-dial Super.” if a three-electrode power valve were substituted for the high-efficiency pentode which was originally specified for the output position. He is particularly concerned as to whether there would be any noticeable falling-off in range as a result of making this alteration.

The answer to this question is that the set works admirably with any good three-electrode output valve. With regard to sensitivity, there is hardly any noticeable falling-off as a result of abandoning the use of a pentode; this is because the general sensitivity of the set is so high that receiving conditions are seldom such that it is possible to avail oneself of full magnification.

To use a triode no alterations need be made except the obvious ones of omitting the H.T. feed lead to the pentode-priming grid and also the tone-correcting resistance-condenser compensator across the loud speaker terminals. Difficulties of “matching” would almost disappear, and so almost any loud speaker of good design could be used successfully.

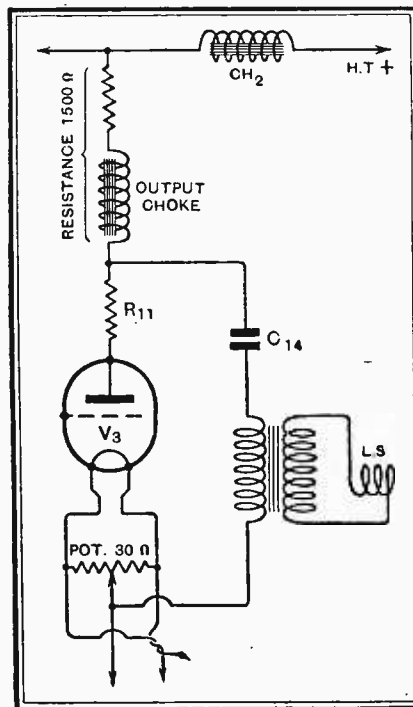

Fig. 1.—Output stage of the Power Radio-Gram modified to allow the use of a loud speaker with separately excited field.

### Free Field Current.

IT would appear from our correspondence that some readers have made a mistake in connecting the field winding of the Amplion loud speaker which was built into the "Wireless World Three" (A.C. model). It will be recalled that this winding was included in the main H.T. supply circuit and acted as a smoothing choke.

In the original model the terminal panel, which is mounted on the loud speaker, was removed, and connection was made direct to the leading-out wires of the winding. In cases where the panel is retained it should be emphasised that the external circuit connections should be made to the terminals marked "negative" and "110 V.," as shown in Fig. 2. If the "negative" and "220 V." terminals are used a series resistance of high value would be included in circuit, with the result that all the valves would

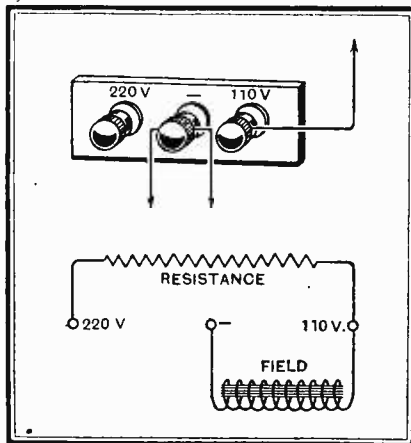

Fig. 2.—Loud speaker terminal panel, showing connections to external circuit, and, below, internal connections of field winding and series voltage-reducing resistance.

receive an abnormally low anode voltage. To make this matter clear the internal connections of the loud speaker are shown in the lower drawing of Fig. 2.

### A Damaged Resistor.

AFTER an accidental H.T. short-circuit in his mains-operated receiver a correspondent has noticed that the glass bulb of his output valve becomes much warmer than previously, and asks us what is the most likely cause of this change in operating conditions.

No details are given as to the precise nature of the short-circuit, but we are inclined to think that an accidental contact was made in such a way as to pass an abnormally heavy current through the output valve bias resistor, which, of course, is included in the main H.T. circuit. As a result of an accident of this sort it is quite conceivable that the resistance has been damaged; for instance, a number of the turns of wire of which it is probably constructed may have become short-circuited, with the result that the total resistance would be appreciably reduced. This means, of course, that a much lower value of negative bias is applied to the output valve; its anode current will increase, more energy will be dissipated, and the bulb will become hot.

### Resistances in Series and Parallel.

SEVERAL readers have noticed that the values of fixed resistances given in the "List of Parts" for the "Power Radio-Gram" do not agree with those indicated in the original circuit diagram (Fig. 1).

This is correct; but, as explained in the article, in several positions it is necessary to connect two resistances, either in series or parallel, in order to obtain the right resistance value combined with a good margin of safety in the matter of current-carrying capacity. For instance, the output valve bias re-

## FOREIGN BROADCAST GUIDE.

### MOTALA

(Sweden).

Geographical position: 58° 32' 50" N.;

15° 02' 40" E.

Approximate air line from London: 775 miles.

Wavelength: 1,348 m. Frequency: 222.5 kc.

Power: 30kW.

Time: Central European (one hour in advance of G.M.T.).

#### Standard Daily Transmissions.

Relays programmes from Stockholm and other Swedish centres.

06.00 G.M.T., physical exercises, sacred service; 10.00; sacred service (Sun.); 14.20, gramophone records (Sun.); 15.00, Children's hour (Sun.), concert; 16.00, weather, news and concert; 17.00, sacred service (Sun.); 18.15, weather, news, time signal; 19.30 concert; 20.45, news, concert (Sun.). Usually closes down at 22.00 G.M.T.

Announcers: Man and Woman.

Call: Stockholm-Motala (phon: Mottallah).

Interval signal: rapid beating of gong (about 80 strokes per minute).

Closes down with the words: *Det var slut pa dagens program; klokken ar nu . . . God nat (twice) och sov got* (That was the end of to-day's programme; the time is now . . . Good Night and sleep well).

sistance of 600 ohms, which passes a current of the order of 50 milliamperes, is made up of a 500-ohm 3-watt resistance in series with one of 100 ohms, but a lower wattage rating; this is permissible, because the voltage dissipated across it is less, although the current passing through the two series-connected resistances is, of course, the same.

## "THE WIRELESS WORLD"

# Information Bureau.

### CONDITIONS OF THE SERVICE.

(1) THE service is intended primarily for readers meeting with difficulties in the construction, adjustment, operation, or maintenance of wireless receivers described in *The Wireless World*, or those of commercial design which from time to time are reviewed in the pages of *The Wireless World*. Every endeavour will be made to deal with queries on all wireless matters, provided that they are of such a nature that they can be dealt with satisfactorily in a letter.

(2) Communications should be addressed to *The Wireless World* Information Bureau, Dorset House, Tudor Street, E.C.4, and must be accompanied by a remittance of 5s. to cover the cost of the service. The enquirer's name and address should be written in block letters at the top of all communications.

(3) The fee of 5s. covers the reply to any wireless technical difficulty, but in special cases, where the enquiry may involve a considerable amount of investigation, an increased fee may be necessary. In such cases a special quotation will be made.

(4) Questions should be clearly written and concisely worded in order to avoid delay. Where enquiries relate to trouble experienced in receivers built to specifications in *The Wireless World* a complete account should be given of the trouble, and especially the symptoms.

(5) Where reference is made to published articles or descriptions of apparatus, the title of the article, the date of publication in *The Wireless World*, and the page reference number should be given, in order to facilitate reply.

(6) Full circuit diagrams, constructional details of apparatus, or values of components for home-designed receivers cannot normally be supplied, but circuit diagrams sent in with queries will be checked and criticised.

(7) Particular makes of components cannot, in general, be recommended, but advice will be given as to the suitability of an individual component for a particular purpose specified by the enquirer.



# The Wireless World

AND  
RADIO REVIEW  
(21<sup>st</sup> Year of Publication)

No. 655.

WEDNESDAY, MARCH 16TH, 1932.

VOL. XXX. No. 11.

Editor: HUGH S. POCOCK.

Editorial Offices: 116-117, FLEET STREET, LONDON, E.C.4.

Editorial Telephone: City 9472 (5 lines).

Advertising and Publishing Offices: DORSET HOUSE, TUDOR STREET, LONDON, E.C.4.

Telephone: City 2846 (15 lines). Telegrams: "Ethaworld, Fleet, London."

COVENTRY: Hertford St. BIRMINGHAM: Guildhall Bldgs., Navigation St. MANCHESTER: 260, Deansgate GLASGOW: 26B, Renfield Street, C.2.

Telegrams: "Cyclist, Coventry."  
Telephone: 3210 Coventry.

Telegrams: "Autopress, Birmingham."  
Telephone: 2970 Midland (3 lines)

Telegrams: "Hiffe, Manchester."  
Telephone: Blackfriars 4412 (4 lines).

Telegrams: "Hiffe, Glasgow."  
Telephones: Central 4837.

PUBLISHED WEEKLY.

ENTERED AS SECOND CLASS MATTER AT NEW YORK, N.Y.

Subscription Rates: Home, £1 1s. 8d.; Canada, £1 1s. 8d.; other countries abroad, £1 3s. 10d. per annum.

*As many of the circuits and apparatus described in these pages are covered by patents, readers are advised, before making use of them, to satisfy themselves that they would not be infringing patents.*

## A DISAPPOINTING DISCUSSION.

**F**EW of our readers can be uninterested in the problem of selectivity, and so special notice must be given to a discussion on selectivity which took place at a recent meeting of the Wireless Section of the Institute of Electrical Engineers. The discussion centred chiefly upon the relation of frequency response to selectivity, and many divergent views were put forward. In fact, we came away from the meeting with the outstanding impression that, considering the importance of the problem, which affects every aspect of broadcasting, the lack of agreement between prominent technicians of to-day was little short of amazing.

Mr. Noel Ashbridge and many other speakers regarded the reproduction of frequencies higher than 5,000 cycles as an essential to first-class quality, and as a result they were of the opinion that to avoid interference the frequency separation of broadcasting stations would have to be increased.

Other speakers, however, maintained that satisfactory quality could be obtained with the present spacing of stations, and in support of their view stated that the presence of the highest frequencies could only be detected by the average person when a rapid comparison was made between the two types of reproduction.

On the more technical side, it was pointed out that modulation interference could, for all practical purposes, be eliminated by using a linear detector and arranging for a high ratio of wanted to unwanted carrier strengths. The necessarily high selectivity for this could be obtained either with band-pass filters or by sharply tuned circuits in conjunction with tone correction. The interference difficulties arose in connection with sideband heterodyning, for there was no known way of eliminating a heterodyne whistle without also removing musical notes of the same frequency.

A useful contribution to the discussion was made by

Mr. Kirke, who pointed out that sideband heterodyning had been experimentally found to be due chiefly to modulation frequencies of about 1,000 to 2,000 cycles. The resulting audible heterodynes, therefore, were above 5,000 cycles with a 9 kc. station separation, and could be largely eliminated by using a receiver which would not respond to so high a frequency.

### Dependence upon the Transmitter.

As it appears to us, the general conclusions are that, with the present distribution of stations, frequencies up to, but not higher than, 5,000 cycles can be reproduced when the selectivity is high enough to eliminate adjacent stations completely, except perhaps for a small amount of sideband heterodyning.

If it be true, therefore, that the presence of musical frequencies higher than 5,000 cycles is not readily noticeable by the majority of listeners, we would then agree that there is little justification for the view that the station separation should be increased in the future. Such an increase must be inevitably accompanied by a reduction in the number of broadcasting stations, and is a political, rather than a technical, question. Even if foreign countries would agree, which is very doubtful, its effect upon the British listener would almost certainly be the abolition of the alternative programme which he now obtains under the Regional scheme.

The suggestion of one speaker was that selectivity should be neglected and a receiver designed for the best quality, freedom from interference being secured by a wider spacing of stations. To build an unselective receiver for reproduction better than what is transmitted and then to wait for the problematical closing down of half the European stations and improvements in transmitters before one can extract any pleasure from it does not seem very practical!

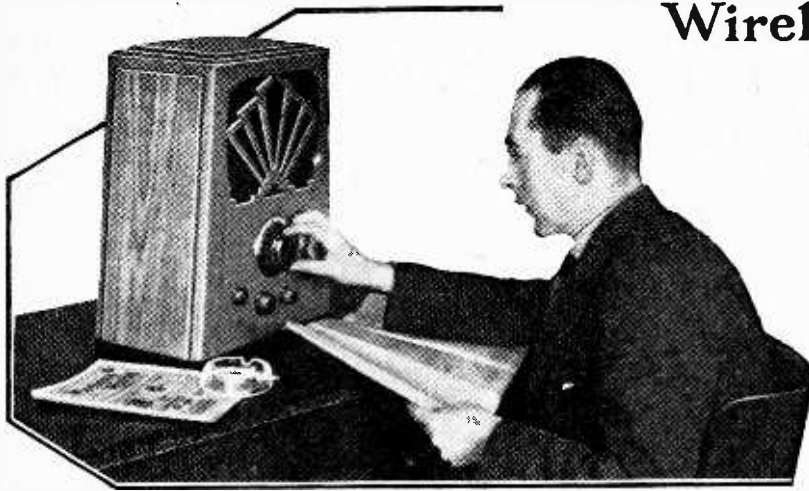

# Wireless World

## THREE

### A Self-contained Highly Sensitive Three-valve Receiver.

By W. T. COCKING.

**N**UMEROUS requests have been received for data on converting *The Wireless World* A.C. Three for operation from direct current lighting mains. It is not generally realised, however, that an A.C. set can seldom be converted for D.C. mains operation without at the same time modifying the original circuit design. The problem of conversion then becomes what is virtually the design of a completely new receiver, for only in this way can the change be so carried out that no loss of efficiency results.

This has been done in the present case, and many modifications have been made to the circuit of the original A.C. set; as a result, the D.C. model has a performance quite equal to that of the earlier receiver. From the circuit diagram it will be seen that the same arrangement of the valves, namely, H.F., power grid

detector, and pentode output, is retained as before.

Two tuned circuits precede the H.F. valve, and are inductively coupled by means of a link circuit to form an efficient and selective band-pass filter. In order to maintain that proportion of the aerial capacity which is transferred to the first tuned circuit at a constant figure throughout the tuning range, and at the same time to avoid complicated switching, the aerial is taken through a 0.0001 mfd. compression-type condenser  $C_1$  directly to the high-potential end of the tuning coil. As a result, the ganging holds accurately throughout both wavebands.

The D.S. screen-grid H.F. valve is coupled to the D.H. power-grid detector by means of the tuned anode circuit, in preference to the tuned grid; this results in a reduction in the number of components required, and permits of a lower value of stray circuit capacity

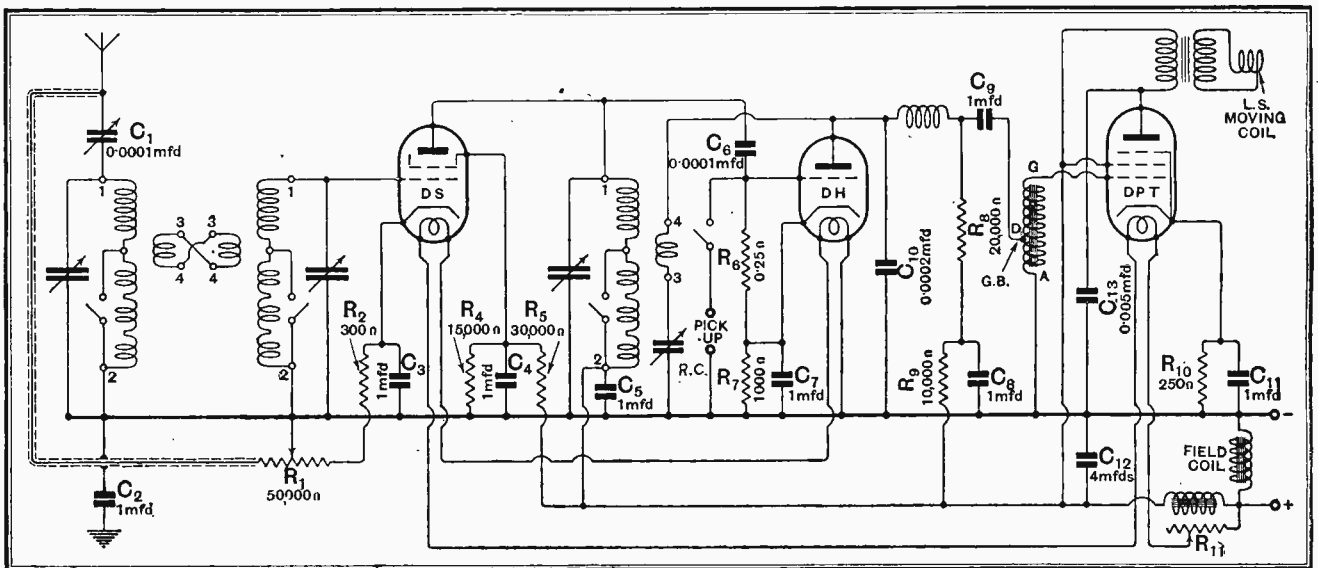

The complete circuit diagram. It will be noted that a screened lead is used between the aerial and volume control and that a differential condenser is used for reaction, although a two-electrode type is shown in the diagram for reasons explained in the text.

**Wireless World D.C. Three.—**

being obtained. Reaction is applied to this circuit in the usual way from the detector anode. A 0.0002 mfd. reaction condenser R.C. is employed, and, as it is connected on the earth side of the reaction coil, its spindle does not need insulating from the metal chassis. A two-electrode control of reaction is used in preference to a differential control, since it has been found to be more effective and less likely to give rise to dead spots. Actually a differential condenser is to be found in the set, but only two of its elements are employed.

Some alternative path for the H.F. currents in the detector anode is needed, partly to prevent H.F. from reaching the L.F. side, and partly to provide adequate signal strength when the reaction condenser is set at minimum. A 0.0002 mfd. condenser  $C_{10}$  is, therefore, connected directly between the detector anode and the chassis, and this, in conjunction with the H.F. choke, ensures the desired results.

Auto-transformer coupling is used between the detector and the D.P.T. pentode; it is, therefore, resistance-capacity fed by the 20,000 ohms resistance  $R_8$  and the 1 mfd. condenser  $C_9$ . Both the pentode and the detector are biased by the method customary in A.C. sets; a 250 ohms resistance  $R_{10}$ , shunted by a 1 mfd. condenser  $C_{11}$ , is inserted in the pentode cathode lead, and a 1,000 ohms resistance  $R_7$ , shunted by the 1 mfd. condenser  $C_7$ , completes the cathode connection of the detector. Negative grid bias is only required on the detector, of course, when this valve is used as an amplifier in conjunction with a gramophone pick-up; the 0.25 meg. grid leak  $R_6$ , therefore, has its lower end joined directly to the valve cathode.

**Volume Control.**

The volume control circuit is rather unusual in a receiver of this type, but it is one which has been found to be both effective and distortionless. It consists of a 50,000 ohms potentiometer  $R_1$ , which is so connected that one portion of it acts as a variable resistance across the aerial and earth, while the other portion acts as a variable resistance in series with the cathode lead of the H.F. valve. As the control is turned to reduce the resistance across the aerial and earth, and so to reduce the signal input, the resistance in the H.F. valve cathode circuit is increased, and so increases the negative grid bias of this valve.

The presence of the aerial series condenser  $C_1$  pre-

vents the resistance from throwing excessive damping on the tuned circuit, and on the bias side, the fixed 300 ohms resistance  $R_2$  serves to maintain a fixed minimum bias on the valve, thus preventing grid current, and the cathode-earth path is made of low impedance to H.F. currents by the 1 mfd. by-pass condenser  $C_3$ .

**FEATURES.**

- Link circuit inductively coupled input band-pass filter with tuned anode H.F. coupling and ganged tuning.
- Power grid detection with straight reaction and auto-transformer coupling to output pentode.
- Built-in moving-coil speaker and provision for gramophone reproduction.
- Volume control by combined simultaneous variation of signal input and bias voltage of H.F. valve, avoiding all detuning effects.
- Indirectly heated 0.25 amp. valves ensuring economical and hum-free operation with a total consumption of about 70 watts.

**Voltage Supply.**

The H.T. current for the whole receiver is smoothed by a single 20H. choke in conjunction with a 4 mfd. condenser  $C_{12}$ , and provides some 180 volts for the combined anode and bias supplies. The current for the pentode screen grid and the anodes of both the H.F. valve and the pentode are taken from the common source without decoupling, and it has been found that no harmful interaction results from this. The detector is decoupled in the usual way by the 10,000 ohms resistance  $R_9$  and the 1 mfd. condenser  $C_8$ , and the H.F. valve

screen grid is fed from the potentiometer consisting of the two series connected resistances  $R_5$  of 30,000 ohms and  $R_4$  of 15,000 ohms, while the 1 mfd. condenser  $C_4$  maintains the screen effectively at earth potential for H.F. currents.

The filaments are run in series, and in the order in

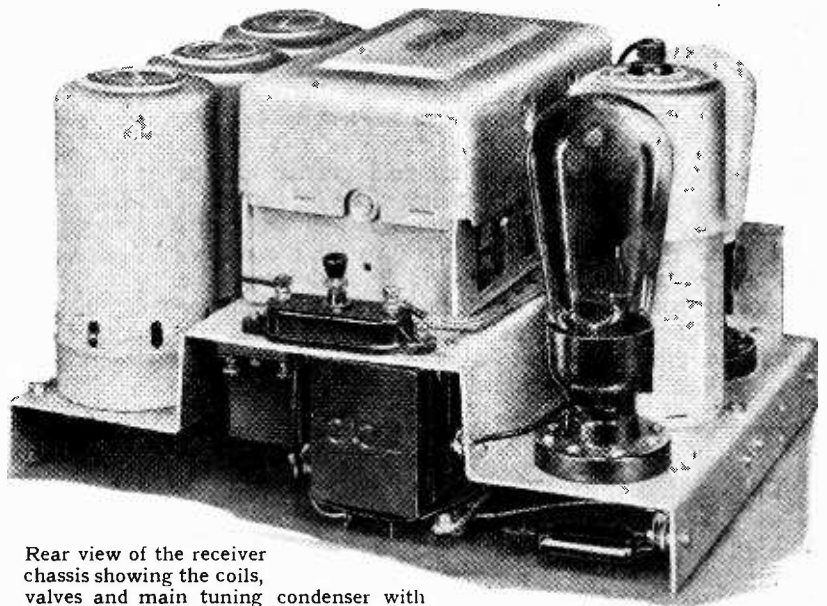

Rear view of the receiver chassis showing the coils, valves and main tuning condenser with screening covers in position.

which the valves are arranged on the chassis; as each valve requires 16 volts, a total of 48 volts is required for the heaters. With 200 volts mains some 152 volts at 0.25 ampere must be dropped in a resistance. Two series connected resistance mats are used, therefore, and

**Wireless World D.C. Three.—**

an additional tapped mat allows of the exact adjustment of current for all mains voltages between 200 volts and 250 volts.

The built-in moving-coil loud speaker is naturally of

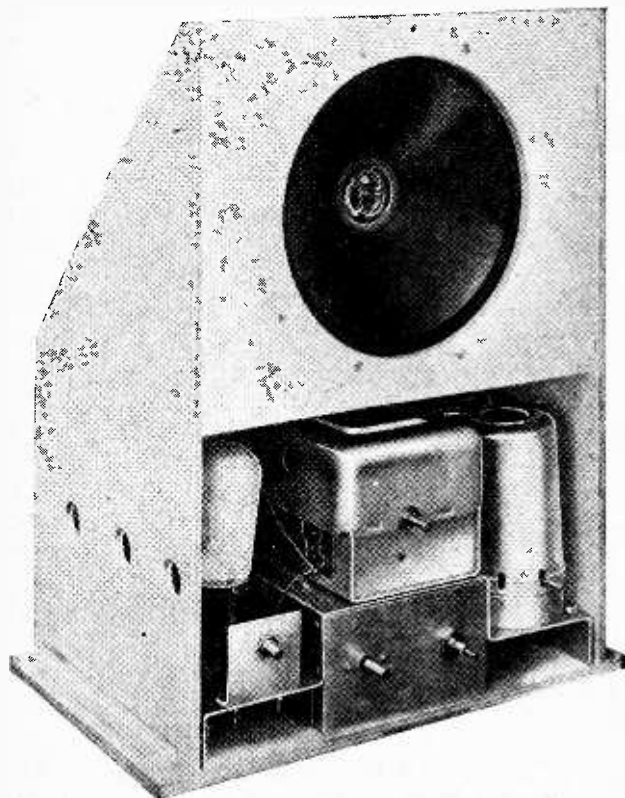

Front view of the chassis in cabinet framework showing the positions of the tuning controls and loud speaker.

the mains energised type, since field current can so easily be obtained from D.C. mains. The field winding is rated for voltages between 200 volts and 250 volts, and is, therefore, connected directly across the mains. A 1 mfd. condenser  $C_2$  is included in the earth lead of the set to prevent a leakage of mains current to earth, for such a leakage might have serious consequences if the positive of the mains be earthed at the generating station. No such condenser is included in the aerial lead, and is

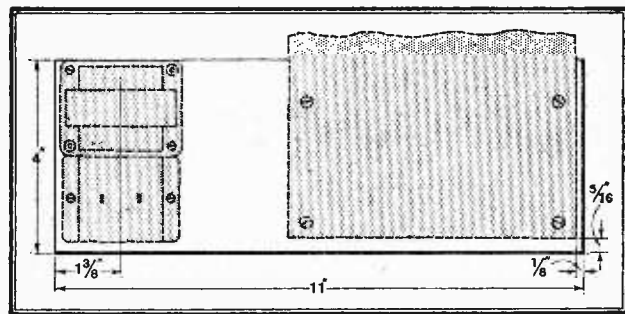

The disposition of components on the narrow shelf directly behind the loud speaker.

probably unnecessary if the aerial be well insulated. If any doubts be felt on this score, however, a condenser of some 0.001 mfd. capacity connected in the aerial lead to the set will effectively prevent any possibility of leakage.

It is important to note that the metal parts of the set, including the chassis, are directly connected to the negative of the mains and are therefore live. Thus, before making internal alterations, the set should not only be switched off at the mains, but the mains plug should be withdrawn from its socket. The trimmers cannot, of course, be set with the receiver switched off, and so an insulated screwdriver should be used for the ganging adjustment.

**Precautions with D.C. Mains.**

It should not be forgotten that the grub screws in the panel controls are in contact with the mains, and care should be taken to see that they are well countersunk. Many of these precautions are perhaps unnecessary if the negative side of the mains be earthed, but they should be scrupulously adhered to if the positive should happen to be the earthed side. It should not be thought that the set is in any way unsafe, but, in common with all electrical apparatus, the proper precautions should be observed. The matter is emphasised for the reason that many are unfamiliar with D.C. mains working, and greater care must be taken than when the more common A.C. supply is used.

(To be concluded.)

**LIST OF PARTS.**

After the particular make of component used in the original model, suitable alternative products are given in some instances.

- 1 Three-gang condenser with fixing screws (British Radiophone)
- 3 Five-pin valve-holders (W.B. large-type base)
- 1 L.F. transformer (R.I. "Parafed")
- 1 Differential condenser, 0.0002 mfd. (Ormond R/190)
- 1 H.F. choke (McMichael Binocular Junior)
- 1 Pre-set condenser, 0.0001 mfd. (Polar)
- 1 Valve screen (Colvern)
- 1 Wire-wound potentiometer, 50,000 ohms. (Colvern)
- 1 Ethovner dial and log (Henry E. Taylor, Ltd., 51-53, Church Street, Greenwich, S.E.10)
- 1 Length of flexible metallic screened sleeving (Lewens) (Goltone)
- 1 Set of coils complete with A.C. chassis (Colvern WW3)
- Strip resistances as under (Colvern)
 

1x250 ohms	1x15,000 ohms
1x300 "	1x20,000 "
1x1,000 "	1x30,000 "
1x10,000 "	
- (Dubilier 1-watt type).
- 8 Fixed condensers, 1 mfd. (T.C.C., Type 65)
- 1 Fixed condenser, 4 mfd. (T.C.C., Type 65)
- (Dubilier, Peak, Forno, Sound Sales, Ferranti, Lissen, Hydra, Loewe).
- 1 Fixed condenser, 0.0001 mfd. (T.C.C., Type M)
- 1 Fixed condenser, 0.0002 mfd. (T.C.C., Type M)
- (Dubilier, Type No. 665).
- 1 Fixed condenser, 0.005 mfd. (T.C.C., Type M)
- (Dubilier, Type No. 670).
- 1 Metallised resistance, 250,000 ohms, 1 watt. (Dubilier)
- 1 Switch (Claude Lyons, B.A.T. 161)
- 1 L.F. choke (R.I. Hypercore)
- 1 Resistance mat, 225 ohms, tapped (Cressall, Type S.R. 35)
- 1 Resistance mat, 400 ohms, 65 watts (Cressall, Type E.R.J.)
- 1 Resistance mat, 200 ohms, 65 watts (Cressall, Type E.R.F.)
- (Bulgin or Cordo Mains Resistance).
- 1 D.C. Minor moving-coil speaker chassis, with pentode transformer (Ultra)
- (Marconi)
- Valves: D.S., D.H., and D.P.T. (Osram)
- Systoflex, wire, screws, etc.
- 1 Cabinet with interior chassis (Clarion, Type S.C. 3)

### ECONOMICAL D.C. MAINS RECEIVER.

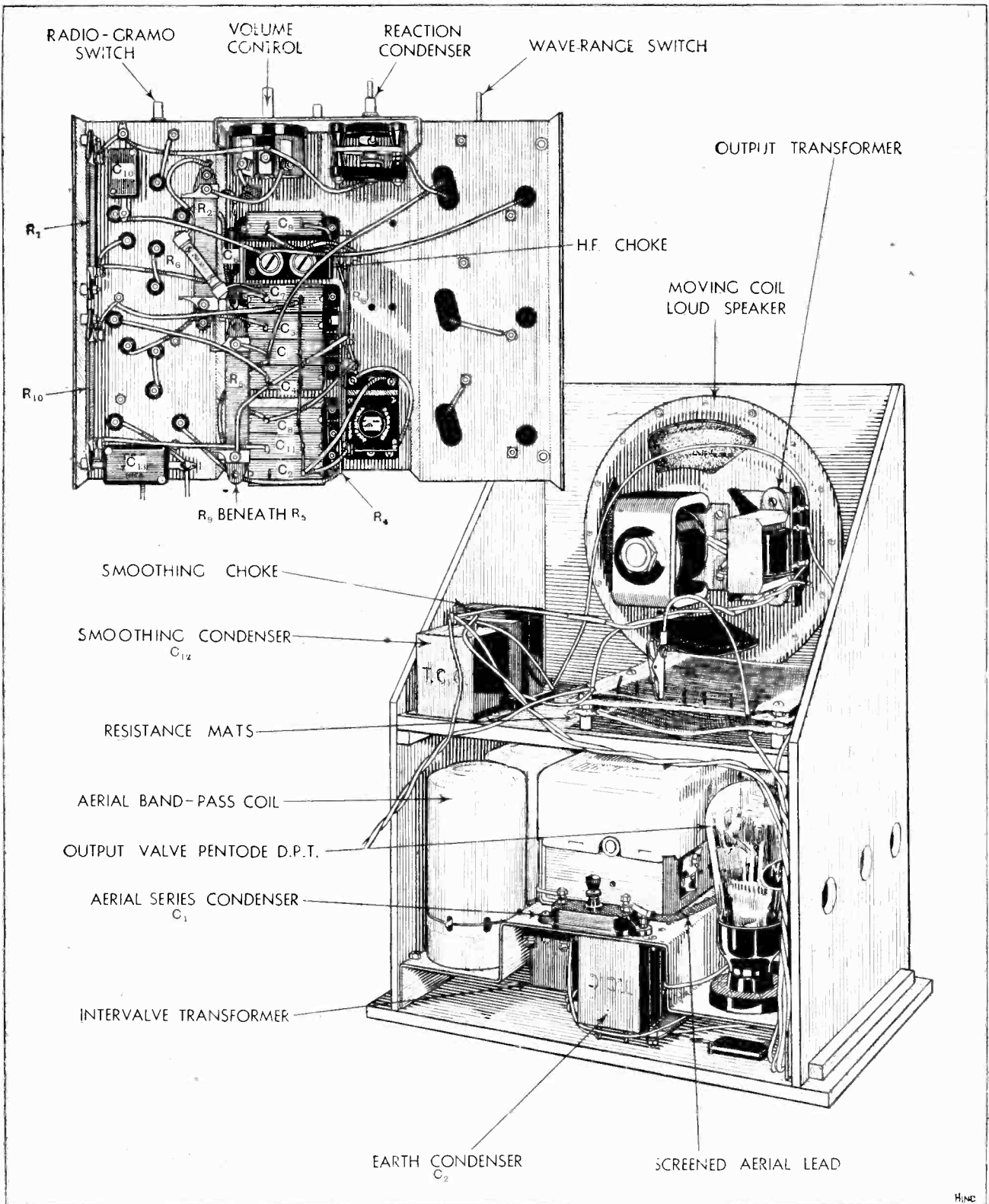

Two views showing the metal chassis and the general layout of components. Compactness is a feature of this receiver.

A 15

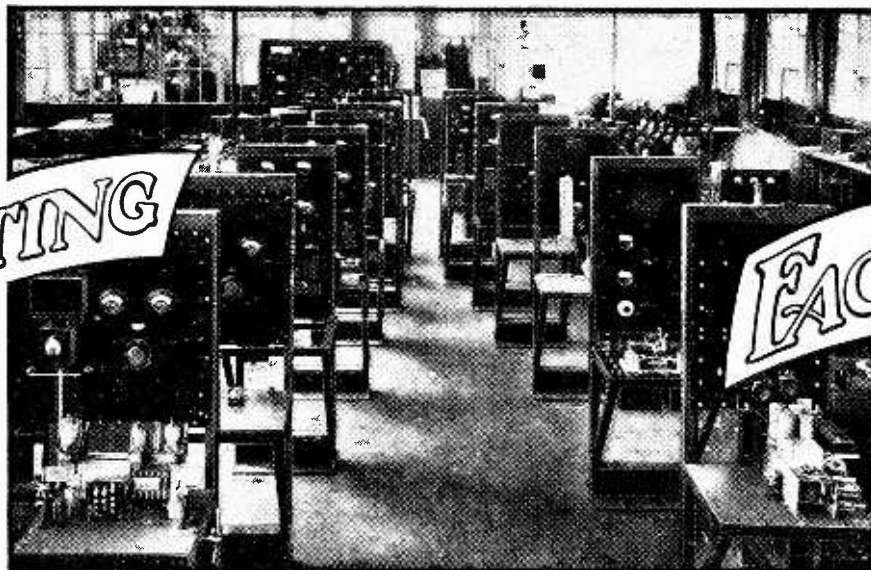
SET  
TESTINGin the  
FACTORY

(Concluded  
from page 161  
of issue dated  
February 17th.)

By  
W. J. BROWN,  
B.Sc., A.M.I.E.E.

## Hum Measurement. Matching Ganged Circuits. H.F. Stage Gain.

**I**N the previous instalment many examples of the procedure in the testing of components were given, together with wiring continuity and audio-response curve tests. Perhaps one of the most vitally important questions in a high-quality radio set or radio gramophone is hum, because with really good bass response it becomes amplified much more than the higher musical frequencies. The H.M.V. Works Test Department have, therefore, adopted the principle of making an electrical measurement of the hum, while the receiver is still in the chassis stage, with the object of making the necessary adjustments to eliminate any hum before the chassis is fitted to the cabinet. Now, the electric currents which produce hum in a radio set are usually of a complex nature—i.e., they are not currents of a single frequency, but contain a number of frequencies. Usually the "hum current" consists largely of a 100-cycle component, together with harmonics of 100 cycles, e.g. 500 cycles; sometimes a 50-cycle component is also present.

The sensitivity of the ear varies so widely with frequency that a direct measurement of the "hum current" or voltage gives no indication of the actual audibility or "annoyance value" of the hum. If the hum takes the form of a deep boom, quite a few millivolts may be allowed, as it will not be detected by ear. On the other hand, if there is any of the characteristic high-pitched drone typical of certain receivers, even a small fraction of a millivolt may sound like a swarm of bees.

It is, therefore, necessary in measuring hum to take account of frequency as well as amplitude, and this is done by passing the hum through an electrical network which is arranged to exaggerate the higher frequencies and suppress the lower ones; the network should, in fact, have the *inverse* of the ear characteristic.

Taking ganged circuits next and assuming careful matching of coils and condensers, it is impossible to guarantee that the stray capacities of wiring will remain consistent under mass-production conditions. It is therefore necessary to provide the gang condensers with small trimmers and to adjust these trimmers to bring each tuned circuit to the same resonant frequency and to see that the ganging holds.

In the palmy days before the introduction of fully ganged receivers the usual method of testing the radio-frequency performance of a receiver was either to listen to broadcasting or to some form of local oscillator. This was usually good enough, since the sensitivity obtainable was determined largely by the operator's skill in tuning the set, and, furthermore, the sensitivity could not vary very greatly between different samples of the same receiver; in other words, if the receiver worked at all it was almost certain to possess normal sensitivity.

The fully ganged receiver has to be treated very differently, however. In this case the sensitivity depends very largely upon the accuracy with which the set remains in gang at all wavelengths, and this may vary considerably from one sample to another for various reasons.

The strength of distant broadcast transmissions, and even of local oscillators, is liable to so many variations that any deficiencies in sensitivity cannot be picked out with any degree of certainty, and the Gramophone Company have decided that in order to ensure that every customer is supplied with a receiver adjusted to maximum performance, it is necessary to make an actual *measurement* of sensitivity on every receiver turned out.

This sensitivity measurement is quite the most interesting test yet discussed, and it has involved a great

*TO the set purchaser, few considerations can be of greater importance than the care which has been expended on testing his receiver before its departure from the factory. In the previous article the author described the careful methods adopted to ensure component efficiency.*

**Set Testing in the Factory.—**

deal of development work in a field which has been very little explored, namely, that of generating and measuring very small but accurately known radio-frequency voltages.

Broadly speaking, the method comprises connecting the input of the receiver through a dummy aerial to a source of modulated radio frequency of known voltage, percentage modulation, and wavelength, and the output to a dummy load (representing the speaker) and an out-

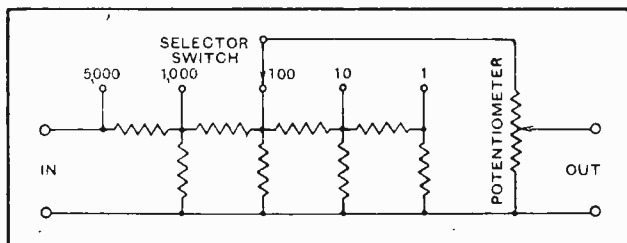

Fig. 1.—An attenuator consisting of a network of resistances.

put meter indicating the audio-frequency power delivered to this load. With the R.F. input adjusted to a given value, the receiver is tuned and adjusted to maximum sensitivity, and it is rejected if it is not possible to attain a specified audio-output power. The test is repeated at a number of wavelengths to ensure adequate sensitivity, no matter what station the user attempts to receive.

The method follows in theory to a certain extent that described by Mr. Thomas, of the National Physical Laboratory, in February, 1930. Since Mr. Thomas employed a pair of screened rooms, one of these having a mercury-sealed manhole, it was obviously necessary to develop the art to a stage where it would be possible to construct a fairly portable apparatus. About this time a portable signal generator of American origin appeared on the market and appeared to offer possibilities. It was decided, however, that for factory use the following requirements were essential: (1) Pre-setting of all wavelengths, signal voltages and modulation percentages so that they could be changed over instantaneously by switching. (2) All-mains operation. (3) Extremely robust construction. (4) Complete freedom from radiation.

**Rapid Measurement of Stage Gain.**

An investigation was put in hand, therefore, with the object of developing a signal generator having these features, and this resulted after several months of intensive research in the "H.F. Gain Set" illustrated herewith.

Briefly this consists of five main portions—a modulated radio-frequency oscillator, a power unit for supplying the oscillator from the mains, a radio-frequency attenuator, an audio-output meter, and valve insertion and contacting devices.

The purposes of these units will be quite clear from the foregoing description, with the possible exception of the R.F. attenuator, the use of which will now be described.

The sensitivity of a modern radio set is of such a high order that only a very minute radio-frequency voltage must be applied to it during test, the actual voltage varying from 1 microvolt to about 200 microvolts, according to the number of valves. It would obviously be a very difficult matter to measure this with any degree of accuracy; on the other hand it is a perfectly simple matter to measure a voltage of the order of 1 volt by means of an ordinary triode voltmeter. The oscillator is, therefore, arranged to deliver a fairly high voltage, which is then passed through a carefully designed attenuator so as to give a known fraction of the input voltage at its output terminals; it is, in fact, provided with a switch for selecting various fractions of the input voltage as required (e.g. 1/10, 1/100, 1/1000, etc.), and it is followed by a potentiometer which permits of adjustment to any intermediate value. The attenuator consists of a network of resistances arranged as shown in Fig. 1, and in principle it is extremely simple.

The oscillator construction is best seen in Fig. 2, which gives a very good view with the screening box removed. The arrangement comprises essentially a number of units which are connected to a single wave-change switch, as shown schematically in Fig. 3. The switch has ten positions, giving five short and five long wavelengths respectively. In each of its ten positions the

Fig. 2.—A signal generator specially developed for rapid measurement of H.F. stage gain.

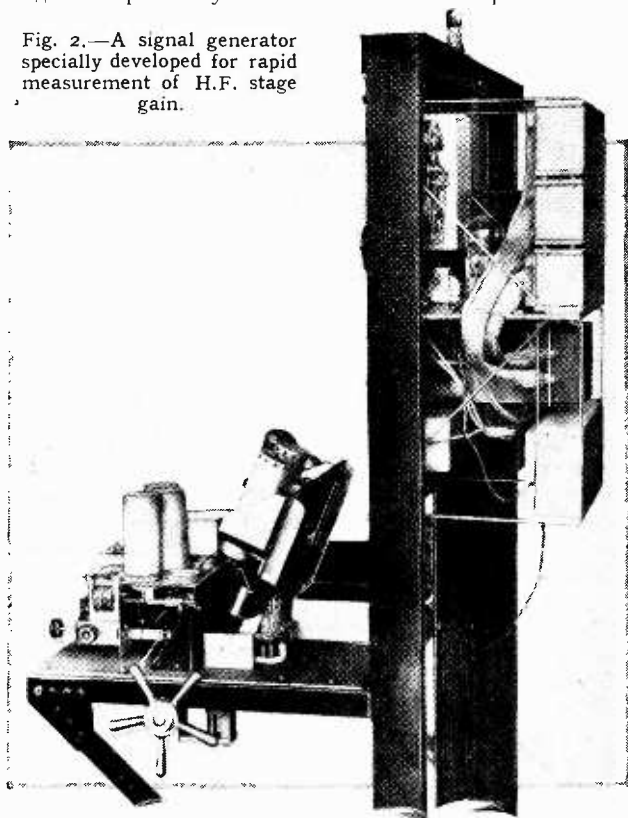

switch connects up the following circuit elements corresponding to the particular wavelengths:—

- (a) Tuning condenser (determining the H.F. wavelength).
- (b) Coupling-circuit resistance (determining the H.F. output voltage).

**Set Testing in the Factory.—**

(c) Modulation potentiometer (determining the percentage modulation).

There are ten of each of the above circuit elements, and these are grouped in screening boxes at the back of the oscillator; they are provided with pre-setting adjustments, which are accessible through small holes in the back of the main screening box for the entire oscillator, thus facilitating rapid measurement.

The small screening boxes referred to are clearly shown in Fig. 2 at the extreme right-hand side. The top box contains the ten H.F. output controls. The second and third boxes contain the ten tuning controls and the oscillator short- and long-wave coils, whilst the lowest box contains the ten modulation controls.

**Testing Pick-ups.**

The wave-change switch, itself carefully screened, can be seen immediately above the lowest box, while the multiple-braided leads interconnecting the boxes can also be seen.

The main screening cover takes the form of an aluminium casting, rather like a small bath-tub, which is bolted tightly up to the front panel.

The power unit is of orthodox design except for its careful screening, and for the fact that it is supplied through a screened transformer. This is necessary in order to prevent feedback of H.F. oscillations to the mains, and hence to the receiver under test. The power unit supplies H.T. at 360 volts, grid bias at 30 volts, and filament current at 4.5 volts to the L.S.5 valves which are used in the oscillator.

The H.F. gain set can be used for making selectivity measurements also, by merely turning the attenuator switch from  $\times 1$  to  $\times 1,000$  and noting the amount of detuning necessary to reduce the output to the standard 50 milliwatts. This is an additional refinement which is being introduced for this year's programme, as a still further assurance that the customer shall get a receiver having a really high and definitely approved standard of performance from all points of view.

This completes the tests which are carried out on the radio chassis itself, but it should be noted that tests of a similar standard are carried out on the other assemblies which go to form the complete instrument, e.g., pick-ups, speakers, valves, and electric motors.

Pick-ups, for instance, are tested on a special device using a gramophone record which runs through the whole gamut of audible frequencies in less than two minutes, and passing the output through a pre-set attenuator to a self-calibrating triode voltmeter.

The major assemblies are consequently all in first-

class condition when they are erected into their cabinets, and nothing remains but to make a careful check on the completed machine, using this time the actual valves with which the customer will be supplied. This is rather a case of "making assurance doubly sure," but it is, of course, a matter of principle that the machine should be tested in its entirety in precisely the condition in which it will be delivered to the eventual customer, and this test is made on actual broadcasting in

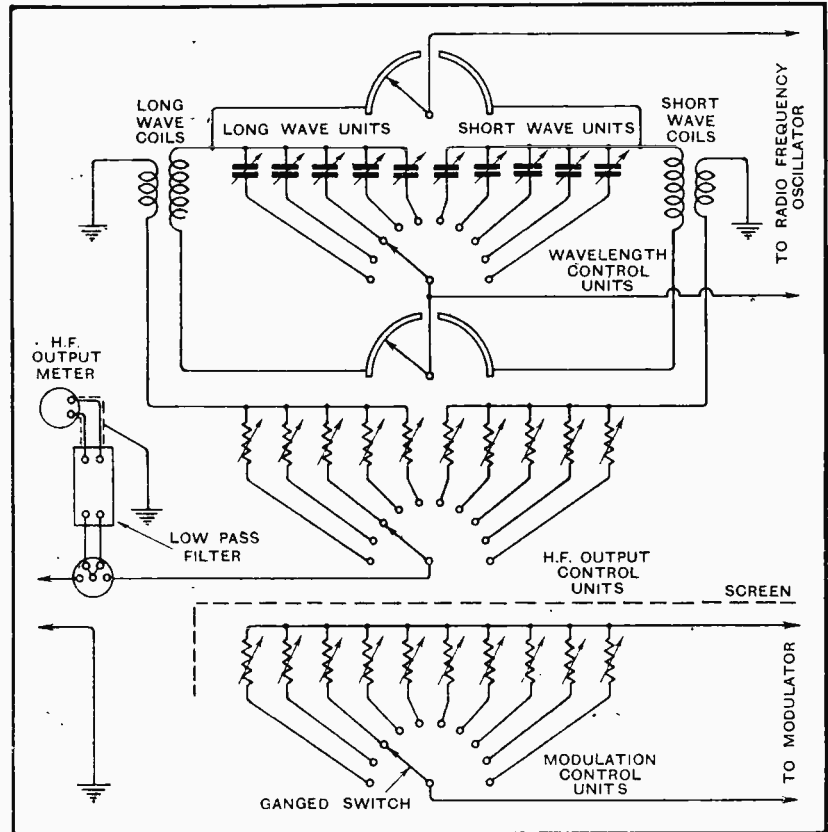

Fig. 3.—Schematic diagram of the oscillator which determines the H.F. wavelength, the output voltage and the percentage modulation.

sound-proof rooms specially constructed for the purpose.

Returning once more to radio chassis tests, which, after all, are the most interesting. A number of these chassis-testing sets, as installed alongside a service conveyor, are shown in the title illustration.

An interesting corollary of this article has probably already occurred to the reader, viz., that mass production means not only *cheaper* radio, but *better* radio. Mass production first emphasised the need for complete stage-by-stage testing, and necessitated the expenditure of large sums on the development of highly technical methods. The use of these methods, in turn, has ensured a uniformly high standard of performance for every article produced. This has been borne out in practice by a reduction in customers' requests for servicing to less than half during the first year of operation of the improved testing methods.



# AGAIN THE DESIGNER CHOOSES MARCONI VALVES

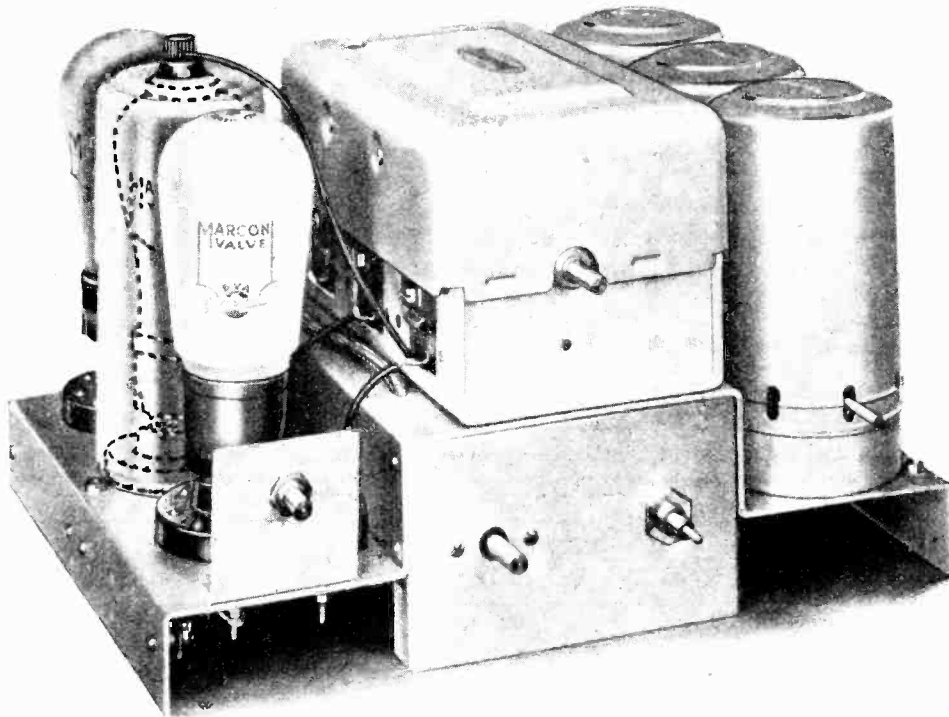

Marconi D.C. Mains Valves  
(16 volt, 0.25 ampère) Types DS, DH, DPT are  
exclusively specified for  
The Wireless World D.C. Three.



THE  
SYMBOL OF  
AUTHENTIC  
RADIO

THE MARCONI D.C. RANGE	}	DS .....	Screen grid .....	22/6
		DSB .....	Screen grid .....	22/6
		DH .....	Gen. Purpose .....	15/-
		DL .....	L.F. & Power .....	17/6
		DPT .....	Pentode .....	25/-

# MARCONI VALVES

THE CHOICE OF THE EXPERTS

ATQ Advertisements for "The Wireless World" are only accepted from firms we believe to be thoroughly reliable.

*Astonishing*  
**VALUE**  
*in* **Radio Batteries**

*British Made  
 throughout*

60 Volts **5/6** 120 Volts **11/-**  
 99 „ **9/-** 9 „ G.B. **1/-**  
 108 „ **10/-** 16½ „ G.B. **1/9**



**SIEMENS**  
**“Cadet”**

*The New*  
**FULL O'POWER**

Now you can get a  
 “Full O'Power” quality  
 battery at the same price  
 as an ordinary battery.

ADVT. OF SIEMENS ELECTRIC LAMPS & SUPPLIES, LTD., 38-39 UPPER THAMES STREET, LONDON, E.C.4

★ **BUILD A SHORT WAVE** ★

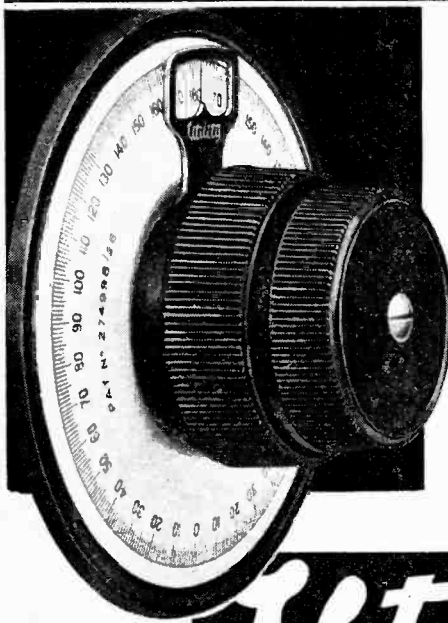

W181 DIAL  
 SEPARATE  
**7/6**

Build a short wave set and roam the world for your entertainment. But remember that dead accurate and hair line tuning is imperative for successful results. That is why a Utility condenser and S.M. dial are essential.

Utility S.W. Log condensers are not small editions of general purpose condensers, but have been specially designed and made for S.W. work. The range includes the following capacities: '00015, '0002, '00025 and '0003.

Utility Slow Motion dials (W181) are ideal for S.W. work. The dial gives true micro control of the condenser, with a 100 to 1 ratio, and backlash is impossible. Readings are by hair line and cursor surveying an aluminium dial calibrated 0-180, both clockwise and anti-clockwise.

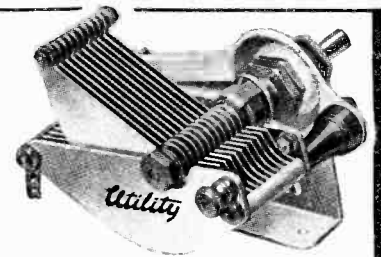

- **PRICES** ●
- Log Condenser '00015 . . . 6/6
  - With W181 dial 13/-
  - Log Condenser '0002 . . . 6/6
  - With W181 dial 13/-
  - Log Condenser '00025 . . . 7/6
  - With W181 dial 14/-
  - Log Condenser '0003 . . . 7/6
  - With W181 dial 14/-
  - W181 dial separate . . . 7/6

*From your dealer or post free from the makers*



**You will come to the Short Waver by degrees.**

**WILKINS & WRIGHT LIMITED**  
 UTILITY WORKS, HOLYHEAD ROAD, BIRMINGHAM, ENG.

AGENTS—London: E. R. Morton, Ltd., 22, Bartlett's Buildings, Holborn Circus, E.C.1; Scottish: E. B. Hammond, 113 Vincent Street, Glasgow; Lancashire and Cheshire: J. R. Easter, 33 Old Road, Blackley, Manchester; Westmorland, Cumberland, Durham, Northumberland, Yorkshire and Derbyshire: H. C. Rawson, Ltd., 100 London Road, Sheffield; South Western: Laurence Fraser, Chelsea House, Lansdown Road, Bath.

Mention of "The Wireless World," when writing to advertisers, will ensure prompt attention.

Belmont.

A20

# Nuts to Crack

## Instructive Problems and their Solution.

THE present series has been started by *The Wireless World* for the benefit of readers who like to work out little problems for themselves and be sure that the results they obtain are correct. From time to time certain wireless problems are presented, and in the following instalment the answers are given with the methods of working them out, and hints on possible points of difficulty. Previously Questions 22 to 24 were given, and below the answers appear, whilst another set of problems is included this week for treatment in the next instalment.

**QUESTION 22.—A coil of 1,266  $\mu$ H. and a condenser of 0.0005 mfd. are placed in series. What is the wavelength to which they are resonant? What would be the resonant wavelength if they were placed in parallel?**

*Answer — 1,500 metres. The same.*

If the components L and C of a series combination of inductance and capacity are expressed in microhenrys and microfarads respectively, then  $\lambda$ , the wavelength to which they are resonant, is given in metres by the formula

$$\lambda = 1,885 \sqrt{LC}$$

In this case

$$\begin{aligned} \lambda &= 1,885 \sqrt{1,266 \times 0.0005} \\ &= 1,500 \text{ metres.} \end{aligned}$$

If we assume that both coil and condenser are entirely free from resistance losses, the resonant wavelength for the parallel combination is precisely the same as for the series case. The essential difference between the two circuits lies, of course, in the impedance which each presents to an alternating voltage of the resonant frequency when this is applied across it. The net impedance offered by the series combination is, theoretically, zero; in practice, of course, while the reactance is actually zero, a certain modicum of resistance is always present, and this operates to limit the very large currents which would otherwise result. The parallel combination, on the other hand, offers at resonance a very large impedance to currents flowing in the line circuit in which it is placed; this impedance becomes, theoretically, greater as the resistance in the combination is less. Thus in theory, if no resistance were present in the components of the parallel circuit, its impedance at the resonant frequency would be purely resistive and infinite in amount. It would, therefore, act as an absolute choke to currents of that frequency.

**QUESTION 23.—The frequency of a certain sound wave is 200 cycles per second. What is the frequency of its third harmonic?**

*Answer — 600 cycles per second.*

The system by which the harmonics of sound waves

are reckoned is sometimes apt to prove confusing. A single sound such as may be obtained by striking a note on the piano contains among the vibrations of which it is composed many other frequencies besides the "fundamental" frequency which chiefly distinguishes the note. These extra sounds, which are higher in pitch, though usually far smaller in intensity than the fundamental, are called "harmonics," and their frequencies are found to be exact multiples of the fundamental frequency. In general the fundamental gives the pitch of the note as we hear it, while the presence or absence of the harmonics gives it its distinctive character. The "first harmonic" is merely another name for the principal constituent or "fundamental" of the composite tone; the second harmonic is the octave of this, i.e., it vibrates with a frequency twice as great as that of the former. Generally, the  $n^{\text{th}}$  harmonic of any pure tone has  $n$  times the frequency of its fundamental.

In the present instance the frequency of the third harmonic is  $3 \times 200$  or 600 cycles per second.

**QUESTION 24.—In a stage of resistance-capacity coupled L.F. amplification the valve has a magnification factor of 32, and an anode A.C. resistance of 270,000 ohms when the working voltages are applied to the circuit. If the anode resistance employed is 500,000 ohms, what is the actual voltage amplification obtained by the stage?**

*Answer — 20.8.*

The total impedance to alternating current in the anode circuit of a valve may be divided into (a) the internal A.C. resistance of the valve itself, and (b) the impedance of the external anode circuit. In a resistance-capacity coupled amplifier this latter is a pure resistance, the alternating P.D. across which is utilised as "input" in feeding any subsequent stage. If, as usual, we denote the anode A.C. resistance of the valve by  $R_0$ , the external resistance being  $R$ , the magnitude of the alternating voltage across  $R$  will be  $\frac{R}{R+R_0}$  of the total alternating e.m.f. supplied by the valve, and this, of course, is  $\mu \times e_g$ , where  $\mu$  is the valve magnification factor, and  $e_g$  is the input voltage to the grid.

The available voltage across  $R$  will thus be

$$\frac{R}{R+R_0} \times \mu \times e_g$$

In other words, the input voltage  $e_g$  is magnified by the factor  $\frac{R}{R+R_0} \times \mu$ ; which is thus the actual amplification.

It is, of course, always less than  $\mu$  itself.

In our example,

$$\text{Amplification} = \frac{500,000}{500,000 + 270,000} \times 32 = 20.8$$

**Nuts to Crack.—**

A word of warning should be added in regard to the value taken for  $R_0$  in the above example. It will often happen that the actual or working value of anode A.C. resistance will much exceed the value quoted by the makers. Especially is this the case with resistance-coupled amplifiers, and the reason is not far to seek. Owing to the D.C. voltage drop due to the passage of steady anode current through the resistance, the actual mean anode potential will often be much less than that assumed in the quoted figures. The mean position of the working point on the anode volts-anode current diagram is therefore moved towards the curved portion of the characteristics, i.e., into the region of greater A.C. resistance, and this should always be taken into account when dealing with this type of amplifier.

**NEXT SERIES OF PROBLEMS.**

**QUESTION 25.**—A coil of 250  $\mu$ H. inductance and 500 ohms resistance is placed in series with a condenser of 0.0005  $\mu$ F. If an alternating e.m.f. of 2 volts R.M.S. at the resonant frequency is applied across the whole combination, what is the amplitude of the resulting current?

**QUESTION 26.**—The makers' rating for the anode dissipation of a certain valve is 6 watts. If the mean H.T. available on the plate is 250 volts, what is the maximum permissible value of anode current?

**QUESTION 27.**—If it were desired to pass a mean anode current of 30 milliamperes through this valve, what would be the maximum anode voltage for safety?

**QUESTION 28.**—If two sound waves have frequencies of 216 and 248 cycles per second, what are the frequencies of the principal "beat" notes when they occur together?

NUTCRACKER.

## OVERCOMING "SKIP DISTANCE" EFFECT. Zeesen's New Short-wave Aerial.

By DR. F. NOACK.

**A** NEW type of aerial by means of which short-wave transmissions should be receivable within the usual skip distance area is arousing considerable interest in Germany, and will shortly be adopted by the famous Zeesen transmitter, near Königswusterhausen, which works on a wavelength of 31.38 metres. Although well received at great distances, this station is heard only with difficulty at short range, but the new aerial, if successful, will mean that the station will be picked up all over Europe as well as overseas. This achievement will be accomplished by arranging that the radiation from the aerial system shall travel parallel to the earth's surface. The Telefunken Company, builders of the present short-wave transmitter at Zeesen (which

now uses a simple vertical wire aerial), are evolving an aerial on the lines shown in the accompanying diagram. As can be seen, the aerial is of the "bird-cage" type. A wooden mast M carries two pairs of cross-bars T, one at the top and the other at a height of about 80ft. Between the ends of these cross-bars are stretched various wires and hemp ropes. There are four horizontal wire "squares," parallel to each other, and spaced about 50ft. Each "square" contains four wires,  $a, a', b, b'$ , separated from each other by several insulators. Each of these wires is itself about 50ft. long. Two wires in each square, i.e.,  $a$  and  $a'$ , and  $b$  and  $b'$ , combine to form an aerial. Each wire oscillates in a half-wavelength, and each individual aerial in one "square" oscillates with a half-wave phase difference between it and the corresponding aerial in the "square" below it. Moreover, the individual four wires in each "square" function as follows:  $a$  and  $b$  oscillate in the same phase, as also do  $a'$  and  $b'$ ; but  $a$  and  $a'$ , and also  $b$  and  $b'$ , are  $180^\circ$ , or a half-wavelength, out of phase. In each "square" the inside ends of  $a$  and  $a'$  are connected to the bus-bar leads  $L_a$  and  $L_{a'}$ , and the inside ends of  $b$  and  $b'$  to similar leads  $L_b$  and  $L_{b'}$ . These leads are continued to the transmitter and act as "feeders."

According to theoretical calculation, the new aerial should give an eight-fold increase in energy at the receiving station, practically uniformly in all directions. It concentrates the radiation towards the earth, and allows practically no waves above an angle of  $20^\circ$  to escape into space.

The diagram does not exactly represent the aerial as actually constructed, but shows more clearly than the photograph the basis on which it is designed.

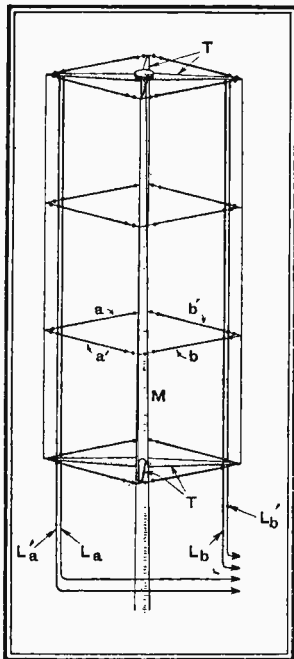

A diagrammatic picture of the new aerial.

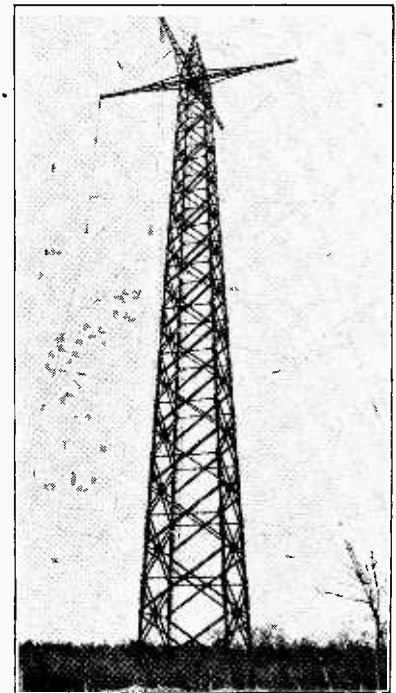

The actual aerial, which has just been erected at Zeesen.

**Sound Films of To-day.—**

An artificial fade, like a sound-mix, must be long to be useful.

A good example of an extended sound fade-in is to be seen in the French film, "Le Million." It opens on roof-tops and chimneys, with the sound of distant music. The camera passes along and over a number of roofs, past a church, coming to rest in front of a skylight.

**Timing an Artificial Fade.**

During the process the music has been getting louder; its origin is disclosed through the skylight window, where in the room beyond a dance is taking place. Such a fade is artificial, because it is done by keeping the sound origin at substantially constant volume and in a fixed position relative to the microphone. The fade is achieved by slowly increasing the main gain. It will, of course, be timed so that it fits the picture. Suppose such a fade has to be over a minute in duration. The sound will start with the lowest permissible modulation, approximately 10 per cent., which can be called one on the gain scale.

During sixty seconds it is required to bring the modulation up in a gradual increase to a hundred per cent.

With twenty transmission units as the gain above one necessary to give this modulation, and assuming the gain control to be graduated in two transmission units per division, the gain knob will have to be turned up one division every six seconds. The same applies to a fade-out, only in the opposite direction, a decrease in gain requiring the same careful handling as an increase.

Mixing in the sense the word most obviously indicates applies more particularly to dubbing and re-recording. Dubbing means recording sound while a picture of the event to which eventually it will be wedded is being projected on the screen. The practice is nowadays almost exclusively confined to music and effects, as the difficulty of obtaining accurate lip synchronisation on dialogue makes it unsatisfactory for that purpose. Sequences in a film to which there is to be only a musical accompaniment and effects are shot "silent" and dubbed. For dialogue, lip synchronisation is only necessary on medium and close shots; on extreme long shots it will not be noticed, the characters not being

large enough for the lips to be seen. Consequently, while dialogue dubbing for close and medium shots is a bad practice, for very long shots it is quite often used.

A more convenient and quicker way of putting sound on to such shots, however, is to record a "wild" track of the words, which the editor may fit in the cutting room. We shall say more of this when we deal with sound editing.

Music recording on film, in the case of balance, presents much the same problem as it does for gramophone and broadcasting.

A real crescendo is less easy in film than in broadcasting owing to the limits of the track. Unless great care is taken, deadness will occur on crescendos and fortissimo passages if the gain is reduced too much and handled heavily. Pianissimo passages will be lost in the hiss if the orchestra is kept too far down by the

conductor, the recordist having to increase his gain to an extent where the hiss level becomes dangerously high. On no account should electrical control be over more than eight transmission units, all other volume adjustments being made by the conductor. Briefly, a conductor recording for film has to reduce his crescendos and sforzandos, to keep his fortissimo always at mezzo-forte and his pianissimo at mezzo-piano.

Wobble or "wow"—to use the expressive American term—is a serious consideration. If there is any possibility of it occurring, it is advisable to shorten sustained chords and bring treble woodwind, particularly flute and oboe, an octave lower than that in which they

would normally play. Wow is not so troublesome nowadays, most modern sound cameras having anti-wow mechanism, but there was a time when the problem was very real, as, in fact, it still is, unless particular care is taken.

**Securing Orchestral Balance.**

There is always the double possibility of the projector wowing as well as the sound camera, and special precautions must therefore be taken to obtain constant speed.

Balancing orchestras is a fascinating occupation, and,

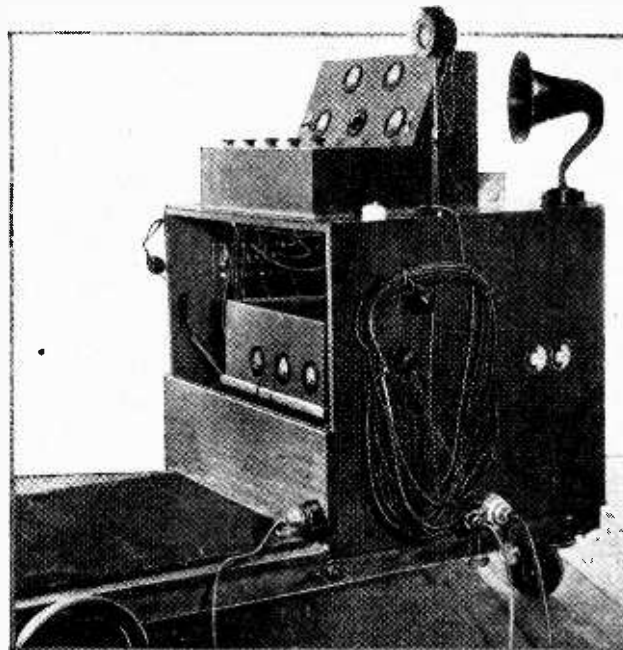

The Visatone mixer and amplifier on its trolley. The microphone controls are clearly seen; behind them, on the sloping panel, are voltmeters for L.T. and H.T. supply and meters for showing peak and mean modulation. The microphone and loud speaker are for communication with the sound camera and main amplifier room.

**Sound Films of To-day.—**

if time allowed, hours could be spent on little niceties of adjustment for each piece. A mean balance is quite good enough, however, for all general purposes. The position of the players depends upon the shape of the frequency curve of the recording system, the type of microphone, and the size and damping of the stage. A heavily damped stage will require that the players

Upper string tone can be ruined by placing the microphone too near the first violins. Although the microphone is pointed down to the leader, it is essential to have it quite ten feet away from him in the horizontal direction. The most difficult instruments to balance properly are flutes, trumpets, and double-basses. Flute tone can be very penetrating; its quality will be spoilt if it is allowed to overshoot. Some flute notes give out much more energy than others; consequently, this instrument has to be watched carefully. Trumpets, especially when muted, have an "edge" which, if overshoot, will sound singularly unpleasant.

**Re-recording.**

The strength of double-basses varies enormously with different instruments, but most, when playing arco, are not difficult to record if they are put in the right position. They only become troublesome when playing pizzicato. A double-bass player should always make his pizzicato playing a shade more piano than he would in a concert hall.

Re-recording in its simplest form is the projection of a track through a sound head, the output from the amplifier of which passes into a recording amplifier instead of loud speakers.

Such work can be done with an ordinary sound projector and recording system, the amplifier output, suitably adjusted, feeding a microphone channel instead of a microphone.

The process is extremely useful for adjusting level, enabling a new negative to be made of any one shot which may be of incorrect sound perspective. If the shot is too loud it can be reduced, or vice versa. More elaborate recording needs a special machine called a re-recorder or dubber. It consists essentially of two or more projecting mechanisms for running the film, electrically driven at accurate speed and mechanically coupled. Each mechanism has

its own photo-electric cell, initial amplifier, and gain control. The outputs are common, and feed the recording system. In a machine with two channels two tracks can be mixed, the resultant negative from the sound camera being a composite of the two. Placing music behind dialogue is invariably done in this way as it is more simple than shooting the two together on the set. If three channels are available three tracks can be mixed; for instance, dialogue, music, and effects.

On the other hand, should it be necessary to re-record three tracks with only two channels, then a re-record of

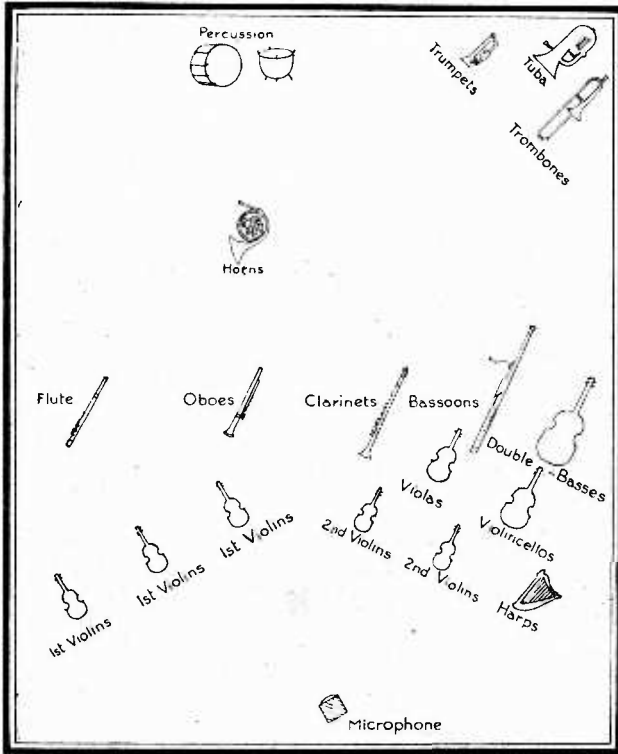

The upper diagram shows the disposition of a sound film orchestra. The microphone is suspended 15ft. from the floor, the face pointing to the leader of the first violins. Below is a dance band arrangement, the microphone being similarly elevated.

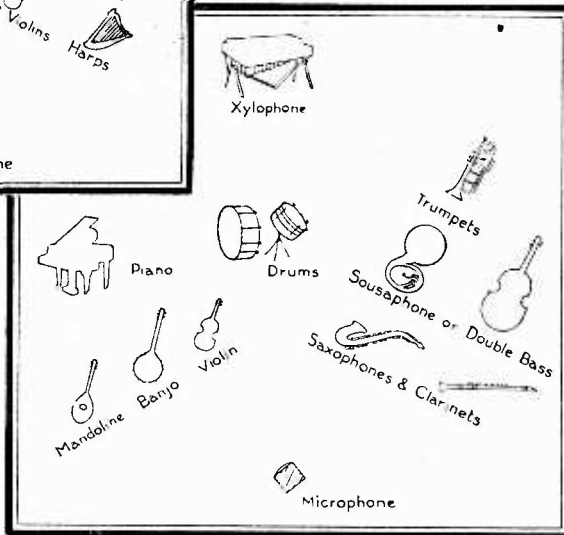

be spread as much as possible, but a disadvantage arises in the case of an orchestra, as it is difficult for a combination to play at its best if the individual players are widely separated.

A lightly damped stage enables a more congested positioning to be used, but in this case care has to be taken that string basses and brass are not too near the microphone. In a large measure balance depends upon the respective sensibility of conductor and recordist. A recordist knows his ideal balance for a particular system, but some conductors want a predominance of certain groups or individual instruments, in which case a correction has to be made.

For R.C.A. and Visatone recording the microphone is suspended 15ft. from the floor.

**Sound Films of To-day.—**

two tracks is made, which is again re-recorded with the third track. The process of re-recording, therefore, takes place twice with two tracks; and the final negative is the result of the process being applied to four different tracks in all. Thus, re-recording could go on indefinitely, but after the third process the results become subject to quality loss and excessive ground noise.—

On this account re-recording is rarely done more than three times.

When all the shots of a film have been taken it is a long way from being the finished article. Editing, i.e., the assemblage of the shots in correct continuity, is a very important part of film production, for the whole character of a film can be changed by the way the shots are placed in sequence, the time they are held on the screen, and the number of "silent" shots which are "cut-in" to tracks of other shots.

**The Synchroniser.**

The editor proceeds, first, by synchronising the sound with the picture of each shot on a machine called a synchroniser. He does this with the aid of marks on the sound track made by clappers (two battens of wood on a hinge which are banged together), which precede every shot. The man operating them on the set stands in front of the camera, causing himself and the clappers to be photographed. When the clappers close they emit a sound, the first sound of the shot, of sufficient modulation and of a wave-shape instantly recognisable. Now, both sound-camera and picture-camera films are running at the same speed; consequently, the moment the clappers meet, as seen on a single picture, will be that at which the sound is emitted.

If, therefore, the single picture and clapper modulation on the track are placed parallel to each other on a suitable machine to take the rolls of film—i.e., the synchroniser—the shot will run synchronously until it finishes. As explained in the first article of this series, a track of this kind is called an unmarried print, and its purpose is to enable the editor to cut the sound track of the whole film independently of the picture. Such a method is more flexible and economical, because a married print need not be made until the film is "cut" or ready for showing to the public.

The unmarried sound and picture prints are called the cutting copy. Having put his shots in synchronisation, the editor then joins them together in rough continuity, as specified by the scenario.

When he has approximately a thousand feet assembled in this way he can be said to have one reel of the complete film "rough cut."

Then starts the most difficult and more creative part of his job.

After cutting off the clapper marks from the track and the photographed clapper from the picture, marks are made to correspond to them by a crayon pencil on the celluloid. Each shot is carefully pruned to its best length. This may seem paradoxical, but it is not so.

A scenario may specify a shot running for a certain time, but when on the screen it may seem too long as part of a particular sequence. This is where the editor's job is so important. It is impossible to visualise accurately on paper a whole film from beginning to end. Many shots on paper may seem fitting to the continuity, of correct length; but the way they are played, the tempo of the action, and so on, will govern whether they are rigidly adhered to, even to the extent of their inclusion. Particularly so, when a shot may be of no specific "story value."

With the aid of a sound movieola, which is really a

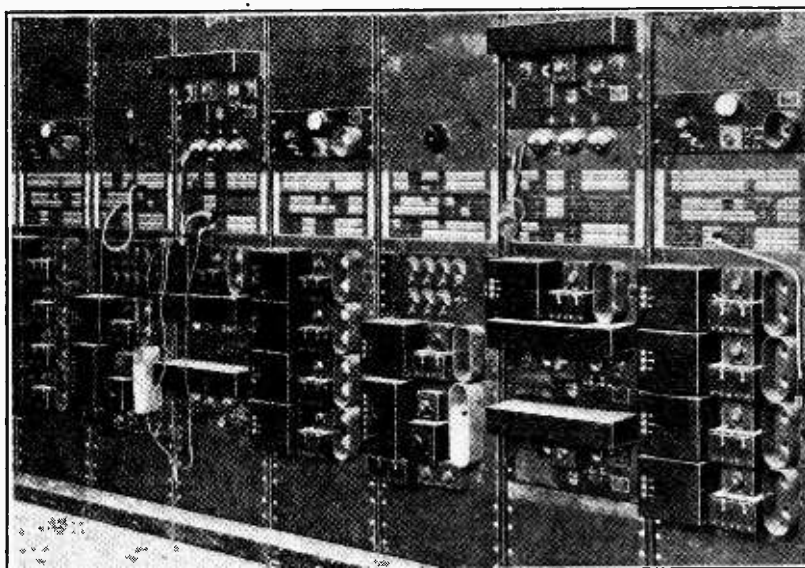

The amplifier switchboard controlling the Western Electric installation at the British and Dominions Studios, Elstree.

miniature projector, the editor can cut scenes in half, carry dialogue of one scene into another; in fact, perform so many tricks that it would require a book to describe them all in detail.

Perhaps the editor's most interesting trick is his use of "wild" tracks. A wild track is one which has no picture counterpart; it is a record of sound only. All manner of noises and sounds are taken in a studio at various times, and there is no reason why an editor should not use these if he wants a particular noise for a certain silent shot.

For instance, a shot of a motor car need not necessarily have the actual sound of the car seen. The shot may be a silent one, with the sound of any suitable car noise wedged to it. Most shots of cars, where there is no dialogue, are mounted in this way. Again, it may be advantageous to put in a certain sound between a pause in dialogue. A wild track of the sound required is made and cut-in to the dialogue track where the pause occurs.

# MAJESTIC



## Midoet Superheterodyne

### Four-valve Receiver with Single-valve Frequency Changer.

It is, at first sight, surprising that some of the smallest receivers should be of the superheterodyne type, for one usually associates these receivers with large cabinets and high cost. The superheterodyne, however, is eminently adaptable to a compact construction, for the reason that it is inherently stable and the components may be placed in close proximity to one another without evil effects.

Five valves are employed in the Majestic Model 15 receiver, but as one of these is the mains rectifier it is more accurate to describe it as a four-valve set. A steel chassis is used, and is housed, together with the moving-coil loud speaker, in a walnut cabinet whose overall external dimensions are only 13½ in. wide by 9½ in. deep by 15½ in. high.

Since the apparatus is of Transatlantic origin, the valves are American, and the type 24 screen-grid first detector is preceded by an inductively coupled band-pass filter in order to reduce second-channel interference to a minimum. A single I.F. stage is used, with a type 51 variable- $\mu$  valve, and the two I.F. transformers have only their secondaries tuned. There are thus only two tuned circuits in the intermediate amplifier, but, in spite of this, a very high degree of adjacent-channel selectivity is obtained.

The second detector is another type 24 screen-grid valve self-biased, by means of a 40,000-ohm resistance in its cathode lead, to act as an anode-bend detector. The L.F. intervalve coupling is by resistance capacity

with a high value of anode-coupling resistance, and a good point is the inclusion of a resistance I.F. stopper in the grid lead of the output valve.

For the output stage a type 47 pentode is used, and is transformer-coupled to the low-resistance moving-coil loud speaker. The 47 pentode is rated to give an undistorted output of about 2,700 milliwatts, so that ample volume is obtainable. A tone control, consisting of a variable resistance in series with a 0.03 mfd. condenser, is connected across the output-transformer primary. The mains equipment follows standard practice, and the speaker field forms the sole smoothing choke, and, in conjunction with high-capacity dry electrolytic condensers, provides hum-free operation. The mains-transformer primary is untapped, but it is

stated to be suitable for voltages between 200 volts and 230 volts; for higher-voltage mains a special resistance must be included in the mains circuit.

#### The Frequency Changer.

The most unusual portion of the receiver is undoubtedly the frequency changer, for a single screen-grid valve is used as a combined first detector and oscillator. The tuned oscillator coil is not connected directly to any valve circuit, but is coupled to a coil which is shunt fed from the detector anode circuit. Reaction is provided by another coil in the cathode circuit, which is also coupled to the tuned winding. At first glance, one would think that such a circuit could

not possibly generate oscillations, but investigation shows that the cathode coil is effectively in the grid circuit of the valve, for it is included in the path between the grid and cathode.

A potentiometer is used for the volume control, but

#### FEATURES.

**GENERAL:** Single-control superheterodyne with four receiving valves. All A.C. mains operated. Built-in moving-coil speaker. Single-valve frequency changer. Output 2,700 milliwatts. Illuminated tuning scale calibrated in kilocycles covering medium waveband only.

**CIRCUIT:** Band-pass pre-selector followed by screen-grid detector-oscillator. Single variable- $\mu$  I.F. stage and screen-grid second detector R.C. coupled to pentode output stage.

**CONTROLS:** Single-dial tuning. Combined volume control and on-off switch. Tone control.

**PRICE:** £16 10s.

**MAKERS:** The Majestic Electric Co., Ltd., Majestic Works, Tottenham, London, N.17.



### HIGHLY SELECTIVE FOUR-VALVE SET.

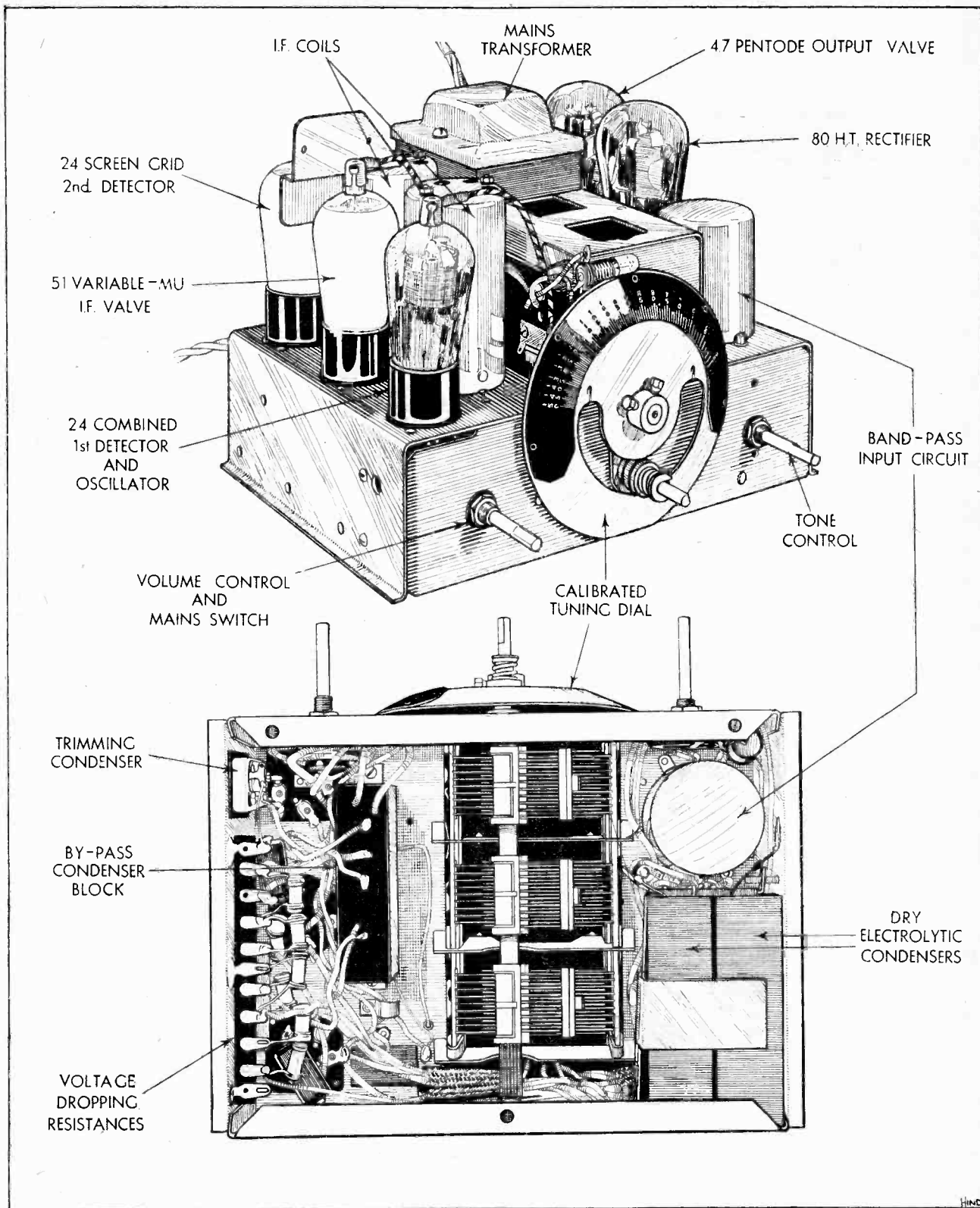

The chassis and under-chassis of the Majestic Midget Superheterodyne. Points of interest are the use of band-pass tuning and variable-mu valves.

**Majestic Midget Superheterodyne.—**

it is so connected that one-half of it acts as a variable resistance in the I.F.-valve cathode circuit, while the other half acts as a variable resistance across the aerial and earth terminals. A simultaneous control of both the bias voltage on the variable-mu valve and the aerial input is thus obtained with a single potentiometer, this arrangement ensuring that a full range of signal control can be obtained, and that the local transmission can be very nearly silenced.

Only three controls appear on the panel: the mains tuning control, which operates the three-gang condenser and the illuminated disc-type dial calibrated in kilocycles; the tone control; and the combined volume control and mains switch. This last consists of the volume-control potentiometer, which is so arranged that when fully rotated in an anti-clockwise direction it

in the I.F. amplifier. The London Regional transmitter, for instance, could be heard over a band of about 30 kc. on either side of its allotted frequency. The selectivity, nevertheless, is quite sufficient for most purposes, and is much greater than that obtainable with a tuned-H.F. set.

As might be expected with such a small cabinet, the reproduction is a little weak in the bass; the high and low notes are well balanced, however; and the general tone is pleasing. Ample volume is obtainable on the weakest stations, and the speaker fitted is evidently of a sensitive type.

**Volume Control.**

The volume control is very satisfactory in its operation, for it is smooth and quiet, and it gives a range

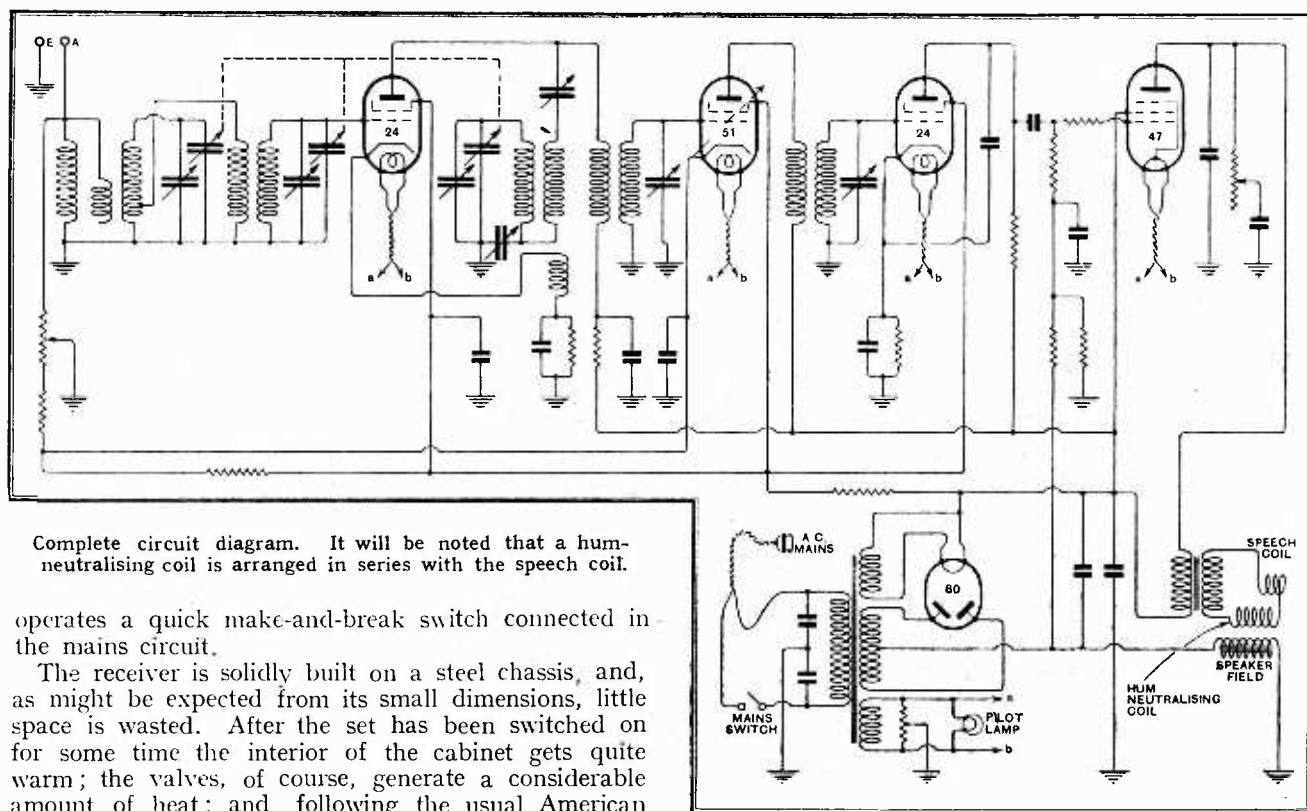

Complete circuit diagram. It will be noted that a hum-neutralising coil is arranged in series with the speech coil.

operates a quick make-and-break switch connected in the mains circuit.

The receiver is solidly built on a steel chassis, and, as might be expected from its small dimensions, little space is wasted. After the set has been switched on for some time the interior of the cabinet gets quite warm; the valves, of course, generate a considerable amount of heat; and, following the usual American practice, both the mains transformer and the speaker field run at a fairly high temperature. No back is fitted to the cabinet, therefore, so that adequate ventilation is ensured.

**Practical Results.**

Tested on a good aerial at about nine miles from Brookmans Park, the receiver gave excellent results. The sensitivity is high enough for all ordinary purposes; indeed, it is sufficient for good reception with only a few feet of wire for an aerial; and the background noise is commendably low. The selectivity is rather lower than the average for a superheterodyne, and this is doubtless due to the smaller number of tuned circuits

of control ample to reduce the strongest local to a whisper. Where the input from the local station is very large there is a tendency for the control to introduce a slight amount of distortion at low volume settings. It is a wise plan, therefore, to limit the size of the aerial when the set is used close to the local station, for the sensitivity is sufficiently high to allow of this course being adopted without a loss of volume on distant stations.

Only the medium-wave range of 1,500-540 kc. is covered in the tuning range, but at the price of £16 10s. the receiver represents excellent value. It is marketed in this country by Majestic Electric Co., Ltd., Majestic Works, Tottenham, London, N.17.

# Current Topics

EVENTS  
of the WEEK  
in BRIEF  
REVIEW

## Moydrum.

FOR those who like sponsored programmes in English, the heavens will open six months hence with the completion of the new high-power broadcasting station of the Irish Free State at Moydrum. We understand that the site is being cleared and that the erection of the station buildings is about to proceed. The transmitter, which is being built by the Marconi Company at their Chelmsford Works, will have a power of at least 120 kilowatts.

## Papal Broadcasting.

THE public address system installed in St. Peter's at Rome now includes twelve moving-coil loud speakers with six microphones distributed at different parts of the building. These microphones can also be connected directly to the Vatican short-wave station, so that services in the Cathedral can be broadcast all over the world.

## France's International Radio Show.

DESPITE the imposition of tariffs on foreign radio apparatus, the French radio manufacturers seem to be determined that the next Paris wireless show, fixed for September 8th to 18th, shall be international in scope. It will be held in the Grand-Palais, Avenue des Champs-Élysées.

## A Place in the Sun.

FRANCE, which has hitherto been considered backward in the matter of broadcast progress, now claims that, with the entry into full service of the Radio Paris (75 kilowatts) and Petit Parisien (20 kilowatts) stations, she will become fourth among European countries in the total power of her broadcasting system.

## A Ministry of Radio.

SO important has wireless and its ramifications become in the eyes of enthusiasts in France that the French Chamber of Deputies has been persuaded to pass a resolution respectfully requesting the President of the Council to provide wireless and all its works with a special Ministry.

## Broadcasting from Portugal.

WE understand that the contract for the new broadcasting station at Lisbon has just been placed with Standard Telephones and Cables, Ltd. It is

probable that the power will be 20 kilowatts, increased later to 80 kilowatts.

According to a Lisbon correspondent, the studios are to be located actually within the Santa Carlos Theatre. It is hoped that tests will begin within seven months.

## Radio in Air Taxi.

AN air taxi fitted with Marconi telephone equipment enabling the pilot to keep in touch with the ground is the latest addition to London's transport facilities. This is the Puss Moth aircraft flown by Captain Laurence Hope, of Air Taxis, Ltd. Incorporating a special telephone transmitter as well as a receiver, the apparatus enables the pilot not only to receive weather reports, but



### AIR-TAXI WIRELESS.

The Marconi radiotelephone equipment in the latest air taxi is operated by remote control from the pilot's seat.

also to speak to the aerodrome himself and ask for any information he may require.

## Small Advertisements.

SLIGHT alterations become necessary in our printing arrangements with the approach of the Easter holidays. The latest date on which small advertisements can be accepted for our issue of March 30th is Tuesday, March 22nd.

## Multi-wave Receivers at Leipzig Fair.

THE annual Spring Fair at Leipzig lost much of its importance this year, from a radio point of view, owing to the withdrawal of several important firms, including Telefunken. However, according to our German correspondent, several interesting trends were observable. Two firms were showing receivers with three wave bands; the new Schaub superheterodyne operates from 18 to 50, 200 to 600, and 800 to 2,000 metres.

Another interesting set shown was the Mende, one of the few German commercial receivers having a special fading compensator valve.

Export of sets and parts to Britain is now impossible, a fact which is sorely felt by the manufacturers.

The general trend in Germany now seems to be towards the superheterodyne in the more expensive class, and the straight three-valver using screen grid in the cheaper market.

## Many Happy Returns.

WHETHER the many broadcasting interests in America whose wings have been clipped by recent legislation really wish the Federal Radio Commission "Many Happy Returns of the Day" may be doubtful, but the vast majority of broadcasters realise that but for the advent of the Federal Radio Commission just five years ago, American broadcasting would have headed for chaos. To be precise, the Commission was founded on February 23rd, 1927, with a handful of clerks, and an annual expenditure of £3,000. Now the staff numbers more than one hundred, and more than £100,000 are required each year to maintain its manifold activities in controlling the wavelengths and licences of America's 617 broadcasting stations.

## The Pamphonic Reproducer.

WHAT can be achieved in electrical sound reproduction when the research engineer is given *carte blanche* in the design of his instrument and the choice of parts was impressively demonstrated at a recital on the Pamphonic Reproducer at Æolian Hall, Bond Street, on Wednesday last, under the auspices of the sole concessionaires, Messrs. Keith Prowse and Co., Ltd.

The occasion was a connoisseurs' concert in which a varied collection of records was played for the benefit of a critical audience. The instrument fully justified the reputation already gained at the Drury Lane Theatre, where this outsize in reproducers—the plate voltage on the final valve is 2,000 and the audio output 50 watts—is used to supply music and effects in the production of Noel Coward's "Cavalcade."

## CORRESPONDENCE

The Editor does not hold himself responsible for the opinions of his correspondents.

Correspondence should be addressed to the Editor, "The Wireless World," Dorset House, Tudor Street, E.C.4, and must be accompanied by the writer's name and address.

**Selectivity and Tone Correction.**

IN your issue of March 2nd there is a letter from the secretary of the British Radiostat Corporation, Ltd. The third paragraph of this letter makes a very broad and rather alarming-looking claim for patent number 344869. The fourth paragraph soothes our alarm by an offer of free licences to amateurs.

If the third paragraph is a correct interpretation of the main claims of the patent specification, then it seems to me that, not the public, but the patentees should feel the alarm, for they might find it hard to support the validity of such a patent.

A claim which covers every means of attaining an obviously desirable end is not good subject-matter for a British patent, and would not be upheld by the courts.

The chief difference between the Robinson patent 344869 and the Willans 233417 seems to be that the Robinson specification introduces a piezo-electric device and great faith. The piezo-electric device is certainly very useful, but it is not mentioned in the first two claims of the specification: what, then, is left in these main claims but the great faith?

I have no doubt that the Stenode can give an excellent frequency response right up to the highest audible frequency, or, alternatively, that it can exclude the high-pitched heterodyne noises caused by an overlapping interfering transmission, but I do not see how it can do both these things simultaneously unless there is some subtle device which is not disclosed in the specification of patent number 344869. R. Sr. Q. LENG.

London, W.1.

MY domestic receiver is a commercial five-valve set of well-known make which, by virtue of an anode detector operated at a high input level, demodulates Northern Regional quite effectively, giving me Langenberg's programmes free from the effects of the former station's overlapping sidebands. It has no sort of tone-correction, but I am proud to learn from Mr. Philpott, of the British Radiostat Corporation, that I may call it a "Stenode" receiver. The makers never let me into this secret. However, I do not propose to write to Mr. Philpott for leave to play about with the set, as it has been ruled that experimental work done on the subject-matter of a patent with a view to ascertaining its properties does not constitute infringement of the patent. In fact, until such cases as *Proctor v. Bayley*, 6. R.P.C.106 are reversed, I suggest that the British Radiostat Corporation would be more profitably employed proceeding for infringement of Patent 344869 Clause 1 against all the best radio manufacturers for turning out sets with good detector stages or something than granting even free licences to amateur constructors of the "Autotone."

Oxford.

DUNSTAN SKILBECK.

**Superheterodyne Tracking Errors.**

Sir,—Since the publication of the articles on single-dial control superheterodynes in *The Wireless World* dated November 25th, December 9th and 16th, I have made certain calculations to ascertain the magnitude of the tracking errors met with in this class of set, the results of which may be of interest to your readers.

The input circuit to the first detector was assumed in all cases to consist of a 200  $\mu$ H coil tuned with a condenser in such a manner that the total effective capacity varied from 50-500  $\mu$ Fs, giving a signal frequency range from 1,590-504 kc. Coil resistances were neglected. The intermediate frequency was taken as 110 kc. The best oscillator inductance value was then found to be 169  $\mu$ H.

With a series padding condenser of 1,920  $\mu$ Fs and a parallel padding condenser across the tuning capacity only of 3.2  $\mu$ Fs, correct tracking takes place at three signal frequencies, 1,590 kc., 1,035 kc., and 504 kc. The maximum error in the resulting intermediate frequency at other signal frequencies is 2.9 per cent, or 3.2 kc.

With the same oscillator inductance, but with a series padding condenser of 1,854  $\mu$ F, and a parallel padding condenser of 3.45  $\mu$ F, correct tracking occurs at the following signal frequencies, 1,475 kc., 1,000 kc., and 558 kc. The maximum tracking error, however, is now only 1.9 per cent., or 2.1 kc., except over the small band of signal frequencies higher than 1,560 kc., when the error rises to 2.8 per cent., or 3.1 kc.

The calculated tracking errors given above may appear at first sight to be considerable, even when the use of 9 kc. band width filters in the intermediate frequency amplifier is taken into account, but in point of fact these errors are rather smaller than, though of the same order as, the errors introduced by the use of coils and condensers guaranteed to be accurate to  $\pm 0.5$  per cent., the highest guaranteed accuracy ordinarily available in these components, to the general public.

Wolverhampton.

D. F. THOMAS.

**The Rise in Copper.**

I HAVE always understood that only British goods are shown at the Annual Wireless Exhibition at Olympia.

If this is correct then the following may be of interest.

Last October, in preparation for the change-over to A.C. I sent for lists from an advertiser in *The Wireless World* after finding out from your Show Number that they had exhibited at Olympia. In February I gave my order for transformers, etc., and on receiving the account for them found the price had been raised nearly 20 per cent. On asking for the reason I was informed that it was *due to the rise in copper*. What nonsense.

Then it struck me. Foreign goods are dearer on account of the Gold Standard. Thereupon I challenged them that their goods were foreign made, and this they eventually acknowledged, but added that *they were now made over here*.

I doubt it.

READER FROM NO. 1.

London, E.C.2.

**Water-pipe Earths.**

YOUR leading article in the issue of March 9th reminds me that at a previous address, where I had a telephone installation, the Post Office engineers connected their earth lead to a main water pipe.

If this practice is common, and if the contentions of the Portsmouth Water Company are capable of being supported by reliable evidence, it would seem that the ordinary wireless amateur may have, in this instance, a quite unusual champion.

South Croydon.

A. W. KEMPE.

**Esperanto.**

IN reply to J. G. Earle's letter in your issue of February 24th. I may say that some forty-five radio stations now broadcast in Esperanto.

Various lexicons of wireless technical terms in Esperanto and other languages have appeared, and may be seen by any visitor to the reference library at this address.

MONTAGU C. BUTLER,

Librarian, The British Esperanto Association.

London, W.C.1.

Wireless  
World

# LABORATORY TESTS



## Review of New Radio Products.

### "HARBROS" ARMoured SLEEVING AND PICK-UP FLEX.

The extraordinary efficiency of present-day valves and receiving circuits, requiring more complete screening of all leads carrying H.F. current than hitherto, has led to a demand by set designers for an armoured type of insulated sleeving through which these leads can be run. The "Harbros" sleeving has a large bore—about 2.5 mm.—with an outer covering of closely woven braided metal. Measurements of the capacity introduced when a length of No. 24 gauge wire is inserted in the sleeving show that this is only some 15 mfd. per foot with the outer casing earthed. Since the minimum capacity across gauged tuned circuits is rarely less than 60 mfd., and often more, the additional capacity can be compensated for in all cases by the

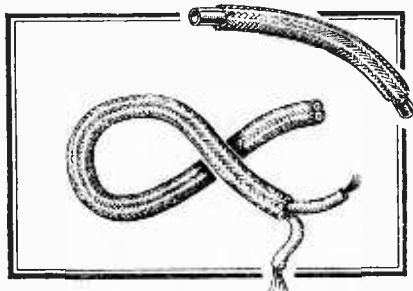

"Harbros" armoured sleeving and special armoured pick-up flex.

small trimmers fitted to each of the condensers. When No. 32 S.W.G. wire is used the capacity is reduced to 13 mfd. per foot.

The armoured pick-up flex consists of two cotton-covered tinsel leads, each of which has an outer covering of cotton braid, and then is finally enclosed in braided metal. The capacity between the two leads with the casing earthed was found to be 49 mfd. per foot. This flex is quite suitable for pick-up connection in a radio-gramophone, but the leads should be kept as short as possible.

The makers are Hart Bros. Electrical Manufacturing Co., Ltd., Queensway, Ponders End, Middlesex, and the price of the armoured sleeving is 9d. per yard. The pick-up flex costs 1s. for 6 feet in twin form, and 9d. for 6 feet in single form.

### SOME NEW BULGIN COMPONENTS.

There has been a marked increase recently in the number of composite components available to the home constructor, their advent being the outcome of the present-day vogue for simplicity of control and neat panel layouts. The latest Bulgin contribution takes the form of a combined volume control and switch. It consists of a wire-wound potentiometer rated to dissipate 15 watts, and a toggle-action single-pole switch capable of handling three amps. at 250 volts.

Contact with the resistance is made via the medium of a spring disc which is pressed on to the wire by the rotating arm. When this reaches the end of its travel in a counter-clockwise direction, a projecting lug engages in a slot in the switch lever and moves it to the "off" position.

This unit is available fitted with resistances of from 2,000 ohms to 250,000 ohms, the price being 7s. 6d. up to 75,000 ohms, and 9s. 6d. for the higher values.

Another new component is a totally enclosed two-pole change-over switch with an "off" position, designed for use as a radio-gramo-switch. The contacts are self-cleaning, and the contacting segments are spring-loaded. The three positions are well defined, and, complete with indicating plate, it costs 2s. 6d.

Bulgin "Soldawyre" will appeal to the home constructor, as it simplifies wiring and enables soldered joints to be made with the greatest ease. It consists of six strands of tinned copper wire with a core

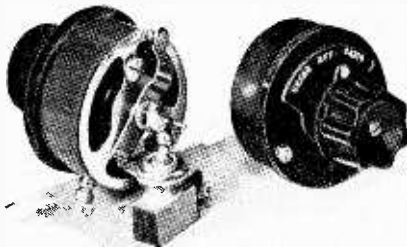

Bulgin switch and volume control. On the right is the radiogram switch.

of pure solder, cotton covered, and finally finished with an outer braided covering. "Soldawyre" is semi-flexible, but sufficiently rigid to retain bends, so that the

wiring can be made as neat as with any solid conductor.

The makers are A. F. Bulgin and Co., Ltd., Abbey Road, Barking, Essex, and the price is 6d. per coil of 8ft.

### "EELEX" LEAD INDICATORS.

J. J. Eastick and Sons, Eelex House, 118, Bunhill Row, London, E.C.1, have just introduced a very useful attachment for battery leads with which are used their indicating plates of the type fitted to "Eelex" terminals. These lead grips consist of a small stud with a slot to accommodate the wire and a small shoulder to position the name-plate. The appropriate indicating plate is first fitted to the stud and is kept in position by the lead when it is threaded through the slot.

The wire grips and indicating plates are made of insulating material, so that they cannot possibly be responsible for short-circuits, even if they touch the wiring. These lead indicators are especially useful where multi-stranded battery cables are employed, but they can be used, also, to

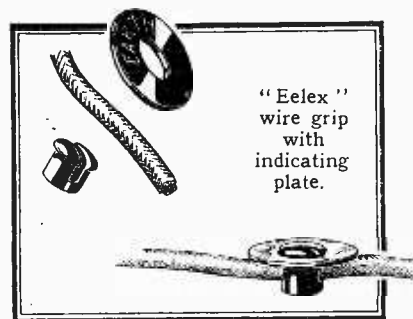

"Eelex" wire grip with indicating plate.

mark wires inside the set, such as grid bias leads, for example. The wire grips cost 6d. a dozen, and the indicating plates, of which there are forty different markings, cost 1d. each, or 9d. a dozen.

### LISSEN DUAL RANGE SHIELDED COIL.

Made by Lissen, Ltd., Lissenium Works, Worples Road, Isleworth, Middlesex, this new coil follows the present-day vogue in that it is wound on a small diameter former, the medium-wave section being a single-layer solenoid, while the long-wave portion is accommodated in two narrow grooves. The spacing between the medium and long wave coils is a shade less than one inch, the intervening space being utilised to accommodate the reaction winding, which in this coil is wound in a single layer. The relatively wide spacing between the two sections of the tuned coil reduces to a minimum the damping introduced when the long-wave section is short-circuited. Incidentally, the wave-change switch is not incorporated in the coil unit, and will be an external fitment. The leads should be kept as short as possible to

limit the coupling effect between grid and anode circuits.

Measurements made with a sample coil gave the medium-wave sections as 182 mH., and the long-wave coil 2,230 mH.; these figures compared favourably with those supplied by the makers, which are 170 mH. and 2,200 mH. respectively.

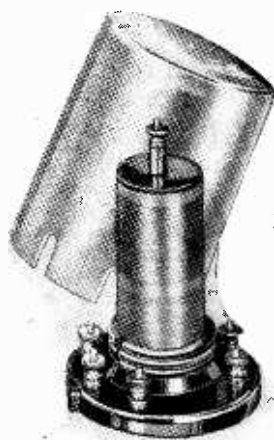

New Lissen dual range screened coil with cover removed.

This coil is satisfactory in every respect for use in modern circuits where small diameter screened coils are specified, the only precaution necessary being to keep the leads to the switch as short as possible. It possesses the distinct advantage that it can be mounted in any position, as the case is securely fixed by a small milled headed nut. The price is 6s. 6d.

#### PILOT AUTOTONE KIT.

We have now had an opportunity of examining a kit of parts for the "Autotone" receiver, prepared by the Peto-Scott Co., Ltd., of 77, City Road, London, E.C.1.

As might be expected, all components are of the types and makes specified by the designers, and minor accessories, such as connecting wire, fixing screws, etc., are included without any extra charge. A full-sized blueprint is included. It is no exaggeration to say that nothing remains for the purchaser to do but to assemble and wire the apparatus, and then to carry out the initial adjustments, which were fully described in last week's issue.

We were particularly impressed by the fact that special care has obviously been taken to ensure that the various parts shall fit together properly—a matter that may always cause a little difficulty when co-ordinating the efforts of a number of separate manufacturers. It is evident that the word "Service," as applied by the Peto-Scott Co. to their organisation for distributing kits of parts, is not an

empty boast, and that the Company do not consider that their obligation to the public is limited merely to handing over a collection of specified parts.

The "Autotone" kit, complete except for valves, batteries, and cabinet, costs £8 2s. Extended payments can be arranged.

#### FERRANTI A.C. MAINS UNIT. Types E.2 and E.3.

Ferranti, Ltd., can claim the distinction of being among the pioneers both in the development and manufacture of numerous types of apparatus for use on the electric supply mains. They were largely responsible for popularising the H.T. supply unit fitted with the Westinghouse metal rectifier, this early preference being still favoured in their latest models.

In the case of the model E.2, a half-wave rectifier is employed, and two D.C. output voltages are provided, rated at 120 volts and 60 volts respectively. The maximum current is 15 mA., and the unit is suitable for most two- and three-valve sets fitted with a small power valve in the final stage. The 60-volt tapping is intended to supply the screen potential for the H.F. valve, but where an H.F. stage is not in use this voltage can be applied to the detector valve.

On test it was found to be quite silent in operation, and satisfactory in every respect, but when used with sets embodying two L.F. stages, the usual anode decoupling was found to be desirable.

The E.3 unit differs from the smaller model in that it provides a large output—150 volts with a maximum of 25 mA.—and gives three separate output voltages. The additional tapping enables a variable voltage to be obtained for the detector stage; a series resistance of the compression type giving a range of from 0 to 140 volts approximately. The maximum voltage at this tapping is governed by the load on the unit, and also, in consequence, the voltage available at the "power" tapping. The screen potential

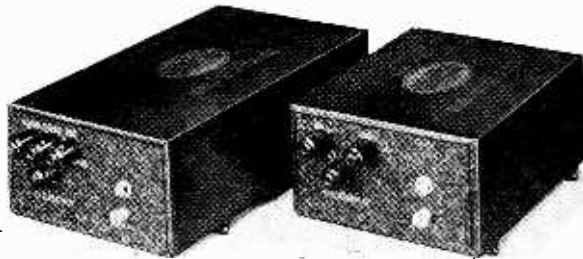

Ferranti A.C. supply units, Models E.2 and E.3, fitted with Westinghouse metal rectifiers.

is derived from a potential divider consisting of two fixed resistances in series, the voltage being between 60 and 80 volts, according to the current load.

The smoothing circuits are adequate, and this model is quite suitable for operating multi-valve receivers, including the superheterodyne types, provided the current demand is within the stipulated figure.

Both these units are enclosed in robust metal cases finished in black crystalline, and completely insulated plug and socket connections are provided. The mains transformers are tapped for A.C. supplies of from 200 to 250 volts, and comply in every respect with the I.E.E. recommendation for mains-operated apparatus.

The makers are Ferranti, Ltd., Hollinwood, Lancashire, and the prices are: E.2, £3 10s. 6d.; and E.3, £4 16s. 6d.

□ □ □ □

#### LONG-PLAYING RECORDS.

##### A New Development at the British Industries Fair.

A new system of recording which has many advantages over existing methods has been shown for the first time at the Olympia section of the British Industries Fair. The firm responsible for this development is Filmophone Flexible Records, Ltd., 12, Oval Road, Camden Town, London, N.W.1, and the new record is known as the "Longanote."

The basic principle of the system is that the rate at which the record passes under the needle is constant from start to finish. Since the circumference of a groove is greater at the outside than at the centre of the record, it follows that to accomplish this the speed of rotation must be steadily increased as the needle travels inwards towards the centre. This is effected by a special governor attachment controlled by the movement of the pick-up tone arm.

The advantages of the system are obvious. A 12-inch "Longanote" record gives a playing period of eighteen minutes compared with approximately four minutes for a record of the ordinary type. Further, in the case of the standard record the speed of rotation is a compromise, since the linear velocity at the centre must not fall below a given minimum (about 10 to 15 in. per second), which will ensure adequate recording of the higher frequencies. On this basis the linear speed of the outside grooves is much higher than it need be, and valuable playing time is sacrificed.

Of course, the success of the system will depend on the accuracy with which the progressive decrease of speed is controlled, and we hope to be in a position to report on this aspect at an early date.

A complete radio gramophone incorporating the new system is being marketed at 48 guineas, and conversion sets for existing machines will be available at 8 guineas.

#### Scientific Short-wave Adaptor.

We understand that the short-wave detector adaptor marketed by the Scientific Supply Stores, 126, Newington Causeway, London, S.E.1, is now available in kit form, and blue prints giving full constructional details can be obtained at the price of 4d. each. A limited number of complete kits is being offered at the special price of 25s. 6d.

#### Change of Address.

Graham Amplion, Ltd., St. Andrew's Works, Slough, Bucks, announce that their sales office has been transferred from Savile Row to the above address.

# READERS' PROBLEMS.

## Long-wave Matching.

IT sometimes happens that the "ganging" of a single-knob set works perfectly on the medium band, but the adjustment no longer holds good on changing over to the long-wave side. When this happens it may almost invariably be assumed that the long-wave inductances are incorrectly matched, or that an unequal proportion of stray capacity is transferred to the long-wave tuned circuits (as compared with that transferred on the medium band).

A statement to this effect, recently published in *The Wireless World*, has given food for thought to a correspondent whose 1-v-1 set, with ganged tuning, works well on the medium band, but who has found that one of the three long-wave coils appears to be deficient in inductance. Being unwilling to disturb the coils, he asks how an external balancing inductance could be connected, and also if it would not be possible to use an extra long-wave balancing condenser; he would much prefer to adopt the latter plan if it is permissible.

It may be stated quite definitely that misganging due to incorrect matching of long-wave inductances cannot be corrected by the addition of capacity. True, the circuits can be aligned at any one point by means of an extra long-wave trimmer, but this adjustment will not hold over an appreciable band of wavelengths.

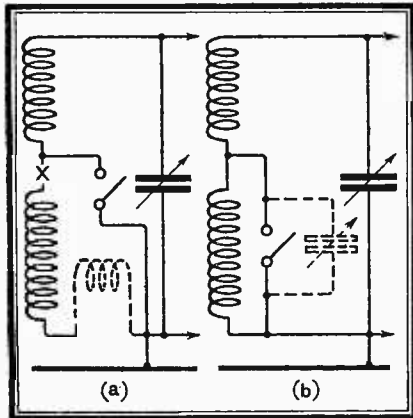

Fig. 1.—Diagram (a) shows alternative positions for a balancing coil for matching long-wave inductances. Although less satisfactory, a small trimming condenser may sometimes be connected as in diagram (b) for compensating for minor inaccuracies.

In cases where there is an objection to interfering with the windings, an extra balancing inductance can be added as shown in dotted lines in Fig. 1 (a). If it is more convenient, the coil may be inserted equally well at the point marked X in the diagram.

Although, for reasons given above, we

can hardly advocate the use of an extra trimmer in these circumstances, it might in practice be useful enough for making good a small discrepancy. It should be wired across the wave-range switch in the manner indicated in Fig. 1 (b), so that it may be effective on the long-wave band only.

## Pick-up Connections for the "Autotone."

AS the "Autotone" receiver contains a tone-correction stage it should be fairly obvious that it can hardly be converted for gramophone reproduction by the usual expedient of inserting the pick-up in the detector-grid circuit, or, for that matter, in the grid circuit of the second valve, which is the tone corrector. The right position for the pick-up is in the grid circuit of the third valve; here as much amplification will be given to its output as is afforded in more conventional receivers.

As to the actual method of connection, it will be necessary to insert a single-pole change-over switch—or a plug-and-socket device carrying out the same functions—in the grid circuit of the valve in the usual manner.

## A Wasted Band-pass Filter.

IT should be emphasised that a band-pass filter can only perform its proper function when its component circuits are accurately tuned to the wavelength of the signals being received; this is one of the reasons why designers of sets are at such pains to devise input-volume-control devices that do not produce any appreciable tuning errors.

A correspondent whose H.F.-det.-L.F. receiver includes a band-pass input filter controlled by ganged condensers, but with separate wave-range switches for each coil, has found by accident that signal input from his local medium-wave station can be reduced to a suitable extent by the somewhat drastic expedient of switching the primary circuit to "long waves" while the secondary is correctly set. In this way the difficulties of an excessively great input from the aerial are overcome; but, not being quite satisfied with the quality of reproduction, he asks whether this scheme is theoretically defensible.

We are afraid that it is not; what he is doing amounts to detuning one element of the filter, and so all the advantages that he has aimed at in the matter of high-note retention are lost. As it so happens that his local station operates at the upper end of the medium broadcast band, we should imagine that the loss of high notes brought about by misuse of the filter is not merely academic, but will be aurally perceptible. It would be worth while fitting a satisfactory form of input-filter control, so that both filter circuits may be accurately tuned for local station reception.

THESE columns are reserved for the publication of matter of general interest arising out of problems submitted by our readers.

Readers requiring an individual reply to their technical questions by post are referred to "The Wireless World" Information Bureau, of which full particulars, with the fee charged, are to be found on the next page.

## Batteries in Series.

IT is asked whether it would be permissible to give a new lease of life to an H.T. dry battery which originally gave 160 volts, but which now only maintains a voltage of about 110 volts on load, by connecting in series with it a new 60-volt battery.

As our querist is using dry batteries of rather higher voltage than usual we take it that the anode circuits of his receiver are adequately decoupled. If this is so there is no theoretical objection to doing as he proposes, but, incidentally, it would be a good plan to obtain a "boosting" battery of lower capacity than that of the original cells.

The reason for our insistence of decoupling in this case is that the old battery is sure to have a high internal resistance, and unless this precautionary measure is included the result of increasing amplification by adding H.T. voltage will probably be either to provoke motor boating or to make incipient L.F. reaction more evident than formerly.

## Bias Across Filament Resistor.

AT one time it was not unusual that arrangements should be made for developing negative grid bias for an amplifying valve or for an anode bend detector across a resistance inserted in the negative filament lead. In some cases it was possible to obtain quite an appreciable bias voltage by judicious mixing, in the same set, of valves having 2-volt and 6-volt filaments.

The valves used in such arrangements were generally chosen for some peculiarity of their characteristics, and most of them are no longer available. Consequently, our reply to querists who ask for information concerning replacements is that it is best to abandon the automatic bias scheme entirely, and to fit either normal battery bias or "free" bias arrangement on conventional modern lines, with decoupling condensers and resistances where necessary.

**Isolating the Circuits.**

**R**ESIDUAL grid-anode capacity in S.G. valves has been reduced to a microscopically low figure, screened coils are readily available and are in general use, and metal chassis construction, which automatically provides a certain amount of screening, is popular. It would, therefore, seem that H.F. instability should be

lish a sketch showing those components which, in a typical H.F. stage, are associated with grid and anode circuits.

The skeleton diagram given in Fig. 2 should be helpful to those who are experiencing H.F. instability, whether actual or incipient. This diagram is more or less self-explanatory, and it brings out a few points that are sometimes ignored.

valve coil, as it is for energy to be fed back directly into the grid circuit.

Whatever system of screening may be adopted, it is inevitable that a certain number of "danger" leads must be exposed to the risks of stray pick-up; these leads are shown by a dash-dot line.

**"Autotone" Coils.**

**A** SOMEWHAT unusual method of construction is adopted for the "Autotone" coils; for instance, the medium-wave reaction winding is inside the corresponding tuned circuit coil, being wound in shallow slots cut in the ribs of the former. This gives close magnetic coupling with low capacity.

In order to prevent the heavy wire winding from collapsing into the reaction winding slots, narrow strips of press-palm are placed over each of the ribs before this winding is put on.

One or two readers seem to have concluded that this insulating material was in the form of a continuous ring round the former between the two coils, and not in the form of strips, as stated above.

**Short-wave Converters.**

**A** READER, who still uses a four-valve receiver with a neutralised three-electrode H.F. valve, asks whether this set would give good results for short-wave reception when operated with a superheterodyne "converter" of the type which has been discussed several times in the pages of this journal. He states that, although the sensitivity of the set on medium waves is rather low when judged by modern standards, its performance on the long-waveband is excellent; as the H.F. stage will be converted into an intermediate frequency amplifier when it is working on the long-wave side he assumes that sensitivity will be ample if there is no unsuspected "snag."

There should be none. If we can assume that the H.F. stage is properly neutralised and will remain stable when the aerial load is virtually removed by the interposition of the converter there is no reason why good results should not be obtained on the ultra-short waveband.

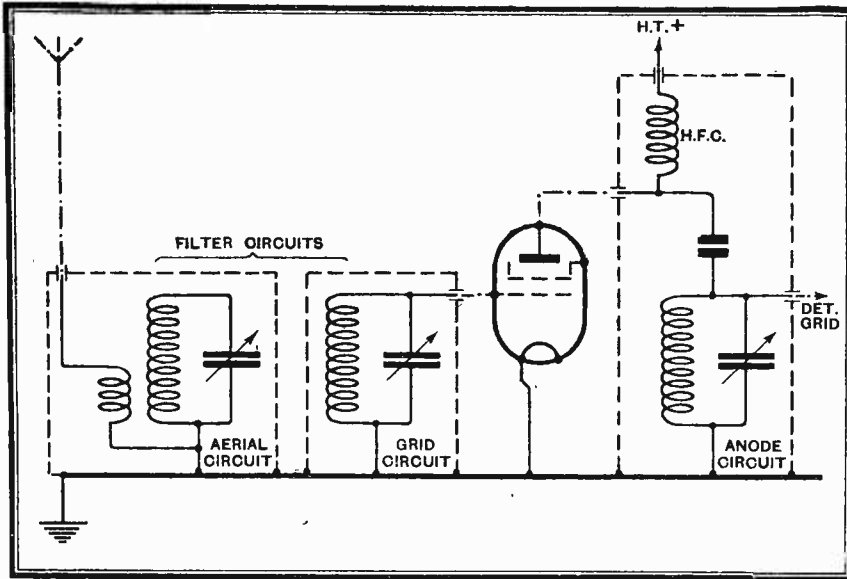

Fig. 2.—Showing grid and anode circuit components that should generally be screened from each other. External connecting wires which may be responsible for instability are indicated by dash-dot lines.

a thing of the past, but it appears that uncontrollable self-oscillation is still quite often the first trouble to be overcome by the builder of an "H.F." set, unless he follows implicitly a hard-and-fast design.

This instability is always due to some form of undesirable interaction between the grid and anode circuits of an H.F. valve. When one understands the cause it is generally easy to apply the remedy, and a correspondent has asked us to pub-

For instance, the tuned grid circuit used as an intervalve coupling, though actually connected across the detector valve, is, from our present point of view, in the anode circuit of the H.F. valve. Similarly, the primary element of the band-pass filter, though apparently isolated from the grid circuit, is always coupled to it electrically, and it is just as dangerous for direct interaction to take place between this coil and, say, an inter-

**"THE WIRELESS WORLD"****Information Bureau.****CONDITIONS OF THE SERVICE.**

(1) THE service is intended primarily for readers meeting with difficulties in the construction, adjustment, operation, or maintenance of wireless receivers described in *The Wireless World*, or those of commercial design which from time to time are reviewed in the pages of *The Wireless World*. Every endeavour will be made to deal with queries on all wireless matters, provided that they are of such a nature that they can be dealt with satisfactorily in a letter.

(2) Communications should be addressed to *The Wireless World* Information Bureau, Dorset House, Tudor Street, E.C.4, and must be accompanied by a remittance of 5s. to cover the cost of the service. The enquirer's name and address should be written in block letters at the top of all communications.

(3) The fee of 5s. covers the reply to any wireless technical difficulty, but in special cases, where the enquiry may involve a considerable amount of investigation, an increased fee may be necessary. In such cases a special quotation will be made.

(4) Questions should be clearly written and concisely worded in order to avoid delay. Where enquiries relate to trouble experienced in receivers built to specifications in *The Wireless World* a complete account should be given of the trouble, and especially the symptoms.

(5) Where reference is made to published articles or descriptions of apparatus, the title of the article, the date of publication in *The Wireless World*, and the page reference number should be given, in order to facilitate reply.

(6) Full circuit diagrams, constructional details of apparatus, or values of components for home-designed receivers cannot normally be supplied, but circuit diagrams sent in with queries will be checked and criticised.

(7) Particular makes of components cannot, in general, be recommended, but advice will be given as to the suitability of an individual component for a particular purpose specified by the enquirer.



# The Wireless World

AND  
RADIO REVIEW  
(21<sup>st</sup> Year of Publication)

No. 656.

WEDNESDAY, MARCH 23RD, 1932.

VOL. XXX. No. 12.

Editor: HUGH S. POCOCK.

Editorial Offices: 116-117, FLEET STREET, LONDON, E.C.4.

Editorial Telephone: City 9472 (5 lines).

Advertising and Publishing Offices: DORSET HOUSE, TUDOR STREET, LONDON, E.C.4.

Telephone: City 2846 (15 lines).

Telegrams: "Ethaworld, Fleet, London."

COVENTRY: Hertford St. BIRMINGHAM: Guildhall Bldgs., Navigation St.

MANCHESTER: 260, Deansgate GLASGOW: 26B, Renfield Street, C.2.

Telegrams: "Cyclist, Coventry."  
Telephone: 5210 Coventry.

Telegrams: "Autopress, Birmingham."  
Telephone: 2970 Midland (5 lines)

Telegrams: "Hiffe, Manchester."  
Telephone: Blackfriars 4412 (1 line).

Telegrams: "Hiffe, Glasgow."  
Telephone: Central 4587

PUBLISHED WEEKLY.

ENTERED AS SECOND CLASS MATTER AT NEW YORK, N.Y.

Subscription Rates: Home, £1 1s. 8d.; Canada, £1 1s. 8d.; other countries abroad, £1 3s. 10d. per annum.

*As many of the circuits and apparatus described in these pages are covered by patents, readers are advised, before making use of them, to satisfy themselves that they would not be infringing patents.*

## EDITORIAL COMMENT.

### Water-pipe Earths.

**I**N our issue of March 9th we drew attention to the recent threat to deprive wireless users of the water pipe as an earth connection, and, as far as we know, at that time the Portsmouth Water Company was the only water supply authority which had taken any action in the matter.

Since then we learn that the Metropolitan Water Board has been investigating the matter, and is likely to issue regulations at a later date. We expressed the view previously that no restrictions of this kind ought to be imposed on frivolous or ill-founded evidence, but at the same time, it must be recognised that if damage to water pipes does occur, then the companies concerned have every right to protect their property.

We would urge, however, that, even if evidence shows that deterioration of water pipes does occur, unless it is of really serious magnitude no onerous restrictions should be introduced. Restrictions of this nature are practically unenforceable, and are likely to be ignored by all but the more conscientious members of the community, so that we doubt whether the object in view would be attained; moreover, it would be necessary in any such regulation to differentiate between types of receivers likely to cause damage and those which would not, and the regulation would probably have to be extended to include other contacts such as telephone earths, which are constantly made to the water-pipe networks of buildings. Also, we have to remember that every type of mains set, under the recommendations of the Institution of Electrical Engineers, should be effectively earthed at certain points, and how, we would ask, is this earthing to be carried out in the case of a very large proportion of the users of wireless sets if the facilities hitherto offered by the water pipe should be no longer available?

We hope that the Metropolitan Water Board will decide that no effective action can be taken in the matter and that, in consequence, it is better not to act but to leave listeners as they stand at present in the peaceful enjoyment of the use of their customary earths. We feel that a responsibility rests with the Metropolitan Water Board, for, no doubt, whatever attitude they adopt will provide a precedent for other suppliers.

### Valve Price Reduction.

**R**EADERS will welcome the news of a substantial reduction in the price of valves. Elsewhere in this issue we give a list indicating the reductions which have been announced in various classes, and it will be seen that in most cases these are quite substantial. No more welcome step could have been taken than this, for the valve is, after all, the key to wireless, and the modern types are now obtainable at what may be regarded as a reasonable figure for the first time.

We understand that the reduction in prices is in no small measure due to the introduction of the protective tariff on valves, for although manufacturers had intended to bring about a reduction in prices as early as possible it seems certain that the change has been expedited as a result of the valve manufacturers being given a feeling of greater confidence in an unhampered market for their products in the future.

The reduction in prices, coming at this time of the year, should be valuable as an assistance to the set designer and manufacturer, who is now in a position to make plans for next season well in advance, and it is to be hoped that the price reduction in valves will influence also the price of other components and complete sets in the near future.

**OCEAN  
NEWSPAPERS**

*The White Star liner "Maestic" on which  
"The Ocean Times" appears daily.*

**Wireless in  
Maritime Journalism.**

By E. C. THOMSON.

**P**EOPLE still beguile themselves into imagining that when they take leave of their ordinary existence and embark on a sea voyage they will rejoice in being cut off from all the familiar associations. Not to be worried with what is occurring in Brixton or Westminster, not to be maddened with what is happening on the Stock Exchange, not to be goaded to fury by the opinions of inescapable celebrities; the thought seems enchanting while these annoyances persist. But when they persist no more, when the feast of reason and the flow of soul are indeed cut off, and the ordinary citizen finds himself on board ship, gaping at the watery horizon and pretending that he has found the peace for which his soul yearned, what then?

The pretence collapses. Hence deck quoits and other curious occupations.

This inability of the average citizen to exist happily in the absence of news is not entirely his own fault. During the last fifty years the Press, by its own energy and enterprise, has steadily increased the public demand for information, so that what was formerly a mild curiosity as to what might be happening round the corner has developed into a raging thirst for news of every kind from all quarters of the globe.

The ocean traveller cannot abandon what now amounts to an hereditary craving, nor need he. Wireless has made it possible for him to have a daily newspaper which differs in little else but size from its prototypes on land. It contains news and literary pages, and, in

addition, a bright collection of advertisements, which in themselves create in the mind of the reader the feeling that he is still in touch with civilisation and can slip into Bond Street or Fifth Avenue at any moment when the mood takes him.

Although it has never been suggested that a man would sail from London to Australia simply for the sake of the wireless news service, the fact remains that, in certain circumstances, sea travellers now get information before their brethren on land. In the case of General Elections, big races such as the Grand

National, and other events of world-wide interest, it often happens that a passenger in mid-Atlantic is reading the results before they have been distributed on terra firma.

Special bulletins are broadcast throughout the day, and, where they are not incorporated in the wireless newspapers, are exhibited prominently for all passengers to see.

All newspapers issued on British ships are now published by an organisation known as the Wireless Press, which, in the first place, supplies ships with copies of the journals prepared in such a way that the news can be printed on shipboard as received by the ship's wireless operator. The same organisation also provides the ships with a regular flow of the latest news, transmitted on the British side from the famous Post Office station, Rugby Radio. By special arrangement, other stations in different parts of the world also bombard the ships with news, but

**T**HANKS to wireless, the ship's daily newspaper has now become an institution on the more important passenger-carrying vessels. This article describes the world-wide organisation for the daily supply of news from Rugby Radio and other high-power transmitters.

Ocean Newspapers.—

more of this later. On receiving the news bulletin, the wireless operator hands it over to the ship's purser, on whom devolves the task of sub-editing it. The sub-edited "copy" is then passed to the ship's press-room or "print shop," set up, and then returned to the purser for final editing and make-up.

The Light Touch.

While the ocean newspapers are strictly non-political, care is taken to give a comprehensive survey of world happenings in a manner calculated to interest all types of voyager, from the commercial magnate eager to read the market reports to the Society debutante whose thoughts may tend more in the direction of the latest wearing apparel. What is never forgotten is that most of the journal's readers find themselves in an unfamiliar environment and are not prepared to concentrate for long periods on weighty leading articles or dissertations which would be quite acceptable to the land-lubber in his carpet slippers at home.

Journalism of this kind calls for an especially light touch, which perhaps finds its best expression in the literary pages. With a little skilful dovetailing on the part of the ship's purser, who is aided by the vigilance of the wireless operator, news and views combine to make a complete newspaper each morning.

Copies are delivered free to passengers in their state-rooms before breakfast, so that not infrequently the ocean traveller, while discussing his egg and toast, is reading in his ocean newspaper the same reports that are gladdening (or saddening) the heart of the *Daily Telegraph* subscriber on land.

More and more shipping lines are now recognising the value of the wireless newspaper services as a welcome amenity on the passenger decks. At present the ocean journals are published on ships of the White Star, Red Star, Atlantic Transport, Canadian Pacific, Cunard, Anchor, P. and O., and the Orient lines.

Although Rugby Radio has a world-wide range, the news, if it is to be really comprehensive, must come from all quarters, hence the Wireless Press organises regular news transmissions from other countries, such

as Canada, U.S.A., Argentine, and Australia. There will be few events in the world that are not covered by the transmissions from one or other of these countries. Each supplies a daily quota of news items, so that, to take an example, a ship in the North Atlantic subscribing to the service can count upon receiving anything from 3,000 to 4,000 words per day, or sufficient to fill three or four columns of an ordinary journal on land.

The supply of news never ceases. Daily throughout the year Rugby Radio transmits three news bulletins—in the early hours, at midday, and during the evening. The cordial co-operation of the Post Office is, of course, essential in the conduct of such a service, and it says much for the efficiency of the staff concerned that the news supply is maintained year by year without a hitch. Lucky though he may be, the ocean traveller has only one newspaper, and if the news services were to break down he could not buy a competing journal.

In addition to the regular news bulletins, Rugby Radio transmits a Saturday night message giving the League football results. This message is in great demand among the crews on cargo boats all over the world.

Lest it should be thought that the ship's newspaper is a new creation, it is worth noting that No. 1, Vol. 1, of the *Transatlantic Times*, the forerunner of the existing publications, appeared on November 15th, 1899! The issue was made in the form of a leaflet on board the s.s. "St. Paul," on which Senatore Marconi had fitted his apparatus. Communication was established with the Needles station, 36 miles away, and reports were printed,

in a somewhat telegraphic style, of the progress of the South African War.

The modern ocean newspaper is an excellent reproduction in miniature of the "real thing," but already there are indications that it may, sooner or later, give place to an exact replica of journals on land. This should ultimately be achieved by means of facsimile telegraphy, which could reproduce on board ship a complete page, printed on land, in a shorter time than would be required to transport the actual newspaper from one end of Fleet Street to the other. Whether anyone wants this luxury is another question.



Experiments are still proceeding in the development of facsimile newspapers for publication at sea. Above is a test page transmitted on 20 metres from New Brunswick to the s.s. "America" in June, 1930.



## PHOTO CELLS *and* ADVERTISING

By R. C. WALKER, B.Sc.

### Shop-window Control of Illuminated Displays.

**T**HE most obvious use of the photo-cell in the field of advertising is the control of illuminated signs, switching on at the approach of darkness, or, in the reverse direction, by the head lamp of an approaching motor car during the hours of darkness.

The mounted components of the amplifier circuit which has previously been described in earlier articles<sup>1</sup> are shown in Fig. 1. The base plate carrying the components can, if necessary, be bolted to the inside of a cast-iron weatherproof case. The simplicity of the set is at once apparent and, with or without a time-delay switch, forms a very convenient unit for general advertising displays. Where it is intended that the sign shall be switched on by the head lamp of an approaching motor car it is clear that daylight must not interfere with the operation, and, in addition, that, once switched on, the sign must remain on long enough to be read and understood.

One method of securing the first requirement is to modify the circuit and to use capacity coupling between cell and valve so that the set becomes responsive to sudden but not gradual changes in illumination. Such a device is sometimes unsatisfactory because daylight changes, though not apparently so, are frequently very large and sudden.

Also, the approach of a car may constitute a gradual change in illumination. More suitable is an arrangement in which two photo-cells and valves are used, one cell directed toward the zenith and the other towards the approaching traffic, the former valve relay closing the grid circuit of the second cell as soon as darkness falls. In this way there is no need to make use of any devices such as shielding the cell with an internally blackened tube which is sometimes used to cut off extraneous light.

Numerous devices exist for enabling the sign to remain on for a specified period. One, consisting of a mechanically operated switch, is shown in Fig. 2. Here the closing of the photo-cell valve relay energises the coil 23 and raises the armature 22 pivoted at 10 to the movable arm 9. Arm 9 rotates clockwise against the tension of spring 5, the pull of which is adjustable.

*ADVERTISING has, in recent years, become such an art that it pays best to advertise when it is done in a manner which is novel and arresting. The public eye is easily caught by any display which is mysterious and lacking in apparent explanation and for this reason the photo-cell is an extremely useful assistant to the modern salesman.*

A boss 12 on the arm 9 bears against a lever 14, causing it to rotate and close contacts 15, 16, of the controlled circuit. At the same time, the movement of the cam 19 allows the pawl 20 on the arm 11 to engage through the medium of the tension on the spring 13. As soon as 19 and 20 engage, the circuit of the solenoid 23 is opened at the contacts 17,

18. The time interval, therefore, starts with the exciting impulse whether the latter continues or not. When armature 22 is drawn right up, pawl 8 engages ratchet wheel 6 and puts in motion the train of wheels

<sup>1</sup> See *The Wireless World* October 14th and November 4th, 1932.

**Photo Cells and Advertising.—**

24, 3, 2. The armature falls by tension of spring 5, and the rate of rotation of the gear wheels is adjustable by movable weights on the pendulum of the escapement I. On running down, the boss 12 bears on the lever 11, and both 11 and 14 rotate until 20 releases 19 and the contacts 15, 16 open smartly. Contacts 17, 18 close ready for the next impulsé. The time can be adjusted from thirty seconds to several minutes.

Shop windows offer wide scope for the employment of photo-electric equipment, whether the control is of an illuminated display or setting in motion a mechanical figure. A simple piece of apparatus which will enable an observer in the street to control a window display consists of an ornamental metal box divided horizontally into two partitions, the upper section containing the photo-cell and the lower a 25-watt lamp, which is mounted exactly behind the lower and larger aperture in the cover. The lower back portion of the box is well ventilated to assist the escape of heat from the lamp, and the front carries an opal plate engraved with instructions for operation.

**The Reflecting Method.**

It is clear that a reflecting surface brought up near the lower aperture will reflect light from the lamp up on to the photo-cell, which is normally dark, and set in operation the display. Sufficient light is reflected from a person's hand to work the apparatus. The

lamp, incidentally, serves to illuminate the instruction panel during the hours of darkness. As the arrangement depends for its operation on light reflected from the lamp, the hand must not come in contact with the

(Inset) The electrical contact system in greater detail.

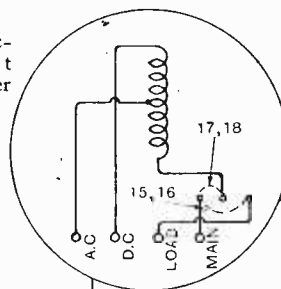
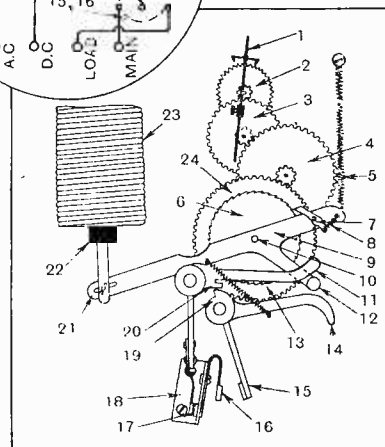

Fig. 2.—(Below) A mechanically-operated switch which allows the sign to remain on for a specified period.



metal surface, otherwise light leaving the lamp cannot enter the upper aperture. As the box is placed in a shop window the thickness of the plate glass is usually sufficient to prevent this occurring.

Interesting displays can be arranged where both the lamp and photo-cell are concealed or disguised. The photo-cell can be fitted on a wooden frame inside a valve carton lying on the table. The outline of the valve is cut out and backed with a piece of ground glass so that light can reach the photo-cell. Covering the carton with the hand sets the figure in motion, the action in this particular case being that of picking up valves and putting them into a wireless set. The general illumination of the surroundings is usually enough to operate the figure, but, if not, an auxiliary lamp must be used. In all cases such as this, where the cell is removed by some distance from the valve, care must be taken to see that the leads are well spaced, otherwise capacity effects may interfere with successful working of the set.

Although the apparatus necessary is of the simplest type, the demonstration of transmitting sound by light waves is still unknown to some, and always provides entertainment to those who can stop and start a loud speaker by motion of the hand. A Neon lamp, fed from a battery, is coupled by a 1:1 transformer to the output stage of an amplifier.

Current fluctuations of audio frequency are thus superimposed on the normal discharge in the Neon lamp and are focused across a space, by means of a mirror, on to a photo-cell connected in the grid circuit of a resistance-coupled amplifier, in the last stage of which is the loud speaker, whence the light fluctuations received by the photo-cell are again converted into sound. The arrangement is best demonstrated by batteries, and the distance between the two pieces of apparatus must not be too small, otherwise capacity coupling will occur and the arrangement will function indifferently even with the photo-cell out of circuit.

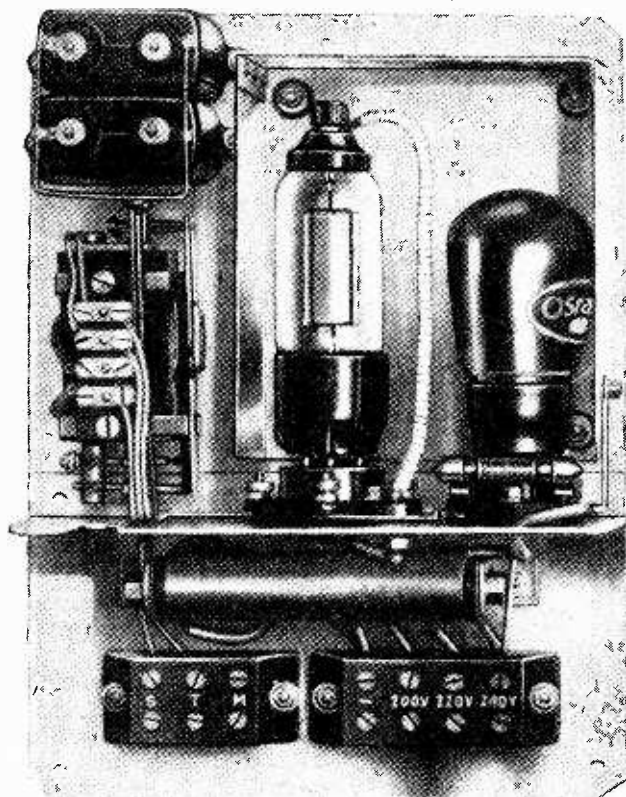
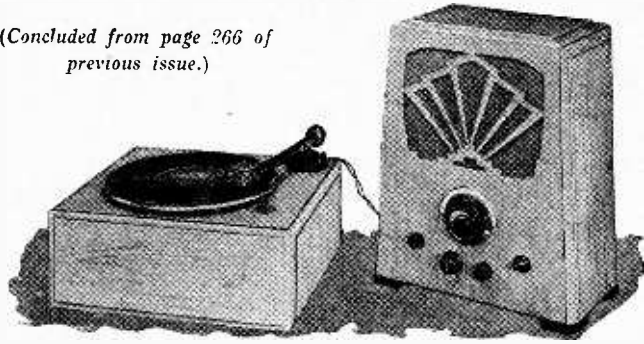

Fig. 1.—A photo-cell amplifier showing the necessary equipment. This forms a convenient unit for advertising display.

# Wireless World DCC THREE

(Concluded from page 266 of  
previous issue.)



## Initial Adjustments and Operating Hints.

By W. T. COCKING.

**T**HE construction is simple and straightforward, for a prepared metal chassis is employed, and is actually the same component as that used for the A.C. receiver described some time ago. The underbase components should be assembled the first, then the valve-holders and coils, followed by the gang condenser. The volume control and reaction condenser can be left to the last, for there is just room for them to be inserted when the other components are in position. The reaction condenser, it should be noted, is of the differential type, but one set of fixed vanes is left free, for it is used as a straight condenser.

The wiring is carried out with No. 22 tinned copper wire run in small-diameter sleeving, and care should be taken to see that the leads are run in the manner shown in the drawings, otherwise instability may be found. Certain resistances and fixed condensers are supported by the wiring, and so care should be taken to see that they are not left in contact with the chassis

or any metal component. The valve-holders should also be watched for short circuits, since the clearance between their terminals and the chassis is not great.

It is very important to note that the aerial lead between the condenser  $C_1$  and the volume control is run in earthed screened sleeving, and on no account must this screening be omitted. The lead from the "Radio-Gram" switch to the pick-up should also be run with screened wire. Terminals for the various external connections are not provided, since it is assumed that suitable leads will be soldered to the requisite points on the receiver.

### Initial Adjustments.

It is a wise plan to include an ammeter in the heater circuit, or to connect a high resistance voltmeter across the heaters, when first trying out the set, so that the tapping on the resistance mat can be adjusted to give the exact value of heater current required. If one is unaccustomed to D.C. mains working, it should not be forgotten that no results will be obtained if the mains plug is inserted in the lamp-holder the wrong way round.

Apart from the resistance mat, the only initial adjustment required is the ganging, and this is readily carried out if the following procedure be adopted. The trimmer on the first section of the gang condenser, that is, the section tuning the aerial circuit, should be fully unscrewed, for the aerial ganging is adjusted by means of the series condenser  $C_1$ . The two trimmers on the remaining two condenser sections should be unscrewed about two complete turns.

A station on a low wavelength, below 250 metres if possible, should be tuned in and each trimmer adjusted for maximum response; the intervalve circuit trimmer should be adjusted first, then the band-pass filter secondary trimmer, and lastly, the aerial series

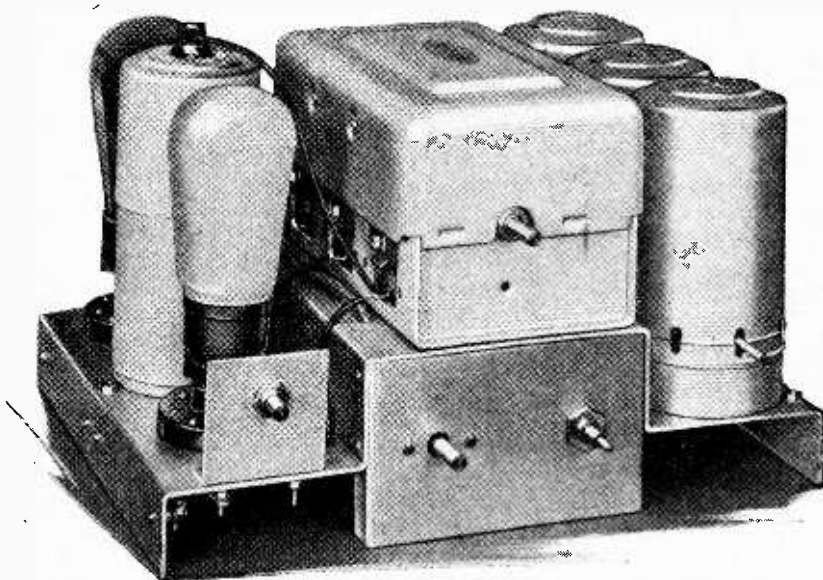

Front view of the receiver chassis with control knobs removed

### RECEIVER WITH INDIRECTLY HEATED D.C. VALVES.

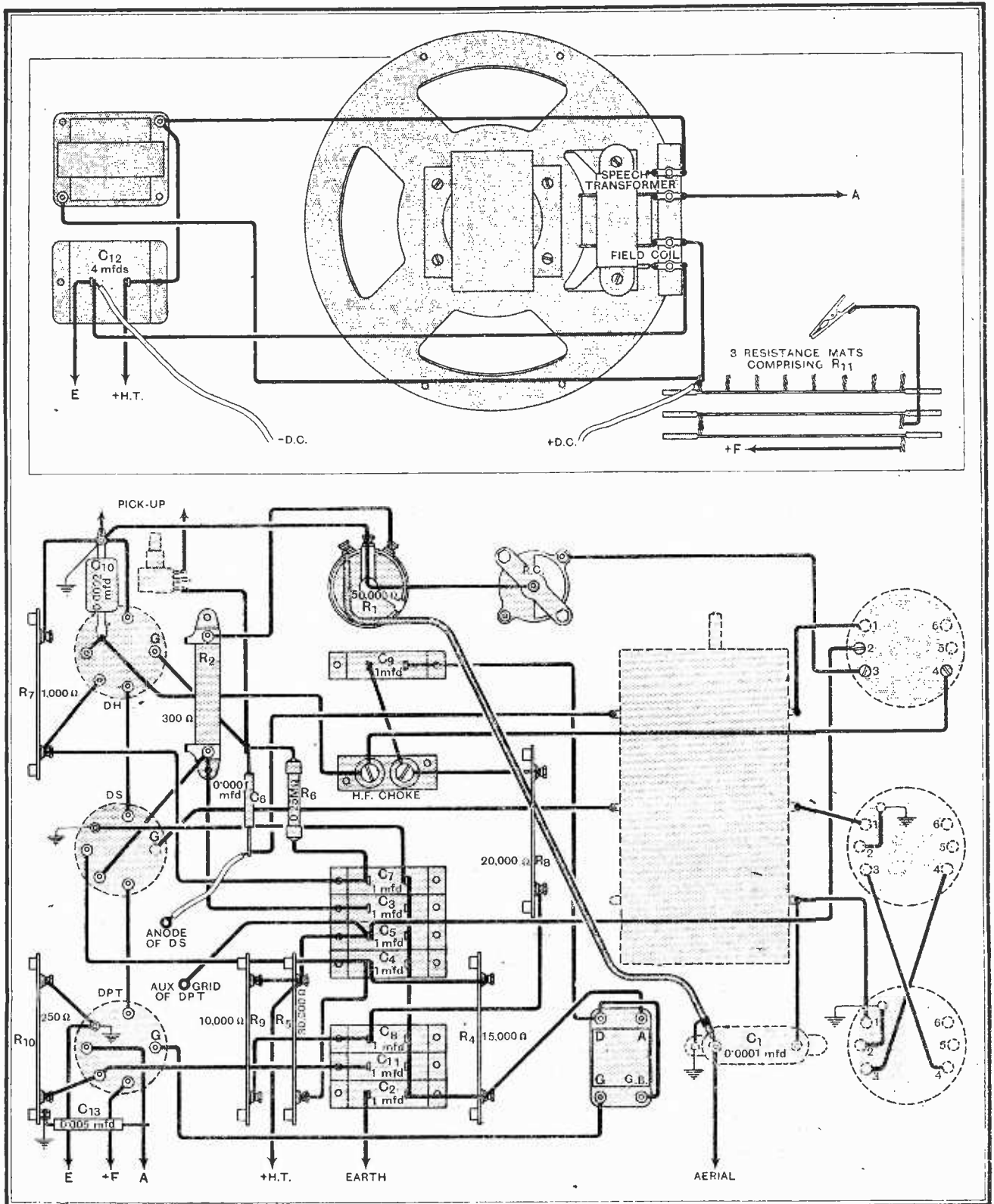

General wiring plan and layout of components.

**Wireless World D.C. Three.—**

condenser. The reaction condenser should be so set that during this process the set is only just below the oscillation point, and the volume control should be given as high a setting as possible; no valve must be allowed to overload, however, and so a weak station should be chosen. When these adjustments have been completed, each trimmer should be so set that either an increase or a reduction in its capacity results in a decrease in signal strength; no trimmer, except that on the first condenser section, which is not normally used, should be either fully screwed home or fully unscrewed.

In a few cases, where the aerial is very small, it may be found that the aerial series condenser has to be

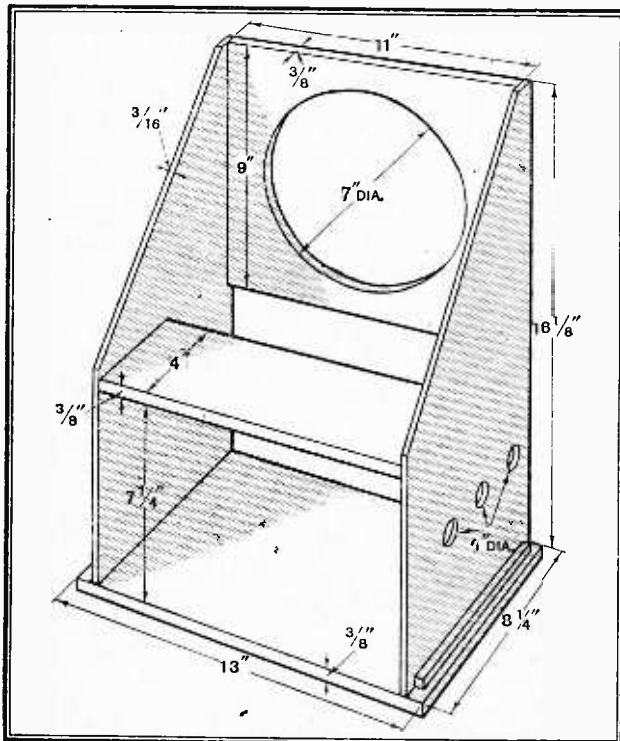

Dimensional data of the wooden framework.

screwed fully in for maximum signal strength. In this case it should be so left, and the ganging of this circuit adjusted by increasing the capacity of the trimmer on the first gang condenser section. When the foregoing procedure has been carefully carried out, it will be found that the ganging will hold over the whole tuning range of the receiver.

The receiver has been thoroughly tested at about twelve miles from Brookmans Park, and the sensitivity is such that after dark all the more powerful Continental stations can readily be received at full loud speaker strength. The normal selectivity is adequate for most purposes, and Toulouse can be received clear of the London Regional station, while many stations situated in wavelength between the two London transmitters are available.

By the careful adjustment of the tuning controls, the normal selectivity can be increased considerably. If, for instance, one reduces the strength of a station by

reducing the setting of the volume control, and then increases the volume to normal by means of reaction, while re-tuning slightly, a very considerable increase of selectivity will result. It is a mistake, therefore, to carry out searching with the volume control at maximum, often a lower setting gives better results.

The power output is adequate for all normal domestic purposes, and the quality of reproduction with the speaker fitted is of a very satisfactory order. Both the lowest and the highest frequencies are audible, and a good balance of tone is maintained in spite of the small dimensions of the cabinet. On all mains with which the set has been tested, hum has been completely absent. On very rough mains, however, it might prove necessary to augment the smoothing equipment slightly, and space is left on the shelf behind the speaker for an additional choke and condenser.

*This receiver is available for inspection at the Editorial Offices, 116-117, Fleet Street, London, E.C.4.*

**BOOKS**

**RUNDFUNK JAHRBUCH 1932: The Year Book of the German State Broadcasting Company.** Published by the Union Deutsche Verlagsgesellschaft, Zweigniederlassung, Berlin S.W.19. 151 pp.

**P**REFACED by an imposing photograph of President von Hindenburg and a signed message from him that "Broadcasting has become not only a means of communication of news, of quite special importance, but also a promoter of culture and a medium to promote understanding between nations," this year book makes its appearance at the end of the "eighth year" of German broadcasting. It is interesting to compare it with the now well-established "B.B.C. Year Book," its English "opposite number." The "Jahrbuch" is less sedate, less a book of reference, than the "Year Book"; and its contents, smaller by about a quarter than those of the latter, include more than twice as many photographs of "outside broadcasts." These, in fact, form the most arresting feature. In addition to this there is a Statistical Section, one interesting item of which gives the statistics of the reasons for abandoning the listener's licence. Dissatisfaction with the programmes accounts for only 2 per cent. of the 1931 cases, compared with 3.2 per cent. in 1930. Music and entertainments took up nearly 40 per cent. of the programmes in 1931, or nearly 60 per cent. if we include "gramophone records," as coming in this class. "Talks" occupied 14.5 per cent.—H. D.

**HÖRERRECHT: Das Recht des deutschen Rundfunkhörers.** By Pridat-Guzatis (Rothgiesser & Diesing AG., Berlin, N.24. Price RM. 12.50)

**Y**ET one more sign of the growing importance of broadcasting is the appearance of literature dealing with the legal side of this activity. Already there is a journal in the United States, the "Journal of Air Law," devoted to it; and now appears this text-book on "Listener's Law: the Law as it Affects the German Listener," with nearly 350 closely written pages dealing with every aspect of the subject, and illustrating the various points by quoting details of actual cases. One chapter deals with prosecutions for disturbance of the peace by means of loud speakers; a whole section is devoted to the question of aërials—tenants' rights, aërials over public streets, etc. The question of "pirates" only occupies a few pages, although the number of prosecutions in Germany amounted to 944 in 1930. The longest section by far deals with the question of interference, beginning with the procedure by which a distressed listener can call in the assistance of the "Radio Aid" organisation to trace the source of interference. A great number of legal cases in the matter of interference are detailed; an interesting defence, put up by a medical man whose high-frequency apparatus brought him into the courts, was that broadcast reception was only a "luxury," serving for the amusement of the listener, whereas defendant was gaining his daily bread by the use of his apparatus. This plea was quashed by the pronouncement that the dissemination of economic and political information and speeches, on every branch of art and science, is an "important social function," and not a luxury.



# MICA BRIDGE MOUNTING

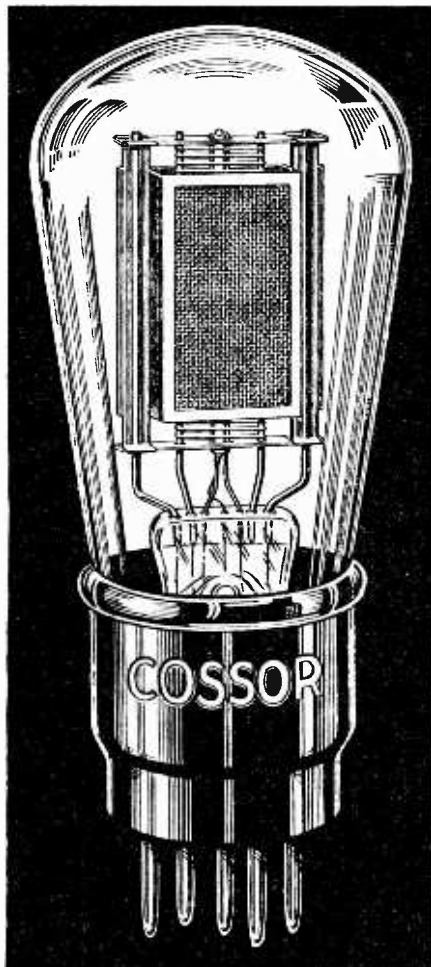

Get one of the new Cossor Station Charts price 2d. Ask your dealer for a copy of this useful novelty or write to us enclosing 2d. stamp.

—the constructional feature that ensures

**EFFICIENCY**  
and  
**CONSISTENCY**

THE employment of Mica Bridge Mounting in Cossor A.C. Mains Valves ensures that every individual valve is true to the characteristics of its particular type. Variation of the electrode spacing and, therefore, of characteristics is impossible. Thus a remarkable degree of efficiency is ensured, each valve fulfilling completely the function for which it was designed.

Cossor A.C. Mains Valves are obtainable from any Wireless Shop, and are stocked by all good Radio Retailers.

**FREE!**

Send for a copy of the most complete Valve Catalogue—72 pages of curves, characteristics and technical data. Ask for Booklet B.14 and mention "Wireless World" when applying.

IN

**COSSOR**  
ALL-BRITISH  
**A.C. MAINS VALVES**

A. G. Cossor Ltd., Highbury Grove, London, N. 5. Depots at Birmingham, Bristol, Glasgow, Leeds, Liverpool, Manchester, Newcastle, Sheffield and Dublin.

46 ♡ R41

BII Advertisements for "The Wireless World" are only accepted from firms we believe to be thoroughly reliable.



Detailed particulars on request.

# QUALITY!

The F.I. Permanent Magnet M.C. Speaker Unit PROVES the supremacy of the horn type unit.

**EXTRACTS FROM CORRESPONDENTS' LETTERS:**

"Man in the Street."—"I am very pleased with the unit."  
 "Experimenter."—"It is very good indeed—better than that in fact."  
 "Theatre Circuit."—"Streets ahead of any other tried in the course of experimental work."  
 "Secretary of Radio Club."—"Mr. B. has tested the unit on his push-pull power amplifier and is highly delighted with the reproduction—to quote his own words: 'It is the first time I have really heard the brass horns on a loud speaker.'  
 "Wireless Set Manufacturer."—"We were greatly impressed by the performance of your L.S. units."  
 "Gramophone Company."—"The reproduction is really excellent."  
 "Radio Dealer."—"Very sensitive; razor sharp on speech."  
 "Numerous Callers."—"Congratulations on your natural speaker units. The unit we have been waiting for ever since wireless started."

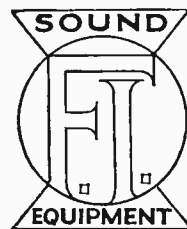

**FILM INDUSTRIES LTD**

**LONDON**

60, Paddington St., W.1.  
218.

ABOVE IS THE DOMESTIC UNIT L.S. 4  
 A larger unit, the L.S. 5, is also available for Public Address and Cinema use, Price - - £15 15 0.

**PRICE £5-5**

**SEVEN DAYS' TRIAL OFFER**

Other people's opinions do not suffice; form your own under your own conditions. Unit sent against remittance; if unsatisfactory, cash refunded in full.

Say  
 Player's  
 please



They always do!

N.C.C. 60



**PIVASPRING  
 PARK ROYAL  
 INSTRUMENTS**

Tested on a special "dithering" machine, which shakes and bumps the instrument continuously. A drastic test proving that the quality of material used and the workmanship is of the best.

Regd. Des. No. 759295

**100% BRITISH  
 ALWAYS ACCURATE**

When you have built the first-class sets which are described in this Journal, you should fit a high grade milli-ammeter and voltmeter. This will ensure that the valves are receiving their efficient working current.

Remember that Park Royal Instruments are used by Government Depts., and you purchase the best possible, backed by our long experience as instrument makers.

Flush mounting, one hole fixing. Diameter of body 1 1/2".

Type 1 1/2" M.C.F.	List Price
<b>VOLTMETERS 0-300</b>	Each <b>33/9</b>
1000 ohms per volt	
<b>MILLI-AMMETERS</b>	<b>30/-</b>

**PARK ROYAL**

**ENGINEERING CO., LTD.,  
 CUMBERLAND AVENUE, PARK ROYAL, N.W.10.**

Telephone: Willesden 2223, 2224 & 4715.

# The "Schooner" Set

**Broadcast Receiver for Operation on Board Small Yachts.**

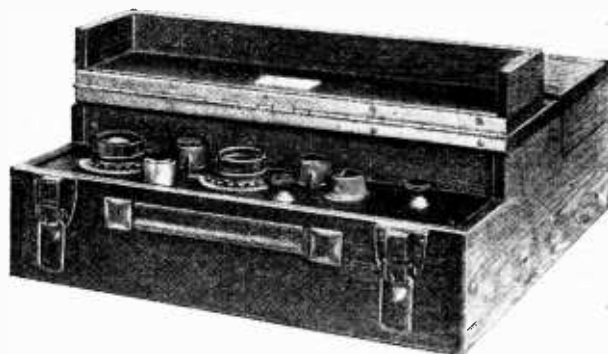

**Compact, Self-contained, and Designed to withstand Rough Usage.**

At this time of year the yachtsman is presumably busy with the task of overhauling his boat for the coming season, and it may justly be urged that the time is appropriate for considering the desirability of installing a broadcast receiver. It is unnecessary to enlarge here upon the attractions of this addition to his equipment; the ability to receive weather reports alone is obviously of value to anyone who ventures beyond the most sheltered waters. To say nothing of the advantages of being able to keep in touch through the news bulletins.

It is generally agreed that the conventional domestic broadcast set is out of place afloat, and several enterprising manufacturers have produced special apparatus designed for the somewhat exacting conditions obtaining on board small craft. Probably the first of these was A. A. Turney, of the Signal Shop, 7, York Buildings, Bridgwater, Somerset; his latest yacht receiver, known

as the Schooner Set, has now been submitted to us for test and review.

It has evidently been considered that, in designing a set for this specialised purpose, extreme robustness and compactness are essential requirements, weight being of less importance. Accordingly, the Schooner Set is mounted in a heavy oiled-teak container measuring 15in. x 15in. x 5in., and so, when secured flat against the cabin bulkhead, it does not project far enough to get in the way. Batteries are enclosed in the case, and the controls are protected by a drop cover.

As to the electrical circuit, high selectivity will not usually be required, but sensitivity must be high enough to give adequate reception with the smallest of aerials that might be fitted on board, say, a small cabin cruiser. Reception conditions are almost always good on the water, but a fair amount of amplification is necessary to ensure good signals when using a short main shroud or backstay, as an aerial, or even a cabin aerial run under the deck. The set is primarily designed to work with aerials of this type.

A more or less conventional H.F.-det.-L.F. three-valve set is clearly the right choice for these requirements, and is embodied in the Schooner Set. The H.F. valve is coupled to a grid detector by means of a double-wound transformer. Reaction between grid and anode circuits of this valve is controlled by a differential condenser, and finally there is a transformer-coupled three-electrode output valve. A Mullard P.M.2 is normally employed for this latter function, and its output

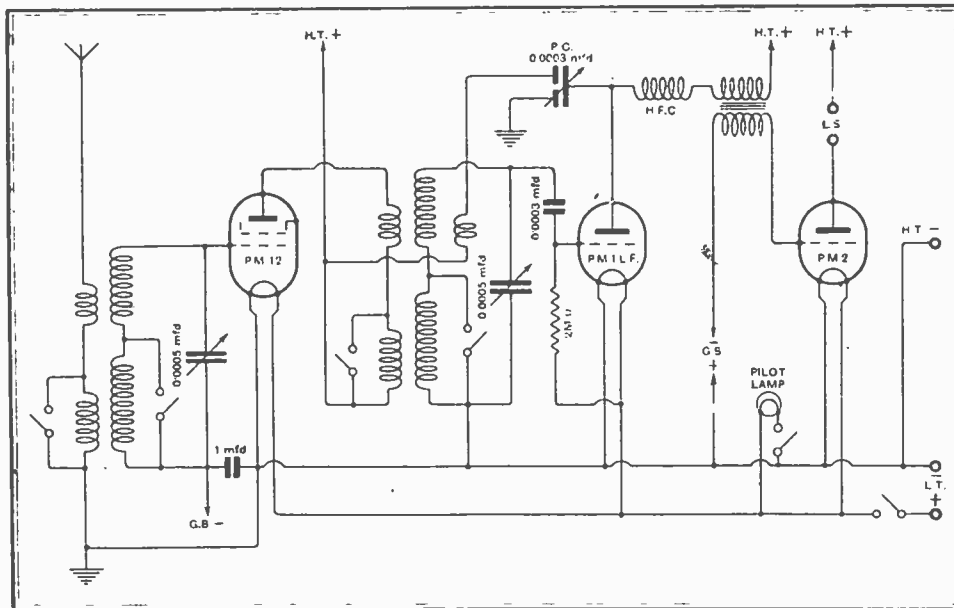

Straightforward H.F.-det.-L.F. three-valve circuit of the Schooner Set.

**The "Schooner" Set.—**

should be ample to fill a yacht cabin. A pentode valve can, however, be fitted to special order when desired.

As the set will often be operated in poorly lit cabins a pilot lamp is fitted for illuminating the tuning dials—there are two of these, as both aerial and intervalve circuits are separately tuned. A minor point of criticism arises in connection with this lamp; it is fitted with a separate switch of a similar type to that employed for switching off the filament circuits, and, as these switches work in opposition, one is rather inclined to think the set is switched off when the filament circuits are actually "on."

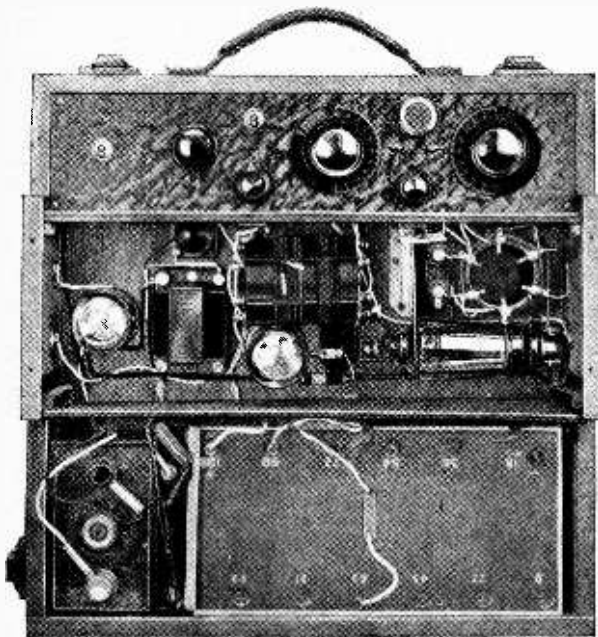

Access to the control panel and battery compartments is obtained by raising hinged sections of the cover, which, for this view, has been completely removed to show the components.

The set is simple and straightforward, and there is little to go wrong; if it does, easy access to the majority of the components is obtained by removing the four screws which secure the top cover. It is noted that all components are of reliable manufacture, including a Ferranti L.F. transformer and Polar tuning condensers. External fittings are strong enough to stand the rough usage to which a yacht set will almost inevitably be subjected. It should be added that the L.T. battery is of the jelly electrolyte type, and so the set can be operated in any position; this is a matter of importance, as some users will doubtless find it convenient to mount the receiver in a position other than that for which it is primarily intended.

**Aerial Considerations.**

It was not possible to carry out a test under the conditions for which the set is designed, but these conditions were simulated as nearly as possible by first

trying a short length of aerial wire of the dimensions that might reasonably be fitted on board a small yacht. Sensitivity was found to be fully up to the standard to be expected from a  $\lambda/4$  set, and, thanks to the small pick-up of the aerial, there were no complaints to register on the score of selectivity. Taking into consideration the small amount of energy dissipated in the output-valve circuit, quality of reproduction was distinctly pleasing. Another test, made with the type of aerial that might be installed on a larger yacht, showed that, in certain circumstances, it might be desirable to insert a small condenser in series with the aerial; this, of course, is a simple matter.

Complete with batteries and valves, the Schooner Set costs £11 10s. The makers inform us that a full stock of spares is always maintained, and any replacement part required is always despatched immediately. Further, sets can, in case of need, be overhauled and returned in twenty-four hours.

**HIGH-VOLTAGE RECTIFIERS.**

**I**NDIRECTLY-HEATED high-voltage rectifiers, similar to the Ostar receiving valves recently described in this journal, are now produced, and are marketed in this country by Eugén Forbat, Nivalight (1928), Ltd., 1, Rosebery Avenue, London, E.C.1. These rectifiers have heating elements designed for all voltages up to 250, and are intended to be connected directly across the mains, without the intermediary of the usual transformer. Full- and half-wave types are manufactured, with outputs of 50, 100, and 130 milliamps. A specimen submitted for test was a half-wave rectifier rated at 100 milliamps 230 volts, and consumed only 30 milliamps A.C. for the heater.

Alternative methods of connection, as shown in the accompanying diagram, are suggested by the makers; circuit (a) provides a rather higher output voltage, and so was adopted for testing purposes. On the full load of 100 milliamps., voltage fell to some 160 volts, but

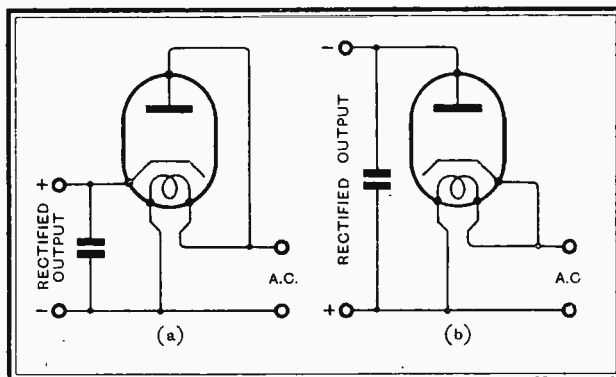

Alternative method of connecting the Ostar high-voltage half-wave rectifier.

when supplying 60 milliamps.—a normal load for an average modern receiver—rose to about 215 volts. At 40 milliamps., the output increased to slightly over 250 volts. These voltages were obtained with a shunt condenser of 8 mfd.; the value of this capacity has an important bearing on output.

In Next Week's Issue—

# THE BATTERY V-M THREE.

**A**BSOLUTE simplicity of construction commensurate with *The Wireless World* standard of efficiency has been the aim in presenting a receiver with the new battery variable-mu valve. The components are universally obtainable and the total cost, excluding valves and cabinet, will be found not to exceed £4 15s. Comprising band-pass tuning with a variable-mu screen grid stage, the set will give adequate selectivity and sufficient sensitivity to ensure good quality reception from the majority of European stations having an entertainment value for British listeners.

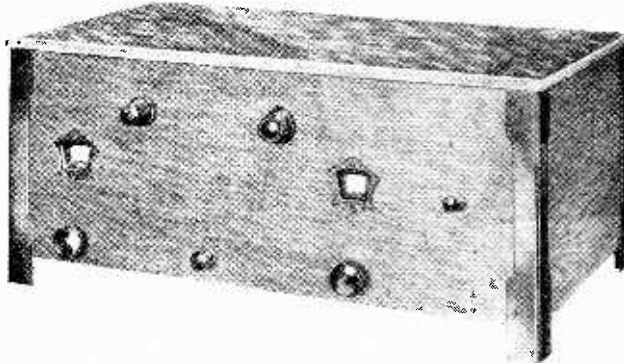

The receiver demonstrates the principle of the variable-mu characteristic as applied to battery sets. A new system of full-range control of volume by H.F. bias variation affords a means of distortionless adjustment of signal strength without alteration of tuning.

## LIST OF PARTS.

After the particular make of component used in the original model suitable alternative products are given in some instances.

- 1 Band Pass filter (Lewcos B.P.F.)
- 1 Screened inter-valve coil (Lewcos A.T.G.)
- 3 4-pin valve-holders, antiphonic, with terminals (Lotus)  
(Benjamin, Burton, Graham Farish, Junit, Lissen, Trix, Wearite, W.B.)
- 1 2-gang condenser, screened, with trimmers, 0.0005 mfd. (Ormond R/429, S2)  
(British Radiophone, Formo, J.B., Lotus, Polar, Utility).
- 1 Single tuning condenser, screened, 0.0005 mfd. (Ormond R/429/S1)  
(British Radiophone, Formo, J.B., Lotus, Polar, Utility).
- 2 Disc dials, geared (Ormond R/361)  
(Brownie, Burton, Formo, Igranic, Polar, Sovereign, Telsen, Utility).
- 2 H.F. chokes (McMichael Binocular Junior)  
(Atlas, Burton, Climax, Sovereign, Telsen, Watmel).
- 1 Spaghetti resistance, 20,000 ohms (Varley)  
(Bulgin, Goltone, Graham Farish, Igranic, Lewcos, Magnum, Ready Radio, Sovereign, Telsen, Tunewell).
- 1 Graded potentiometer, composition type, 50,000 ohms (Watmel No. 3)  
(Bulgin, Centralab, Colvern, Claude Lyons, Magnum, Regentone, Rothermel, Wearite, Varley).
- 1 Grid-bias battery, 9-volt (Lissen)  
(C.A.V., Drydex, Ever-Ready, Grosvenor, Oldham, Pertrix, Ripaults, Siemens).
- 2 Grid-bias battery clips (Bulgin No. 1)  
(Gripsco).
- 1 3-point L.T. switch (Telsen, W.108)  
(Bulgin, Gripsco, Junit, Lissen, Ormond, Ready Radio, W.B., Wearite).
- 4 Terminals (2 blocks) (Lissen, LN308 and LN347)  
(Belling-Lee, Eclex, Junit, Sovereign).
- 1 Metallised resistance, 1,000 ohm, 1-watt type (Dubilier)  
(Burton)
- 1 Variable condenser, Bakelite dielectric, 0.0003 mfd. (Burton)  
(Bulgin, Graham Farish, Lotus, Telsen).
- 1 L.F. transformer, ratio 3½ to 1 (Climax "Mumax")  
(British General, Ferranti, Formo, Igranic, Lewcos, Lissen, R.I., Sovereign, Varley).
- 1 Fixed condenser, non-inductive 0.02 mfd., screw terminals (Dubilier No. 9200)  
(T.C.C., Telsen).

## Features of the Set.

*Input band-pass tuning with constant selectivity.  
Tuned-grid intervalve coupling with reaction.  
Distortionless grid detection. L.F. transformer coupling to triode output valve.  
The battery variable-mu valve provides an ideal volume control. The grid of the H.F. valve is biased negatively, using a potentiometer across the output valve bias battery.*

- 1 Fixed condenser, non-inductive, 0.1 mfd., screw terminals (Dubilier No. 9200)  
(T.C.C., Telsen).
  - 2 Fixed condensers, 1 mfd. (Dubilier, Type "BB")  
(Formo, Hydra, Lissen, Loewe, Peak, Savage, T.C.C., Telsen, Wego).
  - 2 Fixed condensers, 0.0003 mfd. (Dubilier No. 620)  
(Formo, Hydra, Lissen, Loewe, Sovereign, T.C.C., Telsen, Wego).
  - 1 Fixed condenser, 0.0001 mfd., with clips (Dubilier, No. 620)  
(Formo, Hydra, Lissen, Loewe, Sovereign, T.C.C., Telsen, Wego).
  - 1 Grid leak, 0.5 megohm, 1 watt (Dubilier)  
(Graham Farish, Igranic, Loewe).
  - 2 Panel brackets, 6x3 ins. (Bulgin PB3)
  - Metal-screened sleeving (Lewcos)  
(Goltone, Harbus).
- Wool, wire, screws, wader plugs, flex

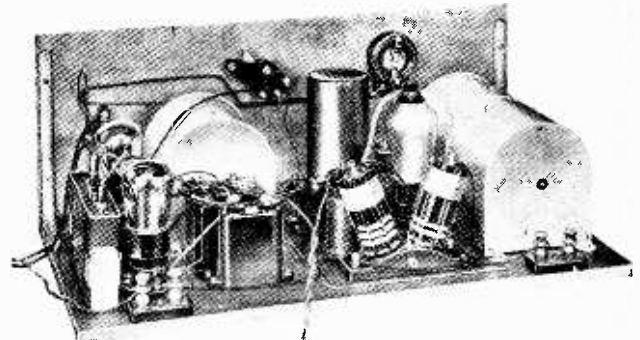

The layout on the wooden baseboard is extremely simple. No soldered connections are used.

- Cabinet** (Byldurons)  
(Apollo, Cameo, Clarion, Digby, Kabilok, Peto-Scott, Pickett, Smiths, Woodcrafts)  
(Panel measures 7in. x 18½in. and the baseboard 18in. x 10in.)
- Valves:** H.F., Cossor 220 V.S.G.; Detector, Cossor 210 H.F.; Output, Cossor 220 P.  
Alternatives for detector stage: Cossor 210 det., Mazda H.L.2 metallised, Marconi L.2B or H.L.2 metallised, Osram H.L.2 metallised, Mullard P.M.1H.L. or P.M.2D.X.
- Alternatives for output stage: Cossor 220 X.P., Mazda P.220 or P.220A., Marconi L.P.2 or P.2, B. Osram L.P.2 or P.2, Mullard P.M.2 or P.M.2A or P.M.2B.

# Current Topics.

## Events of the Week in Brief Review.

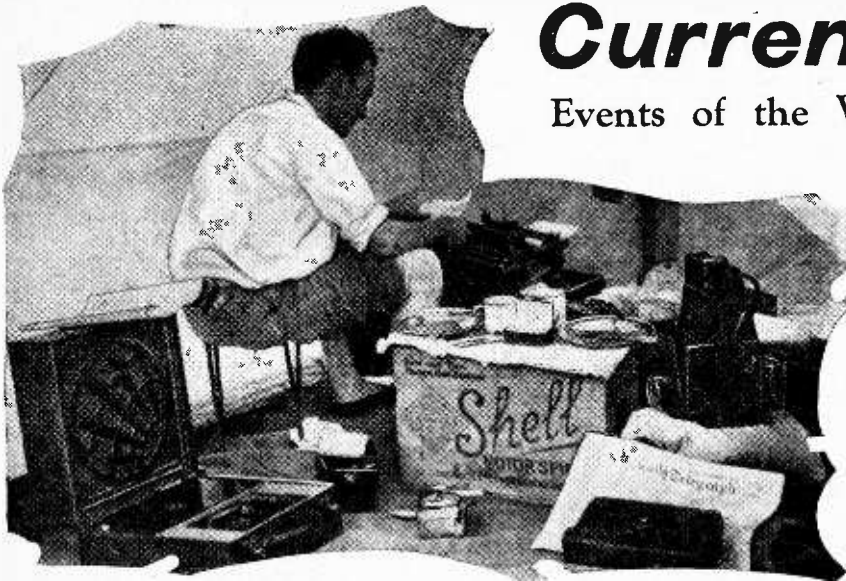

**WATCH HIM WORK!** Our New Zealand correspondent hadn't even time to look round at the North Auckland speed trials. The McMichael portable brought in news from Auckland 1YA (200 miles) and Wellington 2YA (600 miles).

### Radio at the Ideal Home Exhibition.

WIRELESS as handled by the Post Office is to be a prominent feature of the Daily Mail Ideal Home Exhibition, which opens on April 5th, at Olympia. The P.O. display will resemble the Young People's Telephone Exhibition staged in January at the Imperial Institute. Among the attractions at Olympia will be many ingenious methods of electrical illumination in the creation of a City of Light. The Exhibition will remain open until April 30th.

### Slow Morse Practice.

OPPORTUNITIES to pick up slow Morse transmissions are so rare that many amateurs may welcome fresh details of the special tests conducted on Sundays under the auspices of the Radio Society of Great Britain. The tests, which begin at 11 a.m., occupy a total period of thirty-five minutes, during which Morse is sent slowly on wavelengths of 172, 86, and 42.8 metres. The transmitting stations are situated in various parts of the country.

Interested listeners are invited to write for full particulars to the Radio Society of Great Britain, 53, Victoria Street, London, S.W.1.

### Politics and Radio Sales.

"BUSINESS Without Ballyhoo" is the slogan adopted for America's annual radio trade show to be held in Chicago from May 23rd to 26th. The show is being held earlier than usual, according to our Washington correspondent, to prepare dealers for the anticipated boost in radio sales resulting from the political broadcasts at election time. Both the Republican and Democratic national conventions will let loose a flood of radio talk which will be eagerly listened to by the American public.

### French "Howlers."

THE recent publication in *The Wireless World* of "Howlers" in the French announcements of British numbers in the broadcast programmes has met with an instant response on the part of the Paris journal, *L'Antenne*. An editorial note runs: "The English are making fun of the typographical errors which adorn the titles of English songs as published in the French Press. . . . In future, to avoid trouble, suppose we content ourselves with simply speaking French." According to our Paris correspondent, this paragraph is a sly contribution to the campaign against the broadcasting of British publicity programmes by the French stations.

### Wireless and Golf.

EVEN the radio industry finds time for play. Next month the preliminary rounds in the annual competition for the Marconiphone Golf Challenge Trophy will be played, and throughout the summer a desperate struggle will take place, culminating in the final stages to be played during Olympia Exhibition week on a course in the London district. The sight of a typical radio salesman churning up the turf is one that should be available to Exhibition visitors, and we hope, if television is not perfected by August next, that there will at least be a running commentary broadcast throughout Olympia, suitable language filters being switched in when necessary.

### Radio "Battle" on Russian Frontier.

FINLAND has grown tired of listening to propaganda talks in Finnish transmitted by the Leningrad Soviet station, and is now considering the erection of a high-power broadcasting station with which to drown the signals with a flood of contradictions in Russian.

### Rome's Broadcasting House.

ROME'S new radio palace with its eight underground studios is to open on April 21st. Like the new B.B.C. building in Portland Place, the Italian headquarters of broadcasting will incorporate a television studio from which tests are to be made on a wavelength of 80 metres

### Another Italian Station.

TOWARDS the end of next month tests will begin with the new Italian broadcasting station at Bari, which, constructed by the Marconi Company, will be a replica of the station already operating at Florence. The power in the aerial will be 20 kilowatts, and the wavelength about 280 metres. The Bari station will relay the programmes of Rome and Naples.

### More Kilowatts from Spain.

SPAIN will soon be a country to reckon with in the European ether. During the revolution, broadcasting has suffered neglect, but we learn that the Republican Government is now determined to make up for lost time and that a complete plan of broadcast reorganisation is already being studied. Madrid, it seems, will have a station with a power of from 60 to 100 kilowatts, while Barcelona, with a 20-kilowatt station, and Valencia and Seville, each with 10-kilowatt stations, will provide a formidable network. Relay stations of various powers will be erected at Valladolid, Saragossa, Vigo, Bilbao, Coruna, Malaga, and Murcia.

### End of Gramophone "War."

BROADCASTING seems to be of greater value to the gramophone companies than was originally thought by the German firms which recently "declared war" on the broadcasting authorities. The War is now at an end, writes our Berlin correspondent, contracts having been signed whereby the broadcasters, while winning permission to use gramophone records, undertake to restrict the practice to sixty hours per month.

The gramophone industry will supply the stations with records free of charge, but, descending from the sublime to the ridiculous, the agreement decrees that the broadcasters must pay for postage and packing.

### The Radio Language.

NO fewer than ninety-six radio periodicals are at present published in the German language. This is one of the interesting revelations in the second annual volume of the Reichs-Rundfunkgesellschaft's summary of wireless literature. The figure shows an increase of eight radio publications since 1930. It is important to note, of course, that not all these journals emanate from the

Fatherland. Some are published in Austria, Switzerland, and Czechoslovakia.

Statistics show that 56 per cent. of the German radio journals are technical.

**"Hams" but not Japs.**

REPORTS that Japanese amateurs have been ordered to cease communicating with American and Canadian amateurs during the Chinese hostilities are apparently unfounded. Members of the Japanese Amateur Radio League are still very much alive, although the long span across the Pacific makes two-way contact with American "hams" rather infrequent. One little proof that Japanese amateurs are still wide awake is evident in the dispute that has arisen as the result of American radio references to "Japs." Short-wave messages from the Land of the Chrysanthemum indicate that the monosyllable "ham" is infinitely preferred.

**Studies in Radio Transmission.**

MR. T. L. Eckersley, B.A., B.Sc., is the author of a paper entitled "Studies in Radio Transmission," to be read and discussed at the meeting this evening (Wednesday) of the Wireless Section of the Institution of Electrical Engineers. The meeting opens at 6 o'clock.

**Train 'Phone Disappointment.**

THOUGH nearly £17,000 has been expended by the Canadian National Railways for experiments and expenses in installing a train telephone service employing "wired wireless," the average monthly revenue from this service for the twelve months ending April 30th last was less than £15. The train 'phone is installed only on the International Limited running between Toronto and Montreal, but calls can be put through on it for almost any part of the United States and Canada.

**A Lanarkshire Radio Society.**

AN excellent start has been made by the Shots (Lanarkshire) and District Radio Society, the membership having already exceeded expectations. An interesting programme has been arranged, including a series of lectures on "Magnetism and Induction." A warm welcome is extended to all wireless enthusiasts in the neighbourhood, and full particulars can be obtained from the Hon. Secretary, Mr. E. M. Thomson, Cwmnach, Shots.

**A Transmitters' Exhibition.**

AN original amateur spark transmitter exhibited by Mr. R. J. Maidment, who was operating as far back as 1913, was a feature of the recent public display staged by the Medway Experimental Transmitters' Society in the Queen's Hall, Chatham. By way of contrast a 50-watt mains set was shown by the President, Mr. R. H. Hammons, of Gillingham, whose station G2IG is well known. A comprehensive array of members' transmitting apparatus was on view.

The Society possesses twenty-four members, of whom eight or nine are licensed to transmit with an open aerial. The Society is now actively experimenting on the 5-metre band and claims that its tests are the first of the kind to be conducted in Kent.

Hon. Secretary: Mr. J. Nixon, 33, Seaview Road, Gillingham, Kent.

**Handbook of Technical Instruction.**

IT is regretted that a reference to the Handbook of Technical Instruction appearing at the foot of the page announcement of Murphy Radio Ltd., in *The Wireless World* of March 9th, gave to some readers the impression that the Handbook is issued by Murphy Radio. The line in question was a publisher's announcement by Iliffe and Sons Ltd.

**Long Waves for Submarines.**

A SPECIAL long-wave transmitter is under erection by the French Navy at Toulon for communication with submerged submarines. Repeated experiments have shown that short waves refuse to penetrate the ocean depths, and for this reason the new station will work on wavelengths up to 15,000 metres.

**A Question of Locality.**

THE subtle methods of circumventing radio laws carried out by certain American broadcasting organisations are revealed in a regulation, just issued by the Mexican Government, which prohibits Mexican broadcasters from establishing a studio on foreign soil connected by telephone lines. This law, writes our Washington correspondent, is evidently aimed at Dr. John R. Brinkley's powerful station, XER, at Villa Acuna, just on the Mexican side of the frontier near Del Rio, Texas. Dr. Brinkley's studio is actually situated in America, and XER's 75 kilowatts are really intended to serve the United States audience. Its programmes are largely devoted to promoting the sales of the doctor's patent medicines.



**TWO-MAN-POWER STATION.** One of a number of short-wave stations installed in isolated parts of Northern Rhodesia by the Marconi Company. The natives thoroughly enjoy the healthy exercise of generating the necessary 140 watts of electrical energy. Wavelengths of 40 to 60 metres are used.

**CLUB NEWS.**

**Invisible Rays.**

THE Raycraft Kit demonstrated by Mr. Gilbert, of Audiovisors, Ltd., proved a great attraction at a recent meeting of the Wanstead, Woodford and District Radio Society. The utility of the apparatus was shown by its ability to control electric lamps and electric bells. A wide range of relays was exhibited, including a mercury type capable of controlling power up to 1 kilowatt.

The Society now holds its meetings on Fridays instead of Thursdays, from 8 to 10 p.m., at Overton House, 20, High Street, Wanstead, E.11.

**Open to All.**

IN view of the large number of requests for membership, the Pye Short Wave Radio Society, membership of which was formerly confined to Pye Radio employees, now allows any enthusiastic amateur to join. The Society, which contains hundreds of active members, is affiliated to the R.S.G.B. and A.R.R.L. and owns two transmitting stations, G5PI and G6YP.

All communications and applications for membership should be addressed to the Hon. Secretary: Mr. L. W. Jones, Pye Radio Works, Cambridge.

**A Multi-purpose Knob.**

THE two Ekco receivers, the R.S.3 and R.S.2, were demonstrated by Mr. W. B. Bodemeid at a recent meeting of the Tottenham Wireless Society. The lecturer, who has been engaged in the construction of these sets, was able to give a first-hand account of the methods of manufacture, testing, and subsequent calibration employed in the famous Southend factory. The R.S.3, in which the station indicator is fixed under the loud-speaker grille, gave excellent results on test. Using only one knob, it is possible to tune in on both wavebands and to switch in the gramophone connections.

New members will be welcomed at the Society's meetings, and information may be obtained from the Hon. Secretary, Mr. W. B. Bodemeid, 10, Bruce Grove, Tottenham, N.17.

**Westinghouse Metal Rectifiers.**

AT the February meeting of the Liverpool Wireless Society members enjoyed a lecture on the "Westinghouse Metal Rectifier," given by Mr. S. A. Stevens, B.Sc. (Eng.), of the Westinghouse Brake and Saxby Signal Co., Ltd.

After the lecture, which was illustrated by slide and film, Mr. Stevens submitted to a bombardment of questions, which he answered to the satisfaction of all concerned.

Hon. Secretary: Mr. R. Reid Jones, 21, Oak Leigh, The Brook, Liverpool.

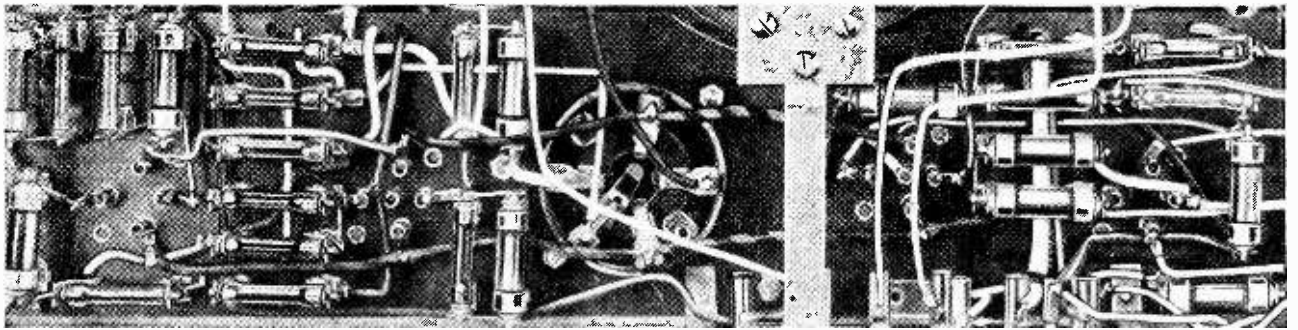

# FIXED RESISTANCES AND POTENTIOMETERS

## Part II.—Their Uses in the Completed Receiver.

By A. L. M. SOWERBY, M.Sc.

CONTINUING the discussion of the resistances contained in the receiver of which the circuit diagram is repeated from the previous part in Fig. 5, we come now to the grid leak,  $R_{11}$ , of the detector valve  $V_3$ . This detector is intended to operate on the "power grid" principle, and it would take us rather far from our course to digress sufficiently far into the characteristics of the rectifying system to evolve a full theory as to the correct value for the grid leak. The reader who wishes to go into details is referred to "A New Development in Power Grid Detection,"<sup>1</sup> and "Power Grid and Leaky Grid"<sup>2</sup>; both these articles have recently appeared in these pages. For our present purpose we will regard rectification as taking place in the two-electrode valve formed by grid and cathode of  $V_3$ ; the rectified current flows through the resistance  $R_{11}$ , developing across it a voltage which is applied to the amplifying triode formed by all three electrodes of the same valve. Grid and cathode, on this view, are common to both functions, which is confusing; nevertheless  $R_{11}$  may still be considered as a coupling resistance whose duty is parallel with that of an anode resistance in an ordinary resistance-coupled stage.

If the value chosen for  $R_{11}$  is low, then, since it is to all intents and purposes in parallel with the tuned circuit feeding the grid of the detector, this circuit will be heavily damped, resulting in badly flattened tuning and a considerable loss in amplification. If, on the other hand,  $R_{11}$  is made very high in value, the usual defect of

resistance coupling with high resistances, loss of the upper notes of music will tend to occur. The extent to which this loss of high notes takes place depends in the present case largely upon the value of the grid condenser, which, since the tuning coil is a virtual short-circuit for all audio-frequency currents, must be regarded as in parallel with the grid leak. It is nowadays customary to use a capacity of 0.0001 mfd. for the grid condenser; if this is done in the present receiver, the loss of high notes will be negligible if the grid leak has a resistance of 100,000 ohms (0.1 megohm). So low a resistance as this, however, will produce appreciable damping of the tuned circuit, so that in most cases a higher value will be preferred. The value of  $R_{11}$  will therefore be chosen to provide a suitable compromise

between the two opposing effects, and the final choice may light on anything from 0.1 megohm (if quality of reproduction is the chief aim) up to 0.5 or even 1.0 megohm (if the small resulting increase in sensitivity and selectivity is valued more highly than the slight loss in high-note reproduction). The value used in most receivers is 0.25 megohm.

The grid leaks for the two remaining valves have to be chosen on rather different grounds. They no longer act primarily as coupling resistances, but are inserted merely in

order that it may be possible to apply suitable bias to a grid blocked off from D.C. voltages by a coupling condenser. Once again their value has to be decided largely by the claims of quality of reproduction of the music being received, but the conditions are utterly different from those governing the choice of  $R_{11}$ . In the detector valve the audio-frequency voltages were generated on

*HAVING discussed in the previous article the developments which have led to the use of such a multiplicity of resistances in a modern receiver, the author examines the circuit of a typical mains set, giving reasons for the inclusion and the values of the twenty-one resistances found necessary.*

<sup>1</sup> *The Wireless World*, by F. M. Colebrook, June 10th, 1931.

<sup>2</sup> *The Wireless World*, by W. L. G. Page, December 2nd and 9th, 1931.



**Fixed Resistances and Potentiometers.**—

the grid itself, behind the grid condenser, with the result that, as has been said, this condenser had to be kept down in size to prevent the partial short-circuiting of high notes to earth. The grids of  $V_4$  and  $V_5$  are supplied with their signals from the anode of the preceding valve; the coupling condenser must therefore be so proportioned that currents of all frequencies pass through it. A large condenser, instead of a small one, will thus be needed.

**Values for Resistance Coupling.**

The essentials of the coupling between  $V_3$  and  $V_1$ , and also, since they are identical in all but detail, of the coupling between  $V_4$  and  $V_3$ , are shown in schematic form in Fig. 6. In this diagram the position of the coupling condenser  $C$  has been altered slightly to bring out the fact that it and the grid leak  $R_2$  form, between them, a potential divider connected between the anode of the preceding valve and earth. The signal-voltages available at the anode of this valve are therefore passed through this potential divider to earth, the second valve receiving only that part of the total voltage which is dropped across the grid leak. Any part of the signal-voltage dropped across the condenser is wasted so far as later parts of the receiver are concerned.

Now, the resistance of the grid leak will naturally be the same to currents of all frequencies, whereas the impedance offered by the condenser will be greater for currents of low frequency, corresponding to the bass notes of received music, than for those of higher fre-

quency. Whatever values may be given to  $C$  and  $R_2$ , it is inevitable that more bass than treble will be lost in the form of unused voltage-drop across  $C$ . All that can be done is to proportion these two components in such a way that the loss of bass is reduced to a negligible amount. This means that with a coupling condenser of given size there is a minimum resistance for  $R_2$  below which the loss in bass notes will tend to become appreciable. Just the opposite, it will be noticed, of the conditions governing the detector grid leak, in the choice of which it had to be remembered that there was a maximum resistance above which the loss of high notes would begin to be heard.

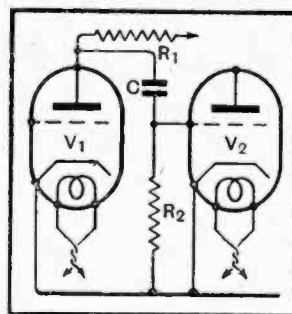

Fig. 6. — The coupling condenser and leak form a potentiometer across the total signal-voltage delivered by  $V_1$ . Only the volts dropped on the grid leak are passed on to  $V_2$ .

Without using an infinitely large resistance and an infinitely large capacity, there is no way of making the loss of bass theoretically zero; one has therefore to lay down some limit of loss and find condenser and resistance values such that it is not exceeded. To comply with the condition that 90 per cent. of 50-cycle notes shall be passed by the coupling as a whole, the pairs of values set forth in Table II are required.

Since we are supposed to be dealing only with the resistances in our receiver, we may assume that the coupling condensers in the two stages are already chosen and built into the set. The choice of grid-leak values for

the two last valves therefore simplifies itself into picking out from Table II the resistance corresponding to each of the condensers, and, since the values of the Table

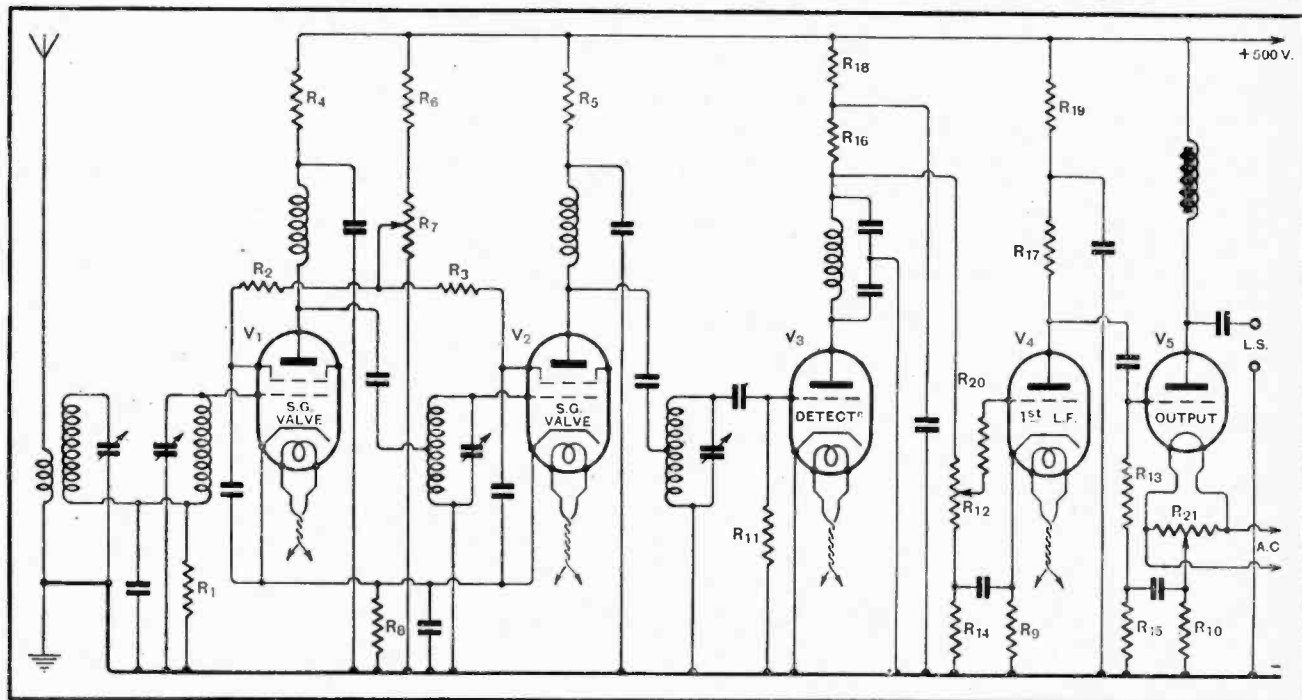

Fig. 5.—This circuit, repeated from the preceding instalment, gives the complete circuit diagram of the set. The many resistances contained in it form the subject-matter of the text.

quency. Whatever values may be given to  $C$  and  $R_2$ , it is inevitable that more bass than treble will be lost in the form of unused voltage-drop across  $C$ . All that

the two last valves therefore simplifies itself into picking out from Table II the resistance corresponding to each of the condensers, and, since the values of the Table

**Fixed Resistances and Potentiometers.—**

are minimum values, taking for  $R_{12}$  and  $R_{13}$  the standard value next higher.

In the diagram  $R_{12}$  is shown as a potentiometer, the grid of the valve being connected to the slider. Varying the position of this varies the proportion of the total voltage developed by the passage of the signals through the leak that is applied between grid and cathode of the valve; in other words, the potentiometer grid leak behaves as a volume control. The introduction of this, as well as the volume control that precedes the detector ( $R_7$ ), is intended to make it possible to load the detector with the correct signal-voltage for distortionless detection irrespective of the volume required from the loud speaker. If all the control is placed before the detector, then when quiet signals are wanted it is

**Table II.**

Coupling Condenser (mfd.),	Grid Leak (Minimum Resistance).
0.001	6.5 megohms.
0.002	3.2 ..
0.005	1.3 ..
0.01	0.65 ..
0.02	0.32 ..
0.05	0.13 ..
0.1	65,000 ohms.
0.2	32,000 ..
0.25	25,000 ..
0.5	13,000 ..
1.0	6,500 ..

necessary to cut down the high-frequency voltage applied to the grid of  $V_3$ , with the result that the process of detection will no longer be taking place under the best possible conditions. By adjusting  $R_{12}$  the detector can be left working at its best while the level of sound at the loud speaker is adjusted to suit the mood of the moment.

**The Detector Anode.**

The two resistances  $R_{11}$  and  $R_{15}$  are decoupling resistances, inserted to prevent hum and feed-back along the grid-bias leads. Further, they tend to remove the bias resistors  $R_9$  and  $R_{10}$  from the grid circuits of their respective valves; the grid circuit completes itself by preference through the lower impedance of the condensers associated with them. The result of this is that bass notes are more fully represented in the output from the amplifier than would be the case if the decoupling components were omitted (see *The Wireless World*, December 2, 1931, p. 649). Suitable values for such positions as this are not easy to fix; nor, fortunately, is a correct choice of resistance of very vital importance. They must not have too low a resistance, or they, instead of the condenser, will carry the signal current; on the other hand, their resistance must not be too high or the grid of the valve will tend to become isolated behind its condenser, and any charge that this may acquire through the momentary flowing of grid current brought about by an atmospheric or other sudden over-loud signal will remain long enough for the temporary paralysis of the receiver to become noticeable. A suitable compromise would be 0.1 megohm for each of the two resistances  $R_{11}$  and  $R_{15}$ .

Returning now to anode circuits again, we have to consider the resistances in the plate circuit of the detector valve. These are indicated in Fig. 5 as  $R_{16}$  and  $R_{18}$ . The first of these is a coupling resistance, inserted so that the signal current flowing in the anode

circuit of  $V_3$  may develop a voltage across  $R_{16}$ , this being then passed through the coupling condenser, as we have seen, to  $V_4$ . To obtain good amplification it is, in general, desirable to make the anode resistance several times greater than the A.C. resistance of the valve which precedes it; at the same time the resistance must not be made too high, or the voltage available at the anode of the valve will be too far reduced.

**Decoupling.**

In the present case our valve is a power detector; it will therefore be expected to consume about 7 milliamps. at a grid voltage fixed by the magnitude of the grid current flowing through the grid leak  $R_{11}$ . These are complicated conditions to work out exactly, even with the full curves of the valves, so we will make an intelligent guess at the valve's probable bias when no signal is being received. In the average indirectly heated valve grid current begins to flow when the grid is about 1.3 volts negative; we may therefore assume that in such a case as this the grid will set

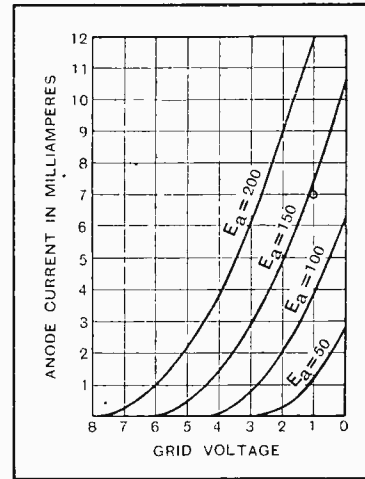
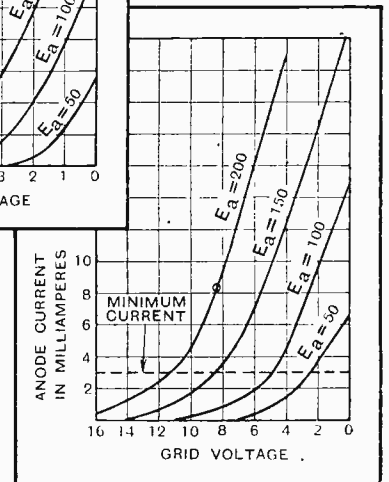

Fig. 7. — (Above) Curves of the detector valve  $V_3$ . The operating point is indicated by a circle; it occurs at 7 mA. at minus lv. grid bias and about 140v. on the anode.

Fig. 8. — (Below) Curves of the L.F. valve  $V_1$ . The operating point is indicated by a circle; the anode current may swing down to about 3 mA. without introducing serious distortion.



itself at about 1 volt negative. Reference to the published curves of this particular valve, reproduced in Fig. 7, suggests that at this grid voltage 7 milliamps. will flow when there are about 140 volts on the anode. The total resistance of  $R_{16}$  and  $R_{18}$ , taken together, will have to be such as to drop the available voltage of 500 down to 140 when 7 milliamps. are flowing through them. The voltage to be dropped is then  $(500 - 140) = 360$ ; the resistance required will be  $360/7 = 51.5$  thousands of ohms. A total of 50,000 ohms will be quite near enough.

**Fixed Resistances and Potentiometers.—**

This total has to be divided into two parts,  $R_{16}$ , the anode resistance proper, and  $R_{18}$ , the resistance used for decoupling. If the coupling resistance only is used, omitting  $R_{18}$ , it is almost certain that the completed set will motor-boat badly, owing to signal-voltages developed across the impedance of the eliminator by the speech currents flowing in the anode circuits of the two following valves. The insertion of  $R_{18}$ , which serves as a barrier to these alternating voltages, combined with the more or less effective earthing of the junction of the two resistances by the decoupling condenser, will serve to prevent this disconcerting behaviour.

The total resistance in the anode circuit of  $V_3$  being fixed at 50,000 ohms, it remains only to divide it between  $R_{16}$  and  $R_{18}$ . Since, in the interests of good amplification, we should like the former to be as large as possible, it will be satisfactory to allot 20,000 only of the total ohms to the decoupling resistance, leaving 30,000 ohms for  $R_{16}$ . If, on trial, it should be found that the receiver motor boats, an interchange of these two resistances will almost certainly cure it.

The two resistances  $R_{17}$  and  $R_{19}$  in the anode circuit of the low-frequency valve  $V_4$  are found in a similar way. The anode current taken by this valve when working under optimum conditions is given in the maker's instructions as  $8\frac{1}{2}$  milliamps.; inspection of the valve curves (Fig. 8) reveals that this current can safely swing, during the reception of signals, down to 3 milliamps. before serious curvature of the characteristic is encountered. Since the output valve takes a grid bias of 91 volts, it will be necessary to include in the anode circuit of  $V_4$  a resistance of such value that a swing of anode current from  $8\frac{1}{2}$  to 3 milliamps. will develop a peak voltage not less than 91; otherwise  $V_4$  will overload and introduce distortion before the output valve is fully loaded. The permissible anode-current change is  $(8\frac{1}{2} - 3) = 5\frac{1}{2}$  milliamps.; the resistance must therefore be  $91 / 5\frac{1}{2} = 16.5$  thousands of ohms. Provided that we can maintain the steady anode current at  $8\frac{1}{2}$  milliamps. with the voltage available a higher resistance than this will provide a useful factor of safety, guarding against premature overloading of  $V_4$ .

**The H.F. Stopper.**

As 20,000 ohms is a value of anode resistance readily available, and offers a small margin of safety, we will see whether we can fit it into the circuit. At  $8\frac{1}{2}$  milliamps. the voltage drop across it will be  $8\frac{1}{2} \times 20 = 170$  volts, so that the working voltage at the junction of  $R_{17}$  and  $R_{19}$  must be this plus the voltage actually at

the anode of the valve; this being 200, the required total is 370 volts. This fits in very nicely, for it leaves us the remaining 130 out of the available total of 500 volts to waste in the decoupling resistance  $R_{19}$ . The measure of decoupling that this implies will certainly be adequate.

Adopting these figures, it only remains to find the resistance to be given to  $R_{19}$  to complete the circuit correctly. To drop the 130 volts that we have still in hand at a current of  $8\frac{1}{2}$  milliamps. requires a resistance of  $130 / 8\frac{1}{2} = 15.3$  thousands of ohms. Again we are lucky; 15,000 ohms is one of the standard values, and we have only to drop it into place.

The meticulous reader will object that in making these calculations we have ignored the fact that we have not got the full 500 volts available, but must sacrifice some of it in providing bias for the valve. Academically, this is correct enough; practically, on the other hand, it is splitting hairs to bother about the odd ten volts or so. Unless very fancy prices are paid, and very special components bought, there is little chance that the anode resistances will be close enough to their nominal values to ensure the voltages in the actual set being within ten volts of the values calculated; nor, to speak the truth, is it possible to make valves with certainty so close to the rated specification that it can be relied upon not to introduce inaccuracies of this order. The simplification made in omitting to take account of the bias volts is therefore justifiable as well as convenient.

The bias resistor,  $R_9$ , for this valve can now be

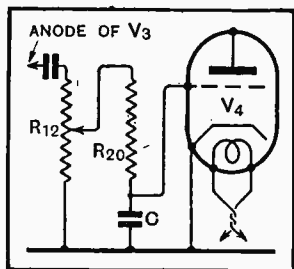
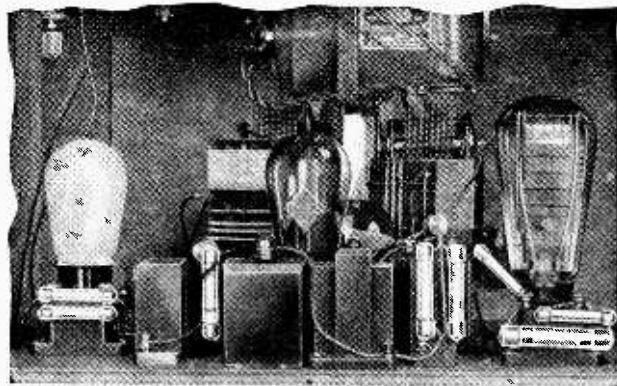

Fig. 9.—How the "grid-stopper" works.  $R_{20}$  and the grid cathode capacity  $C$  of  $V_4$  together make up a potential divider. Only the volts dropped across  $C$  are passed on to the valve; for high frequency this voltage is small.



An amplifier of modern design—the Power Radio-gram.—lately described constructionally in *The Wireless World*.

computed, since we have assured ourselves that we have voltage enough to run it, in spite of the resistances in its anode circuit, at the full rated current. For this the bias required is  $8\frac{1}{2}$  volts; at  $8\frac{1}{2}$  milliamps. the needful resistance is 1,000 ohms.

The resistance  $R_{20}$ , in series with the grid of the valve  $V_4$ , is known technically as a "grid-stopper." Its function is to reduce the high-frequency voltages at the grid of this valve as far as possible, being auxiliary in this matter to the choke in the anode circuit of the detector. At first sight it would appear that as no current flows through this resistance there would be no voltage drop across it, and that it would therefore be completely ineffective. Reference to the diagram of

**Fixed Resistances and Potentiometers.—**

Fig. 9 will show that  $R_{20}$  is really one arm of a voltage divider made up of the resistance in series with the grid-to-cathode capacity of the valve that follows it. Since the capacity offers a much lower impedance to high-frequency currents than the resistance, and a much higher one to currents of speech frequency, the combination acts as a rough-and-ready filter, allowing voltages of low frequency only to appear on the grid of  $V_1$ .

It will be clear from this that the value of  $R_{20}$  must

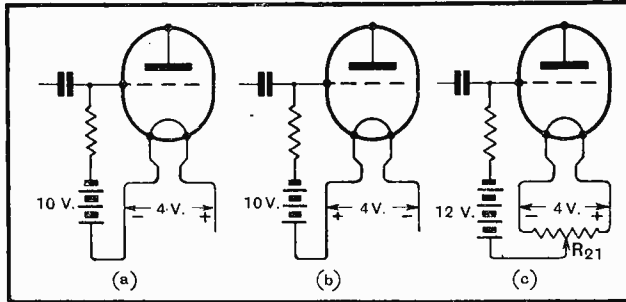

Fig. 10.—The reason for the inclusion of  $R_{21}$ . If the grid were returned to one end of the filament, as in (a), the voltage on the grid would depend on the direction of flow of the A.C. filament current—compare (a) and (b), bias 10v. and 6v. respectively. By returning the grid as in (c) the bias is 10 volts whichever way the filament current is flowing.

depend to a great extent on the magnitude of the capacity with which it is associated. This, in turn, depends largely on the amplification factor of the valve providing the capacity; with the particular valve we have chosen  $R_{20}$  may be about 0.1 to 0.25 megohm. Higher resistances than this will extend the filtering action too far, so that the higher notes of received music begin to be lost, while lower values, while comparatively harmless, will give less effective filtering, and will allow a greater proportion of high-frequency currents to flow in the amplifier. This may result in instability in a bad case, though if the high-frequency choke is doing its duty properly nothing worse than a mild deterioration in quality need be apprehended.

**Bias with A.C. Heating.**

The last resistance in the set is  $R_{21}$ , which is placed across the filament of the directly heated output valve. Since the filament of this valve is heated by the passage through it of unrectified alternating current, first one end and then the other of the filament is negative. Grid bias is reckoned from the negative end of the filament in all cases; reference to Fig. 10 will show that if the positive side of the bias battery were joined to one end of the filament the bias would vary, at the frequency of the supply mains, by four volts. The result of this would be a deep, booming hum. Whatever the direction of the current, the centre of the filament is always two volts positive with respect to the negative end; if, therefore, the bias is increased by two volts and the positive end of the battery or bias resistance is joined to the middle of the filament, the correct bias will at all times be applied, and the hum will vanish.

The centre of the filament is not accessible; as a substitute for it  $R_{21}$  is used, since its middle point is always at the same potential as the middle point of the filament. It is found in practice that the hum is more completely removed if  $R_{21}$  has a comparatively low resistance; if each half has a resistance of 20 ohms the extra current drawn from the transformer will only be  $4/40=0.1$  ampere, which, in comparison with the much heavier current taken by the valve, may be regarded as negligible. Where difficulties are experienced in making the two halves equal, it will be found convenient to use a resistance with an adjustable tapping point, varying this until freedom from hum is experimentally found.

Values for all the resistances in the set the circuit of which is given in Fig. 5.			
Resistance.	Recommended Value.	Resistance.	Recommended Value.
$R_1$	5,000 ohms.	$R_{12}$	0.25 megohm.
$R_2, R_3$	1,000 ..	$R_{13}$	0.1 ..
$R_4, R_5$	60,000 ..	$R_{14}, R_{15}$	0.1 ..
$R_6$	60,000 ..	$R_{16}$	30,000 ohms.
$R_7$	15,000 ..	$R_{17}$	20,000 ..
$R_8$	200 ..	$R_{18}$	20,000 ..
$R_9$	1,000 ..	$R_{19}$	15,000 ..
$R_{10}$	*1,500 ..	$R_{20}$	0.1 to
$R_{11}$	0.25 to		0.25 megohm.
	0.5 megohm.	$R_{21}$	20 ohms each half.

\* Or 1,000 ohms fixed plus 1,000 ohms variable.

**NEW VALVE PRICES.**

**Substantial Reductions in all Popular Types.**

THE prices of nearly all standard types of valves manufactured by members of the British Radio Valve Manufacturers' Association have been reduced as from Tuesday, 15th March. The table below, in which the valves have been classified under main headings, shows, at a glance, the change in price.

Type of Valve.	New Prices.	Old Prices.
Mains S.G. and Variable-mu*	19/-	22/6
H.F. pentodes*	20/-	25/-
Mains triodes high impedance*	13/6	15/-
Mains triodes output*	15/-	17/6
Mains triodes super power*	17/6	20/-
Mains pentodes*	20/-	25/-
Battery S.G. and Variable-mu (2-volt)	16/6	20/-
Battery triodes high impedance (2-volt)	7/-	8/6
Battery triodes output (2-volt)	8/9	10/6
Battery triodes super power (2-volt)	12/-	13/6
Battery pentodes	17/6	20/-
Mains triodes directly heated	17/6	20/-
Mains super power triodes directly heated	25/-	30/-
Rectifying valves (class A)	12/6	15/-
Rectifying valves (class B)	15/-	17/6
Rectifying valves (class C)	20/-	22/6

\* Indirectly heated.

The rectifying valves Classes A, B, and C refer to the new standardised full-wave types with D.C. outputs respectively of 60, 120, and 120 mA., and R.M.S. inputs of 250-0-250 v., 350-0-350 v., and 500-0-500 v.

# Broadcast Brevities.

By Our Special Correspondent.



THE UBIQUITOUS "MIKE." Broadcasting an account of the recent ski championships in the Austrian Tyrol.

## Television at Broadcasting House.

THE establishment of a special television studio at Broadcasting House is clearly an indication that the B.B.C. view the progress of the new art in an optimistic light. A certain amount of money is being spent on development in co-operation with the Baird Company, and before very long it will be possible to see, as well as hear, the B.B.C. transmissions on four nights a week, viz., Mondays, Tuesdays, Wednesdays, and Thursdays, beginning at 11 p.m.

## An Open Mind.

While the B.B.C. is not disguising its willingness to co-operate with the Baird people, I understand that the Corporation intends to preserve an open mind on the question of the choice of system, and will be ready, if circumstances require it, to experiment with any new television method, whatever its origin.

## Awkward Reflections.

The heads of departments at Savoy Hill concerned with the vision side are not having a very happy time, as they feel that many of the artistes, while being eminently suited to broadcasting as we know it to-day, might not be ideal subjects for visual transmission!

## Masks?

Somebody has unkindly suggested that a collection of masks should be available for the use of sensitive artistes; there is more comfort, however, in the reflection that the definition obtained with present-day television is insufficient to make anybody appear either handsome or ugly.

## B.B.C. and Water Pipes.

THE great "earth" question, which seems to be worrying the water supply companies, has caused no sensation among the B.B.C. engineers. This despite the fact that, in the words of one of them whom I buttonholed last week, they "probably use the jolly old water pipe every time."

## Check Receivers.

At Broadcasting House the check receivers are earthed to the constructional steelwork, but this, in turn, is hitched up to the water mains. If the Metropolitan Water Board should forbid the practice, it would be amusing to watch the engineers burying biscuit tins or other metallic articles in Portland Place.

## The New Dance Orchestra.

ALL that is needed, it seems to me, to make Henry Hall's dance band one of the best ever heard over the microphone is a little more verve, or perhaps one should say "pep." The tricks of orchestration, the skilful contrasting of tone values and the excellent solo playing suggest at once a real effort to provide music rather than mere rhythm and noise. Herein possibly lies the sole danger; some people may object that the band is "too good to dance to."

## Brighter Announcements.

Mr. Hall might perhaps instil a little more *joie de vivre* into his announcements, which at present are a little in the pulpit manner, but I have no doubt that when the B.B.C.'s new dance impresario has taken part in a few vaudeville programmes, he will begin to reflect the spirit of enthusiasm which is essential to good showmanship.

## Droitwich.

I answer to many enquirers who are evidently thrilled by the notion of B.B.C. transmissions from Droitwich. I can only say that technical tests are likely to continue for at least three months before a particular site is chosen. And when this part of the business is accomplished legal negotiations will begin which may absorb another two or three months.

The B.B.C. has already had some valuable experience in dealing with tenant farmers, ground landlords, and other folk who are not slow in driving bargains. By now the B.B.C. should be familiar with all the tricks of the trade.

## A Start this Year?

It is hoped that work will begin at Droitwich before the end of the year. If this can be managed, one, if not both, of the transmitters should be ready for operation by January, 1934.

## Thanks for Small Mercies.

THE first of the two Soccer matches to be broadcast by the gracious permission of the Football Association takes place on April 9th, when Mr. G. F. Allison, that doughty hero of a hundred commentaries, will describe the Scotland v. England International match at the Wembley Stadium.

The second will, of course, be the Cup Final, also from Wembley, on April 23rd.

## From Broadcasting House.

The first radio-drama from Broadcasting House is expected to be a revival of Rudolph de Cordova's "Dr. Abernethy," one of the wittiest little plays ever put on the air and one that was very well liked by listeners on the two occasions on which it was heard last year. "Dr. Abernethy" will be broadcast during the first week in May, and at about the same time "Invictus," a play on the Ancient Britons, by Peter Creswell, is to be heard.

## Broadcast Play Filmed.

The film adaptation of Holt Marvell's successful radio romance, "Good Night, Vienna," which was broadcast last January, is now completed. The talkie version, it is predicted by those who have seen it at a private show, is equally as impressive in its artistic conception as the broadcast. It will be at the Capitol Theatre on Easter Monday. Jack Buchanan appears as Count Schilettoff.

## The Prolific Public.

WITH the return of spring, the intellectual sap appears to be rising. For never has the public been more prolific than to-day in devising plays, sketches, musical compositions, and other creations for the broadcast microphone.

I hear that Savoy Hill is inundated with amateurs' efforts, and the distressing feature is that so few of these come within sight of being acceptable.

## Within the Ramparts.

Apart from their unsuitability, there is another factor warring against the acceptance of work by "outsiders." Within the walls of Savoy Hill there are numbers of bright people who, to justify their salaries, must be kept busy on something or other, and, as they know exactly what is required and are always turning out plays and other oddments, their work naturally receives first consideration.

But it would be wrong to suggest that there is no opening for real talent, and I believe that the Productions Director still hungers for genuine works of merit from the outside world.

## Prolonging the Agony.

AT first it was thought that Lance Sieveking's dramatic production on May 14th, dealing with the history of broadcasting from Savoy Hill, would signalise the final leavetaking of the old building. I now learn that this will be only the beginning of the end. Many departments will linger on for several weeks.

The last department to quit will be that indispensable unit—the Press Section—through which the B.B.C. unbosoms its great heart to the world of print and misprint.

# Laboratory Tests

## ON NEW RADIO PRODUCTS.

### CLIX CHASSIS MOUNTING VALVE HOLDER AND "MASTER" PLUG.

Hitherto the skeleton-type valve holder assembled on a thin bakelite disc and used extensively by set manufacturers has not been available to the home

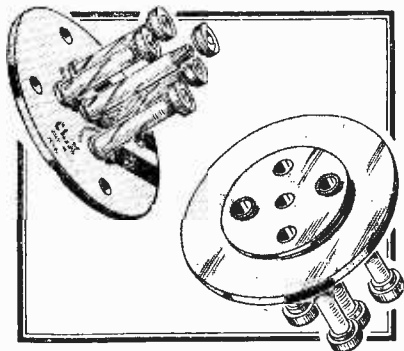

Clix new panel-mounting valve holder.

constructor, but now Lectro-Linx, Ltd., 254, Vauxhall Bridge Road, London, S.W.1, have placed on the market a constructor's model in four- and five-pin types. These are fitted with small screw terminals, and, to ensure accurate centring with the valve pins, crescent-shaped slots have been cut in the supporting plate. These allow the sockets to move laterally, thereby producing a floating effect. Convoluted slots extending for three-quarters of their length are cut in the sockets, imparting the necessary resiliency without impairing the mechanical rigidity. These new valve holders cost 8d. each for the four-pin type, and 9d. each for the five-pin model.

The "Master" plug is fashioned on similar lines to

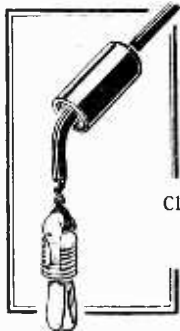

Clix "Master" plug.

the Clix "Vice-grip" wand plug: the prong being made of special hard drawn

wire, somewhat resembling a cotter pin in general form. The tips of the prong are bent inward slightly to facilitate insertion into the socket. There are two styles available: the one with a long shank and insulated body, while the other model is foreshortened in both respects. On the longer type the engraving is on the side of the insulator, but in the short model this is placed on the head. The price is 1½d. each, engraved in both cases.

### RESIN-CORED SOLDER.

Whenever the necessity arises to make soldered joints in the wiring of a wireless set it is advisable always to employ a non-

corrosive soldering fluid or paste, of which there are many excellent examples at present on the market. Some of the most satisfactory have a resin base, and this substance is employed in the resin-cored solder marketed by W. G. Agar, 19, Whitecross Place, London, E.C.2.

The solder is prepared in tubular form with the centre filled with resin. It is clean and easy to handle, and does not creep to any noticeable extent. A perfectly clean, well-tinned soldering-iron should be used. It is now available in small tins containing about four feet of resin solder, and the price is 6d.

### COMPONENTS FOR THE "AUTOTONE"

In addition to the Wearite tuning coils originally specified, we have received specimen coils from Messrs. Simmonds Bros., 38, Rabone Lane, Smethwick.

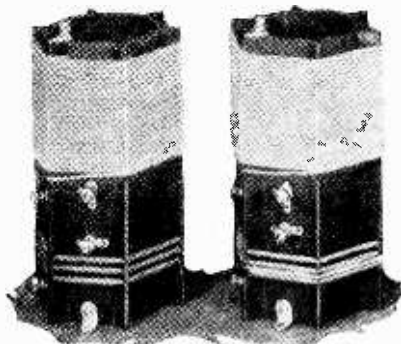

"Berclif" tuning coils for the "Autotone" receiver.

Staffs, and the Peto Scott Co., Ltd., 77, City Road, London, E.C.1. These have been made accurately to specification, and the price in each case is 12s. 6d. the pair. In the Peto Scott coils the single-layer medium-wave windings are protected with cellophane. The "Berclif" (Simmonds Bros.) coils are fitted with neat indicator tags under the terminals, and in their final form will be wound with coloured D.C.C. wire (the coils illustrated are wound with white cotton-covered wire).

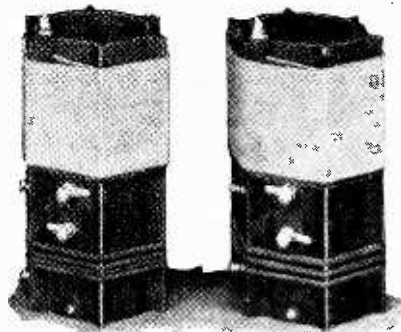

Peto Scott "Autotone" coils.

They can also be obtained with three angle brackets instead of the single-hole fixing.

A compact L.F. choke, suitable for the anode choke CH<sub>2</sub> in the "Autotone" as well as for many other purposes, has been produced by W. Bryan Savage, 292, Bishopsgate, London, E.C.2. at the very

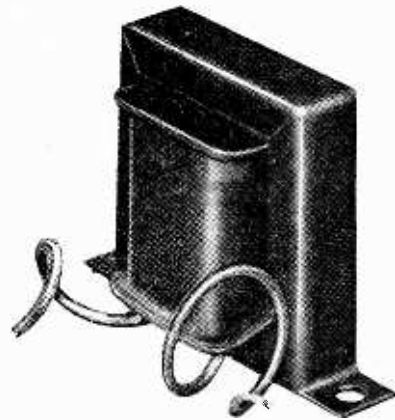

Savage L.F. choke, Type K40M.

reasonable price of 6s. It is known as type K40M, and has a D.C. resistance of 930 ohms. The inductance varies from 20 henrys with 20 mA. of D.C. flowing through the winding to 46 henrys with no D.C. Under the conditions of operation in the "Autotone," the inductance will be about 30 henrys, which leaves an ample margin of safety above the minimum value required. The overall dimensions are 2½ × 1½ × 1¼ in., and the centres of the two fixing screws will fit the holes in the "Autotone" chassis.

The metal screen and base-plate in the accompanying illustration are the work

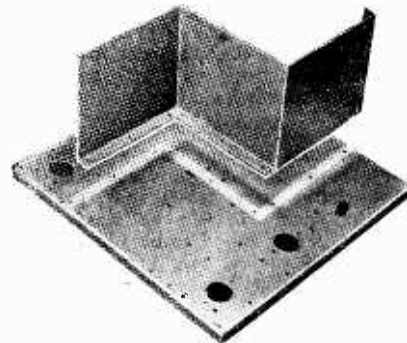

"Autotone" metal chassis and screen by White Bros. and Jacobs, Ltd.

of Messrs. White Bros. and Jacobs, Ltd., 46, Chalk Farm Road, London, N.W.1, who have made an exceptionally clean job of the piercing and bending processes involved. The price complete is 10s.

### Triotron Valve Modification.

The Triotron type K.435/10 power output valve, which is intended to be used as a directly heated A.C. output valve, is now fitted with a filament taking 1 ampere at 4 volts. The other characteristics of the valve remain unchanged.

# Unbiased

by

## Tree Grid

### Unblastable Pianos.

THE result of my recent note *re* the unblastable piano is a very heavy post-bag. To all those who have written asking the date when the B.B.C. intend to install such an instrument, I would point out that they should write to Savoy Hill about it. To the genius who asks why the same principle could not be applied to the violin, I would point out that, apart from other insuperable difficulties, feline viscera are not made of a magnetic substance.

The most hopeful suggestion, however, comes from a man using a pen-name which surely must have been coined by the B.B.C. themselves, namely, "Pianofortephile." He suggests that if each of us had a duplicate piano of the type I described it would only be necessary to connect it up to the output terminals of the loud speaker in order to have real piano music in our own homes; all the delicate musical shading introduced by the pianist at Savoy Hill, he explains, would be faithfully reproduced.

The saddest thing in life is the ugly little fact which so often destroys a beautiful theory, and in this case the ugly little fact is that, owing to the absence of any form of damping on the wires of the piano at the home end, the effect would be the same as if the loud pedal were on all the time. I feel sure that my correspondent will be only too willing to co-operate with any other inventor who finds a way out of this difficulty.

### An Idea!

I SUPPOSE that, like myself, many people have, as the result of broadcasting, become so used to hearing foreign tongues spoken that they are able to name many of them immediately they hear them without first getting a clue from the wavelength indication of the tuning dial.

I have long prided myself on having a special aptitude for this game, but a couple of weeks ago I first picked up a station using a language and a wavelength which defied all my attempts to identify it. Its only programme seemed to be nothing but one long announcement lasting from 1 to 1.30 a.m. each morning.

A friend to whom I related my experience dragged round to my house one night a motley collection of linguistic experts, including an English-speaking American and a well-known jazz band conductor. After listening carefully for a few moments the former was able to assure the assembled company that the strange language was definitely not his native tongue, and the latter was able to disabuse our minds of the idea that a new station built by the natives of West Africa was under-



We had confessed ourselves baffled.

going tests. After several experts, learned in all sorts of languages ranging from Sanskrit to Lancastrian, had confessed themselves baffled, we began to have hopes that we were at last listening to signals from Mars.

Excitement had risen to fever heat when a dreadful anti-climax was provided by an unassuming little man who said he recognised the language as being the least known of the tongues spoken in these islands,

namely, Manx. Whether he was right or not, he gave me an idea. Would it not be a delightful addition to our choice of nightly programmes if the Government of that enchanting land were to establish a low-power broadcasting station for the dissemination of national culture? Lest any indignant Welshman be incited by this suggestion to go and do likewise, I would remind them that, unlike their native country, the Isle of Man is not under the iron heel of the B.B.C. and the P.M.G., as it lies outside their jurisdiction.

### Were You the First?

I HAVE often wondered who was the first amateur to possess a wireless receiver or transmitter in this country, and my interest in this matter has once more been stimulated by a correspondent who asks if I can get him this piece of information.

I see by my diary that I myself cannot make a claim, as my written records go back only to 1908, when I was working a small spark transmitter and a crystal receiver. The particular crystal used was called "Permanite," and I well recollect purchasing it from a London firm,

who, incidentally, are still selling radio nearly a quarter of a century afterwards. I can find no record of ever having a licence of any sort, however, and, although there is no entry about it in my diary, I remember that at a much earlier date I possessed a coherer connected up in such a manner that the electric door bell was rung by the ignition every time a car passed the house—a rare happening in those days.

## CORRESPONDENCE.

The Editor does not hold himself responsible for the opinions of his correspondents.

Correspondence should be addressed to the Editor, "The Wireless World," Dorset House, Tudor Street, E.C.4, and must be accompanied by the writer's name and address.

## A STATEMENT OF POLICY.

**Y**OUR leader, "A Statement of Policy," comes as a breath of mountain air in the muck of present-day journalism.

As a former free-lance journalist, now sales-manager to a radio manufacturing company, the journalistic sincerity, sound policy, and scientific utility of *The Wireless World* appeals to me strongly, and I send you my congratulations.

It is worth mentioning, I think, that, although the firm I serve is one of considerable standing, you have never even remotely suggested a "write up" in connection with an advertisement.

H. MORRIS.

London, N.W.3.

[Very many personal letters of appreciation of our Statement of Policy have been received from readers and from prominent members of the radio industry.—Ed.]

## INFORMATIVE ADVERTISING.

## Preparing Technical "Copy."

**I** HAVE read with a good deal of interest the correspondence from your readers under the above heading, and Mr. Slade has certainly hit on a subject which should be of great importance to every radio manufacturer. The advertisement pages of *The Wireless World* are scanned very thoroughly by the majority of readers. Personally, I look at the advertisement pages first, as often there are new components, etc., illustrated there which are making their first bow to the radio experimenter and constructor.

The sales of a product can easily be ruined by the manufacturers omitting to include instructive data in their advertisements. On the other hand, we are all familiar with the eulogistic type of advertisement mentioned by Mr. Slade, and these are usually read with rather more than the proverbial grain of salt. I agree with Mr. Heathorn that, in regard to components, it is a simple matter to give full and reliable facts, but somehow the manufacturer is inclined to overlook vital points regarding his products, and these points only see the light of day through the medium of the laboratory test report page in *The Wireless World* or the test reports in trade journals, which are usually not available to the "man in the street." The prospective purchaser of a component often likes to have an independent report on the capabilities of, say, a valve.

Probably the failure to include the proper "dope" lies with the particular manufacturer who leaves the preparation of his advertisements entirely to a firm of advertising agents who either do not have on their staff a copy writer who is conversant with radio, or, alternatively, do not co-operate successfully with their clients when it comes to obtaining the necessary data.

Mr. Lebbon, in his letter published in your issue of February 17th, raises rather a controversial point when he touches the question of prices of components. It is a well-known axiom that quality remains after price is forgotten, and this applies very distinctly to fixed condensers. Evidently the difference in prices mentioned by Mr. Lebbon is due to the fact that the condensers advertised at 5s. 6d. are for 400 volts D.C. (peak) working and the types specified by the authors of the "Power Radio-Gram" are for 800 volts D.C. (peak) working, and it undoubtedly would be false economy to incorporate condensers of a lower working voltage than those recommended by the designers.

To conform with the I.E.E. insulation requirements, it is necessary that the minimum test voltage of condensers should be three times the R.M.S. value of the A.C. volts across the condenser.

HARRY A. WOODYER, G2XW.

Kenton, Middlesex.

## H.T. Batteries.

**I**T has been with great interest that I have read your leader of February 10th on the subject of "Informative Advertising," and the subsequent correspondence which has arisen thereon. Upon this subject I would like to put forward a con-

crete example which twelve years' experience as a professional radio engineer has indicated to be in drastic need of "informative advertising."

I refer to the rating of high-tension batteries of the dry type, and the desirability for manufacturers to mark plainly, on the product itself, the maximum discharge rate in milliamperes.

Whilst I have always been an advocate of the present manufacturing policy of the mains-driven broadcast receiver, it must also be remembered that there is still a vast number of listeners in country areas who depend entirely upon dry batteries for their source of anode supply, and for whom there would appear to be no alternative for many years to come. That there is a steady demand, and supply, of H.T. batteries no manufacturer of repute will deny; nevertheless, it is a deplorable fact that in 75 per cent. of cases the purchaser is left in entire ignorance of the one factor which is (or should be) of paramount importance, namely, the maximum discharge rate in milliamperes, which the particular manufacturer recommends for his product consistent with a useful working life.

No manufacturer can be expected to indicate a life figure for his batteries any more than a valve manufacturer can, or would do, for his valves, but I would suggest to battery manufacturers that the public is not interested in "how it is made," but rather in the duty which it now performs after it has been made. If all battery makers of repute would adopt the marking of their products with simply the maximum recommended discharge rate, not only will such a form of "informative advertising" result in increased sales, but it will do much to eliminate the feeling held by the non-technical listener that all H.T. batteries are a necessary evil, and an expensive evil at that.

Berkhamsted, Herts.

G. L. MORROW.

## WATER-PIPE EARTHS.

**I** HATE to think what will happen if, as you suggest might happen, all the corporations forbid the use of the water pipes as earth. What will the poor unfortunates do whose "earth" is five storeys down, and then under two feet of concrete?

And won't His Majesty's Post Office have to do something about it, too? I know our telephone is earthed to the nearest water pipe, but perhaps that is only the lightning earth-path; that seems worse!

I do not know what the equivalent to "bootlegging" would be in this case, but I see a lot of law-breaking ahead if you do not help to get this matter cleared up.

W. O. M. EDF.

London, E.1.

## A READER'S OUTPUT STAGE.

**T**HE output stage described by Capt. Reiss-Smith in your Correspondence column is most interesting, but I have one criticism to offer. I have recently been carrying out a series of tests on inter-valve couplings with the object of determining the effect on transients. Change-over switches were used so that a quick change could be made for comparison, the circuit arrangements being such that the same anode voltage was applied to the detector valve in each case.

Without wasting space in describing the numerous tests made, I will simply say that they proved conclusively to me that the effect of the coupling condenser in the cases of resistance, choke, or parallel-fed transformer, was to ruin attack. This is what might be expected from a consideration of the effect of the condenser when dealing with a steep wave front of transient character. The effect is reduced as the capacity of the condenser is decreased, but, of course, the reproduction of the low frequencies then suffers.

Although at one time an ardent advocate of resistance coupling, since I have had a loud speaker which will reproduce both low notes and transients, I believe that the most satisfactory form of inter-valve coupling is a directly fed transformer, especially as excellent transformers are now available which will carry up to 15 mA. primary current.

Derby.

H. H. DYER, A.M.I.E.E.



# READERS' PROBLEMS

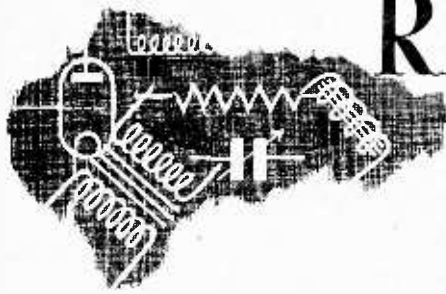

## £ s. d. of Mains Sets.

A READER asks whether there is a simple formula for working out the cost per hour of operating a set fed from a D.C. mains supply, which, he realises, is always a more expensive source of receiver current than an A.C. system. He goes on to say that his set employs four valves of the 0.5 amp. indirectly heated type, connected in series; current costs 3d. per unit, and the supply is at 240 volts.

The cost of operation in pence per hour is easily ascertained by the following formula:—

$$\frac{\text{Watts consumed} \times \text{cost in pence per unit}}{1,000}$$

Wattage is ascertained by multiplying volts by amps.; in the case of the set in question, it is  $240 \times 0.5$ , equal to 120 watts. With this information, and applying our

$$\text{formula, we get } \frac{120 \times 3}{1,000} = 0.35\text{d. per hour.}$$

In assessing consumption, we—and our correspondent—have ignored anode current, which, of course, should, strictly speaking, be added to that passed in the filament circuit. This omission is quite permissible, as the extra energy is most unlikely to exceed 10 watts.

## Ganging "Good" Circuits.

IT was at one time considered that tuned circuits of exceptionally high efficiency could not be controlled by a gang condenser. This was because any slight misalignment in tuning tended to become painfully evident when the resonance curves of individual circuits were sharp.

Thanks largely to improvements in gang condensers this position has undergone a considerable change, and provided the amateur constructor is willing to devote a little time and trouble to the operation of "ganging," there is hardly any limit to the goodness of circuits that can be controlled satisfactorily by means of a single tuning knob.

This point is raised by a correspondent who, noticing that relatively large coils are employed in the "Autotone" receiver, asks whether the method of tuning exemplified in the new set would be applicable to a proposed band-pass filter in which an attempt is to be made to obtain abnormally high selectivity by using coils of high efficiency.

Provided that he uses a tuning condenser with suitably designed segmented end vanes, there should be no real diffi-

culty in making initial adjustments in a similar way to that suggested for the "Autotone," but with obvious modifications in procedure due to the inherent differences between a "single-peak" two-circuit tuner, with regeneration, and a band-pass filter, presumably without reaction.

## Anti-lightning Devices.

ALTHOUGH the risk of damage due to lightning is greatly over-estimated, there can be no question that the cautious wireless user is right in fitting some form of safety device. Broadcast receivers are often blamed for all sorts of untoward happenings for which they are not responsible, and it is wise to avoid all risk of invalidating an insurance policy by taking the conventional precautions.

Several questions have lately been received regarding the best way of fitting a safety switch. The usual plan is illustrated in Fig. 1 (a); this arrangement requires a single-pole change-over switch, which should preferably be fitted with a safety gap, of which the connections are indicated by dotted lines.

When a double-pole switch is employed it should be connected as in Fig 1 (b); here, again, a safety gap between aerial and earth may be added. It is more than doubtful if the complication of a double-pole switch is warranted, and there is always the possibility that leakages will take place through the cross-bar which unites the two blades.

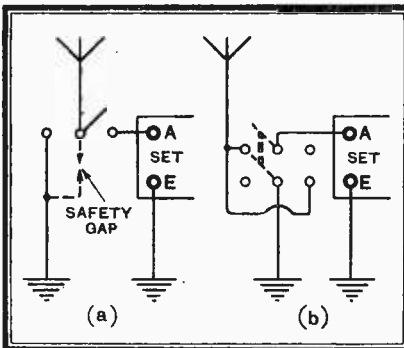

Fig. 1.—Connections of single- and double-pole safety switches, which should be mounted close to the aerial lead-in wire.

If it is to be really effective, the switch should be mounted outside the building, and therefore a vulcanised fibre cross-bar, which is so often fitted to cheap switches, is obviously undesirable, as this material has the property of absorbing moisture. As to the material of the switch base, it is almost impossible to employ any better substance than glazed porcelain.

Finally, those who go to the trouble of installing a safety switch should realise

THESE columns are reserved for the publication of matter of general interest arising out of problems submitted by our readers.

Readers requiring an individual reply to their technical questions by post are referred to "The Wireless World" Information Bureau, of which full particulars, with the fee charged, are to be found on the next page.

that this component requires periodical attention, and that both the contacts and insulating base should be cleaned occasionally. The possibilities of a more or less complete short-circuit across the safety gap should also be borne in mind.

## High-efficiency Pentodes.

SPECIAL loud speakers with windings of high impedance—for example, the Celestion PEN.M.12—have been produced for operation with the new high-efficiency battery-operated pentodes, and are primarily designed for direct insertion in the anode circuit of the valve. But there is no particular reason why, if it is especially desired to do so, they should not be fed through a choke filter arrangement of the conventional type. The only requirement is that the choke should have an inductance that is high compared with that of the loud speaker; any good choke will satisfy this condition.

This point is raised by a correspondent, who has built one of these sets for battery feed, but now has available a D.C. mains supply. He wishes to isolate his loud speaker from the mains by means of a choke-condenser filter, but is afraid that by doing so the matching of valve and loud speaker may be upset.

Another querist, dealing with a similar subject, wants to know if the special Varley output choke, which is designed to match an ordinary loud speaker to a high-efficiency pentode, would do equally well as a coupling between the valve and one of the special loud speakers referred to in the opening paragraph of this reply. The answer is that it could be used quite successfully for this purpose. As a step-down output ratio will not be required, the anode of the valve and the loud speaker feed condenser will both be joined to the choke terminal marked "anode."

**L.F. Feed-back.**

THERE still seems to be some doubt as to how an unwanted feed-back of L.F. energy to the detector grid can take place when this valve is coupled to a preceding H.F. amplifier by a simple tuned-anode circuit. This form of coupling is sometimes responsible for uncontrollable L.F. oscillation or motor-boating, and it is a demonstrable fact that the use of a double-wound transformer or a tuned grid coupling is markedly superior in this respect.

Writing on this subject, a reader asks how it is that L.F. potentials can be fed back when a small coupling condenser, generally of 0.0003 mfd., is interposed between the tuned-anode coupling and the

place, he goes on to say that a tuned grid coupling, in which a similar condenser is employed, should be equally susceptible to trouble.

This is a matter of relative resistances and impedances. Admittedly, the reactance of a 0.0003 mfd. condenser is about 0.5 megohm at 1,000 cycles, but this value is comparable with that of the grid leak. A considerable proportion of the total voltage will therefore build up across the latter, and will be applied to the detector grid.

With a tuned-grid coupling, on the other hand, the detector grid circuit is virtually short-circuited, so far as L.F. impulses are concerned, by a coil of certainly no more than 5 ohms resistance.

The skeleton diagram given in Fig. 2 shows, by means of a dotted line, the path by which energy can be fed back. In this diagram, Z represents an impedance or resistance in the source of H.T. supply (whether battery or eliminator) which is common to several anode circuits. This impedance may be regarded as the source of the voltages which give rise to the trouble with which we are concerned.

**Trimming Procedure.**

IN the article in which the A.C. mains model of the "Wireless World Three" was described, constructors were referred back to the published description of the battery-operated model for detailed instructions as to how to carry out the operation of trimming the gang-controlled circuits. In compliance with requests from several readers who have not access to the back number in which this information was published, we here repeat the essential method of procedure which was recommended.

(1) Screw all trimmers fully home, and then slack off by three half-turns.

(2) Tune in a weak transmission at the lower end of the tuning scale.

(3) Adjust the semi-variable aerial series condenser for maximum response, at the same time making any slight adjustment necessary on the main tuning condenser.

**FOREIGN BROADCAST GUIDE.****MOSCOW (WZSPS) (Trade Union)  
(U.S.S.R.)**

Geographical position: 55° 45' N.; 37° 37' 12" E.

Approximate airline from London: 1,555 miles.

Wavelength: 1,304 m. Frequency: 230.6kc  
Power: 165 kW.

Time: Three hours in advance of Greenwich Mean Time.

**Standard Daily Transmissions.**

06.00 G.M.T., Physical exercises, concert;  
09.00, children's hour; 10.00, 11.00, 15.30, concert or light entertainment, news;  
19.00, international concerts and talks;  
20.59, Kremlin Bells and midnight time signal.

Announcers: Man and woman.

Opening call: *Govoret Moskva Central*; (in French), *Ici la grande station des Unions Professionnelles de Moscou*; (in English), *This is the high power station of the Central Trades' Unions at Moscow calling.*

Languages used: Russian, Swedish, Finnish, French, German, English, Dutch, Polish; Spanish, Danish and Italian.

Opening and closing signal: *L'Internationale* (Gramophone record).

Closing down words: *Dasveedanja, Spakoiny notchi*; *vashi antenni* (Au revoir; Good night. Earth your aeriels).

The broadcasts are also transmitted by Moscow (RV59) on 50m. (6,000 kc.). And, partly, by Moscow (MOSPS) on 378 m. (792.5 kc.) 20 kW.

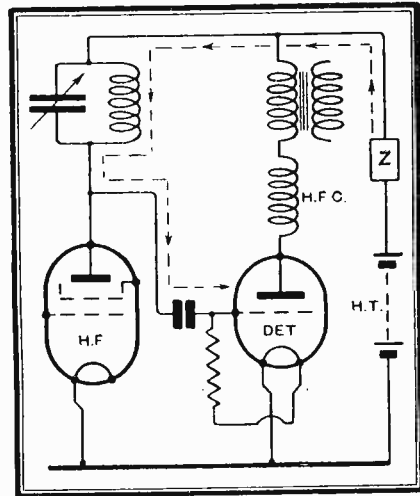

Fig. 2.—Illustrating a weakness of the tuned-anode system of H.F. coupling.

grid of the succeeding valve. He argues that the reactance of this condenser is so high over the audio-frequency range that it is hard to see how any appreciable amount of energy can be passed through it. Even if this feed-back could take

(4) Repeat this procedure with each of the built-in trimming condensers in turn.

During the process of trimming, it is permissible, and often desirable, to sharpen up tuning by applying a certain amount of reaction.

**"THE WIRELESS WORLD"****Information Bureau.****CONDITIONS OF THE SERVICE.**

(1) THE service is intended primarily for readers meeting with difficulties in the construction, adjustment, operation, or maintenance of wireless receivers described in *The Wireless World*, or those of commercial design which from time to time are reviewed in the pages of *The Wireless World*. Every endeavour will be made to deal with queries on all wireless matters, provided that they are of such a nature that they can be dealt with satisfactorily in a letter.

(2) Communications should be addressed to *The Wireless World* Information Bureau, Dorset House, Tador Street, E.C.4, and must be accompanied by a remittance of 5s. to cover the cost of the service. The enquirer's name and address should be written in block letters at the top of all communications.

(3) The fee of 5s. covers the reply to any wireless technical difficulty, but in special cases, where the enquiry may involve a considerable amount of investigation, an increased fee may be necessary. In such cases a special quotation will be made.

(4) Questions should be clearly written and concisely worded in order to avoid delay. Where enquiries relate to trouble experienced in receivers built to specifications in *The Wireless World* a complete account should be given of the trouble, and especially the symptoms.

(5) Where reference is made to published articles or descriptions of apparatus, the title of the article, the date of publication in *The Wireless World*, and the page reference number should be given, in order to facilitate reply.

(6) Full circuit diagrams, constructional details of apparatus, or values of components for home-designed receivers cannot normally be supplied, but circuit diagrams sent in with queries will be checked and criticised.

(7) Particular makes of components cannot, in general, be recommended, but advice will be given as to the suitability of an individual component for a particular purpose specified by the enquirer.

# The Wireless World

AND  
RADIO REVIEW  
(21<sup>st</sup> Year of Publication)

No. 657.

WEDNESDAY, MARCH 30TH, 1932.

VOL. XXX. No. 13.

Editor: HUGH S. POCOCK.

Editorial Offices: 116-117, FLEET STREET, LONDON, E.C.4.

Editorial Telephone: City 9472 (5 lines).

Advertising and Publishing Offices: DORSET HOUSE, TUDOR STREET, LONDON, E.C.4.

Telephone: City 2846 (15 lines).

Telegrams: "Ethaworld, Fleet, London."

COVENTRY: Hertford St.  
Telegram: "Cyclot, Coventry."  
Telephone: 8210 Coventry.

BIRMINGHAM: Guildhall Bldgs., Navigation St.  
Telegrams: "Autopress, Birmingham."  
Telephone: 2970 Midland (3 lines)

MANCHESTER: 260, Deansgate.  
Telegram: "Hilife, Manchester."  
Telephone: Blackfriars 4412 (4 lines).

GLASGOW: 26B, Renfield Street, C.2.  
Telegram: "Hilife, Glasgow."  
Telephone: Central 4937.

PUBLISHED WEEKLY.

ENTERED AS SECOND CLASS MATTER AT NEW YORK, N.Y.

Subscription Rates: Home, £1 1s. 8d.; Canada, £1 1s. 8d.; other countries abroad, £1 3s. 10d. per annum.

*As many of the circuits and apparatus described in these pages are covered by patents, readers are advised, before making use of them, to satisfy themselves that they would not be infringing patents.*

## INTERFERENCE.

**T**HE problem of interference with radio reception has been with us ever since the early days of wireless, but its importance has become more marked since broadcasting began, mainly for the reason that the largest proportion of broadcast receivers are in the more thickly populated parts of the country and, consequently, in areas where interference from various electrical sources is greatest.

We have from time to time drawn attention to this subject and urged the need for a proper investigation of causes of interference in this country with a view to their suppression. Considering the extent of the trouble and the inconvenience which it causes, it is astonishing that it does not appear to be treated in this country more seriously. The difficulty seems to be that no one body here is responsible for investigating the troubles, their cause and cure, and there is no legal redress against those who set up avoidable interference. There is probably no country in the world where there is more interference with wireless reception than our own, and yet it is here, it would seem, that the least effort is being made to suppress it.

### An Example from Canada.

A publication entitled "Radio Inductive Interference," which is issued by the Department of Marine for the Dominion of Canada, has just been received. In the introduction it is explained that this publication has been prepared as a result of the investigation of over 30,000 sources of radio interference, and methods have been devised for the elimination of the major portion of these. It is emphasised that special tests were required in many instances, and new methods have had to be adopted to deal with sources of interference arising from conditions not hitherto encountered. It is obvious that the utmost care has been taken in

the investigation of these troubles, and the publication in question is a matter on which the Canadian Department of Marine is to be congratulated.

But why, we ask, should such a publication emanate first from Canada, where interference must surely be less in proportion to the population than it is here, whilst in this country no Government Department has ever, as far as we are aware, taken any active step even to furnish a fraction of the information which this publication contains?

### The Need for Education.

As time goes on interference increases, because the use of electricity for all sorts of purposes is extending continually; but even those troubles which we anticipated would gradually disappear have, by observation in the London area at any rate, tended to increase during recent months. We refer to interference from spark and other Morse transmissions, which have been far more in evidence within the medium broadcast band of wavelengths than formerly.

In replying to a question in the House of Commons the other day on the subject of electrical interference, the Postmaster-General admitted that there have been cases where remedial measures could have been effected but that the owners of the interfering apparatus had either refused to permit investigation or had declined to adopt the remedy suggested by the Post Office engineers.

Such a state of affairs is, of course, a severe handicap to the Post Office in any good work of this nature which they try to undertake. Until legislation is introduced to give authority to insist on remedies being effected the only remaining course appears to be in publicity.

Is it not time that the Post Office should take steps at least to see that the general public is supplied with information on the avoidance of electrical interference which is capable of cure?

# The Battery

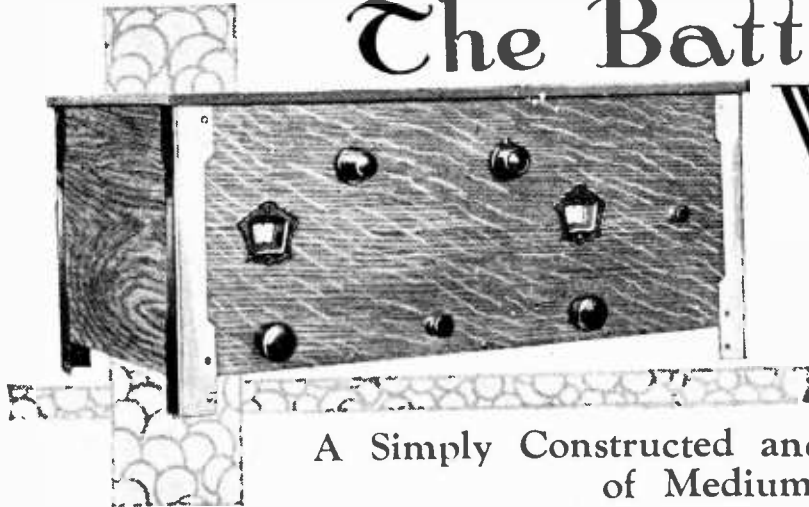

# V<sub>μ</sub>M Three

By W. I. G. PAGE, B.Sc.

## A Simply Constructed and Inexpensive Receiver of Medium Range.

IT is surprising in these days of ultra refinement in wireless receivers to discover how much can still be achieved in the direction of sensitivity and selectivity with a set of simple and cheap design. Even screening can be cut down to the mere shrouding of two or three components, provided that great care is taken in the positioning of parts and wiring; practical proof of this will be found in the results obtainable with the three-valve receiver now to be described.

Just lately there has come on to the market the first example of a battery-operated variable-mu high-frequency valve—the Cossor 220.VSG—which considerably assists in the design of a simple I-V-I receiver. The variable-mu characteristic has been discussed at length in these pages,<sup>1</sup> and its three main advantages can very briefly be enumerated as follows: (1) Absence of cross-modulation interference; (2) absence of distortion of the H.F. wave common to the ordinary screen-grid valve; and (3) provision of an ideal method of pre-detector volume control. With a battery receiver having only one H.F. stage, the first two advantages are not really of vital importance, but the third alone is sufficient justification for the introduction of the valve.

Designers of sets with a screen-grid stage containing a band-pass circuit have been at some pains to devise a pre-detector volume control which will change signals from the local station from full loud speaker strength to a whisper, which will not upset the ganged tuning of a filter, and, lastly, will not introduce distortion at

any volume level. Simple aerial and screening-grid potentiometers, grid-bias controls, and potential dividers to the input of the ordinary screen-grid valve have all been tried, but none have fulfilled exactly the conditions just given. In the variable-mu valve the grid is wound at a non-uniform pitch, which has the effect of extending tremendously the lower extremity of the grid voltage-current characteristic. Instead of the sharp cut-off of signals with three or four volts negative grid bias which one experiences when working with an ordinary S.G. valve, it may need 50 volts negative grid potential with a mains variable-mu valve before the set is reduced to silence.

Fortunately, with the battery counterpart, smaller voltages are needed, and sufficient range of control is had by making the bias battery for the output valve perform the dual function of biasing the first and last valves. A smooth control is obtained by using a 50,000-ohm potentiometer in shunt with the grid battery, as shown in the circuit diagram.

The extended or "tailing" curve, as it is called, becomes straighter as more bias is applied, so that when, for local reception, the volume is intentionally reduced by increasing the bias and so reducing the magnification of the valve (to prevent overloading the detector), the large signal input is accommodated on a linear characteristic. With the ordinary screen-grid valve large inputs

cannot be accepted without a peculiar form of distortion arising from an artificial increase in modulation percentage, because the characteristic is comparatively short and curved; there may also be other undesirable effects.

### FEATURES OF THE SET.

- A three-valve receiver for 2-volt I.T. supply embodying the new battery variable-mu screen-grid valve.
- Absolute simplicity of construction, using a wooden baseboard, has been the aim in designing this set and only components which are universally obtainable have been chosen.
- The total cost, excluding valves and cabinet, will be found not to exceed £4 15s. but a high standard of efficiency has not been sacrificed to bring the set down to a price.
- Comprising three tuned circuits, including a band-pass filter, the set gives adequate selectivity and sufficient sensitivity to ensure good-quality reception from the majority of European stations.
- The variable-mu characteristic provides an ideal pre-detector volume control which does not upset tuning while a full-range variation of signal strength is obtained without the introduction of distortion.
- The demands on the H.T. battery are small, for it is possible with local station reception to work with a total of 5 mA. The average H.T. consumption is 7 to 9 mA.

<sup>1</sup> See *The Wireless World*, November 11th, 1931.

**The Battery V-M Three.—**

From the foregoing it will be evident that the new variable-mu valve provides an attractive system of adjusting volume level without introducing any of the difficulties which have hitherto been hard to overcome.

There is another advantage in using the battery variable-mu valve which is important, as it touches the reader's pocket! Probably the majority of listening hours are confined to local transmissions with which maximum bias is required, the result being that the anode and screen currents of the H.F. valve will be practically zero. This makes for an economical set.

The H.T. consumption of the Battery V-M Three was carefully measured (when listening to the local station), and found to be as follows: H.F. variable-mu valve, anode and screen current, 0.15 mA; detector, 1.9 mA; output valve (220.P. type), 3.0 mA.; total, 5 mA.

1,000 ohms is interposed in the grid return circuit. This, together with  $C_1$ , decouples the grid circuit of the 220.V.S.G., and so obviates the necessity of a one- or two-mfd. condenser between the slider and the earth line. A series aerial condenser  $C_1$  of small capacity is built into the base of the band-pass assembly, and, being tapped into the medium-wave coil at a point near the centre, allows a slightly different proportion of the aerial capacity to be transferred on the two wavebands. To compensate for this the inductance of the two band-pass coils is not exactly the same, but the ganging of the coils  $L_1$  and  $L_2$  is found to hold well over both wave ranges.

To ensure absolute simplicity of construction and to give latitude in the choice of components, the third tuned circuit—that in the intervalve coupling—is tuned with a separately controlled condenser which will be

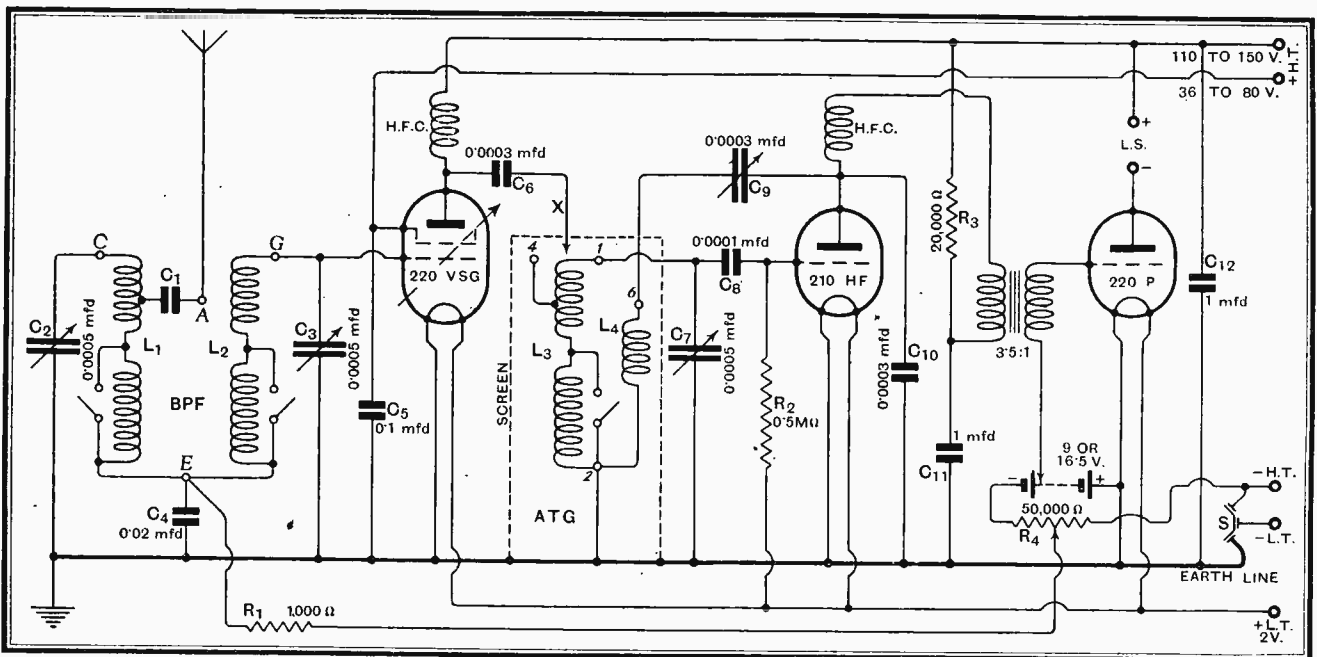

The complete circuit diagram. Note the three point L.T. switch which not only breaks the filament circuit, but isolates the H.T. battery and disconnects the bias potentiometer.

The anode voltage in this case was 100. Using 150 volts H.T., and setting the volume control for distant stations, the total consumption was about 9 mA.

**Circuit Details.**

The circuit is quite straightforward, and needs little explanation. There is magnetic linkage between the two input band-pass coils as well as common capacity-coupling, the two effects acting in such a way as to keep the peak separation practically constant over the tuning ranges. So that a closer coupling is obtained on the long waves, the coils are set at an angle, and resemble the twin-cylinder arrangement on a motor cycle. To prevent the coupling condenser  $C_4$  from being short-circuited when the slider of the bias potentiometer is moved to maximum, a non-inductive resistance  $R_1$  of

found to run almost in step with the two-gang band-pass condenser.

The 220.V.S.G. valve should be obtained with a metallised bulb, and care taken to see that the filament pin marked E is connected *via* the valve-holder to L.T. minus and earth. The screening grid must be properly tied down to earth with a non-inductive condenser  $C_5$  of at least 0.1 mfd., otherwise the valve will tend to act as a triode, and both instability and loss of amplification may result. Intervalve coupling is effected by the choke-condenser-fed tuned grid scheme, and the screened A.T.G. coil (which is linked by a rod to the band-pass coils for single control of wave-band switching) has two input tapping points. The lead X may be taken to terminal 1 with which the amplification will be at the maximum, but if slightly better selectivity is desired, especially when the set is used where the field strength

**The Battery V-M Three.**—

from the local station is high, the connection from  $C_6$  should be taken to tapping point 4. There may be a slight drop in signal strength, but any tendency to instability when the volume control is at the extreme maximum end will at once be quelled. The lead X should be tried first joined to terminal No. 1, and then to tapping point 4.

Reaction is applied *via* a 0.0003 mfd. condenser  $C_9$

to the intervalve coupling, the coil  $L_4$  being arranged in the A.T.G. screened assembly. The detector constants and applied voltages are chosen to give substantially distortionless results when taking into account the rising characteristic of the "Mumax" L.F. transformer. A grid leak  $R_2$  of 0.5 megohm has purposely been chosen of rather higher value than is usual in order to give a slight cut-off of "top." An ample measure of detector anode decoupling is provided by  $R_3$  and  $C_{11}$ , as was

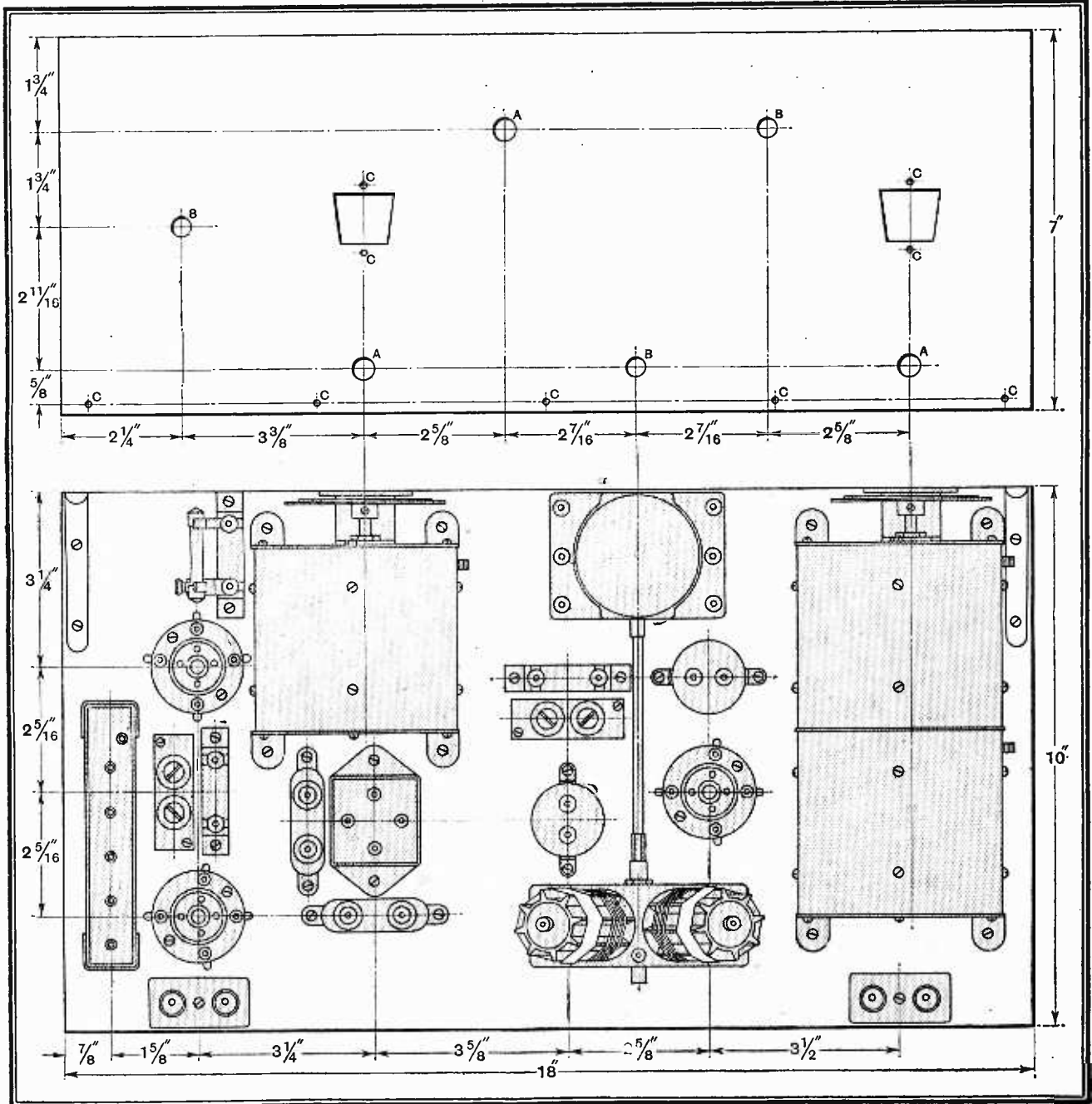

General layout of components and drilling data of the panel viewed from the back. The condenser screens do not quite extend to the baseboard; there is, therefore, space to pass the connecting leads. The drilling of the panel is as follows: A = 7/16in. dia., B = 3/8in. dia., and C = 1/8in. dia.

VARIABLE-MU STAGE WITH BAND-PASS TUNING.

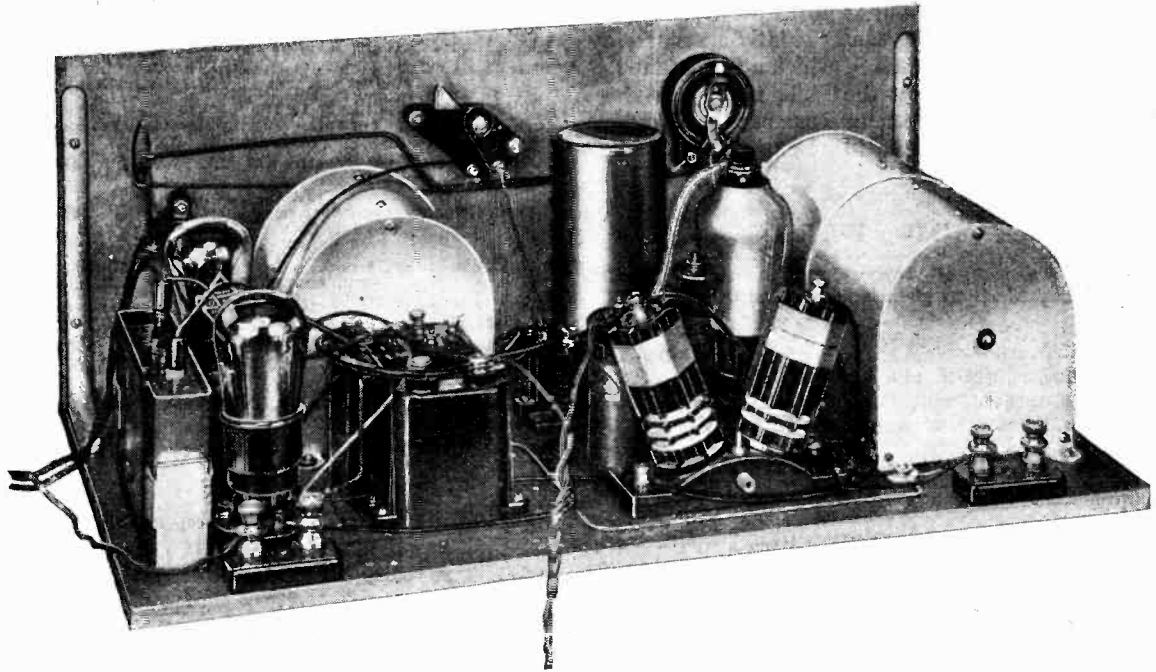

Rear view of the receiver. Metallised valves are used in the H.F. and detector positions and the lead from the anode of the variable-mu valve is screened.

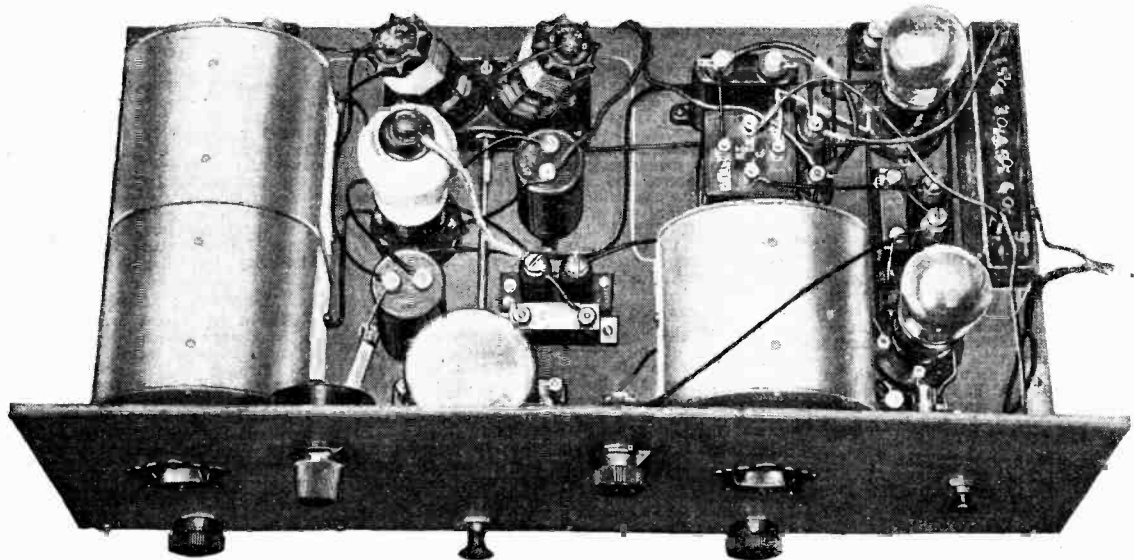

Plan view from which the general layout can be seen. The panel controls comprise two-dial tuning, bias volume control and reaction.

**The Battery V-M Three.—**

easily proved by giving the H.T. source an artificial internal resistance of 1,000 ohms. The set could not be induced to motorboat, and this in spite of the absence of a choke-filter output circuit.

It is essential to break the bias potentiometer connection when the set is not in use. This is arranged by means of the three-point switch S, which also disconnects the L.T. supply and isolates the H.T. battery.

In the concluding instalment constructional details and notes on the performance to be expected from this receiver will be given.

**LIST OF PARTS.**

*After the particular make of component used in the original model, suitable alternative products are given in some instances.*

- 1 **Band Pass filter** (Lewcos B.P.F.)  
 1 **Screened inter-valve coil** (Lewcos A.T.G.)  
 3 **4-pin valve-holders**, antiphonic, with terminals (Lotus)  
 (Benjamin, Burton, Graham Farish, Junit, Lissen, Trix, Wearite, W.B.).  
 1 **2-gang condenser**, screened, with trimmers, 0.0005 mfd.  
 (British Radiophone Formo, J.B., Lotus, Polar, Utility).  
 1 **Single tuning condenser**, screened, 0.0005 mfd. (Ormond R/429/S1)  
 (British Radiophone, Formo, J.B., Lotus, Polar, Utility).  
 2 **Disc dials**, geared (Ormond R/361)  
 (Brownie, Burton, Formo, Igranic, Polar, Sovereign, Telsen, Utility).  
 2 **H.F. chokes** (McMichael Binocular Junior)  
 (Atlas, Burton, Climax, Sovereign, Telsen, Watnel).  
 1 **Spagheiti resistance**, 26,000 ohms (Varley)  
 (Bulgin, Goltone, Graham Farish, Igranic, Lewcos, Magnam, Ready Radio, Sovereign, Telsen, Tunewell).  
 1 **Graded potentiometer**, composition type, 50,000 ohms (Watmel No. 3)  
 (Bulgin, Centralab, Colvern, Claude Lyons, Magnam, Regentone, Rothemcl, Wearite, Varley).

- 1 **Grid-bias battery**, 2-volt (Lissen)  
 (C.A.V., Drylex, Ever-Ready, Grosvenor, Oldham, Pertrix, Ripaults, Siemens).  
 2 **Grid-bias battery clips** (Bulgin No. 1)  
 (Gripso).  
 1 **3-point L.T. switch** (Telsen, W.108)  
 (Bulgin, Gripso, Junit, Lissen, Ormond, Ready Radio, W.B., Wearite).  
 4 **Terminals** (2 blocks) (Lissen, LN308 and LN347)  
 (Belling-Lee, Eelex, Junit, Sovereign).  
 1 **Metallised resistance**, 1,000 ohm, 1-watt type (Dubilier)  
 1 **Variable condenser**, Bakelite dielectric, 0.0003 mfd. (Burton)  
 (Bulgin, Graham Farish, Lotus, Telsen).  
 1 **L.F. transformer**, ratio 3:1 to 1 (Climax "Mumax")  
 (British General, Ferranti, Formo, Igranic, Lewcos, Lissen, R.I., Sovereign, Varley).  
 1 **Fixed condenser**, non-inductive 0.02 mfd., (Dubilier No. 9200)  
 screw terminals  
 (T.C.C., Telsen).  
 1 **Fixed condenser**, non-inductive, 0.1 mfd., (Dubilier No. 9200)  
 screw terminals  
 (T.C.C., Telsen).  
 2 **Fixed condensers**, 1 mfd. (Dubilier, Type "BB")  
 (Formo, Hydra, Lissen, Loewe, Peak, Savage, T.C.C., Telsen, Wego).  
 2 **Fixed condensers**, 0.0003 mfd. (Dubilier No. 620)  
 (Formo, Hydra, Lissen, Loewe, Sovereign, T.C.C., Telsen, Wego).  
 1 **Fixed condenser**, 0.0001 mfd., with clips (Dubilier, No. 620)  
 (Formo, Hydra, Lissen, Loewe, Sovereign, T.C.C., Telsen, Wego).  
 1 **Grid leak**, 0.5 megohm, 1 watt (Dubilier)  
 (Graham Farish, Igranic, Loewe).  
 2 **Panel brackets**, 6x3 ins. (Bulgin PB3)  
**Metal-screened sleeving** (Lewcos)  
 (Goltone, Harbros).  
 Wood, wire, screws, wander plugs, Hex  
**Cabinet** (Byldurone)  
 (Apollo, Camco, Clarion, Digby, Kabilok, Peto-Scott, Pickett, Smiths, Woodcrafts)  
 (Panel measures 7in. x 18in. and the baseboard 18in. x 10in.)  
 Valves: H.F., Cossor 220 V.S.G.; Detector, Cossor 210 H.F.; Output, Cossor 220 P.  
 Alternatives for detector stage: Cossor 210 det., Mazda H.L.2, Marconi L2B or H.L.2, Osram H.L.2, Mullard P.M.1H.L. or P.M.2D.X. High-frequency and detector valves should be metallised.  
 Alternatives for output stage: Cossor 230 X.P., Mazda P220 or P220A., Marconi L.P.2 or P2 or P2/B, Osram L.P.2 or P2, Mullard P.M.2A, P.M.202, or P.M.2.

**NEWS FROM THE CLUBS.****Question and Answer.**

MEMBERS' night with the Slade Radio Society (Birmingham) grows increasingly popular. On the last occasion of this kind many interesting questions were raised, and in each case a satisfactory answer was arrived at. The answers were of general interest, and many problems were solved. All in difficulties with their wireless sets are strongly urged to join the membership of the Society, particulars of which may be obtained from the Hon. Secretary, 110, Hillaries Road, Gravelly Hill, Birmingham.

**Visiting a Regional Station.**

A VISIT to Brookman's Park broadcasting station has been an interesting feature of the programme of the Battersea and District Radio Society. Members made the journey to Brookmans Park and inspected the transmitters on Saturday, February 6th.

"Tungar Rectifiers" were dealt with in a lantern lecture by Mr. A. P. Hill, of the Edison Swan Electric Co., Ltd., at a recent meeting. Hon. Secretary: Mr. S. F. Harris, 13A, Winstead Street, Battersea, S.W.11.

**Lectures for All.**

MEMBERS of the advanced section of the Bee Radio Society profited by an informative talk on "Square Peaks," given by Mr. K. Higginson, on behalf of Messrs. Varley, at a recent meeting.

The lecturer gave a critical review of the three types of band-pass tuning, and during the course of the evening displayed a number of lantern slides showing the coil-winding shops and some of the numerous Varley products.

To non-technical members Mr. Millen, of the Mullard Wireless Service Co., Ltd., recently gave a lecture demonstration on "Good Quality Reproduction."

Hon. Secretary: Mr. A. L. Odell, 9, Westway, Grand Drive, Raynes Park, S.W.20.

**The Year in Huddersfield.**

NEW and better accommodation for members has been obtained by the Huddersfield Radio Society nearer the centre of the town, and, according to an announcement by the Hon. Secretary at the sixth annual general meeting on March 7th, the Society will "move in" before the next session begins. The Society's membership roll is in a highly satisfactory state, and comment was made at the meeting on the willingness with which members come forward to give lectures.

Mr. E. G. Whitfield has been elected Secretary with Mr. C. R. Napier as Treasurer.

The Hon. Secretary's address is Ribber, Gledholt Road, Huddersfield.

**Band Pass Explained.**

A HIGHLY appreciative gathering of members of the Bristol and District Radio and Television Society recently listened with deep interest to Mr. K. Higginson, of "Varley," lecturing on Band-pass Tuning. He outlined the history of tuning up to the present with its demand of selectivity and quality, and showed how it was possible to combine the two without undue sacrifice of fidelity of reproduction. A demonstration of the Varley all-mains receiver and pick-up followed.

Hon. Secretary: Mr. G. E. Benskin, 12, Maurice Road, St. Andrew's Park, Bristol.

**Problems Solved.**

THE South Croydon and District Radio Society has inaugurated a Questions Night, when members bring their problems and find speedy solutions. At a recent meeting questions ranged in scope from Smoothing Chokes to Detector Damping. Meetings of this kind are of special value to amateurs experiencing trouble with their receivers.

Hon. Secretary: Mr. L. L. Cumbers, 14, Campden Road, South Croydon.

**Rotary Transformers.**

MR. R. H. WOODALL, of Rotax, Ltd., recently lectured on "The Design and Use of Rotary Transformers for Radio Purposes," before the Newcastle-upon-Tyne Radio Society. With the aid of lantern slides the lecturer explained very clearly the principles underlying the design of M-L machines, and showed how much care is taken in securing an output free from ripple. A large range of machines of varied watts output was on view and among the exhibits of special interest were the ultralight specimens for use on aircraft.

The Hon. Secretary is Mr. W. W. Pope, 9, Kimberley Gardens, Jesmond, Newcastle.

**Demonstrating the Stenode.**

ONE of the latest type of Stenode receiver was demonstrated by Mr. E. L. Gardiner, B.Sc., at a recent meeting of the Golders Green and Hendon Radio Scientific Society. The lecturer dealt with the experimental work carried out with the Stenode. With the aid of lantern slides he exhibited a full range of curves of the set's performance. The selectivity of the instrument was well demonstrated at the conclusion of the lecture.

Hon. Secretary: Mr. W. A. Hudson, 638, Finchley Road, N.W.11.

**Records in the Making.**

"MAKING a Gramophone Record," a talk by Captain B. S. Take, recently provided an entertaining evening for members of the Sunbury and District Radio Society. The lecturer was able to draw upon many years' experience in the practical side of gramophone manufacture, and his personal reminiscences proved amusing as well as instructive.

New members are urgently needed, and all interested are asked to communicate with the Hon. Secretary: Mr. F. W. Diamond, 21, Rooksmead Road, Sunbury, Middlesex.



# COSSOR

## EFFICIENCY and CONSISTENCY

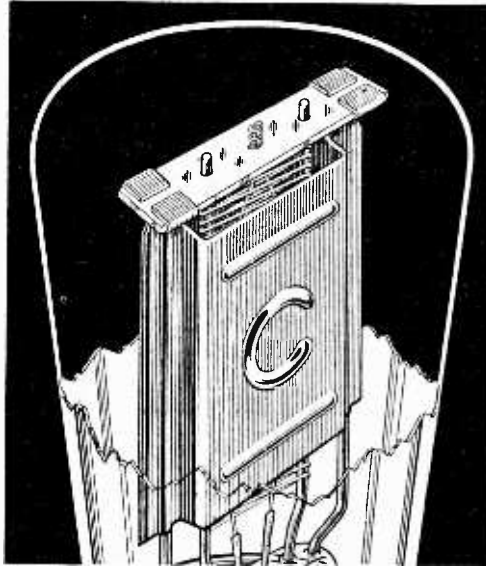

# NOW COST LESS!

**COSSOR VALVES FOR THE 'W.W.' SET DESCRIBED IN THIS ISSUE**  
 "BATTERY V-M 3"

\*220 V.S.G.      \*210 H.F.      220 P.  
 (or 230 XP.)  
 \*Metallised.



**FREE!** Send for a copy of the most complete Valve Catalogue — 72 pages of curves, characteristics and technical data. Ask for Booklet B14 and mention "Wireless World" when applying.

THERE is now an additional reason for replacing your out-of-date valves with the appropriate Cossor types—you can do so at less cost. And it is a step well worth taking. The development of the Cossor Mica Bridge system of construction ensures a much higher standard of valve efficiency — improved performance and a re-

markable degree of consistency. Remember that the Mica Bridge permits microscopic accuracy in the assembly of the electrodes which are rigidly secured in permanent alignment. Variation is impossible. It follows therefore that every valve is true to type, fulfilling, completely, the function for which it was designed.

## ALL THE ADVANTAGES OF MICA BRIDGE CONSTRUCTION FOR A SMALLER OUTLAY

A. C. Cossor Ltd., Highbury Grove, London, N. 5. Depots at Birmingham, Bristol, Glasgow, Leeds, Liverpool, Manchester, Newcastle, Sheffield and Dublin

55 ♥ 223

89 Advertisements for "The Wireless World" are only accepted from firms we believe to be thoroughly reliable.

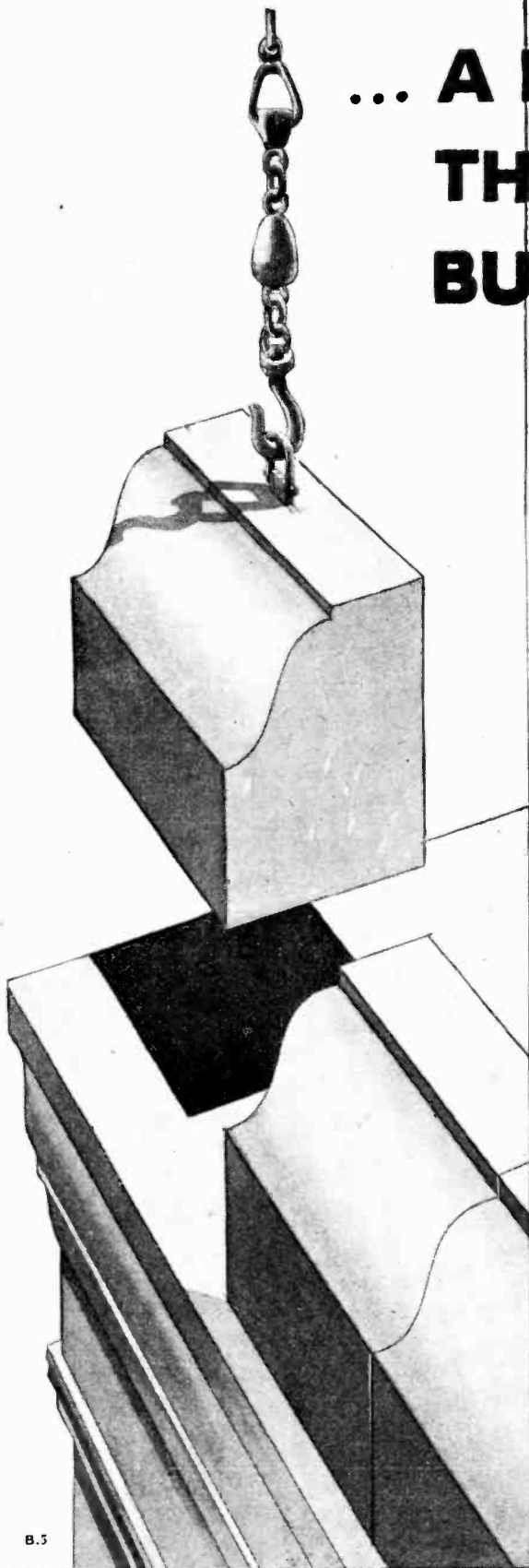

... **A REPUTATION  
THAT HAS BEEN  
BUILT UP ON  
QUALITY**

Radio is relentless in its demands. It has no use for makeshift, no time for "second best." Its every accessory must be as near perfection as human ingenuity can make it, and there is no court of appeal for the component that has been found wanting.

It is because the products of Dubilier have **never** failed that they hold such a proud place in radio to-day. They have built up their reputation on quality that has never faltered and that has marched in time with every step of progress. Let that reputation guide you in your choice of radio components.

**DUBILIER**  
CONDENSERS

B.5

DUBILIER CONDENSER CO. (1925) LTD., Ducon Works, Victoria Rd., N. Acton, London, W.3

*Mention of "The Wireless World," when writing to advertisers, will ensure prompt attention.*

B10

# UNBIASED

## BY FREE GRID

### *Inside or Outside?*

A WELL-KNOWN radio doctor to whom I was talking the other day mentioned that in the course of his business he had found that a repeated cause of failure to receive signals was the fact that home constructors would persist in making connection to the anode terminal of modern S.G. valves by means of ordinary flex; the result was that, more often than not, a loose strand made contact with the metallised coating of the valve, and naturally caused a cessation of all signals, the valve anode being effectively earthed; much grist, he said, had been brought to his mill in clearing this simple fault which had worried many of his "patients."

In spite of his protests, I sought out an acquaintance in the Technical Department of a well-known firm of valve makers, and suggested that members of the B.V.A. might prevent this trouble by metal-spraying the *inside* of the glass envelopes of their valves before the electrodes were put in. Apart from the safeguarding benefit to which I have just referred, metallised valves would preserve their pristine freshness of appearance and not look so disreputably dirty as they do nowadays after you have yanked them in and out of an experimental set a few times before washing the soldering flux off your hands. I reminded my friend that electric-lamp makers had already benefited us in the latter respect by etching the inside of the glass envelopes of their products instead of frosting the outside, thus giving us the cleanly pearl lamp.

He told me, however, that the two cases were in no way parallel, and advised me—probably quite rightly—not to talk through my hat. But, at the same time, I could not help observing that he wandered off in the general direction of Chancery Lane in a thoughtful mood, and, although I did not follow him to see whether he was making for the Carey Street or the Patent Office end of it, I can scarcely imagine anyone

concerned with the making of valves having any legitimate business in Carey Street.

### *The Buzz Brigade.*

IT seems that no sooner have I succeeded in tracking down and earthing one kind of pest than I am confronted with another. It may be remembered that quite recently I was bedevilled by a pestilential child and the offensive noises from his wretched electric train, a matter which I was eventually able to put right by following the advice of a kind-hearted reader. Needless to say, I did not lower my prestige among my neighbours by admitting that the idea was not my own; hence it was that one of them recommended me to a friend in one of London's super-selective suburbs as being a suitable person to nose out the source of a mysterious form of interference which manifested itself on two evenings a week.



A little Sherlock Holmes stuff.

I discovered that the trouble was slow-speed morse conveying messages of a very trivial character, and that all the people affected by it dwelt in a very circumscribed area, the centre of which was the local "village" hall. Furnished with this data, it required very little of the Sherlock Holmes stuff on my part to find out that the local Bad Boys' Brigade had recently embarked on a course of morse instruction, and it was the "spark transmission" generated by practice buzzers at their bi-weekly meetings which caused all the rumpus.

A formal protest was made, and technical advice tendered, regarding the provision of a shunt across the "make-and-break" to stop the radiation; but the only result has been that, the misguided youths being thus presented gratis with the information that their signals were "getting out" over a radius of a few yards, even without aerial and earth, promptly conceived the idea of acquiring buzzers of their own and connecting an aerial and earth across the "make-and-break" in order to communicate among themselves by wireless. The outcome of this is that the area of interference has been increased from yards to miles, and, owing to the sensitivity of modern valve receivers, the whole district is up in arms about it.

At present, therefore, the matter must await the attention of the P.M.G., with whom a formal complaint is to be lodged.

### *The Call of the Tom-tom.*

I READ with much surprise the other day of the very comforting pay-envelope which the B.B.C. Cashier will be handing out periodically to the newly-appointed Director of dance music. I am rather wondering, however, what the Mus.Doc. who has charge of the B.B.C.'s non-negroid musical activities thinks about it. Now, I am no highbrow; on the contrary. I have always believed that too much chamber music was the reason for the charming little bit of javelin play with which a certain biblical potentate rewarded the efforts of his court musician.

At the same time, I have sufficient respect for the classics to believe that a man who can well and truly wield the baton at the Queen's Hall is worthy of greater financial reward than the most accomplished West African tom-tomist who ever beat a merry tattoo on a missionary's skin. It would not surprise me at all to find the learned doctor joining the end of the procession of eminent musicians who are wending their way to the Gold Coast to take an intensive course at the school recently set up by the chief of the N'Gombi for the benefit of European mæstri who desire to earn really big money.

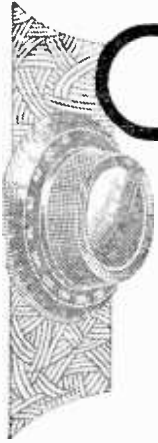

# One Knob Control for Superheterodynes

## A Simple Explanation of the Tracking or Padding Condenser.

By A. L. M. SOWERBY, M.Sc.

**I**N the last few years we have seen the single-stage high-frequency amplifier, with each stage separately tuned, slowly giving way to the more convenient arrangement in which all the tuning condensers are controlled by a single knob, rotating together as one unit.

For the simultaneous tuning of all the various stages to be satisfactory three conditions have to be fulfilled. Of these conditions the first and most evident is that, whatever the setting of the dial, all the various tuning condensers must have identically the same capacity as one another. Next, the inductance of all the tuning coils in the set must be exactly the same.

It might seem that with these conditions satisfied all circuits would automatically tune together without the need for any individual adjustments. They would, if the tuning condensers were the sole sources of capacity present in the receiver. In addition, however, there are the capacities due to the various components—the valves, the valve-holders, capacities due to leads passing near earthed points, and further capacities of coils and other components to the metal screening. All the accidental and unintentional additions to the capacity of the tuning condenser are included in the vague but convenient term “stray capacity,” often abbreviated to “strays.” It will be seen that from the very nature of these strays there can be no guarantee whatever that they will attain the same value in all the tuned circuits.

Since the stray capacities do not vary in amount as the set is tuned from one wavelength to another, the total capacity in the tuned circuit with the highest strays is always the same amount greater than the total capacity in, say, the circuit where the strays are smallest. Provided that the coils and tuning condensers were matched before the set was built it is only necessary, by some artificial means, to increase the natural strays in all the tuned circuits until they have the same value as in the circuit in which they were already

greatest. Small auxiliary variable condensers of the pre-set type, known as “trimmers,” are usually employed for this purpose.

The range of wavelengths covered by a tuned circuit depends solely upon the ratio borne by the total capacity reached with the tuning condenser set at maximum to the total capacity, including strays, when the condenser is set at minimum. If, for example, the maximum capacity of the condenser is 0.0005 mfd., or  $500 \mu\mu\text{F.}$ <sup>1</sup> and the minimum is 0.00002 mfd., or  $20 \mu\mu\text{F.}$ <sup>1</sup> while the stray capacities, which are additional to that of the tuning condenser, amount to  $50 \mu\mu\text{F.}$ , then the total tuning capacity varies from 70 up to  $550 \mu\mu\text{F.}$ , giving a ratio of 7.85 to 1. The ratio of highest to lowest wavelength will be the square root of 7.85, which is 2.8. By suitable choice of coils the set may be made to cover any range of wavelengths in which the highest and the lowest stand in this ratio.

### Capacities Determine the Waverange.

With coils of high inductance, for example, the set might perhaps tune from 1,000 to 2,800 metres, or from 10,000 to 28,000 if the coils were bigger still. Coils of low inductance would enable the range 100 to 280 metres to be covered, while normal medium-wave coils might run from 200 to 560 metres (160 microhenrys) or from 214 to 600 if the inductance were 185 microhenrys. The point that it is desired to emphasise is that the ratio of maximum to minimum capacity fixes the ratio of highest to lowest wavelength, while suitable choice of inductance for the coils will locate the band of wavelengths that the set will cover in any desired part of the frequency-spectrum.

In ganging a superheterodyne the considerations just discussed all have to be taken into account in obtaining satisfactory matching between the various circuits tuned

<sup>1</sup> .0001 mfd. =  $100 \mu\mu\text{F.}$ , or  $1 \mu\mu\text{F.} = .000001 \text{ mfd.}$

**One Knob Control for Superheterodynes.—**

to the frequency of the incoming signal. In addition a fresh problem peculiar to the superheterodyne makes its appearance when we try to gang the oscillator-circuit in with the rest.

The difficulty here is that the oscillator does not have to be tuned to the frequency of the signal, but to a frequency differing from it by the frequency to which the intermediate amplifier is tuned. If, for example, we wish to receive a signal on 1,000 kilocycles (300 metres), and if our intermediate amplifier is tuned to 110 kc., it is necessary to tune the oscillator either to 1,110 or 890 kc. — to a frequency, that is, 110 kc. away from that of the signal on one side or the other.

It is clear that if the set is to be ganged we shall have to make up our minds whether the oscillator is to be tuned to a higher or lower frequency than the signal, and then stick to our decision for all points on the wave-range. Higher or lower—which is it to be?

If the set covers a range of 200 to 600 metres, which is 1,500 to 500 kilocycles, the oscillator, if lower in frequency, will have to run from 1,390 to 390 kc. The highest frequency will then be 3.56 times the lowest, so that the maximum tuning capacity will have to be 3.56 squared, or 12.7 times the minimum. If, as suggested, the tuning condenser itself goes from a minimum of 20 to a maximum of 500  $\mu\mu\text{F.}$ , the total strays must not exceed 21  $\mu\mu\text{F.}$  if this wide range is to be covered. With any reasonably convenient form of construction, so low a value of stray capacity simply cannot be reached.

Let us try, then, tuning the oscillator to a frequency higher than that of the signal. The range to be covered will now be 1,610 to 610 kilocycles. Here the highest frequency is only 2.64 times the lowest, so that the capacity range needs only to be 7 to 1, or a shade less. With the same maximum and minimum capacities for the tuning condenser, the strays may now rise to just over 60  $\mu\mu\text{F.}$ , which is a value very readily attained.

It is clear, therefore, that we shall have to gang the superheterodyne with the oscillator tuned always to a frequency 110 kc. above, and not below, that of the signal.

The figures that we have just found offer a rather fascinating possibility. Why not increase the minimum

capacity to give the range of wavelengths that we require (the highest 2.64 times the lowest) and then adjust the inductance of the oscillator-coil so that the circuit tunes, both at the top and at the bottom of the tuning-range, to the exact wavelength required? The arrangement for this is shown, in its simplest form, in Fig. 1, where (a) represents a circuit (there may be several of them) tuned to the signal, and (b) the circuit of the oscillator.

**A Simple but Unattractive Scheme.**

In each case C denotes the variable condenser, which is supposed, since each is really a section of a multiple-gang condenser, to have the same capacity in each circuit.  $C_1$  brings up the minimum capacity in the oscillator circuit so as to reduce the wave-range to the desired extent, while the coils will have, of course, different inductance values.

At the top and the bottom of the wave-range the ganging is correct—invariably, because we have made it so. But between these points, what happens? Curve A of Fig. 2 shows the frequency to which the signal-circuit (a, of Fig. 1) tunes for each setting of the dial. It is a straight line because the assumption has been made in drawing this curve that a straight-line-frequency condenser is to be used. Curve B shows the frequency to which we require the oscillator to tune at each setting; since this is always 110 kc. above the frequency of the signal, B is also a straight line.

Unfortunately C, which shows the frequencies attained by the circuit of Fig. 1 (b) is not by any means a straight line. The ends coincide with the line B, for the very good reason that we have put them there, but over the

rest of the tuning range C diverges quite widely from B. As indicated, the frequency difference between A and C, instead of remaining constant at 110 kc. as we had hoped, increases as we leave the ends until, at the middle of the range, it has risen to 155 kc. or thereabouts. This means an error of 45 kc. in our ganging, so that when the signal-frequency circuits are tuned to the required station the oscillator will be tuned for the next station but four.

The circuit of Fig. 1, therefore, will not work, though it is clear that by a small alteration in the shape

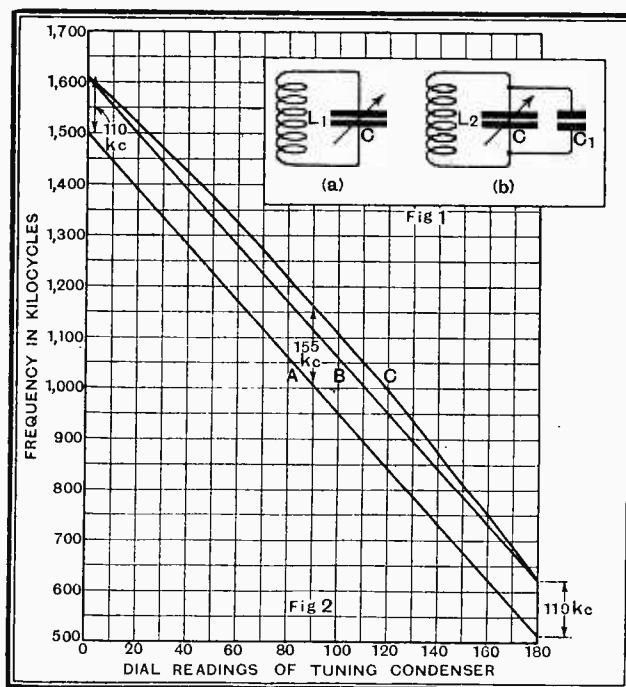

Fig. 1.—(a) Represents a coil tuned by a variable condenser to the frequency of the signal to be received. (b) Shows the oscillator circuit, in which the waverange has been reduced to the correct extent by the fixed condenser  $C_1$ .  $L_2$  then being chosen to gang the oscillator at highest and lowest frequencies. Fig. 2.—Attempted ganging by the circuits of Fig. 1. (A) is signal frequency, (B) required oscillator frequency and (C) oscillator frequency actually obtained.

**One Knob Control for Superheterodynes.** —

of the vanes of the oscillator condenser, leaving the other tuned circuits untouched, Curve C could be altered into the straight line B. This is quite a practical solution of the problem, although it is still necessary to make special arrangements for the long wave-band. A special gang condenser, however, may not always be convenient.

We have learnt from Fig. 2 that if we contract the tuning range of the oscillator circuit by increasing the minimum capacity we do not get satisfactory ganging. What about cutting things down at the other end, and contracting the tuning range by decreasing the maximum capacity? Fig. 3 shows how this can be done, putting in series with the oscillator tuning condenser a fixed condenser to bring the total tuning range down to an extent such that, as before, correct choice of inductance for this circuit will make it tune to the required frequency at the ends of the range. The fixed condenser required for this will have a capacity round about 800  $\mu\mu\text{F}$ . (0.0008 mfd.).

**Adding Series and Parallel Capacity.**

Fig. 4 shows how this scheme pans out in practice, curves A and B being the same as those of Fig. 2, while C shows the tuning curve of the circuit of Fig. 3 (b). Once again C curves away from B, the frequency-difference between signal circuits and oscillator circuit being correct, as before, for the ends of the range, but dropping from the desired 110 kc. to

only 44 kc. in the middle of the tuning range. Once again, therefore, we have failed to find a method of ganging all tuned circuits which is entirely satisfactory.

Comparison of Figs. 2 and 4, however, shows that the two curves C depart in opposite directions from the straight line B which we were hoping to reproduce. If, instead of restricting the tuning range of the oscillator

Fig. 5.—(a) Has the same meaning as Fig. 1 (a). In (b) the waverange is contracted by a combination of methods used in Fig 1 and Fig. 3.

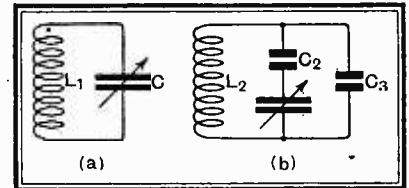

circuit entirely by increasing the minimum capacity (Fig. 2) or entirely by decreasing the maximum capacity (Fig. 4), we were to make a judicious combination of the two, we might get something between the two C curves, and this something might be, if not exactly a straight line, at least so near it that discrepancies would pass unnoticed in practice. The circuit that we should then want for the oscillator is shown in Fig. 5 (b), the variable condenser C having, at every wavelength, the same capacity as its companion C of Fig. 5 (a), which shows the signal-frequency circuit.

The calculation of the best values for  $C_2$  and  $C_3$ , together with the corresponding value of  $L_2$ , is rather too complicated a matter to be dealt with here, but can be found elsewhere<sup>2</sup> by those who are interested. Correct values for one particular case are given here, together with figures showing the deviations from perfection of the finished receiver.

It is assumed that the coils used to tune to the signal frequency ( $L_1$  in Fig. 5) have an inductance of 180 microhenrys, and that the intermediate amplifier is tuned to 110 kilocycles. The following values are then required:

- $C_2 = 0.002246$  mfd.
- $L_2 = 144.05$  microhenrys.
- $C_3 = 48.25\mu\mu\text{F}$ .

In reckoning  $C_3$ , it is assumed that each section of the tuning condenser has a minimum capacity of 20  $\mu\mu\text{F}$ .;  $C_3$  then includes all other strays there may be. The total strays in the signal-frequency circuits will be adjusted to 42.5  $\mu\mu\text{F}$ . if the minimum wavelength of the receiver is 200 metres.

The divergences from correct ganging given by the circuits of Figs. 1 and 3 were shown by plotting frequency against dial reading, and showing that the actual curve departed from the ideal straight line. The errors remaining when the correct choice of ganging constants has been made are far too small to be visible on a diagram drawn in this way, for the biggest error occurring at any point is less than 2½ kilocycles. The discrepancies will therefore have to be shown in some way that shall magnify them up tremendously.

In Fig. 6 is plotted the difference between the frequencies to which the two circuits are tuned. Perfect

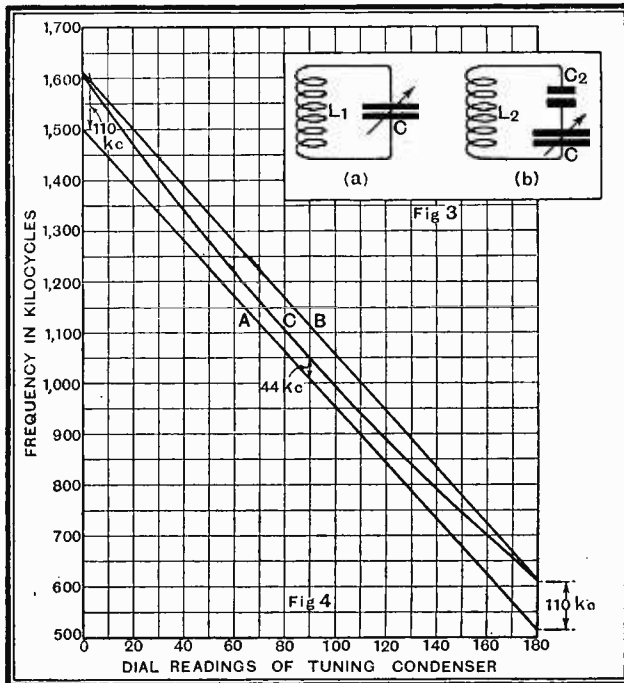

Fig. 3.—(a) Has the same meaning as Fig. 1 (a). In (b) the waverange is contracted to the correct extent by putting  $C_2$  in series with C :  $L_2$  is then chosen to gang the oscillator at highest and lowest frequencies. Fig 4.—Attempted ganging by the circuits of Fig. 3, where (A) is the signal frequency, (B) the required oscillator frequency and (C) oscillator frequency actually obtained.

<sup>2</sup> The Wireless Engineer, February 1932, page 70.

**One Knob Control for Superheterodynes.** -

ganging would hold this constant at 110 kilocycles, thereby making a curve of these differences when plotted against dial readings come out as the horizontal straight line AB. If the bottom of the diagram corresponded to "0 kc." the curve of Fig. 6 would be almost indistinguishable from a straight line, but by including only a very small range of frequencies between the top and the bottom of the figure the errors have been magnified up to give the rather wiggly curve shown.

**Error—One Quarter of a Degree.**

If we convert the errors of Fig. 6 into terms of dial readings the greatest errors are equivalent to mistuning the set by about one-quarter of a degree (100-degree scale) at the shortest wavelengths, where tuning is naturally flattest; or one-tenth of a degree at the longest wavelengths, where tuning is sharpest. Since it is very exceptional to find a set in which ganging does not, in any case, suffer from errors greater than these, one may regard the curve of Fig. 6 as a horizontal straight line for all practical purposes.

It might be thought that in a superheterodyne, where the tuning is so much sharper than in a set of more usual design, the ganging would have to be exceptionally accurate. Admittedly, the intermediate amplifier is usually so sharply tuned that if the oscillator is not set to exactly the right frequency to beat with the incoming signal the resulting distortion is evident. In consequence, the oscillator always is correctly set, leaving the signal-frequency circuits to bear the brunt of any errors there may be in the ganging. In practice, therefore, the circuits tuned to the signal itself will be mistuned from the signal by the amount shown for each point of the tuning dial on the curve of Fig. 6.

In determining the loss of signal strength due to this slight detuning of the circuits normally tuned to the incoming signal we have to remember that it is not the actual number of kilocycles that counts, but the percentage distuning—that is to say, the error divided

by the frequency of the signal.<sup>3</sup> In Fig. 7 the percentage distuning of the signal-frequency circuits of a superheterodyne using the inductance and condenser values given are plotted against frequency. It will be seen that the distuning varies from zero to 0.17 per cent. at different parts of the tuning range, and that

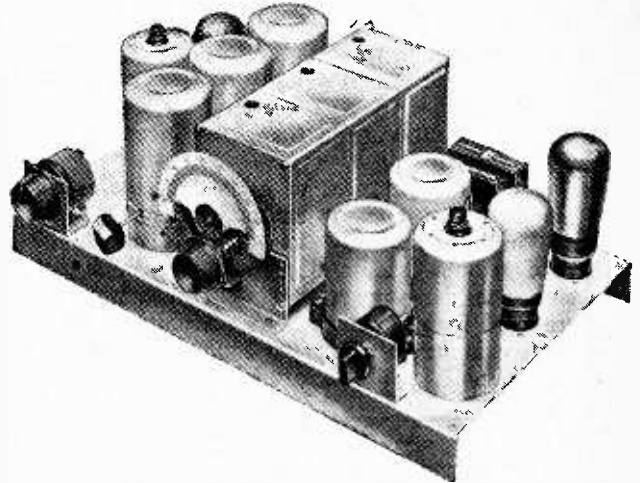

The Wireless World "Single-Dial Super.," in which a padding condenser was used to gang the oscillator.

sometimes the circuits are tuned slightly away from the signal on one side and sometimes on the other. It is specially to be noticed that the error is approximately the same at each of the four points of maximum error. Examination of Fig. 6 will show that the actual error in kilocycles is greater at the bottom end of the wave-range than at the top; this was arranged deliberately to make the percentage distuning approximately even.

The loss in signal strength resulting from this detuning will amount to about 6 per cent. if there are two tuned circuits of magnification 70 coupled in cascade (i.e., through a valve, and not as a band-pass filter). Since this is probably as unfavourable a case as is likely to arise in practice, the loss may be regarded as completely negligible.

In conclusion, it will be seen that a superheterodyne may have its oscillator ganged in with the signal-frequency circuits, while employing an ordinary gang condenser. The oscillator circuit is tuned by one of the sections of a standard multi-gang condenser, the other sections of which tune the remaining circuits. The law of the oscillator section is made different from that of the others by connecting one fixed condenser in series with it to restrict the maximum capacity attained, together with a second fixed condenser in parallel with the whole to prevent the minimum capacity from being too low. The coil, the inductance of which must be carefully calculated, has fewer turns than the others used in the set, but has no other special features. In particular, it is to be noticed that if the suggested method of

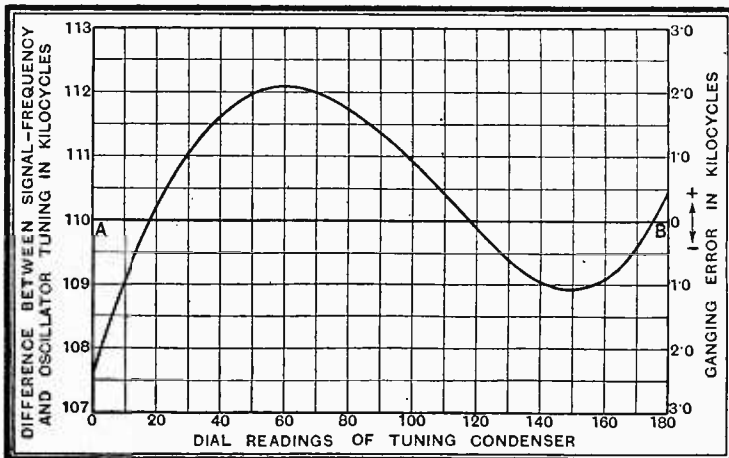

Fig. 6.—Ganging errors in a correctly ganged superheterodyne. The horizontal line AB at 110 k.c. shows the curve that perfect ganging would give.

<sup>3</sup> "Selectivity in Plain Terms," by Beatty, *The Wireless World*, October 19th, 1929, page 435.

**One Knob Control for Superheterodynes.—**

ganging is correctly carried out there is absolutely no need to adjust the law of the oscillator condenser by bending the vanes; to do so would throw the set entirely out of gang, for it is an essential part of the system that this section should be in all respects identical with the others. It does not matter in the least whether the condensers have straight-line frequency, straight-line wavelength, or logarithmic law; nothing is assumed except identity between sections.

**Tracking versus Shaped Plates.**

The practical adjustment of a receiver built on the lines suggested is a very simple matter, though it needs to be systematically done if it is not to be a matter of tedious trial and error. The three points at which the ganging error should theoretically be zero are used for the process. A wavemeter, or oscillating valve is tuned to 1,400 kc., and the signal-frequency circuits of the set are brought into resonance

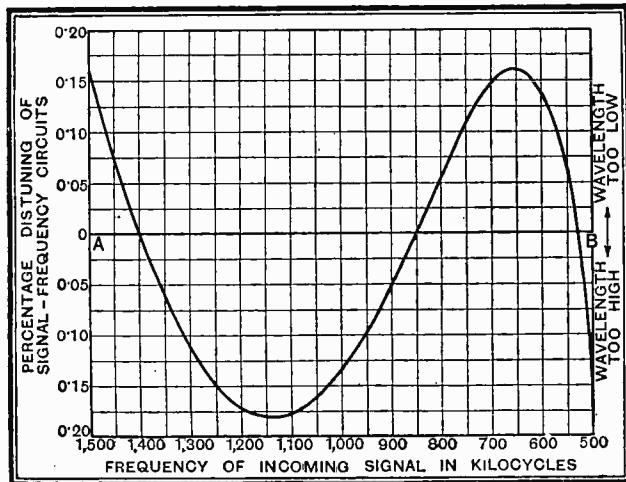

Fig. 7.—Percentage distorting of signal-frequency circuits owing to ganging errors. Note that the maximum error is less than one-fifth of one per cent, and that the error is approximately the same at 1,500, 1,140, 660 and 500 kilocycles.

with it. The oscillator is then pulled into tune by adjusting  $C_3$ . The process is repeated on a frequency of 540 kc., with the difference that the oscillator is tuned this time by adjustment of the preset condenser  $C_2$ , which needs to be of the preset type. There should now be no ganging error at 850 kc.; if a check shows that a slight error exists the inductance of  $L_2$  is altered slightly by adding or removing a turn, and the process of ganging and checking is repeated until perfection is reached.

It must not be thought that the method discussed is the only way in which a superheterodyne can be ganged. The use of an oscillator-condenser with specially shaped vanes is another, and perhaps a better, alternative. Its sole disadvantage is that one has to accept the intermediate frequency and other circuit constants adopted by the condenser makers for their calculations, and may not have ideas of one's own.

**Resonances in Loud Speaker Diaphragms.**

IN a recent paper before the Physical Society, Dr. N. W. McLachlan described a series of experiments conducted on cones of various materials in order to ascertain their frequencies of vibration. Where discs and cylindrical shells are concerned, the vibrational frequencies can be calculated by means of well-known mathematical formulæ. The conical shell is a very difficult thing to deal with mathematically, and, as Dr. McLachlan explained, it was necessary to treat the problem experimentally, since no mathematical formula was available which could be used for general purposes. However, in his researches, he had discovered a formula which was useful in calculations of loud speaker diaphragms. As this formula may be serviceable, it is now given:—

$$f = \frac{1}{2\pi\alpha} \tan\theta \sqrt{\frac{E}{P}}$$

where  $\alpha$  is the radius at the base.  $\tan\theta$  is the tangent of half the angle at the vertex and  $\sqrt{\frac{E}{P}} = v$  is the velocity of sound in a uniform bar of the material of which the cone is made.

For a paper cone (see *The Wireless World*, August 12th, 1931)  $\sqrt{\frac{E}{P}} = v$  is  $1.7 \times 10^5$  cm. per sec.: if  $\alpha = 12$  cm. and  $\theta = 90^\circ$ , then  $\tan\theta = 1$ , so that the frequency is  $f = \frac{1.7 \times 10^5}{2\pi \times 12} = 2,300 \sim$ .

This agrees with the experimental value when the cone is driven by a coil weighing about 8 gm. As the mass of the coil is reduced the vibrational frequency rises, and without any coil it is about 3,200 cycles, so that the formula must be used with discretion.

In the experiments with thick glass and thick aluminium cones very sharp peaks separated by deep valleys were obtained. In one case the resonances were of a knife-edge variety. As the material was reduced in thickness and density the resonances were less peaky, owing to the greater effect of the air damping due to sound radiation. There was a great difference between the resonances of discs and cones. Whereas the resonances of the former were separated by wide frequency intervals, those of the latter occurred in a cluster. The cluster formation was of great utility in loud speaker design, since it tended to uniformity of output.

The influence of the mass of the coil in loud speaker diaphragms was shown very clearly by means of two air-pressure curves. One for a heavy coil of 7.8 gm. had quite a peaked appearance, whilst another for the same diaphragm with a 2.7 gm. coil had a fairly broad, flat top without any peaks. Dr. McLachlan said that in the first case the upper register was weak, whilst in the second it was a little too powerful, and a coil mass between 3.3 and 4.5 gm. was recommended. This, however, depended upon the size of the diaphragm and the transformer leakage.

Curves were given indicating the variation in the main resonance frequency of the cone when the radius of the base is kept constant and the apical angle gradually decreased to 30 degrees. Starting from the paper disc stage, where  $f$  is very small, it steadily increased with the angle to 90 degrees, after which it decreased very slowly. It appeared that angles between 110 degrees and 90 degrees gave the best results for loud speaker work. For angles larger than 110 degrees the resonance frequencies were too low, whilst for angles less than 90 degrees the resonances were too peaked. Also, there was too much focusing of the sound at higher frequencies, and the cone got longer and heavier, which reduced the output.

Curves of the air column vibrations within the cone were exhibited for glass, aluminium, and paper cones. For thick glass and aluminium such resonances were negligible, but with a light paper cone they were of importance. With a 90 degree cone 12 cm. radius the main air-column resonance occurred about 900  $\sim$ .

Lastly, it was shown that so far paper was the best material tested for loud speaker purposes. With aluminium or glass the resonance occurred at much too high a frequency, and was too sharp, whereas with paper the lower density and the greater transmission losses gave a greater range of uniformity of output in the upper register.



# Broadcast Brevities.

By Our Special Correspondent.

## Falkirk Testing.

LAST week certain preliminary tests were begun with the Regional transmitter at Falkirk, and on the results will depend the choice of date for the first public tests after regular broadcasting hours. It is expected that this will be in three or four weeks' time.

The aerial is not yet erected, so don't waste time trying to tune in!

## The Mystery Van.

Meanwhile the sight of the B.B.C.'s mobile transmitter cruising around the Droitwich district is said to be causing a rush on the Post Offices by honest folk in quest of receiving licences. Several spots have been tested, but there being no real hurry, the experiments are proceeding in a very leisurely fashion.

5XX and Midland Regional will remain at Daventry for at least a year after the Empire station has been installed.

## Closing Down.

SIR JOHN REITII'S version of the "Ceremony of the Keys" is to be enacted on Saturday, April 30th, when the "D.G." in the company of a select little band of officials, will formally lock the door of No. 2 Savoy Hill and hand over the key to the landlord.

This dramatic situation loses some of its force because work must continue at Savoy Hill for several weeks after Sir John is comfortably ensconced in his new quarters at Portland Place.

## The Warehouse Studio.

The majority of the office staff will have transferred by the end of April, but the bulk of the programmes will still be going forth from the old building.

"And how long will the warehouse studio remain in use?" asks a reader. The correct answer seems to be that no one knows.

## The Best?

Until the large studio at Broadcasting House passes all tests, the B.B.C. will be in no hurry to part with what is undoubtedly their best studio for large orchestral concerts. The warehouse is rented on a monthly basis, and the only obstacle to its remaining perpetually in the hands of the B.B.C. is the fact that the London County Council will probably require the site sooner or later in connection with new building schemes.

## Sir Thomas Beecham.

The warehouse will certainly be retained until after May 20th, the date on which it will be used for a broadcast of Delius' "Romeo and Juliet" under the baton of Sir Thomas Beecham.

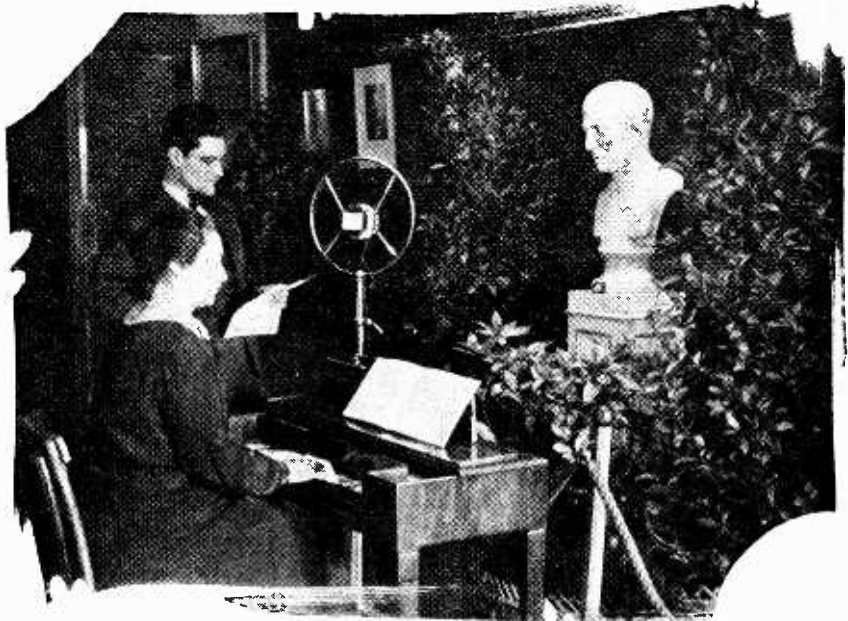

A MUSICAL BI-CENTENARY. To-morrow (Thursday) marks the 200th anniversary of the birth of Joseph Haydn, the famous Austrian composer. Our picture shows a rehearsal in progress for a commemorative broadcast from the Music Museum in Vienna.

## Jack Payne's Opinion.

The warehouse studio has never been a favourite with dance band leaders and conductors of small orchestras. Jack Payne was the first to broadcast from "No. 10"—as it is styled officially—and after his orchestra had played one tune he decided that the place was unsuitable. And now, eighteen months later, the results obtained with Hylton's band in the same studio have confirmed Jack Payne's original opinion.

## Unwanted Echo.

Henry Hall seems to be up against the same sort of difficulty at Broadcasting House. Studio 8a, in which the new B.B.C. band made its debut, has been specially designed for the Wireless Military Band; the echo is far too pronounced for dance band purposes, and Henry Hall and his players have found it necessary to crowd themselves into a corner to avoid unwanted syncopation effects.

## The Dance Band Filmed.

The Henry Hall film now going the rounds of the picture theatres is an excellent piece of showmanship. When I saw it last week I found myself wondering why there is not closer co-operation between the B.B.C. and the film industry. By means of a number of clever camera tricks we were shown far more than would be visible to an ordinary member of a studio audience.

Besides several impressive views (and auditions) of the band in action we were shown "close ups" of the boy oboist, the pianist, and that most fascinating person to watch, the xylophonist.

## Soaring Genius.

ON April 6th, Bach's magnificent Mass in B Minor will be broadcast as the nineteenth of this season's B.B.C.

Symphony Concerts. Dr. Adrian Boult will conduct, and the four vocalists will be Elsie Suddaby, Margaret Balfour, Frank Titterton and Keith Falkner. The B Minor is the only complete mass that Bach ever wrote, and its quality is summed up in the judgment expressed by Spitta when he said of it: "We feel as though the genius of the last two thousand years were soaring above our heads."

## A Poet in the Studio.

W. B. YEATS, the Irish poet, is to broadcast a reading from his own poems on Sunday evening, April 3rd. Listeners have on several occasions heard the poet speak over the microphone.

## A Shakespeare Festival.

AMERICAN listeners are reported to be showing the greatest interest in the B.B.C. plans for relaying the opening ceremony of the Shakespeare Memorial Theatre at Stratford-on-Avon, which is to be performed by the Prince of Wales on April 23rd, the anniversary of the poet's birth. The transmission will be relayed over the transatlantic telephone to the U.S. broadcasting networks, and will also, of course, go out from the Chelmsford short-wave station.

## The Prince of Wales.

The theatre ceremony will be preceded by a banquet at the Stratford-on-Avon Town Hall, and the speakers to be broadcast will probably include Mr. Ramsay MacDonald, Mr. Stanley Baldwin, and Sir Frank Benson. Relays from the banquet hall will commence at 1 p.m., and an hour later listeners will be taken over to the Memorial Theatre.

At 2.20 p.m. the Prince of Wales will deliver his inaugural speech from the balcony.

# DYNATRON

# Universal Radio Gramophone

Model U53 for  
A.C. or D.C.  
Operation.

THE choice of a suitable receiver is always a source of embarrassment to the D.C. mains user, for he is often afraid that a sudden change-over of his lighting supply to alternating current may render his set useless. It is interesting to find, therefore, a receiver which, merely by changing a small and inexpensive power unit, can be operated from either type of current, for such a set can never be put out of date by any change in the nature of the electric light supply.

A glance at the circuit will show that the heaters of the valves, which are all of the indirectly heated cathode type, are separately wired to a multi-way connector. For A.C. working, the insertion of the appropriate plug automatically connects all the heaters in parallel and to the mains transformer secondary; with D.C. mains, however, a different plug is used which connects the heaters in series with one another and with a suitable value resistance for dropping the mains voltage. The valves used are of the A.C. type, even for D.C. working, so that the results obtainable are independent of the supply.

Save for the use of a push-pull pentode output stage, the circuit appears to follow normal practice, and two H.F. stages precede the detector. One would be pleasantly disappointed if one expected only normal results, however, for the performance is distinctly above the average. The selectivity, in fact, is extraordinarily high for a set of this type, and is nearly as good as that of many superheterodynes. At a distance of only nine miles from Brookmans Park, for instance, it is possible to receive Algiers clear of



the London Regional; as the frequency separation is only 18 kc., this speaks volumes for the performance of the set.

### The Tuning Circuits.

This high selectivity is due more to careful design than to any inherent virtue of the circuit, and examination of the chassis shows that the tuning coils are of large diameter and wound with heavy gauge wire. The intrinsic selectivity of each circuit, therefore, is above normal; in order that advantage may be taken of this higher selectivity, however, it is necessary so to connect the coils in circuit that they are not damped, and it will be seen that the anode connections of the H.F. valves are tapped well down the tuned circuits.

In spite of the fact that the detector grid connection is also tapped down its tuned grid coil, the damping of this circuit is inevitably higher than that of the others. It is for this reason, therefore, that reaction is fitted, for by its use the unwanted damping can be removed when interference is present. The

input band-pass filter is of unconventional design, for its coupling is a combination of common inductance coupling and capacity coupling at the high potential ends of the circuits. Naturally, this does not give a constant band-width over the tuning range, but, in conjunction with the other tuned circuits, it gives an even more important property, an approximation to constant selectivity.

Each tuned circuit is individually screened; the detector valve, with its anode circuit filter and the radio-gramophone switch, is contained in another screening box, while the two H.F. chokes for the tuned grid couplings are not only of the astatic type, but are also completely screened. Each H.F. stage is thoroughly decoupled, and that the means taken to avoid instability

### FEATURES.

**General.**—Self-contained radio-gramophone with mains-energised moving-coil loud speaker and universal electric gramophone motor. Provision by means of detachable power units for operation from either A.C. or D.C. lighting mains.

**Circuit.**—Band-pass pre-selector followed by two tuned grid coupled variable- $\mu$  H.F. stages, and reaction from the power grid detector. Push-pull pentode output stage with adjustable tone control and 3 watts output; provision for external speaker.

**Controls.**—(1) Calibrated single tuning control with illuminated dial. (2) Differential reaction control. (3) Ganged volume control for radio and gramophone. (4) Single lever control of waveband switching and change-over from radio to gramophone. (5) Tone control fitted to rear of chassis.

**Price.**—Complete with one power unit, and in walnut console cabinet, £82.

**Makers.**—H. Hacker & Sons, Perfecta Works, Ray Lea Rd., Maidenhead.

### WELL-SCREENED FIVE-VALVE RECEIVER CHASSIS.

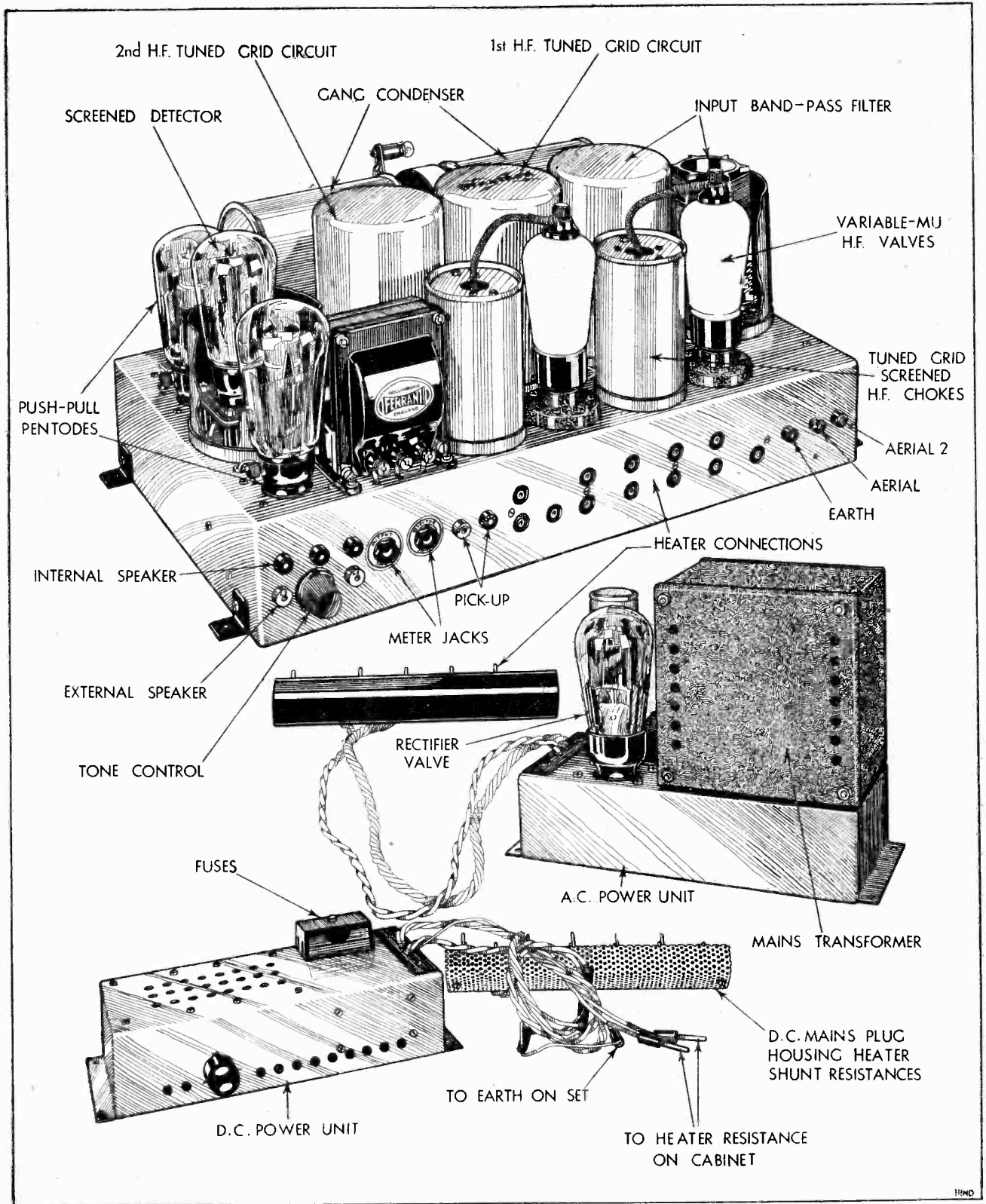

An unusual feature is the use of separate power units.

**Dynatron Universal Radio Gramophone.**— are effective is vouched for by the fact that a considerable degree of reaction is necessary to provoke self-oscillation.

As might be expected with variable-mu valves, the radio volume control takes the form of a potentiometer controlling their grid bias. A separate potentiometer is used for gramophone volume control, and it is ganged to the radio control so that both are operated by a single knob. Both on radio and

detector and the output valves, so that a milliammeter may be inserted as a check on the operating conditions and the state of the valves. The whole A.C. smoothing equipment is built into the chassis; three chokes are employed with the usual condensers, and are effective in eliminating mains hum. On D.C. two additional chokes are included in the power unit; a total of five chokes is used, therefore, and as might be expected, the set is as silent as on A.C.

speaker is mounted on a board of acoustically dead material.

The cabinet work is not only of pleasing appearance, but is very solidly constructed; it would be an improvement if the lid were made to open more widely, for if the set be used in a dark corner, the changing of records and needles is more difficult than it need be. On D.C. mains the voltage-dropping resistance for the valve heaters, which is mounted on the back of the cabinet, runs at a fairly high

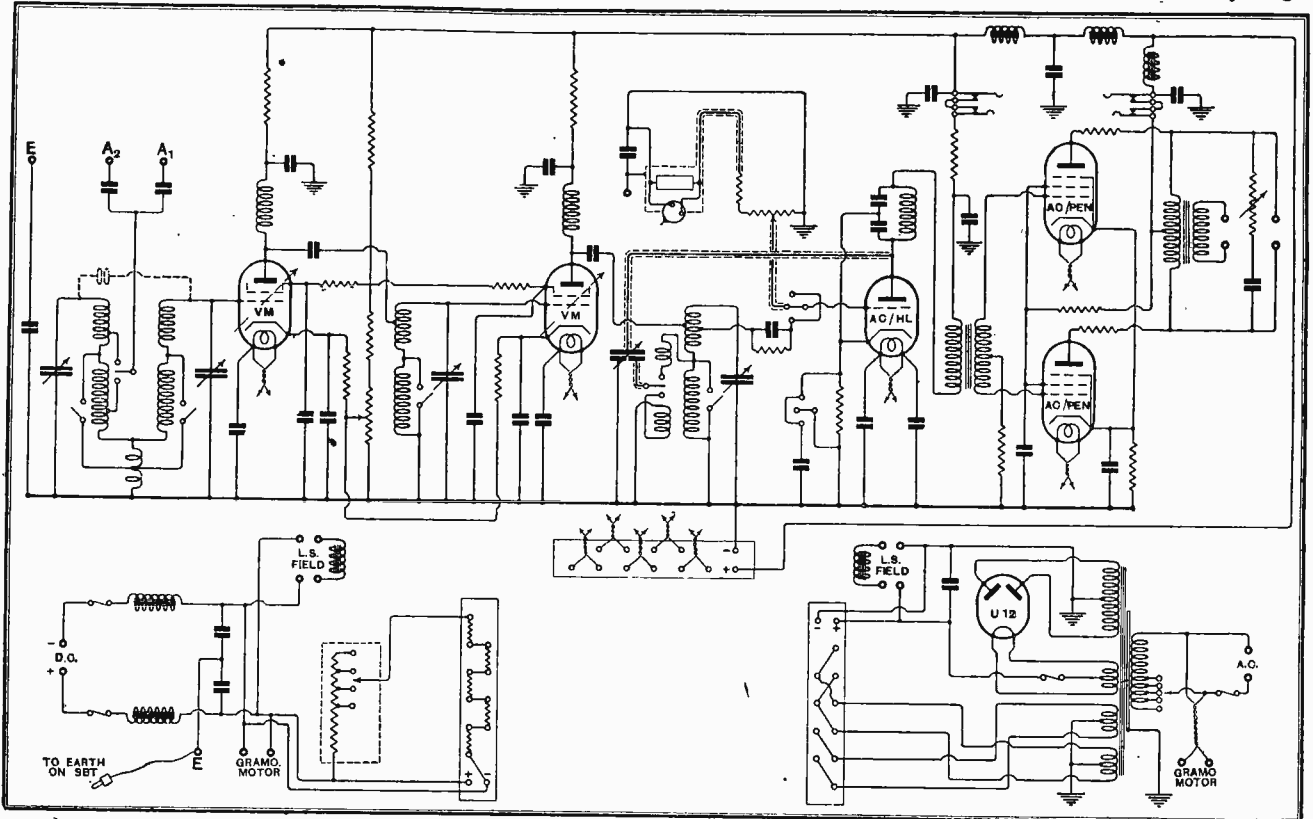

The circuit diagram. It will be noted that the pentodes are employed in the push-pull output stage.

gramophone, their operation is very sweet and distortionless, and an ample range of control is afforded.

The use of pentodes in push-pull for the output stage is unusual, and they are rated to deliver some three watts to the moving coil loud speaker. Anti-parasitic resistances are fitted in the anode circuits, and a tone control is provided by a variable resistance and a condenser connected across the primary of the output transformer. A good point which is worthy of more general application is the inclusion of jacks in the anode circuits of both the

The sensitivity is ample for all normal purposes, and on test with rather a poor aerial it was never necessary to have the volume control at maximum. The quality of reproduction reached an exceptionally high standard, and this is no doubt partly due to the large dimensions of the cabinet, which permit of the lowest notes being effectively radiated. It is pleasing to find, however, that in spite of an ample bass, the high notes are well in evidence, and there is no trace of boominess. Openings are cut in the sides of the cabinet to prevent box resonance, and the

temperature, and it is in consequence advisable to stand the set some little distance from a wall.

The apparatus is claimed to be of entirely British manufacture, and an inspection of the chassis shows that all the components are of well-known and high-quality British makes, even in the case of parts which are normally hidden by screening material. The components are obviously chosen solely on the grounds of their suitability for the function which they have to perform, and not merely for their cheapness.



# PRACTICAL HINTS AND TIPS

## Simplified Aids to Better Reception.

**W**HEN considering the suitability of a particular type of power rectifier to supply the needs of a mains-operated set, it must not be forgotten that bias voltage will almost certainly be derived from the same source, and that the amount of this voltage must be subtracted from the total rectified voltage output before one can determine how much pressure will be available for the anode circuits of the valves.

**A  
REMINDER.**

When one is working towards the limit of the rectified output rating, this becomes a matter of some importance. For instance, a rectifier intended to give 250 volts at 60 milliamperes would hardly do for a receiver taking that amount of current and fitted with an output valve rated at 250 volts maximum. A valve of this type would probably need some 30 volts of grid bias, and so the maximum pressure available for its anode would be in the order of 220 volts. When estimating voltage requirements, grid bias and anode pressures must be added together.

The above is written on the assumption that the valve is to be run "all out." Incidentally, there is much to be said in favour of doing this, as power output falls off very quickly with a reduction of anode voltage, but there is no inherent reason why a valve should not be under-run; its working life, at any rate, is likely to be increased.

**P**USH-PULL amplification is deservedly in favour at the moment, and apparently an increasing number of amateurs are considering ways and means of applying it to their own sets. As is well known, a special type of output transformer, with a centre-tapped secondary, is customarily employed as a coupling between push-pull output valves and the loud speaker, but a very satisfactory arrangement may be devised

**CHOKE  
OUTPUT.**

with the help of a simple centre-tapped choke. The outer ends of this component are joined to the anodes, H.T. current being fed through the centre tapping.

When an ordinary loud speaker is employed it may be connected directly across the outer choke terminals; no feed condensers should be necessary, as there is no difference of D.C. potential between these points, and so no D.C. current will flow through the loud speaker windings.

When it is desired to use a moving-coil loud speaker having a built-in output transformer of the type designed to act as a coupling between the moving coil and a single output valve, connection should be made as in Fig. 1. Here the primary of the built-in, step-down transformer is joined directly across the choke.

Although blocking condensers are not necessary, they may, of course, be inserted in the loud speaker feed leads if it is desired to take special

precautions against the possibilities of an accidental short-circuit; for instance, these isolating condensers should be employed in a set operated from D.C. mains, or, indeed, in any case when long extension leads are employed to link the set and loud speaker.

**T**HE subject of tone-correction is receiving a great deal of attention at present, and so the moment is opportune to point out a possible pitfall that exists when an attempt is made to put the principle into operation without due thought and care.

On analysing a system that may at first sight appear to be promising, it is all too often found that the overall result is attenuation of the

**A TONE-CORRECTION  
PITFALL.**

upper and lower frequencies, while the middle register is left un-

touched. This is just what we want to avoid; the worst receivers of the "bad old days" were always those of the "one-note" type, giving marked over-emphasis to frequencies

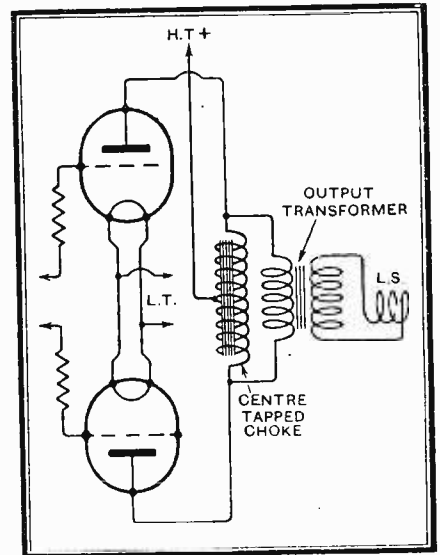

Fig. 1.—A centre-tapped choke as a loud speaker coupling in a push-pull circuit.

in the order of 1,000 cycles. Whatever one's personal views may be regarding the desirable frequency range of the ideal practical receiver, there can be no doubt that reproduction of this type is unattractive.

IN the "Hints and Tips" section of *The Wireless World* of March 9th attention was drawn to the fact that the diode detector has special attractions for the D.C.-mains user, who, by reason of his limited supply voltage, always finds it difficult to employ any other form of equally distortionless detector. A skeleton diagram of a detector-2-L.F. set, suitable for high-quality reception of local broadcasting, was given, to-

**THE DIODE AND REACTION.**

gether with suggested values.

Although the diode, in its latest

form, is reasonably sensitive, an arrangement of the kind under discussion has, of course, a strictly limited range. When it is to be used for long-range reception an H.F. amplifier may be added, but there is another possibility—that of applying reaction—when slightly greater sensitivity than that of the unaided detector is necessary.

As has already been pointed out, the anode of the diode, which is normally not used, may be pressed into service for reaction purposes, the circuit being arranged as shown in Fig. 2. In this diagram a two-circuit aerial tuner is suggested as an aid to selectivity, "top-end" capacity coupling, as indicated by dotted lines, being particularly suitable for an arrangement of this sort, but any other system of linkage may be substituted if it happens to be more convenient.

With regard to the small condensers C and C<sub>1</sub>, a capacity of 0.00004 mfd. has been suggested, but, as components of this value do not seem to be readily obtainable, semi-variable condensers of 0.0001 mfd. maximum capacity may be substituted.

As a high voltage is not required on the detector anode the decoupling resistance R may have a relatively high value—say 50,000 ohms.

With regard to the H.F. chokes, the requirements of H.F.C<sub>1</sub> are somewhat exacting, and it may be advisable to use two chokes in series, but the other choke acts merely as a deflector for purposes of reaction, and so an inexpensive component will do for the purpose.

NO longer is it safe to ask for, say, a 2,000-ohm wire-wound resistance, and blindly to assume that it is certain to carry any current that is likely to be forced through it. High voltages and relatively heavy anode currents are the order of the day, at any rate in mains-operated sets; immunity from breakdown, combined with economy, are the rewards for exercising a certain amount of dis-

**CURRENT-CARRYING CAPACITY.**

crimination in choosing resistors.

These components are generally

rated in terms of the wattage that may be dissipated in them, and in order to assess the stability of a given resistor for any particular position in a receiver, it becomes necessary to translate its "watts" rating into current-carrying capacity in rather a roundabout way.

The first step is to determine the voltage that will be absorbed by the resistor when it is connected in the receiver. This is ascertained by multiplying resistance (in ohms) by current (in amperes or fractions).

All this applies, of course, to resistances used for the purpose of automatic grid bias, as well as those in the valve anode circuits. As an example of a practical problem, we may take the case of a 600-ohm bias resistor for a valve consuming 50 milliamperes (0.05 amp.). The voltage dropped across the resistance will be 30, and consequently the wattage dissipated will be 1.5 watts.

PRACTICALLY speaking, it is impossible to measure with any degree of accuracy the grid voltage applied to an amplifying valve by means of an automatic bias system. At any rate, one cannot do this operation properly without access to special instruments which are not likely to be available to the average amateur. Accordingly, we have to resort to a roundabout method. First, the ohmic resistance of the

**BIAS VOLTAGE MEASUREMENT.**

bias resistor should be ascertained, and then a measurement should be

made of the current flowing through it under practical working condi-

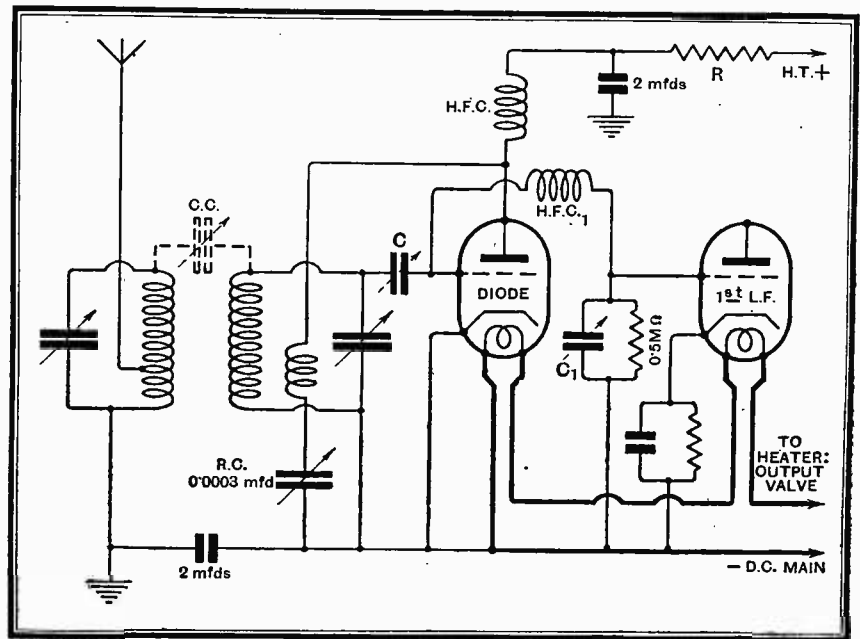

Fig. 2.—Method of obtaining reaction with a diode detector.

Wattage is then found by multiplying "volts absorbed" (as ascertained by the preceding calculation) by "current."

Armed with this information, bias voltage may readily be calculated by multiplying ohms by milliamps. by 1,000.

# CURRENT TOPICS.

Events of the Week in Brief Review.

## A Record-breaking Year.

**STRIKING** testimony to the vitality of Britain's radio industry is provided by the review of business in 1931, just published by our contemporary *The Wireless and Gramophone Trader*. The statistics show that the gross turnover advanced by 50 per cent. during the year, the figure for 1931 of £20,000,000 yielding to one of £29,750,000 last year. The figures are compiled with the co-operation of the General Post Office, which records the issue of listeners' licences, and of manufacturers, who provided details of their own production. The Post Office figures show that 900,000 new licences were issued during the year, while the statistical survey in question discloses that a total of 1,250,000 receivers sold during the period, 600,000 were bought by new listeners, while 650,000 were sold as replacements to existing owners. The balance was made up of "reformed pirates," home constructors and users of coupon gift sets.

## Wireless for Unemployed.

**AN** example which might well be followed in other parts of the country is that of the George Street United Methodist Church in Burton, which has installed a 4-valve wireless set in a room specially set apart for the benefit of the unemployed.

## Broadcasting from Catalonia.

**CATALONIA'S** broadcasting station at Barcelona is now very active from noon onwards. The station, which operates on 251 metres with a power of 1 kilowatt, transmits a cavillon call at noon, 5 and 8 p.m. (G.M.T.).

## Loud Speakers on Air Liners.

**AN** interesting innovation during the University Boat Race was the installation of wireless loud speakers on two Imperial Airways liners which cruised over the course. The innovation was possible owing to the remarkable absence of noise in the cabins of the new Heracles type of machine. It has previously been necessary on air liners to employ headphones for radio reception.

## Eta Valves.

**COMING** at a propitious moment when valve prices have registered a welcome drop, two new folders issued by the Electrical Trading Association, Ltd., make specially interesting reading. The very comprehensive range of Eta valves is displayed pictorially and graphically with full technical data, on a handy sheet suitable for display either at the dealer's counter or in the amateur's den.

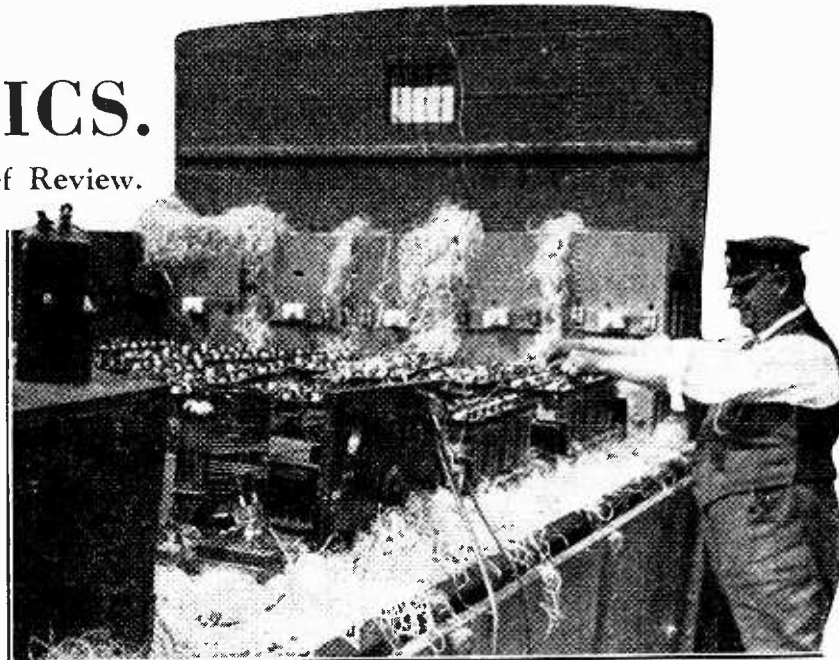

**RADIO IN THE RAW.** This impromptu transmitter is being used by German broadcasting engineers in their search for suitable sites for new high-power stations at Leipzig, Breslau, Hamburg and other cities.

## Television in Hotels.

**A LARGE** New York hotel now adds to its list of superlative attractions the inclusion of complete television units in the de luxe suites.

## The Deaf Amateur.

**STRANGER** than fiction is the story reported by the American Radio Relay League, of Kenneth Ashley, a one-time radio amateur of Tacoma, Washington, who ten years ago became stone deaf as the result of a diving accident. His favourite hobby abandoned, Ashley had to content himself with technical study of modern radio developments until recently, when a letter of his published in a local paper on the subject of the old time enthusiasm for radio, caught the eye of William Gunston, leader of the Tacoma Radio Club. With the co-operation of the club members, Gunston has now provided the veteran amateur with a short-wave receiver operating a neon lamp, and Ashley, who is an expert Morse reader, claims to be able to read the flashes almost as easily as the signals he formerly picked up by ear from all corners of the United States.

## Radio Rum Running.

**DESCRIBED** as Uncle Sam's newest radio Frankenstein, the decommissioned U.S. battleship "Utah" which has been kept afloat for radio experimental purposes, is now to be used as a target ship under remote radio control. The apparatus employed has been developed by John Hayes Hammond, Junior, famous as the inventor of radio controlled torpedoes during the war. Last winter, according to our Washington corres-

pondent, Hammond was approached by a rum-running syndicate with the proposal that he should equip a fleet of radio controlled rum boats. He was offered 50,000 dollars for specifications as to how the controls could be installed and operated. He refused, however, and immediately divulged the proposal to the authorities.

## Better Commercial Art.

**WE** have received from the Bennett College, Ltd., of Sheffield, an interesting and copiously illustrated text book used for tuition purposes in the Commercial Art course. In attempting to raise the standards of commercial art, organisations like the Bennett College deserve the gratitude of all people whose fate it is to gaze daily on press and poster advertisements. By means of attractive prize competitions associated with the now famous features of "Jim Duck" and the exhortation to "change his expression," the College should succeed in evoking a great deal of dormant talent.

## Improved Broadcasting in Australia.

**AUSTRALIAN** listeners will soon enjoy a very much better listening conditions, according to Mr. Fenton, the Federal Postmaster-General. In opening the Crystal Brook broadcasting station, 120 miles north of Adelaide, on March 15th, Mr. Fenton said that when the chain of Regional stations had been completed, at least 95 per cent. of the population would be within satisfactory range. Crystal Brook employs the call sign 5CK. The wavelength is 417 metres.

# Nuts to Crack

## Instructive Problems and their Solution.

**T**HE present series has been started by *The Wireless World* for the benefit of readers who like to work out little problems for themselves and be sure that the results they obtain are correct. At frequent intervals wireless problems are presented, and in the following instalment the answers are given with the methods of working them out, and hints on possible points of difficulty. Problems 25 to 28 have been previously given, and below the answers appear, whilst another set of problems is included this week for treatment in the next instalment.

**QUESTION 25.**—A coil of 250  $\mu$ H. inductance and 500 ohms resistance is placed in series with a condenser of 0.0005 mfd. If an alternating e.m.f. of 2 volts R.M.S. at the resonant frequency is applied across the whole combination, what is the amplitude of the resultant current?

*Answer* — 5,656 milliamperes.

A sine wave of alternating current or voltage may be specified either by its amplitude or by its "root-mean-square" or R.M.S. value, the first being  $\sqrt{2}$  or 1.414 times the numerical value of the latter. For a full discussion of the difference between these, the reader is referred to No. 1 of *The Wireless World* Encyclopedia of Wireless Terms, which appeared in the issue of October 7th last.

It will be seen that the amplitude of the alternating e.m.f. specified in this problem is, therefore, 2.828 volts.

Since the frequency of the applied voltage oscillations is, actually, the frequency to which the series circuit is resonant, the individual reactances due to the inductance and capacity will be numerically equal. They are, however, of opposite sign and cancel out, and for this reason do not enter into our calculation at all. The net impedance of the circuit at this frequency will, therefore, be equal solely to the ohmic resistance of the circuit, i.e., to 500 ohms.

The amplitude of the resulting current oscillations are now simply obtained from Ohm's Law, as follows:—

$$\begin{aligned} I &= \frac{E}{R} \\ &= \frac{2.828}{500} \text{ amperes} \\ &= 5.656 \text{ milliamperes.} \end{aligned}$$

**QUESTION 26.**—The makers' rating for the anode dissipation of a certain valve is 6 watts. If the mean H.T. available on the plate is 250 volts, what is the maximum permissible value of anode current?

*Answer* — 24 milliamperes.

The anode dissipation of a valve, i.e., the D.C. power expended in overcoming the D.C. resistance of the filament-anode path *within the valve*, is given in watts by the product of the number of volts on the anode and the number of amperes of mean anode current. For

every valve, and especially in the case of power output valves carrying comparatively large currents, there is a certain rated value of anode power dissipation which should not be exceeded. This value is usually stated by the makers.

In the present case, if, with 250 volts on the plate, the maximum mean anode current which may be safely taken is denoted by  $x$  amperes, we may write:

$$x \times 250 = 6,$$

whence

$$\begin{aligned} x &= \frac{6}{250} = 0.024 \text{ ampere} \\ &= 24 \text{ milliamperes.} \end{aligned}$$

**QUESTION 27.**—If it were desired to pass a mean anode current of 30 milliamperes through this valve, what would be the maximum anode voltage for safety?

*Answer* — 200 volts.

In applying the formula  $W = EI$ , it is well to express the current in amperes, so that the uniformity of the units (volts, amperes, and watts) may be preserved. Here we have 30 mA., or 0.03 ampere.

The power dissipation is unaltered at 6 watts. If, then, we write  $x$  volts for the required plate voltage, we have:

$$0.03 \times x = 6$$

whence

$$\begin{aligned} x &= \frac{6}{0.03} \\ &= 200 \text{ volts.} \end{aligned}$$

**QUESTION 28.**—If two sound waves have frequencies of 216 and 248 cycles per second, what are the frequencies of the principal "beat" notes when they occur together?

*Answer* — 464 and 32 cycles per second.

The principal "beat" or "interference" notes have frequencies equal to the sum and difference of the two primary tones. In this case the frequencies of the interfering tones will be  $248 + 216 = 464$  cycles per sec. and  $248 - 216 = 32$  cycles per sec. respectively. In practice the upper beat frequencies are seldom discernible by the human ear; the difference-tones are, however, readily perceptible. If the two primary sound vibrations have almost the same frequency, their beats may be counted even if the pitch of the interfering sound is too low to give a recognisable note.

### NEXT SERIES OF PROBLEMS.

**QUESTION 29.**—A certain voltmeter has a resistance of 64 ohms per volt. If the maximum reading on the meter is 100 volts, how much current will be passed at full-scale deflection?

**QUESTION 30.**—If the voltmeter in question were placed across an H.T. battery of 100 volts and internal resistance 500 ohms, what would be the meter reading, and how much current would be passed by the instrument?

**QUESTION 31.**—If a 100-volt meter rated at 1,000 ohms per volt were applied to the same battery, what would be the reading and the current taken?



Wireless  
World



# LABORATORY TESTS

## Review of New Radio Products.

### LOTUS OUTPUT CHOKE.

This is one of the latest additions to the Lotus range of components, and it has been designed for use in sets fitted with an output valve the anode current of which does not exceed some 12 mA. Its nominal inductance is 20 henrys, and the D.C. resistance is stated to be 720 ohms. The sample tested was found to give this value of inductance with 9 mA. of D.C. flowing through the winding, but with smaller amounts much higher inductance values were recorded.

The following table shows the extent to which the inductance is influenced by the value of the anode current :-

D.C. (mA).	Inductance (henrys).
0	162
2	58
4	34
6	26
8	22
10	19
12	17

Output valves of the type most likely to be used with a choke of this size pass between 8 to 12 mA., so that the effective inductance of the choke under average working conditions will be between 22 and 17 henrys.

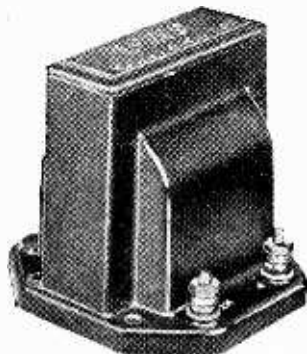

Lotus output choke for use with small power valves.

The measured D.C. resistance of the specimen tested was 780 ohms. The makers are Lotus Radio, Ltd., Mill Lane, Liverpool, and the price is 5s. 6d.

### POLAR AIR-DIELECTRIC DIFFERENTIAL CONDENSER.

An air-dielectric differential condenser, which is eminently suited for use as a volume control in the aerial circuit as the dielectric losses are exceedingly small, is now obtainable from Wingrove and Rogers, Ltd., Arundel Chambers, 188-189, Strand, London, W.C.2. This new condenser is exceptionally compact, and is constructed from brass throughout. The moving vanes are carried in one large ball-bearing fixed to the front plate, while the free end of the spindle is supported by a single steel ball of large diameter kept in

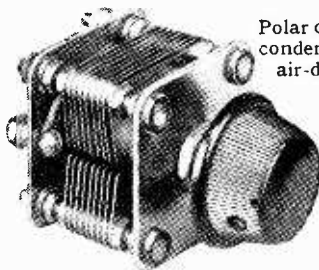

Polar differential condenser with air-dielectric

position by a cup-shaped recess in the end of the spindle and a similar recess in the back plate. A flexible pigtail gives a positive connection to the moving vanes.

This model is available in two sizes, viz., 0.0001 mfd. and 0.00015 mfd. each side, the price being 5s. 6d. in each case, complete with knob.

### CLARKE'S ATLAS D.C. MAINS UNIT. Model D.C. 15/25.

Made by H. Clarke and Co. (Manchester), Ltd., Atlas Works, Eastnor Street, Old Trafford, Manchester, this D.C. mains unit is suitable for operating the majority of receivers hitherto depending on batteries for their power. The overall size is such that it can be accommodated in the battery compartment in portable sets.

Three separate output voltages are provided, two of which can be varied in steps. Of these, one, namely, that marked 60-80 volts, is derived from a tapped potentiometer giving two alternative voltages. The second intermediate output is obtained from a tapped series resistance provided with three tappings marked "Min.," "Med.," and "Max.," respectively, and grouped under the heading "50-90 volts." Finally, there is the power tapping, which

is connected direct to the smoothing choke in the positive main's lead.

A feature of considerable interest is the inclusion of a switch which adjusts the voltages at all tapping points to the same value on loads of either 15 or 25 mA. This is a distinct advantage, since with all mains units of this type the output voltages are inclined to be somewhat in excess of that required to operate the set when some 12 mA. only are drawn from the eliminator.

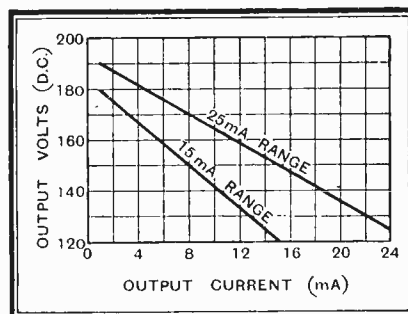

Voltage regulation curves of Atlas D.C. 15/25 mains unit. The input was 210 volts D.C.

The regulation curves on the graph explain this point, as it will be seen that with a load of 12 mA. only the output can be brought down from 158 to 134 volts—comparable with the battery voltage in many cases—by changing to the 15 mA. range.

On test the unit proved entirely satisfactory; the smoothing is adequate even when exceptionally sensitive receivers are employed. Screen potential for the H.F. valve should be taken from the "60-80

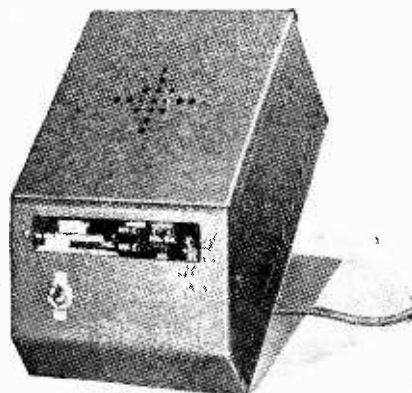

Clarke's Atlas D.C. 15/25 mains unit.

volt" tapping, as the potentiometer serves to stabilise the voltage, while the other intermediate tapping will supply the detector. In some cases it may be necessary to include the usual anode decoupling, particularly in the detector stage.

The price of this unit is 35s. 6d.

**ULTRA "IMP" MOVING COIL-UNIT.**

The model reviewed is of the permanent-magnet type in chassis form. It includes an input transformer and is fitted with a Vickers cobalt steel permanent magnet. A good point in the design of the magnet system is the sealing of the back of the air gap to prevent the ingress of filings or other foreign matter which might be detrimental to proper functioning of the unit.

The sensitivity of the unit is good, and is only just appreciably less than that of some of the best mains-energised moving-coil loud speakers.

Reproduction of speech leaves nothing to be desired, and music is distinguished by unusual brilliance in the top register. The greatest sound output lies between 1,500 and 6,000 cycles, but the response is well maintained up to 8,000 cycles and down to 150 cycles. Between 150 and 100 cycles, however, there is a drop of about

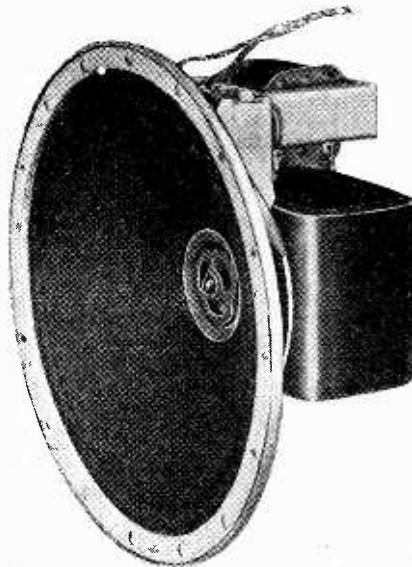

Ultra "Imp" permanent-magnet moving-coil chassis.

12 decibels, but no further decrease of any magnitude was found to take place between 100 and 50 cycles.

The unit is made by the Ultra Electric Co., Ltd., Erskine Road, Chalk Farm, London, N.W.3.

**ALBANY RADIO MAINS TRANSFORMER.**

These transformers are built on very generous lines, and are obviously intended for the discriminating constructor who is not averse from paying a few shillings extra for a sound electrical component. The size of wire used for each winding is carefully chosen, having regard to the maximum current it will carry, with the result that good voltage regulation is claimed. Tests made on a sample "B" type transformer fully substantiate the makers' claims. Indeed, we found that considerable overloads could be tolerated without any substantial reduction of the voltage.

For the purpose of our test the rectifying valve—a Mazda U.U.120/350, requiring 2.5 amps. at 4 volts—was con-

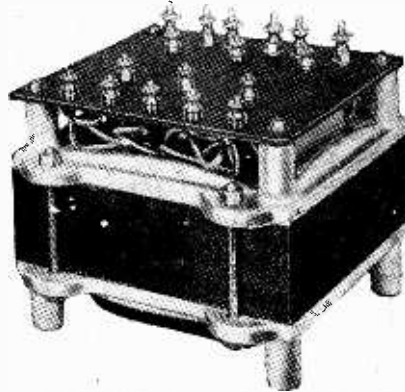

Albany radio mains transformer, Type "B." Engraved terminal plate is fitted to production models.

nected across one of the 3-amp. windings, and the measured voltage with the other windings adequately loaded was 3.91 volts. With the rectifier giving its maximum output of 120 mA., the remaining L.T. windings showed 4.05 volts at 3 amps. and 4.07 volts at 1 amp. respectively.

Voltage regulation of the H.T. secondary is exceptionally good also; the difference between no load and full load was found to be but 2.9 per cent. only.

The production models will be identical with the sample tested, but they will be provided with an engraved terminal plate, and the price of the "B" type has been fixed at 45s. An "A" type giving the same number of output voltages, but with the H.T. secondary

Output voltage regulation curves of Albany mains transformer, Type "B."

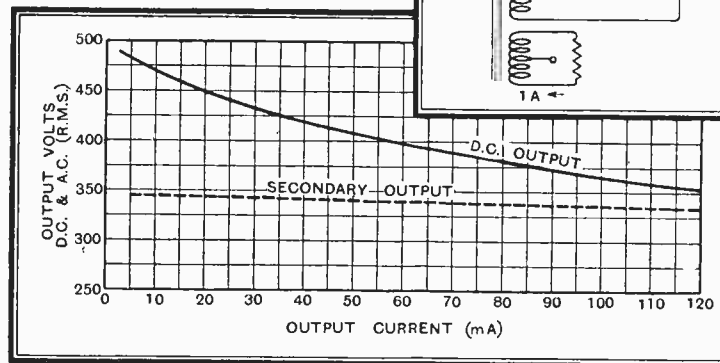

designed for an output of 250+250 volts, is available at 35s., and there is also a "C" type giving 500+500 volts with three L.T. windings available at 55s.

The makers are Albany Radio Products, Albany, Osborn Road, Romford.

**WATMEL VARIABLE HIGH RESISTANCE.**

This component has been developed for use as a volume control in circuits where there is a negligible D.C. current flowing, as it embodies a composition-type resistance element. Pressed firmly against the resistance and held in position by a specially shaped clamping cone is an annular ring carrying a large number of small wire contacts. The moving arm rides over these contacts, thus varying the resistance in steps. There are so many contact points, however, that for all practical purposes there is a continuous variation in resistance.

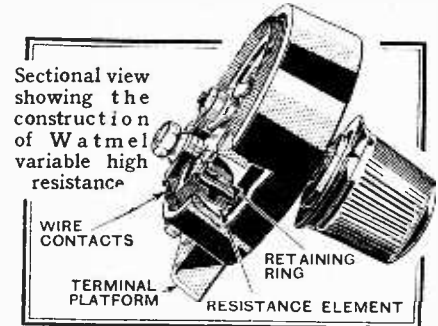

The specimen tested was a potentiometer-type resistance with a nominal value of 500,000 ohms, its measured value being substantially the same. We found it perfectly satisfactory and silent in operation, even though it was connected across a grid battery and employed to vary the potential to the grid of a screen-grid valve for the purposes of volume control.

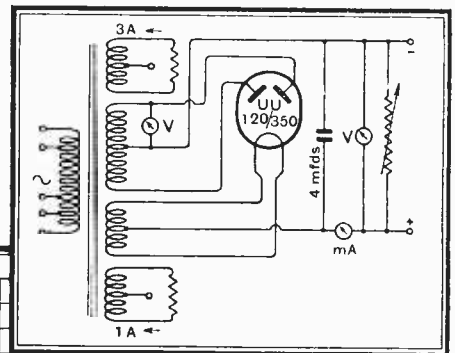

This component is available with resistances of from 50,000 ohms upwards, and the price is 4s. 6d.

The makers are Watmel Wireless Co., Ltd., Imperial Works, High Street, Edgware, Middlesex.

# READERS' PROBLEMS

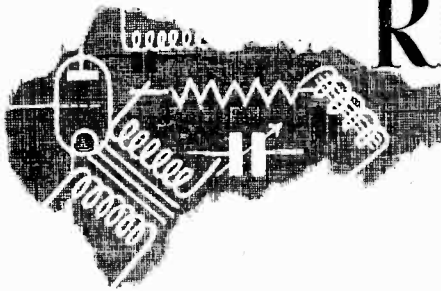

## An Automatic Indicator.

WE are asked what may be deduced from the following experience: A low wattage lamp is used as a limiting resistance for charging H.T. accumulators from D.C. mains; the lamp normally glows quite dimly while the cells are on charge, but recently, on connecting up the batteries, the lamp became abnormally bright, and after a few moments burnt out. It is almost certain that there was no accidental short-circuit. After replacing the lamp and reconnecting the battery, everything became normal.

We feel certain that the polarity of the battery, as it was connected when the lamp burned out, was accidentally reversed. When connections are correct, the mains voltage is in opposition to that of the batteries, and so a relatively small current flows through the circuit, but on reversing the polarity, the two sources of voltage become additive in their effect, and so increased current will flow.

A lamp resistance used in this way is a useful indicator of polarity, and also gives some idea as to the state of charge of the battery. When the voltage of the cells increases, the back-voltage working in opposition to that of the mains supply will rise, and the lamp will automatically burn less brightly.

## D.C. Mains Receiver.

REFERRING to the D.C. receiver discussed in the "Hints and Tips" section of *The Wireless World* for January 27th, it is asked whether an L.F. transformer might be substituted for the L.F. choke which was employed as a coupling between the detector and output pentode.

For this receiver a choke was deliberately suggested as an L.F. coupling for the reason that it provides less magnification than a transformer, and so, even with the limited voltage of a D.C. supply, makes it possible to employ real power grid detection.

If the relatively high amplification of a transformer-coupled stage is essential, it will become necessary to increase the value of the detector decoupling resistance, and so the voltage on the anode of this valve will fall below the value necessary for best detection. But with this modification, the circuit will still be a practicable one, and so may be suitable for our correspondent, provided he realises that extra decoupling will almost certainly be required.

## An Extra Loud Speaker.

WHEN an attempt is made to connect a second loud speaker, particularly one of the moving-iron type, to a receiver which is already operating a moving-coil loud speaker, a certain amount of trouble is generally experienced. In the first place, the reproduction of the original instrument will certainly be adversely affected to some extent, while the added loud speaker, which in the nature of things will not be able to handle as much energy as the other, will probably be overloaded unless special precautions are taken. Both these difficulties have been encountered by a reader who has just made the addition in question, and who now asks for some advice as to how the trouble may best be overcome. His A.C. mains receiver embodies a triode output valve which drives a transformer-coupled moving-coil loud speaker. The extra loud speaker has been connected through a choke feed arrangement, using the primary of the transformer as a choke,

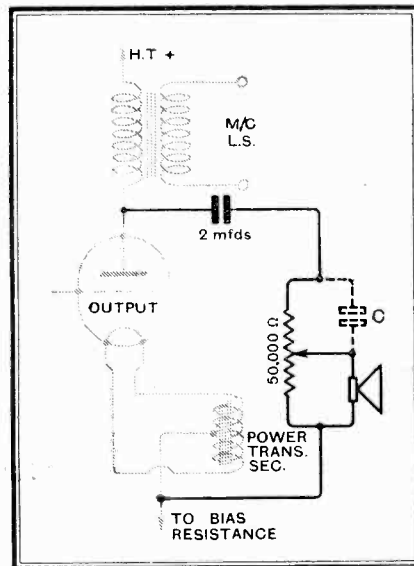

Fig. 1. An extra loud speaker, with its own volume control, connected to an existing receiver.

and in order to reduce volume, a 50,000 ohm wire-wound potentiometer, connected as a series resistance, has been joined in series with the extra loud speaker.

We suggest that the circuit should be rearranged as shown in Fig. 1, the potentiometer being employed to reduce the amount of energy applied to the extra loud speaker. A condenser, C, of about 0.001 mfd., may be connected as indicated by dotted lines in order to compensate for loss of high notes.

No arrangement of this kind is beyond criticism, but the method suggested is capable of giving good results in practice.

THESE columns are reserved for the publication of matter of general interest arising out of problems submitted by our readers.

Readers requiring an individual reply to their technical questions by post are referred to "The Wireless World" Information Bureau, of which full particulars, with the fee charged, are to be found on the next page.

## Condenser Efficiency.

AIR is the most efficient dielectric that can be employed between condenser plates, but when compactness is required some solid material must be substituted.

This is realised by a correspondent who intends to use several fixed condensers up to 0.01 mfd. in a special circuit where no avoidable losses can be tolerated. He asks whether any better material than mica could be employed, and whether ebonite or bakelite would not be superior as a dielectric.

As the possibility of using an air-dielectric condenser is obviously precluded in this case, we feel sure that our correspondent could not do better than obtain mica condensers made by a reliable firm which specialises in making these components. As a dielectric, good mica is vastly superior to bakelite, and is even better than ebonite.

## Using an Oscillator.

A READER, who has been making preliminary adjustments to a band-pass filter with the help of a valve oscillator, finds that double-humped tuning is produced, however weak the coupling between the component filter circuits may be made. He is quite sure that the circuits are adequately screened, and asks for our advice.

We expect that the effect noticed is due entirely to the use of excessively close coupling between the oscillator and the input filter circuit. When doing work of this sort, it is essential to guard against this, and to work with a very loose oscillator coupling; if a sufficiently high voltage cannot be injected into the circuits without running contrary to this principle, our correspondent will find it necessary to set up an oscillator giving a greater power output, or alternatively, to employ a more sensitive indicating device for his experiments.

### The Buzzer Wavemeter.

REFERRING to the published description of a buzzer wavemeter in *The Wireless World* for March 9th, a reader asks us to elaborate the circuit diagram in order to show exactly how the internal connections to the buzzer are made. He needs this information because he already has a "skeleton" buzzer of rather different type to that used in the original instrument, and which is not fitted with terminals.

Another reader wishes to simplify the wavemeter by omitting the long-wave section, saying that he seldom has any difficulty in identifying transmissions on the long-wave band. He asks for a modified circuit diagram.

Both these querists will be able to obtain the information they require from Fig. 2. With regard to the internal connections of the buzzer, it should be

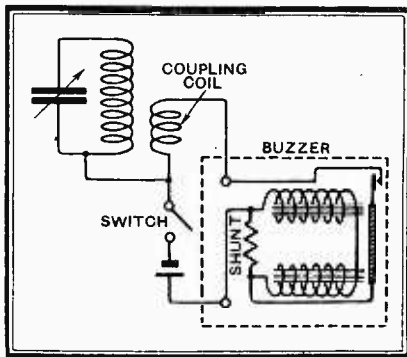

Fig. 2. Single-range buzzer wavemeter, showing internal connections of buzzer.

realised that the coupling coil, switch, and L.T. cell are joined in series with the buzzer windings and make-and-break contact; if not already fitted, a 6-ohm resistance must be shunted across the windings. For a different type of buzzer a higher value of resistance may be needed.

Still another question on the buzzer

wavemeter deals with the subject of increasing output so that the instrument may be used with a relatively insensitive set. Without an exact definition of sensitivity, no hard-and-fast rule can be laid down, and indeed, this matter is best determined by trial and error. Our correspondent will not go far wrong if he doubles the number of turns suggested for each primary coil, and then, if buzzer signals are found to be too loud, turns should be progressively removed until strength is just sufficient to allow an accurate reading to be obtained.

### Excess of Zeal.

A QUERIST, who charges his L.T. accumulators at home from A.C. mains through a rectifier, is concerned about the fact that one of his batteries will no longer hold its charge. The positive plates have become quite black, and are showing a tendency to crumble away; he asks whether this state of affairs would indicate that there has been anything wrong with his methods of charging.

We are afraid that it does. When the positive plates of a cell are in this condition, it can almost invariably be assumed that they have been consistently over-charged.

### Radio and Gramophone.

WHEN a receiver is stated to afford reproduction of high quality on radio signals, but is deficient as a reproducer of gramophone records, one is always inclined to suspect that the L.F. amplifier tends to over-emphasise the higher audible frequencies, and thus gives a measure of automatic compensation for "side-band cutting" in the tuned circuits.

For instance, a correspondent complains that his A.C. set, with pentode output and the usual "compensated" coupling to the loud speaker, though an excellent reproducer of wireless signals, is most unsatisfactory when employed with a pick-up; reproduction is stated to be high-pitched—he describes it as "screechy." There are no side-bands to be "cut" when reproducing gramophone records, and so it

### FOREIGN BROADCAST GUIDE.

## SOTTENS

(Switzerland).

Geographical position: 46° 40' N.; 6° 34' E.  
Approximate air line from London: 465 miles.

Wavelength: 403.8 m. Frequency: 743 kc.  
Power: 25 kW.

Time: Central European (one hour in advance of G.M.T.).

#### Standard Daily Transmissions.

Relays programmes from Lausanne and Geneva.

08.55 G.M.T., carrillon; sacred service 10.00 (Sun.), 11.30-13.00, gramophone records; 13.45, concert; 16.30, children's hour; 18.00, gramophone records, weather; 19.00, concert; 21.00, news; 21.15, dance music relayed from Montreux (Wed.), and from Geneva (Sat.).

Announcers; Man and woman (Lausanne); Man (Geneva).

Call: *Allo! Allo! Ici radio Suisse Romande, studio de Lausanne (or de Genève).*

Good night greetings; *Bon Soir Mesdames, Bon Soir Messieurs.*

The programmes are also transmitted by the Geneva local station on 760 m. (395 kc.) 1.25 kW.

is quite probable that, as the amplifier evidently tends to favour the higher frequencies, some provision for optionally curbing this tendency ought to be made with advantage.

The usual corrector consists of a condenser in series with a resistance across the output choke; to make this device more effective in its action, we suggest that a variable resistance should be used, in order that its value may be reduced when the set is used for gramophone records. Alternatively, a parallel resistance could be thrown in circuit by the action of the radio-gramophone switch.

### "THE WIRELESS WORLD"

## Information Bureau.

### CONDITIONS OF THE SERVICE.

(1) THE service is intended primarily for readers meeting with difficulties in the construction, adjustment, operation, or maintenance of wireless receivers described in *The Wireless World*, or those of commercial design which from time to time are reviewed in the pages of *The Wireless World*. Every endeavour will be made to deal with queries on all wireless matters, provided that they are of such a nature that they can be dealt with satisfactorily in a letter.

(2) Communications should be addressed to *The Wireless World* Information Bureau, Dorset House, Tudor Street, E.C.4, and must be accompanied by a remittance of 5s. to cover the cost of the service. The enquirer's name and address should be written in block letters at the top of all communications.

(3) The fee of 5s. covers the reply to any wireless technical difficulty, but in special cases, where the enquiry may involve a considerable amount of investigation, an increased fee may be necessary. In such cases a special quotation will be made.

(4) Questions should be clearly written and concisely worded in order to avoid delay. Where enquiries relate to trouble experienced in receivers built to specifications in *The Wireless World* a complete account should be given of the trouble, and especially the symptoms.

(5) Where reference is made to published articles or descriptions of apparatus, the title of the article, the date of publication in *The Wireless World*, and the page reference number should be given, in order to facilitate reply.

(6) Full circuit diagrams, constructional details of apparatus, or values of components for home-designed receivers cannot normally be supplied, but circuit diagrams sent in with queries will be checked and criticised.

(7) Particular makes of components cannot, in general, be recommended, but advice will be given as to the suitability of an individual component for a particular purpose specified by the enquirer.