

ELECTRONICS WORLD

MARCH 2006 £4.50

SPECIAL REPORT:

Displays and Solid State

Cost Effective Vehicle Speed Measurement

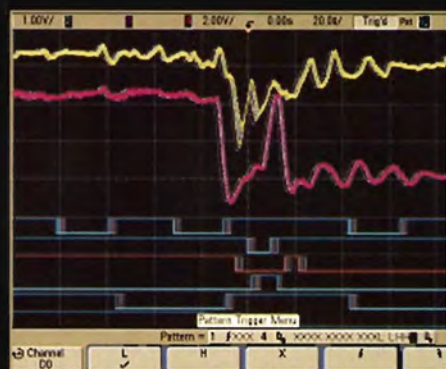

Capturing Elusive Events



● CIRCUIT IDEAS ● CIRCUIT IDEAS ● CIRCUIT IDEAS ● CIRCUIT IDEAS ● CIRCUIT IDEAS

- Novel BPSK Demodulator
- Point-Contact Audio Oscillators
- Auto Shut-Off Utility Light



DIGITAL STORAGE OSCILLOSCOPES

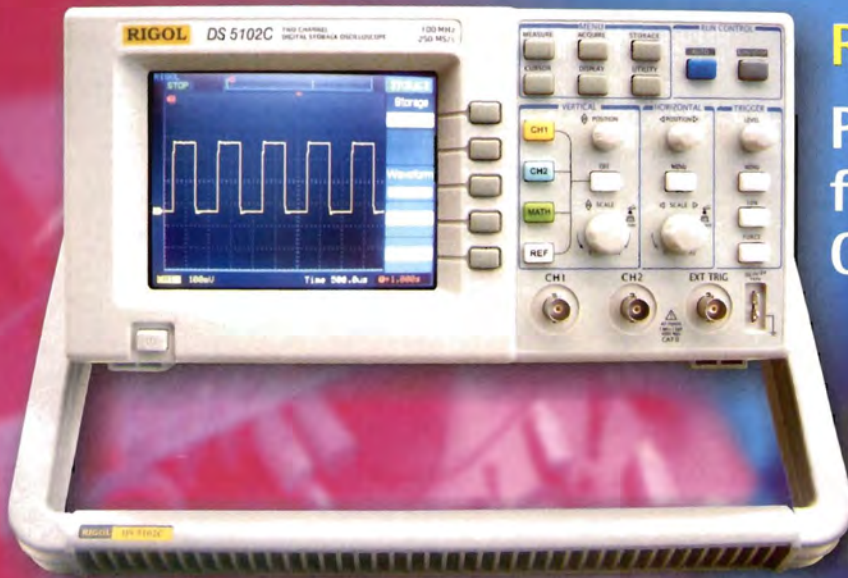

Rigol DS 5000 Series D50

Priced
from
Only **£490.00**

- Outstanding performance @ an affordable price
- Range of 200Mhz, 150Mhz, 100Mhz & 60Mhz models available
- 1GS s/a real time sampling
- 2 channels with ultrazoom for detailed viewing
- Ultrascope PC software via built in USB device
- Automatic voltage frequency and time measurement plus user definable cursor measurements

To see our full range of high quality wireless test equipment covering 802.11 / GSM / WCOM / TETRA and DAB from manufacturers such as WillTek, Litepoint and Tescom, visit www.mcs-test.com

MCS also provides excellent rental rates and will consider the purchase / part exchange of any redundant equipment you have

For further information, Please contact us.

Tel: 01678 520 600



mcs
mobile communications solutions

Mobile Communications Solutions Ltd,
Unit 3, Bala Industrial Estate, Bala, Gwynedd, UK. LL23 7NL
Tel +44 (0) 1678 520600 Fax +44 (0) 1678 521602
www.mcs-test.com sales@mcs-cymru.co.uk

Contents

March 2006

Volume 112

Number 1839

Editor's Comment	3	Tips 'n' Tricks	46
Is nano a no-no?		Win a Microchip PICDEM MC Developer Board for Motor Control Design	
Technology	4	RoHS Forum	49
Top Ten Tips: How to apply for a patent	8	Gary Nevison will answer reader's questions relating to RoHS and WEEE issues	
Insight	10	Book Review	50
Mike Norfield analyses if the days of PMR are over		Gadgets	52
Focus	12	Circuit Ideas	54
There's a pot of gold in delivering TV to mobile phones. By John Walko		<ul style="list-style-type: none">• Novel BPSK Demodulator• Auto-off Utility Light• Point-Contact Audio Oscillators	
Flicker in LCD Screens	15	Products	58
Donald LaFontaine, Mike Wong and Tamara A. Papalias state that LCD panels do exhibit flicker, but adjustments can be made to minimise the effect			
Plasma Display Technology	20		
Much has to be done to generate drives that are suitable for a plasma display panel. By Fawzi Ibrahim			
Blue LEPs	27		
Natasha Conway, Clare Foden, Matthew Roberts, Ilaria Grizzi present a paper that yields a set of design rules for choosing interlayer properties in blue LEPs			
LED Lighting	30		
Faiz Rahman delves into the world of the latest light sources			
Vehicle Speed and Classification Detection System	36		
N. S. Bayindir, H.Ö. Bayindir, H. Demirel, M. Yakup, V. Alsancak and T. Kabakli present an applicable vehicle speed measurement system			
Capture Elusive Events	42		
Johnnie Hancock explains that oscilloscope waveform update rates determine the probability of capturing elusive events			

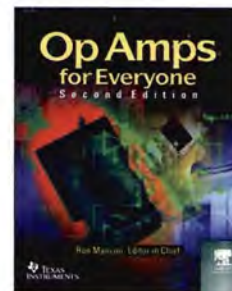

Left: Delivering TV to mobile phones - p12

Book Review - p50



Video devices from the DaVinci platform - p6



Quasar Electronics Limited
 PO Box 6935, Bishops Stortford
 CM23 4WP, United Kingdom
 Tel: 0870 246 1826
 Fax: 0870 460 1045
 E-mail: sales@quasarelectronics.com
 Web: www.QuasarElectronics.com

Postage & Packing Options (Up to 2Kg gross weight): UK Standard 3-7 Day Delivery - £3.95; UK Mainland Next Day Delivery - £8.95; Europe (EU) - £6.95; Rest of World - £9.95 (up to 0.5Kg)
!Order online for reduced price UK Postage!
 We accept all major credit/debit cards. Make cheques/PO's payable to Quasar Electronics. Prices include 17.5% VAT.
 Call now for our **FREE CATALOGUE** with details of over 300 kits, projects, modules and publications. Discounts for bulk quantities.



QUASAR
 electronics

0871

CREDIT CARD SALES

717 7168

Get Plugged In!

Motor Drivers/Controllers

Here are just a few of our controller and driver modules for AC, DC, unipolar/bipolar stepper motors and servo motors. See website for full details.

NEW! Bidirectional DC Motor Controller

Controls the speed of most common DC motors (rated up to 32Vdc/5A) in both the forward and reverse direction. The range of control is from fully OFF to fully ON in both directions. The direction and speed are controlled using a single potentiometer. Screw terminal block for connections.

Kit Order Code: 3166KT - £14.95

Assembled Order Code: AS3166 - £23.95



DC Motor Speed Controller (5A/100V)

Control the speed of almost any common DC motor rated up to 100V/5A. Pulse width modulation output for maximum motor torque

at all speeds. Supply: 5-15Vdc. Box supplied. Dimensions (mm): 60Wx100Lx60H.

Kit Order Code: 3067KT - £11.95

Assembled Order Code: AS3067 - £19.95



NEW! PC / Standalone Unipolar Stepper Motor Driver

Drives any 5, 6 or 8-lead unipolar stepper motor rated up to 6 Amps max. Provides speed and direction control. Operates in stand-alone or PC-controlled mode. Up to six 3179 driver boards can be connected to a single parallel port. Supply: 9Vdc. PCB: 80x50mm.

Kit Order Code: 3179KT - £11.95

Assembled Order Code: AS3179 - £18.95



NEW! Bi-Polar Stepper Motor Driver

Drive any bi-polar stepper motor using externally supplied 5V levels for stepping and direction control. These usually come from software running on a computer.

Supply: 8-30Vdc. PCB: 75x85mm.

Kit Order Code: 3158KT - £14.95

Assembled Order Code: AS3158 - £27.95



Most items are available in kit form (KT suffix) or assembled and ready for use (AS prefix).

Controllers & Loggers

Here are just a few of the controller and data acquisition and control units we have. See website for full details. Suitable PSU for all units: Order Code PSU345 £9.95

Rolling Code 4-Channel UHF Remote

State-of-the-Art. High security. 4 channels. Momentary or latching relay output. Range up to 40m. Up to 15 Tx's can be learnt by one Rx (kit includes one Tx but more available separately). 4 indicator LED's. Rx: PCB 77x85mm, 12Vdc/6mA (standby). Two and Ten channel versions also available.

Kit Order Code: 3180KT - £39.95

Assembled Order Code: AS3180 - £47.95



Computer Temperature Data Logger

4-channel temperature logger for serial port. °C or °F. Continuously logs up to 4 separate sensors located 200m+ from board. Wide range of free software applications for storing/using data. PCB just 38x38mm. Powered by PC. Includes one DS1820 sensor and four header cables.

Kit Order Code: 3145KT - £16.95

Assembled Order Code: AS3145 - £23.95

Additional DS1820 Sensors - £3.95 each



NEW! DTMF Telephone Relay Switcher

Call your phone number using a DTMF phone from anywhere in the world and remotely turn on/off any of the 4 relays as desired.

User settable Security Password, Anti-Tamper, Rings to Answer, Auto Hang-up and Lockout. Includes plastic case. Not BT approved. 130x110x30mm. Power: 12Vdc.

Kit Order Code: 3140KT - £39.95

Assembled Order Code: AS3140 - £59.95



Serial Isolated I/O Module

Computer controlled 8-channel relay board. 5A mains rated relay outputs. 4 isolated digital inputs. Useful in a variety of control and sensing applications. Controlled via serial port for programming (using our new Windows interface, terminal emulator or batch files). Includes plastic case 130x100x30mm.

Power Supply: 12Vdc/500mA.

Kit Order Code: 3108KT - £49.95

Assembled Order Code: AS3108 - £59.95



Infrared RC Relay Board

Individually control 12 on-board relays with included infrared remote control unit. Toggle or momentary. 15m+ range. 112x122mm. Supply: 12Vdc/0.5A

Kit Order Code: 3142KT - £39.95

Assembled Order Code: AS3142 - £49.95



PIC & ATMEL Programmers

We have a wide range of low cost PIC and ATMEL Programmers. Complete range and documentation available from our web site.

Programmer Accessories:

40-pin Wide ZIF socket (ZIF40W) £15.00

18Vdc Power supply (PSU010) £19.95

Leads: Parallel (LDC136) £4.95 / Serial (LDC441) £4.95 / USB (LDC644) £2.95

NEW! USB 'All-Flash' PIC Programmer

USB PIC programmer for all 'Flash' devices. No external power supply making it truly portable. Supplied with box and Windows Software. ZIF Socket and USB Plug A-B lead not incl.

Kit Order Code: 3128KT - £34.95

Assembled Order Code: AS3128 - £44.95



"PICALL" PIC Programmer

"PICALL" will program virtually all 8 to 40 pin serial-mode* AND parallel-mode (PIC16C5x family)* programmed PIC micro controllers. Free fully functional software. Blank chip auto detect for super fast bulk programming.

Parallel port connection. Supply: 16-18Vdc.

Assembled Order Code: AS3117 - £24.95



ATMEL 89xxx Programmer

Uses serial port and any standard terminal comms program. 4 LED's display the status. ZIF sockets not included. Supply: 16-18Vdc.

Kit Order Code: 3123KT - £24.95



NEW! USB & Serial Port PIC Programmer

USB/Serial connection. Header cable for ICSP. Free Windows software. Wide range of supported PICs - see website for complete listing. ZIF Socket/USB Plug A-B lead not incl. Supply: 16-18Vdc.

Kit Order Code: 3149CKT - £34.95

Assembled Order Code: AS3149C - £49.95



www.quasarelectronics.com

Secure Online Ordering Facilities • Full Product Listing, Descriptions & Photos • Kit Documentation & Software Downloads



Is a Nano a No-no?

Something is 'rotten' in the state of nano. There are some conflicting messages coming out of the nanotechnology sectors. Some nanotechnology observers claim that the economic cycles will see consumer interest in nanotechnology evaporate before we find new ways of integrating such devices in ICs in high densities. This is supported with evidence of some companies' recent decisions to cease investment in nanotechnology programmes, even though they have been at the forefront of such developments for some time.

On the other side of the argument, there are figures emerging predicting that by 2010, the global market for nano tools and equipment will be worth in excess of \$3bn.

The question is, if we are going to hit a technology barrier within ten years, then why should anybody bother in spending money on nanotechnology developments now?

Over the past 50 or so years, the electronics industry's growth has been determined by, more or less, single drivers, such as the PC, then the mobile phone, for example. Therefore, they have been the main technology wave drivers. The third wave is a bit of a mystery, however. What is the application or device that will drive this one?

Recently, a lot of words are being spent on 'energy' and how to preserve, save and generate it in environmentally friendly ways. It is not just the generation and transmission companies that are now looking into renewable energies, but electronics and semiconductor firms too. One semiconductor executive told me recently: "We are starting to save energies from the IC upward. You don't want your device to draw too much power from the mains."

Hence, there's an implication that the third technology up-cycle will be driven by energy and the

evidence is beginning to mount up. Photovoltaic systems (solar panel systems), for example, are in high demand at present. This is further strengthened by certain countries' legal requirements to have such systems installed in new builds; countries like Spain and Germany, for example. In turn, there is already a reported shortage of polysilicon, as both photovoltaics manufacturers and the semiconductor industry use it in their products.

So, going back to our nano riddle: If energy is truly going to fire up and drive the next technology up-wave, then where does the current research of nanotechnologies fit in?

SEMI, the association of semiconductor equipment and material manufacturers, has a way of describing the future of the nano state. SEMI categorises nanotechnologies into nanoelectronics – semiconductors that are scaled down to below 100nm, and the rest of nanotechnology, which emerges from the bio and pharmaceutical fields. Then, it further splits the nanoelectronics side into 'evolutionary' and 'revolutionary' veins.

According to its latest figures (submitted in December 2005), 23% of the \$3.1bn of money spent in 2010 on nano tools and equipment will cover the 'revolutionary' side. SEMI says, the advent of nanoelectronics "has started and will not be stopped".

On the other hand, I am still not sure how all these figures tie in with the forecast of an uncertain nano future on the large scale. One thing that is certain, however, is that firms investing in nanotechnology will need to be pretty darn sure that they will see returns on their invested millions before getting in any deeper.

Svetlana Josifovska
Editor

EDITOR: Svetlana Josifovska E-mail: svetlana.josifovska@nexusmedia.com EDITORIAL E-mail: EWeditor@nexusmedia.com

EDITORIAL ADMINISTRATION: +44 (0) 1322 611274 E-mail: EWadmin@nexusmedia.com

PRODUCTION EDITOR/DESIGNER: Jane Massey

SUBSCRIPTIONS: Customer Interface Ltd, Cary Court, Somerton, TA11 7BR Telephone: 0870 4287950, Fax: 01458 271146

SUBSCRIPTION RATES: 1 year: £45 (UK); €115 (Europe); \$150 US & worldwide

DISPLAY SALES EXECUTIVE: Reuben Gurunlian +44 (0) 1322 611261 E-mail: reuben.gurunlian@nexusmedia.com

PRODUCTION EXECUTIVE: Dean Turner +44 (0) 1322 611206

PRINTER: William Gibbons Ltd • ORIGINATION: Impress Repro A1 Parkway, Southgate Way, Orton Southgate, Peterborough, PE2 6YN

NEWSTRADE: Distributed by Seymour Distribution Ltd, 86 Newman St, London W1T 3EX. • PUBLISHING DIRECTOR: Tony Greville

If you are experiencing problems getting copies through your newsagent, please call Debbie Jenner on +44 (0) 1322 611210

Electronics World is published monthly by Nexus Media Communications, Media House, Azalea Drive, Swanley, Kent, BR8 8HU Nexus Media Communications is a trading name of Nexus Holdings Limited. Registered in England. Registered Number 5346404. Registered Office: Hanover House, 14 Hanover Square, London W1S 1HP

ISSN 0959-8332



NEXUS
MEDIA COMMUNICATIONS

Disclaimer: We work hard to ensure that the information presented in **Electronics World** is accurate. However, **Electronics World's** publisher – **Nexus Media Communications** – will not take responsibility for any injury or loss of earnings that may result from applying information presented in the magazine. It is your responsibility to familiarise yourself with the laws relating to dealing with your customers and suppliers, and with safety practices relating to working with electrical/electronic circuitry – particularly as regards electric shock, fire hazards and explosions.

Novel Annealing System Developed for Chip Makers

Pan-European collaborative work led to the development of a revolutionary new annealing technique for wafer fabrication. After wafers have been implanted with high-energy ions, rapid thermal annealing (RTA) is required to repair the semiconductor crystal structure. RTA requires very rapid changes of temperature under accurately controlled conditions for satisfactory annealing. This annealing is conventionally accomplished by focusing the heat from a bank of tungsten filament lamps onto the wafer surface, as furnace heating involves long process times. However, rapid cooling is difficult to achieve.

In the new RTA system, the heat is supplied by conduction rather than by radiation. The semiconductor wafers are precisely floated between two hot graphite blocks, coated with silicon carbide and kept at the process temperature. A stream of hot

nitrogen or helium gas emerges from narrow channels in the blocks to ensure that the wafers are heated and cooled very rapidly and very uniformly across their surfaces. Faster heating and cooling rates and better temperature control can be obtained than with conventional RTA systems. The system is also very suitable for rapid thermal oxidation, even though the oxidation application is not completely ready yet.

The new RTA system can be used at up to 1100°C with heating rates of up to 900°C per second with helium and a high wafer throughput. This 'Levitor' machine is available from ASM International (ASMI) for annealing silicon after ion implantation and for the very fast heating of conducting layers. Power consumption is only 6-20kW for a 300mm wafer system, whereas tungsten filament RTA requires 200-250kW. It has been qualified for 65nm

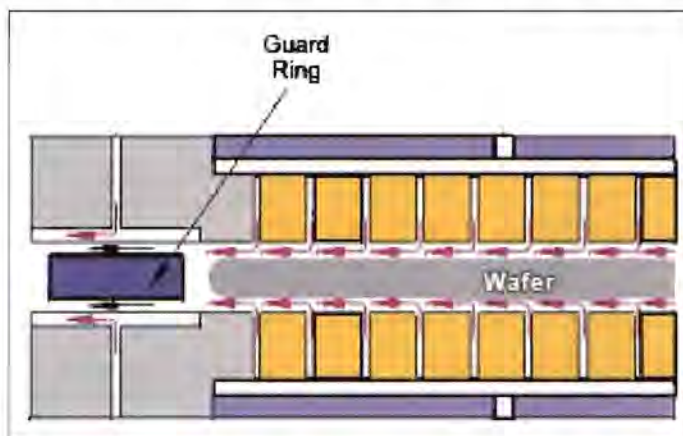

Principle of 'gas-bearing' between two high-mass blocks that act as a thermal flywheel

chip technology and qualification for 45nm is commencing. A simpler, more economical, version is available for use at up to 400°C.

The results of this project should provide Europe with a global lead to boost employment in manufacturing equipment.

The partners who developed the new system are ASMI, ASM Belgium, CEA-LETI, IMEC, Schunk, STMicroelectronics and

Xycarb Ceramics. This Medea+ project, dubbed T303 Contactless Anneal And Silicides System (CLASS), was carried out in Belgium, France, Germany, Italy and The Netherlands. It is one of 34 completed projects of the 70 projects under the Medea+ umbrella.

The Medea+ programme involves 350 partners from 21 European countries and the work of 14,000 person-years.

• Nanowatch • Nanowatch • Nanowatch • Nanowatch • Nanowatch • Nanowatch • Nanowatch • Nanowatch • Nanowatch • Nanowatch • Nanowatch • Nanowatch • Nanowatch • Nanowatch •

New market report by Nexus (the EC-backed Network of Excellence in Multifunctional Microsystems) forecasts the MEMS market to reach \$25bn in 2009, which is more than double on 2004. The "Nexus Market Analysis for MEMS and Microsystems III, 2005-2009" report states that

MST/MEMS sensors and actuators will still remain an important element of the IT peripheral market for read/write heads and inkjet heads, but also enter new areas such as microphones, memories, micro energy sources and chip coolers.

Seagate's nanotechnology facility in Springtown,

Northern Ireland, has received a financial boost of £83m, which it will share with sister plant Limavady, also in Northern Ireland. Between the two, some 300 new jobs will be created. The investment includes backing of £24.8m from Invest Northern Ireland, the main economic development agency there.

University of Surrey's Advanced Technology Institute (ATI) and CEVP have started trials of the world's first tool for low temperature carbon nanotube growth.

The partners envisage releasing the technology – called NanoGrowth – for commercial use in March this year.

Europe Leads in Extreme UV Lithography

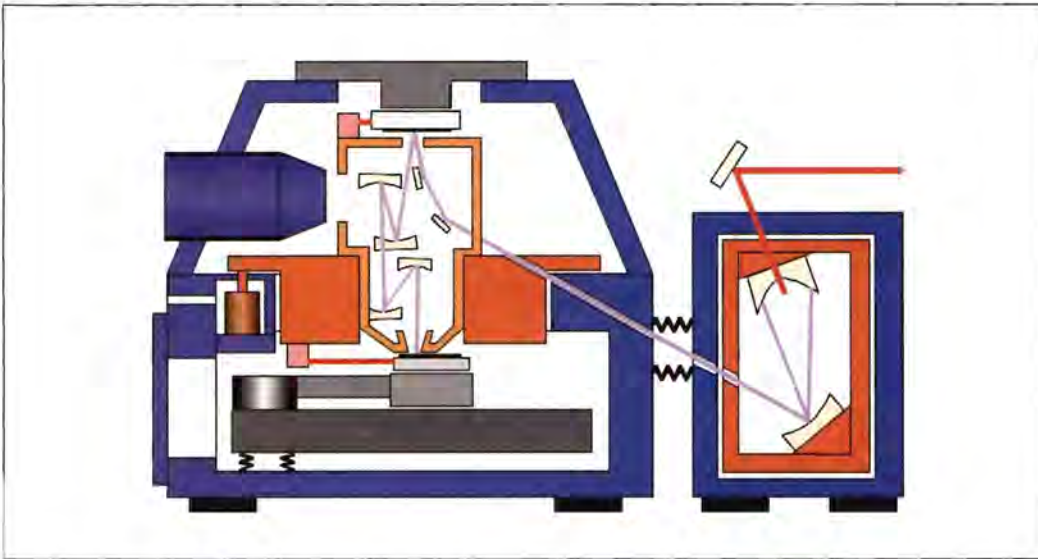

Schematic drawing of the EUV lithography tool

Right: Illuminator optics, **Left:** Six mirror demagnifying optics with mask at top and waferstage at bottom

Extrême UV Lithography (EUVL) will be the technique used to pattern ever more transistors of yet finer dimensions onto silicon chips towards the end of this decade. By then, chips will have feature sizes of 45nm and less, using patterns that cannot be produced by refractive optics. The vital importance of using the shorter EUVL wavelengths was demonstrated at the Medea+ Forum in Barcelona, Spain, in November.

Rob Hartman, of ASML, said Europe will dominate in EUVL by 2009 with an expected turnover of more than €1bn and about 18,000 employees, mainly at a higher technical level. Medea+ is a pan-European organisation that promotes research and development between companies and academics in projects taking place in at

least two countries.

Until recently, a major problem has been that of generating adequate EUV power at the required 13.5nm wavelength to enable EUVL to be used for mass production. However, Hartman said, an EUV power level of 800W over 2-Pi steradians has been achieved at 4kHz. This is an increase of three orders of magnitude over three years, so power is no longer a major issue. The lifetime of the sources has also been increased by several orders of magnitude.

Aachen-based Philips has developed a source using gas discharge plasma containing xenon or tin. Göttingen-based Xtreme has produced both a gas discharge and a laser induced plasma source. However, collector lifetimes, masks and resists are still major problems in this work involving 13 collaborators in

France, Germany, The Netherlands, Poland and Sweden. Critical issues include optics quality and life and reticle protection during storage, handling and use. Reflective optics using mirrors, coated with alternate layers of molybdenum and silicon are used, but it is vital to minimise losses at each mirror, as the EUV undergoes many reflections in the system.

Nevertheless, one full-field EUV tool will be shipped to research facility IMEC in Leuven, Belgium, and another to the University of Albany in the US, in the second quarter of 2006.

Another Medea+ project has led to the development of a mask for aligning and installing an EUV system. It can be fabricated in the AMTC (Advanced Mask Technology Centre) in Dresden and is already available.

MEDEA+ participants have already started a debate on a successor programme. The advanced co-operative R&D programme in microelectronics is coming to a close in 2008, but since it involves over 350 partners from 21 countries, it will take some time before the technical outline and funding for a similar programme are agreed. Prior to MEDEA+, MEDEA and before that JESSI helped advance Europe's capabilities in micro and nanoelectronics R&D and placed it firmly on the map in these fields. MEDEA+ started in January 2001 with the remit to focus on system innovation on silicon for the e-economy.

Ω

The Centre for Integrated Photonics (CIP) has developed a reflective semiconductor optical amplifier offering highly optimised performance for WDM passive optical network (PON) applications. Capable of delivering a gain of 20dB, the semiconductor optical amplifier (SOA) can be modulated at rates up to 1.5Gbit/s to provide wavelength-agile optical data transmission for fibre-to-the-home/premises (FTTH/FTTP) access network architectures – without the expense of a tunable wavelength source. Novel curved waveguide architecture inside the monolithic InP (indium phosphide) based SOA delivers smooth output characteristics with a ripple of just 0.5dB (typical) and a polarisation-dependent gain of 1.5dB. This performance is claimed to be unique on the market and it will boost the development of cost-effective WDM PONs.

Ω

Students at the De Montfort University in Leicester are learning about the next generation of television technology in a unique £300,000 high-definition TV lab, where academics are also conducting a multi-million pound research to develop 3-D TV. The new HDTV lab includes a £23,000 DVB/ATSC combined encoder and multiplexer for processing multiple data streams. The students are also using real-time high-definition editing facilities as well as high-definition cameras, which will soon be used by TV crews around the UK. The research for this project is funded by a 'Network of Excellence' grant from the European Union.

The Association of Franchised Distributors of Electronic Components (AFDEC) released a disappointing forecast for the state of the UK electronic components market for 2006 and 2007. The report found that the total available market (TAM) in the UK declined significantly over the last five years from a peak of £10.2bn in 2000. According to the AFDEC membership, this decline is due mainly to volume manufacturing moving off to Eastern Europe and Asia, and the shift in demand of components from lower volume, complex datacom/telecom type products, to high volume, lower complexity consumer products.

Ω

WiMax has enormous potential, but competing technologies are significant threats, reports In-Stat. The high-tech market research firm forecasts a WiMax chipset market as high as \$950m in 2009, however, among the competing technologies, such as 3G on the cellular side (EV-DO Release 0, A, and B; HSDPA) and Wi-Fi (coupled with wireless mesh networking and MIMO enhancements within 802.11n) on the networking side, this figure may realistically reach only \$450m. In-Stat also suggests that despite tremendous hype surrounding WiMax, the WiMax chipset market has a relatively small number of players, with Intel being the largest and most heavyweight to drive it.

Ω

British children have snubbed nuclear power as an energy source for the future in a recent survey commissioned by the IEE as part of the 2006 Faraday lecture 'Emission Impossible - Can Technology Save the Planet'. The survey also revealed that children are also more likely than their parents to shoulder the blame for climate change and are most concerned about changes to wildlife. "We know that children are concerned about the environment," said Dorrie Giles, IEE's director of qualifications, but she added: "Only 19% of children are aware that engineers can make a difference when, in truth, all environmental technologies have their basis in engineering."



Potential automotive application for the DaVinci technology. A video image can be processed using a DSP camera providing a head-up display

Texas Instruments's DaVinci sees its first products

Texas Instruments (TI) announced the first two video devices based on its recently launched DaVinci platform.

The TMS320DM6443 and TMS320DM6446 act as a video decoder and video encoder/decoder, respectively. As the first generation of devices, they are aimed at IPTV set-top boxes, CCTV monitoring equipment and other video security products.

DaVinci consists of the hardware – an ARM9 core, TI's 64-bit 600MHz DSP and on-board memory; multimedia codecs implemented in software; MontaVista's Linux operating system; a host of device drivers, frameworks

and APIs and the tools for product development.

According to TI, any development engineer will be able to pick up this platform and "run with it" without the need to possess knowledge and working understanding of DSPs. "On the DSP side, there are four major codec engines – for imaging, speech, video and audio – we are providing. If the customer wants, however, they can use the ARM to run the codecs. But, if the customer wanted to access the DSP 'under the hood' then CodeComposer [the development tool] will allow that. We offer a lot of flexibility with this platform," said Jean-Marc Charpentier, DSP business

development manager at TI.

Among the video codecs included in this platform are H.264 and H.263, MPEG-2 and MPEG-4, MP3, WMV9/VC1, AAC/AAC+ and G.711.

"With all the frameworks, operating systems, hardware components and device drivers that we've included in DaVinci, you won't need 50 engineers working on a product for a year any more to get it rocking," said Charpentier. "Before, customers had to run around to get all of these separately. We've simplified that. For example, with our pre-wired software codecs, development time is cut down to less than a month, compared to up to 16 months."

Israeli start-up develops fibre optic technology for flexible screens

Israeli start-up Oree has developed a technology that promises to replace back light units in laptops, televisions and mobile phones. It is based on a flexible, flat, three-ply fibre optic system and uses a new way of dispersing and preserving light.

Currently, the back lighting in larger LCDs typically uses a cold cathode fluorescent lamp (CCFL), which generates a lot of heat, is expensive and, often, low quality. In recent years, CCFLs have been replaced by light emitting diodes (LEDs). However, according to Oree's CEO, Eran Fine: "Current screens have trouble uniformly transmitting light from LEDs to every part of the screen to create a uniform

picture. LEDs also require considerable energy and their efficiency is low."

The inefficiency stems from the light losing energy as it travels between the layers of the screen. The loss of energy, in turn, requires a more powerful source of light, which means a bigger battery and a larger LED. In addition, the dispersal of light within the plastic sheet that separates the screen from the LED is not completely uniform.

Oree offers a different structure for



A part of a mesh module enabling the easy fabrication of a large area backlight unit for LCD screens, as prepared by Oree

the sheet, a new location for the LED and a unique method of dispersing the light within the plastic of the screen. The sheet in which the light is dispersed is built in the form of a three-ply fibre optic made from flexible polymers. The LED is placed in parallel to the sheet, instead of behind it, and most importantly, it is placed

within the sheet, rather than outside it. In this way, the light only passes through one layer to disperse within the sheet, cutting energy loss by 30-50%.

Oree plans to integrate the LED directly inside the sheet, further reducing energy loss. This method should also shorten production procedures of screens, cutting costs further.

Another advantage of fibre optics is their elasticity and flexibility. Since the LED will be placed inside the fibre optic sheet, the light will still disperse uniformly, regardless of the angle in which it is flexed.

The company is at the pilot stage, manufacturing the sheet at laboratory level. The initial applications will be for televisions and mobile phones. It has already signed an agreement with a leading television manufacturer to test how the system functions when attached to the screen.

Shortage of polysilicon continues to affect industry

BP Solar Showcase, Birmingham, UK



Demand for photovoltaic systems continues to cause shortages of silicon for the semiconductor industry – the traditional user of this material.

Photovoltaic systems (solar cells) are growing in demand, due to the recent energy saving policies in the face of a new energy crisis. Countries like Japan and

Germany have subsidies and incentives in place that fuel demand for such systems. Spain, for example, has gone a step further and made it a legal requirement to have solar cells installed in new builds. "Now, focus is on sustainable systems; you'll be buying systems that'll save energies," said Heinz Kundert, president of SEMI Europe, the global association of semiconductor equipment and material suppliers.

Although silicon is readily available (it is basically sand), it is expensive to purify into high-grade polysilicon required in the semiconductor and solar industries. "There's a shortage of polysilicon as sales boom. A lot of materials that used to go into semicon-

ductors are now going into photovoltaics. Polysilicon makers have started to increase capacity, but are trying to be careful how they go about it," said Kundert.

The solar market is currently valued at \$7bn and this industry has shown a sustained growth of up to 40% per year for nearly a decade. Prices for polysilicon have increased ten-fold to reach \$80 per kilo at the end of last year. Certain industry observers claim that even though polysilicon prices are going up, the semiconductor industry can still afford them, but not necessarily the younger solar panel industry, where polysilicon constitutes 80% of the total cell's production costs.

Patented technique provides improved EDLCs

By the use of a unique patented manufacturing process, Israeli firm Cellergy has developed a small footprint, high frequency electrochemical double layer capacitor or EDLC, capable of storing large amounts of energy.

The development is based on an innovative printing technology that allows the inexpensive production of EDLCs in many different sizes with varied dimensions and shapes. Device footprints start from 11 x 11mm, with capacitances of between 18mF and 1.2F and ESRs down to a mere 10mΩ.

Film capacitors store charge by means of two layers of conductive film that are separated

by a dielectric material. The charge accumulates on both conductive film layers, yet remains separated due to the dielectric between the conductive films.

Electrolytic capacitors are composed of metal to which is added a thin layer of non-conductive metal oxide, which serves as the dielectric. These capacitors have an inherently larger capacitance than that of standard film capacitors. In both cases the capacitance is generated by electronic charge and, therefore, the power capability of these types of capacitors is relatively high while the energy density is much lower.

The EDLC or Super Capacitor is a form of hybrid between conventional capacitors and a battery. The capacitance, coined the "double layer capacitance", is the result of charge separation in the solution/solid interphase. On the solid electrode, electronic charge is accumulated with its counter charge gathering in the solution in the form of ionic charge.

The production process involves a printable aqueous electrode paste based on a high surface area carbon paste that is printed in an electrode matrix structure on an electronically conductive film. The electrodes are then encapsu-

lated with a porous ionic conducting separator and another electrode matrix is then printed on the separator.

The finished wafer is then cut into individual EDLCs that are then packaged. The combination of the separator and carbon paste lead to the capability of very high power bursts within low millisecond pulse widths, as required in digital cameras, for example.

The technology will enable assimilation of the low ESR capacitor into a number of applications in which electrochemical capacitors have never before been integrated, such as laptop computers and mobile telephones.



How to apply for a patent

▶▶ Patents are a crucial way of staking your claim on an innovation, but as with all tools, they are only useful if you take care over your application.

▶▶ If you think you have developed a new electronic device or process, a patent will give you the right to prevent anyone from making, using, selling or importing your invention for up to 20 years.

▶▶ During your research and development, search a patent database to make sure that someone else hasn't already patented something very similar to your idea. Repeated efforts can be very costly in terms of time and money. The Patent Office and the British Library offer commercial services, or you can use the services of a patent attorney.

▶▶ If you are satisfied that your idea is novel and want to file a patent, remember to keep your innovation a secret: non-confidential disclosures can harm a later application.

▶▶ In terms of cost, the Patent Office's fees to take an initial application to grant (typically 2-4 years) are just £200. The advice of a patent attorney will be several times this amount, but could prove invaluable in securing the strongest protection possible for your invention. Your application must describe your invention and its operation clearly and completely.

▶▶ If you want protection for your electronic innovation in overseas markets you will need to make patent applications for these within one year of your UK filing date. You may have

to use patent attorneys for these countries as well.

▶▶ Your UK patent application is usually published by the Patent Office 18 months after your initial application, so everyone can read your invention's secrets. If the Patent Office believes your invention is novel and inventive, and grants a patent for it, your patent could become a useful tool for striking a licensing deal or attracting further investment.

▶▶ Last year, the UK Patent Office granted 10,541 patents of which 521 related to electric circuit elements and magnets, 287 to electric power, 178 to electronic circuits and radio receivers, and 1,700 to telecommunications.

▶▶ For more information about patenting, visit the Patent Office website at www.patent.gov.uk

▶▶ For more information about patent attorneys, visit the Chartered Institute of Patent Agents website www.cipa.org.uk

Miles Rees, Business Development Manager at The Patent Office, supplied this month's top ten tips.

If you'd like to send us your top five or ten tips on any subject, please write to the Editor at

EWAdmin@nexusmedia.com

Freescale manufactures 24Mbit nanocrystal memory

Freescale has manufactured the world's first 24Mbit memory array based on silicon nanocrystals. This type of non-volatile memory is denser, faster and more cost-effective than conventional flash memory and, as such, it's likely to replace conventional floating gate-based flash memories.

According to the company, silicon nanocrystal technology offers lower operating voltages, reduced memory module size, simpler process flow and lower manufacturing costs.

Additionally, it requires no new materials or wafer fabrication equipment, allowing for immediate compatibility with existing production wafer fabs.

Embedding floating gate-based flash becomes more difficult to produce cost-effectively at geometries of 90nm and below. At those dimensions, the chip area consumed by the 9-12V high-voltage transistors required to write and erase the conventional flash module cannot be scaled down. Furthermore, engineers cannot reduce the high voltage in floating gate based flash without compromising reliability or risking memory failures

and loss of data.

"The industry anticipates that conventional embedded flash memory technology will reach its scaling limit within the next four years due to high-operating voltages, fabrication process complexity and cost," said Dr. Claudine Simson, Freescale's chief technology officer.

Silicon nanocrystal memories are part of a new class of memories called thin-film storage. They are more scaleable than conventional floating gate-based flash technology, as their tunnel oxide thickness can be reduced without impacting data retention. The charge is stored on isolated nanocrystals and is lost only from those few nanocrystals that align with defects in the tunnel oxide – while the same defects would result in significant charge loss from a conventional floating gate. A thinner tunnel oxide permits lower-voltage operation, substantially reducing the memory module area needed to generate the bit-cell programming voltages and allowing for significant wafer processing simplifications and

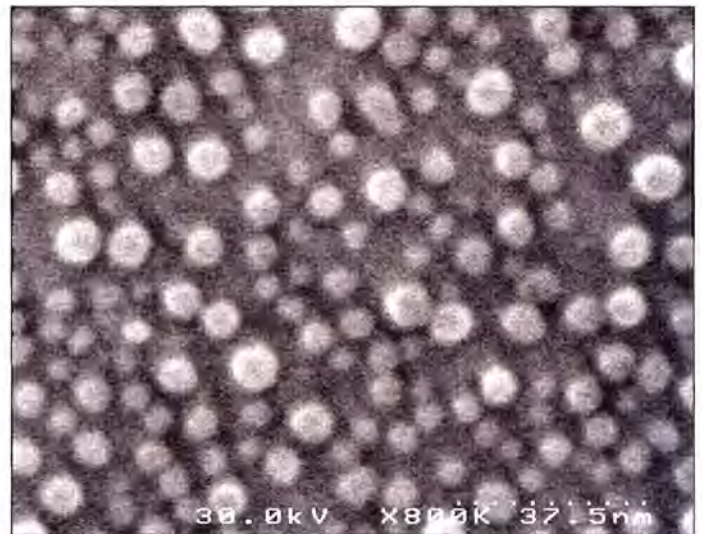

Freescale's new silicon nanocrystal memory structure; **Above:** under the microscope; **Below:** block diagram

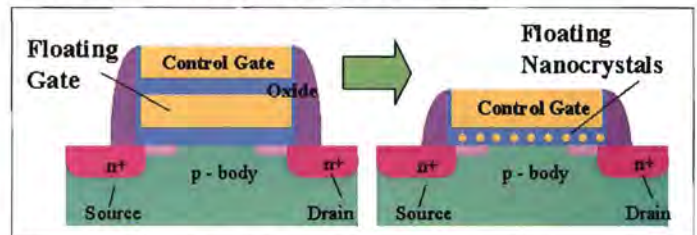

manufacturing cost reductions. The combination of higher bit density and reduced cost translates to lower cost per bit to embed silicon nanocrystal memories.

Freescale has manufactured the 24Mbit memory array technology using 90nm

CMOS bulk technology. During the fabrication process it had to overcome several major challenges, including a uniform depositing of the silicon nanocrystals and keeping the nanocrystal properties intact during subsequent processing.



• easy to use • easy to browse • full text and diagrams of all articles, circuit ideas, letters etc •

ELECTRONICS WORLD ON CD-ROM

SEE PAGE 62



A Call for New Wave PMR

Mike Norfield of Team Simoco analyses if the days of PMR are over

The digital revolution seemed to pass the private mobile radio (PMR) industry by. Instead of seizing the opportunities created by advances in silicon and software, PMR stood back and watched the computer boys eat our lunch. Analogue cellular came, then GSM. Then the Internet and voice over IP came and converged, offering rich media services on both, the PC and mobile cellular platforms. PMR continued to plough its lonely furrow, eschewing these newfangled technologies like they would never catch on.

Indeed, over the 1990s, a large chunk of the PMR potential user-base was lost to cellular, which in terms of technology sophistication had the edge. If it was a technology race, PMR would have disappeared without a trace. Fortunately, although it fell behind in technology, there are a number of compelling reasons why PMR survived and why it will continue to thrive in key market sectors.

Try telling an airport operator or a police chief constable that you are going to put all their communications on a public network. You will get a very short shrift, indeed. What if the network shuts down when everyone is calling to wish each other a happy new year? Public technologies like cellular simply cannot guarantee the same service levels and security as a private radio-based network.

With terrorism being on top of the public safety agenda and open networks like cellular getting more driven by revenue earners like ring tones and even streaming video, which make ever greater demands on bandwidth, it is unlikely that private radio networks will be replaced in the near future.

The introduction of the Tetra digital radio standard was to give customers some of the advanced features of cellular

but with the security of a private network. So, you can stream video, you can send CCTV pictures, plus give better quality of voice. But, the shortage of licences and the relatively high cost means that Tetra currently only addresses the emergency services and transport markets.

The PMR sector has found its own niche by default. Demand for the advanced service has been driven by the public networks but people can now see the benefits of them on PMR. Plus, PMR has an overwhelming cost advantage over the longer term. Once you have installed the system, your calls, data and rich media content are all free. A public network would never be able to compete with this. They have to recover their capital and operating costs through service charges in one form or another.

So having secured its niche, PMR now needs to seize the opportunity presented by new technology to deliver advanced services. This doesn't mean offering ring tones and wallpaper on your handheld systems but, rather, delivering advanced services that will benefit the operator. Tetra addresses the higher end, such as public safety and emergency services, but what about the small to medium sized business end of the market? They too want advanced features.

Strangely, an opportunity to achieve this came about with the introduction of the RoHS and WEEE directives. PMR had to upgrade its technology in order to stay in business. We had a choice to spend millions of pounds to upgrade, just to stay compliant, and, effectively, stand still. Alternatively, we took the opportunity to make a quantum leap and upgrade the technology to take advantage of plug-and-play, IP compatible, software configurable, standard components. Just like the rest of the IT industry.

With various initiatives abound, this industry now has the low capital cost and flexibility advantages of analogue PMR, but with the system management and low cost of ownership benefits of digital. With our own Xfin technology, we can call up a base station over the Internet and reconfigure the controller, without having to send a technician to a remote, windswept hilltop. With digital technology, the PMR industry can offer standard services, such as call logging and teleconnect, which, not so long ago, used to be expensive extras. Such advances will help meet the expectations of a new generation of customers who are used to buying a home computer from PC World that comes already loaded with all the applications they could ever need and even gives them an Internet service thrown into the bargain.

The really exciting prospect for "new wave" PMR is the ability to deliver services to markets that have been completely left out by the cellular business. In Africa, for example, there's a PMR network for a national railway that will be using IP addressable base stations. These can now be connected via WiMax instead of microwave, with Wi-Fi at each location, delivering broadband Internet to the rural community. Only PMR could do this. Cellular is not cost-effective for remote parts of Africa, which are poor and sparsely populated.

There is a great future for PMR if the industry takes on board new technology to bring down costs and deliver the new services that customers will start demanding as standard. We have been paddling in the shallows for far too long. It's time we took heart and started surfing the new wave.

Mike Norfield is Team Simoco's Managing Director, based in the UK.



PCBTrain

PTH PCBs with solder resist and legend from just £30.00 lot price.

Deliveries from

24 Hrs

Visit WWW.pcbtrain.com
for full details.

- ▲ NEWBURY ELECTRONICS, the home of PCBTrain, the UK market leader for low-cost prototype PCBs
- ▲ Exclusive UK representatives for Circuit Mission Ltd (China) - manufacturers of low-cost high quality rigid PCBs
- ▲ Exclusive UK representatives for Sunflex Ltd (Taiwan & China) - manufacturers of flexible circuits



+44 (0) 1635 40347

NEWBURY ELECTRONICS LTD

Faraday Road Newbury Berkshire RG14 2AD UK



Nokia unveiled the N92, as part of the Nseries launch

Eyeing Up a Pot of Gold

By John Walko

Interest in delivering TV to mobile phones and other handheld media players exploded in 2005, first with streaming services over third generation networks, followed by numerous trials of dedicated mobile broadcast networks. Then, in November 2005, Nokia, with much fanfare, demonstrated a phone capable of receiving mobile broadcast TV, dubbed the N92, with an innovative design, using a hinged 2.8-inch display that lets the device sit on a table like a portable DVD player or twist into an LCD viewfinder like a handheld video camera.

Nokia's launch underscores a still uncertain rollout and future for the Digital Video Broadcast-Handheld (DVB-H) version of the mobile broadcast technology. DVB-H is being tested in about 20 pilots in Europe, the US and Korea, but, to date, no network operator has committed to a live service.

That has not stopped them enthusing about it, however. For instance, Sanjiv Ahuja, CEO of UK mobile operator Orange, said that trial results indicate "live TV is really capturing [our] customers' imagination".

While the market researchers are as enthusiastic as the operators and content providers, it is not a given that TV over mobile will turn out to be a workable consumer proposition, once the introductory offers are withdrawn and the novelty has faded. Just ask Sir Clive Sinclair!

One problem with this emerging – some suggest 'killer' – application for next generation mobile networks is that it is beset with protagonists pushing incompatible and, even, proprietary standards. Not surprisingly, there are also regional regulatory concerns, not least the fact that in Europe at least, the spectrum for delivering DVB-H is currently owned in the main by broadcasters rather than mobile network operators.

And while IC makers, mobile network operators and handset and PDA suppliers are eyeing a pot of gold, political intrigues could jolt the most optimistic forecasts about the impact of mobile TV. For it seems clear that the sector will, at least in the early days, remain fragmented.

Lining up against each other and backed by disparate groups, we have terrestrial and satellite delivered versions of South

Korea's DMB (Digital Media Broadcast), which is based on the Eureka Project 147's digital audio broadcast (DAB) technology; the European developed DVB-H version of the DVB-T (terrestrial) specification; and MediaFlo, a proprietary format being pushed by American mobile chip maker Qualcomm. Qualcomm has secured licences in the US for (700MHz) UHF channels and plans a nationwide network of broadcast towers to deliver TV to mobile phones, quite separately from the cellular systems, relieving operators of the potentially huge congestion concerns.

“It is clear that no one company, however large, will dominate the silicon market for mobile TV”

Anthony Sethill, founder and CEO, Frontier Silicon

DMB has taken off in South Korea, but DVB-H is coming up fast on the outside, with small scale deployments planned for next year (with the World Cup starting in June in Germany – a target for many to showcase the technology) and massive rollouts to follow in 2008.

The major stumbling block is that while, in principle, DVB-H is designed for use in numerous UHF frequency bands, there is currently no consensus on which is the best option – Band III, IV or V. At least in the US, it is a given that the tuner for the commercial service Crown Castle plans to start this year will operate in the L-band (1670 to 1675MHz). Crown Castle has a massive trial running in Pittsburgh at the moment.

These differences and options are creating both an opportunity and a concern for all involved, not least the semiconductor makers targeting mobile TV. Well established chip suppliers include Texas Instruments (TI), Philips Semiconductors and





Samsung, but there are also a number of innovative, fast moving start-ups who plan to make their mark.

Perhaps, furthest down the road to delivering silicon is Palaiseau, France-based DiBcom, which at the 2005 3GSM Congress in Cannes demonstrated a demodulator chip complying with the DVB-H specification, functioning on a PDA. The company says that it is at least a year ahead of others with an IC suitable for demodulating DVB-H, as well as DVB-T transmission, and which can work with tuners from either Freescale Semiconductor or Microtune. The part represents a 'fourth generation' device for the company, which has been selling DVB-T only demodulators since 2004.

Success at the silicon level in this market is not straightforward, however. Mobile TV is based on complex technology with large amounts of signal processing required, coupled with computational demands that are not needed for normal TV reception. Systems and handset makers will be looking for total solutions that will require strategic partnerships. A turnkey design will typically comprise an antenna, RF interface, tuner, demodulator and channel decode processors.

DiBcom is lucky and astute as amongst its investors are potentially key-partners too, such as Intel and UMC, the latter being the main foundry for the devices. In addition to numerous venture capital groups, earlier rounds also included funding from Motorola's venture arm, whose interest has now passed to another partner, Freescale.

"We targeted mobile TV right from the start, which is one of our main strengths, building on experience gained from devices for the automotive sector with chips for DVB-T reception. This gave us an excellent insight into the technical and marketing expertise needed for, what we believe, will be the much bigger market of demodulators for use in mobile phones and a host of other mobile devices," said Yannick Levy, president and CEO of DiBcom.

Levy suggests even TI, with its proven RF and silicon expertise will have problems meeting the performance and low power characteristics of DiBcom's fourth generation processor, "and we are clearly ahead of them in terms of having the parts field tested". TI is planning to develop the Hollywood decoder/tuner combo device for this market.

"So far, we can only publicly discuss Siemens as a user of our DVB-H chips,

which is supplying Vodafone for one of its trials, although there are many others looking at the part. The recent investment from Intel will work wonders for us in marketing the parts for use in PCs and laptops," added Levy.

TI announced its Hollywood single-chip device in late 2004. It will integrate a tuner, OFDM demodulator and the channel decoder processor. This is expected to be available in volume in late 2006. It is claimed that the device will deliver video at 24 to 30 frames per second with high quality audio.

Not surprisingly, Philips is also leveraging its RF expertise to develop a single-chip mobile TV tuner/receiver that initially will sample as a system-in-package. Philips claims its part will have a power consumption of less than 40 milliwatts when operating in DVB-H mode, while consuming less than 300mW in DVB-T mode.

Watford, England-based Frontier Silicon is challenging the mobile TV space from a slightly different perspective, that of an established and market leading supplier of silicon for DAB radios. Founded in 2001 and using basic technology licensed from Imagination Technologies, the company has already developed receiver chips for terrestrial DMB and is now readying a multi-standard and multiband integrated tuner and baseband SoC, dubbed Kino 3.

Anthony Sethill, founder and CEO of Frontier, says DMB is already a big money earner for the company, with "several tier 1 handset makers choosing our solution".

"DVB-H, because of regulatory issues regarding spectrum, could be a longer-term play, perhaps three to four years for

real volume, but what is clear is that no one company, however large, will dominate the silicon market for mobile TV. There will be room for several players as handset makers will look to offer different platforms, but clearly, as we have seen in other markets such as Bluetooth, we can also expect some consolidation down the road," he added.

Israeli start-up Siano Mobile has already started sampling a CMOS integrated, multi-standard receiver chipset that, it is claimed by the firm, scores over competitors in low power consumption. The part combines a quad band zero-IF CMOS RF tuner and a demodulator supporting DVB-H, DVB-T, DAB, Enhanced Packet Mode DAB and T-DMB standards, and uses a processor core from ARC International on the demodulator side.

With all this innovation at the chip level, the debate now needs to shift from "Who would ever want to watch TV on their mobile phone?" to some equally important real-world implementation issues. At the top of that list must be frequency allocations and availabilities, network planning, infrastructure costs and, on the handset side, power consumption issues.



WHAT BETTER CHOICE ?

FOR QUALITY, PERFORMANCE & AFTER SALES SERVICE

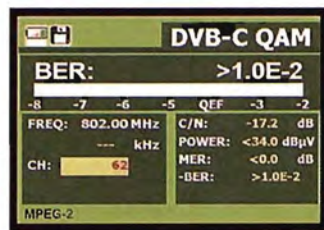
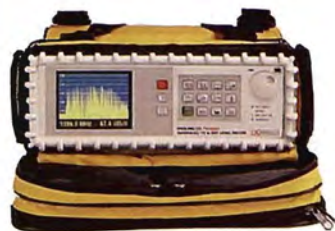
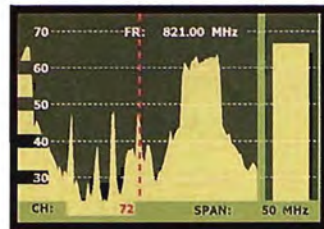
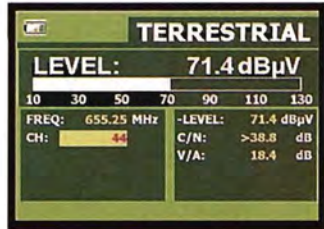
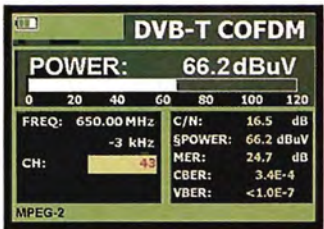
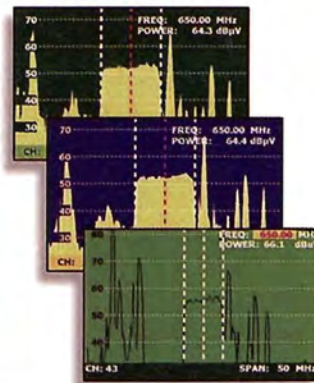
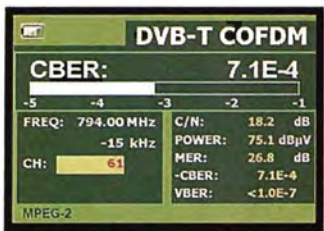

PRODIG 1+

PRODIG 2

MC 577



ALBAN ELECTRONICS LIMITED

THE PROMAX SERVICE CENTRE

6 Caxton Centre, Porters Wood, St. Albans, Herts, AL3 6XT.

TEL : 01727 832266

FAX : 01727 810546

www.albanelectronics.co.uk

info@albanelectronics.co.uk

SALES + SERVICE + CALIBRATION

The Cause of Flicker in LCD Screens

Donald LaFontaine, Mike Wong and **Tamara A. Papalias** state that contrary to popular belief, LCD panels do exhibit flicker, but simple potentiometer adjustments can be made to minimise the effect

When comparing CRT to LCD screens, one of the most popular differences is the issue of flicker. It is a common assumption that CRT screens flicker while LCD screens do not. In truth, both screens have some amount of flicker. The mechanisms are different and methods for correction have varying amounts of success. This article presents the cause of flicker in LCD screens and offers a solution for avoiding flicker in LCD panels.

LCD technology

Liquid crystal displays (LCDs) appeared in 1973 in calculator displays. These first LCDs were screens embedded with 7-segment units, allowing numbers to be displayed. Each segment was driven by a separate control line. The next generation of LCDs appeared in 1980. They were dot-matrix displays, allowing characters and graphics in addition to numbers, like simple monochrome computer screens or the popular toy, "the electronic pet". These matrix designs allowed control of pixels by activating a row and column of the array, instead of a separate control line for each pixel. By the end of the 1980s, colour filters were being successfully and cost-effectively included within the LCD design. Since then, generations of products have focused on the growth of screen size, the weight of the monitor, power efficiency and viewing angle.

While improvements continue, the basic operation of an LCD screen remains the same. LCD screens have an array of pixels constantly illuminated by a backlight. The constancy of the light removes the type of flicker found in CRT screens (phosphors pulsing with each refresh cycle). Instead, an LCD pixel has upper and lower plates with grooves cut perpendicular to each other as in **Figure 1**. These grooves align the crystals to form channels for the backlight to pass through to the front of the panel. The amount of light emitted depends upon the orientation of the liquid crystals and is proportional to

the applied voltage.

The upper and lower plates are polarised perpendicular to each other. The voltage between the plates aligns the liquid crystal in a twisted pattern to match the polarisation of each plate. Light from the backplane is delivered through the aligned liquid crystal elements. Conversely, light is scattered when the liquid crystals are not aligned. The amount of alignment is proportional to the applied voltage and serves to control the intensity.

The external plate is coated with a colour (RGB) filter. A red, green and blue area (each called a sub-pixel) is included within each pixel. The area associated with each colour is addressed separately, allowing a full range of colours and intensities to be displayed. The number of pixels determines the resolution. **Table 1** presents the pixel-array size for a variety of video formats. Note that the numbers for pixel-array size do not convert directly into aspect ratio for the screen since the pixels are not typically square.

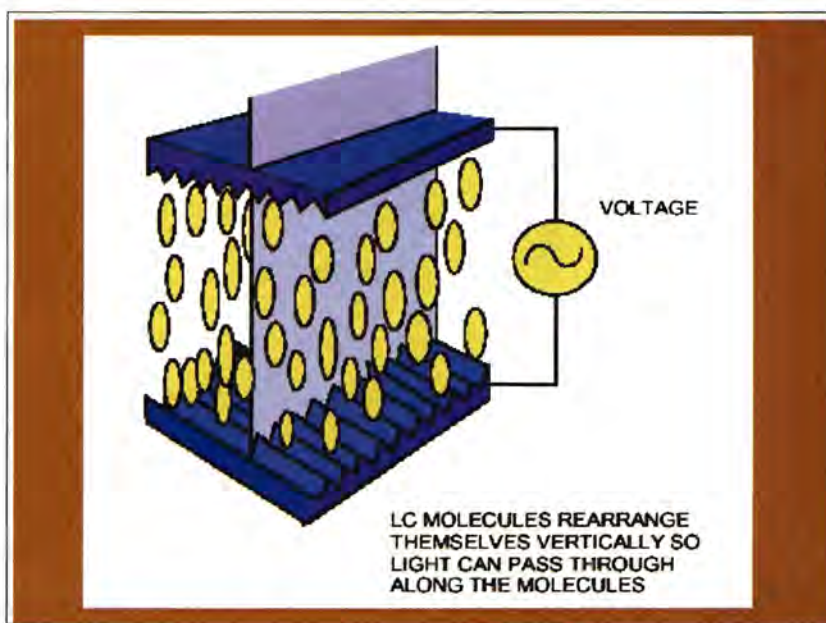

Cause of LCD panel flicker

Flicker in an LCD panel is different from a CRT screen. LCD flicker exhibits itself as washed out colour rather than pulsating light, as shown in **Figure 2 (a and b)**. Figure 2a is an LCD panel that has been adjusted to reduce flicker and Figure 2b is an LCD panel with excessive flicker. This is because of higher refresh rate of the LCD panel up to 300Hz.

The circuit driving a single LCD pixel is shown in **Figure 3**. The gate voltage acts as a switch and is commonly amplified to become -5V to 20V. The video source, typically ranging from 0V and 10V, provides the intensity information that appears across the pixel. The bottom of the pixel is commonly connected to the backplane of the panel. The voltage at this node is Vcom.

While this set-up is functional, it reduces panel lifetime. Assuming the Vcom voltage is at ground, the voltage across the pixel varies from 0V to 10V. Assuming an average of 5V, there is substantial DC voltage across each pixel. This DC voltage causes charge storage, or memory. In the long term, it is a form of aging, degrading the pixels by electroplating ion impurities onto one of the electrodes of the pixel. This contributes to image retention, commonly seen as fading colour on older TFT-LCD panels.

The construction of the LCD panel is symmetrical (Figure 1) and either a positive or a negative voltage can be used to align the crystals. One can capitalise on this aspect by moving the common voltage (Figure 3) to the midpoint of the video signal, 5V. Now the video signal swings above and below the common voltage (Vcom), creating a net zero effect on the pixel. This net zero effect on the liquid crystal eliminates the aging and image retention issues. The trade-off for this technique is resolution, since the video signal travels 5V to full brightness instead of 10V.

To achieve a net zero effect on the display, different inversion patterns can be utilised across an

Video format	Pixel-array size
VGA	640 x 480
SVGA	800 x 600
XGA	1024 x 768
WXGA	1365 x 768
HDTV – CIF (common-image format)	1920 x 1080
PAL	720 x 576
PAL – CIF (common-image format)	352 x 288
NTSC	720 x 480
NTSC – CIF (common-image format)	352 x 240

LCD (**Figure 4**). The simplest type is frame inversion. With this driving method, every pixel on the screen is inverted in each subsequent frame. Frame inversion creates a net zero effect with respect to time on the pixels. Two additional methods include inversion within each frame. Line inversion alternates the phase on each horizontal line. An alternate form of line inversion, called line-paired inversion, applies a common phase to pairs of horizontal lines instead of single lines. Dot inversion inverts the phase to every adjacent pixel, like a checkerboard. These three methods also create a net zero effect with respect to time on the pixels. The inversion pattern is chosen by the manufacturer and embedded within the driving circuitry. In all cases, the inversions alternate with each frame displayed.

The Vcom voltage needs to be placed exactly at the midpoint of the video signal to avoid flicker. To illustrate why a panel will flicker, let's assume that due to manufacturing of the panel the Vcom is 5.5V. If the video signal swings between 0V and 10V, the full-scale voltage will be different on each field. On one field, the full-scale voltage will be 4.5V and on the other, the full-scale voltage will be 5.5V. This difference in full-scale voltage translates to a difference in intensity, experienced as flicker.



Figure 2: Visual example of flicker in an LCD panel
(a) (Left): LCD panel with optimised flicker
(b) (Right): LCD panel with excessive flicker

Figure 5 shows the difference in a panel's light intensity with and without flicker. The (black) trace with the larger DC level is the measurement of a panel without flicker. The measurement was made using an EL7900 light sensor. The light sensor converts light intensity to current. Larger current produces larger voltage deflection on the scope.

In order to understand these results you first need to know there are two types of LCD panels, 'white' panels and 'black' panels. White panels allow light to pass through the crystal in the relaxed (no voltage applied across the crystal) state and black panels block all the light in the relaxed state. As the voltage potential across the crystal is increased, the crystal rotates and either blocks more light (as in the white panel case) or allows more light to pass through (as in the black panel case). The panel tested was a white panel and, therefore, the more voltage you have across the crystal the darker the panel. If the V_{com} voltage is set exactly in the middle (no flicker), then the average AC voltage is zero and the panel will be at its brightest. If the V_{com} voltage is not in the middle, then the resulting AC voltage will be higher and the panel's luminance will be darker.

The washed-out colours in Figure 2b are the result of the error voltage across the crystal due to the imbalance of the V_{com} voltage and not the over all intensity of the light.

Methods to eliminate LCD panel flicker

Due to the variations in construction of each panel, the optimal V_{com} voltage can differ from panel to panel or across a single panel. Original equipment manufactures must, therefore, adjust each of the panels coming out of the factory to eliminate flicker. For small screens, where the backplane can be considered a low-impedance ground, a single potentiometer can be added for common voltage adjustment. Traditionally, this was achieved by using mechanical potentiometers that required additional man-hours. This is acceptable for small panels, even though it is big in size, has low precision and could easily break during assembly, requiring the replacement of the whole module. For panels exceeding 19", the backplane cannot be considered a single low-impedance node. Multiple corrections are needed in various locations of the screen. There may be up to five localised compensation networks, four in the corners and one in the center. In this case, Digitally Controlled Potentiometers (DCPs) allow the manufacturer to automate the process, a necessity for larger panels where a manual adjustment is not practical. **Figure 6 (a and b)** illustrates the mechanical and digital controlled potentiometer solutions.

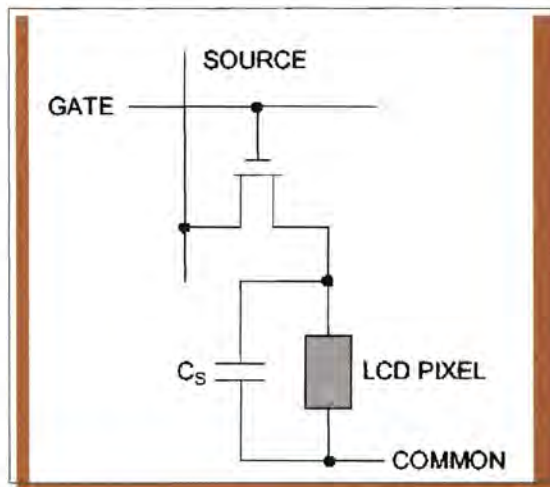
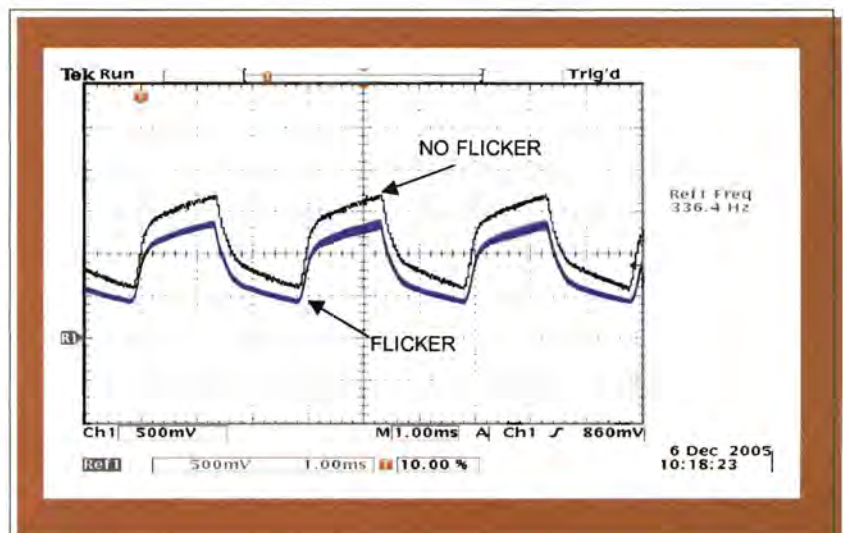
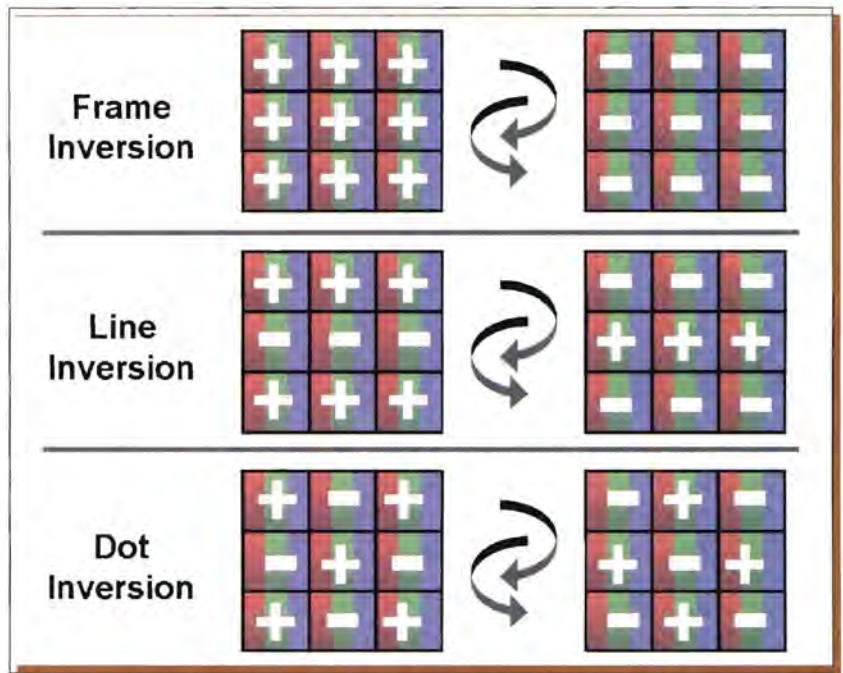

Figure 3 (Right): Circuit diagram for single LCD pixel

Figure 4 (Middle): Distribution of the phase of LCD pixels for the alternating frames for three types of inversion: frame inversion, line inversion and dot inversion

Figure 5 (Bottom): Measurement of a panel using EL7900 light sensor W/WO flicker



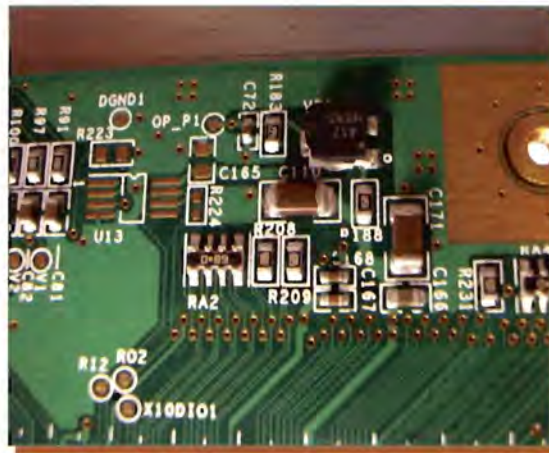
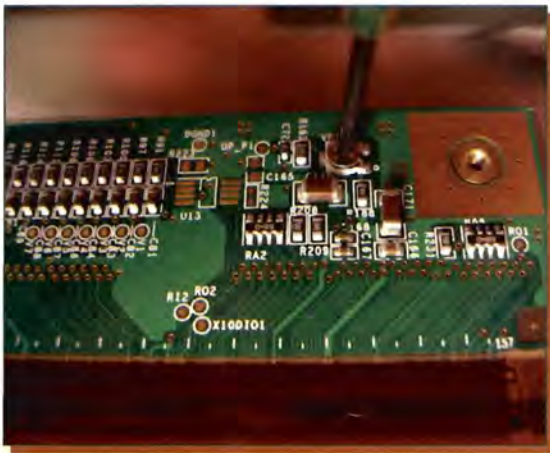
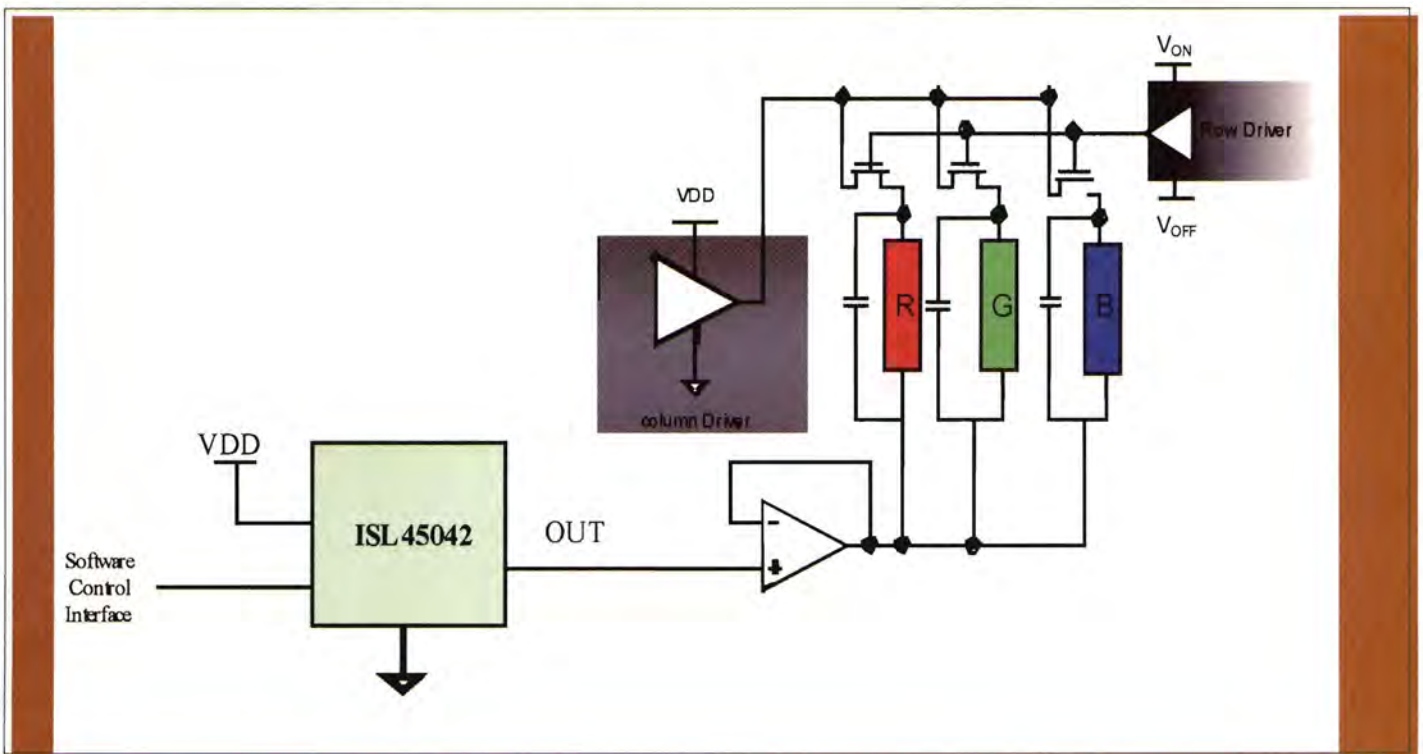

Figure 6: Vcom adjust using a potentiometer or digital controlled potentiometer
(a) (Left): Vcom adjust using a potentiometer
(b) (Right): Vcom adjust using a digital controlled potentiometer

The system implementation and conversion from a mechanical POT to a DCP is simple. **Figure 7** illustrates the system application implementation of a buffered DCP Vcom driver. The ISL45042 is a current output, non-volatile DCP that can operate with an AVDD of up to 20V. The ISL45042 uses a two-wire, up and down interface. It is an extremely accurate 7-bit device with a resolution of 128 steps. The desired Vcom value can be stored in an on-board EEPROM. The digital circuit voltage range is from 2.25V to 3.6V, this enables it to interface with many controllers used today. The analogue voltage supply, running the analogue resistor ladder of the device, can operate from 4.5V to 20V. This is an important characteristic for small panels that typically

require less than 10V of analogue supply, as well as the large panels that may require supply greater than 15V. The DCP output voltage is buffered to the Vcom bus through the EL5111 (180mA output current) amplifier. Contrary to popular belief, LCD panels do exhibit flicker. Simple potentiometer adjustments can be made to minimise the effect since LCD flicker arises from an offset of the common voltage, not a refresh signal. As LCDs grow in popularity and in size, manual adjustment of a single point on the backplane is no longer possible. Using ISL45042 DCP and EL5111 Vcom buffer allow automatic correction of Vcom offsets at multiple sites on the backplane.

Figure 7: DCP software-programmable Vcom implementation



WES **World Educational Services**

341 Hickory Nut Court * Pasadena * Maryland
Phone:410-437-7080, Fax:410-437-7081
Email:masc1@usa.net, Website:www.wesedu.com



A Complete electronics lab for \$450!

Price does not include shipping of \$30.

Includes 5 USB Instruments:

- Digital Storage Oscilloscope (80 Ms/s, 2ch)
- 16 Channel Logic Analyzer
- Arbitrary Waveform Generator (100 Ms/s)
- 2 Programmable Power Supplies
- 2 Programmable Clocks

Plus...

- Probes & Cables
- PC Software
- Easy USB connectivity with Windows

Visit our website to purchase it.

Plasma Display

Much has to be done following reception of a conventional video signal, whether analogue or digital, to generate drives that are suitable for a plasma display panel. This also applies to baseband-video inputs. By **Fawzi Ibrahim**

Plasma display panels can accept video signals from various sources – tuners, scart sockets for external composite and RGB video inputs, and S video inputs. The video signal is then fed to an input switching arrangement that selects input(s) for further processing and switching. See **Figure 1** for the basic video processing system in a plasma TV receiver.

The colour decoder separates the luminance and chrominance components of the composite video signal using a comb filter, and produces RGB video outputs. These are fed to an analogue-to-digital converter (ADC) that encodes each primary colour signal as an 8-bit digital signal, ready for passing to the display formatting section.

The comb filter

For analogue TV transmission, the picture's colour content (the chrominance signal, C) modulates a 4.43MHz subcarrier whose sidebands fit neatly within those of the basic luminance signal (Y) (see **Figure 2**). Separation of the Y and C components of the demodulated video signal must be as clean as possible to avoid high-frequency luminance information being contaminated by colour information and, conversely, colour being contaminated by luminance, otherwise this gives rise to 'rainbow swirls'.

Traditionally, notch filters are used for Y and C signal separation. A much more effective method, however, is to use a digital comb filter. There are several types of comb filter, all of which use the fact that the chrominance signal is phase-shifted by 180° on alternate lines.

The two-line (2L) comb filter mixes two consecutive lines of video information and takes the average. The two lines are added to produce the chroma information and subtracted to produce the luminance information. It's assumed that the two lines are much the same.

This type improves the horizontal resolution and reduces rainbow swirls.

The three-line (3L) comb filter uses three consecutive lines, giving the first one half weight, the second one full weight and the third one half weight. Differences in line content are in this way reduced. If all three lines are identical, the result is perfect. It provides better resolution than the 2L type.



The two-dimensional three-line (2D-3L) comb filter uses three lines in the same way as the 3L type, but the weighting allocation to each line depends on how similar the lines are. If all three lines are identical, the 3L weighting is applied. Otherwise, the weighting is varied. It's called two-dimensional because the mixture is varied vertically.

The 3D (motion-adaptive) comb filter senses motion between one field and the next (hence three-dimensional) and adjusts the weighting given to the lines accordingly. If there is no motion, 2D filtering is used. This type of filter requires a large memory so that adjacent frames can be stored.

ay Technology



Signal manipulation

The luminance and chrominance signals are sampled and converted into 24-bit video, consisting of three separate 8-bit groups for each primary colour, R, G and B. Each colour has a grey scale of 256. The total number of colours is thus $256 \times 256 \times 256 = 16.78$ million.

When it comes to video formatting (see its main elements in **Figure 3**), the received video is interlaced, so the first task is to de-interlace it, normally carried out by the I/P (interlaced/progressive) converter. The process involves the creation of new scan lines between the original successive ones of an interlaced frame.

Several techniques can be used, from very simple line repetition to very complex variations of interpolation and motion adaptation. Some sort of filtering is desirable to smooth out high-frequency artefacts, caused by creating abrupt frame transitions.

With simple intra-field I/P conversion, data from the same field is used, e.g. by repeating the previous line or creating a new line that's an average of two successive odd lines in an odd field or two even lines in an even field. The disadvantages of these methods include horizontal line flicker, still area flicker and low resolution.

Inter-field conversion data from odd and even fields can be combined, which involves two or more fields. Referring to the current one and the one in the previous and/or next field creates new lines. This method doesn't take into account motion between fields. As a result, a 'tearing' effect may appear in areas with movement.

The motion-adaptive method uses either intra- or inter-field conversion depending on the motion between successive interlaced fields. By comparing successive fields, a 'motion value' is produced. This is used to determine the 'bias' toward an intra- or inter-field conversion. Motion detection and estimation are thus critical.

With the motion-compensation method the picture content of successive fields is analysed to find out whether there is motion from one field to the next. If motion is detected, a full frame is woven into the intervening scan lines.

Image scaling

Once the video has been de-interlaced, a scan-rate conversion process may be necessary to ensure that the input frame rate matches the output display-refresh rate. To equalise the two, fields may need to be dropped or duplicated. As with de-interlacing, some sort of filtering is desirable to smooth out high-frequency artefacts, caused by creating abrupt frame transitions.

The purpose of image scaling is to convert the incoming signals, which may be NTSC, PAL or computer-generated VGA, into a form suitable to feed the fixed-format display panel, which in turn may be standard- or high definition. Video scaling is very important, as it enables an output stream of different resolution to the input format to be generated. The only way to avoid image scaling is to crop the image to fit within the confines of a smaller panel. This is the cheapest approach, but is not very satisfactory.

Depending on the application, scaling can be either upwards or downwards. It's important for the scaler to be able to distinguish between purely video content and non-video elements such as text. Failure to do so would distort the non-video parts

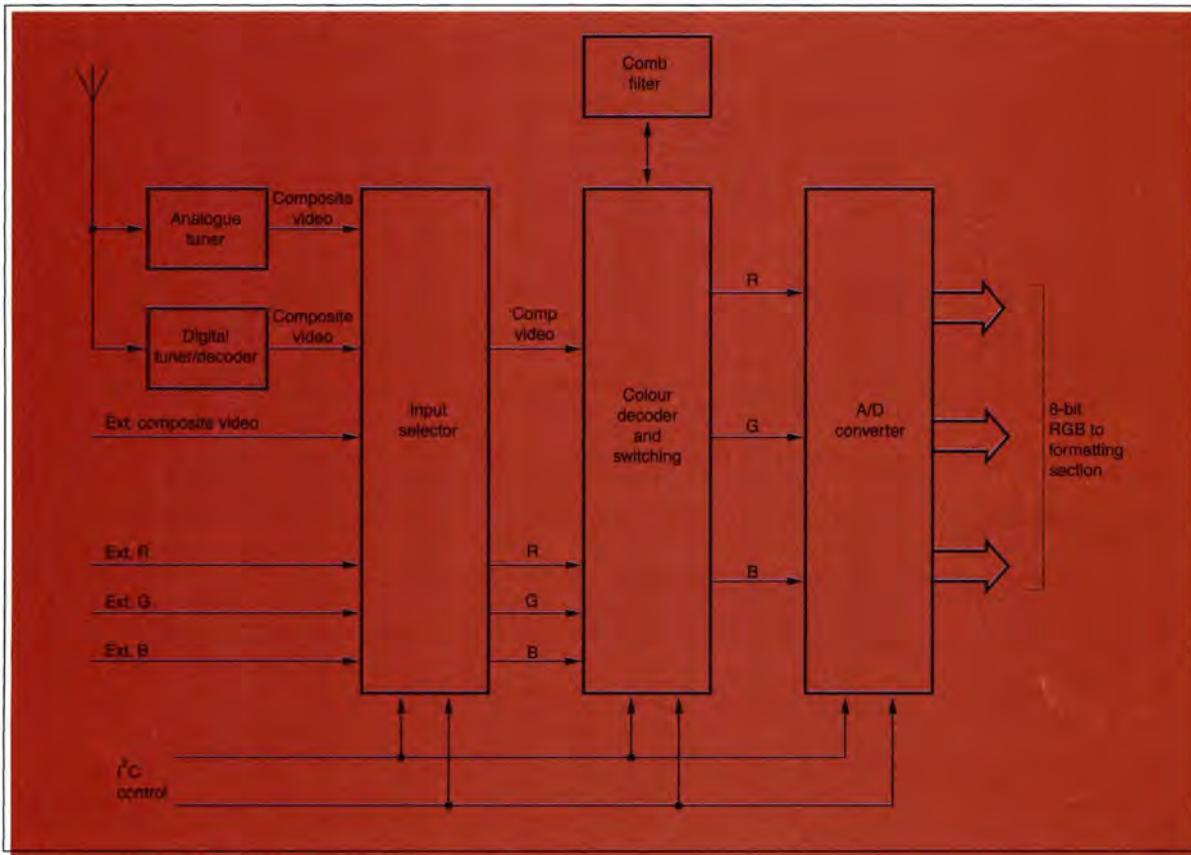

Figure 1 (Left): Basic video-processing arrangement in a plasma TV set

of the display, making text unreadable, or cause some horizontal lines in the scaled image to disappear.

The simplest scaling methods consist of either dropping or duplicating original pixels. For example, when scaling down to a lower resolution, a number of pixels along each line and/or a number of lines per frame are discarded. While this is a low processing load, the results will produce aliasing and visual artefacts.

A small step upwards in complexity uses linear interpolation to improve the image quality. For example, when scaling an image down, interpolation in either the horizontal or vertical direction produces new output pixels to replace initial ones. As with the previous technique, information is still lost so artefacts and aliasing will again be present.

If image quality is paramount, there are ways of carrying out scaling that avoid reduced quality. These methods endeavour to maintain the high-frequency content of the image, consistent with the horizontal and vertical scaling, while reducing the aliasing effects. For example, consider an image being scaled by a factor of $Y \times X$. To accomplish this, the image could be up-sampled by interpolation by factor Y , filtered to eliminate aliasing, then down-sampled by decimation by factor X . These two sampling processes can in practice be combined within a single multi-rate filter.

Digital video interface (DVI)

One of the problems of transferring data at a high bit rate is the bandwidth required. For example 24-bit, 1280 x 1024 resolution video at a refresh rate of 50Hz requires:

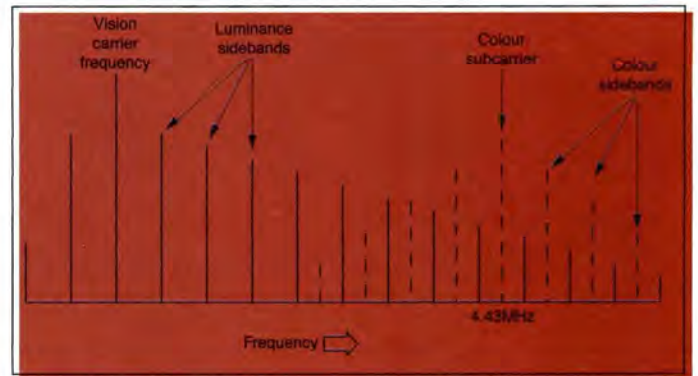

Figure 2: Interleaved luminance and chrominance sidebands with a PAL colour transmission. The side frequencies cluster around multiples of the line frequency

$$1280 \times 1024 \times 24 \times 50 = 1.57\text{Gbit/s}$$

The normal RS-422, RS-485, SCSI and other interfaces have limitations, in terms of bandwidth and interference, which make them unsuitable for use as connectors to an LCD or a PDP screen. Hence, the need for an interface that's capable of handling such data rates, with low power consumption and low interference. This is what the DVI specifications provide. There are two main types of DVI: DVI-D for digital only and DVI-I for both digital and analogue signals.

Three main techniques are in use: LVDS (low-voltage differential signalling), PanelLink and TMDS (transition-minimised

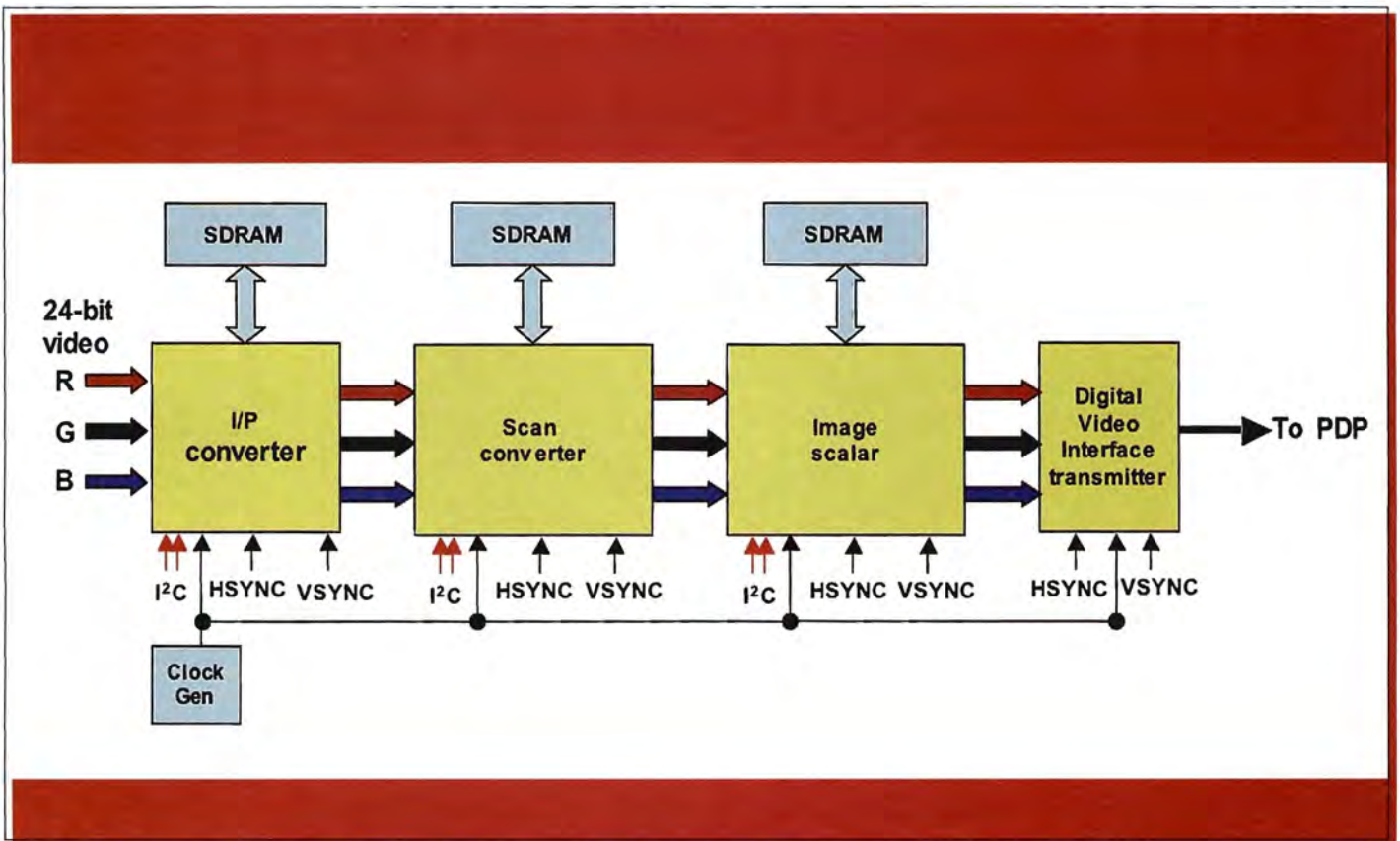

Figure 3: Main elements of a display-formatting system for plasma panel drive

differential signalling).

> LVDS

The LVDS interface (see **Figure 4**) is a unidirectional digital data connection that encodes 24 bits of data using four differential serial-data pairs (each pair consists of two twisted wires). The pixel clock is transmitted using a separate differential pair.

The differential swing is low (355mV) and the nominal impedance is 100Ω, the speed being 500Mbit/s to 1.5Gbit/s.

Parallel input data is fed to a parallel-to-serial converter, then to an LVDS transmitter that encodes the incoming data into four serial channels, to be sent out via four separate data pairs of wires. As shown, the clock is sent via a separate output pair. At the other end, an LVDS receiver decodes the data back to its original format, or another one, as required.

The clock rate is seven times the original pixel rate. Thus, with

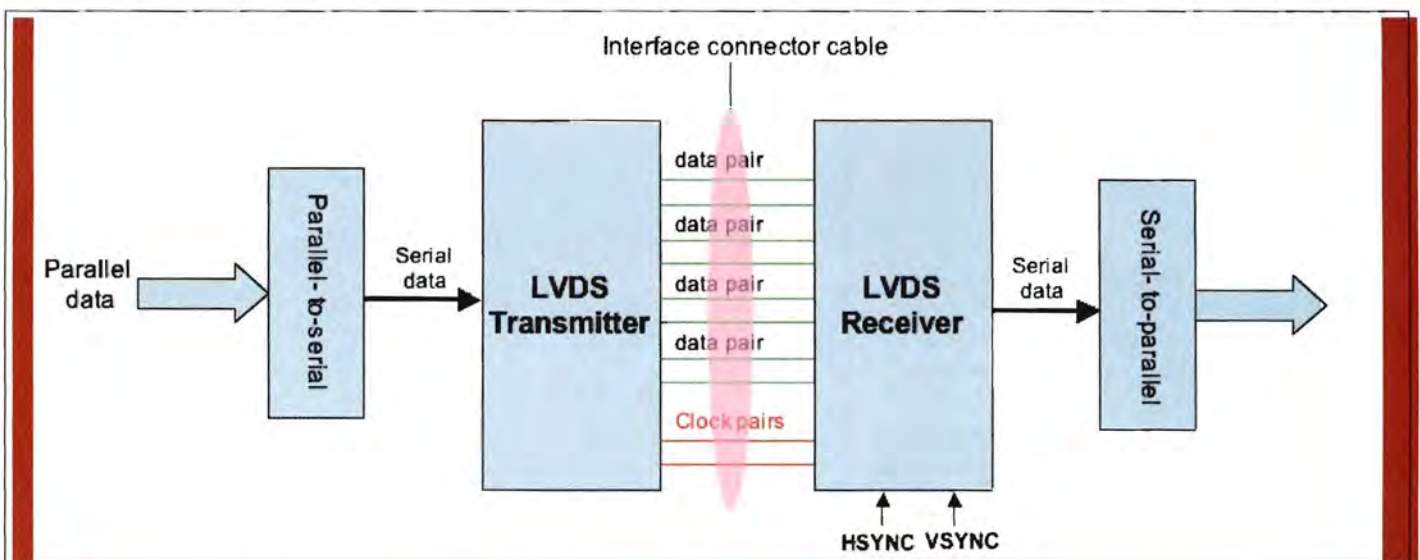

Figure 4: The LVDS interface

four pairs of data:

bits per original pixel clock = $7 \times 4 = 28$ bits per pixel clock

Of these, 24 are used for video. Three of the four remaining bits are allocated to frame sync, line sync and display enable (DE). The final bit is a 'custom bit' that can be used by the manufacturer as required for the application.

For 24-bit data a 65MHz connection will work with a panel that has a resolution of 1024 x 768.

By virtue of its low switching voltages, soft transition and true differential data transmission, LVDS achieves a high aggregated bandwidth, low power consumption and low EMI (electromagnetic interference).

> PanelLink

This interface is similar to LVDS. The difference is that three data pairs are used instead of four. It also isolates the three primary colours and allocates one to each data-pair. By increasing the data rate per channel to ten times the original pixel clock, instead of seven times as with LVDS, capacity can be retained. This is achieved by using an encoding technique known as Silicon Image.

The other basic difference is that PanelLink uses a fixed-current instead of a fixed-voltage transition. The advantage here is that, unlike LVDS, which is suitable for only short distances, PanelLink can be used for distances up to a few metres. The only disadvantage with a fixed current is that a return path has to be provided. The voltage swing for PanelLink is between 500mV and 1V.

> TMDS

Transition-minimised differential signalling is a derivative of PanelLink developed by VESA for computer LCD and PDP monitors. It has a speed of 165MHz, which in the future is expected to increase to 200MHz. Additional pairs may be used for increased capacity. **Figure 6** shows the basic connections to a TMDS transmitter IC.

Chip count

The chip count with flat-panel TV sets continues to decrease as more and more functions are performed by fewer ICs. Functions such as tuner and IF demodulation plus video and audio selection may be incorporated into one chip, with colour decoding, video processing, gamma correction and LVDS encoding carried out by a second chip.

The microcontroller may be embedded in one or both of the above chips, as well as memory stores, including flash memory.

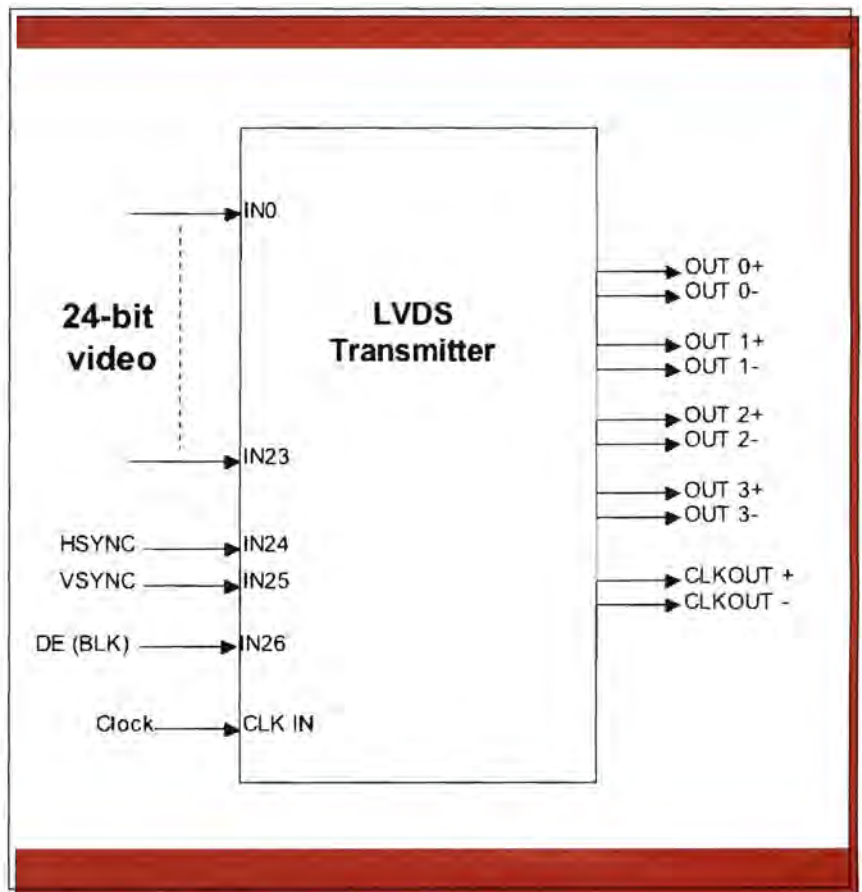

Figure 5: Basic connections to an LVDS transmitter IC.

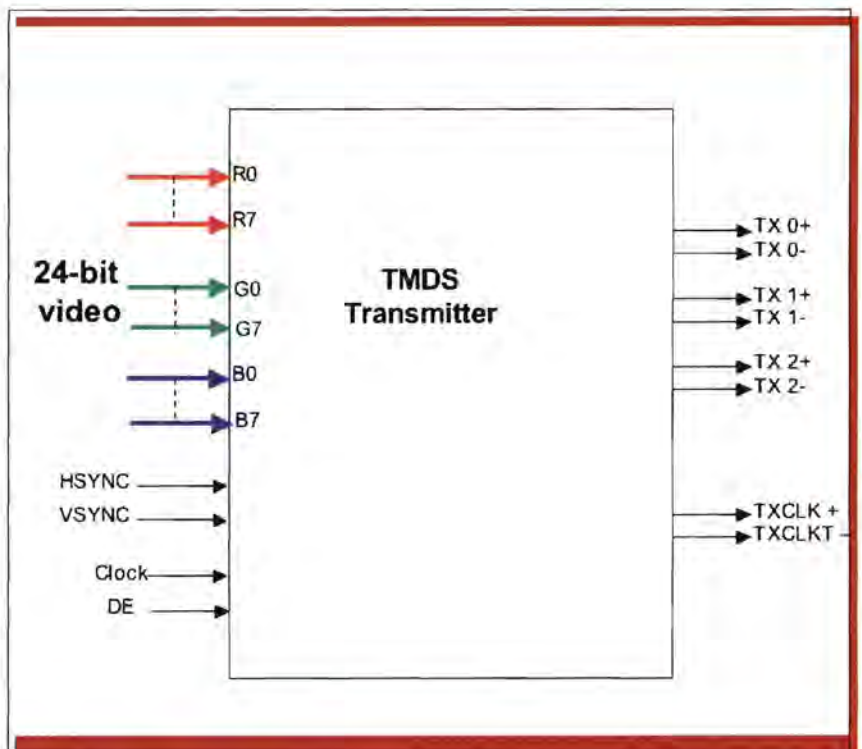

Figure 6: Basic connections to a TMDS transmitter IC

Rechargeable batteries with solder tags.

NIMH

AA 2000mah	£2.82
C4Ah	£4.70
D9Ah	£7.60
PP3 150mah	£4.95

NICAD

AA 650mah	£1.41
C 2.5A	£3.60
D 4Ah	£4.95

Instrument case with edge connector and screw terminals

Size 112mm x 52mm x 105mm tall.

This box consists of a cream base with a PCB slot, a cover plate to protect your circuit, a black lid with a 12 way edge connector and 12 screw terminals built in (8mm pitch) and 2 screws to hold the lid on. The cream bases have minor marks from dust and handling.

Price £2.00 + VAT (= £2.35) for a sample or £44.00 + VAT (= £51.70) for a box.



866 battery pack originally intended to be used with an orbitel mobile telephone it contains 10 1.6Ah sub C batteries (42x22dia the size usually used in cordless screwdrivers etc.) the pack is new and unused and can be broken open quite easily £6.46 + VAT = £8.77



Please add £1.66 + VAT = £1.95 postage and packing per order.

JPG ELECTRONICS

Shaws Row, Old Road, Chesterfield S40 2RB

Tel: 01246 211202 Fax: 01246 550959

www.jpgelectronics.com

Mastercard/Visa/Switch

Callers welcome 9.30am to 5.30pm Monday to Saturday

featured products ▼



£81.50

£61.00

CAN-USB & CAN-232

affordable CAN Bus to USB and RS232 interface solutions

=== Bronze Prize Winner ===
NASA Tech Briefs 2004
Products of the Year



£125.00

DS1M12 USB Scope / Logger

2 x 1MS/s Input Channels + waveform generator output. EasyScope & EasyLogger s/w included.



£36.00

USB-2COM-M

2 Port Industrial USB RS232 Serial with wall mount bracket and DC auxiliary output



Low Profile Version
also available

£65.00

£10.00

UPCI-400HS

4 Port UPCI RS232 Serial Card with Spider Cable or COMBOX IO (extra)

Affordable CAN Bus Solutions

CANUSB is a very small dongle that plugs into any PC USB Port and gives an instant CAN connectivity. This means it can be treated by software as a standard COM Port (serial RS232 port) which eliminates the need for any extra drivers or by installing a direct driver DLL for faster communications and higher CAN bus loads. CAN232 is a very small dongle that plugs into any PC COM Port, or any other RS232 port in an embedded system and gives an instant CAN connectivity. This means it can be treated by software as a standard COM Port (serial RS232 port) which eliminates the need for any extra drivers. Sending and receiving can be done in standard ASCII format.

priced from £61.00 (CAN-232)

USB Instruments - PC Oscilloscopes & Logic Analyzers

Our range of PC Instruments may be budget priced but have a wealth of features normally only found in more expensive instrumentation. Our DS1M12 and PS40M10 oscilloscopes have sophisticated digital triggering including delayed timebase and come with our EasyScope oscilloscope / spectrum analyzer / voltage and frequency display application software and our EasyLogger data logging software. We also provide Windows DLLs and code examples for 3rd party software interfacing to our scopes. Our ANT8 and ANT16 Logic Analyzers feature 8/16 capture channels of data at a blazing 500MS/S sample rate in a compact enclosure.

priced from £125.00 (DS1M12 & ANT8)

1 to 16 port USB to Serial Adapters

With over 16 different models available, we probably stock the widest range of USB Serial Adapters available anywhere. We offer converter cables, multi-port enclosure style models in metal and plastic, also rack mount units with integral PSU such as the USB-16COM-RM. Serial interfaces supported include RS232, RS422 and RS485. We also supply opto-isolated RS422 and RS485 versions for reliable long distance communications. All our USB Serial products are based on the premium chipsets and drivers from FTDI Chip for superior compatibility, performance and technical support across Windows, MAC-OS, CE and Linux platforms.

priced from £20.00 (US232B/LC)

UPCI Serial Cards

Discover our great value for money range of multi-port UPCI serial cards. Supporting from two to eight ports, the range includes RS232, RS422, RS485 and opto-isolated versions. Our 4 port and 8 port models can connect through external cables or the innovative wall mounting COMBOX.

priced from £21.00 (UPCI - 200L)

EasySync Ltd

373 Scotland Street
Glasgow G5 8QB U.K.

Tel: +44 (141) 418-0181 Fax: +44 (141) 418-0110

Web : <http://www.easysync.co.uk>

E-Mail: sales@easysync.co.uk

* Prices shown exclude carriage and VAT where applicable

The role of the transport properties of the interlayer in blue LEP's lifetime

Natasha Conway, Clare Foden, Matthew Roberts, Ilaria Grizzi of Cambridge Display Technology present a paper that yields a set of design rules for choosing interlayer properties to provide optimum lifetime for RGB materials in LEPs

It has been reported previously that efficiency and lifetime in RGB light-emitting polymer (LEP) diodes can be considerably improved by the incorporation of an interlayer between the hole transport layer (often formed from PEDOT) and the emission layer. We believe that the presence of the interlayer increases device efficiency in two ways: firstly, with an increased confinement of electrons in the region where the hole density is also high, and secondly, by blocking excitons, leading to a reduction in exciton quenching by PEDOT, as has been observed experimentally before. This is illustrated in **Figure 1**.

Previous work has linked the degradation of the polymer-LED to the growth of an insoluble layer from the PEDOT/LEP interface. Experimental data using electrical and optical models suggests that the exciton formation zone is peaked close to this interface, and that the inclusion of an interlayer moves the peak away from the LEP/PEDOT interface. It is found that the growth rate of the insoluble layer is considerably slowed and that the device's lifetime is increased by including an interlayer.

Other approaches to solving this problem, such as changing charge balance to move the exciton formation zone away from the anode, have resulted in very low device efficiencies, consistent with an increase in cathode quenching.

The work described above illustrates the importance of keeping the exciton formation zone away from both the anode (PEDOT) and cathode interfaces, in order to achieve high efficiency and long lifetime, and the role of the exciton and electron blocking properties of the interlayer in achieving this. However, the impact of the LEP and interlayer transport properties on the device performance has not been reported in detail. The work related here is a systematic study of the effects of varying the interlayer electron and hole currents on the efficiency and lifetime of a blue LED. The results are then related to our current understanding of device performance.

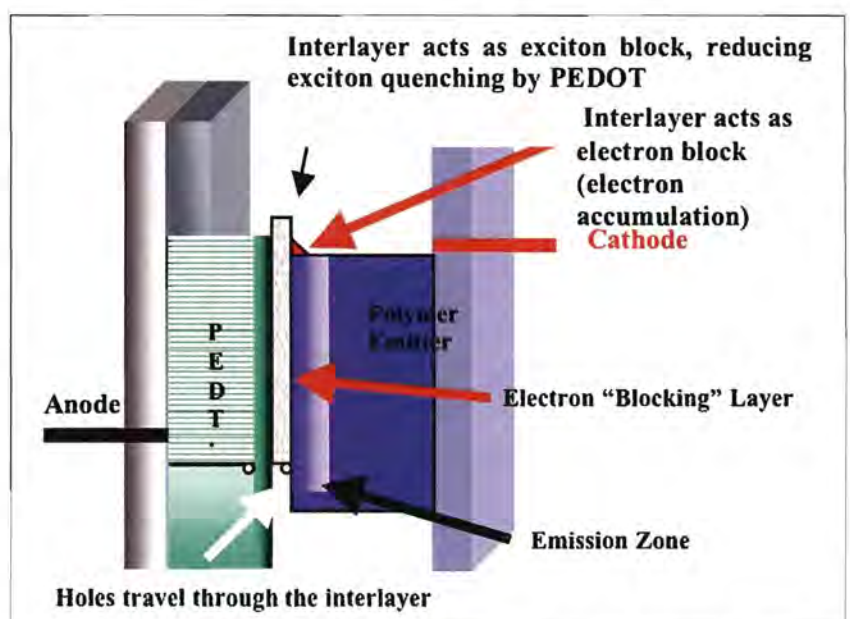
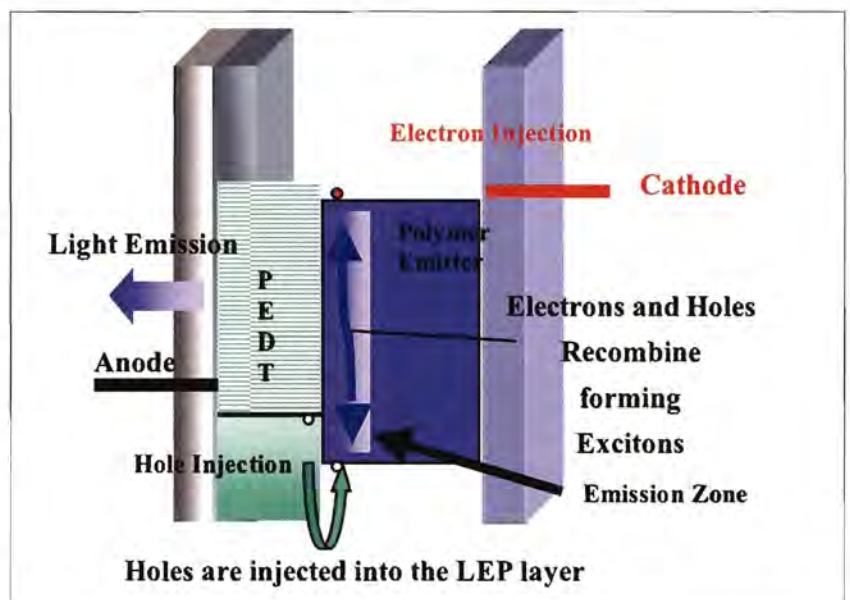

Figure 1: Schematic diagram of LEP structure (a) Top: without (b) Bottom: with interlayer

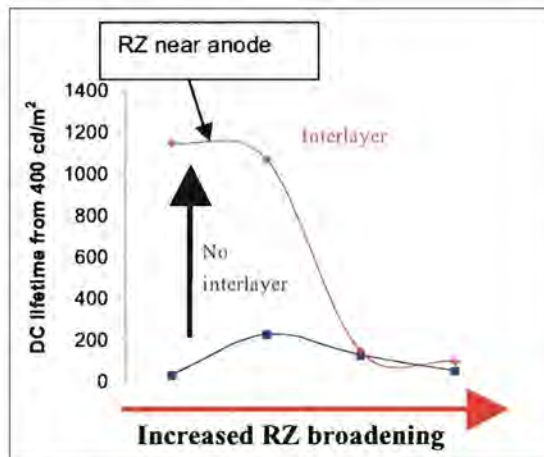

Figure 2: As the recombination zone broadens towards the cathode, the effect of the interlayer on the display lifetime is reduced. (The distribution of the recombination zone was inferred from EL spectra measurements fitted using an optical model).
Note: 'Lifetime' is defined as the time to half initial brightness from a defined start point

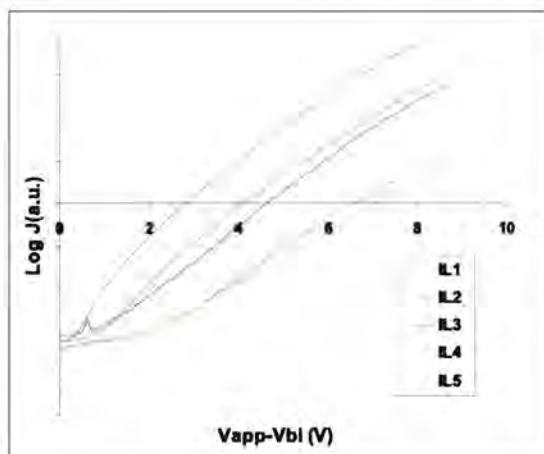

Figure 3: J-V characteristics of electron-only devices as a function of internal voltage

Discussion

The introduction of an interlayer does not benefit all LEP materials. **Figure 2** shows the variation in DC lifetime as we modify the structure of a blue LEP so that the recombination zone is broader and moved towards the cathode. When the recombination zone broadens and the exciton density at the interlayer interface is reduced, we do not observe a lifetime enhancement due to the interlayer.

Note that, for broader emission zones away from the anode, the lifetime of the device is generally much lower. This is due to a combination of charge imbalance and increased cathode quenching, which reduces device efficiency and, as a result, the device has to be driven at very high current to achieve the desired brightness.

The interlayer was modified in order to vary its hole and electron currents and the magnitude of

variation was measured in single carrier devices (with modified electrodes). The electron only J-V characteristics of the series of interlayer materials (coded IL1 to 5) are shown in **Figure 3**. It can be seen that the electron conductivity decreases from IL1 to IL5.

Each of these interlayer materials was tested in the following device structure: ITO/PEDOT (65nm)/interlayer (10nm)/ CDTblue (65nm) /Ba (5nm) /Al.

The variation in the maximum external quantum efficiency (EQE) is shown in **Figure 4a**. As the electron current in the interlayer is decreased, the efficiency of the structure is improved up to IL4. **Figure 4b** shows that the behaviour with respect to lifetime roughly matches this trend, with IL4 giving the best lifetime.

As previously discussed, in the longest-lived blue PLED devices, the recombination zone is near the

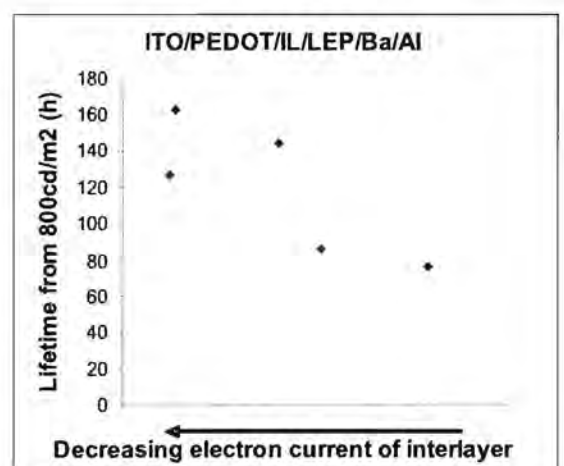
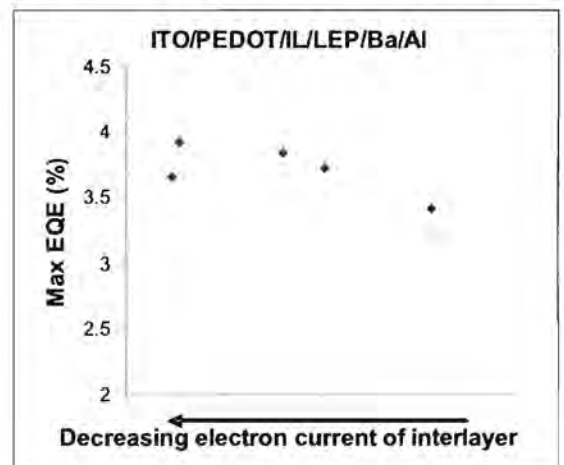

Figure 4: Variation of (a) **Top:** EQE and (b) **Bottom:** lifetime with respect to the electron-only current density of the interlayer at 3V. **Note:** EQE is defined as the proportion of electrons passing through the device which are converted to photons (light)

anode. By reducing the interlayer electron conductivity with respect to the LEP conductivity we expect that electrons will accumulate within the LEP layer

at the interlayer interface. The interlayer can further improve the device performance if, in addition to the electron accumulation, the hole currents in LEP and interlayer were such as to also promote hole accumulation at the interface. The increased accumulation of both electrons and holes would result in an improved exciton formation efficiency and increased confinement of recombination zone at the interlayer/LEP interface, giving the observed improvement in efficiency. The lifetime improvement could be related to this improvement in efficiency as it roughly follows the same trend.

The decrease in performance for IL5 cannot be explained by the small difference in electron current compared to IL4 (Figure 4b). A possible explanation for this result could be the larger hole current exhibited by IL5 compared to IL4 (i.e. approximately three times higher than in IL4). This suggests that there may be an optimum current for maximum lifetime.

Improving efficiency

The gathered data suggests that optimising the electron and hole currents in the interlayer is of key importance to achieve high efficiency and lifetime. However, the presence of the interlayer may also improve lifetime and efficiency by reducing the probability of excitons reaching the PEDOT layer. IL1 to IL5 all have a deeper HOMO and shallower LUMO than the LEP so that the electrochemical band gap of the interlayer is wider than the LEP's band gap (by more than 0.5eV). Therefore, a further interlayer, IL6, was examined in order to try and decouple the effects of exciton blocking from that of varying the transport properties.

IL6 has a similar optical band gap to the LEP layer and, therefore, will not act as an exciton block. However, the electron and hole currents are such that an accumulation of charges at the il-LEP interface would be expected.

Figure 5 shows that IL6 improves the device lifetime by a similar amount to that seen for other inter-

layer materials, which also act as an exciton block. There is however a decrease in efficiency observed with IL6 compared to IL3 (see Table 2), consistent with some of the generated excitons being able to diffuse through the interlayer and become quenched by the PEDOT. This demonstrates how both LEP and interlayer transport properties are key in determining device lifetime by confining the recombination zone at the interlayer-LEP interface. The exciton-blocking character of the interlayer can, however, add a further improvement to the device efficiency.

Table 2: Efficiency data

Interlayer	Max. EQE (%)
None	2.3
IL3	3.5
IL6	3.3

Balancing charges

This work identifies the importance of balancing charges in the interlayer and LEP layers. This ensures that the exciton formation zone is confined within the LEP at the interlayer/LEP interface, and is neither near the interlayer/PEDOT interface nor close to the cathode.

Furthermore, the results with IL6 show that lifetime can still be improved when the interlayer is not exciton-blocking but the recombination zone is still at the interlayer/LEP interface, due to tuning of the electron and hole currents of the interlayer such that electrons and holes accumulate at the interlayer/LEP interface. This is the first evidence to suggest that exciton quenching by PEDOT does not play a significant role in device degradation and, therefore, implies that the role of the interlayer transport properties is of key importance.

These results provide a set of design rules for choosing interlayer properties to provide optimum lifetime for RGB materials. It demonstrates that the transport properties of the LEP and interlayer need to be matched in a way that ensures the recombination zone is confined near the interlayer/LEP interface.

This understanding of the underlying parameters governing device performances should also enable the tailoring of the LEP to ensure that we can achieve best performances whilst keeping the manufacturing process as simple as possible (e.g. by using a single interlayer material for RGB).

In addition, the fact that improved lifetime can be achieved where the interlayer need not be exciton-blocking is of key significance to blue where it may not always be possible to use an interlayer with an increased band gap, particularly for deep blue LEP materials.

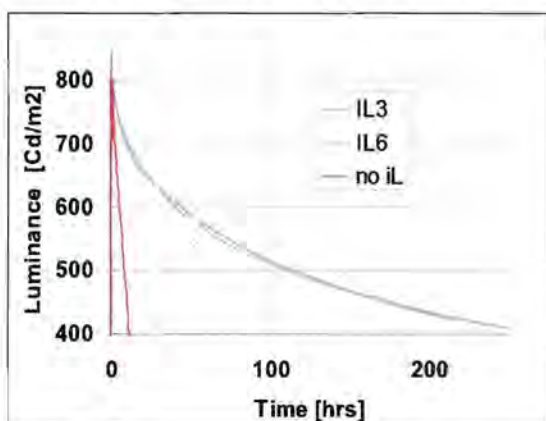

Figure 5: Lifetime from 800cd/m², DC, at room temperature

Solid-State Lighting

In this article, **Faiz Rahman** delves into the world of the latest light sources and helps you figure out what will be the best one for your application

A way from our homes and places of entertainment, a quite revolution is brewing that promises to fundamentally change the way in which we light up our surroundings. Artificial lighting has changed little since the inventions of the filament bulb and fluorescent lighting. These devices are cheap, widely available and easy to use but lack flexibility of illumination characteristic control and are also wasteful of energy. The new luminaries in development are fundamentally different, and with their light control and energy saving features, are extremely well suited for our modern lifestyles. Not only do they promise more pleasant forms of lighting but their low power consumption is a godsend in an increasingly energy-conscious world. Instead of generating light by heating a wire to white hot heat or producing an electrical discharge in a low-pressure gas mixture, these new light sources are completely solid-state devices that work on the same principles that make transistors and integrated circuits possible.

Solid principles

All solid-state light emitters work by allowing electrons to fall from a high-energy band to a low energy band. The difference in energy is radiated away as light particles or photons. There are now two distinct classes of devices that emit light in this way: the semiconductor light-emitting diode and the organic polymer light-emitting diode. The former are usually referred to simply as LEDs, whereas the latter are called OLEDs with the 'O' standing for organic.

Let's first take a look at the physical principles behind the operation of ordinary LEDs. Diodes are made from a combination of electron-rich (n-type) and electron-deficient (p-type) semiconductor

materials. Where these two come together, a region devoid of electric charge carriers, called a depletion layer, is formed. On connecting the n-type material to the negative of a battery or power supply and the p-type material to the positive side of the battery or power supply, electrons are injected from the n-type material through the depletion layer into the p-type material. Similarly, electrons are extracted from the p-type material, which is the same as the injection of electron vacancies, called holes, into the p-type material. The flow of electrons and holes constitutes the diode current. As only holes travel in the p region of a diode and only electrons in the n region, at some point, one effectively changes into the other. This so-called electron-hole recombination takes place inside and close to the depletion region of the diode and results in the release of energy, because it essentially represents a sudden decrease in the electron's potential energy. The energy thus released gets converted into heat and causes the diode to get warm. Diodes capable of emitting light are made from materials where electron-hole recombination results in the emission of infrared, visible or ultraviolet radiation instead of generating heat. These are called compound semiconductors. The wavelength (colour) of the emitted radiation depends on the band gap of the semiconductor used for the LED, with the colour shifting from infrared through the colours of the rainbow to ultraviolet as the band gap of the semiconductor increases.

LEDs for light

LEDs made from compound semiconductors like aluminium indium gallium phosphide (AlInGaP) and indium gallium nitride (InGaN) have existed for many years now and come in several different colours



- A Bright Future

Interior of Boeing's Dreamliner cabin, lit by solid-state sources



ranging from infrared (invisible) through red, orange, yellow, green, blue to ultra-violet. Their efficiencies have also improved over the years so that high power devices are now capable of putting out a decent amount of light.

Initially, for many years, LED applications were restricted to light indicators on electronic equipment. Only as their luminosities increased did they begin to be seriously considered for ambient lighting applications. Hewlett-Packard (HP) was the first to realise the potential of these devices for outdoor commercial applications and, in the late nineties, it brought out new traffic light signals that were built entirely with red, amber and green emitting LEDs. Whereas conventional traffic signal units based on colour-filtered filament light bulbs consume about 150 watts, the new LED-based units consume only one-tenth as much power. What's more, the new traffic lights also proved to be much less maintenance-intensive than the units that they had replaced.

Not surprisingly, most old traffic lights were replaced by these better performing units and, now, LEDs are the standard light sources in almost all new traffic signals. We also see them in service on temporary and permanent highway signs and, again, it is the energy efficiency and long life characteristics of LEDs that make them suitable for such applications.

Even before the widespread adoption of semiconductor light emitters by public sector agencies, LED-based displays had started to be used for commercial sign display and advertisement purposes. The lead, in this case, was taken by Japan, where large format LED dot-matrix graphic displays have been a familiar sight in city centres. This application received a big boost when in 1993 Shuji Nakamura at the Nichia Chemicals Corporation developed the blue-emitting LED. Finally, it was possible to deploy full colour solid-state displays. We are now seeing an increasing use of such displays for commercial applications and all indications are that this sector will continue to grow briskly for the foreseeable future.

Manipulating light

While it is possible to produce white light by combining emissions from red, blue and green LEDs, a more convenient way

is by using blue-excited phosphors in conjunction with a blue LED. The phosphor converts some of the original blue radiation to red and yellow light such that the combination appears white to human eyes. All 'white LEDs' on the market are of this type.

The white light produced by these devices is not particularly pleasant and because it doesn't contain all the colours so it is also bad for rendering coloured objects. Manufacturers are working on overcoming this problem by employing customised phosphor mixes that could produce broadband radiation, which matches the spectrum of natural daylight more closely. Such 'warm' white light LEDs are now becoming available and are being put to use in black-and-white dot matrix displays and spot lights for retail exhibit illumination.

Another area where LED illumination has made considerable inroads is that of automobile lights. Brake lights were the first to switch to LEDs and now headlights are next on the cards. Interior lights have also gone solid-state in several makes and in doing so have opened up the possibilities of large-scale space lighting with LEDs. The first to take the lead in this area are aircraft manufacturers, both civil and military.

Most famously, Boeing revealed last year that it intends to use LED-based lighting in its new 787 Dreamliner. According to the company, travellers will be able to control the intensity and tint of lighting in their seating areas to suit their preferences. This should reduce the effects of jetlag due to crossing time zones.

The images on these pages show the flight deck of the new Boeing plane with cockpit lighting provided by solid-state lighting fixtures, and also the interior of the same aircraft with ceiling and window-side lighting provided by diode-based lamps.

Several other manufacturers of executive and regional jets are also implementing similar schemes for interior cabin lighting. This kind of application brings out the advantages offered by LEDs for space lighting.

Controlling light

Unlike filament lamps that can only be



controlled in intensity, diode-based light sources enable the control of light colour as well. For this, however, LEDs of more than one colour need to be combined in lighting fixtures and electronic circuitry provided to control the different coloured devices independently.

Two approaches are possible here: either separate red, green and blue LEDs could be applied, or multichip devices, each containing red, green and blue chips in the same housing could be used. Generating any desired colour then is a matter of combining different intensities from the three LEDs or chips. This is almost always accomplished by running each colour element with a Pulse Width Modulated (PWM) current drive waveform. Varying the duty cycle of the waveform effectively controls the average current fed to the individual diodes and thus their output intensities.

Three channels are needed for complete RGB control. The PWM waveform could be easily generated either by a microcontroller or by a dedicated PWM generator chip. Several manufacturers, including Freescale Semiconductor, are bringing out optimised microcontrollers for this kind of RGB lamp control.



For greater light output, all that is needed is to interface a larger number of LEDs to the control chip through the use of appropriate power transistors.

Sizing potential

As the size and efficiency of LEDs have increased so has their potential for space lighting applications. Several companies are hard at work developing the high current devices that would, one day, begin to replace conventional tungsten filament-based light bulbs. These companies include GTE, Osram, Philips and several others. At the present time, LED clusters have become available for spotlighting and low ambient illumination purposes.

These units are rated in the range of five to ten watts, feature screw, bayonet and other standard bases and are available for operation with both low voltages (12V DC) and mains supplies. These come in red, green, yellow, blue and white colours with each unit assembled from sixteen standard 5mm diameter LEDs. High brightness surface mount LEDs are also available and can be used for making lighting modules.

The example from Lumileds, shown on the next page, is capable of 1W power

output but other units in this family can deliver up to 5W of power. These LEDs have a special multi-pronged wire bond connection to the chip for ensuring uniform current flow. Multiple chip arrays are also available where a number of Luxeon LEDs are mounted on a metal core PCB that is capable of removing heat much more efficiently than ordinary glass fibre laminate material.

In addition to producing cold light, LEDs require much less power than existing lighting solutions, are small in size, resistant to vibration and shock, immune to ambient humidity, have a very fast "on-time" (less than 1ms compared to 250ms for incandescent lamps), have good colour resolution producing pure colours and present low or no shock hazard. Their directional characteristics, however, make it difficult to incorporate them in omnidirectional lighting units. Westinghouse is attempting to overcome this problem and is marketing LED bulbs that provide all around lighting.

Light extraction

In conventional LEDs it is difficult to extract all the light that is internally generated. Large difference between the refractive index of the semiconductor and air results in low extraction efficiency. However, if the light source is placed inside a microcavity then the emitted light is coupled to the cavity modes and, if proper design is applied, then it can be completely extracted. In recent years, due to the development of nano-scale semiconductor technologies, a number of optoelectronic devices employing microcavity structures have been proposed.

The most notable examples of such devices are Resonant Cavity Light Emitting Diodes (RC LED), realised in the early nineties. The main advantages of resonant cavity LEDs over conventional devices are their higher emission intensities, higher spectral purity and more directional emission patterns. Yet another technique is to integrate LED chips with synthetic opal crystals, which can also be used to improve light extraction efficiency. These and other approaches are helping raise the electricity-to-light conversion efficiency of LEDs to levels where they will start to pose a challenge to existing lighting technologies.

Organic vs inorganic

The LEDs discussed so far are all made from inorganic semiconductors, derived from elements in groups III and V of the periodic table. A quite different type has been under development lately, derived from carbon compounds. These organic light emitters represent one of the most vibrant areas of research and development today. Organic LEDs are built from conducting and light emitting polymers such as poly-para aniline vinylene (abbreviated as PPV). These materials are plastics but with a structure that is capable of conducting current. Although their conductivities are usually lower than that of metals, they have found several applications in electronics.

Intrinsically, conducting polymers often behave like p-type semiconductors and are thus better conductors of holes than electrons. One approach to building light emitting diodes from organic materials is to sandwich them between a glass sub-

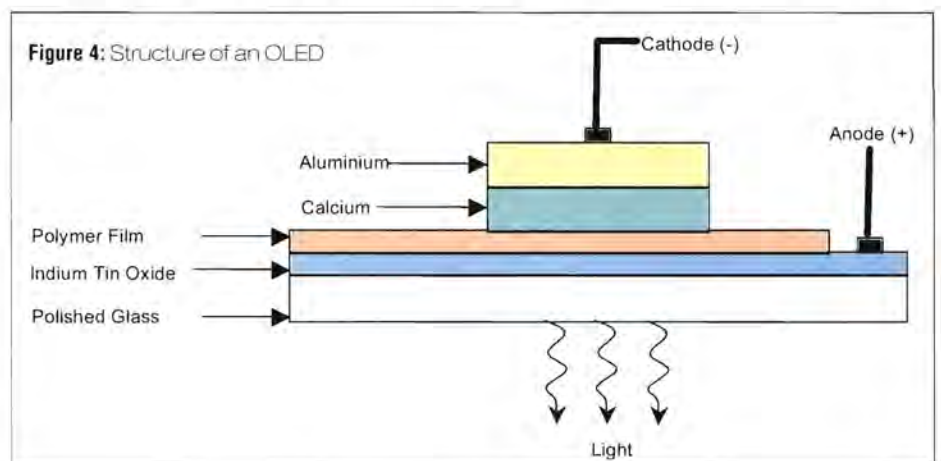

strate coated with a transparent conducting layer e.g. Indium Tin Oxide (ITO) and a low work function metal like calcium, which is capable of emitting electrons into the polymer. When such a device is biased as shown in the illustration (**Figure 4**), holes from the polymer combine with electrons injected by the calcium electrode and light is released.

There are several possible variations based on this structure, designed to increase the efficiency and lifetime of these devices. Depending on the detailed structure of the polymer used, OLEDs can emit any colour in the range from infrared to blue, so it is quite possible to build full-colour displays from these devices. The revolutionary advantage offered by polymeric light emitting materials is that these could be coated on very large area substrates such as plastic



sheets. This opens up the possibility of extended area luminaries, which may well make incandescent light bulbs obsolete in the not too-distant future. These emit a diffuse white glow that is very pleasant to

the eyes. Prototype units have already been made and several companies, including General Electric, are at work perfecting the processes required to produce polymer-based light emitters at price levels

that would be attractive to consumers. These sources will provide shadow-free diffuse light in several different 'tones' like warm white, cool white and daylight replica white.

With ongoing developments in the material, design and fabrication of both inorganic and organic LEDs, we are getting close to seeing their widespread use in space illumination applications. This will

probably not happen for another few years but, when it does happen, then our surroundings will be changed forever as light plays such a crucial role in human life.

The lead in this transformation is being taken by many companies and research labs around the world that are busy developing ever better solid-state lighting products. In turn, consumers have begun to respond by buying LED-based lighting products.

Centre: Lumileds's LEDs have a multi-pronged wire bond connection to the chip for ensuring uniform current flow

No1 Number One Systems

Easy-PC for Windows

The world beating PCB design software



Easy-PC version 9 just gets better

Winning accolades the world over, Easy-PC for Windows V9 is another major milestone in the evolution of this extremely popular software tool. Try a demonstration copy of Easy-PC and prepare to be amazed at the power, versatility and remarkable value for money.

STILL FROM ONLY
£247
PLUS VAT

Version 9 features

- 3D Board View
 - New Win XP User Interface
 - Reverse Engineer SCM from PCB
 - Track Fattening
 - Interactive Schematic Routing
 - New Sliding Toolbars
 - Component Clearance Checks
 - Alphanumeric Pin Names
- Plus many more exciting features.....

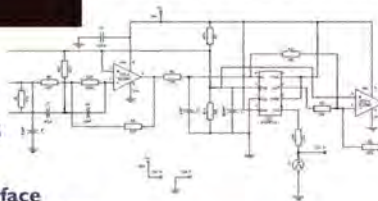

Fully integrated Schematics & PCB layout in a single application complete with forward and back annotation. Design and rules checks at all stages ensure integrity at all times. Professional manufacturing outputs allow you to finish the design process with ease.

Stop press... Stop press... Stop press... Stop press...
Easy-PC imports Eagle files as well as Tsien Boardmaker 2 files

call for a brochure, prices & CD on +44 (0)1684 773662
or e-mail sales@numberone.com
you can also download a demo from

www.numberone.com



Number One Systems - Oak Lane - Bredon - Tewkesbury - Glos - United Kingdom - GL20 7LR UK

HANDYSCOPE HS4

Four channels not enough



512 CHANNELS IS THE LIMIT COMPLETE PACKAGE STARTING AT £ 440

The Handyscope HS4 (50MHz 12/14/16 bit) is a powerful and versatile four channel measuring instrument with extension

WWW.TIEPIE.NL

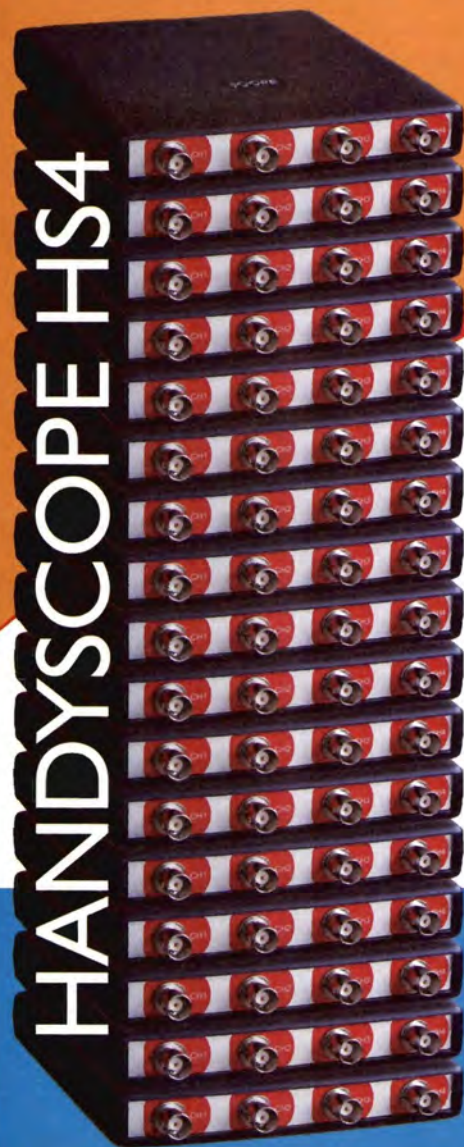

HANDYSCOPE HS4

The Handyscope HS4 starts a new standard for multi channel measuring.

It offers perfect measure qualities and through the USB connection it is easy to connect to every PC. Because of the very versatile software it becomes simple to extend the instrument to 512 channels.

A four channel, 12-16 bit oscilloscope, spectrum analyzer, transient recorder and voltmeter created as a most compact instrument.

- Making virtual instruments (combine maximum of 128 instruments)
- Extension to maximum of 512 channels.
- USB 2.0 connection (USB 1.1 compatible)
- Sample speed up to 50 MHz per channel
- 12 to 16 bit resolution (6 μ Volt resolution)
- 25 MHz bandwidth
- Input sensitivity from 200 mV up to 80 Volt
- Large memory up to 131060 samples per channel
- Four integrated measuring devices
- Spectrum analyzer with a dynamic range of 95 dB
- Fast transient recorder up to 100 kHz
- Several trigger features
- Auto start/stop triggering
- Auto disk function up to 1000 files
- Auto setup for amplitude axis and time base
- Auto trigger level and hysteresis setting
- Cursor measurements with setup read-outs
- Multi window signal display
- Multi channel display

for more information, demo software, software, source code and DLL's visit our internet page: <http://www.tiepie.nl>



TiePie engineering (NL)
Koperslagersstraat 37
8601 WL SNEEK
The Netherlands
Tel: +31 515 415 416
Fax: +31 515 418 819

TiePie engineering (UK)
28, Stephenson Road, St. Ives
Cambridgeshire, PE17 3WJ, UK
Tel: 01480 - 300695
Fax: 01480 - 461654

Cost Effective

Vehicle Speed Measurement, Classification and License Plate Detection System

N. S. Bayindir, H.Ö. Bayindir, H. Demirel, M. Yakup, V. Alsancak and T. Kabakli of the Department of Electrical and Electronic Engineering and Technology Development Center in Turkey present an applicable vehicle speed measurement system

The automatic vehicle speed measurement, classification and license plate detection systems are becoming the vital components of Intelligent Transportation Systems (ITS) as the traffic load increases and, hence, the traffic violations become a serious threat to the transportation safety. Several systems on vehicle speed measurement and classification have already been introduced. The design development and production costs of such systems are so high that the under-developed and the developing countries cannot afford them. On the other hand, these systems consist of several disciplines of Electrical and Computer Engineering, which makes them an attractive project for researchers in the fields of computer software, pattern recognition, electronic circuits and digital signal processing.

In this paper, a cost-effective vehicle speed measurement, classification and license plate detection system has been developed using very low cost equipment, including magnetic loop detectors, an industrial PC, a PIC microcontroller and a digital surveillance camera. The system has been implemented successfully on a motorway in North Cyprus where the speeds of vehicles were measured with an error of less than 3%. Pictures of the vehicles violating the speed limit were captured always at the same spot with excellent zoom and focus conditions, regardless of the vehicle speed, and the license plate could be clearly read. The system also provides statistical information regarding traffic flow on the motorways, which can be used to design efficient traffic control systems and road network.

System workings

An object-oriented Java program was developed to control the operation of the system, which can process data from four successive vehicle channels in parallel, so that the system does not miss any vehicles during the speed detection, image capturing and storing process. As the vehicle passes over the detectors, the time delay between the pulses produced by two magnetic loop detectors is measured by a microcontroller based system, and the speed of the vehicle is then calculated in km/h using this time delay. The picture of the vehicle exceeding the local traffic speed limit is captured using a digital video camera, which is connected to the industrial PC via a low-cost video capture card. The camera is focused at a pre-specified distance beyond

the second loop detector and, in order to capture the picture always at the same precise focused location, an adaptive delay which is inversely proportional to the vehicle speed is applied after the vehicle passes over the second detector. This delay ensures the capture of the vehicle picture always at the same location with the best zoom and focus adjustments, independent of the vehicle speed. The pictures taken by the camera are directly saved into the hard disc of the industrial PC via the video card with a distinctive file name, which contains the date, time, location and the vehicle speed. This picture file is then transmitted to a traffic-monitoring and control center via the wireless data transmission system. In addition to the measurement of the speed, the length of each vehicle is also calculated by multiplying the speed by the time duration elapsed while the vehicle passes over the second loop detector. This information is used for the classification of the vehicles into six categories, whereby important statistical data regarding the traffic flow can be obtained. This statistical data can be used by the research staff at the Traffic Research Center to analyse the characteristics of the traffic flow on various roads and design efficient traffic control systems and optimal road networks.

Hardware and software

The system is operated with an industrial PC, where the main parts of the system shown in **Figure 1** are specified as follows:

- **Magnetic loop detectors:** Two magnetic loop detectors are used to trigger the capture inputs of the microcontroller when the car passes over the magnetic loops.
- **PIC 16F877 microcontroller:** A low-cost PIC 16F877 microcontroller is used where the capture 1 input of the microcontroller is connected to both loop detectors, and capture 2 input is connected only to detector 2.
- **Microcontroller program:** An operating program whose algorithm is presented in **Figure 2** is developed for the microcontroller such that capture 1 is set to detect the rising edges from both detectors (which yield the period Δt_1) elapsed while the vehicle passes between the entries of the two loops. In order to prevent miscalculations due to possible entries in the opposite direction, the program checks whether the rising edge from detector 2 comes before or after that of detector 1. If a rising edge arrives from detector 2 before that of detector

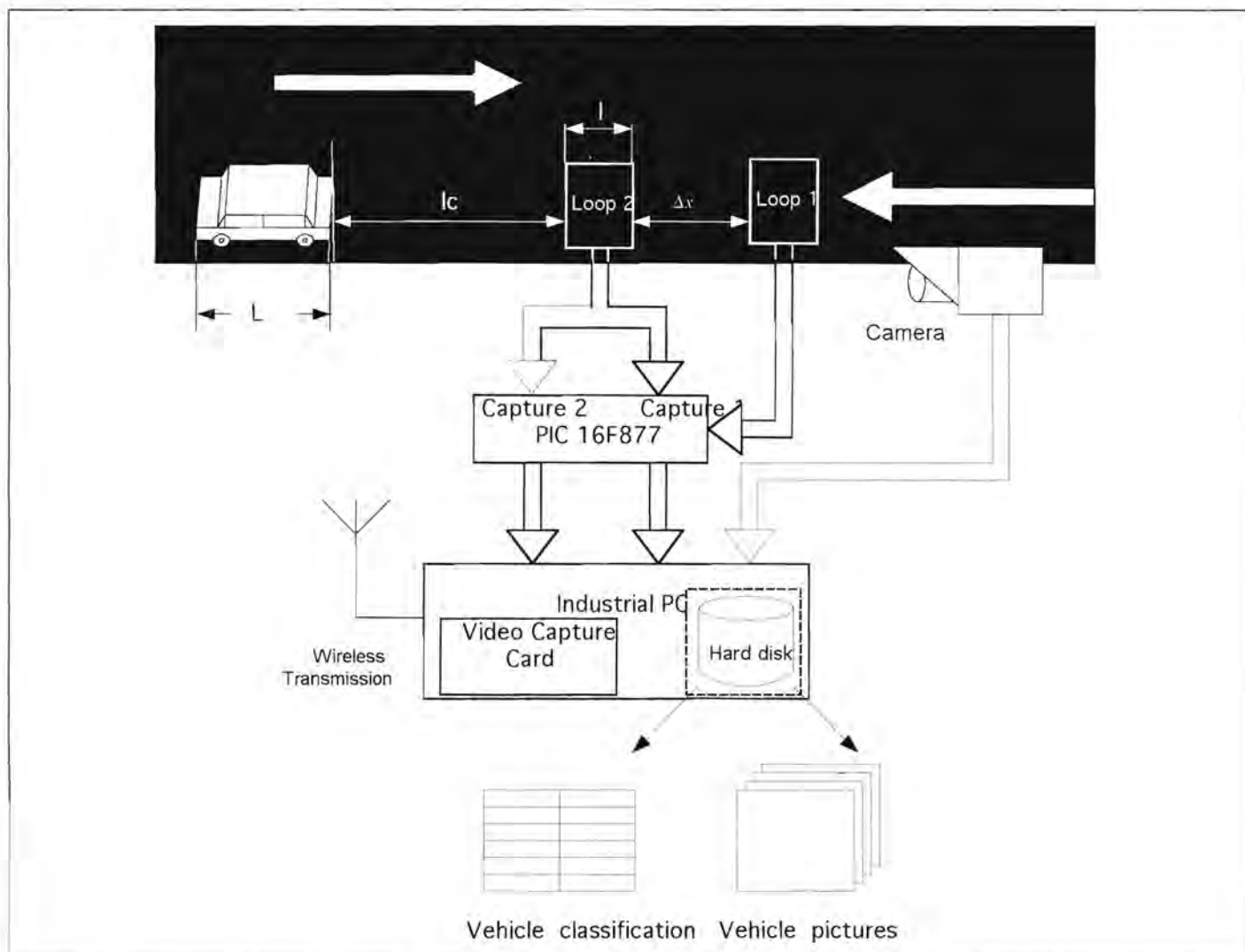

Figure 1: Block diagram of the complete system

1, the program returns to the start to wait for a rising edge from detector 1.

Once the car enters the second loop and the rising edge is detected by capture 2, the current value of the timer (TMR), which yields Δt_1 , is automatically recorded into the capture register CCPR2 and the timer is reset for the measurement of Δt_2 . The control register of capture 2 is then set to detect a falling edge to measure the time elapsed during the vehicle passes over the second loop. The time difference Δt_2 between the rising and falling edges of the pulse coming from detector 2 is equal to the time elapsed while the vehicle passes over the second loop. Δt_2 is then used to calculate the length of the vehicle.

- > **Industrial PC:** A low cost Pentium III 500MHz industrial PC with the Windows 98 operating system was used, where the RS232 serial port of the industrial PC is used to receive the time delays Δt_1 and Δt_2 for calculating the speed of the vehicle, as well as determining the class. Furthermore, an extensive object-oriented program developed using Java software, is designed to control various parts of the system.
- > **Digital surveillance camera:** A standard auto-focus, auto-

exposure surveillance camera, which continuously generates video frames at 24fps and transfers to the industrial PC via the video capture card, is used in this application.

- > **Wireless data transmission:** The measured data and the vehicle pictures stored in the industrial PC are transmitted to the traffic monitoring and control centre by using a 2.4GHz wireless radio link with a bandwidth of 8Mbps, which can communicate over a range of 35km.

Speed measurement

In order to measure the speed of a vehicle, several types of vehicle detectors may be used. Non-destructive infrared detectors can be mounted by the side of the road, however these detectors have high error of around 10% in the measurement of speed and need regular maintenance to keep them clean. Pressure tube technology has also been used in order to detect the presence of a passing vehicle, where the pressure tubes are subjected to wearing, hence, in our application magnetic loop detectors buried into the asphalt has been the preferred option. Two magnetic loops, which are displaced by a fixed distance

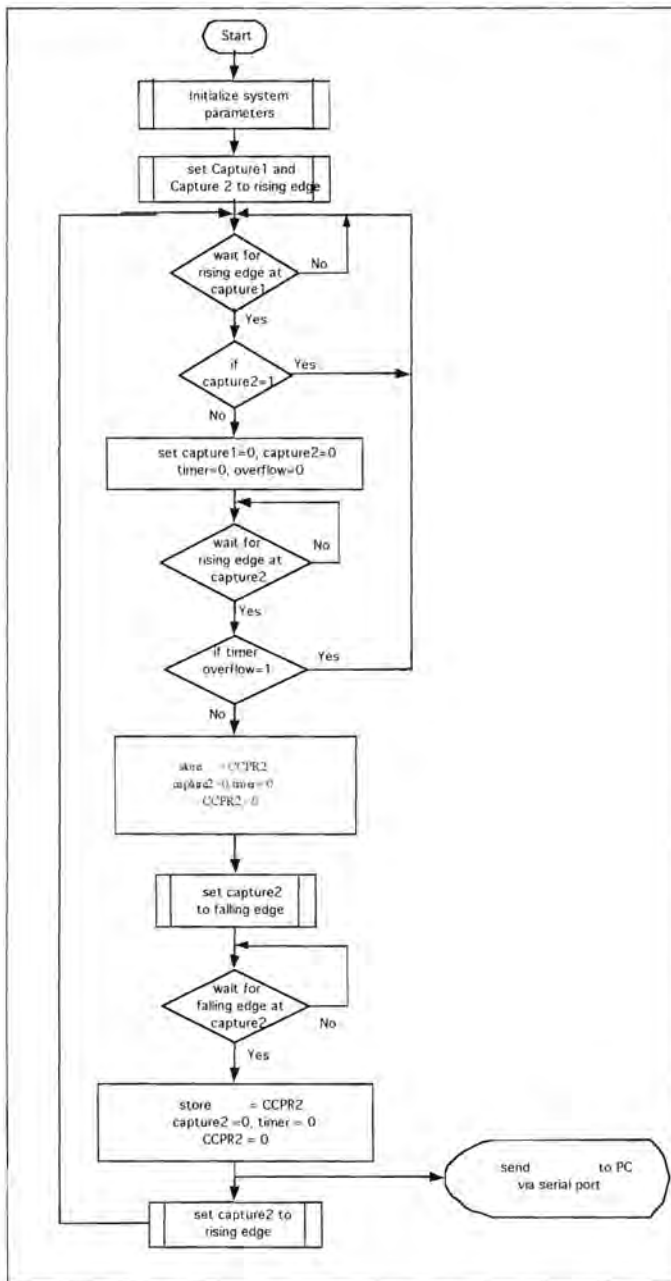

Figure 2: The flowchart of the program developed for the PIC MCU (Δx), are used to detect the presence of the car at two different locations as shown in **Figure 1**. The detectors connected to these loops produce TTL pulses which are applied to the capture inputs of a PIC 16F877 type microcontroller. The software on the PIC microcontroller initialises a timer when a rising edge is received at the capture 1 input from the detector 1 and the measured time delay (Δt_1) is recorded when a rising edge is received at capture 2 input from detector 2, as soon as the vehicle enters the second loop. This time delay is then transmitted to the industrial PC through the serial port for the calculation of vehicle speed.

The measurement of vehicle speed, classification of vehicles and the capturing and saving the video frames are managed by the Java program. Algorithmic details of the program code are

given in the flowchart as shown in **Figure 3**. At the start, the program creates four vehicle objects which can process the data obtained from the microcontroller via the serial port. The program receives the data related to the time differences Δt_1 and Δt_2 from the PIC microcontroller. The transmitted data consists of two parts, the speed data (Δt_1) and the length data (Δt_2), which are received via the serial port in a single pack. When the reception of one pack is completed successfully, it is recorded to a string variable. String data is sent to one of the vehicle objects that is not processing at that instant. By the use of four vehicle objects, the program is capable of processing up to four successive vehicles during the delay time before the capture of the license plate of the first vehicle. Experimental work on the system has shown that four parallel objects are sufficient for the fastest traffic flow conditions.

The vehicle speed is directly calculated using

$$v = \frac{\Delta x}{\Delta t_1} \quad (1)$$

where Δx is the distance between two loops and Δt_1 is the time elapsed while the vehicle passes between these loops.

Vehicle classification

Classification of vehicles based on their lengths provides very important statistical information for the design of transportation networks and traffic flow management. In order to determine the length of a vehicle, the time taken for the vehicle to pass over a single loop detector is measured by the PIC microcontroller. The timer of the microcontroller is triggered with the rising edge of the pulse produced by the second detector arriving at capture 1, when the front of the car enters the second loop. The timer value is recorded when the falling edge of the pulse arrives at capture 2 as the vehicle exits the second loop. This time delay (Δt_2), together with the measured speed (v), is used to calculate the length of the vehicle (L) as

$$L = v \cdot \Delta t_2 \quad (2)$$

Table 1: Classification of vehicles with length

Class	Vehicle length (m)
Cycles	$L \leq 3.00$
Cars	$3.00 < L \leq 5.00$
Pick-up	$5.00 < L \leq 6.00$
Lorry	$6.00 < L \leq 8.00$
Bus	$8.00 < L \leq 9.00$
Long vehicle	$9.00 < L$

Table 2: Statistical speed violation results

Vehicle type	Motor cycle	Car	Pick-up	Lorry	Bus	Long vehicle
Vehicles Passed	136	2310	257	568	379	342
Speed Violations	23	396	96	42	17	58
Speed Violations (%)	16.9	17.1	37.4	14.2	7.4	17.0

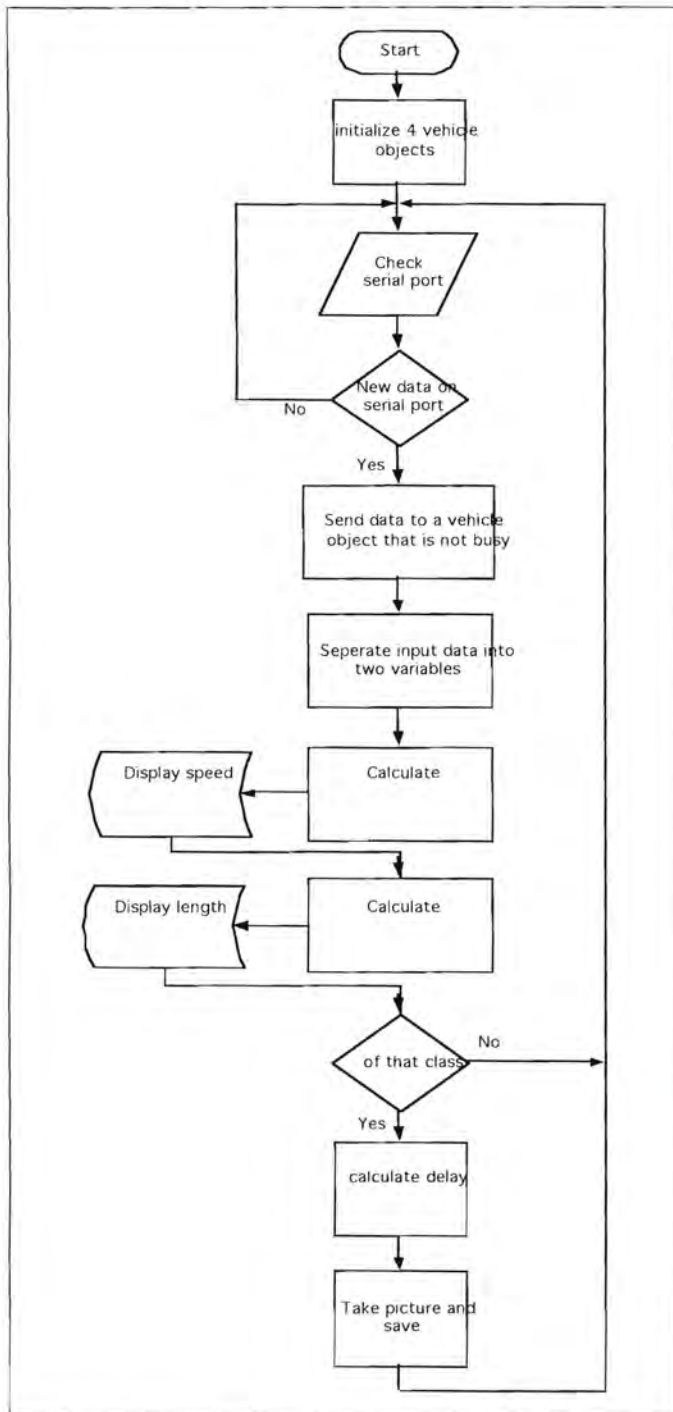

Figure 3: Flowchart of the speed measurement and video capture program

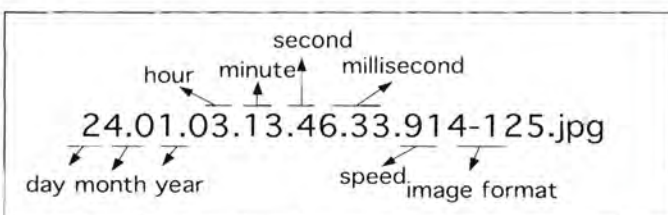

Figure 4: A filename example of the captured images

where l is the length of the second magnetic loop. The vehicles are classified by the industrial PC into six categories according to **Table 1**.

Table 2 presents the statistical average values of the recordings for one day of the vehicles on the main road from Nicosia to Famagusta in North Cyprus. According to these results, on the average, 16% of the vehicles passing on the main road violate the local speed limit.

Image capturing

A low-cost video capture card installed in an industrial PC is used to capture the images of the license plates of the vehicles violating the speed limit. After determining the speed of the vehicle, if the speed exceeds the local speed limit, the picture of the vehicle is taken after a time delay of t_3 , such that the camera will be focused at a specific spot at which the picture will always be captured clearly, independent of the speed of the vehicle. The focus and zoom of the camera is set to produce a picture on which the license plate can be detected clearly as shown in **Figure 5**. The industrial PC applies a delay of t_3 , calculated by

$$\Delta t_3 = \frac{l_c}{v} \quad (3)$$

before it captures the picture of the vehicle, where l_c is the distance allocated between the camera and the second loop to take a picture with least deformation of the license plate. Once the picture of the vehicle is captured, the current time, date, location and speed of the vehicle are printed, the picture is saved into the hard disk for further evaluation.



Figure 5: Picture of the vehicle violating the speed limit

Picture storing and transmitting

The captured picture, which is shown in Figure 5 is the image of a vehicle, which has exceeded the speed limit, on which the license plate is clearly visible. The pictures must be stored for further visual inspection, in order to determine the license plate number. Not only the picture but also the measured speed, the time, location and the date of the measurement are required for the traffic authorities to have complete information in hand. This is achieved by incorporating the time, date and speed information of the vehicle into a filename. The format of a typical picture filename is given in **Figure 4**. The information regarding the speed, date and the exact time of the event is printed on the picture. A 2.4GHz wireless radio link with a bandwidth of 8Mbps, which can communicate over a 35km range, is used to transmit the picture and the measured data from the site to the traffic centre. This range can be extended up to 500km by using active or passive repeaters.

Creating efficient road networks

A vehicle speed measurement and classification system has been developed as part of an Intelligent Transportation

System project, and implemented successfully on a highway where severe accidents due to speed limit violations take place. The speed of the vehicles were measured with an error of less than 3% and the pictures of the vehicles that violate the speed limit were captured always at the same spot, so that the license plate can be read clearly, independent of the vehicle speed. The speed, date and time information is recorded into the filename of the picture, which can be helpful for the authorities to locate if necessary. Valuable statistical data can be collected regarding the speed violations, vehicle classes and traffic density. The data can be processed by the Traffic Research Centre, to design more efficient road networks with a better traffic flow, free from congestion.

Acknowledgement:

Authors wish to thank the Eastern Mediterranean University Technology Development Center for the technical and financial support given to this project



What have you been missing?



Back issues of **Electronics World**

£5 including p+p (UK only)

overseas readers please call for details

Please send correct payment to:

**Electronics World,
Nexus Media Communications,
Media House, Azalea Drive,
Swanley, Kent BR8 8HU**

There are a limited number of back issues from 2002, 2003 and 2004

Call Caroline Fisher on 01322 611263 for details of availability

Hands On Power

represents the future of exhibitions

be part of the experience!

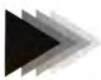

Hands On Power offers the first dedicated working event with testing facilities for equipment within the distributed power sector.

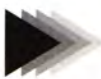

Hands On Power will allow visitors to see equipment working and being monitored under various conditions as well as being tested within controlled environments.

Test facilities include analysis of emissions, noise, vibrations, as well as monitoring under extreme weather conditions and under varying loads. This event is unique and allows visitors to better understand products they are looking to purchase and specify.

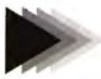

Hands On Power will also run free seminars and workshops in order to offer visitors in-depth market knowledge.



Exhibits at Hands On Power will include: Generating-sets, generators, engines (diesel and gas), rental and hire, test equipment, repair and maintenance, cogeneration, component suppliers, energy solutions, fuel and efficiency, load banks, UPS and ancillary equipment.

Millbrook, Bedfordshire, UK • September 2006

www.handsonpower.com

For more information, contact:

► Mark Skelton: +44 (0)1322 611255

► Matt Colvan: +44 (0)1322 611257

► email: sales@handsonpower.com



Figure 1: Infrequent metastable state captured on Agilent's 6000 series oscilloscope using real-time sampling

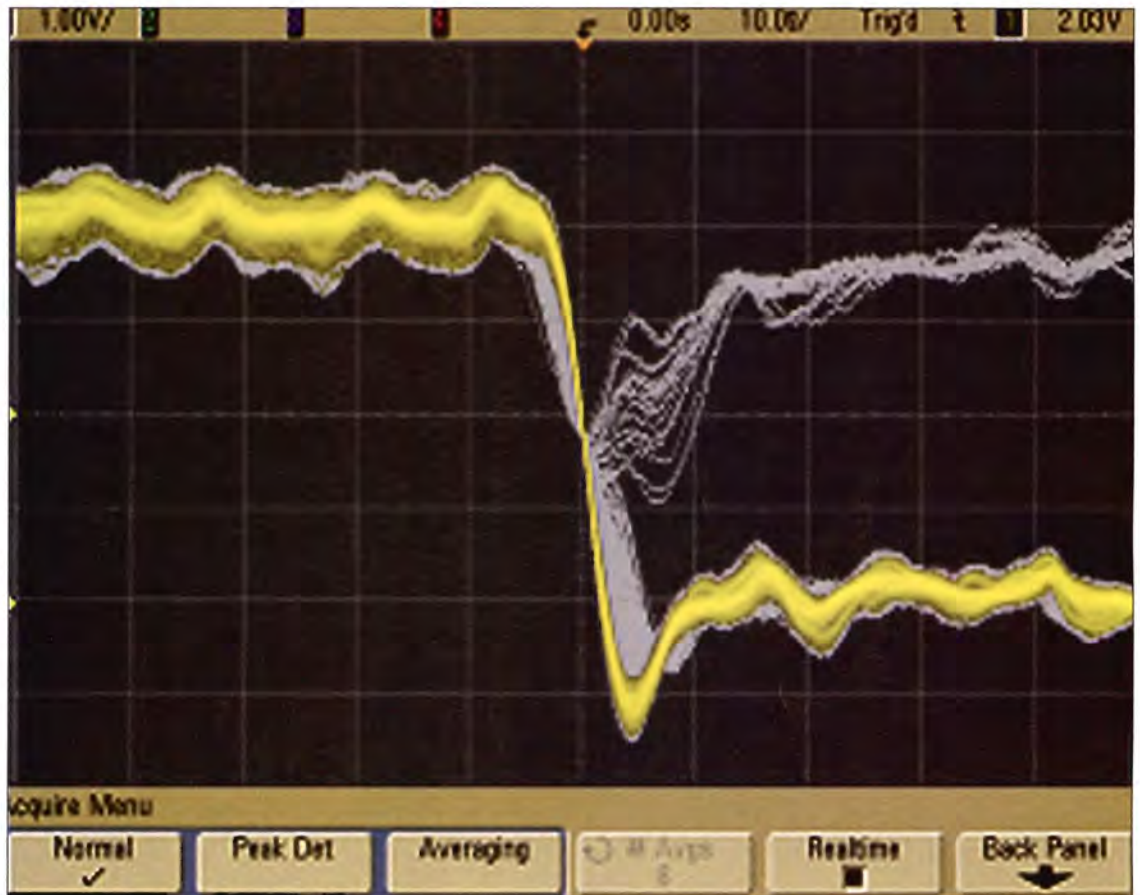

Easier Capturing

Johnnie Hancock of Agilent Technologies explains that oscilloscope waveform update rates determine the probability of capturing elusive events, especially when debugging high-speed digital circuitry

Bandwidth, sample rate and memory depth are the most common specifications engineers evaluate when they select a digitizing oscilloscope. However, waveform update rate is another important factor to consider. The rate at which an oscilloscope acquires waveforms and updates the display determines the probability of capturing random and infrequent events such as glitches. This article uses a debugging application – an attempt to capture a random and infrequently occurring metastable state – to illustrate the importance of waveform update rates. There's also a discussion on the use of special repetitive fast acquisition modes and their possible tradeoffs.

Choosing your tools

When you evaluate an oscilloscope, its responsiveness can influence your decision. To get a good feel for whether a scope is responsive, simply probe a relatively fast repetitive signal and view the response. If the scope's display updates too slowly, the sluggishness can make using the scope a frustrating experience. This is especially true with some of today's deeper-memory oscilloscopes, as processing deep-memory records can slow the update rate. In general, if a scope's display is updated at least twenty times per second, the displayed waveform will appear "live" and the scope will feel responsive. But the importance of waveform update rates extends far beyond responsive-

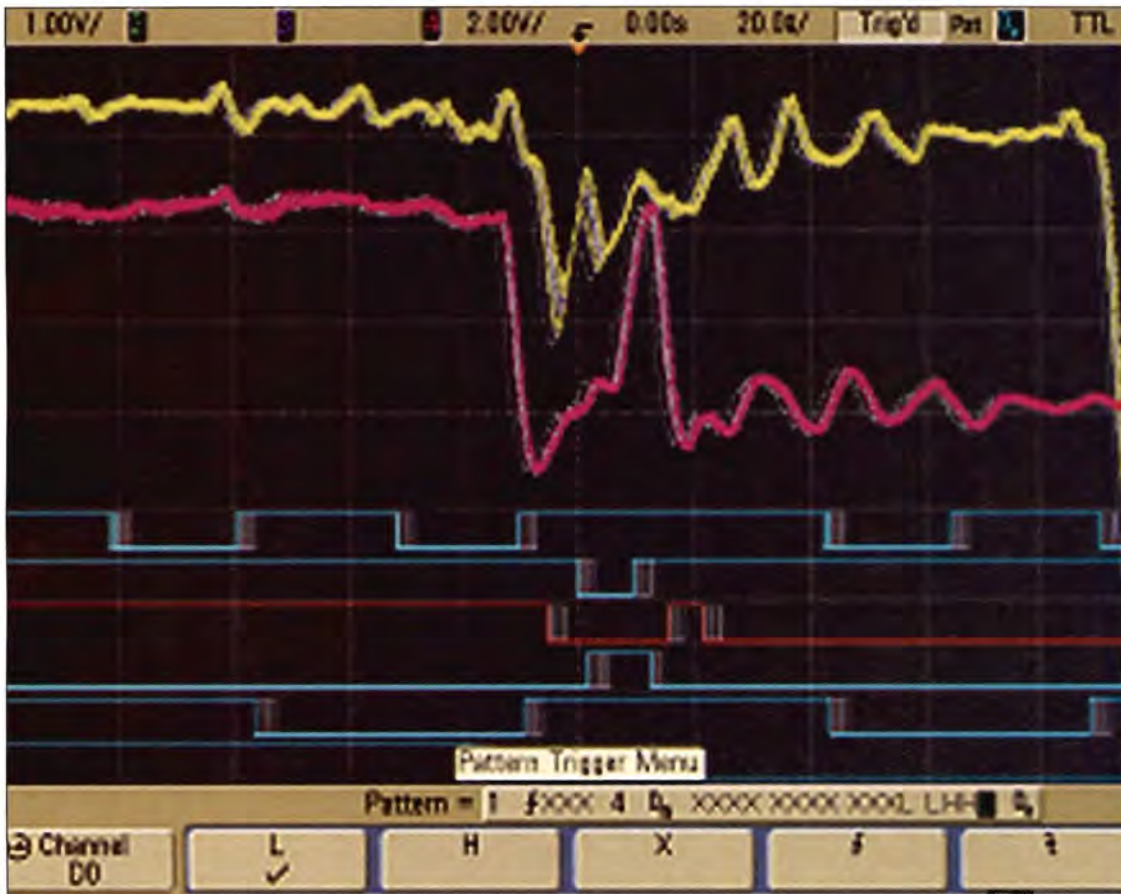

Figure 2: Pattern triggering reveals a setup-and-hold-time violation

of Elusive Events

ness issues. A “live” feel gives no indication of a scope’s probability of capturing infrequent and random events.

Some of today’s scope vendors advertise update rates in the hundreds-of-thousands of waveforms-per-second range, but the human eye cannot discern differences in performance at this level.

However, when you are debugging high-speed digital circuitry, scope update rates in these ranges are critical because they increase the probability of capturing infrequent events. If the signals you need to observe on a scope’s display were always exactly repetitive (no anomalies), extremely fast update rates would not be very important. But when the signals are not exactly repetitive – when anomalies do occur – the random and infrequently occurring events are likely to cause you the most headaches. Faster update rates enhance the probability of capturing elusive events and, thereby, alleviate debugging headaches.

Capturing a metastable state using real-time sampling

Figure 1 shows a random metastable state (glitch) that occurs on average just one time every 50,000 cycles of the data signal. If you knew in advance that this event occurs randomly, you could set up most scopes to trigger on the glitch condition – based on a minimum pulse-width setting – to reliably capture the glitch on each acquisition of the scope. But if you were unaware of the glitch’s existence, you might simply probe various signals in your design to verify proper signal fidelity with the scope set up to trigger on standard rising or falling edge conditions.

Because of their relatively slow update rates, most scopes need to acquire data for more than just a few seconds in order to capture infrequent events. If you plan to use the typical debugging model, where you probe each test point for just a few seconds, and you want to capture the infre-

quently occurring events that may occur at each node, you need a scope with an extremely fast update rate.

The glitch shown in Figure 1 was captured using Agilent's 6000 series oscilloscope, which can update waveforms as fast as 100,000 times per second using real-time sampling, even with $\sin(x)/x$ reconstruction. At this update rate, the scope has a statistical probability of capturing this particular errant signal approximately two times per second. Such high real-time update rates are achieved through the use of Agilent's proprietary third generation MegaZoom III technology.

Once we discover that our circuitry exhibits unexpected behaviour, we can begin to further debug our system. Using the logic channels of our mixed-signal oscilloscope (MSO), we are able set up a combinational logic pattern trigger condition across multiple analogue and digital channels. This process reveals that our system occasionally violates a critical setup-and-hold-time specification due to clock jitter, as shown in **Figure 2**.

Typically on the market today, using other digitising oscilloscope's default real-time sampling modes, waveform update rates range from approximately 60 to 700 waveforms per second. Although 60 waveforms per second is more than fast enough to give an oscilloscope a "live" feel, capturing this particular metastable state that occurs just one time every 50,000 cycles will require maintaining probe contact with the test point for an average of nearly 14 minutes to capture just one glitch. Even at 700 waveforms per second, which sounds pretty impressive, probe contact must be maintained for over one minute to capture a single glitch, on average.

If you were using the typical debugging method of quickly moving your scope probe from test point to test point every few seconds, you would probably miss this event using any other DSO's default real-time sampling mode. To capture this particular errant event within a few seconds, you will need an oscilloscope that updates in the tens-of-thousands of waveforms per seconds, or faster.

Using special acquisition modes

Some scopes on the market today claim to have waveform update rates in the thousands-of-waveforms-per-second range. But this usually requires the selection of a special fast acquisition mode. However, there is usually a tradeoff when it comes to "special" modes of operation in an oscilloscope.

Special fast acquisition modes often tradeoff sample rate and acquisition memory depth – and sometimes require the use of repetitive/equivalent-time sampling modes, as opposed to real-time sampling. In addition, there can also be tradeoffs

concerning measurement functionality of the oscilloscope including measurements, waveform math, and post-acquisition panning and zooming on stored waveforms.

Although special fast acquisition modes of operation may sometimes be the right selection to choose in order to capture infrequently occurring events, you must know when to use and when not to use these "special" modes due to their possible tradeoffs. In addition, even though a particular scope may claim to achieve waveform update rates in the hundreds-of-thousands of waveforms-per-second range using these special modes, these updates rates may only apply for a narrow set of conditions and they may only produce a scattering of dots and not "complete" waveforms for each acquisition cycle.

Defining complete waveforms

Not all waveforms are created equal. How do you define a complete waveform? By definition, when you use real-time sampling with $\sin(x)/x$ reconstruction, each acquisition will produce a complete waveform consisting of a minimum of 500 to 1000 points. But when you use equivalent-time/repetitive sampling, most scopes with "special" fast acquisition modes will produce incomplete waveforms with samples widely spaced on the faster time base ranges. For example, at 200ps/div, one particular scope on the market today produces just 2.5 points (on average) during each acquisition cycle, since the scope limits the maximum sample rate to 1.25GS/s when the special fast acquisition mode is selected. This is clearly an insufficient number of points to define a complete waveform.

Even though this scope may be able to attain an acquisition rate of more than 100,000 acquisitions per second at these faster time base ranges, it does not produce 100,000 complete waveforms per second at these settings. Therefore, to compare waveforms per second between the various oscilloscopes using special equivalent-time sampling techniques, your should normalise the actual acquisition rate on the faster time base ranges in order to compute "complete" waveforms-per-second update rates.

Agilent suggests that a minimum of 500 digitised points should be used as a normalisation factor. So, if a particular scope is able to update at 100,000 acquisitions per second, but only produces 2.5 points per acquisition, it will require approximately 200 acquisition cycles to produce a "complete" waveform consisting of 500 points. This means that the effective waveform update rate is not 100,000 waveforms per second (using special fast acquisition repetitive sampling), but actually just 500 "complete" waveforms per second.

Additional factors

In addition to being cautioned about the truth about special fast acquisition modes, you should also be aware that there are many other setup variables that come into play that can affect waveform update rates. Some of these variables include time base range, measurements, number of active channels, memory, complexity of displayed waveform, etc.

Figure 3 shows a chart of waveforms per second as a function of time base setting for Agilent's new 6000 series oscilloscopes.

Although engineers often overlook waveform update rate performance, when they select a digitising oscilloscope, waveform update rate can have a huge impact on your ability to find and fix intermittent circuit problems. The trick is to use technology that can provide the fastest real-time waveform update rates and one that does not require users to select special operating modes that may entail tradeoffs in performance and functionality.

The number of logic-timing channels is also of great importance to find the root cause of intermittent failures. The more channels there are, the easier the task becomes.

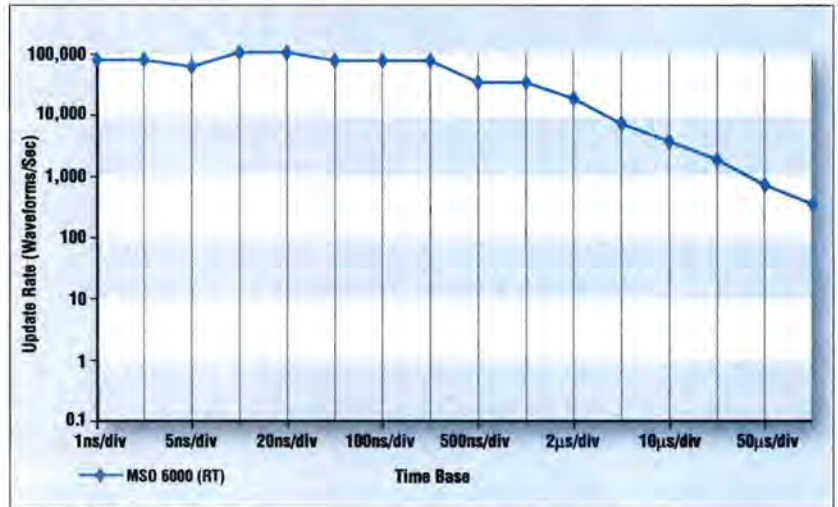

Figure 3: Agilent 6000 series scopes waveform update rates as a function of timebase setting

Telnet

Quality second-user test & measurement equipment

Tel: 02476 650 702 Fax: 02476 650 773

Web: www.telnet.uk.com Email: sales@telnet.uk.com

All equipment is used - with 30 days guarantee and 90 days in some cases. Add carriage and VAT to all goods.
1 Stoney Court, Hotchkiss Way, Binley Industrial Estate Coventry CV3 2RL ENGLAND



Agilent (HP) 3314A Function Generator 20 MHz	£650	Agilent (HP) 54520A 500MHz 2 Channel Oscilloscope	£1000
Agilent (HP) 3325A and B function gen. from	£550	Agilent (HP) 54645D 100MHz Mixed Signal Oscilloscope	£3000
Agilent (HP) 435A/B, 436A, 437B, 438A Power Meters from	£100	Agilent (HP) 8713B 300kHz - 3GHz Network Analyser	£4500
Agilent (HP) 3561A Dynamic Signal Analyser	£2950	Agilent (HP) 8566B 100Hz - 22GHz High Performance Spec. An.	£7000
Agilent (HP) 3562A Dual Ch. Dynamic Sig. Analyser	£3000	Agilent (HP) 8592B 9kHz - 22GHz Spectrum Analyser	£7500
Agilent (HP) 3582A Spectrum Analyser Dual Channel	£1200	Agilent (HP) E4418B EPM series Power Meter -single channel	£1500
Agilent (HP) 3585A and B Spec. An. (40MHz) from	£2950	Agilent (HP) E9300A EPM series sensor for above(18GHz- 100mW)	£750
Agilent (HP) 35660A Dynamic Sig. An	£2950	Agilent (HP) 8648C Signal generator (100kHz-3.2GHz)	£4000
Agilent (HP) 4191A R/F Impedance analyzer (1 GHz)	£2995	Agilent (HP) 8347A R/F Amplifier (100kHz-3GHz)	£2000
Agilent (HP) 4192A L/F Impedance Analyser (13MHz)	£4000	Agilent (HP) 33250A Arbitrary Function Generator (80MHz)	£2150
Agilent (HP) 4193A Vector Impedance Meter	£2750	Agilent (HP) E4406A (opt BAH) Vector Signal Generator (7MHz-4GHz)	£11000
Agilent (HP) 4274A LCR Meter	£1750	Agilent (HP) E4404B (opts 1D5,1DN,A4H) Spectrum An. (9kHz-6.7GHz)	£10000
Agilent (HP) 4275A LCR Meter	£2750	Agilent (HP)34401A 6.5 Digit Bench DMM	£550
Agilent (HP) 4276A LCR Meter	£1400	Agilent (HP) 4194A (50 ohm) Impedance/Gain Phase Analyser	£10750
Agilent (HP) 4278A Capacitance Meter (1kHz / 1MHz)	£2950	Agilent (HP)5350B Microwave Frequency Counter (20 GHz)	£1200
Agilent (HP) 5342A Frequency Counter (18GHz)	£850	Agilent (HP) 5343A Frequency Counter (26.5 GHz)	£1400
Agilent (HP) 5351B Frequency Counter (26.5GHz)	£2750	Amplifier Research 10W1000B Power Amplifier (1 GHz)	£4700
Agilent (HP) 5352B Frequency Counter (40GHz)	£4950	ENI 320L Power Amplifier (250kHz 110MHz) 20 Watts 50dB	£1200
Agilent (HP) 53310A Mod. Domain An (opt 1/31)	£3450	IFR (Marconi) 2051 10kHz-2.7GHz) Sig. Gen.	£5000
Agilent (HP) 54810A Infinium Scope 500MHz	£2995	Rohde & Schwarz SMY01 9kHz - 1040 MHz Signal Generator	£1750
Agilent (HP) 8116A Function Gen. (50MHz)	£1750	Rohde & Schwarz CMD 57 Digital Radio Comms Test Set	£4250
Agilent (HP) 8349B (2- 20GHz) Amplifier	£1950	Rohde & Schwarz XSRM Rubidium Frequency Standard	£3750
Agilent (HP) 8350B Mainframe sweeper (plug-ins avail)	£750	Rohde & Schwarz CMD 80 Digital Radio Comms Test Set	£3500
Agilent (HP) 85024A High Frequency Probe	£1000	R&S SMIQ-03B Vector Sig. Gen. (3 GHz)	£7000
Agilent (HP) 8594E Spec. An. (2.9GHz) opt 41,101,105,130)	£3995	R&S SMG (0.1 - 1 GHz) Sig. Gen.	£1750
Agilent (HP) 8596E Spec. An. (12.8 GHz) opt various	£8000	Seaward PAT 1000S Computerised PAT Tester(New in Box) normally £845 now	£550
Agilent (HP) 89410A Vector Sig. An. Dc to 10MHz	£7500	Tektronix THS 720A 100MHz 2 Channel Hand-held Oscilloscope	£1250
Agilent (HP) 89440A Vector Signal Analyser 2MHz - 1.8GHz	£8950	Tektronix TDS 220 100MHz - 2 Channel Real - Time Scope	£650
Agilent (HP) 33120A Function/Arbitrary Waveform Generator 15MHz	£850	Tektronix TDS 524A 500 MHz - 500Ms/s 2 Channel Scope	£3000
Agilent (HP) 53131A Frequency Counter	£750	Tektronix TDS 724A 500 MHz - 1 Gs/s 2+2 Channels	£3250
Agilent (HP) 53181A Frequency Counter	£750	Tektronix 2465B 400 MHz 4 Channel Scope	£1000
Agilent (HP) 4284A Precision LCR Meter	£5750	Tektronix 11402 (Digitizing Mainframe) + 11A33 + 11A34 plug-ins	£1650
Agilent (HP) 6031A Power Supply (20V - 120A)	£1250	Tektronix 571Curve Tracer	£1250
Agilent (HP) 6032A Power Supply (60V - 50A)	£2000	Wayne Kerr 3260A+3265A Precision Mag. An. with Bias Unit	£5500
Agilent (HP) 6671A Power Supply (8V - 200A)	£1350	Wayne Kerr 3245 Precision Ind. Analyser	£1750
Agilent (HP) E4411A Spectrum Analyser (9kHz - 1.5GHz)	£3500	Wayne Kerr 6425 Precision Component Analyser	£2000
Agilent (HP) 8924C CDMA Mobile Station Test Set	£6000	Wavetek 9100 Universal Calibrator (Opts 100 / 250)	£9000
Agilent (HP) E8285C CDMA Mobile Station Test Set	£6000	W&G PFJ 8 Error & Jitter Test Set	£6500

Various other calibrators in stock. Call for stock / prices

PICmicro Microcontroller DC Motor Control

Every motor control circuit can be divided into the drive electronics and the controlling software. These two pieces can be fairly simple or extremely complicated depending upon the motor type, the system requirements and the hardware/software complexity trade-off. Generally, higher performance systems require more complicated hardware. The tips below describe some basic circuits and software building blocks commonly used to control motors.

TIP 1: Brushed DC motor drive circuits

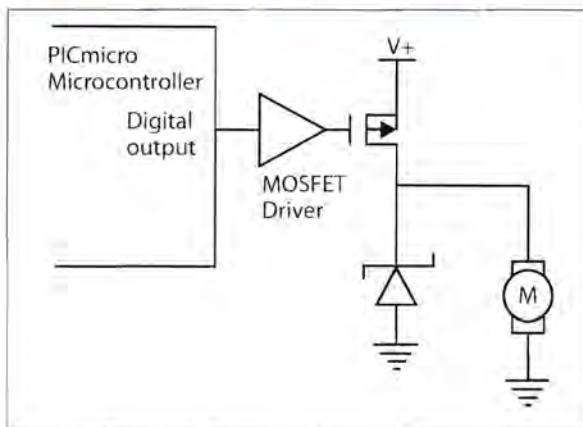

Figure 1: High side drive

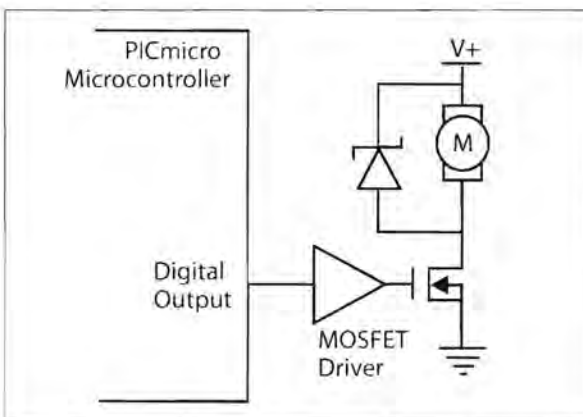

Figure 2: Low side drive

All motors require drive circuitry that controls the current flow through the motor windings. This includes the direction and magnitude of the current flow. The simplest type of motor to drive is the brushed DC motor. Drive circuits for this type of motor are shown in the figures.

This is the lowest cost drive technique because of the Mosfet drive simplicity. Most applications can simply use an output pin from the PICmicro microcontroller to turn the Mosfet on.

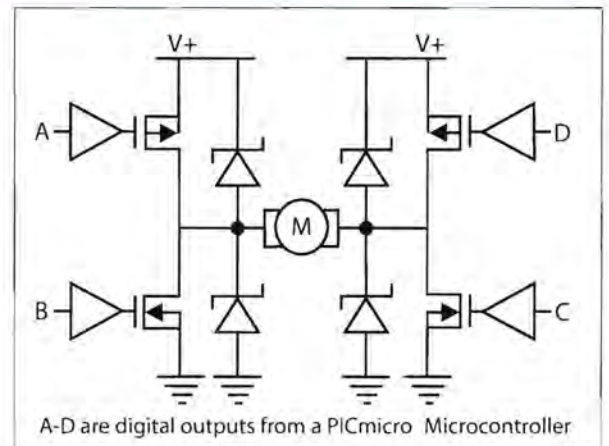

Figure 3: H-bridge drive

The H-bridge derived its name from the common way the circuit is drawn. This is the only solid-state way to operate a motor in both directions.

TIP 2: Brushed DC motor control circuits

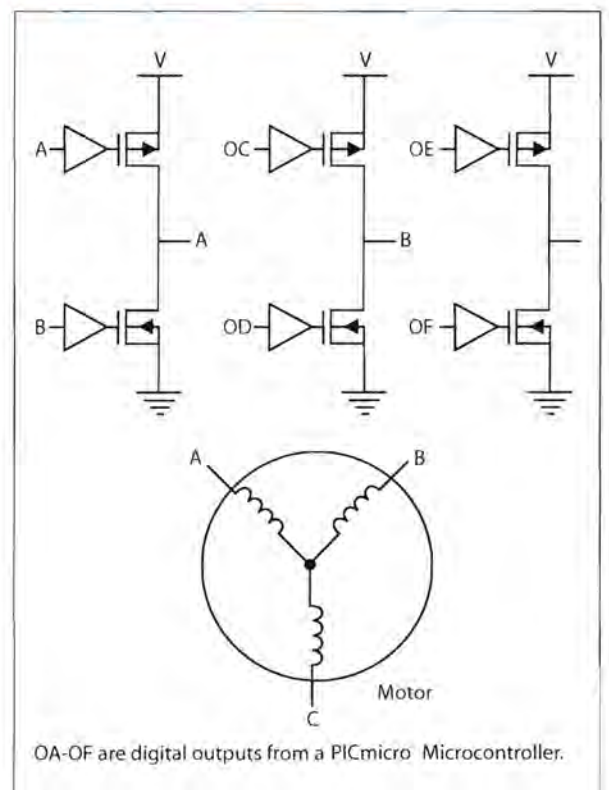

Figure 4: 3-phase brushless DC motor control

A brushless DC motor is a good example of simplified hardware increasing the control complexity. The motor cannot commutate the windings (switch the current

TIP 3: Stepper motor drive circuits

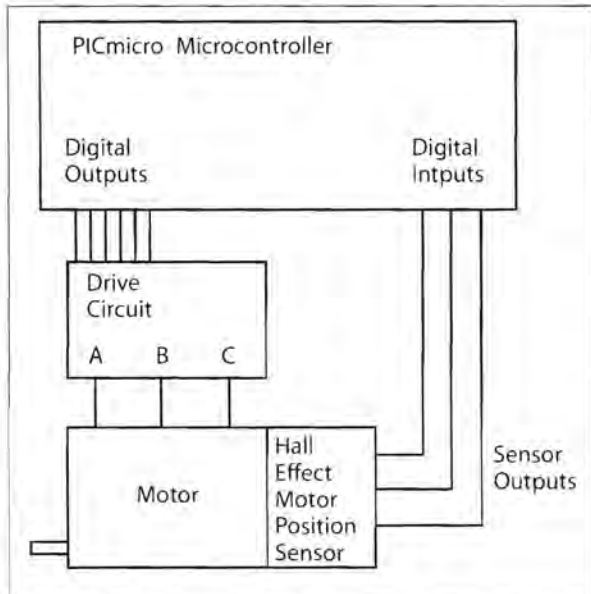

Figure 5a: Quadrature decoder (sensor motor)

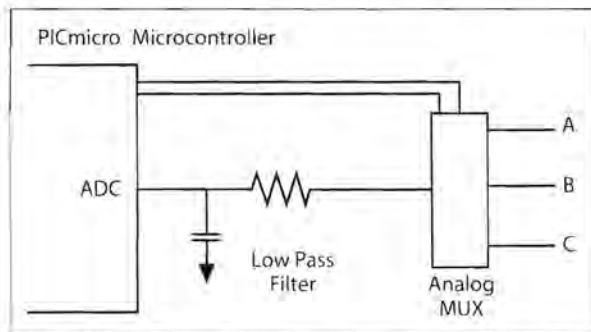

Figure 5b: Back EMF sensing (sensorless motor)

flow), so the control circuit and software must control the current flow correctly to keep the motor turning smoothly. The circuit is a simple half-bridge on each of the three motor windings. There are two basic types of brushless DC motors: sensor and sensorless. Because it is critical to know the position of the motor, so the correct winding can be energised, some method of detecting the motor position is required. A sensor motor will directly report to the controller, the current position of the motor.

Driving a sensor motor requires a look-up table. The current sensor position directly correlates to a commutation pattern for the bridge circuits. A sensorless motor requires that the induced voltage in the un-driven winding be sensed and used to determine the current speed of the motor. Then, the next commutation pattern can be determined by a time delay from the previous pattern.

Sensorless motors are simpler to build due to the lack of sensors, but they are more complicated to drive. A sensorless motor performs very well in applications that don't require the motor to start and stop. A sensor motor would be a better choice in applications that must periodically stop the motor.

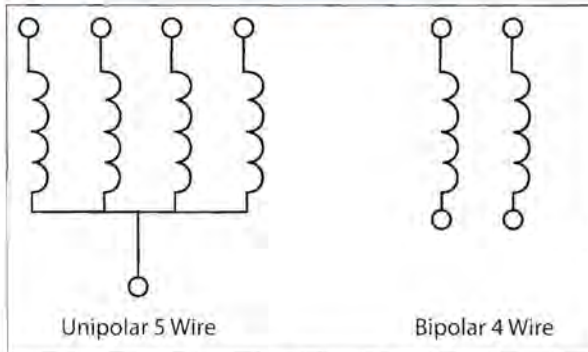

Figure 6: 4- and 5-wire stepper motors

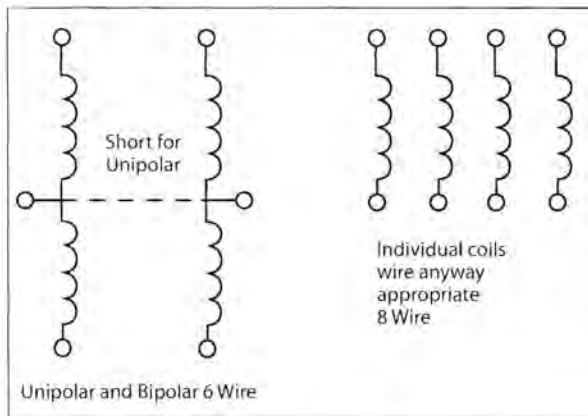

Figure 7: 6- and 8-wire stepper

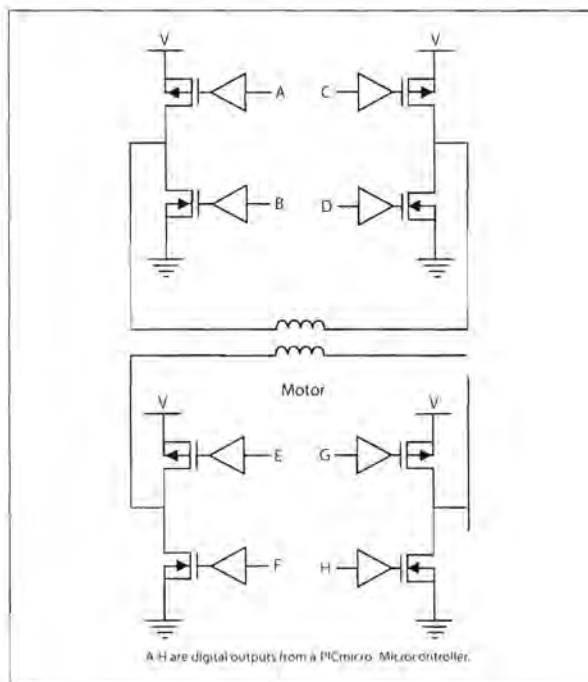

Figure 8: Unipolar motor (four low-side switches)

Stepper motors are similar to brushless DC motors in that the control system must commutate the motor through the entire rotation cycle. Unlike the brushless

Tips 'n' Tricks

motor, the position and speed of a stepping motor is predictable and does not require the use of sensors. There are two basic types of stepper motors, although some motors can be used in either mode.

The simplest stepper motor is the unipolar motor. This motor has four drive connections and one or two center tap wires that are tied to ground or VSUPPLY, depending on the implementation. Other motor types are the bipolar stepper and various combinations of unipolar and bipolar, as shown in **Figure 6** and **Figure 7**. When each drive connection is energised, one coil is driven and the motor rotates one step. The process is repeated until all the windings have been energised. To increase the step rate, often the voltage is increased beyond the motor's rated voltage. If the voltage is increased, some method of preventing an overcurrent situation is required.

There are many ways to control the winding current, but the most popular is a chopper system that turns off current when it reaches an upper limit and enables the current flow a short time later. Some systems are built with a current chopper, but they do not detect the current, rather, the system is designed to begin a fixed period chopping cycle after the motor has stepped to the next position. These are simpler systems to build, as they only require a change in the software.

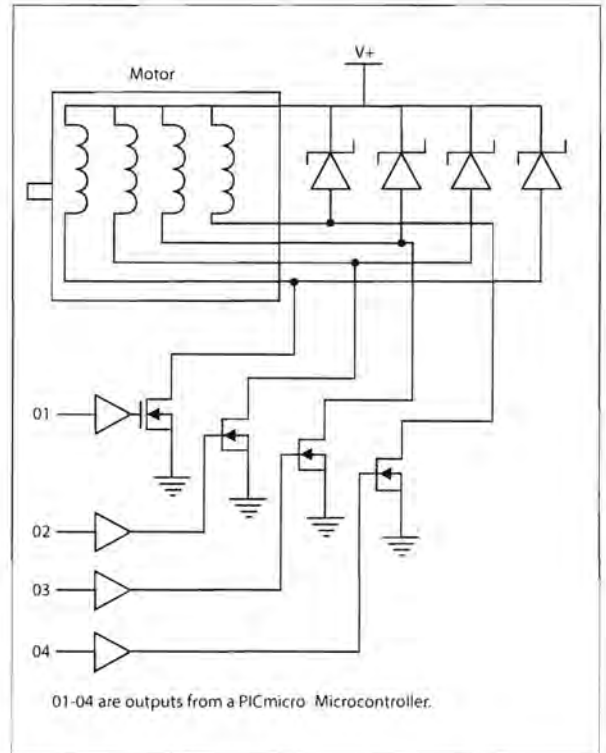

Figure 9: Bipolar motor (four half-bridges)

Win a Microchip PICDEM MC Development Board for Motor Control Design



Microchip's PICDEM MC Development Board makes it easy for engineers of all experience levels to cost-effectively add the efficiency and reliability of electronic motor control to their embedded designs.

The new PICDEM MC supports creation of both AC induction motor (ACIM) and brushless DC (BLDC) advanced motor control applications with the PIC18FXX31 family of MCUs. These devices feature three advanced motion control modules, including a built-in quadrature encoder interface. The PICDEM MC board is also constructed with complete electrical isolation from the power circuitry, allowing users to plug in the MPLAB In-Circuit Emulator (ICE 2000) or MPLAB In-Circuit Debugger (ICD 2) for full programming, debugging and emulation while high power is connected to the board. In addition, the PICDEM MC board's isolated serial-port PC interface to the MC-GUI software enables users to modify their application parameters on the fly. The PICDEM MC combines the above features with included hex, assembler and C source files to provide a complete reference design for ACIM and BLDC motor control applications.

Supported by Microchip's Motor Control Design Centre (www.microchip.com/motor) and the free to download MCGUI, engineers will easily be able to add electronic control to their motor-driven products, reduce development time and costs.

For the chance to win one of these boards, log onto
www.microchip-comp.com/elecworld-picdemmc



RoHS

WHAT'S ALL THE FUSS ABOUT?

RoHS (the Restriction of the use of certain Hazardous Substances) and WEEE (Waste Electrical and Electronic Equipment) is the equivalent of Y2K for the electronics industry. The upcoming EU environmental directives are the most significant developments in electronics legislation to happen in many years and will completely revolutionise the way electrical and electronic products are designed, sold, recovered and recycled. Worryingly, many design engineers are still not fully aware that the upcoming legislation will affect them. For those who are, many questions remain unanswered. Complicated exemption rules, uncertainty about how the directives will be enforced, obsolescence and component availability has left engineers unsure of what they need to do and when. The clock is ticking. With only several months to go, there's no time to lose in the transition to RoHS. If compliant components aren't already part of the design cycle it could well be too late.

Q: What's the update on the latest delays to the WEEE Directive?

A: The Department of Trade and Industry (DTI) announced a further delay to the implementation of the WEEE Directive in December 2005. The WEEE Directive is now not likely to come into force until around January 2007, 17 months behind schedule of the original date of August 2005.

Q: What do I need to consider when deciding to upgrade my solder tools to cope with the introduction of lead-free solders?

A: There are three key areas to consider when upgrading or changing your solder tools: ● Lead-free alloys do not flow (wet) as readily to form the joint and will therefore take slightly longer to form the solder joint ● Lead-free alloys currently being specified melt approximately 400C higher than current tin/lead alloys ● Solder iron tip temperature is only one measure of the available energy to solder. Power and thermal recovery (speed to reach optimum temperature) are equally important.

Q: How do I know if my current solder tips are lead-free compatible?

A: Solder tips have little or no lead content, however, tinning the tip with lead-free solder prior to soldering will eliminate the risk of lead-free contamination during the soldering process.

Q: Would a car radio be within the scope of the RoHS Directive?

A: This is an example of the ruling in respect of equipment that is part of another type of (larger) equipment not covered by the RoHS Directive – a car does not fall within RoHS so, therefore, nor does the car radio.

Q: I understand that a slow-responding iron can be a problem when working with lead-free solders. What is considered slow?

A: A slow responding iron will not recover heat quickly enough to solder lead-free joints repeatedly. As a guide, if the iron reaches operating temperature from switch-on within 10-15 seconds this would be considered good. If the heat-up time approaches one minute, this would be considered poor.

Q: What are the benefits of joining a WEEE compliance scheme?

A: It is anticipated that most producers will use compliance schemes to meet WEEE obligations of which the benefits include: ● Reduced administration processes for the producers ● Pay the same regardless of the amount of waste ● Competitive service provision such as recycling, transportation etc. ● Producers do not become involved in WEEE collection ● Obligations are catered for in a cost-effective and environmentally-compliant way ● Legal liabilities transfer to the compliance scheme ● A choice of business-to-business or business-to-consumer schemes.

Q: Should the wheelee bin sticker be put on a printed circuit board?

A: No, PCBs are considered to be a 'component' and there is no legal requirement to label components.

Q: I manufacture test equipment; do I have to worry about RoHS?

A: Not at the moment, as test equipment is category 9 and does not fall within the scope of RoHS. However, ERA Technology are now reviewing categories 8 and 9 for the EC and are expected to report back on their recommendations in the next few months. If it is decided that these categories should be added to the scope of the RoHS Directive, implementation is not expected before 2010. It is also important to note that test equipment is within the scope of the WEEE Directive and should, therefore, be recycled at end-of-life.

Q: What are the benefits of working with an approved recycling company to meet the requirements of the WEEE Directive?

A: The benefits of working with a recycler include: ● Potential of cost effectiveness for small quantities of WEEE ● Payment only for recycling what the user returns to the recycler ● Advice on design for disassembly ● Help with collection/treatment ● Information on various treatment facilities ● Practical advice on reuse/salvage ● Knowledge of end markets/raw materials

Q: What is the definition of 'homogeneous' material?

A: Homogeneous material means a unit that cannot be mechanically disjointed (by cutting, grinding etc.) in single materials such as plastic, ceramic, glass, metals etc.



Gary Nevison is chairman of the AFDEC RoHS team, board director at Electronics Yorkshire and head of product market strategy at Farnell InOne. As such he is our industry expert who will try and answer any questions that you might have relating to the issues of RoHS and WEEE. Your questions will be published together with Gary's answers in the following issues of Electronics World.

Please email your questions to EWeditor@nexusmedia.com, marking them as RoHS or WEEE.

Op Amps for Everyone (2nd edition)

Ron Mancini

Newnes (Elsevier)

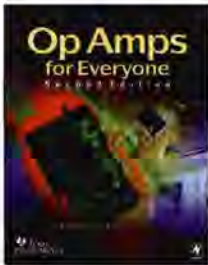

This book takes a different approach from the traditional textbook. It starts with a review of the physics behind op-amps then discusses idealised op-amp models. It is a comprehensive guide to design using op-amps. It gives the readers the basic design and theory of these circuits.

This is an excellent starting reference book. It covers a wide range of circuit and system op-amp based design: feedback theory; ideal and non-ideal op-amps;

feedback and stability factors; a comprehensive comparison between voltage op-amps and current feedback op-amps, instrumentation and wireless communication design; ADCs/DACs and active filters. However, probably the most important coverage is in chapter 11, "Understanding Op Amp Parameters", and chapter 17, "Circuit Board Layout Techniques".

Few books show useful op-amp design, without bothering to explain anything about how they work. This one does. Each chapter stands alone, with good background, and without the necessity of looking at other chapters of the book. Despite the good features there are some shortcomings in the presentation, however.

The circuit equations in Chapter 2 and the calculations relating to them only involve resistors. A general review of circuit

equations should have them expressed in terms of impedance instead of resistance.

In Chapter 3 there is a sign error in Equation (3.4), and (Equation 3.21) is incorrect.

In Chapter 4, plots of input voltage versus output voltage are called transfer curves as shown in Figure 7. It is normal to plot the output (the dependent variable) against the input (the independent variable).

We found the title of the book somewhat misleading, though, as not "everyone" is conversant with the complex frequency variables or with plots and zeros, dealt with, for example in Chapter 7.

Khaled Hayatleh and Bryan Hart

PC-based Instrumentation and Control (3rd edition)

Mike Tooley

Newnes (Elsevier)



Mike Tooley's book is a good practical introduction on how to use a computer to control and monitor external transducers and sensors. I wish I had only known of its existence a couple of years ago when I was commissioned to provide a design for a PC-controlled IC tester, it might have saved my client some of the time and cost it took to investigate the various options.

The first two chapters give in-depth detail on PC hardware architecture, complete with an interesting history of PCs and their growth over the past two decades. Most of the different x86-type CPUs are listed, with a description of their associated chipsets. There is also useful information on PC BIOS data addresses. The ISA, EISA and PCI buses are described in some detail with brief explanations of the AGP and PC104 buses. The features of the USB bus have been comprehensively covered. The second chapter concludes with descriptions of some of the proprietary I/O cards that can be connected to these

buses.

The next five chapters are concerned with how to write programmes to access external hardware. There is a full description on the origins of DOS and its command line interface, together with an explanation on how DOS batch commands are created and implemented. A chapter on programming, giving the basics of software engineering, is followed by a description of assembly language programming. The BASIC and C/C++ languages are also covered in some detail.

There is a very informative chapter explaining the details of the IEEE bus and a chapter on hardware interfacing, where a variety of sensors and transducers are described, complete with circuit arrangements. Following that is a chapter on several commercial software packages.

A chapter on virtual instruments deals, mainly, with digital storage oscilloscopes. Together with descriptions of a proprietary DSOs, it describes how to create an oscilloscope using the computer's sound card as an input and the PC monitor as the oscilloscope screen. A working application program, WinScope, is available free as a download from the companion website.

The chapter on applications gets down to the main object of the book namely "PC Based Instrumentation and Control". Several working examples of real projects, complete with detailed information on

hardware and software, give the reader a solid introduction on how to employ a PC as a controller or an instrument.

In the last chapter, Mike Tooley provides an introduction to software quality control and covers, in some depth, software reliability and fault-finding. For me, the revelation of the existence of the Microsoft utility "DrWatson" is, alone, worth the price of the book. A set of appendices covering all manner of physical and computer data completes the volume.

The content of the book fully justifies the author's claim that it provides sufficient information to make an informed decision on which hardware and software is needed to implement a range of instrumentation and control systems. It is an ideal introduction to PC controlled instrumentation for students and engineers who have some knowledge of PCs and is a useful reference for professional control and instrumentation specialists.

I was disappointed that there was very little information on the Windows API command interfaces pertaining to hardware input/output ports. The PC serial (COM) ports were only mentioned in passing and, to complete the information on programming, it might have been useful to make a brief mention of Delphi ("Visual Pascal").

The requirement for "stand alone" instruments having turnkey operation has given rise for a large demand for "small

board computers”, where the use of assembly language to access external hardware is almost a necessity. The chapter on assembly language programming shows how an experienced engineer may fiddle with the guts of the x86 family of processors. However, I do think that Tooley should have given would be experimenters the warning “Dabbling in assembly language can seriously damage your PC’s hardware”.

I liked the part in the chapter on visual BASIC, where the means of communicat-

ing with the PC’s parallel (LPT) port is described. The address of web sites of several companies or organisations providing parallel port DLLs and ActiveX programs is given.

Mike Tooley states that his book is the end result of several thousand hours of research and development. Anybody reading through the book would find this very evident, considering the variety of different but related subjects covered in five hundred pages. The author’s web site is valuable and has available for download

a complete set of source codes for the programs in the book, plus extra documentation and information about the author. I consider this book to be a useful addition to my technical book shelf.

Mike Button

If you want to buy a copy of any of the books featured in Electronics World, you will receive a 15% discount and P&P free, by writing to us at the usual address or emailing us on

EWeditor@nexusmedia.com

PicoScope 3000 Series PC Oscilloscopes

The PicoScope 3000 series oscilloscopes are the latest offerings from the market leader in PC oscilloscopes combining high bandwidths with large record memories. Using the latest advances in low power electronics, the oscilloscopes draw their power from the USB port of any modern PC, eliminating the need for mains power.

- **High performance: 10GS/s sampling rate & 200MHz bandwidth**
- **1MB buffer memory**
- **Advanced display & trigger modes**
- **Compact & portable**
- **Supplied with PicoScope (oscilloscope/spectrum analyser) & PicoLog (data acquisition) software.**

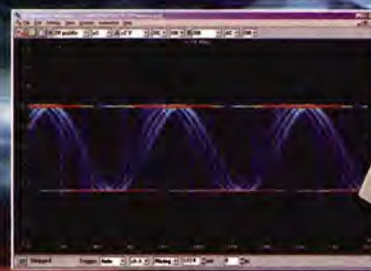

PicoScope	3204	3205	3206
Bandwidth	50MHz	100MHz	200MHz
Sampling rate (effective)	2.5GS/s	5GS/s	10GS/s
Sampling rate (usable)	50MS/s	100MS/s	200MS/s
Channels	2, Can't split	2, Can't split	2, Can't split
Double-buffer channels	Simult. 50/50MHz	Simult. 100/100MHz	Simult. 200/200MHz
Timebase resolution	10ps	10ps	10ps
Speed (max)	0.1s (20000)	0.1s (20000)	0.1s (20000)
Record length	9999	9999	9999
Resolution (accuracy)	10 bits (2.0)	10 bits (2.0)	10 bits (2.0)
Range	10.0V, 1.0V/div	10.0V, 1.0V/div	10.0V, 1.0V/div
PC Config (min power) (max)	0.200W (0.200W)	0.200W (0.200W)	0.200W (0.200W)

Tel: 01480 396395
www.picotech.com/scope333

pico
Technology Limited



Siemens's new Sintesio fire detector is intelligent enough to differentiate between a real fire and the causes of common false alarms, such as cooking fumes, insects, steam and dust, bringing an end to false alarms. It can detect changes in temperature and see smoke particles in the air using fuzzy logic, allowing it to recognise smoke from non-threatening causes such as cooking fumes, burnt toast and cigarettes.

Available early 2006, costing £25-£40 from most electrical outlets

The Plantronics Discovery 640 is the smallest Bluetooth headset on the market, weighing only nine grams. Ideal for gadget lovers who are always on the move between car, office and home, it offers multi-point connectivity and incoming call vibrate alert for seamless switching between Bluetooth enabled devices. A huge benefit to users is the innovative cradle charging system

that gives up to 15 hours talk-time and multiple charge adapters for compatibility with any mobile device. It is compatible with both Bluetooth v1.1 and v1.2 and supports handsfree and headset profiles of all major mobile devices, including Nokia, Sony Ericsson, Motorola and Siemens.



Available now from under £70
www.plantronics.com
 or 0800 587 2915



BT's Trackit is a vehicle anti-theft device. It pinpoints a stolen vehicle's location using global positioning satellite (GPS) technology to within a few feet. The latest in tracking technology is combined with wireless technology, advanced in-car electronics and satellite navigation, so the system can monitor and track a vehicle in order to identify when it is moved without authorisation. The Secure Operating Centre then informs the owner that the car has moved and can liaise with the police to arrange for the vehicle's ignition to be disabled when parked, to help ensure its fast recovery. With this system, a car can be tracked across 27 EU countries and customers can also benefit from police immediate response. **Available now from around £299, with installation at £149 and an annual subscription fee of £149.**



www.trackit.bt.com



Fusing style and technology, Intempo Digital's iDS-01 iPod speaker system and docking station now comes in black, a perfect complement if you can get your hands on the black iPod Nano, which is currently flying off the shelves. Lightweight and portable, this is a powerful speaker system that also allows you to charge your iPod through the built-in dock, while downloading new tracks or listening to hi-fi quality sounds at home, work or at play. It is also compatible with many other audio devices such as a Walkman, MP3 and MiniDisc players and includes powerful 2 x 6 watt RMS with neodymium speakers and 3D Super Bass design. It is mains operated and comes with external AC adaptor and 3.5mm stereo line in jack with a stereo cable for connecting other audio devices.

Available now from around £29.99
Comet, Carphone Warehouse, Amazon.co.uk, dabs.com, misco.co.uk and empire direct

ELECTRONICS WORLD

If you are interested in staying at the cutting-edge of electronic design then Electronics World is the magazine for you. Sign up and be inspired every month. A subscription guarantees your magazine arrives every month promptly and without fail.

Subscribe now!

TO MAKE SURE WE KEEP OUR EDITORIAL RELEVANT TO YOU, PLEASE TICK ANY OF THE FOLLOWING THAT APPLY TO YOU. THANK YOU

- | | | | | |
|--|--|---|---|---|
| 1. | 2. Your profession: | 3. Your interest | 4. Your industry | G Industrial |
| <input type="checkbox"/> A Professional engineer | <input type="checkbox"/> A Management | <input type="checkbox"/> A Analogue | <input type="checkbox"/> A Aerospace | <input type="checkbox"/> H Manufacturing |
| <input type="checkbox"/> B Serious hobbyist | <input type="checkbox"/> B Design | <input type="checkbox"/> B Digital | <input type="checkbox"/> B Automotive | <input type="checkbox"/> I Medical |
| | <input type="checkbox"/> C Purchasing/specifying | <input type="checkbox"/> C Software | <input type="checkbox"/> C Broadcast | <input type="checkbox"/> J Military |
| | <input type="checkbox"/> D Service/maintenance | <input type="checkbox"/> D Project management | <input type="checkbox"/> D Computing | <input type="checkbox"/> K Power |
| | <input type="checkbox"/> E Research | <input type="checkbox"/> E EMC | <input type="checkbox"/> E Communications | <input type="checkbox"/> L Semiconductors |
| | <input type="checkbox"/> F Education | <input type="checkbox"/> F RF/microwave | <input type="checkbox"/> F Consumer electronics | <input type="checkbox"/> M T&M |

If you prefer not to receive promotional mailing from other companies please tick box.
All subscriptions run for their full term no credit will be given for cancellations during this period

Yes I would like to subscribe to Electronics World magazine for:

One year £45 UK, £76 in Europe (€120) and Worldwide (US\$145)

Two years £80 UK, £140 in Europe (€215) and Worldwide (US\$260) saving 10%

Three years £105 UK, £185 Europe (€285) and Worldwide (US\$345) saving 20%

Name

Job Title

Company

Address

Postcode

Tel

Fax

Email

PLEASE NOTE THAT BY GIVING YOUR EMAIL YOU ARE GIVING US PERMISSION TO CONTACT YOU WITH IT

PAYMENT CHOICE:

I enclose a cheque made payable to Electronics World

Please invoice my company

Please debit my card Visa Mastercard Amex Switch Solo

Card No

Issue No (Switch/Solo only) Expiry date

Signature Date

Please complete payment and address details and return this order form to:

Debbie Jenner, Freepost SEA 11436, Electronics World, Media House, Swanley, Kent BR8 8BR (no stamp required)UK only

International address: Debbie Jenner, Electronics World, Nexus Media Communications, Media House, Swanley, Kent BR8 8HU United Kingdom

Ref:404

Novel BPSK Demodulator

Digital modulation techniques play a prominent role in modern communication systems and Binary Phase Shift Keying (BPSK) is widely being employed in many such systems. This circuit idea presents a novel demodulator for detecting the BPSK signal faithfully.

In BPSK communication systems, in order to synchronise the sine wave oscillator in the transmitter and in the receiver, a sine wave sync signal is normally transmitted with the BPSK signal. This can be in the form of a burst signal for a short duration (like a colour burst in the video signal), transmitted along with the BPSK signal. Part of the BPSK receiver is shown in **Figure 1** as a block diagram.

The BPSK signal is received and its signal level raised and conditioned by the usual AGC (Automatic Gain Control) cir-

cuit, so to meet the level corresponding to that of the sub-carrier oscillator producing the sine wave for BPSK detection. The precision BPSK demodulator, in turn, would recover the bit stream $b(k)$ used in the transmitter. The proposed BPSK demodulator consists of three stages: an analogue adder, a precision full wave rectifier with envelope detector and a threshold comparator as shown in **Figure 2**.

The received BPSK signal (v_a) and the sub-carrier sine wave oscillator (v_b) are added in the op-amp Q1 to get the sum (v_c). The sum signal v_c is given to the precision full-wave rectifier consisting of op-amps Q2 and Q3 and a PNP transistor T1. The op-amp Q3 functions as a controlled inverter, which would either buffer its input to the output or would invert it in accordance with the conducting conditions

of the non-inverting terminal (+). The op-amp Q2 is functioning as a zero-cross detector, as it develops a control voltage to the transistor from the received BPSK signal. When v_c is +ve, v_{c1} is also +ve at its saturating voltage, causing the transistor to go into cut-off state. This, in turn, allows the v_c to appear to both the input terminals of Q3. Since equal resistances are chosen at the input and feedback paths of the inverting input (-) terminal, the inverting gain and the non-inverting gain would be -1 and +2 respectively, resulting in an overall voltage gain of +1. Therefore, the voltage v_d at the output of Q3 is of the same amplitude and polarity as v_c . When v_c becomes -ve, the transistor conducts, producing a virtual earth at the non-inverting input terminal (+) of Q3, causing inversion to take place.

Therefore, the output v_d of Q3 is always +ve, irrespective of the polarity of the input, thus functioning as full-wave rectifier. The presence of the capacitor C and the resistor R at the output of Q3 makes the envelope detected at v_d . This is threshold compared at the op-amp Q4 to get the bit stream $b(k)$. The threshold reference voltage V_T for the comparator Q4 is preset to a desired value from V_{cc} through a zener diode and a potential divider. **Figure 3** shows the timing diagram for a typical input.

The circuit of BPSK demodulator presented has a simplified architecture compared to the existing circuits and yields precision results.

Dr K. Balasubramanian
European University of Lefke
Turkish Republic of Northern Cyprus

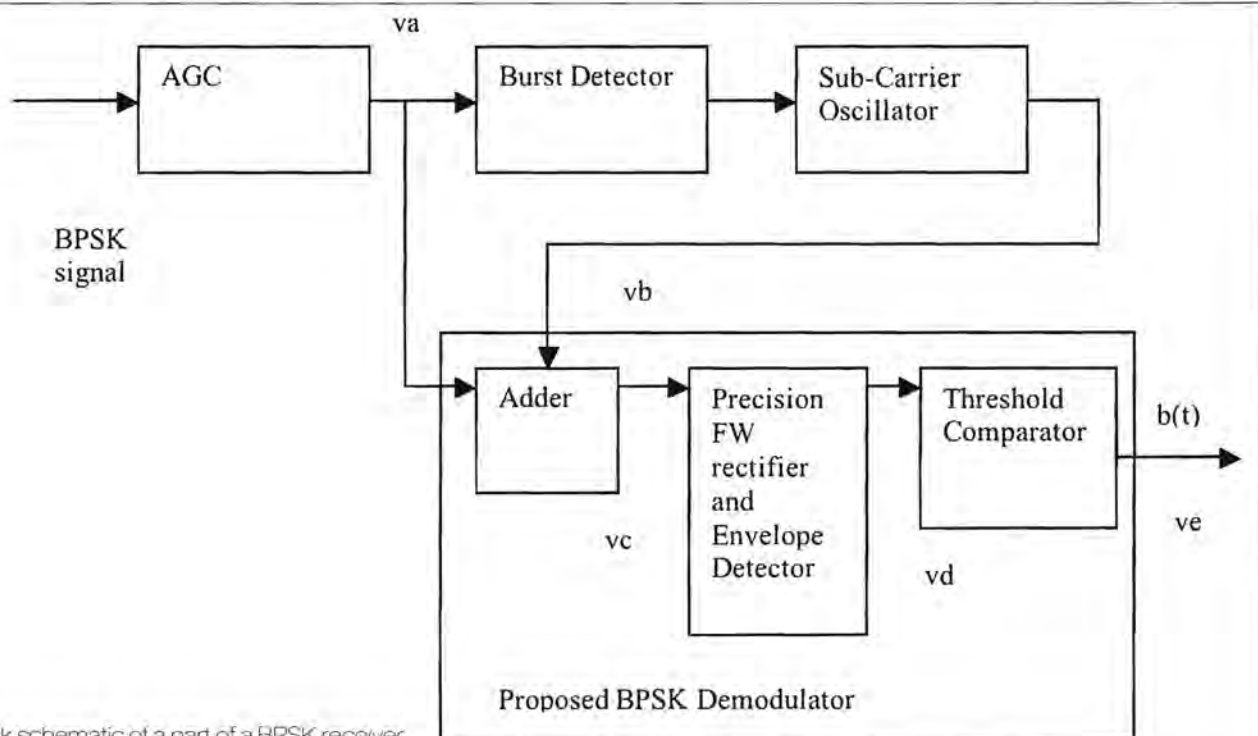
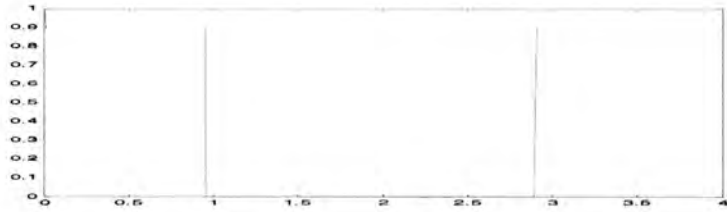

Figure 1: Block schematic of a part of a BPSK receiver

Figure 3: Timing diagram for typical BPSK reception and detection

Figure 2: See overleaf

b(k): bit stream transmitted



b(t), va: BPSK analogue waveform transmitted

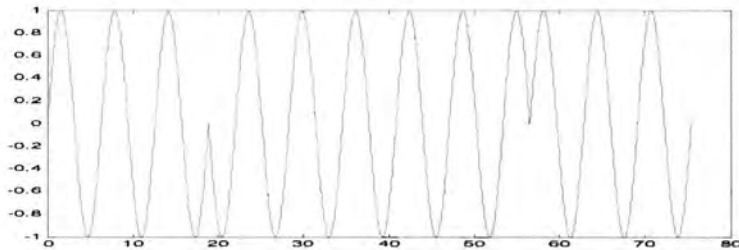

vb: sub-carrier oscillator sinewave

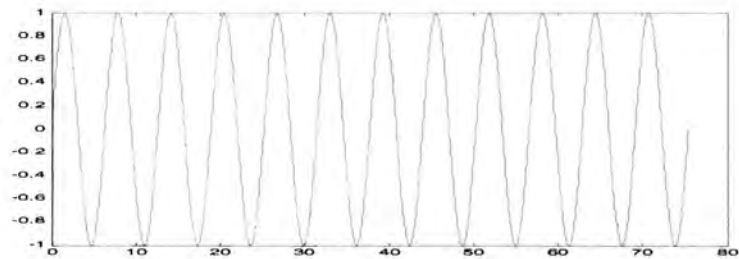

vc: $-0.5 \cdot (va + vb)$



vd: fullwave rectified and envelope detected output

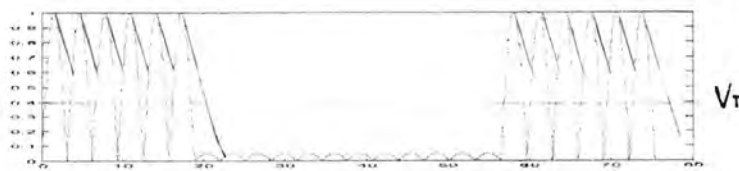

b(k): recovered BPSK



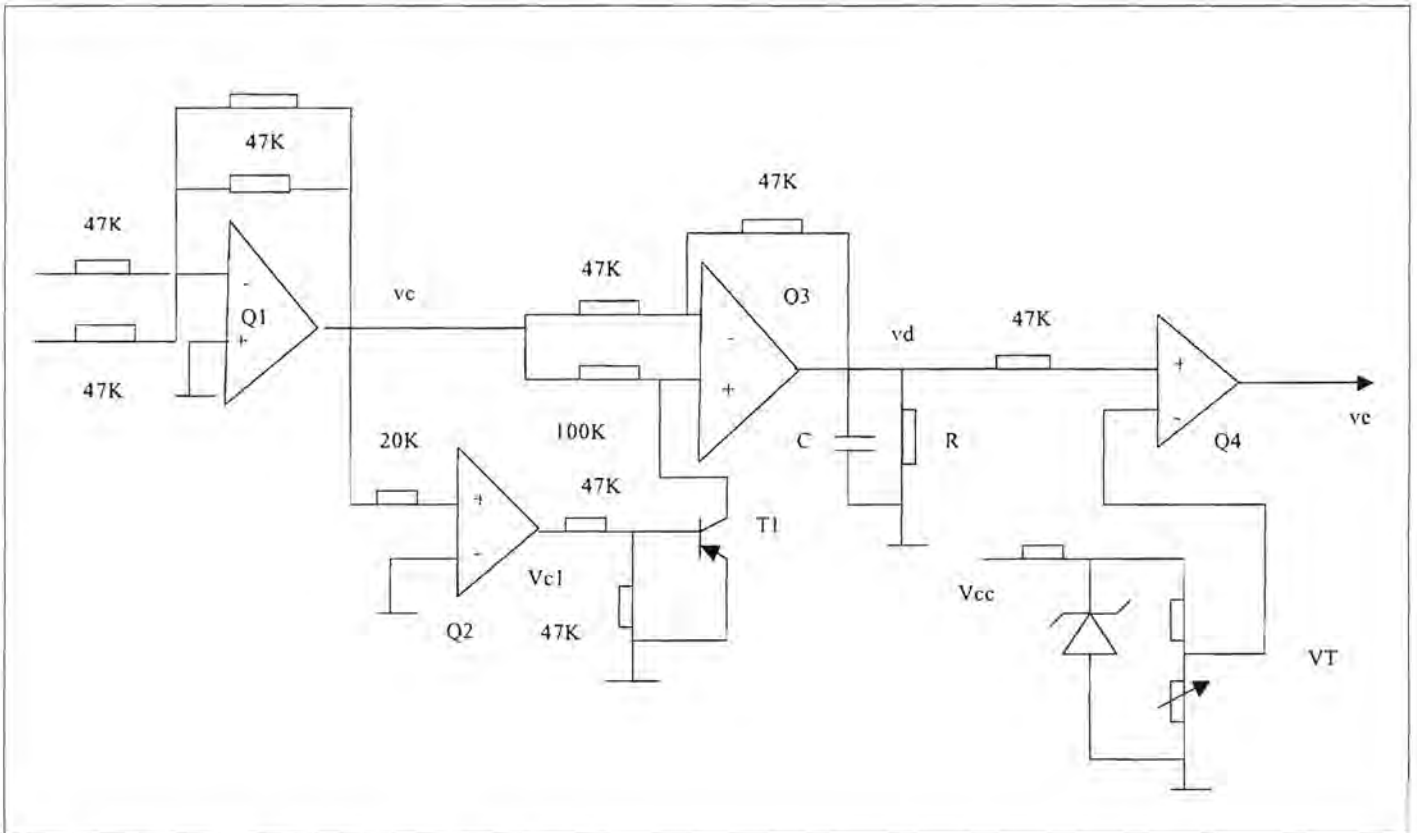

Figure 2: Circuit diagram of the precision BPSK demodulator

Auto-off Utility Light

Here is a circuit idea that shows how to make a simple, practical utility light. You do not have to remember to turn it off as it does that by itself.

This simple but handy circuit has helped feed horses and prevented bruised shins. It turns on when you push the ON button and turns off 15-20 minutes later in a dark room or within several seconds if it sees light, even if its own, reflected light.

Pushing the ON button charges C1 to the battery voltage, 6V. Q1, an emitter-follower, sees enough base voltage and current to turn on Q2. That turns on Q3 the second half of a complemen-

tary pair. The LEDs get essentially the full battery voltage as Q3 saturates. It has about 20mV, 0.02V across it when the light first turns on.

As C1 slowly discharges, the base current into Q1 will finally drop enough to cause Q3 to start showing a moderate voltage loss across it. Eventually, all three transistors will turn off, which turns off the lights.

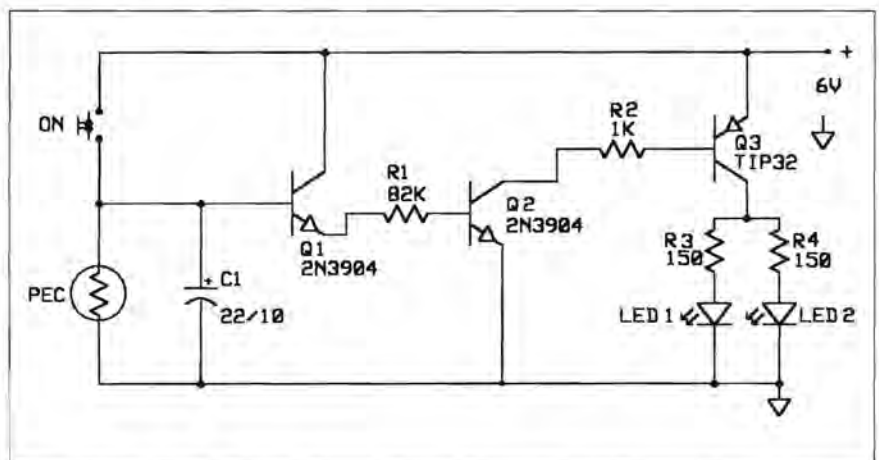

The timing capacitor, C1 sees an impedance approximately equal to the HFE of Q1 times the emitter resistance. Here, that amounts to $\sim 200 \cdot 82000$ or about 16,400,000 ohms. As

they like to say in the ads, individual results may vary. The spec sheets list the dc current gain as 100-300. The input impedance of Q2 adds to the resistance of R1. For practical

considerations, R1 times Beta gives a working figure.

With the values given, the lights will stay on for at least two-three RC time constants: 10-15 minutes. Of course, if the CdS photocell sees light, it will discharge the capacitor sooner, thereby turning off the light in as little as several seconds.

If you need the light longer, make C1 larger or hold down the ON button. If you need more light, add LEDs.

With the values shown, the circuit will drive up to seven or eight more LEDs. With the high-brightness LEDs now

available, that will light up a large area.

In the standby mode, the circuit draws no current. Expect good battery life. Size D alkaline cells run the lights for several years of intermittent service. You can make a more compact light with C cells or even AA cells.

Thanks to this idea, a friend does not have to remember to turn off the light after feeding his horses. The one that I have makes a great automatic night-light when staying at a motel or other unfamiliar location or just to use around the house.

Parts list:

R1 82K 1/4W
 R2 1K
 R3 120-150 ohms
 R4 120-150 ohms
 C1 22-47uF 10V low leakage; tantalums preferred but not essential.
 PEC CdS resistive photocell or phototransistor with collector going to the switch.
 ON switch, momentary contact push-button.
 Q1 2N3904 small-signal, high gain NPN.
 Q2 2N3904 same.
 Q3 TIP32 PNP plastic, TO220

power transistor. A small-signal transistor with a current rating of 200mA would work but would have higher saturation voltage, giving a dimmer light at the start and fading out sooner.

LED1, white or your favourite colour.

LED2, white or any other colour.

Battery 6V. For a 12V operation, such as in a car, make R3 and R4 470 ohms.

Evert Fruitman

Phoenix

USA

Point-Contact Audio Oscillators

The principle of operation of a car horn has been applied to both a ceramic sounder and a loudspeaker. The vibration of the ceramic sounder plate or the speaker membrane causes a break in the supply current. You could implement similar circuits even without a transformer but the voltage range will be limited, there will be too much sparking at the contact point, and pressure and position of the contact become critical. The transformer introduces a feedback mechanism thus eliminating or drastically reducing all mentioned negative effects. An output transformer is used in both circuits: one of the winding is normally 4W or 8W, while the other is at higher impedance. The larger plate of the piezomechanical oscillator goes to positive through the contact, typically an adjustable screw, and the transformer low impedance winding. To get the correct phase relationship you may need to reverse one of the windings for proper operation.

A similar transformer is used for the electromechanical

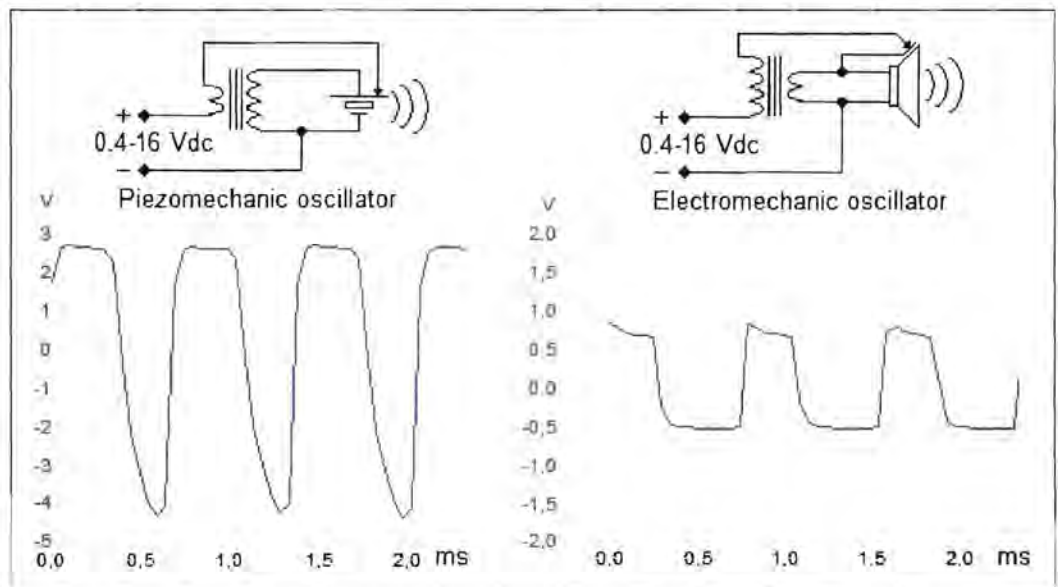

oscillator with the low impedance winding connected to the speaker. Also, in this case, you may need to reverse one of the windings but, first, you must make sure that the speaker cone goes forward when the voltage is applied: reverse the speaker connections if necessary. A small copper strip is glued on the back of the speaker membrane with a screw placed in the speaker casing, so that it

just touches the copper strip.

Frequency of operation depends on the position of the screw on the sounder plate: a higher frequency is given with the contact in the middle of the plate. The frequency for the electromechanical oscillator depends mainly on the speaker-damping factor: best results are obtained with the speaker laid against a flat surface or sealing the front side with a wooden panel.

The reported waveforms were measured directly across the transducers at a 2.4V supply voltage.

Operation below 0.4-0.6V depends on the careful adjustment of the screw and mechanical precision of the assembly.

Domenico Di Mario

Milan

Italy



Linear Technology has introduced a current-mode multi-topology converter with con-

LED driver with 3000:1 PWM dimming range

stant-current PWM dimming for driving high-power LED strings and clusters. The device – the LTC3783 – is based on proprietary techniques to provide a fast PWM load switching with no transient undervoltage or overvoltage issues. Ratios of 3000:1 can be

achieved digitally as True Color PWM dimming ensures colour integrity of white and RGB LEDs.

The LTC3783 allows an additional 100:1 dimming ratio using analogue control. The controller can be used as a boost, buck, buck-boost, SEPIC, or flyback converter, and as a constant-current/constant-

voltage regulator. No RSENSE operation uses the on-resistance of a MOSFET to eliminate the current-sense resistor, increasing efficiency. Applications for the LTC3783 include high-voltage LED arrays and backlighting, as well as voltage regulators in telecom, automotive and industrial control systems.

www.linear.com

Mixed signal MCUs in Versa

Ramtron's Versa Mix 8051 family (VMX51C1xxx) of mixed-signal microcontrollers is a single-chip solutions for a diverse range of signal conditioning, data acquisition, processing and control applications

in the industrial, medical, consumer, instrumentation and automotive markets.

In addition, Ramtron has also added its Versa 8051 family of low-cost, industry standard, 8051-based drop-in MCUs with up to 128kB ISP/IAP flash, designed to simplify device migration.

The Versa Mix (VMX51C1020/1016) offers mixed-signal 8051 microcontrollers with DSP capabilities, featuring a comprehensive set of on-chip peripherals for a complete data acquisition



SoC. The VMX51C1xxx features a single-cycle 8051 processor that provides an average of eight times more processing power than standard 8051s for increased MIPS and efficiency.

The device integrates an enhanced MULT/ACCU unit with 32-bit barrel shifter, 56KB of flash memory and 1280 bytes of RAM.

Peripherals include up to 28 general purpose I/O, three timers/counters, an SPI, two UARTs and an RS-485/RS-422/J1708 compatible transceiver, which enables data transmission over long distances via a twisted pair cable. The VMX51C1xxx operates at 5V and is available in QFP-64 (VMX51C1020) and QFP-44 (VMX51C1016) packages.

www.ramtron.com

Lead-free proof for Henkel

Following a period of extensive lead-free evaluation trials, the electronics group of Henkel has revealed that selected Loctite Chipbonders are not only capable of running lead-free, but are designed to optimise lead-free processes, eliminating chip loss and saving components by low temperature curing systems. The trials involved were testing a range of Loctite Chipbonder adhesives on 'difficult to bond' components. Using Loctite Chipbonder test boards, the trials employed both lead-free and tin-lead dual wave solder machines using a range of Multicore fluxes. The results proved that Chipbonders 3609, 3616, 3621, 3627 and 3629 are optimised for lead-free compatibility.

www.henkel.com

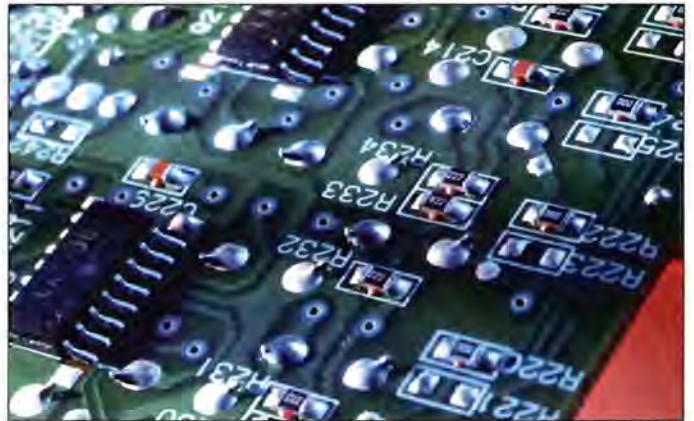

Automotive industry's MOST Straight Junction Box



Molex has recently introduced its MOST (Media Oriented System Transport) Straight Junction Box that offers a lead-

free solution for a vast range of multimedia networking car entertainment and accessory systems. Molex's new junction box has been designed as the interface connector between the car media electronics and the harness that connects many types of devices from speakers to amplifiers.

Molex played a pivotal role in bringing about a common stan-

dard for such applications. The MOST Junction Box has also been developed as a drop-in replacement for competitor parts, so can also be used with competitor harnesses. The MOST Straight Junction Box provides the transport industry with one of the only straight versions available on the market. Molex has also designed many custom right-angle versions to

fit applications where the straight option wasn't suitable.

The junction box can interface consumer automotive devices, such as car stereos and navigation systems, but also transport non-automotive units such as audio systems for lorries or agricultural equipment, as well as entertainment systems for the marine sector.

www.molex.com

Universal input 30/60W switching PSU



Astec Power's new series of external switching power supplies – the DPS50 – is now in production. The new models deliver 30W of total power at 5VDC or 60W at 12V, 15V, 24V or 48VDC. Accepting universal input of 90 to 264VAC or 127 to 300VDC, these power supplies are ideal for external applications requiring flexible implementation worldwide.

The DPS50 series features high efficiency operation (typically >80%), as well as overload, over-

voltage, short-circuit and thermal protection. They include built-in Class B EMI filtering, along with a 2.5mm ID barrel jack for the output and a convenient IEC 320 C inlet that can accept input line cords with virtually any appropriate plug configuration.

The conformity of the Astec DPS50 series to key safety, performance and environmental standards from leading agencies worldwide including UL, CUL, CSA, VDE, NEMKO, CB and CE is another major benefit for designers of electronic systems requiring a universal pre-approved power solution.

All models demonstrate a mean time between failures (MTBF) greater than 550,000 hours at full load in 25 degree C ambient conditions and are designed to meet EN1000-X susceptibility requirements.

www.astecpower.com

Software customisable AC/DC PSU

New generation of software-customisable switching power supplies is now available from Emerson Network Power and features digital management capabilities from Astec Power.

The microprocessor-controlled design is the industry's first AC/DC power supply to offer a fully software customisable power solution with the low cost and immediate availability expected from a standard "off-the-shelf" unit.

Astec's new iMP series allows designers complete software control over every major aspect of the PSU configuration. Custom power solutions from 400W to 1500W can be tailored in software to the specific and individual needs of an applica-

tion, using standard units comprising single, dual and triple output modules in power ratings from 400W to 750W. These modules can be configured in a selection of three customisable MP cases accepting input voltages from 85VAC to 264VAC or 120VDC to 350VDC. Cases can accommodate up to seven individual modules with a choice of outputs ranging from 2VDC to 60VDC.

www.astecpower.com



Picoboard controller board

The Picoboard controller board from DED is specifically designed for use with the Axiohm Electron thermal printer mechanism. The board is small and easy to use; it is cost-effective and suitable for portable applications such as electronic cash registers, electronic fund transfer and test and measurement environments.

The Picoboard is supplied with drivers for Windows 98, 2000 and XP, and an RS232 interface. The board is only 58mm wide, 30mm deep and 13mm high. For integrating a printer driver circuit onto a different PCB, a separate chipset is also available for use with the Axiohm Electron.

In addition, the micro thermal printer mechanism offers simple



integration, high printing speed of up to 70mm/s and an easy paper-loading facility. Its footprint is 68.6mm x 26.3mm and height 30mm. With its low weight of 32g and low power voltage of 3.3 to 5V, it is also suitable for battery-powered devices.

www.ded.co.uk

ELECTRONICS WORLD

Inside next month's issue...

Special report on software development:

- **Beatnik's audio software engine**
- **The University of Hannover uses quality gates in teaching software projects**
- **Green Hills Software and many more**
- **Two researchers from universities in Turkey present simple and fast algorithms that automatically perform either continuous-time to discrete-time or discrete-time to continuous-time conversions for rational system transfer functions**
- **Special news and technology items from the Buses and Boards exhibition in California**

Order yours now... On sale 8 March

To subscribe, call Debbie Jenner on 01322 611210
Email debbie.jenner@nexusmedia.com



To reserve your web site space phone Reuben Gurunlian 01322 611261
reuben.gurunlian@nexusmedia.com

COMPONENT TECHNOLOGY

www.component-technology.co.uk



- PIC microcontroller kits and modules for students and hobbyist.
- 18F45X, 16F87X Proto-Boards for ease and fast development of project ideas.
- Infrared Illuminators for CCTVs in low ambient light security areas.
- Analogue 8-channel high voltage isolator. Data logging.
- 5% discount code 'elwwdir2004' for Electronics World readers.
- Consultancy
- TIG control systems – REIS interface.
- Real-time X-ray Imaging.

DESIGNER SYSTEMS CO

www.designersystems.co.uk

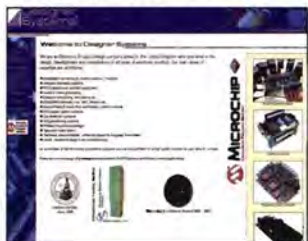

Electronic product design company with over a decade of experience promoting it's own product range and designing and manufacturing innovative products for client companies/individuals.

CONFORD ELECTRONICS

www.confordelec.co.uk



Lightweight portable battery/mains audio units offering the highest technical performance. Microphone, Phantom Power and Headphone Amplifiers. Balanced/unbalanced signal lines with extensive RFI protection.

MCES LTD

www.mces.co.uk



MCES are a specialist electronics company providing a high quality repair, rework and re-manufacturing service to electronic modules and sub assemblies, including handling both large and small volume production and rework for major manufacturers.

Established in 1972 we have continued to make large investments in specialised test equipment, surface mount technology and tooling enabling us to diagnose repair and verify a wide range of electronic modules to a very high standard. We also operate a fitting service for surface mount multi pin IC's and BGA's.

DB TECHNOLOGY

www.dbtechnology.co.uk/



Anechoic chamber and open area test site.

- Compliance Tests
- Fixes included. FCC Listed.
- Flexible hourly booking available.
- Rapid, accurate pre-compliance tests.

PICOTECH

www.picotech.com



Established in 1991, Pico Technology is a worldwide leader in the design, development and manufacture of high performance PC Oscilloscopes and Data Loggers. During this time Pico has built up an impressive portfolio of products; including the PicoScope 3000 series of PC Oscilloscopes, the USB TC-08 Thermocouple Data Logger and the award-winning Automotive Diagnostics Kit.

We pride ourselves on offering innovative, high quality and affordable alternatives to traditional bench top test and measurement equipment, operating under the ISO9001:2000 quality system.

DIGI REPAIRS (UK & IRELAND)

www.digirepairs.co.uk



We specialise in the repair & sales of all makes of Sky Digital receivers including Sky+. We offer FREE COLLECTION when you send more than one box at a time. Fast turnaround time and we give discount for quantities. We will Collect from anywhere in the UK & Eire including Scottish Isles. Tel: 0845 6441628 (local rate) or 02866327293.

TEST EQUIPMENT SOLUTIONS

www.testequipmenthq.com



Specialising in quality second user Test Equipment sales and rental, all equipment is fully refurbished and tested. We supply manuals and accessories with full certification and a 12 month warranty. Savings greater than 70% can be realised over new prices.

Colour screen shot and text will cost just £350 + vat for 12 months



Reader offer:

**x1, x10 switchable
oscilloscope probes,
only £21.74 a pair,
fully inclusive***

*Additional pairs as part of the same order, only £19.24 each pair.

Please supply the following:

Probes

Total _____

Name _____

Address _____

Postcode _____ Telephone _____

Method of payment (please circle)

Cheques should be made payable to Television

Access/Mastercard/Visa/Cheque/PO

Credit card no _____

Card expiry date

Signed

Please allow up to 28 days for delivery

Seen on sale for £20 each, these high-quality oscilloscope probe sets comprise:

- two x1, x10 switchable probe bodies
- two insulating tips
- two IC tips and two sprung hooks
- trimming tools

There's also two BNC adaptors for using the cables as 1.5m-long BNC-to-BNC links. Each probe has its own storage wallet.

To order your pair of probes, send the coupon together with £21.74 UK/Europe to
**Probe Offer, Television,
Nexus Media Communications,
Media House, Azalea Drive,
Swanley, Kent BR8 8HU**

Readers outside Europe, please add £2.50 to your order.

Specifications

Switch position 1

Bandwidth	DC to 10MHz
Input resistance	1M Ω - i.e. oscilloscope i/p
Input capacitance	40pF+oscilloscope capacitance
Working voltage	600V DC or pk-pk AC

Switch position 2

Bandwidth	DC to 150MHz
Rise time	2.4ns
Input resistance	10M Ω \pm 1% if oscilloscope i/p is 1M Ω
Input capacitance	12pF if oscilloscope i/p is 20pF
Compensation range	10-60pF
Working voltage	600V DC or pk-pk AC

Switch position 'Ref'

Probe tip grounded via 9M Ω , scope i/p grounded

2GHz full-performance RF Generator



£2,195

The new TGR2050 is a synthesised signal generator with a frequency range of 150kHz to 2000MHz.

Excellent frequency accuracy is matched with high stability, wide dynamic range, low phase noise and low leakage.

FM, phase and AM modulation modes are incorporated along with RS232 and GPIB (IEEE.488.2) interfaces.

The TGR2050 provides the most cost effective solution available for engineers needing a wide range high performance RF source.

- ▶ 150kHz to 2000MHz frequency range with 10Hz setability
- ▶ -127dBm to +7dBm amplitude range with 0.1dBm setability
- ▶ Better than 1ppm internal accuracy; external frequency lock
- ▶ FM, Phase and AM modulation, internal or external source
- ▶ Direct numeric entry or rotary control with user settable frequency and amplitude increments
- ▶ Non-volatile set-up memories for repetitive testing
- ▶ Full remote control via RS-232 and GPIB interfaces
- ▶ Unrivalled performance and features at this price level !

For applications with a narrower frequency requirement a 1GHz generator, the TGR1040, is available for around £1,200.

For full details of both generators, please contact us directly, visit our website, or circle the reply number below.



Measurably better value

Thurlby Thandar Instruments Limited

Glebe Road, Huntingdon, Cambridgeshire PE29 7DR

Tel: 01480 412451, Fax: 450409, e-mail: sales@tti-test.com

Web: www.tti-test.com

THURLBY THANDAR INSTRUMENTS

PCB-POOL®

SERVICING YOUR COMPLETE PROTOTYPE NEEDS

- Prototypes at a fraction of the cost
- Industry standard quality
- Tooling and setup included
- Follow up series runs
- Any contour
- CAM / CAD consulting
- Fr4 1.6mm, 35µm Cu

PRICE EXAMPLE:
1 EUROCARD DS/PTH
+ Tooling
+ Photoplots
+ VAT

= £ 29.89*

*Sterling rates may vary. Price = D 49



FREE



may differ slightly to model shown



Tel: +353 (0)61 701170
Fax: +353 (0)61 701164
E-Mail: sales@beta-layout.com

Freephone
0800-389 8560

Simply send your files and order ONLINE:

WWW.PCB-POOL.COM

Protel



orcad
A Cadence product family

EDWIN

GraphiCode

AD INDEX

ALBAN ELECTRONICS	P.14
BETA LAYOUT	P.63
EASYSYNC	P.26
JPG ELECTRONICS	P.25
MCS	IFC
NEWBURY	P.11
PC INSTRUMENT	P.19
PEAK	IBC
PICOTECH	P.51
QUASAR	P.2
TELNET	P.45
TEST EQUIP SOLUTIONS	OBC
TIE PIE	P.35
THURLBY THANDAR	P.63
WESTDEV	P.34

Service Link

ARTICLES WANTED

TOP PRICES PAID

For all your valves,
tubes, semi conductors
and ICs.

Langrex Supplies Limited

1 Mayo Road, Croydon, Surrey CR0 2QP
TEL: 020 8684 1166 FAX: 020 8684 3056

FOR SALE

PRINTED CIRCUIT BOARDS

DESIGNED & MANUFACTURED  agar
Circuits

- Prototype or production quantities
- Fast turnaround available
- PCBs designed from circuit diagrams
- Almost all computer files accepted
- PCB assembly - mechanical assembly
- Full product design-manufacture-test-repair

Unit 5, East Bellast Enterprise Park
308 Albertbridge Rd, Bellast BT5 4GX
TEL 028 9073 8897 FAX 028 9073 1802
info@agarcircuits.com

SERVICES

POWER SUPPLY DESIGN

Switched Mode PSU
Power Factor Correction
designed to your specification

Tel/Fax: 01243 842520
e-mail: eugen_kus@cix.co.uk

Lomond Electronic Services

Service Link

For a **FREE**
consultation on how
best to market your
products/services to a
professional audience ring
Reuben on
01322 611261



This Magazine reaches
over
10,000
potential customers

To advertise in this space
call Reuben on
01322 611261

**End of Special Prices
BUT!**

**Order any 2 instruments and
get a free carry case**



the Atlas ESR60

- Automatically measure capacitance and ESR.
- Can be used in-circuit!
- ESR resolution down to 0.01 ohms!
- Supports capacitance up to 22,000µF.
- Protected against charged capacitors.
- Gold plated kelvin crocs supplied.



ESR60
£89.00

LCR40
£79.00

DCA55
£55.00

SCR100
£109.00

Passive components, semiconductors,
power devices, network cabling

Choose your perfect analyser

"Star Pack"

LCR and DCA
in carry case
£130.00

Carry cases
£15.00

**SMD Tweezer
Probes for LCR**
£19.00

Spare Battery
£1.75

accessories & carry cases



the Atlas LCR40

- Automatically identify Inductors, Capacitors and Resistors.
- Inductors from 1µH to 10H.
- Capacitors from 1pF to 10,000µF.
- Resistors from 1Ω to 2MΩ
- 1% Basic accuracy.
- Automatic frequency selection.



Triac and Thyristor Testing

Semiconductor Analysis



Cat5 Cable Testing



Cat5 Cable Testing



www.peakelec.co.uk

all prices include UK Delivery and VAT

prices effective from 1st November 2005

Peak Electronic Design Ltd
Atlas House
Harpur Hill Business Park
Buxton, SK17 9JL, UK
Tel. 01298 70012

TEST EQUIPMENT SOLUTIONS

Quality Second User
Test Equipment
With 12 Months Warranty

The Industry's
Most Competitive
Test Equipment Rental Rates

Sample Stock List - If you don't see what you want, please CALL!

	Sale (GBP)	Rent (GBP)		Sale (GBP)	Rent (GBP)		Sale (GBP)	Rent (GBP)
AMPLIFIERS								
Agilent/HP 8349B 2-20GHz +15dB >50mW Amplifier	2700	108	Agilent/HP 85025A 18GHz Detector	595	30	Advantest TR4135/06 3.6GHz Spectrum Analyser	2950	89
Agilent/HP 8447E 1.3GHz Power Amplifier	950	48	Agilent/HP 85025D 0.01-50GHz Detector	695	33	Advantest U3641 3GHz RF Spectrum Analyser	3250	100
Agilent/HP 8447F 1.3GHz Pre/Power Dual Amplifier	1250	50	Agilent/HP 85032B Type N Calibration Kit	1300	47	Agilent/HP 3561A 100kHz Dynamic Signal Analyser	2250	68
Amplifier Research 25W1000 1GHz 25W Amplifier	6500	260	Agilent/HP 85032B/K05 Type N (F) Calibration Kit	750	28	Agilent/HP 3562A 100kHz Dual Channel Dynamic Signal Ana	2450	74
Anritsu MH648A 100kHz-1.2GHz Preamplifier	650	33	Agilent/HP 8714C 300kHz-3GHz Vector Network Analyser	6950	209	Agilent/HP 3588A/001 150MHz Spectrum Analyser	4650	140
ELECTRICAL NOISE								
Agilent/HP 346A 18GHz APC-3.5(m) Noise Source	1000	39	Agilent/HP 8720A001/010 20GHz Vector Network Analyser	17800	712	Agilent/HP 53310A/001/030 2.5GHz Modulation Domain Ana	3850	160
Agilent/HP 8970B/020 2GHz Noise Meter	4500	180	Agilent/HP 8720B/001 20GHz Vector Network Analyser	19950	802	Agilent/HP 85024A 3GHz Active Probe	1400	59
Agilent/HP 8970B/H18 1.8GHz Noise Meter	3250	130	Agilent/HP 87512A 50 Ohm Transmission/Reflection Test Set	1250	42	Agilent/HP 8566B 22GHz Spectrum Analyser	6950	210
FUNCTION GENERATORS								
Agilent/HP 33120A 15MHz Function/Arbitrary Waveform Gen	995	39	Agilent/HP 8753C/006 6GHz Vector Network Analyser	8500	306	Agilent/HP 8568B 100kHz-1.5GHz Spectrum Analyser	2950	89
Agilent/HP 3312A 13MHz Function Generator	750	29	Agilent/HP 8753C/006A 3GHz VNA With 's' Test Set	7450	298	Agilent/HP 8591A/010/021 1.8GHz Spectrum Ana With TG	3750	113
Agilent/HP 3325A 21MHz Function Generator	775	32	Agilent/HP 8753D/002/010 3GHz Vector Network Analyser	11500	345	Agilent/HP 8593E/004/041/130 22GHz Spectrum Analyser	10950	329
Agilent/HP 3325B 21MHz Function Generator	950	30	Agilent/HP 8753D/006 6GHz Vector Network Analyser	13750	413	Agilent/HP 8594E/041 2.9GHz Spectrum Analyser	4500	135
Agilent/HP 3335A/001 81MHz Function Generator	1450	44	Agilent/HP 8757E 20GHz Scalar Network Analyser	4650	140	Agilent/HP 8595E 6.5GHz Spectrum Analyser	6000	181
Agilent/HP 3336C/04 21MHz Function Generator	1125	35	Agilent/HP 89441A/AT/7/8/9/A/B/UF/G/UG7 DC-2650MHz VSA	18750	565	Agilent/HP 8901A/001/002 1.3GHz Modulation Analyser	950	48
Agilent/HP 8111A 20MHz Function Generator	995	32				Agilent/HP 8903B/001/010/051 20Hz-100kHz Audio Analyser	1800	54
Agilent/HP 8116A 50MHz Function Generator	1495	45				Anritsu MH680A1 100kHz-2GHz Tracking Gen For MS2601B	850	43
Agilent/HP 8904A/001/002/003/004 600kHz Function Gen	2250	70				Anritsu MS2601B 2.2GHz Spectrum Analyser	2950	90
Agilent/HP 8904A/04 600kHz Function Generator	950	35				Anritsu MS2602A/01/02 100Hz-8.5GHz Spectrum Analyser	5750	174
LeCroy LW420A 2 Channel 400MS/S Arbitrary Waveform Gen	2950	128				Anritsu MS2651B 3GHz Spectrum Analyser	3950	120
Levell TG303 2MHz Function Generator	190	19				Anritsu MS2661C/2/8 3GHz Spectrum Analyser	4250	128
Philips PMS132 2MHz Function Generator	150	15				Anritsu MS2711A 3GHz Handheld Spectrum Analyser	2950	89
Philips PMS138/004 10MHz Function Generator	950	35				FCC F-35 100Hz-100MHz Current Probe	550	25
Philips PMS138/021 10MHz Function Generator	950	35				Marconi 2380/83/303G 4.2GHz Spectrum Analyser (no TG)	3950	119
Philips PMS139/004 20MHz Function Generator	1250	38				R&S FSEA20/B4/7/B8 9kHz-3.5GHz Spectrum Analyser	9500	285
R&S AFG 0.01Hz-20MHz Function Generator	1250	38				Racal 9008A Modulation Meter	220	18
LOGIC ANALYSERS								
Agilent/HP 16500C Logic Analyser Mainframe	1650	55	Anritsu MS3401B /01 10Hz-30MHz Network Analyser	2500	75	SRS SR760 100kHz Single Channel FFT Spectrum Analyser	1950	71
Agilent/HP 1650B 80 Channel Logic Analyser	950	55	Anritsu S251B/10A 2.5GHz Dual Port Scalar Network Analyser	5250	158	SIGNAL GENERATORS		
AT/HP 16510B 100MHz Timing 35MHz State 80 Ch Card	890	35	Anritsu AM5035/03/A2 4GHz Scalar Network Analyser	3950	119	Agilent/HP 8648A 100kHz-1GHz Synth Signal Generator	2500	100
Agilent/HP 1651A 80 Channel Logic Analyser	850	43	OSCILLOSCOPES			Agilent/HP 8648D 9kHz-4GHz Synthesised Signal Generator	5950	179
Agilent/HP 16533A 1GS/s DSO Card For 16500 Series	950	40	A selection of Analog and Digital Scopes inc. Agilent/HP,			Agilent/HP 8657A 1GHz Synthesised Signal Generator	1600	48
AT/HP 16550A 102Ch 500MHz/100MHz Timing/State Mod	1550	51	Tektronix, LeCroy and Fluke - Prices range from	350	37	Agilent/HP 8657D/001 1GHz DQPSK Synthesised Signal Gen	1350	41
AT/HP 1660AS 500MHz/100MHz Timing/State 136Ch+DSO	3450	140	Fluke 99 2 Channel 50MHz Handheld Scope	1150	48	Agilent/HP E4431A/UN3 2GHz Digital Signal Generator	5250	210
Agilent/HP 1661A 500MHz Timing 100MHz State 102 Ch	2450	80	Tek AM5035/03/A2 Current Probe System (inc.A6302 Probe)	1350	59	Agilent/HP E4431B 250kHz-2GHz Synthesised Digital Sig Gen	5950	179
Agilent/HP 1662A 500MHz Timing 100MHz State 68 Ch	2350	71	POWER METERS			Agilent/HP E4432A/1E5/1E8 3GHz Synthesised Signal Gen	6250	188
Agilent/HP 1671D/030 102 Channel Logic Analyser	3850	154	Agilent/HP 436A/022 RF Power Meter With GPIB	825	38	Agilent/HP E4433A/1E5 250kHz-4GHz Synth Signal Gen	7950	318
Agilent/HP E2423A SCSI Bus Preprocessor	100	10	Agilent/HP 438A Dual Channel RF Power Meter	1350	43	Anritsu MG3601A/02 1GHz Signal Generator	1600	48
MULTIMETERS								
Agilent/HP 3458A 8.5 Digit System Multimeter	3250	98	Various HP/Anritsu/Gigatronix/Marconi power sensorsfrom	525	27	Anritsu MG3632A 100kHz-2.08GHz Signal Generator	1950	78
Fluke 8010A 3.5 Digit Digital Multimeter	175	18	Agilent/HP 8900C Peak Power Meter	1650	66	IFR 2023B 10kHz-2.05GHz Synthesised Signal Generator	3550	107
Fluke 8050A 4.5 Digit Digital Multimeter	195	16	Agilent/HP 8991A Peak Power Analyser	10750	439	Marconi 2018/GPIB 520MHz Synthesised Signal Generator	750	38
Keithley 179 4.5 Digit Digital Multimeter	250	20	Gigatronix 8541C Single Channel RF Power Meter	1350	41	Marconi 2019A 1GHz Synthesised Signal Generator	900	45
Keithley 238 High Current Source Measure Unit	3350	139	Gigatronix 8542B Dual Channel RF Power Meter	1750	53	Marconi 2024 9kHz-2.4GHz Synthesised Signal Generator	3650	146
Keithley 2400 200V Digital Sourcemeter	2850	86	Marconi 6910 20GHz 100mW Power Sensor	475	29	Marconi 2031/001/002 2.7GHz Signal Generator	4950	149
Keithley 2410 1100V High Voltage Sourcemeter	4150	125	Marconi 6970/001 RF Power Meter	895	45	Marconi 2041/001 2.7GHz Low Noise Signal Generator	6250	189
Kikusui DME1400 4.5 Digit Multimeter	175	18	Marconi 893B AF Power Meter	450	27	Philips PMS330 180MHz Signal Generator	550	33
Thandar 1604 4.75 Digit Digital Multimeter	395	22	POWER SUPPLIES			WIRELESS		
NETWORK ANALYSERS								
Advantest R3767CH 40MHz-8GHz Network Analyser	10950	440	ACDC Electronics EL750B 750W Electronic Load	1350	49	Agilent/HP 8902A 1.3GHz Measuring Receiver	7950	240
Agilent/HP 11500F APC Cable 3.5mm	395	32	Wide Range of Agilent Supplies in Stock from 40W-2000W			Agilent/HP 8922M/001/003/101 1GHz GSM MS Test Set	2500	75
Agilent/HP 11664A 18GHz Detector	375	30	and up to 600V - Prices range from	550	20	Agilent/HP 8922M/001/006/010 1GHz GSM MS Test Set	2950	89
Agilent/HP 11664A/001 18GHz Detector	375	30	Farnell AP100/90 100V 90A 3KW Power Supply	2550	77	Anritsu ME4510B Digital Microwave System Analyser	4750	145
Agilent/HP 35677A 200MHz 50 Ohm S Parameter Test Set	1895	76	Farnell AP60/50 60V 50A Power Supply	1750	63	IFR 2935 GSM Test Set [TRI BAND]	4950	198
Agilent/HP 3575A Gain/Phase Meter	1150	59	Farnell L12-10C 12V 10A DC Power Supply	450	22	IFR 2967/16/17/21 Radio Comms Test Set with GSM	4950	149
Agilent/HP 3577A 5Hz-200MHz Vector Network Analyser	3950	119	Farnell PSD3510A 35V 10A DC Power Supply	365	30	Marconi 2966A/12 1GHz Radio Comms Test Set with GSM	4750	143
Agilent/HP 41951A Impedance Test Kit For 4195A	1700	59	Farnell TOPS 3D 17V 1A Triple Output DC Power Supply	120	12	R&S CMS52/B22/B26/B53/B55 1GHz Radio Comms Test Set	4500	180
Agilent/HP 4195A 500MHz Vector Network/Spectrum Analyser	6950	209	Kikusui PLZ-300W 300W Electronic Load	995	40	R&S R4860/B1/B60/B61 Digital Tester For PDC Phones	2500	75
			Racal 9232 30V/2A Dual Channel PSU	195	20	Racal 6103/001/002/003 Digital Mobile Radio Test Set	9850	299
			SIGNAL & SPECTRUM ANALYSERS			Racal 6104/001/002/003/006/014/04T Digital Mobile RTS	7250	220
			Advantest R3132 3GHz Spectrum Analyser	5300	212	W&G 4106 GSM/DCS1800/PCN1900 Mobile Phone Tester	2250	70
			Advantest R3261A 2.6GHz Spectrum Analyser	3450	104	W&G 4107S Mobile Phone Tester	2450	74
			Advantest R3265 8GHz Spectrum Analyser	5975	247	Wavetek 4201S Triband Digital Mobile Radio Test Set	3650	110
			Advantest R9211A 10MHz-100kHz Dual Channel FFT Analyser	2950	89			

Check out our NEW
2006
Product Guide !!
Call Us Now for Your Copy



The only company with the confidence to offer 12 month warranty as standard, with 24 month available!

FREE
Palm Zire22 shipped with every order over £5K



Prices shown are for guidance in £UK GBP, exclusive of VAT and Ex-Works. All items subject to prior sale. Rental prices are per week for a rental period of 4 weeks. Free carriage to UK mainland addresses on sale items. Rental or non UK deliveries will be charged at cost. This is just a selection of equipment we have available - if you don't see what you want, please call. All items are supplied fully tested and refurbished. All manuals and accessories required for normal operation included. Certificate of Conformance supplied as standard. Certificate of Calibration available at additional cost. Test Equipment Solutions Ltd Terms and Conditions apply. All E&OE.

01753 596000
Fax: 01753 59 6001
www.TestEquipmentHQ.com
email: info@TestEquipmentHQ.com