

Electronics World's renowned news section starts on page 5

ELECTRONICS WORLD



JUNE 2003 £3.25

DRM reception on a PC

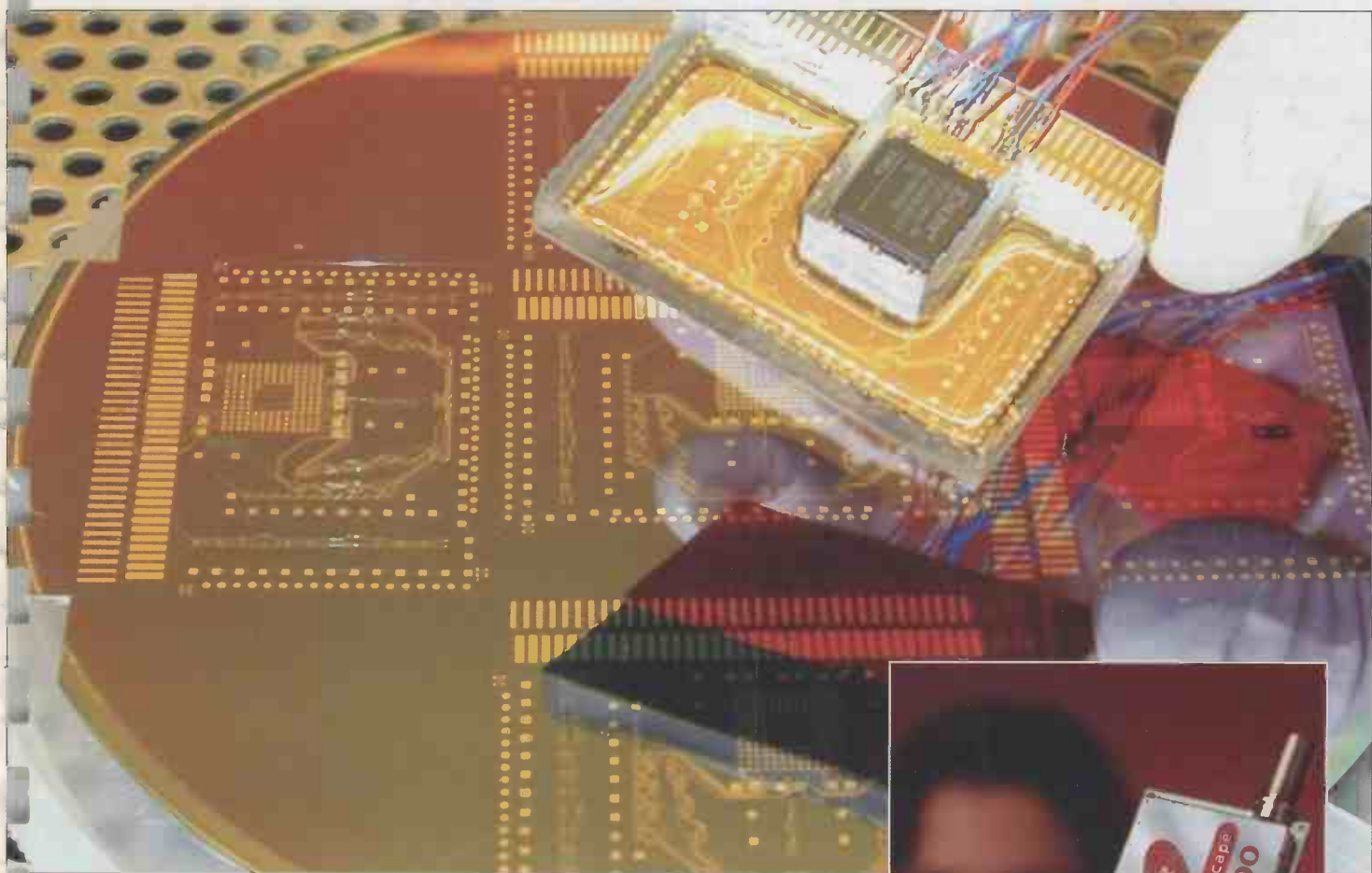

Dinosaur computers

Electronic balun

Understanding ADCs

PC based humidity sensor





Hewlett Packard 3314A Function Generator 20MHz	£1250
Hewlett Packard 3324A synth. function/sweep gen. (21MHz)	£2250
Hewlett Packard 3325B Synthesised Function Generator	£3250
Hewlett Packard 3326A Two-Channel Synthesiser	£3000
H.P. 4191A R/F Imp. Analyser (1GHz)	£4995
H.P. 4192A L.F. Imp. Analyser (13MHz)	£4000
Hewlett Packard 4193A Vector Impedance Meter (4-110MHz)	£3000
Hewlett Packard 4278A 1kHz/1MHz Capacitance Meter	£3750
H.P. 53310A Mod. Domain Analyser (opt 1/31)	£3950
Hewlett Packard 8349B (2 - 20 GHz) Microwave Amplifier	£2500
Hewlett Packard 8508A (with 85081B plug-in) Vector Voltmeter	£2500
Hewlett Packard 8904A Multifunction Synthesiser (opt 2+4)	£1950
H.P. ESG-D3000A 3GHz Signal Gen	£6995
Marconi 6310 - Prog'ble Sweep gen. (2 to 20GHz) - new	£2500
Marconi 6311 Prog'ble sig. gen. (10MHz to 20GHz)	£2995
Marconi 6313 Prog'ble sig. gen. (10MHz to 26.5GHz)	£3750
R&S SMG (0.1-1GHz) Sig. Generator (opts B1+2)	£2750
Fluke 5700A Multifunction Calibrator	£12500
Fluke 5800A Oscilloscope Calibrator	£9995
H.P. 3458A DMM (8.5 digits)	£3750

OSCILLOSCOPES

Gould 400 20MHz - DSO - 2 channel	£695
Gould 1421 20MHz - DSO - 2 channel	£425
Gould 4068 150MHz 4 channel DSO	£1250
Gould 4074 100MHz - 400 Ms/s - 4 channel	£1100
Hewlett Packard 54201A - 300MHz Digitizing	£750
Hewlett Packard 54502A - 400MHz - 400 MS/s 2 channel	£1600
Hewlett Packard 54520A 500MHz 2ch	£2750
Hewlett Packard 54600A - 100MHz - 2 channel	£675
Hewlett Packard 54810A 'Infinium' 500MHz 2ch	£2995
Hitachi V152/V212/V222/V302B/V302F/V353F/V550BV650F	from £100
Hitachi V1 100A - 100MHz - 4 channel	£750
Intron 2020 - 20MHz. Dual channel D.S.O (new)	£450
Iwatstu SS 5710/SS 5702 -	from £125
Kikusui COS 5100 - 100MHz - Dual channel	£350
Lecroy 9314L 300MHz - 4 channels	£2750
Meguro MSO 1270A - 20MHz - D.S.O. (new)	£450
Philips 3295A - 400MHz - Dual channel	£1400
Philips PM3070 - 100MHz - 2 channel - cursor readout	£650
Philips PM3392 - 200MHz - 200Ms/s - 4 channel	£1750
Philips PM3094 - 200MHz - 4 channel	£1500
Tektronix 468 - 100MHz D.S.O.	£500
Tektronix 2213/2215 - 60MHz - Dual channel	£300
Tektronix 2220 - 60MHz - Dual channel D.S.O	£850
Tektronix 2221 - 60MHz - Dual channel D.S.O	£850
Tektronix 2235 - 100MHz - Dual channel	£500
Tektronix 2245A - 100MHz - 4 channel	£700
Tektronix 2430/2430A - Digital storage - 150MHz	from £1250
Tektronix 2445 - 150MHz - 4 channel +DMM	£850
Tektronix 2445/2445B - 150MHz - 4 channel	£800
Tektronix 2465/2465A /2465B - 300MHz/350MHz 4 channel	from £1250
Tektronix 7104 - 1GHz Real Time - with 7A29 x2, 7B10 and 7B15	from £1950
Tektronix TAS 475 - 100MHz - 4 channel	£850
Tektronix TDS 310 50MHz DSO - 2 channel	£750
Tektronix TDS 520 - 500MHz Digital Oscilloscope	£2500

SPECTRUM ANALYSERS

Advantest 4131 (10kHz - 3.5GHz)	£3750
Advantest/TAKEDA RIKEN - 4132 - 100KHz - 1000MHz	£1350
Anritsu MS2613A 9kHz - 6.5GHz Spectrum Analyser	£4950
Ando AC 8211 - 1.7GHz	£1500
Avcom PSA-65A - 2 to 1000MHz	£750
Farnell SSA-1000A 9KHz-1GHz Spec. An.	£1250
Hewlett Packard 182T Mainframe + 8559A Spec.An. (0.01 to 21GHz)	£2000
Hewlett Packard 853A Mainframe + 8559A Spec.An. (0.01 to 21GHz)	£2500
Hewlett Packard 3582A (0.02Hz - 25.5kHz) dual channel	£1500
Hewlett Packard 3585A 40 MHz Spec Analyser	£3000
Hewlett Packard 3561A Dynamic Signal Analyser	£3500
Hewlett Packard 8568A -100kHz - 1.5GHz Spectrum Analyser	£3500
Hewlett Packard 8590A (opt 01, 021, 040) 1MHz-1.5MHz	£2500
Hewlett Packard 8596E (opt 41, 101, 105,130) 9KHz - 12.8GHz	£9950
Hewlett Packard 8713C (opt 1 E1) Network An. 3 GHz	£6000
Hewlett Packard 8713B 300kHz - 3GHz Network Analyser	£5000
Hewlett Packard 8752A - Network Analyser (1.3GHz)	£4995
Hewlett Packard 8753A (300KHz - 3GHz) Network An.	£3250
Hewlett Packard 8753B+85046A Network An + S Param (3GHz)	£6500
Hewlett Packard 8754A - Network Analyser 4MHz -1300MHz)	£1500
Hewlett Packard 8756A/8757A Scaler Network Analyser	from £900
Hewlett Packard 8757C Scaler Network Analyser	£3500
Hewlett Packard 70001A/70900A/70902A/70902A/70205A - 26.5 GHz Spectrum Analyser	£7000
IFR A7550 - 10KHz-GHz - Portable	£1750
Meguro - MSA 4901 - 30MHz - Spec Analyser	£600
Tektronix 492P (opt1,2,3) 50KHz - 21GHz	£3500
Willtron 6409 - 10-2000MHz R/F Analyser	£1250
Tek 496 (9KHz-1.8GHz)	£2500

Radio Communications Test Sets

Anritsu MT 8801C Radio Comms Analyser 300kHz - 3GHz (opt 1,4,7)	£6500
Hewlett Packard 8920B (opts 1,4,7,11,12)	£6750
Hewlett Packard 8922M + 83220E	£2000
Marconi 2955	£1250
Marconi 2955A	£1750
Marconi 2955B/60B	£3500
Marconi 2955R	£1995
Motorola R2600B	£2500
Racal 6111 (GSM)	£1250
Racal 6115 (GSM)	£1750
Racal 6103 (opts1, 2)	£5000
Rohde & Schwarz SMFP2	£1500
Rohde & Schwarz CMT 90 (2GHz) DECT	£3995
Rohde & Schwarz CMTA 94 (GSM)	£4500
Schlumberger Stabilock 4015	£3250
Schlumberger Stabilock 4031	£2750
Schlumberger Stabilock 4040	£1300
Wavetek 4103 (GSM 900) Mobile phone tester	£1500

MISCELLANEOUS

Ballantine 1620A 100Amp Transconductance Amplifier	£1750
EIP 545 Microwave Frequency Counter (18GHz)	£1000
EIP 548A and B 26.5GHz Frequency Counter	from £1500
EIP 575 Source Locking Freq.Counter (18GHz)	£1200
EIP 585 Pulse Freq.Counter (18GHz)	£1200
Fluke 6060A and B Signal Gen. 10kHz - 1050MHz	£1250
Genrad 1657/1658/1693 LCR meters	from £500
Gigatronics 8541C Power Meter + 80350A Peak Power Sensor	£1495
Gigatronics 8542C Dual Power Meter + 2 sensors 80401A	£1995
Hewlett Packard 339A Distortion measuring set	£750
Hewlett Packard 436A power meter and sensor (various)	from £750
Hewlett Packard 438A power meter - dual channel	£2000
Hewlett Packard 3335A - synthesiser (200Hz-81MHz)	£1995
Hewlett Packard 3457A multi meter 6 1/2 digit	£850
Hewlett Packard 3784A - Digital Transmission Analyser	£3750
Hewlett Packard 37900D - Signalling test set	£2950
Hewlett Packard 34401A Multimeter	£450
Hewlett Packard 4274A LCR Meter	£2000
Hewlett Packard 4275A LCR Meter	£2750
Hewlett Packard 4276A LCZ Meter (100MHz-20KHz)	£1400
Hewlett Packard 5342A Microwave Freq.Counter (18GHz)	£850
Hewlett Packard 5350B 20KHz Microwave Freq.Counter	£2000
Hewlett Packard 5385A - 1 GHz Frequency counter	£495
Hewlett Packard 6033A - Autoranging System PSU (20v-30a)	£750
Hewlett Packard 6060A and B Electronic Load 300W	from £750
Hewlett Packard 6622A - Dual O/P system p.s.u	£950
Hewlett Packard 6624A - Quad Output Power Supply	£1750
Hewlett Packard 6632A - System Power Supply (20v-5A)	£695
Hewlett Packard 8350B - Sweep Generator Mainframe	£1500
Hewlett Packard 8642A - high performance R/F synthesiser (0.1-1050MHz)	£2500
Hewlett Packard 8656A - Synthesised signal generator	£750
Hewlett Packard 8656B - Synthesised signal generator	£995
Hewlett Packard 8657A - Synth. signal gen. (0.1-1040MHz)	£1500
Hewlett Packard 8657B - 100MHz Sig Gen - 2060 MHz	£3950
Hewlett Packard 8657D - XX DQPSK Sig Gen	£3950
Hewlett Packard 8901B - Modulation Analyser	£2250
Hewlett Packard 8903A, B and E - Distortion Analyser	from £1000
Hewlett Packard 11729B/C Carrier Noise Test Set	from £2500
Hewlett Packard 53131A Universal Frequency counter (3GHz)	£850
Hewlett Packard 85024A High Frequency Probe	£1000
Hewlett Packard 6032A Power Supply (0-60V)-(0-50A)	£2000
Hewlett Packard 5351B Microwave Freq. Counter (26.5GHz)	£2750
Hewlett Packard 5352B Microwave Freq. Counter (40GHz)	£5250
Keithley 220 Programmable Current Source	£2000
Keithley 228A Prog'ble Voltage/Current Source IEEE.	£2000
Keithley 237 High Voltage - Source Measure Unit	£4500
Keithley 238 High Current - Source Measure Unit	£4500
Keithley 486/487 Picoammeter (+volt.source)	£1350/£1850
Keithley 617 Electrometer/source	£2200
Keithley 8006 Component Test Fixture	£1750
Marconi 2840A 2 Mbit/s Transmission Analyser	£1100
Marconi 6950/6960/6960A/6970A Power Meters & Sensors	from £400
Philips 5515 - TN - Colour TV pattern generator	£1400
Philips PM 5193 - 50 MHz Function generator	£1350
Philips PM 6654C System Timer Counter	£750
Panasonic VP 8175A Sig. Gen. (100KHz-140MHz) AM/FM/CW	as new £650
Rohde & Schwarz FAM (opts 2,6 and 8) Modulation Analyser	£3750
Rohde & Schwarz NRV/NRVD Power meters with sensors	from £1000
Schlumberger 1250 Frequency Response Analyser	£2250
Tektronix 1720 Vectorscope	£1150
Tektronix 1735 Waveform Monitor	£1150
Tektronix AM503 - AM503A - AM503B Current Amp's with M/F and probe	from £800
Wavetek 178 Function generator (50MHz)	£750
Wayne Kerr 3245 - Precision Inductance Analyser	£1850
Bias unit 3220 and 3225L Cal.Coil available if required.	(P.O.A)
Wayne Kerr 3260A + 3265A Precision Magnetics Analyser with Bias Unit	£5500
W&G PCM-4 PCM Channel measuring set	£3750

All equipment is used - with 30 days guarantee and 90 days in some cases.

Add carriage and VAT to all goods.

1 Stoney Court, Hotchkiss Way, Binley Industrial Estate
Coventry CV3 2RL ENGLAND

Tel: 02476 650 702
Fax: 02476 650 773
Web: www.telnet.uk.com
Email: sales@telnet.uk.com

C2

CONTENTS

JUNE 2003

VOLUME 109

NUMBER 1806

3 COMMENT

Failure rewarded

5 News

- Biochips for DNA testing
- Broadband rates to double
- Duracell makes cell to back-up NiMH prismatic



- LCDs go large
- Semelab's transistors are tougher
- Osram enters the high-power LED market



- DAB firm launches module
- Silicon gets hard
- Lords push for national centre
- Noise turns up the heat
- Methanol fuel cell generates 12 W for five hours



12 AN ELECTRONIC BALUN

Ever tried to interconnect domestic and professional audio equipment? **Ian Hickman** explains the problems and offers a solution.

16 HUMIDITY SENSOR WITH PC INTERFACE

Need to measure RH and temperature? Look no further than **Emil Vladkov's** innovative design.

22 UNDERSTANDING INPUTS OF ADCs

Daniel Malik explains how not make mistakes when using ADCs for measurement

25 NEW PRODUCTS

The month's top new products.

34 CIRCUIT IDEAS

- 6-600V AC/DC LED driver
- Anit-sleep alarm
- Tracking transmitter

38 DRM RECEPTION USING THE RX-320

Digital Radio Mondiale is the new AM. **Roger Thomas** has converted his RX-320 to receive the broadcasts

47 DINOSAUR COMPUTERS

Ivor Catt challenged the von Neumann theories years ago. This is his take on what could have been – and some ideas as to why it was not.

52 LETTERS

- EMC is attainable
- In defence of Mr. Miller
- The centenary of Blumlein's birth
- EMC – a flawed discipline
- Motor identity
- A fatally flawed article?

60 WEB DIRECTIONS

Useful web addresses for electronics engineers.

Next issue, dated July on sale June 5



Quasar Electronics Limited
 PO Box 6935
 Bishops Stortford, CM23 4WP
 Tel: 0870 246 1826
 Fax: 0870 460 1045
 E-mail: sales@quasarelectronics.com

Add £2.00 P&P to all UK orders. 1st class recorded - £4.
 Next day (insured £250) - £7. Europe - £5. Rest of World - £10.
 We accept all major credit/debit cards. Make cheques/PO's
 payable to Quasar Electronics. Prices include 17.5% VAT.
MAIL ORDER ONLY.
 Free catalogue with order or send 2 x 1st class stamps
 (refundable) for details of over 200 kits and publications.



QUASAR 0871 CREDIT CARD SALES 717 7168 electronics

Controllers & Loggers

The I/O Module and the Call Logger include plastic cases and don't need to be attached to a computer during operation. Complete documentation available from our web site.

Rolling Code 4-Channel UHF Remote

State-of-the-Art. High security. 4 channels. Momentary or latching relay output. Range up to 40m. Up to 15 Tx's can be learnt by one Rx (kit includes one Tx but more available separately). 4 indicator LED 's.



Rx: PCB 77x85mm, 12VDC/6mA (standby). 2 and 10 channel versions also available.
 Kit Order Code: 3180KT - £41.95
 Assembled Order Code: AS3180 - £49.95

Computer Temperature Data Logger

4-channel temperature logger for serial port. °C or °F. Continuously logs up to 4 separate sensors located 200m+ from board. Wide range of free software applications for storing/using data. PCB just 38x38mm.

Powered by PC. Includes one DS1820 sensor and four header cables.

Kit Order Code: 3145KT - £23.95
 Assembled Order Code: AS3145 - £29.95
 Additional DS1820 Sensors - £3.95 each

NEW! DTMF Telephone Relay Switcher

Call your phone number using a DTMF phone from anywhere in the world and remotely turn on/off any of the 4 relays as desired. User settable Security Password, Anti-Tamper, Rings to Answer, Auto Hang-up and Lockout. Includes plastic case. 130x110x30mm. Power: 12VDC.



Kit Order Code: 3140KT - £39.95
 Assembled Order Code: AS3140 - £59.95

Serial Isolated I/O Module

PC controlled 8-Relay Board. 115/250V relay outputs and 4 Isolated digital Inputs. Useful in a variety of control and sensing applications.

Uses PC serial port for programming (using our new Windows Interface or batch files). Once programmed unit can operate without PC. Includes plastic case 130x100x30mm. Power: 12VDC/500mA.

Kit Order Code: 3108KT - £54.95
 Assembled Order Code: AS3108 - £64.95

Infrared RC Relay Board

Individually control 12 on-board relays with included infrared remote control unit. Toggle or momentary. 15m+ range. 112x122mm. Supply: 12VDC/0.5A
 Kit Order Code: 3142KT - £44.95
 Assembled Order Code: AS3142 - £64.95



PIC & ATMEL Programmers

We have a wide range of low cost PIC and ATMEL Programmers. Complete range and documentation available from our web site.

Programmer Accessories:
 40-pin Wide ZIF socket (ZIF40W) £15.00
 Power supply (PSU201) £5.95
 Parallel Cable (CSLEAD108) £4.95

Enhanced "PICALL" ISP PIC Programmer

Will program virtually ALL 8 to 40 pin PICs plus certain ATMEL AVR, SCENIX SX and EEPROM 24C devices. Also supports In System Programming (ISP) for PIC and ATMEL AVR's. Free software. Blank chip auto detect for super fast bulk programming. Requires a 40-pin wide ZIF socket (not inc.)
 Kit Order Code: 3144KT - £59.95
 Assembled Order Code: AS3144 - £64.95



ATMEL 89xxx Programmer

Uses serial port. No special programming software required. 4 LED's display the status. ZIF sockets not included. 16VDC.
 Kit Order Code: 3123KT - £29.95
 Assembled Order Code: AS3123 - £34.95



P16Pro PIC Programmer

Super low cost programmer for 8/18/28/40 pin DIP serial PICs including 16F84 & 12C508. Software needs to be registered @ £20.95. 17-30VDC or 13-20VAC
 Kit Order Code: 3096KT - £10.95
 Assembled Order Code: AS3096 - £15.95

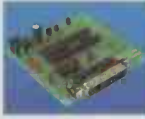

NEW! USB & Serial Port PIC Programmer

USB/Serial connection makes it ideal for field use. Free 9xNT/2000 Windows software. Call or see website for PICs supported. ZIF Socket not incl.
 Kit Order Code: 3149KT - £29.95
 Assembled Order Code: AS3149 - £49.95



Timers & Counters

These modules use a microcontroller and crystal for accurate and low-cost. 4 digit 14mm LED display used on all but 3141.

Presetable Down Counter

Starting count can be set. The 4-digit counter has four modes to control how the output behaves when it reaches zero. Max count rate of 30/sec or 30,000/sec. PCB: 51x64mm. 9-12VDC.
 Kit Order Code: 3154KT - £13.95
 Assembled Order Code: AS3154 - £22.95



4-Digit Timing Module

The firmware included with this motherboard kit is a programmable down timer of 10,000 sec. Timing accuracy: 0.04%. PCB: 51x64mm. 9-12VDC Current: 50mA. 5 other firmware chips can be used with this motherboard. Each has a different timing mode and can be purchased as a pack.
 Kit Order Code: 3148KT - £9.95
 Assembled Order Code: AS3148 - £18.95
 5 Piece Firmware Pack: F3148 - £14.95



Multi Mode Universal Timer

Seven different timing modes in one! Modes and delay ranges are set by DIP switches. Timing delays range between 255sec (1sec steps) and 42.5h (10min steps) Mains rated relay output. PCB: 48x96mm. 12VDC
 Kit Order Code: 3141KT - £14.95
 Assembled Order Code: AS3141 - £21.95



4-Digit Up/Down Counter

Count range is from 0000,1,2.. to 9999. It can also count down. Maximum count rate of about 30 counts per second. Two counters can be connected together to make an 8-digit counter. PCB: 51x64mm. 9-15VDC.
 Kit Order Code: 3129KT - £13.95
 Assembled Order Code: AS3141 - £22.95



Most items are available in kit form (KT suffix) or assembled and ready for use (AS prefix).



www.quasarelectronics.com

Secure Online Ordering Facilities • Full Product Listing, Descriptions & Photos • Kit Documentation & Software Downloads

EDITOR

Phil Reed

p.reed@highburybiz.com

CONSULTANT

Ian Hickman

CONTRIBUTING EDITOR

Martin Eccles

EDITORIAL ADMINISTRATION

Jackie Lowe

020 8722 6054

EDITORIAL E-MAILS

j.lowe@highburybiz.com

GROUP SALES

Reuben Gurunlian

020 8722 6028

ADVERTISEMENT**E-MAILS**

r.gurunlian@highburybiz.com

EDITORIAL FAX

020 8722 6098

CLASSIFIED FAX

020 8722 6096

PUBLISHING DIRECTOR

Tony Greville

MANAGING DIRECTOR

Roy Greenslade

ISSN 0959-8332

SUBSCRIPTION QUERIES

Tel (0) 1353 654431

Fax (0) 1353 654400

Disclaimer

We work hard to ensure that the information presented in *Electronics World* is accurate. However, *Electronics World's* publisher - Highbury Business Communications - will not take responsibility for any injury or loss of earnings that may result from applying information presented in the magazine. It is your responsibility to familiarise yourself with the laws relating to dealing with your customers and suppliers, and with safety practices relating to working with electrical/electronic circuitry - particularly as regards electric shock, fire hazards and explosions.

Electronics World is published monthly. Orders, payments and general correspondence to **Jackie Lowe, Highbury Business Communications, Anne Boleyn House, 9-13 Ewell Road, Cheam, Surrey, SM3 8BZ.**

Newstrade: Distributed by COMAG, Tavistock Road, West Drayton, Middlesex, UB7 7QE Tel 01895 444055.

Subscriptions: Wyvern Subscription

Services, Link House, 8 Bartholomew's Walk, Ely Cambridge, CB7 4ZD.

Telephone 01353 654431. Please notify change of address.

Subscription rates

1 year UK £38.95 O/S £64.50
US\$100.62 Euro 102.55

Overseas advertising agents: France and Belgium: Pierre Mussard, 18-20 Place de la Madeleine, Paris 75008. United States of America: Roy Barnes, Reed Business

Publishing Ltd, 475 Park Avenue South, 2nd Fl New York, NY 10016 Tel: (212) 679 8888 Fax: (212) 679 9455

USA mailing agents: Mercury Airfreight International Ltd Inc, 10(b) Englehard Ave, Avenel NJ 07001. Periodicals Postage Paid at Rahway NJ Postmaster. Send address changes to above.

Printed by Polestar (Colchester) Ltd, **Filmsetting by** Impress Repra by Design A1 Parkway, Southgate Way, Orton Southgate, Peterborough, PE2 6YN

Failure rewarded

As response was favourable on his last article - you'll find another tome from the controversial Mr. Catt on page 47. Over half of you thought his EMC article interesting - a fact borne out by some of the letters this month. I will try and publish the rest next month.

Part of his article suggests that some parts of British industry have a different agenda to that of a 'normal' company that is inventing, manufacturing and selling innovative and cutting edge products. One of the companies he singles out for criticism is Marconi. I'd also like to add some of my own experiences with this company - who I contracted for a few years ago. I too was amazed that some of the engineering department I was in seemed more hell bent on wasting time than actually making the product work. In fact, my immediate boss had his workstation so arranged as not to be seen by any passing management and in fact him neither. I've never actually met anyone before who would sleep during the day and what little he did do was to make the whole engineering process as slow as possible by throwing huge spanners into the works at every opportunity. I would also point out that this was a civilian project. So it was no surprise to me when Lord Simpson departed after having frittered away Lord Weinstock's war chest in a very short space of time. In fact he turned the cash mountain into a £3bn debt. And then, he and his cohort - John Mayo - reportedly walked away with about £4m between them. Which just goes to show that failure is handsomely rewarded in the UK.

As a trial this month (and to try and move a large backlog) we've dropped the type size in the 'letters' section which enables us to get more in. I'll keep it like this unless lots of you complain. I also

know some good shops that do magnifying glasses.

A number of readers (Tony Calligari for one) have suggested a free ads section. Well, we've decided to do it - so if you let me have your 'small ads' as soon as I've got enough for half a page - I'll publish it. I'm envisaging the ads will be for information requests, swaps and magazine back numbers etc. Obviously, I will not take any commercial advertising. To maximise space I would like to limit the contact details to phone numbers and email addresses.



I'm also pleased to announce the winner of the Modular Technology DAB card is Kevin Hudson from Barking, Essex, UK. We will be sending the prize to you very shortly. Thanks to all who entered and to Modular Technology who sponsored the prize.

Phil Reed



HIGHBURY
Business Communications
A SUBSIDIARY OF HIGHBURY HOUSE COMMUNICATIONS PLC



® 19" RACK MOUNTING DISTRIBUTION PANELS WITH IEC 320 SOCKETS AND REAR CABLE MANAGEMENT



4



ELECTRONICS LIMITED

OLSON HOUSE, 490 HONEYPOT LANE,
STANMORE, MIDDX HA7 1JX
TEL: 020 8905 7273 FAX: 020 8952 1232
e-mail: sales@olson.co.uk
web site: <http://www.olson.co.uk>

Biochips for DNA testing

A team of scientists from Germany has produced a chip that collects and transports biomolecules and mixes them with reagents.

Developed by the Fraunhofer Institute, digital inputs to the chip control the movement of the molecules through the device. Such a chip could be used to experiment with DNA.

"We utilise polymer particles whose diameter can be less than one micrometer. DNA sections or other biomolecules adhere to their surface," said Dr. Patrick Wagler from the Institute.

The device uses a technique called

microfluidics. Channels are formed in a plastic layer on top of a silicon chip. Low voltage signals are used to transport molecules and reagents under the chip's surface.

"Current applications for dynamic, programmable biomodules lie primarily in the fields of molecular diagnostics and evolutionary biotechnology," said Professor John McCaskill, head of the Fraunhofer Research Unit for Biomolecular Information Processing.

The Institute added: "It's now possible to couple the location of the molecule with switching and controlling mechanisms. Under the

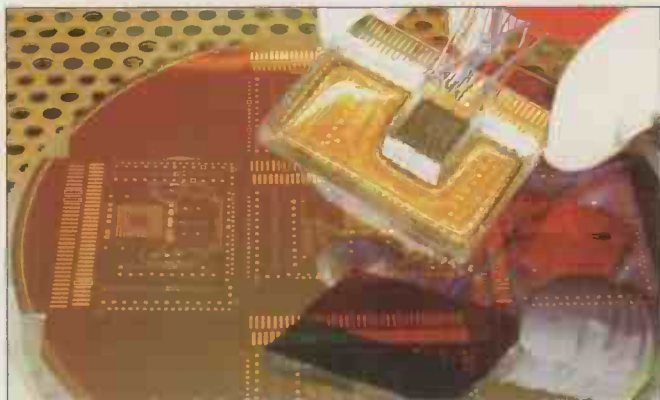

microscope, researchers can visually track the path of the biomolecules, marked with a fluorescent dye, and influence their flow with the push of a button."

Broadband rates to double

Broadband Internet subscribers are being given a boost by recent announcements from rivals BT and Telewest, both of which are set to double their top data rates.

BT is planning to offer a 1Mbit/s ADSL service, while Telewest is also doubling its cable rate to reach 2Mbit/s.

"Not every Internet user will want a 2Mbit connection, but we're now well on the way to offering a menu of broadband services to suit different requirements," said Gavin Patterson, MD of Telewest Broadband.

Telewest reckons that ten per cent of its 300,000 customers now subscribe to its top rate 1Mbit/s

service. The firm has started a 1,500 user trial, while a nationwide rollout is expected by the year's end.

BT, meanwhile, has a similar timescale for its 1Mbit/s ADSL offering, with an autumn trial and wider rollout before Christmas.

In addition BT hopes to widen the area served by ADSL. The current 512kbit/s rate is set by the distance of the subscriber from the exchange due to attenuation over the copper wires.

The acceptable loss over the wires is 55dB, giving a maximum distance of 5.5km. By increasing the loss to 60dB the distance is raised to 6km, which BT said should bring a further 600,000 households into ADSL's reach.

ADSL is by far the most popular way to access the Internet at broadband rates, with some 750,000 subscribers. BT is in the process of upgrading another 206 exchanges and 102 more sites are being considered.

In the meantime, BT is expanding its trial of SDDL, or symmetric digital subscriber line, from 22 to 100 exchanges. Aimed at business users this can give 2Mbit/s data rates or more in both directions.

Service provider Easynet is already offering SDSL following the unbundling of BT exchanges. A 2Mbit/s bi-directional service costs under £6,000 a year, far cheaper than a leased line.

Duracell makes cell to back-up NiMH prismatic

Duracell is to introduce a prismatic 1.5V alkaline cell for portable audio devices.

Called LP1, it is 67x17x6mm and will run a typical solid state audio player (90mW) for over 20 hours, said the company.

It is a similar size to the rectangular NiMH cell found frequently in audio players. "Currently, over 200 digital audio devices can be powered by LP1 batteries," said Duracell, which expects equipment makers to start designing devices particularly for its new cell.

The cells will be available in the UK later in 2003.

Duracell LP1 cell.

Nominal Voltage:	1.5V
Voltage Range:	0.8 - 1.5V
Nominal Impedance:	0.12Ω @ 1kHz
Average Weight:	25g
Volume:	6.8cm ³
Typical Capacity:	1.5Ah @ 100mA to 0.8V
Operating Temp. Range:	-20 to 54°C
ANSI name:	Not yet decided
IEC name:	LP1867
More information at www.duracell.com/prismatics/techLP1.htm	



Lords push for national centre

A House of Lords debate on the future of the UK's chip industry has once again called for a national centre of excellence in IC design.

"The UK should support a single national research institute similar to IMEC in Flanders," said Liberal Democrat Lord Methuen.

Conservative peer Lord Freeman said: "There is clear evidence in the report that in the field of information technology we are not doing enough in this country to exploit innovative ideas."

In March, *EW* reported on Chips for Everything, the House of Lords report that concluded the country needs a national centre of excellence to maintain our world standing.

"The research we are developing could be of vast advantage," said Lord Wade of Chorlton, chairman

of the sub-committee that wrote the report. "There is an opportunity for the UK to take a more important role in the future."

In his response Lord Sainsbury, minister for science, said: "It is clear that if the UK is to remain at the forefront of research in innovative systems, it will need a significant and sustained investment in order to maintain a critical mass of activity."

Scotland's Alba Centre, located in Livingston, and its Institute for System Level Integration could form the cornerstone of Government plans to expand the UK's electronics industry.

The ISLI, noted Lord Methuen, "goes some way to meeting the criteria for a national institute".

Lord Sainsbury described the ISLI as "a great success", adding:

"In preparing the Government's response to the report we shall take into account the Institute for System Level Integration experience and build that into our plans."

His comments were welcomed by Scottish Enterprise, which oversees the Alba Centre.

The Government will now consider its plans, and Lord Sainsbury is to decide whether any future institute should be "a virtual or a single centre or a major programme and what exactly it should cover".

The Chips for Everything report also called for UK research in CMOS technology to be refocused towards processor and architecture design.

Lord Wade argued chip manufacturing is too expensive and risky, especially considering a fab plant can cost upwards of £1bn.

"Current research funding is the wrong way around," he said. Lots of funding goes into CMOS, but that doesn't bring back revenue into the UK, as we have almost no CMOS manufacturing."

However, Lord Sainsbury said basic silicon research is still valid. "At the moment there is considerable commercial exploitation of microtechnology in silicon, not as integrated circuits but as microscale or nanoscale sensors and instruments."

The Government is still expected to issue a formal document in response to the select committee report.

Semelab's transistors are tougher

In response to requests from customers, UK transistor maker Semelab has

introduced a new lead option on TO257 and TO220 high-reliability metal can packages.

"Not only do the new leads enable customers to pre-form and cut them with ease, but because they are pure copper they also reduce AC losses," said Damien Connolly, aerospace product support engineer for Semelab. Prior to this, its high current hermetic packages used copper cored leads that enter the package through a glass seal.

The leads are substantial -

1mm diameter for TO220M - and very stiff. This means that stresses in forming and bending the leads are transmitted to the glass seal, which if incorrectly handled, can be weakened.

Shocks and vibration experienced by the device in service are likewise transmitted to the seal.

The new leads use a two-part construction: a standard rigid lead passes through the glass seal, and this is welded to a softer copper just outside the seal.

www.semelab.com



Osram enters the high-power LED market

Osram Opto Semiconductors has announced a range of 1W LEDs in miniature packages.

Proposed applications for Golden Dragon, as the range is called, include reverse lamps for vehicles, traffic signal lighting and display backlighting for LCDs.

The packages are surface mount and fit in a 1.8x6x7mm volume - four times more space-efficient than Osram's Power TOPLEDs offerings.

Operating temperatures is -40 to +100°C, and Osram claims frequent temperature changes "up to 1,000 times" and tropical climates can be withstood.

Optical efficiency is 20 lm/W and "lifetime can exceed 20,000 hours, depending on operating and ambient conditions".

Initial red and yellow Golden Dragon prototypes are available now, and volume production will begin mid-2003. White versions are currently in development and will be available as prototypes within the next two quarters.

www.osram-os.com

Italian vehicle designer Pininfarina presented this at the Geneva Car Show. Behind the low-profile headlights are high-brightness LEDs from Osram.



DAB firm launches module

Digital audio broadcasting firm RadioScape has developed a module for DAB reception that could cut receiver development time.

The RS200 module needs only a power supply, case, speakers, antenna, display and buttons to complete a DAB receiver.

"The DAB industry, particularly in the UK, is poised to take off," said John Hall, RadioScape's chief executive. "The broadcasting infrastructure is in place. Interesting and different content is being broadcast that people want to hear. The last piece is the availability of reasonably priced receivers in large volumes."

At the core of the module is Texas Instruments DRE200 chip which conforms to the Eureka147 standard. This software programmed system means the module can also receive FM broadcasts, without the need for extra components.

The module has a supply voltage of 5V and measures 110 x 44 x 15mm, making it suitable for

handheld, battery powered systems as well as mains powered units. Prices start at around £25 depending on volume. "RadioScape is in a pivotal position to drive the DAB industry by enabling high volumes of DAB receivers to reach the market at low consumer prices starting from under £100," said Hall.

Options for the software include radio data stream (RDS), integral MP3 player software, infra red remote control, electronic programme guide display with record capability, and I²C for external control of a CD transport.

"Our Software defined radio approach gives us great flexibility to adapt and customise very quickly because we can easily load new features and standards onto the DRE200 in the form of software that runs on the DSP," said Hall.

There are more than 250 DAB stations currently transmitting in the UK. Potential sales of DAB receivers still outstrip supply in the UK.



Silicon gets hard

Researchers in the US have found that nanospheres made from silicon are some of the hardest materials yet discovered.

Spheres from 100 nanometres down to 40 nanometres in diameter have hardnesses in between sapphire and diamond, around four times harder than conventional silicon.

The spheres can withstand pressures of 20 to 50 gigapascals and could be used to toughen up

micro-electromechanical systems (MEMS).

By way of example, stainless steel has a hardness of 1 gigapascal, while diamond is 90 gigapascals.

The work was carried out at the University of Minnesota. Next up to test is silicon carbide, which should approach diamond for hardness.

The small size of the spheres, with perhaps 40 million atoms, allows the tests to be simulated on computer.

The simulated results agreed well with experimental tests.

"Better designs for these sorts of nanocomposites will be based on a better understanding of what goes into them," said William Gerberich, professor of chemical engineering and materials science. "These measurements make it possible to pursue a bottom-up approach to materials design from a mechanical perspective."

LCDs go large

Samsung Electronics demonstrated a 54-inch liquid crystal display recently. The display has 6.2 million pixels and can display images at 60 frames/s.

Viewing angle is claimed to be 170 degrees, while contrast ratio is 800:1, said the firm.

Last year Samsung was the biggest supplier of large area LCDs (panels bigger than 10 inches), closely followed by LG.Philips LCD.

Both firms shipped over \$3bn worth of displays with the market in total worth over \$17bn. Some 18 million large area panels were shipped during 2002.

The top manufacturers are now producing LCDs from glass panels measuring 1,250 x 1,100mm, so called fifth generation production lines.



Oxfordshire display firm gets more cash and additional management.

Harwell-based Printable Field Emitters (PFE) has raised another round of venture capital funding.

"Existing investors 3i, Quester and NIF have continued their support for

PFE by investing a further UK £2.5m," said company CEO Tom Holzel.

Along with the funding comes two new faces.

"3i have also enabled us to strengthen our team by introducing former Philips displays chief Bill Freer to the board as non-executive chairman and Ivor Thomas as chief operating officer," said Holzel.

PFE has now raised UK £10m from the venture capital community and has also had awards from the DTI's SMART scheme and EU's Fifth Framework IST programme.

The company is working on a field-emission display technology, which it aims to licence to big screen TV

makers as a wide-viewing-angle alternative to LCD and long-life competitor to plasma panels.

Freer is already a displays industry insider, having recently managed Philips Mobile Display Systems in Hong Kong for five years. "PFE has probably the only cathode technology which has the stability and long life for use in flat, thin consumer TVs, at a cost approaching that of conventional CRT type TVs," he said.

Thomas is the first full-time financial officer for PFE; needed as the company's intellectual property licensing activities start to take off.

<http://www.pfe-ltd.com>



Noise turns up the heat

Yale University scientists are developing a thermometer based around thermal shot noise through a Josephson junction.

The device will be as accurate as existing primary standards and able to cover from millikelvin to the room temperature range. This is significant as currently multiple standards are needed to cover the temperature scale from close to absolute zero to hundreds of kelvin.

The technique relies on the change in forward and reverse tunnelling through a junction. As temperature increases the shot noise with zero potential across the junction also rises. The system can be calibrated to measure temperature.

Weather database hits 1Pbyte

The US National Center for Atmospheric Research database has reached 1Pbyte (petabyte= 10^{15} , making it one of the largest databases ever assembled.

Information in the archive comes from various sources, including satellite and archaeology, and covers the atmosphere, ocean, and land from prehistoric times to now, as well as holding predictions to 2100 and beyond.

The database crossed the terabyte boundary in 1986, taking 16 years to reach its current size. Now accelerating data acquisition and production will swell it to 11Pbyte in 2005.

Data is stored using a StorageTek automated tape system which includes robot arms to swap tapes in and out of tape drives.

www.storagetek.com

Bluetooth gets shot in arm

Bluetooth, the short range wireless comms standard, has been given a boost by the unveiling of a single chip system from US firm Silicon Wave.

The SiW3000 device combines baseband and radio functions, which until now have been implemented in separate chips - the radio sometimes using discretes.

The radio portion of the circuit is a 2.4GHz direct conversion transceiver while the baseband side uses an ARM7TDMI processor.

Protocol software runs in ROM to reduce cost, although an external flash memory chip could be used for custom software versions.

Jarvis Tou, head of product development at the firm, said the chip was the first to build a direct conversion radio using 0.18µm process technology.

Using a single chip keeps the cost low enough for mobile phone applications. Without the antenna, said Tou, "this is targeting a sub-\$4 bill-of-materials".

Cost is further reduced by cutting out the balun filter or switch between the radio and antenna, he said.

Silicon Wave is partly owned by Intel and Intersil, the wireless-LAN specialist.

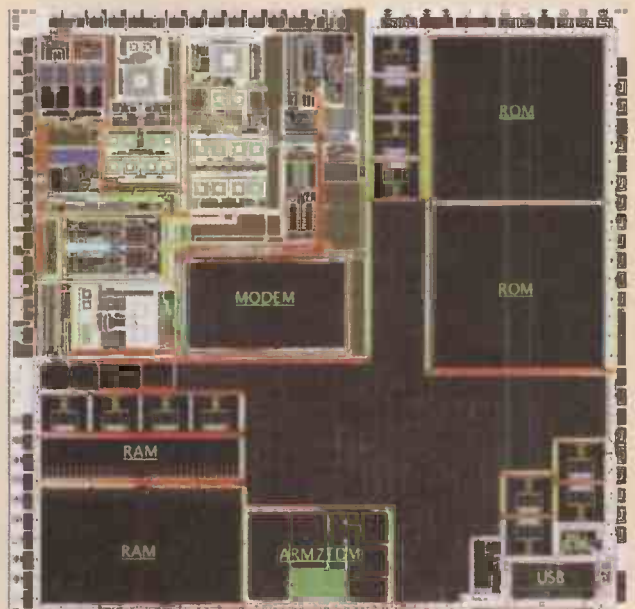



WELDEX 2003

WELDCOME. 11-14 November 2003
National Exhibition Centre Birmingham, UK

11-14/NOVEMBER/03

Join us at Weldex 2003

The international welding, joining, cutting and fabrication exhibition
co-located with Manufacturing Week INSPEX, Tooling and CIM (T.E.A.M)

Weld class event

At Weldex 2003 you will experience, first hand, the very latest products, services and technologies in welding, joining, cutting and fabrication. As the largest international show of its kind in the UK, Weldex 2003 represents a unique opportunity to make contact with some of the biggest and best names in the business, from all over the world.

Weldex 2003 is the event in the UK welding calendar

Whether you are selling, buying, learning, or just staying in touch, Weldex 2003 is the place to do good business in the UK. So make a date to join us at the NEC, Birmingham, 11 - 14 November 2003.

For tickets and early registration visit: www.weldexpo.com or call
Nichola Mitchell: +44(0)1322 660070 **NOW!**

To find out who's exhibiting at Weldex 2003 contact: Karin Allfree or Isobel Roberts:
+44(0)1322 660070

WEEX/VAD/HHC/EW

Supported by:



American Welding Society



Official sponsoring publications:

ENGINEERING
DISTRIBUTOR



Quality Today

weldex news



Waveguide halves optical cost

Defence research firm Qinetiq has developed an all-optical network technology using a hollow waveguide (HWG) structure. The format could halve the cost of optical circuits.

Rather than using a conventional 'rib' or 'ridge' structure, Qinetiq's technique uses a 'hollow' guide. The HWG is etched from a flat substrate, while performance can be improved by coating the walls. A lid is attached

to complete the guide.

This layout simplifies placing components on a substrate, said Malvern-based Qinetiq. Rib structures take light from the component through air and into the waveguide. As the HWG is air, one of the interfaces is removed.

In addition, devices such as MEMS and multi-mode interference devices could be created at the same time as the waveguide.

Methanol fuel cell generates 12W for five hours

Toshiba has announced what it claims is the world's first prototype of a small size direct methanol fuel cell (DMFC) for portable PCs.

The cell currently produces an average output of 12W and maximum output of 20W - and can give approximately five hours of



operation with a single cartridge of fuel. Methanol delivers power most efficiently in a fuel cell at 3 to 6 per cent concentration in water - needing a large tank.

The company has produced miniature ancillary components to go with its cell. The envelope includes interface and electric circuits for power delivery; sensors for methanol concentration, liquid level and remaining methanol; a low-power liquid pump; air pumps; and a DC-DC converter for the pumps.

should last for long periods of time. It is creating this environment in a fuel cell that researchers have struggled with for years."

Enzymes are extremely sensitive to changes in pH and temperature, and even slight departures from ideal conditions can lead to inactivation.

The typical approach to keeping enzymes operating has been to immobilise them by attaching them to the electrodes, but they still tend to decay too quickly to be useful.

Minteer and her colleagues coated the electrodes with a polymer that has specially tailored pores for enzymes to live in. "The enzyme has everything it needs to function for a very long period of time, instead of denaturing like it normally would," said Minteer. "Other bio fuel cell studies have had lifetimes of a few days; our technique allows for enzyme activity over several weeks with no significant power decay. With proper optimisation, these bio fuel cells could last up to a month without recharging."

Minteer's 5cm square cells run on ethanol. She has tested between 30 and 50 of them - and successfully run cells on vodka, gin, white wine and flat beer. "The fuel cell didn't like carbonation," said Minteer.

Performance:

12W average power, 20W maximum.

11V

275 x 75 x 40mm (825cc)

900g

5hr operation on 50cc of methanol, 10 hours with 100cc.

Cartridge:

50cc: 72g 33 x 65 x 35mm

100cc: 120g 50 x 65 x 35mm

operation with a single cartridge of fuel.

Methanol delivers power most efficiently in a fuel cell at 3 to 6 per cent concentration in water - needing a large tank.

Watch or phone?

Japan's leading telecoms firm, NTT DoCoMo, is to start selling a wristwatch mobile phone.

Dubbed Wristomo, the watch is waterproof and includes an email service, transferring data at up to 64kbit/s, and can access basic websites.

When unfolded, the watch measures 172 x 40 x 19mm and weighs 113grams. NTT claims two hours talk time. Unfortunately the phone only works on Japan's PHS networks.



Bio fuel cell drinks vodka

Scientists at Saint Louis University have developed a long-lasting bio fuel cell that can be recharged with drinking alcohol.

Bio fuel cells use enzymes rather than metal catalysts to extract electricity from chemicals and have been studied for nearly half a century without practical cells emerging.

"The only items consumed in a bio fuel cell are the fuel and oxygen from the air," said Dr Shelley Minteer, assistant professor of chemistry at Saint Louis. "Given the proper environment, an enzyme

PROTEUS

The Complete Electronics Design System



Schematic Capture

PCB Layout

SPICE Simulation

Auto Placement

CPU Models

Auto Routing

VSM

Virtual System Modelling

Schematic & PCB Layout

- Powerful & flexible schematic capture.
- Auto-component placement and rip-up/retry PCB routing.
- Polygonal gridless ground planes.
- Libraries of over 8000 schematic and 1000 PCB parts.
- Bill of materials, DRC reports and much more.

Mixed Mode SPICE Circuit Simulation

- Berkeley SPICE3F5 simulator with custom extensions for true mixed mode and interactive simulation.
- 6 virtual instruments and 14 graph based analysis types.
- 6000 models including TTL, CMOS and PLD digital parts.
- Fully compatible with manufacturers' SPICE models.

New Features in Version 6

- Drag and drop toolbars.
- Visual PCB packaging tool.
- Improved route editing.
- Point and click DRC report.
- Multiple design rules (per net).
- Multiple undo/redo.

Call Now for Upgrade Pricing

Proteus VSM - Co-simulation and debugging for popular Micro-controllers

- Supports PIC, AVR, 8051, HC11 and ARM micro-controllers.
- Co-simulate target firmware with your hardware design.
- Includes interactive peripheral models for LED and LCD displays, switches, keypads, virtual terminal and much, much more.
- Provides source level debugging for popular compilers and assemblers from Crownhill, IAR, Keil, and others.

**Works with
PIC Basic Plus
from Crownhill
Associates**

labcenter

Electronics
53-55 Main Street, Grassington. BD23 5AA

Tel: 01756 753440
Fax: 01756 752857

Contact us for
Free Demo CD

www.labcenter.co.uk
info@labcenter.co.uk

An Electronic BALUN

A lot of domestic or 'semi-pro' audio equipment has only unbalanced outputs. This can cause problems when interfacing to a balanced system. This is especially true for 'cost effective' radio microphones and Ian Hickman analyses the problem, provides some practical answers and explains the complexities of balanced circuits in simple terms, into the bargain.

microphones typically provide an unbalanced output from the receiver unit. They frequently come with an unbalanced to balanced adaptor, consisting of a mono 1/4" jack socket wired to a three pin XLR plug. This arrangement may prove unsatisfactory, due to introducing hum problems. This is because the output is still asymmetrical, or unbalanced – and just wired to 'look' like a balanced signal.

The interface

Figure 1 shows a view on the pins of an XLR plug, as commonly used with balanced circuits. Pin 1 is ground and may or may not be connected to the body of the plug, depending on the particular make. Pins 2 and 3 are the balanced signal input pins. In an unbalanced to balanced BSA (between series adaptor), pins 1 and 3 are connected together, the input thus being applied to the remaining balanced signal line. Using a balanced input in this way may prove unsatisfactory for a number of reasons, the most pressing being, often, the introduction of an unacceptable level of mains hum. The circuit described below is designed to circumvent this problem.

'Balun' is the term used to describe a balanced to unbalanced transformer. These are commonly used to interface between equipment and a telephone line, and are also widely used in RF (radio frequency) circuits, as described in Ref.1. Being passive devices, they may be used either way round, to transfer a balanced input signal to an unbalanced output, or vice versa, providing galvanic isolation in the process. Using techniques such as a symmetrical balanced winding and an interwinding screen, they can provide a large CMRR (common mode rejection ratio, a concept explained below). However, a suitable

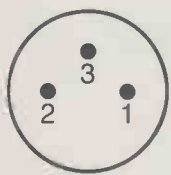

Fig. 1. View on the pins of an XLR balanced circuit plug. Pin 1 is ground; pins 2 and 3, balanced signal.

In many halls, lecture theatres and anywhere 'broadcast', the interface to the sound reinforcement system is a balanced input, typically via an XLR socket or PO jack. While a microphone or microphones may be provided at the lectern or rostrum, many speakers seem to like to go walkabout whilst delivering their talk or lecture – perhaps to point out something on a screen where slides are being shown. In the process, some speakers even commit the heinous sin of actually turning their back on the audience! The result is that, all too often, those seated at the rear of the auditorium cannot hear some, or even a large part, of the proceedings. The solution is to 'wire the speaker for sound' with the aid of a radio mike. But radio

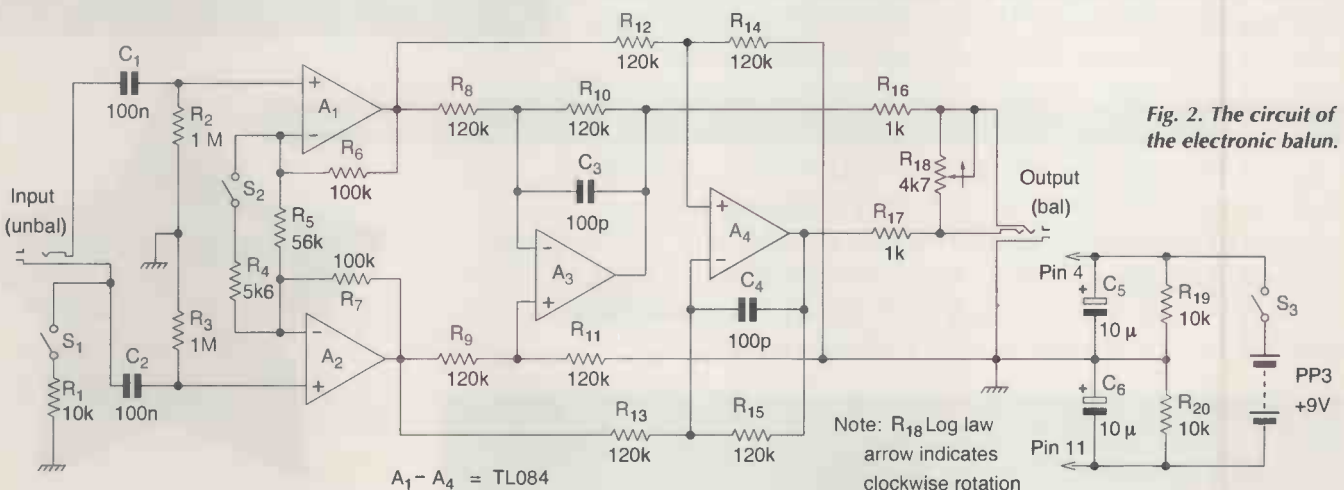

Fig. 2. The circuit of the electronic balun.

design to cover the whole audio band can result in an expensive component and hum pickup from stray mains magnetic fields linking the transformer core may still result in hum in the output. So the circuit described here is an electronic (active) balun, designed to accept an unbalanced signal and provide a balanced output. As such, of course, it is unidirectional and cannot be used in reverse, to interface an unbalanced input to a balanced output. In addition to translating from an unbalanced circuit to a balanced one, it is designed to reject any unwanted common mode signal, such as mains hum. It also provides a comprehensive level adjustment facility, ranging from attenuation to a gain of up to 37dB.

The circuit

Figure 2 shows the circuit of the electronic balun, as it finished up after several modifications as the result of experience in its use. The gain of A_1 and A_2 , set by $R_5 - R_7$, is approximately +14dB, or about +34dB if switch S2 is closed. As A_3 and A_4 operate at unity gain, these are also the overall nominal gain figures to each of the balanced output lines for the completed unit. Thus the nominal maximum gain, unbalanced input to balanced output, is +20 or +40dB. Other values may be arranged, by appropriate modification of R_4 and R_5 .

Since the output of any radio mike which may be connected to the circuit cannot be relied upon to be d.c. free, blocking capacitors C_1 and C_2 are included. This necessitates the inclusion of d.c. return resistors R_2 and R_3 , to bias A_1 and A_2 in the middle of their common mode input range. A_1 , A_2 and A_3 are clearly just an

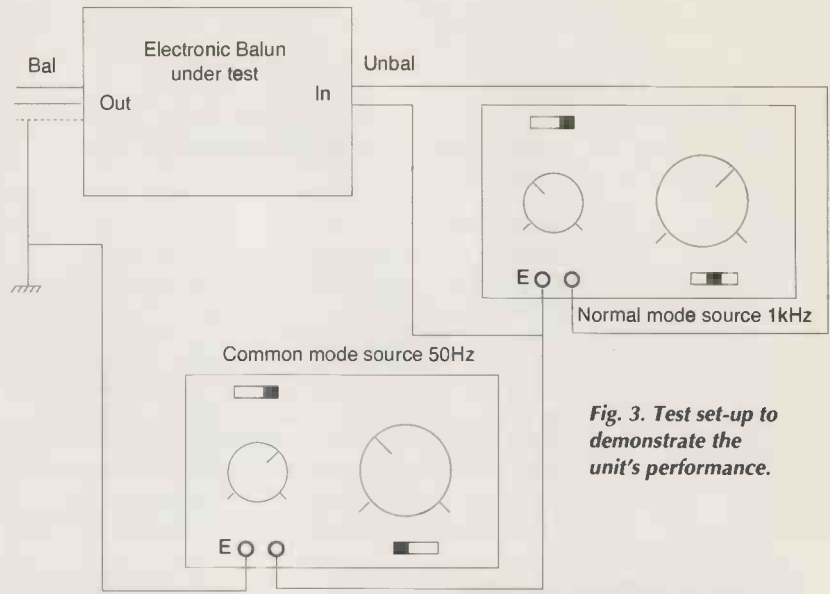

Fig. 3. Test set-up to demonstrate the unit's performance.

instrumentation amplifier identical to Fig. B, its ground referenced output being applied to R_{15} .

A_1 , A_2 and A_4 also form an instrumentation amplifier, the output of which is applied to R_{17} . The signals applied to R_{16} and R_{17} are in antiphase and thus represent a ground-centred balanced output. Potentiometer R_{18} provides a continuously variable gain control, from zero output up to a maximum of 3dB below the nominal gain.

Signals "bal" and "unbal"

In a two-wire circuit, if the voltage at every instant on one line is equal in magnitude but opposite in sign to that on the other line, both being measured with respect to ground, the circuit is carrying a perfectly balanced signal. Fig. A. shows, on the left, a vector diagram of a slightly unbalanced signal, say a 1kHz 200mV (nominal) peak sinewave. Assume the voltage on one line is 101mV, and on the other 99mV; the difference has been exaggerated for clarity. On the right is shown how this can be alternatively represented as the sum of a 200mV perfectly balanced (normal mode) signal and a 1mV completely unbalanced (common mode) signal, i.e. one where the voltage on the two lines is identical. The 'degree of balance' is then said to be 46dB, that being the relative magnitude of the signals.

In this example, the unbalanced component is in phase with the signal on one of the lines, but in other cases it might not be. If it were in quadrature, the amplitude of the two signals would be equal, but one would be advanced in phase and the other retarded, by $\tan^{-1}(1/200)$ or 0.005 radians. Thus the signals on the two lines would not be in antiphase, but separated instead by $(\pi - 0.01)$ radians. In the more general case, the unbalanced component could be at any phase angle relative to the balanced.

In the most general case of all, it could be at a completely different frequency, for example the mains distribution frequency of 50 or

60Hz, a common problem. A circuit which provides 60dB less gain to a common mode signal than to a normal mode signal is said to have a CMRR (common mode rejection ratio) of 60dB. Various nomenclatures are used to describe balanced and unbalanced voltages; for example the audio designer of valve output transformers would talk of 'push-pull' and 'push-push' components. The op-amp designer talks of 'normal mode' and 'common mode', while telephone engineers talk of 'transverse' and 'longitudinal' components (UK) or 'metallic' and 'to ground' voltages (USA).

Balanced circuits are traditionally used for telephony. The last dozen yards from a telegraph pole to a house was often a line with two spaced wires with a nominal characteristic impedance of 600Ω, though often now replaced by a twin core cable. Other impedances encountered in balanced circuits are 135Ω, 140Ω, 200Ω, 900Ω and, in a few countries, 1200Ω. The source supplying a balanced signal may be 'floating' or centre-tapped to ground. In the former case, e.g. the isolated output winding of a balun, the degree of balance of the signal will be determined by strays, mainly the capacitive ones, both in the source itself and in the circuit to which it is connected. In the centre-tapped case, the balance will be virtually perfect, unless the circuit to which the signal is connected is far from ideal. Similarly, the circuit to which a balanced signal is delivered may also be

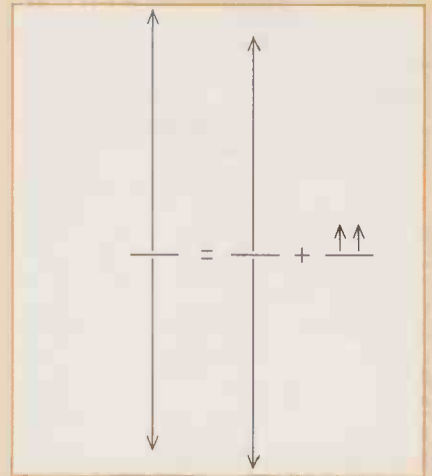

Fig. A. Analysis of an imperfectly balanced signal.

either floating or centre-tapped to ground. In addition, it may be 'terminating', i.e. presenting a load equal to the signal's characteristic impedance such as 600Ω, or 'bridging' (high impedance), as in a measuring instrument such as a psophometer, designed to tap across a circuit in use, without affecting it. Such a balanced transmission system, in addition to conveying the intended balanced signal, may present the receive end with an unwanted longitudinal or common mode signal. Equipments are designed to accept the former, and reject the latter.

The circuit is powered by a 9V PP3 battery, a decoupled centre voltage being supplied by resistors R_{19} , R_{20} and capacitors C_5 , C_6 .

In operation

A test set-up was arranged, as in Fig. 3. To avoid complications with possible earth loops, the two audio frequency generators were battery operated types. They produced a small wanted 1kHz triangular wave riding on a large 50Hz sine wave as shown in Fig. 4a. Also shown is one of the balanced output lines from the unit, with R_{18} set for maximum output. It can be seen that the signal has been amplified whilst the rejection of the common mode component is virtually complete. In Fig. 5, the common mode source has been removed and the negative line (supply plug outer) of a plug-top power supply connected

to the E terminal of the signal source instead. The plug top power supply was part of an Audio-Technica radio microphone, model ATW. The large common mode component is still almost, although not entirely, rejected. The coupling mechanism between the plug-top's mains input and its output is not entirely clear, but appears to be due to internal capacitive coupling. It is common on plug-top supplies to find a plastic 'earth pin' on the standard BS1363 ring main plug arrangement, but the Audio-Technica unit has a proper brass earth pin.

The unit has also been successfully used with a Ross radio microphone, model RWM101. This unit can be powered either by a 6V plug-top power supply, or internal batteries. Its signal output is via an RCA phono socket and hence, of course, like the Audio-Technica unit, is unbalanced.

With other equipments, the common mode supply

The ins and outs of CMRR

Figure B shows a typical instrumentation amplifier schematic. It responds to the normal mode input, while, ideally, completely rejecting any accompanying common mode signal. It may be realised with three separate op-amps, three sections of a quad op-amp, or as a dedicated 'instrumentation amplifier'. The latter often comes with the option of selectable gain, by strapping various pins. A long established example is the Analog Devices AD524, which offers pin programmable gains of 1, 10, 100, and 1000, a CMRR of 120dB (at gain $G = 1000$), low noise, low non-linearity, low offset and drift voltages and a gain bandwidth product of 25MHz.

When designing a balanced input to unbalanced output amplifier with three op-

amps, there are some interesting points to observe in order to achieve the optimum performance. Consider first, the right-hand op-amp A_3 . This will convert a balanced input to a single-ended or unbalanced output, with unity gain if $R_3 - R_6$ are all equal. Thus $-1V$ at the output of A_1 and $+1V$ at the output of A_2 will result in $+2V$ at the output of A_3 . But zero output will result from a common mode input signal - assuming that the CMRR of the op-amp is infinite. Whilst infinite is a little much to hope for, most op-amps provide a CMRR of at least 60dB. For example, the long established and deservedly popular TL08xC series of commercial grade op-amps typically provide a CMRR of 86dB, with a minimum of 70dB, or 75dB minimum for the premium grades. This means that in practice, the CMRR actually achieved will be set by the tolerance of the resistors $R_3 - R_6$.

I long ago settled on 1% tolerance for my stock resistors, at a time when the price differential between 1% and 5% types had become really quite small. The worst case gain error to balanced inputs, and CMRR to common mode inputs will result when all four resistors are on their 1% limit, in various arrangements. However, such an eventuality is exceedingly unlikely. A reasonable guide to the sort of errors which may be encountered in practice can be arrived at by assuming three of the resistors to have 0% tolerance, and the fourth to be on the 1% limit. On this basis, the errors are given in Table 1, for various gains.

The CMRR is defined as the excess of

normal mode gain over common mode gain. It can be seen that at low gains, reducing the gain by 6dB reduces the CMRR by only 3dB, whilst at higher and higher gains, for the one resistor on 1% tolerance case considered, the CMRR becomes asymptotic to $(40 + G)$ dB, where G is the nominal gain. The real worst case is when all four resistors $R_3 - R_6$ are at the 1% tolerance limit. There are two cases to consider. In the first, R_3 and R_5 are both $+1\%$ and R_4 and R_6 both -1% , or vice versa. As the bridge formed by the four resistors is still balanced, common mode signals are completely rejected. However, the gain error is ± 0.174 dB. If however R_3 and R_6 are both $+1\%$ and R_4 and R_5 both -1% , or vice versa, the gain error is halved to ± 0.087 dB, and the CMRR is 33.9dB.

Now consider the input stage, A_1 and A_2 . For a balanced input, the gain of each, with respect to ground, is $(R_1 + R_2)/R_2/2$, so the gain, balanced input to balanced output, is $(2R_1 + R_2)/R_2$ or $2R_1/R_2 + 1$. By making R_1 large compared to R_2 , the gain to balanced inputs, i.e. the normal mode gain G , will be also be large. But however large G , the gain to common mode signals is always just unity, as both amplifiers then operate as simple buffer stages. Thus the CMRR of the input stage, defined as above, is simply G .

The consequence of this is that, for a given required overall gain from the balanced input to the unbalanced output at A_3 , it pays to raise as much of the gain as possible in the input stage. For, as Table 1 shows, reducing the gain of A_3 from $\times 2$ to $\times 1$ will reduce its CMRR by some 3dB, while increasing the gain of the input stage by a factor of two, will increase its CMRR by 6dB, a net overall CMRR gain of 3dB. In principle, it could be advantageous to operate A_3 at less than unity gain, but the bandwidth of the system may then be inadequate, due to the finite gain-bandwidth product of A_1 and A_2 , and the maximum available peak to peak output from A_3 will also be reduced.

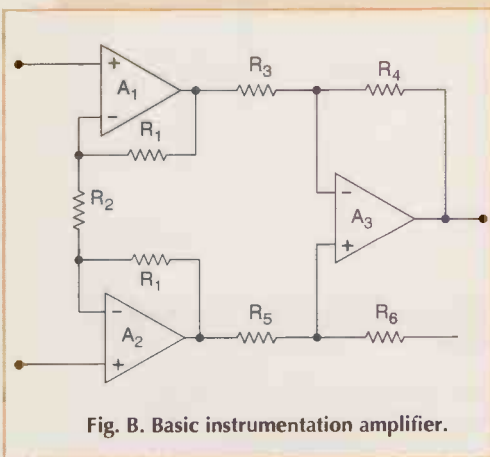

Fig. B. Basic instrumentation amplifier.

Table 1

Nominal gain	$\times 0.5$	$\times 1$	$\times 2$	$\times 5$	$\times 10$
In decibels	-6	0	6	14	20
Gain error dB	0.049	0.022	0.014	0.007	0.004
Common mode gain	-49.5	-46	-43.5	-41.6	-40.8dB
CMRR	43.5	46	49.5	55.6	60.8dB

component could conceivably be even larger, exceeding the common mode supply range of the op-amp. In the case of the TL084c, this extends typically from 3V above V_- , up to V_+ , or worst case to within 4V of either supply rail. Whilst a second PP3 battery could easily be accommodated in the case used, clearly, a more modern quad op-amp type, with rail to rail input common mode range, would be a better choice for this application.

However, another option exists and this is the purpose of R_1 and S_1 . Closing S_1 provides a 'static drain path' for any hum voltage on the earthy line of a radio mike's power supply. Such a voltage will obviously come from a high impedance and there is clearly something wrong if it doesn't! On the other hand, R_1 reduces the common mode voltage to small proportions, while avoiding any possible hum loop due to a direct connection to the output earth of the electronic balun and thence to the input of the sound reinforcement system.

Construction

The unit was constructed in a small aluminium box, the finished unit being shown in Fig. 6. The balanced output was not via a stereo jack socket as shown in the circuit

diagram, but via twin screened leads, terminated in a stereo 1/4" jack plug and a stereo 1/4" jack socket to XLR plug BSA. The metal outer of the stereo 1/4" jack socket was connected to the earthy jack sleeve contact, and to pin 1 of the XLR plug end of the BSA. Strangely, there was no true connection between the metal outer of the stereo 1/4" jack socket and the immediately adjacent metal outer of the XLR plug end of the adaptor. Both were finished in some kind of plating, resulting in a variable contact of about 5Ω between the two metal outers of the BSA.

For a one-off unit of simple design, 0.1" pitch copper strip board forms a quick and convenient alternative to a PCB and was used on this project, as is apparent from the internal view, Fig. 7. The strip board carrying the circuit was mounted on stick-on stand-offs, stuck to one side of the box. A 'Terry' clip was used to retain the PP3 battery, whilst connectors and controls were mounted on the ends of the box.

References

1. Practical RF Handbook, Ian Hickman, 3rd Ed. 2002, Newnes Butterworth-Heinemann, ISBN 0 7506 5369 8.

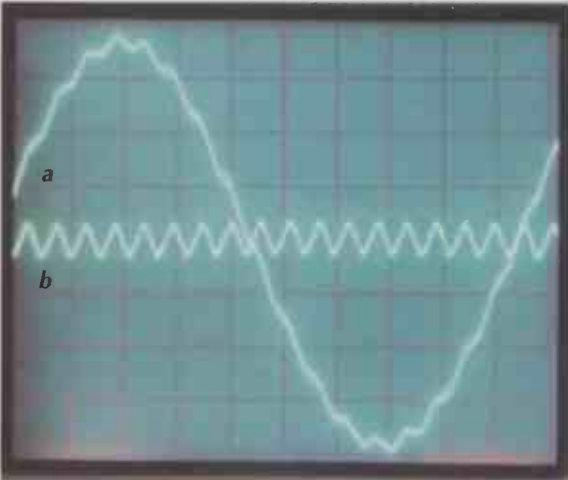

Fig. 4. a) Input, 1kHz triangular wave riding on a 50Hz sine wave. b) Output, one balanced lead viewed relative to ground. Both traces 100mV/div. vertical, 2ms/div. horizontal.

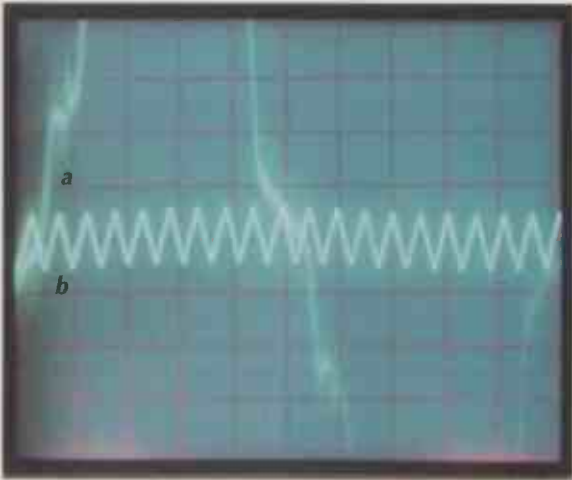

Fig. 5. Showing the common mode component on the output of the power supply of a commercial radio microphone.



Figure 6: A view of the completed unit.



Figure 7: An internal view of the unit.

Humidity sensor with PC interface

Emil Vladkov presents a system for relative humidity and temperature measurement using a calibrated and highly-integrated sensor with digital output. This is a stand-alone meter but it also has a serial interface that can be connected to a PC for data logging and other monitoring applications.

Integrated sensors that are calibrated in precision chambers are now available with digital outputs. This makes designing a humidity and temperature measurement system a tempting task.

The humidity meter described here was designed as a stand-alone system with an intelligent display that shows the actual values of relative humidity and temperature approximately every second.

As the system incorporates a microcontroller it was an easy job to add a serial port to the device, which turns the system into a data logger for humidity and temperature. It simply sends its measurement results every second to the host computer, where these values can be stored for display and post-processing.

SHT11 integrated sensor

The design of such a compact measurement device is only possible with a highly-integrated digital output sensor such as the SHT11 from the Sensirion company. The diagram of the internals of the SHT11 is presented on Fig. 1.

Included in the device are two precision-calibrated

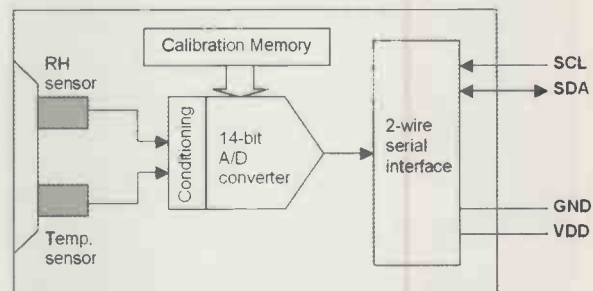

Fig. 1. The SHT11 single chip relative-humidity and temperature sensor.

microsensors – one for relative humidity and one for temperature – that connect to a 14-bit analogue-to-digital converter through conditioning circuits.

A serial digital two-wire interface is integrated on the same chip, so superior results in terms of signal quality are obtainable.

Due to its highly integrated architecture, the device is practically immune to external EMC. The calibration coefficients for each individual sensor are programmed in on-board one-time-programmable memory.

The device's maker suggests applications of the sensor in the field of the automotive industry, instrumentation, medical equipment, air-conditioning systems and so on.

Basic specifications of the sensor are given in Table 1. Although the sensor is capable of operation at a full resolution 12 bit for humidity and 14 bits for temperature, the proposed design uses only 8 and 12-bit resolutions, as its main goal is to achieve compactness and not excessive bit numbers.

The microcontroller reading the measurement results from the integrated sensor has integrated 2k program memory – or 4k if 89C4051 is used. If full resolution is

Table 1. Specifications of the humidity measurement system.

	Parameter	Min.	Typ.	Max.	Units
Humidity	Resolution	0.5	0.03	0.03	%RH
		8	12	12	Bits
	Repeatability		±0.1		%RH
	Nonlinearity		±3		%RH
	Range	0		100	%RH
Temperature	Resolution	0.04	0.01	0.01	°C
		12	14	14	bits
	Repeatability		±0.1		°C
	Range	-40		123.8	°C

used, complicated non-linearity compensation techniques are needed. These employ floating-point maths, which would be difficult or maybe impossible to implement with the microcontroller used.

Nonlinearity Problems

The humidity sensor is a nonlinear device, so software compensation is needed. This can be accomplished by the implementation of a formula supplied by the device manufacturer, given by the equation,

$$RH_{Real} = c_1 + c_2 \cdot RH_{Meas} + c_3 \cdot RH_{Meas}^2$$

The 'c' coefficients have different values for 8 and 12 bit resolution as stated in Table 2. As you can see, complicated floating point maths would be needed for high-resolution linearisation so I decided to use a less computation intensive method. Unfortunately, this method is only available for 8-bit resolution.

The formula used is:

$$RH_{Real} = (a \cdot RH_{Meas} + b) / 256, \%RH$$

Values for the a and b coefficients are given in Table 3.

This implementation involves 16-bit additions and divisions, which are easily implemented on the 89C2051 micro used. Coarse approximation involved in this compensation technique leads to nonsensical results at the margins of the measurement intervals, i.e. 0% RH and 100% RH. As a result, special checks are necessary at these limit values, so that no negative or greater than 100% values result from the linearisation algorithm. These check procedures are described by the conditional operations as given:

If $(RH_{Meas} \leq 107$ and $a \times RH_{Meas} < 512)$ then $a \times RH_{Meas} = 512$
 If $(RH_{Meas} > 107$
 and $(a \times RH_{Meas} + b) > 25600)$ then $a \times RH_{Meas} + b = 25600.$

The temperature sensor in the SHT11 is very linear, so compensation is not needed. Format conversion is needed though, so that the 12-bit binary value is translated into a valid temperature in the range from -40°C to 123.8°C. This simple conversion is done with the formula;

$$T_{Real} = -40 + \frac{T_{Meas}}{25}, ^\circ C$$

This is easily implemented in the integer maths functions of the 89C2051 micro. There is no special instruction for the 16-bit division, so this is done by a software procedure in the firmware.

SHT11 commands

The integrated sensor has a build-in two-wire serial interface, containing a serial data (SDA) and a serial clock (SCL) line. Unfortunately this interface is not a standard one – at least in my opinion – so the available I²C routines for the 8051 cannot be used.

To accomplish the communication protocol between the microcontroller and the SHT11-sensor, dedicated procedures have to be written to control the SCL and the SDA-lines. Fortunately, the device manufacturer gives a



Fig. 2. The 'Transmission Start' sequence precedes every transmission of a command from the microcontroller to the SHT11 integrated sensor.

Table 2. The 'c' coefficients have different values for 8 and 12 bit resolution.

Resolution	c ₁	c ₂	c ₃
12-bit	-4	0.0405	-2.8×10 ⁻⁶
8-bit	-4	0.648	-7.2×10 ⁻⁴

Table 3. Values for the a and b sensor linearisation coefficients.

Measurement range	a	b
0 ≤ RH _{Meas} ≤ 107	143	-512
108 ≤ RH _{Meas} ≤ 255	111	2893

Table 4. Commands sent to the SHT11 sensor by the microcontroller.

Command	Code	Description
Reserved	0000x	Reserved
Measure Temperature	00011	Temperature measurement
Measure Humidity	00101	Humidity measurement
Status Register Read	00111	Read access to the status register
Status Register Write	00110	Write access to the status register
Reserved	0101x-1110x	Reserved
Soft reset	11110	Reset chip, set the status to defaults

software example (in C), part of which I have used in my assembler-routines.

Transmission-start sequence. The 'Transmission Start' sequence precedes every command sent to the SHT11 sensor. After this sequence, three address bits and a 5-bit command follow. Currently, only address '000' is supported. The commands are listed in Table 4 and the transmission start sequence is presented in Fig. 2.

Connection-reset sequence. If communication with the SHT11 device is lost due to interference or some other problem, the sequence described in Fig. 3 can be used to reset the serial interface. The serial clock line has to be toggled 9 or more times.

Measurement commands – temperature and humidity. To accomplish a measurement, the microcontroller issues a measurement command. These are '00000101' for relative humidity and '00000011' for temperature. The controller has to wait 11ms for the 8-bit measurement to complete and 55ms for the 12-bit one to complete, but the firmware program waits around 300ms to provide headroom for valid measurement results.

After the measurement is complete, the SHT11 pulls the SDA-line low to signal the controller. The microcontroller has to read three data bytes – two measurement result bytes and one checksum word.

After receipt of the first two bytes, the micro pulls the SDA-line low to acknowledge valid reception. The



Fig. 3. If communication with the SHT11 device is lost a 'Connection Reset' sequence has to be issued from the microcontroller, which toggles the SCL line nine times or more.

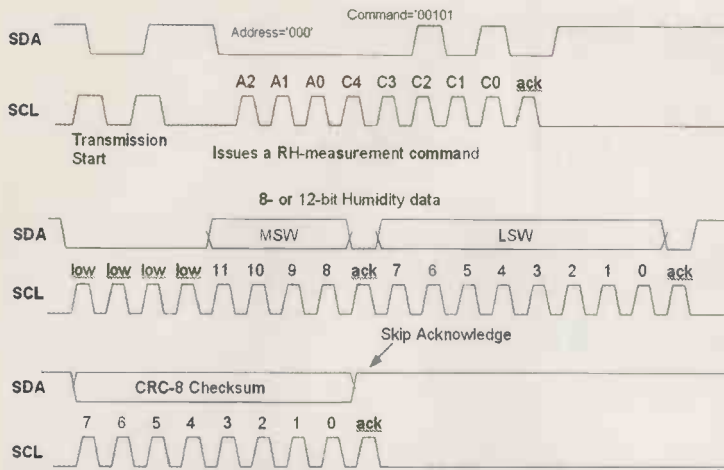

Fig. 4. A typical measurement session consists of a 'Measure Humidity' or 'Measure Temperature' command, sent from the microcontroller to the SHT11-sensor. The sensor responds with two measurement result data words and a checksum. The microcontroller has to acknowledge the reception of the MSW and LSW by pulling the SDA-line low. Reception of the checksum is not acknowledged and the SHT11 returns to sleep-mode automatically.

checksum word is not acknowledged by the microcontroller and so the communication session is terminated.

Data words involved are send MSW (most significant word) first, LSW (least significant word) last. The bits in the MSB are right justified, which means that for a 12-bit measurement, the MSW contains zeros in the first four transmitted bits, and for a 8-bit measurement the whole MSW is composed from zeros.

Timing diagrams for a typical measurement session are given in Fig. 4.

Device configuration commands

Device configuration commands are issued through writing to the status register.

Sensor availability

The SHT11 sensor can be ordered from Farnell using order code 3913065. Prices for low volumes are as follows:

1+	USD 15.00/EUR 16.50
10+	USD 13.25/EUR 14.55
25+	USD 12.50/EUR 13.75
50+	USD 11.85/EUR 13.00
100+	USD 11.45/EUR 12.60,

The device is not the cheapest one available, but don't forget that it's a precision industrial-grade product with all supporting circuitry for data conversion and transmission integrated.

Every bit in the status register has its own function in controlling the SHT11 operation and this is presented in Table 5. So to implement a 8/12-bit measurement in place of the 12/14-bit enabled by default, the microcontroller has to write to the status register 01₁₆.

Through the status register, an on-board heater can be also switched on. This function is not implemented in the proposed design, but it would be extremely useful if the device were to be operated in high humidity environments where condensation can occur.

Implementing the sensor

The circuit diagram of the complete humidity meter is shown in Fig. 5.

Pin assignments for the SHT11-sensor, IC₃, are those given in the manufacturer's data sheet. The device is provided with a power supply, V_{CC}, ground and two data lines for SDA and SCL.

As the main goal of this design was portability and simplicity, I decided to use the 89C2051 from Atmel for IC₁. It is a fully-featured 8051-based microcontroller with 2k on-board flash for the program.

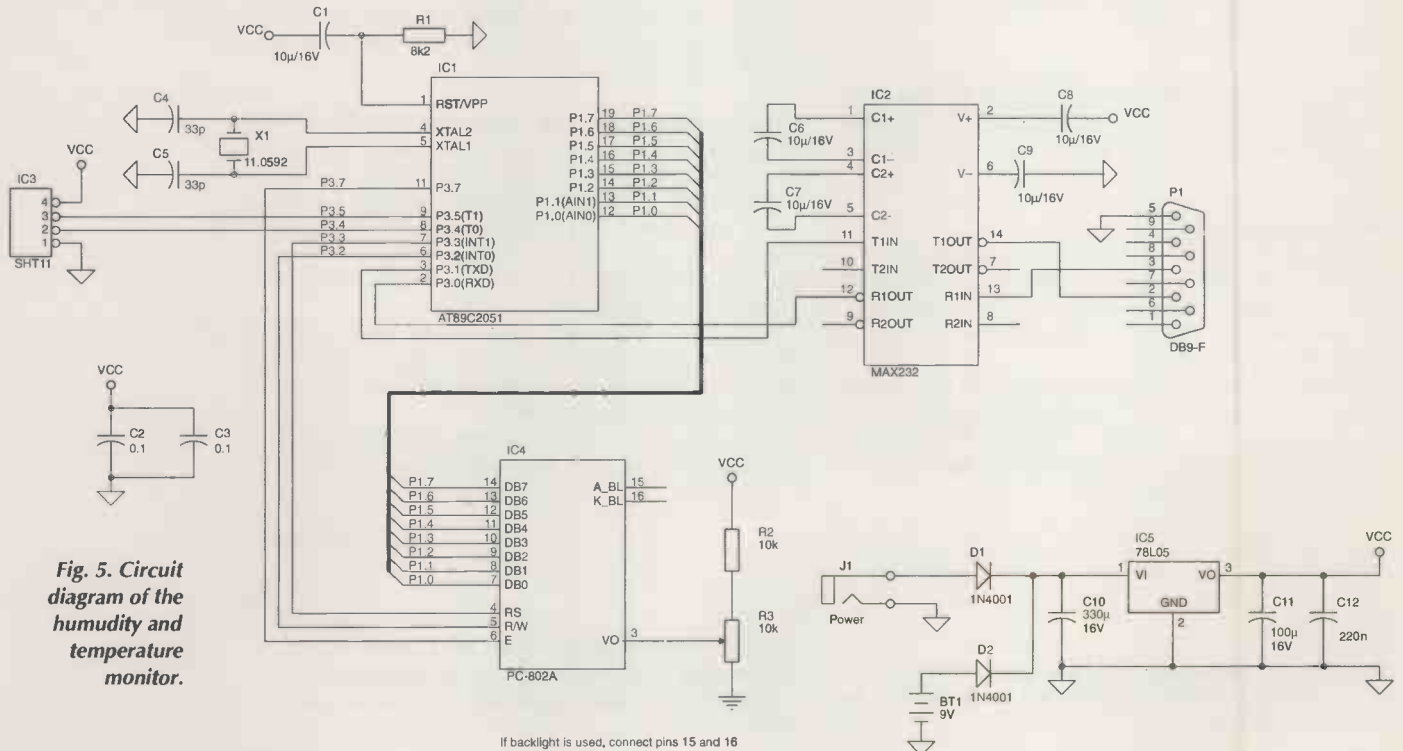

Fig. 5. Circuit diagram of the humidity and temperature monitor.

If backlight is used, connect pins 15 and 16

Two of the general-purpose lines of the micro are used to generate the serial communication signals with the SHT11 – these are P3.4 for SDA and P3.5 for SCL. The clock signal for the microcontroller is supplied by the crystal, X_1 , and capacitors $C_{4,5}$. Reset is provided by components R_1 and C_1 .

Results from measurements are displayed on a two-by-eight alphanumeric liquid-crystal display, IC_4 . The device I used was a PC-802A, but as this is a standard device, you may well find an equivalent. Usually the pin-assignments of the display are standard, but check the device data sheet if you intend to use other display models.

Both command and display ASCII data are applied to the LCD by the Port 1 (P1.7 – P1.0) of the microcontroller.

Three additional control signals are needed to drive the display. These are ‘Register Select’, RS, ‘Read/Write’, RW, and ‘Enable’, E. They are generated in software by three of the general purpose lines of the microcontroller, namely P3.3, P3.2 and P3.7.

Components R_2 and R_3 are used to set the contrast of the LCD. The part that I used did not have a backlight so pins 15 and 16 of IC_4 are not used. You should connect a series resistor with an appropriate rating if you plan to use a device with backlight, but consider the power consumption if you power the device from a battery.

Although the system is intended to be used as a stand-alone device, it may sometimes be necessary to use it as a data logger for humidity and temperature. To meet this need, a serial port, P_1 , is provided, which makes necessary the use of the level converter IC_2 with the associated components $C_{6,9}$. The serial port is built into the microcontroller (pins P3.0-RxD and P3.1-TxD).

Capacitors C_2 and C_3 provide power supply filtering. In my case, power is supplied to the device from an external wall-cube adaptor. It has a DC output but AC can also be used with the arrangement proposed). The raw input voltage between 9V and 15V is regulated with the three-terminal low-power (100mA) regulator IC_5 , which is a 78L05 device.

Capacitors C_{10-12} are power supply filtering components. Diode D_1 is provided as voltage reversal protection or rectifier diode if an AC-power source is used. Diode D_2 is used to decouple the optional battery (9V type) BT1 from the wall-cube power supply.

Device firmware and software algorithm

The firmware is the software residing in the 2k flash of the 89C2051 microcontroller. It controls the SHT11 sensor, the display and the serial port communications.

Object code for the software is given in Listing 1. It can be obtained via e-mail from the editorial offices of EW. The algorithm driving this software and making it work is presented in Fig. 6.

Figure 6a) shows the main body of the code. It consists of an endless loop, which is started after the initial set up of the serial port communication and the liquid-crystal display.

Every measurement session is executed exactly as in the timing diagrams in Fig. 4. Each consists of a command sent from the microcontroller and three result words for measurement data and checksum.

Results from relative humidity measurements are stored in register R5 ready for the linearisation algorithm. Temperature is stored in registers R6/R7 for use by the degree-celsius conversion algorithm.

The two conversion algorithms return integer/fractional results for humidity/temperature in the register pairs R4/R5 and R6/R7 respectively. As the results are in hexadecimal form they need to be converted to a decimal ASCII representation to be printed on the display directly.

Table 5. Every bit in the status register has its own function in controlling the SHT11 operation.

Bit	Type	Description	Default
7		Reserved	0
6	R	End of Life (Low Voltage Detection)	x
5		Reserved	0
4		Reserved	0
3		For Testing only	0
2	R/W	Heater	0
1	R/W	No reload from OTP	0
0	R/W	1 = 8/12-bit RH/temperature 0 = 12/14-bit RH/temperature	0

This is accomplished by an ASCII-conversion routine. It takes the input in TH0/TLO registers and returns an ASCII-string representing the unsigned decimal number equivalent to the 16-bit input hex number.

The ASCII-string is stored in the 89C2051’s RAM, starting at location 50₁₆. It ends with an EOT (end-of-table) marker. This procedure is run once for the integer part of every result and once for the fractional part, which is also stored as unsigned 16-bit number. The comma is printed on the display between the two decimal ASCII results and the final measurement result is presented on the LCD.

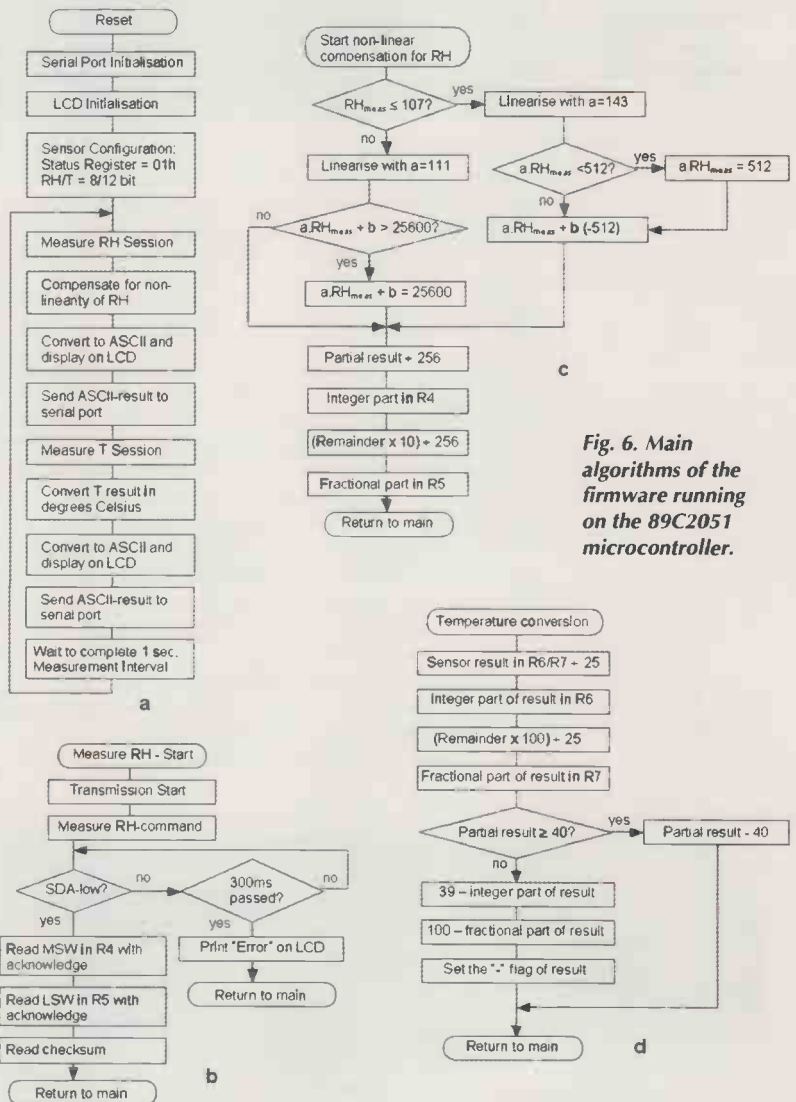

Fig. 6. Main algorithms of the firmware running on the 89C2051 microcontroller.



Fig. 7. Internals of the RHTS-11L device with the display mounted in a piggyback-style and the 89C2051 microcontroller in the middle.



Fig. 8. SHT11 integrated sensor mounted on a dedicated SMT-board with a protective cover.

After every partial result, the corresponding ASCII-string is sent to the serial port for reception by the host computer. When a terminal program is started on the machine and the settings are configured to 9600,8,N,1 then the following data input should be observed:

```
H      58.9   T      20.96
H      58.9   T      21.00
```

and so on. Each line is terminated with a CR and LF and the fields are tab-delimited. This makes the results easy to manipulate and graphed by a spreadsheet on a PC. Using a spreadsheet, relative humidity and temperature trends over a number of hours can be easily observed.

Figure 6b) shows the measurement sequence for relative humidity monitoring. The session starts with the microcontroller issuing the 'Measure RH' command. The algorithm waits for the SDA-line to be pulled low by SHT11. If this occurs then the MSW and the LSW are read in registers R4 and R5.

A read of the checksum follows for completeness, although the checksum is not used in the design proposed here. The algorithm provides a time-out feature: if the SDA-line is not pulled low in 300ms then an error-

Fig. 9. RHTS-11L measurement system.



message is printed on LCD and communication is restarted.

The algorithm for measuring temperature differs only in the command issued by the microcontroller. In this case it is the 'Measure Temperature' command and the registers holding the result in this case are R6/R7.

Figure 6c. outlines the algorithm responsible for compensating for the nonlinearity of the relative humidity sensor. Depending on the value received by the SHT11, the software uses two different coefficient sets with the margin set at $RH_{meas}=107$.

As discussed earlier, the algorithm checks for intermediate values, which will result in values lower than 0% or greater than 100%. If such a case is detected, the system forces the intermediate result to the limit values.

A division by 256 routine is common to the two linearisation segments and is accomplished by a routine for 16-bit unsigned division. This routine returns integer result in R2/R3 registers and a remainder in R4/R5.

The integer result, which fits easily in R3 only, is stored in R4 and forms the integer part of the linearisation result. The remainder is multiplied by 10 and then divided by 256, so that the fractional part of the linearisation – the 'tenths' – is obtained. This fractional part is returned in R5.

The algorithm for the degrees celsius conversion according to the equation described in the section headed 'Nonlinearity problems' section is depicted in Fig. 6d. The value obtained from the SHT11 and residing in R6/R7 is divided by 25. The integer part is stored in R6 and the remainder is multiplied by 100 and again divided by 25, so that the fractional part of the result (the "hundreds") is obtained and stored in R7. A value of -40 needs to be added to this partial result.

If the partial result is greater than or equal to 40, the subtraction is straightforward. If it isn't, the integer part of the partial result is subtracted from 39 and the fractional part is subtracted from 100. The negative sign flag is set in this case.

All the above mentioned subroutines make extensive use of several common subroutines: 16-bit integer division, hexadecimal-to-unsigned decimal number conversion and several print-to-display and print-to-serial port utilities.

Further reading and data sheets

1. SHT1x Humidity & Temperature Sensmitter Data Sheet, Sensirion AG; <http://www.sensirion.com/getfile.asp?pk=601>.
2. SHT1x Humidity & Temperature Sensmitter Application Note: Soldering Procedure, Sensirion AG; <http://www.sensirion.com/getfile.asp?pk=565>.
3. SHTxx Humidity & Temperature Sensmitter Application Note: Compensation of RH non-Linearity, Sensirion AG, <http://www.sensirion.com/getfile.asp?pk=576>.
4. SHTxx Humidity & Temperature Sensmitter Application Note: Sample Code, Sensirion AG, <http://www.sensirion.com/getfile.asp?pk=600>.
5. SHTxx Humidity & Temperature Sensmitter Application Note: Status Register, Sensirion AG, <http://www.sensirion.com/getfile.asp?pk=578>.
6. AT89C2051 8-Bit Microcontroller with 2K Bytes Flash, Atmel, www.atmel.com.
7. PC 0802-A Series LC displays, PowerTip.

My prototype

I built the prototype RHTS-11L meter on a piece of perforated board with the display module attached to it in a piggy-back-style. This can be seen in Fig. 7.

The SHT11 is housed in a Plexiglas box to protect the tiny package. In the middle, just above the sensor, a hole is drilled to provide for air circulation as depicted in Fig. 8.

Figures 9 shows the complete system.

The device's manufacturer does not recommend connecting a serial cable to the sensor that's longer than

10cm because crosstalk and loss-of-communication problems could arise. I used a 20cm interconnecting cable without experiencing any problems, so I suppose the use of even longer cables (up to a 1m) may be possible.

If longer runs are needed – when, for example, the sensor is in an industrial environment that's remote from the meter – additional cable drivers will be needed. I encourage all readers who find the idea of the device worth implementing and who make improvements to the design proposed to share their experiences here. ■

Listing: Object code for the RHTS-11L measurement system running on the 89C2051 microcontroller.

```

:030000000200807B
:08000300323232323232323265
:08000B0032323232323232325D
:08001300323232323232323255
:08001B0032323232323232324D
:0800230012066832323232325B
:1000800075A800D2B4D2B51206961201E574807537
:10009000F052120218748175F048120218748775B4
:1000A000F02512021874C075F05412021874C1754C
:1000B000F0DF1202181202BC7B0112030912024384
:1000C00012031C12048A1201A6794F7720758C0046
:1000D0008C8A12054E75F08412043F12016B7485F0
:1000E00075F02E12021812017D758C008D8A120592
:1000F0004E75F08612042F12016B1201CC12034AC6
:10010000120500120193B9FF09794F772D1201886A
:100110008004794F7720758C008E8A12054E75F019
:10012000C412043F12016B74C575F02E120218122E
:10013000017D758C008F8A12054E7851B6800B18A0
:10014000E608F60876807850763075F0C612042FEF
:1001500012016B1201B9120243120243120243123E
:1001600002430200C00200C00200C07850B6800105
:1001700022C29986993099FDC2990880F0C299757A
:10018000992E3099FDC29922C29975992D3099FD09
:10019000C29922C2997599543099FDC299759909ED
:1001A0003099FDC29922C2997599483099FDC2993A
:1001B0007599093099FDC29922C29975990D3099A6
:1001C000FDC29975990A3099FDC29922C299759913
:1001D000093099FDC2992275F025E4D5F00122D5A8
:1001E000E0FD80F722C2B3C2B212025075903F12F6
:1001F00002111202507590011202111202507590F4
:100200000612021112025075900C120211120250C5
:1002100022C2B7D2B7C2B722C2B3C2B2F59012029D
:100220001112025DC2B2D2B385F090120211120215
:100230005DC2B3D2B2C2B7D2B7E590C2B75480B4F0
:1002400000F322758CFF758AFFD58AFDD58CF722C5
:10025000758C08758AFFD58AFDD58CF722758A1FA3
:10026000D58AFD22C2B57808C0E05480B40004C22B
:10027000B48002D2B4D2B5000000C2B5D0E023C031
:10028000E0D8E7D0E0D2B4D2B520B405D2D1C2B51F
:1002900022C2D1C2B522C2B57808E4D2B520B403D7
:1002A000C38001D333C2B5D8F220D104D2B48002C6
:1002B000C2B4D2B5000000C2B5D2B422D2B4C2B525
:1002C00000D2B500C2B400C2B500000D2B500D261
:1002D000B400C2B522D2B4C2B57809D2B5C2B5D87D
:1002E000FA1202BC221202D5741E120264120378A2
:1002F000221202BC7407120264120378D2D11202D5
:1003000096F9C2D1120296FA221202BC74061202A7
:1003100064120378EB120264120378221202BC7496
:1003200005120264120378780312024330B408D82D
:10033000F8C2D112037822D2D1120296FCD2D11285
:100340000296FDC2D1120296FA221202BC74031266
:100350000264120378780312024330B408D8F8C25A
:10036000D112037822D2D1120296FED2D112029675
:10037000FFC2D1120296FA2230D10122748075F0A8
:1003800045120218748175F052120218748275F0C9
:1003900052120218748375F04F120218748475F0AB
:1003A00052120218748575F021120218748675F0C5
:1003B00020120218748775F02012021874C075F0AC
:1003C0002012021874C175F02012021874C275F060
:1003D0002012021874C375F02012021874C475F04C
:1003E0002012021874C575F02012021874C675F038
:1003F0002012021874C775F020120218780F12022A
:1004000043D8FB1202D5748075F052120218748121
:1004100075F048120218748775F02512021874C01E
:1004200075F05412021874C175F0DF12021822A878
:10043000F0795087F0E81202180809B780F522A871
:10044000F0794F09B780FC1987F0E81202181819E3
:10045000B94FF5B72D0787F0E812021818B88308CE
:1004600075F020E812021818B8820975F020E81219
:1004700002188015B8C30875F020E812021818B8E1
:10048000C20775F020E812021822746BC39D402643
:1004900075F08FEDA4C0E0C0F0C3E5F0940250DFC
:1004A000D0F0D0E075F0027400C0E0C0F0D0E0D031
:1004B000F0C39402802575F06FEDA4C3244DC0E015
:1004C000E5F0340BC0E0C39464400CD0E0D0E0749D
:1004D00000C0E07464C0E0D0E0D0F0FAABF07C0182
:1004E0007D001205E8C0038C8C8D8A120649AA8C07
:1004F000AB8A7C017D001205E8C003D005D0042240
:10050000C006D002C007D0037C007D191205E8C0E8
:10051000038C8C8D8A120649C3120649C3AA8CAB80
:100520008A7C007D191205E8C003D007D006EEC30F
:10053000942850167427BF000104C39EFEBF00021A
:100540008005C374649FFF79FF22FE79002275F055
:1005500050C0D0C000C001C002C003C004C005C06C
:1005600006C007C0F0AEB8CAF8A78277910C2D5AA32
:1005700006AB07AC00AD011205E8A0E04AF05EB70A9
:100580000330D513D2D51205DFD0F0C00A08F6A5
:100590000888F0D000C0F0AA00AB017C007D0A12F0
:1005A00005E8A802A903E84970C520D5107430D029
:1005B000F0C000A8F0F60888F0D000C0F07480D039
:1005C000F0C000A8F0F6D000C0F0D0F0D007D00600
:1005D000D005D004D003D002D001D000D0D0225416
:1005E0000F2490D43440D422C000C0011205F4D0AE
:1005F00001D00022E4F5F0F8F9EA4B6043EC4D70CD
:100600001322EAC39C40137004EB9D400EDDC333ED
:10061000FDEC33FC05F0EC30E7E8EAC39C400670E3
:1006200007EB9D5003C38008C3EB9DFBEA9CFAD304
:100630000E933F9E833F8ECC313FCED13FDD5F0DA38
:100640008B058A048802890322C0F0C0E0E58A7520
:10065000F00AA4F58AC0F0E58C75F00AA4D0F02564
:10066000F0F58CD0E0D0F022C2AC7830C298E59999
:10067000F608B40D0DC2981206AB227830761BD264
:10068000AC223098FDC298E599F608B84F02783050
:10069000B40DEF80E022E587C2E7F587758DFD7523
:1006A0008BFD758921D28E7598502225348543182
:1006B000312C20436F70797269676874204320324F
:1006C00030303220456D696C20566C61646B6F76FA
:00000001FF

```

Understanding inputs of ADCs

Many embedded applications utilise an A/D converter. However many users unknowingly ruin the A/D measurements by connecting incorrect circuitry to the A/D converter input. Daniel Malik explains

Figure 1 shows a typical application circuit of an A/D converter with integrated sample & hold (S/H) circuit – an application so simple, that it almost cannot be incorrect. However it is incorrect and the reading delivered by the A/D converter will be lower than expected.

To understand what is wrong, we have to look at the S/H circuit. Modern S/H circuits are much more complicated than the one outlined here, however the basic principle is still the same. At sampling time the switch is closed and the sampling capacitor is charged. To protect the external circuitry from experiencing the shock of a capacitor being connected to its output an on-chip analogue buffer is used. We have created ideal buffers in theory and everyone uses them on paper, however there is nothing like an ideal buffer in the real world of electronics. The buffer will act as an impedance transformer and the change of

capacitance on its output will be transformed to change of capacitance on its input.

The sampling process is very fast, much faster than the bandwidth of the external amplifier we have connected to the A/D converter input. Therefore whatever happens at the A/D input will be unaffected by the external amplifier.

Figure 2 shows the equivalent circuit, which will enable us to tell what happens at the time of sampling. Before sampling takes place, the combined capacitances of the PCB track and chip pin ($C_T + C_P$) are charged to input voltage V_{IN} . At sampling time the discharged S/H capacitance transformed across the on-chip input buffer (C_X) is connected in parallel to these capacitances and the voltage on the input pin will drop. The only component capable of delivering more charge to the capacitors and lifting the input voltage is the external amplifier, but it will not react until it is too late. How much will the input voltage drop?

$$\frac{1}{2}(C_T + C_P) \cdot V_{IN}^2 = \frac{1}{2}(C_T + C_P + C_X) \cdot V_{IN}'^2$$

$$V_{IN}' = V_{IN} \cdot \sqrt{\frac{C_T + C_P}{C_T + C_P + C_X}}$$

Let's assume some reasonable values, for example: (C_T

Fig. 1. Typical application of A/D converter.

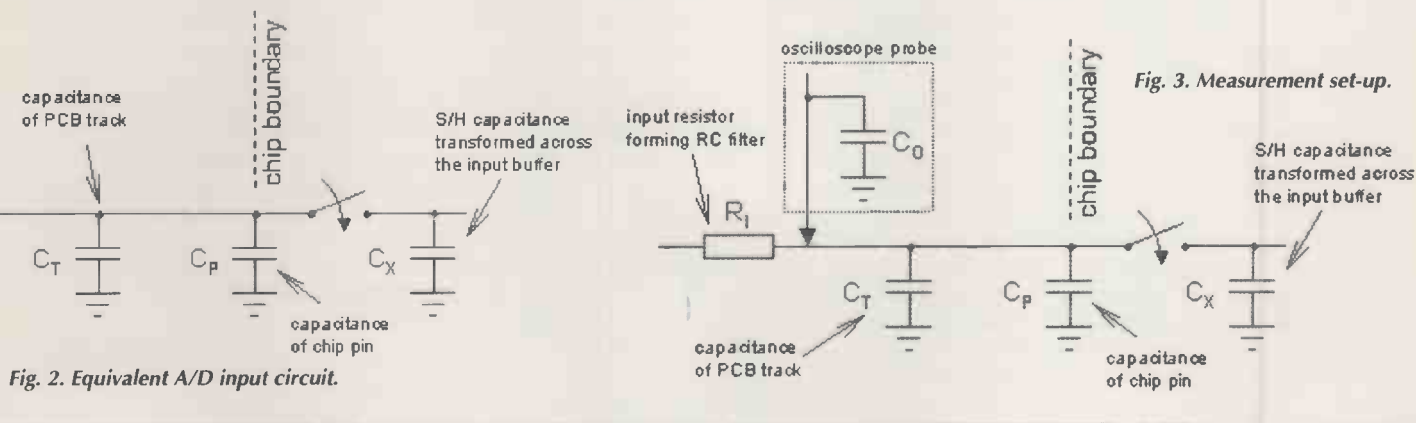
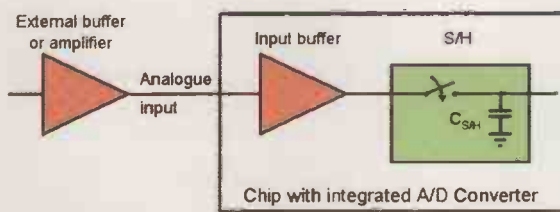

Fig. 2. Equivalent A/D input circuit.

Fig. 3. Measurement set-up.

+ Cp) = 5pF, Cx = 0.5pF. The input voltage will then drop to 95%! It is clear that we can lower the drop by making the capacitance attached to the A/D converter input higher. Let's calculate the minimum capacitance needed to keep the voltage drop below 1/2 LSB of the A/D converter.

$$V_{IN} - V'_{IN} = \frac{1}{2} LSB$$

$$\frac{1}{2} LSB = V_{IN} - V'_{IN} = V_{IN} - V_{IN} \cdot \sqrt{\frac{C}{C + C_x}}$$

$$\frac{1}{2} LSB = V_{IN} \cdot \left(1 - \sqrt{\frac{C}{C + C_x}}\right)$$

$$\frac{LSB}{2 \cdot V_{IN}} = 1 - \sqrt{\frac{C}{C + C_x}}$$

$$\frac{2 \cdot V_{IN} - LSB}{2 \cdot V_{IN}} = \sqrt{\frac{C}{C + C_x}}$$

The conditions will be the worst for maximum allowable input voltage. If we assume an A/D converter with resolution of N bits, then the maximum input voltage equals .

$$2^N \cdot LSB$$

$$\frac{2 \cdot 2^N \cdot LSB - LSB}{2 \cdot 2^N \cdot LSB} = \sqrt{\frac{C}{C + C_x}}, V_{IN} = 2^N \cdot LSB$$

$$\frac{2^{N+1} - 1}{2^{N+1}} = \sqrt{\frac{C}{C + C_x}}$$

$$\left(\frac{2^{N+1} - 1}{2^{N+1}}\right)^2 = \frac{C}{C + C_x}$$

$$\frac{2^{2(N+1)} - 2^{N+1} + 1}{2^{2(N+1)}} = \frac{C}{C + C_x}$$

$$C_x \cdot (2^{2(N+1)} - 2^{N+1} + 1) = C \cdot (2^{2(N+1)} - 2^{2(N+1)} + 2^{N+1} - 1)$$

$$C_x \cdot (2^{2(N+1)} - 2^{N+1} + 1) = C \cdot (2^{N+1} - 1)$$

$$C = C_x \cdot \frac{2^{2(N+1)} - 2^{N+1} + 1}{2^{N+1} - 1}$$

$$C = C_x \cdot \frac{2^{N+1} \cdot (2^{N+1} - 1) + 1}{2^{N+1} - 1}$$

$$C \approx C_x \cdot \frac{2^{N+1} \cdot (2^{N+1} - 1)}{2^{N+1} - 1}, 2^{N+1} \cdot (2^{N+1} - 1) \gg 1$$

$$C \approx 2^{N+1} \cdot C_x$$

Therefore, if we for example, intend to use a 12-bit A/D

converter with input capacitance change of 0.5pF, the minimum capacitance connected to the A/D input must be larger than pF i.e. 4nF to keep the voltage drop below 1/2 LSB.

It is a known truth that chip manufacturers often do not provide the data the designer needs. I have seen many A/D converter datasheets where the change of input capacitance at sampling time was not provided. However things are not lost yet, because we can measure this parameter very easily. The equipment needed for such

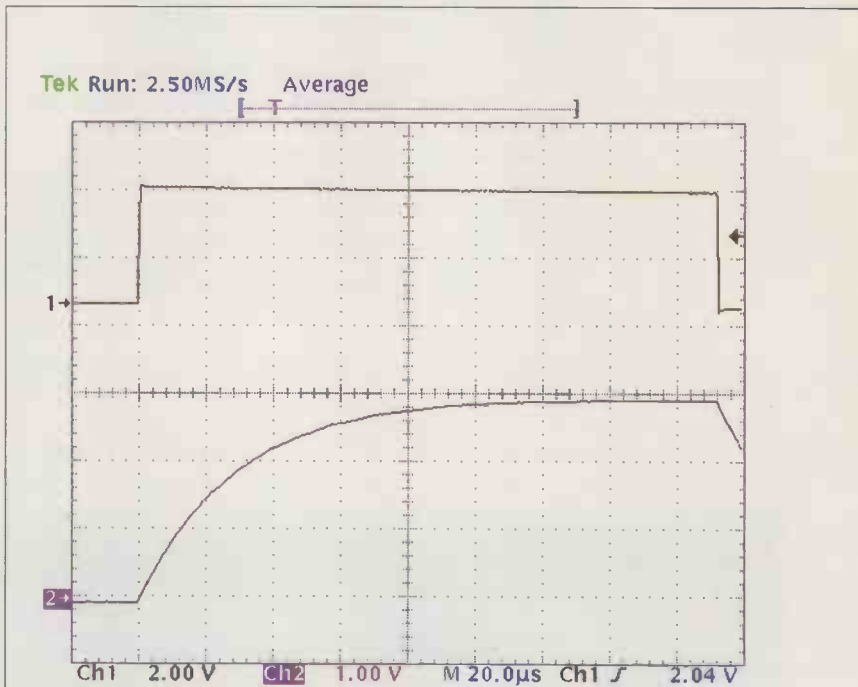

Fig. 4. Measuring input capacitance C.

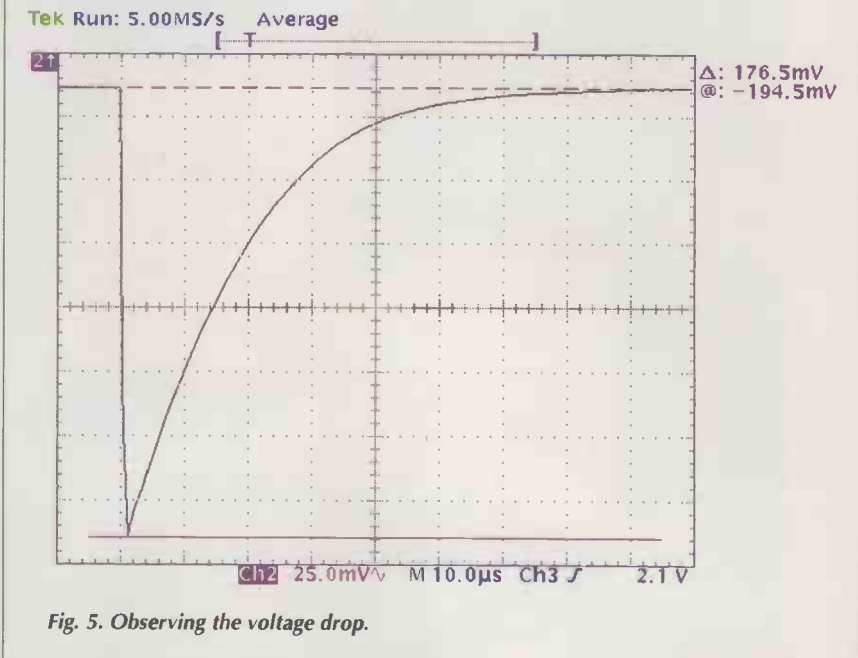
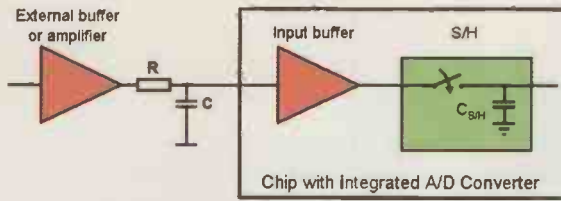

Fig. 5. Observing the voltage drop.

Fig. 6. Correct application of A/D converter.



measurement is an oscilloscope and a signal generator. This simple measurement is not precise, but will give at least rough estimate. We will turn the situation around and compute the change of capacitance from the voltage drop we will observe at the chip pin.

The measurement set-up will look like the one outlined in figure 3. The input resistor R_1 should be quite large to make the time constant of the RC network long enough for comfortable measurement. I have used $1M\Omega$ in my measurements.

First of all we have to measure the capacitance connected to the A/D input ($C = C_O + C_T + C_P$). We will do this by applying a square wave signal to the input resistor and observing time constant of the resulting waveform on the scope (see figure 4). The time constant can be guessed directly from the scope, but it is better to transfer the data into an Excel spreadsheet and calculate it more accurately. In the example shown in figure 4 the time constant comes out to be approximately $28.5\mu s$.

$$\tau = 2\pi \cdot R \cdot C$$

$$C = \frac{\tau}{2\pi \cdot R}$$

In our example $C \approx 28.5\mu s / 6.2832 / 1M\Omega \approx 4.54pF$.

We will now apply the highest allowable DC voltage to the input resistor and start the A/D conversion. The resulting voltage drop can be seen in figure 5 – The voltage drop is around $176mV$ at $3.3V$. Once we have measured the voltage drop, we can calculate the change of A/D input capacitance

$$\frac{V'_{IN}}{V_{IN}} = \sqrt{\frac{C}{C + C_x}}$$

$$\frac{V_{IN} - V_{DROPP}}{V_{IN}} = \sqrt{\frac{C}{C + C_x}}$$

$$\frac{(V_{IN} - V_{DROPP})^2}{V_{IN}^2} = \frac{C}{C + C_x}$$

$$C_x = C \frac{V_{IN}^2 - (V_{IN} - V_{DROPP})^2}{(V_{IN} - V_{DROPP})^2}$$

$$C_x = C \cdot \left(\frac{V_{IN}^2}{(V_{IN} - V_{DROPP})^2} - 1 \right)$$

Amplifiers usually do not like capacitive loads. Therefore an extra input resistor is added in figure 6. This RC network will also provide additional filtering against high frequency noise.

Input leakage current of A/D converter is usually below $1\mu A$. If we choose hundreds of ohms for the input resistor, the voltage drop across it will be around $100\mu V$ and way below $1/2$ LSB.

High Resolution Oscilloscope

- High speed, 5GS/s dual channel oscilloscope
- 50MHz, 80dB dynamic range spectrum analyser
- PicoScope & PicoLog software supplied FREE
- Plug into any desktop or laptop PC
- High resolution - 12 bits
- Large 128K memory
- 1% DC accuracy

NEW
Product
Range



Request your FREE Test & Measurement catalogue and Software & Reference CD, or visit our web site:

www.picotech.com/ds/scope63

Tel: +44 (0) 1480 396395 Fax: +44 (0) 1480 396296 E-mail: sales@picotech.com

PICO
Technology Limited

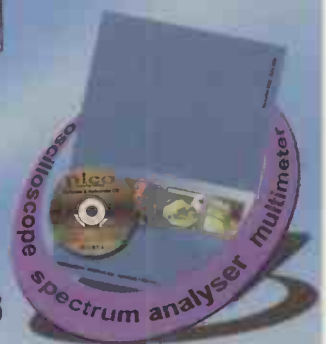

NEW PRODUCTS

Please quote *Electronics World* when seeking further information

Chip capacitors cope with stress

New chip capacitors that can handle up to 400 per cent more mechanical stress have been introduced by Syfer through Flint in the UK, in case sizes from 0603 to 3640. These greatly reduce the risk of



cracking during board assembly. The range is based on the X7R dielectric, and address the issue of stress damage to MLCC (multi-layer chip capacitor) devices caused by board flexing during the assembly process. The devices use a proprietary flexible epoxy polymer termination material, applied under the usual nickel barrier finish. Tests have shown that Flexicap capacitors can withstand between 75 and 400 per cent greater stress before mechanical cracking occurs, depending on the package size. The capacitors can be stored, handled and soldered using the same manufacturing process as conventional capacitors, and offer the same electrical characteristics and performance.

Flint
www.flint.co.uk
Tel: +44(0) 1530 510333

Micro-vias on high density boards

Teradyne is offering deep micro-via technology for customers using what it calls high performance printed circuits (HPC). As package density and technology drive the need for greater density on the printed

circuit board, deep micro-via technology provides several benefits to printed circuit board designers, said Teradyne. Its capabilities include panel sizes up to 24x28in. and micro-vias 3 layers deep or 3 in diameter. The firm's high density interconnector capabilities also include fine lines, thin cores, buried vias and micro vias.

Teradyne
www.teradyne.com
Tel: +4 049 8941 861109

Embedded workbench for ARM

IAR Systems is offering a version of its IAR Embedded Workbench for ARM. This includes a plug-in to the CMX-RTX RTOS, support for the ARM Angel protocol as well as C++ templates. According to the supplier, support for the ARM Angel protocol and the Jeeni JTAG emulator from EPI means new debugging opportunities. The availability of C++ templates and STL should give possibilities to those developers

who prefer object-oriented programming. This release also includes the IAR Embedded Workbench Professional, a toolkit that includes graphical tools for system design, test, and automatic system design documentation in addition to all the traditional features of the IAR Embedded Workbench.

IAR Systems
www.iar.com
Tel: +44(0) 20 7554 8585

Timer module plugs in relay socket

To increase flexibility and reduce inventory, a timer module from Finder is able to operate from any supply voltage. Plugging directly into the relay socket, it allows a standard relay to be used for a wide variety of timing functions. The 86 series timer module can be used with Finder 60 series two and three-pole 10A relays, and also the 62 series two and three-pole 16A power relays. A total of eight timing functions, both power and function initiated, together with



seven time scales from one second to 100 hours are provided. The module is able to operate from AC or DC supplies from 12V to 240V. Function and time scale settings are accessible on the front of the module, yet are physically protected against accidental changes. The module is easily retrofitted without any disturbance to installation wiring.

Finder
www.findernet.com
Tel: +44(0) 1785 818100

Supply gets digital control

TTi (Thurlby Thandar Instruments) has introduced a digitally controlled version of its EL302 laboratory bench power supply. The 30V, 2A unit incorporates an opto-isolated RS-232 interface, and provides users with a basic programmable power supply that is sufficient for many applications where the sophistication and complexity of GPIB is not needed. Voltage and current levels are set digitally using either the RS-232 bus interface or the local controls. Setting resolution is 10mV and 10mA. The all-linear design provides a very low output noise level of less than 1mV, along with fast recovery from transients. The power supply can operate in both constant-voltage and constant-current modes. A simple command set allows

remote control of voltage, current and output enable, along with readback of metering values and operational status. Local control is via three rotary encoders which provide rapid and accurate setting of voltage and current during bench use. The front-panel

controls can be locked out when required, making the unit useful in production and test environments where settings must remain fixed. The EL302P costs £229.

TTi
www.tti-test.com
Tel: +44(0) 1480 412451

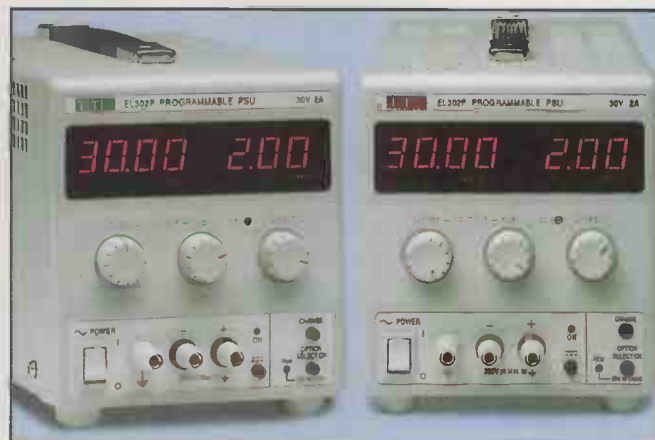

Please quote *Electronics World* when seeking further information

Dual Mosfet in small package

International Rectifier has introduced the IRF 6156, a 20V dual bi-directional power Mosfet in a common drain configuration. Housed in the firm's proprietary FlipFET package, the device is said to be 80 per cent smaller than devices in the TSSOP-8 package, with a profile less than 0.8mm. The small size makes the IRF6156 ideal for Li-ion battery pack safety and protection circuits for mobile phones, notebook computers, PDAs and digital cameras. Li-ion battery packs are

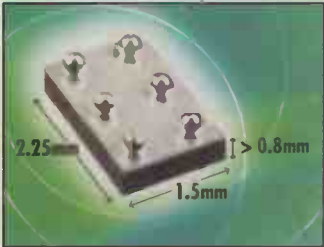

flammable, and require protection circuits to prevent damage from over-charging. A protection circuit is also required to detect a short circuit condition, and disconnect the battery from the load. FlipFET packages use no lead frame or mould compound. In essence, the die is the package, and reduces thermal resistance from junction-to-PCB to 35°C/W compared to >60°C/W for SO-8 packages. All of the terminals are on a single side of the die, so stray inductance and other device packaging losses are minimised or eliminated. *International Rectifier*
Tel: +44(0) 20 8645 8003

Digital scope has 200Msamples

The DL1640S from Yokogawa is the latest addition to the company's DL1640 family of digital oscilloscopes. It incorporates most of the



measurement and display features of the top-end model, but with a price of less than £3,500. It includes 100kword of memory per channel, 200Msample/s sampling, and 200MHz bandwidth. Other features of the 4-channel scope include real-time digital filtering, dual-zoom capability for examining captured waveforms in detail, high-speed screen refresh, and smart search

functions. A 6.4in. wide-angle TFT colour LCD screen is housed in a package measuring 220 mm wide x 268 mm high. As a result, the unit occupies less than an A4 size 'footprint' on a test bench or desktop. It weighs 3.9kg, making the oscilloscope easily portable. Captured data can be stored externally using a PC card drive or Zip drive; a floppy disk drive is also provided for internal storage. A wide range of interfaces includes optional USB and Ethernet connectivity.

Yokogawa
www.martron.co.uk
Tel: +44(0) 1494 459200

Compliance tester supports UMTS release 4

Tektronix has introduced its protocol test support feature for the latest release of the Universal Mobile Telecommunications System (UMTS) standard. The K1297-G20 protocol tester version 2.40 (V2.40) delivers

Transceiver has crystal control

A radio transceiver from RF Solutions aims to provide wireless data transfer in applications such as security systems, EPOS terminals and sensor data logging. The FMRXQ1 is able to operate at either 433.92 or 433.33MHz and uses a crystal-controlled design. This, said the supplier, gives narrow band performance that is superior to SAW based wideband

designs. Channel selection and interference rejection circuitry give the module reliable and robust performance. Mounted on a low profile ceramic dual-in-line PCB measuring 23x30.5mm, the modules suit one-to-one and multi-node wireless links. They are able to achieve data transfer rates of up to 20kbit/s over a line of sight range of approximately

200 metres. Low power requirements, 8µA in standby mode, makes them ideal for use in portable battery powered applications. FMRXQ1 transceivers require a supply voltage of between 3V and 5V and have a operating temperature range of -20°C to +70°C. *RF Solutions*
www.rfsolutions.co.uk
Tel: +44(0) 1273 488880

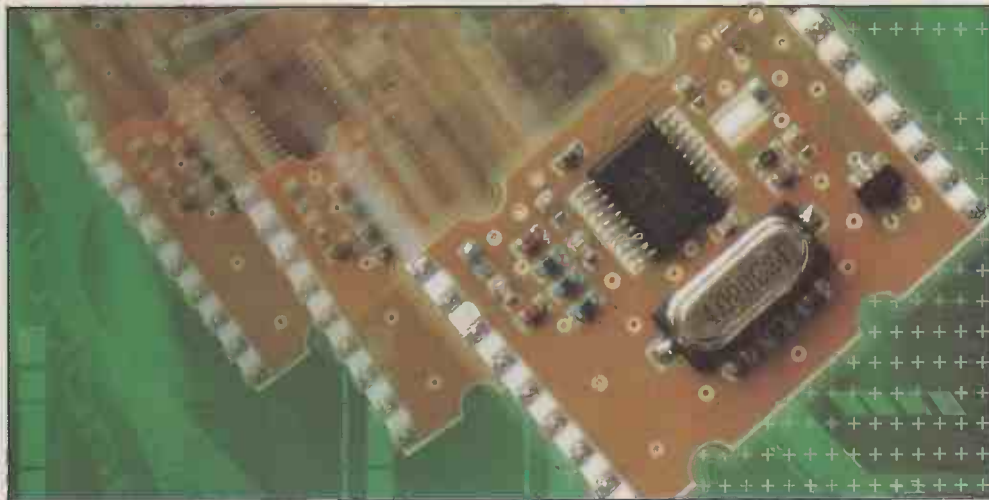

compliance testing of UMTS release 4. The K1297-G20 V2.40 is equipped with test case development tools to enable definition and modification of messages and message sequences and to create scenarios that examine specific functions of network elements. In addition, the test automation feature enables engineers to perform regression tests to ensure intended standards specifications have been implemented correctly and that

GIANT 10" 7 SEGMENT DISPLAYS

bulk purchase enables us to bring to you these GIANT 7 segment digital displays at a now affordable price! The 10" character size gives exceptional readability at long distances and enables a host of applications including, score boards, digital clocks, counters, event timers etc. As the units are a simple electromechanical device and operate from 12 V DC, simple switching via switches, relays, PIC or PC may be used to control single or multiple digits. Units feature integral 'Zero Power' memory which greatly simplifies design. For an excellent DIY practical article, see the May issue of 'Everyday & Practical Electronics' magazine. Ideal School / College construction project. Supplied in good RFE condition, complete with data sheet.



Less than 30% Only £29.95(B) or 4 / £99.00(D) of makers price!
Order RW44 Order PH26

IC's - TRANSISTORS - DIODES

OBSOLETE - SHORT SUPPLY - BULK
10,000,000 items EX STOCK
For MAJOR SAVINGS
CALL or see web site www.distel.co.uk
COMPUTER MONITOR SPECIALS

Legacy products
High spec genuine multisync.
CGA, EGA, VGA, SVGA

Mitsubishi FA3415ETKL 14" SVGA Multisync colour monitor with fine 0.28 dot pitch tube and resolution of 1024 x 768. A variety of inputs allows connection to a host of computers including IBM PC's in CGA, EGA, VGA & SVGA modes, BBC, COMMODORE (including Amiga 1200), ARCHIMEDES and APPLE. Many features: Etched faceplate, text switching and LOW RADIATION MPR specification. Fully guaranteed, in EXCELLENT little used condition. Tilt & Swivel Base £4.75

VGA cable for IBM PC included. Order as CG73

Only £129 (E)

External cables for other types of computers available - CALL

Generic LOW COST SVGA Monitors
We choose the make, which includes Compaq, Mitsubishi, IBM, etc. Supplied ready to run with all cables, Standard RTB 90 day guarantee.

14" £59.00 order TD84	15" £69.00 order TG21	17" £79.00 order TJ66
-----------------------------	-----------------------------	-----------------------------

Supplied in good used condition. Shipping code (D)

19" RACK CABINETS

Europe's Largest Stocks of quality rack cabinets, enclosures and accessories. Over 1000 Racks from stock

This month's special
33 / 42 / 47 U - High Quality All steel Rack Cabinets



Made by Eurocraft Enclosures Ltd to the highest possible spec, rack features all steel construction with removable side, front and back doors. Front and back doors are hinged for easy access and all lockable with five secure 5 lever barrel locks. The front door is constructed of double walled steel with a 'designer style' smoked acrylic front panel to enable status indicators to be seen through the panel, yet remain unobtrusive. Internally the rack features fully slotted reinforced vertical fixing members to take the heaviest of 19" rack equipment. The two movable vertical fixing struts (extras available) are pre-punched for standard 'cage nuts'. A mains distribution panel internally mounted to the bottom rear, provides 8 x IEC 3 pin Euro sockets and 1 x 13 amp 3 pin switched utility socket. Overall ventilation is provided by fully louvered back door and double skinned top section with top and side louvers. The top panel may be removed for fitting of integral fans to the sub plate etc. Other features include: fitted castors and floor levelers, pre-punched utility panel at lower rear for cable / connector access etc. Supplied in excellent, slightly used condition with keys. Colour Royal blue, some grey available - CALL - Can be supplied in many other configurations.

THE AMAZING TELEBOX



Converts your colour monitor into a QUALITY COLOUR TV!!

The TELEBOX is an attractive fully cased mains powered unit, containing all electronics ready to plug into a host of video monitors or AV equipment which are fitted with a composite video or SCART input. The composite video output will also plug directly into most video recorders, allowing reception of TV channels not normally receivable on most television receivers* (TELEBOX MB). Push button controls on the front panel allow reception of 8 fully 'tunable' off air UHF colour television channels. TELEBOX MB covers virtually all television frequencies VHF and UHF including the HYPERBAND as used by most cable TV operators. Ideal for desktop computer video systems & PIP (picture in picture) setups. For complete compatibility - even for monitors without sound - an integral 4 watt audio amplifier and low level Hi Fi audio output are provided as standard. Brand new - fully guaranteed.

TELEBOX ST for composite video input type monitors £36.95
TELEBOX STL as ST but fitted with integral speaker £39.50
TELEBOX MB Multiband VHF/UHF/Cable/Hyperband tuner £69.95
*For overseas PAL versions state 5.5 or 6 mHz sound specification.
*For cable / hyperband signal reception Telebox MB should be connected to a cable type service. Shipping on all Telebox's, code (B)

NEW State of the art PAL (UK spec) UHF TV tuner module with composite 1V pp video & NICAM hi fi stereo sound outputs. Micro electronics all on one small PCB only 73 x 160 x 52 mm enable full tuning control via a simple 3 wire link to an IBM pc type computer. Supplied complete with simple working program and documentation. Requires +12V & +5V DC to operate. BRAND NEW - Order as MY00. Only £39.95 code (B)
See www.distel.co.uk/data_my00.htm for picture + full details

HARD DISK DRIVES 2fi" - 14"

- 2fi" TOSHIBA MK1002MAV 1.1Gb laptop (12.5 mm H) New £59.95
- 2fi" TOSHIBA MK4313MAT 4.3Gb laptop (8.2 mm H) New £105.00
- 2fi" TOSHIBA MK6409MAV 6.1Gb laptop (12.7 mm H) New £98.00
- 2fi" TOSHIBA MK1814GAV 18 Gb laptop (12 mm H) New £149.95
- 2fi" to 3fi" conversion kit for PC's, complete with connectors £15.95
- 3fi" COMPAQ 313706-B21 (IBM) 9 gb ULT/SCSI3 New £199.00
- 3fi" FUJII FK-309-26 20mb MFM I/F RFE £59.95
- 3fi" CONNER CP3024 20 mb IDE I/F (or equiv.) RFE £59.95
- 3fi" CONNER CP3044 40 mb IDE I/F (or equiv.) RFE £69.00
- 3fi" QUANTUM 40S Prodrive 42mb SCSI I/F, New RFE £49.00
- 3fi" MINISCRIBE 3425 20mb MFM I/F (or equiv.) RFE £49.95
- 3fi" SEAGATE ST-238R 30 mb R/LF Refurb £69.95
- 3fi" CDC 94205-51 40mb HH MFM I/F RFE tested £69.95
- 3fi" HP 97548 850 Mb SCSI RFE tested £99.00
- 3fi" HP C3010 2 Gbyte SCSI differential RFE tested £195.00
- 3fi" NEC D2246 85 Mb SMD interface. New £99.00
- 3fi" FUJITSU M2322K 160Mb SMD I/F RFE tested £195.00
- 3fi" FUJITSU M2392K 2 Gb SMD I/F RFE tested £345.00

Many other floppy & H drives, IDE, SCSI, ESDI etc from stock, see website for full stock list. Shipping on all drives is code (C)

TEST EQUIPMENT & SPECIAL INTEREST ITEMS

- ITSUBUSHI FA3445ETKL 14" ind. spec SVGA monitors £24.5
- ARNELL 0-60V DC @ 50 Amps, bench Power Supplies £995
- ARNELL AP3080 0-30V DC @ 80 Amps, bench Supply £1850
- KINGSHILL CZ4031 0-50V @ DC 200 Amps NEW £3950
- 1kW to 400 kW - 400 Hz 3 phase power sources - ex stock EPOA
- IBM 8230 Type 1, Token ring base unit driver £760
- Wayne Kerr RA2000 Audio frequency response analyser £2500
- FODEC 1 U, 24 port, RJ45 network patchpanels. #TH93 £49
- COM 16670 12 Port Ethernet hub - RJ45 connectors #LD97 £69
- COM 16671 24 Port Ethernet hub - RJ45 connectors £89
- COM 16700 8 Port Ethernet hub - RJ45 connectors NEW £39
- IBM 53F5501 Token Ring ICS 20 port lobe modules EPOA
- IBM MAU Token ring distribution panel 8228-23-5050N £45
- ILL 501 Low distortion Oscillator 9Hz to 330KHz, IEEE I/O £550
- MMGON 8360.11805-1880 MHz hybrid power combiners £250
- Send DSA 274 Data Analyser with G703(2M) 64 i/o EPOA
- Marconi 6310 Programmable 2 to 22 GHz sweep generator £4500
- Marconi 2022C 10KHz-1GHz RF signal generator £1550
- HP1650B Logic Analyser £3750
- HP3781A Pattern generator & HP3782A Error Detector EPOA
- P6621A Dual Programmable GPIB 20A 0-7 V 160 watts £1800
- P6264 Rack mount variable 0-20V @ 20A metered PSU £475
- P54121A DC to 22 GHz four channel test set EPOA
- HP130A opt 020 300 MHz pulse generator, GPIB etc £7900
- HP A1, A0 8 pen HPGL high speed drum plotters - from £550
- HP DRAFTMASTER 1 8 pen high speed plotter £750
- C+G Brookdale 950335C Precision lock in amp £1800
- Whitley 590 CV capacitor / voltage analyser EPOA
- ocal ICR40 dual 40 channel voice recorder system £3750
- skers 45KVA 3 ph On Line UPS - New batteries £4500
- skers AP130 2.5KVA Industrial spec. UPS £1499
- Mann Tally MT645 High speed line printer £2200
- Intel SBC 486/133SE Multibus 486 system. 8Mb Ram £945

VIDEO MONITORS

PHILIPS HCS35 (same style as CM8833) attractively styled 14" colour monitor with both RGB and standard composite 15.625 KHz video inputs via SCART socket and separate phono jacks. Integral audio power amp and speaker for all audio visual uses. Will connect direct to Amiga and Atari BBC computers. Ideal for all video monitoring / security applications with direct connection to most colour cameras. High quality with many features such as front concealed flap controls, VCR correction button etc. Good used condition - fully tested - guaranteed. Dimensions: W14" x H12" x 15" D. Only £99.00 (D)

PHILIPS HCS31 Ultra compact 9" colour video monitor with standard composite 15.625 KHz video input via SCART socket. Ideal for all monitoring / security applications. High quality, ex-equipment fully tested & guaranteed (possible minor screen burns). In attractive square black plastic case measuring W10" x H10" x 13" D. 240 V AC mains powered. Only £79.00 (D)

INDUSTRIAL COMPUTERS

Tiny shoebox sized industrial 40 Mhz 386 PC system measuring only (mm) 266 w x 88 h x 272 d. Ideal for dedicated control applications running DOS, Linux or even Windows I Steel case contains 85 to 265 V AC 50 / 60 Hz 70 Watt PSU, a 3 slot ISA passive backplane and a Rocky 318 (PC104) standard, single board computer with 8 MByte NON-VOLATILE solid state 'Disk On Chip' RAMDISK. System comprises: Rocky 318 (PC104) SBC ISA card with 40MHz ALI 386SX CPU, 72 pin SIMM slot with 16 MByte SIMM, AMI BIOS, battery backed up real time clock, 2 x 9 pin D 16550 serial ports, EP/PCP printer port, mini DIN keyboard connector, floppy port, IDE port for hard drives up to 528 MByte capacity, watchdog timer and PC/104 bus socket. The 8 MByte solid state 'disk on a chip' has its own BIOS, and can be formatted, formatted & booted. Supplied BRAND NEW fully tested and guaranteed. For full data see featured item on website. Order as QG36

100's of applications inc: Only £99.00 (D)
firewall routers robotics etc

33U Order as BC44 External dimensions mm=1625H x 635D x 603 W. (64" H x 25" D x 23" W) Only £245	42U Order as DT20 External dimensions mm=2019H x 635D x 603 W. (79.5" H x 25" D x 23" W) Only £345	47U Order as RV36 External dimensions mm=2235H x 635D x 603 W. (88" H x 25" D x 23" W) Only £410
---	---	---

Call for shipping quotation

COLOUR CCD CAMERAS

Undoubtedly a miracle of modern technology & our special buying power! A quality product featuring a fully cased COLOUR CCD camera at a give away price! Unit features full autolight sensing for use in low light & high light applications. A 10 mm fixed focus wide angle lens gives excellent focus and resolution from close up to long range. The composite video output will connect to any composite monitor or TV (via SCART socket) and most video recorders. Unit runs from 12V DC so ideal for security & portable applications where mains power not available. Overall dimensions 66 mm wide x 117 deep x 43 high. Supplied BRAND NEW & fully guaranteed with user data, 100's of applications including Security, Home Video, Web TV, Web Cams etc, etc.

Order as LK33 ONLY £79.00 or 2 for £149.00 (B)

SOFTWARE SPECIALS

- NT4 WorkStation, complete with service pack 3 and licence - OEM packaged. ONLY £89.00 (B)
- ENCARTA 95 - CDROM, Not the latest - but at this price! £7.95
- DOS 5.0 on 3fi" disks with concise books c/w QBasic. £14.95
- Windows for Workgroups 3.11+ Dos 6.22 on 3.5" disks £55.00
- Windows 95 CDROM Only - No Licence - £19.95
- Wordperfect 6 for DOS supplied on 3fi" disks with manual £24.95

shipping charges for software is code B

SOLID STATE LASERS

Visible red, 670nm laser diode assembly. Unit runs from 5 V DC at approx 50 mA. Originally made for continuous use in industrial barcode scanners, the laser is mounted in a removable solid aluminium block, which functions as a heatsink and rigid optical mount. Dims of block are 50 w x 50 d x 15 h mm. Integral features include over temperature shutdown, current control, laser OK output, and gated TTL ON / OFF. Many uses for experimental optics, comms & lightshows etc. Supplied complete with data sheet.

Order as TD91 ONLY £24.95 (A)

DC POWER SUPPLIES

Virtually every type of power supply you can imagine. Over 10,000 Power Supplies Ex Stock - Call or see our web site.

RELAYS - 200,000 FROM STOCK

Save £££'s by choosing your next relay from our Massive Stocks covering types such as Military, Octal, Cradle, Hermetically Sealed, Continental, Contactors, Time Delay, Reed, Mercury Wetted, Solid State, Printed Circuit Mounting etc., CALL or see our web site www.distel.co.uk for more information. Many obsolete types from stock. Save £££'s

display

ALL MAIL TO
Dept W, 29 / 35 Osborne Rd
Thornton Heath
Surrey CR7 8PD, UK
Open Mon - Fri 9.00 - 5:30

18 Million Items On Line Now!
Secure Ordering, Pictures, Information
www.distel.co.uk
email = admin@distel.co.uk

ALL ENQUIRIES
0208 653 3333
FAX 0208 653 8888



All prices for UK Mainland. UK customers add 17.5% VAT to TOTAL order amount. Minimum order £10. Bona Fide account orders accepted from Government, Schools, Universities and Local Authorities - minimum account order £100. Cheques over £100 are subject to 7 working days clearance. Carriage charges (A)=£3.50, (B)=£6.50, (C)=£10, (D)=£15.00, (E)=£18.00, (F)=CALL. Allow approx 3 days for shipping - faster CALL. All goods: subject to our Standard Conditions of Sale which can be viewed at our website and unless stated guaranteed for 90 days. All guarantees on a return to base basis. All rights reserved to change prices / specifications without prior notice. Orders subject to stock. Discounts for volume. Top CASH prices paid for surplus goods. All trademarks, tradenames etc acknowledged. © Display Electronics 2002. E & O E.

NEWPRODUCTS

Please quote *Electronics World* when seeking further information

no unintended changes have been introduced. The monitoring capabilities of the K1297-G20 V2.40 are designed to provide a full set of processing applications and allow decoding to the bit level, enabling engineers to observe behaviour in selected interfaces in the network as they implement UMTS R4 specifications. The K1297-G20 protocol tester supports multichannel and multi-port protocol testing and incorporates a number of conformance test suites.

Tektronix
www.tektronix.com

2.4GHz uses Bluetooth protocol to plug and play

The BRM01 from RF Solutions is a 2.4GHz PCB mountable transceiver that uses the Bluetooth protocol to provide a 'plug and play' radio link. It is for use in serial cable replacement, telemetry, and process control applications. The module is able to achieve a maximum transmit rate of 460.8kbit/s in full duplex. Using a Bluetooth class one based radio protocol provides low-level radio



link management and error correction functions that are completely transparent to the user, said the supplier. The carrier frequency hops at a rate of 1,600hops/s, which according to the company provides resistance to jamming. The transceiver has a maximum output power of 100mW resulting in a line-of-sight range of 200-300 metres when using the integral antenna; range can be extended by using an external antenna. The modules can be configured for point-to-point, point-to-multipoint and multipoint-to-multipoint architectures. The BRM01

requires a supply voltage of 4V to 5.5V and can be mounted directly onto a surface mount PCB.

RF Solutions
www.rfsolutions.co.uk
Tel: +44(0) 1273 488880

Temperature sensors have PWM outputs

Analog Devices has introduced two digital temperature sensors with single-wire, pulse-width-modulation (PWM) outputs. The output of the TMP05 and TMP06 is a square wave; its duty cycle is proportional to the absolute temperature. Both devices offer

accuracy to $\pm 1^\circ\text{C}$ max from 0 to $+70^\circ\text{C}$, an operating temperature range from -55 to $+150^\circ\text{C}$, and a supply voltage range of $+2.7\text{V}$ to $+5.5\text{V}$. They are available in space-saving 5-lead SC-70 and SOT-23 packages. The TMP05 has a push-pull output (CMOS/TTL), while the TMP06 has an open-drain output.

Analog Devices
www.analog.com
Tel: +032 11 300635

Surface mount aluminium capacitors have 100V rating

The NACHL series of surface mount aluminium electrolytic capacitors from NIC Eurotech are housed in miniature cylindrical cases (V-chips). Capacitors are available with voltage ratings of between 10V DC and 100V DC and capacitance values that range from $0.47\mu\text{F}$ to $330\mu\text{F}$. Load-life rating is 5,000 hours at their upper operating temperature of $+105^\circ\text{C}$ and minimum operating



temperature -40°C . Case sizes range from $4 \times 6.1\text{mm}$ to $10 \times 10.5\text{mm}$ depending on voltage and capacitance values selected. NACHL capacitors can be supplied either in bulk or tape and reel packaging for use with automatic insertion manufacturing equipment. All parts are available with an optional lead-free finish.
NIC Eurotech
www.niccomp.com
Tel: +44(0) 1280 813737

Multimeter has analogue bar graph

Wavetek Meterman's latest digital multimeter (DMM) measures temperature,

Point-of-load converter with fast transient response

Lambda's latest non-isolated DC-DC converter is a 5V input, 10A output single-in-line packaged unit with fast transient response and close line/load regulation. Aimed at point-of-load applications, the PL10 in the firm's Tarka

range has a user-selectable output voltage range of 0.9 to 3.3V which is fixed by a single resistor. With an output voltage of 3.3V, for example, the response to a change from 50 to 100 per cent, is typically 80mV with a setting time of

$40\mu\text{s}$, said the supplier. The converter's synchronous design allows it to deliver efficiencies up to 94 per cent at a fixed switching frequency of 300kHz. The converters are available in two package styles: a SIL with 9 pins for through-hole insertion and a 5-pad SM for surface mounting. Both styles are supplied taped and reeled. Lambda is also introducing its PAE65 series of eighth-brick DC-DC converters which are available with output voltages from 0.8 to 12V. Output currents are up to 25A on all models up to 2.5V. The 3.3V unit with an output current of 20A is designed to deliver 66W of power.

Lambda
www.lambda-gb.com
Tel: +44(0) 1271 856666

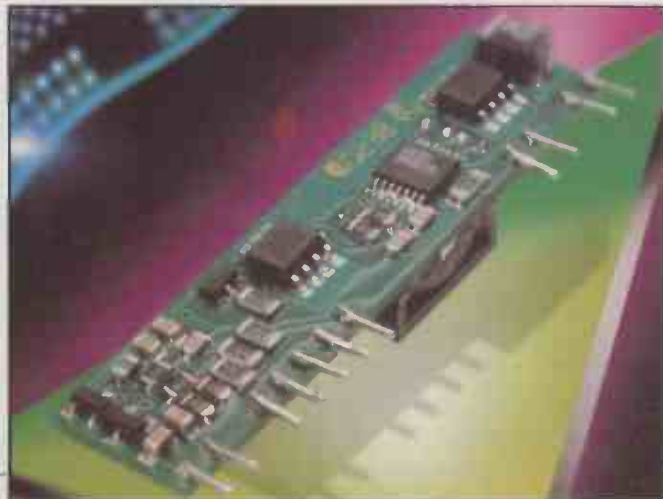

THERE IS INTERESTING NEWS

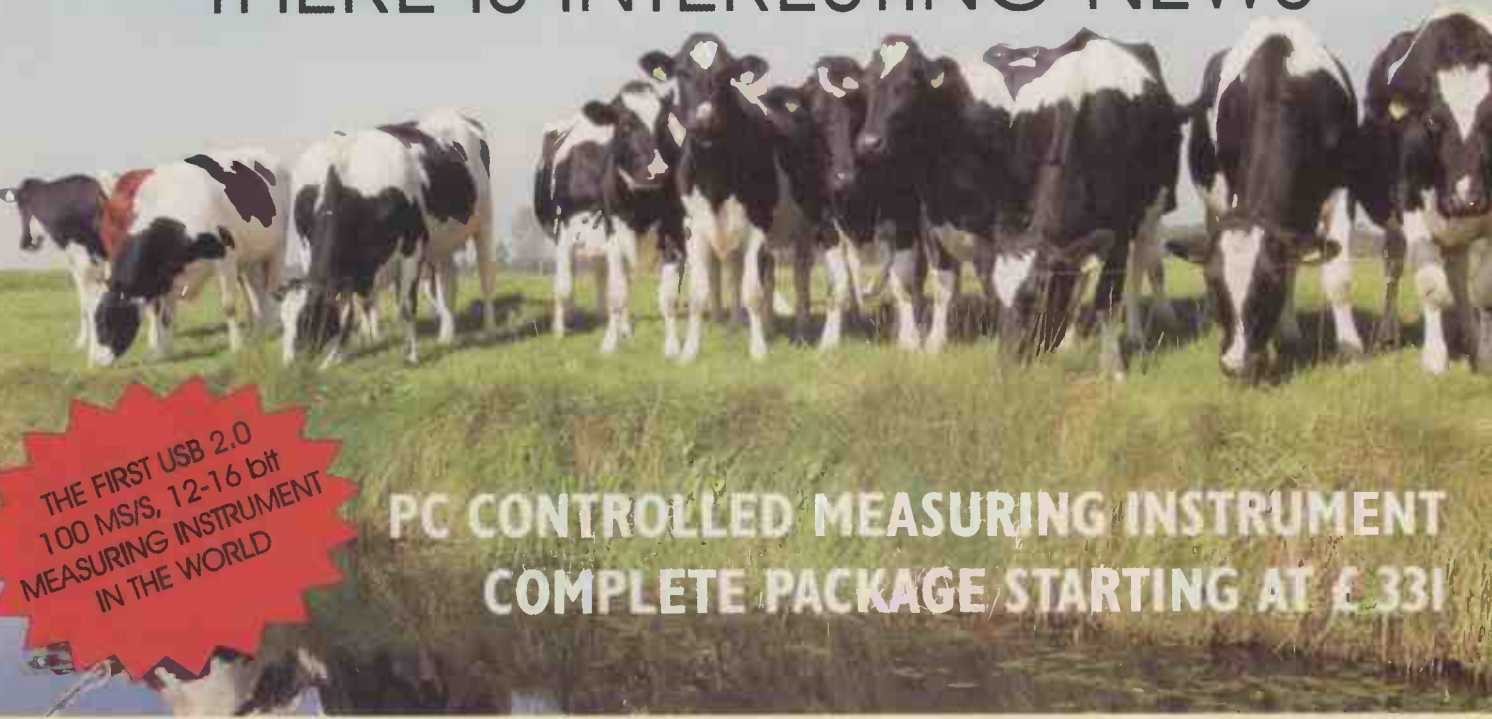

THE FIRST USB 2.0
100 MS/S, 12-16 bit
MEASURING INSTRUMENT
IN THE WORLD

PC CONTROLLED MEASURING INSTRUMENT
COMPLETE PACKAGE STARTING AT £ 331

OSCILLOSCOPE

FFT ANALYSER

VOLTMETER

RECORDER

The Handyscope 3 is a powerful and versatile two channel measuring instrument with an integrated function generator.

- USB 2.0 connection (USB 1.1 compatible)
- sample speed up to 100 MHz per channel
- 8 to 16 bit resolution (6 μ Volt resolution)
- 50 MHz bandwidth
- input sensitivity from 200 mVolt up to 80 Volt
- large memory up to 131060 samples per channel
- four integrated measuring devices
- spectrum analyser with a dynamic range of 95 dB
- fast transient recorder up to 10 kHz
- several trigger features
- auto start/stop triggering
- auto disk function up to 1000 files
- auto setup for amplitude axis and time base
- auto trigger level and hysteresis setting
- cursor measurements with 21 read-outs
- very extensive function generator (AWG) 0-2 MHz , 0-12 Volt

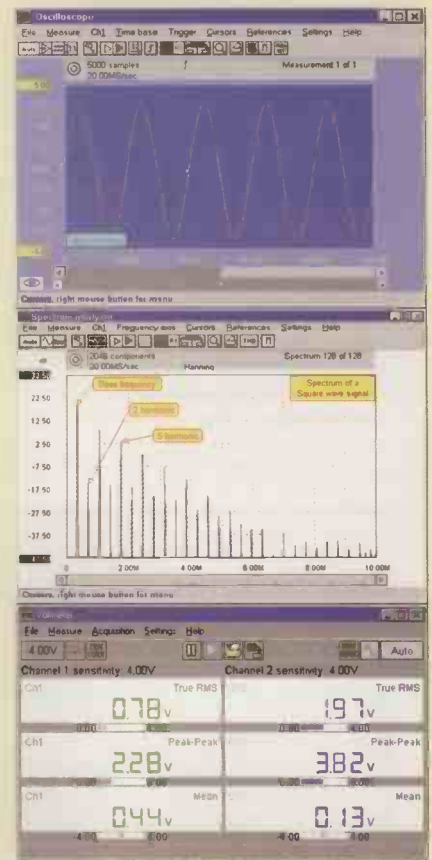

HANDYSCOPE HS3

WWW.TIEPIE.NL

for more information, demo software, software, source code and DLL's visit our internet page: <http://www.tiepie.nl>

TiePie engineering (NL)
Koperslogersstraat 37
8601 WL SNEEK
The Netherlands
Tel: +31 515 415 416
Fax: +31 515 418 819

TiePie engineering (UK)
28, Stephenson Road, St. Ives
Cambridgeshire, PE17 3WJ, UK
Tel: 01480-460028
Fax: 01480-460340

NEWPRODUCTS

Please quote *Electronics World* when seeking further information

capacitance, frequency and 4-20mA loop current percentage. The 10,000 count display with 0.25 per cent accuracy includes an analogue bargraph. Features include a neon backlight, for use in dim environments. The 38XR can be used for data acquisition using an industry standard PC running Windows.

Wavetek Meterman
www.metermantesttools.com

LDMOS power amplifier optimisation device

Xicor has introduced an RF power amplifier bias controller that integrates onto a single chip all of the critical functional elements needed for designs that optimise LDMOS power amplifier performance. The



X9470 is designed to monitor and optimise the operating bias of RF power amplifiers in CDMA, WCDMA, GSM, EDGE, UMTS or other similar basestation applications. The X9470 will work with 2G, 2.5G and 3G systems as well as point to multipoint and wireless local loop systems. During a closed-loop calibration operation, performed between RF bursts, the device's instrumentation amplifier senses the power amplifier bias current and compares this with the desired value stored in EEPROM. A corrected bias voltage is then applied to the LDMOS power amplifier through the output amplifier that has low output resistance and according to the supplier, allows a simplification of the external low-pass filter. LDMOS bias current can be typically maintained to within 4 per cent of its desired value over time and temperature. Operating from a maximum V_{DD} of 30V, the X9470 features a 2-wire interface for programming bias settings and optimising IDQ set point, and bias error direction flag.

Xicor
www.xicor.com
Tel: +44(0) 1993 700544

Mobile IC has imaging interface

National Semiconductor has introduced a GSM/GPRS handset module and chipset which includes audio, power management, a Bluetooth interface, imaging interface, baseband and RF. Both the

chipset and module come with full development kits. The LMX3888 module features on-chip polyphonic ringer, speakerphone and stereo MP3 capabilities. The module is based on



National's GSM/GPRS chipset, which consists of the LMX3413 analogue power unit, the LMX3415 digital baseband, and a complete quad-band, very low power radio. A dual-band module, National's LMX3888 is designed to provide phone manufacturers with a turnkey design for GSM/GPRS mobile handsets. It includes an integrated Bluetooth Link Manager, USB, CMOS camera interface, SD/MMC interface, voice recognition, handsfree speakerphone, MP3, EMS and MMS in a GSM/GPRS class B-10 product offering. It measures 33 x 38 x 3.6mm.

National semiconductor
www.national.com
Tel: +44(0) 870 242171



32-channel PCI converter has A-to-D on each channel

Datel's 32-channel PCI-417N series boards use an A/D converter for each channel to avoid settling delays and speed limitations. Besides the increase in total system speed, the PCI-417N samples all channels in parallel at rates up to 80kHz per channel (5.12Mbyte/s aggregate rate). This concurrent A/D sampling enables time correlated applications such as medical ultrasound, digital signal processing sonar or FFT engine

testing. Each input A/D converter digitises to 14-bit resolution, lowering system noise and increasing system dynamic range. Full scale input voltage ranges of $\pm 5V$ or $\pm 10V$ are selectable per channel. An on-board A/D memory system prevents sample loss streaming. The board's bus controller acts as a temporary DMA PCI bus master to blast blocks of A/D data while the host CPU concurrently processes previous data, all without dropping samples. A CD-ROM and users' manual with full software documentation accompanies each PCI-417N.

Datel
www.datel-europe.com
Tel: +44(0) 1256 880444
Datel

850mW video signal switcher

Rohm Electronics' multimedia IC is aimed at applications that require video signal switching. The BA7615N video signal switcher, as it is called, integrates a 6dB amplifier, a 75 Ω driver and a mute function





Station Road, Cullercoats, Tyne & Wear, NE30 4PQ

Prices Exclude VAT @17.5%
UK Carriage £1.50 (less than 1kg)
£3.50 greater than 1kg
Cheques / Postal orders payable to
ESR Electronic Components.
PLEASE ADD CARRIAGE & VAT TO ALL ORDERS

See Next / Last Months Ad. for
ELECTRONIC COMPONENTS

DIL Sockets

6 Pin DIL 0.3"	£0.07
8 Pin DIL 0.3"	£0.06
14 Pin DIL 0.3"	£0.11
16 Pin DIL 0.3"	£0.12
20 Pin DIL 0.3"	£0.12
24 Pin DIL 0.3"	£0.12
28 Pin DIL 0.3"	£0.13
32 Pin DIL 0.3"	£0.13
40 Pin DIL 0.3"	£0.19

Stamped Pin

6 Pin DIL 0.3"	£0.07
8 Pin DIL 0.3"	£0.06
14 Pin DIL 0.3"	£0.11
16 Pin DIL 0.3"	£0.12
20 Pin DIL 0.3"	£0.12
24 Pin DIL 0.3"	£0.12
28 Pin DIL 0.3"	£0.13
32 Pin DIL 0.3"	£0.13
40 Pin DIL 0.3"	£0.19

Turned Pin

8 Pin DIL 0.3"	£0.11
14 Pin DIL 0.3"	£0.20
16 Pin DIL 0.3"	£0.23
18 Pin DIL 0.3"	£0.25
20 Pin DIL 0.3"	£0.28
24 Pin DIL 0.3"	£0.35
28 Pin DIL 0.3"	£0.39
32 Pin DIL 0.3"	£0.43
40 Pin DIL 0.3"	£0.64

ZIF Sockets

Universal ZIF DIL Sockets	
24 Way 0.3-0.6"	£5.85
28 Way 0.3-0.6"	£6.60
32 Way 0.3-0.6"	£7.50
40 Way 0.3-0.6"	£8.93

Transistor Sockets

T018-4 Base Socket	£0.24
T05 Base Socket	£0.24

IDC Cable Sockets

10 Way Socket	£0.23
14 Way Socket	£0.35
16 Way Socket	£0.37
20 Way Socket	£0.37
26 Way Socket	£0.38
34 Way Socket	£0.39
40 Way Socket	£0.55
50 Way Socket	£0.80

IDC Cable Plugs

10 Way Plug	£0.52
14 Way Plug	£0.58
16 Way Plug	£0.62
20 Way Plug	£0.62
26 Way Plug	£0.70
34 Way Plug	£0.80
40 Way Plug	£0.92
50 Way Plug	£1.12

PCB Box Headers

10 Way Straight	£0.22
14 Way Straight	£0.33
16 Way Straight	£0.32
20 Way Straight	£0.41
26 Way Straight	£0.52
34 Way Straight	£0.58
40 Way Straight	£0.68
50 Way Straight	£1.03
10 Way 90°	£0.32
14 Way 90°	£0.39
16 Way 90°	£0.42
20 Way 90°	£0.63
26 Way 90°	£0.82
34 Way 90°	£0.81
40 Way 90°	£1.17
50 Way 90°	£1.14

PCB Latch Headers

10 Way Straight	£0.39
14 Way Straight	£0.45
16 Way Straight	£0.51
20 Way Straight	£0.55
26 Way Straight	£0.73
34 Way Straight	£0.88
40 Way Straight	£0.92
50 Way Straight	£1.27
10 Way 90°	£0.46
14 Way 90°	£0.48
16 Way 90°	£0.54
20 Way 90°	£0.59
26 Way 90°	£0.81
34 Way 90°	£1.03
40 Way 90°	£1.23
50 Way 90°	£1.41

DIL Headers

14 Way DIL	£0.51
16 Way DIL	£0.53
24 Way DIL	£0.90
40 Way DIL	£1.37

Transition Headers

10 Way Transition	£0.42
14 Way Transition	£0.42
16 Way Transition	£0.48
20 Way Transition	£0.48
26 Way Transition	£0.52
34 Way Transition	£0.56
40 Way Transition	£0.63
50 Way Transition	£0.84

D Type Connectors

9 Way Male Plug	£0.20
9 Way Female Socket	£0.20
15 Way Male Plug	£0.27
15 Way Female Socket	£0.29
15 Way H.D. Plug	£0.42
15 Way H.D. Socket	£0.45
23 Way Male Plug	£0.60
23 Way Female Socket	£0.66
25 Way Male Plug	£0.30
25 Way Female Socket	£0.35

Solder Bucket

9 Way Male Plug	£0.20
9 Way Female Socket	£0.20
15 Way Male Plug	£0.27
15 Way Female Socket	£0.29
15 Way H.D. Plug	£0.42
15 Way H.D. Socket	£0.45
23 Way Male Plug	£0.60
23 Way Female Socket	£0.66
25 Way Male Plug	£0.30
25 Way Female Socket	£0.35

IDC Ribbon Mounting

9 Way Male Plug	£1.08
9 Way Female Socket	£0.93
15 Way Male Plug	£1.30
15 Way Female Socket	£1.32
25 Way Male Plug	£1.10
25 Way Female Socket	£1.13
IDC Crimp Tool	£11.80

Right Angled PCB

9 Way Male Plug	£0.33
9 Way Female Socket	£0.33
15 Way Male Plug	£0.39
15 Way Female Socket	£0.32
15 Way H.D. Socket	£0.58
25 Way Male Plug	£0.43
25 Way Female Socket	£0.50

Plastic B Covers

9 Way Cover - Grey	£0.27
9 Way Cover - Black	£0.30
15 Way Cover - Grey	£0.40
15 Way Cover - Black	£0.40
23 Way Cover - Black	£0.38
25 Way Cover - Grey	£0.34
25 Way Cover - Black	£0.37
9 to 9 Cover / Case	£0.80
25 to 25 Cover / Case	£0.84
9 to 25 Cover / Case	£0.80

Audio Connectors

2.5mm Jack Plug	£0.25
2.5mm Line Socket	£0.24
2.5mm Chassis Socket	£0.12
3.5mm Mono Plug	£0.24
3.5mm Mono Line Skt	£0.24
3.5mm Mono Chassis	£0.14
3.5mm Stereo Plug	£0.35
3.5mm Stereo Line Skt	£0.36
3.5mm Stereo Chassis	£0.22
1/4" Mono Plug	£0.30
1/4" Mono Line Socket	£0.36
1/4" Mono Chassis Skt	£0.46
1/4" Stereo Plug	£0.36
1/4" Stereo Line Socket	£0.32
1/4" Stereo Chassis Skt	£0.38
Neutrik Speakon Plug	£2.83

Phono Series

Red Line Plug	£0.20
Black Line Plug	£0.20
Yellow Line Plug	£0.20
White Line Plug	£0.20
Red Line Socket	£0.20
Black Line Socket	£0.20
Yellow Line Socket	£0.20
White Line Socket	£0.20
Red Chassis Socket	£0.20
Black Chassis Socket	£0.20
Gold Plated Plug Red	£0.68
Gold Plated Plug Black	£0.68

XLK Series - metal

3 Pin Line Plug	£0.96
3 Pin Line Socket	£0.96
3 Pin Chassis Plug	£1.23
3 Pin Chassis Socket	£1.22
Neutrik Line Plug	£1.80
Neutrik Line Socket	£2.10
Neutrik Chassis Plug	£2.24
Neutrik Chassis Socket	£2.40

RF Connectors

BNC Plug 50- Solder	£0.99
BNC Plug 50- Crimp	£0.68
BNC Plug 75- Solder	£1.08
BNC Plug 75- Crimp	£0.69
BNC Chassis Socket	£0.76
F Plug - Twist	£0.20
F Plug - Crimp	£0.18
TNC Plug 50- Solder	£1.08
TNC Plug 50- Crimp	£1.04
TNC Plug 75- Solder	£1.17
TNC Plug 75- Crimp	£0.96
UHF Plug 5mm Cable	£0.63
UHF Plug 11mm Cable	£0.72
UHF Chassis Skt- Sqr	£0.54
UHF Chassis Skt- Rnd	£0.75

Terminals

Colours Red, Black, Green, Blue, White or Yellow	
2mm Solder Plugs	£0.23
2mm Chassis Sockets	£0.28
4mm Plugs - Solder	£0.34
4mm Plugs - Screw	£0.38
4mm Stackable Plugs	£0.40
4mm Shrouded Plugs	£0.74
4mm Chassis Sockets	£0.21
4mm Binding Posts	£0.48
33mm Crocodile Clips	£0.10

Power Connectors

DC Plug 0.7ID 2.35OD	£0.47
DC Plug 1.3ID 3.4OD	£0.17
DC Plug 1.7ID 4.0OD	£0.44
DC Plug 1.7ID 4.75OD	£0.50
DC Plug 2.1ID 5.00OD	£0.24
DC Plug 2.5ID 5.00OD	£0.53
DC Line Socket 2.1mm	£0.68
DC Line Socket 2.5mm	£0.68
DC Chassis Skt 2.1mm	£0.44
DC Chassis Skt 2.5mm	£0.44

IEC Mains 6A 250Vac

3 Pin IEC Line Socket	£1.08
3 Pin IEC Line Plug	£1.89
3 Pin Chassis Socket	£0.55
3 Pin Chassis Plug	£0.56

3 Way Bulgin

8 Pin Line Plug P551	£3.58
8 Pin Chassis Skt P552	£1.27

Toggle Switches

Sub-Miniature 3A 125V 1A 250V	
5mm Ø Mounting Hole	
SPST 5 x 10mm	£0.47
SPST 18 x 30mm	£0.53
SPDT c/o 5 x 10mm	£1.01
DPDT 9.2 x 10mm	£0.63

Miniature

6A 125V 3A 250V	
6.2mm Ø Mounting Hole	
SPST 8 x 13mm	£0.58
SPST 8 x 13mm	£0.55
SPDT c/o 8 x 13mm	£0.65
SPDT c/o Biased 2 way	£0.84
SPDT c/o Biased 1 way	£1.15
DPDT 12 x 13mm	£0.65
DPDT c/o 12 x 13mm	£0.88
DPDT c/o Biased 2W	£1.20
DPDT c/o Biased 1W	£1.28

Standard

10A 250V Push on terminals	
12mm Ø Mounting Hole	
SPST 18 x 30mm	£1.05
SPDT 18 x 30mm	£1.18
SPDT c/o 18 x 30mm	£1.18
DPDT 21 x 30mm	£1.78
DPDT c/o 21 x 30mm	£1.78

Slide Switches

Miniature 300mA 125V	
7 x 15mm Mounting Hole	
DPDT 7 x 23mm	£0.17

Rotary Switches

150mA 250V Make before Break 22mm Ø	
9mm Ø Mounting Hole	
1 Pole 12 Way	£0.84
2 Pole 6 Way	£0.84
3 Pole 4 Way	£0.84
4 Pole 3 Way	£0.84

Push Switches

Miniature Round 250mA 125V 28 x 10mm	
7mm Ø Mounting Hole	
Non Latching Push to Make	
Black, Red, Yellow, Green, Blue or White	£0.23
Non Latching Push to Break	
Black PTB	£0.24

Standard Square

1A 250V 39 x 15MM	
12mm Ø Mounting Hole	
Non Latching Push to Make	
Black, Red, Blue or White	£0.60
Latching - Push On push Off	
Black, Red, Blue or White	£0.65

Rocker Switches

Miniature 13 x 19mm Mounting Hole	
SPST 4A 250V	£0.57
SPST 6A Red Neon	£1.65
SPST 3A Red LED	£1.92
SPDT 6A 250V	£0.75
DPST 4A 250V	£0.81
DPST 4A Red Neon	£1.10
DPST 3A Amber Neon	£1.40
DPST 3A Green Neon	£1.25
DPDT 10A 250V	£0.90

Relays

PCB Mounting 10(SP) 22(DP) x 30mm	
Mounting Hole	
SPST 10A 250V	£0.60
SPST 16A 250V	£0.75
SPST 15A Red Neon	£0.90
SPDT 16A 250V	£0.90
DPST 10A 250V	£0.75
DPST 15A Red Neon	£1.18
DPST Amber Neon	£1.25
DPST Green Neon	£1.25
DPDT 10A 250V	£0.90

Computer Accessories Adaptors

9M Gender Changer	£1.73
9M Gender Changer	£1.73
25M Gender Changer	£2.20
25F Gender Changer	£2.43
9 Male - 25 Female	£1.73
9 Female - 25 Male	£1.73
9M - 6 Mini Din Male	£2.48
9F - 6 Mini Din Female	£2.23
5M Din - 6M Mini Din	£1.73
5F Din - 6M Mini Din	£1.73
Mini Tester 7 LEDs	£4.72
Check Tester 18 LEDs	£6.32
Enhanced+ Switches	£15.18
25D Patch Box M-F	£2.64
Anti-Static Wrist Strap	£4.73
RS232 Surge Protector	£5.46
5A Surge Protector	£5.20
13A Surge Protector	£10.00
4 Gang Surge Block	£10.50

Leads & Cables

1.5m Printer Lead	£2.55
2m BD Printer Lead	£2.98
5m BD Printer Lead	£4.98
10m BD Printer Lead	£9.88
2m IEEE1284 Printer L	£4.38
5m IEEE1284 Printer L	£8.90
10m IEEE1284 Printer L	£16.13
Serial Printer 25M-9F	£4.88
Serial Printer 25M-25F	£4.38
Null Modem Leads	
9 Female - 9 Female	£4.38
25 Female - 25 Female	£6.48
9 Female - 25 Female	£4.38
9825F to 9825F	£4.88
Modem Leads	
25Male to 9Female	£4.08
25Male to 25Female	£3.78
PC Link Leads	
Interlink 25M to 25M	£3.88
Patch Lead	
25Male to 25Male	£3.60
36Male to 36Male	£2.60
Internal Leads	
Floppy Cable A/B	£1.28
Hard Disk 2xIDE	£1.98
Hard Disk 2xATA66	£3.38
Power 3/2-2 x 3/4	£1.88
Power 5/2-2 x 5/4	£1.50
Power 5/2-2 x 3/4	£1.88
Power 5/4-3/4, 5/4	£1.88
Networking	
BNC T Piece MF	£1.71
BNC Coupler F	£0.81
BNC Ratchet Crimper	£15.68
50- BNC Terminator	£0.98
Thinnet Cable per m	£0.38

Boxes & Cases

Many more sizes available	
3.579545MHz	£0.41
3.6864MHz	£0.41
4.0MHz	

NEWPRODUCTS

Please quote *Electronics World* when seeking further information

into a single SIP-10 25.2x10.5x2.8mm package. With four sync-tip clamp inputs, one output and three control terminals, it runs from between 4.5V and 13V and typically has 0dB at 10MHz frequency characteristics. Typical maximum output level is 3.5V_{p-p} and typical channel-to-channel crosstalk is 65dB at 4.43MHz.

Rohm Electronics
www.rohm.co.uk
Tel: +44(0) 1908 282666

Power module design seminar on free CD-ROM

Vicor is offering a free technical seminar on a CD-ROM which is intended to provide designers with information on the subjects of electrical, mechanical and thermal design; as well as control, mounting EMI and paralleling considerations. For a free copy of the CD see the website.

Vicor
www.vicroeurope.com

AC-DC supplies above spec currents

XP has available AC-DC switchers which it claims can repeatedly deliver twice their nominal output current for up to 10 seconds. The aim, said the supplier, is that the CPE and CPI families tackle the problem of having to over-specify AC/DC switchers in industrial applications where short duration, high peak loads occur.

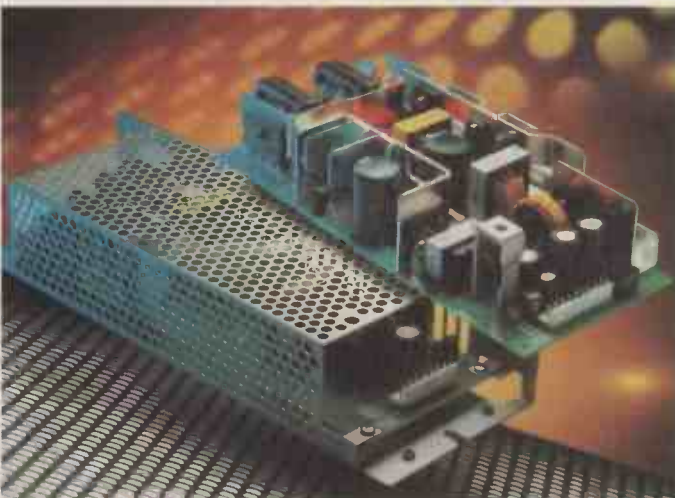

8-bit addressable power driver IC

The A6259KA and A6259LKW ICs from Allegro MicroSystems combine a 3-to-8-line CMOS decoder circuit and accompanying data latches, control circuitry, and DMOS outputs in a multi-functional power driver. The devices are capable of storing single-line data in the addressable latches, or can be used as decoders or demultiplexers. Driver applications include relays, solenoids, and other medium-current or high-voltage peripheral power loads. The CMOS inputs and latches allow direct interfacing with microprocessor based systems. When used with TTL circuitry, they typically require appropriate pull-up resistors to ensure an input logic 'high'. Four modes of operation are selectable with the 'clear' and 'enable' inputs. The devices

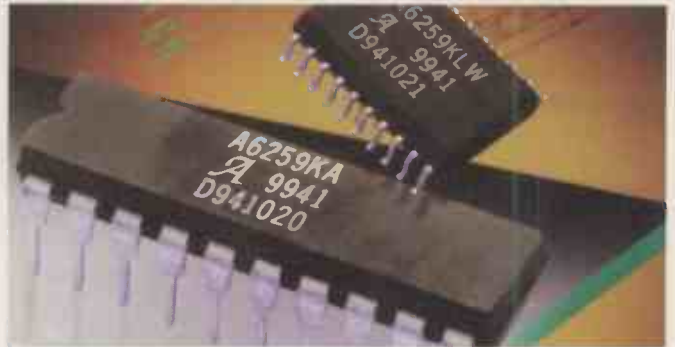

feature a 50V minimum output clamp voltage, a 250mA output current with all outputs on simultaneously, and a typical 'on' resistance of 1.3Ω. The addressed DMOS output inverts the data input with all unaddressed outputs remaining in their previous states. All the output drivers are disabled (with the DMOS sink drivers turned off) when the 'clear' input is

low and the 'enable' input high. The DMOS open-drain outputs are capable of sinking up to 750mA. The A6259KA is housed in a 20-pin dual in-line plastic package. The A6259KLW is supplied in a 20-lead wide-body, small-outline package.

Allegro Europe
www.allegromicro.com
Tel: +33 4505 12359

Both CPE and CPL switches are convection cooled, so the expense of providing forced-air cooling is avoided. Typical applications for the 100 to 240W power supplies are in switchgear, automation and motor control systems. CPE models are single output units rated between 100 and 240W with typical efficiencies up to 87 per cent. Output voltages are 24, 36 or 48V DC, adjustable by ±10 per cent, and maximum line regulation is 48mV and load

regulation ±0.3 per cent from zero to 100 per cent load. CPL versions are dual output, 100 to 225W power supplies offering a standard +5V output for powering logic circuits, adjustable by ±10 per cent, and an isolated +12V or +24V output with high peak current capability.

XP
www.xppic.com
Tel: +44(0) 118 984 5515

USB & serial Port PIC programmer

This professional quality PIC Programmer from Quasar Electronics is ideal for field and general use as it uses the USB or Serial port. It employs the latest FT232BM surface mount pre-soldered to the board and on-board firmware. All components (excluding ZIF Socket) supplied including a gold plated double sided PTH PCB (102 x 78mm) and free Windows Software interface.

The price includes a fully functional 9x/NT/2000/ME/XP software interface which is available for free downloading.

Software accepts HEX files and has Program, Verify, Read, Blank Check, OSCAL and Fuse functions.

Quasar Electronics
www.quasarelectronics.com
Tel: +44(0) 871 717 7168

8051 starter kit gets flash micro

Crossware has added to its 8051-based FLT-32 microcontroller trainer new software and a flash programmable Atmel chip. The microcontroller design trainer is used to teach microprocessor and control principals. The system incorporates a standard 8032 microcontroller and a text based command line monitor, which allows students to download and run programs from a host PC. The Crossware enhancements include an upgrade from the original 8032 chip to the modern Atmel T89C51RC2 microcontroller, which includes 32kbytes of flash programmable memory.

Crossware
www.crossware.com
Tel: +44(0) 1763 853500

PCB-POOL

SERVICING YOUR COMPLETE PROTOTYPE NEEDS

- Prototypes at a fraction of the cost
- Industry standard quality
- Tooling and setup included
- Follow up series runs
- Any contour
- CAM / CAD consulting
- Fr4 1.6mm, 35µm Cu

PRICE EXAMPLE:
EUROCARD DS/PTH
 + Tooling
 + Photoplots
 + VAT

= £ 29.89*

*Sterling rates may vary. Price = € 49

€49

FREE

with first order
(while stocks last)



may differ slightly
to model shown

Tel: +353 (0)61 701120
 Fax: +353 (0)61 701164
 E-Mail: sales@beta-levcoet.com

Freephone
0800-389 8560

Simply send your files and order ONLINE:

WWW.PCB-POOL.COM

Protel orcad EDWIN GraphiCode

**Cable laying problems?
 use licence free,
 call charge free
 Radio Data Transmission**

XL Systems Ltd



www.xls.co.uk

Tel:01883 622778

RANGER 2XL

**The Professional Integrated
 Schematic PCB Layout Package**

Free Download available from www.seetrax.com

from just
£90

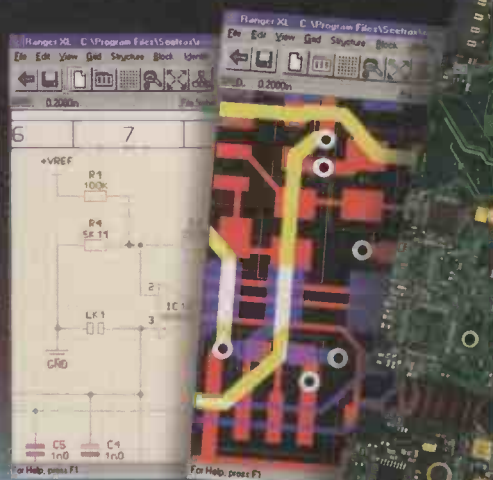

RANGER 2XL	500	1000	2000	Full
Schematic & PCB Layout	✓	✓	✓	✓
Artwork Checking	✓	✓	✓	✓
Ripup/Retry Auto-router	✓	✓	✓	✓
Copper Fill/Pour	✓	✓	✓	✓
Power Planes			✓	✓
Max Signal Layers	2	2	4	32
Max Parts	100	250	500	1400
Max Component Pins	500	1000	2000	16000
Price	£90	£200	£300	£460

Tel: 01730 260062 Email: sales@seetrax.com

CIRCUIT IDEAS

Fact: most circuit ideas sent to *Electronics World* get published

The best circuit ideas are ones that save time or money, or stimulate the thought process. This includes the odd solution looking for a problem – provided it has a degree of ingenuity.

Your submissions are judged mainly on their originality and usefulness. Interesting modifications to existing circuits are strong contenders too – provided that you clearly acknowledge the circuit you have modified. Never send us anything that you believe has been published before though.

Don't forget to say why you think your idea is worthy.

Clear hand-written notes on paper are a minimum requirement: disks with separate drawing and text files in a popular form are best – but please label the disk clearly. Where software or files are available from us, please email Jackie Lowe with the circuit idea name as the subject.

Send your ideas to: Jackie Lowe, Highbury Business Communications, Anne Boleyn House, 9-13 Ewell Road, Cheam, Surrey SM3 8BZ
email j.lowe@highburybiz.com

6-600V AC/DC LED driver

Any voltage between 6 and 600V will light an LED using this circuit. There are two LEDs, one lighting when the drive is AC, the other when the drive is DC.

This circuit will operate a LED with an applied voltage between 6 and 600V, AC or DC. Input voltage is rectified by D_{1-4} and drives the LED through a constant current source. Multiple LEDs may be connected in series if the circuit is to be used to replace filament indicator lamps etc.

Current is sensed by the drop across R_2 which turns Tr_1 on, reducing the gate drive to Tr_2 . This closes the loop and maintains a constant current through the LED.

It is important to use a high voltage

1W resistor for R_1 or use three 330k 0.5W resistors in series to avoid breakdown. Diode ZD_1 is a protection zener. An AC detector circuit comprising C_1 , R_3 , ZD_2 and the low-voltage mosfet Tr_3 lights LED_2 when an AC voltage is detected.

Direct current is blocked by C_1 and the negative half cycles are removed by ZD_2 . Positive half cycles cause Tr_3 to conduct, lighting LED_2 . This LED shares the constant current with no appreciable loss of brightness of LED_1 .

Resistor R_3 discharges the gate source capacitance of Tr_3 , preventing the LED lingering on when the AC voltage is removed. Capacitor C_1 must be rated at 3kV DC or higher. Zener diode ZD_2 also protects the gate/source structure of the mosfet against high voltages.

Both LEDs are on when AC is applied. The LED current is selected using $I_{LED} = 0.6/R_2$. Values for three common LED currents are as follows: 2mA 270Ω, 5mA 120Ω and 10mA 56Ω. A suitable heat sink must be provided for Tr_2 as this device can dissipate up to 6 watts and will overheat if the LED is on for long periods.

Resistors $R_{4,5}$ with zener diode ZD_3 were added as it was found that transients were damaging white LEDs in the prototype when voltages above 400V were applied. No problems with red and orange LEDs

Warning

High voltages can be lethal. Do not attempt to build or use this circuit unless you are familiar with the standards, rules and recommendations relating to working with high voltages.

were apparent and I can only assume that the white devices are less tolerant of short duration overload that may occur as the source starts up. Adding these components has solved the problem with white LEDs.

The voltage range of this circuit may be extended to around 800-900V if the bridge rectifier diodes are rated at 1600V and Tr_2 at 1000V. I suggest using BY228 diodes and a IRFBG20 or STP3NA100FP mosfet.

I have found this circuit useful for many applications, including replacing filament indicator lamps, discharging high-voltage capacitors, providing a constant current for high-voltage zeners and as a test lamp in electrical applications.

Note that as with all high-voltage test equipment, the unit should always be tested prior to use. Double insulation construction techniques should be used and 100mA fused test probes are required if the circuit is to be used as a test aid.

Alistair Borthwick
Edinburgh

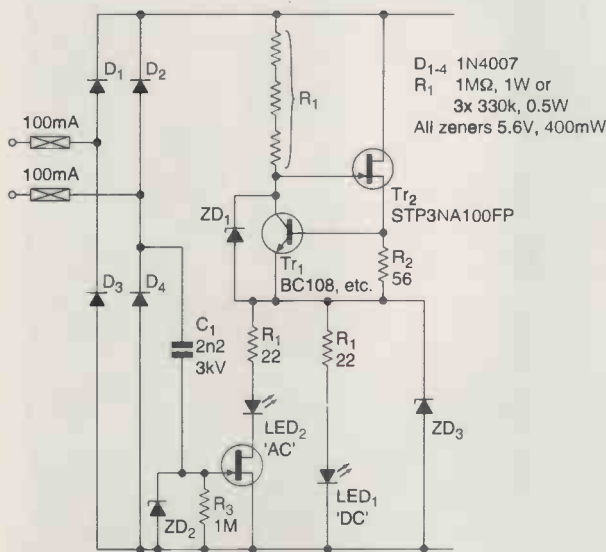

FRUSTRATED!

Looking for ICs TRANSISTORS?

A phone call to us could get a result. We offer an extensive range and with a World-wide database at our fingertips, we are able to source even more. We specialise in devices with the following prefix (to name but a few).



2N 2SA 2SB 2SC 2SD 2P 2SJ 2SK 3N 3SK 4N 6N 17 40 AD
ADC AN AM AY BA BC BD BDT BDV BDW BDX BF
BFR BFS BFT BFW BFX BFY BLY BLX BS BR BRX BRY BS
BSS BSV BSW BSX BT BTA BTB BRW BU BUK BUT BUY
BUW BUX BUY BUZ CA CD DX CXA DAC DG DM DS
DTA DTC GL GM HA HCF HD HEF ICL ICM IRF J KA
KIA L LA LB LC LD LF LM M M5M MA MAB MAX MB
MC MDA J MJE MJF MM MN MPS MPSA MPSH MPSU
MRF NJM NE OM OP PA PAL PIC PN RC S SAA SAB
SAD SAJ SAS SDA SG SI SL SN SO STA STK STR STRD
STRM STRS SV1 T TA TAA TAG TBA TC TCA TDA TDB
TEA TIC TIP TIPL TEA TL TLC TMP TMS TPU U UA
UAA UC UDN ULN UM UPA UPC UPD VN X XR Z ZN
ZTX + many others

Please ask for our Free CD Rom STOCK LIST.
WE STOCK A MASSIVE RANGE OF
COMPONENTS!

Mail, phone, Fax, Credit Card orders & callers welcome.



Cricklewood Electronics Ltd

40-42 Cricklewood Broadway, London NW2 3ET

Tel: 020 8452 0161 Fax: 020 8208 1441

www.cricklewoodelectronics.co.uk

E-mail: sales@cricklewoodelectronics.com

SMALL SELECTION ONLY LISTED - EXPORT TRADE AND
QUANTITY DISCOUNTS - RING US FOR YOUR
REQUIREMENTS WHICH MAY BE IN STOCK

Ring for Latest Reduced Prices on this advert

EXAMPLES OF SPECIAL OFFERS

GOVERNMENT INTENSIFIER NIGHT SIGHTS tested £300 each
MARCONI TF2019A SIGNAL GENERATOR AM/FM 80kcs-1040
MCS, off the stack as come and seen untested £190 - or tested
basic working £300 - or normal Johns Radio workshop test with
warranty £380. All supplied with instruction book - qty available.

TEK 2445A OSCILLOSCOPE - 4 CH - 150 MCS with instruction
book, off the stack as come and seen untested £250 each or
tested basic working £350 - Johns Radio workshop test with
warranty plus two probes and instruction book £400

TEK 2465-2465A-2465B etc available

RACAL DANA 1992 COUNTERS 1.3GHZ tested from £250

RACAL DANA 1999 COUNTERS 2.6GHZ tested from £400

H.P. 53131A COUNTERS 3.0GHZ tested from £750

BENCH + RACK POWER SUPPLIES large range qty from £10

H.P. POWER UNITS 66311B-66312A-66309D in large qty from
£250

H.P. 8922 RADIO TEST SETS TYPE G-H-M-M010 with HP83220 A
OR E GSM CONVERTOR from £500-£1,000 options available
including Spectrum Anz. quantity in stock.

Most previous advertised items available in stock.

ITEMS BOUGHT FROM HM GOVERNMENT BEING SURPLUS, PRICE IS EX WORKS. SAE
FOR ENQUIRIES. PHONE FOR APPOINTMENT OR FOR DEMONSTRATION OF ANY ITEMS,
AVAILABILITY OR PRICE CHANGE, VAT AND CARRIAGE EXTRA. ITEMS MARKED TESTED
HAVE 30 DAY WARRANTY. WANTED: TEST EQUIPMENT-VALVES-PLUGS AND SOCKETS-
SYNCHROS-TRANSMITTING AND RECEIVING EQUIPMENT ETC.

Johns Radio, Whitehall Works, 84 Whitehall Road East,
Birkenshaw, Bradford BD11 2ER.
Tel: (01274) 684007. Fax: 651160

A QUANTUM LEAP IN EMBEDDED CONTROLLERS

Quick FIRE

SUPERCONTROLLERS

Our range provides:-

- The fastest 68000 based Core up to 66 Mhz.
- Extensive I/O:- Serial, IrDA, SPI, I²C, Analogue, Timers/Counters, RTC, etc.
- Large Memory Capacity:- Flash, SRAM, DRAM.
- Supports:- Mono & Colour LCD's, Touch Panels & Keypads, Very Low Power.

ALSO LOW COST

DEVELOPMENT

- target easily & quickly.
- Full ANSI 'C' compiler, assembler & linker all Windows32 based.
- Source Level Debug.
- Full Driver Support with Libraries.
- Real Time Multitasking OS with a free run time licence.
- Free Unlimited email support.

www.cms.uk.com

see our web site for full details

CAMBRIDGE MICROPROCESSOR SYSTEMS LTD



Unit 17-18 Zone 'D' Chelmsford Rd. Ind. Est.
Great Dunmow, Essex CM6 1XG

Telephone: 01371 875644

email: sales@cms.uk.com

35

Anti-sleep alarm

Inattention, daydreaming and sleep are all factors involved in accidents while driving. This circuit provides a short audible alarm every 5 minutes to prevent sleep or loss of concentration when driving. It works by providing three audible 'blips' of 1kHz - generated every 5 minutes.

IC1a is wired as an astable oscillator and it produces the basic 1 second / 300 second timing cycle using a 470µF electrolytic capacitor C1. The longer 300 second period occurs as the capacitor is discharged via a 1MΩ resistor R2 into pin 1 IC1a, having been previously charged via a BAT85 diode D1 and the 3k3 ohm resistor R3 in about 1 second. For C1, use a good quality low leakage type as employed in switched

mode power supply applications.

Two more astable oscillators, IC1b at 1kHz and IC2b at 3Hz, are enabled when the 'out' pin of IC1a is high. The control voltage input of the 1kHz oscillator (pin 11) is modulated by the 3Hz oscillator output via a 270kΩ resistor R8 to produce a distinctive tone. This circuit operates on 5v to 12v DC. Current consumption of the prototype was 13mA (no sound output) with a 5 volt supply. Sound volume and current taken increase with supply voltage. IC2a operates as an inverter, doubling the signal across the loudspeaker LS1. High speed BAT85 diodes on the 'out' pins suppress transients (D2-D5).

R. Turner
Birmingham UK

PARTS LIST

2	NE556 dual timer chips IC1, IC2
5	BAT85 fast diodes D1-D5
1	100Ω sounder LS1
1	470µF 25V electrolytic capacitor C1
1	47µF 25V electrolytic capacitor C4
2	0.47µF polyester capacitor C3, C5
1	0.01µF polyester capacitor C2
2	1M carbon film resistor 1/4W R2, R7
1	270k carbon film resistor 1/4W R8
1	68k carbon film resistor 1/4W R5
1	10k carbon film resistor 1/4W R6
1	3k3 carbon film resistor 1/4W R3
1	4k7 carbon film resistor 1/4W R1
1	2k7 carbon film resistor 1/4W R4
1	PC stripboard 80 x 50mm
2	14 pin DIL sockets
1	Battery snap for 9V cell

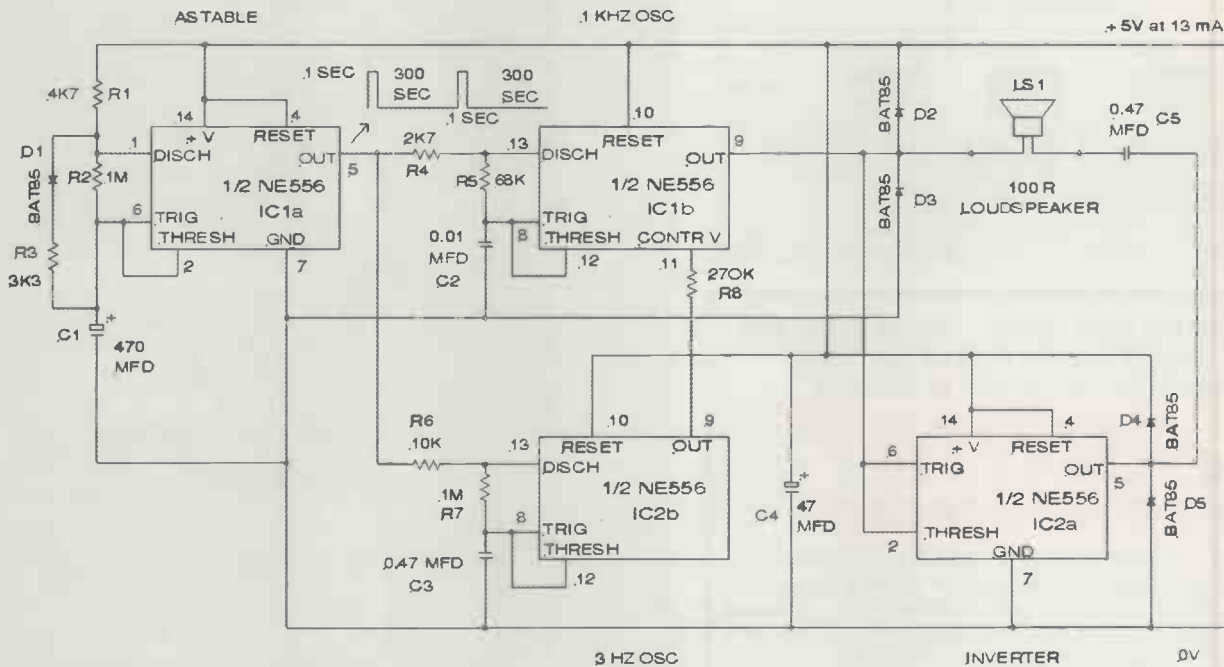

Tracking transmitter

A simple tracking transmitter-receiver can be constructed by adding this circuit to a standard remote control system used for

electric gates, garage doors, etc. The circuit consists of a simple multivibrator, $Tr_{1,2}$, driving a switch. Tr_3 .

Short pulses are generated by the circuit. These are transmitted by the remote control. Because the pulses are kept short, they do not trigger the receiver.

As shown in the inset on the diagram, the remote control unit is modified by shorting out the safety diode and switch. A break

is made in the circuit between the battery negative and the rest of the remote. The circuit connects directly to the remote battery and the negative supply of the remote connects to the collector of Tr_3 .

Modification of the receiver is carried out by removing the relay and associated components. A simple millivolt meter is then connected to the appropriate point to indicate the signal strength.

Amrith Ramjewan
Kwa-Zulu Natal
South Africa

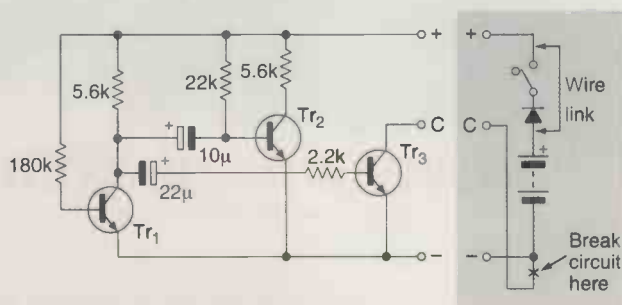

Adding this circuit enhancement to a standard remote control unit as used for garage doors, etc., turns the system into a simple tracking transmitter.



Electronics World reader offer:
x1, x10 switchable
oscilloscope probes,
only £21.74 a pair,
fully inclusive*

*Additional pairs as part of the same order, only £19.24 each pair.

Seen on sale for £20 each, these high-quality oscilloscope probe sets comprise:

- two x1, x10 switchable probe bodies
- two insulating tips
- two IC tips and two sprung hooks
- trimming tools

There's also two BNC adaptors for using the cables as 1.5m-long BNC-to-BNC links. Each probe has its own storage wallet.

To order your pair of probes, send the coupon together with £21.74 UK/Europe to **Probe Offer, Jackie Lowe, Highbury Business Communications, Anne Boleyn House, 9-13 Ewell Road, Cheam, Surrey, SM3 8BZ**

Readers outside Europe, please add £2.50 to your order.

Please supply the following:

Probes

Total _____

Name _____

Address _____

Postcode _____ Telephone _____

Method of payment (please circle)

Cheques should be made payable to ELECTRONICS WORLD

Access/Mastercard/Visa/Cheque/PO

Credit card no. _____

Card expiry date _____ Signed _____

Please allow up to 28 days for delivery

Specifications

Switch position 1	
Bandwidth	DC to 10MHz
Input resistance	1MΩ – i.e. oscilloscope i/p
Input capacitance	40pF+oscilloscope capacitance
Working voltage	600V DC or pk-pk AC
Switch position 2	
Bandwidth	DC to 150MHz
Rise time	2.4ns
Input resistance	10MΩ ±1% if oscilloscope i/p is 1MΩ
Input capacitance	12pF if oscilloscope i/p is 20pF
Compensation range	10-60pF
Working voltage	600V DC or pk-pk AC
Switch position 'Ref'	
Probe tip grounded via 9MΩ, scope i/p grounded	

DRM reception using the RX-320

Last month, Roger Thomas reviewed the Ten-Tec RX-320 computer controlled radio receiver. This month he describes some modifications to the unit that enable it to receive DRM broadcasts. Conversion of this product is entirely at your own risk!!!

Just to re-cap, the 'RX-320 DSP PC radio' is manufactured by Ten-Tec in Tennessee, USA. It is a general coverage radio controlled by a PC, with frequency range of 100kHz to 30MHz. The radio is a triple conversion superhet and reception modes are AM, USB/LSB and CW. In the UK this radio is available from AOR TenTecDIRECT.

DRM background

The Digital Radio Mondiale (DRM) consortium was founded in 1998 and represents broadcasters, academic institutions and manufacturers. Its purpose is to develop a non-proprietary technical standard for the replacement of analogue AM (Amplitude Modulation) radio with digital radio, also called DRM. The International Telecommunications Union (ITU), International Electrotechnical Committee (IEC), and the European Telecommunications Standardisation Institute (ETSI) have all approved DRM broadcasts for frequencies below 30MHz.

As a replacement for AM, the existing channel spacing, medium and long wave 9kHz and 10kHz for short wave, is maintained. A DRM radio broadcast provides FM audio quality and most people will relate to the poor audio quality of AM music. Audio deterioration due to radio propagation fading or interference will not be so evident. Providing the DRM decoder software receives enough data correctly, it will be able to accurately rebuild the audio or data as it was originally coded. Also the display of the name of the radio station, programme text, and automatic tuning to

alternative frequencies will make DRM receivers easier to operate. DRM can also transmit multimedia html pages and data.

Until there is a DRM receiver chip set, the only way for radio enthusiasts to listen to these broadcasts is to modify an existing short wave radio. This requires a signal from the radio before demodulation, to be fed to the soundcard of a PC for decoding. Suitable DRM decoder software has only recently become available (details later).

DRM modulation

The DRM radio signal consists of data transmitted using COFDM (Coded Orthogonal Frequency Division Multiplex). COFDM is a spectrum efficient digital modulation scheme employing equally spaced carriers across the whole of the radio channel (9kHz for long or medium wave, and 10kHz for short wave). The actual number of carriers depends on the mode and channel bandwidth. Fig.1.

Mode A is most likely to be used on medium and long wave using ground wave propagation. On short wave, mode B is for single hop and mode C for long path multi-hop. Mode D is the most robust and could be used for Near Vertical Incidence Skywave (NVIS) broadcasts where the radio signal is broadcast upward and the ionosphere reflects the signal back down. This mode is little used in Europe but is common in the tropical bands as it gives considerable coverage with a single transmitter located in the centre of the broadcast area,

Data to be transmitted is systematically spread across these carriers and each carrier is modulated using QAM (Quadrature Amplitude Modulation). QAM is a mixture of fixed amplitude and phase modulation. DRM incorporates error protection so that selective fading, or interference, with the subsequent loss of some carriers does not affect the overall transmitted data. Although we talk about a DRM signal having many carriers, when the DRM signal is viewed in the frequency domain,

Fig. 1. Summary of DRM broadcast modes.

DRM mode	propagation	carrier spacing	data rate	error protection
A	minor fading	42Hz	highest	lowest
B	as 'A' plus selective fading	47Hz	middle	low
C	as 'B' plus severe fading	70Hz	low	middle
D	as 'C' plus severe Doppler shift	107Hz	lowest	highest

the spectra of each carrier overlaps adjacent carriers.

A typical DRM short wave broadcast (10kHz channel and mode B) would have a data rate of around 21kbps (assuming 64-QAM). A medium wave broadcast that requires the less robust transmission mode A, may have a slightly higher data rate of around 24kbps - even though it occupies less radio spectrum.

DRM multiplex structure

The DRM multiplex is divided into three sub-channels:

1] Each transmission frame contains Fast Access Channel (FAC) data. This FAC 64 bit block contains information to allow the DRM software to decode the multiplex. FAC parameters include: spectrum occupancy, interleaver (0.4 or 2 seconds), MSC modulation mode, SDC modulation mode, number of services, language, audio or data, and programme type.

Whatever the spectrum occupancy or transmission mode, the DRM decoder always needs this FAC information first to know how to decode the rest of the DRM signal. Consequently the FAC is always transmitted in the same place using 4-QAM and at a fixed code rate.

2] The Service Description Channel (SDC) contains information about all the services available and is transmitted every 1.2 seconds. It is primarily intended to give the listener information about the tuned DRM radio station and is similar in operation to VHF-RDS. It includes the radio station name (up to 16 characters), alternate frequency and schedule information, coverage area, time and date.

3] As the name would suggest, the Main Service Channel (MSC) contains the data for all the services contained in the DRM multiplex. The multiplex may contain between one and four services, and each service may be either audio or data. Audio streams comprise compressed audio data and can also carry text messages over several audio frames. These text messages require very little bandwidth (approximately 80bps).

The MSC may use either 64-QAM or 16-QAM on each carrier. 64-QAM provides high spectral efficiency whereas 16-QAM provides a better performance in the presence of errors caused by poor propagation conditions.

Audio coding

DRM uses aacPlus™ Coding Technologies audio compression. This is a combination of MPEG AAC (Advanced Audio Coding) and SBR (Spectral Band Replication). SBR is a technique that increases bandwidth of the audio signal from a combination of a low bandwidth AAC signal and SBR data that reconstructs the higher audio frequency.

An AAC basic audio signal provides a frequency bandwidth of 6kHz, still better audio quality than standard AM (4.5kHz or 5kHz), plus the frequency enhancement using SBR extends this to 15.2kHz (equivalent to FM radio quality).

Radio modifications

We can no longer think in terms of demodulating either AM upper or lower side band with DRM as the data can occupy the whole radio channel. It is true that there is a simulcast mode with DRM occupying the upper side band and the lower side band carrying AM, but the majority of DRM test transmissions occupy the full

channel. Consequently modifying radios for DRM usually involves replacing the IF filters with filters of a wider bandwidth. This modification can cause problems as noise or interference from the local oscillator could be introduced into the IF that were previously outside the AM IF filter pass-band and were thus attenuated.

Also the IF in most short wave radios is typically 455kHz and this has to be mixed with a 433kHz or 467kHz local oscillator (usually a crystal) to produce the IF centred on the 12kHz required by the Fraunhofer DRM decoder software (described later). It is not possible to feed the 455kHz IF signal direct to the soundcard as the frequency is much higher than a soundcard can handle, so the receiver's IF signal needs to be shifted down in frequency.

It is not feasible to connect the audio output from an AM receiver to the PC soundcard. A DRM signal is modulated in QAM, so both the phase and amplitude of the transmitted signal are needed to be able to decode the DRM signal. In AM demodulation all phase information is lost.

RX-320 radio

The RX-320 already has IF filters that are wide enough (15kHz) to accommodate a DRM signal and it has a final IF of 12kHz that feeds the internal DSP from the RF board. This makes the conversion very easy. Unlike the modifications required for other receivers there is no replacing of components or cutting printed circuit board tracks to insert components.

This conversion does *not* affect in any way the reception of existing modes or operation of the radio and you can continue to enjoy AM broadcasts (while they are still transmitted!) If you modify your RX-320, then you will be able to directly compare analogue AM and digital DRM broadcasts and decide if the inherent advantages of digital DRM broadcasts will lead to the demise of analogue AM radio.

Taking the RX-320 apart

The RX-320 consists of two printed circuit boards, on top is the RF board and underneath the aluminium chassis is the DSP board. Both these circuit boards bolt onto the aluminium chassis using stand-offs.

The screened cable is the filter op-amp output carrying the 12kHz signal to the DSP IF board from the RF board. This is the signal that we also want to feed into the computer's soundcard so that the PC can decode the received DRM signal. The RF circuit board needs to be turned over so that a screened cable can be soldered to this 12kHz connector.

Unplug all the leads

Fig. 2. Underneath of RF board showing surface mount components and the position of screened cable for the 12kHz IF.

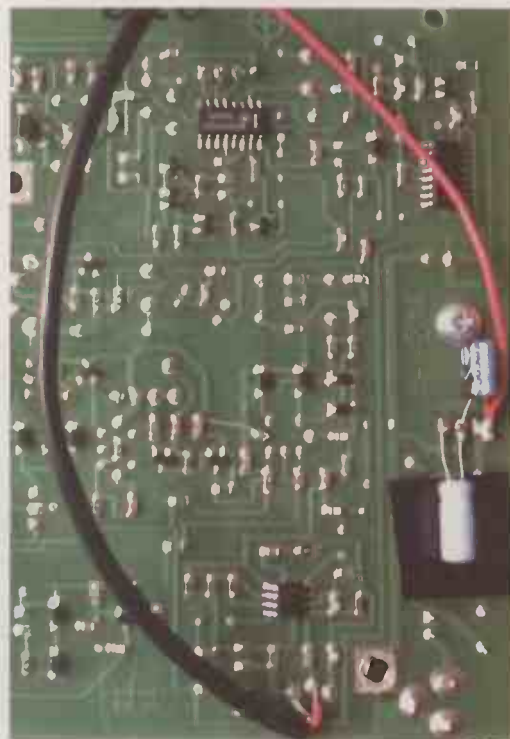

and the telescopic aerial and remove the upper half of the case to expose the top board. The RF board is secured to the chassis by three screws, remove these and gently turn this board over so that the underside is visible with the surface mount components. Care needs to be taken as the external aerial socket is directly mounted to the printed circuit board and protrudes through the back panel.

DRM modifications

Solder one end of a screened cable core to the connector's middle pin and the cable screen to either side of this connector. Replace the board and three screws on the stand-offs. There is sufficient room for this cable to pass underneath the board. This new lead will need to be connected to a suitable jack socket. Note that the wire link visible in the centre of the photo was done by the manufacturer and nothing to do my DRM modifications, Fig. 2.

If you don't like the idea of drilling holes in the case to house the jack socket, then there is an alternative that I used on my RX-320. In fact, there are already two holes drilled in the front panel which are used to hold the Ten-Tec plastic logo. This plastic logo is not just stuck on to the front panel as you would expect but has two locating lugs that secure it to the front panel. To be able to use these holes, the manufacturer's logo has to be removed (sorry Ten-Tec).

On the rear of the front panel remove the glue that holds the plastic logo in place. When all the glue is removed gently push on the two plastic lugs to force the logo from the front panel. This will reveal two small holes of 3mm diameter and 13mm apart.

I removed the front panel by undoing the two screws that hold the panel to the internal chassis, and used a tapered reamer to manually enlarge one of the holes so that a 3.5mm jack socket could be fitted. The jack socket is the same size as the existing audio output sockets on the rear panel so that all the audio leads are

interchangeable. Drilling holes in situ is not advisable as metal debris could fall on the circuit boards.

If you think that there should be the manufacturer's logo on the front panel, then remove the two plastic lugs so that the back of the logo is flush, and glue it in a suitable position on the front panel.

On the 3.5mm jack socket I wired a 0.1µF electrolytic capacitor in series with the 12kHz signal. This capacitor is intended to give some isolation between the radio and PC and should prevent any faults or interference from the computer being fed directly back to the RX-320's DSP, Fig. 3.

The second logo panel hole can also be used to our advantage. There is no indication if the RX-320 radio is switched on so I have used this hole, conveniently 3mm diameter, to accommodate a 3mm LED. It was possible to insert the LED directly in the hole but I used the reamer to slightly enlarge this hole to accommodate a suitable clip so that the LED is held more securely.

I used a high efficiency type LED with a 4k7 current limiting series resistor. The LED is wired direct to the voltage input of the voltage regulator – this is the red wire visible in Fig. 2. There are many other positions on the circuit board for finding a suitable voltage.

Glitches

The two electrolytic capacitors visible in Fig. 2 are not part of the DRM modification. I occasionally found that switching on of some domestic appliances caused a glitch in the mains supply and this produced a momentary drop in audio. This was not a particular problem when listening to AM radio but it did have, literally, an unsettling effect on the level of the DRM signal and sometimes caused the decoder software to lose synchronisation. Adding these capacitors to the input and output of the voltage regulator helped reduce the effect.

Audio connections

There are now two outputs from the RX-320 that need to be connected to the computer's soundcard - the normal demodulated audio from the DSP (rear panel) and the 12kHz IF signal (front panel). The audio line output of the RX-320 is connected to the line-input of the soundcard. The RX-320 line output volume must be set using the RX-320's control program and the mixer microphone input level set low otherwise the fixed amplitude audio signal could overload the soundcard's input, Fig. 5.

The PC's soundcard is used as a low cost analogue to digital converter – the 12kHz signal is treated as an audio signal, but remember that it is not demodulated audio. The 16-bit soundcard needs to support a 48kHz sample rate and must also allow duplex operation so that as the DRM signal is fed into the DRM decoder software it can output the decoded audio.

I have a SoundBlaster Live! 1024 PCI card and found no problems. However, some soundcards will not work,

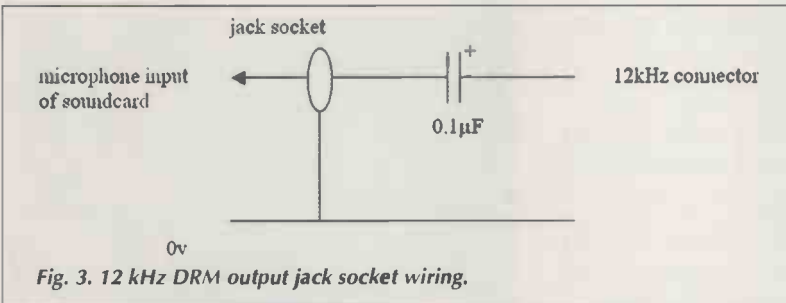

Fig. 3. 12 kHz DRM output jack socket wiring.



Fig. 4. RX-320 DRM modified front panel, incorporating the 12kHz output jack socket and LED.

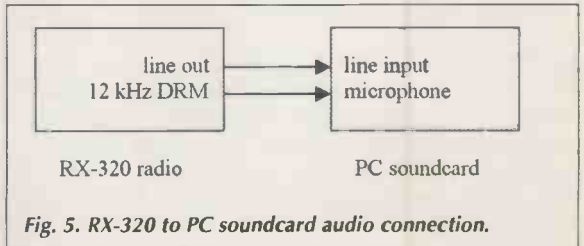

Fig. 5. RX-320 to PC soundcard audio connection.

particularly some of the integrated multimedia devices found on motherboards. The DRM web site has a soundcard forum for more information on this subject.

Mixer program

The Windows Play Control software is required so that the appropriate input can be selected and the output volume set. If the volume control is not visible on the taskbar it can be found in the Accessories/Entertainment directory from the Start/Programs menu (XP). With the SoundBlaster soundcard both volume and microphone have advanced option buttons - the microphone option has a +20dB boost, which should be disabled and the volume control has tone controls. Other soundcards may have different options, but any input filter options or automatic gain control should be switched off.

When the DRM decoder software is running the line-in and microphone input should be muted as the software decoder is sending the DRM decoded audio to the 'wave' output, and you'll need to adjust this wave slider as appropriate. The Play Control slider sets the overall volume.

If you select Line-in or Microphone on the Play Control when tuned to a DRM station all you will hear is high frequency noise. DRM COFDM signals do not have any discernible audio pattern. For normal AM audio - only mute the Microphone input. **Fig. 6.**

The Record Control does not need to be altered, as the above setting will work for either DRM or normal AM audio.

DRM decoder software

There are two programs available that can decode the data transmitted in a DRM signal and produce an audio output.

The DRM consortium decoder software is called 'DRM Software Radio' and is written by the Fraunhofer Institut Integrierte Schaltungen (Institute for Integrated Circuits). Fraunhofer IIS is a founder and leading member of the DRM consortium and wrote DRM decoding software, called 'FhG Software Radio', using the output from a modified AOR AR7030 receiver. This software and modified radio was sold to broadcasters and commercial organisations.

DRM Software Radio is a scaled down version of the commercial FhG Software Radio program and version 1.0.18 was eventually released on the 31st of December 2002. This software is for personal use and cost me £36.71 (60 euro). DRM claim that this software is sold on a not-for-profit basis. This 'nominal modest charge' for the software licence is to cover various royalty and licence payments, primarily for the audio aacPlus codec software, Fraunhofer software development costs and maintaining the drmr.org web site. This software requires over 25 Mbytes of disk space and has over 570 individual files.

What has been left out of the DRM Software Radio version is all the different signal monitoring options - the only option available is to display the spectrum of the input 12kHz signal. The ability to save the decoded digital signal or audio to hard disk is not available.

Also missing are details on the DRM multiplex decoded from the FAC information. This is a strange decision as the FhG Software Radio displays this information. The software is aimed at radio enthusiasts and radio amateurs who would be interested in the more

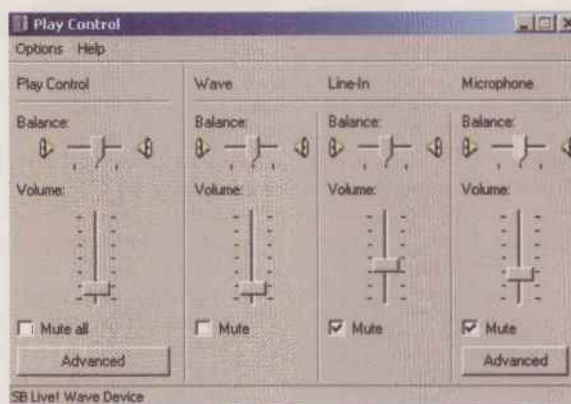

Fig. 6. Windows XP Play Control controls set for DRM.

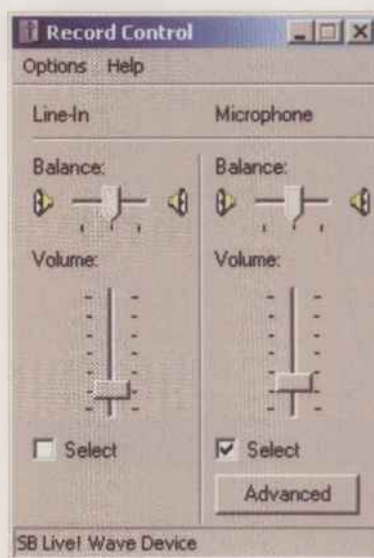

Fig. 7. Windows XP Record Control.

technical aspects of DRM. The software does display information on the individual services as a DRM multiplex may have up to four different services available.

Downloading the software

To get your copy of this decoder software you will need to go on-line to the www.drmrx.org web site and click purchase software. After a few information screens you are transferred to a secure transaction server for details of your credit card, address and e-mail. After successful payment there is a link back to the www.drmrx.org web site where the decoder software can be downloaded. This file is 13Mbyte and took me 50 minutes to download using a 56kbps dial-up modem. The small 'keyfile' to enable the software to run is e-mailed to you direct from VT Merlin Communications.

Support for the software is only available via the drmr.org web site and that the web site will cease operation at the beginning of 2005. New versions are free to registered users to download from the web site.

Set-up

After the DRM Software Radio has been installed, there are very few items that need to be set up. The program prompts for your latitude or longitude and a disk directory. The reason for this is that as DRM is a digital transmission, the usual subjective SINPO (signal

strength, interference, noise, propagation, overall merit figures are no longer relevant. Instead the software can measure the quality of reception by the number of audio data blocks received correctly on a minute by minute basis. The DRM Software Radio software saves this information in a text file in the designated directory.

The latitude and longitude determine where DRM reception took place, this identifies if the listener is in the designated broadcast target area or not. If you don't know your latitude or longitude the software comes with a database of airports(!) Select your nearest airport from the list, then enter your position relative to this airport and the software will automatically calculate your latitude and longitude location. **Fig. 8.**

It is not necessary to do this immediately as whenever the Start Record button is pressed the Record form

Fig. 8.
Pressing Record on the main form displays this pop-up menu.

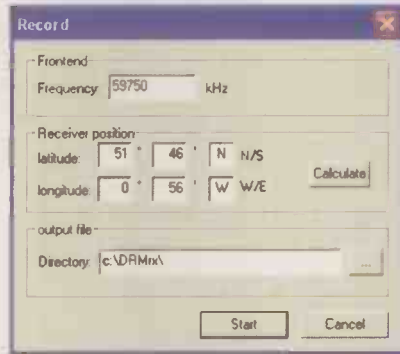
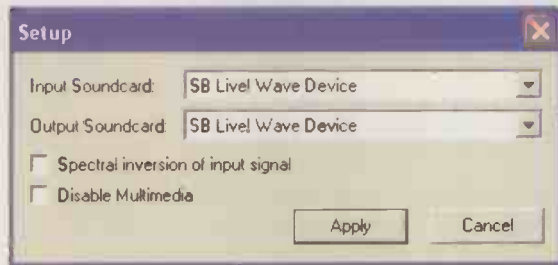

Fig. 9. Setup options form.



appears and the frequency, latitude and longitude numbers can then be entered by the user. Pressing the Calculate button displays the list of airports.

Clicking on the Set-up button produces this simple form, **Fig. 9.**

The software automatically allocates the first soundcard it finds but the option is there to choose another soundcard if your PC has more than one. The spectral inversion option is required as it is possible with an AM receiver that the IF spectrum we are feeding into the soundcard is inverted. This inversion does not matter for demodulation of AM side bands, but it does matter when decoding DRM.

The Disable Multimedia option is required only if the decoder software is running on a computer that does not have an Internet connection and therefore may not have html multimedia support.

Cost of software

Personally I think the cost of this software may put some enthusiasts off the idea of modifying their radio equipment. It is not possible to know how successful any receiver modification has been until the DRM software has been purchased. Although viewing a DRM signal using spectrum analyser software may give the appearance that the signal is being received correctly centred on a 12kHz IF, this does not guarantee that the DRM software can properly decode the phase and amplitude of each carrier.

If the modifications don't work then you may be left with redundant software and a credit card bill.

'Dream' software

There is an alternative DRM decoder software that is free for personal use under the terms of GNU General Public License (GPL).

The Darmstadt University of Technology, Institute for Communication Technology have available for download a DRM decode program called 'Dream' - as in DR(ea)M. These Windows and Linux programs are written by Volker Fischer and Alexander Kurpiers and they should

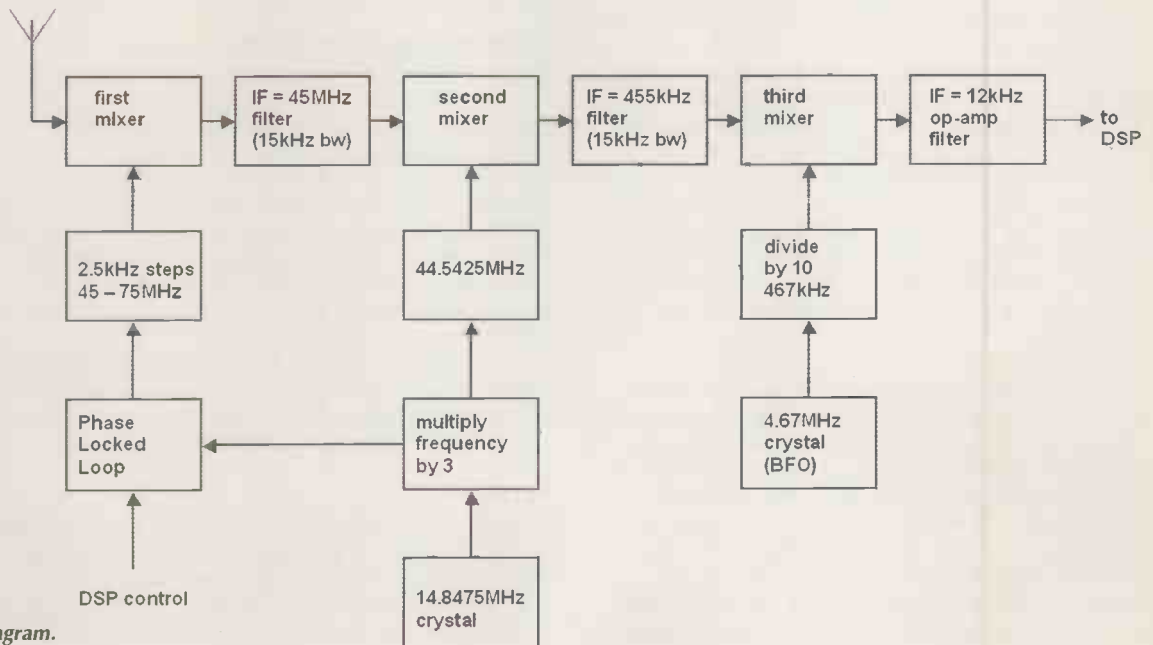

Fig. 10. RX-320 block diagram.

RX-320 tuned frequency (MHz)	RX-320 IF frequency	Fraunhofer software	Dream software
15.443751	15.446250	6.0kHz	will not decode
15.441251	15.443750	9.5kHz	will not decode
▲ 15.440			
15.441250		12.0kHz	will decode
▼ 15.438751			
15.438750	15.436251	14.5kHz	will not decode
15.436250	15.433751	17.0kHz	will not decode

Fig.11. Effects on the DSP IF of tuning either side of a DRM signal centred on 15.440 MHz

be congratulated for putting these into the public domain. However there is no .exe file available from this site, only the Visual C++ source code. The reason for this is the Dream program uses open source code from several sites. Anyone is free to download and use the source code but the licence does not necessarily give the right to distribute the resulting binary or .exe file without paying royalties.

This version of Dream does not have any multimedia support and the SBR part of the audio codec is not yet implemented (only AAC decoding) so the sound quality is worse than the Fraunhofer program. However, as the source code is in the public domain, hopefully other programmers will help improve the software.

Unlike the Fraunhofer software, this DRM decoder software scans the entire sound card bandwidth looking for DRM signals and no particular IF is needed. It is this fact that makes it suitable for use with the RX-320 as we shall see later. For use with other receivers, then a down converter mixer circuit is still required but there is a wider choice for the local oscillator frequency as a mixer using a 467kHz crystal can be expensive. This software expects the DRM signal on the microphone input.

Triple superhet

As already established, the RX-320 radio is a triple conversion superhet with intermediate frequencies of 45MHz, 455kHz and 12kHz. The first local oscillator in the RX-320 operates over a range of 45-75MHz so the incoming radio signal is shifted up in frequency. As can be seen on the block diagram, this first local oscillator synthesiser is tuned in steps of 2.5kHz controlled by the DSP and the fine-tuning is done in DSP software.

Tuning the radio to a particular frequency requires the PC control software to calculate and send three parameters to the RX-320. The first is the coarse tuning and represents the number of 2.5kHz steps required to get as close to the required frequency as possible. The second parameter is for DSP software fine-tuning and represents the difference between the coarse and required frequency. Third parameter is BFO settings if the receive mode is SSB or CW, Fig. 10.

This coarse tuning causes a problem as there are received frequencies that produce a DSP IF that is not centred on 12kHz but either 6kHz, 9.5kHz, 14.5kHz or 17kHz. This is the DSP IF with offset plus or minus multiples of the 2.5kHz tuning step and the whole spectrum of the received IF signal is shifted accordingly.

The RX-320 DSP software then automatically adjusts for this frequency shift using the fine-tuning information

calculated by the PC control software, but the Fraunhofer DRM decoder software requires a DRM signal centred on 12kHz. As we are not using the RX-320's DSP to decode DRM then selecting different filter bandwidths does not alter the 12kHz IF signal, only how the DSP software decodes the 12kHz signal.

Fortunately this multiple IF tuning is not as bad as it first appears, dividing any RX-320 received frequency (in kHz) by 2.5 (tuning step) that yields a remainder of 0 will result in a 12kHz IF. Fig. 11.

Channel spacing

The vast majority of short wave broadcasters use frequencies that either end in 0 or 5 (kHz), therefore for these broadcasts the RX-320 will produce a 12kHz signal suitable for the Fraunhofer DRM decoder. This is the internationally agreed ITU band plan of 5kHz channel spacing for short wave. There are a few short wave stations broadcasting, particularly in the tropical bands, that do not adhere to the 5 kHz channel separation, but practically all the short wave stations that we are likely to listen to in Europe will have this 5kHz spacing.

In the UK and Europe the current band plan for

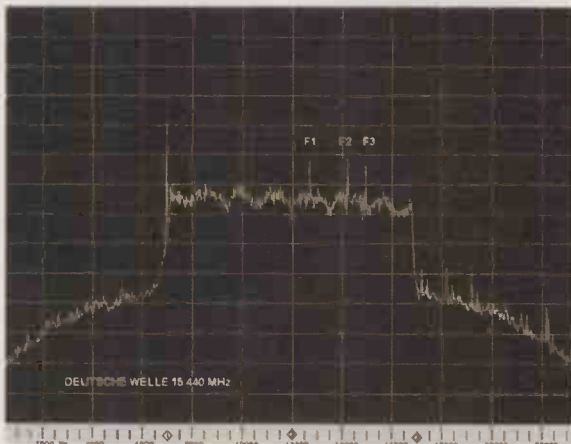

Fig. 12. Spectrum of 12kHz IF DRM short wave radio signal using Spectrum Lab software

Fig. 13. Frequency measurement of DRM FAC carriers

FAC	Measured Frequency	calculated frequency	actual frequency	offset
F1	12672Hz	672Hz	750Hz	78Hz
F2	14172Hz	2172Hz	2250Hz	78Hz
F3	14922Hz	2922Hz	3000Hz	78Hz

medium and long wave is based on 9kHz channel separation. At present in the UK there are no DRM stations operating in these bands and we are unlikely to have any before the widespread availability of DRM receivers.

It is possible due to the nature of the RX-320's synthesised tuning that there will be received frequencies that do not produce a 12kHz IF. On medium wave, frequencies such as 630kHz, 1170kHz, 1215kHz should be received correctly. As can be seen from Fig. 9, frequencies 1kHz either side of a frequency ending with 0 or 5 should also produce a 12kHz IF (such as 909kHz). Any DRM stations on these frequencies should be decoded by the Fraunhofer software. However there are frequencies such as 828kHz, 882kHz, 1053kHz that the Fraunhofer software will not be able to decode, but the Dream software should.

DRM can support single frequency networks so the current band plan will need to be altered. Also the DRM specification allows for many different channel occupation bandwidths including 18kHz for medium wave and 20kHz for short wave. I am sure that the DRM stations, once established, would push for this spectrum increase as it would allow DRM stations to broadcast in stereo and compete with VHF-FM radio.

Spectrum analysis

To view the DRM signal being fed into the soundcard I used the excellent Windows Spectrum Lab program written by Wolfgang Buescher, DL4YHF. This program is free software under the terms of the GNU General

Public License and is a useful initial check to see if the radio modifications result in a 12kHz IF. As stated previously, you cannot assume that because the radio signal is correctly centred on 12kHz that it is suitable for decoding.

Some of the DRM carriers (Fig. 13.) do not transmit programme data but instead are used by the DRM receiver software to synchronise to the DRM signal. These Fast Access Channel (FAC) reference carriers have their amplitude boosted relative to carriers carrying data by a power gain of 2. The DRM software examines the amplitude difference between data carriers and these FAC reference carriers to help achieve synchronisation.

Screen shows the spectrum of a received 12kHz DRM signal sampled at 48kHz with averaging. The three FAC reference frequencies are marked F1, F2, F3.

The difference between the measured frequency and expected FAC frequency can be explained by the RX-320 IF not being exactly 12kHz or the soundcard may not be sampling at exactly 48kHz, probably due to crystal tolerances.

The spectrum plot also shows that there is no spectral inversion as the FAC carriers should be where, in conventional AM, the upper side band would be located. Carriers close to the band edge can also be boosted by a power gain of four, but not all broadcasters do this.

DRM stations received

For DRM reception, the signal to noise ratio (SNR), as measured by the decoder software, is the most important factor. Most transmissions on short wave require a minimum SNR of 12 to 18dB.

The following long-term DRM test transmissions have all been received using the RX-320. Not all transmissions were received on a daily basis, partly because these are test transmissions and are liable to change or cancellation and also radio propagation varies from day to day. Check the Radio Netherlands web site for the latest DRM test timetable.

The aerial used was a long wire feeding a broadband magnetic balun and the 50 ohm output from the balun is connected to the antenna input of the RX-320 using a metre of co-axial cable. The internal telescopic aerial was satisfactory for all the DRM transmissions but the long wire was slightly better for some of the transmissions.

Examples of DRM stations

The following screen shots are of DRM test stations as received using the Fraunhofer DRM Software Radio. Each radio station uses slightly different DRM parameters and this shows up in the audio data rate figure. In general the higher the audio bit rate - the higher the SNR needs to be to decode the audio. The text message is transmitted as part of the audio frames.

Deutsche Welle

Deutsche Welle broadcasts from a transmitter located in Sines, Portugal with these transmissions targeted at Western Europe. This DRM radio station is usually the strongest and most reliable of all the DRM test stations.

BBC World Service

BBC World Service is broadcast from a transmitter located in Rampisham, Dorset, UK and is operated by Merlin Communications. These broadcasts are directed

Fig. 14. Deutsche Welle 15.440MHz broadcast - the boosted band edge carrier is clearly visible.

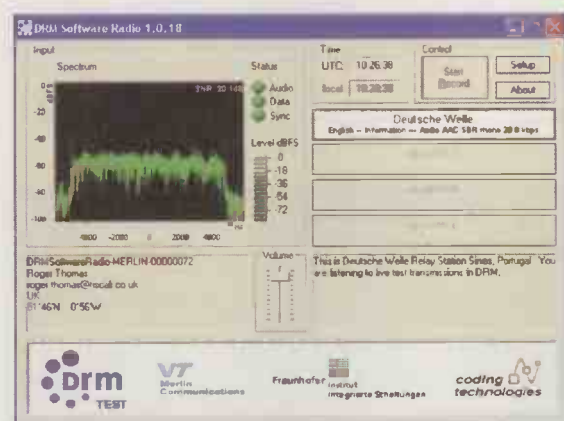
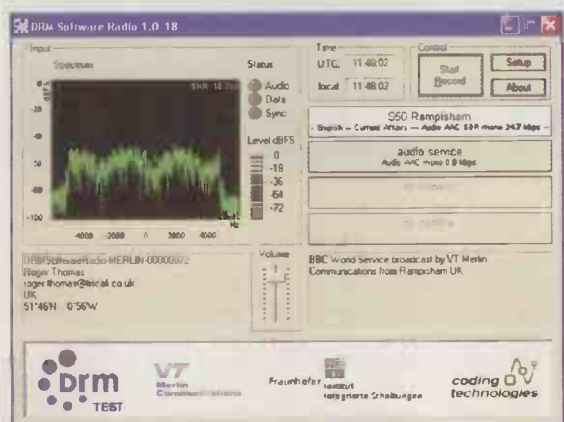

Fig. 15. BBC World Service broadcast from Rampisham, Dorset.



towards Europe or Scandinavia, so reception here was sometimes poor and other times excellent. As these are test transmissions, different parameters and configurations are being tried. Fig. 15. demonstrates this - as the second audio channel does not have any bits allocated!

I have received the 9.78MHz broadcast with AAC mono at only 11.6kbps with audio quality no better than

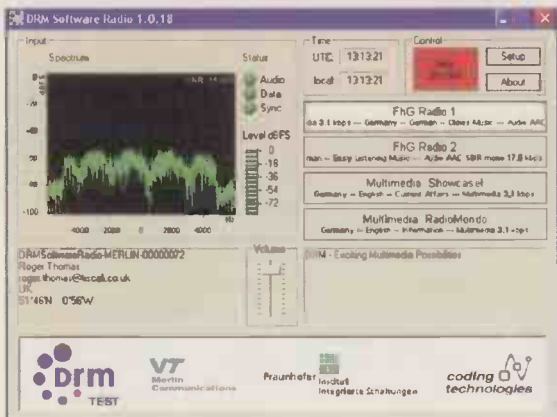

Fig. 16. Deutsche Telekom multimedia broadcast on 5.975MHz from Juelich, Germany.



Fig. 17. DRM transmitted web site from Deutsche Telekom.



Fig. 18. Example of DRM multimedia transmitted by Deutsche Telekom.

AM and broadcasts at a higher bit rate at AAC SBR mono 24.7kbps. The BBC also broadcasts DRM to North America using Radio Canada's Sackville transmitter (6.010MHz).

Deutsche Telekom

DRM multimedia broadcast from Deutsche Telekom (T-Systems), as the jingle says 'DRM ... the digital future of AM radio'. AAC SBR mono audio transmitted at 17.8kbps and multimedia transmitted at 3.1kbps. Although the number of DRM services is overstated, there is actually only one shared audio service, not two separate audio services as suggested. There are two types of multimedia transmitted - those pages associated with the audio service (Program Associated Data) and independent multimedia services. The Fraunhofer decoder software is able to display DRM multimedia pages but not the current version of the Dream software.

Radio Netherlands

The following screen shows the Dream software decoding the Radio Netherlands 15.170MHz night time broadcast from Bonaire, Netherlands Antilles. In case you are wondering where Bonaire is, it is a small island off the coast of Venezuela. These broadcasts were more difficult to receive.

Dream provides more technical information derived from the FAC of the received DRM broadcast than the Fraunhofer decoder, including various chart display options. The software also confirms the small frequency offset inherent in the soundcard sampling.

DRM reception report

Reception information can be saved to disk when using

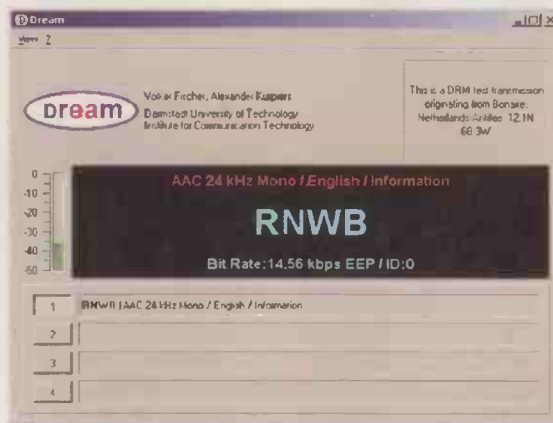

Fig. 19. Radio Netherlands broadcast on 15.170MHz.

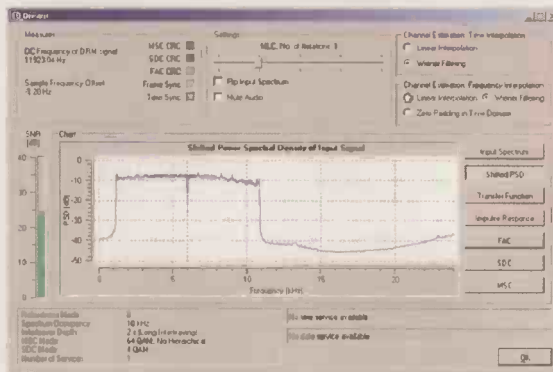

Fig. 20. Selecting the View option displays this form (Radio Netherlands broadcast 15.170MHz).

web sites

- www.drm.org (DRM consortium site)
- www.drmrx.org or www.drmswr.com (DRM software homepage)
- www.codingtechnologies.com (aacPlus homepage)
- www.qsl.net/dl4yhf (SpecLab homepage)
- www.tu-darmstadt.de/fb/et/uet/fguet/mitarbeiter/vf/DRM/DRM.html (Windows Dream page)
- www.tu-darmstadt.de/fb/et/uet/fguet/mitarbeiter/kur/linux-soft.html (Linux Dream version)
- sourceforge.net/projects/drm (Dream source code files and Dream forum)
- www.gnu.org/copyleft/gpl.html (information on General Public License)
- www.audiocoding.com (MPEG-4 audio codecs)
- www.merlincommunications.com (Merlin)
- www.rnw.nl (Radio Netherlands)
- www.rnw.nl/realradio/html/drm_latest.html (latest DRM timetable)

the Fraunhofer decoder by pressing the 'Start Record' button. An example of the contents of a DRM-Software-Radio.log is shown in Fig. 21, this shows reception of Deutsche Welle DRM broadcast from Sines in Portugal using the RX-320 and the telescopic aerial.

Listening to the broadcast I did not hear any fading or audio dropouts. The SYNC column indicates the number of FAC frames received correctly. Apart from minute 8 were one frame was not decoded, all FAC frames were received. The /10 in the AUDIO column indicates there are 10 audio frames per transmission frame in this broadcast. As there are 150 transmission frames per minute this results in 1500 audio frames per minute. The loss of a few audio frames does not cause any loss of audio output.

```
>>>>
DRMSoftwareRadio-MERLIN-00000072
Software Version 1.0.18
Starttime (UTC) 2003-01-01 11:04:34
Frequency 15440 kHz
Latitude 51°46'N
Longitude 0°56'W
```

CRC: 0x6252

Minute	SNR	Sync	Audio	Type
0000	21	150	1500/10	0
0001	21	150	1491/10	0
0002	20	150	1500/10	0
0003	20	150	1500/10	0
0004	21	150	1510/10	0
0005	20	150	1499/10	0
0006	21	150	1500/10	0
0007	21	150	1495/10	0
0008	21	149	1490/10	0
0009	21	150	1500/10	0
0010	20	150	1500/10	0
0011	19	150	1498/10	0
0012	19	150	1500/10	0
0013	20	150	1500/10	0

```
<<<<
```

The format is –
 License number and software version.
 Start date and time in ISO 8601 format.
 MINUTE: minute by minute signal analysis.

- SNR: average signal to noise ratio.
- SYNC: number of frames where the Fast Access Channel data was received correctly.
- AUDIO: number of error free audio frames received / number of audio frames per transmission frame.
- TYPE: 0 = AAC (audio).
- CRC: Cyclic Redundancy Check.

DRM reception

The first thing that I noticed is that speech is clearer and the music quality is good. On reasonable strength signals there is none of the distinctive audio distortion caused by selective fading that we are accustomed to hearing on short wave, or any background noise. Watching the spectrum display you can see the turbulent effects of ionospheric propagation on the radio signal.

With a good signal strength the whole process of synchronisation and decoding can take between 10 to 25 seconds before hearing the transmitted audio. On weak signals the FAC information may be decoded but until the received signal level achieves a higher SNR then there is no audio but when there is no audio there is no noise - only silence.

When the signal strength drops below a critical SNR and audio data is lost due to too many data errors received the FhG software decoder software will for a very short time repeat the last good audio block, in the expectation that the signal level will recover. The Dream software simply mutes the audio.

On short wave DRM listeners will have to put up with an occasional loss of audio caused by a deep propagation fade, this will occur however good the receiver or decoder software. Worst case is the signal strength constantly varying around this critical signal level. The audio becomes very strange with short bursts of sound, then gaps.

When this happens speech can become incomprehensible. Listeners to such a broadcast may conclude that DRM doesn't work. This aspect of digital radio is going to be the most difficult to explain to the mostly non-technical general public. ■

Fig. 21. Contents of file DRMSoftwareRadio.log of received DRM broadcast

Dinosaur computers

In 1962, main memory was either delay line or magnetic core memory. Logic was a completely different technology and comprised circuits made up by wiring together individual transistors and resistors. A limited communication channel between memory and processing, later called 'The Von Neumann Bottleneck', resulted inevitably from the use of two disparate technologies. Following on from an article in the January issue of *Electronics World* by Nigel Cook, Ivor Catt looks at what might have been, had anybody listened.

In R&D at Ferranti Ltd., West Gorton, Manchester, where we designed and built computers, there was an in-house one day conference in late 1962 to discuss the significance for computer design of the newly arriving integrated circuit which contained more than one component fabricated together on a single chip. Semiconductor technology looked set to take over the two previously separate roles; memory and processing.

Ferranti's brightest engineer, K. C. Johnson (Ken Johnson) drew a transistor bistable (= memory bit, now called SRAM) on the board, and pointed out that with a (totem pole of) one further transistor per bit, a full column of bistables could be searched in one cycle to look for the presence of one or more 'ones' stored as shown in Fig. 1. (DRAMs had not been thought of then). This had a traumatic effect on me. It meant that the historic reason for separating processing from memory (via the "Von Neumann Bottleneck") had disappeared.

The first technically achievable stage in complexity would be for a single instruction to cause every word with (say) 1101 as its most significant four bits, to exit memory one at a

time. That was called a 'Content Addressable Memory' or CAM. In England it was called an 'Associative Memory'. That was the next thing to fabricate after we had mastered the fabrication of semiconductor RAM.

These were comparatively primitive times. Note that even some years later, in 1966, the semiconductor house where I worked, Sperry Semiconductor, earned its spurs by successfully fabricating a copy of the Honeywell-Transitron 16-bit memory; a chip containing all of 16-bits of RAM, stored as 16 transistor bistables. This compares with today's 16Mbit RAM, a million times more on a single chip. The next step in sophistication, after causing the reading of words out of memory addressed by their content, would be to cause all words with a certain content to have a specified operation done on them in situ in memory, all in parallel.

Back to the future

Soon after success (i.e. a good yield) with the 16-bit memory chip, the first content addressable memory should have been built, in around 1968. Not only was it not built then; it has still not been built today, a quarter of a century later. The first step towards

distributed processing, or array processing, has not been made. We remain stuck in 1966. My article on the problem, 'Dinosaur among the Data?'¹ was published in *New Scientist*, 6 March 1969, pp501/502, but only because the sub-editor, whom I visited, thought my article discussed the fashionable question;

Fig 1: SRAM upgraded to CAM.

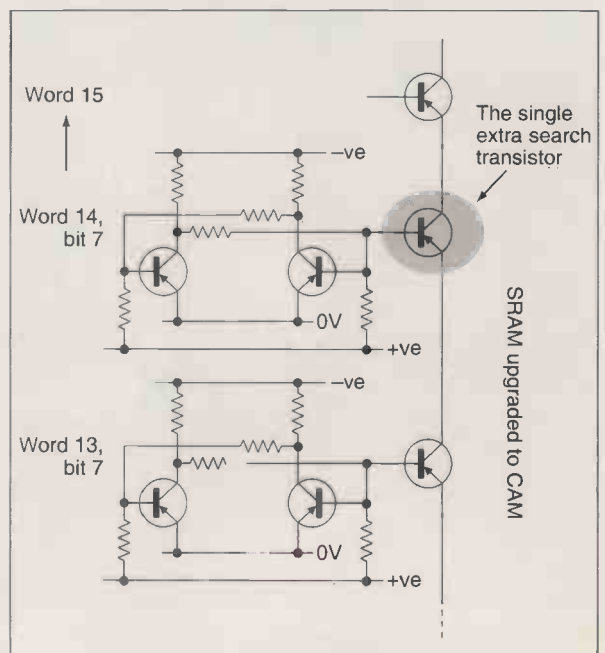

"Can computers think?". I vividly remember his crestfallen face when he realised, too late, that he had been trapped into publishing an article on computer architecture, which had no meaning for him. There was already an embargo on discussion about advances in computer architecture. Programmers wrote books and articles urging that the hardware of computers be frozen for a decade so that the software problems could be sorted out. Meanwhile, Professor Michie and the like boasted that anything we would ever want to do would be achieved with the single processor Von Neumann Computer. He was widely admired for the wisdom of his statement, and for his ability to fathom the hi-tec future.

In around 1970, the late Gordon Scarrott promoted CAFS, a content addressable file system which was used for telephone directory enquiries. However, this was not the needed key breakthrough made possible by merging the two functions, memory and processing, in the single new (semiconductor) technology. Even so, CAFS was revolutionary enough for Scarrott's boss, the head of ICL, to try to fire him, only to be restrained by his board of directors. Hostility to innovation, however great its

financial payoff, ran deep in both the computer and in the semiconductor industries, as it does today. Scarrott was cut off from the microelectronics industry where I worked for many years, so his proposed DAP, Distributed Array processor, was stunted, using conventional chips rather than a complete undiced wafer. So his machine had only 16 or perhaps 64 processors, rather than the million that I proposed. Such (coarse grain) arrays made up of a small number of powerful processors have discredited rather than promoted large scale (fine grain) array processors. Amdahl, who raised \$200 million to fail with his massive brute force WSI programme in his company Trilogy, was so reverred for this failure, that he was then flown over to England by the IEE to tell us that a five processor machine ran no faster than a single processor machine, concluding that there was no point in having more than one processor.

Water cooling spoof

Two months after I arrived to work at Motorola Integrated Circuit R&D in Phoenix in 1966, I proposed a very small (one foot cube) and therefore very fast computer using individual hand wired integrated circuit chips totally immersed in liquid in direct contact with the active integrated circuit chip surface. Short interconnections would make it fast, and liquid would extract the high power of the fast circuits. Walt Seelbach, deputy head of R&D, told me he thought my report was amusing, obviously thinking it was a spoof. That silenced me and I resorted to making only one innovative proposal in each of the companies that hired (and fired) me.

By 1972, after my latest firing, by CTL in England, I had enough material to patent the mature Wafer Scale Integration idea - a self organising, self repairing memory system on a whole wafer². An inventor is wise to get himself fired for technical incompetence before patenting, because this makes it difficult for his employer to claim that it was while working for them that he came up with the brilliant technical invention. He is not acting dishonestly, because if he reports his invention while employed, any British hi-tec company management will make sure neither the company nor anyone else will ever profit from it. Rapidly escalating profitability in a

company, which is what major invention threatens, puts the technology-free management at risk, because they lose control to the technocracy.

Many years previously, I thought it might be possible to insinuate innovation into such a conservative industry without the attempt being noticed and blocked. I planned to try in the following way.

Surreptitious

Even though computers were admired within and outside the industry for their unreliability; for the fact that if only one component failed, the whole £100,000 computer system stopped functioning; I thought that my Wafer Scale Integration (WSI) design of a self-organising, self repairing memory might not cause too much fear and hostility. I would propose a cheaper, because whole wafer, self organising, self repairing WSI RAM memory as a plug-in to replace the conventional, more expensive, less reliable RAM memory made up of individual RAM chips from a diced wafer interconnected on a printed circuit board. My memory would be cheaper because the expensive process of dicing (cutting up wafers) and then reassembling the chips would be avoided. Further, the novel, added advantage that the WSI memory would rebuild itself on switch-on, so that a RAM failure would be no worse than switching the machine off and then on again, should not generate too much fear and opposition. My WSI memory would take its place as a somewhat slower but larger than traditional RAM in the memory hierarchy, much faster than magnetic tape or disc memory. (It was installed in Tandem machines in 1989.)

I hoped to insinuate WSI plug-in replacement memory into IBM computers, IBM then being the big bully, equivalent to Microsoft today, and wait a few years for them to gain acceptance. The idea of WSI memory "would be understood by anyone earning more than £50,000 p.a."; people important enough to be unable to understand the idea of array processing, my real objective for WSI. My memories would have a search facility secretly hidden within them. I would later point out to IBM machine programmers (but not their bosses) that their memory search routines, which slowly, sequentially, searched a block of data in RAM for a particular pattern, could be



Fig 2: Cover page of *Electronic Design*, October 26, 1989

massively speeded up if a jump to the search subroutine were captured by hardware and the search done in parallel by hardware in the WSI memory.

Sir Clive

After a delay of twelve years, when the patents had only a few years still to run, Sir Clive Sinclair set up Anamartic, a company which successfully developed WSI memory as designed by my 1972 world patents. The product came to market in 1989 amid industry acclaim (see Figure 2). However, after evicting Sinclair, the technology-free management in Anamartic played the role I previously feared from IBM management, and froze the product range at memory only, although memory should have been merely a demonstrator for the WSI array processor. Anamartic's WSI memory (see Figure 3) was left to compete with conventional RAM chips, which were generally sold below cost by Far East companies desperate to get market share and to keep their production lines running.

Anamartic, the company set up to develop and exploit my invention, fired me three times, losing the resulting court battles with me twice. During the 17 years it took for my patented machine to reach the market, the 10% of total cost that had preceded dicing the wafer had grown to 80%, so the argument for WSI RAM had collapsed, leaving Array Processing as the only potential winner for WSI because of its high speed and reliability. However, with Sinclair evicted, the accountants and the like who managed Anamartic preferred to stay with a product they could understand and therefore control, despite its inferior market potential both to its discrete RAM competition and to the WSI Array Processor, which was beyond their comprehension. Better for Anamartic to fail with products they understood than succeed with products they could not control. ("I am convinced that [refusal to develop new products] gives the best short and medium term career prospects to middle and upper management It is time that we faced up to discussing the career and security threat that a major innovation with major profit potential presents to a manager in a typical British company." - Ivor Catt, *Computer Weekly*, 18th May, 1978.) I well remember the triumphalism shown by Anamartic's Managing Director Jan

van Riethoff when he took me into his office to fire me, thus demonstrating the victory of his profession, accountancy, over technical invention, even in a company set up to develop and exploit my invention.

For technical reasons which I forget, I could not have new ideas for the six months after Roethoff fired me. At age 50 I should have been no threat to the company that was developing my invention but had fired me, since it is well known that new, inventive ideas only occur to those who are below the age of 25. However, after seven months, an accident occurred. I had a brainwave, the Kernel Machine³, which obsoleted Anamartic's earlier 'Catt Spiral' patents⁴. Obviously, had I taken the new patents to Anamartic, who had just fired me, I would have been dismissed as playing 'yah-booh' games. I decided on a threefold strategy. I would get Kernel published in British journals, and then take those publications to Japanese journalists, since Fujitsu had invested £2 million in Anamartic, that is, in the now obsolete 'Catt Spiral'. Once Kernel was published in the Japanese press, I would forward it to Fujitsu in the hope that they would rise to the bait.

Gone fishing

My first step was to get British publication. I got it into the *Sunday Times* and on the front page of the *Sunday Express* newspapers. However, my main objective was a thorough exposition in *Wireless World* or *New Scientist*. I successfully manipulated the internal politics of the *Wireless World* editorial matrix, and it was published, in March 1989⁵. This article is now on the www at <http://www.ivorcatt.com/3ewk.htm>. In June 2002 it triggered Nigel Cook's article on Air Traffic Control, subsequently published in the January 2003 *Electronics World*⁶.

The second, alternative, thrust of my strategy, to have Anamartic read about Kernel in the press, came into play, and obviated the need to pursue the Japanese route. As I remember, Anamartic directors read the *Sunday Times* 'Innovation' article by Jane Bird, talking about the "first ever trillion flops computer". Unusually, there were technocrats among Anamartic's board of directors, some of whom had invested heavily in Anamartic. They instructed the Managing Director to re-hire me and

WAFAER STACK™
WAFAER-SCALE
STORAGE SUBSYSTEM

Wafer Stack is a whole-wafer computer storage device that fills the gap between fast, expensive main memory and slow, less expensive traditional rotating disk drives.

THE SPIRAL
Optimally, the wafer is a single-parted, serial data memory device mounted on a printed circuit board. Signals and power signals for the wafer are connected to the board by wire bonding. An IPROM (Flash Programmable Memory) is mounted on the board for storing information regarding the configuration of the SPIRAL, clean and the location of functional memory elements.

WAFAER STACK
New class of storage subsystems
The first of a new class of wafer scale storage devices, Wafer Stack is a high-performance computer storage subsystem that fills the gap between fast, expensive main memory, and less expensive but slow, traditional rotating disk drives.

Up to one hundred times faster than conventional disk drives, Wafer Stack's wafer scale memory dramatically reduces I/O bottlenecks, and significantly improves CPU utilization and overall system performance for the full range of I/O-intensive applications.

DEMs and system integrators of high-performance OLTP and other I/O-intensive multi-user applications can now increase overall system performance 50-100%, by adding Wafer Stack to their system storage hierarchy.

Anamartic, the first to make wafer scale integration a reality, is dedicated to optimizing computer function through high performance, wafer scale subsystems.

ANAMARTIC

Fig 3: Part of Anamartic 'Wafer Stack' brochure

also to buy my new Kernel patents. Technology-free management, put in by major shareholders Barclays Bank, bit the bullet and rehired me. However, to admit that technical ideas embodied in patents might have commercial significance was more than good accountants could stomach. (My aphorism about all British companies applied to Anamartic, a British company; "Any attempt to influence a management decision on the basis of technological considerations is a political move against the established management structure of the company.") Management rehired me, but no mention was made of my patents. I was put in charge of 'Future Products' - a well known cul-de-sac, since British hi-tec companies do not have future products. I proceeded to submit regular reports recommending that Anamartic migrate from Catt Spiral to the Kernel Array Processor, until Anamartic fired me again (and I successfully sued them again), this time without using any lawyers.

That is where we stand today, leading to the January 2003 article in *Electronics World* by Nigel Cook about Air Traffic Control⁶, an

The New Bureaucracy

It is helpful to discuss the reason why professionals in the computer industry seemed happy to freeze the computer's architecture for half a century. The "anti-manufacturing-industry" psychosis discussed by Martin J Wiener in his book "English culture and the decline of the industrial spirit"⁸, expanded with a vengeance into hostility to hi-tec. My early peers in the computer industry soon migrated into paper, that is, into programming, away from degrading hardware. They then ganged up with humanities, which is anti-science and has traditionally governed Britain. Lacking technical, or hardware competence, it was helpful for both parties that the digital computer's architecture be frozen, making it

a controllable, standard device for bureaucratic manipulation (by technology-free programmers and by technology-free managers and politicians), so this is what happened. The architecture of today's much-vaunted digital computer is identical to the von Neumann computer of 1950. Its architecture makes no concessions whatsoever to the radically different technologies now used in its make-up. (I have made this assertion more than once in the past and not been contradicted, so by now we should all take it as fact.) This fact is concealed by the total lack of appreciation of, or discussion of, this fact. The result is that no computercrat less than 30 years old knows that the architecture of his machine

has been frozen for half a century, in defiance of increasingly pressing financial and performance imperatives. Generally, they have floated further and further away from the machine proper on a cloud of ever higher-level software packages. It is as though the horse and carriage had been miniaturised and constructed out of aluminium, or some other material more modern than wood, drawn by specially bred dwarf horses, or poodles, while nobody noticed that something irrational and uncommercial was happening. In such a case, the vested interest obstructing progress would have been skilled (dwarf?) drivers of horse drawn carriages, not programmers and politicians.

application which needs an array processor; ideally my Kernel Machine, whose patents have run out.

Thus, my public campaign for the array processor began with my article in *New Scientist* in 1969 entitled 'Dinosaur among the Data?'¹ I argued that computer applications of the future would need an array of processors and that the single processor (von Neumann) machines like those of twenty (now fifty) years earlier would not meet our needs. Next came my March 1989 article in *Electronics World + Wireless World* entitled 'The Kernel Machine', where I discussed the many applications which needed a large array of processors. The latest publication in the list is by Nigel Cook in *Electronics World* January 2003, where he argues that Air Traffic Control must use an array processor. A tangential article was 'The New Bureaucracy', published in *Wireless World* December 1982⁷. (See box).

Liquid cooling

The reason why the Von Neumann computer has minimal problems with heat extraction is because, with only one processor, it does so little computing. Computing consumes power because every time a logic line is raised to the value 1 and then discharged back to the value 0, some electric charge has been dumped down through five volts, thus losing energy. In contrast, memory, which is what virtually the whole of a Von Neumann computer does, does not in principle consume power, especially a DRAM.

A million processor Kernel Machine consumes a helluva lot of

power while working, that is, while computing. A liquid is chosen from the wide range available which boils at the fastest switching temperature for the transistors used. Using boiling liquid on the surface of the chip gives a thermal clamp, so that all components operate at the single boiling temperature. This means that the larger logic swings previously needed to tolerate temperature variations across the machine are not needed. The resulting lower logic swing leads to lower power dissipation. The advantage is startling because power dissipation is more than proportional to voltages used, in the same way as the power dissipated in a resistor depends on the square of the voltage across it. Weirather and Go did the research for me in Motorola R&D to prove conclusively that direct chip contact liquid cooling is perfectly viable, and published a paper on it. Since then, liquid cooling has been totally ignored. This is partly because the USA went lunatic. Liquid cooling is unsuitable slopping around half way to the moon, as is the high power and high speed, which liquid cooling makes possible. There is not much to compute on the way to the moon anyway. However, the core reason for blocking liquid cooling is that we dare not depart from usage of the Ancients, and the way they designed and built computers in 1950. They didn't use on-chip (or for them on-valve) liquid cooling, so why should we?

GEC's contribution to Britain's Defence

The British government set up the National Research Development

Corporation (NRDC) to support new invention and new hi-tec industry. On March 1, 1973, the NRDC wrote that Catt Spiral "could be of fundamental importance in the design, construction and operation of future digital processors and stores" (i.e. computers) - quoted in *The Spectator* in 1974¹⁰. This interest by our government, plus government funding, caused me to leave teaching remedial English and return to the electronics profession I had abandoned. I needed to learn the latest technical buzz-words, some of which change every few years.

I was hired by GEC in Borehamwood, and given the task of designing and building the prototype Fast Fourier Transform (FFT) for Nimrod, the British airborne early warning equivalent of AWACS. Both Nimrod and Tornado had four or eight of these massive boxes of electronics to do the job in parallel in order to achieve the required speed. I told my boss Ian Deegan that "Property 1a", the Catt WSI invention which followed Catt Spiral and was the subject of a government funded project at Brunel University, was ideal for the FFT job, and he agreed. The problem was, how to infiltrate technical innovation into a military system funded by the MoD and designed and developed in Britain.

"Property 1a", the WSI approach, had massive advantages over the approach we were using with conventional chips, interconnected on boards, interconnected on the back plane in a box measuring two feet by one foot by one foot. "Property 1a" would be self repairing and so more

reliable. It would be smaller, lighter, consume less power and therefore less fuel. Using this approach to WSI in the FFT would pave the way to our capturing the world airborne digital signal processing market, both military and commercial.

I asked Ian Deegan what was the best way to try to infiltrate it into a conservative company like GEC. He said I should get the advice of the 'Man in the Green Coat', a Welshman. The Man in the Green Coat told me that it would be very difficult to innovate in GEC, and the best chance was to propose it to Whitehead, the GEC Chief Scientist, so I sent the proposal to him. I sent further copies for a period of six months. Finally I received Whitehead's reply, which was that GEC did not see an immediate application for my proposals and if they were to move in that direction, GEC would expect to buy in from the USA.

An Indian engineer at GEC told me a funny story about Whitehead. GEC was concerned that graduate engineers who joined GEC tended not to stay very long. To improve their morale, young engineers on the staff were invited to a wine and nibbles party. Chief Engineer Mariner walked among the assembled engineers. The Indian asked Mariner; "What has our Chief Scientist Whitehead done?" Mariner replied that Whitehead was the grandson of the great Alfred North Whitehead.

The Indian then said; "But what has he done?" Mariner said; "He and I worked our way up through the company together from the bench." Again, the Indian said; "But what has he done?" Mariner answered; "I'm not going to answer any more of these f***ing questions," and stormed out of the party.

I heard that a man in the MoD was keen on my ideas. I phoned him and asked what the procedure was to propose a technical innovation in a MoD funded weapon being designed and built with MoD funding in GEC. He replied that I needed to convince the staff at RSRE Malvern. He set me up to lecture to the 150 technical staff at Malvern, and their response to my lecture was very positive. I then waited two years and asked what the next step was. Only then did I find out that there was no next step. There is no procedure for suggesting that a British technical innovation being developed with British Government funding be introduced into a British weapon system being developed with British Government funding.

A few years later, the Nimrod project was abandoned after £1 billion of taxpayer's money had been spent and the British forces bought the US alternative, called AWACS - the darned sock on top of a Boeing.

Some years later, I approached GEC again with my WSI proposals. This time, the Chief Engineer Ash and the head of software 'Elbow' invited me to a meeting and

expressed interest, saying they would send one of their engineers to discuss the matter further with me. Sure enough, a bright young engineer appeared later in my garden in Redbourn. I asked him how it was that GEC were pursuing the matter. He replied that he was very bright and had done very good work on detachment in Gloucestershire, gaining a high technical reputation. On return, he now represented a threat to the management. They had sent him to meet me in the hope that the two threats, he and I, would cancel each other out. Since there was no point in his losing his job, I said the obvious way out was for him to give a negative report on the proposal. I heard nothing more from GEC. ■

References

- 1 Dinosaur among the Data? *New Scientist*, 6 March 1969, pp501/502 - see <http://www.ivorcatt.com/31.htm>
- 2 *Wireless World* July 1981, p254.
- 3 *Electronics World* March 1989, see <http://www.ivorcatt.com/31.htm>
- 4 *Wireless World* July 1981.
- 5 See <http://www.ivorcatt.com/3ewb.htm>
- 6 See <http://www.ivorcatt.com/3ew.htm>
- 7 See <http://www.ivorcatt.com/31.htm>
- 8 Martin J Wiener: "English culture and the decline of the industrial spirit", pub. CUP 1982, see <http://www.ivorcatt.com/31.htm>
- 9 Computer Worship, Ivor Catt, pub. Pitman 1973
- 10 *The Spectator*, 9th February 1974, p179

Artificial Intelligence

Prof. Donald Mitchie at Edinburgh promised the moon with the conventional single processor computer. Thus, he blocked advances in computer architecture. I corresponded with him, and nobody, including the government, suckers funding what he called 'Artificial Intelligence' (AI), which turned out to be telling the difference between a cup and a saucer (I promise, on my word of honour!) cared a bit when he failed to deliver two years later what he had promised - getting a computer to detect the difference between a cup and a saucer. They continued to admire his dynamic forward looking work. For me, the primary effect was that advance beyond von Neumann was blocked by programmers like Mitchie calling themselves 'Artificial Intelligence', and saying that the processor would keep getting faster, so one processor would always be enough. In the journal *Computer Weekly* I have published that AI blocked advances in computer architecture.

Years later, a government report said AI was a waste of time and the funding was totally stopped. Around that time, a Walla called Prof. Aleksadner of Brunel, later Imperial, tried to climb aboard my 'Catt Spiral' juggernaut, because that was where the funding had migrated to. Later, his idea, praised in the media, was for a computer to tell whether someone was smiling or not. He called it AI. Like Mitchie, he gained a lot of media acclaim. So AI died.

Years later, a bunch of kids gave the term to another activity entirely, a more reasonable activity, which was more like computers aiding the human, rather than replacing him. (One is religion, the other is technology.) They gained funding.

Around this time, a man with a quasi-religious attitude to hi-tec turned up named Sinclair, and grabbed the Catt Spiral, ostensibly to make money and suchlike, but his hidden agenda (like the one Nigel Cook is drifting towards now) was to make a computer

in the image of Man, the old Tower of Babel fixation. While I welcomed Sinclair's support, I worried that he might come upon my more forceful stuff against AI, perhaps in my book⁹ 'Computer Worship'. At any moment during our very successful partnership, which lasted for many years and brought innovative product to market with acclaim, he could have dismissed me as a heretic. After all, religion is more important than business, as I found much earlier in 1965 when another AI freak, Dr. Narud, head of R&D in Motorola Phoenix, tried to fire me for heresy. He loved the 'hot box', which was a box stuffed with chips and shaped like the human brain. You can see it in the last chapter of the Motorola bible on IC design. Narud insisted that the last chapter discuss neurons and include pictures of neurons. The Motorola bible was later replaced by the Carver Mead Caltech bible, which contains a chapter on 'The Glitch' at the insistence of Chuck Seitz. The Glitch had little relevance to IC design either.

LETTERS

to the editor

Letters to "Electronics World" Highbury Business Communications,
Anne Boleyn House, 9-13 Ewell Road, Cheam Road, Surrey SM3 8BZ
e-mail j.lowe@highburybiz.com using subject heading 'Letters'.

EMC is Attainable

It is refreshing to note that Ivor Catt has lost none of his ability to write a thought-provoking article (EMC - A fatally flawed discipline? *EW*, March 2003). He quotes examples which show there is much confusion, disinformation, and disagreement in the EMC Community.

He contends that the formal test Requirements for electromagnetic compatibility are inappropriate for use with modern equipment. Moreover, he points out that those who set the standards are either unable or unwilling to advise engineers as to how to design equipment to meet those requirements.

With good reason, the Don White manual does not feature in his list of recommended reading.

Having been involved in the design of electronic equipment during the entire period covered by his reminiscences, I can understand his frustration. However, his approach is wrong.

When he discovered that his computers

at West Herts College were tripping the earth leakage detector, he could have put his considerable talent to work to solve the technical problem. His objective could have been to reduce the amplitude of the switch-on current surge created by the mains filters to a level below the threshold of the earth leakage detector, without reducing the efficiency of the filters. Instead, he chose to waste time by trying to change the regulations.

On a more fundamental level, by his repeated use of the word "magician", Ivor shows that he himself has succumbed to the propaganda that the subject of EMC is too complicated for the average engineer. The message propagated by the specialist is that only the elite few are gifted enough to understand the phenomenon: for everybody else, EMC is a form of black magic.

I would contend that EMC is a branch of science, and that a review of electromagnetic theory and circuit theory will reveal that the coupling of

interference can be analysed just as easily as any other aspect of design. I invite Ivor to visit www.iandarney.pwp.blueyonder.co.uk browse through the contents list, and click on the hyperlink to section 5.2.

Ian Darney
Bristol
UK.

Wrong tree

A fatally flawed attack upon a discipline in engineering which has proved itself of value many times over and which has undoubtedly avoided catastrophes and which saves billions of pounds cannot simply be ignored. I refer of course to the article on page 44 of the March issue of this journal by Mr. Ivor Catt.

Whilst it can be argued that there are certain EMC directives, which in the light of today's state of the art and use of digital technology are somewhat arcane, this is not a valid pedestal from which to launch

In defence of Mr. Miller

Well, here we go... I read with somewhat amusement the article on audio amp compensation in the March issue, so here's my take.

The author claims that eliminating the Miller capacitor is to be desired, yet his summary contradicts this view. Indeed, his sentences are inherently contradictory to each other. On one hand the author waffles his words about "...small price to pay for a design which minimises the differential signal, hence improves linearity", yet he claims his actual results show higher distortion and noise. Of course, this is not surprising as the Miller compensation technique is used because it has been consistently shown to be an excellent way to compensate an amplifier. Indeed, one of its very desirable features is that it pole splits the response of the amplifier. That is, it converts what would otherwise be a two pole response into an essentially one pole response, because it moves one pole to a much higher frequency where it can usually be ignored. Without Miller compensation, poles usually interact in complicated ways,

making compensation, over all component variations, quite difficult. And to continue..., there is also a somewhat vacuous claim that a 25mV signal at the input of a Miller input verses a 2mV signal of a PLIL input, had to be "...kinder to the transistors...", yet there was no support at all that this actually made any difference in the sound of the amplifier, or indeed that apples were being compared to apples. In fact, the author noted, "high frequency distortion may increase".

Whether or not a competently designed amplifier would suffer from this alleged "problem" is debatable as even in the early 80's amplifiers¹ were commercially available with slew rates of 100V/ μ s and 20kHz THD at <0.02%.

So, on we go...to a more technical note, it is difficult to see how the author has justified his simulations. All but one of the graphs show some sort of closed loop gain response. It is well known, that to determine stability, one is usually required to examine the loop gain of the system, that is the gain around the loop. From the text of the article, it is not clear at all how even this stated closed loop gain was obtained. For

example, the loop gain of fig 7a, is principally determined via the emitter loop of T1. For example, applying an input via its base will not result in the same loop gain, and in general results can be substantially different. Indeed, Probably, the simplest way to obtain the real loop gain of an amplifier is by placing a voltage source in series with the loop².

As the article stands, it is difficult to make any conclusions on its arguments until it is ascertained what the real loop gains of the systems are, and how the graphs were constructed. In summary, the article seems strong on rhetoric, but lacking in objectivity. There was no technical evidence presented that supported the view that Miller compensated amplifiers had any unresolved issues at all.

Kevin Aylward
Peterborough
U.K.

References:

- 1: Studiomaster MOSFET 1000, 1981
- 2: Automatic loop gain plots, SuperSpice Example AutomaticLoopGain

such an attack. EMC engineering, or any engineering including the EMC aspects as part of its plan, is not some vague furry object with no sound rules, it is a necessary and logical part with very visible and clear methods and objectives.

There are many aspects into which I could delve here, at the expense of many column-centimeters (feet, if some prefer), but let me illustrate simple but real situations in totally different environments which but for EMC evaluation could have resulted in a massive waste and/or ongoing problems or disputes.

Situation 1:

Two sub-contractor companies were to design and build separate units, which were to be flown on a particular satellite mission (I do not intend to name the companies nor the mission, but this is a very real project which was under my examination at the time).

This issue concerned conducted EMC: a power source in the first unit using space-qualified switched-mode supply modules, followed by a number of linear regulator circuits one of which was required to supply some +32Vdc with less than around 10µV of noise to the second unit. The design was sound as far as the data sheets of the devices concerned initially showed: it was only when those features were examined that a problem was discovered and the design adapted accordingly. The switched-mode power module operated at a number of kHz and produced approximately 80mV worst-case ripple entering a three-terminal regulator, which had, on the face of it, an 80dB ripple-rejection capability. This meant a worst-case regulator output ripple of 80mV - 80dB = 8µV, within the specification for the second unit. However, the three-terminal regulator concerned had a ripple-rejection quote on its data sheet when measured at 50 or 60Hz and, due to the low input-output headroom this meant that its internal error amplifier operated at a low bandwidth and did not provide anything like 80dB of rejection at the SMPS operating frequency - the rejection there was only of the order of 40dB, a one-hundred-fold increase of output noise being the worst-case result. Clearly another 38dB minimum of filtering was required in either the first or second units, or both. This was finally resolved by extra filtering before the linear regulator and an input filter in the second unit (remember space and mass are important criteria in space applications).

The application of a proper EMC analysis to this situation illustrated the problem and enabled a proper cure to be effected - and none of this with reference to the "bible" of Don White. It was also conducted sufficiently early in the project as to avoid significant and costly re-

design and re-working.

Some may say that the above work was just a part of correct engineering practice - and indeed it was - it just happened to be termed "EMC analysis" of the design in question. No cagey business practices here.

Situation 2:

For a period of some months an on-site amateur radio club was experiencing a phenomena which basically precluded the use of the 144MHz and 432MHz amateur bands due to a very high level of wideband noise during non-working (free time) hours. The issue was brought to my attention as a member of the Club, even

though I did not make frequent use of these facilities. Initial investigation eliminated any issue of conducted EMC issues, therefore, attention was directed at radiated-EMC possibilities.

Using a mobile station it was discovered that the noise source could actually be detected up to 2km distant from the Club premises and upon further tests using a Yagi directional antenna at various locations in the vicinity, the source appeared to be in the very same premises. It was decided to use an EMC-lab portable receiver together with its DF antenna to attempt to locate the source of the wideband noise. Admittedly, this was not a life-critical issue but was one that

2003 marks the centenary of Alan Blumlein's birth.

At the time of Alan Blumlein's death I was six years old so, understandably, I was unaware of his original work in the fields of Sound, TV and Radar engineering. My ignorance was partially corrected over the ensuing ten years as I struggled to understand first radio then television principles, culminating in building a TV from Government surplus radar indicator units, in time to watch the Coronation of Queen Elizabeth II. That it worked, was a minor miracle.

From 1947, when I bought my first copy, *Wireless World* was and still is, essential reading for me. It introduced me to sync separators, longtailed pairs, bootstrapping, Miller integrators, the block-busting bootstrapped transitron miller integrator and heaven knows what other goodies that became the bedrock for my career in electronics and computing. *Wireless World* has enabled me keep pace with developments since migrating from the bench to the desk and into retirement. Thanks for that.

Blumlein's name cropped up with impressive regularity, during my formative years, arousing my curiosity. This was not only in the context of television, but also in audio as I struggled to build an ultra linear audio amplifier out of government surplus bits, let alone the two that I would need to experience stereo. All efforts to learn more about him, apart from the occasional references in *Wireless World*, came to naught. He hadn't even had any books published whereas O. S. Puckle and M. G. Scroggie had *Timebases* and *Foundations of Wireless*, respectively. In retrospect, who could have resisted such evocative names?

I knew Blumlein had worked for EMI so, when I got a menial job at EMI, I expected to find out more, but was disappointed. The people I worked with had never heard of him. The trail went cold until a few years later, when I found myself working with a group of people who had worked at EMI with people who had worked with Blumlein. They were a happy team, pushing the Germanium semiconductor technology of the day to the limit and succeeding, well ahead of their time. But I still didn't find out anything about Blumlein. The trail went cold for almost ten years. Then, unexpectedly, there he was again! At the time, I was working for an American company and looking at a map of their factory site I

saw a road called Blumlein Way. Subsequently I discovered that the President of that company had met Alan Blumlein, whilst working on the magnetron during the Second World War. Blumlein's engineering work permeated electronic measurement instrument technology at that time and probably still does, quietly, in the background even in this digital age with concepts of feedback, gain stabilisation, delay lines, pulse generation, ramp generation etc. My interest in his work received a new boost, but the trail went cold, this time for thirty years. Robert Alexander's excellent and well researched, book "The Inventor of Stereo: The Life and Works of Alan Dower Blumlein" has gone a long way towards satisfying my curiosity about what made him tick. It has closed the loop to my Indicator Unit TV of fifty years ago, but it leaves me with new unanswerable questions. What else would Blumlein have achieved, had he not met with such a horrific and untimely death? Would he have stayed in the field of "hands on" electronics or would he have ascended to senior company management; started his own company, academia maybe, or even migrated into politics? We will never know what we missed.

In addition to the legacy of his patents, Alan Blumlein certainly left a lasting impression on those who worked with him. What was the secret of his success and can we still learn from his example? I have the impression of a business manager and an enthusiast who never ceased to be an engineer, who never shrank from challenge or criticism, who pushed himself to the limit, who wouldn't quit and who encouraged others to do the same. In other words he was an ideal role model for people embarking on a career and who want to succeed. But how do they learn about his example? Robert Alexander has done all the spadework. Now it just needs someone to turn his book into a film. It might be a bit late, but an accurate film recreating the life and works of Alan Dower Blumlein would be a fitting tribute to him and all the other unsung heroes of the 20th century electronic revolution, now the cloak of secrecy has been raised. 2003, his centennial year would be a good time to start. It could be done but who is up to the challenge?

*Bryce Kearey
Crowthorne
Berkshire
UK*

required the proper approach to find and resolve the problem.

Since the appearance of this problem only occurred during non-working hours, there was not much of a time restriction placed upon this EMC investigation! Nor was there any significant outlay of funds necessary for it to be conducted.

The outcome was that an elderly computer system used by a video club on the same premises to handle loan registrations and other administration was found to be radiating a large amount of 'hash' and, together with its un-shielded set-up it was proposed that it be either replaced or properly enclosed (some grilles and shielding required etc.), and the club committee concerned agreed to take the necessary measures and used our advice in implementing these after which the problem was resolved without recourse to constitutional clauses or any other discontent. Not a whisker of any trouble in resolving this situation either.

EMC conducted emission tests do not assume that an incompatibility (we are after all discussing compatibility between

systems here, which is the 'C' in the abbreviated term) is caused by a single wire (re: box "The fatal flaws"), but rather the entire circuit. A supply and return wire do not necessarily take the same physical lay-out path, so one can view this as one long line and, if they are not co-located they may well form a wonderful antenna. Nothing in this is in contradiction with Kirchoff's Laws.

As regards 'grounding', there is nothing in EMC 'law' which states that individual sub-modules which utilise high frequencies must be grounded in any particular manner; I would agree with Mr. Catt that grounding internal modules in an equipment where the wavelength is less than the grounding methods used is asking for trouble. What should be examined finally, however, is the method and effectiveness of grounding the entire finished and enclosed unit and also the filtering where appropriate of the signal and power lines coupling to that unit. That is what we do.

I note the apparent assumption that "EMC wallahs sweep through frequencies

one at a time"; perhaps it has been forgotten that the use of a spectrum analyser is quite effective in looking at a wide range of frequencies for and in the same test environment. Individual frequencies are only examined one at a time when there is an identified potential problem source at that frequency or at a related, possibly harmonically-related frequency.

As to the suggestion that "EMC wallah's thinking ... resort to averages" and that they "just don't know ... if a digital system loses one bit ... [can] be catastrophic", I have to say that this takes the food right out of the bowl. In situation 1 which I describe above, the very reason for ensuring that the supply line concerned ended up 'clean' was that this line fed a CCD sensor and this sensor, in turn, fed an ADC: the whole issue at stake was the importance of ensuring that no ripple or noise could exceed the value represented by one third of the least significant bit of that ADC's resolution, since otherwise the whole instrument would be drastically reduced in its effectiveness. This is

Personal critique of *ELECTRONICS WORLD*

I wish to provide a few thoughts regarding the current state of *Electronics World*. I am a 61-year old individual in California who has read the magazine for many years, under both its current and older name of *Wireless World*. Currently I am nearing the end of a two-year subscription period. I must say that, to my taste at least, the overall quality of the magazine has gone downhill in recent years. I'm not exactly sure why this is so. Perhaps the higher technical level that the magazine took on in years past has fallen out of favour, and you have found it necessary to lower the technical level in order to find enough paying readers. Or maybe the technical capabilities of your staff have diminished. Or perhaps you just cannot find enough good material to publish, though this seems unlikely. (I should say, however, that I seem to detect some improvement in the most recent issues and I hope this is not just a statistical anomaly.) The latest issue I have received contains more than 10 pages of "New Product" information. This wasteful use of valuable space should be reduced, especially in light of the fact that many of these products can be of little more than very passing interest to most readers. And I know from my own professional experience that most of these pieces are little more than re-prints of material sent out by the producing companies in search of what amounts to free advertising. At the very least I believe you should use smaller print and much smaller photos in this area of the magazine. And remember that readers such as myself are not likely to be very interested in new instruments that cost upwards of a thousand dollars or more, unless they are so novel as to merit attention on that basis alone (and that is quite rare in my opinion). I am currently

building some apparatus that makes use of the article on page 50 of the August 2002 issue. This article, I believe, is along the lines of what you should be publishing more of. It highlights an area that MANY of us are interested in - the more efficient and practical use of microcontrollers, the PIC series in particular. This article is relatively well done, makes microcontrollers easier to use at a practical level, and is of interest to both professionals and hobbyists. If you can find more such material, and publish it, you will likely receive more praise from technical types such as myself. One area that could stand improvement is your up-front recognition of the authors of good articles like this one. Why not put the author's name up 'in lights' at the head of the article? If you do that it will encourage more people to write for you. We all like recognition for the good work we do, and your magazine provides a platform for good authors to be recognized by their own community. One name I used to look for from issue to issue was Pat Hawker. His contributions were many, and of uniformly high quality. You should try to get new traditions started along the same lines, and a big tool for doing that is to provide author recognition in the biggest way possible. (I still am not sure who the author of the referenced article of August 2002 is. Perhaps Roger Thomas?) Neither the article itself nor the Table of Contents makes it at all clear. The bottom line is that if a magazine like *Electronics World* is to survive and prosper, it MUST publish several high-quality technical articles in every issue. A suggestion: Make a list of every technical issue of current practical interest that you can think of. Then send that list out to all prospective authors, soliciting their writings on the subjects on that list. Ask readers to provide candidate subjects for the list. The list might start with subjects like: PIC microcontroller usage, Practical

USB devices Practical FireWire devices, Radio gadgets that make use of unlicensed spectrum, Electromagnetic theory for mere mortals, Relativity for mere mortals and how it relates to EM theory and a regular column on the practical application of the latest chips from semiconductor manufacturers. For less experienced readers, a regular column that discusses some basic part of current circuit theory (e.g., voltage-doubling and tripling power supply circuits, how to get started with PIC assembly language, how to use your PC to log and analyse experimental data, etc, etc). How antennas really do what they do. An aspect of digital signal processing. Current practical battery technologies and how they differ. How multilayer digital networking protocols are designed, and how they can be implemented at home. How the 802.11b protocol works, etc. I hope these ideas are of some use to you, because I really would like to see your magazine grow and prosper. And especially at a solid technical level. In the USA, the old (and excellent in its time) Gernsbach magazine *Radio Electronics* has died and so has *Popular Electronics* and (latest) *Poptronics*. Over a period of years, they slowly made their publications less and less interesting to people like me by making their technical level lower and lower. I hope you don't expire down the same senseless path.

Bob Nelson
California
USA

If you remember, the August 2002 issue was my first with EW and there were lots of mistakes. One of which was not putting Roger Thomas' name 'in lights' at the head of his article. As regards your article ideas - some of these are already in the pipeline. - Ed

nothing like the odd scratch on an LP record or a bit of interference on an old AM radio, or such-like.

Another 'fundamental flaw' in an EMC approach to engineering activity to which Mr. Catt refers is that of calculation rather than measurement: in situation 1 above the problem and its solution was essentially achieved by calculation and confirmed by measurement; in situation 2 above the problem and its solution was essentially achieved by measurement and subsequent calculation. As in other branches of electronics engineering, both calculation and measurement have their equally important roles to play.

Finally I propound that EMC engineering analysis is in no way a "flawed discipline" and in fact is a part of the process of ensuring that various electrical and electronic products in a given environment may co-exist without mutual interference, and that such issues are addressed by all responsible engineers whether they be "microwave plumbers" or "D.C. suppliers" or whatever lies in between. The most important contribution to this effort is communication between engineers and experts in the different disciplines involved; perhaps it could be the case that Mr. Catt has had a few too many experiences of bad communication with previous colleagues (which can always happen) but I give him the benefit of the doubt that certain experience and reflections upon it can direct ones' views.

EMC approaches are no more a way of making money than any other discipline in engineering - we all design things to achieve something which somebody, somewhere, pays for. The different disciplines together achieve the final result.

I think Mr. Catt is miauwng at the wrong branch.

Eima Burdd.
Rijnsburg
Netherlands

EMC - A Flawed Discipline

I read Ivor Catt's piece with enormous interest, but I query whether it should perhaps have appeared in the April issue. I am in two minds whether the author is a foresighted genius or a weird but clever anorak type significantly lacking presentational and diplomatic skills. His swift departure from quite a few jobs does suggest the latter!

I am not a professional engineer and so I have some difficulty in following a direct flow of logical thinking in the article. My discerning of Mr. Catt's statements and arguments is basically that EMC "gurus" do not understand elementary science and engineering, rather that they apply esoteric solutions to the finished product in an attempt to make it EMC-proof. I think

what he is calling for is a symbiotic partnership between the design engineers, the EMC engineers and the production engineers. These three disciplines are substantially different spheres of engineering, each requiring specialist techniques and a fair amount of the black art, and that in consequence the overlap may not be extensive. Indeed, taking Mr. Catt's argument *ad reductio absurdum*, the EMC gurus have screened and/or filtered their engineering knowledge so well that they are incapable of applying relatively simple engineering solutions to the problems of EMC.

In fact your good periodical has printed quite a few articles on how EMC can be substantially reduced by some fairly inexpensive changes to the circuit design and physical layout and so I would have thought by now that the symbiotic

message had penetrated most serious manufacturers (or what is left of them in the UK).

Are his comments on the "torpedo-proof" line printer to be taken seriously? How can any printer, armour plated or otherwise, require 750 amps and at what voltage? Should there be a decimal point somewhere, for example between the 7 and the 5? All I know is that the laser printer (plastic cased) which is printing this letter consumes 1.8 amps maximum at 240 volts AC because that is what the rear plate says.

Would Mr. Catt also explain the connection between ex RAF radio operators and EMC. There is what the lawyers call a *lacuna* in his flow of words. More accurately, *lacunae* because there appear to be a large number of them. Would he also explain why it is

Identity Crisis

Mr C.Holwell asks for details of the TK20 drive motor (Identity crisis EW March 2003) and while I have no details of this particular model I have some on models of a similar vintage.

The TK6,14,17,19,23 and 27 have motors with four connections and the in the various models are connected to the several versions of the mains transformers in the usual complicated Grundig manner. Some transformers are 110/130/220/240v, some 110/220v, some have adjustable tappings for 50/60Hz operation, however there are no capacitors employed in these arrangements.

The TK40,42,45,46,47, TM60, 64 etc. have three connections with transformers with a similar range of voltages and frequency as the previous list. The internal connections of the motors are not shown in the diagram so it is not possible to determine the resistances of the stator windings, however capacitors are employed in these models and changed for the 50/60Hz range.

Mr.N.L.Smith
Stoke-on-Trent
Staffs

Motors

If the motor referred to in the letter in last month's issue is designed to run directly from mains, then it is of a type I think known of as 'PAPST', an inside-out induction motor seen only rarely in makes other than older mid European marques.

I am at this moment using an outer rotor motor to power a small pillar drill (For PCBs etc.), it is only a little larger than the motor often found in older Grundig tape recorders, yet seems to be rated at about 1/10Hp. The 'inside out' design confers several advantages, the chief one being the ease with which the symmetrical stator could be directly wound with a larger number of poles when compared with small motors of conventional layout, resulting in lower speeds and extraordinary torque. While owners of other machines were delighted when they discovered that their machine sported a 4 pole motor instead of the all too common, cheaper single winding two pole variety, the motor in Grundig tape recorders had poles running into the teens.

Since the windings are 'inside' the poles, less wire is needed and so smaller gauge wire can be used. Also the rotor surrounds the stator, (generally consisting of a cylinder of iron moulded around a copper 'squirrel cage') and so it serves to magnetically screen the motor, a distinct advantage in tape recorders. Lastly, as well as running slowly enough to directly drive the capstan (often actually forming the drive spindle of the motor itself), the outer rotor had sufficient inertia to form the flywheel needed to iron out wow and flutter, and could be used to drive the spools (for tape take up, and fast forward and reverse) via idler wheels or belts.

My particular example (gleaned I think from an odds and ends box at a radio rally for 50p) also has three wires, one pair of resistance 150Ω and the other of 230Ω. Since the other pair reads 380Ω, the connections are to two windings commoned at one end. As was suggested a capacitor is needed and '2μF' is marked helpfully on the rotor, but this is definitely a capacitor 'run' motor, i.e. the higher resistance winding must be left connected to the supply via the capacitor. A description of connections with the same resistance between each pair is mysterious, and suggests star or delta connected three phase windings.

The outwardly similar variation seen so often nowadays in videos, disk drives and small fans in fact has a multi-pole permanent ring magnet on its inside surface, and since it can only be driven by a (usually integrated) multi-phase driver, it is a very different beast.

A. Ziemacki
Rotherham
UK

More Grundig

Please find enclosed a copy of the complete schematic concerning the Grundig TK 20 tape recorder.

All details of the motor's circuit are given; the capacitor (C 32) is a self-healing MP dielectric : 1.2 microfarad 230 volts AC service.

Hoping all this will answer Mr. Holwill's query,
Paul de Lattre
Tilff Belgium

Duly passed on to Mr. Holwill - Ed

impermissible to measure susceptibility to EMC by measurement rather than by calculation. If the measurement is flawed then the premise behind the technique is flawed and so would be the calculations. Surely the essence of all science and engineering is the ability to measure the parameter under investigation consistently and accurately. If that cannot be done then one must rely on the black art of intuition and hope, which is not science but which might lead to discoveries that then advance the science.

I found the whole article more like one of those brain teasing questions in *Round Britain Quiz* on Radio 4, you know "What is the connection between a sacked engineer, a bizarre line printer that appears to consume more current than a domestic household and an engineering company substantially staffed by milkman?" I think we should be told more.

Michael O'Beirne
Surbiton
Surrey

Catt sinks

Ivor Catt's seamen who may have borne painful witness to his printer's impunity to torpedo attack, "EMC", EW March, reminds me of the occasion when, during competitive trials in foreign parts, various companies were trying to hawk military radios to the local army. One of our competitors' salesman was obsessed with the claim that their loudspeaker/amplifier accessory, which plugged into an h.f. man-pack, was capable of surviving a bomb blast. I enquired what utility this was unless they made their radio operators equally as robust.

David Bridgen
Camberley
Surrey
UK

The Catt Came Back

Welcome back Ivor Catt! Now that was a really enjoyable piece on EMC, especially on the why of things and how the decisions are made.

That Fourier article; more please, quite thought provoking. Very much food for thought there. It seems that all is not quite as it should be. Come to think of it, this might explain why house-bricks have sharp edges that stick up! Does Gibb's tombstone have ears on it as well?

As to more please; I thought that "Joules Watt" was extinct, so it was a pleasure to read that letter in the March issue. A long time ago it was a pleasure for me to struggle through his dissections and illumination of the more obtuse aspects of the theoretical body of knowledge. At this point I must declare an interest; can you please persuade him to dissect the dark corners of FM? As a radio amateur I am

beginning to suspect that in being forced to 12.5Kc/s NBFM channel spacing we have been "sold down the river". Something is wrong and unless someone can "do the numbers" on this for me I am urinating into the wind. It starts with 2.5k of deviation plus 3k of audio all doubled equals eleven Kc/s. That is the conventional sum for the bandwidth required. Looking at some equipment that was accused of vile distortions (Tait T300 series used on the GB3ES repeater at Hastings), I find that the receive IF filter is only some 7.5k wide at the nose. This does not compute. Neither does it look good on the bench. Perhaps "Joules Watt" knows the rules? What is more, you might even talk him into enlightening us.
William R. Blankley, G8CMK.
St Leonards on sea
East Sussex
UK

EMC - A fatally flawed article ?

Went into W H Smith - Spotted leading article 'EMC - A fatally flawed discipline'. Quick read - Verdict - Buy to digest. Bleagh . Where was the meat ? It reads like the counter person in a fast food restaurant moaning about their cruel lot ! (Could not find the bun (or the point) either) .

Far too much about defence industry rip-off's. We have all heard the stories that a \$1 screwdriver purchased by the Pentagon costs \$200. Perhaps the editorial staff are Egyptian (Too much blind CATT worship??)

Too much rudeness about GEC (and Weinstock). At least he ran a fairly stable, profitable company for many years (and so was able to provide the shilling of convenience Mr. Catt was willing to take (and did Mr. Catt back the engineer who said 60dB was enough - or did the free thinker just sit on his hands?) GEC (Marconi) was all but destroyed and the pension funds of thousands have been damaged (perhaps forever) by some who thought they knew better...

Part of the problem is that EMC is a broad subject (and it has been around for a long time!) The first EMC regulations were late 19th century, relating to 'Flicker' or voltage fluctuations and pre-date the RAF airborne radar operators!

The work of CISPR dates from the 1930's, when as radio became more widespread the importance of interference generated from the growing number of items of electrical equipment was swiftly recognised. This work still carries on today, and generates international standards and guidance documents. The work of CISPR was the basis of BS800 - the compulsory RFI compliance document for much electrical equipment which pre-dated the current European legislation by many

years. (You can tell when something has started to fail and no-longer meets these limits by the lines on the telly and the crackles on the radio - It may be a relay or the thermostat in your neighbour's gas boiler!) If Mr. Catt had read some of the widely available reference material it might not have taken him quite so long to discover some of the BUZZ WORDS (e.g. LISN) and the basic simplicity of the concepts involved rather than whinging about the inaccessible 'Don White Bible'.

Some of this work may seem dated as processor speeds romp away, but that's the standards world for you! - Ah yes microprocessors! There are all sorts of pulse (and hence broadband tests) that are applied to digital systems e.g. IEC 1000-4-4, the fast transient test for example.

As regards RCD's, students and computers, the RCD is an excellent device, however the implications of their use are sometimes not even fully appreciated by those who manufacture, recommend and install them. The most common RCD ratings are 100mA (protection from fire) and 30mA (protection from electric shock). The typical RCD will trip at a continuous leakage current of half these values. It's all a question of choosing a suitable value.

Filters and product safety - product safety standards do not normally dictate a design. They will say what is not regarded as acceptable (e.g. leakage current @ 50Hz). The filter network I designed for Spark Ignition Systems was an industry first, and went into production.

(The management wanted to use a large expensive commercial filter - Because it seemed easiest, just not cost effective or sensible...!)

Also I was instrumental in getting the standards re-written to more sensibly test the product (Yes, Mr. Catt, it can be done)

Finally EMC compliance does not involve hiring an expensive consultant / expensive tests. (Type testing is only mandatory for Transmitters, and is supervised by the Radio Communications Agency). If you have the B***S to stand by your own test results, design notes and reports that in many cases can be enough.

Yes I Design things, make them meet safety standards, test for EMC compliance, then re-design if required. (And I used to work for GEC (Marconi) .

You can find some background at one of my websites <http://jprdesign.port5.com> (no WWW!)

Will sign off now as run the risk of becoming as incoherent (spatially or temporally) as Mr. Catt! And if you feel the need for some factual (and amusing) articles on EMC or Product Safety I'm your man....

And finally, the article on Fourier Synthesis raised the status of the magazine purchase!

John Blythe
UK

FREE Catalogue Available On Request



WCN Supplies • Dept EW • The Old Grain Store • Rear Of 62 Rumbridge Street • Totton • Southampton • SO40 9DS
 Telephone or Fax On Southampton 023 8066 0700 • Email: info@wcnsupplies.fsnet.co.uk

Telephone, Fax Or Email For Your Free Catalogue

SPECIAL OFFERS

TEKTRONIX 2445A 4 Ch 150MHz Delay, Cursors etc. Supplied with 2 Tektronix probes

ONLY £425

TEKTRONIX 2232 Digital Storage Scope. Dual Trace 100 MHz, 100m/s with probes. £525
 H.P. 54501A Digitizing Oscilloscope 100MHz, 4Ch £425
 CIRIUS RCL254 Sound Level Meter with Calibrator. 80-120dB, LED. £95
 BECKMAN HD110 Handheld 3 1/2 digit DMM, 28 ranges with battery, leads and carrying case. £30
 WAYNE KERR B424 Component Bridge. £80
 RACAL 9300 True RMS Voltmeter 5Hz-20MHz usable to 60MHz 10V-316V. £50
 RACAL 9300B as above. £75

H.P. 3312A Function Gen 0.1Hz-13MHz AM/FM Sweep/Tri/Gate/Burst etc. £300
 FARNELL AMM255 Automatic Mod Meter 1.5MHz-2GHz Unused. £300
 FARNELL D561 Low Frequency Syn Sig Gen 0.001Hz to 99.99kHz, Low Distortion TTL/Square/Pulse Outputs etc. £95
 FLUKE 8060A Handheld True RMS DMM 4 1/2 digit As new £150. Used £95
 H.P. 3310A Function Gen 0.005Hz-5MHz Sine/Sq/Tri/Ramp/Pulse £125
 FARNELL FL1/4 Sine/Sq Oscillator 10Hz-1MHz low distortion, TTL Output, Amplitude Meter. £125
 H.P. 545A Logic Probe with 546A Logic Pulsar and 547A Current Tracer. £90
 FLUKE 77 Multimeter 3 1/2 digit Handheld. £80
 FLUKE 77 SERIES II. £70
 HEME 1000 LCD Clamp Meter 0-1000A. In Carrying Case. £60

Raeal 900B Automatic Modulation Meter AM/FM 1.5MHz-2GHz

ONLY £95

Datron 1061A High Quality 6 1/2 digit Bench Multimeter 2MHz, TTL etc. £225

BLACK STAR ORION PAL/TV Colour Pattern Generator from £75-£125
THURBY/THANDER TG210 Function Generator, 0.002Hz-2MHz, TTL etc. £80-£95
THURBY/THANDER P.S.U. PL320QMD, 0V-32V, 0A-2A (late colour). £200

STEWART OF READING

110 WYKEHAM ROAD, READING, BERKS RG6 1PL
 Telephone: (0118) 9268041 Fax: (0118) 9351696
 www.stewart-of-reading.co.uk

Callers welcome 9am-5.30pm Monday to Friday (other times by arrangement)

JUST IN

HP. 8640A Signal Generator AM/FM 500KHz-512MHz. £250
 KENWOOD CS4025 Oscilloscope Dual Trace 20MHz. £125
 LEADER L60523 Oscilloscope Dual Trace 35MHz. £140
 GOULD OS300 Oscilloscope Dual Trace 20MHz. £95
 NATIONAL PANASONIC VP7705A Distortion Analyser. £125
 KENWOOD VT176 Millivoltmeter 2 Channel. £50
 KENWOOD FL140 Wow & Flutter Meter. £50
 KENWOOD FL180A Wow & Flutter Meter Used. £75
 Elements for the above. £75
 BIRD 43 Watt Meter. £75
 Elements for the above. £75

MARCONI 893C AF Power Meter, Sinad Measurement. Unused £100 Used £60
 MARCONI 2610 True RMS Voltmeter Autorangin 5Hz-25MHz. £195
 GOULD J3B Sine/Sq Osc. 10Hz-100kHz Low distortion £75-£125
 AVO 8 Mk6 In Ever Ready Case, with leads etc. £80
 Others Avos. from £50
 GOODWILL GV7427 Dual Ch AC Millivoltmeter 10mV in 12 Ranges Freq 10Hz-1MHz. £100-£125
 SOLARTRON 7150 DMM 6 1/2 digit True RMS - IEEE £95-£150
 SOLARTRON 7150 PLUS. £200

HIGH QUALITY RACAL COUNTERS

9904 Universal Timer Counter, 50MHz. £50
 9916 Counter, 10Hz-520MHz. £75
 9916 Counter, 10Hz-560MHz, 9-digit. £50
 RACAL/AIM 9343M, LCR Databridge, Digital. £200
 Automeasurements of R.C.L.Q.D.
 HUNTRON TRACKER Model 1000. £125
 MARCONI TF2015 AM/FM sig gen, 10-520MHz. £175

Portable Appliance Tester Megger Pat 2

ONLY £180

FARNELL AP60/150 3KW Autorangin. £2000
 FARNELL AP100/90 3KW Autorangin. £2000
 H.P. 6012B DC PSU 0-60V; 0-50A 1000W. £1000
 FARNELL AP60/50 1KW Autorangin. £1000
 FARNELL H60/50 0-60V 0-50A. £750
 FARNELL H80/25 0-80V; 0-25A. £400
 Power Supply HPS3010 0-30V; 0-10A. £140
 FARNELL Dual PSU XA35-2T 0-35V 0-2A Twice QMD LCD Display. £180
 FARNELL L30-2 0-30V; 0-2A. £80
 FARNELL L30-1 0-30V; 0-1A. £60
 Many other Power Supplies available.
 Isolating Transformer 240V In/Out 500VA. £40

FARNELL DTV 12-14 OSCILLOSCOPE DUAL TRACE 12 MHz TV. COUPLING

ONLY £75

FARNELL LFI 12-14 Sine/Sq OSCILLATOR 10 MHz - 1 MHz

ONLY £75

OSCILLOSCOPES

TEKTRONIX TDS350 Dual Trace 200MHz 16S unused. £1500
 TEKTRONIX TDS320 Dual Trace 100MHz 500M/S. £1200
 TEKTRONIX TDS310 Dual Trace 50MHz 200M/S. £950
 LECROY 9400A Dual Trace 175MHz 5G/S. £750
 HITACHI VC6523 Dual Trace 20MHz 20M/S. etc unused. £500
 PHILIPS PM3092 2+2Ch 200MHz Delay. £800 As New £950
 PHILIPS PM3082 2+2Ch 100MHz Delay etc. £700 As New £800
 TEKTRONIX TAS465 Dual Trace 100MHz Delay etc. £750
 TEKTRONIX 2465B 4Ch 400MHz Delay Cursors etc. £1500
 TEKTRONIX 2465 4Ch 300MHz Delay Cursors etc. £900
 TEKTRONIX 468 Dig Storage Dual Trace 100MHz Delay. £450
 TEKTRONIX 466 Analogue Storage Dual Trace 100MHz. £250
 TEKTRONIX 485 Dual Trace 350MHz Delay Sweep. £550
 TEKTRONIX 475 Dual Trace 200MHz Delay Sweep. £350
 TEKTRONIX 465B Dual Trace 100MHz Delay Sweep. £325
 TEKTRONIX 2215 Dual Trace 60MHz Delay Sweep. £250
 PHILIPS PM3065 2+1 Ch. 100MHz Dual TB/Delay Autoset. £375
 PHILIPS PM3055 2+1 Ch. 60 MHz Dual TB/Delay Autoset. £275
 PHILIPS PM3217 Dual Trace 50MHz Delay. £200-£250
 GOULD OS1100 Dual Trace 30MHz Delay. £125
 HAMEG HM303.6 Dual Trace 35MHz Component Tester. As new. £240
 HAMEG HM303 Dual Trace 30MHz Component Tester. £200

MANY OTHER OSCILLOSCOPES AVAILABLE

WILTRON Swept Freq Synthesizer 6747A-20 10MHz-20GHz. £5000
 MARCONI 2955 Synthesised AM/FM Sig Gen. £925-£750
 10KHz - 1.01MHz LCD Display etc.
 H.P. 8657A Syn 100KHz - 1040MHz Sig Gen. £2000
 H.P. 8656B Syn 100KHz - 890MHz Sig Gen. £1350
 R.S. APN62 Syn 1Hz - 280kHz Sig Gen. £295
 Balanced/Unbalanced Output LCD Display. £425
 PHILIPS PM5328 Sig Gen 100KHz - 180MHz with 200MHz Freq Counter IEEE. £250
 RACAL 3081 Syn AM-FM Sig Gen 5MHz - 520MHz. £250
 H.P. 3325A Syn Function Gen 21MHz. £500
 MARCONI 8500 Amplitude Analyser. £1500
 H.P. 4192A Impedance Analyser. £5000
 H.P. 4275A LCR Meter 10KHz - 10MHz. £2750
 H.P. 8903A Distortion Analyser. £1000
 WAYNE KERR Inductance Analyser 3245. £2000
 H.P. 8112A Pulse Generator 50MHz. £1250
 MARCONI 2440 Freq Counter 20GHz. £1000
 H.P. 5350B Freq Counter 20GHz. £2000
 H.P. 5342A 10Hz - 18GHz Freq Counter. £800
 H.P. 1650B Logic Analyser 80 Channel. £1000
 MARCONI 2305 Mod Meter 500KHz - 2GHz. £750

JUST IN

H.P. 66312A PSU 0 - 20V/0-2A. £400
 H.P. 66311B PSU 0 - 15V/0-3A. £400
 H.P. 66309D PSU Dual 0 - 15V 0-3A/0-12V 0-1.5A. £750
 H.P. 6632B PSU 0 - 20V/0-5A. £500
 H.P. 6623A PSU Triple Output ranging from 0-7V 0-5A to 0-20V 0-4A
 H.P./Agilent 34401A DMM 6 1/2 digit. £400/£450
 H.P. 3476A DMM 5 1/2 digit. £275
 FLUKE 45 DMM Dual Display. £400
 KEITHLEY 2010 DMM 7 1/2 digit. £950
 KEITHLEY 617 Programmable Electrometer. £1250
 H.P. 4338B Millihohmmeter. £1500
 RACAL Counter type 1999 2.6GHz. £500
 H.P. Counter type 53131A 5GHz. £850
 H.P./Agilent 33120A Function Gen/ARB. £900/£1000
 100micrHz - 15MHz
 SONY/TEKTRONIX AFG320 Arbitrary Function Gen. £1250
 H.P. 8904A Syn Function Gen DC - 600KHz £1000/£1250
 BLACK STAR JUPITOR 2010 Function Gen 0.2Hz - 2MHz with Frequency Counter. £140
 H.P. 8116A Pulse Generator 1mH-50MHz. £1950
 H.P. 8857B Syn Signal Gen 0.1-2080MHz. £2500
 CO-AXIAL SWITCH 1.5GHz. £40
 IEEE CABLES. £10

SPECTRUM ANALYSERS

H.P. 8581B 50Hz - 6.5GHz. £5000
 H.P. 8580A 50Hz - 2.9GHz Synthesised. £5000
 H.P. 8594E 9KHz - 2.9GHz. £4500
 H.P. 8591E 1MHz - 1.8GHz 75 ohm. £2750
 H.P. 8534 with 8559A 100KHz - 21GHz. £1750
 H.P. 8558B with Main Frame 100KHz - 1500MHz. £750
 H.P. 3586A 20Hz - 40MHz. £2500
 H.P. 3580A 5Hz - 50KHz. £800
 ADVANTEST RA131B 10KHz - 3.5GHz. £2750
 EDATON/Aitech 757 0.001 - 22GHz. £750
 MARCONI 2382 100Hz - 400MHz High Res. £2000
 MARCONI 2370 30Hz - 110MHz. from £500
 H.P. 182 with B557 10KHz - 350MHz. £500
 H.P. 1411 Systems
 8553 1KHz - 110MHz. £500
 8554 500KHz - 1250MHz. £750
 8555 10MHz - 18GHz. £1000
 H.P. 8443 Tracking Gen/Counter 110MHz. £250
 H.P. 8444 Opt 059. £750
 B & K 2033R Signal Analyser. £650
 H.P. 8754A Network Analyser 4MHz - 1000MHz. £1250
 H.P. 3577A Network Analyser 5Hz - 200MHz. £3000
 H.P. 53310A Modulation Domain Analyser Opt 001/003. £5000
 ONO SOKKI Portable FFT Analyser. £1500
 H.P. 8720C Microwave Network Analyser 50MHz-20GHz. £12500

RADIO COMMUNICATIONS TEST SETS

MARCONI 2955/2955F. from £1000
 Rohde & Schwarz CMT 0.1 - 100MHz. £1500
 Schumberger 4040. £750

USED EQUIPMENT - GUARANTEED. Manuals supplied.

This is a VERY SMALL SAMPLE OF STOCK. SAE or telephone for lists. Please check availability before ordering. CARRIAGE all units £16. VAT to be added to total of goods and carriage.

The Electronics World Book Service offers access to our team of specialist publishing experts. We can order any book or CD-ROM currently in print from *War And Peace* to the *Reference Data for Engineers*. All books are delivered free of charge within the UK unless otherwise stated. Contact us at the numbers below:

Telephone: **01737 812727** or **01737 812676**

Fax: 01737 813526

Email: salesteam@boffinbooks.demon.co.uk

THE ART OF ANALOG LAYOUT

Roy Alan Hastings

This text aims to provide students with a broad understanding of the issues involved in successfully laying out analog-integrated circuits - ranging from the mechanics of layout to essential information about many related areas, such as device physics, processing and failure modes and effects.

Oct 2000 ▲ 559 pages ▲ HB
Code PEAR 0 13 08706 7



£30.99

DESIGN-FOR-TEST: FOR DIGITAL INTEGRATED CIRCUITS AND EMBEDDED CORE

Alfred L Crouch

An introduction to the basic concepts of Design-For-Test, an area in chip design.

July 1999 ▲ 350 pages & CD-ROM
Code PEAR 0 13 084827 1



£59.99

HIGH SPEED DIGITAL DESIGN

Howard W Johnson & Graham Martin

Re-issue

Focusing on the field of knowledge lying between digital and analog circuit theory, this text sets out to help engineers working with digital systems shorten their product development cycles and help fix their latest design problems. It covers signal reflection and crosstalk.

820 pages ▲ HB
Code PEAR 0 13 395724 1



£44.99

RF CIRCUIT DESIGN: THEORY & APPLICATIONS

Reinhold Ludwig; Pavel Bretchko

This practical guide introduces RF circuit design fundamentals while emphasizing a circuit based approach. It provides MATLAB routines to carry out simple transmission line computations and uses a PC-based commercial RF circuit simulation tool to demonstrate actual circuit behaviour.

Oct 1999 ▲ 656 pages ▲ HB
Code PEA 0 13 095323 7



£35.99

VERILOG DEVELOPER'S LIBRARY

Bob Zeidman

Verilog is one of the most used hardware description languages. This text contains a library of useful code for those users who do not want to recreate identical code for common tasks.

Jul 1999 ▲ 450 pages ▲ PB
Code PEA0 13 081154 8



£79.99

PASSIVE COMPONENTS FOR CIRCUIT DESIGN

Ian Sinclair

Designed for technician engineers and anyone involved in circuit design, this text provides an introduction into a key area of analogue electronics. It covers all component types capable of power amplifications, including: resistors, capacitors, transformers, solenoids and motors.

Nov 2000 ▲ 301 pages ▲ PB
Code H80 7506 4933 X

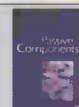

£22.99

ELECTRONIC PROJECTS FROM THE NEXT DIMENSION: PARANORMAL EXPERIMENTS FOR HOBBYISTS

Newton Braga

A guide to making and using paranormal research electronics. It describes practical electronic circuits to be used in experiments involving instrumental transcommunication (ITC), the electronic voice phenomenon (EVP), and paranormal experiments involving ESP, auras, and Kirlian photography. White and pink noise generators for use in instrumental transcommunication (ITC) experiments; Kirlian photography; plasma experiments; extrosensory perception testers; magnetic fields sensors.

Nov 2000 ▲ 256 pages ▲ PB
Code H80 7506 7305 2



£27.99

BASIC AC CIRCUITS

Clay Rawlins

A step-by-step approach to AC circuits for beginners, providing thorough coverage of theory and practice. The text provides individualized learning goals covering electronics concepts, terms and the mathematics required to understand AC circuit problems.

2nd Edition ▲ Oct 2000 ▲ PB
Code H80 7506 7173 4



£33.99

INTERFACING WITH C

Mike James & Howard Hutchings

An exploration of interfacing personal computers using C. An introduction to C; loops and data conversion; data acquisition using C; essential mathematics; convolution; digital filters; Fourier transforms; correlation; Kalman filters; data conversion; investigating the spectral and time-domain performance of z-transforms using computer-managed instruction; introducing audio signal processing using C; standard programming structures. Dewey: 005.71262

2nd edition ▲ Dec 2000 ▲ 308pages
Code HB 0 7506 4831 7



£19.99

SELF ON AUDIO

Douglas Self

This work offers a collection of *Electronics World* articles, including self-build projects. It aims to demystify amplifier design and establish empirical design techniques based on electronic design principles and experimental data.

Jul 2000 ▲ 256 pages ▲ PB
Code H80 7506 4765 5



£26.99

BUILD AND UPGRADE YOUR OWN PC

Ian Sinclair

This third edition of *Build and Upgrade Your Own PC* is based around building and upgrading to the very latest systems running processors with speeds over 2.0 Ghz and ultrafast buses. It also covers upgrading to Windows XP and Windows Me.

3rd edition ▲ Jul 2002 ▲ 335 pages ▲ PB
Code HB 0 7506 5758 8



£22.50

PRACTICAL ELECTRONICS HANDBOOK

Ian Sinclair

A collection of all the key data, facts, practical guidance and circuit design basics needed by a spectrum of students, electronics enthusiasts, technicians and circuit designers. It provides explanations and practical guidance, and includes new sections on SHF techniques and intruder alarms.

5th edition ▲ Feb 2000 ▲ 571 pages ▲ PB
Code HB 0 7506 4585 7



£16.99

ANALOG CIRCUIT TECHNIQUES WITH DIGITAL INTERFACING

Trevor Wilmshurst

Aimed at Junior undergraduates, this textbook offers comprehensive coverage of analogue electronic circuit design with two full chapters devoted to the use of SPICE in circuit simulations. programmes leading to 1Eng MSc Electronic conversion type courses.

Mar 2001 ▲ 320 pages ▲ PB
Code H80 7506 5094 X



£19.99

ELECTRONICS FOR SERVICE ENGINEERS

Joe Cieszynski & Dave Fox

From simple mathematics and circuit theory to transmission theory and aeriols, this text provides the range of knowledge required to service electronic and electrical equipment. Questions and worked examples illustrate the concepts described in each chapter.

Mar 1999 ▲ 294 pages ▲ PB
Code H80 7506 3476 6



£20.99

FABRICATING PRINTED CIRCUIT BOARDS

Jon Varteresian

Engineers are often faced with the need for small quantities of a certain board design for construction of a small number of devices. This book describes the process of making a printed circuit board, from the conversion of a schematic diagram into a board layout to the making of the board itself.

Jul 2002 ▲ 251 pages ▲ PB
Code HB 1 878707 50 7



£21.99

REFERENCE DATA FOR ENGINEERS: RADIO, ELECTRONICS, COMPUTERS AND COMMUNICATIONS

Mac E Van Valkenburg

Written by professionals for professionals, this title is a complete reference for engineers, covering a broad range of topics. As well as addressing radio technology data, this reference volume covers digital electronics, computers and communications.

9th edition ▲ Aug 2001 ▲ 1568 pages
HB & CD-ROM
Code H80 7506 7291 9



£90.00

PRACTICAL RF HANDBOOK

Ian Hickman

A hands-on-guide for engineers, technicians, students and enthusiasts working in RF design, this comprehensive text covers all the key topics in RF, including: analogue design principles; transmission lines; transformers; couplers; amplifiers; oscillators; modulation; and antennas.

3rd edition ▲ Feb 2002 ▲ 289 pages
150 line drawings ▲ PB
Code HB 0 7506 5369 8



£19.99

NEWNES TELEVISION AND VIDEO ENGINEER'S POCKET BOOK

Eugene Trundle

This text provides a pocket tool for service engineers. It presents a range of essential information in a compact form, covering television reception, satellite and cable television, video recorders, colour camera technology, teletext and fault-finding.

3rd edition ▲ Oct 1999 ▲ 512 pages ▲ HB
Code HB 0 7506 4194 0



£17.99

BEBOP TO THE BOOLEAN BOOGIE
Clive Maxfield

Comprehensive introduction to contemporary electronics - friendly, funny and quirky. Whether you're an engineer, hobbyist, or student who needs a thorough and up-to-date electronics reference or a non-technical person who wants to understand more about this electron dance that has seemingly taken over the world, this book is the answer. Hundreds of diagrams that clarify even the most difficult subjects.

2nd Edition ▲ Jan 2003
Code HB 0 7506 7543 8 **£27.50**

NEWNES GUIDE TO DIGITAL TV
Richard Brice

Covering all aspects of digital television (terrestrial, satellite and cable), this text has been updated with developments since the 2000 edition. Foundations of television; digital video and audio coding; digital signal processing; video data compression; audio data compression; digital audio production; digital video production; the MPEG multiplex; broadcasting digital video; consumer digital technology; the future.

2nd edition ▲ Sep 2002 ▲ 304 pages ▲ HB
Code HB 0 7506 5721 9 **£24.99**

NEWNES DICTIONARY OF ELECTRONICS
SW Amos & R S Amos

Aimed at engineers, technicians and students working in the field of electronics, this dictionary provides clear and concise definitions, including TV, radio and computing terms, with illustrations and circuit diagrams.

4th edition ▲ March 2002 ▲ 394 pages ▲ PB
Code HB 0 7506 5642 5 **£12.99**

RSGB RADIO AND ELECTRONICS COOKBOOK
Radio Society of Great Britain

Only a basic knowledge of electronics is assumed for this collection of electronics projects, and it is ideal for all electronics and DIY enthusiasts and experimenters. Designed by the RSGB, the UK radio amateurs federation, the projects are clearly explained step by step.

Nov 2000 ▲ 336 pages ▲ PB
Code HB 0 506 5214 4 **£17.99**

ELECTRONIC SERVICING AND REPAIRS
Trevor Linsley

Updates the previous text taking into account changes in the City and Guilds courses 2360 and 2240. Also features hardware topics, testing and fault diagnosis, PLCs and CAD software, and new chapters. Health and safety; electronic component recognition; electronic circuit assembly techniques; electronic semiconductor devices; electronic circuits in action; testing electronic circuits; digital electronics; electrical circle theory; electronic systems; communication systems; security systems; sensors and transducers.

3rd edition ▲ Aug 2000 ▲ 261 pages
Code HB 0 7506 5053 2 **£18.99**

DIGITAL LOGIC DESIGN
Brian Holdsworth & Woods

This undergraduate text on digital systems covers first and second year modules and HND units, and can also be used as a reference text in industry. Updated topics in the fourth edition include: EBCDIC, Grey code, practical applications of flip-flops, linear and shaft encoders and memory elements.

4th edition ▲ Aug 2002 ▲ 448 pages
Code HB 0 7506 4582 2 **£19.99**

NEWNES INTERFACING COMPANION: COMPUTERS, TRANSDUCERS, INSTRUMENTATION AND SIGNAL PROCESSING
Tony Fischer-Cripps

Provides the fundamentals of electronics, transducers, computer architecture and interfacing techniques needed to use a simple PC or PLC-based system for the collection of data previously only obtainable from expensive dedicated equipment.

Aug 2002 ▲ 320 pages ▲ HB
Code HB 0 7506 5720 0 **£24.99**

NEWNES RADIO AND RF ENGINEERING POCKET BOOK
Steve Winder & Joseph J Carr

With a mass of information and data for students, radio and telecommunications engineers, RF circuit designers, radio hobbyists and technicians, this guide covers all aspects of radio and communications engineering from low frequencies to microwaves, with an emphasis on mobile communications.

3rd edition ▲ Jul 2002 ▲ 352 pages ▲ HB
Code HB 0 7506 5608 5 **£16.99**

ROBOTICS, MECHATRONICS, AND ARTIFICIAL INTELLIGENCE: EXPERIMENTAL CIRCUIT BLOCKS FOR DESIGNERS
Newton C Braga

This work simplifies the process of finding basic circuits to perform simple tasks, such as how to control a DC or step motor, and provides instruction on creating moving robotic parts, such as an "eye" or an "ear".

Nov 2001 ▲ 317 pages ▲ PB
Code HB 0 7506 7389 3 **£21.99**

EMBEDDED MICROPROCESSOR SYSTEMS: REAL WORLD DESIGN
Stuart Ball

Providing an introduction to the design of embedded microprocessor systems, this edition covers everything from the initial concept through to debugging the final result. It also includes material on DMA, interrupts and an emphasis throughout on the real-time nature of embedded systems.

3rd edition ▲ Nov 2002 ▲ 368 pages ▲ PB
Code HB 0 7506 7534 9 **£35.00**

POWER SUPPLY COOKBOOK
Marty Brown

Providing an easy-to-follow, step-by-step design framework for a wide variety of power supplies, including linear, switching and quasi-resonant switching. There is also discussion of design topics such as magnetics, feedback loop compensation design and EMI/RFI control in straightforward terms.

2nd edition ▲ Jun 2001 ▲ 336 pages ▲ HB
Code HB 0 7506 7329 X **£24.99**

MIXED-SIGNAL AND DSP DESIGN TECHNIQUES
Walt Kester

Mixed-signal processing implies the use of analogue and digital in the same system; this is a specialized type of signal processing that requires a high level of experience and training. This book focuses primarily on signal processing hardware - how it works, how to interface it, and design it.

Oct 2002 ▲ 336 pages ▲ PB
Code HB 0 7506 7611 6 **£39.99**

UNDERSTANDING AUTOMOTIVE ELECTRONICS
W B Ribbens

Covering the most recent technological advances in operation and troubleshooting of electronic systems and components, including low-emission standards, on-board diagnostics and communications, digital instrumentation, and digital engine control. A practical text, suitable for the automotive technical, student, enthusiast, or professional who wants to upgrade his or her background in electronic systems found in the automotive.

6th ed. Dec 2002
Code HB 0 7506 7599 3 **£24.99**

DESIGNING EMBEDDED INTERNET DEVICES
Brian DeMuth & Eisenreich

This guide to designing internet access and communications capabilities into embedded systems takes an integrated hardware/software approach, using the Java programming language and industry-standard microcontrollers. The CD-ROM has Java source code and a version of the text.

Aug 2002 ▲ 320 pages
PB & CD-ROM
Code HB 1 878707 98 1 **£35.00**

PIC IN PRACTICE: AN INTRODUCTION TO THE PIC MICROCONTROLLER
David W Smith

An exploration of the PIC microcontroller, designed to be used at a variety of levels. It introduces the reader to the range of tasks the PIC can perform and makes use of readily available components. The PIC used in the examples is the re-programmable EEPROM 16C84/16F84.

Apr 2002 ▲ 261 pages ▲ PB
Code HB 0 7506 4812 0 **£14.99**

If you are ordering by credit card, need further information, or would like to use our search facilities call
01737 812727 Fax 01737 813526.
The order/helpline is open from 9am to 5pm, or leave your order on our out of hours answerline or email us at
salesteam@boffinbooks.demon.co.uk.

When placing orders please quote
● Name ● Address (home & delivery) ● Daytime telephone number ● Debit/Credit card number ● Expiry date ● Details of order. Please note that prices may change, but are correct at time of going to press.

Boffin Books Ltd., 24 Walton Street,
Walton-on-the-Hill, Tadworth, Surrey KT20 7RT, UK

ELECTRONICS WORLD ORDER FORM

Please order or search the following:

Code	Description	Qty	Price
POSTAGE & PACKING FREE IN THE UK*			TOTAL
Name	Daytime Tel		
Address	Postcode		
Delivery address (if different)	Postcode		
I enclose a cheque/postal order value £ _____ payable to 'Boffin Books Ltd'			
Please debit my Access/Visa/Switch/Delta card Issue number (Switch only) _____			
Card Number _____	Expiry Date _____		
Signed _____ email:salesteam@boffinbooks.demon.co.uk			

*Postage charges outside the UK available upon request or email to salesteam@boffinbooks.demon.co.uk
Post to: Boffin Books Ltd., 24 Walton Street, Walton-on-the-Hill, Tadworth, Surrey KT20 7RT, UK



WEB DIRECTIONS



Put your web address in front of 18,000 electronic fanatics. Electronics World acknowledge your company's needs to promote your web site, which is why we are dedicating 2 pages in every issue to WEB ADDRESSES.

Linage only will cost £150 + vat for a full year.

Linage with colour screen shot will cost £350 + vat for a full year, this will include the above plus 3cm shot of your web site which we can produce if required.

To take up this offer or for more information telephone

Reuben Gurnlian

Tel 0208 722 6028

E-mail

r.gurnlian@highburybiz.com

in our extensive database covering Akai, Alba, Bush, Ferguson, Goldstar, Hitachi, LG, Marantz, Matsui, Nokia, Saisho, Sanyo, Sony, Sharp, Thomson, Panasonic, Philips, Samsung, Tascam, Teac, Toshiba, Yamaha and many more. In addition huge ranges of Lasers, Laptops, Remote controls and Semiconductors may be accessed.

CHYGWYN

<http://www.chygwyn.com>

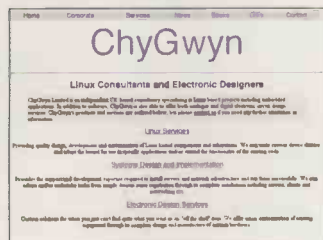

ChyGwyn Limited offers electronic design and embedded software development for remote monitoring, embedded appliances, set-top boxes and similar devices. We are experts in customisation of Linux and write device drivers for custom hardware.

CONFORD ELECTRONICS

<http://www.confordelec.co.uk/index.shtml>

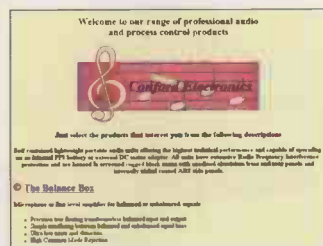

Lightweight portable battery/mains audio units offering the highest technical performance. Microphone, Phantom Power and Headphone Amplifiers. Balanced/unbalanced signal lines with extensive RFI protection.

CRICKLEWOOD ELECTRONICS

<http://www.cricklewoodelectronic.co.uk>

Cricklewood Electronics stock one of the widest ranges of components, especially semiconductors including ICs, transistors, capacitors, all at competitive prices.

DB TECHNOLOGY

<http://www.dbtechnology.co.uk/>

EMC Testing and Consultancy. Anechoic chamber and open area test site.

- Compliance Tests
- Rapid, accurate pre-compliance tests.
- Fixes included. FCC Listed.



● Flexible, hourly booking available.

DESIGNER SYSTEMS CO.

<http://www.designersystems.co.uk>

Electronic product design company with

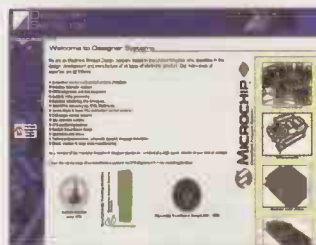

over a decade of experience promoting it's own product range and designing and manufacturing innovative products for client companies/individuals.

EAGLE PCB DESIGN SOFTWARE

<http://www.puresoft.co.uk>

● Professional PCB design made easy!



● Fully functional freeware download.
● Schematics, Layout & Autorouting.
● Free tech support

EasySync

<http://www.easysync.co.uk>



EasySync supplies a wide range of USB-RS232 and USB-RS422/485 converters. It also specialises in USB test and measurement devices.



FELLER UK

<http://www.feller-at.com>

Feller (UK) Ltd. manufacture Fully approved cordsets (Moulded mains plugs and connectors) and Power Supply Cables for all industrial Countries to National and International Standards

FUTURE TECHNOLOGY DEVICES INTL. LTD.

<http://www.ftdichip.com>

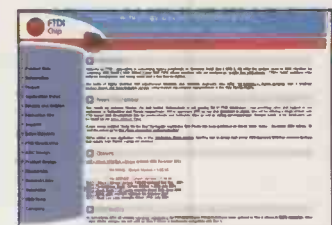

FTDI designs and sells USB-UART and USB-FIFO interface i.c.'s. Complete with PC drivers these devices simplify the task of designing or upgrading USB peripherals

GREENWELD

<http://www.greenweld.co.uk>



Audio ● Batteries & Chargers ● Books ● Communications ● Computer ● Cable ● Capacitors ● Car Equipment ● Craft Goods ● Disco Equipment ● Enclosures ● Electrical ● Fuses ● Graphic supplies ● Hardware ● Instrumentation ● Kits ● Lighting ● Mechanical ● Optical ● Photographic ● Power supplies ● Transformers ● Resistors ● Semiconductors ● Software ● Soldering Irons ● Surplus goods ● Switches ● Relays ● Telephone Accessories ● Tools ● Plus much more.

Whether your interest is in electronics, model engineering, audio, computer, robots or home and

ANASOFT LTD

<http://www.anasoft.co.uk>

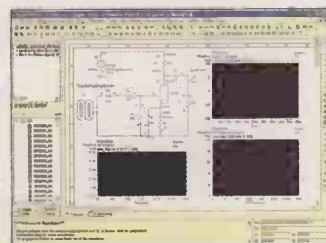

SuperSpice, the affordable, mixed-mode windows circuit simulator. Written by an analogue design engineer for those Teletubbies who like keeping things simple.

CHARLES HYDE & SON Ltd

<http://www.charleshyde.co.uk>

Search for both original and copy spare parts

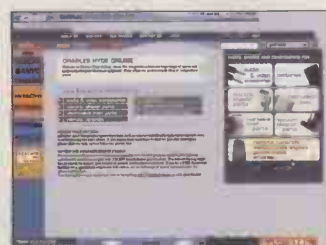

To reserve your web site space phone Reuben Gurunlian
 Tel: 020 8722 6028
 Fax: 020 8722 6096



leisure products (to name just a few) we have a wide range of new and surplus stock available.

J W HARDY COMMUNICATIONS

<http://www.jwhardy.co.uk>



R.F. Network Specialist. Shop online - for R.F. network components. We supply a full range of TV, radio reception equipment to receive analogue/digital signals from both terrestrial and satellite sources. We provide a free planning service for your R.F. networks, MATV and SMATV etc

LOW POWER RADIO SOLUTIONS

<http://www.lprs.co.uk>

LPRS produces radio modules with embedded "easy-Radio" software protocols for short range radio applications. We also represent Circuit Design narrow band modules in the UK.

MATRIX MULTIMEDIA LTD

www.matrixmultimedia.co.uk



Matrix Multimedia publishes a number of highly interactive CD ROMs for learning electronics including: Complete electronics course, Analogue filter design, and PICmicro(R) microcontroller programming (C and assembly).

NORCALL Ltd

<http://www.norcall.co.uk>

e-mail Norcall@aol.com

Suppliers programmers and repairers of new and refurbished two-way radio equipment. Retuning and recrystalling service available. All types of batteries chargers and aerials supplied.

PHAEDRUS LTD

www.phaedrusltd.co.uk

Manufacturer and supplier of low cost general purpose and serial I/O digital modules and accessories. PC based software for data logging and control applications.

QUASAR ELECTRONICS

www.quasarelectronics.com

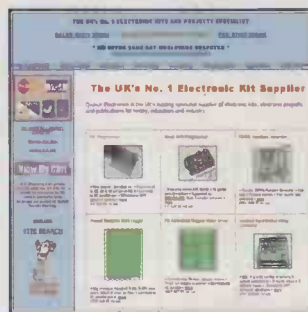

Over 250 electronic kits, projects and ready built units for hobby, educational & industrial applications. TEL: 01279 467799, FAX: 07092 203496 or EMAIL: ewsales@quasarelectronics.com

RADIOMETRIX

<http://www.radiometrix.co.uk>

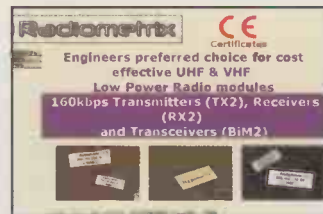

Radiometrix specialises in the design and manufacture of VHF & UHF, RF data modules. We offer a broad range of PCB mounted miniature transmit, receive and transceiver modules for OEM use. They comply with European harmonised standards EN300 220-3 and EN301 489-3 and are CE certified by an independent Notified Body.

SOFTCOPY

<http://www.softcopy.co.uk>



As a PC data base or hard copy, SoftCopy can supply a complete index of Electronics World articles over the past ten years. Photo copies of articles from back issues are also available.

TELNET

<http://www.telnet.uk.com>



Top quality second-user Test and Measurement Equipment
 eMail sales@telnet.uk.com

TELEVES

<http://www.televes.com>

Tel: 44(0) 1633 875821
 email hbotas@televes.com

Televes website was launched as an easier way to keep in contact with our World-wide Network of Subsidiaries and Clients. This site is constantly updated with useful information/news plus you can download info on our range: TV Aerials & accessories, Domestic and Distribution amplifiers, Systems Equipment for DTT and Analogue TV, Meters and much more.

TEST EQUIPMENT SOLUTIONS

<http://www.TestEquipmentHQ.com>



Test Equipment for rental or second user sale at the industry's lowest prices. All types of equipment from all leading manufacturers including general purpose, communications and Industrial test. Items fully refurbished with 1 year warranty. Rental rebate given on purchases.

TELONIC

<http://www.telonic.co.uk>



Telonic specialists in laboratory AC & DC Power Supplies, Electronic AC & DC Loads, Electrical Safety Testing and complete test systems. Plus RF Filters, Attenuators, Diesel Engine Smoke Measurement, Quartz Crystal Microbalances.
 Tel +44 (0) 118 9786911

TECHNICAL AND SCIENTIFIC SUPPLIES

<http://www.technicalscientific.com>

Suppliers of pre-1985 equipment and components.

- Test/Measurement equipment
- Valves and semiconductors
- Transducers and pressure gauges
- Scientific books and catalogues
- Manuals and data sheets

THOSE ENGINEERS LTD

<http://www.spiceage.com>

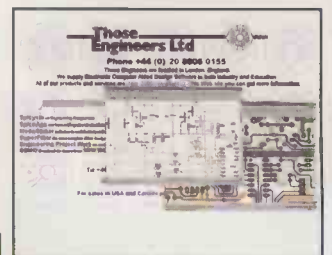

Working evaluations of SpiceAge mixed-mode simulator, Spicycle PCB design tools and Superfilter demo (synthesises passive, active, digital filters). Tech support, sales links and price list.

TOTAL ROBOTS

<http://www.totalrobots.co.uk>

Robot Kits and Control Technology products, including OOPic the first Object-Oriented Programmable Integrated Circuit. Secure on-line ordering and fast delivery.

To reserve your web site space
 phone Reuben Gurunlian
 Tel: 020 8722 6028
 Fax: 020 8722 6096

ULTRA-CREA OY

<http://www.ultra-crea.fi>



Our business idea is to provide our customers complete service, i.e. design from the customer specification to the delivery of finished and tested products.

Our offerings are as follows:

- RF transmission line filters from 100MHz to 3GHz
- Special antennas to frequencies as above
- Transmitter and Receiver modules
- RF-subunits such as amplifiers, oscillators, directional couplers etc.

VUTRAX PCB DESIGN SOFTWARE

<http://www.vutrax.co.uk>



Vutrax electronic schematic and pcb design system for Windows 95/98, ME, NT, 2000, XP and Linux. Limited capacity FREE version downloads available, all upgradeable to various customised level.

WILMSLOW AUDIO

<http://www.wilmslow-audio.co.uk>

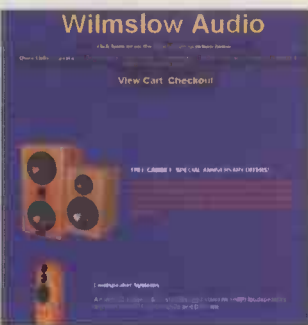

"Uk's largest supplier of high quality loudspeaker kits and drive units. Comprehensive range of components and accessories, including damping products, connectors and grilles materials. Demonstration facilities available.

Ten year index: new update



Photo copies of *Electronics World* articles from back issues are available at a flat rate of £3.50 per article, £1 per circuit idea, excluding postage.

Hard copy *Electronics World* indexes on paper for volumes 100, 101, and 102 are available at £2 each, excluding postage.

www.softcopy.co.uk

Hard copies and floppy-disk databases both available

Whether as a PC data base or as hard copy, SoftCopy can supply a complete index of *Electronics World* articles going back over the past nine years.

The computerised index of *Electronics World* magazine covers the nine years from 1988 to 1996, volumes 94 to 102 inclusive and is available now. It contains almost 2000 references to articles, circuit ideas and applications - including a synopsis for each.

The *EW* index data base is easy to use and very fast. It runs on any IBM or compatible PC with 512K ram and a hard disk.

The disk-based index price is still only £20 inclusive. Please specify whether you need 5.25in, 3.5in DD or 3.5in HD format.

Existing users can obtain an upgrade for £15 by quoting their serial number with their order.

Ordering details

The *EW* index data base price of £20 includes UK postage and VAT. Add an extra £1 for overseas EC orders or £5 for non-EC overseas orders

Postal charges on hard copy indexes and on photocopies are 50p UK, £1 for the rest of the EC or £2 worldwide.

For enquires about photocopies etc please send an sae to SoftCopy Ltd.

**Send your orders to SoftCopy Ltd,
1 Vineries Close, Cheltenham GL53 0NU.**

Cheques payable to SoftCopy Ltd, please allow 28 days for delivery.

ADVERTISERS INDEX

Beta Layout	33
Cambridge Microprocessor Systems.....	35
Cricklewood Electronics	35
Display Electronics.....	27
Johns Radio.....	35
JPG Electronics.....	63
Labcenter.....	11
Olson Electronics	4
Peak Electronic Design.....	IBC
Pico Technology	24
Quasar.....	2
Seetrax Advanced Systems.....	33
Stewart Of Reading.....	57
Telnet.....	IFC
Test Equipment Solutions	OBC
Tie Pie Engineering	29
Westdev	63
WCN Supplies	57
Weldex	9
XL Systems.....	33

WATCH SLIDES ON TV MAKE VIDEOS OF YOUR SLIDES DIGITISE YOUR SLIDES (using a video capture card)



"Liesgang diatv" automatic slide viewer with built in high quality colour TV camera. It has a composite video output to a phono plug (SCART & BNC adaptors are available). They are in very good condition with few signs of use. For further details see www.diatv.co.uk £91.91 + vat = £108.00

Board cameras all with 512x582 pixels 8.5mm 1/3 inch sensor and composite video out. All need to be housed in your own enclosure and have fragile exposed surface mount parts. They all require a power supply of between 10 and 12v DC 150mA.

47MIR size 60x36x27mm with 6 infra red LEDs (gives the same illumination as a small torch but is not visible to the human eye)..... £37.00 + vat = £43.48

30MP size 32x32x14mm spy camera with a fixed focus pin hole lens for hiding behind a very small hole..... £35.00 + vat = £41.13

40MC size 39x38x27mm camera for 'C' mount lens these give a much sharper image than with the smaller lenses..... £32.00 + vat = £37.60

Economy C mount lenses all fixed focus & fixed iris

VSL1220F 12mm F1.6 12x15 degrees viewing angle..... £15.97 + vat = £18.76

VSL4022F 4mm F1.22 63x47 degrees viewing angle..... £17.65 + vat = £20.74

VSL6022F 6mm F1.22 42x32 degrees viewing angle..... £19.05 + vat = £22.38

VSL8020F 8mm F1.22 32x24 degrees viewing angle..... £19.90 + vat = £23.38

Better quality C Mount lenses

VSL1614F 16mm F1.6 30x24 degrees viewing angle..... £26.43 + vat = £31.06

VWL813M 8mm F1.3 with iris 56x42 degrees viewing angle..... £77.45 + vat = £91.00

1206 surface mount resistors E12 values 10 ohm to 1M ohm 100 of 1 value £1.00 + vat 1000 of 1 value £5.00 + vat

866 battery pack originally intended to be used with an orbitel mobile telephone it contains 10 1.6Ah sub C batteries (42x22dia the size usually used in cordless screwdrivers etc.) the pack is new and unused and can be broken open quite easily..... £7.46+vat = £8.77



Please add 1.66 + vat = £1.95 postage & packing per order

JPG ELECTRONICS

Shaws Row, Old Road, Chesterfield, S40 2RB

Tel 01246 211202 Fax 01246 550959 Mastercard/Visa/Switch

Callers welcome 9:30 a.m. to 5:30 p.m. Monday to Saturday

Easy-PC for Windows

World Beating Value in PCB Design Software

from
£97

High performance Windows based PCB Design Capture, Simulation and Layout software at prices you'd expect from your local computer store!



NEW! Easy-PC Version 6

- Online design rule checking
- PCB footprint and schematic symbol wizards
- Import DXF from your mechanical system
- Single shot postprocessing plus much much more.....

Stop press... by customer demand, now with Tsien Boardmaker 2 design import...

Number One Systems delivers true 32 bit Windows software applications including features that a few short years ago would only have been available in software tools priced in the thousands!

Test drive Easy-PC and Easy-Spice for yourself and be prepared to be amazed at the super value...

Call for a brochure, price list and demo CD on +44 (0)1684 773662 or email sales@numberone.com



No1 Number One Systems

Number One Systems
Oak Lane, Bredon
Tewkesbury, Glos GL20 7LR
United Kingdom

or download from
www.numberone.com

As an advertiser you can be certain that your sales message is going to be read by decision-making electronics professionals with the power to purchase your products.

Service Link

The pre-paid rate for semi-display setting is £17 per single column centimetre (maximum 4cm). Box number £22 extra. All prices plus 17½% VAT. All cheques, postal orders etc to be made payable to Highbury Business Communications Ltd. Advertisements together with remittance should be sent to Electronics World Classified, Highbury Business Communications Ltd, Anne Boleyn House, 9-13 Ewell Road, Cheam, Surrey SM3 8DZ.
Tel: 020 8722 6028. Fax: 020 8770 2016.

ARTICLES WANTED

BEST CASH PRICES PAID

FOR VALVES KT88, PX4 AND MOST AUDIO/OTHER TYPES.

Tel: 01403 784961

Billington Export Ltd.
Sussex RH14 9EZ
Fax: 01403 783519
Email: sales@bel-tubes.co.uk
Visitors by appointment

ARTICLES WANTED

TOP PRICES PAID

For all your valves, tubes, semi conductors and ICs.

Langrex Supplies Limited

1 Mayo Road, Croydon, Surrey CR0 2QP
TEL: 020 8684 1166 FAX: 020 8684 3056

FOR SALE

RF DESIGN SERVICES

All aspects of RF hardware development considered from concept to production.

WATERBEACH ELECTRONICS

www.rlaver.dial.pipex.com
TEL: 01223 862550
FAX: 01223 440853

FOR SALE

LAB CLEAROUT

Excellent quality
1970's - 1990's

Test Equipment for Sale

Tek, HP, Philips, Racal Dana Leader, Marconi, Datron etc.

Call for lists, prices & photos:
TEL: 01427 754490
FAX: 01427 754498

peter@owston-grange.com

PRINTED CIRCUIT BOARDS

DESIGNED & MANUFACTURED 

- Prototype or production quantities
- Fast turnaround available
- PCBs designed from circuit diagrams
- Almost all computer files accepted
- PCB assembly - mechanical assembly
- Full product design-manufacture-test-repair

Unit 5, East Belfast Enterprise Park
308 Albertbridge Rd, Belfast BT5 4GX
TEL 028 9073 8897 FAX 028 9073 1802
info@agarcircuits.com

SERVICES

POWER SUPPLY DESIGN

Switched Mode PSU
Power Factor Correction
designed to your specification
Tel/Fax: 01243 842520
e-mail: eugen_kus@cix.co.uk

Lomond Electronic Services

WESTDALE ELECTRONICS

We would welcome the opportunity of quoting for your requirements.

If you have a problem with your semiconductors or relays, give us a call and we will locate them for you.

We also have access to inventory Stateside ie
Current, Obsolete, MIL, Spec

Call: Bryan on -
Tel/Fax:
0115 9402127



SERVICES

PCBs Conv/PTH/Multi-Layer/Flexible • UK & Far East production
 • CAD Layout • Electronic Design • Assembly (prototype & production)
 • SMD m/c assy @ 18,500 cps/hr

Deliveries from
24 Hrs

Prototype PTH PCBs from just
£40.00

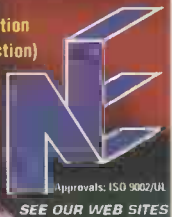

Tel: 01635 40347

Newbury Electronics Ltd
Faraday Road Newbury Berks RG14 2AD
Fax: 01635 36143
e-mail: circuits@newbury.tcom.co.uk
http://www.newburyelectronics.co.uk

Visit
www.pcbtrain.com

The low cost source for prototype PCBs from 1 to 6 layers

From Concept To Production

48 HOUR SERVICE

Electronic design and manufacturing services for the new millennium:

- Embedded monitoring & control
- PSTN telephones and test equipment
- Datacom interfacing, line driving etc.
- Switch Mode & linear PSU and battery management
- Gas detection systems
- Printed Circuit Board design
- Technical documentation, schematic layout & language translation
- Wireless telemetry systems
- Audio & Video processing
- GSM/telemetry via SMS or data (TCP/IP)
- DVD player control systems
- GPS positioning systems
- Specialist cable looms
- Small, medium & large scale manufacturing

Email: sales@designersystems.co.uk
Tel/Fax: +44 (0) 1872 223306



for more information see our web site @
http://www.designersystems.co.uk

WANTED

WANTED Surplus or Obsolete Electronic Components

Turn your excess stock into instant cash!

SEND OR FAX YOUR LIST IN STRICTEST CONFIDENCE

Will collect anywhere in the UK



Mushroom
COMPONENTS

28 College Street, Kempston, Bedfordshire, MK42 8LU
Tel: 01234 363611 Fax: 01234 326611
E-mail: sales@mushroom.co.uk
Internet: www.mushroom.co.uk

For a FREE consultation on how best to market your products/services to a professional audience contact REUBEN on 020 8722 6028

Service Link

atlas LCR

£79

Passive Component Analyser (Model LCR40)

fully inclusive UK price

Just clip on the test leads and press test. The Atlas LCR will automatically identify the type of component, apply the appropriate test level and frequency, display the component's value and more!

Probes are detachable too, so you can use the optional SMD tweezers for your tiny unmarked passives - fantastic.

- Automatic component identification (Inductor, Capacitor or Resistor)
- Component value measurement
- Auto frequency (DC, 1kHz, 15kHz, 200kHz)
- Inductor DC resistance measurement
- Non-volatile probe compensation memory
- Detachable probes allowing use of optional test prods, SMD tweezers, etc...
- Hands free mode with value hold

Supplied with mini-hook grabbers as standard

Inductance range: 1 μ H to 10H
 Capacitance range: 1pF to 10,000 μ F
 Resistance range: 1 Ω to 2M Ω
 Basic accuracy: 1%
 Test signals: 1V, 3mA max

"Astonishingly, this little unit seems to pack most of the punch of a large and very expensive automated LCR bridge into its tiny case."

Andy Flind - EPE Magazine March 2003



Accessories:

- Carry case
 - Tweezer Probes
 - Crocodile Probe Set
 - Large Grabber Probes
- (more available soon)

atlas DCA

£60

Semiconductor Analyser (Model DCA55)

fully inclusive UK price

NOW MEASURES
TRANSISTOR
LEAKAGE!

Check and identify your semi's

- Automatic component identification
- Pinout identification
- Transistor gain measurement
- MOSFET gate threshold measurement
- PN junction characteristics measurement
- Shorted Junction identification
- Transistor leakage measurement
- Just connect the part anyway round and press the button!
- Auto power on/off

NPN bipolar
Darlington

Diode protection
between C-E

Resistor shunt
between B-E

Current gain
Hfe=126

Enhancement mode
N-Ch MOSFET

Gate Threshold
Vgs=3.47V

RED GATE BLUE
Base collector emit

Delta
beta = 770

P

aka
= 0.2

"It's the kind of instrument that should be on every engineers and enthusiasts bench."

EPE Magazine
March 2000

enclosure colours may vary

atlas PACK £129!

LCR40 and DCA55 Pack

fully inclusive UK price

Why not order both analysers at the same time and take advantage of our special offer, saving you £10!



Visit www.peakelec.co.uk to download the data sheets, user guides and copies of independent reviews. You can pay using a cheque, postal order, credit or debit card and even pay securely online. Please contact us for your volume requirements.

Also available from: (prices vary)

Farnell

MAPLIN
ELECTRONICS

PEAK
electronic design ltd

Atlas House, Kiln Lane
 Harpur Ind. Est., Buxton
 Derbyshire, SK17 9JL, UK

www.peakelec.co.uk
sales@peakelec.co.uk

Tel. 01298 70012 Fax. 01298 70046



TEST EQUIPMENT SOLUTIONS

Quality Second User
Test Equipment
With 12 Months Warranty

The Industry's
Most Competitive
Test Equipment Rental Rates

	Sale (GBP)	Rent (GBP)		Sale (GBP)	Rent (GBP)		Sale (GBP)	Rent (GBP)			
AMPLIFIERS						TELECOMS					
Amplifier Research 10W1000B 1GHz 10W RF Amplifier	2950	89	HP 438A Dual Channel RF Power Meter	1550	56	HP 3784A PDH 139MB/s Transmission Analyser	1800	65			
Amplifier Research 1W1000 1GHz 1W RF Amplifier	950	48	HP 8481A 10MHz-18GHz 100mW Power Sensor	450	27	HP 37717C/A30/UKK/UH3 PDH/SDH Analyser	5950	215			
Kalmus 737LC 25W 10KHz-1GHz Amplifier	4750	171	HP 8482A 100KHz-4.2GHz 100mW Power Sensor	650	33	HP 37717C/UKJ PDH Transmission Analyser	2450	88			
CALIBRATORS			Marconi 6910 20GHz +20dBm Power Sensor	350	18	HP 37732A 50BPS-2MBPS Telecom/Datacom Analyser	4000	144			
Fluke 5500A/SC300 Calibrator With 300MHz Scope Option	10500	379	Marconi 6970/001 RF Power Meter	1175	43	HP 3788A/001 2MBPS Error Performance Analyser	1350	40			
HP 58503B GPS Time And Frequency Reference Receiver	2950	107	POWER SUPPLIES			IFR 28515/005/013 2MBPS Bert Tester	6500	234			
COMPONENT ANALYSERS			Various DC supplies, inc GPIB units	from 150	15	Marconi 2840A 2MB Handheld Transmission Analyser	1250	45			
HP 4155B Semiconductor Parameter Analyser	18250	657	Kikusui PCR1000L 1KVA Voltage/Frequency Converter + IEEE	3750	135	Tek CSA803C Communications Signal Analyser	6250	225			
Tek 370 Curve Tracer	9950	359	Kikusui PLZ150W 150W Electronic Load	595	25	Trend AURORA DUET Basic & Primary Rate ISDN Tester	3250	117			
DATACOMS			PULSE GENERATORS			Trend AURORA DUET Basic Rate ISDN Tester	995	45			
Fluke DSP4000 Cat 5e/6 LAN Cable Tester	3500	126	HP 8013B 50MHz Pulse Generator	1250	45	TTC Fireberd 41800 2.048Mb/Nx64k Interface Module	1150	34			
Tek 1503C/03/04 Metallic TDR	2950	107	HP 8082A 250MHz Pulse Generator	1350	49	TTC 4020A Lab Interface For Fireberd 6000	395	12			
ELECTRICAL NOISE			HP 8112A 50MHz Pulse Generator	2450	89	TTC Fireberd 30447A DS1C/ DS2 Interface	395	11			
HP 346C 26.5GHz APC3.5 Noise Source	1595	65	 <p>Checkout our new Summer 2003 Product Guide !! Call Us Now for Your Copy</p>			TTC Fireberd 30524 8MB/s G703 Interface	950	28			
HP 8970B/020 2GHz Noise Meter	7250	218				TTC Fireberd 30608 G703 64KB/s Interface	950	16	TTC Fireberd 30609 2MB/s G704 Interface	650	19
EMC						TTC Fireberd 40323 G703 64KB/s Interface	495	18	TTC Fireberd 42522 V35/RS449/X21 Interface	750	28
Keytek MZ-15/EC ESD Simulator	2950	89				TTC Fireberd 42522 V35/RS449/X21 Interface	4250	153	TTC Fireberd 6000A Communication Analyser	4250	153
R&S EB100 20MHz-1GHz EMC Test Receiver	1950	75				TTC Fireberd 6000A/6004/6007/6008 Comms Analyser	4500	162	TTC TIMS-45 TIMS Test Set For Fireberd 4000/6000	750	28
Schaffner NSG1025 Fast Transient/Burst Generator	2950	99				W&G DST-1 Handheld E & M Signalling Tester	750	35	W&G PFA-35 2MB/s Digital Transmission Analyser	3850	115
FREQUENCY COUNTERS						RF SWEEP GENERATORS			TV & VIDEO		
EIP 548A/06/08 26.5GHz Counter	1950	71				HP 8340B 26.5GHz Synthesised Sweep Generator	14950	539	Minolta CA-100 CRT Colour Analyser	2500	90
HP 53131A/010 DC-225MHz, 10 Digit Universal Counter	895	32				HP 83752A/1E1/1E5 0.01-20GHz Synthesised Sweeper	16000	576	Philips PM5518GT/RGB TV Pattern Generator	1750	53
HP 5342A 18GHz Frequency Counter	895	65				HP 83752B/1E5 0.01-20GHz Synthesised Sweeper	15750	567	Philips PM5518TN & Y/C TV Pattern Generator	1750	53
HP 5372A 500 MHz Frequency/Time Interval Analyser	4550	164	SIGNAL & SPECTRUM ANALYSERS			Tek 1751 PAL Vectorscope	2500	75			
Racal 1992 1.3GHz Frequency Counter	1150	35	Advantest R3361A 9KHz-2.6GHz Spectrum Analyser With TG	5950	179	Tek VM700A/11 Automatic Video Measurement Set	6950	251			
FUNCTION GENERATORS			Anritsu MS2601B 2.2GHz Spectrum Analyser	4250	153	WIRELESS					
HP 3325B 21MHz Function Generator	2950	89	Anritsu MS2711A/05 3GHz Handheld Spectrum Analyser	3950	119	Anritsu ME4510B Digital Microwave System Analyser	11950	375			
HP 3326A 2 Channel 13MHz Synthesised Function Gen	2750	99	Anritsu MS610B 2GHz Spectrum Analyser	2650	85	HP 3708A Noise & Interference Test Set	7950	287			
Racal AWG2021 125MHz-250MS/s Arbitrary Waveform Gen	4950	149	HP 339A 110KHz Distortion Analyser	1250	38	HP 83201A Dual Mode Cellular Adapter For 8920 Series	250	20			
LOGIC ANALYSERS			HP 3561A 100KHz Dynamic Signal Analyser	2750	99	HP 83220A DCS1800 (1710-1880) Test Set	1750	52			
HP 16500C Logic Analyser Mainframe	2350	71	HP 3562A 100KHz Dual Channel Dynamic Signal Analyser	3650	110	HP 83220A/022 DCS/PCS1800 (1710-1900) Test Set	1950	60			
HP 16510A 100MHz Timing/25MHz State 80 Ch Card	975	36	HP 35660A 102.5KHz Dual Channel Dynamic Signal Analyser	3250	98	HP 8902A 1.3GHz Measuring Receiver	9750	351			
HP 1662A 500MHz Timing/100MHz State 68 Ch	2900	95	HP 3585B 40MHz Spectrum Analyser	7250	261	HP 8920A/1/4/7/13/14/103 1GHz Radio Comms Test Set	3950	119			
HP 1663AS 500MHz Timing/100MHz State 34 Ch with DSO	2950	107	HP 8562A 22GHz Spectrum Analyser	10950	327	HP 8920A/3/4/5/50 1GHz Radio Comms Test Set	4750	143			
MULTIMETERS			HP 8562E 13.2GHz Spectrum Analyser	16500	594	HP 8920B/1/4/11/102 1GHz Radio Comms Test Set	5950	215			
HP 34401A 6.5 Digit Digital Multimeter	650	33	HP 8563A 22GHz Spectrum Analyser	12000	432	HP 8920B/1/4/13/14/102 1GHz Radio Comms Test Set	5950	176			
Schlumberger 7150+ 6.5 Digit Precision Multimeter	395	29	HP 8563E 9KHz-26.5GHz Spectrum Analyser	10950	328	HP 8920B/1/4/13/14/101 1GHz Radio Comms Test Set	5950	176			
NETWORK ANALYSERS			HP 8566B 22GHz Spectrum Analyser	19500	702	HP 8920B/1/4/13/14/5/1/102 Radio Comms Test Set	5950	176			
HP 3577A 5Hz-200MHz Vector Network Analyser	4750	142	HP 8590L/041 1.8GHz Spectrum Analyser	3500	126	HP 8920B/1/4/7/13/14/5/1 1GHz Radio Comms Test Set	3950	119			
HP 4195A 500MHz Vector Network/Spectrum Analyser	9500	342	HP 8591A/010/021 1.8GHz Spectrum Analyser With TG	4950	149	HP 8922M/001/003/101 1GHz GSM MS Test Set	5950	178			
HP 8714C/1E1 300 KHz-3GHz Vector Network Ana c/w TR	7250	261	HP 8594E 2.9GHz Spectrum Analyser	6250	225	Marconi 2955B 1GHz Radio Comms Test Set	3500	126			
HP 8753ES 3GHz Vector Network Analyser c/w S Param	16950	508	HP 8901A/001 1.3GHz Modulation Analyser	950	48	Marconi 2957B Analog AMPS Adapter for 2955B	250	12			
HP 89441A 2-2650MHz Vector Signal Analyser	14500	522	HP 8903B/10/5/1 20Hz To 100KHz Audio Analyser	2450	75	R&S CMD55/B1/4/6/9/11/42/43/44/51/61/018/U20 Test Set	6550	236			
OPTICAL FIBRE TEST			SIGNAL GENERATORS			R&S CMD60/B1/3/4/6/11/44/61/62/K61 DECT Test Set	12500	450			
Anritsu MW9070B/0972C OTDR 1310/1550NM	5950	179	HP 83732B/1E1/1E5/1E8 0.01-20GHz Synth Signal Gen	15950	478	R&S CMS52/B1/B5/B9/B15/B28 1GHz Radio Comms Test Set	5500	165			
Prior G104 Optical Fibre Microscope	250	15	HP 8642A/001 1GHz Hi Performance Synth Signal Generator	1650	59	R&S CMS56/B1/4/6/9/11/13/101/U9 1GHz Radio Test Set	1950	58			
OSCILLOSCOPES			HP 8648B 2GHz Synthesised Signal Generator	3950	119	R&S CMU200/B11/B21/B41/B52/K21/K22/K23 Radio Test Set	19750	711			
HP 54111D 2 Channel 500MHz 2GS/s Digitising Scope	2400	87	HP 8648B/1E5 2GHz Signal Generator	4500	135	Racal 6102/04E GSM MS Radio Comms Test Set	2950	89			
HP 54501A 4 Channel 100MHz 20MS/s Digitising Scope	1250	45	HP 8657A/001 1GHz Synthesised Signal Generator	1750	52	Racal 6103/001/002/014/04T GSM/DCS Mob Radio Test Set	6500	195			
HP 54825A 4 Channel 500MHz 2GS/s Digitising Scope	7200	216	HP 8657D/001/002 1GHz DQPSK Synth Signal Generator	1350	49	Racal 6103/01/03 900 / 1900 Digital Mobile Radio Test Set	6950	251			
HP 54845A 4 Channel 1.5GHz 8GS/s Digitising Scope	10950	395	HP 8672A 2-18GHz Synthesised Signal Generator	4250	128	Schlumberger 4015/IEEE/DU/PLEX SYNTHESIS 1GHz Test Set	3950	119			
Lecroy LCS34L 4 Channel 1GHz 1GS/s Digitising Scope	6750	243	HP E4421B 3GHz Signal Generator	5500	198	Schlumberger 4039 1GHz Radio Comms Test Set	950	37			
Tek TD53054/3FFT/3TRG 4 Channel 500MHz 5GS/s DPO	6500	195	HP E4433B/100/005/UND 4GHz RF Signal Generator	8950	270	W&G 41075 GSM/DCS1800/PCN1900 Mobile Phone Tester	2850	103			
Tek TD5644A 4 Channel 500MHz 2.5GS/s Digitising Scope	6500	234	HP E4433B/202/UN8/UN9/UND 4GHz RF Signal Generator	9950	300	WaveTek 42015 Triband Digital Mobile Radio Test Set	3950	119			
Tek THS720A 2 Channel 100MHz 500MS/s Handheld Scope	1750	63				WaveTek 42025/AM Triband Digital Mobile Radio Test Set	4500	135			
POWER METERS											
HP 436A/022 RF Power Meter With GPIB	750	32									
HP 437B RF Power Meter	1350	60									

If you don't see what you want, please CALL!

See our extensive online catalogue at www.TestEquipmentHQ.com

Flexible commercial solutions available on all products



FREE

Palm Zire shipped
with every order
over £5K

Prices shown are for guidance in £UK and are exclusive of VAT. Rental prices are per week for a rental period of 4 weeks. Free carriage to UK mainland addresses for Sales. This is just a selection of the equipment we have available - If you don't see what you want, please call. All items supplied fully tested and refurbished. All manuals and accessories required for normal operation included. Certificate of Conformance supplied as standard; Certificate of Calibration available at additional cost. Test Equipment Solutions Terms apply. E&OE.

01753 596000

Fax: 01753 59 6001

www.TestEquipmentHQ.com

email: info@TestEquipmentHQ.com