

**FREE INSIDE - VALUABLE 24 PAGE BOOKLET**

# Wireless Magazine

DECEMBER

**GEORGE  
NEWNES  
LTD. LONDON**

**AND MODERN TELEVISION**

Edited by **PERCY W. HARRIS M.I.R.E.**

The  
"Winning Three"  
the latest Three-valve  
Battery All-waver  
Full Constructional Details

Join the New  
British Long Distance  
Listeners' Club  
FREE Membership  
Full Particulars Inside

Choosing a New  
Set for Christmas

How to Build an  
Inexpensive Electrically  
Reproducing Gramo-  
phone for Battery Users

FREE COMPETITION  
Valuable Prizes

**1/-**



**SPECIAL  
CHRISTMAS NUMBER**



# Don't Envy the Engineer!

## YOU CAN MAKE EVERY TEST — TRACE EVERY FAULT

with Accuracy and Ease

### Valve Testing SIMPLIFIED



### The AVO DAPTER

(Regd. Trade Mark)

Every valve test can be made externally on the bench, thus doing away with the annoyance of grovelling about inside the set or having to sever connections. Tests are thus made with ease and accuracy, and under actual working conditions. Instantly adaptable for 4-pin, 5-pin or 7-pin valves. **25/-**



### The 9-PIN AVO-COUPLER

This attachment renders the Avo-Adapter instantly suitable for testing 9-pin valves. Complete with instructions. **12/6**



### "AVO"

**TESTING ACCESSORIES**  
Accurate yet simple, testing is carried a further step forward by this boxed Kit of "Avo" Testing Accessories. It does away with those nondescript lengths of wire which confuse testing. You can test more quickly and are safeguarded against making dangerous mistakes. For use with any testing meters. **2/6**

THE fame of the Avometer, the world's most widely used combination meter, has given rise to an insistent demand for other combination instruments which would provide similarly dependable testing facilities for all classes of professional and amateur wireless technicians. In response to this demand, a full series of "Avo" Instruments has been produced to fulfil every need. Each instrument is simple to use, self-contained, and unexcelled for accuracy.

Write for fully descriptive pamphlets of the complete range of "AVO" Testing Instruments.



### The WORLD-FAMOUS D.C.

## AVO MINOR

(Regd. Trade Mark)

This compact moving-coil combination meter gives 10 different ranges of readings in milliamps, volts and ohms. It is invaluable for testing circuits, valves, components, batteries, power units, etc. Provides greater testing facilities with a standard of accuracy unapproached by any other instrument at anywhere near its price. In handsome case with pair of leads, interchangeable crocodile clips and testing prods, and complete instruction booklet showing how to make every test.

- CURRENT**  
0—6 milliamps  
0—30 "  
0—120 "  
**VOLTAGE**  
0—6 volts  
0—12 "  
0—120 "  
0—240 "  
0—300 "  
0—600 "

- RESISTANCE**  
0—10,000 ohms  
0—60,000 "  
0—1,200,000 "  
0—3 megohms

**40/-**

DEFERRED TERMS IF DESIRED  
5/- down and 1/- per week

### The UNIVERSAL AVO MINOR

(Regd. Trade Mark)

This ingenious instrument has met with a reception that testifies to its usefulness and to its fulfilment of a long-felt need. It gives 22 different ranges of readings, (A.C. and D.C.). Has 3 in. scale. Total resistance 200,000 ohms. Complete with instruction booklet, leads, and interchangeable crocodile clips and testing prods.



#### 22 METERS IN ONE

D.C. VOLTS	A.C. VOLTS
0—75 millivolts	0—5 volts
0—5 volts	0—25 "
0—25 "	0—100 "
0—100 "	0—250 "
0—250 "	0—500 "
0—500 "	
MILLIAMPS	RESISTANCE
0—2.5 milliamps	0—20,000 ohms
0—5 "	0—100,000 "
0—25 "	0—500,000 "
0—100 "	0—2 megohms
0—500 "	0—5 "
	0—10 "

**95**

LEATHER CASE  
**10/-**  
Deferred Terms if desired

# 'AVO'

## Accurate Testing Instruments

BRITISH MADE

### An Invaluable Testing Manual "Radio Servicing Simplified"

NEW ENLARGED EDITION

This invaluable book explains every phase of fault-tracing and testing in non-technical language. Multitudinous tests are so set forth as to be a matter of straightforward procedure. The comprehensive information and numerous diagrams enable everyone to test sets and apparatus with ease and success.

Post Free 2/9 **2/6**

# Wireless Magazine

Technical Editor :

AND MODERN TELEVISION

Assistant Editor :

G. P. KENDALL, B.Sc. Vol. XXII : DECEMBER, 1935 : No. 131

T. F. HENN.

Edited by Percy W. Harris, M.I.R.E.

## FOR THE CONSTRUCTOR

THE WINNING THREE. Designed by G. P. Kendall, B.Sc., and described by the Editor .....	329
THE HARRIS ELECTROGRAM. Designed by Percy W. Harris, M.I.R.E. ....	349
PUTTING THE FINISHING TOUCH TO YOUR RADIO UNIT AND AMPLIFIER. By L. O. Sparks and T. F. Henn .....	356
THE SHORT-WAVE SUPER AT WORK. By G. Howard Barry .....	372

## TECHNICAL ARTICLES

A RECHARGEABLE "DRY" BATTERY. By R. W. Hallows, M.A. ....	338
GETTING DOWN TO THE VERY SHORT WAVES. By G. Howard Barry .....	341
SOMETHING NEW—AUTOMATIC BASS COMPENSATION. By P. Wilson, M.A. ....	353
HOW LOUDSPEAKER CONES ARE MADE .....	359
FAULT FINDING OLD AND NEW. By G. P. Kendall, B.Sc. ....	362
QUERIES OF INTEREST .....	376
TAKING CARE OF YOUR METERS. The Serviceman's page by G. P. Kendall, B.Sc. ....	377

## Contents

TESTS OF THE NEW SETS :	
MARCONIPHONE 236 A.C./D.C. CONSOLE .....	383
PILOT ALL-WAVE A.C./D.C. RECEIVER .....	384
H.M.V. POPULAR A.C. RADIOGRAM .....	385
PETO SCOTT BATTERY CLASS-B FOUR .....	386
AN IMPROVED MOUNTING FOR CRYSTAL TWEETERS. By P. Wilson, M.A. ....	395
A PROBLEM IN FAULT FINDING. By P. Wilson, M.A. ....	398

## TELEVISION SECTION

WHAT IS HAPPENING IN TELEVISION. By Paul Woodward .....	340
HOW TELEVISION RECEIVERS WORK. By Percy W. Harris, M.I.R.E. ....	369

## GENERAL ARTICLES

WHAT DO YOU THINK—Free competition—Valuable prizes .....	322
IN TUNE WITH THE TRADE. By Examiner .....	324
OUR CHRISTMAS NUMBER. The Editor's page .....	327

"MUSIC HATH CHARMS" .....	336
THE BRITISH LONG DISTANCE LISTENERS' CLUB. Great New Organisation for All Radio Enthusiasts :	
THE AIMS OF THE B.L.D.L.C. ....	343
ADVANTAGES OF MEMBERSHIP .....	339
PROBLEMS OF LONG-DISTANCE RECEPTION ENROLMENT FORM .....	346
NEWS FROM THE B.B.C. By T. F. Henn .....	347
"W.M." SHORT-WAVE IDENTIFICATION PANELS. Compiled by Jay Coote .....	360
INTERNATIONAL CALL LETTERS : BUREAU OF STANDARDS CALIBRATION SIGNALS.—Short-wave Data Sheet No. 2 .....	361
BETWEEN OURSELVES. By Broadcatcher .....	365
RADIO NEWS FROM ABROAD. By Jay Coote .....	375
HOW TO CHOOSE A NEW SET FOR CHRISTMAS. By the "W.M." Set Selection Bureau .....	379
"TUNEFUL RECORDS." A Review of the Latest Gramophone Records .....	388
NEWS FROM THE RADIO SOCIETIES. Conducted by G6QB .....	392
UNIQUE ORCHESTRAL SERVICE .....	394
WHO HEARD THE FIRST WIRELESS SIGNAL? By J. Godchaux Abrahams .....	396
NOTES AND JOTTINGS .....	397
COUPONS : FREE ADVICE FOR SET BUYERS : INDEX TO ADVERTISERS .....	400

Subscription Rates: Inland and Abroad, 15s. 6d. per annum; Canada, 13s. 6d. per annum.

Editorial and Advertisement Offices—"Wireless Magazine," George Newnes, Ltd., Southampton Street, Strand, London, W.C.2. Registered at the G.P.O. for transmission by Canadian Magazine Post.

**ONLY** the finest procurable materials and highest standards of workmanship make possible the established reputation of Garrard products for ideal reproduction of gramophone records.

Models exist to satisfy the most discriminating user whatever his requirements.

The name



ensures

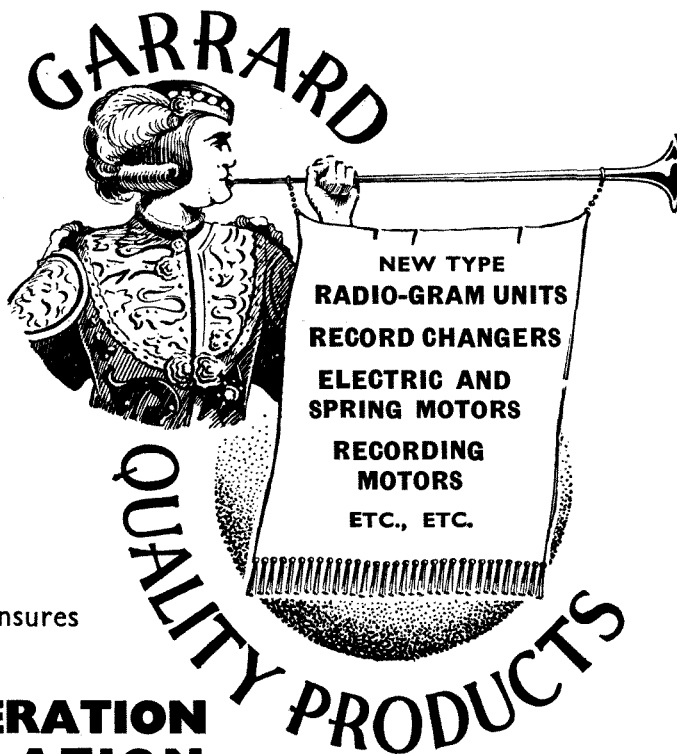

**PERFECTION in OPERATION  
EASE OF INSTALLATION**

Write for full particulars

**GARRARD ENGINEERING & MANUFACTURING COMPANY, LTD.**  
SWINDON, WILTS. Telephone : Swindon 534 & 535 (2 lines). Regent 7596. 17, GRAFTON ST., W.1

# What Do You Think?

*By Entering this Simple Competition You May Win a New All-wave Receiver*

**1st Prize :** A ready-built replica of the **Winning Three.**

**2nd Prize :** Hyvoltstar Kit for Building **All-wave A.C./D.C. Receiver.**

**3rd Prize :** Ready-built model of the **Standard Four-valve Short-waver.**

**4th Prize :** Set of Four Hivac valves to the value of **£1 10.**

**5th Prize :** Amplion **Harmona Loudspeaker.**

*Below we give a list of questions which are constantly under discussion when radio fans meet. We want your opinion on them, and are offering five useful prizes to the readers whose opinions we consider to be the most interesting and constructive.*

## Conditions of Entry

1. Entries must be clearly written on plain paper, setting out the answers to the questions in the order given in "Wireless Magazine."
2. Each entry must be accompanied by the coupon to be found on page 400. No entry fee is required.
3. Entries must be addressed to: Competition Department, "Wireless Magazine," 8-11 Southampton Street, London, W.C.2, and should reach this office not later than first post on December 23, 1935. No entry received after that date will be accepted.
4. Entries will be judged by the Editor and a special committee, and the prizes will be awarded to those readers whose answers are, in the Editor's opinion, most constructive and best considered.
5. No responsibility can be taken for letters going astray in the post; proof of posting cannot be taken as proof of delivery.
6. Employees of George Newnes, Ltd., and their relations are not eligible for this competition.
7. The Editor's decision is final.

## What Do You Think?

1. Are you in favour of sponsored programmes in which the sole advertising announcement is standardised to "This programme comes to you through the courtesy of —, makers of —"?
2. Would you like "setting-up exercises" or gymnastic instruction from 7.30 a.m. to 8.30 a.m. at quarter of an hour intervals?
3. Would you like lectures and instructional talks confined to one station kept specially for the purpose?
4. Do you think the Children's Hour a waste of time?
5. Would you like a weekly talk on "How to make the most of your wireless receiver"?
6. Which of the following listening periods do you use most?
  - (1) Before lunch
  - (2) 2—5 p.m.
  - (3) 5—7 p.m.
  - (4) 7—9 p.m.
  - (5) 9 p.m. till midnight
7. Do you like a standard accent for the B.B.C. announcers\*?
8. What subject not at present dealt with in the programmes would you like to have treated by the B.B.C.?
9. If you were a member of the Ullswater Committee, what recommendations would you make regarding the future programme policy of the B.B.C.? Give your opinions in less than 100 words.

## A Word About the Five Prizes

**A**LL the prizes awarded in this competition are useful ones. The first prize, a ready-built model of the "Winning Three," needs very little comment; full details of the set will be found on pages 329 to 335 of this issue. This set has been designed by our Technical Editor who assures us it is the "goods."

Prize No. 2 is a complete kit of parts for building a Hyvoltstar all-mains three-valve receiver and is supplied with comprehensive wiring instructions and valves. The set is for operation off either A.C. or D.C. mains.

Prize No. 3 is a ready-built version of the Standard Four-valve Short-waver, a set which has been described in both A.C. and battery forms in recent issues of "Wireless Magazine." The actual model supplied to the successful entrant will depend on whether the user has electric mains, or whether he is a battery user.

The fourth prize, a set of four Hivac valves up to the value of £1 10, is a useful one. The successful competitor will make his own choice, but only four valves in all will be awarded.

And lastly, the fifth prize, is an Amplion "Harmona" loudspeaker, a new model just released, which can be used either as a built-in reproducer or as an extension speaker. The speaker employs a new nickel aluminium alloy magnet and is fitted with a multitude of output ratios enabling it to be used with sets having a single, push-pull, or class-B output stage.

In our next issue, on sale December 20, we will devote a small space to illustrate the range of five prizes. But remember you must send your entries to the Competition Department so as to reach us by first post on *December 23, 1935.*

The results will be announced in the February issue of "W.M."

**Tell Your Friends About "W.M." and Especially About the B.L.D.L.C.!**



## DEPENDABILITY

For over twenty-one years Dubilier have built upon the firm foundation of integrity of product and purpose. Time has strengthened their resolution of adherence to this policy, so that to-day the name Dubilier stands synonymous with Dependability.

Type 9200

Non-inductive paper condensers.  
Working volts 250 D.C. to 900 D.C.  
Prices from 1/9 each.



# DUBILIER

CONDENSER CO. (1925) LTD.

DUCON WORKS, VICTORIA ROAD, N. ACTON, W.3

## HARRIS ELECTROGRAM

An electric gramophone run from an ordinary H.T. battery—no more bothering about pick-up plugs in your radio—it works independently of the set.

In it is a Class-B Input Transformer, and a Class-B Output Choke, both by Varley. Send now to Woolwich for interesting illustrated Catalogue describing these components. Bloomfield Rd., Woolwich, S.E.18.

**Varley**  
(Over Pat Control Ltd.)

Rejuvenate  
your set  
with

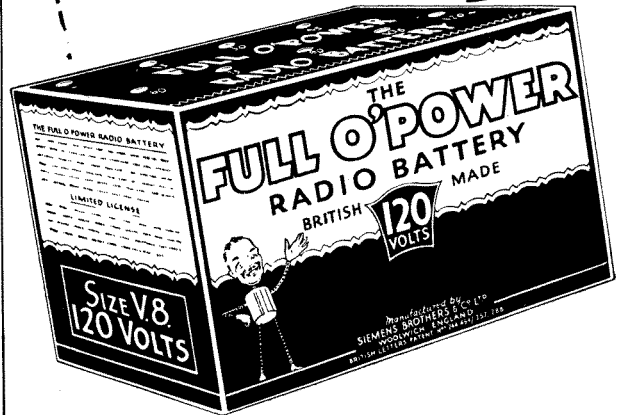

No, there's no need for a new set! Plug in a FULL O' POWER to-night—let it pour new life, new brilliance into your radio.

Special manufacturing processes give FULL O' POWER its exceptional strength, help it to maintain its quality and tone.

Your set will sound brand-new again with FULL O' POWER!

Buy one on your way home and hear for yourself.

## FULL O' POWER RADIO BATTERIES

British Made by **SIEMENS**

**FULL O' POWER BATTERIES**  
are specified for the  
**ELECTROGRAM** described in  
this issue

CADET TYPE		STANDARD RANGE— SUPER TYPE	
H.60	60 volts 3/9	H.1	60 volts 5/6
H.99	100 .. 6/3	H.2	108 .. 9/6
H.108	108 .. 6/9	H.3	120 .. 10/6
H.120	120 .. 7/6	POWER TYPE— VERTICAL	
H.G.120 III v. + .9G.B	8/9	V.4	60 volts 8/-
H.L.120	120 .. 7/6	V.8	120 .. 16/-

FREE BOOKLET WITH 1st LEAGUE FOOTBALL  
FIXTURES and full battery information. Ask your  
dealer or write to address below.

SIEMENS ELECTRIC LAMPS & SUPPLIES, LIMITED,  
38/9 Upper Thames Street, London, E.C.4

For the  
**"WIRELESS MAGAZINE"**  
**WINNING**  
**THREE**

**ROLA**  
*the World's Finest Reproducers*

**F720—PMT**  
**35/-**  
**is SOLELY**  
**SPECIFIED**

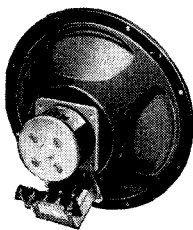

This Rola model is exactly suited to the Mullard PM22A Output Valve used in this receiver. It is a 9½ in. **WIDE RANGE RESPONSE MODEL HAVING A GREATLY IMPROVED FLUX DENSITY AND GIVING 50% BETTER PERFORMANCE.** It embodies:

a one piece moulded cone and in design and construction is the most advanced speaker you can buy. Ask your dealer to demonstrate or order direct from the manufacturers.

**ROLA EXTENSION SPEAKERS**

Are 9½ in. wide range response models.  
 Give exact matching without the use of complicated matching devices.  
 Give 50 per cent. better performance  
 Are the most advanced P.M. speakers you can buy.

MODEL F720-P.M.M.

**27/6**

(Or in Walnut, Oak or Mahogany Cabinet, 55/-) For all receivers with low impedance extension terminals.

MODEL F720-P.M.T.

**35/-**

(Or in Walnut, Oak or Mahogany Cabinet, 62/6) Special speaker for all receivers or extension speaker for all receivers with high impedance extension terminals.

MODEL S720-P.M.V.

**32/6**

(Or in Walnut, Oak or Mahogany Cabinet 60/-) Special Model for H.M.V. and Marconi Receivers.

Available on Easy Payments from the London Radio Supply Co., 11 Oat Lane, Noble Street, E.C.2.

**OVER 6 MILLION IN USE**

**THE BRITISH ROLA CO. LTD.,**  
 Minerva Road, Park Royal, N.W.10

Phone: Willesden 4322-3-4-5-6

# In Tune With the Trade

Examiner's Review of the Latest Catalogues

**"A CAMERA COMMENTARY ON RADIO IN THE HOME"**

**T**HIS is the title of a really first-rate 24-page booklet produced by the Gramophone Co. which I recommend you to get because it includes a number of extremely attractive photographs showing H.M.V. instruments in use in various types of home. Of special interest is the story revealing for the first time the history of the Gramophone Company's trade mark—the picture of the dog listening to an old-fashioned gramophone.

You can obtain copies of this book through this free service, or direct from the Gramophone Company, Ltd., at 99a Clerkenwell Road, London, E.C.1. **493**

**DUBILIER'S NEW OIL-IMMERSED CONDENSERS**

**I**N connection with certain new valves that are making their appearance on the market, a demand has arisen for a 10-microfarad condenser for 750 volts D.C. working. Dubilier, always in the front line as usual, has arranged to market immediately a 10-microfarad oil-immersed condenser for 750 volts working to meet the demand. The price of the new condenser is 17s.

With this information, Dubilier sent me a copy of their booklet entitled "Dubilier Condensers and Resistances for Constructors and Service Engineers," which I mentioned last month, and point out that the new oil-immersed type will be similar in appearance to the existing range of type 951 condensers outlined on pages 7 and 8. If you have not yet applied for a copy of the 24-page Dubilier booklet, do so now! **494**

**"THE SENTINEL OF YOUR SET"**

**I** DON'T think that many of us, nowadays, burn out so many valves through dropping the H.T. lead on the wrong spot as we used to in days gone by. Nevertheless, I still have the strong opinion that every set, battery and mains, should be well protected by means of fuses.

It is this conviction that prompts me to draw your attention to a folder sent me by Messrs. A. F. Bulgin & Co., Ltd. This folder describes the many types of fuses available, and shows how and where to connect them to your radio set. Mr. Bulgin issues a warning concerning the use of ordinary flash-lamp bulbs as fuses. He says: "Flash lamp bulbs are mostly rated at 300 milliamperes and some do not blow at even 500 milliamperes. They are therefore not to be recommended as radio fuses." **495**

**SIEMEN'S COMPLETE BATTERY LIST**

**A** HANDY little booklet comes to hand from Siemen's Electric Lamps and Supplies, Ltd., of 38 Upper Thames Street, describing the complete range of Full O' Power batteries for radio, pocket-lamp, and cycle purposes. All the various ranges are fully described, together with the size and price of each type of battery. There is also a list of special replacement batteries for portables, trans-portables, and kit sets which will be found of use by owners of commercial battery sets.

And I would remind you that five full pages are devoted to a football section—the Association football fixtures of Division 1 of the League from August 31, 1935 to May, 1936. **496**

**COSSOR 1935-1936 RADIO**

**A** NOTHER attractive set catalogue I have received is from Cossor. It will be found of major importance to the man who is prepared to pay from £5 15s. to £10 for his set, whether mains or battery. Cossor are known universally as the pioneers of reliable receivers priced within the reach of the average working man, but what is not generally known, is that they do make de-luxe receivers.

There is a High-fidelity Console Auto-radiogram for A.C. mains

Please turn to page 387



**YOU CAN  
NOW SERVICE  
YOUR OWN  
RADIO**



With this instrument any faults are quickly found in either a Battery or Mains Set (A.C. or D.C.), Valves, components, Batteries, (H.T. or L.T.), wiring, etc. Will save you pounds in Service Bills and ensure perfect radio reception at all times.

Ask your dealer to-day to show one or write for Pifco Testmeter Folder, post free from PIFCO, LTD., SHUDEHILL, MANCHESTER, or 150 Charing Cross Road, London, W.C.2.

The "ALL-IN-ONE" RADIO-METER for A.C. or D.C.—For testing electric or battery radio sets Anybody can trace faults with this wonder instrument. Finished in black bakelite. Size of dial, 1 1/2 in. by 1 in., complete with leads, Price 12s. 6d.

**12/6**

**PIFCO 'All-in-One' RADIOMETER A.C. AND D.C.**

**PIFCO ON THE SPOT WILL TRACE YOUR TROUBLES LIKE A SHOT**

**"This is SANTA CLAUS speaking"**

Connect a mike to your set for Xmas party fun and surprise your kiddies and guests. Have announcements, crooning, competitions, surprise items, etc. Transverse, current type mike, complete with chromium table stand and transformer and full instructions 22/6 post free. Works in conjunction with any standard receiver. For more important P.A. work: dances, meetings, etc., you need the

**Shaftesbury "BIO-TRAN"**

See "W.W." test report July 26th, 1935. "Definitely more sensitive... background hiss exceptionally low." 7 days approval, carriage paid, price 55/- Type Z Transformers, Shrouded model, 10/-. Open type, 7/6. Chromium Table Stands, 15/-. Chromium Telescopic Floor Stands, 27/6. Telescopic Collapsible Stands, 32/6.

**VELODYNE** (velocity dynamic ribbon principle) microphone—unique—amazing—complete with stand and transformer, 9 gns. Write for details.

**SHAFTESBURY SUPPLIES**  
224 Shaftesbury Avenue, London, W.C.2  
Temple Bar 4175, Branch Exchange.

Also 94 Tottenham Court Road, W.1. 17 St. Mary Street, Southampton.

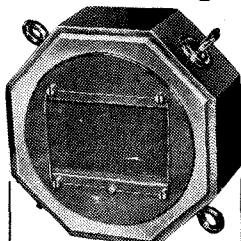

Send also for Special Catalogue of BARGAIN LINES. Components, Speakers, etc., etc., at rock bottom prices, 3d. post free.

**THIS XMAS  
WHY NOT BUILD  
THE 1935 RADIOGRAM P**

Complete kit of first specified parts, valves, speaker, pick-up and gramophone motor. PRICE £21.

**The A.C. STANDARD 4-VALVE  
SHORT-WAVER**

Complete kit of first specified parts, valves and speaker  
PRICE £13.

**The 1935 A.C. STENO NODE RECEIVER**

Complete kit of first specified parts, valves and speaker. PRICE £15 10s.

All carriage paid, cash with order or C.O.D.

**CHAS. F. WARD**  
46 Farringdon Street, London, E.C.4  
Telephone: Holborn 9703

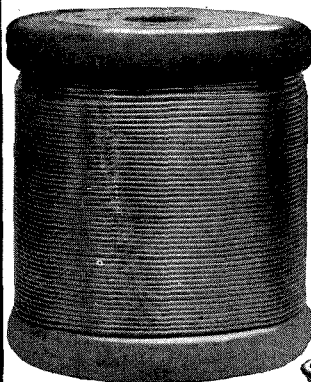

**B.I.**

**RESINKOR SOLDER  
AND  
CORALINE PASTE**

B.I. Resinkor Solder, which carries its own flux, is supplied in 9-in. sticks, in coils of 1 to 20 S.W.G. weighing up to 28 lbs., and all but the largest sizes can also be supplied on reels.

For use with ordinary solder, B.I. Coraline Soldering Paste is excellent. It gives off no spray or fumes, does not run or dry, and is very economical, as only a trace is required. Sold in tins from 1 oz. to 7 lbs.



**BRITISH INSULATED CABLES LTD.  
PRESCOT - LANCASHIRE**

Telephone No. PRESCOT 6571

London Office: Tel. Nos.:  
Surrey House, Embankment, W.C.2. Temple Bar 4793-4-5-6

THERE IS OF COURSE NO RADIO BETTER THAN

# MARCONIPHONE

— *the REAL thing* —

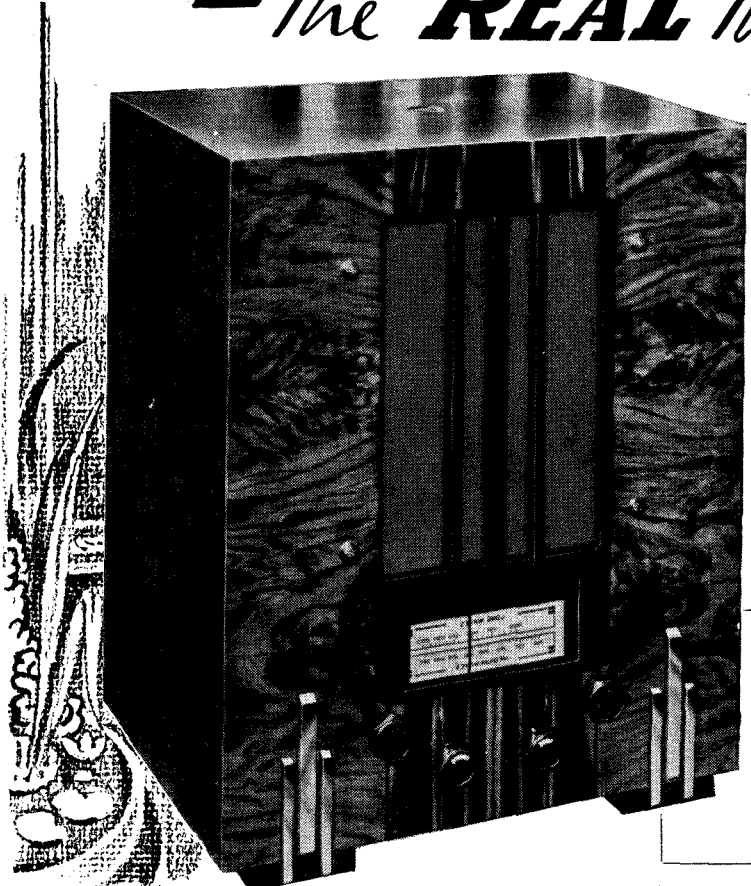

**FROM THOSE WHO OWN THEM!**

"Having one of your Marconiphone Table models, I should like to mention how pleased I am with same. Tone, range and selectivity is all that one can desire. I have not heard a set to come up to it yet." W., Birmingham.

"I would like to say how pleased I am with your new Table Grand—a first-class set." S. E. E., Crediton.

"I have heard many sets in the course of the last four years, but I reckon this latest model of Marconi's—for its price—the best of the lot." C. E. H., Bangor.

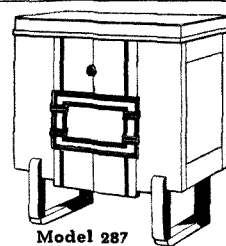

Model 287

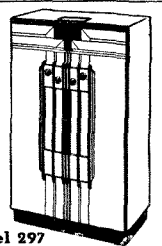

Model 297

**MODEL 264** for A.C. Mains. A typical Marconiphone—a magnificent 5-valve, 7-stage table grand superhet with every desirable feature including 'quiet' A.V.C., adjustable sensitivity, tone-compensated volume control and multiple Marconi valves. Housed in an exquisite inlaid Walnut and Macassar Ebony cabinet finished in chromium - **12 1/2 GNS.**

The same chassis is employed in an imposing Console Cabinet, **Model 297** **17 GNS.**

and also in **Model 287**—a fine quality radio-gramophone giving brilliant reproduction **22 GNS.**

*Small additional charges for non-standard voltages and frequencies.*

**EXCEPTIONALLY EASY TERMS**

*Send this coupon and let us advise you*

There are fourteen models in the Marconiphone list. Fill this in and we will advise you which model is best for your home and where you can buy it from a recommended dealer.

NAME .....

ADDRESS .....

W.M. Dec. 264

Have you electric supply?.....A.C. or D.C.....Voltage.....

Approximate amount you wish to spend.....

**TO THE MARCONIPHONE COMPANY LIMITED, RADIO HOUSE, TOTTENHAM COURT RD., LONDON, W.1.**

Advertisers like to know you saw it in the "Wireless Magazine"



# Wireless Magazine

and Modern Television

The Editor's Page

December, 1935

## Our Christmas Number

**A** HAPPY CHRISTMAS to all "Wireless Magazine" readers at home and abroad! Just as radio brings us all in touch with one another, so the growing circulation of our magazine in distant parts forms one more link with the homeland. We are proud to think that listeners in all quarters of the globe are regularly studying our pages and we take this opportunity of sending them Christmas greetings.

As this is a special Christmas number, we are celebrating the occasion by presenting with each copy a useful booklet of unique character. Never before has such a valuable gift been given with a wireless journal. To use a very old expression "good wine needs no bush" and the briefest perusal of the "Wireless Magazine Set Users' Record and Calibration Guide" will reveal a multitude of uses.

You, of course, are a reader of "W.M.," but possibly you have friends who do not yet read it. Will you please show them the handbook and let them know that they, too, can have one by purchasing the current number? The bigger our circulation the better magazine we can give, and therefore the better it will be for you. Thank you!

**T**he recently published "W.M." receivers are earning for themselves an enviable reputation, and are being built more and more by personal recommendation. This is the highest praise a set can gain and to earn it is the aim of every conscientious designer. We never claim that a particular set meets every need, or even the needs of the majority of listeners, for each discriminating home constructor has his own problems, but we do claim that each design is worked out on sound radio engineering principles just as are the best commercial receivers.

The most popular of all our recent designs is the "Certainty Three" while all our short-wave designs have found a ready welcome—battery and mains models alike. This month we are presenting what we think will prove the most popular set of all—The "Winning Three," an astonishingly efficient three-valver designed to receive not only the medium and long wavebands, but also the increasingly popular short waves. The short-wave portion is no inefficient compromise, in-

cluded just to say that short waves *can* be received, but is a properly engineered job with its own tuning dial and convenience of handling. In far too many "all-wave" receivers tuning in short waves is by no means an easy task, the stations being too crowded on the dial. In the Winning Three this difficulty has been entirely removed.

The Harris Electrogram, also described this month, is the answer to those who wish to get the best modern electrical reproduction of gramophone records without going to the expense of building or buying the radiogram, and without the inconvenience of that often unsatisfactory compromise—the attachment of long leads to the pick-up terminals of a wireless set. It is self-contained, can be carried into any room and with its easily controllable volume, from a whisper to dancing strength, yields a remarkably fine tone-quality. A little later we hope to publish the mains version of this useful instrument.

**A**nd now for an important announcement that we have left until last. In this issue you will find first particulars of the British Long Distance Listeners' Club, a new organisation sponsored by "W.M." for the encouragement of organised listening. There is no entrance fee or subscription and members incur no financial commitments of any kind. Log books, and identification sheets for forwarding to stations recorded as well as an attractive and artistic badge, are available to members at reasonable prices, and will, we think, help them with their work, but it should be emphasised that the purchase of these is quite optional and is not made a requisite of membership. We have great plans for the B.L.D.L.C. and will tell you more about them next month. Meanwhile, fill in the membership form to be found on page 346 and send it in. Later you will be proud to be among the first to join.

Again a Happy Christmas and Good Listening to All!

*Percy W. Harris.*

**You Must Join the British Long Distance Listeners' Club!**

*New*



# PEDIGREE RADIOGRAM AT 16 GNS!

—or at the rate of 5/- a week by hire purchase  
*with small deposit*

**N**EVER before has it been possible for you to enjoy true "H.M.V." tone and performance on records as well as radio at such low cost. Now there's absolutely no reason why you should "put up" any longer with inferior record reproduction and radio reception.

With this instrument you not only get the best of the British and Continental radio programmes, separate from each other, but you also hear your records as they *should* be heard! The powerful electric motor is fitted with the standard "His Master's Voice" stopping and starting device. The "H.M.V." pick up is designed to give good tracking and negligible record wear. The interior of the lid has a "flock-wool" finish which localises the acoustic sound of the needle in the record grooves.

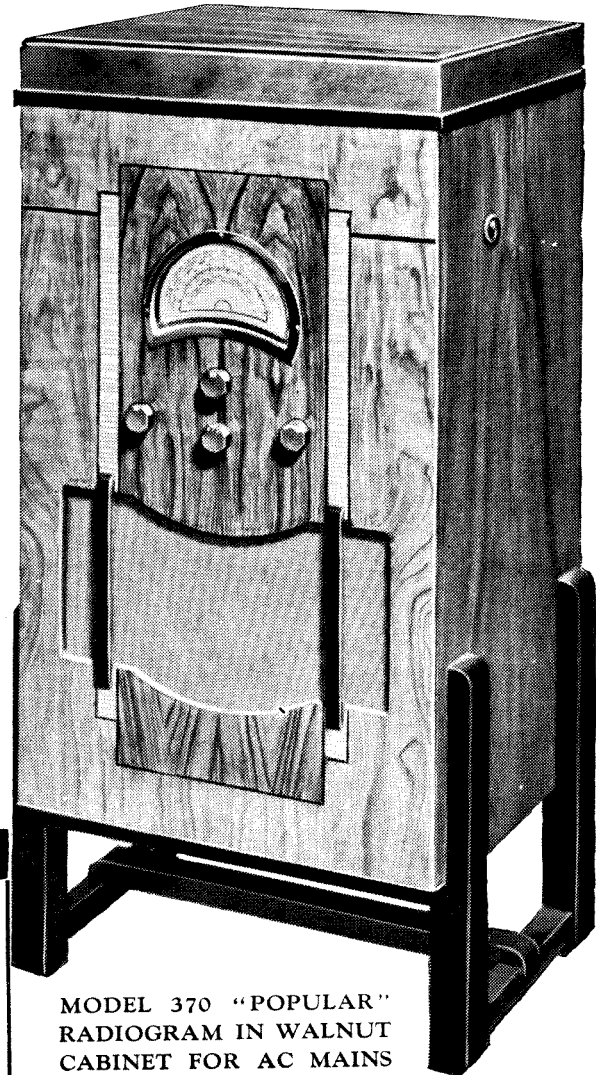

MODEL 370 "POPULAR"  
RADIOGRAM IN WALNUT  
CABINET FOR AC MAINS

## DON'T MISS THIS OPPORTUNITY

"HIS MASTER'S VOICE"

108B, CLERKENWELL ROAD, LONDON, E.C.1.

I shall be glad to receive details, without obligation, of your new 16 gn. Radiogram, and a free copy of "A Camera Commentary on Radio in the Home."

Name .....

Address .....

Post unsealed, 1d. stamp

12.35



# The Winning Three

Five Wave-ranges Covered  
Without Coil Changing



Short Waves an Integral  
Part of the Design—not  
an Afterthought



Constant Efficiency  
on all Wavebands

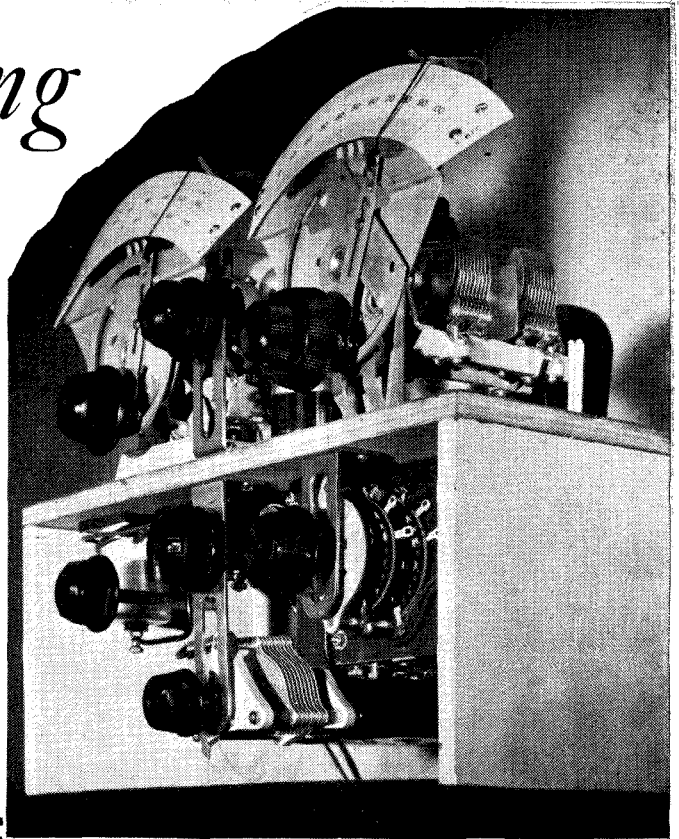

Designed by G. P. KENDALL, B.Sc. :: Described by the Editor

IT is the policy of "Wireless Magazine" to place before its readers from time to time full constructional descriptions of receivers designed to meet a definite set of requirements. No attempt is made to cover all requirements in one set—this is manifestly impossible—but each receiver so described can be relied upon to give a first-class performance in line with modern requirements.

This month we are pleased to present to you the Winning Three, so named because after a prolonged editorial conference and a study of the various successes we have recently had with our designs, together with an analysis of readers' letters, this particular design was considered to be a winner.

### Properly Engineered Design

It is, first of all, what is commonly called an "all-wave" set, covering short waves, medium, and long. It is not the first all-wave set described in these pages or elsewhere, but then there are all-wave sets *and* all-wave sets! The Winning Three follows our policy of sound design from one end of the set to the other, and the short-wave portion has neither been included as an afterthought nor inserted in a crude form just to make the claim that the set will cover all the broadcasting bands.

Thus, instead of endeavouring to cover all bands with one tuning knob, which so often results in so compressed a short-wave scale as to be practically unusable, two

separate tuning dials are used, each with its own purpose. The left-hand dial, looking at the illustration, tunes the medium and long wavebands with a nice open scale clearly marked and, if you desire it, illuminated, while the right-hand dial, equally large and just as clearly marked, is made to cover by switching three distinct short wavebands without any crowding anywhere. Furthermore, a particularly smooth fine adjustment is provided, giving what may be termed medium-wave precision in short-wave tuning.

### How the Controls Work

"One-knob" sets are sometimes desirable, but in our opinion an efficient all-wave set of this type is much better designed in the way we have chosen.

Before we proceed to a study of the circuit and constructional details, let us look at the front of the set so that we may see for what purpose the various knobs are designed. As mentioned above, the left-hand dial is for the medium and long wave and the right-

**An  
All-wave  
Battery-driven  
Three-valve Receiver  
Covering a Wave-range of  
about 13 to 80 Metres in  
Addition to the Usual Wavebands**

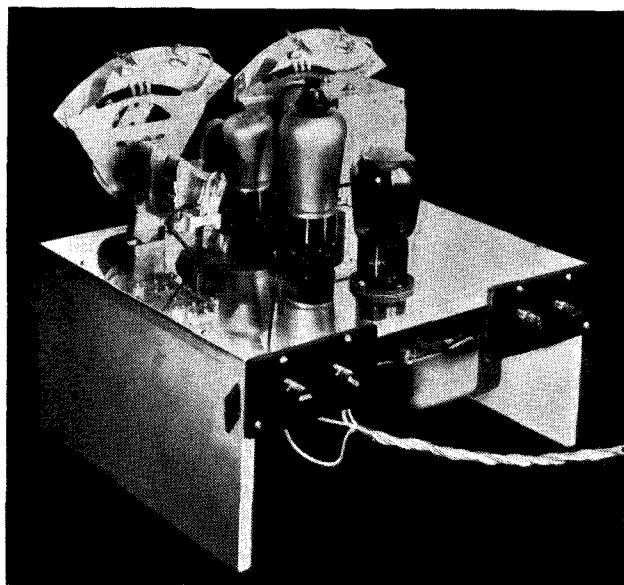

hand for the three separate short wave bands, while volume on medium and long wavebands is controlled by the knob between the two dials.

Switching often presents considerable difficulty in a set of this kind and *may* add greatly to the complication of wiring, particularly when a large number of different combinations are required on one switch shaft. Complications of this kind have been overcome in the Winning Three by logically sub-dividing the switching. Thus beneath the left-hand dial will be found a two-position switch changing from the medium to the long wave, while beneath the right-hand or short-wave dial a similar switch selects the three short wavebands.

*The photo on the right gives a clear view of the various controls: the tuning dial on the left is for the medium and long waves, the knob between the dials is the volume control, with the main change-over switch and the reaction condenser below it. The separate wave-change switches fall to the left (medium and long) and to the right (short wave)*

*The new set is built on the semi-professional system first introduced by "W.M." and since proved highly efficient by so many of our readers. A neat appearance has been produced by keeping practically the whole of the wiring below decks*

Centrally between these two switches is a third which in its centre position turns the whole set off, when turned to the left switches on the medium or long wave-band, and in its right-hand position connects the short-wave coils.

### Simplifying Operation

If, as so often happens, the family prefers to devote its time to the medium and long waves, the right-hand side of the set can be forgotten until the enthusiast of the family turns the central switch to the right, just as conveniently ignoring the left-hand side. For the finest adjustment on all three bands a very smoothly operating reaction control is provided, and this knob is found immediately beneath the central switch.

So much, then, for the controls. It will be seen that everything is logically placed and one so to speak "drops

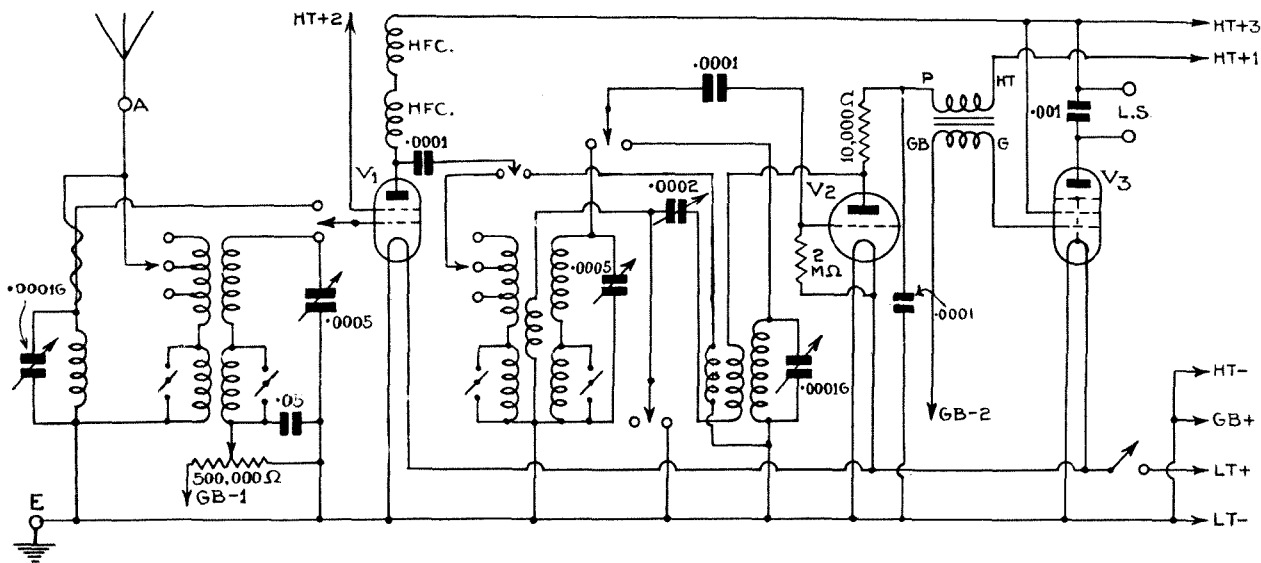
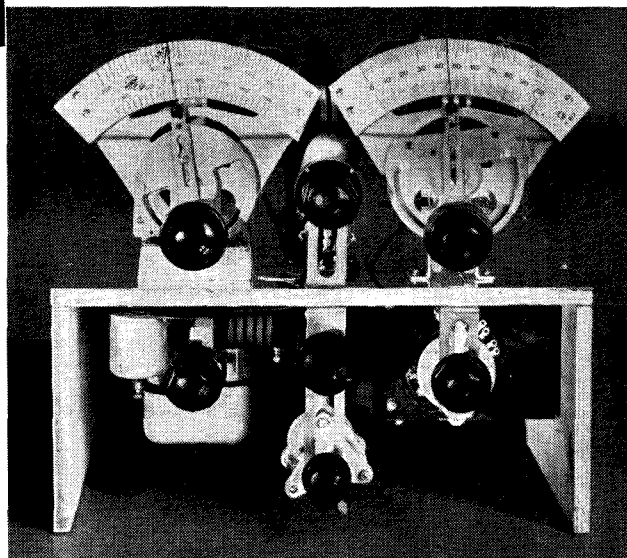

*The circuit employs a variable-mu screened-grid stage, triode detector with reaction, and transformer-coupled output pentode. The switching has been drawn in the simplest possible manner here to show its electrical functions, the actual short-wave range switching being omitted*

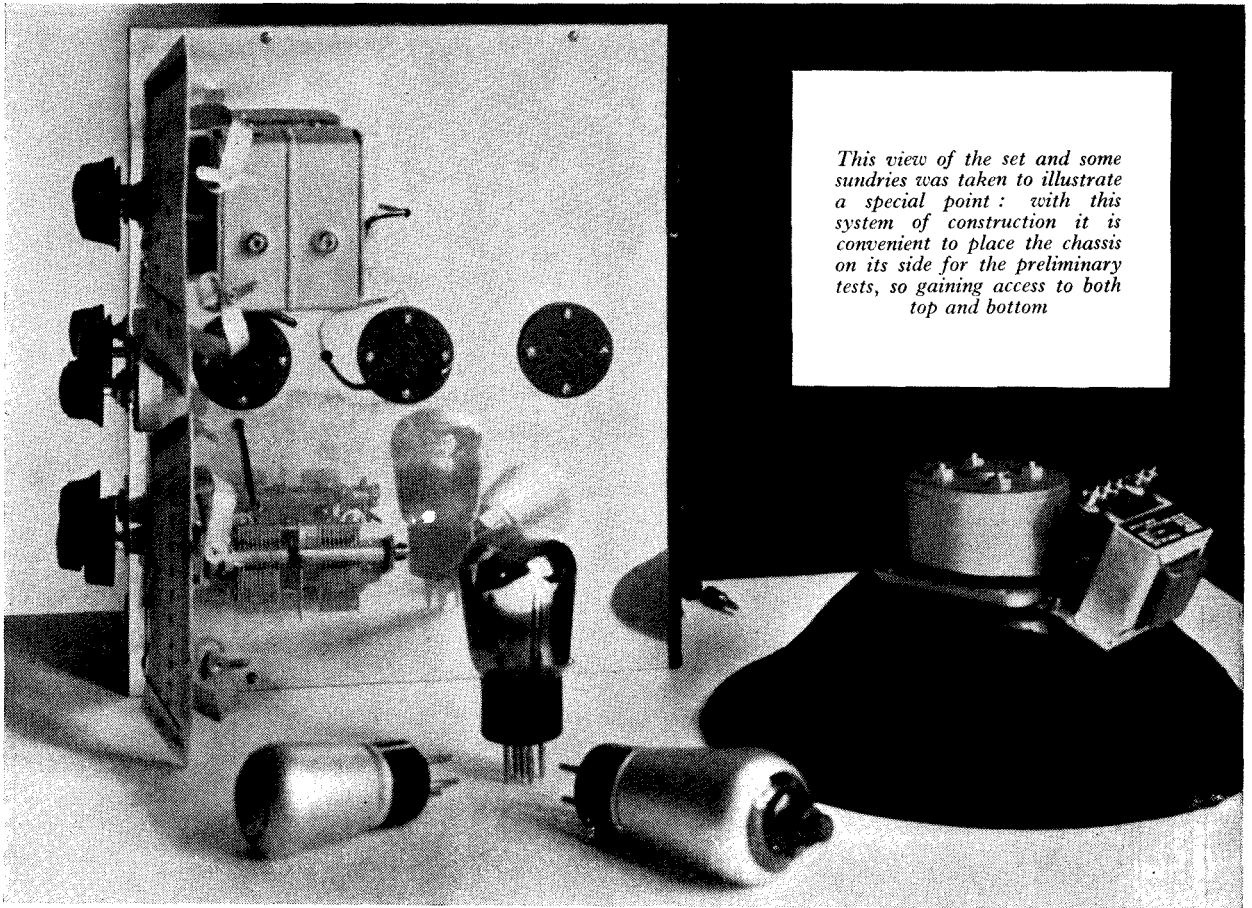

*This view of the set and some sundries was taken to illustrate a special point: with this system of construction it is convenient to place the chassis on its side for the preliminary tests, so gaining access to both top and bottom*

in" to the handling of this receiver in a very few minutes.

Even if you are accustomed solely to the use of single knob sets you will not find any practical difference because the two tuning dials are not used together as in some receivers but one at a time, according to whether one is listening on the medium and long wave or on the short wave. This is due to the fact that in order to get the highest efficiency there are two pairs of ganged condensers and one pair does *not* have to serve for all the five wavebands receivable.

#### How the Circuit Works

Now for the circuit. This section of the article is for the more advanced reader, and you can skip it if you like, going straight on to the constructional details. For our part we consider that the reader who is capable of appreciating the circuit diagram likes to know just what he is building, but on the other hand the design has been so worked out and the constructional side described that no knowledge of the circuit is needed in order to build and operate the set.

The circuit contains three valves: a screen-grid variable- $\mu$  high-frequency valve, of the short base variety, a valve of the HL type as detector, and an economy pentode for the output. Rather an ingenious method has been adopted in the aerial circuit giving high efficiency together with considerable simplification of switching.

The short-wave assembly, which is purchased complete and ready wired up to its switch, consists of two triple

coils placed at right angles to one another and screened by the metal sheet shown. The switch incorporated chooses the particular short waveband required on *each* coil but makes no provision for changing over from short to the medium or long waves.

The first triple coil is therefore left permanently connected to the aerial through a very small condenser made up of twisted wires insulated from one another. This condenser offers a negligible opposition to the very high frequencies of the short waves but is for all intents and purposes a disconnection on the medium and long waves, while on the other hand the primary of the medium- and long-wave coil assembly acts as a short-wave choke when the set is on the short wave side.

#### "Automatic" Wave-change Switching

The switching from short wave to medium and long can therefore be said to be "automatic," and this, of course, saves a good deal of complication in wiring. In order, however, that the grid of the high-frequency valve can be connected to the correct coil a simple, single-pole two-way switch is provided as shown in the circuit diagram, and this is actually a section of the switch placed immediately below the volume control. In its central position the grid is connected to neither coil, and as this switch is linked with the on-and-off switch the central position is made to correspond with the "off" on this latter.

The medium- and long-wave coils are also provided as an assembly, being carefully screened in the best modern style. Through the centre of this assembly





passes a switch which changes from medium to long wave in the normal manner and this is found immediately below the medium- and long-wave dial. There are incidentally, three tapings on the primary of the first medium- and long-wave coil and which of these you choose is dependent on your particular aerial; naturally with very long aerials a lower tapping is used whereas the highest tapping is required for small indoor aerials.

The volume control operates on the control grid of the variable- $\mu$  valve and is *not* in circuit on the short wave. There are two reasons for this: first of all there is the matter of electrical simplicity which has been very carefully looked after in this design, and secondly on short waves the reaction control is the true volume control as every short-wave listener knows. For reasons which are given later the reaction control is particularly effective and will be found to give everything desired in the way of volume control on the short waves.

### High-frequency Coupling

In the plate of the variable- $\mu$  valve are two radio-frequency chokes in series, the lower in the circuit diagram being that for short waves and the upper for the medium and long waves. The parallel feed scheme is used for coupling the high frequency valve to the detector and the simple switching scheme shown changes over both primaries and secondaries.

In one position the short-wave coils are in circuit, controllable thereafter by their own switch for the particular band, while in the other position the medium- and long-wave circuits are available, again to be chosen by their individual switch. All this sounds rather complicated when describing the circuit but actually, as indicated in the first part of this article, the practical operation is simplicity itself.

It is customary to place in the plate circuit of the detector valve a radio-frequency choke in order to obtain a reaction effect, the radio frequency currents passing from the plate through the reaction coil and the condenser back to filament. The impedance offered by this choke is the sought-after property and while it is possible to get a choke which works satisfactorily on the medium and long wave the same choke is not necessarily good for the short waves.

### Reaction Circuit Switching

There is a number of reasons for this which the more experienced reader will know. It has been found, however, that a series *resistance* will achieve just the same result and having no natural period of its own is much to be preferred for some short-wave circuits. A resistance is, therefore, used in this set in the place of a radio-frequency choke.

Two reaction coils are used in series in the

"Winning Three," being divided from one another by the reaction condenser. The short-wave reaction coil with its very few turns has a negligible effect on the medium and long waves while, of course, the medium and long-wave reaction coil is much too big on the short wave.

Each reaction coil is connected to its own particular set of tuning coils and an arrangement is made whereby the medium- and long-wave reaction coil is short-circuited during short-wave reception. The values being correctly chosen smooth reaction is therefore obtainable with a little adjustment on all five bands.

There is little to say about the output which is of

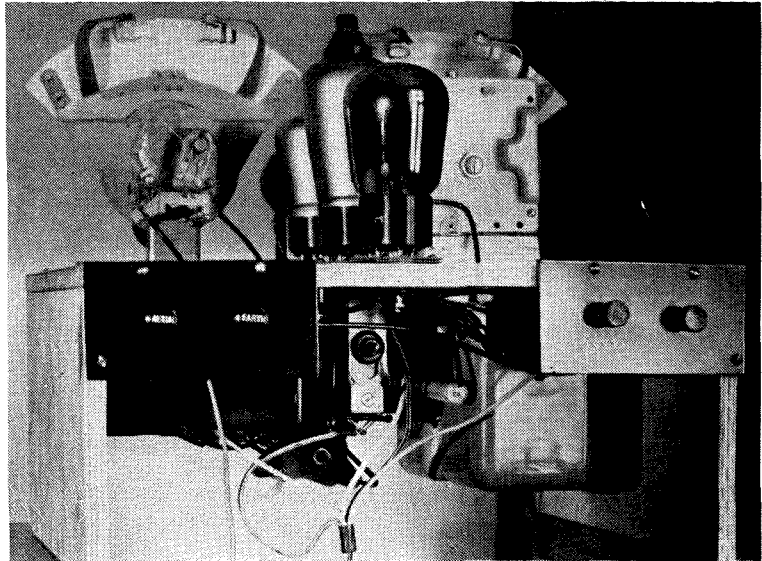

*Note how the terminal strips are attached with three screws each: they serve to stiffen up the side members of the wooden chassis assembly and keep them from sagging*

### COMPONENTS— OUR POLICY

*COMPONENTS used in receiver designs published in "Wireless Magazine" are chosen for their suitability, efficiency and reliability. Their selection must not be taken to indicate any more than this, nor that other good-quality components are not equally suitable, save in a few cases clearly indicated where there are no suitable alternatives*

standard and well-proven construction. As this is a battery set an economy pentode has been chosen for the output giving signals if excellent strength and quality with very reasonable current consumption. A .001 condenser is joined across the loudspeaker in the usual way.

### Constructional Methods

There are several ways of designing a set for home construction. You may for example use a metal chassis with the securing holes for the various components already stamped out very much after the style of the factory built receiver; we can use the "pastry-board" method with all the parts laid out on one plane with the exception of the condensers secured to the panel; or finally, and particularly in a set of this kind, we can think of electrical efficiency first and design the set so as to give the shortest and most efficient connections possible at some sacrifice of simplicity of construction.

This last method has been chosen for the Winning Three and although the set is a little more difficult than some to build we would not insult our readers by suggesting that this method will present much difficulty to them, particularly if they examine the diagrams and photographs carefully and follow the instructions given.

You will notice that the baseboard carries on the top only the valve-holders, the volume control and the two

**COMPONENTS NEEDED TO BUILD THE WINNING THREE**

	s.	d.		s.	d.		s.	d.
<b>CHASSIS</b>			<b>CONDENSERS, VARIABLE, AND DIALS</b>			<b>SWITCHES</b>		
1—Peto Scott Plymax-topped to specification	...	...	1—Polar two-gang, type E	5	0	1—Wearite, type 122	...	...
<b>CHOKES, HIGH-FREQUENCY</b>			1—Polar two-gang midget	11	0	1—Wearite, type 123, with two coupling pieces, short extension rod, and two mounting brackets	...	...
1—Varley Nicore	4	6	1—Arcuate Micro-drive for type E	7	9	<b>TRANSFORMER, LOW-FREQUENCY</b>		
1—Bulgin, type HF3	2	6	1—Arcuate drive for midget	5	9	1—Ferranti, type AF8	...	11 6
<b>COILS</b>			<b>RESISTANCES, FIXED</b>			<b>VALVE-HOLDERS</b>		
1—Wearite, type BP1	12	6	1—Dubilier 10,000-ohm, 1-watt type	1	0	1—Clix Airsprung, 5-pin	...	1 3
1—Wearite, type TG, with 9 in. spindle	12	6	1—Dubilier 2-megohm, 1-watt type	1	0	2—Clix Airsprung, 4-pin	...	2 4
1—B.T.S. multi-range short-wave unit	17	6	<b>RESISTANCE, VARIABLE</b>			<b>LOUDSPEAKER</b>		
<b>CONDENSERS, FIXED</b>			1—Erie 1/2-megohm volume control, without switch	3	6	1—Rola, type F720 P.M.T.	...	1 15 0
1—Dubilier .001-microfarad, type 620	2	0	<b>SUNDRIES</b>			<b>VALVES</b>		
1—Dubilier .0001 - microfarad, type 620	1	3	1—Bulgin 5-way battery cable	1	6	1—Mullard, type PM12M	...	12 6
2—Dubilier .0001 - microfarad, type 665	1	0	3—Peto-Scott mounting brackets, say	9	9	1—Mullard, type PM1HL	...	5 6
1—Dubilier .05-microfarad, type 4503	1	4	2—Small terminal ebonite mounts, say	4	4	1—Mullard, type PM22A	...	13 6
			Clix battery plugs, wire, screws, etc., say	1	6	<b>BATTERIES</b>		
			4—Clix terminals	1	4	1—Drydex 9-volt grid-bias, type Super 9	...	1 3
						1—Drydex 120-volt Square Super	...	10 6
						1—Exide 2-volt accumulator, type DFG/C	...	9 0

pairs of ganged condensers, all the rest of the parts being secured below. As the condenser assemblies are of somewhat different height, in order that they may match symmetrically one pair of condensers is mounted on a block of wood  $\frac{3}{4}$  in. thick. Actually in the set illustrated it was a piece of  $\frac{3}{4}$ -in. plywood.

**Mounting the Tuning Dials**

No difficulty will be found in mounting up the tuning dials and full instructions for this are issued by the makers with the dials. On the under side of the base-board a medium- and long-wave coil assembly is mounted on a  $\frac{3}{8}$ -in.-thick block of the dimensions shown so as to bring the switch rod in a symmetrical position. To make testing and final adjustment easy the set is so designed that it can be operated before being placed in the cabinet chosen, the various parts being mounted on the brackets indicated in the list of components.

The brackets are slotted to take the components they have to carry but it is necessary in the case of the bracket carrying the reaction condenser to drill a  $\frac{3}{8}$ -in. hole to take the spindle of the central switch. The spindle is actually only  $\frac{3}{16}$  in. in diameter but the slight difference is necessary for clearance purposes. (The spindle must *not* make electrical contact with the bracket.)

**Points about Construction**

All of the components are mounted as shown but the central switch assembly should be mounted last and as much wiring as possible done before this is fitted into place. Note that the brackets carrying this central switch assembly both have their feet pointing towards the *back* of the set.

When mounting the switch have all spindles and coupling pieces in position to ensure accuracy in lining up. The mounting should be really done before the wiring is commenced, and it is suggested that the best procedure is that which follows : fit the switches at an early stage of the operations, and see that the brackets are correctly

positioned, then dismantle everything again and proceed with the rest of the construction and the wiring. Actually, as much of the wiring as is possible without the switches should be done before they are again fitted in place.

**Strong Turning Effort**

Another point about the switches : there are really two units being operated from the single knob, and the type chosen is one requiring a fairly strong turning effort to move it from one position to another. This means that care must be taken to attach the knob and the two coupling pieces really firmly.

A strong screwdriver is needed, and those who like to make doubly sure may even care to file a little flat place on the appropriate spindle for the points of the

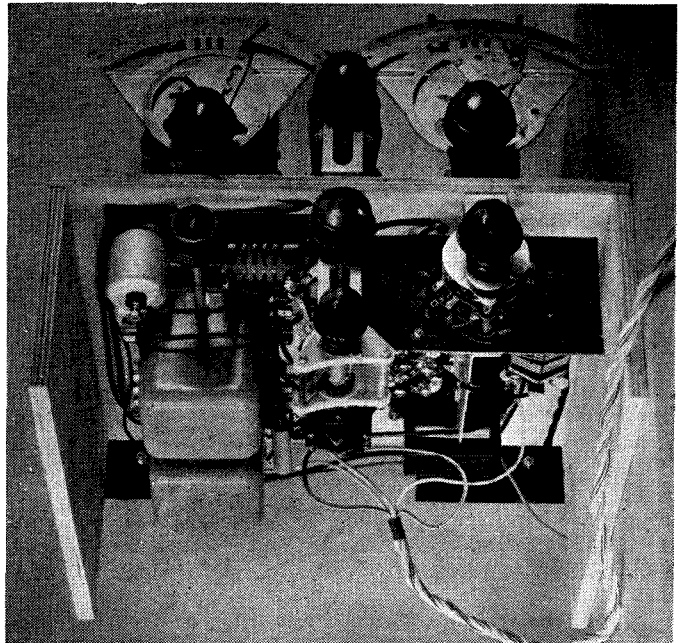

*Compactness is important in an all-waver, and to secure it one must snip off the corner of the S.W. coil unit front plate nearest the reaction condenser with a pair of scissors, likewise the projecting blank portions of the dial scale plates which would otherwise touch in the middle*

**The Ideal Set for all B.L.D.L.C. Members**



grub-screws to bed down upon. It is very essential that the two switches should really turn fully to the intended position when the knob is operated, and it is even worth while to watch the contacts when the knob is first turned so that one may check that they really are opening and closing in the required manner.

### Earthing Precautions

The baseboard being made of metal covered plywood this must be earthed. This is done by using a screw and nut as one of the securing screws of the short-wave gang condenser, earthing wires being connected to the nut on the underside of the baseboard. As the medium- and long-wave tuning condenser frame is *not* in contact with the metal covered baseboard owing to the use of the  $\frac{3}{4}$ -in. mounting block, a wire should be taken from the casing of this condenser to the screw holding down the bracket of the volume control which is, of course, in contact with the metal baseboard covering.

All wiring is very clearly shown in the diagram, the blueprint of which is obtainable as usual for those who like to work from a full-size drawing, and actually some of it is a little simpler than appears.

For example, the .0001 fixed condensers near the detector valve socket are actually secured to the switch lugs by their own tag ends (which are long for soldering purposes): the diagram shows them joined by wires in order to make the connections clearer. The other ends of these condensers are again soldered to the wire end of the grid leak in one case and to the wire leading to the nearest end of the short-wave high-frequency choke in the other.

By the way, a little care is needed in fitting the condenser connected to the grid of the detector. There isn't a great deal of room around this neighbourhood, and it is advisable to do as much assembly and wiring as possible before the reaction condenser is fitted; in particular, care must be taken to see that the fixed condenser just mentioned does not "short" itself against the spindle of the multiple change-over switch.

### Important Details

To make sure of this the constructor should watch closely to see that the exposed metal end tag of this condenser does not touch either the switch spindle itself or the heads of the grub screws in the connecting piece used to attach the extension spindle carrying the control knob to the switch spindle proper.

To get safe clearances all round, the two fixed condensers in question should be worked into the slightly sidewise position seen in one of the photographs. A

little trial and error will be needed here, but since the condensers are attached by soldering it is simple enough to bend the lugs a trifle this way and that.

When the set is fully wired up and the battery cords attached, H.T.3 can be given 120 volts, H.T. 2 the voltage specified by the valve maker for the screening grid, and H.T. 1 a suitable voltage for the detector valve—probably about 90 volts.

### Setting It To Work

The two grid bias negative plugs 1 and 2 are given the bias for the variable-mu valve and the output pentode respectively, and the set switched on. Try the medium waveband first by turning the central or main switch to the left and setting the medium- and long-wave switch in the medium position. Set reaction at zero and the volume control at maximum.

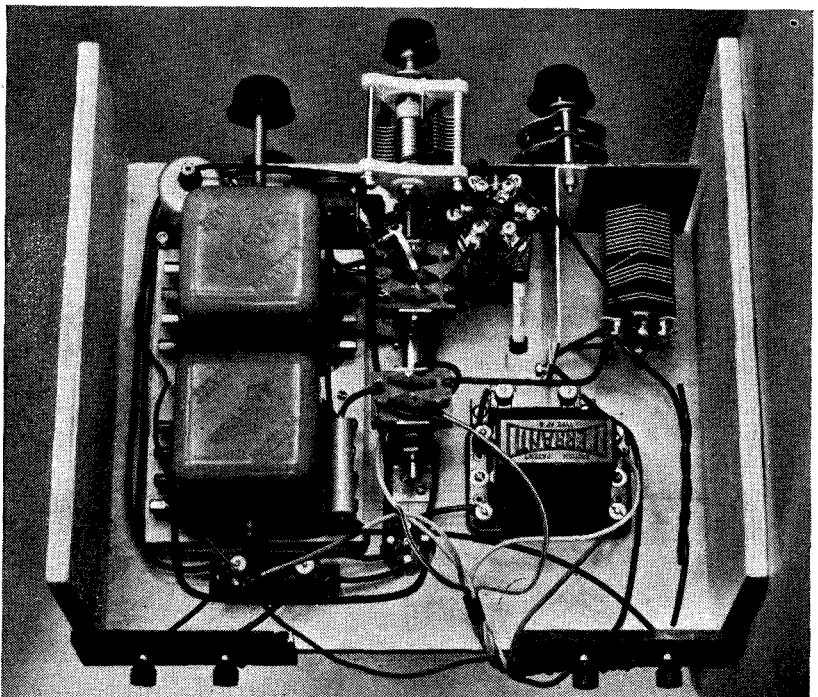

*Immediately below the reaction condenser one can see here the two small fixed condensers associated with the detector valve: notes in the text explain how these are to be fitted. Note also the twisted wire and Systoflex "condenser" in the right-hand corner*

Now tune in in the usual way to a nearby station, reduce the volume control till the signal is fairly weak, and then adjust the trimmers on the medium and long-wave tuning condenser so as to bring both circuits in tune and to bring the indicator in the correct position on the dial for the wavelength chosen.

Try out the volume control and the reaction control, and if all is well change over to the short-wave position.

Next month a more detailed description will be given of how to tune and where to find the various stations in this band; meanwhile we have provided you with full particulars for the construction of a set which we know will prove exceedingly popular.

**The Best "All-wave" Battery Design Yet!**

# "Music Hath Charms"

A B.I.P. film with Henry Hall and his band as the star performers. It will be shown in the West End next month and it is expected that the film will be generally released early in the New Year

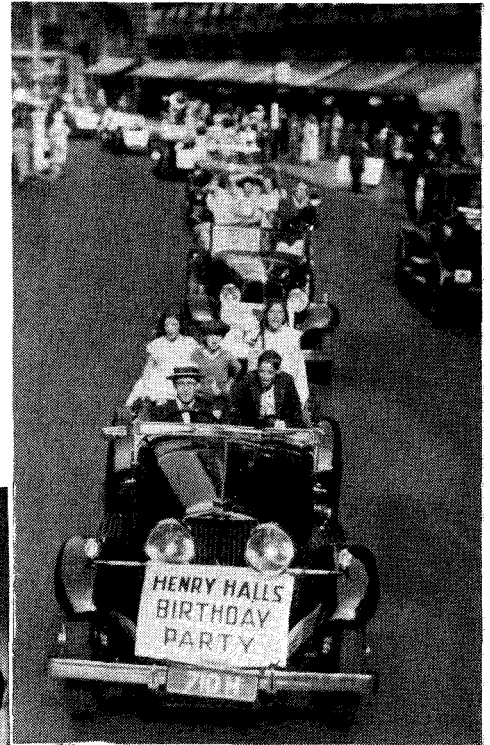

Henry Hall's birthday party en route down Regent Street for the country. One member of the band is in each of the following cars, playing his instrument with the children singing at the tops of their voices

Henry Hall looks rather annoyed with his crooner, who dares to whistle on top of the mike!

By courtesy of Wardour Films, Ltd. we are able to reproduce some of the scenes from the new B.I.P. film, "Music Hath Charms," which features Henry Hall and the B.B.C. Dance Orchestra, Hildegard, Billy Milton and other radio personalities. Everyone interested in the activities of the B.B.C. dance band will thoroughly enjoy seeing this film, for it portrays the entire day's work of Henry Hall and the members of his orchestra

From "Music Hath Charms." Two isolated Englishmen in the jungle are attacked by natives who, upon hearing Henry Hall's music, change tactics and fête instead of kill!



One of the striking scenes from the film "Music Hath Charms," showing Henry Hall and band in the studio during an afternoon broadcasting session

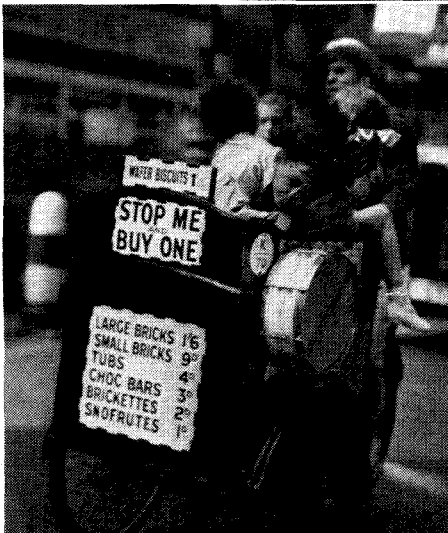

(Left) Coming back from the country party, Sam Lee packs four children, drum and himself on an ice-cream tricycle—just one of many amusing incidents!

Constable (looking for escaped lunatic) meets Henry Hall looking for his 200 children. Constable decides he has made a capture, and says the usual: "Well, well; you had better come along o' me"

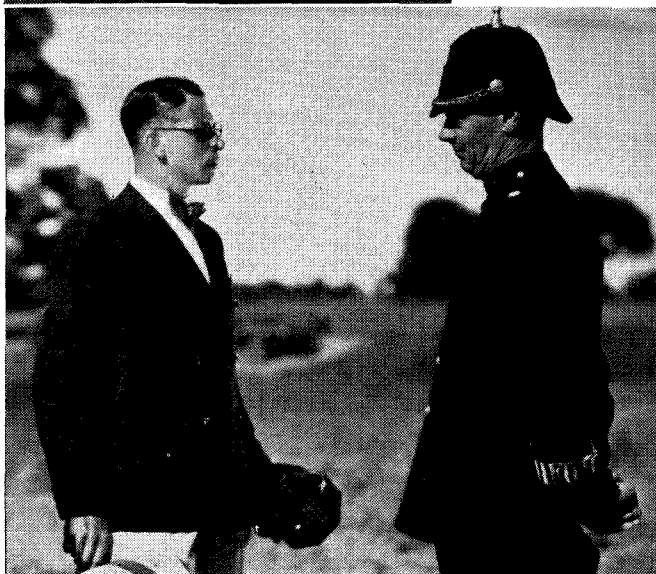

## "Music Hath Charms—" a film that Every Listener Should See

**T**HE task of writing a scenario for a film, the sole object of which is to introduce a famous radio personality, is no easy one; but in the new B.I.P. film, "Music Hath Charms," L. du Garde Peach has definitely produced a plot which grips you from beginning to end of the film.

The main subject of the story is the big party arranged by Henry Hall for 200 kiddies. They set off from London in a dozen or so "posh" cars, singing and shouting on their way through London, for a day in the country, where they play hide and seek and Henry Hall loses both children and band.

Wandering around looking for them, Henry meets a cop (who has previously been warned that a lunatic has escaped from a nearby asylum) and asks if he has seen his 200 children. The constable ponders, and decides that he has made a capture. Henry is taken to the local lock-up, and the sergeant 'phones the asylum.

Meanwhile, the car drivers, fed up with waiting, decide to abandon the party. Henry escapes, and dashes back to Broadcasting House just in time for his 5.15 broadcast, but without the band.

He plays his own signature tune on the piano whilst thinking how to produce forty-five minutes of dance music without a band. Fortunately, the band arrives one by one within the first five minutes and the situation is saved.

I was surprised. Henry is the ideal screen star, and everyone, children and grown-ups, will thoroughly enjoy the film.—S. M. B.



# A Rechargeable 'Dry' Battery

R. W. HALLOWS, M.A., Describes Mr. Leonard Fuller's Latest Development

IT must have occurred to most people who have to use it that, convenient though it is in many ways, the primary dry cell such as we employ in flash-lamp refills, wireless high-tension batteries and so on, is an extraordinarily wasteful means of supplying electric current. We buy it ready charged, subject it to a single discharge, and then throw it away.

All that we have really used up is the electrolyte and the depolarising compound—and one or other of these still probably contains a considerable amount of active material, though we cannot use it.

From the waste point of view the wet Leclanché cell is an improvement, since its zinc may be made to survive two complete discharges; but it suffers from one sin against economy that is common to all primary cells: every one of them works by using up metal, usually zinc.

## Not Reversible

The metal is attacked by the electrolyte and passes into solution: we cannot, by any known charging process, reverse the action and make zinc pass back from the solution to build up the negative electrode of the cell again.

Very different is the working of the accumulator or secondary cell.

By connecting the discharged accumulator to a source of direct current (which may be supplied from A.C. mains by means of a rectifier) it can be recharged for further use.

The great point is that the material is not irretrievably lost as in the primary cell and the electrolyte is not "used up" by becoming saturated. Whatever is taken out of the various components of the secondary cell during discharge is put back again into its proper place by the recharging process. In time the electrolyte may require renewal; in time the plates will disintegrate. But a well-made and well-treated secondary cell stands up without serious deterioration to very many discharges and recharges.

If the primary cell makes such a bad showing when examined from the point of view of wastefulness, why is it that it is so widely used? There are several answers to this question. The first, and most important, is that hitherto the only cell that could be made up in dry form was the primary. Actually, only one kind of primary cell lends itself to this make-up—the Leclanché.

The advantages of the dry cell are great. You cannot upset it or spill it; it can be made up conveniently into batteries from which small amounts

rises fairly rapidly during discharge and may reach a surprisingly high figure when the cell has seen a good deal of work; lastly, it is prone to lose moisture by evaporation owing to the effects of heat and since in ordinary dry cells there is no means of replacing this moisture its loss may lead to an untimely end.

## First Steps

It was considerations such as these that led Mr. Leonard Fuller to consider whether it would not be possible to produce a dry version of the accumulator cell.

The way to the dry accumulator was opened some time ago when Mr. Fuller produced his "plateless" wet accumulator. By making his negative plate a hollow cylinder surrounding the cell and his positive plate a cylindrical rod in the centre he was able to save a great deal of space and to evolve an accumulator of small bulk in proportion to its capacity.

From the plateless cylindrical wet secondary cell to the dry accumulator was in some ways but a step.

Fig. 1 shows in section the Fuller rechargeable dry cell.

Its most important component parts are shown in further detail in Fig. 2. In appearance it is almost exactly like a dry cell from a flash-lamp refill or high-tension battery. The only visible point of difference is that it has a small cane vent plug. Both dry cell and accumulator have metal cans; each is sealed with black bitumen; in each the central positive electrode is covered with a little brass cap.

## Convincing Tests

During a most interesting visit to the Block Batteries Factory, where the rechargeable cell has been developed, I saw not only accumulator cells of the same size as those used in primary dry high-tension batteries of both standard and super capacity, but also cells of capacities up to 45 ampere hours intended for filament heating.

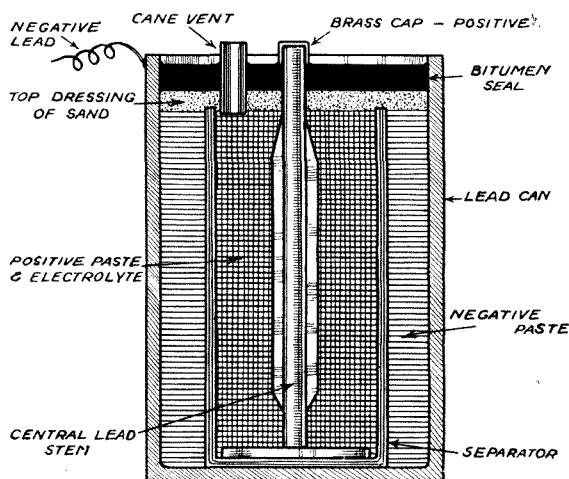

Fig. 1—Section of Fuller Rechargeable Cell

of current at high voltage are required; it is light; it is compact; it is to all intents and purposes fool-proof; last, but not least, it is readily adaptable to mass-production methods and it can therefore be sold very cheaply.

The standard-capacity 120-volt high-tension battery which sells today at 6s. 6d. contains 80 separate dry cells. The retail price is therefore less than one penny per cell.

But, in addition to the drawback of not being rechargeable, the dry cell has many other qualities which are far from ideal. The current load to which it will stand up is comparatively small; though its E.M.F. is 1.5 volts, or a little more when it is new, there is an immediate loss when it is placed under load and this loss is progressive during its life; its internal resistance is not constant, but

So that I might see whether they lived up to their name or not I was invited to remove the vent plugs from any that I liked, to turn the cells upside down and to shake them hard over a piece of white blotting paper. Not the most minute droplet could be shaken out of any of them.

Now let us examine Figs. 1 and 2 in detail. The cell is contained in a solid drawn lead can, the interior of which is pasted with negative material. The inner surface of this negative material is again pasted, this time with the separator, the non-conducting compound necessary to separate negative from positive element.

So far, then, we have a hollow cylinder consisting of a lead "skin" lined with negative paste, which latter is in its turn lined with the separator. Several different materials can be used to form the separator; in the cells that I examined, powdered pumice was employed. This forms a kind of porous cement.

#### How It is Made

Into the hollow lined by the separator is inserted the central rod. This is again made of lead and it is shaped rather like a flat-headed mushroom with a long thin stem carrying four flutes. Once the rod is in place positive material, mixed into a paste with dilute sulphuric acid, is rammed in. The cell is then given a top dressing of sand, and when the cane vent plug has been placed in position it is sealed off with bitumen. When the central rod has been capped with brass and a wire has been soldered on to the lead case the cell is complete.

And now you will want to know what these cells can do. I have had no opportunity so far of testing them personally, but I was allowed to see the records of the results obtained in long series of tests made both at the Block works and at the National Physical Laboratory. Each cell, no matter what its size, behaves in much the same way as an ordinary wet secondary cell. That is to say, its E.M.F. when fully charged is in the neighbourhood of 2.2 volts; this falls fairly rapidly to 2 volts and steadies down at that figure. When the voltage has dropped to 1.85 a recharge is required.

A filament cell of 45-ampere-hour capacity is contained in a square bakelite case measuring approximately 3 in. by 3 in. by 6 in. high.

For high-tension battery purposes two cells have so far been developed.

The first is of exactly the same dimensions as that used in standard-capacity batteries— $\frac{3}{4}$  in. in diameter by  $2\frac{1}{4}$  in. high. The second, measuring  $1\frac{1}{4}$  in. in diameter by  $2\frac{1}{4}$  in. high, has precisely the same measurements as the dry cell used for power or super capacity batteries.

Both sizes have given a good account of themselves under test, but it was about the larger one that I asked most questions, since this seems to be the ideal size for running economically a battery-driven set from which good performance, good quality, and good volume are expected.

In all the tests this cell had been charged at one-eighth of an ampere and discharged at *two hundred and fifty milliamperes*. The best primary dry cell in the world could not stand up to a continuous discharge at this rate for very long.

If you disbelieve me, purchase a flash-lamp refill containing two of them in series, connect them to a flash-lamp bulb, leave the combination running and note how long it takes for the filament of the bulb to decline from full brilliance to something a little better than a dull red glow.

The accumulator "dry" cells discharged under exactly similar conditions, will keep a flash-lamp

bulb glowing brilliantly for nine hours on the average. Since such bulb requires a current of 250 milliamperes each cell has a capacity of 2.25 ampere hours at this heavy rate.

But remember that whereas the E.M.F. of the primary cells is falling constantly and heavily, that of the dry secondary cells remains almost constant.

The question of weight is to some extent important, though. The primary cell of the size that I have mentioned weighs about three ounces. A Fuller dry accumulator cell of the same dimensions turns the scale at seven ounces.

But remember that the nominal E.M.F. of a primary cell is 1.5 volts, whereas that of a Fuller cell is 2.0. Thus for a 120-volt high-tension battery you will require 80 primary cells, but only 60 secondary. Further a battery made up of primary cells will retain its nominal E.M.F. for only a short time under working conditions, whilst one consisting of secondary cells will keep it without serious loss until the time comes for a recharge.

However, since the accumulator battery contains only three-quarters as many cells of the same size as those composing a primary cell battery to give the same total voltage, it is clear that it is a much more compact affair.

How do the cells stand up to work? The reports that I have seen show that for 22 weeks they have been discharged under a load of 250 milliamperes, then recharged at one-eighth ampere and then immediately discharged under the load mentioned.

After fifty complete cycles of charging and discharging, no appreciable deterioration could be detected. A further more remarkable point is that during the whole of the 22 weeks of the N.P.L. tests not one single drop of water was added to any cell.

#### Not In Production

I should make it plain to readers that the Fuller rechargeable dry cells are not yet in commercial production, so that neither the cells themselves nor batteries built up from them are yet obtainable. It is therefore of no use to place an order for such batteries or to write to the company asking for further particulars. As soon as the production stage is reached the fact will be announced.

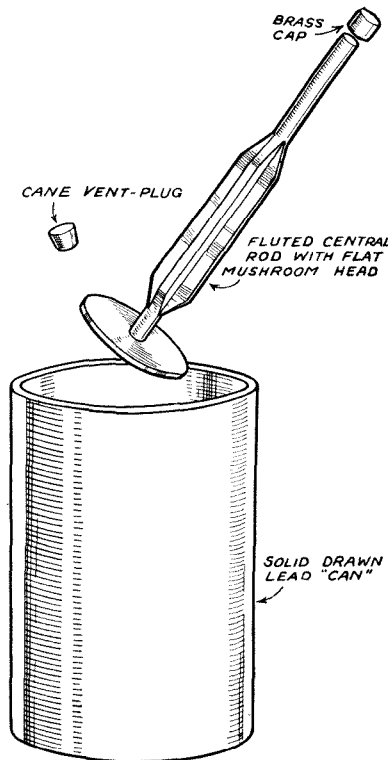

Fig. 2—The component parts of the cell



Popper photo

Like sound broadcasting, television pictures will have to be carefully checked before reaching the transmitting aerial. Here you see the television control desk at the Berlin television station

WHILE we wait and fret there is news of one country after another preparing to get ahead of us on high-definition television; the latest is Australia, where plans are being made for the establishment of experimental transmitters at Sydney and Melbourne in what is described as "the near future." That probably means quite soon, because our Australian relatives have go-ahead ideas in these matters.

The basis of the new development is an agreement between Baird Television, Ltd., and the Australian Radio Manufacturers' Patents Association, whereby the latter body becomes the representative of the Baird organisation in Australia, both for the construction and working of television transmitting stations and the manufacture of receivers under Baird patents.

From Berlin comes news that the new transmitters to replace those destroyed in the fire at the Radio Exhibition are nearing completion; rumour suggests that the German authorities are taking advantage of the opportunity to try out, possibly only on an experimental basis, something rather sensational in the way of ultra-high definition. Very possibly something will have been heard of this by the time these words are in print, or very soon after.

In this country one of the most interesting of the month's news items concerns the reported intention of the Baird Company to stage a public demonstration of television under picture-theatre conditions. Pro-

visional plans indicate the Dominion Theatre, in London, where the screen is 24 ft. wide, as the probable scene of the experiment; the transmission will be from the Baird station at the Crystal Palace, and I understand that the "intermediate-film" process will be used.

The methods of projecting a really big picture are not perhaps of very much direct application to amateur work, but they are not without technical interest. In the intermediate-film system, for example, the apparatus runs a ciné film past a cathode tube viewing device which projects an image upon it very much as does the lens of a ciné camera in action. The film then goes through a series of developing, washing, and "fixing" tanks and is finally run to an ordinary cinema projector, thus throwing the developed picture upon the screen in just the usual fashion.

The interest of the process is really in the extraordinary speed with which all these normally slow operations are carried out with the aid of special methods developed for the purpose: a total time of half a minute is by no means impossible, and even then the photographic quality of the picture is quite passable, and amply good enough for dealing with news events.

With due apologies for the digression, I should like to draw the attention of the keen television experimenter

# What is Happening in Television

The Month's News: by PAUL WOODWARD

to an article which will appear in the next issue from the pen of Mr. Reyner on the subject of some modern methods of frequency correction in high-fidelity amplifiers. This subject is likely to be of great importance in high-definition television work, for the accompanying sound transmission if not for the picture signal.

It is well to remember that these sound transmissions will be potentially of very high quality indeed, and it will be extremely interesting to see what sort of reproduction one can get from them. With due care it should be possible to obtain something very much more faithful than the standard to which the B.B.C. is at present limited by ether conditions.

On the ordinary broadcast band familiar factors make it impossible to include those higher components needful in high-fidelity reproduction as it is known in the laboratory. On the ultra-shorts, however, no such limitations apply.

I have heard, for example, a transmission containing all frequencies up to 20,000 cycles a second in due proportion, and this, applied to a suitable circuit and loudspeaker system, gave reproduction of quite startlingly life-like quality. A very interesting field, this.



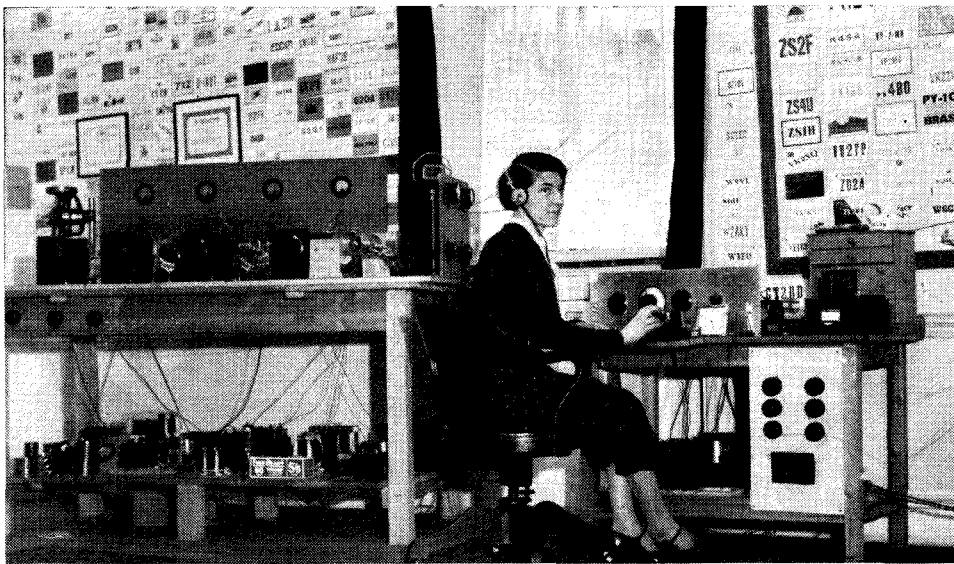

Miss Nellie Corry—(G2YL), who recently made contact with amateurs of every continent on 10 metres, seen in her "den" at her home at Walton Heath, Surrey. Miss Corry's transmitter is on the left and she is seen at the controls of her receiver

# Getting Down to the Very Short Waves

By G. HOWARD BARRY

SOME short-wave receivers—or possibly some owners of short-wave receivers—seem to be afflicted with a peculiar disease these days. The only way in which I can describe this particular malady is to call it an attack of "thus far but no farther."

In short, people are finding that their short-wavers have a limit at the bottom end of their scale. Sometimes it is as high as 30 metres—in others it may be 13. But ask the vast congregation of short-wave listeners how many of them can get down to 10 metres and you will start finding them out.

When one considers that most of the well-known short-wave circuits will oscillate pretty comfortably down to  $2\frac{1}{2}$  metres, or even lower, it becomes apparent at once that it's the workmanship, not the material, that is at fault.

## Developments of 10-metre Listening

In view of the recent sensational work on 10 metres, which has included Miss Nellie Corry (G2YL) making contact with five amateurs in six continents, the regular reception of Australia in this country and frequent two-way contacts, most of us want to listen down there or, at any rate, to make sure that we *can* do so when the need arises. Let us, therefore, see why some of us can't!

I put the trouble under two headings—bad layout (which includes long wiring) and "damping." Good old "damping" covers a multitude of sins, but I am thinking chiefly of the infamous habit of setting up a beautiful low-loss tuned circuit and then killing it by hitching a large aerial straight on to one end.

Think of it in this way: The modern 8-h.p. car will tackle any main-road hill in this country nowadays; but hitch a 15-cwt. trailer on to it and you'll find a few that may beat it. Tie a heavy caravan on, and you'll *certainly* come to an ignominious stop at one or two spots I could mention.

Similarly, the modern tuned circuit with its nice little four-pin coil, low-loss runing condenser, and short wires joining the two, is all very well. Just hitch a heavyweight aerial on to it, however, and its limitations become apparent.

## Tight Aerial Coupling Unnecessary

The joke, of course, is that one hasn't the slightest need to use tight aerial coupling for these very high frequencies—but people *will* try to do it, and spoil the performances of their receivers by doing so.

Take Fig. 1 as the standard receiver circuit. I suppose we all use something very nearly related to it for our detectors. Your aerial can be coupled in three ways—straight on to the coupling coil  $L_1$ , or through the neutralising condenser on to the top of the grid coil  $L_2$ , or, again, through the neutralising condenser on to the coupling coil  $L_1$ .

The last method gives a perfectly satisfactory degree of coupling for wavelengths below 20 metres, and introduces a negligible amount of damping into the circuit. One can tell that at once by comparing the selectivity of the receiver in the three conditions mentioned. Direct capacity coupling is usually the worst of all.

(Please turn overleaf)

Tight (untuned) inductive coupling is all very well, but some of the commercial coils seem to have the aerial winding rather *too* tightly coupled. Just insert your small condenser between the top of that winding and the aerial, however, and you have an easily controllable degree of coupling which, at one end of the scale, cannot really be made excessively tight. That is just what you want.

Now, to go back to the layout question. Your set may be perfect down to 20 metres, and then suddenly start misbehaving with hand-capacity effects and failure to oscillate. Why? Well, it's about ten to one that long wiring in the H.F. leads is the root of the trouble.

**Keep the Wiring Short !**

Wiring between the coil and the condenser may be quite short; but when you get down to 10 metres and have, possibly, only two small-diameter turns in the coil, even two or three inches of wiring will assume a different aspect and have quite a large inductance by comparison with the rest of the circuit.

Modern coils are small-diameter affairs, and you can

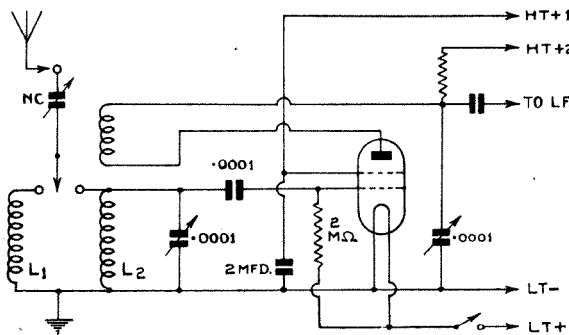

Fig. 1.—A standard detector circuit which the author talks about in his article

well forget the old fetish of keeping the coil a long way away from metal objects such as the condenser that tunes it. Put your coil close up to the condenser; it's field is pretty small, anyway, and short wiring is more important than anything else.

Fig. 2 shows the dimensions and specification of a coil I am using (in the Fig. 1 circuit, by the way) for getting down to about 8 metres. It does it with the greatest of ease, and I think another coil with half a turn less in the grid circuit would go down well into the television band.

Doubtless many readers who cannot read morse will be left quite cold by the 10-metre amateur band, in which telephony is pretty scarce. But I am sure there are many receivers that will not get down to 13, or even

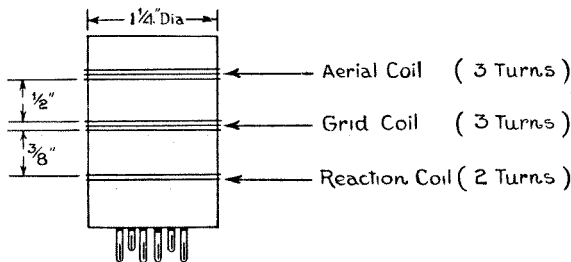

Fig. 2.—Showing the dimensions and specification of the coil used by the author for getting down to 8 metres

16 metres, simply on account of the same shortcomings that I have mentioned.

If the trouble is failure to oscillate, I should suspect the aerial coupling first. If it is hand-capacity, then I should at once turn to the layout and especially the wiring of the tuned circuit.

Fig. 3 shows a useful scheme for shortening wiring. The four-pin coil is mounted horizontally, its holder being fixed to a wooden upright. This brings the terminals conveniently close to the condenser connections, without actually bringing the windings any nearer than they were before. You can reduce your closed-circuit wiring to a total of one inch, or even less, by evolving some scheme of this sort to suit your particular receiver.

**Question of Valves**

Some valves, of course, are better oscillators on the high frequencies than others; but if you happen to have a bad one its performance would almost certainly be poor before you started really "getting down to it."

All battery valves of the "HL" type, unless they are faulty specimens, should go down to 10 metres with ease, and the average indirectly-heated A.C. valve is even better. My own all-mains receiver works down to 10 metres with an "HL" type, an ordinary S.G., or an H.F. pentode as detector.

Superhets using heptode or triode-hexode frequency-changers should do the same, although a few modifications to the oscillator circuit may be necessary in some cases.

There is one other point that I have not mentioned, because I don't think it is very common. Some people, however, will *never use enough* high tension on their detectors. A resistance-coupled detector should have at least 50 volts on the anode, which may mean applying 100 or 120 to the external H.T. terminal in some cases.

There's no disadvantage whatever in piling on the H.T. voltage, provided that it doesn't upset the reaction control. I once had a friend who habitually used 210 volts on his detector and always had beautifully smooth reaction—but that was carrying things a bit too far.

**Advice About Aerials**

Regarding aerials, the old advice holds good. Use the best one you can, and couple it loosely. And don't, for a moment, run away with the idea that a small aerial coupled tightly will give you the same results.

You may find that it gives you the same dial readings and the same apparent selectivity, but that is where the resemblance ends. The background-to-signal ratio is sure to be bad with a small aerial, particularly an indoor one.

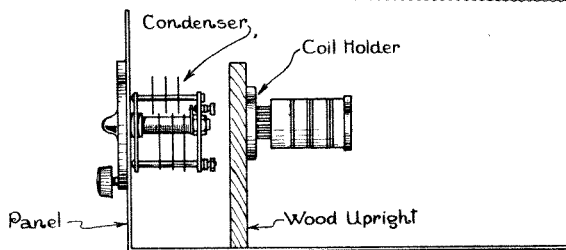

Fig. 3.—A useful scheme for shortening wiring; the coil is mounted horizontally behind the tuning condenser

# The British Long



# Distance Listeners' Club

**Great New Organisation for All Radio Enthusiasts**

*Wireless listening began as a hobby and the great radio industry which has since arisen has been built on the foundation so securely laid by the amateurs. Amateur transmitters pioneered the short waves which have revolutionised broadcasting and made high-definition television possible. Why not join the growing band of short-wave and long-distance listeners who are getting so much enjoyment from short-wave receiving? Join the British Long Distance Listeners' Club and get a new thrill from listening. Membership is free, and the club is sponsored by "Wireless Magazine" in the interest of listeners generally*

## *The Aims of the B.L.D.L.C.*

**T**HE tremendous development of short-wave reception during the last few years, and the ever growing possibilities of receiving wireless transmissions from all parts of the world, have called into being a new movement which, in Anglo-Saxon countries especially, has spread widely and already has hundreds of thousands of supporters. This is the movement of DX reception (DX means Long Distance) which particularly in the last year has taken such a surprising foothold, and—if the signs are not deceptive—will put the present reception of radio

by the average listener on a much broader basis.

The discovery by American and English amateurs of the extraordinary possibilities of short waves in the years shortly after the War, has found a very strong echo in commercial work: and if today we find it simple to bridge the greatest distances on earth with the help of short waves, it is as well to remind ourselves that it was the amateurs—students, former army wireless operators and schoolboys—who have turned the one-time plaything into a world power.

This has been recognised by the wireless industry and many receiving sets which used to show only 200-2,000 m., now have a third scale for the short waves, of 10-100 m.

### **Extending the Range**

It is to be remembered, too, that the ordinary listener, whose choice of programme used to be confined to European stations, has been given the opportunity to go beyond the European continent into the distant world, for the highly developed technical construction of the modern set has greatly extended the range of medium waves, the maximum of which used to be 1,000-2,000 miles. A good set today allows the English listener, at least during the winter months, to pick up low-power stations in North and South America without even owning a short-wave receiver.

All the wireless papers regularly publish reports of winter-time reception in all parts of England of foreign stations on the medium wave band, and this enlargement in the choice of programmes has attracted large numbers of English listeners. In the U.S.A. during the last few years many groups and associations

### **Advantages of Membership**

- |   |   |
|---|---|
| (1) No enrolment or membership fees.  | (6) Members in same district placed in touch with one another when desired. |
| (2) Organisation centred in <b>Great Britain.</b>   | (7) Special meetings and visits to be arranged.                             |
| (3) Standardised log-books and verification sheets and badges available for members at reasonable prices. | (8) Monthly problems for short-wave listeners.                              |
| (4) Monthly report in "Wireless Magazine."  | (9) Members' competitions and numerous other advantages to be announced.    |
| (5) Interchange of ideas with fellow members.   |   |







The short-wave listeners' clubs all over the world have tried to keep their members well informed of any such changes by regular publication of these items of news. Their attempts have been mostly quite successful.

Those who do not know the publication will find valuable help in the regular bulletins of the American Department of Commerce, which publishes under the title "World Short-wave Radiophone Transmitters" an excellent survey of all the short-wave stations. These lists, the price of which is extremely low, give a complete geographical list of the stations and a frequency list from 1,510-40,100 kilocycles and other valuable help to the short-wave enthusiast.

### Very Valuable Publication

They quote the identification signals of the important transmitters, an alphabetical and a numerical index in six different languages, which should be of great help in identifying stations, while the Bureau of Standards has contributed valuable maps of the approximate ranges of radio waves throughout the frequency range. These publications also contain a time-zone chart of the world, a list of international call letters, and a schedule of radio emissions of standard frequency. No other publication of such a comprehensive kind exists for the short-wave listener.

Unfortunately, however, the best identifications of the different stations and the most accurate reports to the transmitting companies concerned are of little use if you do not get a reply. Just as the sportsman goes shooting for the excitement's sake and treasures nothing more than the antlers of his quarry, so a short-wave enthusiast treasures the "verification cards" which reward him for the stations he has managed to pick up on his daily hunt.

## BRITISH LONG DISTANCE LISTENERS' CLUB

### Enrolment Form

I wish to enrol my name as member of the British Long Distance Listeners' Club, it being clearly understood that no financial obligation is thus incurred. I am interested in long distance listening and <sup>have</sup> ~~have not~~ a short-wave receiver at present in use. I am especially

interested in { <sup>medium-wave\*</sup>  
short-wave  
ultra-short wave } listening.

Full Name (Block letters).....

Address .....

\* Strike out words not needed.

### Optional

Please forward me..... pads of 50 log-book sheets price 1s. 6d.

.....badge price 1s. each

.....pads of 50 verification forms price 1s. 6d.

for which I enclose cheque  
postal order for £.....

## THIS MONTH'S PROBLEM



The B.L.D.L.C. is anxious to ascertain the extent to which certain of the listed short-wave stations are received in this country. It is thought that members may care to have the stations named as "problems" for reception each month. We, therefore, ask our readers to listen to the stations listed below. Please observe the transmissions of these stations as exactly as possible and send us your reports. Your observations will be published in the earliest possible issue of "Wireless Magazine."

This month we ask for reception reports of the following stations :

- (1) **Khabarovsk** RV15 70.2 m. (4,273 kc/s) or 70.65 m. (4,250 kc/s) transmitting in Russian from 6 a.m. till 2 p.m.
- (2) **Singapore (S.S.)** ZHI 49.85 m. (6,018 kc/s) or 49.90 m. (6,010 kc/s) transmitting Mondays, Wednesdays, Thursdays from 11 p.m. till 1.30 a.m. Sundays from 3.30 a.m. till 5.10 a.m.
- (3) **Suva (Fiji)** VPD 22.94 m. (13,075 kc/s) transmitting daily from 6.30 till 7.30 a.m. except Sundays.

In cases where no reception could be registered a report on this fact is just as useful to us as the report of a very fine reception.

Please address your letters to :

**The Secretary,**  
British Long Distance Listeners' Club,  
8-11 Southampton Street,  
Strand, W.C.2.

Ever since short-wave transmissions have existed, it has been international good manners and custom to confirm the report of a reception by a so-called QSL card. The voluntary work done by a listener (and listening-in for hours and sometimes for days in the hope of getting new stations is strenuous work) was thus rewarded. After the private broadcasting stations which had introduced the practice were superseded by commercial and government stations, we noticed with pleasure that these intended to carry on the old polite custom of QSL cards.

The service done to the transmitters by listeners in all parts of the world through their regular observations cannot be valued too highly. Only in this way is it possible for the transmitting stations to ascertain the effective range of their programme. Unfortunately, however, it has been noticed lately that a certain number of stations have stopped acknowledging reports sent in to them, even when international reply coupons have been enclosed to cover the postage of the verification cards.

### Unanswered Reports

Those who know how thousands of listeners write every month can well reckon the amount of money thus thrown away and it seems high time that an end should be put to this scandal. We would therefore suggest that the B.L.D.L.C. should be informed of those stations which do not reply to reception reports when an international reply coupon is enclosed.

If complaints about such stations accumulate, the management of the B.L.D.L.C. will make an official inquiry as to whether an acknowledgment of the receipt of such reports is to be expected or not. Should the reply be unsatisfactory, then these stations will be "black-listed" and the short-wave enthusiast's own interests will demand a cessation of reports to them. To avoid any misunderstanding it must be mentioned now that a number of commercial stations—for example, the transmitters of the Transatlantic Telephone

Please turn to page 399

Five New Studios at  
Maida Vale



Henry Hall's Band to  
be Enlarged?



Progress on the New  
High-power Regionals



Leslie Bridgewater Joins  
the B.B.C. Staff

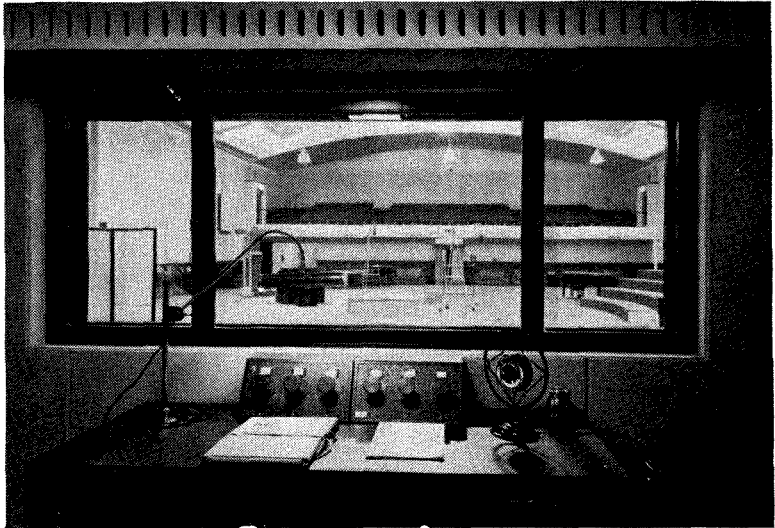

A view of the largest of the five new B.B.C. studios at Maida Vale as seen through the window of the control room

# News from the B.B.C.

AT the time of writing there is no concrete news about the Christmas programmes. The only scrap of concrete news is that the B.B.C. hopes to relay a message by His Majesty on Christmas Day. That sentiment, I am sure, is expressed by us all. In fact, I cannot imagine, nor do I want to, Christmas afternoon without that homely message from the head of the world's greatest family.



You will have seen in the daily papers that the B.B.C. has now put into service the five studios built *inside* a disused skating rink at Maida Vale. On the face of it, such a statement may not seem to warrant any fuss, but everyone who has been in close contact with broadcasting and has seen it grow cannot but realise the immense relief that will be felt by those responsible for studio arrangements at Broadcasting House.

B.H. has never been big enough for the B.B.C. staff, not even on the day it was opened; the people who designed the building never realised that broadcasting would grow with such leaps and bounds as it has done in the past few years. Today, various departments are housed in private houses and office buildings all round the big house.

I was one of a privileged party to be shown round Maida Vale before it was put into full use. A little way back I said "*inside* a disused skating rink." The five studios at Maida Vale have been built inside the old building without disturbing the original walls and roof, each studio forms an entirely separate structure built of

By T. F. HENN

brick and extending from the clay sub-soil up to just underneath the steel framework of the original building.

Actually they are buildings within a building!

As I walked round I could not help thinking how ideas of studio design have changed even since Broadcasting House was built. I believe I am right in saying that these five Maida Vale studios are larger than any at Broadcasting House, save for the Concert Hall and the military-band studio on the top floor. Studio One is the largest broadcasting studio in the world; it is big enough to house the whole B.B.C. Orchestra of 119 players together with a huge chorus and an audience of a couple of hundred people.

Two of the other studios are suitable for large orchestras, the floor area of each being about 30,000 sq. ft. Studios 4 and 5 are somewhat smaller, being intended

for small orchestras and dance bands—Henry Hall has taken possession of one of them. Special care has been taken with decoration and acoustical properties; the largest studio has an "echo" of two seconds, which should do much to avoid that nasty deadness that I, at any rate, have come to associate with British broadcasting.



Talking of Henry Hall reminds me that Eric Maschwitz promised as part of his autumn plans for brightening dance music that we should no longer have ninety minutes' music by one band. I inquired why the promise had not been carried out and whether it was to be carried out later on.

Apparently the time between now and the New Year is a period of preparation and experiment, but



An old radio favourite, Will Hay, the Schoolmaster Comedian



Associated Talking Pictures will release the film "Midshipman Easy" early in the New Year with Hughie Green, of radio gang fame, as the star. Midshipman Easy—Captain Marryat's immortal story of the glorious days of Nelson—is a Basil Dean production directed by Carol Reed. Hughie Green is seen in this scene from the film on the left

things are going to happen in the New Year. I did hear that the B.B.C. was to form another dance orchestra. This rumour has been current before and, frankly, I did not attach much importance to it.

It is, though, very probable that the B.B.C. dance band will be enlarged quite substantially. If I remember rightly, when the B.B.C. band was formed some three years or so ago, it consisted of fourteen members; now it consists of seventeen, excluding Mr. Hall and the manager-announcer. Actually this is quite a small number for a leading dance band; Jack Hylton has over twenty, I think, and Ambrose nearly as many.

I believe that the powers are toying with the idea of increasing the personnel of the B.B.C. band, so that they can then apply the division-system as is done with the Symphony Orchestra. "You are listening to Henry Hall directing Section B of the B.B.C. Dance Orchestra" sort of thing!

Now we have got to wait until 1936 to see just what is going to happen.



The time for the opening of Northern Ireland Regional is getting very near; it should be heard testing soon after Christmas. It will be the first B.B.C. transmitter to make use of the single-tower aerial. The aerial consists of a lattice tower—there is no actual aerial wire—and its major asset is that it counteracts fading and produces a strong ground wave. In London, at the moment, we hear nothing of Belfast worth talking about, and the other Irish station, Athlone—a 50-kilowatt—is little use after dark. It will be very interesting, and instructive, to see

how the performance of this latest B.B.C. venture turns out.

In Scotland, work on the new North Scottish Regional at Burghead, near Elgin, is going along to schedule. The roof is already on; this does not sound too important, but it does mean that in spite of the winter, the work of installing the Diesel engines, generators and transmitters can be undertaken without setback.

At Bewclay Farm, near Corbridge, 15 miles west of Newcastle, the site is being cleared ready for work to begin on the new North Eastern Regional. This might be ready for service late next year, but it is very doubtful.

I am a trifle hard-headed and still think that there is something wrong with this policy of erecting high-power stations to serve large areas. What is needed is a number of smaller stations, not necessarily relays in the sense of a transmitter with a power of .25 or .5 kilowatt, but 1- or 2-kilowatt stations to serve comparatively well-populated areas outside the recognised service areas of regional stations.

For instance, Thanet, and the South Coast between Folkestone and Portsmouth are almost off the map as far as British broadcasting is concerned. To my mind, the provision of a small transmitter in these areas, if only to relay the National programme, is a decided

necessity which should be considered by the B.B.C. The eastern districts round Norwich, too, are badly served, but I learn that some sort of relay may be provided in the distant future.



We have all enjoyed the delightful broadcasts by Leslie Bridgewater and his small orchestras. Now comes the news that he has joined the musical staff of the B.B.C. and is to handle outside relays of light music. His genius in light-music presentation should do much to ensure that listeners are provided with only the best. We wish him all the best of luck in his new position.

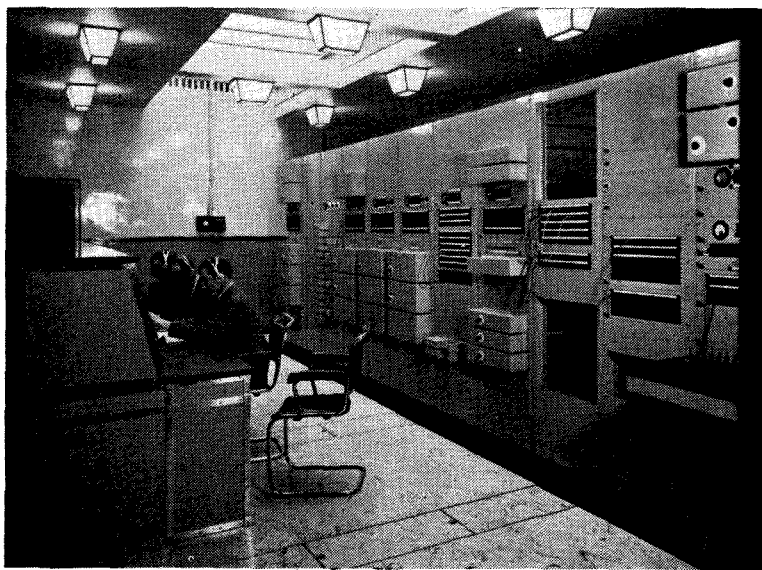

This is the control room at Maida Vale. All lines from the five studios and the steel-tape and disc recording rooms, which are also at the Rink studios, pass through this control before passing to Broadcasting House and thence to the transmitters all over the country



Designed by  
**PERCY W. HARRIS,**  
 M.I.R.E.

Here we present complete details of an entirely self-contained battery-operated electric gramophone that can be built easily in an evening. We hope to describe an A.C. model in a future issue of "W.M."

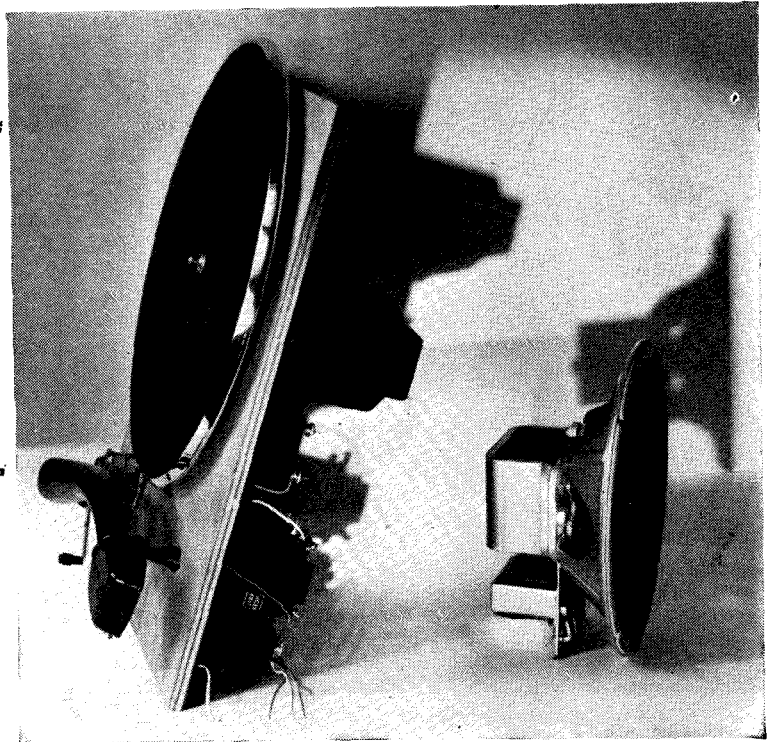

Lifted from the cabinet, the Electrogram is seen in its simplicity. All parts with the exception of the loudspeaker are accessibly mounted on the motor board

# The Harris Electrogram

First-class Gramophone Reproduction with the Minimum of Expense

AT the present time if you wish to obtain first-class electrical reproduction of gramophone records there are three possible ways. First of all, you can use the gramophone portion of a radiogram; secondly you can fit an electrical pick-up to your existing gramophone and take leads from it to the pick-up

terminals of a radio set; thirdly you can join the said pick-up to a special low-frequency amplifier. Yet it often happens that none of these are convenient.

Consider first the radiogram. You either have one or you haven't one. If you *have* one this article may not be of immediate application to you, but if you are one of the many thousands of people who possess a good wireless set without gramophone attachment, please read on. If your present set has pick-up terminals, I would like to ask you a plain question. Do you ever use the pick-up terminals and do any of your friends? I very much doubt it! I would be prepared to wager that 99 per cent of the sets built and sold with pick-up terminals are never used with pick-ups.

### Why They Are Not Used

There is more than one reason for a lack of interest in this pair of specially marked terminals. It is rarely convenient to shift a set once

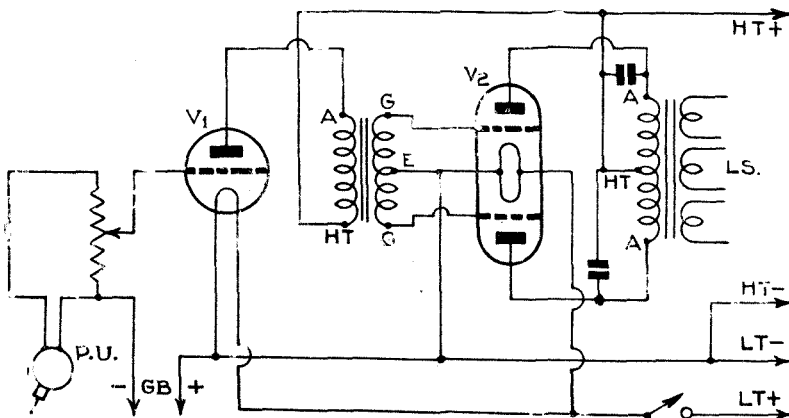

A standard class-B circuit is used. The volume control has a value of 50,000 ohms

You Can Build the Harris Electrogram in an Evening

## LAYOUT AND WIRING DIAGRAM

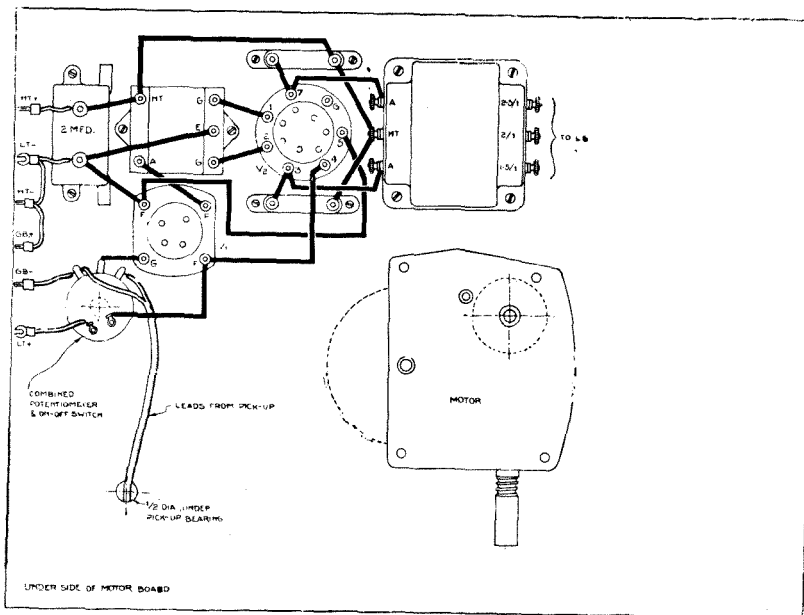
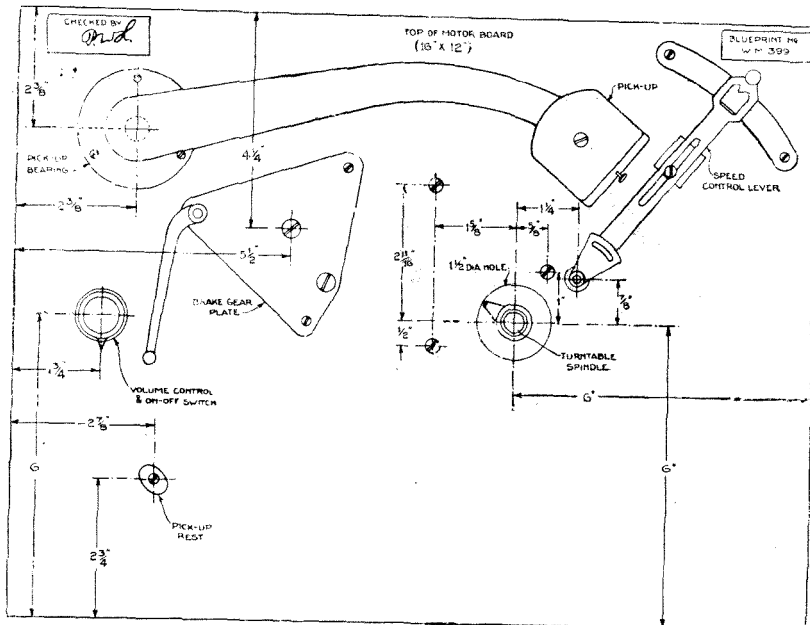

If desired a full-size blueprint of the Harris Electrogram can be obtained for half price, that is 6d., post paid, if the coupon to be found on the last page of this issue is sent with the remittance to the Publishers before December 31. Ask for No. WM399

it is suitably installed in the living-room, and it is still less convenient to place an ordinary gramophone in such a position that the leads from the pick-up to the pick-up terminals are not unduly long and unsightly. And long pick-up leads are bad, electrically as well as visually, being the frequent cause of hum and instability.

Even if you have indulged in the luxury of a special amplifier, designed for such work, such as that described in a recent issue by P. Wilson, M.A., you may have trouble in finding a corner of the room where the amplifier, loudspeaker, and turntable can be set without making the room "all untidy." "Have you got

to bring all *that* in here?" I can hear your wife saying, "Just as I have tidied up for the visitors. You men are a nuisance!"

Well, what are we going to do about it? I think the proper solution is to build a neat little electric gramophone which is no more unsightly than an ordinary wireless set, and occupies about the same space. Strangely enough few people have heard of this solution and many a man has built a complete new wireless set in the form of a radiogram so as to get the one advantage—unconnected with radio—not possessed by his previous instrument.

### Reasonable Price

There is no need to do this if you have a good wireless set at present, and by designing the Harris Electrogram without the complications and expense of an added wireless set, I have been able to make it very attractive from the point of view of cost.

It works splendidly, is readily portable, contains its own batteries, and gives a better reproduction than many expensive radio-gramophones. There are no trailing leads of any kind, and it can be carried from one room to the other with the greatest of ease. Volume can be controlled with precision and the normal wireless set is left entirely free for the purpose for which it was designed.

### Why It Was Designed

The idea for building this occurred to me one day when a friend was bemoaning the fact that he had no radiogram and was afraid he would have to build one. "But why?" I asked. "Your present wireless set works perfectly and gives you all you require from the radio angle, so why build a complete radiogram when the radio part will be no better than your present set: you really only require the gramophone part."

"Well, where is the design for one?" he replied "You give me the design and I'll build it!"

And so the Harris Electrogram came into being. The design work proved fascinating from the start because one had only to consider the reproduction of gramophone records and there were none of those wretched compromises which are so often the bane of the designer's life. Pick-up leads in the modern radiogram are rarely as short as the designer would like them to be, and almost invariably they have to go through a switching scheme which does not add to the efficiency. In the Electrogram the pick-up leads are as short as they possibly can be and go right where they are wanted in a circuit which has no other purpose.

This month the model is for batteries, as there are more battery set users than mains users at the present time. A standard, good quality, clockwork motor is incorporated and by the use of class-B amplification with a driver valve adequate undistorted volume is obtained at a very low consumption both of accumulator current and high-tension current. The constructional work could scarcely be simpler and as there are no coils and variable condensers to buy the complete cost works out remarkably low. In fact, the electrical portion of this apparatus is, roughly speaking, one half of the normal wireless set, and the cheapest half at that!

**Parts You Can Use**

While many readers will doubtless have all the parts required to build this without purchasing new components, there are many others who may require everything new and so full details are given of the parts

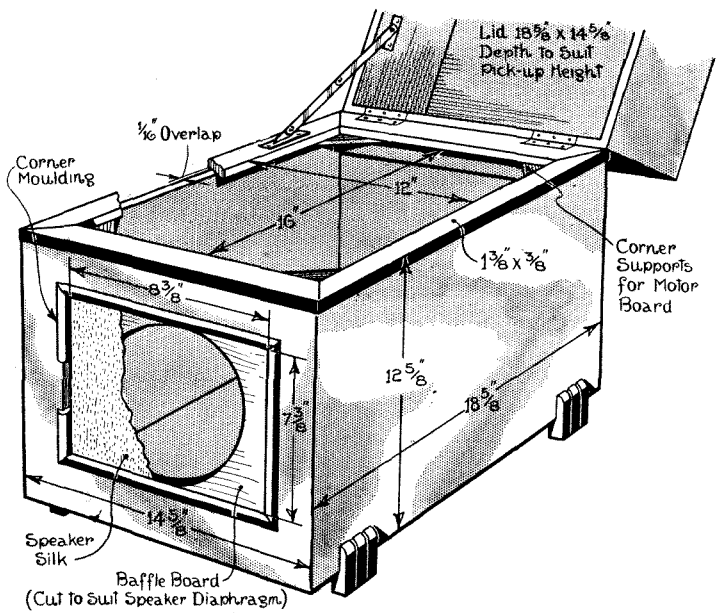

*A suitable cabinet design for the Harris Electrogram. Any of the cabinet manufacturers advertising in "W.M." will make this up for little cost, or the dimensions given will enable you to make it up at home quite easily and cheaply*

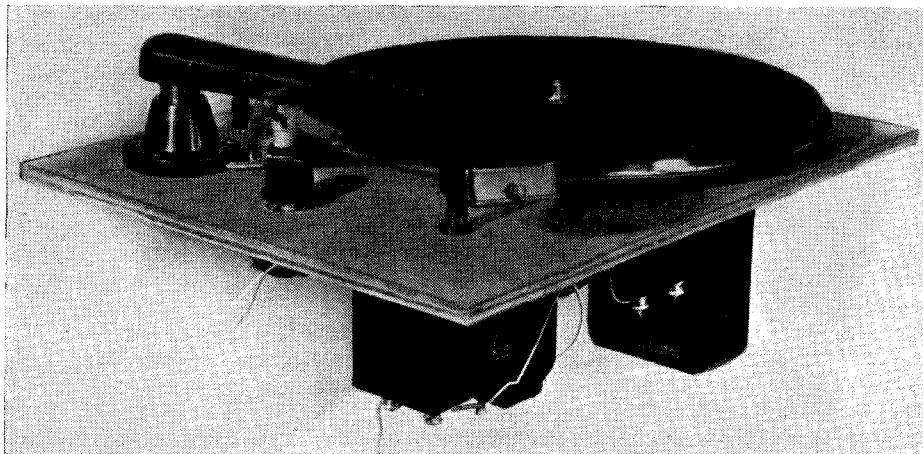

*A view of the upper side showing the turntable, pick-up and combined on-off switch and volume control. An automatic stop is fitted to the gramophone motor*

actually used in this set. There is, however, a wide choice available to you these days in high grade components, so that if you have any favourite makes you like to use you need have no hesitation in doing so. Remember, this design is worked out, first of all, with regard to its

efficiency, and although it may seem strange to you to see valves upside down in this set there is no harm whatever in their being placed this way and the simplicity of construction is greatly helped by so doing. It is, of course, necessary to use good quality valveholders and those specified suit admirably as they grip the valve pins securely.

**Short Pick-up Leads**

Notice how the leads from the pick-up go straight to the volume control and valve concerned.

There is, as you will notice, only one control in this set, an on-and-off switch, and a volume control combined. By adding to the complications and expense I could have provided one of those modern circuits and controls which enables either bass or treble to be accentuated or repressed, but this is scarcely necessary to-day when electrical recording is so well done. Tone control in most cases merely serves to reduce the amount of "top" in those few cases where records are unduly shrill or when the user likes



*Inverted, the motor board is seen to carry all the parts, including valves. Constructional work is particularly simple.*

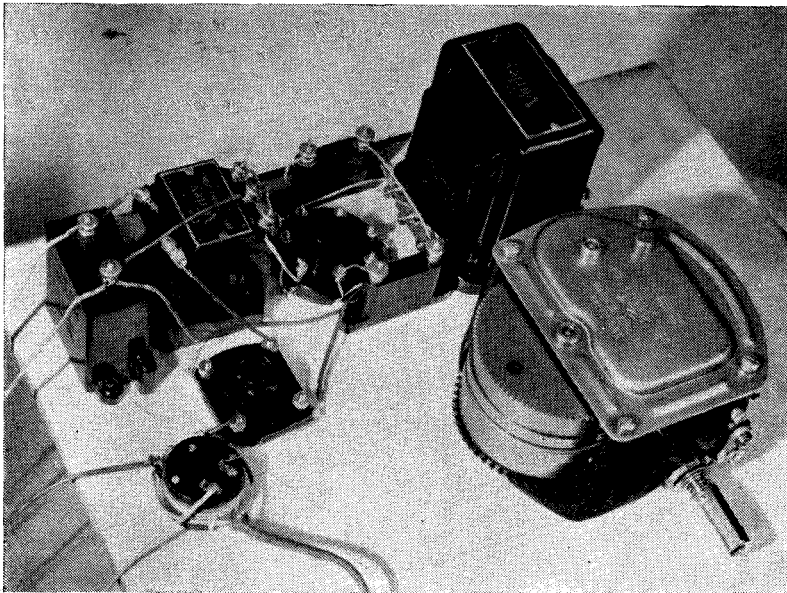

This photograph taken of the completed outfit, minus valves, will aid the constructor working from the blueprint

a little less top than the recording engineer has given him. In practically all cases you will want to use the full quantity of top provided by the record and pick-up.

### Simple Construction

Construction begins by taking the motor board and mounting the motor in the central position as shown, together with the automatic stop: particulars of fitting are provided by the makers. The pick-up is then installed, together with the combined on-off switch and volume control. The other parts are easily placed and wiring up is carried out by placing the motor board upside down on the table with the turntable beneath, just as if the underside of the motor board were the baseboard of an ordinary wireless set. While this is being done it will be found convenient to support the motor board on books or blocks of wood at each corner so as to keep the board quite steady.

### Connecting the Loudspeaker

When work on the motor board is finished the loudspeaker can be attached to the baffle and fastened in place in the cabinet. There are two leads from the loudspeaker, both of which can be made flexible, and attached to the output terminals of the output choke. Three other pairs of leads go respectively to the grid-bias battery, the accumulator and the high-tension battery, but as these three pairs are attached, together with their wander plugs

and spades, before the motor board is turned over, all that needs to be done after the loudspeaker has been fixed in position is to turn the motor board the right way up, lower it into the cabinet and connect up the leads as shown. There is scarcely more than an evening's work in the whole job and the superb results obtained will, I am sure, astonish you.

Two concluding notes: volume from the outfit described is equal to that of a standard portable gramophone. Those requiring still greater volume should substitute one of those pick-ups giving a large output, e.g., the Ediswan or Rothermel crystal type.

Instability: always a possibility with class B. I find it wise to connect suitable resistances (about 10,000 ohms) across each half of the driver transformer secondary. This is a positive preventative, and I suggest the constructor should adopt it.

## FROM HERE AND THERE

Following on the success of their model 98, Philco have now produced a smaller A.C. set on the same lines, which will be known as the Empire Six. The price of this new all-waver is only 17 guineas.

Exide inform us that they now have available a range of 19 different types of Drydex midget batteries for use with midget receivers. The range varies from an 18-volt type priced at 2s. to a 75-volt type at 8s.

Handisets, Ltd., of 21 Lime Street, E.C.2, has just introduced a midget portable receiver selling at the low price of £3 15s. The set is fitted with three Hivac midget valves, Drydex high-tension batteries, and an Exide jelly-acid accumulator. It is self-contained in an oak carrying case 9½ in. high, 5 in. wide, and 4 in. deep. Six stations can be received under normal conditions on the single headphone ear piece supplied.

Perhaps the most interesting point about the new set is that the high-tension consumption is only 1 milli-ampere.

"Interference Suppression" is the title of a 70-page book recently published by Belling & Lee, Ltd., of Cambridge Arterial Road, Enfield, Middlesex. The book deals with the causes and cure of electrical interference of almost every conceivable type, and no doubt any victim will get some consolation if he follows the methods of cure so ably explained by Mr. Lee and his Research Department in this undoubtedly fine shillingsworth. Copies can be obtained from the above address.

### LIST OF PARTS NEEDED FOR THE HARRIS ELECTROGRAM

	£	s.	d.		£	s.	d.
<b>CABINET</b>				<b>VALVEHOLDERS</b>			
See drawing and text				1—Benjamin four-pin	...	...	10
<b>CONDENSERS, FIXED</b>				1—Benjamin seven-pin	...	...	2 0
2—T.C.C. .001-microfarad, type 34	3	6		<b>VALVES</b>			
1—T.C.C. 2-microfarad, type 50	3	6		1—Hivac B230	...	...	10 6
<b>RESISTANCE, VARIABLE</b>				1—Hivac D210 or L210	...	...	3 9
1—Rothermel 50,000-ohm Radiohm with switch	4	6		<b>LOUDSPEAKER</b>			
<b>MOTOR</b>				1—Amplion Harmona	...	...	1 5 0
1—Garrard No. 30 clockwork motor with automatic stop	3	0	0	<b>BATTERIES</b>			
<b>PICK-UP</b>				1—Full O' Power 4.5-volt grid-bias	...	...	9
1—Garrard pick-up without volume control	...	...	...	1—Full O' Power 120-volt high-tension	...	...	10 6
<b>TRANSFORMERS</b>				1—Exide 2-volt accumulator, type DFG/C	...	...	9 0
1—Varley class-B input transformer, type DP40	...	...	11 6				
1—Varley class-B output transformer, type DP42	...	...	13 6				



By P. WILSON, M.A.

This is the first of a series of special articles in which Mr. Wilson will describe some novel circuits likely to have considerable applications in radio receivers of the near future. Like A.V.C. and Q.A.V.C. circuits, many of them are adaptations of principles that have been known to telephone engineers for a good number of years



Gulliland Photo.

Something new in sets and homes. The receiver is the new Telefunken "Heimklang"; it certainly looks ideal in the delightful setting of a modern German home

# Something New — Automatic Bass Compensation

IT is a commonplace that the aim of all sound reproduction, whether by means of broadcasting, sound film or gramophone record, is to create an illusion of reality; to simulate an original performance so closely that the listener can easily delude himself that he is listening to the real thing.

Ever since the telephone engineers made a science as well as an art of the business, investigations have been going on to find out what conditions have to be fulfilled for the illusion to be possible.

## No Simple Problem

The problem is not quite so simple as it may appear at first sight. It has not only involved a consideration of the physiological and psychological processes of hearing, but also a continuous refinement of methods of attack in order to avoid the physical limitations of the materials which the engineer has to use; and under this heading must be included such matters as reproducing conditions, ether congestion and price of apparatus as well as the more tangible materials of valves,

coils, resistances, etc. which the engineer can control directly.

It is perhaps not surprising, therefore, that the modern radio receiver, though more easily worked by the man-in-the-street, is becoming a much more intricate affair in its design than the cumbersome article with which most of us began our novitiate.

It is not so long ago that I used to pride myself on being able to read a circuit diagram as readily and as quickly as any expert musician of my acquaintance could read a musical score, but I have gazed in wonder more than once at some of the complicated tributes to the resistance-condenser manufacturers that many of the modern circuits seem to be.

Sometimes it becomes virtually impossible, especially if component values are not stated, to elucidate how a circuit will function unless the designer has given some hint of his object.

Take, for example, the circuit which I show in Fig. 1. It is an important new circuit which I hope to explain fully in a future article, since I believe that it is bound to

capture the radio receiver market just as A.V.C. did—or at any rate either this circuit will or something equivalent to it. It is simple in appearance yet I doubt whether more than one person in a hundred will be able to tell how it operates, even though they are given the hint that it is a control circuit for a self-tuning receiver.

## Solving the Reality Problem

This is but one illustration of a number of circuits that are being developed to deal with particular aspects of the reality problem which I mentioned at the beginning of this article. Many of these circuits are already in use in one form or another by the G.P.O. in its international telephony service, but their adaptation to commercial radio receivers, which are operated by Tom, Dick or Harry and in which the price factor is of pressing importance, presents problems of its own.

In subsequent articles I hope to describe a few of these circuits and to explain how they may be brought into service in radio broadcasting during the next few years.

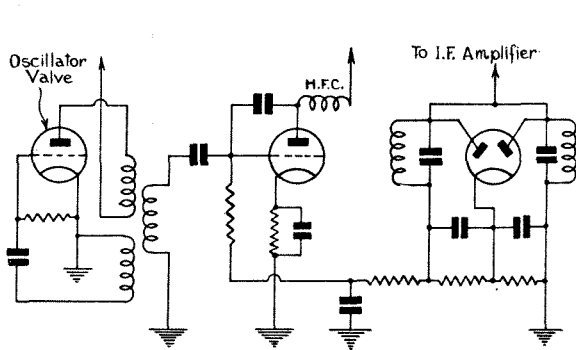

Fig. 1.—Can you discover how this circuit works? The author mentions it in his article and will describe how it works in a future contribution to this series

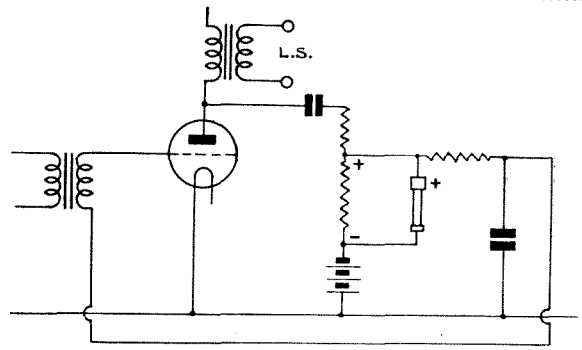

Fig. 3.—The Westinghouse battery economiser circuit is an example of a control voltage derived by rectifying a part of the audio output of a receiver

The one which I deal with in this article has already made its debut in one receiver in this country. At the moment I am not altogether happy about it, but I fancy that my doubts may be due to other features of the receiver which are irrelevant to the circuit in question.

### Straight-line Amplification

Readers are no doubt fully familiar by this time with the doctrine of straight-line amplification as it has been developed during the past decade. That doctrine asserts that for perfect reproduction all frequencies within the audible range should be amplified, or otherwise transmitted, in equal proportion.

That is to say, if any two frequencies are present in the original performance before the microphone in a certain ratio, then they should appear in the reproduction in that same ratio.

Put in this way, the doctrine seems to be so reasonable as to be almost self-evident. Unfortunately it doesn't happen to be true. There are certain limitations missing from the statement. Questions of binaural listening and room conditions have to be taken into account, and volume level is also important.

### An Easy Way Out !

In fact it seems that perfect reproduction could only be obtained in conditions which are so difficult to fulfil that it would be much easier for everyone to go and listen to the original performance !

The doctrine, however, though useless in itself, has served to point the way to securing a greater illusion of reality. Thus we can ask ourselves, and we can to some extent answer, the question : what departure from straight-line amplification is desirable if the volume level of the reproduction

is to be much less than the volume level of the original performance before the microphone ?

A similar question, though a much wider one than the former, is this : in what ways can the frequency response of the reproduction differ from that of the original before the ear either notices a difference, or in the last resort becomes dissatisfied ?

I do not propose at the moment to say anything about the second question beyond remarking that a very valuable clue is found in the fact that the frequency response of a performance varies according to the position of the hearer, and that the ear is not incomed by any frequency response in reproduction which it might have heard naturally ; but it is not tolerant of sudden discontinuities, whether these are caused by resonances or sharp cut-offs (e.g. those due to sharp band-pass tuning).

As regards the former question, there are two schools of thought. One of them says that the natural way of reducing the volume of sound which impinges on the ear from an original performance is to listen from a greater distance, and since treble notes carry farther than bass notes, therefore the treble should be relatively accentuated in a reproduction at lower volume than the original as it was picked up at the microphone.

The other school argues on opposite lines. They point out that when the volume level is reduced to living-room proportions without altering the relative strengths of the various frequency components, it is found that the music sounds thin, as though there were a serious deficiency of bass notes !

They say that this is only to be expected since the ear is much less sensitive to bass notes than it is to those in the 2,000-4,000-cycle region :

a million times as much energy is required to make a note audible at 50 cycles as at 2,000 cycles. From this they argue that in order to produce the effect of a true-tone balance at low volume levels it is necessary to over-amplify the bass relative to the treble.

Both schools, it will be observed, appeal to the Caesar of experience and to Caesar accordingly they must go. Although hitherto I have myself rather tended to the first school and have deliberately arranged in my amplifiers for a response increasing with frequency, I can well imagine

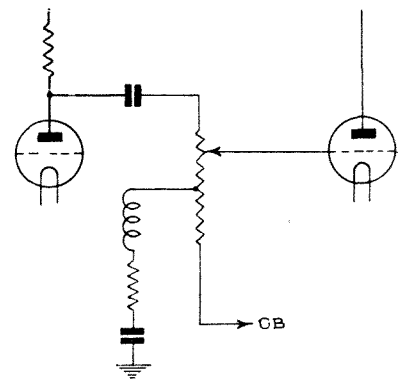

Fig. 2.—Tapped potential divider used to provide tone-compensated volume control

that there may be some virtue in a response rising in the lower bass by an amount varying inversely as the volume level, provided that the difficulties occasioned by bass resonances in loudspeakers and by room reverberation can be avoided.

Thus, a compromise between the two schools might be effected by having a bass response varying with volume level superimposed on a response rising with frequency.

The various alternatives are certainly worth trying.



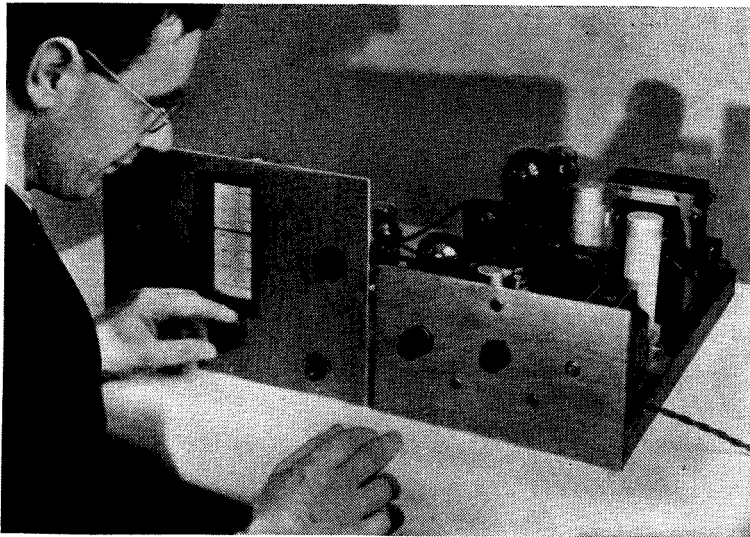

Designed by L. O. Sparks  
and T. F. Henn

In the September and November issues of "W.M." our contributors described the construction and operation of a 5-watt A.C. amplifier and a two-valve radio unit, which when used together form the ideal high-power local-station receiver. In these notes a few final instructions are given to ensure that every constructor is getting the best from his outfit

## Putting the Finishing Touch to Your Radio Unit and Amplifier

BY now most builders of the Listener's Amplifier and its Radio Unit will have reached the stage where the outfit is hooked up and working. We gave fairly exhaustive details last month about connecting up and there really should be no need to cover the ground again.

One reader has written saying that he would like to use the more familiar horizontal full-vision scale in preference to the vertical type we have used. The alteration is quite permissible and we recommend the Polar type; the panel will have to be wider, though he may save a matter of an inch or so in depth.

We explained fully last month the method of connecting the unit to the amplifier, and little further comment is required. Don't forget to earth the metallised braiding covering the two leads from the gramo-radio switch on the panel of the Radio Unit to the potentiometer and jack on the control panel of the amplifier. In some cases it may not be necessary, while in others some advantage may be gained by covering the lead from the 100,000-ohm resistance to the gramo-radio

switch (on the unit) with metallised braiding also; we found this latter precaution entirely unnecessary.

Ganging is quite a simple job of work, though it is surprising how few constructors can do it really thoroughly. We found that the coils and condenser gang up especially well provided the task is carried out with the normal amount of care.

A millimeter in the anode circuit of the Osram MH4 detector valve is the surest indication, though a good ear will serve the purpose almost as well. If a millimeter is used it should be preferably read from 0 to 5 milliamperes, though a 0-3 type can be used; the anode current of the detector valve being about 2 milliamperes.

The procedure of ganging is to tune in a station, preferably not the local, round the 300-metre mark; then adjust the trimmer farthest away from the panel until the signal is at its loudest—don't forget to make a slight backward and forward movement of the tuning control to ensure that you *are* tuning dead on the station—or the millimeter needle is at its maximum dip.

After this adjust the other two trimmers in a similar

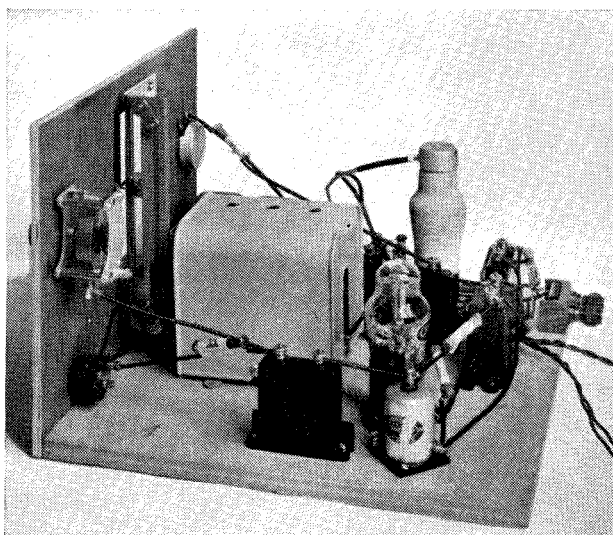

A photograph showing the "output" side of the Radio Unit. The leads from the gramo-radio switch should be covered with metallised braiding



# A Cabinet for the Radio Unit and Listener's Amplifier

Here are two designs for a cabinet to house the Listener's Amplifier and Radio Unit. All the dimensions are given so that enthusiastic carpenters can build their own; alternatively any cabinet maker would build one for a moderate sum

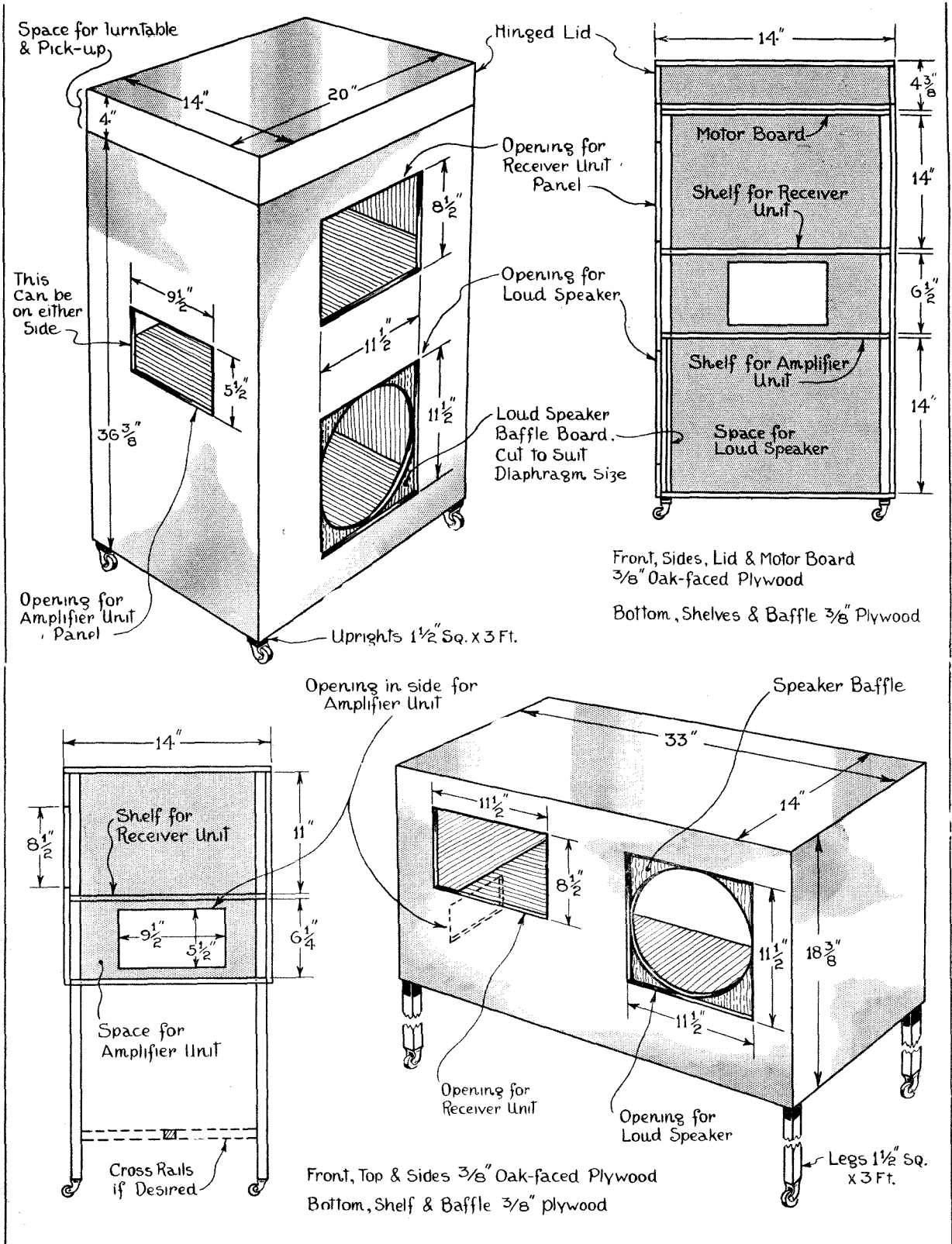

fashion for the loudest signal or maximum dip of the meter needle. A check on the ganging should be made at the top end of the scale around 500 metres, after which a further check around 370, to make sure that everything is just right, would not be amiss.

On no account take the trouble to gang up on the long waves; one cannot get the extreme accuracy necessary to hold good for the medium waveband.

Actual operation of the controls on the unit and amplifier needs little explanation. It is better to set the amplifier controls to suit your pick-up reproduction, then these can "stay put" when the outfit is switched over for radio. If more volume is required than is possible to get with the volume control and the reaction control on the unit at their maximum settings, then the amplifier volume control can be brought into use.

As a matter of fact we found in our tests that if the

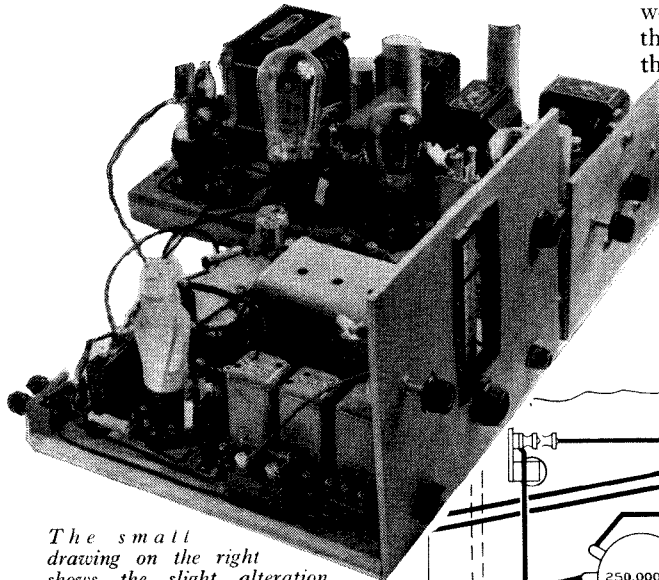

*The small drawing on the right shows the slight alteration necessary to the wiring of the amplifier panel, and the two leads to the switch on the panel of the Radio Unit. Note that only one wire is removed*

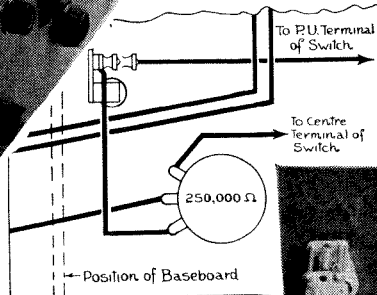

amplifier controls were set to give us the best results from gramophone reproduction, we could forget them entirely when listening to broadcast. Here in London both London National and Regional could be logged at almost full volume with the amplifier volume control at the half-way position, the reaction control on the unit at zero and with plenty to spare on the unit volume control.

### Effect of Adding a Tweeter

Our listening tests, indeed, proved that the combined outfit was the ideal powerful local-station set, yet we had no difficulty in tuning in some ten or twelve foreign programmes as alternatives. Since last month we have tried adding a Rothermel tweeter loudspeaker and the effect on reproduction certainly warrants us recommending others to do the same. The tweeter adds that "bite" to trumpets and violins and women singers, and makes one sit back and feel very proud of his work.

Even on the long waves, where a number of sets cut off high notes, the effect of the tweeter was noticeable, though whether it is worth while when playing gramophone records is a matter of personal taste. The tweeter

rather emphasises the scratch, and whilst we were quite prepared to put up with the hiss, we realise that a number of listeners would prefer to be without it.

There is one point we would like to mention concerning the aerial. We have arranged for two aerial terminals on the radio unit. One gives a direct lead to the aerial coil, and the other via a .0003-microfarad condenser. Those living outside an area of about ten or twelve miles from a Regional station will find that adequate selectivity is obtained using the terminal giving the direct lead to the coil, though if their aerial is of the old-fashioned 50-ft. high, 100-ft. long type, probably better results will be obtained with the other tapping.

### Iron-core Coils and Good Selectivity

Those who are situated close to a B.B.C. station will find the series condenser of some help. Actually we were highly delighted with the selectivity given by the three Wearite coils and this is no doubt due to the fact that they are of the iron-core variety. Selectivity is such that with a 60-ft. outdoor wire we were able to get Hamburg on 331 metres quite clear of the Regional, and even better selectivity was obtained if we used the old dodge of maximum reaction and minimum high-frequency gain, though this method is apt to spoil the quality somewhat.

We could not find a standard cabinet to house both amplifier and unit, and rather than fix on one design we have passed our suggestions for a radio-gram cabinet, and for another for those who want radio only, to the "W.M." draughtsman, asking him to produce drawings to enable the handyman to build his own.

Cabinet manufacturers who advertise in this journal, not forgetting Peto-Scott, would willingly make one or the other for quite a modest sum.

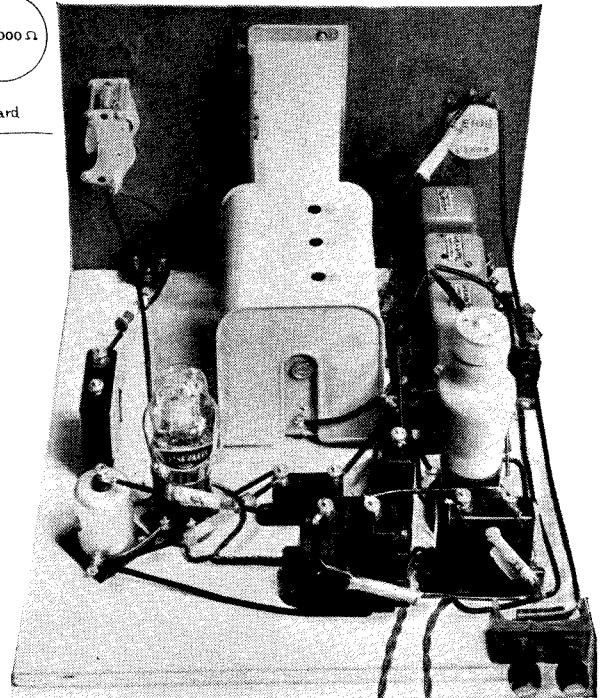

*The constructional design of the Radio Unit is so simple that any ordinary amateur can build it in the course of an evening*

# How Loudspeaker Cones Are Made

*Describing the H.M.V. Moulding Process*

**M**OST people, when they see a modern radio receiver in a shop window, do not realise the great care that is taken during manufacture to ensure the purest possible quality of reproduction. At the H.M.V. factories at Hayes, Middlesex, many delicate processes are entailed in the production of pure tone, and one of the most interesting is the making of loudspeakers.

Obviously, the most important part, as far as acoustic efficiency is concerned, is the cone. It is of the greatest importance that this should be of the correct weight and thickness, and that it should not warp when subjected to varying atmospheric conditions. To meet these requirements, H.M.V. has developed a process whereby the cone, instead of being made by merely folding a paper sheet, is made in one piece direct from pulp.

**T**he exact quantity of pulp required to make one cone is measured out and spread over a rough gauze mould. The greater part of the water in the pulp is then removed by suction, leaving the pulp evenly spread over the mould. After this rough shaping, both mould and pulp are placed on a centrifugal spinner, which revolves it at 1,000

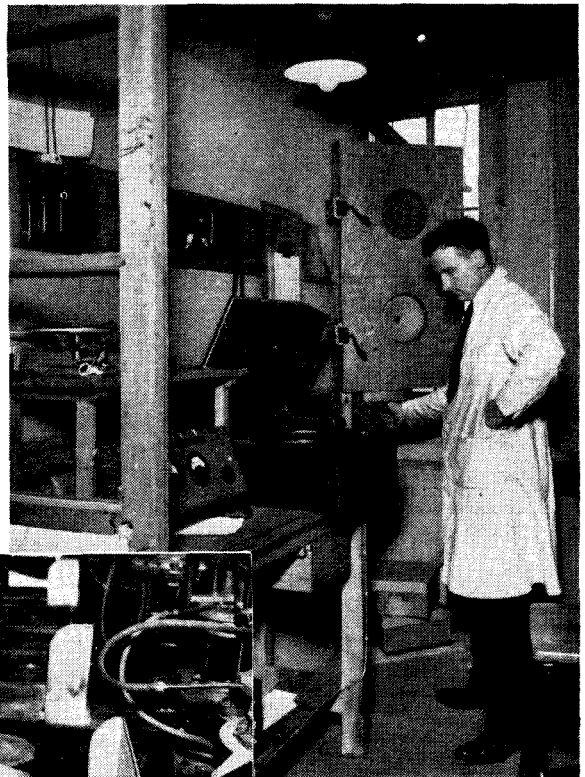

*The final test for every H.M.V. loudspeaker consists of comparing its quality with a standard test speaker of known performance*

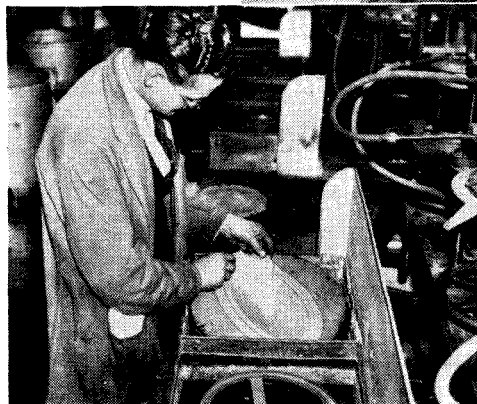

*Removing a cone in a soft state from a centrifugal spinner; this removes excess water and spreads the pulp evenly*

revolutions per minute. The centrifugal force has the effect of throwing out all the water and spreading the pulp evenly over the surface of the mould.

The soft cone is then transferred to a press, where it is subjected to a blocking process similar to that used in the manufacture of bowler hats. The tremendous heat of the press reduces the thick pulpy form down to a closely woven cone of the desired thickness.

**T**he cone then passes through a series of tests as to its fibrous structure, porosity, weight, and thickness. The thickness of the cone has to be accurate within three thousandths of an inch, and the weight within one-fiftieth of an ounce.

After being sprayed with shellac varnish and re-

*Continued Overleaf*

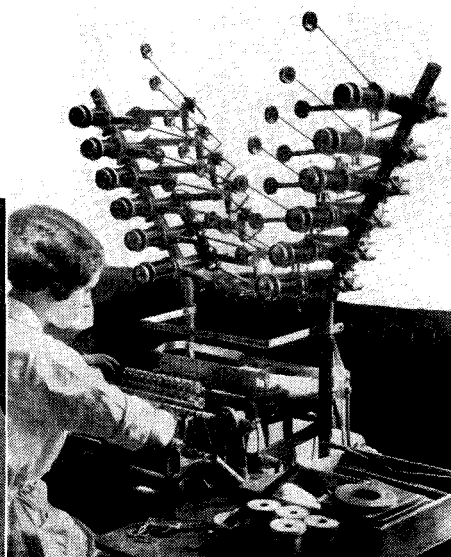

*(Above) A high-speed machine winding energising coils for H.M.V. loudspeakers. (Left) The thick pulpy cone is subjected to a "blocking process" which reduces it to a closely woven material of the correct thickness and weight*

Compiled for "W.M." by JAY COOTE

## The "W.M." Short-wave Identification Panels

**Metres: 29.04 RUYSELEDE (ORK) Kilocycles: 10,330**  
(Belgium)  
**Power: 9 kw.**

**Geographical Position:** 03° 20' 06" E; 51° 04' 52" N.  
**Approximate Distance from London:** 158 miles.  
**Standard Time:** Greenwich Mean Time.  
**Languages:** French and Flemish.  
**Announcer:** Man.  
**Call:** " Ici Bruxelles I.N.R., Emission spéciale pour le Congo Belge par la station de Ruyselede ORK."  
**Times of Transmission (G.M.T.):** Daily, 17.30-19.00.  
Closes down with the playing of the Belgian National Anthem, *La Brabançonne*.

**Metres: 29.24 BANDOENG (PMN) Kilocycles: 10,260**  
(Java, Netherlands East Indies)  
**Power: 3 kw.**

**Geographical Position:** 137° 36' 01" E; 07° 06' 48" S.  
**Approximate Distance from London:** 6,750 miles.  
**Standard Time:** G.M.T. plus 7 hours 20 minutes.  
**Languages:** Dutch and English.  
**Announcer:** Man.  
**Call:** " Hier Bandoeng " (Java).  
**Interval Signal:** Three notes (reed tones).  
**Times of Transmission (G.M.T.):** Daily 13.45-15.00. Sundays 08.30-10.30.  
The last item of the programme is a gramophone record, *The End of a Perfect Day*, followed by good-night greetings in English, and in Dutch: " Goeden Nacht, en wel te rusten."

### BUDAPEST-SZEKESFEHÉRVAR (Hungary)

Call:	Metres:	Power:	Kilocycles:
HAT4	19.52	6 kw.	15,370
HAS3	32.88	6 kw.	9,125
HAT2	43.86	6 kw.	6,840

**Geographical Position:** 18° 24' 00" E; 47° 09' 40" N.  
**Approximate Distance from London:** 903 miles.  
**Standard Time:** Central European (G.M.T. plus 1 hour).  
**Language:** Magyar; occasionally English and French.  
**Announcers:** Man and woman.  
**Call:** " Hallo! itt Radio Budapest " (also frequently in French, German and English).  
**Interval Signal:** Nine chords, as Budapest medium-wave station.  
**Times of Transmission (G.M.T.):** 14.00-15.00 (Sundays), on 19.52 metres. 23.00-24.00 (Sundays), on 32.88 metres or 43.86 metres. Closes down with the call repeated in several languages, followed by the Hungarian National Anthem.

**Metres: 49.67 MIAMI BEACH (W4XB) Kilocycles: 6,040**  
(Florida)  
**Power: 2.5 kw.**

**Geographical Position:** 80° 08' 25" W; 25° 48' 45" N.  
**Approximate Distance from London:** 4,430 miles.  
**Standard Time:** Eastern Standard Time (G.M.T. less 5 hours).  
**Language:** English only.  
**Announcer:** Man.  
**Interval Signal:** Three notes, when relaying N.B.C. programmes.  
**Call:** " You are listening to W4XB, relaying Miami Beach, the Wonderful Isle of Dreams."  
**Times of Transmission (G.M.T.):** 17.00-19.00; 22.30-05.00 (weekdays). 16.30-20.00; 22.00-05.00 (Sundays).  
Relays W10D, Miami Beach and the N.B.C. programmes from New York and other cities.  
**Closing words:** " A Happy Good-night, and God Speed."

## How Loudspeaker Cones Are Made

Continued from previous page

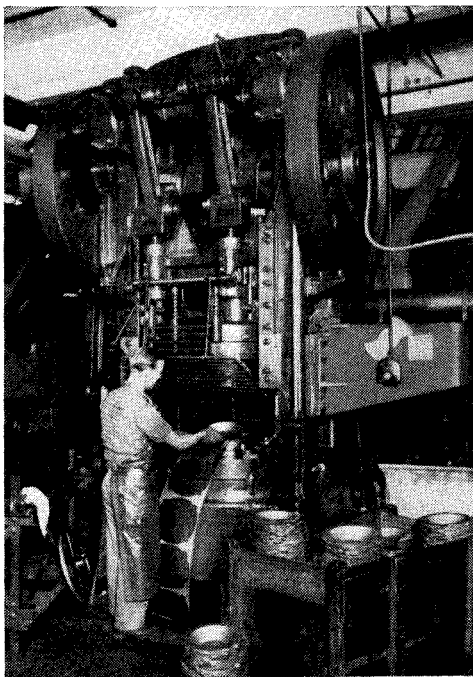

The huge press used at Hayes for making the metal cone chassis for the speakers (Right) Where H.M.V. sets and loudspeakers are made; the works at Hayes—the largest radio factory in the British Empire

tested, the cone is ready for mounting on to the loudspeaker chassis. In the case of the " Duo-diffusion " loudspeakers used in the H.M.V. High-fidelity instruments, a special aluminium cone is fixed to the centre of the main cone. At least twice a day a cone is taken from every batch and sent to the research laboratories, where it undergoes exhaustive tests of its mechanical properties.

The exciting coil for the magnet consists of 73 layers of wire interleaved with paper. In all, 22,000 turns of wire are wound

on each coil, representing roughly 3 miles of wire.

When the loudspeaker is complete it is given a final listening test; each loudspeaker is compared with a standard one, for which performance curves have been plotted and checked at regular intervals. The test is carried out in a soundproof room and a special record is employed containing a variety of musical passages, speech and constant-frequency notes. Each loudspeaker tested has to be not merely as good as, but better than the standard speaker.

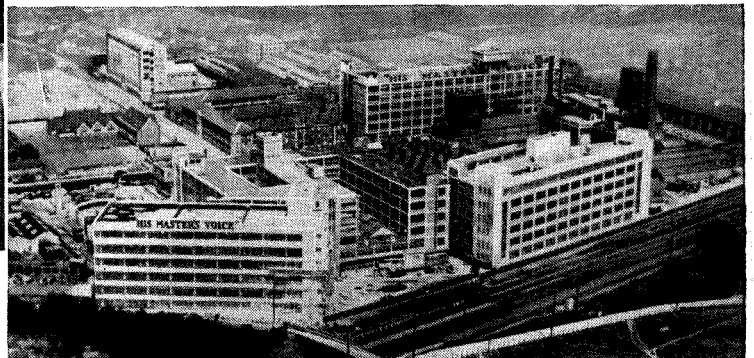

## "W.M." Short-wave Data Sheets—No. 2

# International Call Letters

Interest shown by ordinary listeners in the reception of short-wave broadcasts is steadily increasing, and "W.M." intends to foster this hobby and to do all in its power to assist the listener to get the very best results. It is worth while learning a few of the more important call-sign rules, in order that one may be able to recognise the country of origin on hearing the call of the station concerned. The simplest and most helpful rule is that in all the standard-form call-signs, consisting of three to six letters or one or more letters and one or more numbers, the initial letter or letters gives the key to the nationality of the station. A list of these key letters will be found below

Call Letter	Country	Call Letter	Country	Call Letter	Country
CA to CE	Chile	LA to LN	Norway	TS	Saar Basin
CF to CK	Canada	LO to LV	Argentina	UH	Hedjaz
CL to CM	Cuba	LZ	Bulgaria	UI to UK	Netherland India
CN	Morocco	M	United Kingdom	UL	Luxembourg
CP	Bolivia	N	United States	UN	Yugoslavia
CR	Portuguese colonies	OA to OB	Peru	UO	Austria
CS to CU	Portugal	OH	Finland	VA to VG	Canada
CV	Rumania	OK	Czechoslovakia	VH to VM	Australia
CW to CX	Uruguay	ON to OT	Belgium and colonies	VO	Newfoundland
CZ	Morocco	OU to OZ	Denmark	VP to VS	British Colonies
D	Germany	PA to PI	Netherlands	VT to VW	British India
EA to EH	Spain	PJ	Curacao	W	United States
EI	Irish Free State	PK to PO	Netherland India	XA to XF	Mexico
EL	Liberia	PP to PY	Brazil	XG to XU	China
ES	Estonia	PZ	Surinam	YA	Afghanistan
ET	Ethiopia	RA to RQ	Russia	YH	New Hebrides
F	France and colonies	RV	Persia	YI	Iraq
G	United Kingdom	RX	Panama	YL	Latvia
HA	Hungary	RY	Lithuania	YM	Danzig
HB	Switzerland	S	Siam	YN	Nicaragua
HC	Ecuador	SA to SM	Sweden	YS	Salvador
HH	Haiti	SP to SR	Poland	YV	Venezuela
HI	Dominican Republic	SU	Egypt	ZA	Albania
HJ to HK	Colombia	SV to SZ	Greece	ZK to ZM	New Zealand
HR	Honduras	TA to TC	Turkey	ZP	Paraguay
I	Italy and colonies	TF	Iceland	ZS to ZU	Union of South Africa
J	Japan	TG	Guatemala		
K	United States	TI	Costa Rica		

## BUREAU OF STANDARDS CALIBRATION SIGNALS

THOSE who wish to calibrate their short-wavers accurately may note that the American Bureau of Standards station WWV at Beltsville, near Washington, puts out some very useful signals twice a week.

Tuesdays and Fridays are the days, and the actual radiations are as follows: from 5 to 6 p.m. (G.M.T.) signals on 15 M/c (20 metres); from 6.15 p.m. to 7.25 p.m., 10 M/c (30 metres); from 7.30 p.m. to 8.30 p.m., 60 metres.

To quote the official description: "The emissions consist mainly of continuous, unkeyed carrier frequency. . . . For the first five minutes the general call (CQ de WWV) and the announcement of the frequency are transmitted. The frequency and the call letters of the station (WWV) are given every ten minutes thereafter.

"The accuracy of the frequencies transmitted is at all times better than a part in five million. From any

of them, using the method of harmonics, any frequency may be checked."

The Bureau of Standards desires to receive reports on reception of these emissions. The data desired are approximate field intensity, fading characteristics, which of the three frequencies is received best, and the suitability of the signals for frequency measurements.

It is suggested that in reporting on intensities, the following designations be used where field intensity measurement apparatus is not used: (1) hardly perceptible, unreadable; (2) weak, readable now and then; (3) fairly good, readable with difficulty; (4) good, readable; (5) very good, perfectly readable.

Statements are desired as to the intensity of atmospherics and as to whether fading is present or not, and if so, its characteristics, such as time between peaks of signal intensity. Correspondence should be addressed to National Bureau of Standards, Washington, D.C.





# Fault Finding— Old and New

By G. P. KENDALL, B.Sc.

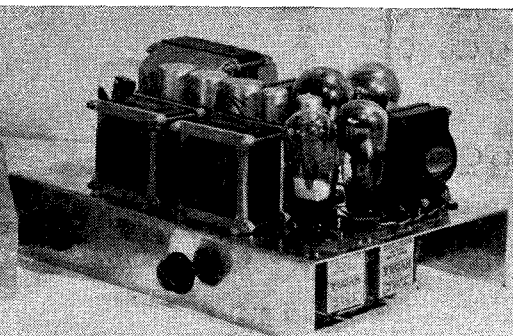

WHEN it was suggested that I should write a fault-finding article for the Christmas number (Query: Did they think it was a seasonable subject, I wonder?) my first impulse was to object that the topic had been written to death already; on reflection I had to admit that the situation has changed a good deal in recent years, and that it is perhaps time to re-open the whole question of amateur fault-finding methods.

During all the earlier years of radio the so-called deductive method was the only one open to the amateur, and we all used to pride ourselves upon our ability to diagnose a fault correctly after observation of the symptoms and perhaps the application of a few simple tests. Then came the era of scientific servicing methods, and now it is considered *dernier cri* to do everything by the methodical use of instruments according to the book of rules.

## Amateur's Point of View

That is all very fine, but to find anything but the simplest of faults that way demands an equipment such as only the professional service engineer can afford, and there is some danger that the amateur may find himself left out in the cold: that is why I feel that it is perchance time to review the whole question from his point of view.

I have thought the problem over and should like to offer some suggestions which are at least *intended* to be helpful! Whether the reader will find

them so in any given case is beyond the wit of man to guess, because modern sets are getting so complicated, but I hope that at the end he will at least have to say, "Oh, well, I expect he meant well!"

## Instruments Now a Necessity

It would appear to me that the older deductive method is no longer adequate when dealing with the more complex types of circuits, superhet in particular, and that even the amateur must be prepared to use some kind of instrumental aid. It is true that he cannot in most cases afford the elaborate sort of gear that the professional uses so skilfully, but even a milliammeter

will enable him to do just the essential little bit of measurement and checking that is needed to back up his attempts at pure diagnosis.

Given the possession of such an instrument, it becomes possible at any rate to check over the anode currents of all the valves, and to watch for certain informative abnormalities while the receiver is actually working, and that is a great step forward.

Now, much of the success of measurement checks in the hands of the professional depends on the fact that he is usually in possession of the necessary data as to the *normal* currents and voltages at the key positions of the particular receiver when in a state of health; if the amateur is to exploit successfully a modified form of the same method he must obtain the same information regarding his own set.

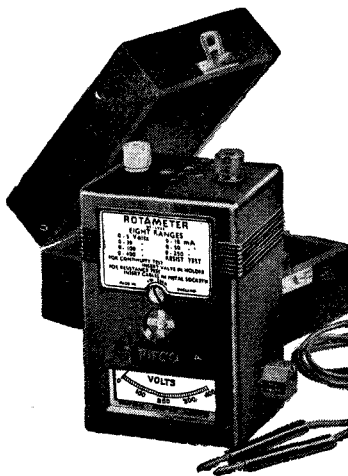

A combined voltmeter-milliammeter is a very handy thing for fault-finding work: this is the Pifco "Rotameter"

This means that he should really adopt the wise precaution of measuring up all the working anode currents of his receiver when it is functioning normally and filing the figures away for future reference in case of trouble.

Now, it is sometimes suggested that this can most easily be done by inserting the milliammeter in series in the common high-tension negative lead, and removing the valves from their sockets one by one, noting the drop in total current as each is taken out; that is probably quite a good method for the simpler type of battery set, although it must be remembered that even then it will be slightly misleading in the case of screened-grid and pentode valves, since it will result in lumping together the screen and anode currents.

### False Readings

In the case of mains sets the method is quite definitely undesirable, since all the working voltages, even those of the valve heaters, will tend to be upset when valves are removed and so false readings will be obtained. In some cases the high-tension voltages may even rise so much when nearly all the valves have been removed that the various smoothing and decoupling condensers may be endangered.

It is really better to arrange for the anode currents to be measured under working conditions, even in battery sets, and to do this easily one needs one of those handy little "split anode" adaptors sold for the purpose by, among others, Messrs. Bulgin. To use this device



*A combination meter like the invaluable "Avomator" in conjunction with a valve-base adaptor enables one to do a very systematic job of fault-tracing*

one has merely to connect the meter to its two terminals, take the valve out of its socket, insert the adaptor, and put the valve back on top thereof: the tube then works as usual, but the meter is brought into circuit in series with the anode and reads the current flowing.

To cope with all the different valve bases now in use one may need several adaptors, ranging from four- to nine-pin types, but a couple is usually enough to deal with an ordinary sort of set.

Granted, then, that the first step should be to check over all the anode currents, what may we expect to find? If the main fault-symptom has been a complete absence of signals, we are quite likely to discover that one valve is passing no anode current at all, and then we shall

find it necessary to apply a modified form of the old diagnostic method to localise the fault.

The cause of the lack of anode current, we may be pretty sure, is a definite break in the anode or cathode circuit, and a little thought will enable us to track this down very quickly. Consider first the anode circuit; here there will probably be a component of some sort with a wire winding, such as the primary of an intermediate-frequency or low-frequency transformer or a tuning coil, and one or more decoupling or voltage-dropping resistances.

First short-circuit the terminals of the component containing the winding and watch the milliammeter:

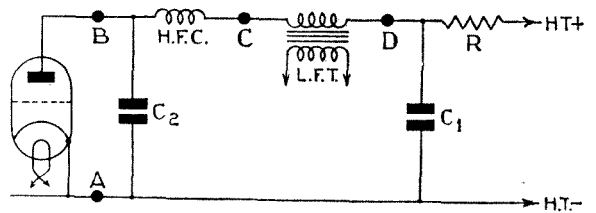

*The progressive method of fault-location can readily be applied to a circuit like this, working along from point to point with a voltmeter (Fig. 1)*

if you now get a current you know with certainty that the winding in question has broken down.

Assuming, on the other hand, a negative result here, our suspicions must be transferred to the various resistances, but in this case the short-circuiting method will not serve us; to short out a voltage-dropping unit might result in the application of a harmfully high voltage to the valve.

The proper method here is to connect in parallel with the suspected resistance a spare one of somewhere near the same value—anything from one-half to four times the figure will serve. If we now get a current of some sort we shall know that our suspicions about the resistance in the set are well founded.

### Simple Fault Finding

If we draw a blank right through the anode circuit, even after tracing it right back to its junction with the common high-tension circuit, there remains (in the case of a mains set only) the cathode circuit, and here practically the only likely spot for the break is the bias resistor. Test this by connecting in parallel a spare resistance of any figure up to, say, 5,000 ohms so long as it is not less than the normal value of the bias unit, and see whether you then get a current reading of some sort.

If we still fail to find anything amiss, the next step should be to satisfy ourselves that the break is not in the wiring of the anode or cathode circuits, and simple inspection will usually suffice to do this.

If the answer is still in the negative, we have two probable explanations: the valve in question may be defective, or there may be a short-circuit in one of the decoupling condensers shunting away the high-tension voltage and preventing it from reaching the valve at all. In the latter case it is probable that the drain on the high-tension circuit will be so heavy as to cause a drop in the anode currents of the other valves and so we should get a clue.

To confirm the diagnosis, disconnect in turn one

side of each of the decoupling or by-passing condensers in the anode circuit of the valve that is passing no current: when you come to the right one the anode current will reappear.

It will be noted that I have assumed so far that a milliammeter is the only instrument available, but the procedure becomes very much simpler if a suitable voltmeter can be used in addition. Apply the voltmeter first between anode and cathode of the valve holder itself: if you get a fairly normal sort of reading (this should have been taken and recorded at some time in

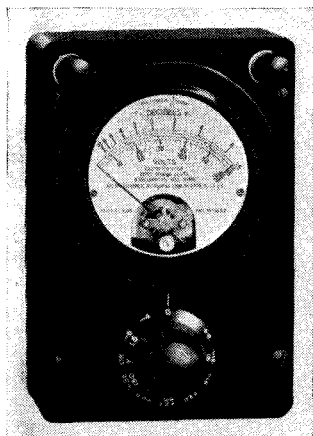

*The Weston power-level meter: very useful for output stage investigations and other work in conjunction with a modulated oscillator*

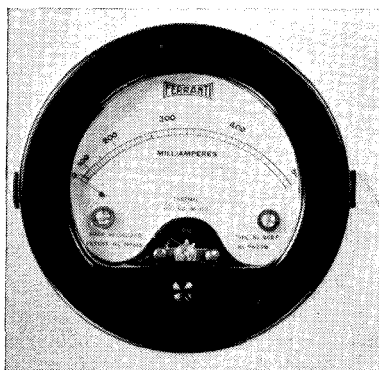

*A high-range milliammeter, such as the Ferranti illustrated here, can be used for making valuable preliminary checks on the total H.T. current of mains sets*

the past) you may be fairly confident that the valve itself is the cause of the trouble.

If there is no voltage at all showing at this point we conclude as before that there must be a break in cathode or anode circuit, so we should next try the meter between anode and earth in the case of a mains receiver. This eliminates the bias resistor, and if we now get a reading the latter is incriminated.

### Testing with a Voltmeter

Should we still get no voltage indication we are led to conclude that the break must be in the anode circuit, and now, instead of testing by substitution as we did in the absence of the voltmeter, we can locate the fault more rapidly and certainly by applying the instrument to a series of points along the anode circuit, starting at the anode point on the valve holder and gradually working back towards the high-tension source. Presently we shall find a component on one side of which we get no reading, with a normal reading on the farther side, and here is our fault located.

Thus, in the case of the detector valve, we might get no reading on the anode itself, but upon testing on the high-tension side of the high-frequency choke we might find the normal voltage in evidence, and from this we should conclude that the choke winding had broken down. In a nutshell, the component to

suspect is the one giving this indication: no voltage on the valve side, full voltage on the high-tension side.

This step-by-step method of location is an important basic system, and since I want to make sure that I have explained it clearly, I propose to run over a typical case with the aid of a diagram. If you will refer to Fig. 1 you will find that I have drawn just the anode circuit of a common sort of detector valve, with transformer coupling to the next stage and simple decoupling, and this will serve our purpose.

We should start by applying the voltmeter between points A and B, and it will be assumed that we should get no reading. Next we put the meter on point C, keeping the other lead on A: a reading here indicates that the choke winding marked H.F.C. is broken down. No reading here tells us that the fault is farther back, so we go next to point D, and if we got a voltage shown here we should know that the primary of the low-frequency transformer had failed.

### Point to Point

If we got no voltage at D, suspicion would fall upon the decoupling resistance R, but we should remember that a short-circuit in the condenser C, might be responsible, so we should try disconnecting one side of this, as already mentioned, and see whether a voltage then appeared at point D. If it did not do so, it would show that R was the culprit, assuming always that other tests had already established that the high-tension source was delivering the goods as usual.

It will have been noticed that I have as yet made no mention of the effect of a possible short-circuit in the high-frequency by-pass condenser C<sub>2</sub>; such a fault is very unlikely, because this condenser will normally be of the reliable mica dielectric type, but if you should fail to find the fault elsewhere it is well to try disconnecting this component and noting whether the high-tension voltage then reappears.

### Readily Adaptable to Other Stages

I have used the detector valve for the purpose of illustration, but it will be realised that the same method can quite readily be adapted to the special circumstances of any other stage in the set, with due allowance for the characteristics of the particular components concerned. These are mostly obvious matters, but I should perhaps just give a word of warning regarding the testing through of anode circuits containing high resistances: unless the voltmeter is of high resistance only low voltages will be shown here, but they will serve the purpose.

I have reached the end of my allotted space, but I will continue this discussion of modernised fault-finding in a future "W.M."

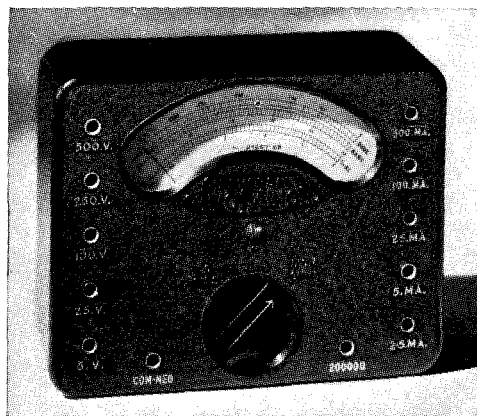

*For the man who has to deal with both alternating and direct current sets the Universal "Avomitor" is an extremely helpful instrument*

# Between Ourselves

By BROADCASTER

IT'S going to be a wonderful season, as far as I can see, for long-distance reception. In theory, conditions on the medium and long waves shouldn't be quite so good this winter as they were last, since we are now on the way to what is known as a sunspot maximum. In practice I fancy things will work out pretty well all round. There are heaps of stations available on any evening with a set that has any pretensions to efficiency, and now that high power has become so widely used the number of stations from which you can obtain reception of almost "local" quality is a big one.

## Try This on Your Friends

I wrote *almost-local* quality, but it often takes an expert nowadays with a very fine ear to detect whether a station received on a good set is 20 or 200 miles away. There are still some who decry foreign listening, regarding it as a pastime for the young and maintaining that you can't get anything like decent quality from far-away stations. If you have any such among your friends—and it is more than probable that you have—try this little experiment on them.

Make a note beforehand of the exact dial readings on your set not only of the local transmitters but also of a number of Continental stations which you can receive

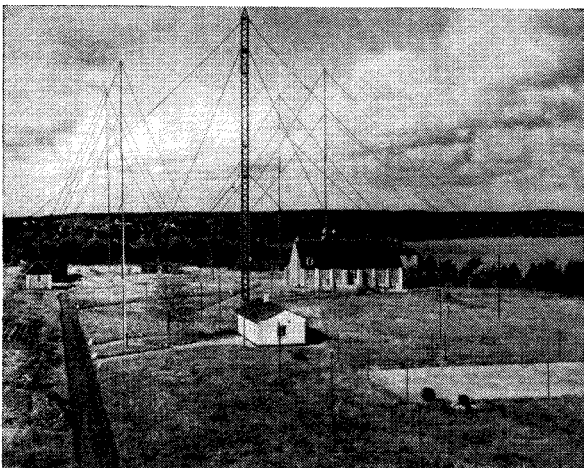

*A new station erected by the Danes at Lyngby to provide a service to their countrymen resident in Iceland*



*Two musically-minded maids with the "streamlined" Ekco AC86—a five-valve super for A.C. mains operation. The AC86 is a new season's set that does work well!*

at full volume and without interference. Now invite one or two of your sceptical friends to spend a wireless evening with you. Tell your audience that you are going to tune in say ten items of which some will be from home stations and some from foreigners.

Provide them with pieces of paper and ask them just to write down "home" or "foreign" against the number of each item. Don't swoop from station to station: turn the volume control right back and keep it there until the indicator shows that you have the tuning of the required transmission. Then bring up the volume. Should you be unlucky enough to strike a transmission of speech the show will be given away; that particular item must be cancelled and another substituted.

You can, however, guard very largely against this by running through the detailed programmes beforehand and making your selections accordingly. I am willing to wager that if you choose your stations with care and let each transmission come through at about the same volume very few of your listeners will succeed in compiling completely correct lists. Anyhow, it is an interesting and amusing experience and you will find it provides good entertainment, especially for a Christmas party.

## Sunspots and Wireless

Just now I mentioned that we were on our way towards a sunspot maximum. In case you are rather hazy about the meaning of this let me explain briefly. Though there are generally a few spots on the sun's glowing surface, these increase and decrease in number and size in regular cycles. Every eleven years they work up to the maximum, and once this is passed they are

less and less in evidence until the minimum period is reached, roughly five and a half years later.

We have just passed the minimum period and by all the rules old Sol should become steadily spottier and spottier for the next few years. Sunspots, particularly when they are big and numerous, cause electromagnetic disturbances around this world of ours and these have considerable effects upon wireless waves.

### Swings and Roundabouts

As we draw nearer and nearer to a maximum outburst of sunspots long-distance reception on the medium waves appears to become worse and worse ; but what we lose on the swings we gain on the roundabouts, for the short-wave transmitters seem to become better and better performers. I say "appear" and "seem" because only one complete sunspot cycle has taken place in the whole history of broadcasting and hardly sufficient data has yet been collected to enable us to say with absolute certainty that these things always occur.

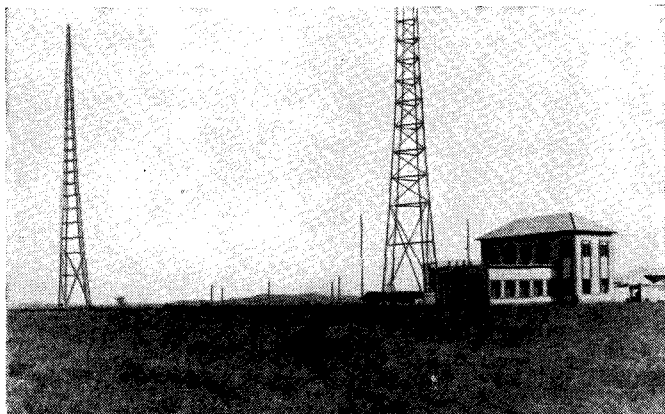

*The radio station at Addis Ababa, the Abyssinian capital. It was from this station that the Empress of Abyssinia broadcast a peace message to the world which, unfortunately, was not heard through bad jamming*

So far, though, predictions have been fulfilled and there is really little doubt that future sunspot cycles will show the same effects upon wireless transmissions. They may, though, be somewhat less noticeable as more and more powerful transmitters are brought into use.

### Television Details

Now that both Baird and E.M.I. have published the full technical details of their scanning systems those manufacturers who intend to turn out television sets have at last a fair chance of getting down to work. All sets will, of course, have to be made so that they can be adapted easily for reception by either method, since during the provisional period the two systems will be used alternately. There is, of course, no guarantee that either of them will eventually be adopted as the standard method for the country.

Our manufacturers now need a regular service of experimental transmissions by both methods so that they may be able to get on with their laboratory and research work. There can't be any doubt in the minds of readers that these transmissions should be provided at once. They are essential if we are to make proper progress.

When the French Government decided to

erect a high-definition transmitter at the top of the Eiffel Tower the authorities realised that some months must elapse before it could be in working order. They, therefore, made immediate arrangements for the installation of a temporary transmitter which will be at work by the time that you read this note. *That's* the way to do things.

### Forefathers and Foresight

A week or two ago the Metropolitan Police found themselves up against what appeared to be a rather thorny problem. They wanted to prevent the use of vans equipped with loudspeakers of the public address type for advertising purposes, but the trouble was that there was no law or regulation referring to the use of loudspeakers in this way.

Then some genius rose to the occasion. "Have a look at the Metropolitan Police Act of 1839," he said. It seemed rather absurd on the face of it to bother about turning up an act nearly a hundred years old in the hope of finding something that would cover apparatus so eminently modern as the public address loudspeaker.

But there it was right enough when the Act was read. The tradesman who had used such apparatus in his delivery van to advertise his goods whilst driving through the streets was summoned for "unlawfully using a noisy instrument, to wit a loudspeaker, for the purpose of selling goods." Naturally the word "loudspeaker" does not appear in the original act, but anything appropriate can be inserted in the summons, after "to wit." The shades of those who drafted the act when Queen Victoria was a young girl must have chuckled over its consequences in the twenty-fifth year of her grandson's reign !

### The Set One Dreams Of

The other day I was thinking what a wonderful receiving set could be evolved if the designer was allowed to use any reasonable number of valves, and was instructed that the price of the finished article could be anything from thirty to fifty pounds. Actually the position at present is a very curious one. You can spend anything you

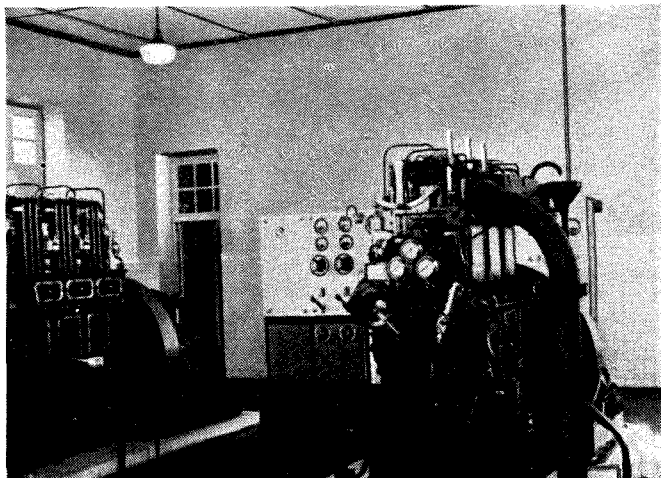

*The motor room at the Addis Ababa radio station. Two 75-horsepower diesel engines are used for driving the main generators*



like up to a couple of hundred pounds on a radiogram containing umpteen valves, but you would have a job to discover a purely wireless set containing more than about seven valves or priced much higher than thirty pounds.

In other words the really big receiver can be bought only as a radiogram. Funny, isn't it?

There must be heaps of people who don't want radiograms, but would like to have the very last word in wireless sets. And what would that "last word" be like? Here are my suggestions.

An all-waver, of course, with the short waves split up into at least three and preferably four bands, each being well and truly spread. It would probably contain from sixteen to eighteen valves, though only a few of these would be employed as radio-frequency, intermediate-frequency or audio-frequency amplifiers. The rest would find jobs of a variety of other kinds. The nearest possible approach to perfection in automatic volume control would be essential.

Then there might be automatic tuning such as that found in one of the Murphy receivers. This means that if you don't tune in a station to exact resonance the device automatically pulls the tuning until it is exactly as it should be. Automatic selectivity is another feature that would be incorporated. By means of this the set adjusts its own degree of selectivity to suit the strength of the incoming signal. You thus obtain the highest possible quality from any transmission.

Automatic volume expansion, truepush-pull output from a pair of triodes, and a real silence when you wanted it in between stations would be other delightful refinements.

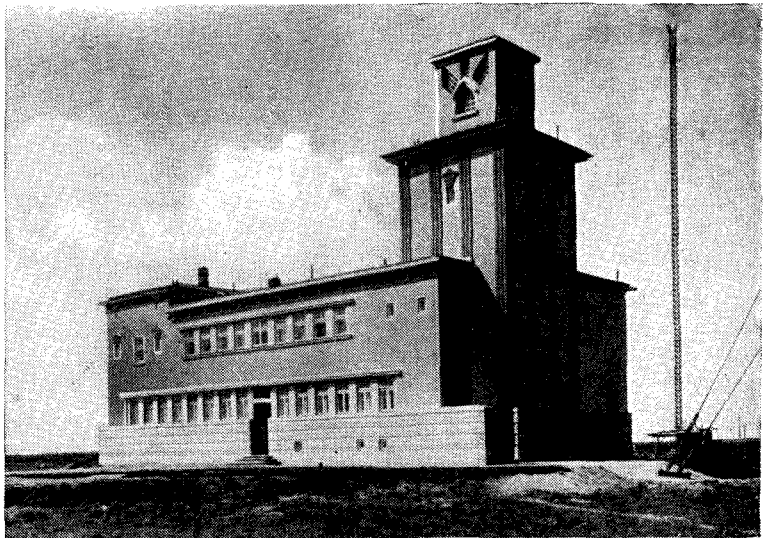

*This is the fine modern-looking building which houses Roumania's new 150-kilowatt transmitter*



*Victor Stankovits, a new announcer on the staff of the Hungarian Broadcasting Co.*

### Wouldn't You Like One?

Such a set would be a glorious thing to use and I feel quite sure that if any manufacturer were bold enough to put it on the market he would be quite surprised at the demand it evoked. Somehow radio manufacturers often find it hard to realise that there is a big section of the public that wants the very best and is quite prepared to pay for it. A good many years ago when the radiogram was in its infancy one firm asked my advice about making one containing all the refinements that were then known and housed in a beautiful cabinet.

The price could not be less than the then unheard of figure of a hundred pounds. Did I think that it would sell? I said that I was sure that it would—and it *did*. They couldn't turn them out fast enough. I haven't a doubt that a real *Rolls Royce* among receiving sets would be equally successful.

### Hard Cases

One comes across too many cases in which purchasers of receiving sets do not receive the treatment that should be theirs. Probably the manufacturers are not directly to blame in the majority of instances; it is local service men of the inefficient kind who are frequently at the bottom of the trouble. These are happily becoming fewer and fewer, but there is no question that some of those who supply the free service offered with the guarantee would be much better employed at other jobs.

Here is an instance of the kind of thing



*Women announcers are greatly favoured in Continental radio circles. Here is Madame Magda Cretsoin, the chief lady announcer of Radio Bucharest*

that I am driving at. The set is bought and within a very short time some small defect develops. When the local man is called in he is clearly puzzled, but he takes the set away and keeps it for some days. Upon its return it is found to be as bad as ever. After two or three more shots, what time things go from bad to worse, the service man confesses that he can't remedy the trouble and says that the set must go back to the manufacturers. Back it goes and the purchaser soon finds that he is up against what may be a stiffish bill for labour charges in rectifying the fault.

By this time the purchaser is not unnaturally exasperated and this bill seems to him like adding insult to injury since he has had so little satisfactory working from the set. Manufacturers are perfectly within their rights in making the charge, for the fact that they will do so is distinctly stated in the guarantee.

#### What is to be Done About It?

The position is an unfortunate one since it leads to heart-burning on both sides. The manufacturer takes the attitude that the purchaser cannot have for nothing



*Crystal microphones are now being extensively used by the German broadcasting organisation. Here is one in use for the broadcast of a sports relay. Its comparative lack of sensitivity enables the commentator's voice to be distinctly heard without crowd-noise interference*

something to which he is not entitled; the purchaser on the other hand says "since my set was never in proper working order in the first couple of months it is surely up to you to give me satisfaction."

Firms should, I think, keep a much stricter eye on the doings of the local men who do the servicing of their sets under the guarantee. If complaint after complaint is received from a particular locality steps should be taken to see that a more efficient man handles the work. Further, I would suggest that labour charges should not be hard and fast—unless these are fixed at some small

flat rate, no matter how big the job may turn out to be.

Hard cases should be treated on their merits and if it is found that the customer did not receive from the local man the service that should have been his, then a nominal charge should be made when the set has to be returned to the factory. This kind of thing would pay in the end for a dissatisfied customer with a just grievance is something to be avoided at all costs.

#### Battery Valves Today

It is remarkable what results you can get from a few valves, even those of the battery type, today. They are not as efficient type for type as mains valves, but you could hardly expect that in view of the very great differences in the watts that they use. Most mains valves require one ampere at four volts, or four watts apiece, for heating purposes.

All present-day battery valves are of the two-volt pattern and their current requirements vary from 0.1 to 0.4 ampere.

Even the greediest of them thus consumes only 0.8 watt, or one-fifth as much as a mains valve, and only one-twentieth of this amount is needed to work the small battery triode. But despite their small appetites for low-tension current, some of them, and particularly those of the portmanteau class, are wonderful little fellows.

#### What Four Valves Can Do

I am using just now a battery-operated superhet containing only a quartet of valves. Though its total drain on the accumulator is only .6 ampere, which makes the wattage 1.2 for all the valves put together, it brings in very nearly as many stations as most mains sets. Naturally it can't give anything like the volume that mains sets do—its undistorted output is less than one watt as against anything from two to ten for the mains set—but the quality is remarkably good and in a moderate-sized room one watt is enough for most people.

Actually when you come to work out the circuits you find that each of its valves is equivalent to two or three triodes. No. 1, for example, is an octode frequency-changer which boils down to a triode oscillator and a high-frequency pentode in the same bulb. No. 2, the intermediate-frequency amplifier, is high-frequency pentode, which probably gives as much magnification as two triodes in cascade. No. 3 is a double-diode-triode—which has the three different duties of second detector, supplier of automatic volume control and driver for the output stage. No. 4 is a class-B valve, the double-pentode type.

#### A Triode Comparison

To obtain anything like the same results with the triode, which not so long ago was the only available battery pattern, you would require at least nine valves and you might find that you wanted a tenth. In place of No. 1 you would certainly need two triodes, an oscillator and a first detector. I think you would also have to have a high-frequency amplifier to obtain the same degree of sensitiveness. Two triodes, and therefore two I.F. stages, would be needed to replace valve No. 2.

You would require three to do the work of valve No. 3: a second detector and A.V.C. valve and a driver of the small power type. Another pair would be required to replace the output valve No. 4; and even so you might require an additional L.F. valve in front of the driver in order to achieve the same volume.

Television for the Busy Man—No. 4

# How Television Receivers Work

By PERCY W. HARRIS, M.I.R.E.

ONE of the simplest forms of television receiver, that is using a Neon lamp and a perforated scanning disc rotating in front of it, was described last month. There are many objections, however, to this form of receiver. For instance, the amount of light available is always small and is but a tiny fraction of the total that reaches our eye when we look at the unscreened Neon lamp.

You must remember that the

effect produced in the eye is due to persistence of vision and thus the total luminous effect is merely that yielded by the tiny aperture in the scanning disc, spread over the area scanned.

Another objection is the difficulty of making a Neon tube with a big enough plate to give a picture that can be viewed without a magnifying glass. Furthermore, the colour is not a pleasant one. What other methods are available?

The "mirror drum" is one of these. Here we have an arrangement of a lamp, a concentrating lens, a fixed mirror, a series of rotating mirrors and some form of translucent screen.

The lamp could be of several kinds so long as it was one the light of which varies practically instantaneously with the variation of current, so that the changes of light could faithfully follow the modulations of the television. This scheme however, has been replaced by the more efficient "light valve" method.

The light valve itself is a very interesting device and in one form is known as the Kerr cell. Space does not permit me to describe in full the theory of this cell and it is sufficient in a short series of articles such as this to state that it is a small transparent container with a certain liquid inside, together with certain polarising crystals and a pair of electrodes. The application of the modulated voltage to these two electrodes alters



"... in order to get a reasonably large picture a very large tube must be used. . . ."

the optical property of the liquid and affects the transmission of the light after it has passed through the crystals.

## Simple Optical System

If now we pass the light from the lamp through this cell and apply the modulation from the receiving circuit to these electrodes, then we can vary the intensity of the light passing through the cell. At the same time it is possible to arrange a simple optical system which will concentrate the light of the lamp into a small and highly luminous spot. This spot is now thrown on to the fixed mirror which in turn reflects it on to one of the mirrors of the mirror drum.

Now the mirror drum carries a number of small mirrors fixed to the periphery of the drum, each being at a slight angle to the next. If now the spot of light is thrown on to one of the rotating mirrors it is reflected from this on to the

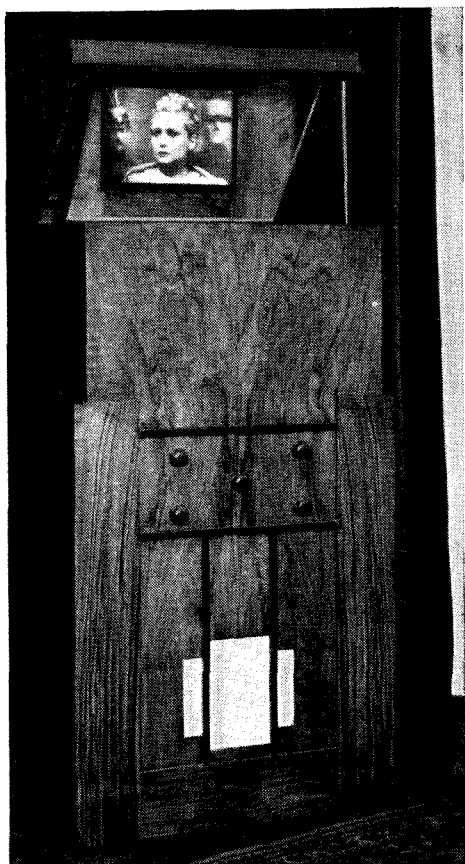

This is the Baird receiver referred to by Mr. Harris as being capable of giving a 12 in. by 9 in. picture and so serving for a roomful of people

back of the translucent screen. As the drum rotates so the spot moves from top to bottom or across the translucent screen according to the direction of its axis.

As soon as the spot reaches the end of its travel, another mirror picks up the light and starts the spot at the top again. This time, however, it is slightly to one side of the previous position, the angles of the adjacent mirrors to one another being so arranged that the screen is properly traversed without gaps.

A moment's thought will show you that there must be as many mirrors as there are lines to the image, and that while it is com-

of the speed of the motor rotating the drum or screw. This is generally achieved by a kind of magnetic brake consisting of a toothed wheel on the end of the motor shaft. Electro-magnets controlled by the synchronising impulses "hold down" the speed of the motor to exactly that required for proper synchronisation.

The mirror-drum or mirror-screw method of scanning the received image can, of course, be operated either from the constant light of a lamp, the intensity of the beam being modulated by a light valve such as the Kerr cell, or this cell can be dispensed with if the lamp itself faithfully follows in variation of light the modulation of the received signal. It is difficult enough to obtain satisfactory lamps to operate on 30-line television, but for high definition or 240-line television images, the difficulty is practically insuperable.

Fortunately we have available for television a most interesting device known as the cathode-ray tube which dispenses with all moving mechanism and its attendant difficulties. A rough-and-ready explanation of the workings of a cathode-ray tube follows.

First of all, in a suitably shaped glass tube we place an electrode covered with a substance which can be made to emit electrons very freely. The electron-emitting surface is known as the "cathode," and if now we place near it a positively charged plate (corresponding to the anode of the ordinary valve) the electrons can be made to form a stream from the cathode to the anode across the intervening vacuous space, the electrons returning from the plate to the cathode by way of an electrical circuit.

Fundamentally, up to this point, we have not greatly differed from the technique of the ordinary valve where the cathode emits a stream of electrons which flow to the anode, thence through the electrical circuit and so back to the cathode.

If now we make the tube of funnel shape with the cathode at the narrow end of the funnel and the wide end closed in with glass, if furthermore we coat the inside of this glass end with certain fluorescent substances, and if, between the cathode and this end, we introduce an anode with a hole in it, some of the electrons will shoot through this hole, speed on, hit the covered end and produce a luminous effect. Electrical arrangements can also be made to concentrate the electron stream into a narrow beam, the electrons being accelerated through the centre of an anode and reaching the flat end or "target" in the form of a concentrated beam.

### Luminous Spot

If the materials of which the end is covered are correct and the voltages are suitably arranged, the impact of these electrons will produce a luminous spot which can be seen through the very thin layer of the substance constituting the covering and therefore will appear as a bright spot when the tube is looked at from the big end.

### Brilliance and Colour

Now the brightness of this spot is dependent upon the constitution of the material forming the target, the voltages applied and other factors. The colour likewise is dependent upon the material used. How small and therefore how concentrated a spot can be made is dependent upon a number of factors

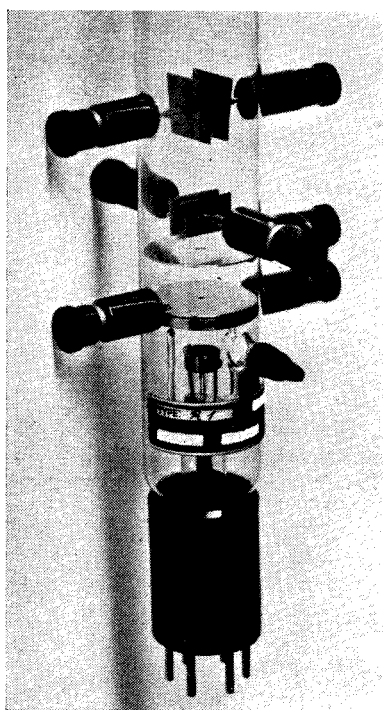

The essential parts of the cathode tube : note the pairs of control electrodes set at right angles to each other

paratively easy to make a mirror drum receiver for low definition, or 30-line television, the problem becomes much more difficult when we are dealing with a high-definition system of 240-lines.

The mirror screw is a very similar device for achieving the same purpose, namely, reflecting the spot of light on to the screen so that the received picture is properly scanned. In this case the edges of a large number of staggered plates are used. It will be obvious on a moment's consideration that the successful working of any of these devices is dependent upon the rigid control

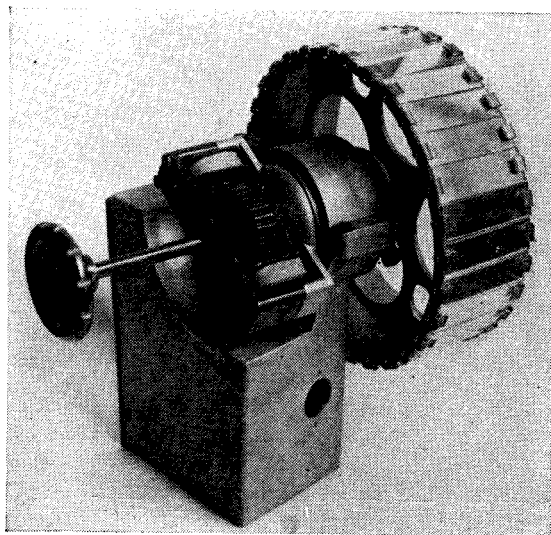

A typical mirror-drum device, showing the toothed wheel synchronising apparatus

and it suffices to say here that for high-definition television it has been possible to make the spot very brilliant and very small and sharply defined. The colour, which at one time was a rather unpleasant greenish-blue, can now be made pure white, or yellow if desired.

### Moving the Beam

Now how can we move this beam about? It is possible to seal into our cathode ray tube two other pairs of electrodes, one pair being at right angles to the other. By applying voltages to one pair of plates the beam can be moved backwards and forwards in one direction while voltage applied to the other pair of plates will move the beam in the direction at right angles to the first movement.

By a suitably arranged circuit, one pair of electrodes can be made to sweep the beam laterally across the screen when at the end of the traverse a voltage applied to the other pair of electrodes will cause the next passage across the anode to take place in a slightly different path. In this way, by adjusting the circuits suitably the spot can be made to scan the end of the tube from top to bottom or from side to side, just as by mechanical methods with the rotating disc, the mirror drum or the mirror screw, we can scan the received picture correctly.

### Advantages of Cathode Tube

There are several big advantages connected with the use of the cathode-ray tube for television receivers. First of all, as indicated above, it is entirely free from mechanical moving parts; secondly, the intensity of the light spot can

be made to follow very faithfully the variations of intensity of the modulated received signal without the slightest time lag; thirdly, the scanning spot can be easily synchronised with the transmitter, and fourthly it is not at all difficult to get a good, bright image.

In the Baird receivers, high-definition television pictures 9 in. by 12 in. in size, of great brilliance, with a clean cut black-and-white image, have been shown on a number of occasions. Such a picture can be easily viewed by a roomful of people and the intensity of light is such that it is not necessary to extinguish all lights in a room before the picture can be seen.

The disadvantages of the cathode-ray tube are that in order to get a reasonably large picture a very large tube must be used and this means a fair expense; secondly, such tubes do not have an indefinite life and therefore replacements are rather expensive; thirdly, they are fragile. I do not think, however, that the cost of these tubes will remain high as soon as television really "gets going." The cost of replacement will probably be no more than it takes at the present time to replace a set of valves in an ordinary broadcast receiver.

I think, too, that the fragility has been rather overstressed in some quarters as one does not move a television set about. It would be quite a different matter if we were trying to use such tubes in a portable set!

The cathode-ray tube television receiver is such a neat affair and so

silent in operation that many people have imagined that mechanical scanning is out of date. I would not go so far as to say this, for mechanical scanning, provided it can handle the high definition required, may possess certain other advantages, particularly when we aim to get a bigger picture such as would fill a cinema screen. At the Berlin Wireless Exhibition, several German firms showed high-definition television with mechanical scanning, and very successfully too!

### Use of Cinema Film

Another method of receiving scanning, of great interest, but unlikely to play any important part in the home reception of television, is that using a cinema film in the intermediate stage. In this the scanning line moves in one direction only and is focused upon the cinema film, which moves steadily downwards and thus by its own movement takes care of the spacing between the lines. The film passes straight from the scanning into a developing and fixing machine, after which it is washed, partially dried and brought into the projecting aperture of a cinema projector which thereupon throws it on to the screen in the normal fashion.

*Continued on last page*

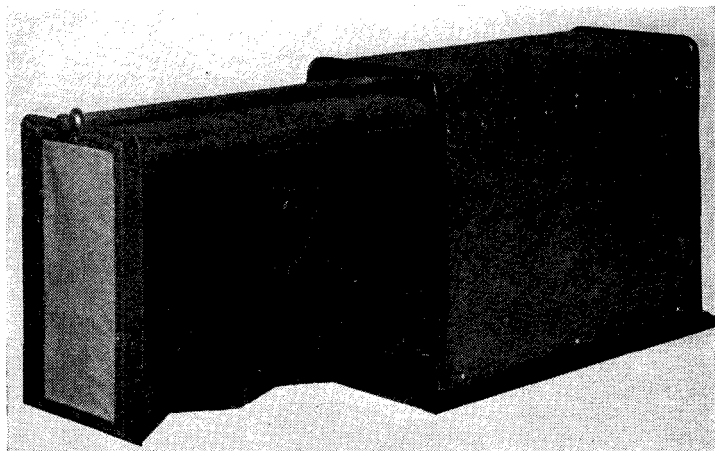

The projection screen of a mirror-drum outfit, showing a sliding bellows arrangement used for "focusing" purposes

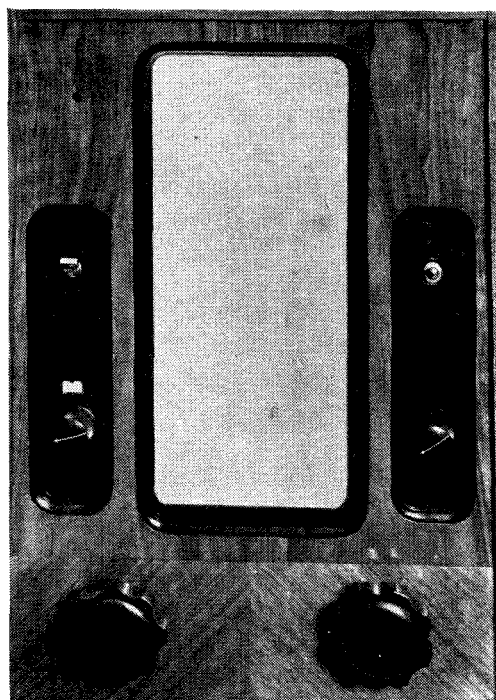

The viewing screen and controls of the projection-type receiver used until recently at Broadcasting House





Here is more useful information, mostly about operation, for builders of the "W.M." Simplified Short-wave Super, which was fully described in our last issue. Interest in short-wave reception is growing rapidly and those who are seriously thinking of joining the happy band of short-wave fans could do no better than make this set their starting point

# The Short-wave Super at Work

By G. HOWARD BARRY

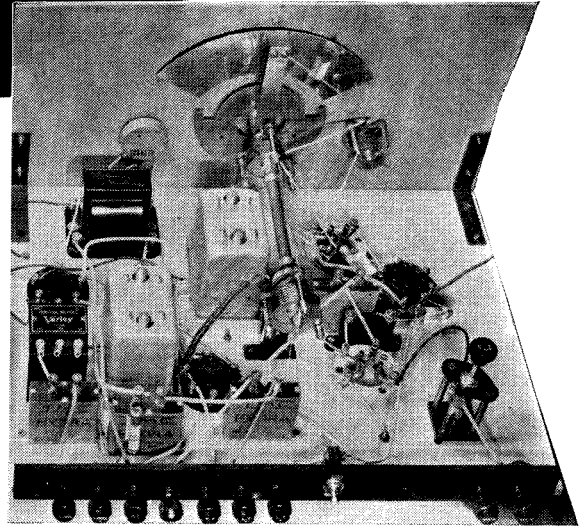

Anyone can build the Simplified Super; even a schoolboy!

SINCE last month's article describing this receiver was written the set itself has been in fairly continuous operation. I have not been content to use it as my only receiver, however, since that would have given no real indication of its capabilities.

It has been working side by side with my permanent "stand-by" set, an all-mains three-valver employing S.G., detector, and 1 L.F. Stations logged on one set have immediately been searched for (and invariably found) on the other.

### Extraordinary Quietness

The chief point about the "W.M." Simplified Short-wave Super is its extraordinary quietness. To be quite candid, I am rather at a loss to account for it, since a four-valve superhet usually produces quite an amount of background noise. In this case, however, the signal-to-noise ratio is far better on the superhet than on the three-valver—and I had always imagined that to be particularly good.

The superhet is quite disconcerting to handle at first. Tuning is extremely sharp, and in between stations there

is that dead silence that leads one to imagine that the aerial has come unshipped, or that the oscillator has stopped oscillating! One soon becomes used to it, though, and it is a very soothing sort of receiver to handle, particularly if one has been used to something "hissy."

There is one little point about the

set that was not covered last month. If you will refer to the scale layout and wiring diagram, quite near the centre of the picture you will see a letter "X" with an arrow pointing to a lead. In the circuit diagram this is the lead from the reaction coil of the oscillator section of the heptode, going eventually to H.T.+1, and

## G. Howard Barry's Station Log of the "W.M." Simplified Short-wave Super

This list of the principal short-wave stations was compiled by the designer on the original receiver. They should be of considerable assistance to constructors, though it is unlikely that any two sets will give exactly the same readings

LB (Light Blue Spot) Coil		Sydney, VK2ME	
Station	Dial Reading		
Daventry, GSG	.. 30	Daventry, GSC	.. 46
Bound Brook, W3XAL	.. 31	Schenectady, W2XAF	.. 48
Schenectady, W2XAD	.. 55	Rio de Janeiro, PRF5	.. 49
Wayne, W2XE	.. 56	Ships on 36 metres	.. 66-70
Pittsburgh, W8XK	.. 57	Amateurs (40 metres)	.. 90-100
Daventry, GSF	.. 58.5	<b>R (Red Spot) Coil</b>	
Amateur (20 metres)	.. 65-75	Amateurs (40 metres)	.. 0-8
<b>Y (Yellow Spot) Coil</b>		Moscow, REN	.. 20
Amateurs (20 metres)	.. 0-5	Caracas, YV3RC	.. 27
Pittsburgh, W8XK	.. 30	Pittsburgh, W8XK	.. 29
Rome, I2RO	.. 31	Wayne, W2XE	.. 31
Daventry, GSD	.. 33	Bound Brook, W3XAL	.. 32
Pontoise, FYA	.. 34	Skamlebaek, OXY	.. 34
Madrid, EAQ	.. 40	Miami, W4XB	.. 35
Lisbon, CT1AA	.. 44	Vatican City, HVJ	.. 37
		Air Force Stations (60 metres)	55-70

being by-passed to earth on its way by the 1-microfarad condenser from screen to earth.

After I had laid out the set and got it working, I looked over the circuit diagram, and suddenly saw something! Why, I wondered, was that .0001-microfarad reaction-control condenser having any effect at all on the oscillator? The same point from which it is taken to earth goes down to earth through 1 microfarad! But it *was* having an effect, and I put it down to the inductance of the wiring and of the 1-microfarad condenser itself.

**The Lead Marked "X"**

Should any readers find that the little .0001-microfarad condenser has insufficient effect, I recommend them to break the lead from the reaction coil to the 1-microfarad condenser (just where it is marked "X") and to insert a 3,000-ohm resistance at that point. The ordinary wired-end 1-watt type is all that is required.

If, then, the oscillator section of the heptode does not function at all, disconnect the lead from the 1-microfarad condenser and take it, instead, to a new tapping on the H.T. battery—but still with the 3,000-ohm resistance in series with it.

**Full Control**

Once the resistance has been inserted, you should definitely find that you have a full control over oscillation with the .0001-microfarad condenser. Probably you will leave it set about one-quarter or one-third in; but, as a matter of fact, it makes quite a useful fine-tuning adjustment on occasions.

*This view of the receiver shows the completed outfit with the valves and coils in position. Note that there are two interchangeable coils and that terminals are provided for battery leads; the main on-off switch is also fitted to the terminal strip.*

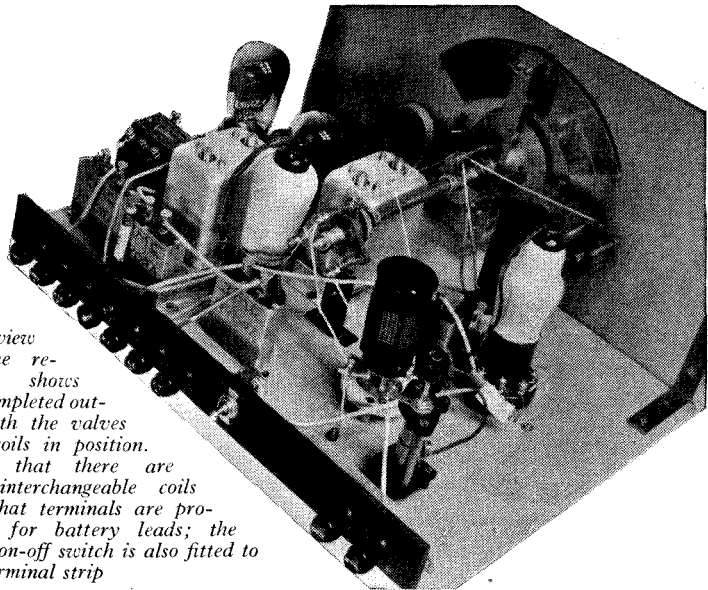

Another remark concerns the ganging of the two condensers. I find that I have settled down with the oscillator condenser (nearest the front panel) always a little farther *in* than the detector condenser. I suppose the actual amount of off-setting is about 10 degrees. Start with your two condensers like this, and arrange your final trimming by careful setting of the neutralising (aerial-coupling) condenser.

Luckily, it is not really critical; but a certain amount of intelligent adjustment of these two variable controls will probably result in an all-round improvement as regards sensitivity.

Adjustment of the intermediate-frequency transformers is apt to be a rather tricky business as there are three separate settings to be made on

each—the two trimmers and the variable coupling. It is as well to carry out this operation on a fairly weak signal, and I suggest that a regular order of adjustment should be adhered to. Don't touch the variable coupling at all—at first. Look after the two trimmers on I.F.T.1, then finish off on I.F.T.2.

**A Clue to Trouble**

If it is found that any one of the four trimmers sends the intermediate-frequency stage off into oscillation at any particular point, something is wrong. By adjusting just short of that point results will be passable, but you will definitely be losing sensitivity that you might make use of if the stage were stable.

Make sure that the braided covering of the flexible connector to the

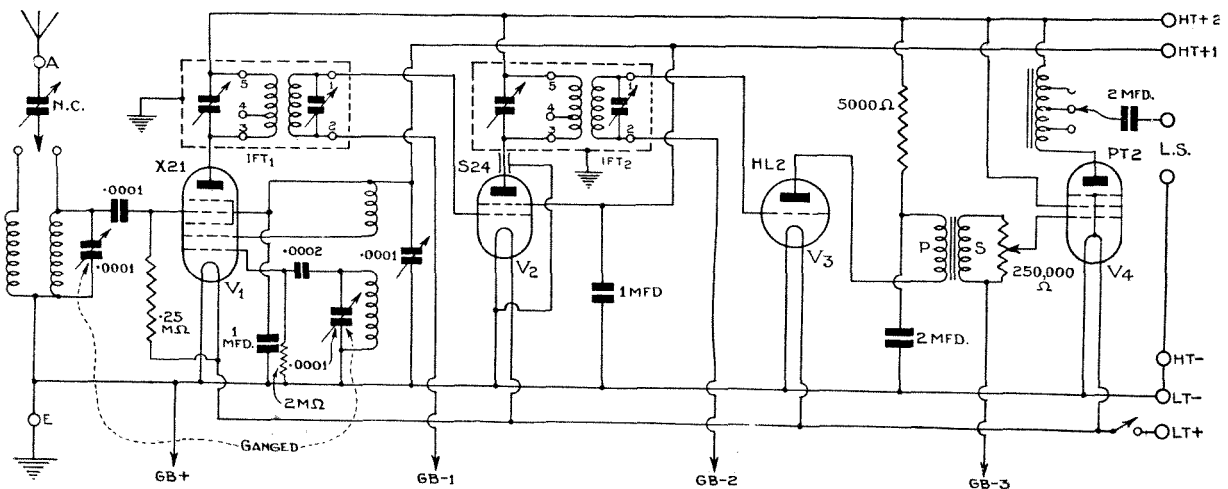

*The simple theoretical circuit of the "W.M." Simplified Short-wave Super : four valves in superhet sequence*

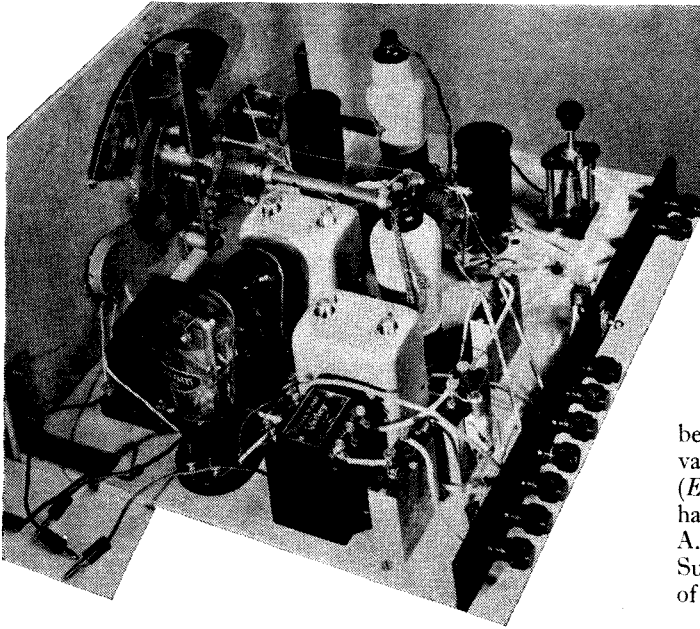

A view of the Simplified Super taken from the low-frequency end. The two intermediate-frequency transformers with the adjusting screws can easily be picked out

I.F. anode is earthed to the nearest point. Adjustment of the screen voltage will also be necessary. It should, in the ideal state of things, be impossible to make the I.F. stage oscillate, whatever you do to the various transformer adjustments.

**Output Stage Adjustment**

Another adjustment that was not mentioned last month concerns the output stage. Three tappings are provided on the pentode output choke. One of these will suit your particular loudspeaker better than the other two. That's all that need be said about that.

I have used the set quite a lot for listening to American amateur telephony on the 20-metre band, and have found it excellent for the purpose. On one night 44 U.S.A. stations were logged. It is not, of course, suitable for C.W. reception.

If one can make the I.F. stage oscillate, one can receive C.W. reasonably well.

**Special Test**

I have been testing it with an entirely separate oscillator designed to beat with the intermediate frequency (about 465 kilocycles) and wired up entirely separate from the set itself. By this means C.W. may be received with almost the same quiet background that is a feature of the set when telephony is being tuned in.

By the time this appears in print, I hope to be well under way with the A.C. version of the same set. I don't imagine that the circuit constants will be altered in any way, but I intend to make a chassis layout of it for extra convenience in wiring; bearing in mind also the extra efficiency of A.C. valves and therefore the need for more screening. (Editorial note: Since writing this article Mr. Barry has completed a rough experimental model of the A.C. mains version of his Simplified Short-wave Super, and reports that it bids fair to be a receiver of really striking performance.

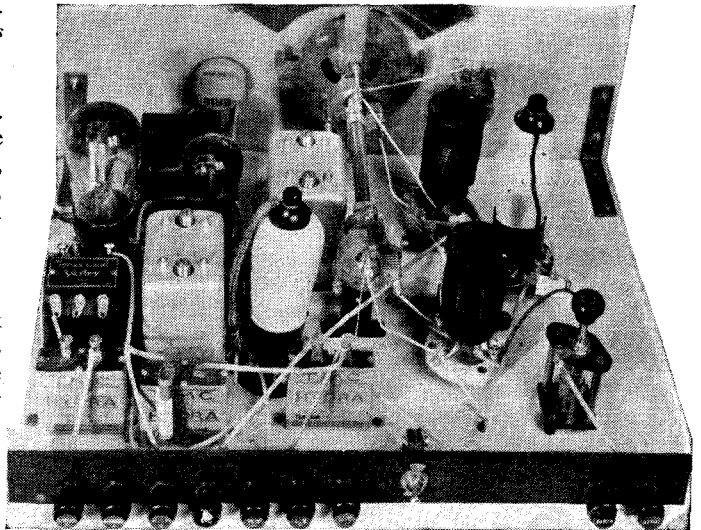

Building the set will give you many pleasant hours in the work-room, and still more pleasant hours touring the ether searching for stations from the five continents

**LIST OF PARTS NEEDED FOR THE "W.M." SIMPLIFIED SHORT-WAVE SUPER**

BASEBOARD ASSEMBLY		£ s. d.	DIAL		£ s. d.	TRANSFORMER, LOW-FREQUENCY		£ s. d.
1—Plain wooden panel, 16 in. by 8 in. by ½ in., say	...	1 0	1—J.B. neutralising condenser	...	3 6	1—Ferranti, type AFS	...	11 6
1—Metallised baseboard, 16 in. by 12 in. by ¾ in., say	...	3 0	1—Eddystone wide-vision vernier dial, type 973	...	10 6	<b>VALVE-HOLDERS</b>		
<b>CHOKE, LOW-FREQUENCY</b>			<b>RESISTANCES, FIXED</b>			2—Eddystone Frequentite 4-pin valve-holders, type 949	...	2 10
1—Varley Pentode Nichoke	...	11 6	1—Erie 2-megohm grid leak, 1-watt type	...	1 0	1—W.B. 7-pin baseboard mounting valve-holder	...	1 6
<b>COILS</b>			1—Erie 250,000-ohm, 1-watt type	...	1 0	3—W.B. 5-pin baseboard mounting valve-holders	...	3 9
2—Sets of Eddystone 4-pin coils, types LB, Y and R	...	1 1 0	1—Erie 5,000-ohm, 1-watt type	...	1 0	<b>VALVES</b>		
2—Varley Air-tune I.F. transformers, 465-Kc.	...	1 10 0	<b>RESISTANCE, VARIABLE</b>			1—Osram X21	...	18 6
<b>CONDENSERS, FIXED</b>			1—Erie 250,000-ohm (volume control)	...	3 6	1—Osram S24	...	12 6
1—Dubilier .0001-microfarad, mica type 620	...	1 3	<b>SUNDRIES</b>			1—Osram HL2	...	5 6
1—Dubilier .0002-microfarad condenser, type 670	...	1 0	1—Ebonite strip, 15 in. by 1½ in.	...		1—Osram PT2	...	13 6
2—T.M.C.-Hydra 1-microfarad 250-volt working	...	4 6	9—Belling-Lee terminals marked Aerial, Earth, L.T.—, L.T.+, H.T.—, H.T.+, H.T.+1, H.T.+2, L.S.+ , L.S.—	...	4 6	<b>BATTERIES</b>		
2—T.M.C.-Hydra 2-microfarad 250-volt working	...	6 0	1—Eddystone extension control outfit	...	1 3	1—Full o' Power 9-volt grid-bias, type G2.	...	1 3
<b>CONDENSERS, VARIABLE</b>			1—Eddystone adjustable insulated bracket	...	1 6	1—Full o' Power 141-volt high-tension	...	14 6
3—Eddystone .0001-microfarad microcondensers	...	15 0	<b>SWITCH</b>			1—Exide 2-volt accumulator	...	10 6
			1—Bulgin on-off switch, type S102	...	1 3	<b>LOUDSPEAKER</b>		
						1—W.B. Stentorian, standard cabinet model, PMS2	...	2 4 6

# Radio News From Abroad

By JAY COOTE

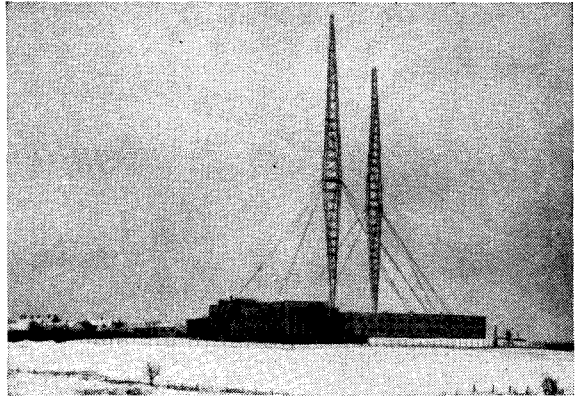

The huge size of the two aerial towers of the Vienna station can be appreciated by a glance at this photo. The station building has four storeys, too!

**CZECHOSLOVAKIA**  
CONSIDERABLE extension is to be made to the Czech broadcasting network in the course of the next twelve months. Following the opening of the Banska-Bystrica station work is to be started on a 120-kilowatt transmitter at Nitra (Neutra) to replace the plant now operating at Bratislava. It is also proposed to build a station at Uzhorod (pre-war Ungvar) for supplying special programmes to the inhabitants of the Carpathian district. Banska-Bystrica will work on an unusual channel, namely, 765 metres (392 kilocycles).

## ESTONIA

In view of the development carried out by neighbouring Baltic states, the Estonian Broadcasting Company proposes to transfer the present station from the capital to Tartu, and to endow Tallinn with a 60-kilowatt transmitter. On a wavelength of 410.4 metres (731 kilocycles) listeners in the British Isles should find no difficulty in hearing the programmes when the power has been increased.

## FRANCE

The new interval signals which have been adopted for the State transmitters will shortly be heard by listeners. In the meantime, Poste de l'Île de France (better known as Radio Vitus, Paris) opens and closes its programmes with a fanfare of trumpets. Try for the station as it comes on the ether at G.M.T. 07.00 every day.

By the end of 1936, the French State network will consist only of super transmitters, as in addition to the new stations being completed, it

is the intention of the PTT authorities to increase the power of Radio Strasbourg to 100 kilowatts. Notwithstanding the State control of broadcasting, no move has been taken so far to hamper the development of the privately-owned transmitters. The owners of Radio Lyons are erecting a new 25-kilowatt station at Dardilly, fifteen miles from Lyons.

Radio Cité is the new call of the old Radio LL, Paris, station which has now been taken over by one of France's important daily newspapers *l'Intransigeant*. The wavelength has been altered to 280.9 metres (1,068 kilocycles) and the announcements are made in both French and English.

## GERMANY

An S O S may not necessarily be of a dramatic nature. Deutschland-sender, in order to assist good Germans to establish their pure Aryan descent, broadcasts every Tuesday evening a series of appeals from persons anxious to make up their family tree.

Notwithstanding contradictory statements in the press, the German broadcasting authorities have decided to erect a 17-kilowatt transmitter in the neighbourhood of Saarbruecken; it is to be ready by 1936, and will work on 240.2 metres (1,249 kilocycles), the channel allotted to, but refused by, Luxembourg. In the meantime, a 700-watt station is to be installed immediately, of which the power is to be increased as soon as possible to 1.5 kilowatts.

## LATVIA

You may possibly pick up English announcements on 238.5 metres; they emanate from Kuldiga which, as

Radio Normandie, Luxembourg, Poste Parisien and others, has started sponsored-programme broadcasts.

## POLAND

For the relay of the Polish national programmes, Polskie Radio has been permitted to use the 20-kilowatt SPW transmitter, working on 22 metres (13,635 kilocycles). This station, which is usually engaged in traffic with the United States and Japan, may be regularly taken over for broadcasts destined to Polish Nationals overseas.

## PORTUGAL

Radio Paredé, which has been on the ether regularly for over two years, was recently destroyed by fire. It was an independent station maintained by voluntary contributions. As the State is operating a transmitter at Lisbon, it is not anticipated that any other private medium-wave station will be licenced.

## SWITZERLAND

When the Lucerne Plan was adopted in 1933 it was mooted that a further conference would be held in 1936 in order that a revision of the scheme might be carried out. As, however, barring a few alterations, the original plan is working well, there is to be no radio conference in 1936.

## UNION OF SOVIET SOCIALIST REPUBLICS

Plans, are being prepared to give the U.S.S.R. capital the world's largest transmitter with a power of 2,500 kilowatts, which would carry the programmes over several continents. Precise details are lacking.

# QUERIES OF INTEREST

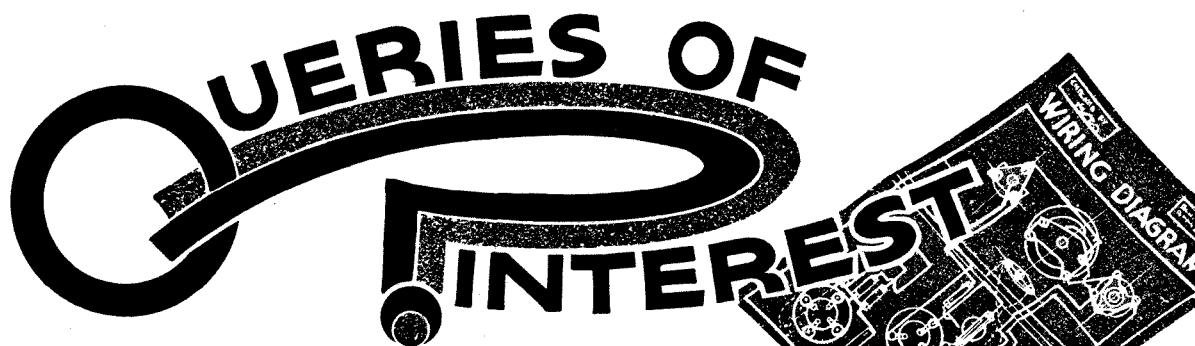

The selection of questions and answers appearing below is the result of a search through our post bag in quest of matter which we consider of general interest and having a direct bearing upon everyday practical problems. The readers who actually asked these questions have, of course, received a reply through the post

**W.H.C.** (Bath), expresses interest in the Minutube receiver, and would like to know, first, whether it can really be expected to operate a moving-coil loudspeaker, and second, if it can be run from a mains high-tension unit.

The minute size of the output valve should not be taken as an indication of the power it will deliver. It is actually quite comparable with the "economy-type" pentode with which we are already quite familiar; it *will* operate a good moving-coil speaker at a volume level adequate for a room of moderate size (the kind of room for which this compact little set is expressly intended).

There is no reason why a mains supply unit should not be used, so long as one does not yield to the temptation to give the valves excessive voltages: it is wise to keep to the limit of 100 volts suggested in the original article.

**R.J.Q.** (Southampton) writes to say that he is going to learn Morse with a view to increasing the interest of short-wave listening and asks whether we agree that he can quite well do so by fitting up a buzzer and key circuit and practising the alphabet thereon until it is firmly impressed upon his memory before attempting the "reading" side of the matter. Most decidedly we do *not* agree. It is a very natural mistake to make, but a mistake it is. Many people have learned in this way, and practically all have found that it has imposed a severe handicap upon them that only years of reading practice can remove.

Experience has shown that it is very much better to learn to read

first: one should even memorise the alphabet by its sound as transmitted by a teacher, gramophone record or mechanical device. It is in fact important at first to train the memory to work in the direction of recognising the sound of the letters, rather than to think of a letter by name and then try to recall its Morse symbol.

**W. M. B.** (Cardiff) writes that he has noticed in certain of the photographs of the "Standard Short-waver" that the J.B. neutralising condenser appears to be mounted up a little from the metal-coated baseboard, and asks whether this is important. In the original receiver the component in question was mounted up with the aid of a couple of little spacers so that it was about half an inch above the baseboard, but this is really one of those things the enthusiast does because he likes to take extra precautions. Tests have shown that the component can quite well be screwed to the baseboard if desired. Those who wish to emulate the special care of the designer may like to know that the spacers used were actually the insulating sleeves taken from a couple of battery plugs.

**B. S. J.** (St. Neots) writes to the effect that, although he expects to be right outside the service area of the London television transmitter, he is interested in the problem of designing a receiver for the intended forms of scanning and would like to know exactly what must be done to enable both systems to be received.

It is by no means certain that we shall indeed be so unfortunate as to

need two radically different types of receiver: there is more than a chance that a comparatively small modification of what may be called a standard type of cathode ray receiver will serve. When we have to provide for the reception of both interlaced and sequential scanning it is only necessary to duplicate certain of the control circuits of the cathode tube, that is, the scanning portion of the apparatus. Some idea of the nature of the problem can be gathered from the details appearing on pages 277-279 of our last issue.

**A. P. B.** (Bournemouth) raises a point concerning the .1-microfarad condenser connected to the earth end of the first coil secondary winding in the "Certainty Three." (See circuit diagram on p. 91 of September issue). He wishes to use a condenser of .5 microfarad he happens to have in stock and asks about the pros and cons.

So long as this condenser is of the non-inductive type, its capacity is immaterial, provided it is above a certain minimum value. Its purpose is to complete the first tuned circuit direct to earth without including any portion of the volume-control potentiometer in the path of the high-frequency currents.

Any fairly large capacity will do this, but it is to be noted that, since there is no such condenser in series with the second tuned circuit, the capacity must be great enough to have a negligible effect on the tuning. A smaller value than that given would serve quite effectively as a by-pass, but would make it difficult to get the two circuits to track properly; one would be driven to continual adjustment of the trimmers.



## Hints for the Service Engineer

Mr. Kendall departs somewhat from his usual technical hints for service engineers in his contribution to these pages this month: instead he deals with the care necessary when handling and using expensive measuring instruments. His "little sermon" on the fitting of fuses should interest both servicemen and the more serious-minded constructors

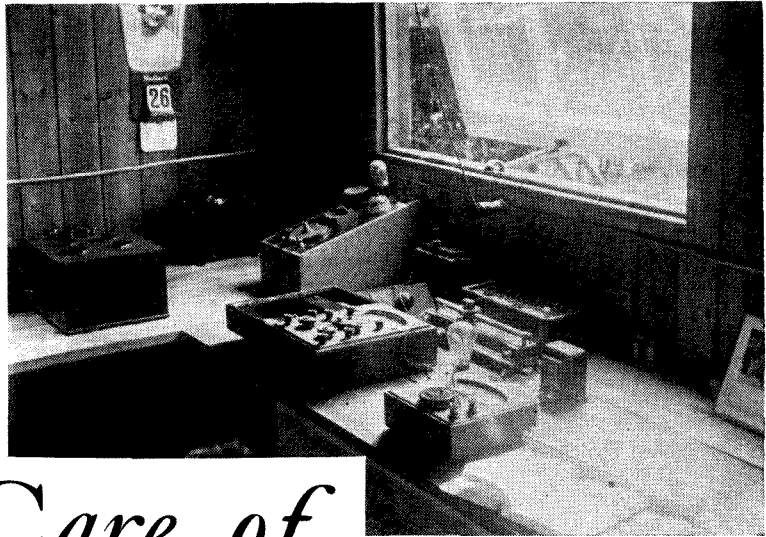

"Damp should be avoided because when a meter is taken into a warm room the moisture condenses on the inner surface of the glass face."

# Taking Care of Your Meters

By G. P. KENDALL, B.Sc.

CONSIDERING how dependent is the service engineer upon his test apparatus, it always surprises me to see with what scant respect some members of the profession treat quite expensive instruments. It may be natural to regard one's everyday tools with a certain familiarity, but there is reason in all things, and I am going to yield to the temptation to preach a little sermon on the subject this month in the hope that it may prevent a few burnt-out milliammeter windings and bent voltmeter needles!

Before you decide to turn over the page in search of something more interesting, let me try to catch your attention with a question: do you know how to prevent the needle of a sensitive micro-ammeter from swinging wildly about and perhaps damaging itself or the delicate movement when the instrument is carried about? Agreed that few people are fortunate enough to possess such a meter, nevertheless, the question will serve its purpose of demonstrating that there is more than meets the eye in this matter of the care of instruments.

Having asked the question, I had better answer it: in some cases a delicate meter of this type is fitted with a device for locking the needle for carrying, but this is not always provided; one then wants to know how to safeguard what is inevitably a pretty costly instrument.

It is actually quite a simple trick, consisting merely in the shorting together of the terminals of the meter with a bit of wire. The effect is to provide a path for the currents generated in the windings by the swinging of the needle and its attached coil, and so to allow them to set up magnetic effects opposing the motion. One thus adds a strong electro-magnetic damping action quite capable of stopping harmful oscillation of the movement so long as the instrument is handled with ordinary care when it is carried about.

have done it at least once, yet the risk is one capable of elimination by a very simple precaution: one has but to make a habit of asking oneself what current is likely to be found in the circuit, and then always applying a meter with a full-scale reading *not less than double the expected figure*.

A difficulty arises when the circuit is not known within even very wide limits, but even then there is no reason why any real risk should be run; a milliammeter reading up to 500 m/a is a useful sort of instrument to possess in these days of universal valves, and if one makes it a rule to insert this as a first rough check in any circuit carrying an unknown current, one can find out with certainty which of one's lower scale meters may safely be used to make an accurate measurement.

## Safety First Fuses

Again, it is no bad idea to consider fitting fuses to protect all milliammeters, human forgetfulness being what it is; Ferranti meters incorporate such fuses as an integral part of the design, and although they may cause a certain amount of irritation by blowing on very small overloads at awkward moments, they must have saved their users hundreds of pounds in repairs by now.

It is quite a simple matter to fit a fuse to almost any milliammeter, since one knows precisely what current must be carried, and the peace of mind resulting is well worth going to a trifle of trouble to get. It is not, perhaps, so generally known as it should be that fuses in a great variety of ratings, and guaranteed to blow on a very small overload, can be obtained very cheaply for these purposes.

The type of fuse I have in mind consists, I believe, of a film of deposited gold produced by a special process, and it is sold under the name of "Microfuse." I

have no interest in the firm that makes them (I wish I had!), so when I suggest that my readers would do well to investigate their merits, I trust it will be realised that my advice is not influenced by any ulterior motives!

The multi-range meter presents its own special problems if it is to be used with the minimum risk of overload, but it is quite easy to learn a habit guaranteed to ensure safety: simply make a rule to set the switch or other range-selecting device to the *highest* range before placing the meter in circuit. Take a rough check reading, then turn to the scale where this figure will be conveniently placed for making a proper measurement.

### Fuses for Multi-range Meters

If that is always done as a matter of invariable course, the risk of burn-outs will to all intents and purposes be eliminated: the chance of the current coming off the top of the highest scale is pretty remote with the more common types of multiple instruments.

To fit effective fusing to a multiple meter is usually rather difficult, by the way; an external fuse can only be rated to give protection on the highest current range, for obvious reasons, and an internal one is not as a rule very easy to fit. Some multi-range instruments are provided with such a fuse, the "Avo" being a typical example, and in these cases it is commonly placed in series with the actuating winding and so is unaffected by the action of the various shunts for the higher ranges.

### Interfering With the Innards

One is rather in the dark with any multiple meter, but it is usually safe to assume that on the lowest current range the actuating winding is being used unshunted, and to insert in series with it a fuse of suitable rating for that range. Naturally, this involves interfering with the innards of the meter in a manner of which the maker might not approve, and one should think twice about doing it.

The multi-range voltmeter is generally a simpler proposition. The same safety rule of starting off with the highest range for a rough check in all cases of doubt will avoid practically all risk of damage, so long as the top range is something like 500 volts, as it usually is. This simple trick has saved me many an unpleasant surprise, and at the risk of being boresome I would strongly urge every user of meters to adopt it as regular procedure.

To fit a fuse to a voltmeter one must know its full-scale current, and this is readily obtained from a knowledge of its "ohms per volt" rating. For example, in the common 200 ohms per volt type, one simply multiplies the full scale reading by 200 to find the total resistance and then applies Ohm's Law to find the current flowing when the maximum voltage is applied.

At least, that is what you do if you want to proceed in stages and so more readily understand what you are doing: if you merely want the result quickly, all you do is to divide 1,000 by the ohms per volt, and there is your current in milliamperes!

It works out this way: you first take the total resistance of the meter, which is  $OPV \times E$ , "OPV" being the ohms per volt rating and "E" the full-scale reading, and then insert this in the " $C = E/R$ " form of Ohm's Law, thus:  $C = \frac{E}{OPV \times E}$ . Here we have an expression with "E" both above and below the line so we can cancel it out and are then left with  $\frac{1}{OPV}$ . This is the current expressed as a fraction of an ampere, so next we multiply by 1,000, and arrive at  $\frac{1,000}{OPV}$ , and that was what we set out to get (the current in milliamperes).

### General Precautions

General precautions for the care of meters, such as the avoidance of severe bumps and vibration are pretty well understood by most people, but there are one or two little known snags that should be mentioned. For example, how many of us always remember that powerful magnetic fields are bad for any kind of meter of the electro-magnetic type? The point does not often arise, but I *have* seen a voltmeter rested on the field magnet of a dynamo while the brush voltage was being read!

That kind of thing is really very naughty, for it must be remembered that the accuracy of a meter depends upon the state of health or otherwise of the permanent magnet it contains, and moreover, if the meter is placed in a strong field the reading taken at that moment cannot be accurate.

Again, few types of meters intended for use in temperate climates are completely sealed against the entry of moisture, so it behoves one to adopt reasonable precautions. If for no other reason, damp should be avoided because when the meter is taken into a warm room, the moisture condenses on the inner surface of the glass face; rather an obvious point, perhaps, but one *does* forget about it sometimes!



"... a habit guaranteed to ensure safety; make a rule to set the switch to the highest range before placing the meter in circuit."

The New Year Number of "Wireless Magazine" will contain Special Articles for Short-wave Enthusiasts and More News of the British Listeners Long-distance Club.

Before I close for this month I should just like to explain for the benefit of those who are building the modulated oscillator designed for us by Mr. Tyers that some further information about a dummy aerial circuit for use therewith is now being prepared for publication. The article is nearly finished and I hope that space will be found for it in an early issue.

# How to Choose A New Set for Xmas

By the "W.M." Set Selection Bureau



This article has been primarily written to introduce the "W.M." Set Selection Bureau and its work to new readers. We have explained the six questions to which answers have to be given by readers when requesting advice, and have shown the important part price plays in the selection of a receiver. This article should do much to help the ordinary listener understand which set is suited to his own particular requirements



WHEREVER you go, in the train, in a café, in your club, a topic of conversation that usually leads to nowhere is the discussion of a new radio set. Invariably when the vital question comes into the open: "What set do you recommend?" the answers given are vague; more often than not the question is by-passed by the reply, "I've got a so-

and-so, which isn't too bad, but if I were you I would try such-and-such."

Unfortunately as time goes on set makers by the dozen are introducing many new sets, which on paper all seem to be as good as each other, and the half-frantic set buyer really does not know which way to turn.

Therefore for the benefit of new readers, of whom we

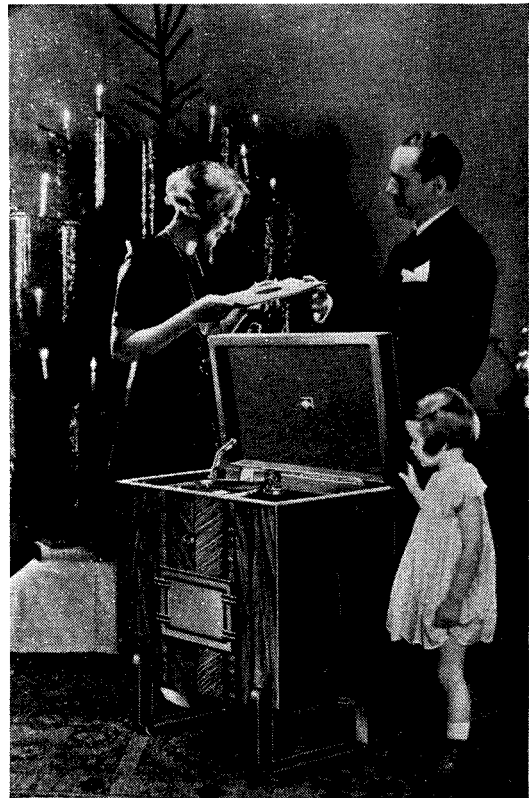

An ideal family present for the Christmas season is a radiogram. Really good radiograms can be purchased for as little as £20 to £25. This Marcomiphone 287 is a recommended type

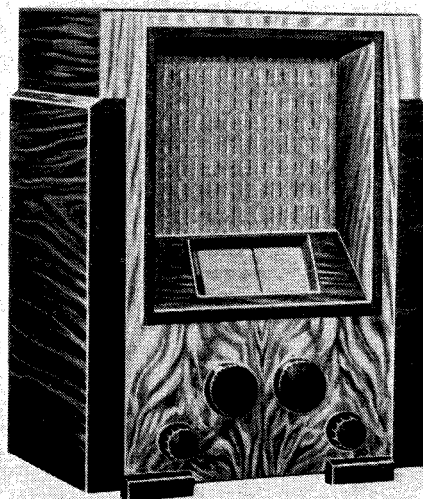
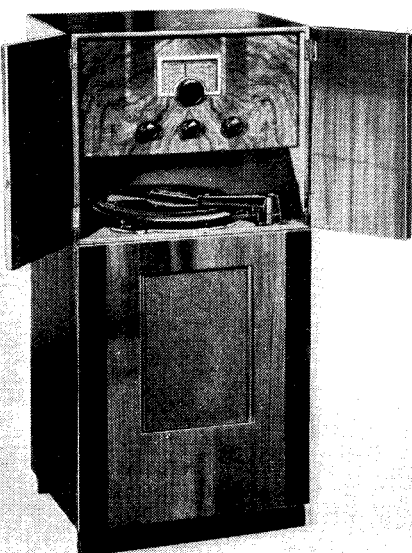

(Left) Blue Spot manufacture a rather unusual form of radiogram known as the model AG5G for A.C. mains operation. Accessibility seems to be the chief merit of this design

(Right) The Halcyon model ACT, a very attractive receiver with many refinements, including visual tuner, A.V.C., and a form of automatic volume compensation

expect quite a number this month, we propose to describe the methods and aims of the Set Selection Bureau and to give a few pointers which will make the choice of a new set not such a difficult matter as it would appear at first sight.

Every month we publish a panel with six simple questions, and those seeking advice from the Bureau must answer each one of these.

Question (1) concerns the maximum price you wish to pay. Radio receivers are very much like saucepans in the matter of price; the more you pay the better receiver you will get, though it must be remembered that there are exceptions to every rule.

Price at least above, say, the £12 mark, does not govern the number of stations you are likely to receive. For £10 to £12 you can buy a sensitive superhet receiver that will enable you to log fifty stations with little trouble. If you are prepared to pay £50 for a receiver alone what then can you expect to receive for the extra £40? In a nutshell, the higher price means that (1), the cabinet will be better; (2) the quality and volume should be better and greater; and (3) it should be easier to handle, though that is by no means a general rule.

On the other hand one can pay as much as £70 for a receiver that will get just the two local stations and perhaps half-a-dozen of the more powerful European stations. The real advantage in a set of this type is that volume is usually more

than is wanted for domestic requirements and the question of quality of reproduction has been tackled so thoroughly [that one is led to believe that perfection has at last been obtained.

This question (1) is really part and parcel of question (3). It is a fairly safe rule that the fewer stations required, the better will be the quality, and the more one is prepared to pay the better will be the quality.

Question (2), the locality in which the set is to be used, is of considerable importance. If the set is to be installed two or three miles from a Regional centre then obviously the question of selectivity comes before all others.

A superhet is always advised when the listener lives within an area of about ten miles from a local B.B.C. regional centre. And if the particular centre happens to be Droitwich then the most selective of superhets is essential.

Listeners outside these areas can, if they wish, use a straight set with one or two high-frequency stages. This discussion is bringing us to the old problem of whether the straight set is better than the superhet or vice-versa. There isn't space to go fully into that subject here, but our honest opinion on the matter is that better quality can be obtained from the straight receiver. And 80% of British sets today are superhets!

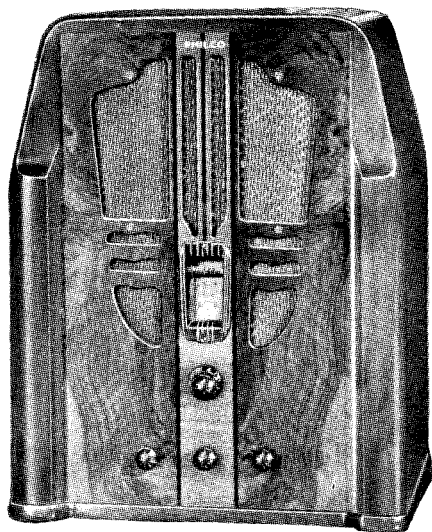

Philco's seven-valve all-wave receiver for A.C. mains operation—an outstanding example of the best in all-wave radio

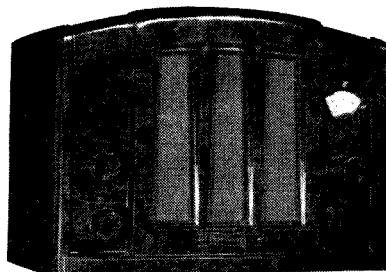

Six-and-a-half guineas is the price of this Phillips two-valver, which is for operation off A.C. mains. An ideal set for those who want local station reception at a low cost

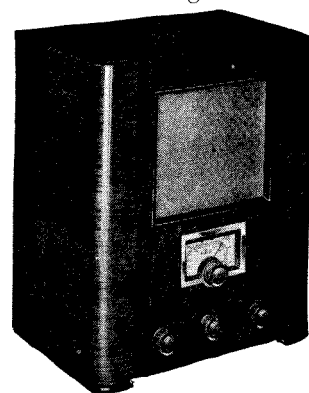

For the battery-set user who wants a de-luxe three-valver, the G.E.C. Battery S.G.3, which incorporates a built-in moving-coil loud-speaker

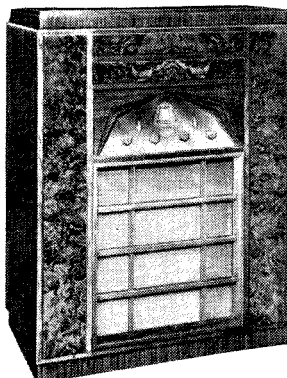

For those who have plenty of money to spare and who want the best that radio engineers can devise—the R.G.D. all-wave automatic A.C. radiogram

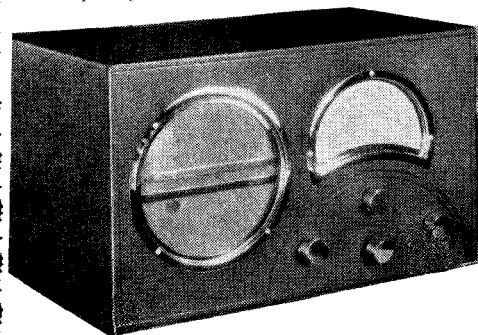

(Left) An outstanding example of the straight three A.C. mains receiver, the model 235 made by Marconiphone

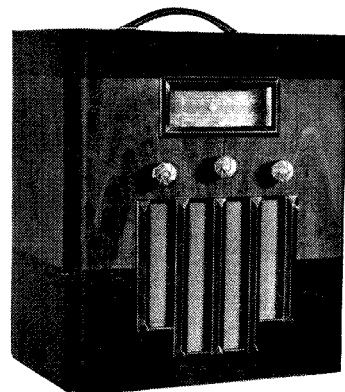

Portables are preferred by many battery-set users. Here is the Pye model T/Q, which has a moving-coil loudspeaker and a daylight-lit scale

Superhets will give you wonderful selectivity and will enable you to log and listen to dozens of alternatives to the B.B.C. programmes, but we prefer less selectivity and fewer stations together with that little better quality that the superhet cannot give, as yet.

This year we have noticed that several big manufacturers have entered the market with straight sets employing one high-frequency stage. Not one, though, has brought out a straight A.C. receiver with two high-frequency stages costing less than £15. Such sets are more difficult to turn out from the testing point of view, but we think the extra trouble, which would mean extra cost, would repay manufacturers in the long run because such a receiver would find a ready market among set buyers who put quality before anything else.

If there is a set maker marketing two-H.F. receivers for A.C. mains for less than £15 we apologise for our remarks, and we will make amends in a future issue of "W.M."

Question (4) needs little explanation. The obvious advantage of a self-contained set is that you can move it about from room to room, or place to place, without

bothering about aeriels and earths. A particularly useful set in this class is the mains transportable for one can get all the benefits of a mains set, better quality and greater volume, the only external connection necessary being a lead to a mains socket.

Disadvantages are practically nil. Most sets of this type have an extra high-frequency stage to make up for the loss of efficiency due to a small built-in aerial, and our tests have shown that as far as station-getting is concerned there is little to choose between them and ordinary sets requiring external aerial and earth.

The question of power supply can be boiled down simply to the rule that if you are blessed with an A.C. mains supply, then obviously have an A.C. receiver; if the domestic supply is D.C. and there is little likelihood of its being changed to A.C. then invest in a D.C. set; if the supply is D.C. and it is to be changed to A.C. then an A.C./D.C. set is called for. Anyone on D.C. mains should before buying a D.C. receiver, get in touch with

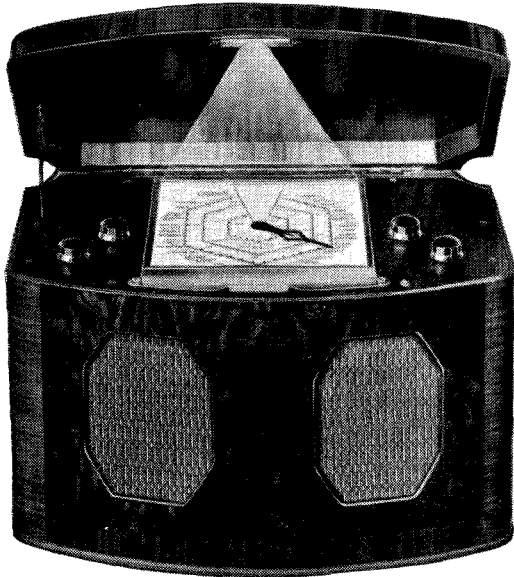

One of the few twin-speaker superhets on the market today, the McMichael model 135 has probably a larger tuning scale than any other British-made radio receiver

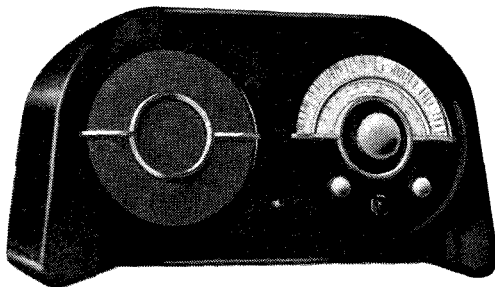

One of the most successful A.C. superhets in the popular price class, the Ekco model AC 86 has an all-bakelite cabinet

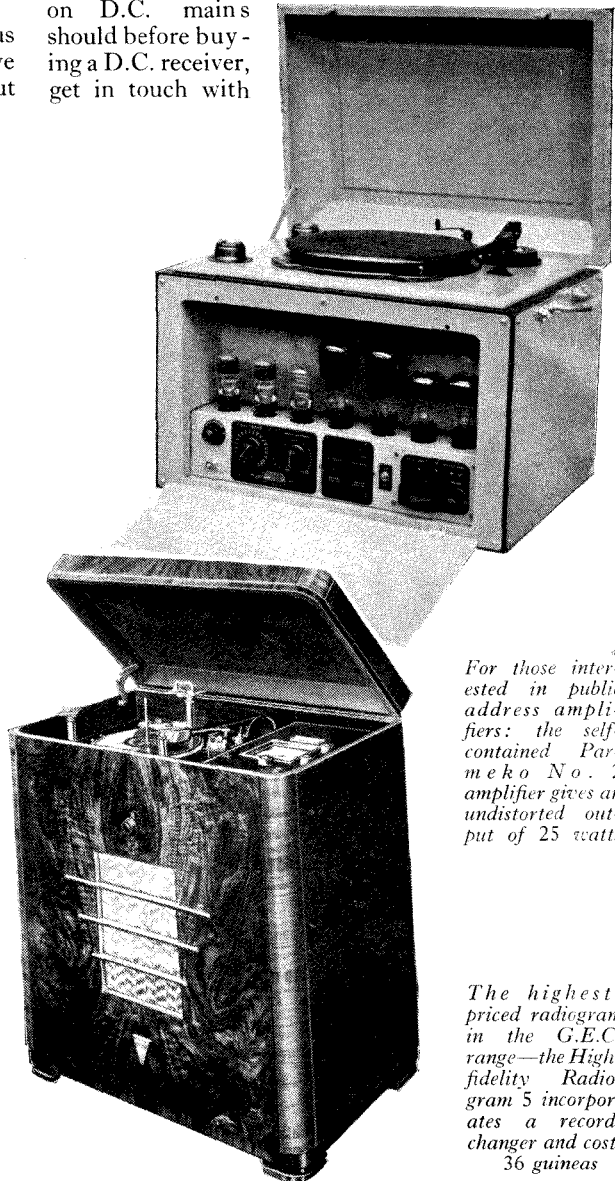

For those interested in public address amplifiers: the self-contained Parmeko No. 2 amplifier gives an undistorted output of 25 watts

The highest-priced radiogram in the G.E.C. range—the High-fidelity Radiogram 5 incorporates a record-changer and costs 36 guineas



the local supply company and make sure whether the supply is to be changed in the near future; in consequence of the grid system D.C. mains are being changed to A.C. with increasing rapidity.

Question (6) is the medium for you to express your own particular whims regarding appearance; whether a radiogram, table or console, and for explaining fully the conditions under which the set will be used. When writing to the Bureau we ask you to make the fullest use of this question for it is the remarks here that enable us to give real personal help to the enquirer.

An example of this is shown in the Bureau's article in the last issue. From here it will be seen that quality every time is the major requirement and money is usually of little concern when considering the question. Even cabinet looks are completely forgotten in the modern quest of true reproduction.

Our remarks have been directed primarily for the man who wants a radio set only. When considering a radio gramophone the listener must be generous about the price he is prepared to pay. In ninety-nine cases out of a hundred the set chassis of a radiogram is also

marketed in a table cabinet, the price of which is about £10 less than the radiogram.

A reliable radiogram for mains operation can be purchased for as little as £20 or £25, and the set chassis used is that which would be found in a table receiver priced between £10 and £15. At the time of going to press, however, a well-known firm has released details of a radiogram for A.C. mains for as little as

### Free Advice for ALL Set Buyers —see the last page of this issue

sixteen guineas; the set chassis being a three-valver, for A.C. mains operation, with a 2.5-watt output valve. We expect the performance of this to be of a very high level—our report will appear shortly.

We have attempted to show you in the limited space at our disposal the reasons for the six questions in the advice panel.

We have deliberately refrained from discussing the various makes of set available and concentrated more on types needed to fulfil certain conditions.

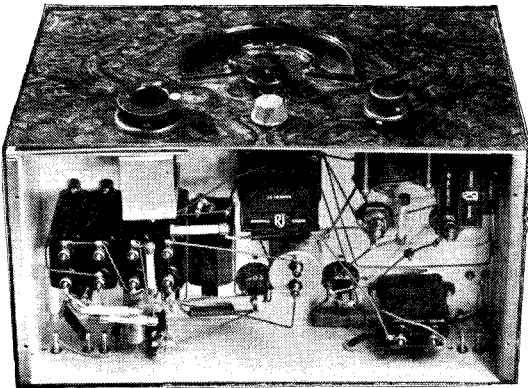

For short-wave enthusiasts who prefer to build their own receivers—the B.T.S. A.C./D.C. kit. A blueprint and wiring diagram with full instructions are provided with the kit of parts

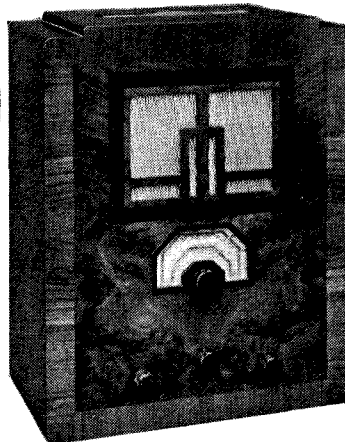

An ideal form of mains transportable, the Kolster Brandes model 425 is for operation off either A.C. or D.C. mains

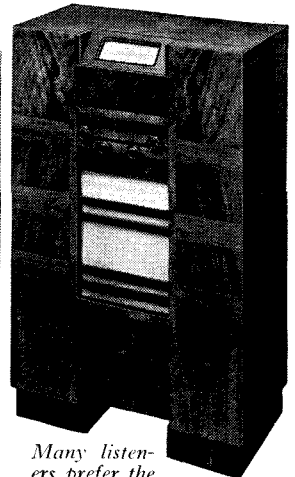

Many listeners prefer the console type of receiver. Here is a typical H.M.V. model, the Superhet QAVC Console Five, an ideal set of its type

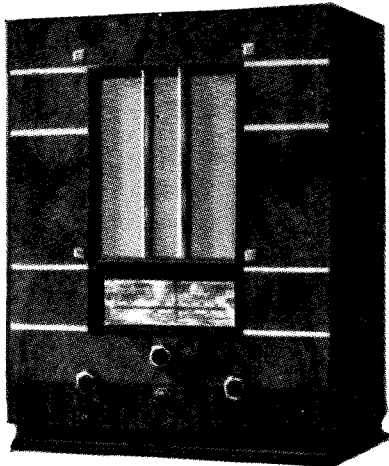

Ferranti sets are notable for the provision of a large tuning scale calibrated in wavelengths and station names as well as indicators for all controls. This set is their famous Arcadia, one of the best of table superhets



Here is Hildegarde, the charming Continental cabaret and broadcasting artist, listening to her new Cossor receiver—model 369, a straight three-valver for operation off A.C. or D.C. mains, costing £8 18s. 6d.

# Marconiphone 236

## A.C./D.C Console

**F**RANKLY, we prefer the console type of receiver, such as this Marconiphone 236, to the more conventional type of table receiver. In the first place, the increased baffle area afforded to the loud-speaker as opposed to the more cramped-up layout of the table set does help to improve the quality of reproduction; further, as a piece of furniture the small extra cost is really worth while.

The cabinet of this 236 is very tastefully designed though modern in looks, and of still greater importance, the wood used and the finish are good.

The set chassis makes use of a three-valve circuit and is for operation off A.C. and D.C. mains without alteration. As you can see from the specification panel, the circuit is a particularly advanced one, the three valves all being of the multi-grid type. Another important feature of the specification is that Litz-wound coils are used and this, no doubt, accounts partly for the very satisfactory performance of the receiver.

Three controls and the tuning scale are mounted on the face of the cabinet; from the left these are the volume control, tuner and wave-change switch. The on-off switch is separate, being fixed on the left-hand side of the cabinet at a very convenient height. Incorporated with the tuning control is a push-pull sensitivity switch, the knob being pulled outwards for maximum sensitivity.

**O**n test we found this control of real value. In the "maximum" position the set behaved well; almost any station could be logged, though the background noise was a little fierce for the very weak ones. This, however, is to be expected in any superhet, especially the smaller types.

In its "in" position, we could log only the locals and the more powerful foreigners, but they were heard free of any form of crackle and general noise.

The tuning scale is brilliantly illuminated when the set is on and the wavelength and station-name calibrations can be read easily at some distance from the set. On the back of the set are sockets for earth and two aerial tappings; the choice of aerial tappings is purely and simply a matter of personal test. There is no provision for the use of a pick-up.

We give the makers full credit for the "safety-first" arrangement of the mains lead and the fact that the set cannot be used when the back protection has been removed. When the back is taken off the circuit of a safety-switch device is broken and the mains supply is disconnected from the set chassis. Further, there is a fuse in each lead, and a spare fuse is provided on a fuseboard fitted to the chassis.

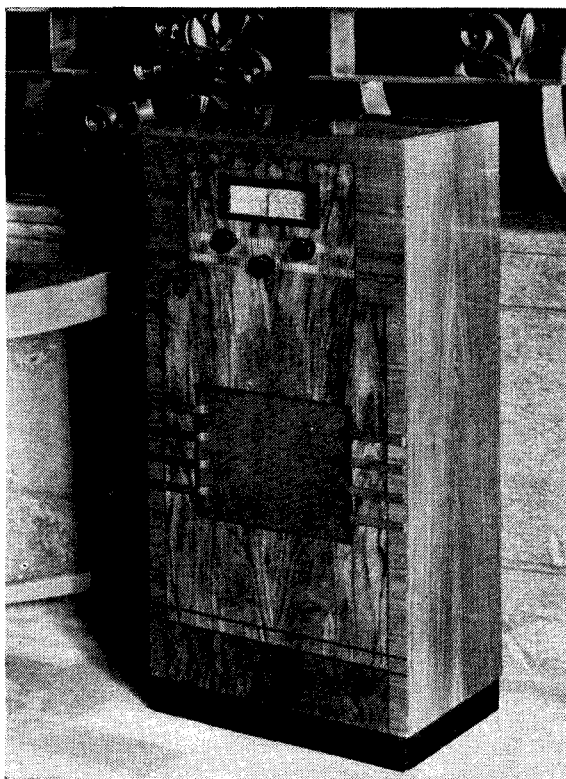

*"The cabinet of this 236 is very tastefully designed, and of still greater importance, the wood used and the finish are good"*

So much for what the set is. Now for what it will do.

We were extremely pleased and surprised with the performance. We admit that at first we counted three receiving valves and were a little sceptical about the performance, especially in daylight hours. Our greatest surprise was undoubtedly obtained during our first daylight tests.

**T**he performance was more up to the standard of the five-valve receiver as far as sensitivity was concerned. We found that with an average 60-ft. outdoor wire and a good earth we could log all the British locals and eight or nine foreigners at any time of the day. Radio Normandy was so strong that we had to make full use of the volume control. This result was, of course, obtained with the sensitivity switch at the "maximum" position.

Long waves, too, gave us a similar satisfactory performance; both selectivity and sensitivity were good. At night we experienced no difficulty in tuning-in any European station; in fact, our medium-wave log reached the large figure of fifty-two stations.

The output pentode gives roughly 2.5 watts undistorted output and this feeding into a large moving-coil loudspeaker provided extremely pleasant quality.

The power consumption is of the order of 90 watts; which means about eleven hours' entertainment for the price of one unit of electricity.

### BRIEF SPECIFICATION

BRAND NAME: Marconiphone.

MODEL: 236.

PRICE: £15 15s.

VALVE COMBINATION: A four-valve (including rectifier) superhet with a heptode combined oscillator and first detector (Marconi X30), a combined intermediate-frequency amplifier, second detector and A.V.C. valve (Marconi WD30) resistance-capacity coupled to a steep-slope output pentode (Marconi N30). The fourth valve (Marconi U30) acts as a high-tension rectifier on A.C. mains and low series resistance on D.C.

POWER SUPPLY: A.C. or D.C. mains, 195 to 255 volts (A.C. mains frequencies of 25 and 60 cycles).

MAKERS: The Marconiphone Co., Ltd., Radio House, Tottenham Court Road, London, W.1.

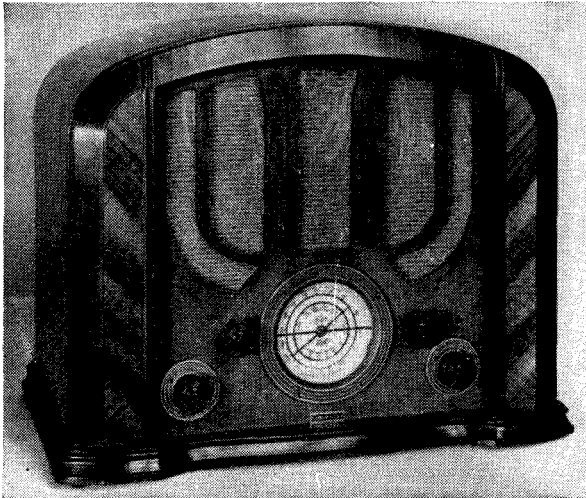

*"Its price is so reasonable that we know it will find a ready market among set buyers in this country and abroad"*

**U**SEFUL set, this new Pilot any-mains all-waver ! Its specification is so comprehensive, and its price so reasonable that we know it will find a ready market among set buyers in this country and abroad. By the way, the set is made in the U.S.A.

It is for use on either A.C. or D.C. mains (details in the panel) and it covers a wave-range of from 16 to 51 metres on the short waves, 182 to 555 metres on the medium, and 731 to 2,140 metres on the long.

Technically, the circuit is an advanced one; it contains all the refinements that are the making of a good receiver. First of all, it has a stage of high-frequency amplification before the detector oscillator, and this ensures good sensitivity—a point clearly demonstrated during our short daylight tests. You will note from the panel that the set is suitable for use on rather low mains voltages—110 to 125 volts.

**A**ctually this is the correct input voltage to the receiver. On the higher 200-250-volt ranges—the usual standard in this country—an external mains-dropping resistance in the form of a mains-connection cord is provided with the receiver.

Some idea of the specification can be appreciated by a glance at the controls on the front of the cabinet—this, by the way, is quite small and of quite pleasing appearance, measuring some 14½ in. wide overall, 12 in. high, and 8½ in. deep. Nearly a midget !

From left to right, the first knob is a combined on-off switch and *tone* control; the second is the volume control. In the centre is a clock-face dial, calibrated in metres for the long and medium waves in the top half, and in metres for the short waves, and a further kilocycle calibration for the medium waves in the bottom half. This scale is brilliantly illuminated when the set is on.

The third knob is the main tuner, which when pulled outwards gives an 80 to 1 slow-motion drive for the short waves. The fourth knob is the wave-change switch for the three

## Pilot All-wave A.C./D.C. Receiver

bands. Inside the cabinet one will find a "typical American" chassis with every component, except the output valve and rectifier, completely screened. A small lead projects from the chassis for the aerial connection; no earth is needed. The loudspeaker is of the energised moving-coil type; quite small with a 4½ in. diameter cone.

**W**e spent many pleasant hours in company with the Pilot 125. Particularly were we pleased with the performance on the short waves. The slow-motion drive enables one to tune with little trouble and this fact, coupled with the set's amazing sensitivity, makes us feel that anyone who can handle an ordinary broadcast set would immediately become an enthusiastic short-wave fan.

We first tasted the short-wave capabilities of the 125 during a mid-day sitting and were rewarded with Rome, Berlin, and Moscow giving good entertaining reception and with some British amateurs, who were talking about

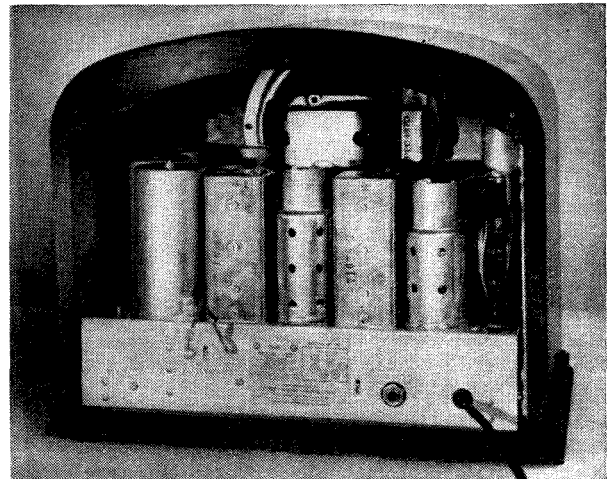

*"A typically American chassis with every component, except the output valve and rectifier, completely screened"*

the merits of various types of mikes. At night, North America was an easy bag, sponsored programmes being obtained from six different sources. W2XAF on 31.48 metres was almost up to "local" standard.

On the medium waves we found the most impressive feature, and one which any user cannot but appreciate after one sitting, was the high degree of sensitivity. At night there is a station at any and every point on the scale; even below London National we logged ten stations worth hearing.

Quality was satisfactory. There is ample volume available to fill an average room, although the rated speech output is only 1 watt.

### BRIEF SPECIFICATION

**BRAND NAME:** Pilot.  
**MODEL:** 125.  
**PRICE:** £13 13s.  
**VALVE COMBINATION:** Six valves (including rectifier) in superhet sequence. The combination consists of a preliminary high-frequency amplifier (R.C.A. 6D6) before the combined oscillator/detector (R.C.A. 6A7); then follows a single intermediate-frequency amplifier (R.C.A. 6D6), diode-triode second detector (R.C.A. 75), and pentode output (R.C.A. 43). The rectifier is an R.C.A. 25Z5.  
**POWER SUPPLY:** A.C. and/or D.C. mains, 110-125 volts, 200-250 volts (for the higher voltages a special resistance lead is necessary and is provided in the equipment).  
**BRITISH DISTRIBUTORS:** Streamline Radio, Ltd., 146 Theobalds Road, London, W.C.1.

TESTS OF THE NEW SETS

# H.M.V. Popular A.C. Radiogram

H.M.V. has asked us to pass judgment on an A.C. mains radiogram that can be bought for as little as sixteen guineas. Remember that this firm has a reputation (a thing that takes years to build up, and that can be lost in a night), which had to be considered before any thought could be entertained of putting such a cheap instrument on the market.

Our judgment is that the marketing of this radiogram has enhanced that reputation. There is no excuse for anyone to say that the price of a good radiogram is out of his reach; we can assure every listener that the standard of performance of this model 370 lives up, among many things, to the H.M.V. reputation for true-tone reproduction.

The cabinet is rather small, though well made of walnut; it is 34½ in. high, 16 in. wide and 14 in. deep. The design is based on familiar H.M.V. lines.

This model 370 incorporates a straight three-valve circuit with a fourth valve as rectifier. There are four controls on the front of the cabinet. In the centre is the tuner above the combined wave-change and gramo-radio switch; to the left of these is the "Sensitivity" control, consisting of a simple reaction condenser in the detector-anode circuit. The control on the right is the volume control operative on both radio and gramophone.

This control embraces two potentiometers ganged together; as the control is turned the first half-turn operates the potentiometer shunted across the pick-up and the second half turn brings into play a variable resistance connected between cathode and earth of the high-frequency valve. This arrangement ensures that when the gram side is at normal volume the high-frequency valve is set for maximum bias (minimum amplification) and therefore there is no chance of radio being heard as a background to record reproduction.

The on-off switch is fixed to the right-hand side of the cabinet. A feature of the set is its fine tuning scale, semi-circular in shape and calibrated in wavelengths and with the names of over thirty stations. When the set is switched on, a circle of light appears with a fine black line across its centre. As the tuner is turned so this spot of light moves across the scale.

On the motor-board one has all the refinements of the modern radiogram. The electric motor is of a special low-consumption type and is fitted with an automatic stopping and starting device. The cabinet lid is lined with a thickness of flock



"There is no excuse for anyone to say that the price of a good radiogram is out of his reach"

and this prevents any "pick-up chatter" from being audible when the lid is closed.

We need say nothing further about the set itself, except that the loudspeaker is of the energised moving-coil type and is of very generous proportions.

We were more than pleased with the performance on test. On records the quality was good, and we were pleased to notice that the top-note response was well in evidence; further, the bass was definite and there was no trace of boom. Volume was more than adequate for the average room; it should be, for the rated undistorted output is a full 3 watts.

On radio our tests were made on a standard outdoor aerial some 70 ft. long and about 20 miles from London Regional. We tested selectivity first and were rewarded by getting Berlin entirely free of London Regional—this we did with the reaction control well advanced

and with the volume control retarded as much as possible. Altogether on the medium waves we logged 24 stations giving listenable programmes.

On making a further test on a 15-ft. indoor aerial, of ordinary rubber-covered flex, we easily logged sixteen stations on the medium waves and twelve of these fully loaded the pentode output stage.

In daylight the sensitivity was little short of amazing. Nine or ten foreigners was an easy bag. Long waves provided six stations at full strength.



"Four controls on the front of the cabinet . . . on the motor-board one has all the refinements of the modern radiogram"

## BRIEF SPECIFICATION

BRAND NAME: H.M.V.  
MODEL: 370 Radiogram.  
PRICE: £16 16s.

VALVE COMBINATION: Three-valve A.C. (rectifier as fourth) straight receiver. The arrangement consists of a screen-grid high-frequency amplifier (Marconi VMS4B), detector (Marconi MH41) and steep-slope pentode output (Marconi N41). The rectifier is a Marconi U12).

POWER SUPPLY: A.C. mains, 200-250 volts, 50-100 cycles.

MAKERS: The Gramophone Co., Ltd., 98-108 Clerkenwell Road, London, E.C.1.

# Peto-Scott Class-B Battery Four-valver

**T**HIS set arrived in a large carton at our laboratories—rather big, we thought, for an eight-guinea battery four-valver. On unpacking we had many pleasant surprises. The first of the little packages on the top revealed a couple of aerial insulators—white porcelain, too; the second a substantial length of covered wire—this was copper-stranded; next a carrying handle for the accumulator.

After this another package, a little larger, containing a 9s. 9d. Oldham's 2-volt accumulator, with the useful capacity clock for visual indication of the state of charge, an Oldham's 120-volt dry battery and a 9-volt grid bias battery.

In other words a *complete* radio

## BRIEF SPECIFICATION

BRAND NAME : Peto Scott.

MODEL : 1936 Band-pass Battery Class-B 4.

PRICE : £8 8s. (including batteries and accessories).

VALVE COMBINATION : Variable- $\mu$  high-frequency pentode as High-frequency amplifier (Tungsram HP211), triode detector (Tungsram HR210), first-low-frequency amplifier (Tungsram LD210) and class-B output valve (Tungsram CB220).

POWER SUPPLY : 2-volt battery for low-tension; 120-volt high-tension battery and 9-volt grid-bias battery.

MAKERS : The Peto Scott Co., Ltd., 77 City Road, London, E. C. 1.

installation except for the aerial pole!

We were rather taken aback with the large size of the cabinet, by far the largest of all the table-cabinet sets we have tested this year; it measures 17 in. across, 20½ in. high, and 10½ in. deep.

Anyone will be able to install the receiver; the instruction booklet is clearly written and there is more than enough room for housing all batteries on the shelf behind the loudspeaker.

The circuit is a well-tryed one, and one that is capable of giving good all-round results. There is a band-pass input circuit to the variable- $\mu$  pentode H.F. amplifier, then follows another tuned circuit, of course, before the detector, making three tuned circuits in all. One is therefore assured of a reason-

able degree of selectivity.

Reaction is provided in the detector stage, which is followed by a class-B amplifier, consisting of a driver and class-B output valve, the latter giving an undistorted output of 1½ watts with 120 volts high-tension.

This output is fed into a fair-sized permanent-magnet moving-coil loud-speaker of Peto Scott's own manufacture.

**T**he four controls on the front of the cabinet, which, by the way, is finished in walnut veneer, follow the usual practice. In the centre is the tuner above the wave-change switch; on the left a combined on-off switch and high-frequency volume control; while the fourth control on the right is for reaction.

The circular tuning scale is calibrated in metres; the left half for medium waves and the right for long waves. When the medium waveband is in use the left-hand side of the scale is illuminated, and again, the other side is illuminated when the long waves are in use.

As is usual with our tests of battery receivers, we first measured the total anode current taken by the four valves.

The figure varies on a class-B receiver according to the volume. For normal room-strength the anode current varied between 10 and 12 milliamperes. The quiescent current, that is the current with no signals, was just under 10 milliamperes.

With the B.B.C. Symphony Orchestra making a large noise and the volume control set to give the full 1½-watt output, the milliammeter needle flicked between 12 and 16 milliamperes. From these figures we can safely deduce that the average current over a period would probably amount to about 14 milliamperes.

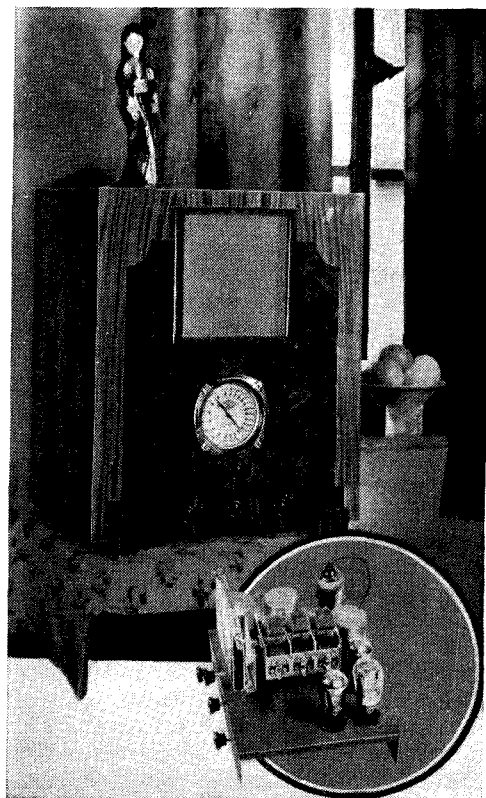

"Major attractions . . . good quality and ample volume from the local stations and more powerful foreigners"

We consider that one of the major attractions of this set is the good quality and ample volume one can get from the local stations and more powerful foreigners. One can truthfully say that, except for a slight deficiency in the bass, it would be hard to tell whether it was a mains set or not.

**S**electivity was as we expected—very satisfactory. There are two aerial tappings and we found with the tapping A1, for maximum sensitivity, we could log twenty or so alternatives to the local station on the medium waveband. On the long waves we logged five stations well, including Droitwich.

Just two further important points. One: there is no provision for connecting a pick-up, and two: we found that a good earth was essential for the best results. Sensitivity was fairly uniform and there was no noticeable falling off at the top or bottom ends of the wavebands, which are from 200 to 550 metres, and from 1,000 to 2,000 metres.

This is a good battery receiver and we feel that it will appeal to those who want plenty of volume and good quality.



## In Tune With the Trade

Continued from page 324

operation only, priced at fifty-five guineas. This has nine valves in superhet sequence, a push-pull output stage delivering 6 watts to a large moving-coil loudspeaker, all housed in one of the neatest super cabinets I have ever seen.

Another Cossor production that rather takes my fancy is a sixteen-guinea table radiogram for A.C. mains. I could write pages about these Cossor sets, but space is limited and, after all, you can get a catalogue and see for yourself. Just fill in the coupon!

497

### GOLTONE RADIO AND ACCESSORIES CATALOGUE

I THINK I am right in saying that the Goltone annual is the largest of all radio gadget catalogues. Each page measures some 8 in. by 11 in. and there are sixty pages.

To give you even the barest outline of all the apparatus listed would take two or three pages of this journal, but here is a list of some of the more interesting items.

Electric soldering irons from 5s. upwards; fuse plugs for protecting radio clocks and receivers; iron-cored coils for all types of receivers; aerial accessories including the Statofomer system for stopping electrical interference; A.C. chargers for charging the low-tension accumulator at home (a .5-ampere charger costs only £1 2s. 6d.—a very profitable investment); switches, meters, and a host of interesting gear. This catalogue, you must agree, is well worth having!

498

#### SEND TO US FOR THESE CATALOGUES!

Here we review the newest booklets and folders issued by six manufacturers. If you want copies of any or all of them, just cut out this coupon and send it to us. We will see that you get all the literature you desire.

Please indicate the numbers (seen at the end of each paragraph) of the catalogues you want below:—

My name and address are:—

Send this coupon in an unsealed envelope, bearing i.d. stamp, to "Catalogue Service," WIRELESS MAGAZINE, 8-11 Southampton St., W.C.2.  
Valid till December 31

## CHRISTMAS PRESENT SUGGESTIONS

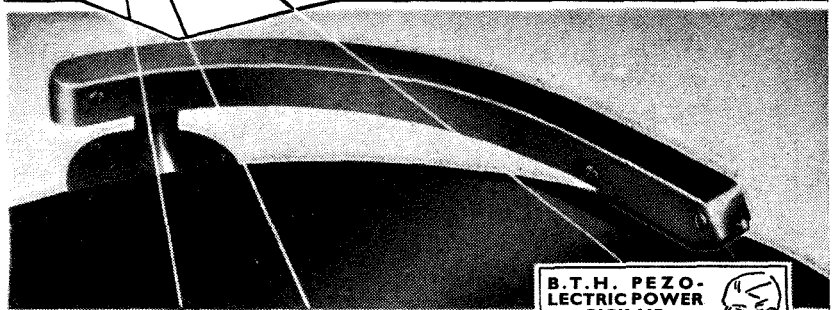

**B.T.H. PEZO-ELECTRIC POWER PICK-UP**  
"The most important contribution to better record reproduction since the original B.T.H. Pick-up." Price **42/-**

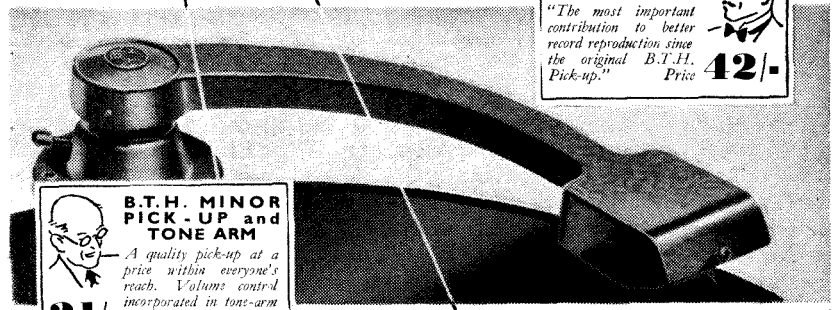

**B.T.H. MINOR PICK-UP and TONE ARM**  
A quality pick-up at a price within everyone's reach. Volume control incorporated in tone-arm pillar. Price **21/-**

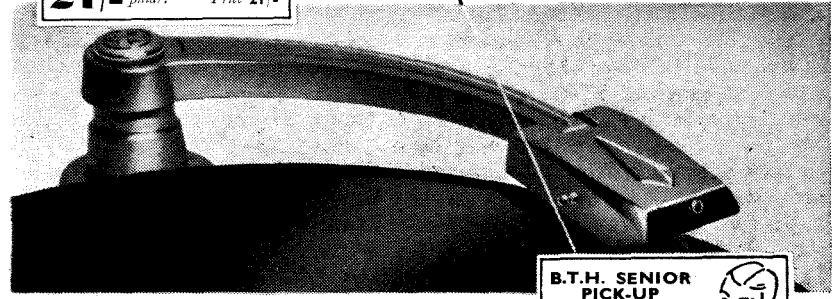

**B.T.H. SENIOR PICK-UP**  
A connoisseur's instrument with a lower voltage output than the Pezo-electric. Price with vol. control **40/-**

HERE is no gift more acceptable to the set-owner than a B.T.H. pick-up. More, it is as much a compliment to the good sense of the sender as it is to the sound judgment of the recipient . . . the sort of gift you don't like parting with.

EDISWAN RADIO 



# PICK-UPS

The Edison Swan Electric Co. Ltd., 155 Charing Cross Road, London, W.C.2

Distributors for The British Thomson-Houston Co. Ltd., Rugby

# "Tuneful" Records

A Review of the  
Record Companies'  
Latest Releases



This photograph of the Rocky Mountaineers, who, by the way never appear in public, was taken in the Columbia recording studios when they made their first record (FB1113). The Mountaineers are a popular radio turn

Strauss' *Thousand and One Nights* is as intoxicating as champagne. . . . *La Villanelle* will leave you breathless with wonder." A record to hear.

Another H.M.V. disc, or rather series of discs, that I have thoroughly enjoyed hearing is Chopin's *Les Sylphides Ballet*, played by the London Philharmonic Orchestra under Dr. Malcolm Sargent on C2781 to 2783 (4s. each). The rendering is good and brings out all the melodious grace that we associate with the name, Chopin.

Somehow or other all the "ordinary" records I have received this month are notable for their tunefulness. Parlophone has sent three 10-in. records of songs from Tauber's new film, *Heart's Desire*, sung by the great Richard himself. I recommend the film's theme song, *Vienna, City of My Dreams*, and *Let Me Awaken Your Heart*, on R020286, as being the most delightful of the four records issued.

William Primrose, viola, records two nice tunes on Columbia DB1585 (2s. 6d.). They

FOR music lovers (serious), the most important event of the month is the formation of "The Purcell Club" by the Decca people. Purcell, who died in 1695, is a neglected composer, and it is the intention of Decca's Purcell Club to foster the interest, which has become evident during the last half-century, in this composer's works. The actual plans of the Club are uncertain, for they depend entirely on the enthusiasm of musicians and record purchasers.

The first work to be released is a complete version of the opera *Dido and Aeneas* in one album, containing seven double-sided 12-in. records at 35s. This opera was composed in Purcell's thirtieth year for a certain Mr. Josias Priest, for performance by the young ladies of his Chelsea Academy. It was heard again in 1700, and it never saw daylight again for over two centuries. I suggest that those really interested write for full particulars to the Purcell Club, at 1-3 Brixton Road, London, S.W.9. By the way, the artists in *Dido and Aeneas* include Mary Hamblin, Mary Jarred, Roy Henderson and the Boyd Neel String Orchestra, under Clarence Raybould.

Sometimes compilers of record catalogues are rather apt to overdo their enthusiasm when describing a masterpiece, but I must pass on what H.M.V. say about *La Villanelle* and *Thousand and One Nights* as sung by Miliza Korjus on H.M.V. C2784 (4s.). It is really a delightful record. H.M.V. say: "This is the best record the Northern nightingale has ever made. She has lost none of the marvellous agility and girlish freshness that first made her name. . . . Her singing of Johann

## B.B.C. THEATRE ORCHESTRA MAKES ITS RECORDING DEBUT

Decca has released two fine 12-inch records of the B.B.C. Theatre Orchestra this month—the first records ever to be made by this much-liked B.B.C. combination. One is a selection of Grace Moore's latest film "On Wings of Song" and the other a selection of Lionel Monckton's most popular tunes. The orchestra is assisted by Isobel Baillie and the Revue Chorus and the productions are conducted by Stanford Robinson. That the standard of performance is par excellence goes without saying and the records will find a large public in the admirers of what is probably the country's finest light orchestra. (Decca K790 and K791, 2s. 6d. each).

are Kreisler's *Liebesfreud* and *Caprice, No. 17*, by Paganini. This is the kind of record you will fall for as soon as you hear it; beautifully played by a brilliant artist and really "easy to listen to."

Sydney Gustard, on the organ of the Gaumont Palace, Chester, plays Gounod's *Funeral March of a Marionette*, and Arndt's *Nola* on H.M.V. BD245. This record comes under the category of light entertainment and therefore costs only 1s. 6d. Recording is good.

Parlophone's orchestral contribution to the month of tuneful discs is Weber's beautiful *Oberon* overture. It is recorded on two ten-inch records by the Grand

Please turn overleaf

# Give Yourself a PIFCO DE LUXE ROTAMETER this Xmas

Buy yourself to-day a Pifco Rotometer-de-luxe (Moving-Coil) and you will receive a complete set of 3 Pifco Valve Adaptors costing 15/- in velvet lined case for 7/6. A Rotometer and set of Valve Adaptors will form a complete test set for your radio.



### PIFCO VALVE ADAPTORS

Each adaptor has a 5-pin base with top sockets for "plug-in" testing of 5, 7 or 9-pin valves under working conditions without alteration to set wiring. Four nickel-plated terminals complete with strapping links are fitted to connect meter in either grid or anode circuit of valve.

### ROTAMETER- DE-LUXE

(9 Ranges including valve test.) Every conceivable test, also valves, can be made with this amazing instrument (400 volts—500 ohms per volt). Black bakelite finish; complete with leads. In handsome velvet-lined case. Price 42/-.

**PIFCO** Ask your dealer to-day to show you Rotameters and Adaptors, or write for Pifco Testmeter Folder, post free, from PIFCO, LTD., SHUDEHILL, MANCHESTER, or 150 Charing Cross Road, London, W.C.2

**ROTAMETERS and RADIOMETERS**  
PIFCO ON THE SPOT WILL TRACE YOUR TROUBLES LIKE A SHOT

## 'Parmeko' features ensure reliability & excellent results

**PARMEKO**

AMPLIFIER

No. 2



Don't buy until you have seen and heard the 'Parmeko' No. 2 amplifier put through its tests. In this amplifier we have a model far above the average in both performance, design and quality. Please get into touch with us and arrange for a demonstration.

Made by: PARTRIDGE & MEE, LTD. Aylestone Park, Leicester

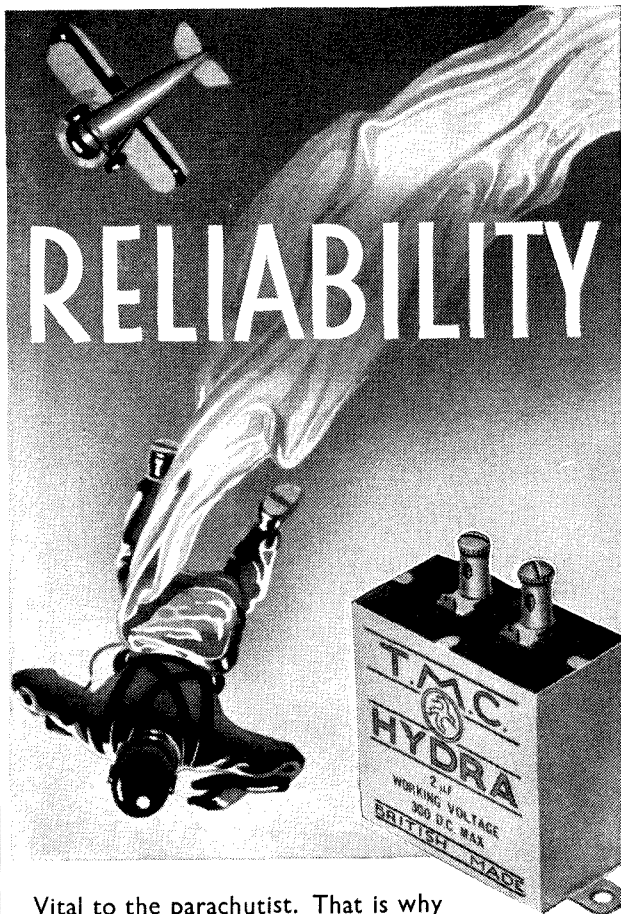

Vital to the parachutist. That is why every item in making up the parachute is tested by lynx-eyed inspectors time and time again. With T.M.C.-HYDRA condensers failure may not be a matter of life and death, but they are just as stringently tested at every stage of their manufacture: all possible precautions are taken to prevent failure or breakdown—that is why T.M.C.-HYDRA condensers are as reliable and as perfect as good condensers can be.

**T.M.C.**   
BRITISH MADE  
**HYDRA**  
**CONDENSERS**

Write for a copy of the new illustrated price list.  
T.M.C.-HARWELL (SALES) LTD  
Britannia House, 233 Shaftesbury Avenue  
London, W.C.2. (A few doors from New Oxford St.)  
Telephone: Temple Bar 0055 (3 lines)

Made by TELEPHONE MANUFACTURING Co. Ltd.

Mention of the "Wireless Magazine" will ensure prompt attention

Symphony Orchestra, under Arthur Bodanzky (2s. 6d. each). I have heard this played a little better, I think; the strings seem a little thin in places.

One more "tuneful" before the really light records: H.M.V.'s Light Opera Company in a double-sided twelve-inch selection of Romberg's *Student Prince*. All the best tunes from the show and very well rendered. (C2785, 4s.)

I have been patiently waiting to tell you about a Parlophone dance record: *Solitude* (Duke Ellington) and *Limehouse Blues*, played by a certain Joe Paradise and his Music. I am told that this is a mystery combination. The band is English and includes three guitars—Albert Harris is one of them—piano, violin, and double bass. The leader is Joe Paradise, a name hiding the identity of one of the most versatile musicians in the country.

I have fallen for the unusual quiet twang of the guitars in *Solitude* and for the "hot" violin and guitar

RECORDS FOR DANCERS

Two records for dancers in strict tempo, without vocal chorus. "Tuckin'" and "Send Me," piano-forte solos by Gerald Moore, Parlophone F297, 1s. 6d.; and "You're Dancing on My Heart" (quickstep) and "Love Passes By" (waltz), Victor Sylvester and His Ballroom Orchestra, Parlo. F240, 1s. 6d.

playing of *Limehouse Blues*. It is really the most sensational dance record of recent months. (Number F288, price 1s. 6d.)

Radio's new film, *Top Hat*, has been responsible for a glut of really good dance records; good, not so much because of the execution, but because the tunes themselves are so catchy. We have on Brunswick Fred Astaire himself accompanied with Leo Reisman and Orchestra. Of these records I like *Cheek to Cheek* and *No Strings*. On H.M.V. Ray Noble presents *Top Hat* (the theme song) and *Piccolino*, with the vocal choruses ably sung by Al Bowly, whilst Decca's best is Ambrose playing *Top Hat* and *Isn't This a Lovely Day*. The



Ray Noble, the famous dance-band conductor and composer, photographed at the H.M.V. studios during his recent visit to England. Ray is second from the left

numbers are RL296 (2s. 6d.), BD247, and F5739 respectively, all priced at 1s. 6d. except the Brunswick.

A special recommendation is Herbert Kuster's Piano Orchestra playing two foxtrots, *Jockey* and *Kleine Sonja*, on Decca F5738 (1s. 6d.). Those of you who turn round the dial of your wireless set for the more melodious type of dance music as heard from German stations will

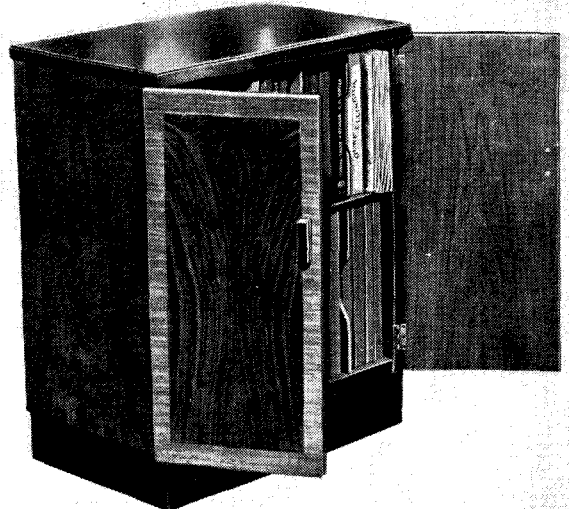

The new record filing cabinet introduced by H.M.V. holds 400 ten- or twelve-inch records. It will also accommodate albums. Finished in figured walnut, it costs only five guineas and is the ideal accessory for radiogram users

enjoy this record. It is a remarkable example of terrifically fast fingers.

Maurice Winnick makes his debut on Parlophone. I recommend F300 with *The Rose in Her Hair* (a charming waltz) and *Just as Long as the World Goes Round and Around* (a really catchy tune from the film, *And I Go Around With You*).

As I was about to finish these notes a further box from Decca arrived with two more *Top Hat* records. This time it was Ginger Rogers, who partners Fred Astaire in the film, singing some of the most popular numbers; you will like her in *Cheek to Cheek* and *The Piccolino* (F5747, 1s. 6d.).

T. F. Henn.

ELIZABETH SCHUMANN SINGS A DUET WITH HERSELF

A novelty from H.M.V.—and a very attractive one—is a record of Elisabeth Schumann singing a duet with herself (DA1439, 4s.). This is the "Evening Prayer," from Humperdinck's fairy opera "Hansel and Gretel," and here we have Miss Schumann singing the parts of both Hansel and Gretel. On the other side she sings two solos from the same opera, "Folk Song" and "Sandman's Song." Another recording, which is in its way a novelty, is the Arthur Bliss Clarinet Quintet, issued by Decca on K780-783; a first-rate performance by Frederick Thurston and the Griller String Quartet. Price 10s. complete.

Registered Trade Mark

# WEARITE IRON-CORED COILS

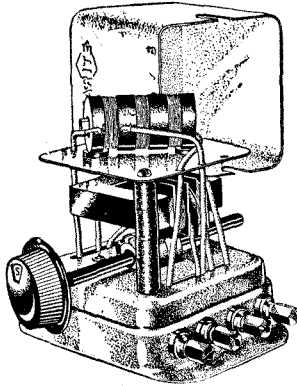

SPECIFIED FOR THE  
'WINNING'  
THREE

- ONE TYPE B.P.1 12/6
- ONE TYPE T.G. 12/6
- Extension Spindle ... 6d.

Also Specified . . . .  
ONE TYPE 1.22 Switch (2 way) ... Price 3/6

Please send me a copy of your NEW and REVISED book (M735) of Wearite components and technical data, also "Lack" prints of NEW series of circuits.

To Messrs, Wright & Weaire, Ltd,  
740 High Rd., Tottenham, London, N.17

NAME .....

ADDRESS .....

W.M. 12.35 .....

CA 7956

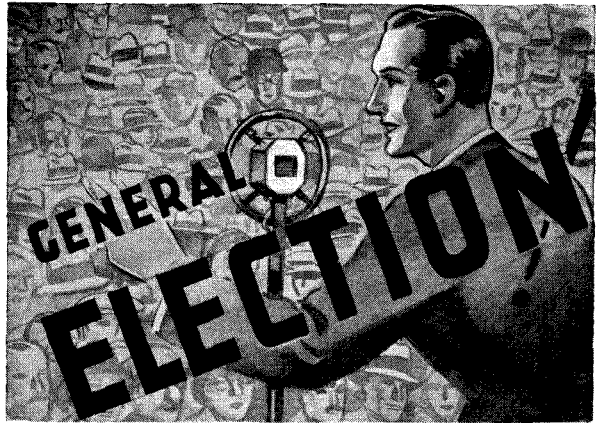

Here is a convenient  
**PORTABLE P.A. OUTFIT**  
that answers a widespread  
and profitable demand

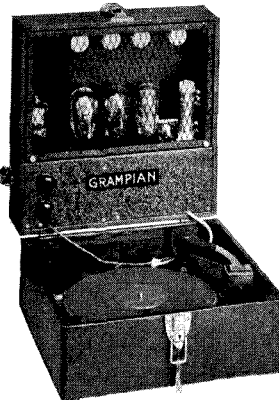

THE 'rush' General Election has caused an intense and unprecedented demand for light portable P.A. Apparatus easily moved from point to point in the constituencies. The Gramplan is the only P.A. Outfit that really fulfils all requirements, and in addition its Gram' attachment allows of the speaker's voice being reproduced from a record anywhere.

● Specification:—  
Universal Amplifier 200-260 volts A.C./D.C. Mains. Marconiphone pick-up. Gramplan High Quality moving coil mic. Electric Turntable. Tone control to suit acoustics in different halls and audio output of 8 watts delivered to Permanent Magnet Moving Coil Speaker. Frequency response of Amplifier within 3 decibels from 30 to 8,000 cycles. Input and output impedance—18 ohms. Hum level 0.2 volts.

The Gramplan P.A. Outfit is completely self-contained. It includes both Gram' section for records, reproduction and Microphone apparatus for direct speech. Weighing but 35 lbs., it packs into a case only 14 in. by 14 in. by 13 in.

**PRICE 24 GNS., WITHOUT GRAM 20 GNS.**

Fulllest details from:—

# GRAMPIAN

PUBLIC ADDRESS EQUIPMENT

GRAMPIAN REPRODUCERS, LTD., KEW GARDENS, SURREY.

## 6 MONTHS GUARANTEE

# 362

**DON'T BE SATISFIED**  
because your "wireless set is all right"—fit 362 Valves and **BE DELIGHTED**  
Replacements for all Standard types

### BATTERY VALVES

SG2 and VS2	7/6	LP2	... ..	4/-
VP2	... ..	P2	... ..	4/6
H2	... ..	ME2 Pentode	... ..	10/-
HL2	... ..	BA2 & BX2	... ..	9/-
L2	... ..	P225	... ..	8/-

### D.C.—UNIVERSAL AND CAR VALVES

UVP	... ..	13/-
UFC	... ..	15/-
UHL	... ..	7/6
UHdd	... ..	9/-
ULP & CLP	... ..	9/-
UPX	... ..	13/-
UME & CME	... ..	13/-
DB (Double Valve Class B)	... ..	20/-

### A.C. MAINS VALVES

A.C. Mains I.H.

ACSG4 & ACVS4	12/6
ACVP4	13/-
ACFC4	15/-
ACHL4	7/6
ACHL4dd	9/-
ACPX	9/-
ACME4	13/-
ACME4C	13/-

### A.C. MAINS D.H.

ACPX4a	... ..	9/-
ACME4a & b	... ..	13/-
ME25	... ..	30/-
PX25	... ..	20/-
PX50	... ..	50/-
RB41	... ..	7/6
RB42	... ..	10/-

FULL DATA & LATEST LIST  
by return from

# RADIO VALVE (CO.) LTD

STONEHAM WORKS  
LONDON, E.5. CLISSOLD 6607.

Mention of the "Wireless Magazine" will ensure prompt attention



# News from the

Conducted by  
G6QB

## Radio Society of Great Britain

**D**ETAILS of several forthcoming R.S.G.B. contests have now been announced. The first is the 3.5-mc. (80-metre) Transmitting contest, held during the week-end November 23 and 24. This and the other tests (excluding the B.E.R.U. contests in February) begin at 16.00 GMT on the Saturday, and finish at 20.00 on the Sunday, with a "closed" period between 11.00 and 15.00 on Sunday.

Thus all operators have exactly 24 hours "on the air," if they make use of the full time, and have an allowance for a few winks of sleep and a Sunday dinner!

The 1.7-mc. (160-metre) contest is staged for January 11 and 12 under the same rules.

An important series of trans-oceanic tests on the 80-metre band has been arranged for December.

# Radio Societies

*Under this heading we publish reports every month of the activities of short-wave and transmitting societies. We shall be pleased to give publicity to any announcement of forthcoming events, etc., and secretaries of short-wave societies, whether national or local, are asked to make the fullest use of this space*

Numerous American stations are always heard on the 80-metre band during the winter months, but this year the tests have been organised in rather greater detail than usual.

In the first series (December 15-18) all European stations are asked to keep silent between 23.45 and 24.00 GMT; all others to be silent from 00.00 to 00.15 GMT; and a "free for all" period lasts from 00.15 till 02.00.

During the second series (December 19-22) these three periods become, respectively, 05.00 till 05.15; 05.15 till 05.30; and 05.30 till 08.00. The band has also been split up in an arbitrary fashion so that telephony and C.W. do not overlap too seriously.

All receiving stations should find much to interest them during this period, since it is not often that one has an opportunity of listening

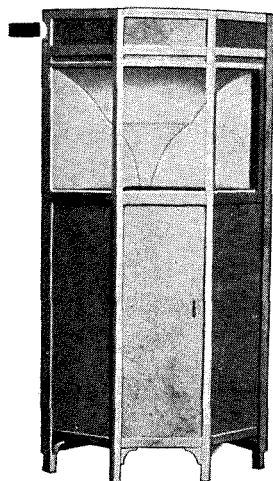

The luxury walnut cabinet loud-speaker illustrated in the review that appeared in the October issue is £46 15s. complete ex works D.C., or £53 15s. A.C.

*The performance of the Speaker fully justifies the price.*

... when did you last hear real music?

### YOU NEED A VOIGT

... with all the possible features which improve the performance, namely, intense magnetic field, horn loading, twin diaphragm, bass chamber, distributing reflector, and aluminium wire and speech coil



VOIGT PATENTS LTD.

WRITE FOR DETAILS

The Courts, Silverdale, Sydenham, London, S.E.26

Telephone: Sydenham 4141.

Reg. Office, 22 Castle St., E.C.1

# POLAR

SPECIFIED FOR THE  
**'WINNING THREE'**

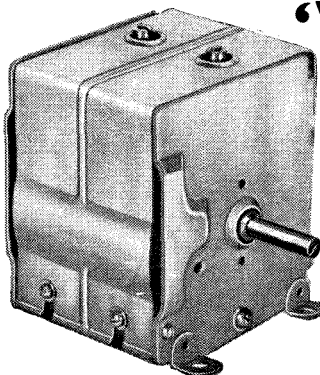

### The POLAR MIDGET TWO-GANG CONDENSER

One-piece steel frame. Ball-bearing shaft. Sections matched within  $\frac{1}{2}$  per cent. or 1 mfd., whichever ever is the greater. Trimmers operated from top.  
Price ... .. 11/-

also made in

Three-Gang ... .. 16/6  
Four-Gang ... .. 22/-

### The POLAR ARCULATE DRIVE

(used with the 'Midget' Condenser)  
Slow motion. Bevelled scale in wavelengths.  
Price ... .. 5/9

● Send for fully illustrated catalogue of Polar and N.S.F. Components.

### The POLAR TYPE 'E' TWO-GANG S.W. CONDENSER

Soldered brass vanes mounted on "Steatite" base.  
.00016 x .00016 ... .. 10/6  
Also made in .00016. Price 5/-

### The POLAR "MICRO DRIVE" ARCULATE "

(used with the Type 'E' Condensers)  
With two reduction ratios 100 to 1 and 7 to 1 each operated independently by concentric knobs.  
Price ... .. 7/9

**WINGROVE & ROGERS, LTD.,**  
188/189, Strand, London, W.C.2

Phone: Temple Bar 2244. Works: Old Swan, Liverpool

on 80 metres with Europe "turned off."

The B.E.R.U. contest will run during the four week-ends of February, as usual, and National Field Day has been arranged for June 6 and 7.

The annual general meeting will be held on Friday, December 20, and will be followed by a lecture: "British Wireless Services."

**International Short-wave Club**

The I.S.W.C.'s Birthday contest during October was very well supported, and the results will probably be made known in a very short time. Well over 40 special transmissions were made from stations all over the world, and lucky (or skilful) was the member who succeeded in freeing them all from the inevitable interference.

One good example of co-operation must be noted. W1XX, Boston, in the 31-metre band, remained silent during one of its usual transmitting periods, to enable a programme from Bombay (nominally on the same wavelength) to be received.

**The Ultra-short-wave Club**

A club has been formed with the above title, its object being to assist co-operation between both local ultra-short-wave societies and individual workers in this particular field of radio.

Full particulars may be obtained from Mr. Oliver M. Derrick (2AJP), Gowanhill, Drip Road, Stirling, Scotland.

**Institute of Scientific Research (Short-wave Section)**

The above society has started a "QSL Bureau" for the convenience of non-members of the R.S.G.B., and full details are available from the Secretary, West Park Drive, Roman Avenue, Leeds 8.

**Loughborough Short-wave Society**

A short-wave society has been organised in Loughborough, and meetings are to be held every Friday evening at 7.30 p.m., at 5 Park Street, the address of Mr. P. Newton Nield, the organiser.

Mr. Nield will be pleased to welcome prospective members or to give any information concerning the progress of the scheme.

Please Turn Overleaf

Secure high efficiency in operation and save 25 per cent. on valve costs by choosing Hivac.

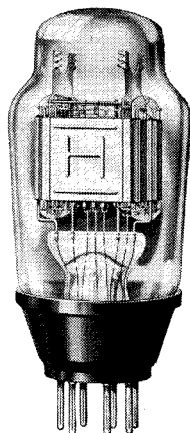

B230

For your new set, or, for new life in your old one, choose Hivac. Full details and which to use are given in Hivac Valve Chart "W.M." Free on request.

**HIVAC**  
THE SCIENTIFIC  
VALVE

BRITISH MADE

Chosen by Mr. Percy W. Harris for his  
**"ELECTROGRAM"**

All owners of Battery type receivers will, we believe, thank Mr. Harris for showing them an efficient and economical way of enjoying the electrical reproduction of gramophone records.

By choosing the Hivac B230 valve, considerable power output is obtained with a minimum H.T. consumption. The Driver valve chosen by Mr. Harris is the Hivac L210.

HIVAC B230 **10/6**

HIVAC L210 **3/9**

Obtainable through all dealers. If any difficulty, order direct.

**Put New Life into Your Old Receiver**

The marked deterioration of the performance of your set is invariably caused through gradual loss of emission in the valves; there is no cure for this other than by replacing them with reliable counterparts. For increased efficiency and economy in cost—fit Hivac.

**HIGH VACUUM VALVE Co., Ltd., 113-117 Farringdon Rd., London, E.C.1.**

**"CLIX" PREVENT CLICKS!**

If you were to ask any radio service engineer which was the most common fault found when servicing receivers, the answer would be "Contacts." Extreme care is always taken in the wiring up of a job, but just because valveholders, plugs, sockets, etc., are small components, their contact quality is often overlooked.

For years now the designers of sets described in this and all the British radio publications have consistently chosen CLIX, because Clix have and still do specialise in producing the finest and widest range of Perfect Contact Components. To prevent Clicks—Ask for "CLIX."

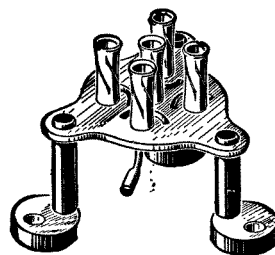

**CLIX VALVEHOLDERS**

Our new lines for 1936 include Baseboard and Chassis mounting valveholders for short and ultra-short-wave work.

The Baseboard type (see V7) are supported on ebonite legs. The only metal employed is the one-piece tagged sockets. The Chassis type have low-loss ceramic bases.



**PANEL TERMINALS**

Extremely robust and soundly made. Hexagonal shoulder, when held by spanner while nuts are made tight, greatly facilitates mounting. Insulated and non-removable head. Provision for secure, solderless connection. Clear and easily read markings. **4d.**

**"MASTER" PLUGS**

The most important feature in these is the efficiency of the pin, which is non-collapsible and is so constructed that it will give perfect contact with the varying sizes of sockets so often found in different makes of H.T. batteries. Long or short insulators and standard markings. **1½d.**

**CLIX SPECIFIED FOR THE "WINNING THREE" and "ELECTROGRAM"**

**CLIX "AIRSPRUNG" VALVEHOLDERS**

Just over two years ago these were introduced to the public, and, because of their anti-microphonic construction, which damps out physical shocks to the valve, they are used by all well-known set designers.

4-pin, 11d. 5-pin, 1/- 7-pin, 1/1.

There are two New Clix Folders "W.M." ready for you—FREE

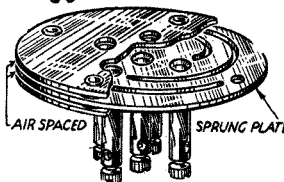

**LECTROLINX LIMITED,**  
79a ROCHESTER ROW, LONDON, S.W.1

**CLIX**

## News from the Radio Societies

Continued from previous page

### South London and District Radio Transmitters' Society

The S.L.D.R.T.S. continues to hold regular meetings on the first Wednesday of each month, at 8 p.m., at Brotherhood Buildings, West Norwood, S.E.27. On November 6, Mr. J. D. Chisholm, G2CX, gave an interesting lecture on "The History and Organisation of Amateur Radio," and on November 15 a party of members visited Droitwich.

Membership of the society is not confined to amateur transmitters. Details may be obtained from the Secretary, at 144 West Hill, Putney, S.W.18.



### The Folkestone Radio Amateurs

A new society with the above designation has been formed in Folkestone. The President is Mr. G. Anthony Chapman (G2IC), and the Secretary, Mr. G. Emrys Jones (G6XB). Full particulars are obtainable from the Secretary at 71 Sandgate Road, Folkestone.

### Radio, Physical, and Television Society

The annual general meeting was held on October 18. The various reports of the society were read and the election of officers for the coming year took place. It was decided that meetings should be held twice monthly on Fridays at 8 p.m. as before, and that should membership increase sufficiently, weekly meetings would be held.

The society extends a cordial invitation to readers of "Wireless Magazine" to attend any of the lectures, which are held at 72a North End Road, West Kensington. The small annual fee of 2s. is charged, with 3d. payable at each meeting attended, but visitors are not expected to pay anything for the first few meetings.

Further details may be had from the hon. secretary, M. E. Arnold, 12 Nassau Road, Barnes, S.W.13.

**JOIN THE B.L.D.L.C.**

## Unique Orchestral Service

To meet the needs of restaurant proprietors, Marconiphone has inaugurated a special Orchestral Service, whereby small restaurants, hotels and licensed houses may have their own music without all the trouble and expense of Performing Rights and licenses. For a weekly payment of 12s. 9d. any restaurateur can now have a Marconiphone model 289 automatic radio-

**SPECIAL NEW YEAR ISSUE OF "W.M."**

On Sale December 20

gram, twelve shillings' worth of records per month (chosen by himself), all licences paid, except the usual 10s. due to the P.O. and all maintenance and service carried out by his suppliers free of charge for two years. At the end of this period the instrument and records will become his property for a single payment of £1.

# ★ HYVOLTSTAR offers you DISTINCTIVE STYLE with REVOLUTIONARY RESULTS on all Wave Bands!

★ from 13-2000 metres

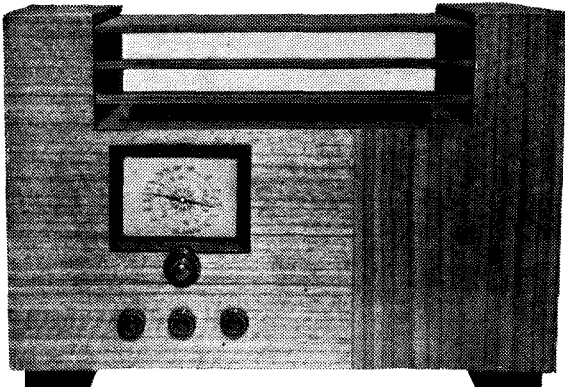

An ideal Christmas Gift

**UNIVERSAL ALL-WAVE SUPERHET FOUR.** Chassis, 10½ guineas. Table Model, 13½ guineas. Radiogram, 18½ guineas.  
**UNIVERSAL ALL-WAVE SUPERHET FIVE.** Chassis, 13½ guineas. Table Model, 17 guineas. Radiogram, 23 guineas.  
**UNIVERSAL ALL-WAVE SUPERHET SIX.** Chassis, 14½ guineas. Table Model, 18 guineas. Radiogram, 24 guineas.  
**UNIVERSAL ALL-WAVE SUPERHET SEVEN.** Chassis, 21 guineas. Table Model, 24½ guineas. Radiogram, 30 guineas.  
**UNIVERSAL ALL-WAVE SUPERHET TEN.** Chassis, 30 guineas. Table Model, 35 guineas. Radiogram, 42 guineas.

"Revolutionary Sound Diffusion by Means of Sound Reflectors."

Working on 100-250 volts A.C. or D.C. without alteration, HYVOLTSTAR is the only set which incorporates the famous OSTAR-GANZ UNIVERSAL High Voltage Valves. Not a Mass-produced article, but an individual job, for every model is constructed throughout by one of our highly skilled technicians.

Write to us to-day for complete details of our NEW PROGRAMME of Receivers, Radiograms and Amplifiers. We will send you a set "on approval" without any obligation whatsoever.

**UNIVERSAL HIGH VOLTAGE RADIO LTD.**  
 28-29 SOUTHAMPTON STREET, STRAND, LONDON, W.C.2.  
 Telephone: Temple Bar 4985, 8608

**OSTAR-GANZ**  
 UNIVERSAL HIGH VOLTAGE

**VALVES**

THE VALVE OF THE FUTURE  
 and the World's Best

**IMPROVES SELECTIVITY and SENSITIVITY**

Why not Build your Receiver with Ostar-Ganz H.V. Valves? For they will so greatly improve the set as to make it comparable with up-to-date models. These valves give you more sensitivity than any other valve.

We have converted all kinds of models and makes with these valves and have hundreds of unsolicited testimonials, proving the superiority of O.G. Valves—for their longer life—greater efficiency, and cheaper consumption place these valves in an unrivalled position. **NO BARRETTERS, NO CUT DOWN RESISTANCES, and NO MAIN TRANSFORMERS REQUIRED.**

There is a valve for every purpose and backed with a **6 months' guarantee.**

(SEE THE SUPPLEMENT FOR PARTICULARS OF OSTAR-GANZ KITS.)

Write to Sole Agent and Distributor for details and new prices.

**EUGEN J. FORBAT** 28-29 SOUTHAMPTON ST., STRAND, LONDON, W.C.2.  
 Telephone: Temple Bar 4985, 8608.

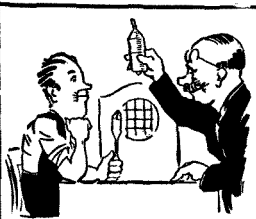

Cried a wireless-mechanic named Lane.  
 "These soldering jobs give me a pain!"  
 His Dad said "My Son,  
 Use FLUXITE with the GUN.  
 And you'll never have trouble again."

See that FLUXITE is always by you—in the house—garage—workshop—wherever speedy soldering is needed. Used for 30 years in government works and by leading engineers and manufacturers. Of Ironmongers—in tins, 4d., 8d., 1/4 and 2/8.

Ask to see the FLUXITE SMALL-SPACE SOLDERING SET—compact but substantial—complete with full instructions, 7/6.

Write for Free Book on the art of "Soft" Soldering, and ask for Leaflet on CASE HARDENING STEEL and TEMPERING TOOLS with FLUXITE.

**TO CYCLISTS!** Your wheels will NOT keep round and true unless the spokes are tied with fine wire at the crossings AND SOLDERED. This makes a much stronger wheel. It's simple—with FLUXITE—but IMPORTANT.

**THE FLUXITE GUN** is always ready to put Fluxite on the soldering job instantly. A little pressure places the right quantity on the right spot and one charging lasts for ages. Price 1/6.

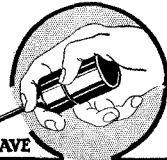

ALL MECHANICS WILL HAVE

**FLUXITE**

IT SIMPLIFIES ALL SOLDERING

Fluxite Ltd., Dept. 332, Dragon Works, Bermondsey St., S.E.1

**A.C. LISTENERS  
 5-WATT AMPLIFIER**

**MAINS TRANSFORMER :**

425-0-425v. 150m.a. 4v. 2a.c.t.,  
 4v. 2.5a.c.t., 4v. 5a.c.t.  
 Super shrouded 2½ per cent  
 regulation, £1 10 0.

250-0-250v. 60m.a. 4v. 1-2a.c.t.,  
 4v. 2-4a.c.t. Shrouded, 12/6

350-0-350v. 60m.a. 4v. 1-2a.c.t.  
 4v. 2-4a.c.t. Shrouded 16/-

350-0-350v. 120m.a., 4v. 1-2a.  
 c.t., 4v. 2.5a.c.t., 4v. 2-5a.c.t.

Shrouded, 17/6. Super

shrouded £1 1 0.

500-0-500v. 150 m.a., 4v. 2.a.c.t.

4v. 2a.c.t., 4v.2a.c.t., 4v. 2.5a.c.t.

4v. 5.a.c.t. Shrouded terminals,

£1 15 0.

60 watt auto. Shrouded, 10/6

120 watt auto. Shrouded, 12/6

12 watt A.C. 3 stage amplifier

for microphone or pick-up

use. Complete £12.

**VORTEXION**

182 THE BROADWAY

TEL. LIBERTY 2814 WIMBLEDON, S.W.19.

**An Improved Mounting  
 for Crystal Tweeters**

By P. Wilson, M.A.

**I**N my article on crystal loudspeakers a few months ago I mentioned the possibility of rattle being set up due to mechanical inter-action between a moving-coil loudspeaker and a crystal tweeter. I suggested that to minimise this possibility it is desirable to mount the tweeter not directly on the baffle but on a ring-shaped surround of stiff rubber or flexible leather, this ring then being screwed to the baffle.

I now find that a simpler form of mounting has some advantages. In this form the tweeter is mounted on four strips of rubber about 1 in. by 2 in. by ¼ in. thick, and these rubber strips are screwed to the baffle. In addition, bolts and nuts are fixed in the other four holes of the tweeter chassis so as to ensure that the perimeter of the tweeter cone is firmly attached to the chassis.

The details will, I think, be clear from the accompanying drawings.

It should be noted that this method of mounting creates an annular gap between tweeter and baffle. This will

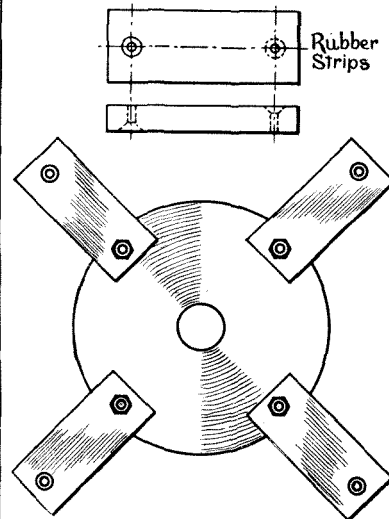

Drawing showing improved method of tweeter mounting.

tend to equalise the phases of the acoustic pressures on the two sides of the tweeter diaphragm. So far as high notes are concerned this will not matter. For low notes it tends to prevent the tweeter from acting as a microphone and feeding back into the electrical circuit low notes given out by the moving-coil loudspeaker.

**THERE  
 IS  
 A REASON**

**Benjamin Radio Components are consistently specified by all well-known circuit designers—and the reason is that they can be relied upon to give continuous and lasting satisfaction under the most severe conditions. Hence their inclusion in the Harris Electrogram.**

**BENJAMIN VIBROLDER**

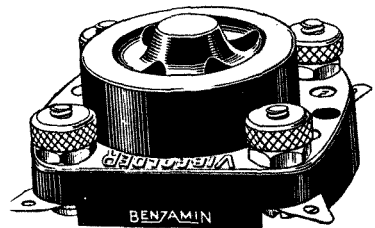

Self-aligning spring contacts, dust-proof base and safety-stop to prevent injury to contacts. Bakelite Body. Price, each 10d.

**7-PIN VALVEHOLDER**

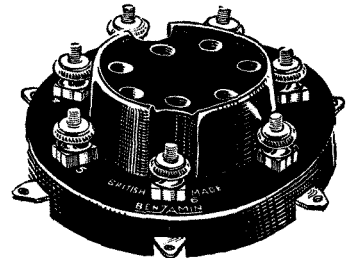

Best quality Black Polished Bakelite with special self-cleaning contacts, soldering tags and easy-wiring terminals which are reversible for under chassis mounting. Price, each 2/-

Benjamin Radio Components including the above valveholders are obtainable from all high-class radio dealers. Should you have any difficulty, DO NOT ACCEPT SUBSTITUTES, but apply to us.

**BENJAMIN  
 ELECTRIC LTD.**

Brantwood Works, Tottenham  
 LONDON, N.17

*Inexpensive long-life METERS...*

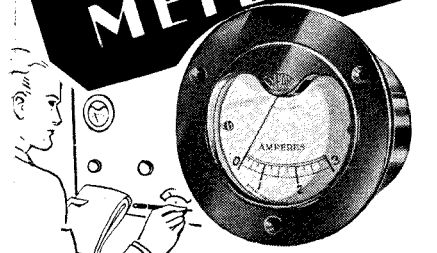

**for all your radio tests!**

**MAGNETIC CONTROLLED. D.C. ONLY.**  
 Attractively priced and finished, these meters are widely used for all general purposes. Semi-flush panel fitting. 2 1/2 in. overall; 2-in. hole in panel.  
**Voltmeters.** Available up to 20 volts at 7/6  
**Ammeters.** In all ranges from 1-0-1 to 30-0-30 at 7/6  
 Or up to 10 amps. at 7/6  
**Milliammeters.** In all useful capacities from 10 to 500 m.a. 10/-



Post this Coupon today.  
 Please send your fully illustrated list No. W.M.1.  
 Name.....  
 Address.....  
 (Use Block Letters).  
**SIFAM ELECTRICAL INSTRUMENT CO., LTD.,**  
 Hollydale Road, London, S.E.15.  
 Phone: New Cross 2168.

**A SIFAM TEST'S A SAFE TEST**  
 Carew Wilson

**"HARMONA"**  
*The Speaker Specified for the*  
**"ELECTROGRAM"**



**PRICE 25/-**

**IMPORTANT!**  
 The Moving Coil Unit of the "HARMONA" is of entirely new design. It employs the very latest development in Permanent Magnet Construction—the New Type Nickel Aluminium Alloy Magnet. The resultant improvement in sensitivity and life-like reproduction is an outstanding achievement.

*The "Harmona" is fitted with the standard Amplion Universal Transformer to match all Types of Output Valves.*

**AMPLION**

**AMPLION (1932) LTD.**  
 82-84 Rosoman St., Rosebery Ave., London, E.C.1

# Who Heard the First Wireless Signal?

By J. Godchaux Abrahams

**T**HE Germans claim that Heinrich Hertz was the discoverer of the electromagnetic wave, and inasmuch as he was the first person to make known publicly the existence of such a wave, the claim has been generally accepted.

As a matter of fact, an Anglo-American electrician, David Edward Hughes, had already played with this discovery some years earlier, and without doubt the first wireless signals were actually heard by him in his laboratory some fifty-six years ago.

Hughes was born in London on May 16, 1831, but when he was seven years old his parents emigrated to Virginia and he was educated at a Kentucky College. Although at the age of nineteen years he was giving music lessons at the College of Bardstown, Kentucky he was more interested in electrical phenomena, and resigned from his musical post in 1854.

One year later he took out a patent for a typeprinting telegraph instrument which met with such success in America that in 1857 he decided to bring it to Europe where it was generally adopted in France.

## First Microphone

During the years he spent in Paris he devoted all his time to the development of telephony, and returning to London Hughes brought out the first microphone which, replacing the old Bell transmitter, made the telephone system a commercial possibility.

Working one day with the induction balance, and failing to secure good results, he put down the fault to lack of insulation in the coils, but discovered later that a loose contact was the cause of the trouble. From this trivial mishap much was to be learnt, for upon investigation he found that when he installed a microphone-telephone circuit at some distance from the induction balance he could pick up sounds even when this "hook up" was several feet

away. Every time an intermittent current passed through the coils, a distinct click was heard in the headphones. This primitive apparatus undoubtedly was the first radio transmitter and receiver in existence.

Carrying on further experiments by means of a small clockwork motor, he operated the transmitter automatically thus permitting himself to walk about the house carrying a microphone and telephone. Signals were picked up at varying distances even when strolling down Great Portland Street, in which vicinity his house was situated.

## Greatly Discouraged

Although between 1879 and 1888 many demonstrations of his aerial transmissions were carried out in the presence of eminent scientists such as Professors Dewar, Huxley and Stokes, he was unable to convince his audience that his theory of aerial electric waves was proved by his experiments, and this attitude greatly discouraged him.

Sir William Crookes, who in 1879 and again in 1892 had assisted at some of the demonstrations, later wrote that within a restricted radius of a few hundred yards, telegraphic transmission without wires was possible. "Some years ago," he says, "I assisted at experiments where messages were transmitted from one part of a house to another without intervening wires."

It is mainly due to him that details have been available of the marvellous work done by Hughes in this connection, as so late as 1899 the latter refused to publish his observations in connection with these "wireless" transmissions. There is little doubt that had his contemporary colleagues recognised the practical proofs which Hughes gave of Clerk Maxwell's theories, the facts of radio transmission of energy would have startled the scientific world at an earlier date than has been the case. Nevertheless, Hughes was the man who first heard wireless signals.



**The SHORT WAVE FAN'S Own MAGAZINE**

*at Last!*

**The SHORT WAVE CONSTRUCTOR** 3<sup>o</sup>

NO. 1 VOL. 1

A MAGAZINE FOR SHORT WAVE ENTHUSIASTS

**B.T.S.**

Published by BRITISH TELEVISION SUPPLIES LTD., Bush House, London, W.C.2

No. 1 **"The SHORT WAVE CONSTRUCTOR"** ... packed full with short wave articles of absorbing interest. Describes in detail 3 entirely new Short and Ultra-Short-Wave Circuits, etc., etc. ... the very latest in short wave technique. Obtainable through all branches of W. H. Smith and Sons, Radio dealers, or send 3d. direct to the Publishers:

**NOW on SALE**

**B.T.S.—THE ACKNOWLEDGED LEADERS IN SHORT WAVES**

**SPECIFIED WINNING THREE**

**B.T.S. COMPONENTS**, again chosen for their reliability and undoubted superiority. Produced by specialists—preferred by experts.

**B.T.S. TRIPLE RANGE Short Wave DUAL COIL UNIT**

Readers coil changing unnecessary and obsolete. Comprises two coils completely insulated and screened, mounted directly on to the switch, allowing entire unit to be attached to panel with single hole fixing.

Ranges 1:12-25  
2:19-40, 3:30-80 metres.

TYPE DCU

**17/6**

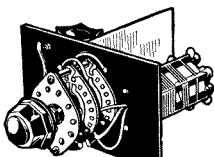

**B.T.S. REACTION CONDENSER**

Vernier motion of 10:1. Perfectly smooth action and minute accuracy. Hard brass vanes, with ball-bearing spindle, knob and pointer. Special low-loss material end plates.

.0002 mfd.

TYPE RC32

**5/6**

FROM ALL DEALERS

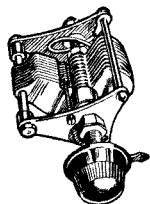

**B.T.S.**

**BRITISH TELEVISION SUPPLIES, LTD.**  
BUSH HOUSE, Dept W.M., LONDON W.C.2

**Notes and Jottings**

**W**E have just received a leaflet dealing with the range of extension loudspeakers manufactured by Philips for use with their receivers. A feature of these loudspeakers is that they are fitted with a special no-loss volume control so that you can listen to your set wherever you like, altering the volume to suit the size of the room and your own particular requirements.

There are four models available: The Junior Model, type 4516, price 37s. 6d.; the Senior Model, type 4519, price 45s.; type 4518, which is last year's model continued for this season at the reduced price of 42s.; and, finally, a three-guinea model which is the de Luxe version of type 4519.

An error unfortunately occurred in the list of parts for the Listener's Amplifier. The Epoch loudspeaker specified was given as type 667, price £7 2s. 6d., whereas the speaker recommended by the designers is type 66/120J, price £6 12s. 6d.

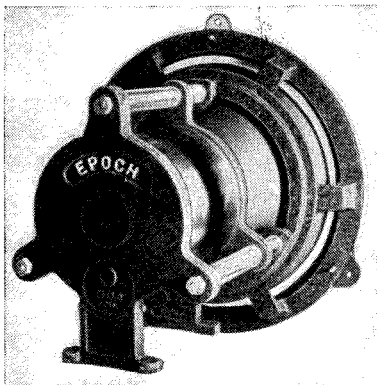

Showing the Epoch loudspeaker for the Listener's Amplifier, note the rectifier unit is not shown

We have been asked for copies of "Wireless Magazine" dated March, 1931, and January, 1932, and as these are out of print we shall be grateful if any reader can supply us with them. If you have a copy of either of these issues and are prepared to part with it, please write to the Editor (but do not enclose the copy). We will pay 1s. and postage for each copy.

In our last issue on page 320, in the Blueprint Coupon panel, we gave the blueprint number of the Listener's 5-watt A.C. Amplifier as WM393; this should have been WM392 and the price 1s. 6d.

**PILOT AUTHOR KITS**

for sets featured in "Wireless Magazine" and all other Technical Journals are only obtainable direct from Peto-Scott.

**SEND FOR DETAILED PRICED LISTS OF PARTS.**

**THE WINNING THREE**

**DETAILED LIST OF PARTS ON REQUEST.**

**KIT "A" CASH OR C.O.D. £6/19/6**  
CARRIAGE PAID YOURS FOR

Author's Kit of First Specified Parts including Ready Drilled Plymax Chassis, less Valves, Cabinet, and Speaker. **12/6**

Balance in 11 monthly payments of 12/9.

**KIT "B"** As for Kit "A," but including set of 3 Specified Valves, less cabinet and speaker. Cash or C.O.D. Carriage Paid. **£8.11.0.** Or 12 monthly payments of 13/9.

**KIT "C"** As for Kit "A," but including Valves and Peto-Scott Console Cabinet, less speaker. Cash or C.O.D. Carriage Paid. **£9.10.6.** Or 12 monthly payments of 17/6.

- 1 Peto-Scott ready-drilled Plymax Chassis... 7 6
- 1 B.T.S. Triple-range Short-wave Coil Unit 17 6
- 1 Rola Speaker, type F.720 P.M.T. 1 15 0
- Or 2/6 down and 9 monthly payments of 4/-
- 1 Peto-Scott Console Cabinet... 19 6

**HARRIS ELECTROGRAM**

**DETAILED LIST OF PARTS ON REQUEST.**

**KIT "A" CASH OR C.O.D. £1/17/6**  
CARRIAGE PAID YOURS FOR

Author's Kit of First Specified Parts, less valves, accessories and cabinet. **4/6**

Balance in 8 monthly payments of 4/6

- 1 Set of 2 Specified Valves... 14/3
- Peto-Scott specified "Electrogram" Cabinet, £1/17.6. Carriage and packing 2/6 extra. Or 5/- down, balance in 6 monthly payments of 6/6.
- 1 Garrard No. 30 Spring Motor... 1 5 0
- or 2/6 down, and 10 monthly payments of 2/6.
- 1 Garrard Pickup... 1 12 6
- or 2/6 down, and 11 monthly payments of 3/-.
- 1 Amplion "Harmona" Speaker... 1 5 0
- or 2/6 down, and 10 monthly payments of 2/6.

**Peto-Scott TRIUMPHANT!**



Personally Guaranteed Battery and All-Electric Receivers—backed by a Famous Organisation

REVIEWED ON PAGE 386

**Peto-Scott 1936 BANDPASS Battery CLASS "B" 4**

Tone and volume equal to a powerful 411-mains model, yet unusually economical in battery consumption.

**Peto-Scott 1936 Class-B Moving-Coil Speaker.** British Variable-mu H.F. Pentode, Reacting Detector, Class-B Driver and Class-B output valves. Illuminated circular aeroplane dial, bronzed escutcheon. Long and medium waves. 200-2,100 metres, no-trouble switch. Output 1½ watts. Oldham 120-v. H.T. and 2-v. L.T. Accumulator and G.B. Batteries. Aerial equipment. Walnut Cabinet illustrated. Ready to play.

**CASH OR C.O.D. Carriage Paid. £8/8/0**

Or 7/6 down and 18 monthly payments of 10/3.

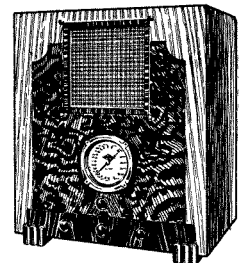

**Peto-Scott 1936 SCREENED-GRID BATTERY 3**

CASH OR C.O.D. Carriage Paid... **£6/12/6**  
Or 5/- down and 18 monthly payments of 8/3.

Send for 20-Page illustrated Catalogue of Mains and Battery Sets.

**PETO-SCOTT CO., LTD.**

77 (W.M.10) CITY ROAD, LONDON, E.C.1. Clerk 9406/7  
West End Showrooms: 62 (W.M.10) High Holborn, W.C.1  
Hol. 3248

## EASY TERMS

Everything Radio supplied on the lowest available terms. Send list of requirements for quotation by return. Prompt delivery. Price lists free.

### NEW LISSEN SHORT WAVE 3 KIT

(world wide reception).

Cash price £3.9 6. or 6/4 with order and 11 monthly payments of 6/4.

### SPEAKER UNITS

	Cash Price	Payment with order	Number of Months	Monthly Instalment
W.B. Stentorian 36S	42/-	2/6	11	4/-
W.B. Stentorian 36J	32/6	2/6	11	3/-
Blue Spot Senior	29/6	2/6	7	4/2

Rola Units and extension speakers supplied similar terms.

### ELIMINATOR

Atlas T10/30 H.T. unit and trickle charger combined	69/6	5/-	12	5/11
---	------	-----	----	------

### PICK-UPS

Blue Spot (with volume control)	27/6	2/6	6	4/6
B.T.H. Piezo Electric	42/-	2/6	11	4/-
Marconiphone 25	32/6	2/6	11	3/-

All makes of pick-ups supplied. Illustrated price lists available.

### VALVES

(every type supplied) S.G., Det. and Power, any make. Cash price £1.5.0. or 5/- with order and 5 monthly payments of 4/6.

#### ALL CARRIAGE PAID

To avoid delay please send first payment with order.

Est. 1925 THE 'PHONE: NATIONAL 1977

## LONDON RADIO SUPPLY COMPANY

11, OAT LANE, NOBLE STREET, LONDON, E.C.2

Specified for Reliability

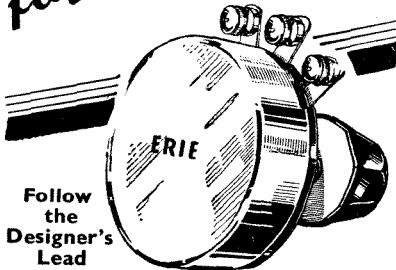

Follow the Designer's Lead

Fit your set with the Erie Volume Control—the result of years of research. It will never develop faults. The Erie resistance element plus precision construction ensure smooth, positive contact, without hop-off noises, for a life-time's use. All sizes 2,500 ohms to 2 meg-ohms. At all good radio shops.

**SPECIFIED** for the "WINNING THREE" "HARRIS Electrogram" ERIE Resistors specified for the "W.M. SIMPLIFIED SUPER"

or with built-in Mains Switch 5/-

**ERIE** Write for Erie Colour Code Chart.  
**VOLUME CONTROL**  
& ERIE RESISTORS  
The Radio Resistor Co. Ltd., Golden Square, London, W.1

# A Problem in Fault Finding

By P. WILSON, M.A.

ONE of my receivers developed a fault with curious symptoms the other day. The receiver is a mains superhet consisting of a variable-mu tetrode high-frequency stage transformer-coupled to a heptode frequency-changer, followed by a variable-mu tetrode intermediate frequency stage and then a full-wave double-diode detector.

A.V.C. is fed back from the grid leak of the double diode to the H.F. and heptode valves and a separate A.V.C. line is taken from a tap on the grid leak for the intermediate-frequency valve. There is a milliammeter in the anode circuit of the H.F. valve to act as a tuning meter; when a signal is tuned in, the current through the detector grid leak, and therefore the voltage fed back as bias, increases. The anode current and therefore the reading of the milliammeter is thus at its minimum when the tuning to a signal is exact.

This is the normal state of affairs. One day the milliammeter reading went up instead of down on tuning in a signal and then later began to wobble. Music was still heard from the set but somewhat distorted. I put another milliammeter in the anode circuit of the I.F. valve and the reading of this decreased on application of signal in the normal fashion. All the valves were O.K. The essentials of the circuit are shown in the diagram.

**Problem.**—What was likely to be wrong and why did the reading

of the tuning meter begin to increase instead of decrease?

**Diagnosis.**—A.V.C. bias was clearly not being fed back to the H.F. grid, but it was being fed to the I.F. grid. When a signal was tuned in, the anode current of the I.F. valve decreased on application of A.V.C. bias, and owing to this reduced current drain through the resistances and chokes in the H.T. + line the H.T. voltage in that line increased.

Since the H.F. valve was no longer controlled by A.V.C. bias its anode current would increase owing to the higher voltage applied to anode and screen-grid and therefore the reading of the tuning meter went up. I, therefore, tested for faults in the A.V.C. line to the H.F. valve, suspecting that either a condenser had short circuited (but not  $C_1$  since that would have earthed the grid and therefore stopped the application of a signal) or a resistance had open-circuited. The likeliest culprits were  $R_1$ ,  $R_2$ , or  $R_3$  or  $C_3$ . Actually it was  $R_3$ .

**Corollary.**—What would you have deduced if the reading of the tuning meter had slowly increased to maximum and the music slowly faded away?

**Answer.**— $C_1$  short-circuited.

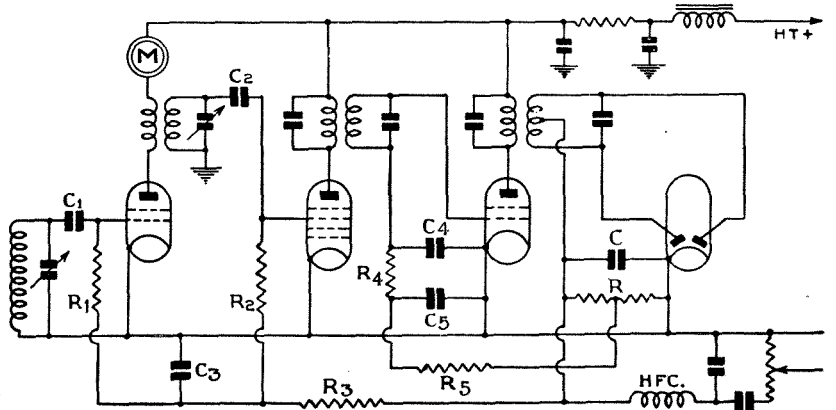

Here is the circuit of part of the mains superhet referred to by Mr. Wilson

## AN EXTRA SET for 37/6

Fit a Philips extension speaker in the kitchen, bedroom, study, and have all the benefits of two sets at a negligible cost. The Junior model costs 37/6, the Senior model (illustrated) 45/-, the deluxe model 3 guineas.

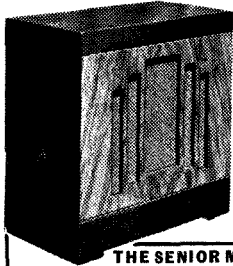

**NO LOSS  
VOLUME  
CONTROL**

Philips extension speakers enables the volume to be adjusted independently of the receiver without loss of quality.

**THE SENIOR MODEL, Type 4519**  
Incorporates a superfine unit in a superb walnut cabinet. Price 45/-.

Write for full details of

# PHILIPS

MOVING COIL EXTENSION SPEAKERS

Philips Industrial, Philips Lamps Ltd.,  
145 Charing Cross Road, London, W.C.2

### ● THE WINNING 3

Complete Specified Kit

10/9 Per Month ●||● Cash 95/-  
or C.O.D.

### ● S. W. SUPER

KIT EXACT TO SPECIFICATION

11/7 Per Month ●||● Cash £5  
or C.O.D.

● LISTS FREE ● HARRIS' ELECTROGRAM &  
all other kits—lowest prices

MELFO-RAD QUEENS HOVE  
PLACE

## Engineers' Guide

containing the widest  
choice of engineering  
courses in the world

Outlines The T.I.G.B.'s up-to-date home study Courses in Wireless, Electrical and Mechanical Engineering, etc. Shows how to become A.M.I.E.E., A.M.I.W.T., A.R.A.A., etc., and how to qualify for a well-paid post. Training until Successful Guaranteed. WRITE NOW for Free Guide.

THE TECHNOLOGICAL INSTITUTE OF GREAT BRITAIN,  
105 Temple Bar House,  
London, E.C.4 (Founded 1917,  
19,000 Successes.)

## To Success



**THE WINNING THREE.** Guaranteed specified Kit, 26/5/0. **SHORT-WAVE SUPER,** ditto, 26/10/0. All "Wireless Magazine" circuits at competitive prices. **HIGHEST ALLOWANCES** for used and discarded apparatus, etc., in **PART EXCHANGE** for anything radio. **CASH, C.O.D. or EASY TERMS.** Write now for free lists and quotations. **JAP RADIO, Terminus Place, BRIGHTON**

## Problems of Long-distance Reception



Cont. from page  
346

Service—send no verification cards on principle, because the excellence of these stations would throw too much additional work on the staff.

It is therefore useless to add international reply coupons when sending reports to these stations and it is only natural that these transmitters, which are doing public work and are not dependent on reports from amateurs, cannot be put on the list of discourteous stations.

With the aid of such notes as this, after a while every member of the B.L.D.L.C. will know from which stations he may expect a QSL card.

These are some of the problems created lately by DX reception. The management of the B.L.D.L.C. will tackle all such problems most earnestly and try, if necessary, to remove any actual difficulties by direct negotiations with the responsible authorities. We would like to remind readers that the DX section of the "Wireless Magazine" will also deal with any inquiry about long-distance reception and we would welcome the closest possible co-operation of our readers; their opinions and suggestions will always find space in our pages.

### Verification Reports to Brazil

We are officially informed from Brazil that in future international reply coupons issued abroad will no longer be accepted by Brazilian post offices: it is therefore useless to enclose these when sending reports.

### SHARE YOUR EXPERIENCES WITH FELLOW-MEMBERS!

ONE of the great problems of long-distance reception is the choice of aerial. Hundreds of kinds have been described in hundreds of articles published by the wireless press during the last few years.

What, in your opinion, is the best aerial for long-distance reception? If you have secured good results on short waves, which kind of aerial have you used? With which type have you obtained the best reception? Please write us a few lines on this subject—we shall be glad to publish the most interesting letters for the benefit of those listeners who are in trouble with their aerials. Address your letters:

The Secretary,  
British Long Distance Listeners' Club,  
8-11 Southampton Street,  
Strand, London, W.C.2.

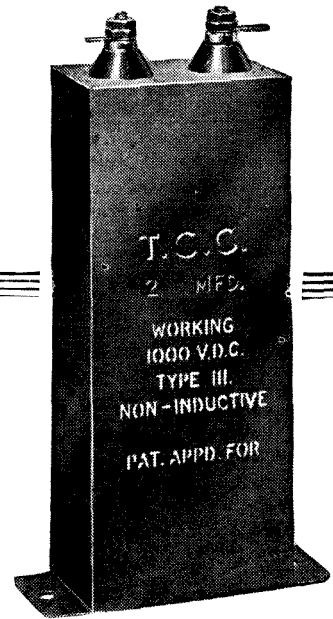

## for the HIGH VOLTAGES

Your Television and "Quality Output" activities carry you amongst voltages much in excess of those previously encountered. . . . Again T.C.C. are foremost in meeting your needs with these

## PETROLEUM JELLY-IMPREGNATED PAPER-CONDENSERS

Built on entirely new principles, they are specially designed for Television, etc. They work up to 2,000 V.D.C. Jelly-impregnated, there is **NO FREE LIQUID**—thus having all the advantages of oil but without risk of leakage or "creeping."

LONGER LIFE—NO "CREEPING"      NO LEAKAGE—SMALL SIZE

SAFER AGAINST BREAKDOWN—NO FREE LIQUID      TEMPERATURES UP TO 140° F. PERMISSIBLE

Wherever high voltages or temperatures are involved these condensers fill the most exacting need. Made in all capacities from 0.1 to 10 mfd. Prices from 3s. 6d. to 54s. Write for details.

# T.C.C.

ALL-BRITISH  
CONDENSERS

THE TELEGRAPH CONDENSER CO., LTD.,  
Wales Farm Road, North Acton, W.3.

## BLUEPRINT COUPON

Valid only until Dec. 31 1935 (or until Jan. 31 1936, for overseas readers)

### FOR ONE BLUEPRINT ONLY

If you want a full-size blueprint of any one of the sets constructionally described in this issue for half price, cut out the above coupon and send it, together with a postal order, to Blueprint Department, WIRELESS MAGAZINE, 8-11 Southampton Street, Strand, London, W.C.2.

This coupon is valid for one blueprint only at the price indicated:—  
**THE HARRIS ELECTROGRAM** (page 349), No. W.M. 399, price 6d., post paid.  
**THE WINNING THREE** (page 329), No. W.M. 400, price 6d., post paid.

## INFORMATION COUPON

Valid only until Dec. 31 1935 (or until Jan. 31 1936, for overseas readers)

If you want to ask any questions, cut out the above coupon and send it, together with a postal order for 1s. and stamped, addressed envelope, to the Information Bureau, WIRELESS MAGAZINE, 8-11 Southampton Street, Strand, London, W.C.2.

Under no circumstances can questions be answered personally or by telephone. All inquiries must be made by letter so that every reader gets exactly the same treatment.

## HOW TELEVISION RECEIVERS WORK

Continued from page 371

Such a high degree of proficiency has been reached in the photographic part of this apparatus that it is possible to project the received picture with considerably less than a minute's delay, so that it is possible for an audience to see, say, a horse race on the cinema screen within a minute of its occurring miles away. This is no idle dream of the future and has actually been demonstrated on several occasions.

Photographically inclined readers may wonder how it is possible to record the photograph, develop, fix and wash the negative, produce the positive, develop, fix, and wash this, and dry it all within so short a period. Actually, however, no positive is required. The original negative is that projected, for in television it is easy to reverse the light and shade and therefore to obviate the necessity of making a positive. The emulsion used for this work is naturally of a special character, as also are the developing and fixing solutions, and the washing is of the briefest character.

The sound is also recorded on the film at the same time, otherwise, of course, there would be a lag between the picture and the sound, and this would entirely ruin the effect.

A really useful radio accessory and one from which listeners can get good entertainment and fun during Christmas festivities is the Shaftesbury mike priced at £5. Anyone with the slightest technical knowledge can connect the mike to their radio receiver. The mike is marketed by Shaftesbury Supplies, W.C.2.

## INDEX TO ADVERTISERS

	Page
Amplion (1932), Ltd.	396 and Cover iii of Booklet
Automatic Coil Winder & Electrical Equipment Co., Ltd.	Cover ii
Baker's Selhurst Radio, Ltd.	14 of Booklet
Belling & Lee, Ltd.	22 of Booklet
Benjamin Electric Ltd.	395
British Insulated Cables Ltd.	325
British Rola Co., Ltd. (The)	324
British Television Supplies, Ltd.	397
Bulgin, A. F. & Co., Ltd.	Cover ii of Booklet
Chloride Electrical Storage Co., Ltd.	Cover iv
Dublier Condenser Co. (1925) Ltd.	323
Eddystone (Stratton & Co., Ltd.)	Cover iv of Booklet
Edison Swan Electric Co., Ltd.	387
Forbat, Eugen J.	394 and page 14 of Booklet
Fluxite Ltd.	395
Garrard Eng. & Mfg. Co., Ltd.	321
Grampian Reproducers, Ltd.	391
H.M.V.	328
High Vacuum Valve Co., Ltd.	393
Jap Radio	399
Lectro Linx Ltd.	393 and page 14 of Booklet
Letts, Charles, & Co.	400
London Radio Supply Company (The)	395
Marconiphone Co., Ltd.	326
Melfo-Rad	399
Partridge & Mee, Ltd.	389
Peto-Scott Co., Ltd.	397
Philips Lamps Ltd.	399
Pifco, Ltd.	325 & 389
Radio Development Co.	22 of Booklet
Radio Resistor Co., Ltd.	398
Shaftesbury Supplies Ltd.	325
Siemens Electric Lamps & Supplies, Ltd.	323
Sifam Electrical Instrument Co., Ltd.	396
Telegraph Condenser Co.	399
Technological Institute of Gr. Britain	399
Telephone Manufacturing Co.	389
Varley (Oliver Pell Control, Ltd.)	323
Voigt Patents, Ltd.	392
Vortexion	395
Ward, Chas. F.	325
Wingrove & Rogers Ltd.	392
Wright & Weaire Ltd.	391
362 Radio Valve Co., Ltd.	391

## FREE ADVICE FOR SET BUYERS

To make the most of this free advice service, we ask you to answer the following questions:—

- (1) The maximum price you wish to pay, and whether you are prepared to exceed this if there is no suitable set at your desired price.
- (2) The locality in which the set will be installed.
- (3) The stations required, that is, locals only or a selection of foreigners.
- (4) Whether you want an entirely self-contained set or one with external aerial and earth.
- (5) Whether battery or mains driven, if the latter, whether A.C., D.C., or A.C./D.C.
- (6) Special requirements: Quality needs; appearance, etc.

A stamped-addressed envelope for our reply is your only expense. Address your inquiry to Set Selection Bureau, "Wireless Magazine," 8-11 Southampton Street, Strand, London, W.C.2.

## What Do You Think? COMPETITION COUPON

This Must Accompany Your Entry  
 Valid until Dec. 23, 1935.

## WIRELESS DIARY

Size 4½" × 2¾". Cloth - - 1/-  
 Refillable Leather Case - 2/6

Contains a mass of useful information and Tables of real assistance to the listener.

OF ALL STATIONERS,  
 STORES and BOOKSTALLS

Published by

Charles Letts & Co. Diary House, LONDON

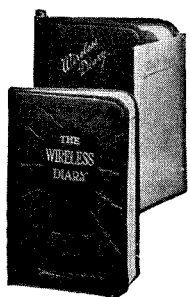

When  
 Replying to  
 Advertisers  
 be sure to  
 mention  
 "Wireless  
 Magazine"



# "Wireless Magazine" Blueprint Service

These blueprints are full-size. Copies of appropriate issues of "Practical Wireless," "Amateur Wireless," and of "Wireless Magazine" containing descriptions of most of these sets can be obtained at 4d. and 1s. 3d. each, respectively, post paid. Index letters "P.W." refer to "Practical Wireless" sets, "A.W." refer to "Amateur Wireless" sets, and "W.M." to "Wireless Magazine" sets. Send, preferably, a postal order (STAMPS OVER SIXPENCE UNACCEPTABLE) to "Wireless Magazine" Blueprint Dept., Geo. Newnes, Ltd., 8-11 Southampton Street, Strand, W.C.2.

## CRYSTAL SETS

**Blueprints, 6d. each.**  
Four-station Crystal Set ... 31.3.34 AW427

## STRAIGHT SETS (Battery Operated)

**Two-valvers: Blueprints, 1s. each.**  
Iron-core Two (D, QPP) ... 12.8.33 AW396  
Unicon AC/DC Two (D, Pen.) ... Sept '35. WM394

**Three-valvers: Blueprints, 1s. each.**

Transportable Three (SG, D, Pen) ... Feb. '32 WM271  
Multi-mag Three (D, 2 Trans) ... June '32 WM288  
£6.6s. Radiogram (D, RC, Trans) ... Apr. '33 WM318  
Simple-tune Three (SG, D, Pen) ... June '33 WM327  
Tyers Iron-core Three (SG, D, Pen) ... July '33 WM330  
Economy-pentode Three (SG, D, Pen) ... Oct. '33 WM337  
All-wave Three (D, 2LF) ... Jan. '34 WM348  
"W.M." 1934 Standard Three (SG, D, Pen) ... Feb. '34 WM351  
£3.3s. Three (SG, D, Trans) ... Mar. '34 WM354  
Iron-core Band-pass Three (SG, D, QP21) ... June '34 WM362  
1935 £6.6s. Battery Three (SG, D, Pen) ... Oct. '34 WM371  
Graduating to a Low-frequency Stage (D, 2LF) ... Jan. '35 WM378  
P.T.P. Three (Pen, D, Pen.) ... June '35 WM389  
Carrier Short-wave (SG, D, Trans) ... July '35 WM390  
Certainty Three (SG, D, Pen.) ... Sept. '35 WM393  
Minutube Three (SG, D, Trans) ... Oct. '35 WM396

Class-B Three (D, Trans, Class B) ... 22.4.33 AW386  
New Britain's Favourite Three (D, Trans, Class B) ... 15.7.33 AW394  
Home-built Coil Three (SG, D, Trans) ... 14.10.33 AW404  
Fan and Family Three (D, Trans, Class B) ... 25.11.33 AW410  
£5.5s. S.G.3 (SG, D, Trans) ... 2.12.33 AW412  
1934 Ether Searcher: Baseboard Model (SG, D, Pen) ... 20.1.34 AW417  
1934 Ether Searcher: Chassis Model (SG, D, Pen) ... 3.2.34 AW419  
P.W.H. Mascot with Lucerne Coils (Det, R.C., Trans) ... 17.3.34 AW337A  
Pentaquester (HF, Pen, D, Pen) ... 14.4.34 AW431  
£5.5s. Three: De-luxe Version (SG, D, Trans) ... 19.5.34 AW435  
Lucerne Straight Three (D, RC, Trans) ... 9.6.34 AW437  
"Wireless League" Three (HF Pen, D, Pen) ... 3.11.34 AW451

**Four-valvers: Blueprints, 1s. 6d. each.**

Calibrator (SG, D, RC, Trans) ... Oct. '32 WM300  
Table Quad (SG, D, RC, Trans) ... Nov. '32 WM303  
Calibrator de Luxe (SG, D, RC, Trans) ... Apr. '33 WM316  
Self-contained Four (SG, D, LF, Class-B) ... Aug. '33 WM331  
Lucerne Straight Four (SG, D, LF, Trans) ... Feb. '34 WM350  
£5.5s. Battery Four (HF, D, 2LF) ... Feb. '35 WM381  
"HK" Four (2HF, D, LF) ... Mar. '35 WM384  
Varsity Four (Superhet) ... Oct. '35 WM395

"A.W." Ideal Four (2 SG, D, Pen) ... 16.9.33 AW402  
Crusaders' A.V.C. 4 (2 HF, D, QP21) ... 18.8.34 AW445  
(Pentode and Class-B outputs for above; blueprints 6d. each) ... 25.8.34 AW445A

**Five-valvers: Blueprints, 1s. 6d. each.**

Super-quality Five (2 HF, D, RC, Trans) ... May '33 WM320  
New Class-B Five (SG, D, LF, Class B) ... Nov. '33 WM340  
Class-B Quadradyne (2 SG, D, LF, Class B) ... Dec. '33 WM344  
1935 Super Five (Battery Superhet) ... Jan. '35 WM379

## Mains Operated

**Two-valvers: Blueprints, 1s. each.**

Economy A.C. Two (D, Trans) A.C. ... June '32 WM286  
Consoelectric Two (D, Pen) A.C. ... 23.9.33 AW403

## ★ SPECIAL HALF-PRICE OFFER

Blueprints of the following "Wireless Magazine" sets described in this issue are obtainable at the special prices, given below, if the coupon on facing page is used before Dec. 31

Harris Electrogram ... WM399 6d.

The Winning Three ... WM400 1/-

**Three-valvers: Blueprints, 1s. each.**

D.C. Calibrator (SG, D, Push-pull Pen) D.C. ... July '33 WM328  
Simplicity A.C. Radiogram (SG, D, Pen) A.C. ... Oct. '33 WM338  
Six-guinea AC/DC Three (HF Pen, D, Trans) A.C./D.C. ... July '34 WM364  
Mantovani A.C. Three (HF Pen, D, Pen) A.C. ... Nov. '34 WM374

**Home-lovers' New All-electric Three (SG, D, Trans) A.C. ... 25.3.33 AW383**

**S.G. Three (SG, D, Pen) A.C. ... 3.6.33 AW390**

**A.C. Triodyne (SG, D, Pen) A.C. ... 19.8.33 AW399**

**A.C. Pentaquester (HF Pen, D, Pen) A.C. ... 26.6.34 AW439**

**Four-valvers: Blueprints, 1s. 6d. each.**

A.C. Quadradyne (2 SG, D, Trans) A.C. ... Apr. '32 WM279  
All Metal Four (2 SG, D, Pen) A.C. ... July '33 WM329  
"W.M." A.C./D.C. Super Four My 1935 Radiogram (SG, D, 2 LF.) ... May '35 WM386  
AC/DC Straight A.V.C. 4 (2 HF, D, Pen) A.C./D.C. ... 8.9.34 AW446

## SUPERHETS

**Battery Sets: Blueprints, 1s. 6d. each.**

Super Senior ... Oct. '31 WM256  
1932 Super 60 ... Jan. '32 WM269  
Q.P.P. Super 60 ... Apr. '33 WM319  
"W.M." Stenode ... Oct. '34 WM373  
Modern Super Senior ... Nov. '34 WM375

1934 Century Super ... 5.12.33 AW413

**Mains Sets: Blueprints, 1s. 6d. each.**

1932 A.C. Super 60, A.C. ... Feb. '32 WM272  
Seventy-seven Super, A.C. ... Dec. '32 WM305  
"W.M." D.C. Super, D.C. ... May, '33 WM321  
Merrymaker Super, A.C. ... Dec. '33 WM345  
Heptode Super Three, A.C. ... May '34 WM359  
"W.M." Radiogram Super, A.C. ... July '34 WM366  
"W.M." Stenode, A.C. ... Sep. '34 WM370  
1935 A.C. Stenode (A.C. Superhet) ... Apl. '35 WM385  
1934 A.C. Century Super, A.C. ... 10.3.34 AW425

## SHORT-WAVES (Battery Operated)

**One-valvers: Blueprints, 1s. each.**

New Style Short-wave Adapter ... June '35 WM388  
Roma Short-waver ... 10.11.34 AW452

**Two-valvers: Blueprints, 1s. each.**

Home-made Coil Two (D, Pen) ... 14.7.34 AW440

**Three-valvers: Blueprints, 1s. each.**

Experimenter's 5-metre Set (D, Trans, Super-regae) ... 30.6.34 AW438  
Experimenter's Short-waver ... 19.1.35 AW463

**Four-valvers: Blueprints, 1s. 6d. each.**

"A.W." Short-wave World Beater (HF Pen, D, RC, Trans) ... 2.6.34 AW436  
Standard Four-valve Short-waver (SG, D, 2LF) ... Mar. '35 WM381  
Simplified Short-wave Superhet ... Nov. '35 WM397

## Mains Operated

**Two-valvers: Blueprints, 1s. each.**

Two-valve Mains Short-waver (D, Pen) A.C. ... 10.10.34 AW453  
"W.M." Band-spread Short-waver (D, Pen) A.C./D.C. ... Aug. '34 WM368

**Three-valvers: Blueprints, 1s. each.**

Emigrator (SG, D, Pen), A.C. ... Feb. '34 WM352

**Four-valvers: Blueprints, 1s. 6d. each.**

Gold Coaster (SG, D, RC, Trans), A.C. ... Aug. '32 WM292  
Standard A.C. Four-valve Short-waver (SG, D, RC, Trans) ... Aug. '35 WM391  
Trickle Charger ... 5.1.35 AW462

**Amplifiers: Blueprints, 1s. 6d. each.**

Radio Unit for Listener's A.C. Amplifier (2-v.) ... Nov. '35 WM398  
Enthusiast's Power Amplifier ... May & June '35 WM387  
Listener's 5-watt A.C. Amplifier ... Sept. '35 WM392

**"PRACTICAL WIRELESS"**

Sixty-shilling Three ... 2.12.33 PW34A  
Nucleon Class-B Four ... 6.1.34 PW34B  
Fury Four Super ... 27.1.34 PW34C  
A.C. Fury Four Super ... 10.2.34 PW34D  
Leader Three ... 10.3.34 PW35  
D.C. Premier ... 31.3.34 PW35B  
A.C. Leader ... 7.4.34 PW35C  
Atom Lightweight Portable ... 2.6.34 PW36  
Ubique ... 28.7.34 PW36A  
Four-range Super-mag. Two ... 11.8.34 PW36B  
Summit Three ... 18.8.34 PW37  
Armada Mains Three ... 18.8.34 PW38  
Midget Short-wave Two ... 15.9.34 PW38A  
All-pentode Three ... 22.9.34 PW39  
£5 Superhet Three ... 27.10.34 PW40  
A.C. £5 Superhet Three ... 24.11.34 PW43  
D.C. £5 Superhet Three ... 1.12.34 PW42  
Hall-mark Three ... 8.12.34 PW41  
Universal £5 Superhet ... 15.12.34 PW44  
A.C. Hall-mark ... 26.1.35 PW45  
Battery Hall-mark 4 ... 2.2.35 PW46  
Universal Hall Mark ... 9.2.35 PW47  
Hall-mark Cadet ... 23.3.35 PW48  
Short-wave Converter-Adapter ... 23.2.35 PW48A  
F. J. Camm's Silver Souvenir (All-Wave Three) ... 13.4.35 PW49  
F. J. Camm's A.C. All-Wave Silver Souvenir Three ... PW50  
Cameo Midget Three ... 8.6.35 PW51  
F. J. Camm's Two-valve Superhet ... 13.7.35 PW52

"Wireless Magazine" Blueprint Service George Newnes, Ltd., 8-11 Southampton Street, Strand, W.C.2



a **NEW**



# Exide BATTERY

**TYPE GFG4-C.** 2 volts, 24 ampere hours. Price 10/6

DIMENSIONS:  $3\frac{3}{8}'' \times 3\frac{3}{8}'' \times 7\frac{9}{16}''$  high

*Fitted with the invaluable Exide Charge Indicator*

R.153.

An analysis of present day battery receivers shows that 91.6% have an L.T. current consumption above 0.4 amperes. Receivers now employ more valves than they used to.

This high consumption is well above the economical discharge of the 'Mass' Type DTG and DFG. Batteries that are so popular, and a new type of battery of small dimensions is called for. Exide now meet this need with the GFG4-C.

The GFG4-C is identical in size and appearance with the DFG, but it has these advantages. For a discharge

of 0.5 amperes—moderate for a four valve set—the GFG4-C will give 35% more life per charge and 91% more life at 1.05 amperes. In addition it maintains its voltage better, can be recharged quicker and, at these higher discharge rates, has a longer life.

The Exide GFG4-C is therefore a suitable battery for most modern receivers where space is limited but L.T. consumption is high. Where consumption is low the Exide DTG and DFG, with their capacity for standing on open circuit for long periods without harm, still hold their own.

Obtainable from Exide Service Stations and all reputable dealers. EXIDE BATTERIES, EXIDE WORKS, CLIFTON JUNCTION, NEAR MANCHESTER. Branches at: London, Manchester, Birmingham, Bristol, Glasgow, Dublin and Belfast.