

PORTABLES :: SHORT WAVES :: GRAMO-RADIO

Wireless Magazine

EDITOR: BERNARD E. JONES

TECHNICAL EDITOR: J. H. REYNER, B.Sc. (Hons.) A.M.I.E.E.

VOL. 7, No. 42.

JULY, 1928
ONE SHILLING

*The
Sidecar
Portable*

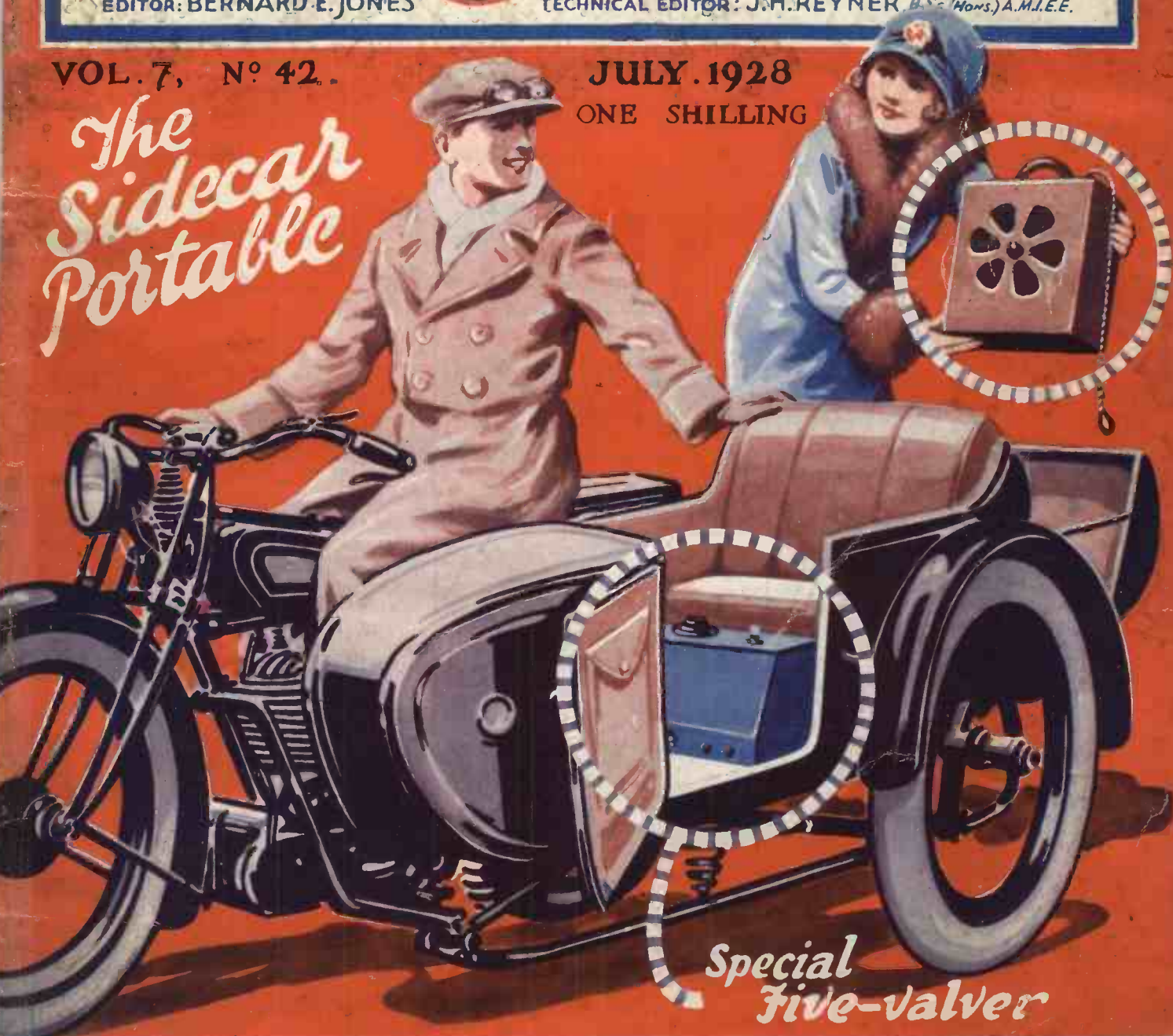

*Special
Five-valver*

MORE ABOUT THE CHUMMY FOUR!

AMATEUR SET-CONSTRUCTOR'S FULL-SIZE BLUEPRINTS

Photographic contact prints from the draughtmen's original designs, which act as drilling templates, layout guides and simplified wiring diagrams, are available of all sets described in the "Wireless Magazine" and of most sets described in "Amateur Wireless"

CRYSTAL SETS

All these 6d. each, post free.

For the R.C. Enthusiast	WM13
Fonotrol Set	WM14
Hi-lo Set	WM18
Two-programme Set	WM25
Half-hour Set	WM28
Centre-tap Set	WM50
Alternative-programme Set	AW 39
Super Set	AW 64
Tapped-coil Set	AW 95

ONE-VALVE SETS

All these 1s. each, post free.

One-valver for a Frame Aerial	WM47
Long-range Hartley	WM54
Reflexed One for the Loud-speaker	WM66
All-wave Reinartz	AW 2
Hartley D.X.	AW 27
Reinartz Plug-in One	AW 46
Constant-coupled	AW 65
Economy One	AW 71
Loud-speaker Special	AW 78
Ultra-sensitive Hartley One	AW103

TWO-VALVE SETS

All these 1s. each, post free.

Loftin-White 2 (D, Trans) Price 1s. 3d., with copy of "W.M."	WM30
One-dial 2 (D, Trans)	WM23
Girdle Two (D, Trans) Price 1s. 3d., with copy of "W.M."	WM30
Mains-fed 2 (D, LF)	WM37
British Broadcast 2 (D, Trans)	WM44
Two-programme 2 (D, Trans)	WM56
Q-coil 2 (D, Trans)	WM62
Crusader (D, Trans)	WM60
Flat-dweller's 2 (HF, D)	WM76
KL1 2-valver (D, Trans)	AW 5
One-control 2 (D, Trans)	AW 6
Wide-world Short-wave (D, Trans)	AW 11
Reinartz 2 (D, Trans)	AW 21
Empire Short-wave	AW 28
Next Step 2 (D, Trans)	AW 34
Centre-tap 2 (D, Trans)	AW 42
Three-option 2 (D, Trans)	AW 51
Rover 2 (HF, D)	AW 53
General-purpose 2 (D, Trans)	AW 55
All-wave (D, Choke)	AW 57
Yule (D, Trans)	AW 59
30/- 2 (D, Trans)	AW 61
Economical 2 (D, RC)	AW 66
Britain's Favourite (D, Trans) Price 7d., with copy of "A.W."	AW 74
Home-and-Abroad 2 (D, Trans)	AW 77
Two-wave (D, Trans)	AW 83
Ultra-selective Hartley (D, Trans)	AW 90
Oceanic Short-wave (D, Trans)	AW 91
Trapped Reinartz (D, Trans)	AW 92
"Q" 2 (D, Trans)	AW 99
Long Distance Two (HF, D.)	AW109

A blueprint of any one set described in the current issue of the "Wireless Magazine" can be obtained for half-price up to the date indicated on the coupon (which is always to be found on page iii of the cover) if this is sent when application is made. These blueprints are marked with an asterisk (*) in the above list and are printed in bold type. An extension of time will be made in the case of overseas readers.

THREE-VALVE SETS

All these 1s. each post free.

Continental (HF, D, RC)	WM 7
Wave-catcher (HF, D, Trans)	WM10
Screened-grid (HF, D, RC)	WM21
Five-guinea 3 (HF, D, Trans)	WM29
Mains Three-valver (D, 2LF)	WM34
Dominions Short-waver (D, 2 Trans)	WM39
Tuned-anode from the Mains (HF, D, LF)	WM43
Screened-grid Short-waver (HF, D, Trans)	WM51
Metropolitan (D, 2 LF)	WM48
Everyday (D, 2 Trans)	WM52
Music Changer (D, RC, Trans)	WM60
Britannia (D, RC, Trans)	WM67
Home and Garden 3 (D, RC)	WM78
*Signal Three (HF, D, Trans)	WM84
M.C.3 Star (HF, D, Trans)	AW 16
Split-primary (HF, D, Trans)	AW 24
Lighthouse 3 (D, 2 Trans)	AW 29
Modern Tuned-anode (HF, D, Trans)	AW 35
Tetrode 3 (HF, D, Trans)	AW 36
Alternative-programme 3 (D, 2 Trans)	AW 38
All-from-the-Mains (D, 2LF)	AW 41
Special (D, 2LF)	AW 44
Economy 3 (D, 2RC)	AW 48
Short-wave (D, RC, Trans)	AW 50
Ether-searcher (D, RC, Trans)	AW 52
Standard (D, 2 Trans)	AW 56
Hartley D.X. (D, RC, Trans)	AW 63
Britain's Favourite (D, RC, Trans) Price 7d., with copy of "A.W."	AW 72
Broadcast 3 (D, RC, Trans)	AW 76
Selectus 3 (HF, D, Trans)	AW 81
Q-coil 3 (D, RC, Trans)	AW 84
Clarion 3 (D, 2 Trans)	AW 88
Miniature Hartley Three	AW101
Summer-time D.X. Three (HF, D, Trans)	AW106
Three-valve Mains Receiver (HF, D, Trans)	AW110

FOUR-VALVE SETS

All these 1s. 6d. each, post free.

Revelation (HF, D, RC, Trans)	WM24
Simplicity (HF, D, 2 Trans)	WM49
Astral (HF, D, 2 RC)	WM53
Trapped 3-4 (D, 2RC Paralleled)	WM61
Station-finder (HF, D, 2RC)	WM68
Gramo-Radio 4 (D, RC, 2 Trans Push-pull)	WM70
Q-coil 4 (HF, D, Trans, RC)	WM71
*All-from-the-Mains Four (HF, D, LF)	WM86
Screened grid 4 (HF, D, 2RC)	WM77
All-purpose 4 (HF, D, RC, Trans)	AW 43
Tuned-anode 3-4 (HF, D, 2 Trans)	AW 49
C.T. 4 (HF, D, RC, Trans)	AW 58
Special 4 (HF, D, 2LF)	AW 70
I.H.C. 4 (2HF, D, Trans)	AW 87
"Q" 4 (HF, D, RC)	AW 98

FIVE-VALVE SETS

All these 1s. 6d. each, post free.

1927 Five (2HF, D, 2 Trans)	WM 6
Two-volter's 2 (Trans-Parallel Power)	WM11
Exhibition 5 (2HF, D, RC, Trans)	WM33
Phoenix (2HF, D, 2LF)	WM42
1928 Five (2HF, D, 2 Trans)	WM46
All-the-world 5 (2HF, D, 2RC)	WM63
Cataract 5 (HF, D, RC, Push-pull)	WM79
Individual 5 (2HF, D, 2 Trans)	AW 25
School 5 (HF, D, 2RC)	AW 85

SIX-VALVE SETS

1s. 6d. each, post free.

Nomad (2HF, D, RC, Push-Pull Trans)	WM31
Short-wave Super-6 (Super-het, Trans)	AW 67
Long-wave Adaptor	AW67a

SEVEN-VALVE SETS

1s. 6d. post free.

Simpladyne (Super-het)	WM22
--------------------------------	------

PORTABLE SETS

	Price, Post Free
Springtime 2 (D, Trans)	WM12 1/4
Countryside 4 (HF, D, 2 Trans)	WM17 1/6
Handy 3 (D, 2 Trans)	WM27 1/4
Sunshine 5 (2HF, D, 2 Trans)	WM74 1/6
Chummy 4 (HF, D, RC, Trans)	WM80 1/4
*Sidecar Portable (2 HF, D, RC, Trans)	WM83 1/6
Motorists 4 (HF, D, 2 Trans)	AW 14 1/6
M.C. 3 (HF, D, Trans)	AW 23 1/4
Holiday 3 (D, 2 Trans)	AW 32 1/4
Easter 7 (Super-het, RC, Trans)	AW 80 1/6
Table Grand 4 (HF, D, 2RC)	AW 93 1/6
Attache Portable 2 (HF, D)	AW 90 1/2
Companion 5 (2HF, D, RC, Trans)	AW 103 1/6
Daventry Portable (D, Trans)	AW 105 1/4
Daventry Loud-speaker Portable (2HF, D, RC, Trans)	AW 107 1/6

AMPLIFIERS

All the e 1s. each, post free

Two-valve D.C. Mains Amplifier	WM16
Range Extender (HF Unit)	WM38
True-tone Amplifier (3 valves)	WM47
Gramo-radio Amplifier (2 v.)	WM72
One-valve D.X. Unit	AW 37
Utility (RC, Trans)	AW 68
Screened-grid HF Unit	AW 75
One-valve LF Unit	AW 79
Add-on HF Unit	AW 82
Super-power Push-pull	AW 86
Hook on Short-waver	AW104
Purity Amplifier	AW108

MISCELLANEOUS

Volume-control Unit	WM40 1/6
A.C. Mains Eliminator	WM41 1/4
Cone Loud-speaker	WM55 1/4
A.C. Adapter for "Simpler Wireless" Sets	WM57 1/4
Moving-coil Loud-speaker	WM58 1/4
D.C. Mains Eliminator	WM59 1/4
Wavetrap	WM51 1/4
Valve Tester and Paralleling Unit	WM58 1/4
Portable Cone Loud-speaker	WM73 1/4
Permanent-magnet Moving-coil Loud-speaker	WM71 1/4
"Junior" Moving-coil Loud-speaker	WM81 1/4
*Universal Short-wave Adaptor	WM82 1/4
Heterodyne Wavemeter	AW 7 1/4
Rectifying Unit for "Simpler Wireless" Sets	AW 62 1/4
H.T. from A.C. Mains	AW 73 1/4
"A.W." Moving-coil Loud-speaker	AW 97 1/4
H.T. Eliminator for A.C. (200 v. output)	AW 102 1/4

Send a postal order (not stamps)

TO
**Wireless
Magazine**

Blueprint Dept., 58/61
Fetter Lane - E.C.4



If
Albert Sandler
is your favourite

You have heard him from Eastbourne. You have heard him from London. You heard him last on Sunday, the 27th. And feasts of feasts, you are going to hear him regularly for some time to come. You will hear him make wonderful melody and harmony on the strings of his famous violin. You will hear his music as he would like you to hear it if you use a Lissen New Process Battery in your set. For there comes from this battery such fine power that your loud-speaker utterance keeps clear and loud all the time, natural and true. All the light and shade of fine music conceived by a master mind and played by a master's hand is there for you to enjoy if you use the Lissen New Process Battery. The fine current of this battery is due to the new process and new chemical combination which is known and used only by Lissen, and you can get it in no other battery. Ask for a Lissen New Process Battery at any one of 10,000 radio dealers. If you value fine radio reproduction ask for it in a way that shows you intend to take no other.

- 60 volt. (reads 66)7/1 1
- 100 volt (reads 108)12/1 1
- 60 volt Super Power13/6
- 9 volt Grid Bias.....1/6
- 4½ volt Pocket Battery (4/6 doz.) 5d.



LISSEN LTD., Friars Lane, Richmond, Surrey. Managing Director: Thomas. N. Cole.

Although details of it were published only a month ago, the Chummy Four is "going great guns." This set is the first portable to use a screened-grid high-frequency valve and the results it gives are really astonishing. In one evening thirty-one stations were received on the loud-speaker—and that in South London where conditions are none too good!

The Chummy Four Makes Friends!

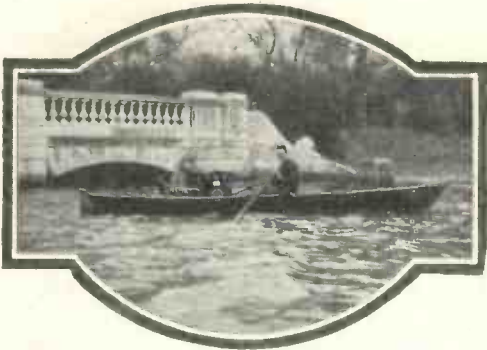

RIGHT from the day of publication of the previous issue of the WIRELESS MAGAZINE, in which full constructional details for making it were given, the Chummy Four has made friends with everybody who has read about it. During the past few weeks the original WIRELESS MAGAZINE set, which, it will be remembered, was the first portable set to make use of a screened-grid valve, has been demonstrated to a number of well-known people in the wireless trade and all of them without exception have expressed keen interest in the design.

Although it weighs 30 lb. when all the batteries are in position, the Chummy Four is not cumbersome; for it is so well balanced and the case is so narrow that it swings freely by the side of the legs. It is undoubtedly the ideal receiver for those who want good radio reception with the minimum amount of trouble.

Although the design of the Chummy Four is very compact and the space available has been used to the best advantage, there is no difficulty at all about the construction and those who work from a full-size blueprint will be able to put the receiver together in a few hours.

In his original test of the Chummy Four, Mr. J. Godchaux Abrahams received and identified on the loud-speaker no less than twenty-one stations and in an independent test a member of the WIRELESS MAGAZINE Staff achieved the reception of thirty-one stations, although all of these were not identified.

We shall be delighted to have from WIRELESS MAGAZINE readers detailed reports of the results they obtain from this receiver.

The Best Portable Set Yet Produced: Makes Use of a Screened-grid Valve Designed, Built and Tested by the "Wireless Magazine" Technical Staff

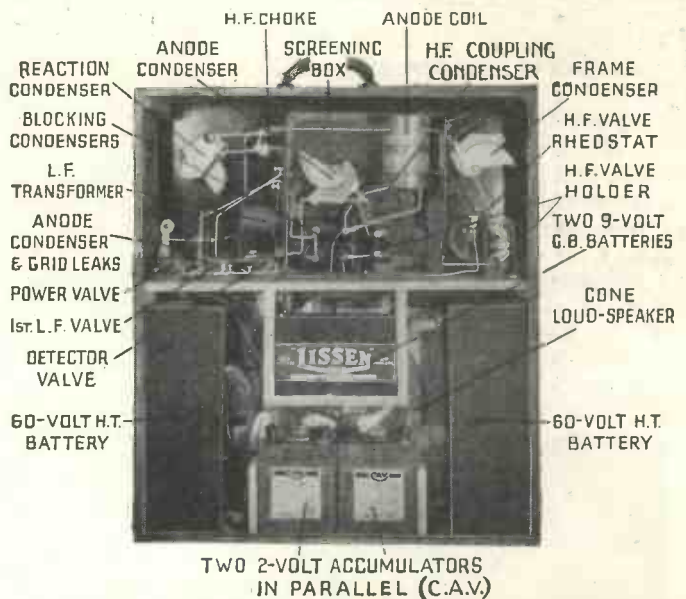

The arrangement of all the parts in the Chummy Four is clear from this photograph. It consists of a high-frequency amplifier, a detector, a resistance-coupled low-frequency amplifier and a transformer-coupled amplifier



This photograph clearly shows the various controls of the Chummy Four



Trying out the Chummy Four after a car journey. Vibration does not affect it

Some Advice to the Constructor

IN these pages are reproduced for the benefit of those who missed it last month a number of photographs which make clear the special character of the design of the Chummy Four, the first portable set to make use of the screened-grid valve. Only representative photographs are included and for full constructional diagrams, the reader is referred to pages 399 to 406 of the June issue of the WIRELESS MAGAZINE.

Normally, the complete set of parts

The Chummy Four (Continued)

valve to be utilised.

Not only does the full-size blueprint indicate the exact positions of all the components, but it also acts as a very clear wiring diagram, all the points to be wired together being indicated by small letters, the alphabetical sequence of which coincides with the simplest

distance tests, and the addition of extra terminals and a switch so that the high-tension supply can be obtained from an eliminator or other source of supply, if desired, when the set is used indoors.

Although it is possible to get twenty-five to thirty stations on the loud-speaker the number could, of course, be very greatly increased with headphone reception and this modification is being made at the request of a large number of listeners.

One Evening's "Bag" by Mr. J. G. Abrahams

Wave-length in metres	Station	Dial No. 1	Dial No. 2	Reaction	Wave-length in metres	Station	Dial No. 1	Dial No. 2	Reaction
236.2	Stettin.....	36	15	40	364	London (2LO).....	101	71	No R.
241.9	Nuremberg.....	43	19	38	365	Leipzig.....	104	76	40
250	Muenster.....	45	23	40	379	Stuttgart.....	107	81	36
279	Lille.....	59	32	50	380	Toulouse.....	112	85	36
283	Cologne.....	62	40	42	396	Hamburg.....	114	89	59
297	Hanover.....	73	46	50	428	Frankfurt.....	123	98	54
319	Dublin.....	81	57	42	468	Langenberg.....	138	112	58
322.6	Breslau.....	85	61	49	491	Daventry (5GB).....	142	118	20
337	Copenhagan.....	90	65	55	535.7	Munich.....	150	124	66
340	*Frenchman (Petit Parisien?).....	92	65	55	549.3	Milan.....	155	130	50
					555.6	Buda-Pesth.....	160	135	60

(Tested on April 29, 1928.) *This station could not be identified; for thirty minutes it broadcast election results, but gave no call!

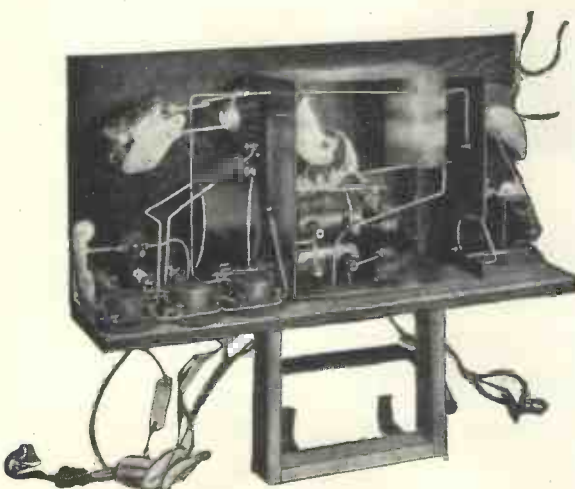

How the parts are arranged in the Chummy Four

costs approximately £15, but this price may be reduced by the use of alternative parts as specified in the list of components required, which is again reproduced on the opposite page. There is, of course, no alternative for the screened-grid high-frequency valve, which is a Cossor, as this is at present the only 2-volt type on the market and there is no room in the cabinet for a 6-volt accumulator, which would be necessary were any other screened-grid

sequence of wiring up.

These blueprints, which are 1/6 post free (they cannot now be obtained under the half-price coupon scheme), are available from the Blueprint Department, WIRELESS MAGAZINE, 58/61 Fetter Lane, E.C.4. When sending for a blueprint enclose a postal order for 1/6 and simply ask for No. W.M.80; your copy will then be sent by return of post.

In the next issue we shall describe a number of interesting modifications

which constructors can make to their receivers should they so desire. It should be clearly understood, however, that these modifications are not essential and in no way affect the reproduction. The points that will be explained are the inclusion of terminals for the use of an external aerial and earth for experimental work, the inclusion of a headphone jack for long-

Further Comments

By J. GODCHAUX
ABRAHAMS

FOR the past fortnight, by hook and by crook, I have held on to the Chummy Four. In a weak moment the Editor of WIRELESS MAGAZINE allowed me to take it away from his den, "for a further test," I suggested. Since that moment IT (the set, not the Editor, of course!) has been my constant companion.



A welcome addition to the tea party—the Chummy Four quickly makes friends

Amazing Success of the First Screened-grid Portable

When I tested out the Chummy Four last month I dwelt more on the question of selectivity and ability to reach out than on the quality and tone of its reproduction. Now, at my leisure, I have tuned into the different stations I had picked up previously and logged, have checked the condenser readings carefully, and have held each individual transmission for a reasonable period. I have *listened* to concerts, not merely *listened-in*; there is a wide difference between the two terms.

I selected four stations, namely, Copenhagen, Stuttgart, Hamburg, and Milan; they were taken at random from my log, but were those I can receive almost nightly on a seven-valve super-het. The Chummy Four captured and held them for me, and if the volume was not quite equal to that obtained with the larger receiver, the portable scored one advantage: it brought in less mush and, if anything, the tone was purer and clearer.

Cutting Out the "Local"

From the roof of my house I can see the 2LO aerial; I doubt whether it is much more than a mile away, yet the moving of the vernier dials some two or three degrees will cut out the London transmission. In my case the reception of the local concert through an ordinary three- or four-valve receiver proves too powerful for my loud-speaker.

Not so with the Chummy Four, as to control volume it is only necessary to dim the filament of the screened-grid high-frequency valve by means of the rheostat knob. There is no need to detune or to turn the frame aerial away from the station, both of

COMPONENTS REQUIRED FOR THE CHUMMY FOUR

- | | |
|---|---|
| <ul style="list-style-type: none"> 1—Ebonite panel, 16 in. by 8 in. (Resiston, Becol, or Raymond). 1—Metal screening box with lid (Magnum or Formo). 2—.0005-microfarad variable condensers (Formo 1928 Log). 2—Vernier dials (McMichael). 1—.0002-microfarad variable condenser with small dial (Cyldon). 1—7-ohm panel rheostat (Lissen, Igranic, or Peerless). 1—Screened-grid valve-holder (Burndept). 2—2-microfarad fixed condensers (Lissen, Dubilier, or T.C.C.). 1—Anode coil as specification (Burne-Jones). 1—High-frequency choke (Omnora, Wearite, or Igranic). 1—Low-frequency transformer, ratio 4 to 1 (Mullard). 3—Anti-microphonic valve holders (Redferns). 1—On-off switch (Bulgin Midget, Lotus, or Lissen). 1—Pair small panel brackets (Magnum, Camco, or Bulgin). 2—2-megohm grid leaks with clips (Loewe). 1—.005-microfarad fixed condenser with clips (Loewe). 1—.0003-microfarad fixed condenser with clips (Loewe). 1—.25-megohm grid leak with clips (Loewe). 1—Ebonite strip, 2½ in. by 1½ in. (Resiston, Becol, or Ready Radio). | <ul style="list-style-type: none"> 2—Ebonite washers, ¾ in. bore and ¼ in. thick (Ready Radio). 6—Lengths Glazite. 3—yards thin rubber-covered flex (Lewcos). 2—60-volt high-tension batteries (Lissen). 2—9-volt grid-bias batteries (Lissen). 2—2-volt accumulators (C.A.V. type 2NS9, with jellied acid). 1—Loud-speaker unit (Goodman doubt-acting). 1—Piece gold-finished cone paper (Goodman). 1—Piece rubber sheet, 1 ft. square (any sixpenny stores). 10—Wander plugs, 6 red and 4 black (Igranic). 10—Indicating tabs for flexible wire, marked: two H.T.+, one H.T.—, two G.B.+, one G.B.—, one L.T.+, one L.T.—, one L.S.+, one L.S.— (Bulgin). 1—Cabinet with baseboard, battery brackets, loud-speaker, front and back (Ready Radio). 2—Ozs. No. 28-gauge d.s.c. wire for frame aerial (Lewcos). 8—Ebonite strips, 1½ in. by 1 in. (Ready Radio). 12—6B.A. 1 in. round-head screws with nuts (Bulgin or Ready Radio). 36—½ in. No. 3 brass wood screws (Bulgin or Ready Radio). 2—1½ in. brass wood screws (Bulgin or Ready Radio). 3—Dial indicators (Bulgin). 1—Station log, small (Bulgin). |
|---|---|

which processes invariably spoil the clarity of the reproduction.

The actual tuning of the receiver is mere child's play; just log the stations received. As soon as you have done this, unless the transmitters should change their wavelengths, you may find them again and again without any further trouble. A frame aerial possesses one great advantage, the condenser readings cannot vary.

An easily-constructed wireless set which will give you a selection of some twenty-five to thirty stations

at any favourable time of the day or night is an excellent investment.

On My Conscience!

Whether the Editor ever gets this receiver back again is a moot point; it must entirely rely on my conscience. But I have never felt so tempted to break the eighth commandment!

Failing this alternative, I shall be compelled to build the Chummy Four myself—whatever happens, I *must* have one.

J. GODCHAUX ABRAHAMS.

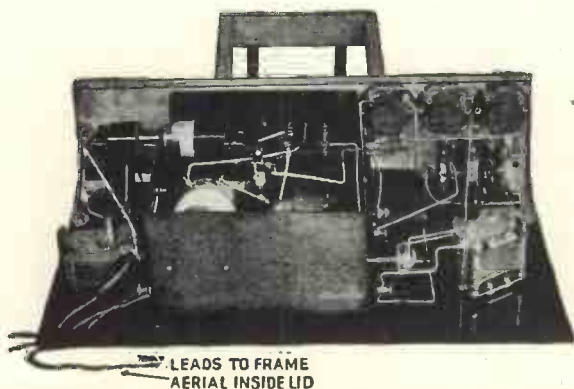

Receiver unit of the Chummy Four photographed from top of panel. Note the bracket for the grid-bias batteries

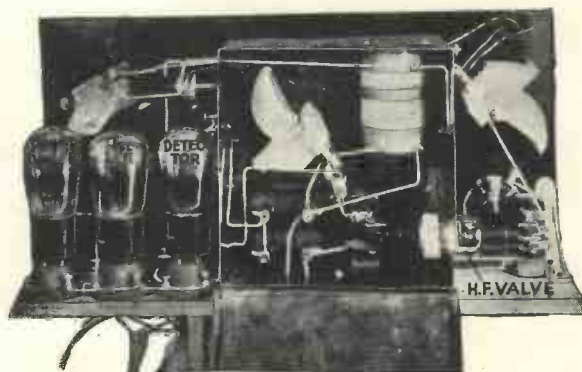

View of back of Chummy Four receiver. The lid of the metal screening box has been removed

New Valves With Five Electrodes!



Similar in appearance to any three-electrode valve, the extra connection required by the Pentone is brought out to an extra terminal on the base. The valve fits the standard four-pin holder and does not necessitate any circuit alterations.

A new era in receiver design is heralded by the announcement of a special type of five-electrode power valve (it gives equivalent results to two ordinary valves), which the "Wireless Magazine" is able here to give special advance details for the benefit of readers.

results in both the Chummy Four and the Sunshine Five portables.

Known as the Pentone, because it contains five electrodes, the new valve contains normal filament and anode between which are placed three grids. That nearest the filament is the ordinary operating or control grid such as employed in the ordinary three-electrode valve, while the next grid (that is, the central electrode) has applied to it the same high voltage as fed to the anode. The third grid (nearest the anode) is connected internally to the filament.

This combination produces a valve

structural difficulties about the use of Pentone valves, and readers can rest assured that as soon as they become available the WIRELESS MAGAZINE will lose no time in publishing details of a receiver that will make the best possible use of them.

Two- and Four-Volters Only

At first only two-volt and four-volt Pentones will be produced and these will be known as the Mullard PM22 and PM24 respectively. We are able to give here, for the benefit of WIRELESS MAGAZINE readers, the first details of the new valves:—

Mullard PM22

- Filament voltage, 2 volts.
 - Filament current, .3 ampere.
 - Maximum anode voltage, 150 volts.
 - Auxiliary grid voltage, same as anode.
 - Anode impedance, 62,500 ohms.
 - Amplification factor, 82.
 - Mutual conductance, 1.3 milli-amperes per volt.
- (The impedance, amplification factor and mutual conductance quoted are these measured at 100 anode volts, zero volts on control grid, and 100 volts on auxiliary grid.)

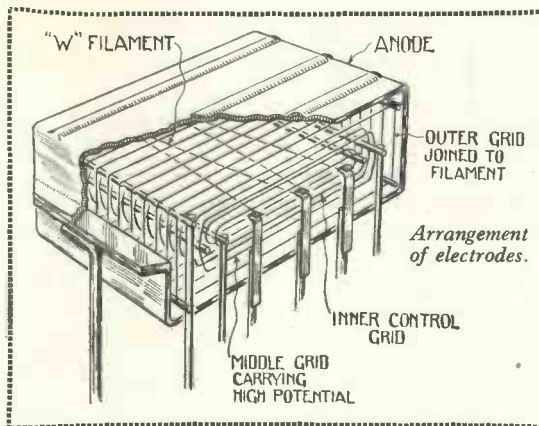

IN every receiver intended for really good loud-speaker reproduction it is necessary at present to incorporate at least two stages, and in many cases three stages, of low-frequency amplification.

Two Valves Only

The advent of an entirely new type of power valve with five electrodes will make it possible, however, in the very near future to work a loud-speaker at full volume from a simple receiver consisting of a good detector and only one of the new power valves.

Hitherto no details of these valves have been published, but in these pages the WIRELESS MAGAZINE is able to give its readers some most interesting advance information concerning them. It must be clearly understood, though, that the valves will not be on the market for some weeks to come.

A Mullard Development

In the meantime everybody will be glad to know something of this latest development, which is due to research work carried out during the past few months by the Mullard Wireless Service Co., Ltd., whose new Perma-core transformer has given such fine

with remarkable characteristics and constitutes one of the most revolutionary developments of recent months. It is no exaggeration to say that these new valves will, in a very short time, revolutionise receiver design. (Readers will remember that Capt. Round foreshadowed this development in his article, "Need We Improve the Valve?" which appeared on page 218 of the April issue of the WIRELESS MAGAZINE.)

Moreover a point that will particularly appeal to the home-constructor is that the new valve can be used in the standard four-pin holder, the connection to the auxiliary grid which carries a high potential being brought out to a terminal at one side of the ebonite base.

There will, therefore, be no con-

How elaborate is the construction of the Pentone can be judged from this special "Wireless Magazine" photograph. The valve has given excellent results in our laboratories. The price will be 22s. 6d.

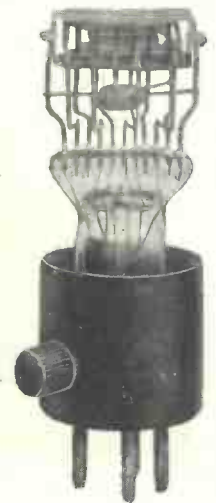

Mullard PM24

Filament voltage, 4 volts.
 Filament current, .15 ampere.
 Maximum anode voltage, 150 volts.
 Auxiliary grid voltage, same as anode.
 Anode impedance, 28,600 ohms.
 Amplification factor, 62.
 Mutual conductance, 2.3 milliamperes per volt.

(The impedance, amplification factor and mutual conductance quoted are those measured under the same conditions as for the PM22.)

The remarkable nature of the new valves is evident from these particulars. Particular note should be made of the enormous amplification factor of these valves, for that of a standard three-electrode power valve is in the neighbourhood of 3 to 5. The high impedance is no drawback because of the large anode-current output that is available—as much as 33 milliamperes at zero grid volts in the case of the PM24, with 125 volts on the anode and auxiliary grid.

It will be evident that with its high amplification and large anode current one Pentone will give results equal to those at present obtained from an ordinary two-valve amplifier comprising a medium-impedance and low-impedance power valve, but

there will be a great saving of filament current and one intervalve coupling will be obviated. This will, of course, greatly simplify receiver design and is a point that will at once make a strong appeal to the home-constructor, who wants the best possible reproduction with the least amount

a slope of only 1.3 milliamperes per volt the four-volter has a slope of 2.3 milliamperes per volt, which means, of course, that it is a very much more efficient amplifier. Moreover the filament current required by the four-volt valve is only half that needed by two-volt type.

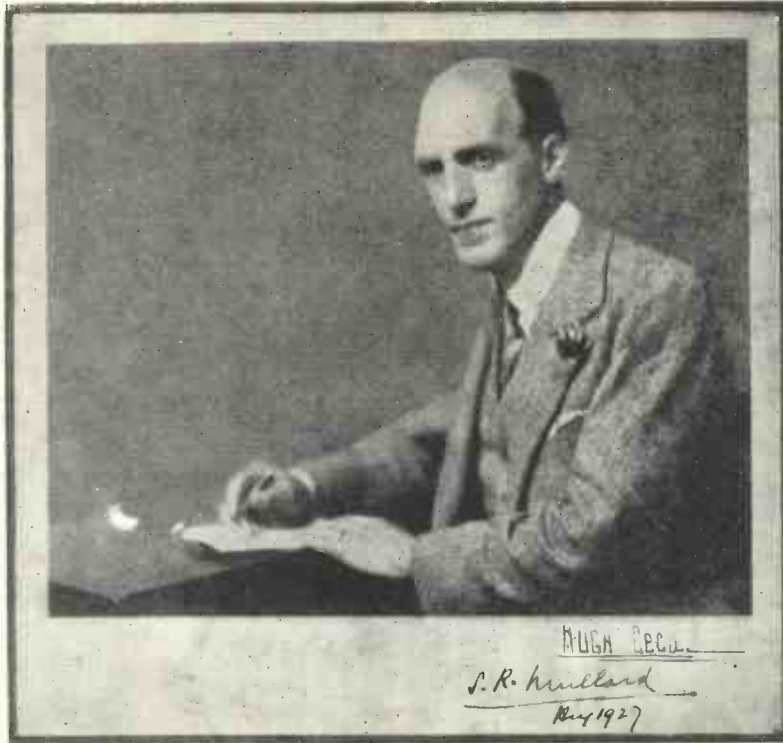

This is to introduce Mr. S. R. Mullard, Managing Director of the Mullard Wireless Service Co., Ltd., to "Wireless Magazine" readers

of trouble in building and operating.

The case for developing four-volt valves rather than abolishing them (the latter course has been strongly advocated in some quarters) is well emphasised by these PM22 and PM24 characteristics. It will be noted that while the two-volt valve has

how to use Pentones to the greatest advantage.

We have had an opportunity of testing the new valves and know from personal experience that they are really good. For the rest, readers must possess themselves with patience for a few weeks!

Not for Sale

These advance particulars will undoubtedly create great interest in amateur radio circles everywhere, but once again the WIRELESS MAGAZINE wishes to point out that these are *advance* details and that the valves themselves are not yet available. As soon as they are on the market full operating particulars will be published in these pages and readers can rest assured that the Technical Staff is sparing no pains in preparing to give the amateur, when the time comes, the best information on

A LISTENER in this country usually receives a mild shock when he goes abroad for the first time and hears Berlin, for example, within a mile of the capital itself.

Reception Noticeably Different

He finds that reception is noticeably different. The station doesn't seem the same Berlin as that to which he listened on his set at home. For one thing, the local reception is much louder, unless he has a super set. And for another, he is hearing it for the first time as the station is meant to be heard, namely, locally.

What Are Other Stations Like?

This is not meant to be a slight on Berlin, but it must be remembered that every station (except 5SW) caters for listeners within its normal zone. London does not cater for German listeners, so conversely, it seems strange to a British listener to hear Berlin without any distance distortion or fading.

Programmes? That is a different matter. There are not many *regular* listeners to Continental and other centres who would willingly

exchange our B.B.C. programmes for those of the French, German, or American broadcasters.

All these do, occasionally, broadcast some item of outstanding merit, and it may, on that particular occasion, be better than anything being "put on the air," by the B.B.C. But these times are rare.

Without wishing to take over the rôle of publicity man to the Corporation, I may say that I think most of us prefer the consistent good-quality B.B.C. matter to the periodic spurts of stations in many other countries.

QUEUE.

The ALL-FROM-THE-MAINS FOUR



The rectifying unit on the right is added for A.C. working

Can be Operated Direct from Direct-current or Alternating-current Electric Mains

Described by J. F. JOHNSTON

Built by the "W.M." Technical Staff

THERE are still quite a lot of experimenters to whom no trouble is too great to be undertaken in the cause of wireless. Such people take a keen delight in tinkering with, caring for, and generally looking after, their wireless gear, and would not take much interest in a set which never required any attention.

But the very great majority of the people who use wireless nowadays do so simply and solely for the sake of the programmes they are thereby enabled to enjoy. The ideal set for this great class of people would be one which could be entirely forgotten until the moment it was required for use—a set which required no other attention than the touching of a switch to start it and stop it when required.

Battery Troubles

Now, it is perfectly obvious that no receiver which depends for its current supply on any kind of batteries can even approach this ideal, as if such a set is to be always available for use, one has constantly to keep in mind the state of the batteries and when they require renewing or replacing.

A great step towards achieving real trouble-free wireless is taken when all the necessary current is derived from the lighting mains, thus

eliminating batteries altogether. One can then at least be sure of a steady, continuous and never-failing supply.

To work entirely from the mains in this way is now no novelty, but until recently the only way to do so was to use "battery eliminators" and an ordinary receiver. That is to say, to use a set designed to be worked from batteries, but to replace these latter

with pieces of apparatus which could be connected to the mains and which would supply to the set current of the same nature as that previously supplied by the orthodox batteries.

The introduction of the "Simpler Wireless" system inaugurated a new order of things. A "Simpler Wireless" set is a mains set in itself, and does not require either batteries or battery eliminators.

Several "Simpler Wireless" sets have already been described in the WIRELESS MAGAZINE, but the one with which this article is concerned is the first four-valver

to be dealt with in this periodical.

Those readers who have studied the articles dealing with previous "Simpler Wireless" sets will find the circuit diagram familiar—to new readers the circuit will, no doubt, appear rather strange at first.

The set is intended to work from D.C. electric-lighting mains, having a voltage of from 200 to 240 or, with

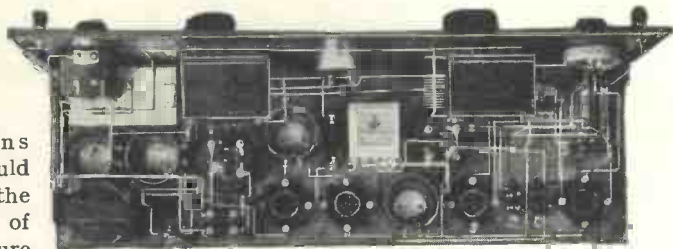

Plan view of the All-from-the-mains Four

the attachment of the rectifying unit, here described, from A.C. mains of a similar voltage. The filaments of all the valves are connected in series with each other and with a number of resistances. All the valves used are of the .1-ampere type and the resistance of the series circuit (which is connected across the mains, or the output of the rectifier) is varied until a milliammeter shows that the correct current is passing.

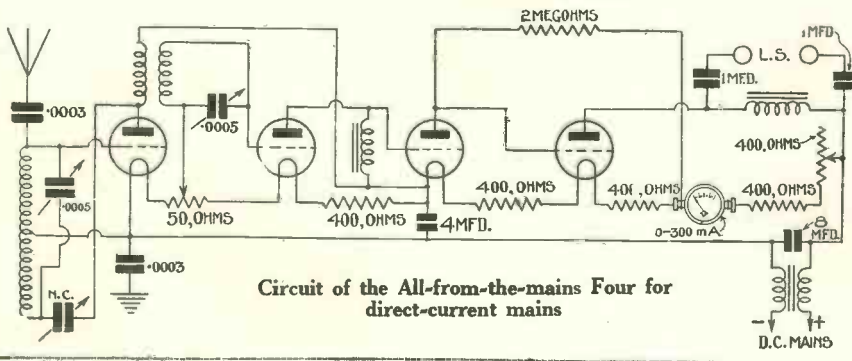

Circuit of the All-from-the-mains Four for direct-current mains

Constant Voltage Drop

As the current is .1 ampere, there will obviously be a voltage drop of one volt across every ten ohms resistance. Looking at the circuit, it will be seen that, according to this, the filament of the second valve is five volts positive with respect to the filament of the first valve, while there is a difference of as much as 40 volts between the filaments of the second and third valves, and also between

those of the third and fourth valves. The first valve is, of course, an H.F. amplifier, and is neutralised. There is nothing at all out of the ordinary about this stage. The second valve is an anode-bend rectifier, and can be given a negative bias of anything up to five volts by altering the point at which the return grid lead joins the 50-ohm resistance.

is correctly adjusted. As regards safety, which is a matter of some consideration when dealing with the mains, it may be pointed out that the two high-voltage condensers, one

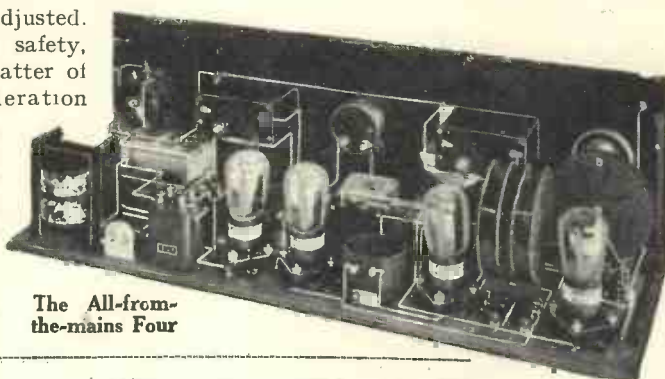

The All-from-the-mains Four

"Direct" Valve Couplings

The coupling between the second and third valves is of the "direct" type, peculiar to the "Simpler Wireless" system. The anode of the second valve is directly connected to the grid of the third valve, and this makes possible even greater purity than could be obtained by resistance-capacity coupling, on account of the absence of a coupling condenser or grid leak. Direct coupling is also used between the last two valves, so that practically perfect amplification may be depended upon from the L.F. side, provided that the correct components and valves are used, and that the set

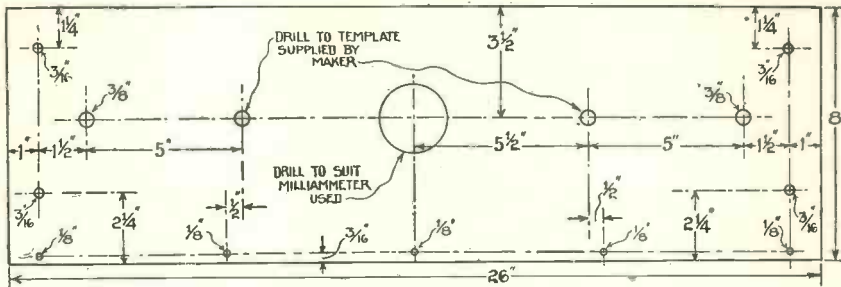

Panel layout of the All-from-the-mains Four

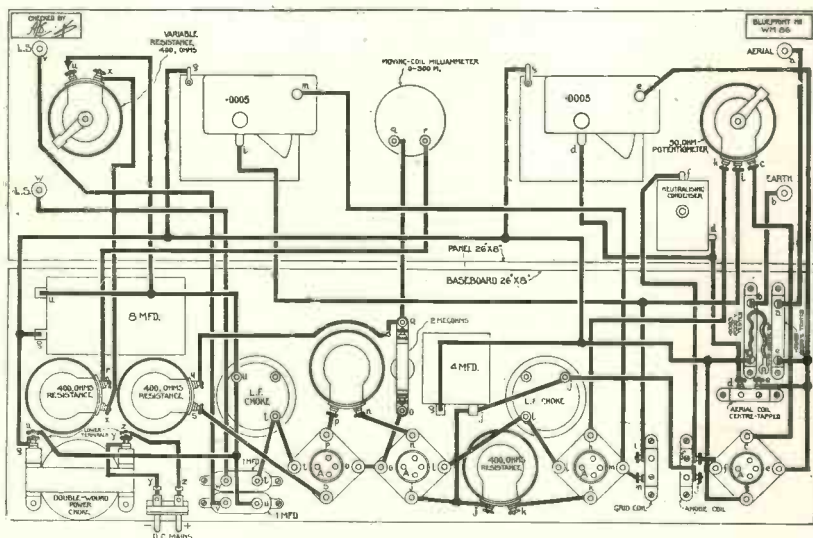

This layout and wiring diagram can be obtained as a full-size blueprint for half-price—that is 9d. post free—if the coupon on page iii of the cover is used before July 31. Ask for No. W.M.86

loud-speaker, thus effectually insulating it.

When building this set, the components specified must be used, if the set is to operate satisfactorily. "Simpler Wireless" sets have many peculiarities and may be quite upset if unsuitable components are used.

This is a very easy and straightforward set to build, and may safely be attempted even by those who have never built a set before. The four terminals, two variable condensers, two potentiometers, and the milliammeter are mounted on the panel, and rest of the components are fixed on the baseboard. The

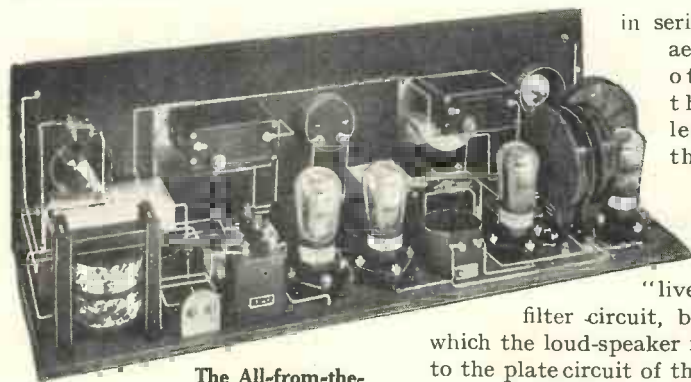

The All-from-the-mains Four

in series with the aerial and the other with the earth lead, ensure that neither the aerial nor the earth wire will be "live," while the filter circuit, by means of which the loud-speaker is connected to the plate circuit of the last valve, has a condenser on each side of the

neutralising condenser, however, is first screwed to a small block of wood which, in turn, is screwed to the baseboard. This is done to get the spindle of the neutralising condenser parallel to the baseboard. A clearance hole is drilled in the panel, through which the spindle of the neutralising condenser passes.

How to Wire Up

In wiring up, first connect all the points marked *a*, then all the points marked *b*, and so on.

A point to notice is that nothing

The All-from-the-mains Four (Continued)

The All-from-the-mains Four

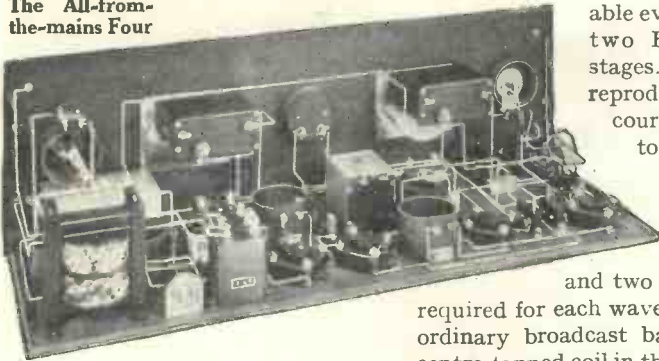

on the front of the panel is "live" when the set is connected up to the mains. The aerial, earth, and loud-speaker terminals are, as already explained, insulated by fixed condensers, while even the grub-screws which secure the dials of the variable condensers to their spindles are not "live" as the spindles of the Burndeft condensers are made of an insulating material.

Results to be Expected

The performance of the set, as far as range and volume go, will be very similar to that of any good four-valver with one H.F. and two L.F. stages. There is nothing about the H.F. stage to make it any more or less efficient than the H.F. stage of any other set.

As regards the L.F. side, the amplification will be about the same as that given by one transformer-coupled stage, plus one resistance-capacity coupled stage, but the quality will, if everything is correctly adjusted, be better than that obtain-

able even when using two R.C.-coupled stages. This fine reproduction is, of course, due entirely to the direct coupling of the L.F. valves.

One centre-tapped and two plain coils are required for each waveband. On the ordinary broadcast band a No. 60 centre-tapped coil in the aerial socket and two No. 75 untapped coils in the other two sockets were found to be the best combination, although for some aerials it may be better to use a No. 75 centre-tapped coil in the first position. 5XX was well received using a No. 200 centre-tapped coil in the aerial socket and two No. 200's in the other sockets. Here, again, it may sometimes be better to use a No. 250 centre-tapped coil instead of No. 200 in the aerial circuit.

The valves to be used in a "Simpler Wireless" set need, of course, very careful choice. In the present set an H.F. valve will be required in each of the first two positions, an R.C. valve in the third stage and a power

valve or, preferably, a super-power valve, in the last stage. As all the valves must, of course, take a filament current of .1 ampere, the last position is the most difficult one to fill. However, the Cossor Stentor Six is ideally suitable for the last stage of a "Simpler Wireless" set, as not only is it a .1-ampere valve, but it is also a super-power valve and a very good one at that.

As a Cossor Stentor Six is undoubtedly the best valve available for the last stage, the rest of the set has been designed to take other Cossor valves

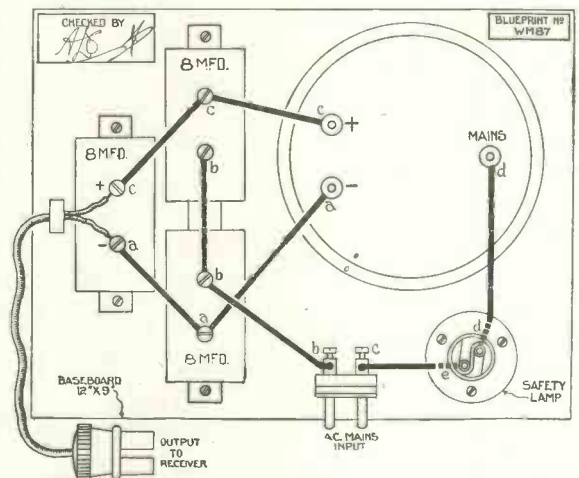

This layout and wiring diagram of the improved rectifying unit can be obtained as a full-size blueprint for half-price—that is 6d. post free—if the coupon on page iii of the cover is used by July 31. Ask for No. W.M.87

COMPONENTS REQUIRED for the ALL-FROM-THE-MAINS FOUR

- | | |
|---|---|
| 1—Ebonite panel, 26 in. by 8 in. (Becol, Radion, or Raymond). | 2—Low-frequency chokes (Watmel, Lissen, or Faradex). |
| 2—.0005-microfarad variable condensers with vernier dials (Burndeft or Geophone). | 4—400-ohm baseboard resistances (Faradex). |
| 1—2-megohm grid leak with holder (Graham-Farish, Mullard, or Lissen). | 1—4-microfarad fixed condenser, 750-volts test (Hydra, Faradex, or Dubilier). |
| 1—50-ohm panel potentiometer (Faradex or Igranite). | 1—8-microfarad fixed condenser, 750-volts test (Hydra, Faradex, or Dubilier). |
| 1—Neutralising condenser, panel mounting (Bulgin or Peto-Scott). | 2—1-microfarad fixed condensers (Dubilier, Lissen, or Hydra). |
| 1—Milliammeter, reading 0-300 (Sifam). | 1—Double-wound low-frequency choke (Faradex). |
| 1—400-ohm rheostat or potentiometer (Faradex). | 1—Safety mains plug and socket (Bulgin). |
| 4—Terminals, insulated type, marked: Aerial, Earth, L.S.+ , L.S.— (Belling-Lee). | 1—Cabinet with 8 in. baseboard (Arctcraft). |
| 3—Single-coil holders (Lotus, Lissen, or Magnum). | |
| 2—.0003-microfarad fixed condensers, tested to 2,000 volts (Dubilier type 577). | |
| 4—Anti-microphonic valve-holders (Benjamin, Lotus, or W.B.). | |

A.C. RECTIFYING UNIT

- | |
|---|
| 1—"Simpler Wireless" rectifier (Faradex). |
| 3—8-microfarad fixed condensers, 700-volt test (Faradex, Dubilier, or Hydra). |
| 1—Batten-type lamp holder (Bulgin). |
| 1—Safety mains plug (Bulgin). |
| 1—Baseboard, 12 in. by 9 in. (Arctcraft). |

and the combination recommended is two Cossor 4-volt H.F. valves in each of the first two positions, a Cossor 4-volt R.C. valve in the third position, and a Cossor Stentor Six in the last stage. The equivalent 2-volt Cossor valves may be used in any of the first three positions, but the 6-volt valves do not seem to suit the set so well.

Other Makes of Valves

Other makes of valves may be used in the first three stages, but, as there is no other .1-ampere super-power valve available, it is strongly recommended that only the Stentor Six be used in the last stage. If an R.C. valve other than a Cossor is used in the third stage, it may be necessary to use a different value of anode resistance in the plate circuit of the third valve.

All L.T., H.T. and G.B. Direct from the Mains

The operation of the set needs little explanation except, perhaps, to say that it is intended that reaction should be controlled by means of the neutralising condenser. When searching for a distant station, besides the two variable condensers and the neutralising condenser, the 50-ohm potentiometer controlling the grid potential of the anode-bend rectifier should also be adjusted. During our tests, carried out 10 miles from London, besides the local station and 5GB, Langenberg, Stuttgart and Frankfurt were received at very great strength without changing coils. Several other stations were, of course, also received at fairly good strength, but no other was quite so loud as those mentioned.

The set itself, as has already been stated, is suitable for D.C. mains having voltages of from 200 to 240, the 400-ohm variable resistance having sufficient variation to compensate for the different voltages. The set is also quite suitable for use on A.C. mains of any frequency and having voltages between 200 and 240, providing that the rectifier unit now to be described is interposed between the set and the mains.

Improved Rectifying Unit

The rectifying unit is a very simple affair, requiring only a very few components, which are mounted on a baseboard measuring 12 in. by 9 in., and the few simple connections are clearly shown in the wiring diagram. The improved Faradex rectifier is similar to the one used in the "Simpler Wireless" rectifying unit described in the WIRELESS MAGAZINE a few

months back, but both the cells and the electrodes are much longer than before and, in fact, the rectifier contains just twice the quantity of electrolyte used previously.

The rectifier has been re-designed so as to make it more suitable for prolonged spells of hard work. The electrolyte in the original model used to evaporate rather quickly if the set was used for several hours each

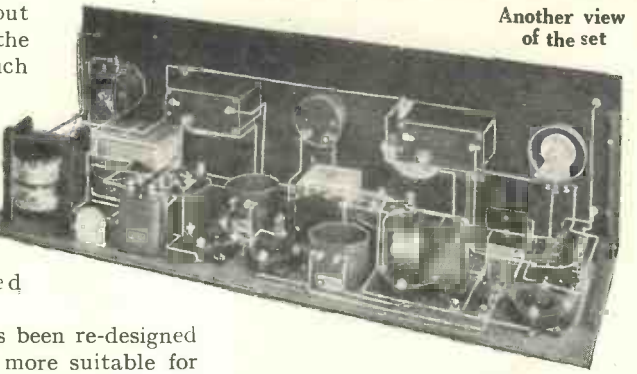

Another view of the set

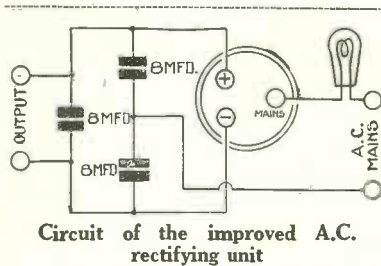

Circuit of the improved A.C. rectifying unit

day, and trouble from overheating occurred when users omitted to keep up the electrolyte level by the addition of distilled water. The new model will be found to keep very cool, even when used

for several hours on end.

It is necessary to use a lamp as a resistance in the rectifying unit and this is, of course, inserted in the battery-type lamp-socket. The correct lamp to use will depend upon the voltage of the A.C. supply. In any case a 110-volt lamp should be used, but the wattage should be 40 when the mains have a voltage of 200 to 220, while a 30-watt lamp should be used for 230 or 240 volt mains. Increasing the wattage of the 110-volt lamp will increase the current through the set, which should not, of course, be allowed to exceed 100 milliamps.

It is hardly necessary to say that the rectifier unit should be placed in a position where the various "live" parts are not likely to be accidentally touched. It should not, however, be placed in a tightly-closed box, as the rectifier can only be expected to keep cool if the small amount of heat generated is able to radiate away.

There will be, of course, a right and a wrong way of attaching the set to the rectifier, just as there will be when plugging the set into D.C. mains. It will not matter much which way round the rectifying

unit is plugged into A.C. mains, though even here it will be worth while to try both ways, as there may be a slight background in the loud-speaker with the plug one way round and not when the plug is reversed.

A No-trouble Outfit

From the foregoing description it will be seen that the use of the All-from-the-Mains Four run direct from D.C. lighting mains or through the improved rectifying unit from A.C. mains provides a no-trouble radio outfit that can be maintained at a very low cost.

Mixing Battery Juice

THE following rule-of-thumb proportions may prove of use when it is required to mix accumulator acid. Final checking should always be made with an hydrometer. By volume, one part of water to one of acid (s.g. 1.842) gives a solution having a specific gravity of 1.42. One part of acid to three of water gives an acid with an S.G. value of 1.21, and one of acid to four of water a solution of 1.17 S.G. value.

By weight, one part of acid to two of water gives a resultant of 1.18.

K. B.

Simplified rectifying unit

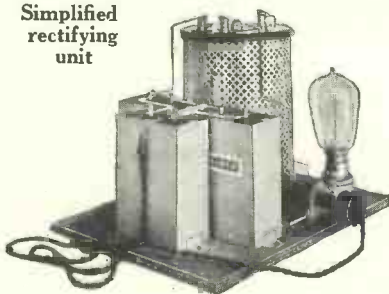

Another view of the rectifying unit

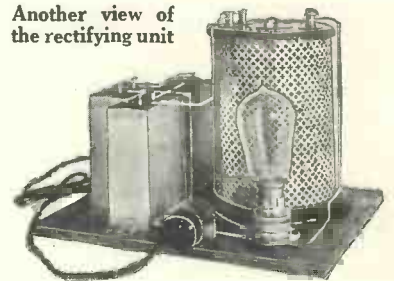



The Problems of Miss Priscilla Playne-Smythe

By HUGH R. SEELEY

which I am still not quite clear. Do you think you could help me? Now, what is a *Kw*? I presume it is a foreign word, because although we have all tried here, we cannot pronounce it. Some stations appear to possess four of them, and others, less favoured—or is

things worse, for it would mean that Gävle not only uses eight times *more* waves than Daventry, but *also* broadcasts eight times *more often*. Dear Mr. Editor, this makes the mystery more *perplexing* still!

I have come to the conclusion that there may still be some *small* abstruse aspect of wireless which I have failed to master and if you could clear up my difficulty in your next issue, in just a few *illuminating* words, I should be *ever so deeply* indebted to you.

Yours very truly,
(Miss) PRISCILLA PLAYNE-SMYTHE.

P.S.—When using the fifth stud and wave No. 133, last evening on the “long” with the round wires touching each other, I heard what I took to be a woman’s voice singing a melody similar to *Boys and Girls Come Out to Play*. Where would this be? I do not see this mentioned in any programmes.

P.S.S.—Mr. Candlemas, who was with me at the time, assures me that it was a Saxophone; he is *so* clever at music. He was *positive* it was one of the old London street cries: *Buy, Buy, Blackbirds!* It is *so* interesting. Could you enlighten me?

MISS PRISCILLA PLAYNE-SMYTHE STILL WANTS TO KNOW

Stewcombe Manor,
Little Bodley,
Near Hurdham.
19th May, 1928.

DEAR SIR,

I *do* think it was *so considerate* of you to have replied to my last letter by post and to have *dismissed* my difficulties at once instead of leaving me *floundering* until your next issue.

In a general sense, more or less, I *quite* follow all you were good enough

MISS PRISCILLA PLAYNE-SMYTHE WANTS TO KNOW

Stewcombe Manor,
Little Bodley.
Near Hurdham.
15th May, 1928.

To the Editor, WIRELESS MAGAZINE
DEAR SIR,

I really feel I *must* tell you, as no doubt *so very* many have done already, how *completely* I appreciate your *splendid* paper, which is a perfect *boon* to those of us who live in such secluded places as this. My nephew, Tom—a promising lad—built me the *uncanniest* wireless set last winter, and, thanks to it and to your valuable periodical, I am *never* at a loss for the most *nourishing* entertainment nowadays, be it lectures or even music, in *several* languages.

In my spare time, I have been studying my receiver, also from the *scientific* point of view, with the help of your technical articles, and I already understand *quite* a great deal about “impediments” (or is it impedencies?), potential-meters and so on.

But there are *two* things upon

it due to lack of funds?—only seem to have a *part* of one. Is this fair?

From the *exhaustive* World’s Broadcasting list which you publish every month I can see quite clearly, the waves used by each station and some of them my set is able to capture *quite* well, even though their frequencies are not always so *very* many. But when it comes to the little *wee* waves which I presume are *much lighter* and *easier* to send out, the results are not so good, although your table shows them to be *ever so much* more frequent!

Does it not seem to you that the reverse should be *absolutely* the case, and that if Gävle (in Sweden, I *believe*) takes the trouble to use waves as *profusely* as 1,470 times, my set should apprehend them *more* easily than those of Daventry, which only sends 187 of them. Yet, *try as I will*, I cannot get a *murmur* from Gävle which should reach me nearly *eight* times more clearly (187 into 1,470)!

Mr. Candlemas, our organist, suggests *most cleverly* that *perhaps* the “frequencies” refer to the number of programmes broadcast, but you see, *of course*, that this only makes

to write me, but when I try to apply your advice practically, I am afraid I am not *nearly* so successful. Mr. Pringle, of our local garage, who regularly rejuvenates my battery, has pointed out *most helpfully* that my set has valves for both high and low frequencies—it is the set my nephew built last winter, and it is a most *handsome* one—and that I should use them “according,” but I find that if I turn on *exclusively* the high frequency valve for the little tiny waves or the low frequency one for the long waves, I simply *do not get any of them* at all!

When I use *all* the valves at once (which seems *so* wasteful, for my sitting-room is quite a small one), I still only get two stations clearly, of which one is London and the other is not. Now and again I hear *fuzzy* echoes from other places, but hardly think they can be from the Continent, because the only words I could recognise were spoken by a man who wanted to be told how he looked when he was asleep!

I can assure you that I switched off the set at once as I felt sure that this was a private communication. I do not know whether I ought to tell you this as I believe my licence *forbids* it.

Now I realise, *of course*, that there can be no stations like our British ones, but one should make it a duty to hear foreign ones also, don't you think? You see, although one may not understand what they say, it is only *equitable* to hear both sides of the question, is it not?

I have been pondering a great deal on the *scientific* aspect of wireless and it has occurred to me that I may have stumbled upon the reason why I and so many of your correspondents do not get quite *all* the results of which these *magical* machines are capable.

Does it not depend upon the position of the set, I mean its *distance* from the sender? To put it still more *concretely*, I should explain that if my house is, say, 160,400 metres from Daventry, then Daventry's wave of 1,604 metres would bound or ricochet one hundred times before it reaches me, after having been released, and the end of the wave—*surely its very clearest and most perfect point*—would just touch my receiver.

But if, on the other hand, my set were half or any other fraction of a wavelength nearer to, or further *from*, Daventry, then, of course, it would merely catch the last incomplete bound *on the hop*, as it were, and the results would be *quite* otherwise.

I do hope you will agree with me that this may be the *right* explanation and that neither my *knowledge* or *management* of my set are at fault. If I am right—and I *sincerely* do not see how I can be otherwise—then it will merely be a question of finding out the *exact* distance from any station to my house, dividing this by the wavelength and, if there is “nothing over” I *must* get perfectly clear results, must I not?

Do please excuse the length of this letter, but I find the more *esoteric* side of the wireless so entirely *engrossing*, don't you?

Yours very truly,

(Miss) PRISCILLA PLAYNE-SMYTHE.

P.S.—Mr. Candlemas, our organist, tells me that the man who asked somebody to tell him how he looked when he had retired for the night, was *singing* a new dance tune. I had not noticed it. I think I must have caught an American wave, because his accent was *not at all* English. Could you say whether it was a New York station? I should *so* like to know?

P.S.S.—Please reply, as it would delight my nephew Tom *so* much, he made the set, you know.

MISS PRISCILLA PLAYNE-SMYTHE MAKES A DISCOVERY

Stewcombe Manor,
Little Bodley,
Near Hurdham.

31st May, 1928.

DEAR MR. EDITOR,

I feel I cannot await your reply to my last letter before informing you that the wireless book you advised me to read has proved *such* a disappointment. I began to read it in a most *hopeful* and *unprejudiced* spirit, but I find its peculiar misuse of ordinary English words makes it almost unintelligible. How *does* one oscillate without moving; if “frequencies” do not mean *oftennesses*, what are they, and, finally, does not a grid *always* leak?

Also this writer takes such an utterly *materialistic* attitude towards his subject, leaving out of account altogether, the *finer*, more quintessential aspect, that he leaves me with a feeling of being *bismirched*. To me, wireless is something transcendent and infinitely *precious* in its subtle appeal and it does seem such a pity to reduce it to the grosser terms of *mechanics* and commerce.

The writer comes to his subject with a perpetually leaking grid in one hand and a soldering bit in the other, and, to me, his attitude is frankly tantamount to *sacrilege*.

Neither is it necessary at all to go into these crude *anatomical* details. On the contrary, even quite simple folk, like myself, can contribute *something*, even though we do not *swathe* ourselves in the debased technical *patois* which seems to me to be merely a cloak for ignorance.

It is quite a personal little matter, but I could mention—since it is for the benefit for real, *reverent* scientific research—a small discovery which I made only the other day with the assistance of Mr. Bonecraft, our local veterinary surgeon, and a most *charming* man, who had called quite professionally, because of some most *alarming* symptoms which I had observed in one of my cats.

We were partaking of tea after the consultation, when he asked me to demonstrate my set (a most *handsome* one, built by my nephew last winter), as he has one of his own in the village and he would like to compare results.

Almost quite immediately, I was able to attune myself to the wave from London and we enjoyed the programme for several minutes, though it *still* consisted of an *impassioned appeal* by some most *feverish* person to be told how he looks whilst asleep. In trying to focus another wave, I must have moved one of the small rings on the lid, for a loud *keening* sound proceeded from the box, only ceasing when I removed one of the wires which convey the influence from the electrical battery.

When I re-tied the wire, the wail—oh, such a *sad* one!—was still there and Mr. Bonecraft, who is not only charming and a widower, but most accomplished, at once suggested that this must be oscillation

Do Not Miss Capt. Round's Article on Page 548

The Problems of Miss Priscilla Playne-Smythe (Continued)

(but *nothing* was moving) and he showed me just how to banish it.

I had observed this phenomenon many, *many*, times before, but had always thought that at last I had captured a stray wave from some opera house, and, not being very versed in this *modern* music, I had merely disconnected my set after waiting for the end of the act, which *never* seemed to come.

Mr. Bonecraft proceeded to explain that when my receiver made this noise I was, in fact, a little broadcasting station on my own, and he had often wondered *who* it could be that had the *enterprise* to broadcast at Hurdham. Then a great idea flashed across my mind; an idea, I venture to say which could only have *illuminated* a brain uncluttered with leaking grids and *ironmongery*.

At once I saw that if I could send a wave, however unmelodious, then *anyone* could receive it and listen to it, and *if* this was so and *since* Mr. Bonecraft also owns a set (though most *unlike* mine, he assures me), then all I need do to call him, if Pussy needs him again, is to broadcast an appeal to him to come to see her.

Heseemed to think the suggestion a little *unprofessional* at first, but I soon persuaded him that I was only actuated by a sense of *strict* duty, and we agreed upon a simple little code.

All I had to do was to disconnect the wire and to *stroke* the left-hand top button with its end, whilst taking care that the two little rings on the lid were sufficiently close

Kel Keech



together. An experiment made on the spot resulted in a most *encouraging* succession of ear-piercing squeaks.

So, in future, three low moans and a short squeal were to serve to

inform Mr. Bonecraft (at any time when he might be listening) that his little patient was not quite so well, whilst, on the other hand, should Mr. Bonecraft feel anxious and *require* news, then he was to oscillate sharply twice, to which I should reply by one or two shrieks as the case might be, to indicate an improvement or *otherwise*.

It was almost *providential* that we had made this arrangement for that *very* evening pussy was worse, or at least she appeared so to me, and it was a *great boon* to secure Mr. Bonecraft's *invaluable* advice within a few minutes of my call to him. Unfortunately the complaint would appear to be a most *complicated* one. Since our first experiment we have extended our little code *considerably*, but this development of our research work can hardly be expected, of course, to interest you!

I have written you at some length, because I am confident that you will like to know to what *useful* ends, wireless can be applied, even (or should I say *especially*?) by *unbigoted* minds.

If the *technique* of our methods is still not quite clear to you and you would like more explicit details or even a demonstration, I shall *indeed* be most happy to supply them.

Yours most truly,
(Miss) PRISCILLA PLAYNE-SMYTHE.

Just Pushing the Button!

WHEN you come to think of it, quite a number of the more recent radio inventions have come about simply because most people are naturally lazy.

The present vogue of "just pushing the button," in order to switch on a set has come about because listeners would sooner push one button than operate an L.T. switch, an H.T. switch, and an aerial-earth switch.

There is yet another "push-the-button" craze, which has more reason for its existence, namely, the pushing of a selector button for each station. Push button A, and London comes in; button B brings in Daventry; C, Berlin, and so on.

This is really quite a natural development, because for the "uninitiated" tuning-in is still a tricky business, and pushing a button is much to be preferred to operating tuning controls.

Without wishing to assume the rôle of prophet, I think that push-the-button sets of this kind will become increasingly popular, despite the fact that they must be "pre-set" by someone experienced in tuning.

There are two ways of solving the push-the-button-to-tune problem, one mechanical and the other electrical. The simple act of pushing the "Daventry" button, say, may set in action some ingenious clockwork mechanism which will put the dials

to the correct position. That is the mechanical solution.

Alternatively, the buttons for each station may be so connected that touching one of the controls directly alters a condenser value and brings a common circuit into correct tune for the station it is desired to receive. That is the electrical method, and is really the simpler of the two.

A simple method of receiving either station A or station B, alternatively, is to have two distinct tuning circuits, and a D.P.C.O. switch to bring either circuit into action. Several D.P.C.O. switches of the push-button or pull-button type are marketed.

AERO.

A FOLDING FRAME AERIAL

ALTHOUGH it is intended specially for use with the Sidecar Portable, described on page 497 of this issue, the folding frame aerial illustrated on this page is equally suitable for use with any other receiver if the method of connecting it to the set is slightly modified.

Cost of Building only a Few Shillings

The photographs reproduced here show clearly into what a compact shape the aerial folds when it is desired to carry it about and the design will undoubtedly appeal to a very large number of WIRELESS MAGAZINE readers. Moreover the cost of this folding frame aerial is very low and all the wood can be obtained for a shilling or so.

In use with Sidecar Portable

Designed and Built by the "W.M." Technical Staff



On the left the frame is seen folded ready for carrying

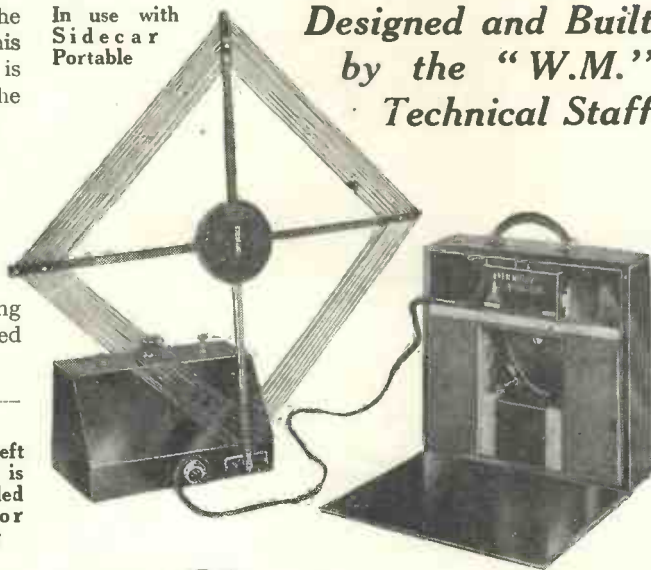

Briefly the aerial consists of four arms, three of which are pivoted at the centre, rigidity being given to the whole device by two circular clamping discs as illustrated.

The bottom arm is fixed, while the two side arms fold downwards. The top arm is pivoted so that it folds at right angles to the clamping discs, passing through a slot provided in one of them. When the aerial is erected this top bar is held in position by a wood locking bar, the position of which is clear from the sketch of the complete aerial.

For the Low Waves

For the medium-wavelength band, that is approximately 250 to 600 metres, eight slots are provided at each side of each arm. This will be clear from one of the detail diagrams. Before starting to wind the frame, tie the two side arms by means of string to

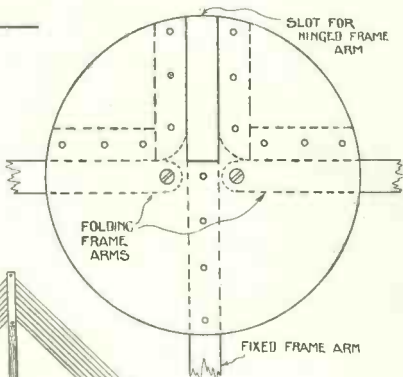

wire is being put on.

Obtain a box of Lewcos silk-covered frame aerial wire (this actually contains 100 ft.) and begin winding inside at the bottom of the frame, first passing the wire through a hole to anchor it as shown.

Wind one turn on the front of the frame

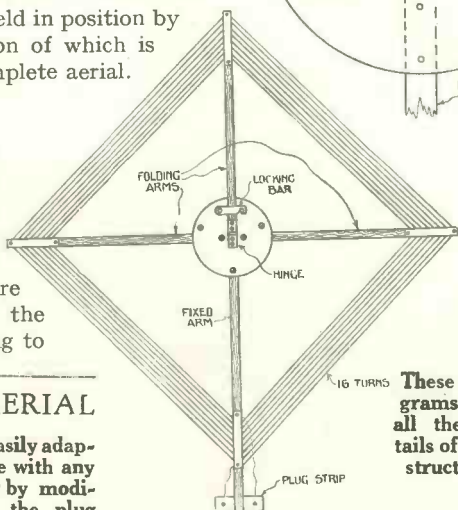

These diagrams show all the details of construction

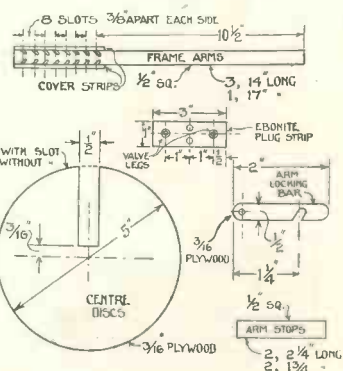

FOLDING THE FRAME AERIAL

To fold the frame the wooden bar that locks the top arm in position must be released

It can be easily adapted for use with any receiver by modifying the plug and socket mount

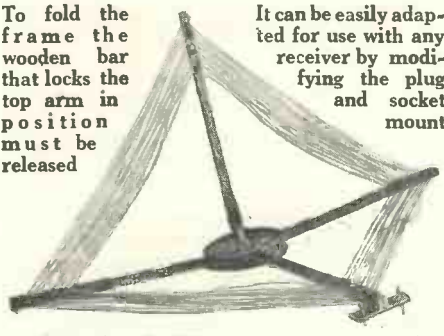

the top arm (which should be locked in position) so that they do not slip downwards when the

and then wind another turn in the corresponding slots at the back of the frame. When two turns have been thus wound, wind the third turn on the front again and the fourth on the back and so on until eight turns have been placed on both back and front of the frame.

For reception on the higher waveband, twenty-five slots spaced $\frac{1}{8}$ -in. apart instead of $\frac{3}{16}$ -in. apart should be provided on each side of the arms. The winding can consist of the same type of wire.

Roadside Adventures!

The "SIDECAR PORTABLE"
IN USE



Exhilarating speed on the road with a big Harley-Davidson combination and afterwards the additional pleasure of listening with the Sidecar Portable!

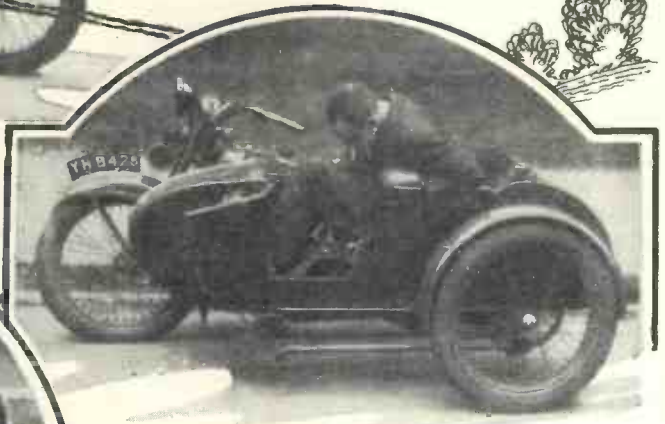

The receiver portion of the Sidecar Portable (described in detail in the following pages) fits easily into the sidecar and does not get in the way of the passenger's legs. The loud-speaker and battery case can be accommodated in the rear locker.



Although the loud-speaker and battery case includes a two-volt accumulator, with such a machine as the electrically-equipped Harley-Davidson it is possible to run six-volt valves from the lighting battery

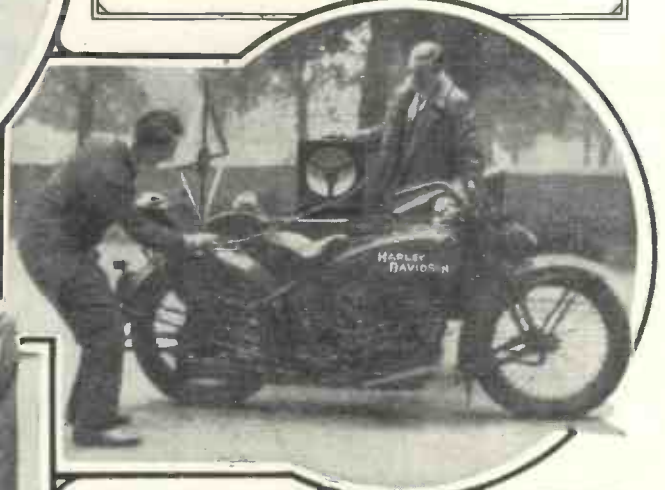

In the above photograph the Sidecar Portable is seen in use in the country, while on the right the frame aerial is being folded, and the loud-speaker and battery case put into the rear locker. The construction of a special frame aerial is described on the preceding page. On test the Sidecar Portable has given extraordinarily good results and it will be greatly appreciated by every sidecar enthusiast.



The Sidecar Portable

"She shall have music wherever she goes"

CAN BE ACCOMMODATED IN
ANY STANDARD MACHINE

A Special Five-valver Designed,
Built and Tested by the
"Wireless Magazine" Technical
Staff

Comprises Two
Aperiodic High-
frequency Stages,
Detector, Resist-
ance-coupled Low-
frequency Amplifier
and Transformer-
coupled Low-
frequency Amplifier

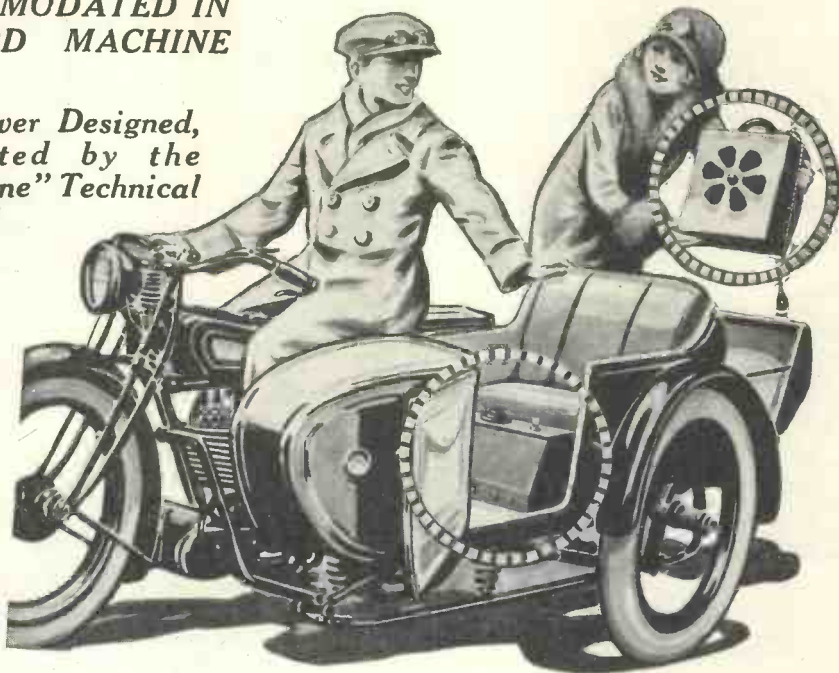

OBVIOUSLY the design of a portable set for the sidecar calls for special consideration. The essentials are that the case occupies only a convenient position and that it can be fixed so that it does not rattle about when the machine is on the road. The WIRELESS MAGAZINE Technical Staff believes that it has solved the problem in the design of the five-valver described and illustrated in these pages.

For convenience the whole outfit is comprised of three separate units, which are arranged as follows:

1. Frame Aerial.—This is a simple affair and can be easily folded when being transported. (A rather more elaborate folding frame aerial is described in another article in this issue.) Normally the frame is wound for recep-

tion on the lower broadcast band, but the receiver covers both bands. If it is desired to receive on the upper broadcast band, a separate long-wave frame must be wound.

2. Five-valve Receiver.—The shape of this receiver can be seen from the photographs and the position it occupies in the sidecar is illustrated above.

The overall dimensions are so

small that the case will not foul the passenger's legs at all in the normal sidecar. The height to the top of the main tuning dial is 8 in. and the depth 7½ in. The coupling for the two high-frequency valves is aperiodic (that is, untuned), and covers both upper and lower broadcast wavebands. A single knob in the centre of the top panel controls the condenser tuning the frame aerial. The other only controls are a small reaction condenser and an on-off filament switch.

3. Loud-speaker and Battery Case.—A separate case which, during transit, can be carried in any position, either in the nose of the sidecar or in the locker usually provided at the back, contains the cone loud-speaker and low-tension, high-tension, and grid-bias batteries. A special cord provided with a plug fits a socket on the receiver

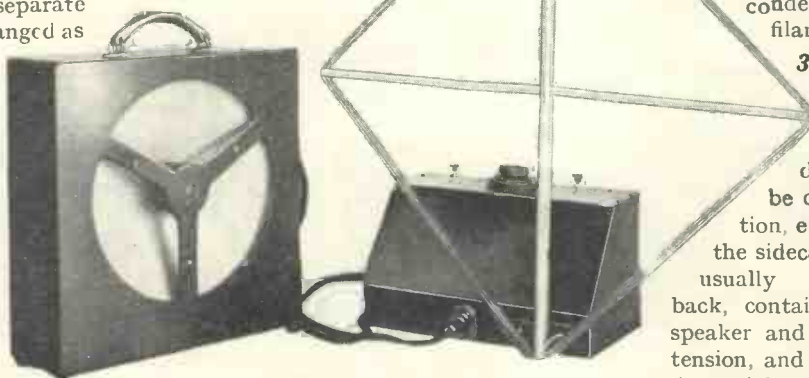

On the left is the loud-speaker and battery case, while the receiver and frame aerial are on the right

COMPONENTS REQUIRED

- 1—Ebonite panel, 12 in. by 4 in. (Raymond, Will Day, or Beccol).
- 1—Neutralising condenser (Gambrell or McMichael).
- 1—.0005-microfarad variable condenser (Formo 1928 Log or Peerless).
- 1—Vernier dial (McMichael).
- 1—On-off switch (Deckorem, Lissen, or Lotus).
- 1—Dual high-frequency coupling unit (Polar).
- 3—Anti-microphonic valve-holders (Pye, Lotus, or W. & B.).
- 1—.0003-microfarad fixed condenser (Lissen, Dubilier, or Graham-Farish).
- 1—.0005-microfarad fixed condenser (Lissen, Dubilier, or Graham-Farish).
- 1—Resistance-capacity coupling unit (Lissen, Trix, or Carborundum).
- 1—.25-megohm grid leak (Lissen, Dubilier, or Ediswan).
- 1—2-megohm grid leak (Lissen, Dubilier, or Ediswan).
- 1—400-ohm potentiometer, base-board mounting (Lissen or Igranic).
- 1—Low-frequency transformer, 4 to 1 (Gecophone, Mullard, or Igranic).
- 1—6-way battery connector (Igranic).
- 2—Small plugs and sockets (Lectro Linx).
- 1—Cabinet (Ready Radio).
- 4—2-ft. lengths Glazite.
- 2 yds. rubber-covered flex (Lewcos).

Loud-speaker and Battery Unit

- 1—Loud-speaker unit complete with cone and frame (Electron).
- 2—60-volt high-tension batteries (Ever-Ready, Winner or Lissen).
- 2—9-volt grid-bias batteries (Ever-Ready or Lissen).
- 1—2-volt unspillable accumulator (C.A.V., type 2NS13).
- 1—Cabinet with fretted front for loud-speaker (Ready Radio).

unit and provides all the necessary battery and loud-speaker connections.

Useful for Other Purposes

From the foregoing it will be appreciated that although the Sidecar Portable is specially intended for a motor-cycle combination, it can be used for other purposes if a three-unit outfit is not objected to. (Other quite self-contained portable receivers of up-to-date design recently described in the WIRELESS MAGAZINE are the Sunshine Five—May—and the Chummy Four—June—the latter being the first portable set to incorporate a screened-grid valve.)

The Sidecar Portable (Continued)

The circuit used for the Sidecar Portable is similar to that employed in the Sunshine Five, except that the low-frequency stages incorporate a resistance-capacity coupling and a transformer coupling in place of two transformer couplings.

The Circuit Explained

A glance at the circuit diagram will make the arrangement clear. The frame aerial is tuned by a .0005-microfarad condenser. The dotted line enclosing that part of the circuit comprising the two high-frequency amplifying valves indicates that the parts are made up as one complete unit, which must be bought as it is by the constructor. Values for the respective components cannot be given in these pages, as the unit is a proprietary article manufactured by the Polar people.

Leaky-grid rectification is employed for the detector valve, further critical control being obtained by means of a potentiometer, to the slider of which one end of the grid leak is attached. The reaction condenser consists of what is virtually a "neutralising" condenser.

The resistance-capacity coupling unit for the first low-frequency stage is another complete unit, but note should be made of the fact that



This case contains the cone loud-speaker, high-tension, low-tension and grid-bias batteries

in the grid circuit of the first low-frequency valve is an extra .25-megohm leak, which acts as an "H.F. stopper." The final transformer-coupled stage is arranged in the ordinary way.

The points on the circuit diagram marked with figures in dotted circles are those which are connected to the socket for the plug attached to the six-way connecting cord which is provided in the loud-speaker and battery case.



The controls at the top are the reaction condenser, main tuning control, and on-off switch. Below are the socket for the battery cord and the sockets for the frame aerial

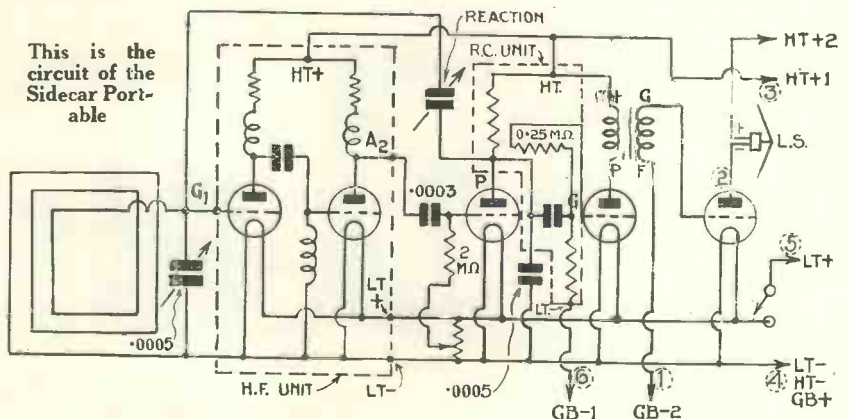

This is the circuit of the Sidecar Portable

Extremely Compact Yet Highly Efficient

Although the construction of the receiver is very simple indeed and all the essential particulars are reproduced in these pages, a large number of readers will prefer to work from a full-size blueprint. This can be obtained for half-price, that is, 9d., post free, up to the end of July, if the coupon on page iii of the cover is used.

Send for Blueprint No. W.M. 83!

Ask for blueprint No. W.M.83, and address your inquiry to Blueprint Dept., WIRELESS MAGAZINE, 58/61 Fetter Lane, E.C.4. Remittances should be made by postal order.

When constructing the set, what is really the back should be treated as the base and the part of the cabinet on which the battery socket is mounted should be placed uppermost.

can be adjusted.

A glance at the plug on the battery cord will show that two leads (black and green) are brought to a common point. Disconnect the green wire and attach it to the centre guiding socket (which has a soldering tag attached),

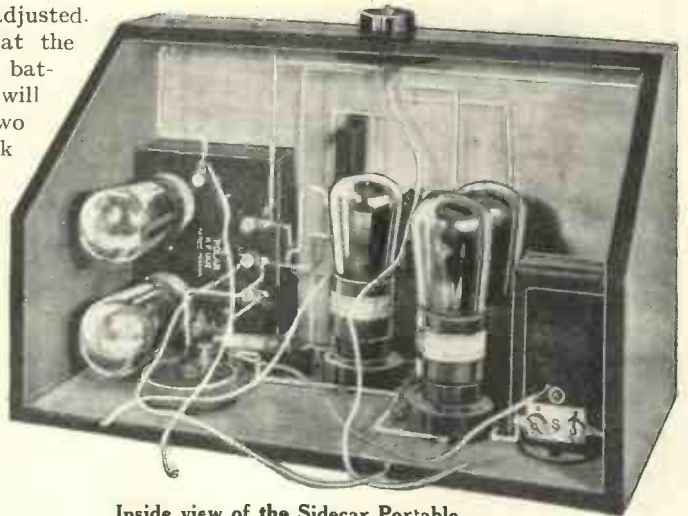

Inside view of the Sidecar Portable. Note the special high-frequency coupling unit on the left

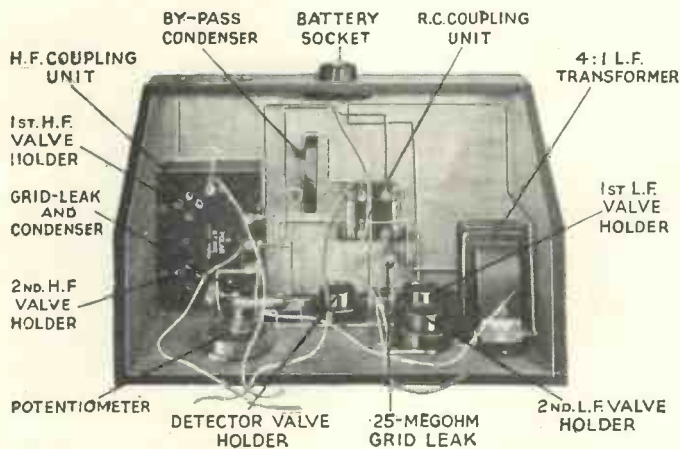

Another view of the Sidecar Portable, which clearly shows the disposition of the components

There is no need here to refer in detail to the positions of the various parts; they are comparatively few in number and can easily be recognised, even by the novice, on the blueprint or the reduced reproduction included in these pages.

Components Connected with Flex

It should be noted that the two holders for the low-frequency valves are placed so that the filament tag of one overlaps the filament tag of the other and is soldered to it, thus obviating one lead. Note also that the panel components are connected to the rest of the set with flexible leads and that the panel should not be screwed into position until after a test has been carried out, so that the grid-leak potentiometer

as possible, all those points on the wiring diagram marked *a*;

this making the lead for G. B. - 1 (No. 6 on the circuit diagram).

When all the components have been firmly screwed into position, wiring up can be started. First connect together with one wire, or as few wires

then connect all those points marked *b*; and so on through the alphabet to *o*.

Battery-cord Connections Explained

As regards the battery cord, note that point *m* (No. 1 on circuit diagram) goes to G.B. - 2; *n* (No. 2) goes to negative of loud-speaker; *g* (No. 3) goes to H.T. + 1; *d* (No. 4) goes to L.T. -, H.T. -, and G.B. +; *o* (No. 5) goes to L.T. +; while *h* (No. 6, centre point) goes to G.B. - 1.

Next tackle the construction of the frame aerial. This is very simple, and all the constructional details are indicated on the diagram. Ten turns of thin rubber-covered flex should be provided. A more elaborate frame aerial, also suitable for the Sidecar Portable, is described elsewhere in

VALVES TO USE IN THE SIDECAR PORTABLE

Make.	1st H. F. and Detector.	2nd H. F.	1st L. F.	2nd L. F.
B.T.H.	B210H	—	B210L	B215P
Cosmor	210RC	210LF	210LF	220P
Cosmos	SP18B	—	SP18R	SP18RR
Ediswan	—	DR2	GP2	PV2
Marconi	DEH210	HL210	DEL210	DEP215
Mullard	PM1A	PM1HF	PM1LF	PM252
Osram	DEH210	HL210	DEL210	DEP215
Six-Sixty	SS210RC	SS210HF	SS210LF	SS230SP

The Sidecar Portable (Continued)

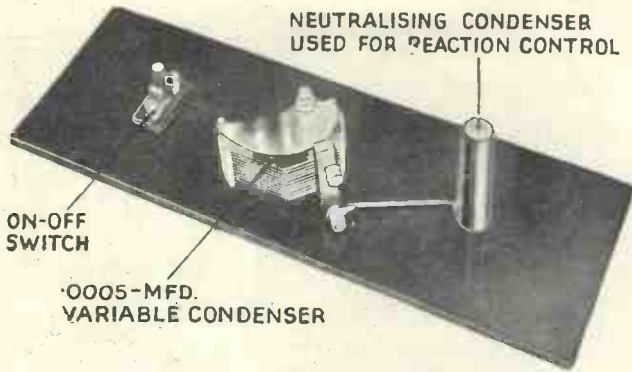

Arrangement of the components on the top panel of the Sidecar Portable, which must be connected with flexible leads

this issue. For the upper band of wavelengths, thirty-five turns should be provided.

There is little difficulty about the assembly of the battery and loud-speaker box. The cone loud-speaker is bought as a complete unit mounted in a metal frame, and this can be easily screwed into position. The two high-tension batteries are placed one on either side of the case, while the 2-volt accumulator, which is supplied with jellied acid and is therefore quite unspillable, is placed between them. At the top of the cabinet are accommodated the two grid-bias batteries and the six-way cord when the set is not in use. The various connections are clearly indicated in one of the diagrams reproduced on this page.

At one side of the cabinet is provided a small slot, through which the battery cord can be drawn when required. When not needed, it can be pushed back into the cabinet without difficulty.

Suitable Valves

As regards valves, these are the same as required for the Sunshine Five. Both the first high-frequency amplifier and the detector can be of the high-impedance type, with an impedance of 60,000 to 80,000 ohms. The second high-frequency amplifier should have a lower impedance, in the neighbourhood of 25,000 ohms. The first low-frequency valve should have an impedance of the order of 15,000

ohms, while the final valve should have as low an impedance as is possible taking into account filament and anode consumptions; anything below 5,000 ohms will be suitable.

To carry out a preliminary test of the Side-

part of the receiver and pull up the knob of the on-off switch (on the right of the main tuning dial looking from the front of the receiver).

Adjusting the Reaction Control

Next adjust the reaction control (on the left of the main tuning dial) until the slight rustling or hissing sound is heard from the loud-speaker which indicates that the set is on the verge of oscillation. Now turn the main tuning condenser until a station is picked up, when the grid-leak potentiometer mounted on the base of the receiver should be adjusted for maximum sensitivity.

At this stage the various battery voltages can be readjusted if desired. The more grid bias that is applied the lower will be the high-tension current consumption and therefore the more economical the

operation of the set.

When the set is working satisfactorily (and it will do so without a great deal of special adjustment), the top panel can be screwed into position. When the receiver is actually being carried in the sidecar, it is recommended that two small wood blocks be screwed to the floor to hold the case against the seat so that it does not slip forward.

Great Scope for Ingenuity

As the frame aerial is arranged it is, of course, necessary to take the set out of the sidecar in order to carry out reception.

If this arrangement does not appeal to the constructor, there is great scope for ingenuity in mounting a frame-aerial socket on some part of the sidecar, so that a folding frame can be placed in position and connected to the receiver

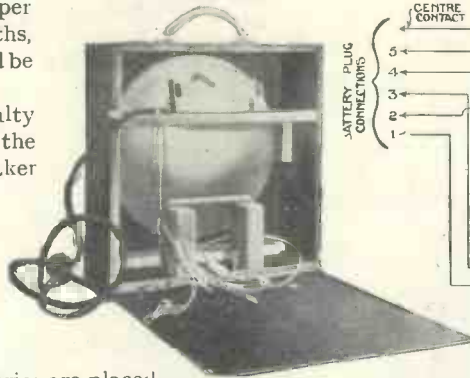

On the left is a view of the battery and loud-speaker case, while on the right is a diagram of connections

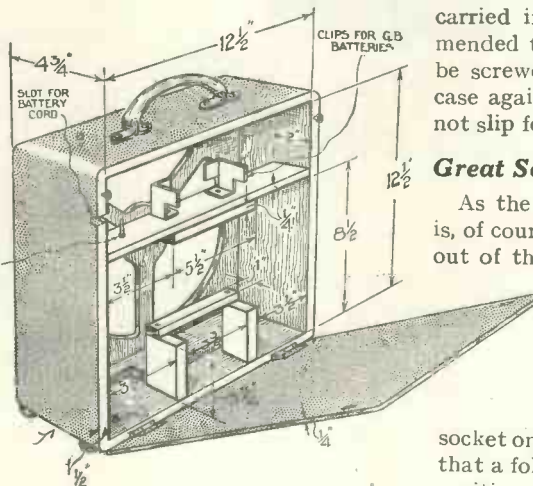
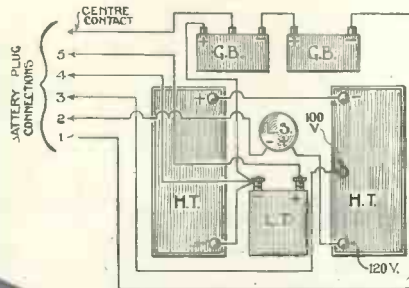

Details of the loud-speaker and battery case

car Portable, insert the necessary valves in their holders and plug in a suitable frame aerial (that is, one wound either for the lower or the upper broadcasting bands of wavelengths). Next insert the plug on the cord from the loud-speaker and battery case into the socket at the lower

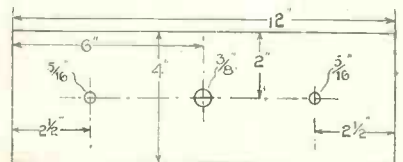

Top panel layout of the Sidecar Portable

A Special Five-valver

itself by means of two flexible leads. With some sidecars, for example, it is possible to arrange a plug-and-jack

damage being done. The other batteries are held firmly in position by means

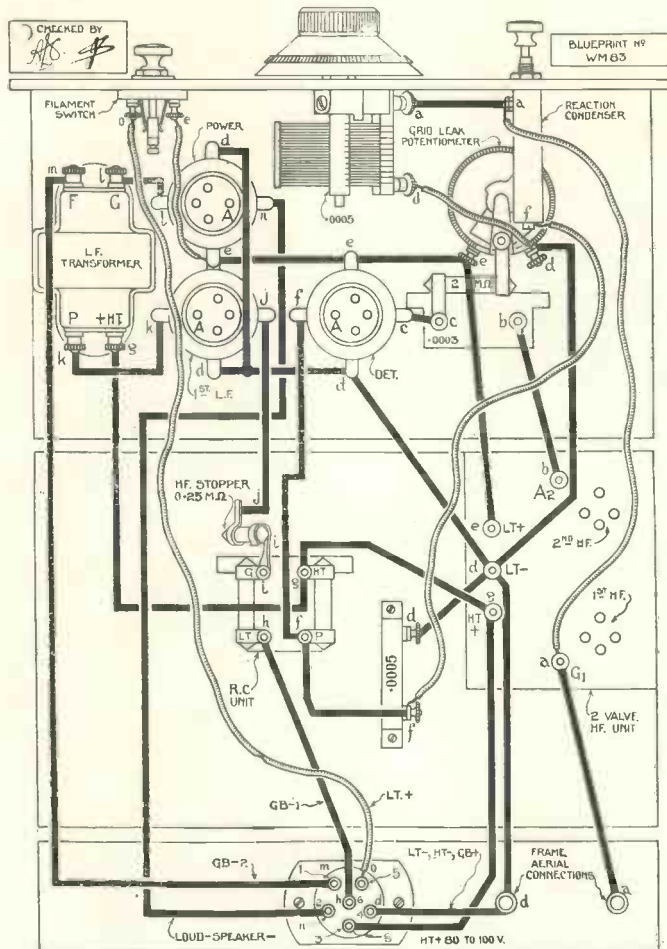

This layout and wiring diagram of the Sidcar Portable can be obtained for half-price, that is, 9d., post free, if the coupon on page iii of the cover is used by July 31

mount on the sidcar, so that the frame can be swung in any position without difficulty. We shall be interested to hear from constructors of this set who invent any special aerial fitting for their own particular machines.

Foolproof Battery Unit

Especial attention is drawn to the fact that the loud-speaker and battery case can be carried in any position, although it should not be subjected to excessive vibration. The accumulator used is filled with jellied acid and can be placed at any angle without the slightest chance of any

IF YOU WANT A REALLY GOOD PORTABLE SET OF ORTHODOX DESIGN YOU WILL NOT BE ABLE TO BEAT THE CHUMMY FOUR, DESCRIBED IN THE PREVIOUS ISSUE

- TWO 9-VOLT GRID-BIAS BATTERIES
- COMPLETE CONE LOUD-SPEAKER UNIT
- TWO 60-VOLT HIGH-TENSION BATTERIES
- 2-VOLT ACCUMULATOR

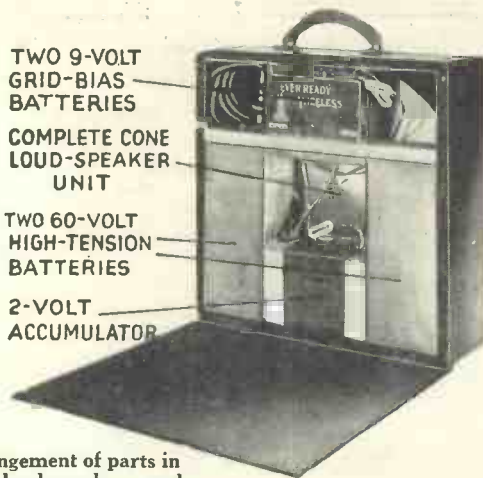

Arrangement of parts in the loud-speaker and battery case

of wooden battens and brackets as shown. It will be realised that this battery and loud-speaker unit can be used in conjunction with

any existing receiver, if the latter is provided with a socket to take the plug attached to the six-way cord. Alternatively an ordinary six-way cord provided with spadge tags and wander plugs can be utilised, without altering the connections shown.

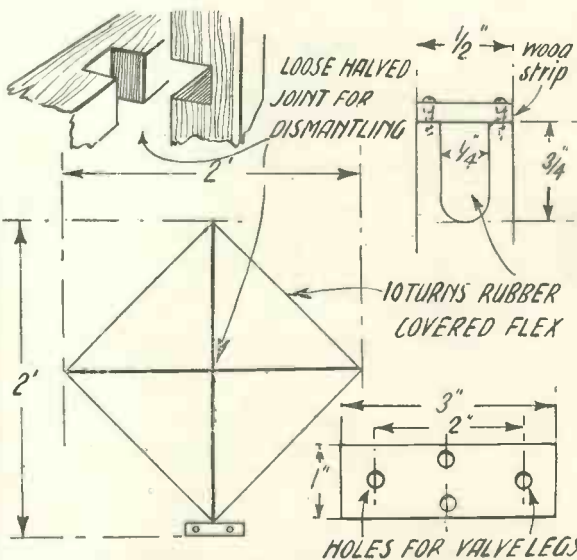
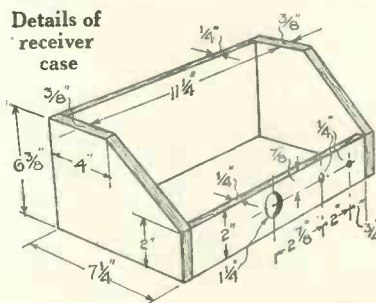

Details of simple frame aerial which can be folded without difficulty. One frame is required for each wavelength band (thirty-five turns for the long waves). A more elaborate type of frame is described on page 495.

Curing Troubles That Prevent the Crystal From Doing Its Best

Is Your Crystal As Good As A Valve?

WHEN you listen to the broadcast programmes on your crystal set, do you just sit back in an easy chair, with a smile of contentment, whilst your headphones resound with signals that would do credit to a one-valver? Or do you, on the contrary, have to spend most of the time fiddling with your detector, engrossed in that exasperating pastime of "searching for a sensitive spot" on the crystal?

What Can Be Done

If the latter describes your experience of broadcast reception with a crystal receiver, just listen to this (unless, of course, it makes you feel too envious).

At the moment of writing, I can hear (faintly, but unmistakably) the sounds of music emitted from a pair of headphones lying on the table six feet away. They are connected to a simple crystal circuit tuned to 2LO, which is five miles distant from my aerial.

"Ah," you say, "then you have just been adjusting the crystal detector to a nicety."

Not a bit of it. My crystal detector has not been touched at all for ten days.

"Well, then," you retort triumphantly, "you must be using an exceptionally sensitive permanent detector."

An Ordinary Detector

But again, emphatically no! The detector in my set is just an ordinary one, of the glass-enclosed type, containing a really sensitive crystal (one of the many good makes now on the market), used in conjunction with a catwhisker made of fine copper wire.

This detector almost invariably remains in good adjustment for a week or more at a stretch; it is unaffected by an ordinary amount of vibration, and when at last it does need readjustment, a fresh sensitive spot can always be found in a matter of seconds. Nevertheless, there is nothing really exceptional about this; it merely does what any efficient

This Crystal Set in a nutshell is the work of an ingenious German amateur



type of crystal detector can be made to do.

The principal explanation of those troubles which give rise to the impression that crystal detectors are inevitably unreliable and difficult to adjust is simply that so many listeners put up with minor faults in the detector, which could be quickly and easily put right, but which if neglected will seriously mar reception.

The cause of the trouble can generally be located at once if you note carefully the "symptoms," so to

To get a good point on a catwhisker cut off the wire at a slanting angle, as indicated in the sketch below

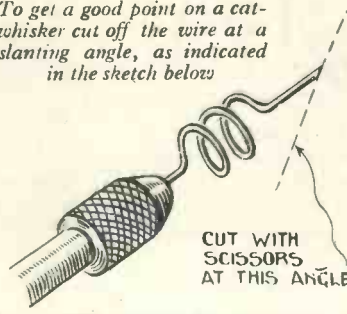

speak, which are exhibited by your detector.

One annoying fault, for example, manifests itself in the following way: As you adjust the detector, there is no sound when the point of the whisker first touches the crystal; but on pushing the rod further home, the signals eventually come on with an unpleasant scratching sound (instead of the sharp click which indicates that all is well with the whisker) and are not nearly as loud as they should be.

The effect is somewhat as though there were a film of foreign matter between the point of the whisker and the surface of the crystal, which has to be penetrated before rectification can take place.

Tracking the Trouble

The trouble is invariably due either to the point of the catwhisker having become slightly corroded, or to a deposit of dust or grease on the surface of the crystal. The former is the only likely cause if the crystal is protected by the use of a properly designed glass cover.

The remedy for the catwhisker trouble is quick and easy; just take a sharp pair of scissors, and (by holding them at an angle to the wire) make a slanting cut close to the tip of the whisker so that the latter is brought to a very sharp point and a new, clean metallic surface is exposed.

When you have done this, and replaced the rod carrying the whisker in the detector, you should find that adjustment is quick and reliable, and that signals come on and off with a clean, sharp click as contact is made or broken.

If, however, the trouble is not entirely cured, it may be necessary to clean the surface of the crystal, or preferably (provided that the piece of crystal is large enough to permit of this) break it in two so as to expose an entirely new surface.

Signs of Another Trouble

The indications of another trouble frequently met with are as follows: Each time you adjust the detector, you get fairly good signal strength at first, but after a few moments the signals fade away slowly until they become inaudible. This is almost invariably due to the crystal having worked loose in its cup, or not being secured sufficiently rigidly by the set-screws or screw-cap which hold it in position. The remedy is obvious—tighten up the latter.

In this connection it should be emphasised that satisfactory results can hardly be expected from a crystal detector in which any part of the parts are loose or shaky. The rod

which carries the whisker should glide backwards and forwards smoothly and evenly, not jerkily, or in a shaky, wobbly fashion, while the ball-socket joint should be equally steady in action.

Tightening the Rod

If the rod works loose, it can be tightened up as follows: Pull it out of the short tube in which it moves, place the tube vertically on a hard surface, and lightly tap its ends with a hammer, so that the interior diameter of the ends is slightly reduced. The rod will then fit sufficiently tightly.

Looseness of the ball-joint can be remedied, in most ordinary types of detector, by slightly bending the clip or clips which form the socket in which the ball moves.

The catwhisker itself is one of the most frequent causes of trouble in a detector. In many crystal sets one finds that the whisker has to be very carefully adjusted so that its point makes exceedingly light contact

with the surface of the crystal. This, of course, means that it gets thrown out of adjustment at the slightest vibration.

Although there are some crystals that really do need a very light contact in order to give the best results, in most cases the apparent necessity for lightness of contact is due to the use of a catwhisker that is too thick and stiff, and it disappears entirely when the whisker in use is replaced by one made of much thinner, more flexible wire.

When a piece of fine copper wire, for instance, is coiled into a little spiral in the usual way, and the end cut to a sharp point in the manner already described, it will generally be found that the whisker thus made can be pressed quite firmly on to the surface of the crystal without any perceptible loss of signal strength. This firmness of contact, combined with the flexibility of the thin wire, makes it almost impossible to upset the adjustment with any ordinary amount of vibration.

Of course, different types of crystal work best with different contact-points; but, as a general rule, a rather thick, stiff whisker (such as many listeners are in the habit of using) seems to transmit vibration to the point of contact with the crystal, thereby upsetting the adjustment, whereas a really spingy, flexible whisker appears to act rather as a kind of shock absorber.

Part of the Circuit

It should be remembered that the metal parts of the detectors are just as much a part of the circuit as, say, the terminals and wiring in the set; hence it is important to see that they are kept bright, clean and free from corrosion at the points of contact.

Provided that attention is given to these small but important details, there is no reason why a crystal detector of an efficient type should not prove nearly as reliable and easy to adjust as a rectifying valve. W. OLIVER.

Can You Read a Circuit Diagram?

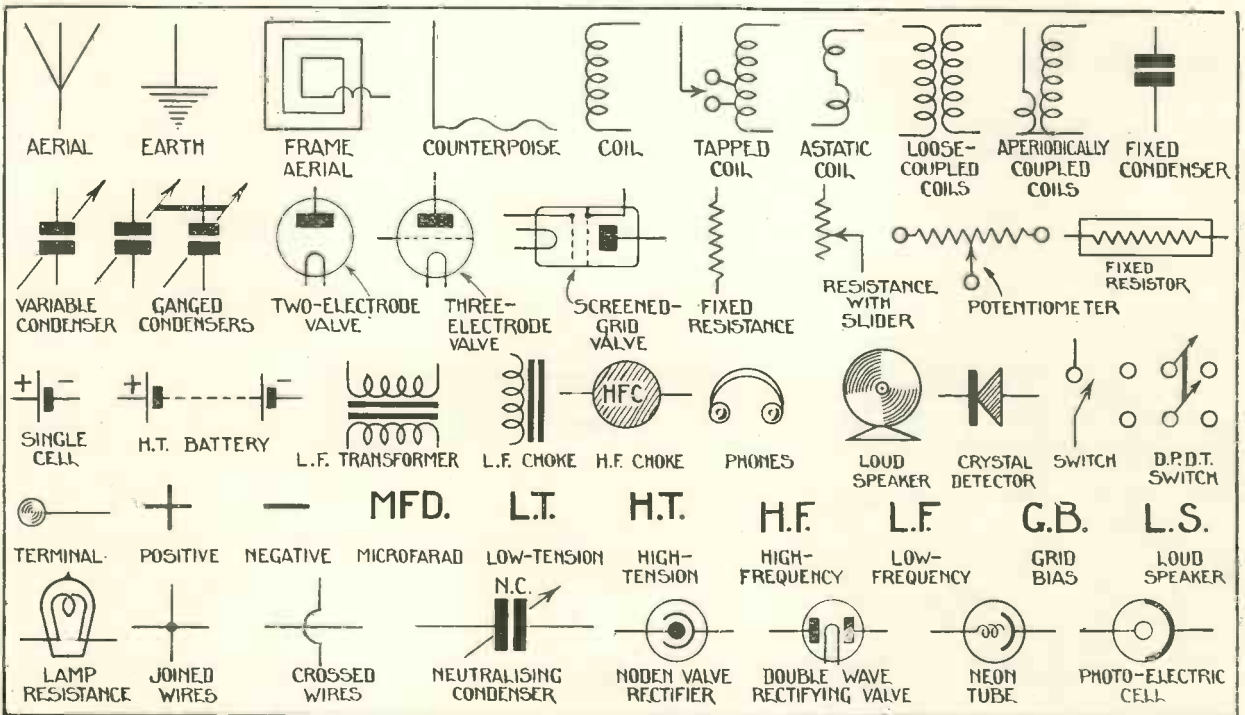

An astatic coil is one in which the magnetic field does not extend beyond the actual winding, except to a negligible amount.

An aperiodically-coupled circuit is a combination of a tuned and untuned coil in very close proximity.

Ganged condensers are separate variable condensers operated in unison by a common control.

Two-electrode valves are used as rectifiers only, usually in eliminators for obtaining current from the mains.

A screened-grid valve contains two

grids, one of which acts as an electrostatic screen and prevents feed-back. These valves are therefore self-neutralising.

Low-frequency and high frequency chokes prevent the passage of low-frequency and high-frequency currents respectively in circuits where they are undesirable.

Is Short-wave Work Beyond the Ordinary Listener?

THIS article shows what can be done with simple apparatus just "knocked up" without much trouble being taken over it, but it should not be looked upon as an excuse for slipshod work. To guarantee good results one must always play for a factor of safety and take the usual precautions.

As many people are fearful of tackling short-wave work on account of the frequent statements by various writers that for successful reception one must be most careful and have soldered joints, air-spaced coils, low-capacity condensers for tuning, and correctly designed wiring, etc., I think it would do no harm to retail my own first experience in making up a short-wave set.

Deterred from Starting

I had long been deterred from starting on this, for me, new adventure, by the above-mentioned remarks of my betters, especially as, if I had followed their advice, I should have had to spend time and money which I could then ill-afford.

Lately, however, having more time, but very little more money, I ordered a new special coil former and base from the local retailer. Pending the arrival of this, and before buying any more gear, I thought it would not be a bad idea to try, just for fun, what I could do with a rough "hook-up," made from a skeleton one-valve medium-wave set I had by me.

How I Set About It

I set about it. The coil was wound on the lid of a Mullard valve box, and consisted of one turn No. 20 gauge D.C.C. cotton-covered wire for aerial coil and three turns of the same wire as grid coil, and a reaction coil of three turns of No. 34 gauge D.C.C. wire. The coil was wound for Reinartz reception.

The only decent variable condenser I had by me was a .0005-microfarad

Dubilier K.C., which I connected across the grid coil in series with an old .001-microfarad fixed condenser. That reduced the capacity to decent limits. The reaction condenser was a problem, but in the end I raked out an old Polar mica variable one with a maximum of about .0005 microfarad and used that.

The grid condenser was of .0001-microfarad, and two grid leaks of 2 megohms each connected in series between grid and positive filament completed the grid circuit. The valve used (please note that only one valve was to be tried) was a Mullard PM1H.F. The aerial consisted of 4 yards of bell-wire slung across my bedroom ceiling, and the earth was on to a water-pipe.

There were no soldered joints anywhere on the set, and some of the joints (Oh, shades of the experts!) were just

rather faint, but, in view of the nature of the set, distinctly encouraging to a somewhat muddled amateur.

Better Oscillation

The next day, April 30, I altered the H.F. choke to one of thirty-five turns, and to my surprise the set oscillated over two-thirds of the grid variable condenser scale. I should have probably left it at that and not touched the set again until I dismantled it when the proper short-wave gadgets had arrived, but I happened to wake at 2.30 a.m. on May 1, and decided to listen in for a bit. Nothing doing at first, then one or two Morse stations and the rumble of what I think must have been one of the automatic beam stations.

Then a strong "carrier," and with one hand on the reaction condenser, the other on the grid variable, I managed at last to get speech and music. Then an hour's rather hectic tuning took place for I had no extension handles, and once I had got the correct tuning I had to keep my hands where they were in order to keep the station on the phones. The slightest movement meant retuning.

An American Station

Well, the station I had got was 2XAF relaying the General Motors Company "family party" broadcast. A band played *The Song of the Volga Boatmen*, followed by an old German march, and then the Second Hungarian Rhapsody. The rest of the programme until General Motors "signed off" was heard, but the announcements were not, with the exception of the final remarks, after which the station sent out dance music for about an hour.

The name of one piece was *Hullo, Montreal*, quite a new title and also a new tune to me; but that may mean nothing, as I do not belong to a dance club. I hung on to this station until they signed off, at what the announcer said was 11.1 p.m., U.S.A. summer time.

(Continued on page 517)

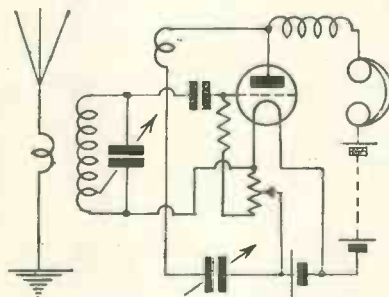

The Author's Short-wave Hook-up

two ends of wire twisted roughly together.

The rest of the outfit consisted of a high-frequency choke of 150 turns (plug-in type), H.T. battery of 40 volts of Ever-ready flashlamp batteries, and a pair of Brown's Feather-weight telephones.

The "installation" was "completed" on the afternoon of April 29, and to my surprise actually oscillated over about one-third of the lower scale of the variable condenser.

I got some Morse from ABJ, presumably German, and also call letters 4NM and IDO, all in Morse. During the evening the Caterham broadcast was heard for a little while

Do You Give Modern Music a Chance?

By SIR DAN GODFREY

In this special article the famous musician explains why listeners should not be prejudiced against modern music before hearing it!



Sir Dan Godfrey

IF you have been induced to believe that ultra-modern music is quite different from that of the time of, say, our Grand Old Man Bach, you are mistaken. Please do not think that by saying this I am setting out to belittle the "moderns." Quite the reverse.

Do You Recognise It?

Music has developed since Bach's time in the same proportion as most other arts, but when all is said and done, the development has been very natural. I doubt if there are many listeners who, without definitely recognising a piece of broadcast music, could locate it in its proper period. So I think it may fairly be asked: "When modern music is broadcast, do you always recognise it as such?"

It is so easy, when you have a preconceived notion that you will dislike a thing, intensely to hate it on actual hearing. If you don't like modern music, and are satisfied on the point, there is no more to be said. But beware of falling into the error of switching off *before* modern music is broadcast. You can never come to like it if you never hear it, so give Elgar, Holst, Schonberg, and the others a chance to speak for themselves.

A Music Fallacy

A common criticism, and a very silly one, of the music of to-day is that it has no "tune." By this is meant it has no tune which the critic can recognise. Immediately you see the fallacy. One does not expect to "recognise" the plots and phrases of Edgar Wallace, because his novels are modern and new and contain new thoughts and ideas. But because some people cannot familiarise the tunes of modern music they fail to find them at all, and condemn the music in consequence.

Many folk songs and sea shanties contain really good tunes, melodies which might truthfully be described as "household tunes," and which will instantly be recognised by listeners with any musical knowledge whatever. The National Anthem typifies some people's idea of a good tune, but I doubt if it would be so regarded were it not instantly familiar to all except the deaf! Truly, it is my experience that prejudice against new tunes is so great that many would refuse to stand up if they heard "God Save Our Gracious King" played to any but the familiar tune!

Will you grant, then, that the reason a piece of modern music may on first hearing seem tuneless is that the tune is not familiar? Tune is, of course, essential, and nobody holds any brief for music which has no tune. Music is nothing without melody.

Some Other Essentials

Consider other essentials, namely, harmony and rhythm. It would be easy to take a well-known tune, Handel's Largo for example, and to put it in a modern setting conforming to modern notions of rhythm and harmony. What differences would an average listener notice? The whole thing might conceivably be prefaced with a striking time-signature and the harmony would be re-set with much clashing of unrelated keys. The effect would be new and, perhaps, novel, but were one to hear it together with the original Largo *heard for the first time*, I am not at all sure that fair criticism would be against the modern version.

Striking key-signatures need not strike terror, for there are more natural forms of rhythm than the Charleston and the waltz! Two-time or four-time and three-time do not cover the whole gamut of natural rhythm. A seven-four time-signature

is quite natural to me. Count the beats for yourself and try the effect.

Composer's "Inspiration"

In any music worth remembering one must consider "inspiration." This, in the sense of musical composition, simply means that the composer has been gifted with an idea which he wishes to express in melodies. Melody, harmony, and rhythm are the materials he uses. It is at this point where so many modern composers go wrong, and why I am on rare occasions tempted to join the band who switch off to modern broadcast music.

Music of the men whose names are household words to-day expresses only the primary emotions—love, anger, joy, peace, and so forth. Far too many present-day composers try to express in melodies complex emotions which would be far better if aired in a poem or a 100,000 word novel. It simply cannot be done without tying a patient hearer into mental knots. The business of music is not to perplex.

Queer Tricks of Rhythm

To render their inspiring ideas intelligible to listeners some present-day composers use complicated harmonic tricks and queer forms of rhythm which they would never dream of adopting were their "inspirations" not so complex. Short-story magazines are better mediums than music for expressing the emotions which some of our moderns have tried to paint in tone-pictures—to put it rather crudely.

Do You Give Modern Music a Chance? (Continued)

Another fault of much present-day music—a fault which should not exist but which is causing ignorant listeners to condemn modern compositions as a whole—is that inspiration is often totally lacking.

Vital Inspiration

Certain schools of music are turning out budding composers who have all the harmonic tricks and general technique at their finger tips, and who are tempted to make use of their knowledge before their experience gives them vital inspiration.

Please do not think, however, that because a small proportion of modern music is all technique and no tune that the compositions of the better-known moderns are all tarred with the same brush.

We have musicians to-day who are doing much useful work which, when viewed in the right perspective, will compare favourably with that accomplished by the Old Masters.

Not all composers are imitative

bores or producers of senseless discords, and out of the mass of mediocre productions present in every age of music one or two compositions stand out as striking examples of the progress made since Bach wrote his famous "Forty-Eight."

Please remember that modern musicians are discovering an entirely new avenue, and, of course, they make mistakes from time to time, in thinking that everything bizarre is the result of some inspiration.

Musical cranks will always want to strafe with musical conventionalists. My advice to you is to hear as much modern music as possible, and don't on any account shut your eyes to progress.



et hoc genus omne; they can wire up a perfectly efficient set and consider soldering merest child's play.

A bright lad of thirteen years some time ago, whilst playing football, received a rather severe injury to his right knee. He was an intensely highly strung morsel of humanity, rightly or wrongly declaring that if he were operated on he would die under chloroform.

Surgeons nowadays are much more considerate than formerly in listening to the legitimate objections expressed by patients regarding operations, but if ever the knife was sorely needed, it was in this case.

Continuing His Hobby

Before the injury the lad had started interest in wireless, and when fit to sit up in bed, with a special invalid table, he was able to continue his hobby, and it was really wonderful to see the delicate wee fingers handle small screws and the like so successfully without losing a single one while making up the set.

Almost from the hour he began playing with his set a noted improvement in his general condition became apparent; one is happy to relate that the operation on his knee went through without a hitch, and to-day the boy is as well as he ever was . . . more of a wireless maniac than ever.

His parents and others declare that his life was really saved by getting his mind off his trouble with wireless, thus enabling him to bear his operation with fortitude.

Another special sense which in many cases is much indebted to wireless is that of touch; in fact, Ham-handed Henry is an individual of the past and it is well that this is so. Many will recollect a friend remarking a few years ago: "Oh, it's all very well for you to talk about building sets, but I never handled a tool or a soldering bit in my life."

How They Have Benefited

P'raps not . . . but most of those self-same folk *have* learned how to handle tools, solder, and so forth, thus benefiting themselves mentally, physically, and financially, because they can now do odd jobs about the house and do them well too.

So, with wireless reception we have again another wonderful manifestation for our benefit, which we should be devoutly grateful for whether in sickness or in health. DOC PAGE.

Radio and Our Special Senses

"YES, thanks, my hearing has improved wonderfully." Such was the reply to a question put to Colonel F. D. (retired) who had been suffering for some time from progressive deafness.

After some preliminary treatments it was found that the best results were achieved by the use of sensitive earphones whilst listening in. Needless to say the old soldier was as pleased as the doctor, considering that such a very simple remedy was just at hand, the results being far removed from miraculous.

"Hearing" Apparatus

As is well known, the hearing apparatus consists of three small bones, the malleus, incus, and stapes (hammer, anvil and stirrup) which, acting with the tympanum (diaphragm) enable us to hear properly. As age progresses, however, trouble may arise producing complete or partial deafness, either of which is

an exasperating condition, to be avoided if possible.

In this case the parts had evidently fallen into an "atonic" condition which had been considerably relieved by the stimulating action of the wireless vibrations. Taking into account how easy and simple of application such treatment is, it should be most certainly given a trial in suitable cases.

In dismissing this subject the words of an eminent aurist should be taken to heart by every one. He said: "Never pick the ear with anything smaller than your elbow, and at the first sign of diminished hearing, consult an aurist at once." Sage advice in truth.

Could our forbears return to this sphere and see the precocity of present-day youth, it would be interesting to hear their comments.

Schoolboys, aye and girls as well, from the age of nine upwards talk glibly of volts, amperes, microfarads,

How to Choose a Moving-coil Loud-speaker

ONE reason why the home-constructor will give careful attention to the choice of his moving-coil loud-speaker is that in most cases he will have to assemble it himself, and it is therefore a much more personal proposition than is the selection of an ordinary wireless component.

In this article I shall assume that the prospective buyer of a moving-coil loud-speaker already possesses a set that is capable of operating it efficiently; for this point was very fully dealt with in the previous issue of the WIRELESS MAGAZINE, and needs no further comment here.

Many Shapes and Forms

A glance through the pages of the June issue will show the reader that coil-driven loud-speakers take many shapes and forms, although fundamentally they all resolve themselves into a cone diaphragm, a small moving coil and a powerful magnetic system, in which the coil moves backwards and forwards.

In the first place, moving-coil loud-speakers can be divided into two distinct groups: (1) Those in which the field for the moving coil is provided by means of permanent magnets, either of the bar or horse-shoe type, and (2) others in which the magnetic field is obtained by passing a current through a field coil contained in an iron or steel magnet "pot."

Permanent Magnets

Let us consider the permanent-magnet type first. The great advantage of this type of moving-coil loud-speaker is, of course, that no field current is required, and therefore the ordinary current supply as used for the existing receiver need not be augmented. These permanent-magnet loud-speakers will therefore appeal very strongly to those who have difficulty in getting accumulators

By D. SISSON RELPH

charged or whose houses are not provided with direct-current electric mains.

The volume obtained from them is not quite so great as can be obtained

direct-current electric-light mains of anything from 200 to 240 volts; (2) those in which the current is obtained from a 6-volt accumulator, the consumption being approximately $\frac{3}{4}$ ampere; (3) special loud-speakers with small pots, usually run from a 6-volt accumulator, the consumption being only $\frac{1}{2}$ ampere or a little less. (Normally, it is not convenient to operate a moving-coil loud-speaker from alternating-current mains, as the supply must first be converted into direct current).

Mains Models Best

During the past few months I have had experience of all these types of moving-coil loud-speaker, and have come to the conclusion that in the majority of cases a 200-volt model run direct from the lighting mains gives the best results, although the special small

pots referred to in class 3 are very good indeed with a small diaphragm. As a matter of fact, many 200-volt pots give far stronger signals than are required for domestic use, and the volume obtained from one of the small 6-volt loud-speakers is adequate for all general purposes.

Centering Devices

Having, then, decided which particular type of pot will best suit his needs, the home-constructor must give attention to the adjustment provided for centering the moving coil in the air gap which, by the way, should be as small as possible, so that the magnetic field is very highly concentrated around the moving coil. But the very fact that the air gap is so small (it may vary from $\frac{5}{8}$ in. to round about $\frac{3}{8}$ in.

necessitates a very fine adjustment control.

A common method of adjusting the position of the moving coil is by means of three screws arranged in



On the left is a Webson output choke, specially designed for moving-coil loud-speaker work. Its inductance is 40 henries

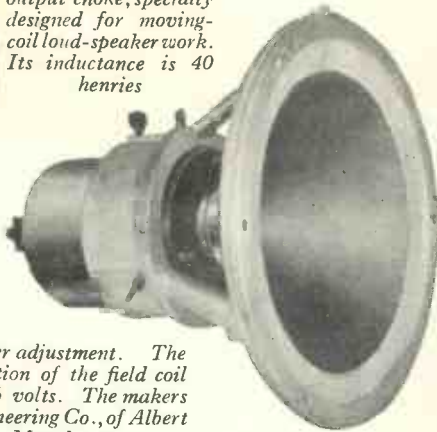

The aluminium frame of this Webson loud-speaker is provided with a micrometer adjustment. The current consumption of the field coil is .5 ampere at 6 volts. The makers are the Star Engineering Co., of Albert Street, Didsbury, Manchester

from the second type of loud-speaker, however, but the great convenience which results from their use will, in the opinion of many users, outweigh this limitation.

As regards the second type of loud-



Note the attractive grille over the front of the cone diaphragm



This New Era loud-speaker has a specially moulded cone diaphragm of 7½ in. diameter. It is made by the New Era Wireless and Electrical Co., of Hobmoor Road, Small Heath, Birmingham

speaker, in which the magnetic field is obtained by means of a field coil located in a pot, these can again be divided into three classes: (1) Those in which the current is obtained from

How to Choose a Moving-coil Loud-speaker (Continued)



Although it is claimed to be cheaper than any other model on the market, the pot of the Epoch loud-speaker contains 7 lb. of No. 20-gauge enamelled wire and consumes 7 ampere at 6 volt. The makers are the Epoch Electrical Society, Ltd., of 53 Gracechurch Street, E.C.3

triangular formation round the outside of the pot itself. The "throw" at each point should not be too restricted and, moreover, the thread of the screws should not be too coarse, otherwise it will be difficult to obtain the correct adjustment without a great deal of trouble.

Advantage of Cotton Support

It is an advantage also if provision is made for the bottom of the cone and moving coil to be supported by a cotton thread, as with a large cone there is some tendency for the moving coil to tilt downwards and rub against the sides of the opening. The cotton support ensures that the axis of the moving coil is kept exactly horizontal.

The next point is the type of framework in which the pot and cone support are mounted. This should preferably be of metal, but care should be taken to see that it is cast and finished accurately. If the framework is made of wood see that it is of substantial dimensions, for moving-coil loud-speaker pots are heavy things and "bed down" during use if the framework is not absolutely rigid.

Facilities for Transporting

It is also a convenience if the framework is provided with some kind of handle so that the loud-speaker can be moved about without difficulty.

Most cone supports will accommodate a diaphragm of 9 in. or so in diameter but there is no need to use a

cone of this size and excellent results can be obtained with a cone of 6 in. or so in diameter. Readers will remember that Rice and Kellog, the two pioneers in moving-coil loud-speaker work, have come to the conclusion that a cone of this size is ample. I have tried a 200-volt type loud-speaker with both a 9 in. cone and a 6-in. cone, about 1 in. of supporting material being left round the periphery in each case, and for myself I prefer the smaller cone. For one reason the moving coil attached to the cone is not so likely to tilt downwards in the air gap of the magnet pot and it is therefore easier to adjust. As regards volume, I have not been able to detect any difference between the two.

If a small cone is used in a large frame, the supporting material should be fixed to a thick cardboard or, better still, 3-ply ring, the outer periphery of which is screwed to the framework of the loud-speaker.

There is a great deal of controversy as to what is the best material for the cone support—leather, oiled silk and rubber being in common use. The Rice-Kellog loud-speaker now on the market as a complete unit makes use of a leather support, and leather is recommended by such authorities as Capt. Round and J. H. Reyner.

On the other hand, Dr. McLachlan in last month's issue recommended a rubber support, while the WIRELESS MAGAZINE Technical Staff suggests that oiled silk is the easiest material with which to work.

In this respect the constructor must make his own choice. If leather is used it must be very supple, while only good quality rubber will be found of any use.

Some cone diaphragms are provided with a smaller re-entrant cone or "pip" over the moving coil, so that there is no air gap in the centre of the diaphragm. It is extremely doubtful whether it is worth while inserting this re-entrant cone, but in some cases it does result in an improvement in bass reproduction. I recommend that it should be omitted when the loud-speaker is first constructed and added afterwards if the quality does not seem to be all that it should be.

In order to get anything like good

reproduction it is essential that a baffle should be employed and the area of this should be as large as is practicable. The object of the baffle is to prevent the air waves produced at the back and front of the cone from turning over the edge of the diaphragm and "colliding." The effect of an adequate baffle is most pronounced on the bass notes.

The Best Baffle to Use

For very best results a baffle about 3 ft. or 4 ft. square will be suitable. Moreover, it should be made of heavy wood ($\frac{1}{2}$ in. boarding or 7-ply will do). But I feel that this rather a counsel of perfection and for practical experimental work a thick cardboard baffle, even as small as 2 ft. square, will give quite good results during the preliminary work. A small baffle cannot be recommended on technical grounds, however, and is suggested only as a practical expedient.

When Chattering Occurs

In conclusion it should be pointed out that should a chattering sound be heard when the loud-speaker is in operation this is nearly always due to the moving coil touching the sides of the opening in the magnet pot at some point and is seldom due to distortion in the receiver.

A few hours' practical work will teach the reader more about this part of the work than anything that can be put on paper.



A permanent-magnet type of loud-speaker with bar magnets, that needs no field current. It is made by Baker's, of 42 Cherry Orchard Road, East Croydon, and gives excellent reproduction

The Wrecker of Ohms!



Specially drawn for the "Wireless Magazine" by GLOSSOP.

The Universal Short-wave Adaptor

Can Be Used
in Conjunction
with Any Set
Incorporating
One or More
Stages of
Low-frequency
Amplification

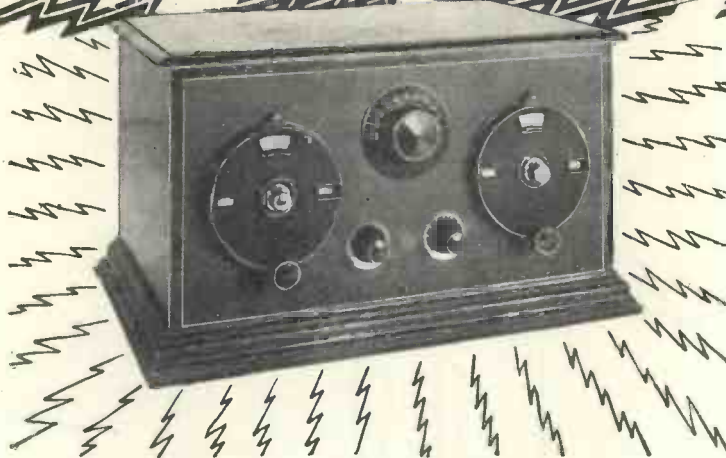

Designed,
Built, and
Tested by
the "W.M."
Technical
Staff.

Easy to
Construct

TO the man who wants distant reception nothing ever quite equals the thrill experienced when listening to a short-wave station, be it morse or telephony, somewhere at the other "end" of the earth.

And the thrill is not at all difficult to obtain, for with the adaptor described and illustrated in these pages any existing receiver incorporating one or more stages of low-frequency amplification can be utilised for short-wave work without the need for any constructional alterations.

What the Adaptor Actually Is

In brief the Universal Short-wave Adaptor consists of a detector-valve unit that covers the band between 25 and 75 metres. The output from this unit is taken to a plug that can be inserted in place of the detector valve in any set with low-frequency amplification, the voltages normally being applied to the detector now be fed to the detector valve in the adaptor unit.

Used with the Exhibition Five

Thus, for example, the Universal Short-wave Adaptor used with the Exhibition Five would result in a three-valve short-wave receiver

comprising a detector, resistance-coupled low-frequency amplifier and a transformer-coupled low-frequency amplifier.

A glance at the photographs reproduced in these pages will show how few are the components and how simple is the wiring. Short leads are essential in this type of receiver and appearance should not be studied if this entails long leads as, in fact, it does.

Great sensitivity is ensured by using leaky-grid rectification in conjunction with a potentiometer, by means of which the voltage applied to the grid of the valve can be controlled within very fine limits.

Reaction is obtained by a combination of magnetic and capacity couplings, the result enabling very fine control to be obtained without difficulty.

It is, of course, essential that the high-frequency choke in the anode circuit of the valve should be wound specially for short-wave work, otherwise no reaction will be obtained.

Earthing the Unit

A further point to note is that no earth terminal is provided, the adaptor being earthed (through low-tension negative) by the connection to the ordinary broadcast receiver, which should be kept connected to earth in the ordinary way.

Critical control of the detector valve is obtained by means of a filament rheostat provided in the adaptor unit. If a rheostat is also provided for the detector valve in the ordinary receiver this should be adjusted to its maximum position.

Some notes on the actual components used in the original adaptor as constructed by the WIRELESS

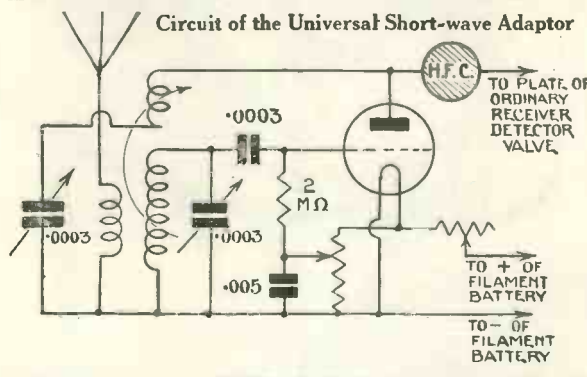

For the sake of the novice, it may be explained that longer wiring is not of nearly so great importance for reception on the normal broadcast band of wavelengths, although short leads are to be preferred.

It will be seen from the circuit diagram that the aerial tuner comprises an aperiodic coil auto-coupled to a secondary tuned by a .0003-microfarad variable condenser.

MAGAZINE Technical Staff will not be out of place. The tuner is bought already assembled and covers a wavelength range of 25 to 75 metres. It is wound on a low-loss ebonite former with tinned-copper "tape."

In the top end is a small reaction winding wound on a slab-like former.

Special Short-wave Condensers

A special feature of the two variable condensers (one for grid tuning and the other for reaction) is that the plates are separated by a comparatively large air gap when they are out of mesh. Consequently they have a large effective capacity range and a very low minimum. They are, moreover, provided with celluloid covers to keep out dust.

There are actually five controls on the front panel which tend to make the unit look complicated, but really its operation is not difficult. The two large dials are of the vernier type; that on the left of the panel tunes the grid circuit, while that on the right is a capacity reaction control, being used in conjunction with the magnetic control, which takes the form of a small knob placed between the two large dials.

Other Panel Controls

Below these large dials are the knobs of the grid-leak potentiometer (left) and of the filament rheostat (right).

All the essential details needed for constructing the adaptor are included in these pages, but many

constructors will prefer to work from a full-size blueprint, which acts as drilling template, layout guide and wiring diagram.

These blueprints can be obtained for half-price, that is, 6d. post free, if a postal order for that amount, accompanied by the coupon on page iii of the cover, is sent by July 31 to Blueprint

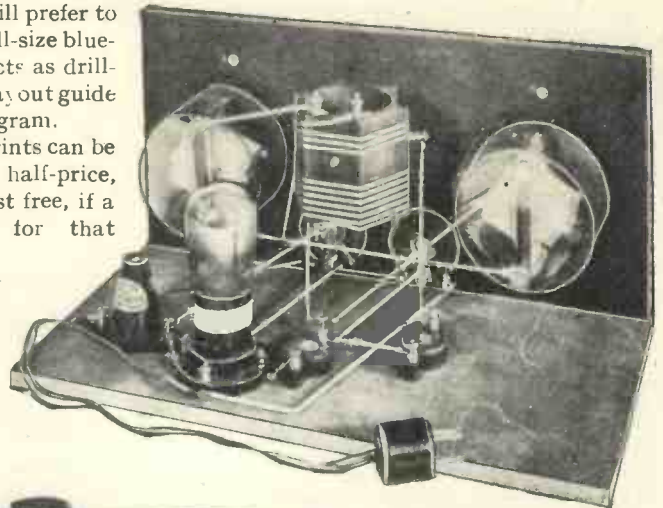

Rear view of the Universal Short-wave Adaptor



Plan view of the Adaptor

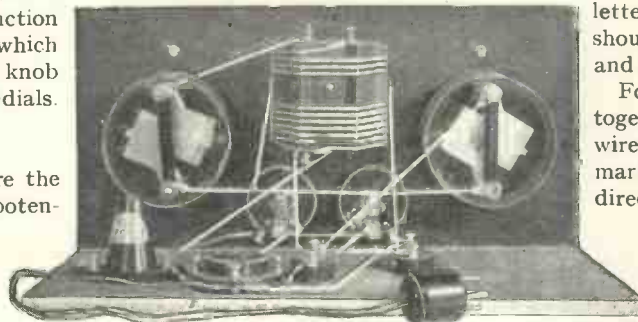

Another view of the Adaptor

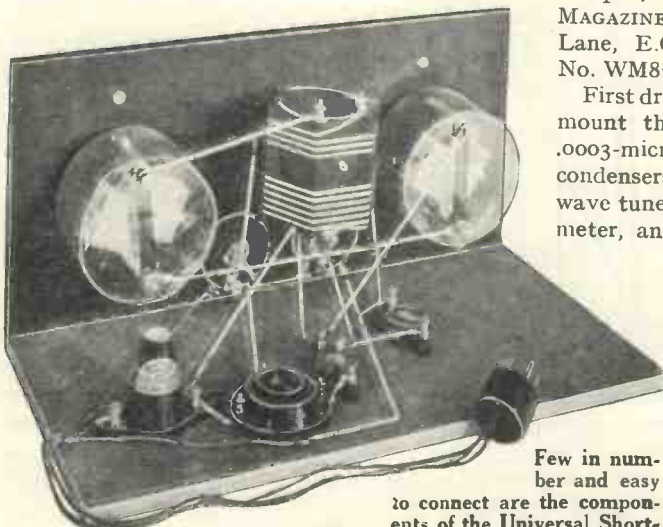

Few in number and easy to connect are the components of the Universal Short-wave Adaptor

exactly as in this way the leads can be kept at a minimum.

When all the components have been fixed into position, wiring up can be started. In this respect the wiring diagram or blueprint should be followed. It will be observed that each terminal point is marked with a small letter of the alphabet; these letters indicate which points should be connected together and in what order.

For example, first connect together with one wire, or as few wires as possible, those points marked *a*, taking the connections direct from point to point without bends; next connect up the points marked *b*; and so on through the alphabet.

Choice of Suitable Valve

Before the adaptor can be used a suitable valve must, of course, be obtained. Normally the detector valve used in the ordinary broadcast receiver will be equally suitable for use as detector in the Universal Short-wave Adaptor. In the case of transformer-coupled sets two new valves may be specially mentioned; these are the Mullard PM4D (for 4-volt accumulators) and the Marconi or Osram HL210 (for 2-volt accumulators).

Using the Adaptor Unit

To use the adaptor remove the detector-valve from the ordinary broadcast receiver and insert the adaptor plug in its place. Now put the detector-valve in the holder in the adaptor unit. Remember to keep the ordinary receiver earthed and take

Dept., WIRELESS MAGAZINE, 58-61 Fetter Lane, E.C.4. Ask for No. WM82.

First drill the panel and mount thereon the two .0003-microfarad variable condensers, the short-wave tuner, the potentiometer, and the rheostat. Then screw the panel to the baseboard and place the remainder of the components in the positions shown on the layout should be followed

The Universal Short-wave Adaptor (Continued)

COMPONENTS REQUIRED

- 1—Ebonite panel, 14 in. by 7 in. (Becol, Will Day, or Raymond).
- 2—.0003-microfarad variable condensers with covers (Newey).
- 2—Vernier dials (Pettigrew and Merriman).
- 1—Short-wave tuner (Wearite).
- 1—15-ohm rheostat, panel mounting (Lissen, Igranic, or Peerless).
- 1—Potentiometer, panel mounting (Lissen or Igranic).
- 1—Anti-microphonic valve-holder (W. & B., Lotus, or Igranic).
- 1—Short-wave high-frequency choke (Magnum or Wearite).
- 1—.0003-microfarad fixed condenser with 2-megohm grid leak combined (C.D.M.).
- 1—.001-microfarad fixed condenser (C.D.M., Dubilier, or Edison-Bell).
- 1—Multi-plug (Lectro Linx).
- 2 yds. rubber-covered flex (Lewcos).
- 3—2-ft. lengths Glazite.
- 1—Cabinet with 7-in. baseboard (Pickett's).

casting band. A length of 30 ft. is ample and it is best for the aerial to be vertical if possible.

With an ordinary aerial a fixed condenser of the order of .0001-microfarad capacity should be connected between the aerial lead-in and the aerial terminal of the short-wave

This fact is mentioned so that readers are not deterred from taking up short-wave work because they have no facilities for a good aerial.

Taking Reasonable Precautions

When dealing with the short waves it is always worth while taking a chance for it often comes off—but it is, of course,

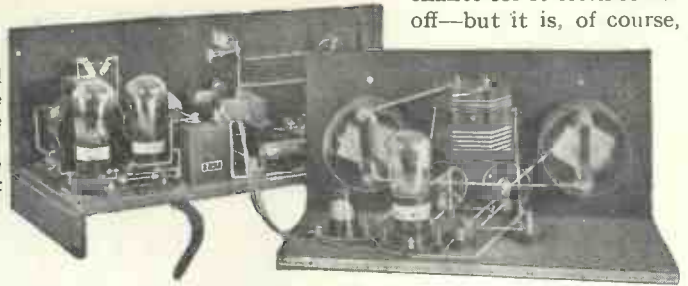

The Universal Short-wave Adaptor in use with an ordinary five-valve broadcast receiver

adaptor unit. This has the effect of shortening the effective length of the aerial and its use will be essential in most cases.

much better to take reasonable precautions if possible and so work with some factor of safety.

Once again we would remind WIRELESS MAGAZINE readers that reports of sets described in this journal are always received with great interest. Names and addresses of the senders of such reports as are published in these pages will be omitted.

[SPECIAL NOTE.—This Universal Short-wave Adaptor can be used as a single-valve set, if desired, by providing terminals with the following markings:

- Earth, Phones+, Phones-, H.T.+, H.T.-, L.T.+, and L.T.-.

Instead of taking flexible leads to the multi-plug, as at present shown, connect the free end of the high-frequency choke to Phones-, the positive filament lead to L.T.+, and the negative lead to L.T.-. Connect Phones+ to H.T.+ and H.T.- to L.T.-; also connect the bottom side of the grid-tuning condenser to the earth terminal.

It is not at all a difficult matter to arrange a terminal strip in this way and thus produce a one-valver. If this is done the operation of the set is carried out in exactly the same way as already explained.]

the aerial to the terminal on the short-wave Tuner.

Switch on the rheostat and adjust the reaction condenser until the slight rustling or hissing sound is heard which indicates that the set is on the verge of oscillation; when this occurs it is in its most sensitive condition for reception. By a little manipulation of the reaction condenser and moving reaction coil it is possible to obtain very fine control of oscillation.

Tuning the Unit

Next turn the knob of the grid-tuning condenser until a transmission is picked up. As soon as a signal is heard (tuning should be carried out very carefully even with the vernier dials or stations will easily be missed) re-adjust the reaction controls and turn the knob of the grid-leak potentiometer until the position of maximum sensitivity is obtained.

In most cases better results will be obtained with a shorter aerial than normally used for reception on the 250- to 500-metre broad-

Results with An Indoor Aerial

The results obtained on the short wavelengths, between 20 and 100 metres that is, are really amazing. One member of the WIRELESS MAGAZINE Technical Staff is able to get excellent results with an indoor aerial in the South of London.

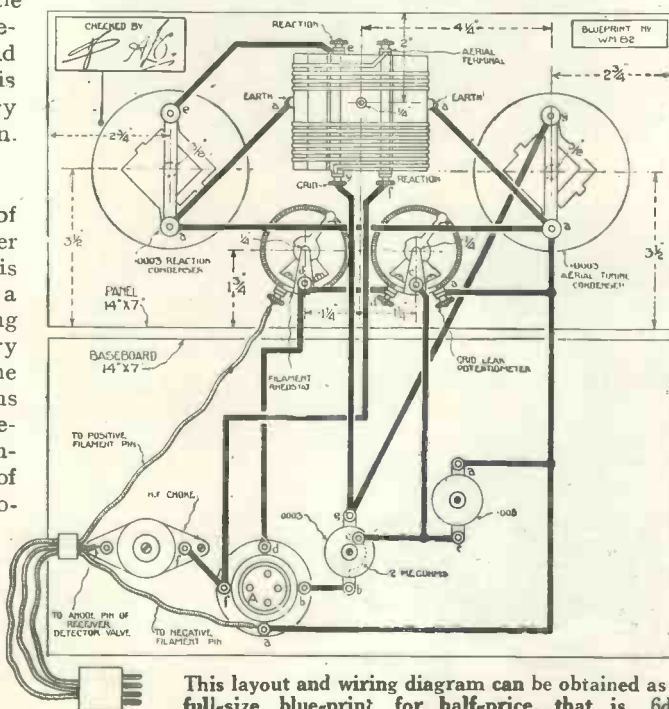

This layout and wiring diagram can be obtained as a full-size blue-print for half-price, that is, 6d., post free, if the coupon on page iii of cover is used by July 31. Ask for No. WM82

HALYARD'S Chat on the Month's Topics

Sketches by GLOSSOP

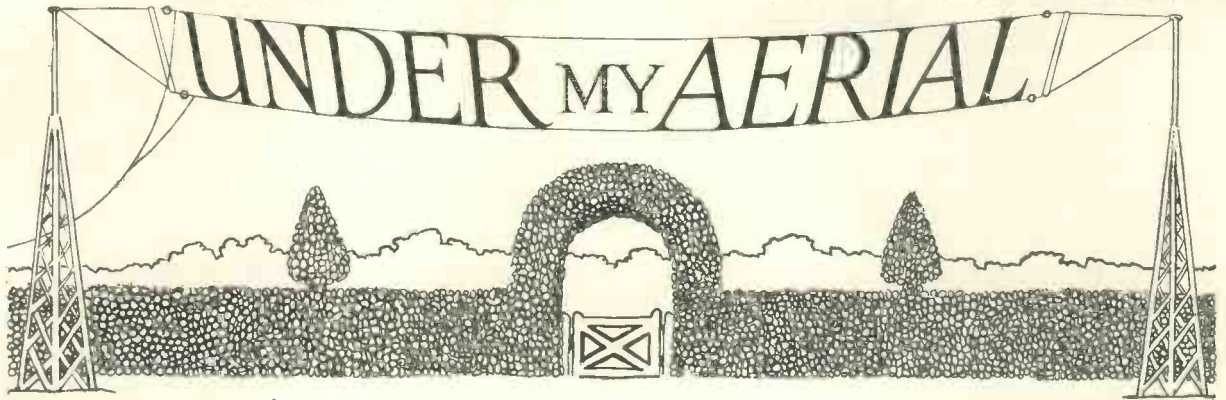
**Outside**

IOW are you getting on with your loud-speaker out of doors this summer? You ought to be getting better "outside" results this year than last, you know, considering the additional skill you have acquired in the manipulation of your set during the winter months.

I don't know what you think of listening-in out of doors, but I consider it to be one of the best things in wireless. There is only one troublesome feature about it and that is the possibility of annoying your non-wireless neighbours.

You can very easily underestimate the chance of annoying others with your loud-speaker out of doors and I'll tell you why. The carrying power of a loud-speaker out of doors, or its range, if you like, is very deceptive. A loud-speaker that is scarcely giving you satisfactory volume in your own garden may be audible fifty yards away.

Try it and see. Put your loud-speaker in the garden and walk away

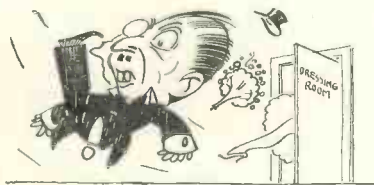

Outside

from it in some direction. I think you will be surprised at the distance you can hear the loud-speaker. Your test will show you, I am sure, that your loud-speaker out of doors may easily be a nuisance.

May I express the hope, therefore, that, when you are using your loud-speaker out of doors this summer you are as considerate of your neighbours as you can be?

Those Talks

A great deal has been said against the number of talks which are being broadcast to us from our B.B.C. stations. When you come to look into things, however, you find that the majority of these talks are interesting to some of us, to a good many of us, in fact.

Take those talks on holidays



A great deal has been said

abroad, for example. As I happen to have had one holiday on the Continent already this year, and am not in the least likely to be able to afford another one, you would scarcely expect to find me interested in those talks, would you?

But I am, and I have been specially interested because the speakers have told us something of the disadvantages as well as of the advantages of the places they have described. To quote one instance, we have been told of the swarms of hungry mosquitoes in Italy. Now I happen to have had a little experience of mosquitoes in Canada, and I should think twice before I chose to spend my holiday in a place spoilt by those little pests.

A curious grumble I have recently heard about our broadcast talks is that some of the best come in the afternoon when folk are hard at work. One series of talks specially mentioned to me in this respect is that on poultry-keeping.

Speaking of talks reminds me that my schoolmaster friend told me a few days ago that the broadcast

talks to schools this term are exceptionally good and are being greatly appreciated.

It strikes me that, if we were to look into things carefully, we should find that our broadcast talks form one of the best features of our present broadcast programmes.

Wireless Magic

"Anything new?" asked George as he seated himself comfortably in my arm-chair last night.

"Well! yes, there is," I said as I pulled an ordinary hard chair from under my writing desk and sat down. "There's an interesting description of what can be done with a new American short-wave valve. I'd like to go through the article with you, George."

"Very good, carry on."

"This new valve, George, transmits on a wavelength of six metres with a power of fifteen kilowatts. When it is working, a copper bar, lying on the floor, blisters the hand

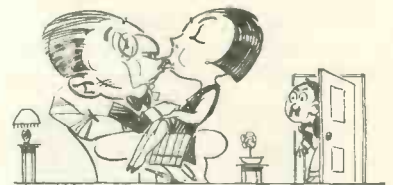

My arm-chair last night

that picks it up although the metal is cold."

"What a shame."

"Electrical meters in adjacent rooms run wild and delicate instruments are twisted or broken——"

"Will it put a next-door neighbour's piano out of action?"

"The article does not say, George, but, with this high-frequency valve some very unusual experiments in cooking by wireless were carried out."

Under My Aerial (Continued)

"Were the experimenters able to swallow the results obtained?"

"I should imagine so, George. In one experiment a sausage was cooked some distance away from the radiating aerial. The sausage was placed in a glass tube which was hung from the end of the receiving aerial. In a few minutes, the sausage started steaming. When it was finally taken out of the glass tube, the sausage was found to be cooked by the high-frequency currents that had been induced in it."

"Did the skin burst?"

"I cannot tell you, George. The article does not say and the photograph of the sausage is a small one; why?"

"Personally I always like the skin of a sausage to burst on cooking. Otherwise it might be a case of tough luck, you know."

Crash—Bang

Cr-r-r-r-ash.

Two or three minutes perfect reception.

Cr-r-r-r-r-r-r-r-r-ash.

More perfect reception, then,

Cr—cr—CR—R—R—RASH.

You realise what I am trying to describe, don't you? If you have been listening-in these summer evenings, you will have heard pretty well all you want to hear of this crash-bang type of atmospheric.

Last Sunday, I had what would otherwise have been a really good evening's reception spoiled by these crashes. I started on the high wavelengths and I had to abandon an interesting programme from Hilversum because of the crashes. I

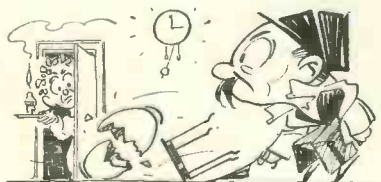

Crash—Bang

switched over to the medium wavelength band, but the crashes followed me. After a short period of 5GB, with an accompaniment of loud crashes, I gave up and went outside to see if lightning were visible on the distant horizon.

To my mind this crash-bang type

of atmospheric is the most annoying of wireless nuisances. I do not think there is any way of cutting out these crashes. It's no good writing to the B.B.C. about them, nor is it any good getting the Post Office to put a van on their track.

All you can do is to note carefully whether the crashes get louder and louder. If they do, you must be ready to switch off and earth your aerial the moment the loudness of the crashes suggests that the thunderstorm, electrical disturbance, or whatever it is, has come too near for safety.

As far as I and these crash-bang atmospheric are concerned, I am a firm believer in the old proverb, discretion is the better part of valour.

The New Station

Don't you think the B.B.C. ought to have a proper christening ceremony when the first of the new high-power twin-wavelength regional stations is "put on the air?" We should all be delighted to listen at



Don't you think?

our end of the air, shouldn't we? Many of us might even feel constrained to send a post card of congratulations.

I do not know what sort of a ceremony you would suggest, but my suggestion would be a ceremony similar to that which takes place on the launching of a ship. A waste of good champagne, you say. Well. Instead of smashing a fifteen-shilling bottle of champagne on the aerial mast or the earthing plate, a burnt-out transmitting valve might be used. George says he would actually prefer the valve so as to make sure that the christening ceremony would go off with a bang.

Of course, the most important thing about a christening ceremony of any kind is the name and the suggestion I have made above has set me wondering what name this new regional station is to have. Will

the new station inherit the familiar call-sign, 2LO, of the present London transmitter, or will it be given a new call-sign?

If the call-sign of the new station is to be a new one, I should think that 2NL (North London) might be a likely choice. Another possible choice might be 5PB (Potters Bar).

Cricket

Speaking as an old cricketer, I am more than a little sorry that we do



Cricket

not have running commentaries on the big cricket games broadcast to us during the summer months.

In the days before I began to wield the soldering bit on a Saturday afternoon I used to wield the willow and, on more than one occasion, I must have made more runs than there are turns on a—well—er—short-wave coil. Perhaps I had more success with the ball than with the bat.

Anyhow, I am still a keen follower of the grand old summer game, and I have few opportunities of seeing county cricket. Hence I should welcome cricket broadcasts, especially if they came on after the tea interval, when I am usually free to enjoy the wireless programmes. I am quite certain that there are thousands more who would, like me, welcome cricket broadcasts enthusiastically because of their knowledge of, and their old connections with the game.

The idea seems to prevail that cricket is a difficult game to broadcast. Difficult, maybe, but not impossible. If the B.B.C. would experiment a little on the broadcasting of commentaries on county cricket matches, I feel sure they would soon be able to give us cricket broadcasts as good as the football broadcasts they give us during the football season.

An Old Friend

A week ago to-day, I had the good fortune to meet an old school-boy

Halyard's Chat on the Month's Topics

acquaintance whom I had not seen for many years. This old friend of mine had only been home a few days after an absence of ten years on a rubber plantation in British North Borneo.

At the end of an interesting exchange of reminiscences my old friend told me he had purchased a four-valve receiver for the "old folks at home," and had not been able to make much of it.

Now I make a great point of never having anything to do with a commercial wireless receiver if I can help it, but I felt that I ought to make an exception in the case of my old friend so I volunteered to have a look at the set and see if I could improve matters.

Accordingly, that same afternoon I went to my old friend's home and had a good look at the set. My luck was in for it did not take me long to locate the trouble. There was a grid-bias battery hidden away in the space beneath the "works," and an excessive amount of grid bias had been applied to the amplifying valves.

Before I left we had an interesting talk on wireless conditions in Borneo. My friend's home there is within a few degrees of the equator and, as you would expect, atmospherics are a terrible nuisance. However, he

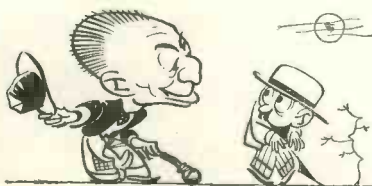

An Old Friend

has made up his mind to take a short-wave set back with him and have a shot at the Australian short-wave stations.

The Bogey

From what has been written the last few months on the future educational policy of the B.B.C., one might come to the conclusion that education is the blackest and squiggiest bogey that, in his mind's eye, the imaginative listener has ever seen.

Is education a big, black bogey

to you? Possibly it was in your school-days when it was administered to you by an irritable tyrant who was far too handy with his cane. Well, I dare say most of us looked upon education as an unnecessary evil in those days, and I dare say most



The Bogey

of us have often wished since that we had made more use of our opportunities at school.

Do you know, I really doubt if I can stir myself sufficiently to join in a spirited protest against the efforts of the B.B.C. to educate me. My early experience of education was that the more you protested the more you got, and the more you got the more unpleasant it got.

One writer recently suggested that I—along with other listeners, of course—should write a post card to the B.B.C. concisely, if pungently, giving

LAMENTATION!

Any "Wireless Widow" to Her Husband.

DEAR heart, when I asked for a
radio set
I meant what I said when I said it,
I wasn't prepared to be jilted, my
pet—

I didn't expect you to wed it.
Too often I chance to return to our
digs

To find you engrossed in your
hobby,

Eternally twiddling those
thingummyjigs,

Not to mention that
thingummybobby!

It's hard on me, dear, though I
wouldn't complain—

I certainly don't expect courting,
But there you go at it again and
again,

Do you think, dearest heart,
that it's sporting?

You'd better abandon that intricate
set—

Send it round to your wireless-fan
brother,

Or keep it for picking to pieces, my
pet,

And go out and buy me another!
C. P. P.

my opinion for or against the recommendations of the famous Hadow committee on broadcasting and adult education. Rather a one-sided suggestion, so it seemed to me. I should scarcely write *pungently* in support of the recommendations of the said committee, should I?

My plan with regard to this educational trouble is a very simple one indeed. If the B.B.C. want to educate me, and I don't want to be educated, then I shall just switch off. Simple, isn't it?

George says that my scheme is the exact opposite of the old days when if you objected to education it was often a case of switch on.

The Young Idea

A kindly schoolmaster friend of mine has sent me a school magazine in which there appears a wireless article written by one of his boys. The article is on the familiar problem of how to install a wireless set. I have thoroughly enjoyed reading this article, and I venture to pass on to you a few extracts which I am sure you will enjoy as much as I did:—

It is best after all to let someone else erect the aerial and take the blame. As before, let someone else fix the earth.

Accumulators are unsociable. They



The Young Idea

always "run out" when you need them most.

Variable condensers are the "vanest" part of the set.

A valve is a delicate instrument. It is always in a state of exhaustion.

There are many different types of crystal. Good reports have been heard from dynamite.

A creditable imitation of atmospherics may be produced by eating toast with the phones on.

Not so bad, is it? I should rather like to read more of this young writer's philosophy of wireless. HALYARD

Decorating Your Loud-speaker Baffle!

When you have assembled your moving-coil loud-speaker some attention must be given to its mounting and decoration. In this article are given details of a suitable stand and designs for decorating the baffle which will no doubt appeal to many "Wireless Magazine" readers.

There is great scope for individual ingenuity in the matter of baffle decoration.

THERE is no doubt whatever that the superiority of the coil-driven loud-speaker over the reed-driven cone and horn types is fast becoming generally recognised. Coupled to a suitable amplifier, the full, rich tones of the bass are so conspicuous, and the rendering is so thoroughly realistic, that the most casual observer is immediately moved to exclaim: "This is undoubtedly the most perfect reproduction I have yet heard."

Necessity for a Moving-coil

After the tinny emptiness and muffled blaring of horn loud-speakers—even after the comparative truthfulness of the reed cone—the moving-coil is so refreshingly faithful that one at once feels the necessity of installing an instrument of its class.

Certain difficulties still attaching to the patent rights in the invention, it is customary to buy a set of parts and assemble the moving-coil loud-speaker one's self. This will hardly be regretted by the experimenter, for loud-speaker construction has not hitherto been a hobby readily accessible to him, and, now, with moving-coil loud-speaker parts, he may experiment to his heart's content; it need not worry the non-technical man either, because, unless one wishes to dabble in cones and baffles, the putting together of the parts presents no more difficulty than piecing together the bits of a mincing machine.

What the Parts Are

The parts, incidentally, consist of a magnet unit, wound to suit the voltage with which it is intended to operate the loud-speaker, a framework to support the cone, the cone itself, and, usually, a cradle for the magnet pot.



Arrangement of stand for moving-coil loud-speaker

I have before written in WIRELESS MAGAZINE regarding the importance of loud-speaker position, treating especially of the horn loud-speaker. The problem of the best position for a moving-coil loud-speaker, and the best method of mounting it, offers greater difficulty.

A friend of mine, a well-known amateur transmitter, holds that the ideal coil-drive loud-speaker would be built into the wall—obviously by this method of erection the utmost is made of the possibilities of the baffle. I have seen in a restaurant in Baker Street a speaker so mounted as a matter of fact; but unfortunately for the purpose of a comparative test it was a reed-driven instrument.

Such a mounting is impossible, however, for all practical uses; and we are left with the question of how to mount the instrument in conditions to suit the general listener.

A shelf on the wall, or a table, is the obvious solution, and one or the other is almost invariably adopted by the convert. Yet, on consideration, each has its disadvantages: the mounting of the loud-speaker near the wall restricts the emanation from the back of the cone—the waves are reflected into the room before they have a chance to disseminate, and a table, as a rule, possesses that most common fault of being too low, and projects the sound from too low a point.

These difficulties confronting the writer led to his deciding that the most desirable mounting was a high movable stand—something like a flower-pot stand—and in casting about for the best design it occurred to him to imitate the microphone stand in the broadcasting studio. A stand along these lines was accordingly constructed and is shown in the sketch.

It will be seen that by building it of strong, heavy wood—lengths of 2 in. square oak were used in the original—the stand can be made sufficiently substantial to support the weight of the speaker—a not inconsiderable amount—and can be mounted on

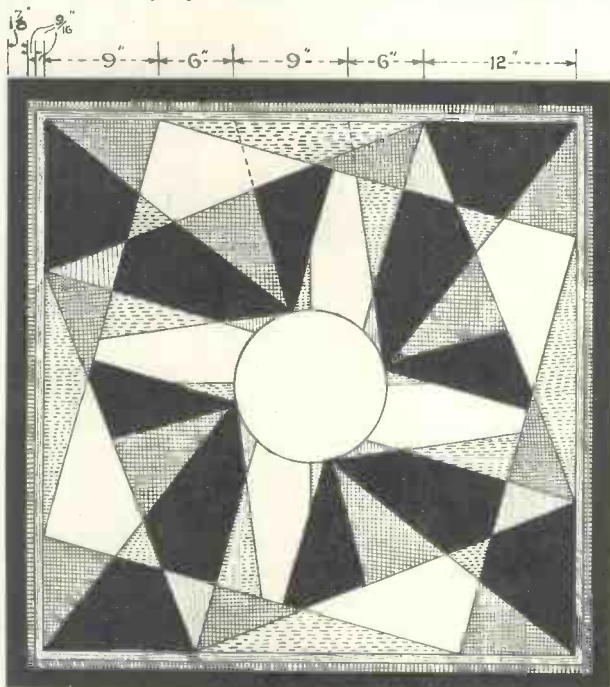

Design for baffle decoration suggested by the author

castors to facilitate removal from one room to another and to enable the best position in any room to be ascertained.

Somewhere around 4 ft. 6 in. to 5 ft. will be found to be the most suitable height, as this is approximately the mean between the height of the ear when sitting and standing.

Fixing the Pot Cradle

The way in which the components are set up on the flat top will depend on their design and the type of cradle available with the pot—in most cases it will simply be a case of screwing down the cradle legs. In others a little ingenuity must be exercised.

In cases where the energising current is to be supplied from a storage battery—as in the original—a shelf is provided for its accommodation (as shown in the drawing); if desired, the under part of the top, that is, the top part of the legs, may be boarded in to form a cupboard with a door to the back in which the battery is housed. The shelf or cupboard will also serve to take the choke-filter components or phone transformer if either is in use and is not incorporated in the set.

The baffle is arranged—as is quite the usual procedure—to be readily detachable from the aluminium frame supporting the cone; it may be found necessary to remove it when taking the loud-speaker about the house. A 4 ft. square of plywood is desirable, and this is rather ungainly to handle.

Making the Baffle Attractive

It can be made quite attractive by painting upon it some bright design of the type of the two suggested patterns accompanying the article. If less futuristic fulsomeness is wished for and art is not a strong point resource should be had to stencils, in which a variety of characters is obtainable.

Incidentally, it must not be forgotten that the rake of the stand legs must be such that they are not fouled by the lower edge of the baffle. W. HADFIELD CRAVEN.

Is Short-wave Work Beyond the Ordinary Listener?

(Continued from page 504)

I don't say this is in the least wonderful, but I do think it shows that no one need be afraid of tackling short waves because of having to be *extra* careful. By all means be careful—you will get better results if you

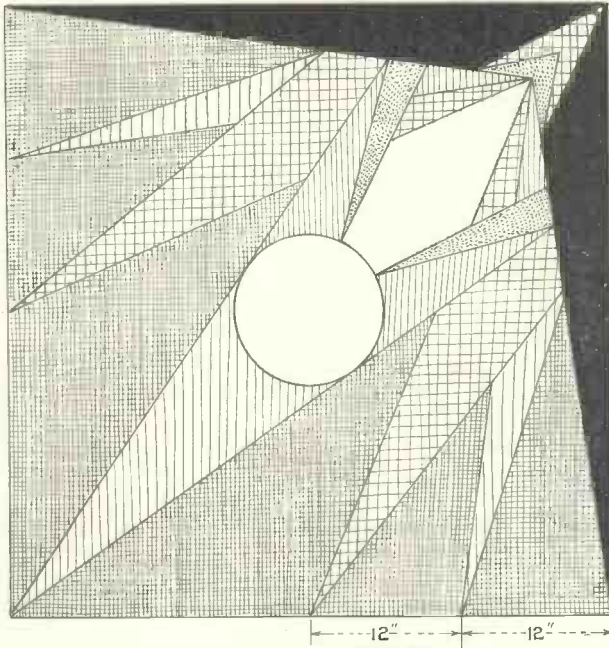

Another suggested form of decoration for a loud-speaker baffle board

are—but don't let the idea of having to take great precautions keep you off an interesting wavelength.

If you don't like to solder, then, don't solder; but make sound connections, all the same.

One thing I would, however, advise—put extension handles on both tuning and reaction condensers, and get a proper reaction condenser with air dielectric and lower capacity than the one I have mentioned. My listening to America was not improved by having to remain absolutely still.

The diagram of my rough hook-up is given on page 504. And if you go in for short-wave work don't oscillate more than necessary in picking up telephony! A. R. B.

Slow and Sure!

ONE of my wireless neighbours has just told me of an experience he had recently when he went to help a wireless beginner to fix up an aerial.

This neighbour of mine had had a look over the beginner's site. There was a convenient tree at the end of the garden, and there was a convenient chimney on the garden side of the house. All that was wanted was a metal bracket with pulley fixed to the brickwork of the chimney.

Usual Keeness

My wireless neighbour arranged with a workman, of the general jobbing variety, to meet him one afternoon at the house of the beginner. With his usual keeness, my neighbour took aerial wire, insulators, rope, in fact everything, he was likely to require for the new aerial, fully expecting to finish the business and have the set working that afternoon.

The workman kept the appointment, but he brought neither ladder nor tools with him. My neighbour expostulated with him and the reply he got was:

"You didn't expect me to start the job straight away, did you? I always have a good look round beforehand, you know. It pays. It will be a couple of days or so before I can get a ladder long enough to reach to that chimney. Then I've got to arrange for somebody to go up that ladder while I holds it."

AERIAL.

"Wander" Plugs

NOWADAYS valves only infrequently die of old age. Mostly they are burnt out accidentally long before the *finis* of their useful life, and in nine cases out of ten the accident is due to "wandering" of the H.T. wander plugs or leads.

It is quite a good plan to slip a stout rubber band round the side of the battery box, over the H.T. leads, thus clamping the leads tightly to the side of the battery. Accidental pulling on the leads will not then cause them to fly from their sockets and perhaps short to other components.

The same method can also be applied to grid-bias battery plugs and leads. K. B.

A CEREMONY of INDUCTION

By W. HADFIELD CRAVEN



NOBODY in Middle Wiggle loves Rudlark, and that is purely and simply because Rudlark loves nobody but himself. In a little community like ours, hemmed in by cows and cut off from the rest of the land by a sleepy old one-coach train that bumps between us and the junction six times a day, one must develop that communal feeling, one must be matey. (I often say that Marxian followers are in error in calling their British brothers "comrades"; it should be Mate Smith and Mate Robinson, as every plumber knows.)

It's no good being aloof and autocratic and standoffish and thinking yourself the only person who matters like Rudlark does; you must mind

other people's business—you must ask Farmer Swingletree how his pigs are coming on, even if you hate the sight of pork, and you must ask after young Mrs. Spudhoe, who's about to have her annual increase, no matter how you dislike her dolt of a husband.

Rudlark never can be big enough, hence it was not altogether a surprise when we learnt from Miss Gadabout that letters were arriving for him from Messrs. Grabbitt & Pinch, the celebrated auctioneers and estate agents, for we thought he was about

due for another outbreak of importance. Miss Gadabout, by the way, is what you might call, if you were excessively generous, a civil servant. Actually she's our postmistress, so you'll see what I mean.

Like most good Marxians, to stick to my earlier simile, she has a way of thinking everybody else's property her own—and the name and address was on the back of the envelopes.

Of course, the sole topic in the Bull and Bustle was the reason for Rudlark's correspondence with the redoubtable firm. Was he leaving us? Too good to be true! Was he moving to larger, more important quarters? That was more likely, since he had frequently hinted that the enormous Dower House, which he had occupied since Squire's son was killed in the war, was much too cramped for his family of three, and anything in the nature of a more pretentious abode would be calculated to warm his heart.

Eventually the news came out. Mr. Rudlark had taken Wappentwyke Manor, recently vacated by the decease of a retired colonial bishop, which meant, despite its name and to our inestimable disgust, that he still remained within the confines of Middle Wiggle.

The great moving-in was to take place almost immediately, and was to be followed by a house-warming to which Mr. Rudlark would ask his solicitor, Mr. Pothbury of London, the Hon. Mrs. Agnes Hugg, who by some remarkable chance of which none envied him (many, indeed, said it served him right) happened to be his mother-in-law, and several other little-known but self-important personages.

About this time I happened to drop in on Easingdrop, "the man with the wireless," as some Middle Wiggle wags call him. His usually beaming countenance wore a troubled look, his heavy, horn-rimmed spectacles lay beside him on his desk, his left hand raked his untidy blackish hair, and his right figured worriedly with a blunt stub of a pencil on a sheet of dirty, thumb-marked paper.

"My dear Easingdrop," I expostulated, "not another pet circuit, please. And at this time in the morning, too; you ought to be feeding your chickens."

Easingdrop, as you will have gathered, was the radio fan of our village; a smug, fleshy, daft-looking fellow, who was not half such a bad sort and not quarter such an idiot as he looked.

"Yes and no," responded the worthy enigmatically. "Fact is," he added, "I'm borrowing old Fotheringhay's barn in the Bottom Hill Close for a while. Doing some experiments there."

"Fotheringhay's barn? Bottom Hill Close?" I reflected. "Easingdrop, that building is within thirty

yards of Wappentyke Manor and I cannot suppose you have any desire to be in such close proximity to the new tenant. You are up to some devilment, Easingdrop. I foresee another uncomfortable time for Mr. Rudlark."

Easingdrop was fond of bringing Rudlark a cropper. His studious face was inscrutable.

"I am investigating psychic phenomena," he responded solemnly, blinking in a way that might have been meditative, or, equally well, facetious.

"Psychic fiddlesticks," returned I. "Where are your spirits—your ghosts anyhow?"

"Unfortunately, at Wappentyke Manor."

"At Wappentyke Manor. H'm. Why unfortunately?"

"Unfortunately for Rudlark, in that I fear they will disturb him. Unfortunately for me, because I suppose I shall be unable to carry my investigations as far as I should like; Rudlark has no love for me and will not permit me to mix with his house party."

"Neither of which latter points you regret in the least."

I let my mind wander back over the long years I had existed in Middle Wiggle and all the tales I had heard of this dreamy countryside.

"I seem to remember some yarn attached to Wappentyke,"

I said. "Nothing very definite and nothing of recent years."

"The spirits dislike change. Once a tenant has proved his suitability they leave him in peace. They were very favourably impressed, I believe, by the late colonial bishop. No manifestation has taken place since he came here forty years ago."

"And you are suggesting that now that

Rudlark is taking over the manifestations will begin again?"

"It is the chance of a lifetime for any student of the occult," said Easingdrop impressively.

I nodded benevolence.

"And what have you got there?"

I inquired, pointing to his diagrams. "Spook circuits?"

Easingdrop coughed modestly, and, murmuring something about "intricate calculations," blotted the sheet of paper so carefully that he hid from me everything on it. And you will remember that he was using a pencil.

Four days later Rudlark paid a visit of inspection to his new home. According to Gaffer Haggelthwaite, our oldest inhabitant, who retails the day's (and much older) news in the Bull and Bustle at so-much the pint, he went in at the front and out at the back in such a short space of time that it seemed incredible that he could have fully enjoyed the beauties of the ancient seat.

Later in the week there was a similar occurrence, this time with an unheard of sequel—Mr. Rudlark was seen in the Bull and Bustle having a little brandy. Rumour had it that the following Saturday Mr. Rudlark went to bed in his boots and complained of seeing things. Doctor prescribed rest and a sedative.

I met the man of medicine the Monday after.

"What's the matter with Rudlark?" I asked.

"Everyone's talking about him."

"Ah, poor fellow." He stroked his shaggy white moustache in a professional non-committal gesture. "A very alarming experience. Vcry alarming. I am not a believer in the supernatural myself. Still . . . one never knows. One never knows."

"The supernatural? What do you mean?"

"The ghost of Wappentyke Manor. The occult . . . apparently. Manifestations of . . . er . . . ahem."

"I'm afraid I don't follow you, doctor."

"It must be thirty . . . no, what am I saying, forty . . . yes, forty-five years since the last talk of manifestations," he ruminated. "I had never believed the stories, they were so vague. And I, not believing in the psychic . . . er . . . psycholog— . . . er . . . ghosts. My father, though; I remember his mentioning something, now that Mr. Rudlark tells how . . . er . . . ahem."

"Has Rudlark seen a ghost?" I demanded.

"A ghost . . . er? Well, no. That is . . . er . . . an alarming experience. Some noises: wailings. A door opened, and, I believe, closed suddenly before Mr. Rudlark had fully passed through, trapping his left forefinger . . . or was it his right thumb? Yes, I think it was his left thumb."

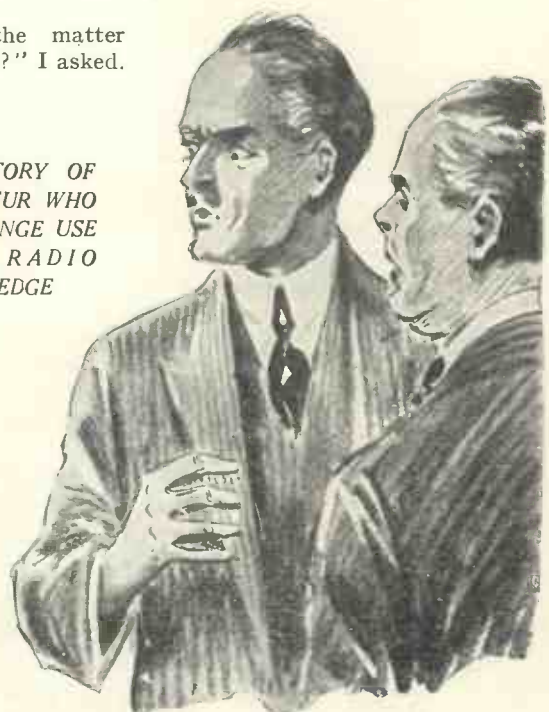
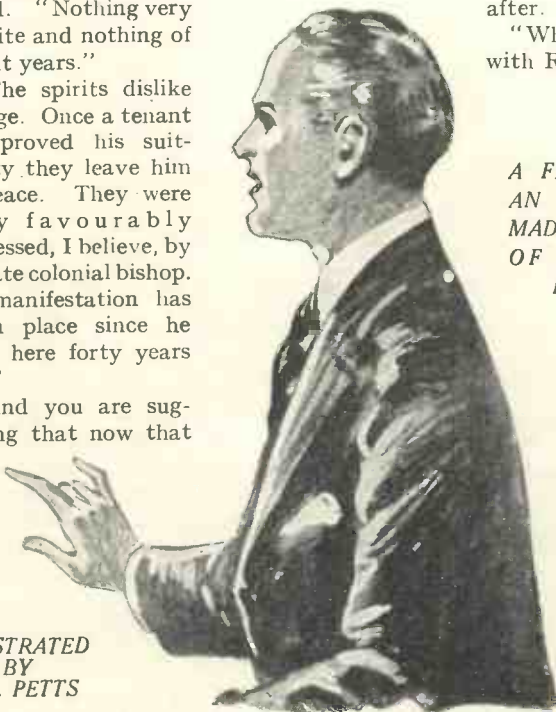

A FINE STORY OF AN AMATEUR WHO MADE STRANGE USE OF HIS RADIO KNOWLEDGE

ILLUSTRATED BY K. J. PETTS

A horrible, moaning wail met me as I threw open the door. It began with a low, gurgling grunt and rose to a piercing scream of anguish.

A Ceremony of Induction (Continued)

"What was the story of Wappentyke Manor you heard, doctor?" I inquired, interested.

"Well, now, let me see. Wasn't it that manifestations took place on the arrival of a new tenant? Yes. Let me see, it must be about fifty . . . I would say forty years since the late bishop came amongst us. That was the last I heard of the business. A sort of ghostly ceremony of induction takes place, or something."

I mused. I was thinking of Easingdrop. He had told practically the same story. I was wondering exactly how far his experiments had carried him, and just why he, the mischief-maker, should have taken up a subject that appeared to clash so violently with the interests of the hated Rudlark.

"Perhaps Mr. Rudlark will not care to take the Manor after his experiences," I ventured.

"Ah!" Doctor waxed confidential. "He is a proud man, of course . . . we all know. It seems unlikely that he would be deterred . . . and yet," he bent over, with the very nearest approach to a wink, "they say, I remember, that unless the ghosts take a fancy to the new tenant they give him no peace: of course, they liked the late bishop, but Mr. Rudlark might not . . . er . . . ahem."

Unrestrained by professional qualms, I contrived to answer freely.

"I should jolly well think not!"

At that moment there was a cry from up above Grubb's Stores, and much to the amusement of myself and the several other villagers, who, it transpired afterwards, had witnessed the event from the security of their doorsteps, no less a person than Rudlark himself came gallivanting down the road in an excited and undignified manner.

"Doctor, Doctor . . . I want you to come—," he stopped short on seeing me. Then apparently unable to conceal his distress, even at the expense of letting me know its nature, he broke out:

"You must come over to the Manor with me. I cannot go there again alone. Both of you come. For heaven's sake say whether what I see

is really true or that I am mad!"

Nothing loath, I started off in the direction of the mysterious house. Doctor, mumbling consolingly in Rudlark's ear that he must not excite himself, followed close behind, guiding the great man.

Ten minutes later we entered the sumptuous grounds and crossed to the main entrance. It was growing dusk, and in the distance, barely thirty yards away, I could discern Fotheringhay's barn in the Bottom Hill Close. I wondered what Easingdrop was doing, and whether or not he was there experimenting.

Rudlark opened the door. He had left it unlocked in his haste to fetch a companion. We passed into the deserted hall. The setting sun cast red-gold shafts through the high, stained-glass windows on the staircase, chasing an eerie pattern on the flooring and intensifying the gloom of the corners. All was quiet.

We moved across towards the heavy oaken door that led to what had been the departed bishop's morning-room. Inside the light straggling through a few stray cracks in the closed shutters revealed the dismal emptiness of a room whose constant occupant has gone. Still and cold, a little musty-smelling, yet no more uncanny than any other empty room in an old, rambling, empty house. We passed to the dining-room: again abundant cheerlessness, but no sign of unnatural occupants.

I turned to Rudlark and said, a trifle testily, "Nothing here. You must be mistaken."

"Nothing here? Mistaken?" Terror crept into his tone. "Come."

He pushed ajar the library door, bidding us enter first.

Doctor bowed ceremoniously for me to precede him. I nodded acquiescence and went in boldly, a thought at the back of my mind.

A horrible, moaning wail met me as I threw open the door. It began with a low, gurgling grunt and rose to a piercing scream of anguish. I wondered vaguely, in a moment divided between fear and amusement, where I had heard it before. Doctor,

behind me, twirled his moustache furiously. "Great heavens!" he exclaimed. Rudlark clapped his hands to his ears and sobbed convulsively.

The sound died away and was not repeated. After standing tense on the threshold for possibly five minutes, I edged further inside. The room was pitch black, save for the slanting shaft of light the open door admitted.

"No, no!" Rudlark cried out. "Don't go in, man!"

"Why not?"

"The eyes . . . Its eyes!"

I peered around the inky, cavernous space. From a remote corner two tiny, malevolent eyes gleamed, staring at me, as it were, with a look of intense hatred. What might have been a faint, vibrant breathing accompanied the beastly apparition.

I stepped back, a trifle aghast. Then, on a sudden impulse, I crouched down and sprang across the room.

The baleful eyes disappeared as I grappled something faintly warm and slippery in the darkness. I came back, grinning wanly, nursing a hand that ached from a violent knock.

"Are you hurt? Gracious, why can't you be more careful. You don't know what it might have done to you." Doctor examined my hand.

We were all inside the room now, and, without warning, there was a click as the door closed upon us.

"Trapped!" Rudlark screamed, banging his clenched fists on the stout panels.

I pushed him aside and wrenched the doorknob with my left, undamaged hand. It felt as if it were being held against me by someone outside in the hall. I tugged again, and, with a suddenness that sent me reeling, the door came open. There was no one there.

Rudlark made for the outer door. He was babbling drunkenly, and seemed unable to keep a limb still.

"That settles it," he vowed, as he rushed out into the open, "I'm not taking Wappentyke Manor at any price. Now you've seen for yourselves."

Doctor twirled his moustache, and,

ARE YOU BUILDING THE CHUMMY FOUR YET?

A Fine Wireless Story for Everybody!

muttering half inaudible instructions to Rudlark on the preservation of his health, led the Manor's brief tenant down the drive homeward, a sorry and dejected shadow of his former self. I locked up the house, handing the key back to Rudlark before he went away, and then turned across the fields on a short cut home through Bottom Hill Close.

When I shoved my way through the mass of packing case pieces and sacking that does duty for a door at Fotheringhay's barn, Easingdrop was bending over an elaborate spark coil that provided the chief feature of a rough and ready bench in the centre of the grimy building. He was, moreover, on the point of uttering a very loud and vehement "Dam n!" Above him was slung a short length of aerial wire, and around his feet were batteries almost submerged in huge quantities of junk.

"Won't it work, Easingdrop?" I asked, sympathetically treading warily among the entanglements. "Always the way, isn't it, when one wants to demonstrate?"

He stared up at me suspiciously, his little beady eyes blinking, and made a few comments that I won't record. He's got quite a colourful vocabulary, has Easingdrop.

"I don't think the fault is there," I added, as he scrutinised some curious piece of apparatus.

"What do you know about it, anyway?" he snapped.

"Not a great deal. I'm no wireless man. But I once went to the Science Museum at South Kensington and was very interested in the exhibits. I believe it was a thing you call a coherer that I broke."

"Where? At South Kensington?"

"No. At Wappentwyke Manor—over in the corner by the eyes. The eyes, by the way, were not very expensive lamps, were they? I'm afraid I damaged them, too. The bell-hammer affair that you used for tapping the coherer was so vicious." I caressed my aching hand.

"You swine!"

"Oh, not at all. It was quite an interesting experiment, and went off very well. You energised the coherer by means of the spark coil, I presume? That made the lamps glow?"

"You are quite right, but I don't thank you for playing the detective."

"And you had a wireless-controlled relay working the door?—I must have strained that as well. I gather you twiddled a few knobs here to produce the mournful chirps on that little receiver in the corner? I wondered where I'd heard the sound before. Of course, you were never given to sets that wouldn't oscillate, were you?" Easingdrop has spoilt my broadcast many a night with his cursed searching.

He glared at me most savagely.

"There is one thing I should like to know," I pursued. "How did you know when to begin experimenting? How did you know when your victim entered the library?"

"I suppose you didn't see a selenium cell at the Science Museum?" snarled Easingdrop.

"I believe I did."

"Well, you needn't have gone as far. There was one in the shaft of light from the library door."

"Well, now fancy that! I never saw it. Most ingenious. And what did it do?"

"Oh, simply worked a relay to switch on an old wavemeter in another corner. That gave me a warning note. It turned on the receiver as well, so that I could induce the squeals."

"And all done by wireless at thirty yards range. Wires would have been seen, of course. Very, very clever, Easingdrop."

Easingdrop had passed from rage to mortification.

"This is what comes of dropping hints to a friend," he said bitterly. "He spoils my plans and smashes my apparatus."

"But I forgot to tell you that Rudlark isn't going to take the Manor," I hastened to explain. "He seems quite a changed man."

And then Easingdrop grinned.

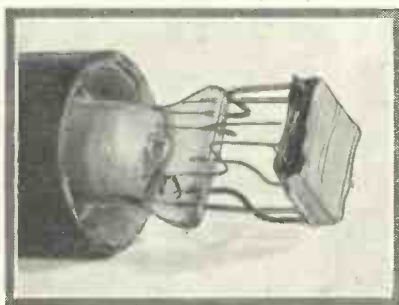

SEE how the anode of the valve shown in the photograph above has warped. And well it might, for it was recovered from the debris remaining from a fire at a well-known wireless manufacturer's factory!

Even after going through this strenuous test of fire and water (the base of the valve was badly burned) the valve, which is a Mullard, was found to be in perfect working order before being broken open for an inspection of the electrodes.

A photograph of the debris from which the valve was recovered is shown on the right. It was a REAL fire, as can be seen!



THROUGH FIRE AND WATER!

How a Valve Survived an Accidental Yet Most Strenuous Test.



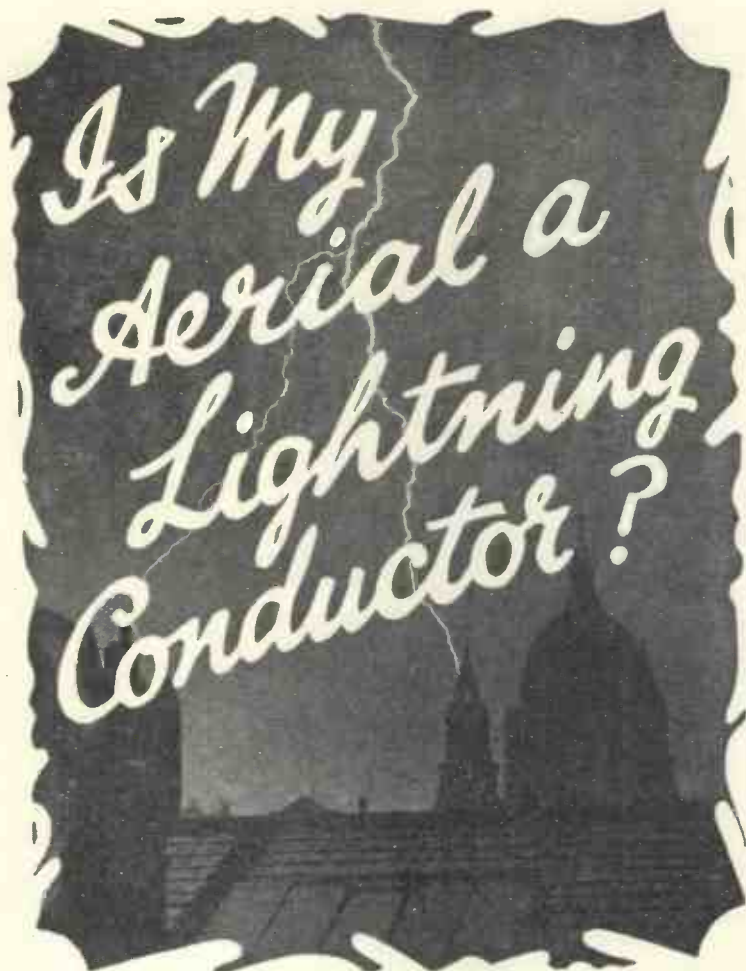

WHEN flashes of lightning are playing in the vicinity of the wireless aerial the listener naturally asks himself: "Does my aerial really attract lightning?" Well, the answer is that an aerial does not exercise any "attraction" for lightning in the ordinary sense of the word, but it may provide a lower resistance path to earth than anything else in the immediate neighbourhood.

In the event of a direct hit by lightning, however, we can estimate its probable behaviour and effect on the installation. If the aerial is earthed from the *outside* of the house, so that a direct path from the elevated wire to earth is provided, the aerial is, in effect, a lightning conductor. As such, it is more a *protection* than a source of danger.

When the Aerial Might Be a Source of Danger

Suppose that the aerial, instead of being earthed from the outside, is brought *into the house* by a lead-in wire and left suspended "in the air," then the aerial might be a *source of danger*. For, in the event of a direct hit—and remember that, as far as the aerial is concerned, we need only protect ourselves against a *direct* hit—the lightning discharge would take a haphazard course to earth and might cause considerable damage.

There is no reason to suppose that an aerial, earthed or unearthed, is any greater "source of attraction" to lightning than, say, a telephone wire or an elevated power cable, but certain precautions should be taken by every listener against the possibility of damage resulting

from a direct hit. The most satisfactory method of earthing the aerial is by means of a large double-pole change-over switch mounted *on the outside wall* of the house in the vicinity of the aerial down-lead.

The aerial and earth leads should be connected to the two centre points of the change-over switch. The aerial and earth terminals of the receiver should be connected to one side of the switch and the two remaining connections on the other side of the switch, joined by a short piece of wire, so that in one position the aerial is directly earthed and in the other position the aerial and earth are connected to the receiver.

Guarding Against Possible Damage

When the receiver is not in use, the switch should be thrown over to the "earthed" position. This is really the only safe way of guarding against possible damage that may result from a lightning discharge.

The only disadvantage of this device is that during reception no provision is made for an accumulated (static) electrical charge to leak to earth. Hence, when there is "thunder in the air," but no actual storm is taking place, the aerial may become highly charged with static electricity (in the same way that a condenser becomes charged), and there is the possibility of a sudden discharge through the tuning system of the receiver to earth.

To guard against this fairly remote eventuality a lightning arrester can be installed. This is a device consisting of either two sharply pointed copper elements or two saw-toothed copper elements so arranged that there is a small air gap between them. If one side of the device is connected to the aerial and the other side to earth, any accumulated charge on the aerial will spark across the gap directly to earth without damaging the receiver.

Providing Against All Possible Dangers

A combined lightning arrester and double-pole change-over switch provides against all possible contingencies. The lightning arrester should be connected across the two centre points of the change-over switch so that when the receiver is in action, so also is the lightning arrester; but when the receiver is out of action the aerial is directly earthed, in which case there is no need for the lightning arrester.

The foregoing remarks should not lead the reader to believe that there is any very great risk of the aerial being struck by lightning. Actually, the chances are some millions to one, and it is interesting to note that most fire insurance companies consider the extra risk as negligible.

ALAN S. HUNTER.

IF YOU WANT A REALLY
GOOD PORTABLE SET BUILD
THE SUNSHINE FIVE OR THE
CHUMMY FOUR

An Idea for the Home Constructor

A Combined Loud-speaker and Bookcase

THE accompanying design for a combined loud-speaker and bookcase, perhaps, will be welcome to those who have not much spare room. Also, it provides for the use of a very efficient horn—not less than 54 in. in length—which is an advantage, whilst at the same time what would otherwise, perhaps, appear to be an unsightly horn is well camouflaged.

Easy to Construct

The construction has been kept extremely simple, so as to be within the reach of any amateur joiner, and no joints are needed. Common wood, deal, or pine, may be used throughout for the carcass, anywhere from $\frac{1}{2}$ in. to 1 in. thick, but the measurements shown in the design are for wood $\frac{1}{2}$ in. thick.

When finally completed (see Fig. 1)

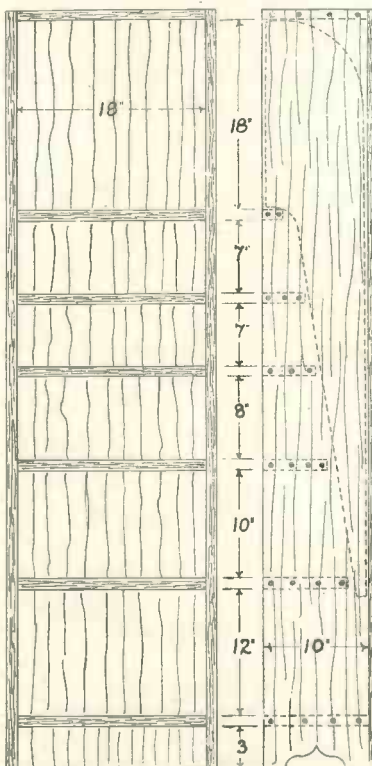

Fig. 2.—Front and sides of the case

the two sides of the case and the front edges of the shelves may be covered with thick oak-grained paper (which may be purchased from a painter and decorator) to hide the screws and to give the case the appearance of being made of oak. This thick paper should be attached to the wood by means of good strong glue and thick flour paste mixed together.

Provision has been made for five shelves for books, each 18 in. long, and the widths of these, beginning at the bottom, are respectively 10 in., 8 in., 6 in., 5 in., and 4 in. Above these, to form a space 18 in. square, one piece of wood 18 in. by 10 in. for the top, and one piece 18 in. by 2 in. on which the bottom portion of the flare of the horn rests, are required.

Positions of the Shelves

The distance apart of these various shelves is shown in Fig. 2, but if wood less than 1 in. thick is used these measurements will be varied. Of course, the constructor may please himself as to the number and position of the shelves.

The two side portions measure 6 ft. by 10 in., and the shelves may be fixed merely by screws through the sides as shown, but be sure that the flat heads of the screws are sunk flush with the surface of the wood.

The back portion need be only $\frac{3}{8}$ in. or $\frac{1}{2}$ in. thick, and may be made up from 6 ft. strips, these being fixed with screws both top and bottom.

The shape of the sides for the horn is shown by the dotted lines in Fig. 2, and it will be found better to draw a full-size outline of this portion on one of the sides. Then two pieces may be cut to this shape from $\frac{3}{8}$ in. or $\frac{1}{2}$ in. wood. Two lengths of thin,

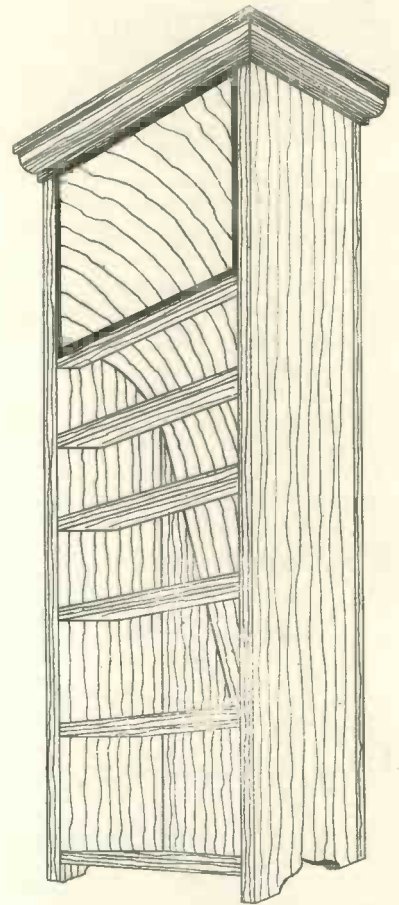

Fig. 1.—View of the completed loud-speaker and bookcase

pliable wood will be needed to complete the horn, and the lengths of these may be got by measuring along either side of the first portion, the width of these tapering from 18 in. at the top to 2 in. or less at the bottom of the bookcase.

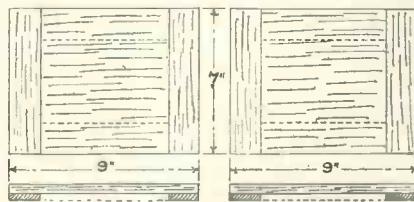

Fig. 3.—Doors for top cabinet

The flexible strips of wood should be glued and fixed with an occasional fine nail to the edges of the thicker pieces. When the horn is completed

a length of tape should be glued along each of the four joints, to make it sound-tight.

Finishing Off the Horn

The horn may then be placed in the case, with the bottom edge of the flare resting on the 2 in. shelf. To give a finish, lengths of moulding may be put round the 18 in. opening of the case, and a panel of muslin be inserted.

A Combined Loud-speaker and Bookcase (Continued)

Fitting the back completes the case, after which it may be covered as described previously. It may be left plain, but its appearance may be improved by fixing a mould round the top, as shown in Fig. 2.

The top shelf will be found very narrow for books, and this portion may be made into a smoking cabinet or a small medicine chest, by fitting two doors. The simplified construction of these doors is shown in Fig. 3. Smooth three-ply tea-chest wood will be found a suitable material to use,

as it may easily be stained to match the rest of the case.

The main portion of each door consists of a piece 9 in. by 7 in., and a strip 7 in. by 1½ in. should be glued (and fixed with pin points) on either end of the door, as shown in Fig. 3. Finally, strips 6 in. by 1½ in. should be glued similarly on the door, as shown by the dotted lines, when the effect will be to give a panelled door. This method of panelling may be used also for the sides of the case, if desired. E. J. G.

Make Your Own Photo-electric Cell

ONE of the "snags" connected with making experimental television apparatus is the comparatively high cost and difficulty of construction of the light-sensitive cell.

Selenium is the generally accepted sensitive material employed, but as there are quite a number of other elements and combinations which respond in electrical resistance to light variations, these may be given a trial.

One such alternative is a simple cell consisting of two copper plates in a solution of copper sulphate.

Cutting the Plates

The plates should be cut out of copper sheet in the shape of accumulator plates, that is, they should have small lugs at the top for convenience in making connections. Each plate should be about two or three inches by one inch, this giving a useful surface area to assist the chemical action.

When the copper plates have been cut, they should be thoroughly cleaned and then placed face to face with two small glass strips or rods to separate them by a small amount. Rubber bands may be used to keep the assembly together.

The plates should be placed in a small container with a fairly weak solution of copper sulphate in water. As the water should preferably be

slightly acid, it is better to use tap water than distilled water for the purpose.

Leave the plates in this solution for a few days, and it will be found that a deposit (copper oxide) will form upon the surfaces of the plates. This oxide is light-sensitive, that is to say, if a light be shone upon it the cell will produce quite a useful current.

To test the action, a pair of phones should be placed across the two plates and a strong light shone upon one surface. A current will immediately be produced and will cause crackling noises in the phones.

There are quite a number of other types of "wet" light-sensitive cell, making use of metal plates and solutions of the salts of various acids. The copper-plate copper-sulphate combination is possibly the cheapest to rig up, and is equal in light-sensitivity to the others. TELEVIZ.

Are My Mains A.C. or D.C.?

BEFORE buying a high-tension eliminator of any kind it is first necessary to find out if the house-lighting supply is alternating or direct current.

The obvious plan is to go "straight to the horse's mouth," as it were, and to obtain the information from the local electrical people or to decipher the markings on the consumption meter.

Disadvantages

The first plan may entail too much waste of time, while the second may necessitate clambering about in dusty cupboards or cellars.

A rough-and-ready tip often put forward for detecting A.C. from D.C. mains is the following: Pass the hand, with the fingers outstretched, rapidly to and fro under a lighted lamp. If the supply is direct current, then the hand and fingers will be seen simply as a blur, provided it is wagged sufficiently quickly.

If the bulb is supplied with A.C. current, though, the filament will in effect be rapidly switched on and off by the A.C. pulsations.

Illuminated in Pulsations

This will have the effect of illuminating the hand in pulsations, and the fingers can be seen quite clearly, no matter how fast the hand be moved. If the hand be moved at approximately the frequency of the A.C. supply, then the hand will appear to be stationary.

A metal-filament lamp should preferably be used for this test, as the filament cools rapidly between each half-cycle. A bulb of the half-watt type may fail to give the desired result. BIM.

OUR HALF-PRICE BLUEPRINTS

AS some slight confusion seems to exist regarding the special half-price blueprint coupon given with each issue of the WIRELESS MAGAZINE we wish to point out this can only be used for obtaining blueprints of sets described in the current number.

Thus the coupon on page iii of the cover of this issue is only available for any one set described in this issue up to the end of July. Not more than one blueprint can be supplied at half-price for each coupon. Overseas readers will be allowed an appropriate extension of time when applying for blueprints under this scheme.

THE SIGNAL THREE

Neutralised Split-primary H.F., Detector and Transformer-coupled L.F.



Designed, Built and Tested by the "W.M." Technical Staff

THIS set is an all-round general-purpose type of receiver that will appeal to a large number of WIRELESS MAGAZINE readers. It consists of a perfectly straightforward circuit arrangement and the layout is convenient for the home-constructor. The fact that it incorporates a stage of high-frequency amplification and only one stage of

Note that there is only one tuning control

The simplicity of the circuit is clear from the diagram reproduced below. A double-tapped coil is

A split-primary transformer is utilised for the high-frequency coupling, the secondary of this being tuned by the other half of the dual condenser. Neutralisation is carried out in the ordinary way, while reaction is applied to the secondary by the Reinartz principle and controlled by the .0001-microfarad variable condenser already referred to.

Leaky-grid Rectification

Leaky-grid rectification is employed for the sake of sensitivity, the free end of the leak being taken to filament positive. In the anode circuit of the detector valve is placed a high-frequency choke to prevent high-frequency impulses from leaking through into the low-frequency side of the receiver.

For the protection of the loud-speaker a choke output or filter circuit is included. This consists of a low-frequency choke used in conjunction with a 2-microfarad condenser. This prevents the direct current from the anode supply from flowing through the loud-speaker windings and possibly demagnetising them if connected up the wrong way.

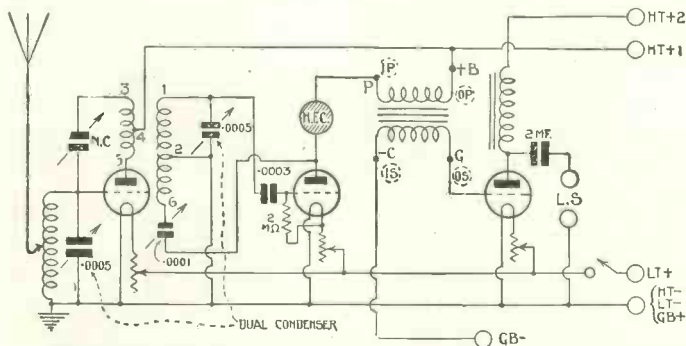

Circuit of the Signal Three, which comprises one high-frequency stage, a detector, and one low-frequency amplifier

low-frequency will make it particularly useful (for a three-valver) to those listeners whose local station is not very near.

A particular feature of the Signal Three is that both the aerial and high-frequency circuits are tuned by a dual condenser which is operated by one knob.

Dual and Gang Condensers

The difference between a dual condenser and a two-gang condenser is that in the former the two halves are mounted on a common spindle and not insulated from each other, and the instrument is therefore cheaper.

Altogether there are actually three knobs on the panel. The large one in the centre controls the dual condenser and is therefore the main tuning dial. On the left of this is the reaction condenser, while on the right is a simple push-pull on-off switch.

used in the aerial circuit for the sake of increased selectivity and this is tuned by one half of the dual condenser.

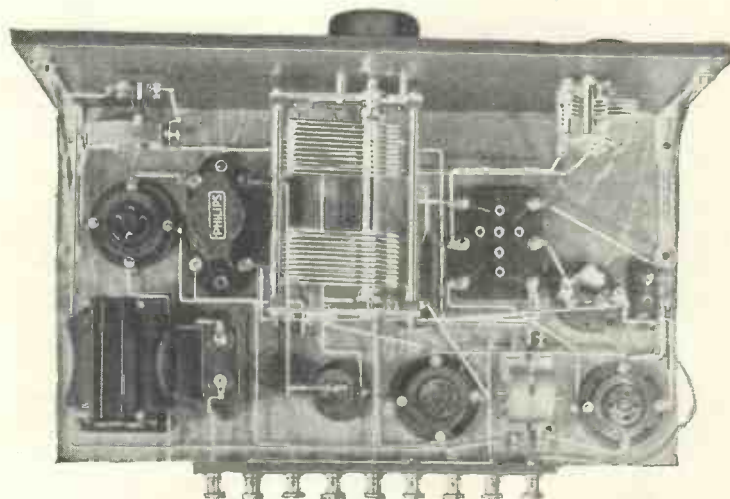

Plan view of the Signal Three, showing disposition of the components. The condenser is of the dual type and not a two-gang instrument

The Signal Three (Continued)

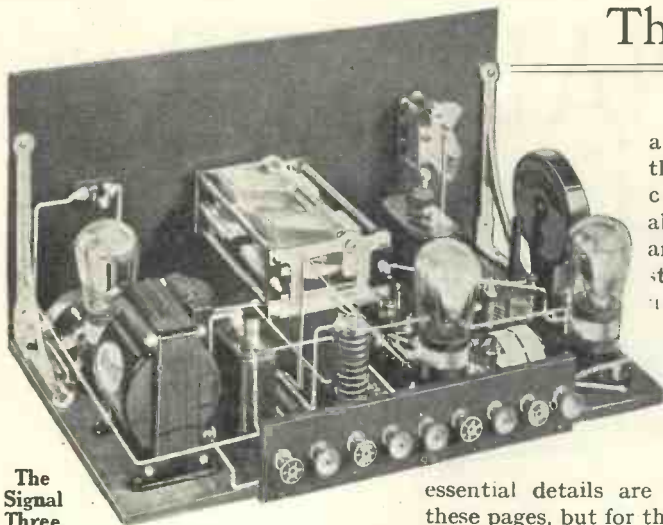

The Signal Three

Two terminals are saved by connecting H.T.—, G.B.—, and L.T.— to a common terminal (marked L.T.— on the receiver itself).

COMPONENTS REQUIRED

- 1—Ebonite panel, 16 in. by 8 in. (Becol, Raymond, or Will Day).
- 1—.0005-microfarad dual condenser (Cyldon).
- 1—.0001-microfarad variable condenser (Cyldon Bébé or Peto-Scott).
- 1—On-off switch (Deckorem, Lotus, or Lissen).
- 1—Single coil-holder (Lissen or Lotus).
- 3—Anti-microphonic valve-holders (Lotus, Trix, or W. and B.).
- 1—Neutralising condenser (Igranic, Bulgin, or Jackson).
- 3—6-ohm baseboard rheostats (Peerless).
- 1—Six-pin coil base (Lewcos or Cason).
- .0003-microfarad fixed condenser with insulated series clip (Dubilier).
- 2-megohm grid-leak (Dubilier or Lissen).
- 1—High-frequency choke (Wearite, R.I. and Varley, or Trix).
- 1—Low-frequency transformer (Philips or Mullard).
- 1—2-microfarad fixed condenser (Dubilier, Lissen, or T.C.C.).
- 1—Output choke (Ferranti type B1, Igranic, or R.I. and Varley).
- 2—Dial indicators (Bulgin).
- 1—Pair panel brackets (Camco).
- 1—Cabinet with 9 in. baseboard (Camco).
- 1—Terminal strip, 9 in. by 2 in. (Becol, Raymond, or Will Day).
- 9—Terminals, marked: Aerial, Earth, L.T.—, L.T.—, H.T.—, H.T.—+1, H.T.—+2, G.B.—, L.S.—, L.S.— (Eelex).
- 5—2 ft. lengths wire (Glazite).

essential details are reproduced in these pages, but for those who desire it a full-size blueprint is available. This acts as a drilling template, layout guide and wiring diagram and is obtainable for half-price, that is 6d. post free, up to the end of July, if the coupon on page iii of the cover is used by that date.

Address your enquiry to Blueprint Dept., WIRELESS MAGAZINE, 58-61 Fetter Lane, E.C.4, and ask for Blueprint No. W.M.84.

The first operation in building the set is to drill the panel and mount thereon the dual .0005-microfarad variable condenser, the reaction condenser and the on-off switch. The panel can then be fixed to the baseboard.

Building the Receiver

Next mount the rest of the components on the baseboard; looking from the back of the panel, these are, on the right of the dual condenser, the holder for the double-tapped plug-in aerial coil, the neutralising condenser, the holder for the high-frequency valve, two baseboard rheostats for the high-frequency and detector valves and the six-pin coil base.

In front of the dual condenser are the holder for the detector valve and the high-frequency choke. To the left

of it are the low-frequency transformer, the holder for the low-frequency amplifying valve, the output choke and the 2-microfarad fixed condenser. When all the parts have been firmly fixed into position wiring up can be started and this will be found a simple operation if the wiring diagram or blueprint is carefully followed.

Terminal Points Marked

It will be observed from a glance at either that each terminal point is marked with a small letter; these letters indicate which points must be wired together and in what order.

For example, first connect together with one wire or as few wires as possible those points marked *a*; then connect those points marked *b* in the same way; and so on through the alphabet.

Before the receiver can be tried out, suitable valves and coils must be obtained. For the high-frequency amplifier a valve

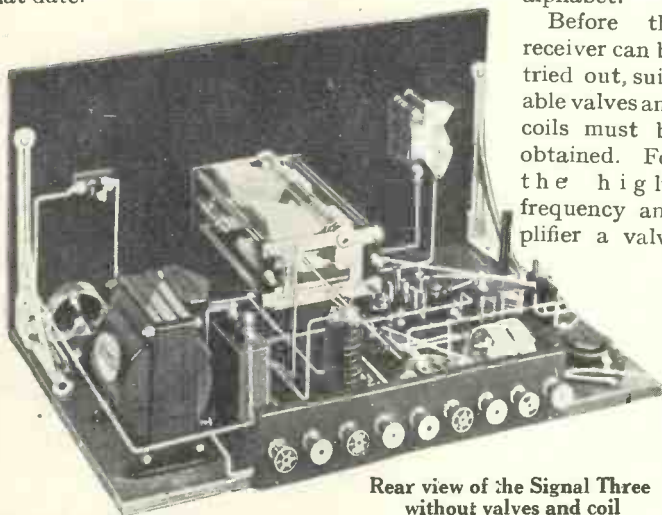

Rear view of the Signal Three without valves and coil

with an impedance of 20,000 to 30,000 ohms will be suitable; for the detector a valve of slightly lower impedance, say, 15,000 to 20,000 ohms; while the last valve should be of the power or super-power type, with an impedance of 8,000 ohms or less.

It is not easy to recommend a particular size of aerial coil for so much depends upon individual circumstances. With the average aerial a No. 60 double-tapped coil will be large enough for the reception of both London and Daventry Experimental.

The high-frequency transformer should be of the binocular type; two sizes are available—one for the lower broadcast band and the other for the upper broadcast band.

A General-purpose Set

To carry out a rough test of the receiver insert the various valves and coils in the respective holders and connect up the external accessories. To H.T.+r apply 60 to 80 volts positive and to G.B.— about 6 to 9 volts negative, depending upon the type of valve used.

Operating the Signal Three

The set is put in action by pulling out the knob of the on-off switch on the right of the panel and adjusting the reaction control on the left until the slight rustling or hissing sound is heard which indicates that the set is on the verge of oscillation and in its most sensitive condition.

Now turn the knob of the dual condenser in the centre of the panel slowly until a transmission is picked up, when the reaction control should be readjusted. The next step is to neutralise the high-frequency valve.

How to Neutralise

To do this switch off the filament, but leave the valve in position. (It is assumed that a station has been tuned in as described before this operation is carried out.) Now turn the spindle control of the neutralising condenser until the signals become quite (or nearly) inaudible.

When this occurs the valve

has been neutralised and no feed-back is taking place. At this stage switch on the filament again by means of the rheostat.

Although there is nothing sensational about the Signal Three it is a good

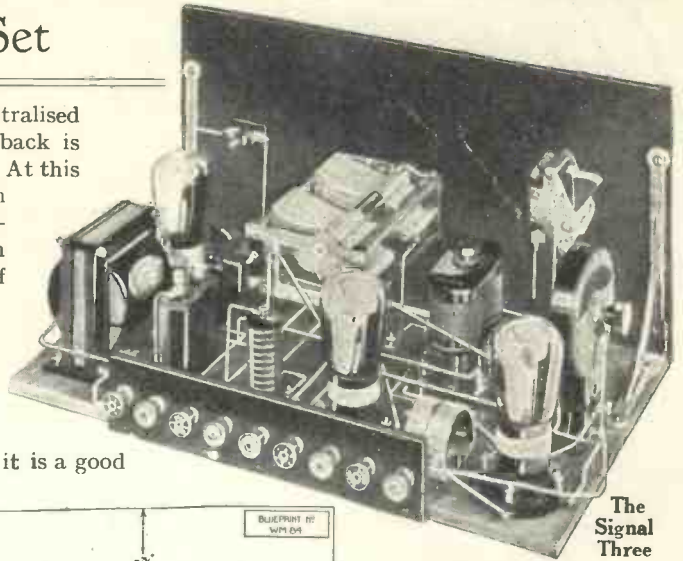

The Signal Three

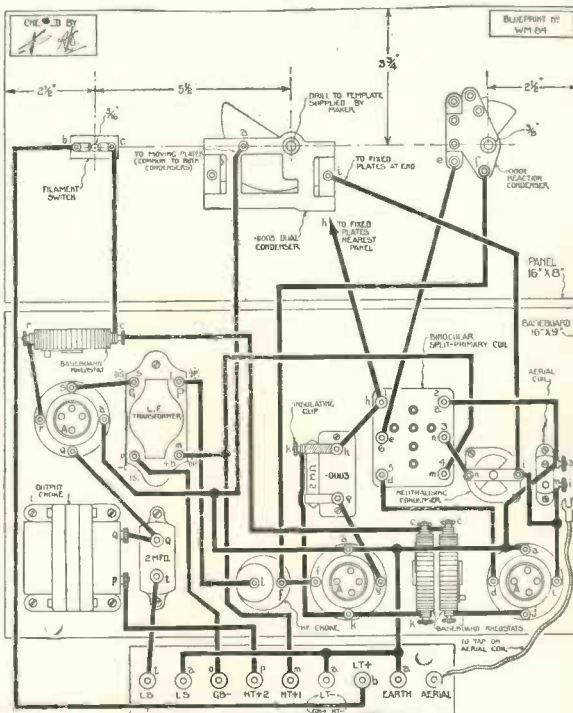

need a simple and efficient receiver that will give no trouble either in construction or operation.

A Lesson in Neatness

MANY an amateur could learn a good lesson from a visit to the receiving centre of one of the large Post Office or Marconi stations. Unfortunately this is a privilege reserved for a select few.

The chief lesson is that of neatness. Most of the receivers employed are of the super-het type, having more valves than amateurs would care to handle, and divided into many-sectioned compartments.

Each section of the receiver is in a separate box, and there are, perhaps, as many as twenty or thirty

of these boxes, mounted on shelves and looking for all the world like schoolboys' "grub" lockers in a class-room.

Hardly a wire is visible and the number of controls is reduced to the absolute minimum. Yet these apparently plain receivers are capable of listening to Press messages from the far side of the Atlantic, or to "beams" from Australia.

MORAL: Neatness pays. B.

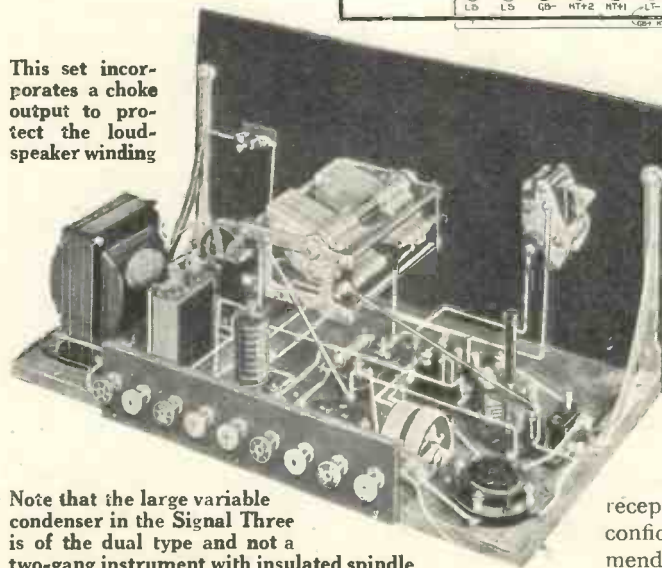

Note that the large variable condenser in the Signal Three is of the dual type and not a two-gang instrument with insulated spindle

This layout and wiring diagram of the Signal Three can be obtained as a full-size blueprint for half price—that is, 6d.—post free, if the coupon on page iii of the cover is used before July 31

three-valver that will be found to give what may be called really good results for "general purpose" reception. It can be confidently recommended to all who

Charging Your Accumulator At Home

All amateurs—particularly those who live in distant country places—who have trouble in getting their accumulators charged will find this article helpful because it offers a simple solution to a great difficulty

THE charging battery to be described, when composed of four cells, will keep a 2-volt battery fully charged if connected up through a D.P.D.T. switch in the manner shown in the diagram. The switch acts as on-off switch for the set. The materials required for one cell are as follows:

Materials Required

One 2 lb. jam jar fitted with a wood stopper about $\frac{1}{2}$ in. or $\frac{5}{8}$ in. thick, with a central hole to take 2 B.A. screwed rod, and another hole near each edge, one to thread a wire through, and the other to allow any gases to escape.

About $2\frac{1}{2}$ in. of 2 B.A. screwed rod with two nuts and a terminal head.

A block of cast zinc, about $\frac{3}{8}$ in. or $\frac{3}{4}$ in. thick, round or square, as large as will comfortably go into the neck of the jar.

A strip of copper about 6 in. by $1\frac{1}{2}$ in. about $\frac{1}{16}$ in. thick.

A piece of fairly stout insulated copper wire.

One pound of sulphate of copper.

Regarding the actual making-up of the cell, the only thing that presents any difficulty is the cast zinc. This can be cast at home quite easily. Obtain some old zinc or any zinc scraps, and melt them down in an iron ladle or similar receptacle.

When thoroughly molten, pour out carefully into a tin lid the required size.

Value of a Rusty Tin

If poured into a rusty tin, or an iron mould, the block can easily be tipped out, but if poured into a clean tin, or anything with a tin or brass surface the zinc will adhere to it and the block will not come out.

When the zinc has been poured, the end of the screwed rod, held with a pair of pliers, should be pushed into the centre of the molten metal, and held there until the zinc has set. It will be an advantage to smear the end of the rod with a little Fluxite before pushing it into the zinc.

When cold, polish the bottom surface

of the block with sandpaper or an old file. The 2 B.A. rod may then be put through the wooden cover, with one nut above and one below and both tightened up.

Next it will be necessary to prepare

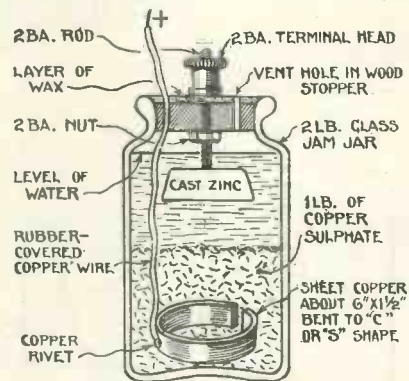

Details of the Primary Cell

the copper strip. The shape does not matter, it may be bent to form a letter C or a letter S. The insulated wire must be rivetted to the copper strip with a copper rivet. No solder must be used anywhere in the battery.

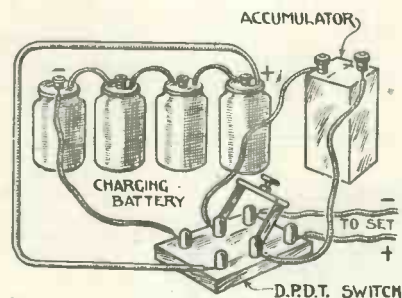

How to connect up the charging battery and accumulator

Reference to the diagram will show exactly the assembly of the whole thing.

The copper is lowered into the jar, and one pound of copper sulphate (crystals or powder, but preferably crystals) poured in and levelled off.

The end of the wire is then threaded through the cover.

Before closing up the jar, the underside of the lid and the top of the zinc should be thickly smeared with vaseline, and it would be well to smear the whole length of the wire as well.

Filling Up the Cell

All is now ready for closing up. Fill with distilled, or boiled water, poured in slowly, up to about $\frac{1}{4}$ in. below the wooden cover, and then push the cover firmly into its place. The whole of the cover should now be covered with molten wax, which will seal the joint between the wood and jar and prevent creeping.

Before pouring the wax, place a piece of wood or a match stick in the vent hole; this may be withdrawn after the wax has set. Great care should now be taken not to shake the jar, which should be placed where it is intended to rest.

Four of these cells connected in series will keep a 2-volt accumulator fully charged, when used and connected through a D.P.D.T. switch as shown. The accumulator is either connected to the set or to the battery, and no other switch is necessary as on-off switch for the set.

Completing the Assembly

When the battery is complete and all the cells connected in series, fasten two pieces of copper wire, or two pieces of zinc, to the remaining positive and negative poles and immerse these in a jar of clear water, keeping the ends as far apart as possible in the water. The whole should be left in this position for four or five days when it may be connected up to the switch for use.

The wire is the positive, and the terminal the negative pole, and must be connected to the accumulator in parallel, positive to positive.

PHILIP C. ROLLASON.

ARE YOU BUILDING THE CHUMMY FOUR YET?

CONTINENTAL NOTES

Special authoritative notes on broadcasting developments in all parts of the world garnered by JAY COOTE specially for the "Wireless Magazine"

FROM a list I have before me I see that there are about two hundred and fifty European broadcasting stations on the air daily; this figure includes the fifty-odd transmitters which form the Russian broadcasting net. Although the number at first sight may appear to be a large one, it is evident that many countries do not yet consider that they possess an adequate and efficient service, for monthly—if not weekly—it is possible to register new-comers to the ether.

Three Belgian Stations

During the past few weeks three small broadcasters have switched on their microphones in Belgium alone. Radio Schaerbeek, a small station to which I referred in these notes last month, is going strong, and has come to stay. Schaerbeek is a suburb of Brussels; the small transmitter borrowed from the military authorities, is run by a local wireless association in competition with Radio Belgique.

The entertainments consist of short talks, a review of the daily press (mostly read from the morning newspapers), relays of orchestral concerts from a near-by cinema, and occasionally the transmission of a play from a theatre.

At Ghent a new station has been erected by the students of the High Technical School attached to the Flemish University in that city. The transmitting plant is of low power (about 200 watts) and works on Sundays between 11.30 and 12.30 noon (B.S.T.); on Thursdays and Saturdays, from 8.30 p.m. until midnight.

University Mouthpiece

Acting as an unofficial mouthpiece for the University, the studio broadcasts talks intermingled with a musical entertainment mostly contributed by amateurs. The wavelength utilised is one allotted to Belgium, namely, 275 metres.

Ghent is at no great distance from London, and it is quite possible you will pick up these transmissions on

favourable nights. The call is: *Ici Radio Gand*, coupled to its equivalent *Radio Gent*; all announcements being made in both the French and Flemish languages.

Then again, during the last week or so, you may have picked up the words: *Radio Wallonie*. If so, you may log the call as belonging to a new station financed by a Socialist newspaper in that city, and lent to a small group of enthusiastic *amateurs Liégeois de T.S.F.* It was formally opened on Sunday, May 13, and since that date has broadcast entertainments on a wavelength of 291 metres.

For the present the programmes are limited to Thursdays and Saturdays (6 to 10 p.m.) and on Sundays from 11 a.m. to 1 p.m. and from 4 to 10 p.m.

Activities in Liege

On one or two occasions, through Brussels, you will have heard concerts from the Liège Conservatoire, and you will no doubt remember the International S.B. which enabled British listeners to assist at a gala fête given by the world-famous Légia Choral Society. In future, I believe, Liège will handle its own native talent, and I am informed that subscriptions have been pouring into the club coffers with a view to sustaining the local effort.

So Belgium now possesses four separate and individual broadcasters.

Now to our log this month we make two additions in France, namely, Radio Nimes and Radio Savoie. For some time past the inhabitants of the old city of Nimes—it dates back to the Roman era—have envied both Toulouse and Montpellier the possession of a broadcasting station. So far as I know, official authority to erect one, although promised, was not forthcoming; the *bons Nimois* lost patience, passed the hat round, and secured sufficient funds to build their own transmitter.

It lies in one of the most picturesque and historical districts of France, somewhere midway between

Avignon and Montpellier. Its choice of a wavelength (230 metres) was, I take it, quite arbitrary to suit its own purpose; it is not a happy one, and no doubt by this time the engineers may have moved it up or down in their search for a more favourable position in the broadcast band.

No Time Wasted!

As a general rule, you will notice that the French stations do not waste time in consulting their neighbours, but merely plump themselves down in any little space which momentarily may be found vacant in the ether. *Qui va à la chasse perd sa place* is the motto adopted by most of them.

In Nimes and its surrounding district there should be no dearth of local talent, and at some future date, perhaps even during the present summer, we should be given an opportunity through this transmitter of assisting at a performance from the ancient *al fresco* theatres of Arles or Avignon. At present, Radio Nimes broadcasts daily (Sundays excepted) from 8.45 p.m. B.S.T.

In the case of Radio Savoie, the small regional station opened at Chambéry, the local radio club was able to secure the co-operation of the French Ministry of Posts and Telegraphs, from which much of the necessary equipment has been borrowed. Chambéry is situated about fifty-five miles south-east of Lyons, from which city listeners are also able to hear daily transmissions. Radio Savoie, operating on a wavelength of 210 metres, limits its entertainments to Saturdays and Sundays, on which days concerts are given at 8.30 p.m. B.S.T.

Keen Competition from Lyons

Whether this station is a permanent one is a moot point, for competition to secure the regional transmitter to serve the south-east of France is a keen one, and Lyons, the economic centre, is all out to obtain this signal honour. The latest news from that city mentions the steps which are

Jay Coote's Continental Notes (Continued)

being taken for the erection of a "worth-while" transmitter (some 10 kilowatts) in the immediate neighbourhood of that busy centre.

The advent, since last month, of the new high-power station at Vienna and Budapesth has considerably extended our horizon. Almost nightly we may now capture concerts or operatic transmissions from the Austrian capital, or, at a later hour—frequently until midnight—midnight broadcasts from famous Hungarian hotels and restaurants.

A New High-power Station

These concerts from Budapesth are distinctly refreshing and sharply contrast with the dance music of the "grunt and stutter" variety generally broadcast at night by the majority of European studios.

The music offered to us by the genuine Tzigane bands, of which there are but few left, is truly gipsy in character; most of the programme is extemporised by the *Tziganer-primas*, the leader of the orchestra, to an equally extemporised running accompaniment by his colleagues, and in the course of half an hour he will have given you an unconventional musical switch, embodying in a masterly manner not only Hungarian folk songs of bygone days, but excerpts from the latest operettas, and even up-to-date dance successes, to which the orchestra adds a quaint Czardas touch.

No Identification Difficulty

If you do pick up these transmissions, and I see no reason why you should not, you will have no difficulty in identifying the broadcast, for from

the studio at times will come the call, "*Hallo! Hallo! itt Budapest.*" intervals being filled by the playing of a curious little melody on an instrument closely resembling a dulciphone or toy musical box. There is but one fly in the ointment, morse, which on many evenings, until the later hours, is persistent in this portion of the waveband. Still, there are compensations.

Polish Improvements

Since I wrote on the subject of Polish broadcasting developments, complementary information has reached me. Radjo Polskie, the Warsaw headquarters in conjunction with the provincial programme companies, has in view a complete reorganisation of the system, and many are the improvements laid down in its new plans.



Wave-length in Metres	Station	Call Sign	Wave-length in Metres	Station	Call Sign	Wave-length in Metres	Station	Call Sign	Wave-length in Metres	Station	Call Sign
24	Chelmsford	5SW	288.5	Edinburgh	2EH	379.7	Stuttgart	—	549.3	Milan	—
30	Bergen	—	289.3	Radio Lyon	—	384.6	Manchester	2ZY	555.8	Budapest	—
30.2	Hilversum	—	294.1	Dundee	2DE	391	Toulouse	—	—	Hamar	—
36	Lyon (PTT)	—	—	Hull	6KH	394.7	Hamburg	—	566	Augsburg	—
37	Vitus (Paris)	—	—	Innsbruck	—	400	Bilbao	—	—	Cracow	—
45.3	Doerberitz	—	—	Stoke-on-Trent	5ST	—	Cadiz	EAJ3	—	Hamar	—
61	Paris	Radio LL	—	Swansea	5SX	—	Cork	6CK	575.8	Freiburg	—
158	Doerberitz	—	297	Liverpool	6LV	—	Mont de Marsan	—	576	Vienna (Wien)	—
192	Beziers	—	—	Radio Agen	—	401	Plymouth	5PY	588	Zurich	—
198	Akureyri	—	—	Hanover	—	405	Aachen	—	680	Lausanne	—
204.1	Biarritz	—	300	Algiers	—	405.4	Salamanca	EAJ22	720	Ostersund	—
217	Kaiserslautern	—	—	Bratislava	—	408	Glasgow	5SC	760	Geneva	—
230	Radio Luxembour	—	302	Radio Vitus	—	411	Reval	—	766	Liabach	—
236.2	Ste. Etienne	—	303	Koenigsberg	—	416	Berne	—	775	Kiev	—
238.1	Schaerbeek	—	306.1	Belfast	2BB	416.7	Notodden	—	695.5	Leningrad	—
240	Stettin	—	309.2	Zagreb	—	420	Grenoble	—	1,000	Leningrad	—
246	Bordeaux	—	310	Oviedo	—	422	Goteborg	—	—	Basle	—
241.9	Nimes	—	310.2	Marseilles	—	434.8	Rabat	—	1,069	Hilversum	HDO
252.1	Juan-les-Pins	—	312.5	Newcastle	5NO	—	Kattowitz	—	1,080	Strasbourg	—
256	Nurnberg	—	319.1	Dublin	2RN	—	Frankfort	—	1,111	Warsaw	—
259	Muenster	—	322.6	Breslau	—	435	Freidriksstad	—	1,180	Stembol	—
260.9	Bradford	2LS	326.1	Bournemouth	6BM	441	Seville	—	1,153	Kalundborg	—
264	Cassel	—	323.9	Almeria	—	448	Wilno	—	1,180	Stamboul	—
267	Montpellier	—	329	Gleiwitz	—	448.4	Brunn	—	1,190	Boden	—
272.7	Kiel	—	333.3	Naples	—	450	Rjuiken	—	1,250	Königswusterhausen-Zeesen	LP
273	Toulouse	—	—	Reikjavik	—	453.8	Rome	—	1,380	Motala	—
275	Malmö	—	335	San Sebastian	EAJ8	—	Moscow	—	1,450	Moscow	RDW
275.2	Lille (Poste du Nord)	—	337	Cartagena	—	458	Stockholm	—	1,525	Lahti	—
277.8	Strasbourg	—	340.9	Copenhagen	—	460	Paris Ecole Sup.	—	1,604	Daventry	5XX
278	Sheffield	6FL	—	Paris	Petit Parisien	461.5	Belgrade	—	1,700	Khar'kov	—
278.8	Bremen	—	344	Huizen	—	462	Oslo	—	1,750	Angora	—
280	Danzig	—	344.8	Posen	—	470	Barcelona	—	1,800	Paris	—
280	Klagenfurt	—	348.9	Barcelona	EAJ1	477.7	Langenberg	—	—	Bucharest	—
283	Limoges	—	353	Prague	—	484.6	Lyons	—	—	Norddeich	—
288	Ghent	—	357.1	Cardiff	5WA	491.8	Berlin	—	—	Chahage	—
288	Dresden	—	361.4	Graz	—	500	Daventry Experimental	5GB	1,850	Huizen	—
288	Nottingham	—	365.8	London	2LO	504	Aberdeen	2BD	1,870	Kosice	—
288	Leeds	5NG	370	Leipzig	—	508.5	Porsgrund	—	—	Huizen	—
288	Bordeaux	2LS	370.4	Paris	Radio LL	517.2	Svergrund	—	1,950	Scheveningen	—
288	Renne	—	375	Bergen	—	535.7	Viennsels	—	2,000	Kovno (Kaunas)	—
288	Colognes	—	—	Helsingfors	—	545.6	Munich	—	2,650	Paris	FL
				Madrid	EAJ		Sundsvall	—	2,800	Temesvar	—

Wireless Magazine

GRAMO-RADIO SECTION

THE inauguration of a special Gramo-Radio Section in last month's issue of the WIRELESS MAGAZINE made an immediate appeal to that already large, yet ever-growing, band of enthusiasts who see in the combination of the gramophone with a radio receiver the ideal form of home entertainment.

Test Records

This month we are again devoting a number of pages to the question of Gramo-Radio, and those who are taking up the work for the first time will find Capt. Barnett's article on test records of particular utility. In this article the author mentions a selection of records of various types which will enable a searching test of any gramo-radio outfit to be undertaken.

Controlling Volume

Not the least advantage of reproducing gramophone records through the medium of a radio amplifier and loud-speaker is that any desired degree of volume can be obtained, but in the case of very loud records it may be desirable sometimes to reduce the output a little and for this purpose a volume-control unit is a very great advantage. Such a device, which can be added to any existing gramo-radio outfit, is described in this section.

Another article that will appeal particularly to radio men is one which gives a brief outline of gramophone developments; the illustrations of this article will be found of particular interest.



A modern cabinet-type gramophone, as manufactured by the Gramophone Company, Ltd., of Hayes, Middlesex. It contains a special matched-impedance horn, designed on electrical principles

Gramo-Radio Sets

On another page are reproduced photographs of three receivers specially adapted for gramoradio work which have been described in recent issues of the WIRELESS MAGAZINE. Full-size blueprints of these receivers are obtainable from the offices of the WIRELESS MAGAZINE.

A De-luxe Receiver

Next month we shall publish details of a real de-luxe broadcast receiver, which will be known as the Connoisseur's Six. This is switched so that the detector and low-frequency amplifying stages can be utilised for gramophone reproduction. The pick-up is kept permanently connected to the receiver and is brought into use when required by the operation of a simple push-pull switch. Look out for this fine set!

By the way, we shall be especially glad to hear from WIRELESS MAGAZINE readers their experiences in Gramo-Radio work and, as explained below, we are always ready to help those who may be in difficulty.

IS THERE ANYTHING SPECIAL YOU WANT TO KNOW ABOUT GRAMO-RADIO?

Whatever you want to know about Gramo-Radio, consult the "Wireless Magazine" Technical Staff. For many months they have kept abreast of this latest development and can reply to any query that may be raised in connection with it.

If your pick-up does not give the results you think it should—if your amplifier is not quite distortionless—in fact, if you are in trouble of any sort, the Technical Staff can put you on the right track.

So that the Staff is not absolutely overwhelmed with

queries (and to avoid the trouble of answering any of a frivolous nature, which results from a free service) a nominal fee of 1s. is charged for each question asked.

Write your query or queries (not more than two can be answered for each reader) on one side of a sheet of paper and send it, together with a stamped addressed envelope, a postal order for 1s. and the coupon from page iii of the cover, to Gramo-Radio Queries, "Wireless Magazine," 58/61, Fetter Lane, E.C.4.

Three Gramo-Radio Sets to Choose from

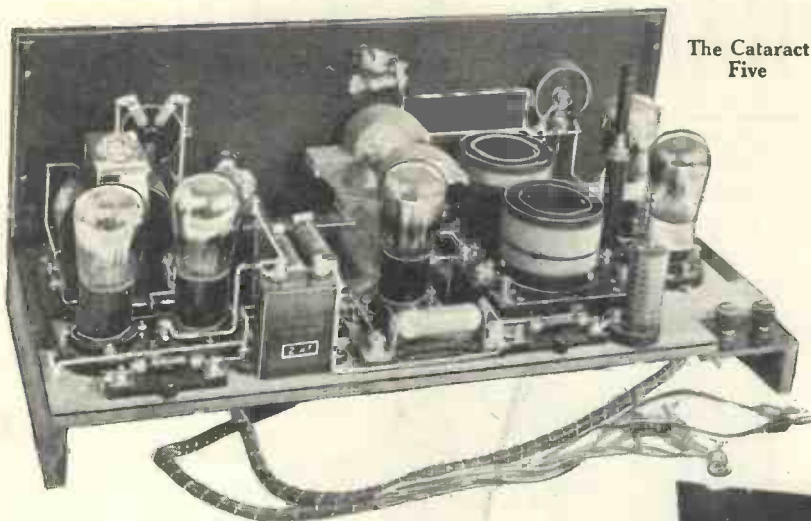

The Cataract Five

SPECIALLY designed for the operation of a moving-coil or other large loud-speaker, the *Cataract Five* (WIRELESS MAGAZINE, June, 1928) comprises one high-frequency stage, detector, and three resistance-coupled low-frequency amplifiers, the last two being arranged in parallel with a choke filter output.

Full size blueprints (No. W.M. 79) are available for 1s. 6d. post free, if a postal order for that amount is sent to Blueprint Department, WIRELESS MAGAZINE, 58/61, Fetter Lane, E.C.4

ALTHOUGH not specially designed as a gramophone radio set (as are the other two receivers illustrated on this page), the *Trapped Three-Four* (WIRELESS MAGAZINE, March, 1928) is nevertheless specially suitable for this purpose since it incorporates a detector—

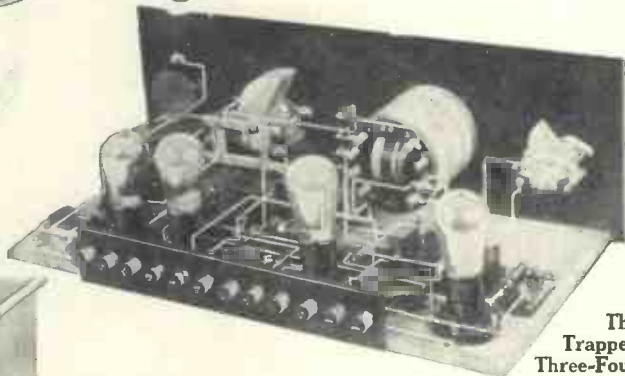

The Trapped Three-Four

—and three resistance-coupled stages of low-frequency amplification, the last two valves again being arranged in parallel.

The number of the full-size blueprint, which is 1s. 6d. post free, is No. W.M.61



Front view of the Trapped Three-Four

IN constant use for gramophone radio tests in the WIRELESS MAGAZINE Constructional Department is the *Gramo-Radio Four* (WIRELESS MAGAZINE, May, 1928). It comprises a detector, one resistance-coupled stage and two transformer-coupled stages arranged on the push-pull system. Special points are that the pick-up is brought into action when required by a simple switch and a milliammeter is provided in the output circuit.

No. W.M.70 is the number of the full-size blueprint, which can be obtained post free in return for a 1s. 6d. postal order sent to the address given above.

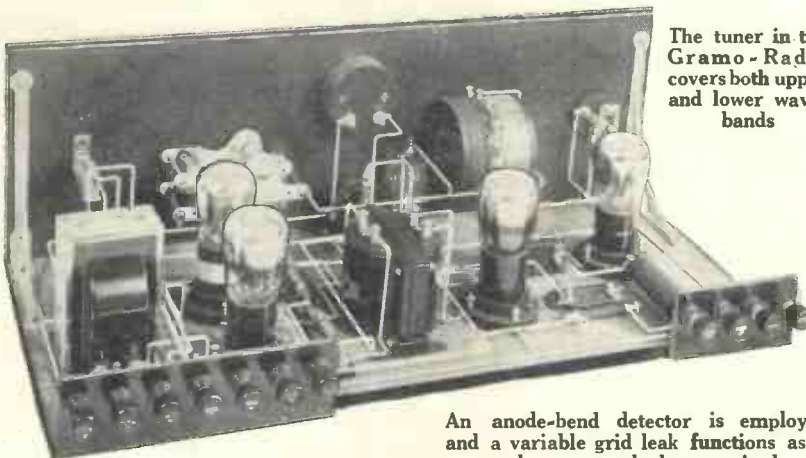

The tuner in the Gramo-Radio covers both upper and lower wavebands

An anode-bend detector is employed and a variable grid leak functions as a volume control when required

Test Records for Gramo-Radio

By H. T. BARNETT, M.I.E.E.

NOW that so many wireless fans have rigged up a gramophone motor and tone arm on a cretonne-covered soap-box, so that by use of a pick-up they may be able to play gramophone records by radio, it may be useful to indicate a few records, themselves of exceptional beauty, which will serve to indicate by the results obtained when playing them the general value of the set for all-round perfection of reproduction.

Very Highest Sound

To begin with the very highest sound—that, no doubt, is the hiss which must be made every time the letter *s* is spoken.

I am sorry we must go to a comic song for a record packed full of this letter, but it is an amusing song, well sung and perfectly recorded: "Mr. Waterhouse's House" (Winner, 2s. 6d.).

A spoken record (you may prefer the speaking to the singing voice) with many an *s* in it, and all of them clear except the first, is Sir Baden Powell's "Address to Boy Scouts" (Winner, 2s. 6d.), an acoustic recording showing some megaphone effect from the recording horn, but not marred by this characteristic, which would be fatal to some records, for one can hardly picture the Chief Scout addressing a great assembly of his boys without a megaphone.

Exceptionally high notes in the treble of the musical scale come next in order down the ladder of pitch; failing a record of the squeak of a mouse, which is such a high note that many people cannot hear it at all, we must find a violin solo with very high harmonics in it.

High Harmonics

"Turkish March," played by Tossy Spiwakowsky (Parlophone, 3s.), has some very high harmonics near the end and, in common with all Parlophone records, they are particularly clear, musical, and vigorous, the exact pitch of the very highest note being instantly recog-

nisable, unless one's ears are faulty.

Now next below fiddle-top harmonics we have a choice between sustained and percussion music. The purer sound is usually the sustained one, so the next test I should advise is to play "Cantilene Nuptiale" (4s. 6d.), a grand-organ record on the H.M.V. list.

I can only get the top notes on this record with fine-gauge steel grip needles, either Sympathetic or Euphonic.

For exceedingly brilliant and clear high notes on a percussion record, take "Rhapsody No. 8," played by Mark Hambourg (H.M.V., 3s.). The piano used sounds just like the magnificent five-hundred pound American instrument used by Percy Grainger in recording the "Chopin and Brahms Sonatas" (Columbia); on my gramophone even the very highest note is free from woodiness and true to pitch, and over the whole of the long compass that the composition embraces the tone is pure pianoforte tone of great brilliance and beauty.

If the treble of this record sounds more like a dulcimer than a piano, and if the bass notes sound like hitting suspended sheets of boiler plate with a hammer, then you may at once condemn your reproducing apparatus for being as impure as a gramophone with a long sheet-metal horn—about the most unsuitable thing with which to reproduce brilliant percussion records, but not necessarily untrue with sustained tone.

In the middle of the scale you had better test your set for instrumental characteristic. A record in which every instrument stands apart from every other with extraordinary truth is Edith Lorand's "Scenes Pittoresques" (Parlophone, 4s. 6d.); it is really good and convincing, from the highest fiddle tone to the vigorous timpani.

Now take the magnificent Victor recording of "William Tell," obtainable on two Zonophone half-crown ten-inch discs, and see whether you can identify the Cor Anglais and the

flute in the lovely passages they play together.

For the bass of the scale I know nothing so convincing when the 32-ft. pipe comes in as "Easter Hymns," a 10-in. organ record (H.M.V., 3s.).

Do not worry yourself about deep fundamentals (whether they can be recorded, whether reproduced, whether, in fact, *heard*), but if your loud-speaker *plus* your room proves able to recreate the fundamental from the harmonics so that you can *feel* the throb of the deep bass tone shaking the floor and perhaps also the arms of the chair on which you may be sitting, then you have nothing to complain about on this score.

Louder than the Full Organ

If you prefer secular music, get "Blue Danube Waltz" (H.M.V., 3s.). It is played by Arthur Meale, and just at the very end he brings in a grand tone, roughly three octaves below middle D. This note should be heard louder than the full organ at any other part of the record.

Having proved your set acoustically, the next thing to do is to see if you can upset any of the mechanical arrangements. The confused and complicated notes of the French horn will try every balance and joint to the utmost. In "Funeral March, Gotterdammerung" (Parlophone, 4s. 6d.), you get a lot of horn work, and in one place two instruments are playing closely contiguous notes. It is magnificent Wagnerian music, and the timpani work in it is excellent.

Satisfaction!

The record itself is free from blast, so far as I can judge. If your needle, your pick-up carrier, the pick-up itself, the tone arm, and the loud-speaker diaphragm will all function purely without any sort of vibration or upset when you are reproducing this record at full strength, then you may show your results to the most critical and also you may expect to find no wear on your records.

A useful addition
to any amplifier

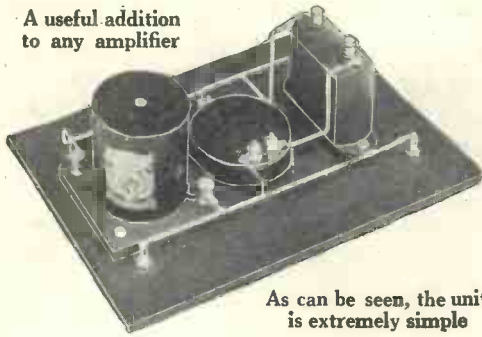

As can be seen, the unit
is extremely simple

The Gramo-Radio Volume Control

Designed and Built by the **WIRELESS
MAGAZINE Technical Staff**

ONE of the greatest benefits the amateur gains by operating his gramophone through the medium of an amplifier and loud-speaker is that of increased volume, which is in many cases of particular value. But there are times when too much sound can be a great nuisance and every gramo-radio outfit should therefore include some kind of volume control.

The WIRELESS MAGAZINE Technical Staff has produced the unit described in this article for the benefit of those who are using amplifiers

that do not at present incorporate any special system of controlling the sound output.

It may be mentioned here that it is bad practice to control volume by reducing the filament current or high-tension voltage of low-frequency amplifying valves—such methods almost always lead to distorted reproduction and should be avoided.

Amplifier Characteristics

Any method of volume control that is adopted should not affect the amplifier characteristics in any way. This point has been watched in the case of the unit illustrated on these pages, for the load imposed by it on the last valve of the amplifier remains constant under all conditions.

As a matter of fact, the unit, as can be seen from the circuit diagram, also incorporates a choke output circuit so it is really a combined filter and volume control.

The low-frequency choke and fixed condenser effectively prevent

all about the construction of this unit; the photographs show how simple it is. There are only three components—the low-frequency choke, 2-microfarad fixed condenser and high-resistance potentiometer—and four terminals.

Full-size Blueprint

Those who desire a full-size blueprint for the sake of the drilling marks, can obtain one for half-price, that is 6d. post free, up to the end of July if the coupon on page iii of the cover is used. Send a postal order to Blueprint Dept., WIRELESS MAGAZINE, 58/61 Fetter Lane, E.C.4 and ask for No. W.M. 76.

As soon as all the parts have been fixed into position, the unit can be wired up. First connect those points marked *a*, then those points marked *b*, and so on.

Using the Unit

To use the volume control, connect the input terminals to the output or loud-speaker terminals of the receiver proper and connect the loud-speaker itself to the terminals provided on the volume-control unit. Adjustment of the knob of the high-resistance potentiometer will control the volume as desired.

FURTHER PARTICULARS OF THE
VOLUME-CONTROL UNIT APPEAR
ON THE OPPOSITE PAGE

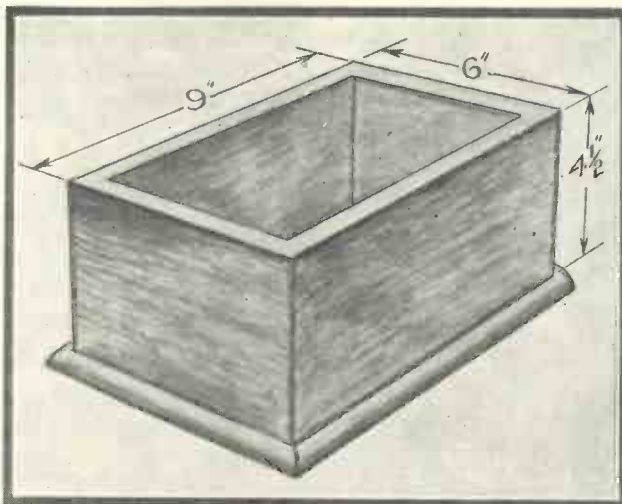

Dimensions of cabinet for the Gramo-Radio Volume Control

the direct anode current from flowing through the loud-speaker windings with the attendant possibility of demagnetising them, while at the same time it offers no impedance to current fluctuations caused by incoming signals.

Across the whole circuit is placed a very high resistance, which acts as a constant load on the last valve under all conditions. The loud-speaker connection is taken from one end of this resistance and any point along it. It will thus be seen that according to the position of the tapping point, so is the amount of current flowing through the loud-speaker regulated.

There is no difficulty at

On the
left are the
input
terminals

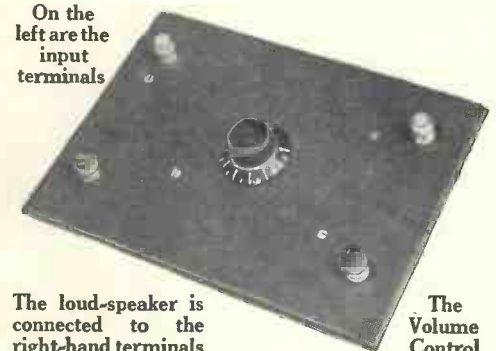

The loud-speaker is
connected to the
right-hand terminals

The
Volume
Control

COMPONENTS REQUIRED

- 1—Ebonite panel, 9 in. by 6 in. (Becol, Raymond, or Ready Radio).
- 1—Low-frequency choke (Success, Watmel, or Formo).
- 1—High-resistance potentiometer (Dubilier).
- 1—2-microfarad fixed condenser (Lissen, Dubilier, or Hydra).
- 4—Terminals, marked: Input +, Input -, L.S. +, L.S. - (Belling-Lee).
- 1—Cabinet, 4 1/2 in. deep (Camco).

This layout and wiring diagram can be obtained as a full-size blueprint for half-price, that is 6d. post free, if the coupon on page iii of the cover is used before July 31. It is No. W.M.76

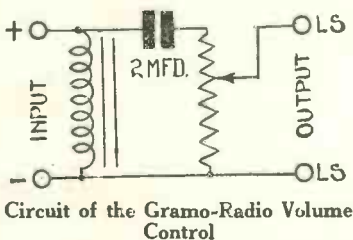

Further Details of the Gramo-Radio Volume Control

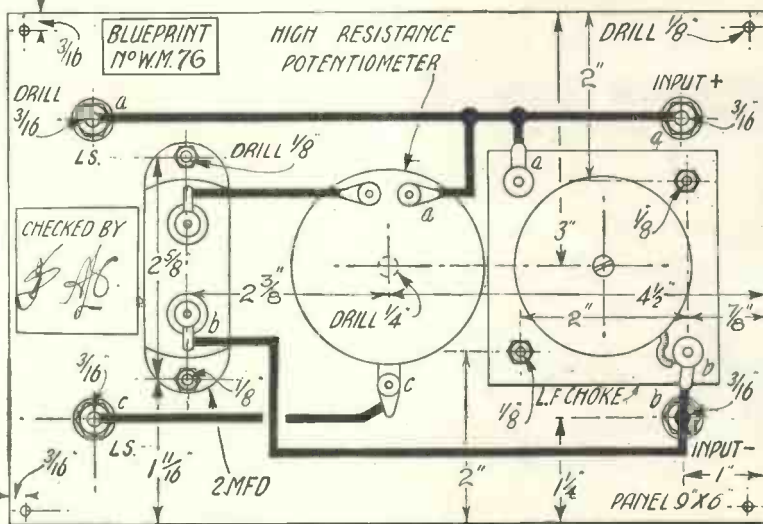
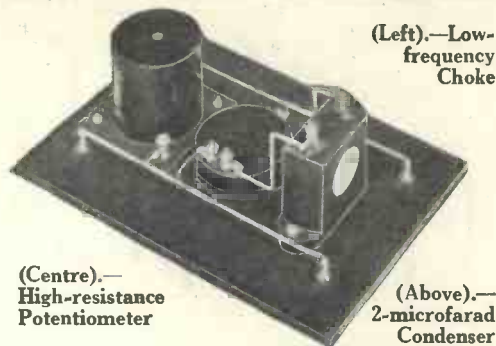

A ROMANCE OF THE FUTURE

*A London fog, she lost her way,
It surged about her thick and grey.
For many hours she wandered round,
The fog had muffled every sound.*

*And then—she heard a well-known voice
That made her weary heart rejoice.
Her lover hurried to her side.
“Oh, Dick!” she rapturously cried.*

*“How did you find me?
Tell me, dear!
How did you know that I was here?
The fog is, oh, so black and thick!”
“I ‘noctovised’ you,” answered Dick.*

LESLIE M. OYLER.

Look Out For This Fine Gramo-Radio Set Next Month!

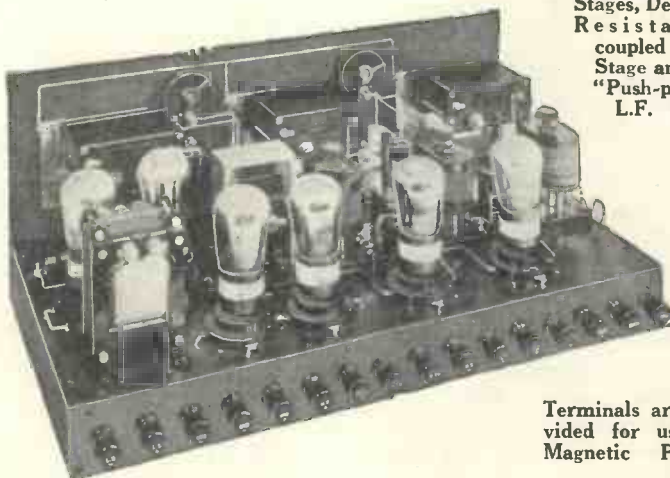

Comprises two neutralised H.F. Stages, Detector, Resistance-coupled L.F. Stage and two “Push-pulled” L.F. Valves

Terminals are provided for using a Magnetic Pick-up

The Name Explains Itself—
The Connoisseur's Six!

An Outline of Gramophone Developments

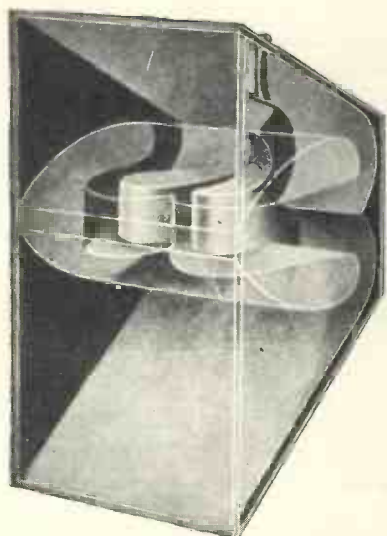

How a matched-impedance horn is arranged. That shown is an H.M.V.

NOW that it is possible to play gramophone records by means of a valve amplifier many amateurs are turning their attention to this new use for their wireless sets.

It is felt, therefore, that a brief survey of the latest developments in the gramophone will be of considerable interest to gram-radio enthusiasts, especially as these advances are largely due to the work of electrical engineers.

Electrical Recording

When broadcasting started it looked as if the gramophone was doomed, but electrical recording was introduced, and from that time the gramophone came into its own. The developments have been so rapid in the last two years and the sale of records and instruments has increased to such an extent, that it can be safely said that the industry has a tremendous future.

Before the electrical method was perfected, recording was done by mechanical means. The artists had to sing and play into a large horn, which carried the sound waves on to

the recording apparatus. Owing to the insensitiveness of the whole system, the records gave out poor volume and had a very limited musical range, many of the bass notes being suppressed and the upper end of the scale being quite inaudible.

The orchestras to be recorded were limited in size, and what few instruments there were had to have amplifying devices attached to them before they were loud enough to be recorded.

Electrical recording depends, like broadcasting, upon a microphone and valve amplifiers for its operation. The music to be recorded is picked up by the "mike," the electrical impulses amplified by the valve amplifier and used to operate a sensitive reed, which registers the sound waves on the wax disc. The music is amplified many times before being recorded, giving to the modern record a much greater volume than its predecessor.

Further, owing to the sensitivity of the valve amplifier and modern microphone the record has a vastly increased musical range. Part of an opera or concert can now be recorded while it is being performed in the theatre; in short,

anything that can be broadcast can be recorded, and it is no longer necessary for the artists to go to the recording studio. The studio comes to the artist.

Gramophone Advances

The benefits derived from electrical recording would have been useless without the advances that were made in the gramophone itself. Many people still possess a machine manufactured four or five years ago, and though they may be satisfied

with the reproduction, such a gramophone cannot do justice to the modern records.

No machine of that date has the musical range of the modern gramophone, and so a great deal of the depth of tone of modern recording is lost to the user. Further, the life of a record is much increased on the modern machine, and for the following reason:

As probably every reader knows, the grooves of a record are of a wave-like formation and represent the music to be reproduced. The greater the amplitude

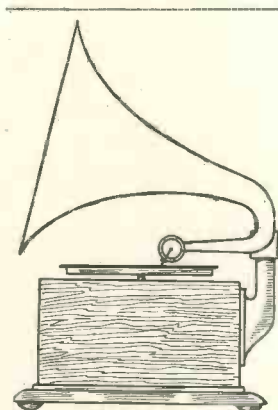

First type of gramophone for flat disc records

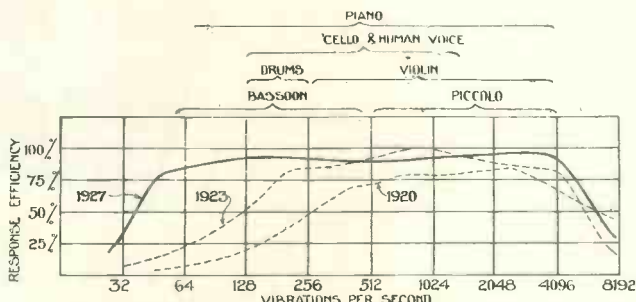

The black curve shows how the latest Columbia machines compare with those of earlier date

of these sound waves the greater the volume of sound heard. It is as well to point out that the sound waves vary from side to side in the grooves, and not up and down, as many people imagine.

Why Damping Is Necessary

The needle travels in the grooves and converts the sound waves into vibrations, which are transformed into air waves by the diaphragm. In order that the needle should create the necessary vibrations, it must offer a certain resistance to the lateral movement imparted to it by the grooves. This resistance is called damping.

When recording was done mechanically the amplitude of the sound waves was quite small, the needle movement was small, and the damping was high. Modern recording, owing to the greater amplitude of the sound wave, requires a larger needle movement and lighter damping than is present in the old type sound-box.

A modern record wears out fairly soon on an old gramophone because the needle cannot respond well enough to the movement required, whereas on a modern gramophone the record has a much longer life, due to the improved sound-box construction.

Needle Tracking

Correct needle tracking is another development to reduce record wear. If the needle does not run in the groove at the correct angle, it will tend to drag on one wall, widening it at some points and finally breaking through into the next groove. The gramophone of to-day is not merely an assembly of parts in an elaborate cabinet, but is the result of a vast amount of research work, and is itself a scientific instrument, although simple to look at and operate.

The prevalent idea that the more expensive gramophones merely have more elaborate cabinet work is quite wrong when applied to the modern machine. The higher-priced machines give far better reproduction than the cheaper type.

Perhaps the following notes on sound may help the reader to appreciate the advances made in gramophone reproduction. The air vibrations which constitute sound have a frequency of from 30 to 3,500 cycles

per second. According to the rate of these vibrations so we get the pitch of a note called its fundamental.

Apart from the fundamental, each musical note consists of harmonics, causing a combination of vibrations giving to that note its timbre or quality. It is because of these harmonics that we can differentiate between two instruments, although they may both be playing the same note.

These harmonics may go as high as 10,000 cycles per second. Obviously, then, for true reproduction the harmonics, as well as the fundamentals, must be heard.

Another important requirement for true reproduction is that all fundamentals and their harmonics should be reproduced in equal proportion, otherwise some notes will come out more prominently than others, creating a blaring or resonance effect, and so spoiling the musical "balance."

The two most important components in a gramophone are the sound box and internal horn, but it is only recently that the latter has

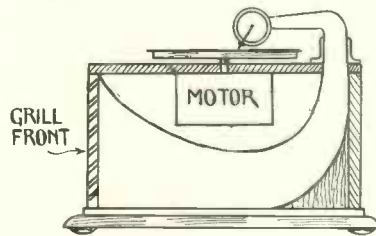

First type of internal horn, used previous to electrical recording

had much attention paid to it. Four or five years ago the horn was quite short and was shaped more to the design of the cabinet than to any scientific requirements. Consequently volume was poor and the reproduction gave rise to the name "gramophony."

Logarithmic Horns

As most readers know, a horn should be as long as possible and of a certain shape to reproduce the bass as well as the treble. This type of horn, called a logarithmic horn, is now fitted to the leading makes of gramophones and has, without a doubt, greatly improved the reproduction. In fact, the modern machine, fitted with a logarithmic horn and modern sound box, playing an electrical record, gives

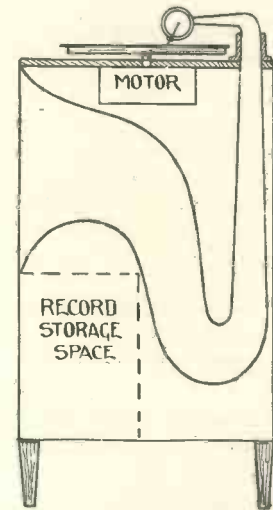

Logarithmic type horn, introduced at the same time as electrical recording. Note that the tone arm is an integral part of the horn

results that many people would call perfect.

It has, however, three faults which, although not serious, mar the wonderful results to be obtained from a modern classical record: the music has a decided "horny" effect, there is a certain amount of resonance on some parts of the scale, and the top notes are rather shrill.

The Gramophone Company have recently overcome these disadvantages by applying a new principle to their machines, and the His Master's Voice gramophone, using this principle, namely, "matched impedance," was put on the market early in the year.

Even Reproduction

Impedance is an electrical term, and means the resistance in a circuit to a current flowing through it. In a low-frequency circuit the electrical impulses passing through represent the music received. A well-designed amplifier and loudspeaker should have an equal impedance to all impulses, thus reproducing all audible frequencies evenly and so preserving the musical balance.

The Gramophone Company have used this matched-impedance principle in a mechanical sense; the impedance in the gramophone being the resistance of the needle and sound-box to the vibrations created by the record grooves and that of

Gramophone Developments (Continued)

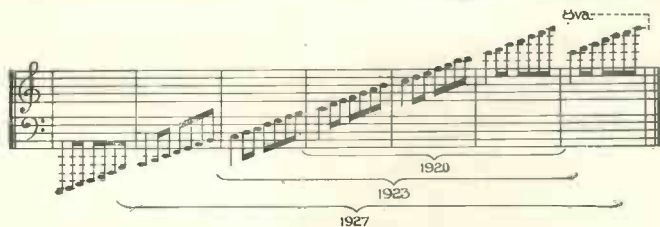

How the range of reproduction has been extended from three octaves in 1920 to six octaves in the latest Columbia machines

sound waves all flow at the same speed, thus helping to eliminate the "gramo-phony" effect.

the tone arm, horn, etc., to the sound waves created by the sound-box. The resistance of all these parts has been reduced and carefully matched so that the impedance is even throughout all audible frequencies. There is thus no resonance on any part of the scale, and owing to the design of the sound-box no shrillness on the upper notes.

No "Horny" Effect

Owing to the peculiar construction of the "matched-impedance" horn, the "horny" effect is absent. The curves are flattened so that the

In the ordinary logarithmic horn the curves are fairly steep, and so the sound waves on the outer curve have farther to travel than those on the inner, thus causing them to lag and give an unnatural effect to the music.

Owing to its size, the matched-impedance horn is only fitted to the large cabinet gramophones, and since it takes up most of the available space, no room is left for storing records. However, the greatly improved quality of reproduction more than compensates for the lack of storage space.

J. H. GALLOWAY.

Pick-ups Are Not Always To Blame

I AM afraid that quite a number of people who are dissatisfied with their gramophone pick-ups should blame themselves and not the unfortunate "needle-holders."

It is not the fault of the WIRELESS MAGAZINE that some amateurs buy expensive pick-ups and connect them in most haphazard fashion, expecting to get first-class results.

A Common Criticism

A very common criticism I have heard levelled against some pick-ups is that they alter the natural tone of the record. Usually the effect is that the tone is lowered.

The trouble, in most cases, is not due to the pick-up itself, but to the way in which it is connected to the amplifier. It should be remembered that the average pick-up is a magnetic device, and any capacity shunted across its windings will alter the output.

If the pick-up leads are very long there will be considerable

capacity set up, and it is this external capacity, and not the pick-up, which is to blame for lowering the tone of the records.

The cure should be obvious, and in general all pick-up leads over about 10 ft. in length should be suspected. GRAMO.

Turning Music Into Volts

HOW many people know the voltage output of a gramophone pick-up in action? It is well worth knowing, particularly if a pick-up is to be used with a large L.F. amplifier, and all the other constants of the amplifier (grid-voltage swings and so forth) have been determined.

With dance records, and others of that ilk, the movement imparted to the needle is quite large, with the result that a comparatively large output voltage is given by the pick-up. The average commercial pick-up gives a voltage output of from .1 to 2 or 3 volts, according to the needle movement. BIM.

Use A Moving-coil Loud-speaker For The Best Results

FOR gramo-radio work, where volume and purity are of equal importance, it is impossible to improve on a loud-speaker of the moving-coil type. Many different types are available, but one that will appeal to many readers is that

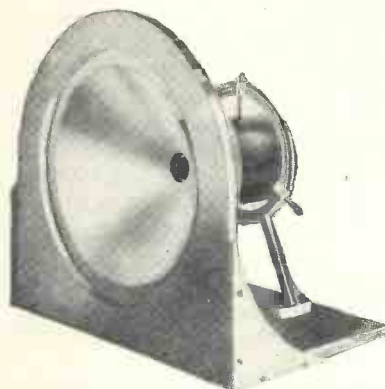

Front of the "Junior" Moving-coil Loud-speaker

described under the title "Making a 'Junior' Moving-coil Loud-speaker" in the previous issue of the WIRELESS MAGAZINE.

This loud-speaker is provided with a special small magnet pot which consumes only .5 ampere at

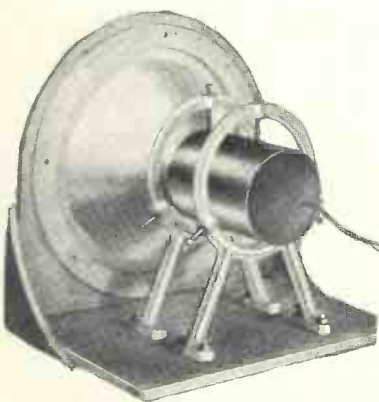

Rear View of the "Junior" Moving-coil Loud-speaker

6 volts; moreover, it costs less than £3 10s. to build. Full-size blue-prints (No. WM81) can still be obtained for 1s. each, post free.

The firm that supplies the necessary parts are Goodman's, of Farrington Street, E.C.4.

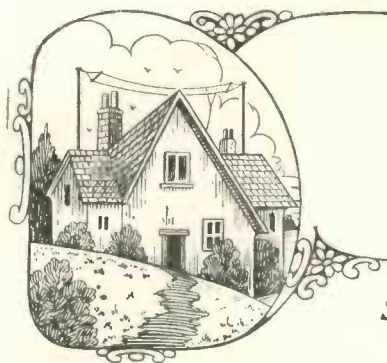

Some B.B.C. Autumn Programme Revelations

Specially Contributed to the *WIRELESS MAGAZINE*
by B.B.C. Officials

READERS of these notes have already been given brief details from time to time of the construction of programmes; of the skeleton which is compiled at a conference held at Savoy Hill five weeks prior to the date of broadcasting; of the work of building up on this skeleton by provincial stations, which fit in their own items with due consideration for the requirements of headquarters; of the further conference at Savoy Hill when the original skeleton, with additions from the provinces, comes up for re-arrangement—all this work being accomplished within a fortnight—and of the discussions and suggestions which take place in the remaining three weeks before broadcasting, in order to secure an ensemble as near perfection as possible.

Programme Changes

When a programme is prepared in practically its final form, it is circulated to the departments chiefly concerned for survey and comment, and changes may be made even up to a few hours before the programme is due to go out on the ether. But much of this work, which has hitherto been confined to a brief five weeks' period, is now being tackled far in advance.

This may be taken as an indication that the programme officials' ideas as regards broadcasting needs are becoming more clearly defined and that the old postulation that in catering for a multitude of tastes it is only possible to satisfy a comparatively small number is accepted as less true than formerly.

Early in the spring, for instance, it was decided what were to be the main features of broadcasting over a period of a year, from August, 1928, to August, 1929. "Proms.," national

concerts, performances by the Hallé Orchestra and Chorus, chamber-music concerts, selections from the world's great plays, and libretto operas were allocated to fixed dates.

Skeleton Programme

Thus a sort of skeleton programme was compiled, such as used to be prepared only five weeks ahead; its arrangement well in advance will not only give the B.B.C. station officials throughout the country definite knowledge of compulsory simultaneous broadcasts, but will provide them with the opportunity of negotiating with other organisations desirous of obtaining broadcasting facilities, while avoiding dates which would clash with headquarters' instructions respecting S.B. arrangements.

There is another aspect of the matter which, it is expected, will find favour in interested quarters, namely, important organisations who arrange concerts and other entertainments will be enabled to formulate their plans so as not to conflict with important broadcast events.

While these fixtures are earmarked in the forthcoming programmes as events for which all the B.B.C. stations will have to make allowance as compulsory broadcasts, they will hardly be allowed, important as they are, to interfere with programmes of outstanding interest in the provinces.

Special Consideration

Special consideration will, for instance, be given to the case of Cardiff, where the second season of the National Orchestra of Wales begins on October 4 and extends over twelve weeks. The Welsh Orchestra's third season begins on January 10, 1929, and will again last for twelve weeks.

As regards the "Proms.," the

success which was achieved last year in a six weeks' season has encouraged the B.B.C. to plan this year a season of eight weeks, starting on August 11. Sir Henry Wood, whose name is inseparably linked with these concerts, will again conduct, and the performances will follow the lines adopted last year.

The last promenade concert takes place on October 6, and on October 12 the season of national concerts opens at the Queen's Hall, although it is not yet definitely settled that they will be known by the name of "National" concerts.

Twelve "National" Concerts

A series of twelve will be given at roughly, fortnightly intervals, with Sir Henry Wood and other eminent musicians conducting. These will run concurrently with a series of ten Hallé concerts, starting on October 18 and extending to March 14 of next year, while the national concerts will finish on April 12.

It is intended that these "national" concerts, whatever their nomenclature may be, shall sustain the high level of their predecessors at the Royal Albert Hall in 1926-7 and the Queen's Hall and People's Palace in 1927-8. To that end a step now under consideration is the placing of the national chorus on a permanent amateur basis with a membership roll of about 250. This will add to broadcasting an organisation which will take a prominent place in the development of choral music in this country.

The chamber-music concerts will be given on the first Monday in each month, starting on September 3, and will include a greater number than the eight so far decided.

From the inception of broadcasting,

READ ABOUT THE CHUMMY FOUR ON PAGE 483!

Some B.B.C. Autumn Programme Revelations (Continued)

operatic performances have occupied a prominent place in the programmes, relays from Covent Garden and elsewhere being supplemented by studio performances. A year or more ago the effort to popularise opera was still more clearly manifested by the publication of libretti; that is to say, printed booklets containing the words of operas performed in the studio, supplemented by biographical notes about the composer and a synopsis of the dramatic action, were published for the convenience of listeners.

Justification

The public reception which greeted this step has justified the B.B.C. in developing along the same line and, starting on September 26, a series of studio operas will be given on the last Wednesday in each month up to August 28, 1929. Each performance will be preceded by a transmission of the same opera on the last Monday in the month from 5GB, starting on September 24 next and ending on August 26, 1929.

The works to be included in the series are *Cavalleria Rusticana*, *Pagliacci*, *Pelleas and Melisande*, *Samson and Delilah*, *Blue Forest*, *Lakmé*, *Coq d'Or*, *Ivanhoe*, *Flying Dutchman*, *Jongleur de Notre Dame*, *The Swallows*, *Werther*, and *Le Roi l'a dit*.

A New Development

Then comes a new development which, from the production point of view, is regarded as comparable with the national concerts and other big musical features. It is an attempt to do for national drama what has been already done for national music, and comprises the staging before the microphone of a series of the world's great plays. The series proper will start on September 12; but it will receive a send-off in the broadcasting, on July 18, of a Shakespearean play which has never yet been given by the B.B.C., namely, *Hamlet*.

The Production Department is now engaged on the task of selecting plays that will be suitable for transmission and for reception by listeners of all ages and types, and at the same time representative of the world's best works.

This is not an attempt to evolve a new form of technique for the microphone—a separate problem with

which the Production Department is still grappling—but is an experiment in the adaptation of plays which were designed for stage presentation and

GENE GERRARD, THE STAGE COMEDIAN



for which it will be essential to employ the best talent of the theatre.

The series will consist of twelve of the world's masterpieces, broadcast at the rate of one a fortnight and each performed twice, on the second

Wednesday of the month from 2LO, 5XX, as well as all other stations except 5GB, and on some other day of the same week from the Daventry experimental station.

On September 12, then, the B.B.C. will start with a representation of English drama, Shakespeare's *Julius Caesar*; France will next be represented by Molière's *Le Bourgeois Gentilhomme*; Ibsen will be representative of all Scandinavia, with *Brand* and *John Gabriel Borkman*; Belgium by Maeterlinck's *Monna Vanna*; Russia by Tchekov's *Cherry Orchard*; Spain by Calderón's *Life's a Dream*; and India by Khalidasa's *Sakuntala*.

Blank Dates In Reserve

Germany, Japan, and the United States of America may be expected to figure in the list; but some blank dates are at present being held in reserve, as the final performance is not due until August 14, 1929.

The selection of the plays for various dates will depend largely on the talent available at the particular moment; and this will be, no doubt, the main difficulty, as the celebrities of the dramatic world are tied up with stage engagements to such an extent that it is not an easy matter to secure their assistance for broadcasting on only one or two evenings. However, the chief parts will certainly be played by the leading actors and actresses.

H.T. Eliminator Voltages

PERHAPS the most usual method of obtaining various voltages from an H.T. eliminator is by means of a high-resistance potentiometer (about 10,000 ohms) shunted across the output terminals, tapings being made to points along the potentiometer wiring.

Generally, it is desired to predetermine the tapping voltages to be obtained, and it is generally thought easy to do this with the aid of Ohm's Law.

Actually, though, the calculated voltage will only be correct when no load is placed on the potentiometer. Immediately the set is connected the effective voltage at the points will drop.

Value of Practical Test

Allowance should be made for this when making tapping points, and a practical test with a good voltmeter is far better than calculation.

QUEUE.

LOOK OUT NEXT MONTH FOR A REAL DE-LUXE
RECEIVER—THE CONNOISSEUR'S SIX!

Half Hours with the Professor



A CHAT ABOUT SHORT WAVES

"HA, HA! Ha, ha!! Ha, ha!!!
Extremely ludicrous!"

Megohm looked up with a jerk, slide rule in hand, an indignant frown furrowing his brow. "Oh," he said, with a sigh of resignation when he noticed the intruder, "it's you, Amp, is it? What can I do for you?"

"Oh, nothing special, Professor," said the Amp, a little abashed. "I didn't realise you were busy. I only came in for a chat."

Amp Amuses Himself

"Well, I shall have finished this in a moment or two," replied the Professor. "Just amuse yourself with that set for a time." He pointed to a small set, having three large dials on the panel, which was standing on one of the benches.

Amp's eyes gleamed. "Two toones and a hooter, I suppose?" he queried. "I mean," he added hastily, seeing the look of consternation on the Professor's face, "two tuning controls and a reaction."

"I don't know where you get these expressions from," sighed Megohm wearily. "Yes, you are quite right, it is two tunes and a reaction control. Now play about with it and keep quiet for a bit."

A Fearful Howl

Megohm resumed his calculations while young Amp struggled with the set. For a long time he produced no noise whatever beyond a click when switching the set on or off, but after a time he succeeded in evolving a fearful howl from the instrument. Quickly shutting it off with a hasty glance at Megohm, who was continuing his labour quite unconscious of any disturbance, he tried again and after a short time he achieved some clear and intelligible speech. He listened for a few moments and then exclaimed excitedly, "Gee, Professor, what an American accent."

Megohm wrote down some figures

on his pad, laid down his slide rule with an air of contentment, and leaned back in his chair, scrutinising the lad with a twinkling eye.

"Not altogether surprising, is it, my boy," he said, "considering that the transmission is coming from America?"

"What," exclaimed Amp, in tones of wonder, "do you mean to tell me that I have tuned in America?"

"You have," agreed the other, rising, "and you have, at the same time, put an interesting test on that receiver for me. This is actually a little three-valve short-wave set, and I wanted to see if you would be able to tune it properly."

"But," objected the boy, "I thought that short waves were frightfully difficult to tune."

"It doesn't seem so, does it?" was



How a wireless wave is propagated

the smiling reply. "As a matter of fact, that particular set does make the tuning a little more easy than usual because there is a stage of high-frequency amplification being used, but even on an ordinary detector circuit the tuning is not too difficult. Come and look here," he added, going over to another bench, where a skeleton arrangement was laid out.

"This," he resumed, "is a simple detector, followed by two low-frequency amplifiers, and consequently there is only one tune and the—er—'hooter,' I think you called it. The adjustment here is a little more critical, naturally, but you will find that we can get stations just as easily."

So saying, he picked up a pair of telephones and after a little adjustment handed them over to the boy to listen.

"Yes, it is obviously the same station," exclaimed the Amp, and leaning over to the bench he turned one of the knobs in a casual sort of way. A moment later he was busily adjusting both of the knobs, a look of consternation on his face.

Megohm watched him in silence until the boy finally turned and said: "Whatever is the matter? I seem to have lost him completely."

Mis-tuned

"You have merely mis-tuned him," was the answer; "and you have forgotten that the tuning is rather more sharp than you will find on an ordinary broadcast station." So saying, he took the telephones again and, after a short period of adjustment, handed them back to the boy with the station again comfortably audible.

"Then it isn't absolute child's play?"

"One requires a little more care, that is all," answered the Professor. "This receiver employs a simple detector circuit with a Reinartz reaction arrangement, and in order to receive signals from such a great distance, it is necessary that the set shall be adjusted to the maximum point of efficiency. This means that you must be somewhere near the oscillation point with your detector. Consequently, it is only when you have the receiver really carefully adjusted that you are able to hear signals."

Short Waves Too Tricky?

"But is that the only difference?" objected Amp. "I always thought short waves were much too tricky for ordinary blokes like me."

"The difference," explained Megohm, "is merely one of frequency. These short wavelengths are radiated by currents oscillating at a very much more rapid rate than the ordinary broadcast transmissions. A station

Half Hours with the Professor (Continued)

operating on a wavelength of 300 metres carries currents in its aerial oscillating backwards and forwards one million times per second. If you wish to produce a wavelength of 30 metres, you must bring the frequency of the oscillation to ten million. This set, in particular, is radiating on 21.97 metres, which corresponds to a frequency of 13,650,000 cycles per second.

Telephony Modulations

"Now the telephony modulations take up a small band of about 10,000 cycles only, as you probably know. Ten thousand cycles in one million is 1 per cent.; in ten million it is 0.1 per cent., and therefore the space on the dial, as it were, occupied by the actual sound is ten times as small."

"Then," broke in the boy, "is this the reason that I found it difficult to tune in?"

"Yes. The method of tuning in is exactly the same, but the adjustment has to be made much more carefully."

"Is that the only difference, then?"

"Practically so," agreed Megohm. "There are various effects which one encounters in a wireless receiver which are accentuated when receiving the short waves. One of these is the effect of any capacity in the circuit. Stray capacities between different wires may have a negligible effect in ordinary broadcast reception, but on short waves they will have quite an appreciable action, due to the fact that the frequency of the current is ten times as great."

Design Straightforward

"If we pay attention to these points, however, the design of a short-wave set is straightforward and its operation is no more difficult than an ordinary receiver, allowing for the

greater care necessary in actual use."

Amp thought this over for some time. "Well, Professor," he said, "that is interesting. I think I must try myself. I had no idea that any ordinary mortal like myself could get any luck on these short waves."

Megohm nodded his approval. "Certainly, my boy," he said. "Try it for yourself by all means. You will find a number of short-wave sets to

we take a straight line from a point on the surface of a globe, it is clear that it will go out into space and will never come back again unless it is deflected."

Here Megohm produced his usual stubby bit of pencil and scribbled a diagram like that shown on page 541.

"Good lor', Professor," exclaimed the boy, "I never thought of that."

"Few people do," smiled the other, "but nevertheless, right from the beginning of wireless this problem began to worry the minds of scientists. When Marconi signalled across the Atlantic for the first time and the reception was definitely proved, it became clear that there must be some influence at work causing the wave to bend.

Bend in Upper Atmosphere

"To cut a long story short, it is now definitely established that the waves are caused to bend by electrification in the upper atmosphere. This causes the wave to deflect rather as light waves are deflected from a mirror. All waves are deflected in this manner, the extent of the bending being dependent upon the wavelength.

"There is, however, another effect, because when the wave reaches this electrified atmosphere, there is a certain absorption of energy."

"That seems reasonable," interrupted the boy. "You mean there is some friction or other?"

Electrical Friction

"Yes, you can consider it as electrical friction, if you like. At any rate, there is a weakening in the strength of the wave. Now this absorption gets worse and worse as we reduce the wavelength, until we reach a point where there is a resonance.

"I can't go into this deeply, but

EUROPE'S BROADCASTING STATIONS



No reader will have difficulty in understanding these graphic statistics

try in the various periodicals. There is quite a good adaptor to start on in this month's WIRELESS MAGAZINE."

"Why do they use these short waves, anyhow?" asked the boy.

The Professor remained silent for a few moments before replying. "If I gave you a complete answer to that question," he said, "we should be here for a few days. In fact, I do not know that I could give you even a reasonably complete explanation, because there are many points about the behaviour of these short waves which we do not know ourselves yet. I think, however, I can explain the matter briefly without going into too much detail.

"The real question is, 'How does a wireless wave get round the earth at all?' Electro-magnetic waves are bound to travel in straight lines. If

Have You Told Your Friends About the Chummy Four?

A Chat About Short Waves

there are numbers of free particles of electricity or electrons in the atmosphere, and these have a certain natural vibration rate determined by the strength of the earth's magnetic field. If the frequency of our wireless wave coincides with this rate, then the absorption is very high."

Amp nodded. "Yes, Professor, I can understand the idea. Where does this absorption take place, then?"

'Ware 214 Meters!

"In the neighbourhood of 214 metres," was the reply, "and below this point the absorption begins to fall off. When we get considerably below it, the frequency of the wireless wave is so great that the earth's magnetic field ceases to have any appreciable effect. In consequence, the damping which is noticeable on the long wavelengths is not present and waves are transmitted with very little loss.

"So much is this the case that waves have been definitely traced to

go twice round the world and to be definitely audible at the second time."

"By Jove," said the boy, "how on earth do they detect which is which?"

"Well," replied Megohm, "the wave takes a little time to go round the world, and therefore the second impulse comes just after the first one and you get a sort of echo effect. In fact, there are all sorts of interesting peculiarities in these short waves. The height of the reflecting layer varies by night and by day, and therefore the distance of satisfactory reception is quite different in the two periods. It is also quite different according to the wavelength and the wave which is received well at night may not be received at all well by day and vice versa."

"Then is there any wave which we can choose which does equally well at all times?"

"No, that is not possible, but we can choose to work with one wavelength during the daytime and

another during the night, and in this way obtain good strong signals at distances of 10,000 miles or more practically all the time."

Amp thought this over for some time. "Well, Professor," he remarked, "I almost wish I hadn't started you on this, because there are so many points I want to ask you. But that is always the way when you start explaining things and I suppose I shall have to be content with small mercies."

Do Not Worry!

Megohm smiled. "I think, my boy," he said, "you will find most people feel like that at times when they come up against the wonders of Nature. Perhaps some time we will be able to talk about it a little more, but at any rate, you need not worry from a practical point of view. If you go ahead and make up a short-wave set, as you suggested, I have no doubt you will be positively amazed at the results."

What is the Resistance of Your Battery?

FEW people realise that a *producer* of current such as an H.T. battery has a resistance, just as the resistance of a current *consumer*, such as a valve filament, can be measured.

The resistance of H.T. batteries, when they get to the sear and yellow stage, is a frequent cause of L.F. howling, and it is rather interesting to find out just what the internal resistance of an H.T. battery is at any time of its life.

Internal Resistance

The average internal resistance of "super-capacity" dry cells is about .25 ohm per cell when the battery is new, rising to as much as 5 ohms per cell with age. It will be seen that in a large battery, with many cells, the internal resistance may be quite considerable.

To the actual resistance of the cells must be added, of course, the resistance of the battery leads and of the contacts at the "wander" points.

H.T. accumulators have a much lower internal resistance than dry cells, but the value varies greatly

according to the state of charge.

It should be remembered that when a battery of either type is old its total internal resistance may be of the order of 300 or 400 ohms. This is by no means a negligible resistance to place in an anode circuit. B.

JACK SAYES, RADIO'S "LAUGHTER" - SMITH



If the Aerial Neutralises

SCREENED-GRID valves give automatic neutralising in an H.F. stage, for which amateurs should be very thankful. One of the most difficult jobs connected with building and operating a neutralised H.F. set (with three-electrode valves) is the initial neutralising of the electrode capacity.

The business of adjusting the small neutralising condensers is not always an easy one, and a "snag" sometimes encountered is that a neutralised-H.F. set, although O.K. on the home aerial, will not work well if taken to a neighbour's house and tried on a strange aerial.

Aerial-to-earth Capacity

The reason is that the set was not properly neutralised in the first instance, but relied, perhaps, on exceptional aerial-to-earth capacity for its stability. "When tested on an aerial having not so great a capacity, the oscillation control is "all over the place."

When making an initial test of a neutralised-H.F. set, it is a good plan to try it on various aeriels, making sure that the neutralisation is efficient. M. K.

BROADCAST — MUSIC — OF THE MONTH

Dorothy
Kitchen



LOOKING casually at the programmes of June, the first impression is that music in its true sense is lacking sadly. Short "recitals" by more or less unknown people abound, but the real orchestral concerts, which it is evident by the success of the National Sunday League, give the most pleasure are missing. More and more talks are to be found, speeches and long plays in super-abundance, the bright spots being found when outside broadcasts are made from theatre and restaurant.

Leslie
England



Ida Sargent,
Singer



Special Event

An outstanding event of the month, however, is the return to broadcasting of Signor Emilio Colombo. One of the greatest classical players, as proved by his recent recital at Aeolian Hall, where his playing of the Cesar Franck



(Above),
Elsie Suddaby

Sydney
Coltham



the ether.

The scheme to form a national chorus of 250 voices, by the B.B.C., in place of using the choirs of well-known choral societies such as the Civil Service, the

Stock Exchange, and the Royal Academy of Music, is another unnecessary piece of expenditure on the part of the B.B.C. Huge bodies of voices, or executants, do not broadcast well, and it is proved again and again that the small picked orchestra of the restaurant or a sextet of players or voices do much better than the overwhelming mass production which blurs and deafens when amplified.

Apart from the excellent restaurant music of Colombo and his orchestras at the Hotels Metropole and Victoria, the Carlton Orchestra, under René Tapponnier, and the concerts held once more by Albert Sandler at the Park Lane Hotel, the lighter side of instrumental music has been left to Mr. Jack Payne, late of the Hotel Cecil.

Complicated Scoring

He has apparently just discovered that the B.B.C. Orchestra contains some first-class symphony players, and accordingly he proposes to introduce a somewhat complicated scoring of dance tunes, on the Wagnerian principle.

Much time and effort are also unnecessarily devoted by the B.B.C. to "discovering" the young composer, the result being that many programmes are flooded with crude immature productions by people who would be well advised to choose some other profession.

The excuse that "they otherwise might find it difficult to secure a hearing for their work" is surely no reason why the

(Continued on page 546)

(Above),
E. Casati,
who gives
French
talks

Esther
Coleman



Used in the "Chummy Four"

The new portable
Receiver described
in the June issue

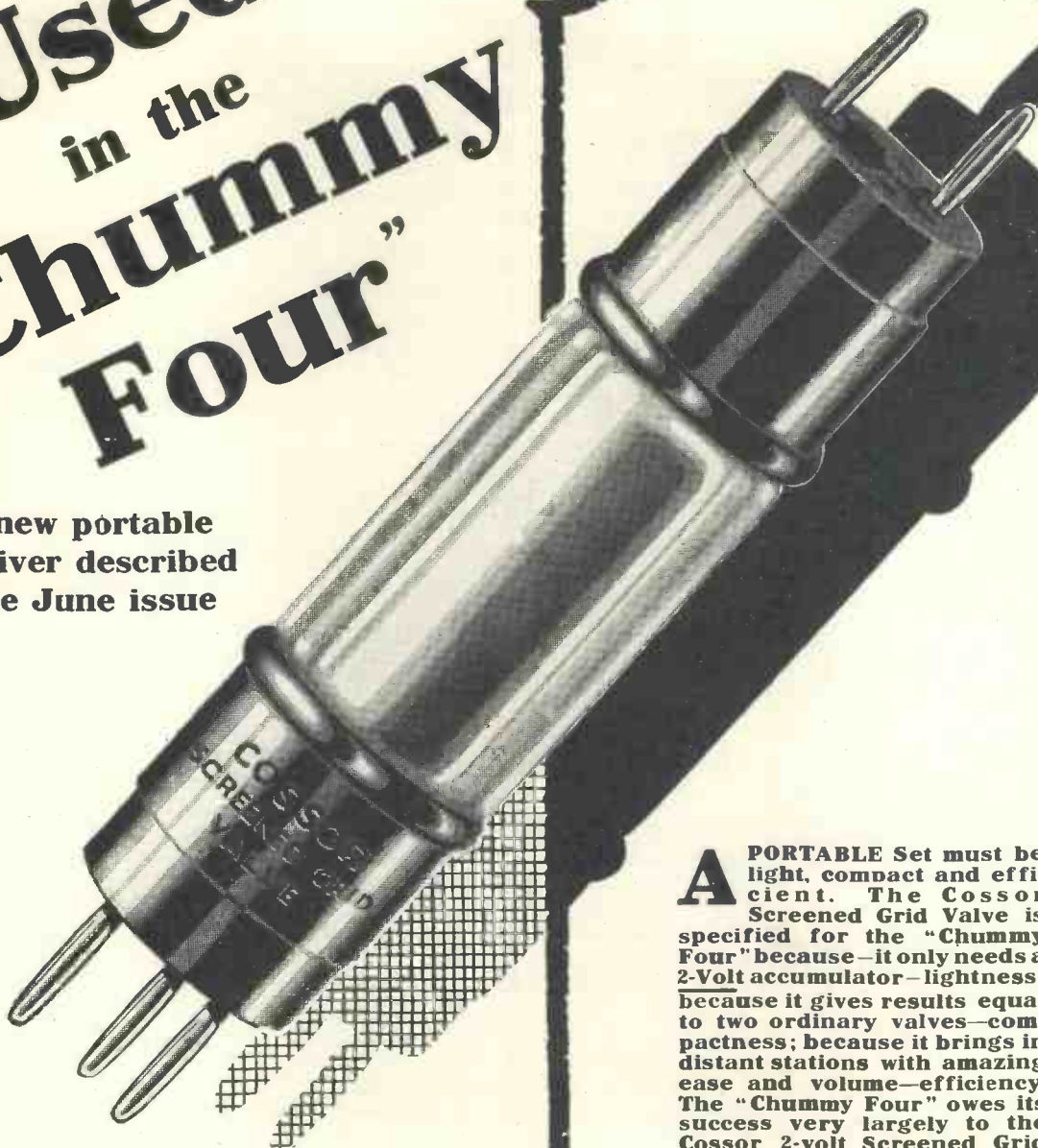

A PORTABLE Set must be light, compact and efficient. The Cossor Screened Grid Valve is specified for the "Chummy Four" because—it only needs a 2-Volt accumulator—lightness; because it gives results equal to two ordinary valves—compactness; because it brings in distant stations with amazing ease and volume—efficiency. The "Chummy Four" owes its success very largely to the Cossor 2-volt Screened Grid Valve. Cossor Valves brought success to the "Melody Maker." Cossor Valves make any Set successful.

Cossor 2-volt Screened Grid
Valve Consumption .1 amp.

Price 22/6

COSSOR 2 VOLT SCREENED GRID VALVES

THE "CONCERT FOUR"

By Percy W. Harris, Editor, "Wireless Constructor."

Components as specified:

2 Ormond .0005 mfd., with S.M. Dials, 22/-; Panel Mounting, .0001 Var. Condenser, 5/6; Utility D.P.D.T., Lever Pattern, 4/-; 2 P.P. Switches, Ormond, 2/8; Copper Screen, 8i x 6, to stand on baseboard, 2/6; 4 Lotus or W.B. Valve Holders, 7i/-; 2 Coil Stands, 2/-; 4 Tempyres and Base (cartridge type), 10/-; Neutralising (Jackson), 3/6; 2 Lissen .0003 Fixed, 2/-; .0001, 1/-; .01 Mullard (Mica), 3/-; Lissen 2 meg., 1/-; Dubilier meg. and Clips, 2/9; Lissen H.F. Choke, 5/6; E.L.-Varley (Type A), E.O.C. Unit (important), 20/-; Geophone 4-1 L.F., 20/-; Lissen or Dubilier, 2 mid., 3/6.

List Total £5 17 9

FREE 21 x 7, High quality panel, (drilled); Strips, 8 x 11 and 2 x 11; Pair Brackets; 12 Engraved Terminals; Wood Screws and Connecting Wire; 5-ply Baseboard, 21 x 10 1/2, with above

Climax Autobot Transformer, 35/-; Heavy Mains Choke, 21/-; Pot Divider, 5/-; Special Choke, H.T., 10/6; H.F. Choke, 8/6; Igranite, L.F. Choke, Type 5, 27/6; Smoothing Choke, 25/-; Indigraph Dial, 7/6; Universal High Resistance, 5/6; Facet Jacks from 2/-; Ask for List No. J.386; Lissen Electrical Pick-up, the finest at the price. Without adapter, 15/-; With adapter 16/6; E.L.-Varley Super-Power Resistances, for Battery Eliminators, various from 500 at 50 m/a to 3,000 at 20 m/a ohms, 12/9 Each; Mullard Permacore L.F. Transformers, 25/-; Special Winding

Valves, all latest stocked, D., L.F., H.F., E., 10/6 and 12/6 each; D.U.10, 15/-; Mullard P.M.4.D., 12/6; Cosor, Mullard, Ediswan, Marconi, Osram, Six-sixty, Sifam New Model Pocket Voltmeter, H.R., 4,000 ohms, heavy socket 9/6 each; E.C.G. Units, various, Lissen, 4/-; Cosmos, 8/6 (with V.H. 10/6); Magnum, 7/6; Carborandum, 8/6; Marconi A" 7/3, and "B" 8/6; Dubilier 7/-; Ampion Vivavox Gramophone Pick-up, with volume control plug, adapter and leads 50/-; Ampion A.C.13, cone unit assembly 50/-; Sifam Moving Coil milliammeter 0-50 25/-

GABINETS

Large stocks of really useful cabinets kept or made to order. Solid Oak, American type, hinged lid, baseboard. Carriage 1/6.
12 x 8 x 9 .. 10/6
14 x 7 x 9 .. 13/6
16 x 8 x 9 .. 13/11
18 x 8 x 10 .. 15/11
21 x 7 x 9 .. 18/6
Also Cabinets in stock for E.M. Nelson-de-Luxe, Raleigh, Mullard 3, Cosor 3, Britain's Fav. 3, do. 2. Cheap (good), also in expensive quality.

LISSEN

Valve Holders, 1/-; Fixed Con., 1/-; 1/6; Leaks, 1/-; Switches, 1/6, 2/6; Latest 2-way Cam. Vernier, 4/6; Rheostats, 2/6; B.B., 1/6; Lissenola, 13/6; L.F. Transformers, 8/6; 100-v. H.T., 12/11; 60-v. H.T., 7/11; Coils, 60 X, 6/4; 250 X, 9/8; 60-v. H.T., 7/11; 100-v., 12/11; Super 60-v., 13/6; Grid Bias, 1/8; 4-0, 6d.

ALWAYS IN STOCK

WE ARE OPEN

ALL DAY SATURDAY
ALL DAY THURSDAY
ALL DAY EVERY DAY
Hours: 9 a.m. to 8 p.m.
Sat.: 9 a.m. to 9 p.m.
Sunday morning: 11-1.

Quotations for all circuits.

PRICE LISTS FREE
State requirements

MULLARD MASTER THREE

No solder—only 20 wires to connect (all ready for use.)

SPECIFIED PARTS:

2 Strips	.0005 J.B.	Master 3 Coils
1 Base	.00035 J.B.	4 Named Terminals
2 Brackets	3 Valve Holders	E.L. Varley L.F.
Climax Choke	Bulgin Switch	Do. Unit, "Type A"
A.B.C. Links	Mullard .0003	2-megohm Leak
Spade Terminals	Flex and Screws	8 Plugs
and 3 MULLARD P.M. Valves (state voltage).		

£6 17 6

FREE EXTRA quality aluminum Panel, 18 x 7, drilled (surface specially frosted); 9-volt Grid Bias; 100 volt H.T. (good make), OR you can have Oak Cabinets, 18 x 7, hinged lid, American type, instead of H.T. Battery. Carriage 2/6.

COSSOR MELODY MAKER

GENUINE COMPONENTS £4 10 0 kit.

2 Ormond .0005; 2 De. S.M. Dials; 6 T.O.O. Condensers, .001, .002, two .0003, .0001, 2 mfd.; 2 Grid Leak Clips, 2 B. 1; 1 Var. B.B. Rheostat; 3 Grid Leaks, 25, 3, 4 Mer.; 3 Lotus V.H.; 1 Ferranti A.F.3; 2 Panel Switches; 1 Cossor Melody Wound Coil; Terminals, Name Tabs, Glazite, 9-v. Grid Bias, Walnut Choke.

FREE CARRIAGE 1/-.
with kit. Drilled High-grade 21 x 7, Polished Panel, with Radio Strip and 5-ply Base.

K. RAYMOND

27 & 28a LISLE STREET, LONDON, W.C.2

Come to Leicester Square Tube.

This address is at the back of Daly's Theatre 'Phones 1 Gerrard 4637 and 2821.

Broadcast Music of the Month (Continued from page 544)

British public, helpless to resist except by shutting off their sets, should be literally forced to listen. Until proper competition is allowed, there should be some prior claim to popularity before work is broadcast.

The true solution of the provision of light and popular music has been solved at the stations of Manchester, Liverpool, Sheffield, Leeds, and Hull, where during the next few months concerts will be broadcast from leading holiday resorts, concerts given by the municipal orchestras of the town, and concert-makers who, having to earn their living by the results of their labours, have learned in the hard school of experience just what the public wants, and pays for.

Municipal and other concerts of Southport, Buxton, Scarborough, Llandudno, Harrogate, and Blackpool figure in the scheme. All the London listener wants to know is why are some of them, to say the least of it, not relayed in place of some of 2LO's endless talks and syncopated noises of negroid element?

Interesting Performances

With the cessation of relayed German opera, the coarse voices of many of the singers being still further hardened by transmission, several more or less interesting performances have been given in the studio. Puccini's opera, *Girl of the Golden West*, the plot of which revolves round the rush for gold in California, included in the caste Joseph Farrington. The concert version of *The Rebel Maid* included two famous artists of the original version, Clara Butterworth and Thorp Bates.

The vocalists are most varied, and many early favourites have figured prominently. Parry Jones, one of the best B.N.O.C. singers, has appeared in many of the big song recitals, and Sydney Coltham, another early broadcaster, has been heard on several new occasions.

Coloratura singing has been particularly well represented this month by the various appearances of such famous and also early broadcasters as Elsie Suddaby, Dorothy Bennett, Megan Thomas, and Esther Coleman. The latter artist sings with just as much charm when unaccompanied by piano, an art not easy to accomplish.

On the masculine side we have heard the South African bass singer, John Van Zyl, George Boyd, a capital baritone, and Dorothy Kitchen, a very charming young singer.

Many concerts given this month may be described as "stunt" programmes designed to please just one section of the public, though possibly of more outside interest. Under this heading may be included the famous Heckmondwike Lecture, held in unbroken succession for 167 years, constituting a unique phenomenon in the north of England. The Aldershot Command searchlight tattoo, the national programme of Polish music, and the Jewish musical festival from Kingsway Hall, each had their points of interest.

On the Variety Side

On the variety side of the programmes we have had some very weak material, and there is room for improvement. The recent work from Miss Mabel Constanduros, Mr. Ronald Frankau, and some other artists requires literary strengthening.

On the other hand, for those who like that form of entertainment, some pleasant work has been done by Mme Maria Saberonne, a clever bird mimic.

French talks are of little use, even when as well done as by M. E. Casati, who broadcasts from Aberdeen, and M. Stephan from 2LO, but when it comes to French plays, then both from an educational or an amusing standpoint, they must necessarily fall flat for the main bulk of listeners. It is to be hoped, therefore, that the performance of Max Maurey's play, *Rosalie*, presented by Middle Alice Gachet on June 14, will not create a precedent.

Good Talkers

The talkers crowd thick and fast. Amongst those who have a really intimate knowledge of their subjects may be mentioned Mr. F. A. Wilshire and Mr. Clifford Collinson, whose books on travel are also known.

For the rest, the programmes still contain too many speeches. One is glad to know that *Charlot's Hours* are to be continued, and some light farces promised.

THE WINNER



In
DARK BLUE CONTAINERS

- 60 VOLTS 7/-**
- 66 VOLTS 7/6**
- 99 VOLTS 11/6**
- 9 VOLTS GB 1/3**

On
COST & SERVICE
these Batteries provide

**THE FINEST
H.T. VALUE
OBTAINABLE**

EVER READY Regd

BRITAIN'S BEST BATTERIES

Their pure tone makes listening worth while

CAPTAIN ROUND TAKES A BUSMAN'S HOLIDAY!

In this article he recounts for the benefit of "Wireless Magazine" readers his impressions of reception conditions in the Mediterranean area



Capt. Round's apparatus in a stern cabin of S.S. Ranchi

A HOLIDAY at sea in the Mediterranean has given me the opportunity, without doing any serious work, of learning at first hand some of the difficulties those far away from broadcasting stations have to contend with.

Living in the full sunlight of 2LO, I find one hardly realises how insignificant a station it really is, and how long ago, it would have been forgotten but for its giant planet 5XX, for after leaving the Thames in S.S. Ranchi on May 3, I heard no more directly from London until I arrived home on May 31.



Lost in An Ether Tangle

At one time, no doubt, a "super" would have been able to pick it up, but now it is completely lost in a tangle of German stations, heterodyne notes and sparks.

I took with me two receivers, a loud-speaker, and the necessary batteries, and by the kindness of the P. & O. Company I was allowed to erect these in an unused

(Continued on page 550)

A SUMMER DOWNPOUR DRIVES THEM IN



CLARKE'S "ATLAS" BATTERY ELIMINATOR

provides Silent Power for the largest receiving set. Radio Enjoyment is a double pleasure because Clarke's "Atlas" Battery Eliminator requires NO Valves, NO Liquids, NO Moving Parts.

The A.C.50 Model as illustrated is priced at £12-17-6 (including Royalty), and incorporates the Westinghouse Metal Rectifier.

Write for leaflet No. 31 which shows the new A.C. Models.
H. CLARKE & Co. (M/cr.) Ltd., "Atlas" Works
Old Trafford, Manchester

Take the Speaker on to the Lawn



You will want to listen outdoors these summer days but make sure that the long leads from the set will not impair quality or short the H.T. batteries. Connect the Igranitic "C.C." Output Unit between the set and the loudspeaker and the long leads will have no damaging effect.

The Igranitic "C.C." Output Unit

is a self-contained filter which may either be built into the set or connected externally to the loudspeaker terminals as desired. You will be surprised at the improvement in quality which it makes with even ordinary length leads.

Price 21/6

Write for List No. J573 which gives full particulars

149 Queen
Victoria Street,
LONDON, E.C.4
Works: Bedford



Branches:
Manchester, Bir-
ingham, Cardiff,
Leeds, Newcastle,
Bristol, Glasgow.

RESTORE ITS OLD ZEST WITH A TOUCH OF THE BEST

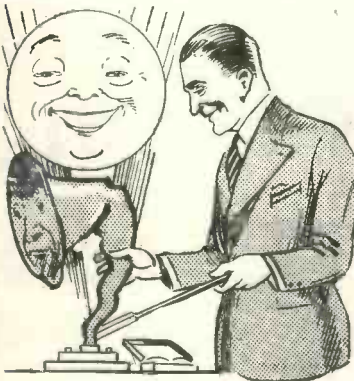

**FLUXITE
SOLDERING
SET—complete
7/6
or LAMP only 2/6**

FLUXITE

-IT SIMPLIFIES SOLDERING

All Hardware and Ironmongery Stores sell FLUXITE in tins, price 8d., 1/4 and 2/8. Another use for Fluxite—Hardening Tools and Case Hardening. Ask for leaflets on improved methods.

FLUXITE LTD.
(Dept. 332)
Rotherhithe, S.E.16

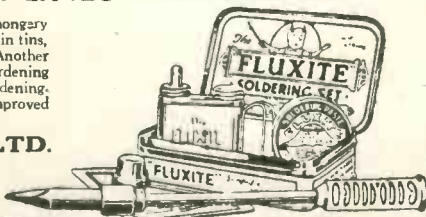

The Right Components in the Right Place!

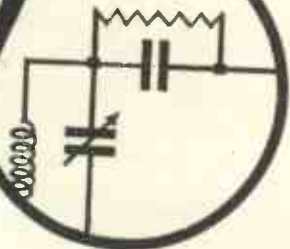

WHERE a Fixed Condenser was wanted you wouldn't dream of installing a Transformer; no more should you instal any component of doubtful efficiency when you can buy Dubilier and be sure of getting 98 per cent. better efficiency constantly maintained.

Dubilier components are not only good to start with—their efficiency is steady. If the place is right and the components are Dubilier, then all is right.

1. DUBILIER "K.C." CONDENSER.

Complete with Knob and Dial and Vernier.

12/-

2. DUBILIER MICA CONDENSERS.

Type 620 (upright), Type 610 (flat), 21 standard capacities between 0.00005 and 0.015 at prices ranging from 2/6 to 4/6 each.

3. DUBILIER DUMET-OHM RESISTANCES.

In 9 Standard Values, 0.25 to 10 megohms, 2/6 each.

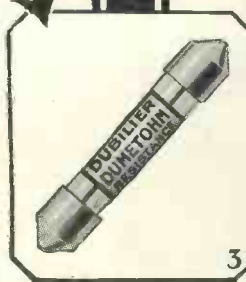
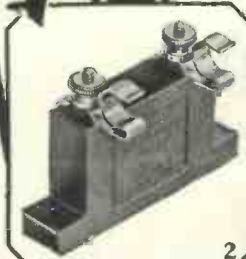
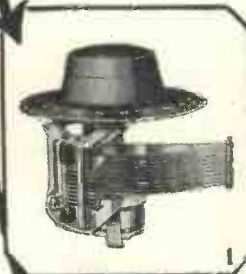

Dubilier Built is better built

Adv. of the Dubilier Condenser Co. (1925) Ltd., North Acton W 3. U 154

Capt. Round Takes A Busman's Holiday (Continued from page 548)

cabin at the stern of the boat, far away from the electrical centre of activity in the engine-room.

Noisy Place for Working

What a nasty noisy base to work on a commercial liner can be is only to be told by those who have tried to use "super" receivers on them.

Warships, particularly battleships, are splendid receiving places: their solid metal structures with the lead-covered wiring bonded to the vessel at every point render them practically as silent as any desert island would be, but commercial boats seem to be one seething radiating mass—transmitting all wavelengths at once continuously with a result that one cannot take in less than a certain field strength on any wavelength.

Notwithstanding this, I found that atmospherics were the real limitation on long wavelengths, but ship noises were the limiters on the super short waves, such as used by 5SW (Chelmsford).

The normal broadcasting receiver

which I used was a Marconi 61—a six-valve receiver—in which three screened-grid valves are used for H.F. amplification, followed by an anode-bend detector and two R.C. coupled L.F. magnification stages.

As quality was not an important consideration, 120 volts H.T. and a DE5A valve were all that were used. Only loud-speaker results were considered, for, as far as I am concerned, the phone habit has gone.

The long-wave receiver was fitted with a frame aerial about 1 ft. square and the ranges of wavelength that could be received were from 250–500 and 1,000–1,800 metres.

Outside Aerial Necessary

I very soon found out that a small outside aerial would be necessary, because the cabin was a complete metal box except for door and portholes and shielded one completely. Two aerials were used in the course of the voyage—one consisting of a single wire running forward from the cabin porthole up to about half-way

on the rear mast, and another was erected a little later as far astern in the ship as I could get—quite a small wire, only about 30 feet long—and this aerial I found generally more free from ship noises than the first one, particularly on the super short waves. It certainly seems that for short waves a doublet erected at the back of the boat, preferably projecting out from the stern, would give the best results.

Great Sensitivity

The long-wave receiver with these aerials was tremendously sensitive for on its frame only under normal conditions it will receive practically everything, and actually I was never able to use the full magnification, because atmospherics in general would have been far too strong. I had, in fact, a receiver which would give me the practical limit possible at the present day.

My short-wave receiver—seen in front of the other one in the
(Continued on page 552)

Every quality that radio science demands!



In Lewcos coils you have every quality that makes for more selective tuning

- ① **MAXIMUM INDUCTANCE** is ensured by close magnetic interlinkage between turns.
- ② **MINIMUM SELF CAPACITY** is ensured by scientifically spaced sectional windings.
- ③ **CIRCUIT ADAPTABILITY** and coils are interchangeable and you have an option of centre-tapping.
- ④ **CONSTANT MAGNETIC CENTRE.** All coils have the same external dimensions.

Obtainable from all good radio dealers.
THE LONDON ELECTRIC WIRE CO. & SMITHS, LTD.
 Church Road Leyton, E.10

COIL NUMBERS
 25, 35, 40, 50, 60, 75. Price 3/6
 100, 125, 150, 200, 250, 300. Price 5/3

DOUBLE TAPPED
 No. 75X Price 4/9
 No. 300X Price 8/6

LEWCOS

CENTRE TAPPED COILS

FOR SELECTIVE TUNING

"ALL-FROM-THE-MAINS FOUR" COMPONENTS specified by the Designer. See this issue

Faradex Double Choke, current-carrying capacity, 100 m.a., total inductance, 40 henries, D.C. resistance, 130 ohms each winding. Ref.: MR100/100. Price 30/-. Postage 9d.

Faradex Rectifier, improved "Simpler Wireless" model, specially designed by J. F. Johnston for use with "Simpler Wireless" sets. Ref.: FG2/SW. Price 35/-. Postage 1/6.

Faradex 8-mfd. Fixed Condensers 750-volts test. Price 12/3 each. Postage extra.

Faradex 400-ohms Resistances, baseboard-mounting. Ref.: 1000/1. Price 2/6 each. Postage extra.

Faradex 400-ohms Potentiometers, panel-mounting. Ref.: 1000/2. Price 4/-. Postage extra.

Faradex 50-ohms Potentiometers, panel-mounting. Ref.: 1000/3. Price 2/6. Postage extra.

(The above resistances and potentiometers have been specially designed for use in "Simpler Wireless" sets and are guaranteed to carry the current without overheating.)

Seaford Coils, as used in the original tests of the "ALL-FROM-THE-MAINS FOUR."

Centre-tapped	75	100	400	Plain	75	250	—
Price	2/-	2/2	4/9	Price	1/6	3/3	—

Faradex Components for use in Battery-eliminators and Main Sets

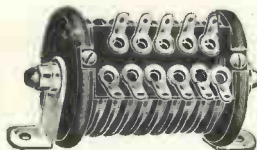

Potential Divider

Faradex Double Choke as described above.

Faradex Single Smoothing Choke similar to double choke, but one winding only. Current-carrying capacity, 100 m.a., inductance, 20 henries, D.C. resistance, 130 ohms. Ref.: MR100/S.B. Price 35/-. Postage 9d.

Faradex Potential Divider, resistance 20,000 ohms, wound with silk-covered wire in ten sections on fibre former. Alternate sections wound in opposite direction, giving non-inductive winding. Tapped each section. Ref.: MR/20. Price 7/6. Postage extra.



Faradex Mains Transformer, primary winding tapped to suit A.C. mains, having voltage 200 to 240 and frequencies of 40 to 60, large centre-tapped secondary giving 250 volts on each side of tapping, small centre-tapped secondary for heating filament of rectifying valve. Suitable for D.C. outputs of up to 200 volts 60 m.a. Ref.: MRI/D.B. Price 35/-. Postage 9d. (Also made for 100/120-volt mains.)

Faradex Fixed Condensers for mains work. Full range of capacities either 500 or 750 volts test. List on application.

Obtainable from principle wireless dealers or direct from the manufacturers:

ROOKE BROS., LTD.,

55, Cardington Street, Euston, LONDON, N.W.1

IN A CLASS BY ITSELF

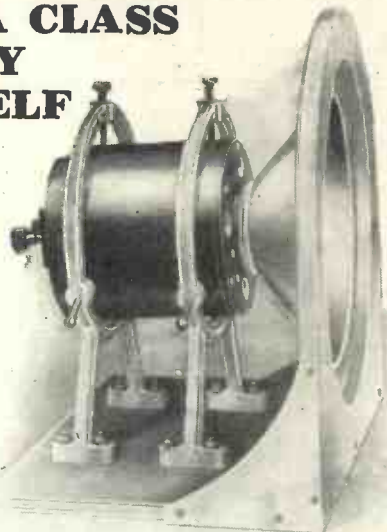

THE GOODMAN "MINOR" Moving Coil Speaker Equipment, at £4.4 the complete Set of Parts for 6 volts, with a consumption of .5 amps, is in a class by itself. Any voltage or consumption supplied. GOODMAN'S Moving Coil Speaker parts are distinguished by fine workmanship, scientific design and best possible materials. The price is low, but not at the expense of the Speaker. No better speaker can be had for home use. Moving Coil Speakers reproduce the whole range of audible frequencies—provided your set delivers undistorted signals, and you use only the best Loud-speaker Components. GOODMAN'S have had years of experience in always specialising in high-grade Loud-speaker Components.

Ask your dealer—or send us full particulars of your set, etc. and we will give you our candid advice.

Lists for MINOR Model sent free on request. Other Models available.

GOODMANS
27 FARRINGDON ST. LONDON, E.C.4



15/6

THE WATMEL L.F. TAPPED CHOKE.

This is the famous Choke that is used in the "All-from-the-Mains 4" (see page 488).

This Choke contains, wound on its patented core, over a mile of wire. It is tapped so as to give values of 40, 60 or 100 Henries at will, and it has a straight choking curve for all audio frequencies giving entire freedom from peaks.

WatMel

WATMEL WIRELESS CO., LTD.
Imperial Works, High Street,
EDGWARE, MIDDLESEX.

Telephone:
Edgware 0323

Capt. Round Takes A Busman's Holiday *(Continued from page 550)*

photograph—consisted of two screened-grid valves, an oscillating detector and two L.F. stages, to which I added externally another stage to enable the loud-speaker to be worked comfortably.

Standard

Both these receivers are standard arrangements described in my book on the shielded four-electrode valve and since that was written only minor changes have been made in the designs.

The track taken by the *Ranchi* is shown on this page, and one can get a pretty comprehensive radio view of the Mediterranean on such a tour. My "view" was only interrupted at Constantinople, where all apparatus has to be disconnected by order of the police.

I very soon gave up more than a casual attempt to receive the ordinary broadcast band of signals from

250-550, because of spark jamming, and except for an occasional listen to 5GB and listening to the local stations, such as Naples, Rome, etc., I

seldom paid much attention to that range. It was noticeable in general for weak or freaky signals, also bad X's and spark jamming.

The long-wave range is quite different and competes with 5SW quite well up to the South of Italy at least, and in winter months, I should estimate it would carry well past that distance.



Track of the S.S. *Ranchi*'s tour.

5XX and Radio-Paris

I managed with an effort to keep both Daventry (5XX) and Radio-Paris through the Straits of Gibraltar in the day time, although there is a serious weakening of signals in this area, due, obviously, to the large amount of land in the way, but from Spain to Italy signals are very fair, both in daylight and at night time, but, of course, atmospherics are pretty severe. The last day of audibility of these long-

wave stations was May 13, when we were off Greece and I cannot do better than give my notes of that day:—

(Continued on page 554)

"Of proved efficiency" **BAKER'S SELHURST RADIO**

The Leading Manufacturers of high-class Moving-coil Speaker Components can now supply a new 6-volt .5 amp. model for

£3 - 10 - 0

for complete set of parts.

Works:—
42 CHERRY ORCHARD ROAD,
EAST CROYDON STATION
20 minutes non-stop from Victoria Station.
(Always Open) Phone: Croydon 1618



Write for Lists

SPECIFIED BY COSSOR

The W.B. Antiphonic Valve Holder is being specified more often than any other in the best circuits of the radio journals. The greatest success of the season—the set that thousands have built and thousands more are building, the Cossor Melody Maker, definitely specifies W.B. Antiphonic Valve Holders. You will appreciate the absolute freedom from microphonic noises of the valve floated on the W.B. valve holder springs. From all good dealers.

PRICE **1/9** EACH
with terminals, or 1/6 without terminals.

WHITELEY BONEHAM & CO., LTD.
NOTTINGHAM RD., MANSFIELD. Notts.



FORMO ARTHUR PREEN & CO. LTD.

"1928" LOG CONDENSER
As specified for the

"SIDECAR PORTABLE"
DESCRIBED IN THIS ISSUE

The **SMALLEST, LIGHTEST** and most **EFFICIENT CONDENSER** obtainable

PRICES

.0005 } **5/-**
.00035 } **DUAL GANG**
15/6
TRIPLE GANG
£1 : 1 : 0

THE FORMO CO., Crown Works, Cricklewood Lane, LONDON, N.W.2.



5/-



1928 FIVE

Described in "Wireless Magazine" Jan., 1928

SPECIAL OFFER OF EBONITE PARTS

LARGE SALES

Write for particulars to the Sole Makers

THE BRITISH EBONITE CO., LTD.
HANWELL, LONDON, W.7.



"NEWY" CONDENSER

Specially Designed for Short-wave Work

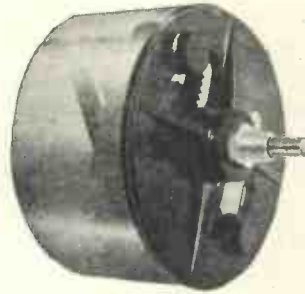

Note Celluloid Dust Cover

The NEWY Type S.W. Variable Condenser is the finest yet designed for short-wave work. Its unique design incorporates a minimum of metal and the special arrangement of the vanes provides an extremely low minimum capacity. It is sold complete with celluloid cover that absolutely prevents any dust accumulating on the vanes.

A specially-designed slow-motion dial marked 0/320° and having an absolute minimum of metal parts eliminates all hand capacity.



PRICE Complete with Slow-motion Dial **15/-**



Note wide airgap between Vanes Sold by The Patent Slow-motion Dial
PETTIGREW & MERRIMAN (1925), Ltd.
2 BUCKNALL STREET, LONDON, W.C.2.

WEARITE

COMPONENTS

Are Absolutely Guaranteed.

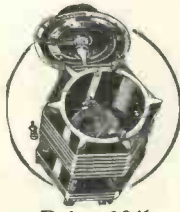

Price 10/6

SHORT-WAVE TUNER SINGLE HOLE FIXING
comprises a grid coil with loosely-coupled Aerial-winding and an internal rotating Reaction Coil. It has a normal range of 30-70 metres. This tuner is adopted in the—
"UNIVERSAL SHORT - WAVE ADAPTOR."

THE WEARITE CHOKE

has so firmly established its reputation as an instrument of the very highest efficiency, that it needs no further introduction. It is the choke specified in the "SIGNAL THREE" and many other "W.M." circuits.



Price 6/6
Special Anode Coil for "THE CHUMMY FOUR" ... 4/6
Special Screening Box and lid for same ... 8/6

Write for Free Lists

Always ask for WEARITE Components

WRIGHT & WEAIRE, Ltd.

740, HIGH ROAD :: TOTTENHAM :: N.17
Phone: TOTTENHAM 3132. Grams: "WRITWEA, TOTTLANE, LONDON."

MAGNUM COMPONENTS

are specified and used in all efficient Radio Apparatus.

To ensure perfect reception insist on genuine Magnum Components as specified by the designers.

Specified and used in the "CHUMMY FOUR"

Magnum Special Anode Coil ... 5s. Od.
Magnum Screening Box and Lid ... 10s. Od.
Magnum Small Panel Brackets (pair) 1s. 6d.

Lists dealing with several new Magnum Products are now ready and will be sent on receipt of 1½d. stamp.

Magnum Power-driven Moving-coil Speakers. Magnum Roadside Four Portable Receiver. Magnum Purity Three Receiver. Magnum Wavetrap. Magnum Wire-wound R.C. Unit. Magnum Power Amplifier, etc.

BURNE-JONES & CO. LTD.,

"Magnum" House, 288, Borough High Street, London, S.E.1.
Telephone: Hop 6257 (two lines). Telegrams: Burjomag, Sedist, London.
Cables: Burjomag, London.



MOVING-COIL CABINETS, BAFFLE-BOARDS, TABLE MODELS, &c. 30/-

Post this coupon now for full details and list of Camco Cabinets.

To CARRINGTON Mfg., Co., Ltd., CAMCO WORKS, SANDERSTEAD ROAD, SOUTH CROYDON.
Telephone: Croydon 0623 (2 lines)

Please send me full details of the "Moving Coil" and other Camco Cabinets

NAME

ADDRESS

Ascendancy

For three years now "Celestion" has been climbing steadily to its goal of ascendancy. To-day "Celestion" has not only reached that goal, but is maintaining it firmly. "Celestion's" enviable position is due to its guarantee of ability to survive the six most stringent tests of every high-class loud-speaker. These are . . .

- EVEN RESPONSE.
- EXTREME SENSITIVITY.
- ONE ADJUSTMENT.
- IMPERVIOUS TO CLIMATE.
- IMPROVEMENT WITH AGE.
- DISTINCTIVE CRAFTSMANSHIP.

Moreover "Celestion" is BRITISH MADE THROUGHOUT

Summarised, the foregoing reveals the pre-eminent loud-speaker. Experts look to it as their standard of comparison, the public and trade papers are loud in their praise of its outstanding merits, whilst we have in our possession literally hundreds of congratulatory letters from satisfied users.

There are four "Celestion" models varying in price from £5 10 0 to £25. They are supplied in oak or mahogany, and we shall be glad to forward to you our free illustrated literature giving particulars of all models, and our "Wood-rotte" Type Gramophone Pick-up



MODEL C14
(Made under Licence)

CELESTION

The Very Soul of Music

Write to Dept. K

THE CELESTION RADIO CO.,
Hampton Wick, Kingston-on-Thames.

Showrooms:

33/35, VILLIERS ST.,
LONDON, W.C.2

Affiliated Company:

CONSTABLE & CO.,
PARIS

Capt. Round Takes A Busman's Holiday

(Continued from page 552)

Sunday—Midday, (May 13)

Paris not over strong, better than near Gibraltar.
Konigswusterhausen, fair. } Obvious limit of day reception.
Daventry, carrier only. }
Hilversum, nil. }
Very strong station at 1,100 metres.
Think Russian: gives name Nil olayef Popoff; cannot find in published list.

Sunday—Night

Daventry, weak.
Konigswusterhausen, strong.
Hilversum, nil.
Paris, heterodyned.
Moscow, strong.
Nikolayef, strong.

Strong Russian Station

I was very surprised to find the strong Russian station on 1,100 metres (or about that) for his strength must be considerably greater than Daventry—I could not find this station recorded in any published list, but I am fairly sure of his name and nationality.

On all days previously to this date, right back to when we were off Cape Finisterre, Radio-Paris had shown itself as stronger than Daventry. This effect is probably due to greater distance and shorter wavelength.

Bad Atmospherics

Atmospherics through all these tests would have rendered demonstrations quite difficult, except when within six hundred miles of 5XX or Paris, but I have no doubt that in colder weather some very decent programmes could be received and

(Continued on next page)

JUST WHAT EVERY ELIMINATOR USER HAS BEEN WAITING FOR

The



ELIMETER

THIS new Elimeter with a resistance of 100,000 ohms, comes at a time when thousands of battery eliminator users are eagerly waiting for a Voltmeter that will accurately indicate both total voltage and all intermediate tappings and—at a price within everybody's reach! The current consumption is only 2 milliamps at 200 volts. Mr. J. H. Reyner, the well-known radio authority, says: "The figures indicate a surprisingly high resistance, and I must congratulate you on the production of such an instrument at the relatively low price of 30/-."

When writing ask for particulars of the full range of popular priced meters. There is a Sifam Radio Meter for every radio measuring requirement.

Free Leaflet "Detecting Distortion" from (Dept. M) THE SIFAM ELECTRICAL INSTRUMENT CO., LTD., New Address: Radiometer Headquarters, BUSH HOUSE Aldwych, London, W.C.2.

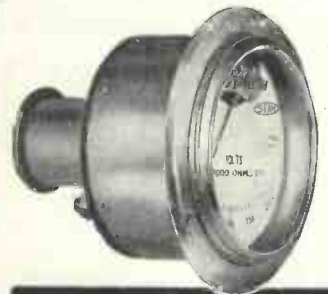

The Sifam Elimeter. Heavy Nickel Case. White Ivory board dial. Calibrated up to 200 volts.

30/-

SIFAM LEADS AGAIN!

M.B.

Buy
"Amateur
Wireless"
3d.
Weekly

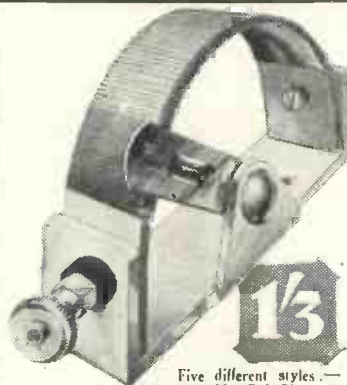

SPECIFIED IN THE "SIGNAL THREE"

Peerless Varistors are specified in the "Signal Three," described on page 525 of this issue. They economise in space—they stand easily accessible yet out of the way of the wiring—they are ideal for this particular set and any other circuit which demands an efficient filament resistance taking up minimum space.

Ask your radio dealer for the

1/3 PEERLESS VARISTOR

Five different styles.—3, 6, 10, 15 & 20 ohms.

In case of difficulty in obtaining, write direct:

BEDFORD ELECTRICAL & RADIO CO. LTD., 22 Campbell Road, Bedford
London: 21 Bartlett's Bds., Holtorn Circus, E.C. Glasgow: 113 St. Vincent St., Ca

Capt. Round Takes A Busman's Holiday

(Continued from preceding page)

they would have the advantage over the short waves of not fading.

From Greece onwards, on the long-wave band, Russian stations dominated the map, particularly Nikolayef and Moscow.

Super Short Waves

With regard to the super short-wave signals, my impressions are very mixed, and in general I was disappointed. Contrary to expectations, daylight signals were generally weaker than night signals, but the day fading seemed to be slower.

I got a general impression of strength falling off with distance, particularly in the day time, and it is very hard to imagine after listening at Cyprus that good rebroadcastable programmes are being obtained in South Africa and Australia.

Atmospherics were absent for all practical purposes, but the general mush produced by the ship was a distinct nuisance as also was the ship's vibration, which was particularly bad in the cabin I was using. This vibration made it quite a difficult job to get very near to the oscillation point on the reaction detector.

I paid very little attention to anything but 5SW, as I was chiefly desirous of determining the practical possibilities of reception from this station in the Mediterranean area (and I was never allowed to forget I was on holiday!), but I occasionally tuned up to the Philips station in Holland, which at night was about the same strength as 5SW.

Up to the Grecian coast, where 5XX was lost, 5SW was of good

strength, but always of an extremely fading nature, and this fading was definitely increasing as our distance increased.

Probably spaced-aerial reception, the only possible on land, would render 5SW quite a good proposition in these areas, but this is, of course, out of the question on a ship. I noted no serious quality distortion, which says a good deal for the steadiness of the wavelength at the transmitter.

Further Diary Extracts

The following extracts from my notes at Rhodes and Cyprus, will convey my impressions of reception at those places:—

May 14—Rhodes

Midday: 5SW moderate and then slow fade out to carrier only.

Night: At about 6 p.m., good signals, but considerable fading, later about 10 p.m., strength big, but fading about 1 or 2 second periods. Heard Frank Titterton sing "Love went a-riding."

May 15—Cyprus

Midday: 5SW much better than at Rhodes; would be good, but for ship's noises, but receiver all out to get full strength; slow fading about 2 minute periods.

Night: Not so good as midday; rapid fading and comparatively weak.

Knowing the erratic nature of these short-waves—and their great variations of strength from day to day. One cannot take any single strength test as of serious value, but fading seems to be in general, very serious.

At night, sometimes, the fading is so rapid that I have heard piano music with so many of the individual notes missing that the tune is quite unrecognisable.



Whatever kind of set you use

... look to the valve holders. If they are Lotus, they are best for your set. They will protect your valves from shocks, prevent irritating microphonic noises, and ensure pure, clear reception. Owing to the sockets being split, they expand on inserting the valve legs, and thus grip the legs throughout the whole socket depth. The valve cannot work loose.

Whether you buy your set or make it yourself, insist on Lotus Valve Holders.

From all radio dealers at 1/6 without terminals, 1/9 with terminals.

LOTUS
BUOYANCY
VALVE HOLDER
ANTI-MICROPHONIC

Made by the makers of the famous Lotus Remote Controls, Lotus Vernier Coil Holder, and Lotus Jacks, Switches and Plugs.

GARNETT, WHITELEY & CO. LTD.,
Lotus Works, Broadgreen Road, Liverpool.

Specified for the "SIGNAL 3"

The "Cylidon" Dual Condenser ('0005) is recommended by the Designer of the "Signal 3." Avoid imitations. "Cylidon" quality is essential to best results.

Dual Condenser ('0005) Price Complete 25/6
Bébé Condenser ('0001) " " 7/6

CYLDON

Write for FREE Booklet "Concerning Variable Condensers" and Booklet of Six Selected Circuits, Post FREE.

SYDNEY S. BIRD & SONS LTD.
Cylidon Works, Enfield Town.
Phone: Enfield 2071/2.

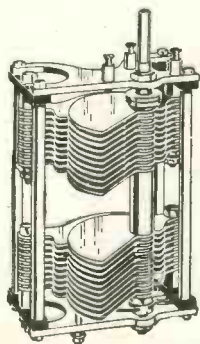

Buy
"Amateur
Wireless"
3d.
Weekly

EPOCH MOVING COIL PARTS

are guaranteed to be
the
**FINEST IN
CONSTRUCTION.
FINEST IN
PERFORMANCE.
FINEST IN FINISH.**

Price only
£3:10:0
complete

Try one on approval for 10 days and convince yourself.
From all dealers and from
EPOCH ELECTRICAL SOCIETY LTD.,
53 Gracechurch St., London, E.C.3. Phone Royal 8570.
(Full particulars on application.)

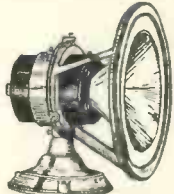

BULGIN

RADIO PRODUCTS

SAFETY FIRST!

THIS neat plug fitting makes it impossible for you to receive a shock or accidentally short-circuit your lighting mains when using them to supply H.T. or L.T. The twin socket-plug is connected to the mains leads and is heavily protected by a polished bakelite moulding, made to correct electrical specification. As recommended by "Simpler Wireless" Sets.



The High Voltage Mains Safety Plug

Price **3/9** Each

A.F. BULGIN & CO

RADIO MANUFACTURERS,
9, 10, 11, CURSTON ST. CHANCERY LANE, E.C.4.
Phone: HOLBORN 2072

THE BATTERY THAT LASTS FOR YEARS!



SAVE MONEY ON H.T. SUPPLY

What a waste! Constant replacements, dry battery after dry battery, and the ever-present bogey of spoiled programmes. Banish this for ever! Install the Standard Wet H.T. Battery—it recharges itself overnight. 2 Unibloc Cabinets 98 volts, 8/1 down and five monthly payments of 8/1. No references. Cash £2:8:5.

STANDARD
PERMANENT
H.T. SUPPLY

Free Book from The Wet H.T. Battery Co. (Dept. E) 12, 13 and 14 Brownlow Street, W.C.1.

A Crystal Set As A Transmitter!

MOST wireless listeners are only too familiar with the fact that an ordinary valve set, when in an advanced state of oscillation, tends to function as a kind of low-power transmitter. Generally the "transmissions" from it take the form of squeals and howls, accompanied, perhaps, by distorted re-radiation of any broadcast transmission to which the set is tuned.

On Neighbours' Sets

Occasionally one finds also that if a person speaks into the phones or loud-speaker connected to the oscillating valve set, the sound of his voice can be picked up on neighbouring sets.

Crystal receivers, on the other hand, are generally supposed to be innocent of any form of radiation or re-radiation; actually, however, this is not so, as the following novel experience shows:

A few days ago, I was receiving some short-wave telegraphy from amateur stations working on about 45 metres. Chancing to tune up a little above this wavelength, I found that I could hear the sound of piano music clearly and at fair strength on two valves—detector with one note-magnifier. The playing was unmistakably amateurish; but the curious thing about it was that it could be heard at almost uniform strength over a waveband of at least 10 metres, and there was no carrier wave behind it at all!

Naturally Puzzled

I was naturally puzzled at first, but after a few moments a possible explanation suddenly dawned on me. I removed my headphones and went out into the garden. From the open folding-doors of the house next door I could hear the strains of piano music.

After pausing long enough to memorise the melody that was being played, I went indoors and put on the headphones again. Yes—it was the same tune!

At the Same Time

To make assurance double sure, I hastily linked on extension leads and took the phones out into the garden, so that, by removing one earpiece from my ear, I could hear the sound of the piano music direct through the air, and via the wireless, at the same time.

The music was unquestionably identical in origin, but I found that only the higher notes were coming through on the wireless; the low notes were inaudible.

I know for a fact that the only set my neighbours possess is a small home-made

crystal receiver, tuned permanently to 2LO. The aerial to which it is connected runs parallel to my own, but is very much lower and not very close to it.

Evidently the sound of the piano was picked up by the earphones connected to the crystal set, and, in some mysterious fashion, was being radiated from the aerial, so that this weak emission was picked up by my own aerial and rendered audible in my phones.

But the most curious point about the whole affair was that the piano music was not audible when my set was tuned to the same wavelength as the crystal set in question—that is to say, 2LO's wavelength—but could only be heard on a waveband around 50 metres.

Can any reader put forward a solution to these problems? But don't get excited about it—there is no prize offered!

W. OLIVER.

Australian Call-signs

To the Editor of the "Wireless Magazine"

SIR,—Whilst going through some old copies of WIRELESS MAGAZINE, I came across a paragraph of Halyard's commenting on the partiality Australia had for the numbers 2, 3, and 4 in her call-signs.

There is no partiality for these numbers, but just a system of identification that could be well adopted by amateurs in England's many counties.

In Australia we have six states, each represented by numbers from 2 to 7, namely:

- No. 2.—New South Wales.
- „ 3.—Victoria.
- „ 4.—Queensland.
- „ 5.—South Australia.
- „ 6.—Western Australia.
- „ 7.—Tasmania.

Some examples of this are shown under:

	Metres	Watts
2FC, Sydney, N.S.W. ...	442	5,000
2BL, Sydney, N.S.W. ...	353	5,000
3LO, Melbourne, Victoria...	371	5,000
3AR, Melbourne, Victoria	484	1,600
4QG, Brisbane, Queensland	385	5,000
5CL, Adelaide, S. Australia	395	5,000
6WF, Perth, W. Australia	1,250	5,000
7ZL, Hobart, Tasmania ...	525	250

These are the A-class stations of Australia, and are worth the attempt to receive them in the small hours of the morning.—E. B. BENSON (Townsville, Australia).

CLAROSTAT



The Regal Range of Resistances!

There is a "CLAROSTAT" for every resistance purpose, each the last word in neatness and efficiency. Made in the following types:—

POWER Clarostat. GRID LEAK Clarostat.
STANDARD Clarostat. VOLUME CONTROL Clarostat.
(rating 40 and 20 watts)—TABLE TYPE Clarostat.
chiefly for eliminators. ("A distant control of Volume.")

From all good dealers in case of difficulty we supply direct
Literature on whole range FREE and POST FREE

CLAUDE LYONS, Ltd., 76 Old Hall St., LIVERPOOL

Beautifully Made. Micrometer Adjustment.

How to Trace and Cure Instability

Sets Which Are "Gay"

IN these days of neutralised-H.F. stages, screens and screened coils, screened valves and so forth, it is not often that one comes across sets which are capable of giving very good results when properly handled, but which are almost impossibly difficult to control.

"Roughly Speaking"

Yet there are at least a few such receivers. Some of them are made up according to one of the numerous descriptions published in the WIRELESS MAGAZINE—not made up *exactly* as described, but just "roughly speaking." Others of this ilk are generally pre-broadcasting in origin, or were conceived about 1925, when radio knowledge amongst practical men was not what it is now.

The symptoms are that the set performs almost in every way as it should, namely, signal strength and sensitivity are good and tuning sharp, but control is far more tricky than it should be, reaction is fierce and often the set "loses its tune" after it has been in operation a few minutes and has to be readjusted.

As the receiver is otherwise working well, it always seems a pity to have to disturb the internal arrangements in order to rectify the trouble; but it, nevertheless, is worth while, if only for the increased satisfaction that ease of tuning gives.

The trouble may be due to one of several factors. With sets having one or more stages of H.F. instability is only to be expected if neutralising (or some other method of controlling stray inter-electrode capacity) is not employed. In the case of a neutralised-H.F. set, incorrect neutralisation will make the H.F. valves difficult to keep in hand. The remedy is obvious; a practical cause of the trouble is often to be found in "over-neutralising" for one wave-band, and resulting "under-neutralisation" for another. Some neutralising condensers, too, are not so easy to adjust as they might be, and can be improved by lengthening the handles.

Process of Elimination

With "straight" sets having no H.F. stages, it is generally quite simple to trace the cause of instability by a sort of process of elimination. Probable causes include loosely-mounted coils in a moving holder, coils not spaced far enough from one another, or untidy and irregular wiring causing stray capacities.

If you have one or two spare condensers of 2-microfarads capacity, or thereabouts, try shunting each H.T. tapping.

A change of grid leaks, moreover, will often effect a cure.

QUEUE.

A Reader's Opinion of the 1928 Five

THIS fine set, a revision of the renowned 1927 Five, makes use of home-constructed plug-in coils (WIRELESS MAGAZINE, January, 1928).

A Banffshire reader makes the following comments on its performance:—

A few months ago I sent for blueprint of the 1928 Five, and commenced building it. After giving it a good trial, I thought I should like to write and let you know of its performance. It does all you say for it—and a heap more. The way you glide from one station into another is wonderful, and on the high waves I get Radio-Paris, 5XX, Copenhagan, Lahti, Hilversum, Königswusterhausen, Motala, and several others I have not yet been able to identify.

I am always interested to read in the WIRELESS MAGAZINE of other builders of this great set, and I should think it hard to improve on. Tone and quality is all one could desire, while range is practically unlimited.

I am using ordinary power valves—

and not "super" as recommended, and at present only 75 volts H.T. However, I am adding two "supers," and adding extra H.T. to make 120 volts, and I expect with this to again add more power and range.

I have used all components suggested and thank you for one of the finest radio sets ever published.

I might mention I am a radio dealer and I see lots of sets in a year's time, but I've still to see the set that comes anything near to the performance of your 1928 Five.

Attractive panels with gold corners are now available for the home-constructor at a small extra cost; their use will enhance the appearance of any receiver. Two qualities are available, Resiston and Radion panels de luxe, and further details can be obtained from the manufacturers, the American Hard Rubber Co. (Britain), Ltd., of 13a Fore Street, E.C.2.

THE CHUMMY FOUR

described in "Wireless Magazine," June issue, is a wonderful set. But to obtain the best results a really good Loudspeaker Unit had to be used. That is why the GOODMAN P.G3 Unit and Cone Paper were selected. Don't spoil your Set by a poor Loudspeaker.



The GOODMAN P.G3 Reed Unit is Four pole, Double Acting, Adjustable, ultra sensitive, yet handles huge volume, and gives wonderfully pure and undistorted reproduction. Your dealer can supply you, or write to us direct.

D.A. UNIT P.G3, 27/6 including Cone Bush and fixing Screws. NEW PROCESS CONE PAPER 2/-

GOODMANS
27 FARRINGDON ST. LONDON. E.C.4



HURRAH!
If you want to lengthen the life of your battery, If you want to build an eliminator, If you want the best value, use
Tested on 500 volts D.C. (working 240 D.C.)

A BETTER CONDENSER

HYDRA

ALL CAPACITIES MADE

Obtainable at all good dealers or direct from:—

LOUIS HOLZMAN
34, KINGSWAY LONDON, W.C.2
Telephone: Holborn 6209

OMNORA LTD.

THE SET BUILDERS SUPPLY STORES

Build the SIDECAR PORTABLE as described in this issue

	£	s.	d.
1-Cabinet as described ..	2	2	6
1-Ebonite panel, 12 in. by 4 in. ready drilled	3	1	
1-Gambrell Neutralising Condenser ..	5	6	
1-Formo 1928 Log Condenser .0005 ..	5	0	
1-M.H. Vernier Dial ..	5	6	
1-On and Off Switch ..	1	6	
1-Polar Dual H.F. Coupling ..	2	2	0
3-Pye Antiphonic valve-holders ..	6	0	
1-Lissen .0003 fixed condenser ..	1	0	
1-Lissen .0005 fixed condenser ..	1	0	
1-Lissen R.C. unit ..	4	0	
2-Lissen grid leaks, .25-meg. ..	2	0	
2-Lissen grid leaks, 2-meg. ..	2	0	
1-Lissen Potentiometer, 400-ohm B/M type ..	1	6	
1-Gecophone L.F. transformer, 4 to 1 ..	1	0	0
1-Irganic 6-way Battery Connector, complete ..	15	0	
2-Clix small plugs and sockets ..	6		
4-2 ft. lengths Glazite ..	9		
2 yds R.C. flex ..	4		
1-Electron loud-speaker unit, with cone and frame ..	1	15	0
2-Lissen 60-volt H.T. batteries ..	15	10	
2-Lissen 9-volt grid batteries ..	3	0	
1-C.A.V. 2-volt non-spill accumulator type 2NS13 ..	15	0	
	£11	8	0
4-Valves, as specified ..	2	2	0
1-Valve, as specified ..	12	6	

The above Receiver can be supplied ready wired and tested, or any of the components separately as required. We are specialising in the "Short Wave Adaptor," "Chummy Four," and other sets described in "Wireless Magazine." An interesting range of lists will be forwarded on receipt of 1/4d. stamp.

OMNORA LTD.
Home Construction Specialists,
258 NEW CROSS ROAD, LONDON, S.E.14
Phone: New Cross 1273

Come out into the open!

The Wireless World says:

"We hope that other dry battery makers will follow Messrs. Ripault's lead and come out into the open with details of the average life which may be expected from their cells."
—See page 478, May 2nd issue.

FACTS AND FIGURES

The figures shown below in respect of a "High-class Ordinary Battery" are as a matter of fact identical with those published in an article on Dry Batteries appearing in the May issue of *Houston's Radio News*, and from the figures quoted it will be noticed that:

RIPAULT'S SELF REGENERATIVE H.T. DRY BATTERIES

have very nearly double the life of an ordinary high-class battery.

60-Volt STANDARD CAPACITY at discharge rate of 5 m/amps
RIPAULT'S Self-regenerative Battery, 550 Hours' Life Price 10/6
High-class Ordinary Battery, 320 Hours' Life.

60-Volt DOUBLE CAPACITY at discharge rate of 10 m/amps.
RIPAULT'S Self-regenerative Battery, 475 Hours' Life Price 15/6
High-class Ordinary Battery, 260 Hours' Life.

60-Volt TREBLE CAPACITY at discharge rate of 15 m/amps.
RIPAULT'S Self-regenerative Battery, 500 Hours' Life Price 19/6
High-class Ordinary Battery, 280 Hours' Life.

RIPAULTS LEAD IN EFFICIENCY AND VALUE
Note the "Life" and the "Price"

Write for "Life Chart" and "Right Choice" table W/M.99 with full range of voltages and prices, also complete copies of technical press "test" reports.

Obtainable from all Dealers. If any difficulty locally write us

Ripaults Ltd.

1, KING'S ROAD, LONDON, N.W.1

"Wireless Magazine" REFERENCE SHEETS

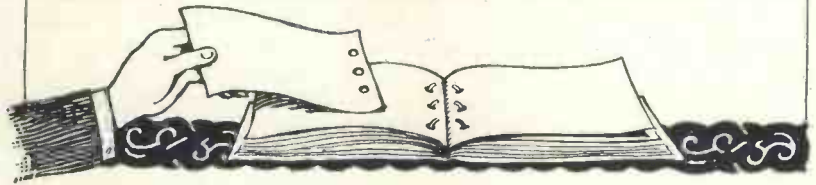

Compiled by J. H. REYNER, B.Sc., A.M.I.E.E.

Month by month these sheets can be cut out and filed—either in a loose-leaf folder or on cards—for reference. The sequence of filing is a matter for personal choice. In a short time the amateur will be able to compile for himself a valuable reference book.

WIRELESS MAGAZINE Reference Sheet

No. 71

Permeability, Differential

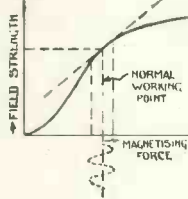

Curve shows variation of permeability

THE general meaning of permeability has been explained in Sheet No. 28. Iron and steel have the property of offering a much more ready path to magnetic flux than ordinary air and this is allowed for by saying that iron and steel have a much greater permeability.

The actual value of the permeability depends entirely upon the conditions under which the iron is being used at the time. In general, the value is of the order of several hundreds, but the effective permeability varies with the particular conditions. First, permeability of iron in a power transformer and in an intervalve transformer or choke are entirely different. In a power transformer, all the magnetic field

is alternating in character, rising to a maximum and falling to zero again in consequence of the fluctuations of the current flowing.

In an intervalve transformer, or an iron-cored choke coil, there is a steady direct current flowing which produces a fairly heavy steady magnetisation, while the alternating currents are superposed on top of this. The effect, therefore, is that the magnetisation of the iron increases and decreases about a steady value instead of rising from zero to a maximum value each half cycle, which is the case with a power transformer.

Clearly the conditions are quite different and the behaviour of the iron will also be substantially different. Actually, in this second case, we make use of the differential permeability which is the effective permeability of the iron when the magnetisation is increased and decreased about a given mean value as just described.

This varies with the actual value of the steady magnetisation and in design a value must be assumed for this steady flux and the permeability obtained for this particular set of conditions.

WIRELESS MAGAZINE Reference Sheet

No. 72

Magnetisation Curve

CURVES showing the magnetic field produced in different classes in iron and steel under different degrees of magnetisation are extremely valuable in the design of transformers and chokes. The magnetisation depends upon the current, and the number of turns and is inversely proportional to the actual length of the iron circuit. (See also Sheet No. 76.)

It is convenient, therefore, to plot to magnetisation curve against the magnetising force in terms of "ampere turns per centimetre." This is the product of current in amperes and the number of turns divided by the length of the magnetic circuit in centimetres.

The chart given in Sheet No. 73 shows the flux density produced in various classes of iron at varying magnetisations. The permeability is obtained by dividing B by the ampere-turns per centimetre and multiplying by 0.8. The differential permeability is obtained by taking a tangent to the curve, at the particular value required. Thus, if we wish to know the permeability at the point where the flux density B is equal to 12,000, we draw a tangent to the curve at this point. This is shown dotted on the curve for Stalloy on Sheet No. 73.

We now have to find the slope of this curve, which is the change in the flux density B

divided by a given change in the magnetising force. Thus, in the case in point, the value of B on this dotted line, when $I_s/l=0$ is 10,000, while a little farther up we have $B=13,500$ when $I_s/l=10$. This gives us a slope of $3500/10$, and we have to multiply this by 0.8 to get the permeability. Thus, at this particular point, the differential permeability is 275 approximately.

This is the value which would be used when designing iron-cored chokes or transformers which have to carry a steady current. (See also Sheet No. 71). The actual steady magnetisation must be worked out.

The accompanying table gives the approximate values of differential permeability for Stalloy with various values of field strength.

Flux density (lines per sq. cm.)	Permeability
10,000	800
11,000	350
12,000	275
13,000	160
14,000	60

WIRELESS MAGAZINE Reference Sheet

No. 73

Magnetisation Curves, Representative Samples

THE curves appended show the connection between the magnetising force H expressed in ampere-turns per cm. and the magnetic field strength B produced in the iron, measured in lines of force per sq. cm. The curve is often referred to as a "B-H" curve. (See also Sheets 71 and 72.)

The usual value of B is about 10,000 to 12,000. "Stalloy" is a special kind of steel designed to reach this value of field strength with only a small magnetising force. Wrought iron is poorer with low magnetising forces, but does not saturate quite so quickly.

Cast steel requires nearly three times the magnetising force of Stalloy to give $B = 10,000$, while cast-iron will not give more than 6,000 lines per sq. cm., however great the magnetisation.

For this reason Stalloy cores are generally used for low-frequency transformers and chokes of good manufacture as it enables an efficient instrument to be constructed. Some manufacturers are now, however, making use of wrought iron.

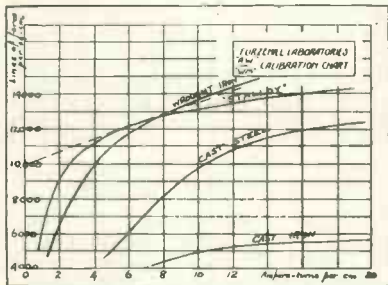

Representative Magnetisation Curves

WIRELESS MAGAZINE Reference Sheet

No. 74

Pick-up Connections

THE use of an electrical pick-up in order to permit of the reproduction of gramophone records through the medium of the ordinary amplifier and loud-speaker is becoming of widespread application. Little alteration is necessary in order to convert any existing receiver to take a gramophone pick-up of this nature.

A simple scheme is shown in the diagram attached. A jack is inserted across the grid and filament of the detector valve and the pick-up may be connected to a plug and inserted in the jack when it is desired to use it.

The insertion of the pick-up in series with the filament return is not satisfactory where grid rectification is being employed, as the presence of the grid condenser exercises a high and varying impedance to the low-frequency currents. By connecting the pick-up across the grid and filament direct, this condenser does not enter into the circuit whilst its relatively high impedance prevents the tuning coil from acting as a short-circuit. There is a certain danger that the higher tones will be shunted by the condenser, but for ordinary usage this is not a serious effect.

Grid-bias is not required on the detector valve, provided that a volume control is employed. This may conveniently take the form of a resistance shunted across the grid and filament of

the valve. If the resistance is of the order of 1 or 2 megohms, it has little or no effect upon the signal strength, while if the resistance is reduced, the signal strength is progressively cut down. The same resistance may be used in its maximum position as a grid leak when the set is being used for wireless reception.

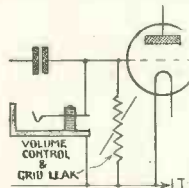

How to connect a pick-up

altogether, then special arrangements must be employed for applying grid-bias to the detector valve and for disconnecting the remainder of the detector circuit completely. The arrangement just suggested, however, gives excellent results in practice.

This volume control should be connected to the positive L.T. and not to the negative, for with the positive connection the grid-filament path of the valve is of relatively low resistance and consequently does not adversely affect the quality or produce serious distortion. (See Sheet No. 44.)

Where it is desired to avoid grid current altogether, then special arrangements must be employed for applying grid-bias to the detector valve and for disconnecting the remainder of the detector circuit completely. The arrangement just suggested, however, gives excellent results in practice.

WIRELESS MAGAZINE Reference Sheet

No. 75

Mains Testing

IT is often desired to ascertain certain factors about mains as to whether they are A.C. or D.C. or which is the positive lead in the case of D.C. mains. There are one or two arrangements which may be used in such circumstances which are of interest.

In general, a test for A.C. or D.C. can be obtained by moving a pencil or stick slowly backwards and forwards underneath a lamp. The rod should be moved reasonably slowly, say, once to and fro in a second, and if the supply is alternating there will appear to be a succession of rods forming a somewhat mistily defined plan.

This is because the light is actually fluctuating in character and gives maximum illumination at a series of points during the travel of the stick to and fro so that at these particular points, the stick is more clearly defined. The test obviously depends upon the fact that the light is entirely from

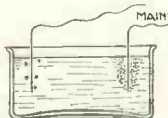

Simple method of testing mains

alternating current lamps and it cannot be performed satisfactorily in daylight. With direct current, there is no suspicion of flicker at all and the stick remains perfectly defined throughout the whole of its travel.

A test for polarity on D.C. mains can readily be obtained with the assistance of a glass of water. By placing two bare wires connected to the mains in the water and switching on the current, bubbles will be found to form at the ends of the wires. At one wire, however, there will be a considerably greater number of bubbles than at the other and this is the negative main.

Obviously when conducting this experiment, the supply should be switched off while making the necessary connections and on no account should the two wires be allowed actually to touch when the supply is switched on. The action depends upon the presence of a certain amount of dissolved salt in the water and if the water is soft, the addition of a pinch of common salt will assist in the electrolysis, of which the bubbles are the outward and visible sign.

This test can also be used as an indication of the type of mains, for if alternating current is used, the bubbles are of equal intensity at both electrodes.

THE GUARANTEE OF THE PERFECT TERMINAL

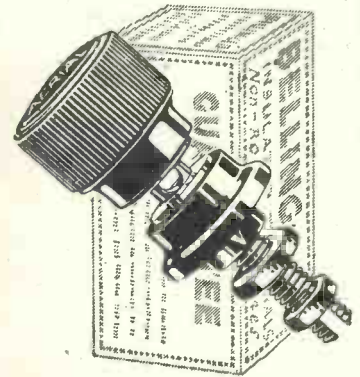

Every Belling-Lee Terminal—the most perfect terminal in the world—is sold in an attractive Carton containing a year's guarantee. All discriminating Wireless enthusiasts choose Belling-Lee terminals. Are you numbered amongst them?

PRICES.

- Type "B." Bakelite insulated—9d. each.
- Type "M." As type "B" but smaller, and non-insulated—6d. each.
- Type "R." Cheap competitive insulated terminal with rotating name—3½d. each.

Each type made with 30 different engravings.

BELLING-LEE TERMINALS

Bellink & Lee, Ltd., Queensway Works, Ponders End, Middx.

BETTER THAN WIRE WOUND



GRAHAM-FARISH

OhmitE ANODE RESISTANCES

PRICE 10,000 ohms to ½ meg. **2/3**

Especially suitable for ANODE FEED CIRCUITS or wherever heavy loads are likely to be used.

The GRAHAM-FARISH MFG. Co. BROMLEY, KENT.

READY RADIO SUPPLY CO.

41 Newcomen Street, London Bridge, S.E.1
Telephone: Hop 6787

THE SIDECAR PORTABLE

1—Ebonite panel, 12 in. by 4 in. (Raymond)	3 0
1—Neutrafising condenser (Gambrell)	5 6
1—.0005-microfarad variable condenser (Formo 1928 Log)	5 0
1—Vernier dial (McMichael)	5 6
1—On-off switch (Deckkore)	10
1—Dual high-frequency coupling unit (Polar)	2 2 0
3—Anti-microphonic valve-holders (Pye)	6 9
1—.0003-microfarad fixed condenser (Lissen)	1 0
1—.0005-microfarad fixed condenser (Lissen)	1 0
1—Resistance-capacity coupling unit (Lissen)	4 0
2—.25-megohm grid leaks (Lissen)	2 0
2—2-megohm grid leaks (Lissen)	2 0
1—400-ohm potentiometer, baseboard-mounting (Lissen)	2 6
1—Low-frequency transformer, 4 to 1 (Cecophone)	1 0 0
1—6-way battery connector (Igranic)	15 0
2—Small plugs and sockets (Lectro Linx)	6
1—Cabinet, complete with battery container (Ready-Radio)	2 2 6
20 ft. Glazite	1 8
2 yds. rubber-covered flex (Lewcos)	4
LOUD SPEAKER AND BATTERY UNIT—	
1—Loud-speaker unit complete with cone and frame (Electron)	1 15 0
2—60-volt high-tension batteries (Ever Ready Winner)	7 0
2—9-volt grid-bias batteries (Ever Ready)	2 6
1—2-volt unspillable accumulator (C.A.V., type 2NS13)	15 0
5—Valves, as specified	2 14 6
	£13 15 1

Any of the above parts can be supplied separately. Drilling free. With every Order over Two Pounds, the Official Blueprint will be included Free of Charge. Apply for detailed price lists of remaining sets, and all "Wireless Magazine" circuits.

THE CHUMMY FOUR

(The first published portable to use the screened-grid valve)
Cabinet Completely Fitted, including compass and frame aerial .. £2 6 0
All other parts in stock ..
This remarkable set can be supplied ready for use .. Price £18 10 0
(Inclusive of Royalties).
INLAND: All goods sent POST FREE.
OVERSEAS: All orders over £5 Carriage Paid.
EVERYTHING WIRELESS

The "RADIOLA"

Takes your Set
MOVING COIL L.S. and Batteries



A Stately HOME
From £5-5-0

"RADIOLA" de luxe

Fully Guaranteed

WINS HIGHEST APPROVAL of Radio Press, Leading Experts, over 3,000 delighted clients, 3 ft. high. Rich Solid Oak or Mahogany—a magnificent finish—at Loud-speaker cost only.

LET US HELP YOU. Suggestions and FULL LIST of exclusive designs FREE. Send now to actual makers:—



M.G. WORKS BEXLEYHEATH : KENT

ODD JOTTINGS

Next Month's Issue

OWING to the great pressure on our space this month we have been obliged to hold over until the next issue the second of John Simple's articles and some notes by J. H. Reyner on the performance of his Sunshine Five in the north of England.

Other articles that will appear next month are "Summertime D.X. Work," by R. W. Hallows; "Successful Short-wave Working," by J. H. Reyner; and "The Value of the Four-volt Valve," by D. Sisson Relph.

Lewcos Removal

TO increase the efficiency of their service to customers, the London Electric Wire Co., and Smiths, Ltd., are removing their sales, orders, and accounts departments from Playhouse Yard to larger offices at Leyton on June 16. From this date all correspondence with these departments should be addressed to them at Church Road, Leyton, E.10.

A Useful Valve Booklet

OF particular interest to listeners is the new Osram valve booklet issued by the General Electric Co., Ltd., of Magnet House, Kingsway, W.C., copies of which can be obtained by readers post free if the WIRELESS MAGAZINE is mentioned.

The full title of the booklet, which contains twelve pages, is "Osram Valves for Power Amplification with Cone and Moving-coil Loud-speakers."

Two sections of especial value to the amateur who desires to improve his reproduction are those on running valves in parallel and in "push-pull."

"W.M." Reference Sheets

NOTE the following corrections in Sheet No. 28, "Permeability":—
In the second paragraph, the words occur "the magnetic field . . . may rise to a value fifty times as great as it was formerly." This should read "many hundred times" instead of "fifty times."
In the middle of the third paragraph, the words occur "until it reaches a maximum value which usually lies between 50 and 100." This should read "between 500 and 1,000."

All-from-the-Mains Four

The correct cabinet for this set is the one we supplied; it is a well-constructed cabinet, artistic and yet reasonable in price.

In Oak 37/6 In Mahogany 45/6

We have a splendid selection of cabinets for all types of receivers. Send for Free Illus. Catalogue.

The Arcraft Company
156 Cherry Orchard Road, Croydon

USE
EELEX
TREBLE DUTY TERMINALS
AND OTHER WIRELESS ACCESSORIES
J.J. EASTICK & SONS.
EELEX HOUSE, BUNHILL ROW, LONDON, E.C.1

All-from-the-Mains Four

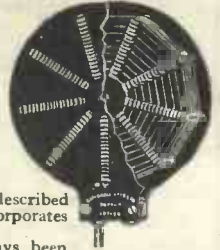

This Mains Receiver, described in this issue, incorporates Gambrell Coils. These coils have always been recognised for their high efficiency and still maintain their lead as the original low-loss type. Their strength and rigidity, and the fact that they are totally enclosed makes them specially suitable for Mains sets and for receivers where screening is employed. Gambrell Coils are repeatedly selected and used by contributors of constructional articles to the technical press. The illustration shows the patented method of construction and winding which is responsible for their remarkable efficiency.
Obtainable from all Dealers

The "Side-car Portable"

The perfect, all-round high quality of the Gambrell Neutrovernia is proven by the fact that it has been used and specified by the designers of no less than ten popular receivers within the last few weeks. And now it has been selected for the "Side-car Portable" described in this issue. This condenser has a delightfully smooth and uniform control over a wide range. It is dust- and damp-proof and its convenient design makes it ideal for incorporation in portable receivers.

From all Dealers, PRICE 5/6

Write for descriptive booklets on Gambrell Coils and Neutrovernia

GAMBRELL BROS. LTD.
76 VICTORIA STREET, LONDON, S.W.1

Index to Advertisers

Arcraft Co.	560
Baker's Selhurst Radio	552
Bedford Electrical & Radio Co.	554
Belling & Lee, Ltd.	559
Bernard Jones Pub. Ltd.	Cover ii
Bird, Sydney S. & Sons, Ltd.	555
British Ebonite Co., Ltd.	553
Bulgin, A. F. & Co.	556
Burne-Jones & Co., Ltd.	553
Carrington Mfg. Co., Ltd.	553
Celestion Radio Co., Ltd.	554
Clarke, H. & Co. (M/cr.), Ltd.	548
Cossor, A. C. & Co., Ltd.	545
Dubilier Condenser Co. (1925) Ltd.	549
Eastick, J. J. & Sons, Ltd.	560
Electron Co., Ltd.	Cover iii
Epoch Electrical Society	556
Ever Ready Co., Ltd.	547
Fluxite, Ltd.	549
Formo Co., The	552
Gambrell Bros., Ltd.	560
Garnett Whiteley & Co., Ltd.	555
Goodmans	551 and 557
Graham Farish Mfg. Co., The	559
Holzman, Louis	557
Igranic Electric Co., Ltd.	549
Lissen, Ltd.	482
London Electric Wire Co., The, and Smiths, Ltd.	550
Lyons, Claude	556
Mullard Wireless Service, Co.	Cover iv
Omora, Ltd.	558
Pettigrew & Merriman (1925), Ltd.	553
Picketts	560
Raymond, K.	546
Ready-Radio Supply Co.	560
Ripaults, Ltd.	558
Rooke Bros., Ltd.	551
Sifam Electrical Inst. Co., Ltd., The	554
Wamel Wireless Co., Ltd.	551
Wet H.T. Co.	556
Whiteley Boneham & Co., Ltd.	552
Wright & Weaire, Ltd.	553

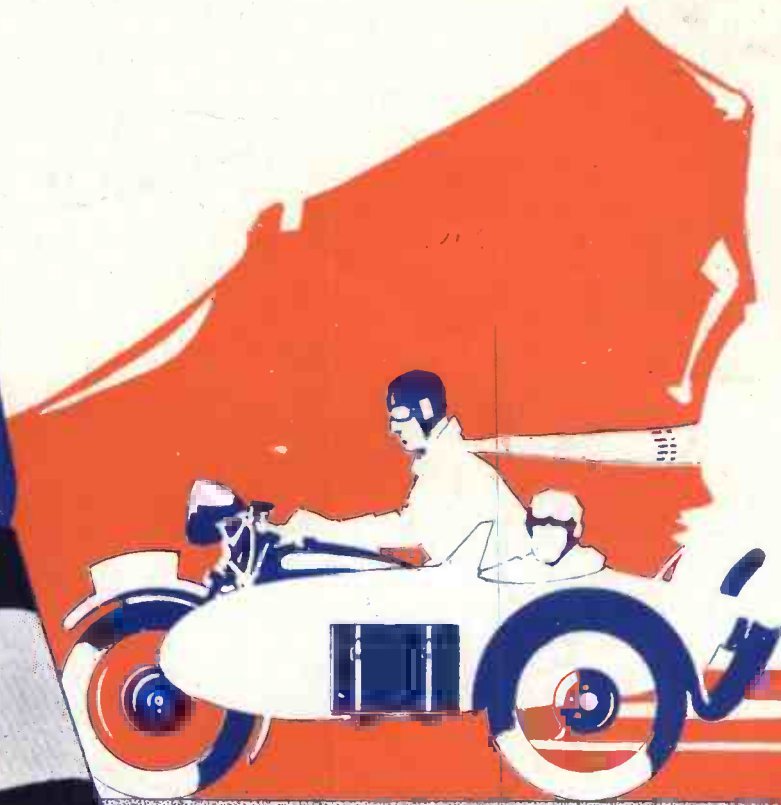

SIX-SIXTY

for the Sidecar Portable



SIX-SIXTY Loud-speaker Assembly **35/-**

SIX-SIXTY—the name which means the best in radio—has again triumphed. The new SIX-SIXTY Loud-speaker Assembly has been specified for the "Sidecar Portable."

This new Assembly, ideally suited to the portable type of receiver, will, when used in conjunction with the famous SIX-SIXTY valves, yield the most amazing results.

Valves with very strong filaments are obviously essential for portable receivers, which have to withstand all sorts of excessive vibration. To indicate the phenomenal strength of the SIX-SIXTY filament we reproduce below an extract from a letter recently posted to us by a satisfied client:—

" . . . It appeared then that the TWO-VOLT valves had been working off a SIX-VOLT accumulator for nearly six months without giving out. . . . This undoubtedly proves the strength of the filament of the Six-Sixty Valve."

Ask your dealer or write to us to-day for attractive book illustrating the full range of SIX-SIXTY valves.

THE ELECTRON CO., LTD. 122-124 Charing Cross Road, LONDON, W.C.2.

Tel.: Regent 4366

iii

Half-price **BLUEPRINT** Coupon Valid until July 31, 1928
FOR ANY ONE SET CONSTRUCTIONALLY DESCRIBED IN THIS ISSUE.

Fee of **INFORMATION** Coupon Valid until July 31, 1923
NOT MORE THAN TWO QUESTIONS TO BE ASKED AT A TIME



THIS special enlarged number of "Radio for the Million" is waiting for you . . . send the coupon to-day. In it there are over 20,000 words of intense interest to every radio owner and a special message to those contemplating the possession of a first radio receiver embodying every modern refinement.

America on the Master Three

The tens of thousands of owners of this amazing three valve receiver are given in this new issue the magic key to the reception of American, Continental and Australian stations on the fascinating short waves. Many letters from owners of Mullard P.M. Sets are published describing remarkable trans-world results.

The Mikado P.M.

—a wonderful two valve version of the Master Three, giving pleasing, powerful and certain results in return for a minimum outlay of time and money. Anyone can construct the Mikado P.M. regardless of experience or skill. Complete instructions and simplified Blue Print are supplied free with every copy of this issue. Make sure of your copy.



Mullard

MASTER · RADIO

The Editor, "RADIO FOR THE MILLION" Dept. 6,
63, Lincoln's Inn Fields, London W.C.2.
Please send me FREE No. 6 "Radio for the Million"
complete with Blue Print for the MIKADO P.M.

NAME

ADDRESS