

HOW TO RECOGNISE THE FOREIGN STATIONS

# Wireless Magazine

Edited by  
Bernard E. Jones

January, 1926

Vol. 2,  
No. 12.

COMPOSED  
BY BENNETT

ONE SHILLING



A STEP-BY-STEP  
SUNSET  
Full of Practical Details

With Free  
Coloured  
"Structograph"  
of Distortionless  
Three-valver

THE WORLD'S GREATEST MAGAZINE OF WIRELESS

# Do you burn Money?

**YOU DO**—every time you inadvertently try to put a valve into its holder the wrong way round. An accident that can easily happen, it can be permanently prevented by using the Dobilier Dubrescon.

You just insert it in one of the H.T. leads, and it acts as a permanent safeguard against a sudden rush of H.T. current.

The Dubrescon is not a fuse, but a permanent valve protector, and it only costs 6/-. It does not interfere in any way with the passage of the H.F. currents.

Buy one to-day and make sure!

The Dobilier Condenser Co. (1925) Ltd. also manufacture Fixed Mica Condensers, Variable Air Condensers, Anode Resistances, Grid Leaks, the Ducon Aerial Adaptor, the Mansbridge Variometer and the Minicap Switch. The Company are also sole concessionaires for the Products of the Mansbridge Condenser Coy., Ltd.

## Specify Dobilier



The Dobilier Dubrescon  
Valve Protector,  
6/-



REGISTERED  TRADE MARK

# DUBILIER

CONDENSER CO (1925) LTD

Radiolux models in two sizes and various finishes are available at prices from £4-15-0.

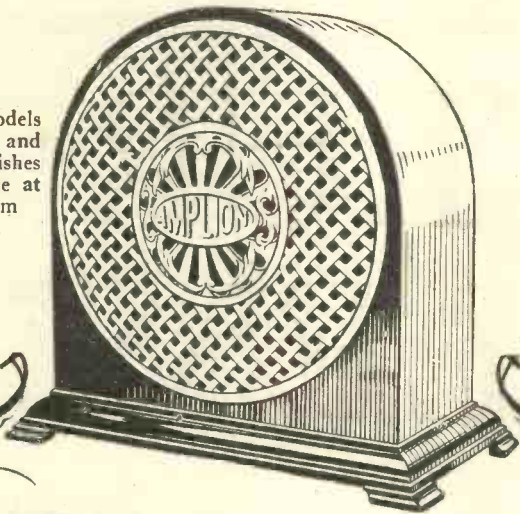

# Radiolux AMPLION

## Real Music Enters Every Home

where an AMPLION is installed, for, in wireless reception, the living voice and true musical values are no longer idle dreams but realities.

### An Outstanding Triumph in Loud Speaker Design

THE RADIOLUX AMPLION is a wireless Loud Speaker totally different in appearance, in construction and in results.

Not only is the spoken word and the song of the vocalist true to life, but instrumental music is almost indistinguishable from the original studio performance.

Outwardly resembling the English bracket clock, the cabinets possess that beauty of form and superlative finish which denote the *masterpiece*.

THE  
WORLD'S  
STANDARD

# AMPLION

WIRELESS  
LOUD  
SPEAKER

### For Better Radio Reproduction

Demonstrations during business hours at: 25-26, Savile Row, W.1; 79-82, High Street, Clapham, S.W.4; 10, Whitworth Street West, Manchester; and 101, St. Vincent St., Glasgow.

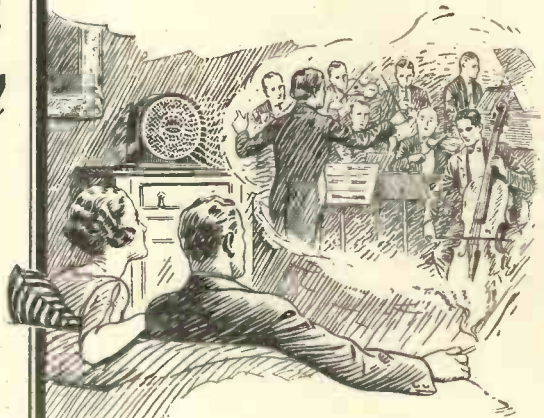

The supremacy of the AMPLION, invariably in evidence, is again emphasised in the introduction of the Radiolux Series of Hornless Loud Speakers, conceived and developed upon original lines with an ever-present ideal.

Products of the House of Graham are moreover covered by a full and unconditional guarantee of satisfaction and free service.

Solely upon its merits the AMPLION has achieved the pre-eminent position of

**The World's Standard Wireless Loud Speaker.**

ACCEPT NO SUBSTITUTE FOR A GENUINE AMPLION.

Obtainable from AMPLION Stockists, Radio Dealers or Stores.

Patentees and Manufacturers:

**ALFRED GRAHAM & COMPANY (E. A. GRAHAM),**  
St. Andrew's Works, Crofton Park, London, S.E.4.

All inclined towards a "horn" loud speaker can in addition have the choice of the well-known "Dragon" and "Swan Neck" models from 25s. upwards.

In writing to advertisers, please say you saw the advertisement in THE WIRELESS MAGAZINE.

# “AMATEUR WIRELESS”

## *The Great Pioneer Paper*

**B**ECAUSE you like the WIRELESS MAGAZINE for its expert detailed constructional articles and the many interesting phases of wireless, which it so admirably presents, you cannot but like AMATEUR WIRELESS.

THE WIRELESS MAGAZINE, as you know, leads the monthlies: AMATEUR WIRELESS is foremost of the weeklies.

Every issue of AMATEUR WIRELESS contains remarkably useful constructional articles, helpful contributions on receiving and transmitting, novelties and new developments, and—finally and particularly—the best possible news service.

*Take “Amateur Wireless”  
Each Week and Get  
the Best Results from  
Your Set.*

IT IN TERESTS  
FORMS  
STRUCTS  
SPIRES

**3** D.  
*Every  
Thursday*



Cassell & Co., Ltd., La Belle Sauvage, E.C.4

*In writing to advertisers, please say you saw the advertisement in THE WIRELESS MAGAZINE.*

# 'You Can't Miss a Station!'



THE EXTRAORDINARY tuning facilities given by the GECOPHONE Low-Loss Slow-Motion Condenser are crystallised in the spontaneous statement of a user—"You cannot miss a station with it!"

THIS GREAT SELECTIVITY is a result of the remarkable micrometer movement, obtained by an entirely original method employing friction-drive gearing, enabling you to *creep* round the dial and to control your set to an extent impossible hitherto.

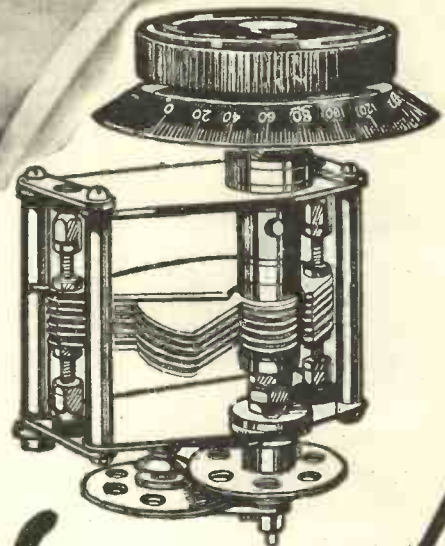

## GECOPHONE

### LOW LOSS-SLOW MOTION VARIABLE CONDENSER

#### PRICES.

.0002 mfd. - 22/-	.0003 mfd. - 24/-
.00025 mfd. - 23/-	.0005 mfd. - 27/6
.001 mfd. - 32/6	

GECOPHONE Components are described in Booklet B.C. 3759.

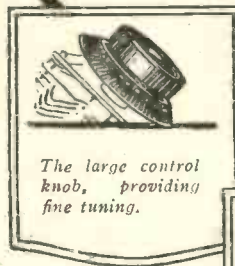

The large control knob, providing fine tuning.



Losses minimised by insulating fixed plates outside electrostatic field.

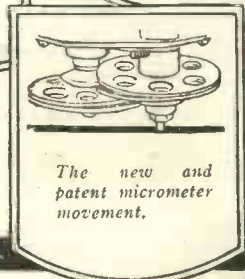

The new and patent micrometer movement.

Sold by all GECOPHONE Service Depots, Wireless Dealers and Stores.

Advt. of The General Electric Co. Ltd., Magnet House, Kingsway, London, W.C.2.

In writing to advertisers, please say you saw the advertisement in THE WIRELESS MAGAZINE.



## Useful "Amateur Wireless" Handbooks

Each 1s. 6d. net, of all Booksellers and Newsagents, or 1s. 9d. post free from the Editor of "Amateur Wireless," La Belle Sauvage, E.C.4.

### Crystal Receiving Sets and How to Make Them

A Simple and Efficient Receiving Set. A Single-Slider Set. Set with Semicircular Tuner. Crystal Set with Tapped Single Coil. A Loose-Coupled Set. Set with Plug-In Basket Coils. Combined Crystal and Valve Receiver. Some Miniature Receiving Sets. Crystal Circuits. How Crystals Work. Making a Buzzer. Receiving C.W. Signals on a Crystal Set. Making a Wavemeter from a Crystal Set. Converting Low-Resisting Phones. The Morse Code.

### Simple Valve Receiving Sets and How to Make Them

A Single-Valve Set with Basket-Coil Tuner. A Single-Valve Set with Side Inductance. A Single-Valve Heterodyne Receiving Set. One-Valve Variometer Set. A Portable Single-Valve Set. Adding a Valve. A Two-Valve Set. A Three-Valve Amplifying and Detecting Unit. The "Amateur Wireless" Unit Set. An Improved Unit Set.

### Wireless Telephony Explained

The Electron; Induction and Electro-Magnetism; Waves and How They Travel; Inductance and Capacity; Rectification; Amplification; Reaction and Beat Reception; Aerials and Earths; Transmitting Systems; Receiving Sets; Useful Formulae and Data.

### Wireless Telegraphy and Telephony and How to Make the Apparatus

General Principles of Wireless Telegraphy. Some Informative Experiments. Tuning and Resonance Explained. Transmission and Reception. Various Detectors Explained and Described. Thermionic Valves as Detectors, Amplifiers, and Generators. Making a Single-circuit Receiving Set. Making a Complete Short-wave Receiving Set. Making a Valve Panel for Receiving Set. Making a Five-Valve Amplifier. Wireless Telephony.

### Wireless Component Parts and How to Make Them

Components and Their Varied Purposes. Crystal Detectors. Coils: Making and Mounting. Condensers. Variometers and Vario-Couplers. Resistances or Rheostats. Transformers. Making a Test Buzzer.

### Practical Guide to Wireless (1/- net)

By post 1½d. extra.

An Outline of Present Broadcasting. The Aerial. Tuners and Tuning. The Crystal Set. The Valve and Valve Sets. Telephones and Loud-Speakers. Current for Valve Filaments.

Cassell's, La Belle Sauvage, E.C.4

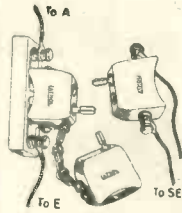

### AERIAL-EARTH PLUG

As simple as the simplest switch but twice as efficient. Separates set from aerial; couples aerial direct to earth. Spark-gap attachment is provided. Plugs and sockets air spaced and mounted in high-grade electrical porcelain.

A safety insurance for 4/6.

**ATHOL ENGINEERING Co.**  
Cornet St., Higher Broughton, Manchester  
Telephone: Higher Broughton 469.



### EVERY HOME A WIRELESS SET EVERY WIRELESS SET A HOME

The "MORRIS" Standard Wireless Cabinet accommodates any kind of receiver and panel up to 30 ins. X 18 ins., with all accessories. Solid oak throughout and perfect workmanship guaranteed. (Smaller size 56 lbs. net.) No plywood used.

Model A	22½ in. inside, solid Oak	£4 15 0
" A	25 " " " "	" 5 5 0
" C	22½ " " " "	" 5 10 0
" C	25 " " " "	" 5 15 0
" C	30 " " " "	" 6 15 0
" A	30 " " Pinewood	£2 10 0

Money returned if not satisfied.  
Carriage paid and packed free England and Wales.

**MAKERIMPORT CO. (Dept. 25),**  
Melvill Chambers, 50a, Lord Street, LIVERPOOL.

A new "Amateur Wireless" Handbook

## Loud-Speaker Crystal Sets

HOW TO MAKE AND MANAGE THEM

Working instructions are given on the building of a number of highly efficient crystal sets with which particularly loud signals have been obtained. The special system of operating a loud speaker from a crystal set—with results comparable to those obtained with one and possibly two valves—is fully described 2/6 net with diagrams and illustrations.

Cassell's

# F.W. LOWENADLER'S

TRELLEBORG

## FAMOUS GENUINE EBONITE PANELS

**Q** A clear explanation  
A startling prophecy

# Talks About Wireless

By SIR OLIVER LODGE

Who would not wish to read what the famous scientist has to say regarding the most wonderful and most entertaining phenomenon of the present time? Sir Oliver Lodge's book is at once authoritative and suggestive. It comprises not only a survey of wireless from the earliest discoveries down to existent conditions, but also arresting prophecies of possible future achievements.

"A book simply written and popularly presented by one of the foremost minds of the day; both beginners and advanced students all the world over will eagerly peruse this book."

DAILY GRAPHIC



Extra crown 8vo, 276 pages, with a number 5/-  
of Illustrations in the Text. Cloth. net

Cassell's, Publishers, London, E.C.4

*The Wireless  
Book you  
should not  
miss!*

By

**ARTHUR R.  
BURROWS**

*Asst. Controller  
and Director of  
Programmes, B.B.C.*

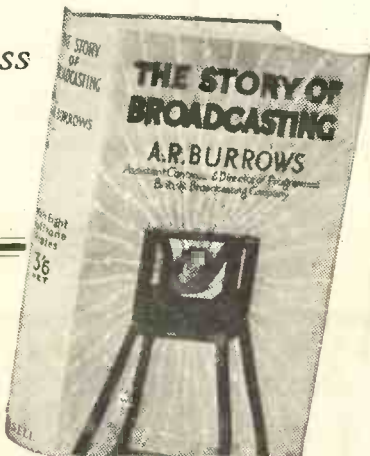

## The Story of Broadcasting

The theory of wireless, little known examples of its use in peace and war, wireless telephony, peeps into the control room, the amazing possibilities of broadcasting in the future, simply and delightfully recorded. With 8 pages of illustrations.

"A book of importance, to which people's attention should be drawn."—*Sunday Chronicle*.

"A first-rate history of wireless."—*Daily Dispatch*.

**3/6**  
net

Cassell & Co., Ltd.



London, E.C.4.

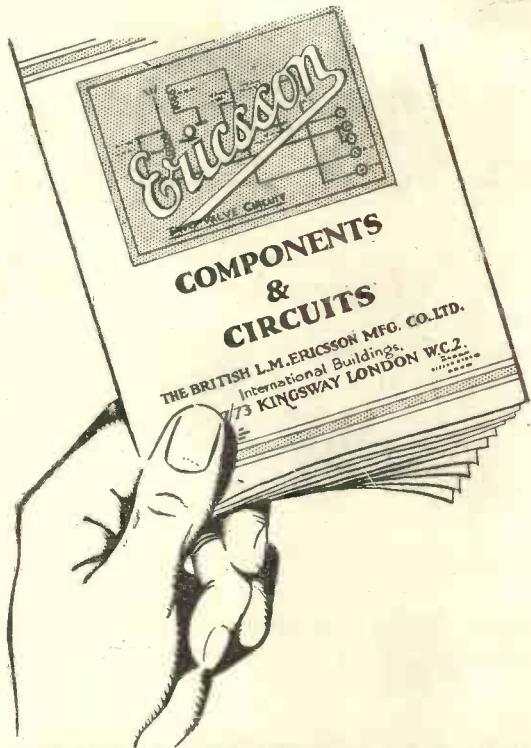

# FREE! and full of wiring diagrams

DO you want to get the best from your set? Do you want wiring wrinkles? Do you know how best to place your components on the panel? Do you...? Well, if so, send to-day for the Ericsson Handbook of Components and Circuits. Full from cover to cover with useful radio information—and post free to every constructor.

*Write to-day for your copy and  
get busy on that new super set.*

The BRITISH L.M. ERICSSON MFG. CO., Ltd.  
67/73, Kingsway, London, W.C.2.

# Ericsson

**COMPONENTS  
and CIRCUITS  
HANDBOOK**

In writing to advertisers, please say you saw the advertisement in THE WIRELESS MAGAZINE.

# Marconi VALVES

*For Supreme  
results*

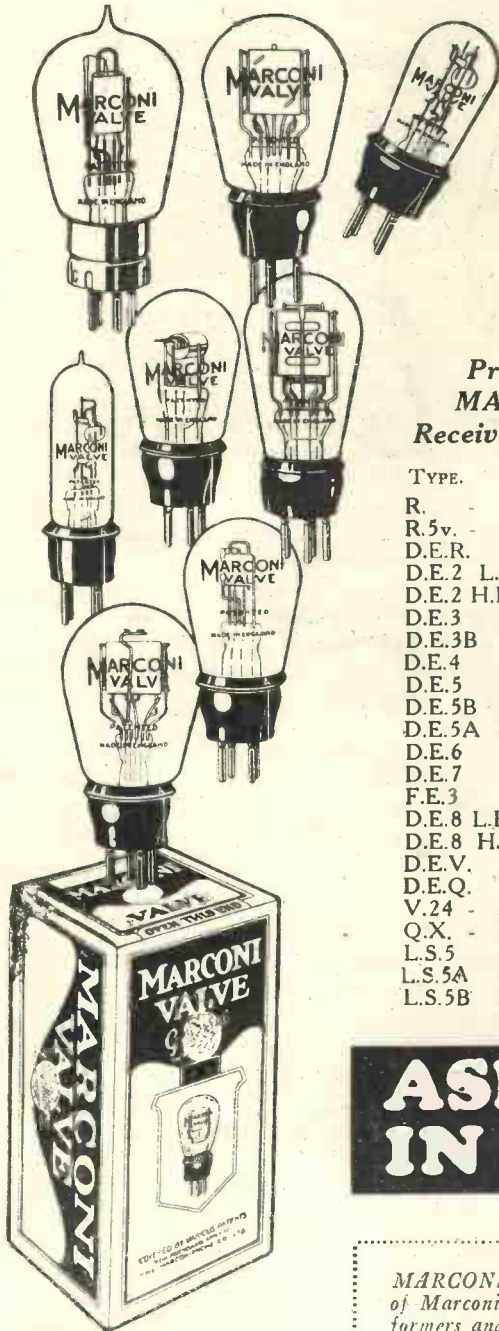

*Prices of  
MARCONI  
Receiving Valves.*

TYPE.	PRICE.
R.	8/-
R.5v.	8/-
D.E.R.	14/-
D.E.2 L.F.	15/6
D.E.2 H.F.	15/6
D.E.3	16/6
D.E.3B	16/6
D.E.4	22/6
D.E.5	22/6
D.E.5B	22/6
D.E.5A	26/-
D.E.6	18/6
D.E.7	37/6
F.E.3	27/6
D.E.8 L.F.	22/6
D.E.8 H.F.	22/6
D.E.V.	25/-
D.E.Q.	27/6
V.24	20/-
Q.X.	20/-
L.S.5	40/-
L.S.5A	40/-
L.S.5B	40/-

FOR receiving, amplifying or transmitting, the valve is of paramount importance. An indifferent valve—indifferent results; a good valve—good results; a *Marconi Valve*—supreme results.

Marconi Valves are designed to give the best that a valve can give. For performance, tonal purity, volume and durability, Marconi Valves are unsurpassed. Why? Because they are soundly constructed on scientific lines and each type is specifically constructed in relation to the function for which it is intended.

Therefore, choose Marconi Valves, and look for the name *Marconi* on each valve before you buy. It is the name with the greatest goodwill amongst radio users and guarantees absolute satisfaction.

*Full descriptive list of Marconi Valves, No. W.M. 435, giving particulars of each type, sent on request.*

**ASK FOR THE VALVE  
IN THE PURPLE BOX**

*at your Radio Dealers.*

*MARCONI—The name first and foremost in radio for 30 years, guarantees the supremacy of Marconiphone products—Receiving Sets, H.F. and L.F. Amplifiers, "Ideal" Transformers and components, also the famous Sterling Loud Speakers, Sets and Components.*

## THE MARCONIPHONE COMPANY, LIMITED

Registered Office: Marconi House, Strand, London, W.C.2, and 210-212 Tottenham Court Road, London, W.1.  
Branches: Aberdeen, Bristol, Birmingham, Belfast, Cardiff, Cheltenham, Dublin, Glasgow, Leeds, Liverpool, Manchester, Newcastle, Nottingham, Southampton, Swansea.

*In writing to advertisers, please say you saw the advertisement in THE WIRELESS MAGAZINE.*



# The Wireless Magazine



Vol. 2

CONTENTS FOR JANUARY 1926

No 12

	PAGE		PAGE		PAGE	
RECOGNISING THE FOREIGN STATIONS WHEN YOU HEAR THEM. A special article by J. Godchaux Abrahams . . .	560	The S.O.S. A Wireless story by J. D. Millard . . .	606	Ripples . . .	617	
The "W.M." Map of Principal European Broadcasting Stations . . .	563	Scotch Both Ways. A Drawing . . .	609	Broadcast Music of the Month. With 17 photographs . . .	618	
DID SENATORE MARCONI INVENT WIRELESS? An Authentic Interview . . .	564	Gadgets, Hints and Tips . . .	610	My Favourite Circuit . . .	620	
Under My Aerial. The Chat of the Month . . .	570	<b>HOME-CONSTRUCTOR SETS</b>			A Story Without Words. A Drawing by René Bull . . .	621
Wonderful Wireless Waves . . .	574	<i>A DISTORTIONLESS THREE-VALVER.</i> With free Structograph plate. A set especially suitable for loud-speaker work . . .			566	
Expressions. A Drawing . . .	575	<i>A STEP-BY-STEP EIGHT-VALVE "SUPER HET."</i> Built up in a particularly compact form. Something quite new in receiver design . . .			587	
How the Valve Works . . .	576	<i>A ONE-CONTROL CRYSTAL SET WITH WIDE WAVELENGTH RANGE</i> . . .			615	
STUDIO IMPRESSIONS. By Watson Lyle . . .	578	<i>A ONE-VALVE LOW-FREQUENCY AMPLIFIER.</i> Suitable for use with either a crystal or valve set . . .			626	
A Battery Tester . . .	579	AN AMERICAN AT THE COURT OF KING RADIO. A special article by Fred Smith, Director of W L W Station, Cincinnati . . .	611	Crystal Curves! By J. Hartley Reynolds . . .	622	
Irish Broadcasting . . .	580	ADVERTISING BY WIRELESS. By Sir Charles Higham . . .	614	Prof. E. Sopp's Fables. No. 5.—The Maids of Diverse Dispositions . . .	624	
Novelties and New Apparatus. Illustrated and Described . . .	582			The Origin of S O S . . .	630	
At It Again! By Fishglue . . .	584			THE WHOLE ART OF TUNING . . .	632	
Where the Dull-emitter Scores . . .	585			What Readers Think of Our Sets . . .	636	
Keeping the Crystal Detector Warm! "MY FIRST BROADCAST." Sensations and impressions of well-known people on broadcasting for the first time . . .	596			Blake Boanerges' Banter . . .	638	
How the Valve May Help the Physician . . .	599			Wireless Femininities . . .	640	
Condenser Care . . .	601			The World's Broadcasting . . .	642	
When a Ship Loses Itself! . . .	602			About the Use of Reaction . . .	643	
Anode or Plate? Which Term Should We Use? . . .	605			What the B.B.C. is Doing . . .	644	
				What the Reader Thinks . . .	646	
				Continental Notes . . .	648	
				Keeping the Lead-in Dry . . .	650	
				Is a High Aerial Best? . . .	650	
				Temporary Earth Connection . . .	650	
				Piezo Electricity . . .	651	
				Questions Simply Answered . . .	652	
				Ebonite—and Ebonite! . . .	653	
				Catalogues and Pamphlets . . .	654	
				Below the Broadcasting Belt . . .	656	
				Jottings on the Month's Progress . . .	660	
				The Buyers' Guide . . .	664	

**Announcements.**—THE WIRELESS MAGAZINE, edited by Bernard E. Jones, is published about the 25th day of the month, and bears the date of the month following. One Shilling Net. Subscription rates are 15s. 6d. a year, post free; Canada, 13s. 6d. a year, post free. Contributions, accompanied by stamped and addressed envelopes, are invited. All editorial communications should be addressed to The Editor, THE WIRELESS MAGAZINE, La Belle Sauvage, London, E.C.A. Subscriptions should be addressed to The Publisher, THE WIRELESS MAGAZINE.

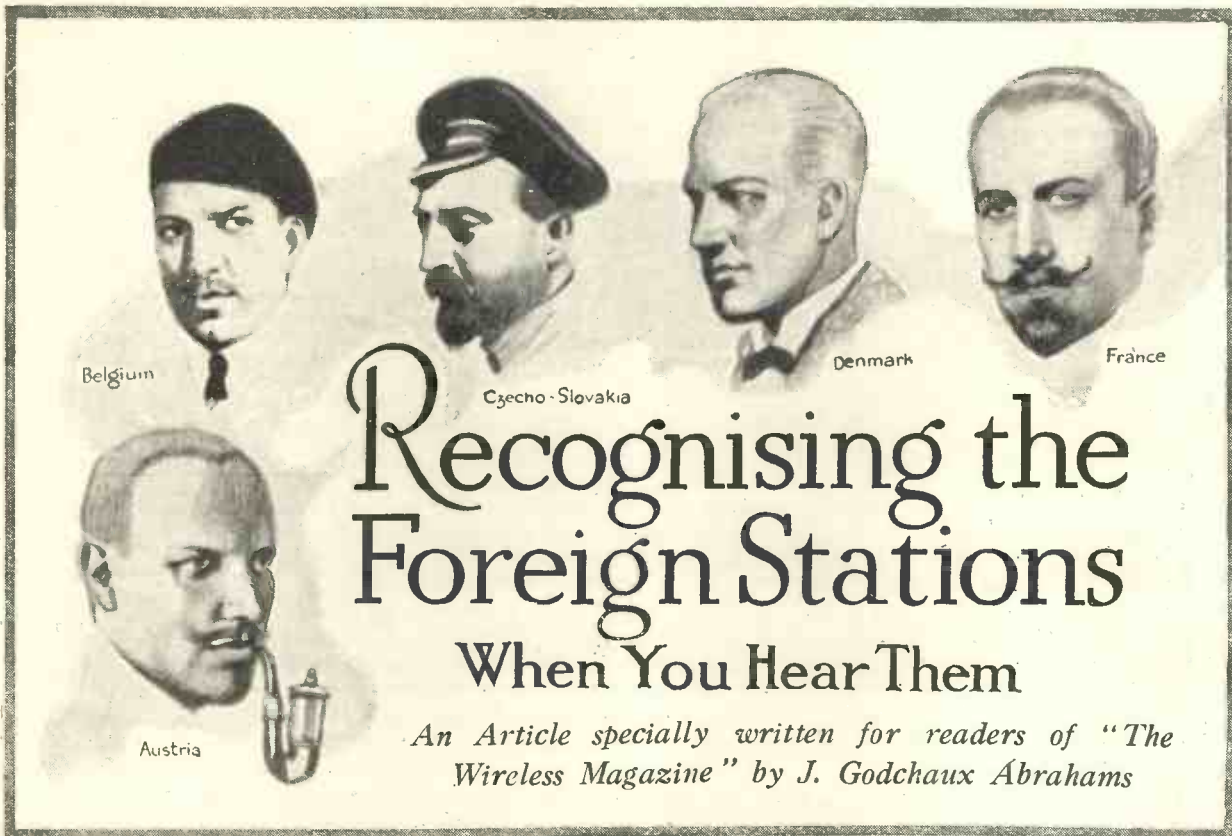

# Recognising the Foreign Stations When You Hear Them

An Article specially written for readers of "The Wireless Magazine" by J. Godchaux Abrahams

FROM the start, it is absolutely essential that the amateur should constantly keep by his receiver a list of the home and foreign broadcasting stations in order of wavelengths; such a list is to be found in the last pages of THE WIRELESS MAGAZINE, and in the current issues of *Amateur Wireless*.

## Memorising Coil Numbers

In the ordinary way most listeners owning receivers, be they of the single- or multi-valve variety, pick up more than merely their local station, and from visits I have paid to such friends, I find that, in all instances, they are able to memorise the numbers of the coils used and their respective condenser settings.

But to trust to one's memory is not sufficient; as soon as some kind of transmission has been tuned-in, a note should be made without delay of these factors.

Now, if you do this on every occasion, as soon as you have established the identity of a few stations, it will be quite easy to place the others in their proper position in the published list of wavelengths.

Have I made this clear to you? If not, here goes: We will presume that we have tuned-in Birmingham on three coils—namely, aerial circuit,

No. 50; secondary or anode, No. 75; with reaction coil No. 50 or 75. We find that the condenser settings read for the A.T.C. 48 degrees, and for the anode coil 50, but variation of the coupling of the reaction coil may slightly modify these readings. We know that 5 IT works on 479 metres.

At some time we may have picked up P T T, Paris, on the same coils but with lower condenser readings, say, A.T.C. 39 degrees, anode 44 degrees. Here again, we also know that P T T operates on 458 metres. On this occasion we have tuned-in a further station, and the A.T.C. reads 41 degrees and the anode 48 degrees. Very well, who is it?

Now you know—or should know—that an increase in the capacity, that is, a higher reading on the condenser, must mean an increased wavelength.

The data we possess provides a very excellent clue. Our friend is obviously transmitting on a wavelength between those indicated by our fixed factors. Look at the list. We have Barcelona (Radio-Catalana) on 460 metres, Königsberg on 463, Linköping on 467, and Frankfort-on-Main on 470 metres. It must be one of these "broadcasters," but which?

Our next move is to take a list of times and transmissions such as "Broadcast Telephony" in *Amateur Wireless*. We need only look up four stations and can easily ascertain which are working. By a process of elimination we shall reduce our probabilities and for the final clinching argument will rely on our identifying a piece of music, a lecture, a talk or a call.

If we hear speech, although an announcer may not mention the name of the station, we shall again narrow down the issue, as the recognition of even a few words of the language broadcast will indicate the country from which the transmission emanates.

## Clear Calls

If—this is a big if—all stations gave their calls as clearly and at such regular intervals as do those of the B.B.C. we should never be in doubt, but, unfortunately, they do not, and, failing this information, we are compelled to fall back on other peculiarities in order to establish satisfactorily the identity of our unknown friend.

Shall we now—before we go a step farther—presume that by the method I have described we can get some idea of the wavelength we have

picked up? If so, there can be little difficulty in stating, without fear of contradiction, that we are tapping either the 250-350, the 350-500 or the higher wavebands. As you will, no doubt, agree, this proves a great help to us.

If we pick up the beginning or the end of a transmission we shall, in most instances, get the call, but at times we may have to wait for an hour before the station discloses its identity and must therefore apply other methods of identification.

### Station Peculiarities

Many stations, without actually giving the name of their town, preface the different items of their programme by:—

1. The word *Allô*, repeated two or three times. If the H is not aspirated, you will find that this is nearly always a French or Belgian broadcaster.

2. By the warning *Achtung* (pronounced *Aarktoong*), which is typically German, Swiss or Austrian, although with some of them the word *Hallo* (*Haa-low*) is also used.

3. By the word *Atencion* (*Aa-ten-thee-own*). Any lisped call of this nature comes to us from Spain.

4. By morse signs as an opening signal or to allow listeners to tune-in to the wavelength during intervals in the entertainment.

5. By the ticking of a metronome, the sound of a gong or other mechanical device.

6. By special time signals, or by other peculiarities.

One word you are sure to pick up very frequently, and that is *Radio* (pronounced *Rah-dee-owe*). When it is used you will mostly find it followed by the name of the city in which the station is located. You must, however, bear in mind that our name for a particular town may not be the one used locally. As examples I give Helsinki for Helsingfors, Talinn for Reval, Praha for Prague-Strasnice, and Wien (Veen) for Vienna.

Of the transmissions most heard in the United Kingdom, I would place France, Spain and Germany in the order of their reception by amateurs.

Eiffel Tower, with its concerts on 2,650 and 2,200 metres, is so distinctive as regards its wavelengths that once it has been picked up there should be no hesitation in recognising the station. The concerts frequently follow a time signal, and

you will hear the announcer intone in a very monotonous voice a series of numbers in French.

The call cannot be mistaken, it is *Ici la station radio-téléphonique de la Tour Eiffel*; and the master of ceremonies usually adds in very solemn tones *Notre émission est commencée*, intimating that the hour has now come and the concert begun!

Should you not pick up the initial call—it is not repeated very frequently—listen for any allusion to *Les Amis de la Tour*, the club responsible for these transmissions, or reiterated references to the *auditions artistiques*. It is the Eiffel Tower.

Radio-Paris, through its very popular speaker *Radiolo*, gives a breezy *Allô, Allô*, followed by the words *Emissions de la Compagnie Française de Radiophonie*. He also informs you that it is the umpteenth transmission! At 13.00 and 15.00 G.M.T. you will pick up the sound of chimes, which are not relayed from any local church but, as in the old days at 2 L O, merely struck in the studio.

As to *Le Petit Parisien*, on the lower wavelength, you can never be in doubt, as the announcer gives the call in both French and English, and the name of the Paris newspaper operating the station is advertised at every opportunity.

But the P T T Paris station, apart from its preliminary announcement, *Emissions de l'Ecole Supérieure des Postes et Télégraphes*, frequently leaves you in the dark as to its identity. If, however, you hear a transmission which appears to be a relay from a public hall possessing an audience, speeches—of the long sententious variety—or a play, obviously performed in a theatre, or again, noises inherent to automobile races, and the monotonous "chug-chug" of the motor bike—in fact, the broadcast of outside stunts—you may plump for the *Ecole Supérieure*.

### P T T Privileges

Owing to its official standing it is the only station in France which enjoys the privilege of using the telephone land-lines and, what is more, of relaying performances from the Paris theatres.

P T T possesses relays in other parts of the country, and should you pick up any of them you will find that a similar call is given to that of the "Mother-ship," but these are sometimes varied by the words *Ici la poste du Midi de Lyon* or *de Toulouse*, as the case may be.

The only other station in France of any consequence is that of Radio-Toulouse, run by an association of wireless clubs. It is heard over here at considerable strength.

In order that no confusion should exist with its P T T confrère—or, rather, competitor—in the same city, the announcer gives you, from time to time, its full title *Le poste de Radio-Toulouse. Emissions de la Société Régionale de Radiophonie du Midi*, and repeats the call *Radio-Toulouse* before each item in the programme.

A military march, *La Toulousaine*, played by the station orchestra opens all transmissions, and in true patriotic manner *La Marseillaise* concludes the entertainment.

### Spain

Let us turn to Spain. Here we find many broadcasters, and it is quite possible that by the time this article is in print further newcomers will have appeared on the scene.

I find from experience that all stations located in the Iberic peninsula repeat their individual calls as frequently as is customary with our home stations. As previously stated, every announcement is prefaced by the conventional *Atencion*, and the call letters and figures are always added.

The letters allocated to Spain are E A J, followed by one or two numerals. Listen for them as pronounced by the gentleman or lady in charge of the studio, *Ay-ah-Khota* and the figures.

Madrid, E A J 6, never fails to add that you are hearing a concert broadcast by the *Estacion Radio Iberica* (*Ess-tar-thion Raa-dee-oh Ee-bear-ee-ka*). Its competitor in the capital also makes it clear that the particular entertainment is provided by *Oo-nee-on Raa-dee-oh*. By arrangement these two broadcasters work late on alternate nights in order not to interfere with each other.

If, on a Sunday afternoon, you capture sounds depicting the assembly of a large cheering crowd intermingled with the gallop of horses, and short speeches in a Latin tongue, it is more than likely you are listening to the relay by the Union Radio station of one of the celebrated bull fights in that city.

Madrid also possesses a third station, E A J 4, whose call is *Radio Castilla*. It works until midnight on certain days of the week.

Generally speaking, in order to

## Recognising the Foreign Stations (Continued)

assist the identification of broadcasters in the Iberic capital, it is wise to consult the times of transmission, which, in all three cases, vary for each day.

In Barcelona we again have two stations which cannot be mistaken. E A J 1, calling itself *Radio-Barcelona*, and E A J 13, *Radio-Catalana*.

In Bilbao we find further "twins," E A J 9 and E A J 11. Unfortunately in this case both term themselves *Radio Vizcaya* (pronounced with a lisp), and it is essential that you should pick up the distinguishing numbers following the call letters.

### E A J 11

You will be able to identify E A J 11 if you hear references to *El pueblo Vasco*, the journal supplying the news bulletin, or if the announcer mentions *El gran Orquesta Moderna* in connection with the titles of musical selections to be executed by the band.

Cadiz, E A J 3, opens its transmissions with the ticking of a metronome (*tic-tac para syntonizar*), which is also heard during the programme intervals. The call is conventional, *Radio Cadiz*. (Oh, that lisp!)

Probably San Sebastian is the Spanish station which has aroused most interest in this country in view of the strength at which it is received. At one time it was possible to recognise it by the fact that, apart from Rome, it was the only studio possessing a lady announcer.

Unfortunately for us—from a wireless point of view—ladies are in great demand at Spanish stations, and several of them have undertaken this particular r. l. e. But San Sebastian, E A J 8, gives you, in its calls, not only the letters, figures and name of the town, but also the geographical position of its transmitter.

Many times during the evening you will distinctly hear *Ay-ar Rhotaocho 'Ah-key Sar Sebastian instalar-dar en ell Monty Egg-well-dough*, or, as it really reads in Spanish, *Aqui radio or Estacion San Sebastian instalada (installed) en el Monte Igueldo* (on the mount of that name).

Frequently, when the official interpreter is present in the studio, the same sentence is given in French and English.

Seville (*Radio Club Sevillano*)

merely gives its town after the call letters. Most of the Spanish stations use the sentence *Cierre de la Estacion* when closing down.

Now if we listen to Germany, we must draw a distinction between the main and relay stations, as the latter are equally well picked up on this side of the Channel. The Germans, as a rule, follow the original custom of using the word *Achtung* or *Hallo*, and add the name of the town, but in the event of your picking up a transmission from one of the relays, you will, of course, get the announcement from the main station.

In the United Kingdom, when the news is broadcast from every transmitter you hear *This is the London station calling the British Isles*, and your locality, whether you live in Nottingham, Plymouth or Aberdeen, will not be mentioned. Not so with Germany. You may tune-in an *Achtung, hier Norag. Die Sender Hamburg auf Welle 395 meter, Bremen auf 279 und Hanover auf 296 meter*, and it will be necessary for you to determine, by the methods mentioned in the earlier paragraphs of this article, which of these wavelengths you have captured.

The fact that Hamburg uses a gong will not help you, as the same sound will be heard through the relay stations. Such an argument equally applies to Munster, Dortmund, and Elberfeld; Frankfort-on-Main and Cassel; Leipzig and Dresden; Munich and Nuremberg.

### Different Wavelengths

However, the wavelengths are so different that you should have no trouble in separating a relay from a main transmitter and thus definitely establishing from which particular city or town you are receiving the S.B. programme.

At the time of writing Berlin can be heard on three different wavelengths, namely, 505, 576 and 1,300 metres—the higher figure being that of the Königswusterhausen station—all relaying the concert from the Voxhaus studio. In each instance you will receive, at intervals, the morse letter B (— . . .), the initial of Germany's capital city.

On Sunday morning Königswusterhausen broadcasts its own concert, but the call *Hier Hauptfunkstelle Königswusterhausen* is re-

peated on frequent occasions. When this station relays Berlin, on high power, the Voxhaus announcer calls Europe (*Hört Europa*) before every item.

Munster sends out the letters M S (— . . .) at five second intervals as a preliminary signal and also for tuning purposes during gaps in the programme.

Hamburg, Breslau and Munster all use gongs to denote the finish of an item, and by the strokes indicate the number of minutes interval before the concert will again proceed.

### Many Stations

There are at present so very many stations broadcasting entertainments on the Continent that space will not allow me to dilate on each one in turn. I can, however, furnish you with rough indications which will allow you to log them.

In Austria we only find two transmissions, those from Vienna and Graz. The former opens with two or three V's (. . . — . . . —) and the German conventional call of *Hallo, hallo, Hier Radio-Wien auf Welle 530 meter*; Graz starts with a morse sign R V (— . . . —) and gives out a similar announcement.

Until the stations in Czechoslovakia have increased their power they will not be picked up regularly in this country, but Prague-Strasnice introduces itself to you with *Zde Radio-Journal Praha* (Prague) and terminates the entertainment with the anthem *Kde, domov muj* or *Pod Tatrou se blyska*. Brünn calls in the same manner, but has christened itself *Radio-Brno*.

Farther north we encounter Helsingfors, whose call is misleading to the uninitiated—*Radio Helsinki*; then, in turn, Reval, boasting of *Radio Ringhaaling Tallinn*—its new name—and the Moscow main station, which, if heard, should satisfy any listener: *Eto goboryt Moskowskaia Centralnaia Radiotelefonia stantsia imeni Kominterna*. Enough to shatter the ether!

Let us take a quick run to Italy. Rome is always recognisable by its lady announcer and its reiterated references to the *Unione Radiofonica Italiana* and *Radio-Roma*. Besides, she possesses a deep sonorous bell-like voice, accentuates every

(Continued on page 577)

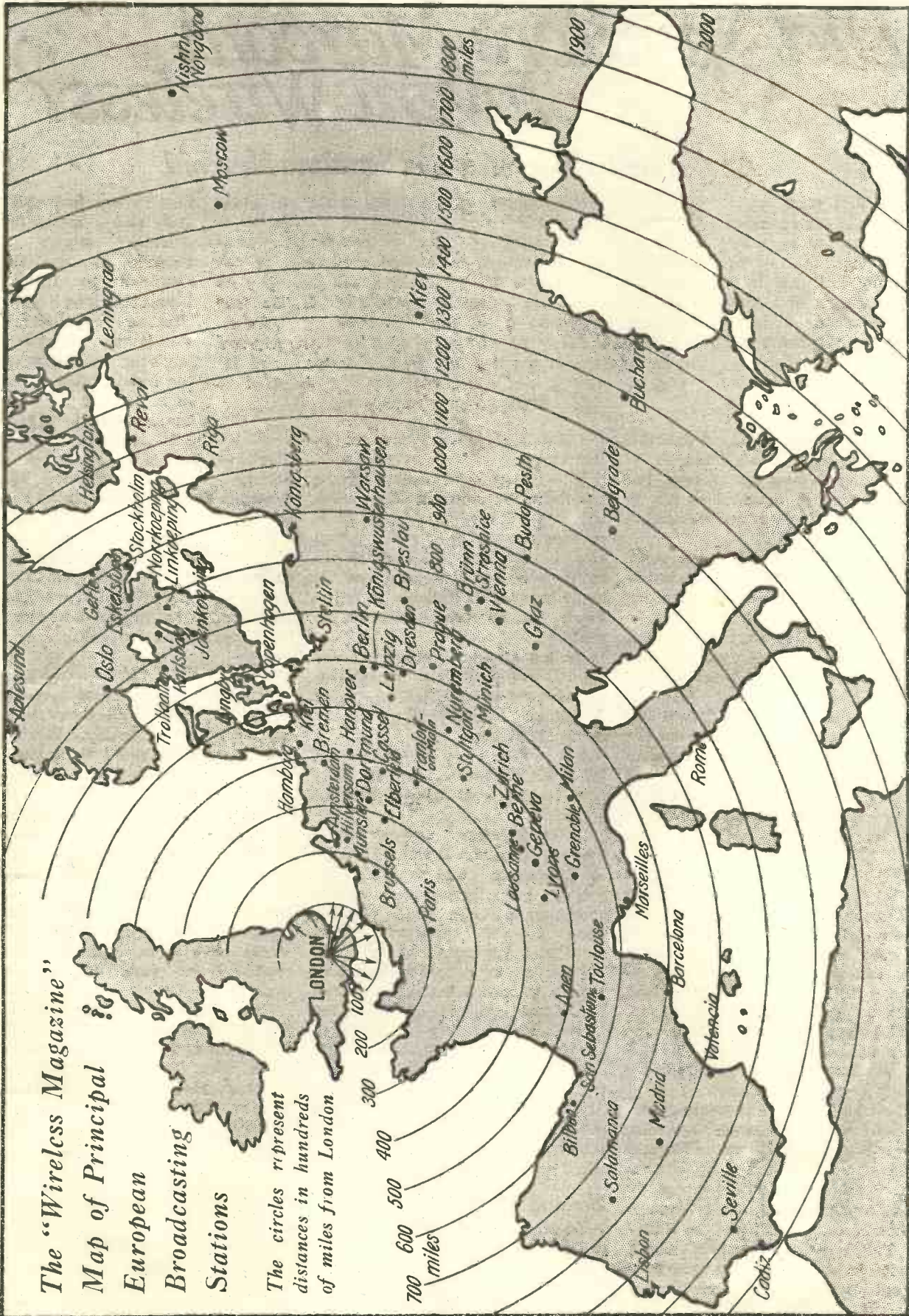

The "Wireless Magazine"  
 Map of Principal  
 European  
 Broadcasting  
 Stations

The circles represent distances in hundreds of miles from London

# Did Senatore Marconi Invent Wireless?

## An Authentic Interview with Senatore Marconi

ALMOST thirty years have passed since the invention of wireless telegraphy, and we are not yet free from controversies and contradictions of all kinds with regard to the actual inventor himself.

There are many who even dispute the identity of the inventor, forgetting in their enthusiasm that this epoch-making discovery cannot be attributed to any one person, but must rather be regarded as due to the combined efforts and researches of several scientists.

Many people associate the name of Senatore Marconi with the invention of wireless. Certainly his name has always been before the public eye in connection with the science, and therefore it is not unnatural that people should come to look upon him as the inventor.

This is not strictly true, however, for it must be remembered that the essentials of wireless telegraphy were known, though merely as facts of purely scientific interest, some years before Senatore Marconi commenced his investigations.

### Converting Principles to Facts

Thus, the fact remains that if we do not owe the actual invention of the principles of wireless to Senatore Marconi, he is certainly responsible for converting these principles to actual facts and developing them into a practical commercial form, and consequently our debt towards him remains heavier than if he had merely been the first to discover the principles.

So many letters have been written, there has been so much argument, that, even though Senatore Marconi himself has delivered many lectures on the subject, the public apparently remain unconvinced, chiefly through ignorance. Accordingly the Editor of THE WIRELESS MAGAZINE determined to give his readers some facts about his life from Senatore Marconi himself, and with this end in view

granted to Mr. Erskine Brydges on behalf of THE WIRELESS MAGAZINE and submitted in manuscript to the Senatore, who carefully revised it with his own hand and finally initialed it for publication exclusively in this magazine. The Editor has great pleasure in presenting his readers with this most valuable contribution to the long discussion as to who is the true "inventor" of wireless, and on their behalf he wishes to thank Senatore Marconi for his kindness in granting this special interview, and for the great courtesy and exceptional facilities extended to Mr. Brydges, our representative.

I called at Marconi House for an interview.

It was my good fortune to be granted a few minutes of his valuable time—I say valuable, for he is perhaps one of the hardest working men in England. And independently of nationality—being, as his name implies, an Italian—the Senatore's labours benefit the whole world.

"I am afraid I cannot tell you much," was his reply to my obvious question. "I hate talking about myself, and I don't want you to say much about me."

Not unlike some other men of international fame, Senatore Marconi loathes personal publicity of any form.

"But, Senatore," was my reply, "you must have seen various articles in the papers, more especially the weekly magazines, about certain claimants to the invention of wireless? I would appreciate a few facts from yourself."

"Well, as far as that is concerned, I think I cannot do better than repeat what I had occasion to say at another interview, that to my mind wireless has existed since prehistoric times, when man first understood the meaning of a smile, when human beings first succeeded in talking to each other, and to understand and decipher signals or signs made to them from a distance.

### National Claimants

"Yes, there has been much discussion as to whether I am or not the inventor of wireless. It is difficult for me to enter into this personal controversy, but I would

like to say just this: Italy claims me as the inventor; many in England attribute the invention to Lodge; Russia stands by Popoff; France ascribes the merit to Branly; America tends in my favour by the award, made to me in New York in June, 1922, of the joint gold

medal of the American Institute of Electrical Engineers, the American Society of Civil Engineers, The American Society of Mechanical Engineers, and The American Institute of Mining Engineers, as the inventor of wireless telegraphy; while the Germans are not strong in any advocacy. The point of view seems, therefore, to be largely determined by a question of nationality.

### "What I Have Discovered"

"Certainly the work of Maxwell and Hertz made possible the methods which we employ to-day. What I have discovered, and I think there can be no question about it, even supposing I did not invent anything, is that electric waves will cover the great distances of the earth, and I am the first to have communicated by wireless across the Atlantic. I think that if Lodge were with us now he and I would perfectly well agree as to what each of us and others have done, and the same applies, I am sure, to Professor Branly."

"Well, Senatore, being personally acquainted with Professor Branly, I have often talked and exchanged views with him on this subject. As far as he is concerned, I can assure you, sir, that he puts you forward as the inventor. But please go on," I pressed.

"Of course, from early boyhood I had been extremely interested in electricity and everything appertaining to it. I got carried away by the subject and used to amuse myself working out problems. It was when I was about seventeen or eighteen years of age that Hertz's laboratory

*In this Interview, Exclusive to THE WIRELESS MAGAZINE,  
Senatore Marconi Discusses his "Invention" of Wireless*

discoveries startled the world of science, and, among other things, fanned the flame of research that was already kindled within me.

"I determined to investigate, and success in my investigations emboldened me to improve upon and develop the great scientist's discovery. It might be claimed that my subsequent discoveries are only developments of principles and means already known. If so, parallels may be found in the practical applications of the early principles of any discovery.

"As in the case of the X-ray, it was Sir William Crookes who discovered the X-ray, but it was Röntgen who discovered that by putting a hand between the X-ray and a sensitive plate a bone photograph was obtained.

"I discovered and made practical the transmission and reception of electric waves across distances."

"Now, Senatore, has wireless from the purely scientific point of view still the same interest for you now that it has opened up and developed so many different branches?"

"Yes, the scientific as well as the practical side still engrosses me as much as ever.

"In these respects I can really say that my work is my pleasure, and I am never happier than when carrying out or following experiments on board my yacht, the *Elettra*," Senatore Marconi answered me.

"As a point of general interest, do you work out your problems by the standard . . . ?"

"Yes, I do, but I frequently also do not follow any particular law or recognised theory. In spite of

the apparatus at my command, I am still an amateur."

"*Par excellence*," I put in.

**Amateur Investigations**

"As you will," he smiled. "But I am confident that the efforts and attainments of amateurs will always assist the development of wireless. With the real amateur enthusiast wireless is an all-absorbing interest, and he relies on his instru-

by their patient and persevering observations and experiments to the latter-day development of wireless in its most popular form, but I am afraid I cannot admit their priority in many of the improvements and attainments which is claimed on their behalf, and especially with regard to short-wave work, because this was the basis of my very earliest experiments as long ago as 1896, but which I temporarily abandoned in favour of long waves as being at the time of greater commercial importance, but which I took up again in the early years of the War and have been perfecting ever since into what is now generally known as the beam system.

"After I already had got through on short waves to Australia amateurs succeeded in communicating to New Zealand, a slightly greater distance; which performance I was among the first to applaud and admire."

Interviews with Senatore Marconi are very few and far between, owing to his intense dislike of publicity, so I was all the more sensible of his extreme courtesy in granting me this short but, in my opinion, very momentous one.

Accordingly, I did not press him further, having been amply rewarded for my first visit by his kind attitude and his simple and sincere replies to my few questions, no less than by his modesty concerning his very great achievements.



A New Portrait of Senatore Marconi.

ments for his interest and amusement, not for his living. There is in this much to incite him to investigate and find out things for himself, and that is often how important discoveries and inventions are made. However, time is on the wing, and I must be off.

"But before I go there is just one thing I would like to say with regard to the amateurs. They have undoubtedly contributed a great deal

*G M*  
26<sup>th</sup> Nov 1925

Structograph Coloured Plate for this Set Free with this Issue

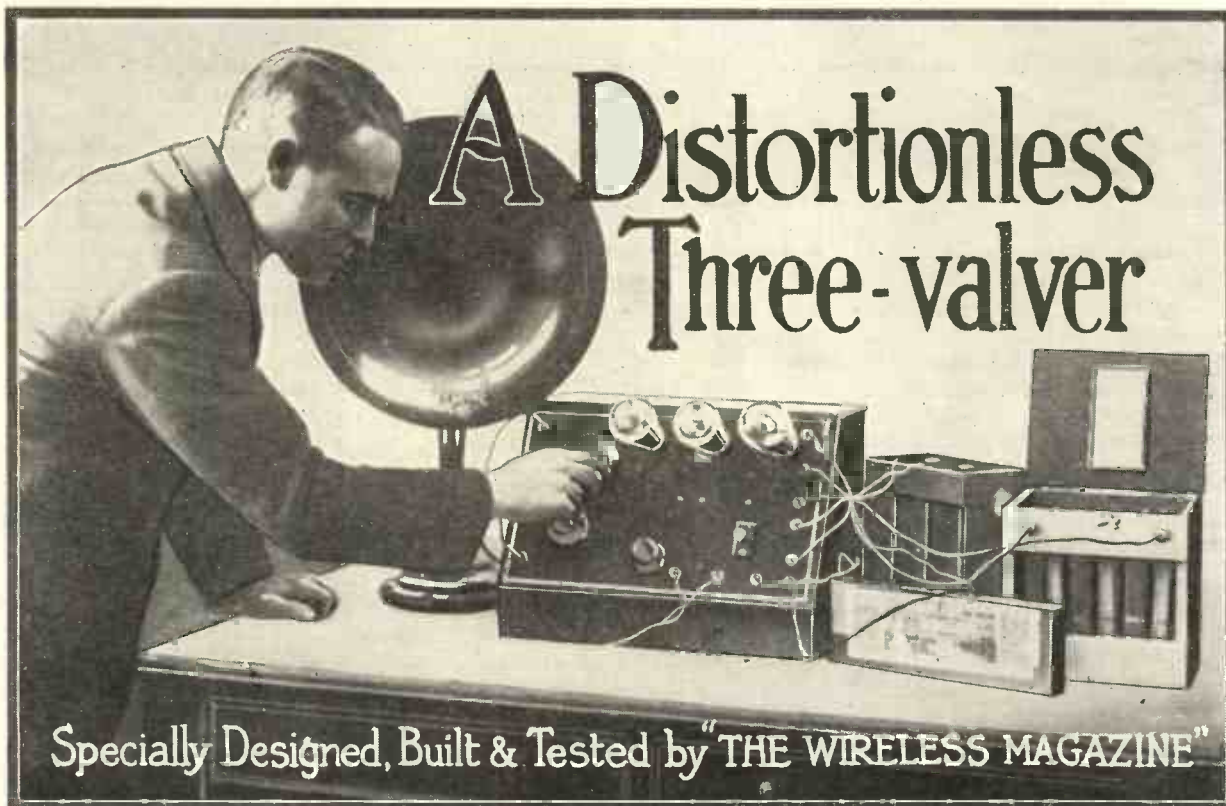

IN the design of low-frequency amplifiers the elimination of distortion is becoming more and more the predominant factor, with the result that the resistance-capacity method of amplification is coming into more general use.

The resistance-capacity coupled amplifier is commonly supposed to be quiet and free from distortion. As a

matter of fact such an amplifier can (without grid bias) produce as much volume as a transformer-coupled amplifier—and more distortion.

Then we come to the choke-coupled amplifier which, if properly handled and designed, will retain the advantages of the other two methods with none of the disadvantages. If carelessly constructed, however,

the disadvantages of all the types are present with none of the advantages.

The choke is intended to allow direct current to pass unhindered, but to offer an impedance to all low-frequency currents. The impedance of the choke is nearly equal to that offered by the resistance in the resistance-capacity type without having the disadvantage of the high H.T. battery voltage required by the latter type.

#### Efficiency of Choke Coupling

With regard to efficiency the low-frequency choke, if well designed, has all the peculiarities to be found in the best transformers, but even if badly designed it will not distort so much as a bad transformer.

The receiver to be described employs a valve detector, followed by two stages of choke-coupled low-frequency amplification. Reaction is obtained in the ordinary way by coupling a coil in the plate circuit of the detector valve to the aerial coil, which is tapped and tuned by a variable condenser in parallel.

The choke units, which we have found particularly efficient in operation, not only consist of the choke

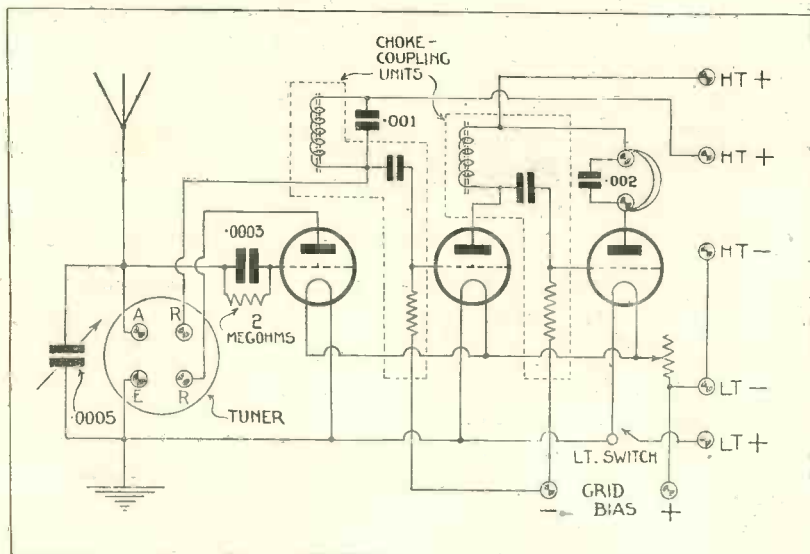

Circuit Diagram of Distortionless Three-valver.



# AN EXCELLENT SET FOR LOUD-SPEAKER WORK

itself, but contain the grid condenser and leak necessary for coupling one valve to the next.

A list of the components required for the construction of this efficient receiver is given below.

### Components Required

Ebonite panel, 14 in. by 8 in. by  $\frac{1}{4}$  in. thick. (British Ebonite Co., Ltd.).

2 choke-coupling units (Seagull).  
Regenerative aerial tuner (Efesca).  
.0005-microfarad variable condenser (G.E.C.).

3 panel-mounting valve holders.  
Filament rheostat (Burndept).  
11 terminals (Belling Lee).  
.002-microfarad fixed condenser (Atlas).  
.001-microfarad fixed condenser (Atlas).

2-megohm grid leak and .0003-microfarad grid condenser (Mullard).

Push-pull switch for breaking filament circuit.

To save time the panel should be bought cut to the size, 14 in. by 8 in., and it should be seen that the edges and corners are true.

Now take the Structograph given with this month's issue of THE WIRELESS MAGAZINE, and place it flat over the panel so that the edges

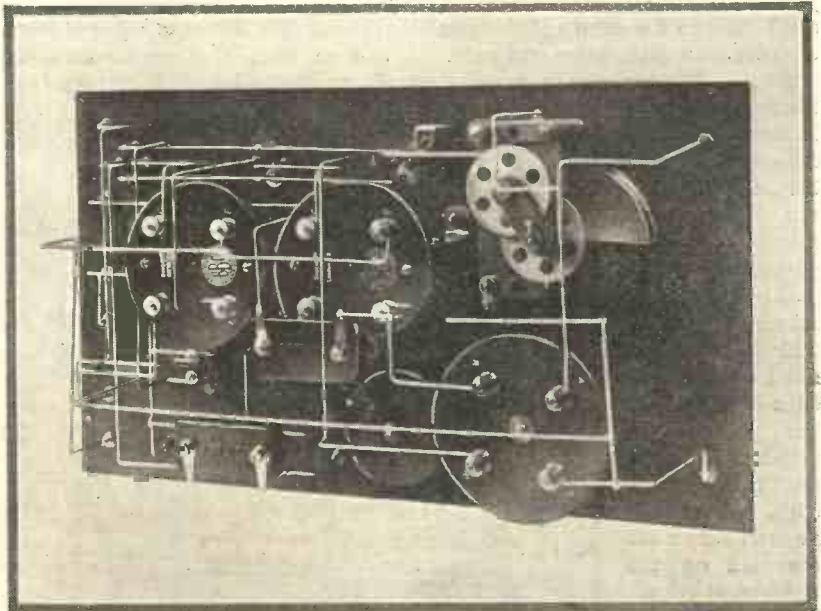

Back-of-panel View of the Distortionless Three-valver.

of the panel drawn on the Structograph and the actual edges of the panel coincide. With a sharp tool mark through on to the panel the centres of all the holes to be drilled.

The Structograph may now be removed, and holes of the sizes shown on the Structograph drilled at the marks thus made.

The components may then be mounted on the panel in the positions shown in the photographs and in the Structograph.

On the left of the panel, looking at the front, the tuner and variable condenser are mounted, one above the other, and the three valve holders are mounted along the top of the

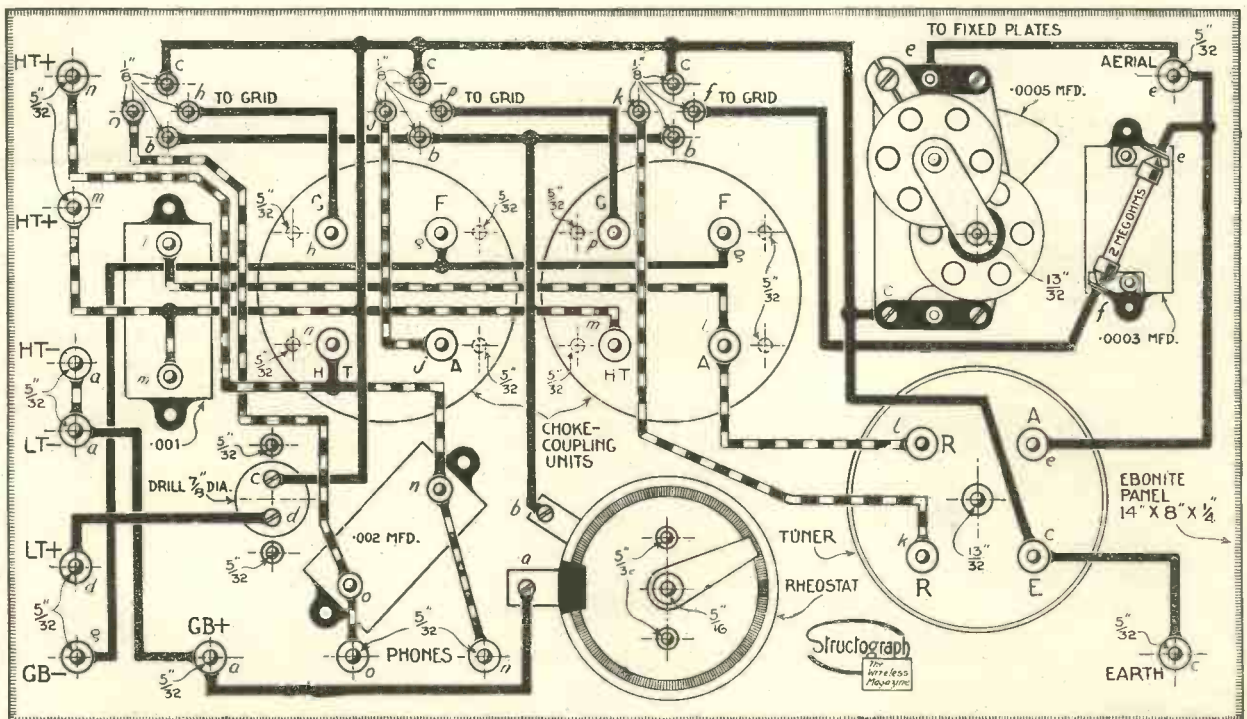

Reduced Reproduction of the Structograph Coloured Plate of the Distortionless Three-valver, Free with this Issue.

## A Distortionless Three-valver (Continued)

panel. The two choke-coupling units are bolted to the centre of the panel each by four 4BA. bolts and nuts.

At the bottom of the panel the filament rheostat is seen, with the filament-circuit-breaking switch on the right, symmetrically mounted with the tuner.

Of the terminals, the aerial and earth are fixed on the left edge of the panel, the phones and grid-bias terminals on the bottom edge, whilst the remainder are mounted on the right-hand edge.

If the Structograph is studied it will be seen that every terminal (including those mounted on the instruments) is marked with a small letter of the alphabet.

For instance, several terminals are marked *a*, some *b*, others *c*, and so on. This affords an indication of what order the instruments should be wired in. All the terminals marked *a* should be wired up first with one wire or as few wires as possible. Then all those marked *b* are wired up in a similar manner, and so on until the wiring is completed.

The .001 and .002-microfarad condensers are held in position by the wiring, and are not bolted or screwed to the panel.

The wire used for connecting up should be of such a gauge that these small components are held rigidly without any other method of fixing. No. 16-gauge round tinned copper wire is very suitable.

It should be noted that the medium + H.T. terminal (second from the top on the left-hand side of the panel, looking at the back) is connected to the + H.T. terminal

of the first choke, and applies to the plate of the detector valve a lower voltage than that applied to the plates of the two L.F. valves.

Marconi R5V; low-frequency valves, Mullard DFA1. If large volume is required a Marconi LS5 with a plate voltage of 200-300 volts will give

excellent results in the last stage of amplification.

Tuning is extremely simple. The wavelength range of the receiver is wide enough to include the low-wavelength broadcast stations and also Daventry. By placing the switch arm of the tuner successively on each of the sevenappings and turning the variable condenser dial slowly throughout its entire movement each time the setting of the switch arm is altered, the set can

be tuned to any wavelength within the limits previously indicated, that is, practically any broadcasting station can be received without the trouble of plugging in different sizes of coils.

Reaction is obtained by adjusting the small knob in the centre of the switch arm.

Having tuned-in any station, the best results may be obtained by experimenting with the voltages applied to the detector and L.F. valves, and also the grid-bias battery voltage.

On test it was found that the quality of reproduction from this receiver was extraordinarily pure. The operation is so simple that the set is ideal for the beginner, and the number of stations that can be tuned-in is really surprising.

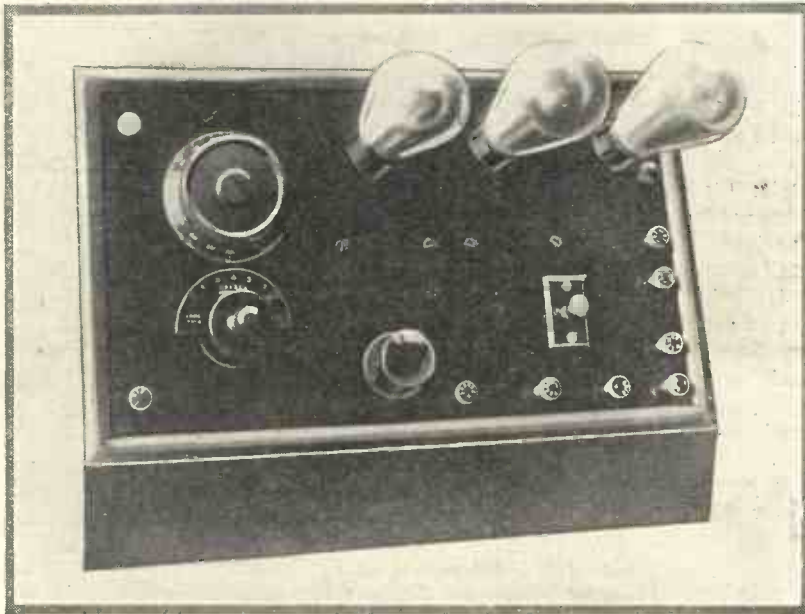

View of Completed Distortionless Three-valver showing Positions of Controls.

The completed receiver may now be placed in its cabinet, which can be obtained from Henry Joseph & Co., of Victoria Street, S.W.1.

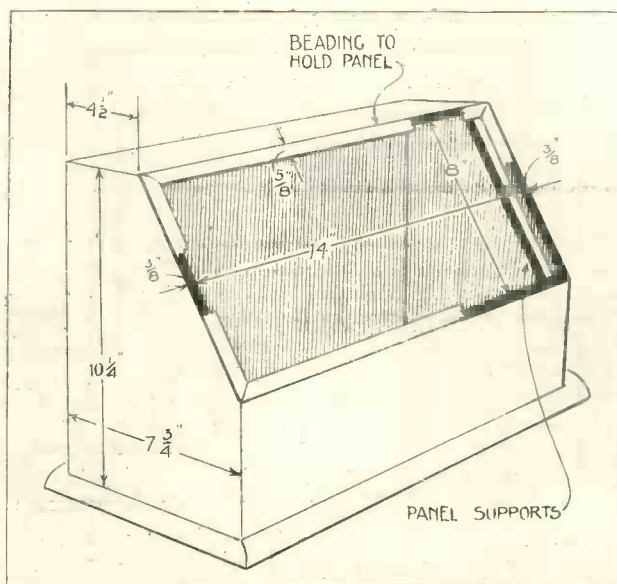

Details of Cabinet of the Distortionless Three-valver.

As a detector valve; any one of the well-known general-purpose valves may be used. A very good combination is as follows: detector valve,

EVEN our foreign competitors are having to admit that British wireless goods are the goods.

BACK-OF-PANEL PHOTOGRAPHS OF THE DISTORTIONLESS THREE-VALVER SHOWING POSITIONS OF COMPONENTS AND THE WIRING

*"Keep to the Structograph"*

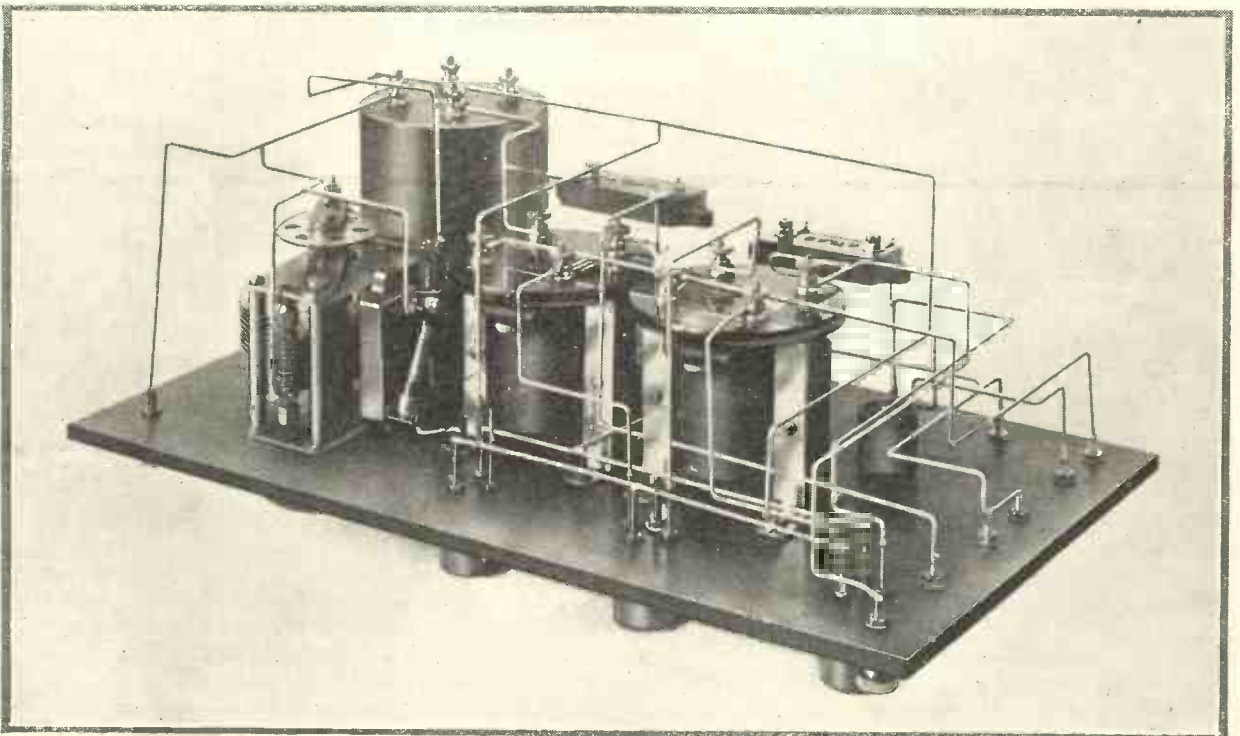
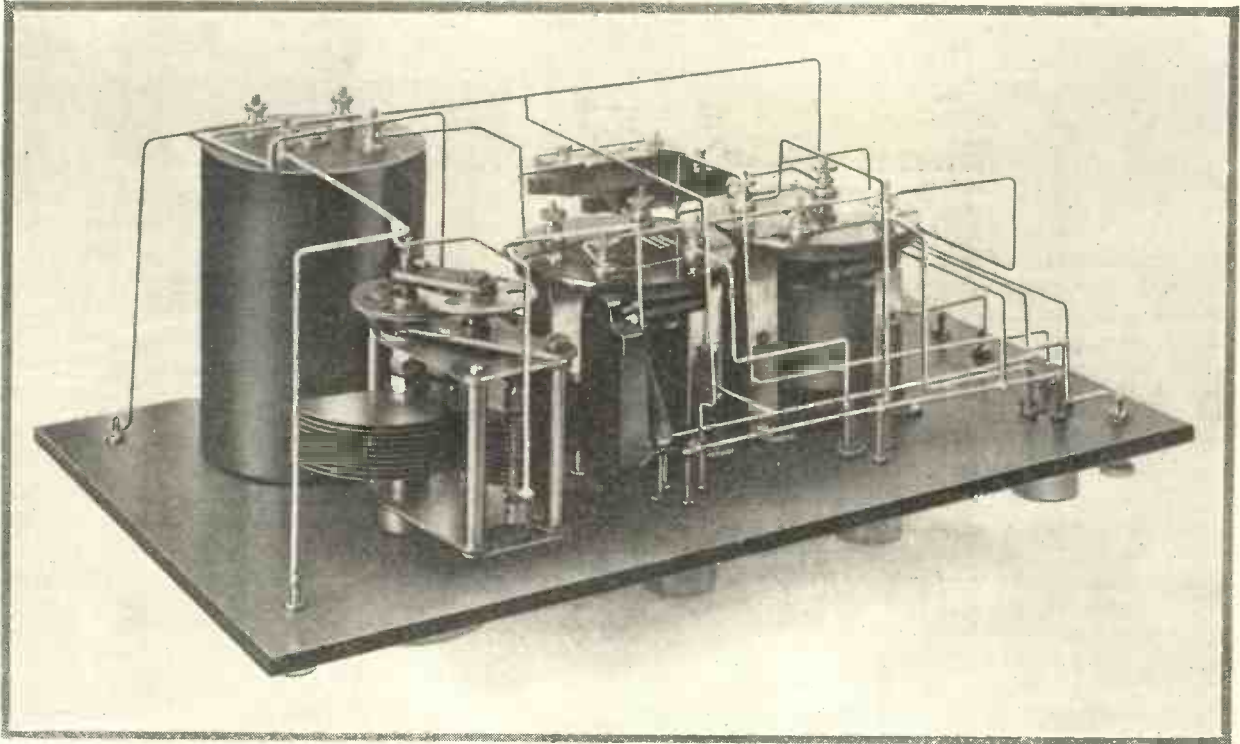

# A DISTORTIONLESS

Combined Drilling Template and F

(For full particulars, see article in "The

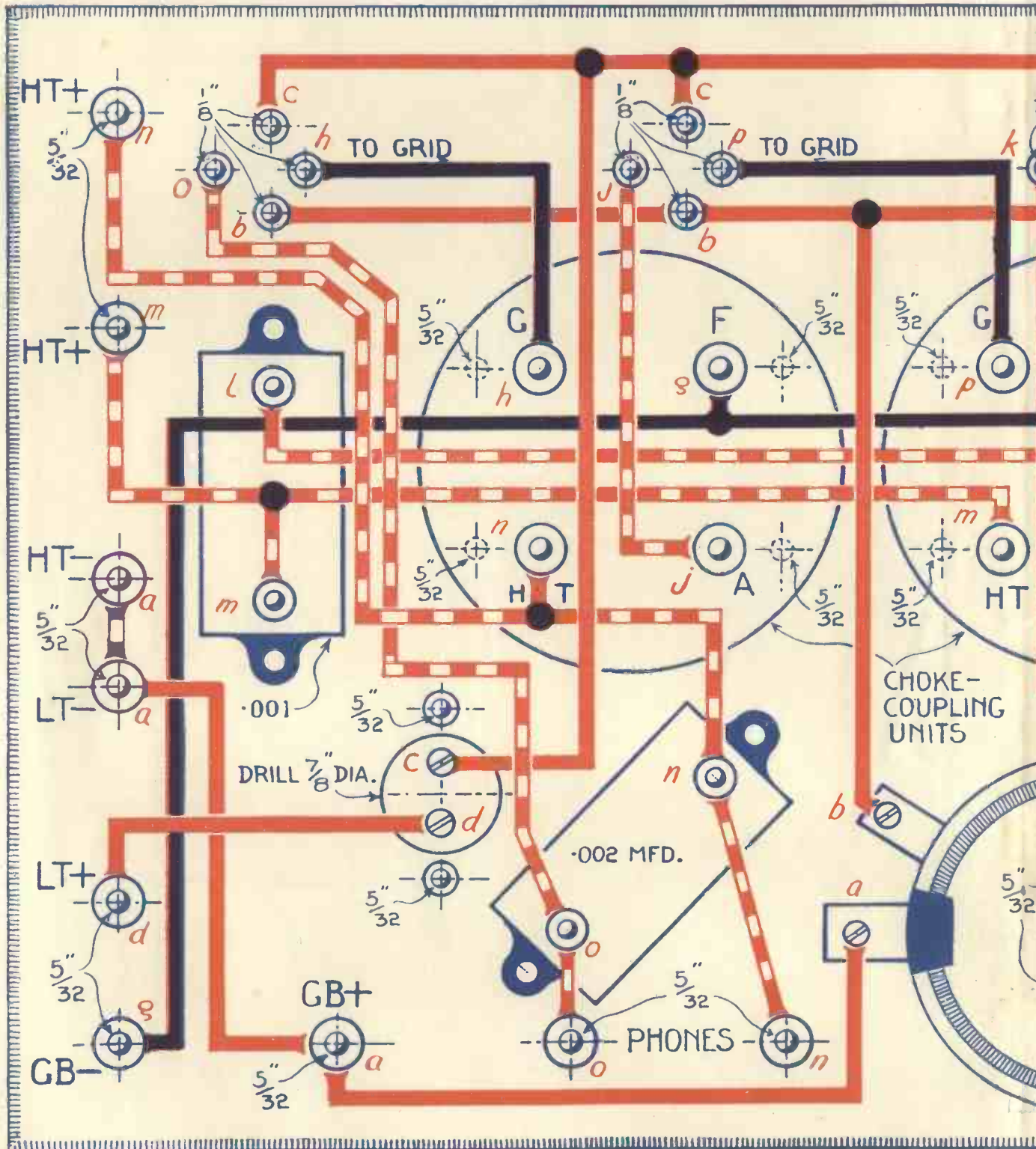

**HOW TO USE THIS DIAGRAM AS A TEMPLATE** :— The blue shaded outline indicates underside of panel the drilling centres pricked through, the template thus serving many times if so required, and the whole plate

**SPECIAL INSTRUCTIONS FOR WIRING** :— There is a choice of three methods. (1) Follow the wiring lines in black lines the grid circuit. A black circle at the intersection of two wires indicates that the two are soldered together. (2) Ignore the lines of the wiring, if you like, and work entirely by means of the red letters shown at the various terminals; thus all the a's together, all the b's together, and so on, and you should do so in alphabetical order, the a's first, then the b's, and so on. (3) The ideal method is to combine (1) and (2).

# S THREE-VALVER

Full-size Layout and Wiring Diagram

(From "Wireless Magazine" for January, 1926.)

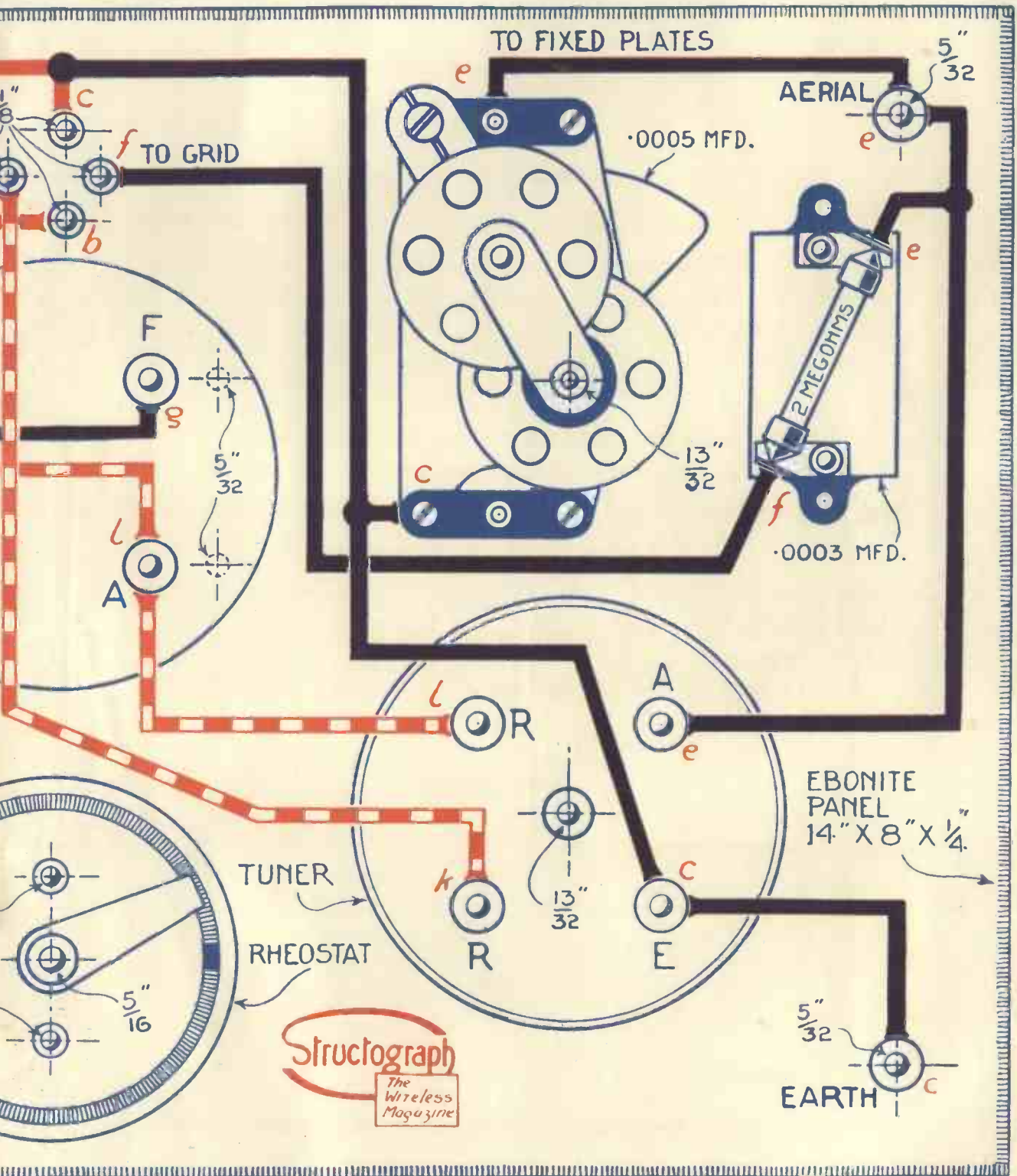

**Structograph**  
The Wireless Magazine

: all blue lines relate to either panel or components. This template should be laid on the panel and te being retained for use as a layout and wiring diagram.  
nes, red lines indicating the filament-lighting circuit; red-and-white lines, the H.T. or plate circuit; and d together. At all other intersections there is no connection between the two wires. (2) You can us terminals. You just connect all like letters together with one wire or with as few wires as possible, first. By this method you cannot go wrong if you are careful, it having been carefully worked out to save



**In Borneo**

AS I was returning home the other afternoon carrying a charged accumulator, I stopped to talk to the old gardener in the park near my house.

"Still doing a bit in the wireless line then, sir?" asked my old friend.

"Just a bit now and then," I replied.

"Had a letter from the boy this morning. He tells me he is setting up with wireless."

I was very interested, for the "boy" happens to be a fine fellow of thirty who is in charge of a rubber estate in British North Borneo.

"What station does the boy expect to listen-in to?" I asked.

"He says he will hear Manila when conditions are favourable, but he says that won't be often. The air isn't as suitable out there for wireless as it is here, you know, sir, there's too much *electricity* in it."



**Present "Difficulties"**

Do you contemplate giving one of your non-wireless friends a wireless set as a Christmas or New Year



A present "difficulty."

present this year? If so, you will have thought of the following difficulties with regard to such a present.

First difficulty. Should you purchase a wireless licence to go along with your wireless present? Some people might feel a trifle offended if you included the licence. On the other hand, other people might not appreciate a present which called for an immediate outlay of ten shillings. It is a little difficult to know what

is the right thing to do about the licence, isn't it?

Second difficulty. Aerial and earth. How can you put up an aerial and install an earth at your friend's house a day or two before without his knowing? It can't be done unless your friend happens to be away from home.

The alternative is to take the set complete with aerial wire, insulators, earth wire and clips to your friend first thing in the morning, and to start straight away with the erection of the aerial and the installation of the earth.

I am sure that your fortunate friend would appreciate such kindness, and you can take it from me that there is nothing more likely to give you a good appetite for your dinner than the erection of a wireless aerial and digging for an earth



**My Gramophone**

I have just purchased a new gramophone. Pretty serious fall from grace for one as interested in wireless as I am, isn't it?

Not only have I purchased a gramophone, but I have purchased the very latest model, one of the very best type it is possible to obtain at the moment.

Wait a minute though, before you brand me as a backslider or a sinner past repentance. Let me tell you all about it.

This new gramophone of mine has been purchased primarily to help certain little people to acquire a good pronunciation in their French lessons. A special attachment has been fitted to the gramophone in order to get the best possible reproduction of speech from the records.

When the demonstrator brought the gramophone to me, I thought it an excellent opportunity to com-

pare the powers of speech reproduction of the gramophone with those of my loud-speakers. The demonstrator was an expert with the gramophone, and he certainly got all that could be got from the gramophone.

One of the test records the demonstrator brought with him was the reproduction of a speech on sportsmanship by H.R.H. the Prince of Wales. I had not long previously heard the Prince of Wales broadcasting an appeal for the British Legion's Poppy Day. It was easy enough to make comparisons between the gramophone and the loud-speaker.

My candid opinion is that, although the gramophone may reproduce some things as faithfully as certain of our relay and main broadcasting stations it cannot be compared for reproduction with good reception of the high-power station.

There are times when I can get Daventry with a perfectly silent background. You can never get a silent background even with the best and most expensive gramophone.

So you see that I am far from being a convert to the gramophone, though



My gramophone

I have purchased one of the most up-to-date "wax scratchers."



**A Very Old Friend**

During the "audition" of my gramophone, the demonstrator asked me if I would like to hear something of a humorous nature.

"Certainly," I replied, "What have you got?"

"I have a record here, a very popular one, spoken by Tom Clare. I think you will like it."

The record was placed on the gramophone, the starting-switch was moved over to the "off" position and away we went. It only took a few sentences of the record for me to recognise our old friend the German, at whose house "the vind had blown down de shutter," and who wanted a carpenter, a "verkman," and who ended his telephone talk with a very English-like "Oh! go to blazes."

It was the first time I had heard that record direct from a gramophone, but I had heard it many times before via wireless.

That record took me back to those pre-broadcasting days when there were such giants in the land as 2 F Q, 2 O M, 2 K T, etc. I wonder

have used years ago. Where are the improved component parts, then?

First of all there are the two geared variable condensers. I consider these low-loss slow-motion variable condensers one of the greatest achievements of 1925. Then there is the new shock-absorbing low-loss



Look over your set carefully.

valve-holder, another of our 1925 improvements.

Last, but not least, there is my new Reinartz coil, in my opinion one of the best of 1925 discoveries, and due entirely to an English experimenter. This is by no means the only improved 1925 coil I possess. I have a number of the improved Lorenz coils so strongly recommended by THE WIRELESS MAGAZINE.

It seems to me that the year 1925 will go down to wireless history as a year of great improvements in component parts.



### Remote Control Needed

"How's the five-valve set going?" I asked my rich relation the other morning.

"Very well, thank you. It is so powerful now I know how to work it properly that we listen-in in bed at night. The set is in the drawing-room underneath our bedroom."

"What do you do when you want to switch off for the night?"

"Oh! I have to get out of bed, of course, and go downstairs to turn off the valves and put the earthing switch over."



Remote control needed.

"Rather a danger of your dropping off to sleep and leaving the set on all night, isn't there?"

"Not at all. Not at all. When my wireless set is working, it would be perfectly impossible for anyone to go to sleep in the house. It is a very fortunate thing that my house stands in its own grounds. If we had any near neighbours I am afraid my set would keep them awake as well."

I have had many a chuckle over the picture of my rich relation going downstairs at night in his night—er old-fashioned night attire and bare feet to turn off his five-valve set.



### Big Trouble

What is the biggest piece of trouble you have ever struck in all your experience of wireless? I think if each one of us were to write an account of our worst wireless trouble, a most interesting and entertaining book would be the result.

Sometimes big trouble comes to us in the way of an aggravating and elusive error in wiring, sometimes big trouble is caused by a defective component part, and sometimes big trouble comes to us by



Big trouble.

way of a little ball of solder which has entrenched itself in a secret hiding place all of its own.

I have just been talking to a wireless neighbour of mine to whom big trouble has come in a most peculiar form. This is what he told me of his trouble.

"The funniest thing imaginable has happened to my set. You know I have been using bright-emitters for a long time. Well, one of those bright-emitters went west, so I thought I might just as well take the opportunity of changing to dull-emitters. I bought three dull-emitters and I was hoping for great results from them, particularly as I had some visitors stopping with me for a fortnight. Would you believe it? When I came to try those dull-emitters, I could get nothing but a weak distorted squeak from the set. Thought it was the loud-speaker, so I borrowed another loud-speaker. No better. Got a new high-tension battery. No better.

"I took the whole set to the dealer and he tried it in the shop. With dull-emitters, reception was awful, but on changing to bright-emitters reception was as good as ever it had been."

I made one or two suggestions to my troubled neighbour, but I am afraid I did not help him much, I wonder what your guess would have been at the cause of his big trouble?



Something of a humorous nature.

which one of those giants it was who was so fond of the "German at the telephone" record?

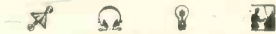

### Wireless in 1925

I suppose that we should all agree that the chief wireless feature of the year 1925 has been the improvements made in various familiar component parts.

Look over your set carefully, and I am sure you will see no really new component part. You may have some greatly improved 1925 types of the old familiar components.

My most improved valve set, a one-valve Reinartz, is in front of me as I write. What is there noticeable in it? What is there in it which would not have been in it a year ago?

There are the same old terminals, except that those terminals are nickel-plated instead of brass finish. There are the same old two-megohm grid leak and the same old three-noughts-three grid condenser. There is the same old square-section tinned-copper connecting wire with just one little bit of three-year-old round tinned-copper wire (I had run out of the square wire before I had finished the wiring of the set).

There is a carbon-pellet rheostat in place of the wire rheostat I should

**Uncle Sam v. John Bull**

Writing in a recent number of an American wireless periodical, an American correspondent states in no uncertain manner that American broadcasting is far superior to English broadcasting.

This American writer is a wireless operator on board an American ship. The observations on which he has based his conclusions were made during a voyage from a port on the Pacific coast of the United States to London via the Panama Canal.

While his ship was sailing across the Atlantic Ocean in a north-easterly direction, this American wireless operator was only able to hear 5 X X satisfactorily at a maximum distance of 1,700 miles, whereas he could hear the American broadcasting stations equally well at distances up to 3,000 miles.

Since 5 X X is supposed to use 25 kilowatts of power while the American broadcasting stations are rated at 1 kilowatt only, this American enthusiast concludes that



American observations.

his case for the superiority of American broadcasting over English broadcasting is indisputably proved.

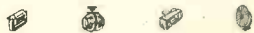

**Obsolete Parts and Sets**

What becomes of all the old-fashioned wireless sets and component parts discarded by the progressive listener and experimenter? Is there a second-hand wireless market somewhere, where one can pick up cheap good-conditioned wireless relics of the past in the same way that one can pick up an out-of-date but useful motor-car?

If there is such a wireless market I should very much like to pay it a visit. There ought to be some excellent wireless bargains to be picked up somewhere if one only knew where.

For example, what has become of all the variable condensers with semicircular vanes? There used to be no other type of variable condenser on the market, yet nowadays one sees nothing but variable condensers with rotary vanes of the square-law type.

I would rather like to pick up one or two good old-fashioned variable condensers with semicircular vanes. Such condensers can always be used as the reaction condenser in a Rein-



Obsolete.

artz receiver or as the tuning condenser in a crystal circuit.

Everybody seems to be buying the new spring or anti-pong valve holders these days. What will happen to all the old-fashioned valve holders that nobody wants?

It would be most interesting to know what really happens to surplus component parts. I wonder if some of them are melted down and done up again in the newer types.

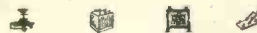

**A Good Earth**

I have had a plumber working for me this last week and I have had a number of interesting talks with him on wireless subjects of various kinds.

One afternoon the talk ran on "earths" and my plumber asked me what kind of an earth I was using. I described to him how my earth consisted of a number of short pieces of lead pipe buried horizontally in the ground at a depth of eighteen inches, together with a length of iron pipe driven vertically into the soil of a flower-bed.

"I reckon the best earth I know of is one used by one of the ex-soldiers up at the hospital," said my plumber.

"What kind of an earth is that?" I asked.

"That earth, sir," replied the



A good earth.

plumber, "consists of ten feet of two-inch copper piping at four shillings a foot. I was working at the hospital on the hot-water system and I actually saw that ex-soldier making off with that length of copper pipe. I said nothing about it, but we had to charge for it in the job. Fine results he is getting with that earth, and so he ought to."

"What kind of a set is it?" I asked.

"Oh! Nothing special at all. The set is just an ordinary two-valve set. It's that earth which gives him the results he is getting, and a cheap earth it was to him. I wish I could get one as cheap as he got his."



**Call Signs**

Have you ever wondered who the ingenious person is who invents the call signs for our broadcasting stations? Do you think he is an official of the British Broadcasting Company, or do you think he is just somebody in the Post Office?

No matter who he is or what he is, I have a considerable amount of admiration for him, since his call signs have provided me with a basis for a little mental relaxation at times.

I have never really fathomed the mystery of the numbers in the call signs of our British broadcasting stations, but I think I have got to the



Ingenious inventor of call signs.

bottom all right as far as most of the pairs of letters are concerned.

Some of the letters are very obvious, as for example L O for LONDON, B E for BElfast and S T for SToke. Other letters are not quite so obvious, but are pretty easy to spot, as for example B M for BourneMouth, B D for aBerDeen, E H for EdinburgH, L S for LeedS, N G for NottinGham, D E for DundeE, P Y for PIYmouth, L V for LiVerpool and F L for sheFfieLd.

N O for Newcastle might make one think a bit unless one remembered the full name, Newcastle-On-tyne. W A for Cardiff seems a bit odd until one remembers that Cardiff is in WAles. S C for Glasgow puzzles one until one remembers that Glasgow is in SCOTland.

I can find where the H in the KH for Hull comes from, but what right has Hull to the letter K? Similarly, what right has Swansea to the letter X?

Talking about the right to certain letters, what right has Birmingham to the letter T, even if it can claim the letter I on two counts? What right has Manchester to either of the two letters Z or Y?



When the new Dublin station was first proposed I made a guess at its call sign. My guess was 2 D N. Not so bad, was it, considering that the call sign is to be 2 R N ?

I'll leave you to see if you can spot the origin of the call letters R N for Dublin. It isn't an extraordinarily difficult task.



### Distance Work

Has it ever struck you that the very best set for distance work is a one-valve set with telephones? A three-, four-, or five-valve set with



Maximum and minimum strength.

loud-speaker is about the worst thing you can try if you want to get good reception of those elusive distant stations.

Although I can do pretty well in distance work with my three-valve set using a loud-speaker, I can always do better with a one-valve set using a good pair of telephones.

Last week I made a new type of single-valve set, and at my first sitting with this new set, to my great delight I picked up most clearly those two main broadcasting stations which I invariably fail to get with my three-valve loud-speaker set.

A single-valve set possesses one great advantage in distance work over a multi valve set, and that is that "fading" is much less noticeable with the single-valve set.

Suppose that you are listening to a distant station with a one-valve set and that "fading" is taking place, the maximum signal strength being two and the minimum one. Suppose that you listen to the same distant station with a multi-valve set having an amplification factor of fifty.

As compared with the one-valve set, the maximum signal strength will be fiftytimes two, or one hundred, while the minimum signal strength will be fifty times one or fifty.

Thus with the multi-valve set you have a variation of signal strength from a hundred to fifty, whereas with the one-valve set, the variation in signal strength is only from two to one. No wonder "fading" is so much less noticeable with a one-valve set than with a multi-valve set.

### Accumulator Fires

One of my wireless neighbours was considerably upset on reading an account of an inquest on a poor woman who was burnt to death by fire caused in the first place by the shorting of a wireless accumulator.

I did what I could to reassure him, and I pointed out that there was little or no danger if one of the leads to an accumulator was always taken off from the accumulator terminal when the accumulator was not in use.

Still, I have always thought the celluloid case of an accumulator a source of danger, and I take great care that none of my own accumulators ever get placed near a fire.

I have had one experience of the shorting of an accumulator, and I shall not forget it. With the idea of getting an increased current for the valves of a two-valve set one evening, I connected two accumulator cells in parallel before removing the metal bar which connected the two cells in series.

In a very short time the piece of d.c.c. wire I had used for the parallel connection heated up so much as to burn off all the cotton covering and reveal a red-hot wire underneath.

There was no time for unscrewing a terminal. I quickly grasped the hot wire and snapped it. The wire



Two cells in series.

left a white mark across the insides of my four fingers, but it was only a surface mark. I did not feel any pain from the burn, but I have been very careful with accumulators ever since.



### Buzz-z-z-z-ing Ears

The other night I went to bed with my ears buzzing as if I had a smooth-running dynamo inside my head. I had been using a one-valve set and I had been wearing an old pair of French headphones for about a couple of hours.

For the last few months I have been using a three-valve set with loud-speaker, and I have seldom worn a pair of headphones for more than a few minutes at a time. I suppose my ears had become unaccustomed

to the pressure of a pair of phones and the noise thereof.

You see, I happened to be doing a rare and interesting bit of long-distance work, and I was blissfully unconscious of the way my headphones were affecting my ears. When I did switch my valve off and remove my phones from off my head, I became immediately conscious of a most fearful buzzing in my ears.

I went to bed thinking that, as soon as I lay down, the buzzing would buzz off, but no, I was kept awake for a long time by the continuous-way buzzer inside my funny old head.

Take my tip over using headphones



Buzzing round like an angry wasp.

after a long period of loud-speaker reception. Go easily at first. Break your ears in again gradually. Use your headphones for a quarter of an hour, say, the first night, half an hour the next night, and so on.

I tremble to think what the effect would be on me if I stayed up half the night listening-in on a pair of headphones. I am afraid I should go buzzing round like an angry wasp.



### The New Year

What will the year 1926 bring forth in the world of wireless? He would indeed be a rash prophet who would venture a definite prophecy. There are, however, a number of possibilities which one might hint at with a fair margin of safety.

For example, the year 1926 might see some great stride forward in television, although I doubt if this stride forward will come in time for us to see, by wireless in our homes, the play in the England-Australia cricket Test matches.

Again, the year 1926 might see the invention of a substitute for the valve, although I think most of us will still be using our good old valves when 1926 gives way to 1927.

In the world of broadcasting, I suppose the likeliest change is the closing down of the relay stations and a compensating increase of power in the main stations.

Anyhow, whatever happens, a Happy New Year to you all, and may 1926 be your best wireless year so far.

HALYARD.

# Wonderful Wireless Waves!

IF you place your ear against the surface of the table and tap the wood with one finger you hear the sound very loudly indeed. It is borne from the tip of the finger to your ear by means of waves which travel through the wood.

## Sound Vibrations

What actually happens is this. As your finger strikes the table the wood gives under it; it *bends*, even if it is several inches thick, and a little pit is formed for a tiny fraction of a second in the surface. The next instant the wood rebounds and the result is that a train of waves is sent out from the centre of the disturbance; that is, the point struck by your finger, to all parts of the table.

If you hit it hard with your closed fist or with a mallet you can actually feel the waves or vibrations. A second experiment with waves consists in tapping the table whilst your ear is not in contact with it. Again you hear the sound, this time not nearly so loudly as before. In this case the table vibrates and communicates the agitation of its surface to the surrounding air.

The air is thus caused to vibrate and the waves set up in it strike the drum of your ear which, in response, move very slightly to and fro, with the result that you hear the sound.

## Speed of Waves

Waves in air travel quite slowly, their speed being about 1,100 feet a second. Through wood they travel more quickly and through iron or steel more rapidly still, because these substances are more rigid.

The loudness of the sound that you hear depends upon the size of the waves, or, to use a technical term, upon their amplitude. The amplitude of a wave is the distance from the top of its crest to the bottom of its trough.

Sound; vary also in their pitch; the squeak of a bat is so shrill that not one person in a hundred can hear it, and down at the other end of the scale we have the largest organ pipes with their deep booming notes.

The pitch of a sound depends

entirely upon the number of vibrations that take place in a second. When, for example, you strike the middle C of a piano you cause the wire to move to and fro about 256 times a second. The C next above is the result of 512 vibrations a second, and that below the middle C of 128.

The pitch of a note then depends upon its frequency, and we may define frequency as the number of waves which pass a given point in one second.

In wireless, both transmission

*In the excitement of actual broadcast reception we are apt to take too much for granted.*

*By explaining their nature and the phenomena that they undergo Mr. Francis Horne's article reminds us how wonderful these waves are.*

and reception are done entirely by means of waves which travel not through the air but through that mysterious medium which we call the ether. We must regard the ether as something intangible, invisible and weightless which pervades everything and offers no resistance at all to the passage of bodies through it.

It must be more rigid than steel, for waves which travel in the ether all move at the same terrific speed of 186,000 miles a second. And if the passage of waves through the ether is rapid their frequencies in this medium are stupendous as compared with those in the air or in other substances.

## Pitch

Ether waves have also their pitch depending upon the frequency. The slowest of them that our senses can perceive are those which produce the sensation we know as heat. The "pitch" of heat is between  $12\frac{1}{2}$  billion and 395 billion vibrations a second.

More highly pitched still is light, and beyond that we have the various forms of X-rays. Wireless waves occupy the frequencies between 10,000 and 300,000,000 or rather

more a second. We do our tuning-in by adjusting the receiving set to the pitch of the transmitting station.

## Resonance

If, for example, we wish to receive 2 L O's programme, what we actually do, though we possibly do not realise it, is to turn the knobs of our condensers until the circuits of the set are each so adjusted that they are in resonance with a frequency of 824,140 cycles a second, whilst when we tune in one of the short-wave stations on 100 metres we adjust our circuits to a frequency of three million a second.

Wireless waves can travel through the interstices permeated by the ether of any substance that is a good insulator. The air itself fulfils this condition at ground level and for some considerable distance above the surface of the earth.

Conductors have upon wireless waves precisely the same effect as mirrors have upon light rays; they deflect or bend the waves. It is for this reason that those who live in iron-framed buildings or in districts where there are large metallic deposits underground find that their signals are weak. But it is a very good thing for us that wireless waves are bent back by conductors.

## Air as a Conductor

The range of a lighthouse, even if its beam is very powerful is, as you know, quite limited. Our coasts are the best lighted in the world, but so far as I know we have no light which is visible for more than about thirty miles seaward.

This is because the surface of the earth is curved and light rays travel in straight lines. If wireless waves behaved in the same way the utmost range of broadcast or commercial stations would be round about a hundred miles, even if masts of enormous height were used to support the transmitting aerials.

But high above the surface of the earth a very curious change takes place in the qualities of the air. At the surface of the earth the pressure of the air is such that in normal weather it can support a column of mercury 30 inches in

height. Thirty-five miles up the pressure has become so small that the mercury in a barometer at this level would be only 1.25 inches above the bulb.

**Heaviside Layer**

At this pressure air suddenly ceases to become an insulator and takes on all the properties of a good conductor. We must imagine that surrounding the world and at a distance of thirty-five miles from its surface is a thin shell of air at this pressure which is so good a conductor that a thickness of only half-an-inch of it is impervious to any wireless wave. The Heaviside layer, as it is called, plays the part of a gigantic reflector to wireless waves, bending them back towards the ground and forcing them to follow the curved contours of the world instead of travelling in straight lines as they otherwise would.

There is also another curious effect which takes place every twenty-four hours in the atmosphere. As the sun rises, its rays pass through the air causing the process known as ionisation in the lower-lying layers of the atmosphere.

Ionisation means that the detachable electrons of the atoms become much less closely bound at their nuclei, and the air in this condition is a better conductor. Unfortunately the ionisation takes place irregularly, so that the lower surface of the conducting layer in the atmosphere is rough and jagged.

In their passage from one part of the world to another during the hours of daylight, wireless waves strike ionised patches in the air and lose much of their energy by absorption. At night time when the sun is no longer shining de-ionisation takes place, and waves travel to

much greater distances without losing energy on the way.

This is the reason why the range of reception at night time is so much longer than it is during the hours of daylight.

The worst time of all for reception is at noon, and the best round about five o'clock in the morning.

**Short Wavelengths**

The greatest wavelength in commercial use is that of Bordeaux, which transmits on 23,500 metres. At one time it was thought that long-distance problems would be solved by the adoption of long waves and enormous power. Recently, however, Senator Marconi has shown that ultra-short waves focussed into a beam can cover immense distances, though the transmitting station may be using quite a small amount of power.

**Expressions of Opinion**

By C. EVERARD

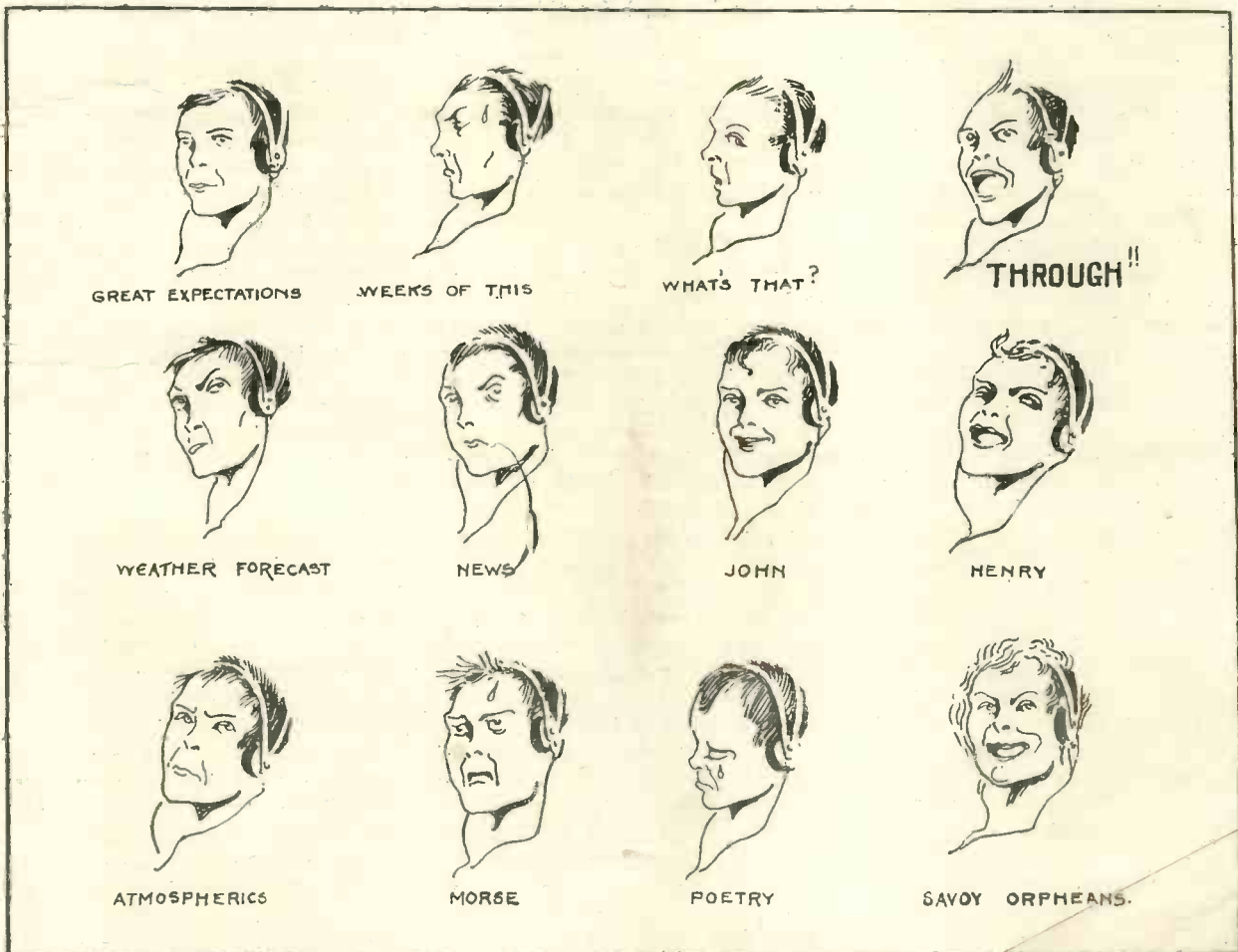

# How the Valve Works

TO the ordinary man electric actions are exceedingly difficult to visualise. The passage of an electric current along a conductor, or the existence of a difference of potential between two bodies, are events that make no direct appeal to the senses.

It is only by their secondary effects that electrical disturbances are made manifest; for example, the heating to incandescence of a valve filament, the

sound vibrations from a telephone diaphragm, or the movement of the pointer of an ammeter or voltmeter.

The student of electricity is undoubtedly handicapped in this respect as compared with the mechanical engineer. However complicated a piece of mechanism may be, it is capable of analysis into simpler elements, and with the aid of drawings or models the shapes of the part may be examined. Moreover, the machine as a whole can be watched in operation, until a complete understanding of its working is attained.

## Lack of Insight

This method of attack is denied to the electrician. With the exception of dynamos and motors, electrical apparatus is generally stationary when in operation, and very little insight is to be obtained either by examining it in action or by disassembling its component parts. These remarks are particularly applicable to the study of the thermionic valve and its associated circuits.

Attempts have accordingly been made, from time to time, and with varying degrees of success, to "visualise" the working of a valve by means of mechanical models. The diagram illustrates a particularly ingenious apparatus which has been

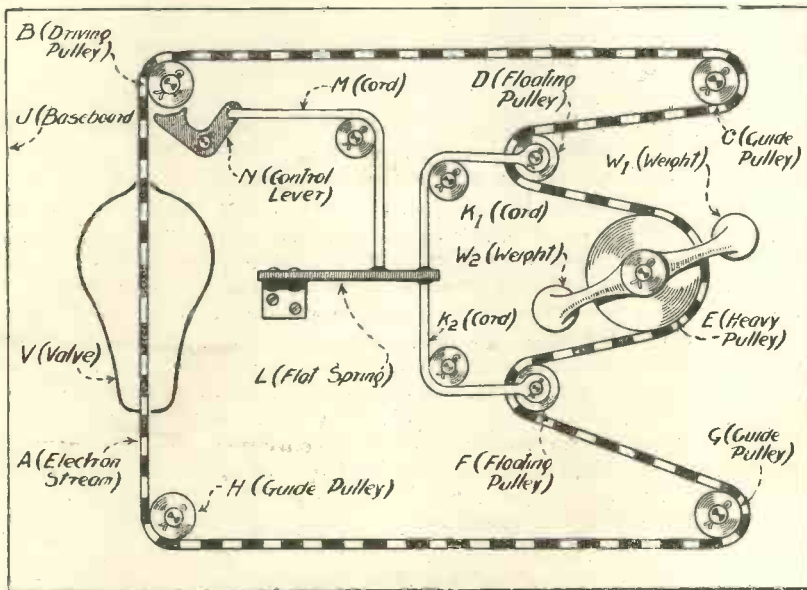

Fig. 1.—Apparatus for Explaining Valve Action.

recently invented for this purpose. (Patent No. 229374. British Thomson-Houston Co.)

By making use of the well-known analogy of mechanical inertia to electric inductance, and of ordinary electricity to electric capacity, the model exhibits what is in effect a "slow-motion picture" of the valve at work. The actual apparatus is indicated in Fig. 1, whilst the corresponding valve diagram is shown in Fig. 2, equivalent parts being indicated by corresponding reference letters.

An endless cord A (the electron stream or current) is passed around a pulley B, which is driven by a small motor (H.T. supply). The cord then passes in serpentine fashion around small guide pulleys C, D, to a larger pulley E, which is weighted by masses  $W_1$   $W_2$  (inductance) mounted on opposite ends of a radial arm. From here it passes around further guide pulleys F, G, H, back to the driving pulley B.

The spindles of the pulleys B, C, E, G, H, it should be noted, are mounted on the baseboard J, whilst those of the pulleys D, F, are "floating," and are attached by cords  $K_1$   $K_2$  to the free end of a flat spring L (capacity), the opposite end of which is firmly clamped to the base J.

The pulley B, in addition to being driven by the motor, is controlled by a centrifugal speed-regulating brake (not shown) of the kind used in gramophones, the control lever N of which is connected by a cord M to a point on the spring L in such a way that a downward movement of the spring accelerates the speed of the motor, whilst an upward movement reduces it. The figure V represents the

valve (as a whole, not distinguishing between its parts.)

## How It Works

When the motor is started in a clockwise direction, the cord A tends to drive the heavy pulley E, but the inertia of the latter offers considerable resistance to rotation, and sets up an extra tension in the cord between the points E and F. The small floating pulley F is, in consequence, pulled to the right, and the spring L is moved downwards. This, in turn, exerts a pull on the cord M, and moves the brake lever N so as to accelerate the motor.

During this period, however, the heavy pulley E has been gaining speed, and presently it is moving faster than the motor pulley B. It now shows the same disinclination to slowing-up as it previously showed to acceleration. Consequently the spring L is dragged upwards by the string  $K_1$  past its normal position, and allows the lever N to brake the motor.

The spring L thereupon drops towards its central position, and so a state of constant vibration is set up, the pulley E continually rising and falling in speed, and the spring L moving up and down from its normal position.

Referring to the corresponding

electrical circuit, shown in Fig. 2, it will be seen that the movement of the cord A corresponds to the current flow in the plate circuit, due to the H.T. source,  $B^1$ .

The spring L, which in the mechanical apparatus acts as a buffer to take up sudden changes in the movement of the cord A, is replaced by a condenser  $L^1$  connected across the coil  $E^1$ . The cord M, attached to the spring L and controlling the speed of the cord A (through the pulley B), is replaced by the grid condenser  $M^1$  connected between the upper plate of the condenser  $L^1$  and the grid of the valve.

**Function of Grid Condenser**

The function of the grid condenser therefore becomes apparent. It is to ensure that potential variations on the condenser  $L^1$  react on the grid potential and so accelerate or retard the electron flow through the valve. In other words, the cord M utilises the strain on the spring L to control the speed of the cord A.

When the various parts of Fig. 1 have settled down to a steady motion, it will be seen that the cord A (which should be painted in black and white patches) moves forward in a series of jerks, but always in the same direction, thus representing the pulsating, but uni-directional, electron current through the valve and its plate circuit.

The oscillatory current passing into and out of the condenser  $L^1$ , Fig. 2, is indicated by the oscillatory movement of the cords  $K_1$ ,  $K_2$  attached to the spring L, Fig. 1. By careful observation, it will be noted that this latter movement is in quadrature with the pulsations of the cord A, that is to say, that at the moments when the cord A is

moving at its maximum speed, the cords  $K_1$ ,  $K_2$  are at rest, and the spring L is in one of its extreme positions.

The amplifying action of a valve, as distinct from the generation of

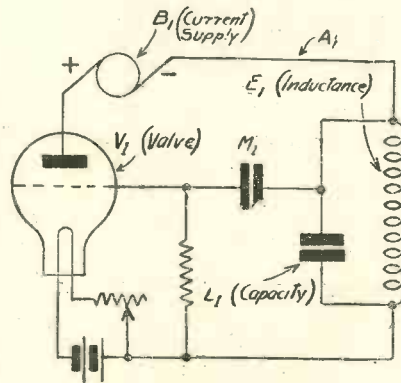

Fig. 2.—Circuit Explained by Fig. 1.

sustained oscillations, may be demonstrated by removing the cord M from the model (that is, eliminating reaction), and vibrating the brake lever N by hand. These vibrations will be reproduced in amplified form in the

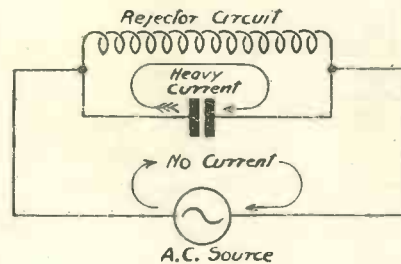

Fig. 3.—Rejector Circuit.

movements of the pulley E. The degree of amplification will vary with the applied frequency, and will be at a maximum when the applied vibrations occur at the natural frequency of the mechanical system

formed by the heavy pulley E and the spring L (resonance effect).

The pulley B may be disconnected from the motor and the cord A vibrated by hand. When the vibrations are slow, the pulley E is able to reverse its movements without much difficulty, so that the spring L and cords  $K_1$ ,  $K_2$  hardly move. This shows clearly that a low-frequency current will pass through an inductance coil without producing any substantial current flow into and out of a condenser shunted across the coil.

**High-frequency Vibrations**

On the other hand, if the applied vibrations are of high frequency, the pulley E will not be able to get into motion. Instead, practically all the movement of the cord A is taken up by the cords  $K_1$ ,  $K_2$  and spring L. This indicates that a high-frequency current passes through a condenser in preference to a coil in parallel with it.

If, however, the applied vibrations are at the resonance frequency of the pulley E and spring L, the movements of these become equal in amount, but opposite in direction, and a large swing is quickly built up. Moreover, this swing is accompanied by practically no movement of the cord A, although considerable tension is applied to it by the external force.

This provides a complete demonstration of the well-known action of the loop or rejector circuit, Fig. 3, in which a large alternating E.M.F. applied across the loop results in the passage of practically no current from the source, but at the same time creates a heavy "swirl" of current inside the rejector circuit itself. W. LOCK.

**RECOGNISING THE FOREIGN STATIONS** (Continued from page 562)

syllable, and adds dignity to the most bald announcement.

Milan, now working, advertises its arrival as *Radio Milano* and repeats its full titles in French.

Of the Swiss stations, Zurich, Berne and Basle use the German language. There is nothing peculiarly individual about their calls; they scatter them fairly frequently during the programmes. Lausanne and Geneva broadcast in French, the former always mentioning the *Société Romande*, the latter styling itself *Radio-Genève*.

In Sweden, we strike a main station—*Hallo, hallo, Radio-Stockholm*, and a big bunch of small relays who take their programmes from the capital city. It is therefore seldom one hears the actual name of the individual transmitter.

Stockholm's neighbour, Christiania, now re-christened Oslo, frequently announces in the English language.

Travelling south, we stop at Copenhagen, a new station putting out its call in Danish, German, French and English but, unluckily for us, not regularly. Should you

pick up Ryvang or Lyngby, this will be made clear to you by their respective speakers.

Finally, before closing down for the night, we pay a visit to Holland. Surely this will not puzzle you. There is only one station of any importance in that little country—Hilversum, on a wavelength well separated from other broadcasters. *Hier Het Hilversumsche Omroep. Radio Statie Hilversum* pierces the ether, and the announcer, aware of his great British audience, usually adds *Hilversum suanon calling*.

An Hour at 2 L O

# Studio Impressions

:: An Article  
by  
:: WATSON LYLE

WHEN one investigates even a little of what happens in a broadcasting studio the tremendous amount of detail and the several factors contributing towards a good transmission to the listeners, maybe thousands of miles distant, become apparent.

At least, so it seemed to me recently when, by the kindness of my friend, M. Pouishnoff, and the courtesy of the B.B.C., I enjoyed the privilege of spending an evening in the big studio at Savoy Hill while a concert programme was being broadcast. Besides listening to the distinguished pianist, I remained in the studio for the performances of most of the artists, being anxious as journalist and musician to learn all I could about broadcasting from within.

Before that experience wireless was chiefly interesting to me as a demonstration of the practical application of a natural phenomenon—the sound-wave—which, as every educated musician knows, is probably as old as the world itself. There were man-invented things termed transmitters and receivers which enchain this power of nature, and a thing called a microphone that made possible the harnessing of the sound-waves for the use, or amusement, of humanity, and that was really all there was about it.

One simply spoke, sang or played near the microphone, and Ned Roberts in Brixton, or Silas B. Canned, in Chicago, with the headphones on, promptly became aware of the event.

I am but little of a scientist and nothing of an engineer, so I shall not launch forth upon a dissertation regarding the catwhiskers, broomsticks, crystal sets and other paraphernalia of witchcraft and wireless



M. Pouishnoff.

that the city man babbles about so glibly to his fellow travellers when homeward bound to suburbia.

My concern is with broadcasting before it becomes wireless, so to say, although I'm afraid that sounds rather Hibernian; with the influences that operate in the studio before and during the capturing of the sounds by that uncanny-looking item of the whole magic, the microphone.

The spacious and lofty studio in which I sat had the walls and vaulted ceiling entirely covered with a heavy, pale fawn, or greyish, cloth stuff, which hung in folds innumerable from top to bottom of the walls, and was tightly stretched across the ceiling. The glass of the window was covered with canvas, while even a telephone box near to one door was draped in khaki overalls.

The conventional simplicity of this interior was only slightly disturbed by the vivid colouring of a meagre ceiling decoration in carved wood, and a small, circular mirror at the farther end of the studio. There, too, stood a collection of plain wooden chairs and music stands for the accommodation of members of orchestras.

The mirror would enable the conductor when facing it to see the electric-lamp indicators arranged in pairs by the door behind him; also to note when the red light above the door flashed out the warning that the transmission was in operation. It signified, too, that all within the place who were not engaged in making a noise (joyful or otherwise) to be

broadcast must become silent as the proverbial tomb.

Indeed, the room, with its uncanny knack of absorbing sound, much as good blotting-paper absorbs ink, was suggestively ghostly. Ghosts are reputed to gesticulate and beck and sign in cryptic fashion, and such was the manner of communication between the inhabitants of that chamber, eerie and bizarre, with these silently moving figures, and the

pathetic collection of deserted furniture in the gloom of the background, huddled there by a housemaid long since dead, and left to the ravages of dust and cobwebs.

There is certainly a weird kinship between the results of these two entirely modern developments of art—the cinema and wireless.

### Extra Senses

In the first, mere one-dimensional creatures, the mechanical productions of the camera, take to themselves the semblance of the actual, of life and movement in nature, and challenge the vision; in the second, human voices, and other sounds that we associate with a natural origin, assail the hearing from space, and both appear to endow us with the extra senses claimed by the clairvoyant and clairaudient as their especial possessions.

But even by holding the imagination in check, and allowing cool reason and a knowledge of acoustics to prevail and explain away the why and wherefore of the dumb show and the tense, sound-damped atmosphere, the microphone, alluring instrument, pregnant with suggestion, magnetised the attention and re-kindled afresh the feeling of mystery.

For surely into the box of orange silk stuff that served as casket for the sensitive microphone, the visitants to this haunted room consigned their wishes, their ideas, their messages to mortals in the outer world—the outer world that, sitting there, one vaguely felt must be on another planet.

And who knows but, perchance, wireless may one day establish connection with other worlds than ours, those of which astronomers write to-day? A wild suggestion this.

Art, and especially musical art, is so often alluded to by that aggravatingly dense individual, "the plain person," as a kind of excrescence, instead of as the heart and symbol of civilisation, that one cannot help emphasising its usefulness.

The inclination of the artist who is broadcasting appears to be like that of the average individual compelled to speak on the telephone and unaccustomed to it, and who thinks that his voice will be better heard the louder he speaks.

Only two out of the nine artists to whom I listened in the studio—Pouishnoff, and W. H. Squire—seemed to bear in mind the fact that a calculation of tone-volume rather

under than over what might be used in the concert hall, is far likelier to transmit well than a *ff* that is really *fff*, and a *pp* that is never softer than *p*, with intermediate gradations of sound in proportion.

There would not appear to be any occasion for vocalists to become apoplectic and show bulging veins on forehead and neck—as two of those I saw did—at tonal climaxes, when we reflect how, in the early summer of 1924 Beatrice Harrison secured a broadcast of the song of the nightingales in the shrubbery of her garden, and that, since then, the even more subdued and delicate voice of another bird vocalist, the roller singing canary (whose artificial song is derived from that of the nightingale, as a rule) has been transmitted.

I thought also that the fact that all the items were broadcast from memory, just as the artists would have done in concert halls before the public, was eloquent testimony to the generally recognised hindrance imposed by the mere presence of a score to anything individualistic in interpretation.

Too often the layman, and even some of the critics, judging by what one reads at times, regard the performance of a long programme from memory, by an instrumental or vocal soloist, simply in the light of a stunt.

### The "Engine Room"

Equally as wonderful as the studio, but not at all mysterious, was the "engine room" to which we ascended up two flights of stairs. Here I was shown how, by simply pressing a succession of little knobs, like those on a telephone switchboard, I could listen, at one second in London, at another in Bournemouth, at the next in Liverpool, and so on, journeying on a magic carpet from place to place with a friendly engineer as guiding genii, at a speed undreamt of by Douglas Fairbanks in "The Thief of Bagdad."

But when we emerged from the engine room I knew that everybody about me was really very human—even those "ghosts" I had left in the sound-deadened room—because, while listening-in to Liverpool (or was it Bournemouth?) I had heard a member of the staff confiding something as a dead secret—so he put it—on the phone totally oblivious of the presence of at least half a dozen other folk in the room. That essentially human foible shattered all illusions of the occult.

## A Battery Tester

A SIMPLE hydrometer and one that will give excellent service can be made at home for a few pence. The only thing that need be bought is a pipette—that is a glass tube brought to a fine end and fitted with a rubber pinch bulb. The pipette should be about 6 in. long with a diameter of  $\frac{1}{8}$  or  $\frac{1}{4}$  in.

Obtain the loan of a scaled hydrometer and with its aid mix two test-tubefuls of dilute sulphuric acid solution, using the best brimstone acid and distilled water. The first must have a specific gravity of 1.22, the second of 1.17. A specific gravity of 1.22 is the usual figure for a fully-charged accumulator. Some makes,

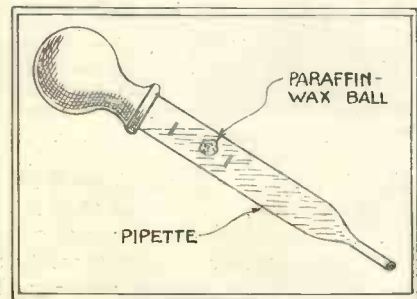

Completed Battery Tester.

however, have a different specific gravity, so make the first solution equal to this and increase the second in proportion.

Now roll between the finger and thumb a little ball of paraffin wax that will fit easily into the tube of the pipette. Press lead filings in till it floats, just touching the surface in the first test-tube.

Place the ball in the pipette and draw up about 4 ins. of the solution from the first test-tube. Mark a line on the glass opposite the top of the liquid. Empty the pipette and draw up solution from the second tube until the scratch on the glass is reached. The wax ball will now be found to be floating some distance from the top of the column of liquid. Make a second mark to indicate the spot reached by it.

When testing accumulators the pipette must always be filled to the top mark. The position of the ball will then indicate their condition. If it just touches the surface the cell is fully charged. When it reaches the lower mark the cell is right down and should be charged without delay.

R. G. H.

# IRISH BROADCASTING



At the Dublin broadcasting station. Leaning on the rail is Mr. Mulligan, Chief Engineer of the Irish Free State Post Office.

HAVING just returned from the Green Isle, I feel sure that a brief account of the conditions that affect the amateur "over there" will be of interest to the amateur here. Although the Irish Free State and Northern Ireland have been functioning independently for the past two years, the people of this country have not yet grown out of the habit of regarding Ireland as a unity (nor are they ever likely to do so, of course).

Yet few things mark the severance of Ireland into independent states more clearly than the difference that exists in relation to broadcasting in the two states.

## Northern Ireland

In Northern Ireland there is only one station in operation—at Belfast. This is controlled by the B.B.C., and for all practical (and unpractical) purposes the amateur in Northern Ireland is in exactly the same position as his brother amateur over here. The Belfast programmes are a mixture of local talent and selections relayed from the other B.B.C. stations.

The Northly-Irish amateur (I hope that is correct) who goes a-hunting in the ether on his own for B.B.C. stations rarely has any difficulty in getting Daventry and Glasgow. Manchester is also popular, particularly among Belfast amateurs, and Newcastle gets a fair share of attention.

There is only one broadcasting station in the Free State at present, that is 2 R N, Dublin, and Free State amateurs have to pay a licence fee of £1 to the Government. It is estimated by many who seem qualified to judge that the ratio between licensed amateurs and pirates is about 1 to 4.

As the former now number over 3,000, this would put the total number of amateurs in the Free State at 15,000 approximately. The majority of these, of course, are in the neighbourhood of Dublin.

One Dublin amateur told me that he received both Manchester and Daventry quite regularly on a crystal. The Irish Channel occupies five-sixths of the route from Manchester to Dublin, and Dublin itself is actually "on the sea"; a five-minute tram ride from the centre of the city takes you to the edge of it.

It was from an amateur in a country district that I first got some idea of the difficulties that are likely to confront the government now that broadcasting has got going in the Free State. He was expressing his opinion on the £1 licence fee. (I had already heard the same opinion expressed by other amateurs in different parts of the country.) "A pound indeed!" he declared indignantly. "For listening to stations that the English amateurs can listen to for ten bob! Is it fools they think we are?"

"Of course," I put in casually, "the government might argue that the pound fee is for permission to erect an amateur receiving aerial, irrespective of what stations you receive."

"Oh, aye, to be sure," he acquiesced smilingly. "That's right enough. But what harm will an argument do anyone?"

The remark did not seem altogether illogical somehow.

## "Bit of a Cod"

"Besides," he added, knowingly, "I'm thinking it's all a bit of a cod, between you and me; with the advertisements telling us we could get all the English stations on two valves. It's a three-valve set I have, and one of the best aerials around Dublin—and a double-wire aerial at that; two hundred feet long, if it's an inch! But devil a thing I've heard yet that sounds like an English station."

"Gosh! Not bad for a pirate!" I gasped inwardly.

"But isn't it possible," I suggested presently, with due deference towards one so daring—"isn't it possible that the length of your aerial will get you into trouble? I understand that the 100-foot regulation applies—"

"Trouble indeed!" His eyes fairly danced with joy. "And how are they going to measure it? Would you tell me that? Isn't my



word as good as theirs any day?" he added triumphantly, and, I thought, with a touch of scorn at my simplicity.

"But suppose they insist on taking it down to measure it," I ventured doggedly. That was the last straw, of course.

### Taxpayers' Money

"Arra go on," he laughed, giving me a gentle push, "is it sixty-foot ladders they're going to send all over the country for taking down aerials to measure them? Sure that isn't what the taxpayers' money is for."

I had a sudden, vindictive longing to ask him if he were a taxpayer, but the fear of appearing an utter simpleton in his eyes restrained me.

"Anyway, they're welcome to take mine down to-morrow, for all the good it is to me—after all the trouble I had getting it across two streets over a whole row of houses!"

This last remark might well have flooded me if I had not had previous evidence of the apparent indifference with which local authorities in the Free State regard the erection of aerials over public thoroughfares.

I do not suggest that the foregoing record of my friend's attitude towards the "broadcasting situation" in the Free State is in any sense typical. Nor do I place much reliance on the computation that puts the ratio between licensed amateurs and pirates at 1 to 4.

### Received Seriously

In fact, my conversations with numerous amateurs and listeners in different parts of the country convinced me that broadcasting is going to be received very seriously and enthusiastically—"when our own stations get going." And now Dublin has "got going."

In their attitude towards one aspect of the subject I found almost unanimous agreement among those who were genuinely interested. Broadcasting in the Free State is not going to be developed along British lines. That in itself is regarded as a cause for satisfaction. The government, it is felt, has done something original, something independent, in refusing to follow the British method of granting a monopoly to a public company.

At that point, however, the feeling of satisfaction is replaced by one of frank suspicion at the prospect of a

state-controlled broadcasting service, for the Free State government has decided to foster and develop broadcasting under one of its own departmental wings.

The chief doubt entertained by amateurs who are interested in politics (and who is not vitally interested in politics in Ireland?) arises out of the possibility of the broadcasting service being used for purposes of political propaganda.

Reception conditions in Ireland appear to be particularly good,

from leaves during thundery weather conditions, was partly responsible for the heaviness of the "mush" atmospherics that filled the phones night after night.

I remember one or two nights in particular when the persistent din in the phones reminded me of some of my worst experiences of reception in the tropics—a comparison which can only be appreciated by others who have experienced the delights of tropical reception.

### Satisfactory Results

Apart from the bad atmospherics, however, results were very satisfactory, signals from 5XX, at a distance of about 300 miles, being clearly audible at twenty feet from the phones. Belfast (170 miles) was next best, and Radio-Paris was sufficiently loud to be enjoyable. Several of the other B.B.C. stations were picked up from time to time, as well as two Continental stations (French and German) on the same waveband, but the prevalence of atmospherics made it difficult to differentiate these clearly.

Broadcasting is certain to have a big future in Ireland. Already one can detect a keen interest among amateurs in reference to American reception.

It might almost be said that America is the Irishman's "spiritual home." Many an Irishman has spent his life "making up his mind to go to America." Many others have gone there.

### America Nearer and Dearer

America, in truth, is felt to be a much nearer and dearer neighbour than England has ever been. In the geographical sense alone has she been a "distant land." And now broadcasting is going to sweep away the great rolling ocean that separates the small island from the vast continent.

Small wonder then that Irish amateurs have already begun to dream of a high-power station—somewhere on the west coast of Galway, maybe—that will relay American programmes regularly, bringing music and voices from the golden west into the thousands of farms and cottages and hillside homesteads—aye, and hillside hovels—where silent, aged parents have little else to do during the long winter evenings but think and think and think about their emigrant lads and lasses.

PADDY.

### 2RN—DUBLIN'S NEW TRANSMITTER.

The transmitter is a Marconi type Q broadcasting instrument consisting of four panels—rectifier, independent drive, main oscillator and modulator.

Power is derived from two 6 kw. motor alternators delivering current at 500 volts 200 cycles. A 22-volt 500-ampere-hour battery is used for filament lighting.

The power from the generator passes through a transformer, and the high oscillating voltage resulting is converted by the rectifier valves and a suitable arrangement of chokes into a unidirectional voltage for the high-tension supply to the remaining transmitting panels.

This voltage is in the neighbourhood of 11,200 volts.

Thirty-eight galvanised-steel earth plates are used for the main earth, each measuring 30 in. wide and being buried to a depth of 29 in.

The two masts are each 120 ft. high and 362 ft. apart. The aerial is of the T type and consists of a 4 ft. 6 in. diameter cage of 7/16 silicon-bronze wire.

except for one factor—to wit, atmospherics, which seem to be particularly bad. Amateurs from all over the country report "bad atmospherics," and certainly my own experiments with a two-valve receiver, in one of the midland counties, substantiated these reports.

Although my aerial was quite a high one, it was surrounded almost entirely by still higher trees, which, no doubt, by virtue of the "brush discharge" that is said to emanate

# Novelties and New Apparatus

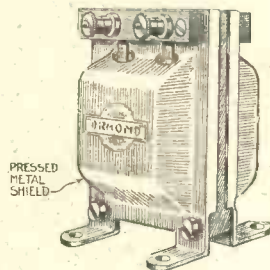

Although the standard ratio is 1 to 5, Ormond low-frequency transformers are made in other ratios between 1 to 1 and 1 to 10.

The primary resistance of the 1 to 5 ratio instrument is 1,000 ohms, and the secondary resistance is 5,000 ohms.

The address of the Ormond Engineering Co. is 199-205, Pentonville Rd., King's Cross, N.1.

Unless the crystal set is kept in a very light part of the room difficulty may be experienced in setting the catwhisker to the best point of adjustment.

To overcome this trouble a small four-volt bulb is placed underneath the glass cover of the Trix detector. The arrangement is clear from the drawing. A small turn-switch is incorporated for switching the bulb on and off.

When the detector is used in a crystal-valve reflex set the bulb can be connected to the filament-lighting accumulator. Care should be taken, however, to see that the voltage is not too high, or the bulb will soon be burnt-out.

The manufacturer is Eric J. Lever, of 11, Clerkenwell Green, E.C.1.

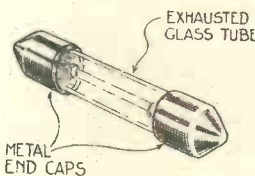
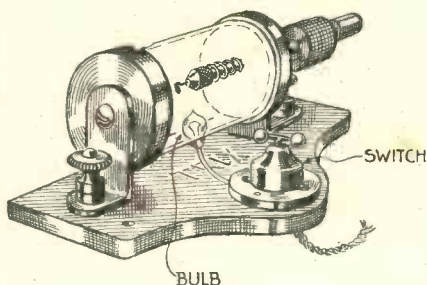

Having the resistance element enclosed in an evacuated frosted-glass tube, the new Edison grid leak is not subject to changes in resistance caused by the chemical action of the atmosphere or harmful light rays. It is made in the following resistances: 5, 1, 2, 3 and 6 megohms.

The grid leak will fit the standard clips.

The address of the Edison Swan Electric Co., Ltd., is 123-5, Queen Victoria Street, E.C.4.

This E. & R. patent panel holder is a device of more than usual interest to the home constructor. The method of using it can be understood from the illustration.

There can be no doubt that the use of a pair of these holders greatly facilitates the wiring and testing of a set. The clamp rotates on the stand, and the panel can thus be turned over at any angle for inspection.

The stands can be used for a panel of any length and almost any width.

It will be noticed that three clamping screws are provided. The two side screws hold the panel in the clamp, and the third locks the clamp when it has been placed in the desired position.

The distributors are Gregory and Sutcliffe, of Huddersfield.

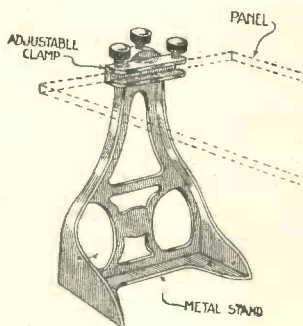

In this filament rheostat the resistance of the vernier portion is controlled by the same knob as is the main resistance, and from the same spindle.

This type of filament rheostat is of particular use for controlling the detector valve of a set. Most good detector valves require critical adjustment of the filament voltage if the best results are to be obtained.

This component is one-hole fixed.

The rheostat, which is made by the Ormond Engineering Co., of 199-205, Pentonville Rd., King's Cross, N.1., is supplied with a resistance of 6, 15 or 30 ohms for use with different types of valve and different voltage batteries.

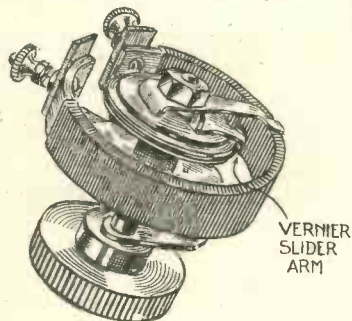

Home construction of sets is still further simplified by the use of this new Bretwood device, which consists of a combined valve holder and filament rheostat which is one-hole fixed.

Such components save a great deal of time and trouble. The manufacturers of this one are Bretwood, Ltd., of 12-18, London Mews, Maple St., W.

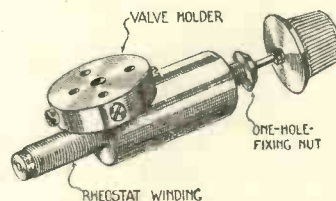

# Illustrated and Described

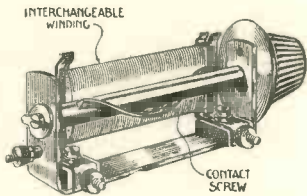

As the resistance units are interchangeable, this Baltic instrument can be used either as a filament rheostat or as a potentiometer, as desired. Units with the following resistances can be supplied: 1, 4, 8, 15, 30, 60, 300 and 700 ohms.

The English agents for Baltic apparatus are L. J. Hydeleyman & Co., of 32, Queen Victoria St., E.C.4. The manufacturers are the Baltic Co., Ltd., of Stockholm, Sweden.

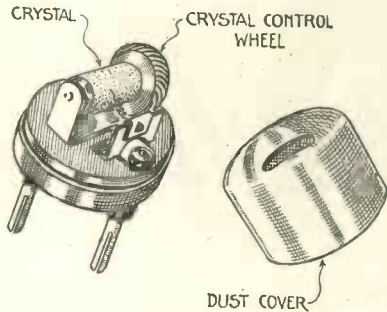

Some advantages of the Harlie detector, which has a semi-automatic adjustment is that: (1) It can be adjusted in the dark; (2) contact is continuous, even whilst being adjusted, and (3) once adjusted it will withstand vibration and even hard knocks.

From the illustration it will be seen that the construction of this detector is very simple and there is practically nothing to get out of order.

The makers are Harlie Bros., of 36, Wilton Rd., E.S.

With this Atlas Vermaknob either coarse or fine tuning can be carried out at will. It can be fixed to  $\frac{3}{8}$ -in., 2BA., or  $\frac{1}{4}$ -in. diameter spindles of the three-hole or one-hole fixed type of variable condenser.

Such a dial as this is the very thing to have on each variable condenser in a set that is desired to be selective. Indeed, without some such vernier control many stations may be missed altogether.

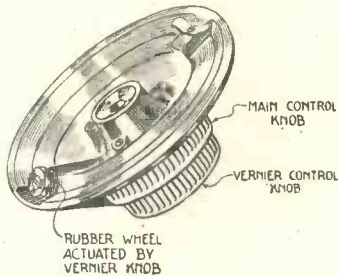

The manufacturers of Atlas products are H. Clarke & Co. (Manchester), Ltd., of Atlas Works, Old Trafford, Manchester, well known as the producers of Atlas plug-in coils.

Many home constructors will be thankful that the design of wireless apparatus has progressed so far that such a comparatively bulky unit as the R.I. H.F. tuned intervalve coupling is provided with a one-hole fixing device.

The unit has five tappings, and the coil is wound in such a way that the impedance of each tapping keeps the reactance value nearly constant for all wavelengths covered by the instrument.

Many amateurs suffer a great deal of annoyance (although not in silence!) from interference caused by electrical machinery operating in the neighbourhood, and to these the Trotman "smoother" is of interest.

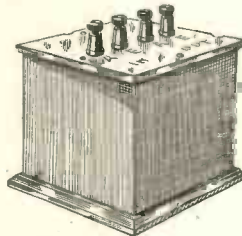

The manufacturer is A. E. R. Trotman, of 11, Highury Hill, N.5.

This "smoother" is intended to cut out interference from lighting mains, trams, lifts, electric railways and power stations. It is connected in the aerial circuit of the set.

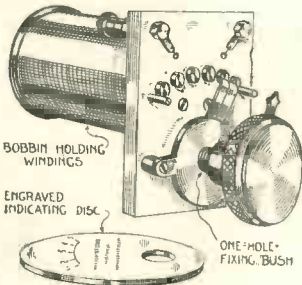

It is very well finished and enclosed in an ebonite protecting cover.

This particular unit has a wavelength range of 200 to 4,000 metres. The address of Radio Instruments, Ltd., is 12, Hyde St., Oxford St., W.C.1.

Dielectric losses in fixed condensers can only be reduced to a minimum by using air as the dielectric—a fact that is appreciated by the makers of Baltic fixed condensers.

These condensers, as can be seen from the example shown in the illustration, are interchangeable and are made in the following capacities: .000028, .000055, .00011 and .00022 microfarad.

They are especially suitable for use in short-wave receivers.

The English distributors are L. J. Hydeleyman & Co., of 32, Queen Victoria St., E.C.4.

AIR-SPACED FIXED CONDENSERS

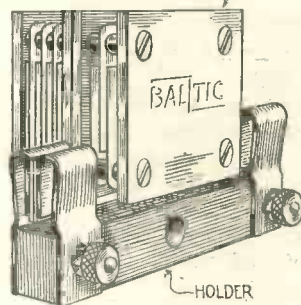



Like the man who threw the coffee jug at his wife.

HELLO, everybody! I'm at it again, although in fairness to the Editor, he has warned me; but, as Socrates says, life's a risky job, sort of "Here we are, and now, where are we," so I'll risk it.

Now then! We've all got a soft spot somewhere for wireless, haven't we? They tell me mine's in my head, see, 'cos it's wireless week in and week out until I've developed a sort of "weak end."

In the words of that song which would have won the war, if they had given it a fair chance, let's "Couple up and whistle."

First of all, like the man who threw the coffee jug at his wife, I've good grounds for complaint. Our programmes are all wrong!! They will persist in giving us stuff we don't want, and when we've got a set that can't get it, it's aggranoying.

Now just suppose I had control!!! (Don't suppose this too much because "In this way madness lies," as W. Shakespeare, Esq., late of Stratford-on-Avon, points out.)

I've got the brains (a lady said I'd been left a lot by my grandfather, but for the life of her she couldn't see where), and I'm naturally adapted for it. (This, of course, isn't a riddle, and no answers are required for it, thank you.)

In fact, let me tell you a secret that no one has ever even suspected yet—I'm a genius, smart like.

Assuming no responsibility, then, et's start!!:—

Over the ether wide and free,  
Broadcasts the sheik of 6 L V;  
His Havanother band,  
At his command,  
Kicks up a shine till 6 from 3.  
With jazzy wand and syncopated arm,  
The bold, bad sheik chap doesn't give  
a darn.

# AT IT AGAIN!

By FISHGLUE

CHORUS—

'Cos I'm the sheik of 6 L V,  
The waves belong to me;  
At night, when you are asleep,  
On sneaky chords I'll creep.  
The stars that shine above,  
On Brahms can waste their love;  
You'll only get jazz from me,  
The sheik of 6 L V.

Of course, we might have a bit of music now and again, on birthdays or funerals or state occasions, or bonfire nights.

And now to attempt a translation of the exquisite little chanson, "Je suis seul" (Got no girl):—

I'm all alone, by the microphone  
(Because there's nothing else to do),



The Sheik of 6 L V.

All alone, by the microphone,  
Wondering if the thing can hear me  
sing;  
And my last note, to the microphone,  
Was B-flat, and rather blue;  
And there's not much doubt,  
You'll get burnt out,  
Unless you leave your set  
All alone too!

(By the way, I hope all this won't remind you of the first line of the verse, which says something about "Just like a malady that lingers on—")

Have you ever heard the canary whistling this little song lately?

Salamoniac, I love you, I love you, I do,  
Salamoniac, my wet cells won't work  
without you.

You're polarising, you won't let a  
milliamp through;

Oh, can't you see, I'm waiting,  
My sweet Salamoniac, for you.

The other day, I had a letter from Prof. Bde. Bôñça, late Professor of Ludo, Wireless and Parlour Games at Boudles aux Boudles University, enclosing his thesis for the degree of Docteur de Telegraphic Sans Fils, which he sent up, also sans fee, so he'll get it per return — peu-têtre. Here are some extracts:—

Young Rupert, for short, sàppelle  
Rupe:  
Il se trouvait, toujours, dans la soupe:  
Il mit son D.E.,  
Right across his H.T.,  
And the filament bust, tout à coupe.

Here is another, sung by Louis X<sup>3</sup> to Joan of Arc the very day after she never smiled again:—

The valve de ma mie,  
Est une .06 D.E.,  
Elle obtained it buckshee,  
Last Nel, from me.  
Mais la valve de ma mie  
Simply must be D.E.,  
'Cos il n'y a que deux volts  
On the family H.T.

This is the charming sort of nonsense they used to sing in those days.

And now, if you'll allow me to reply to my readers, I'm ready, like Nelson at Trafalgar or dinner time, I forget which.

\* \* \*  
"Can't See" from Blindville,  
writes:—

Can't get the grid to leak,  
Loud-speaker will not speak;  
Can't get a single thing right,  
Can't get a single howl,  
Family begins to growl.  
Haven't had a station all night,



Sung by Louis X<sup>3</sup> to Joan of Arc.

Can't get Mr. Baldwin's speech,  
 Can't hear Buttrozini screech,  
 Can't get the chimes of Big Ben,  
 Don't know the price of milk,  
 Or if Winston's taxing silk,  
 Don't know when it's quarter to ten.  
 Neighbours use a crystal set,  
 Never missed an item yet,  
 Simply put the phones on, and  
 then :  
 2 L O calling, 2 L O calling,  
 Just one minute, if you please,  
 Barometer's falling,  
 Weather just appalling,  
 Big depression coming over our way  
 shortly.  
 2 L O calling, 2 L O calling,  
 Last news bulletin now ;  
 Shanghai's on the ramp,  
 More trouble in the camp,  
 Butter's going up again,  
 So are cheese and eggs and bacon.

Near East's very black,  
 Business is awfully slack ;  
 More chaps going on the dole,  
 The building scheme is nothing like  
 completed yet,  
 You'll be lucky if you find a single  
 house to let.  
 2 L O calling, 2 L O calling,  
 London station closing, good night.

The only thing I can suggest is that  
 you read one of my previous articles.

Poetical Percy, Utopia : The only  
 rhyme for "supersonic" I can think  
 of is "simply chronic."

Patsy, Lesser Mugworth : No ;  
 you mustn't bob the catwhisker, or

you'll bingle, I beg your pardon,  
 bungle the whole outfit.

\* \* \* \* \*  
 Soft and Simple, Belfast : The  
 crystal, for preference, should not be  
 fixed in with spearmint, whose ad-  
 hesive properties, while excellent, are  
 marred by the rather high specific  
 resistance which characterises the  
 compound. Try Mo-jo !

\* \* \* \* \*  
 Well, je suis fatigue,  
 It's time that I stopped,  
 The fire's gone out,  
 And the temperature's dropped.

In fact, I can't even think of  
 another line.  
 So, cheerio, everybody !

## WHERE THE DULL-EMITTER SCORES

**L**OW-TEMPERATURE valves  
 are gradually winning their  
 way into the heart of listeners-in  
 throughout the country. The pro-  
 cess is a slow one, however. There  
 are still large numbers of amateurs  
 whose hostility to this new type of  
 valve seems to be due solely to the  
 fact that it gives a "bad" light.

### A Valuable Characteristic

Did these critics but know it,  
 the poor light that emanates from  
 the filament of a low-temperature  
 valve is a particularly valuable  
 characteristic. All the light given  
 off by a valve—any type of valve—  
 is wasted energy. The valve that  
 wastes the least amount of light,  
 therefore, is—other factors being  
 equal—the most efficient.

Low-temperature valves (or, as  
 they are more commonly called,  
 dull-emitter valves) waste very little  
 energy in the form of light.

Prejudice against dull-emitters on  
 this score is quite understandable,  
 however. The ordinary bright valve  
 with which we are all familiar gives  
 a good light when working at its  
 best.

Normally, it gives a fairly white  
 light, but when it begins to get old  
 and worn it gives a weaker light with  
 a yellow tinge, and its efficiency  
 decreases appreciably.

Moreover, if the accumulator that  
 feeds a bright valve is not sent to be  
 recharged at the proper time, the  
 valve burns dully with a definite  
 yellow glow and signals become very

weak. A dull, yellow glow thus be-  
 comes associated with bad results in  
 the mind of the amateur who is accus-  
 tomed to work with bright valves.

For this reason it is rather un-  
 fortunate that low-temperature valves  
 work at their best when emitting a  
 dull, yellow glow !

In order to appreciate this charac-  
 teristic of dull-emitters, it should be  
 remembered that the purpose of  
 passing a current of electricity  
 through the filament of a valve is  
*not* to produce light, but to produce  
 heat. The light emitted by a valve  
 is produced accidentally, as it were.  
 It is a necessary evil ; a secondary  
 effect ; a waste product. The sole  
 object of passing an electric current  
 through the filament of a valve is  
 to heat the filament.

In this respect there is a very im-  
 portant difference between the func-  
 tion of the current that flows into  
 an ordinary electric-light bulb and  
 the function of the current that flows  
 into the filament of a valve.

In the former case the function of  
 the current is definitely to produce  
 light, in the course of which process  
 it also produces a certain amount of  
 heat ; this heat represents so much  
 waste energy.

In the case of the valve, however,  
 the purpose of the current is to  
 produce heat, and any light that  
 is yielded as a secondary effect  
 represents waste energy.

This is not the only count, however,  
 on which the low-temperature valve  
 can claim to be more efficient than

the bright valve in the matter of  
 economy of energy.

When the filament of a valve is  
 heated it shoots off electrons in all  
 directions across the valve. For a  
 given filament the number of elec-  
 trons thus discharged depends upon  
 the heat generated in the filament ;  
 that is, upon the temperature of  
 the latter.

Filaments can be made of different  
 materials, however, and it is found  
 that certain substances do not need  
 to be heated to so high a temperature  
 as others in order to obtain the same  
 electron discharge. And since a low  
 temperature means a low current  
 consumption, the most economical  
 type of filament is one which gives  
 a high electron discharge at a low  
 temperature.

### Consumption

A bright valve consumes, on the  
 average, about .7 of a unit of current  
 under normal working conditions,  
 whilst no dull-emitter on the market  
 (other than special power amplifiers)  
 consumes more than .35 of a unit.  
 Many other dull-emitters work on .15  
 of a unit, or thereabouts ; and there  
 is a special type of dull-emitter which  
 is capable of bringing in good signals  
 on a filament consumption of .06  
 of a unit.

These very low-temperature valves  
 are designed to operate entirely on  
 dry cells.

The dull-emitter type of valve is  
 certainly the valve of the future—  
 and the duller the better ! M. E.



Fig. 1.—Experimental Detector Taken Apart.

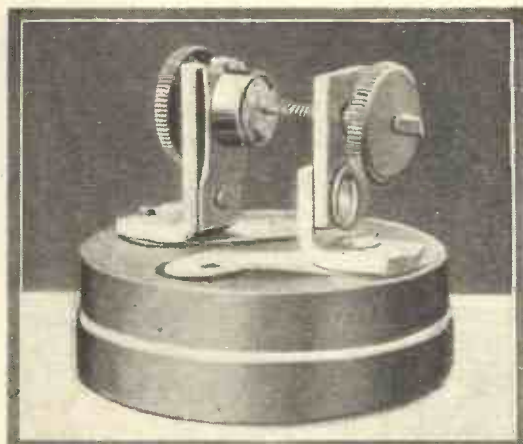

Fig. 2.—Crystal Detector Unit.

# Keeping the Crystal Detector Warm!

IN a recently published article on making crystals the author stated that if the temperature of a galena crystal rectifier as a whole was raised above that of the surrounding atmosphere, to approximately 45° C., increased sensitivity resulted. This was discovered quite by accident.

## Increased Sensitivity

It was subsequently ascertained, however, that increased sensitivity in a crystal detector resulting from the application of heat (an effect similar to that produced on applying a D.C. potential) had already been noted by Capt. H. J. Round and others.

In order to carry out a few experiments with the object of investigating the phenomenon further, a simple arrangement for supplying a uniform temperature for a moderate length of time was made as follows, and the experiments carried out with this detector proved of great interest.

## Detector

The detector, the components of which are shown in Figs. 1 and 2, was made in the following way: A cheap thermos flask was purchased, costing one shilling and threepence, and into the mouth of the flask a short test tube was inserted, a ring of indiarubber being placed around the test tube to form a suitable joint between the tube and the flask

when the remaining parts of the detector were in place.

This tube, being less than 1 in. in diameter, necessitated the exercise of a little ingenuity in designing a suitable rectifying unit, and one of the galena type, having a graphite contact element, was evolved in the manner indicated in Fig. 2.

Fig. 3 shows in detail another rectifying unit.

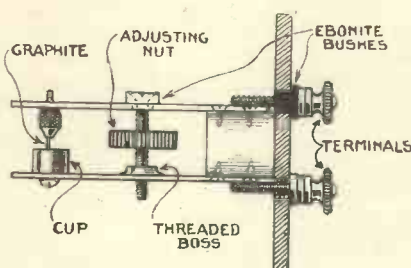

Fig. 3.—Alternative Detector Unit.

The rectifying unit was attached to the inner side of what is normally the drinking cup of the flask, and a packing of indiarubber was provided on the inner side thereof to ensure that when the whole of the components are *in situ* the connection between the test tube and the flask is properly made.

To use the detector, the flask is partially filled with hot water, and the temperature thereof read on a chemical thermometer. If the temperature is too high, the flask is allowed to remain open until the water has attained the right temperature, according to the reading of the

thermometer, when the flask is closed, and the experiment continued.

## Critical Temperature

Certainly this arrangement is by no means ideal, but it served to indicate that a critical temperature apparently exists at which a given crystal yields its best results, the sensitivity increasing with the rise of temperature to this point, and decreasing with a further rise of temperature after this point has been passed.

Of course, when experimenting with such an arrangement, care has to be taken that the contacting elements of the rectifying unit are not disturbed, more particularly as it has been found that, so long as contact is maintained, better rectification can often be obtained by applying heat over a short period.

## Amount of Current

In carrying out these experiments, a microammeter was placed in circuit to indicate the amount of current passing. Such a microammeter may easily be constructed from a Weston relay.

A more practical scheme would have been to have carried out the experiments in a steam oven or some similar device, but the expense of this was not warranted in the present instance, and would only be justified when doing things very seriously, where accuracy is of vital importance.

H. J. H.

# A Step-by-step Eight-valve "Super het"

This set is something more than an ordinary eight-valve "super het"—it is all that and an exclusive "Wireless Magazine" design in addition.

We believe that we are correct in claiming that this eight-valve "super het"—designed, built and tested in "The Wireless Magazine" workshop—is more compact than any other British set containing an equal number of valves.

Moreover, the cost of building this set is not prohibitive to the amateur of moderate means. He can enjoy all that a "super het" means—selectivity, range, distortionless reproduction, ease of control and volume—for a comparatively small expenditure of money.

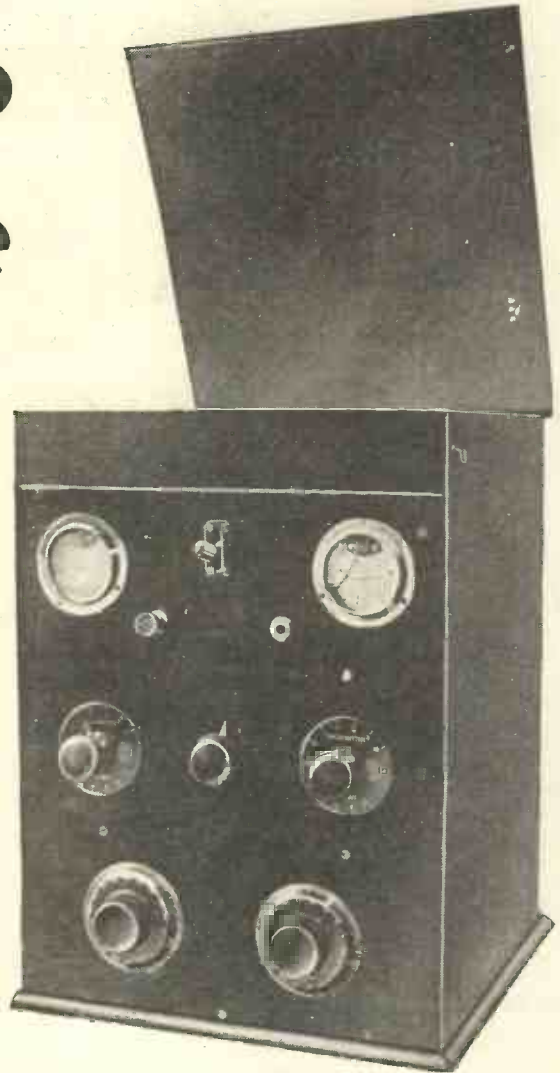

AN unlimited receiving range, remarkable volume, distortionless reproduction, compactness, ease of control, and selectivity—these are the features of the "super het"



The Set in Use.

described in this article. And the cost of making it is approximately £15 (excluding valves and batteries).

A great deal of time and trouble has been expended in producing this really efficient "super het." It was decided, for instance, that a very convenient and, indeed, the logical method of constructing a set of this type so as to avoid the use of large, expensive ebonite panels housed in long, coffin-shaped cabinets, would be to build the receiver in tiers or "steps," each step comprising a special unit of the receiver.

### Sequence of Operation

The apparatus on the lowest step, for instance, receives the incoming oscillations, and heterodynes them, producing oscillations of a lower frequency; these lower frequency oscillations are amplified and rectified by the apparatus on the second or middle step.

They then pass up to the top step, where the rectified oscillations are amplified by low-frequency amplifiers and pass through the loud-speaker.

Thus the three phases of super-sonic-heterodyne reception are carried out on the three steps. This system makes for extreme compactness without loss in efficiency.



Details of Terminal Strip.

The set is enclosed in a polished mahogany cabinet, having the dimensions shown in the sketch. The panel covers the two side pieces and does not fit in flush. A strip of wood is provided at the top so that plenty of

# A Step-by-step Eight-valve "Super Het" (Continued)

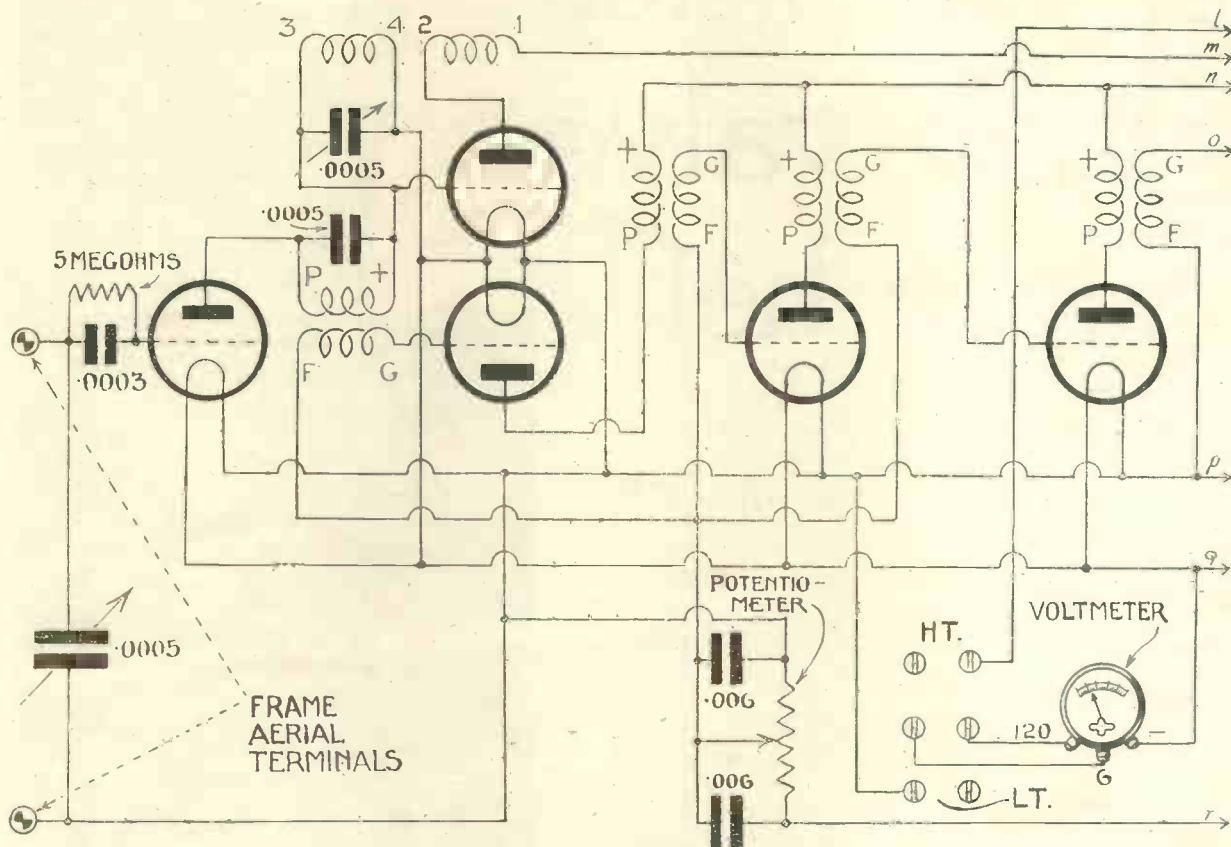

Circuit Diagram of the Step-by-step Eight-valve "Super Het"—

## DETAILS OF THE "SUPER HET" STEPS

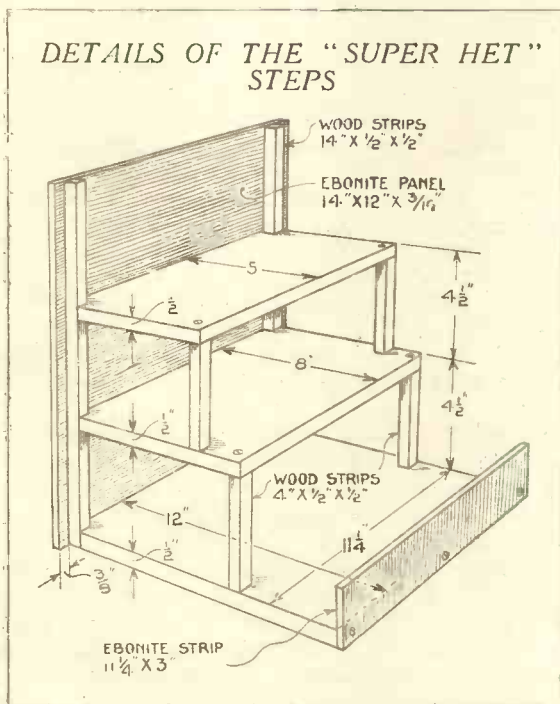

room is allowed for the insertion of the two L.F. valves on the top step. A slot is cut out of the back of the cabinet at the bottom so that the ebonite terminal strip screwed to the back of the baseboard can project through flush with the back.

### Cabinet

Unless the constructor is expert in the use of carpenter's tools the making of the cabinet should be entrusted to some reputable firm of cabinet makers who specialise in this type of work. The cabinet used in the original set was made for us by the Caxton Wood

Turnery Co., Ltd., of Market Harborough.

The remainder of the components required are given in the following list. We recommend our readers to use the components specified:—

Ebonite panel, 12 in. by 14 in. by  $\frac{3}{16}$  in. (American Hard Rubber Co.).

2 filament rheostats (Radio Instruments Duostats).

Potentiometer (Igranic).

2 L.F. transformers, ratios 2 to 1 and 4 to 1 (B.T.H.).

2 .0005-microfarad variable condensers (Newey).

D.P.D.T. lever switch (Burndept).

5-point push-pull switch (Lissen).

Supersonic heterodyne kit, including oscillator coils, filter, .0005-microfarad fixed condenser and 3 I.F. transformers (Bowyer-Lowe).

8 baseboard-mounting valve-holders (Peto-Scott).

2 .0003-microfarad grid condensers (Dubilier).

2 grid leaks, 5 megohms and 2 megohms (Dubilier).



## Designed by "The Wireless Magazine" Staff

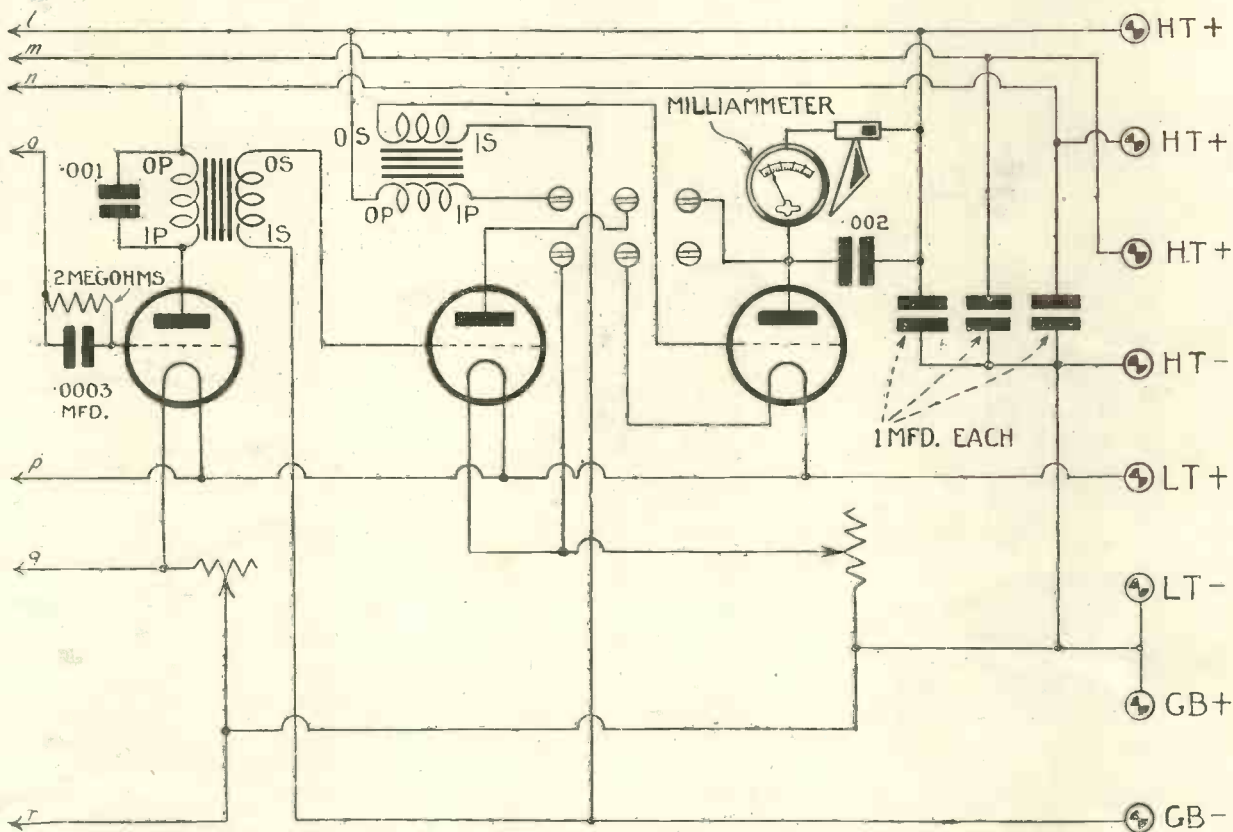

—Specially Designed, Built and Tested by "The Wireless Magazine" Technical Staff.

2 .006-microfarad fixed condensers (T.C.C.).

.001-microfarad fixed condenser (Watmel).

.002-microfarad fixed condenser (T.C.C.).

3 1-microfarad fixed condensers (T.C.C.).

Double-range voltmeter, reading 0 to 6 and 0 to 120 volts (Sifam).

Milliammeter reading 0-10 milliamps. (Sifam).

8 terminals (Belling Lee).

Polished mahogany cabinet (Caxton Wood Turnery Co.).

Frame aerial (Success Collapsible type).

3 boards, 12 in. by 11½ in. by ½ in. thick, 8 in. by 11½ in. by ½ in. thick, and 5 in. by 11½ in. by ½ in. thick.

Piece of wood, ½-in. square section, 5 ft. long.

Ebonite terminal strip, 11½ in. by 3 in. by ¼ in. thick (Paragon).

Plug and jack (General Radio).

The panel, which is a standard size, needs no cutting, so that drilling

may be started immediately. Two large holes are required for the mounting of the flush-type voltmeter and ammeter seen on the top of the panel.

### Holes

These holes may be made by means of a special cutter or by the following method: Mark on the panel the centres of the two holes, and by means of pointed steel dividers draw out the exact sizes. Concentrically with, and inside each of these circles, draw another circle having a diameter less by ⅛ in. than the outer circles.

CABINET FOR THE "SUPER HET"

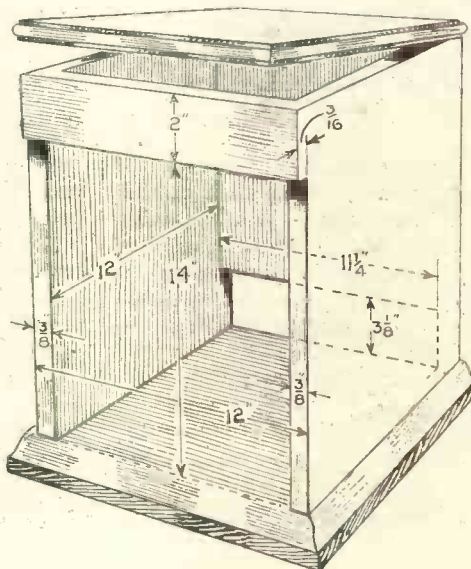

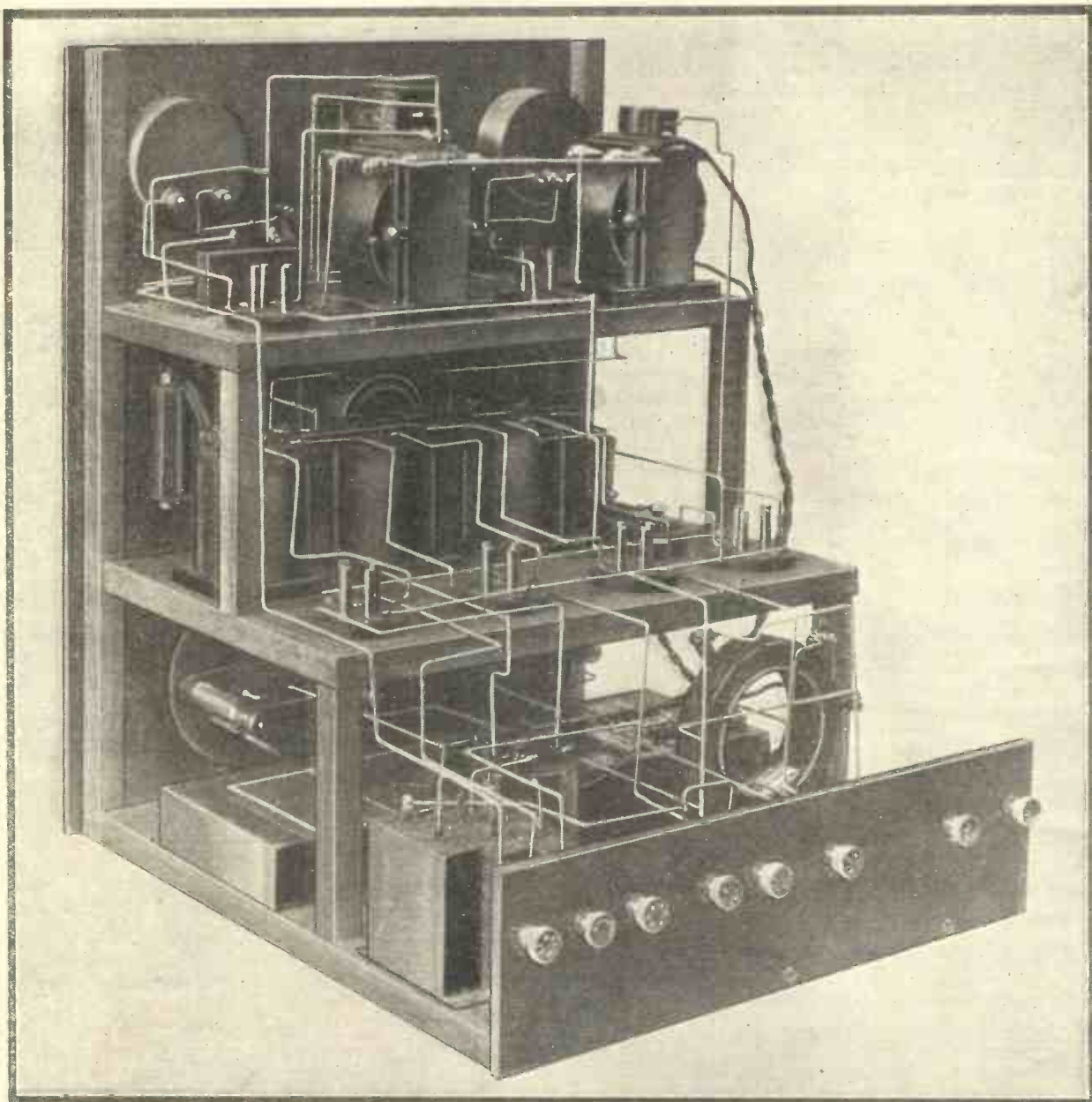

Photograph showing the Compactness of the Step-by-step Eight-valve "Super Hat."

A large number of holes should then be drilled, having their centres on the inner circles. A  $\frac{1}{16}$  in. twist drill should be used, and the holes should be close to each other so that consecutive holes are separated by a very thin piece of ebonite.

#### Smoothing the Holes

By means of a sharp knife or, better still, a fret-saw blade, the entire centre piece of each outer circle can be cut. The holes, of course, will present a jagged appearance, but this can be remedied by carefully smoothing the points off by carefully filing with a half-round file.

It is better to make the holes a

tight fit for the instruments than to have the former so large that the latter can fall easily in or out.

The instruments are then placed in position and the centres of the three holes in each of the flanges of the meters marked through on to the panel.

With the exception of the Burndept switch and the Igranic potentiometer the remainder of the components mounted on the panel are of the one-hole fixing type. Mounted on the bottom of the panel are the two variable condensers, of the low-loss type. Both sets of plates move—the entire movement requiring a  $360^\circ$  rotation of the dial.

On the centre of the panel is mounted the potentiometer, with a filament rheostat on each side, whilst at the top in the centre the Burndept switch is mounted with the voltmeter and ammeter, one on each side.

#### Symmetry

A little lower down between the potentiometer and the Burndept switch, the phone jack and the Lissen push-pull switch are symmetrically mounted on opposite sides of the vertical centre line of the panel as can be seen in the photograph on p. 587.

Photographs of the back of the panel are given showing how the

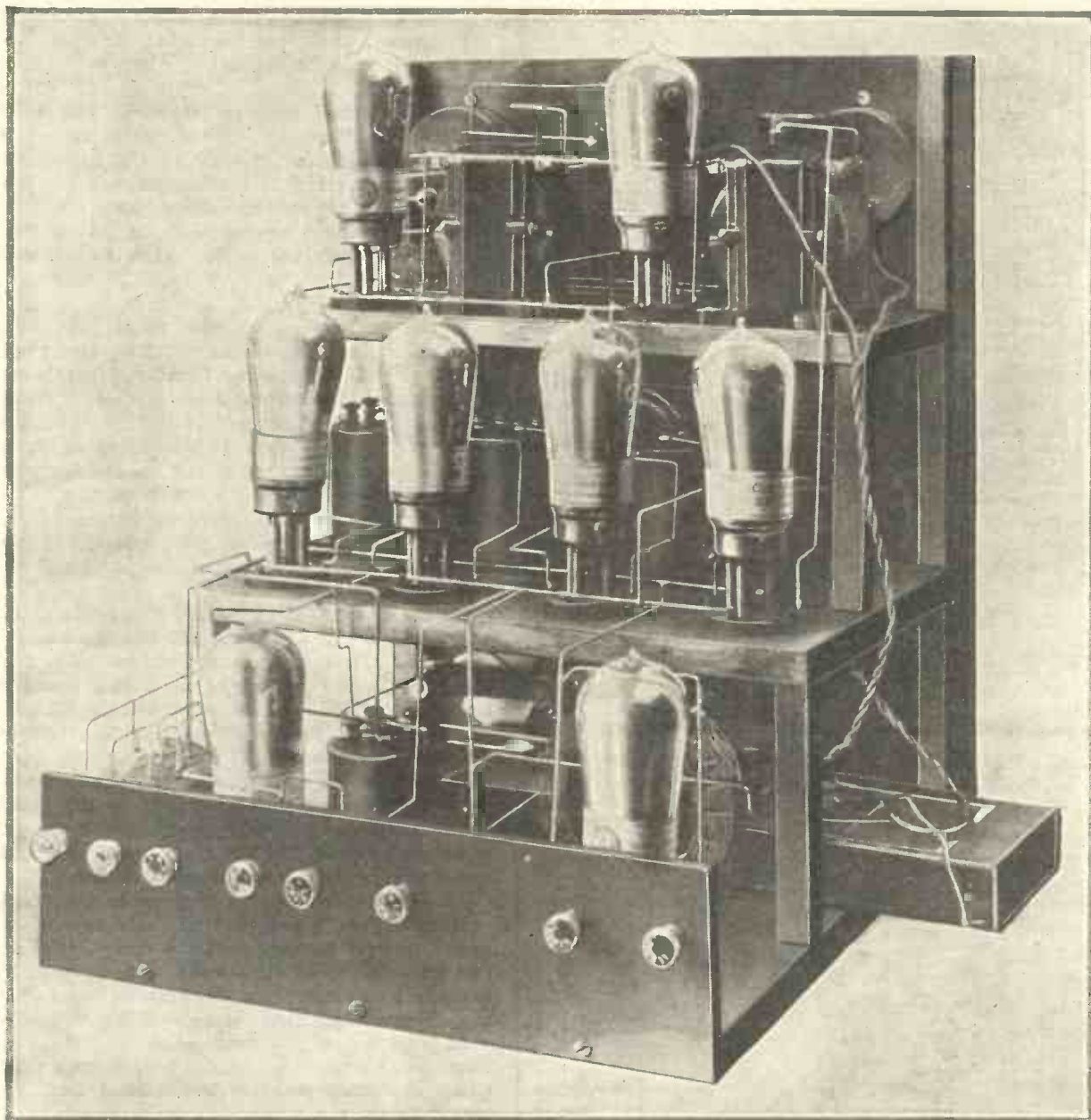

Another Photograph of the Complete "Super Het" with the Valves in Position.

components are fixed, and the relative position of each to the others.

### Framework

Attention must be turned next to the construction of the wooden framework on which the components are mounted. Referring back to the list of components it will be seen that three boards are required. These boards are mounted on top of each other—the largest at the bottom and the smallest at the top, thus forming a series of "steps."

At the two adjacent corners on the longer side of each board a rebate is made that measures  $\frac{1}{2}$  in. by  $\frac{1}{2}$  in. This allows each board to fit close to the

panel between the two upright wooden  $\frac{1}{2}$ -in. square battens. An illustration of the framework is given in the accompanying sketch.

The best method of constructing the framework and mounting the components is as follows: Screw the panel with its wooden supporting uprights to the lowest and largest board. Next, mount the second board temporarily on to the panel and the two 4-in. wooden supporting uprights.

The oscillator coils, filter, first detector and oscillator valve holders, grid leak and condenser, and the three 1-microfarad fixed condensers, are so arranged on the lowest board

that they do not foul the second board.

An indication of the positions of these components is given in the wiring diagram. They should be screwed down by brass wood screws.

### Terminal Strip

The ebonite terminal strip is then screwed to the back edge of the bottom board. Before proceeding any further with the construction the second board should be removed and the variable condensers wired to the oscillator coils and frame-aerial terminals respectively, and all the components mounted on the bottom board wired up as far as possible.

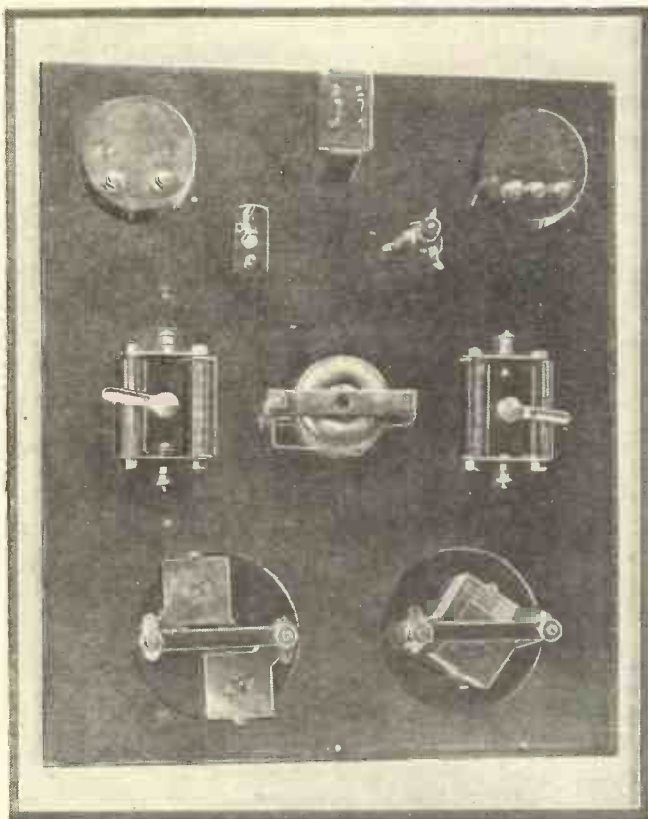

Back of Front Panel of the Eight-valve "Super Het" Before Wiring.

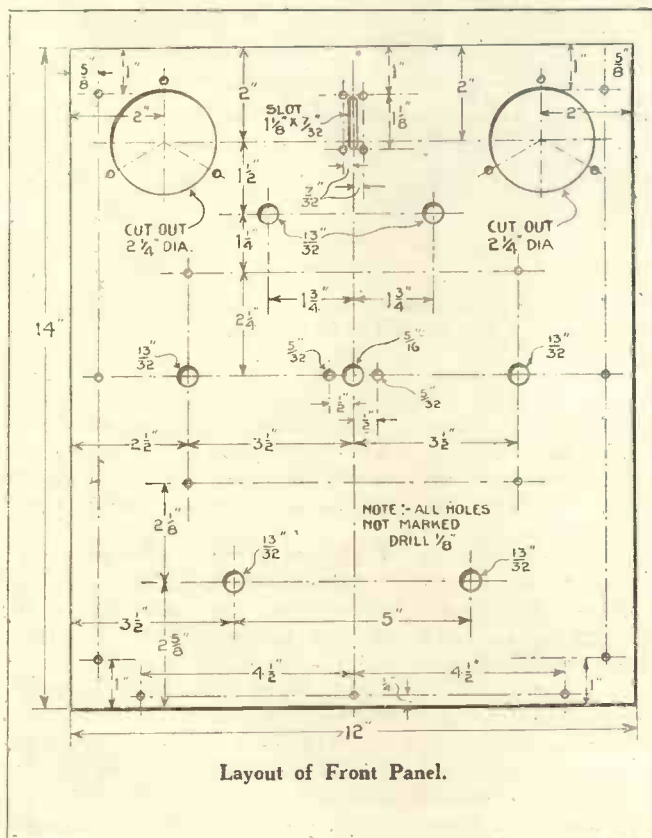

Layout of Front Panel.

The second board, forming the second step, is next screwed to the panel uprights, the panel, and to the 4-in. wooden supporting pieces as shown in the sketch.

On the second step are mounted four valve holders the three I.F. transformers, two .006-microfarad fixed condensers and the second detector valve's grid leak and condenser. The four valve holders are screwed down along the back edge of the second step so that the valves, when inserted in the sockets, do not touch the top step.

### Rheostat Positions

If the components on the panel have been mounted according to the panel-drilling diagram, it will be found that the two filament rheostats and the potentiometer clear the top of the second board.

As in the case of the bottom step, the wiring of the second step should be completed as far as possible before proceeding to the top and last step.

The top step is fixed in a similar manner to the middle step, the board being supported at the back by two wooden pieces 3/4 in. square, and 4 in. in length, and is screwed to the panel and the panel uprights at the front.

On the top step the two L.F. transformers, two valve holders and a .002-microfarad condenser are mounted. The .001-microfarad condenser connected across the primary of the first L.F. transformer (ratio 4 to 1) is not screwed down, but rests on the top of the transformer and is held in position by the wiring.

In between the L.F. transformers the first low-frequency valve holder is screwed to the panel, whilst the second L.F. valve, which can be brought in or out of circuit by the double-pole switch, is mounted directly behind the milliammeter.

The wiring of the top step may now be completed.

It should be noted that in the entire wiring of the receiver no wires (with the exception of the two grid-bias flexible leads) run without an intermediate connection from the bottom step to the top. Hence the wiring throughout can be neatly done step by step. Seven wires are connected from the bottom step to the second, and three wires, excluding grid-bias connections, from the second to the top step.

### Grid-bias Leads

Grid-bias leads are made with flex of sufficient length to be connected to a grid-bias battery placed out of the way under the second step.

The wiring of any eight-valve set is a tedious job, but nevertheless it should not be hurriedly finished. Remember that a wrong connection in the filament or H.T. leads may result in the burning-out of eight valves, or perhaps the ruination of the accumulator or H.T. battery. Each wire should be carefully soldered to its proper terminals and checked in conjunction with the wiring diagram.

A little difficulty may be experienced in wiring up the push-pull switch operating the double-range Sifam voltmeter, which possesses a common negative terminal.

It will be noticed that in the wiring diagram showing this switch the soldering lug which is *not* attached to a spring contact is connected to the

middle terminal of the voltmeter. If the actual switch is placed in a similar position to that shown in the diagram and the connections made in the same manner the difficulty may be easily overcome.

Another point arises in connection with the oscillator coupling. There are four terminals on this coupling marked 1, 2, 3 and 4 (the marks are on the side of the ebonite former).

### Polarity of Coupling

To ensure that the polarity of the coupling is correct and that the proper coil is connected up the terminal marked 1 is joined to + H.T.; 2 is joined to the plate of the oscillator valve; 3 to the grid of the same valve and also to + of the filter, and 4 is joined to - filament. The oscillator tuning condenser is connected across 3 and 4.

Too much emphasis cannot be laid on the necessity of using suitable valves of reputable make. If the constructor particularly wishes the current consumption from his accumulator to be as low as is possible with eight valves, then he must use those having a low consumption. We have used Cleartron valves, type CT 25B for detectors and type CT25 in the other positions. Type CT08 is also suitable.

Before connecting up the set to the external apparatus for a preliminary trial, it is advisable to test through the H.T. and L.T. connections to ensure there is no possible danger of damaging the valves.

This should be done as follows: Place all the valves in their sockets and connect up the accumulator to H.T. -, and each of the H.T. + terminals in turn. If the valves light up there is a short-circuit between one of the H.T. +'s and L.T. +. This must be located and remedied before anything else is done.

Now take all the valves out and connect the accumulator to the L.T. terminals with a flashlamp bulb or a voltmeter *in series*. If any short-circuit exists between L.T. + and L.T. -, the fact will be demonstrated by the lighting up of the bulb or the movement of the voltmeter needle.

### Everything All Right

Having made sure that everything is all right, the set may be connected up to the frame aerial, phones, H.T., L.T., and grid-bias batteries.

Put the Burndept switch lever in the "down" position, thereby cutting out the last stage of L.F.

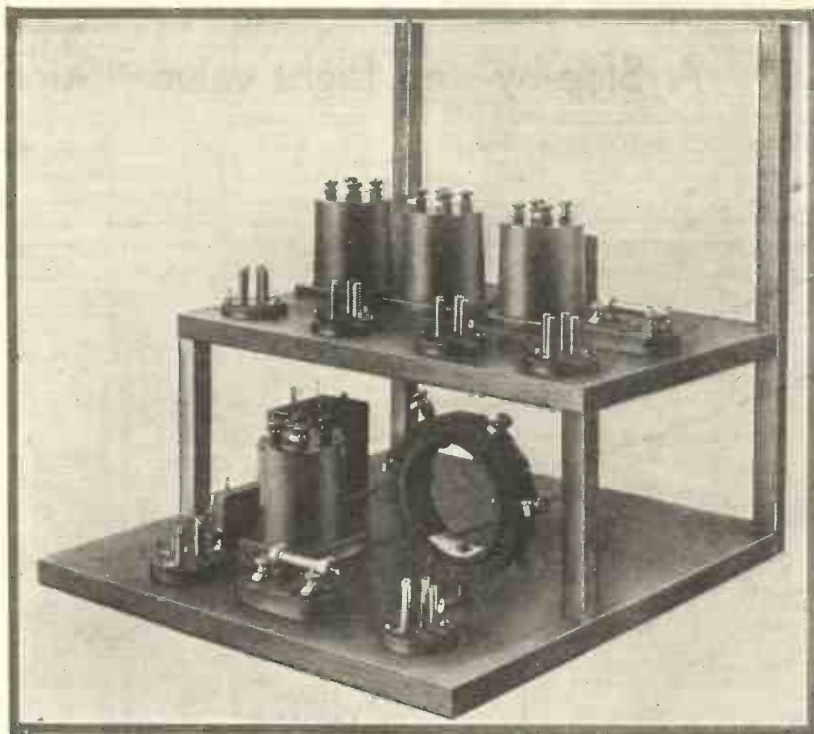

First and Second Steps in Position Before Wiring.

amplification. Turn the two rheostat knobs until the filament voltmeter registers the voltage recommended by the valve manufacturers.

Now turn the potentiometer knob one way or the other so that the set is just short of the oscillating point. This point is denoted by a slight "hiss" in the phones.

Set the frame-tuning condenser at about 180°, that is, with the plates half interleaved. Slowly rotate the oscillator-condenser dial (the right-hand dial) until signals are heard in the phones.

Now slowly rotate the frame aerial, when it will be found that signals are stronger with the plane of the frame

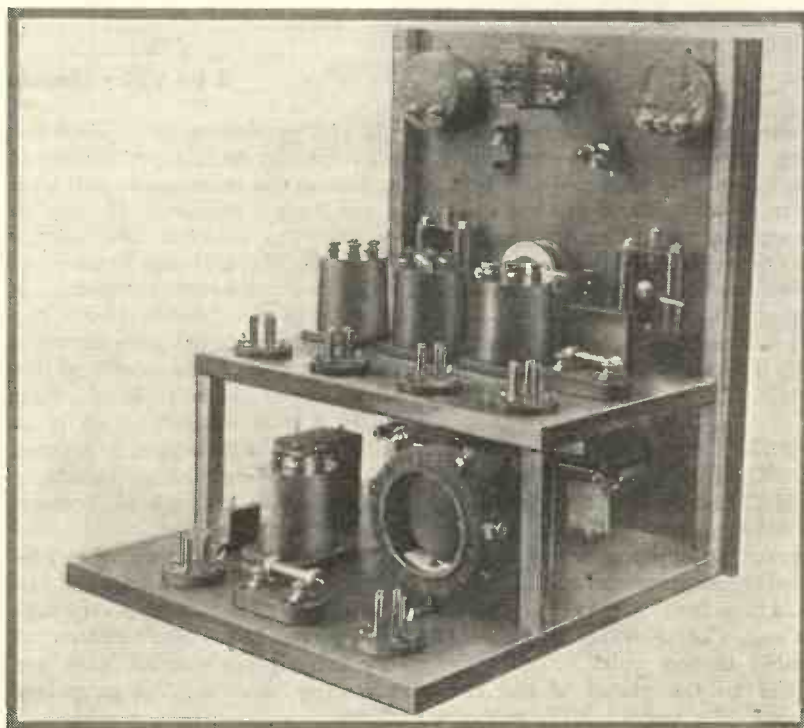

First and Second Steps, and Front Panel, in Position.

# A Step-by-step Eight-valve "Super Het" (Continued)

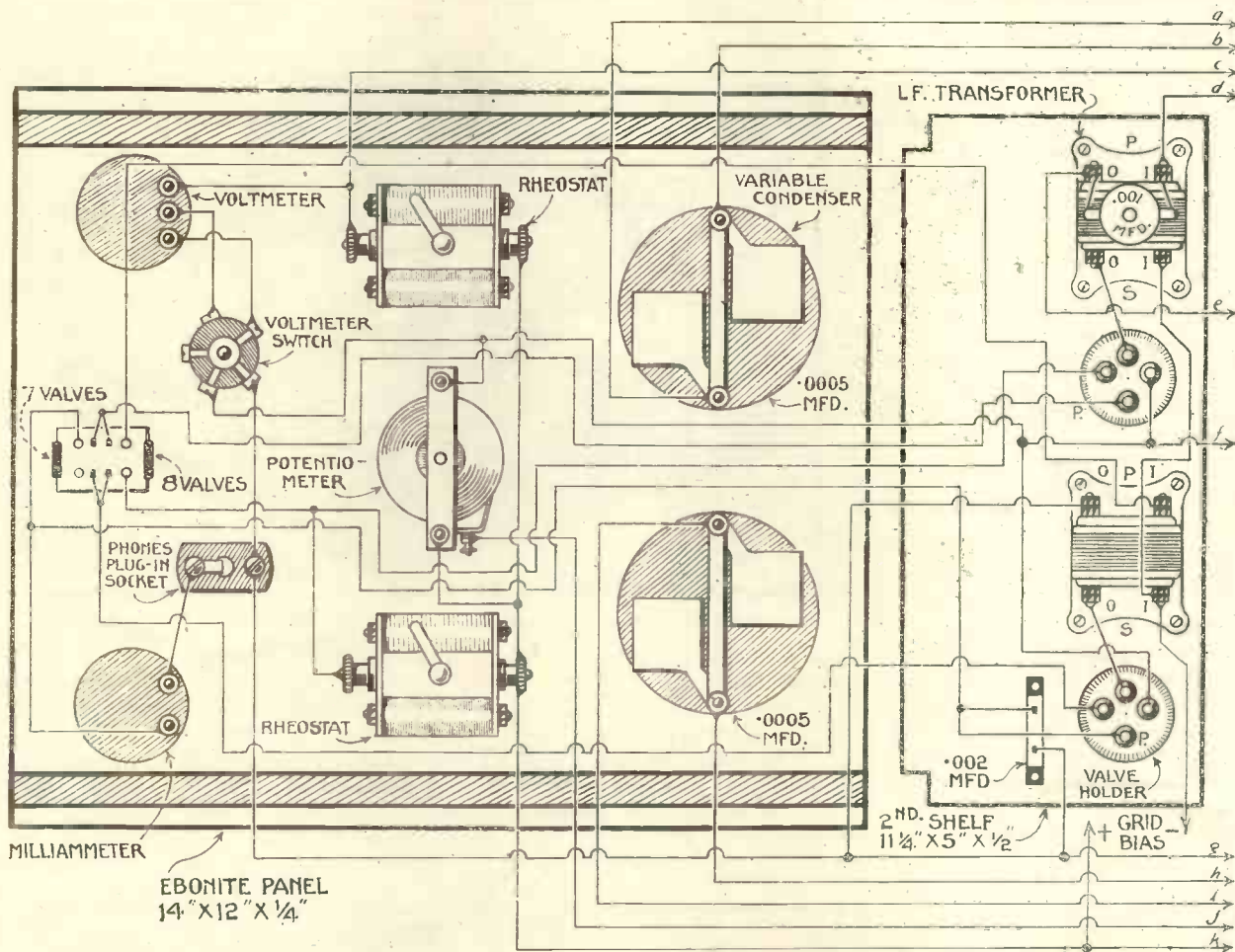

If the Wiring Diagram is Carefully Followed there should be—

pointing towards the station that is being received. Leave the frame pointing in this direction and bring the received signals up to maximum strength by careful readjustment of the frame-tuning condenser, the potentiometer and the oscillator condenser.

It will be noticed that the potentiometer gives a very smooth reaction effect.

### Adjusting the H.T.

Next, adjust the wander plugs on the H.T. battery until best results are obtained. Any slight distortion can be cured by applying a larger negative grid-bias potential to the grid of the L.F. valve. A grid-bias voltage of about 3 or  $4\frac{1}{2}$  volts will be found suitable if 100 volts or over are applied to the plates of the L.F. valves. The correct H.T. voltages can only be found by experiment.

If greater volume is required the last valve may be brought into circuit by placing the Burndept switch lever in the "up" position. It may be necessary to readjust the voltage applied by the grid-bias battery.

The milliammeter connected in series with the phones shows the current flowing in the plate circuit of the last valve. The needle of the milliammeter should keep quite steady. If it fluctuates this is an indication that distortion is present, and the grid-bias voltage should be adjusted until the needle becomes steady.

The H.T. voltage on the L.F. valves should not be increased just for the sake of obtaining a very high reading on the milliammeter. A very large plate current does not necessarily mean a large output of volume.

It will be noticed, for instance,

that with no negative voltage on the grid of the L.F. valves the milliammeter will give the highest reading, and reproduction will be great in volume but distorted.

With the application of negative grid bias the plate current will be decreased, and consequently the milliammeter will register a lower reading. The volume, however, will still remain the same, and reproduction will be much better in tonal quality.

Having adjusted every control until the best results are obtained, it is recommended that a note be taken of the position of each control and the readings given by the voltmeter and milliammeter.

### Voltmeter Switch

By pushing the voltmeter switch in the voltmeter will register the voltage applied to the filaments of all the valves except the L.F. amplifiers.

## Specially Designed by "The Wireless Magazine"

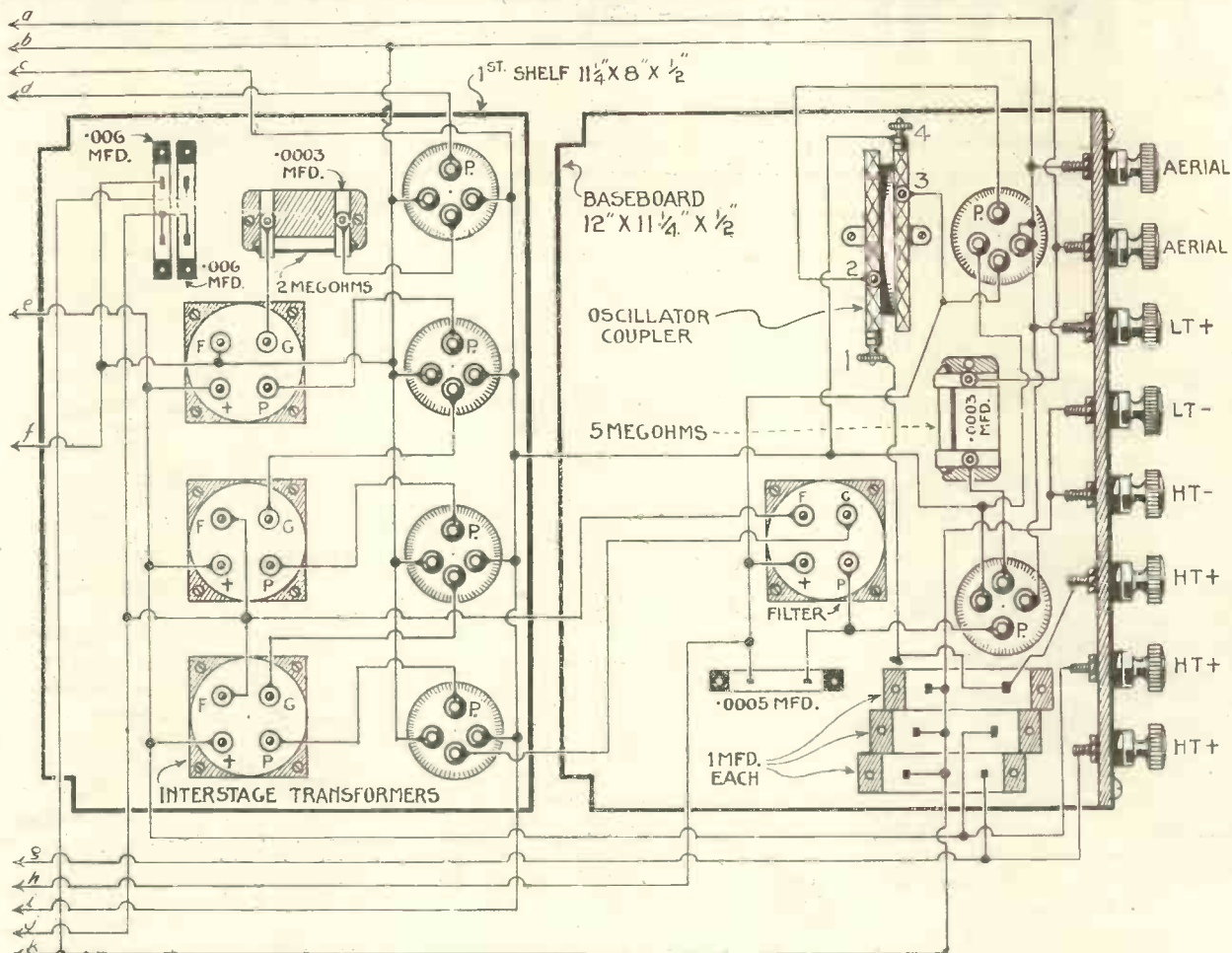

—no Difficulty in Constructing this Eight-valve "Super Het."

With the same switch pulled out the voltmeter shows the value of the H.T. voltage applied to the plates of the L.F. valves.

The set may now be placed in its cabinet and the external apparatus connected to the terminal strip projecting through the back. Owing to the special construction of the set it will be found that the valves can be easily inserted or withdrawn from the top.

### Ease of Control

Perhaps the most outstanding feature of this receiver is the ease of control. The potentiometer gives an excellent control of oscillation and, indeed, the whole set has a particularly smooth "feel" about it.

Approximately 7 miles from 2 L O Cardiff could be received on the loud-speaker with no trace of London in the background. By the careful

adjustment of the potentiometer and the two variable condensers most of the main B.B.C. stations were received on the loud-speaker. Birmingham, Glasgow, Bournemouth and, of course, London were received with tremendous volume. Of the continental stations L'Ecole Supérieure, Madrid, Brussels, Oslo and five German stations were received with beautiful clarity. Several other stations were also logged, but the operator, who was not a linguist, was unable to identify them. Only when exceptional volume was required was it found necessary to use both stages of L.F. amplification.

For the benefit of those who find themselves in any difficulty, we give a few suggestions to remedy the troubles usually encountered in super-sonic heterodyne sets.

If it is found that the set completely refuses to work, the trouble

usually lies in bad connections between valve legs and sockets, or in some other loose contact—always assuming, of course, that the set is correctly wired up.

Uncontrollable oscillation is also generally caused by a loose connection.

### Oscillator Condenser

The oscillator-condenser control should be and is usually very critical. If the voltage applied to the plate of the oscillator valve is too low the tuning of the oscillator will become very flat. The remedy is obvious.

Be sure to use a grid leak of high resistance for the first detector valve. About 5 megohms is a suitable value.

So we are to have a night of Scottish humour. That ought to be a programme with plenty of the right spirit in it.

# "MY FIRST BROADCAST"

*The sensations and impressions of Cathreen Morland (Catherine Countess of Westmorland), Kate Winter, Maurice Cole, Willie Rouse, Gladys Palmer, Frederick Ranalow and Evadne Price on broadcasting for the first time in their lives, recorded by themselves and collected by Pearkes Withers.*

PRACTICALLY all the clever people who entertain us, instruct us, or charm us to a tear, a laugh, or a gurgle of satisfaction with the aid of the ether and the B.B.C., come to regard it—with practice—as quite an easy and pleasant thing to speak, or sing, or play into the microphone.

But most of those who broadcast for the first time in their lives find it a disconcerting business in the extreme. Indeed, there is on official record the case of a man (*not* a woman, mark you!) whose nerves went so completely to pieces when he attempted to deliver a "talk"—which is, of course, really a reading—that he could only stammer breathlessly and incoherently till the announcer mercifully cut off the sounds of his anguish and led him away from the instrument of torture.

The inanimate little object in its soft rubber bed looks remarkably harmless in its photographs, and it looks just as harmless in the studio—so long as one doesn't have to face it.

But the knowledge that it is disconnected up (if one may use such a contradiction in terms) with more than a million homes and anything from five to seven million pairs of human ears is quite sufficient to disturb the strongest mind and stir the most sluggish heart to palpitation when it comes to making one's wireless debut through its perforations and other quiet, but disquieting, properties.

## CATHREEN MORLAND

(Catherine Countess of Westmorland)

My first introduction to the wireless world came about through Madame Alice Holman, a well-known teacher of voice production in Brighton, with whom I was studying at the time.

She saw that Metropolitan-Vickers, in Manchester, were asking people to go and make tests for broadcasting from that station, and, as she felt that I should be successful, wrote to them and arranged a day on which we should go.

We arrived in the afternoon, and a car was sent by Metropolitan-Vickers to take us to Trafford Park about half-past three. I was very nervous, because it was such an entirely fresh experience and also because anyone who has ever done any public work realises that a "test" is a very trying ordeal.

We were most kindly received, and all the necessary details were explained; then I proceeded to the room from which the broadcasting was done.

It was a small room, the walls and floor padded so

Actors and actresses regularly find it a terrifying business to face an audience on a "first night" at a theatre; but as the audience begins to warm up and respond to the art of the players the terror diminishes, and finally vanishes.

To face an audience one cannot see—that cannot visibly respond—must, in the very nature of things, be more intimidating than to face an audience that can approve and applaud. The atmosphere is dead, and one's efforts, consequently, must seem lifeless too.

Indeed, it is fairly safe to say that if the officials of the B.B.C. were less understanding, encouraging and helpful than they are to broadcasting beginners, the bulk of those beginners would silently fade away at the last moment, while the minority, having stronger nerves and indomitable souls, or (perhaps better still) having served a sort of apprenticeship to broadcasting by recording for the gramophone people, would stand their ground and go through with the thing to the bitter end.

But can anyone be really happy in a first encounter with the formidable "Mike"? I have sought and obtained from a number of well-known people, including singers, speakers, entertainers and players, true and faithful accounts of their own initial efforts at broadcasting. Let these popular people answer the question in their own way; their experiences, in any case, make extremely interesting reading:—

that all resonance should be concentrated into the microphone. I stood in front of the microphone, and I commenced to sing.

The sensation was very odd; there being no resonance, I felt sure that no one could hear my singing as I could hardly hear it myself. However, as soon as my song was finished a light was flashed up into the box on the table—which indicated "O.K."

This, I was told, meant that my transmission had been excellent. And then the gentleman who had been making the test came in and congratulated me, and told me that although they had had several hundred tests, mine was the best so far.

I was tremendously excited and delighted, of course; and they then asked me to sing two songs at the next concert.

Madame Holman had always been very particular about my diction, and I have her to thank for impressing upon me the great step it is towards successful singing. It is always a big and important thing on the stage or the concert platform, but for broadcasting it is quite an essential, just as it is for making gramophone records.



**KATE WINTER**  
(The Popular Soprano)

My debut before the microphone was indeed an experience never to be forgotten. Always of a highly nervous temperament, I suffered terribly from nervousness on this occasion. I remember how madly my heart beat when I faced the queer "box of tricks" for the first time.

The microphone, in those early days, was just like a huge soap-box with a weird and wonderful array of wires attached, and it seemed strange to have to sing to this unfriendly object instead of to the kindly faces of a sympathetic audience.

However, the whole business fascinated me, even while I strove to conquer my fears, and I well remember the station director's words to me when

my ordeal was over: "You have sung to your largest audience to-day."

It was a wonderful thought to me, and I felt then, as indeed I feel every time I broadcast, a great responsibility. "Old Mike," representing thousands of unseen listeners, demands the very best we can give, and therein lies its fascination and delight.



**MAURICE COLE**  
(The Distinguished Pianist)

I experienced a certain amount of nervousness when playing at my first wireless concert. Not only did I feel that it was the equivalent of a concert performance, and that I must play as I would on the platform, but I had anxiety in having been told not to use too much sustaining pedal, and to keep the bass part fairly big while playing, as this came out rather weakly in transmission.

Further, I liken some of my feelings to those which one might have in ringing up some friends on the telephone and then playing into it, with the uncertainty as to whether the instrument was capable of reproducing properly.

My first wireless performance took place in 1922, forming part of a concert transmitted from Marconi House (2 L O) to the Horticultural Hall, Westminster, where the first All-British Wireless Exhibition was being held. This was, of course, before the advent of the B.B.C.

I was inclined to doubt if anyone was listening at all to my first performance, for in those days I had never

"listened," and was under the impression that it was a matter of chance whether one heard satisfactorily or not.

I also wondered if the transmitting apparatus was working properly all the time I was playing, or if I should be "cut off" in the middle of a piece; and the fact that every ten minutes the station had to close down for three minutes was worrying, for I feared my items might take too long.

On one occasion an item did; and I was just saying I was sorry I had taken up so much time, when the announcer silenced me, for the microphone was still in circuit.

I became more anxious about my performances as broadcasting advanced, for I began to realise what a power wireless was becoming, and what a vast audience it was creating.

Developments have been so great in the past two years that nobody can do more than speculate as to its future,

but, no matter how these future developments may affect me personally, I hope I shall never forget the early days of broadcasting, and those who were connected with my "first experience."



**WILLIE ROUSE**  
(“Wireless Willie”)

Having been before the public as an entertainer for over thirty-five years as an organist, an accompanist, and a humorist all over England, I suppose I didn't suffer with nerves quite as much as some, although I well remember my knees playing a faint drum solo when first I appeared before the "Mike."

I could almost hear the rattle, and my lips became fairly "gluey"; in fact, there was very little left in the studio water-bottle by the time my debut was over.

It's a strange experience for the funny man, this broadcasting—I venture to suggest it's much easier for the singer and instrumentalist, as we are so dependent on laughs, and when they don't come there is that awful pause after the joke. *Oh that silence!* It was terrible to me at first.

After my experience of stage work I felt I was the most unfunny creature on earth, talking to that little

"box." Talk about telling a deaf Scotsman a joke—it was nothing to it!

However, we are very happy now at 2 Savoy Hill, and one's vast unseen audience send some most delightful letters of appreciation. Of course, one gets the other kind too. I once received an anonymous postcard with simply these words: "Why 'Wireless Willie'?—I call him 'Witless Willie.'"

Broadcasting is like golf, it's a great game to take the conceit out of you!



## "MY FIRST BROADCAST" (Continued)

### GLADYS PALMER

(The Popular Contralto)



I first sang at Marconi House when broadcasting was in the experimental stages.

The room was right at the top and very small, practically filled by a piano, a couch, and two desks. There was a small, raised platform in the centre, and a microphone on a brass stand which moved up or down according to one's height.

The first time I

sang I had already started before I discovered that the mouthpiece was too high; consequently distraught signs went on between myself and other people in the room.

It seemed quite necessary to shout, for one's mouth was close to the mouthpiece and it seemed quite impossible for people to hear otherwise, so many miles away.

However, having once begun, I found that a natural voice carried quite well (or, at least, so I was told) and the only precaution necessary was to be careful with the words. And in the end I was very interested and quite enjoyed the experience.

At Savoy Hill everything is really easy—a nice room, most comfortable, and only an instrument some distance away. I always feel just as if I were in my own music-room, and get so interested in my song that I forget there is really a listener outside the studio.

### FREDERICK RANALOW

(The Actor-vocalist)

You know—or, perhaps, if you are lucky, you *don't* know—the sort of feeling one gets while sitting in the luxurious anteroom at the dentist's—waiting to have a tooth out!

But, you will say, what connection is there between this and the subject in hand—one's sensations when broadcasting for the first time? A very definite connection, I venture to think—with conditions all in favour of the dentist's room.

Here at 2 L O is no luxuriously furnished room, no society papers to cheer and distract one; just a bare, lofty room. And on the threshold a sturdy janitor, who will shortly summon one



from the "condemned hold" to the torture chamber, whence one will not return till one has given an exhibition of all one's weaknesses, which will, one thinks, delight the hearts of all one's rivals!

Why, oh why does one always feel one wants to cough or sneeze just when all the world is listening-in? ("Listening-in" sounds so much more sinister than just "listening"!)

However, even torture must come to an end, and if during the process you are fortunate enough to see the kindly face of the head jailer—he sits in a little box like a public telephone—and to observe that he sits there with up-turned thumbs, you may conclude that you are not to be thrown to the lions, and that, with luck, you may

live to be tortured another day!

### EVADNE PRICE

(The Actress-journalist of *The Sunday Chronicle*)



On encountering the microphone for the first time I was seized with the most ghastly attack of "stage fright" I can ever remember in the whole of my theatrical and journalistic career. My throat went dry, my head swam, and my fingers trembled so badly that it was only by a miracle I was able to hang on desperately to the typed pages of my part.

name was, I felt convinced, that preceding my death. The miscalled "harmless" little gauze-covered microphone leered at me with malevolent glee. The invisible thousands of listeners-in became to my distorted mind a pack of hungry vultures waiting anxiously for my life's blood.

The sensations of loneliness and self-pity dominated the horror, and the fact that I had only myself to blame for my sorry plight did not improve matters.

"You *would* do this," I told myself bitterly. "You *wanted* to broadcast."

Then I began to speak.

Miraculously my nerves vanished. I began to sit up and take notice. I began to enjoy the experience. It is certainly an experience. But, frankly, in my opinion, not a very thrilling one. To any actress who loves the wave of understanding and appreciation that links her with her audience the microphone will always be something rather cold and terrifying.

The moment preceding the announcement of my

# How the Valve may help the Physician

## *The Use of Radio-frequency Currents in the Treatment of Disease*

THE practice of diathermy, or the use of radio-frequency electricity as a means of curing or alleviating disease, is the natural outcome of an association that dates back to the time of the celebrated Gilbert of Colchester, who combined the duties of Physician in Ordinary to Queen Elizabeth with his famous researches into the mysteries of magnetism and electricity.

### First Investigations

The first direct investigations into the physiological effects of electricity were, however, made about the year 1766 by another medical man in the person of Aloysius Galvani, who was Professor of Anatomy in the University of Bologna. Galvani was astonished one day to observe a decided twitching in the limbs of a dead frog, which had been hung up by copper hooks from an iron railing in the laboratory.

This miraculous appearance of resuscitation from death subsequently gave rise to a widespread but exaggerated belief in the curative powers of electricity—a belief that is still exploited in the advertisements of certain modern electromagnetic appliances of the "cure-all" type.

### What Really Happened

In actual fact, the contact of the toes of Galvani's dead frog with the iron railing merely closed an electric circuit between the rail and the copper hooks, through the saline fluid in the veins of the animal. The whole system, in short, formed a voltaic cell comprising iron and copper electrodes, and a salt solution as electrolyte.

The passage of a small electric current caused the leg muscles of the frog to contract, and thereby break the circuit. Presently the muscles expanded again, until the toes touched the iron shelf, whereupon the dead frog promptly gave another kick. Nowadays, we should regard the "miracle" merely as a very inefficient buzzer circuit.

Galvani in this way discovered

the fact that the passage of an electric current through nerve and muscle tissue gave rise to certain physiological effects, and he may therefore fairly be regarded as the father of modern electro-therapeutics.

However, the serious application of electricity to medical practice is of more recent origin. Towards the

*There is a fundamental relationship between wireless practice and the production of high-frequency currents used in medical treatment.*

*In this article our contributor explains an application of the valve in medicine.*

end of last century the action of a static electric charge derived from the Wimshurst type of machine was found to increase the regularity of the pulse, raise the blood pressure, and open the pores of the skin. It also quietens the nervous system and acts more or less as a sedative.

The application of current, as distinct from static, electricity falls into two categories. In galvanic treatment a *direct* current is applied directly to the patient's skin from large electrodes, fitted with pads moistened with a saline solution, the current passing from one electrode through the body and out through the other electrode. Or it may be applied to the patient in a bath of salt water, the latter then acting as one large electrode.

### Faradic Treatment

In faradic treatment, *alternating* current is used. The generating apparatus comprises a primary coil with a suitable make and break switch, and an induction or secondary coil, the circuit of which is made to include the patient's body. Here also a convenient method of treatment is to place the patient in a bath of warm salt water.

In both these systems a limit is placed upon the amount of current

that can usefully be applied because of the physical pain experienced at the point where the electrodes touch the body.

Actually the human skin is not only very sensitive but has also a relatively high electric resistance, so that the patient is unable to stand any lengthy treatment without being blistered or severely inconvenienced.

### High-frequency Currents

In 1891 Nikola Tesla suggested the use of *high-frequency* currents for curative purposes. D'Arsonval, who studied the action of such currents upon the human body, found that with frequencies of from 20 to 30 per second, tonic muscular contractions were produced, the intensity of the spasms increasing as the frequency was raised from 30 to 300.

Beyond the latter point, however, D'Arsonval discovered that the spasms gradually diminished in intensity as the frequency of the current was raised. At a frequency of 10,000 per second all muscular contraction ceased. Apparently the nerves involved are incapable of responding to stimuli repeated so rapidly.

### Skin Effect

It is also probable that the well-known skin effect exhibited by high-frequency currents (whereby they tend to spread over the surface of the conductor instead of penetrating into the substance of it) may help to diminish the nerve sensitivity.

Nowadays, in diathermy treatment, currents having a frequency of half a million per second and upwards are applied to the patient's body.

These currents are generally produced by means of thermionic-valve generators, using circuits of the Hartly oscillator type or any other recognised means of back-coupling between the grid and plate. The high-frequency currents in the plate circuit are applied by means of large flat electrodes and pass right through the patient's body from one electrode to the other.

## The Doctor's Three-valve Stethophone Amplifier

*How the Valve Helps the Physician to Hear Body Sounds*



*Practically any number of doctors can listen-in to a patient's body sounds simultaneously by means of the Western Electric Stethophone.*

Apart from its possibilities in diathermy the valve already helps the physician in its function as an amplifier; it is used in this way in the Western Electric Stethophone illustrated by the photographs on this page.

By holding a special contact transmitter against any part of a patient's body all the internal sounds are conducted to the three-valve amplifier, which is capable of magnifying the impulses 100,000,000 times.

The magnified currents from the amplifier are passed to a special receiver attached to an ordinary medical stethoscope, as can be seen in the illustrations (the actual receiver case is hung on the doctor's coat).

Besides making audible sounds that could not possibly be heard without its use, the Western Electric Stethophone allows the doctor to cut out (by means of special filters) all body sounds but the one in which he is particularly interested.



*Portable Western Electric Stethophone in use.*



*Battery Accommodation in Portable Stethophone.*

## CONDENSER CARE

WHEN once the variable condensers have been installed in a set they should not be forgotten. It is true that some of the better makes are so constructed that they never need attention, but most English condensers are not built in such a way that they will stand long and heavy usage without care.

Although the condensers are generally installed in a cabinet behind the panel they are not really dust-proof, for dust will readily find its way into any cabinet unless it is absolutely airtight, a desirable property rarely encountered.

### Removing Dirt and Dust

A habit should therefore be made of periodically inspecting the interior of the cabinet and removing the dust and cleaning between the condenser blades. This latter should not be accomplished by the aid of a pipe cleaner as is sometimes advocated. These are useful articles in appearance, but although of a suitable thickness and covering they are generally too woolly and loose in their construction, and the "cleaning" results in the depositing of several stray hairs between the vanes, a source of constant noise and annoyance.

It is better to use a piece of No. 18-gauge copper wire swathed with a piece of clean *new* silk, inserting this between each pair of vanes and cleaning out the dust by a clean sweep. The silk has not the loose pieces of hair and other material adhering to its surface that are usually found on the pipe cleaners.

The bearings of the condenser will probably need attention, especially if they are of the type wherein tension is applied to the moving vane bearings by means of a phosphor-bronze spring. Such condensers are apt to give out an unpleasant grating noise after a lot of use, and the smallest possible spot of vaseline (not oil) should be applied to the bearing spring in order to put matters right.

A. J. C.

The diagram illustrates a typical thermionic valve circuit used in diathermy. Both the plate and filament voltages are derived from a step-up transformer (T) fed from the house mains, the filament current being taken from a separate tapping on the secondary as shown. The high-frequency currents flowing in the oscillatory circuit LC are transferred through the coupled coils L and LI to the patient's circuit.

This is provided, as shown, with large electrodes which are applied to the body, so as to complete the circuit and allow the passage of the radio-frequency current.

### Heating the Body

Practically no inconvenience is felt at the point where the electrodes touch the skin. In fact the currents heat both the skin and the internal organs to an equal degree, and thereby allow the full beneficial healing effect to be applied directly, even to organs deeply seated inside the body. These could not be warmed to the same degree by the use of direct or low-frequency currents without causing considerable inconvenience to the patient.

A radio-frequency current of 0.2 ampere can be safely applied by skilled hands from a diathermy generator without producing any other sensation than heat. A larger current than this causes a certain "sparking" or tingling sensation in addition to the heating effect.

After treatment with radio oscillations the whole temperature of the body is found to be appreciably raised. This induces increased oxidation and, under prolonged treatment, a loss in weight (obesity treatment). Among other effects the pores of the skin are opened, blood pressure may be raised or lowered according to the method of application, and the nerves may similarly be stimulated or inhibited. Deep-seated pain is lessened both by the ameliorating influence of the generated heat and by the stimulation of the local blood circulation. In particular, various types of disease can be subjected by diathermy to direct and effective treatment in a way that is otherwise impossible.

Radio-frequency currents of greater strength than those used in diathermy are now being employed in surgical operations. Not only can local disfigurement such as warts, etc., be removed by the fulguration electrode—which is practically a painless cauterisation process—but extensive cutting operations can be also performed. The high-frequency "radio-knife" cuts through human bone as well as tissue with ease, leaving a wound that is automatically sterilised. Another striking feature of radio-surgery lies in the fact that such operations are practically bloodless.

A more recent development in radio technique, as applied to medical science, is to be found in the theory of "cell vibrations." Very briefly this theory asserts that the human organism is built up of various chemical elements in the form of cells, each of which is normally vibrating at a certain definite rate, and radiating ether waves of a corresponding frequency. Disease is manifested as a disturbance of the normal radiation equilibrium.

An apparatus capable of receiving or discerning these high-frequency oscillations would, it is claimed, not only furnish a clue to the nature of the disease, but also provide a remedy by applying radiations of the correct frequency to stimulate or revive the weakened cells.

The so-called "magic box" of the late Doctor Abrams, recently

received a certain amount of support from other medical authorities in this country as well as in France and America, and may in time throw a new light upon the mysterious and fascinating "vital processes" of the human body.

B. A. R.

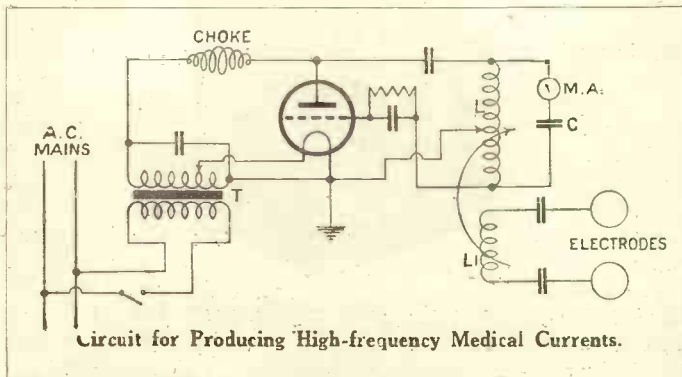

Circuit for Producing High-frequency Medical Currents.

601

# When a Ship Loses Itself!

The Ship's Navigator can find his position by observing the sun, stars, landmarks, etc. But what is his plight in stormy weather when nothing is visible?



By means of a wireless direction finder the navigator can ascertain his bearings when vision is impossible. This article describes the apparatus & explains how it is used.

THE greatest advantage of wireless from some points of view is its greatest disadvantage from others. Thus for broadcasting, whether it be entertainment or S O S messages, the fact that a wireless message radiates evenly in all directions is the one fact that makes it so useful.

## Secrecy Impossible Without Codes

On the other hand, this property of wireless renders secrecy impossible unless codes are used, and also allows of no indication to the receiving station whence the signals are proceeding.

Practically ever since the commercialising of wireless, designers have been aiming at a system which will either (a) transmit in one direction only, or (b) tell from the receiving end the direction from which signals are coming.

The Marconi beam system has solved (a), while two separately conducted fields of research have resulted in the solution of (b). The name given to the latter feature of reception is "direction finding."

There are two systems in general use, one is the Robinson system, and the other the Bellini-Tosi.

The former direction-finding system relies on the directional properties of the frame aerial, while the latter employs a special type of loop aerial in conjunction with an instrument called the "radiogoniometer," which is rather like a variometer.

## Strongest Signals

A frame aerial will receive signals strongest when it lies in the plane of the transmission; in other words, when its edge points to the place whence the signals proceed.

When the frame is at right angles to the line of the oncoming signals it will pick up no current. When it is at any other angle, it will receive current to a degree proportionate to the angle.

These facts are used in the Robinson direction

finder, and two frame aerials accurately fixed at right angles are employed. The appearance of a typical installation is given in Fig. 1, in which the aerials are shown attached to the top of a long spindle which projects from the top of the receiver cabinet. In actual marine practice, the set would be in the chart-room and the aerials on the roof.

## Rotating the Aerials

By means of a control-wheel on the instrument the operator is able to rotate the aerials to any desired position, and a pointer and dial show the exact angular location of the frames relative to some fixed line—usually the fore and aft line of the ship.

In the majority of cases the frames used with the Robinson system are 2 ft. 6 in. square. The receiver used in conjunction with them is sufficiently powerful to enable audible signals to be obtained over hundreds of miles.

Both aerials are connected in series, but a switch is fitted so that the connections of the second aerial may be changed over at will. Because of the series connection, the resulting total current will be either the sum or difference of that in each separate loop, according to which way the second loop

is connected to the first.

## Currents Assisting and Opposing

This is because with the second aerial connected one way the currents will assist one another; while when connected the other way they will be in opposition.

Assuming that the operator wishes to find the position of a station, he first of all tunes-in a signal in the ordinary way, forgetting the existence of the frames. He then changes over the switch.

In most cases the signal strength will be different with the switch in the second position from what it was

Fig. 1.—Typical Marconi D.F. Installation.

in the first. This is natural, because unless the second loop is exactly at right angles with the plane of the signals it will contain current, and therefore with the switch in one position this current will assist (add to) that in the first aerial; and oppose (subtract from) the first current with the switch reversed.

It is clear, therefore, that if the operator rotates his aerials, and as he does so changes over his switch from time to time, he will eventually strike the point at which a changing over of the switch produces no difference in signal strength.

This can happen only when the switched aerial is at right angles to the plane of the signals, for in that position it contains no current and cannot therefore add to, or oppose, that in the first aerial.

As the aerials themselves are at right angles, it follows that in the last position mentioned the first aerial is in the plane of the signals, and therefore their direction has been found.

It must be pointed out, however, that the transmitting aerial might be at either end of the ascertained line.

In most cases the operator will know which end it is, however, or he can easily find it out from the navigating officer who may be in the chart-room with him.

A typical aerial installation for the Bellini-Tosi-Marconi system is given in Fig. 2, where it is shown housed on the deck of a ship. Here, again, loops disposed at right angles are used, but each loop is approximately in the form of a triangle with the base parallel to the deck.

The four leads from the loops are

taken to the field coils of the radiogoniometer, an illustration of which appears in Fig. 3. The example shown is made by Marconi's.

The latter instrument is rather like

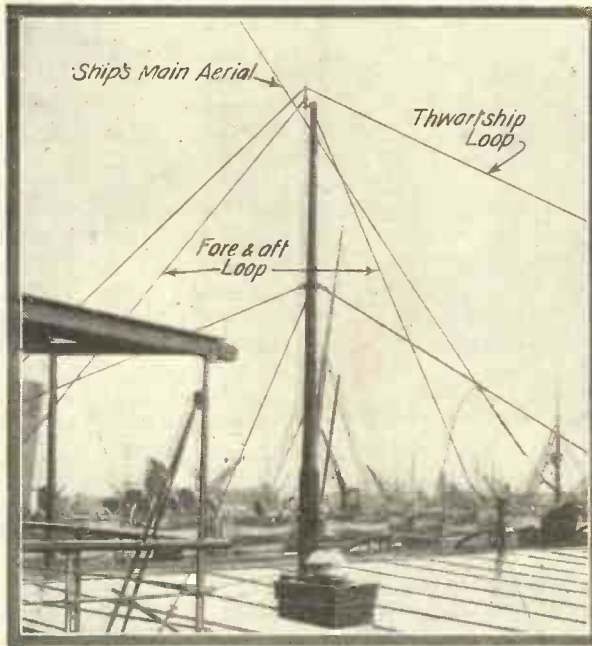

Fig. 2.—Aerial for Bellini-Tosi-Marconi System.

a variometer having two stator windings fixed at right angles, and in which the stator windings are

be seen that the fields are connected only to the loops except at one place, known as the "mid-point," from which a lead is taken to a three-way switch, shown on the right.

The search coil is connected to a high-frequency transformer having an earthed metallic shield. The secondary goes to the receiver, while it is tuned by means of a large variable condenser. Connected to one stud of the three-way switch mentioned above is a resistance coil, known as the "sense resistance."

A further coil, known as the "sense coil," may be considered a second primary winding of the high-frequency transformer.

So far, then, we have three distinct components of the direction finder:— (a) the aerials, which are fixed and may be put in any convenient position, (b) the radiogoniometer, which may also be put anywhere, even remote from the aerials, say in the ordinary operator's cabin, and (c) the combined transformer and sense coil, an accessory of (b).

In addition to this will be the receiving set, which in ordinary Marconi practice will be a six- or seven-valve instrument having four or five stages of high-frequency amplification, a detector, and one stage of low-frequency amplification.

Reverting now to the goniometer. Since the field coils are connected to the aerials, the current which the latter pick up will be transferred to the coils, and in an exactly similar proportion. Thus, supposing that one aerial is strongly energised, and the other only weakly

so, then the field coil connected to the first aerial will be energised to a degree similar to that aerial, and the second coil will have a current

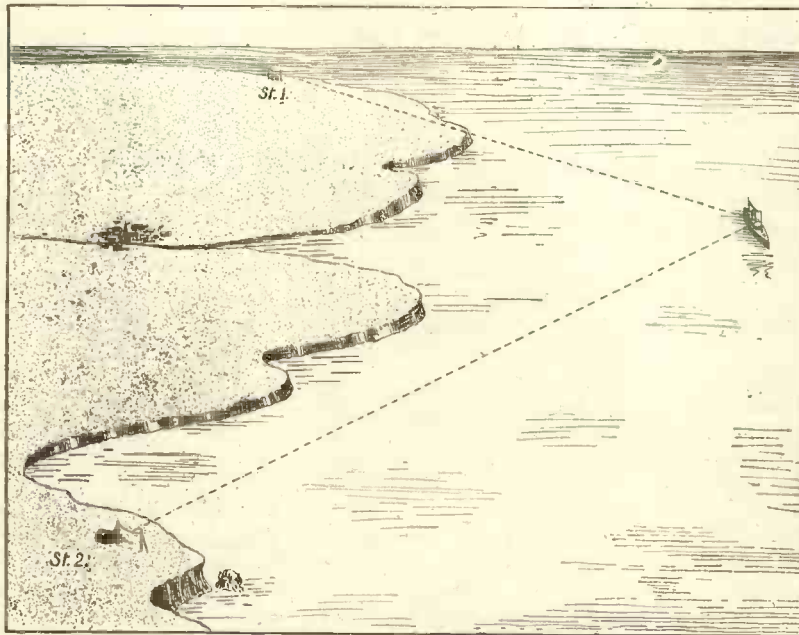

Fig. 6.—Ship Taking Bearings from Two Shore Stations.

called the "field coils," and the rotor the "search coil."

Reference to Fig. 4 will show how the coils are connected. It will

## WHEN A SHIP LOSES ITSELF! (Continued)

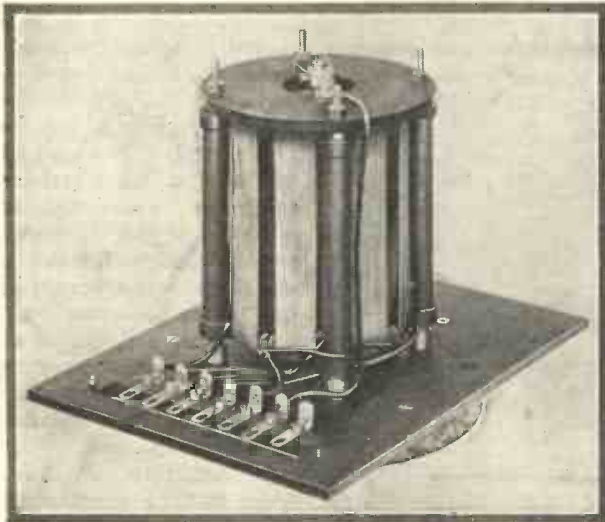

Fig. 3.—Marconi Radiogoniometer.

in it proportionate to the current in the aerial to which it is connected.

The search coil, rotating as it does within the fields, may be considered a little frame aerial on its own; one which depends for its action on the field coils as the sole supply of energy.

Further, the search coil will be energised most strongly when it lies in the plane in which the fields are energised.

Thus the goniometer is a complete direction-finding instrument, and from the position of the search coil in relation to the fields will the direction line of the signals be found.

### True Line of Signals

All that is necessary to ascertain the true line of the signals relative to the fore-aft line of the ship, or the points of the compass, is for the dial of the goniometer to be suitably fixed and engraved.

We can now go on to describe the manner of operating this system. Bearings are taken in three distinct operations, each operation being made with the three-way switch in a different position. These positions are marked "D.F.," "Stand-by" and "Sense" respectively.

The first operation, which is done merely to pick up a signal regardless of any D.F. effect, is carried out in the stand-by position of the switch, by which the mid-points of the loops

are connected to earth, via the sense coil.

During this operation two distinct current impressions are received on the loops. The first has an almost negligible effect on the search coil, and travels to the receiver by way of the sense winding (it being remembered that in reality this is a second primary of the H.F. transformer).

The second impression does pass through the search coil, but is so small as to be negligible compared with the first, so that the receiver does actually work as an ordinary non-directional one, capable of receiving any signal the operator may desire.

When the operator has obtained the required signal he places his switch in the D.F. position. Reference to Fig. 4 will show that in this position the sense winding is entirely out of circuit. Thus the received current can travel to the receiver only through the search coil and the H.F. transformer.

There are four places at which the operator may take readings, two main and two subsidiary. In the first place he may take a reading where signals are strongest or where they are weakest, and these positions are situated at ninety degrees.

Secondly, diametrically opposite to those positions, are two further ones, which are duplications as far as signal strength is concerned.

In the Marconi system it is usual

to take either of the weakest positions—these being considered the more strongly defined.

### "Sense"

So far, the operator can find the plane of the signals, but he has now to find from which end of the plane they are proceeding. This is done by moving the switch into the sense position, in which the mid-point of the loops is connected to earth, and the current may travel there via the sense resistance and sense winding.

It will be remembered that when the first reading was taken, two separate components were impressed on the receiver, one bigger than the other.

Now, with the switch in the sense position, a high resistance is placed in the circuit of the bigger component, and this reduces that component sufficiently for it to be comparable with the other, the latter previously having been so weak that no notice was taken of it.

The result of this is that only in one position of the 360 degrees movement of the search coil will a minimum signal strength be found. Electrically, this position is that at which the current in the primary of the H.F. transformer opposes that in the sense coil.

(Continued at foot of next page)



Fig. 5.—Complete Marconi D.F. Receiver.



# Anode or Plate?— WHICH TERM SHOULD WE USE?

ISN'T it really a little remarkable how quickly the beginner in wireless picks up the familiar terms and allows them to roll off his tongue so easily in conversation?

I have been talking recently to a wireless recruit who purchased his first valve a matter of a week or so ago. In a most entertaining conversation, the new recruit informed me that he always put twenty more volts on the *anode* than the maker's stated maximum.

"Anode?"

"Anode?" I asked. "What do you mean by anode, my good sir?"

"Plate, of course," he replied. "Anode is a more scientific name for plate, you know."

Now I rather like to be given scientific authority for the use of a new or unfamiliar wireless term, but I am not at all sure that my informant was right in stating that anode was a more scientific name for plate. What he might have said was that the two words had the same significance in wireless, but that the word anode had seen a lot more scientific service.

In scientific work on the flow of electricity through liquids and gases, the word anode is always used in conjunction with the word cathode. In fact, the two words anode and cathode are as inseparable as the Siamese twins. Were we to call the plate of a valve the anode, then to be properly consistent, we ought to call the filament the cathode.

Could you bring yourself to call the filament of your valve the cathode? Could you always talk of the *cathode* rheostat? I doubt if I could. It doesn't seem to sound at all good to me.

## Objections to "Plate"

The oft-repeated objection to the word "plate" is that the plate of a valve is seldom shaped like a plate these days. Personally, I am not a stickler for a literal interpretation in such a matter. I have a distinct recollection of having seen the funniest-looking, dome-shaped "plates" you could possibly imagine. Your dentist would no doubt show you one of the kind I mean if you asked him nicely. AERIAL.

## When a Ship Loses Itself (Continued from preceding page)

The position thus obtained in this final operation will be found roughly to coincide with one of the previously located minimum positions. It is immaterial whether it is accurate or not, for the operator will have memorised the first, and all the last indication does is to show which of the two original positions was the correct one.

In this manner is the direction of the station found, and although on paper it may sound a long and complicated process, in reality it is not so, and may be done in a few seconds with great accuracy.

An illustration of the complete receiving apparatus is given in Fig. 5.

It now remains to show the uses to which direction finding is put. Possibly its greatest use in marine work is for the guidance of vessels in fog,

and this guidance may be obtained either from a fixed point, such as a land station or a lightship, or from a moving point, such as another ship.

A fog-bound vessel can be guided completely by wireless by taking bearings on a fixed station—that is, by finding the angle between, say the N.S. line, and the line on which the station is located.

After a definite time interval, during which the speed of the ship has been ascertained, a further bearing would be taken. The two may then be plotted on a chart, and the course of the ship found out. These operations may be continued indefinitely.

Two near-by vessels in a fog may steer clear of each other by adopting the following process. The operator of one will transmit to the other, asking him to give a simultaneous wireless and sound signal (syren). The first operator will then measure the time interval between his reception of the two signals.

Since his wireless reception may be considered simultaneous with the transmission, and sound travels very slowly indeed (1,100 ft. per second), he can estimate fairly accurately the distance between the two ships.

## Ships Heading Dead on for Each Other

Should further signals show a smaller interval of time, then it would prove that the ships were heading dead on for each other. The operator's duty would then be to inform the officer, so that the course may be changed and a collision averted.

Finally, one word for the oscillating fraternity. It is possible to use a direction finder with great accuracy for this purpose, and there is little doubt that portable instruments on lorries will be used to check the oscillating nuisance, in a manner similar to that which is used to discover unauthorised transmission. In America this is done quite frequently—and very successfully. R. B. H.

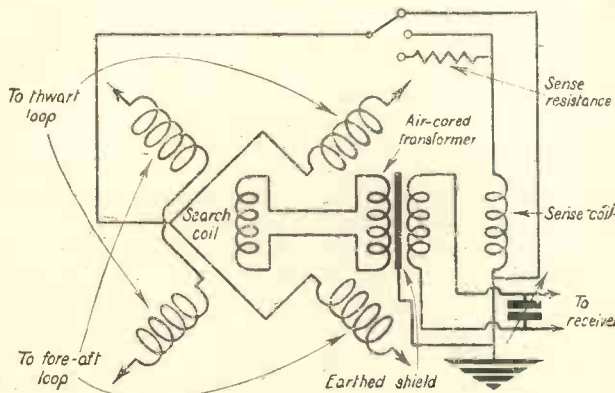

Fig. 4.—Connections of D.F. Coils.

Fig. 6 shows a further method where two land stations are used. This is simpler, and consists of taking bearings on both stations with as short a time interval as possible (a few seconds will suffice).

Two lines, each at a different angle, will thus be obtained, and these are drawn out on a chart. Where they meet is the position of the ship.



A Wireless Story by J. D. Millard

Illustrated by Stanley Lloyd

THE magnificent steam yacht, *White Empress*, rose and fell with the rhythmic motion of the water as she swung at her moorings in Cowes Roads. In her cabin, her owner, Mr. Anthony Crichton-Deane, was comfortably seated in a deep armchair with his after-dinner cigar making wreaths of smoke above his head.

Mr. Anthony Crichton-Deane was not, however, in the contented frame of mind which is properly associated with the after-dinner cigar. Unhappily, he had been compelled to take his dinner quite alone, except for his captain—a fact which was doubly annoying to Mr. Anthony Crichton-Deane as he had been expecting a party of friends from the mainland, who unfortunately had to put off the engagement owing to an outbreak of illness among their number.

It was therefore a bored and vaguely irritated Anthony Crichton-Deane who sat idly twirling the condenser dials of his sumptuous five-valve receiver, passing rapidly from one station to another.

It was more luck than anything else that caused him to come to rest on London's programme, and even that was continually chopped into by the "zip zip zippity zip"

of ships' Morse. The band had just concluded a piece, when the announcer came to the microphone and spoke. At his words Mr. Anthony Crichton-Deane's indifference gave place to a sudden interest and a faint smile hovered round his lips. The announcer said:—

"Before we continue with our orchestral programme, I have been asked to broadcast the following SOS:—'Will Mr. Crichton-Deane, of Brook Street, Mayfair, who is believed to be cruising in his yacht somewhere in the English Channel, go at once to Shelton Manor, Surrey, where his brother, Stephen, is lying dangerously ill.'"

By the time the announcer had repeated the SOS, Mr. Anthony Crichton-Deane had crushed his half-finished Corona into an ash-tray, and was dashing up to the deck, where he encountered Mr. M'Tavish, his skipper.

"I've got to get to Portsmouth on urgent business at once," exclaimed Mr. Anthony Crichton-Deane. "Can we make it within the hour?"

The skipper doubted it with the pessimism of all Scots skippers, but gave a grudging promise to do his utmost.

As it turned out, within fifty

minutes Mr. Crichton-Deane had bundled himself, his revolver, and pocket flash-lamp (without which, for a reason which will be made clear in due course, he never stirred abroad at night) into his high-powered, but silent, racer, which he garaged at Portsmouth when he was cruising in the Channel, and was already eating up the miles between Portsmouth and Shelton Manor, which was situated near Guildford.

\* \* \* \* \*

Shelton Manor is one of the few remaining "stately homes" of England, and is approached by a long drive. When he turned into the entrance gates Mr. Anthony Crichton-Deane saw at once that the lodge-keeper's house was unoccupied. He drew his car silently up on to the grass at the edge of the drive and continued the remainder of his journey to the house on foot, moving stealthily through the pines which separated him from the front door, and making no sound on the thick bed of needles.

As he left the cover of the trees and made as if to cross the moonlit strip of drive to gain the door, Mr. Anthony Crichton-Deane, whose actions had all along been very unlike those one would expect from one on a visit to what was probably

the death-bed of his brother, noticed that a french window on the left-hand side of the front porch was open.

Approaching cautiously across the flower-beds, Mr. Anthony Crichton-Deane edged up to the open window, keeping well up against the wall. With his head pressed back flat against the wall, he listened intently for two or three minutes. Apparently satisfied with what he had heard, or rather not heard, he boldly walked in through the open window. The room on the other side was a library.

By the moonlight which was streaming in through the window Mr. Anthony Crichton-Deane could see that the room was unoccupied. In the wall opposite the window was a door, which stood slightly ajar. This was apparently the only way into or out of the room besides the window through which he had entered. Mr. Anthony Crichton-Deane crossed over to the door as quietly and as stealthily as he had approached the french window, and listened.

Again, as when he had heard the SOS in the cabin of his yacht, a smile wreathed his lips, and he returned as silently as he had come. He crossed to the window, and, pulling a penknife from his pocket, he neatly snipped off two of the blind-cords. These he coiled up and placed on the library table.

Then he made himself comfortable in one of the leather-upholstered armchairs. He had chosen his chair so that it was in the shadow and yet commanded a full view of both the window and the door. Mr. Anthony Crichton-Deane had not long to wait.

After he had been seated for a few minutes the door of the library was pushed open, and four men entered the room by it.

"Stick 'em up, please," drawled Mr. Anthony Crichton-Deane, "or somebody

might get hurt." And he played on the faces of four startled men with the pocket flashlamp which he held in his left hand. His right was occupied with holding the business-like revolver which glinted in the moonlight.

"Thank you," said Mr. Anthony Crichton-Deane as the four men slowly and reluctantly raised their hands above their heads. "That's right, Mr. Tubby, just put that little bag on the table. And you on the right there, put 'em right up, please."

Mr. Anthony Crichton-Deane carefully uncrossed his legs, lazily stretched himself, and went over to his four captives. Rapidly he passed his hands over their persons and unearthed a revolver and a handful of miscellaneous jewellery from each of their pockets, which he placed on the table beside the bag. Then he addressed the lean and lank man who stood on the right of the little group.

"Just take the cord you see coiled on the table"—and he pointed out the blind-cords he had previously cut down—"and tie up the wrists of your tubby companion in iniquity behind his back. That's the way. Thank you. Let me cut the ends off neatly for you. Now do the same service for your other friends."

The three neatly trussed-up captives were stood in a row in front of the door, with their backs to it, under the menace of Mr. Anthony Crichton-Deane's revolver, who then proceeded himself to the tying up of the fourth burglar.

"Now let's see what you've been able to find," said Mr. Anthony Crichton-Deane, and he picked up the jewels as well as the bag which



Stanley Lloyd  
"Here, guv'nor," he asked, "now you've got us tied up, aren't you going to wake up the household? What's the game?"

## THE SOS—A Wireless Story (continued)

Mr. Tubby had been carrying, which proved also to contain jewellery, and examined them by the light of his torch. He was interrupted in his examination by the tall man, who had helped with the tying-up.

"Here, guv'nor," he asked, "now you've got us tied up, aren't you going to wake up the household? What's the game?"

"No, why should I? Do you particularly want me to have you handed over to the police? I don't quite see what I get out of it, if I do that."

"Then what the——"

"Ssh!" interrupted Mr. Anthony Crichton-Deane. "Not so loud."

"Look here, guv'nor. I don't know who you are, but what are you doing here at this time of night? How did you get in here?"

"Through the window, the same as you, my friend," answered Mr. Anthony Crichton-Deane.

"Then you aren't one of the house-party?" exclaimed the man in an injured tone. "I've half a mind to yell and get you pinched, even if it means getting caught ourselves."

"Now, don't be rash, my friend," whispered Mr. Anthony Crichton-Deane. "Don't forget I'm not tied up and could get away before any alarm could be raised. I have my own reasons for being here to-night, and bandying words with you is not one of them. I have, too, a very excellent and plausible explanation of my presence in the event of any trouble. So just keep quiet, in case this little gun goes off."

Mr. Anthony Crichton-Deane turned his attention to the jewellery once more, while his adversary gritted his teeth in his impotent rage. His inspection revealed a collection of rings, brooches, pendants and gold slave-bangles. Mr. Anthony Crichton-Deane cast an appraising eye over them.

"Rather a job lot, I'm afraid. One decent diamond among the lot, two fair-sized rubies that will have to be spoilt by cutting to disguise them, half a dozen worthless sapphires, a rope of imitation pearls, and a couple of nine-carat gold bangles—hollow ones at that. No, my lads, if ever you get a chance to bring off another little deal of this kind, don't try one of the few

remaining stately homes of England. Their stately owners have mostly sold their family heirlooms long since, and those that haven't, keep them in safe-deposits and wear imitation replicas. Try one of our war-profiters next time, or one of our new rich."

It was at this point that the fat little man spoke for the first time.

"You seem to know your way about a bit. What are you, an insurance tout, or a jeweller's assistant?" he sneered.

"Neither," replied Mr. Anthony Crichton-Deane. "Although I find it useful to combine a slight knowledge of precious jewels with my craft."

"Look here, old chap," continued the fat man. "See here, we'll make you a sporting offer. You've got us beaten just at the moment—we'll admit that. Suppose we let you share the plunder and you undertake to allow us a clear get-away?"

Mr. Anthony Crichton-Deane's eyebrows shot up in a mock expression of pained and shocked surprise. He looked at the speaker with a tolerant smile on his face.

"Bribery and corruption! Terrible, terrible!" he mocked. "And a bit cool, don't you think? So kind of you to let me share the—er—'swag,' isn't it called? Especially as I've taken the jewels already without consulting you in the matter at all."

A gasp of indignation was emitted by the fat man.

"So you're going to round on us, are you? We thought at first you were one of the house-party. Now you turn out to be no better than we are, for all the airs and graces you give yourself."

Mr. Anthony Crichton-Deane had apparently tired of the dialogue, for he took no further notice of his captives and commenced emptying the jewels into a little leather bag. This he placed in his pocket. His actions were watched in growing indignation and amazement by his four captives. They stared all the more as he withdrew the penknife from his pocket, opened it, and placed it on the arm of the chair he had just vacated. They were prevented from doing justice to their feelings by the

open door and the danger of giving the alarm.

Having completed these preparations, Mr. Anthony Crichton-Deane spoke to his captives once more:

"Although by so doing I shall be guilty of the crime of aiding and abetting you, I have determined to give you an opportunity of making good your escape." He smiled to himself at his little jest.

Then he continued: "As you have seen, I have left you my pocket-knife opened on this chair. When I have gone, doubtless one of you will be able to take it in his teeth and cut the bonds of one of the others, and so you will be able to free yourselves. You will not be able to display any undue haste in freeing yourselves for the purpose of pursuing me with any mistaken idea of revenge, because if you do you are sure to rouse the household; and I fancy you would find it rather difficult to persuade the good people of the house that the real burglar was three fields away, and that you were merely disinterested spectators!"

The four prisoners heaved a sigh of relief. So this extraordinary young man was not going to call the police, or rouse the household, or do anything of that kind. Instead, he was going to help himself to the plunder which they had risked imprisonment to steal; and he was going to give them a chance of clearing out without any greater harm than a severe fright.

One of the other men, who had so far not spoken, voiced the general opinion of the four when he said:

"Well, you aren't such a bad sport, after all. You might have left us here, trussed up, without any means of freeing ourselves, and the certainty of getting caught like mice in a trap in the morning. But what put you on to our game? Who are you?"

"Hasn't that occurred to you yet?" smiled Mr. Anthony Crichton-Deane.

"What are you getting at? Who are you?"

Mr. Anthony Crichton-Deane hesitated a moment or two before replying. Then he spoke.

"I am by name Anthony Crichton-Deane, but, unfortunately, not of

Brook Street, Mayfair." He relished their astonished faces.

"Yes," he went on, "the millionth chance, which you never thought of, came off. Where did you get the brilliant idea of supplying the B.B.C. with a faked SOS?"

"It was Tubby, here," answered the tall man. "He first thought of it. You see, we all live in different parts of London, and for professional reasons we preferred to keep our addresses private."

"Trusted one another a lot, didn't you? Then how did you communicate with each other?" asked Mr. Anthony Crichton-Deane.

"Through the personal column of *The Times*," replied the other, who continued: "Then Tubby had the idea of the bogus SOS. It was much quicker, and of course cheaper than an announcement in *The Times*. We agreed beforehand upon the name of a fictitious person, and decided that he was to be called home to see a dying brother from a yachting cruise in the Channel. So there could be no mistaking a real SOS for ours. The name we made up was 'Crichton-Deane!' Then when any of us heard of a promising house, he would explore the possibilities, and finally decide upon a night when circumstances would favour a raid. He would then turn up at the London broadcasting station armed with forged doctors' certificates which showed the necessity of Mr. Crichton-Deane's going at once to the house in question. In this case, Tubby had found out all about the house-party at this place, Shelton Manor. So when we each heard over the wireless the SOS asking Mr. Crichton-Deane, believed to be yachting in the Channel, to go at once to Shelton Manor, Surrey, we knew at once that it was Tubby's intimation of to-night's little piece of business, and set off here, where we all met at the lodge gates."

"But, unfortunately, the name of your fictitious personage happened also to be the name of a real one. You never thought there would be a real Mr. Crichton-Deane, who might answer your faked SOS—hence our present relative positions, eh?"

"Yes, coupled with the fact that you're too cute for the lot of us."

"Oh—tut, tut. I had to rush at once to my brother who was lying dangerously ill at Shelton Manor, hadn't I?"

"Yes, that's it. But why didn't

you walk up to the front door and ask for him if you really believed in our SOS?"

"For two reasons," replied Mr. Anthony Crichton-Deane. "In the first place, I noticed the open french window, and, as I happen to be in the same line of business as yourselves, I drew my own conclusions. I had thought at first somebody wanted

to decoy me away from my yacht, but then I thought they couldn't do much harm there with my Scots skipper aboard, to say nothing of the crew. And my second reason for not walking up to the front door was that I have no brother. Bye-bye!"

And he passed out through the open window.

### SCOTCH BOTH WAYS

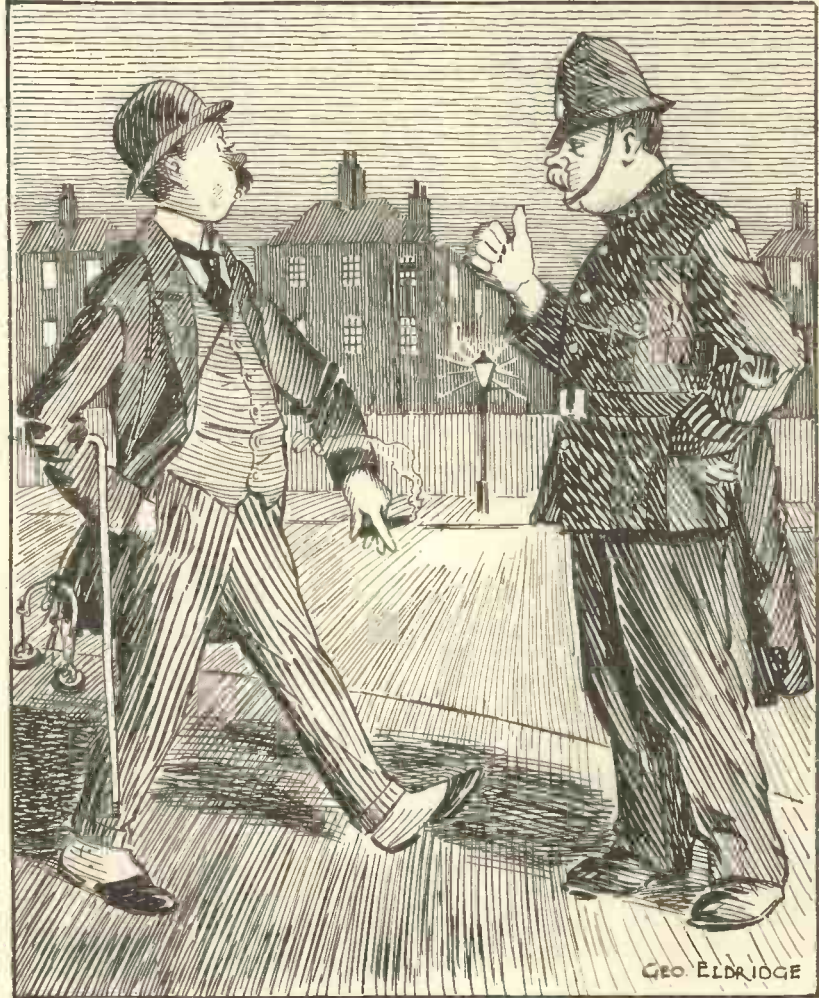

One of the boys: "Jusit been round the stations with some wireless pals an' we finished up with 5 Sc—(sic)—5 Sc."

Policeman: "All right old man, don't trouble to spell the rest. Just get along home."

WIRELESS is said to be useful for developing the imagination. Judging from some of the stories of QSL collections that we hear, it does it very well.

PROFESSOR Low says that a loud-speaker can be made with an ordinary trumpet. Listeners will be able to borrow one of these from their local M.P. when he isn't using it.

A LONDON amateur recently transmitted gramophone music half-way round the world. A case of using one record to break another.

A FRENCH amateur has written to the Press to say that he owes the B.B.C. a debt of gratitude for some of their recent programmes. The usual sort of French debt, it will be noticed.

# Gadgets, Hints and Tips

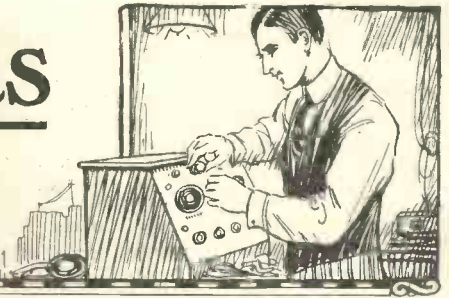

## Illuminating the Controls

THE illustration shows a simple method of illuminating the controls of a portable or other type of receiver which is likely to be used in the dark.

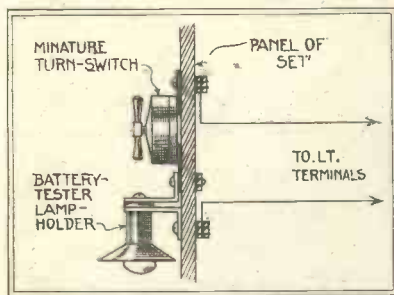

Method of Illuminating Panel.

A miniature turn-switch is mounted on the panel, together with a miniature screw-bulb lampholder.

The arms of the latter should be cut off at a distance of about  $1\frac{1}{4}$  in. from the holder proper, and drilled and bent at right angles for attachment to the panel.

Current for operating the light is obtained from the L.T. accumulator. I. M. R.

## Grid Bias from H.T. Battery

GRID bias can be obtained from an H.T. battery quite satisfactorily in the following way: The lead (1), which is joined to L.T. — in the set, is taken

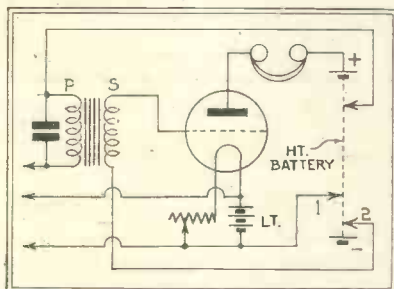

Grid Bias from H.T. Battery.

to a low tapping on the H.T. battery (according to the valve in use). Lead (2) is taken to a tapping nearer the negative end of the battery.

To vary the value of the grid bias move the tappings. D. W.

## Fixing Crystals

CRYSTALS should not be subject to heat when being fixed into a cup. If proper Woods' metal (which melts at a very low temperature) cannot be obtained, pack the crystal in with ordinary tinfoil, such as chocolate is wrapped in. X.

## Panel Indicator

THE panel indicator illustrated below is not only neat and distinct, but costs nothing, and is simple to include in either existing sets or those in course of construction.

It consists of about  $1\frac{1}{4}$  in. of any size of wire; it can be mounted flush with the panel, or on top.

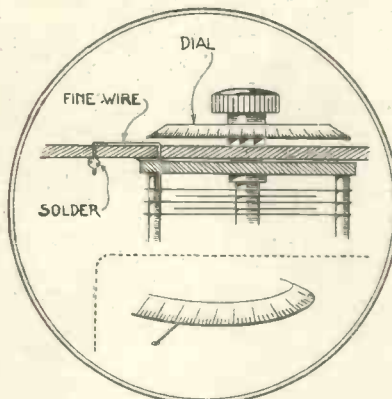

Simple Type of Panel Indicator.

After drilling two small holes, insert the wire, pull tight with pliers, bend ends about  $\frac{1}{8}$  in. underneath the panel, and attach a small blob of solder to each end. It is best to let the wire go underneath the condenser dial for about  $\frac{1}{4}$  in. C. L. L.

## Accumulator Electrolyte

ACCUMULATORS should be given just as much attention during the winter months as they are during the summer. The level of the electrolyte of a battery kept in a warm room in the winter will fall just as rapidly as during the hottest months of summer. Z.

## L.F. Amplifier Switching

A LOW-FREQUENCY amplifying valve, following a detector valve with reaction, may be easily switched as follows:—

The reaction-coil leads are attached

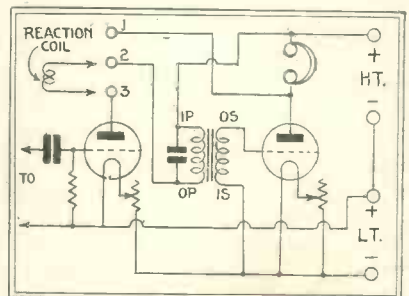

Details of L.F. Amplifier Switching.

to plugs, and three sockets are connected as shown in the diagram.

Socket (3) is always in use. The L.F. valve is, or is not, in use according as socket (1) or (2) is employed. The purpose of socket (3) is to enable the reaction coil to be reversed. H. R.

## Aerial Safeguard

WHEN erecting your aerial a piece of lead, of weight greater than the total weight of the cord which is used for tightening the aerial, fastened in such a position that when the aerial is stretched it will not run against the

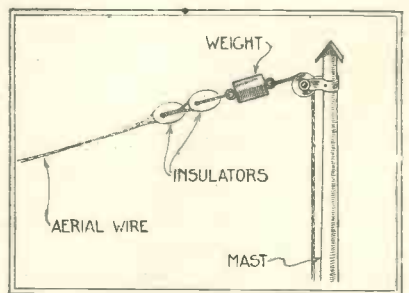

Position of Weight on Aerial.

pulley-block, will be very serviceable in case the aerial is blown down.

By just paying out the cord, the pulley rope, insulators and the end of the wire will be brought down to the ground by the weight. S. M. T.

# An American at the Court of King Radio



A Special Article by Fred Smith, Studio Director of the Crosley WLW Station, Cincinnati, who has just completed a tour to study European broadcasting conditions.

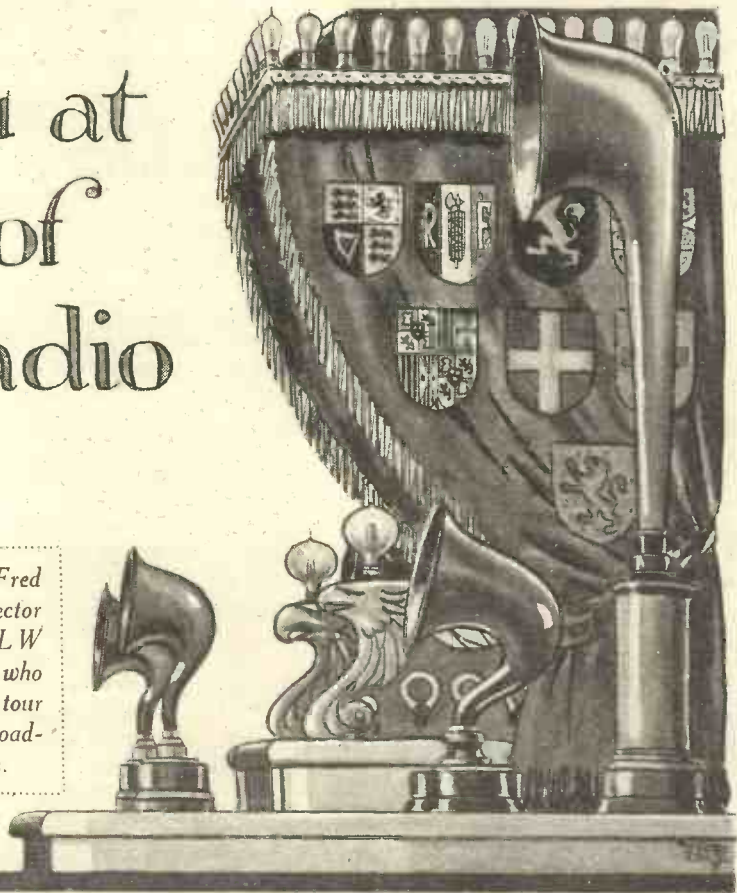

AN ambition which journeyed with me through eight countries on my visit to the Court of King Radio was to sit upon the Alps and listen to the world. And the dream came true—almost. In Zurich a radio fan invited me to listen with him. Several times my wife and I sat from ten till midnight with young Charles Mussler, earphones clamped tight, stop-watch upon the table, and in our hands the programmes of the radio stations of two hemispheres.

## One by One They Came

One by one through the summer static they came at our call—Rome, London, Paris, German stations in quantities, Brussels, and others still away to the east of Switzerland. How I longed for a winter night and a universal language!

One evening, while we were sitting there expressing the wish now and then that we might hear some station in the United States, my thoughts flew back to the little Indiana town where I was born and raised.

In that village there was a brass band which rehearsed every Thursday night in the hall over Ben Russell's

grocery store, and gave a concert now and then on the street corners for the benefit of some function such as an ice-cream social given by the Ladies' Aid Society.

Among the fifteen members of this band was a carpenter named Purse Schum, who used to speak earnestly of music and his slide-trombone, saying invariably that so far as reading music was concerned he "was all right till it came to the damned rests!"

Listening to King Radio in Zurich reminded me often of that band and Purse Schum. We would find a station and wait breathlessly for a number to finish in order that we might hear the announcement and thus verify our calculations as to the location of the station.

## An Example

For example, Rome would come pounding in with beautiful modulation and excellent music. The piece would end. I would push the stop-watch upon the table, following with eager gaze the big hand as it made the circuit.

A minute would go by. Thirty

seconds more. Twenty more. At last the voice. Total, one minute and fifty seconds. By this time, long since beyond the point of desperation, I would comfort myself by paraphrasing Purse with: "Radio would be all right if it weren't for the damned pauses!"

## National Characteristics

Travelling from nation to nation with rapidity one is struck immediately by an expression of the dominant national characteristics in the broadcasting systems which prevail. France expresses a national characteristic by balancing state interests against private interests. England, by a governmental franchise to a monopoly carefully controlled. Holland, by mercenary cautiousness. Germany, by defiant idealism. Spain, by unrestrained freedom. And Switzerland, by pure patriotism.

So far as I have been able to discover, England has set up the most gigantic and efficient system to be found anywhere.

To epitomise: The British Broadcasting Company has a monopoly on

## An American at the Court of King Radio (Continued)

broadcasting in the British Isles; its pay roll numbers five hundred and sixty-two names; it owns and operates twenty stations and one high-power station now going at twenty-five kilowatts; it has the definite assurance of a fixed income by means of taxation enforced by the government; it is guided by the powerful personality of J. C. W. Reith; and it has plans and ambitions for the future wherein the sky alone is the limit.

### A Potent Factor

In other words, the B.B.C. has become, and means to grow more and more into, a potent factor in the life of the Empire.

\* \* \* \* \*

In Belgium I had expected to find the government at the back of broadcasting with definite and enthusiastic support. I had imagined that the government was rigidly taxing the listeners and turning the money over to well-organised broadcasting companies furnishing the very best of programmes to the public. I found only a group of earnest men working desperately to accomplish something against great odds. The Brussels station is well known and well liked throughout the other European countries I have visited.

But alas! The government not only does not help the broadcasting station, but makes it pay a tax of 1,000 francs annually per kilowatt for the right to broadcast. On the other hand, the listeners are taxed. Each set owner pays the government twenty francs a year.

One is left to form his own opinions as to why this tax is not increased a little and a certain per cent. turned over to the broadcasting station.

### Dutch Broadcasting

Cautious Holland collects money in three ways for its broadcasting: in the first place, the station is owned and operated by a manufacturing concern having as its product marine transmitters and radio receiving sets. The direction has been clever enough to persuade the Dutch citizens that if they want a Dutch station they should help support it by voluntary contributions — and they do.

And several large firms, in appreciation for announcements over the air, pay for the famous Amsterdam symphony concerts and other features.

The first, and most enduring, impression one receives concerning the broadcasting situation in France is that the obstacles which impede the natural progress of the art are stupendous. The government has taken no definite stand about taxation. Theoretically, users of receiving sets are supposed to pay one franc a year for licences. But nobody pays. Therefore, there is no definite income.

An astonishing amount of jealousy exists between stations. The Tour broadcasts music only one hour daily. The other three stations in Paris struggle heroically to make a showing. But Paris and France cannot hope for a first-class radio service until all the broadcasting interests come to some helpful understanding about concerted effort.

### Switzerland and Spain

Switzerland, the land of William Tell, Arnold von Winklereid and Zwingli, is expressing its national dominant idea of pure patriotism with characteristic earnestness in its broadcasting. For the moment there is but one station of importance, the one in Zurich. But others are sure to follow very quickly.

In Spain there are more antennæ sticking from the house tops than in any country I know, including the United States. Last winter Spain went mad over radio. The enthusiasm has subsided temporarily, much to the unhappy amazement of the sellers of sets, but will probably revive in the autumn.

Radio-Barcelona has secured a contract, costly but spectacular, which will enable it to broadcast excerpts from the Opera at the Liceo every night during the coming season.

\* \* \* \* \*

The national culmination of the broadcasting plan in Germany will be the permanent connecting of all stations by telephone lines. There are at present nine broadcasting companies operating, with a probability of another entry soon. This means that the German broadcasting system is in reality made up of a

number of separate interests working alone in different sections of the country. Long-distance telephone service in Germany is not excellent because of inefficient equipment.

### Two Problems

There are, consequently, two important problems to be solved in this matter of the national culmination of broadcasting: First, a centralisation plan which will enable the nine operating companies to work amicably and advantageously together. Second: funds to put the telephone lines into first-class condition.

\* \* \* \* \*

Again and again, in country after country, I have asked the questions: "What are the great tendencies in broadcasting? What are your ideals for the future? After what ideal do you fashion your programmes?"

It has been very difficult to extract answers to these questions. A few men perceive what radio is doing. Mr. Reith of the B.B.C. answered me very definitely with: "The ideal of radio is to perform the service of culture in its broadest and highest sense."

Herr Hands Bredow, German Secretary of Wireless, replied to my "What is the finest influence of radio?" with "I think radio will become the best member of the family."

Count Arco of Telefunken calls radio "A school for grown-ups."

### Helping Peace

And when I asked Mr. Arthur Burrows in Geneva about radio and peace, he replied:

"The warlike tendency is the outcome of the separation of nations. Wireless is bound to help work for peace because it is working against the separating factors."

\* \* \* \* \*

The men I have quoted are playing great rôles in the Court of King Radio. But there are other influences and tendencies which exercise great power in the Court. Broadcasting stations are generally controlled by engineers or business men who either do not see artistic evolution ahead of them or are afraid of the expense.



## An American's Impressions of European Broadcasting

The director of a prominent station on the Continent told me that before beginning broadcasting he went to England for two months to study. "Excellent," I thought to myself; "this man is on the right track—he went to study the arrangement of programmes."

### The Mechanical Side

I communicated my enthusiastic thought to him; but he replied with a tone of pity for my misunderstanding of the great values of radio broadcasting: "Ah no! I went only to study the mechanical part of it. We make our own programmes. They are excellent. They are as good as you will hear anywhere. Come to the station to-night, and you will hear for yourself."

Well, that night I did go to his station. I went hoping that my deductions were fallacious. I went in the spirit of preferring a pleasant surprise rather than verifying an unhappy suspicion. But Truth had no sympathy for my sentiment,

I remained through two hours of painful listening and watching. The programme was not bad, just hopelessly mediocre, devoid of radio showmanship and altogether lacking in that finer spark of understanding which might have been expressed through the personality of a capable performance director.

And all of this might have been pardoned if there had been any excuse or apology for lack of funds, lack of support, lack of interest. No, the missing entity was *vision*. The dominant and killing factor was egotistical super-confidence.

\* \* \* \* \*

The King in the Court of Radio is the Opinion of the Public. Let us who are working with all our energy in broadcasting not imagine for one single instant that our opinion and our judgment alone are valuable, nor that we alone are intelligent enough to gauge the values of broadcasting.

At very best, we can hope to represent but a small per cent. of

humanity's intelligence. The intelligence of humanity at large will demand of us impossible feats of achievement and set up before us unattainable ideals in the programme of the future.

A part of the programme of the future must be the extraordinary personality of the announcer. For the most part, persons of authority in European broadcasting stations confine themselves to daylight labours

down. One of Spain's greatest bull-fighters used to say: "No bull will ever kill me. Only the Public can kill me!"

### Importance of the Programme

Perhaps the mistake in radio lies not so much with underestimating the importance of the announcer as underestimating the importance of the programme itself. For if the programme is to continue as a hodge-podge of musical and literary fragments, then well and good, and let us give up broadcasting altogether. But if radio art obeys natural law—and what can keep it from obeying?—and evolves into a presentation of cultural entertainment parallel with radio possibilities, the programmes themselves will require an infinite amount of attention.

Happily, the evolution is already evident. Both in America and in Europe the idea of the thematic programmes is already blossoming. But as yet the school of radio technique is embryonic. The greatest lesson I have learned during a summer spent in examining the broadcasting conditions in eight countries is that the *radio show* is coming most certainly, and for my part I mean to devote all of my energy to its development.

Radio must become for humanity something more valuable, something more ennobling, than a mechanical toy, a material wonder. As Mr. Reith said: "It must render to humanity the service of culture in its highest and broadest sense." The evolution toward the highest form of radio performance may be quite painful and slow. We who labour to bring about this evolution may have to pass through many a test of fair or unfair criticism.

### The Ideal Programme

But the ideal programme, based largely upon music, the divinest of the arts, will lure us on and compensate our efforts with tenderest appreciation, the reward of a mind conscious to itself of right.

### THE INTERNATIONAL HANDSHAKE



Three prominent wireless men greet one another. Left to right, Mr. Hiram Maxim (U.S.A.), M. Belin (France), and Mr. Gerald Marcuse (Great Britain).

and nocturnal absences. There seems to exist some sort of fear that the announcer, or speaker, will become a star and, consequently, unmanageable.

Even in the British Broadcasting Company I was told by one member of the staff that "the B.B.C. was not a stage for stars," and that announcers were given very little publicity.

Beware! Let us remember that our opinions are not infallible, and that our preferences will have little favour with the King if they do not please him. I have watched and studied the King for a long, long time, and I have seen that he *always* admires stars. Thumbs up—thumbs

# Advertising by Wireless

*A Special Article by Sir Charles Higham*

THE use of wireless for advertising purposes is a big subject. There is much to be said for and against it. In the United States it is a common practice to pay for ten minutes' broadcasting about any commodity under the sun.

I think its advantages outweigh its disadvantages, because I am firmly of the opinion that the people of the world want to know as much about the services that advertisers render to them as they want to hear music or anything else.

## *Good Speakers Essential*

The advertising story must be told, first of all, by a person who knows how to broadcast, and secondly, by someone who knows how to speak interestingly on the subject.

If we ever come to using wireless for advertising purposes, I think we have got to explain to those who receive messages the reasons for devoting a certain amount of time each day or night for the purpose of telling them the merits of articles which they ought to buy.

I think there is a bigger field for advertisement by wireless than the mere advertising of commodities, and that is the advertising of services—such as the need for buying British goods, the advantages of using Sheffield steel, the quality of British cotton goods, and the supremacy of British woollens; why you should read the advertisements in your newspapers; the advantages of cleanliness, the reasons for brushing your teeth, the advantages of having your shoes cleaned, and the effect of careful and neat dressing in the battle of life. Such subjects as these could be made more interesting to listeners-in, and I think it would be much more interesting than some of the so-called humour which I occasionally listen to on my own set.

I think the last election was won, to a much larger extent than people imagined, for the Conservative Government by the thoughtfulness of the present Prime Minister in going to the station and making his address properly, while the leaders of the other two parties took their chances with the microphone at their meetings.

Recently, in the United States, the Governor of the State of New York, believing that a certain piece of legislation was of advantage to the voters, promptly told them so by broadcasting, and he carried his bill overwhelmingly through the legislature.

I believe that if Sir Auckland Geddes had, during the sitting of the Food Commission, explained to the people why he was taking a certain length of time to get to the bottom of the food trouble, and why it took considerable time to issue his report, and explained to the people by wireless that all his committee had agreed with him that they should not print a hurried report, I believe the criticism of his committee which appeared in the Press would have ceased.

All this is advertisement as I understand it.

During my recent visit to the United States I "radio-ed" eleven times in sixteen days from various stations on "Why the People of America Should Drink Tea," and I know by letters received by the broadcasting people themselves, and by myself, that the people not only did not resent it, but, on the other hand, welcomed the information which I gave them.

## *Getting Information*

I think that wireless is of incalculable value to the people of the world for getting information. I think it is educating the people to a remarkable degree, because each person who speaks by wireless has to be very careful of the words he chooses, as the listener-in sees no gestures, appreciates no personality, and feels no magnetism.

Broadcasting has taught us how much personality there is in voices, quite apart from the clear intonation, pitch and timbre. We have learnt to be attracted and repelled by voices as easily as we are by the personalities we meet in the flesh.

We will listen with pleasure to an attractive voice speaking on a scientific subject that is beyond our grasp. We like and dislike the speaker on sound—quite a new

experience, since hitherto it has always been on sight.

If, then, the information delivered can be rather dull in substance, and yet hold us by the charm with which it is spoken, such charm will become the deciding factor when broadcasting is used to distribute commercial news.

In my opinion such a development is inevitable; although exactly what line it will take, how direct or indirect will be the fashion of its presentation, it is difficult to conjecture. Yet one must remember that very soon an all-day service of news and entertainment will be offered, and the filling of those hours will be the advertiser's opportunity.

## *Medium for Advertising*

Wireless will probably become one of the finest media for collective advertising, as I have indicated in the earlier part of this article.

Advertising by wireless cannot be done successfully by the process known as "wangling"; it must be *bona fide* publicity.

The subjects of interest to householders that also have advertising value to groups are very many. Everything that encourages a well-run home, a well-cooked meal, artistic interior decorations, the proper appreciation of good wine, fruit, milk, well-built houses, the economical running of cars, the intelligent planning of travel, and buying of books—all these subjects are related to trading, and what profits a trade profits the individuals in it.

Group advertising in the Press will, in the near future, be supplemented by such lectures, which may easily become as attractive and reliable as any other spoken form of education.

Wireless may also become the most economical form of Government publicity dealing with facts (but not opinions!). The public will always listen to a Minister, and facts concerning health, agriculture, transport, education, overseas trade, etc., might often be distributed with an almost magical alacrity, to the great benefit of us all.

# A One-control Crystal Set with Wide Wavelength Range

**B**ECAUSE of the fact that the ordinary crystal set consisting of a variometer or coil and condenser tuner possesses a limited wavelength range, considerable difficulty is experienced by the novice in finding out how to increase the wavelength of his receiver.

The purpose of this article, therefore, is to describe a crystal set, having a wide wavelength range, controlled by one knob only.

From the circuit diagram it will be seen that an ordinary variometer is used as a means of varying the amount of inductance in the aerial circuit, whilst in parallel with the variometer a variable condenser is connected. Both the variometer and the variable condenser are geared together by a slow-motion friction device.

### Rotated Together

By rotating the latter the dials of the variometer and condenser are rotated together at the same speed. By using an ordinary semi-circular plate condenser (not the square-law type), the wavelength graph is approximately a straight line through-



*Specially Designed  
& Built by "THE WIRELESS MAGAZINE"*

Variometer (Igranic).

.001 - microfarad variable condenser (Jackson Bros.).

Four plugs and sockets (Belling-Lee).

Two knobs and dials of identical form and dimensions.

Slow-motion friction device (Sparks Radio Supplies).

.002 - microfarad fixed condenser (Dubilier).

Crystal detector (Burndept).

Prodonite crystal (S. B. Smith & Co.).

Ivory dial and pointer.

Baseboard, 7 in. by 7 in. by 1/2 in. thick.

out the entire movement of the dials.

The few components required for the building of the set are as follow :

Ebonite panel, 7 in. by 5 in.

Ebonite strip, 6 in. by 2 1/2 in.

### Mounting the Components

The variometer and variable condenser are mounted side by side on the 6 in. by 2 1/2 in. ebonite strip in such a manner that approximately 3/8 in. of space is left between the edges of the two dials.

Between the dials the friction device is mounted so that the rubber friction wheel bears on the bevelled edges of each of the dials.

The bracket of the slow-motion friction device is bolted to the sub-panel.

The strip bearing these components

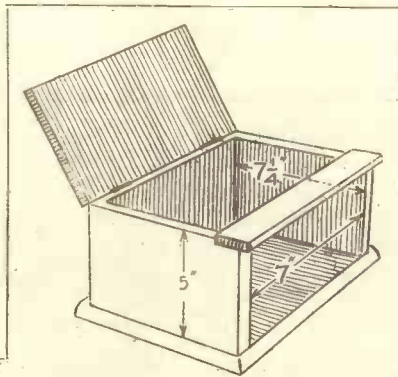

(Above).—Details of Cabinet.

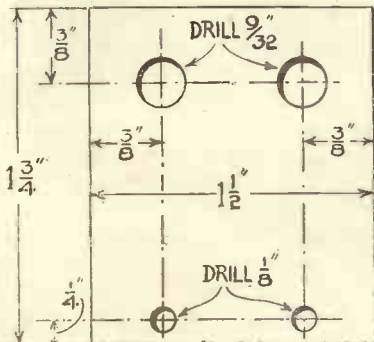

(Left).—Layout of Plug-socket Block.

(Right).—Layout of Sub-panel.

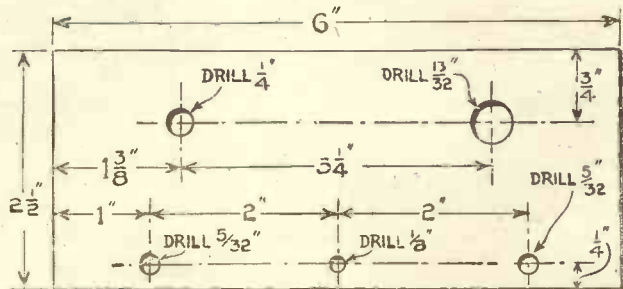

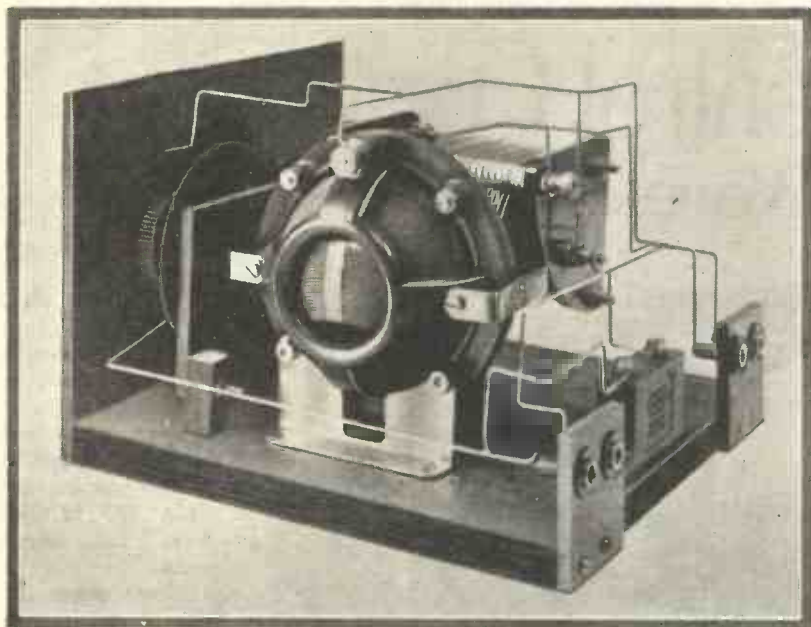

Photograph of Wiring of One-control Crystal Set.

is then mounted in a vertical position  $1\frac{1}{8}$  in. from the front edge of the baseboard by means of two small wooden brackets screwed to the baseboard and to each bottom corner of the ebonite strip.

### Crystal Detector

On the front panel, on the right-hand side, the crystal detector is mounted, whilst on the opposite side directly in line with the moving spindle of the variable condenser a hole is drilled through which a thin brass rod projects.

### MAINTENANCE HINTS

Keep the set free from dust as far as possible: an ordinary cycle-tyre pump is useful in this respect.

Dirt that collects between the condenser vanes can be removed with a pipe cleaner.

Wood's Metal—and not solder!—should be used for fixing crystals in the cup.

A falling-off in strength after a few weeks may be due to the catwhisker becoming blunt: try resharpening the point.

Keep your phones in a dry place and do not knock them about or the magnets will be affected—and results as well!

Remember that aerial insulators become covered with conducting grime after prolonged exposure: clean them occasionally.

Earth connectors should also receive periodical attention if the best results are to be obtained.

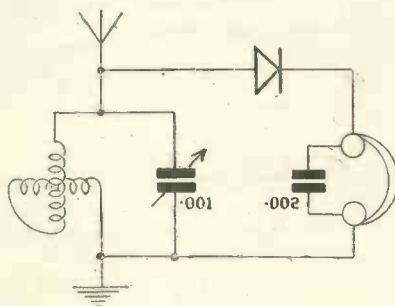

Circuit Diagram.

### OPERATING HINTS

First plug-in the aerial and earth, and then the phone connectors.  
 Make sure that the local station is transmitting by looking up the programmes in your newspaper.  
 Carefully adjust the detector until the catwhisker is resting lightly on the surface of the crystal.  
 Turn the knob on the front of the panel slowly until you hear signals in the phones.  
 Now re-adjust the crystal detector until you get the best results.  
 When searching do not turn the tuning control knob too quickly—you may easily pass a station without hearing it.  
 If your phones are of the adjustable type make sure that they are set to the most sensitive point.  
 When you have finished listening withdraw the aerial and earth connectors from the sockets on the set.

This rod is soldered to the spindle of the condenser at one end and a pointer is fixed to the projecting end. A  $180^\circ$  scale is fitted concentrically with the hole. The pointer indicates the position of the moving vanes of the variable condenser.

Another hole is drilled in this panel so that the operating spindle of the friction device may protrude.

On the back edge of the baseboard at each corner two small ebonite pieces are screwed for the purpose of mounting the plug-sockets.

The method of wiring is indicated

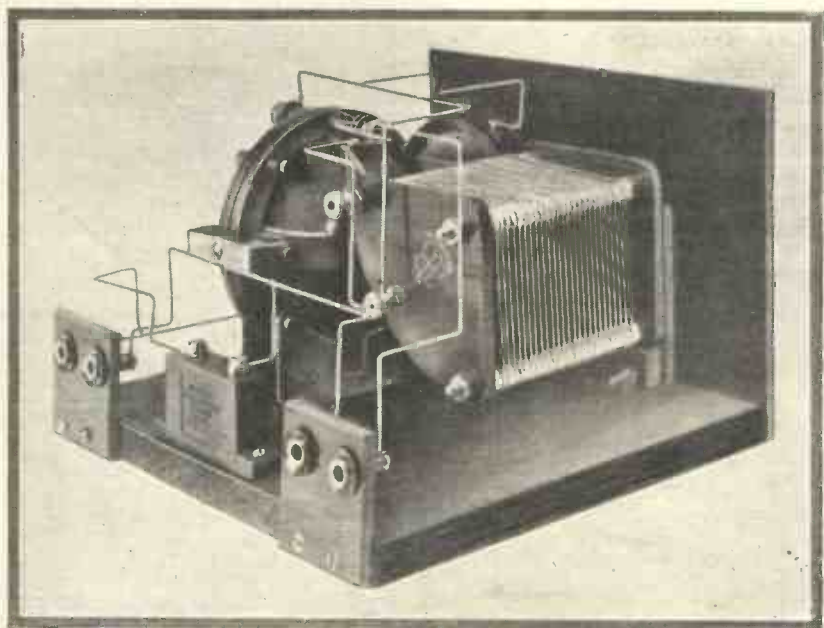

Another View of Wiring of One-control Crystal Set.

## RIPPLES

A LECTURE on special forms of insanity was given recently from one of the American stations. As shingling was not mentioned, it is evidently regarded as one of the ordinary forms.

AN expert has complained that the American announcers spoil their elocutionary effect by snatching their breath too quickly. Well, short pants always were the fashion over there.

THE 2 B D lecture on "Historical Scottish Phrases" was very interesting, but why were we not told the derivation of that essentially Scottish exclamation—"This is my turn, gentlemen!"

A SKETCH that was performed at 2 L O bore the title "Brains, Limited." There are a good many people who bear titles to whom the same remark might apply.

THE B.B.C. admits that it is confronted with the problem of improving its music. And, we would add, its jazz as well.

FISHERMEN are reporting a marked shortage of fish in the English Channel lately. Evidently they have migrated to the North Sea to be within range of Daventry.

TWENTY German sergeant-majors recently came to London. It looks as though the British loud-speaker industry will have to apply for protection against foreign competition.

A FEW days ago a man stated in the Press that the saxophone was a German instrument. He evidently wanted to give us cause for starting another world war.

THE "Modern Relics of Barbarism" that Sheffield has broadcast are quite all right, but why has there not been any mention of the charabanc tripper?

A LISTENER who heard their band from Glasgow wants to know why the R.A.F. need musical instruments. Surely he knows that the aeroplanes have to be tuned up each morning. PARIS has been sending out quotations from the fish market. We hope they won't include any quotations from the vocabulary of the porters.

A CLERGYMAN has been lecturing on happiness from 2 E H. He ought to have performed enough marriages to know that there is no such thing.

### LAYOUT AND WIRING DIAGRAM

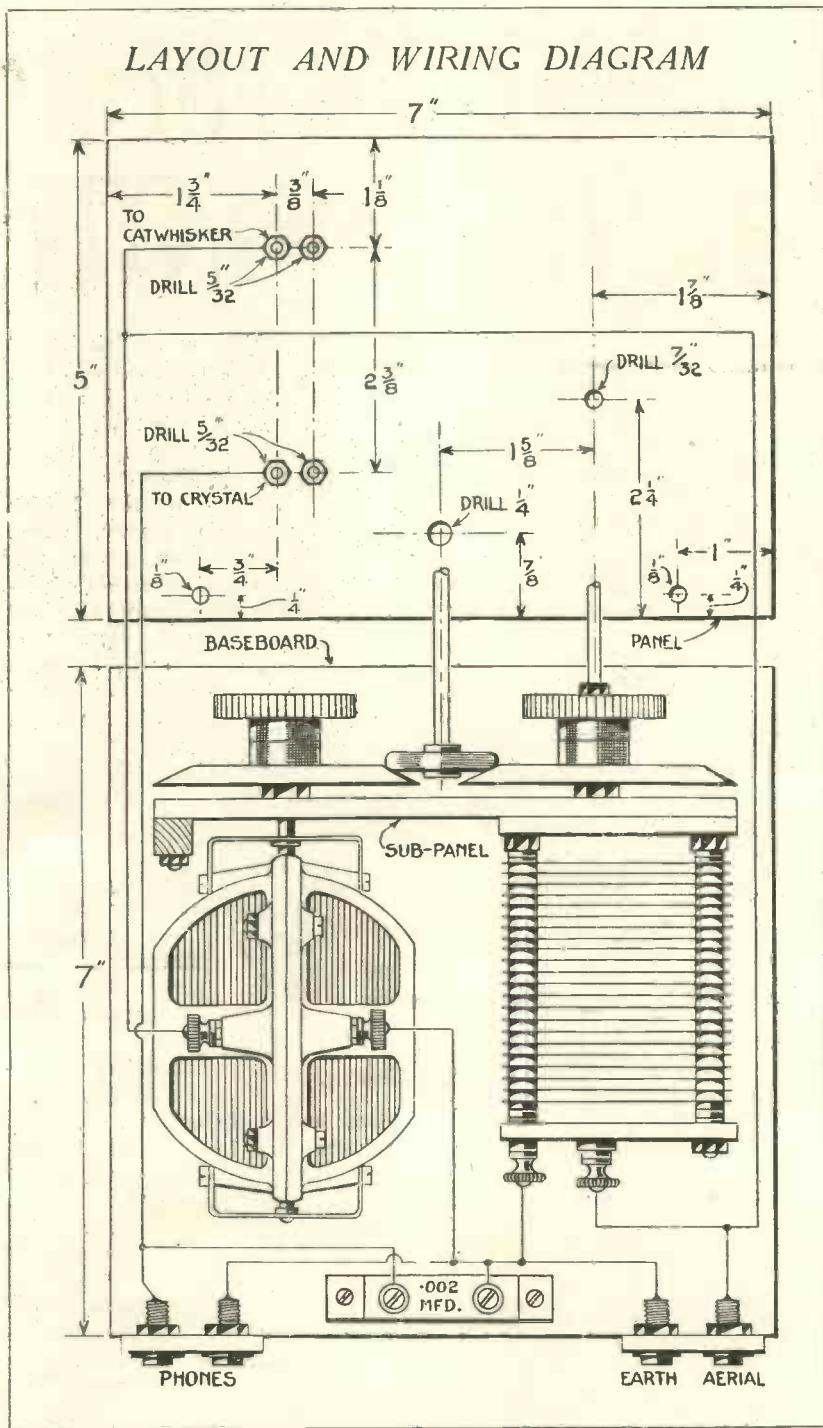

in the photographs and in the wiring diagram. Tinned copper wire of fairly heavy gauge (No. 16- or 18-gauge) should be used and all joints soldered. Remember that the catwhisker of the crystal detector should be connected to the aerial.

Several specimens of crystal were tried in the crystal detector and it was very forcibly demonstrated how a crystal can increase the range of the set. Best results were obtained

from a new crystal called Prodonite, to be obtained from S. B. Smith and Co., 10, Savoy Street, W.C.2.

Using this crystal, results were excellent. On an aerial in London 2LO came through at quite good loud-speaker strength at a distance of 2 miles. Croydon was very distinct on the phones, and Daventry could be heard although the set was not tuned up to the latter's wavelength.

# BROADCAST MUSIC OF THE MONTH



Miss Norah Blaney and Miss Gwen Farrar.

It is as yet too early to be able to state definitely what policy will be adopted by the British Broadcasting Company in the year to come, but there is no doubt that during this past month they have broadened their outlook and aimed to get more variety, and possibly entertainment also, into their schemes.

However, variety is the key-note observed, and a glance at the programmes shows that a very great effort has been made to keep "laughter uppermost."

The humorous element has been maintained by two sections. On one side the wise employment of Mr. R. E.

Jeffrey's excellent revues, *Winners* and *Radio Radiance*, and on the other, what we may term "outside broadcasts," such as *Mercenary Mary* and cabaret shows.

Mr. Jeffrey's revues have one element of success, and that is by adopting what we used to call in the old days a "stock" company. Having got a caste admirably suited to his needs, he is enabled to change the "numbers" and ensure, more or less, the same success with every new "edition."

Miss Phylis Panting, Miss Joan Hay, Miss Maudie Dunham, Miss Iris White, Miss Helen Gilliland and Miss Jean Alistone, as well as Messrs. Eddie Morris, Tommy Handley and James Whigham, possess excellent voices, and the knack to "carry over" well. All of them have had a wide theatrical experience, and Mr. Handley will be remembered as the original officer in that favourite variety sketch, *The Disorderly Room*, which was broadcast last month under his personal direction.

With the addition of Mr. Donald Calthrop to the Entertainment Advisory Board, some further developments have been made, and one, under the title *Lend me your Ears*,

with Wilkie Bard and Mark Lester, made very pleasant hearing. These, with the aid of the old musical comedies, such as *The Belle of New York*, have added to the lighter side of the programmes.

The activities of the British National Opera Company, whose tour ended at Birmingham this month, gave music lovers an opportunity to hear once more *Tosca* and *Carmen*. Miss Noel Eadie is one of the clever members of this company. We look forward to having further broadcasts from the company during their next season.

In *Carmen*, the last opera broadcast, Mr. George Baker was a member. He is a singer we do not hear broadcast

nearly frequently enough.

Under the heading of special features may be placed some of the best-known names in light entertainment. Mr. Norman Williams, at present acting at the Gaiety, Mr. Melville Gideon of the Co-Optimists, Mr. Sterndale Bennett, and those two popular favourites, Miss Norah Blaney and Miss Gwen Farrar, were heard, the last two prior to their departure for a world tour.

Quite recently, too, we have had



Miss Phylis Panting.



M. Paul Molchanoff.



Miss Dorothy Howell.



Miss Joan Hav.



Mr. Norman Williams.



Mr. Anthony Bernard.



Miss Gladys Haysack.



Mr. Melville Gideon.



Miss Helen de Frey.

ample recognition of the stage, for Milton Rosmer, who has been intimately connected with the earliest broadcasting of Shakespearean plays, has been heard several times before the microphone. Recently he has been superintending The Irish Players.

Another appearance of interest was that of Mr. Charles Cochran, the famous revue manager.

Instrumental music necessarily plays a great part in the programmes of the month, and the popularity of the Wireless Symphony Orchestra led by Mr. Kneale Kelley has become firmly established. Conducted by Mr. Percy Pitt, a fine rendering of Elgar's "Empire March" has been secured.

Amongst the vocalists have figured Miss Mary Foster, Miss Gladys Haysack, a favourite broadcast artist from Daventry as well as 2 L O, and Paul Molchanoff, a fine Russian singer whose adventures in escaping from the Russian Bolsheviks would of themselves make a book.

Miss Helen de Frey is another favourite; while on the instrumental

side again must be mentioned Mr. Yorke Bowen, who accompanied Mr. Lionel Tertis last month, Mr. Evelyn Howard Jones, the pianist, and Mr. Gilbert Stacey, director of the Royal Bath Hotel at Bournemouth, who sang again this month,

old-fashioned, though possibly not a particularly interesting, programme being prepared. The same date being the anniversary of Beethoven's birthday gave opportunities for a special programme with Sir Landon Ronald to conduct it, followed later by a recital by the great Lamond, the pianist who has made Beethoven's music his especial forte.

The Radio Revel for 2 L O, arranged for Olympia, was well organised by Mr. G. P. Catchpole, Director of Organisation of The Faculty of Arts.

Special functions were held also at Cardiff and Bournemouth.

Of the special Christmas arrangements perhaps the most prominent features are the performance of Bach's "Christmas Oratorio," conducted by Mr. Percy Pitt and the broadcasting again of the famous Bow Bells, which were heard in November and which will ring on Christmas morning from 10.35 to 11 o'clock.

Nor can anyone complain of lack of variety in respect of composers or conductors.

STUDIOS.



Mr. Eddie Morris.

Mr. Tommy Handley.

and played at the piano some of his own compositions.

December has had announced some special features which have made it an outstanding month.

As a contrast to the performance announced of *The Belle of New York* at 2 L O, Manchester prepared *The Messiah*.

The anniversary of Jane Austen's birthday also allowed of a special



Mr. Sterndale Bennett.



Miss Mary Foster.



Mr. Milton Rosmer.



Miss Noel Edie.

# My Favourite Circuit

WHAT can be described as the best circuits for selectivity and for range must be subject to certain reservations, such as the efficiency of the aerial and earth system, the directional properties of the aerial itself and its self-capacity, the quality of the components used and their arrangement, and even the skill in operating.

All these are uncontrollable and practically unknown quantities, and must not be forgotten when we describe a circuit as *the best*. But in spite of this it may be stated what *is* the best, having given one particular set of conditions.

Circuits by the score—reflex, autoplex, etc.—have been tried at different times, but have been found lacking in the smoothness of handling and stability which is associated with the “straight” circuit. Because of this, the writer’s faith in the “straightforward” circuit is even greater now than it was before stunt or compound circuits were introduced.

## Reliable

The accompanying circuit is one that gives all the advantages of range combined with selectivity, and is thoroughly reliable. It consists of two sections, one for tuning and one for amplifying.

The tuner consists of a loose-coupled circuit tuned by .0003-microfarad variable condensers. (In this connection it was found best to keep these condensers as small as possible and arrange the coils in slightly smaller steps than is supplied by the trade. On the lower wavelengths this is easily and efficiently done by winding basket coils, fitted with some means to ensure quick interchangeability.) A tuned-anode is used with reaction in the plate circuit of the detector valve, and is found to be very selective. To adjust the grid potential of the first valve (H.F.) a potentiometer

P is inserted, the slider being connected to the lower end of the secondary tuning coil.

In this section a pair of phones may be permanently connected, and are in circuit when switch A is in the downward position, and makes this section complete in itself.

pocket-lamp batteries of 3 volts each.

A particular feature of this circuit is that separate H.T. and L.T. batteries are used in each section, the reason for the split H.T. being that the majority of batteries are incapable of withstanding the strain imposed upon them by four valves.

With regard to the low tension, it is the writer’s experience that in a set such as the one under discussion, when tuning in a distant signal by one or two valves and using the phones, one goes to a deal of trouble in adjusting, which includes careful adjustment of the

filament resistances. Then when additional valves are switched on to the same accumulator the flow of current is correspondingly reduced in the first valves, and more often than not the signal disappears. The transformer connections are marked on the diagram.

## General Remarks

No extravagant claims are made for this circuit, but readers have the writer’s assurance that it is very simple to operate, very selective indeed, and when using the tuner section with phones it will be found that the range is equal to or greater than the more complicated circuits. In fact, in the writer’s opinion, this circuit is really *the best*. H.

THE name of a German cook who has been broadcasting kitchen hints from Berlin is Beer. We would not mind betting she is stout, too.

AN Austrian professor is going to talk on the chief animals that are hunted in his country. Here, of course, they are known as taxpayers. It must be admitted that announcers sometimes make a mistake, says a writer. Like the Scotsman who fired his car for the insurance without first removing his whisky flask from the tool box.

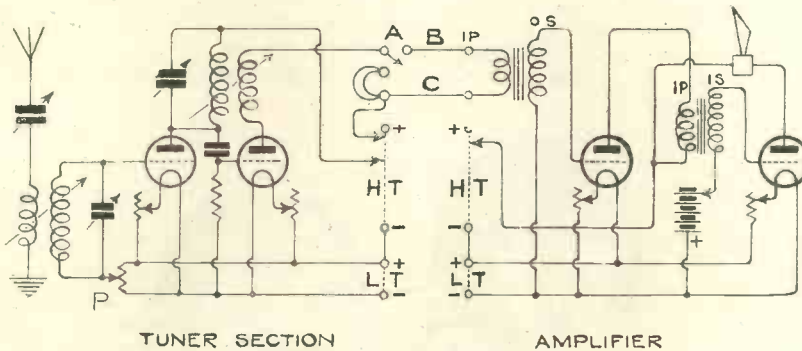

TUNER SECTION                      AMPLIFIER  
Four-valve Circuit in Two Sections.

## Amplifier

For loud-speaker work a separate amplifier may be brought in by placing switch A to the right, thus breaking the phone circuit and con-

**DO YOU WANT TO BUY A SET?**

*We shall be glad to advise you as to which types of sets are the best for your personal use.*

*Tell us how much, roughly, you wish to spend; where you are situated; what stations you wish to receive; whether you intend to use phones or a loud-speaker, and we will advise you as to the general lines of sets that will answer your purpose.*

*Send your enquiry with coupon (p. iii cover) and stamped addressed envelope to—*

*“Buyer’s Advice Bureau,”*  
THE WIRELESS MAGAZINE,  
La Belle Sauvage, E.C.A.

necting up the bus bar B—the second bus bar connection C is permanent. It will be noticed that an adjustable grid bias is provided for the last valve and is fed by three



# A Story Without Words

—Drawn by—  
RENÉ BULL

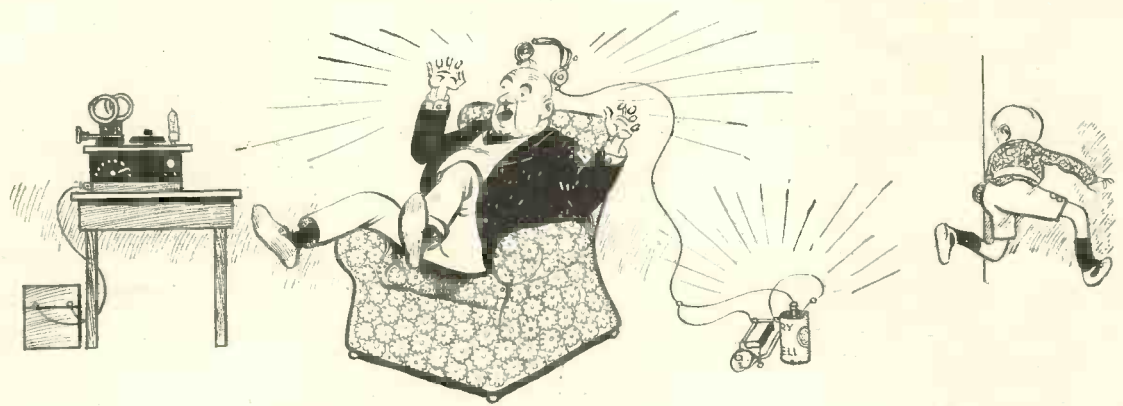
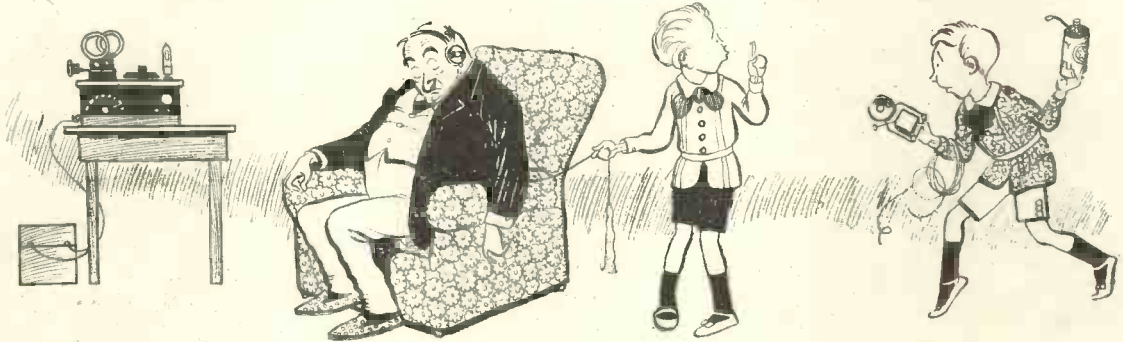

René Bull

# Crystal Curves!

By J. HARTLEY REYNOLDS

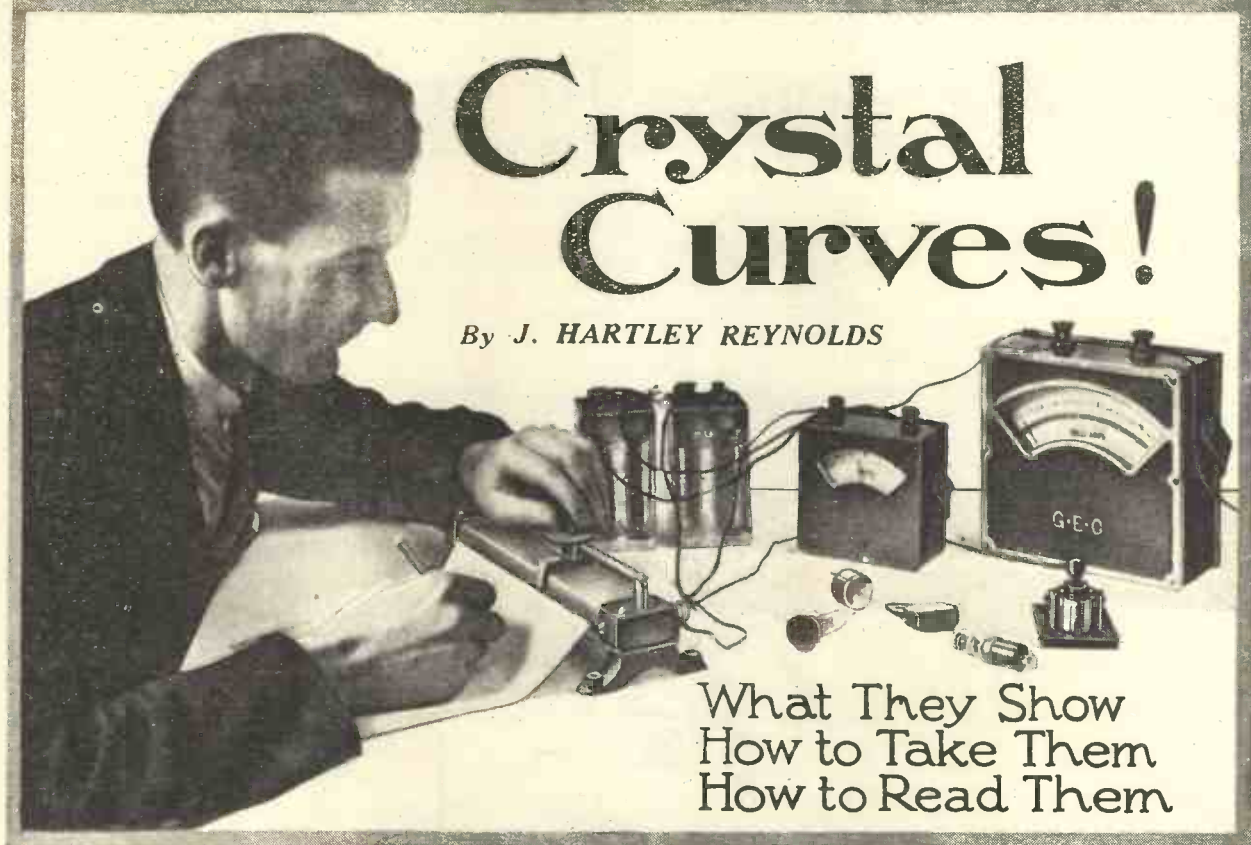

What They Show  
How to Take Them  
How to Read Them

YOU have seen a horse shy at a piece of white paper lying by the roadside. On catching sight of it he stops short and endeavours to go the other way. When urged forward he goes past it unwillingly and giving it the widest possible berth.

This is exactly the attitude of many wireless folk to anything that looks like a curve or a graph. They shy at it and pass on to something else. There is nothing dangerous in a bit of paper, though some scientist once deduced that shying in a horse was the result of an ancestral memory, and that the fiercest foe of the equine race several thousands of years ago was a flat white thing about the size of a dinner plate!

## Simple, Straightforward

On the same lines we may possibly infer that the primeval worst enemy of man was something rectangular in shape and marked off into squares. This deduction, however, rather breaks down in view of the recent popularity of the cross-word puzzle. Actually, the curves used in wireless are very simple and straightforward things, and once you realise what

they are all about you will find that an examination of one of them makes it a great deal easier to understand what goes on in a wireless set than the reading of many printed pages.

I am going to try in this short article to make everything plain sailing, and if you will endeavour not to shy before you reach the end of it I believe that you will find yourself cured of the habit for good and all.

## What Happens in a Circuit

Let us see how we can record graphically what takes place in a circuit such as that shown in Fig. 1. The circuit consists simply of a battery whose voltage we can vary by means of a wander plug, and a fixed resistance of any known value. In the circuit I have taken one of two ohms to make matters easy. If we make the E.M.F. 1 volt Ohm's law shows us that the current (voltage divided by resistance) must be .5 ampere. Increasing the voltage to 2 raises the current to 1 ampere, and so on.

Take a piece of squared paper—a sheet from a book of cross-word blanks will do admirably—and rule in two lines corresponding to A B

and C D in Fig. 2. Now along the right-hand portion of C D make divisions to represent volts positive. On the upper part of A B make similar divisions representing amperes and half amperes. We are now ready to plot a curve showing what happens in the circuit in Fig. 1.

If we make the top of the resistance 1 volt positive a current of .5 ampere flows. Place your pencil on the 1 volt positive mark and run straight up until you are opposite the .5 ampere mark. When you get there make a dot. Do the same for 2, 3, 4, 5 and 6 volts.

Next unwire the battery and change it round so that its negative end is where the positive was. Current will now be flowing in the opposite direction, and we can make divisions on the left-hand half of C D and on the lower portion of A B to represent volts negative and amperes respectively.

## Drawing the Curve

Proceed to make notes as before, and when these are finished you can rule the line X Y, which is the "curve" representing the performance of the circuit.

This curve takes the form of a straight line because the circuit follows Ohm's law that current is directly proportional to the voltage applied and to the resistance encountered.

You will see that the curve drawn enables you to discover, without any calculation, exactly what the current must be in either direction for any E.M.F., whether the volts are whole numbers or fractions. Now, the curves that we use in wireless are not a bit more difficult to follow than the one in Fig. 2, and they give us a wonderful insight into the working of crystal and valve. They show, as we shall see, that both of these do the work which they are called upon to perform because they do *not* follow Ohm's law.

### The Crystal

We will tackle the crystal first of all. Here we are still working in volts so far as the E.M.F. is concerned, but when we come to current we find that it is no longer a question of amperes, but that we are dealing with microamperes—a microampere being the millionth part of an ampere.

Fig. 3 shows the kind of curve which we obtain from a crystal by means of the circuit seen in Fig. 4. In this circuit a potentiometer and a battery consisting of two 2-volt cells enable us to make the potential across the crystal anything between 2 volts positive and 2 volts negative. The potential is read by means of the voltmeter.

The microammeter shows the current passed by the crystal. We find that the curve that results is no longer a straight line. If we make the E.M.F. a positive one,

starting with, say, .1 volt and increasing it by one-tenth of a volt at a time, we shall find that very little current indeed flows in the circuit until a potential of about .3 volt positive is reached. From this point

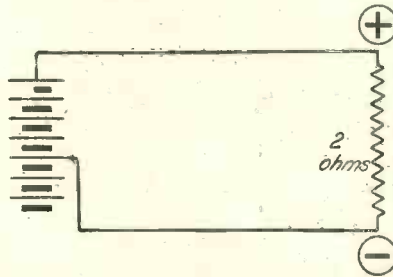

Fig. 1.—Circuit for Experiments.

onwards the current increases very rapidly as the voltage is raised.

Reference to the curve in Fig. 3 shows us that at .4 volt positive the current is .6 microampere, whilst at .6 volt positive it is 1.6 micro-

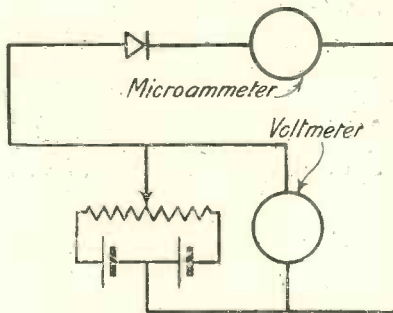

Fig. 4.—Circuit for Taking a Crystal Curve.

amperes, reaching 3.8 microamperes at 1 volt positive and 6 microamperes at 1.4 volt positive.

On the negative side matters are very different. As we, make the potential more negative by suc-

cessive steps of one-tenth of a volt the microammeter shows only minute increases—actually they are so tiny that it requires an exceedingly delicate instrument to detect them at all—in the current flowing in the opposite direction. At 1.4 volts negative the current has risen to only .3 microampere. From this point onwards a fairly rapid increase in current takes place as the potential is made more negative.

Now, what do we want the crystal to do for us? We require it to rectify oscillating impulses, that is, to strain out one-half of each wave and to deliver direct current to the phones. The curve shows us exactly how it does its duty.

### Crest and Trough Values

Let us suppose that an impulse comes in whose crest and trough have values respectively of 1 volt positive and 1 volt negative.

By placing a pencil on the 1 volt positive mark and running it straight upwards until it meets the curve we see that the current passed is 3.8 microamperes. The following half-wave makes the potential across the crystal 1 volt negative, and the curve shows us that the current at this potential is .2 microampere.

The crest of the wave then gives a comparatively large flow of current through the phones, whilst its trough produces only a minute one in the opposite direction. The net result we can easily see by means of a simple comparison. A man rows a boat 3.8 miles up a river. In an endeavour to moor he is carried .2 mile down by the force of the stream. The net result of his exertions is that he has advanced 3.6 miles up the river. In the case of the crystal

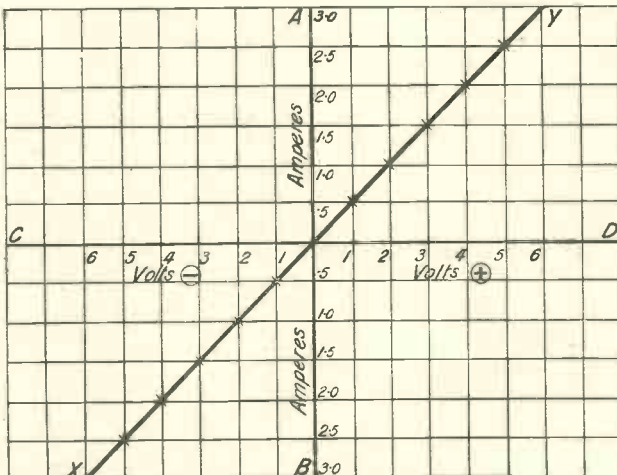

Fig. 2.—"Curve" showing Effect of Voltage on Current.

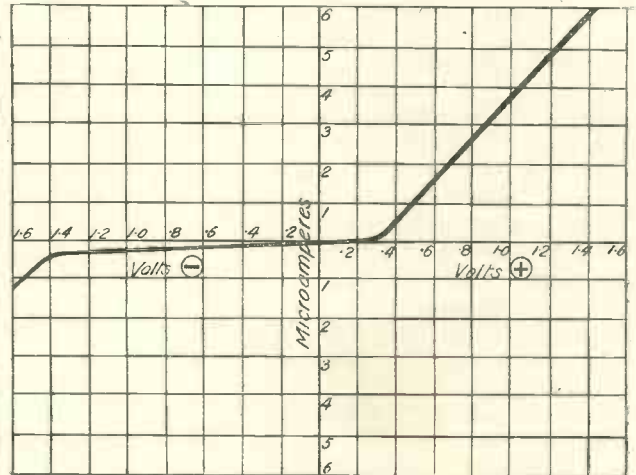

Fig. 3.—Typical Crystal Characteristic Curve.

the net result of the arrival of the wave with crest and trough values of 1 volt is 3.8—.2, or 3.6 microamperes of rectified current.

### What the Curve Shows

This curve, which, though it is not taken from any particular crystal, is yet fairly typical of most of those in general use, also shows us something else. A crystal with such a curve would give practically no response in the ordinary way to a weak impulse at crest and trough values of .3 volt or less, for neither the crest nor the trough would cause sufficient current to flow to work the phones properly.

But suppose that by means of a battery and a potentiometer we apply a steady voltage of .3 volts positive across the crystal, we shall get far better results. Let us see just what will happen now if a weak signal with crest and trough values of + and - .3 volt comes in.

As the potential is already + .3 volt the crest of the impulse will carry it up to + .6 volt and there will be a flow of 1.6 microamperes. The trough will make the potential + .3-.3 or zero volts, and the flow of current will be nothing.

Even on this weak signal, then, we shall obtain 1.6 microamperes of current through the phones and shall be able to hear, though probably very faintly, a signal which would otherwise be inaudible. And we shall also obtain some benefit on strong signals; for example, the wave which we originally discussed with crest and trough values of one volt will now take the potential up on the positive side to 1.3 volts with a current of 5.2 microamperes, and on the negative side down to .7 volt with a flow of 1 microampere.

### Improved Results

The applied voltage will thus give us 5.1 microamperes of rectified current instead of 3.6 if the crystal is used without a battery and a potentiometer. There is hardly a crystal of any kind whose performances are not improved by applying a tiny voltage to it by means of a battery and potentiometer. Any readers who care to make the experiment will find for themselves that this is so, and they will have a practical illustration of the value of curves.

J. H. R.

(Next month: Value Curves)

# Prof. E. Sopp's Fables

Specially Revised and Brought Up to Date

## NO. 5.—THE MAIDS OF DIVERSE DISPOSITIONS

ONCE upon a Time, there lived in the Reign of the Great Bibeeeci two young and comely Maidens, Noble daughters of a Proprietor of Foreign and Strange Films who dwelt in a (Picture) Palace of vast and magnificent Proportions.

One day, at the Time they were disporting themselves in a Shady Grove, they were overcome by heat and Fatigue and made to rest themselves by the Wayside. Whereupon there came to Them a Woman of very advanced Years, of halting Gait, who supported Herself by Alms begged from passing Travellers and by a stout Staff cut from a neighbouring Tree.

As She espied the two Sisters, She directed this Discourse to them: "Pray ye, have pity on the Aged, my good Children. I am footsore with my Peregrinations and a-hungred," saying the which She limped towards one of Them who, a bad Girl, bade her begone with an uncourtly Gesture.

But the other Maid, who was of a kindlier Disposition, took a small Portion of dry wheaten Bread from a Wallet which hung by her Side and tendered it to the Old Dame, saying, in sweet Tones: "Eat heartily thereof, poor Mother."

The Witch, for so the ancient Hag happened to be, smiled on Her, but turning to the bad Girl did go into a great Fret and raised her Staff. "Thy Perfidiousness," said She, "only too well deserves a Penance and shall not go unrewarded"; whereupon She cast upon Her a magic Spell, as she knew enough of that diabolical Art to execute such a horrible Contrivance.

In angry Tones, she continued: "Ugly shalt Thou be and foul-mouthed. When Thou openest Thy Mouth, Thou shalt bring forth all Species of Horrors. So shalt Thou, by Iblis, be punished for Thy flint-heartedness."

But the Good Sister she blest, saying as She also cast a Spell upon Her: "I will show my Gratitude by endowing Thee with all the Qualities of Wisdom, Goodness and Virtue." She then pronounced certain magical Words and vanished from their Gaze in a cloud of pungent Smoke.

Now, some years later, the Spells the old Witch had cast upon them took Effect, and all came to pass as She had willed. For when the Good Girl spoke, the most beauteous and costly Objects poured from her Mouth, such precious Gems as "Wireless Mags," radiograms, flashes of sparkling Wit, Fables such as these, and similar high-brow Writings of great Value.

Moreover, the Witch, in the Goodness of her Heart, had blessed the Maid with perfect Speech such as could only flow from the lips of a Two-Ello Announcer. Step by step, rung by rung, she quickly scaled the Ladder of Life until she was rightly entrusted with important Duties by the reigning Sultan-Bibeeeci the All-Powerful—whereupon, within the space of Twelve Moons or one Post Office licence, she had broadcast herself unto Death.

Now the Bad Sister, cursed by the old Witch, was also under the Spell, and when SHE spoke she hissed and oscillated to a great Degree.

All kinds of vile Things came from her Mouth, such as condensers of the "wonky" pattern, dull lamp-valves which did eat many Amps of Joos, earphones of strange and weird Conception brought to the Land from Foreign parts, as well as power crystals of doubtful Rarity which could not translate harsh and unmusical Voices from the distant Land of Kay-dee-Kay-Ay.

Whereupon her reputation travelled throughout the Sultan's Empire and came to the Ears of a Dishonest Merchant who lived in a neighbouring Khan. And so it came to pass that he took Her to Himself as Wife, and within the period of a few Moons they had amassed considerable Wealth and had acquired four Goats, a Vacuum Cleaner, a Cat-whisker of pure Gold and a Rollsford horse-less vehicle of sumptuous design. Their Children were as numerous as the Sands on the Sea-shore and they lived happily to a ripe old Age.

Moral . . . (Well?—Ed.)

Translator's Note: I have carefully searched Prof. E. Sopp's manuscript, but cannot find a Moral to this Fable. JAY COOTE.

LISSENIUM

# Switching on a receiver almost by thought

WE have evolved something entirely new. It is a device which we call the LISSEN TELEPATHIC CONTROL, because the valves of a receiver can be lit up no matter how far away from the receiver you are. The action is almost uncanny.

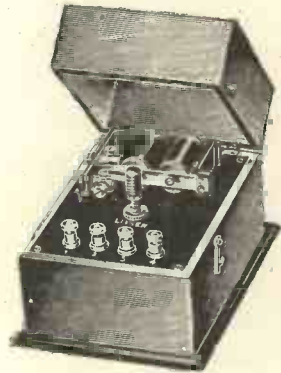

An ordinary remote control invariably requires separate batteries or extra wiring in some way or another. But all that is required with the LISSEN TELEPATHIC CONTROL is that it should be interposed between the receiver and the loud speaker at the receiver end. No other connections are required—there are no batteries to renew or extra wires to run—the two usual leads run to the loud speaker. The new LISSEN TELEPATHIC CONTROL operates in this way. If one connection is removed from the loud speaker terminal the *valves on the receiver are thereby put out*. If the connection is made to the terminal, so that the two loud speaker terminals are in circuit with the LISSEN TELEPATHIC CONTROL the *valves on the receiver will be alight automatically*, even though you may be at the top of the house and the receiver at the bottom of it. This is the best idea yet of remote control. A great advantage is that where loud speaker plug points are already wired for, no extra wiring or batteries are needed to bring the loud speaker into operation in any room where one may be.

The LISSEN TELEPATHIC CONTROL is provisionally protected.

**Price - - - - £2 : 10 : 0**

*The only thing of its kind available—ASK YOUR DEALER TO SHOW AND DEMONSTRATE. Or send direct for descriptive pamphlet.*

## LISSEN LIMITED

LISSENIUM WORKS, 500-520, FRIARS LANE, RICHMOND, SURREY.

Phone: Richmond 2285 (4 lines).

'Grams: LISSENIUM, PHONE, LONDON.

### ALMOST A "THOUGHT" SWITCH

In writing to advertisers, please say you saw the advertisement in THE WIRELESS MAGAZINE.

# A One-valve Low-frequency Amplifier



Completed One-valve Amplifier.

This one-valve low-frequency amplifying unit can be used in conjunction with almost any kind of existing receiver, whether it be crystal or valve, and is a thing that every listener should have in his or her possession.

A SINGLE-VALVE low-frequency amplifier mounted on a panel and completely contained in a separate cabinet is a very useful accessory for the experimenter.

It has the advantage of being quickly connected to an existing receiver, when greater volume is required.

Again, such an amplifier will work a loud-speaker from a crystal set provided

that originally the crystal set gives good loud signals in the phones. although by duplicating the terminals mounted on the right-hand side of the panel along the left-hand side, the amplifier is equally suitable for connection to the output terminals of a valve receiver.

### Limit to Number of Stages

It should be remembered, of course, that an amplifier of this type will not work well in conjunction with a valve set already possessing any more than one stage of low-frequency amplifications. It is very difficult to obtain pure distortionless reproduction with a set in which a total of three stages of transformer-coupled amplification is employed.

The components required to construct this amplifier are as follow:—  
Ebonite panel, 10 in. by 7 in. by 1/4 in. thick (Paragon).

Low-frequency transformer (General Radio Co.'s type 84).

Filament rheostat (General Radio Co.).

Valve holder (Lissen).

.002-microfarad fixed condenser (Dubilier).

2-microfarad fixed condenser (T.C.C.).

11 terminals (Belling-Lee).

(Continued on page 628)

### Use With Valve Receiver

The amplifier described in this article is primarily intended for the purpose—working a

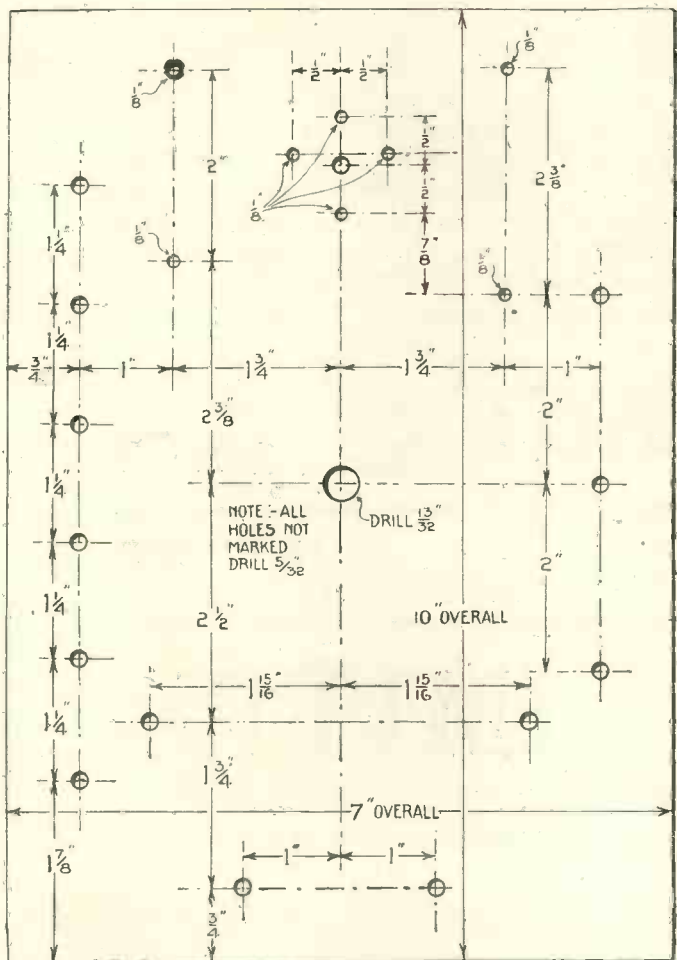

Layout of Amplifier Panel.

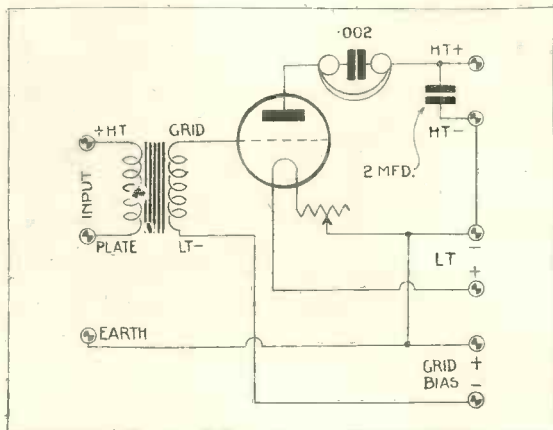

Amplifier Circuit Diagram.

OURSELVES—AND THE

ELECTRICAL IMPULSE



*his secrets are ours*

Think of it! Seventeen years' patient study of the vagaries of our jolly impulsive friend, the electrical impulse. And our laboratory experts have come through with intellects unscathed. Nay! Not only unscathed, but brightly furbished. They were able to establish friendly contact with the electrical impulse; he helped them with their plans for building radio sound reproducing instruments and encouraged their scientific research. Now, this electrical impulse uses his electrical energy to bring the radio as far as your receiver. To get him to talk easily and naturally is an operation we have perfected with his own help and advice. Seventeen years' study of the best way to capture and transform this spirit of radio sound has helped us to build the best radio speakers of the age; his secrets are ours. Get a Brandes and you will know that the properties of radio sound are harnessed as effectually as you can possibly desire.

*Any good dealer stocks Brandes*

**THE TABLE-TALKER**

The new goose-neck design is the result of research in radio acoustics, which definitely establishes its value in relation to the diaphragm fitted. Patent material used in the construction of the horn eliminates metallic harshness. Volume and sensitivity controlled with small lever located at the rear of the base. Elegantly shaped, tasteful neutral brown finish, felt-padded base. Height 18 ins., bell 10 ins.

30/-

**MATCHED TONE HEADPHONES**

The whole secret of Matched Tone is that one receiver refuses to have any quarrel with its twin. Aply schooled in these generous sentiments by our specially erected Matched Tone apparatus, their synchronized effort discovers greater sensitivity and volume and truer tone. There is no possibility of the sound from one earpiece being half a tone lower than its mate.

20/-

**THE AUDIO TRANSFORMER**

Ratio 1 to 5. The main objects in view are high amplification of applied voltage, together with a straight line amplification-frequency curve. That is to say, for a given input voltage, the amplification is constant over a wide band of frequencies, thus eliminating resonance. Mechanically protected and shielded so that the transformers may be placed close together without interaction.

17/6

**THE BRANDOLA**

Specially built to bring greater volume with minimum current input and exceptional clarity over the full frequency range. A large diaphragm gives new rounded fullness to the low registers and new clarified lightness to the high. Reproduction controlled by a thumb screw on the base. Polished walnut plinth with electro-plated fittings. Height 26 ins., bell 12 ins.

90/-

Brandes, Limited, 296 Regent St., London, W.1. Works—Slough, Bucks.

# Brandes



EXPERTS IN RADIO ACOUSTICS SINCE 1908

29/233

Service Advertising

In writing to advertisers, please say you saw the advertisement in THE WIRELESS MAGAZINE.

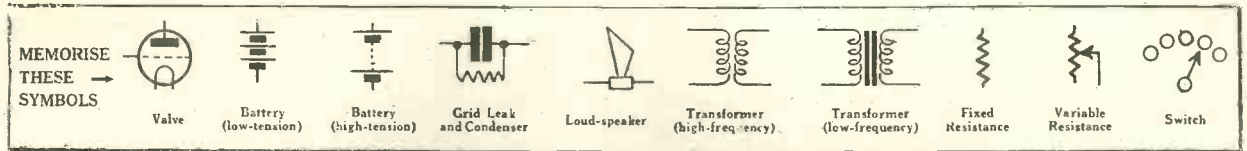

## A ONE-VALVE LOW-FREQUENCY AMPLIFIER (Continued from p. 626)

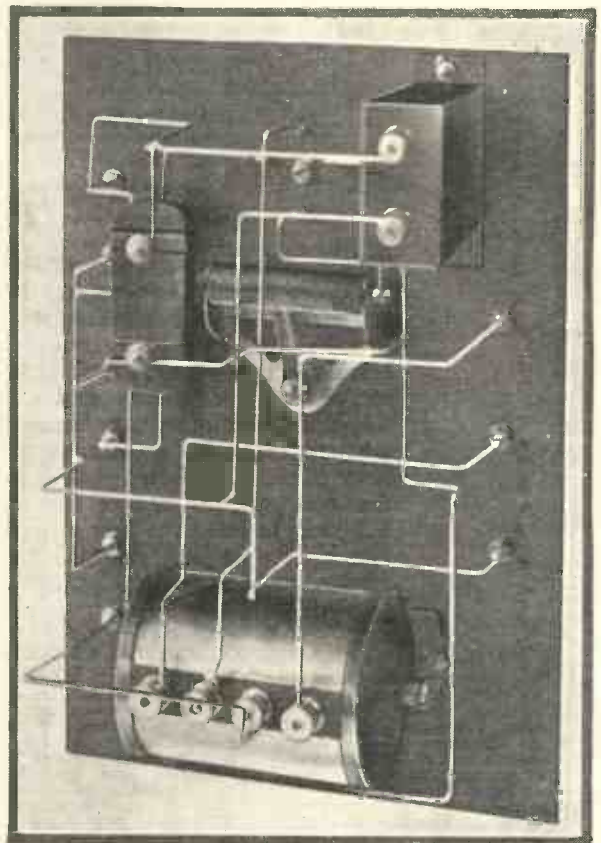
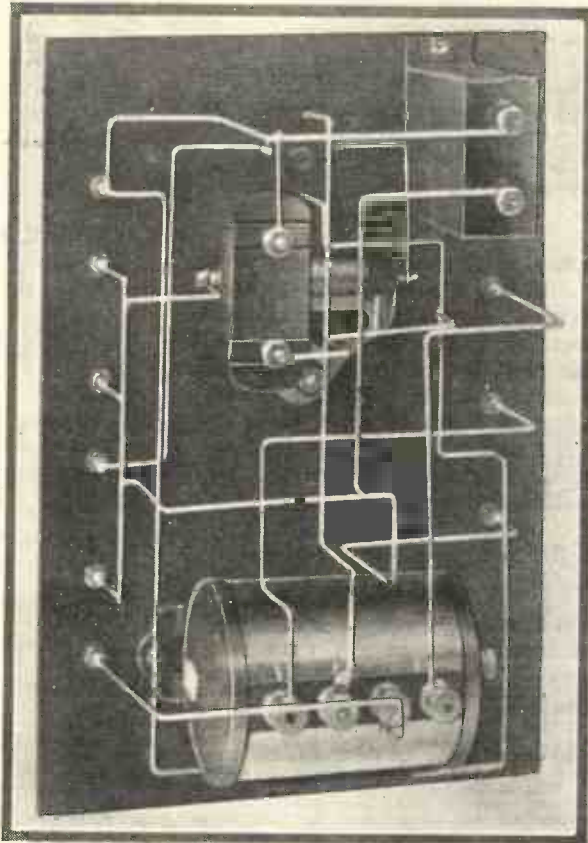

Two Photographs showing the Wiring of the One-valve Low-frequency Amplifier.

Small oak cabinet made to the dimensions shown in the sketch.

### Panel

The panel may be obtained cut to the size indicated from Peter Curtiss, Ltd., and drilling operations can be started immediately. As a guide a panel-drilling diagram is given showing the positions and sizes of the holes to be drilled.

For convenience it is better to redraw this diagram full size on a piece of stiff paper, thus making a template which can be laid flat on the panel; the holes can be either drilled straight through the paper template and the ebonite panel, or the centres of the holes can be trans-

ferred through on to the panel by means of a sharp steel point.

Having drilled the panel and removed the burrs from the edges of the holes, the components may be mounted as shown in the wiring diagram. The valve holder is mounted at the top of the panel in the centre, whilst directly underneath, held by a one-hole fixing device, is the filament rheostat.

At the bottom of the panel the low-frequency transformer is mounted and the terminals are placed in the positions shown along each side of the panel.

Of the two fixed condensers the larger is bolted to the panel beside the valve holder, whilst the smaller

is not actually fixed to the panel, but is held in position by the thick wire used for connecting purposes.

Wiring is a comparatively simple matter if carried out in conjunction with the wiring diagram. The pins of the valve holder should be connected up first, after which the wiring of the transformer should be completed.

### Transformer Terminals

It will be noticed that the terminals of the transformer are conveniently marked by their proper designation, thus avoiding the confusion introduced by labelling these terminals OP, IP, OS and IS.

*(Continued on page 630)*

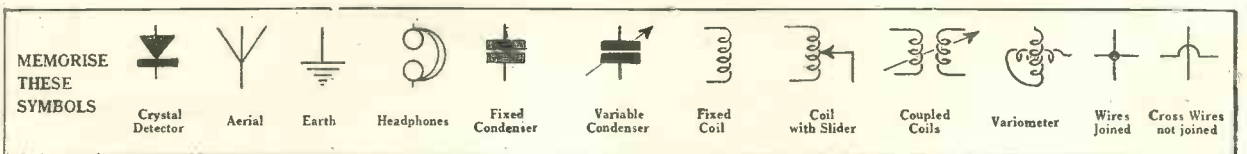





# Ribbons of steel

—the same century-old principles of construction are employed in every Cossor Grid.

FROM bank to bank across a girder bridge a train speeds on its way. A hundred tons or more of living freight suspended in mid-air on a few ribbons of steel. Such is the skill of man. Rigidity is the Alpha and Omega of bridge construction. Without rigidity no bridge can withstand the devastating forces of Nature.

Rigidity, too, is the very essence of successful Valve construction. Without rigidity there must be distortion and microphonic noises. Compare the Cossor Grid with the ordinary spiral Grid and you'll instantly appreciate why the Cossor Valve has won such a unique reputation for purity of tone.

The Cossor Grid is a wonderful piece of miniature engineering. It is built up on a stout metal Grid band, and each turn of the wire is secured in three positions—35 places in all. Was there ever such rigidity?

Combine that with the Cossor electron-retaining system of design and you'll readily recognise why the Cossor is by far the most popular British Valve.

Everywhere it is earning golden laurels for a mellowness of tone hitherto considered impossible.

Before choosing your next Valve ask your Dealer to show you the Wuncell — the Cossor Dull Emitter. Functioning at a dull red glow (almost invisible in daylight) it is, indeed, a super-economy valve with an abnormally long life. For the first time it is possible to obtain a low temperature valve in every way as sensitive as the best bright emitter. The secret of Wuncell success is to be found in its wonderful filament. Instead of a wire, whittled down to the point of fragility, the filament used in the Wuncell is built up layer upon layer under the Cossor patent process. Instead of weakness there is strength.



**The Wuncell Dull Emitter**  
Voltage 1·8 volts. Consumption '3 amp.  
•W1 for Detector and L.F. 14/-  
•W2 for H.F. amplification 14/-

**The Cossor Loud Speaker Valve W3**  
Voltage 1·8 volts. Consumption '5 amp.  
Price 18/6

\*Also in WR Series, with special switch and resistance in base to enable Valve being used with 2- 4- or 6-volt Accumulator:

WR1 for Detector and L.F. 16/-  
WR2 for H.F. amplification 16/-

# Cossor

Issued by A. C. COSSOR LTD., Highbury, London, N.5

Gilbert Ad. 3934

In writing to advertisers, please say you saw the advertisement in THE WIRELESS MAGAZINE.

## A One-valve Low-frequency Amplifier (Continued from page 628)

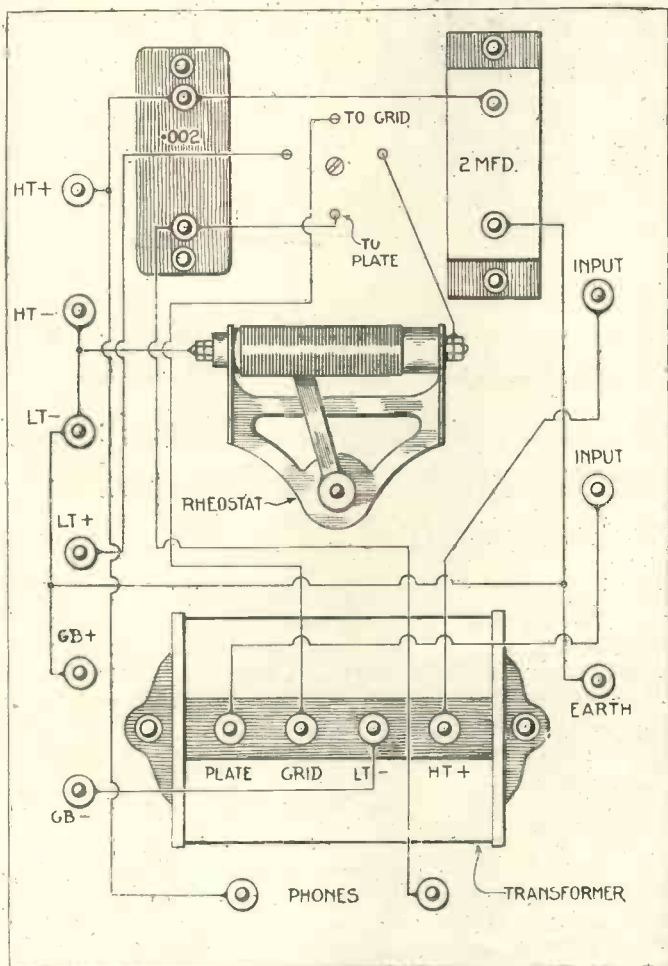

Wiring Diagram of One-valve Amplifier

From the photographs on page 628 it will be seen that a terminal mounted on the end of the transformer has been left disconnected. This terminal is connected internally to the iron core of the transformer, and is intended to be wired to the earth terminal should any inclination on the part of the amplifier to howl be noticeable.

Having completed the wiring the amplifier may be mounted in the oak cabinet.

### Connection

The phone terminals of the crystal set are connected to the two "input" terminals of the amplifier, and the earth terminal on the amplifier is connected to the earth terminal of the crystal set, and thence to earth.

To the battery terminal on the right-hand side of the amplifier the H.T., L.T. and grid-bias batteries are connected, whilst the phones or loud-speaker are connected to the phone terminals at the end.

### Suitable Valve

A suitable valve to use is the Mullard PM 4, which is specially designed for low-frequency amplification. For loud-speaker work the H.T. voltage applied to the plate of the valve should be approximately 100 volts, whilst the voltage of the grid-bias battery should be adjusted until no distortion is noticeable. A 4-volt accumulator will supply the necessary current for heating the filament.

With a good crystal set and this amplifier a loud-speaker may be operated with sufficient volume to fill a large room situated within six miles of the local station, and within 75 miles of Daventry.

## The Origin of S O S

:: Why It  
:: Was Chosen

ALTHOUGH in most cases it is commonly stated that the significance of the above three letters is "Save our Souls" or "Save our Ships," this definition did not occur to the minds of the members of the Wireless Telegraphy Conference held at Berlin in 1906 when the well-known distress signal was adopted. The first suggestion that a special combination of letters should be used by any ship in need of assistance was put forward by the Italian delegates to the preliminary Wireless Conference held at Berlin in 1903. It was then proposed to adopt: S S S D D D,

and instructions were to be given to all ships that, in the event of such a signal being received, telegraphic traffic should be immediately stopped.

### "C Q D"

The other delegates present at this conference agreed to the proposal, in principle, and the final decision was to be left to a special Conference. Shortly afterwards, however, the Marconi Co. recognised the necessity of the immediate adoption of some special signal to meet the case, and on February 1,

1904, definitely instructed their staff to use the famous C Q D, the last letter, coupled with the signal C Q, to indicate danger.

In 1906, in Berlin, the German Government suggested that ships in distress should broadcast the letters S O S, and this was immediately accepted by the Wireless Telegraphy Conference.

The letters were not chosen at random, but on account of the ease by which they could be transmitted, the simplicity of the signal presenting the least possibility of errors.

J. G. A.

# Brown

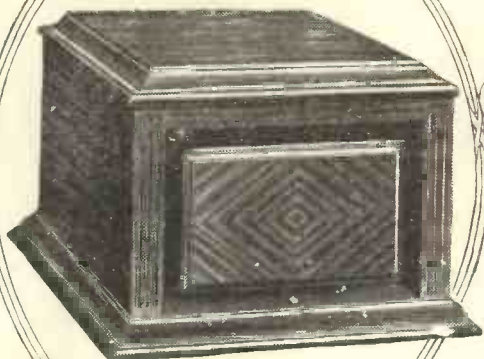

**CABINET MODEL**  
2000 or 4000 ohms £6 6 0

The incomparable  
Brown in seven  
superb Models



**The New HQ**  
(Height 20 ins.)  
2000 or 4000 ohms - £6 0 0



**The New H3**  
(Height 15 ins.)  
2000 or 4000 ohms - £3 0 0



**The New H4**  
(Height 20 ins.)  
2000 ohms . . . £1 10 0

**O**F all the Loud Speakers on the market to-day one is unique. One—by a brilliant application of an entirely original principle—achieves results which can be obtained in no other Loud Speaker. The **Brown**. Here is an instrument which steadily—month by month—has so grown in public favour that it is now recognised as the one great interpreter of true radio music.

**Brown** principles of design and construction can be found only in **Brown** Loud Speakers. The famous tuned-reed mechanism which permits the use of a super-sensitive cone-shaped aluminium diaphragm as thin as paper is responsible for a tonal purity and mellowness which must be heard to be fully appreciated.

The new Cabinet **Brown** marks a sensible innovation which will instantly appeal to many. A really perfect Loud Speaker capable of a volume equal to the more conventional type is now available in a model which will readily harmonise with the appointments of any room.

The new **HQ** (height 20 inches) is an instrument which will conform to to-day's demands for a

more handsome Loud Speaker in which efficiency has not been sacrificed at the shrine of beauty. Equipped with the same fine quality **Brown** reproducing mechanism, the **HQ** will readily command respect for its wonderful volume wherever it is used.

The new **H3** (height 15 inches) is a successful effort to produce a high-grade Loud Speaker at a moderate price, while the new **H4** is a truly remarkable manufacturing achievement. Here for the first time is a genuine **Brown** Loud Speaker available at the price of a pair of high-grade headphones.

## Brown Headphones

**F-type (Featherweights)**

Weighing only 6 ounces including cords. Chosen as the standard equipment by a very large number of hospitals—obviously a high tribute to their dependability and comfort. . . 4000 ohms **20/-**

**New A-type**

The new de luxe reed-type **Brown** Headphones. Ultra sensitive and ideal for long-distance reception. Contains all the essential features of the famous **Brown** A-type Headphones, standard throughout the world. 4000 ohms **30/-**

Make arrangements to hear these splendid instruments at your Dealer's. He may not have all of them in stock. Owing to the immense demand we are having difficulties in filling orders, but we re working hard to fill all orders with the greatest possible despatch.

**S. G. Brown, Ltd., N. Acton, London, W.3**

Showrooms: 19 Mortimer Street, W.1. 15 Moorfields, Liverpool.  
67 High Street, Southampton.

Depots (Wholesale only): 13 Bushy Park, Bristol.  
Cross House, Westgate Road, Newcastle.

The Trade should order direct if difficulty in getting supplies



# The Whole Art of Tuning



**T**HE whole art of tuning lies in the knowledge of which knob to turn first. Every set possesses control dials which are, or should be, labelled with the purpose they serve.

One will be marked "Aerial-tuning Condenser," "A.T.C.," or simply "Tune." Another may be labelled "High-frequency Tuning Condenser," "H.F.T.C.," "H.F.C.," or "Anode-tuning Condenser," and another "Reaction," whilst several smaller knobs will be marked "Filament Resistance" or merely "Filament," with an arrow marked "Increase." Possibly there may be another knob marked "Potentiometer" or "Grid Leak."

Another type of set may have a switch arm which rotates and makes contact with one of several studs mounted on the panel. This may be labelled "Tuner" or "Wavelength Range."

## Switches

Then there are switches, but these are usually clearly indicated for what purpose they serve, and in any case they cause little trouble.

Each of these controls is incorporated in the set for a specific purpose, and for the reception of any station they must all be turned until each is working in conjunction with the others and the best results obtained.

Without some fixed system of operation, however, the chances are a thousand to one that one or even two controls are upsetting the adjustment of the others.

Let us assume, then, that we have

before us a valve set which we have never seen before.

The first thing to do is to connect the aerial and earth to the terminals thus marked, the phones to the phone terminals, and the high-tension battery and accumulator to their respective terminals. Next we carefully place the valves in their sockets.

Now we slowly turn the filament rheostats in the direction of the arrow marked "Increase," having previously determined that the accumulator switch (if any) is in the "on" position. As the rheostat knobs are turned the filaments of the valves will slowly light up.

Having been successful so far, we have a rest and survey the many knobs on the panel. The first point to remember is this:

Signals are received at the aerial and are tuned-in by means of the dial marked "Tuner," "Aerial-tuning Condenser," "Variometer," or in some cases by *two* controls in the form of a switch arm rotating on studs and a separate dial marked as mentioned.

Without these controls being adjusted so that the instruments they control are brought to a state in which they can respond to the signals received at the aerial, it will be impossible for the signals to penetrate to the remainder of the apparatus in the set.

Hence the tuning controls must be the first to be adjusted.

Reaction is the cause of most of the difficulty experienced in correct tuning. There must be thousands of amateurs who heartily wish reaction

had never been invented. Properly used reaction transforms what appears to be a "dead" set into a very sensitive piece of apparatus. Reaction can be used in such a way that whilst the most can be obtained from a set the quality of reproduction retains its excellence. To use reaction properly a slight knowledge of its theory is practically a necessity.

## What Reaction Is

Reaction consists of a method whereby the signals received at the aerial, tuned-in and amplified by a valve, are fed back again to the aerial circuit, thus giving a tremendous "boosting" effect to the signals already present in the aerial.

This effect is usually obtained by coupling a coil connected in the plate circuit of the valve to the aerial tuner. Another effect of reaction is the greater selectivity obtained—that is, one of two stations transmitting on wavelengths differing by a few metres can be tuned-in without interference from the other.

A fault that appears in a large number of receiving sets is known as reaction overlap. When the reaction control is slowly rotated it will be noticed that signals will first become stronger up to a certain point, after which their strength starts to decrease until a loud "plonk" is heard in the phones, followed by a slight hissing sound. This is called oscillation.

On tuning the reaction control slowly in the reverse direction another "plonk" will be heard when the oscillation ceases. These two

(Continued on page 634)

# He never gets let down now!

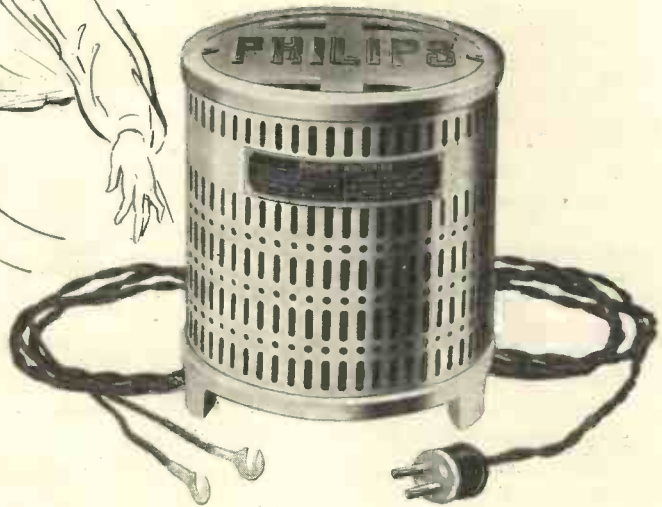
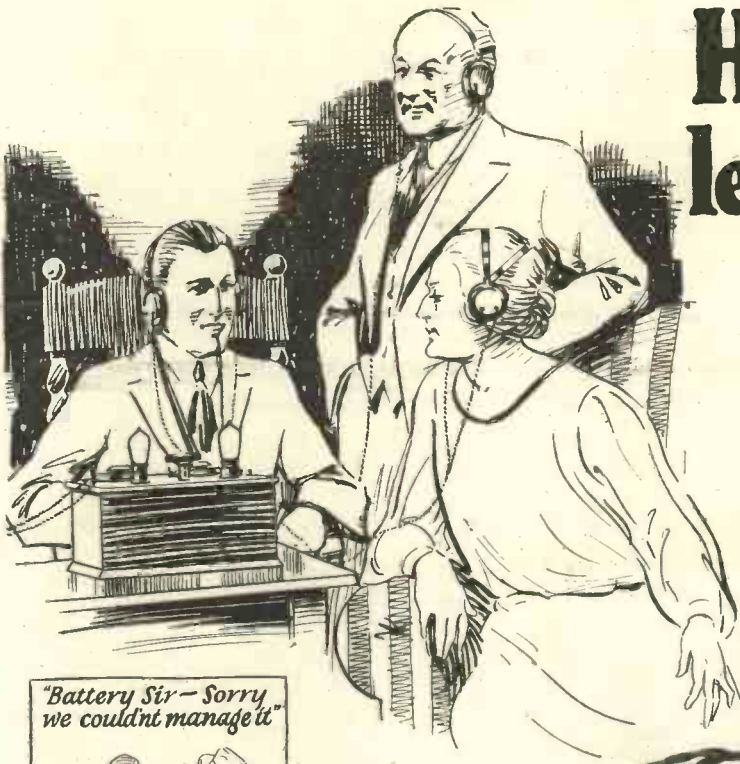

"Battery Sir - Sorry we couldn't manage it"



"Sorry, the Battery has run out."



## A Feeling of Complete Confidence

He knows how to avoid those disappointing evenings when he had to announce to his friends in the middle of an enjoyable programme, "Sorry; the battery has run out."

He remembers, too, how that meant missing the following evening's programme as well, because he wasn't able to get his batteries charged in time.

To-day, it's all changed. A month with PHILIPS RECTIFIER has given him a feeling of complete confidence that he will never be let down now, and that there is one battery charger that always gives complete satisfaction.

Philips Rectifier works off A.C. supply, requires no supervision, works silently, and automatically regulates the current supply.

There are no objectionable chemicals, no buzzing noises, and you have, in fact, a most reliable battery feeder with an extraordinarily low running cost.

**SIMPLE. CONVENIENT. EFFICIENT.**

It charges while you sleep.

Write for leaflet W.M., free on application. Trade enquiries invited.

**£4.15.0**  
COMPLETE

# PHILIPS RECTIFIER

Advt. Philips Lamps, Ltd., 60, Wilson Street, London, E.C.2.

In writing to advertisers, please say you saw the advertisement in THE WIRELESS MAGAZINE.

# THE WHOLE ART OF TUNING (Continued from page 632)

"plonks" should occur at the same setting of the reaction control. More often than not, however, the two "plonks" occur between quite an appreciable arc of the reaction-control dial, and this is known as overlap.

A set in which overlap is present is very difficult to tune without producing a number of squeals and howls. The amount of overlap should be made as small as possible by adjusting the voltage of the high-tension battery, which should be of the tapped type supplied with sockets for the insertion of wander plugs.

Overlap generally indicates that the voltage tapped off from the high-tension battery is too high. Adjustment of the filament rheostat often helps matters, whilst if a grid leak is fitted this should also be adjusted.

Having so eliminated overlap we should be able to tune without squeals, for the squealing is not only heard by the operator himself but is received by countless listeners for miles around—and they don't like it.

## Tuning Without Squeals

Tuning without squeals can be accomplished by the exercise of care and by being always on the look out for oscillation whilst tuning is in progress.

As the set approaches the oscillating point a "rustling" sound will be heard in the phones. The "rustling" is a sign that reaction is being pushed too far, and the reaction dial should be turned a little in the opposite direction.

With the set in the "rustling" state the reception of telephony will probably be very strong but bad distortion will be introduced.

Now, although it is easy to pick up the local station without oscillating, the reception of distant

stations under similar conditions is a different proposition. A squeal now and then when searching for an elusive station is pardonable, so long as the tuning is not accompanied by one long shriek.

In order to receive a distant station adjust the set to the "rustling" point already mentioned and, keeping

The method of tuning is now slightly different: The tuning dial and the additional dial or dials must be slowly operated together in the following manner. Place the tuning dial at zero and, as before, bring the set to the "rustling" condition. Now slowly rotate the additional dial throughout its entire range.

If no signals are heard, set the tuning dial at about 5 degrees and repeat the operation with the additional dial.

This series of operations should be continued for every 5 degrees of the dial until a station is tuned-in.

All this time the set should be "rustling," and if on tuning the other dials any tendency to squeal is evident—or if the "plonk" is heard—correct the reaction setting.

As each station is tuned-in, the

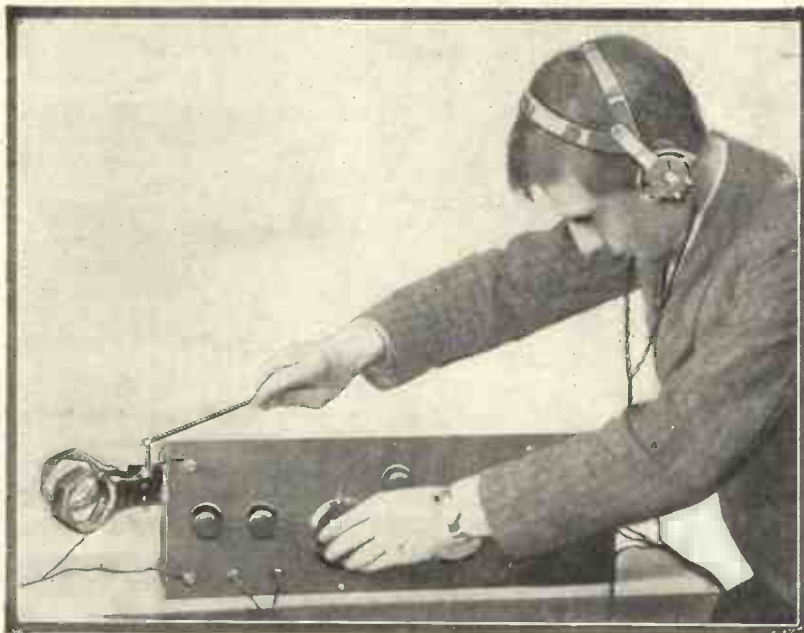

When tuning-in, more haste means less speed—and poor signals when you get them!

it in this condition, search round for signals by *very slowly* turning the tuning dial.

To do this properly one hand should be on the reaction control, keeping the set in the "rustling" condition, whilst the other hand slowly turns the tuning dial. If the latter control is turned too quickly the chances are that the desired station will be passed and repassed without detection.

Tuning the aerial and adjusting reaction is all that is required for many sets employing a valve detector and one or two low-frequency amplifying valves.

The inclusion of a high-frequency amplifying valve, however, complicates the tuning, for there are an additional number of controls which must be operated in conjunction with the tuning dials.

The additional dials will be marked "Anode-tuning Condenser" or one of the equivalent labels mentioned at the beginning of this article.

should be noted, so that on future occasions the same station can be tuned-in with little difficulty.

## Hand-capacity Effects

In many receiving sets which are at present in use the tuning is rendered particularly difficult by what is known as hand-capacity effects.

What happens is this: The operator successfully tunes-in a certain station and brings it up to good volume with little or no distortion. Satisfied with the tuning he removes his hands from the dials, and immediately the familiar squeal is heard in the phones or loud-speaker.

In such circumstances anything like correct tuning is impossible.

Hand-capacity effects may be caused by several things. A poor earth, for instance, will render any set very unstable. Reaction overlap is one of the chief causes, whilst the internal wiring of the receiver may be responsible. D. C. ROGERSON.

# Extensive Experimenting Emphasises Ediswan Worth!

The greater your adventures in Wireless, the greater will be your appreciation of Ediswan Valves—the clearer will each experiment demonstrate that Ediswan Valves are unexcelled by any other make in the World.

The best results will obviously be obtained by Ediswan co-operation. There is an Ediswan Valve for every specific purpose.

THE VALVES TO USE.		
Receiving.	Accumulator or battery. Volts.	Power.
A.R.	4	P.V.5.
A.R.D.E.	2	P.V.6.
A.R.06.	3	P.V.8.

As time goes on you will be all the more astonished at the long life of these valves and of their unusual economy.

*For the best results use Ediswan H.T. and L.T. Accumulators with Ediswan Valves.*

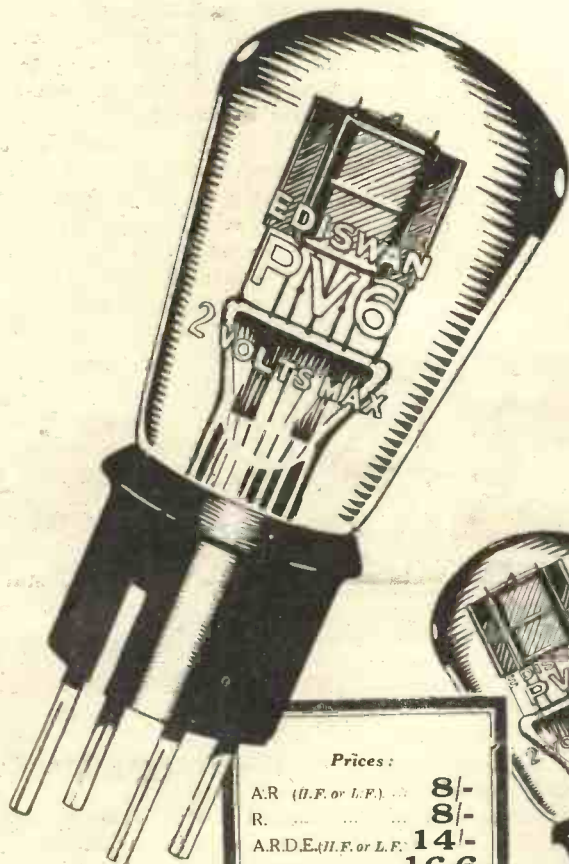

Prices:

A.R. (H.F. or L.F.)	8/-
R.	8/-
A.R.D.E. (H.F. or L.F.)	14/-
A.R.06. (H.F. or L.F.)	16/6
P.V.5.D.E.	22/6
P.V.6.D.E.	18/6
P.V.8.D.E.	22/6

ASK YOUR  
WIRELESS DEALER  
FOR

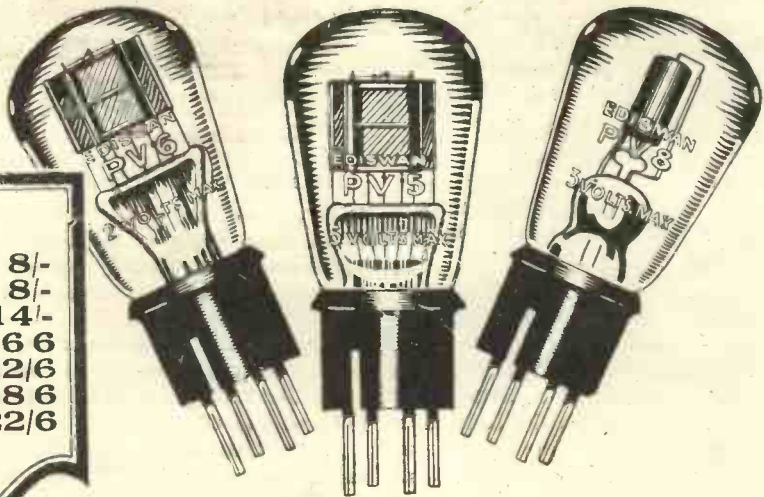

# EDISWAN VALVES

Will Improve  
ANY Set

THE EDISON SWAN ELECTRIC CO., LTD., 123-125, Queen Victoria St., London, E.C.4.

In writing to advertisers, please say you saw the advertisement in THE WIRELESS MAGAZINE.

# What Readers Think of Our Sets

## A Loud-speaker Three-valver

SIR,—I have constructed the family three-valver as per instructions given in the May issue, and I offer you my thanks for such a splendid circuit. I have been trying it to-day and have got splendid results. My aerial is terribly inefficient, being 20 ft. at one end and 4 ft. 6 in. at the other, and screened all round.

I got Bournemouth this evening, and I am confident I will "get almost anywhere" with it eventually. I might add that up to the present I have been using a famous reflex set, but your set absolutely knocks the other one out.—W. F. DENE (Chelsea).

SIR,—Allow me to congratulate your staff on the loud-speaker three-valve set. You missed one word from the title—"powerful." I have, during the past eighteen months, made over a dozen sets from circuits in contemporary magazines, all of them with high-sounding published results, but I only experienced mediocre results.

I thought your set would be in the same category, but on completion I was amazed at the volume with which the local station came in.—J. A. BATTYE (Bradford).

## Picnic Set

SIR,—I feel that I must write and compliment you for the explicit instructions given for making the picnic portable set, in the June issue. After carrying out some very exhaustive tests I can certainly endorse your remarks that the results fully justify the care taken in designing same. The local station 5 P Y (which is only a relay station) is received at distances up to 15 miles quite easily, and I have also received Bournemouth on it several times, every word being quite audible. I am really delighted with the set and can recommend it with confidence to any of your readers who wish to possess a "real" portable set.—H. A. BLACKBURN (Plymouth).

SIR,—I should like to utter my praises for the one-valve picnic set. I have added to the set an L.F. amplifier so that one or two valves can be used.

Besides receiving Bournemouth at very good loud-speaker strength, I have had Cardiff on the phones, 2 L O mid-day transmissions, rather faintly, and a German station.

The tuning is most critical, and Bournemouth can be cut out and Cardiff tuned in with ease. The set, by the way, has only been used indoors so far.

It is all that could be wished for, as it is entirely self-contained. I enclose a photograph.—E. J. B. CURTIS (Bournemouth).

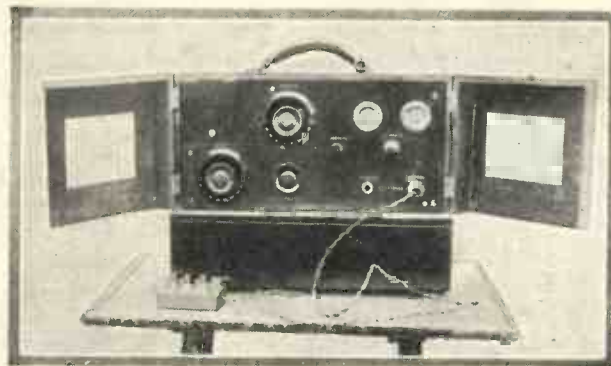

The Picnic Set made by Mr. E. J. B. Curtis.

## Three-valve Neutrodyne Receiver

SIR,—You may be interested to know that I have made up the three-valve neutrodyne receiver described in the July issue of THE WIRELESS MAGAZINE, and in view of the results it behoves me to write and tender my thanks to the particular member of your staff who evolved the circuit.

After balancing the set (I found much the better way was to roll a small tube of paper and place it in the valve socket), I received 2 L O so loudly that I had to detune on the loud-speaker to get comfortable music. The part that is so pleasing, however, is the fact that I was able to tune out 2 L O (you will note I am very close to 2 L O) and get "Le Petit Parisien" at very good phone strength. I also received Birmingham and Aberdeen whilst London was working. Later, when 2 L O closed down, I received several

foreign stations at good strength, and during intervals from 2 L O have received nearly all B.B.C. stations.

This is undoubtedly the most selective three-valve set I have tried.—B. GLADSTONE (London, W.14).

## Two-valve H.F. Amplifier

SIR,—I must congratulate you upon the excellence of the two-valve high-frequency amplifier, described in the July issue.

When added to a one-valve Reinartz receiver I can tune in all the B.B.C. stations, and I have already had, at different times, thirty-three stations, including Rome, Madrid, Brussels, Vienna, Radio-Paris, Leipzig, Hamburg, Eiffel Tower, Breslau, Lausanne, and L'Ecole Supérieure.—J. DALGLEISH (Newcastle).

THOUGH the B.B.C. director at Cardiff has been made a bard, we understand he won't be barred from the programmes.

PARIS has been putting on the ether a talk on "What is Life?" To most married men, of course, it is a matter of history.

## BURNT-OUT PHONE WINDINGS

LUCKILY it does not often happen that telephone windings burn out, but sometimes they will "go" either through the use of a high-tension voltage that is excessive or through allowing the set to get into violent oscillation, in which case very high potentials indeed may occur.

It is not generally known that new bobbins ready wound to various resistances can be purchased for trifling sums. These will fit many standard makes of telephones and it is not at all a difficult business to remove the old ones and to replace them with new.

Failing this there are several firms who specialise in re-winding burnt-out telephones for a small charge.

J. H. R.



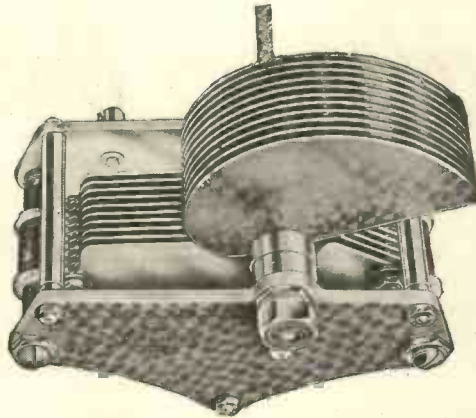
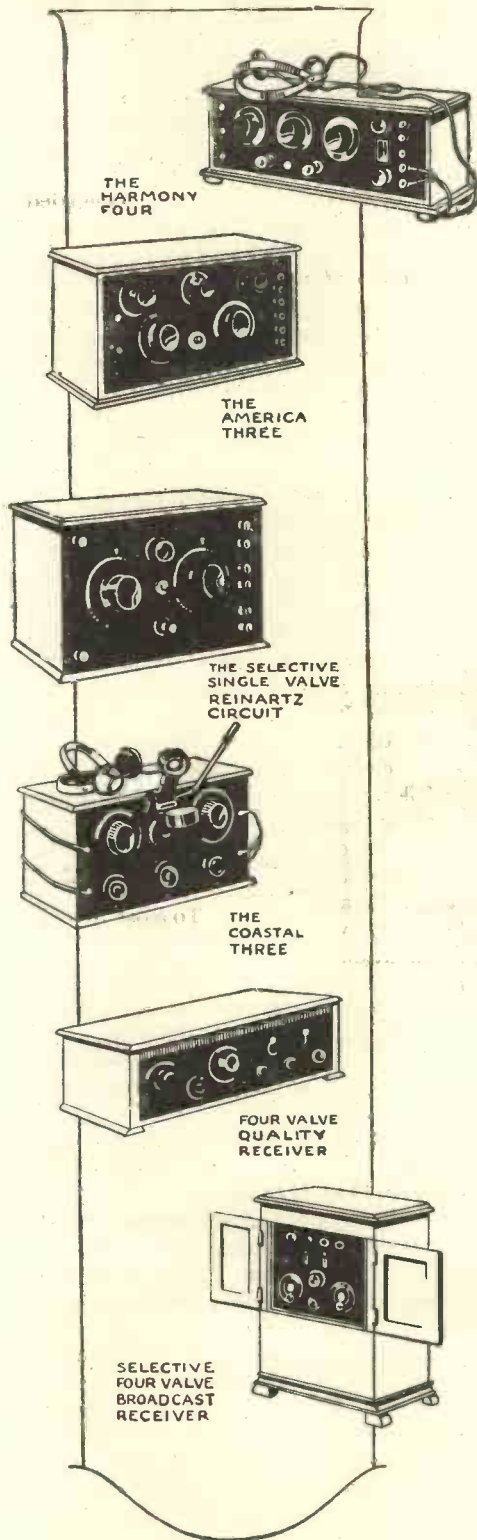

IGRANIC Low-Loss  
Square-Law  
Variable Condenser.  
Patent No. 220312.

## The most popular condenser

In the competition "Which is the most popular component" held in connection with the Manchester Wireless Exhibition, popular vote of the radio public endorsed the opinion of constructional experts by "plumping" for the Igranic Low Loss Square Law Variable Condenser.

The first choice went to a popular make of head-phone, and second to the Igranic Low Loss Square Law Variable Condenser—so that of *all* components which go to *build* a receiver, the Igranic Variable Condenser was given pride of place. This is not surprising when one notes the receivers illustrated for which the authors have recommended the Igranic Variable Condenser. Volume, purity of tone, very sharp tuning, super-selectivity—these are the result of using this precision instrument. Build them and all IGRANIC RADIO DEVICES into your next circuit.

A point to point comparison proves the superiority of the Igranic Low Loss Square Law Variable Condenser.

1. **LOW LOSSES.** Special method of mounting fixed plates reduces dielectric losses to an absolute minimum.
2. **LOW EFFECTIVE RESISTANCE** connected to moving plates by means of flexible spiral conductor ensures positive electrical contact and noiseless operation.
3. **EARTHED ROFOR.** Moving plates electrically connected to frame of condenser—provides adequate shield and eliminates stray capacity effects.
4. **SMOOTH ACTION** ensured by special ball bearings. Facilitates precise tuning adjustment.
5. **SQUARE LAW OR STRAIGHT LINE.** Specially shaped plates give straight line tuning relations between dial settings and wave-lengths.
6. **ROBUST CONSTRUCTION.** Fixed and moving plates of heavy gauge brass sheet. Perfectly rigid and will not warp.
7. **METAL FRAME.** Adequate shielding and strength are provided by a frame of specially prepared hardened aluminium alloy.
8. **INSTRUMENT FINISH.** Highest quality scientific instrument finish, handsome combined tapered knob, and 4 in. "Bakelite" bevelled dial.
9. **EASY TO MOUNT AND CONNECT.** Drilling templates provided with each condenser. Soldering tags to facilitate making connections.

PRICES :  
.00015 mfd., 19/6 each. .0003 mfd., 21/- each.  
.0005 mfd., 24/- each. .001 mfd., 27/6 each.



include : Honeycomb Duolateral Coils, Variable Condensers, Fixed Condensers, Filament Rheostats, Intervolve Transformers, Variable Grid Leaks, Variometers, Vario-couplers, Coil Holders, Potentiometers, Combined Instruments, Vernier Tuning Devices, Switches, Anti-microphonic Valve Holders, Stand-off Insulators, etc., and also the Igranic Supersonic-Heterodyne Receiver Outfit.

All carry the IGRANIC guarantee.

Write for List Z895.

**IGRANIC ELECTRIC CO. LTD., 149, Queen Victoria Street, London.**

Works : BEDFORD.

Branches :—BIRMINGHAM : 73-74, Exchange Buildings; BRISTOL : British Dominions House, Tramways Centre; CARDIFF : Western Mail Chambers; GLASGOW : 50, Wellington Street; LEEDS : Standard Buildings, City Square; MANCHESTER : 30, Cross Street; NEWCASTLE : 90, Pilgrim Street

In writing to advertisers, please say you saw the advertisement in THE WIRELESS MAGAZINE.

# Blake Boanerges' Banter

I SUPPOSE that the perspicacious reader has observed how, speaking generally, every trade has its own particular type of salesman each of which differs from the others in glory.

## Distinguished!

The tender wiles of the haddock-slapping fishmonger distinguish him from that loquacious pleader the barber's assistant with the Genuine Bay Rhum. Nor is the taciturn, superior chemist to be for a moment confused with the young man at the Co-op; or the milkman, who purveys the suburb's secret domestic history to the suburb's domestic helpers, with the brilliant talker who has the manners of an earl—a nice, polite earl—but sells motor-cars as a paying hobby.

If I am correct in my supposition I need scarcely point out the fact that the wireless trade or the sale of receivers, their parts, accessories and frillings, as distinct from the erection of high-power transmitters, has in the matter of a few short broadcasting seasons produced a well-defined type of high priest.

Sometimes he is just a salesman and sometimes he is a wireless "engineer," but mostly he is an "expert."

Now an "expert," as I have noticed, is a man who is much given to illustrating his remarks with diagrams, drawn with a stub of pencil on the cleanest wall he can find handy. I believe that if a wireless "expert" had to explain reaction in a room papered in black he would either burst or develop suckers so that he could hang from the ceiling. I refer, of course, to the technical expert.

## Salesman-expert

But the new sub-variant, the salesman-expert, is neater in his habits and well repays study, as the botany books say.

You enter his lair casually and demand a twopenny brass terminal. He sizes you up, probably by the appearance of your trousers; a fallacious method, because I know a man, one of the three real wireless

## Reflections on the Salesman-expert and Old Accumulators

geniuses of the world, whose trousers stamp him as millionaire-amateur keen on supersonic-heterodyne sets with filters every six inches of the circuit.

Well, he sizes you up, and while he is setting out the latest thing in terminals—Fixits or Griphards—or just plain binding-posts, he cunningly elicits from you your nefarious purposes.

If you are "building" a set he demands to know the circuit. You explain in your usual vague, modest way that it is only a sort of a hook-up with a few doo-hickeys and a gadget or two. This gives him a pain; it is so very amateurish. You hasten to add that, of course, you have a *real* set, with acres of ebonite and knobs enough to make a church organ kick its blower through the east window into the graveyard out of impure envy.

## His Opinion

He says brightly, as one expert to another, "Superhet, I s'pose?" and if you say "No," he tells you that it has all other kinds of receivers cold and stiff, whereas if you say "Yes," he says that in *his* opinion there is nothing like a *good, straight circuit* after all.

He is also of opinion that the wireless trade—he calls it "game"—is overcrowded on account of the accession of many upstarts whose legitimate arena is the bicycle-shop, and he adds that he, *personally* (not by proxy, mark you!), has been "in the game" since 1919. His object is to impress you with the thought that you are talking to an old timer, a regular dyed-in-the-wool Ben Franklin and Heinrich Hertz rolled into one.

He asks you what you can "get" and what you can "cut out" and when you falter under his brilliant cross-examination he pins you down to the fact that your tuned-anode is not what it ought to be.

You buy a Goodger's Aperiodic Anode Adaptor ("Pat. applied for,") and sneak away feeling as if

you had been caught listening without a licence.

\* \* \* \* \*

Some earnest truth-seeker once asked where all the myriads of pins go. Another once deplored the scarcity of defunct Neddies; he seemed to consider it an affront that a man cannot see a dead donkey if he so require.

## Writer's Dreams

I could answer both conundrums, given sufficient space and a senile editor, but I have neither of these; they are what writers dream of and never find both together.

Hence I will propound a riddle of my own, namely, where do all the old accumulators go, those sulphated, celluloid-covered blocks which once were the pride of an amateur's heart and the meat of brutal garage-owners who regulated their ampere-hours by the clock?

I once had a 6-volt 80-ampere hour fellow weighing about as much as an army fighting kit. It perished of Pb SO<sub>4</sub> on the +ve plates and the body cumbered the house for weeks.

I thought of burying it, but the family would not allow that; I might disturb Rover, who was R.I.P. this two years and not forgotten. So I used it as a doorstep, till its fumes caused the door-handle to wilt. I placed it in the gutter of the road at 11.0 p.m., hoping for the best, and had the inevitable policeman to argue with at 2.0 a.m.

## Into the Dustbin

Finally, flat against the skilled advice of our lady kitcheneer, I dropped the thing plump into the dustbin and waited for Thursday, 7.0 a.m. The dustman arrived. Behold me, quaking on my wakeful couch. Heavy footsteps, the rattle of the lid, and then a pregnant silence. I could *feel* the man's imprecations. A grunt and the sound of a laboured walk. Cheers! He's taken it! And he had.

I had bribed him with every bottle I could find in the house and demesne. *It was the only way.* But can it be that there is really an economic relation between broadcasting and the glass-blowing trade?



**Help yourself!**

TAKE your choice of any part of the world. With an Ormond Condenser station after station can be tuned in quickly and sharply, no matter how closely the wave lengths approximate. Paris, Madrid, Rome, Breslau—any part of Europe, any part of America. With an Ormond Condenser nothing is simpler. But it must be an ORMOND—the result of 25 years' British Manufacturing experience.

**Ormond Low-Loss Condensers**

SQUARE LAW (Patent applied for.)

Supplied in the following sizes:

Size.	Price with Vernier.	Price without Vernier.
.00025	8/-	6/6
.0003	9/-	7/6
.0005	9/6	8/-
.001	10/6	9/-

Complete with knob and dial.

We specialise in turning Brass and Steel Screws and Machined Parts and Accessories of all descriptions.

Ask your dealer to show you these Ormond Condensers—the best dealers stock all Ormond products.

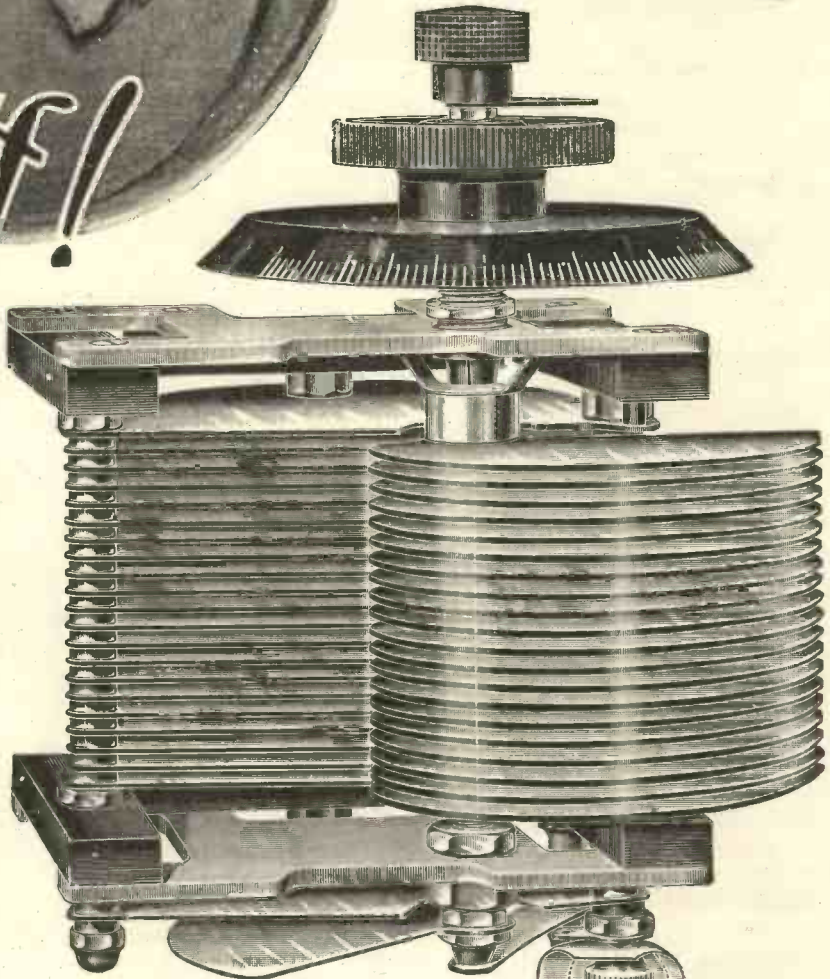

192-205, Pentonville Road King's Cross, London, N.1

Phone: Clerkenwell 9344, 5, and 6.  
Grams: "Ormondengi, Kinross."

Factory:—Whiskin Street, Clerkenwell, E.C.1.



See the Inspection Label on every Condenser

**25 YEARS' BRITISH MANUFACTURING EXPERIENCE.**

In writing to advertisers, please say you saw the advertisement in THE WIRELESS MAGAZINE.



# Wireless Femininities

THANKS to the B.B.C., whose middle name is variety, not many things remain to be tried in their daily programmes. But, except for the children, their enterprise seems to stop short of fiction. I commend to their notice the entirely original notion of running a broadcast serial.

## B.B.C.'s Advantage

The newspapers do it regularly, and the films used to—so why not the B.B.C.? They'd have the great advantage neither of the others possessed, of the direct use of the expressive human voice, the best of all story-tellers.

It would have to be a regular thriller, of course, in the best film and penny dreadful tradition, and be broadcast by an actor who knew how to express every emotion tellingly. Think of love, fear, menace, conveyed through this medium. The breaking off at some critical point would leave us gasping for the next evening's instalment.

\* \* \*

## Thought Transference

The recent interesting attempt to transfer thought via the microphone, while it certainly proved nothing, also, it seemed to me, disproved nothing. No unbiased judgment can be formed on a single failure, and one hopes that while the New Year is still young the B.B.C. will try another telepathic experiment, and one on lines that—to people with some practical experience of thought transference—offer greater prospects of success.

No doubt the concentration of a huge number of listeners-in on a given subject was considered to intensify greatly the chance of this topic being transferred to those in the locked

mind on one thought is no easy matter to the majority of people. Probably many of them inevitably let other ideas creep in, and these would help to confuse the "receivers." Indeed, we cannot prove that some of the many topics they named were not being concentrated on, perhaps unconsciously, by numbers of transmitters.

I would like to see a test made in which one person, known to possess strong concentration, should attempt to transmit ideas to another person at a distance known—or claiming—to be unusually receptive to this type of suggestion.

The "receivers" chosen last time were all very well-known people. But fame and telepathic ability don't necessarily go together.

\* \* \*

I am hoping the new London broadcasting studios will keep up the wonderfully high decorative tradition set by the old one. Whenever I enter this lovely room I wish fervently that some of its most beautiful colour effects were feasible in the ordinary small house, for it is harmony and yet vividness exemplified.

## A Description

Let me describe it to you. It is a big room, of course, carpeted in a deep soft blue. Couches and chairs are of dull greyish green, with jade tapestry cushions. Heavy jade curtains and pelmets hang at the long windows, which shut out daylight with brown canvas curtained over with warm-tinted net, through which the light shines a wonderful soft orange.

But all this lovely colour, which

room at the Savoy Hotel; and certainly this would be the case if every one of the ten million listeners-in *did* undividedly concentrate.

But bending the whole of the

sounds as if it would clash violently, is harmonised partly by the unusual size of the room, but mainly by its unique background—actually the result of a technical necessity, though admirably artistic too. All the walls and all the ceiling are draped with fold on fold of plain grey casement cloth, the ceiling being divided into panels with bands of bright *papier mâché* fruit. A hanging mirror is framed to match.

## Soft Background

This grey background is most beautiful, not because it is grey, for it might be any other colour. But it is so much softer than wallpaper or distemper, so much more graceful in its long slim folds. The sight of it always makes me feel that there is a great deal to be said for mediæval days before wallpaper was discovered, when walls were hidden with subdued tapestries or flowing silks.

But I'm afraid that will never happen again until we are all millionaires—except in a broadcasting studio.

\* \* \*

When any new feature has become accepted in modern life, the limerick arrives to immortalise it lightly-heartedly. Aeronautics reached this glory *ad absurdum* some time ago, and the turn of radio must be about due.

## Setting the Ball Rolling

Though no poet, may I just set the nonsensical ball rolling with the following gems:

Smith once was a radio learner,  
But now he's an expert much sterner.  
He sells beef and muttons,  
But—see him twirl buttons,  
You'd think, "Not a butcher—  
a turner."

Whatever that thing called Flewelling,  
It's certainly past my poor telling.

Though Welsh to the ear,  
It's wireless, I hear,  
But I'm not even sure of the spelling.

If someone would thoughtfully christen some new wireless parts by words that rhyme with either "crystal" or "valve," it would help us poor limerickers enormously, don't you think? A. M. M.

# Osram VALVES

## Types R. and R5v.

Designed for wireless users preferring bright emitter valves at a keenly competitive price. Each type embodies qualities which ensure strength, efficiency and reliability.

Type R5v. is the only 5 to 6 volt valve built like a power valve and sold at 8/-



### Characteristics. Type R.

Filament Volts ..... 4  
Filament Current ..... 0.7 amps  
Anode Volts ..... 30-100  
Impedance ..... 40,000 ohms  
Amplification Factor ..... 9

Price 8/- each

### Characteristics. Type R5v.

Filament Volts ..... 5  
Filament Current ..... 0.7 amps  
Anode Volts ..... 30-100  
Impedance ..... 30,000 ohms  
Amplification Factor ..... 9

Price 8/- each

Sold by all leading  
Wireless Dealers, Electrical  
Contractors and Stores.

Advt. of  
THE GENERAL ELECTRIC Co., Ltd.,  
Magnet House, Kingsway,  
LONDON, W.C.2.

In writing to advertisers, please say you saw the advertisement in THE WIRELESS MAGAZINE.



We earned £3 in spare time last week—and we want to beat that this—so when Dad has had his tea we're going to get busy!

The work's awfully interesting and it only cost us a few shillings for tools and Two Guineas for the Patent Licence.

The Company buys our output at a good profit when we have any over from local orders—but with Wireless and one thing and another we have more work than we can do!

If you would like to "get busy" too, write for full particulars—which will be sent you entirely without obligation and in plain wrapper—enclosing 1½d. stamp, to:

The England-Richards Co.,  
7D, King's Lynn, Norfolk.



Old Man Santa says:  
"This is YOUR 1926 OPPORTUNITY — a STOCKING won't be big enough NEXT Xmas!"

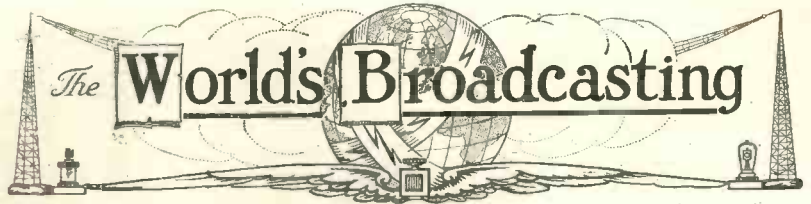

Wavelengths, Names, and Call Signs of the Principal European Stations

Wave-length in Metres.	Station.	Call Sign.	Wave-length in Metres.	Station.	Call Sign.
195	Seraing .	—	390	Dublin .	2 RN
205	Liège (Radio Central)	—	392	Madrid (Radio Iberica)	EA J 6
221	Karlstädt	SM X C	395	Hamburg	—
233.5	Kiel	—	404	Graz (relay)	—
241	Stettin	—	404	Newcastle	5 NO
243	Eskelstuna	—	410	Münster	—
251	Gleitwitz	—	415	Bilbao	EA J 9
259	Elberfeld (relay)	—	416	Breslau	—
260	Norrkoeping	SM V V	422	Glasgow	5 SC
265	Brussels	—	425	Rome	1 RO
265	Joenkoeping	SM Z D	428	Stockholm	S A S A
270	Malmö	S A S C	440	Belfast	2 BE
273.5	Cassel (relay)	—	441	Radio Toulouse	—
279	Bremen (relay)	—	446	Stuttgart	—
280	Radio-Lyon	—	450	Moscow (Trades Union Council)	—
283	Dortmund (relay)	—	452	Leipzig	—
285	Liège (Radio Wallonie)	—	458	L'École Sup.	PT T
286	Gothenburg	S A S B	460	Barcelona (Radio Catalana)	EA J 13
296	Hanover (relay)	—	463	Königsberg	—
301	Sheffield	6 FL	467	Linköping	—
302	Berne	—	470	Frankfort-on-Main	—
304	Madrid	EA J 4	479	Birmingham	5 IT
306	Stoke-on-Trent	6 ST	480	Lyon-la-Doua (relay)	—
310	Bradford	2 LS	482	Swansea	5 SX
310	Toulouse (relay)	PT T	485	Munich	—
315	Liverpool	6 LV	495	Aberdeen	2 BD
318	Radio Agen	—	505	Berlin (Vox Haus)	—
324	Barcelona	EA J i	515	Aalesund	—
325	Gefle	—	515	Zurich (Höngg)	—
326	Nottingham	5 NG	530	Vienna (Radio-Wien)	—
327	Milan	—	545	Sundsvall	S A S D
328	Edinburgh	2 EH	546	Strasnice	A D
331	Dundee	2 DE	576	Berlin (Vox Haus)	—
335	Hull	6 KH	588	Buda-Pesth (Csepel)	—
338	Plymouth	5 PY	750	Brünn	OK B
340	Copenhagen	—	850	Lausanne	HB 2
340	Nuremberg (relay)	—	875	Grenoble (relay)	—
345	"Le Petit Parisien"	—	940	Leningrad	—
345	Trollaattan	SM X Q	1,000	Kiev	—
346	Leeds	2 LS	1,010	Moscow (Popoff)	—
348	San Sebastian	EA J 8	1,050	Hilversum	H D O
350	Marseilles (relay)	—	1,100	Geneva	HB 1
350	Reval	—	1,100	Haeren	BA V
350	Seville	EA J 5	1,150	Kbely	—
353	Cardiff	5 WA	1,160	Ryvang	—
360	Cadiz	EA J 3	1,250	Karlsborg	—
364	London	2 LO	1,300	Königswusterhausen	LP
370	Falun	SM Z K	1,350	Boden	S A S E
370	Helsingfors	—	1,450	Moscow	RD W
373	Madrid	EA J 7	1,600	Daventry	5 XX
375	Moscow (Radio Peredacha)	—	1,650	Belgrade (Rakovitza)	H F F
378	Manchester	2 Z Y	1,750	Radio-Paris	C F R
382	Oslo	—	1,955	Amsterdam	P C F F
383	Bilbao (Radio Vizcaya)	EA J 11	2,650	Eiffel Tower	—
386	Bournemouth	6 B M			

Some of these wavelengths may have been altered before the next number of THE WIRELESS MAGAZINE is published. But under the heading of "Broadcast Telephony" a similar list of European broadcasting stations is published in AMATEUR WIRELESS every week, and you can keep yourself up-to-date from that.

In writing to advertisers, please say you saw the advertisement in THE WIRELESS MAGAZINE.

## ABOUT THE USE OF REACTION

THE much debated reaction coil, which is used in regenerative valve sets, is often the cause of a great deal of worry and annoyance, both to the user and the immediate neighbours.

Some people find that either the coil refuses to react or strengthen signals, or else reacts too heartily. Others suffer from the defect that one tightens up the coupling slightly with a corresponding gain in signal strength, after which, just as one is on the point of grabbing the signal with both ears, as it were, they disappear into nothingness and the set goes "pop," and screams lustily.

Should the set entirely refuse to oscillate, the reaction coil leads should be reversed. If this fails to have the desired effect, a coil a size larger should be tried and the process repeated.

The set should never plunge straight into oscillation with only slight adjustments of the coupling; there should be plenty of margin where oscillation does not begin, and just a little space left between the coils when maximum amplification has been obtained. The size of the reaction coil governs this to a certain extent.

The "popping" of the reaction into oscillation, where a distinct "plop" is heard in the phones, may be cured by reducing the H.T. voltage and filament brilliancy, or both. Alternatively, the grid leak resistance may be decreased with beneficial results and without losing signal strength when receiving without reaction.

A. J. C.

PRIZES amounting to £50 have been awarded by the Radio Communication Co., Ltd., in connection with the Polar Window-display Competition at the All-British Wireless Exhibition at the Royal Albert Hall.

Competitors, it may be remembered, were required to judge twelve window displays, placing them in order of merit.

The prize-winners are as follows: *First Prize* (£25)—Mr. L. B. WHISSON, Glenhurst, Linden Gardens, Leatherhead; *Second Prize* (£15)—Mr. THOMAS H. WYATT, 24, H Block, Sutton Estate, Chelsea, S.W.3; *Third Prize* (£10)—Master G. J. R. BUNN, 34, Barley Lane, Hastings, Sussex.

# FELLOWS WIRELESS



**BUY BY POST**  
**SAVE 6'8 IN THE £1**

Under the new policy recently inaugurated by the Fellows Magneto Co., the middleman's profit has been entirely eliminated, and all the well-known products of this firm are now offered to the public at what are *practically Trade Prices*. All goods are fully guaranteed and sent on *Seven Days' Approval* against cash. Goods also are sent packing free, carriage forward, unless postage is stated. This is a unique opportunity and one which the judicious purchaser cannot afford to miss. Fill in the coupon to-day and post to us.

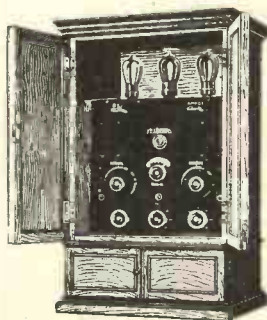

### THE VOLUTONE.

Without doubt the finest value obtainable in Loud Speakers. The adjustable diaphragm gives you the rich clear tones associated with instruments of several times the price. In addition, its pleasing lines and graceful proportions make it one of the most attractive looking Loud Speakers on the market.

Price 55/-



### THE FELLOPHONE THREE-VALVE GRAND.

One of the outstanding successes of the Fellows Company. An ingenious circuit arrangement obtains for it the full power and range of a four-valve set at the far lower initial cost and running expenses of an ordinary three-valve set. Its handsome cabinet which is fitted with folding doors provides an exceptionally attractive setting for it and eliminates entirely the untidiness usually associated with wireless sets. The set complete comprises H.T. Battery, 6-v. Accumulator (25/-), 1 pair of Headphones (11/6), 3 Louden Valves (4/6 each), Aerial and Insulators (3/6).

Set only, **£11 : 17 : 6** Set complete, **£14 : 10 : 0**  
*Marconi Royalty paid.*

### THE LITTLE GIANT TWO-VALVE SET.

Easily the cheapest and most efficient two valve set on the market. Combines ease of operation, simplicity of tuning and extreme selectivity. Has given entire satisfaction to thousands of listeners. Set complete includes H.T. Battery (9/-), 6-v. Accumulator (20/-), 2 Louden Valves (4/6 each), Aerial and Insulators (3/6), and FELLOWS JUNIOR LOUD SPEAKER as illustrated (19/6).

Set only, **£3 : 15 : 0**  
Set complete, **£6 : 15 : 0**

*Marconi Royalty paid.*

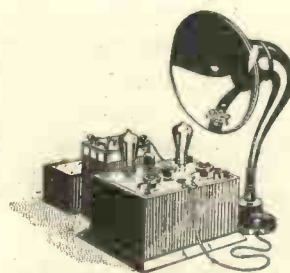

WRITE FOR SPECIAL ILLUSTRATED CATALOGUE FREE

which tells you how you can save 6/8 in the pound on all your wireless requirements. The above sets can be obtained on Deferred Payments. Write for full particulars.

TO THE FELLOWS MAGNETO CO., LTD.,  
Cumberland Avenue, Park Royal,  
Willesden, N.W.10.

Herewith Remittance Value.....

Please forward me.....

on conditions as per your advertisement.

Name .....

Address .....

Please write clearly in BLOCK LETTERS and register Cash or Treasury Notes.  
W.M. January.

# What the B.B.C. Is Doing

*Specially Contributed by the Officials at 2, Savoy Hill, W.C.2.*

CERTAIN influences are at work to further the claims of the valve user in connection with what may be described as multi-reception, and to discount the importance of the crystal user, who is, after all, practically dependent on one, and that his local station for broadcast reception.

## *Criticism of Our Policy*

The criticism of our policy is concerned with the use of a power of three kilowatts at the Oxford Street station, and the critics' case is that the value of the three- or four-valve set is reduced, so far as variety of reception goes, to that of the humble crystal. It has even been said that at ten miles' distance from London a three- or four-valve set can receive only a London programme.

The argument appears to be that the removal of 2 L O some two miles westwards has precluded the possibility of "reaching out" with a valve set housed ten miles from Charing Cross, although it was possible, before the removal, to secure selectivity. If such be the case, it is possible that the set needs overhauling.

The fundamental principle of successful selective reception is that the latest advances in the art of broadcasting shall be adopted by receiver as well as transmitter. We can only advance the service in terms of the ability of the receiver to adapt itself to modern development, and it creates an impossible position to suppose that while the transmitting apparatus constantly undergoes improvement, the receiving apparatus needs no adjustment to meet the altered conditions.

However, the policy of higher power and fewer stations will give the multi-valve user, in common with the crystal and single-valve user, a better and not a worse service, provided the ordinary methods of achieving reasonable selectivity are adopted.

Progress for the million must not be prejudiced because the few are in possession of obsolescent sets; and, before the policy of fewer stations and higher power comes into operation, the listener who wishes to have

a wide choice of programmes must consider the necessity of investing in the better type of set, instead of complaining of a service which is providing the facilities for all who will co-operate by taking advantage of them.

Much misdirected zeal is apparent in the efforts that are made to foretell the future of broadcasting. To put the thing in a nutshell, no one on earth can tell what the future may

"I'VE LISTENING-IN!"



*One thing the B.B.C. is doing—giving enjoyment to youngsters like this.*

hold, and it is a mistake to repose too much confidence in the prophets. This does not apply only to the scientific mysteries that radio telephony enshrouds. It applies equally to the more practical question of programme schemes. A warning has, for example, often been given in these columns against the ambitious expectations raised in some quarters as regards alternative services.

When the Daventry station was opened it was stated that a future step would be to make alternative services available to as many people as possible. But—and this is very important—it would be regarded as the wisest policy to develop the alternative programme schemes by easy stages.

Somehow the idea got abroad that immediately Daventry was established in full working order, its independent programmes, given at first on Tuesday and Thursday, would be extended to other days of the week, and this idea was fostered by many ill-informed writers. We

never at any time made any extravagant claims for, nor indulged in any prophecies respecting, Daventry. In this respect, as in most other phases of our work, we merely set the service going and carefully watched the results.

Experience over a period of three months proved that although Daventry's programmes were intended to be alternative to the programmes of other stations within the Daventry zone, and particularly to the London programmes, they were not, in fact, more than about ten per cent. alternative.

In addition, many listeners to the high-power and other stations show a steadily increasing predilection for a larger share of London's programmes. This is, to some extent, an unexpected development, and the period of three months has been sufficient to upset some of our preconceived plans.

While, however, all the provincial main stations admittedly achieve a high standard of service, London, with its extensive field of talent of all kinds on which to draw, has unique advantages over the rest of the country; a consideration to which increased attention will be given in the efforts to provide service in the future.

## *No "Instantaneous" Reports*

In a recent criticism of broadcast programmes, a laudable attempt was made by a well-known M.P. to suggest items which might bring broadcasters and listeners within measurable distance of the ideal. The suggestion that we should broadcast descriptive matter during the progress of a sporting event is, however, an American idea, and cannot be adopted in this country in view of the stipulation in our licence that no news or information in the nature of news shall be broadcast except such as we may obtain on payment from the established news agencies or from any other news agency approved by the Postmaster-General.

Another suggestion is that it would be a good thing if broadcast concerts could be open to the public, and an



audience of 100 or so people invited to go in free, or for a small charge, so as to be able to judge from their response as to the suitability of the items given.

Now, we have at intervals done this very thing, and the small charge made for admission has been devoted to philanthropic objects; but the vital problem of acoustics has to be taken into consideration in any extension of the idea of transmissions from outside halls. Not every outside hall is suitable for broadcasting purposes, and an eminently good programme might easily be spoiled if it were put out from a place that was ill-adapted to the purpose.

Then the question of the use of line relays is important. It is sometimes the case that a telephone line is bad, or fails temporarily when brought into use for the actual relay, although during a test an hour previously it may have worked extremely well.

In view of the possibility of difficulties arising of this nature, the present policy of inviting small audiences to the studio seems to be the most satisfactory means of keeping a finger on the pulse of the listening public.

### Impromptu Entertainment

Still another development is that now being attempted to get away from the formal, stereotyped sort of programme. Although listeners are thus deprived of the advantage of having a detailed programme before their eyes when they are listening, they probably approve of the change in procedure in view of the artistic talent that the producer is able to concentrate in his "Gather Round Donald Calthrop" features.

The whole idea is to keep these features on as high a level as the "first nights" at the leading theatres, and the audiences in the studio include representatives of all the talents. For none of these "Gather Round" entertainments has Mr. Calthrop any prearranged plan of production. He merely works along the following lines: he "spots" some scientific, literary or artistic notability in the audience, and calls upon that person to broadcast. Representatives of the musical world, the stage, the concert platform, the more serious professions and of social life are pressed into the service of the listener.



## Moisture and Dirt

—a Radion panel checkmates these twin robbers of signal strength

**R**ADION is a unique panel material. Although it has a hard rubber base it is much more than ordinary ebonite. It was the first—and to our knowledge is still the only—panel material specifically produced for wireless use. Because it is made with a high percentage of rubber its insulation properties are exceptional, and owing to its unique formula it can be drilled, tapped and sawn without a suspicion of a crack. Indeed, Radion—in spite of its toughness—is the easiest material of all to work.

Just now experts are debating this serious question of low loss. When dealing with weak signals you cannot afford to take risks with your panel. Indeed the panel can be said to exert a greater influence over your set than any other part. Radion is recognised as being the highest grade of panel in the world.

Moisture and dirt are the twin thieves of signal strength. Use a Radion panel and you checkmate their activities. Its superb mirror-like surface repels dirt and is impervious to moisture. Ask your Dealer to show you a Radion panel. Instantly you will appreciate why technical journalists specify it so frequently in their sets.

DIALS  
KNOBS  
HORNS

Black and Mahoganite  
in twenty-five sizes

VALVE-  
HOLDERS  
PANELS

TRADE MARK

# RADION

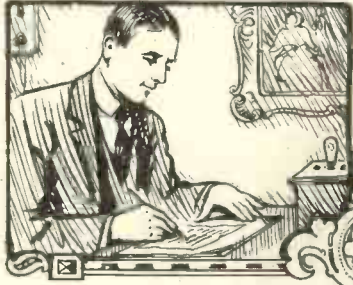

# What the Reader Thinks

## B.B.C. Transmissions

SIR,—There has been much controversy of late on the volume of British transmissions as compared with continental transmissions, and much stress has been laid on the fact that British stations do not "carry" far in comparison.

A writer points out that the reception of "Le Petit Parisien" in England is far louder than any B.B.C. station (excepting 2 L O) when listened to in greater London. Toulouse is another good station for British listeners.

The B.B.C. could easily extend their range. The reason that our stations do not carry so well is because the engineers refuse to modulate beyond a certain point—for fear of blasting.

Their transmissions are the finest in the world, but do they overdo quality at the expense of volume and distance, and incidentally our national prestige in this respect is lost.—E. A. ARNOLD (West Ham).

## Is D.X. Work Worth While?

SIR,—In regard to your correspondent's letter in the November issue concerning D.X. work, I would like to point out the obvious reason for his failure to receive long-distance stations at reasonable phone strength.

No amount of L.F. amplification will make signals any better unless they are fairly strong in the first place, and in this case they will have to be magnified before reaching the detector valve, which is done by H.F. amplification.

If C. B. W. tries this, I am sure he will find that D.X. work is worth while.—S. K. LAZELL (Sevenoaks).

## A Working Man's Point of View

SIR,—Re your article in the November number on voting for programmes, I think it is time something of this sort was done, as it appears that the majority of programmes are made up to appeal to the classes and not to the masses.

I really think, though, that the matter can be carried further than your article suggests.

Take the case of the programmes given during the past week. All were of the slow, mournful, or classical order (according to your fancy) till we come to the Georgians who submitted the same programme on two evenings. Theirs was what one may term a popular programme.

But assuming your vote took place on a week's programme only, the result would be that these would lead the way on votes, to the exclusion of others.

What I think would be the ideal way of voting would be to place a voting

coupon in the official organ, and give everyone a vote extending over everything transmitted over the period since broadcasting began.

The working and middle classes are not catered for except perhaps once a week, and the so-called high-brow stuff put over for us honestly turns us up.

But we do not want Savoy Bands, etc., which is only another way of pandering to the classes who dance till midnight, and for whose benefit the pro-

Have you any interesting comments or suggestions to make on any phase of broadcasting that will interest other readers of THE WIRELESS MAGAZINE?

If you have, then write them briefly on a piece of notepaper (write on one side only, please) and address them to The Editor.

To the writers of the letters published each month we award valves. This month's letter-writers will each receive a Marconi valve; next month's writers will be sent an Osram valve each.

gramme starts at the time when the average working man thinks of going to bed.

This means that the share of the programme allotted to the average workman is all the talk stuff and gramophone records, and then, when the B.B.C. get down to business he has to shut off and prepare for his early rising or go without his sleep if he wishes to hear anything special.—H. A. HALL (Horsham).

## Announcer's Showmanship

SIR,—Nowadays one hears and reads a considerable amount of comment on the lack of showmanship in presenting radio programmes. It is very necessary for the B.B.C. that interest should be sustained, and I think one point which made for interest was the adding of the announcer's name to the programme.

Listeners of long standing will, no doubt, remember the various names and voices. Who could forget Victor Smyth of 2 Z Y and his hearty "Good-night" after once hearing it?

One becomes attached to one or two of the announcers of the local station whose personality seems to "get over" better than some others, and an added interest is aroused in their individual showmanship in presenting the programmes.

Would not the new listener be just as interested in the name, and various little details which filter through about the announcer?—M. HIRST (Bootle).

## The Telharmonium

SIR,—Listening-in to the various musical renderings as broadcast, a fact that is noticeable is that some instruments sound much better than others. Why not have a musical instrument devoted to wireless purposes?

When the late Sir William H. Preece, head of the electrical department of the G.P.O., was in America some years ago, he was much impressed by a musical instrument he saw and heard there. It is called the telharmonium, the invention of Dr. Cahill, of New York.

At a lecture that Sir W. H. Preece gave to the members of the Institute of Electrical Engineers, he declared this instrument was the most wonderful thing he had seen and heard in America, and stated it would oust the orchestras from theatres, opera houses, music-halls, etc.

Here is Sir W. H. Preece's description of the instrument:—

"It has a keyboard like an organ . . . the energy is entirely in the electrical form and is virtually instantaneous. The manipulation of the keyboard, pedals and stops set up electric waves, which are the exact counterparts of the sonorous aerial vibrations it is desired to excite. The player controls everything, and discourses sweet music of a character hitherto undreamt of. The effect is most wonderful. The tones of the piano, harp, violin, 'cello, trumpet, flute, clarinet, and all kinds of music, separate or orchestrally combined, are manufactured in electric currents of varying frequency, amplitude and vibration, and the result is a new music!"

If all the foregoing is correct, surely we have here the ideal musical instrument for wireless purposes?—J. S. PEARSE (Plymouth).

## With a Six-valver

SIR,—It was with considerable interest that I read C. B. Wignall's letter in the November issue.

My set is a six-valver (three H.F., detector and two L.F.), and here are some recent results which will prove, I hope, that high-frequency amplification and D.X. work are really worth while.

I have received W G Y as strong as the local station (this is 5 X X, three miles away) on a one-valver, also K D K A and W B Z. These were easily readable on the phones. I get Madrid, E A J 7 and E A J 6, on a loud-speaker. Also all the B.B.C. stations, and French and Germans galore on the loud-speaker.—T. JAMES (Swansea).

YOUR SET STANDS HERE



**STANDARD  
MODEL**  
(Oak or Mahogany)  
£12 : 12 : 0

**DE LUXE  
MODEL**  
(Oak or Mahogany)  
£16 : 16 : 0

*another CLEARTRON product*

## THE CONSOLE MASTER SPEAKER

A beautiful cabinet of superb design, ingeniously conceived and brilliantly executed. It is CLEARTRON-built and well fitted to maintain CLEARTRON ideals; a cabinet of imposing line which dispenses with unsightly accessories and conceals a powerful loudspeaker unit.

You are able to house all batteries, spare components and other kit, making your whole wireless unit the very acme of compactness. One pull of the handle lowers the front, giving convenient access to the batteries and the loudspeaker.

The loudspeaker is designed on the

same principle as a gramophone, a special tone-arm being located behind the silk covered grill. A scientifically constructed wooden sound-box amplifies the reception without the stridency of the ordinary metal horn. Substantial, practical and tasteful, the Cleartron Console Master Speaker is protected, as usual, with the CLEARTRON Ironclad Guarantee.

Height 30". Length 38". Width 18".

Send for details and full specification.

Full technical data concerning CLEARTRON Dull Emitter Valves will also be sent on request. See prices below.

### CLEARTRON RADIO LIMITED

1 CHARING CROSS, LONDON  
AND BIRMINGHAM

Phone: Regent 2231. Grams: Cleartron Westrand, London

C.T.08 and C.T.15  
**12/6**

Also makers of American type C.T. 199 at 12/6. Full technical data on request. ALL CLEARTRON VALVES ARE DULL EMITTERS.

24/28r

Service Advertising



**BRITISH MADE**

*America's foremost Valve made in Britain's newest factory with British bases for British sockets.*

C.T.25 and C.T.25B  
**15/-**

Also makers of American type C.T. 20rA at 15/-. Full technical data on request. ALL CLEARTRON VALVES ARE DULL EMITTERS.

In writing to advertisers, please say you saw the advertisement in THE WIRELESS MAGAZINE.  
647



**NO SUDDEN JERKS**

Just a soft, smooth movement brought about on the worm and pinion principle, together with a compensating spring to balance the weight of the moving coil. That is the secret of the soft, silky action of the L. & P. coil holder. If you have any difficulty in getting distant stations, fit an L. & P. coil holder and your difficulties will vanish. Send for our Booklet; it will interest you.

LONDON & PROVINCIAL RADIO COMPANY, LTD.,  
33 Colne Lane, Colne, Lancs.

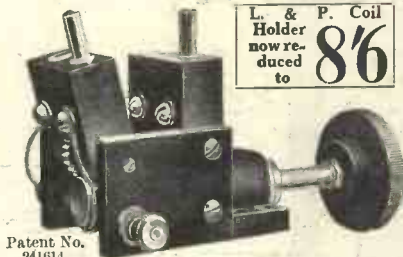

L. & P. Coil Holder now reduced to **8/6**

Patent No. 241614.

From all Good Dealers, or Write at once for list. Sent free on request.

Other leading "Ellanpee" Lines.—L. & P. Valve Windows enhance the appearance of any set. Small size 2½d. each. Large size 3½d. each. L. & P. Miniature Switches, D.P.D.T., 1/6 each. L. & P. Pull & Push Switch, positive action, positive satisfaction, only 2/- each.



**That Book you want!**

Foyles can supply it. Immense stock (second-hand and new), on Wireless, other Technical, Scientific and all other subjects. Write for Catalogue 567 (free), mentioning requirements. Books sent on approval.

**Books Purchased.**  
**FOYLES**  
121-125 Charing Cross Road, London W.C.2

**Amateurs! Let us make your Cabinets**

In beautiful polished mahogany or oak, and sent on approval. De Luxe Models, Parlour Models from 25/- to 25/. Crystal Cabinets from 1/6, any size made to order. Designs and Lists free. Estimates per return. Panels and accessories post free. Send to actual makers.  
**PICKETT BROS.** (Members of B.B.C.)  
M. G. Cabinet Works, Bexley Heath, S.E.

**The Boy's Book of Wireless**

ERNEST H. ROBINSON

By the aid of this splendid book you can gain a thorough knowledge of what Wireless is and how it works. With 8 Half-tone Plates and 150 line diagrams. 5s. net.

Cassell's

**FREE** Our "New Year" Greeting  
26 Novelties & New Issues

Including Alexandria (provisional), Alaouites (pictorial), Austria (Air Mail), Cameroons (native scenes), Bulgaria, Germany (Rhine Land Commemorative), New Zealand (Map), Grand Liban (pictorial), For. Said (provisional), Syria, Trans-Jordania. Set of 3 unused Russia &c., &c.  
F.R. 30 DAYS ONLY (Colours 60 days) above Collection gratis to every Stamp Collector sending 1½d. for cost of postage.

ERRINGTON & MARTIN, Ltd., LONDON, E.5

In writing to advertisers, please say you saw the advertisement in THE WIRELESS MAGAZINE.

# Continental Notes

AT the time of writing I have just picked up very faint squeaks from two little broadcasting stations which have been installed by private enterprise at Liège, one "Radio Wallonie," operated by the Belgian newspaper of that name, and the other styling itself "Radio Central."

I also understand that another small transmitter has been erected near Seraing by a local wireless club, but have not, as yet, heard the call.

**Closed Down?**

Of course, by the time these notes are in print, there is a possibility these newcomers may have closed down. Such stations, fed by voluntary contributions, spring up like mushrooms during the night in some European countries, and after having, as it were, made their bow to the ether, gracefully retire through lack of regular income. A sheer case of accelerated inanition!

And this goes to prove how essential it is that broadcasting for the public welfare should be organised in a sound and systematic manner. Of all European countries, Great Britain, Germany, Scandinavia, and perhaps little Switzerland, have put their house in order, from the start, with the result that broadcasting in these lands has developed into a regular public service.

It is true that the foreigners have undoubtedly copied our methods and system, but does this not conclusively demonstrate that after having studied the conditions in Great Britain, they realised the manifold advantages of centralisation and unified control?

The use of direct reaction on the aerial circuit has caused so much interference in some countries that it is not surprising that newcomers to the broadcasting world should take strong measures to protect the average listener from unpleasant howls, squeaks, and such noises which go to spoil the enjoyment of a broadcast programme.

In Roumania, where a new Wireless Telephony Bill has now been passed, a clause has been inserted in the receiving licences to the effect that aerial reaction is allowed in all

districts in which not more than ten wireless sets have been installed.

Of course, this is tantamount to saying, in a gruff official manner, "Thou shalt not oscillate!" but it is perhaps more politely put.

You must imagine some little "one-horse" township in Roumania, where live eleven proud possessors of a wireless installation. One evening, in the still hours of a winter's day, the ether is rent by one fell "ooooout!"

Up go the listeners' ears, down go their headphones. Within a few minutes they will have tracked the miscreant to his lair, and then—well—I have no idea what kind of torture is favoured in the Near East, but I have read some blood-curdling yarns of the Balkans!

\* \* \* \* \*

Once upon a time, in the good old days, when we had tuned-in a transmission and heard the silvery notes of a female voice, we patted ourselves (metaphorically) on the back and exclaimed, with great glee: "Aha, this is Rome!"

To-day we may hear announcements made by many a studio "mistress of ceremonies," for more than one station has engaged a lady for the part.

With a "superhet," I took, the other night, a leisurely stroll around Europe, and in the course of my wanderings heard Oslo, Hamburg, Toulouse, San Sebastian, Rome and Madrid. In each instance I noticed that a female announcer "bossed" the studio.

**More Particular with Calls**

It is possible that they were not in charge during the entire programme, as I know for a certainty that Madrid, Oslo, Toulouse and Hamburg favour the masculine sex, but it is to the credit of the ladies that they are much more particular than their male colleagues in their calls, and that, in every instance, the name of the station was mentioned before each item.

If only all European broadcasters would bear in mind that their transmissions are not only heard by the local population, but that there exists thousands of listeners in

comparatively distant lands who nightly pick up these concerts, and patiently, with unsympathetically hard telephones clamped over their ears, wait, wait, and wait for a clue enabling them to identify the transmitter.

**“Hört, Europa!”**

“London and Daventry calling” is heard regularly on the Continent, and at no time have I ever seen any complaints in respect of our own stations. If anything, I consider that 5 X X is too modest, in view of the distance at which its transmissions are picked up, but on the other hand, Königswusterhausen’s preliminary announcement of “Hört, Europa!” (Listen, Europe!) rather savours of hats!

There may be congestion of the ether to-day among the smaller stations, but what will be our reception when all the 10, 15 and 20 k.w. telephony transmitters now planned are in full blast?

It strikes me that Geneva, that European incubator city, where all the sittings take place, will not be able to rest on its laurels, even after the new wavelengths have been allotted, but that in the very near future will be confronted by an equally serious problem on the higher waveband. *Nous verrons!*

\* \* \* \* \*

The new Frankfort-on-Main broadcasting station, which may be in operation by the time this magazine is in your hands, will possess a new device for the “bottling” or “canning” of the spoken word or of musical transmissions with a view to such “extracts” being released at a future date.

The system employed, so far as I have been informed, will not be the one described in the Christmas Number of THE WIRELESS MAGAZINE. I am told there are several appliances on the market.

**Innovation in Programmes**

What will this lead to? Surely an innovation in the programmes. In a distant future the studio announcer will inform his listeners that the next item is to be a rendering by the world-renowned tenor, Signor Spaghetti, of Enrico’s famous aria in the opera *Marcaroni y Risotto* sung some umpteen years ago.

Which reminds me of the slogan adopted by some Californian fruit growers: *We sell what we can and we can what we can’t.* JAY COOTE.



**The Spirit of Adventure**

**T**HOSE courageous mariners of old were not content to take life as they found it. For them the humdrum spelt inaction. So leaving the sheltered comfort of their homes they set out to brave the dangers of the unknown—to return, maybe, with rich prizes.

It was this same restless spirit which prompted the designers of the Eureka to forsake the old and seek new ideas in transformer construction. The extent of their success can be gauged by the fact that the Eureka is now the largest selling quality transformer on the market. Obviously such a rapid recognition of merit is proof of the many exclusive features possessed by the Eureka. The non-laminated core—the 2½ miles of wire—the hermetically sealed contents—the coppered steel case. These are the features which have built up a nation-wide reputation for Eureka.

Eureka Concert Grand . . . 25/-    No. 2 . . . 21/-  
 Baby Grand, Nos. 1 and 2 . . . 15/-    Reflex . . . 15/-

**EUREKA**

## Keeping the Lead-in Dry

WATER running off the aerial may penetrate into the lead-in tube and cause trouble through providing a short-circuit to earth.

The difficulty can be overcome by placing round the aerial wire a cone made from an old gramophone record, which should be cut as

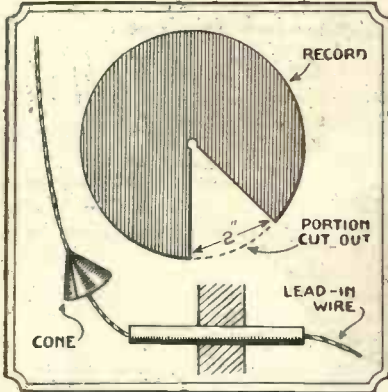

Method of Keeping Lead-in Dry.

indicated in the diagram and bent into shape when warm.

The cone should be fixed to the wire with some wax placed at the apex. G. A. W.

## Is a High Aerial Best?

THOSE persons possessing sensitive receivers may be tempted to elevate their aerials to great heights in order to receive distance signals. Such an action will not always have the desired effect, as a high aerial collects far more interference from static and the like and becomes apparently flatter in tuning than does a low one.

Therefore, despite the fact that such an aerial will collect slightly more energy, the enhanced sensitivity will be spoiled by the stronger stations which will be heard over a greater portion of the condenser scale, and thus cause the desired weak signals to be unheard.

It is suggested that a good effective height for an aerial (unscreened) would be at the most 40 feet if long-distance signals are desired, and that the extra efficiency desired should be obtained in the receiver itself where points of sensitivity and selectivity may be well looked after. A. J. C.

## Temporary Earth Connection

WHENEVER required for experimental purposes a temporary earth connection can easily be made as shown in the sketch.

It consists of a few turns of bare wire wrapped round the fork handle

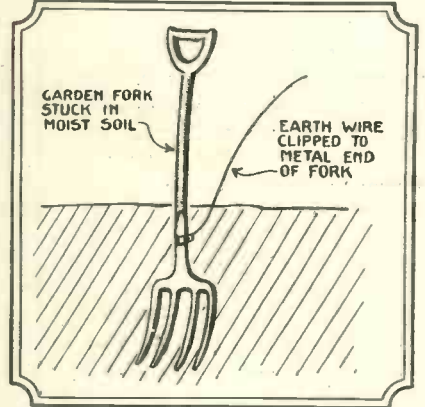

Temporary Earth Connection.

and taken thence to the set. The metal on the fork should, of course, be cleaned before wrapping the wire on. It is not necessary, of course, to solder the wire. C. H.



# The Secret in the Base

THE tone of a "Sparta" has a difference that you can appreciate at first hearing. It is full, clear, convincing.

You can control it. The six stops of the tone modulator cover the whole range of vocal and instrumental reproduction. The new patent Magnetic Compensator gives a remarkably distinct rendering. The secret is in the base . . . there is no other speaker like it.

# SPARTA

Fuller

LOUD SPEAKER  
ELECTRIC WORKS, LTD.

ESSEX

Telegrams: "Fuller, Chadwell Heath."

The Type B "Sparta" is supplied with diaphragm adjustment and tone controller for six positions.  
120 ohms ... £5 15 0  
2,000 ohms ... £6 0 0  
4,000 ohms ... £6 0 0  
The Type A Model, without tone controller, supplied for 120, 2,000 or 4,000 ohms, £4 15 0

The "Little Sparta" is supplied in the same three resistances for ... £2 10 0

FULLER'S UNITED  
CHADWELL HEATH  
Telephone: Ilford 1200.

London Depot:  
176 Tottenham-Court Road, W.1.  
Telephone: Museum 9008.

174/49.

In writing to advertisers, please say you saw the advertisement in THE WIRELESS MAGAZINE.

## PIEZO ELECTRICITY

INTEREST in that very curious electrical phenomenon, piezo electricity, has been revived by the introduction, in America, of a new type of wavemeter in which quartz crystals are used as resonators. I remember that, when I first saw the term piezo electrical in a standard work on mineralogy, I was struck by the curious spelling, and I was sufficiently interested to hunt up the derivation of the word *piezo*.

I did not find the actual word itself but I found the word piezo-meter. The derivation of this word was given as from the Greek words *piezo*, "I press," and *metron*, "measure." There you have an explanation of the term piezo electricity, *pressure* electricity.

### "Pressure Electricity"

When certain minerals are compressed they become electrified, and electricity produced by applying pressure to these minerals is called piezo electricity—that is, pressure electricity.

Crystals of Rochelle salt are amongst the best known of the piezo-electrical substances. Quartz crystals do not possess this curious property to the same extent as Rochelle salt, but they have the great advantage of mechanical strength.

### Quartz

The chemical name for quartz is *oxide of silicon*, and here we see a relationship with an element very familiar to users of crystal detectors. Pure quartz is colourless. Impure quartz includes amongst its forms and colourings such precious stones as amethyst, agate, cornelian, jasper and onyx. An interesting thing with most interesting connections is this piezo electricity.

AERIAL.

HAVE you a cabinet for the new set you are building? If not, you should see about it at once, for even the best of sets will rapidly deteriorate if left exposed to the atmosphere. In this connection the Caxton Wood Turnery Co., of Market Harborough, remind us that they are willing at all times to submit prices for special cabinets.

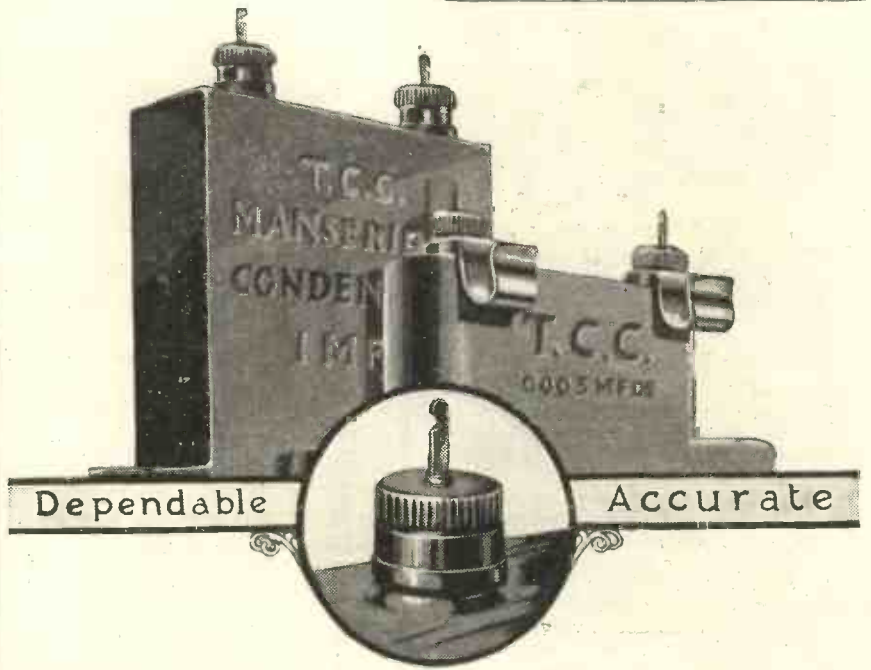

## Twenty years of knowing how!

THERE'S one thing every manufacturer needs but which money can't buy—experience. It is experience which has brought T.C.C. Condensers to the forefront today. Experience in manufacturing all types of fixed condensers—experience in dealing with the problems peculiar to insulation and capacity—experience in producing millions of condensers, large and small, Mansbridge and Mica.

Money could not buy this experience. It can only be obtained by paying the price—the price of

the passing years. For twenty years the Telegraph Condenser Co. Ltd., have been designing and building all types of Condensers. This invaluable knowledge is now passed on to you in the form of T.C.C. Condensers. By specifying T.C.C. in your next Set you will be assured of extreme accuracy and uncommon dependability. Remember, all T.C.C. Condensers in metal cases are genuine Mansbridge, while those in moulded cases are Mica. Each case is green in colour and bears the sign T.C.C. stamped on its side.



Look for the name T.C.C. Mansbridge stamped on the side of the green metal case

#### PRICES AND CAPACITIES.

Mansbridge, 2 mfd. -	4/8	Mansbridge, .1 mfd. -	2/6
Mansbridge, 1 mfd. -	3/10	Mansbridge, .09 to .01 -	2/4
Mansbridge, .5 mfd. -	3/4	Mansbridge, .009 to .005 -	2/-
Mansbridge, .4 mfd. -	3/2	Mica, .004 to .001 -	2/4
Mansbridge, .25 mfd. -	3/-	Mica, .0009 to 0.001 -	2/4

Every T.C.C. Mica Condenser is contained in a moulded green Case.

# T.C.C. MANSBRIDGE Condensers.

The Telegraph Condenser Co. Ltd., West Park Works, Gilbert Ad. 3969.

In writing to advertisers, please say you saw the advertisement in THE WIRELESS MAGAZINE.

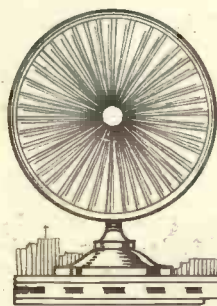

# Questions Simply Answered



## Receiving Through Earth

**Q.**—I use an indoor aerial in conjunction with a crystal set, and find that signals are stronger when the aerial is joined to the earth terminal of the set, and earth to the aerial terminal. Would you explain the reason for this?—F. C. (Bow).

**A.**—You are receiving your signals via the earth, the indoor aerial acting to all intents and purposes as a counterpoise or balanced earth.

Balancing is no doubt very poor, but nevertheless quite good results are often obtainable.

The experience is not unusual and should always be tried where an indoor aerial is employed.—Z.

## Three-valve for Distant Stations

**Q.**—I have built the special three-valver for distant stations as described in No. 7 of THE WIRELESS MAGAZINE, and have obtained exceedingly satisfactory results on the short waves.

Is it possible to use the set for the reception of 5 X X and, if so, what modifications are necessary?—M. S. (Willesden).

**A.**—The only radical change is that concerning the H.F. transformer. Wind another transformer with 160 turns of No. 36-gauge copper wire for the primary and 200 turns of the same gauge wire for the secondary. Tap the latter at the 100th turn for connection to the neutralising condenser.

By plugging-in a No. 150 coil for the aerial, and a No. 200 coil for reaction, satisfactory results should then be obtained.—K. M.

## H.F. and L.F. Amplifying

**Q.**—I have learnt that to increase the receiving range of a set H.F. amplification should be used, whilst to magnify the volume of sound for loud-speaker work L.F. amplifiers should be employed. This does not seem very clear, and I should like a little further explanation.—P. R. (Coventry).

**A.**—Whether a valve or crystal detector is employed for receiving purposes it should be realised that only impulses of a certain magnitude or power will operate them.

Some impulses emanating from a distant station may not be of sufficient power to make their presence felt when reaching the detector. It is therefore necessary to employ a valve to act as an amplifier, before the signals or impulses reach the detector.

As these signals are fluctuating at radio or high frequency, the amplifier must be tuned to respond to such frequencies.

## LET US HELP YOU

*IN operating or constructing a set you may possibly meet with some difficulty that you cannot solve yourself. It may be something to do with bad reception or you may be in difficulty over some connection.*

*Whatever it is don't worry yourself; let the Technical Staff of THE WIRELESS MAGAZINE do all the worrying for you.*

*Replies to queries of general interest are published each month on this page, but every querist is answered direct by post.*

*Please observe the following rules:*

*Ask one question at a time; write on one side of the paper only; attach to your query the coupon on cover iii, and send it with a stamped addressed reply envelope to The Editor, THE WIRELESS MAGAZINE, La Belle Sauvage, London, E.C.4.*

The design of such amplifiers does not lend itself to the most efficient amplification, consequently very little increase in volume is noticeable.

When once signals are of sufficient power to actuate the detector, they may be converted into audible frequencies and magnified to almost any power for loud-speaker work. Such magnifiers are known as audible-frequency or low-frequency note magnifiers, or amplifiers, and are the most efficient form of amplifiers possible.

With two such magnifiers sufficient volume can be obtained to work a loud-speaker.—L. A. C.

## Coil for Reinartz Reflex Set

**Q.**—What size coil should I use for the fixed coil-holder in the one-valve Reinartz receiver with reflex action described in No. 9 of THE WIRELESS MAGAZINE?—M. H. (Croydon).

**A.**—Insert a standard No. 75 plug-in coil in the anode circuit of this receiver. For the short-wave relay stations a No. 50 coil may be found to be better.—L. A. C.

## Aerial and Counterpoise

**Q.**—I am using a counterpoise instead of a direct-earth connection. When my set is not in use is it sufficient merely to connect the aerial and counterpoise together or should both be connected to earth?—A. S. (Windsor).

**A.**—It is not sufficient merely to join together the aerial and the counterpoise. In the event of lightning striking either the aerial or counterpoise there is no direct passage to earth.

Such should be afforded to all receiving systems to obviate danger.—L. A. C.

## Howling in L.F. Amplifier

**Q.**—Having built the three-valve amplifier for crystal purity described in No. 5 of THE WIRELESS MAGAZINE, I find that when the third valve is plugged in a howl or low whistling note is caused. Can you suggest a remedy?—T. R. (Wandsworth).

**A.**—Yes. Connect the negative terminal of the low-tension battery to earth.

If this does not stop the howl, then it may be due to microphonic interaction between the valves and the loud-speaker, but this should not be the case, especially if you have employed the anti-phonic valve holders as specified.—K. R. D.

## Disconnecting the Batteries

**Q.**—I have built the four-valve set described in your February issue, but am not sure whether there is any necessity to disconnect the H.T. battery when the switch is in the central position.—F. A. (Cardiff).

**A.**—When the set is not in use and the switch is in the central position, the filament circuit is broken.

This automatically stops the internal action of the valve and so prevents current flowing from the H.T. battery. There is no real need for an H.T. switch in this receiver.—L. A. C.

## Best Valve for Single-valver

**Q.**—What do you consider the best type of valve for a single-valve set, irrespective of make?—F. C. (Windsor).

**A.**—A soft valve or one having a certain percentage of gas injected into the bulb after evacuation is undoubtedly the best.

A soft valve will give off a blue glow from the anode when between 30 and 45 volts are applied to it.

A repaired valve will often be found to be a good detector, as some of these are not fully exhausted.—J. M. C.



**EBONITE—  
and Ebonite!**

THE difficulty in choosing ebonite is that the appearance to the eye is no criterion of worth or value. Really bad, dangerous stuff may look almost as good as the highest quality insulation.

It comes to this, then, that you are at the mercy of the dealer, and if he likes to sell you bad stuff you may not be able to discover this fact for yourself until you have built your set, and repeated tests and trials have shown you that something is radically wrong.

**Price**

The price you pay for ebonite is a rough, but not a sure, guide. As a general rule in business you get what you pay for—sometimes less, but seldom more—and you cannot reasonably expect to get at one shop for 1s. 6d. per lb. what you get at another shop for 3s. 6d. per lb.

It is very easy to give way to the temptation to buy cheap components and cheap materials, and run away with the belief that they are “just as good.” They seldom are, and I suppose they *never* are in the case of ebonite.

From very costly experience I am convinced that there is only one sure guide in buying ebonite, and that is to buy *branded* ebonite—the material that is advertised in the wireless papers, and one that is either stamped by the manufacturer or packed in his own unmistakable way.

**Research**

These brands are always dearer in first cost than the cheapest grades of unbranded ebonite. Often they cost just about the same as the best makes of unbranded ebonite, but you do know what you are getting—a material behind which is the guarantee of a manufacturer who has probably spent thousands of pounds in research; who tests his product regularly and who could, if you so wished, send you a copy of a certificate showing exactly the electrical properties of the stuff he is selling.

I am all the time for branded ebonite, and I think as the amateur constructor gets wiser in the game, he will agree with me absolutely.

E. J. B.

**Jim Vesey builds the  
Modern Wireless  
Special Five—**

A few days ago I ran into Jim Vesey in the Strand. “I want you,” he said, “to come over to Golders Green one evening next week to see my new set.” “What, another new one?” I asked, for Jim has made so many that I lost count. “Yes,” said he, “but this one is a winner. Bournemouth on the Loud Speaker without a trace of 2 L O—how’s that for selectivity?” “Easy,” I said, with a chuckle, “when London has closed down.” “No, don’t be silly—I have really built a selective set at last, and if you come along I’ll show you how it’s done.”

Of course, with my curiosity thus whetted I couldn’t resist going over to Golders Green to see this wonderful set. “Here you are,” said Jim, pointing to an imposing-looking five-valve set. “Yes,” I replied, “but I came to see the one you built.” “That is the one,” he said, indignantly. “Except for the cabinet, which cost three guineas, I built up the whole set.” I hastened to congratulate him and smooth his ruffled feelings. “Splendid,” I said, “it is a better-looking set than my neighbour, Alec Hurley, paid £43 for last month.” “And I’ll bet it gives better results,” cut in Jim, as he lifted up the lid and exposed the rear of the panel.

“What peculiar-looking coils!” I remarked. “Yes,” he replied, “they are the little fellows that enable me to cut out 2 L O, and get Bournemouth on the Loud Speaker. Pass me that H.T. Battery and we’ll see what’s on.” He connected up, adjusted the rheostats and plugged in the Loud Speaker. “London calling,” said the voice, “Mr. Walter Hyde will now sing ‘Vagabond’ by



John Ireland.” The song began. “Now listen,” said Jim, as he rotated the three dials a few degrees to the left. “In three minutes the Bournemouth Orchestra will play ‘La Berceuse;’” came a voice from the Loud Speaker. “There,” said Jim, “now be convinced.”

“Well,” I had to admit, “it is a good job I heard it myself as I should not have believed it possible to cut out 2 L O as close as this. Tell me, how long did it take you to build this set?” “Two evenings only,” he said, “one to assemble the components and one to wire up.” “But what about the drilling and cutting of the panel?” I asked. “Oh, you don’t need to worry about that—do as I did—send to Peto-Scott’s for a complete kit. It comes already for assembly with panel drilled and engraved—everything down to the last screw. All the lot cost me only a ten-pound note.” “Good heavens! that’s cheap,” I said. “Yes,” he replied, with a twinkle in his eye, “and if you make a mess of it they’ll put you right for a few shillings! Just send for a copy of their Pilot Manual\* and read all about it.”

\* Detach the coupon below and post to us with three penny stamps to cover postage and we will send you a copy.

**PETO-SCOTT CO. LTD.**

77 CITY ROAD, E.C.1

BRANCHES: 62 High Holborn, London, W.C. 1.  
Walthamstow: 230 Wood Street.  
Plymouth: 4 Bank of England Place.  
Liverpool: 4 Manchester Street.

**Pilot Sets  
for home Constructors**

Peto-Scott Co. Ltd.  
77 City Road, E.C.1

Please send me a copy of the Pilot Manual, giving detailed working instructions and illustrations for building many of the well-known Radio Press Sets. I enclose 3d. to cover cost of postage, etc.

Name.....

Address.....

Gilbert Ad. 3951

A USEFUL device which automatically indicates the types of valve to use with two-, four- and six-volt accumulators can be had from The General Electric Co., Ltd., Magnet House, Kingsway, London, W.C.2.

Particulars of Igranic components will be sent on application to Igranic Electric Co., 149, Queen Victoria Street, London.

The new catalogue published by Falk, Stadelmann & Co., Ltd., 83-93, Farringdon Road, London, deals with the full range of Efesca components.

Economic Electric, Ltd., of 10 Fitzroy Square, London, W.1, will send their new catalogue on request.

The new catalogue issued by The Dubilier Condenser Co. (1925), Ltd., Ducon Works, Victoria Road, North Acton, London, W.3, contains full particulars of Dubilier products.

Details of the Athol reversible valve holder are given in a booklet issued by The Athol Engineering Co., Cornet Street, Hr. Broughton, Manchester.

A folder giving full details of their "super het" receiver outfit has been issued by Igranic Electric Co., Ltd., 149, Queen Victoria Street, London.

A catalogue giving details of some of the principal components made in various countries throughout the world has just been completed by Will Day, Ltd., and Dayzite, Ltd., of 18-19, Lisle Street, W.C.2. A copy will be sent post free for 6d. (callers free).

# Catalogues and Pamphlets

Philips-Mullard valves and Mullard accessories are described in leaflets issued by The Mullard Radio Valve Co., Ltd., 45, Nightingale Lane, Balham, London, S.W.12.

"A Talk to Valve Users" is the title of a handy little book obtainable from Metro-Vick Supplies, Ltd., 4, Central Buildings, Westminster, London, S.W.1.

All readers should write for these catalogues, which will be sent gratis and post free if THE WIRELESS MAGAZINE is mentioned.

The Homecharger, for charging either H.T. or L.T. batteries at home, is fully described in a leaflet issued by The Carpax Co., Ltd., 312, Deansgate, Manchester.

Radio Instruments, Ltd., 12, Hyde Street, New Oxford Street, London, W.C.1, have recently issued a pamphlet giving full particulars of their high-frequency reactive anode unit.

Sparta radio accessories are described in the new catalogue obtainable from Fuller's United Electric Works, Ltd., Chadwell Heath, Essex.

Autoveyors, Ltd., 84, Victoria Street, Westminster, S.W.1, will send a leaflet describing their new connecting wire, Radio Condit, on request.

A. J. S. receivers are fully described in a new publication issued by A. J. Stevens & Co. (1914), Ltd., Radio Branch, Wolverhampton.

A new edition of the "Reliability Wireless Guide" has just been issued by J. H. Taylor & Co., Macaulay Street, Huddersfield.

Literature dealing with the Chakaphone range of receivers can be had from the Eagle Engineering Co., Ltd., Warwick.

Prince's Electrical Clocks, Ltd., 173, New Bond Street, London, W.1, have issued a booklet which fully describes the Princeps receiver.

Tools of interest to wireless set constructors are described in a folder issued by Rockwood Co., Ltd., 147, Queen Victoria Street, London, E.C.4.

The publications issued by Enterprising Mfg. Co., Ltd., Electric House, Grape Street, Shaftesbury Avenue, London, W.C.2, give full details of components and wireless accessories.

Particulars of Clear Speaker wireless products are contained in leaflets obtainable from Clear-Hooters, Ltd., Hooterland, Highgate Square, Birmingham.

USE

# SIEMENS BATTERIES

And

## ENSURE SATISFACTORY RECEPTION

MANUFACTURED THROUGHOUT AT WOOLWICH

Obtainable from all leading dealers

SIEMENS BROTHERS & CO., LTD., WOOLWICH, LONDON, S.E.18



REG. TRADE MARK

In writing to advertisers, please say you saw the advertisement in THE WIRELESS MAGAZINE.

# Two outstanding developments in Radio Design



## Polar-Twin

A Two-valve, single dial, Loud Speaker Set, at a remarkably low price, and without any complications.

The Polar-Twin Set is for use with dry cells or accumulators, can be switched on or off with a single knob, and has a surprising "Loud Speaker" range. It will readily operate a Loud Speaker at a distance of 20 to 60 miles from a main Broadcasting Station, and has even proved effective in loud-speaker reception up to 400 miles. (See letters of testimony in our possession.)

### Tuning is Effected with a Single Knob

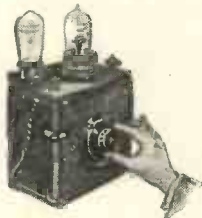

A unique plug-in Aerial-Reaction coil System is used, and tuning for all B.B.C. short-wave stations is effected on one dial.

The Complete Set at £12 12s. includes the Polar-Twin Receiver, 2 Mullard Polar D.3 valves; 2 H.T. Batteries, 66 v. each, and Plugs: 1 C.A.V. 2 v. accumulator completely charged; 1 Short-Wave Coil Unit; 1 Daventry ditto; 1 Amplion A.R.38 Loud Speaker and the necessary connecting wires.

**Complete £12 12 0**

Cabinet as illustrated above, £1 7 6 extra.



## Polar-Four

A Four-valve powerful Set with dual tuning systems and a unique system of Remote Control.

The Polar-Four has been designed so that it can be placed inconspicuously in any room or in the garage, etc., and by means of a simple system of triple lead-covered wire and specially designed Jack Boxes the Loud Speaker and Remote Control can be plugged-in and operated from any point of the wiring system. Wherever these are plugged in, on the system, complete control can be obtained just as if the Set itself were present.

### The Remote Control Box

Permits switching over from one station to the other at will. It also regulates and turns on and off the filament current.



PRICE, without accessories, but with Remote Control and L.S. Jacks, Coil Units for two Stations and Leads, including royalty,

**£32 10 0**

Polar Service Agents will install, adjust and maintain your Polar-Twin or Polar-Four Set. You can have one fitted within 24 hours. Write for name of nearest Agent and descriptive leaflet, sent post free.

Write for descriptive leaflets and all particulars to

**Radio Communication Co. Ltd.** 34-35 Norfolk St. Strand, W.C.2.



In writing to advertisers, please say you saw the advertisement in THE WIRELESS MAGAZINE.



THE centre of amateur activity this winter is the band of wavelengths between 30 and 50 metres, familiarly known as the "45-metre band."

### Generous Treatment

The generous treatment accorded to British amateurs in allowing them a choice of "camping ground" between 44 and 46 metres, has very considerably lessened interference on this side; but our portion of the band is still very crowded, particularly on Sunday mornings when certain operators persist in taking up more than their fair share of the ether with telephony experiments.

The "ham" is a reasonable soul, and believes in giving everyone a

chance to do what they want to do; but there is a strong feeling arising amongst the "brass pounders" that a distinct band of frequencies should be given over to short-wave telephony experiments, leaving the morse people with a chance of getting out and receiving without the perpetual "srri, om, QRM," which is the constant cry on Sunday during the hours of daylight.

Morse, when it is continuous wave, can be very sharply tuned; but telephony, in common with other modulated transmissions, like interrupted continuous waves, and the raw altern ting current that is so popular with certain Continental amateurs, occupies quite a large band.

The laws which govern trans-

mission and reception on the broadcast belt, and above, would seem to be reversed in the case of the 45-metre band. As every BCL knows, reception of broadcast telephony is better by night than it is by day, when distant stations are being received.

### Increased Strength

Directly the sun has gone down, all sorts and kinds of stations that cannot be picked up, or only faintly, during daylight, come in at good strength. On the 45-metre band British and Continental stations become very faint with the setting of the sun, and many of them are not to be heard at all.

(Continued on page 658)

# Cassell's "AMATEUR MECHANIC" AND "WORK" HANDBOOKS

1/6 each net or 1/9 post free from the Editor of  
"Amateur Mechanic," La Belle Sauvage, E.C.4.

#### NEW SPRING ISSUES

Electrical Toys and Tricks  
Motor-car Overhaul and Adjustment  
Practical Leather Working  
Practical Upholstery Illustrated.  
Wood Turning Made Easy.

Basket Making  
Beehives and Bee Keepers' Appliances  
Bent Iron Work. Bookbinding  
Boot Making and Mending  
Camera Making  
Clock Cleaning and Repairing  
Conjuring Apparatus  
Cycle Repairing and Adjusting  
Domestic Jobbing  
Dynamo and Electric-motor Building  
Dynamo and Motor Erection and Management  
Electric Accumulators  
Electric Bells and Telephones  
Electric Clocks Electric Lighting

Electric Primary Batteries  
Furniture Repairing  
Gilding, Silvering and Bronzing  
Glass Writing, Embossing and Fascia Work  
Gramophones and Phonographs  
Handyman's 1,000 Practical Receipts  
House Painting and Decorating  
Household Repairs  
Incubators and Chicken Rearers  
Induction Coils  
Knotting and Splicing Ropes and Cordage  
Magneto Repair and Adjustment  
Metal Turning Made Easy  
Miniature Electric Lighting  
Model Aeroplanes  
Motor Cycles and Side-cars; Erection, Construction, Management etc.  
Oxy-acetylene Welding  
Patents, Designs and Trade Marks  
Photography Simplified

Pianos  
Poultry Houses and Appliances  
Pumps and Hydraulic Rams  
Rustic Carpentry  
Sewing Machines  
Small Dynamos and How to Make Them (including Electric Motors)  
Small Electric Apparatus  
Small Lathes—Making and Using  
Small Workshop Appliances  
Soldering, Brazing and Welding  
Stage Illusions and Entertainments  
Tailoring Taxidermy  
Ticket-writing and Sign Painting  
Tinplate Work  
Toy Making  
Violin Making and Repairing  
Watch Cleaning and Repairing  
Wireless Telegraphy and Telephony  
Wood Finishing  
Workshop Arithmetic  
Workshop Hints for Metal Workers

Cassell's,

In writing to advertisers, please say you saw the advertisement in THE WIRELESS MAGAZINE.



# Enchantment -



The R.I. Lyrianette Receivers are the only really self-contained sets on the market, there being only two connections outside the set.

Lyrianette 2-Valve ... £19 3 0  
 Marconi Royalty £1 5 0 extra.  
 3-Valve Model ... £23 12 0  
 Marconi Royalty £1 17 8 extra.

Spellbound by the beauty of the music, she sees a wealth of wonderful pictures in the heart of the glowing fire and a host of her own particular fairies with their magic wands tipped with the sweetest sounds ever heard. Yes! it's a real boon to have a wireless set that gives perfect musical reception, for only the best music can hold one spellbound and lend that wonderful air of enchantment.

The new R.I. 4-Valve Cabinet Receiver gives all this and more. The amplification of every note is perfect, and those delicate overtones portraying soul and personality are all present, combining to build up a beautiful structure of musical architecture.

All the latest R.I. improvements are embodied in this set which covers a range of 300-4,000 metres and employs one stage of high-frequency-tuned anode—one detector and two low-frequency valves. R.I. Duostats are fitted so that either dull or bright emitter valves may be used, and aerial reaction is employed in conjunction with the R.I. Retroactive Tuner.

The R.I. 4-Valve Cabinet Receiver combines Perfect Musical Reception with Beautiful Finish.

**Price £21 10 0**

Marconi Royalty £2 : 10 : 0 extra.

Write for the new R.I. blue and gold Catalogue.

**THE MARK OF BETTER RADIO**



Advt. R.I., Ltd., 12, Hyde St., New Oxford St., London, W.C.1.

P.S.2

In writing to advertisers, please say you saw the advertisement in THE WIRELESS MAGAZINE.

# BELOW THE BROADCASTING BELT (Continued from page 656)

It is a curious thing to pick up an American or Australian station working with a Briton, and be able to hear the far-distant amateur at good strength, and then find the home station almost inaudible, if you can hear him at all. The reason for this phenomenon is not really known, but investigations are proceeding, and by the time the winter season is over we may know something about it.

### Times to Listen

Something is going on between 30 and 50 metres almost every hour of the day and night, and it is difficult to switch on a short-wave receiver at any time without picking up something; but there are definite times when the greatest number of stations can be heard.

If you like to get up at 5 a.m., for instance, you will be richly rewarded. For at least half an hour you should hear the short-wave programme sent out by the American broadcast station W G Y on about 39 metres, and you can, of course, pick up other telephony on rather higher wavelengths.

But the greatest interest is in the amateur work that is going on. Any amount of American and South American stations can be picked up, and, as daylight begins to come along, you should hear Australians and New Zealanders as well.

They get very strong round about 8 a.m. and then seem to disappear until the afternoon, when they can be heard again from about 2 p.m. until two or three hours after sunset.

But conditions vary with different states of the atmosphere, and good and bad conditions seem to be more sharply and clearly defined on the 45-metre band than they are on higher waves. We hope to learn a great deal about atmospheric conditions as they affect wireless from our work this winter.

The luncheon hour seems a favourite with certain Continental amateurs, particularly those in Holland, Belgium and Italy, and several can usually be heard between 35 and 45 metres any time between noon and 2 p.m. There is a great deal

going on, on a good evening, between 5 p.m. and 7 p.m., but after that, as a rule, the Continental stations fade out, as I have before explained.

### Twenty-metre Band

The 20-metre band, in which Britons are allowed to participate on a fixed wave of 23 metres, seems more or less deserted now, though there are a few faithful souls still clinging to it. They are mostly Americans, with a few Britons to keep them company.

This band is very good indeed for daylight communication over great distances, but it is not so good for all-round day and night communication.

Most of us can only keep one transmitter going at a time, and so the enthusiasts who have special permits have most of them taken up their abode between 44 and 46 metres, and have left the lower waves alone. I suppose they will tackle them in the summer. That is the programme I have laid out for myself.

5 Y M

## "Now a word on handling RADIO CONDIT,"

says CLIXIE



"CLIXIE"

Fingers  
to bend  
CONDIT.  
No pliers,  
please!

"If you'll always remember what RADIO CONDIT is and act accordingly, you'll never go wrong in handling it," says CLIXIE.

"CONDIT is copper tape curled up into split tubing (= 16 s.w.g.). The two reasons why you shouldn't twist it about like ordinary wire are obvious. First, because it amounts to wire with the middle left out; second, because it's split.

"So bend CONDIT carefully with your fingers. Avoid acute angles. With normal care you can 'persuade' it into practically any shape without opening the split. If the tubing does open at the split, no real damage is done; the effect of the split is to eliminate lateral surgings. That effect is unimpaired:

"When you to use pliers for terminal-loops and the like, make them round-nosed pliers, please!"

## RADIOCONDIT

The H.F. Conductor

(P. Patd.)

Per packet of six 2-ft. lengths ..... 2/-  
Per coil of 12 ft. ....

Obtainable from all Wireless Dealers  
or direct from the Patentees:

AUTOVEYORS LTD., 84 VICTORIA STREET, LONDON, S.W.1

## The Secret of Better Reception

Every day more and more wireless users are finding out what an immense improvement in reception is effected by the new GECOPHONE Super-Capacity H.T. Radio Batteries. These Batteries are the latest development in BRITISH battery manufacture and are distinguished for

LONG LIFE  
LARGE CAPACITY  
SILENCE IN USE and  
MINIMUM INTERNAL  
RESISTANCE



# GECOPHONE

Super-Capacity High Tension RADIO BATTERIES.

Prices from 7/6 to 21/6.

Sold by Wireless and Electrical Dealers everywhere.

Manufacturers: The General Electric Co., Ltd., Magnet House, 6, 1/2, 3, 4, 5, 6, 7, 8, 9, 10, 11, 12, 13, 14, 15, 16, 17, 18, 19, 20, 21, 22, 23, 24, 25, 26, 27, 28, 29, 30, 31, 32, 33, 34, 35, 36, 37, 38, 39, 40, 41, 42, 43, 44, 45, 46, 47, 48, 49, 50, 51, 52, 53, 54, 55, 56, 57, 58, 59, 60, 61, 62, 63, 64, 65, 66, 67, 68, 69, 70, 71, 72, 73, 74, 75, 76, 77, 78, 79, 80, 81, 82, 83, 84, 85, 86, 87, 88, 89, 90, 91, 92, 93, 94, 95, 96, 97, 98, 99, 100.

In writing to advertisers, please say you saw the advertisement in THE WIRELESS MAGAZINE.



**NO  
CONDENSER**  
of the Mansbridge type is a genuine product of the Mansbridge Condenser Co. Ltd.—unless the words MANSBRIDGE CONDENSER are plainly embossed on the metal case. The colour of the case is maroon. Guaranteed by the Dubilier Condenser Co. (1925) Ltd. who are the sole concessionaires.



**Specify Mansbridge  
PRICE AND CAPACITY.**

Capacity.	Price.	Capacity.	Price.	Capacity.	Price.
0.02-0.05 mfd.	2/6	0.25 mfd.	3/-	0.50 mfd.	3/6
0.10 "	2/6	0.30 "	3/-	1.00 "	4/-
0.20 "	2/8	0.40 "	3/3	2.00 "	5/-

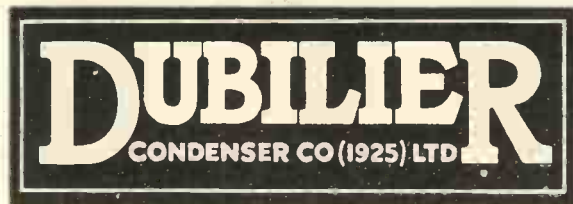

ADVT. OF THE DUBILIER CONDENSER CO. (1925), LTD.,  
DUCON WORKS, VICTORIA ROAD, NORTH ACTON, LONDON, W.3.  
Phone: Chiswick 2241-2-3. E.P.S.3

In writing to advertisers, please say you saw the advertisement in THE WIRELESS MAGAZINE.

# Good Sound Furniture

ECONOMICAL and LONG-WEARING

CASH or EASY PAYMENTS.—  
Free and Safe Delivery to all parts.



If not approved of, can be returned at our expense, and any money paid will be refunded in full.



£2 down, and 17/6 monthly for 24 months. Cash price: 20 guineas.



The "Osborne" Suite of Settee (one end adjustable) and Two Easy Chairs. All of comfortable size—our standard reliable upholstery work, interior coppered steel springs—British Web—best canvas—fibre and wool—patent push-in Castors—Loose Down Cushions, covered in Tapestry or Corded Velvet, in pretty shades of Greys, Browns, Reds, Greens, or Golds. Patterns on application.

**FREE** Our Fully Illustrated Catalogue, together with Terms, etc. A perusal of this will save you Pounds in Furnishing.

**GLOBE** Furnishing Co. Ltd. (Dept. R), Pembroke Place, LIVERPOOL  
J. R. GRANT, Governing Director.

## Build Your Own Set

We specialize in all Components for the Home Constructor, including the Distortionless 3 Valver, Step-by-Step Super Het., One Valve Amplifier, Crystal Set, and all apparatus described in "Wireless Magazine."

LISTS ON APPLICATION.

**OMNORA LTD.,**  
Specialists in Wireless Apparatus,  
288, Borough High St., London S.E.1

## READY-TO-MAKE CABINETS.

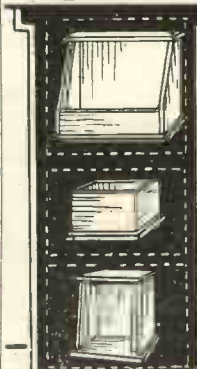

Make a Cabinet to fit your set from these parcels where the parts are already cut to size. All you have to do is to glue or screw together. Supplied in five different styles—for crystal or valve—and all nicely grained mahogany, planed and cut ready for use with instructions enclosed.

**PARCELS OF MAHOGANY CUT TO SIZE—1/6 to 6/6**

FREE

You will be interested in our illustrated Wireless Wood Lists. They will be sent upon application to Dereham as below or obtainable at any branch.

A SPECIAL LIGHTNING POLISH IS ALSO MADE WHEREBY A BRILLIANT FINISH CAN BE OBTAINED

**HOBBIES LTD (Dept. 26) DER HAM NORFOLK**

# Notings on the Month's Progress

THE B.B.C. hope to arrange a series of transatlantic telephony tests towards the end of January for the special benefit of British and American amateurs anxious to try their hand at long-range work under organised conditions.

## Tabulated Results

Results on both sides of the water will be tabulated, and are expected to provide an interesting basis of comparison as to the respective merits of the various types of receiving circuit used.

Owing to the prevalent ether congestion American practice has inclined more generally to the use of various "super" selective circuits such as the "super het" and neutrodyne, and their derivatives, than is the case here, where the ordinary straight circuit is more widely favoured.

It will be interesting, however, to see which type of receiver will prove

most efficient for long-range work during the tests in question.

\* \* \*

## The Washington Conference

The International Radio Conference to be held in Washington this spring is the most important gathering of its kind since the London Conference of 1912. Invitations to attend have been addressed to no less than forty-two different governments, most of whom have expressed their intention to accept.

The subjects to be discussed include the revision of the International Radio Telegraph Convention, and the matter of ways and means for the international supervision of radio communication between high-powered stations.

The whole subject of broadcasting will be treated from an international aspect, including measures for reducing mutual interference between different transmitting stations, and

the safeguarding of S O S and similar distress signals from broadcast interference.

Standardised regulations governing the use of direction-finding equipment, both for marine and aerial navigation, and also the provision of "radiophares," or wireless light-houses, along dangerous coast lines are tabled for discussion, together with various other aspects of radio practice which have sprung into being since the 1912 Conference.

\* \* \*

## Crystal Oscillators

Captain Round, of the Marconi Company, has recently secured a patent covering the use of a regenerative or oscillating crystal for increasing the normal range of crystal reception. His circuit arrangement is similar to that published some months ago by the Russian physicist Lossev, and comprises a crystal of

(Continued on page 662)

# More **TRIX** Products

Regd.

## The **TRIX** Illuminated Detector

(Patent applied for.)

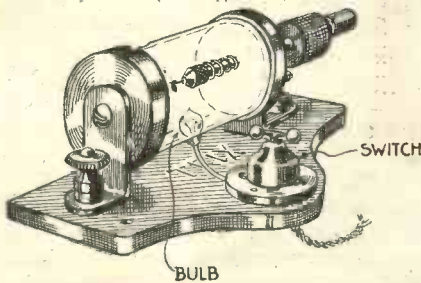

## Be kind to your Crystal—

Don't poke at it blindly in the dark. Here is a micrometer detector with an **ELECTRIC LAMP INSIDE**, controlled by a switch on the base. A flash lamp battery will light the lamp.

Experimenters report improved reception when the lamp is alight. This opens up new possibilities.

British Made.

5/-

## Ask for

- | Cat. No. | Description  | Price |
|----------|--|-------|
| 16.      | "Trix" Anti-capacity Valve Grips, 8d per set.  |       |
| 37.      | "Trix" H.F. Variable Transformer, Plug-in Type, 300.3,200, 17/6 each.  |       |
| 111.     | "Trix" Variable Condensers, Square Law. Cut Ebonite End Plates. All Capacities. (0005 with Vernier, 9/6 complete.) |       |
| 176.     | "Trix" 4-way Battery Cord (for connecting H.T. and L.T.), 2/9 each.  |       |
| 179.     | "Trix" 1-way "Pull and Push" Panel Switch, 1 Hole Fixing, 1/3 each.  |       |
| 189.     | "Trix" 2-way Ditto, 1/9 each.  |       |
| 190.     | "Trix" "T" Bus Bar Connectors, 4d. per doz. (It makes soldering easy.)   |       |
| 192.     | "Trix" Micro Adjustment Adaptor. (It will turn any Standard Detector into the Micrometer Type.) 6d. each.          |       |
| 134.     | "Trix" Pole Finding Book (12 pages) 2d. per book.  |       |
| 182.     | "Trix" Basket Coil Holder, plated phone terminal connections, extra large disc, 2/- each.                          |       |
| 17.      | "Trix" Hertzite crystal (in glass tubes). 1/- each.  |       |
| 145.     | "Trix" Battery Connector Board (for assembling pocket batteries). 2/6 each.  |       |
| 256.     | "Trix" L.F. Shrouded Transformer, Ratio 5—1. 7/6 each.   |       |
| 239.     | "Trix" Panel Mounting Angle Brackets (For Pull-Out Panels).  |       |
| 255.     | "Trix" H.F. Barrel Type Transformers, Cut Ebonite. Sizes 00 to 3. 7/- each.  |       |

## The **TRIX** Inspection Lamp

(Patent applied for.)

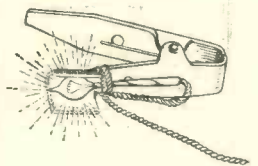

Throws a light on all your radio troubles. Clips on to any convenient point in your receiver, and will work from a flash lamp battery or a 4-volt accumulator.

2/6

## TRIX PARTS

Obtainable from all dealers. Factors, Trade and Shippers only supplied.

Manufactured by  
**ERIC J. LEVER**  
33, CLERKENWELL GREEN, LONDON, E.C.1.

In writing to advertisers, please say you saw the advertisement in THE WIRELESS MAGAZINE.



# THE "ONDIA"

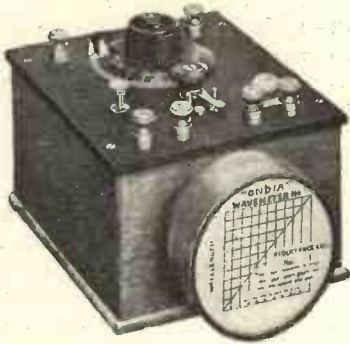

## WAVE METER

Measures from 25 to 25,000 m., and is guaranteed accurate within 1½ to 2%. Equally suitable for calibrating inductances and capacities. Price complete with 4 coils and 5 calibration charts for standard range of 80-4,500 m. or as required.

£4 : 4 : 0

Descriptive Booklet upon demand 2d. postage.

**GOODCHILD & PARTNERS LTD.**

57 EAGLE STREET, LONDON, W.C.1

## YOU WANT THE BEST

When buying coil holders, ask for "Lotus" and you will get the best.

### "LOTUS" Coil Holders

are made from Bakelite mouldings with nickel-plated fittings; they are an ornament to any set and they give the best results.

**TESTIMONIAL.**—"I should like to take this opportunity of saying how glad I am that I fitted your coil holder. I can now, without any other alteration in my set (Det. L.F.) receive 6 stations with comparative ease, where before tuning in of 3 was an achievement."

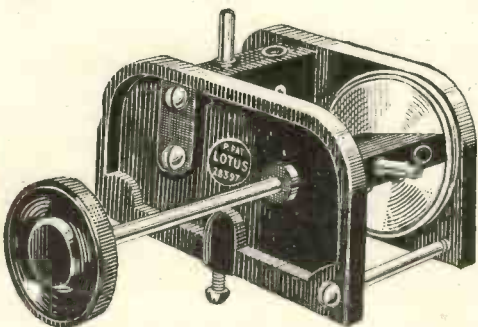

THERE ARE TWO TYPES OF "LOTUS" COIL HOLDERS  
 For Outside Panel Mounting. For Inside Baseboard Mounting, 6 in. handle. Two way, 7/-; Three way, 10/6. Two way, 8/-; Three way, 12/6  
 The Vernier movement is actuated by three sets of encased Precision Cut Gears, representing a reduction of 8 to 1.  
 MOVING BLOCK CANNOT FALL.

**GARNETT, WHITELEY & CO., Ltd.,**  
 Lotus Works, Broadgreen Road, LIVERPOOL.

# Why Worry?



## EFESCA COMPONENTS solve all the problems of the amateur

All the difficulties of wireless construction disappear when you build your set with EFESCA One-Hole-Fixing Components. They embody the latest developments in wireless practice; are made with engineering precision and instrument finish, and enable the amateur to make a set of finished appearance and highest efficiency.

### EFESCA Regenerative AERIAL TUNER

is a specially designed form of Tapped Aerial Coil incorporating Aerial Reaction in a self-contained unit. Reaction is effected by means of a rotor revolving in a separately wound section of the Aerial Coil, thereby effecting maximum and uniform reaction over the whole wave band covered by the coil. Wavelength range 150 to 2,600 metres in conjunction with a .0005 Variable condenser in parallel. Price, complete with Knob, Pointer and Scale, 32/-.

### EFESCA L.F. TRANSFORMER TYPE "B."

Primary winding consists of the number of turns necessary to produce an impedance at average speech frequency to match the average impedance of our "R." type valve.

Turns ratio, 4 to 1. One hole fixing, price 23s.

### EFESCA VERNISTAT.

Ideal for delicate filament control. 5 ohms or 30 ohms resistance, 6s. each.

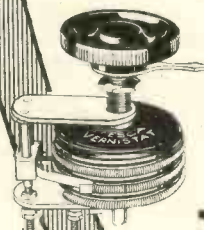
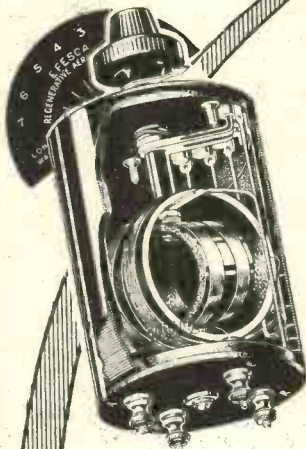

Ask Your Wireless dealer for

# EFESCA COMPONENTS

Or write for Catalogue 559/11—it is free, and full of interest.

WHOLESALE ONLY:—

**FALK, STADELMANN & CO., LTD.,**  
 Efesca Electrical Works,  
 83, FARRINGDON ROAD, LONDON, E.C.1.

500,000 to 10,000  
365  
185  
10

# JOTTINGS ON THE MONTH'S PROGRESS (Continued from page 660)

arsenite, zincite, tellurium, or magnetite shunted across the aerial inductance in parallel with a high-tension battery, the latter being in series with a resistance.

### Like a Crystal

Captain Round points out that a metallic plate coated with a film of oxide will act in just the same way as a piece of crystal. The oxidation may be produced naturally by exposure to the atmosphere, or artificially by treatment with an electric arc. A zinc plate which has first been coated with white oxide and has then been subjected to an arc discharge, producing a reddish brown deposit, has given particularly good regenerative results on relatively short wavelengths.

### Improving Results

The "oscillating" property of an ordinary crystal can be considerably improved by setting the crystal in a cup by means of Wood's metal and then connecting the metal cup in series with a resistance of 7 ohms

across a high-tension battery of 100 volts. A small carbon electrode is connected to the negative pole of the battery and is brought close to the face of the crystal until an arc is struck across the two. The carbon is then moved backwards and forwards several times, so that the arc is drawn out and contracted. A slight crater of darkly glazed material is thus formed on the crystal, and is found to be highly sensitive as an "oscillating" medium.

Apart from their use in reception, such crystals can of course be utilised to generate oscillations suitable for transmitting signals over short distances.

### Colloidal Rectifiers

A novel form of wireless detector, at present in the experimental stage, consists of a special cell containing a solid electrode of aluminium or nickel, co-acting with a second electrode of finely divided graphite or silver suspended as a colloidal solution in sulphuric acid.

The incoming waves are applied

across one terminal (connected to the nickel electrode) and a second terminal making contact with the upper surface of the colloidal solution. The intervening layer of the solution is found to possess rectifying properties, passing current in one direction but not in the other. By inserting a grid or control electrode between the two primary electrodes, and inserting a high-tension battery across the latter, the received energy can be amplified by a similar action to that of an ordinary valve.

### Heating Coil

The active materials may also be made up in dry-cell form, but here it is necessary to use a heating coil in order to start the rectifying action. Once the action has started, however, the heating coil can be cut out of circuit.

The so-called Colloid rectifier now being widely used for recharging accumulators at home from A.C. electric-light mains depends upon the same curious property of silver in the colloidal state. B. A. R.

## FAULTY INSULATION! CAXTON 4-VALVE CABINET

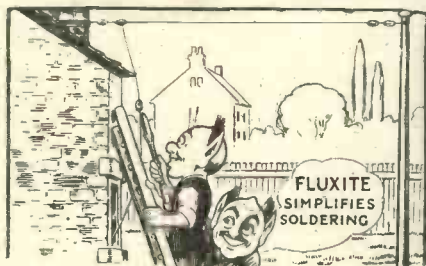

Solder those joints with FLUXITE, and they become one unbroken piece of metal. You will be surprised at the improvement in the quality of your reception.

### FLUXITE SIMPLIFIES SOLDERING

and makes it easy for every wireless enthusiast to ensure maximum results from his set.

Ask your Ironmonger or Hardware Dealer to show you the neat little

### FLUXITE SOLDERING SET

It is perfectly simple to use, and will last for years in constant use. It contains a special "small-space" Soldering Iron with non-heating metal handle, a Pocket Blow-lamp, FLUXITE, solder, etc., and full instructions. Price 7/6. Write to us should you be unable to obtain it.

Price 7/6



### FLUXITE SIMPLIFIES SOLDERING

All Hardware and Ironmongery Stores sell FLUXITE in tins, price 8d., 1/4, and 2/8.

Buy a Tin To-day.

FLUXITE LTD. (Dept. 332), West Lane Works, Rotterhithe, S.E.16

Hardening Tools & Case Hardening  
ASK FOR LEAFLET on improved methods.

ANOTHER USE FOR FLUXITE.

Made for Editor of Wireless Magazine for Set "As good as money can buy" described in issue February, 1925.

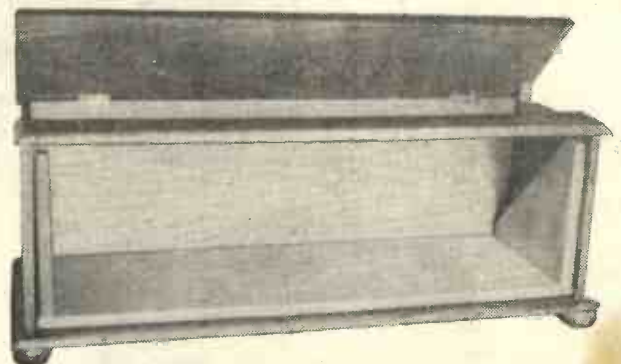

Cash with Order. Fumed Oak ... £1 5 0

or Real Mahogany polished ... £1 14 0

With detachable recess fitted Base Board to mount 21 in. by 7 in. panel to slide out of Cabinet front.

Extra 10/- with two beaded front doors totally enclosing fitted panel.

Cabinet overall length 22½ ins. Width 8½ ins. Height 9 ins.

Polished with the new enamel that gives a glass hard surface that cannot be soiled or scratched.

SENT FREE.—Catalogue of standard Wireless Cabinets in various sizes and woods. Special Cabinets made to customer's orders.

PACKED AND DELIVERED FREE IN U.K.

CAXTON WOOD TURNERY CO., Market Harborough

In writing to advertisers, please say you saw the advertisement in THE WIRELESS MAGAZINE.

# Announcing the New—



Rotax High Tension Battery.



Rotax High Tension Battery.

## Super Capacity DRY BATTERIES High and Low Tension



Rotax Low Tension Battery.

**F**OR a considerable period we have carried out extensive research and experiment to produce a Dry battery with greater capacity than hitherto made. We have now much pleasure in announcing that we have produced a high grade battery, capable of withstanding really heavy continuous discharge and giving 3 to 4 times the life of the usual type now being sold.

They are made with special large capacity cells, the construction of which is based on secret formulae, while minute care has been taken to ensure perfect insulation—a very important feature.

Supplies are actually available—and the prices are exceedingly reasonable. The following extract is from our List which will be sent on application.

Type	Voltage	No. of Cells	PRICE	
			Without Tappings	With Tappings
H.G. 2	30	20	9/9	10/-
H.G. 3	5	30	14/6	15/-
H.G. 4	60	40	19/-	19/6
H.G. 5	40	60	28/6	29/6
H.G. 6	105	70	33/6	34/6
L.T. 3	4½	3	PRICE 1/6 EACH	



Rotax Grid Bias Battery. Type G.B.3.

## ROTAX HIGH GRADE LOW TENSION ACCUMULATORS

**P**ERFECT radio reception is more dependent upon the efficient performance of the low tension Accumulator than is fully realized. This is the outstanding feature of Rotax Accumulators. While our high reputation as battery makers is your guarantee, in itself, for dependability, it is in actual use that their sterling qualities are fully appreciated.

A wide range of sizes and capacities is available. They are constructed in best quality ebonite cases, and marketed at reasonable prices. The sizes opposite are extracted from our list, which will be sent to you on application. We wish to emphasize the fact that Rotax Ebonite Accumulators eliminate the risk of FIRE associated with celluloid.

Cat. No.	Volts	Capacity Ignition Amp. Hrs.	Capacity Actual Amp. Hrs.	PRICE	
				Un-chgd.	Price of Crate
E.W. 140	6	60	30	36/-	6/6
E.W. 143	2	80	40	15/3	5/9
E.W. 146	4	80	40	30/-	6/6
E.W. 149	20	40	40	43/9	7/-

**THE ROTAX HIGH TENSION ACCUMULATORS** in glass cases are offered for users of large sets to whom initial cost is not a material consideration. Prices and particulars on application.



Rotax Low Tension Ebonite Accumulator. Eliminates the fire risk.

### ROTAX BROADCAST RECEIVING EQUIPMENT

**OUR Special Wireless Broadcast Receiving Equipment Catalogue, describing our latest 2 and 3 Valve Receivers, will be published at an early date.**

May we send you a copy when ready?

**ROTAX (MOTOR ACCESSORIES) LTD., WILLESDEN JUNCTION, LONDON, N.W.10**  
 Telephone: Willesden. 2480 (Private Branch Exchange)      Telegram: Rotax Ltd., London      Code: ABC 5th Edition and Manual International.

#### BRANCH WORKS AND DEPOTS:

BIRMINGHAM: Landor St. Telephone: East 410.      TAINTON: Tainton Works. Telephone: Tainton.      GLASGOW: 19/21, Oswald St. Telephone: Central 379.      MANCHESTER: 291/3, Deansgate. Phone: Central 7415.      BRISTOL: 7, Temple Street. Telephone: Bristol 5756.      LEEDS: 11, Park Lane. Telephone: 26788.      TELEGRAMS: Rotax Ltd., London.      TELEGRAMS: Rotax Ltd., London.      TELEGRAMS: Rotax Ltd., London.

# "The Wireless Magazine" Buyers' Guide

The announcements below mentioned are in the August, 1925—January, 1926, issues (Volume 2).

<b>Accumulators and Batteries</b>	<b>PAGE</b>	<b>Components (continued)</b>	<b>PAGE</b>	<b>Phones</b>	<b>PAGE</b>
England-Richards Fluid-Free Cell Co.	642	Mullard Wireless Service Co., Ltd.	Cover iii, Nov.	Bowerman's Phones	319
General Electric Co., Ltd.	658	A. Mundav, Ltd.	549	Brandes, Ltd.	75, 181
Radio Service Co.	319, 428, 547	Omnora, Ltd.	659	Falk, Stadelmann & Co., Ltd.	429
Rotax (Motor Accessories), Ltd.	663	Peto-Scott Co., Ltd.	424, 653	Simpson's (Brighton), Ltd.	547
Siemens Bros. & Co., Ltd.	654	Philips Lamps, Ltd.	315, 633		
		Radio Instruments, Ltd.	657	<b>Sets (Crystal)</b>	
<b>Battery Chargers</b>		Rapinet, Ltd.	207, 431	Belling & Lee, Ltd.	556
Philips Lamps, Ltd.	497, 545	Simpson's (Brighton), Ltd.	314	B. T. H. Co., Ltd.	185
		A. J. Stevens & Co. (1914), Ltd.	297	Falk, Stadelmann & Co., Ltd.	429
<b>Books &amp; Publications</b>		Wates Bros., Ltd.	103, 549	General Electric Co., Ltd.	401
American Technical Society	192			Lissen, Ltd.	393
Cassell & Co., Ltd.	554, 656	<b>Condensers</b>		Radio Instruments, Ltd.	Page iv, cover, Nov.
Daily Graphic	3	Dubilier Condenser Co., Ltd.	Cover ii, Jan.		
Foyle's	192, 308, 416, 536, 648	General Electric Co., Ltd.	293	<b>Sets (Valve)</b>	
Press Exclusives	308	Ormond Engineering Co., Ltd.	639	Belling & Lee, Ltd.	556
University Tutorial Press	97	Peto-Scott Co., Ltd.	103	British L.M. Ericsson Manufacturing Co., Ltd.	435
		Pettigrew & Merriman, Ltd.	289	British Radio and Portable Case Mfrs.	199
<b>Cabinets</b>		Telegraph Condenser Co., Ltd.	307, 423, 531, 651	British Thomson-Houston Co., Ltd.	185
Carrington Mfr'g Co., Ltd.	314, 434			Falk, Stadelmann & Co., Ltd.	299, 429
Caxton Wood Turnery Co.	662	<b>Crystals and Detectors</b>		General Electric Co., Ltd.	401
G. A. Hanchard	540	Will Day, Ltd.	207	Pell, Cahill & Co., Ltd.	97
Hobbies, Ltd.	659	The Paramount Wireless Co., Ltd.	422	Peto-Scott Co., Ltd.	212, 541
Makerimport Co.	416, 547, 557	Radio Instruments, Ltd.	86	Radio Communication Co., Ltd.	89, 191, 291, 415, 655
Pickett Bros.	648	Tungstallite, Ltd.	214, 435, 557	Radio Instruments, Ltd.	Page iv cover, Nov.
				B. Taylor	416
<b>Coils and Coil Holders</b>		<b>Ebonite</b>		<b>Soldering Flux</b>	
Athol Engineering Co.	427	American Hard Rubber Co., Ltd.	203, 297, 426, 547, 645	Fluxite, Ltd.	418, 546, 662
Garnett, Whiteley & Co., Ltd.	661	F. W. Lowenadler	428, 547, 556		
Igranic Electric Co., Ltd.	403	<b>Loud-speakers</b>		<b>Terminals</b>	
Lissen, Ltd.	393	Brandes, Ltd.	75, 283, 509, 627	Autoveyors, Ltd.	212, 427, 658
London and Provincial Radio Co., Ltd.	536, 648	S. G. Brown, Ltd.	411, 515, 631	Belling & Lee, Ltd.	299, 423
		Falk, Stadelmann & Co., Ltd.	429		
<b>Components</b>		Fuller's United Electric Works, Ltd.	542, 650	<b>Tools</b>	
Athol Engineering Co.	317, 547	Alfred Graham & Co., Ltd.	553	Economic Electric, Ltd.	430
Autoveyors, Ltd.	427	Scientific Supply Stores	3		
Belling & Lee, Ltd.	423, 531	Sterling Telephone and Electric Co., Ltd.	437	<b>Transformers</b>	
A. F. Bulgin & Co.	308, 536			Peto-Scott Co., Ltd.	538
Brandes, Ltd.	395	<b>Miscellaneous</b>		Portable Utilities Co. Ltd.	649
British L.M. Ericsson Mfg. Co., Ltd.	557	Athol Engineering Co., Ltd.	556	Radio Instruments, Ltd.	Cover iv, Nov.
British Thomson-Houston Co., Ltd.	543	Bennett College	212, 324	S. Smith & Sons, Ltd.	413, 537
Climax Radio Electric, Ltd.	303, 425	Globe Furnishing Co., Ltd.	317, 427, 659		
Dubilier Condenser Co. (1925), Ltd.	Cover ii, Dec.	Goodchild & Partners, Ltd.	661	<b>Valves</b>	
Will Day, Ltd.	314, 548	International Correspondence Schools, Ltd.	198, 304	Cleartron Radio, Ltd.	513, 647
Economic Electric, Ltd.	212, 430	John Player & Son, Ltd.	Cover iv, Jan.	A. C. Cossor, Ltd.	397, 517, 629
Ellis & Sons, Ltd.	430, 538	Prince's Electrical Clocks, Ltd.	317, 424	Economic Electric, Ltd.	107, 434
Falk, Stadelmann & Co., Ltd.	661	L. Rees & Co.	317, 427	Edison Swan Electric Co., Ltd.	81, 195, 419, 511, 635
Fellows Magneto Co., Ltd.	533	B. Taylor	308	General Electric Co., Ltd.	641
General Electric Co., Ltd.	527, 555			Marconiphone Co., Ltd.	438, 558
Goodchild & Partners, Ltd.	551			Mullard Wireless Service Co., Ltd.	Page iii, cover Jan.
Igranic Electric Co., Ltd.	93, 187, 307, 403, 523, 637				
Henry Kennett	101				
Lissen, Ltd.	218, 393, 507, 625				
E. J. Lever	319, 660				

# A Dull Filament Valve in the TRUE Sense



## The Wonderful "N" Filament valve

Requires only ONE-TENTH AMPERE filament current from 3 dry cells or a 4-volt accumulator.

Gives majestic volume free from microphonic disturbance.

The heat present in the unique "N" filament is so small that no sign of glow can be discerned.

**THE FINEST LOUD SPEAKER  
VALVE EVER PRODUCED**

**THE P.M.: 4 - 22/6**

Leaflet V.R. 26, free from any dealer, gives complete information.

# Mullard

**THE MASTER VALVE**

ADVT.—THE MULLARD WIRELESS SERVICE CO., LTD., BALHAM, LONDON, S.W.12

In writing to advertisers, please say you saw the advertisement in THE WIRELESS MAGAZINE.



Regd. No. 154011

*Tobacco & Cigarettes*

*Sold by all dealers in Tobacco.  
Packed only in packets and tins.*

P 987

ISSUED BY THE IMPERIAL TOBACCO CO. (OF GREAT BRITAIN & IRELAND), LTD