

Wireless on Your Holidays



The Wireless Magazine

Edited by
Bernard E. Jones

VOL. 2, NO. 7.

August, 1925



Special Articles on Portable Sets

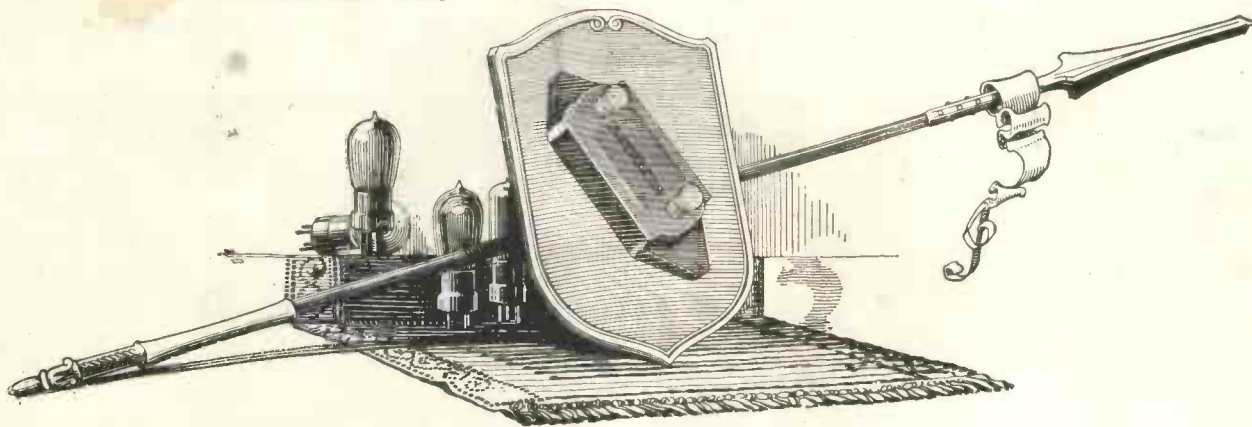

PROTECT YOUR VALVES *with the* "DUBRESCON"



THE disconcerting flash that occurs when the filament terminals of a valve are accidentally touched across the anode and grid sockets of the valve-holder is one of the expensive kind—say 8/- or more. Every amateur probably flashes away quite a lot of money this way every year. There is also a similar effect when the H.T. leads are mistakenly connected to the L.T. terminals, and the valves switched on.

These mistakes are like all others — expensive.

Valve immunity, however, can now be purchased for SIX SHILLINGS. That is the price of the new Dubilier Dubrescon, which makes it impossible for valves to be burnt out by accidental short-circuiting or similar causes.

The Dubrescon must be inserted in series in one of the H.T. leads—quite a simple operation. The H.T. current can then never exceed the usual filament current, and your valves are secure for ever. The Dubrescon does not interfere with the passage of the H.F. currents.

It is advisable to buy one now, ready for next time. And in doing so, be sure that you

Specify Dubilier

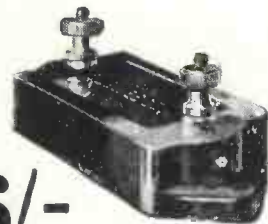
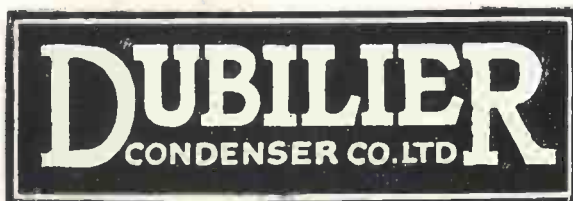

6/-

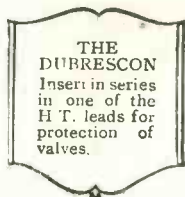

THE
DUBRESCON
Insert in series
in one of the
H.T. leads for
protection of
valves.

ADVERTISEMENT OF THE DUBILIER CONDENSER CO., LTD., DUCON WORKS, NORTH ACTON, LONDON, W.3. TELEPHONE: CHISWICK 2241-2-3.

In writing to advertisers, please say you saw the advertisement in THE WIRELESS MAGAZINE.

E.I.S. 102

The
World's
Standard

AMPLION

Wireless
Loud
Speaker

*for Better Radio
Reproduction*

THIS "outdoor season" will see the world-famous AMPLION in greater demand than ever, because, amongst other features, of its unequalled clarity and wonderfully natural tone. This supremacy is due to special and

quite exclusive details of design and construction, rendering the AMPLION the only loud speaker which can be invariably relied upon for open-air, as well as indoor, performance of the highest standard. Make sure of an AMPLION for Summer Radio Broadcast NOW.

Write for illustrated folder describing the unique series of AMPLION Models ranging from 25/- upwards. Obtainable from AMPLION STOCKISTS and other Radio Dealers of repute.

Patentees and Manufacturers:

ALFRED GRAHAM & CO. (E. A. GRAHAM),
St. Andrew's Works, Crofton Park, London, S.E.4

*Demonstrations gladly given during Broadcasting hours at:—
25-26, Savile Row, W.1, and
79-82, High Street, Clapham, S.W.4.*



*It's a Better
Loud Speaker!*

In writing to advertisers, please say you saw the advertisement in THE WIRELESS MAGAZINE.



Essentially a practical paper—exclusively devoted to the interests of all Listeners-in

Amateur Wireless

Edited by BERNARD E. JONES,
Editor of "The Wireless Magazine"

It deals with every phase of this fascinating subject in an informative, interesting and helpful way; it is lavishly illustrated with photo reproductions and many explanatory drawings and diagrams. A great feature is Expert Replies to Readers' Questions. Other regular features, all fully illustrated, are—On Your Wavelength! (Chatty paragraphs by "Thermion"), Practical Odds and Ends, Components You Can Rely Upon, Around the Showrooms, Progress and Invention, Latest News in Brief, Times and Wavelengths of Home and Foreign Stations, Chief Events of the Week, Club Doings and Correspondence. Brightly written and brimful of information, "Amateur Wireless" informs, instructs, directs, advises and enthuses its readers.

Every
Thursday

3^D

Take "Amateur Wireless" Each Week
and Get the Best Results from Your Set

Cassell's :: Publishers :: London

In writing to advertisers, please say you saw the advertisement in THE WIRELESS MAGAZINE.

CABINETS



CABINETS

A CAMCO CABINET means a professional finish to your set. WRITE AT ONCE for our illustrated list of 100 varieties of cabinets for radio sets, or Phone, Clerkenwell 6903.

The two models featured in this issue are :—
THE SPECIAL 3-VALVER FOR THE DISTANT STATIONS.
 In Polished Oak, 24/- . In Polished Mahogany, 27/-.

A HOLIDAY 2-VALVE SET
 Covered in Black Camera Leatherette Cloth, 50/-.

TRADE ENQUIRIES ESPECIALLY INVITED.
CARRINGTON MANUFACTURING CO., LTD.,
 18/20, Norman's Buildings, Mitchell St., Central St., E.C.1.

FOR LOUD, CLEAR OUTDOOR LOUDSPEAKING

Apart from their well-known superiority over other Horns in PURITY and VOLUME—the "Scientific" NON-METALLIC HORNS make their special appeal to Portable Set owners, since being non-metallic they are LIGHT and PRACTICALLY UNBREAKABLE. Finish—an attractive dull bronze.



	Approx. Ht.	Approx. Flare.	Price
SMALL SWAN-NECK	16"	8"	5/9
" with Petal Flare, as illustrated	16"	10"	7/9
SMALL WESTERN pattern	19"	10"	7/9
MEDIUM WESTERN pattern	21"	11"	8/9
" with Petal Flare	21"	12"	9/9
LARGE WESTERN pattern	24"	14"	11/9
CURVED HORN, for Amplion Juniors	—	12"	11/9
" with Petal Flare	—	13"	12/9
LARGE SWAN-NECK	24"	13"	14/9
" with Petal Flare	25"	15"	15/9

(When ordering please state dimensions of Ferrule required.)
 Postage, packing and crate, 1/9 extra.
SCIENTIFIC SUPPLY STORES Phone: Hob 4177
 80, NEWINGTON CAUSEWAY, LONDON, S.E.1.
 Branches: 126, Newington Causeway, S.E.1; 7, St. George's Circus, S.E.1; 16, Manette Street, Charing Cross Road, W.1; 207, Edgware Road, W.2; 84, Church Road, Upper Norwood, S.E.23.

A. MUNDAY, Ltd.

Electrical and Wireless Engineers.

59, WATLING STREET, E.C.4.

(One door from Queen Victoria St., and Queen St.)

and at 45, EASTCHEAP, E.C.3.

Tele. : CITY 2972.

Tele. : ROYAL 4632.

We are Stockists of—

- Wade Condensers
- Barrett & Paden Condensers.
- King Cardwell Condensers.
- Bremer Tully Condensers.
- Dubilier, Ormond and Jackson.

- Bowyer-Lowe Super-Het.
- Rauland All American Super-Het.
- Precise One-control Super-Het.
- & Tropadyne.

ALL COMPONENTS IN STOCK.

All well-known English parts.

25,000 BIRTHDAY PRESENTS FREE TO YOUNG READERS

of the

DAILY GRAPHIC

Here is a wonderful opportunity for boys and girls everywhere. The *Daily Graphic* is organizing a gigantic Children's Birthday Club which promises to be the greatest club in the world. 25,000 handsome birthday presents, totalling

£7,000 IN VALUE



are being presented to members. All children are free to take part and there are no irritating conditions, no entrance fees, no time limits. Each member on joining has his or her name inscribed in the Giant Birthday Book and is presented with a Badge of Membership. Then on the Birthday will come a splendid present of either a "Blackbird" Fountain Pen (value 6s.) made by the famous Swan Pen People, or a handsome box of Cadbury's choicest chocolates. Besides the wonderful birthday presents there will be other privileges later for members. Read the simple conditions on coupon—and join at once.

To be sure of the

DAILY GRAPHIC

order it regularly from your newsagent.

YOU CAN USE THIS COUPON.

IMPORTANT. Fifty coupons are required. The other 49 must be cut from the *Daily Graphic*.

Pin or clip coupons together.

'Daily Graphic' Children's Birthday Club.

25,000 BIRTHDAY PRESENTS FREE.

NAME

ADDRESS

DATE OF BIRTHDAY..... AGE NEXT BIRTHDAY.....

TO BECOME A MEMBER.

Collect 50 of these coupons (one appears every day), as quickly as you like, and send them to Children's Birthday Club, "Daily Graphic" Tallis Street, London, E.C.4. Your name will then be entered in "Uncle Jack's" Giant Birthday Book. You will receive your Membership Badge at once and on your birthday a wonderful present of the famous 6s. "Blackbird" Fountain Pen or a handsome box of Cadbury's Chocolates. With the coupons you must send, on a separate piece of paper exactly the same size as this coupon, the names and addresses of two friends who have promised you to become members in the same way.

W.M. Cut coupon neatly round the line. Illustration by G. C. C.

In writing to advertisers, please say you saw the advertisement in THE WIRELESS MAGAZINE.

The only synthetic **CRYSTAL**

TUNGSTALITE

BRITISH MADE

*guaranteed -
for perfect reception*



BLUE LABEL
1/6

Amazing Testimony from the
Continent.
23, Staalstraat, Utrecht,
Holland.

*It will perhaps interest you to
learn that we can get Chelmsford
with your TUNGSTALITE on a
simple crystal set without any mag-
nification. So we have heard the
nightingale on the 1st June.*

(Signed) V. ULLEFEN.

The original of this and
many other letters proving
reception at 100, 200, even
700 miles range may be in-
spected at the offices of the
manufacturers.

GOLD LABEL
2/-



Secure your specimen to-day
—from any Radio Dealer from
TUNGSTALITE Ltd.
LONDON: 47, Farringdon Road, E.C.1
Phone: Holborn 2557.
LEEDS: 41, Call Lane.
Phone: Leeds 21375.

*"The
Pleasure of a Treasure"*

In writing to advertisers, please say you saw the advertisement in THE WIRELESS MAGAZINE.



CONTENTS



MY IDEAS FOR YOUR PORTABLE SET (see page 6) is an article by Capt. P. P. Eckersley, in which he emphasises the need of compactness and sensitivity, and comments on the suitability of the "super het" and reflex systems.

WHAT SHOULD BE DONE TO THE OSCILLATOR? (see page 30) is a symposium of suggestions, brutal and otherwise, by seventeen well-known men, garnered by Pearkes Withers. It is illustrated with six original cartoons.

	PAGE		PAGE
<i>My Ideas for Your Portable Set.</i> By CAPT. P. P. ECKERSLEY	6	<i>A Visit to Radio House</i>	62
<i>The Eternal Triangle</i>	10	<i>Wireless for the Motorist.</i> By RICHARD TWELVETREES	64
<i>Camouflaging the Loud-speaker</i>	11	<i>A School for Wireless Salesmen!</i>	66
<i>Some Well-known Portable Receivers for Holiday Use</i>	12	<i>Get a Loud-speaker!</i>	67
<i>Under My Aerial. The Chat of the Month</i>	14	<i>See a Valve Made!</i>	68
<i>QST. Some Common Wireless Abbreviations and their Meanings</i>	18	<i>A Wireless Poetaster</i>	71
<i>Broadcasting in Russia</i>	19	<i>Wanted—A Patron Saint!</i>	71
<i>Politics on the Wireless.</i> By Lieut.-Com. the Hon. J. M. KENWORTHY, R.N., M.P.	20	<i>My Favourite Circuit</i>	72
<i>His Master's Vice! A page drawing.</i> By A. M. ROBBIE	23	<i>Polishing Ebonite</i>	74
<i>A Special Three-valver for the Distant Stations</i>	24	<i>Wireless Femininities</i>	76
<i>Wavelets</i>	28	<i>How to Broadcast Speech.</i> By C. WHITAKER-WILSON	78
<i>Novelties and New Apparatus of the Month</i>	29	<i>The Strong Man's Set! A Drawing</i>	80
<i>What Should be Done to the Oscillator? Suggestions by Seventeen Well-known Men</i>	30	<i>Absolutely for the Novice! Listening-in for the First Time</i>	82
<i>Will Wireless Prevent War?</i>	35	<i>At 2 Savoy Hill, W.C.2. Specially contributed by the B.B.C.</i>	84
<i>A Crystal Set for the High-power Station</i>	36	<i>For the Wireless Bookshelf</i>	86
<i>Wireless to the Rescue</i>	38	<i>Novelties and New Apparatus of the Month Described</i>	87
<i>Wireless on your Holidays! With 13 Photographs</i>	39	<i>How the Weather Affects Wireless</i>	88
<i>Adapting the Rheostat for Dull or Bright Emitters</i>	42	<i>To Lucilla. A Poem</i>	90
<i>A Little Misunderstanding</i>	43	<i>Catalogues and Pamphlets</i>	91
<i>How Wireless Makes the Seas Safe.</i> By BENNETT COPPLESTONE	44	<i>Cousin Crysta's Corner. A Section for the Boys and Girls</i>	92
<i>A Holiday Set. How to Make a Two-valve Reflex Set with Crystal Detector</i>	47	<i>Continental Notes. Some Adventures with a Portable Set</i>	94
<i>Gadgets, Hints and Tips</i>	51	<i>What the Reader Thinks</i>	96
<i>Doctor Z. A story.</i> By ARTHUR RUSSELL	52	<i>Questions Simply Answered</i>	98
<i>Can We Transmit with the Crystal?</i>	55	<i>Our Cross-word Puzzles</i>	99
<i>Her Wavelength! A drawing</i>	56	<i>Jottings on the Month's Progress</i>	100
<i>Famous Instrumentalists who have Faced the Microphone</i>	57	<i>Our Cross-word Puzzle Solution</i>	100
<i>A Low-capacity Tuning Coil</i>	60	<i>The World's Broadcasting; Principal European Stations</i>	101
		<i>Below the Broadcasting Belt</i>	102
		<i>The Buyers' Guide</i>	104



The Wireless Magazine
for the Holiday
Month of August,
1925.

ANNOUNCEMENTS.—THE WIRELESS MAGAZINE, edited by Bernard E. Jones, is published about the 25th day of the month and bears the date of the month following. One Shilling Net. Subscription rates are 15s. 6d. a year, post free; Canada, 13s. 6d. a year, post free.

ANNOUNCEMENTS.—Contributions, accompanied by stamped and addressed envelopes, are invited. All editorial communications should be addressed to the Editor, THE WIRELESS MAGAZINE, La Belle Sauvage, London, E.C.4. Subscriptions should be addressed to The Publisher.

A Special Article Written at the Editor's Invitation

MY IDEAS FOR YOUR PORTABLE SET

by Capt P. P. Eckersley

The B.B.C.'s Chief Engineer emphasises the need of compactness and sensitivity in the portable set and he comments upon the suitability of the super-het and reflex systems

IT is sometimes amusing, and it may even be useful, to have a wireless set that can give one broadcast reception wherever one may be. The bored man travelling by road a long night through, if he could clamp his head in a pair of phones and hear music, news, stories, speeches, or whatever it might be, would beguile a tedious journey. The picnic party, if we are to believe our eyes, is never complete without a loud-speaker, and we even see the svelte beauty of a bathing naiad adorned by headphones—probably waterproof!

The train journey, when railway literature has failed any longer to dim the rumbling, the heat, and the irritating sniff of a fellow traveller, may be shortened (and incidentally the sniff eliminated) by "the portable set."

Incomplete without Wireless

Holidays may seem incomplete without the space-annihilating powers of wireless, and yet we can neither take away with us that beloved shelf loaded with coils, wire, transformers, batteries and valves, nor, if we are

possessed of a standard set, are its etceteras easily portable—those etceteras that cost about as much as the set, take up far more space, and make our living rooms look like junk shops.

In writing about portable sets one is creating an interest (at least I hope so!) not only in portable sets themselves but in compact design generally, a point to my mind in which many sets fail. There seems to me to be a great deal of room for ideas in making receiving sets more compact—there is a ready market for the set which contains, all in one box, batteries and loud-speaker.

Desiderata

Let us consider the desiderata for a portable set. They are, I think:

- (1) Extreme sensitivity.
- (2) Extreme compactness.
- (3) Few valves.
- (4) Low filament consumption.
- (5) Good quality reproduction.
- (6) Selectivity.
- (7) No possibility of oscillating.
- (8) Easy adjustment.

(1) and (3), (2) and (5) are mutually antagonistic, and one must balance

between erring too absurdly in favour of any.

In sensitivity generally, I favour either reflex circuits or the super-heterodyne, but in either case the quality is never really good. The quality can be made good enough, however, for use with headphones. For ease of adjustment the super-heterodyne is excellent except, of course, that it is sometimes not easy to find stations, as these come in with the local oscillator in two possible positions.

The valves must in all cases be of low filament consumption, and for the note magnifier this should not present much difficulty, if loud-speakers are to be used, as low-consumption-power valves are now on the market.

Loud-speakers

I do not, however, favour portable sets with loud-speakers, as very small loud-speakers do not generally give the quality desirable. There should be no difficulty, however, in using as many as six valves and still lighting them from dry batteries.

I should say that an open aerial

(The heading photograph is of Llanbedrog Mountain, and is reproduced by courtesy of the L.M.S.R.)

would be better than a frame; by an open aerial I mean just a short length of wire which can be slung conveniently near the instrument, but for universal use obviously a frame either built permanently into the movable lid of the box, or detachable and fitted in some way when the set is in use, would be best.

Having considered these general points, it may be interesting to discuss some circuits. The Americans undoubtedly have developed some most ingenious methods for condensing sensitivity into a small compass. In Washington a leading

after rectification of the complex combined oscillations another frequency $N_b = \pm N_r \mp N_s$ is produced.

(This can be illustrated by making

lower frequency in circuit N_b . The oscillation in N_b can be amplified by the long-wave amplifier, detected again, "note magnified" and so finally passed to the phones.

Let us now simplify this for a portable set. In the first place we are to use a frame aerial, but this need produce no difficulties. I should like to see a coupled circuit with a frame, its directional properties being rendered abortive if it is,

as it must be without a coupled circuit, earthed, but really this is not important enough to warrant the space. We can do away with the two

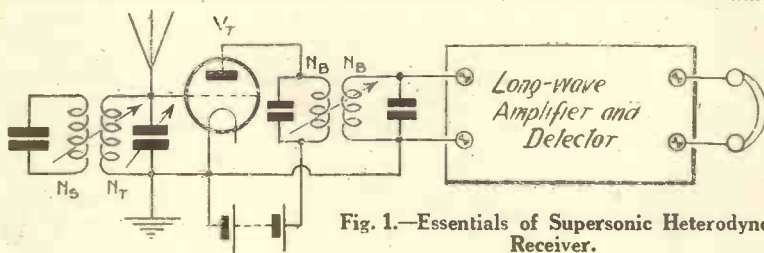

Fig. 1.—Essentials of Supersonic Heterodyne Receiver.

two musical notes; if they are very close to one another in note a beating effect—an apparent rising and falling in intensity at a frequency

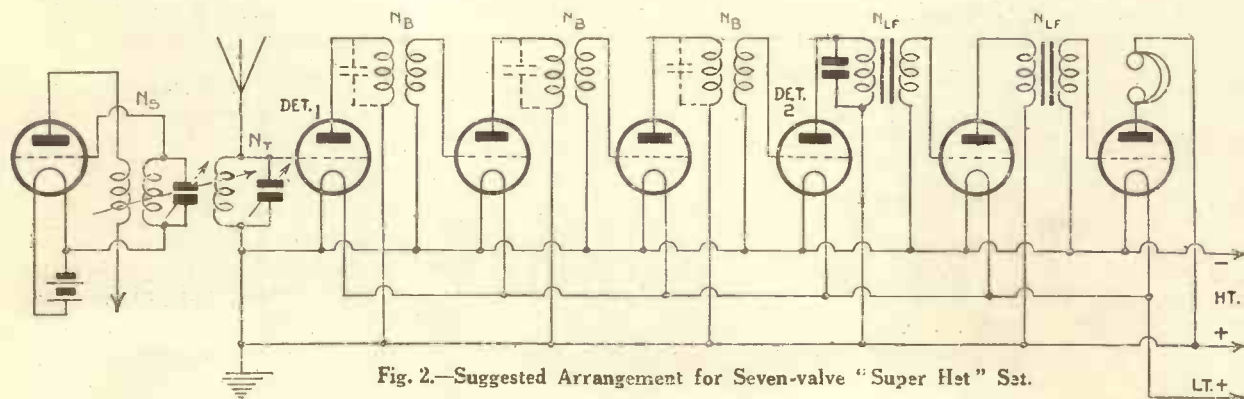

Fig. 2.—Suggested Arrangement for Seven-valve "Super Het" Set.

engineer showed me a six-valve set which, placed on a table, there and then gave us reception up to several hundreds of miles—and the set complete measures about 12 in. by 12 in. by 8 in. The principle of the super-heterodyne was used—but used in the most ingenious manner.

I give the "super het" pride of place for use as a portable set. In principle, as my reader is probably aware, the circuit relies for its action upon superimposing local oscillations upon the oscillations received from the distant station.

If the frequency of the received oscillation is N_r , and that of the superimposed oscillation is N_s , then

equal to the difference of the two— is produced.)

The method in essence is, illustrated in Fig. 1. Here the circuit N_s is

coupled circuits N_b ,—they were drawn in Fig. 1 for simplicity so as not to earth our high-tension positive. We can use a copper transformer

which is not aperiodic (they never are) that has an optimum response where we like (one of the windings may be tuned with a small condenser).

For the broadcast band of 300 to 500 metres I should advise a beat wavelength of something like 3,000 metres. If we make this lower we are in danger of receiving the waves direct; if we make it higher the adjust-

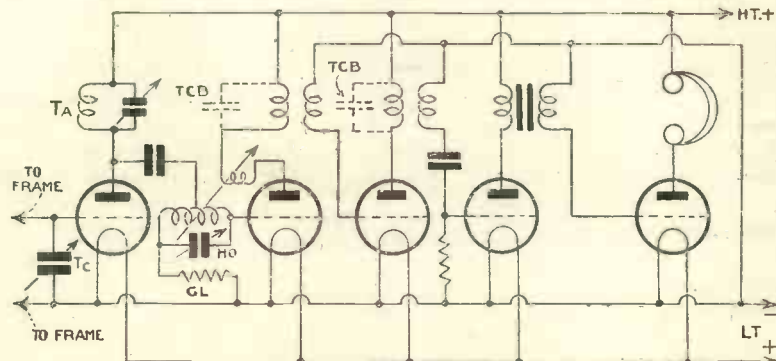
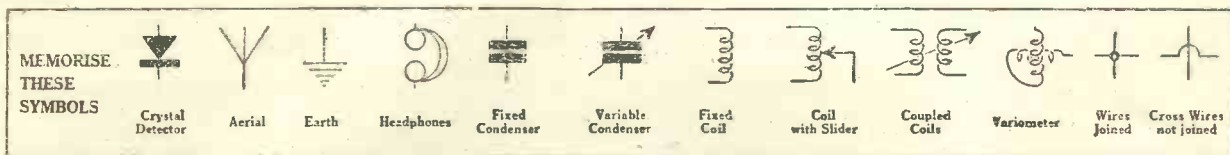

Fig. 3.—Five-valve "Super Het" with One Stage of H.F. Amplification.

adjusted to oscillate at some frequency slightly different from N_r , and the superimposition of the two frequencies produces in the rectifying valve V_r oscillations of much

ments get too fine. The long-wave amplifier should be as sensitive as possible consistent with stability, and again the copper transformer should be used—one



winding being again tuned by a small condenser. The valves should have, of course, the lowest filament consumption possible—almost any

Fig. 2 represents a suggested arrangement which is almost the same as that used by the author and his staff at Writtle for receiving short waves.

On the whole, if you are to concentrate on quality, avoid all but the simplest circuits.

We are, however, discussing port-

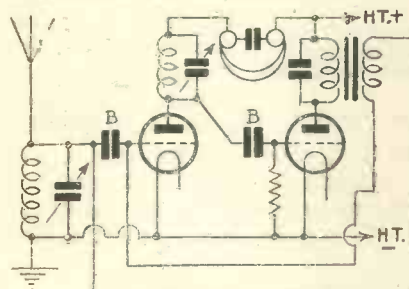

Fig. 4.—Typical Reflex Circuit.

Fig. 3 shows a circuit of a superheterodyne using a high-frequency stage and using one valve only as detector and oscillator.

Reflex Circuits

Economy in valves, which means space and filament consumption, can be obtained by using one valve both as high- and low-frequency magnifier. I am not altogether in favour of this type of circuit if first-class quality is desired; it can be arranged, how-

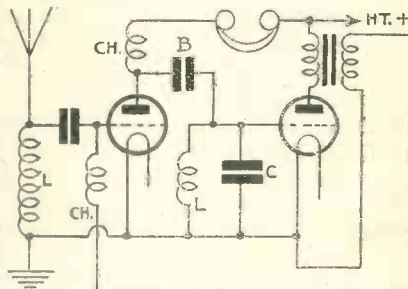

Fig. 5.—Improved Reflex Circuit.

good high-frequency valve will do. Shielding is important, and the whole of the long-wave part might be conveniently shielded.

In order to minimise the effect of the oscillations being induced directly into the aerial, a high-frequency stage before the beat detector might be introduced with advantage. This means another adjustment, but in being "calibratable" it gives an otherwise lacking indication if ever different types of aerial are used.



A Portable Set adds vastly to the enjoyment of a holiday.

able sets where space, weight, low filament consumption and sensitivity are all required.

A typical example of a reflex circuit is given in Fig. 4, which is in reality the basis of the Marconiphone V2. Captain Round produced in his own "16" circuit an almost identical arrangement about ten years ago.

H.F., Detector and L.F.

The first valve is an ordinary high-frequency magnifier with a tuned anode. The detector valve has in its anode circuit a transformer, and the low-frequency impulses are handed from primary to secondary. The secondary being connected in the grid circuit of the first valve produces low-frequency currents in the anode circuit, and these are detected by the phones.

Obviously, as drawn, the arrangement "circuits" very badly; the secondary of the transformer being in the grid of a high-frequency valve is bad style to say the least of it.

Increasing Sensitivity

I should advise two note magnifiers with transformer coupling to increase sensitivity and to get over the necessity of the use of a high value of H.T., unless a loud-speaker is to be used, when a fairly high value of H.T. will be necessary and resistance-capacity low-frequency can be used with advantage, as it is cheap, compact, light, can be made efficient, and gives better quality.

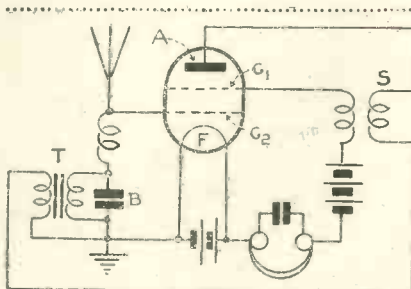
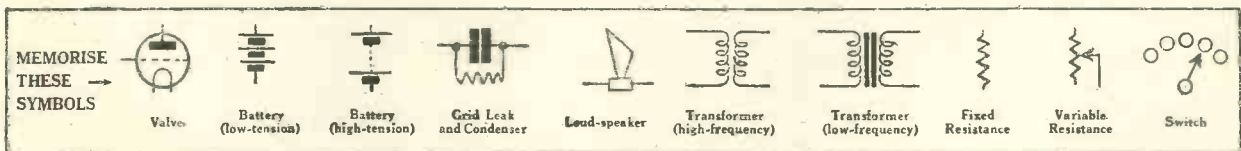

Fig. 6.—Four-electrode Valve Circuit.

ever, for most of the more ordinary loud-speakers if great care is taken.



To overcome this, the circuit of Fig. 5 is desirable; it is in fact, the circuit of the well-known Marconi-phone V2 receiver. Here so-called top-feed circuits are arranged, and air-cored chokes prevent the high-frequency currents from leaking back to earth.

Four-electrode Valve

Where a less sensitive arrangement is desired the four-electrode valve can be made to do the work of three (nearly). In the circuit given in Fig. 6 it will be seen that by an ingenious method of reflexing, the valve acts as high-frequency magnifier, detector and note magnifier all in one. Captain Round of the Marconi Company used this circuit a few years ago.

Consider G_1 as an anode first, and consider simply the high-frequency circuits. As far as the transformer T goes, which we can for a moment neglect, the grid G_2 is oscillated in potential at a high frequency, causing magnified high frequency pulses to flow between G_1 and F. These pass through the high-frequency transformer. The secondary S has thus induced in it impulses causing A to go positive and negative as regards the filament.

On becoming more positive than the filament it causes current to flow through the primary of the low-frequency transformer T; on becoming negative to the filament no current flows—rectification has been

achieved. The secondary of the transformer T is connected in the grid circuit of what may be termed the first valve, that is the three-electrode system comprising G_1 (as

G_1 and F, low-frequency magnification is again achieved—in one valve we have high-frequency amplification, detection and note magnification all at the same time.

Conclusion

The ingenious reader will see that there can be many combinations of these circuits. The four-electrode valve with its one filament could be the amplifying part of an Armstrong, a crystal being used as detector and only two valves being required for a sensitive arrangement. Reflexing may be constantly applied, both in high-frequency and low-frequency.

In working for sensitivity, remember that every stage must do its work. Thus in detection use, if you have a low-impedance crystal or valve, a high ratio of transformer and you score a lot. In a high-frequency magnifier cut down valve capacity; the cartridge type of valve often helps. Use as a note magnifier a valve with a large M value as principle.

Design

I leave the ingenious reader with his own mechanical and electrical design, believing in all sincerity that articles such as this should be meant as a stimulus to the invention and ingenuity of the reader rather than

THE B.B.C.'s CHIEF ENGINEER

"Matt" Sketches Him for "The Wireless Magazine"



PETER PENDLETON ECKERSLEY

was appointed Chief Engineer to the British Broadcasting Company in 1923, being at the time already well known to the public through his experimental transmissions from the Marconi station at Writtle.

During the war he served as Squadron Wireless Officer with the Royal Flying Corps in Egypt and Salonica. He was promoted captain and later became brigade wireless officer in charge of aircraft wireless

on the Somme. He was finally posted to the experimental establishment of the Royal Air Force and worked on duplex telephony for aircraft.

As superintending engineer for aircraft wireless of Marconi's Wireless Telegraph Company, which he joined in 1919, he was largely responsible for the design of the Croydon station. In 1921 he became head of the Marconi Company's experimental department.

anode), G_2 (as grid), and F (the filament).

Thus, as regards the phones in the H.T. circuit formed between

as an "infallible guide" which leaves him with a made-up set of which he is unlikely to understand the first principles!

The Eternal Triangle!

I'm up against it. Mentally, I mean, not physically. But just as a motor-car cannot get any "forrarder" when it comes up against a blank wall, so am I stuck because of a wall—a figurative one, of course. How I'm to get beyond it I don't know.

Well, it's like this. You've heard of the eternal triangle—one man and two women. One of them his wife and the other, well—the "other woman!" The problem is more or less simple. He is in love with one or the other, the mere fact of there being another implying the direction of his affections.

Which is it to be? His conscience draws him to his lawfully-wedded wife; his heart to the "other woman." The stronger wins, as in everything, and, not being domiciled in Turkey (where he could have both), he chooses his wife, or his lover, as the case may be. That settles that!

But it's quite different with me. No such simple solution exists for me. You see, in *my* triangle my conscience and my heart both agree. They don't travel in different directions; they both tread the same paths, to my wife and to my other love.

I love my wife, honour and obey her (sometimes). She is my companion in my hours (or moments) of gladness and moments (or hours) of sadness. She feeds me and heeds me. To her I pour out my troubles, always to receive that measure of sympathy which acts like healing balm.

It is true I am sometimes utilised as a "whipping horse" for her troubles, which appear to reach their zenith by the time I arrive home of an evening.

When I mildly inquire why *I* am chosen as the "safety valve" (excuse the mixed metaphor!) of her accumulated worries, she retorts something (not very clear or logical) to the effect that she *must* find somebody

to pour out her troubles to, and if *I* can't be used for that purpose, what is the good of me, why on earth did she marry me, and so forth. That, however, is another story.

My aim, although it has taken me a long time to get to the point, is to prove how indispensable to me is my wife, and how well we get on together.

You may ask, why, in the face of what I have just said, there should be "another" in the case?

Well, my other love is also very dear to me. She soothes me after a hard day's work at the office. When I come home, tired of a long stretch of mental strain, I turn to her with feelings of relief. For hours on end we hold communion, just she and I.

IN TROUBLE?

If so, let us solve your problem for you.

Send your query (together with a stamped addressed envelope and the coupon on page 103) to:—

The Editor,

THE WIRELESS MAGAZINE.

La Belle Sauvage, E.C.A.

I tend her carefully and she is delicately responsive.

Sometimes I do not pay her sufficient attention and she, in her feminine way, becomes dumb and utters no word of welcome or otherwise until I gratify her needs.

At other times, through my own tactlessness or through pure misfortune, her eyes suddenly flare up and then—utter silence for the rest of the evening! No amount of coaxing will bridge the breach.

My only remedy—although a sure one—is a visit to a certain emporium on my homeward journey the following evening, and a subsequent peace-offering. You should see how brightly she smiles at me then—all troubles fade away.

Her conversation is wonderfully interesting. I can listen to her for hours. Her singing is entrancing.

I must confess, however, that her voice is not always equally pleasing—the weather seems to affect her—and there are times, too, when she is in a contrary mood, when everything seems wrong with the world, and in desperation I am driven to adopt the drastic measure of compelling her silence.

Such is my other love. I am quite happy with her, as with my wife. I cannot for the life of me see why I should not be allowed to be happy with both. But it is not to be.

Although *she* looks on indifferently during periods of visible affection between myself and my wife, on the contrary and regrettably, the latter is not so tolerant of her—my wife is, in fact, in the grip of that "green-eyed monster" which has caused the breaking-up of many happy homes.

So obsessed is she with jealousy that she has on more than one occasion threatened that one day I shall have to make my choice, one or the other. In her opinion, the house is not large enough to contain both.

Physical violence against her rival has she even threatened. Many a time have I reached home in fear and trembling expecting to find chaos where formerly was order. Right glad was I, however, to find on all such occasions that my fears had been groundless.

The fatal day has arrived at last, and, as I stated at the beginning, I am right up against it. Life has become absolutely intolerable—I can't stand it any longer.

Both I love and want; both I desire with all the longing in my being. But both am I denied. The gauntlet has been thrown, the ultimatum launched.

Which shall it be?

My wife or my wireless?

HARRY A. EPTON.

Camouflaging the Loud-speaker

FOR those who wish to disguise their loud-speakers the following method has much to commend itself. The disguise, when effected, is very artistic, and may be carried out so as to match the general furnishing of any particular room.

Another point worthy of notice is that the disguise does not have any detrimental effect on the subsequent reproduction; in fact, in the writer's case the drapery over the flare of the horn had the effect of sweetening the tone and doing away with that metallic sound usually associated with loud-speaker reception. The volume of the received signals was not in the least diminished.

Disguising the Horn

The artistic disguise for the horn, shown in the photograph at the top of this page, was made from silk. The silk should be of a colour that will harmonise with the furnishing of the room in which the speaker is to be used.

As to the length of material required, this will depend on the size of the speaker itself. The instrument illustrated is a medium-sized Ampion, and required one yard of single width silk.

The silk was cut down the centre so as to form two strips, each 18 in. wide. The ends of the strip



were then sewn together so as to form an endless belt. After this the edges of the strip were hemmed so that elastic could be inserted in the hems.

Thread one of the hems with elastic and draw tight. This forms the centre of the rosette. The other hem is also threaded with elastic and drawn tight, so that when slipped over the edge of the flare it remains in place, and forms pleats.

To the outer edge of the silk is now sewn silk ribbon, which should be gathered so as to give the effect shown in the illustration.

The artificial flower which forms the centre is fastened on to the silk with thin wire. A small hole is drilled in the back of the speaker horn through which is threaded the

wire attached to the artificial flower, the whole being drawn tight so as to draw in the centre of the silken covering and give it a concave shape.

The Base.

The base of the loud-speaker is enclosed in a triangular box, as shown in Figs. 1-5. The box, the size of which will, of course, be governed by the size of the base of the speaker, may be made of three-ply wood. A hole is bored in the top of

(Continued on page 19)

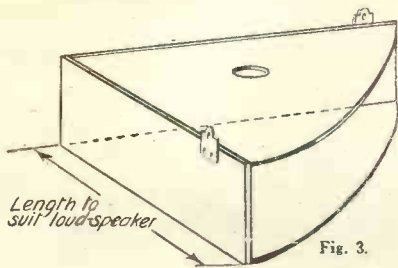

Fig. 3.

Figs. 1 and 2.—Bottom and Top Pieces of Box.

Fig. 3.—Method of Assembly.

Fig. 4.—Loud-speaker Base in Position.

Fig. 5.—Completed Box.

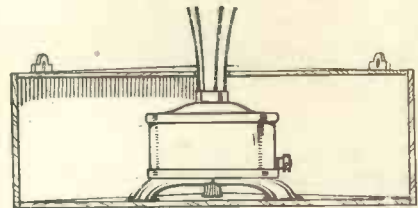

Fig. 4.

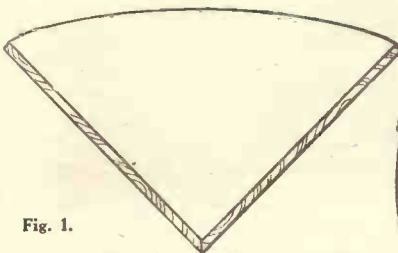

Fig. 1.

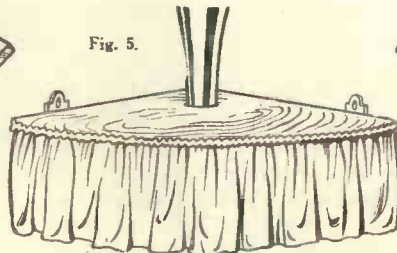

Fig. 5.

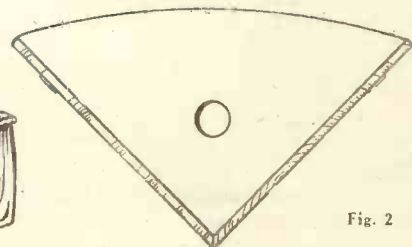

Fig. 2.

Some Well-known Portable

On these pages we give brief particulars of some well-known portable sets



Although the valves in the **FELLOWS PORTABLE THREE** are normally run off dry cells, a non-spillable accumulator can be fitted if desired. The frame aerial is fixed in the movable side of the case.

The manufacturers are the **Fellows Magneto Co., Ltd.**, of Cumberland Avenue, Park Royal, N.W. 10.

Designed for reception on the broadcast wavelengths only the **R.I. LYRIANETTE** is completely self-contained—even to the inclusion of a loud-speaker.

The set is made with either two or three dull-emitter valves, and weighs 18 lb. without batteries. A suitable aerial



can be quickly erected by slinging a length of wire over any convenient object.

Radio Instruments, Ltd., of 12, Hyde Street, New Oxford Street, W.C. 1, claim that no skill is required to manipulate this set, the controls having been reduced to an absolute minimum. Plugs are provided for phones when these are required.



Complete with batteries, the **RADIOLA** portable receiver weighs 23 lb. and measures 13 in. high by 16 in. wide and 6 in. deep. It is made by the **British Thomson-Houston Co., Ltd.**, of Coventry.

For fine tuning a special "micrograde" condenser is fitted and a compass is provided for taking advantage of the directional effects.

Although intended for use in conjunction with the Radiola portable receiver, this **B.T.H. PORTABLE LOUD-SPEAKER** with two-valve low-frequency amplifier can be used equally well with other sets.

The loud-speaker is adjustable, and the valves are let into the panel to obviate accidental damage when the outfit is in use.



Receivers for Holiday Use

Further details can be obtained on application to the manufacturers

This set weighs 19 lb. and measures 16½ in. by 12 in. by 7½ in.



Based on the Picnic Set described in the June issue of THE WIRELESS MAGAZINE, this set, the PORTAPHONE, is made by the British Radio and Portable Case Manufacturers, of 8 and 16, Market Street, Mayfair, W.1. Closed, it measures 14 in. by 6½ in. by 11 in. high.

The set is entirely self-contained and weighs only 12 lb. Non-spillable batteries are supplied. (This illustration is to a smaller scale than others on these pages.)

Built by the Edison-Swan Electric Co., Ltd., of 123-5, Queen Victoria Street, E.C.4, the portable TOOVEE receiver works with two AR06 valves run off a 4-volt 5-ampere-hour non-spillable accumulator.

Two pairs of phones are provided, these being accommodated in a special compartment.



Working with four dull-emitters, the DUODYNE PORTABLE IV has a guaranteed loud-speaker range of 25 miles from a 1½-kilowatt broadcasting station. It is manufactured by Peter Curtis, Ltd., of 75A, Camden Road, N.W.1.

By a simple switching arrangement two, three or four valves can be used. The circuit comprises one stage of H.F. (Curtis constant-tuned), detector and two stages of L.F. amplification.

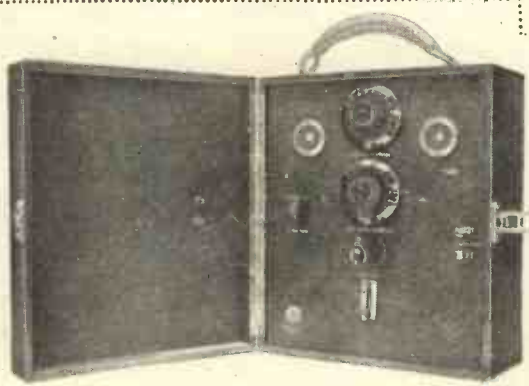

Made by C.A.C. Radio, Ltd., of 10, Rangoon Street, E.C.3, this C.A.C. portable set weighs 16 lb. (complete with batteries) and measures 14 in. by 12 in. by 8 in. Although easily accessible, the valves (four are used) and batteries are concealed and protected. The non-spillable batteries operate the set for 28 to 30 hours at one charge.

The wavelength range can be extended indefinitely from round about 300 to 30,000 metres. Once the tuning is adjusted, a master switch puts the set into operation.

A range of 20 to 25 miles with a loud-speaker is, 'he makers claim, quite normal with this set.



Portable Aerials

WHEN fixing up a portable set in the country, the part of the work I enjoy the most is slinging the cord over a branch of a tree preparatory to hoisting the free end of the portable aerial.

I wonder how you would set about the task of slinging a long cord over a convenient branch of a tree. I have my own particular method of doing the trick quickly and I am rather proud of it.

Some folk, when they have chosen the tree for their portable aerial, look around for a fairly stout stick about a foot long. This, when they have found it, they attach to the end of the cord, and then they make numerous endeavours to throw the stick over a selected branch. Other folk tie a stone to the end of the cord.

The worst of the stick method is that there is always a chance that the stick will get wedged in the fork of a branch and will refuse to come unwedged, with the result that the



Other folk tie a stone to the end.

cord has to be broken. The stone method is not one I like because of the difficulty of tying the stone securely to the end of the cord. If you have ever tried to do it you will understand.

Another method I have known to be employed was to use a strong catapult. One friend of mine who was an adept in the use of a catapult for this purpose used to take round with him a large nut, which he always tied to the end of the cord. It was no trouble to him with his

catapult to fire the nut and the cord it carried over a high branch of a tree.

I rather think my friend with the catapult got his idea from a method used by wireless signallers during the war. In this army method a rifle was used instead of a catapult, and a special kind of rifle grenade was fired to carry the cord over the tree.

I have never tried the catapult and nut method and I am not going to do so. There are too many other kinds of nuts about even in the country districts.

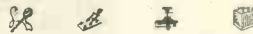

My Method

Whenever I go out into the country with my portable set, I do not carry with me a special stick or stone or nut for slinging my cord over the branch of the tree selected for the free end of my portable aerial.

No. I take with me a small-size Sorbo ball. You know the kind of ball I mean. It is made of spongy rubber. The beauty of this type of ball is that you can tie the cord round the ball so securely. In fact, you can pull the cord so tightly round the ball that the cord will make a deep ridge in which to lie. You might, of course, drive a nail right through the ball and tie the cord to the two ends of the nail, but I have never tried that method.

Mention of my Sorbo ball reminds me of an amusing incident which happened the first time I ever used it in connection with the hoisting of an aerial.

This aerial was not a portable one, but a permanent one, the leading-in end of which was to be attached to a wire passing over the ridge of the roof of a house.

To get this wire over the ridge of

the roof, I tied my Sorbo ball to the end of a long cord and threw the ball over the ridge from the front of the house. My first shot hit the ridge of the roof and the ball bounced back again to the ground.

My second shot also hit the roof. The ball rebounded upwards and jumped over a couple of telephone wires which ran from a chimney on the roof of the house. Of course the cord twisted and twisted round in the most absurd fashion. The ball was out of reach and pulling on the free end of the cord only caused the telephone wires to come together and actually touch at times as the suspended ball swung in a fairly strong breeze.

Something had to be done, so I got the kitchen steps and called to my aid my tallest wireless neighbour. We put the steps just under the swinging ball and my tall neighbour was just able to reach the ball from the top of the steps. I had to pass him up a pair of scissors and let him cut the ball from off the cord,



My next shot was a beauty.

though, before we could pull the cord down from the telephone wires.

My next shot was a beauty and we soon had the aerial up, but I have often wondered whose telephone wires they were that we played such a game with that afternoon.



Sunspots

An attempt has been made to add atmospherics to the already long list of things for which sunspots may be to blame. In years gone by,

sunspots have been suspected as being the cause of famines in India, devastating cyclones in the Indian Ocean, floods in various parts of the world and even of commercial catastrophes of the first magnitude.

Our British "clerk of the weather," a few years ago, stated that the most effective relationship he knew of between sunspots and a terrestrial phenomenon was that between sunspots and the level of the water in Lake Victoria Nyanza.

Now, these somewhat overworked sunspots are likely to be looked upon as being one of the great causes of atmospheric noises which we frequently get in our phones. There is a certain



Sunspots.

amount of justification in trying to connect sunspots with atmospheric if we accept the discovery of an American astronomer that sunspots apparently possess magnetic properties of great intensity.

Perhaps the most interesting thing about the possible connection between sunspots and atmospheric is that we may expect to be more troubled with atmospheric this year than we were in 1924, that is, of course, if the connection is a real one. This is because there will be more sunspots this year than there were last year.

Not only that, but we may expect atmospheric to get more and more troublesome each year until 1929, after which year they will be on the downward grade. The sunspot theory fixes 1935 as the next year in which atmospheric will be at a minimum as they were in 1924.



Little Ben

A week ago, I happened to be in a small Midland town. After a hard morning's work, I went into a restaurant for my midday meal. Mastering the preliminary shyness which I always feel on entering such a place, I glanced round the room. Over to my left I saw, to my great surprise, a friendly face smiling at me.

For a while I was puzzled, but, eventually, I recognized in the smiling face that of an old

cricketing friend of twenty years ago.

My old friend joined me at my table and we began a lively conversation. Reminiscences of the old cricketing days kept us busy for the greater part of our meal, but, towards the end, our talk ran to wireless. I suppose it is *my* fault that, before I have been talking to anyone many minutes, the talk somehow or other turns to wireless.

Of course, my old cricketing friend was interested in wireless. Who isn't?

In fact, he was more than usually interested, for he had had a valve set installed in his house only the previous week.

My friend could always tell a good story well in the old days and he had not lost the art. He related to me, in his own inimitable way, the story of the installation of his set. It ran something like this:—

"The afternoon the local wireless expert put up my aerial was one of the wettest I have ever known. We stuck at it for a couple of hours in the pouring rain and we went in wet through. I had to lend the expert an old suit to put on while his own was drying in the kitchen.

"After a meal, we connected up and switched on. The expert took the phones and the novices sat round him in expectancy.

"'Shush,' said the expert and we all shushed. We were dying to know what he was hearing, but the only answer we could get to a question was 'Shush.'

"Half an hour went by. Three-quarters. An hour. Nothing but a frantic twiddling of the knobs and



"Shush!"

a muttering of many shushes. Then the great man's face lit up. He was connected to the accumulator.

"'Ah,' he said, 'got it at last.' And then came a savage 'Shush' to the question 'What?'

"Deathly silence for a whole minute. Then, turning to us with satisfaction written all over his face, our expert remarked:

"'I have just heard Big Ben strike the hour.'

"'Nay, my boy, I don't think so,' I said to him. 'That was little

Ben, our hall clock, but he does sound rather like his illustrious namesake.'"

I asked my old friend if his set was working well now and he replied:

"Rather, but it was no wonder to me that the thing was a washout on such a wet afternoon. I don't think an aerial is any better than I am on a wet wicket."



The Delay Paid

I had an amusing experience in connection with the drop in the price of valves. Very frequently I am commissioned by one of my



I completely forgot the valves.

wireless neighbours to make various wireless purchases when I am about to pay a visit to one of the big wireless shopping centres.

I received one such commission for the purchase of three valves about a week before the reductions in valve prices became operative.

I made one journey to town and I was so taken up with my own business that I completely forgot the valves I had been asked to purchase.

My friend who desired the valves was somewhat disappointed, for he had a perfectly new home-made three-valve set waiting for the valves.

I made a second journey to town a few days later and again I forgot the valves. On the occasion of my second lapse, my friend applied a little sarcasm to his speech with me. He suggested various aids to the memory, such as a piece of No. 22 d.c.c. wire twisted round my little finger and a large knot in my handkerchief.

However, I was most apologetic and I promised to do better next time. I did do better next time, very much better, for the day on which I actually purchased the valves was the very day on which the reduced prices took effect. My forgetfulness saved the purchaser of those three valves no less a sum than twelve shillings.

I should not advise anyone, though, to wait for the next drop in valve prices.

Lightning

I have had a most interesting and intriguing talk with my meteorological friend on the subject of aerials and lightning. Perhaps you would like to know what conclusions we came to.

"Is an aerial a source of danger during a thunderstorm?" I asked him.

"It all depends whether the



"Lightning Conductors in the City."

lightning strikes it or not," was his reply.

"I know that, Mr. Weatherman. What I want to know, though, is this. Is the lightning likely to strike the aerial?"

"Relatively yes and no."

"I do wish you would be sensible. What do you mean by relatively yes and no?"

"Relatively speaking, lightning is more likely to strike an aerial than it is a clothes line. Again relatively speaking, lightning is less likely to strike an aerial than it is a telephone wire."

"I see, but how likely it is that the lightning will strike the aerial?"

"Thunderingly likely."

"Silly ass. I wish you could be sensible. I am asking these questions not so much on my own behalf as on the behalf of others."

"What others?"

"Never you mind. Just answer my question if you can. Is lightning likely to strike an aerial?"

"The odds are heavily against it, but lightning is more likely to strike an aerial in the open country than an aerial in the crowded city."

"Why is that?"

"Well, there is so much more protection from lightning in a city in the way of lightning conductors and overhead wires."

"That's rather interesting."

"Then again, a lot depends on the way the aerial wire is suspended at its free end. If the free end is attached to an oak tree, it is fifty times more likely to get hit by lightning than if it were attached to a beech tree."

"How about a mast?"

"With a metal mast, or even a wooden one provided the wood is dry, there is very little danger, far

less than when the aerial is suspended from a tree."

"Is an aerial any protection against lightning for anyone standing underneath it?"

"A single wire might give a little protection, a double wire would give more, but anyone standing underneath an earthed umbrella-shaped aerial would be very well protected against lightning."

"Nobody seems struck on umbrella aerials these days."

"Oh! well, nobody is like'y to be struck under one then."



The Wicked Chair

A schoolboy relative of mine recently went to listen-in at a neighbour's house where a powerful valve set and a large loud-speaker are used for wireless reception.

"How did you like listening-in the other night?" I asked him.

"Not much," he replied.

"How was that?" I asked.

"Well, you see, I happened to have to sit in the wicker chair and every time I moved the least little bit, the chair creaked and that made everybody glare at me. You can't expect a fellow to enjoy wireless when folks keep on glaring at him."

"Pretty bad luck getting a wicker chair on such an important occasion. There are two of them at my house and I must say I take pretty good care they do not get into the listening-in room."

"Can't you stop a wicker chair from creaking?"

"I am afraid not, old man. They get worse as they get older, you know. We have one in the kitchen that is so bad that everybody calls it the wicked chair. Next time I should sit on the floor when you listen-in, if I were you."



Criticism

An American critic, I notice, says that it is an enigma to him why the B.B.C. stations use so much power and radiate such a small quantity of that power into the ether, and that he has strong suspicions that it may possibly be due to the poor quality of the apparatus used by the B.B.C., the type of circuit adopted, or inefficiency on the part of the operating personnel.

Dreadful isn't it? But the worst is over now. What do you think of it all?

Personally, my chief regret in the matter is that this kindly-disposed American critic did not go on to make the obvious suggestion that John Henry be appointed Engineer-in-Chief to the Broadcasting Company on the grounds that the said John Henry's first remark on taking



A kindly-disposed American critic.

up his new duties would almost certainly be "It's all wrong, you know."

I should like to put forward a suggestion here which has evidently escaped our American wireless friend who thinks so unkindly of the B.B.C. What his observations amount to is this:

Dividing the Atlantic Ocean into two parts, a western part and an eastern part, it is possible to hear in the western part the American broadcasting stations only, while in the eastern or British part of the Atlantic, it is possible to hear both the American and the British broadcasting stations. Here is my suggestion.

Does not all this point to a superiority of the British ether over the American ether?

Let the American wireless critics say what they like against our British broadcasting and our British receiving sets, but let them say one word against our good old British ether and I will have at them per return of post.

For instance, I have just been getting splendid loud-speaker results with two valves from 5 X X, at a distance of over 200 miles. They cannot do that with the American ether.



Wireless Lullabies

A schoolmaster friend of mine who lives in the north of England has discovered that, of all the bedtime attractions it is possible to have for boys these days, or rather nights, wireless is far and away the best.

My friend has two boys, the older one being fourteen and the younger

twelve. A loud-speaker has been specially installed in the boys' bedroom, its position being on the top of a wardrobe where it cannot easily be got at. This loud-speaker is connected to a receiving set in a room downstairs.

As soon as bedtime comes round, the boys go off to bed very willingly, for they have the promise of half an hour's wireless concert after they are in bed.

I asked my schoolmaster friend if he had any difficulty in choosing suitable items for his boys' evening lullabies.

He replied most emphatically that there was plenty of choice since he could get either Chelmsford, Manchester, Birmingham, Newcastle and Glasgow at good loud-speaker strength.

"What do the boys like best of all?" I asked him.

"They like unusual musical items best," he replied. "I mean such things as the Barnardo Musical Boys, the Anglo-Hawaiian Players, and banjo solos.

"I can always tell when there has been something the boys do not like," he went on with a smile. "When they disapprove of something they throw paper pellets at the loud-speaker, and I find the pellets the next day on the top of the wardrobe,



Something the boys do not like.

and sometimes a specially good shot puts a pellet down the loud-speaker horn."



"Earths"

I dare say you know all you want to know about "earths" and why you use one, but I rather think you will enjoy this little account of a recent conflict of opinion on this simple and familiar wireless matter.

A certain thirster after wireless knowledge of my acquaintance sent the following inquiry to three different founts of wireless information:

Why is an earth necessary in wireless?

The first authority to reply to the query wrote thus:

An earth connection is *not* necessary. A counterpoise may be employed in lieu of an earth to form a

complete oscillatory circuit for the reception of wireless signals.

This reply puzzled my seeker after knowledge severely, and he brought the reply to me for further enlightenment. The only comment he got from me, however, was:

"Somebody seems to have sold you a pup, old man."

The two other replies came later on that same morning and gave us



A certain thirster after knowledge.

food for serious thought. The second authority consulted said:

"An earth is necessary at a receiving station because that station must be an exact electrical counterpart of the broadcasting station."

"What do you think of that?" asked my friend the information seeker.

"It is a good answer," I replied. "The only difficulty, though, is that some transmitting stations use a counterpoise instead of an earth, for example, the French station Saint Assise."

"Then you ought to have both an earth and a counterpoise and use whichever of the two the transmitting station uses. Isn't that the idea?" asked my friend.

"Never heard of such a thing being done, but that doesn't say it wouldn't be a fine scheme, though," I replied.

The reply of the third authority was as follows:

"A receiving aerial forms one plate of a condenser. An earth is necessary to form an opposing plate for that condenser."

"What do you think of that?" asked my interrogator.

"Pretty good," I replied. "I should frame that answer."

Just then another authority on wireless wandered towards us, name of George.

"Let's ask George his opinion," said my friend.

"Carry on then," said I.

"I say, George, why is an earth necessary in wireless?"

"I'd like to know how on earth you'd put up your aerial masts without one," said George.

If there had been a valve for the best answer, I should have awarded it to George, wouldn't you?

Wire Gauges

Looking through a box of old and discarded wireless tools the other day, I came across a rusty wire gauge. This little rectangular piece of steel, with its gauge-measuring slits all round its edges, was one of my hardest-worked wireless "gadgets" two or three years ago.

I believe I was never to be found on wireless bent without that handy little wire gauge in my pocket. But now, I scarcely ever think of using a wire gauge.

I wonder how long it is since my one-time trusty wire gauge found its way into my box of "good-old-has-beens." It must be at least a couple of years.

Have you ever possessed a wire gauge? If you have, I am fairly certain it is now to be found in your junk box.

The disappearance of our wire gauges seems to me to show that we are not so particular these days over the gauge of our wires as we used to be time back. A year or two ago, we never took a manufacturer's word for the gauge of his wire. No, we measured it.

Moreover, if the designer of a wireless set signified No. 26 wire for a certain coil, we got No. 26 gauge wire even if we had to tramp all over the town for it, and when we



We never took a manufacturer's word.

got it we measured it to see that we had got it. I am not so sure that some of us did not measure the gauge of the wire at the beginning of the winding of the coil and at the end of the winding as well.

I remember, on one occasion years ago, I had mislaid my wire gauge and I borrowed one from my nearest wireless neighbour. *Within half an hour he sent for it back.*

The wire we use these days is on the whole very much thicker than the wire we used years ago. There must be a great deal less of the finer gauges used to-day than there was say a couple of years ago. I suppose we all find it a lot easier to judge by eye the gauge of our thicker wires, and that we do not feel the need for an accurate determination of the thickness by means of a wire gauge.

HALYARD.

WIRELESS amateurs who sit up late at night after the official broadcasting stations have closed down will have heard on various occasions amateur transmitters on the lower wavelengths. Those of the listeners who are sufficiently versed in morse are able to take down messages from wireless "fans" in the United Kingdom and abroad, as most of these communications are not sent at very high speed, but when reduced to the ordinary letters of the alphabet these messages will frequently puzzle the "eavesdropper." Most of the combinations are merely abbreviations of quite ordinary words and in that form may be termed "the jargon of the ether."

International Language

Although there is a movement on foot for the adoption of an international language, "Sparks" has long since established his code of abbreviations, and amongst wireless transmitters they are so well understood that foreigners of all lands have adopted them for their daily—or should we say nightly?—use.

Most of these abbreviations have been used by ships' operators for quite a long time, but the amateur appears to have increased the vocabulary to a very great extent.

For the benefit of interested listeners a list of the more common terms is given hereunder:

- R (received); K (come along); GM (good morning); GD (good day); GE (good evening); GN (good night); OM (old man); YL (young lady)—this is quite unofficial; FB (good business); HR or ERE (here); HV (have); VY (very); MNI (many); NIL (nothing); NM (no more); ND (nothing doing); HW (how); NW (now); GLD (glad); SRI (sorry); SIGS (signals); WRK (work); TMRW (to-morrow); 2NITE (to-night); CLD (called); CLG (calling); U



(you); UR (your); RU (are you); CU (see you); CUL. (see you later); CUAGN (see you again); B4 (before); DX (long distance); OK (all correct, all right); PSE (please); TKS (thanks); 73, 73S (greetings, kind regards); HI (high).

QR Abbreviations

The QR abbreviations, consisting of three letters from QRA onwards, are officially recognised for the purpose of wireless transmissions, and the full list can be found in the manuals published by the Marconi and other wireless transmitting companies. Those mostly used by the amateur transmitters are given hereunder. The same combination of letters can be used as a question or a reply.

- QRA. What is your name and address? (My name and address is . . .)
- QRB. How far are you from my station? (The distance between our stations is . . .)
- QRH. What is your wavelength? (My wavelength is . . .)
- QRK. How are you receiving me? (I am receiving you well.)
- QRL. Are you receiving badly? Shall I transmit so . . . so that you can adjust your receiver? (I am receiving you badly, etc.)
- QRM. Are you being interfered with? (I am being . . .)

- QRN. Are the atmospherics very strong? (The atmospherics are very strong.)
- QRO. Shall I increase my power? (Increase your power.)
- QRP. Shall I decrease my power? (Decrease . . .)
- QRQ. Shall I transmit faster? (Please transmit faster.)
- QRS. Shall I transmit more slowly? (Please transmit more slowly.)
- QRT. Shall I stop transmitting? (Stop. I have nothing to transmit.)
- QRU. I have nothing for you.
- QRV. Are you ready? (I am ready.)

- QRW. Are you busy? (I am busy with . . . Please do not interrupt.)
- QRX. Shall I wait? (Wait.)
- QRZ. Are my signals weak? (Your signals are weak.)
- QSA. Are my signals strong? (Your signals are strong.)
- QSB. Is my tone bad? (Your tone is bad.)
- QSL. Have you got the receipt? (Please acknowledge receipt.)
- QSS. Do my signals fade? (Your signals fade.)
- QST. General call to all stations.

Message in Code

The above sentences are self-explanatory and are suitable for most ordinary transmissions—in particular, long-distance calls. A message might be picked up as follows: "UR SIGS QRZ HR SOME QSS OM PSE QSL CRD 73S CUL." By this would be understood: "I am receiving your signals very weakly here. Atmospherics are very strong. Your signals fade. Please acknowledge receipt by card, old man. Kindest regards. Hope to hear from you later (see you later)."

All transmitting stations, whether professional or amateur, have special call-signs allotted to them by the respective authorities, and it is customary, when sending out messages which may be picked up abroad, to

prefix the call-sign with an initial letter showing the country from which the transmission emanates.

Prefix Letters

The following are the nationality prefix letters:

EA Spain; F France; FN Finland; G Great Britain; HB Switzerland; H Hungary; I Italy; J Japan; KB Germany; LA Norway; M Mexico; N (or U) United States of America; ON (or B) Belgium; OU (or D) Denmark; P Portugal; PA Holland; Q Cuba; R Argentine Republic; SA (or SM) Sweden; VA Canada; VH Australia; VL New Zealand; VN South Africa; VO Newfoundland; VT India.

As an example: 4AU (Belgium) would call up 6XX (London) in the following manner: G6XX G6XX G6XX de (frequently omitted) B4AU B4AU B4AU.

As already stated, all amateur transmitting stations are given call-signs by the authorities, and these consist of combinations of letters and figures. The different countries adopt certain groups of figures, and some of these indicate the location of the transmitter.

For instance: U.S.A., Nos. from 1 to 9: Nos. 2 and 3 indicate stations on the Atlantic Coast; 4, South; 5, Texas; 6 or 7, Western States; 8 and 9, Central States.

Great Britain, Nos. 2, 5 and 6 (to date).

France, the number 8 prefixing the letters.

Belgium, Nos. 1 and 4; No. 2 after letters.

Holland, 0.

Denmark, 7.

Finland, Nos. 1, 2 and 3, often 3 letters.

Germany (Occupied Territory), Nos. 1, 4 and 8.

Luxemburg, 0 and 1.

Italy, 1 or 3.

Switzerland, 4 or 9.

Canada, 1, 2 or 3.

Argentine Republic, usually No. 8 after letters.

New Zealand, 1-4 indicating districts: Nos. 1 and 2, North; 3 and 4, South.

Australia, 1-3.

When examining lists of "calls heard" it may have been noticed that such additions as 0-V-1 or 1-V-2 are found at the bottom of the column. This indicates the number and kind of valves used. The first figure denotes the number of H.F. valves used, the V indicating the

detector or, what would be more accurate, the rectifier, the last figure showing the number of L.F. valves in the receiving circuit.

Such an expression as 2-V-3 would therefore indicate that, at the time of reception, the notifying amateur was using 2 H.F., one rectifying, and 3 L.F. valves.

Comparison of Strength

In order to compare the strength of signals received, the following list of R numbers has been more or less adopted by amateurs the world over, and the signs are usually found in brackets next to the call letters of the station to which reference is made.

R1. Signals weak and hardly readable.

R2. Dots and dashes just readable.

R3. Readable.

R4. Signals easily read if interference is not too great.

R5. Clearly readable.

R6. Comfortably readable.

R7. Strong signals.

R8. Very strong signals.

R9. Exceptionally strong signals.

These R signs were, of course, originally compiled for the use of telegraphy, and are now adapted to telephony.

Owing to limitations of space it has only been possible to give a general outline of the methods used and the jargon adopted by wireless amateurs, but sufficient particulars have been given to enable the average listener to make sense of the abbreviations in general use.

JAY COOTE.

Camouflaging the Loud-speaker

(Continued from page 11)

the box so as to allow the horn to fit into the socket in the base (Figs. 2 and 3). A plan view of the bottom of the box is given in Fig. 4.

When the box for the base has been completed it should be draped round its sides with a piece of frilled velvet or other suitable material.

This covering has its top edge hemmed, into which is inserted a suitable length of elastic. When slipped over the base the elastic will serve to keep the covering in place.

The covering for the flare of the horn may be enhanced by inserting into the centre a small flashlamp bulb, which may be lighted up from a concealed flashlamp battery when the loud-speaker is in use. H. P.

BROADCASTING IN RUSSIA

FROM reports received in this country from Russia, it would appear that Moscow has been badly bitten by the wireless-bug!

The advent of three broadcasting stations and a regular service of concerts, entertainments and lectures has so taken that city by storm that the number of listeners will soon vie with that already existing in other broadcasting centres. Aerials are daily springing up in all quarters of Russia's capital, and as the communistic spirit still prevails, use is made of any house, whether it belongs to the enthusiastic amateur or not!

No Permission Asked

No permission is asked, but wires are slung in a haphazard manner from roof to roof, from dwelling to a tree in a neighbour's garden, or to any telegraph or electric-light standard in the street which may occupy a convenient position!

Broadcasting in Moscow is not an unmixed blessing, as many of the larger buildings house several families; and where sundry loud-speakers are bellowing forth in the same house, on different floors at the same time, the public at large gets all the musical entertainment it requires—or more.

Receiving Licences

Receiving licences are only granted to Russian citizens—that is, born Nationals—and all apparatus must first be submitted to the authorities to be officially approved and sealed. The cost of a licence varies according to the different classes of society. Members of the Red Army, of the Bolshevik Navy, and Government officials of all ranks pay from one to three roubles yearly; "the man in the street" is charged ten roubles for the same privilege, and the same fee is collected from all educational institutions.

A licence to employ a loud-speaker in a public hall to which admission is charged costs 25 roubles, but where a wireless installation is required for "picking up" Stock Exchange quotations and market prices, the owner is mulcted to the extent of 125 roubles.

Equality as regards wireless telephony does not appear to exist in Sovietland!

J. G. A.



WE politicians are beginning to waken up to the possibilities of wireless telephony. This is not to say that there are not members of Parliament who have taken a lively interest in the science from the beginning. But its great potentialities are only partially understood even now.

Present Position

The present position with regard to the broadcasting of political speeches is that, generally speaking, it is not permitted, and only the party leaders at a general election are invited to give one full-blooded political speech; and then there are no more politics on the wireless until the election results are announced on polling night.

In the last general election Mr. Asquith, now Earl of Oxford and Asquith, the Rt. Hon. Ramsay MacDonald, and the Rt. Hon. Stanley Baldwin, now Prime Minister, then leader of the Opposition, each broadcast one speech.

Mr. Asquith had broadcast a speech which he delivered at Paisley in a public hall when he was subject to heckling and interruptions, and in consequence the listeners-in missed some of his best pronouncements.

In the same way Mr. Ramsay MacDonald broadcast a speech at a

public meeting; and although the Earl of Oxford always stands still at a table on which is erected a small box to represent the dispatch-box from which he has so frequently orated in the House of Commons, Mr. MacDonald has a habit of marching about on the platform, with a result that can be imagined for the listeners-in.

On the other hand, Mr. Baldwin devoted a speech to broadcasting only, and did not, at the same time, address an audience of people. In consequence his speech was probably the best from the listeners-in point of view, especially as he has a very good wireless voice. I have heard it said that this one speech was worth hundreds of thousands of votes to his party.

Now, this *non possumus* attitude towards broadcasting politics will not continue. Of that we may be sure. During the month of May, Mr. Ramsay MacDonald and the Prime Minister both broadcast speeches which, while not strictly partisan, touched very much on current politics, the Prime Minister speaking on matters of the Empire and patriotism, and Mr. Ramsay MacDonald on the evils of secret diplomacy, the latter especially being a somewhat controversial matter.

We may take it, therefore, that

before many years elapse, or perhaps many months, it will become usual for political speeches to be broadcast.

I myself have frequently broadcast from our excellent relay station at Hull, on such subjects as naval experiences in my past life, League of Nations arguments, etc.; and I hope to be permitted to speak on current political problems before much more water has flowed under the bridges.

No Compulsion to Listen

And why not? No one need listen who objects to hearing politics. He or she has only to take off the headphones.

But I have known electors wedged into a crowded political meeting and anxious to leave because they did not agree with the sentiments expressed, or had trains to catch, and found it physically impossible to get out!

There is the case of a man who persistently interrupted the candidate with: "What did Mr. Gladstone say in '64?" Eventually the stewards ejected him, forcing a passage through the crowd. A friend later asked him: "What did Mr. Gladstone say in '64?" "Bothered if I know," said the one who had been ejected. "But I couldn't bear

that atmosphere any longer and had to get out in the fresh air somehow."

Now, members of Parliament and candidates whom I have sounded on the matter may be divided broadly into three groups.

There are first those who object to wireless because it is new. Theirs are the type of mind which objected to the motor-car and the aeroplane for the same reason; and their ancestors, no doubt, objected to steamships instead of sailing ships, and earlier still, to sailing ships instead of galleys rowed by slaves.

A Minority

Further back still, their forbears probably found fault with hollowed-out trees carrying men on the surface of the sea instead of people swimming by their own unaided efforts. With this kind of person nothing can be done except to submit them to a surgical operation. But they form a small and, fortunately, diminishing minority.

The second group consists of those politicians who do not rely on what they say, or their speaking, to get them into Parliament. They lean rather on the political complexion of their constituents, the work of their sisters, cousins, wives, aunts and other relatives at election times, the band of enthusiastic workers in the cause, generous and lavish subscriptions to clubs, institutes and other corporations in the neighbourhood; and, in some cases, to their names and reputations.

They are the kind of people who always have a bad cold at election times, and are quite unable to address the voters, and who obtain some smart young man to write their election addresses for them. The last thing these people want is to enable the voters to hear them in the calm and undisturbed surroundings of their own homes where listeners-in can weigh their words and digest their arguments.

Wireless will make things very difficult for this type of gentleman, and I can imagine him resisting the broadcasting of political speeches as strenuously as the broadcasting of the proceedings of Parliament, his

own part in which the less known about the better, from his point of view.

The third group of politicians and candidates are those who have a message for the electors, who rely on their oratory, their arguments, their power of stimulating thought or creating enthusiasm, and for them broadcasting should be a great boon.

With the vast electorate to-day it is impossible by means of the public meeting, even if one holds three a night in the largest halls available during the whole of a normal campaign, personally to address more than one-third of the electors. Many candidates always address three and sometimes four meetings a night, and open-air meetings during the day as well, but they know well that there

candidate, have a habit of following him around from meeting to meeting, especially if he is not the type of person who has only one speech, or possibly two, for the whole campaign.

Again, there are many persons who, owing to their work or occupations, or the need of looking after the children at home, are unable to get to political meetings; and, lastly, in recent years there has been a recrudescence of trouble and disorder at political meetings not confined only to one party, and many timid people in these circumstances are afraid to attend them.

For these reasons I consider that the broadcasting of political speeches at election times will be a great help to the working of our constitutional system, and for giving fair play to democracy. It means that whatever the weather and however afraid the people may be of not getting in to political meetings because of the crowds or other reasons, they may yet sit quietly at home and listen to the candidate explaining his policy.

Fair Chance for All

Naturally the views of all candidates must be given an absolutely fair chance, and here no complaint can be made against the British Broadcasting Company. Whilst the British Broadcasting Company has only broadcast the speeches of the leaders at general elections, it has given them all the same chance and showed its fairmindedness by permitting one of the Communist leaders in the last election to broadcast one speech on the same terms as the leaders of the other parties.

I suggest that in each constituency it might be arranged for each candidate to give two speeches from the local relay station during the campaign, at times to be mutually agreed upon, and balloted for in case of dispute. There would have to be an arrangement for non-interference; and, in fact, the campaign programmes would have to be arranged like any others.

There are 615 constituencies in England, Scotland, Wales and



Lieut.-Com. the Hon. J. M. Kenworthy, R.N., M.P.

are thousands upon thousands of voters who have no chance of hearing them.

For one thing, it is only the keen political people, and more often than not those of only one way of thinking, who come to one's meetings. The candidate is most often speaking to the already converted. Also, the same people, keen supporters of the

local relay station during the campaign, at times to be mutually agreed upon, and balloted for in case of dispute. There would have to be an arrangement for non-interference; and, in fact, the campaign programmes would have to be arranged like any others.

There are 615 constituencies in England, Scotland, Wales and

Northern Ireland, and about 1,200 candidates stand throughout the country at each election. An election campaign lasts about three weeks. There will, therefore, have to be very careful organization to give every candidate a chance of a couple of speeches to his own constituents.

The necessary arrangements may appear difficult at first sight, but I believe the obstacles could be, and should be, overcome.

No Meetings To Be Broadcast

I do not consider it a good plan to broadcast a public meeting, but better to let the candidate speak from the microphone room at the relay station. There will, of course, be certain disadvantages in delivering a speech under these circumstances, one of them being that one has no contact with one's audience.

After all, many of the best speeches that have ever been delivered on political platforms have been stimulated by the sympathy and response of a great gathering favourable to the orator.

* * * *

With regard to the question of broadcasting Parliament, this has been postponed, unfortunately, until the end of the year, when a Select Committee of both Houses is to be set up to look into the whole question, not only with regard to the question of broadcasting Parliamentary proceedings, but the future of broadcasting generally, including the position of the British Broadcasting Company. That Parliament will be broadcast one day is certain.

The argument that Parliament will lose dignity is bosh. If the Prince of Wales has broadcast, and the Archbishop of Canterbury's religious observations are available for listeners-in, and the King's speech at Wembley is thrown into the ether, Parliament need not be afraid for its dignity.

There are, as far as I can gather, no technical difficulties, and if the people wish to hear the representatives whom they send to Parliament, they have a perfect right to do so.

I think it would be a mistake if only the members of the Government and the leaders of the Opposition were heard; in other words if only the Front Bench speakers broadcast, as it would be unfair to the private members, many of whom, after all, are the Cabinet Ministers of the future, and because the voters naturally want the chance of hearing the man who represents them personally, and to be able to form some opinion as to whether he is safeguarding their interests and keeping his own end up.

* * * *

The whole future of broadcasting will have to be seriously considered by Parliament before very long. The British Broadcasting Company's licence comes to an end in December, 1926.

Whether the British Broadcasting Company is to be bought out by the Government, whether the plant is to be leased to other bodies, whether competition is to be introduced, to what extent there should be Government control, or whether wireless should be entirely in the hands of the Government of the day, are matters for urgent discussion and consideration; and, whether politicians of all parties like it or not, this matter must be taken very seriously.

Wireless telegraphy itself has, of course, been before Parliament for many years, and it is very regrettable that party politics have hampered the establishment of an all-red Empire wireless chain. No doubt the War held up the project, but there have been other and inexcusable delays.

A high-power station is in course of erection at Rugby to carry out the policy of providing Empire wireless communication by means of special stations. An arrangement was made for the Dominion Governments to provide similar stations.

Beam Transmission

The Marconi Company, however, in the meantime perfected an invention known as the "beam" system, which it is believed will provide the necessary service for a certain number of hours of the day at a much smaller cost. This system is being given a trial and a "beam" station is in course of erection for communication with Canada, and negotiations proceed for a similar service to South Africa, Australia and India.

An Imperial Committee, under the chairmanship of the Assistant Postmaster-General, with representatives of the Dominions and India, is being set up to supervise the working of the Imperial Wireless service. This is a great step forward, and it is hoped that there will be no further delay, and that Parliament

will insist on the early completion of an imperial wireless telegraphy system.

Wireless telegraphy was studied in the past by a comparatively small number of members, but the introduction of wireless telephony and the growth of the numbers of listeners-in and amateur experimenters has stimulated Parliamentary attention, with the result that a much greater number of politicians realise the importance of the subject and give it attention.

A JOLLY GOOD TIME?

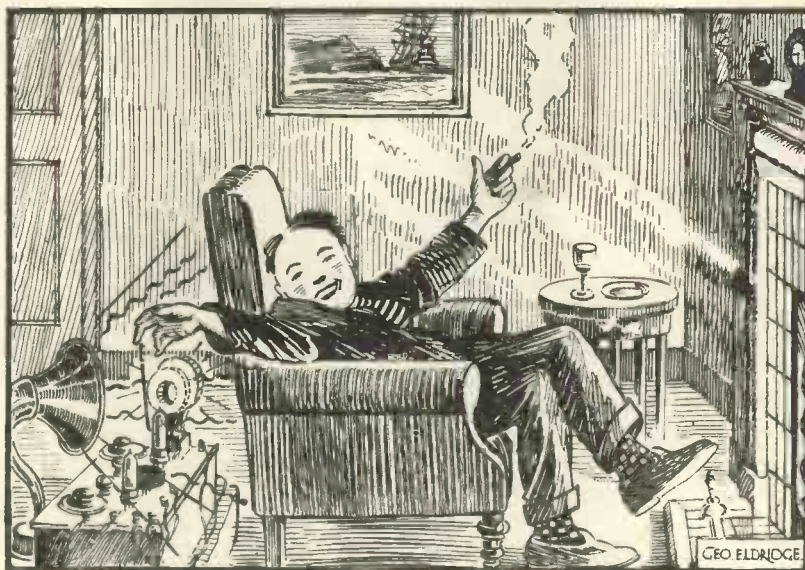

The Young Villain: "I've had a glass of port, one of Dad's cigars, and now I'm interfering with half the British Isles!"

HIS MASTER'S VICE!



A Special Three-valve for the Distant Stations

Designed, Built & Tested by
"THE WIRELESS MAGAZINE"
Technical Staff, this set embodies
features that make it specially
suitable for long-distance work.



ALTHOUGH it is probable that there are more valve receivers making use of a circuit comprising detector and one stage of low-frequency amplification than any other, it is certain that an additional one-valve high-frequency amplifier correctly designed and properly used would bring in those far-distant stations out of the range of the usual two-valve.

Besides adding sensitivity to a set, an H.F. amplifier also greatly increases the selectivity.

We emphasise this fact for the reason that we have had numerous complaints from listeners residing on the east coast concerning the amount of jamming and interference experienced there.

An argument that is repeatedly laid against the H.F. amplifier is that results obtained from a detector and H.F. valve are no better (sometimes even worse) than those obtained from the detector valve alone.

In answer to this it may be said in the first place that an H.F. amplifier must be well designed. This means that all stray capacities

existing in the wiring and in the valve itself must be balanced or neutralised.

However carefully the amplifier has been designed, maximum efficiency cannot be obtained unless these stray capacities are balanced.

Secondly, the novice finds he obtains no better results when using a stage of H.F. amplification than

The use of the neutrodyne method of coupling H.F. valves is not only more efficient than the usual straight method, but makes tuning easier. To those who still persist in crying down the H.F. amplifier we would recommend the handling of a receiver embodying one stage of neutrodyne H.F. It is safe to say that they would be no longer in doubt as to the efficiency of H.F. amplification.

The three-valve receiver described here is intended to receive the local station on the loud-speaker and to bring in B.B.C. and other stations at phone strength. The operation of the set is extremely simple, and after the neutrodyne condenser has once been adjusted there are only three controls, including reaction.

The control of H.F. amplifiers is complicated by the tendency of the valves to burst into self-oscillation when the grid and plate circuits of the valves are in resonance. For this self-oscillation to take place there must exist either static or magnetic coupling between the grid and plate circuits.

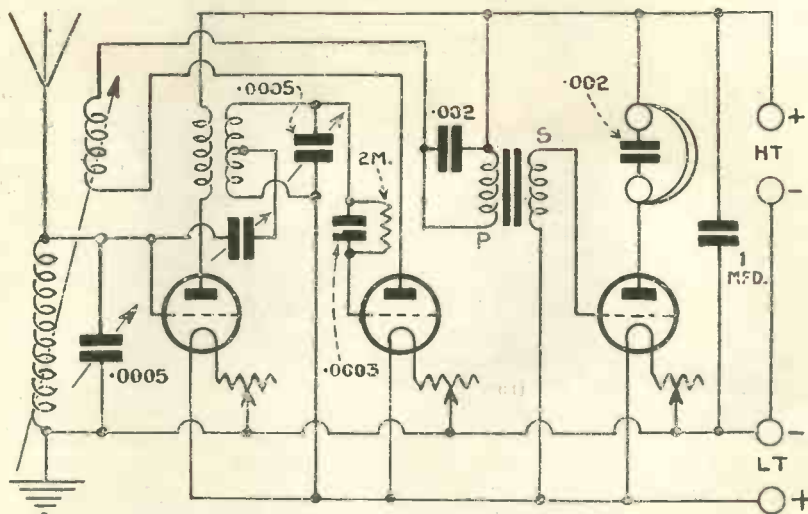

Circuit Diagram of Special Three-valve Set.

when not using it. The reason for this is obvious and lies in the fact that owing to the increased number of controls he finds tuning more difficult.

It cannot be taken as an argument that the H.F. amplifier is inefficient because the majority of amateurs are unable to handle it properly.

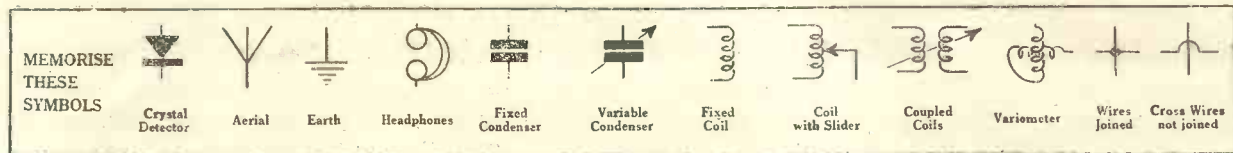

A small amount of static coupling exists between the grid and plate electrodes of the valve itself, and this is quite sufficient for the transference of energy from one circuit to another. There is also a small capacity in the wiring of the set. These small static couplings form the "stray capacities" already mentioned, and they are neutralised by the small neutrodyne condenser which, at any moment, has a capacity opposite in phase to that existing between the grid and plate of the H.F. valve.

By suitable adjustment of the neutrodyne condenser the stray capa-

the mid point of the secondary winding, that is, at the 33rd turn. The two coils are then clamped together and mounted on an ebonite strip 4 in. long by 1 in. wide.

The ends of the two coils and the tapping from the secondary should be left projecting so that connections to them may be easily made.

Other Components Required

Other components required for constructing the receiver are:

Radion ebonite panel, 18 in. by 7 in. by $\frac{3}{16}$ in. thick (American Hard Rubber Co.).

.0003-microfarad grid condenser and 2-megohm grid leak.

Oak cabinet (Carrington Manufacturing Co.).

A dimensioned sketch of the cabinet is given for the benefit of those amateurs who are their own carpenters. The two end pieces should first be made up identical to each other and accurately square.

The back should next be made with two slots at the bottom for the terminal strips to project through. The two sides, the bottom and the back pieces are glued and screwed together. A lid is attached to the

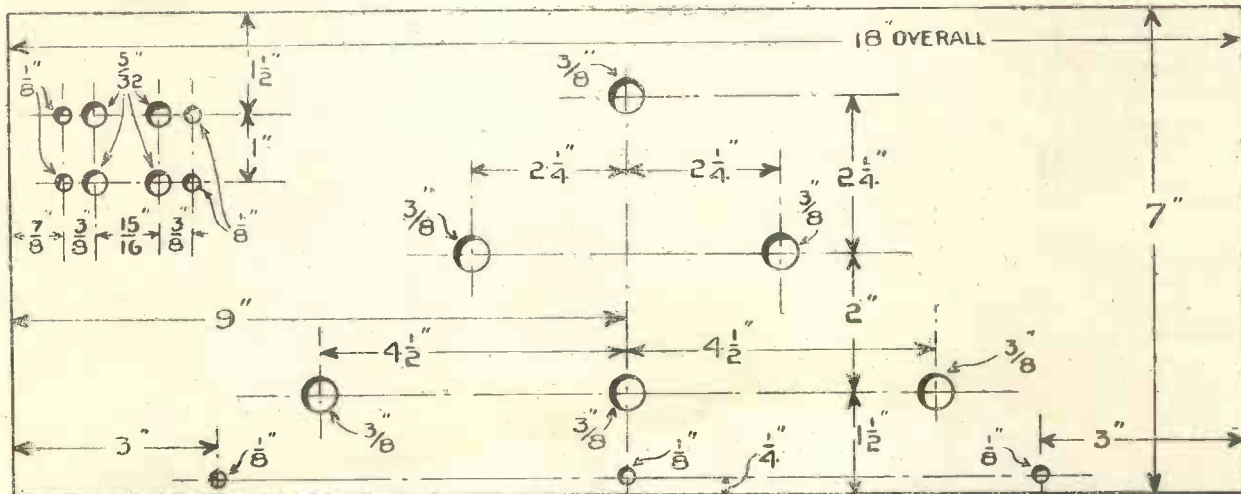

Layout of Panel of Three-valve Set.

cities are neutralised, and once adjusted, it need not be again altered.

A very efficient home-made neutrodyne transformer may be constructed as follows: Two basket coil formers are required, each having 11 slots and an inside diameter of $1\frac{1}{2}$ in. The primary winding of the transformer consists of 25 turns of No. 22-gauge d.c.c. wire wound on one of the formers, while the secondary winding consists of 65 turns of No. 26-gauge d.c.c. wire.

A tapping should be taken from

- 2 variable square-law condensers, .0005-microfarad each (Peto Scott).
- Neutrodyne condenser (Gambrell).
- 3 filament rheostats (Lissen).
- L.F. transformer (Lissen).
- Two-way coil holder (Burne-Jones).
- 3 valve holders (Burne-Jones).
- Fixed condenser, 1-microfarad (T.C.C.).
- 2 fixed condensers, .002-microfarad (T.C.C.).
- 8 terminals (Belling Lee).
- 2 ebonite terminal strips, 6 in. by 1 in. and 3 in. by 1 in.

top of the cabinet, so that easy access to the instruments is possible.

A similar cabinet, well made and finished, may be obtained from the Carrington Manufacturing Co., 18 to 20, Normans Buildings, London, E.C.1.

The panel is a standard size of the American Hard Rubber Co., and does not require cutting or truing-up.

Three holes are drilled along the bottom for its attachment to

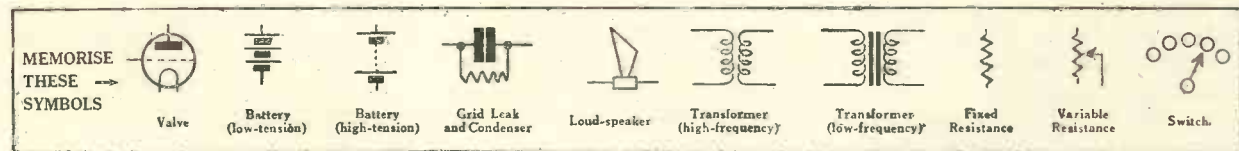

A Special Three-valver for the Distant Stations (Continued)

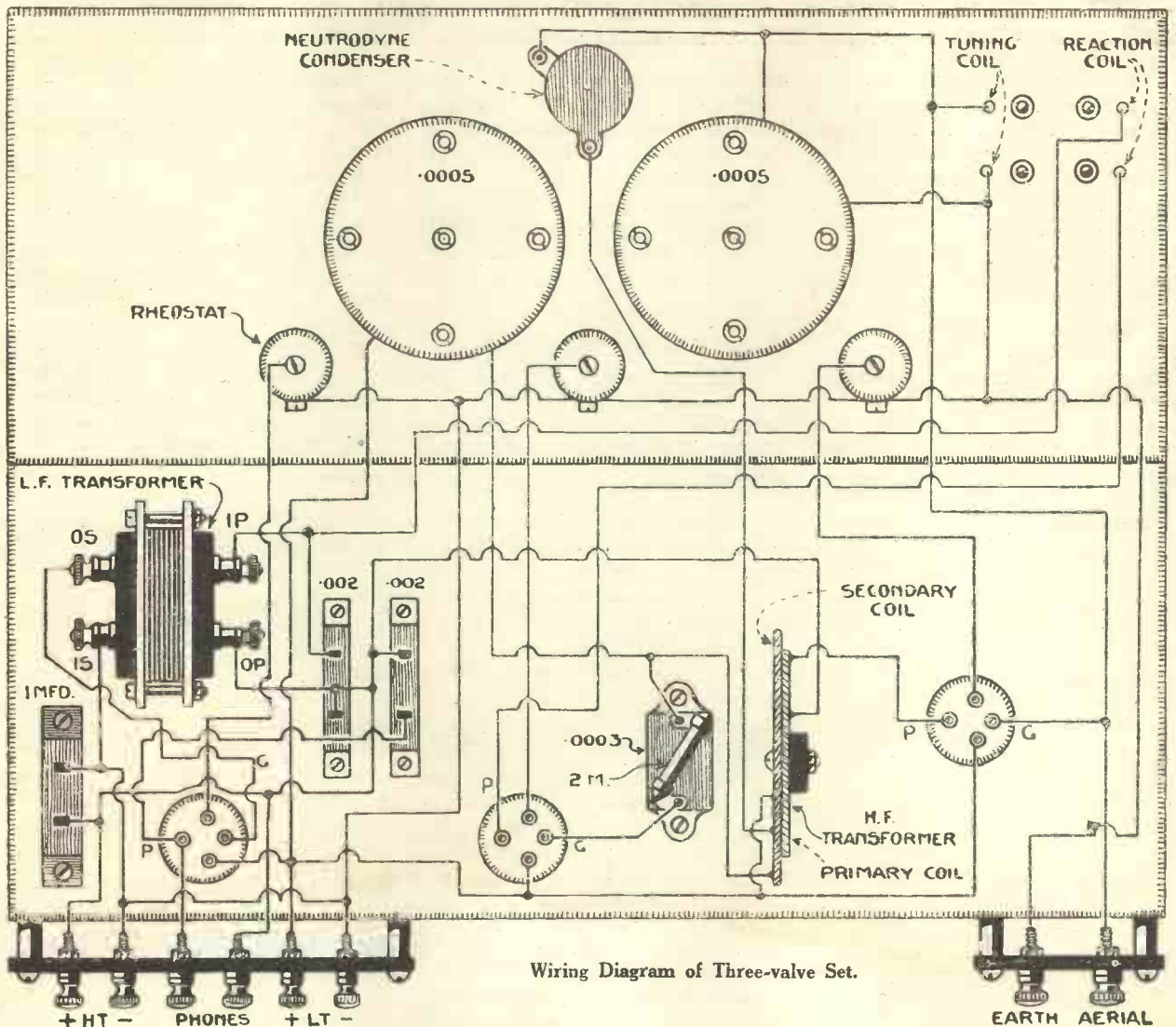

Wiring Diagram of Three-valve Set.

the baseboard by means of three 1-in. brass wood screws.

Condenser Mounting

The two variable condensers of the one-hole fixing type are seen in the photographs mounted on each side of the centre of the panel. Underneath the variable condensers are mounted the filament rheostats, while above is fixed the neutrodyne condenser. The two-way coil holder is mounted on the left-hand top corner of the panel.

A layout of the panel is given showing the holes to be drilled and the disposition of the components.

The baseboard consists of a piece of 1/2-in. teak or oak, 17 in. long by 8 in. wide, on the back edge of which

are mounted the two ebonite terminal strips, one at each end. The strip carrying the aerial and earth terminals is screwed to the edge of the baseboard on the extreme right looking from the back.

The other terminal strip carries (reading from left to right) H.T. +, H.T. -, phones -, phones +, L.T. +, and L.T. -, and is mounted on the extreme left of the baseboard. On the baseboard itself are fixed the three valve holders, L.F. transformer, three fixed condensers, grid leak and condenser, and the H.F. neutrodyne transformer.

As the components are well spaced wiring is an easy matter. It is advisable to keep the panel and baseboard separate, and to wire up

as much of the apparatus as possible before screwing together.

Tinned copper wire of square section was used for connections except in the case of the moving coil of the two-way holder, where two lengths of flexible wire were more satisfactory.

Spaced Wiring

Keep the wires well spaced, especially those leading to the H.F. valve and transformer. A wiring diagram is given which will be easily followed by those of our readers who prefer the pictorial to the theoretical form of circuit diagram.

Connections to the H.F. neutrodyne transformer should be as follow: plate of H.F. valve to outside of

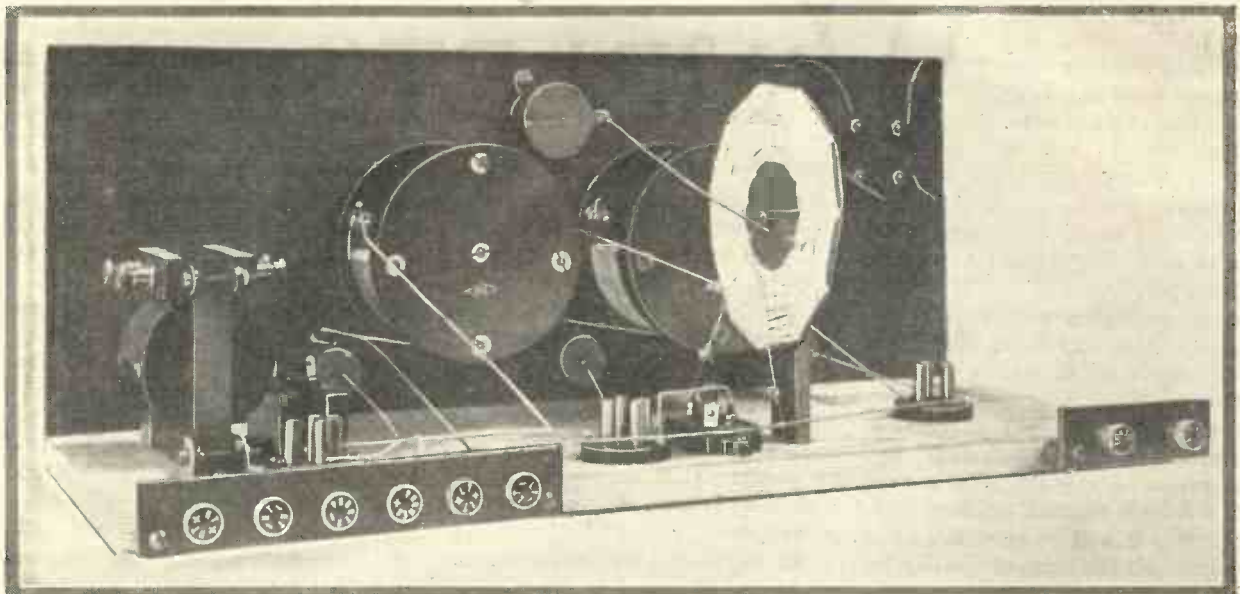

Photograph of Back of Three-valve Set in Course of Construction.

primary winding, H.T. + to *inside* of primary winding; grid condenser of detector valve to *outside* of secondary winding, L.T. + to *inside* of secondary winding. The centre tap of the secondary winding is, of course, connected to one side of the neutrodyne condenser.

Valves to Use

Best results were obtained by using one of the new Mullard white-ring detector valves (type D 3) in the detector socket, a pink-top Cossor in the H.F. socket, and a Mullard D.F.A.1 power valve as an L.F. amplifier.

The use of a special detecting valve such as the one mentioned is very strongly recommended. General-purpose valves are good in their own way, but there is no doubt that the use of special valves for special purposes increases the efficiency of a receiver to an extent of which the average amateur appears to be unaware.

Having wired the set, the batteries, phones, and aerial and earth leads should be connected to their proper terminals for a preliminary listening-in test.

Keep the reaction coil at right angles to the aerial coil and tune in

a station by *slowly* rotating the two variable condenser dials.

Final Adjustment

Now take the H.F. valve out of its holder. The station will still probably be heard, but readjustment of the two condensers will be required to bring it up to maximum strength. Now stick a piece of paper over *one* of the filament legs of the H.F. valve and replace it in its socket. The filament, of course, will not light up, but the grid-to-plate capacity of the valve will be in circuit, and signals will still be

(Continued at bottom of next page)

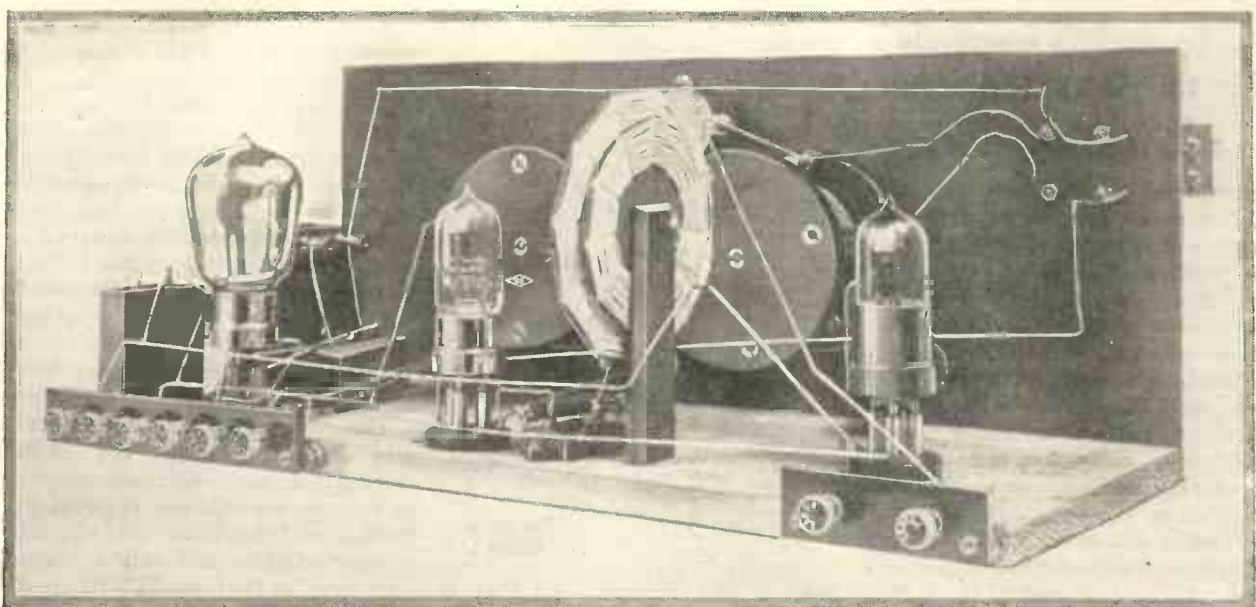

Photograph of Completed Three-valve Set.

CAPTAIN ECKERSLEY says that one American factory can turn out wireless sets at the rate of two a minute. They sound like a certain type of four-wheel set.

WIRELESS is being mentioned in the Law Courts nearly every day. This comes of having formed a wireless "society."

THE woman listeners of Glasgow have had a lecture on how to keep bees. The answer is, of course, in their bonnets.

IT has been said that a recently-formed wireless organisation was the result of a stunt. Its growth has not been stunted, anyhow.

SOME day it will be possible to disseminate all the news of the day by wireless, says a journalist. And what will the barber do then, poor thing?

A WELL-KNOWN firm has been advertising wireless sets on the easy payment system, in a Scottish newspaper. Easy payments—they must be optimists.

A TALK entitled "Seasonal work amongst the strawberries" is described as being for farmers. We cannot help thinking that it was really intended for the Children's Hour.

A FURNITURE expert has been advising us on "Ideas for Antique Cabinets." Unless the Wireless Bill is modified we shall begin to think we have an "antique Cabinet" at Westminster.

WAVELETS

The Gamblers is said to have been an exceedingly hard play to broadcast. Not "hard-up," like most gamblers we know.

SOME people still prefer to hear a gramophone to a wireless set, says a writer. We advise them to attend the next Communist meeting held in their locality.

"OCCUPIES practically no space," says the advertisement of a new accessory. That sounds more like the description of an excursion passenger.

WIRELESS plugs are fitted by the side of every member in the Italian Parliament. We could do with plugs of a different kind for some of our members.

AMERICAN stations have been broadcasting advice on how to fill up Income Tax forms. The best way is to fill up the paper-basket with them.

BECAUSE his neighbour's set was howling, a Surrey listener hit lum on the head with a hammer. "Go thou and howl likewise" was evidently his Biblical authority for the incident.

A TALK on how chocolates are made was recently broadcast for children. We understand that they are very anxious to hear the sequel—how chocolates should be eaten.

WIRELESS listeners have had several harp performances recently. It is rather unkind of the B.B.C. thus to insinuate that we won't hear enough of that instrument hereafter.

NOR to be outdone by Paris, Berlin is building a wireless Eiffel Tower. That will make the German listeners look up.

WIRELESS houses are being erected at Sheffield. Officials of the Bricklayers' Union, we understand, are providing the loud-speakers.

EMPIRE wireless is in a state of fog, says a critic. But he should remember that it would be mist if we tried to do without it.

"WIRELESS, like the poor, will always be with us," says Sir Landon Ronald. Yes, but it will not be so dole-ful.

GOTHENBURG is sending out fishery reports on a length of 700 metres. This beats the reports we receive from the members of our local angling society by about six inches.

THE Radio Corporation of America says that Big Ben has been relayed by W J Z, W G Y and W B C. Who in future will dare to say that wireless is not appreciated by men of letters?

A VOCABULARY of wireless terms has just been issued in five languages. But not in one of them have we discovered the precise term which we apply to the oscillation merchant who lives in the next street.

A Special Three-valver for the Distant Stations

(Continued from previous page).

heard faintly. The neutrodyne condenser should then be adjusted until signals are eliminated altogether, or as much as possible.

When this has been done the internal capacity of the valve has been balanced.

Remove the paper from the valve legs, and the H.F. amplifier will be found to be working at its utmost efficiency, and the set can be operated without fear of self-oscillation.

Tuning will be found to be very simple, and with the judicious use of the reaction coil most of the B.B.C. and Continental stations should be

tuned-in. The reaction coil should be tested and altered, if necessary, for correct polarity.

The set can now be permanently

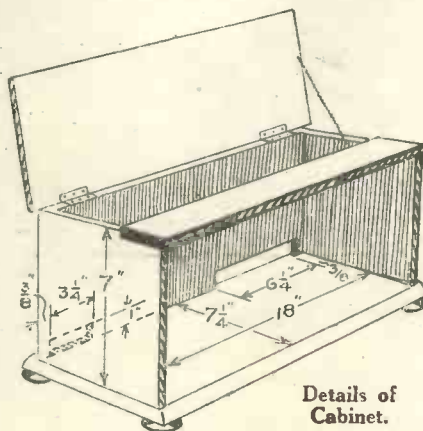

Details of Cabinet.

fixed in the cabinet. All that is required for fixing purposes are two

brass wood screws clamping the panel to two wood fillets at each end of the cabinet (not shown).

The terminals project from the back of the cabinet so that the panel front presents a clean appearance, free from wires leading to external apparatus.

On a fair-sized outside aerial and a good earth all the main B.B.C. stations were received. Several of the continental stations working on a low wavelength also came through with beautiful clarity and at good strength.

The neutrodyne condenser operates efficiently, making the set a delight to handle. A certain amount of care is, nevertheless, required in tuning, as it was found that the set is very selective and only a slight movement of the controls is required to cut a station right out.

Novelties & New Apparatus of the Month

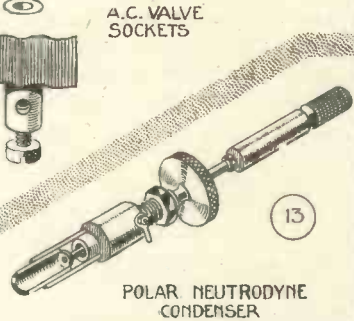
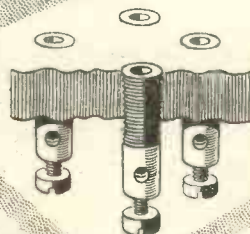
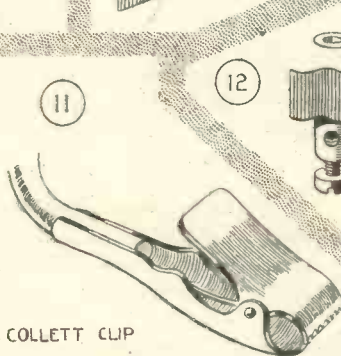
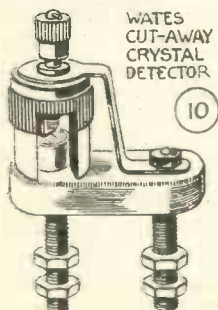
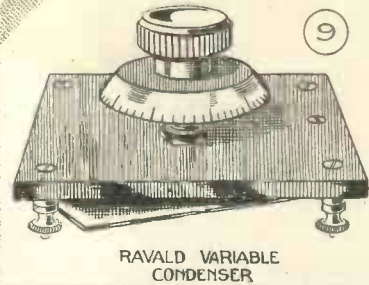
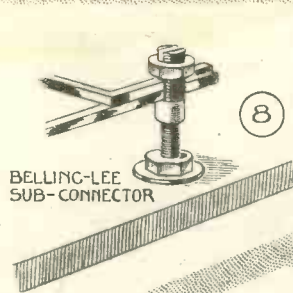
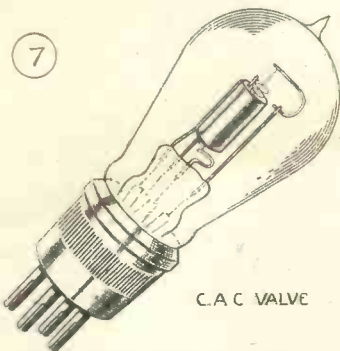
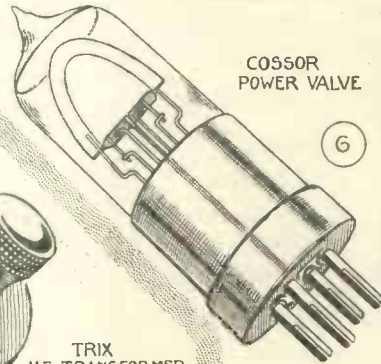
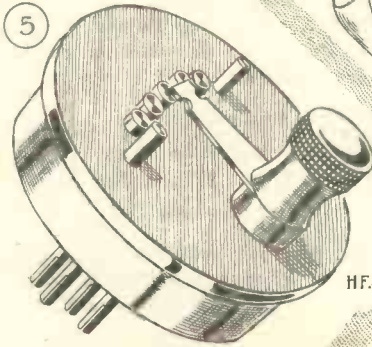
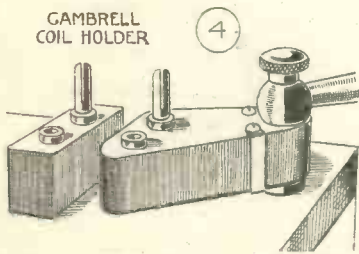
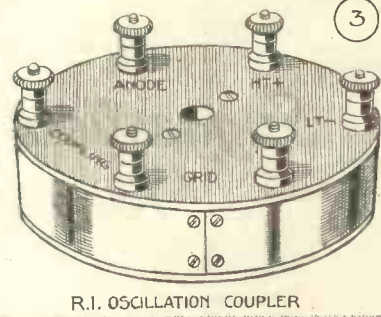
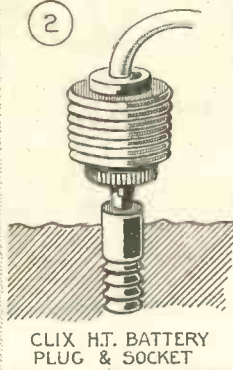
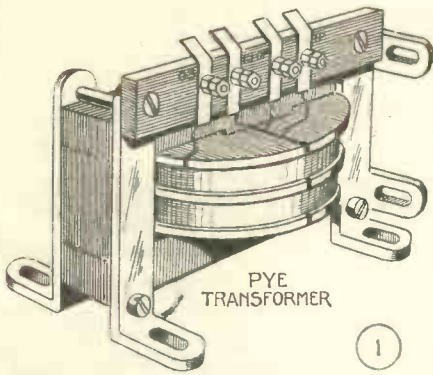

(For descriptions see page 87.)

What should be done to the Oscillator?

Suggestions Brutal & Otherwise

Garnered by PEARKES WITHERS

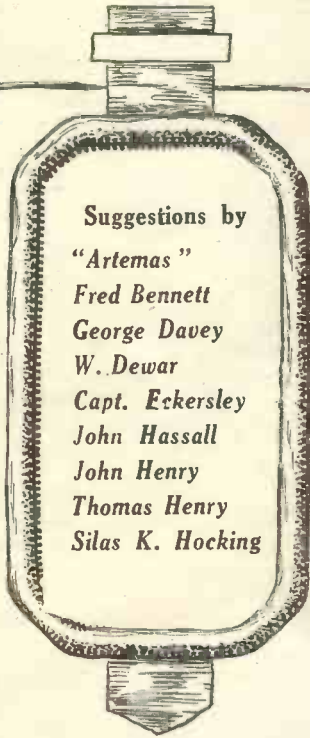

The Oscillator has been given a variety of names, in addition to the one he inherited from his father and the others he received at his baptism (if any).

He has been called:

- Ether Hog,*
- Wireless Bad Man,*
- Aerial Pest,*

and (in fairly outspoken family circles) he is known by many other names, the majority of which could not possibly be set up in type.

Whatever else he may be, he is no "gentleman." It is even contended in some circles that he is no man; though this contention finds little favour with those members of the fair sex who happen to know a grid leak from a transformer and who are not by any means "reaction"-aries.

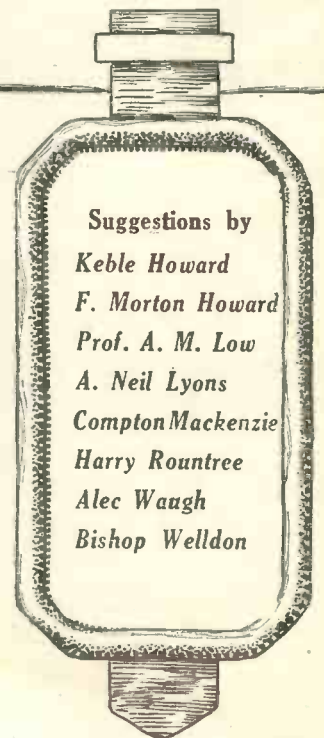

It is pretty generally agreed that one of the greatest nuisances in the world of wireless—if not indeed the greatest nuisance of all—is the Oscillator.

In nearly every district, nearly every night, the Oscillator—either by sheer accident or by diabolical intention—misuses his reaction coil, fills the immediate ether with shrieks and howls, and creates agony and anger in the souls of the comparatively innocent wireless enthusiasts who happen to live in the neighbourhood.

Thirsting for Blood

And most of these comparatively innocent wireless enthusiasts are rapidly becoming moral murderers, since above all things, and very naturally, they thirst for the Oscillator's blood.

It must, however, be pointed out that there are two distinct types of Oscillator.

There is the fellow who uses his reaction coil with colossal selfishness to express his dislike and disapproval

of any particular item in the B.B.C. programme, and who, just because he doesn't want to listen to the item himself, renders it impossible for his neighbours to listen by drowning it beneath a host of awful sounds like unto the lamentations of lost souls.

And there is the other fellow who wanders from one wavelength to another, in his misguided efforts to tune in to one particular station, and keeps his reaction coil going in full blast all the time lest he should travel past his station.

First-class Oscillators

The first-class Oscillator is beyond redemption; the second-class Oscillator usually has a dud set. He expects to obtain, with one or two valves, the strength and quality of reception other people sometimes fail to obtain with three or four valves; and as he hasn't sufficient power of amplification he makes the most of his power to oscillate. He derives (as it would appear) satisfaction from distorted stuff and condemns any

number of victims in the vicinity to suffer from his distortions.

What should be done to the Oscillator? Captain P. P. Eckersley, the Chief Engineer of the B.C.C., is always pleading with him to mend his ways, but pleadings are evidently in vain. And, at present, the Postmaster-General's legal powers are limited to depriving the Oscillator of his set.

The Radio Association are on his track, with the aid of several cars fitted with direction-finding instruments of an improved type, and several fixed stations; and the Radio Association intend to place all the information they can glean concerning the activities of individual Oscillators in the hands of the Postmaster-General, so that he may tackle violent reaction with more or less counter-action.

But at present the utmost action the Postmaster-General can take is to cancel licences. Is this enough? It is not enough!

What should be done to the Oscillator? Should he be fined, imprisoned, or shot? Should his licence and his set be taken from him, or should some peculiar punishment be devised to fit his crime? And if so, what particular form of punishment would be fittest?

Fearing lest my own ideas upon this subject should be too drastic, since I have suffered much (though not by any means in silence) at the hands and coils of local Oscillators, I have sought the opinions of a number of well-known people, including artists, authors, listeners and experts.

Here are their replies, pictorial and literary, lively and severe (especially severe), which are recommended to your notice and to the notice of the authorities:—

Z. Martin Howard

The Well-known Humorous Writer.

Personally, I am fortunate in being able to retain the services of a private wizard. He has been with our family now for several centuries and is really a very discreet and dependable old chap. Indeed, the only error I have ever heard of him committing was when he took down the dragons' blood bottle, instead of the camomile tea bottle, from his shelves. . . . As a result, my great-great-uncle Ichabod had to keep away from petrol for ever so long; and, of course, the stuff didn't do his asthma the least good.

My private necromancer is very good at parlour magic, spells, jumper-knitting, incantations, cross-word puzzles, and divination (except as applied to horse-racing). His strongest suit, however, lies in changing people into inanimate objects. . . . We've had quite a lot of mysterious disappearances in our neighbourhood lately.

So far as Oscillators are concerned, our plan is simplicity itself. To make their punishment fit their crime, my private wizard merely changes them into

slate-pencils, and I drop them outside infants' schools. . . .

"Artkmas"

The Famous Humorist (A. Telford Mason).

¶Assuredly there is no penalty under the sun that cometh up to the deserts of these.

If he be a man, let him be garbed in Oks-Ford bags of the colour of sin that men may know him for what he is.

And if she be a woman, then let her be condemned in this wise: that not a hair of her head shall be touched

AN OSCILLATOR

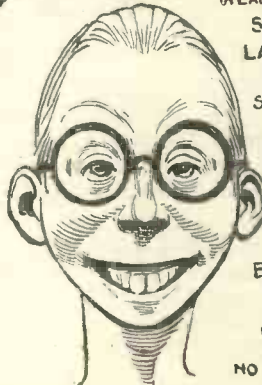

INFALLIBLE CHARACTERISTICS

- LIGHT HAIR.
- EYES TOO CLOSE TOGETHER.
- WEAK, SWOLLEN EYELIDS.
- SHORT, THIN NOSE.
- LARGE FLABBY LIPS.
- RECEDING CHIN.
- SHORT, THIN BEARD AFTER AGE 19.
- THIN, SCREWABLE NECK.
- LARGE DAMP HANDS WITH BULBOUS KNUCKLES.
- COMPLEXION PINK & WHITE.
- NO SENSE OF HUMOUR AT ALL.
- A GOOD BOY TO AGED MOTHER IF ANY.
- NO FATHER LIVING AGE FROM 16 TO 45.

John Hassall, R.I., presents a composite drawing of all the best-known Oscillators, with the phrenological specifications jotted down the margin.

by scissors nor shall her locks be shorn by any manner of means.

So only shalt thou teach them that it were better for such as these that they had been cut off early in the days of their youth.

A. M. Low

Professor A. M. Low, D.Sc., the Inventor.

I never feel quite certain if the Oscillator should have his licence endorsed, or whether a Society for the Protection of Oscillators should be formed. It is not

What Should be Done to the Oscillator?—(Continued)

long since I attended a meeting at the House of Commons where the position of the Oscillator was discussed at some length. The fact that his name should have reached thus far leads one to suspect that there may be a certain amount of justice upon his side. No cause ever grew with extreme rapidity unless it was subjected, in the first instance, to intensive abuse.

The Oscillator seriously damages musical programmes; he may reply that the word music is a matter of opinion. He can seriously interfere with important wireless transmissions, and he may easily reply that if wireless sets are so infantile in their design that they are capable of interference from such a cause it is time that science looked to its laurels. Unfortunately such an attack is difficult to meet.

The Oscillator always brings home to me how very immature are our ideas of wireless. A schoolboy with a piece of sugar and a needle can pick up a confidential message. The Oscillator could probably have something to say even to the new Rugby station, and could joyfully attack Governmental conversations just as he deals

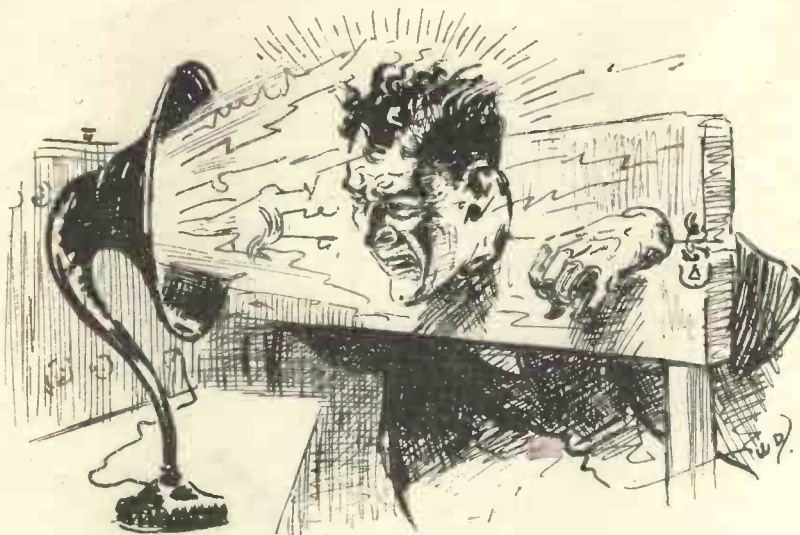

W. Dewar would put the Oscillator in a pillory and keep him there while all his victims oscillated at him through a loud-speaker.

What YOU do to the Oscillator?

We will send a dull-emitter for each of the best six suggestions received by us by first post, August 24.

other people, and would resent very heartily any attempt to prevent that delight in other people's misfortune of which they know themselves to be the cause.

The receiving set in a condition of transmission is attempting two things at the same time—this alone should give food for thought when it is realised that the real cause of the trouble is gross ignorance.

That such a factor as oscillation should be capable of causing serious interference, and that selectivity, beam and short-wave wireless should still be in the experimental stage, is a magnificent illustration of the fact that the greatest knowledge of wireless to-day will probably amuse the schoolboy in twenty-five years to come.

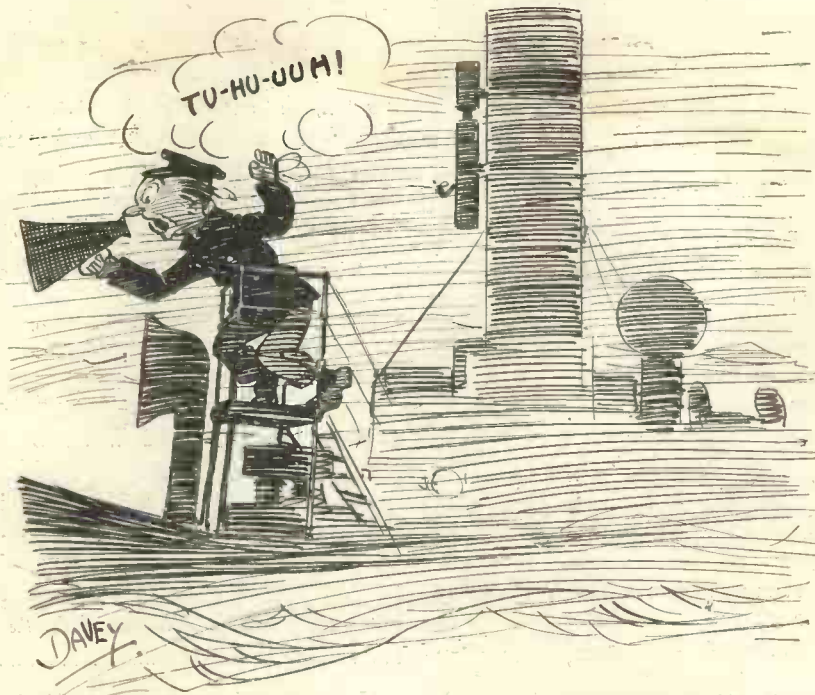

George Davey says that to fit the crime he would sentence the Oscillator to twenty-four hours in a Channel fog, in charge of a steamboat siren.

Silas K. Hoodking

The Popular Novelist.

I'm not good at riddles, or guessing competitions, or cross-word puzzles, and the conundrum you have sent me has already given me a headache, so I'll get rid of it at once. Isn't there an old saying about catching your hare before cooking it? And do you know of any certain method of catching the lunatics of whom you speak?

When my children were young I kept dangerous weapons out of their reach. I have no faith in punishment as a reforming agency, especially for the weak-minded. If you can catch the imbeciles who misuse their wireless sets, the rational thing to do, it seems to me, is to take them away and cancel their licences.

Merky

Chief Engineer of the B.B.C.

If the Oscillator is oscillating on purpose, well knowing that he is interfering with many thousands of people's reception, there is no punishment that I can think of that is bad enough for him; but obviously the one that fits the crime is that his set should be removed.

If he is unknowingly oscillating, he should be educated into the proper use of reaction. We, on our hand, have distributed in tens of thousands a pamphlet stating what not to do. I have talked over the broadcast, and I have even published a book in which everything is set cut.



Harry Rountree's idea of punishment is ingenious as well as merciless. He says: "First see that his ears are in perfect condition, then tie the Oscillator to a post and let giant parrots yell at him for the term of his natural life!"



Fred Bennett says that he would like to see the Oscillator hoisted upside down to the top of the tallest aerial mast he can think of, so that by means of a transmitter his torments might afford some joy to those who are annoyed by his oscillations. (See inset.)

Compton Racheysu

The Famous Novelist.

I have never yet had the good fortune to listen-in without hearing the hideous sounds to which you allude. If this is caused by Oscillators I can imagine no punishment sufficiently unpleasant for them, and if when all Oscillators are exterminated I shall be able to listen to music unaccompanied by these hideous noises, why, then, perhaps I shall like wireless as well as I do the gramophone.

Meanwhile, as an outsider, may I suggest that you catch an Oscillator, torture him slowly, and broadcast his shrieks of agony during the Children's Hour as a warning to the young of this generation? It is dreadful to think of all the little potential Oscillators that are being trained every evening to oscillate.

What Should Be Done to the Oscillator?—(Continued)

A. Neil Sykes

The Famous Novelist and Humorist.

—passes on an idea from Lancashire. It was submitted to an editor by a native of Bolton.

"This here notion of cooking our Oscillator in boiling tar is too ladylike," he wrote. "When we catches the villain, we ought to treat him as Wellington treated Napoleon—send him to live at St. Helens."

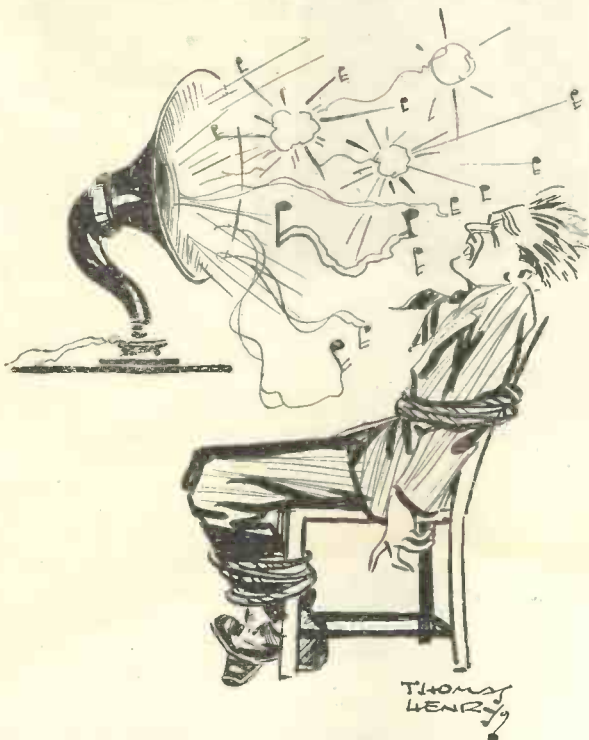

Thomas Henry says that what he would do to the Oscillator would be to give him a dose of his own physic until cured.

Keble Howard

The Famous Novelist.

This is no matter for jesting. Oscillators are peopling our asylums—by proxy, I regret to say. The remedy lies with the makers of receiving sets. Misuse of the reaction coil could easily, I suppose, be made to cause death by electric shocks, but that would be rather cruel since many of the worst offenders are infants, domestic servants, and cats.

Quite seriously, it is useless to appeal to good feeling and to good taste. Millions of people can neither feel nor taste. So howlers will howl until the capacity for howling is eliminated from the set.

John Henry

Of Broadcast Fame.

I've come to the conclusion that the best thing that could be done with Oscillators would be to catch a couple of them, attire them chastely in barbed-wire shirts, trimmed with nettles, tie them up in a dungeon and introduce to them: (1) Capt. Eckersley, (2) Me, and (3) Joe Murgatroyd.

Let (1) lecture them, using as a subject his famous "Don't Do It!" and (2) and (3) sing to them, all at the same time.

The remains could then be either buried or burned.

J. E. C. Walker

The Rt. Rev. Bishop of Durham.

In the quiet retreat of the College at Durham I am not greatly troubled by Oscillators. But it is clear to me that nobody is entitled to act in such a way that he makes himself a nuisance to his neighbours; and if an Oscillator acts in the way which you describe, I think he should be fined, and fined so heavily as to make an end of his ill-doing. It cannot, I think, lie beyond the power of science to remedy so great an evil.

Alec Waugh

The Famous Novelist.

I have never heard of Oscillators. From what you tell me of them, I consider that they should be given a fair trial before a responsible jury principally composed out of the Committee of the Athenæum Club. Their defence would be that wireless is the enemy of literature and good talk, and that anyone who discourages people from listening-in is entitled not to punishment, but to reward.

Will Wireless Prevent War?

IT is with a very keen sense of pleasure that I find myself turning from my usual literary work to discuss in the columns of a magazine which I am convinced has a great future the two phases of wireless in which I am most deeply interested.

There is a side to wireless greater by far than the technical; greater also than the musical; greater than the educational; greater even than the power it possesses to bridge vast distances with messages of vital international importance.

Need for Peace

There has existed on earth until recently a great need. For so long a time have we been conscious of this need that until the advent of wireless we had almost given up hope that a means would ever be found to supply it.

Civilisation has progressed through countless ages from the individual to the family entity; from the family to the clan; from the clan to the walled town and from the walled town to the walled state. Considerations both of defence and mutual welfare have brought these changes about until to-day we find great nations bound by the ideals of patriotism into a communal whole where, by means of mutual organisation and honest government, the best use may be made by the individual of such a short span of life as the Almighty grants to humans.

And yet, having progressed from the condition where each man was a nomad, dependent entirely upon his own resources for sustenance and safety, to the comparative Utopia of a civilised existence where organised humanity is separated into distinct divisions only by absolute difference in racial characteristics, we have not yet achieved the millennium.

Why War Exists

It makes little difference whether one man fights his neighbour or one nation fights a neighbouring nation so long as warfare continues. And it is only by virtue of the distinct division of the world's human creatures into clans that warfare can exist.

Having progressed through civilisation to fellowship within the confines of national boundaries, let us now extend our ideals in the direction of fellowship limited only by the confines of the terrestrial sphere upon which we live.

Thus, and thus only, shall Humanity achieve its final and perfect existence upon earth.

But there are many vast obstacles in the way of those who pursue such an ideal.

The greatest of these is, without a doubt, that of creating world-wide understanding and world wide amity. It is to-day almost an impossibility to hope that the natives of Central Africa may ever be brought to understand and harmonise with the peasants of Nizhni-Novgorod.

But, with the advent of wireless, it is no impossibility to attempt the

Those who have watched critically the progress of wireless during the past five years can have no doubt as to its amazing influence on the people who avail themselves of its service. In this article our contributor explains his belief that wireless, by bringing together all the nations in a common bond of brotherhood, will prevent war and herald a new era of peace.

linking of the two greatest English-speaking nations of the world. When one realises that America—I should say the United States of America—is still in its adolescence, it must be admitted that no basic differences exist between the man in the street in New York and his prototype in London.

It is therefore amazing that such lack of mutual understanding should characterise the dealings between the two governments. Without a doubt the first step towards international harmony should be the creation of a better understanding between the U.S.A. and England, and this wireless has put it in our power to achieve.

When the day comes on which every man who now possesses a wireless set capable of tuning-in perfect music and speech from his nearest broadcasting station can

with equal ease listen to speech and concerts direct from America, the problem will have been solved.

Determined and organised efforts are being made to establish two-way international communication by telephony. Even to-day it is possible for the possessor of an expensive set to listen almost nightly to concerts broadcast from U.S.A. The last international tests are said to have proved that consistent reception from the American continent is not yet possible, but I personally am not prepared to agree with this view.

Communicating with America

I do not think that the tests proved the impossibility of establishing two-way communication with America with reasonable reliability; nor, even, that they proved that the average listener must possess an expensive set to obtain reception of American stations.

But I do think that they proved the impossibility, under present conditions, of working over these vast distances on wavelengths any higher than a hundred metres. The excessive prevalence of "static" interference on the higher wave band, due to the more closely approximating frequencies of the two currents, is quite sufficient to render long-distance reception, on five nights out of seven, a practical impossibility.

Short-wave Broadcasting

It follows from this statement that the international aspect of wireless and short-wave work are very closely bound up together. It is many months since my interest in the international side of wireless problems led me to concentrate upon reception and transmission upon wavelengths verging round fifty and a hundred metres, and it is my firm belief that before very long we shall have broadcasting stations transmitting programmes especially for the benefit of distant countries on wavelengths as low as one and two metres.

I believe it is a fact that one American station already transmits on fifteen metres. E. C. D.

A CRYSTAL SET for the HIGH-POWER STATION

— AND THE LOCAL STATION, TOO

SPECIALY DESIGNED,
BUILT & TESTED IN
"THE WIRELESS MAGAZINE"
WORKSHOP



WITH the high-power station at Daventry, in the Midlands, listeners in the south of England will find it much more difficult to tune-in this station now than they did Chelmsford.

Wavelength Range

The aerial and earth system will have to be made thoroughly efficient, and, as most of the sets used to receive Chelmsford were simply ordinary sets for use on 300-500 metres, with the addition of a loading coil, a description of an efficient receiver designed primarily to receive wavelengths from 250-1,700 metres will not be out of place.

The receptive quality of all sets depends to a great extent on the tuning coil.

The coil used in the set described here was wound with thick wire on a special low-loss former, thereby reducing somewhat the self-capacity and resistance of the coil.

Two aerial terminals are pro-

vided in the set—one for short waves (with a .0003-microfarad fixed condenser in series) and the other for the long-wave high-power station (aerial direct to coil).

Tappings are taken from the coil and brought to sockets well spaced and in a straight line on the panel. This is much better than the old switch arm and contact studs.

All wiring, which is carried out

with No. 16-gauge square-section tinned-copper wire, is taken the shortest distance between the components to be connected.

The layout is very compact and the set looks very neat when completed.

Components Required

In the original receiver the following parts were used:—

Ebonite panel, 6 in. x 9 in. (American Hard Rubber Co.).

Ebonite low-loss coil former, 8 in. long by 3 in. diameter (Fuller's United Electric, Ltd.).

Fixed condenser, .0003-microfarad (Atlas).

Fixed condenser, .001-microfarad (Atlas).

Variable condenser, .001-microfarad (Polar).

$\frac{1}{2}$ lb. No. 22-gauge double cotton-covered wire.

Crystal detector (Belling-Lee).

5 terminals (Belling-Lee).

6 sockets (Belling-Lee).

1 plug (Belling-Lee).

Tinned copper wire for wiring.

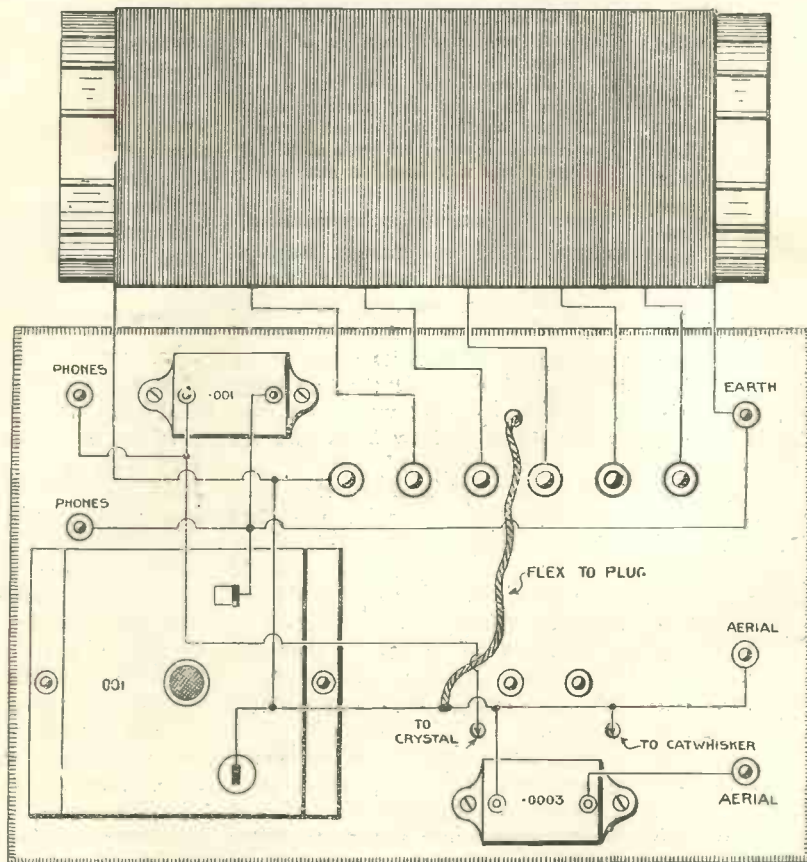

Wiring Diagram of Crystal Set for the High-power Station.

Construction of Coil

The coil is wound with 180 turns of No. 22-gauge d.c.c. on a former of somewhat unusual construction, and tapings are made at the 20th, 35th, 55th, 85th, 125th and 180th turns.

At each end of the former a hole is drilled for a 2 B.A. rod, which keeps the coil in position on the panel.

The panel is drilled and tapped 2 B.A. to receive these rods, which are left $1\frac{1}{2}$ in. above the panel.

The coil is pushed on to these rods and a nut is screwed on either side to hold it in place.

Wiring the Set

The leads to the sockets on the panel should be soldered on before the coil is put into position. Afterwards the coil can be placed in position and the wires from the

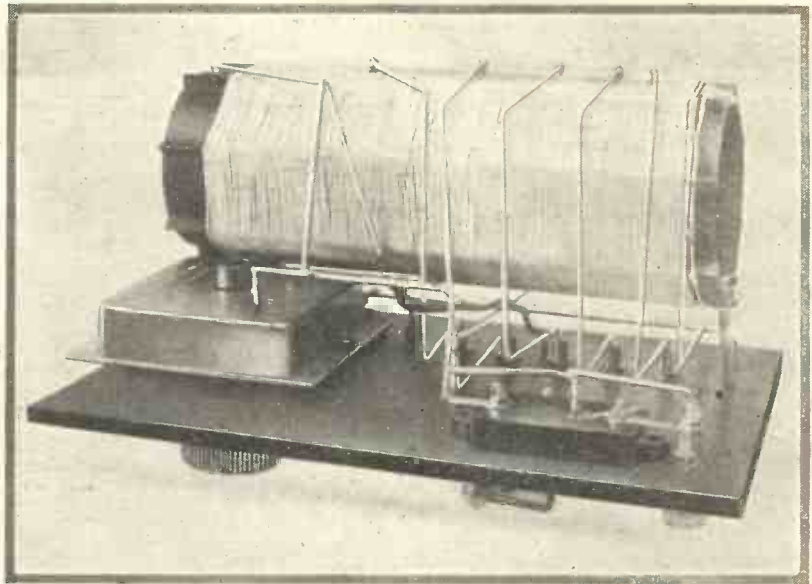

View of Underneath of Panel.

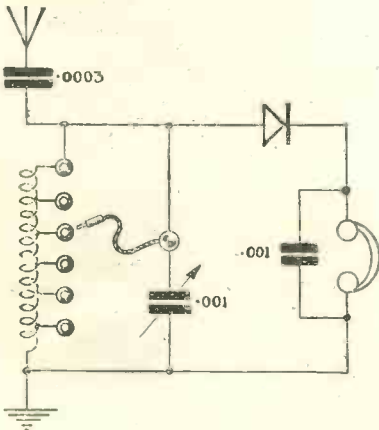

Circuit Diagram.

sockets soldered to the various tapings on the coil. The photographs show this quite clearly.

All joints should be soldered, and the wiring of the original set followed as closely as possible.

The phone and aerial fixed condensers are not fixed to the panel, but are held in position by the wires soldered to them.

Terminals and Sockets Loose

After soldering, it may be noticed that the terminals and sockets have become loose, due to the heat applied to them. These should all be tightened up with a small flat spanner.

When the wiring is finished a small cabinet may be made to contain the set. The cabinet used for the original set was made from light polished mahogany.

The panel should fit inside the cabinet and rest on two fillet pieces

fastened on either side $\frac{3}{16}$ in. from the top, so as to allow the panel to lie flush with the top of the cabinet when placed in position.

Operating the Set

To operate the set fix the aerial to the left-hand top terminal and attach the earth and phone leads to their respective terminals. Adjust the crystal detector and tune-in the local broadcast station by plugging in to the first or second socket from the top.

If the set is used at a great distance from the broadcast station, the aerial lead should be connected to the top middle terminal and the

plug inserted in the bottom socket. The set should then tune-in the high-power station.

In tuning try to have as much coil and as little parallel capacity as possible. The plug should be varied until minimum capacity is used to tune-in the station (when the pointer on the condenser is as near as possible to zero).

Results

With an aerial about 50 ft. long and, in a screened district, 40 miles from the Chelmsford station, the programme was received at sufficient strength to work five pairs of telephones.

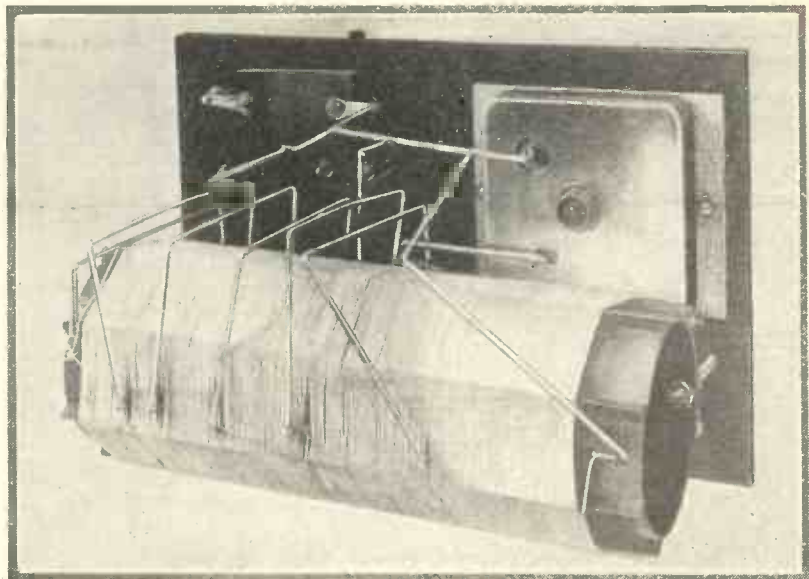

Another View showing Coil Tappings.

A Crystal Set for the High-power Station (continued)

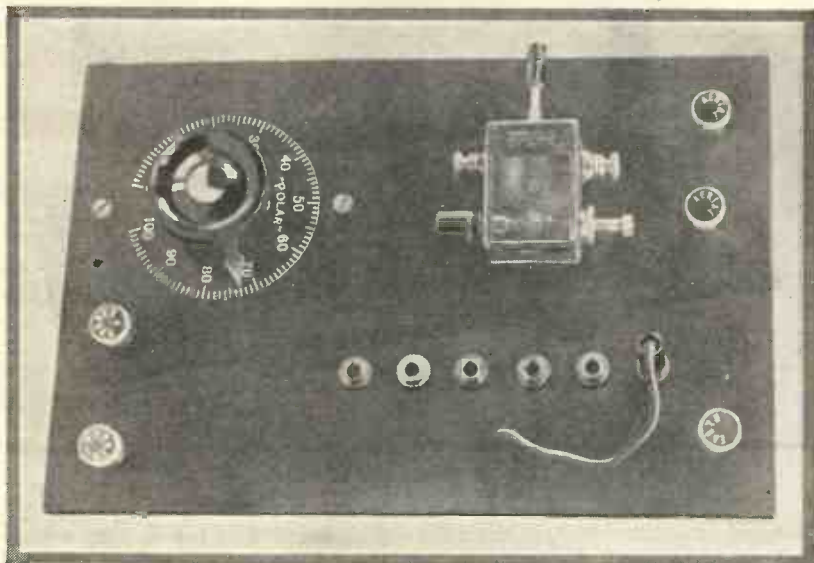

View of Panel Showing Positions of Components.

In this case the plug was in the lowest socket and the condenser set at 75°. The reading of the condenser will, of course, vary considerably with different lengths of aerial.

Varying Readings

Compared with a set adapted to receive Chelmsford (loading coil and condenser) the increase in strength was very noticeable.

On the ordinary broadcast band tuning was quite sharp and the London station, two miles away, was

received at sufficient strength to work a small loud-speaker, and music could be heard about six feet away, while speech was distinctly heard at two feet.

"THESE crystals don't miss anything," says an advertisement. Made in Scotland, of course.

THE jokes that have been made about "Aberdeen Calling" seem to have overlooked the fact that Aberdeen never calls out of its turn.

WIRELESS TO THE RESCUE

IN September last a forty-foot sailing boat, the *Lief Erikson*, with a crew of four men, left the port of Julianhaab, in Greenland, with a view to reaching the North American coast. The boat had been specially built for Arctic service and the members of the crew were seasoned fishermen.

Drifting with Wind and Tide

The leader of the expedition, a Norwegian named Nutting, had planned to allow his boat to drift with wind and tide in order to ascertain, by this means, the exact spot on the American coast at which the original *Lief Erikson* had landed at the beginning of the 11th century.

Only once was the small expedition sighted, in the neighbourhood of South Greenland, after which it was not seen again.

Towards the end of November, the United States Government despatched a small cruiser which, with the aid of three seaplanes, patrolled Baffin's Bay as well as about 93,000 square miles of Alaskan waters. No trace of the Norwegian party was found.

KDKA Takes a Hand

As most of the distant outposts of the Hudson's Bay Company are equipped with wireless receiving plant, and in view of the fact that during the Christmas and New Year holidays they are regularly visited by the trappers and Esquimaux, the East Pittsburgh station of the Westinghouse Electric Co. (KDKA) broadcast full particulars of the missing explorers.

At the same time the Hudson's Bay Company instructed members of its personnel, at outposts, to supply the explorers with all food and wearing apparel they might need and to aid them, in every instance, to the best of their resources.

Up to the present, no news has been received which might point to the safety of the *Lief Erikson* and its crew, but there is still a possibility that they are out of touch with any civilised district which could pass on to the Hudson's Bay Company news of their arrival. JAY COOTE.

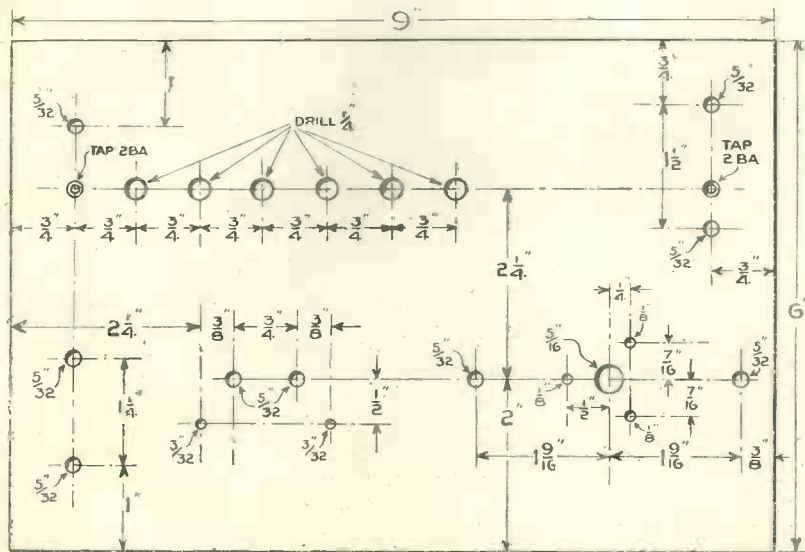

Layout of Panel.

SHALL I take a wireless set with me when I go for my holidays this year? If so, what kind of a set shall I take?

How many times during the last few weeks have you asked yourself the above two questions? Perhaps you have found what others have found, that it is by no means an easy matter to make a decision either one way or the other. Let us see, then, whether we can help each other to come to a thoroughly satisfactory decision.

First of all, we shall suppose that you would like to take with you the very best type of holiday set it is possible to devise, that is the crystal set. There are no heavy, messy batteries to carry with such a receiver, and there are no valve filaments to place at the mercy of the porters who handle your luggage at the crowded railway stations.

A crystal set has everything to commend itself for a holiday set except its very restricted range of reception. However, by glancing at the map on page 40 we can soon see whether a crystal set is a practical proposition for your holiday or not.

Ranges of Stations

This is a map of the British Isles. On this map circles are drawn showing the approximate range of crystal reception for each of the stations of the B.B.C. For the main broadcasting stations circles are drawn to a scale radius of twenty miles, and for the relay stations the circles have a scale radius of ten miles. The circles for the high-power station are drawn to a scale radius of eighty miles.

Possibly it may be thought that these crystal ranges are on the high side, but they are well within the ranges obtained by the writer with a carefully constructed crystal set of ordinary design.

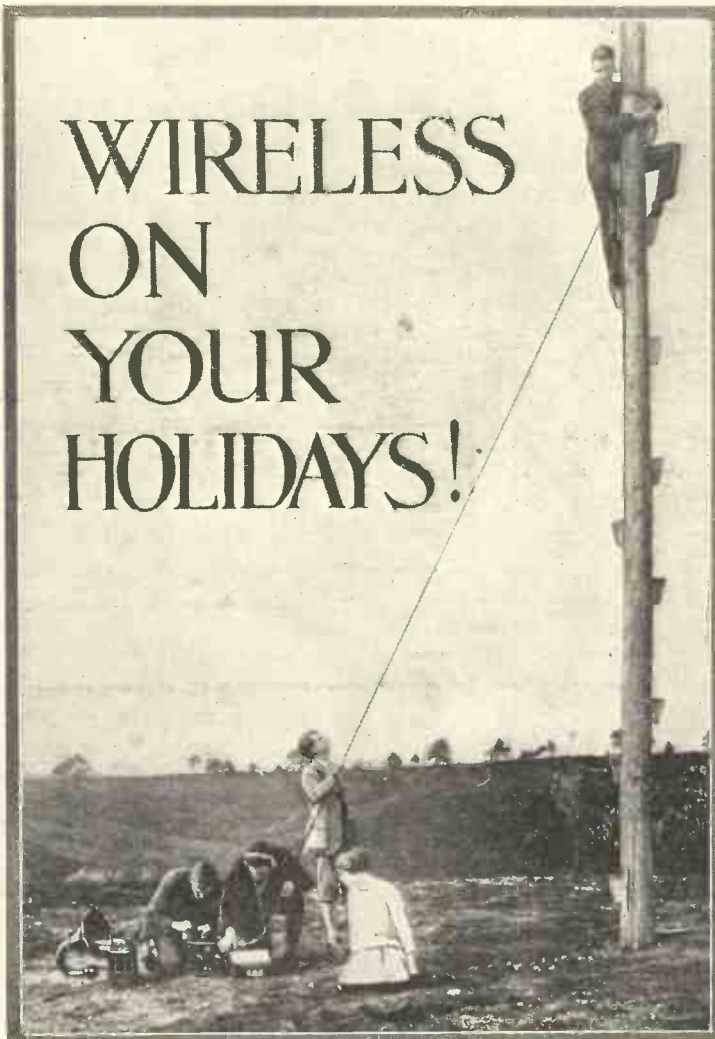

WIRELESS ON YOUR HOLIDAYS!

points on the Wirral peninsula.

A few other seaside places where a crystal set would prove useful are Weston-super-Mare, where Cardiff would be heard; Looe, where Plymouth would be heard; St. Andrews, where Dundee and possibly Edinburgh would be heard, and Aberdeen.

Before leaving the subject of crystal sets on holiday, there is one suggestion I should like to make. If you want a *real* wireless holiday, what could be better than a tramp up the Thames Valley with the idea of finding out just how far you can hear London and the high-power station on a crystal set?

Valve Sets

Coming now to the question of taking a valve set when one goes on holiday, it is much more difficult to lay down any hard-and-fast rules. There are so many types of valve sets in common

use. There are also so many different types of valves available.

Again, some valve sets are made to get distance. Others, however, are built to get volume from the local station.

Under the circumstances, the best thing we can do is to consider just simply distances from the broadcasting stations. We can do this from the second "range" map on page 41. In this case the circles are drawn to a scale radius of fifty miles round the main stations of the B.B.C. Round the relay stations the circles are of a twenty-five mile scale radius. For the H.P. station the circle is of a scale radius of one hundred and twenty-five miles.

These chosen distances bear no exact relationship to possible reception with any particular valve set. It may be taken, though, that a one-valve set with reaction should be good enough for excellent telephony reception anywhere within the circle for any particular station. These

It is fairly evident from the map that the coasts of our islands are very badly served by our broadcasting stations as far as crystal reception goes. There are, however, some of our best known and most popular seaside holiday resorts within crystal range of one or other of the stations.

If you are going to spend your holiday anywhere on the East Coast between Hunstanton and Southend-on-Sea, or again, anywhere on the Kentish or Sussex coasts, you would be perfectly well advised to take a crystal set with you, especially if that set were designed primarily for the reception of the high-power station. There is scarcely any need for me to remind you, though, that crystal reception anywhere demands the best of aeriels and earths.

Of course, if you want loud-speaker crystal reception on your holiday you had better go to Bournemouth, although you might possibly get Liverpool at loud-speaker strength on a crystal set at various



Capstone Hill, Ilfracombe.



The Promenade, Minehead.



Ilfracombe.



Port Erin.



Bowness-on-Windermere.

Wireless on Your Holidays! (continued)

circles may also be looked upon as reasonable limits for loud-speaker reception on a two-valve set, a good aerial and a good earth being assumed.

It is therefore apparent that certain places on the East Coast, Clacton-on-Sea and Southend-on-Sea, for example, are very favourably situated for the reception of both London and the

H.P. station. Well-known resorts on the South Coast, from Hastings to Bognor inclusive, are also favourably situated for the reception of these stations.

On the coasts of Lincolnshire, Norfolk and Suffolk a one-valve set would be most useful for the reception of the H.P. station, although there is little doubt that other stations would be heard.

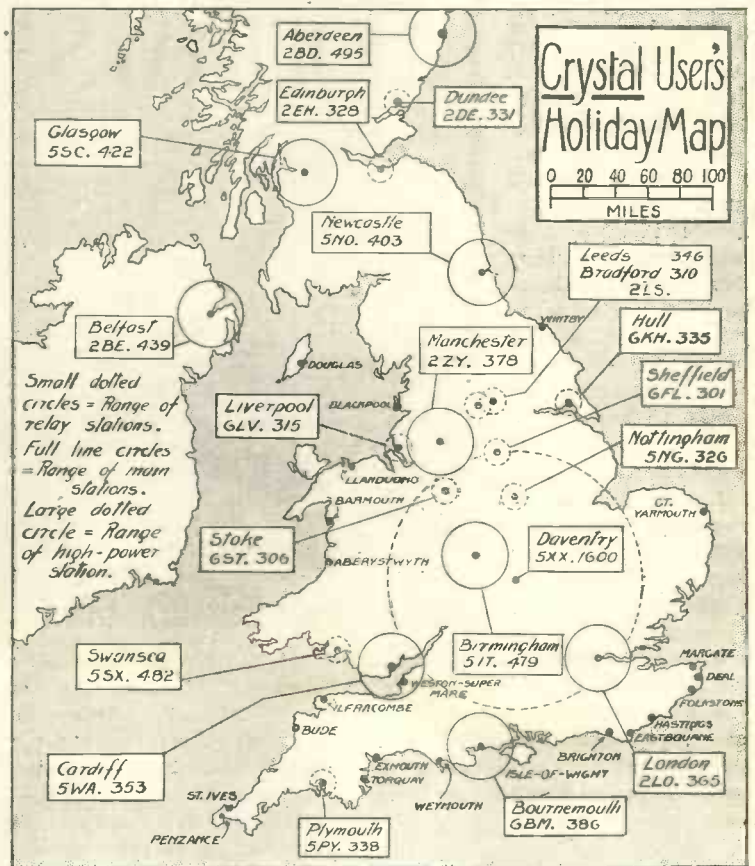

Scarborough.



Wye Valley.

Ranges of Valve and Crystal Sets

A striking fact with regard to the second map is that Cornwall, West and North Wales, the Lake District, and the Isle of Man all appear to be badly situated for reception with a one-valve set. The crowded circles in the midland districts of the second map show how well the B.B.C. has catered for the populous centres.

The important holiday centre, Cornwall, which is not included in any one of these circles, would doubtless be well served by the relay station Plymouth.

How these "crystal" and "valve" maps can be put to use for any particular case may best be understood, perhaps, from a couple of examples. Suppose that

(Continued on next page)



Salcombe.



Bournemouth.



Looe.



The Promenade, Exmouth.



Whitby.



Lyme Regis.



Clovelly.

WIRELESS ON YOUR HOLIDAYS! (Continued)



Kynance Cove.

You decide to spend your holidays this year at Yarmouth. What can be done in the way of wireless reception there? The map tells you that you would be able to pick up the high-power station on a crystal set, but that you would not be likely to hear any other stations. If the H.P. station programmes received on phones are all that you desire during your holiday, then take a crystal

set only. A glance at the second map will tell you that if you want loud-speaker reception at Yarmouth during your holiday you will have to take a three- or four-valve set, if you want to hear anything more than Daventry.

As a second example, let us suppose that you are going to Aberystwyth this year for your holiday. A glance at the

map tells you that crystal reception is out of the question, so it is no good your thinking of taking a crystal set. Another glance tells you that a one-valve set will be of little use to you at Aberystwyth, but that a three- or four-valve set would most likely bring in Cardiff, Birmingham, Manchester and Daventry.

Even if you decide against taking



Clacton-on-sea.

a wireless set with you on holiday this year, it is well worth while studying the maps in this article. If you do so you will gain a good idea as to the *minimum* claims likely to be made by the local wireless experts when you get amongst them.

J. R.

[The holiday photographs that accompany this article are reproduced by the courtesy of the G.W.R., the L.M.S., the L.N.E.R., and the S.R.]

ADAPTING THE RHEOSTAT FOR DULL OR BRIGHT EMITTERS

WHEN 30-ohm rheostats are in use on a set with dull-emitter valves, of the '06 ampere type, difficulty is experienced when a change is made either to bright valves or to the D E R type taking 4 ampere at 2 volts, as the valve becomes very sensitive to the least movement of the rheostat knob.

This can to a large extent be remedied by fixing across the terminals of the rheostat a coil of resistance wire. For bright valves the value of the resistance thus fixed should be approximately 10 ohms, or for D E R valves, 5 ohms.

The resistance coil may be made of No. 30-gauge Eureka wire; 54

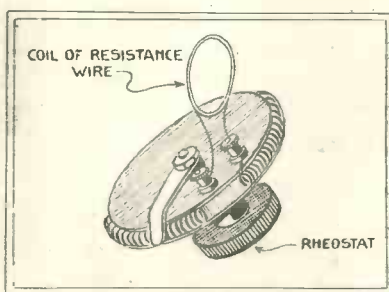

Rheostat with Shunted Coil.

in. will be needed in the first case and 27 in. in the second.

The extent to which this opens out the scale of resistance in the case of a 30-ohm rheostat having a range of movement of 300 degrees of a circle is shown in the table reproduced here.

A switch will of course be necessary to cut the valve out altogether, but in most cases this is already incorporated in the set elsewhere.

H. M. L.

	Resistance.						
	Zero	1 ohm	2 ohms	3 ohms	4 ohms	5 ohms	6 ohms
Rheostat without extra coil	0°	10°	20°	30°	40°	50°	60°
Same with 10-ohm coil	0°	11°	26°	43°	67°	100°	150°
Same with 5-ohm coil	0°	13°	35°	80°	218°	—	—

LIKE the streets, the ether is getting overcrowded. But whilst tubes are a cure in the former case, what the Yanks call "tubes" are the cause in the other.

A Little Misunderstanding

"GOOD morning, sir," said the salesman, briskly, noting with satisfaction that the thoughtful-looking young man who had just entered his shop was carrying several wireless catalogues and a bulky note-book. "You have dropped in at the psychological moment, if I



"I do not see any prices marked,"

may say so! Fortune has indeed smiled upon you, sir!"

The young man looked surprised. "I don't quite follow," he said, "anything special on the broadcasting this morning?"

A Bargain Sale

The salesman placed both hands on the counter and leaned forward confidently. "Our first annual bargain sale begins to-day, sir, and we were just going to get our bills out. It will be your privilege to take first pick," he continued, enthusiastically. "As one of our greatest philosophers so truly said, 'Opportunity knocks but once'..."

"Excuse me," interrupted the young man, laying down his catalogues, "I had better tell you what I want."

"It is no matter," declared the salesman. "From our bargain counter we can supply you with the pick of the world's wireless market. Shop-soiled it may be, and, strictly speaking, not of the very latest pattern, but goods of sterling worth, free from frills and fads, and the price—my dear sir—the price! You will positively find it necessary to pinch yourself to discover whether you are awake or dreaming! You will ask whether I have not made a ridiculous mistake!"

Fine Adjustments

The young man looked more thoughtful than ever. "I take it," he said, "that you have a three-o's-five square-law condenser with fine-tuning adjustment, and a coil holder with fine adjustment?"

The salesman rubbed his hands together with every symptom of satisfaction. "Our condensers have evoked the encomiums of the leading experimenters. Our stock is replete with square-law, round-law and scout-law condensers, and when we say they condense we mean they condense! Efficient condensation is a hobby with us," he averred, benignly.

The Leading Expert

"As for coil holders, they are the envy of our competitors and the joy of our customers. Only the other day, one of our leading experts, in fact no less than Mr. Droxford Smith himself, dropped in to buy a terminal and spoke of our coil holders in most gratifying terms. But step over to the bargain counter, sir, and note the surprising variety of superior goods."

"I do not see any prices marked," said the young man, examining the



"Two members of the West Ham Troop."

miscellaneous collection carefully, "and most of it seems very old. Where are the square-law condensers, by the way?"

"Why, sir," replied the salesman, with an air of great surprise, "by your right hand, to be sure; in the square boxes, of course, and the round-law ones are over on the other side of the table, in the round celluloid cases."

In Great Demand

"We have only a few scout-law condensers in stock at the moment—they are in great demand among the younger generation on account of their cheapness, but, naturally, they are not such accurate, scientific instruments as those you see there. Only a day or two ago, two members of the West Ham Troop, intent, no doubt, on doing their daily good deed, entered this shop and purchased a couple of our scout-law condensers which, apart from moving

plates and knobs, were as complete as the higher priced ones."

"Quite!" remarked the customer, briefly. "Now, what would you say Mr. Droxford Smith would have offered you for the whole of the—er—gear on the bargain counter?"

One Hundred Pounds!

"My dear sir," replied the astonished salesman, faintly, "the entire stock of valuable wireless apparatus on the counter before you? Why, Mr. Droxford Smith, who is one of my oldest customers, would not value that unique assortment under one hundred pounds, containing, as it does, scientific instruments of the highest class!"

"Um!" ejaculated the young man, "then what would you say if I told you that Mr. Droxford Smith would describe the stuff on this table as junk of the vilest kind, and worth about a couple of shillings as scrap metal?"

The salesman gasped. "You speak very confidently, sir," he said at last. "May I ask whether you are in the trade?"

An Offer

"Well, not exactly," replied the thoughtful-looking young man, as he gathered up his catalogues, "but, as I said, my offer for this lot of useless junk would be two shillings, and I'll trouble you not to refer to me as one of your customers. It's the sort of advertisement I don't care about. Good morning."

Going to the back of the shop, the unhappy salesman took a cheap crystal detector from a shelf, and



"Dashed it violently to the ground."

grinding his teeth, dashed it violently to the ground.

ALFRED HEARD.

A SCIENTIFIC application of wireless can make plants come up quicker. But not quicker than our neighbour's cat!

"HOW," asked an old underwriter at Lloyd's, lamenting the depressed condition of the market for insuring ships, "how can we ever get up the rates of premium when this beastly wireless is knocking off most of the risk?" He was a man of the old school, who had been brought up on fat risks and fat rates of premium to correspond.

The perils of the sea, and especially the perils to the lives of those who go down to the sea, have been enormously reduced because wireless has for ever destroyed the solitude of the sea. Now as ships move anywhere over the oceans they are linked to one another and to the land by the mysterious ether, and by those even more mysterious oscillations of the ether which we call wireless waves.

A ship which, a few years ago, was the centre of a vast lonely circle of silence, now steams through an impalpable network of crackling morse in which, over the whole round of the clock, there is scarcely one moment of complete silence.

The Change

This change from solitude to a noisy crowd has all come in twenty years, and has developed vastly during the last ten years. It was the demand of the sea for etheric communications which first gave encouragement in well doing to Marconi, De Forest, and other pioneers of wireless, and it was the accelerated demand of the Great War that has given us the modern valve, the continuous wave, wireless telephony, and broadcasting. And, as was no more than just, it is the lives and safety of those who use the sea which have benefited most by the development of wireless communication.

To most of us on land wireless is a hobby and a fascinating amusement;

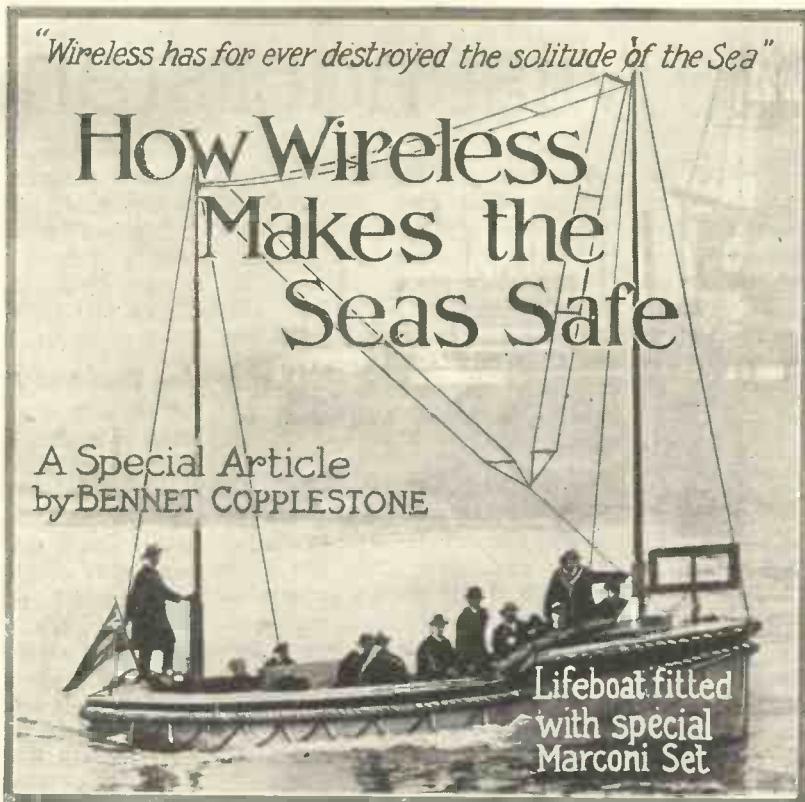

to all travellers by sea it is a sure guide amidst the perils of the deep. It has given to ships warnings and guidance: it warns them of storms and cyclones and the deadly drift of ice; it tells them by direction-finding apparatus where they are, and by how much their own reckoning is at fault; it gives them time signals by means of which they may correct their chronometers; and then when disaster threatens it carries their distress calls to the ears of those, on land or on sea, who are best placed for quickly rendering urgent assistance.

When you are trying on land to pick up a distant station and you are aggravated by the intrusion of ship's morse, do not curse impatiently—just remember what this morse means in safety to the ships.

Equipment of Ships

The full value of wireless communications at sea will not be realised until all ships carry wireless apparatus as they carry anchors and boats—as part of their fundamental equipment. We have not yet reached that ideal, though we have gone a long way towards it.

By law now every passenger ship of British registry (except summer excursion steamers and some boats plying in the remote Scottish Islands)

must carry wireless transmitters and receivers. And every British sea-going ship of 1,600 gross tons and upwards—whether or not it carries passengers—is required to be similarly equipped.

This is not a requirement of the law laid down and then left to be ignored. It is sternly enforced by Board of Trade inspectors and surveyors who are themselves old shipmasters. The normal transmitting wavelength is 600 metres (spark or continuous wave), and the range must be at least 100 miles. There

must also be in all these British ships an emergency apparatus—not dependent for power on the ship's dynamo—which can be operated instantly from accumulators.

Emergency Range

The emergency range of this plant for big ships must be 80 miles, and for small ships 50 miles. After the first of July all big passenger liners must, in addition, carry an approved wireless installation in one or more of their lifeboats.

These minimum requirements of a paternal Government—as administered by that fairy godmother of British seamen, the Mercantile Marine Department of the Board of Trade—are much exceeded in practice. For shipowners and shipmasters have from the first realised the infinite value of wireless.

Many vessels carry plant far more powerful than is required by law, and many ships, too—cargo boats as well as passenger liners—have added direction-finding apparatus, by means of which they can pick up their bearings from land stations in bad and foggy weather.

The old spark is being rapidly superseded by the continuous wave both on land and sea, so that telephony can be employed as well as morse. The spark, maybe, has had

its little day, though we must always feel grateful to it. But for the immensely penetrating spark or arc transmission, with its huge range on the old carborundum crystal, there might to-day have been no valves or continuous waves or broadcasting for us to play with. It is always the first step that counts.

Shore Stations

Ships equipped with wireless are in constant communication with one another and with the shore, and it is through the shore stations that much of the value of wireless for life-saving comes in. I will explain presently the elaborate life-saving chain, which came into full operation last October, by means of which the Post Office and Admiralty stations are linked up with the coast-guard service and with the Royal National Lifeboat Institution's stations round our thousands of miles of seaboard.

For the moment one must describe the machine before dealing with its working. There are four kinds of shore stations. First, we have the ordinary spark and arc transmitting stations on 300, 600, and 800 metres, which so often crash into our private wireless receivers.

These stations are situated at places like the North Foreland, Land's End, and Fishguard. With these may be grouped the private stations, licensed by the Post Office, of the cross-Channel steamship companies.

Secondly, we have high-power stations using the long continuous wave, such as Devises at present and Rugby in the near future. Thirdly, there are the invaluable direction-finding stations, either combined with Post Office establishments like Niton on the Isle of Wight and Cullercoats at Tynemouth, or else solely used for D.F. work, such as the Admiralty stations at the Lizard and Flamborough Head.

Ships whose officers are uncertain about their positions can call up one or other of these stations—or if they are in remote seas those corresponding with them in foreign countries and our Dominions—and receive their bearings from those stations. It will be clear to everyone that bearings received in this way from two widely distant stations can be plotted on a chart and will yield the position of the ship at their point of intersection.

Then finally we have the wireless beacons which send out signals so

that ships equipped with direction-finding apparatus may pick them up and take bearings on them. This beacon system is the converse of that just described. If a distant ship works out its bearings on two beacons it will get its position in the same way as does a ship which receives its bearings from two direction transmitting stations.

The ships at sea with their equipment, and the several kinds of shore stations with their equipment, together form the constantly expanding machinery for a twenty-four-hour intelligence service extending over the civilised world.

Listening for Distress Calls

The famous distress call which is represented in morse by the letters SOS (. . . — — — . . .), three dots, three dashes and three dots—a call which receives instant priority over all other wireless signals—is listened for by every ship at regular times every hour all round the clock.

The SOS call has added a household expression universally understood in every language, and its use is regulated by the International Convention for Saving Life at Sea.

Ships are directed to send it out slowly and emphatically so that it cannot possibly be mistaken for anything but what it is.

All British and most foreign ships are required by law to suspend their wireless work for three minutes every half-hour (at 15 minutes and 45 minutes past each hour by Greenwich time), and to listen for the distress call, and to its brother the alarm call (in morse T T T, — — —, three dashes). Watch must be kept on the 600-metre wavelength.

No Interference

Any ship receiving the distress call or the alarm call acknowledges at once and does its best not to interfere with other ships which are also receiving and acknowledging the call. The alarm call is used in order that ships or shore stations may broadcast information of urgency, such as the position of icebergs, derelicts, cyclones and typhoons, or of any other of the many perils to general navigation.

The alarm call, also known as the danger or safety signal, ranks next in importance to the SOS. But the distress call, of course, comes before everything else, and must be attended to and followed up without regard to any commercial considera-

tions. This makes it of the highest importance that the distress call, SOS, should never be cast upon the ether unless the urgency of the sending ship is beyond question.

The SOS in Practice

Ever since wireless first came to the aid of mariners there has been a flavour of high romance about the SOS and its effects. Again and again the imagination of the land-keeping public has thrilled to the mental vision of a sinking ship in mid-ocean calling through the void upon its fellows for assistance.

Just fourteen years ago the White Star liner *Titanic* was ripped open by an iceberg while on her maiden voyage and went down, taking with her a large number of seamen and passengers. Those who were picked up from boats owed their preservation to the SOS sent out continuously by the wireless operator on duty until he, too, went into the depths with his ship. He gallantly refused to leave his post at the transmitting key.

Wireless was then, fourteen years ago, in its comparative infancy, and the ship which was nearest to the scene of tragedy did not happen to be listening. That cannot happen now. So long as a ship in distress floats for half an hour and continues to call, all ships within wireless ear-shot must hear the SOS.

The officers and crew of the *Trevesa* were not left alone in June of 1923 to make their immortal 1,700 miles voyage in open boats because their distress call was not heard. But the nearest ships were 300 miles away in the Indian Ocean; they rushed towards the point where the ship had sunk, but could not find her boats. Had one of those boats possessed a small spark transmitter the world would have lost one of the finest sea exploits on record.

The successes to the credit of wireless far outnumber the comparative failures.

On the 11th of January, 1921, the Norwegian steamer *Onteneda*, in distress in the North Atlantic, sent out the SOS together with the latitude and longitude of her assumed position. But her officers were much out in their reckoning, and several ships which steamed to her assistance failed altogether to find her.

It fortunately happened that there was a British steamer, *Fanaid Head*, not far off, which was equipped with a direction-finding frame and an

operator of intelligence. He judged from the direction of the distress call and from its volume that the *Onteneda* was near a spot in ocean some ninety miles to the north of that sent out by her officers. The skipper of the *Fanad Head* trusted to his operator rather than to the *Onteneda*, made for the position indicated by the direction-finder, and had the immense satisfaction of rescuing the whole of the *Onteneda's* crew just as she was going down. Those 31 men owed their lives directly to that wireless operator and his accurate equipment.

A similar case, also that of a Norwegian steamer, the *Mod*, which was lost in the North Atlantic on January 22nd, 1922, may be given. She sent out the SOS on the 21st, but was 78 miles wrong in the position indicated. As with the *Onteneda*, vessels steamed up from all quarters and failed to find the *Mod*. But happily there was one vessel, the *Melmore Head*, which, on the following day, picked up on her direction-finding apparatus one of the distressed and sinking *Mod's* last calls, and was able to fix her correct position.

Avoiding Mistakes

The *Melmore Head* steamed at once along the line indicated by her wireless operator, and rescued twenty-three out of the *Mod's* crew of thirty-three. These mistakes in position are common enough, especially when officers have been for some time without a sun or star observation and have had to depend upon dead reckoning. It is for the correction of such mistakes that direction-finding equipment ashore and afloat and wireless beacons have been developed.

Since October last there has been in operation upon our coasts a very complete organisation by means of which ships in distress, yet out of sight of land, may quickly receive from the shore the assistance of tugs and of the fine boats of the National Lifeboat Institution's service.

In brief, this system provides that the distress call shall be transmitted, as soon as it is picked up, to that part

of the coast-guard and life-boat organisation which is best fitted to deal with it in the shortest space of time. The essence of the system is time saving, which in practice means life saving. The best way to explain how the business is carried through is to take an example and follow it from step to step.

We will suppose that the Post Office wireless station at Cullercoats (Tynemouth) hears an SOS distress call, followed by the information that the ship calling is in Lat. 55 degrees 40 minutes and Long.

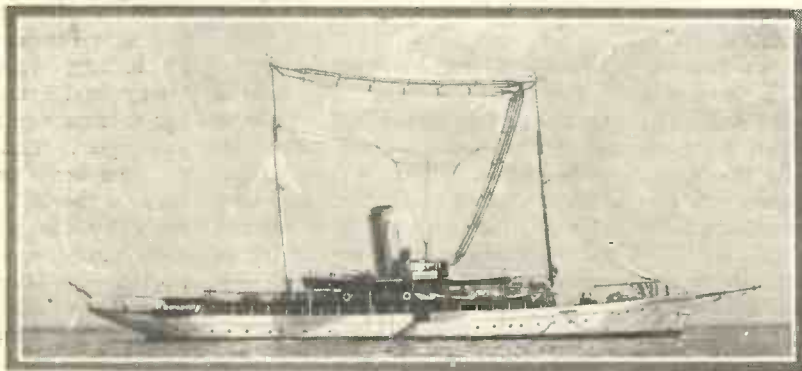

Senatore Marconi's yacht, the "Elettra," on which many experiments with apparatus of maritime use have been carried out.

1 degree 40 minutes west. He acknowledges the call at once, and then has to deal with it.

Now, this operator has little knowledge of charts or of navigation, and has no means of deciding for himself to what quarter on the coast that message may most suitably be transmitted. But under the system of the Life Saving Coastal Chain he knows exactly what to do, and does it without the loss of a moment. He has a liaison coast-guard station at Blyth, and under his standing instructions he sends the call by telegraph or telephone (under Post Office life-saving priority) to the officer in charge at Blyth exactly as he receives it. Every Post Office and Admiralty Station has in similar fashion a liaison station hard by, chosen because it possesses an officer skilled in the service of the sea who will be able to make effective use of the information.

We will now assume that the officer at Blyth has received the message. He goes at once to his charts and discovers that the ship in distress is about ten miles east of the Farne Islands. His coast-guard chart informs him that under the prevailing conditions, with a southeasterly gale blowing, the Newton

coast-guard district will be the best one with which to communicate. So he wires or telephones at once (under priority) to the officer in charge of the Newton coast-guard district.

This officer in turn consults his charts and his "field state," revised daily, which shows what lifeboats of the National Institution are immediately ready for service. He decides that lifeboats shall go out from North Sunderland and Holy Island, and, very likely, telephones also to Berwick for tugs.

The officers of the National Institution, who work in hand and heart with the coast-guard, at once carry out the instructions, and within about fifteen minutes of that SOS reaching the Post Office Wireless Station at Cullercoats, the lifeboat crews from North Sunderland and Holy Island and those tugs from Berwick have been called up and are ready to be off to the ship in distress ten miles east of the Farne Islands.

No Time Lost

That briefly is the system. On the busy coasts of eastern and southern England it can be worked within fifteen or twenty minutes; on the less fully organised coasts of northern and western Scotland it may occupy three-quarters of an hour. But, complicated as it may sound, it is quite simple in practice, and it does ensure that the best-placed and the most readily available lifeboats and tugs shall be directed within the minimum of time to the spot where their services are urgently needed. And when the lifeboats have gone out and the officers of coast-guard have time to breathe, the system is reversed.

Newton informs Blyth what he has done, Blyth informs the Post Office station at Cullercoats, and Cullercoats sends out over the ether a message of succour to the distressed ship. So that no time is lost at any point in the chain, and when the boats approach the ship she guides them by her rockets and flares and is eagerly ready to receive them.

A Holiday Set

How to make a Two-valve Reflex Set with Crystal Detector, Specially Designed, Built & Tested by The Technical Staff of "THE WIRELESS MAGAZINE"



THERE must be hundreds of our readers who spend their week-ends during the summer on the river, in the country or by the sea. All of them are interested in wireless, and naturally they wish to keep in touch with matters wireless. It is only logical, therefore, that such people would get

it will bring in far-distant stations. That is not its purpose.

We have designed this receiver for the reception of the local station at fair loud-speaker strength with (what is even more important) clear, distortionless reproduction.

Points in Design

Such a set must incorporate the following advantages: It must be entirely self-contained, having no harassing external accessories. In addition to this it must be compact and easy to carry. Tuning must be simple and easily controlled by any member of the party.

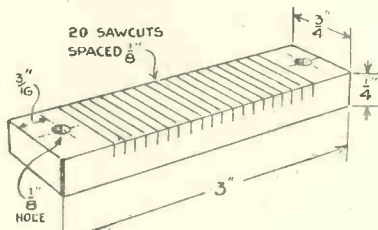

Support for Frame-aerial Wire.

a great deal of pleasure and amusement with a portable set capable of receiving the local station on the loud-speaker.

It is for this purpose that the set illustrated in the accompanying photographs and sketches has been designed. We do not claim that

Howling

There are too many portable "supers" at the present time which, at the slightest provocation, will utter ear-splitting howls and squeals requiring the services of a highly skilled operator to handle in order to produce reasonable results.

Such a set is only interesting to the man who understands it. The rest

of the family studiously avoid it, and when it is brought out and tuning operations commence everybody sits with a resigned expression, waiting for the howls to cease and the broadcast to begin.

Returning to the set described here, it will be seen on looking at the theoretical circuit diagram that the first valve acts as a high-frequency and low-frequency amplifier, followed by crystal rectification and one stage of low-frequency amplification.

Phone Connections

The phones are thus connected in the plate circuit of the first valve in series with the tuned-anode coil. Across the phones is connected a fixed condenser of fairly large capacity in order to allow the H.F. currents in the plate circuit of the valve to pass the phones through the condenser.

No reaction has been included in the set in order to simplify tuning, but if this should be desired it is a simple matter to modify the circuit accordingly.

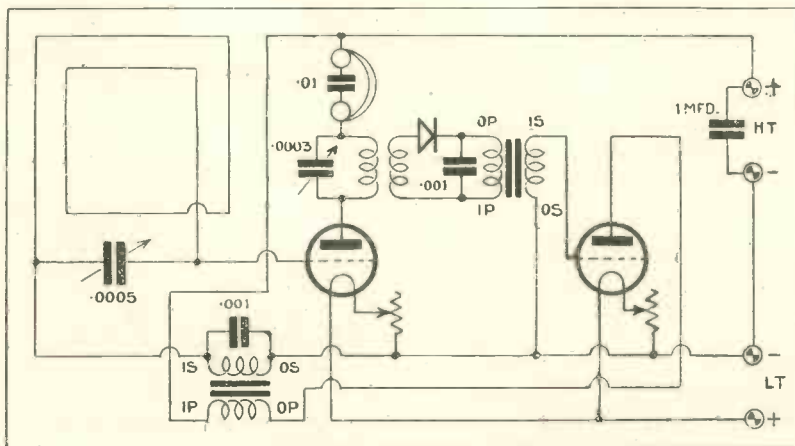

Circuit Diagram of Reflex Set.

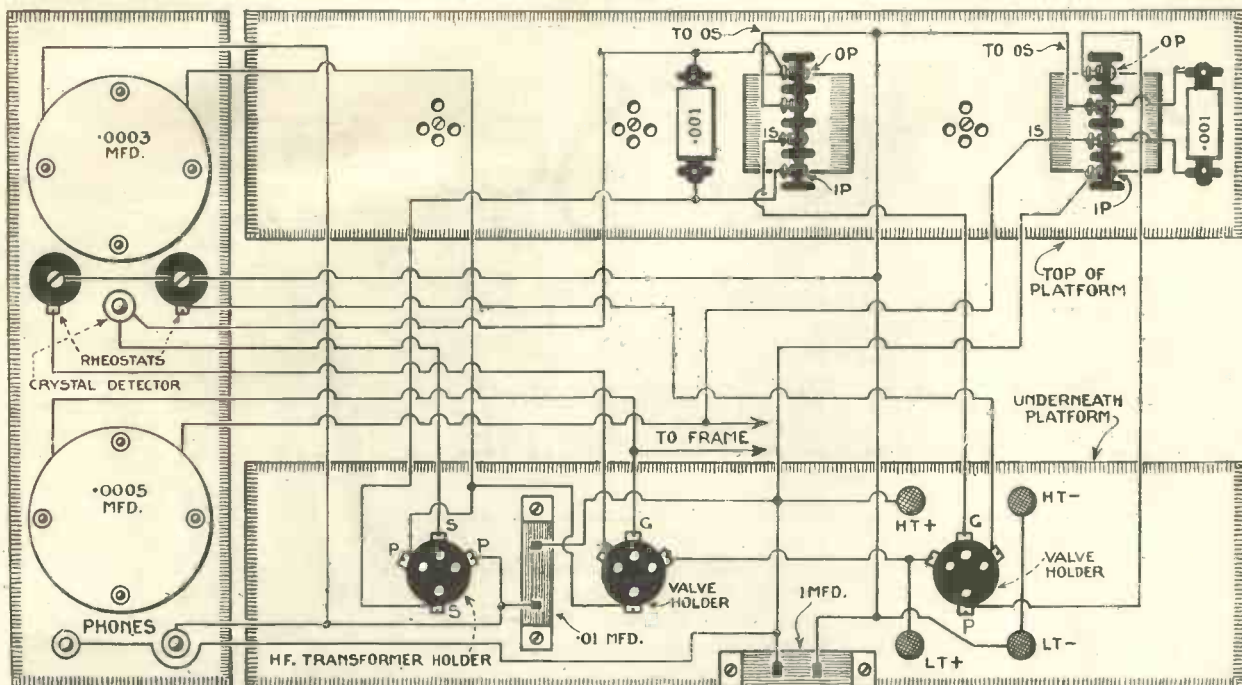

Wiring Diagram of Two-valve Reflex Set with Crystal Rectification.

The components required for the construction of this portable set are as follow :

- 2 ebonite panels, one 18 in. by 4 in. by $\frac{1}{4}$ in. thick, and the other 12 in. by 4 in. by $\frac{3}{8}$ in. thick.
- 2 L.F. transformers (Igranic, 1st and 2nd stages).
- 1 variable condenser, .0005-microfarad square-law (Peto-Scott).
- 1 variable condenser, .0003-microfarad square-law (Peto-Scott).

- 2 filament rheostats (Lissen Major).
- 1 crystal detector (Liberty, permanent type).
- 3 valve holders.
- 1 fixed condenser, 1-microfarad (T.C.C.).
- 2 fixed condensers, .001-microfarad (Therla).
- 1 fixed condenser, .01-microfarad (T.C.C.).
- 1 H.F. transformer, 300 to 600 metres (McMichael).

- 6 terminals (Belling-Lee).
- 1 portable case (Carrington Manufacturing Co.).

Accommodation for Components

The constructor is advised to use the components specified. Apart from the fact that these were used in the original set it might be found that other apparatus, although giving equally good results, would not fit in the special case.

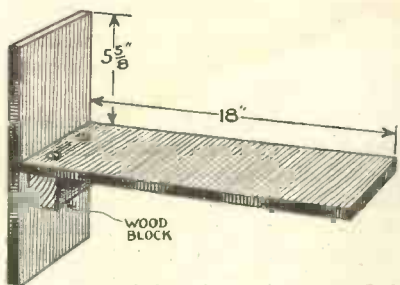

Left—Arrangement of Panels.

Right—Layout of Front Panel.

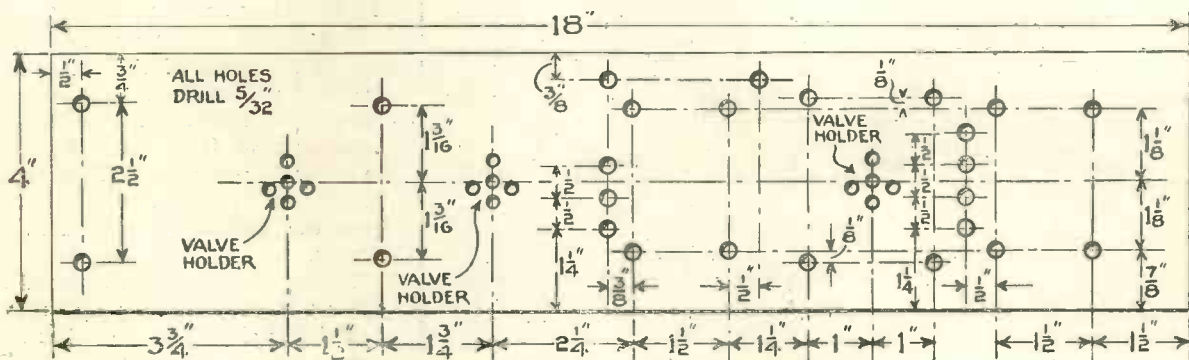
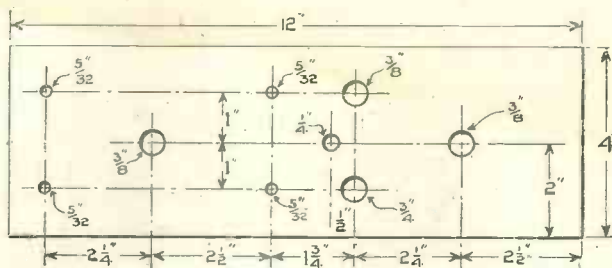

Layout of Horizontal Panel of Portable Reflex Set.

The case was specially made to our design by the Carrington Manufacturing Co., of 18-20, Norman's Buildings, Mitchell Street, Central Street, E.C.1. As will be seen from the photographs and sketches, it presents a particularly neat and pleasing appearance.

When the set is not in use the control panel is completely covered by a hinged door, thus preventing the intrusion of dust. The left-hand side of the cabinet is hinged at the bottom, so that easy access to the apparatus is possible.

Frame Aerial

The frame aerial is wound on slotted ebonite strips screwed on to the hinged side of the case.

There is plenty of room underneath the valve and transformer platform for the high-tension and low-tension batteries.

Room can also be found for a pair of phones. Thus the receiver is entirely self-contained.

A dimensioned sketch is given for the benefit of those who possess the tools and the ability to make up their own cases. In order to withstand our changeable climate the case is covered with leatherette, which gives a pleasing finish and does not show to the same extent the dents and scratches that appear even with the most careful use on polished mahogany.

As the two panels are not of standard dimensions they must be cut carefully, and the edges and corners squared up.

Particular care should be taken over this, for if the 18-in. panel is not truly square at the end which is fixed to the upright panel the other end will probably be so far out of alignment that difficulty will be experienced in mounting it in the case.

Drilling the Panels

Start drilling the upright panel (carrying the controls) first. All the components mounted on this panel are of the one-hole fixing type, so that it should not be difficult to drill.

The .0003-microfarad variable condenser is mounted on the top. Directly underneath the two filament rheostats and the permanent type crystal detector are mounted, while the .0005 microfarad frame-tuning condenser is fixed to the bottom of the panel.

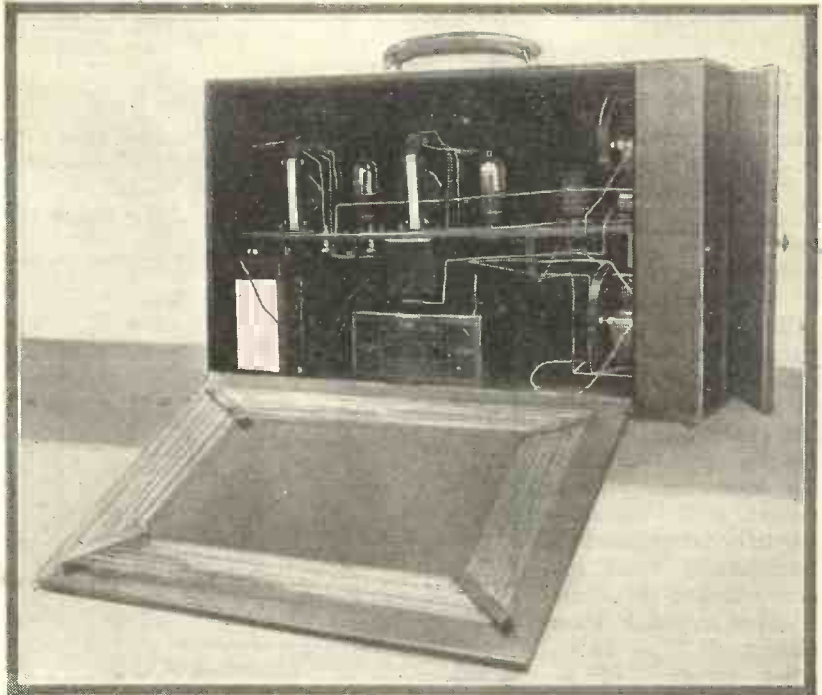

View of Completed Portable Reflex Set.

In addition two holes are drilled $6\frac{1}{2}$ in. from the top of the panel for the purpose of attaching the two panels together.

Having drilled all the holes, the components mentioned may be mounted and the complete panel put aside until the second panel is finished.

On the top side of the 18 in. panel

the two L.F. transformers are mounted. Holes are drilled beside each transformer so that wires leading to the terminals may be pushed through from the underside of the panel.

The three valve holders (of the sub-panel fixing type), the 1-microfarad and the .01-microfarad fixed condensers are mounted on the under-

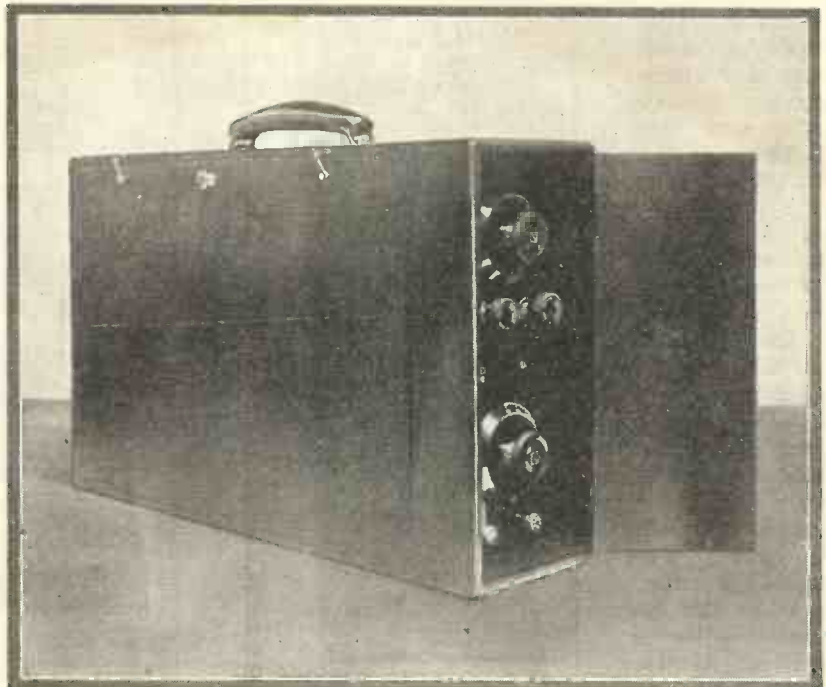

End View of Portable Set, showing Controls.

A HOLIDAY SET (Continued)

side of the panel together with the H.T. and L.T. terminals.

Drilling layouts and a wiring diagram showing the dimensions of the two panels and the sizes and positions of the holes are given in these pages.

The next step in the construction is to complete as much of the wiring as possible before fixing the panels together. On the 18-in. panel the following connections may be made: H.T. - to L.T. - and to one terminal of the 1-microfarad fixed condenser and to the OS terminal of each L.F. transformer. H.T. - to the other terminal of the 1-microfarad fixed condenser, to one terminal of the 0.1 - microfarad fixed condenser and to IP of the outside L.F. transformer. One filament socket of each of the two valve holders (not the H.F. transformer-socket) to L.T. + The plate of the last valve to OP of the outside L.F. transformer. The grid of the same valve to IS of the other L.F. transformer. The plate socket of the H.F. transformer-holder to IP of the latter L.F. transformer.

The two panels are fixed together by means of 1-in. brass wood screws fixed into a wood fillet $1\frac{1}{4}$ in. square by 3 in. long. A sketch is given showing the method of fixing.

When this has been done the remainder of the wiring may be completed. Keep

the wiring close to the panels in order to leave plenty of room for the batteries underneath.

Having completed the wiring the

panels are ready to be fastened in the case. The control panel is fixed to a fillet at the top and bottom of the case, while the instrument platform behind has its free end screwed to another fillet fixed to the far end of the case. Four brass wood screws—two for each panel—are sufficient to keep the whole together.

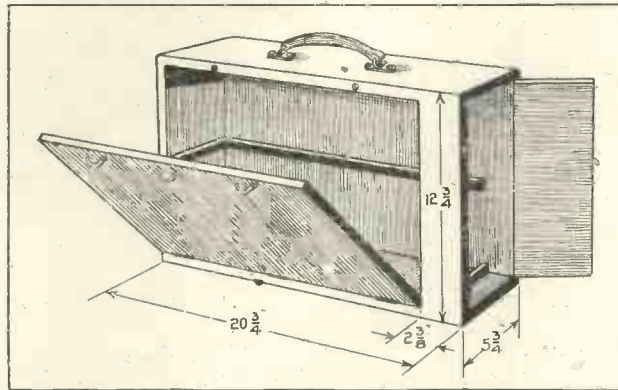

Dimensions of Case.

Frame Aerial

The frame aerial itself consists of wire fixed inside the lid on four ebonite strips, 3 in. long by $\frac{5}{16}$ in. wide by $\frac{1}{4}$ in. thick.

Good, dry hardwood may be used instead of ebonite for the strips.

Twenty saw-cuts spaced $\frac{1}{8}$ in. apart are made in each of the ebonite strips sufficiently deep and wide to take No. 24 gauge d.c.c. wire. A sketch of one of the four strips is given, showing the dimensions of the frame and the position of the saw-cuts. All four strips are identical.

The ebonite strips are screwed diagonally at the four corners of the hinged side of the case. No. 24-gauge d.c.c. wire is used for winding the frame aerial. Start by winding the wire round through the four inner slots so that each complete turn forms a rectangle greater than the previous turn. In order to present a neat appearance the wire should be kept fairly taut at every turn.

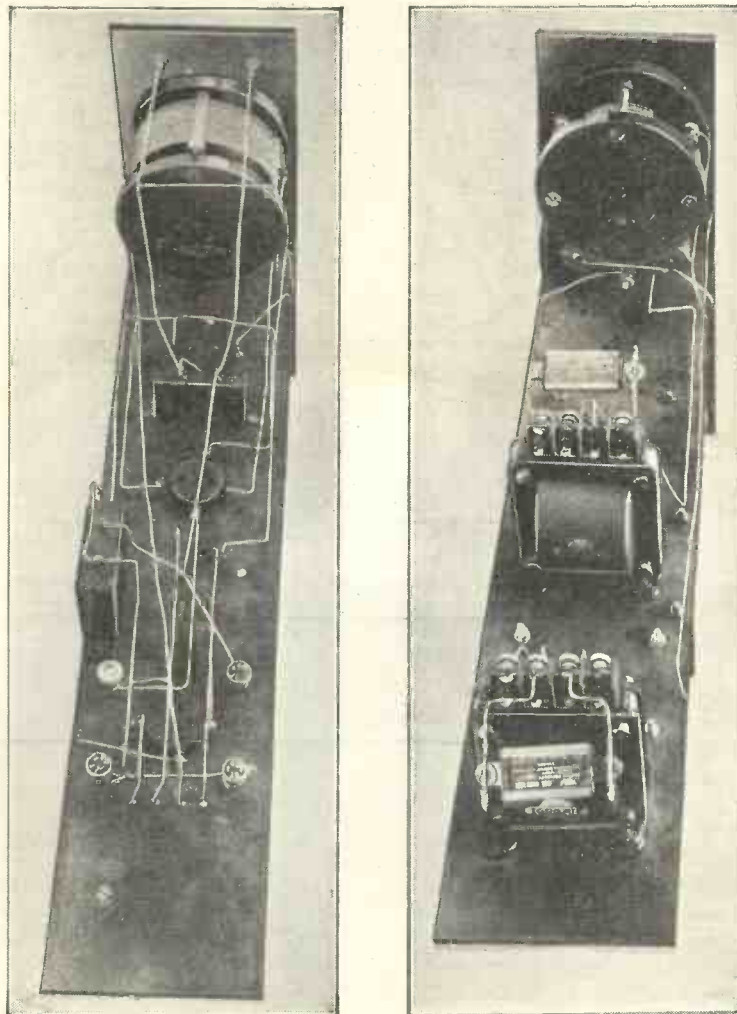

Two Photographs showing Arrangement of Components on Panels.

(Continued on page. 85)

Gadgets, Hints and Tips

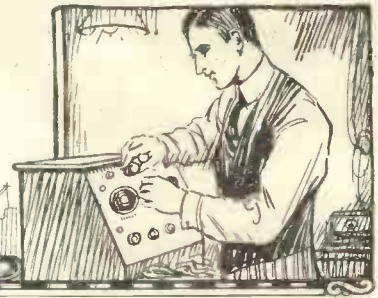

Valve Connections

WHEN mounting valves inside a cabinet on a shelf difficulty is very often experienced in making connections to the valve legs. Here

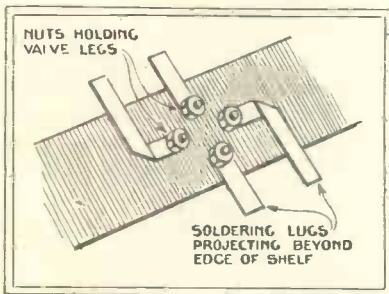

Valve Connections.

is a method of overcoming the difficulty.

It will be noted from the diagram that metal strips are made long enough to be attached to the valve leg and to protrude a little beyond the edge of the panel (a hole is punched to fit over the valve leg). Soldered connections are made to the ends of these strips.

L. S. P.

Basket-coil Formers

If the slots of a basket-coil former are formed as indicated in the

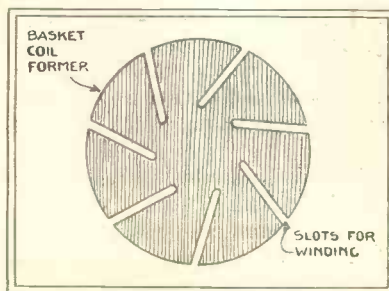

Improved Basket-coil Former.

diagram winding is greatly facilitated without impairing the efficiency.

It is a great convenience to make a template from thin sheet copper, which is easily cut with an ordinary pair of scissors.

G. M. M.

Below Minimum Adjustment

WITH sets using a coil tuned by a parallel condenser it is often found when searching for unknown and far-distant stations that a carrier wave will be picked up on the minimum wavelength of the set.

Should this happen, place any available coil (the size is almost immaterial) in parallel with the one in use by connecting it to the aerial and earth terminals of the set.

The decrease of inductance thus obtained will make it possible for the desired signals to be tuned-in.

G. M.

Simple Lead-in

SHOWN by the diagram is a very simple and satisfactory kind of

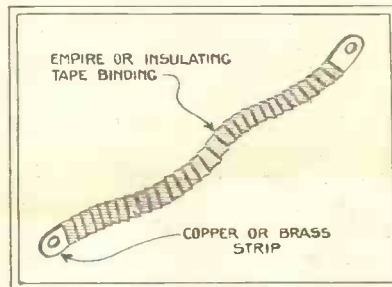

Simple Lead-in.

lead-in. It consists simply of a strip of copper or brass protected and insulated with a layer of empire tape.

It is of special convenience in cases where it is not desired to bore a hole in the window frame to accommodate the more orthodox lead-in tube.

K. J. B.

Polarity Indicator

A POLARITY indicator can easily be made by taking a piece of glass tube about $\frac{1}{2}$ in. in diameter by $2\frac{1}{2}$ in. long. The tube should be filled with a solution of salt and water, and the two ends plugged with rubber corks.

Through the centre of these plugs should be passed a piece of No. 16— or 18—gauge wire, the ends of which are taken to two terminals on a small baseboard.

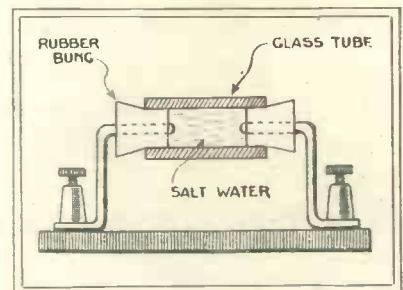

Polarity Indicator.

When a D.C. potential is applied across the indicator the bubbles show the negative end.

W. J. C.

Grid Bias

A GOOD method of securing grid bias on a valve, and one that saves the necessity of an extra battery, is to connect the secondary (O.S.) of the intervalve transformer to a terminal on the panel (instead of to the L.T. — as usual) and make the connection from this terminal to H.T. —

The terminal marked H.T. — should then be plugged into the

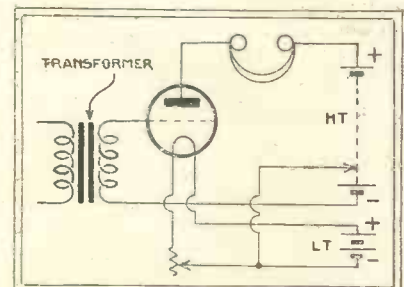

Method of Obtaining Grid Bias.

H.T. battery (3, 6, 9 or any required voltage).

Of course, in this circuit H.T. — would have to be joined to L.T. — and not to L.T. + 5 R. W.

Doctor Z — A Story by Arthur Russell Illustrated by Charles Crombie



I
A SARDONIC smile spread over the face of Dr. Zimmerman as with a little shrug of his shoulders he lifted the telephone receiver. "Now for the fun," he muttered. "Enter the villain."

Before him was a large map of the world, ruled and dotted with red ink. Alongside were several sheets of paper covered with figures.

On a shelf nearby a large wireless set was installed, both the transmitting and receiving gear being the latest thing in wireless. A little apart from the ordinary sending key was another such instrument, different from the first in that it was almost double the size, while the knob of thick vulcanite had a heavy protecting ring of the same substance. "Highly dangerous. Do not touch!" it was labelled.

"Five double four X," ordered Zimmerman, saying each word slowly and deliberately, a smile still playing round the corners of his mouth. "The Southern Shipping Company."

He chuckled as he waited, patiently toying with a pencil the while.

"The Southern Shipping Company? Thank you! Will you switch me through to your managing director, please."

Zimmerman was as unconcerned,

almost, as if the conversation he was about to engage in was the most commonplace in the world. He heard the click as the connection was made, and then came the voice of the shipping magnate.

"Your firm, I understand, is the agent for the *Boadicea*?" Zimmerman began, knowing full well that this was so.

Startling were his next words, yet he uttered them without a quiver. "Unless your cheque for five thousand pounds is in my hands before five o'clock this evening, the *Boadicea* will be blown up. Send the money to Doctor Z., Snowtown Mansions. And, mind, no funny business. A word to the police and not only that boat but others of your fleet will suffer. What's that? Me mad? Not at all. I am merely anxious to make money easily. Mind now—Hello! Hello!—"

With a chuckle Zimmerman replaced the receiver. The telephone was "dead." Connection had been broken.

* * * * *

Alec Jackson, wireless man on the *Boadicea*, juggled with his tuning coil as he waited. It was not yet six o'clock, and a little early for regular business. A few "strays" scratched in his phones, probably from a boat or station thousands of miles away.

Otherwise, except for static, which was much in evidence, everything was quiet.

He removed the receivers from his ears, at the same time pushing over the lever of the aerial switch. A touch on the converter switch brought a loud whirr from the generator. He was about to don again the receivers when, with wonderful clearness, came a voice.

"Doctor Z. speaking. To the operator on board the *Boadicea*. Listen! In twenty minutes' time your vessel will be wrecked—blown up. Warn the master, and urge him to take to the boats at once. Five minutes before the time I shall start to count, continuing at intervals of thirty seconds. On the word 'ten' being spoken, the ship will be destroyed. Understand!"

"God, boy, what damned nonsense is this?"

Jackson, deathly pale, looked around.

"Captain Gale," he said hoarsely, pointing a trembling finger at the receivers lying on the table. "You—you heard. I—"

Again came the mysterious voice audible to both men.

"If you would save yourselves hasten."

Jackson snatched up the wireless receivers and listened. Everything was still—uncannily so. He glanced over his set and gasped with amazement. He beckoned to the captain. "The aerial switch, sir," he said. "It is on the 'off' position. The aerial is not connected to the set."

Jackson turned a pair of frightened eyes to the captain. He was not a coward, but he felt that he was now up against something which he could not fight.

"Twenty minutes, sir. You heard," he said. "Some scientific lunatic, perhaps, sir. He must have got in touch with us in some way clear of the aerial."

"Damned nonsense!" roared the captain. But the look on his face showed that he appreciated the seriousness of the threat.

He turned to Jackson. "If this is a practical joke, boy, I'll clap you in irons for the rest of the voyage and let the wireless go hang. Get me?"

With this he strode from the cabin, leaving the young operator almost in a state of collapse.

Straight to the bridge the captain walked, saying a few words to the mate, who was sweeping the horizon with his glasses. His hand hesitated on the handle of the ship's telegraph. Then: "Slow! Dead slow! Stop!"

More signals followed, and a few sharp orders from the mate. A splash told that the main anchor had been dropped.

Captain Gale glanced at his chronometer, muttering a curse against the unknown who was causing so much trouble. Time was passing quickly. If there was anything in the threat of the etheric voice, much haste would be necessary.

"Rubbish!" he muttered, wavering. "I'm a fool to take any notice of it. What could happen? That wireless kid was trying some foolish ventriloquial stunt, doubtless!"

Of the old school, Captain Gale did not yet take kindly to wireless.

The boats were being provisioned. Stewards and pantry men were working at feverish speed.

The captain paced the deck. He felt that he was weak in acting as he was. Fifteen minutes had gone and nothing had happened. If he had fallen to some silly joke, he would never hear the end of it!

Breaking in on his thoughts came in clear tones a voice from the wireless cabin.

"One! Two! Three . . ."

"Lower and man the boats!" rang out the order.

A final glance around the ship.

"Four! Five! Six . . ."

The captain sighed as his eyes went over the vessel. He had captained the *Boadicea* for many years, piloted her through the heaviest of storms. Salt spray momentarily dimmed his eyes, when a shout from the mate in the boat caused him to jump just as the boat was pushed off. He felt guilty in so leaving the ship. Even now, he was half inclined to go back.

"Seven! Eight!"

The voice as it came to them seemed to be amplified a hundredfold.

With an effort of will power the captain pulled himself together. He realised that he had the lives of the crew in his hands, as it were.

"Row like hell!" he ordered, standing up and keeping his eyes fixed on the vessel.

"Nine!"

They stopped rowing. All eyes

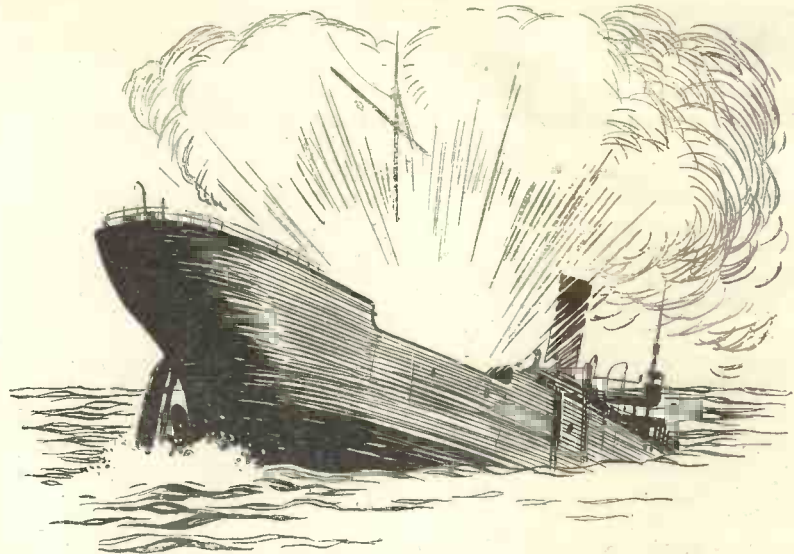

From 'midships came a loud, reverberating explosion and the *Boadicea* crumpled up and sank before their eyes.

were on the ship. To the watching men it seemed ages since the previous number had been counted.

"TEN!"

The barest fraction of a second later a ring of fire seemed to play around the ship's aerial. From 'midships came a loud, reverberating explosion, and the *Boadicea* crumpled up and sank before their eyes.

II

At the office of the Southern Shipping Company Tommy Dickson, detective, and one of the "top dogs" of his class, smiled grimly as he listened to the story of the mysterious telephone conversation of the previous day, and of the loss of the vessel some hours later.

"Doctor Z!" he mused. "I fancy I know him."

The boats' crews of the *Boadicea* had been picked up by a passing vessel and the story wirelessed to the agents.

"He threatened a similar disaster to the *Lucy Lee*, you say? Claimed ten thousand pounds this time?" Tommy Dickson had grown excited as the story was unfolded to him. Crash came his fist on the table. "Don't pay him a single cent. You need have no fear for the safety of the vessel. Leave everything to me. I'll see to Zimmerman."

With this he departed, making straight for his office, where he threw himself into an easy chair to ponder over what he had heard.

"Doctor Zimmerman!" he muttered.

As the name escaped his lips the door-bell tinkled.

"Dr. Zimmerman to see you," announced the office boy, a moment later.

"Well, I'm——" began Dickson, as the other entered, pushing past the lad, who tried to block his passage until he received the word from Dickson.

Zimmerman nodded pleasantly to the detective. "So you are engaged by the Southern Shipping people to investigate the disaster to one of their ships, my dear Dickson," he purred as, without an invitation, he drew up a chair alongside the young detective and seated himself comfortably.

"Take my advice, my friend, and drop it at once. It will lead you nowhere, and you can't afford to ruin your reputation."

"How the hell do you know anything about it?" cried Dickson savagely, his temper rising at the patronising tone of the other.

"You are heated, my friend. Swearing is bad form, too. You know something of my methods, surely. If the telephone authorities will run their wires in a leaky cable, you cannot blame me for listening to the cross-talk. So they believe the story of the ship's being blown up by wireless! A bit thin, don't you think? More likely the officers robbed the strong-room and scuttled the boat. I heard that the vessel was carrying——"

Tommy Dickson rose to his feet and shook his fist in the face of the man seated before him. "You know

very well that the ship was blown up," he shouted, cutting in on the other's well modulated sentences. "It's your doing, and I'll bring the disaster home to you, clever though you are."

"Heavy drama, my young friend! Cannot you control yourself? How absurd to suggest such a thing! How could you? Go on, tell it to the world. Telephone the newspapers now. Ring Z 5178—the Central News Bureau—and offer them the scoop. I doubt whether you would get one newspaper to print a line of it. It's not right, Tommy," he went on, in an aggrieved tone. "You'll damage my reputation with such wild statements. Just because I dabble a little in science you, without any cause, blame me for sinking a ship hundreds of miles away. You're jealous of me, and you know it."

Dickson took a step forward as if to throw his unwelcome visitor from the room. "You—you—" he shouted, swallowing hard, and shaking his fists threateningly before Zimmerman.

"Dear, dear! Cut out the heavy stuff, if you please. No violence. When will you learn to curb that temper of yours, Tommy? Were I

not so forbearing with you—" "Out of this!" ordered Dickson. "Straight away. Get!"

Without any loss of dignity, Dr. Zimmerman rose to his feet. He was still smiling as he finally turned and faced Dickson.

"As you will, boy. A word before I leave. You appear to be interested in shipping disasters—let me give you a little tip. Despite your watchfulness, there will be another vessel wrecked within the next few hours." He shrugged his shoulders expressively. "The *Lucy Lee*—but why talk? You are one of those mulish beings which nothing can shift. I'm sorry, Tommy, very sorry— for you. Good-bye!"

"I was right," burst from Dickson as Zimmerman left. "He practically admitted that he was at the bottom

of the terrible business. He dared me to prove it. The ship, undoubtedly, was destroyed by a bomb exploded by wireless impulses sent out by him. I wonder how many more vessels he has loaded with his infernal machines!"

The detective at once got busy. His first duty was to send a telegram, after which he thoroughly tested his wireless set. Some time later he telephoned Zimmerman's house. Dr. Zimmerman was away . . . had received a telegram . . . but he would be back at six o'clock as he had some important work to attend to.

Tommy smiled grimly, well know-



Tommy Dickson rose to his feet and shook his fist in the face of the man seated before him.

ing the nature of the "work" to which Zimmerman had to attend.

At a few minutes to six, Dickson was waiting at his wireless instruments, the receivers to his ears. As the clock-bell boomed out the final stroke of the hour, came the voice of Zimmerman: "To the operator on board the *Lucy Lee* . . ."

Even though Dickson had got in touch with the ship by wireless he shivered as, fifteen minutes later, Zimmerman's voice began slowly to count: "One—two—three . . ."

He waited for the final signal, the letter Z transmitted three times, and then he cut out. Dr. Zimmerman had flashed into space the fatal signal, and by this time the *Lucy Lee* should be at the bottom of the sea.

* * * * *

The smile playing round the mouth of Tommy Dickson gradually spread until it wreathed his whole face as he again telephoned Dr. Zimmerman. This time it was the doctor himself who answered the ring.

"There won't be any shipping disaster to-day, Doc," he said gaily.

"What do you mean?" snapped Zimmerman. "It is early yet, and—"

"The *Lucy Lee* has just wirelessly her agents that all is well. I knew you'd be anxious. Something deucedly queer about that boat, Zimmerman. The operator found a powerful bomb hidden below his table, connected with his detector valve, and joined to the aerial clear of the switch. Curious, wasn't it? I wonder how it got there! You had a look over the ship's installation when she was last in port here, I understand."

Dickson gave a little laugh as a muttered curse came to him through the receivers. "Curious about that bomb, Doc," he continued. "I wonder if it is identical with the one I found slipped behind the main terminal screws of my wireless set after your last visit to me!"

MRS. H. A. L. FISHER says that wireless is a good deal more exciting than the Sunday paper. Then she doesn't read the same Sunday paper as a good many people.

AN amateur protests, in the Press, against the prosecution of oscillators. We quite agree. It is far too mild a punishment for them.

CHINESE mariners are using wireless with good effect in protecting themselves from pirates. We must find out the wavelength to which our income tax collector reacts.

If hats are an index to character, as stated in the recent talk from Bournemouth, Winston Churchill must have a more variegated character than many of us saddled him with.

Can We Transmit with the Crystal?

WHAT effect will the oscillating crystal have upon the valve? Is it likely to supersede the valve as a detector and amplifier or even as a transmitter of wireless waves?

The average crystal costs only a few pence while the valve costs more than a few shillings. Against this is the fact that the oscillating crystal is at present very unreliable as compared with the valve; it does not give anything like the same degree of amplification, and, of course, the oscillating crystal as a generator of wireless waves is only in the embryo stage and cannot as yet be compared with a valve transmitter.

Regenerative Crystals

However, even at the present time it is possible to have a regenerative crystal receiver which will detect and amplify, similar to the single-valve set with reaction. To this can be added a high-frequency crystal amplifier, for increasing the range; or a low-frequency crystal amplifier for louder signals, in the same way that we add H.F. or L.F. amplification to the valve detector.

Everyone will admit that this appears revolutionary, yet it so happens that the experts cannot make up their minds whether the oscillating crystal is a revolutionary discovery, or whether it is nothing more or less than a new version of the ordinary electric-arc lamp, with some minor differences.

An Electric Arc?

If the oscillating crystal is merely an electric arc, in a new suit, as it were, it is hardly likely to replace the valve, for the latter is much better and more convenient for generating wireless waves than the arc. It is believed in certain circles that any improvement in the oscillating crystal will only demonstrate its similarity to the arc, and if this turns out to be the case, the crystal may have a certain vogue as an amplifying receiver, but is hardly likely to equal the valve for generating waves or for amplification purposes.

On the other hand if the oscillating crystal is found to be an entirely new phenomenon, its importance cannot be over-estimated, and no

one can tell what improvements will not be effected. In this case it is quite possible that the crystal will surpass and replace the valve both as a transmitter and receiver.

M. Lossev, the discoverer of the oscillating crystal, believes that the amplification and regenerative powers of the crystal are due to the

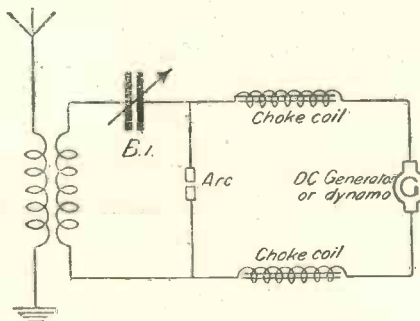

Fig. 1.—Simple Arc Circuit

presence of a minute arc taking place between the steel point and the crystal, and so the problem is, what resemblance does this crystal arc bear to the ordinary arc? Is it the same or is it different? This is the point which is puzzling investigators.

To get at the root of the problem it is necessary to know something about the arc system which functions in exactly the same way as the oscillating crystal, and in the follow-

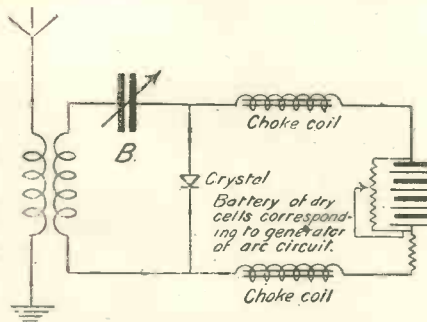

Fig. 2.—Oscillating Crystal Circuit

ing it is possible, in many cases, to substitute the word "arc" for "oscillating crystal," for, as will be explained later, their operations are practically identical.

An arc, in the case of the arc lamp, is defined as a luminous discharge of direct current taking place between two points or electrodes. When the

arc is taking place the electrodes are vaporized, and it is through this gas, caused by the vaporisation, that the arc takes place.

Discovery of Transmission

It was discovered many years ago that if a condenser and inductance were joined in series with the arc, the system was capable of setting up an alternating current of electricity which, if of audible frequency, could be heard as a musical note when telephones were connected. And further, if the values of the inductance and condenser were suitably increased, high-frequency oscillations were set up and wireless waves radiated.

The reason why the arc circuit can radiate continuous wireless waves is due to what is known as "negative resistance," which means, as far as practical work is concerned, that the resistance of the circuit, instead of being of a more or less fixed quantity, increases whenever the potential, that is, the voltage, is increased. Also when the potential difference across the arc is increased the current in amperes is decreased, and conversely when the current is increased the potential difference is decreased.

Production of Oscillations

Now when an arc is connected to a condenser and inductance, some of the current from the arc flows into the condenser, causing the arc to lose some of its current.

Owing to the "negative resistance," when the current across the arc is reduced the potential rises, and this increase in potential across the arc continues to charge up the condenser with the result that the current across the arc is still further reduced.

At length the condenser becomes fully charged, and then commences to discharge across the arc. Consequently, owing to the factor of "negative resistance," this increase in current causes a drop in potential until finally the condenser is almost completely discharged—when the same cycle of operations will take place all over again, the condenser being alternately charged and discharged. This repeated charging

POSSIBILITIES OF THE OSCILLATING CRYSTAL

and discharging of the condenser across the arc, together with the inductance in the circuit, produces high-frequency oscillations which in turn create wireless waves.

Capacity and Inductance

The speed and frequency at which the condenser is charged and discharged depends upon the capacity of the condenser and the size of the inductance, and an increase in either will increase the wavelength, while a decrease will reduce the wavelength.

Fig. 1 is a diagram of a simple arc circuit for generating high-frequency oscillations, and Fig. 2 is a diagram of the oscillating crystal circuit. It will be seen that they are almost identical, with the exception of the initial voltage and sizes of the various components; and the phenomenon which takes place in the arc circuit, as described above, is the same as that which occurs in the oscillating crystal circuit.

For instance, the current from the battery in Fig. 2 supplies direct current for the crystal in the same way as the dynamo supplies direct current for the arc. The condenser B in Fig. 2 is charged and discharged across the crystal in the same way as the condenser B₁ is charged up and then discharged across the arc, and, of course, the phenomenon of "negative resistance" is common to them both.

Therefore it would appear that the oscillating crystal is really a young edition of the arc—yet there is a doubt.

For instance, before an electric arc can take place an enormous temperature is required.

This is not the case where the oscillating crystal is concerned, for if the crystal is heated, even slightly, it loses its power of generating waves and its "negative resistance" properties.

In fact the crystal will cease to function as an oscillator if it is

heated beyond a temperature of 100 degrees Centigrade, while the temperature of an arc is about 3,000 degrees Centigrade; and so there is the distinct possibility that the oscillating crystal is not due to the action of an electric arc, but is something entirely new.

What is It?

If it is a different phenomenon which is taking place it may be capable of vast improvement, and M. Lossev may have discovered a new method of radiating wireless waves,

which owing to its cheapness may oust the valve with its fragile filament, heavy current consumption, and large initial expense.

The deciding factor, however, is the little bright glow at the point where the cat-whisker or steel point joins the crystal, and which can be seen on some crystals quite clearly through a microscope. What is this glow? Is it actually an arc or is it a new discovery in wireless? G. H. D.

HER WAVELENGTH!



AN American journal speaks of the popularity of the wireless lyre in that country. We hope there has been no mistake in the spelling.

AN amateur complains that nearly every night he picks up a Frenchman who never gives a call sign. We thought this characteristic was confined to Scotsmen.



Famous Instrumentalists

Who Have Faced the Microphone

Pianists
Violinists
'Cellists
Harpists

Miss Daisy Kennedy.

Mr. Michael Zacharewitch.

THERE is one phase of wireless history in which few people seem to realise the change—that is in the status of the artist. While the highest praise was being lavished on the scientific side of wireless, the task of finding the right people ready to demonstrate its possibilities before the microphone was, right up to this year, one of considerable difficulty for the B.B.C.

“Cohorts” Rolling Up

Countless scores, who considered themselves fully qualified, rolled up in “cohorts,” as one might say, and it speaks volumes for the first musical director, L. Stanton Jefferies, that we did not have more mediocrities.

The mistaken policy of the big agents in banning broadcasting opened up a field for a huge number of hitherto untried and unheard performers, who would never otherwise have reached a public audience.

An undying debt of gratitude is due to the members of the British National Opera Company, who “stood by” the B.B.C. in its earliest days and gave of their best to the first listeners-in.

Banning Clause Omitted

During this last year, however, a “change has come o’er the spirit of the dream”: the banning clause has been omitted by more and more agents and, consequently, not only has the personnel of the programmes been altered, but also their character, for, quite naturally, the great classical artists could not be persuaded to change their repertoire to please their vast unseen audiences, so the audience was expected to change its taste in music.

This in turn has created a dilemma, for once the novelty of being able to hear world-famous artists had worn off, the public,



Mr. Albert Sammons.



Miss Jeanne Chevreau.



Sir Hamilton Harty.



Mr. B. Moisewitch.



Mr. Cedric Sharpe.



Mr. Lef Pouishnoff.



M. Paderewski.

though willing to admire the greatness of the executant, was still unreasonable enough to demand something more melodious in the way of composition and, as this is not forthcoming, it remains now to be seen in the future which it chooses, great artist or great work.

Our National Instrument

The piano has been called the national instrument; it is certainly the most popular in this country, and therefore it is only natural that interest has been aroused in the group of great pianists who have been heard this year.

Headed possibly by Paderewski, who still holds the reputation as the world's greatest pianist, in quick succession have come the other giants of their art—Benno Moise-witsch, Frederic Lamond, Harold Samuel, Francesco Ticiati, Leff Pouishnoff, Ivan Philipowsky, while earlier were heard Herbert Fryer, Evelyn Howard-Jones and Irene Scharrer.

The performance of Paderewski at a "star" concert like that of Tetrzzini's was of general interest, not only on account of the actual

music, but because most people wanted to be able to say that they had heard the ex-president of Poland.

Executive Genius

To the classical music-lover there is no doubt that the executive genius of Frederic Lamond, the Scottish artist, appeals strongly, for he has established himself as a player of Beethoven, just as Pachmann has made a special forte of Chopin and Harold Samuel of Bach. The last has even given weekly series of daily Bach programmes at the Aeolian Hall this year and, in broadcasting, he has toured all the stations.

Few people know that he is also a composer, amongst his works being

Rubinstein Stipendiary Prize which took him to Vienna under Leschetit-sky. His début over here was made unobtrusively enough at the Town Hall, Reading, in 1908. He made his first great London appearance at Queen's Hall the following year, from which time he has become world famous.

Younger Pianists

Amongst the pianists of the younger school are Francesco Ticiati, a brilliant Italian, and Leff Pouishnoff, who, after a supremely hard struggle to prove his artistic genius, succeeded in capturing London very early in his career. He was the "mystery pianist" who was heard during a temporary "artistic break," in the programme, but owing to his existing contract his name could not be announced at the time.

Since then he has obtained "free-dom."

Sir Hamilton Harty, recently knighted, was known as a pianist long before his marriage to Miss Agnes Nicholls, the great oratorio singer; he was one of the first accompanists to Miss Marie Hall when she made her début in London.

One of the finest pianists over the ether is the Australian artist, William Murdoch, heard most frequently in collaboration with Mr. Albert Sam-mons.

Heard directly and indirectly from Manchester by means of relay con-certs there have been Mr. Edward Isaacs, Mr. Victor Wittgenstein, Mdme. Fanny Davies, Mr. E. B. Appleyard and Miss Marie Novello.

Though the violin is not such a general favourite as the piano, British listeners were fortunate in



Miss Marguerite Meredyll.

the songs for *As You Like It* at His Majesty's Theatre (1907), a com-plete musical comedy, *The Hon'ble Phil* (1908), and numerous operettas, songs and sketches.

Benno Moise-witsch, as he is known here, is the son of Russian parents; he was born and educated in Odessa, where at the age of nine he won the



Mr. Arthur Catterall.



Mr. C. Draper.



Ysaye.

hearing the finest players of this instrument very early in the musical history of wireless.

Miss Daisy Kennedy, who made a firm stand for the freedom of the artist, was soon followed by England's best-known player, Albert Sammons.

He made a debut outside London, at the Kursaal, Harrogate, in 1906, but his powers soon brought him to London, not only as a solo violinist but as leader in all the great orchestras, including the Philharmonic and Beecham's Symphony. He had the honour also of being the youngest member of the King's Private Orchestra. He was the founder of the London String Quartet, and is one of the best known of the classical chamber-music players.

The Great Ysaye

The performance of the Belgian artist, Ysaye, may really be termed a wireless "stunt," for his reputation is world wide. A pupil of the great composers Wieniawski and Vieuxtemps, he was trained in the music of their school.

Another triumph for wireless was the performance by Michael Zacharewitch, the Russian prodigy violinist. Himself a pupil of Sevcik and Ysaye, he has outrivalled both, in sheer virtuosity, and when he made his debut at the age of 12, playing Tchaikovsky's own concerto in Odessa, the composer himself presented him with a wreath, and was loud in his praise.

Making his London debut in 1904, he has since travelled all over the world, appeared before every royal court, and played with every great conductor, including Mengelberg, Nikisch, Weingartner, Sir Landon

Ronald, and Sir Henry Wood. He has just now completed another world tour, and is off again in September for 180 concerts in America.

Omar Khayyam

As composer, too, he is equally brilliant, one of his best-known works being a setting of the Rubaiyat of Omar Khayyam under the title "The Phantasy of Life," and a setting of "The Pilgrim's Progress" heard recently.

Exponents of the 'cello have been some of the best known. There is Miss Beatrice Harrison, whose playing charmed even the nightingales, and Cedric Sharpe, soloist composer and chamber-music player, who is



Mr. Harold Samuel.

Octet, led by Mayer Gordon; the Casano Octet, with Frederick Casano; and the Meredyll Pianoforte Quartet.

Other instruments which have had famous exponents include the clarinet, played by Mr. Charles Draper, best known for his work with the big quartet players at Æolian and Wigmore Halls. In his hands the clarinet becomes as seductive as any voice and a wonderful solo instrument.

Harp

Then there is the harp under the hands of that clever artist, Jeanne Chevreau, the harpist of the British National Opera Company.

Perhaps the most popular item of all is the fine balalaika orchestra, led by Vladimir Vladimoff, who formed his orchestra after Andreef's Imperial Orchestra first showed the power of the national instruments of Russia at the Coliseum.

A great point about M. Vladimoff's Orchestra is that it consists only of the ancient Russian instruments, the balalaika, the domra and the goosli, with the addition of no modern instrument. STUDIUS.



Miss Beatrice Harrison.

a member of the Virtuoso String Quartet, which numbers Marjorie Hayward, the violinist, as leader.

W. H. Squire, too, has been heard, while for concerted music we have had the Kutcher String Quartet, led by a brilliant young violinist, Samuel Kutcher; the J. H. Squire Celeste



Vladimir Vladimoff.



Mr. F. Ticciati.



Mr. E. Appleyard.

A Low-capacity Tuning Coil

HAVING tried several types of home-made inductance, including those wound on a proprietary winding machine, the writer has evolved the design described below, which is highly efficient and within the compass of the most humble pocket, albeit it is not the quickest type to construct; but where efficiency and monetary considerations are the greatest, and one has some spare time, it is easily the best for the amateur.

Air-spaced Windings

The windings are air-spaced, both laterally and radially—that is, there is an air-space around practically the whole surface of the winding; there is no need to use shellac or any other binder for the winding (this reduces the self-capacity of the coil considerably), and the completed coil is very strong.

The first step is to make a jig for the cheeks of the bobbin upon which the coil is to be wound.

This jig may be made of paper if only one or two coils are needed, but if a dozen or so coils are to be made it will be found advisable to make the jig of sheet tin, copper or brass.

Making the Jig

The writer's jig is exactly as shown in Fig. 1, but there is no reason why the number of sides should be eight. It just happened to be an easy shape to sketch out with the aid of a protractor. Take a piece of a condensed milk or fruit tin about 4 in. square, and upon it describe a circle $3\frac{3}{4}$ in. in diameter, and with a protractor or dividers divide the circumference into eight equal parts. Draw lines between the centre and each of the eight marks around the circumference, and then mark the eight sides of the outline of the jig.

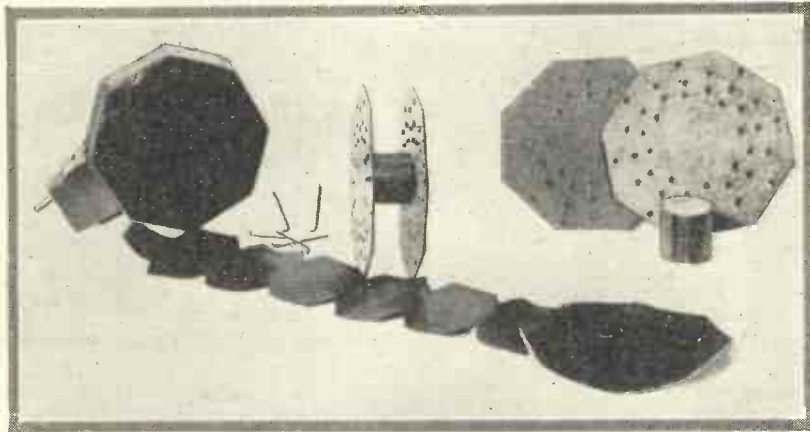

Finished Coil and Former in Various Stages of Construction.

A line has now to be drawn between the centre of each side and the centre of the circle, and, using the same centre, describe five circles having the following diameters:— $1\frac{3}{4}$, $2\frac{1}{8}$, $2\frac{1}{8}$, $2\frac{1}{8}$, and $3\frac{1}{4}$ in.

Where these circles intersect alternate radiating lines a small hole is drilled or punched. Cutting around the outline completes the jig.

TURNS PER LAYER AND SIZE OF WIRE

No. of turns.	Turns per layer.	Size of Wire.
25	5	24 d.c.c.
30	6	" "
35	7	" "
50	10	" "
75	15	" "
100	20	" "
150	30	26 "
200	40	28 "
250	50	30 d.s.c.
300	60	30 "
400	80	34 "
500	100	36 "

A core has to be made for each bobbin, as in Fig. 2. An old blind roller comes in very useful here. The size is 1 in. long by about 1 in. in diameter, and the only care necessary is to make sure that the ends are cut square.

Next make the cheeks of the bobbin from two pieces of cardboard, strawboard, or any other similar material. These are to be made

exactly the same size and shape as the jig, and a small hole drilled or punched through each hole in the jig; a 1-in. circle should be described on the inside of each cheek as a guide for placing the core.

The cheeks and core are then given one or two coats of shellac, and while they

are drying, the wire supports, Fig. 4, can be prepared.

These are merely $1\frac{3}{8}$ -in. lengths of Nos. 16- or 18-gauge copper wire with $\frac{1}{8}$ in. bent over to a right angle at one end.

Finishing the Former

When dry the cheeks are carefully glued or shellacked to the core, and put under the family flat-iron for pressure until the glue or shellac is hard. Of course, the corresponding sides of the two cheeks must be in line. Fig. 6 shows the completed bobbin. Before commencing to wind the coil a small hole is bored through one cheek at *a* and *b* (Fig. 1), to bring out the two ends of the winding. A small knife-cut in the edge of each cheek is also useful.

Winding a Coil

The gauge of the wire will depend on the number of turns, a larger size of wire being possible for a 50-turn coil than for a 100-turn coil.

Assuming a 50-turn coil is being made, there will be 5 layers of 10 turns each, and Nos. 24 or 26 d.c.c. wire may be used.

First of all, push eight of the wire supports through the inner circle of holes in both cheeks, and turn over the end which is not already bent, as in Fig. 5.

Then take the wire and push about 6 inches through the hole from the inside, then through the hole *a*, and proceed to wind ten turns around the supports, each turn being spaced from the next, as in Fig. 7.

Having wound the first layer, slip the wire into the knife-cut in the edge of the bobbin so that it will not slacken off while the second circle of wire supports are put into place. (These may have their ends turned down after the coil has been wound.)

Low Self-capacity

Then wind the second layer of ten turns, starting from the same cheek as the first layer was started from, and spacing the same as before, in order to keep the self-capacity down.

The third, fourth, and fifth layers are wound in the same way, and the end brought out through the hole *c*. This hole should be in the cheek which is nearest to the end of the winding, in order to keep it well away from the starting end.

The ends of the supports are then all turned down as in the first layer, and the coil is ready for mounting and finishing off.

Mounting and Finishing

The coil is finished off with a covering of leather-cloth such as Rexine or any similar material, or the constructor may elect to cover it with varnished silk or empire cloth.

The Rexine is only required in small scraps, such as may be obtained cheaply from an upholsterer or motor-body builder. Quite a quantity of leather-cloth scraps may usually be obtained from either of these sources for a few coppers; the material is useful for covering windings on various components, and is a good insulator, as the base of the coating is made of rubber.

Cut a strip as shown in Fig. 8, with six V-shaped cuts in each side and the ends shaped as shown. A paper pattern is useful here. Cut two other

pieces the same size and shape as the cheek of the bobbin.

Feed one end of the winding through the pinhole *a* in one end of the Rexine strip, and fasten both the wire and the strip under one clamp of the coil mount, which should be one of the tapered pattern.

Fixing the Strip

Then, holding the mount firmly against the nearest side of the coil, draw the strip tightly around the coil and fasten the other end of the strip and winding under the other clamp of the mount. Care should be taken, of course, that there is good electrical connection between the ends of the winding and the coil-mount clamps. The ends of the wire may be soldered to the clamps after mounting to make doubly sure of this point.

The coil is now firmly anchored to the mount, and the sides of the Rexine strip may be turned down against the cheeks of the bobbin, and one of the octagonal pieces stuck on

the layers are spaced at closer intervals and more layers put on, with less turns to a layer.

No Wire on Bobbin

A layer could also be wound on the core of the bobbin, but this again will decrease efficiency slightly by increasing the self-capacity.

The photograph shows the coil in various stages of construction, and the accompanying table gives the number of turns per layer for 5-layer coils, and the gauges of wire for various coils. A. J. F.



CYNICS are saying that the Government dropped the Wireless Bill because it would have burned their fingers.

APROPOS the proposal to lengthen broadcasting hours, we have received representations from many readers in favour of adhering to the old-fashioned 60 minutes' variety.

THE Mormon sect in America has a broadcasting station of its own. One would have thought that a man with half a dozen wives would get sufficient listening-in as a duty, without wanting it as a hobby as well.

ONE of our M.P.s wants convicts to be provided with wireless. They will certainly find broadcast more welcome than broad arrows.

It is suggested that cabaret music shall be broadcast until midnight. The call sign, no doubt, will be H I C.

A BOOTBLACK has fitted a wireless set to his stand. A shining example to his rivals.

PIGEON owners have announced that they are willing to supply corks for the corking of wireless aerials. We wondered why pigeon clubs were always held at licensed houses. Now we know!

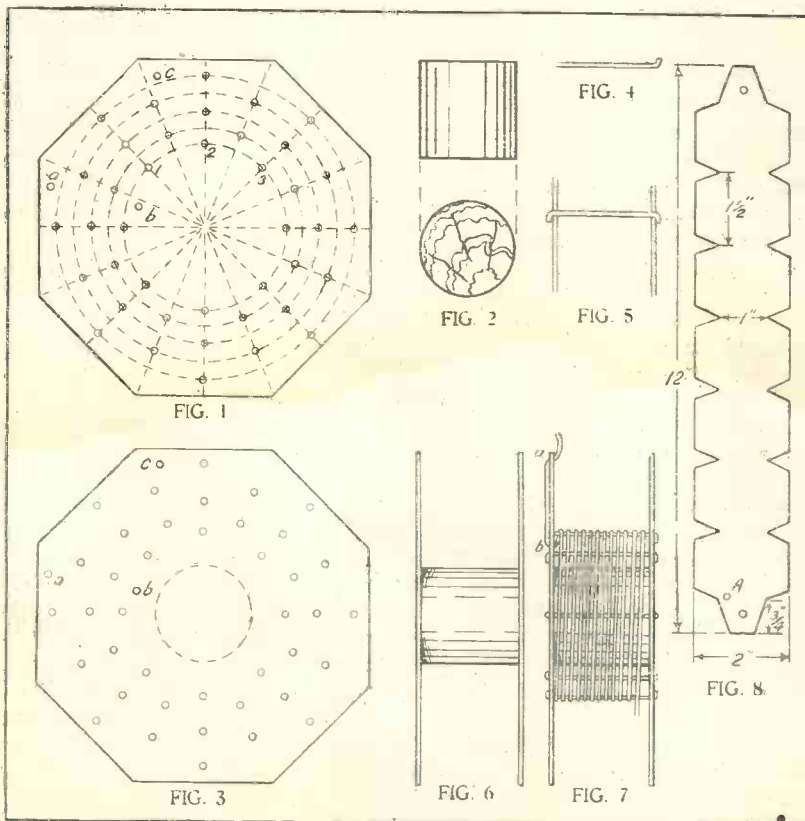

Figs. 1 & 3—Layout. Fig. 2.—Core. Fig. 4.—Wire Support. Fig. 5.—Fixing Support. Fig. 6.—Completed Bobbin. Fig. 7.—Spacing Turns. Fig. 8.—Covering Strip.

each side with shellac or liquid glue.

For a coil having a high inductance value, such as a 400-turn coil, it will not be possible to have an air-space between turns of a layer, as the coil will require 80 turns to a layer, unless



AT Wilson Street, in the City of London, not more than a stone's throw from Liverpool Street Station, is the nerve centre of commercial wireless, Radio House. It is a vastly different place from any which the average wireless enthusiast would imagine it to be—there are no huge alternators, no immense inductances or condensers, not even an aerial; but from here, nevertheless, wireless messages are sent right across the world at a speed and accuracy which is equal to any cable undertaking. You naturally ask, "How is it done?" We will, therefore, take a walk round the building and see.

Scenes of Activity

On going through the doors we enter a room not unlike an ordinary cable office. Here are smart uniformed messenger boys ready to take your message to the conveyors, busy telephonists and telegraphists taking in messages from the branch offices in London and the provinces, all to be passed on to the wireless transmitters.

There are two ways in which your message, should you have one, may be sent—the ordinary and the urgent. With the former you pay quite a modest fee and take your turn. With the latter your telegram will go immediately; and in a matter of minutes your wishes will be conveyed to friends or business people in New York, Canada, Europe, where you will.

From the receiving office a step will take us to the central sorting department. Here all the telegraph forms are sent to be sorted into groups indicating either destination or priority. The forms are taken by

clerks, who sit at desks at the back of which are numbered and lettered pigeon-holes. From there run the conveyors, which are quite automatic in action and are most fascinating things to watch.

We are all familiar with the system of overhead rails in large stores along which hollow wooden balls convey our money and bills to and from the central cashier's department. In Radio House exists a similar but faster and more automatic scheme.

The forms, once sorted, are placed into baskets directly below the rails of the conveyors. Along comes one of the travelling clips, which dips as it approaches the basket, and as it does so picks up the contents. It immediately rises again taking the form with it.

One of the most interesting features of the conveyor system is that it has quite a number of stations in different parts of the building. By means of ingenious trips, the moving clips deposit their load only at the correct station, passing any intermediate ones. Thus from the one sorting department all the forms are dispatched, bearing their messages to the various operators, ready for transmission to their far-flung destinations.

Considering the hundreds of forms which are handled every minute, one may imagine the time and trouble which the conveyor system saves.

We will now leave the sorting department and pass on to the central transmitting and receiving office. Here there is a continuous sound of typewriters and automatic telegraph instruments.

The messages taken from the

conveyor baskets are stacked by the side of the operator. In front of him is an instrument with an alphabetical keyboard, very similar to that of a typewriter. The whole machine, however, is somewhat larger, and to one side may be seen a small electric motor and a reel of paper tape which is being unrolled.

As the keys are depressed so the paper becomes punched with small holes situated on either side of the centre of its line. An examination of the perforated strip shows that some of the holes are opposite one another while others are arranged obliquely.

When two holes are opposite they represent the morse symbol the dot, while when they are oblique a dash is indicated. Larger spaces between two series of dots show that the complete symbols for a letter have been made, while a still larger space indicates that a word has been started or finished. In this manner the printed message on the original telegraph form is converted into morse code represented by perforations on a paper tape.

Wheatstone Transmitter

The tape now has its sole but important duty to perform. It is fed into a machine known as a Wheatstone transmitter. This instrument is also driven by an electric motor, and in the main closely resembles two motors placed at right angles. As the paper travels along an ingenious mechanical device causes an electric circuit to be completed wherever a hole has been punched.

The apparatus is so timed with the perforations that it finally results in morse symbols being electrically

transmitted along a wire. The speed at which this may be done can be varied from the comparatively low one at which a manually operated key works—30 to 35 words per minute—to other rates as high as 200 words per minute.

There is no definite fixed speed at which the telegrams are put through; it depends entirely on the kind of message and the atmospheric conditions prevailing at the time of transmission. The essential letter accuracy of the message is the most important factor bearing on the speed.

For instance, in certain business communications in code, an error or omission of one letter in the whole message may make a difference of thousands of pounds to the sender or recipient. These messages, therefore, are sent at comparatively slow speeds to ensure absolute accuracy. On the other hand, Press reports, ordinary private messages of greeting and other matters of a similar nature are relatively unimportant as regards extreme accuracy, for a word misspelled or a letter omitted are comparatively immaterial and lead to no misunderstanding. A very high speed may therefore safely be used for this kind of message.

We have now arrived at the point at which telegrams are transferred from their original written or type-written form to a series of electrical impulses, and it is at this stage that the crux of the wonderful Marconi telegraph organisation is reached.

Radio House is linked by special land-lines to wireless stations at Carnarvon, Ongar and Brentwood, of which the first two are trans-

mitting stations and the last are receiving stations.

When the Wheatstone machine at Radio House allows a tiny current to flow, it travels along the wires to Ongar or Carnarvon and by means of relays—devices by which a small current liberates a larger one—the huge transmitting apparatus at those stations is operated. Thus there is no delay, no manual duplication of messages with consequent chances of error; Radio House is merely a remote control of the transmitters which in the case of Carnarvon are nearly 250 miles away, and so great is the speed of electricity that there is an interval only of seconds before a message is received in America. Carnarvon works with New York and Glace Bay, while Ongar transmits to Paris, Berne, Madrid, and Barcelona.

Brentwood Station

The receiving is done in almost exactly the same manner except that it all proceeds from the Brentwood station. Here the wireless impulses, which, by the way, are clarified by no less than seven different rejector circuits in addition to purely directional reception, are allowed to pass on to the land-line to Radio House, where they are caused to operate either a paper perforator or a machine called an undulator.

The tape machine does exactly the same thing as the transmitting perforator except that it is operated by electricity instead of by a key-board. The tape, having been perforated, is put through another machine which prints the message

in ordinary block letters on another tape. The latter is then cut into strips of convenient length and pasted on the telegraph form in the manner with which we are all familiar.

Undulators use a very different system, and their chief use is for checking purposes. They cause a wavy line to be drawn in ink along a moving strip of paper, and according to the shape of the wavy line are the different morse symbols distinguished.

There are now only the urgent telephone room and the final dispatch departments to be seen. The former is down a few stairs immediately to one side of the operating room. This is a private exchange by which certain firms having private wires are connected direct to Radio House. By this means urgent messages are received without loss of time and given immediate priority.

Finally we come to the dispatch department, which is a triumph of the card-index system. Marconi's Wireless Telegraph Co., Ltd., have certain regular customers running into many thousands, and for each customer a number of envelopes are ready waiting in the files with their addresses printed in readiness for a telegram.

The system of indexing is so complete and simple that it takes only a few seconds to find the correct envelope, and the message, once put in, is then delivered by special messenger. Very urgent received messages are telephoned where possible, and a telegraph form sent later to confirm and check it.

R. B. H.

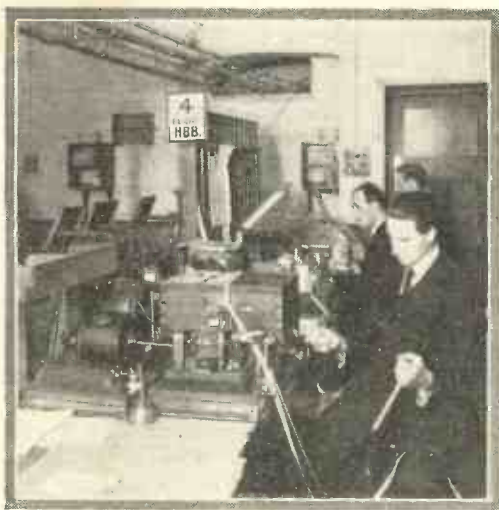

Operating the Berne Circuit at Radio House.

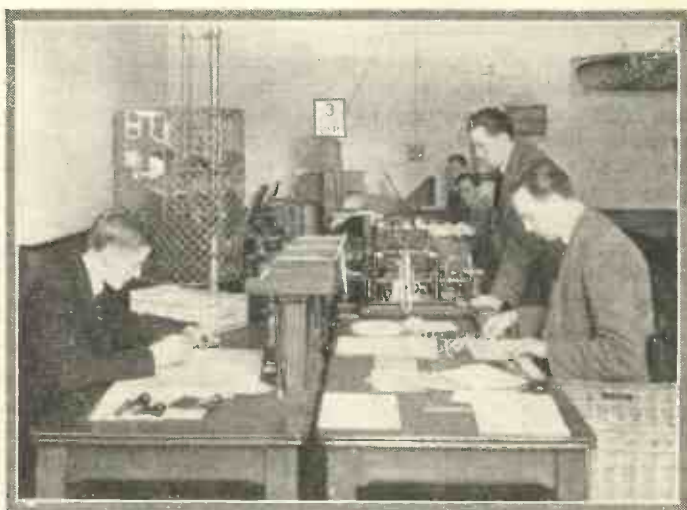

High-speed Transmitters (in background) and Receivers (in foreground).



Wireless for the Motorist

by Richard Twelvetrees

FROM the early days of broadcasting the attention of motorists has been attracted towards wireless as an added pleasure to touring and for roadside entertainment during week-end trips and picnics in the country. Some of the early attempts to install wireless receiving sets in motor-cars were not altogether successful, for it was not generally realised that the conditions obtaining in a moving car are very different from those where stationary sets are used for ordinary purposes.

Limited Accommodation

In the first place we have to remember that a car's accommodation is limited, and to carry a wireless outfit capable of giving loud-speaker results at any appreciable distance from a broadcasting centre means that at least one of the seats has to be left vacant, or else that the other impedimenta connected with touring or picnicking has to be unduly curtailed.

The following description may give an idea of the equipment used in some early experiments: An elaborate multiple aerial mounted on two lattice masts was very prominent, whilst for short-range work a frame aerial mounted behind the driver's seat was used. The

set itself occupied a considerable amount of space in front of the rear passengers, and though satisfactory results were obtained, the installation could hardly be regarded as sufficiently compact for everyday use.

Small-car Tests

The next real attempt to introduce wireless sets as a part of small-car equipment was made by the manufacturers of the B.S.A. car in conjunction with the Marconi Company, and an interesting series of experiments was carried out by using a number of small cars so equipped. Readers will probably remember the reports appearing at the time, and a great deal of interest was aroused by a large motor-car wireless gathering held in Windsor Great Park.

In this case reception was carried out by slinging wires over the branches of trees to serve as aerials, and though the receivers were conveniently mounted on the running boards, it was necessary to disturb the passengers to get at the amplifier unit and the loud-speaker.

But the novelty of motor-car wireless outweighed the disadvantages and people were prepared to submit to the inconvenient arrangement, though at the present time

wireless users possessing motor cars demand more consideration and insist upon compact sets which do not decrease the passenger-carrying capacity of their vehicles.

Realising the future for this kind of equipment, the writer designed and built a very compact reflex set, which was permanently attached to the fascia board of the four-seater car shown in one of the photographs.

The range of this instrument permitted good reception on the loud-speaker at a distance of forty miles from a broadcasting station by using a small frame aerial, the car-lighting batteries being used for the valve filaments.

It may be mentioned that this particular outfit was submitted to a very severe test on the occasion of the Whitsun run organised by the Motor Cycling Club from London to Edinburgh in 1924, and some most interesting results were obtained, including a tour of Newcastle with the loud-speaker in full blast.

Difficulties Experienced

Notwithstanding the efficiency of the set in the hands of a more or less expert operator, it was found that difficulties were experienced when novices tried to handle the instrument. Furthermore, whilst crystal detection was satisfactory

WIRELESS FOR THE MOTORIST (Continued)

up to a point, a certain lack of stability existed, whilst the character of the circuit rendered the set liable to undue oscillation.

Music—Not Experiments

One of the things to be remembered in connection with wireless sets for motor-car use is that the receiver has to be regarded more as a musical instrument than an experimental appliance, and the attentions of the "knob-twiddling" fanatic are anything but welcome in a picnic party.

At the same time the use of a set on the car enables one to collect a considerable amount of valuable data concerning such points as blind spots and the effect of fading under certain conditions.

For example, when passing along a road bordered by telegraph wires, the screening effect is very remarkable, whilst the reception is practically cut off when passing under bridges. The influence of road contours on the volume given out by the set is extremely interesting, for the hills appear to shoot off the waves, very much in the same way as air currents are deflected by the wind screens of fast-moving cars.

With the object of testing reception at high motor speeds, the writer also carried out some experiments with a very fast racing car at Brooklands. The car was the Alvis racer which won the Two Hundred Miles Race of 1923, and the set used was a Marconi portable seven-valve receiver. A small frame aerial was fitted in the lid of the case and, when travelling round the track in the region of eighty miles an hour, it was possible to pick up 2 L O on those sections where the direction was right.

Fading

As the limitations of space in the racing body prevented the set being moved to correct the direction, the reception faded away at parts of the course; but the test was nevertheless interesting as it proved that the transmission could be picked up at high speeds and was, moreover, audible above the noise of the engine.

To avoid any interference with the operation of the set it is advisable



Working a Loud-speaker with a Three-valve Reflex Set

to screen the magneto of the car. This can be done in several ways, but possibly the simplest method is that of covering the whole magneto with copper gauze so that any stray charges are allowed to pass direct to earth.

Screening High-tension Wires

The high-tension wires should also be screened; for this purpose it is possible to purchase special high-tension cable covered with a metal sheathing, and this should be used in conjunction with special

sparkling plugs with shrouded terminals, such as are used for wireless-equipped aeroplane engines.

This latter method has been adopted on the wireless-equipped tenders belonging to the famous Flying Squad of Scotland Yard.

Many owners of small cars, whilst anxious to avail themselves of the pleasures of out-door wireless reception, fear that the cost of the outfit may be prohibitive, but as a matter of fact the entire apparatus can be installed at a very moderate cost if one goes the right way to work.

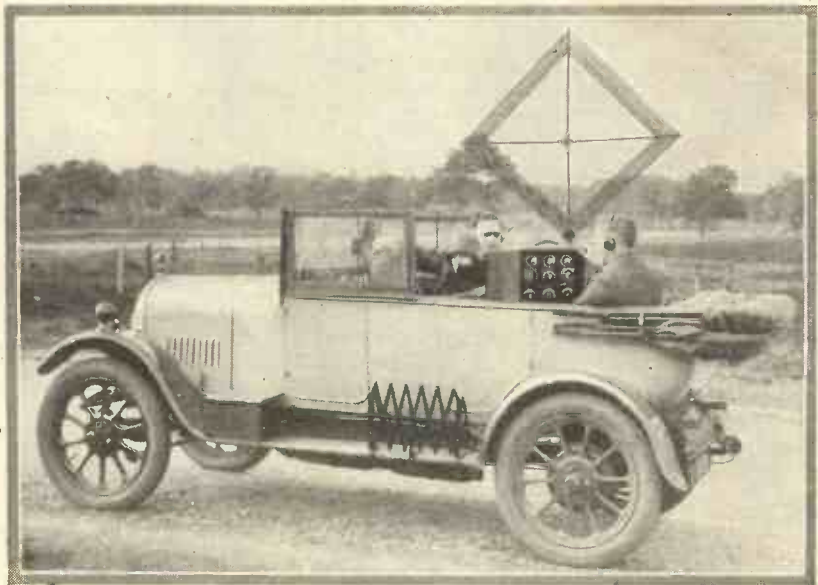

Car Equipped with Radiola Receiver.

The Polar Twin set, a perfectly standard production of the Radio Communication Co., Ltd., can be used on the small family type of car with extremely good results, and the installation shown in one of the accompanying photographs depicts one of the Rover Nines fitted out with a set of this description.

As is well known, the set has two valves and occupies an extremely small space, due largely to the nature of the components used in the construction. For this outfit a Eureka folding aerial was used and an Amplion Dragon-fly loud-speaker served to give a sufficient range for outdoor reception.

Reasonable Volume

As a matter of fact, too much volume from a loud-speaker is a

three-valve receiver and the other a two-valve amplifier combined without a loud-speaker.

At Windermere, a distance of 260 miles from London, most of the British stations were tuned-in with great ease by using a small collapsible frame aerial, and, thanks to the selectivity of the receiver, it was possible to switch over from one station to another, whilst the loud-speaker was in action, without the use of the headphones.

Attracting Attention

Up to a distance of forty miles from London the set was used whilst the car was in motion without the aerial, the strains from the loud-speaker attracting considerable attention from passing motorists. For the convenience of carrying this apparatus the car was provided



Small Car Equipped with Polar Twin Receiver.

disadvantage rather than otherwise where small picnic parties are concerned, for one's privacy is liable to be disturbed by curious spectators.

One of the best of the portable sets on the market seems to be the Radiola set manufactured by the British Thomson-Houston Company. The writer recently had the opportunity of testing this outfit under somewhat severe motoring conditions during a reliability trial which, including the return journey, amounted to a distance of one thousand miles.

This instrument comprises two portable cases, one containing a

with two expanding luggage grids, one on each foot-board. The cases were protected from the weather by waterproof covers.

To give an idea of the general convenience of this apparatus it may be mentioned that both the cases and the frame aerial could be unpacked and the set tuned-in within a space of three minutes, the tuning process being greatly simplified by the aid of a small tablet fixed to the inside of the receiver, showing the various wavelengths of the stations and the corresponding settings of the control knobs.

A School for Wireless Salesmen!

THE school for wireless salesmen has come at last, and in America of all places. You would never have thought that the Americans would have been first in such an enterprise, now would you?

Here is the news item in all its original glory. A big American wireless company has come to the conclusion that its counter staff must know more about the wireless sets and component parts handled than the mere price. Accordingly that counter staff is going to be put through a regular slap-up, intensive training dealing with the principles under-lying wireless. At the same time, that staff is going to be educated in the art and practice of selling talks and talking sales.

The Chemist

Well! Perhaps a school for wireless salesmen is a good notion in some ways, but I am not so sure that it appeals to me altogether. One of our most knowledgeable salesmen of to-day is the pharmaceutical chemist. Yet how often does that chemist use his knowledge to work off on us "not quite the same thing but something just as good" as the thing we ask him for. I expect you have had *your* little experiences with this gentleman. You know the kind of thing I mean. You go into his shop and whisperingly ask for a tin of Keating's Powder.

"A New Type of Thing"

"I am sorry," says the chemist quite loudly and without shame, "but I am out of Keating's Powder at the moment. However, I have plenty of a new type of thing, flea dynamite, just as good, you know, if not better. Some people prefer it."

Too much knowledge of wireless on the part of the wireless salesman might lead to a lot of this substitution kind of thing.

Can you imagine anything more annoying in wireless than to find oneself going home with a valve, an accumulator and a dry battery when one has set out merely to buy a piece of hertzite?

AERIAL.

Get a Loud-speaker!

Go and buy a loud-speaker! What terrors that may inspire. Many a would-be experimenter, constructor or broadcastee (a good word that?) has had his enthusiasm damped by hearing the weird yelps, whines, moans and groans emanating from some terrible contraption in the hands of the noise hog.

Brown, 30 miles from 2 I. O., receives that station on the loud-speaker with one valve and a G. J. K. 47532 circuit. He says you can hear it 400 yards away. You, perhaps, are sceptical (no wonder!), but you succumb to an invitation to come and

see or hear for yourself. The noise demon warmly welcomes you and gets you into the torture chamber.

The contraption is set going and a perfect torrent of noise belches forth from the loud-speaker. You note I said noise—not music or speech. You listen, stricken dumb by the awful agony which the noise conveys. You twist and turn in your seat wondering what on earth is the matter, and Brown, his face wreathed in smiles of contentment, takes your silence for an admission of his claims. A perfect pandemonium fills the air.

It gradually dawns upon you that the set is behaving in its normal manner and you are listening to his wonderful reception. In the end

you begin to feel a twitching of the hand, a stabbing in the ear—subconsciously you wonder what part of Brown you can hit with the most telling result, and whether, if you attempt to demolish the valve, he is strong enough to prevent you.

Now let me whisper (or write) a few words of comfort and good cheer to you. A good loud-speaker will work as sweetly as telephones on a crystal set if you treat it kindly and feed it well.

By the former statement I mean do not overload it: and, by the latter, use a straight circuit for reception.

It's no use expecting the loud-speaker to amplify and pour forth liquid sparkling music or crisp clear speech if the works which come before it distort and mutilate the signals, and correspondingly, if it is an ordinary electromagnetic loud-speaker of medium size, it is of no use expecting the poor diaphragm to respond with light and nimble vibrations to signals which are arriving with the punch of a Georges Carpentier.

I have sat and listened to loud-speaker music for hours and tested upward of six different varieties, and find almost all of them give excellent quality of music, some giving greater volume than others according to their type and construction.

Do not be afraid of the loud-speaker. He will not torture you if you don't torture him. A. J. C.

TRANSMISSION AND RECEPTION!



ABERDEEN has been broadcasting lectures designed to stimulate the civic spirit. The other sort of spirit, of course, is already popular enough.

With the Welsh Guards' Band figuring in the programmes, listeners should be specially watchful for "leeks."

A HULL listener says that the B.B.C. broadcasting service is second to none in the world. So that, if we meet any grumblers now, we shall have to tell them very politely to go to Hull.

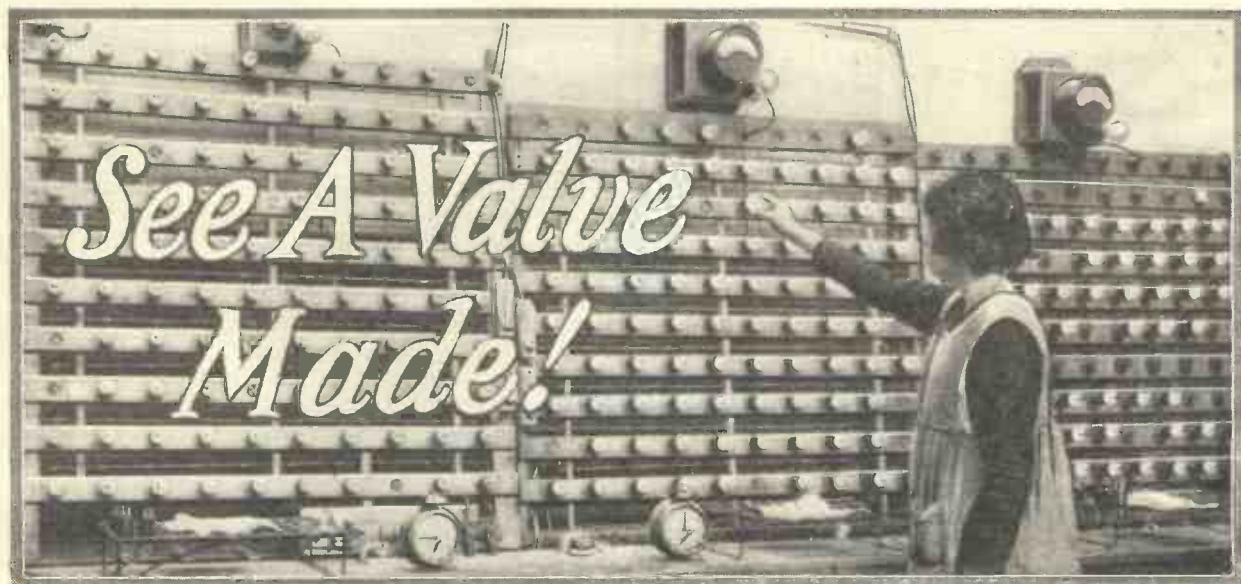

A few weeks ago we accepted an invitation to visit the Cossor Works, and we now show you in word and picture the making of a highly-efficient modern valve.

IT is over forty years ago that Edison first observed the curious phenomenon in connection with the ordinary incandescent electric lamp that makes the thermionic valve possible. There is much in common between the domestic electric lamp and the valve, though perhaps not so much as we generally assume; the former is for the avowed purpose of producing light, while the production of light in the latter is an undesired effect which present-day investigation is striving to avoid.

With present-day methods of manufacture the production of an incandescent lamp is a fairly simple

matter, but with the valve the glowing filament is but one factor in the means to an end; there are others which are equally important and which, moreover, if the valve is to be efficient, must bear a distinct relation to each other.

"Comparisons are Odious"

As so much has to be taken into account in the manufacture of valves, the comparison with the electric lamp, therefore, from the point of view of manufacturing difficulties, and also cost, is most unfair to the former.

In all there are some fifty processes in the manufacture of a

valve, and as much of the initial work takes place concurrently, the valve cannot be said to "take shape" until the results of many of these processes are assembled.

The accompanying photographs, taken at the works of A. C. Cossor, Ltd., give a good general idea of some of the various stages in the making of a Cossor valve, and a study of them will reveal the fact that not until the valve is ready for test can it be said to have much resemblance to the finished article.

Four distinct classes of work enter into the making of a valve. First there are the mechanical pro-



The blank for the anodes are first stamped out and then pressed to shape.



The stems are spot-welded to the electrodes.



A blow-pipe flame is used for joining the wires.



The electrode supports are all carefully gauged.

cesses involved in the production of the electrodes; secondly there is the glass-blowing necessary for the bulb and pinch; thirdly there is the assembling of these parts, and fourthly the exhaustion of the bulb followed by capping and packing. Gauging and testing follow practically every operation.

Electrodes and Supports

One of the initial processes of manufacture is that of making the electrodes and supports. In the first place the unit pieces of these are punched and formed by powerful presses and then the supports with lead wires attached are assembled by being pinched in the glass which later forms the base of the valve.

This pinch is made from a short length of glass tubing and is spun, when softened by gas flames, to the required shape.

The next process is the mounting of the filament, grid and plate. Each of these is attached by electrical spot-welding to its support, part of the welding being done in an atmosphere of hydrogen as shown in one of the photographs.

To those who are not



The electrode supports are cut the correct lengths.

conversant with spot-welding it may be said that it is a means of fusing two metals together at the point of contact by the passage of an electric current. No metal is added as in soldering, and the joint, therefore, is neat and the two parts are homogeneous.

Making the Grid

The grid, of course, has been made previously by winding the wire in loop form over the grid base and strengthening it by an interlacing wire. The construction of the grid calls for some deft work on the part of the operator, for upon the proper spacing of the wires largely depend the characteristics of the valve when completed.

The pinch with its filament, grid, plate and lead wires is now ready for insertion in the bulb, which at this stage resembles the thistle funnel as used in laboratories, the wide open end being the same size as the base of the pinch. The latter is inserted in the funnel and the two are fused together in the centre of a ring of blow-pipe flames.

At this stage in production in place of the pip



An ingenious machine makes the glass pinch automatically.

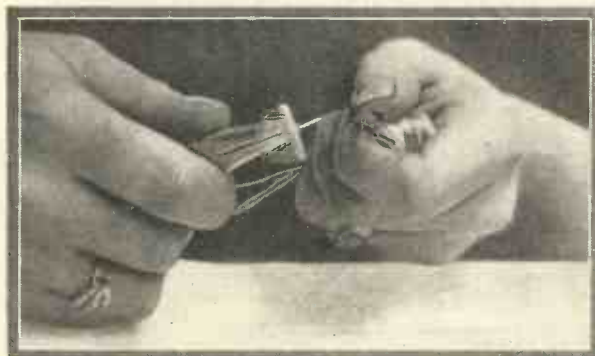

The grid is made by hand.



Grids and plates are assembled by hand.

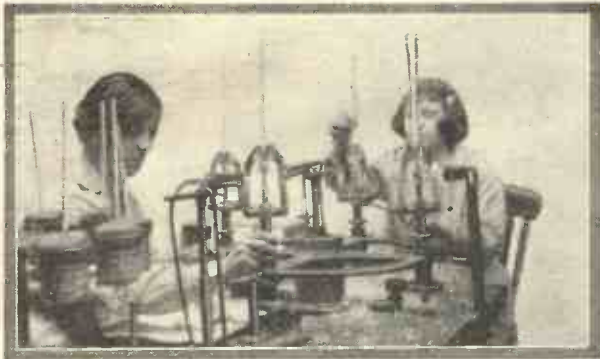

The operation of sealing the pinch in the bulb is automatic.

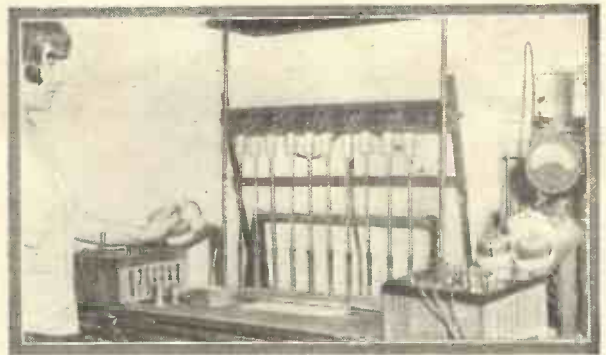

During exhaustion the amount of "blue glow" shows the state of the vacuum.

at the top of the valve there is a glass tube some ten inches long for attachment to the vacuum pump during the exhaustion process.

pumps, and the second, which is termed "gettering," in which any residual gas that may have been occluded in the glass or metal parts is freed so that it may be removed.

and the leads soldered to the legs with a gas-heated soldering bit.

Then there follows what may be called a seasoning process, during

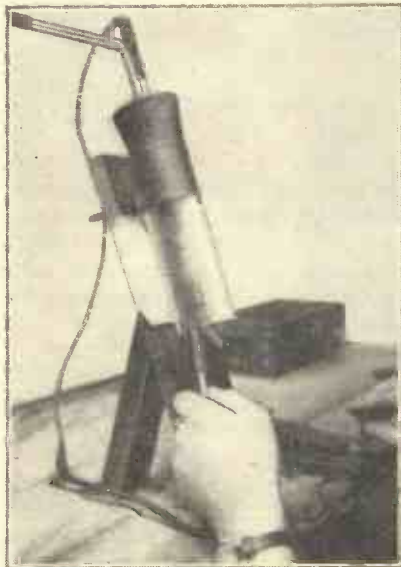

Some of the welding is carried out in an atmosphere of hydrogen.

Pumping

As the pumping proceeds the bulbs in batches of about a dozen are heated and at the same time the anodes and grids are maintained at a high potential whilst a current is passed through the filament.

The effect of this is to make both grid and anode very hot by electronic bombardment and occluded gases are driven out of the metals.

The condition of the vacuum as the pumping proceeds is revealed by the "blue glow" in the bulb, which as any air or gas becomes more and more scarce is observed to disappear. A blow-pipe flame is then applied just below the bulb and the pressure of the atmosphere causes the tube to collapse at this point and the valve is sealed off, leaving the familiar pip.



The lead wires are soldered to the legs by means of a gas-heated bit.

The exhaustion of the bulb is probably the most interesting of all the processes of manufacture to the observer. There are two stages in this, the first, in which the air is removed by mechanical

Although this last process completes the essentials of the valve it by no means completes the manufacture of the commercial article. The bulb has to be capped

which the valves are burnt at normal brilliancy for some hours. Afterwards come delicate tests for emission, current consumption and voltage, each individual valve being given a separate test.

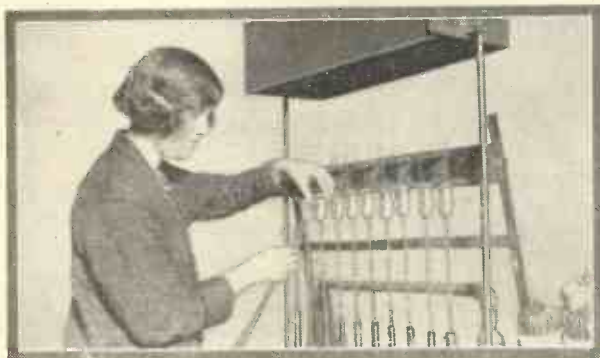

When the "blue glow" has disappeared the valves are sealed off.



A final test of all the characteristics is made.

A Wireless Poetaster

Poetaster: A Petty Poet.
(Any Dictionary)

IN spite of all I've said about wireless sets, some people simply will have them. Just like the mumps. I told a child they were bad for him, but he had them all the same. Mind you, I listen-in a bit myself, but then I know what I'm doing, which makes all the difference.

After night has hung her sable curtain up, and pinned it with two stars, one at each corner, I wrap myself up on the inside of a pair of phones, talk nicely to the accumulator, then it goes something like this:—

Not a howl was heard, not a single note,
As from wavelength to wavelength we hurried
(An amateur here would get flustered and hot,
But we remained calm and unflurried).
We listened-in darkly at dead of night,
With tapered fingers turning
A.T.I., A.T.C., filament knob,
And the D.E.'s dimly burning.

Now then, it's getting exciting!
Couple up a little closer, and we'll go on!
Now then, we play the confounded thing like a piano, for about half an hour, and then start thinking.

And we thought, as we swung each condenser in vain,
That perhaps there was no one transmitting:
But we knew we should get them, with howls in their train,
P.M.G., D.V., weather permitting.

That is, providing that it would work so as you'd notice it, and that we were lucky. Then we started to look for the trouble. You never find some of this world's troubles unless you look for them. Wireless faults are an example.

We had a look round, and the trouble we found,
Just a slight slip, we'd never suspected:
The H.T. was "shorted," the aerial "ground,"
And the last L.F. quite disconnected.

Listening-in on my set, supposing you go on until you hear something, is jolly good preparation for solitary confinement.

Just to add another little vice, while I am waiting for something to happen in the phones, I solve swear-word puzzles. If I won a prize I might be able to buy a glass hammer for putting the D.E.'s out

with, and so save by not having to use a switch to cut the L.T. out.

As nobody seems to have written about cross-word puzzles yet, let me give you an idea, then some papers will publish little morceaux on the subject.

But the consul's brow is sad and the consul's speech is low,
The word has thirteen letters, and, of course, it will not go.
"The closing date is on us!" in blank despair he cries,
"And if it is not in in time, what hope to win the prize?"

This has got nothing to do with wireless really. I just dragged it in to show you, once and for all, that I'm clever at it. See?

Now let's come back to our wireless sets again. A lot depends on the circuit. We used to use straight circuits, but since

The Armstrong reflex has come out of the West,
And is louder, more sensitive, doubtless the best,
We do some funny things with tinned 18's.
Why not have the latest?
On a superonic heterodyne,
One hears the items nicely:
Such as "Daddy, don't go down the mine"
Plus an obbligato, twicely.
On three valves one can get the Yanks,
Or a song by a Thibetan fakir
(We can also get Irish, and sometimes get Scotch,
While their nearest place is Jamaica).

Why can't we have the programmes we want? Let's send 2 L O a "round robin!"

Yes! we want no sopranos,
We want no sopranos to-day:
We get London and locals,
With tripe from the yokels,
And women's half hours—but say!
We want the Orpheans all the week-end
Oh!

Plus beaucoup jazzy crescendo,
And we don't want to hear your soprano,
We want no sopranos to-day.

Mind you, they've got their redeeming features, same as a pawnbroker, 'cos they will work the loud-speaker when nothing else will.

As far as that goes, of course, nobody may want to hear this, so I'll stop, but, knowing more about wireless than a moth does about

skirts, perhaps a few hints will be acceptable to the public.

Don't leave your best valves on the floor,
Unless you can afford lots more;
Don't bend the whisker till it scratches,
Inside the valve set don't throw matches:
Don't shout or sing in your elation,
When first you get a distant station:
Work in your attic like a hermit,
And never, never buy a permit.

Of course, you might get caught at it, and then

The day will be filled with sadness,
And you'll get horrid dreams all the night:
'Cos you'll have to stump-up many shekels,
Or be put safe in jail, out of sight.

Good night, everybody—Good night!
FISH GLUE.

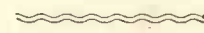

Wanted—A Patron Saint!

ACCORDING to a Paris journal, French wireless amateurs are searching for a patron saint.

Many well-known names have been placed on the list of candidates, and amongst others is mentioned St. Anthony of Padua, whose voice, whilst he was preaching on a country road, was clearly heard in the little village church of St. Pierre des Quatre Chemins. St. Philomene was suggested by some readers, as eligible for the honour, as the name could be read "Sans Fil—amen," but seriously-minded judges have set their face against such unseemly levity.

Joan of Arc, Maid of Orleans, according to the same journal, holds very strong claims for the post of "Radio Saint," as she distinctly heard voices, and can therefore be termed an "enthusiastic listener."

But why go to all the trouble of a prolonged search? Why not St. Radio?
JAY COOTE.



A RECENT lecture on green salads was all right, but the speaker did not explain how the cigars were manufactured from the lettuce that were left over.

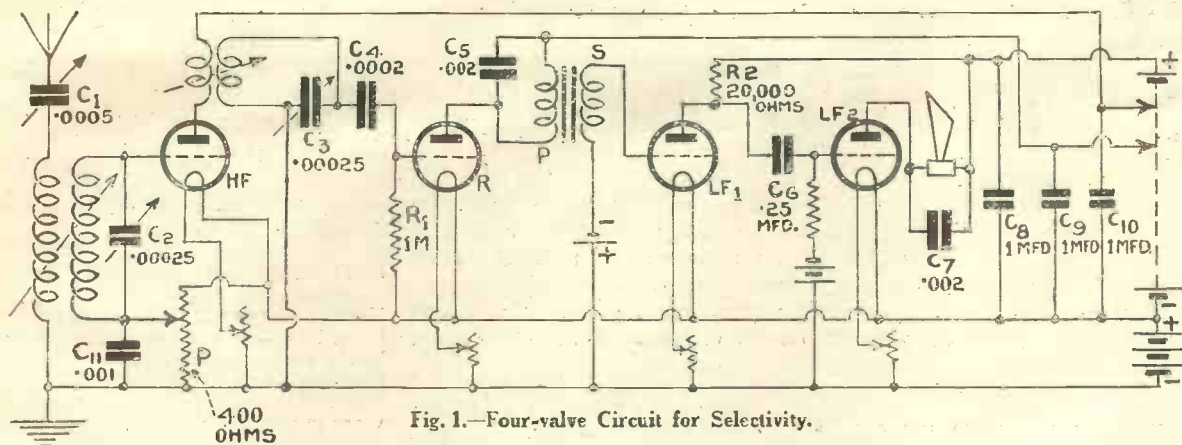

Fig. 1.—Four-valve Circuit for Selectivity.

My Favourite Circuit

1—RANGE AND SELECTIVITY

By J. Hartley Reynolds

BOTH for long-distance work and for selectivity on the medium wavelengths, my favourite circuit is that shown in Fig. 1.

The circuit shown in the diagram consists, as will be seen, of a high-frequency valve, a rectifier and two note magnifiers. The tuner is of the double-circuit pattern, Gambrell or Lissen inductances being generally employed here. An anti-capacity switch (not shown in the diagram) enables the A.T.C. to be used either in series or in parallel. The series position is generally preferred, though if the condenser is placed in parallel with a smaller A.T.I. there is not the

reduction in signal strength that theoretical considerations would lead one to expect.

The A.T.C. and the C.C.C. have a very small maximum capacity. This is, I think, essential for selectivity. Both of these condensers, as well as C3 which tunes the secondary of the H.F. transformer, are of the square-law type. Those actually used are made by Messrs. Bowyer-Lowe. A 400-ohm potentiometer is used not so much for stabilising the set as for bringing the high-frequency valve to its correct working point. The coupling between the first and second valves consists of a pair of well-designed inductances mounted on a two-coil holder.

It will be seen that three high-tension plus connections are pro-

vided. This is quite necessary if the best results are to be obtained, for it is essential that the valve should be worked at the point in its characteristic curve appropriate to the duty that it has to do. The voltage supplied by the low-frequency H.T. busbar is 100, but as the resistance R2 has a value of 20,000 ohms, the actual voltage on the plate of the second note magnifier is in the neighbourhood of 50.

It will be noticed that a condenser is placed between each high-tension busbar and H.T. This arrangement makes for stability as well as for quiet working, for each portion of the high-tension battery is thus properly shunted. The only other point to note is that the secondary circuit is earthed, which again increases the stability of the set.

Long-distance Work

Most of my long distance work is done on the very short waves between 50 and 150 metres, and for this work my preference is for the circuit shown in Fig. 2. This again is a perfectly straight layout, the only departure from the standard procedure being that the aerial is untuned. The A.T.I. consists of five turns of No. 20 d.c.c. wire, with spacing between turns, wound on a cylindrical former and fixed to an ordinary plug and socket mounting. Both the C.C.I. and reaction coil are Gambrell A2 inductances, and the three are mounted in a three-

(Continued on page 74)

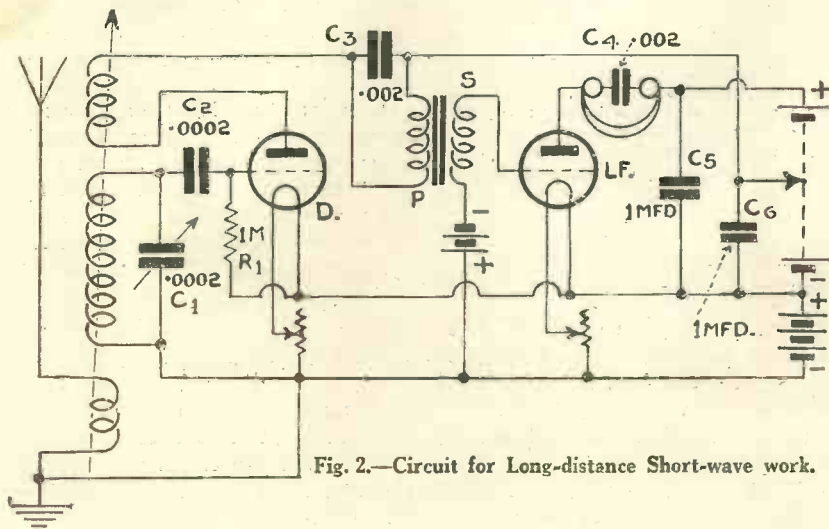

Fig. 2.—Circuit for Long-distance Short-wave work.

LISSENIUM

TONE and tone control



Loud speaker tone can be raised or lowered by the use of Lissen Fixed Condensers of different capacities, connected across the loud speaker terminals. Volume can be controlled and an improvement in purity obtained by fitting a Lissen Variable Grid Leak across the secondary of the last transformer or across the loud speaker terminals. A Filter Circuit, to prevent the H.T. passing through the loud speaker windings and to improve the tonal quality, can be made with a Lissen L.F. Choke and fixed condenser.

Such devices control and improve tone—they do not make tone—that rests with the ability of the receiver to faithfully reproduce the music received.

Some L.F. transformers are very apt to cause distortion, many being designed simply to give amplification without consideration of purity. Lissen Transformers are designed with purity as the first consideration.

The right way to obtain pure low frequency amplification is to use a coupling at each stage which has been designed to meet the technical requirements of the position. The importance of the first stage cannot be over-estimated, for any distortion here is magnified with each succeeding stage.

The Lissen T.1 Transformer is particularly recommended for the first stage, for which position it has been specially designed, and distortionless amplification is obtained by means of the exceptional coil used and skilful design throughout.

For second and third stages such an expensive coil is not so necessary and the Lissen T.2 or T.3 Transformers give powerful amplification of outstanding purity. For reflex circuits, too, they prove particularly suitable and the Lissen T.3 Transformer, on account of its small size and skilful design, is excellent for portable sets.

The Lissen L.F. Choke has become very popular and gives amplification of a purity comparable with the best resistance capacity coupling.



T.1 TRANSFORMER.

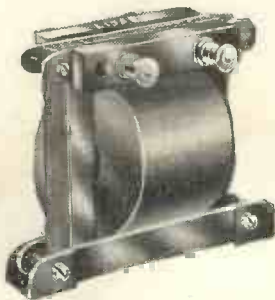

T.2 TRANSFORMER.

LISSEN T.1 Transformer	30/-
" T.2 "	25/-
" T.3 "	16/6
" L.F. Choke	10/-

Send for Text Book of LISSEN Parts—free to readers of this magazine.

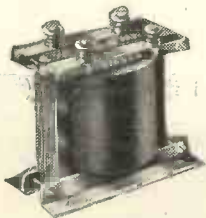

T.3 TRANSFORMER.

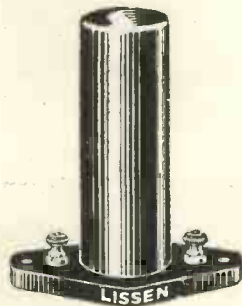

L.F. CHOKE.

LISSEN LIMITED

LISSENIUM WORKS,

500-520, Friars Lane, Richmond,
Surrey.

'Phone: Richmond 2285 (4 lines).
'Grams: "LISSENIUM," London.

BUILT WITH ALL LISSEN PARTS, YOUR RECEIVER WILL GIVE RESULTS WHICH WOULD NEVER BE POSSIBLE WITH MIXED PARTS.

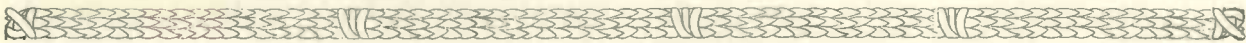

In writing to advertisers, please say you saw the advertisement in THE WIRELESS MAGAZINE.

MY FAVOURITE CIRCUIT

(Continued from page 72)

coil stand, the fixed inductance being the secondary.

It is most important to supply two high-tension tappings in this circuit, the voltage required by the rectifier being only about 30, whilst the low-frequency valve works best with 100 volts on its plate. The secondary condenser, which must be of small maximum and minimum capacity is the only variable one in the set. With this circuit K D K A and other short-wave stations can be heard on practically any night, and when conditions are favourable the addition of a two-valve note-magnifying unit with resistance-capacity coupling for both valves is generally sufficient to bring him up to good loud-speaker strength. Frequently one of the note magnifiers can be dispensed with.

2—FOR TELEPHONY

By B. A. R.

FOR receiving the broadcast programmes and Continental telephony I use a straight three-valve circuit as shown. The set has a good

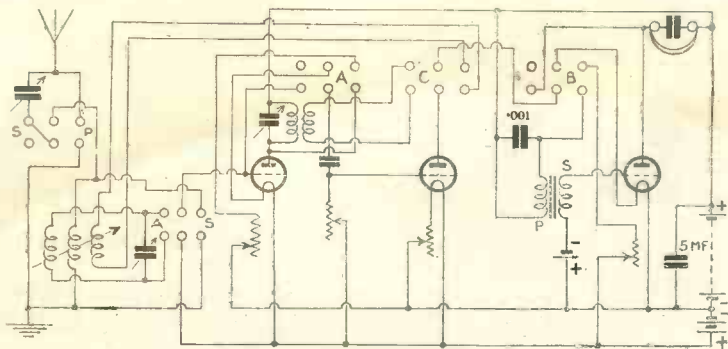

All-round Three-valve Circuit with Switching.

all-round efficiency and is quite suitable for family use with the loud-speaker, but cannot by any means be ranked as a "super" receiver. The main features of interest are:—Series-parallel, and open-aerial or closed-secondary switches; additional switches A and B for cutting out either the high-frequency or low-frequency stage as desired; a switch C for coupling the reaction coil in the plate circuit of the detector valve with either the aerial

or tuned-anode inductances at will; separate rheostat control for each valve; a biasing battery in the low-frequency grid circuit; variable grid leak; and vernier control on each of the tuning condensers.

Loud-speaker with One Valve

With fairly heavy reaction on the aerial and careful tuning, sufficiently strong reception can be secured from 2 L O (12 miles away) to give clearly audible loud-speaker strength on the detector valve alone. Using less reaction, the detector and low-frequency combined will amply fill a room fourteen feet square.

With the high-frequency stage in circuit, audible loud-speaker reception has been obtained from every home B.B.C. station except Belfast. Also from Radio-Paris, Le Petit Parisien, Brussels, Königswusterhausen, Vox Haus, Hamburg, Frankfurt and Madrid.

With a Frame Aerial

On a frame aerial of three-foot sides 2 L O comes in clearly on the phones, using high-frequency and detector. Reaction is direct on to the frame windings. All three stages give clear phone reception from Bourne-mouth and Cardiff.

All the stations mentioned above have been received on the phones with 2 L O in operation, using a standard P.O. aerial. The adjust-

to self-oscillation, but with careful handling will give a high degree of selectivity. Another plan is to leave the aerial-secondary switch in the "aerial" position and to utilize the secondary coil and condenser as an absorption circuit, which is closely coupled to the aerial inductance and then tuned until 2 L O disappears.

POLISHING EBONITE

MOST ebonite as sold has a high polish which must be removed before it can be used; this results in a matt surface which does not compare in finish to the original polish. Some special panels have a non-metallic polish that need not be removed at all.

To get a fine polish, all that is required are a few pieces of fine carborundum cloth, a piece of bath brick and a little finely-crushed whitening or plate powder.

After the panel is ready for fitting, go carefully over the whole of it with a piece of the carborundum cloth wrapped around a flat piece of wood, going in one direction only and moistening the panel with water frequently.

When a fine surface results and all the original polish has been removed, powder the brick into a saucer of water. Then, with the panel well wetted, go over it again with a cloth pad dipped in the brick paste.

Removing Scratches

Do not let the panel get dry or the cloth will drag, especially at the holes if these are already drilled. When all the carborundum-cloth scratches have been removed (do not scamp this operation), the panel is ready for polishing with the whitening or plate powder.

Obtain a soft cloth and dip it in the powder, previously made into a cream with water, and go over the panel again until satisfied with the depth of the polish. Wash off and dry with a soft duster. The ebonite is then ready for polishing with a good liquid metal polish (not paste or oil). Finally wash off all traces of metal polish with soap and water.

This polish will last for years, will not turn the panel green, and has the appearance of french polish. The above method is equally suitable for articles turned in the lathe.

W. K.

Brandes

The name to know in Radio



All Brandes products carry our official money-back guarantee, enabling you to return them within 10 days if dissatisfied. This really constitutes a free trial. Brit. Manuf. (B.B.C. Stamp)

BRANDES LIMITED
296 Regent St., London, W.1
Works: - - Slough, Bucks.

-for Young Bill

The fever of the experimenter has fired young Bill's ambition. In the picturesque vernacular of our American friends he's "cottoned on to the hull bunch"—vacuum tubes, hook-ups, new wave bands, right down to the last binding post. He tunes in the distant stations now with his *Matched Tone Headphones*, and is content. They bring in the faintest signals, their delicate supersensitivity making them unexcelled for long range telephony.

And the *Table-Talker* is just fine. To his credit, Bill refuses to acknowledge the family's praise. "It's not me tinkering about," he says, "the *Table-Talker* always came through as if you were actually in the studio, and with no scratchy notes." Ask your Dealer for Brandes.

Table-Talker
42'

Matched Tone Headphones
20'

In writing to advertisers, please say you saw the advertisement in THE WIRELESS MAGAZINE.



Wireless Femininities

TO some listeners it must be a source of disappointment that so few country hotels offer wireless to their patrons. I am excepting, of course, those magnificent establishments scattered here and there where every possible enjoyment may be found at a magnificent price. But in the average country hostelry, comfortable but not luxurious, facilities for listening-in are as conspicuous by their absence as if they cost a fortune.

Those Dull Evenings

Actually these are the very places where wireless would be welcomed, especially in the later part of the summer when the evenings begin to draw in; for it is just in country places, which have none of the pier concerts and other gaieties of Brighton and Bournemouth, that visitors all agree in finding the hours after dinner exceedingly dull.

The grand hotel has its dancing floor and its orchestra to beguile the evenings; London and other large centres offer theatres, concerts, and music-halls; but rural districts and small market towns boast at most a single cinema—often open on only certain nights of the week.

I spent a short holiday recently at such an inconspicuous place in Hampshire, where there are two good country hotels. A glorious place by day, with its yachting, steamer trips and excursions to the New Forest; but after dinner—how dull!

The drawing-room was small, and its seats of that peculiar hardness only found in country hotels; the visitors were not of the type to whom the one picture palace appealed. Mostly we used to wander forlornly about the town till the last streak of daylight had gone and then crowd

into the unappealing drawing-room till the chiming of ten o'clock announced that we could decently go to bed.

How listening-in would have brightened those evenings! But though aërials swung between the chimney pots of many private houses in the place, apparently the hotel had never heard of wireless. Other experiences suggest to me that the same is true of the bulk of such hostelries everywhere.

Certainly I do know of one West of England hotel where listening-in flourishes; but it is reserved for the kitchen staff!

A Remedy Against Boredom

Now it is easily understandable that the modest country hotel cannot afford to lay down a dance floor or engage an orchestra; but wireless, which gives the greatest amount of pleasure at a minimum cost, would provide nightly concerts and make impromptu dancing possible on certain evenings a week.

If the drawing-room must be reserved for those who prefer boredom, then surely one of the numerous private sitting-rooms, which never seem to be all engaged at once, might be devoted to listening-in.

A Feminine Wireless Tip

A month or two ago I lamented over the little difficulty so many women listeners-in experience—that of the screws or other parts of the headphones catching in and pulling the hair. Since then I've been experimenting, and, ladies all, here's a tip worth trying.

Fasten a tennis bandeau firmly round your head before slipping on the phones. This will give a smooth surface in which the phones can't catch and also protect the hair underneath. And the wave that counts for so much to a shingled head won't get dragged out by the adjusting and removing of the phones.

Not being officially connected with education in any way, I cannot claim

to speak with any authority when I wonder how much benefit all these scholastic transmissions are to the children who hear them. Are they really a step forward or are they simply an educational craze which will pass away as others have done?

I don't doubt that the children find them a welcome respite from ordinary lessons, but this is hardly a test of their usefulness. Both from broadcasting myself and from much listening-in I am convinced there is a definite loss of personality—and hence of "tellingness"—which broadcasting makes inevitable, and from past experience of teaching children I imagine this is even more felt by them than by older folk, and that therefore attention would wander more from the subject.

Great Interest

Naturally a child will listen under any conditions to a subject in which he is *overwhelmingly* interested; but the talks transmitted to schools are so varied, and usually so "les-sony" in character, that there must be few occasions on which any given child is vitally interested.

It is, of course, true that by means of wireless, school children can hear authorities who are not available to give them ordinary lessons; but it seems to me an open question whether a big name and vast learning carry any weight with a youngster.

The essential power to *interest* may be possessed by a teacher whose knowledge of her subject is small, and may be lacking in an erudite professor. In fact, it is well known in the newspaper world that the most learned are frequently the dullest, because they are unable to approach their subject from the point of view of the ignorant.

In any case I imagine that lecturing to children is like writing for children—a gift in itself, which is not often bestowed on the most brilliant of grown-up writers.

A. M. M.

The Great "HOW-TO-DO-IT" Weekly

A paper devoted entirely to helping all who like to turn their hands to some useful domestic job or interesting practical hobby.



☐ MONEY-MAKING

It helps you to make profitable use of your spare time.

☐ MONEY-SAVING

It gives reliable help with in-and-out-door repairs and construction.

☐ PRACTICAL

It is written and illustrated throughout by people who know the amateur's difficulties and needs.

☐ INTERESTING

Its well-illustrated articles are always fresh, original and varied in scope.

Special Offer

A free copy of the current issue of "The Amateur Mechanic" will be sent post free to any reader who sends a postcard to the Editor, "Amateur Mechanic," 30 La Belle Sauvage, London, E.C.4.

"The Amateur Mechanic" makes all the difference to you between failure and the supreme satisfaction that comes from "something attempted, something done." It is edited by Bernard E. Jones, editor of "The Wireless Magazine," Cassell's "Work" Handbooks, "Amateur Wireless," and other famous technical publications; and the contributors to it—each an expert in his own department—not only know the Amateur's difficulties, but know exactly how to direct the Handyman to achieve his purpose. The articles are simple, practical, clear and illuminating.

For 3d. a week "The Amateur Mechanic" will save you pounds a year

3^D

Every Thursday



In writing to advertisers, please say you saw the advertisement in THE WIRELESS MAGAZINE.

THERE is no question about it: broadcasting is very much an art. And, as is the case of art in any form, he alone is the successful artist who has sufficient imagination to ignore adverse conditions when they exist. That they do exist where a microphone is concerned no one who has ever done much broadcasting will be likely to doubt.

Now, although it does not do to think too much about it when actually broadcasting, the speaker must not forget that the microphone is in no way under his own control, and therefore it follows that no question of technique on his part can arise. The control lies in the keeping of someone else. And, moreover, the sooner he realises that no machine (however delicate or however powerful) can be expected to assume the human touch and feeling *unless he himself operate it*, the sooner is he going to overcome the first great difficulty of broadcasting.

Making Friends with the "Mike"

A microphone is not like a car. Anyone who drives a car knows that the controls (by reason of their being under his own immediate operation) soon begin to develop a personality of their own, with the happy result that a kind of friendship between car and driver soon springs up. But let no one ever imagine for a moment that he is going to make friends with a microphone.

If he took his meals with one every day for ten years he would not get on familiar terms with it.

A microphone is as cold as death itself, and the speaker cannot tell in the slightest degree what his voice sounds like through it. Nor, indeed, has he the least idea as to whether or not what he is saying is being broadcast at all.

And so it comes about that the first principle of the art of broad-

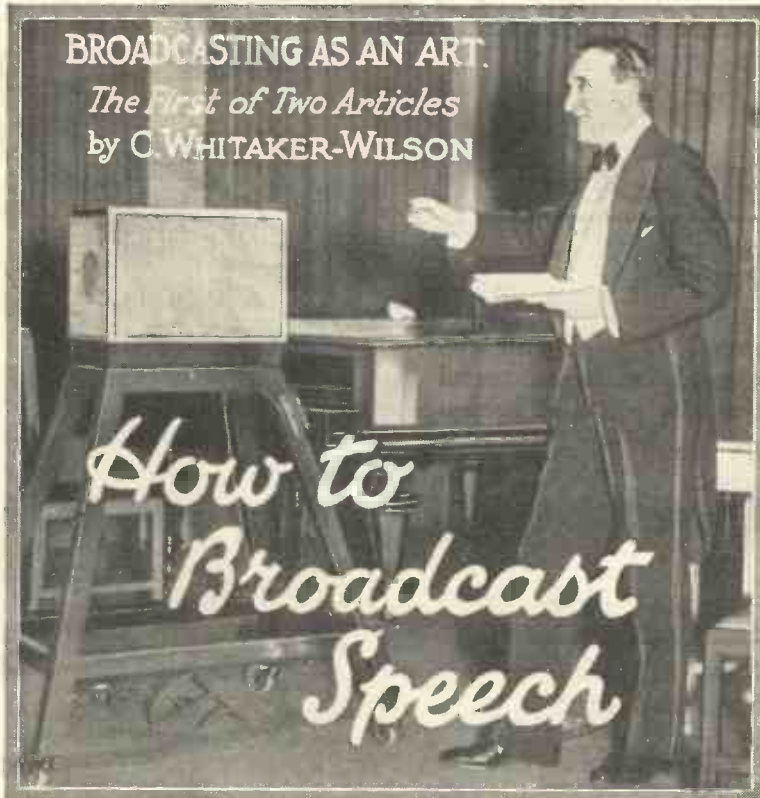

casting is to ignore the microphone altogether. But it is not the easiest thing in the world to stand or sit before one of these strange-looking things in a large studio—often quite alone—and to persuade yourself that you are doing something quite sane and sensible, and not merely cultivating the objectionable habit of talking to yourself.

That is the trouble. You cannot help being unseen, but it is perfectly certain that you must broadcast your personality as well as your script, all the same. You are not in the position of a public speaker or of an actor who can bring gesture into play, and so save many a situation by his personal charm of manner. You are absolutely dependent upon the power of your utterance.

I am quite aware that I am saying what has been said many times before, but it is my intention to try to be practical for the sake of those who have yet to broadcast. And, as a voice-trainer and teacher of elocution, I submit that the voice and the voice only is responsible for your success—or failure. But I also submit that there is no limit to the influence and power of a beautiful speaking voice.

It is not, admittedly, everyone

who possesses a beautiful speaking voice. But, even so, I am persuaded that it is largely people's own fault if their voices sound unpleasantly shrill or harsh.

They should treat the matter as they would treat any other disease, and have it altered for them. It is quite possible—it is *easily* possible—for people to do much for themselves in this respect by taking infinite care in everyday conversation. But be this as it may, I know of no experience more calculated to make one think of the tone of one's voice than that of broadcasting.

Success is dependent upon the infusion of personality (by way of the microphone and the telephones) into the homes of all who hear.

All high tones, in speaking through a microphone, should be avoided. There is an acoustical reason for this into which I do not go here. But I say, unhesitatingly, that the deep tones are the best.

High-pitched voices are not sought by the B.B.C. for their speaking staff, who are, evidently, also chosen for the purity of their inflection. Provincial accents are neither sought for nor welcomed.

Practical Hints

And now for some practical hints. In the first place there is nothing to be gained by unduly raising the voice. You only give the controlling engineer the trouble of toning you down to prevent your blasting on every set in the kingdom. Neither should you reduce the tone to any marked degree. One is as bad as the other. Nor yet does monotone strike the desired medium.

On the contrary, anything monotonous should be strictly avoided. The voice should rise and fall, *but distinctly within limits*; and if the voice drops at the end of a sentence

(Continued on page 80)

TWENTY-FIVE YEARS  MANUFACTURING EXPERIENCE

"ORMOND" "ORMOND" "ORMOND" **ORMOND** "ORMOND" "ORMOND" "ORMOND"

ENGINEERING  COMPANY

ORMOND LOW LOSS CONDENSERS—Square Law.

A new departure in British Condenser design, giving the following advantages:—

- (1) Practically negligible losses.
- (2) One-hole fixing—one $\frac{3}{8}$ in. diam. hole is needed to fix this condenser to panel.
- (3) Rigid construction—cannot warp; end plates of stout aluminium, perfectly flat.
- (4) Fixed vanes supported by $\frac{1}{4}$ in. ebonite strips.
- (5) Smooth action, spindle tension is maintained by specially designed friction washer.
- (6) Moving vanes and end plates are at earth potential.
- (7) One-piece knob and dial—supplied loose. Secured by 4 BA Set Screw.

Supplied in the following sizes:—

Size	Price with Vernier	Price without Vernier
.00025	8/-	6/6
.0003	9/-	7/6
.0005	9/6	8/-
.001	10/6	9/-

All Cheques and Postal Orders should be crossed and made payable to "The Ormond Engineering Co."

This Condenser is fitted with optional soldering Tags, or Terminals, and can be supplied with or without Vernier as desired.

There is no variation in price, the prices being the same as our ordinary Square Law Condensers.

We specialise in turning Brass and Steel Screws and Machined Parts and Accessories of all descriptions.

Write for our new (1925) Catalogue.

Trade Terms on Request.

See the Inspection Label on every Condenser.

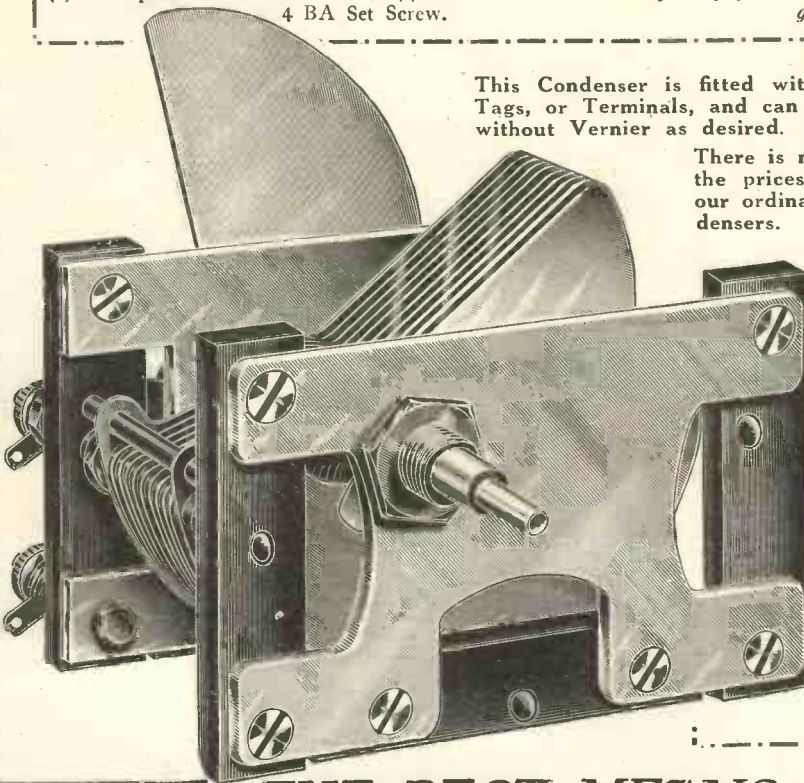

THE BEST MEANS —
ORMOND

199-205,
PENTONVILLE RD.
KING'S CROSS.
LONDON. N.1.

Factory:—
Whiskin Street,
Clerkenwell.E.C.1

Telegrams:—
"ORMONDENGI.
KINCROSS."

Telephone:—
CLERKENWELL
9344(3lines).

"ORMOND" "ORMOND" "ORMOND" "ORMOND" "ORMOND" "ORMOND" "ORMOND" "ORMOND"

In writing to advertisers, please say you saw the advertisement in THE WIRELESS MAGAZINE.

HOW TO BROADCAST SPEECH

(Continued from page 78)

—an impressive device if properly carried out—the greatest care should be taken to give a little more weight to the dropping syllables. Otherwise the microphone will let you down badly.

Choosing Your Words

The best tone and manner of speech is that which you would use to someone whom you have met for the first time—you being particularly anxious to impress him for some reason. I say this because upon such an occasion it would mean that you would choose your words carefully and enunciate them carefully also.

The essence of a good transmission is, of course, good tone in every sense of the word. Let us examine the principles of speech for a moment. Words consist of sounds—vowel sounds, that is, divided up by consonants. In order to broadcast the following five words: *harm*, *havsh*, *hart*, *half*, *harp*, there are three essentials. There must be an aspirate, a broad-sounding vowel (*ah*), and a clear enunciation of final consonants in each case in order that the words can be determined.

It is not enough to sound the vowel and leave the consonants; confusion results immediately.

Neither is it sufficient to bite off the consonants and leave the vowel sound weak; that means distortion. And a microphone is like a camera; it knows all there is to know about distortion. Ex-

tremes, therefore (either way) must be avoided.

Speed is very important in talking through a microphone. They tell you at the studio that 100 words to the minute is the ideal pace, but I think that this is too slow. As a matter of fact most of the announcers speak at the rate of about 120 words per minute.

It is fatal, however, to attempt to adopt any uniform speed. Nothing is more trying to the listener.

Constant variation of speed consistent with perfect variation of tone does more to hold the listener than anything else in the absence of the incalculable help which facial expression gives in the ordinary way. And that brings us right down to the truth that matter intended for the Press and that intended for broadcasting purposes is by no means the same thing. For broadcasting, every sentence should be read (and re-read) *aloud* before being passed. No sentence should be so involved as to stand the slightest risk of being lost,

and above all, the sentence should be rhythmical.

Blank Verse

In fact, I am inclined to go further and suggest that they should *scan*, even if only roughly. To those who are not familiar with the rules of prosody (and who do not feel inclined to take up that fascinating study) I humbly recommend either of two courses. The first is a little practice in reading good blank verse. The Shakespearean plays are invaluable for this, especially as the language is quaint.

The other is one which I sincerely hope my readers will take as being given seriously. It is to read Virgil aloud. Whether you can understand Latin or not does not matter. The act of reading those beautiful, soft sounds, all of which are strange to the eye of all but the initiated, constitutes the very best practice for all speech (whether broadcast or not) on account of their rhythmic flow. And, finally, study

your words for the sake of getting home some good effect through the microphone. Words are to speech what cadences and modulation are to music.

And to this desirable end, I sincerely commend to your consideration the act of committing to memory all that you broadcast. I do not mean that you should go without your script; in fact, they will not allow you to do this, and quite rightly so. But there is everything to be gained, and certainly nothing to be lost by knowing your work sufficiently well to avoid all possible risk of bad grouping of words, faulty inflection and hesitation.

THE STRONG MAN'S SET



Charlie Input, a professional boxer and a keen motorist, takes up wireless really seriously.

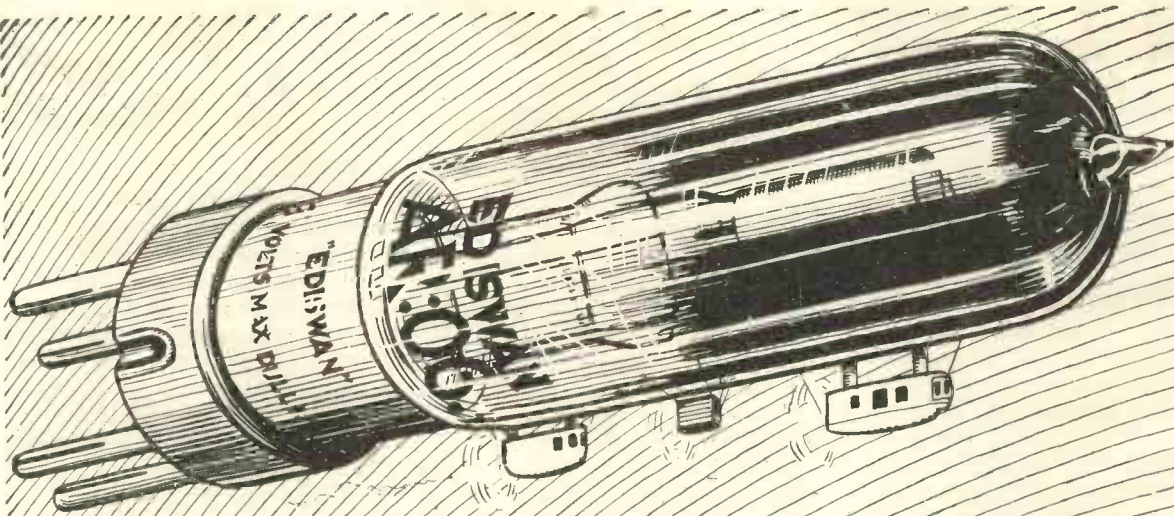

**1st Class Travel to EVERYWHERE
on the *Ediswan* Line**

FURTHER than England, further than Europe —right round the world Ediswan Valves will take you at your bidding. Seated in a comfortable armchair the musical treasures of France, Germany, Holland, America are yours without effort.

Ediswan Valves give you first-class travel on these aerial trips. Their wonderful construction ensure undistorted reception of the programmes and a true perspective of their merits.

**EDISWAN
VALVES**

*Will improve
ANY set*

P.V.5.D.E.	Fil. Volts, 5.0. ...	22/6
P.V.6.D.E.	Fil. Volts, 1.8-4.0. ...	18/6
P.V.8.D.E.	Fil. Volts, 3.0. ...	22/6
A.R. (L.F. or H.F.) ...	Fil. Volts, 4.0. ...	8/-
R.	Fil. Volts, 4.0. ...	8/-
A.R.D.E. (L.F. or H.F.)	Fil. Volts, 1.8-2.0. ...	14/-
A.R.0.6. (L.F. or H.F.)	Fil. Volts, 2.5-3. ...	16/6

(H.F. Valves distinguished by Red Line : L.F. by Green.)

Ask your dealer for particulars or write to :—

THE EDISON SWAN ELECTRIC Co., Ltd.,
123, QUEEN VICTORIA STREET, LONDON, E.C.4.

In writing to advertisers, please say you saw the advertisement in THE WIRELESS MAGAZINE.

Absolutely for the Novice!

Listening-in for the First Time

HAVING got aerial and earth leads attached to the set, and the phone leads attached to the phone terminals, the catwhisker of the crystal detector is adjusted until it very lightly touches and makes contact with the crystal.

Next slowly move the slider along the slider bar of the inductance, or if tuning is done by selector switches move the "tens" switch handle to the first point, then the "units" handle slowly over every point, and if no sound has been heard at all in the phones, bring back the units handle to the starting point, move the "tens" handle on to the second point and run the "units" handle over its own range of contacts once more, continuing this sequence of movements until something is heard. Quite likely this something may not be music.

A.C. Buzz

If it is a continuous buzz, it is probably induced by current flowing in some near-by electric-lighting circuit.

Sometimes, indeed, these lighting circuits give a lot of trouble in that way, especially if the supply is alternating current.

If you hear an intermittent chirping or scraping, which stops and re-starts, this is morse signalling, and will do at least to test whether the catwhisker is adjusted aright. To make the test, lift up the arm carrying the "whisker" and dab it down once or twice upon various parts of the crystal's surface, at times a little more lightly and sometimes rather less so.

You will very soon find which is the loudest signal. Leave it at that and once again re-start tuning. If there is a broadcasting station within range of the set, and if aerial and earth are properly put up, and always supposing the station is transmitting its programme at the time, you will presently tune-in the concert, faintly at first, but more and more strongly and clearly as inductance, variable condenser or variometer is more finely adjusted.

Far from attracting lightning to

the house, an aerial when connected up with a wireless set, and the set with the earth wire, is a good lightning conductor and safeguard against danger from thunderstorms. To prevent the set being the worse for its usefulness at such times, it is well to remove aerial and earth leads from the set and connect them together. Possibility of danger from an aerial only arises when its lead-in

from the tuned inductance to detector and phone terminals, no connection is made with them at all.

The second inductance has about half as many turns again as the first, or aerial-circuit inductance. It is called the closed-circuit inductance, is also usually of the plug-in type and tuned by a .0005-microfarad variable condenser. Connection is made from it with crystal detector and phone terminals as though it were the aerial inductance of a single-circuit set.

What happens in a double-circuit set is that oscillations in the aerial inductance set up a sympathetic "induced" response in the similarly tuned closed-circuit inductance, and these latter feed the detector. The advantage, with a crystal set, lies almost wholly in sharper tuning, less trouble being experienced from unwanted overlapping signals of wavelengths differing slightly from the one required.

In valve sets, double-circuit tuning has the additional advantage that oscillations in the closed-circuit inductance suffer less damping from capacity of the aerial, with the result that the set is more sensitive to faint signals, though also much more liable to howl when carelessly handled.

Damped and Undamped Waves

Wave trains which die down after energising the inductance, as the energy in the aerial subsides, give rise to damped oscillations. All oscillations set up in receiving sets must be damped to be of use for clear telephony reception.

Waves which become over-reinforced from local current from the high-tension battery, so that they continue to build themselves up after the original aerial energy giving rise to them has subsided, are termed undamped waves. They serve a useful purpose in wireless transmission, but none at all when generated unintentionally in a receiving set, for, as we know, they then give rise to the unpleasant "howling" called oscillation.

COLIN BENNETT.

BEFORE YOU TUNE-IN

- make sure that a transmission is taking place.
- put the phones on your head.
- see that the aerial is not connected to earth.
- make certain that everything is connected up properly.
- see that your tuner will reach the right wavelength.

IF YOU HAVE A CRYSTAL SET

- see that you have a good piece of crystal.
- make sure that the catwhisker is springy and has a sharp point.
- find out whether your phones are of the right resistance.
- make sure that the detector is properly adjusted.

IF YOU HAVE A VALVE SET

- see that the valves are properly in their sockets.
- make sure that the H.T. battery is connected.
- find out whether the reaction coil is the right way round.
- make sure that you are not oscillating and so causing interference with your neighbours.

wire is left totally unconnected with any electrical conductor.

A method of tuning sometimes found in crystal sets, but much more often in valve sets, is that where two inductance coils are placed fairly close together. The first coil is the aerial inductance, already described, usually a fixed inductance of the plug-in type and tuned by a .001-microfarad variable condenser. Instead of the usual branch wires going

A Clarion call to all Loud Speaker users

EVER since Broadcasting began, users of Loud Speakers have been confronted with the difficulty of obtaining a reasonably priced Power Valve capable of producing a rich sonorous tone without the aid of an extravagant high-tension voltage. They have yearned for a Power Valve which does not necessitate the rebuilding of the Receiving Set or the purchase of an elaborate or costly Power Transformer to obtain the desired amplification. The solution of these problems is at last to be found in the new Cossor W3 Loud Speaker Valve—a masterpiece of ingenuity and workmanship. Operating at 1.8 volts and consuming only .5 amps., it needs but the moderate plate voltage of 80 to 120 in order to produce a tonal purity and mellowness which has yet to be equalled by any other Valve. We venture to predict that, as its virtues become more widely known, it will be selected by a discriminating wireless public as the standard British Loud Speaker Valve.

Price 18/6 from all Wireless Dealers.



A. C. COSSOR LTD. - - - MANUFACTURERS OF VALVES - - - HIGBURY GROVE, N.5

In writing to advertisers, please say you saw the advertisement in THE WIRELESS MAGAZINE.

Gilbert Ad. 3011

AT 2 SAVOY HILL, W.C.2.

*A Page Specially
Contributed by the
B.B.C.*

THE opening of Daventry high-power station may be said to mark the beginning of a new broadcasting epoch in this country. When Chelmsford was opened as an experimental high-power station, our policy was questioned in many quarters, as it was thought that we were showing too great a disregard for the valve-set user and were pandering to the supporters of crystal reception.

Instead, however, of the sales of valve sets being adversely affected, these have increased considerably during the past six or eight months, and an enormous field has been opened up.

If Daventry brings in an additional million crystal listeners, the high-power policy will be fully justified, but the existing facilities enjoyed by crystal-set users in other parts must admittedly be maintained, while the facilities for listening must be extended to districts which are at present without crystal service.

It is estimated that about 78 per cent. of the total population is now served by crystal sets. In the normal course of expansion another 3½ millions might be brought in, making a total of 90 per cent., and this should be achieved by the increase of power and without the erection of a single additional station.

The number of continental stations working on a higher power than B.B.C. stations is constantly increasing—a fact which must be watched vigilantly in considering the question of broadcasting in Britain.

An ever-fruitful source of discussion and controversy is that of broadcast "talks." Criticism does not come proportionately to anything like the same extent from without as from within, and we find among those fairly intimate with the inner workings of the service an attitude of mind keenly critical of our accepted policy.

This is a healthy state of affairs, because it is hoped that, contrary to the general belief that a house divided against itself will fall, the house will in this case take on added strength to carry out its indubitable

duty of maintaining the highest possible standard of entertainment for the benefit of the largest body of opinion that any public service of the kind has ever known.

It must be remembered, in the first place, that the broadcast programmes consist mainly of the lighter forms of entertainment, and consequently in trying to make the best of both worlds, we are combining the two functions of providing a programme of entertainment with a scheme for improving general knowledge.

In the second place, the influence of a broadcasting service such as we control is unique. That influence can be used either for good or ill, and if, in deference to a comparatively few critics, the programme "talks" were confined to light and ephemeral subjects, the interest of the more serious minded body of listeners would be eliminated.

Any weakness—if weakness there be—does not lie in the composition of the programmes broadcast from any one station; and in the present conditions of broadcast, the aim must be to introduce as much variety as possible into each programme.

The day will possibly come when additional facilities will be available for catering for the wants of different classes of listeners, when those who do not want to listen to the serious talks will be provided with the kind of fare desired from one transmitting station, while those in search of knowledge will get it from some other station.

The problem of the programmes, like the poor, we have with us always; but a surprisingly small amount of constructive criticism that may assist in the solution of the difficulties is received at Savoy Hill. Everyone realises that perfection is impossible in this imperfect world, and the best that we can do is to strive after improvement—most elastic and elusive of terms, when applied to broadcast

entertainment—until it can be taken for granted that the majority of listeners are within measurable distance of becoming satisfied.

These reflections are called forth by the correspondence in a prominent journal, wherein, for every two letters in strong support of the present make-up of the programmes, a couple were published disapproving of the broadcast fare and the method of its presentation.

For instance, it has been suggested that the Savoy Bands are popular enough to justify their engagement for broadcasting every evening. The argument against this course is that broadcast artists are catering for the same people at every performance, and every effort is, therefore, made to avoid what is likely to bore them.

An extension of the hours of broadcasting until midnight, or later, has also been suggested. The argument against that course is that experimenters are already limited as to the hours during which they may conduct their experiments, and have, in fact, at present to carry on most of their work when the majority of us have retired to rest. Would it be fair to whittle away their facilities until they had almost disappeared?

The suggestion that morning broadcasts should be transmitted is made on behalf of night workers and invalids. The answer is that the staff is already severely taxed so far as the hours of duty are concerned, and an additional burden can scarcely be put upon it. The alternative would be to make considerable additions to personnel—practically to double the existing staff—a course which would not be warranted in the results, and an expenditure which would not, therefore, in present circumstances, be justified.

While taking all these factors into consideration, we are, nevertheless, ready to fall in with the wishes of the majority of listeners whenever a good case can be made out for adopting a course which perhaps the best counsels would not entirely favour; for the chief object is to maintain our character as a public service.

THE HOLIDAY SET

(Continued from page 50)

When the winding has been completed, strips of empire cloth or stout paper should be stuck with shellac varnish over the slotted ebonite strips to prevent the winding from springing out of the slots.

This completes the frame aerial, and all that is now necessary is to connect the two ends of the aerial to the terminals of the '0005-microfarad variable condenser.

Using the Set

It is essential to use dull-emitter valves in order that the filament-lighting battery may have the smallest possible dimensions, thus keeping down the total weight of the receiver. Dull-emitter valves of any reputable make may be used. The H.T. battery used in the original set was a 60-volt Hellesen, which is just small enough to be accommodated.

These two batteries, the valves and the H.F. transformer being connected up, tuning is accomplished by very slowly rotating the two condenser dials until signals are heard.

Adjustment of the crystal detector will still further increase the signal strength. The filament brilliancy of the valves will be found rather critical and should be carefully adjusted.

It should be remembered that a frame aerial has marked directional properties, and the set should therefore be held in one hand by the handle and slowly turned in one direction and then in the opposite direction. As the set is rotated in this manner a point will be found where signal strength is at its maximum. The set should be put on the ground pointing in this position.

A CIRCUS performance is to be broadcast from New York. We are also considering the broadcasting of Parliamentary proceedings in this country.

AERIALS of the T style are said to be used extensively in U.S.A. And drinks of the same nature, we believe.

Do you know of an amateur with the call signal HAM, asks a facetious correspondent. Well, we have never heard of him, so if he exists he will be merely small fry.

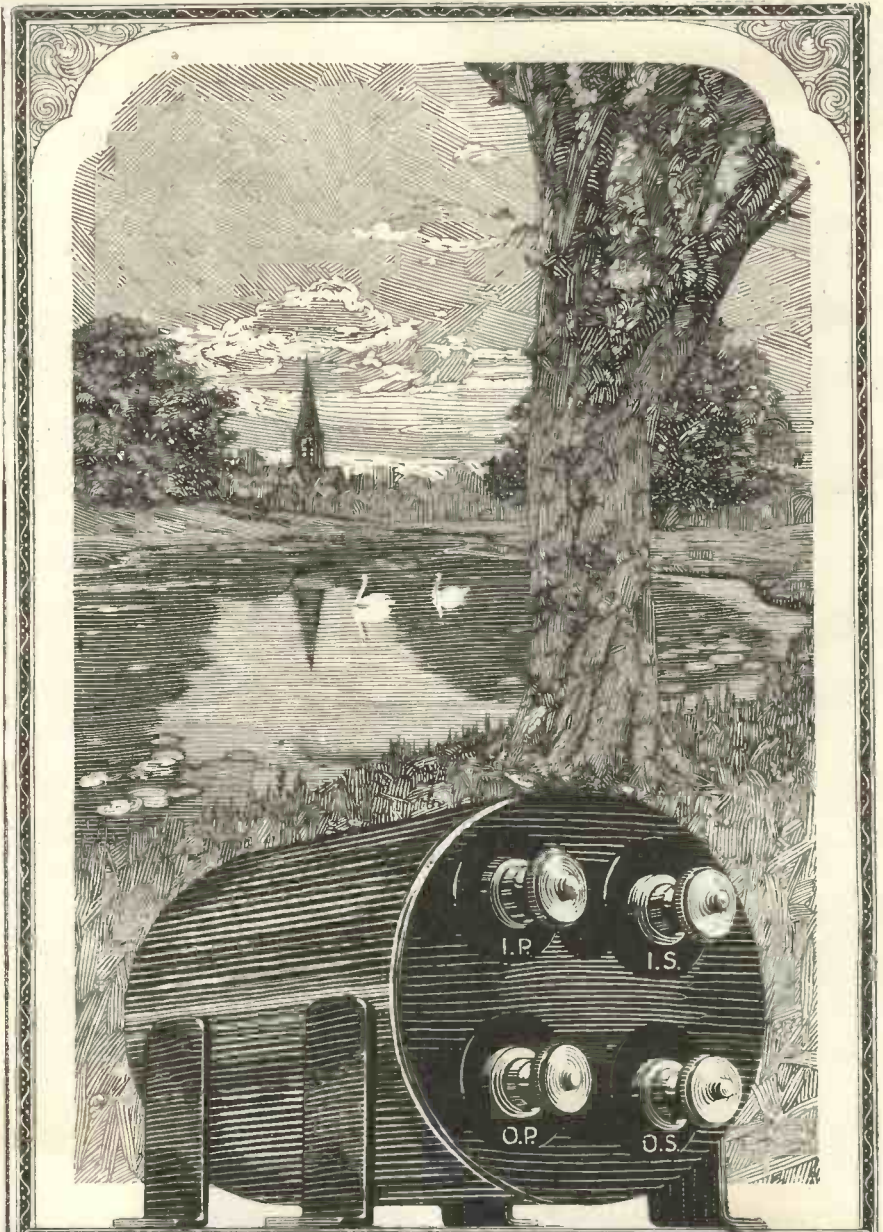

The angelus!

YOU must have heard the melody of the old church bells wafted in the breezes never a discord—never a harsh note, but such music as will linger in your memory for many a day. And so it is with any Receiving Set equipped with Eureka Transformers. Such tone purity and volume that wireless enthusiasts are everywhere saying that the Eureka truly sets a new and higher standard for Loud Speaker reproduction.

Concert Grand, 30/- Eureka No. 2, 22/6 (for second stage)

EUREKA



Why Crystals have Come Back

Constant adjustments and varying receptions were quickly driving crystal detection into disfavour. Its revival is welcome because a crystal is the finest detector in the world, could it only sustain a real degree of permanency.

Now the R.I. Permanent Detector is the solution:

The General and Technical Press have welcomed it as something of marked interest to everyone who appreciates a crystal because everyone will welcome a permanent crystal.

That this detector has filled a long-felt want is proved by the thousands of grateful letters we have received from every section of the public. It is the most practical and useful component produced since Broadcasting commenced.

Write for new booklet.
"THE DISCOVERY OF 1925."

The R.I. Detector is now obtainable from all reliable dealers or direct from the makers.

Price 6/-

Complete with metal brackets and screws for mounting.

**12 HYDE STREET
NEW OXFORD ST.
LONDON, W.C.1**

Contractors to the Admiralty and all Government Departments.



For the WIRELESS BOOKSHELF

"Radio: Beam and Broadcast"

DESPITE the enormous number of patents that have been granted in connection with wireless, Mr. A. H. Morse in his book, "Radio: Beam and Broadcast," (published by Ernest Benn, Ltd., London, price 12s. 6d.), states that the evolution of wireless has been characterised by very few inventions of outstanding merit and commercial utility.

So many devices are now on the market that one is often unable to distinguish between what is old and what is new. In view of such a state of affairs it is not altogether surprising that endless time and considerable money are often expended in inventing a device a prototype of which has long been in existence.

With such a book as this, however, one is able to trace many of the inventions and patents that are already in existence, for in compiling the history of the science recourse has been made to the American and British Patent Offices' returns.

The book is full of useful data and contains, as one would expect from an author so widely experienced, much valuable information.

The reference to the beam system of wireless communication is particularly interesting, and the Author explains clearly this latest development in the science.

"Junior Technical Electricity"

The student undergoing a First year course in electrical engineering cannot fail to derive much help with his studies from "Junior Technical Electricity," by Robert W. Hutchinson, M.Sc., A.M.I.E.E.

Mr. Hutchinson has compiled many treatises on electricity and allied subjects, and this latest product from his pen is the result of numerous requests from teachers of physics and electrical engineering who felt there was a need for such a publication.

Whilst the main object of the publication is "to give the reader a clear insight into the fundamentals of electrical theory," several chapters

are devoted to wireless telegraphy and telephony.

Published by the University Tutorial Press, Cambridge, price 4s. 6d., the book is one that can be recommended to all students of electricity.

"Kelly's Directory of the Electrical Industry, Wireless and Allied Trades"

The second edition of "Kelly's Directory of the Electrical Industry, Wireless and Allied Trades" (published by Kelly's Directories, Ltd., London; price 30s.) will be found indispensable to those connected with the wireless trade.

In compiling the book the publishers have gone to endless trouble to ensure that the information contained in it shall be easily accessible, and indexes are given which make the looking up of any desired information only a matter of a few seconds' work.

A feature which should appeal to many is the inclusion in the publication of a list of proprietary articles and trade names.

"All About Your Wireless Set"

To explain the workings of a wireless set in such a manner that it will be comprehensible to the merest amateur is no easy task, and Capt. Eckersley, in his book "All About Your Wireless Set" (published by Hodder and Stoughton, London, price 3s. 6d.), warns the reader that "knowledge and an appreciation of the art requires an effort on the part of the reader just as much as on the part of the author."

MR. HERMAN DAREWSKI

IN our July issue we stated that Max Darewski was appearing with his orchestra at the Spa, Bridlington.

We should have stated that Herman Darewski was so appearing. Mr. Herman Darewski has been obliged to make a similar correction again and again, and we are very sorry that we should have added to any existing confusion.

IN suggesting a new broadcasting service for Scotland, the promoters make it clear that they do not propose it shall be on a money-making basis. We congratulate them on facing facts from the outset.

In writing to advertisers, please say you saw the advertisement in THE WIRELESS MAGAZINE.

NOVELTIES AND NEW APPARATUS DESCRIBED

BELOW we give brief descriptions of some of the novelties illustrated on page 29.

(2) Good contacts mean low losses, and for this reason Auto-veyors, Ltd., of 84, Victoria Street, S.W.1, are making these H.T. battery inserts for use in conjunction with Clix plugs.

(3) "Super het" constructors will be interested in the new R.I. oscillation transformer, which has a wavelength range of 260-450 metres.

(4) The units of the new Gambrell coil holder are made separately and can thus be easily mounted on a panel in any desired position.

(6) Specially designed for loud-speaker work, the Cossor dull-emitter power valve has a filament consumption of 5 ampere and needs from 80 to 150 volts H.T. supply.

(7) The new C.A.C. GP valve consumes 6 ampere on the filament and needs an H.T. supply of from 45 to 120 volts. It is equally efficient as detector or amplifier.

(8) The necessity of soldering connections is obviated by the use of these new Belling-Lee devices.

(9) The capacity of the Ravald condenser is varied by altering the distance between two facing metal plates.

(11) For making quick connections to accumulators, etc., the Collett clip is very useful, and saves a deal of trouble with terminals.

MR. GILBERT YOUNG recently broadcast a lecture entitled "Set Britain Singing." We suspect that he is a director of some throat-pastille company.

THE Canadian railways are carrying out experiments with a view to broadcasting from moving trains. We hope they will not broadcast anything of a heavy nature for fear of hurting men who are working on the line.

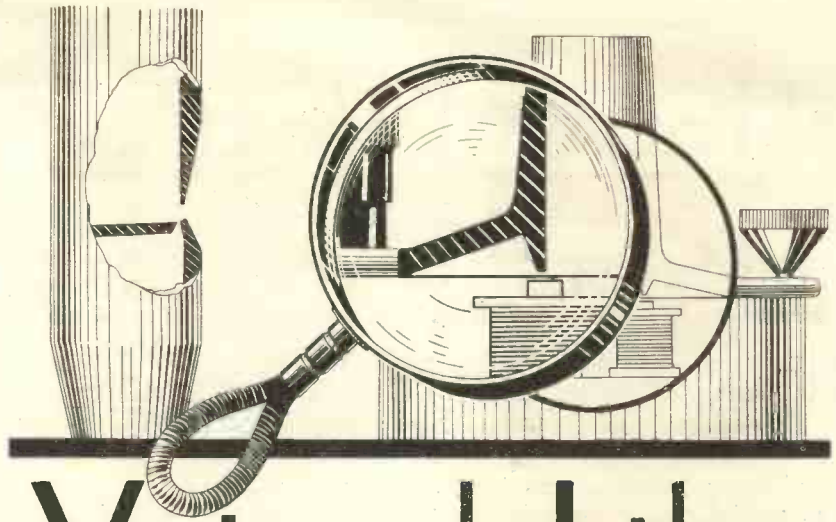

Voiced Like an Organ

*The voice is
in the mouth
of the horn ;
not in the box.*

FOR true reproduction a Loud Speaker should amplify the vibrations of the diaphragm. It should not add any Harmonics, or take any away.

In certain types of organ pipes, it is necessary to produce the **pure fundamental tones**. The lip of the pipe is the place where the voicer's art is applied to **obtain this result**. The lip of the Loud Speaker is the part which has to be considered for fine reproduction.

You appreciate MUSIC.
You will appreciate the RADIOSUN.

In sunlit mahogany finish.
Price £5

Write for leaflet describing the Wonderful Difference, and ask your dealer to arrange with us for a demonstration.



AUTO SUNDRIES LTD.,
10, LOWER GROSVENOR PLACE, LONDON, S.W.1.

In writing to advertisers, please say you saw the advertisement in THE WIRELESS MAGAZINE.

How the Weather affects Wireless

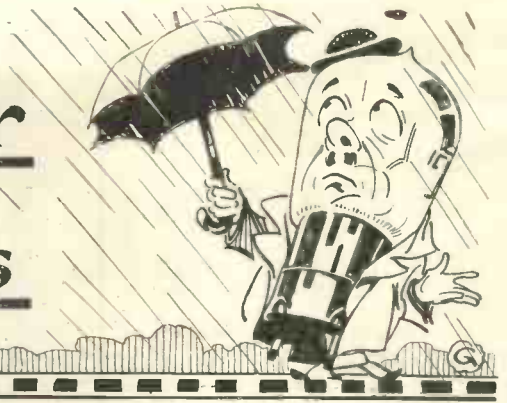

ON Saturday night reception on your broadcast receiver is everything that can be desired—you can almost hear the announcer breathe. Which is well, for tomorrow, being Sunday, a few of your rather sceptical friends are coming to hear "the wireless."

Comes Sunday evening—and your friends. Everything is in readiness. The accumulator is "well up," and you have even dusted in between the valve sockets. You tune up.

"Funny," you mutter, after about fifteen minutes. "It isn't as loud as usual. I'm afraid it won't stand more than one pair of phones, instead of the usual three pairs."

Your friends smile.

Blame the Weather

It may be of some comfort to know that this falling off in signal strength is not always due to a faulty set but very often to the weather. For although wireless waves are waves in ether and therefore non-material, investigation has shown that the weather, which is a material phenomenon, has quite an appreciable effect on wireless, and this is one of the principal reasons why wireless signals sometimes vary unaccountably from day to day.

Many British amateurs have noticed, for instance, that American or even New Zealand amateurs are received very much better when the weather is damp and cloudy than when it is fine and dry. It has also been noticed that a dull, cloudy day will mean good transmission or reception that night.

The reason why clouds should have this effect on wireless is not very properly understood, but it is believed to be due to the fact that clouds absorb certain of the sun's rays which have the effect of ionising our atmosphere. And the trouble is

that an ionised atmosphere tends to damp out wireless waves.

It follows, therefore, that the presence of the clouds will prevent this ionisation of the atmosphere by absorbing some of the sun's rays, and consequently the waves will be propagated more freely during or after cloudy weather.

Rain also has a very decided effect on wireless communication. The effect of rain on wireless was first discovered during the South African war, when it was found that after a very heavy rainfall on the veldt, the range of a wireless transmitter was considerably increased. This is due to the law that a good conductor of ordinary electric current, like copper, is a bad conductor of wireless waves.

Our Enemy is Water

Now water is a fair conductor of ordinary electric current, and the falling rain forms a film of moisture over the surface of the ground. This film of moisture being a fair conductor of ordinary current is a bad conductor of wireless waves, and will not allow the waves to pass through into the earth. Consequently, the waves cannot dissipate themselves into the earth, and thus retain their strength longer and are propagated for greater distances.

This is, of course, also the reason why transmission over the sea is much superior to transmission over the land. Waves propagated over dry ground tend to sink in and get damped out, as the earth, when dry, is a fairly good conductor of wireless waves.

It might be thought that as moisture screens wireless waves in this way, that falling rain might also tend to prevent the waves from passing through it. But this effect has not been noticed, and it is supposed

that the rain on the ground counteracts the effect of the falling rain.

Rain also aids transmission and reception by reducing the resistance of the aerial-earth system, just as we improve our signals by throwing a few buckets of water over the earth plate during dry weather.

On the other hand, rain can reduce the radiation of a wireless transmitter by forming a layer of moisture on the aerial and lead-in insulators, thus allowing a certain amount of energy to escape to earth. The same applies, to a smaller extent, at the receiving station.

In the old days of wireless, when a 10-in. spark coil was the last word in modern transmitters, it was sometimes almost impossible to radiate at all owing to the leakage across wet insulators, and big fat sparks could frequently be seen jumping from the aerial to near-by guys.

This leakage to earth over the lead-in and other insulators may also happen in the case of snow (water crystals), especially if the lead-in insulator happens to be erected parallel to the ground, when the snow will have a good chance of collecting thereon. It is therefore important, if possible, that the lead-in insulator be erected vertically with regard to the ground.

Rain will also cause hissing; that is, a hissing sound in the phones which is caused by the electrified rain striking the aerial.

Wastage due to Frost

Perhaps the most serious loss of energy through weather occurs when frost sets in after rain or a snow-storm. A coating of ice will then be formed, not only on the insulators, but also on the aerial. In countries having a continental climate

(Continued on page 90)

Build your Set the Labour-Saving Way



THE Polar Blok System simplifies the building of Wireless Sets in just the same way as the use of steel framework, interlocking parts and standardised sections have simplified the building of works, of houses and of motor-cars.

The Polar Blok Method reduces the labour and time required for *assembling*, and leaves you more time for actual experimenting—for the testing of a thousand and one circuits, the adjusting of values and the developing of your set to full efficiency.

There is no workshop practice needed with Polar Blok; no sawing, drilling, filing or soldering. An interlocking metal framework is used, on which standard, ready-assembled panels are mounted in any sequence or combination you please. Insulated wire is provided, which readily permits the angular

method of wiring, giving the set the desirable neatness beneath panel, in addition to the excellent appearance of the exterior. You can extend your set at will with the Polar Blok System, making it perfectly practicable to add any number of improvements or further valves without "scrapping" any previous parts.

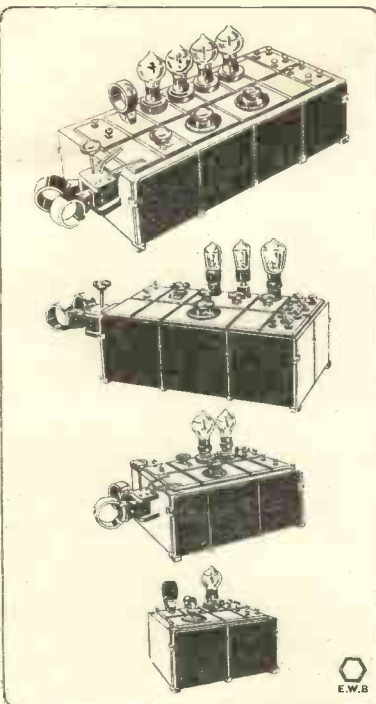

POLAR BLOK

For real Experimenting—
without workshop, litter or
labour.

Pliers and Screw-
driver the only
tools needed.

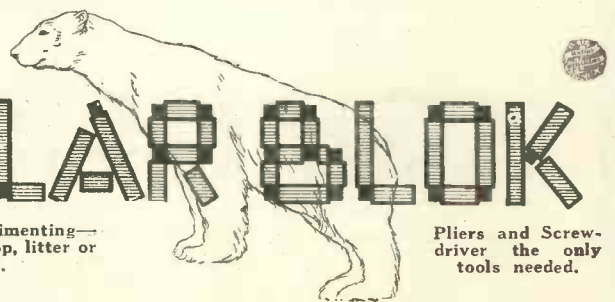

Polar Blok Parts are sold by all good-class Radio Dealers.

Write for 16-page Polar Blok Booklet, 7d. post free, giving full details of six complete sets, incorporating resistance-capacity coupling, with wiring diagrams, lists of components, and prices.

Radio Communication Co. Ltd. 34-35 Norfolk Street, Strand, London, W.C.2

In writing to advertisers, please say you saw the advertisement in THE WIRELESS MAGAZINE.

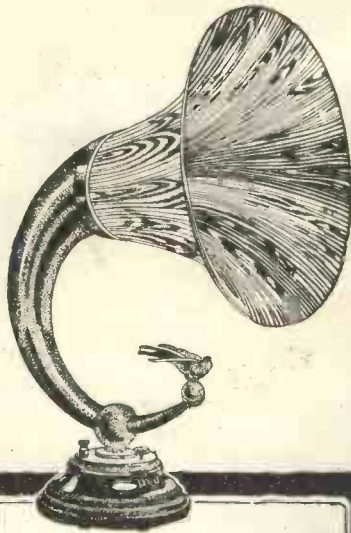

A
masterpiece
of design

THE quiet dignity of the new Q-type Loud Speaker is in thorough keeping with the Brown reputation for high-grade Radio apparatus.

With its magnificent polished mahogany flair and its sweeping lines of great beauty it is indeed a superb example of sound technical skill. But hear its tone and you will realise that at last Science has produced her masterpiece. Such volume and richness of tone has never before been available on any Loud Speaker. Its success is a fitting reward to the years spent in perfecting the Brown Loud Speaker—work which began long before Broadcasting was contemplated.

Price: 59
£15 15 0
in all resistances

S. G. BROWN LIMITED
Victoria Road, N. Acton, W.3

Showrooms:
19 NORTIMER STREET, W.1
15 MOORFIELDS, LIVERPOOL
67 HIGH ST., SOUTHAMPTON

Brown
Wireless Apparatus

G.A. 3022

How the Weather Affects Wireless

(Cont. from page 88)

the cylinder of ice formed on the aerial is sometimes heavy enough to break the wire; and at some high-power stations a special apparatus is necessary to heat up the aerial wires and melt the ice.

When a layer of ice is formed over the ground, however, especially fairly level ground, transmission is greatly improved, as the ice has the same effect as a layer of moisture.

Although fading is generally thought to be due to variations in the condition of the Heaviside layer, there can be no doubt that some fading is due to fog. In fact, from data collected by the American Bureau of Standards, fog would sometimes appear to have the same effect on weak signals as a mountain; that is to say, the fog causes a wireless shadow.

For example, a fog suddenly envelopes a certain receiving station, when immediately signals from a transmitting station 150 miles away fade right out. Fifty miles farther on, in the same direction, is another receiving station, and here signals from the same transmitting station continue to come in at normal strength. This would appear to prove more or less conclusively that fog causes fading—but why it should do so is a great mystery.

A dry wind usually brings atmospheric, whereas a wet wind usually means a quiet spell, but this, of course, depends on the season of the year. There is no hard and fast rule about atmospheric and the wind, but it is believed that some X's are entirely due to the uneven potential of the static electricity in the atmosphere brought about by the dryness of the wind. It has also been suggested, rather tentatively, that a dry warm wind striking a high range of mountains sets up atmospheric disturbances due to the sudden cooling of the wind—and this is supposed to explain why X's are sometimes so prevalent in mountainous districts.

It is now believed that 75 per cent. of the atmospheric which we hear in our phones are due to weather

conditions, and in this respect some very interesting data has been collected by the British Radio Research Board.

Tracing Atmospherics

It has long been known that atmospheric come from a certain definite direction, which can be found with an ordinary frame aerial, and it has been the work of the Radio Research Board to trace these X's to their lair. In some cases X's heard in England have been found to originate in some thunderstorm in Northern Africa, and it has also been ascertained that other X's have originated in a distant but ordinary rainstorm in the Near East.

It will be seen, therefore, that despite the general belief, weather has a considerable effect on wireless,

TO LUCILLA

On being bidden to play Tennis.

(With apologies.)

TELL me not, dear, I am unkind,
Nor take it ill that I
From tennis—which is such a grind—
To listen-in now fly.

True, a new five-valve set I've bought,
Against which you inveigh,
And oft complain I think of naught
But tuning-in all day.

Yet my devotion, love, is such
As I will prove to you,
I'll share the set I prize so much
And let you listen too!

LESLIE M. OYLER.

and so by studying the weather forecasts it is possible to ascertain to some extent what days are likely to be good for wireless work, and vice versa.

In addition to this, it is sometimes possible, by taking the international weather reports from Eiffel Tower, to ascertain the weather which is likely to be prevalent in places as far apart as Copenhagen, Constantinople, and San Francisco, which is very useful for long-distance reception. In all probability the time is not far distant when amateurs, owing to meteorological information, will be able to fix a day, perhaps weeks in advance, which will be ideal for attempting special long-distance communication.

G. H. D.

In writing to advertisers, please say you saw the advertisement in THE WIRELESS MAGAZINE.

Catalogues and Pamphlets

When writing for these Catalogues, mention
THE WIRELESS MAGAZINE, please.

BATY'S two-valve receiver is fully described in a circular obtainable from E. J. Baty, "Rathfanham," Luton, Bedfordshire. The circular also contains many testimonials from users of this highly efficient receiver.

The Grafton Electric Co., 54, Grafton Street, London, W.1, have recently issued a leaflet describing the well-known Grafton components.

A catalogue giving full particulars of a wide range of books on technical and scientific subjects (new and second-hand), will be sent to any reader on application to W. and G. Foyle, Ltd., 121-125, Charing Cross Road, London, W.C.2.

A new summer catalogue containing details of many useful components has recently been issued by the Goswell Engineering Co., Ltd., of 12a, Pentonville Road, London, N.1.

The current price list of A. F. Bulgin and Co., 9-11, Cursitor Street, Chancery Lane, London, E.C.4, contains full descriptions of the various Decko components.

A leaflet describing the famous Fuller Ironclad transformer will be sent to any reader on application to Fuller's United Electric Works, Ltd., Woodland Works, Chadwell Heath, Essex.

A folder describing the well-known A. J. S. condenser may be had from A. J. Stevens and Co. (1914) Ltd., of Wolverhampton. This firm are now putting most of the components used in their 2-, 3-, and 4-valve receivers on the market, and particulars of any special component will be sent on request.

"Sterling Reaction Controls" is the title of a useful pamphlet issued by the Sterling Telephone and Electric Co., Ltd., 210-212, Tottenham Court Road, London, W.1. A copy of the publication, which contains several useful circuit diagrams, will be sent free on request.

In writing to advertisers, please say you saw the advertisement in THE WIRELESS MAGAZINE.



Many
Handicrafts
Easily Acquired!

CASSELL'S "WORK" HANDBOOKS

Lavishly illustrated and written by experts in straightforward and lucid manner, each of these famous manuals gives the essential information to enable even the veriest amateur to become proficient. Purchase one and begin work at once. There is money in it for you.

Each 1/6 net

- | | |
|---|--|
| Basket Making. | Metal Turning Made Easy. |
| Beehives and Beekeepers' Appliances. [ances. | Miniature Electric Light. |
| Bent Iron Work. | Model Aeroplanes. |
| Bookbinding. | Motor Cycles and Side-Cars: Construction, Repair and Management. |
| Boot Making and Mending. | Mounting and Framing Pictures. |
| Building Model Boats. | Oxy-Acetylene Welding. |
| Camera Making. [ing. | Patents, Designs & Trade Marks. |
| Clay Modelling and Plaster Casting. | Photography Simplified. |
| Clock Cleaning and Repairing. | Pianos. |
| Conjuring Apparatus and How To Make It. | Poultry Houses and Appliances. |
| Cycle Repairing and Adjusting. | Pumps and Hydraulic Rams. |
| Domestic Jobbing. [Building. | Rustic Carpentry. |
| Dynamo and Electric-Motor Management. | Sewing Machines. |
| Dynamo and Motor Erection and Management. | Simple Lathe and Its Accessories. |
| Electric Accumulators. | Small Dynamos and How to Make Them (including Electric Motors). |
| Electric Bells and Telephones. | Small Electric Apparatus. |
| Electric Clocks. | Small Lathes: Making & Using. |
| Electric Lighting. | Small Workshop Appliances. |
| Electric Primary Batteries. | Soldering, Brazing and Welding. |
| Electro-Plating. | Stage Illusions & Entertainments. |
| Fishing Rods and Tackle, Making and Mending. | Tailoring. |
| Furniture Repairing. | Taxidermy. |
| Gilding, Silvering and Bronzing. | Ticket-Writing and Sign-Painting. |
| Glass Writing, Embossing and Fascia Work. | Tinplate Work. |
| Gramophones and Phonographs. | Toy Making. |
| Handyman's 1,000 Practical Receipts, The. | Violin Making and Repairing. |
| House Painting and Decorating. | Watch Cleaning and Repairing. |
| Household Repairs. | Wireless Telegraphy and Telephony. |
| Incubators and Chicken Rearers. | Wood Finishing. |
| Induction Coils. [Cordage. | Workshop Arithmetic. [Workers |
| Knotting and Splicing Ropes and Magneto Repairs and Adjustment. | Workshop Hints for Metal |

Of all Newsagents and Bookstalls, 1/6 net,
or direct from the Publishers 1/9 post free.

Cassell's
Publishers
London

USE DIFFERENT CRYSTALS

I WONDER how many of you use the same crystal for receiving the local station and 5 XX, the B. B. C.'s high-power station. Most of you, I daresay. Yet the crystal may not be quite suitable for reception from both stations.

The higher the wavelength of the signals received the higher should be the resistance of the crystal used. For this reason a crystal that gives ideal reception from the local station may give very poor reception when the station tuned-in is of a much higher wavelength.

It is always as well to have several crystals on hand so that if the signals are not all that they might be a change of crystals can be tried.—W. T.

VALVE DON'TS

DON'T burn valves too brightly; filaments subjected to continual excessive heat do not last long.

Don't use too much H.T. Cut the supply down until it is at the minimum for efficient reception.

Don't pluck the valves out of the sockets as soon as they have been turned out. Let them rest a little to allow the filaments to cool and then remove them carefully.

—C. C.

GETTING BETTER CRYSTAL RESULTS

QUITE a lot can be done in the way of improving the average crystal set at the cost of a little time and a few coppers. One of the simplest ways of obtaining louder signals is to connect a fixed condenser of small capacity between the aerial and the aerial terminal of your set.



The value of this condenser should not be more than about .0003-microfarad—.0001- or .0002-microfarad will do quite well. Such a condenser may be purchased quite cheaply or can be constructed at home, by fixing a piece of mica

will be found that a different setting of the tuner dial will be necessary owing to the decrease in the self-capacity of the aerial system.

Another simple method of improving the crystal set is to rewind the coil or coils with specially thick wire. If the existing coil is of the plug-in type an appreciable increase in signal strength may be obtained by substituting a basket coil wound with No. 16- or 18-gauge d.c.c. copper wire.

The coil may be conveniently wound on slotted cardboard formers and mounted on an ordinary plug-in basket coil holder. No shellac or other similar medium should be used on the cotton covering of the wire as the idea is to keep down the self-capacity of the coil to an absolute minimum.

—R. N. W.

A PERFECTLY SWEET WIRELESS SET

WHEN I walked down the lane I found
A wireless set upon the ground,
'Twas made of toffee, strange to say;
I meant to listen-in all day!

A butter-scotch loud-speaker stood
Quite near at hand—it looked so good
And headphones made of chocolate
cream—
But then I woke, it was a dream!

LESLIE M. OYLER.

$\frac{3}{8}$ in. by $\frac{3}{8}$ in. and .002 in. thick between two plates of copper or brass foil $1\frac{1}{2}$ in. by $\frac{3}{8}$ in.

Two ebonite plates 2 in. by 1 in. by $\frac{3}{16}$ in. or $\frac{1}{4}$ in. thick and two

WHERE ARE YOUR PHONES?

IN a crystal set the phones should always be connected up so that they are on the "earth" side of the crystal. If connected on the aerial side of the crystal the phones form a path for the received signals across the crystal through the body of the listener to earth. Reversing the phone leads often increases considerably the strength of the incoming signals.—S. G.

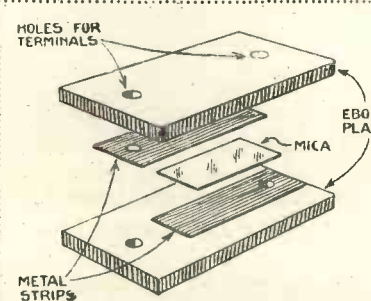

Fig. 1.—Condenser Parts.

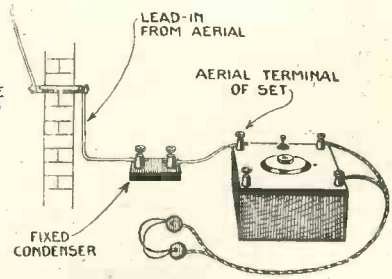
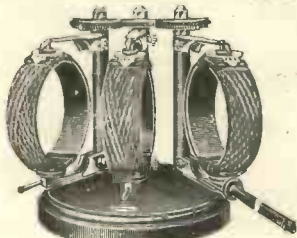
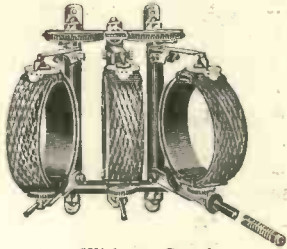

Fig. 2.—Condenser in Use.



With Stand.



Without Stand.

IGRANIC GIMBOLDER COIL HOLDERS
Specially designed for use with Igranic Gimbal type coils—by means of which extremely accurate tuning is obtained.

With stand, for 3 coils ... 21/-
" " " 2 " ... 16/6
Without stand for 3 coils ... 15/-
" " " 2 " ... 10/6

IGRANIC GIMBAL ADAPTOR
To enable a Gimbal type coil to be used in a plug type holder ... 5/-

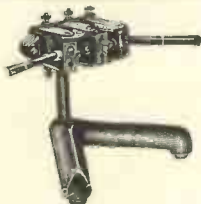

With Stand.

IGRANIC TRI-PLUG COIL HOLDER
Nickelled fittings, instrument finish.
Price with stand and ebonite operating handles ... 21/-
For panel mounting ... 15/-



Without Stand.

IGRANIC BI-PLUG COIL HOLDER
Nickelled fittings, instrument finish.
Price with stand and ebonite operating handle ... 16/6
For panel mounting ... 10/6

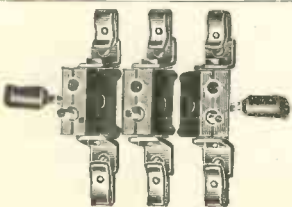

INDEPENDENT COIL HOLDER UNITS
Set of 3 with 2 ebonite operating handles and fixing brackets ... 8/6



AT Coilholder Socket

Signal Strength is at its weakest where your A.T. coil goes

THINK what this means—the least fraction of “leakage” through a faulty Coil Holder will be magnified a hundredfold. Inferior ebonite, indifferent conductor parts, closely spaced terminals and poor provision for the elimination of hand-capacity effects, are the main causes of loss in signal strength when poor coil holders are used. Look to yours—see the name IGRANIC on every holder you fit. The conductor parts and fittings are of hard brass, the ebonite used of highest quality only, the terminals widely spaced, and highly efficient anti-hand-capacity operating handles fitted.

Bi-plug and Tri-plug types have a scale and pointer to facilitate easy adjustment, and spring clip terminals in order to enable quick and reliable connection.

The fittings being triple nickel-plated, IGRANIC Coil Holders give a very handsome finish to the set.

INDEPENDENT UNITS.

In order that you may obtain IGRANIC efficiency from single holders, the tri-plug pattern is obtainable in units consisting of three holders complete with two ebonite operating handles and fixing brackets for 8s. 6d.

IGRANIC RADIO DEVICES INCLUDE:

Honeycomb Duolateral Coils, Variable Condensers, Fixed Condensers, Filament Rheostats, Intervalve Transformers, Variable Grid-Leaks, Variometers, Vario-couplers, Coil Holders, Battery Potentiometers, Vernier Tuning Devices, etc., etc.
All carry the IGRANIC guarantee.

All reputable dealers carry stocks.

Write for List Z 596.



BRANCHES:

BIRMINGHAM: 73-74 Exchange Buildings.
CARDIFF: Western Mail Chambers. GLASGOW: 50 Wellington Street.
LEEDS: Standard Buildings, City Square.
MANCHESTER: 30 Cross Street. NEWCASTLE: 90 Pilgrim Street.

Works: BEDFORD.

149, Queen Victoria Street, London.

Continental Notes

Some Adventures with a Portable Set

GOOD friends, I have crossed the Styx; I am penning these notes from the other side because it is holiday time. Have I led you to believe that I am no more in the land of the living? I trow not. No, I have crossed the Channel and, just for this once, intend to write of wireless reception on the Continent itself, of both foreign and British stations.

I am in the position of any amateur on the mainland of Europe who, in his leisure hours, potters around the ether and, in a similarly forcible way to ours, curses the local transmitter for hampering his reception of 2 L O or 5 I T or even Aberdeen, as the case may be. So here goes!

Before Broadcasting

In days of yore, my annual holiday was incomplete unless I was able to tramp the country with a heavy leather case slung over my shoulder, such a case containing an equally weighty quarter-plate reflex camera. Why this should have been so I know not, as, undoubtedly, of the many dozen negatives made but few were actually used for exhibition purposes; as to the remainder, it would have been cheaper to have bought local picture postcards of the districts visited.

To-day—well—to-day, since the advent of the wireless regime, I am still a slave to a scientific companion, and having forsaken the black, or should we say the black-and-white art, must needs lug about with me a portable two- or three-valver. (Needs must when wireless drives.)

The receiving set I have taken with me is similar, in some ways, to that described in the June issue of THE WIRELESS MAGAZINE, and, believe me, I have derived considerable enjoyment from it. I must admit that I have received much help from the designer of this set; as a matter of fact, I *looked on* whilst he made it.

For the purposes of the foreign Customs, I had suggested that it would be desirable to disguise it as a tin of condensed milk or as something equally inoffensive; I anticipated trouble and awkward questions. But no, the wireless

bug hath bitten all classes alike, irrespective of status or creed.

On my arrival at Ostend I made my way to the Douane, where I met what I thought was the most formidable excise officer I had ever encountered in my wanderings abroad. He tapped with his hand the suit-case looking arrangement I had gently laid on the counter; tremblingly I opened the catches.

"Aha," he said, "le broadcast. Vous vous occupez de T S F." (You are interested in wireless.)

I smiled; my confidence had returned to me. I expatiated on its various good points, I explained the circuit to him as, fortunately, I am at home in the French language. Luck was my way; I had struck "un sans-filiste"—an ardent amateur—who, through the interest he took in the circuit, quite forgot the fact that the apparatus was probably dutiable.

We parted excellent friends, and without more ado I got on to the Ostend-Vienna express and was soon leaving the Belgian coast far behind me. End of first lap!

German frontier. Train was late, as usual, so only a cursory examination was made by the Customs from carriage to carriage. My set *looked* like a hand-bag and I remained seated, munching sandwiches quite innocently. Soon the engine emitted its usual low-toned whistle, the stationmaster waved his magic wand, the porters stood at attention and we were on our way to Cologne. The frontier had been successfully negotiated.

I was quite at home in occupied territory and made my way out to a friend's house about 15 miles distant from the city. His "Schloss" (as all manors of a respectable size are termed in Germany) lies on top of a small range of hills, roughly 700 feet above the level of Cologne.

From there the plain stretches to the North Sea; reception of British stations should be favourable. But sufficient for the day was the evil thereof.

Next morn, figure to yourself, as our French friends say, brilliant sunshine from the earliest hour with every prospect of a record "scorcher." I was up with the—

well, whichever bird gets up first. (I really believe the lark had over slept that day.)

I dressed speedily, yet scantily, grabbed at the two-valver, and carried it to a meadow on the side of the hill, from which point I enjoyed a clear view of 30 miles around.

I threw a length of cable over two trees, as far as I could reach, plugged into the turf a short length of copper tube, connected up, twirled the condenser and listened. Speech came in clearly, and Bremen (about 170 miles), relaying the information from Hamburg, gave me a time signal, weather forecast, and the early morning news.

It struck me at the time that the good "Hamburgers" must have been out to catch the early worm or whatever other dainty they favoured for their breakfasts. I do not know whether the sleepy-headed Britons would enjoy a news bulletin broadcast at 6.45 a.m. Would not the announcer have some difficulty in suppressing a yawn?

"Accompaniments"

Apart from that, with the studio window open, the whistling of the engines at Charing Cross would, no doubt, mingle with the sounds of rattling milk-cans as the "moo-man" deposits them on the front door steps of the Adelphi.

Later, an added coil, a different condenser setting brought in the "pronostiques météorologiques de la Tour Eiffel."

Of course, both Frankfurt (100 miles) and Münster (75 miles) were within easy range, and owing to their different wavelengths there was no question of the two transmissions interfering with one another.

This was the amateur's paradise, as, owing to the restrictions made by the occupying authorities, there was no local broadcaster to hamper one's reception of more distant stations.

Can you imagine a spot where one does not pick up a howl, where one possesses no oscillating neighbour nearer than about 75 miles away? There are a few favoured members of the Armies of Occupation who are allowed wireless receiving sets within the prohibited zone, but they

never, never oscillate. (What, never? Well, hardly ever!)

The same friend lent me a second L.F. amplification unit, so, adding a small loud-speaker to the outfit, I made my way in the evening to my chosen spot on the hill. Atmospheric conditions appeared favourable, so I tuned-in to 2 L.O.

The sound of a step crunching on the stony path the other side of the fence caused me to turn round. A burly farm labourer—a typical blonde German giant—stood leaning up against the broken stile, spade, rake and pitchfork thrown across one shoulder.

"Guten Tag," he began, quite pleasantly, "Pig Pen."

At first I did not quite follow the remark, but the loud-speaker was booming out the chimes and the truth dawned upon me.

"My friend," I said, in my best German, "you are right first time! This is the great Benjamin's voice, but, mark you, in London, even in our most depressed political moods, we do not refer to him as Pig Pen. Big Ben as much as you like. Moreover, how did you know?"

Every Night

"Die Grosse Glocke" (the big bell), he replied. "From over there, from the Englishman's house on the hill, I hear it every night as I come home from my work. I could not believe it at first, but he proved that what he said was true, as the trumpet spoke words which are not of our language. It is the tongue of your troops in Cologne."

Shades of the B.B.C.! This seemed to be a base insinuation levelled against the perfect English spoken by the 2 L.O. announcer, but there was no German equivalent for the word in my vocabulary so, like Brer Rabbit, "I lay low and sed nuffin'."

Lying on my back in the meadow, in the stillness of the July night, I listened in turn to Radio-Paris, Radio-Toulouse, Bournemouth, 5 X X, Hamburg, Vienna, Zurich, and Prague.

One of the last items tuned-in was the news bulletin broadcast by 5 X X at 10 p.m., and the sound of the English voice breaking the quietude of the night brought my friends from "the big house on the hill" nearer home. "5 X X calling!"

Do you realise what this means to Britons abroad? JAY COOTE.



Useful "Amateur Wireless" Handbooks

Each 1s. 6d. net, of all Booksellers and Newsagents, or 1s. 9d. post free from "Amateur Wireless," La Belle Sauvage, E.C.4

Simple Crystal Receiving Sets and How to Make Them

A Simple and Efficient Receiving Set. A Single-Slider Set. Set with Semicircular Tuner. Crystal Set with Tapped Single Coil. A Loose-Coupled Set. Set with Plug-In Basket Coils. Combined Crystal and Valve Receiver. Some Miniature Receiving Sets. Crystal Circuits. How Crystals Work. Making a Buzzer. Receiving C.W. Signals on a Crystal Set. Making a Wavemeter from a Crystal Set. Converting Low-Resistance Phones. The Morse Code.

Simple Valve Receiving Sets and How to Make Them

A Single-Valve Set with Basket-Coil Tuner. A Single-Valve Set with Slide Inductance. A Single-Valve Heterodyne Receiving Set. One-Valve Variometer Set. A Portable Single-Valve Set. Adding a Valve. A Two-Valve Set. A Three-Valve Amplifying and Detecting Unit. The "Amateur Wireless" Unit Set. An Improved Unit Set.

Wireless Telephony Explained

The Electron; Induction and Electro-Magnetism; Waves and How They Travel; Inductance and Capacity; Rectification; Amplification; Reaction and Beat Reception; Aerials and Earths; Transmitting Systems; Receiving Sets; Useful Formulæ and Data.

Wireless Telegraphy and Telephony & How to Make the Apparatus

General Principles of Wireless Telegraphy. Some Informative Experiments. Tuning and Resonance Explained. Transmission and Reception. Various Detectors Explained and Described. Thermionic Valves as Detectors, Amplifiers, and Generators. Making a Single-circuit Receiving Set. Making a Complete Short-wave Receiving Set. Making a Valve Panel for Receiving Set. Making a Five-valve Amplifier.

Wireless Component Parts and How to Make Them

Components and Their Varied Purposes. Crystal Detectors. Coils: Making and Mounting. Condensers. Variometers and Vario-Couplers. Resistances or Rheostats. Transformers. Making a Test Buzzer.

Cassell's

The Boy's Book of Wireless

ERNEST H. ROBINSON

By the aid of this splendid book you can gain a thorough knowledge of what Wireless is and how it works. With 8 Half-tone Plates and 150 line diagrams. 5s. net.

Cassell's

That Book you want!

Foyles can supply it. Immense stock (second-hand and new), on Wireless, other Technical, Scientific and all other subjects.

Write for Catalogue 567 (free), mentioning requirements. Books sent on approval.

That Book you do not want!

Foyles will buy it—a single volume up to a library.

FOYLES, 121 Charing Cross Road, London, W.C.2.

The Home for Your Wireless Set!

MORRIS SOLID OAK STANDARD CABINET WITH LOCKS,

to lock up any set and batteries with panel up to 36" x 18"

Sent on Approval.

Trade Supplied.

Price carriage paid and packing free:

22" wide inside £4 15

25" " " £5 0

36" " " £8 0

MAKERIMPORT CO.

(Dept. 25)

50a, Lord Street, LIVERPOOL.

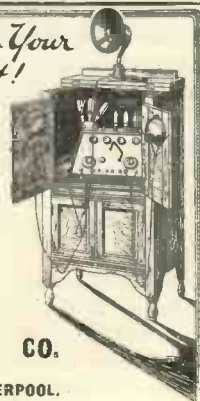

In writing to advertisers, please say you saw the advertisement in THE WIRELESS MAGAZINE.



What the Reader Thinks

Frame Aerials for Crystal Sets

To the Editor of "The Wireless Magazine."

SIR,—I would like to hear some of your readers' opinions on frame aerials for crystal sets. I myself have been experimenting with frame aerials and, so far, I have had very good results.

Situated about two miles from 5 S C in a tenement house, an outdoor aerial is out of the question. I tried running four wires along the roof of my room about a foot apart, and also various other ways. I then made a frame three feet square, wound with fifty feet of No. 20 gauge d.c.c. wire, and connected the beginning and the end of the winding together.

When connected to the set in the usual manner, that is, one wire from aerial to set, and one wire from earth to set, I had better results with this aerial than with any other. I don't suppose this is anything new, but it may help readers placed in a similar position. Wishing your valuable paper every success.—A. H. DOBBIN (Glasgow).

That Amplification

SIR,—With regard to the respective merits of high- and low-frequency amplification, probably my experiences will throw some light on the matter.

I have received the Glasgow station, using a crystal and one stage of low-frequency amplification.

With a crystal and one high-frequency I can tune-in six B.B.C. stations, besides three Continental stations.

By inserting a transformer and changing to a reflex circuit with crystal detector, I receive at good strength all the B.B.C. stations (except Belfast), Breslau, Hamburg, Barcelona, Madrid, W G Z and W J Z (America).

Although signals can be received with only L.F. amplification, in my opinion the operation of tuning is so critical and tedious that the exclu-

sion of H.F. amplification is not warranted.

Furthermore, I believe that anything to be received can be received with one stage of high-frequency amplification only, L.F. amplification being added as desired.—STEPHEN F. RUSSELL (St. Albans).

Hand-capacity Effects

SIR,—I noticed, in a recent issue of THE WIRELESS MAGAZINE, some comments on hand-capacity effects, especially when using a series aerial condenser.

Having had trouble in this direction myself, I tried the effect of using a thick rubber glove when tuning-in, and was really astounded

To the writers of the letters printed on this page we have awarded Marconi-Osram Valves. The writers of the letters printed next month will receive Cossor Valves.

at the difference this made in bringing in distant stations.

Another great advantage, especially when using dull-emitters, as I do, is the placing of soft rubber pads on the base of the cabinet.—W. HARDING (South Shields).

Results with a Crystal Set

SIR,—I am situated approximately 12 miles from Stoke and 30 miles from Manchester, and use a home-made crystal set tuned by a flat variometer of peculiar design.

One night recently I connected a lead on to my wire mattress for an aerial and another to the heating pipes for an earth. Neither was soldered. Using a cheap single phone I clearly received both 6 S T and 2 Z Y.

I was extremely surprised, and put it down to freak reception. The next night, however, I tried again, and obtained the same results. This went on until, with the advent of the long evenings, signals faded. They are now too weak to be worth

the trouble of setting the crystal.—JOSEPH A. HADLEY (Stoke-on-Trent).

Dust

SIR,—Most amateurs zealously clean away any dust that accumulates between valve legs, etc., on the undersides of their panels, but seldom give a thought to the dust that always gets on the topsides of their panels, which is of course just as undesirable. This is especially important with regard to switches, etc.—W. A. HAWKINS (Rugby).

Appreciation from Natal

SIR,—From a distance of some seven thousand miles THE WIRELESS MAGAZINE is read with the keenest of interest and will be looked forward to each month, kept and bound as each volume is published.

You must be congratulated for this fine publication. The coloured plates and blueprints are most useful to beginners.

The components required for some of the wonderful sets are a bit difficult to obtain by amateurs in this country, but I am going to make an attempt at one of the sets.

Wishing your magazine the success it deserves.—L. F. McCLINTOCK (Natal, S. Africa).

A GOOD wireless set is too precious to be allowed to depreciate by getting damp. At this time of the year, too, many lady bathers at the seaside seem to think the same thing about themselves.

A WRITER says that English will become the international wireless language. The possibility of having to learn it, in this event, is being viewed with alarm by hundreds of London listeners.

WITH their wireless van Scotland Yard recently captured a "wanted" taxi-driver. We understand they broadcast a noise like a sixpenny tip, and thus threw the victim off his guard.



Honest—

Upon the river's bank serene,
A fisher sat where all was green,
And looked it.

He saw when light was growing dim,
The fish, or else the fish saw him,
And hooked it.

He took with high erected comb
The fish, or else the story, home,
And cooked it.

Recording angels by his bed,
Weighed all that he had done or said—
And booked it.

ANON.

Player's Navy Cut Cigarettes.



'It's the Tobacco
that counts.'



P.1201

Now Ready.

Price 5s. 6d.

A Text-Book of WIRELESS Telegraphy and Telephony

By W. GREENWOOD, B.Sc. (Eng.), A.M.I.E.E., A.C.G.I.,
Wireless Engineer, His Majesty's Signal School, Portsmouth.

In this book the subject of wireless telegraphy and telephony has been dealt with simply and concisely, yet scientifically and adequately. The instruments, apparatus and circuits in amateur sets, in radio-stations, in aeroplanes, and on ships receive full treatment, and at the same time the essential theory underlying the whole subject is thoroughly investigated and explained.

A Descriptive Prospectus of the above and Complete Catalogue of Educational Books post free on application.

UNIVERSITY TUTORIAL PRESS, LTD.,
25, High St., New Oxford St., London, W.C.2.



THE POPULAR PELICAN

Why go to the trouble and expense of dangling unsightly aerials and complicated apparatus when you can enjoy the Broadcast programmes with the Pelican self-contained Wireless Set.

The Pelican is absolutely portable, it has only one control and gives perfect reception at all times. There are no extras—the Pelican is sold complete with valves, batteries and all equipment including loud speaker or earphones from £12. As an added feature every set has attachments for outside aerial and earth, and is fitted for long-wave coils. The Pelican is also fitted with the Univernier Micro-Selective Tuning Dial. In performance and service the Pelican is better than many sets at twice the cost.

NO AERIALS, NO EARTH, NO TROUBLE.

Write or 'phone us for a free demonstration in your own home.

PELL CAHILL & COMPANY LTD.,
Manufacturers of Radio Apparatus,
64, Newman Street,
LONDON, W.1.

Telephone : Museum 9236.
Telegrams : "Pelcarad, Wesdo, London."



THIS
IMPROVED



MEANS
INSULATION
ATHOL components.

Send for list of

Reversible
VALVE HOLDER
SPECIALLY SUITABLE FOR
BASEBOARD
MOUNTING

and can be used back or front of
Vertical and Horizontal panels
We will send goods post free
if you mention dealer's name

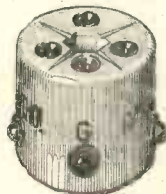

Athol ENGINEERING CO
CORNET STREET, H. BROUGHTON, MANCHESTER

1/3
each.

In writing to advertisers, please say you saw the advertisement in THE WIRELESS MAGAZINE.

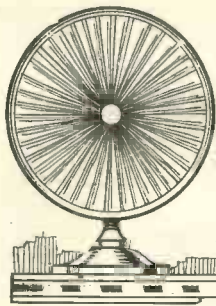

Questions Simply Answered

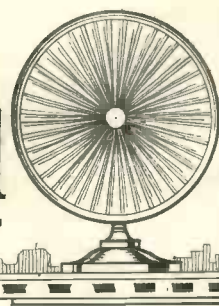

Falling-off in Signal Strength

Q.—I have noticed a curious, but rather pronounced, falling off in signal strength during the last few weeks. I feel sure it is due to no fault in the receiver, as I have checked and cleaned all connections, and even renewed the H.T. battery, etc.

Can you suggest a probable cause and remedy?—F. M. (Somerset).

A.—Your trouble is by no means uncommon, especially at this time of the year. For reasons that are difficult to explain definitely, reception during the summer months is generally poorer than during the winter.

Keep your earth connection clean, and if a buried plate is used for the earth, be sure that the surrounding earth is kept in a moist condition.

Apart from paying attention to the usual points for maintaining efficiency we are afraid that you cannot obviate the natural tendencies of decreased signal strength in summer-time.—P. A. Z.

L.T. Supply for Portable Set

Q.—As I am contemplating the construction of a portable set I should like your advice as regards L.T. supply.

For D.E. valves it is often suggested that dry batteries are suitable, but as I shall be using at least three valves, will this recommendation still hold good?—F. G. (Pendleton).

A.—Apart from the question of constant current supply there is also that of weight to be considered.

There are undoubtedly many reliable makes of dry cell suitable for D.E. valves, but in order to supply the demand of three or four valves a fairly large dry battery is necessary.

Several firms market very useful unspillable 2-volt cells which, in addition to having fairly satisfactory capacities, are also light in weight and should prove an asset to any portable receiver used.—C. P. T.

Lightning Dangers

Q.—Having just installed a wireless receiver, I should be pleased to learn whether these lightning dangers of which one hears are real or fancied.—H. J. (Glos.).

A.—These dangers are very real indeed, and every amateur will do well to guard against them.

You are advised to fit on aerial earthing switch, which entirely disconnects the receiver from both the aerial and the earth.

This switch should preferably be

placed outside the house and mounted upon some material that will not easily ignite.

Always ensure that the aerial is switched to earth when the set is not in use. An added precaution is the inclusion of a lightning arrester across the aerial and earth terminals for safety when the set is actually in use.—L. A. C.

Position of Grid Leak

Q.—I have noticed quite a number of different positions for the grid leak in multi-valve tuned-anode sets and cannot understand why these connections should vary. Will you please enlighten me?—R. F. (Manchester).

A.—The position for the grid leak in a multi-valve set depends upon the duty of the valve to whose grid the leak is attached.

For instance, an H.F. amplifying valve invariably requires a negative grid potential, therefore the leak should be joined between the grid of the H.F. valve and negative L.T.

A detector valve, however, often

works best when its grid is given a positive potential, therefore the leak is generally joined between grid and positive L.T.

The grid leak must never be joined across the grid condenser when tuned-anode H.F. amplification is employed.—GRID.

Current Passed by Electric Lamps

Q.—How may I ascertain what current is passed by electric lamps? The only known quantities are the voltage and the wattage of the lamps.

The information is required for charging purposes when employing D.C. mains.—H. C. (Windsor).

A.—Knowing the voltage and the wattage of the mains and the lamps, it is a simple matter to determine the current passed by the lamps.

Watts = volts × current. Therefore

$$\text{Current} = \frac{\text{watts}}{\text{volts}}$$

For example, taking a 60-watt lamp for 110-volt mains, the current passed is:

$$\frac{60 \text{ w.}}{110 \text{ v.}} = \text{amps.}$$

$$= 0.54 \text{ amps. approx.} \text{—B. K.}$$

YOU CAN'T SOLVE IT ?

You don't know to where that connection should go or why your set works well one day and badly the next ?

Well, why worry ? We keep a staff specially to solve such problems as yours. Let them have your queries so that they may give you the benefit of their long and varied experience.

Replies to queries of general interest are published each month on this page, but every querist is answered direct by post.

Please observe the following conditions :

Ask one question at a time; write on one side of the paper only; attach to your query the coupon on page 103, and send it with a stamped addressed reply envelope to: The Editor, "The Wireless Magazine," La Belle Sauvage, London, E.C.A.

Remember Our Query Service is Free!

Position for Filament Rheostat

Q.—Where do you advise me to place my filament rheostats; in the negative or the positive lead of the L.T. battery?—S. V. (Cardiff).

A.—Filament rheostats should always be wired in the negative lead of the L.T. accumulator. This is very important in multi-valve sets, but need not be adhered to in a single-valve detector set.—L. A. C.

Condenser Across Primary of Transformer

Q.—Why is it that a fixed condenser is usually shunted across the primary of a low-frequency transformer?—D. C. (Maidstone).

A.—The generally accepted theory is that this condenser affords a by-path for high-frequency currents.

In addition to this, however, the condenser alters the audible-frequency amplifying curve of the transformer and often improves loud-speaker reproduction from an otherwise poorly designed amplifier.

The condenser across the loud-speaker or phones performs the same duties.—GRID.

Our Cross-word Puzzles

CLUES

In the upper wires—up and down—
 Something that's worth quite half-a-crown;
 But in the lower—t'other way—
 Is all that anyone has to pay!

Across

3. Personal. 4. A pair of terminals. 6. A conductor. 7. Resistance. 9. A sheet. 10. A gas. 12. Colour of some panels. 13. Connecting H.T. to filament. 15. Toughen. 16. Extracts metal. 17. A process. 23. What some valves do. 28. After "counter." 29. Wireless medium. 30. What 6 (down) also is. 31. You. 32. Floats on water. 33. Design. 34. Same as 31.

CLUES

Down

1. Distribute again. 2. Head-gear. 3. Enthusiasm. 5. Unit of heat. 6. A cloak. 8. Not less. 9. Shut up. 11. A small hill. 12. Tin. 14. Correct. 18. A primary terminal. 19. Added to 5, writes for "A.W." 20. Gladly. 21. A composition. 22. Critically examined. 23. Keep waiting. 24. About morals. 25. They. 26. Ease. 27. The better side.

AN amateur says he has picked up the Eiffel Tower three nights in succession. We suppose that by the rules of the game it now becomes his own property.

THE PANEL DE LUXE



GOOD news travels apace—and it is not surprising, therefore, to find that wireless enthusiasts are gladly paying the few shillings extra for Radion Panels. Already they have realised that at a very small extra cost they can insure against surface leakage and all the deadly ills to which cheap ebonite is prone.

Radion is available in 27 different sizes in black and mahogany. Radion can also be supplied in any special size. Black 1d. per square inch, mahogany 1 1/2d. per square inch.

RADION

Trade Mark

American Hard Rubber Company (Britain) Ltd.

Head Office: 13a Fore Street, London, E.C. 2
 Depots: 120 Wellington Street, Glasgow.
 116 Snow Hill, Birmingham.

Irish Agents: 8 Corporation Street, Belfast

G.A. 3037.

A FINISH TO FIDDLING

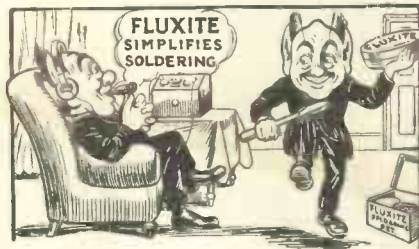

There's no tinkering about with joints once the wiring of your set is soldered.

A soldered circuit is one unbroken piece of metal. It will never need another moment's thought.

Soldering is simple with FLUXITE. It becomes a job anyone can do without a chance of failure. Men who are soldering all day long don't attempt to work without it.

Ask your Ironmonger or Hardware Dealer to show you the neat little

FLUXITE SOLDERING SET

It is perfectly simple to use, Price 7/6 and will last for years in constant use. It contains a special "small-space" Soldering Iron with non-heating metal handle, a Pocket Blow-lamp, FLUXITE, solder, etc., and full instructions. Price 7/6. Write to us should you be unable to obtain it.

FLUXITE SIMPLIFIES SOLDERING

All Hardware and Ironmongery Stores sell FLUXITE in tins. price 8d., 1/4, and 2/8.

Buy a Tin To-day.
 FLUXITE LTD. (Dept. 332), West Lane Works, Rotherhithe, S.E. 18



ANOTHER USE FOR FLUXITE. Hardening Tools & Case Hardening. ASK FOR LEAFLET on improved methods.

In writing to advertisers, please say you saw the advertisement in THE WIRELESS MAGAZINE.

Notings on the Month's Progress

THE possibility of transmitting wireless signals in such a way that they can be heard only by specially equipped receivers is one of general interest. The project is quite simple in theory but presents many difficulties in practice. If, for instance, an ordinary broadcasting station varied the length of its carrier wave in some periodic but irregular manner, the ordinary selectivity-tuned receiving aerial would only pick up unintelligible fragments of the transmission.

This could, of course, be overcome by continually changing the tuning of the receiving aerial so as to keep it constantly in step with the transmitting aerial, in which case the whole message would be heard. The difficulty, however, is to discover a simple and economical, yet at the same time reliable, method of synchronisation. The same difficulty, in fact, lies at the root of the problem of television.

A more thoroughly secret system consists in abstracting at the transmitting station certain of the side-band frequencies formed by the mixture of carrier and microphone currents.

In addition, the natural voice frequencies can be distorted or inverted, so that the low tones become high-pitched, and vice versa. The receiver is fitted with a local oscillating valve to replace the missing carrier-wave components, and with a second modulator to reverse the deliberate distortion and restore the original speech-form of the transmitted signal.

Any ordinary type of receiver, whether crystal or valve, tuned-in to the original carrier wave would only pick up an unintelligible jumble of sounds.

Telephoto Transmission

The latest contribution to the problem of transmitting pictures telegraphically comes from Germany. An engineer named August Boss claims to have perfected an apparatus capable of sending a complete picture over a line wire in a small fraction of a second.

Tests have been carried out over a distance of thirty miles, and are

stated to have been remarkably successful, reproduction at the distant station being practically instantaneous.

If the method can be successfully applied to wireless transmission, it will bring the problem of wireless television within measurable distance of success.

Bottled Wireless

It is understood that the B.B.C. are considering the question of making a permanent record of certain transmissions so that they may be subsequently repeated for the benefit of those unable to listen to the original performance. This appears to be an excellent suggestion as regards items of historic interest or outstanding merit.

It would also enable the B.B.C. to fill in the vacant morning hours in an economical way by repeating selected extracts from the previous night's programme. There are certain difficulties, however, in making a gramophone record directly in the microphone room. It has been suggested to pass part of the microphone current through a separate series of amplifying valves, and to utilise the output to control a heated stylus which then traces out a direct record on a gramophone disc.

Alternatively a recorder of the electromagnetic type could be em-

ployed in which the voice frequencies are permanently impressed as magnetic images upon a metal film or ribbon, as the latter is moved slowly across the poles of an electro-magnet energised by the microphone currents. To reproduce from such a record, the magnetised strip is unwound between the poles of a second magnet which in this instance carries windings inserted in series with the grid of an amplifying valve.

The use of such recorders opens up a fascinating prospect for the future. We shall see emissaries of the B.B.C. scouring the world for new and strange effects not otherwise to be imported into the transmitting studio. A short speech by the Dalai Lama in Tibet, the roar of Niagara Falls, typical vocal efforts ranging from the war-cries of the savages of Central Africa to the love songs of the Esquimaux at the Pole, are some of the many titbits that may serve to mitigate what some consider the monotony of the daily programmes.

Short-wave Tests

It is interesting to note that several English and French amateurs have succeeded in exchanging signals with Mr. Schnell of the A.R.R.L., at present operating from an American warship cruising in the South Pacific. During the day a standard wavelength of 20.54 metres is emitted. For night work this is increased to 54.40 metres. These very exact emissions are rendered possible by using an "oscillating" quartz crystal for stabilising transmitting circuits and so keeping an absolutely constant wavelength.

In addition, there are frequent special signals sent out on 20, 40 and 80 metres. The power used is one kilowatt, and the call sign is NRRL. During the daytime Mr. Schnell tunes-in to receive signals between 20 and 40 metres, and at night between 75 and 125 metres.

B. A. R.

An American journal prints an article on its conception of a wireless paradise. We presume it is a place where there are no L-shape aerials.

OUR CROSS-WORD PUZZLE SOLUTION



Solution of July Puzzle.

The World's Broadcasting

PRINCIPAL EUROPEAN STATIONS

Wavelength Metres.	Station.	Call Sign.
260	Norrköping	S M V V
265	Brussels	—
265	Joenköping	S M Z D
270	Malmoe	S A S C
275	Radio-Toulouse	—
279	Bremen	—
288	Cassel	—
290	Gothenburg	S A S B
292	Dresden	—
296	Hanover	—
300	Cadiz	—
300	Cartagena	—
302	Sheffield	6 F L
306	Stoke-on-Trent	6 S T
310	Bradford	2 L S
315	Liverpool	6 L V
325	Barcelona	E A J 1
326	Nottingham	5 N G
328	Edinburgh	2 E H
331	Dundee	2 D E
335	Hull	6 K H
335	Madrid	E A J 2
338	Plymouth	5 P Y
340	Nuremberg	—
345	Bloemendaal	—
345	"Le Petit Parisien"	—

Wavelength Metres.	Station.	Call Sign.
345	Trollaattan	S M X Q
346	Leeds	2 L S
350	Seville	E A J 5
353	Cardiff	5 W A
365	London	2 L O
370	Falun	S M Z K
370	Helsingfors	—
370	Karlstadt	S M X 9
370	Madrid	E A J 20
378	Manchester	2 Z Y
382	Oslo	—
385	Warsaw	P T R
386	Bournemouth	6 B M
392	Madrid	E A J 6
395	Hamburg	—
403	Newcastle	5 N O
404	Graz	—
410	Münster	—
415	Bilbao	E A J 8
418	Breslau	—
422	Glasgow	5 S C
425	Rome	1 R O
425	San Sebastian	E A J 18
427	Stockholm	S A S A
433	Barcelona (Radio Catalana)	E A J 13
439	Belfast	2 B E
443	Stuttgart	—
450	Moscow (Trades Union Council)	—
454	Leipzig	—
458	L'Ecole Sup.	P T T
463	Königsberg	—

Wavelength Metres.	Station.	Call Sign.
470	Frankfort-on-Main	—
479	Birmingham	5 I T
482	Swansea	5 S X
485	Münich	—
490	Madrid	A R E
495	Aberdeen	2 B D
500	Berlin (Witzleben)	—
505	Berlin (Vox Haus)	—
515	Aalesund	—
515	Zurich (Höngg)	—
530	Vienna (Radio-Wien)	—
545	Milan	S I T I
545	Sundsvall	S A S D
555	Prague (Strasnice)	—
565	Buda-Pesth (Csepel)	—
775	Copenhagen (Kjobenhavns Radiofoni)	—
800	Lausanne	H B 2
950	Buda-Pesth (Csepel)	—
1,010	Moscow (Sokolniki)	—
1,060	Hilversum	H D O
1,190	Ryvang	—
1,300	Königswusterhausen	L P
1,450	Moscow (Central)	—
1,600	Daventry	5 X X
1,650	Belgrade	—
1,750	Radio-Paris	C F R
1,800	Brünn	O K B
1,955	Amsterdam	P C F F
2,200	Eiffel Tower	—
2,400	Lyngby	O X E
2,500	Boden	S A S E
2,650	Eiffel Tower	—

PHONES, 4,000 OHMS

Featherweight	4/9
N.K. Pattern	6/9
Special Line	7/9
Aluminium	8/6
Foth adjustable diaphragms	9/6
Dr. Nesper, latest type	12/6
TELEFUNKEN Lightweight Genuine E.H. 333 Pat. adjustable diaphragms	15/6

LOUDSPEAKERS

Nesper	19/6
C.A.V. Tom-tit	30/-
Amplion Junior	27/8
Telefunken Jewel	19/6
Telefunken Pearl	30/-

VALVES

Farmer Valve	4/-
Dutch Detector	3/10
" Amplifier	3/10
" Power	4/6
Marconi	8/-
Coscor	8/-
Phillips	6/-
Telefunken	7/6

Chelmsford Coils	1/9
Sets of Basket Coils	1/9, 1/11
Matchless Coils	2/3, 2/9
Mounts for same, each	10d.
Wave Traps (Cut out unwanted Stations)	54/-
Set of 5 Coils, mounted, 25, 35, 50, 75, 100	10/-

Special Soldering Irons ... 61d.

NOT OPEN SUNDAY

ASK FOR SPECIAL PRICE LIST.

TELEPHONE :
NORTH 2351

HENRY KENNETT

11, LIVERPOOL ROAD, ISLINGTON, N.

ESTABLISHED
1861

Variometers	2/6, 2/11, 3/6, 6/6
Voltmeter	5/-
Combined Voltmeter and Ammeters	6/-
Voltmeters reading to 100	10/6

AERIAL WIRE

Ribbon Aerial, 100 ft. K Brand	2/3
7/22 Hard Copper	2/3
5/28	1/11
Electron Wire	1/8
Hekoo Phosfor Bronze 25% better reception 110 ft. non-corrosive	3/3
Climax Earth	5/-

CRYSTALS

R.I. Detectors	6/-
Tungstallite	1/6
Hertzite	1/-
Neutron	1/6

Square Law Condenser, with dial, .0005, 6/6; .0003, 5/6	
With Vernier, 1/- extra.	

H.T. Batteries, 30 Volt	3/9
" 60 Volt	6/9
Pocket Batteries, doz.	4/6
B.T.H. Dry Cell for Dull Emitter Valves, each	2/-

Grid Leaks	2/-
Lissen Grid Leak	2/6
Phone Cords	1/6

TRANSFORMERS

Croix, 8/- ; Igranic, 21/-	
R.I., 25/- ; Simplex, 7/6	

Flush Valve Sockets	4 for 6d.
Red and Black Spade Terminals	each 2d.

Phone Terminals, with Nuts	1 1/2d.
Terminals with Nuts	1d.
Extra Large, with Nuts	1 1/2d.
Crystal Cups	2 for 1 1/2d.
Crystal Cups, Improved	1 1/2d.
Shellac Varnish	9d.
Valve Legs, with Nuts	1d.
Valve Sockets, with Nuts	1d.
Spade or Pin Terminals	1d.
Switch Arms	7d.
Studs, with Nuts	doz. 6d.
Stops, 2 1d. Wander Plugs pair	3d.
Twin Flex	yard 2d.
Lead-in Wire	2 1/2d.
Earth Wire	2d.
Adhesive Tape	roll 3d.
Insulated Hooks	each 1d.
Insulated Staples	doz. 3d.
Panel Transfers	sheet 4 1/2d.
Sleeving, yd., 3d. Rheostat	1/10
Solder for Panels	stick 3d.
1/2" Square Panel Wire 12 ft.	9d.
Special Lightning Switch	1/-
Fluxite, 8d. Outfits	7/6
Rawplug Outfits	3/6, 5/-
Red and Black Twin Flex, yard	2d.
Copper Foil, 6 in. wide	foot 6d.
Earth Clips	2 1/2d.
Fibre strip for coil mounting yd.	3d.

BEST SHEET EBONITE

6 x 6	1/6	1/6	12 x 12	4/-	6/-
9 x 6	1/6	2/3	15 x 12	5/-	7/6
9 x 9	2/3	3/4	15 x 15	6/3	9/3
12 x 6	2/-	3/-	24 x 12	8/-	12/-
12 x 9	3/4	4/6			

Oldham Accumulators, all sizes.
ORDERS OVER 2/6 CARRIAGE PAID, BY RETURN OF POST.

In writing to advertisers, please say you saw the advertisement in THE WIRELESS MAGAZINE.

Broadcasting Below the Belt

HOLIDAYS will be now claiming many of us and it is likely that there will not be much practical work done in the wireless way. There is likely to be a deal of thinking, though, and the making of plans.

A holiday away from any possibility of "messaging about" with one's apparatus is a good thing in that it enables a definite programme to be laid out. Whether it is followed or not, a programme is beneficial. It crystallizes our difficulties for us.

Short-wave Work

To those who have not yet gone in for short-wave work but who are hankering to do so I would say—don't hesitate any longer. The great beauty of experimental work below the broadcast belt is that it does not require any expensive apparatus. All it needs is patience and some knowledge of wireless. Coils made from a few turns of thick wire are all that are necessary for tuning, together with one or two really good variable condensers of about 00025-micro-

are the results that can be obtained. A detector and one stage of note magnification are all that are required.

If the reading of morse signals is aimed at it is not even necessary that the intervalve transformer shall be of special make. A transformer

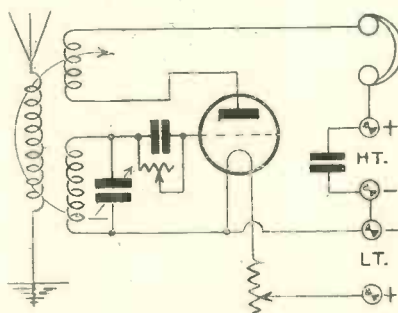

Fig. 2.—Ordinary Straight Circuit.

discarded from an old set because it distorted telephony will often prove the very thing for giving loud, clear morse. This is specially the case with ex-W.D. transformers, which were specially made for the maximum amplification of morse signals.

Some Circuits to Try

My favourite circuit for short-wave work is the Reinartz, which is shown in Fig. 1. It may be said at once that the coils used in short-wave working should be "low loss."

The ordinary straight reaction circuit appeals to many experimenters, but it has a disability. Any alteration of the coupling of the reaction coil alters the wavelength, which is not a good thing when dealing with the extremely sharp tuning necessary in this kind of reception. The lower we dive after the transmissions of our enthusiastic amateurs the worse the disability becomes. Two useful forms of the ordinary straight circuit are shown in Figs. 2 and 3. They are quite useful between 50 and 200 metres.

The Hartley circuit is shown in Fig. 4. This arrangement necessitates the use of tapped coils for the secondary; but it is quite easy to make basket-weave coils with tapings, or the coil can be arranged as an air-supported solenoid.

The Use of the Choke

It will be noticed that in the Reinartz circuit a choke coil is used between the plate of the detector valve and the phones, or the primary of the intervalve transformer when a second valve is part of the circuit. This choke coil is necessary to keep the H.F. oscillations from straying. A 250- or 300-turn plug-in coil can be used, but I find it better to wind a special choke consisting of 300 turns of No. 26 d.c.c. wire on a 2½-in. former of cardboard. For very short wavelengths it is sometimes an advantage to use a smaller number of turns.

When the short-wave receiving set is connected straight on to the aerial—I mean the outdoor aerial—it may be found that on some point between 100 and 200 metres the set stops oscillating.

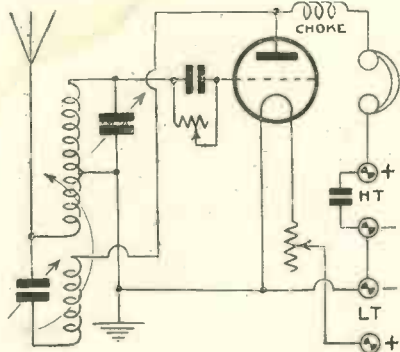

Fig. 1.—Reinartz Circuit.

farad maximum capacity, and there are half a dozen or so circuits that can be tried.

There is no need to worry about the difficulties of high-frequency amplification, as advanced experimenters have definitely proved that the simpler the circuit the better

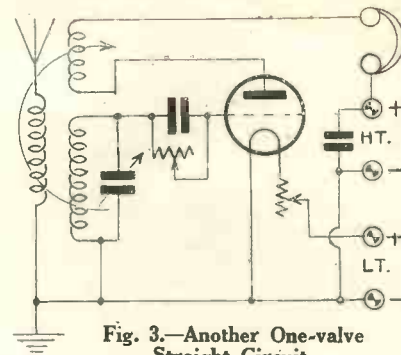

Fig. 3.—Another One-valve Straight Circuit.

This point is the actual wavelength of the aerial system. To get over this difficulty it is necessary to place a condenser in series with the aerial coil which, for this kind of work, has always a few turns of wire coupled with the secondary or grid coil. This condenser

should be of the air-dielectric type, and I used to make up special condensers of about .00025-microfarad capacity. I have recently found, however, that better results can be obtained by using a variable condenser.

A maximum capacity of .0005 microfarad is a useful size, but .00025 microfarad will serve; the only difficulty is that it does not give much margin, generally having to be "all in" to give useful results. On very short wavelengths I have found a "dual" condenser of the type used to tune two high-frequency circuits at once very useful.

In this case I connect in a special way. The fixed plates are connected to the aerial and the moving plates to the coil. I fancy the maximum capacity given by this arrangement is in the neighbourhood of .000125 microfarad, but I have not measured it. The series condenser put in circuit in this way seems to give very good results in the neighbourhood of 20 metres. There is one "crab." It means another adjustment to be made; but I find that once it has been set it can be left

alone over a considerable wavelength band.

For reception on waves below 50 metres it is usually necessary to use an aerial shorter than that commonly used for broadcast re-

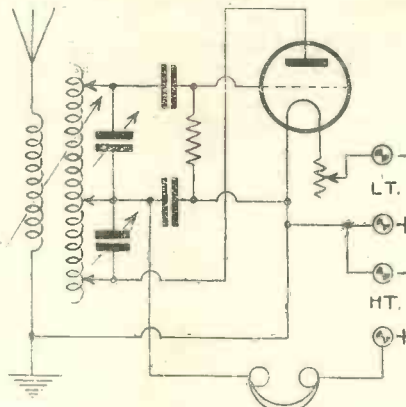

Fig. 4.—Hartley Circuit.

ception, though I have had very strong signals between 30 and 40 metres on an ordinary P.M.G. aerial, using the series condenser mentioned above. But it is a common experience that these short-wave signals come in very often without any aerial or earth

at all. I have received K D K A's 68-metre telephony without any aerial or earth connections at very good strength, very little less than when the set was connected to the outdoor aerial.

A very good aerial for short-wave work can be made by stretching about ten metres of wire round the room, or even ten feet across the room. The earth connection can consist of a counterpoise made by putting a "fan" of insulated wire beneath the carpet of the room, taking care that the free ends of this counterpoise are not bare.

Hand-capacity effects are sometimes troublesome in short-wave tuning, but they can usually be overcome by using condensers in which the moving plates are connected to a metal frame and end-plates. In this case the moving plates should always be connected to the low-potential side of the circuit—otherwise the earth side.

It is essential to keep the coils well away from the condensers and to provide long handles with which to make adjustments.

5 Y M.

Reliable Reception

chiefly depends upon your choice of accessories and component parts. We have always placed foremost the matter of dependability allied with reasonable cost. These three examples go to prove that we have succeeded in our aim.

PYRAMID HIGH TENSION BATTERIES ARE BRITISH MADE THROUGHOUT

Complete "Freedom from Noises." Constant Voltage.

PRICES:
15 Volt - 2/9
33 Volt - 6/9
60 Volt - 11/9
90 Volt - 17/9



"K" AUTOMATIC CRYSTAL DETECTOR

Ends all Crystal Troubles. Stop fiddling with that catswhisker! Only a turn of a milled Knob finds the sensitive spot—the whisker does not leave the crystal. The whole is enclosed, and the special crystal gives results almost equal to the addition of another valve. Fits to the panel in sockets. Price, 5/-

AN INTERCHANGEABLE FIXED CONDENSER. THE "K" TUBULAR FIXED CONDENSER.

Fits to the panel in clips (just like a grid leak). Capacities can be changed in 30 seconds without the need for working behind the panel with a screw-driver or soldering iron. Accurate Capacities.

PRICES: 0.001 } 2/- each. { 0.003 | 0.0001 } 1/9 each. { 0.0003
0.002 } 0.006 | 0.0002 }

Wate's Products are sold by all discriminating Radio Dealers, who will willingly demonstrate. We can supply carriage paid, but your Dealer's name must be enclosed with order.

WATES

BROS., LTD.

Head Office—12, 14, GT. QUEEN STREET, KINGSWAY, W.C.2.
'Phone: Gerrard 575-576. Grams: "Zywateseng, Westcent."
WORKS: LONDON, BIRMINGHAM and WESTCLIFF.



This vernier Condenser was designed by a practical Wireless Engineer

EVERYONE knows the disadvantage of the usual single plate vernier condenser. How impossible it is to record the exact dial reading, owing to the difficulty of knowing exactly where the vernier plate is situated. Everyone knows, too, how difficult it is to bring a distant station when contact to the moving spindle is made by rubbing instead of by a permanent spring. This new Peto-Scott de luxe Square-law Condenser has been designed by a practical wireless engineer. It is the ideal condenser—built by a man who knows how imperative it is to use a slow motion for all the plates and not to use a separate vernier plate. Its slow movement is obtained by means of a smooth 8 to 1 rubber friction gearing. Only solid ebonite is used—no cheap substitutes. All metal parts are well plated and the whole Condenser is an excellent example of the instrument maker's art. Scrap your old-fashioned Condenser—invest in the Peto-Scott and get new delights from long distance reception.

Specification:

Maximum capacity .0005 mfd. Solid ebonite turned plates. All metal parts plated and polished. Three-inch engraved dial with separate knob to control vernier movement. Adjustable rubber friction drive. Permanent coiled spring contact to centre spindle. One-hole fixing for main-shaft. Absolutely no backlash in movement. Price 21/-

Send 3d. for copy of our Pilot Chart showing illustrations of more than 30 Sets for home construction. Catalogue of Components, 3d. post free.

PETO-SCOTT Co. Ltd.

Head Office, Mail Order and Showrooms: 77, City Road, LONDON, E.C.1. Branches—LONDON—62, High Holborn, W.C.1. WALTHAMSTOW—230, Wood St. PLYMOUTH—4, Bank of England Place. LIVERPOOL—4, Manchester Street.

p.s. 3232.

In writing to advertisers, please say you saw the advertisement in THE WIRELESS MAGAZINE.

"The Wireless Magazine" Buyers' Guide

The announcements below mentioned are in the February-August issues. Numbers in bold type are in present issue.

Accumulators	PAGE	Crystals and Detectors	PAGE	Sets (Valve)	PAGE
Imperial Motor Industries, Ltd.	110, 325	Will Day, Ltd.	106, 351	British Engineering Products Co.	112, 229, 341
Aerial Equipment		A. Hinderlich	107, 239, 345	British Radio and Portable Case Mnfrs.—Cover iv, Aug.	
A. Munday, Ltd.	463	W. Molback	220, 227, 234, 344	British Thomson-Houston Co., Ltd.	439
New London Electron Works, Ltd.	455, 679	Radio Instruments, Ltd.	678, 86	Pell Cahill & Co., Ltd.	97
Battery Chargers		Tungstaliite, Ltd.	364, 476, 588, 4	Falk, Stadelmann & Co., Ltd.	126
Chase Electrical Manufacturing Co., Ltd.	343, 465	Ebonite		General Electric Co., Ltd.	331
Gran-Goldman Service	109, 229	American Hard Rubber Co., Ltd.	463, 571, 685, 99	Peto-Scott Co., Ltd.	237
Lionel Robinson & Co.	232, 353	Bowyer-Lowe Co., Ltd.	Page ii cover, Feb.-Mar.	Radio Communication Co., Ltd.	329, 445, 557, 689, 89
Books & Publications		Grid Leaks		Radio Instruments, Ltd.	Page iv cover, Feb. and May
Cassell & Co., Ltd.	2, 77, 91, 95	Dubilier Condenser Co., Ltd.	319	Sterling Telephone & Electric Co., Ltd.	363
Daily Graphic	581, 687, 3	Igranic Electric Co., Ltd.	237	A. J. Stevens & Co. (1914), Ltd.	549
Foyie's	342, 456, 474, 586, 95	Mullard Radio Valve Co.	332		
Press Exclusives	122, 336	E. Shipton & Co., Ltd.	105, 205		
University Tutorial Press	97	Watmel Wireless Co.	467, 579, 691		
Cabinets		Loud-speakers			
British Radio and Portable Case Mnfrs.	Cover iv, July	Auto Sundries, Ltd.	461, 573, 87	Soldering Flux	
Carrington Mnfr'g Co., Ltd.	3	Brandes, Ltd.	195, 435, 547, 661, 75	Fluxite, Ltd.	467, 579, 691, 99
Makerimport Co.	95	S. G. Brown, Ltd.	457, 682, 90	Terminals	
Coils and Coil Winders		Alfred Graham & Co.	473, 585, 1	Autoveyors, Ltd.	575, 689
Igranic Electric Co.	571	Scientific Supply Stores	685, 3	Belling & Lee, Ltd.	239
Lissen, Ltd.	433	Sterling Telephone & Electric Co., Ltd.	127, 363	Tools	
Radio Instruments, Ltd.	671	A. J. Stevens & Co. (1914), Ltd.	197, 437	Economic Electric Co.	121
Components		Miscellaneous		Transformers	
Athol Engineering Co.	695, 97	A. F. Bulgin & Co.	229, 336, 456	Beard & Fitch, Ltd.	225
Craik & Smith	238, 345	John Player & Son, Ltd.	675, 97	Gaston E. Marbaix	122
Economic Electric, Ltd.	347, 695	Pomona Rubber Co.	120	Grafton Electric Co.	465
Falk, Stadelmann & Co., Ltd.	242	Rockwood Co., Ltd.	460	Ormond Engineering Co.	209, 321
Grafton Electric Co.	239, 341	H. J. Searle & Son, Ltd.	108, 230	Portable Utilities Co., Ltd.	677, 85
Igranic Electric Co., Ltd.	685, 93	M. Verstraeten	115, 236, 470	Radio Instruments, Ltd.	325
Henry Kennett	582, 693, 101	Phones		Valves	
Lissen, Ltd.	433, 545, 659, 73	Brandes, Ltd.	195, 315, 435, 75	Bishopsgate Electric Supply (1924) Co.	120, 236, 465
A. Munday, Ltd.	357, 474, 3	British Thomson-Houston Co., Ltd.	663	British Thomson-Houston Co., Ltd.	219, 323, 551
Peto-Scott Co., Ltd.	689	Goodman's	220, 236, 357	A. C. Cossor, Ltd.	553, 667, 83
Radio Instruments, Ltd.	Cover iii, August	Imperial Motor Industries, Ltd.	110, 216	Craik & Smith, Ltd.	575, 695
Scientific Supply Stores	105, 232	J. W. Miller	109, 238, 353	Economic Electric, Ltd.	471, 583
E. Shipton & Co., Ltd.	205, 344	Sterling Telephone & Electric Co., Ltd.	243, 475	Edison Swan Electric Co., Ltd.	81
Wates Bros., Ltd.	225, 689, 103	Sets (Crystal)		Marconi-Osram Valve Co., Ltd.	669
Condensers		B. T. H. Co., Ltd.	439	Mullard Radio Valve Co., Ltd.	Page iii cover, July
Bowyer-Lowe Co., Ltd.	Page ii cover, Feb.-Mar.	Falk, Stadelmann & Co., Ltd.	126	Valve Repairers	
Dubilier Condenser Co., Ltd.	Cover ii, July-Aug.	General Electric Co., Ltd.	199	G.W.I., Ltd.	231, 353
Falk, Stadelmann & Co., Ltd.	126	J. W. B. Wireless Co.	231, 343	Valve Renewal Co.	353, 357, 470
Fallon Condenser Co., Ltd.	205	Lissen, Ltd.	193		
A. Munday, Ltd.	120, 239	National Wireless & Electric Co.	347		
J. H. Naylor, Ltd.	362, 474, 586	Radio Instruments, Ltd.	Page iv cover, May		
Ormond Engineering Co., Ltd.	79				
Peto-Scott Co., Ltd.	583, 103				

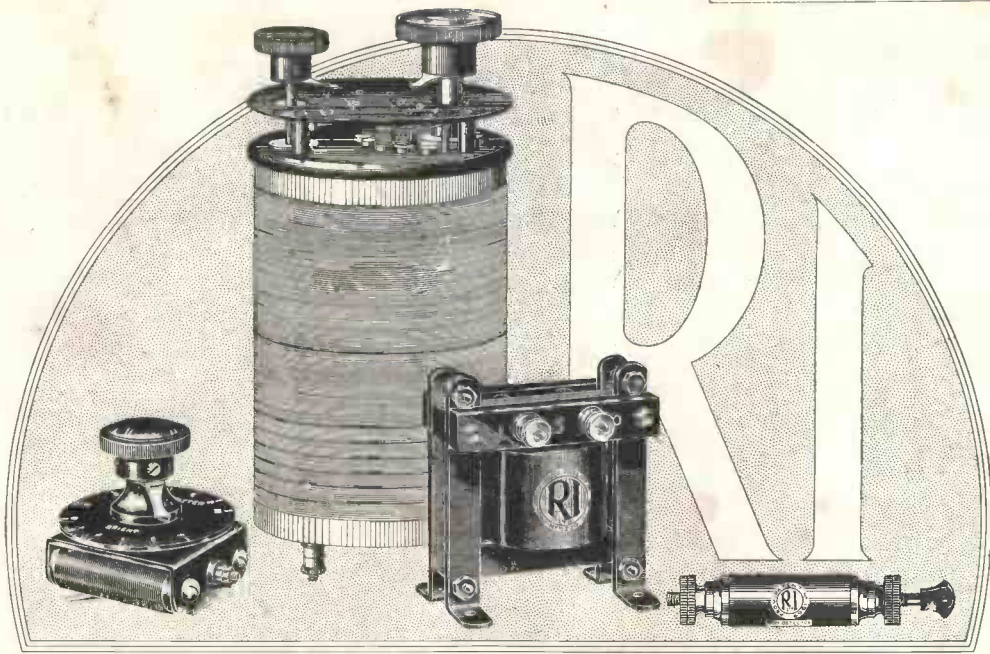

Every One A Success

Firstly because each R.I. component has been designed to overcome the existing difficulties of the wireless amateur.

Secondly because each component when put on the market was unique in design and is still unique in the quality of its results.

For whatever purpose you require it there is an R.I. component—and an R.I. component is not just an ordinary unit ; it is a product built on many years' experience designed to better in every detail present-day radio reception.

The R.I. Transformer, famous for its unique sectionalised construction, giving the lowest possible self-capacity (only 18 micro-microfarads), and used by over half a million wireless enthusiasts.

Price - - 25/-

The R.I. Retroactive Tuner is unique in that it covers a range of wave-length from 150/4,000 metres, with aerial reaction suitable for giving maximum efficiency over the entire range of wave-length. "Far better than coils."

Price - - 39/6

The New R.I. Duostat, one-hole fixing, affords perfect radiation, and can be used with both bright and dull filament valves.

Price - - 7/6

The R.I. Permanent Mineral Detector has marked a new era in wireless research. Absolute permanency, simplicity, and reliability, together with maximum efficiency, are a few of the reasons why the R.I. Permanent Mineral Detector is steadily finding its way into the set of every crystal user in the country.

Complete with Metal Brackets and Screws for mounting.

Price - - 6/-

Write for R.I. Catalogue, free on application.

12 HYDE ST! NEW OXFORD ST! LONDON W.C.1

Contractors to the Admiralty and all Government Departments.



In writing to advertisers, please say you saw the advertisement in THE WIRELESS MAGAZINE.



LATEST AMAZING WIRELESS WONDER

Human ingenuity yet conceived.

No earth or aerial required—see particulars below :

The Portaphone

Supplied absolutely complete. Just switch on and listen-in.

This super receiver, with improved cabinet design, is the outcome of much research spent on the original one as described in the June issue of the W. M. The range of this set is now increased to 50 miles, under normal conditions. An entirely new ultra-sensitive circuit is employed. (Pat. applied for.) The materials used are British and of the best quality, and include one pair of headphones, although four pairs of 'phones can be effectively and simultaneously worked from it.

This is the most sensitive yet compact Portable Receiver ever devised. It is smaller and lighter than a suit case, and being entirely self-contained will operate anywhere, indoors or out of doors. Total weight, 12 lb.

It is absolutely fool-proof, and once set to the wavelength desired may be put into action at once by turning centre dial. Non-spillable batteries are fitted which operate the instrument for 2 to 3 months at a time.

FLAT DWELLERS. It is impracticable for flat dwellers to erect aeriels. This portable set is therefore ideal—it is complete in itself.

HOUSEHOLDERS. If you wish to avoid the trouble and expense of aeriels—the bother of wires throughout the house—get a Portaphone.

HOTEL RESIDENTS. If you live in an hotel you will realise that the Portaphone is the set for you. No aeriels—no earth.

FOR INVALIDS. It is particularly suitable for the requirements of invalids and convalescents.

AT THE SEASIDE. It is in every sense a perfectly ideal outfit.

ON THE RIVER. You do not need to fix aeriels over trees—just put your Portaphone in the boat.

IN YOUR MOTOR. Take your set with you and enjoy the journey.

£12 12s.

Carriage Paid.

Results from the Picnic Set—Reprinted from *The Wireless Magazine*, June.

£10

Results with this set have fully justified the care taken in design.

At Eastbourne the set was taken on to the beach, and London, 65 miles away, was heard faintly. Bournemouth, 120 miles away, came in strongly on the phones, during daylight.

In the evening, Newcastle, 340 miles away, was received on two pairs of phones, every word of the announcer being audible.

Le Petit Parisien has also been heard distinctly in

London. It is interesting to note that in London Bournemouth can be received any evening with no interference from the local station.

Recently the receiver was taken to Hindhead where London and Bournemouth were received, quite good signals being heard in broad sunlight.

It was also taken into the vault of a bank in Kensington (40 ft. below ground and partly covered in with steel). 2LO was received here loud enough to operate three pairs of phones.

THE BRITISH RADIO AND PORTABLE CASE MANUFACTURERS,

8 & 16, Market Street, Curzon Street, Mayfair, W.1.

The Cabinet is a Regd. Design.
Patent applied for set.

Telephone: Grosvenor 2984.

Approved by the
P.M.G. and the B.B.C.