

The Wireless Constructor

6^d

INCORPORATING "MODERN WIRELESS"

Vol. XVII.

MARCH, 1934.

No. 89.

JOHN SCOTT-TAGGART'S

**ST. 300
STAR**

**LATEST
TRIUMPH**

*Full
Constructional
Details*

AND

**FREE
BLUEPRINT
INSIDE**



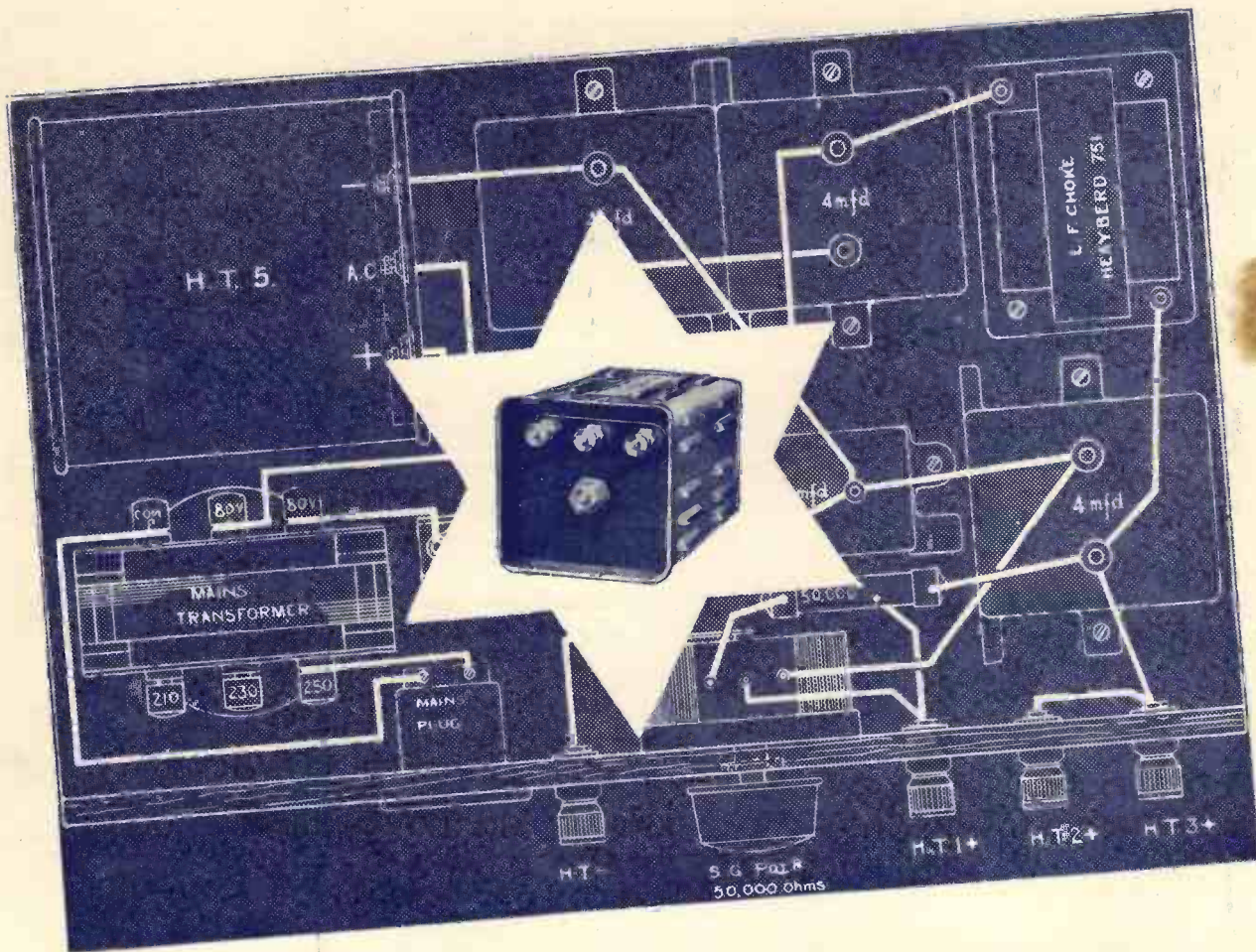

BUILD YOUR OWN ELIMINATOR

for the **S.T.300 STAR**

When building a new receiver, remember . . . its performance depends on the power supply. Start right—be sure of a constant and lasting H.T. supply with no replacements or renewals. Build this A.C. Eliminator, (which has been approved by Mr. John Scott-Taggart), equipped with a Westinghouse Metal Rectifier, and get the permanent never-failing high tension necessary to obtain the best results from your S.T.300 Star. The attached coupon and 6d. in stamps will bring you blue-print and constructional details.

WESTINGHOUSE METAL RECTIFIERS

GET YOUR BLUE-PRINT NOW!

THE WESTINGHOUSE BRAKE & SAXBY SIGNAL CO., LTD.,
82, York Road, King's Cross, London, N.1.

Please send me the blue-print and constructional details of how to build The A.C. Eliminator for the S.T.300 STAR. I enclose 6d. in stamps.

NAME.....
ADDRESS.....

CONTENTS

	Page		Page
The Editor's Chat	227	Radio Experts Praise the S.T. Manual	253
"S.T.300" Star Brings the Stations of Europe to You ..	228	This Year's Valves	255
"S.T.300" Star	230	Questions I Am Asked	258
What They Said About the "S.T.300."	234	Round the Dials	260
Six Points Which Make The Star	239	As We Find Them	262
B.B.C. News	251	In Lighter Vein	264
		From My Armchair	267
		Our News Bulletin	279

As some of the arrangements and specialties described in this Journal may be the subjects of Letters Patent the amateur and trader would be well advised to obtain permission of the patentees to use the patents before doing so.

PUBLISHED BY THE
AMALGAMATED
PRESS LTD THE
FLEETWAY HOUSE
FARRINGTON STREET
LONDON E.C.4



**CHEAPER
POWER
FOR
BATTERY SETS**



BRITISH MADE

THE BEST BATTERY EVER BUILT NOW COSTS YOU LESS

The **INCOMPARABLE**
FULL O' POWER
'POWER' TYPE Triple Capacity
RADIO BATTERIES

	<small>OLD PRICE</small>	<small>NEW PRICE</small>		<small>OLD PRICE</small>	<small>NEW PRICE</small>
V.4 60 volt.	12/-	8/6	V.7 108 volt.	20/-	15/-
V.5 45 volt.	9/-	7/6	V.8 120 volt.	24/-	17/6

FULL O'POWER BATTERIES ARE SPECIALLY
SELECTED FOR THE **S.T.300 STAR**

Advanced scientific methods of manufacture enable these exceptional reductions to be made.
Made by **SIEMENS** specialists in battery manufacture for over 60 years
Write for free booklet 667 of up-to-date battery information to address below.

Order of **SIEMENS ELECTRIC LAMPS AND SUPPLIES LIMITED, 38/39, Upper Thames Street, London, E.C.4.**

Not so simple
as it looks



38 SEPARATE PARTS IN A COSSOR VALVE

An ounce and a half of metal and glass—an elaborate little structure, patiently assembled stage by stage with meticulous care — accurate to one thousandth of an inch—the modern Aladdin's Lamp on which millions of discriminating listeners rely for their nightly radio entertainment—a Cossor Valve.

Year by year Radio technique advances with giant strides. Month by month new discoveries are made—new circuits are evolved. And always in the forefront are Cossor

research engineers developing new valves to take advantage of these ever-changing conditions.

Whatever your valve requirements—whether it be a replacement valve for a simple Battery Receiver or one for an elaborate All-Electric Super Het you will find it in the Cossor range. More than 80 different types available—and every one manufactured to the same exacting standards of accuracy and efficiency.

NEW STATION CHART

Get one of the new Cossor Station Charts which gives the revised wavelengths, etc., of over 80 foreign stations and has space for entering your own dial readings, price 2d. from your Dealer or write to A. C. Cossor Ltd., Melody Dept., Highbury Grove, London, N.5, enclosing 2d. stamp.

COSSOR VALVES



To A. C. COSSOR LTD., Melody Department, Highbury Grove, London, N.5.

Please send me free of charge, a copy of the 72-page Cossor Wireless Book B.V.33.

Name

Address

W C. 1/3/34



THE
EDITOR'S
CHAT

THE WIRELESS CONSTRUCTOR

INCORPORATING
MODERN WIRELESS

The "S.T.300" STAR: The Best Three-Valver—To Solder or Not to Solder

ON January 15th, 1932, Mr. John Scott-Taggart first described his "S.T.300" receiver in this paper. Since then he has not designed another three-valve set.

We will admit that from time to time during these two years we have been inundated with requests from readers who have wanted Mr. Scott-Taggart to design another three-valver.

But our distinguished contributor has always replied: "Well, why not build the 'S.T.300'?" And when readers have retorted that they wanted something "more up to date," as they had built the "S.T.300" some months ago, Mr. Scott-Taggart has replied that he did not expect to develop any new set which would compete with the "S.T.300" for some time.

But now Mr. Scott-Taggart feels that the time has arrived when readers of THE WIRELESS CONSTRUCTOR should have the opportunity of building another "S.T." three-valver, and in this issue he describes his "S.T.300" Star.

Something Better

Mr. Scott-Taggart points out that the "S.T.300" Star is the first to replace any of his designs, and that from now on the "S.T.300" is obsolescent. Readers are asked, however, to realise that "obsolescent" has a very different meaning from "obsolete." Mr. Scott-Taggart means that he has now produced something better than the "S.T.300," and that when readers ask him what three-valver to build in future he will say "The 'S.T.300' Star."

As readers of THE WIRELESS CONSTRUCTOR know by now, Mr. Scott-Taggart's first and foremost aim is to design a set which, in performance, will give readers something better than they could hope to obtain

by purchasing a factory-built set in the same price range.

The "S.T.300" Star possesses to a maximum degree the technical qualities which Mr. Scott-Taggart has recommended, and which thousands of constructors have endorsed in the past, as absolutely necessary for up-to-date reception.

THOSE WAVELENGTHS



Although it is now several weeks since the Lucerne Plan came into operation, experts in many European countries are constantly occupied in trying to contrive methods of bettering the scheme. Engineers at the Tatsfield (Surrey) checking station (a corner of which is seen above) are among those most concerned with European wavelengths.

Those of our readers who in the past have built the "S.T.300" will notice, when they examine later on the details of the "S.T.300" Star, that the set has an extra control—the aerial reaction knob.

As the designer admits in his article describing the receiver, this certainly adds one more complication,

but "actually it is no more a complication than the ordinary reaction knob found on practically every straight receiver, and the merits of this aerial reaction are so enormous that as regards selectivity and signal strength, the 'S.T.300' Star is far superior to the 'S.T.300.'"

Here then, in the "S.T.300" Star, those thousands of readers who have been asking Mr. Scott-Taggart to describe another three-valver will find an answer—and a very good answer—to their requests. The "S.T.300" Star is Mr. Scott-Taggart's latest design, and as such we confidently leave you to build it and to enjoy another first-rate set from the hands of radio's master designer.

Readers' Views

The request we published recently for the views of our readers concerning the great problem: "To solder or not to solder," has resulted in some interesting correspondence.

Mr. C. H. Hopwood, M.B., Ch.B., of Talstock, Cornwall, takes the view that "the components of to-day, of yesterday, and of to-morrow, are too uncertain in their action to be permanently fixed. I used to hard solder (silver) my joints until I found that inside the components the ends were nearly always twisted round the terminals, so it was a waste of time doing so. Soldering is quite easy to one who is not all thumbs, but it is only useful where several wires go to common junctures."

Mr. J. Dick, of 33, Strathord Street, Glasgow, writes to say that "the chief merit of soldering is that the joints are not easily broken. The amateur constructor wants them easily broken—when it suits his purpose—so that he can chop and change and make as much use of his components as possible.

(Please turn to page 278)

S.T. 300 STAR BRINGS THE STATIONS OF EUROPE TO YOU!

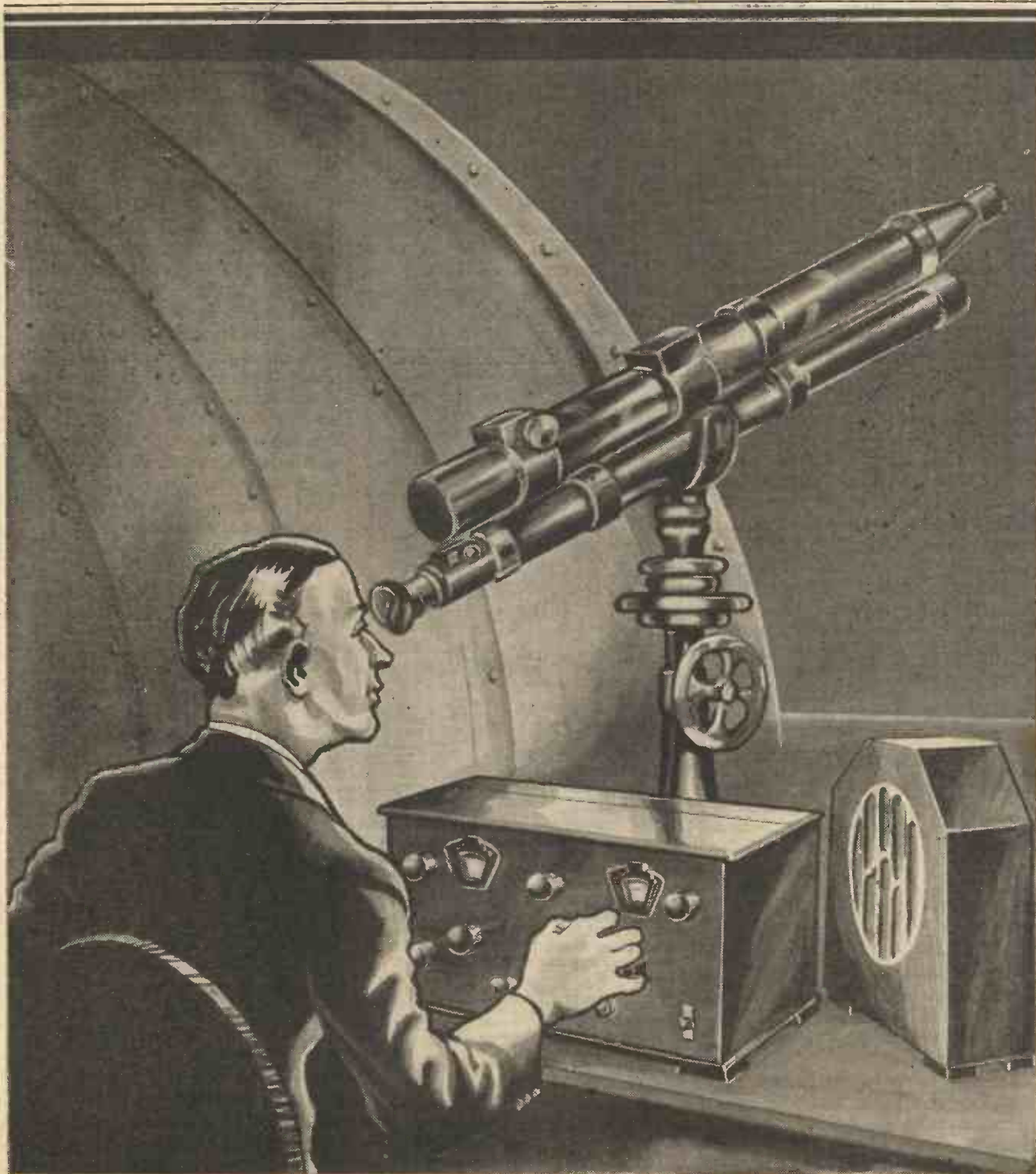



How many of these star entertainers can you "place" on the map? And does your set get its fair share?

EUROPE'S PRINCIPAL BROADCASTING STATIONS IN ORDER OF WAVELENGTHS.

WAVE-LENGTH (Metres)	NAME OF STATION.	WAVE-LENGTH (Metres)	NAME OF STATION.	WAVE-LENGTH (Metres)	NAME OF STATION.	WAVE-LENGTH (Metres)	NAME OF STATION.
203.5	Bournemouth	259.1	Moravska Ostrava	328.6	Limoges P.T.T.	491.8	Florence
203.5	Plymouth	261.1	West National	328.6	Dniepropetrovsk	499.2	Sundsvall
209.9	Newcastle	261.1	London National	331.9	Hamburg	499.2	Rabat
216.8	Warsaw II	263.2	Turin	338.6	Graz	506.8	Vienna
219.6	Cracow	265.3	Horby	342.1	London Regional	522.6	Mühlacker
222.6	Milan II	267.4	Belfast	345.6	Poznan	531	Athlone
222.6	Lodz	271.7	Naples	349.2	Strasbourg	539.6	Beromünster
222.6	Konigsberg	274	Vinnitsa	349.2	Simferopol	549.5	Budapest
222.6	Dublin	274	Barcelona	356.7	Berlin	559.7	Wilno
224	Montpelier	276.2	Zagreb	360.6	Moscow IV	569.3	Ljubljana
227.1	Budapest II	278.6	Bordeaux	368.6	Milan		
230.2	Danzig	283.3	Bari	373.1	Scottish Regional		
231.8	Salzburg	285.7	Scottish National	377.4	Lwow	1107	Moscow II
231.8	Linz	288.5	Leningrad II	382.2	Leipzig	1145	Lahti
233.5	Aberdeen	288.5	Rennes	386.6	Toulouse P.T.T.	1186	Oslo
235.1	Stavanger	291	Heilsberg	391.1	Midland Regional	1224	Leningrad
235.1	Porsgrund	293.5	Madrid II	395.8	Katowice	1261	Kalundborg
238.5	San Sebastian	296.2	Tchernigov	405.4	Munich	1304	Warsaw
238.5	Rome II	296.2	North National	410.4	Tallin	1345	Huizen
238.5	Riga	298.8	Bratislava	415.5	Kiev	1389	Motala
240.2	Luxembourg	301.5	Hilversum	420.8	Rome	1400	Minsk
241.9	Cork	304.3	Genoa	428.1	Stockholm	1500	Davenport
243.7	Gleititz	307.1	West Regional	431.7	Paris P.T.T.	1571	Konigs Wusterhausen
245.5	Trieste	309.9	Grenoble	437.3	Belgrade	1639	Reykjavik
247.3	Lille	309.9	Odessa	443.1	Sottens	1639	Kaunas
249.2	Prague II	315.8	Breslau	449.1	North Regional	1714	Moscow I
251	Frankfurt	318.8	Goteborg	455.9	Langenberg	1796	Radio Paris
253.2	Kharkov II	318.8	Algiers	463	Lyons		
255.1	Copenhagen	321.9	Brussels (Flemish)	470.2	Prague I		
257.1	Monte Ceneri	325.4	Brno	483.9	Brussels (French)		

ON LONG WAVES

(The above wavelengths are correct up to the time of going to press. Some slight adjustments may be made in certain cases.)

1-FULL SIZE S.T. 300 STAR BLUE PRINT

DESIGNED BY
JOHN SCOTT-TAGGART
 FOR THE WIRELESS CONSTRUCTOR
 MARCH 1934

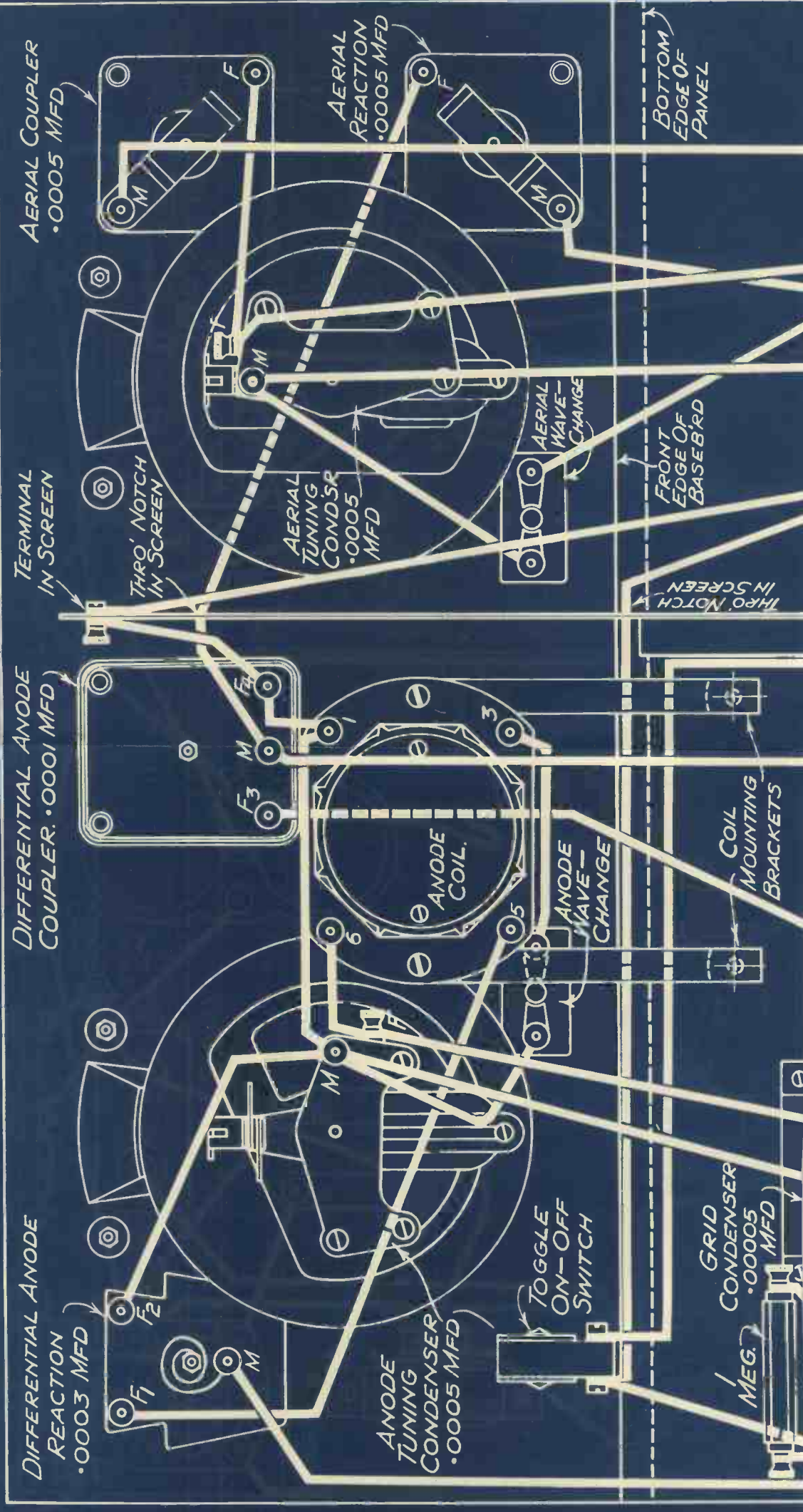

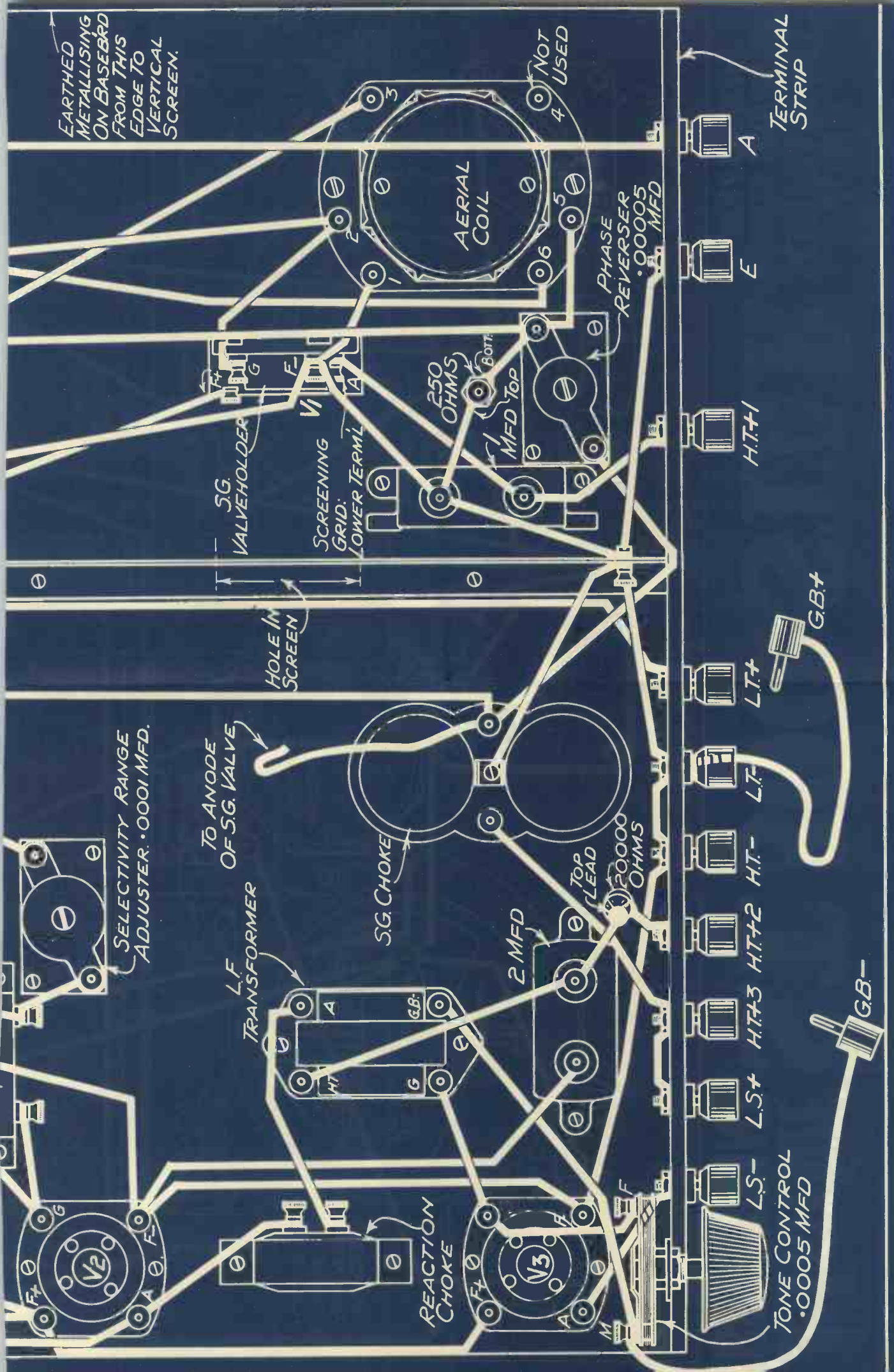

EARTHED METALLISING ON BASEBOARD FROM THIS EDGE TO VERTICAL SCREEN.

SELECTIVITY RANGE ADJUSTER. .0001 MFD.

TO ANODE OF S.G. VALVE

L.F. TRANSFORMER

S.G. CHOKE

REACTION CHOKE

2 MFD

20000 OHMS

TOP LEAD

PHASE REVERSER .00005 MFD

250 OHMS

Bot. MFD

Top MFD

S.G. VALVEHOLDER

SCREENING GRID LOWER TERM.

HOLE IN SCREEN

AERIAL COIL

NOT USED

TERMINAL STRIP

H.T.+1

L.T.+1

L.T.-1

H.T.-2

H.T.-3

L.S.+1

L.S.-1

TONE CONTROL .0005 MFD

GB-

GB+

A

E

GB+

GB-



FOR nearly two years I have been worried and perplexed.

The worrying has come from readers and the perplexity has arisen in my own mind.

On January 15th, 1932, in this magazine, was published an account of the "S.T.300" receiver, with which, after a rest of five or six years, I returned to the arena. Since that day I have not designed another three-valve receiver, and as the bulk of home constructors have retained a loyalty to the three-valver, there has been some criticism of my policy.

The Three-Valve Man

My retort to those who desire a three-valve set has always been: "Well, why not build the 'S.T.300'?" As often as not the reply has come back: "Oh, yes, but that was designed three months ago. I want something more up to date."

I have replied that I had nothing more up to date, and that I did not expect to develop anything which would compete with the

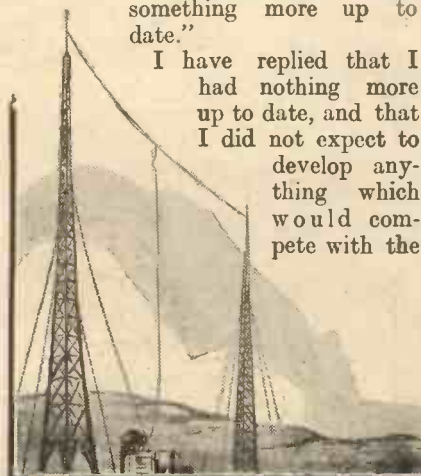

"S.T.300" for many months. Whereupon my critics would go away sadly, and decide to wait patiently or to build the "S.T.300."

A few, possibly, built someone else's three-valve set, but this is unlikely, judging from the figures which I keep

In 1932 "S.T.300" swept the whole country with a tremendous wave of set-building enthusiasm, and scored an absolutely unique triumph among wireless constructors.

In 1934 the distinguished designer has raised his own standard of success, and here presents a new and in every respect a better three-valver—

—A STAR SET FOR YOU

of the number of sets described in the technical press and built by the public.

My Job as Designer

Let me say a few words about the job of designer as I conceive it. And forgive me if I talk about myself a good deal.

I am afraid that this is inevitable if I am to explain my methods and technical policies. I believe in taking readers into my confidence, even if it occasions a few grunts of disapproval from those who would make of radio journalism an arid waste and of technicalities a bloodless lecture.

What, then, is my job as regards you people who read my

articles? First and foremost it is to design for you wireless receivers which in performance will give you something better than you could hope to obtain by purchasing a factory-built receiver in the same price range.

Better than "S.T.300"!

But that is not all. With the exception of one set, I have attempted to give something more than the factory-built set provides, and that has been a degree of security against obsolescence.

In this number I am describing the "S.T.300" Star, which is the first to replace any of my designs. From now on the "S.T.300" is obsolescent. This is a very different matter from saying it is obsolete. It simply means that I have produced something better than the "S.T.300," and that from now onwards I shall answer the question "What shall I do with three valves?" by suggesting the "S.T.300" Star.

A Long Life

It has never been my contention that finality can be reached in set design. But I do contend that any set for the public should have a long life and give the constructor excellent service, for two or three years at the least. I do not mean, however, that radio is going to stand still for that period, or that my own inventive and design faculties will snore their way through two or three years.

There is a chance that within, say,

STAR

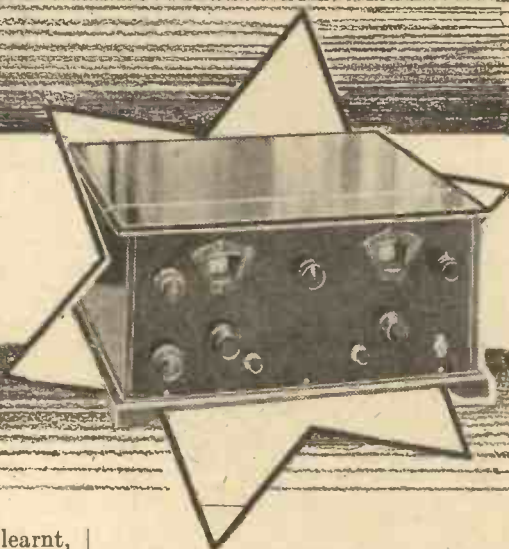

six months I shall have developed some small improvement which, however, would not justify the issuing of a new set design. I would refuse to whimper with excitement or expect readers to become hysterical with praise.

A Vigorous Attack

I caused a pretty commotion two years ago when I launched a vigorous attack against the policy of issuing swarms of redundant set designs cynically flung at a wireless public fondly believed to be as stupid as the designers were optimistic.

My attitude was regarded as outrageous and calculated to harm the technical journals and the industry. It was alleged that manufacturers of components would suffer if the existing policy were changed and that the magazines would suffer in circulation if the public were not given something "startling" every week or month.

Constructor Placed First

This, of course, proved a fallacy. But even the publishers of my own set designs and articles wondered, for a moment, whether it was wise to change the policy and to rely on fewer sets.

The fact has proved that I rightly estimated both public and trade feeling in this matter. It is almost twenty years since I published the first set design for wireless amateurs, and since 1918 I have, I suppose, been more closely associated with the home constructor and amateur movement than anyone in this country.

The one big thing that I have learnt, and preached, is that the technical press and the manufacturers not only should not, but cannot, benefit at the expense of the wireless public. It is not my purpose here to lecture the publishing industry on how to run a

VOLUME—“‘S.T. 300’ Star is miles ahead of the ‘S.T. 300’ as regards loudness of signals.”

SELECTIVITY—“It is, and obviously must be, far superior to its predecessor of two years ago.”

Designed & Described by

**JOHN
SCOTT-TAGGART**

wireless paper, but I will say this, that the interests of the constructor must be placed first, not merely as a moral question, but as a sheer business proposition.

Continuous Firework Display

After a lapse of five or six years I returned to radio journalism with, I believe, a fresh outlook, and the first thing I saw was that a whole mass of set designs were being thrust and, in some cases, foisted upon a public which—and it is not to be wondered at—had become bemused by a continuous display of fireworks.

The same designer

would work on the moving-belt principle: no sooner had he completed one set than he would trot out a new design far more wonderful and far more epoch-making than the previous one.

One would imagine that common sense alone would make it clear that the wireless public would never have time to examine any one of his sets, and they would know that within a week or two another design would be forthcoming which would replace the previous one.

Simply “Re-Hashes”

Actually, of course, the various sets were not wonderful improvements. They were simply re-hashes in which words took the place of wires and adjectives the place of amplification.

Mind you, the public was not blameless in this matter. It has taken me two years to “put over” my own policy, both with the public and the manufacturer. The great majority of readers agreed

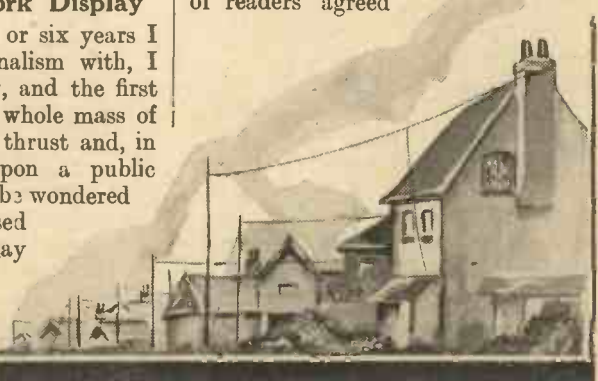

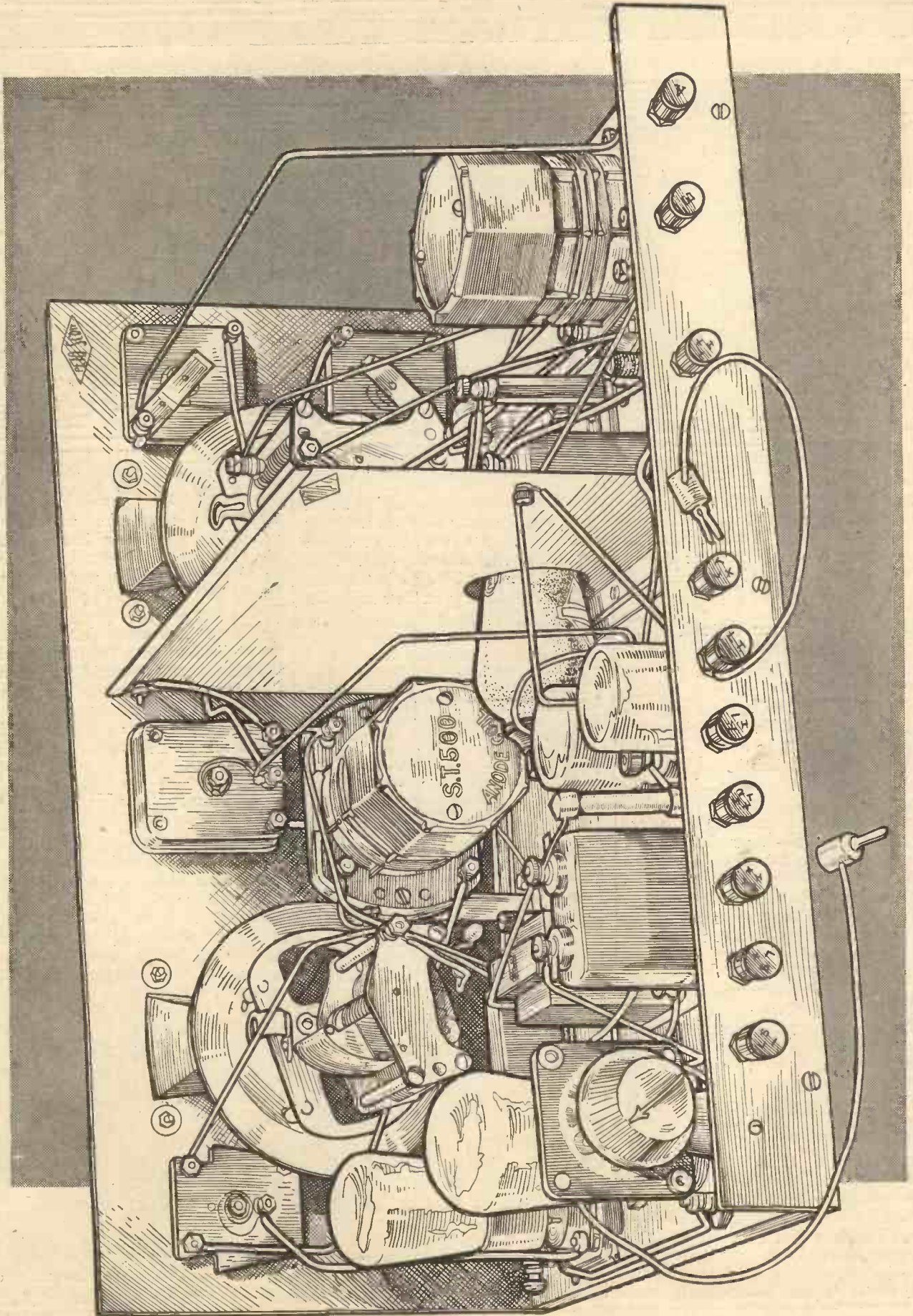

"Miles Ahead of the 'S.T.300' as Regards Loudness"

with my policy, which, although it had not before been put in black and white, was, in fact, an echo of what they themselves had been feeling. But there was a troublesome minority that said: "Well, the 'S.T.300' seems a good set, but it is now a month old, and I think I'll wait until a thing more up to date comes out; Scott-Taggart is sure to be doing another set before long." That man has had to wait exactly two years and one month.

Current for a Long Time

This is a good example of the working of my policy. What it really means is that if you do not happen to like a set of mine you will have to wait, perhaps, two years before anything of the same kind or in the same category is designed by me. This, of course, may annoy a few readers who feel that there is a hint of the take-it-or-leave-it attitude.

Well, perhaps there is. But the spirit is not one of carelessness of the

receiver requires some explanation from a technical point of view; that is why considerable space has usually been devoted to the explaining of the various features which go to make one of my sets.

Although some readers may complain that they have to wait too long for a new type of set in a particular class, yet those who have built the set previously have the satisfaction of knowing that it has not been, and will not be, readily displaced by a new design.

It is only over a considerable period that it is possible for me to obtain the fullest support from readers who may at first not fully understand that my sets have a long life. Let me say now definitely that in any particular category a set of mine will remain current for a long period and that no reader need be concerned about the apparent out-of-dateness of a set published several months before.

I want him to know that the set has been designed not to cope with

The first principle that I laid down in my first set, the "S.T.300" (my first, I mean, since my return to radio journalism), was that the receiver should have means for adjusting the selectivity to suit future conditions. The "S.T.300" has done this to a large extent, although in the case of some stations at some definite expense of signal strength.

The second important requirement in a broadcast receiver of this kind

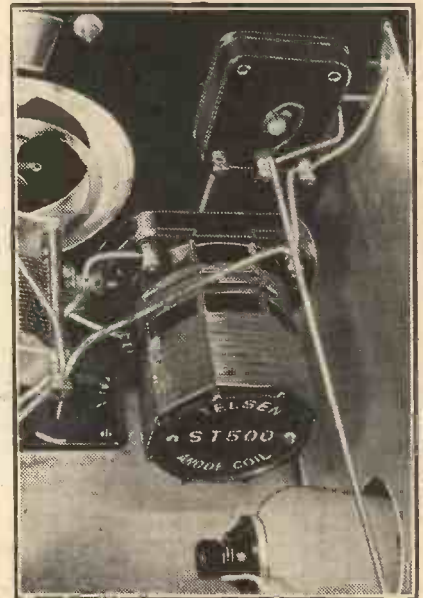

CLOSE-UPS FOR CONSTRUCTORS

The anode coil, shown to the right, is mounted on two pillars which are fixed to the baseboard. The coil is thus placed horizontally, well above the baseboard. To the left, the wiring of the screened-grid (V1) valve holder and adjacent components are clearly depicted.

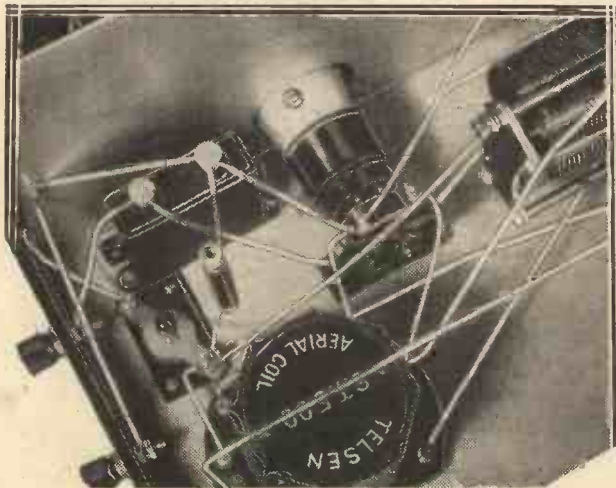

public or a conceited conception of my own infallibility.

What it really amounts to is this: Each big set I produce is developed with the carefully planned idea that it will remain a current design for a long period. The design must also appeal to a very large number of constructors.

I have not the time to design a plethora of receivers catering for those with special requirements. I therefore concentrate on sets which aim at an outstanding success amongst the largest number of home constructors.

Such a set is not necessarily an obviously popular one. Usually, the

present conditions only, but with the future, and that I shall not be designing anything in the same category for a considerable period. With this assurance and with the backing of tens of thousands of satisfied constructors of my set, there is no need for a wait-and-see policy.

The "S.T.300" Star comes from the same stable, so to speak, as my previous sets, "S.T.300," "S.T.400," and "S.T.500." It possesses to a maximum degree both qualities which I have recommended as desirable and thousands of constructors have endorsed as necessary.

was that the receiver should be capable of being adapted to different conditions.

The third requirement—and this was of a technical rather than of a general nature—was that the selectivity of both aerial and anode circuits should be adjustable to the fullest extent, and that the adjustments should be panel-controlled so that the user of the set can, with the utmost ease, operate the receiver so that it is working under the most efficient conditions for any particular station.

Overwhelming Success

Now, these requirements were neither admitted at the time of the introduction of the "S.T.300," nor have they been fully admitted by the majority of wireless set designers today, but that the policy has been correct is proved by the overwhelming success of tens of thousands of constructors of the "S.T." sets which embodied these principles—namely, the "S.T.300," "S.T.400," and "S.T.500."

What they said!

"SET OF SETS"

"Longfrie,"
St. Peters,
Guernsey, C.I.

".... There is no difficulty in tuning in well over 50 stations that can be properly heard.

"As regards selectivity, your claims are fully justified.

"Thanks for giving us that set of sets."

E. A. JAMES.

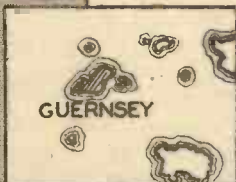

"POSITIVELY AMAZING"

54, Govanhill Street,
Glasgow, S.2.

".... I cannot express my delight in the 'S.T.300.' Sufficient to say that the results are positively amazing. Hitherto seemingly impossible foreigners—on a three valve set—are now coming in at full loudspeaker volume."

JNO. CLARK.



"A SPLENDID SET"

Templepatrick,
Belfast.

".... I can get any station worth while in Europe full loudspeaker strength, without reaction.

".... I would like to thank Mr. Scott-Taggart for a splendid set at a reasonable price."

W. H. ADAIR.



"MARVELLOUS"

Leigh-on-Sea,
Essex.

".... I finished it on Sunday and must say the results are little short of marvellous. This afternoon in daylight I tuned in on the loudspeaker 35 stations"

S. C. BONE.



"THE FINEST CIRCUIT"

176, Wellington Street,
Luton, Beds.

".... I congratulate you on the finest circuit I have ever found, and I might say I have made dozens of sets.

".... All the stations I received were full loudspeaker strength."

L. E. SNOW.



"INCREDIBLE SELECTIVITY"

88, Pembroke Road,
Clifton, Bristol.

".... Incredible selectivity, hypersensitivity, excellent quality and great volume, together with extreme simplicity of construction and handling."

A. MORE-O'FERRALL.



about the S.T.300

"DELIGHTED"

173, Gossett Street,
London, E.2.

".... Made up the 'S.T.300,' and I am delighted with the results.

"I have logged over forty stations, all fully identified."

W. IRONS.



"GOT AMERICA"

Craig-a-Charran,
Portree,
Isle of Skye.

".... This part of the world is notoriously a bad spot for reception. But the 'S.T.300' gets me all the programmes I want at night (I even got America one night at 3 a.m.!)"

R. C. SCOTT, M.D.



"ALL YOU CLAIM"

101, Sycamore Road,
Aston,
Birmingham.

".... I have had it in constant use. It is all you claim it to be in the way of selectivity.

".... I would like to thank you again for an excellent circuit."

L. A. PERRINS.



"WONDERFUL ACHIEVEMENT"

The Firs,
Gilwern,
Nr. Abergavenny.

"I wish to compliment you on the wonderful achievement you have made in the wireless world by the 'S.T.300.' I have just made one up and it is everything you claim for it"

R. O. WILLIAMS.



"A WINNER"

Liverpool,
Lancs.

".... When I heard that you were coming to 'The Wireless Constructor,' I told my wireless customers to look out for your first set. I staked my foresight and I am pleased to say you came up a winner."

A LIVERPOOL
NEWSAGENT.



"BEST THREE VALVER"

New Road,
Willerby,
Hull.

"How it works! Stations never heard before came in at full strength. I was astonished. I must have had at least 50 stations clear of each other. The set is by far the best three valver I have ever handled."

J. A. RAWCLIFFE.



(Continued from page 233)

In each successive season these sets have been built on a scale several times greater than that of any other set design by the home constructor.

Since all the wireless papers are in close touch with all the wireless manufacturers, it becomes a very simple process for any one of them to ascertain the success of any particular design. If, for example, 80,000 "S.T.400" coils have been made by one firm, 20,000 by another firm, and 10,000 by a third, one knows that at least 110,000 sets of that type have been built.

Vastly Superior Results

It is not unfair for me to stress the fact that these three receivers of mine have enjoyed extraordinary successes. In fact, it is necessary that I should be permitted by you to emphasise this fact since it shows that there is a huge public which has appreciated the features common to all my receivers, and which have proved no barrier to popularity, in spite of certain disadvantages.

I am the last person to conceal the apparent defects of my ideas. It would be foolish if I did so, because the average constructor is a sound critic, and even if he misses an adverse point his friends are sure to tell him.

It is, therefore, for me to recognise quite frankly any defects either apparent or real, and to show that they are either not defects at all when closely examined, or else that they are the inevitable defects of a system which gives vastly superior results which swamp and more than counterbalance the disadvantages.

Easy to Work

Since the "S.T.300" was introduced, two years have elapsed—quite a considerable time as wireless history goes. During that period large numbers of new readers will have attached themselves to this journal and, consequently, it is necessary to explain certain features of the "S.T.300" Star which would not need stressing to the same extent to those who have consistently taken this journal and followed my activities and technical opinions.

The first objection which is always liable to arise when considering such a receiver is the number of the controls. "How on earth," will say many a novice, "shall I be able to operate all those knobs, and yet achieve anything like success?"

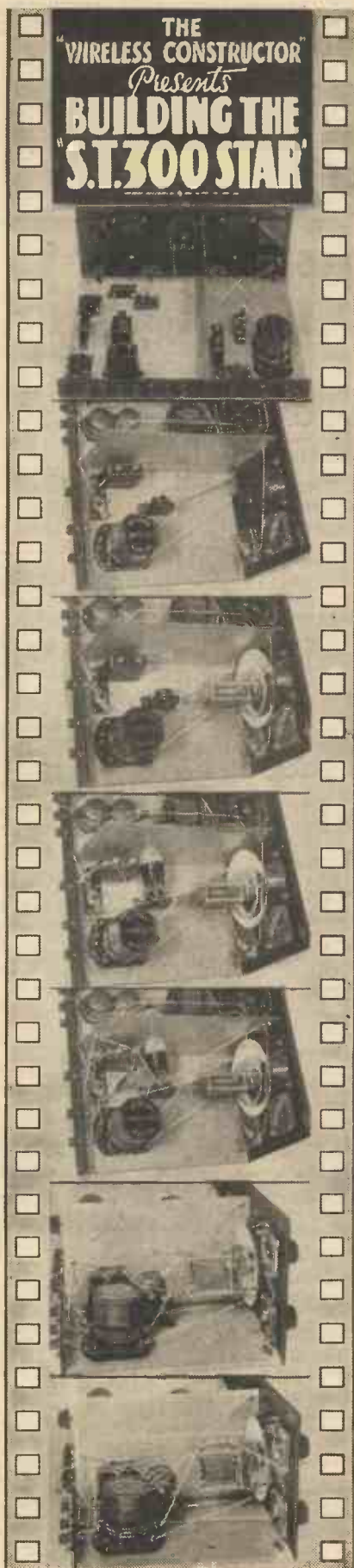

The fact remains that the extra controls are not only necessary but easy to work, and cause no anxiety even to the complete novice. This is because each control produces an effect which is immediately recognisable and which makes no practical difference to the remainder of the set.

Some controls, on a wireless receiver, unless accurately adjusted, will cause a complete failure of the set. The result is that the receiver resembles a safe which cannot be opened unless the combination is correctly carried out.

Maximum Performance

But the controls which I arrange do not affect the operation of the receiver as a whole in such a way as to make it unworkable. All the controls do is to raise the performance, either in regard to signal strength or selectivity, above the standard which would normally be received.

"But why," may ask many a reader, "is it necessary to have any controls at all? Should not a set be so designed that it will give a maximum performance under the worst conditions?"

This is a very sound and reasonable question to ask, but unfortunately, no one has been able to combine cheapness and perfect performance. In the motoring world, for example, it would be highly desirable to produce a motor-car which would cope with all kinds of conditions, such as high speed on a level road and a climb on an Alpine ascent.

Every motorist would like to have a car which would accelerate rapidly from four miles an hour to seventy miles an hour on top gear. Can it be done? No.

The Three Choices

But by the use of gears great acceleration can be obtained. But even so, greater power is required for greater acceleration and better performance. In the case of a wireless receiver, we have three choices:

1. A costly and expensive receiver designed to give the best results under the very worst conditions.
2. A simply worked receiver of average efficiency which will serve to give good results on many stations or in many situations.
3. A multi-control receiver of maximum flexibility and highest performance.

The first type of set is more or less an ideal one, but if you are prepared to pay enough money and use enough valves it should be theoretically possible to produce a receiver of high

(Continued from previous page)

performance giving maximum results with minimum control.

One of my receivers, the "Olympia Radiogram" (an A.C. set), provides a high degree of selectivity with one-knob control. This set comes really into the commercial class, i.e. it could be manufactured for the general public which possesses no technical knowledge whatever.

It is not very cheap, it uses A.C. valves and a certain amount of trimming is required before the set is passed into the hands of a non-technical user.

"Compromise" Receivers

The "S.T. Super" which I described in the December issue of THE WIRELESS CONSTRUCTOR is a superheterodyne of much higher performance, but again the cost was more than twice that of most of my receivers, and although the operation is simpler, if anything, than in the case of most of my sets, yet certain preliminary adjustments are necessary.

The second class of set, which I have perhaps a trifle scornfully referred to in the past as a "compromise receiver," is what is normally offered to the home-constructor. It will give fairly good results in good average circumstances, but no more.

It is often very simple to work and has one or, at the most, three controls. It is the kind of set that I abhor. It has all the flashy attractiveness which is undoubtedly possessed by the simple-looking receiver, but it is designed for one set of circumstances only, and the result is that only a small proportion of its builders will approve it.

Varying Conditions

How many of you, I wonder, have really seriously considered what the various circumstances are that affect a home-made wireless receiver?

There are a dozen different reasons why one set will give worse or better results than an exactly similar set built by another reader to the identical design. How different are the circumstances attaching to the use of a car! In the latter case the same car can be relied upon to give much the same performance wherever it is in England.

It is true that road conditions may vary slightly and that the car may be used in hilly country or on the level. But provisions for these conditions are made by the manufacturers who provide gears, which conform to the

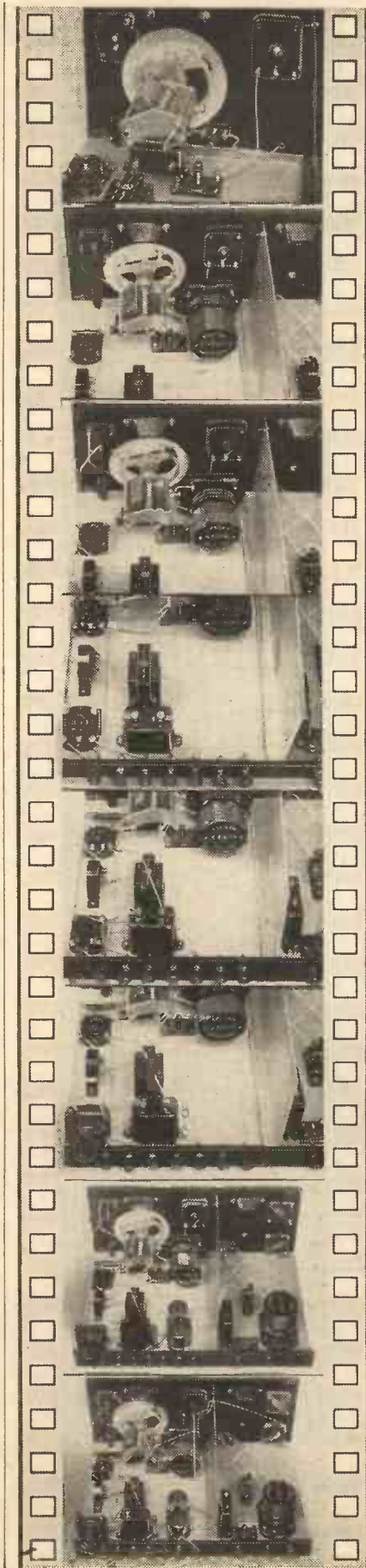

controls in a wireless set. But otherwise the cars themselves are identical, or nearly so, and the petrol and oil consumed are also standardised.

But just compare this with the position of an owner of a wireless set. In the first place radio has not reached the exact standard of engineering. There is not a single component in a wireless set which is sold to a specification even remotely approaching that of an engineering job such as a motor-car.

Non-Standard Components

I am not referring now to the purely mechanical components such as valve holders, which are reasonably uniform amongst themselves, although different types vary enormously as regards capacity between sockets, dielectric losses, etc.

This raises the point that the designer of the home-constructed wireless set never knows what components his reader is going to use. One of the charms of home construction is that the same parts may be used over and over again in different circuits, but this does not alter the fact that the parts themselves vary enormously as between different manufacturers.

For example, there is no such thing as a screen-grid choke of standard inductance and self-capacity and external field. Variable condensers for tuning may have the same maximum capacity approximately, but the "law" may vary widely, and the dimensions of the condenser also are rarely the same in two cases, this altering the stray field of the condenser.

Reaction chokes differ widely from each other, and preset condensers of different makes, but of the same maximum capacity, will have utterly different minimum capacities. Inductance coils, likewise, differ enormously, but this is a component which the constructor regards as special to any set, and while he disapproves of having to buy a new set of coils he very wisely does not attempt to use other than recommended types.

A Desirable Attitude

You would not be able to build a motor-car using A's chassis, B's hood, C's bonnet, D's seat, E's accumulator. They just would not fit together. You might be allowed a certain choice as regards horns, headlamps, windscreen-wipers and other accessories, but even they very often are not fully interchangeable. But the wireless constructor expects to be able to use all his apparatus on any receiver!

I am not criticising this attitude at

“Balanced-Phase Double-Reaction Gave an Improvement of 5000%”

ANODE CIRCUIT

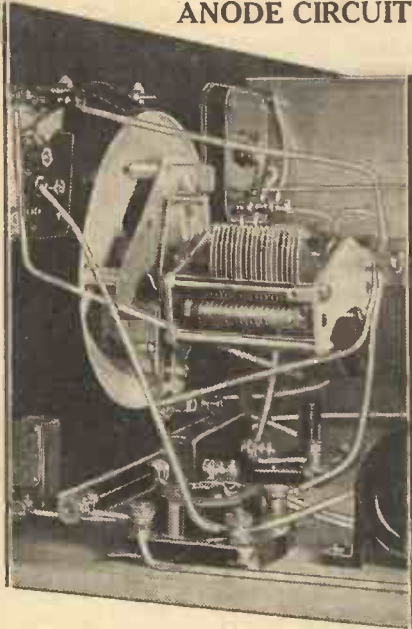

The differential anode coupler, the anode reaction knob, and the right-hand tuning dial, together with the right-hand wave-change switch, control the anode circuit. In the bottom left-hand corner of the photograph can be seen the toggle on-off switch for low tension.

all. I think it is a desirable one, provided his apparatus is of really good quality and lends itself to being interchanged.

But however good the apparatus may be, it may not work well in combination with other components. It is exactly here that the experienced designer for the home constructor must differ radically from the designer for a manufacturing firm, who can specify exactly what components and what sizes and values are to be used.

Radio's Greatest Curse

The “S.T.300” Star will, no doubt, be built by thousands of constructors. Do I know what components they are going to use? Not at all.

Those who have good L.F. transformers (and unfortunately those who have not) may decide to retain them. Similarly those with screen-grid chokes may likewise use them in their version of my set. This policy is both the foundation of radio as a hobby and also its greatest curse.

It is of value because thousands who would never buy a complete new set of apparatus for every new design are able to experiment and try out new circuits. But the disadvantage is that if a constructor has a poor component, then all his results will be poor, and an

excellent design will fail in his case because of the apparatus used.

It is easier in many cases for a camel to pass through the eye of a needle than for a set designer to persuade a reader with poor apparatus to replace it. There is, in my opinion, a floating wireless population of at least one hundred thousand which cannot or will not throw overboard inferior apparatus in the form of components of inefficient design.

These people blame a set simply because their peculiar and inefficient version of it does not give the desired results. Sometimes a constructor will buy the very cheapest apparatus he can, regardless of merit, and the result is that when he builds a design there may be a falling off of 50 per cent in the performance—even assuming that the set works at all!

EFFICIENT CONTROL

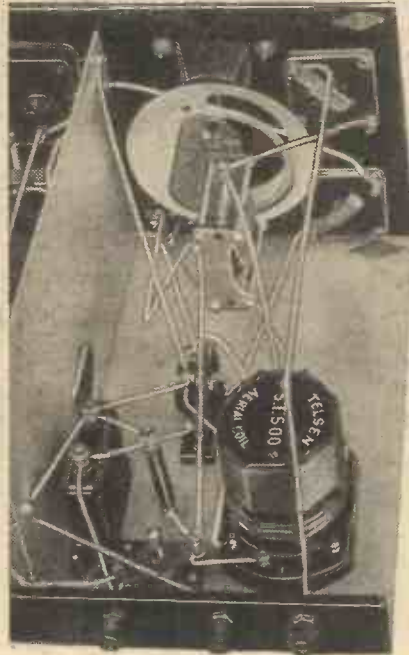

AERIAL CIRCUIT

The aerial coupler, the aerial reaction and the left-hand tuning dial form the three main controls for the aerial circuit, while the wave-change switch enables one to receive the long or the medium waves at will.

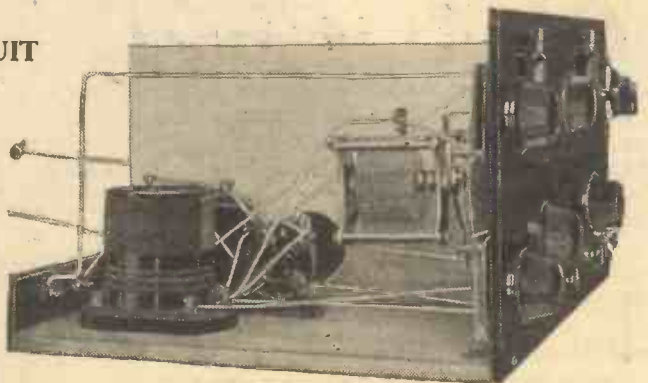

The best idea, of course, is to build a set exactly as the designer did, but this is a counsel of perfection, and I, at any rate, recognise that a set should be so designed, if possible, that variations in the components will make as little difference as possible, or can be compensated by some alteration of an additional control.

Annoying Variations

Even if exactly the same components are used in a wireless receiver as in the designer's own model, it is unlikely that any of the components will be exactly the same as regards their values.

For example, a 20,000-ohm resistance may actually vary as much as from 17,000 to 23,000 ohms in the case of some manufacturers.

It is thus possible to get a variation of 6,000 ohms in the resistance value—supposedly the same—in two different sets. A fixed condenser of .0003 mfd. may turn out to be a .00025 or a .00035 mfd. Here we have a difference of about .0001 mfd. as possibly occurring between two different sets.

The Worst Offenders

Valves, however, are the worst offenders, and here a variation of fifty per cent is quite common even between different samples of the same valve type as made by a single manufacturer. Needless to say, there are always wide variations between different manufacturers' versions of a valve for a given type, e.g. screen-grid, detector, output valve.

The type and characteristics of the valve will alter the selectivity of the set, its amplification, its stability, the smoothness and the amount of the reaction, the amount of distortion, loudness of the output signals, and so forth.

Do you see what I am getting at?

6 POINTS WHICH MAKE

The STAR



and What they Mean!

- 1 DIFFERENTIAL ANODE REACTION.** Anode circuit selectivity is improved by reaction, and also by differential anode coupling and a specially-chosen value of grid condenser.
- 2 DIFFERENTIAL ANODE COUPLING.** Controls the balance between selectivity and sensitivity on the tuned anode circuit.
- 3 AERIAL COUPLING.** Provides for variable selectivity of the aerial circuit and also makes an excellent volume control.

- 4 AERIAL REACTION.** The aerial circuit reaction, which is obtained from the screen-grid valve, enables "the big bad wolf of aerial damping" to be driven from the door of the receiver.
- 5 PHASE REVERSAL.** Ensures that the phase adjustment of the reinforcing electromotive forces is absolutely correct.
- 6 TONE CORRECTION.** A cheap and entirely effective method of adjusting the tone to suit the needs of the moment, and the degree of interference experienced.

The S.T.300 STAR

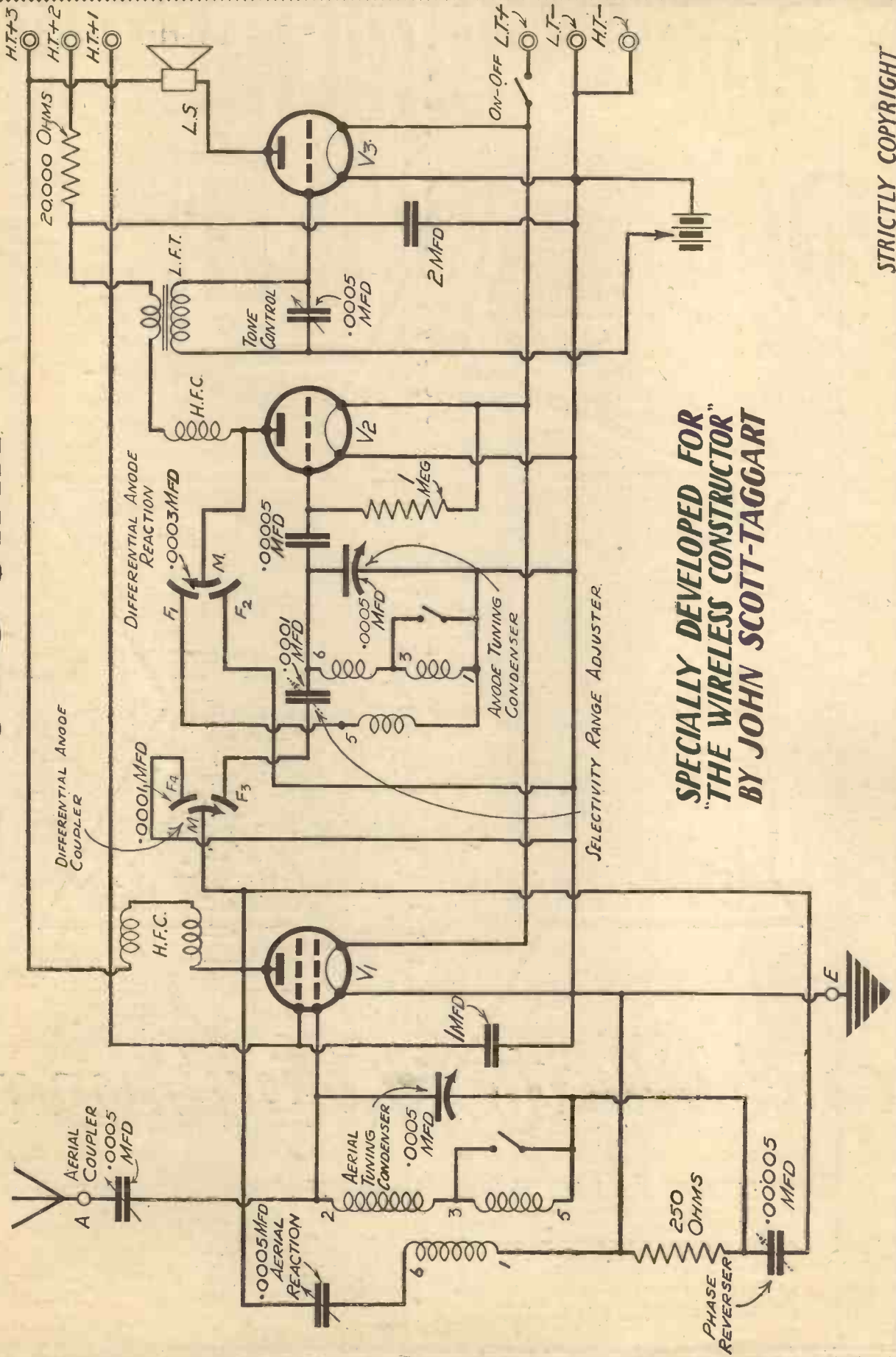

**SPECIALLY DEVELOPED FOR
"THE WIRELESS CONSTRUCTOR"
BY JOHN SCOTT-TAGGART**

STRICTLY COPYRIGHT

“Universally Good Results No Matter Where the Constructor May Live”

Do you realise how easy it is for a set which, in the designer's hands may give good results, to be a complete failure when actually built up by other people who are unable to duplicate exactly the designer's receiver or, in many cases, make not the slightest attempt to do so?

Perhaps, owing to my closer contact with the actual people who build sets and the greater experience of what goes on in their own homes, as a result of many personal visits there, I recognise

to the transference of energy from the anode circuit to the grid circuit in such a direction as to produce a reaction effect of an undesired type.

A little of this reaction effect may, in some cases, be an advantage, but in the ordinary receiver it is not under any kind of control. The result is that the designer's receiver may be perfectly stable and work quite well, but the moment someone else builds the same set, using their own valves and their own components and their

ponents are used, or what valves, the high-frequency stage will remain absolutely stable.”

He is, in fact, designing the set to a much lower standard of sensitivity than is necessary. To obtain stability in almost every kind of set involves a loss of sensitivity, and the result is that a fairly safe set is liable to be a thoroughly inefficient one.

Differential Anode Coupler

My own policy, however, is entirely different. On the one hand, I do not design a receiver which while giving good results in my own case will prove unstable in the hands of others; but on the other hand, I do not design a wireless set which is so safe as to be dull and inefficient.

The way I have carried out this policy on the “S.T.300” Star is to use a differential anode coupler, which feeds the anode tuned circuit with the amplified high-frequency energy.

This differential coupler controls the balance between selectivity and sensitivity on the tuned anode circuit, enabling different combinations of

HOW TO MARK AND DRILL THE PANEL

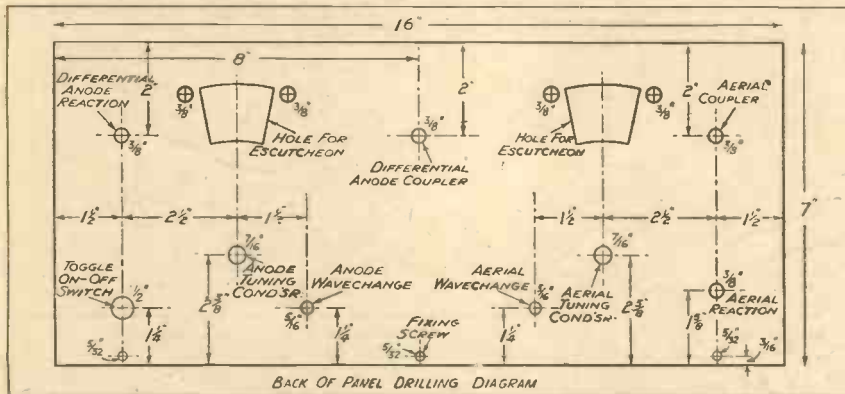

BACK OF PANEL DRILLING DIAGRAM

This back-of-panel drilling diagram should be compared with the photograph. Note that the position of the escutcheon and escutcheon fixing holes relative to the control holes is found from the templates supplied with the Polar condensers.

very deeply the different conditions under which a given set design will be expected to operate. Consequently, I have provided extra controls which not only have certain special merits of their own as regards balancing selectivity against sensitivity and so on, but which enable all reasonably built sets using the circuit to be compensated so that their performance will correspond to my own.

A Question of Stability

Perhaps the most striking case where different components, valves, etc., affect the receiver is as regards its stability. The moment a stage of high-frequency amplification is used, this problem of instability arises.

It is due to the fact that there is a tuned circuit in the grid circuit of the screen-grid valve and a tuned circuit in its anode circuit. When these two circuits are tuned to the same wavelength, namely that of the incoming signals, the screen-grid valve will tend to oscillate.

It is, of course, extremely important that this should not occur. It is due

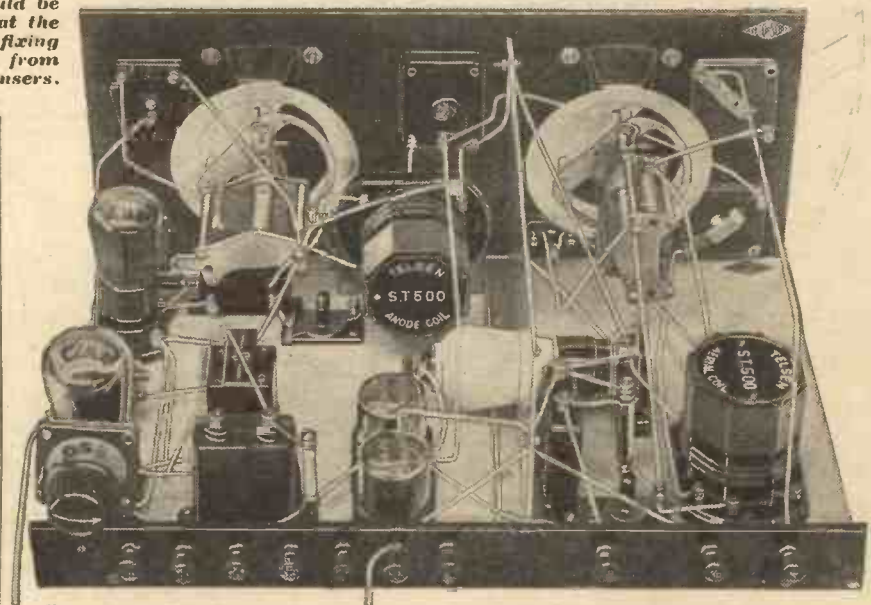

A general view of the back of the set, showing the valves in position.

own batteries, then the set may give any amount of trouble due to instability.

What does the designer do after he has learnt by bitter experience that many of his followers have troubles due to self-oscillation? He may say to himself: “I will make my next set so stable that no matter what com-

ponents are used, or what valves, the high-frequency stage will remain absolutely stable.”

these qualities to be obtained. But it also serves the purpose of adjusting the set to the right “distance” off instability. In other words, the coupler may be so adjusted (actually it is turned to the right for this purpose) that the set is amplifying to the absolute maximum extent while not being unstable.

**THE WIRING
OF THE
"S.T.300"
STAR**

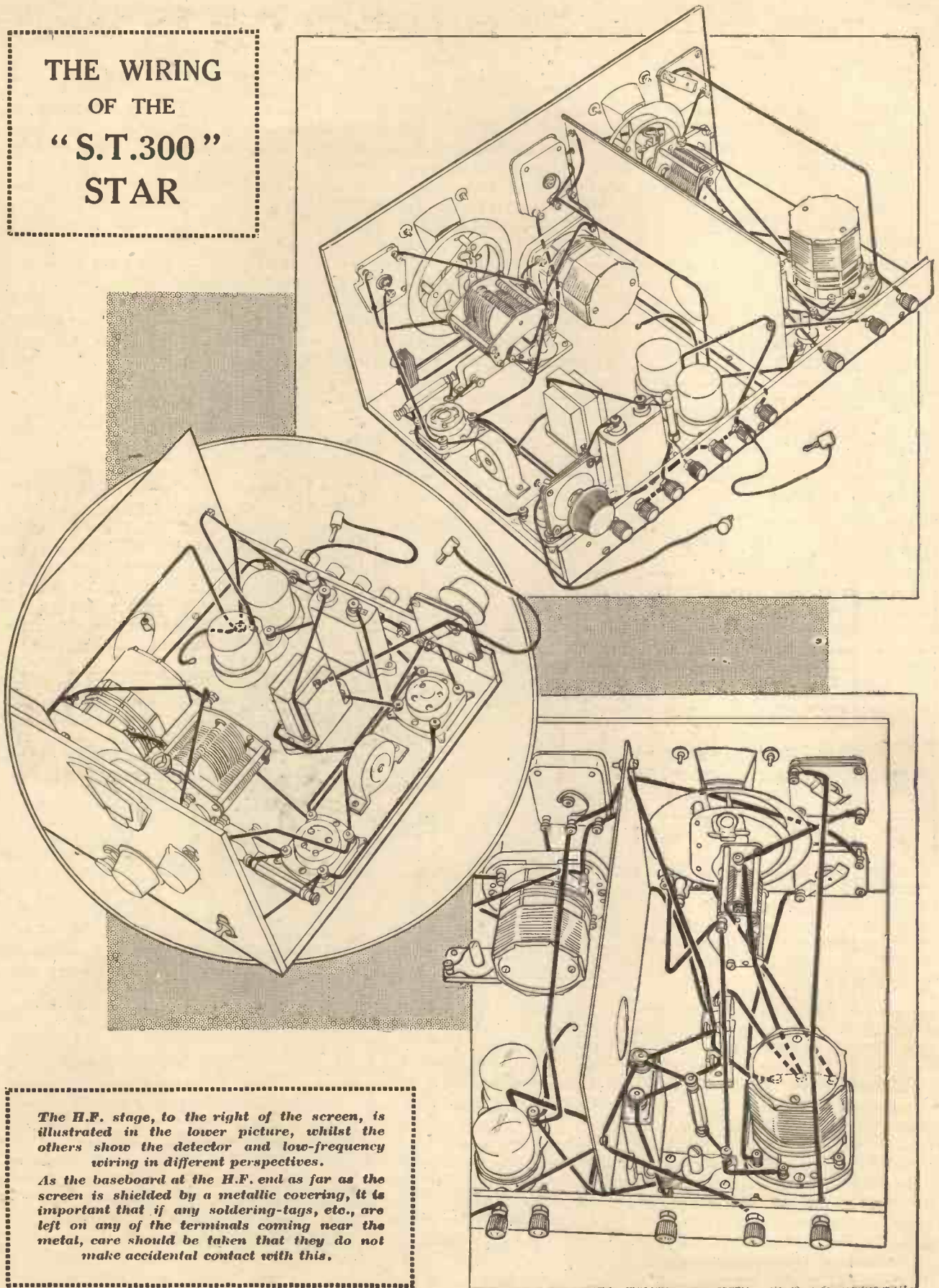

The H.F. stage, to the right of the screen, is illustrated in the lower picture, whilst the others show the detector and low-frequency wiring in different perspectives.

As the baseboard at the H.F. end as far as the screen is shielded by a metallic covering, it is important that if any soldering-tags, etc., are left on any of the terminals coming near the metal, care should be taken that they do not make accidental contact with this.

“Constructors will be Amazed at the Smoothness of the New Control”

There is a second, baseboard adjustment, which is labelled “selectivity range adjuster,” and its purpose is also associated with this question of sensitivity and stability, and also with selectivity.

At this stage I do not propose to explain each individual control and its action, but only to point out how extremely useful these controls can be to compensate for differences between sets.

Suppose, for example, one reader has a particularly efficient screen-grid valve. This high-frequency amplifying stage will tend to oscillate, but this tendency can immediately be checked by turning the differential anode coupler knob a little more to the left.

the same voltage as his neighbour's, and that his accumulator is not likely to be exactly charged to the same extent. While I do not recommend the use of high-tension batteries of less than 120 volts, it is to be expected that a very large number of batteries will be partially run-down and yet capable of giving quite good service.

Perfect Compensation

In the case of an ordinary receiver with fixed anode coupling we again have the peculiar disadvantage of not providing for all conditions. With fixed anode coupling, the sensitivity of the set may be at its best at 120 volts, but if this voltage falls to 100, sensitivity may fall off enormously.

because of the aerial or earth, or because of low battery voltages or poor valves, or because of the particular components in use, enables the user of the set to increase the high-frequency amplification by means of the differential anode coupler. By turning this a little more to the right, greater amplification is obtainable under such conditions, whereas in an ordinary set this would not be possible.

So much for the use of the differential anode coupler as a compensating device. Let us now consider the use of the aerial coupler, which consists of a condenser in series with the aerial circuit.

No doubt all of you have at some time or another heard the advice to

TWO CORNERS OF THE “S.T.300” STAR

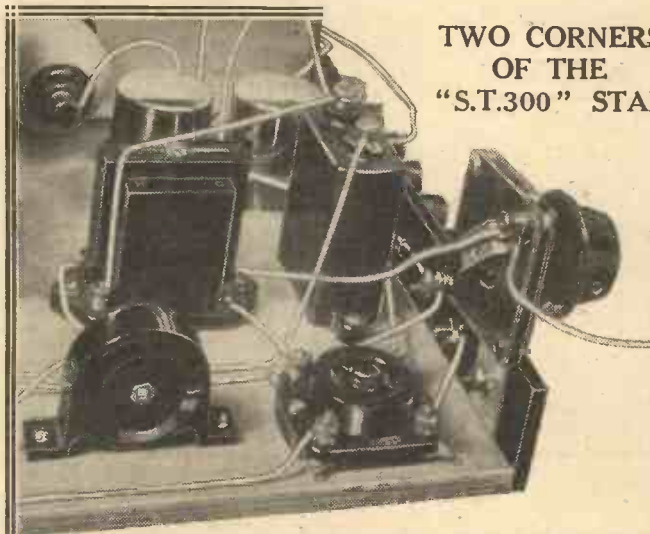

One of the differences between the “S.T.300” and the “S.T.300” Star is that the latter embodies tone correction and control.

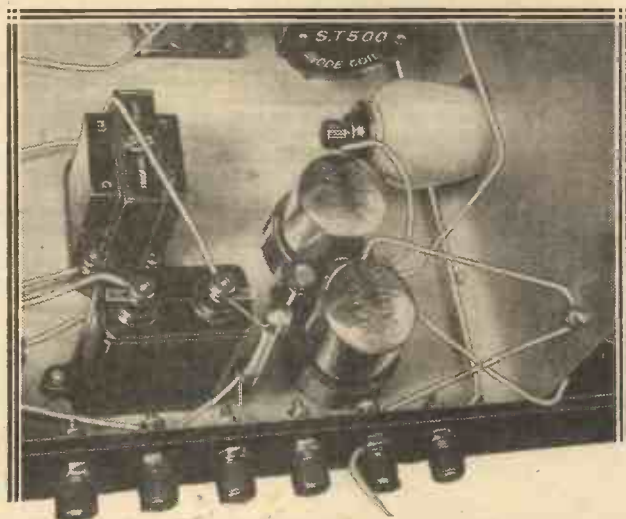

Here are shown in detail the leads in an important corner of the set. Note how the Dubilier resistance is suspended between the 2-mfd. condenser and the H.T. +2 terminal.

If, on the other hand, another reader has a screen-grid valve which is somewhat below par, either due to age, a different type of valve or one of the poorer specimens of the same type, the loss of signal strength may be made up by turning the anode coupler to the right.

Different Battery Voltages

If the anode coupler simply consisted of a fixed condenser, as it does in other sets, it is clear that the receiver would either be unstable on good valves or needlessly insensitive on poorer ones. Only with a valve exactly like the designer's own specimen will the set give the results the designer has aimed at.

The need for stability control will be apparent also if you consider that a constructor's batteries will not have

In the “S.T.300” Star, however, a slightly different adjustment of the differential anode coupling will enable a greater degree of amplification to be obtained from the screen-grid valve, and therefore the reduction in signal strength is compensated for.

Then again, the aerial and earth system of a set affects its stability. A small aerial, for example, will introduce less damping in the aerial circuit of a set and will tend to cause instability.

If, in an ordinary set, the design is so arranged with fixed anode coupling that the set will be perfectly stable with a small aerial, it follows that it will be insensitive on a large aerial. The set, in fact, is too stable.

By using my differential anode coupling, however, any additional stability which is given to the set

reduce the length of your aerial to improve selectivity. This recommendation, in my opinion, verges on the criminal in practically every case. Only if every single station comes in with excessive strength is it justifiable to use a smaller aerial.

Variable Selectivity

I refuse to believe that more than one in a hundred constructors ever reach such heights of perfection. I certainly do not do so myself. There are always some stations which are too weak to be received effectively on a small aerial. If, however, a large aerial is employed they come in perfectly well.

What is the man with the short aerial going to do when he turns his dial a few degrees from a powerful station to

“Reaction for Each Tuned Circuit is Obtained from its Own Valve”

one that is inadequate? Is he to go outside the house, extend his aerial again, and come in and enjoy the programme?

Obviously he cannot do this as he turns his dials to different stations, but the use of an aerial coupler enables

FOR BETTER SELECTIVITY

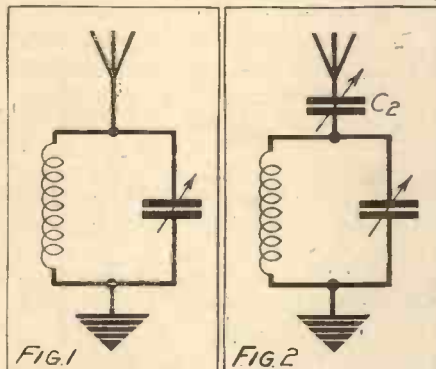

Fig. 1 shows a simple tuned aerial circuit, whilst Fig. 2 shows how a small condenser, C2, is inserted to improve selectivity.

the equivalent operation to be carried out on the panel of his set. The small movement of the aerial coupler knob on the “S.T.300” Star corresponds to increasing or decreasing the length of the aerial, so that on a weak station the coupler may be turned a little more to the right, while on a strong station it can be turned more to the left.

The aerial coupler obviously makes an excellent volume control for the set, but it is far more than this. It also provides variable selectivity of the aerial circuit.

With the aerial coupler more to the left, the selectivity improves, but signal strength falls off. If the aerial coupler is moved more to the right, signal strength improves, but selectivity falls off somewhat.

For National Use

All my sets are designed for national use, and will be found in every village from Land’s End to John O’ Groats. But it did not need a great tour of England and Scotland, such as I accomplished in connection with the “S.T.400,” to make me realise that no two aeriels and no two sets of conditions are alike.

One constructor may be fifty miles from a broadcasting station; another may be ten miles. In one place a great deal of interference is experienced from a certain station, while several hundred miles away the conditions

may be utterly different. Moreover, we all know that the degree of interference varies at different points of the dial; some stations suffer a great deal of interference while another station a little farther up the dial may be comparatively free from interference.

The object of my various controls is to enable you to get the most out of any individual station. When selectivity is required, you can obtain selectivity. When signal strength is the thing to bring up, the controls are there on the panel, and only need a slight turn to increase the volume.

If the controls were not there you would certainly have a simpler set, but the performance would be inferior. It is therefore for you to choose whether you prefer a mediocre performance plus

BENEFITS OF REACTION

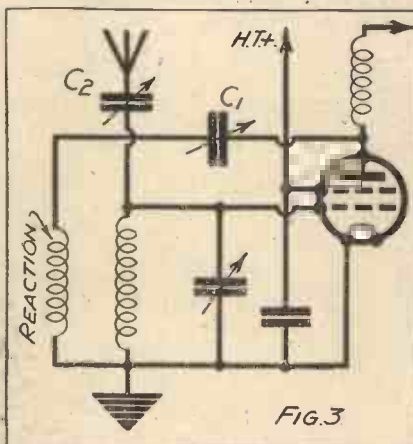

If reaction is applied to the very first valve in a receiver using H.F. amplification, all its benefits are obtained right at the beginning and before the rest of the set helps in tackling the question of selectivity and sensitivity.

simplicity, or maximum performance with some little extra adjustment.

Nevertheless, the “S.T.300” Star can be adjusted to give an excellent average performance by leaving the aerial coupler and anode coupler in a normal average position, and leaving the aerial reaction knob at zero. If it would make you any happier you are at perfect liberty to take the knobs off the controls so that there will be no temptation to use them! I wager, however, that sooner or later you will want to derive their benefits.

In driving a motor-car one has to adjust the throttle and the gears to suit the traffic. When hemmed in by other vehicles you drop into a lower gear and reduce speed; but once on the

open road, the top gear is used and full throttle.

It is much the same thing in a wireless set. There are occasions when interference is so great that one has to be more wary. Greater selectivity is called for and a little more care in adjustment.

Adjustable Reception

But, on the other hand, there are frequently times when it is possible to let the set rip, so to speak. But on an ordinary receiver this is not possible. It is designed for a fixed set of conditions, and the user can do nothing to improve matters.

Take, for example, reception during daylight hours. Fewer stations are obtainable, but you want them at full strength. How useful it is, then, to have the additional controls of the “S.T.300” Star to bring these stations right up to the full strength during hours when, normally, they would be weaker than at night-time. During the evenings the set would usually be operated with more regard for selectivity, since the stations are not only louder, but more interfered with. Here, then, we can adjust the controls so as to give the desired selectivity.

Another case to consider is that of constructors who live in different parts

VERY REMARKABLE IMPROVEMENT

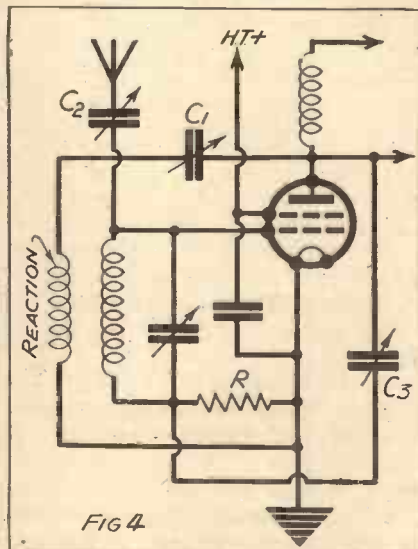

By applying reaction to the aerial circuit in absolutely correct phase signal strength is increased as selectivity is being improved by reaction. The effect is very remarkable, and is strikingly opposed to what is ordinarily obtained when efforts are made to obtain selectivity on an aerial circuit.

Not for Present Conditions Only, but Also for the Future

of the country. If you design a wireless receiver so that it will receive signals without interference when the receiver is situated a long way from the B.B.C., the same set will probably be hopelessly jammed when brought close to one or other of the Regional stations.

If, on the other hand, you design a receiver so that it will give good selectivity close to the B.B.C., it will probably be far too expensive to

you desire a receiver which will get the last ounce out of any station to be received, and which will give universally good results no matter where the constructor may live, then here, I believe, is a set you ought to build.

Those familiar with the "S.T.300" will, after an examination of this article, see that there is an extra control on the set—namely, the aerial reaction knob. This certainly adds one more complication, but actually

The merit of applying reaction twice over, both on the aerial circuit and on the anode circuit, has been discussed by me on two previous occasions—namely, in connection with the "S.T.400" and the "S.T.500" sets. In both cases it has won its spurs in the battle against interference.

Increased Signal Strength

As far as the general public is concerned, the principle of double reaction is only a little more than a year old, but well over a hundred thousand people have proved that not only is it simple to operate, but produces a great increase in selectivity and signal strength. Although it is a novel and original method, it has been tried out in that most reliable of all laboratories—the home of the wireless constructor himself.

For the benefit of newer readers, let me summarise the benefits of a system which in the "S.T.300" Star

WHAT TO PUT IN THE THREE VALVE HOLDERS

H.F. valve : Cossor S.G.220, or Mullard P.M.12A., Mazda S.215B., Marconi S.22, Osram S.22.
 Detector : Mullard P.M.2D.X., or Cossor 210Det., Marconi H.L.2, Mazda L.2, Osram H.L.2, Tunggram P.D.220.
 Output : Mullard P.M.2A., or Cossor 220P.A., Mazda P.220, Osram L.P.2, Marconi L.P.2.

construct, and the strength of weaker stations will be inadequate; and the same set used farther from the B.B.C. will be quite incapable of competing with a receiver which lacks a little extreme selectivity, but possesses greater sensitivity.

Over and beyond all these arguments, however, is the great advantage of being able to adjust a set to cope with conditions as they become worse. There is no doubt that interference is going to increase. I fully anticipate that our own B.B.C. stations will be compelled, in self-defence, if for no other reason, to increase their power.

The long-wave station at Droitwich is the thick end of a still thicker wedge which will make foreign-station reception more difficult. Reserves of selectivity should, therefore, be embodied in every set which is not to start becoming obsolete from the day it is built. Any set with fixed selectivity, or nearly fixed selectivity, is bound to be out of date a year, six months, one month, probably a week after it is constructed.

Universally Good Results

The tide of interference rises, and you can do nothing to stop it. How much better off will you be if you construct a receiver which provides adjustable selectivity which can be improved month by month as conditions in the ether get worse.

Well, there is my "apology" for the extra controls on the "S.T.300" Star. If you like fewer controls, remember that you can set any of mine to their normal positions and leave to some future day their adjustment. If, on the other hand,

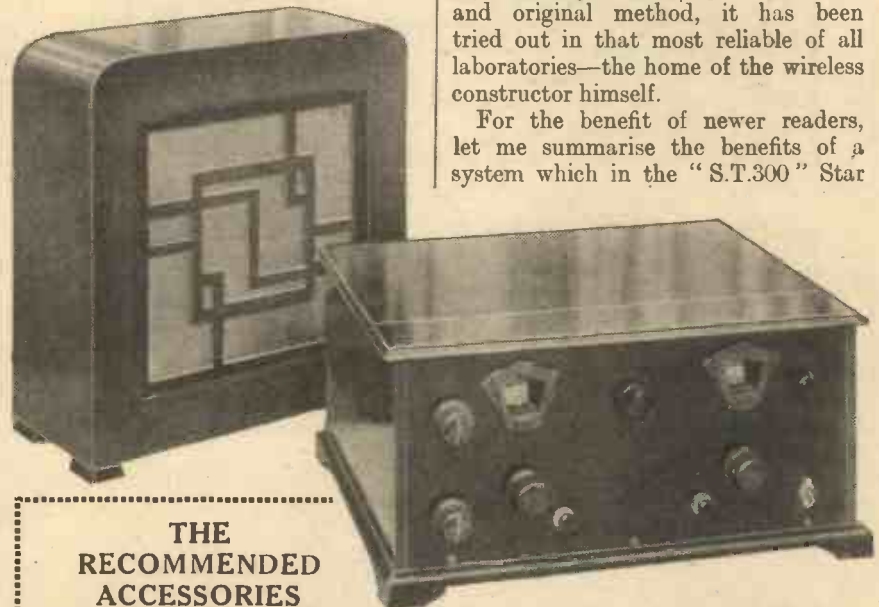

THE RECOMMENDED ACCESSORIES

LOUDSPEAKER : W.B., Celestion, Rola, E. & A., Blue Spot, Ferranti, H.M.V., Amplion, Marconiphone, G.E.C., Cossor.

(Note : If a speaker of the chassis type is chosen, the necessity of using a baffle board can be overcome by means of a Howe Box Baffle.)

BATTERIES : H.T. 120 volts : Siemens Full O' Power.

G.B. 9 volts : Pertrix, Drydex, Ever Ready, Siemens, Lissen, Marconiphone.

L.T. : 2 volts : Block, Lissen, Pertrix, G.E.C., Ediswan, Exide, Oldham.

AERIAL AND EARTH EQUIPMENT (if required) : Electron "Superial" Gol-tone, "Akrite," British Radiophone "Receptra" down lead, Bulgin lightning switch, Graham Farish "Filt" earthing device.

it is no more a complication than the ordinary reaction knob found on practically every straight receiver, and the merits of this aerial reaction are so enormous that, as regards selectivity and signal strength, the "S.T.300" Star is far superior to the "S.T.300."

is applied for the first time to a three-valve set :

The selectivity of a wireless receiver is due to the sharpness of tuning of a tuned circuit. Each circuit consists of an inductance tuned by a variable condenser, and the two dials on the "S.T.300" Star control the tuning of the aerial and anode circuits respectively.

Now the selectivity of a single-tuned circuit by itself is poor. It can weed out interfering signals to some extent, but the additional circuit greatly helps. In fact, the magnification obtainable with the receiver on any given wavelength is the multiple of the magnification of the aerial circuit and the magnification of the second circuit and the screen-grid valve.

A STAR DESIGN

Most of the wires go straight from terminal to terminal, thus simplifying the construction and ensuring correct spacing.



The blueprint shows the exact positions for mounting all the components, but the actual "run" of the wires is best seen from this and the other illustrations.



The detector (V2) valve holder is the one near the anode tuning condenser, the grid leak being supported on its own wiring from the grid and filament terminals.



The grid condenser, which is mounted on the baseboard below the anode tuning condenser, is of smaller capacity than usual, with consequent advantages in selectivity and smoothness of reaction control.



Note how the detector and output valve holders are arranged with their grid terminals facing inwards and towards the panel, to shorten the leads that have to go to them.

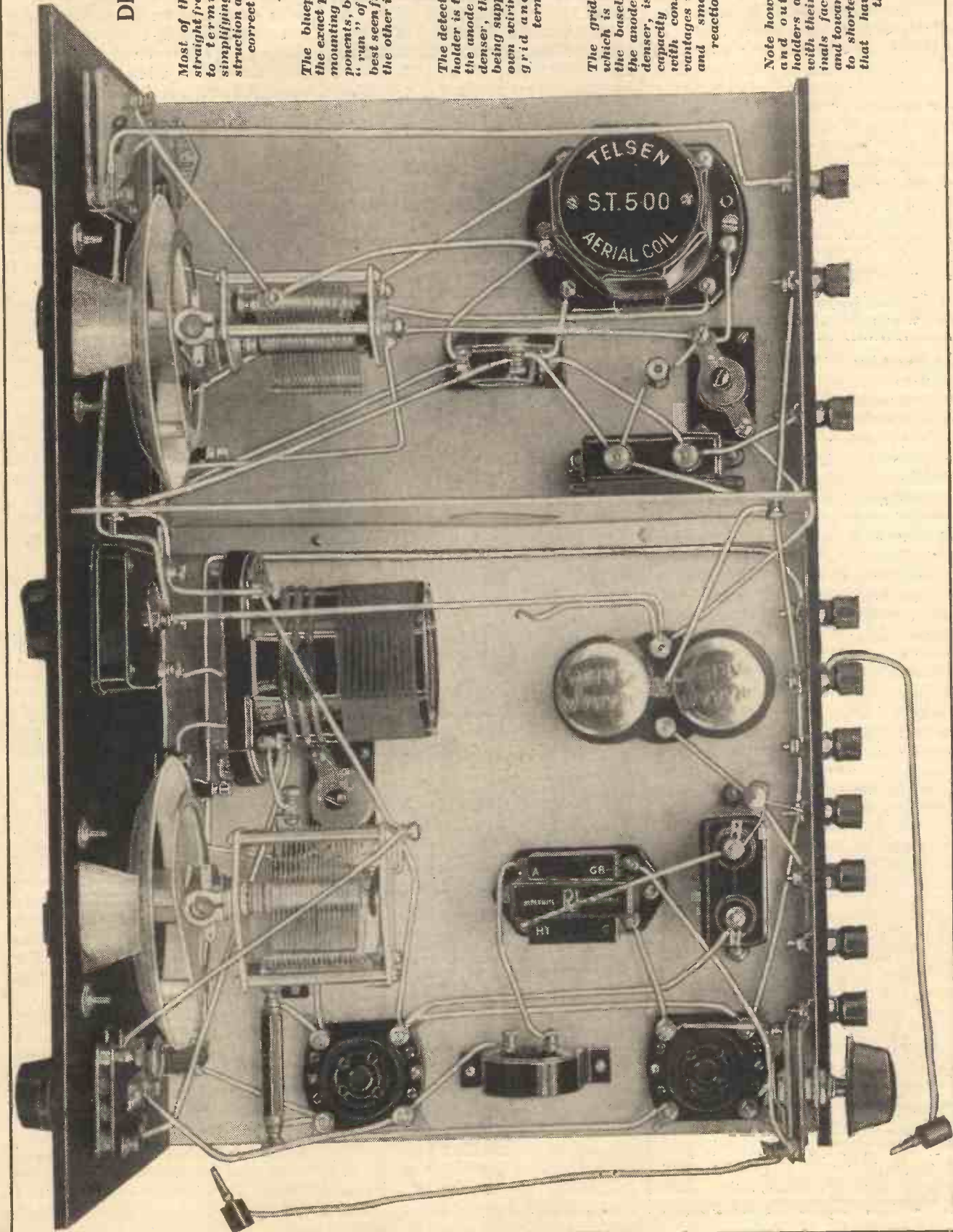

"Strength is Increased as Selectivity is Being Improved"

It will thus be seen that it is to our interest to make each circuit as selective as possible. The anode circuit has its selectivity improved by the differential anode coupler, by the reaction which can be applied to the circuit from the detector valve (i.e. the usual reaction), and the low value of grid condenser which I have chosen, and about which I shall have more to say later.

Adjustable Aerial Coupling

The aerial circuit, however, on all other types of sets other than my own is left to its own devices. In other words, its selectivity is simply that of an ordinary tuned circuit associated with an aerial.

This selectivity may be enhanced by reducing the damping effect of the aerial system with the aid of a variable condenser in the aerial lead. As the aerial selectivity requires to be adjusted at different points of the dial to deal with different stations, I have made the aerial coupler (which controls the aerial selectivity) adjustable on the panel.

5,000 Per Cent Better

But even with all the benefits of an aerial coupler of this kind, the selectivity obtainable with the aerial circuit is never very great. In fact, it cannot be any more than the selectivity of a tuned circuit consisting of an inductance and a condenser. Such a circuit, of course, possesses poor selectivity at the best of times, and the only effort which has been made to improve the results it gives is to develop iron-core coils.

Such coils are capable of reducing the resistance of the inductance and a

fifty per cent improvement is obtainable. This is useful, but is negligible compared with the benefits obtained by the use of my double-reaction method.

The "S.T.300" as originally produced exactly two years ago has no provision for reaction on the aerial, and therefore the selectivity of the aerial circuit was very much less than on the present "S.T.300" Star. Nevertheless I decided to see what improvement could be made in the original "S.T.300" by the employment of an iron-core coil. I am afraid that I was greatly disappointed.

I therefore had made a special iron-cored coil of very much greater efficiency than any at present on the

Of course, the double-reaction system could be applied also to iron-cored coils, but there would be no advantage in doing so, and the air-cored coils for this set are so extremely cheap that constructors should be appreciative of such an extremely economical method of improved selectivity.

Enormous Benefits

Many of you at some time or another will have operated a "det. and L.F." receiver using reaction. In such a set the benefits of reaction are enormous, as you will agree. It is therefore not surprising that if reaction is applied to the very first circuit in a wireless receiver using H.F. amplification, all these benefits are obtained right at the beginning and before the rest of the set helps in tackling the question of selectivity and sensitivity.

In the "S.T.300" Star the method of applying the reaction to the aerial circuit differs from that employed in the "S.T.400." It was inevitable that an improvement would be made on the technique of applying reaction twice over. In the "S.T.400," the processes involved are very much more complicated and the actual operation is also less simple than on the "S.T.300" Star.

The Two Methods

As I regard all builders of my sets as friends who at some time or another have to advise others as regards their sets, it may be as well to compare the two methods employed so that the "S.T.400" users may note an improvement which they can explain and recommend to those of their friends who are in search of a three-valve receiver giving a performance considerably greater than

SUGGESTIONS FOR MAINS UNITS

Make.	A.C. Mains.	D.C. Mains.
Atlas	A.2	D.C.15/25
Ekco	A.C.18	D.C.15/25
Heyberd	D.120	H.D.C.150

NOTE.—These suggestions for mains units for use in conjunction with the "S.T.300" Star are based upon the assumption that valves of the type actually specified, or valves with similar electrical characteristics, are used.

market, but again, although there was a slight improvement, the results were not to be compared with the increased efficiency and selectivity obtained by the use of aerial reaction. My balanced-phase double-reaction system as used in the "S.T.300" Star gave an improvement of 5,000 per cent over the best iron-core coils made.

This is a startling figure enough, but it represents the minimum which any constructor of this set can expect.

THE COMPONENTS RECOMMENDED FOR THE "S.T.300" STAR

- 2 Polar No. 4 .0005-mfd. variable air condensers with disc drives, or British Radiophone, Ormond slow-motion type R493, J.B., Telsen, British Radiogram.
- 2 Telsen "S.T.500" (or "S.T.400") coils, or Colvern, Wearite.
- 1 Graham Farish Twin Screen H.F. choke, type L.M.S., or Telsen binocular, Lewcos, R.I., dual astatic, Bulgín, Ampion, Wearite.
- 1 R.I. Hypermite L.F. transformer, or Lissen Hypernik, Varley, Ferranti, Multitone, Lewcos L.F.T.6A, Bulgín "Senator."
- 1 W.B. universal valve holder, horizontal mounting type.
- 2 Benjamin 4-pin valve holders, "Vibrolder" type, or Lissen, Graham Farish, Telsen, W.B.
- 1 Lissen Disc Type H.F. choke, type LN 5092, or Graham Farish, Telsen, Lewcos, Ampion, R.I. Quad Astatic.
- 3 Graham Farish .0005-mfd. mid-log-line solid dielectric condensers, or Polar, Telsen, British Radiogram.
- 1 British Radiogram .0003-mfd. differential condenser with insulated spindle, or Polar.
- 1 Telsen .0001-mfd. differential condenser (latest type as illustrated), or Graham Farish, British Radiogram, J.B., Polar.
- 2 Bulgín 2-point push-pull switches type S22, or Telsen, British Radiogram, Lissen, Benjamin, Wearite, W.B., Ormond.
- 1 J.B. .00005-mfd. baseboard preset condenser, or Graham Farish.
- 1 J.B. .0001-mfd. baseboard preset condenser, or Graham Farish.

- 1 Bulgín on/off toggles witch, type S.80, or British Radiophone, Claude Lyons.
- 1 Dubilier 2-mfd. fixed condenser, type BB, or T.C.C., Graham Farish, Telsen, Ferranti.
- 1 T.C.C. 1-mfd. fixed condenser, type 50, or Dubilier, Telsen, Graham Farish, Ferranti.
- 1 Dubilier 20,000-ohm metallised resistance, 1-watt type, or Graham Farish, Varley, Watmel, Claude Lyons, Bulgín, Erie.
- 1 Graham Farish 250-ohm "Ohmite" resistance, or Dubilier, Bulgín, Erie, Varley.
- 1 Lissen .00005-mfd. fixed condenser, or Dubilier, T.C.C., Graham Farish.
- 1 Graham Farish 1-meg. "Ohmite" resistance, or Dubilier, Varley, Erie, Claude Lyons, Bulgín.
- 1 Peto-Scott panel, 16 in. x 7 in. x 1/8 in., or Goltone, Permcol, Wearite.
- 1 Peto-Scott cabinet and baseboard, 16 in. x 10 in. with Metaplex 6 1/2 in. x 10 in. at one end.
- 1 Peto-Scott "S.T.300" Star screen.
- 1 Peto-Scott tone control bracket.
- 1 Peto-Scott terminal strip, 16 in. x 1 1/2 in. x 1/8 in.
- 10 Belling Lee indicating terminals engraved as follows: "A," "E," "L.S. +," "L.S. -," "H.T. -," "H.T. + 1," "H.T. + 2," "H.T. + 3," "L.T. -," and "L.T. +," or Bulgín, Chix, Eelex.
- 6 Chix Wanderplugs or Belling Lee, Eelex, Bulgín.
- 2 Chix L.T. spade terminals, Screws, Glazite, etc.

Differential Coupling Compensates for Different Conditions

that of any three-valve set using only a single stage of reaction.

In the "S.T.400" I distributed the reaction from the anode circuit of the detector to the aerial circuit and to the tuned anode circuit of the set. The disadvantage of this arrangement is that the differential anode coupling forms an essential link in the reaction chain. If there were no coupling there would be no reaction on the aerial circuit. In actual practice there never exists no coupling, but it can be reduced to a very low figure.

Independent Reaction Sources

In the "S.T.300" Star, however, the reaction for each tuned circuit is obtained from its own valve. For example, the aerial circuit reaction is obtained from the screened grid valve which, incidentally, is an excellent valve for this purpose. The tuned-anode reaction, however, is obtained from the detector valve and thus we have two independent sources of reaction, neither of which is dependent upon the degree of coupling between the valves.

That is to say if the differential-anode coupling is at zero, giving a very high selectivity on the anode circuit, the aerial reaction will fulfil its purpose perfectly well. The "S.T.400" therefore requires a little more skill in adjusting the reaction and the two circuits are not as independent as they are in the "S.T.300" Star, where each is practically in a separate compartment.

How Controls are Arranged

The controls, for example, are designed for the same purpose and operate in the same way. The aerial coupler, the aerial reaction and the left-hand tuning dial form the three controls for the aerial circuit, while the wave-change switch, although not a control, enables one to receive the long waves or the medium waves at will.

These knobs or controls form the left-hand or aerial portion of the panel while the differential anode coupler, the anode reaction knob and the right-hand tuning dial, together with the right-hand wave-change switch, form the controls for the anode circuit.

If the two circuits are regarded in this way as separate, and if the controls appertaining to the circuits are treated in the same way to obtain the same effect, then the user will have not the slightest difficulty in operating

the "S.T.300" Star to the best advantage. Special hints are given on operating the set, but the point I wish to make clear is that the controls are grouped into two sections, each section containing a coupler or feed control, a reaction control, and an ordinary tuning dial.

You tune each circuit to the incoming signal, feed it with the desired amount of energy through its coupler, and increase signal strength and selectivity with the reaction.

The method of applying the reaction to the aerial circuit required a great deal of development work to be done to ensure that the best results would be obtained. The introduction of aerial reaction in almost any way

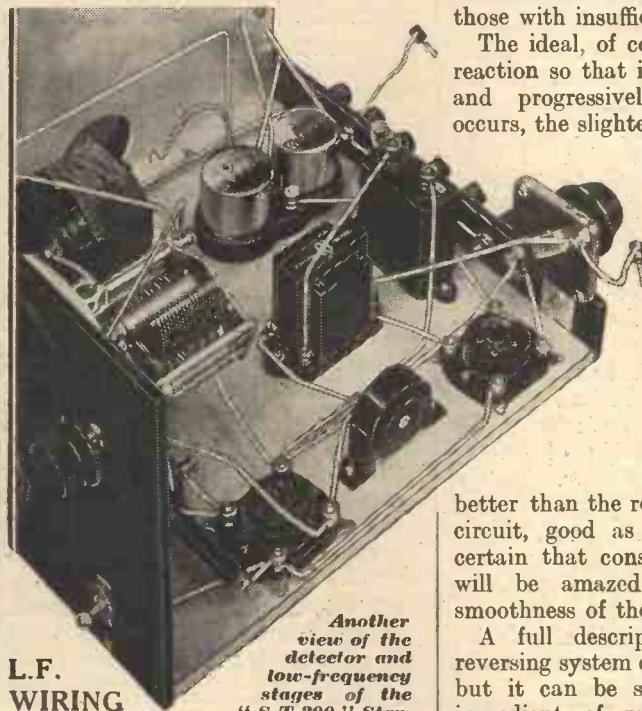

L.F.
WIRING

Another view of the detector and low-frequency stages of the "S.T.300" Star.

would have been a great stride forward in the production of a three-valve wireless set, but the experiments I conducted showed very clearly that, while all methods were good, one was superlatively so, and I have termed it balanced-phase reaction.

There is a great deal about reaction that we do not know, and I believe that there are still secrets to be wrested from the process, but we do know that the proper application of reaction is not nearly as simple as many people think. Ploppy reaction and "reaction hysteresis" are two common faults which trouble designers and constructors alike.

Oscillation may set in long before reaction has reached its maximum value; when this is the case reaction will increase signal strength up to a certain point but then, instead of increasing it still further, the set oscillates.

Amazing Smoothness

Another trouble, commonly called reaction hysteresis, occurs when reaction is increased until the set oscillates and then, on reducing the reaction, the set continues to oscillate instead of coming out of that state and returning to the reaction condition. By the time that the reaction knob has been turned to stop the oscillations, conditions in the set are equivalent to those with insufficient reaction.

The ideal, of course, is to have the reaction so that it increases smoothly and progressively until oscillation occurs, the slightest reverse turning of the reaction knob stopping the oscillation.

With regard to the double-phase reaction scheme used on the "S.T.300" Star, I can say that the aerial reaction is smoother and better than any other kind of reaction. It is, in fact,

better than the reaction on the anode circuit, good as that is, and I am certain that constructors of this set will be amazed at the ease and smoothness of the new control.

A full description of the phase reversing system cannot be given here, but it can be stated that the first ingredient of reaction is that the circuit should be stable before reaction is applied, and that there should be no question of reaction on one circuit causing instability on the other.

Extremely Important

This is a point of very considerable importance when a stage of high-frequency amplification is employed because this stage on all wireless receivers tends, to some extent, to be unstable. A second important factor is that the phase adjustment of the reinforcing electromotive forces should be absolutely correct.

Here again the fact that there are two tuned circuits, one in the grid

Ample Reserves of Selectivity are Embodied in this Set

and one in the anode circuit of the screen-grid valve, renders the situation much more complicated from the design point of view. In the case of the "S.T.300" Star, the reaction is obtained from the choke coil in the anode circuit of the screen-grid valve.

Six Vital Features

The influence of the tuned circuit following the screen-grid valve is not a wholesome one from the point of view of reaction adjustment, but the "S.T.300" Star overcomes all these various difficulties. They have concerned me, of course, as the designer, but they do not concern the operator of the set from whose path the various "snags" have been brushed away.

The following are the differences between the "S.T.300" and the "S.T.300" Star:

1. Aerial reaction is employed, in addition to anode reaction.
2. Balanced-phase reaction is employed.
3. Tone correction and control is embodied.
4. An aerial coupler of about 12 times the capacity is employed.
5. A grid condenser of half the value is used.
6. A selectivity range adjuster is now inserted.

These features are of such importance that they produce what is equivalent to an entirely new design of set, although I have retained the basic principles of the "S.T.300" which resulted in its outstanding popularity amongst home-constructors.

I have dealt with the double-reaction system, but closely associated with it is the change-over to an aerial coupler of about twelve times the size of that used on the "S.T.300." The latter set employed an aerial coupler having a capacity of .00004-mfd. Why, then, have I suddenly changed my policy and used an aerial coupler of .0005-mfd?

That "See-Saw" Law

Actually, I have not changed my policy at all. My object then, as now, was to obtain as much selectivity on the aerial circuit as possible. This selectivity, however, could only be obtained at the sacrifice of a certain amount of signal strength. The old see-saw law controlled the circuit. An increase of selectivity means a decrease of sensitivity, and vice versa.

This law has hitherto been inexorable

and inescapable on all wireless sets, and in the "S.T.300" I was as much a victim of it as any other designer. To obtain aerial selectivity I had to reduce the coupling between that circuit and the aerial and earth system. I believe that my method was, and is, better than other systems, and the panel control adjustment, of course, was of the greatest value and importance. But, nevertheless, the selectivity was being obtained at the expense of signal strength.

Very Remarkable Effect

Now, however, in the "S.T.300" Star, the old law has been repealed. By applying reaction to the aerial circuit, signal strength is increased as selectivity is being improved by reaction. The effect is very remarkable

action do not cease here. Aerial reaction cancels out the losses imposed by the aerial-earth system. The greater the coupling between the aerial and the aerial circuit, the greater will be the signal strength, but also the greater will be the losses.

Wiping Out the Losses

When we have no aerial reaction, this is a very serious matter, and we have to sacrifice signal strength in order to obtain a reasonable amount of selectivity. With reaction, however, we can go on increasing the coupling between aerial and the aerial circuit, and simply wipe out the added losses by a little more reaction.

We thus obtain not only a reaction effect on the aerial circuit but we are enabled to feed that circuit with very

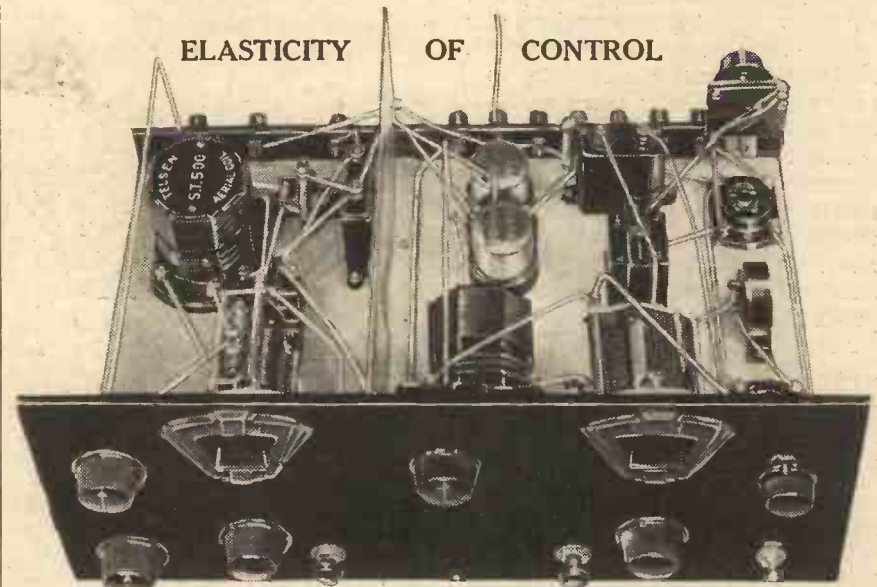

The object of the various controls is to enable you to get the most out of any individual station. When selectivity is required, you can obtain selectivity. When signal strength is the thing to bring up, the controls are there on the panel, and only need a slight turn to increase the volume.

and is strikingly opposed to what is ordinarily obtained when efforts are made to obtain selectivity on an aerial circuit.

The big bad wolf of aerial damping is now driven from the door of the receiver, and instead now of gaining either signal strength or selectivity at the expense of the other, we obtain both advantages by slightly turning the aerial reaction knob to the right. It is all so simple that within five minutes of handling the "S.T.300" Star, you will be blessing this control—and, I hope, myself!

But the advantages of aerial re-

much larger amounts of energy from our signal collector—the aerial.

A Most Valuable Merit

It is difficult to exaggerate this merit. Reaction with a .00004-mfd. aerial coupler would give vastly greater selectivity and signal strength, but the receiver could not work on any stronger signals than those passed into it through the aerial coupler adjusted to its maximum position. By increasing the size of the aerial coupler we shall be able to receive on the set much stronger signals and yet not suffer from the disadvantages of excessive

Sensitivity Adjustable for Daylight or Darkness

aerial losses, since these can be wiped out by reaction.

The full effect is not noticeable so much at the bottom end of the medium waveband, but as one proceeds up the dial, and more particularly as one goes on to the long waves, the results are strikingly better. I am referring now to the use of a larger aerial coupler.

Far Superior Scheme

The aerial reaction, therefore, provides a double merit. Those who cannot erect a full one-hundred-foot aerial, and also those who enjoy listening to stations such as Radio Paris, will derive the maximum benefit from the larger aerial coupler, and the "S.T.300" Star is miles ahead of the "S.T.300" as regards loudness of signals.

As regards selectivity, it is, and obviously must be, far superior to its predecessor of two years ago, since a flatly tuned aerial circuit now becomes an exceedingly sharp watchdog for interference.

The tone control requires little comment. It is a cheap and entirely effective method of adjusting the tone of the receiver to suit the mood and the type of music being heard, and the degree of interference experienced.

The grid condenser of the "S.T.300" Star is of much smaller capacity than is usual. In fact, it is half the capacity of the .0001 mfd. which I have used on previous sets, and this figure itself was a third of the .0003 mfd. which for many years has been treated as sacrosanct.

The size of the grid condenser affects half a dozen factors in a wireless receiver, including selectivity, tone, reaction and signal strength.

A reduction in the electrical size of the condenser will reduce the grid current damping effect and will therefore increase selectivity. The value of .00005 mfd., which I have chosen, improves selectivity and smoothness of reaction, while retaining sensitivity.

Choosing the Components

The construction of the "S.T.300" Star follows very closely that of the "S.T.300," and the principles of rapid construction contained in THE WIRELESS CONSTRUCTOR of February, 1932, may be applied. Similar principles were adapted for the "S.T.400" (THE WIRELESS CONSTRUCTOR, December, 1932), and for the "S.T.500"

("Popular Wireless," October 21st, 1933).

The panel screen and other features are maintained the same size, as in the case of the "S.T.300," so as to enable all owners of that popular set to convert to the "S.T.300" Star. Needless to say, there is no need to discard "S.T.300" components provided these are of a type approved in one or other of my sets.

I do urge, however, that you do not depart from my list of alternative components. If you do, you do so entirely and absolutely at your own risk.

This will cause a good deal of confusion, and those who find out this trouble can reverse the connections to the fixed vanes terminals of the differential which is working wrong way round.

You may find, for example, that the set oscillates violently with the anode reaction knob at zero (full left). If you are using a different differential for anode reaction your reaction knob should be full right for zero reaction.

The anode coupler is also a differential, and here again you may find that

SOME POINTS ABOUT THE L.F. SECTION

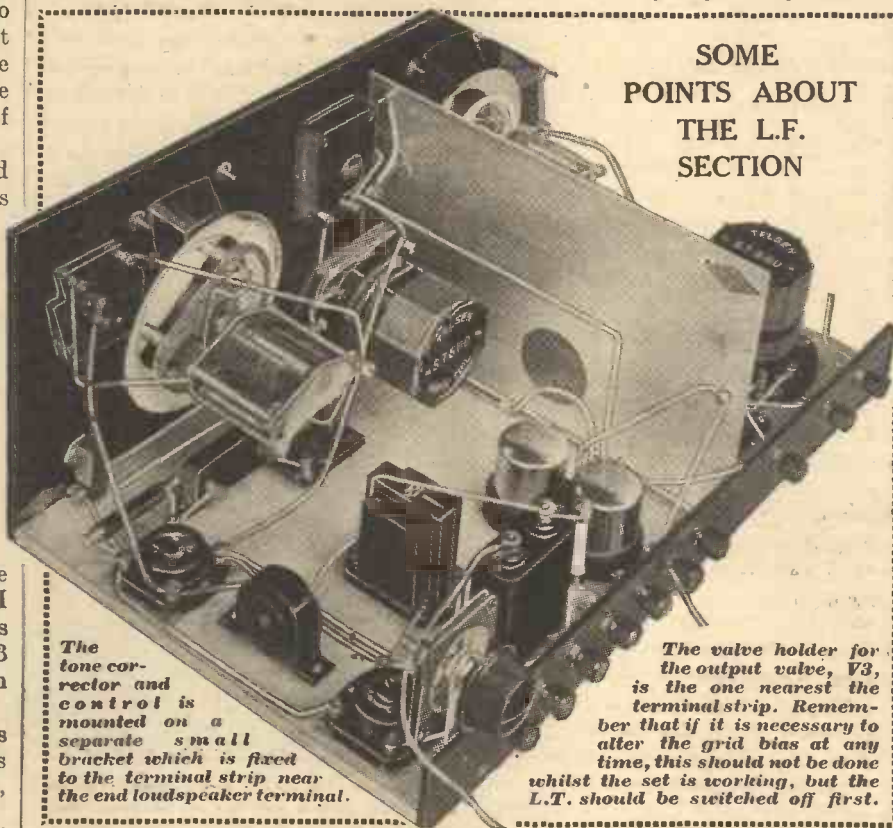

The tone corrector and control is mounted on a separate small bracket which is fixed to the terminal strip near the end loudspeaker terminal.

The valve holder for the output valve, V3, is the one nearest the terminal strip. Remember that if it is necessary to alter the grid bias at any time, this should not be done whilst the set is working, but the L.T. should be switched off first.

If a beginner you should emphatically use the actual makes of differential condensers specified first, i.e. those in my own version. The Telsen, it should be noted from the photographs, is their latest pattern.

The reason I mention the differentials is because there is no standard as regards the terminal positions. The middle terminal is the moving vanes and a "pigtail" connection is made to them. But if you use other makes of differential, the set will work just as well, but possibly the differential condenser knobs will have to be turned to the left when my operating instructions tell you to turn them to the right.

by turning the knob to the left signals, after slight retuning on the right-hand dial, do not decrease in strength as they should do, but increase. This is an indication that the differential is working the wrong way round. You can either get used to the effect or reverse the leads to the fixed vanes, or buy differentials similar to the ones I use.

Disc-Drive Tuning

The tuning condensers are of the escutcheon type, which is preferred by some constructors. Some readers believe this type looks more modern, and as I have not used such dials

(Please turn to page 274).



**More Alternatives ?
The B.B.C. Orchestra
Lady Announcer Mystery**

THE B.B.C. has never yet been caught napping by a Parliamentary inquiry and no doubt it is something of the same spirit of vigilance that is responsible for discussions I have heard of a current complete review of programme policy. If my information is correct, this review will touch all departments of programme work and the recommendations may result in important changes of policy.

I would not be surprised, for instance, to see a curtailment of the powers over programmes now exercised by the National Council for Adult Education. Also, there is a good chance of entertainment getting a larger share of programme time. I hope the much-discussed "alternatives" will come well out of the inquiry.

B.B.C. and Gaumont British

The B.B.C. is stirring itself to protective methods against the supposedly growing hostilities of Gaumont-British interests. The exact situation is still difficult to define, but I have noticed several indications of a new attitude on the part of the B.B.C. A struggle on a wide front between the B.B.C. and Gaumont-British would certainly provide fun for the spectators.

Adrian Boulton Wins

Dr. Adrian Boulton, the indefatigable Music Director of the B.B.C. has won another important victory against intrigue. Some time ago influences hostile to him both inside and outside the B.B.C. formed a kind of unholy alliance to deprive him of most of his authority by splitting up his job.

The most strenuous endeavours have once again failed and the B.B.C. as a whole is to be congratulated on the victory. Adrian Boulton must be protected. His greatest task of making the B.B.C. Orchestra unassailably the finest in the world has still some way to go. But he alone can achieve this objective.

**BY OUR SPECIAL
CORRESPONDENT**

Where is Mrs. Borrett ?

Mr. Roger Eckersley, who was particularly concerned, along with Mr. Whitley, in bringing Mrs. Borrett into the B.B.C., went out of his way at the termination of the trial to make it clear that Mrs. Borrett, reverting to her acting personality as Sheila

MILE END TO MAYFAIR



The youngest band leader in London, Len Dight, aged 20, broadcast in January as leader of the May Fair Hotel Orchestra. Dight is a Cockney, and started playing in a Mile End cinema.

Borrett, would be anxiously sought to appear in B.B.C. Dramatic productions, the Children's Hour, and other sections of the programmes.

One would have thought that the Director of Entertainment (Mr. Roger Eckersley), supported by the Chairman (Mr. Whitley), would have been strong enough to carry through this laudable intention, but one looks

**Those "Canned" Broadcasts
The B.B.C.'s "Archangels"
Jack Payne Again ?**

almost in vain for any reference in the programmes to the former Lady Announcer. Why ?

Gramophone Record Troubles

The growth in the proportion of gramophone record programmes broadcast by the B.B.C. is causing alarm among artistes and instrumentalists. While it is admitted that the recognised copyright charges are made to the gramophone companies, and the Performing Rights Society, it is pointed out that if the preference for recorded programmes develops much farther than it has gone already, there will be a serious curtailment of the opportunities for direct microphone appearances.

In America there is hardly any recording on the air because the public will not stand for it; here, however, the same prejudice does not exist; so artistes have to defend their own interests.

I hear Jack Payne is likely to take up the matter in the interests of the "direct performers." Even from the point of view of broadcasting, it would be unwise to let the tendency go so far as to discourage "direct talent."

New Jobs at Broadcasting House

It is nearly a year since Sir Charles Carpendale and his staff-recruiting assistants at Broadcasting House set out to find a "mobile reserve" of a dozen or so bright young men who, after a period of general training, would be fitted into vacant jobs. Despite the sifting of an enormous number of applications, more than 80 per cent of the jobs are still "going."

What is the reason for this ? Is it that the standards of the B.B.C. are ridiculously high, or is it that there is really a paucity of suitable talent ? From what I can glean, I feel that the B.B.C. is asking far too much, and that, in its present mood, it will never find its dozen "archangels."

Foreign Relays Fail to Please

Requirements include distinguished university records, good "family," high character, literary ability, "safe" politics, ambition, amenability to discipline, disregard of financial rewards or prospects, "devotion to the cause of broadcasting," and successful experience in at least one job, preferably of a public kind.

People who have such qualifications simply are not looking for jobs, least of all in a place where they are supposed to sink their individuality in a sort of "Nirvana" of devotion to a "cause."

The Future of Henry Hall

In two months' time Mr. Henry Hall and the B.B.C. will be talking about revising his contract for another period. The signs are strong that the B.B.C. will attempt to get Mr. Hall to continue on much the same terms as at present. Whether he will accept is another matter. I think he will rightly ask for a more generous reward both for himself and his "boys."

On the other hand, I hardly imagine he will wish to break with the B.B.C. yet awhile. The time has not come for him to emulate Jack Payne by going outside to reap a golden harvest based on the broadcasting background.

A FIRST BROADCAST



Seymour Hicks photographed in the studio during his first broadcast. He played the part of Scrooge in "A Christmas Carol." Note the chains of Marley's Ghost!

That will be in about two years' time, when I would not be surprised to see Henry Hall switch over with Jack Payne.

New International Policy

For some time the B.B.C. has been moving farther and farther away from the regime of "Nation shall speak peace unto Nation." A stronger sense of National and Imperial responsibility tends to dominate the policy at Broadcasting House. Difficulties on the Continent have aided the progress.

The B.B.C. is now quite ready to carry on without the International Broadcasting Union. The departure of Mr. Vernon Bartlett has meant stressing the patriotic motive. Public indifference to relays from other countries has changed programme policy. Talks on International subjects are more definitely from the British angle than ever.

100 Years Ago

The Central Council for Broadcast Adult Education has approved a proposal that the Tolpuddle Martyrs' Centenary Celebrations should be given broadcast publicity. The scheme is to dramatise incidents in the history of the Trade Union Movement.

AMONG all the broadcasting band leaders it is probable that Roy Fox (who will be leaving the Kit Cat at the beginning of March and going back to the Café de Paris) has the reputation of being the best looking. Tall, rather hatchet faced and immaculately dressed, it is not surprising that his "fans" are many. Started as a trumpeter in an American brass band at the age of fourteen and three years later joined a Californian dance band. London first welcomed his band four years ago when, after numerous successes in the States, he came over here to play at the Café de Paris, moving later to the Monseigneur Restaurant and, later still, to the Kit Cat, which was structurally altered so that his band might broadcast.

He is a strict disciplinarian but none the less popular with his band for that. He knows what he wants—musically and otherwise—and sees that he gets it.

* * *

Not long ago a young lady went to the studios of the Parlophone record company to make a private record for

VOICES ON THE AIR
 Making the acquaintance of the People in the Programmes.

her own use. So impressed was the studio manager that she now records officially for the company. She also succeeded in impressing Albert Coates and Sir Henry Wood to such an extent that they bullied the B.B.C. into letting her broadcast. She has appeared before the microphone regularly ever since.

Who is she? Eileen Joyce is her name, she is just twenty-one and she plays the piano. She is also remarkably pretty. Her adventurous life started in Tasmania, moved to the bush of Western Australia, and continued with the nuns of Loreto Convent, where she played the piano to such good purpose that Backhaus persuaded her to go to Leipzig for further training.

Visitors to the Victoria Ballroom at Nottingham during non-dancing hours have often been surprised to find a tennis ball being vigorously slammed against the wall of the ballroom. Closer inspection of the gentleman with the racket has revealed Billy Merrin (whose band has been doing quite an amount of "special programme" work lately).

Billy, who is not yet thirty-four, was an infant prodigy. Before he was nine he was an expert with the banjo and mandoline. When he was twelve he had written his first dance tune. The basis of that tune he still uses to-day for his signature number, "Troubles are like Bubbles."

Thoroughly versatile, he arranges all the numbers for his band, singing the vocal choruses, and has also written a play for his local church, and a musical comedy, "Cupid and the Pilot," which has been broadcast.

Is the most popular of the "out of town" dance leaders and is married. (Nottingham ladies, please note!)

PATRICK CAMPBELL.

RADIO EXPERTS

THE S.T. MANUAL

PROFESSOR E. V. APPLETON, F.R.S. :

"One of the most notable features of modern journalism is the high technical standard of the popular wireless papers. What we may call 'the average electrical knowledge per head of population' has increased enormously during the last ten years, and I have no hesitation in attributing this progress largely to the influence of the wireless journals. They teach the amateur that enthusiasm is not enough, and that a keener pleasure can be his when knowledge and understanding are added.



PROF. E. V. APPLETON.

"Mr. Scott-Taggart's book seems to me admirably suited to assist in our general electrical education. It is attractively written and is illustrated by most excellent diagrams. It is thoroughly up to date, and gives a full account of the remarkable progress in valve and circuit technique which has taken place during the last eighteen months."

W. W. BURNHAM
(Chairman of the Radio Manufacturers' Association) :

"I have now had an opportunity of reading through this book. It is certainly some time since a book has appeared from the pen of Mr. Scott-Taggart, but a study of this work shows that he has not lost his fluent style and knack of explaining radio problems in a manner which makes them easily understood by the average radio listener.

"I am pleased to note that the book is right up to date, because it generally happens that this is not the case with text-books, probably owing to the delay between the date they are written and the date they are published.

"I think that the chapter on 'Decoupling Devices and Filters' is particularly well done, the copious diagrams making the action of these devices perfectly clear.

"I think that 541 diagrams must be nearly a record for a book of this size.

"I think that this book is perhaps the best of its class, and every radio enthusiast who is not content to turn



W. W. BURNHAM.

There has never before been offered to wireless enthusiasts such a remarkable publication as John Scott-Taggart's "The Manual of Modern Radio."

On other pages you can read how this unique work may be brought into your home at but a fraction of its actual cost.

Meanwhile, see what leading radio experts—who have had an opportunity of reading the Manual—think about the most comprehensive guide to modern radio ever published.

a-knob, but would like to know why, ought to make an immediate resolution to get hold of a copy of this book somehow."

PHILIP R. COURSEY, B.Sc., M.I.E.E. (Technical Director, Dubilier Condenser Co., Ltd.) :



PHILIP R. COURSEY.

"The new Manual written by Mr. Scott-Taggart, which has been issued by The Amalgamated Press, is an attractive volume. The author has set himself a task of

no small magnitude in preparing such a book with a wide range of appeal.

"The non-technical reader can find in it simple explanations of the elements of radio reception, while those who require detailed information about recent developments—such, for example, as Quiescent A.V.C. applied to superheterodyne receivers—can find it explained with clearly drawn diagrams. A number of photographic illustrations also adds to the general interest. The book should, I think, be much appreciated."

CAPTAIN de A. DONISTHORPE
(The General Electric Co., Ltd.) :

"I have just completed reading that very excellent text-book, 'The Manual of Modern Radio,' by John Scott-Taggart, and must compliment you on its production.

"It is of particular interest to me, as I have known Scott-Taggart since his first association with radio.

"I can say that I have not seen a more complete text-book in years and one that will appeal to both amateur and professional alike. I like it



DR. W. H. ECCLES.

because it is right up to date, and in these days of such tremendous strides in radio design it is a hard matter to keep pace with the rate of progress; and at the same time the fundamental principles are

there for those who wish to refer to them."

DR. W. H. ECCLES.

"I thank you for the copy of Mr. Scott-Taggart's book, 'The Manual of Modern Radio.' I have looked through it with the greatest interest; it is a remarkable collection of practically all the technical developments of

Radio Experts Praise the S.T. Manual—continued

recent years in radio receivers, and in allied apparatus such as radio-gramophones.

"Progress in wireless devices and circuits has been very great in the past five years, and even for the expert it is a constant struggle to keep up to date; for the amateur it must be almost impossible. But this book does a great deal to bring the amateur nearer the expert, for it is right up to the moment and is written in clear and concise language. I think that readers who start with a sufficient groundwork will find it a valuable instructor and a safe guide to further studies."



P. P. ECKERSLEY.

P. P. ECKERSLEY, M.I.E.E.:

"Mr. Scott-Taggart has a truly encyclopedic knowledge. The practice of radio—or electronics, as one prefers to call the whole art—is becoming more and more extensive. The cataloguing, even, of the bits and pieces which go to make up circuits is an undertaking itself; but when, in addition to that, we have Scott-Taggart's gift of writing, coupled with his knowledge, something is produced which is, in the best sense of the word, 'useful.'"

"The Manual of Modern Radio' is unique in its own field, and I can confidently urge readers to grasp this opportunity of obtaining it."

R. FERGUSON

(Joint General Manager, Marconi International Marine Communications Co., Ltd.):

"I was very pleased to receive a copy of Mr. Scott-Taggart's book, 'The Manual of Modern Radio.'"

"From a cursory examination, it would appear to be well up to the standard of Mr. Scott-Taggart's usual technical work, and should prove of real help to those anxious to master the fundamentals of radio technique."

V. Z. de FERRANTI
(Managing Director, Ferranti, Ltd.):

"I am sure 'The Manual of Modern Radio,' by John Scott-Taggart, will be of interest to the radio amateur, and will help in the education of the public."

S. R. MULLARD:

"I think 'The Manual of Modern Radio' is a wonderful piece of work, and it should be of great value to the listener with a slight knowledge of electricity."

"It will also be of value as a reference book in any library."

C. C. PATTERSON, O.B.E.,
M.Inst.C.E., M.I.E.E., F.Inst.P.
(Research Laboratories, The General Electric Co., Ltd.):

"The technique of wireless reception has moved so rapidly during the past two years that many who were



R. FERGUSON.

once expert have failed to hold the pace, whilst those who come to it anew and would fain understand it, hold back in alarm at its complication. To all such, this book will come as a godsend. "Those who are really expert do not always realise, as have the promoters of this book, the value to the industry of an understanding public. They are doing a great service by interpreting to the intelligent public the present state of this vital and fascinating branch of free-electron engineering."

DR. J. H. T. ROBERTS, F.Inst.P.:

"Mr. Scott-Taggart has put us still further into his debt by the publication of his latest book, 'The Manual of Modern Radio.' It is written in extremely clear and simple style, and is a veritable mine of information on the modern developments of radio technique. Such a Manual was badly wanted by the vast radio public, and no one was better fitted to provide it than the author."

"I had the pleasure to be associated with 'S.T.' in the early days, when he was pioneering in radio publications,

and was amazed then—as I have continued to be ever since—at the quantity of his energy and the quality of his work. How he does it all is one of the prevailing mysteries of radio!

"Your readers cannot afford to be without this Manual."

DR. JAMES ROBINSON (Inventor of the Stenode):

"It was a happy thought of the Amalgamated Press to publish J. Scott-Taggart's 'The Manual of Modern Radio.' In his own skilful manner the author has brought the reader to a very definite stage, i.e. the design of the modern broadcast receiver as made by the leading manufacturers."

"So many new devices are employed in these receivers that it is important to have a book which describes them, and it will now be possible, without elaborate filing systems, to turn up accounts of Automatic Volume Control, Variable-Mu Valves, Second Channel Elimination, Decoupling System and various other devices."

"For the student this is very useful, and whilst making him understand what is happening in wireless design to-day it will also prepare him for future developments."

CAPTAIN H. J. ROUND, M.C., M.I.E.E.

(The famous radio pioneer and late Chief of Research of the Marconi Co.):

"This is a very comprehensive Manual of broadcast radio circuits, bringing together in an interesting way a large amount of information up till

now only obtainable by much searching.

"Mr. Scott-Taggart should be congratulated on his fine effort."

A. C. COSSOR, Ltd.

The Managing Director says:

"The Manual of Modern

Radio' should provide a very ready source of information to those users of radio sets who are desirous of knowing more of their technical design and construction."



DR. ROBERTS.

(Please turn to page 275)

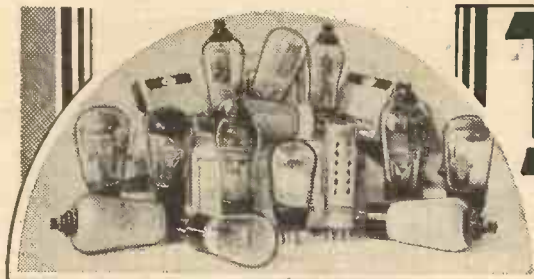

THIS YEAR'S VALVES

THR last ten or fifteen months have been outstanding in radio, and to be able to single them out in this manner from among other periods means a great deal when we consider how rapidly radio science is developing.

Wonderful Advances

Every year since broadcasting began we have seen developments of major importance in that branch of radio which is peculiarly our own—broadcast reception, and the advances since 1922 have become more and more wonderful and of increasing importance.

It is hopeless to attempt to particularise, but as we look back we recollect such exciting arrivals as wavechange coils, dull emitter valves, indirectly-heated mains valves, gang condensers, differential reaction, iron-cored coils, superhets, radiograms, and so forth. We do not attempt to place them in order, but a moment's

thought will revive old memories of scores of advances, big and small, that have all gone to make radio reception what it is to-day.

And recent months have seen such a galaxy of development that it is im-

Recent months have been particularly outstanding in radio development, but valves must take pride of place for the greatest advance. Indeed, many of the new schemes would not have been practicable without the new valves, the most important of which are dealt with in this review.

possible in a short article to deal adequately with a tenth of it; we can but hope to focus our attention on the high lights in the picture of progress.

And considering those high lights we find that valves must have pride of place. Iron-cored coils, it is true, have come greatly to the fore, but they were first introduced to the home constructor in this country in 1932, at the Radio Exhibition in

August. And it must be conceded that, even with iron-cored coils, we should not get the remarkable results we can achieve unless the valve had also advanced and enabled us to make full use of the high inductance-resistance ratios provided us.

We refer, of course, to the screen-pentode valve, which is threatening the screen-grid (tetrode) valve we know so well, and which eventually will probably completely supersede it.

The First Multi-Mu's

At first the screen pentode was available only as a mains valve for A.C. working, and it arrived originally as a fixed slope amplifier, to be rapidly partnered by a multi-mu valve of similar maximum characteristics.

Thus we had, first, Cossor H.P.T., and later Mullard S.P.4 and the V.P.4, the latter being the extremely fine multi-mu brother of the former. Ferranti, too, were well to the fore

TYPICAL MODERN TYPES

The A.C.2Pen. is one of the most amazing of modern mains valves, being capable of an output of 3,400 milliwatts for an input voltage of about 3. As can be seen from the illustration below, this valve has the new shaped bulb.



When multi-mu screen-pentodes were first introduced they were available only as mains valves. But battery types, such as the metallised one above, which is the Osram V.P.21, are now on the market. Two of these valves were used by Mr. Scott-Taggart in the "S.T. Super."

The Cossor 220 V.S.G. is particularly useful in a second H.F. stage, because of its long grid base. It is, of course, one of the popular battery type multi-mu S.G. valves.

A short grid-base valve like the Cossor 220 V.S. enables volume control on the multi-mu principle to be achieved with a small applied grid-bias voltage.

Shown above is a mains type multi-mu screen-pentode valve, the Mullard V.P.4. An interesting point about the metallising on this valve is that it is of copper, and not the more usual deposit of zinc.

A Mains Valve of Marvellous Efficiency

in this regard with the S.P.T.4 and V.P.T.4, and subsequently screened pentodes were produced by all the leading valve concerns.

These pentodes are undoubtedly good. They are definitely better in performance than the screen-grid valve (tetrode), and provided the shielding of the receiver concerned is adequate for the extra amplification provided, the pentode can usually be substituted for the tetrode in a set without any serious change of circuit. What alterations have to be made concern the bias resistance and the H.T. voltage potentiometer feeds to anode and screen.

Seven-Pin Bases

We are referring to the mains pentode, of course. The battery variety, of which at the time of writing there is only one type extant, cannot so be plugged into the S.G.'s valve holder unless an adaptor is used, for the battery screen pentode has a seven-pin base.

"Why," you may ask, "should this apparent complication be employed?" The reason is that it is intended that the screen pentode be as universally useful as possible, and this is best done by bringing out to separate points not only the usual grid, filaments, screen grid and anode, but also the suppressor grid and the metallised coating of the valve. This makes seven separate connection points; the anode being on the top of the valve thus leaves us with six live valve pins in the base and one dummy.

Special Purposes

The reason for this separation of the suppressor grid and the metallised coating (they can normally be connected inside the valve to L.T.—) is so that the valve can be used in various unconventional circuits. For instance, without that separation of the suppressor grid, the "S.T. Super" could not have been made with the circuit desired, for the suppressor grid injection of the "mixer" valve necessitated its isolation from other electrodes.

The seven-pin valve holder seems to

have come to stay, for, beside the screen pentode and the now well-known Class B valves, of which much has been heard during the last few months, we have the ordinary mains output pentode using seven pins, and also, of course, such hybrids as the double-diode triodes, double-diode pentodes, and double-diode tetrodes.

We learn that eventually here, again, some form of reduction of types is likely in the comparatively near future, and that the double-diode triodes and tetrodes will give place to the double-diode pentode. At present

set using A.V.C. run from batteries. This valve is of the five-pin type, not seven, as are all the mains double-diode valves, such as the A.C./H.L./D.D., T.D.D.4, D.D.Pen., M.H.D.4., H.4D., and so forth, made by Mazda, Mullard, Cossor, Marconi and Osram, and Ferranti.

The Heptode

A particularly interesting, though little used (so far), valve is the Heptode, of which Ferranti have produced a standard model for use in their superhets. Thus, the V.H.T.4 is a multi-electrode arrangement in which the first detection and the "mixing" of a superhet circuit is carried out in one valve, but quite separately, having individual electrodes for the task. Much more will be heard about this class of valve during this year, and inevitably other valve manufacturers will be getting to work on the matter.

Unique Properties

We said that the ordinary output pentode had "gone over" to seven pins. This is true in certain cases, and notably in the A.C.2Pen.—a Mazda valve of unique properties. Probably others will rapidly follow the seven-pin fixing, for the sooner we arrive at standardisation (it does not matter whether it is for 7 or 5 pins) the better.

But to get back to the A.C.2Pen. The valve is an A.C. type having a four-volt heater taking 1.75 amps, but its capabilities are astounding. The maximum anode and screen voltages are 250 volts, and the total H.T. current is 38 milliamps. With this the valve will deliver a maximum undistorted A.C. output of 3,400 milliwatts.

But it is the sensitivity of the valve that is so outstanding, for its figure is 485 MW/Vg₂ or, in plain English, it will provide 485 milliwatts of power for every grid volt input squared. Thus, theoretically, for 1 grid volt input we get 485 milliwatts output. For 2 volts input (the square is 4) we get 485 × 4 = 1,940 milliwatts

(Please turn to page 277)

EFFICIENCY

The efficiency of present-day valves is one of the outstanding features of modern radio, and the various types are adaptable to a remarkable number of different purposes. Below (left) is a Marconi valve

ADAPTABILITY

of the Class B type which is designed to work with a small grid bias. A well-known make of non-metallised valve is portrayed to the right below. Readers will recognise it as a Ferranti, the type number being V.P.T.A.



Illustrated in the centre of this trio of up-to-date valves is one of the range of highly efficient Tungrams. It is a multi-mu screen-pentode tube, and is available in both five- and seven-pin types.

we have such a variety of peculiar valves that it is difficult to find distinct niches for them.

A Battery D.D.T.

Mazda have taken the step of producing not only mains double-diode valves, but also a battery double-diode triode, L2/D.D., which should be remembered by those who desire a



S.T.300 STAR

PILOT AUTHOR KIT EXACT TO SPECIFICATION

The Pilot Kit SERVICE was founded in 1919.

See the PILOT on the carton. It's a real guarantee.

PETO-SCOTT S.T.300 STAR CABINET

The beautiful Cabinets illustrated below were specially designed and manufactured at the request of Mr. John Scott-Taggart for his S.T.500. Their popularity has been amazing, and we therefore offer them as ideal cabinets for the NEW S.T.300 STAR.

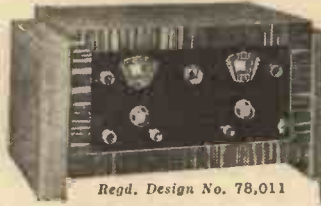

Panel Size: 16" x 7". Baseboard Size: 16" x 12".

Regd. Design No. 78,011

19%

TABLE MODEL Original design Table Cabinet with Veneered Macassar and Pine Walnut finish. Hand French polished. Constructed of the finest wood by London's leading craftsmen. Cash or C.O.D., 19/6. Carriage and Packing, 2/6 extra. Or 6/- Deposit and 3 monthly payments of 6/-. (Including carriage and packing.)

PETO-SCOTT S.T.300 STAR WALNUT CONSOLETTA



Panel size: 16" x 7". Baseboard Size: 16" x 12". Top Loud Speaker and Battery Compartment, size 16" x 10" high x 12" front to back.

Regd. Design No. 787,010

25%

An outstanding example of cabinet craftsmanship. Hand French polished. Veneered Macassar and Walnut finish by experts. Cash or C.O.D., 25/-. Carr. and Packing, 2/6 extra. Or 6/- Deposit and 4 monthly payments of 6/-. (Including carriage and packing). Baffle-Baseboard Assembly, 3/6 extra.

SEND FOR NEW CABINET CATALOGUE. **S.T. SUPER**

KIT "A" CASH - C.O.D. £4-7-6

These are the Parts used and specified by Mr. John Scott-Taggart.

	£	s.	d.
2 Polar Standard .0005-mfd. variable air condensers with disc drive	18	0	
2 Telsen "S.T.500" coils	8	0	
1 Graham Farish L.M.S. H.F. choke	4	6	
1 R.T. Hyperute L.F. transformer	12	6	
1 W.E. universal valve holder	1	0	
2 Benjamin 4-pin valve holders, "Vibroider" type	1	8	
1 Lissen reaction choke, type LN.5092	2	0	
*3 Graham Farish .0005-mfd. solid dielectric condensers	6	0	
*1 British Radiogram .0003-mfd. differential condenser (with insulated spindle)	3	0	
1 Telsen .0001-mfd. differential condenser	2	6	
2 Bulgin 2 pt. push-pull switches	1	9	
*1 J.B. .00005-mfd. B.bd. pre-set condenser	1	10	
*1 J.B. .0001-mfd. B.bd. pre-set condenser	1	10	
1 Bulgin on-off toggle switch	1	6	
*1 Dubilier 2-mfd. fixed condenser, type BB	3	6	
T.G.C. 1-mfd. fixed condenser, type 50	2	6	
1 Dubilier 20,000-ohms resistance, 1-watt type	1	0	
*1 Graham Farish 250-ohm "Ohmite" resistance	1	8	
*1 Lissen .00005-mfd. fixed condenser	1	6	
*1 Graham Farish 1-meg "Ohmite" resistance	1	6	
1 Peto-Scott ready drilled panel, 16" x 7"	1	6	
*1 Peto Scott METAPLEX baseboard, 16" x 12"	3	3	
1 Peto Scott "S.T.300" Star screen	1	9	
1 Peto-Scott ready drilled terminal strip, 16" x 1 1/2" x 3/8"	1	9	
1 Peto-Scott tone control bracket	9		
10 Belling-Lee indicating terminals	2	6	
wire, screws, etc.	2	2	
KIT "A," Cash or C.O.D.	£4	7	6
1 Set of specified valves	£1	11	3
*Items marked with an asterisk in above list of parts are included in this Conversion Kit.			

OR YOURS FOR 12 MONTHLY PAYMENTS OF **8/-**

KIT "A" Author's Kit of First Specified Components, including Ready-Drilled Panel, and Terminal Strip, with METAPLEX Baseboard. **CASH OR C.O.D. CARRIAGE PAID £4-7-6** or 12 monthly payments of 8/-

KIT "B" As for Kit "A," but with Set of Specified Valves only. **CASH or C.O.D. Carriage Paid. £5-18-9** or 12 monthly payments of 10/9

KIT "CT" As for Kit "A," but with Valves and PETO-SCOTT S.T.300 STAR Table Cabinet. **CASH or C.O.D. Carriage Paid. £6-18-3** or 12 monthly payments of 12/9.

KIT "CC" As for Kit "A," but with Valves and PETO-SCOTT S.T.300 STAR Consolette Cabinet with Shelf and Baffle, less Speaker. **CASH or C.O.D. Carriage Paid. £7-7-3** or 12 monthly payments of 13/6

FINISHED INSTRUMENTS

TABLE MODEL. Ready assembled S.T.300 STAR. Complete in PETO-SCOTT Cabinet. With valves, Aerial tested. Cash or C.O.D. Carriage Paid, **£8-15-0** Or 12 monthly payments of 18/-.

CONSOLETTA MODEL. Ready assembled S.T.300 STAR. Complete in PETO-SCOTT Walnut Consolette Cabinet, with PETO-SCOTT Speaker and valves. Aerial tested. Cash or C.O.D. Carriage Paid **£9-12-6** Or 12 monthly payments of 17/6.

CONVERT YOUR S.T.300 to the S.T.300 STAR



PETO-SCOTT S.T.300 STAR Conversion Kit. Complete in FIRST SPECIFIED parts required to convert your S.T.300 to the new S.T.300 STAR, but less valve. **CASH or C.O.D. Carriage Paid 25/-.**

YOURS FOR 5/- BALANCE IN 5 MONTHLY PAYMENTS OF 4/6

H.P. Deposit 5/-; balance in 5 monthly instalments of 4/6.

If POLAR CONDENSERS and NEW PANEL required, add 2/13 to cash price. Or, complete yours for 6/-; balance in 9 monthly payments of 5/-.

CONVERT YOUR S.T.300 to CLASS "B" with the PILOT CONVERSION KIT

Converts your present Battery Set to Class B Amplification. Complete with all necessary components, including driver transformer. **Class B Output Choke, W.B. 7-pin valve holder, B.V.A. 240B valve, wire and screws, etc.** Full-size Blue Print, assembly instructions and diagrams. **Cash or C.O.D., 37/6.** Balance in 7 monthly payments of 5/6.



YOURS FOR 5/-

37/6

IMPORTANT. Parts, Kits, Miscellaneous Components, Finished Receivers, or Accessories for Cash, C.O.D. or H.P. on our own System of Easy Payments. Send us a list of your wants. We will quote you by return. C.O.D. orders value over 10/- sent Carriage and Post Charges Paid. **GREAT BRITAIN ONLY.** Irish orders executed for Cash only.

IMMEDIATE DELIVERY - CASH or C.O.D.

PETO-SCOTT CO. LTD., 77, CITY RD., LONDON, E.C.1. Tel.: Clerkenwell 9406-7. West End Showrooms: 62, High Holborn, London. W.C.1. Tel.: Holborn 3248.

Dear Sirs,—Please send me CASH/C.O.D./H.P. _____ for which I enclose £.....d. CASH/H.P. Deposit.

NAME _____

ADDRESS _____

T.W.C., 3/34.

ANY ITEM SUPPLIED SEPARATELY—ORDERS OVER 10/- SENT C.O.D. CARRIAGE AND POST CHARGES PAID

QUESTIONS I AM ASKED



JOHN SCOTT-TAGGART

Q. 69. I have studied your "S.T. Super" circuit and am astonished that one who professes to know at least the rudiments of radio, proceeds to use a totally unnecessary large decoupling condenser of 2-mfd. and a resistance of 5,000 ohms for the anode of the first valve—an H.F. amplifier—and a mere 5,000 ohms and 1-mfd. as a decoupler for the detector, in your "S.T. 500" circuit, where decoupling is really needed. Have you any excuse? I won't say "reason."

A. Rudeness versus rudiments. Here, however, are my "excuses": The decoupling on the "S.T. 500" detector is admittedly less than is customary on most sets, but remember that a battery would be used with this set, not a mains unit.

The decoupling is ample. Why, however, should I use a small value of resistance? Because, this receiver is designed for as much as 2,300 milliwatts output. Hence it needs a big grid swing on the Class B output.

On the local station the detector is readily choked up. Hence the merit of a large anode voltage on the detector valve. Better quality and louder signals are obtainable when the detector H.T. is larger, assuming the H.F. input is of large amplitude.

On the "S.T. 500" theory is borne out in practice and louder and clearer signals result from a large anode voltage when strong local signals are received. To obtain the large voltage, one reduces the decoupling resistance.

If one had 20,000 ohms instead of 5,000, a current of 1 milliampere in the detector anode circuit would cut down the anode voltage by 20 volts. Three milliamperes would reduce it by 60 volts. To avoid overloading and under-amplification I used 5,000 ohms.

As regards decoupling the "S.T. Super," the anode decoupling of the H.F. valve was not excessive because I was not solely concerned with

keeping the H.F. out of the anode H.T. apparatus (battery or mains unit). I also wanted L.F. decoupling, or rather, "smoothing."

Minute potential variations, especially due to mains hum on a mains unit (advised for this set), modulate incoming carrier waves and produce a loud hum on such a sensitive set.

It is virtually impossible to remedy modulation hum, which only occurs when you provide a signal for the H.F. valve to modulate. To avoid it you must prevent it, and a very good way is to smooth thoroughly the H.T. to the H.F. valves. This I did.

In this popular monthly feature Mr. Scott-Taggart deals with a selection of readers' queries, and explains in his well-known lucid manner some of the technicalities that so often puzzle constructors. The questions are chosen for their wide appeal to radio enthusiasts in general.

Q. 70. The other day I tried reversing the aerial and earth connections to my set and found I could still get very good results. Is this usual?

A. Quite a common experience. The aerial circuit often consists of (a) the aerial; (b) a small coil coupled to the first tuned circuit, and (c) the earth. High-frequency currents are induced into the first tuned circuit from the coil in the aerial circuit.

In this arrangement the connections to the aerial and earth make little difference. When, however, the accumulator chassis and H.T. battery have the aerial connected to them, and the grid of the first valve is earthed, you will nearly always get a weakening of signals.

There will be a substantial capacity—and perhaps some leakage—to earth. Probably one in ten sets have the aerial and earth connections the wrong

way round. Similar wires coming from a window are often mistaken. I once found a reader using the cord of the blind as an earth.

Q. 71. My mains unit only gives 60 volts to 80 volts for the detector H.T. Is this all right?

A. In my opinion it is all wrong. By the time a 20,000-ohms decoupling resistance is in circuit, you can imagine (or, better still, calculate) the drop in H.T. voltage on the detector anode. If you use also a parallel-fed transformer (and why shouldn't you?), the coupling resistance will further decrease the H.T. voltage on the detector anode. If you use resistance coupling you may have as much as 120,000 ohms in series with your 60 to 80 volts!

I fancy that mains units were all cut and dried before the modern type of circuit, with decoupling, etc., became popular. The average mains unit is all right for detector and L.F. sets, but not for many others.

What can you do about it? Well, you may be able to use the full voltage of the mains unit and apply it to the detector. But you are pretty sure to need extra decoupling on your set—perhaps an extra resistance and condenser as explained in my "Manual of Modern Radio."

Q. 72. I have invented a special kind of receiver in which two crystal detectors rectify both half-waves, the resulting current being used to work the pick-up, or rather recording needle of a sort of gramophone machine, a second pick-up being used to pick up the recorded signal.

The pick-up would be connected to an amplifier working on, say, 500 volts H.T. A switch would bring in a neon lamp instead of the loudspeaker, and so you would have a television receiver. Don't you think my invention a good idea?

A. No.

AGAIN this Leading Designer

CHOOSES A 'MICROLODE'

A "MICROLODE" was Mr. John Scott-Taggart's first choice for the S.T. Super. For his new S.T.300 Star his first choice is again a "MICROLODE."

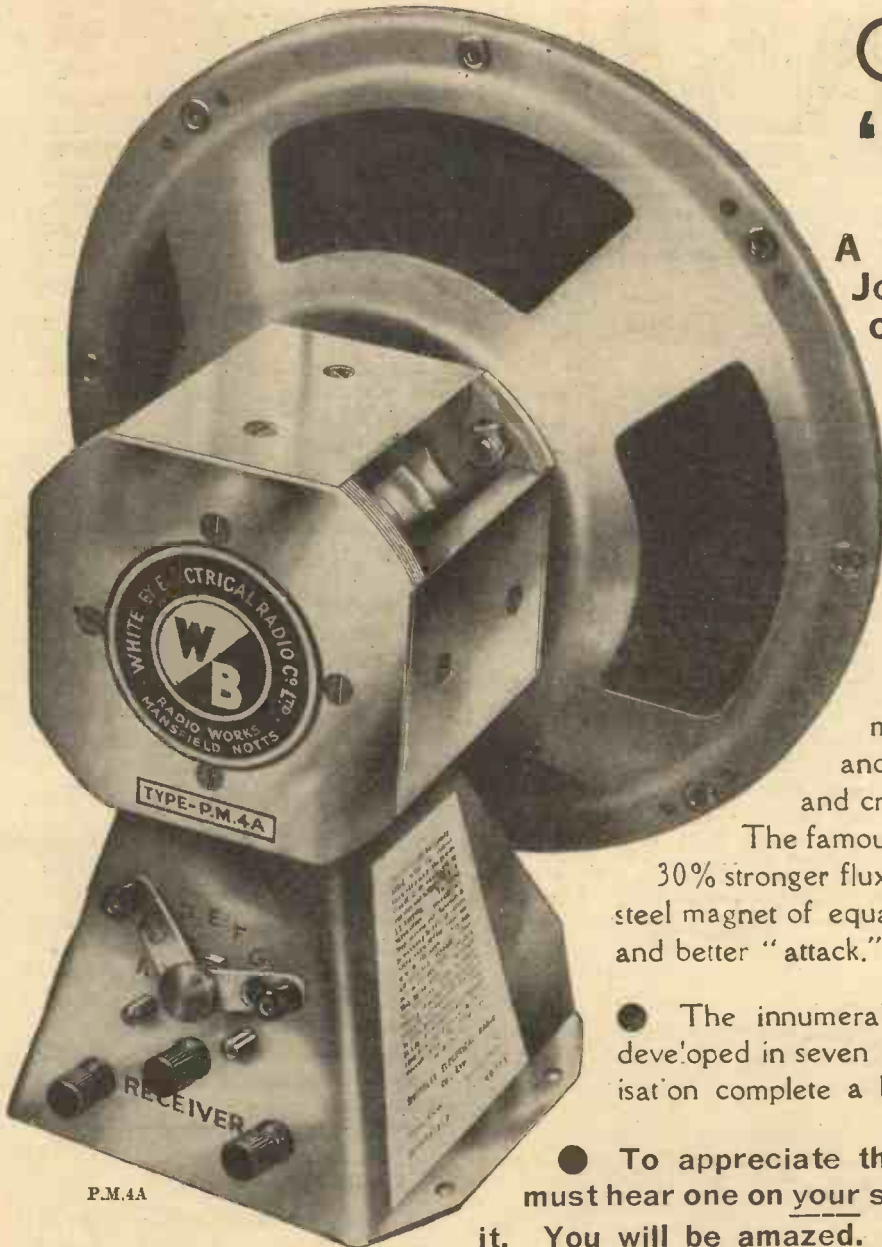

● There are solid reasons for these consistent recommendations by leading radio technicians.

● The unique "MICROLODE" feature, with its 17 ratios for accurate matching to power or pentode valves and 4 for Class B, brings balance of tone and crisp top notes otherwise unobtainable.

The famous Mansfield magnetic system, giving 30% stronger flux density than a good ordinary cobalt steel magnet of equal weight, produces greater sensitivity and better "attack."

● The innumerable small refinements in technique developed in seven years of moving coil speaker specialisation complete a brilliant and advanced design.

● To appreciate the improvement in results you must hear one on your set. Ask your dealer to arrange it. You will be amazed.

'MICROLODE'

(Regd. Trade Mark.)

MOVING-COIL SPEAKERS

P.M.6 = 32/6 P.M.2A - 79/6
 P.M.4A - 42/- P.M.1A - 120/-

Write for the new folder.

Whiteley Electrical Radio Co., Ltd., Dept. C., Radio Works, Mansfield, Notts.

Sole Agents in Scotland: Radiovision Ltd., 233 St. Vincent St., Glasgow, C.2. Sole Agents in I.F.S.: Kelly and Shiel, Ltd., 47 Fleet Street, Dublin.



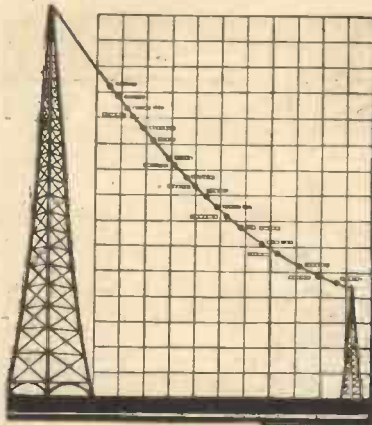

ROUND the DIALS

Here are some practical hints concerning the reception of foreign programmes and how these may be easily identified.

ALL the recent wavelength changes make this a good opportunity to say a few words on the best methods of identifying foreign stations. Most set-owners are rather haphazard about this, not realizing that much of radio's entertainment value is lost unless one gets acquainted with the possibilities of programmes from abroad.

A proper tuning chart is by far the best method of making the most of the set's capabilities in the way of long-range reception. A chart is easy and interesting to draw up, and ensures that every station received is quickly identifiable. The owner of such a chart can always tell exactly what his

dial-reading should be for any given wavelength—a great advantage.

But if the construction of a chart seems too much trouble, there is everything to be said for keeping a pencil and paper in or near the set, so that a note can be made of any interesting dial-readings. It is surprising how much information can be gathered in this way, and how greatly it increases the entertainment value of your set.

Apart from wavelength, actual identification is easy provided one knows something about station peculiarities. To take some examples, let us examine the top of the medium waveband, taking North Regional as a starting point, and working up to higher dial-readings. These stations are coming over excellently at the moment of writing, and are well worth investigation.

Just a degree or so above the North Regional we have Langenberg, on 455.9 metres. The guttural German accent is unmistakable, and although the word Langenberg is not announced frequently, one often hears "Westdeutscher Rundfunk" (West German Broadcast), which serves as an identification.

And just above is Lyons—unmistakably French, and pronouncing the city's name often, though it sounds more like "Lee-awn" to English ears.

Next above is Prague, and here again the native pronunciation is quite different from our own. It sounds like "Pra-ha."

The "Frenchman" transmitting a little above Prague's programme is nothing of the sort. He uses the French language, but the programme comes from the Brussels No. 1 station. (About half the people of Belgium habitually speak French.)

Florence, further up, is easily recognised to anyone who has noticed the mellifluous Italian language. But English ears might easily be forgiven for never suspecting that the word "Fi-ren-ze" is the way the Italians pronounce that city's name.

A few degrees further up is Vienna. He announces as "Hallo Radio Veen." Our old friend Mühlacker is just above that, and the words "Stuttgart" and "Sudfunk" will generally be heard in his announcements. Athlone, of course, is easily recognised just above, but who is the German above that? Another language-trap! For although the voice and language are characteristically German, the station is a Swiss.

It is Beromünster, on 539.6 metres. And you can listen in vain for that name, because what the announcer generally says is "Hier Schweizerischer Landessender." The names you will often pick up are those of the studios which serve Beromünster—Basle and Berne.

If you can go up further, to Budapest, you will find no snags, for he often and clearly announces as "Radio Boodapest." But our examination of just this section of the waveband shows how diverting this identification business can be. P.R.B.

SOLDER ECONOMY

CONSTRUCTORS who doubt the ability of terminals to retain firm contact, and use solder as an alternative, sometimes find that after a period they have several small pieces of solder on hand. These oddments should never be thrown away if economy is a consideration.

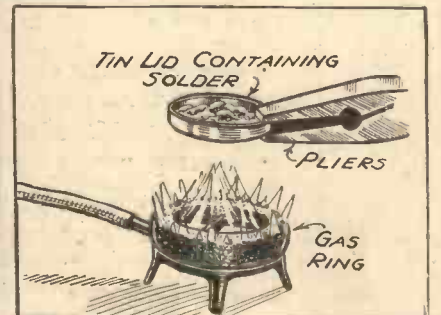

Small pieces of solder can be melted down in a tin lid.

The lid of a boot polish tin will serve excellently as a container in which to heat the solder until it has reached a liquid state. When this occurs it can be poured out into a suitably shaped receptacle.

BERLIN'S LEAD-IN



Samples of the lead-in cables used at the Berlin broadcasting station.

SLOT

AERIAL FILTER

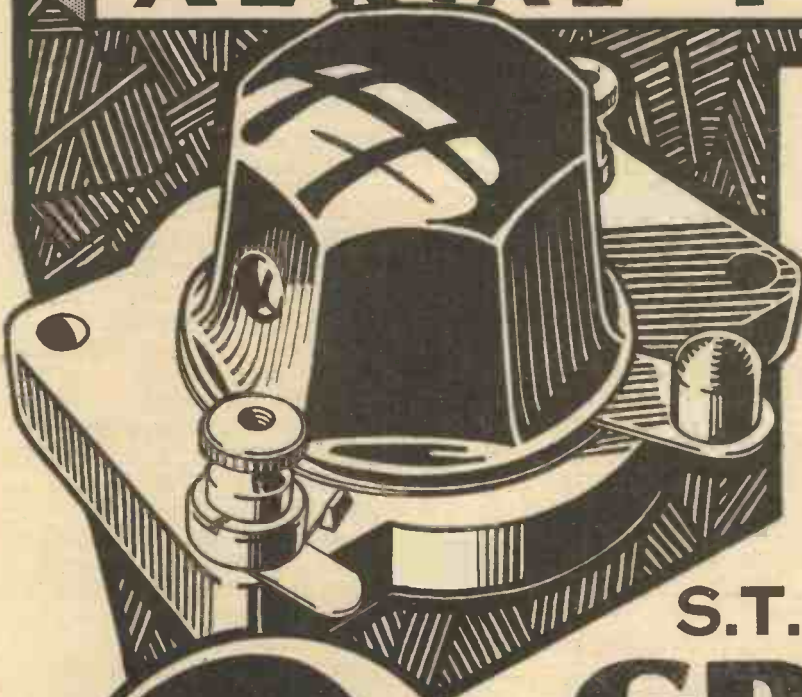

The "SLOT" Aerial Filter is the only satisfactory method of adapting your receiver to the new wavelengths. It enables your set to pick up stations on the lower broadcast wavelength that many sets cannot get without its aid.

"SLOT" increases selectivity—reduces interference and overlapping.

"SLOT" enables you to get the maximum from your receiver.

"SLOT" costs but a trifle—it is fitted in two minutes and will improve reception for good.

2 EACH

FREE!

A STATION TUNING-CHART showing all the NEW WAVELENGTHS will be presented Free with every SLOT purchased.

S.T. AGAIN USES

GRAHAM FARISH PRODUCTS

FOR THE S.T.300 STAR



L.M.S. CHOKE 4/6



LITLOS DIFFERENTIAL CONDENSER
Price 2/- each

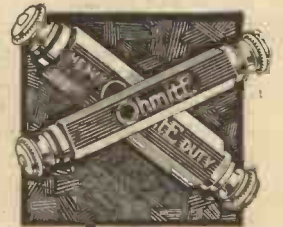

OHMITE RESISTANCES, $\frac{1}{2}$ watts 1/6
 $\frac{3}{4}$ watts 2/3

Send a postcard for our Catalogue which describes all our products

Obtainable from all Dealers or post free from Sole Manufacturers

GRAHAM FARISH LTD., MASONS HILL, BROMLEY, KENT



**AS WE
FIND
THEM**

**NEW
APPARATUS
TESTED**

The Exide Indicator Battery

ONE of the difficulties with which most battery-set owners are faced is that of knowing accurately the condition of their L.T. accumulators at any moment.

In the absence of a hydrometer or voltmeter there is no way of ascertaining the state of charge, unless the battery itself incorporates some form of "tell-tale."

It is true that the more expert constructor is able to tell to a certain extent whether the battery is charged or discharged solely by the colour of



**VERY
INGENIOUS**

This is the new Exide Indicator Battery. As the photograph shows, it is fitted with a scale and pointer, giving a direct reading of the state of the cell at any moment.

the plates, but this requires a degree of expertness which the average listener does not possess.

In the new Exide Indicator battery (illustrated on this page) any doubt which may exist as to the amount of charge in the cell is at once dispelled by a glance at the special device with which the battery is equipped.

This comprises scale and pointer, the scale being clearly marked with the words "Full," "Half," and "Empty." Intermediate states of charge or discharge can be seen immediately from the position of the indicator along the scale.

Thus the listener knows precisely how much or how little power there is in the cell at any given moment.

That this Exide battery will achieve a well-merited popularity goes without saying. The indicator is a definite safeguard against maltreatment and

Interesting reviews of the latest apparatus submitted by radio manufacturers and traders for examination and test in "The Wireless Constructor" laboratories.

properly used will ensure the maximum life from the battery.

At the present time two models are available, viz., the D.T.G.-C. and D.F.G.-C., priced at 5/- and 9/- respectively. The makers state that in the near future they hope to supply the whole of the D type series of batteries with the indicator.

For further details, readers should write to Messrs. Exide Batteries, 137, Victoria Street, London, S.W.1.

A Resistance-Fed Unit

One of the most compact resistance-fed transformer coupling units we had tested is that manufactured by the Igranic Electric Company, 149, Queen Victoria Street, London, E.C.4.

The dimensions are a mere $2\frac{1}{8} \times 1\frac{7}{8} \times 2\frac{1}{8}$ in., and in this small space are a highly efficient L.F. transformer, together with its feed and decoupling resistances, and a coupling condenser.

COMBINED CONTROLS

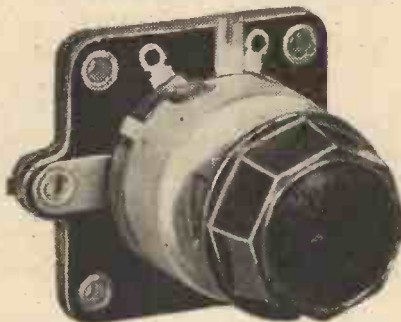

A combined volume control and differential condenser made by Messrs. Wilkins & Wright. The first 180 degrees of movement varies the volume control, and the remaining 90 degrees the reaction.

Moreover, the transformer has a primary inductance of about 100 henries, a figure which ensures excellent reproduction. Not only is the response one of exceptional uniformity, but the amplification given by the 1:4½ step-up ratio is also very satisfactory indeed.

The transformer is internally screened and can therefore be used in a compact layout without fear of interaction.

Another feature is the fact that the decoupling resistance can be cut out of circuit when not required.

This Igranic unit costs 10/6, a very moderate figure in view of its fine results, and we can recommend it.

Simplifying Design

The Utility range of components, manufactured by Messrs. Wilkins and Wright, of Holyhead Road, Birmingham, includes a very practical and useful combined volume control and reaction condenser.

Both components are mounted on a common spindle and have a single knob for adjustment. The control, however, is not simultaneous. The first 180 degrees of movement varies the potentiometer, and the remaining 90 degrees the reaction condenser.

The potentiometer is available in three values, viz., 5,000 ohms, 10,000 ohms, and 25,000 ohms, and the reaction condenser, which has a capacity of .0003 mfd., can be supplied in either the differential or plain types.

In use, the potentiometer is first turned through its full movement from minimum to maximum volume, and then a further rotation of the knob brings the reaction condenser into operation to increase the sensitivity of the set. Conversely, the reaction is reduced to zero on a powerful station and the volume control brought into use.

We found the movement to be perfectly smooth and the component functioned very satisfactorily on test.

**COMPACT
AND
EFFICIENT**

The Igranic coupling unit includes a decoupling resistance which can be cut out of circuit when not required.



EXPERTS INSIST ON 'ATLAS'



Mr. Scott-Taggart's
FIRST CHOICE for the
"S.T.300 STAR"

MR. SCOTT-TAGGART, like every other discriminating set designer of the day, puts his whole faith in "ATLAS" Mains Units. For the new "S.T.300 STAR," described in this number, all the leading makes were given exhaustive tests. "ATLAS" again proved the leader.

For A.C. mains, ask for the "ATLAS A.2." at 52/6. For D.C. mains, ask for the "ATLAS D.C. 15/25 B" at 39/6. Both models can be obtained for 10/- down and the balance in easy monthly payments. Remember that, besides being the designer's first choice, no other units have ever won the Olympia Ballot for two years in succession. Insist on "ATLAS."

FOLLOW THE EXPERTS' LEAD

★ **POST THIS COUPON NOW!** ★

H. CLARKE & CO. (M/CR.) LIMITED,
Atlas Works, Patricroft, Manchester.

Please send me a copy of Booklet 87 telling me how to convert my Battery Set to Mains Operation with an "ATLAS" Unit.

Name

Address
57/14a

ATLAS

MAINS UNITS CLARKE'S **ATLAS**

There is an "ATLAS" Unit to convert any Battery Receiver to Mains Operation in a few minutes without alteration to set or valves; giving more power, improved tone, sharper selectivity at one fiftieth of the cost of dry batteries.

Prices **39/6** cash or from 10/- down

TRY ONE ON YOUR SET

Ask your dealer for a free demonstration and send coupon for FREE Booklet to H. CLARKE & CO. (M/CR.) LIMITED, Patricroft, Manchester. London: Bush House, W.C.2. Glasgow: G.E.S. Co. Ltd., 38, Oswald Street.

ASK YOUR DEALER — HE KNOWS

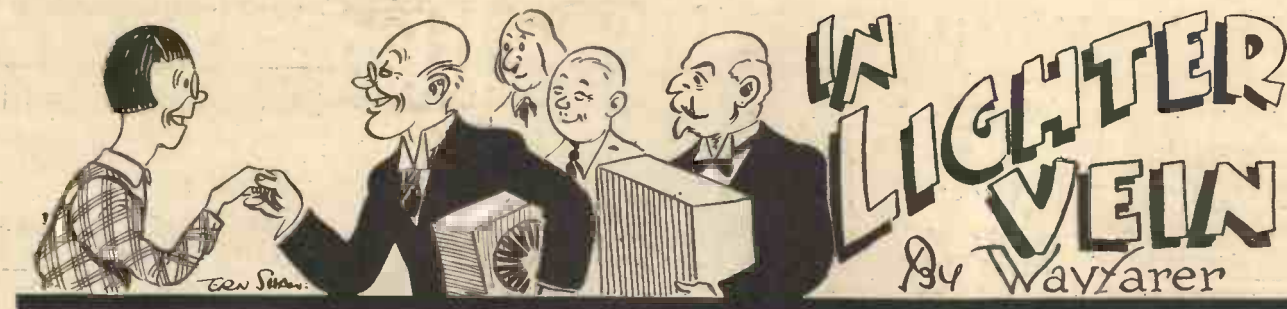

THE Professor and I have not yet quite settled down to the new wavelengths under the Lucerne Plan. What fun these plans are! First came the Geneva Plan, whose sponsors proudly told the world that it had been subscribed to by every important country in Europe. One concluded afterwards that it must be the unimportant countries that do the heterodyning.

AN EYE FOR A NOSE



"It formed the basis for many a friendly discussion."

Then the Prague Plan, which was simply splendid, because this time all Europe signed on the dotted line—and then proceeded to do exactly what it liked. The Lucerne Plan is still in its infancy. It will probably be superseded by the Nastikoff Plan in a year or two's time. Then we shall have the Amsterdam Plan and a good many other plans ere the Wigan Plan is brought forward about 1984 as the very last word in ether clearers.

Learning Them Over Again

These things keep our bright young men busy, and that, of course, is all to the good. But to you and me and the rest of the world they mean forgetting all the wavelengths that we have so carefully learnt, and then learning them all over again. I wouldn't mind their changing wavelengths and things if only they would leave the order of stations the same. When you have got thoroughly used to finding Rome just above Stockholm, they go and upset your appercart by putting Stockholm just above Rome.

Poor Edward Bugsnip, the Professor's laboratory assistant (though Mrs. Goop calls him the gardener), is fearfully upset. "I don't mind wavelengths," he remarked to me the other

day in pathetic accents; "it's these 'ere killosickles as I can't rightly get into my 'ead."

Making Things Difficult

And just to make things a bit easier for us all, the people who do the wavelength tables go and give stations different names. No sooner had we found Sottens in our atlases than highbrow compilers of station tables renamed it Radio Suisse Romande. They turned Beromünster into the Schweizerischer Landessender, which sounds like the kind of thing that they ask you to say when you (note that I write *you* and not I) are accused of zigzag motoring in the wee small hours.

But the best joke of all is Berlin, which shortly after it began its career

As might have been expected, the wavelengths were not changed last month without a certain amount of confusion in the Wayfarer household. But Wayfarer himself is not the man to miss an opportunity of making a little money—whether by fair means or foul—and his successful efforts in this direction make most amusing reading this month.

as a long-wave station changed its name to Königswusterhausen, aptly translated by the Professor as King's Sausage Houses. Just for the sake of variety Königswusterhausen became Zeesen, and now it has turned into the Deutschlandsender. Try Wayfarer's little German pronunciation exercise in your bath three times every morning: *Der Schweizerischer Landessender ist ein besser Sender als der Deutschlandsender.* It is guaranteed to remove adenoids and to freshen up the tonsils.

The Professor and I both possess sets equipped with what the makers, with their tongues fixed firmly in their cheeks, were pleased to describe as "scales marked with the actual names of stations, whose almost uncanny accuracy makes tuning child's play." Being children at heart and loving a little good, clean fun we thought that these would be just the things for us. They were.

Before the Lucerne Plan came into being the Professor would bring his set round to my den, or I would take mine to his. Then we would indulge in a little child's play, tuning. Each of us would turn to Toulouse and then switch on. Generally I got Prague and the Professor Nürnberg, but this was by no means a certainty, since the scales were apt to slip a little from night to night. However, it formed the basis for many a friendly discussion, as a result of which the Professor often limped home holding a steak to a black eye, and I would appear at the office next morning with my nose in a sling.

A New Game

One of the greatest nights that I can remember was the one immediately after the coming into force of the Lucerne Plan. Captain Bucket, Tootle, Pimpleson, the Professor and I were all invited round to a Lucerne party by Miss Worple. A neat little aerial for each member of the party was slung across the room, whilst earth connections were there for the asking. Everybody was requested to

LIKE A SIPHON



"Miss Worple rang her little handbell for silence."

bring with him a wireless set with a station-name dial, and a competition on entirely novel lines was staged.

As a preliminary, each of us was requested to put sixpence in the kitty. Then Miss Worple called a station, and the first person to tune it in scooped the pool.

Since neither of us could raise a bean when we entered the house the sixpenny ante's seemed at first to present an insuperable problem. However, we were allowed to put I.O.U.s into the kitty, and so far all was so

For the "S.T.300 STAR"

SPECIFIED

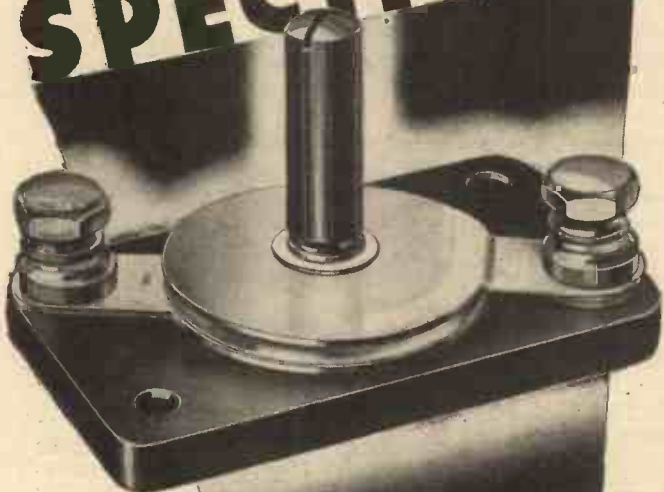

A very simple and neat trimmer condenser for balancing out stray capacities in gang circuits, and all other preset adjustments within the capacity range.

- 1 J.B. Baseboard preset condenser . . .00005 1/-
- 1 J.B. Baseboard preset condenser . . .0001 1/-



J.B. LINACORE

By sending this coupon now, you will receive free a blueprint of an Ideal battery or mains model "Linacore" circuit which from three valves will give results equal to a "Superhet." Enclose 2d. only for postage. For Battery Receivers, type B.P.B. (as **69/6** illustrated)
For Mains Receiver, type B.P.M.



PRECISION INSTRUMENTS

To JACKSON BROS.,
(London) Ltd., 72 St. Thomas Street, London, S.E.1.

Please send Free blueprint of Mains Model
Battery Model } Delete one not required
I enclose 2d. in stamps for postage.

NAME _____
ADDRESS _____
C. _____

Specified for S.T.300



Specified by Mr. Scott-Taggart for quality of reproduction and purity of tone.

HYPERMITE L.F. TRANSFORMER

For high amplification without distortion, the "Hypermite," with its NICKALLOY CORE, is the safest and most satisfactory transformer for L.F. stages in all modern circuits. It is specified because of its high primary inductance, general superiority of performance and small size for compact 12/6 assembly. List No. D.Y.20. Price 12/6

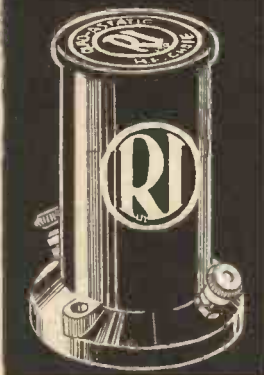

QUAD-ASTATIC H.F. CHOKE

Gives absolute freedom from resonant losses and blind spots and ensures absolute stability. Its method of astatic winding prevents H.F. interference with adjacent components. List No. F.Y.2. Price 3/6

The R.I. Dual Astatic Choke is also specified for the "S.T. Three Star."
List No. F.Y.1. Price 7/6.

All these Components contribute to the great success of the R.I. . . .

WREN-EASTON MICRIONISED 'CLASS B' RECEIVER

This circuit, designed by R.I., has placed selectivity within reach of all. It is the easiest set in the world to build and all components necessary are specified in the R.I. Wren-Easton Photoprint Instruction Broadsheet, a complimentary copy of which will be sent to all who post the coupon below.

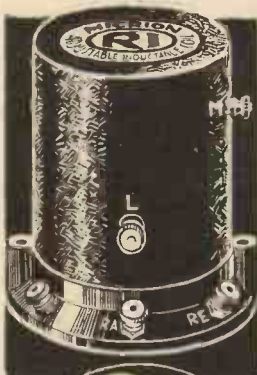

MICRION ADJUSTABLE INDUCTANCE COIL

The marvellous iron-core coil, which is the secret of the great selectivity of the R.I. Wren-Easton Receiver, can be easily fitted to almost any set and enables station after station to be brought in with perfect separation. Furthermore, it can be matched with existing coils and valves and does not necessitate recalibration of the receiver when fitted. It was described by "Wireless World" as 40 per cent better than the ordinary type of air-cored coil.

List No. B.Y. 36. Price 12/6



POST COUPON TO-DAY

for free copy of the R.I. Wren-Easton Broad-sheet. Enclose 2d. in stamps for postage.

Name _____
Address _____
_____ W.C.

Radio Instruments Ltd., Croydon, Surrey

In Lighter Vein—continued

good. The Professor was filled with that determination to win which comes only to the man who is wearing a paper dicky to hide the absence of a shirt, and whose socks are painted upon his insteps and ankles with the last few drops from his ink-pot.

"Woad, my dear fellow," said the Professor, "was the war-paint of our ancestors. Following their noble example, I go into battle garbed largely in blue-black ink."

A Special Chart

The Professor had armed himself with a very special conversion chart, worked out after much burning of midnight oil.

"If," he said, "under the old order of things Toulouse was represented on my scale by Nürnberg, then it follows that, nowadays, Budapest will be Petrozavodsk, and Vienna, Marrakesh. So for the whole list of stations. Thus I know that if Miss Worpel calls Munich, I have to turn to Dniepropetrovsk, and if she asks for the Schweitz—Schweitsch—that's to say—"

"My dear fellow," I expostulated, "you are spluttering like a soda-water siphon struck by lightning. What you mean is the Schweish—er—the Schweiveiweissch—er—er—what you said."

"Let's try something easier," suggested the Professor. "Should she ask for Rome—"

SCOOPING THE POOL

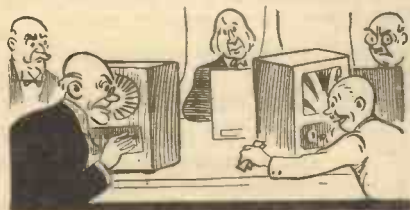

"Reaching for the kitty, I remarked with a smile that Uszhorod was the up-to-date name of Kosice."

"Come, come," I remarked. "In the best circles, nowadays, we never mention stations by names that can be found on any map. What the common herd call Rome is known to the élite as Radio Nazionale Italiano. I know that it sounds like a new kind of ice, but never mind that. Let us keep abreast of the times."

We were still discussing things when Miss Worpel rang her little handbell for silence, and announced that the competition had begun.

"The first station," she cried, "is Uszhorod."

The Professor feverishly consulted his chart. Captain Buckettt began twiddling like anything. Tootle's brow was furrowed by a myriad of wrinkles. Primpleson gasped like a fish out of water.

"Uszhorod," I repeated into my loudspeaker, and gave the single-tuning knob of my set a slight twirl.

Speech in a language sounding more like atmospherics than anything else poured from the loudspeaker, but at intervals the word "Kosice" was clearly heard. Reaching for the kitty, I remarked with a smile that Uszhorod was the up-to-date name of Kosice.

Weighted with Sixpences

And so the evening went on. Again and again I was able to scoop the pool which, despite the fact that each round contained an I.O.U. from the Professor, was distinctly worth having. On our way home my right hand coat-pocket was so weighted with sixpences that I had to walk crab-wise, whilst such was the accumulation of I.O.U.s on the other side that I could barely button my overcoat.

The Professor asked me to drop into the *Microfarads* for what might have been a cup of cocoa, but actually wasn't. My first act on entering his den was to present him with the whole wad of his I.O.U.s. The narky reader may say that there was nothing generous about this, since their value was, in any case, nil. Let me only reply that it is quite beside the question. Always take the will for the deed. Sometimes you will be right, but usually you will be left. You see what I mean? Thank you. It's more than I do.

A Question of Brains

"And now," said the Professor, "perhaps you wouldn't mind telling me how you managed to find all these stations so quickly to-night?"

"Brains," I replied, with a deprecatory shrug of the shoulders, "just brains."

"Yes, but whose brains?"

"Why, mine, of course."

"Come, come," cried the Professor, "you must have had an assistant."

"Oh, well, yes! I admit I had a little help from your lab. man, Edward Bugsnip."

"If you had examined my earth wire, you would have found that it

was, like Army forms, in triplicate. Alongside the real earth wire were two others, connected to my loudspeaker. Their far ends, which I tossed lightly out of the window, were gathered by Edward and attached to a pair of telephones. I repeated the name of the station

EDWARD THE LAB. MAN



"He proceeded to make weird, spluttering noises into one of his telephone receivers."

rather loudly into my loudspeaker. He heard it and then proceeded to make weird, spluttering noises into one of his telephone receivers, interspersing these with the required station name at intervals."

"Halves," remarked the Professor sternly.

Setting aside the five bob that Mr. Bugsnip had so fully earned, I resigned myself to the inevitable and turned over half of my hard-earned gains to the Professor.

* FROM A READER *
* "I have yet to come across a two- *
* valver half as good as the "Con- *
* structor's Two." *

To the Editor,

THE WIRELESS CONSTRUCTOR.

Dear Sir,—I have just made up the "Constructor's Two" given in the November number.

I have not had long yet to be able to give a full list of the number of stations I have been able to receive, but during daytime I am able to receive eight, and during the evening, on just going round the dial, I was able to count fifteen.

As regards selectivity, this is of a high order, even during the evening.

I have had quite a lot to do with two-valve sets, as many people in this village have two-valvers, but I have yet to come across one half as good as the "Constructor's Two."

Yours faithfully,

A. C. L. JOTCHAM.

The Parsonage, Compton, Berks.



FROM MY ARMCHAIR

by **S.T.**

SEVERAL letters have come to me from far-flung outposts of our Empire (on which the sun never sets). Here is one from Mr. G. J. Humphrey, manager and director of Gold Produce Estates, Chipandi Estate, Njuli, Nyasaland.

I cannot shut my eyes to the catholicity of this concern's activities. Their letter-head proclaims an interest in tobacco, coffee, general produce, high-class furniture (any design made to order), timber merchants, qualified consulting engineers, thoroughbred poultry a speciality.

I think we in the Old Country specialise too much. I have always thought my own qualifications a fair assortment,* but supposing I added: consulting engineer, ham and eggs a speciality, dealer in old junk, lecturer in economics, air navigator, sardine sandwiches freshly cut, permanent building society, turf commission agent, carpets cleaned and swept, panel patients 2-3 p.m., good pull-up for spongers, anything up to £5,000 on note of hand, sausage rolls.

An Invitation to Shoot

Still, I suppose in Nyasaland a man might want thoroughbred poultry one day and he'd never come again. But you may be sure he'll want some tobacco, or some timber, or some high-class furniture (any design made to order).

* Mr. Scott-Taggart has the diplomas of three professions: barrister-at-law, physicist, and chartered electrical engineer.—ED.

It is little wonder that Mr. Humphrey is interested in radio. And when not hunting the wireless bug-bears he is chasing lions. You may recall that he previously invited me to shoot lions out there.

Components to Avoid

But to return to his letter. He gives me a few warnings about designing a set for East Africa.

The type of components to be avoided are all those which have paper,

There's a deal of fun to be had from any scientific hobby and John Scott-Taggart has not been slow to realise it. His monthly notes, written in off-duty moments, from the friendly companionship of his armchair, are an intimate chat between the famous designer and all his readers. Look this month at the fun which S.T. extracts from his pet Henrocites; from Carlos X of Portugal; from Empire short-waves. Good-humoured fun, all of it, which shows our contributor in his most amusing vein, and does much to foster the confidence which S.T. enjoys of constructors in all parts of the world.

silk, or cotton coverings, varnished chokes with wire exposed.

He explains that "the small fish moth we have loves these things, and devours them regardless of short-circuiting your receiver."

* * *

Those who sneer at the ravages of the inductance weevil (which I am proud to say is 100 per cent. British, Nordic and Aryan) will thus see that there are more parasites in coils and condensers than are dreamt of in their philosophy.

As for the condenser moth which I have kept up my sleeve—the fish moth of East Africa is an obvious infringement—I don't think I'll tell you about it now.

But Mr. Humphrey has another warning: "Holes in components should also be avoided, as they provide resting-places for the small egg laying insects which abound out here."

How nasty! What would Carlos do in E.A.? He grouses enough about his hoppers.

I am not sure whether "small egg laying insects" means that the eggs are small or the insects are small.†

Nor, I suppose, must there be any holes in a cabinet through which jungle worms can creep. "The successful set must have a metal cabinet, and must use a small H.T. Dry batteries deteriorate in our great heat."

Why do people live in these hot climates

* * *

I have had several other letters from different parts of the Empire, including Bralupan (or Burlpink, Brulhouk, Buhapun, Bralujim, Bringuam), Cossipore, Halgranaya, Sholapur, and Balham.

His Whole Life Story

One of these tells me his whole life-story. He was nine when I had to leave off to write these notes. He is sixty-seven. Don't people live a long time? I suppose it is all these new-fangled inventions which prolong life.

When he gets to thirty-two I shall go for my summer holiday—and finish the letter next winter.

† Messrs. Lyons sell what they call a Thin Captain Biscuit. It is a perpetual source of curiosity to me—whether the Captain or the Biscuit is Thin.—J. S. T.

He Wants to Keep Cockroaches Out of the Set

Another has built twenty-seven short-wave sets, and is at present describing each.

We are now at the fourteenth, and on 25.2 metres. No, no; we have just got Daventry on 31.3 metres, but

through the jungle. Dry batteries fall to pieces in the wet season. Dynamo is best, but oil and petrol are unprocurable. [Suggest dynamo driven by hands or feet of *ayahs*, *buck-sniffers*, *yulas*, *dingahs*,

and warps in the hot season. Metal essential.

All the letters are unanimous about the trouble caused by atmospherics (except the man at Balham who wants to keep cockroaches out of his set; he says they nestle round his Class B valve).

Well, you can't do anything about atmospherics except build local stations stronger than the atmosphere. We've all invented dozens of atmospheric eliminators but without much success.

I am churning over all your letters. I am delighted to have them—and I only wish they contained more "local colour." Meanwhile, I am at work on a short-wave adaptor which will open the gates to those who are new to the waveband below 100 metres.

Carlos Bulletin

It is not possible to give Carlos X of Portugal the whole of the space intended for my notes, but his experiences would easily fill it.

Apparently the first day everything went well. But next day, owing to background noises, his friend "in the morning went over it and he was so lucky in his proceeding he did send the four valves to hell."

Tut, tut, Carlos! Remember this is a respectable family journal, read by the children of clergymen and 'bus drivers. I'm the only one allowed to swear in these columns, and then it has to be of the hearty, man-to-man, jovial, I'm-human-like-the-rest-of-you kind which so endears me to my great public.

Carlos apparently gets a lot of "distortion" in the night time, but he has his successful moments: "to finish we reach 'usa' and the Spanish Speaking America. We heard distinguishingly the man speaking and the station's music (not gramophone discs), but were unable to catch the town's name, pity enough, it was about over two in the morning."

Spare a Tear

The next report says: "We are persecuted with hazard. Our accumulator 80 hamp is distinguished in eight days. Then the aerial variable condenser becomes deffectuous, the central shaft pin between the demultiplications wheel had broken, but the new one works with some attrite—friction."

British constructors, who will have their little squeal, can certainly spare a tear. In all my experience, I have



Carlos X of Setubal, is in trouble again this month—no unusual occurrence. We see him here, looking eagerly for some solution to his "S.T. 400" troubles, which include a sardine can-

ning factory, an electric fan, valves which burn out with unfailing regularity, an accumulator which is "distinguished" every two days, and—worst of all—a loudspeaker which boasts "histles and barkles." But Carlos, as befits the former owner of the silver inkstrain, an article you may remember of "antique valuer"—has not lost heart. Indeed, he actually succeeded in receiving an American station the other evening! This, for him, amazing result has led Carlos to the happy conclusion that his "S.T. 400" must be too good for reception in Portugal. Further developments are expected!

it has faded at 9.32 South African time.

Rules for Manufacturers

The requirements of an Empire receiver—and the information is free to all commercial set manufacturers—are, judging by a number of my letters:

1. Great sensitivity is required. Selectivity doesn't matter.
2. Great selectivity is required. Sensitivity doesn't matter.
3. Dry batteries are useless. The heat causes deterioration. H.T. accumulators are best.
4. H.T. accumulators are useless. Nearest charging station is 70 miles

or *luki-lukis*, i.e. native boys.—J. S.-T.]

5. American superhets the only sets that are any good.
6. American superhets are a wash-out here.
7. Short waves only any good.
8. Medium waves essential. Often receive Europe.
9. Automatic volume control essential. Fading terrible.
10. Automatic volume control useless here. Signals disappear altogether for an hour at a time.
11. Teak advised for cabinets. Metal oxidises and disintegrates in the wet season.
12. Wood useless for cabinets. Cracks



**50% reduction
in H.T. and
prolonged battery life**

**Easily incorporated in
most battery sets. Re-
quires no special
transformers or
valves.**

D.P.44 15/6

In addition to its other advantages just consider the resultant economy of the "Power Puncher." For example, in an average 3-valve set (1 S.G. Detector and small Pentode) you save 50% of H.T. consumption. In other words you save at least one H.T. battery renewal per year and in some cases two. A complete unit in itself—requires no extra rectifier or resistances.

Write to-day for our new components' leaflet—it is free.

Advert. of Oliver
Peel Control Ltd.,
Kingsway House,
103, Kingsway,
W.C.2. 'Phone:
Holborn 5303



MAINTAINED EFFICIENCY

That's what you want in
H.T. supply to ensure good
reception. That's why the

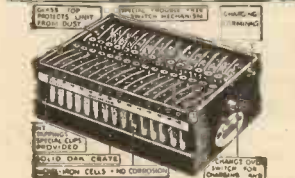

is the best of all forms of
H.T. supply.

An independent investigator, pointing out the wastefulness of cheap H.T. dry batteries, states that they reach the end of their useful life in less than three weeks. Tests showed that the voltage dropped 10 volts during four hours discharge at normal rate. Consider this discharge curve of a 120 volt Single capacity Milnes Unit. The voltage has not dropped 5 volts in eight hours continuous discharge at 22 milliamps. And remember that between each spell of use the Milnes Unit recharges itself from the L.T. accumulator so that it starts again fully up to voltage. Remember, also, that the Milnes Unit will last for twenty years and more and will save up to 80% of running costs throughout that period.

Learn more about
the Milnes Unit.
Send the coupon
TO-DAY, for Big
Free Book.

Prices from
£3:3:0
Hire Purchase
terms from
6/3 monthly

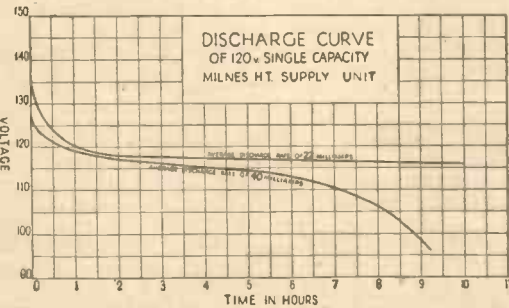

MILNES RADIO CO., LTD., CHURCH STREET, BINGLEY, YORKS.

Please send Free Book describing the Milnes Unit. No obligation.
Name.....
Address.....
w.7

USE the NEW UNIVERSAL SCREENED COILS

—and bring YOUR
**SET
UP-TO-
DATE**



**TUNES
180 — 550
and
850 — 1950
METRES**

**PRICE
EACH - - 5/-**

Is your set making the most of the new Lucerne arrangement? Do your present coils cover the wider wave bands? If not modify it now by using the new Wearite Universal Coils. Fully Screened—modern in design they definitely **COVER THE NEW LUCERNE ARRANGEMENT.**

Whatever the circuit, a straight three with or without Band-pass—any combination—the 'Universals' adequately meet the situation. Modernize your set NOW!

★ Leaflet giving special circuits is available. Fill in this coupon.

Reg. Trade Mark.

WEARITE COMPONENTS

COUPON To Messrs. Wright & Weaire Ltd.,
740, High Rd., Tottenham, London N.17.

Please send me leaflet giving full particulars of the new Universal Coil and diagrams; also send your Booklet C.12, together with Constructional details and blue print of the Wearite Teamster. Three penny stamps are enclosed.

NAME.....
ADDRESS.....
W. Con. 3/34.....
Please write in Block letters.

“Seriously Preoccupied in an Hazard Trouble”

never had a condenser deffectuous through a breakage in the desmultiplifications wheel shaft. But these things are actually happening in Portugal.

A “Supper Receiver”

No wonder Carlos asks: “What do you indicate to proceed?” His patience and good temper are amazing. Listen to this:

“As we think and testify it is a supper receiver for the excellence contested under the day’s time. We reach the conclusion ‘S.T.400’ is to good for our conditions here, and we should remain humble merciful if you would be willing to indicate us the way how to spoil it to a less sensitive one so we could here the afternoon’s programme.”

Apart from “histles and barkles” from the electric-light mains, he has had trouble with the speaker, and has had to send to Lisbon “for the ratification of its needle.”

The set is so sensitive “we hear distinctly under nights the electrones hopes from the dinamo/generator. It is quite distinctively heard the generator’s buzz-noise.”

Another comment: “Regard the presets, we have ascertain satisfactorily by now and obtain the automatic reaction all over the wavebands as well the selectivity, but this one we can’t abuse otherwise the valve accuse oscillations.”

His valves appear to burn out every few days and his patron friend is getting fed up. Carlos writes: “My friend has already manifested his annoyance not to have acquired some fabric-made commercial known receiver, but I have told him it is not yet the end.”

Eight-Valve Hectoridyne

Nov. 1st, 1933. Better news. “In the last days the evenings tune in programmes have come exquisitely pure and enormous strength like an American eight valves hectoridyne but absolutely different in tune clearness and naturals sounds purity which makes the admirations of the amateur enthusiasts to the performance fidelity.”

But things are not yet right: “We are very seriously preoccupied in an hazard trouble. Our L.T. runs down hill in two or three days, and the set under 45 degrees reproduces the programmes only in jerks.”

Setubal, December 2nd, 1933. “Excuse me come back to torment your godself with inquisitions on your ‘S.T.400’ glory, but am instigate by my fellow partner. We are continuously befogged by a lote of electrons tumbling into the speakers. We are continued hearing terrible electrons fall into the speaker with frequently descharges just as it were a bomb exploding in it. Only on the local stations we can realy fill the selectivity without having the speaker full of particles and bombs. This in addition to the histles and barkles undernights. Couldn’t we filter the aerial input through any condenser, paper or chemical and, earth is?”

Any Advice?

A difficult and delicate problem. Other readers troubled with “histles

mains trouble (he lives next door to a transformer house, apparently), he has other obstacles to surmount. “We have a great number of fish packing houses which, to dry the sardines, employe big tunnels where they place the grills containing the fish, and through these tunnels made of wood they send warm air impulsed by a big 3 or 4 feet about fan electric propulsioned by a three-fase dinamo without whatsoever arrangement for interception to interrupte the noise coming out into the mains carrier. Would any of the Dubilier dielectrics serve the purpose?”

He ends his last letter:

“You are our hopes for years to come and a big stone in years gone bye. How shall we escape from your keel water whirls?”

THE BIG NEWS IS OUT!



S.T. writes: “Just as I was keeping a close watch on the two henrocites (inductance weevils) photographed by the aid of my ultra-micrographic microscope, they stopped savaging the reaction winding of an ‘S.T.400’ aerial coil. Their appetite had apparently gone. I placed a speck of colloidal copper near them. They went up to it, sniffed at it, looked up at me, sniffed at me and lay down again. After three days’ careful watching, during which they never moved an Angstrom unit, I was gratified to see them both busying themselves with wisps of silk from the wire. One of the henrocites carried the wisps, while the other—the female, I presume—weaved them into the shape of a bird’s nest. This nest was slung between the twelfth and thirteenth turns on the coil—a rather unlucky position, I thought. At this stage my technical activities called me to Tallis House. When I returned yesterday, I was delighted to find the nest occupied by the larger of the two adult henrocites and six baby henrocites. There was no sign of the smaller adult henrocite which I had taken to be the mother. But careful search in the neighbouring maquis disclosed what I can only suppose is the skeleton of the mother. The children all look very vigorous and their coats, though downy, have a coppery sheen. Schools will be interested in my theory that the young henrocites eat their mothers. The happy, peaceful look on the father’s face corroborates this theory.”

Our picture (taken with the aid of the new microscope, which magnifies 200,000,000 times) shows the male henrocite shepherding his young for their first ramble abroad. Note the very close resemblance between the children and their father, a peculiarity of henrocites.

and barkles” are invited to offer advice. I still suspect those hoppers he mentioned—the ones which seemed to be the cause of the length in the deep of the speaker.

Apart from ordinary three-phase

“Your reputationless but earnest
“Signid,

Carlos ———”

Little did I think when the silver inkstrain was threatened that it would

(Please turn to page 278)

POLAR

SPECIFIED

for the **S.T.300**

STAR



POLAR No. 4

A precision condenser similar to the famous No. 2 S.M. Aluminium with brass pillars. Ball bearing spindle.

TWO REQUIRED
'0005 - Price each **4/-**

POLAR
'PANEL-MOUNTING'
DISC DRIVE

Slow motion with bevelled scale. Provided with lamp holder and moulded escutcheon.

TWO REQUIRED **5/-**
Price each - -



ALSO REQUIRED ...

POLAR 'COMPAX'

Three '0005 - - PRICE each **2/6**

POLAR 'DIFFERENTIAL'

One '0003 - - - - - Price **3/-**

One '0001 - - - - - Price **3/-**

Send for Polar Catalogue to :

WINGROVE & ROGERS LTD.

188/189, STRAND LONDON, W.C.2.
Works: OLD SWAN, LIVERPOOL.

'Phone: Temple Bar 2244.
4510

SPECIFY EXCLUSIVELY

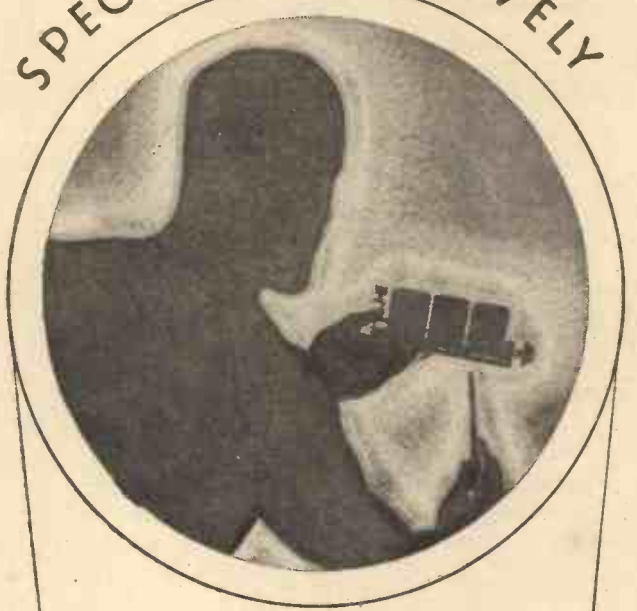

men of science use Colvern

SPECIFIED FOR THE S.T.300 STAR

Leading set designers and wireless constructors all over the country use Colvern because they are the most accurate coils ever made—the result of years of experience and research. The unparalleled success of Colvern coils is indeed a triumph of modern engineering precision. Every coil is thoroughly tested and guaranteed. Specify Colvern for your set.

For the S.T.300 Star—2 Colvern S.T.500 Coils at 8/- per pair.

COLVERN

SPECIALISE

IN COILS

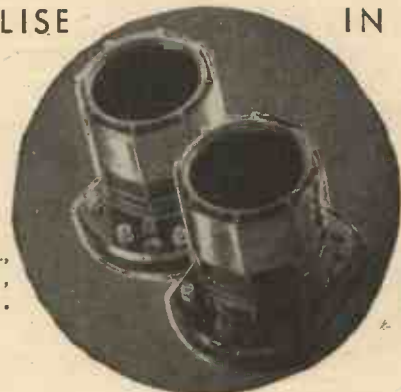

Colvern, Ltd.,
Romford,
Essex.

London
Depot: 150,
King's Cross
Road, W.C.1.

Amazing
Book
Offer!

by THE
WIRELESS
CONSTRUCTOR

£1-1-0 Presentation
Volume

For every reader



THE
MANUAL
OF
MODERN
RADIO

SCOTT-TAGGART

THE MANUAL
OF
MODERN RADIO

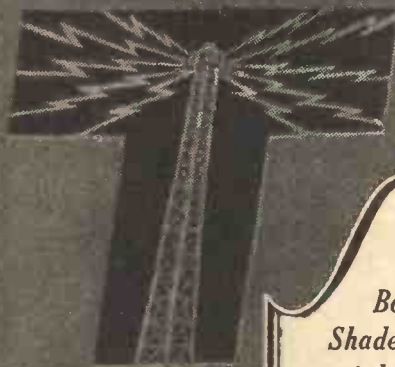

JOHN SCOTT-TAGGART

*Superbly
Bound in a Rich
Shade of Green Cloth
with Silken Finish
and containing*

**36 CHAPTERS
424 PAGES**

Over
**500 DIAGRAMS
AND CIRCUITS**

*Complete Dictionary
of Wireless Terms*

**40 PAGES OF
ART PLATES**

*Thousands of Facts
and Explanations*

JOHN SCOTT-TAGGART'S GREATEST BOOK

The MANUAL OF MODERN RADIO has been acclaimed as the finest all-round book on radio yet offered to the public.

Every radio enthusiast needs this book; it is a sure guide to knowledge and success in everything connected with the technical side of wireless, written by a man whose qualifications are unrivalled, the greatest living expert in set designing to-day.

Three-quarters of a million copies of John Scott-Taggart's books have been bought by the wireless public!

It is seven years since Mr. John Scott-Taggart has found time to write a wireless book. His "Manual of Modern Radio" is a monumental work—a landmark in the literature of wireless technique. Within its pages he has brought the whole art of radio reception and the use of valves.

The Manual is "red hot" as regards recent developments. If you are interested in such things as H.F. Pentodes, Iron-Core Coils, the Double-Diode Pentode, Cathode-Injector systems, Metal Detectors, Class B Amplification, the Capehart Circuit, Metal Valves, Quiet Automatic Volume Control, the Pentagrid—here in this book will you find all you want to know.

But if, on the other hand, you are a novice who would like to know a little about "how the wheels go round," here again is the book for you. Scores of circuit diagrams are duplicated in pictorial form to help the beginner, and it has been assumed that the reader knows nothing whatever about electricity or science. All one needs is the ability to read.

"The Manual of Modern Radio" will occupy an honoured place on your bookshelf. Beautifully bound in green cloth and printed in clear type, it will form a treasure-house of facts and advice from which to draw.

A superb volume (completely devoid, of course, of any advertising matter), which would ordinarily be sold at a guinea, can become yours for a purely nominal expenditure, but only if you act at once.

Every word of the Manual is newly written by John Scott-Taggart, and every diagram has been specially prepared solely for this great compendium of the radio knowledge of to-day.

Our offer of John Scott-Taggart's "Manual of Modern Radio" is the bargain of a radio lifetime. We urge you to seize the opportunity now.

*The DE LUXE Edition
will cost you ONLY 1/9 MORE
You can have it if you wish*

**Beautifully Bound in Royal Blue Paste Grained
Real Leather with Grey Art Vellum Sides Lettered
in 22-carat Gold**

There is a very special edition choose, you will be more than of the MANUAL OF MODERN satisfied, but those who select the RADIO known as the de luxe de luxe binding will have the added edition, which you can have for the satisfaction of having in their home very small extra charge of 1s. 9d. a book of outstanding beauty and only. The additional charge is a service. Be sure to indicate clearly on mere trifle—the extra value is remarkable. Whichever edition you your Gift Voucher which edition you desire. This is MOST IMPORTANT.

GIFT VOUCHER

Affix your tokens in the spaces below

1	2
---	---

Affix Gift Tokens taken from two consecutive issues of THE WIRELESS CONSTRUCTOR in the spaces provided above and send together with the label below to

Wireless Constructor Presentation Book Dept.
(G.P.O. Box No. 184a), Cobb's Court,
Broadway, LONDON, E.C.4

Please forward me a copy of the

STANDARD/DE LUXE

(Strike out the edition NOT required)

MANUAL OF MODERN RADIO

The Gift Tokens attached here have been cut from THE WIRELESS CONSTRUCTOR. I enclose remittance value—

2/9 for the STANDARD EDITION
or
4/6 for the DE LUXE EDITION

which includes cost of carriage, packing, insurance, etc

Name.....
(Mr., Mrs. or Miss)

Full Address.....

LABEL

BOOKS WITH CARE Carriage Paid Home

Name.....
(Mr., Mrs. or Miss)

Full Address.....

Nearest Railway Station.....

If undelivered return to WIRELESS
CONSTRUCTOR Book Dept.,
Bear Alley, Farringdon St., E.C.4.

HOW TO OBTAIN THIS BOOK

COLLECT two gift tokens cut from the bottom left-hand corner of the last page of reading matter of WIRELESS CONSTRUCTOR and affix them in the spaces provided on the Gift Voucher above. Any two tokens will do so long as they are consecutive. When this Gift Voucher is complete, write your name and address both on the Gift Voucher AND on the label below it. Enclose a P.O. for 2/9 if you choose the standard edition, or 4/6 if you select the de luxe binding, to cover the cost of the volume, carriage, cardboard container for packing, and insurance.

Make your P.O. payable to WIRELESS CONSTRUCTOR and cross *t Co.*

The MANUAL OF MODERN RADIO can only be supplied to readers who complete the necessary Gift Vouchers.

It is regretted that overseas readers are not eligible under this scheme.

(Irish Free State readers should send their completed Gift Vouchers and P.O. to 73, Middle Abbey Street, Dublin—Standard Edition only, 3s. 3d.

A RADIO CHANCE OF A LIFETIME

THE "S.T.300" STAR

—continued from page 250

before on a simple set, I thought I would do so as a change. But the constructor can please himself.

The escutcheon hole is cut in the ebonite panel by preparing a string of small holes in the shape of the escutcheon hole. The centre piece of ebonite is then removed by breaking down or cutting through the small spaces between the small holes.

Instructions for mounting the Polar Disc Drive are given on a sheet of information provided with every drive. This sheet also has printed on it a template which greatly simplifies the job.

Baseboard Partly Metallised

The aerial side of the baseboard is either covered with metal foil or the baseboard is Métaplexed where the foil would go. The metallised surface should not extend beyond the screen.

The baseboard components are fixed to the baseboard after the fixing-hole screws have been pricked through the blue print, which is laid face upwards on the baseboard. The holes for the pillars which support the anode coil are also prepared, but the coil is not fitted at this stage.

When the baseboard components are wired, turn your attention to the panel components, which are fixed in position and wired. Then fix the panel to the baseboard and complete the wiring; the anode coil is fixed on its pillars at this stage. The fixing of the vertical screen is left to the last.

The superfluous terminal C on the W.B. universal valve-holder is removed. Discard the bent metal socket. The terminal itself is used for fitting to the vertical screen.

Operating the "S.T.300" Star

It is proposed to describe the operation of the "S.T.300" Star in detail next month, but some preliminary remarks will no doubt be welcome.

The set should be tested first without its cabinet. The wiring should, of course, have been carefully checked.

A good 9-volt bias battery is placed behind the terminal strip. Insert G.B.+ plug in the + socket of battery; G.B.— is plugged into —3 volts if a small power valve is used (which I would advise if you want sensitivity; for loud signals on a strong local, a larger power valve, e.g. P.M.202, may be employed, but you will sacrifice some signal strength on the weaker stations. If such a valve is used, the G.B.— should be plugged into about $-7\frac{1}{2}$ volts).

A 2-volt accumulator is placed behind the set and a 120-volt H.T. battery to the right of the accumulator. The H.T.+1 is plugged into 72 volts or thereabouts; H.T.+2 is given about 80 volts.

Both these voltages may be varied during tests to give the best results. The H.T.+1 should not go above about 80 volts, but H.T.+2 (the detector voltage) may be adjusted to any value to give sensitivity or smooth reaction.

Suggested Valve Team

The speaker is probably best placed to the right of the receiver; avoid directing the sound from the speaker on to the valves.

The valves given in my list are advised for this set. A combination illustrating the types to use is: Cossor 220S.G. for the S.G. valve, Mullard P.M.2D.X. for detector, and for the last valve a Marconi or Osram L.P.2 or Mullard P.M.2A. (or P.M.202 may be preferred in some cases).

JOHN SCOTT-TAGGART

has written a new book for you.
He has called it

THE MANUAL OF MODERN RADIO

and you can obtain a copy for yourself at but a fraction of its normal cost. For full details of this remarkable offer

TURN TO PAGES 272 and 273

Adjust the phase reverser .00005-mfd. preset to nearly minimum.

Set the anode coupler at normal, i.e. with the knob pointer vertical corresponding to the half-way position of the differential. Set the aerial and anode reaction knobs to zero (full left). Adjust the aerial coupler so that it is about quarter way off full left. Tighten the selectivity range adjuster to maximum capacity.

The set is now operating as a normal receiver. With the wavechange switches both out, tune in the local station with the two dials.

Adjusting Selectivity

Tuning will probably be rather flat. Now turn the aerial coupler to different positions, returning to the signal with the left-hand dial. You will find that signals are weaker (but the set is more selective) if the aerial coupler is turned to the left, and vice-versa.

Now experiment in a similar way with the anode coupler. If it is turned to the left, signals become weaker but selectivity improves.

Turning the anode coupler to the right decreases selectivity but increases signal strength; if the set oscillates when the anode coupler approaches its full-right position, you need not worry as this is not abnormal. You must keep "to the left" of oscillation. Retuning slightly is necessary after altering the anode coupler.

The anode reaction control presents no feature for comment. This control affects the anode circuit, and you should always mentally divide the panel controls into those associated with the aerial circuit and those with the anode circuit, as explained earlier in my article.

Aerial Reaction Control

There remains the aerial reaction knob in the bottom left-hand corner of the panel. This is a very important feature of the "S.T.300" Star, but the selectivity of the receiver is such that you may not always require it.

Its action is tied up with the phase reverser .00005-mfd. preset. This latter only requires a slight adjustment when the set is first installed and an approximate adjustment is enough; it should be set so that it is nearly at zero (screwed out). But when you are satisfied with the rest of the set you can try adjusting it to different values; as the capacity is increased, reverse reaction is increased and more normal reaction will be found necessary on the aerial reaction knob.

The First Tests

Your first tests with aerial reaction should be made with the anode reaction at zero and the anode coupler at about "11 o'clock," i.e. nearly full left. The aerial coupler also can be set at about 10 o'clock (nearly fully left).

The smoothest aerial reaction effects are obtained when the anode coupler is between full left and vertical. To obtain aerial reaction with the anode coupler full left, it is essential to use one of the more efficient types of S.G. valve, such as those recommended.

An S.G. valve of the type originally used in the "S.T.300" will give an aerial reaction effect, but not under all conditions, and certainly not with the anode coupler at full left.

A double-reaction effect is obtainable when you are thoroughly familiar with the working of the controls. Very high selectivity results from this system, and the aerial and anode circuits are both tuned and "reactioned" to the desired signal.

But let me give you a warning. If signals are already loud, you will miss the benefits of double reaction. You

(Continued on next page)

THE "S.T.300" STAR

—continued from previous page

will merely get distortion and poor selectivity. Signals should be definitely weak to start with, and double reaction will bring them up to full strength, simultaneously providing great selectivity.

But, in spite of this warning, I know that hundreds will start applying aerial reaction with signals already strong. Signals must be weak to begin with if you are to obtain the great benefits of double reaction, and the best way of reducing the initial signals is to turn the aerial coupler to the left to the required extent. The anode coupler can also be turned more to the left with advantage.

The aerial coupler, by the way, makes an excellent volume control, but, after altering either of the couplers, you should slightly retune on the dial affected; thus, an alteration of the aerial coupler will need a slight alteration of the left-hand dial, while the anode coupler requires a slight readjustment of the right-hand dial.

Provided you bear in mind the effects of each control on its own circuit, the operating of the "S.T.300" Star will be found quite simple after an hour's working. And then you will begin to rejoice in its flexibility, and take a real pride in the achievements made possible by its special controls.

J. S.-T.

RADIO EXPERTS PRAISE THE S.T. MANUAL

—continued from page 254

THE GRAMOPHONE COMPANY, Ltd.

The Chief Engineer, Technical Department (H.M.V.), says:

"The Manual of Modern Radio' is a well compiled treatise dealing with all phases of radio reception, and will fill a gap in radio literature. It should be in the hands of all persons who intend to take the sale and service of radio receivers seriously and efficiently."

"THE BROADCASTER"

The Editor says:

"I am very much obliged to you for giving me an opportunity of seeing Scott-Taggart's 'The Manual of Modern Radio,' which I understand has been specially written to interest those amateurs who are anxious to know something of the technicalities of radio, and which you are so generously

(Continued on next page)

**MULTUM
IN PARVO**

The famous 'M' type
Mica Condenser

PHYSICALLY minute, yet with what care are they built — and tested . . . 00005 mfd. to .01 mfd. and innumerable values in between . . . all accurate within very fine limits. Fulfilling a hundred and one needs, designed for ease of wiring — 'between wires' or to terminals, the 'M' type is consistently used by commercial set makers — consistently specified by set designers — because of their utility and dependability. Follow the lead of the 'professionals' — use T.C.C.

Prices range from 8d. (.00005 mfd.) to 2/- (.01 mfd.)

T.C.C.
ALL-BRITISH
CONDENSERS

THE TELEGRAPH CONDENSER CO. LTD., WALES FARM RD., N. ACTON, W.3

♥4475

RADIO EXPERTS PRAISE THE S.T. MANUAL

—continued from previous page

presenting to the regular readers of THE WIRELESS CONSTRUCTOR.

"A simple explanation of the complicated technique of radio is a difficult thing for the listener to acquire. I think that Mr. Scott-Taggart has produced a handbook which should succeed in persuading many thousands to take a keener interest in the fascinating technical story of modern radio communication."

LONDON RADIO COLLEGE

The Manager says :

"We thank you for the copy of 'The Manual of Modern Radio' by John Scott-Taggart. We have given this book a very close study and we are frankly of the opinion that the subject has never before been put so clearly to 'the man in the street.'

"The absence of complicated formulae and the simplicity of the language in which it is written make it an ideal work for all those who are interested in radio, but who have not the time nor the inclination to study the deeper technicalities of the science."

THE EDITOR'S CHAT

—continued from page 227

Mr. A. L. Chadwick, of Bourne-mouth, bluntly remarks that he prefers soldering because :

"(1) Soldering is more efficient. Terminal connections deteriorate. (2) Soldering means a considerable saving in cost."

"Easily Mastered"

The art of soldering, adds Mr. Chadwick, is quite easily mastered. A little practice and a good flux, and if constructors cannot do it they are stuck with the few components which still require it. For example, the grid switch in the "S.T. Super" Radiogram.

Colonel Dennis, of County Wicklow, writes an interesting letter and points out that he has been accustomed to soldering (both hard and soft) off and on for considerably over fifty years, and, of course, the art offers no difficulties to him.

Colonel Dennis in his letter goes on to say :

"Many — indeed most — modern components which are fitted with terminals are also supplied with

'soldering tags' on the terminals, which tags are frequently very flimsy. In these cases the joint has to be soldered to the 'tags,' which, to my mind, has no advantage over a direct connection by a neatly made loop of the wire itself. It certainly gives more contact area at the terminal, and theoretically a lower resistance, provided the soldered joint between wire and tag is sound, but the same result can be obtained by slightly flattening the loop on the wire with a hammer. Therefore, for the average constructor, I consider a direct loop wire connection to the terminal to be safer.

Joining Two Wires

"Where one wire is joined to, or branched off from another, soldering is, of course, essential, and it is perhaps here that there is the greatest risk of a 'dry' joint, as unless both wires are really clean the solder is apt to run over the joints without running in between them or really adhering properly to either, but looking beautiful!

"To avoid this, both wires should be cleaned with fine emery paper and should be *separately* tinned at the point of junction before they are soldered together. The cold process used in tinning 'tinned copper wire' is not altogether satisfactory as a soldering basis—witness some old tinned wire where it is often found that the tin coating has flaked off in spots.

"The soldering 'tags' referred to above are for some unknown reason most often supplied nickelled. The nickel coating is the worst possible for soldering purposes as it does not adhere well to the brass of the 'tag.' Often a wire soldered to the nickel can be pulled off, bringing the nickel coating with it.

Little Flux Needed

"Use the minimum of flux when soldering has to be done. The least trace, applied with a pointed match, is sufficient if the surfaces are clean. One sixpenny tin of 'Fluxite' has lasted me for over 5 years, and there is still plenty left."

And, to conclude with, Mr. J. M. Sellers, of Purley, writes to say: "I have a splendidly fitted workroom, with every convenience for soldering, and as an amateur mechanic I have been using a soldering iron for forty years (often on jobs more critical and delicate than wireless connections), but I vote for TERMINALS every time. I do not mind a certain amount of soldering in a receiver, but if every connection had to be soldered, I am afraid I should never make up another set!"



Matched and Tested Kits for S.T. 300 STAR

S.T. 300 STAR DE LUXE KIT

SPECIFICATION.

	£	s.	d.
2 Polar condensers and Disc Drive ..	15	0	
2 Colvern "S.T.500" Coils	8	0	
1 Graham Farish L.M.S. Choke	4	6	
1 R.I. New Hypermu transformer	15	6	
1 W.B. Universal valveholder	1	0	
2 W.B. 4-pin valveholders	1	0	
1 Wearite type H.F.P.J. Choke	2	0	
3 Graham Farish '0005-mfd. condensers	6	0	
1 Polar '0003-mfd Differential condenser			
with insulated spindle	3	0	
1 Graham Farish '0001-mfd. Differential	2	0	
W.B. Push-pull switches	1	8	
2 J.B. Presets, '00005 and '0001 mfd. ..	2	0	
1 Bulgin S.102 Toggle Switch	1	3	
1 Dubilier 2-mfd., type B.S.	2	6	
1 Dubilier 1-mfd., type B.S.	2	0	
3 Erie resistances—1 meg.; 20,000 ohms;			
250 ohms	3	0	
1 Dubilier '00005-mfd. Mica condenser ..	6		
1 "ACE" Panel, drilled	3	0	
1 Baseboard and foil	1	6	
1 "ACE" S.T.300 STAR Screen	1	6	
1 Terminal strip, drilled	1	0	
1 Bracket	3		
10 Belling Lee Terminals	2	6	
Screws, wire flex, etc.	1	10	

"ACE" Kit "A" - £4.2.6

"ACE" De Luxe Kit "A" Battery Model - - - £4.2.6

"ACE" De Luxe Kit "B" £5.13.9

Table Model Cabinet - 17.6

Consolette Cabinet - - £1.10.0

For those who would like a cheaper kit, we have prepared the SPECIAL—

"ACE" S.T.300 Star Kit "A" at £3.0.0 only

Complete to the last screw and fully covered by the usual "ACE" guarantee of quality and performance.

For those on A.C. or D.C. Mains we have the—

"ACE" S.T.300 Star De Luxe Mains Kit "A" at £6.17.6

Mains Valves £2-8-6 extra.

Full constructional details supplied with each kit.

Convert your 1932 S.T.300 to the S.T.300 Star with the "ACE" Star Conversion Kit 15/6 Post paid. DEMONSTRATIONS DAILY.

MARCUS, OVERTON RADIO LIMITED, SPECIALISTS IN HAND-MADE QUALITY RADIO, 62 Borough High St., London Bridge, S.E.1
Phone : HOP 4431. Trade Supplied.

THIS YEAR'S VALVES

—continued from page 256

and for 3 volts we obtain an output of $485 \times 9 = 4,365$ milliwatts.

This latter is unobtainable without a certain amount of distortion, the maximum grid input being something of the order of 2.8 volts R.M.S., at which figure the output of about 3,400 milliwatts is obtained. But it is a remarkable valve, is it not?

Other high amplification mains valves have also been produced recently by Mazda, Marconi and Osram, and Tungram. These are the A.C.2H.L., the M.H.41 and the A.R.495. They all have similar characteristics, possessing amplification factors of round about 75-80 and impedances of only some 13,000 to 18,000 ohms.

"Coming Shortly"

Then coming shortly are more Hep-todes and nine-pin triode-pentodes for super-het mixer circuits, and a new Mazda diode-pentode using the new A.C.2 Pen.

Class B, in spite of its psychologically bad name—Class B does not really mean second-class, even if that impression is given—has come to stay. The biased "B" valve (B.21) has arrived, and also a combined driver and "B" valve in one envelope (Hivac). A matched Q.P.P. double pentode (Q.P.21) has also arrived from the Marconi and Osram stable.

We have not mentioned D.C. valves, though there are a number in the lists of most valve manufacturers from which to choose. Mazda have both .1 and .5 amp. D.C. valves, Mullard goes in for .18 amp. types, while Marconi Osram and Cossor favour .25 amp. heater currents. All these are for series heater connection, and the new types of screen pentodes, double diodes and so forth are available.

Suggested 13-Volters

There is a persistent rumour going round that at least one group of valve manufacturers is making a determined attempt to oust the long-standing 4-volt 1-amp. A.C. valve, choosing a universal 13-volt low-consumption valve which can be used either for series connection in D.C. sets, or for parallel connection from a 13-volt transformer-winding for A.C. Again, it can be used in series for A.C., if desired.

The reason 13 volts were chosen is not so remote and strange as it may seem at first—it was to allow car sets to be built with the valves running off a 12-volt accumulator. K. D. R.

S.T. 300

John Scott-Taggart Specifies "Bulgin"

From the earliest days of Broadcasting to the present day every set of importance includes Bulgin Products. Their marked originality, advanced design and unrivalled quality have placed them in a class alone.

Technical Details.

BULGIN S.80 TOGGLE SWITCHES. Perfect examples of precision engineering, rated 250 volts 3 amps. Insulation resistance above 50 megohms. Contact Resistance average 0.01 ohms. Large terminal connections.

BULGIN S.38 PUSH-PULL SWITCHES. Highly finished, neat design with excellent snap action.

BULGIN H.F.9 S.G. CHOKE. Inductance 250,000 mH., self-capacity 2.5 mmF. approx. Chokes smoothly 97% approx. at 200-1,800 m. 400 ohms D.C. approx.

BULGIN "SENATOR" TRANSFORMER. Primary Inductance between 75 and 95 Henries, varying with signal strength. Uniform amplification from below 50 to 8,000 cycles. Ratio 1-4.

BULGIN A.R. 250-OHM RESISTOR. Wire-wound 10-watt type, complete with terminals. Accuracy 5%.

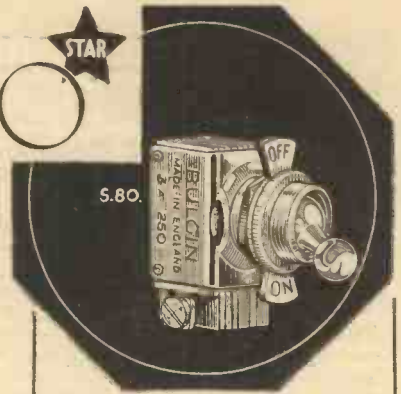

COUPON

Cut out this list and hand to your Dealer. In case of difficulty write direct.

Please supply the following :

- 1 BULGIN S.80 TOGGLE SWITCH 1/6
- 2 BULGIN S.38 SWITCHES @ 10½d. 1/9
- 1 BULGIN H.F.9 S.G. CHOKE 3/6
- 1 BULGIN "SENATOR" TRANSFORMER 6/-
- 1 BULGIN A.R. 250-OHM RESISTOR 1/-



Telephone: **A. F. BULGIN & CO. LTD.,** Grange Wood 3266-3267. BARKING, ESSEX.

NAME

ADDRESS

80 Page Catalogue No. 153 'C.' Enclose 2d. Postage

EASY TERMS PROMPT DELIVERY

Any Amplion, Blue Spot, Baker, Celestion, Epoch, Ferranti, Gramplan, Igranic, Lamplugh, Magnavox, Ormond, R & A, Rola, Sonochorde, or W.B. Speaker supplied.

Send 5/- only

and pay balance by monthly instalments. No references. Entirely private and confidential.

KITS, PARTS, SETS, ELECTRIC CLOCKS ON EASY TERMS.

Send for List of 83 Speakers and state requirements.

TURNADGE & PARTNERS, LTD., 110-111, Fleet Street, London, E.C.4. Telephone: Central 1903.

HAVE YOU HAD?

Particulars of the famous "Magnum" Short Wave Adaptor, which is now available for every type of receiver?

Full particulars with a list of short wave stations and free trial offer, on request.

BURNE-JONES & Co. Ltd. (Dept. C), 296, Borough High St., London, S.E.1

Write for Illustrated Catalogue of **RADIO-GRAMOPHONE CABINETS** of exclusive modern design, made by craftsmen in highly figured Oak, Walnut, or Mahogany, post free.

REMARKABLE VALUE Cabinets made to order a speciality. Maker, under licence, of the **HOWE BOX BAFFLE** Recommended by the B.B.C. Full details on request.

GILBERT SWINDON Cabinet Maker, Estimates Free. Estd. 1866.

Engineers' Guide

Containing the widest choice of engineering courses in the world. Quality for a well-paid post in Engineering by studying at home with The T.I.G.B. Become an A.M.I.C.E., A. M. I. Mech. E., A. M. I. E. E., etc. Training until Successful is Guaranteed for the one fee. WRITE NOW for "The Engineers' Guide to Success," stating branch, post or qualification that interests you, to

THE TECHNOLOGICAL INSTITUTE OF GT. BRIT. 21, Temple Bar House, London, E.C.4. Founded 1917. 19,000 Successors



To Success

All applications for Advertising Space in "Wireless Constructor" must be addressed to the Advertisement Department, John Carpenter House, John Carpenter Street, London, E.C.4.

WE invite readers to support our Advertisers—care being taken to accept only announcements of reputable firms.



HERE'S YOUR 1934 RADIO GUIDE!

Have you got the Heayberd 1934 Handbook?—if not, get it NOW. Contains all useful information on how to run your radio from the mains. Fifteen blueprints showing how to build your own mains unit or battery charger, etc. Two pages of helpful radio hints for all amateurs. The third edition, published in February, contains SPECIAL TELEVISION SUPPLEMENT.

Cut out this advertisement, write your name in the margin, and send with 3d. in stamps for your copy.

F. C. HEAYBERD & CO.,
10, FINSBURY STREET, E.C.2. W.O.

S.T. 300 ★

R type terminals of course.



Belling Lee R type terminals again specified. You will require the following 10 indications. A, E, LS+, LS-, HT-, HT+1, HT+2, HT+3, LT-, LT+.

White lettering on non-removable Bakelite heads. Unique sub-connector nuts.

Note new indications for Cathode Ray television work: **GN.A1, A2, B1, B2.**

No other terminal offers you so many good points.

BELLING & LEE LTD
CAMBRIDGE ARTERIAL ROAD, ENFIELD, MIDD

WHOLESALE DEPÔT
LEONARD HEYS FOR ALL STANDARD MAKES OF COMPONENTS, KITS OF PARTS, etc., as advertised in this Journal and elsewhere. All usual sundries. Write for Cat. enclosing **SPEEDY & PAINLESS** singtrade card (Bona-Faithing Service) for Traders only.

LEONARD HEYS: FARADAY HOUSE
HENRY STREET, BLACKPOOL.
ELEVEN YEARS EXPERIENCE IN THE WIRELESS TRADE

Micromesh Literature and prices on request.
THE MODERN VALVE Standard Telephones & Cables Ltd.
St. Chad's Place, 364, Gray's Inn Road, W.C.1. Telminus 6255.

RADIO GRAM CABINETS 65/- FLOOR MODEL 35/-
NO MIDDLE PROFITS!
As supplied to B.B.C. A quality and value impossible to better. Beautifully hand polished.
DIRECT ON FREE TRIAL. SEND FOR LIST.
PICKETT'S CABINET R.C. WORKS, Bexleyheath, Nr. London.

PLEASE be sure to mention "Wireless Constructor" when communicating with Advertisers. THANKS!

FROM MY ARMCHAIR

—continued from page 270

lead to the terrible troubles that have come to our old friend Carlos. He is in terrible straits and all the while his patron friend is wishing he had bought ducks. I am not surprised.

It Is Amazing Value

You will find in this issue an announcement regarding my new "Manual of Modern Radio." Those of you who have known me for years will be aware that I never make claims or statements which would affect a reputation which I hope will continue for another twenty years.

Well, this Manual is the best thing I have done. As regards the merits of its contents there are others who speak. But as a book I can assure you it is amazing value. I have published many books, but for 2s. 9d. you are offered what is a really wonderful production of the book printers' and binders' art.

Helpful to Beginners

This Manual would ordinarily be sold for about a guinea. It is offered, of course, to attract regular readers, but also to encourage them to take an interest in the technical side of radio.

It is a large book, but I have assumed that the reader knows nothing! Not flattering, perhaps, but helpful to beginners.

Every modern development is fully explained. I have never discussed more than ten per cent. of its contents before in magazines.

About forty thousand people have already obtained the Manual, but WIRELESS CONSTRUCTOR readers are now given the chance of obtaining a book which the highest in the land could not obtain except in the way prescribed.

It has only been published a week or two, and is more comprehensive than any other book on radio that I know. As far as an author can be impartial, I can confidently recommend the acquisition of "The Manual of Modern Radio."

He Wants a Job

Amongst my mail I always receive one or more letters from those seeking work. Unhappily I can do nothing. Here is one from a boy of 16:

"I have been an apprentice electrician and wireless engineer for just over a year. I then took over a job

in a bakery, and then went back. Now my employer is a very hard man. Any fault in the battery service—say, an uncharged battery, wrong-charged ones, and things like that—and I get the blame.

"Now I would like you to understand that I was in charge of the batteries and the charging plant. Well, the girl in the office attended to the shop and sometimes, when I was out, she would come down and put an uncharged battery in the charged section. My employer wouldn't take my word for anything like that. Now, Mr. Scott-Taggart, I am just telling you these facts so that you may get a glimpse of the man's nature.

Committing Every Blunder

"I have had insults hurled at me till I have felt like giving him a dressing down, but as it was not my place to do so I kept my mouth shut until he refused to take my word the other day. Result: A week's notice—with a spiteful sneer thrown in gratis.

"I am of a quiet disposition. I make 5s. per week out of playing the banjo at dances. I can also play the violin, and I can clown, too. I have no theory but I am a good listener."

There are five pages of this. And this youngster does not know that every page would turn a possible employer against him. Only one man in ten can write a good letter applying for a job. An employer can only judge by letters in the first place.

Our 16-year-old commits every blunder possible—criticising his employer, blaming others, introducing personal matters.

Postscripts

R. L. W., of Ramsgate, is worried. "I find that on certain notes of the new B.B.C. organ various ornaments on the piano rattle and even move about. Amongst these, in a silver frame, is a photo of my wife's mother. The other day it nearly fell off."

Some people won't let Nature take its course.

* * *

A disciple at Birmingham has sent me a pork-pie as a Christmas gift. It has arrived a fortnight late. He sends a note: "It has been delayed as I could not find a box to put it in."

I could suggest a suitable container, but I suppose one must put a gift pork-pie in the mouth. Moreover, in the words of Tennyson, "We needs must love the highest when we see it."

J. S.-T.

OUR NEWS BULLETIN



NOBODY can accuse the B.B.C. officials of lack of interest in television. They have encouraged the development of various television systems, and now it is reported that a new television studio has been secured at No. 16, Portland Place—a private house which the B.B.C. has acquired close to Broadcasting House.

* * *

Probably by the time this issue of THE WIRELESS CONSTRUCTOR is on sale this studio will be ready, and a new series of television programmes will be coming across—for the benefit of two or three thousand people.

Very Few Amateur Outfits

One of the strange things about the science of television is the fact that, despite all the boosting various systems have had, and despite the undeniable fact that technique has considerably improved during the last few years, there are, comparatively speaking, very few amateurs who possess television outfits.

One would have thought that at least 50,000 people in this country would have been interested enough in the experiments to spend a few pounds on the necessary equipment.

Too Much Ballyhoo

As we have pointed out time after time in the past, there has been so much ballyhoo about television that thousands of people have been "put off."

This is a great pity, because although television has not yet reached the stage of development which would entitle it to be regarded as a service entertainment, it does undoubtedly provide a definite field of amusement; and with the development of the new cathode tubes, the enthusiast who installs an outfit will certainly get his money's worth in thrills and interesting experimental work.

The Technical Side

Technical changes in television from the B.B.C.'s point of view are due very shortly; the contract with the Baird Company for 30-line television transmissions on four evenings weekly expires on March 31st, and thereafter the number of television transmissions will be reduced to two a week.

* * *

The B.B.C. is also experimenting with a short-wave transmitter on the roof of Broadcasting House, and if the experiments are successful, the Corporation will probably begin a regular series of 120-150 line transmissions.

World's Biggest Station

Have you heard the new giant 500 kw. station at Cincinnati? This station—the most powerful in the world—is now on the air with the call sign W 8 X O.

Talks can be heard every day from 6 a.m. on a wavelength of 428 metres, and any good three-valver, capable of getting the big Continental stations, should easily pick up this new American giant.

No Politics for France

French listeners will not be bored in future with political broadcasts. An official communiqué states that the Government recently authorised French stations, controlled by the State, to broadcast political gatherings of all shades of opinion, but it appears that there has been such a public outcry from French listeners that the Government has now forbidden political broadcasts in the future!

Rounding Up Pirates

Now that licences have reached the six million mark, we hear that the Post Office intends renewing the war against radio pirates. Apparently the P.O. officials believe that there are

(Continued on page 280)

DUBILIER CONDENSERS

*Unfailing
reliability—
Superlative
performance—
characteristic
of Dobilier
Condensers*

SPECIFIED FOR THE
S.T.300 STAR



TYPE
B.B.

one 2 mfd.
3/6 each

The following
Dobilier Metal-
lised Resistance
is also exclusively
specified.
One 2,000 ohm
Resistance 1 watt
1/- each

*Follow the
leading radio
designers
and insist on
Dobilier*

DUBILIER CONDENSERS

DUBILIER CONDENSER CO. (1925) LTD.
Ducon Works, Victoria Rd., North Acton, London, W.3

OUR NEWS BULLETIN

—continued from previous page

still at least one million pirates to be rounded up.

During February, Post Office detector vans will scour Yorkshire, paying special attention to Leeds, Bradford, and Huddersfield. They will then visit Cardiff, Newport and Swansea, and in April, the Nottingham district, including Mansfield, Newark, Grantham, Loughborough and Derby.

The B.B.C has officially denied the rumour that circulated recently to the effect that the headquarters of the B.B.C. in Edinburgh have proved unsatisfactory, and that broadcasting activities were to be transferred to Glasgow. How these rumours get about is something of a mystery, but Scottish listeners may take it for a fact that Edinburgh will still be the B.B.C.'s H.Q.

Radio Luxembourg

Something ought to be done about Luxembourg. This is definitely a pirate station. Despite the Lucerne Plan, Luxembourg continues to operate on 1,304 metres. Recently this station broadcast band music which gave the impression that Henry Hall and his band were performing.

Whether it was deliberate or unintentional is yet to be ascertained, but Mr. Hall talking to a reporter said, "It is an outrage. Whether it was intentional or not, it is obvious that thousands of people will have connected me with the pirate transmission. If I were to take my band to Luxembourg, it would cost those responsible at least a thousand pounds."

"A Question of Ethics"

The position is rather curious, for when an official of the B.B.C. was questioned about this example of broadcast piracy, the reply was: "It is a question of ethics and good taste. These programmes have, we know, been broadcast before, and we have no power even to protest."

Why? Surely the B.B.C. are not going to sit still while a continental station broadcasts band music (even with Henry Hall's signature tune) and a voice similar to that of Mr. Hall's is "used" to give the impression that Henry Hall and his band are actually broadcasting?

Seeing Broadcasting House

Most listeners have the impression that Broadcasting House is guarded

hour by walking round as though he were in a museum (probably he thought he was).

Quite Easy

The stranger turned out to be a provincial inspector of police. In an interview, he said: "I was in London with a friend. We were in plain clothes, and really went to Broadcasting House to see the audition rooms."

Well, these two gentlemen got into Broadcasting House, and, as the inspector explained, "We walked into the vestibule and waited. No one took any notice, so we went upstairs. We opened doors, peeped into offices, and could have inspected papers on the desks if we wanted. We were not even challenged when we asked a man about

NEXT MONTH
THE WIRELESS CONSTRUCTOR
 will contain
MORE ABOUT THE "S.T.300" STAR
 By JOHN SCOTT-TAGGART, A.M.I.E.E., F.Inst.P.
 and
THE "ADAPTO" 3
 A UNIQUE AND ADAPTABLE SHORT-WAVE RECEIVER

like the Bank of England: stern-visaged porters, attendants, lift guardians, etc., etc., are literally strewn about the entrance hall. Therefore, it is all the more surprising to learn that the other day a complete stranger wandered into Broadcasting House and entertained himself for half an

the statuary on the façade of the building. Having seen all we wanted, we went out."
 If any reader of THE WIRELESS CONSTRUCTOR is equally lucky in getting a free look round Broadcasting House, we shall be very pleased to hear from him.

INDEX TO ADVERTISERS	
	PAGE
Belling & Lee, Ltd.	278
Bulgin A. F. & Co., Ltd.	277
Burne-Jones & Co., Ltd.	277
Clarke H. & Co. (M/or), Ltd.	263
Cole, E.K., Ltd.	Cover iv
Colvern, Ltd.	271
Cossor, A. C., Ltd.	226
Concise Universal Biography	Cover ii
Dubilier Condenser Co. (1925), Ltd.	279
Gilbert, J. C. (Cabinets)	277

	PAGE
Graham Farish	261
Heyberd, F. C. & Co.	278
Heys Leonard	278
Jackson Bros. (London), Ltd.	265
Marcus, Overton Radio, Ltd.	276
Milnes Radio Co., Ltd.	269
Peto-Scott Co., Ltd.	257
Pickett Bros. (Cabinets)	278
Radio Instruments, Ltd.	265
Standard Telephones & Cables, Ltd.	278
Siemens Electric Lamps & Supplies, Ltd.	225

	PAGE
Technological Institute of Gt. Britain	277
Telegraph Condenser Co., Ltd.	275
Turnadge & Partners, Ltd.	277
Varley Products	269
Westinghouse Brake & Saxby Signal Co., Ltd.	Cover ii
Whiteley Electrical Radio Co., Ltd.	259
Wingrove & Rogers, Ltd.	271
Wright & Weaire, Ltd.	269

All communications concerning advertising in "Wireless Constructor" must be made to Advertising Department, John Carpenter House, John Carpenter Street, London, E.C.4.

Printed and published on the 15th of each month by the Proprietors, THE AMALGAMATED PRESS, LTD., The Fleetway House, Farringdon Street, London, E.C.4. Advertisement offices: John Carpenter House, John Carpenter Street, London, E.C.4. Registered for transmission by Canadian Magazine Post. Subscription rates: Inland and Abroad, 8/6 per annum; Canada only, 7/6 per annum. Sole Agents for South Africa: Central News Agency, Ltd. Sole Agents for Australia and New Zealand: Messrs. Gordon & Gotch, Ltd. S.S.

A Companion Work to the **CONCISE UNIVERSAL ENCYCLOPEDIA**

CONCISE UNIVERSAL BIOGRAPHY

Edited by **SIR JOHN HAMMERTON**

A Standard Work of Reading and Reference published in the convenient form of

6^o Weekly Parts

20,000
Life Stories
of Famous
Persons of
all Times
and all
Countries

This is the most important popular work of reference published for many years; it is an essential complement to an encyclopedia, and is another welcome addition to the famous series of concise reference books prepared under the editorship of Sir John Hammerton.

CONCISE UNIVERSAL BIOGRAPHY is a tribute to Human Achievement, a temple of fame containing over 20,000 separate biographies of men and women famous in all walks of life, of all times and of all countries. It is a work that fulfils a long-felt need, providing in readable form a wealth of information concerning the vital personalities who have made their mark in the world since the world began.

Arranged alphabetically for easy reference, it offers to the intelligent man and woman a never-ending source of inspiration.

CONCISE UNIVERSAL BIOGRAPHY is *not* a collection of hard, dry facts; it is far otherwise. Great and varied human interest will be found in its pages, where bishops and bruisers jostle each other; actors and astronomers are placed almost literally cheek by jowl; poets and politicians, profligates and puritans, each in his place in the serried ranks of the great. Nor must the many women therein be forgotten, whether saints or sinners, rulers or writers, for the selection of them is as catholic and comprehensive as is the case with the men. It includes, for instance, all the noteworthy film stars of to-day.

CONCISE UNIVERSAL BIOGRAPHY draws its characters not from Great Britain alone, but from all nations, living and dead alike, and it is thus unique among modern biographical publications.

It is supremely well illustrated. Care has been taken to avoid the monotonous effect of assembling a large number of portraits of nearly equal size by illustrating in many cases places and things associated with the personalities described in the text. There are 5,000 illustrations in the work altogether.

CONCISE UNIVERSAL BIOGRAPHY is a publication for which the "Self-Binding" method is particularly suitable, as it is essentially a work of reference, although every page is made as attractive and readable as though it were a popular magazine. A new and improved Self-Binder is therefore being provided for those to whom that economical method of preserving the volume appeals.

PART 1
Now on Sale 6^d.

At all Newsagents and Bookstalls.

COMPLETE IN ONE VOLUME
FULLY ILLUSTRATED



3 GREAT SAVINGS

1 SAVE MONEY

19s. 7d. IN THE £.
 Obtain H.T. for your Radio from one of the NEW AND IMPROVED EKCO UNITS and you save 19s. 7d. in the £. Sound design and utmost efficiency enable running costs to be reduced to 1/- per year.*

* Based on 3 hours daily use of an average 3-valve set.



2 SAVE TIME

NO MORE ACCUMULATOR CHARGING. Use an EKCO Combined Power Unit, which not only gives H.T. but keeps your accumulator fully charged.

3 SAVE TROUBLE

PRICES FROM
37/6

or by Easy Payments.

NO MORE BATTERIES. Connect the suitable EKCO Power Unit in place of the battery, plug into the electric light and switch on—that's all! No alterations to set, valves or wiring. Silent in operation; outstanding in performance.

The latest EKCO Power Units are housed in attractive all-insulated bakelite cases. Size 9" x 5" x 3 3/8". Ask your dealer for literature or post coupon below!

EKCO

RADIO POWER UNITS

To: E. K. COLE, Ltd. (Dept. D.I.), Ekco Works, Southend-on-Sea.
 Please send me full details of Ekco Radio Power Units.

Name.....

Address.....