

The Wireless 6d Constructor

RADIO CONSULTANT-IN-CHIEF CAPT. P. P. PECKERSLEY M.I.E.E.

Vol. XIII.

DECEMBER, 1931.

No. 62.



This
**BOOK
FREE!
INSIDE**

AND NOTE THIS MONTH'S
SPECIAL FEATURES

**HOW TO MAKE
THE "MIDGET" THREE**

A new addition to one of the
most popular series of sets ever
produced.

THE "DUO-VISE" TWO

Something entirely "different"
in radio receiver design.

**ROUND THE WORLD
WITH THE "I.E." THREE**

More about an amazing set
which "ranges over the whole
World" without coil-changing
or switching.

**SELECTED
CIRCUITS**

ALL THOROUGHLY PRACTICAL— ALL CAREFULLY TESTED

A wonderfully comprehensive collection of seventy-seven specially picked circuits covering all kinds of radio set and unit arrangements. Battery circuits from one to five valves, mains sets, mains units, rejectors, special units, etc., etc., are included. Every instrument described has been made up and given extensive practical tests, and comes up to the highest standard of efficiency. Never before has such a magnificent assembly of up-to-the-minute designs been presented in one book.

SIXPENCE

PRICE



*The
Selectivity
Problem*
**SOLVED BY
LEWCOS**

The
LEWCOS
REGD.
BAND PASS FILTER
Price 12/- (Screen 2/6 extra)

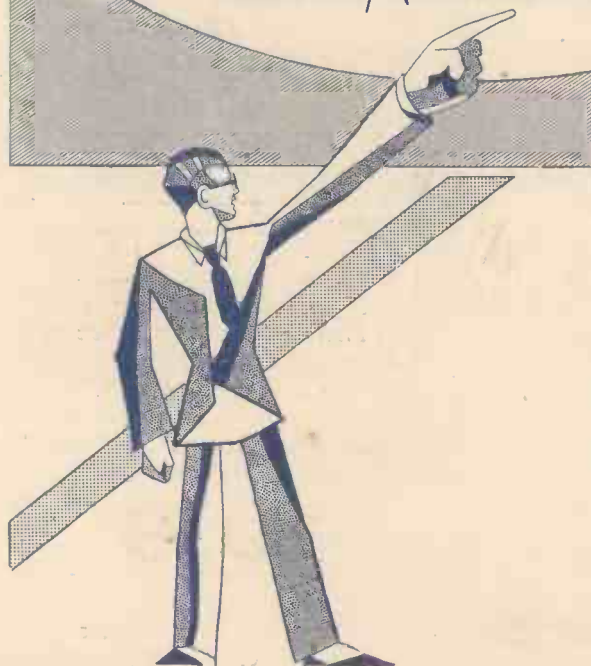

Here at last is a component over which you will naturally enthuse because it ensures selectivity such as you've heard of, but never before experienced.

THE LEWCOS BAND PASS FILTER actually increases the range of any Receiver because stations which are normally inaudible, due to swamping by local transmissions, now have a place on the dial free from interference.

The phenomenal selectivity of this unique device is apparent on both long and medium wave bands; hence it is infinitely superior to any existing selectivity unit, such as wave traps, etc.

Write for fully descriptive leaflet, Reference R.73, showing flat-topped response curves.

A LEWCOS H.F. CHOKE AND A P.V.1 COIL ARE SPECIFIED FOR THE "I.E. 3" RECEIVER described in this issue.

LEWCOS RADIO PRODUCTS FOR BETTER RECEPTION

THE LONDON ELECTRIC WIRE COMPANY AND SMITHS LIMITED, CHURCH ROAD, LEYTON, LONDON, E.10

CONTENTS

	Page		Page
The Editor's Chat .. .	71	Pick-up Hints and Tips .. .	98
Queer Queries .. .	72	Savoy Hill News .. .	99
Choosing Your Circuits .. .	73	A Useful Unit .. .	102
Round the World with the "I.E." Three .. .	75	Misleading Meters .. .	103
The "Double-Tone" Cone .. .	78	A Practical Man's Corner .. .	107
The B.B.C.'s New Noises .. .	79	Wireless Woodwork .. .	110
The "Duo-Visé" Two .. .	81	With Pick-up and Speaker .. .	112
Round the Dials .. .	86	Regarding Rectifiers .. .	115
Points for Purchasers .. .	86	In Lighter Vein .. .	118
As We Find Them .. .	87	Our News Bulletin .. .	122
The "G.B." Regulator .. .	89	The Speech Inverter .. .	128
"On the Grid" .. .	92	The Birth—or Death—of an Electron .. .	130
The Month on Short Waves .. .	92	H.T. From Flashlamp Refills .. .	131
The "Midget" Three .. .	93	The "Kilotrap"—Leatherette Finish for Cabinets—Round the Trade .. .	132

As some of the arrangements and specialties described in this Journal may be the subject of letters patent, the amateur and trader will be well advised to obtain the permission of the patentees to use the patents before doing so

Chief Radio Consultant:
 Capt. P. P. ECKERSLEY, M.I.E.E.



IGRANIC

MIDGET TRANSFORMER

Specified for the
"MIDGET" THREE

The only way to judge a transformer is by its performance—QUALITY OF REPRODUCTION. By embodying an Igranic "Midget" Transformer in your set you are assured of extreme satisfaction. Because of their known quality and efficiency, experts specify Igranic components.

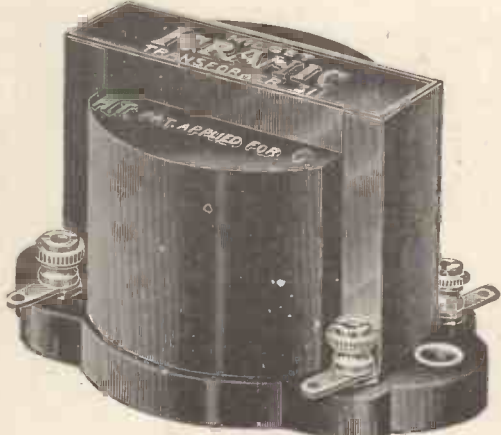

Price
10/6

If you are unable to obtain Igranic components locally, write direct to us to Dept. J.1159.



IGRANIC ELECTRIC CO., LTD.
 149, Queen Victoria St., London.



Bring in those feeble stations

—at full Loud Speaker strength

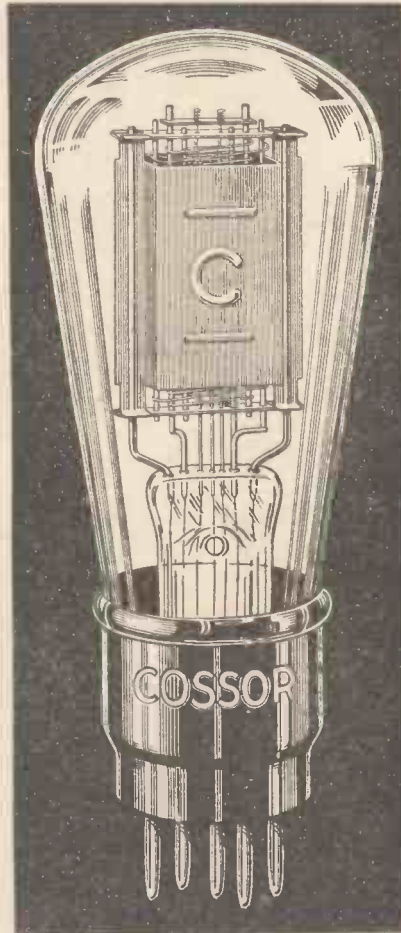

Cossor Pentodes are available from any Wireless Shop in types to suit Battery and A.C. Mains Receivers

THOSE faint "foreigners" that now you can only just hear will come in at full volume if you replace your Power Valve with a Cossor Pentode. When receiving a distant station louder signals are obtained with a power valve than with a super-power type. This is because the amplification given by the power valve is greater. But the super-power valve is preferable for receiving

strong signals because the volume of pure sound it can handle is greater than that which a power valve can deliver. In Cossor Pentodes amplification greater than that obtainable from a power valve is combined with the power handling capacity of the super-power valve. Therefore, by fitting a Cossor Pentode, distant stations that before could only be heard as a whisper come in at local station volume.

— use a

COSSOR PENTODE

To Messrs A. C. Cossor Ltd., Highbury Grove, London, N.5.
Please send me free of charge Folder No. L.34 which gives full technical details of Cossor Pentode Valves.

Name.....
Address.....
W.C. 12/31.

The WIRELESS CONSTRUCTOR

Published by the Amalgamated Press, Ltd., Fleetway House,
Farringdon Street, London, E.C.4.



THE EDITOR'S CHAT

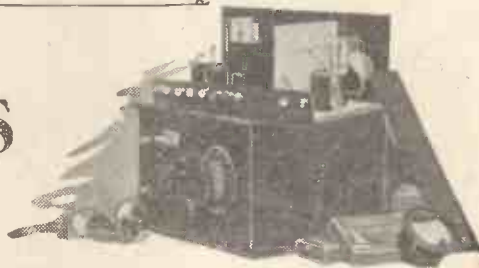

A few words concerning our wonderful free gift to readers, and comments on other items of outstanding interest.

THE book which we give away with this issue should make an appeal to every keen home constructor. A reference book of good, sound, reliable circuits is always a handy thing to have about you, and a glance through our production, to which I have given the title "77 Selected Circuits," will give you not only a considerable amount of information, but will perhaps open your eyes to the fact that there are so many really reliable circuits for the constructor to choose from.

Guaranteed Circuits

Every one of the circuits in this gift book has been made up in practical form in the shape of an experimental test receiver, and each receiver has been given a searching examination. In all, the laboratory staff must have tested over 150 circuits, from which were selected the 77 which are diagrammatically reproduced for you in the book.

I think you will agree that the book constitutes a work of reference which you will do well to keep by you; and if there's one thing this book ought to prove it is the fact that there is no truth in the theories one hears these days that radio design is getting stale, that all modern receivers are more or less alike, and that the only difference is in unimportant detail.

Readers of the WIRELESS CONSTRUCTOR know better than that, and if they want any proof they need but look through the pages of the book.

A Novel Set

That is one of the great joys about radio—there is always something new cropping up, and I have no doubt that in a year's time there will be quite a number of new circuits to add to the 77 we have chosen.

Whether you build it or not, have a careful look at the "Duo-Vise" Two described on other pages of this issue. It is definitely a novelty. It fits quite nicely on to the top of a loud-speaker cabinet or on the mantelpiece. There is a quick change-over from one to the other of the two locals, with indicating signal lights showing which is tuned in and also acting as a warning that the set is switched on. Incident-

AS USED BY THE B.B.C.



A perfect model of a 500-ft. mast as supplied by the Radio Communication Co. for the new B.B.C. stations. It was on show at the recent exhibition of Engineering at Olympia.

ally, the "Duo-Vise" is tunable, like an ordinary receiver, and, finally, is quite simple to build.

The constructional details of the "I.E." Three were given fully in the last issue of the WIRELESS CONSTRUCTOR, but in this issue you will find more hints about this receiver, for it is a good example of a new phase in circuit design.

That "Pirate Spotter"

A definite denial is given to the suggestion made in a newspaper that the Post Office wireless detection campaign was all bluff.

A Post Office official stated that no claim had been made on behalf of the wireless detector van which could not be fully substantiated.

It is stated that proceedings have already been taken against 100 users of unlicensed wireless sets, and many more are pending. These are due entirely to the activities of the vans.

It is also claimed these vans can pick out a wireless set, whether working or not, and by reference to licence records it is simple to find whether or not the set is licensed.

"Material Moral Effect"

The Post Office considers that the moral effect of these vans has been material in reminding wireless users to buy licences, but technical detections have been followed by prosecutions.

The van against which these statements were made was not working at the time, and the whole report is false in every particular. Perhaps! But the P.O. authorities are rather over-doing it when they claim they can detect a set whether it is working or not!

It is exaggeration of this sort which inclines pirates to regard the P.O.'s campaign as chiefly bluff.

QUEER QUERIES



Some details about unusual radio faults and some suggestions that may help you towards better reception.

By P. R. BIRD.

THE good old question of receiving America has cropped up again.

A hot-and-bothered Sheffield reader won't believe that people in this country can pick up American broadcasting direct from the States, except on short waves.

He is wrong. It can be done sometimes on ordinary wave-lengths. Last year I happened to tune-in at 2.30 one morning, and got WPG (Atlantic City) on 276 metres. That was on the "A.C. Paratune," and plenty of readers have had similar experiences, on simpler and less powerful sets.

There is a good deal of luck in it, of course, but the fact remains that on a good night American broadcasting does sometimes come over with quite a thump, even on ordinary wave-lengths.

On the short waves, of course, it is commonplace, and hundreds of WIRELESS CONSTRUCTOR readers hear American stations almost every night they like to listen for them.

A Tricky Fault

A really choice example of a tricky fault recently caused a friend of mine an exciting hour. He is in the wireless business, and in the course of his day's work he deals with so many radio faults of one kind or another that he has become thoroughly accustomed to them. In fact, he rather likes them!

So when an acquaintance of his built a three-valver which wouldn't work, and wanted help with it, my friend incautiously said: "I'll soon fix it for you," or words to that effect.

But it nearly drove him crazy to find that fault! New valves were no good, his new accumulator didn't help one iota, and when a new H.T. battery as well was hooked up, and still there was no improvement, he began to do some real thinking.

Realising it was something unusual, he then started to look systematically for the fault. And he soon proved to his own satisfaction that the 2nd and 1st L.F. stages were O.K., but nothing was being put into them from the detector. Aerial, earth and

A VALVE-HOLDER HINT

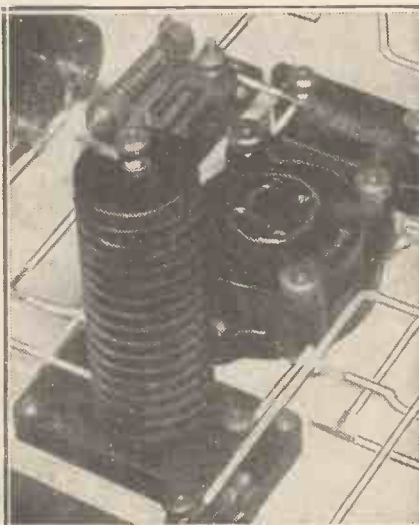

Before screwing down a valve holder and connecting wires to it, make sure of its hidden connections. The screw-heads or nuts on the underside should be tightened before it is used, or they may work loose and cause no end of trouble.

all wiring (soldered) looked perfect, so he felt sure it must be something wrong with the first valve holder.

Two minutes with screwdriver and pliers sufficed to remove that component, and then a new one was fitted, and the set switched on. No better!

Taking off his coat and drawing a deep breath, the searcher then "sailed into" that set for all he was worth—and at last he found the trouble.

It was a thin film of insulation completely covering a soldering tag on the grid condenser! Apparently a "killed spirit" had been used for soldering, and to remove traces of this a resinous paste of some kind had been wiped over the various joints.

No Contact

This soldering tag was firmly soldered to its wire, but it was insulated by the film or coating from the nut which was screwed down on to it.

Being absolutely convinced by what he had read about trouble-free radio from the mains, a Surrey WIRELESS CONSTRUCTOR reader scrapped a good battery-run set in favour of a 5-valve A.C. circuit.

He had a good A.C. H.T. mains unit available, so all he needed was an L.T. mains unit, and the new valves, etc.

The programmes came in as soon as the valves warmed up—but the results were not at all good.

In fact, he came to the conclusion the new receiver was certainly no better than his old set.

Insufficient L.T.

Yet it was the same design as one giving splendid long-distance and quality—similar valves, too. So he got his valves tried out on the other set, and proved they were O.K.

"Must be the high-tension unit, then," he thinks. So he borrowed the other fellow's, and got no better results.

He didn't suspect the low-tension unit, because the man he got it from had been using it successfully for weeks before. But inquiry showed that this was on a three-valver, whilst his own was a "five," requiring two more amperes in filament current.

And a test proved that that was the trouble—the L.T. unit was starving the heaters.

HOW IS YOUR SET BEHAVING NOW?

If you are troubled by a radio problem, remember that the "Wireless Constructor" Technical Queries Department is fully equipped to help you.

Full details of the service, including scale of charges, can be obtained on application to the Technical Queries Department, "Wireless Constructor," Fleetway

House Farringdon Street, London, E.C.4.

SEND A POSTCARD, on receipt of which the necessary application form will be sent by return.

LONDON READERS, PLEASE NOTE. Application should not be made by telephone, or in person at Fleetway House or Tallis House.

CHOOSING YOUR CIRCUITS

by VICTOR KING

Our popular contributor deals with the problems of circuit selection from the set-designer's point of view, and by so doing gives you a clear insight into the considerations governing the evolution of new receivers.

SLIPPED between two of the pages of this issue of the WIRELESS CONSTRUCTOR you will find a book containing a more comprehensive collection of modern circuits than has ever before been gathered together.

77 to Select From

Owners of this book will not only possess a most valuable work of reference, but will also have on hand the material for gaining a clear insight into the complexities of set design.

The "Seventy-Seven Selected Circuits" completely cover the field and range over every worth-while individualistic pattern of circuit symbols. Nevertheless, it cannot be claimed that every possible "hook-up" has been included.

You could double that 77 and still leave quite a few circuits out in the cold. But it is certain that you have in the book a complete representation of modern reception technique. It is quite unnecessary to apologise for the omissions in that their intrinsic equivalents are pretty sure to be represented.

You should be able to spend several interesting hours merely examining the circuits and endeavouring to pick out the important features of each one as you come to it. And as you become conversant with the motifs underlying the patternings of the hook-ups, you will find it fascinating to attempt analyses—comparing the one similar-looking circuit with another and trying to determine the nature and importance of their differences.

Cascade Couplings

At times these differences may appear so slight as to be almost negligible, and you may wonder where lies the justification for the existence of two such "samenesses."

In such an instance it will probably be necessary to look a bit farther than the actual circuit symbols themselves, for, remember, such things as values of components and compo-

nent groupings can make a vast amount of difference to the working of a given hook-up.

Take, for instance, band-passing—which is very popular at the moment. The circuit of a straightforward inductively-coupled cascade of tuning circuits, such as was used fifteen or more years ago, could quite well pass as the circuit of a band-pass scheme.

But the band-passing effect depends entirely upon the degree of coupling existing between two tuned circuits, and there is no commonly used circuit symbol to show such a factor.

A "Request" Reply

And that, by a roundabout approach, brings me to the real theme of this article—a generalisation concerning the methods adopted by a set designer in fashioning his circuits.

This is in response to the requests of several correspondents who, in

diverse manners, have asked me whether there are any rules or regulations governing the pursuance of my craft (set designing), or whether one operates on a quite haphazard component-juggling basis.

Off the Beaten Track

I am able to reassure my correspondents. We work methodically, just as do motor or aviation engineers. We are striving towards ideals, and the measure of our success can be gauged from the results of our work.

We are obliged to stick to a more or less straight road, bounded on the one side by ether conditions and on the other by public demand. And the foundation of the road itself is to a great extent composed of material provided by other set designers and by the radio trade.

The set designer who wanders away from this road is asking for

A DEMONSTRATION AT THE "R.R." STATION



Dr. Mary Taylor demonstrating the short-wave analysis instrument at the Slough Radio Research Station to a party of professors from Czechoslovakia.

Choosing Your Circuits—continued

trouble, though I'm not going to say but that he might not also strike a little Eldorado. I myself make such excursions every now and then, but I get back as quickly as I can and try and mould the material gathered "off the beaten track" in accordance with the conventions.

What the Public Wants

Getting down to brass tacks, these are the problems, as I see them, that have to be faced in set design.

First and foremost, we have the public demands for better quality of reproduction, greater freedom from extraneous noises, lower cost, simpler controls, and more programmes. I am not suggesting that each constructor is conscious of all these as burning requirements, but that in the aggre-

are, of course, considerably aided, if not absolutely dependent upon, the fruits of the labours of the hundreds of independent research workers and thousands of employees of research laboratories all over the world; the set designer who is so foolish as to try and plough a furrow entirely of his own and ignore all these others is not likely to go far.

But while the radio industry contributes largely to the common stock of new ideas, it is the trade itself which tends to put a brake on progress.

This is not due to deliberate reactionary efforts on its part, but to the circumstances of its organisation. Let me illustrate this point so that you can see exactly what I mean.

Supposing during my researches

"We could make such a valve, but the retail price of it would be at least two guineas."

If I knew no more about the inner workings of trade and commerce than I did twelve years ago, I would be aghast and say: "But my valve ought to be every bit as easy to make as an ordinary valve."

Step-by-Step Progress

"We agree," they would say; "but ordinary valves are produced by mass-production, in accordance with tried and tested schemes, from which every atom of waste have been eliminated through the sieve of time."

It would be useless to suggest that the public would simply crave for the new valve, and that it would be quite safe to go into production with hundreds of thousands of them. It would cost a mint of money to lay down the plant necessary, and no firm can these days afford to take such risks as lie in the possibility of a public demand not forthcoming, or a new valve of even greater powers being discovered.

No; the industry does not look kindly upon radical departures in component design, or upon revolutionary inventions that, at a stroke, render current productions obsolete. What is preferred is a general improvement which can be applied in tiny steps, as it were.

On the other hand, it must be admitted that the industry is in certain ways quite elastic. It is able to react to radical changes that lie within its scope of adaptability.

Where Constructors Score

The Extenser provides an apt illustration of this. But, you see, it so happens that the Extenser can be fashioned on the same machines that make ordinary condensers.

The above are considerations such as the set designer must bear well in mind all the time he is at work, and, as can be imagined, many find the temptation to stick to standard apparatus very hard to resist.

In conclusion, I must point out that the home constructor is in the unique position that he is always able to take advantage of the "stop press" news of radio progress, but the manufacturer often has to ignore such "interim" developments.

THE G.P.O. RADIO FLYING SQUAD



Two of the new radio detector vans leaving the G.P.O. for a "pirate-tracking" tour round London. These vans are not able to do quite all that has been attributed to them, but their existence certainly provides an excellent stimulus to the taking out of wireless licences.

gate these are the things the listening public undoubtedly wants. And they are, of course, quite reasonable demands.

Then, present-day ether conditions necessitate a much higher selectivity than in former years. And with the increasing numbers of high-power stations that are springing up on the continent it is likely that revision after revision will be called for in our standards of "station separation."

So far so good. All the above are the targets at which we aim. We

and investigations I discover a way to obtain greater selectivity plus improved fidelity and amplification which involves the use of a valve of special construction.

Those New Valves

I might go to a valve-maker and say: "Is this valve a practical proposition from a manufacturing point of view? Would you be prepared to market it?"

A most probable answer would be something on these lines:

Round the World with the "I.E." Three

A FIRST glance at the title of this article might suggest it was going to be something in the nature of a "travelogue." New readers especially might suppose that "Round the World with the 'I.E.' Three" inferred that I had packed the set up and taken it on board ship with the idea of giving an account of its performance while on a world-tour.

Actually, of course, such an attractive programme as that was quite out of the question. For one thing it was in only last month's issue (November) that the set was first described, and even Post and Gatty could hardly have gone round the world and described it in the interval!

Collecting Continents

Nevertheless, the title of this article does mean something quite exciting, for it deals not with my travels, but with your own. And its purpose is to assist you to find your way to America, Africa, the East Indies, perhaps to Australia—by radio.

In last month's issue of the WIRELESS CONSTRUCTOR there was not sufficient space to deal as fully with the "I.E." Three as that remarkable set deserved. In fact, after its construction was described there was room for only the barest details of operation and performance.

This month we can take a more leisureed look at the set. And as there is already evidence of enormous interest in it, I should like to take the opportunity of saying a preliminary word about how it works.

Particularly Interesting Features

Being the very first three-valver of its kind ever evolved, it presents many features that have evoked special interest.

Several readers, for instance, have queried the absence of a pick-up switch, and wondered how the change-over to gramophone reproduction is made without one.

Others are not clear about the wave-lengths covered. They fancy they ought perhaps to pull out a



Builders of the magnificent set described in last month's "Wireless Constructor" will be glad to read these practical operating hints and the details of final adjustments for getting maximum results.

By VICTOR KING

switch, or a coil or something, when changing from medium to short waves. So let us follow an imaginary programme on its journey through the "I.E." Three.

We will suppose that the time is 10.15 p.m., and that the programme

in question really started out from East Pittsburgh, U.S.A. Owing to world-time differences it will be 5.15 p.m. there, and the KDKA announcer will be saying: "You will now hear a tea-time programme of music from KDKA, East Pittsburg, the Pioneer Broadcasting Station of the World, working on 25.25 metres."

Wonderful Carrying Power

As you are aware, those short-wave stations have wonderful carrying power, and it is quite possible that on a good night your aerial will have in it

GETTING THE MAXIMUM SENSITIVITY

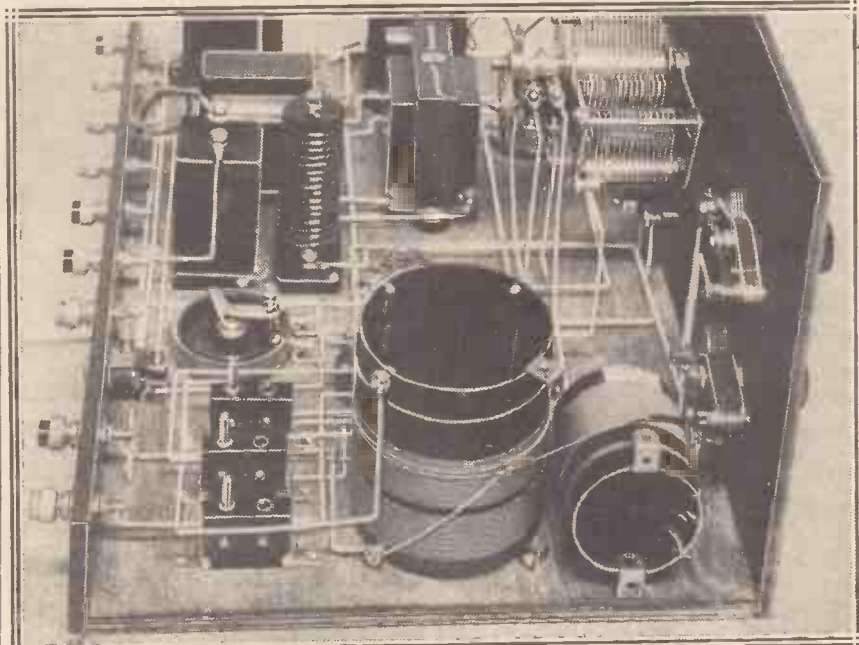

The potentiometer can be set to just that right value to give the very smooth and reliable reaction which is so valuable for fetching in the far-away stations.

Round the World with the "I.E." Three—continued

a small but sufficient high-frequency current coming from K D K A, and carrying the impress of those words. How will the "I.E." Three deal with it?

Let us glance at the fascinating process. One end of the aerial is fixed to a short-wave aerial coil, and the current flows through this, along the wire to the Extenser self-changer contact and across it to the movable spindle, and so to earth.

Effective Magnification

In flowing through the coil it sets up another and exactly similar current in the adjacent grid coil, which, being tuned by the Extenser connected across it, responds readily. And as one end of the coil-and-condenser combination is joined to the detector's filament, and the other end (via the grid condenser) to its grid, the detector valve starts to take a hand in the proceedings.

Every voltage variation across its grid-filament electrodes causes similar (but enlarged) variations in the detector's plate circuit. And as there is an H.F. choke barring the way in one direction, current starts to flow between filament and plate via the reaction-condenser and reaction-coil route.

Owing to the feed-back between the reaction coil and its adjacent grid coil, the original weak impulses are "helped along" by this reaction, and become strong enough for the valve to detect.

As soon as this happens the low-frequency stages get to work. Impulses corresponding to the speech-frequencies flow through the first low-frequency transformer, which passes them to the next valve's grid and filament for amplification.

America on the Speaker

Here the process is repeated, and the second L.F. transformer hands out appreciable voltages to the last valve. And this, in turn, operates the loud speaker which announces clearly and unmistakably that "You will now hear a tea-time programme of music from K D K A, East Pittsburg, the Pioneer Broadcasting Station of the World, working on 25.25 Metres."

Described in that way it all sounds extremely simple. doesn't it? And that is how you will feel about the "I.E." Three when you get used to

it, for it is one of the simplest sets to handle that can be imagined.

We will return to the subject of successful short-wave reception in a moment, but first let us see how a turn of the dial cuts out the short waves and brings in your local station or Continentals instead.

No Bothersome Switches

There is no coil-changing to do and no bothersome switches. You simply turn the dial of the Extenser and at the appropriate point its self-changer contacts come into action and dis-

has brought a medium-wave reaction winding into action.

Thus the mere turning of the dial swings the set over either of the wave-bands, making all the necessary circuit changes without fail and without fuss. No wonder the "I.E." Three has caught on.

Now let us examine each of the controls separately and see how the maximum efficiency can be obtained in handling it. The Extenser, as we have seen, looks after all the actual tuning, and no more need be said about it except a passing tribute to

SIMPLIFIED "SWITCHING" FOR THE RADIO-GRAM

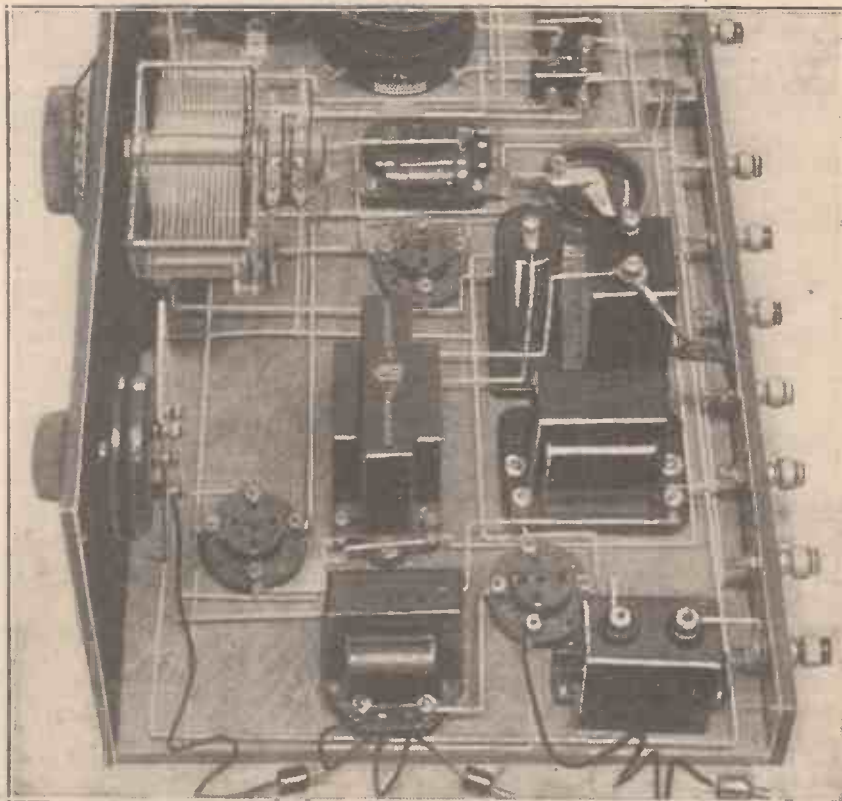

After the pick-up has been connected its jack can be left in place if desired, the necessary change-over to radio being smoothly carried out on the "fader" volume control.

connect the short-wave coils from the moving spindle.

The tuned circuits are now quite different, and the set is tuned to ordinary wave-lengths. Currents from the aerial, finding no pathway direct from the short-wave coil to earth, are compelled to flow through the selectivity condenser and aerial winding of the P.J.2. Here they are linked with the grid coil, and this is tuned by the Extenser to medium waves, while at the same time the third Extenser self-changer contact

its smooth and silky action, and to its efficient change-over from one wave-band to the other.

Close Selectivity Control

To the left of it are the reaction (top) and selectivity controls. The latter is out of action on short waves (dial readings below 100), but on medium waves gives maximum selectivity when the vanes are all-out, and maximum strength when all-in. You will soon get the knack of setting it correctly for the various

Round the World with the "I.E." Three—continued

YOUR SHOPPING LIST FOR THE "I.E." THREE

- | | |
|--|--|
| <p>1 Panel, 16 in. × 8 in. × $\frac{1}{8}$ in. (Wearite, or Permcot, Becol, Red Seal, Goltone).
 1 Cabinet for above panel size, with baseboard 10 in. deep (Camco, Pickett, Gilbert, Osborn).
 1 '0005-mid. Extender with slow-motion drive. Note that slow-motion drive for this particular set is essential. (Wavemaster, Cydon, Formo, J.B.).
 1 '0003-mid. ordinary-type reaction condenser (Ready Radio, or Telsen, Lotus, Polar, Graham Farish).
 1 '00075-mid. "Brookmans" type solid-dielectric variable condenser (Ready Radio, Polar).
 1 L.T. on-off switch (Telsen, Ready Radio, Bulgin, Junit, Goltone, Lotus, Igranic, Wearite, Graham Farish).
 1 1-megohm fader-type volume control. This enables the set to be changed over from radio to pick-up without switching. (Magnum, A.E.D.)
 3 Baseboard-fixing plug-in coil mounts (Lotus, Igranic, Bulgin, Red Diamond, Wearite).
 3 Sprung-type valve holders (Telsen, Wearite, Lotus, Bulgin, W.B., Graham Farish, Burton).
 1 '0003-mid. fixed condenser (Dubilier, or Telsen, Mullard, T.C.C., Igranic, Graham Farish, Lissen, Ediswan).
 1 Grid-leak holder (Wearite, Graham Farish, Telsen, Varley, Watmel, Ediswan, Igranic, Lissen, Mullard).</p> | <p>1 2-megohm grid leak (Dubilier, etc.).
 1 400-ohm baseboard-mounting potentiometer (Sovereign, Igranic, Lissen).
 1 H.F. choke. This must be of the universal type suitable for all waves from 20 to 2,000 metres. (Lewcos, R.I. Varley, Wearite, Graham Farish, Peto-Scott, Sovereign, Ready Radio).
 2 2-mid. condensers (Formo, T.C.C., Dubilier, Mullard, Igranic, Helsby, Telsen, Lissen, Ferranti).
 2 L.F. transformers of fairly low ratio (R.I. General-Purpose, Lotus, Telsen, Igranic, Mullard, Lewcos, Lissen, Varley, Ferranti, Graham Farish).
 1 L.F. output choke (Ferranti, Igranic, Varley, E.I., Wearite, Bulgin, Lissen).
 1 P.V.1 coil and one P.J.2 (Lewcos, R.I., Parex, Peto-Scott, Formo, Wearite, Goltone).
 1 25,000-ohm "Spaghetti" resistance (Telsen, Ready Radio, Bulgin, Varley, Igranic, Magnum, Lewcos).
 1 Pick-up jack and plug (Bulgin, Igranic, Lotus).
 9 Engraved-type terminals (Belling & Lee, Eelex, Igranic, Clix).
 Strip of ebonite, 16 in. × 2 in. (for terminal strip).
 3 Wander plugs for G.B. leads (Igranic, Eelex, Belling & Lee, Clix).
 Glazite, Lacoline, Quickwire (for wiring).
 Flex, screws, etc.</p> |
|--|--|

degrees of selectivity required for different stations.

Above it is a more important control—reaction. This operates on both wave-bands, and is a very important adjunct to good long-distance reception on both. Set it "all out" for strong local-station reception, but use it knowingly for foreigners.

For the very weak stations it must be increased to the point where the set is nearly—but not quite—oscillating. And it should come into action smoothly and sweetly, with no "plop" and no overlap.

This smooth control of reaction is necessary for medium waves, but for the very weak and distant short-wavers it is absolutely essential. It is for this reason that the potentiometer is provided.

Perfect Reaction Control

If you set the slider round towards the positive end (that end connected to the switch) you get maximum sensitivity. But sometimes this is accompanied by "ploppiness" of reaction, in which case push the slider to the position shown in last month's wiring diagram. Also try a few volts more or less on H.T. + 1, if possible.

If necessary the slider should be pushed still farther round towards its negative terminal, until the ploppiness is cured. You cannot get good long-distance reception unless reaction is really smooth, and the potentiometer with accompanying H.T.

alterations should enable you to adjust it perfectly.

The remaining control on the panel is the "fader," and when searching for weak stations this should always be hard over, with its slider resting against the No. 1 terminal which is joined to G. on the transformer. Generally speaking, keep it in this position when reaction is being used, but for loud stations requiring no reaction

it can be slacked back as required.

Turning it back past the half-way position brings the pick-up volume control into play, and when gramophone records are being reproduced electrically the volume is adjusted as required for the particular record being played.

Wonderful Versatility

Throughout this article I am assuming that the set has its short-wave coils plugged in; but, of course, long-wavers could be employed instead if desired.

But I would like to point out to those who wonder which is better—a long-wave or a short-wave set of coils—that for sheer value for money and interest, short waves are best.

However, the set enables you to have medium waves with either long or short as well—in fact, it tunes to virtually every station worth hearing in the world.

Add to this its ease of operation, its adjustable selectivity and its very reasonable cost, and I think you will agree that no matter where you look, nor how much you pay, you will have a job to procure a set of such sheer satisfaction and many-sided merits as the "I.E." Three.

CONCENTRATED EFFICIENCY IN TUNING

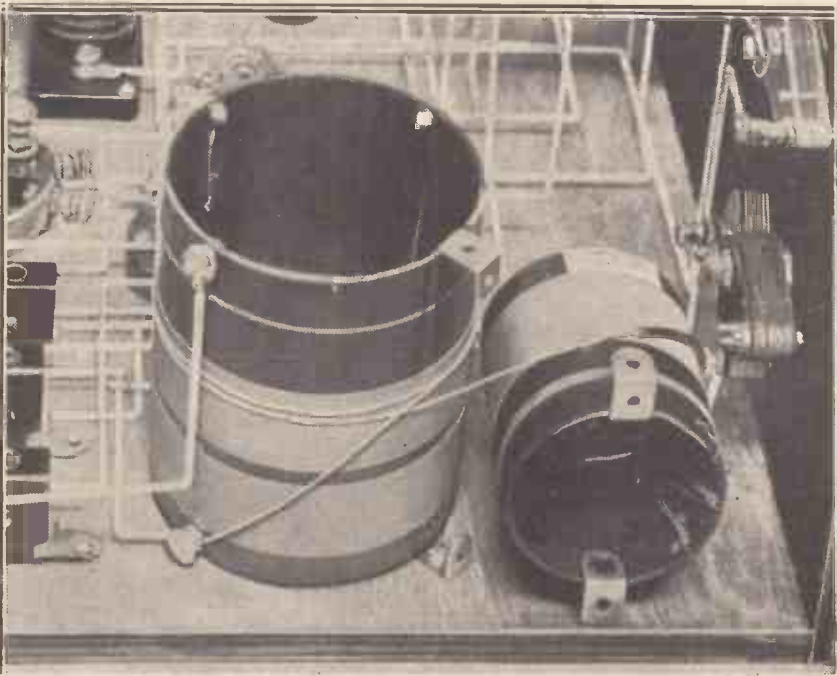

Here are the medium-wave coils in position, with the other coil sockets waiting to receive either long- or short-wave coils. The "I.E." Three is the first "three" ever designed to cover ordinary and short waves without coil-changing or switching.



The "DOUBLE-TONE" CONE

A very interesting constructional article which tells you how to make a really good quality loud speaker.

By H. T. SAVAGE.

In my experiments with numerous moving-iron units, which is the not very euphonious appellation which we may give to the ordinary cone loud-speaker unit, I have had it borne in upon me that it is scarcely fair to expect that a single unit will have the merits of all.

A Splendid Idea!

Some units, in fact many, are excellent on the high and middle registers, whilst there are others whose strong point is the emission of bass. It is extremely interesting to employ two units simultaneously, of widely differing characteristics.

I have for long used two speakers with this end in view, with gratifying results to myself and those of my friends gifted with musical ears.

I have constructed a cabinet containing two units, and the photographs of the back and front give a general idea of the construction. As will be seen, the units are mounted on separate wooden beams, which are screwed into the sides of the cabinet.

The cones, of cartridge paper, are 13 in. in diameter. The top one is mounted on $\frac{3}{4}$ -in. square section sponge rubber. This is a favourite mounting of mine.

It is very resilient, and has the advantage that it can be placed out of sight behind the baffle board, and nothing is seen from the front except the cone. The lowermost cone is mounted on strips of sheet rubber.

Cabinet Construction

The framework is of $1\frac{1}{4}$ -in. square wood, and its sides, baffle board and fret are of plywood. The size of the cabinet, 41 in. high, 26 in.

wide, and 14 in deep, is the least that, in my opinion, will give an adequate baffle-board effect. A space of at least a $\frac{1}{4}$ in. should separate the fret from the baffle board, to avoid any chance of vibration occurring.

A piece of gauze is glued by its edges to the back of the fret. If the cones, with the mounting, are given a water-stain similar in colour to the baffle board, they will not show through the gauze.

Preventing "Box Resonance"

There is no objection, acoustically, to making the cabinet larger. The back should not be boarded in, neither

INSIDE THE CABINET

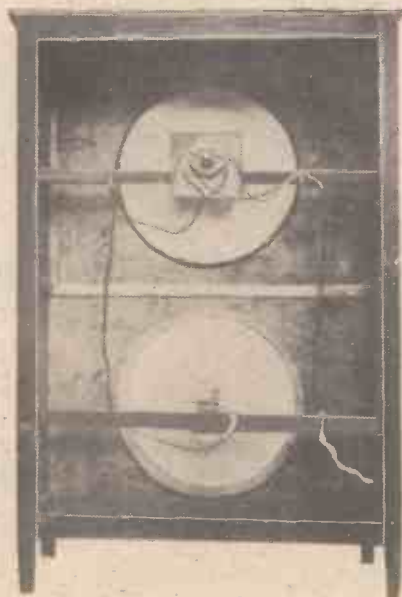

Here is a back view of the finished instrument showing how the two separate loud speakers are mounted one above the other.

is it necessary to place a complete shelf in the bottom.

To close it in entirely would be to court "boxy resonance." A piece of silk may be tacked across the back.

I have placed the high-note unit in the uppermost portion. There are, as I have said, a number of units which will do well in this position.

For the lower cone I have placed a unit which is remarkably strong on the lowest register. Two units of widely-differing characteristics give a wonderfully realistic reproduction of such a transmission—for example, as the Queen's Hall Orchestra—and I would not willingly return to the use of a single speaker—at any rate, for the reception of music.

Series or Parallel?

With my own set I find that I get the best results with the units connected in parallel; with other sets and units it may be that better results will be obtained by joining them in series.

The change-over is quickly made, and, the point once settled, the leads may be taken to a pair of terminals inserted in one of the sides of the speaker. If the high notes are too much in evidence, a fixed condenser across the terminals will tend to reduce them.

As to any objections that may be made as to the size of the cabinet by the ladies of the household, you must remember that the loud speaker is a musical instrument, and, anyhow, it is not so big as a piano!

*
* **A SUNDAY SURPRISE!** *
* Reader gets America first time! *
*

Sir,—May I also thank you for the "Kelsey" Adaptor. Unable to get all the parts required, I made a rough screen from an aluminium hot-water bottle, a Vim carton for coil former, and my tie-clip for alligator clip. Being Sunday night, I made it up roughly in about an hour, using flex to wire it (twisted joints). Imagine my surprise when I received Moscow straight away, and W 2 X A F at loud-speaker strength, and since I have logged Rome, W 8 X K, W 3 X A L, Lisbon, Vatican City, Eindhoven, Zeesen, and dozens more I can't identify. Wishing you every success.

Yours truly,
A. G. RICE.

Weymouth



THE B.B.C.'S NEW NOISES

WILL the B.B.C. make regular use of talking films for sound effects in connection with radio plays?

I am tempted to ask because, talking the other day to a man who is responsible for the wind, thunder, door-slamming, trains and church-bells which adorn most wireless plays, I learned how thoroughly "canned" effects have taken the place of effects made on the spot.

Always "On Tap"

There was one noise in the play *Mary Celeste* which seemed rather tricky to produce manually, and I asked this "effects" man how it was done.

"It wasn't 'faked,'" he said. "It was a gramophone record of the real noise, switched on at the right moment in the play. We have several of these records."

But that wasn't all.

One of the "effects" men has seen the film recorder used by the American G.E.C. at Schenectady, and the B.B.C. may try it. Real noises used in wireless plays are recorded on the film—which has no picture side, but only the sound track—and this is run through a small projector having a sound "gate" when the noise is needed in the programme. This has many advantages over gramophone records.

"Canned" Cackles

"At Schenectady recently," said the "effects" man, waxing enthusiastic about the film system, "a man who was to give an advertising talk on poultry wanted to add realism by bringing a few hens to the studio and letting their cackling be heard as a background to his talk.

"The station official refused this, but said that he might let the hens be recorded on the film and allow this to be run through with the talk. The microphone was connected to the

The Radio Play officials have dropped the old way of creating effects for plays, and special new gramophone records and talking films are being tried, as explained.

By a Special Correspondent.

sound recorder, and as the chicken cackled a film was made.

"Some difficulty was found in making the record, as the chicken found the studio surroundings somewhat strange, and developed microphone fright. In attempting to get them to cluck in natural fashion one of the control men shushed them. This film, after developing, was ready to be reproduced as

a background for the speaker. "When the film was run through, however, it sounded like the midnight raid on a hen roost! Corn placed about the microphone was next resorted to.

"However, when the film was reproduced the rapid pecking sounded like a tap dance. The problem was solved by scattering the corn on a felt mat.

A Large Selection

"But still," said the B.B.C. man, "if we had the film system as a regular thing we could probably do without hen noises!"

It is rather surprising, though, what a large number of noises have been recorded by the B.B.C. The "effects" man went on to tell me of

ARTIFICIALITY PROVIDES SURPRISING REALISM!

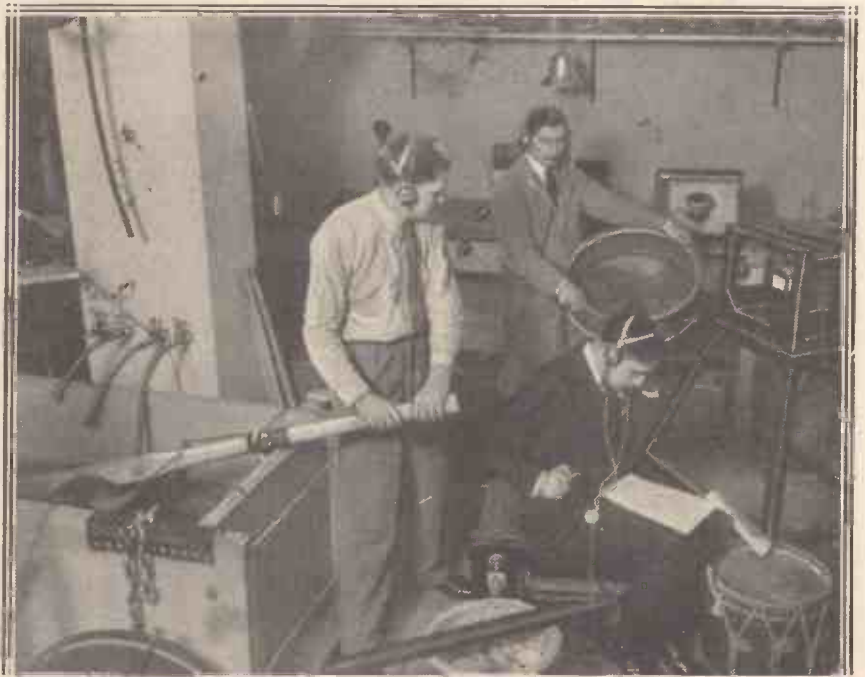

Rehearsing the noises for "The Wrecker" in the Savoy Hill Effects Department. At one time the B.B.C. used to go to great lengths to collect as many real noise effects as possible, but they soon found that in many cases greater microphone realism was given by purely "artificial" sounds. Now, however, a natural noise technique is being developed on new lines.

The B.B.C.'s New Noises—*continued*

records made at Oxford Circus for a recent radio play in which lift, escalator and electric-train noises were needed.

On the "Underground"

The noises could have been "hand-made," but the B.B.C. took the easier course of having a permanent record made of the real thing. For a few days some of the engineers of the Outside Broadcast Department and a gramophone concern monopolised special trains, lifts, and escalators at Belsize Park, Oxford Circus, and other of the larger stations.

Practically every noise connected with the Underground was put on record—the clicking of lift gates, the moaning of the lifts going up and coming down, the thumping of the escalators, and the roaring of the trains, and the general noise of the bustling passengers at rush hours.

An Early Morning Job!

Most of the "permanent noises," such as those made by the lifts, escalators, and so on, were recorded in the early hours of the morning, and a disused lift at Oxford Circus housed the receiving apparatus for some time.

Crowd noises had, of course, to be captured at the busy time of the day.

Nor was this any too easy, for a microphone, unfortunately, does not listen in the same way as the human ear.

All kinds of echoes in places such as the Underground, which the ear tones down, are unnaturally accentuated by the "mikes." The only way to cure this was by using two or three microphones judiciously placed, and balancing up the output from each before recording.

Several Snags

Another snag encountered was the liability of the microphone to be affected more by the mechanical vibration than by the sound waves it was desired to capture. With the special type of microphones used by the gramophone people this trouble was not serious, but still it had to be watched.

A long time was spent in getting realistic microphone impressions of an Underground train starting up on full load, of the noise caused by its cargo of conversing passengers, and of the grinding of the brakes as the train came to a standstill.

Some of the scraps of noise picked up in this way were certainly not suitable for permanent recording! This was more especially so because

none of the passengers were informed that a stunt was on hand.

When you consider that it is almost impossible to work a portable set in the London Underground, owing to the electrical interference picked up by the low-frequency stages of the amplifier, it is all the more to the

NEW FILM SYSTEM



A talkie film apparatus is used by an American station in connection with its noise effects. Readers will remember that the B.B.C. has broadcast the sounds from talkie films and that these came over very well.

"THE THUMPING OF THE ESCALATORS"



The O.B. Department has made permanent records of the various noises heard on Underground Railway stations.

credit of the B.B.C. and gramophone engineers that such good radio noises were "bagged."

Without proper L.F. shielding and fully protected leads from the microphones to the sound-recording apparatus and from the amplifiers to the accumulator banks, hum would have been picked up from the Underground Railway power supply.

A Difficult Business

Balanced-armature electro-mechanical gramophone-record cutters are sensitive things, and to operate them and their associated multi-valve amplifiers in the intense interference fields present within a few feet of an electric-train power supply takes *some* doing.

Personally, I shall hear with greater patience now when I hear the howling of the wind in a wireless play. I shall think not of the man who used to rub sheets of paper near the microphone, but of the unhappy band of engineers who went out in a real storm to make a record of this particular noise!



The "DUO-VISE" TWO

By A. JOHNSON-RANDALL

This receiver is something entirely "different" in the way of set designs. Nevertheless, it is unusually efficient and no sacrifices are made in order to achieve the unique form that it takes.

A SHORT while ago a friend said to me: "What is your ideal home receiver?" I at once replied: "A set that will give me the choice of alternative programmes at the touch of a switch; a set that doesn't require constant adjustment; and, moreover, a set which can be operated by any member of the family, however unskilled he or she may be."

Wanted by Thousands

And I honestly believe that in this respect my ideas must be similar to many thousands of listeners. I know the fascination of being able to tune-in distant continental transmissions at will, but I also know how unsatisfying such reception can be, except perhaps as a brief interlude in an evening's entertainment; but, at the same time, I like to know that my set is capable of "reaching out" when required.

So, in the "Duo-Vise" Two I feel that here at last is a local station set which most nearly approaches the ideal for family use, because it fulfils all the above requirements—and more.

Let me tell you something about it! In the first place the design is entirely novel and distinctive. The cabinet is somewhat unusual in shape without in any way being freakish. There are certain definite advantages in this. For instance, it is a cabinet which any handyman can make for himself, easily and inexpensively.

Striking Signal Lights

There are no awkward crevices to harbour dust, and the flap on the front enables the set to be kept closed up even when working.

Then just above the controls there are two little signal lamps, and these tell you to which station you are listening.

One lamp represents the National and the other the Regional, so that

when the switch is "over" for the National the right-hand lamp will light and vice versa.

So you see there is never any doubt as to which of the two stations you are listening. Moreover, the fact that one of the signal lights is glowing shows that the set is "live"; hence you cannot leave it on by accident when the broadcasting is finished.

On the control panel there are two

knobs and a tuning dial. The knob on the left is the station selector. In one extreme position you are tuned to the National and in the other the Regional. When the switch is in the middle position the set is "off."

Interference Prevented

When you switch over to the Regional the National transmission is automatically "trapped" and

AN EASY SET TO BUILD

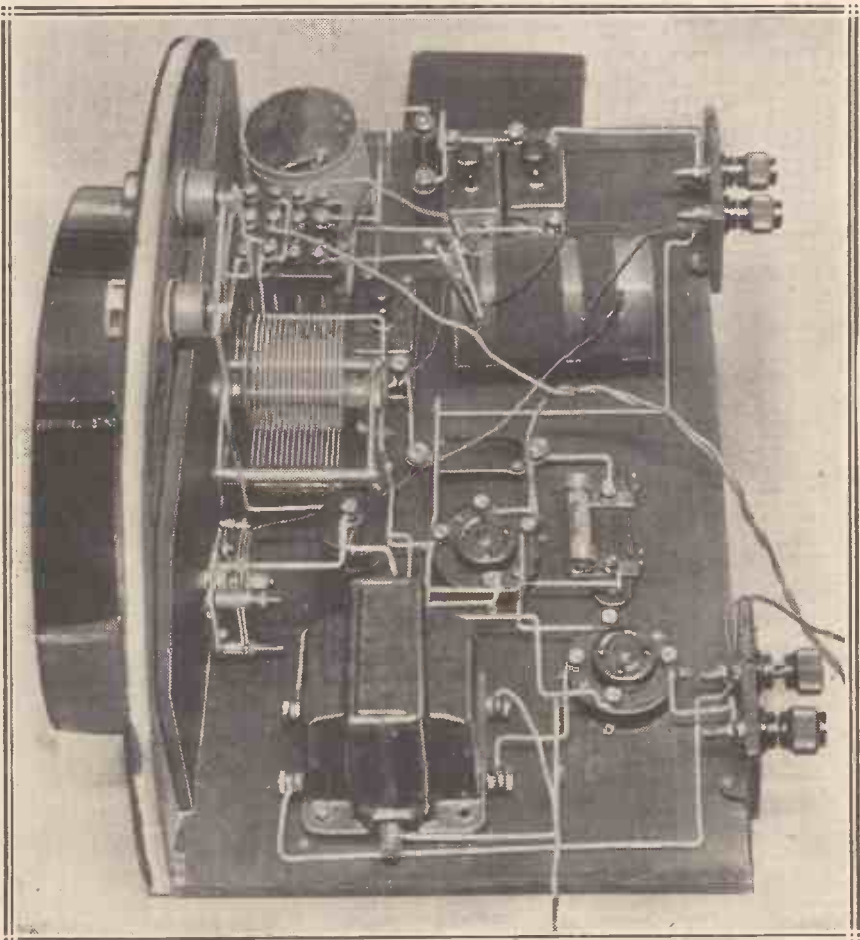

There are no complications in the construction of the "Duo-Vise," and the metal visor and front flap are quite simple items.

The "Duo-Vise" Two—continued

therefore cannot break through and interfere with the programme. In the same way the Regional is cut out when the switch is set for the National programme.

Those who reside within the "swamp" area of Brookmans Park, or one of the other B.B.C. Regional transmitters, will appreciate this.

Distant Stations as Well

But possibly you may wish to do a little searching some evenings when the programmes do not appeal to you. Very well, then, in these cases the receiver can be used in the same way as any "straight" two-valver simply by rotating the tuning dial and applying reaction in the usual manner.

And so here is a two-valve receiver combining all the advantages of pre-selection with those of range and selectivity. It is easy to build, inexpensive in first-cost and upkeep, and absolutely reliable.

HOW TO CUT THE PANEL

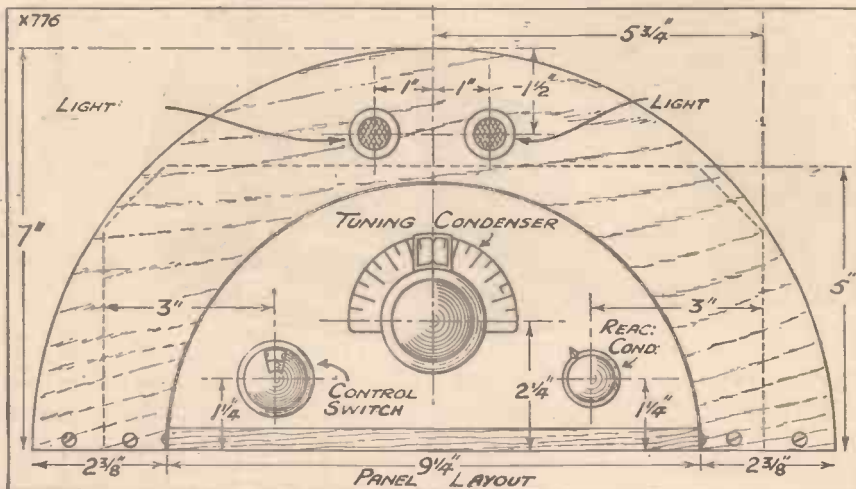

This drawing clearly shows the vital how-to-make details concerning the front of the set.

Now I would like to say something about the construction of the set.

If you glance at the photographs

and the wiring diagram you will notice that the panel does not run the whole length of the baseboard, and that the two signal lamps are attached to the cabinet front and not to the control panel.

Perhaps we had better deal with the panel first of all. This is a sheet of ebonite, 11 1/2 in. by 5 in., and cut diagonally at two corners. The reason for this is self-evident. These corners must be removed in order to accommodate the panel to the cabinet. If they were permitted to remain they would project beyond the semi-circular wooden front of the cabinet.

There are three components on the panel itself, and these are the reaction condenser, tuning control, and the control switch.

Only Five Holes

Mark off the panel to the dimensions given in the panel layout diagram and then carefully drill the three holes for the components. Drill also two more holes for the fixing screws which secure the panel to the baseboard.

It is advisable to countersink these so that the screw heads are flush with the panel face. This is important, as you will see when you commence to build the cabinet round the set.

The panel will now be ready for securing to the baseboard.

Right! Take the baseboard and make two marks each 2 3/8 in. from either end, and then cut a slot 9 1/4 in. in length and equal in depth to the thickness of the panel.

You see the idea? This is so that

"TWO-WAY" STATION ELIMINATOR

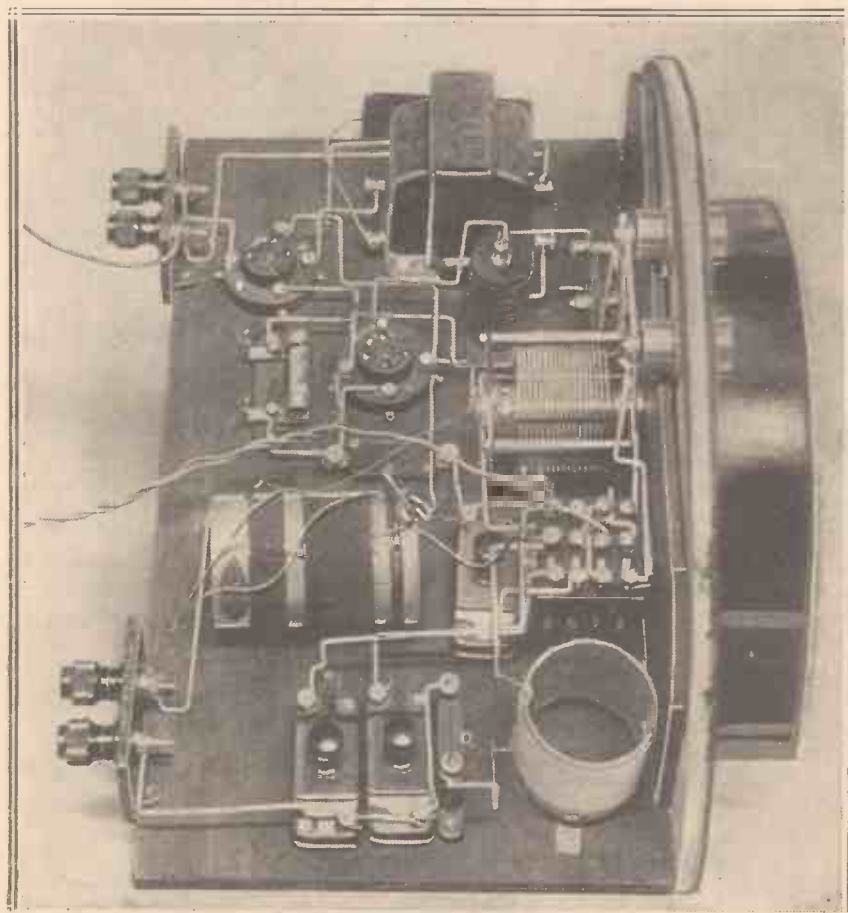

As you switch over from one station to the other, either of two interfering transmissions is entirely suppressed.

The "Duo-Vise" Two—continued

the panel will be flush with the edge of the baseboard.

Screw the panel to the baseboard and mount the three controls in position.

After this, screw the two terminal blocks to the back edge of the baseboard and you are ready to commence the baseboard layout.

The Wave-Trap Coil

On the right-hand side of the set (looking at the back) is the rejector coil, which you can easily make yourself.

It consists of a former of any good insulating material, such as Pirtoid,

THE FINISHING TOUCH

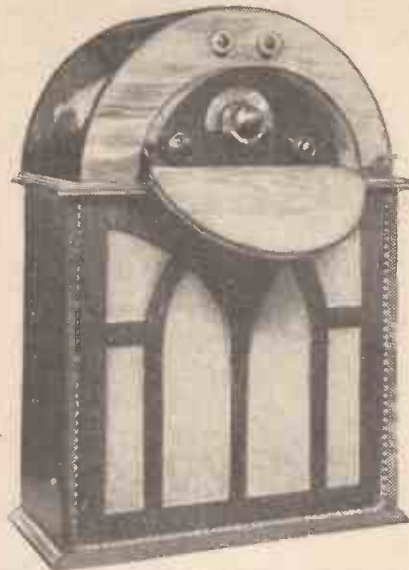

The "Duo-Vise" can stand on almost any cabinet speaker, and assume a most distinctive appearance.

Paxolin, ebonite, etc., 2 in. in length and 2 in. in diameter. The coil is a simple single-layer winding of 50 turns of No. 24 gauge D.S.C. To wind the coil, make two holes in one end of the former and pass the wire through the holes two or three times, leaving a short length for connecting-up purposes. Then wind on the 50 turns, taking the end of the wire through two more holes in the former so that the coil cannot come unwound.

Method of Connecting

One end of the coil is joined to a .001-mfd. fixed condenser and the other to the middle end terminal on

USE THESE PARTS—

To build this set you will require :

- 1 Panel, 5 in. × 11½ in. (Permcot, Goltone, Lissen, Parex, Wearite).
- 1 Baseboard, 14 in. × 8 in. × ¾ in., and material for special cabinet (see text).
- 1 .0005-mfd. variable condenser (J.B., Cyldon, Polar, Lotus, Ready Radio, Telsen, Formo, Astra, Graham Farish).
- 1 .0001-mfd. reaction condenser (Lotus, Ready Radio, Polar, Dubilier, Cyldon, Telsen, Graham Farish, J.B.).
- 1 4-pole change-over switch, panel-mounting type (Wearite, Utility).
- 2 .001-mfd. max. compression type condensers (Telsen, Goltone, Formo, Polar, Lewcos, R.I., Igranie, Sovereign, Graham Farish).
- 1 .0003-mfd. max. compression condenser (Telsen, or see above).

- 1 P.J.1 coil (Peto-Scott, Goltone, R.I., Wearite, Parex, Ready Radio, Formo).
- 2 Valve holders (Graham Farish, Telsen, Igranie, Lotus, Bulgin, Formo, Wearite, Lissen, W.B.).

- 1 .001-mfd. fixed condenser (T.C.C., Telsen, Dubilier, Ferranti, Igranie, Goltone, Graham Farish, Formo, Ediswan).

- 1 .0003-mfd. fixed condenser (Dubilier, or see above).

- 1 2-megohm leak and holder (Lissen, Dubilier, Telsen, Ferranti, Graham Farish, Ediswan, Igranie).

- 1 H.F. choke (Ready Radio, Lewcos, Telsen, Peto-Scott, Dubilier, Lotus, Varley, Atlas).
- 1 L.F. transformer of medium ratio (Telsen Radiogrand, Igranie, Ferranti, R.I., Goltone, Lotus, Lewcos, Varley, Atlas).
- 2 Panel lights (Bulgin, Ready Radio).
- 2 2-terminal blocks (Belling & Lee, Sovereign).

—FOR YOUR "DUO-VISE"

- 1 Crocodile clip (Bulgin, Goltone).
- 4 Engraved-type terminals (Belling & Lee, Igranie, Clix, Bulgin, Eelex).
- Glazite, Lacoline, Quickwire, or Jiffilix, for wiring. Flex, screws, etc.
- Battery plugs (Belling & Lee, Clix, Igranie, Eelex).

MATERIAL FOR TRAP COIL :
Former, 2 in. diameter and 2 in. long.
1 oz. of No. 24 D.S.C. wire.

ACCESSORIES

Loud Speaker.—(Amplion, Celestion, B.T.-H., Blue Spot, Undy, Mullard, W.B., H.M.V., Graham Farish.)

Accumulator.—Voltage to suit valves. Capacity about 20 amp. hour actual or more (Exide, Pertrix, G.E.C., Lissen, Ediswan).

Mains Unit.—With suitable output (Hayberd, Lotus, R.I., Atlas, Tannoy, Ekco, Regentone, Tunewell, Formo).

H.T. Battery.—120 volts (Ever-Ready, Drydex, Pertrix, Magnet, Ediswan, Lissen, Columbia). 1 G.B. battery, 9-15 volts, to suit output valve.

Valve.—One detector, and one small power type (Mazda, Cossor, Osram, Mullard, Eta, Marconi, Six-Sixty, Fotos, Tungram, Dario, Lissen).

A MULTI-PURPOSE AUTOMATIC CHANGE-OVER

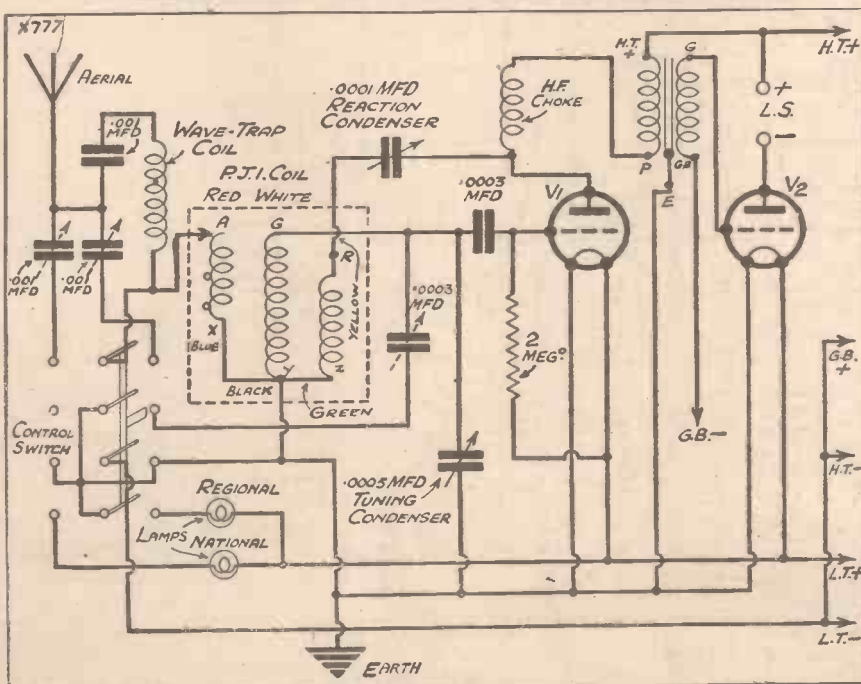

The receiver can be pre-set to any two stations, and either immediately brought in at any future time by a flick of the control switch. At the same time the other station is "trapped" and an identifying panel light springs into view.

The "Duo-Vise" Two—continued

the control switch (see wiring diagram).

When you have completed the wave-trap coil you can go ahead with the baseboard layout, keeping

the components as near as possible to the positions shown in the photographs and wiring diagram.

Don't forget that the P.J.1 coil is placed with its aerial winding (the small

winding) nearer the control switch.

As soon as this job is finished and all the components are screwed down to the baseboard you can start the wiring up.

YOUR GUIDE TO THE "DUO-VISE" WIRING

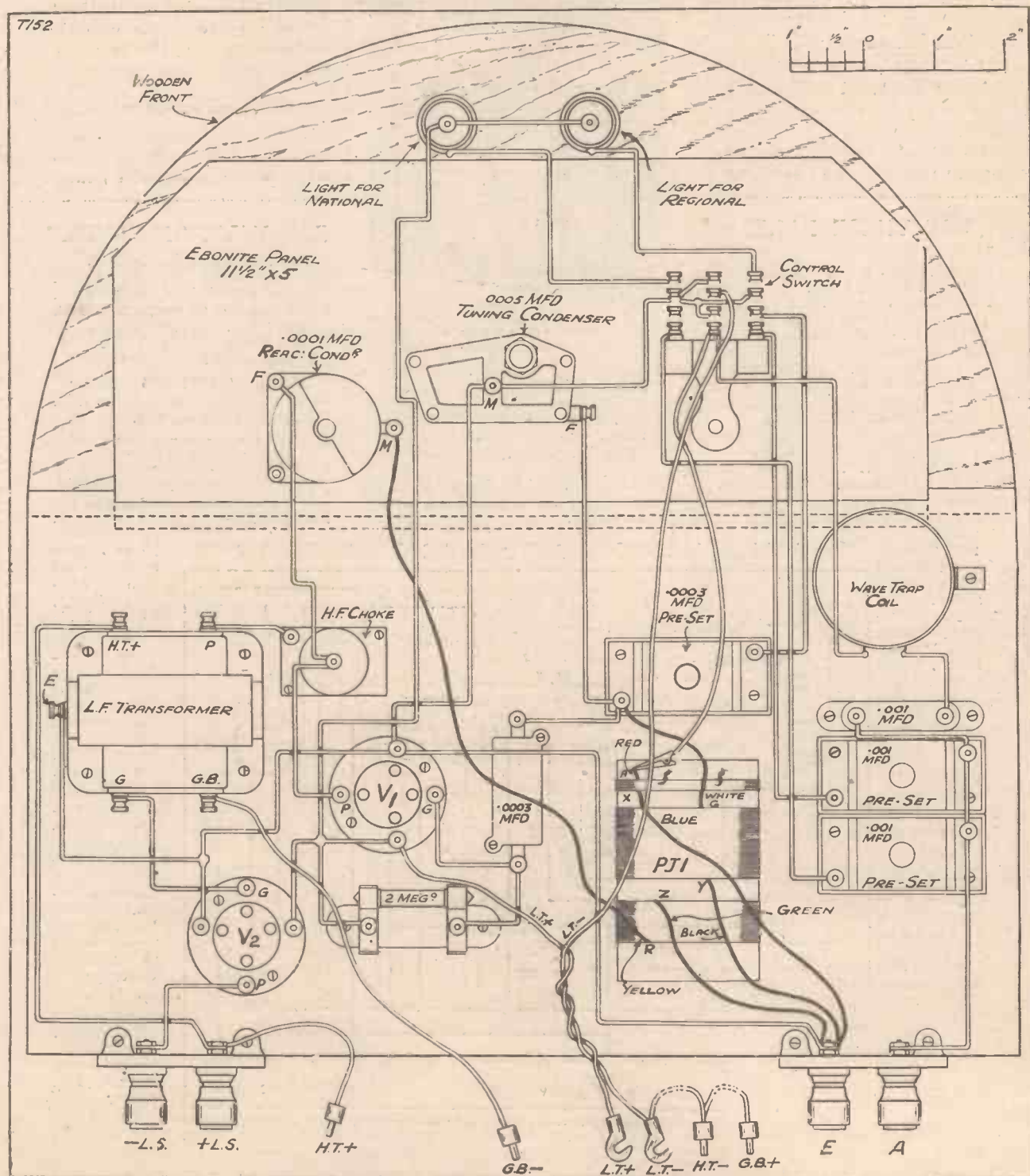

As you can see, the wiring is a perfectly straightforward business

The "Duo-Vise" Two—continued

Follow the wiring diagram very carefully, completing the wiring with the exception of that which goes to the two signal lamps.

coil on the red tapping (A) tune in the National transmission.

To cut out the Regional, adjust knob on the compression condenser

you hear the Regional transmission at its greatest volume.

Then to cut out any interference from the National which may be heard in the background adjust the knob on the second wave-trap pre-set condenser. (The one on the right-hand end of the baseboard between the pre-set condenser near the aerial terminal and the .001-mfd. fixed condenser.)

THE "WIRELESS CONSTRUCTOR" "DUO-VISE TWO"

Circuit: Detector and 1 L.F. with automatic station-change.

ADJUSTMENTS.

Adjust pre-set condenser nearest back right-hand end of baseboard to cut out Regional transmission. Tuning control should first be set to receive National at maximum volume, and control switch should be rotated anti-clockwise.

Place control switch in clockwise position and rotate knob on .0003-mfd. pre-set condenser to tune in Regional, with tuning control set for National as before. Adjust pre-set condenser next to .001-mfd. fixed condenser to eliminate National.

Try crocodile clip on P.J.1 coil tapings until best results are obtained. Red tapping gives greatest volume.

OPERATION.

Control switch rotates anti-clockwise for National. Clockwise for Regional. Middle position for switching off set. Right-hand knob is reaction control. Turn clockwise to increase volume.

VALVES.

H.L. or special detector type for 1st position, power type for 2nd position (nearer terminals).

VOLTAGES.

H.T., 120 volts. Grid bias to suit power valve.

Everything Ready

You are now in a position to switch backwards and forwards from the Regional to the National transmissions without any adjustment on the tuning control.

Of course, you can use the reaction control during the preliminary adjustment if this should be necessary in order to bring up the strength a little.

If more selectivity is required the crocodile clip may be tried on one of the other tapings on the P.J.1 coil.

To use the set as an ordinary two-valver for distant-station reception the control switch should be placed in the National position, but before you alter the tuning dial remember to make a note of the setting for the National transmission.

You will not be able to do this until you have cut the cabinet front.

The front of the set is simply a semi-circular piece of wood—stained white wood or plywood if you wish—cut to a circle having a radius of 7 inches.

A second semi-circle is cut in the wood on a radius of $4\frac{5}{8}$ inches in order to accommodate the control panel.

Now you must cut out this second semi-circular piece of wood with care, because it will be used as a flap for closing up the control panel.

Around the inside of the circular opening for the control panel is a strip of metal, which you can paint to suit your own particular taste.

Completing the Construction

The strip used in the original set was a piece of thin copper 2 in. in width. A screw is passed through each end of this strip to take the wooden flap, which is arranged to fit snugly into the inside outer edge of the strip.

Thus the flap can be opened outwards, or closed, as required, the two screws through the strip acting as a hinge.

A second semi-circular piece of wood has to be cut for the back, and the cabinet completed by placing a length of copper sheet over the tops of the two pieces of wood forming the front and back of the cabinet.

The metal can be painted to match the woodwork.

To adjust the wave-trap rotate the control switch anti-clockwise, and with the crocodile clip for the P.J.1

nearer the aerial and earth terminals. The final setting is, of course, the one which gives freedom from interference.

Next rotate the control switch clockwise, passing through the central position, which switches the set "off." This is the position for the Regional.

Leave the tuning control set as before for the National and adjust the .0003-mfd. pre-set condenser until

STRAIGHTFORWARD BASEBOARD ASSEMBLY

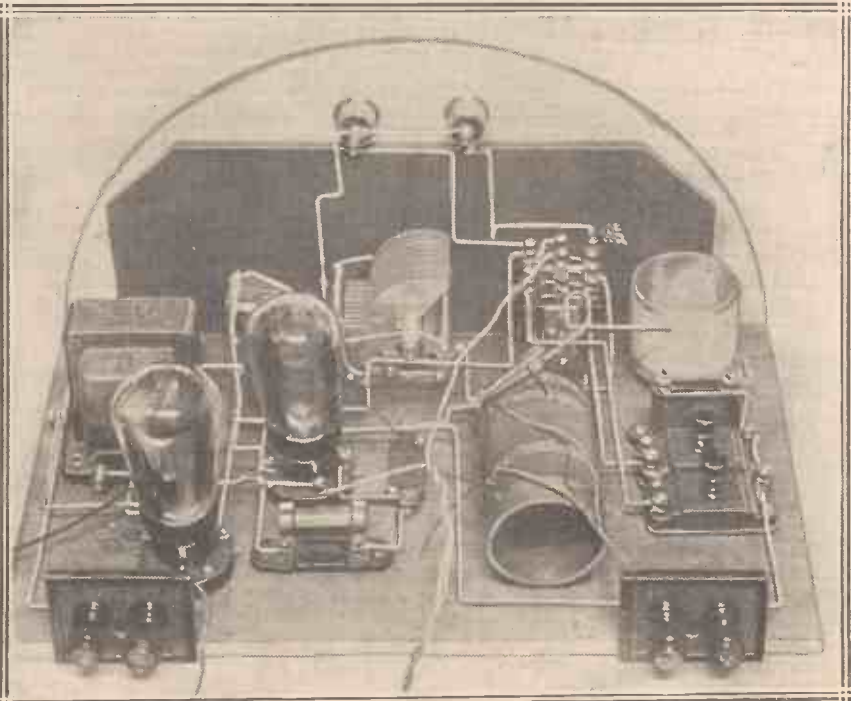

All the components are mounted on a baseboard and panel in the usual way.



ROUND the DIALS

Practical notes on what stations to look for and how to get the foreigners that are coming over well.

It is a pleasure to record that many old favourites are now returning with great force to British aeriels. Budapest, for instance, who was a little uncertain even in October, seems now to have settled down to his old reliability, and another old friend is Madrid, on 424 metres.

Katowice, Stockholm, Lyons La Doua and Algiers are all notably good, while the German stations, almost without exception, are simply overpowering.

Powerful Long-Wavers

The long waves have been providing some especially good programmes, too, and it is quite fallacy to suppose that the wave-lengths above 1,000 metres are not well worthy of constant attention. The new Radio Paris—now officially opened—is providing plenty of punch, and both Eiffel Tower

and Huizen have been rather above normal.

Konigswusterhausen, on 1,635

UNDER THE ICE!



These two are members of the crew of the Polar submarine "Nautilus," in which Sir Hubert Wilkins went under-sea to Polar regions. They are examining one of the Exide batteries used on board.

metres, is always well worth trying for, whilst Warsaw, on 1,411 metres (Europe's biggest station, with a power nearly five times greater than that of Daventry National), has been getting over excellently.

Oslo and Motala, too, have both been very obliging in providing good strength programmes of late, whilst a great many of the Kalundborg items are as attractive as those arranged specially for listeners in this country, consisting as they do of American and British records. He is a good station to try for on Sundays.

"Five-Year Plan" Stations

Although the stations named are the most important regular ones, there are many others well worthy of attention. Recently a surprise was provided for long-wave listeners by the appearance of a programme from Vienna, and several of the new Russian stations, brought into being by an ambitious five-year radio plan, appear to be testing or experimenting.

Add to this the fact that long-wave transmissions are singularly strong in daylight as compared with medium-wave transmissions from similar distances, and it will be realised that to neglect this wave-band is to lose much of the pleasure that broadcasting can bring. Finally, it is often forgotten that where interference from neighbouring sets is rife, or where disturbance due to electrical machinery, etc., is experienced, the simple expedient of tuning into a long-wave instead of a medium-wave station will often bring relief.

"WEARITE" components, of which there is a truly astonishing range, are illustrated and described on the firm's latest list, which takes the form of an attractive folder.

Copies are available to all readers of the WIRELESS CONSTRUCTOR on application to Wright & Weaire, Ltd., 740, High Road, Tottenham, London, N.

Circuits for Constructors

Admirers of the Benjamin products will be greatly intrigued by the latest Benjamin catalogue. It gives not only the usual clear descriptive matter regarding the various lines, but also schematic circuits of three different receivers.

The names, "Local-Station" Two, "All-Mains" Three, and "Super-Four," indicate the types of circuit covered—the latter using two S.G.'s

 * **POINTS FOR** *
 * **PURCHASERS** *
 * *Interesting details from manufac-* *
 * *turers about recent trade activities.* *

and a pentode; and as the point-to-point connections are clearly shown and easy to follow there is sure to be a big demand for the catalogue.

It will be sent to any reader of the WIRELESS CONSTRUCTOR on application to Benjamin Electric, Ltd., Tariff Road, Tottenham, N.17.

British Blue Spot

The latest literature obtainable from the British Blue Spot Co., Ltd., attractively sets out the firm's many activities. These will prove sur-

prisingly numerous to those who associate the name chiefly with the original "B.S." loud speaker.

Now there are wide ranges of loud speakers and complete sets, as well as such accessories as wave-traps, disturbance eliminators, pick-ups, etc. Descriptive folders are available on application to The British Blue Spot Co., Ltd., Blue Spot House, 94/96, Rosoman Street, Rosebery Avenue, London, E.C.1.

The Price of Terminals

Our attention has been drawn to the different prices stated for the Belling-Lee "R" type terminal, advertised on page 334 of the October WIRELESS CONSTRUCTOR.

The correct figures for these very popular terminals are as follow: type R, 3d.; type M, 4½d.; type B, 6d.



AS WE FIND THEM NEW APPARATUS TESTED

THE OSRAM "FOUR"

THE G.E.C. can always be relied upon to turn out a first-class job, and the Osram "Four" (New Music Magnet) for 1932 is no exception.

The circuit, as the name implies, comprises four valves, viz., two fully-tuned screen-grid H.F. stages, a leaky-

A SENSITIVE SET



The Osram "Four" is a splendid long-range receiver, and is an extremely simple set to operate. There is only one tuning control.

grid detector, and one transformer-coupled L.F.

The receiver is supplied as a kit set, and the instruction sheet is so clearly written that the veriest novice should have no difficulty in assembling the receiver and obtaining excellent results.

The two screened-grid stages and the detector stage are arranged in the form of units which are completely enclosed in aluminium boxes. These units are attached to a metal base-board, and since all the metal-work is at earth potential the receiver is perfectly stable on both wave-bands.

Tuning is carried out by a triple-gang condenser, the assembly being shielded in the same way as the

remainder of the H.F. side. Trimmers are provided across each condenser section.

Selectivity is adjusted by a series aerial condenser, which also acts as a volume control.

The wave-change switch is ingenious and gives an instantaneous change-over from one wave-band to the other by a half turn of the knob.

The differential reaction condenser operates on the detector grid circuit, and the receiver is therefore non-radiating.

Pick-up terminals are provided in order that the set may be used as a radio-gram outfit.

Attractive Cabinet-work

Externally the receiver is wonderfully attractive, the cabinet-work being of walnut with panel to match.

We tested the receiver on an average aerial approximately 15 miles S.E. from London, and stations on the medium and long wave-bands literally rolled in at loud-speaker strength.

Many of the continental transmissions required the use of the volume control, which incidentally had to be kept at its minimum for the two Brookmans Park transmitters. The reproduction was very good indeed.

The valves used were two S.215's in the S.G. stages, a D.E.H.210 for the detector, and a P.2 in the output. We tried an L.P.2 in the output stage, but this valve was not large enough to handle the energy, in view of the fact that our tests were carried out on a moving-coil speaker.

The voltages were as recommended by the makers, H.T. being derived from super-capacity dry batteries.

Perfectly Stable

The results of the tests prove the Osram "Four" to be a receiver possessing remarkably high sensitivity combined with perfect stability and ease of handling.

The G.E.C. also supply an A.C. conversion kit for this receiver so that indirectly-heated valves can be employed, the set then becoming "all electric." This special A.C. all-power unit is designed for 100-150 volts or 200-250-volt, 50-80-cycle mains, and the price of the conversion kit complete with a U.10 rectifier valve is £6 1s. 6d.

The conversion from battery to "all electric" presents no difficulty, because the makers provide a simple instruction sheet and plan of the modifications required. The price of the Osram "Four" kit, including four indirectly-heated valves and the A.C. All-Power Unit, is £17 15s. As a battery receiver the kit retails at £10 15s. (complete with four 2-volt valves).

NEAT POWER UNIT



The Osram "All Power" Unit enables the Osram "Four" to be converted to "all mains" with the minimum amount of trouble. Five-pin valve-holders are already incorporated in the set.

As We Find Them—continued

Bulgin Components

Messrs. A. F. Bulgin & Co., Abbey Road, Barking, Essex, have recently placed a number of new components on the market.

One of these is a delayed action switch. The switch is intended to be used in mains-operated receivers such as those employing indirectly-heated

A GOOD UNIT



The Graham Farish cone loud-speaker chassis utilises a cone which is made of a fabric material. The suspension is remarkably free.

valves. With these valves the heaters take an appreciable time to warm up, and during this period the valves have no emission.

In consequence, the H.T. side of the equipment is virtually on "no load," i.e. no anode current is flowing. Hence the voltage rises to its peak value, thus imposing a considerable dielectric strain upon such items as smoothing- and by-passing condensers.

Unless an adequate factor of safety is allowed in the design of the equipment there is a possibility of one of the condensers breaking down.

The Bulgin delayed-action switch when connected in circuit permits the high-tension circuits to be connected only after an appreciable interval of time, thus giving the valve heaters the required warming-up period.

The action of the switch is thermostatic; that is to say, the heating-up of a metal contact strip causes the strip to bend and to make connection with another contact, thus completing the circuit.

The thermostatic strip is surrounded by a coil of wire, which when joined in parallel with the L.T. winding of the power transformer consumes about 3 watts.

The switch contact remains closed for a short time after the power has been switched off, thus enabling the condensers to discharge before the thermal strip cools down.

This useful component is obtainable in two types, one having a 4-volt heater, and the other a 7½-volt heater. It retails at 7s. 6d.

Messrs. Bulgin's new lines also include a double-pole toggle switch designed to carry up to 4½ amps. at 250 volts, and a double-pole change-over switch with a rating of 4 amps. at 250 volts.

Other components are a very neat enclosed fuseholder containing two tubular fuses in a bakelite moulding, tubular fixed condensers having mica dielectrics, and heavy-duty Spaghetti resistances.

The A.C.4 Chassis Speaker

Messrs. Graham Farish, Ltd., Masons Hill, Bromley, Kent, have sent us one of their new A.C.4 chassis speakers.

The unit comprises a 4-pole cobalt-steel magnet system giving a high flux density. The cone itself is of a fabric material and possesses a very free suspension.

The supporting framework and housing for the unit are of black crystallised finished aluminium and the chassis is light in weight.

This A.C.4 type chassis is an attractive component, and while it is sufficiently sensitive for use with sets

of the smaller types, the provision of an adjusting knob on the unit renders it capable of handling reasonably large outputs. The tone is good and the price 21s.

Coil Quits

Messrs. Redfern's Rubber Works, Ltd., of Hyde, are now marketing coil quits suitable for WIRELESS CONSTRUCTOR circuits. These coil quits are the standard 2½ in. in diameter and are convenient for winding Contradyne coils, etc.

The quits are flanged so that a number can be fixed together according to the type of windings required, and are supplied already slotted, drilled and turned for 6d. each.

Clix Kits

It is very convenient to have all the terminals, wander plugs and connecting tags correctly engraved. Such a procedure eliminates errors in joining up the various leads. Messrs. Lectro Linx, Ltd., 254, Vauxhall Bridge Road, S.W.1, the well-known makers of Clix accessories, are now producing terminal kits for home-constructed designs.

We have recently received a sample kit suitable for the "Popular Wireless" "P.V. Plus," comprising the necessary terminals, wander plugs, and L.T.+ and L.T.— terminal tags. These are all excellently finished and clearly engraved, the complete kit retailing at 3s. 6d.

A GROUP OF WELL-MADE COMPONENTS

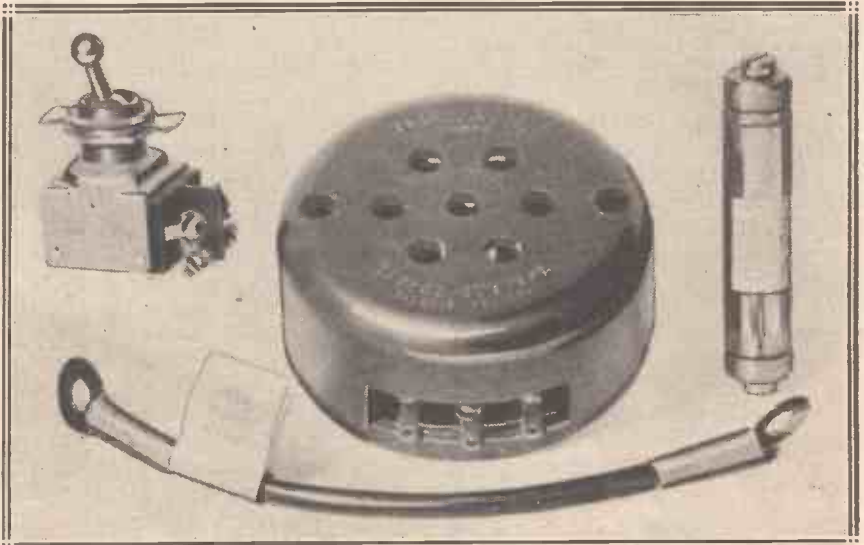

A group of Messrs. A. F. Bulgin's new lines. In the centre is the delayed-action switch intended for use with mains sets, and, on the right, one of the new tubular fixed condensers.

THE "G.B." REGULATOR

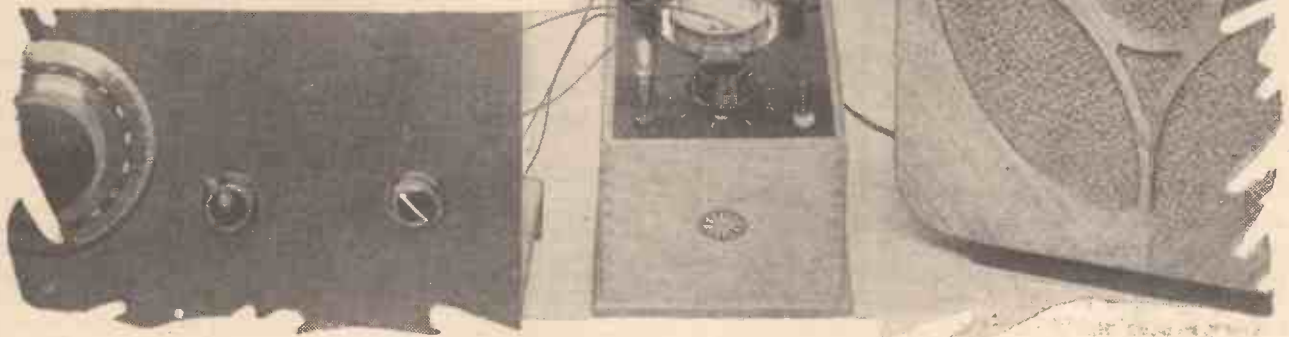

THE grid-bias battery is a very important accessory. I expect you have read that before, for it has often been rubbed in that the quality of your results, the life of your H.T. battery and the protection of the power valve all depend upon the G.B. battery.

Don't Ruin Your Batteries

But it is all true, and the importance of this little battery which is so often completely overlooked cannot be over-emphasised. Do you take note when you read that insufficient grid bias will ruin your H.T. batteries (if you use them), and that too much will produce distortion? And do you follow the good advice of switching off the set or disconnecting the H.T. supply when altering the value of grid bias?

Quite possibly you decide it is all too much bother, and do not give much thought to the subject of grid bias. Or perhaps you wisely adhere to what you read, but at the same time feel it is rather a nuisance and wish the matter could be simplified and made more definite.

Whichever you do—and we sincerely hope it is the latter—you will be very interested in the little unit we are going to describe. It indicates at "one and the same time" whether you are using the right value of grid bias, and whether the power valve is being overloaded, and also reduces the complicated business of adjusting grid bias to the mere turning of a knob while the set is working.

Needn't Alter the Set

Incidentally, it also provides a neat and convenient housing for the grid-bias battery. In most cases it does not necessitate the slightest alteration to the set, and when it does, only

Are you sure your valves are biased properly? If not you may either ruin them and perhaps your H.T. battery, or else you may be getting distortion due to partial rectification. These troubles are obviated by the use of this neat and ingenious little gadget.

Designed and Described by the "Wireless Constructor" Research Department.

one wire has to be removed from one component.

If you look at the diagram showing the method of connecting up the unit to a set you will see the theoretical circuit of the unit in the top right-hand corner. The scheme is as follows. There is a milliammeter for connecting into the H.T. supply lead of the power valve to indicate when the grid bias is properly adjusted,

and also to show whether the power valve is being overloaded or not.

Then there is a rotary switch with many contact studs for actually altering the value of the grid bias supplied, instead of the usual method of moving the position of a wander-plug. In between each stud that is joined to a tap on the battery is a blank stud which prevents the switch shorting sections of the battery as the arm is rotated.

A Safety Resistance

At first you may wonder why, when the arm of the switch is on a blank stud, grid bias is not completely removed and the grid of the valve left free. Such a condition would, of course, be very likely to result in damage to the power valve, due to a sudden rush of heavy anode current.

SAFEGUARD YOUR VALVES AND BATTERIES

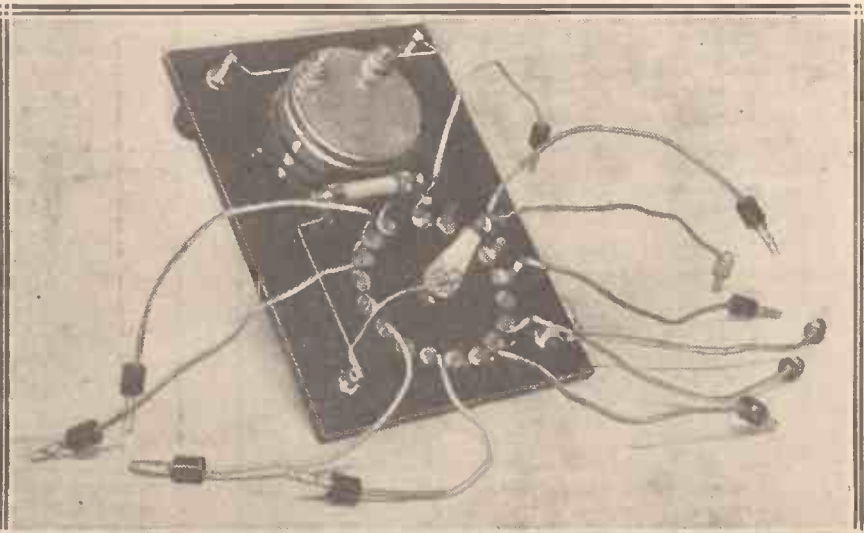

The underside of the regulator, showing the grid-battery leads and the studs by which tappings are taken.

The "G.B." Regulator—continued

What actually happens when the switch-arm is on a blank stud is that the maximum grid-bias volts available are applied to the output valve. The H.T. current through it will therefore temporarily be reduced, and that will not do any harm.

Follow out the circuit and you will see that this effect is obtained by means of a 1-megohm resistance. The grid bias for the power valve is obtained across the two terminals marked G.B. + and G.B. -2, therefore the whole of the voltage of the G.B. battery is obtained in series with the resistance. The resistance will not drop the voltage, since there will not be any current flowing.

Easy-to-Make

When the arm is moved to a live stud, the G.B. - 2 socket on the unit goes to a definite value on the battery, and the resistance is shorted out in series with a part of the battery. No current "worthy of the name," however, will flow through the resistance, due to its high value.

The G.B. - 1 socket is used when necessary to supply grid bias to a first L.F. stage, and is fixed at a suitable value.

THE FEW PARTS REQUIRED

- Ebonite panel, $6\frac{1}{2} \times 4\frac{1}{2} \times \frac{3}{8}$ or $\frac{1}{2}$ in. (Red Seal, or Lissen, Paxolin, Goltone, etc.).
- Cabinet for above (see text re depth).
- 1 0-30 milliammeter (Competa, or Ferranti, Weston, Sifam, etc.).
- 1 Rotary switch with 18 contact studs (Wearite "Star-Turn" type).
- 1 1-megohm resistance (Lissen, or Ediswan, Mullard, Dubilier, Igranic, Ferranti, etc.).
- 2 Terminals (Belling & Lee, or Igranic, Eelex, etc.).
- 3 Sockets for battery plugs (Clix, or Eelex, etc.).
- 11 Battery plugs (Clix, etc.).
- Screws, flex, etc.

The constructional work calls for little comment. The diagrams show quite clearly how to drill the panel, mount the components, and wire the unit. The case should be made fairly

deep so that it will take three of the 9-volt type slab grid-bias batteries.

The milliammeter does not need to be an expensive instrument, although the better it is, naturally, the better. You should make marks on the panel to indicate when the switch is on a live stud. These can either be scratches or painted on with artists' white.

The switch provides a choice of ten values of grid bias, which progress in steps of $1\frac{1}{2}$ volts. The voltages shown will be found to provide a suitable tapping for most power valves generally in use.

Simple to Use

However, should you find you require a lower value, start the taps at $4\frac{1}{2}$ volts instead of 9, and if you want a higher, start them at, say, 12 or 15 volts. The flex lead attached to the G.B. - 1 socket is, of course, joined direct to the desired value of bias for the first L.F. valve, which will usually be about $4\frac{1}{2}$ volts.

The method of connecting the unit

ABOVE AND BELOW THE PANEL OF THE REGULATOR

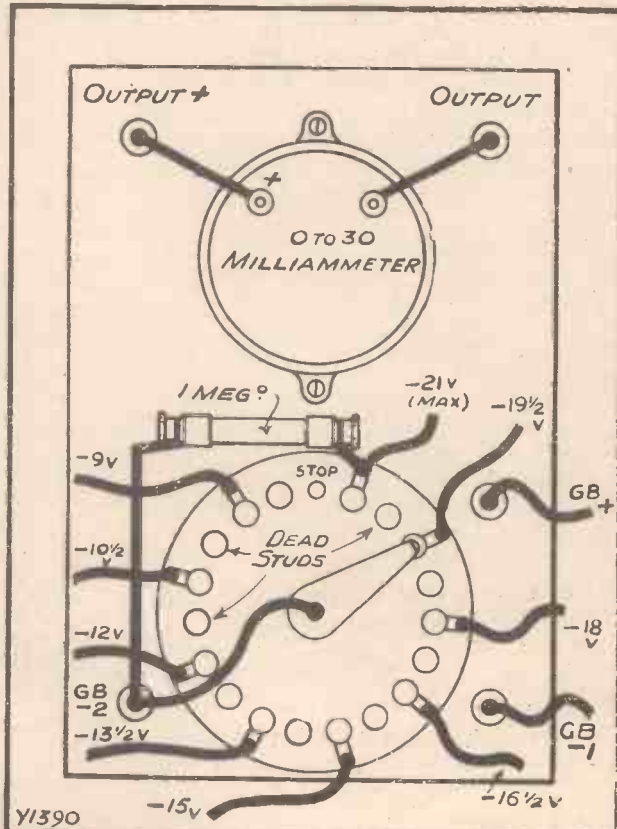
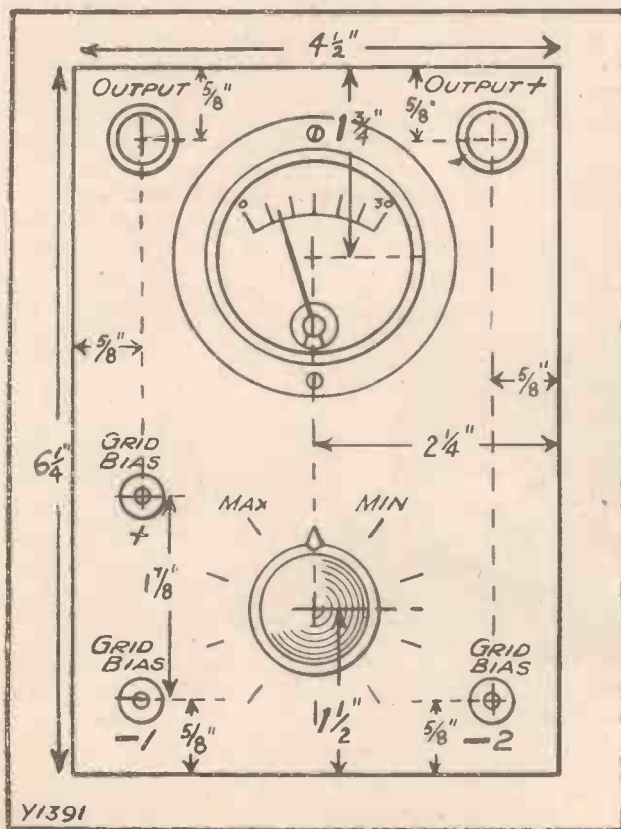

These front-and back-of-panel diagrams show all the details necessary for the construction of the unit. Suggested values for the grid-bias taps are given but, of course, these should be arranged to suit the particular set with which the regulator is to be used.

The "G.B." Regulator—continued

to a set which has no output filter circuit is as follows: Take the grid-bias positive plug to the positive socket, and the first G.B. negative lead to the G.B. — 1 socket, and the second G.B. negative lead to the G.B. — 2 socket.

Next disconnect the loud-speaker lead which goes to the L.S. — terminal (the one joined to the plate of the last valve), and take it instead to the output terminal on the unit marked positive. The other output terminal is then connected up to the L.S. negative terminal on the set.

Straightforward Connections

In the case of a set employing an output filter and which has an entirely separate H.T. positive terminal for supplying the last valve only, connect the unit up in just the

The "G.B." Regulator tells you :

- (1) If the bias is correct.
- (2) If you are overloading.
- (3) If the emission of the valve is right.
- (4) If the H.T. is correct.

same way so far as the three G.B. leads are concerned. Do not touch the L.S. leads, however, but disconnect the lead from the H.T. supply to the H.T. positive terminal for the last valve, and join it instead to the output + terminal of the unit. The other output terminal is joined to the H.T. + terminal thus freed.

Should your set employ a filter, but not have a separate supply for H.T. to the last valve, or should you not be sure about the latter point, proceed as follows: Treat the G.B. leads as before, and disconnect the lead running to the side of the L.F. output choke which is not joined to the plate of the last valve.

Join it instead to the output + terminal of the unit, and join the now free terminal of the L.F. choke to the other output terminal.

Watch that Needle!

The way to adjust the grid bias is as follows: If loud passages in the transmission cause the needle of the meter to kick down more than up, then turn the regulating knob towards the max. If the needle kicks up more than down, turn the knob in the opposite direction.

Should the needle move equally both ways, it indicates that the

power valve is being overloaded and the volume should be reduced. It is a good idea to turn the control knob right to the left, or minimum, when switching off the set.

The 9-volt G.B. batteries should be joined in series, namely, the negative of one to the positive of the other, and then considered as one large battery.

PLUS AND MINUS

 * A reader raises an interesting query regarding loud-speaker connections. *

A NORTHAMPTONSHIRE reader of a sceptical turn of mind raised a query recently that may interest others who have been careless about their loud-speaker connections. He says :

Vital Markings

"Ever since March I have been working the loud speaker connected as shown in the sketch, and I had never noticed that one lead was marked + and the other —. Now I learn that + should be joined to the terminal which goes to H.T. battery +, and I have altered it accordingly.

"But there is no difference. Is it one of those 'improvements' that are all right in theory, but don't work in practice?"

The sketch referred to shows that there was no output filter in use, but all the H.T. to the last valve was going through the loud speaker. And, as connections were at first it was going through in the wrong direction.

Bad for the Speaker

Fortunately, it was detected before serious damage was done to the loud-speaker magnets, but it is quite likely that such connections would have ruined reception if they had not been spotted. For when joined in this way the electro-magnetism of the plate current opposes the permanent magnets, and it is only a question of time before the latter show signs of the struggle.

Marked Depreciation

Generally the symptoms of demagnetisation are decreasing sensitivity and a marked falling off in quality and clearness. With a well-magnetised L.S. unit it may take a long time to reach this state—as in this case—but wrong connections are certain to be detrimental.

That is why the makers use red and black indicating leads, or mark the loud speaker + and —. They know that the instrument can't work properly unless any steady current flowing through it does so in the right direction.

SMOOTH AND SURE GRID-BIAS ADJUSTMENT

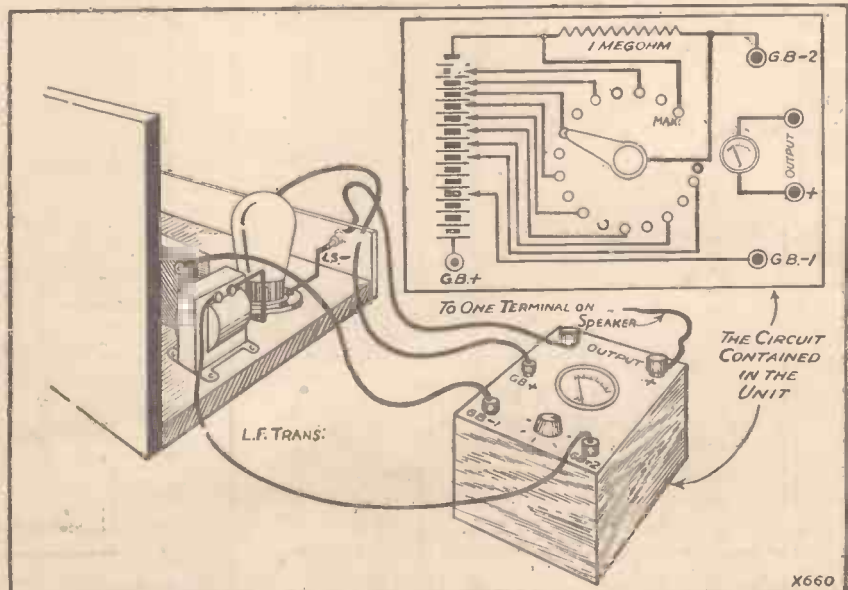

The theoretical circuit and a sketch of the external connections are given in this diagram. The G.B. tapplings for all the L.F. valves are taken to the battery inside the regulator, and no battery on the baseboard of the set or elsewhere is required.



A Greedy Scheme—A Much-wanted Screwdriver—Have You Tried This?

THE idea of using a pentode valve as detector is being mooted more and more of late, and not only in connection with mains valves. Anywáy, I hope nobody attempts to use one permanently for this purpose and employ the "leaky-grid" principle (anode-bend is quite a different matter).

Pity Your Battery!

Just think what the anode current would be with the grid return taken to positive L.T., or even to negative for that matter. And think of the poor dry battery should one be employed!

Of course, if a strong station were being received there would be a considerable drop in anode current. But, even so, I tremble to think how quickly the filament would run out of electrons.

However, for experimental purposes I think a pentode used in this way would be very useful for a valve

voltmeter (you know, the arrangement used to compare the efficiencies of various tuning coils, etc.). With the H.T. cut down, the change in milliamps when tuned to the input would be sufficiently large for quite small variations in efficiency to be noted.

I wonder when someone will put a—well, I'm "blowed" if I know the correct name for it—let's call it a "split" or "arched" screwdriver on the market at a reasonable price. No doubt they are obtainable, and I expect I shall receive many catalogues from tool makers as the result of this note.

Special Terminal Tool

Many a time have I thought, as I spotted the cut across a nut in some awkward corner, how nice it would be to have an assortment of "split" screwdrivers for such difficult places, which make a tiny pair of pliers seem

like some immense fire-tongs! Perhaps, though, terminals will disappear one day and components be connected up by wireless, who knows?

At one time the only remedy for L.F. howling was to try reversing the connections to the primaries and secondaries of L.F. transformers, but that was in the days before decoupling schemes were invented. Still, even to-day the trouble sometimes arises and proves most obstinate.

A "Howling" Cure

If the plague visits you at any time and will not respond to the usual treatment, here is something to try, providing a thoughtful designer has not already incorporated it. Place a sheet of copper foil over the whole of the baseboard.

This does not mean that all the components must be removed and later replaced. The foil will be just as effective if placed under the baseboard.

Of course, it must be joined to earth, or it may make matters a jolly sight worse. Also, if the coil windings are right close to the baseboard, cut the foil away underneath them, or you will upset the dial readings and possibly the set will not cover the right band of wave-lengths.

A good way to earth the foil is to leave a little lag on it when cutting out, and to fix this under a terminal on the terminal strip.

A. S. C.

I SAT down one evening early this month with intent to log my second "H.M." station. I suppose I must have been "knob-twiddling" for upwards of three hours, and after that—thoroughly chilled in more ways than one—I went to bed without having heard a single "Yank!"

Not a Single "Yank"

It would not have been so bad but for the fact that when I first switched on I found a really "beefy" carrier in the neighbourhood of 25 metres—just about where I usually log KDKA. "This," I said to my short-wave friend who was present, "must be Pittsburgh. And, by jove, isn't the Westinghouse Band coming over well-to-night?"

The transmission was, in fact, of such excellent quality and strength that we continued to listen through three lengthy musical items, and when the announcement did finally come believe me we were not a bit

THE MONTH ON SHORT WAVES

pleased to learn that we had been listening to G5SW!

To say that I had a shock would be putting it far too mildly. For in the ordinary way our own short-wave station is received at very poor

=====

THIS MONTH'S "H.M." STATION

=====

Location: Sydney, Australia.
 Call-sign: VK2ME.
 Wave-length: 31.28 metres (the same setting as P O J, Eindhoven, Holland).
 Time of transmission: 5 to 7 a.m., 9.30 a.m. to 3.30 p.m., and 7 to 9 p.m., G.M.T., every Sunday.

strength in my district, whereas KDKA—his "next-door neighbour" almost—comes over more often than not at loud-speaker strength with quite a simple sort of set.

As a result of this particular evening's complete American "wipe-out," I was all for rebuilding the set right away. In fact, the very next night I came home with the full intention of stripping the set and building a new one, but my soldering iron is still cold! For, as it happened, I switched on prior to dismantling it, and there, as loud as ever, was KDKA, with G5SW weak, as usual, next door!

A Hard "Nut"!

I thought by now that I was fairly hardened to erratic short-wave conditions, but not to have heard so much as a whisper from America after three hours' listening—well, who wouldn't have suspected the set?

Since then I have been having fairly good results, but conditions have hardly been what I should call good. For that reason I am giving you a fairly easy "H.M." station this month. By the way, I find he comes over best between 5 and 7 a.m. G.M.T.

The "MIDGET" THREE

Designed and Described by A. S. CLARK.

The earlier "Midget" sets described by Mr. Clark in the "Wireless Constructor" must be included among the most popular receivers of all time and we feel sure that equal success is completely assured for his latest achievement in a sphere of reception technique peculiarly his own. This present receiver is modern in every sense of the word, and if it is "Midget" in name and dimensions it certainly is not in regard to results!



It was a particularly noticeable feature of the receivers at the Radio Show this year that the majority of them were definitely smaller than the receivers of last year. This question of smallness is one with which we all must agree, for there are no real drawbacks to it, and, on the other hand, there are a number

of quite important advantages that accrue from it.

Compressed Efficiency

In the first place, there is the advantage of convenience, for it is much easier to find a suitable place for a compact receiver than for a large, rambling one. Then there is the

consideration of neat appearance, and the fact that quite a pleasing impression of compressed efficiency is obtained.

As a matter of fact, this matter of efficiency is not entirely a thing of impression only! There is a very definite reason why a compact set that is properly designed should gain in

YOUR SHOPPING LIST FOR THE "MIDGET" THREE

- 1 Panel 12 in. by 7 in. (Peto-Scott, Permcol, Becol, Goltone, Wearite).
- 1 Cabinet for above, with baseboard 10 in. deep (Peto-Scott, Cameo, Osborn, Gilbert, Pickett, Ready Radio).
- 1 Terminal strip 12 in. by 1 1/2 in.
- 9 Indicating terminals (Belling Lee, Eelex, Igranic, Clix, Goltone).
- 1 .0005-mfd. Extenser with cam joined to moving vanes, with dial or disc drive (Cyldon, Formo, Wavemaster, J.B.).
- 1 .00035-mfd. differential reaction condenser (Lotus, Ready Radio, Telsen, Igranic, Polar, J.B., Cyldon, Graham Farish, Parex).
- 1 1-meg. volume control (three-terminal type) (Igranic, A. E. D., Magnum, Sovereign, Varley, R.I., Wearite, Graham Farish).
- 1 L.T. on-off switch (Ready Radio, Telsen, Bulgin, Igranic, Peto-Scott,

- Goltone, Lotus, Graham Farish).
- 1 Aerial tuner (Telsen).
- 3 Ordinary valve holders (Lotus, Graham Farish, Telsen, Wearite, Clix, Igranic, Magnum, Formo, Bulgin, W.B., Lissen).
- 2 Medium-ratio L.F. transformers of small size (R.I., Igranic, Varley, Graham Farish, Mullard, Telsen Ace, Lotus, Ferranti).
- 1 Small-type output choke (Varley, Igranic, R.I.).

- 2 2-mfd. fixed condensers (T.C.C., Formo, Telsen, Dubilier, Helsby, Ferranti, Igranic, Hydra).
- 1 2-megohm grid leak (Graham Farish, Telsen, Dubilier, Igranic, Mullard, Loewe, Ferranti, Ediswan, Varley).
- 1 .0003-mfd. fixed condenser (Dubilier, Mullard, Ediswan, Telsen, T.C.C., Igranic, Ferranti, Graham Farish, Goltone, Watmel).
- 1 25,000-ohm Spaghetti resistance (Lewcos, Telsen, Peto-Scott, Ready Radio, Graham Farish, Parex, Varley, Igranic, Bulgin).
- 1 10,000-ohm Spaghetti (Varley, etc.)
- Grid-bias battery clip (Bulgin).
- Battery plugs (Clix, Belling & Lee, Eelex, Igranic).
- Crocodile clip (Bulgin, Goltone).
- Flux, screws.
- Piece of copper foil about 12 in. by 9 in.
- Glazite, Lacoline, Quic wire, Jifflix.

A TRIED AND TESTED CIRCUIT

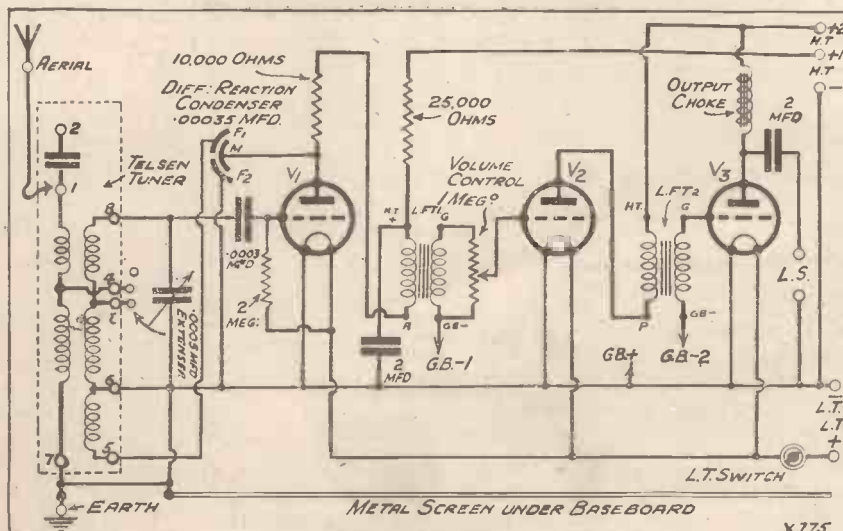

The circuit is a Det.-2-L.F. with Extenser tuning and differential reaction. The detector is "de-coupled," and there is a filter output so that complete stability is assured.

The "Midget" Three—continued

efficiency over one of a similar type that is arranged along straggly lines.

The point I have in mind is the wiring. Naturally, in the small set all the wiring will be shorter.

Short wiring seems to add more to the efficiency of a receiver than a theoretical consideration of the known advantages of short wiring would seem to indicate. The effects of capacity between wires and between wires and components evidently have a greater bearing on efficiency than they are usually credited with.

Some Wiring Advantages

But to return to our original theme of commercially-made sets being small. There is no reason why economy in space should be confined entirely to factory-made receivers.

True, the manufacturer has the advantage that he can make special components for special purposes, and can make his design as complicated as he likes. Nevertheless, it is possible to design a receiver for home construction that is compact and at

the same time so easy to make that anyone can tackle it with confidence and a light heart.

You will see from the photographs that the "Midget" Three is such a

receiver, and that there are many really short leads. As a matter of fact, like the "Midget" One-Valver described years ago, and which was a very popular receiver, the "Midget"

"STRAIGHT-LINE" PANEL CONTROLS

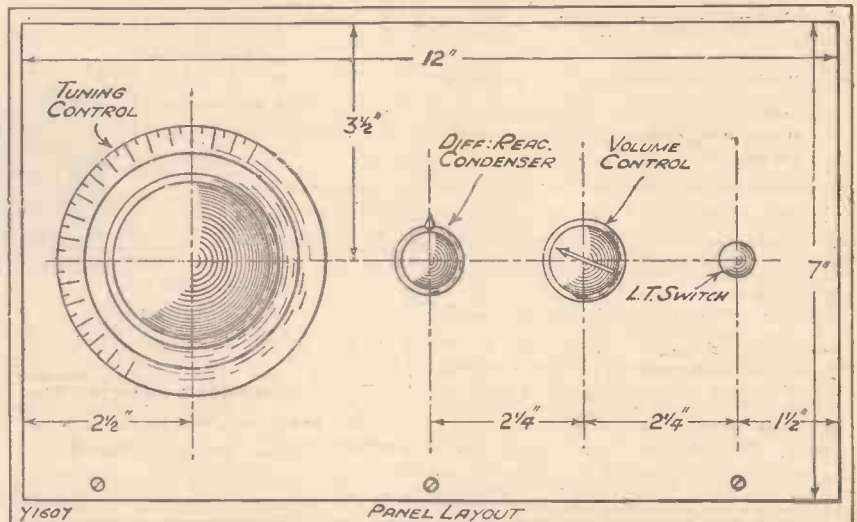

The controls are four in number and are placed in a convenient and orderly straight line.

SHORTER AND BETTER WIRING

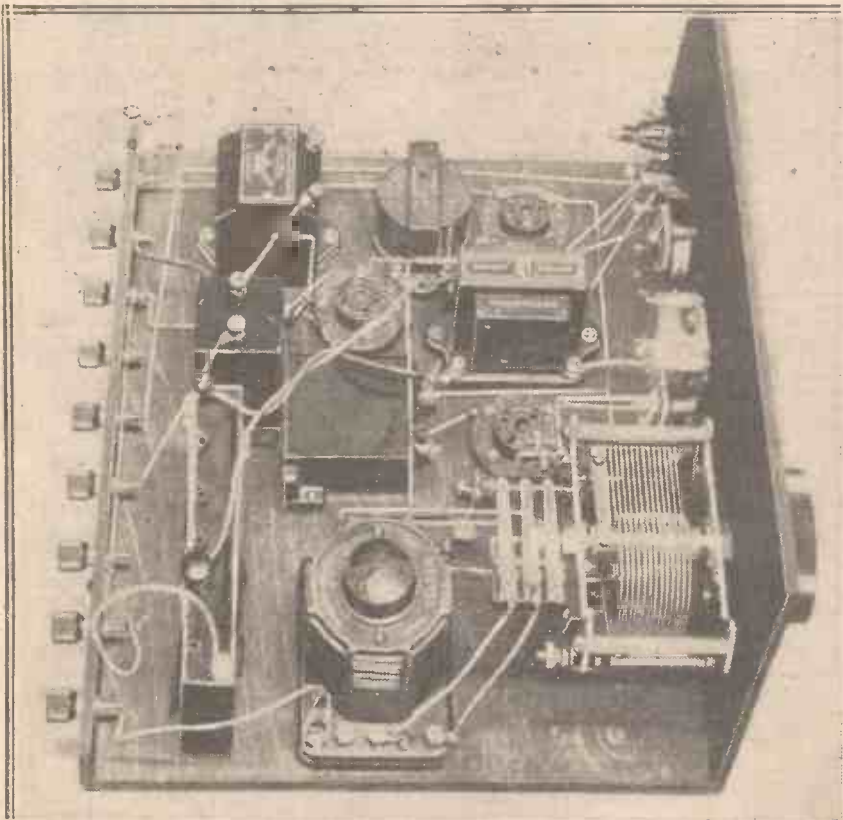

One of the outstanding features of this "Midget" set is its extremely short wiring, and the direct leads contribute considerably to the unusually high degree of efficiency achieved.

Three is compact because it was designed to have as short wiring as possible. It is not a case of getting short wiring incidentally.

So you will see that efficiency was placed first, but that in obtaining it ease of construction and appearance have not been sacrificed. In fact, it is a particularly easy set to make up, both from the point of view of assembly and wiring.

What Will It Do?

But what will the set do? Well, I will put it briefly.

It will tune over both broadcast wave-bands without any switching, because an Extenser is employed. Tested in south-west London and in the City, it easily separated foreign stations from the locals. And it will bring in a large number of continental transmissions at full loud-speaker strength on both the long and medium waves.

Let's just run over the circuit diagram together. The first thing we spot is the Extenser wired up to a dual-range tuner.

This is a commercial unit, and the variable series aerial condenser is incorporated in it. This is for the purpose of adjusting the degree of selectivity, so that the set can be made to suit any particular aerial and set of

The "Midget" Three—continued

conditions. The condenser is fixed inside the tuner and is controlled by a knob on top of it.

copper foil is fixed under the set. To prevent this complicating the construction in any way it has been

placed *under* the baseboard and joined up to the earth by a tag which comes round from underneath the baseboard and fits under the L.S. terminal that is wired up to the earth terminal.

The copper foil should end level with this point and not run underneath the tuning coil. Otherwise it will upset the tuning range of the windings, and you will not be able to cover the broadcast bands so well.

Feed-Back Prevented

Further, to ensure good quality and make certain that no trouble can occur due to feed-back in the H.T. supply, a de-coupling resistance and condenser are arranged in the detector's anode circuit, and an output filter is used for the last valve. It is thus just as satisfactory to run the set from a mains unit as from a dry battery.

Differential reaction is used, and a note should be made of the fact that

THE "WIRELESS CONSTRUCTOR" "MIDGET" THREE

Circuit: Det. and 2 L.F. (dual wave-band and Extended).

VALVES.

- 1st (nearest Extenser). Special detector or H.L. or H.F. type.
- 2nd (nearest L.T. switch): L. or L.F. type.
- 3rd (nearest terminal strip): Small power or super-power type.

(Valves may have filament rating of 2, 4 or 6 volts.)

VOLTAGES.

- L.T.: 2, 4 or 6 volts, to suit valves.
- H.T.+1: 60 to 80 volts (adjust this value to obtain good reaction control).
- H.T.+2: 120 volts.
- G.B.—1 (from transformer nearer panel): 1½-4½ volts.
- G.B.—2 (value recommended by makers of power valve used).

CONTROLS.

- (Working from left to right of panel.)
- 1st (Tuning): Two-figure readings are for medium waves, three-figure ones for long waves.
 - 2nd (Reaction): Turn in a clockwise direction for increase. (Always have this control at minimum when cutting down volume with third control.)
 - 3rd (Volume Control): Turn in clockwise direction for increase.
 - 4th (Switch): Pull out to turn on receiver; push in to switch off.

ADJUSTMENTS.

Place spring clip attached to aerial terminal on terminal 1 of coil. If selectivity is not sufficient, place on terminal 2 of coil and adjust knob on top of tuning unit until desired degree of selectivity is obtained. Turn clockwise to increase selectivity. A compromise between best selectivity for medium waves and for long may have to be made.

The condenser does not have to be touched once the best setting for it is obtained, and a terminal is provided which enables it to be left out of circuit in cases where it is not found necessary. To facilitate connection to either terminal, a flex lead attached to the set's aerial terminal is provided with a spring clip for attachment to the desired terminal on the unit.

The Selectivity Setting

When adjusting this condenser it should be remembered that a compromise may have to be made between the best setting for the long waves and the best for the medium waves. This compromise point should also be borne in mind when deciding which of the two terminals (1 or 2) on the unit is best for the spring clip to be attached to. Remember that on terminal 1 the series condenser is out of circuit.

Another point which stands out in the circuit is the use of two transformer-coupled stages. It is due to this that the set has such power on distant stations as well as on the locals. Bearing in mind that it may very likely be too strong on the local, a volume control has been provided across the secondary of the first L.F. transformer.

Particular care has been taken that the great volume available shall not be at the expense of quality. For instance, you will see that a sheet of

A KEY TO THE COMPONENTS

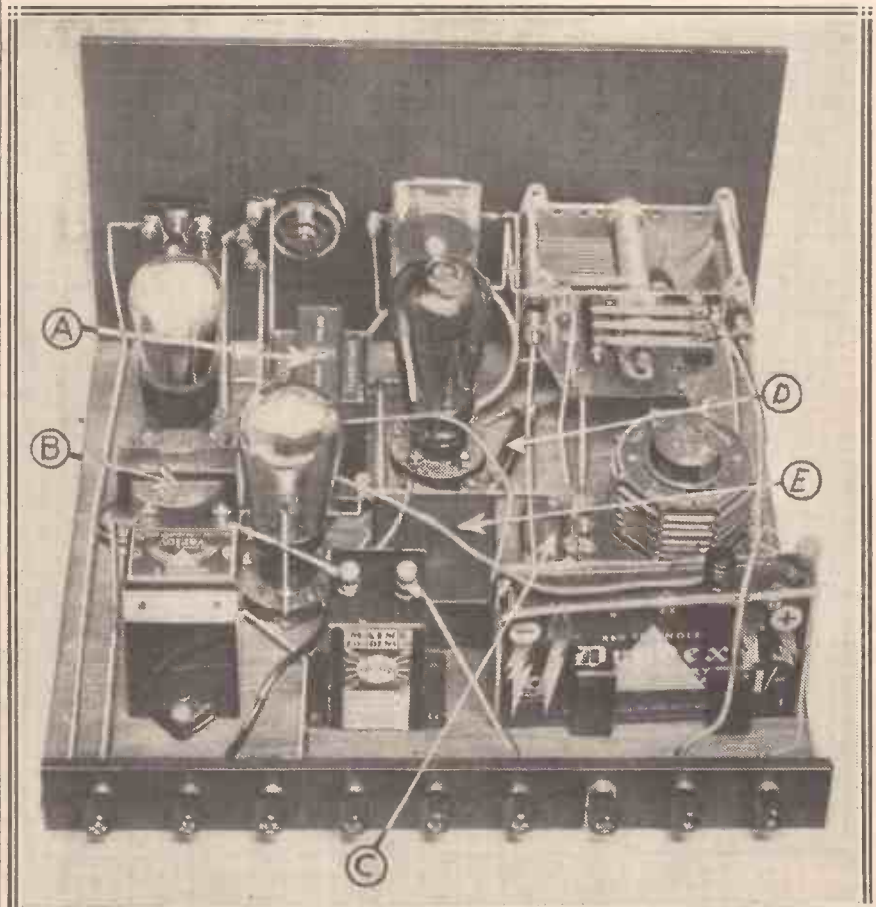

The letters indicate: (A) first L.F. transformer; (B) second L.F. transformer—this couples the two L.F. valves together; (C) grid condenser; (D) grid leak; and (E) the de-coupling 2-mfd. fixed condenser.

The "Midget" Three—continued

the capacity of the reaction condensér is .00035, and not the usual .0001 or so. One last thing to mention is that a resistance of the Spaghetti type is employed in the anode of the detector instead of an H.F. choke for reaction purposes.

Concerning Components

So far as the components are concerned there are not many restrictions, in spite of the small nature of the

receiver, as you will gather by a glance at the complete list of parts needed. You will probably find that it is necessary to use transformers of the small kind with special cores. This also applies to the output choke.

Usually two transformers of the same type must not be used. It is hardly necessary to mention this old axiom, but it is just possible that someone may not have come across

it, and prevention is always better than cure.

So far as the general constructional work is concerned, there is really very little to say, so I think it will be better if I confine my remarks to a few points that are worthy of specific mention. So here goes.

About the Panel

To facilitate marking out the panel, all the points to be drilled for components are arranged along one straight line at the centre of the panel. There is not much weight in the components on the panel, and for this reason panel brackets were not considered necessary. There is, of course, no harm in using small ones if you want to make a particularly rigid assembly, and there is ample room for them.

The terminals on the terminal strip are all $1\frac{1}{2}$ in. apart, and the end ones are 1 in. from the ends of the terminal strip. This is $1\frac{1}{2}$ wide, as mentioned in the list of components, and the terminals are $\frac{1}{2}$ in. from its top edge.

Some people prefer to screw the panel and terminal strip to the baseboard before mounting the terminals and components that go thereon. Personally, I find it more convenient to mount both the terminals and components before attaching the ebonite to the baseboard.

In any case I should advise you to put the terminals in place before screwing the terminal strip to the baseboard, because there are four terminals on it that have to be all wired together, namely, H.T. —, L.T. —, L.S. and Earth. It is quite easy to wire these up before the terminal strip is fixed in place—and don't forget the foil connection.

Really Easy Wiring

So far as the wiring is concerned there is no need to solder at all, but if you do solder the connections, as I did in the original, then take my advice and employ soldering tags for every single point. That is, excepting the terminals on the terminal strip, where connections can be soldered directly to the shanks.

My procedure in wiring a set with soldered joints is to get sufficient tags together for all the terminals, and to tin these with a small blob of solder before putting them on the

AN ATTRACTIVE ASSEMBLY

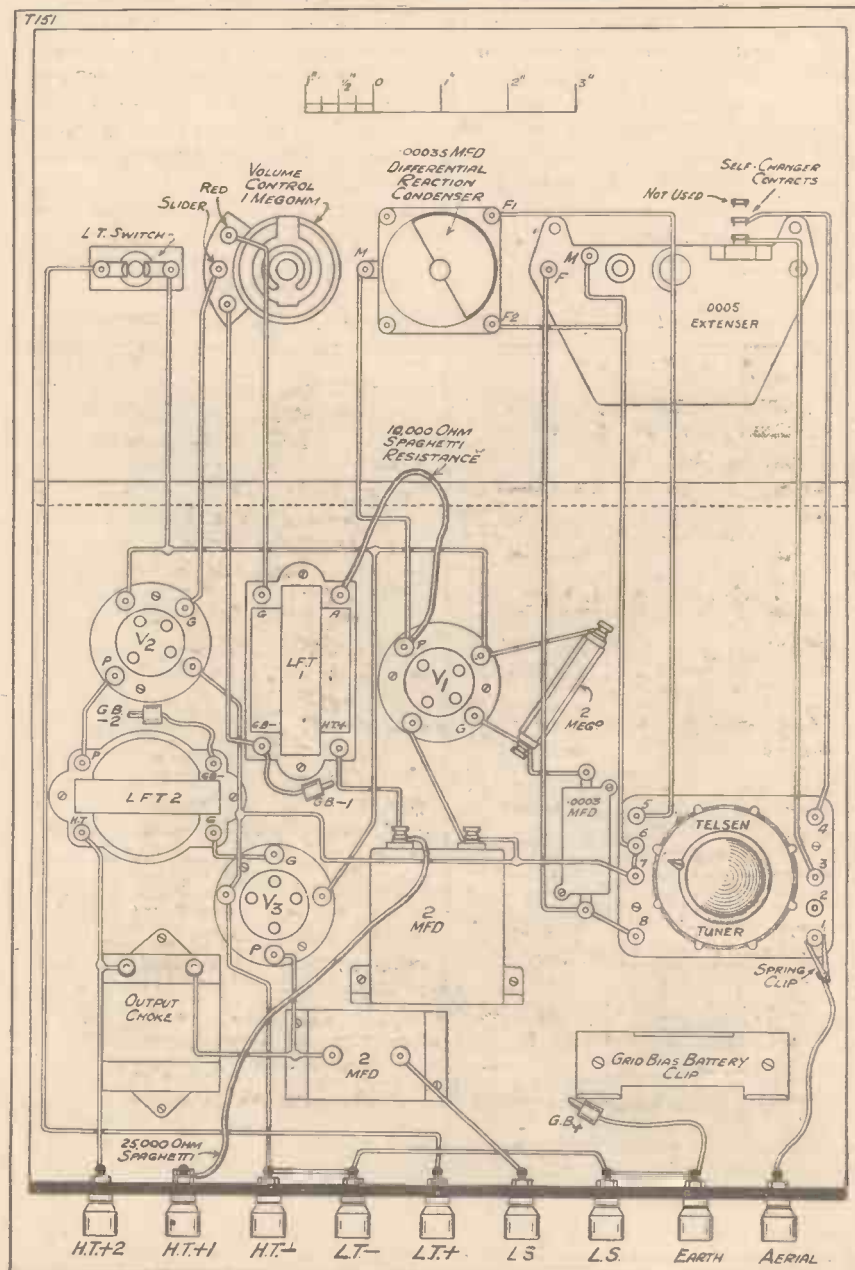

Besides contributing towards the set's efficiency, the identically short wiring makes the "Midget" Three a very easy set to wire up.

The "Midget" Three—continued

components. The tags are clamped really tightly under the terminals before any of the components are mounted.

It is thus never necessary to fiddle with pliers and spanners in awkward corners made by the various components. Also the blob of solder makes it seldom necessary to apply

ACCESSORIES

Valves. 2-, 4-, or 6-volters. One detector, H.L. or H.F. type, one L.F. or L. type, and one power or super-power type (Osram, Mullard, Six-Sixty, Mazda, Cossor, Fotos, Eta, Tungram, Dario).

Batteries. 120-volt H.T., of super-capacity if large output valve is used (Ever Ready, Pertrix, Drydex, Magnet, Ediswan, Columbia, Lissen). 9-volt grid-bias battery (or two if power valve requires). (As above.)

Accumulator. 2-, 4-, or 6-volt accumulator for L.T., according to valve rating (Exide, Ediswan, Pertrix, G.E.C., Lissen).

Mains Unit. One with at least two positive tapings and capable of giving ample power to suit valves used. State type, voltage, etc., of mains when ordering and describe set (Regentone, Tannoy, Ekco, Lotus, Heayberd, Atlas, R.I.).

Loud Speaker. (Amplion, Undy, B.T.-H., Blue Spot, Celestion, W.B., Graham Farish.)

extra solder to the joints when wiring; all that is necessary is to stick the end of the wire in the flux, hold it up against the soldering tag, and apply the iron.

The G.B. Battery

You will find a good idea to follow when wiring (no matter whether you solder or not) is to run all wires direct in a straight line from point to point when no bends are necessary. In the case of wires that have to be bent it is best to use right-angle bends, as these not only look nice, but also generally allow the best spacing to be obtained.

There is ample room on the baseboard behind the tuning coil for a grid-bias battery, or two if a large power valve is to be employed. A G.B. battery clip is shown in this position in the wiring diagram, and also in the photographs.

So much for the construction, and now a few words about the accessories. These are given in brief.

both in the list with suitable makes mentioned, and also in the operating panel, so we need not go fully into all the details here.

Remember that the set has a great amount of amplification, and if you use a small power valve for the output the volume control will certainly have to be used on several of the stations obtainable if overloading is to be avoided. Also be sure to use the amount of grid bias advised by the makers of the power valve.

Pick-Up Connections

If you use any output valve other than an ordinary small power you should use large batteries of the triple or super type, unless a mains unit is to be employed. Beyond that there is nothing to be said and the operation is fully covered in the operating panel.

Before closing, however, I should

plugs and sockets and also a single-pole change-over switch.

These are mounted on the panel just below the reaction condenser. It is not desirable to mount the terminals or sockets for the pick-up leads at the back of the set, because this would entail leads that might upset the set's working.

The wiring alterations are as follows: Disconnect the grid of the detector valve V_1 from the grid leak and grid condenser, and take these latter points to one of the outside contacts of the change-over switch.

The other outside switch contact goes to one of the pick-up terminals, and its common contact to the grid of the detector valve. The remaining pick-up terminal is connected via a flex lead to $1\frac{1}{2}$ volts negative on the grid-bias battery.

And now I have said the last word on this receiver, so I must leave you to

AND YET THERE IS NO CROWDING!

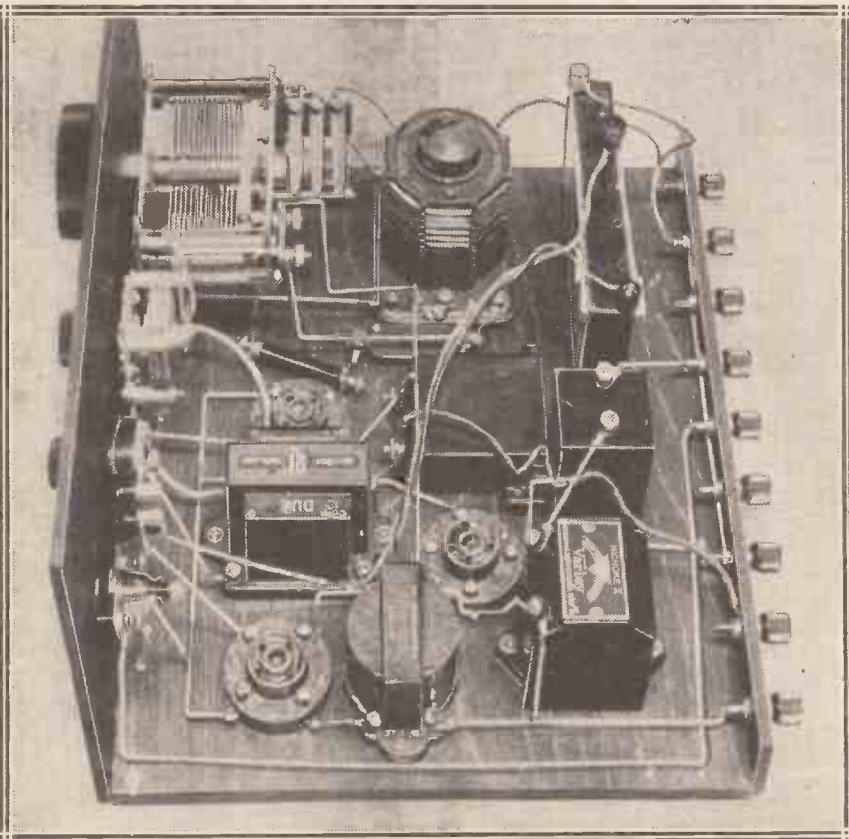

Despite its compactness there is no over-crowding in the "Midget" Three. There is even plenty of room on the baseboard for the G.B. battery, as you can see.

like to give details of how a pick-up can be fitted if you want to use one. You should obtain two terminals or

do your bit, with the promise you will not be disappointed in any way with your results.

PICK-UP HINTS and TIPS



Interesting notes on various practical aspects of radio-gram reproduction.

By A. BOSWELL.

AMPLIFIERS that howl seem to be all too common. So many receivers appear to give trouble when the pick-up is switched into circuit, although apparently they are quite O.K. on radio.

Why is this? I think the trouble can usually be ascribed to the arrangement of the pick-up leads.

Frequently they are allowed to trail across the set, thus linking up the input from the pick-up with the output end of the amplifier. This completes the chain back from the output circuit to the pick-up input, and so produces instability.

The remedy is to keep the pick-up leads well away from the amplifier itself, and also from the speaker leads. The bigger the space between these two sets of leads the better.

The Earth Connection

Another possibility of instability is when the pick-up arm is not earthed. A number of the latest pick-ups have a third terminal or connection for earthing purposes.

In those cases where the additional lead is not provided it is an easy matter to make a suitable connection to one of the tone-arm holding-down screws.

A pick-up can be tried on practically any radio set, and it is not essential to use a special radio-gram switch.

The pick-up leads are simply joined directly across the grid and filament negative of the detector valve, or to the grid and G.B. negative of the first L.F. valve. When the pick-up is in use the tuning controls must be set at zero, or in any position in which radio is not received. Otherwise broadcasting will be superimposed upon the record with dire results to the music.

This scheme is by no means ideal, and it is much better to have a switch for cutting out the radio side of the set altogether.

It doesn't matter much whether the H.F. valve filament—if any—is switched out, unless battery economy is essential.

Even so, it is really only the milliamps that are important, because the filament of an S.G. valve imposes

TRY THESE

RECORDS WORTH HEARING.

Orchestral.	
Pique Dance.	
Philharmonic Orchestra	H.M.V.
Symphony No. 5 in E Minor.	
Philadelphia Orchestra	H.M.V.
"White Horse Inn" (Selection).	
London Orchestra	Zonophone
Dance.	
Pardon Me, Pretty Baby.	
Jack Harris and His Band	Broadcast
Honeymoon Lane.	
Manhattan Merry-makers	Broadcast
Only a Dancing Sweetheart.	
New Mayfair Dance Orchestra	H.M.V.
I'd Rather Be a Beggar With You.	
Jack Payne	Columbia
My Brother Makes the Noises for the	
Talkies.	
Jack Payne	Columbia
Vaudeville.	
I Wanna Sing About You.	
Bob and Alf Pearson	Broadcast
Sally.	
Gracie Fields	H.M.V.
Faithfully Yours.	
Jack and Jill	Zonophone
Piano.	
Following the Drum.	
Rale da Costa	H.M.V.

but a small drain on the L.T. supply, and if the L.T. accumulator is of substantial capacity—which it should be—half an hour or so of record playing will scarcely be noticeable.

On the other hand, those who are compelled to use dry battery H.T. cannot afford to feed an S.G. valve, which is temporarily unemployed, with anode current at the rate of 3-4 milliamps.

How much power in the output circuit is necessary to drive a moving-coil speaker at good volume?

One might equally well say: "How many square yards in a field?" It depends on the size of the field and, in the case of a speaker, upon the size of the room to be filled.

How Much Power?

For instance, a very large room or small hall would probably require 3 watts, whereas an ordinary living-room might require anything from 4 to 1 watt.

Three watts is out of the question with battery amplifiers and 2-volt valves. To obtain this amount of energy necessitates high anode voltages and big valves.

It is possible to get adequate power for ordinary domestic purposes with a good modern super-power or pentode valve, assuming the loud speaker to be reasonably sensitive. Fortunately, there is not much wrong with the sensitivity of the latest permanent-magnet moving coils or the inductor-dynamic types.

They are amazingly efficient from this point of view, which means, incidentally, that it is now possible to bring out the bass without expending a relatively great amount of power in the anode circuit of the last valve.

Needle-scratch still troubles some pick-up enthusiasts. A resistance of suitable value across the pick-up will cut most of it out. I am unable to suggest a value because this varies largely with the design of the pick-up, but I notice that the makers usually mention suitable values on their instruction leaflets.

Cutting Out "Scratch"

Other "dodges" are to shunt the L.F. transformer secondary with a resistance, or to connect a small condenser (about .0001 mfd.) across the anode resistance of an R.C. amplifier.

Personally I have no time for these methods, since they affect the radio reproduction, which in nine cases out of ten already suffers from high-note cut-off caused by selective H.F. coupling or by the use of reaction.

No, leave the amplifier alone if it has also to be employed for broadcasting, and confine the scratch elimination to the pick-up itself.

Mind you, I am not adverse to using an adjustable tone control between the amplifier and the speaker. You can always set this to suit the particular needs of the moment.

SAVOY HILL —NEWS—



A Real Radio Christmas—Regionals and "Interchange"—Orchestras and Chamber Music—The "Emergency" Religious Service—Organ Improvisations—Programmes from America—The Daily Dozen—Future of 5 SW—Next Year's Prom. Arrangements—A Caste System.

A Real Radio Christmas

THIS year, far more than ever before, people will depend upon broadcasting as their main source of amusement and diversion at Christmas. The prospect seems to be understood at Savoy Hill, where comprehensive plans have been worked out for Christmas radio.

One result, at least, of the economy in programme expenditure will be welcomed by many—that is, in the replacement by gramophone records of such varied items as the Bach Cantata and the Foundations of Music.

Gramophone record programmes are increasingly popular provided they are handled by Major Christopher Stone, who has come to be one of the most popular of the contemporary microphone personalities.

Major Stone is a brother-in-law of Mr. Compton Mackenzie, with whom he works intimately. Both share that sound appreciation of microphone technique which enables speakers to convince each of the several million listeners that the talk or explanation is meant for him or her only.

Regionals and "Interchange"

The latest effect of retrenchment at Savoy Hill is the pooling of Regional programme resources for the purpose of more frequent interchange. The idea was that as long as there was one definite contrast to the National programme it would not matter where it originated.

Thus instead of having separate and characteristic Regional programmes from Manchester, Birmingham, and Cardiff, there would be one composite Regional made up of the best elements of all three, and repeated on each Regional wave.

This idea, which was thought out at Savoy Hill, was received with a good deal of suspicion by the Regional

staffs, who, recollecting their periodical struggles to preserve their independence and distinctiveness, suspected "profiteering" by the "centralisers" at headquarters.

There were lengthy conferences and appeals in various directions. In the end interchange is to stand, but in a modified form, permitting of the retention of most of the features distinctive to each region.

Orchestras and Chamber Music

There has been some grumbling of late in the ranks of B.B.C. orchestras at the alleged increasing tendency to include "Chamber Music" works in ordinary orchestral concerts without extra payment. The players complain that Chamber Music requires special rehearsals and much more care and skill than ordinary orchestral work.

A compromise has been reached, the B.B.C. undertaking not to put

Chamber Music into the ordinary concerts; and the players agreeing not to consider as Chamber Music work which can be rehearsed during the normal times for rehearsal.

The "Emergency" Religious Service

The new mid-week religious service, broadcast at 10.30 p.m. on Thursdays from St. Michael's, Chester Square, is regarded by the B.B.C. as such a marked success that it will probably be made a permanent programme feature.

The Rev. W. H. Elliott, formerly Canon of St. Paul's, and now Vicar of St. Michael's, seems to have struck just the right note. In addition to the considerable response from the general listening public there has been a most gratifying attendance at the Church even at that unfavourable hour.

REPEATER EQUIPMENT AT A RECENT EXHIBITION



The gear illustrated above was used at the Shipping, Engineering and Machinery Exhibition at Olympia as a band repeater. It fed a large number of loud speakers installed throughout the hall, and was also employed to enable visitors, on the opening day, to hear the conversation which took place between the President of the Exhibition (Lord Wester Wemyss) and the Captains of the "Homeric" and "Empress of Britain."

Savoy Hill News—continued

At Savoy Hill the success of this service is regarded as another tribute to the sound judgment of the Director-General, who did not have by any means the unanimous support of his staff when the matter was being discussed.

Organ Improvisations

The Music Department of the B.B.C. has been recently considering whether the improvisations of some of the organ recitals are as satisfactory as they might be.

The view is that the charm of improvisation is considerably discounted when the performer has not the advantage of an actual audience. So, in future, improvisations at the organ

from the heart of Kentucky's mountains; a running commentary on a big gangster round-up, by no less a person than Mr. Mulrooney, the head of New York's police; a bird's-eye view of New York described by Mayor Walker; plantation songs from a real plantation on the Mississippi, and so on.

There is a good deal of value along this line of development, and I gather the expense is not excessive. I hope that something more may be heard of the matter before these words are actually in print.

The Daily Dozen

The B.B.C. is as stubborn as ever about the proposal that physical

More will be heard of this agitation, and the B.B.C. will have to give way in the end; how much better to take the initiative now and make a move not as the result of pressure.

Future of 5 S W

Despairing of getting any official co-operation, or even sanction, to go ahead on their own with a permanent Empire station and service to replace the lash-up, G5SW, at Chelmsford, the B.B.C. may abandon the whole thing early in the year.

There is still no sign of decisive official action. On the other hand, there is an alternative proposal that contains distinct possibilities. I mean to run the Empire service on a time-selling basis, so that it would be financed by British industry and business.

It would be understood that no foreign firms would be included. If this step is sanctioned then the deadlock of the last three years will be eased. The television problem might be solved simultaneously.

Next Year's Prom. Arrangements

Plans are already framed for the 1932 Prom. season. There is to be a strengthening of the solo artistes, and a rearrangement of the second half. Sir Henry Wood will again be in charge, this being his thirty-eighth season, and probably his last.

In 1933 the B.B.C. will make new arrangements, probably introducing two orchestras and two conductors.

One advantage of the two orchestras would be competition; another would be less strain on conductors and instrumentalists alike. The trouble this year was strain. The members of the Prom. orchestra had only four days' leave before they had to start rehearsing for the B.B.C. Symphony Season.

A Caste System

Some amusement and not a little irritation have been caused among the B.B.C. staff by the curious attempt that is being made to provide at Broadcasting House cloakrooms for each class of person, preventing overlapping.

The reason given for this is that senior administrators might wish to talk confidentially to each other and that it would be unfortunate if their words of secret wisdom were to fall upon the ears of the *canaille*!

A NEW GERMAN INVENTION



Herr Bruno Helberger, a German inventor, at the keyboard of his latest "Electric Piano." The instrument works a large number of loud speakers, and he claims that it can replace a whole orchestra. It was demonstrated at the German Radio Exhibition this year.

will be frowned upon except in the case of Sir Walford Davies from St. George's Chapel, Windsor.

Programmes from America

There has been an inexplicable hold-up in the carrying through of the plan for exchanging programmes with America which was completed and sanctioned during Sir John Reith's visit to America last summer.

There was much talk then of British listeners getting the real "low-down" on the peaks of America's broadcasting, both N.B.C. and C.B.S. I heard of songs straight

exercises should be broadcast in the early mornings. This is now the only considerable country in the world equipped with radio that has no service of health exercises.

The argument about economy hardly holds water. The argument that the Ministry of Health is against it is not borne out by inquiries at that department. The argument that an extra burden would be placed on the staff is true; but then, if this is a proper addition to the programme service, the staff arrangements should be accommodated to meet it, either by additions or by a new system of shifts.

Every READY RADIO Kit is Matched—Tested—and Passed before dispatch, under the supervision of Mr. G. P. Kendall, B.Sc.

Chief Engineer, READY RADIO.

Get the whole world on the "I.E." Three

Kit "A" £6:11:0

(Less Valves and Cabinet)

or 12 monthly instalments of 12/-

Kit "B" £7:18:6

(With Valves, less Cabinet)

or 12 monthly instalments of 14/6

Kit "C" £9:1:6

(With Valves and Cabinet)

or 12 monthly instalments of 16/9

COMPLETELY ASSEMBLED "I.E." THREE

Completely assembled Receiver, Aerial Tested. Royalties Paid .. £10:11:6

or 12 monthly instalments of 19/6

TO INLAND CUSTOMERS.—Your goods are dispatched Post Free or Carriage Paid.

TO OVERSEAS CUSTOMERS.—

Everything Radio can be supplied against cash. In case of doubt regarding the value of your order, a deposit of one-third of the approximate value will be accepted, and the balance collected by our Agent upon the delivery of the goods. All goods are carefully packed for export and insured. All charges forward.

- | | |
|---|-------|
| 1 Ebonite panel, 16 in. x 8 in. x 1/2 in., drilled to specification | 1 5 6 |
| 1 "Londor" cabinet, with 10-in. baseboard | 1 3 0 |
| 1 "Wavemaster" Extensior, '0005, with slow-motion drive | 15 6 |
| 1 ReadRad '0003 Brookmans condenser | 3 6 |
| 1 ReadRad '00075 Brookmans condenser | 3 6 |
| 1 A.E.D. Fader-type volume control | 10 6 |
| 3 "Junit" valve holders | 2 0 |
| 1 T.C.C. '0003 fixed condenser, Type 34 | 1 6 |
| 1 ReadRad on/off switch | 10 |
| 3 Lotus single-coil holders | 2 0 |
| 1 ReadRad 2-meg. grid leak and holder | 1 4 |
| 2 T.C.C. 2-mfd. condensers, Type 50 | 7 8 |
| 1 R.I. General Purpose L.F. transformer | 10 6 |
| 1 Lotus L.F. transformer (No. 1) | 5 6 |
| 1 ReadRad Standard H.F. choke | 4 6 |
| 1 R.I. General Purpose L.F. choke | 12 6 |
| 1 Lewcos 25,000-ohm Spaghetti resistance | 1 6 |
| 1 ReadRad 400-ohm baseboard-mounting potentiometer | 2 9 |
| 1 P.V.1 coil unit | 3 0 |
| 1 P.J.2 coil unit | 2 0 |
| 1 Ebonite terminal strip, 16 in. x 2 in., drilled to specification | 1 6 |
| 9 Belling-Lee indicating terminals, Type "R" | 2 3 |
| 1 Lotus pick-up jack, No. J.K.1 | 2 0 |
| 1 Lotus plug, J.K.1 | 2 0 |
| 1 Packet "Jifilinx" | 2 6 |
| 3 Belling-Lee wander plugs | 6 6 |
| 3 Lewcos plug-in coils, Nos. 100, 150, 200 | 13 6 |
| 1 Set Atlas S.W. coils, 2, 4, 6, 9 | 10 0 |
| 3 Mullard valves, as specified (P.M.1.H.F., P.M.1.L.F., P.M.2) | 1 7 6 |
| Flex, screws, etc. | 8 |

£ s. d.

RECOMMENDED BATTERY AND LOUD-SPEAKER EQUIPMENT

- | | |
|------------------------------------|--------|
| 1 Pertrix 120-v. Standard H.T. ... | 15 6 |
| 1 Pertrix 9-v. Grid-Bias Battery | 1 6 |
| 1 Pertrix Accumulator, type PXC3 | 11 0 |
| 1 Blue Spot Speaker, type 44R .. | 2 12 6 |

£ s. d.

Complete Kit, including battery and loud-speaker equipment, and one Ready Radio Kit "C" £13 2 0
or 24/- deposit and 11 monthly payments of 24/-

Completely assembled Receiver, together with battery and loud-speaker equipment .. £14 2 0
or 26/9 deposit and 11 monthly payments of 26/9.

Ready Radio Mains Unit, for use with the "I.E." Three .. £3 3 0
If required with an "I.E." Three Kit, add £3 3 0 to Cash Price, or 6/- to Easy Payment Price.

Send four 1d. stamps for your copy of Kendall's booklet, "10 Hours for Modern Radio Constructors."

Ready Radio's 1932 Catalogue is now ready—a complete encyclopedia of modern radio apparatus. Send for your copy—1/-, post free.

If you are interested in the "Duo-Vise," or the "Midget" Three, write to Ready Radio for full price lists.

Total (including Valves and Cabinet) .. £9 1 6



Head Office & Works:
Eastnor House, Blackheath, S.E.3.

'Phone: LEE GREEN 5678.
'Grams: Readrad, Blackvil.

Showrooms:
159, Borough High Street,
London Bridge, S.E.1.
'Phone: HOP 3000.

CASH or C.O.D. ORDER FORM

To READY RADIO LTD.,
Eastnor House,
Blackheath, S.E.3.

To READY RADIO LTD.,
Eastnor House,
Blackheath, S.E.3.

EASY PAYMENT ORDER FORM

Please dispatch to me at once the following goods.....

Please dispatch to me the following goods

for which (a) I enclose (b) I will pay on delivery (Cross out line not applicable) £.....

for which I enclose first deposit of £

Name
Address
W.C. 12/31.

Name
Address
W.C. 12/31.

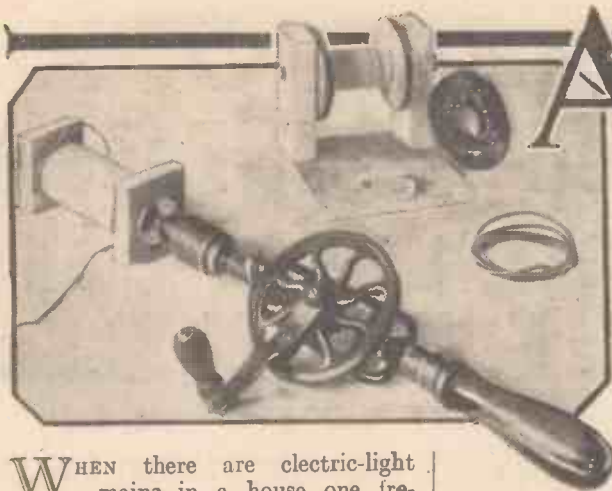

A USEFUL UNIT

Do you get any interference from your electric light mains, even though you are using batteries for your H.T.? If so, you should build this handy little gadget.

By C. P. ALLINSON, A.M.I.E.E.

WHEN there are electric-light mains in a house one frequently gets a hum in the loud speaker, even though the set is being run entirely off batteries.

There are two places where such a hum can get in, either by the aerial or by induction into the loud-speaker leads.

In the latter case it may often be found that simply running the leads clear of the wall or taking them along

THE "HUM" TRAP

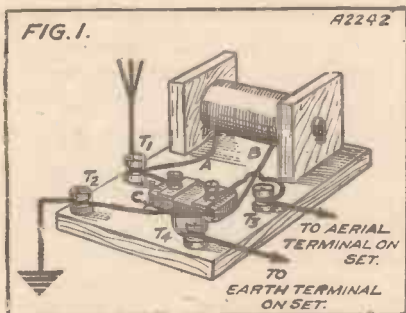

Here you see how to connect up the finished instrument. It just goes in series with the aerial and earth leads to the set.

a different line will cure the trouble. The case of hum picked up by an aerial lead, however, cannot always be cured in this way, though sometimes altering the run of the aerial lead will work wonders.

Quite Inexpensive

This form of trouble is usually most difficult to get rid of when the "Det. and 2 L.F." combination is being used, for any hum that comes in on the aerial is impressed on the grid of the detector valve and is passed on in amplified form till it finally reaches the loud speaker.

If you are one of those unlucky listeners who suffer from this kind of interference, the unit I am going to describe is just what you want. As well as helping in this particular form of trouble, it will be found very

useful in reducing, and even sometimes entirely eliminating, induction from telephone and telegraph wires.

To make up this unit you will want about 1 oz. of 36 gauge D.S.C., a cardboard tube or former about 1½ in. in diameter, a fixed condenser of .0003-mfd. capacity, and four terminals. If you happen to have a .0005-mfd. condenser by you, try it before you buy a new one, and the same applies to one of .0002-mfd. capacity.

The wire is wound on the tube so as to form a choke. In order to minimise the risk of the end of the winding breaking off short, the 36-gauge wire should be soldered to a length of stranded flex, which is first fixed to the former with a bit of insulating tape, and is wound two or three times round the tube as well.

Winding the Choke

After this is done, 500 turns of the 36-gauge D.S.C. are put on. A convenient way of winding this choke is by means of an ordinary geared brace. The tube is held between a couple of round wooden or metal cheeks on a length of screwed rod which is gripped in the chuck of the brace, as shown in the photograph.

Find out how many times the chuck rotates every time the handle is turned. If, for instance, you find it is 10 turns, then 50 turns of the handle will put on 500 turns of wire on the former.

Try to wind the wire on the tube fairly progressively from one end to the other; put it in regular lumps, if you like, but don't run backwards and forwards from one end to the other.

The Wiring

Having wound on the 500 turns of wire, solder the end of the winding to a length of flex in the same way

as the beginning, and fasten this to the former.

Now fasten the tube to a small wooden baseboard to which the four terminals have previously been fixed—two each side. Fix the condenser alongside the choke, and carry out the simple connections shown in the sketch in Fig. 1.

How to Connect Up

Connect the aerial to terminal T₁ and the earth to T₂, and join terminals T₃ and T₄ to the aerial and earth terminals of the receiver itself respectively. If you find the use of one unit reduces, but does not entirely get rid of the interference, then a second unit may be made up and the two connected together, as shown in Fig. 2; but this should only be done if the set has ample power, as a slight reduction in volume may result.

FOR BAD CASES

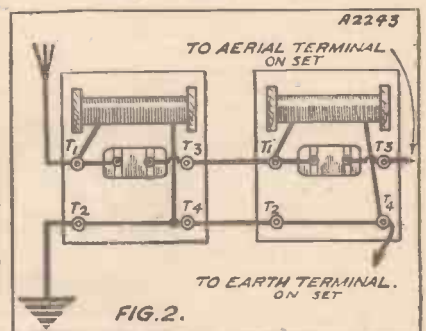

If in your particular case hum is very bad, you should make two of these gadgets and connect them in series. This is an almost certain cure.

Of course, they are bound to take a certain amount of power away from your receiver. But most sets nowadays can spare a little, and it is well worth it if you can get rid of that annoying mains hum. At any rate, try it and see if there is any improvement.

MISLEADING METERS



It never pays to buy one of the "cheap and nasty" type of voltmeters, as you will see after reading this article.

By L. DIVER.

I WONDER how many amateurs possess voltmeters? And how many use them with discretion? Not many, I fear.

Now a voltmeter will give a correct voltage reading when it is actually connected, but as soon as it is disconnected up jumps the voltage. This particularly applies to those nasty little voltmeters which are given away with a pound of tea, or look like it, anyway!

MR. OHM'S LAW!

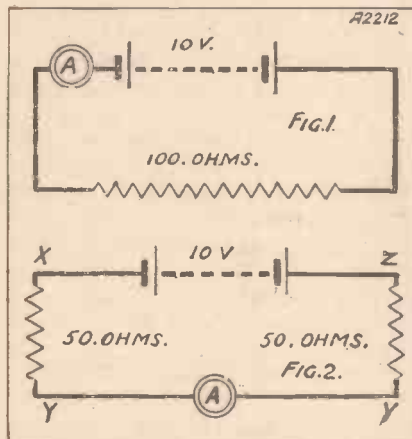

According to Ohm's law the current in a circuit is equal to the voltage divided by the total resistance. In both the above diagrams the resistance is 100 ohms, therefore the current is the same, namely, one-tenth of an ampere.

Some of the cheap voltmeters on the market will consume as much as 50 m.a. for a full-scale deflection, and will, in consequence, give a totally wrong idea of the applied voltage; to say nothing of running a battery down.

Law Abiding

To discover the why and wherefore of this discrepancy we shall have to revert to the first law of electricity, namely, that due to Simon Ohm, and known throughout the world as Ohm's law.

Unfortunately, a lot of people seem to fight shy of anything in the way of

rules or laws relating to electricity, thinking that they must be intricate and involved. In the case of Ohm's law nothing could be farther from the truth!

Actually, Ohm's law states that the current flowing in a circuit (in amps.) is equal to the pressure in volts divided by the resistance in ohms. Surely nothing could be simpler than that.

Its Three Forms

This formula, however, is too long to write every time we want to use it, so it is abbreviated thus: $C=E/R$.

Now, like any other equation, this may be juggled around and the results kept the same. Consider the following little lesson in elementary arithmetic: $6=12/2$. Altering the relative position of the figures we can get $2=12/6$ and $12=2 \times 6$. That's obvious, isn't it?

Well, in the same way we can alter $C=E/R$ (1) to $R=E/C$ (2); that is, the resistance is equal to the voltage divided by the current. Again, we can read it as $E=C \times R$ (3). In the latter case the voltage is found by multiplying the current by the resistance.

Turning to Fig. 1, we see a battery connected up to a resistance and an ammeter. For our present purpose we will assume that the ammeter has no resistance.

In Practice

From Fig. 1 we see that the battery has a pressure of 10 volts and the resistance a value of 100 ohms, and from equation (1) above we see that the current is .1 amp.

Had we not known the volts, but been able to read the current as shown by the ammeter, we would have been able to find the volts by equation (3), for $.1 \times 100 = 10$.

Once more, just to make it quite clear. If we knew the volts and could read the current, we could easily find the value of the resistance by the equation (2), for $10 \div .1 = 100$.

In Fig. 2 we see the same values, but this time the resistance is split up into two parts each of 50 ohms.

The applied volts remaining the same, the current will be the same, and the voltage across each resistance may be found by equation (3). Between XY it will be $.1 \times 50 = 5$, and across YZ will be $.1 \times 50 = 5$. Total 10.

If, as in Fig. 3, we add a resistance in parallel with the part YZ we get a different state of affairs, for the total resistance has decreased and is $50 + 25 = 75$ ohms.

Effective Resistance

To find the total resistance of two resistances in parallel we must take the reciprocal of the sum of the separate reciprocals. In this case it is as follows: $\frac{1}{50} + \frac{1}{50} = \frac{2}{50} = \frac{1}{25}$.

Now, with 75 ohms and 10 volts the current, equation (1) will be .133 amp. By working with equation (3)

PARALLEL PATHS

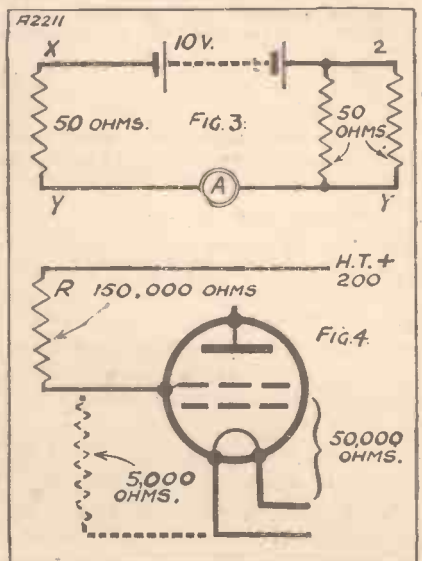

With the help of these two diagrams and the accompanying article you will see that if two resistances are connected in parallel the total resistance is reduced.

Misleading Meters—continued

we get for XY 6.6 volts and for the portion YZ we get 3.3 volts.

Thus by adding another resistance to the portion YZ we have altered the voltage across the portion XY, though still keeping the original voltage.

Let's see how this works out using values found in wireless. In Fig. 4 we have a screen-grid valve where the screen is fed with a voltage which has been dropped through a resistance.

(nearly). To find the volts across resistance R we use equation (3), which works out at 195 volts, leaving 5 volts on the screen!

It is understood, of course, that no one would go and put an actual resistance of 5,000 ohms across screen and filament, but this is what virtually happens every time a cheap voltmeter is used in that position.

If we replaced this 5,000-ohm resistance in Fig. 4 by a voltmeter of the same resistance it would read 5

on every experimenter's table, and should be used in preference to a voltmeter. However, should a voltmeter only be available, the best way to use it is as follows:

With the voltmeter connected, adjust the resistance R until the correct reading is obtained, then disconnect the meter and replace it by a resistance equal in value to the voltmeter.

High-Resistance Meters

This is not to be recommended unless the voltmeter has a fairly high internal resistance, say, 1,000 ohms per volt.

It is hoped that the foregoing will enable users to realise what inaccuracies can creep in if due allowance is not made for their resistance.

So when you buy a voltmeter, make sure that it is a good one with a high internal resistance.

ENTERTAINING THE STORK



Is he really enjoying it? More probably he wants to know what all the noise is about. He certainly looks rather supercilious about it!

Let's say that the resistance from screen to filament is 50,000 ohms, and volts required is 50, then from equation (1) the current will be .001, or 1 m.a. The supply voltage is 200, therefore the resistance R will have to dissipate 150 volts. Its value can be found from equation (2), and will be 150,000 ohms.

A Surprising Result

Now let's see what happens if we connect a resistance of, say, 5,000 ohms between screen and filament. Total resistance will now be 150,000 + 4,500 = 154,500, and current, from equation (1), will be 1.3 m.a.

volts, and the natural inclination would be to cut down the resistance R until an approximate reading of 50 was obtained.

However, as explained already, as soon as the voltmeter was disconnected the volts would jump up to some impossible figure which might render the valve totally inoperative.

The best way, then, to get at the voltage on any H.T. circuit is not by a voltmeter but by the use of a milliammeter. It is simply obtained by multiplying the current by the resistance.

Indeed, the milliammeter is such a useful instrument that it should be

 * **THE "EXTENSER" THREE** *
 * *What a reader thinks of it.* *

Sir,—Having made up your "Extenser" Three since last May, I wish to convey my appreciation to your staff for producing what I term a 100 per cent three-valve receiver. It is as you claim it to be—very loud; long-wavers come in galore, and are quite good; in fact, it is so loud on some, especially Radio Paris, Konigs-wusterhausen, Mühlacker, Toulouse, and Rome, that reaction is unnecessary, and only slightly so with the others. I am quite proud of it when I have visitors, they are amazed at the reproduction of it, especially when they examine it internally. I employ an R.I. dual coil, home-made Contradyne, Formo -0005 Extenser condenser, Telsen -0001 diff., Sovereign volume control, Marconiphone L.F. transformer, Telsen transformer, Lissen L.F. choke, Cossor detector, Triotron H.F., and Mullard power, backed up, of course, with the wonderful clear-cut cone and Blue Spot 66R unit, and a good aerial of 75 ft. Trusting I haven't bothered you in any way with my lengthy description, and wishing you and your book every success.

Yours truly,
 GEO. H. HALL.

Pec'ham,
 London, S.E.15.

TELSEN CONDENSERS

TELSEN MANSBRIDGE TYPE CONDENSERS

Telsen have installed the most advanced plant in the world for the manufacture of Mansbridge Type Condensers. Only genuine Mansbridge foil paper and the finest linen tissue are employed in the exclusive method of manufacture. Every Telsen Mansbridge Type Condenser is hermetically sealed from the atmosphere and Post Office standards of insulation are adopted throughout.

The preliminary research, the most modern plant in the world, the finest raw materials, the latest methods of manufacture and the final test, all combine to give Telsen Mansbridge Type Condensers a high insulation through years of service with freedom from breakdown. The type of construction employed makes them genuinely non-inductive.

Telsen Mansbridge Type Condensers, made in capacities from .01 to 2.0 mfd., from 1/6.

TELSEN FIXED MICA CONDENSERS

(Prov. Pat. No. 20287/30)

Telsen fixed mica condensers are made in capacities from .0001 mfd.-.002 mfd. They can be mounted upright or flat, and the .0003-mfd. Telsen fixed mica condenser is supplied complete with patent grid-leak clips to facilitate series or parallel connections.

Telsen Fixed Mica Condensers. Price 6d.

TELSEN

THE SECRET OF PERFECT
RADIO RECEPTION

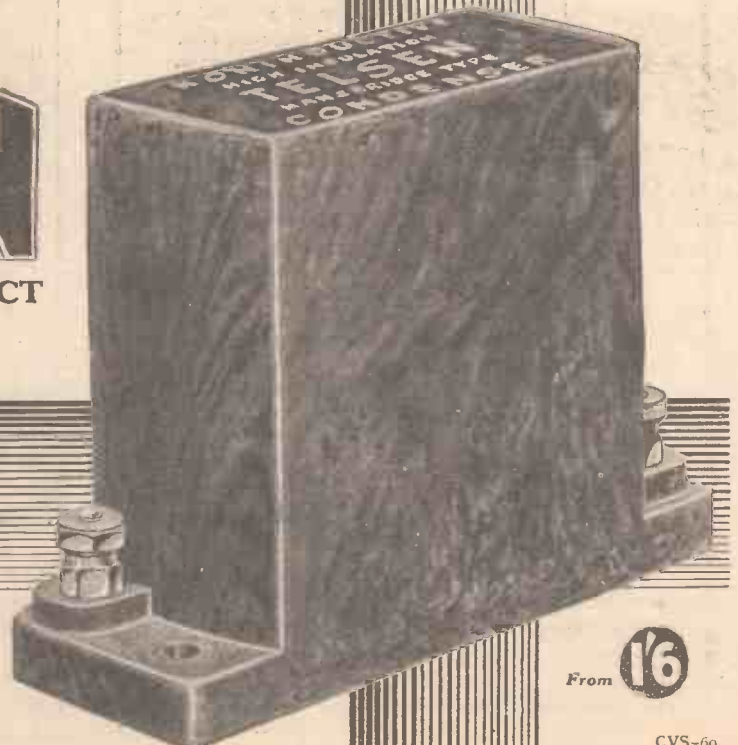
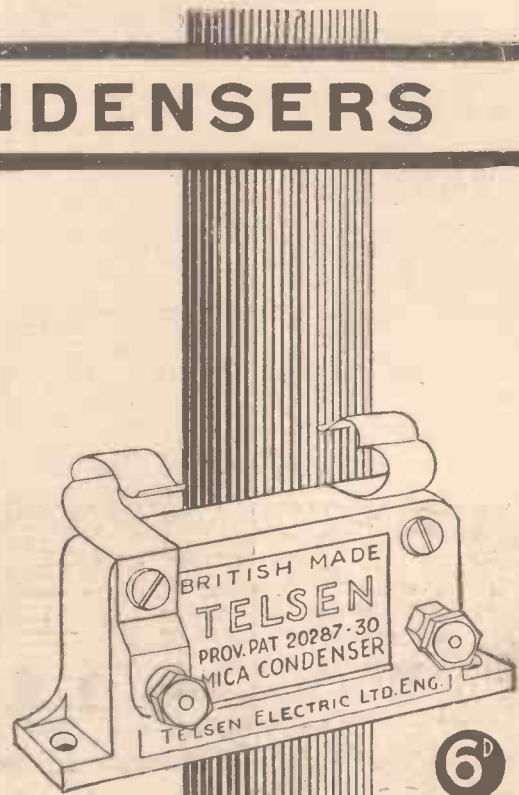

Send for the "Telsen Radio Catalogue" and book of "All-Telsen Circuits" to The Telsen Electric Co., Ltd., Aston, Birmingham.

CVS-60

Do You Know?

Historical Signs—No. 1



The Sign of St. Crispin

CRISPIN, a Christian martyr and shoemaker of Soissons, because of his goodness to the poor in making their shoes without payment, was, after his martyrdom in 286 made the patron saint of the shoemakers. In the middle-ages and onwards the sign of St. Crispin was used by all true craftsmen among leatherworkers.

To-day, in the same way, "the green case" is a recognised sign of condenser efficiency—indicating as it does the product of experience and skill. For every T.C.C. Condenser is the result of a quarter of a century's specialised experience—that of designing and making condensers—and condensers alone. Be sure your next condenser has this backing—be sure its T.C.C.

Look for the initials
T.C.C.
on the condenser
in the green case

T.C.C.

CONDENSERS

The Telegraph Condenser Co. Ltd., Wales Farm Road, N. Adon, W.3

♥ 9144



Have you had your copy of the 1932 "All-Metal Way"?

If you are going to build an all-mains receiver, or convert an existing battery-operated set, you need this booklet. It tells you how to construct high- and low-tension eliminators and trickle-chargers, and contains full details for running moving-coil loud speakers from A.C. mains. There are additional chapters on many all-mains radio problems; and questions which were not fully dealt with in our 1931 issue are now discussed in detail.

If you would like a copy of this new "All-Metal Way," fill in the coupon and send it to us with threepence in stamps.

 **WESTINGHOUSE** 

METAL RECTIFIERS

THE WESTINGHOUSE BRAKE & SAXBY SIGNAL CO., LTD.,
York Road, King's Cross, London, N.1. 'Phone: NORTH 2415.

Westinghouse Rectifiers are all-metal in construction, and, as far as we have been able to ascertain, permanent in normal use. Prices of the H.T. units are from 12/6;

-----**COUPON**-----

Westinghouse Publicity, 82, York Rd., King's Cross, London N.1.
Please send me a copy of "The All-Metal Way, 1932," for which I enclose 3d. in stamps.

PLEASE USE BLOCK LETTERS

Name.....

Address.....

W.C. 12.31.



A PRACTICAL MAN'S CORNER

In this section, which is of special interest to the set-builder, many valuable hints on construction and the handling of tools are given.

By R. W. HALLOWS, M.A.

RECENTLY I have been using a delightful kind of wire when making up receiving sets and other radio apparatus. This is Quickwyre, made by Messrs. Bulgin, which I can recommend to your notice. The No. 18 gauge tinned copper wire has an inner winding of cotton and an outer covering of coloured braided material.

The Ends Don't Fray

"Nothing very startling about that," says the reader. Wait a moment. The coverings are so put on that when you want to bare the end all that you have to do is to push them both back together with your finger and thumb. "Oh, yes," says the reader, "I know all about that, and then the braided covering frays out and looks like nothing on earth."

Wrong again. This is a very special kind of braiding which does not fray out. I don't quite know how it is done, but I do know that if you try to fray it it is quite a business to make even a small fringe of threads appear. With the ends of the insulation just pressed back it makes as neat a wiring job as you could wish for, and the No. 18 gauge wire is just stiff enough to make leads "stay put" and not too stiff to enable you to make neat loops with a pair of bottle-nosed pliers.

Speeds-Up Wiring

Wire of this kind greatly speeds up the job of making connections, for you have none of the fiddling business that occurs with ordinary double-cotton-covered wire. Nor is there any need to finish off the ends of the covering with a binding of thread as is the case with other kinds of wire with a braided covering.

If, by the way, you are using

ordinary double-cotton-covered wire, here is a tip for making off the ends neatly but quite quickly. As you know, one layer of the insulation winds off clockwise and one anti-clockwise. Unwind an inch or so of the outer covering and with it tie a single knot round the wire. Pull quite tight and cut off.

Then unwind the inner layer, and with this tie a single knot right on top of the other. Pull tight and cut off as before. This doesn't take long to do and it completely stops any tendency to unravel or to fray out.

FOR QUICK WIRING

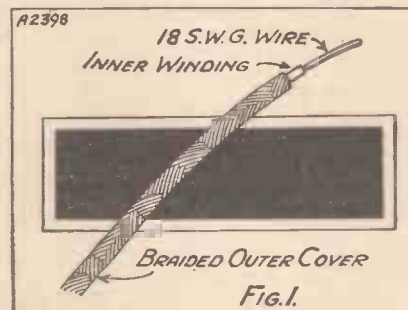

A sample of the wire referred to by our contributor. In order to bare the conductor it is necessary only to push back the outside covering.

I picked up the other day a screwdriver of a particularly good sort for the wireless constructor. It is illustrated in Fig. 2. Readers will see that it is of my favourite long type with a "cylindrical" handle. The blade is $\frac{3}{16}$ in. wide and so well shaped that it is a good fit for most ordinary small screws.

In the shank there are two useful scrapers, one large and one small, for removing the insulation from wire. The total length is 10 in. and the price is one shilling. You can obtain this kind of screwdriver from any

good toolshop, and if you haven't already something of the kind I am sure that you will not regret your purchase.

Making Loud Speakers

Any amount of people used to build their own loud speakers in the past, but this year the number of loud-speaker constructors has greatly increased owing to the large numbers of balanced-armature units which are available at remarkably small prices, together with suitable cones and chassis, as well as complete moving-coil units.

The simplest method of construction is, of course, to provide nothing more than a vertical baffle of solid wood or five-ply fixed with screws and brackets to the edge of a horizontal baseboard. The chassis is then secured to a suitable mount and the job is done. Many people, though, prefer to build cabinets for their loud speakers.

So far as looks are concerned I most certainly agree with them, though unless you are both careful and lucky in the construction of your cabinet you are apt to get a certain amount of resonance from it. In some cases the resonance puts in a bass which really isn't there!

Use Stout Wood

None of my own speakers is enclosed in a cabinet; in fact, one or two that arrived clothed in this way have since been undressed, so to speak, and left with nothing but baffles between them and the world. If you want to build a cabinet, don't choose either solid wood or three-ply that is very thin, for if you do you are certain to get marked "drummy" effects.

Use something fairly solid, such as $\frac{5}{8}$ - or $\frac{3}{4}$ -in. plain wood or stout five-ply.

A Practical Man's Corner—continued

Five-ply is an excellent material, since you can buy it so cheaply with a beautiful veneer of ornamental wood such as oak, mahogany, walnut or rosewood. Don't make the cabinet too small if you want to avoid "boxy" reproduction.

Here is a method which answers well. Make a frame as shown in Fig. 3, about 2 ft. square. The four pieces—top, bottom and sides of the cabinet—are secured together by means of battens as shown in the drawing.

The rear ends of the battens are flush with the back of the cabinet, but their forward ends are about an inch and a half short of the front edge. Large holes—two or three inches in diameter—should be made in the sides to prevent boxiness. The baffle-board, which may be of five-ply or of asbestos sheeting, is fixed by means of screws to the forward ends of the battens.

The Cabinet's Back

Whether or not the cabinet is fitted with a back is a matter of personal preference. I rather advise against a wood back, for the reason that it, again, may cause boxiness in reproduction. If you want a back simply to keep the dust out, why not make it of doped linen or even imitation

FOR DOUBLE DUTIES

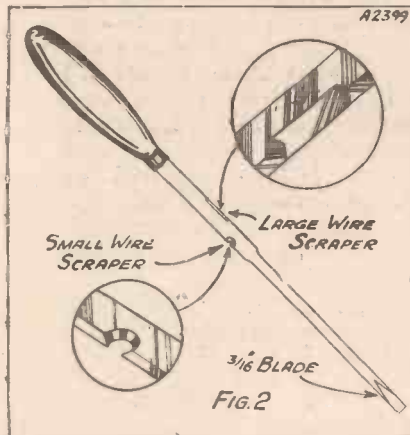

This useful screwdriver, besides doing its normal work, can be used as a wire scraper; a couple of slots being provided for the purpose in the shaft.

leather paper? If the paper is torn it is easily replaced.

In front of the baffle-board, to hide the rather unsightly gaping mouth of the loud-speaker's cone, you would probably like to have a thin piece of wood with a fretwork design. Then by all means have it. If you are a

skilled hand at fretwork you can make your own, but if you are not you can buy ready-made fronts in quite a number of attractive designs from almost any good shop that deals either in wireless goods or in tools and woodworking materials.

Covering the "Mouth"

The cost is quite small, two or three shillings at the outside. Sometimes it is difficult to find one of these fret fronts large enough for the best kind of cabinet; however, you can always "enlarge" them by fitting a frame, cut from a moulding, and made exactly on the lines of a picture frame. The front of the cabinet may be fixed by screws to the forward edges of the top, bottom and sides. Behind it there may be a veil of silk of any colour that pleases your fancy.

Here is a job that will appeal to many readers of an experimental turn of mind. It is quite easy to construct, at almost absurdly small cost, high-voltage electrolytic condensers of large capacity. An experimental model can be made up from aluminium wire, a short piece of thick copper wire, a jam-pot, and a small quantity of borax and boracic acid.

Here, briefly, is the principle of the electrolytic condenser. When an aluminium anode is immersed in a solution of borax and boracic acid, and a direct current is passed through the cell from a cathode of copper or other suitable metal, an insulating film of very small thickness forms on the aluminium.

Self-Repairing

This is the dielectric of the condenser. So thin can the film be made that the capacity of the condenser may be as high as 10 or 12 microfarads per square inch of anode. For wireless purposes, though, it is advisable to make it rather thicker, but even so a capacity of over 2 microfarads per square inch of anode is obtainable. If the condenser breaks down through overloading it repairs itself when the voltage is reduced.

The aluminium wire required is of about No. 10 or No. 12 gauge. Wind it into a close spiral about an inch in diameter. Obtain a cork bung that is a good fit for the mouth of the jam-jar and make in the centre of it a hole through which the end of the wire can

just be pushed. Before you insert the wire into the cork, work on to it a piece of cycle valve tubing long enough to extend from the underside of the cork to the top of the electrolyte.

Above the cork form the aluminium wire into a loop. Close to the outside edge of the cork make a hole through which a piece of copper wire can be

IMPROVING LOUD SPEAKERS

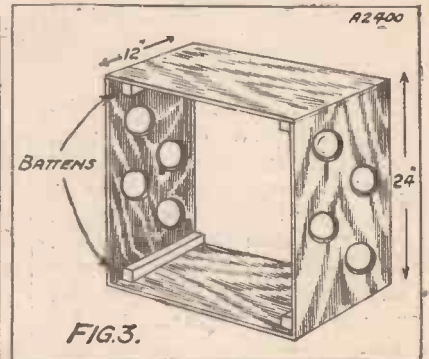

Many speakers when enclosed in a cabinet suffer from a preponderance of bass, mainly due to box resonance. Read all about the cabinet illustrated above, which effectively cures this complaint.

passed. The copper wire need only be long enough for its lower end to be well immersed in the electrolyte.

Condenser Forming

As before, thread on some cycle valve tubing and make a loop in the upper end of the wire. Fill the jar within about one inch of the top with solution composed of a teaspoonful each of borax and boracic acid dissolved in a pint of water. Put in the cork and notice carefully that the copper wire is well clear of the aluminium spiral.

The condenser now has to be formed by passing direct current through it for some time. You can do this from D.C. mains, or from A.C. mains through a rectifier. Connect a 50-watt lamp between the positive lead and the loop on the aluminium anode. The negative lead is connected to the copper wire. Forming in this way with a voltage of 200 takes three or four days.

You can tell when the process is complete by inserting a milliammeter into the negative lead. At first the current passing will be fairly heavy, but when the condenser is ready for use it will have dropped to a fraction of a milliamper.



WITH THESE IMPROVEMENTS

1. **THE NON INTERCHANGEABLE TERMINALS.** Positive and negative screw terminals shaped and coloured differently, and of different sized threads. They are moulded as part of the lid and cannot let acid creep past and so cause corrosion.
2. **NAME SLOT.** A convenience to both owner and recharging station. Mistakes impossible.
3. **LARGER FILLER AND CAP.** Easy to screw and unscrew, and rendering the battery almost unspillable.
4. **TROUGHED LID.** A finely finished moulded lid with high insulating properties.
5. **THE NEW CARRIER.** It makes the moving about of the battery a matter of ease and safety.



Exide "D" TYPE BATTERY

You cannot find all these improvements on any other battery. Look at the battery! An accessory sympathetically designed for the wireless set of to-day. Remember that the Exide "D" Series is the perfect low tension supply where only a moderate discharge is needed. Under these conditions it will last a very long time

before it will need recharging. Without risk it can wait months, as it positively cannot take harm. Therefore you can use a larger battery and so reduce recharging. You make certain of a smoother reception at far less cost when you install the Exide "D" Series Battery for low tension.

PRICES per two-volt cell • DTG—20 amp. hours—4/6. • DFG—45 amp. hours—8/6. • DMG—70 amp. hours—11/-.
DHG—100 amp. hours—14/6 • *These prices do not apply in the Irish Free State.*

From Exide Service Stations or any reputable dealer. Exide Service Stations give service on **EVERY** make of battery. Exide Batteries, Exide Works, Clifton Junction, near Manchester. Branches at London, Manchester, Birmingham, Bristol, Glasgow, Dublin and Belfast.

N. 50



WIRELESS WOODWORK

Some useful hints which will help you tremendously in turning out "good-looking" sets.

By R. TEECE.

As most of us know, the most worrying little job in making a wireless cabinet is forming the corners. There are several practical

EVEN SO!

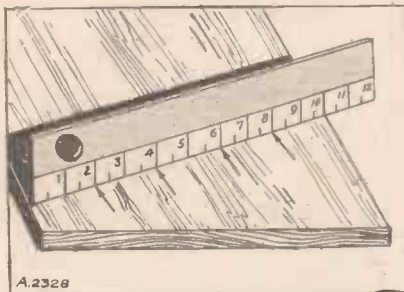

Fig. 1. Here is a handy little dodge which will enable you to work off an "odd width" plank evenly. Read all about it below.

methods of overcoming the trouble, a particularly useful one being shown in Fig. 5.

The side of the cabinet is secured to the base by screws, and these screws pass through hardwood dowels after they enter the base. While a good many cabinets are made by driving screws, and sometimes even nails, into "end-grain," the only satisfactory way of doing this (if the screws must go into the timber this way) is to fit dowels as shown.

HIDING THEIR HEADS

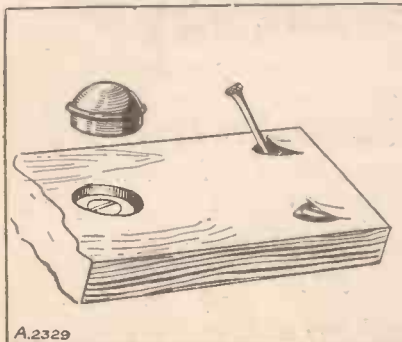

Fig. 2. These two methods of hiding the heads of nails and screws are well worth remembering.

Without these, if the wood is not quite seasoned the sides will pull away in time. In modern cabinets where the battery equipment is carried inside the case such methods as screwing end-grain are hopeless for supporting the extra weight of the batteries.

Will Not Warp

Now, if we look at the base and note its relation to the sides of the case we shall see that if it were turned round with the end-grain towards us this would bring the sides of the base into contact with the sides of the cabinet, that is, with the grain running towards the front of the cabinet.

It is easy to see that if we did this we should not require the dowels, but

BRACING THE PANEL

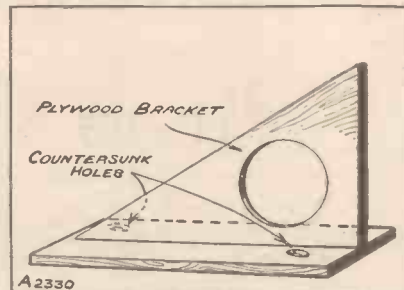

Fig. 3. A very efficient panel support can be made from two pieces of plywood fixed together as shown here.

this method is again unsuitable, for it leaves the base free to warp in the front of the cabinet, as there is no proper means of supporting the fibres, and those who want a good job are strongly advised to leave such an arrangement alone.

Putting the Lid on It

If it is desired to have a lid to the cabinet, a piece as shown at the top of the sketch will serve as a support and further brace for the sides. This piece is also dowelled at "X," but a metal dowel is used. This prevents



Fig. 4. The panel is "raked" slightly, and supported by the bracket shown in Fig. 3.

all movement when the joint is screwed up.

A feature of this cabinet is the neat chamfer at the corner, with the half-round moulding on each side, and this is all the decoration the cabinet needs. This moulding also hides the screws used in fixing the sides. If it is so desired the mould can be used round the opening for the panel. The mould should be glued on.

(Continued on page 127.)

FIXING THOSE CORNERS

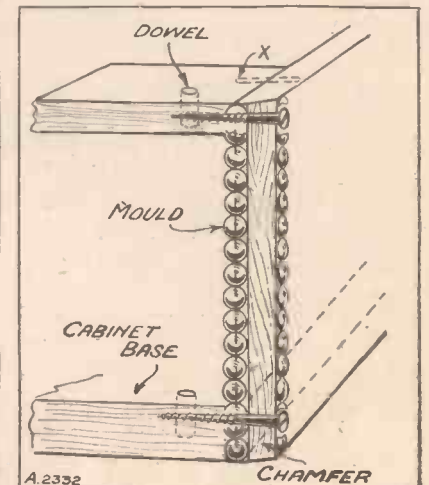
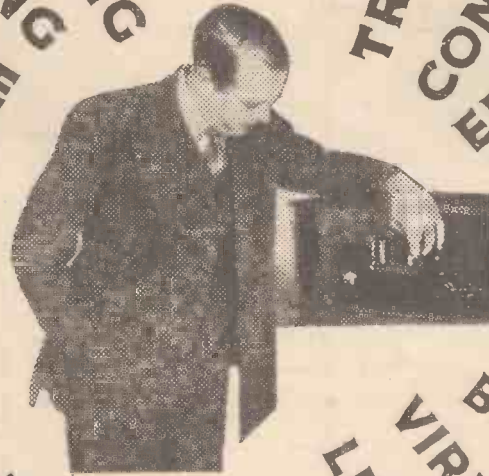

Fig. 5. Usually the corners of the home-made cabinet look very home-made indeed! But here is a method of obtaining a really professional finish.

CHALLENGING
INTERESTING
HELPFUL
CRITICAL
SCATHING
TRENCHANT
CONSTRUCTIVE
ENTERTAINING
FORCEFUL
EXPERT
UNIQUE
VIGOROUS
BLUNT
VIRILE
LIVE
OUTSPOKEN
PROVOCATIVE
FRANK
BRIGHT
USEFUL
TOPICAL
INTRIGUING
INSTRUCTIVE



Read **Capt. P.P.**
Eckersley's

Radio Feature

World-famous as one of the pioneers of broadcasting, both with the Marconi Co. and the B.B.C., Captain P. P. Eckersley is now Wireless Editor of *The Daily Mail*.

every Wednesday in The

DAILY MAIL

WITH PICK-UP *and* SPEAKER



By
A. JOHNSON-RANDALL

Radio-Gram Progress—About Loud-speaker Cabinets—A New Pick-up.

WHAT progress has been made in radio-gram equipment during the past year? After a consideration of modern equipment I am convinced that great improvements have been made in radio-gram outfits, pick-ups and loud speakers.

In the first place the price level is noticeably lower. Look at the number of moving-coil speakers of the permanent-magnet type which are now within the reach of the shallowest pockets.

Sensitive Loud Speakers

The advent of cobalt-steel magnets has made it possible to produce speakers of vastly increased selectivity. No longer is it necessary to have an amplifier supplied with high anode voltages and employing valves requiring heavy anode current.

Adequate volume for domestic purposes is readily obtainable with a super-power valve or pentode working on 120-150 volts H.T.

It is, of course, not essential to possess a moving-coil speaker in order to get high-quality reproduction. A good moving-iron type of unit will give excellent results, and the sensitivity of speakers of this class is amazing.

Bringing Out the Bass

It is not so very long since it was necessary to put considerable power into the output circuit to bring out the bass notes in their proper proportions. To the average listener the problem was insurmountable because he could not supply the anode current needed to ensure the degree of distortionless punch that such an outfit required.

Now, however, speakers are much

more sensitive, mains units and mains receivers are becoming common, and valves have improved beyond recognition, so there is no excuse for those who are unable to obtain "quality."

"Box" Resonance

While on this subject of loud speakers I should like to say a few words about "box" resonance. I have listened to a number of perfectly good speaker movements which have been spoilt by being placed in an unsuitable cabinet.

A SENSITIVE PICK-UP



The new Zonophone pick-up has an output of approximately 1½ volts and retails at the very moderate figure of 15s.

Why have a cabinet with a solid back? It isn't necessary, because a piece of muslin material will serve the purpose of keeping out the dust and reproduction will not suffer.

Then, again, I don't like the idea of the unit being secured to a thin baffle forming part of the cabinet. The cabinet-work needs to be stout and solid, otherwise it may tend to vibrate on certain notes.

My own moving-coil is not in a cabinet, but simply consists of a unit screwed to a 3-ft. baffle 1 in. thick.

Unfortunately it isn't very attractive in appearance and the household

objects to such an article having a place amongst the remainder of the drawing-room furniture. And so, at the moment, I am busy looking for a solidly built cabinet which will give me results free from any extraneous resonances.

However, I have no doubt that I shall be able to obtain what I require from one of the firms specialising in speaker cabinets. Some of those I have come across are very beautiful pieces of work and, moreover, the prices are right.

Moderately Priced

The "Zonophone" people have recently brought out a very moderately priced pick-up, having an output of approximately 1½ volts. This means that the sensitivity is high, and in consequence it will function with any ordinary straightforward amplifier. It retails at 15s., and the weight is 130 grammes (about 4½ oz.).

The construction is of metal with a bronze finish, and the arm rotates very freely.

The firm has also produced a three-valve kit set of the detector and two resistance-coupled L.F. type, having a pentode output. The pick-up can be plugged into two pick-up sockets which are provided at the back of the cabinet.

Value for Money

The kit set is at present undergoing tests in the WIRELESS CONSTRUCTOR laboratory and will be dealt with in a forthcoming issue.

In the case of the pick-up, this was found to give excellent sensitivity and good reproduction. It is a value-for-money product.

Ready Radio Catalogue

CASH OR EASY PAYMENTS

HEAYBERD ELIMINATOR KITS

Model C.150.—H.T. only. 3 Tappings, giving a maximum of 150 volts at 25 ma. £3 16 0. 7/- deposit. 11 monthly payments of 7/-

Model C.200.—H.T. only. 4 Tappings, giving a maximum of 250 volts at 60 ma. £6 17 6. 12/9 deposit. 11 monthly payments of 12/9

Full constructional details and wiring plan enclosed with each Kit.

READY RADIO MAINS UNIT FOR A.C. MAINS

Type R.I.—120 volts at 20 ma. 3 H.T. Tappings. £3 3 0. 8/6 deposit. 8 monthly payments of 8/6

Type B.S.—Specially designed by Mr. G. P. Kendall, B.Sc., for use with any receiver not using more than 5 valves, 150 volts, 25 ma. 4-amp. trickle-charger, 2, 4 or 6 volts. £5 17 6. 10/9 deposit. 11 monthly payments of 10/9

Varley Square Peak Coil with H.F. Transformer and Dubilier '04 Condenser. £1 5 6. 9/- deposit. 2 monthly payments of 9/3

KITS

R. for M (V.3). £5 17 6. 10/6 deposit. 11 monthly payments of 10/6

Mullard 1932, without cabinet. £6 10 0. 12/- deposit. 11 monthly payments of 12/-

Cossor 1932, No. 234, with cabinet. £6 15 0. 12/3 deposit. 11 monthly payments of 12/3

Cossor, A.C. Mains. £9 19 6. 18/3 deposit. 11 monthly payments of 18/3

Six-Sixty Chassis Kit. £6 17 6. 12/6 deposit. 11 monthly payments of 12/6

Osram Mew Music Magnet 4. £10 15 0. 19/8 deposit. 11 monthly payments of 19/8

BLUE SPOT LOUD-SPEAKERS

44 R. Cabinet Speaker, in Oak (incorporates 66 R. Unit). £2 12 6. 8/- deposit. 6 monthly payments of 8/-

100 D. Inductor, in Oak Cabinet (moving-coil quality at cheap cost). £3 3 0. 8/6 deposit. 7 monthly payments of 8/6

Goliath 30 P.M., in Walnut Cabinet (moving-coil reproduction at its best. Very sensitive). £5 10 0. 10/- deposit. 11 monthly payments of 10/-

66 R. Unit and special chassis. £2 2 6. 7/9 deposit. 5 monthly payments of 7/9

100 U. Inductor Unit Chassis. £1 19 6. 7/3 deposit. 5 monthly payments of 7/3

Permanent Mag. Moving Coil Speaker Chassis, with Output Matching Transformer. £3 15 0. 6/9 deposit. 11 monthly payments of 6/9

INSTAMAT OUTPUT TRANSFORMERS

For all speakers except low-resistance moving-coil. £1 7 6. 10/- deposit. 4 monthly payments of 5/-

For low-resistance moving-coil speakers. £1 17 6. 10/- deposit. 6 monthly payments of 5/-

B.T.H. R.K. MOVING-COIL LOUD-SPEAKERS

SENIOR A.C. £7 15 0. 24/10

Or deposit of 15/9 and 6 equal monthly payments of **MINOR PERM. MAG.** with matching transformer. £3 1 8. 11/3

Or 6 equal monthly payments of

GRAMOPHONE EQUIPMENT PICK-UPS

A.E.D.—With Tone Arm No. 60r. Every note perfect. Negligible record wear. Perfect tracking. £2 2 0. 7/9

Or 6 equal monthly payments of

A.E.D. "Beta" type, with Tone Arm No. 612. £1 10 0. 5/6

Or 6 equal monthly payments of

B.T.H. SENIOR. £2 5 0. 8/3

Or 6 equal monthly payments of

BLUE SPOT. £3 3 0. 8/6

Or 8 equal monthly payments of

H.T. ACCUMULATORS

FULLER, Type DMHG.—120 volt, 6,500 ma. capacity. £4 1 0. 7/6

Or 12 equal monthly payments of

FULLER.—150 volt, 6,500 ma. capacity. £5 1 3. 9/3

Or 12 equal monthly payments of

H.T. BATTERIES

PERTRIX.—150-volt Super Capacity H.T. Battery, No. 30r. £1 11 0. 5/9

Or 6 equal monthly payments of

FOR CASH ONLY

BLUE SPOT MAINS DISTURBANCE ELIMINATOR 10/6

SPECIAL EXPERIMENTER'S KIT of useful "Odds and Ends" containing flex wire, nuts, screws, terminals, crocodile clips, formers, sleeving and 26 and 34-gauge wire, etc., etc. 7/6

SPECIAL EXPERIMENTER'S KIT OF TOOLS, containing hand-wheel brace, set of drills, 2 screw-drivers, 1 pair pliers, 1 soldering iron, flux and solder, scriber, counter-sinking bit, dusting brush 20/-

BLUE SPOT WAVE-TRAP 15/-

R.I. DUASTATIC BAND FILTER COIL 15/-

HARLIE TONE CONTROL 10/-

READIRAD RADIOGRAM VOLUME CONTROL 5/9

VARLEY PICK-UP WITH TONE-ARM (New Model) 42/-

WESTINGHOUSE RECTIFIER Type H.T.8 (250 volts 60 ma.) 21/-

R.I. MAINS TRANSFORMER Type E.V.32 for above 27/6

WEARITE EARTH TUBE 3/6

BRITISH GENERAL BAND PASS TUNING UNIT 14/6

READIRAD RADIOGRAM SWITCH 2/9

READIRAD DIAL LIGHT 2/3

FORMO NEW INDOOR AERIAL WIRE (20 ft.) 4/6

CASH or C.O.D. ORDER FORM

To: **READY RADIO LTD.**, Eastnor House, Blackheath, S.E.3.
Please dispatch to me at once the following goods:

for which (a) I enclose (cross out line) £
(b) I will pay on delivery (not applicable)

Name
Address
W. Con. 12/31. All Cash Orders of 10/- or over, post free.

EASY PAYMENT ORDER FORM

To: **READY RADIO LTD.**, Eastnor House, Blackheath, S.E.3.
Please dispatch to me the following goods:

for which I enclose first deposit of £

Name
Address
W. Con. 12/31.

Gifts That Always Please



Take this List when you go shopping!

British Gift Books for Boys and Girls of All Ages

THAT ever-perplexing question, "what to give," is easily solved if you give books this year; they are the best gifts and never fail to please. Here are the very best books for boys and girls of all ages—the pick of the Children's Annuals, packed with lively fun in picture and story. They are strongly bound in brightly coloured covers, and most of them contain beautiful coloured plates and many pages printed in colours. If you want a present that will thrill any boy or girl, and one that will keep them happy during the long winter days ahead, you cannot do better than to choose one or more of these famous All-British Annuals—on Sale at all Newsagents and Booksellers.

For Boys and Girls at School

CHUMS Annual	12/6
The MODERN BOY'S BOOK of AIRCRAFT	7/6
BOY'S CINEMA Annual	6/-
MODERN BOY'S Annual	6/-
CHAMPION Annual	6/-
HOBBY Annual	6/-
HOLIDAY Annual	6/-
The NEW ZOO Annual	6/-
SCHOOL FRIEND Annual	6/-
SCHOOLGIRL'S OWN Annual	6/-
BRITISH BOY'S Annual	5/-
BRITISH GIRL'S Annual	5/-
LITTLE FOLKS' Annual	5/-
GOLDEN Annual for Girls	4/6
POPULAR BOOK of GIRLS' STORIES ..	2/8
POPULAR BOOK of BOYS' STORIES ..	2/6

For Boys and Girls from 6-12 Years

PLAYBOX Annual	6/-
TIGER TIM'S Annual	6/-
PLAYTIME Annual	6/-
PUCK Annual	6/-
CASSELL'S CHILDREN'S Annual ..	5/-
BRUIN BOYS' Annual	3/6
Mrs. HIPPO'S Annual	3/6
RAINBOW Annual	3/6
BUBBLES Annual	3/6

For Very Little Children

CHICKS' OWN Annual	3/6
BO-PEEP'S BUMPER BOOK	3/6
TINY TOTS Annual	2/6

For Older People

PICTURE SHOW Annual	6/-
"BEST WAY" COOKERY Gift Book	4/6

Easy to Pack—Cheap to Post—Certain to Please.

REGARDING RECTIFIERS

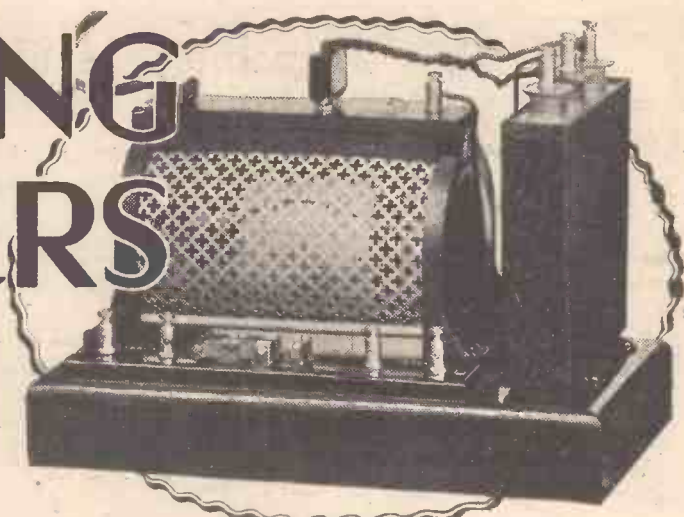

In all cases where H.T. is obtained from alternating current mains it is necessary to employ a rectifier of one sort or another. Read all about the process in this illuminating contribution.

By HANDEL REES.

CIRCUIT diagrams of rectifiers in mains-unit circuits may sometimes appear somewhat complicated, but there is no reason why their wiring should not be quite as straightforward as that of a "straight" receiver.

To make their composition quite clear we must first consider a few outstanding points. It is well known, for instance, that an alternating current is one that alternates or reverses in direction.

The Cycle of Current

Thus if we take a wire carrying A.C., the current first flows one way, reaching a maximum in that direction, and then falls to zero. It now grows to a negative maximum, i.e. the direction of the current is reversed. Finally, it falls from the negative maximum to zero again, the complete series of changes constituting a cycle.

This simply means that the polarity of wires carrying A.C. becomes alternately positive or negative

for each half-cycle, and we might represent the changes by the curve shown in Fig. 1 (a), distances above the line OX being positive, and those below, negative.

Half- and Full-Wave

The alternations are, of course, extremely rapid. Thus if the frequency of the supply is 50 cycles per second, one cycle obviously takes only 1/50th of a second, or, since a half-cycle occupies only half this time, a given point is positive or negative for a matter of only 1/100th of a second.

Now, such a current is useless for radio purposes until, first, the half-cycles in one direction are eliminated. That is, the current must be rectified so as to flow only in one direction. One way of doing this is to make use of devices that will permit a current to pass through them in one direction

only, cutting off the reverse half-cycles; the resulting output is indicated by the curves in Fig. 1 (b), and we have half-wave rectification.

Alternatively, the same devices may be arranged in such a way as to utilise both half-waves. The half-

A TWO-ELECTRODE "TUBE"

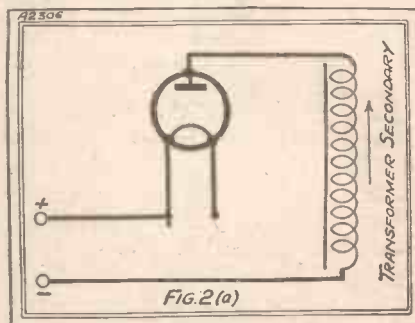

The above circuit clearly shows how single-wave rectification is obtained. Electrons can flow through the valve only in one direction, namely, from filament to plate.

SOME EXAMPLES OF CURRENT CURVES

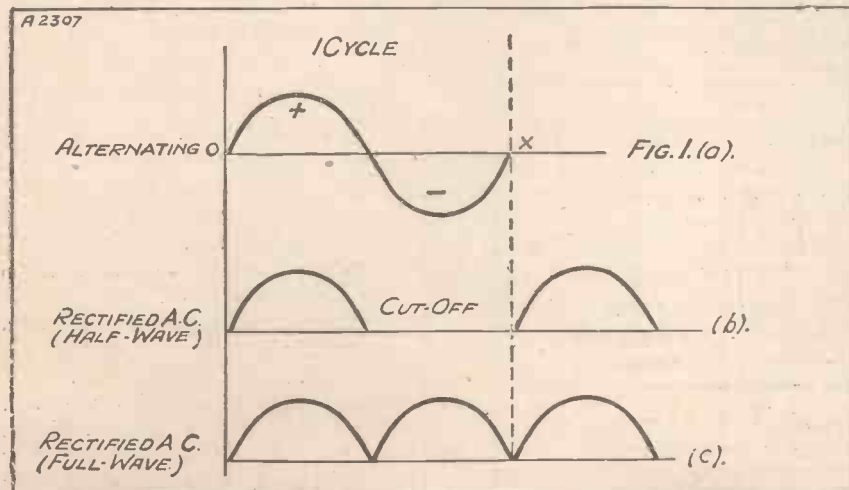

A full cycle of alternating current is shown in the top diagram, Fig. 1 (a). If single-wave rectification is used, one half of the cycle is eliminated, and the uni-directional pulses appear as in Fig. 1 (b). The better method, however, is to employ full- or double-wave rectification, thus making use of the full alternation as in Fig. 1 (c).

cycles removed in (b) are now reversed, as shown in 1 (c). Since the whole cycle is thus utilised, full-wave rectification, as this is termed, is evidently more satisfactory in certain respects than the half-wave method.

The currents shown in Fig. 1 (b) and (c) are now in one direction, but they are quite unsteady and require smoothing before being suitable for operating a set. In fact, they are pulsating currents, and to compare the two methods of rectification just mentioned it will be useful to observe that the frequency of the pulsations is different in the two cases.

Two Main Types

Whichever method is adopted, the rectifier will consist essentially of a device that will conduct current only in one direction, i.e. it must possess

Regarding Rectifiers—continued

uni-directional conductivity. The form of rectification obtained depends upon the arrangement and connections of these devices, and, to-day, two main types are in general use, viz., the valve rectifier and the *dry* type rectifier.

It is well known that a valve will only pass current when the plate is made positive and the filament negative. Fig. 2 (a) shows a valve (minus the grid) connected in circuit with one of the secondary output leads of a mains transformer.

The Cut-Off

For simplicity the filament heating arrangements are omitted. From what has already been said it is clear that the polarity of the secondary is alternating at the frequency of the supply. The valve, however, passes current only when the plate is positive.

Thus if we assume the direction of a "positive" half-wave to be upwards, as shown by the arrow, negative electrons will at this interval flow from filament to plate, and thence through the transformer secondary. During the next half-cycle nothing will occur, because the plate is now negative. In effect, then, the reverse half-cycles are cut off, giving half-wave rectification, and the effect of Fig. 1 (b).

Regular Reversals

Fig. 2 (b) shows an arrangement of two such valves for full-wave rectification; the filament connections being now added. The two ends of the transformer secondary are taken

to the plates of the two valves, another tapping being taken from the centre of the winding.

A small winding is added to supply the filament, and another output lead taken from the centre of this, which is at zero potential to earth. Consider again the current in the

FOR FULL-WAVE WORKING

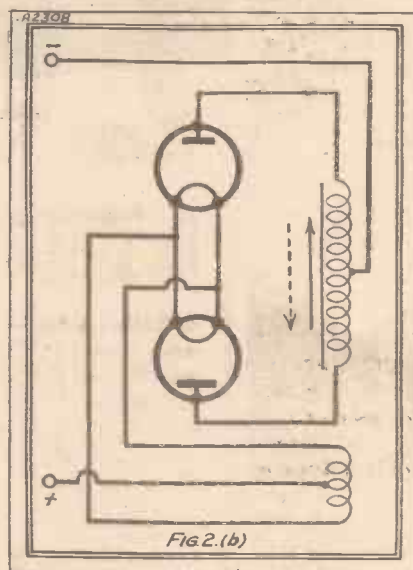

These are the connections for full-wave valve rectification. It gives a comparatively steady output.

secondary to be flowing upwards during a "positive" half-cycle.

The plate of the top valve will be positive and that of the lower negative. Under these conditions current will flow only from the top valve, making the centre tapping from the transformer negative, and

the tapping from the filament winding positive.

During the next half-cycle matters will be reversed, the lower valve now coming into operation and the top one having a negative plate potential. A little consideration will show that the flow will still be outwards from the secondary centre tap, thus giving the same output polarity as before.

The Two-Plate Types

Instead of using two separate valves, a full-wave type with two separate plates may be employed, the two ends of the transformer winding being taken to these instead of the plates in 2 (b). The principles and connections are otherwise exactly the same as 2 (b), except, of course, that only one filament is used.

It is worth noting that the output voltage of a transformer designed for a full-wave valve must be twice the maximum anode voltage to be employed. Thus if the maximum anode volts are 150, each half of the secondary must give 150 volts, or the whole winding 2×150 .

Coming to the well-known Westinghouse types of *dry* rectifiers, these obviously possess the unique advantage that no filament heating is required, and the device is considerably more robust and lasting than a valve. We need not enter into the theory of rectification here, and, in fact, there is little to be said about the connections, since they are quite straightforward.

Limits of Current

The connections of the well-known H.T.3 type for a half-wave output of 120 volts, 30 milliamps., are shown in Fig. 3 (a). The only point to note is the reservoir condenser of 4 mfd. coupled across the output. This is additional to the other condensers used for smoothing, and besides in itself resulting in better smoothing it adds materially to the average output of the rectifier.

The main precaution required with dry rectifiers is not to exceed the maximum rated current, and it is therefore very advisable to use H.T. fuses that will break circuit should the current exceed this for any length of time. Otherwise these units will give lasting satisfaction, and are used with great success on a large number of present-day mains devices.

A STEP IN THE RIGHT DIRECTION

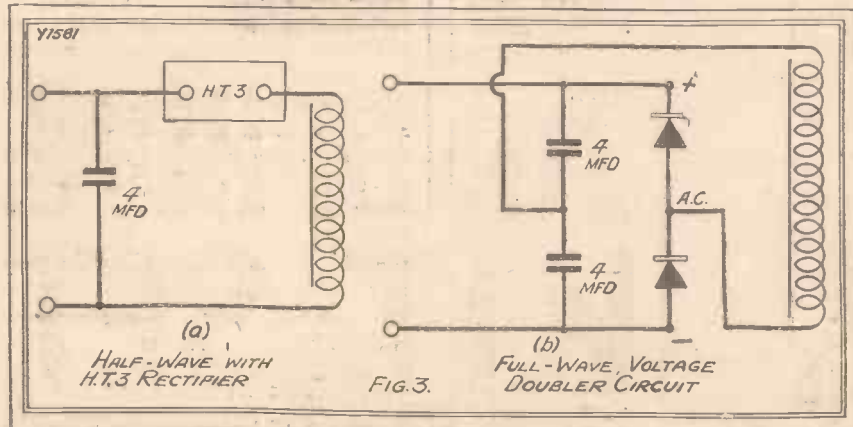

One disadvantage of the valve rectifier is that it requires a certain amount of power to heat its filament. No such separate energising is needed for the dry rectifier. The left-hand diagram shows the connections for single-wave working, and the one on the right for a full-wave voltage doubler.

LET US HELP YOU—

to get better reception with your "Duo-Vise" or "Midget" Three. Years of experience enable us to supply only the very best components.

WEARITE P.J.I. COIL

This coil is recommended for the "Duo-Vise" Two. It is guaranteed correct to specification and approved by the "P.W." Research Department. Price 2/9

PAXOLIN PANELS

Supplied in Mahogany, Black or Walnut finish. All sizes supplied. Drilled to specification.

Write for particulars.

WRITE FOR FREE ILLUSTRATED LIST.

WEARITE VOLUME CONTROL

Specified for use with the "Midget" Three. This volume control will give every satisfaction. 1-meg. volume control. Price 4/-

WEARITE 4-POLE SWITCH

Wearite 4-pole change-over switch, D.P.D.T., panel-mounting type, G.6. Price 2/-

WEARITE COMPONENTS

WRIGHT & WEARE LTD. 740, HIGH RD., TOTTENHAM, N.17 Phone: Tottenham 384718/9

-CLIX-

CONSTRUCTOR'S KIT
Saves you Time and Money.



Contains an assortment of nineteen Clix fittings specially selected for the set builder.

Contents:—2 Spade Terminals engraved L.T.; 2 Plugs and Sockets (A and B); 7 Terminals, H.T., L.T., L.S., 6 Wander Plugs, H.T. and G.B. Value 3/5 Price 3/-

Buy a Clix Kit for your next set and save fivepence.

Obtainable from most dealers or direct.

Fully Illustrated Folder "C" Free.

LECTRO LINX LTD.
254, Vauxhall Bridge Road, S.W.1.

Cheapest PERFECT Contact

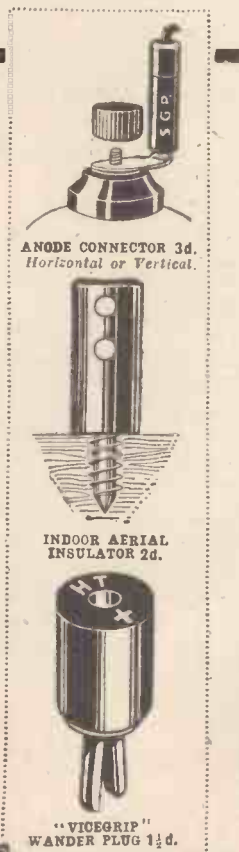

ANODE CONNECTOR 3d.
Horizontal or Vertical.

INDOOR AERIAL INSULATOR 2d.

"VICEGRIP" WANDER PLUG 1 1/2 d.

Quality Radio for £6.6.0

SEVEN VITAL FEATURES

- Self-Contained Loud Speaker ● Band-Pass Tuning and Pentode Output giving Astonishing Selectivity and Power ● Economical Battery Consumption ● Full Broadcast Range (230-550 & 1,000-2,000 metres) and Easy Operation ● Entirely New and Simple Colour-Coded Assembly without Soldering ● Fixed Pick-up Sockets ● Compact Walnut Cabinet ●

At its amazing low price the Zonophone Kit Set brings Quality Radio within the reach of the most modest purse. The simple and ingenious construction of this set is praised by expert and amateur alike.



GRAMOPHONE ENTHUSIASTS!

The Zonophone Pick-up is the finest value in the world at

15/=-

AND OF COURSE ZONOPHONE BATTERIES

Highest Efficiency
Greatest Economy

ZONOPHONE KIT SET

Famed alike for ZONOPHONE Radio and Records



Prices shown do not apply in Irish Free State.



IN LIGHTER VEIN
**PROF. GOOP'S
BIRTHDAY
PARTY**

"NEXT 'Friday,'" announced the Professor, "is my birthday."

"Hullo-o-o-o-o, singlets," I chanted, "and don't forget to look in the coal-scuttle."

The Professor held up his hand for silence.

"This," he remarked, "is no occasion for unseemly ribaldry. The birthday of such a man as myself is, if I may say so, an event certainly of national and probably of international importance."

Another New Valve

I hastened to agree. Further, I assured the Professor that though the world at large might not see fit to celebrate his birthday as a holiday, I at any rate would refrain from all work to mark the occasion.

"As usual," snapped the Professor.

"Well, look here, if you're going to be nasty about it I jolly well will do some work."

"Then it will indeed be an event."

"Few," I said, "realise how hard I do work. You, Goshburton-Crump and Tootle and all the rest of them are

"LOW RESISTANCE!"



"I pulled out my handkerchief, and my shoulders heaved a little."

always saying that I do nothing, whereas really there is nobody in Mudbury Wallow who toils and moils as I do. It is really most cruel." I pulled out my handkerchief and my shoulders heaved a little.

"Tut, tut," cooed the Professor, patting my shoulder, "did'ums was'ums then. Smile now and uncle will give him a nice new valve."

This cheered me up at once, and I added to the pentode, already reposing

in my pocket, which I had sneaked while the Professor's back was turned, a really beautiful multi-Mu.

"Well, tell me more about this birthday of yours?" I said, choking down my sobs.

Pentodes for Presents

"I propose to give a party."
"Not give," I corrected. "It isn't done nowadays."

"What on earth do you mean?"

"Parties nowadays are thrown, not given."

"Very well, then," said the Professor, "I will throw a party, and if any party becomes uproarious at my party I will jolly well throw that party out of the party that I have thrown. What, by the way, are you going to give me as a birthday present?"

"I had thought," I replied, feeling in my pocket, "of a nice pentode valve. A real one, I mean, with three grids and a thingmejig."

The Professor explained that this was his golden birthday, since he would be attaining the age of fifty. I told him that I for one had gone clean off the gold standard, and that if he wouldn't have the pentode my present would be something from Woolworth's.

The "Choke and Grid Leak"

"Perhaps," I suggested, "you would like a birthday ode?"

"I will take anything good that's going," smiled the Professor. "You run away and think out a jolly present for me."

Next day I ran across Captain Bucket, Pimpleson and Goshburton-Crump. Each of them had been invited to the party and they were all a little worried over the present business.

"The old scoundrel," snorted Captain Bucket, pulling out his invitation card. "Professor Goop requests the presence of Captain Bucket." I always think that they might just as well write 'requests the presents' on birthday and wedding invitations."

I had a bright idea.

"Why," I asked, "should we not go into the door outside which we are

now standing and think matters over properly?"

They all looked up. It was the hospitable door of the "Choke and Gridleak." We went in.

THE LOCAL "PUB"



It was the hospitable door of the "Choke and Grid Leak."

"The best thing to do," I remarked, "is for us to club together; pool our resources, so to speak. Let us see what we can raise." Captain Bucket produced one-and-three, Pimpleson had one-and-sevenpence-halfpenny, Goshburton-Crump planked down a florin which he said he hoped was good though he was not quite sure; I had four lucky threepenny-bits, nine halfpenny stamps and two farthings.

The resources having been placed on the table, I promptly pooled them.

"Talking and thinking," I remarked, "are thirsty work. I am sure that in every case our electrolyte is below the tops of the plates, a condition which is well known to be fraught with risk. Let us top-up our cells immediately. I can positively feel myself sulphating."

The Topping-Up

Having topped up, we continued gassing. It was clear that the specific gravity was not yet all that it should be, so we did it again. In order that there should be no suggestion of selfishness about the proceedings we were careful to honour the toast of Professor Goop on each occasion.

"We have now," I said, "turned our pooled resources into liquid assets, which I have always understood to be sound business. Unfortunately, though, nothing remains for any solid present to the Professor. I tell you what! Instead of mere footling presents, let's get up an entertainment

TELSEN RADIO COMPONENTS



6^d

TELSEN VALVE HOLDERS (Prov. Pat. No. 20286/30). The Telsen four- and five-pin valve holders embody patent metal spring contacts, which are designed to provide the most efficient contact with split and non-split valve legs, and are extended in one piece to form soldering tags. Low capacity and self-locating.

Telsen 4-pin Valve Holder Price 6d.
Telsen 5-pin Valve Holder Price 8d.

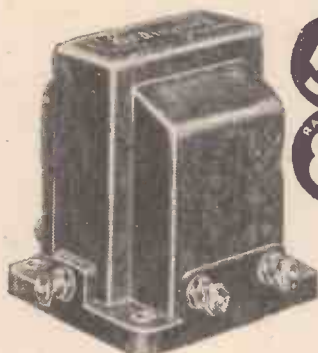

5⁶
RADIOGRAND
8⁶

TELSEN L.F. TRANSFORMERS

Ace, ratios 3-1 and 5-1 5/6 each
Radiogrand, ratios 3-1 and 5-1 8/6 "
Radiogrand, ratio 7-1 12/6 "
Super low ratio Transformer, 1.75-1 12/6 "



5⁴

TELSEN BINOCULAR H.F. CHOKE

Hailed unanimately by the leading experts as the perfect H.F. Choke. The Telsen Binocular Choke is called for wherever highest efficiency is desired. Its highest inductance (180,000 microhenrys) and exceptionally low self-capacity (.00002 mfd.) ensure a very high impedance at all wave-lengths, and its excellent efficiency curve is free from parasitic resonances. Price 5/-



5⁶

TELSEN LOUD-SPEAKER UNIT

The Telsen Loud-speaker Unit is pleasing to the most sensitive ear. The deep notes of the bass, the brilliance of the soprano, and the crispness of diction are clearly reproduced without distortion.

It employs cobalt steel magnets, and the detachable rod which carries the cone is fitted with cone washers and clutch. The entire unit is enclosed in a beautifully moulded bakelite dust cover Price 5/6



ALL-BRITISH RADIO COMPONENTS

Also include:

Output Transformers	12/6
H.F. Chokes from	2/-
Output Chokes	8/-
Power Grid Chokes	8/-
L.F. Coupling Chokes	5/-
Slow-Motion Dial	2/6
Fixed Condensers from	6d.
Pre-set Condenser	1/6
Variable Condenser	4/6
Spaghetti Resistances from	6d.
Loud-Speaker Chassis	5/6
Fuse Holder	6d.
Grid-Leak Holder	6d.

Send for the "Telsen Radio Catalogue" and book of "All-the Radio Circuits" to The Telsen Electric Co., Ltd., Aston, Birmingham.



7⁶

TELSEN DUAL-RANGE AERIAL COIL

It incorporates a variable series condenser and is suitable for all districts. It has been tested in various parts of the country, and down to distances of five miles from Regional stations a single tuned circuit will definitely separate the Regional programmes. A reaction winding is provided Price 7/8
Telsen H.F. Transformer and Aerial Coil. Price 5/6



9

TELSEN GRID-LEAKS

Telsen Grid-leaks are absolutely silent and non-microphonic, and practically unbreakable. They cannot be burnt out and are unaffected by atmospheric changes. Telsen Grid-leaks are not wire wound and therefore there are no capacity effects. Their value is not affected by variation in the applied voltage.

Made in values from 1-5 megohms.
Telsen Grid-leak Price 9d.

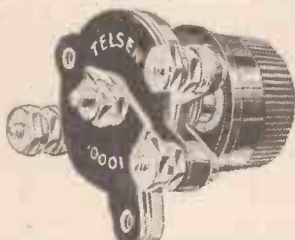

2⁴

TELSEN BAKELITE DIELECTRIC CONDENSERS

The moving vanes are keyed on to the spindle and there is a definite stop at each end of the travel. The connection to rotor is made by a phosphor-bronze pigtail so there is no cracking due to rubbing contacts. The connection to the stator vanes is absolutely positive—a very important point. All Telsen Bakelite Condensers are supplied complete with knob.

Differential Condenser—
Capacities .0003, .00015, .0001, Price 2/-
Reaction Condenser—Capacities .0003, .00015, .0001, Price 2/- .00075, .0005, Price 2/6.
Tuning Condenser—
Capacities .0005, .0003, Price 2/-



1³

TELSEN PUSH-PULL SWITCHES

(Prov. Pat. No. 14125/31).

The Telsen Push-Pull Switches employ a proper electrical knife switch contact and are soundly constructed on engineering principles. The centre plunger is wedge-shaped, so that as it is pulled out it forces the inner fixed contacts outwards, tightly gripping the moving contacts. There is no fear of cracking with Telsen Push-Pull Switches. Their low self-capacity makes them suitable for use in H.F. circuits.

Two-point Price 1/-
Three-point Price 1/3
Four-point (2 pole) Price 1/6

In Lighter Vein—continued

in his honour. We will spring it on him as a surprise. He will simply love it and it won't cost a cent."

This struck them all as a typically bright idea.

"But what," asked Pimpleson, "are we going to do?"

"Oh, that's easy!" I cried. "Miss Worple, as you know, revels in classical dances. She can do the 'Dance of the Electrons' to a flute obligato by Tootle; Captain Buckett can sing sea-shanties; Sir K. N. Pepper can tell his thrilling story, 'The White-hot Chutney of Cawnpore'; Goshburton-Crump can resuscitate the 'Escape' series by describing how he escaped being drowned as a kitten; Pottleson can do tricks with the wireless set, though he needn't try to borrow mine for the job."

My Own Part

"And what about you?" they chorused.

"What, me?"

"Yes, you."

"You mean me?"

"Yes, YOU."

"Oh, now I understand. You are asking what I am going to do. Correct me if I am wrong."

They assured me that I was not.

"DANCE OF THE ELECTRONS"



"Miss Worple, in a kind of cross between a surplice and a bathing suit."

"Well, I thought that I might sort of generally supervise the show, if you see what I mean."

Apparently they did not. There was a distinct demand that I should make my contribution to this Goopian holiday.

Not a Super-het

"You mean," I inquired, playing for time, "that you think I ought to do something?"

That apparently was the idea.

"Very well, I agree. I will do my famous conjuring turn."

"If you mean the one in which you build a seven-valve super-

heterodyne receiver out of parts borrowed from friends during their absence," said Captain Buckett, "I think that that is hardly suitable for the occasion. We have all seen it done rather too often."

Frequent Re-charging

I told them that they were barking up the wrong tree. The last thing, I explained, that I would do was to borrow anything from anyone.

"It was the last thing you did to me," sighed Pimpleson, with some feeling.

At this point I suggested that I had an inkling that all resources had not been pooled. Forceful searching of Pimpleson resulted in the discovery of a ten-shilling note, and as we were by this time almost in that run-down condition which, as is well known, demands immediate re-charging, unless serious damage is to follow, appropriate steps were taken.

Everything promised well when we assembled for the party thrown by the Professor. And not only everything, but everybody. Each guest as he arrived, in fact, explained that the time of high jinks had coincided with that of low water, and promised a present some time, somewhere, somehow.

To say that the Professor's face fell as he greeted guest after guest would be a serious understatement. It positively flopped. Things brightened up, however, when the surprise entertainment was announced and Miss Worple, in a kind of cross between a surplice and a bathing suit, performed the "Dance of the Electrons."

"The Mixer"

"If that's classical dancing," remarked Sir K. N. Pepper, "thank goodness I was on the Modern side."

Others, though, were much more appreciative. No one applauded more heartily than the Professor, though he was overheard to say that there was a little something missing in Miss Worple's transition from the "filament" to the "anode" movements.

Captain Buckett's sea-shanties very nearly brought down the house, for the "Microfarads" is a post-war baby, built mainly of asbestos sheeting, and the old salt's top notes started many nails. Sir K. N. Pepper carried everything except favour, and Goshburton-Crump gave a practical demon-

stration of escaping by ducking neatly to avoid the "disposals" egg flung by a member of the audience, who shall be nameless.

My own turn came last of all. Having borrowed a top hat from Sir K. N. Pepper, a watch from Professor Goop, and a poker from the

STRIKING A RESONANCE!



"Captain Buckett's sea-shanties very nearly brought down the house . . ."

fireplace, I proceed (a) to pulverise the watch; (b) to place it in the hat; (c) to pour into the same receptacle a couple of pounds of flour; (d) to break a couple of eggs over the mixture; (e) to whisk it up with the point of an earth tube; and (f) to cook it over the flame of a soldering lamp. The smell produced by the burning of the nap of the hat overcame some of the audience, but the majority held out, awaiting the denouement.

The Final Results

I will not say that the audience were agog with excitement. They were far more than that. They could, in fact, hardly contain themselves when I emptied into the hat the dregs of a cup of coffee and the contents of the Professor's best accumulator.

I went on stirring. They went on watching. It was a great moment.

"Great Scott!" I cried suddenly. "It's a failure!"

Even since then Sir K. N. Pepper has been dunning me for a new hat. Professor Goop wants a new watch. Mrs. Goop wants some new eggs.

It's a hard world. True talent is seldom properly appreciated.

WHATEVER YOU DO
DON'T MISS
THE JANUARY NUMBER
OF THE
"WIRELESS CONSTRUCTOR"

Out DEC. 15th Price 6d.

THE PERFECT CONDENSER FOR GANGING

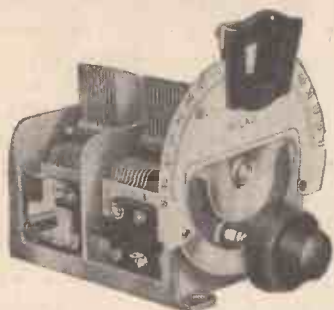

THE "UNI-KNOB"

A Two-Gang Condenser built in a rigid die-cast frame which ensures accurate matching being maintained under all conditions of use.

Air dielectric trimmer is fitted and controlled from the front by a knob concentric with main control. Slow-motion drive. Attractive moulded escutcheon with pilot lamp holder.

Capacities : 0005 x 0005, 21/-

POLAR



CONDENSERS

Obtainable from all dealers.

24-page catalogue on request.

WINGROVE & ROGERS, LTD., 188-9, Strand, W.C.2.; Old Swan, Liverpool.

YOU CAN'T GO WRONG!

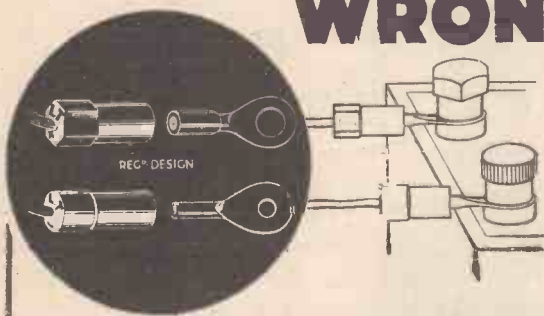

BELLING-LEE ACCUMULATOR CONNECTORS.

The safest and most efficient device for connecting accumulator and radio set.

The lead-plated and non-corrosive eye sockets are permanently fastened to the accumulator terminals and, having different-sized holes, it is impossible to attach them wrongly to accumulators with non-interchangeable stems.

The insulated connectors (lettered L.T. + and L.T. -), attached permanently to the wires from the set, have different-sized sockets, and cannot be plugged on the wrong eye. Further, the positive is red and hexagonal, to conform in shape with the positive terminals in certain accumulators, while the negative is blue and round. Thus under no circumstances, deliberately or accidentally, can a wrong connection be made.

Being completely insulated even when disconnected, the Connectors cannot blow your valves by touching H.T. sockets or wires. The Insulators have vaseline-filled cavities to prevent acid creeping back to the wires from the set.

(Extra pairs of non-corrosive eyes for spare accumulators, 3d. per pair.)

WRITE FOR LISTS.

PRICE 9^d. per pair.

BELLING-LEE
FOR EVERY RADIO CONNECTION

Advt. of Belling & Lee, Ltd., Queensway, Ponders End, Mdx.

AMPLION MOVING COILS

M.C.6 UNIT. PERMANENT MAGNET

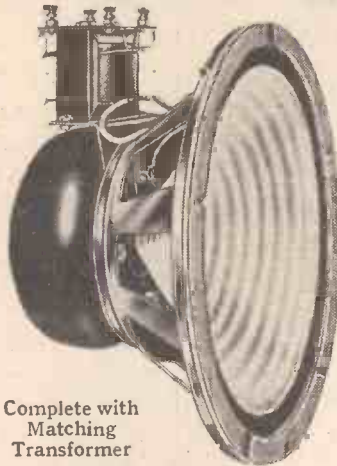

Complete with Matching Transformer

67/6

This famous Amplion M.C.6 Unit is acknowledged as the most efficient moving-coil speaker of its type. Its sensitivity and true reproduction are really remarkable, and it handles without distortion adequate volume for all normal requirements. It is as sensitive as a balanced armature speaker, and the universal transformer which is fitted enables the speaker to be correctly matched to either power, super-power or pentode output from standard 2-, 3-, or 4-valve receivers.

THE E.M.644 UNIT. D.C. ENERGISED MODEL

Another of Amplion's successes is this D.C. Energised Model. Ideal for A.C. sets. Its perfect performance and reproduction has been proved by its inclusion in the famous "Amplion Six" receiver, which has reached record sales. Ideal for home constructors to incorporate in A.C. receivers and radio-grams. A most efficient unit for D.C. voltages 100/110, 200/240. Full details of alternative methods of operation supplied with each model.



UNIT ONLY

29/6

UNIT WITH MATCHING TRANSFORMER

42/-

M.C.9 UNIT PERMANENT MAGNET

The M.C.9 Unit is a permanent magnet, but is much larger and more powerful than the M.C.6. A suitable matching transformer for this model can be supplied at 15/- extra.

UNIT ONLY. £6:0:0

GRAHAM AMPLION LTD., 26, Savile Row, W.1

royds



OUR NEWS BULLETIN

A "Hot" Transmitter

METROPOLITAN-VICKERS, LTD., have produced a short-wave wireless transmitter which is capable of propagating waves which will severely burn anyone standing near the aerial. It is reported that the radiation is so powerful that a coil of wire of a certain length held near the transmitter emits a long flame at each end.

This effect is produced by the extremely short wave-lengths used—5 metres—together with the high power of 20 kw.

We understand that experiments are being made with this new transmitter with a view to it being used

later on for localised broadcasting by the B.B.C.

B.B.C. Helps Television

Now that the B.B.C. has included television in the programmes it will be interesting to see whether there is an increased sale in television receivers. Nobody can say that the B.B.C. hasn't been generous in affording facilities for these television transmissions. Certainly it was a good idea to get Jack Payne and his popular dance band televised.

Many Television "Listeners"

We understand that there has been an increase in the number of television subscribers recently, and that roughly 8,000 listeners possess television apparatus. It is reported that when Jack Payne was televised the transmission was picked up in Madeira, 1,700 miles distant.

Baird in America

Television in America also seems to be causing a stir, especially in connection with the 10 ft. square screen. Mr. Baird is now in America arranging for the mass production of television sets in the United States. We understand that the American branch of the Baird Company will be reorganised, and expects to manufacture sets at the rate of 2,000 weekly, or 1,000,000 a year, selling far below anything now offered on the American market.

That "Radio City"

A famous man was over here a few days ago in the person of Roxy, whose real name, of course, is Samuel Lionel Rothfel. He began his career as an office boy, and is now a cinema magnate and the inspirer of New York's Radio City. The idea is to spend about \$250,000,000 on the Radio City, and, when finished, it will be able to entertain 25,000,000 people simultaneously.

Absolutely the Last Word

Radio City will contain an opera house with 4,500 seats, a music-hall with 6,500 seats, a cinema with 3,000

(Continued on page 124.)

SILENT AMPLE SAFE

FOR POWER

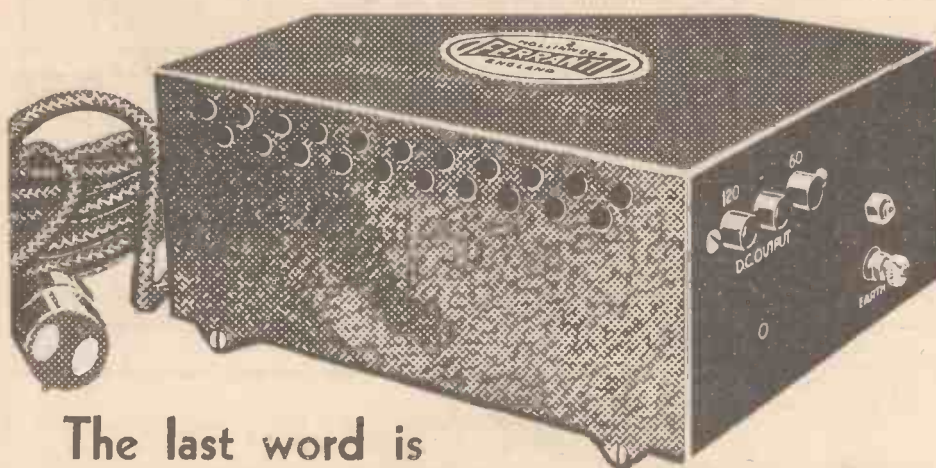

New H.T. units for all needs. Your surest way to better radio. Settle your H.T. problem with a Ferranti H.T. Unit.

E1.	115 m/a	200 volts	£11 11 0
E2.	15 m/a	120 volts	£3 10 6
E3.	25 m/a	150 volts	£4 16 6
E4.	70 m/a	240 volts	£8 11 6
and 4 volts 5 amps. A.C. for indirectly heated, & 4 volts 1 amp. for Output Valves ...			

FOR ALTERNATING CURRENT ONLY.

The Eliminator type E4 has been designed specially for Super Hets.

The last word is

FERRANTI

FERRANTI LTD. Head Office & Works
HOLLINWOOD, LANCASHIRE
LONDON: Bush House, Aldwych, W.C.2

LATEST "SQUARE PEAK" [REGD TRADE MARK]



**CANNED COILS-
THEY GANG TOGETHER**

DEVELOPMENT

The new "Square Peak" Canned Coils... the last word in selectivity and stability... Extremely adaptable, allowing the use of either Band-Pass capacity-coupling, inductive-coupling or mixed filter. Completely screened. Each coil individually tested and matched to within 1%. Special rotary wave-change switches with self-cleaning gold-silver alloy contacts. Switch Control insulated between coils.

Can be obtained separately as follows, each coil complete with switch knob and ebonite coupling, ready for ganging in any desired combination.

- BP 9 Aerial Band-Pass Coil 11/6
- BP10 Secondary Band-Pass Coil 12/6
- BP11 Intervalve Coil (Tuned Grid or Tuned Anode) 11/6
- BP12 H.F. Intervalve Transformer 11/6

Ask for leaflet B.

Also supplied in sets of 3-4 coils assembled on aluminium base.



Advert. of Oliver Pell Control, Ltd., 103, Kingsway, London, W.C.2.

Telephone: Holborn 5303

*Here's a Paper
He'll read
right through!*

Read it from cover to cover and enjoy every word—a clean, healthy paper that is packed with fascinating facts about the things which interest a boy most. Such is MODERN BOY. Every issue is brimful of thrilling stories and articles on the very latest Invention, Adventure, Hobbies, etc., as well as the best fiction. It is the paper for the youth of to-day.

Modern Boy

Every Monday 2d.

High-Grade RADIO GRAMOPHONE CABINET

of exclusive modern design, hand-made and polished on Queen Anne legs.

- Figured Oak - - - - - £5 : 5 : 0
 - Figured Walnut or Mahogany £5 : 19 : 6
- Carriage Paid.*

THE ACME OF CRAFTSMANSHIP

Radio-Gram Cabinets from £3 : 19 : 6 to £21

Wireless Cabinets - - - - - from £2

Photographs and 30-page illustrated Catalogue Free.

Cabinets made to order a speciality.

Furniture at Maker's prices.
**GILBERT,
CABINET MAKER,
SWINDON.**

Estimates Free. Estd. 1866.



WIRELESS CONSTRUCTOR

Advertisement Rates

- Single Insertion - - - - - £60 0 0
per page and pro rata to eighth page.
- 6 CONSECUTIVE Insertions 55 0 0
per page and pro rata to eighth page
- 12 CONSECUTIVE Insertions 50 0 0
per page and pro rata to eighth page.
- ONE INCH single col. (2 1/4" wide) 2 5 0
- Minimum Space, half-an-inch 1 2 6

IMPORTANT. Copy and Blocks must be in hand by 25th of each month for issue placed on sale 15th day of the following month.

ALL communications respecting advertising must be made to:

JOHN H. LILE, Ltd., 4, Ludgate Circus, London, E.C.4

Phone: CITY 7261

OUR NEWS BULLETIN

—continued from page 122

seats, a roof garden and park, a restaurant, fire-brigade, police department, broadcasting studios, and television equipment.

It sounds good!

The "Mounties" Log

The "Yorkshire Post" reported the other day the achievement of three officers of the Royal Canadian Mounted Police, who, at the outpost established at Bernard Harbour, in the Arctic, logged 300 stations with their set.

It appears these policemen have heard all the stations of the Canadian National Railways from Vancouver to Moncton, New Brunswick, New Orleans, Miami, Tampa, Mexico City, and Havana. They picked up nearly all the B.B.C. stations and a number of stations in Germany, France, Spain, Norway, Sweden, Russia, Iceland, and even some from China and Japan, and from Brisbane, Australia.

Sent by Sleigh

We understand the set used was a super-heterodyne. The curious thing

is that the report of this fine list of stations received was sent to Montreal and travelled most of the way by dog-sleigh. In all, the report took 185 days to travel from Bernard Harbour to Montreal.

The Western Regional

The B.B.C. has officially announced that the site for the Western Regional station has been fixed at Washford Cross, Somerset. Work on the new station will start almost immediately, but it will be twelve months before the official tests are made. The new station will compare in size with the North Regional and will cost about £150,000. The twin transmitters will operate on a power of 70 kw.

Letting the Cat Out!

It was hardly fair of the newspapers to give away the Post Office Hush-Hush Van campaign, but the General Post Office are rather to blame for trying to get across the story that wireless sets not in operation could easily be detected by the G.P.O. wireless detectives.

A Bit Too Tall

Even pirates who know nothing about wireless are hardly likely to swallow a story like that. The Post

Office rather overdid the story, and if they want to round up the pirates they should make the affair much more mysterious and not try to get away with a stunt which to anybody who knows anything about wireless these days is rather ludicrous.

A Good Cause

All the same, the newspapers might have left the story alone, for, after all, it is the honest listener who benefits if these pirates are rounded up; and not only the listener, but the B.B.C., the Treasury and, in fact, the Nation.

More Revenue for B.B.C.

Anyway, the first results of the campaign were very successful, for over 80,000 pirates were rounded up in a week. Consequently, the B.B.C. benefited very nicely by an additional revenue, which we hope will result in a little more variety in the National, Midland and London Regional programmes.

Numerous Prosecutions

In fact, it meant a gross increase in wireless revenue of nearly £40,000. The General Post Office says that since the van started over 100 prosecutions of unlicensed listeners have

(Continued on page 126.)

KITS RADIO FROM EVERYTHING PETO-SCOTT

CASH - C.O.D. - H.P. as usual

ACCESSORIES

10/- down AND 11 MONTHLY PAYMENTS OF 10/10
V.3. RADIO FOR THE MILLION
 Screened-grid, Detector and Power. With Valves, less Cabinet. **CASH PRICE £5 : 17 : 6**

EPOCH J.1 PERMANENT MAGNET MOVING-COIL SPEAKER, with multi-ratio input transformer. Cash price, £2 : 5 : 0. Balance in 11 monthly payments of 4/2 only **4/2**

ROLA PERMANENT MAGNET SPEAKER. Complete with Input Transformer. Cash Price, £2 : 17 : 6. Balance in 8 monthly payments of 7/1 only **7/1**

W.B. PERMANENT MAGNET MOVING-COIL SPEAKER P.M.3. Complete with 3-ratio input transformer. Cash Price, £2 : 12 : 6. Balance in 11 monthly payments of 4/10 only **4/10**

AMPLION M.C.8 MOVING-COIL SPEAKER, permanent magnet, with output transformer. Complete. Cash Price, £3 : 7 : 6. Balance in 11 monthly payments of 6/2 only **6/2**

COSSOR 234 EMPIRE MELODY MAKER
 Screened-Grid, Detector and Power. With Valves and Cabinet **10/-**
CASH PRICE £6 15s. Od. WITH ORDER
 Balance in 11 monthly payments of 12/6. Finished Instrument, Royalties Paid, £7 10s. Od. Cash or £2 deposit and 11 monthly payments of 11/-

"MIDGET" THREE Described this month.
KIT "A" (Author's Kit, less valves and cabinet) **£4:0:0**
 or 12 monthly payments of 7/4
KIT "B" (Author's Kit, with valves, less cabinet) **£5 : 7 : 6**
 or 12 monthly payments of 9/10
KIT "C" (Author's Kit, with valves and Cabinet) **£5:15:6**
 or 12 monthly payments of 10/7
 Any parts supplied separately. If order value over 10/-, sent carriage or post paid.

THE "DUO-VISE" TWO Described in this month's issue.
KIT "A" (Author's Kit, less valves and cabinet) **£2:16:9**
 or 12 monthly payments of 5/2
KIT "B" (Author's Kit, with valves, less cabinet) **£3:15:9**
 or 12 monthly payments of 6/11
 Any parts supplied separately. If order value over 10/-, sent carriage or post paid.

"I.E." 3-WAVE SET Described in October issue.
KIT "A" (Less valves and cabinet) **£4:8:11**
 or 12 monthly payments of 8/2
KIT "B" (With valves, less cabinet) **£5 : 7 : 11**
 or 12 monthly payments of 9/11
KIT "C" (With valves and cabinet) **£6 : 2 : 11**
 or 12 monthly payments of 11/4
 Any parts supplied separately. If value over 10/-, sent carriage forward. C.O.D., we pay post charges.

"EXHIBITION 4" Described in October issue.
KIT "A" (Less valves and cabinet) **£8:4:8**
 Or 12 monthly payments of 15/2
KIT "B" (With valves, less cabinet) **£10:12:2**
 or 12 monthly payments of 19/6
 Any parts supplied separately. If value over 10/-, sent carriage forward, C.O.D., we pay post charges.

PETO-SCOTT CO. LTD. 77 CITY ROAD, LONDON, E.C.1.

Showrooms at 62, HIGH HOLBORN, LONDON, W.C.1.
 MANCHESTER: 33 WHITELOW ROAD, CHORLTON-CUM-HARDY.
 NEWCASTLE: 7 ALBANY ROAD, STAFFS.

SEND 3/- POSTAGE FOR NEW CATALOGUE

EXPRESS ORDER FORM
 Please send me C.O.D./CASH/H.P.
 I enclose Cash/H.P. Deposit £ s d.
 Name.....
 Address.....
 W.C.12/31

One of these days you will buy new valves !

Oh yes, you will !

And when you do, you will want the highest efficiency at a reasonable price. And you will want valves that will last. Between the best valves there is little difference. HIGH PRICE IS NOT THE ACID TEST. It is the valve itself that counts.

ETA Valves are international. Nation listens to Nation with them. They are the finest quality, the longest lived and most efficient valves it is possible to make to-day. Their price is lower than most and yet by no means "cheap-jack." It is an honest price for a fine valve.

Be sure and get ETA VALVES.

ETA

THE INTERNATIONAL VALVE

THE ELECTRICAL TRADING ASSOCIATION LIMITED,
ALDWYCH HOUSE, ALDWYCH, LONDON, W.C.2.

Telegrams: Eltradax, Estrand, London. Telephone: Holborn 8139

IRISH & SCOTTISH AGENTS: W. J. Byrne, 21, Temple Lane, DUBLIN,
R. G. Jackson Nisbet, 132, Renfrew Street, GLASGOW.

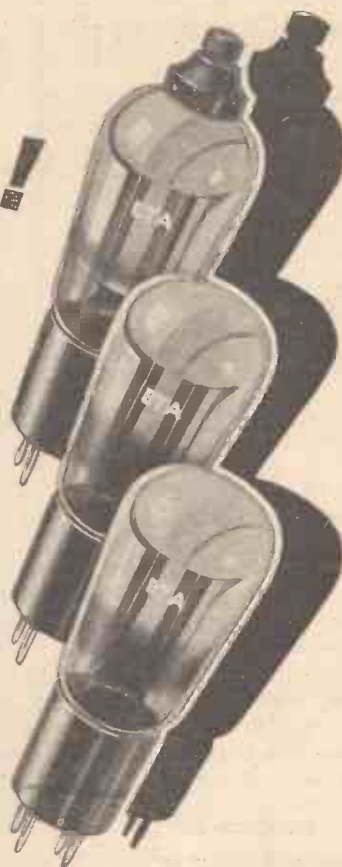

12/6

45/-

Comparisons—

The acid test of a loud speaker's qualities, or lack of them, lies in performance. Appearances can be deceptive, and price is no criterion. Compare the R. & A. '100' with any other Permanent Magnet Moving Coil at any price and note its superiority. Compare it with other low-priced P.M.M.C. Speakers and the difference will amaze you. You need a speaker which will faithfully reproduce speech and music, and render years of unvarying service and a high quality of reproduction. In short, you need an R. & A. '100.' Ask your dealer to demonstrate and refuse a substitute. Write us for descriptive leaflet, Post Free.

REPRODUCERS & AMPLIFIERS, LTD.
Frederick Street,
Wolverhampton.

The
R & A
"100"
PERMANENT MAGNET
MOVING COIL
REPRODUCER

THE

"I.E." Three, "Midget" Three, "Duo-Vise" Two and all "Wireless Constructor" sets are available as constructional kits, ready wired and tested, or parts separately. Full range of lists, including a list of Short-Wave Stations and a descriptive looklet on the "Stenode," free on request.

MAGNUM FADER TYPE VOLUME CONTROL



1 megohm, as specified for the "I.E." Three. Price 10/-

MAGNUM VOLUME CONTROL



For the "Midget" Three. 3-terminal type, 1 meg-ohm. Price 5/-

BURNE-JONES & CO. LTD.

"MAGNUM HOUSE" 296, BOROUGH HIGH STREET, LONDON, S.E.1.

Telephone: Hop 6257 and 6258

Scottish Agent: Mr. Ross Wallace, 54, Gordon Street, Glasgow, C.1.

OUR NEWS BULLETIN

—continued from page 124

been authorised in London alone, and thousands more are being considered. In all, five wireless detective vans have been touring the streets of London. Each van can cover about 100 miles a day.

Getting a Move On

A G.P.O. official stated that when the van appears in the streets with the frame aerial on the top there is always a good deal of fluttering of consciences, and it is reported that one elderly woman dashed into the nearest Post Office with ten shillings, saying: "Quick! Give me a wireless licence; the van is in our street!"

Closing Indian Stations

It seems from news from India that the broadcasting stations in Bombay and Calcutta are to be closed down and the plant sold, for broadcasting is not paying its way in India. In fact, the holders of wireless licences number only a few thousands, and last year the Government lost £9,375 on its broadcasting service.

A "Pretty" Thought

It is estimated that during the first six months of this year American broadcasting companies received the tremendous sum of £2,400,000 for broadcasting advertising.

We wonder how much the B.B.C. could make if it hired out the Midland Regional station occasionally. Probably quite a bit!

What About That?

A correspondent in the "Daily Telegraph" strongly protested against the Wireless Correspondent of that paper referring to pirates as "careless or mean people." The writer said that like countless others he has lost employment and cannot afford to renew his wireless licence. He stoutly maintains that to use his set without a licence would be the last thing he would do.

The King's Portables

It is reported in the press that the King has bought a new four-valve portable set. There is a permanent set installed at Buckingham Palace, but it is said that the King also likes to have a portable set to take about with him when he travels. It is reported that he has bought a new one each year for the last five years.

COLOURFUL CABINETS
 Some Useful Hints About
 Woodwork Finishes.

THE modern tendency in the finish of cabinet work, especially oak, is to ingrain the unpolished surface with white or bright colours. The process of inserting the pigments, however, is one which cabinet "up-getters" are averse to talk about.

The easiest method of preparing the wood is as follows:

Soak, or rub, the face of the work constantly with water until the finger nail can be easily impressed. With the aid of a teasel, or any other wire-haired brush, brush out the sap by working the surface in the direction of the grain.

For a white ingrain, fill in with an equal mixture of whiting and plaster of Paris, and scrape off the superfluous material before drying. Sandpaper to the required finish when perfectly dry.

Never use a smoothing plane after filling, that is, if you respect its cutting iron.

For coloured ingrain, showcard colour (procured at any shop catering for artistic trades at 6d. per pot) may be added to the above mixture. W.W.

ACCURATE

CONTROL

MADE EASY



Exceedingly powerful, reliable and simple to fit. Mounts on baseboard independent of panel. Height to match J.B. Gang Condensers. Ratio 16/1. Oxidized silver or bronze panel plates.

7/6



Takes panels up to 1/4 in. Fitted easily—only one round hole to cut. Scale mounted neatly behind panel. Smooth action. Complete with lampholder.

5/-



Smooth, powerful friction drive, ratio 16/1. Drum completely insulated from condenser, forms an anti-capacity shield. Ivorine scale flush with panel for easy reading. Bronze or oxidized silver finish.

4-in. diam. drum, 10/6.

3-in. diam. drum (Ratio 12/1), 9/6.

Illuminated models same price.



PRECISION INSTRUMENTS

Advertisement of Jackson Bros., 72, St. Thomas' Street, London, S.E.1. Telephone: Hop 1837.

WIRELESS WOODWORK

—continued from page 110

In Fig. 2 are shown three useful dodges for hiding screws and panel pins. A centre-bit is used for sinking the hole for the screw and afterwards a plug is glued in the hole, this hides the screw and gives a pleasing effect.

In the case of the others a small chisel is used to raise a small portion of the wood, and after the work has been carried out the fibres are glued back into place and smoothed down with glasspaper.

Simple Division

In woodwork it is often necessary to divide the surface of a board or other piece of timber into an exact number of parts. Now this is simple enough in the ordinary way, but it often happens that the stuff in question is some fraction of an inch either way.

Suppose we had a board as in Fig. 1 and we wanted to divide it into a number of parts, say, five parts, and the board is $8\frac{1}{2}$ in. wide after planing the edges.

Some would go to endless bother in a case like this, but a practical man would simply lay his rule across the board, as shown in the sketch, and proceed to mark the board off every two inches. The result would be more accurate and take only a quarter of the time wasted in calculation—try it.

Supporting Panels

Figs. 3 and 4 show a simple way of bracing the panel of your next set. The baseboard is planed a little out of square so that when the panel is screwed to the edge it leans slightly inwards. Next a bracket is made as shown, and this consists of two pieces of plywood about 4 m.m.

This bracket must be made perfectly square on two edges and is stuck firmly to the small piece acting as a base, with a good cement. When the two parts have set the bracket is pushed well up behind the panel and screwed home, this has the effect of squaring up the panel and makes a firm job. A matter of 2 per cent is plenty for the angle of the panel.

YEAR IN YEAR OUT

FOR ALL-ROUND QUALITY

BULGIN

The Choice of Critics

Quickly switches over from Radio to Gramophone 2/-

GRAMOPHONE SIGNAL LAMP.

A signal lamp and a beam of light on the turntable, 2/6

Gramophone needle-cup in Walnut or Mahogany Bakelite 2/6

UNIVERSAL FUSE HOLDER.

Safeguards valves from both H.T. and G.B. 1/6.

A. F. BULGIN & CO. LTD.
 ABBEY RD., BARKING, ESSEX
 Phones: Grangewood 3268 & 3267
 London Showrooms:
 9-10-11, Cursitor Street, Chancery Lane, E.C.4. Phone: Holb. 2072

A GOOD JOB!

British Radio Constructors still show their recognition of a good job well done. Since their introduction Benjamin Switches and valveholders have established unrivalled popularity. They will continue to maintain their sterling quality. Write for our New 1932 Radio Catalogue—it contains three very interesting and original circuits by a prominent designer.

The Benjamin Electric Ltd.,
 Tariff Road, Tottenham, N.17.
 Tottenham 1500.

BENJAMIN

USED IN THE BEST SETS

BECOL EBONITE

GUARANTEED AND READY FOR USE
 USE THE FAMOUS LOW-LOSS FORMER—TESTED
 APPLY FOR PRICE LIST
 SOLE MAKERS:
THE BRITISH EBONITE CO., LTD.,
 HANWELL, W.7

—SOLVE ALL—
H.T. TROUBLES

Per doz.	No. 1.		No. 2.	
	s.d.	s.d.	s.d.	s.d.
Jars (waxed)	13	16		
Sacs	12	19		
Zincs	10	11		
Rubber Bands (24)	4	4		
Terminals	6	10		

Trade Supplied.

TAYLEX
 ~ SELF GENERATING ~

LONG LIFE : SILENT : ECONOMICAL
 Sample doz. (18 volts), complete with bands and electrolyte. No. 1. 4/1 No. 2. 5/-; post 9d. terminals extra. No. 3. with terminals, 7/6 (10,000 milli-amps). sample unit 6d. Orders 10/- carr. paid. New illustrated catalogue cost free.
FREE Bargain List of Receivers, Amplifiers and Components
C. TAYLOR, 57, Studley Road, Stockwell, London.

There's no substitute for **cyldon**

CYLDON EXTENSER
 Type EX5. Fitted with a perfectly timed, adjustable wave-change switch and noiseless brush wipe contacts. 4" Bakelite, 300° Dial 1/6 extra. **12/6**

CYLDON SLOW MOTION EXTENSER
 Type EX5V. Fitted with wedge drive, disc type, Slow-motion Control. Hair line sight. 5 to 1 reduction. Perfectly timed Extenser wavechange switch. **16/6**

CYLDON SLOW MOTION DIAL
 New wedge friction drive, 8:1 ratio, non-slip, rotation in same direction as condenser, illuminated scale, hair-line sight. Sector vision. **7/6**

SYDNEY S. BIRD & SONS LTD.
 CYLDON WORKS,
 SARNESFIELD ROAD, ENFIELD

**THE SPEECH
INVERTER**

*How They Twist the Transatlantic
Phone Speech in Order to Make
it Secret.*

By K. S. D.

UNDOUBTEDLY one of the most ingenious and interesting devices employed in electrical communication is the speech inverter, designed to ensure privacy on commercial radio channels. The method of speech inversion has been employed by the Post Office for some time past at the Rugby station for prevention of eavesdropping on the transatlantic radio-telephone service, and listeners who have chanced to tune in the transmissions of the Rugby station will need no further proof of its effectiveness.

As its name indicates, the speech inverter distorts the speech wave from the transmitting subscriber by transforming high frequencies into low, and vice versa. In this distorted form the voice frequencies pass into the speech input of the radio transmitter and are picked up at the receiving station. Here, after detection in the usual manner, they are passed

through a second inverter, which restores the frequency components to their original values before they are passed over the telephone line to the receiving subscriber.

Modulation and Demodulation

The operation of the speech inverter depends upon the use of the thermionic valve as a modulator and demodulator; processes which are now generally familiar. It is well known that if a carrier frequency is modulated by a voice frequency, the output from the modulator will consist of a carrier frequency of constant amplitude, together with two "side" frequencies consisting of the sum and difference respectively of the carrier and voice frequencies.

These are known as the upper and lower side frequencies respectively. If instead of a single voice frequency the carrier frequency is modulated by a speech wave, consisting of a band of different frequencies, in place of the side frequencies, we shall have two "side bands," since each individual frequency contained in the speech wave will give rise to its own side frequencies.

The characteristics of the speech wave are conveyed entirely by the side bands; consequently, in radio transmission it is not essential that

the carrier frequency should be transmitted, or even both of the side bands. It is sufficient merely to transmit one side band, but in order to recover the original voice frequencies from that side band it is necessary that the original carrier frequency should be restored; this may be produced by a local oscillator.

The output from this oscillator, together with the received side band, are applied to the grid of a "demodulator" valve, and, provided the frequency thus used in demodulation is equal to the original carrier frequency, the original speech wave will be recovered. If, however, the demodulator frequency is not equal to the original carrier, or modulator, frequency, the original voice frequencies will not be recovered in the process of demodulation, but instead we shall obtain a band of frequencies whose values will depend upon the difference between the frequencies of the modulator and the demodulator. By suitable choice of these fre-

**Use the
condensers
with a
world-wide
reputation**

THIS latest range of moulded-in mica types fulfils the long-felt need for the best possible condensers at an extremely low cost, built as only Dubilier can build them.

All radio dealers stock them.

Type 665

'0001, '0002, '0003 mfd. 6d. ea.
'0005 mfd. 9d. "

Type 670

'0001, '0002, '0003 mfd. 1/- ea.
'0005, '001 '002 mfd. 1/3 "
'005 and '006 mfd. 1/6 "

Types 610 and 620

Prices 'rom 1/8 to 3/- each.

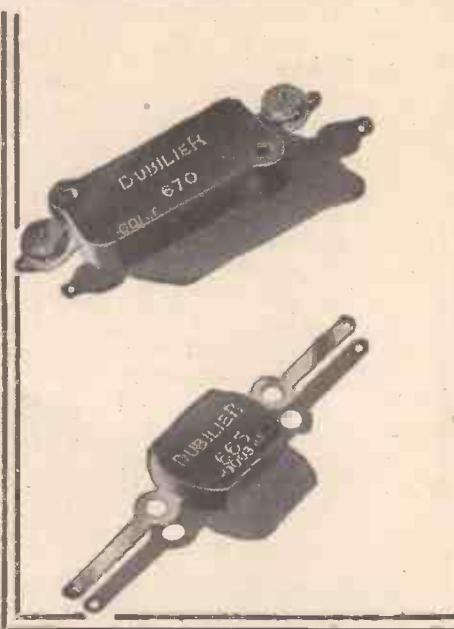

DUBILIER
CONDENSER CO. (1925) Ltd.

Ducon Works,

Victoria Road, N. Acton, London, W.3

Made in England by British work-people by a British Company.

NEXT MONTH

The January number of the
WIRELESS CONSTRUCTOR
will be a

**SPECIAL
SHORT-WAVE NUMBER**

Absorbing to the Expert—
Illuminating to the Novice

Order Now On Sale Dec. 15th
Usual Price—SIXPENCE

quencies it is possible to produce inversion of the input voice frequency band.

Speech Inversion

An example will make this clear. Suppose the speech wave from the transmitting subscriber comprises a range of frequencies of from 200 to 2,200 cycles. By means of a modulator valve we cause this wave to modulate a frequency of, say, 10,000 cycles.

The result will be the production of a carrier-wave of 10,000 cycles, an upper side band of from 10,200 to 12,200 cycles, and a lower side band of from 9,800 to 7,800 cycles. It is possible, by the use of a special type of "balanced" modulator, to prevent the production of the carrier frequency, and if by means of a band-pass filter we suppress the lower side band, we are left with a band of frequencies ranging from 10,200 to 12,200 cycles.

If, as we have seen above, we
(Continued on page 129.)

THE SPEECH INVERTER

—continued from page 128

demodulate this frequency band with a frequency of 10,000 cycles, we shall recover the original speech wave. If, however, we employ in the demodulator a frequency of, say, 13,000 cycles, the frequency of 10,200 cycles will become (13,000-10,200), or 2,800 cycles—while the frequency of 12,200 cycles will become (13,000-12,200), or 800 cycles.

A Reversing Effect

Thus the combination of modulator and demodulator has caused the frequency of 200 cycles to be converted into 2,800 cycles, and 2,200 cycles into 800 cycles. It is easily seen that such an arrangement will "invert" all frequencies over a range of 0 to 3,000 cycles, and that only the mean of these, viz., 1,500 cycles, will pass through unchanged.

The speech inverter then consists essentially of a balanced modulator, with its associated filter for suppressing the unwanted side band, together with a demodulator whose frequency differs from that of the modulator by the width of the voice frequency band it is desired to invert.

It will be noticed that the inverted wave still consists of voice frequencies, and as such is suitable for transmission over ordinary wire and radio circuits. On any particular channel, of course, two inverters are necessary, one to invert the speech wave before it passes over such portions of the circuit as may be liable to overhearing, and the second to render the received speech intelligible to the receiving subscriber.

Difficult to "Tap"

Speech inversion thus provides a perfectly automatic, reliable and practically distortionless means of ensuring secrecy in commercial radio telephony. The inverted speech wave, consisting as it does of components of voice frequency, necessitates no modification to the radio transmitter and receiver, while it is impossible for the transmissions to be overheard except by the use of an inverter precisely similar to that employed at the transmitter.

NEXT MONTH

A Special Short-Wave Number

ORDER YOUR COPY NOW

UNIQUE 2/6 GIFT



"MODERN WIRELESS"

RADIO MAP FREE TO-DAY

Here is a broadcasting map which is entirely NEW—different from any you have ever seen. It is the most complete and comprehensive Broadcasting Map ever published in this or any other country. Compiled from the very latest official information, it shows not only the ordinary broadcasting stations, but those working on the short waves in addition to those devoted to television. A great feature of this unique map is the very full index.

ANY ONE OF 1000 STATIONS IDENTIFIED IN A MOMENT

It is a stupendous gift which should not be missed by any owner of a wireless receiver
It is given FREE inside.

MODERN WIRELESS

USUAL
PRICE

1/-

ON SALE TO-DAY

MAKE SURE
that your
EXTENSER
has this patent
SILVER-GOLD
AUTOMATIC
WAVE SWITCH

14/6



ONLY



MAKE IT

The Formo design and construction of the Extenser Condenser incorporates features of special importance for the experienced constructor, who desires to choose the best components available. The slow and fast-motion dials give a silky smoothness essential for the tuning of close stations, whilst the special type of wave-switch is fitted with silver-gold contacts ensuring perfect electrical continuity. Tested to 200 volts before despatch and guaranteed exactly to specification.

0-100 covers 230-530 metres.
0-200 covers 1000-2000 metres.

FORMO DUAL
RANGE
COIL

12/6



The Formo Dual Range Coil is scientifically tested and absolutely reliable. Universally acknowledged the best type for radio construction. It is of superior finish, being wound on a well-designed moulding with accessible terminals. For best results and easy assembly make sure that you get a "FORMO."

Complete Catalogue from:
ARTHUR PREEN & CO. LTD.,
Golden Square, Piccadilly Circus, London, W.1
Crown Works, Southampton.

THE BIRTH—OR DEATH
—OF AN ELECTRON

An article which takes one in imagination to the outer confines of space.

By **G. H. DALY.**

SOMEWHERE out in space, far beyond the confines of the Milky Way, something of a most extraordinary nature is happening to the electron—the same type of electron, by the way, which flies from the filament to the plate of a wireless valve.

Now, any fresh news about the electron is of interest to the wireless community, and so this mystery is worth investigating.

Sir James Jeans has just stated in America that the electron and the proton are being annihilated out there in space, and that the cosmic radiation which we pick up here on earth is a sure sign of this destruction. It is interesting to note that he also accepts this as the final sign of the running down of the universe.

Destroying Matter

This theory, coming from a scientist of Sir James Jeans' eminence, is of far-reaching importance, because, if the electron really is being destroyed, then matter, of which the electron is the foundation stone, is also being

annihilated. This, of course, is contrary to all orthodox teaching, for we were distinctly taught that matter was indestructible, that it might be changed from one form to the other, but never by any chance destroyed.

But that is not all, for one of America's most famous scientists, Professor Millikan, takes the exactly opposite view to Jeans. He says, in fact, that "out there" the electron is not being destroyed, but that it is being created. That electrons and protons are being built up into atoms, and that that is the message of the cosmic radiation, he thinks. Here, again, we have old theories confounded, for we were told that creation of matter was just as impossible as the destruction of matter.

Both May Be Right

It is difficult to know on which scientist to place our money, for both arguments seem equally sound when examined. They are hardly likely to be both wrong, and it may happen that both are partially right.

But whichever of the two is correct something extremely important, as far as we are concerned, is taking place out in the remotest parts of space. Appallingly tremendous electronic energy is being released—it is as though we can hear faintly the noise of some terrible conflict—either the birth cry or the death struggle of the electron.

TREMENDOUS ELECTRONIC ENERGY

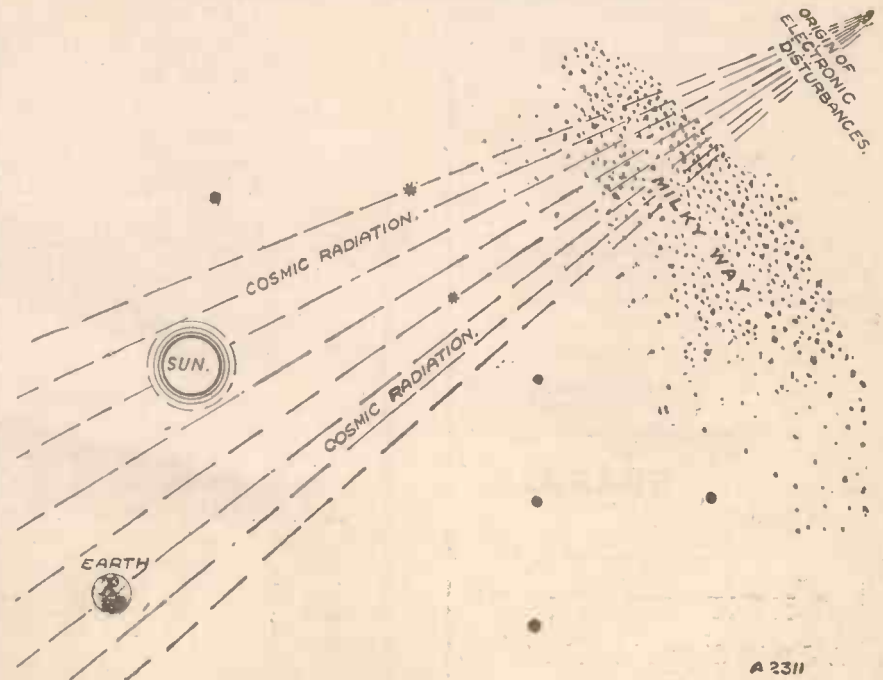

Is the electron being destroyed or created? That is the vital question scientists are trying to answer.



A HANDSOME RADIO-GRAM CABINET

The Camco "Berkeley," with its quartered veneer panels and fine finish, is a worthy addition to the furniture of any room. It is constructed with the usual Camco soundness and is suitable for Panels up to 18" x 7", with 15" base-board. In Oak Veneer, £12; Mahogany, £12.12.0; Walnut, £14.14.0. Write for FREE copy of the 1932 24-page Radio Cabinet Catalogue to: THE CARRINGTON MFG. CO., LTD. Showrooms: 24, Hatton Garden, London, E.C.1. Phone: HOL 9202. Works: S. Croydon.



Name.....
Address.....
W.C.S.

PERMCOLOUR

Nothing looks worse than a dull and discoloured panel. Use mirror polished PERMCOLOUR, the new Ebonite which is guaranteed never to discolour. Its beauty and polish will delight you, and its cost is less than 3d. per square inch. Don't spoil that set but insist on PERMCOLOUR, the modern permanent colour Ebonite. From all dealers or direct. THE BRITISH HARD RUBBER CO. Ltd., PONDERS END, MIDDLESEX.

* H.T. FROM FLASHLAMP *
* REFILLS *

I AM having such good results from using standard flashlamp refills for H.T. that I thought perhaps other readers may like to give it a trial.

It was through dissecting a few old batteries after scrapping that the uneven condition of the cells—some run-down, others with life still in them—showed the large wastage that was taking place, this being more pronounced when a multi-valve set was used.

Unequal Loading

With the different H.T. tappings, one section of the block had to supply all three valves, the next section two valves, and the third section only one valve, with the result that a battery is scrapped with at least one-third of its useful life unused.

I purchased twenty-seven refills (121.5 v.), made a tray with connections, and all was well for a time. Then I built a 4-valve set with power valves, and a consumption of 12 m.a., which was out of the question for ordinary refills, as their limit is about 6 m.a.

But my power valve only, with suitable grid bias, took 5 m.a., which was within the refill capacity, so I evolved my present method of using them. I have a battery of refills for each valve.

Easily Replaced

Housed in a tray of suitable dimensions, they are neat and not bulky, and will repay the first cost of installation, which is not as much as a super block, and the upkeep is hardly felt. A periodical inspection, any time you have a few minutes to spare, a faulty one or two replaced, and your batteries are kept up to standard.

Voltage always being up, your set is at its best all the time. Having separate batteries for each valve, you have also separate negative leads. These I bring out to valve sockets in an ebonite block on the side of the tray, and connect all up by plugging in valve pins on a brass bar, and then away to common negative on set.

On switching off, I also take off this bar, thereby cutting off all H.T. and eliminating any leakage should there be any.

G. F. P.

"Wireless Constructor" Recommends HEAYBERD



Recognised as the products of mains specialists, Heayberd Units are recommended always by "Wireless Constructor" for use with the new Sets. Follow the choice of experts and be certain of success.

MODEL C.150
Output 150 v. @ 25 m.a. Three tappings: 60/80 v. Variable S.G., 120 v. Fixed, and 150 v. Fixed. Assembled in Metal Case. Requires wiring up only. Guaranteed Three Years. Price 76/-

Send 3d. stamps for Lst 947 showing how simple it is to build the Mains Unit—best suited to your particular Receiver.



MASTERS OF THE MAINS.

10, Finsbury Street, LONDON, E.C.2.



ENSURE THE BEST RECEPTION

FRAME AERIAL

A first-class frame aerial which can be used with any circuit, with or without centre tap, for only 20/-. The milliwatt output is higher than any other aerial, definite minimum silent point.

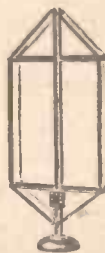

SHORT WAVE CONVERTER

If you fit the new Eelex Converter your present set can be used for reception on the ultra short waves. It is an indispensable addition, it will add 50 stations to your set.

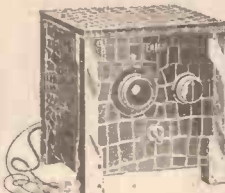

BYLDURONE CABINET

The ideal system for the home cabinet maker. You can safely use "Byldurone" because no experience is needed to build a cabinet the "Byldurone" way. Ask your dealer about "Byldurone."

WRITE FOR LIST-L.3.

J. J. EASTICK & SONS
EELEX HOUSE, 118, BUNHILL ROW,
LONDON, E.C.1.

Phone: Metropolitan 0314/5/6.

The Picture Paper with the MOST News—
SUNDAY GRAPHIC
and SUNDAY NEWS.



Radio Furniture De Luxe PICKETTS
Will delight you! Individually made: not mass produced (Used by famous experts, B.B.C.) Advantages also of PIANO TONE! Baffle chamber, pure mellow tone that thrills! Reduced prices: 55/- to £10 cash—or 10/- monthly. Photographs FREE.
PICKETTS Piano Tone Cabinet Works (G.W.), Albion Road Bexleyheath.

THE "KILOTRAP"
A Reader's Appreciation.

Sir,—I feel I must write and congratulate you on the design and performance of the "Kilotrap." I have constructed this set, and have already had much pleasure from it. Although I had only finished the construction of the set an hour before the Nairobi broadcast, I was able to pick up quite a good deal of that transmission. I have also heard the following stations since: Dutch station on 42.6 metres, W 3 X A L (New Jersey), Berlin, K D K A (Pittsburg), Moscow, W 2 X A F (New York), Chelmsford (G 5 S W).

I am indeed delighted with the results.

Yours faithfully,
 Surbiton. JOHN ATKINS.

**LEATHERETTE FINISH
 FOR CABINETS**

FOR those who have failed in their attempt to leatherette a common deal cabinet, the following might be useful.

Never use ordinary joiner's glue. Its inclination to set quickly leaves no time for shaping and recutting. Ordinary commercial gums are likely to discolour and affect the face of the material being used; and lastly it is impossible to remove these unsightly errors successfully.

A reliable leather paste can be made by pouring 15 parts by weight of water over 4 parts of glue. Allow to

soak for a few hours, then warm until the glue is entirely dissolved. Next add 60 parts of water and stir well in. After this make a solution of 30 parts of starch and 200 parts of cold water. Pour the glue solution, which should be boiled, into this starch solution. Stir thoroughly and boil. Use when cold.

Coloured sealing wax is effective for stopping and filling bad joints, etc.

ON SHORT WAVES

If you are interested in short-wave reception, make sure of next month's "Wireless Constructor," which will be devoted specially to this amazingly interesting aspect of radio.

Don't miss it, but
ORDER NOW OUT DEC. 15th
USUAL PRICE
 January number of the
"WIRELESS CONSTRUCTOR"

Warm in a pan and apply with a brush. This is the easiest way for treating tricky corners and moulds.

Use drawing pins to keep material in position, and always stretch before use.

W.W.

ROUND THE TRADE

WATMEL WIRELESS Co., LTD., have prepared a neat new folder illustrating the firm's tuning units, potentiometers, wire-wound resistances, H.F. chokes, pick-up carriers, screening boxes, etc.

It will be sent on application to this firm at High Street, Edgeware, Middlesex.

Hustler, Simpson & Webb, Ltd., of "Double Two" fame, advise us that this year they are marketing a 1932 "Super Two" in oak cabinet, fitted with valves, 4-pole balanced-armature loudspeaker, 100-volt H.T.B. (super capacity), G.B. battery, and 2-volt accumulator, the all-in price being £4 4s.

Without valves or batteries the price is £2 12s. Without valves it is £3 11s., or without batteries it is £3 5s.

The firm is also introducing a three-valve radio-gram at an inclusive price of £16 16s. Full details can be obtained from local dealers, or will be posted to any reader of the WIRELESS CONSTRUCTOR on application to Hustler, Simpson & Webb, Ltd., 317, Hoe Street, Walthamstow, E.10.

"The True Road"

A great deal of information of interest to the more serious wireless constructor is contained in a large, well-bound and well-illustrated book we have just received from Ferranti, Ltd. It is entitled "The True Road to Radio Reproduction."

The contents include sections dealing comprehensively with H.F. amplification, detection, audio-frequency amplification, the power stage, the loudspeaker, and so forth, and detail much original work done in the firm's laboratories.

With copious illustrations, etc., it is obviously a costly production, but arrangements have been made whereby the book is available to the public, at a price of 5s., through many of the radio dealers.

INDEX TO ADVERTISERS

	PAGE
Amalgamated Press Annuals ..	114
Belling & Lee, Ltd. ..	121
Bonjamin Electric Co., Ltd. ..	127
Bird, Sydney S., & Sons, Ltd. ..	127
British Blue Spot Co., Ltd. ..	Cover iv
British Ebonite Co., Ltd. ..	127
British Hard Rubber Co., Ltd. ..	131
British Zonophone Co., Ltd. ..	117
Bulgin, A. F., & Co., Ltd. ..	127
Burne-Jones & Co., Ltd. ..	125
Carrington Manfg. Co., Ltd. ..	131
Cossor, A. C., Ltd. ..	70
"Daily Mail" ..	111
Dubilier Condenser Co. (1925), Ltd. ..	128

	PAGE
Electrical Trading Association, Ltd. ..	125
Exide Batteries ..	109
Eastick, J. J., & Sons ..	131
Ferranti, Ltd. ..	122
Forno Co. ..	130
Gilbert, J. C. (Cabinets) ..	123
Graham Amplion, Ltd. ..	121
Heaybord, F. C., & Co. ..	131
Igranic Electric, Ltd. ..	69
Jackson Bros. ..	126
Lectro Linx, Ltd. ..	117
London Elec. Wire Co. & Smiths, Ltd. ..	Cover ii
Lotus Radio, Ltd. ..	Cover iii
"Modern Wireless" ..	129
"Modern Boy" ..	123

	PAGE
Peto-Scott Co., Ltd. ..	124
Picketts' Cabinets ..	131
Ready Radio, Ltd. ..	101, 113
Reproducers & Amplifiers, Ltd. ..	125
Taylor, C. ..	127
Telegraph Condenser Co., Ltd. ..	106
Telsen Electric Co., Ltd. ..	105, 119
Varley Products ..	123
Westinghouse Brake & Saxby Signal Co., Ltd. ..	106
Wingrove & Rogers, Ltd. ..	121
Wright & Weaire, Ltd. ..	117

All communications concerning advertising in "Wireless Constructor" must be made to John H. Lile, Ltd., 4, Ludgate Circus, London, E.C.4. Telephone: City 7261. FOR ADVT. RATES SEE PAGE 123.

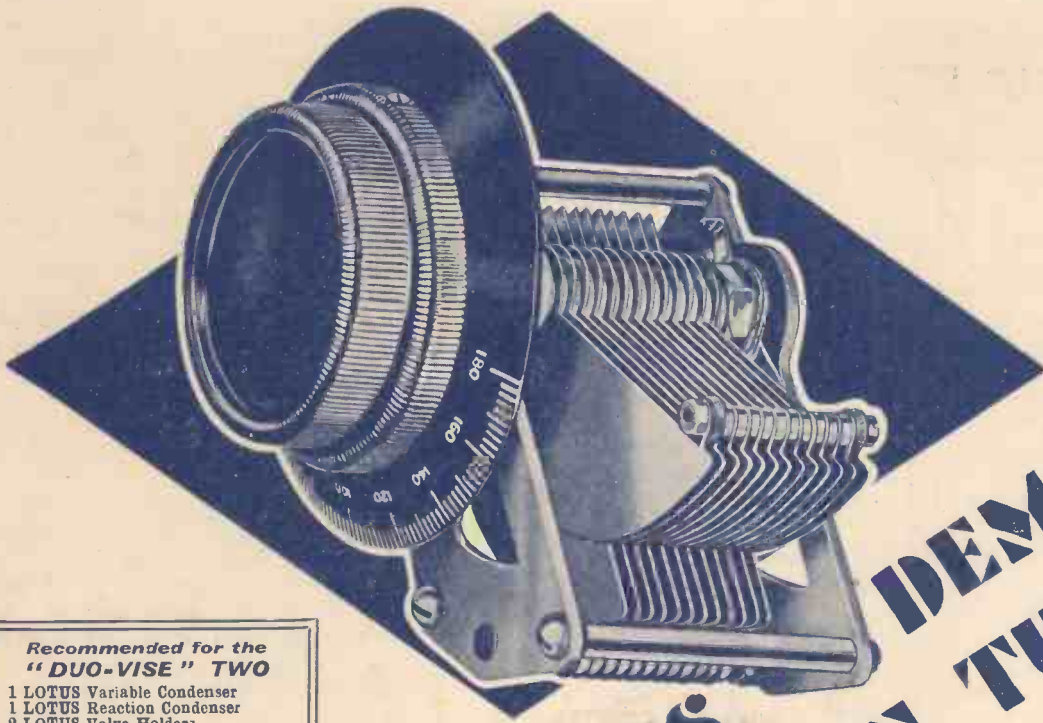

**MODERN SETS
PRECISION
TUNING**

DEMAND

**SLOW MOTION
LOG CONDENSER**

6/6

·0003 & ·0005 CAP.

- Recommended for the
"DUO-VISE" TWO**
- 1 LOTUS Variable Condenser
 - 1 LOTUS Reaction Condenser
 - 2 LOTUS Valve Holders
 - 1 LOTUS H.F. Choke
 - 1 LOTUS L.F. Transformer
- THE "MIDGET" THREE**
- 1 LOTUS Differential Reaction Condenser
 - 1 LOTUS L.T. On-Off Switch
 - 3 LOTUS Valve Holders
 - 1 LOTUS L.F. Transformer
- (Both sets described in this issue.)*

LOTUS Condensers afford the last word in precision tuning. Control is delightfully smooth and absolutely silent, while sturdy construction ensures a lasting accuracy and unfailing reliability. Ask or write to-day for your copy of the LOTUS Component Catalogue. It is full of interest to the home constructor.

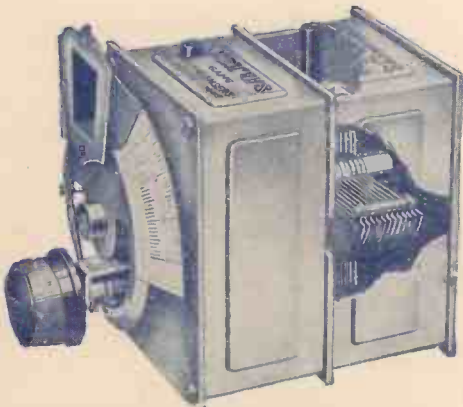

GANGED CONDENSERS

Specially heavy vanes and end-plates ensure a permanent accuracy of matching of 1% between units. Trimmers are accessibly placed and are easily adjusted by fingers or screw-driver. Each Unit is completely screened from the others, and pressed aluminium covers also protect the condensers from dust. These assemblies are smaller than most other gang condensers and are simple to assemble in all types of receivers.

2-GANG with Disc Drive
Type DS/CH.2 **25/-**

SLOW MOTION LOG CONDENSER

Constructed throughout of aluminium, this Component is highly efficient, perfectly smooth and noiseless in operation. A ball-drive integral vernier device is concealed in the spindle and both direct and slow drives are controlled by the double Knob-Dial supplied with the Condenser. With braided pigtail connection to rotor. Specially suitable for Super-Hets. The reduction gear is 7-1.

Capacities ·0003 Type SM/3
and ·0005 Type SM/5 **6/6** EACH.



RADIO COMPONENTS

LOTUS RADIO LTD., MILL LANE, LIVERPOOL.

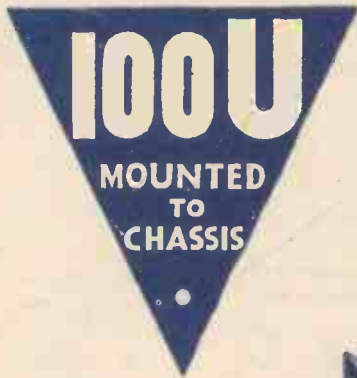

**INDUCTOR
TYPE**



Owing to its extreme sensitivity the input should not exceed 1200 milliwatts.

**BRITISH MADE
THROUGHOUT**

A TRULY WONDERFUL UNIT

Blue Spot 100U is the equal of the most expensive Dynamic Speakers. That is a big claim but it is justified. Severe tests by experts have but served to prove the exceptional merit of this truly wonderful unit. There is nothing like it at anywhere near its price.

Every radio enthusiast who has not heard 100U should make a point of doing so at once. It can be used with any type of receiver and also with Pentode Valves since no matching transformer is required. Its sensitivity is such that perfect reproduction with good volume is ensured from very small inputs. In the difficult bass notes particularly, its performance is genuinely remarkable. Distortion, muffling, rattle and discordancy are unknown to 100U. But hear it for yourself.

Price complete mounted to chassis

39'6

Write for catalogue W.C.11 for details of Blue Spot units, speakers and receivers.

THE BRITISH BLUE SPOT COMPANY LTD.

BLUE SPOT HOUSE, 94-96 ROSOMAN ST. ROSEBERY AV., LONDON, E.C.1

Telephone : Clerkenwell 3570.

Telegrams : "Bluospot, Isling, London."

Distributors for Northern England, Scotland and North Wales : H. C. RAWSON (Sheffield and London) Ltd., 100, London Road, Sheffield: 22, St. Mary's Parsonage, Manchester: 183, George Street, Glasgow.

