

The Wireless Constructor

6^d
MONTHLY

EDITED BY
PERCY W. HARRIS, M.I.R.E.
Vol. VII. FEBRUARY, 1929 No. 28.

THE "PENTWIN"

DESIGNED BY
PERCY W. HARRIS
M.I.R.E.

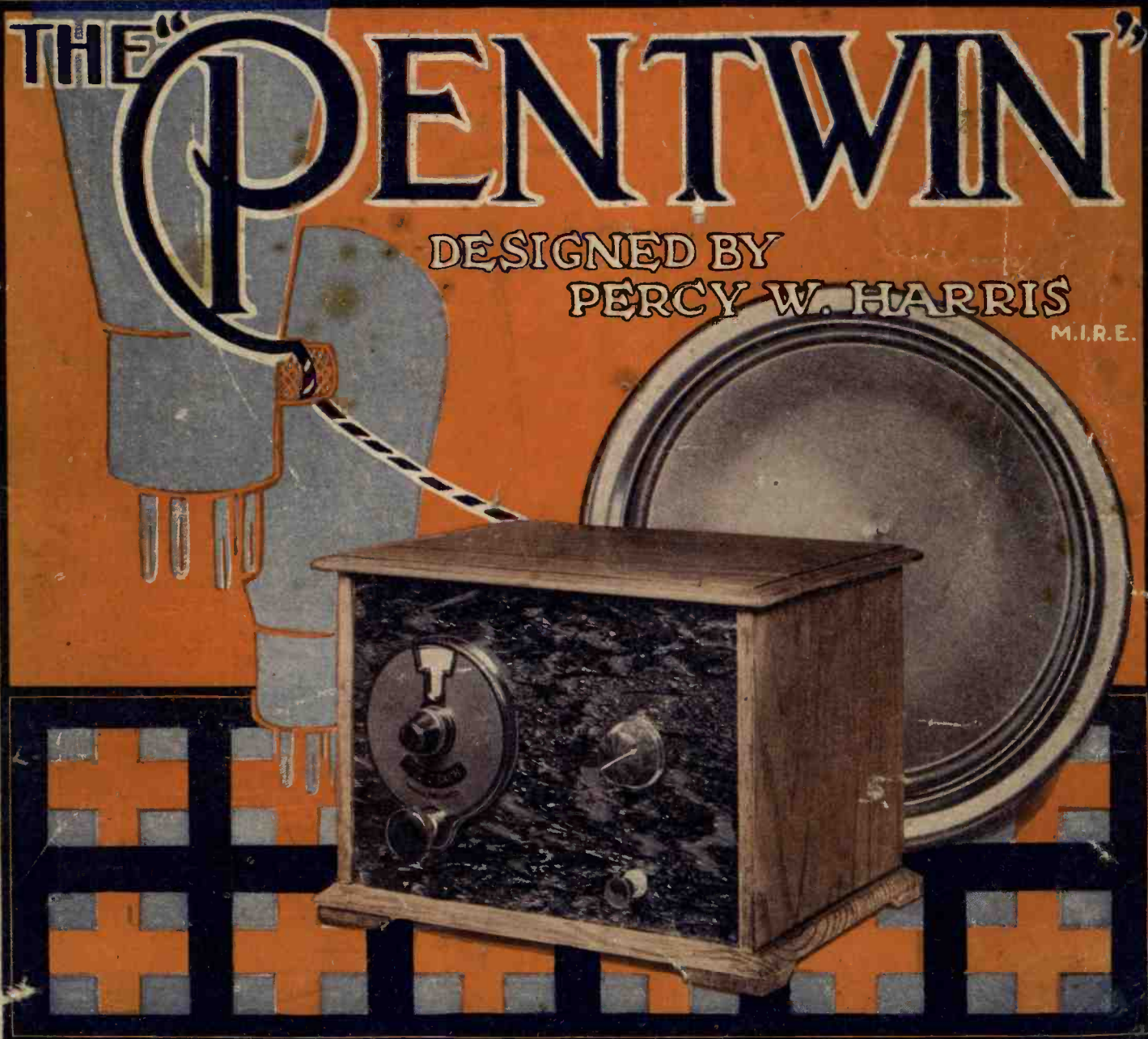

Music wherever you go



In any room, at your own home or your friends', anywhere and everywhere you go you can hear radio music at its best. The wonderful Mullard Master Five Portable Receiver makes you independent of an aerial and earth and gives you music anywhere at the touch of a switch. Receiver, batteries, aerial, loud-speaker are all contained within the attractive cabinet.

Operation is of the simplest—one dial tuning! The Mullard Master Five gives amazing choice of programmes and is highly efficient on the long as well as the broadcast wavelengths—an achievement rare with portable sets. Its tone is rich and realistic—no sacrifice of quality is made to its compactness and portability.

The Mullard Master Five is the modern version of ideal radio.

The Mullard MASTER FIVE



You can build the Mullard Master Five yourself quite easily and save yourself pounds. Its construction is simpler than that of many smaller and less efficient receivers. The unique Plan of Assembly is your assurance of success. No previous radio experience is necessary.

Post coupon now for full details and free copy of "Radio for the Million," Vol. 2, No. 4.

To Dept. 18,
Radio for the Million,
63, Lincoln's Inn Fields, W.C.2.
Please send me free Plan of Assembly of the
Mullard Master Five and copy of "Radio for the
Million," Vol. 2, No. 4.

Name.....
(Block letters)

Address.....

W.Con.

CONTENTS

	Page		Page
The Editor's Chat	253	Cartoon	278
The "Pentwin"	255	Happenings at Savoy Hill	279
Queer Queries	260	Laboratory Notes	283
Adding Punch to Your Short-Waver ..	261	Experimenting with the 31 New Circuits	287
Long Waves on the "New Business		A Variable H.T. Unit	288
Man's Four"	265	In Lighter Vein	291
What the Pentode Really Does	267	Within the Vacuum	294
The "D.C." Four	269	What's New	298
Radiogramphonics	274	Chats at the Worktable	302
Transatlantic Tendencies	275	Our News Bulletin	308

As some of the arrangements and specialities described in this Journal may be the subject of Letters Patent, the amateur and trader would be well advised to obtain permission of the patentee to use the patents before doing so.

EDITED BY

PERCY W. HARRIS, M.I.R.E.

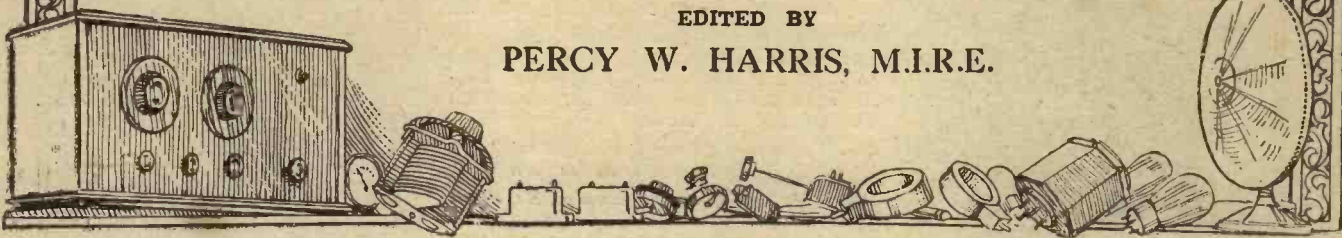

MARCONIPHONE TRANSFORMERS

At its introduction, the "Ideal" Transformer achieved an immense advance in wireless reproduction. To-day all transformers are judged by that high standard. Not only is every "Ideal" guaranteed against mechanical trouble, but each one has a guaranteed amplification curve within 5% of the standard. From the top of the scale, right down to the lowest register, every frequency is perfectly interpreted and amplified; every note is given its own true value, undistorted, uninterrupted

"IDEAL" TRANSFORMER

This famous Marconiphone Transformer combines particularly high inductance with an unusually low self-capacity, whilst the large iron core precludes any possibility of saturation under normal working conditions. The "Ideal" is, to all intents and purposes, distortionless throughout the musical scale, and guaranteed against mechanical and electrical defects for twelve months. In four ratios: 2.7 to 1, 4 to 1, 6 to 1, and 8 to 1. Price 25/- each.

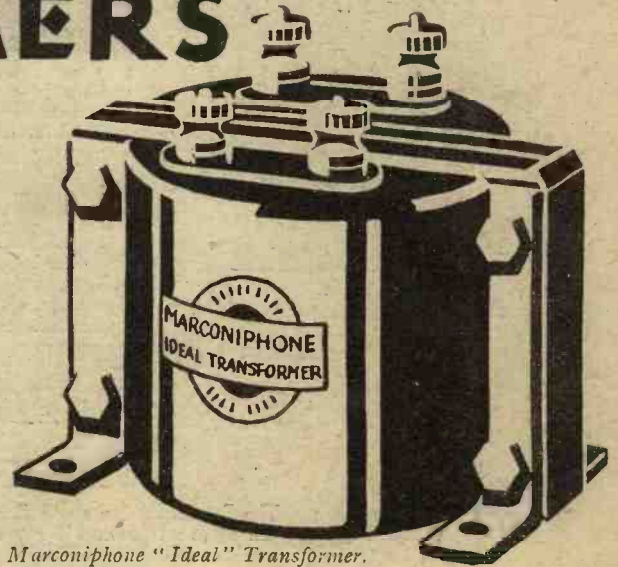

Marconiphone "Ideal" Transformer.

POPULAR TRANSFORMER

An inexpensive but efficient little instrument suitable for small receivers or portable sets. Price 12/6

UNIVERSAL TRANSFORMER

These have a higher inductance than any other at a similar price, and offer extraordinary value. Two ratios are available: 2.7 to 1 and 4 to 1. Price 16/-

THE MARCONIPHONE COMPANY, LTD.

(Dept. P), 210-212, Tottenham Court Road, London, W.1.

Showrooms:

210-212, Tottenham Court Road, W.1, and Marconi House, Strand, W.C.2.

Leadership

MAGNAVOX

The Originators of the Moving Coil Speaker

And now read what others say:—



R.4

The "Wireless Constructor."

The Magnavox Speaker gave a rendering of programmes which was a sheer delight to the discriminating ear.

The "Broadcaster."

Our tests convinced us that the Magnavox is the best moving-coil speaker sold. The reproduction was as realistic as could be.

Mr. W. James in the "Morning Post."

Regardless of price the very best I have ever heard.

Radio Editor of a well-known Northern Newspaper.

No other speakers compare in the slightest degree with the Magnavox.

To endeavour to publish all the testimonials which we have received from the leading Radio Engineers and amateurs in the country would mean our booking all the advertising space in this journal.



D.80.



Lyric.

REALISM—

You can hear the bowing of the strings of the double bass and the beats of the drums in their true tone colour. There are no jarring sounds and the harp does not sound like a flute with Magnavox Speaker Units. There are models for A.C. or D.C.

TYPE R.4	£8 0 0
" R.5	£8 5 0
" D.80/1	£11 0 0
" D.80/2	£11 0 0
" M.7.K.	£4 2 6

Belvedere Fire Screen Baffle for all		
Magnavox Units	£4 0 0
The Lyric, with M.7.K unit	£4 2 6
Lyric Baffle only	£1 0 0

REMEMBER THAT ALL MAGNAVOX SPEAKER UNITS ARE EQUIPPED WITH INPUT TRANSFORMERS, 10-FT. INPUT AND FIELD CORDS AND FIELD SWITCH



Belvedere.



THE GREAT VOICE

The Second Edition of the Great Voice Booklet is now ready. This booklet tells you all about Moving-Coil Speakers, Pick-ups, Volume Controls and Amplifiers for A.C. and D.C. There are 36 pages full of illustrations and diagrams. Send for your copy of this new booklet to-day, price 3d., post free.

Telephone: Mayfair 0578-9

The
ROTHERMEL
CORPORATION, LTD.
24-26, MADDOX ST, LONDON, W.1.

Telegrams:- Rothermel, Wesdo, London



Quality Tells!

MANY manufacturers of the finest receiving sets and eliminators use Electrad Resistance Controls. Scores of radio engineers and technicians specify them exclusively. Only controls of perfected designs, proven performance and dependability could enjoy such universal endorsement.

Electrad specializes in a full line of resistance controls for all radio purposes. Dealers everywhere sell them.

Truvolt All-Wire Resistances

The unique, air-cooled construction of Truvolts makes for unusual accuracy and permits the carrying of heavy current loads with a high factor of safety.

Truvolt Variables simplify H.T. Eliminator construction by eliminating difficult calculation and making all adjustments easy. Twenty-two stock types. 15/6 each.

Truvolt Fixed resistors are adjustable to different set values by the use of sliding clip taps—an exclusive Truvolt feature! Made in all desirable resistance values and circuit ratings.

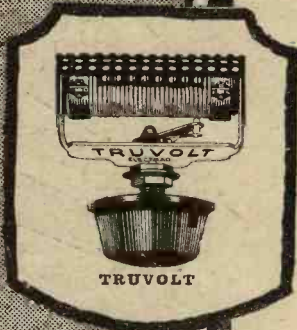

Royalty Variable High Resistances

Here is a Variable High Resistance that is entirely free from harmful inductance and capacity effects. It is widely recommended wherever a unit of this type is required in the circuit. Eleven types covering a range for every purpose. 8/- each. Potentiometers 9/- each.

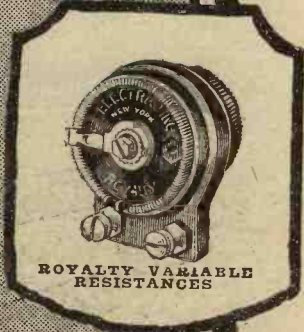

TONATROL

Perfect control of volume to adapt your reception to the occasion and individual taste is necessary for the full enjoyment of your radio. Tonatrol Volume Controls are designed in types to meet the specific needs of all circuits—A.C. or conventional battery type. Furnished in standard types or with filament switch or power switch attached. 8/- to 15/6 each.

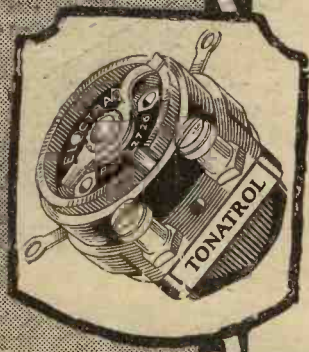

Please send me descriptive folder on all Electrad products, and put me on your mailing list for similar literature.

I am particularly interested in.....

Name

Address

Represented by The
ROTHERMEL CORPORATION, LTD.,
 24-26, Maddox Street, London, W.1.

Phone: Mayfair 0578-9, 4286.

Telegrams: "Rothermel," Wesdo, London.

ELECTRAD Inc

ANYONE

EVEN A MERE NOVICE CAN GET 23 STATIONS



LACK of selectivity limits the range of any Receiver. There is no pleasure in listening to a foreign programme if you can hear your local station all the time. With the wonderful new Cossor Melody Maker you can get full enjoyment from the continental broadcast. It has knife-edge selectivity, it will cut out your local station like magic. It has enormous range. Even a novice can bring in programmes from 23 stations. The skilled operator can bring in many more. Get the pick of the programmes with the new Cossor Melody Maker. Anyone can build it in 90 minutes. It's as simple as Meccano. Fill in the coupon now.

YOU WILL PROBABLY GET MANY MORE ON THE NEW

COSSOR Melody Maker

Please send me free of charge one of your Constructor Envelopes which tells me how to build the new Cossor 'Melody Maker'.

Name.....
 Address.....
 W. Con. Feb.

Adv. A. C. Cossor Ltd., Melody Department, Highbury Grove, London, N.5

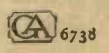

The WIRELESS CONSTRUCTOR

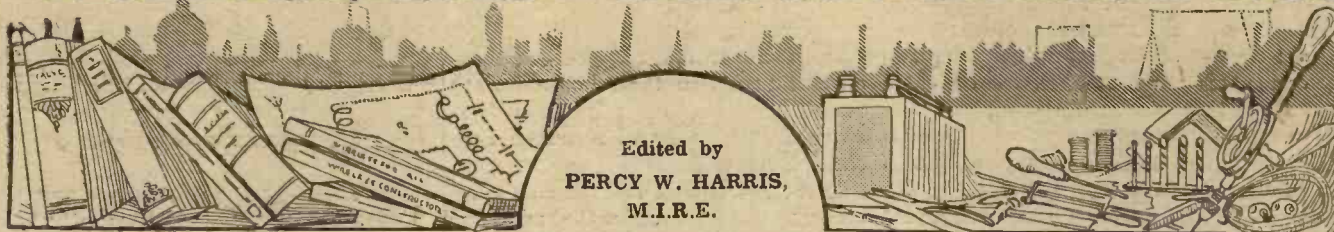

Published by the Amalgamated Press, Fleetway House, Farringdon Street, London, E.C.4.

THE EDITOR'S CHAT

In which Percy W. Harris, M.I.R.E., the Editor of the "Wireless Constructor," discusses The "Pentwin," The New "Business Man's" Four, and other items of interest to all readers.

WIRELESS enthusiasts who are new recruits to the hobby, and who have had their first experience of long-distance reception this winter, will have noticed the remarkable variations of conditions from night to night and, indeed, from hour to hour. With aerial and earth, batteries and valves remaining precisely the same, it will have been found that on one night almost any station in Europe seems to come in with clarity, while on others even the most careful use of reaction fails to reveal more than a few.

Bad Nights and Good

The experienced listener, being well acquainted with these peculiarities, is able to allow for them, but it often happens that a newcomer to the art, testing a receiver for the first time on what we generally call "a bad night," is particularly disappointed with the results he obtains. Similarly, another new enthusiast trying his new set on a good night may get a quite exaggerated idea of its general capabilities.

New "Business Man's" Four

By picking a particularly good evening, or by collecting the results of several good evenings' work, it is possible with a most mediocre receiver to compile a test report of a very alluring variety. But although such reports may create interest they do not tell what the average reader particularly wants to know, namely, what a given set is likely to do under normal conditions with the average aerial.

Regular readers of the WIRELESS CONSTRUCTOR are well aware that in all our articles we endeavour to give the reader just such an idea, for which reason we are publishing this month a second test report on the New "Business Man's" Four, one of the most remarkable designs we have yet published. Last month we gave a one-hour test report on the 200- to 600-metre band, and this month we are giving another report

taken over an even shorter period immediately after the tests with the long-wave coil had been completed. Neither night was specially picked.

What the "Pentwin" Does

The New "Business Man's" Four was exhibited and demonstrated at a meeting of The Wembley Wireless Society recently, when its great sensitivity and ease of handling aroused much favourable comment.

ALL-ACROSS-AFRICA RADIO

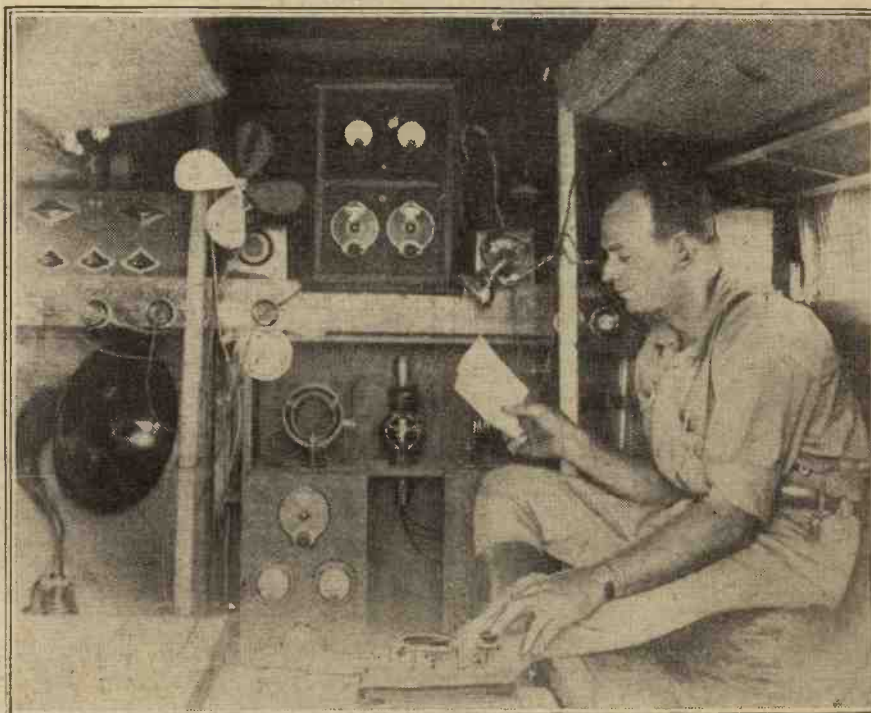

This view shows the interior of a Chevrolet van which recently roughed-it all the way from Cape Town to London, keeping in radio touch all the time by means of the short waves.

The Editor's Chat—continued

In the case of the "Pentwin"—our "star" receiver this month—it would have been very easy to compile a long list of stations heard, but as conditions vary so much from night to night at the present time of the year we are contenting ourselves by stating that its distance-getting properties are fully equal to those of a well-designed set using a detector and two stages of low-frequency, while the strength of reproduction is about the same as that given by a three-valve set with one stage resistance and one transformer coupling.

Pentode Facts

The Pentode valve is comparatively a newcomer in the wireless market, so that at the time of writing there is still some difficulty in obtaining delivery of these valves, and it is a little early to pass any opinion as to whether the Pentode type of valve will ultimately displace the ordinary low-frequency type. In order that readers may fully understand the many problems connected with this valve we have arranged with Mr. G. P. Kendall, B.Sc., to describe the new device in detail in the present number, and this article should be carefully studied by all who like to get at the real facts.

An American Analysis

In response to a large number of requests, we are publishing in the current issue an analysis of American commercial wireless circuits in order that our readers may compare them with arrangements used in this country. We believe it is the first time any such analysis has been published, and we believe the article will be found of great value not only to the experimenter and home constructor but also to the industry at large. A further article of this type is now in preparation.

Another "request" item, as they say in the broadcasting programmes,

NEXT MONTH—

Picking up Pictures from
VIENNA
with the
**NEW "BUSINESS
MAN'S" FOUR!**

is the complete all-mains D.C. receiver designed for those many people who cannot make use of alternating current apparatus but have direct current mains in their house. The results given by this receiver are particularly good, and although the construction may seem rather elaborate it must be remembered that this set contains not only the wireless receiver but a complete plant for converting the electric current from the mains, with its many irregularities and high voltage, into that required not only for the lighting of filaments, but also for the provision of perfectly smooth and hum-free plate current. Even grid bias is provided from the mains, so that there is not even *this* small battery to change.

Next month I hope to tell you of some really remarkable developments in the WIRELESS CONSTRUCTOR laboratory, and of the results of a series of most interesting experiments at present being completed. Meanwhile, I would take this opportunity of thanking the numerous readers who sent us appreciations of the WIRELESS CONSTRUCTOR.

* **REPORTS FROM READERS** *
* The "P.C." Three—The "Seven-Valve Super-Het." *

SIR,—About three months ago I made up the "P.C." Three, which was published in the WIRELESS CONSTRUCTOR for August. The coils I made as specified (except for the 34 D.S.C., instead of which I used Litz 9/38).

The results are simply amazing, as up till now I have had forty-three stations on the loud speaker, some of them at good strength, and with a one-valve amplifier they all come in at excellent strength.

Some of the stations received are:

- | | |
|-------------|--------------|
| *Vienna. | *Madrid |
| *Brussels | *Leipzig |
| *Aberdeen | *London |
| *Langenberg | *Prague |
| *Frankfurt | *Paris |
| *Glasgow | *Bournemouth |
| *Toulouse | *Breslau |
| *Stuttgart | *Dublin |
| *Newcastle | *Nurnberg |
| *Belfast | *Viborg |
| *Dundee | *Nimes |
| *Edinburgh | *Orebro |

- | | |
|-----------------------|----------|
| Cologne | Biarritz |
| *Lille | *Kiel |
| Nice (Juan les Pins). | |

The stations marked with a star all come in at good strength, with just the three valves.

The forty-three stations I have logged are all in the broadcast band, as I have not wound a long-wave transformer yet. My aerial is about 30 ft. high and 50 ft. long, being about six miles from the Glasgow station. This performance strikes me as being very good for a three-valve set. The selectivity is very good, as well as the range of the receiver, because I can tune in Stuttgart at 63 deg. without a trace of Glasgow hardly, which comes in at 68 deg.

Wishing you and your paper the best of success.

Yours sincerely,
R. M.

Near Glasgow.

The "Seven-Valve Super-Het"

SIR,—I have constructed the super-het designed by you and described in the July WIRELESS CONSTRUCTOR, and I wish to tell you what an extraordinary receiver I think it is. The input from the two intermediates to the A.F. stages is so enormous that I have had to put a Marconi P.625A in the last stage, which improves matters considerably. (My first six are Mullard P.M.5X.)

Distant stations such as Breslau, Prague, Vienna, Budapest, Madrid and Barcelona come in at enormous strength on the speaker (Brandes Ellipticon), and the clarity of speech and quality of music and singing is wonderful.

I find that with 140 v. H.T.3, 80 v. H.T.2, and 60 v. H.T.1, with 21 v. grid bias on the output valve, the whole receiver consumes 25 m.a. when potentiometer is near oscillating point; rather more, of course, when turned back towards positive for reception of 2 L O and 5 G B and other powerful stations. I don't think this consumption is excessive.

On the whole, for range and quality combined, I think this is the most satisfactory set I have ever handled or heard of.

Many thanks for making so excellent a receiver available to your readers.

Yours truly,
GEORGE S. C. C.

Berks.

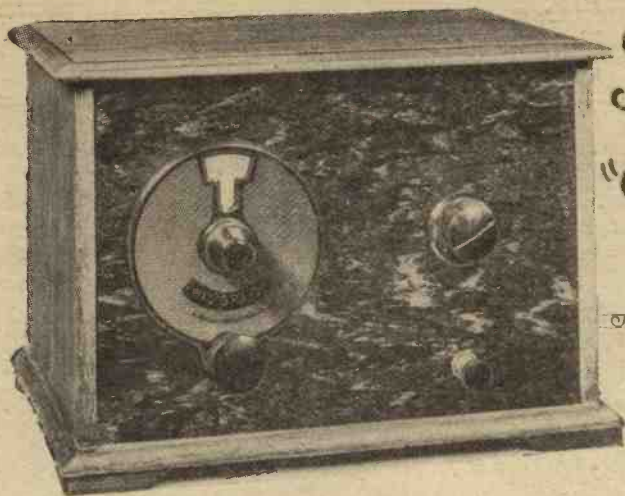

The "PENTWIN" by PERCY W. HARRIS MIRE.

This set is a revelation of what two valves can be made to do—in fact, it is a two-valver which gives three-valve results. Read this article and "get in" on this remarkable receiver, which everyone will soon be building.

WHEN you set out to build for yourself a wireless receiver you may aim at long-distance reception, using telephones only; at short-distance reception on the loud speaker; at long or short distance on

LIST OF COMPONENTS

(Parts actually illustrated are in brackets.)

- Cabinet to take 10 in. × 7 in. panel and 7-in. baseboard (Camco). (Raymond, Caxton, Arterraft, Bond, etc.)
- 1 10 in. × 7 in. panel for same, $\frac{3}{16}$ or $\frac{1}{4}$ in. (Ripault). (Radion, Ebonart, Trolite, etc.)
- 1 Variable condenser, .0005 mfd. (Lotus). (Lissen, J.B., Cyldon, etc.)
- 1 Miniature reaction condenser, .0001 mfd. (Bowyer-Lowe). (Cyldon, etc.)
- 1 On-and-off switch (Benjamin). (Bulgin, Duco, Lotus, etc.)
- 1 Six-pin base (Lewcos). (Colvern, Duco, etc.)
- 1 Lewcos Super coil, C.A.C. size, with No. 4 primary for the lower band and
- 1 Lewcos Super C.A.C. 20 coil with 10 or 12 primary for upper band.
- Terminal strip with 10 terminals (Magnum).
- 1 Fixed condenser, .0003 mfd., and clips (Lissen). (Dubilier, Mullard, T.C.C., Atlas, Magnum, etc.)
- 1 grid leak, 2 megohms (Dubilier). (Lissen, Mullard, Igranic, etc.)
- 1 Radio-frequency choke (Lissen). (R.I.-Varley, Lewcos, Wearite, etc.)
- 1 Good quality low-frequency transformer (Marconiphone Universal). (Igranic, Mullard Philips or other small size type.)
- 2 Valve holders (Benjamin). (Formo, Bowyer-Lowe, Lotus, Magnum, etc.)
- 1 Fixed condenser, 1 mfd. (Dubilier). (T.C.C., Ferranti, Hydra, etc.)
- 1 Special pentode output transformer (Marconiphone).
- 1 Wire-wound resistance with terminals, 20,000 ohms (Lissen).
- 1 Vernier dial (Indigraph). (Any good vernier dial will suit.)

the loud speaker, or even, in the simplest possible case, at short-distance reception on telephones only.

If you are fortunate enough to be free from any financial care and can invest in just whatever apparatus

you like, you may perhaps wish to build something very elaborate, with a multiplicity of valves and all kinds of arrangements for long-distance reception of the finest possible quality, but if you are representative of ninety-nine out of every hundred readers, then there will be certain definite limitations which you will have to impose upon yourself in cost, size and work involved.

Local and D.X.

Although for first-class long-distance reception one or more stages of radio-frequency preceding the detector are highly desirable, if not imperative, there is no gainsaying the fact that a well-designed detector

circuit with accurately controllable reaction, followed by efficient note magnification, is a thoroughly reliable circuit for a good deal of our reception. For this reason a detector with reaction followed by two stages of low-frequency magnification is by far the most popular of all arrangements, and when well made, properly used, and connected to a good aerial and earth, it will bring in quite a number of stations other than the local and the "alternative."

A number of designs of this type with sundry modifications for special purposes have appeared from time to time in our columns, a recent example which is finding many adherents being the receiver entitled

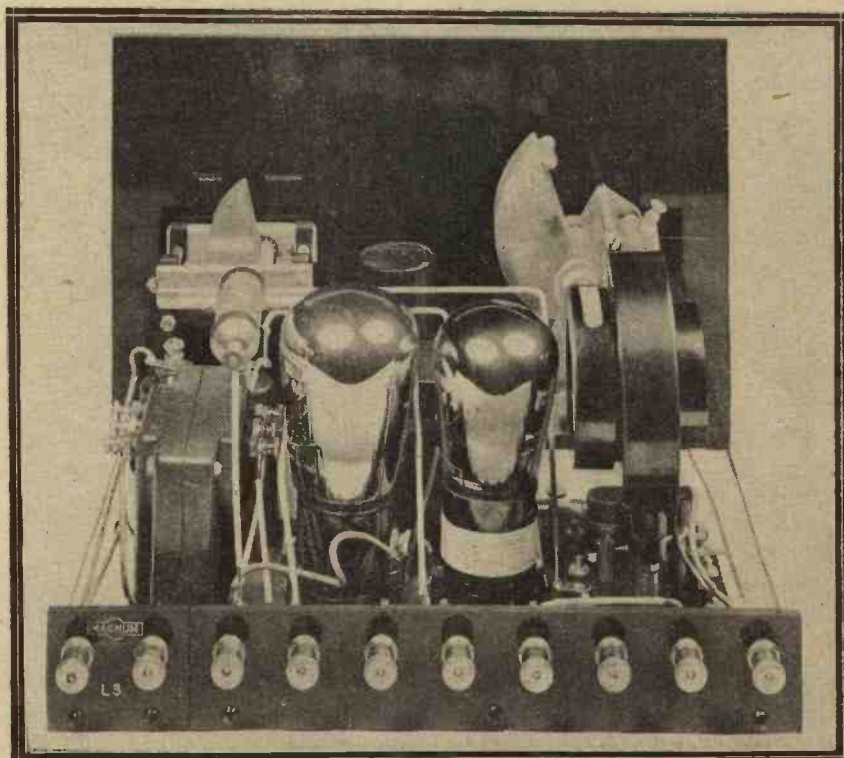

The completed "Pentwin," with valves and coil in position.

The "Pentwin"—continued

"Big Ben." This, you will remember, is a detector with one stage of resistance coupling and one transformer coupling with a new wave-changing scheme and other desirable features.

A 16 in. by 8 in. panel was used, and even with this size of cabinet the parts had to be well laid out in order to avoid undue cramping. Several designs put out by the valve manufacturers have been much larger, even as big as 21 in. by 7 in. by 10 in. deep for a three-valver without any special output device.

Compact and Efficient

In many cases, however, we may desire to build a very compact and simply operated loud-speaker set for reception of the local and alternative programmes, together with 5 X X, Radio-Paris and a number of continentals on the lower band. Is there any way in which we can make the set smaller and more compact without adversely affecting either the efficiency of the set or its ease of construction? There is a way, and that only recently possible, namely, by the utilisation of the "Pentode."

The pentode, which was an outstanding feature of the autumn wireless exhibition, is a five-electrode valve, and gives a much greater magnification with one valve in a low-frequency stage than has hitherto

of all our low-frequency problems, and unless it is properly used the results obtained with it may be quite inferior to those to which we are accustomed. It has one great virtue, however—it enables a set to be made

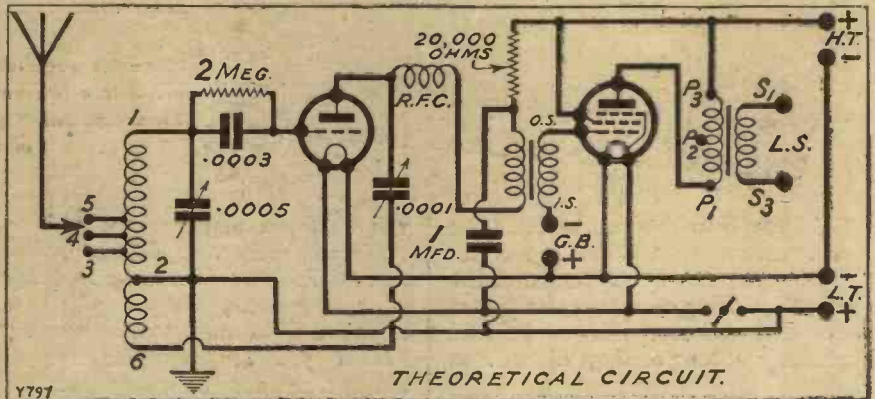

been possible. The pentode has its own peculiarities, and these are clearly dealt with in an article by Mr. G. P. Kendall, B.Sc., in another part of this issue.

The pentode is not, as some people have thought, an automatic solution

much smaller than would otherwise be the case, and thus when sitting down to plan a receiver which would give loud-speaker results under the conditions named, using only a very small cabinet with single tuning control, the special virtues of the pentode were carefully borne in mind.

Like a Three-Valver

The "Pentwin," which is the name I have given to a new two-valve receiver described in this article, is a set with real three-valve performance and many virtues hitherto associated only with a much larger set. Used on the average aerial it will bring in as many stations as the conventional good three-valver (and many more than some), it gives exceptionally good quality with a modern loud speaker of the cone and moving coil type, while the filament consumption of the whole receiver is quite modest in proportions, thus enabling a small accumulator to be used.

On the other side of the balance sheet the high-tension consumption is practically as large as that of a detector and two stages of low-frequency magnification, using a super-power valve in the output. This I must say, is inevitable with the pentodes at present on the market, if they are used efficiently and as the makers intend.

The circuit of the "Pentwin" is shown in Fig. 1, from which it will be seen that a form of Reinartz reaction

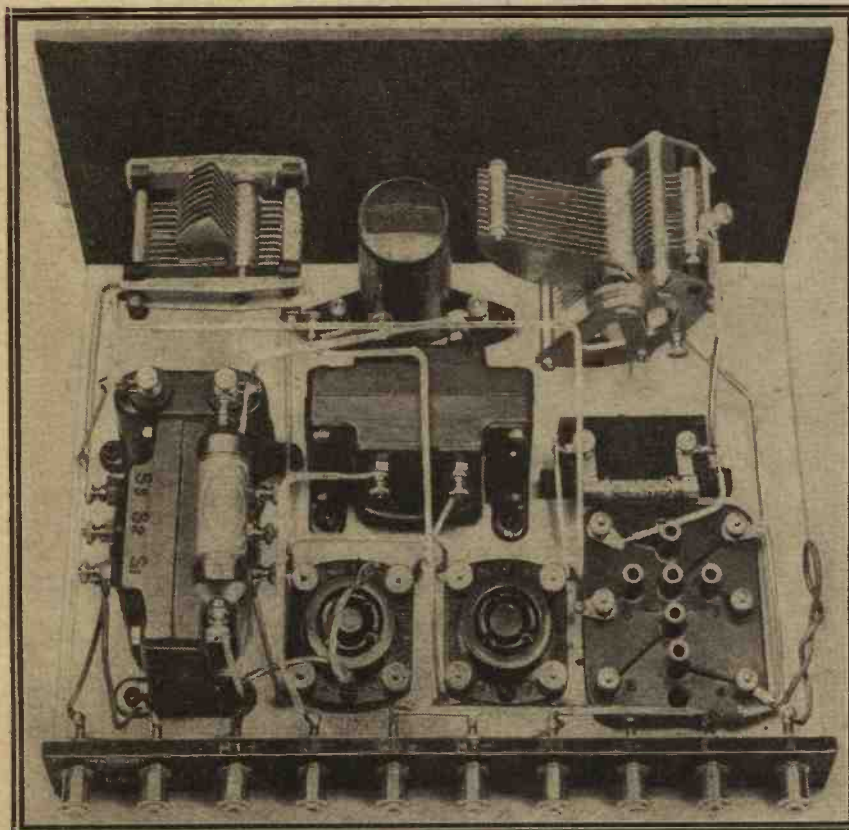

This "plan" view, clear enough to be equivalent to another wiring diagram, shows the essential simplicity of the "Pentwin."

The "Pentwin" —continued

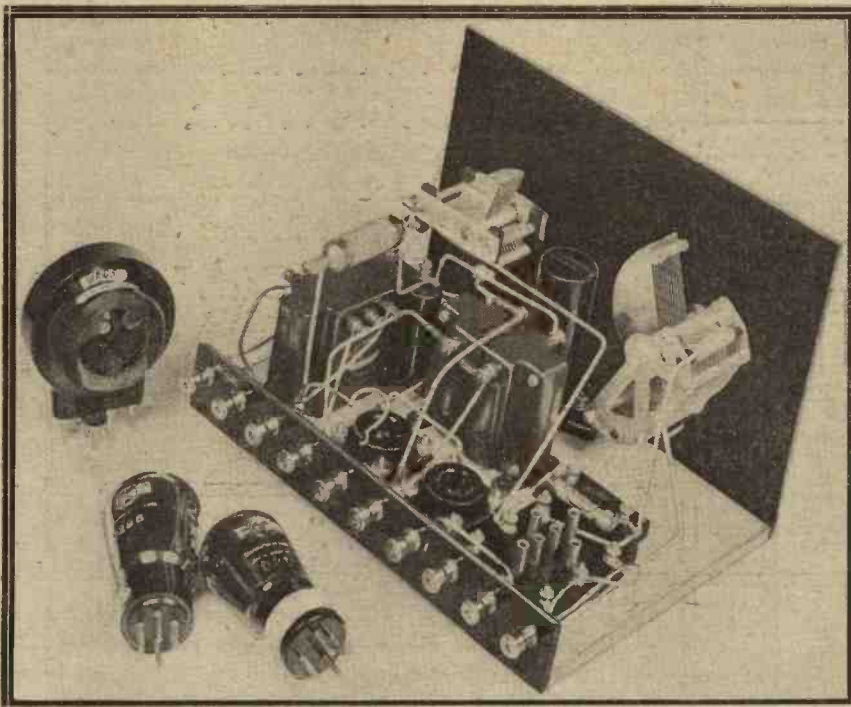

The "Pentwin" is just two valves, one tuning coil, a small set—and a wonderful performance!

is used in the detector circuit, and a special output transformer. By careful design it is possible to build the set efficiently in a cabinet using a 10 in. by 7 in. panel, while the single tuning dial and the small reaction knob, together with an on-and-off switch, are the sole controls visible.

It might be thought that it would have been simpler to omit the output transformer, thus saving a little space and cost, but experiment shows that the pentode valve will not work satisfactorily with many of the ordinary loud speakers unless a special output transformer is used. The transformer incorporated in this case has been specifically designed to operate in the plate circuit of the pentode, and I am more than satisfied with the quality given by the whole receiver.

Transformer Coupling

The detector, it will be seen, is coupled to the pentode by a low-frequency transformer, this being the best form of coupling in the circumstances, having in mind that we want to get both power and good quality. A resistance stage could have been used here, but there would have been no appreciable gain in quality with one stage and quite an appreciable amount of strength would

have been sacrificed. A good modern low-frequency transformer has an excellent curve, and when only one stage is used the results given by a good transformer will be indistinguishable to the ear from those given by the best types of resistance-capacity units.

An Important Resistance

If you make a further examination of the circuit diagram you will see that in the anode circuit of the detector valve we have a radio-frequency choke, the primary of the low-frequency transformer, and a resistance, this latter being joined on the transformer side to a large fixed condenser which is taken down to the filament circuit. This resistance serves no less than three separate and distinct purposes.

In the first place it serves to reduce the high-tension voltage supplied to the detector down to the figure we require, thus enabling us to use only one high-tension positive throughout. Secondly, it serves as an anti-motor-

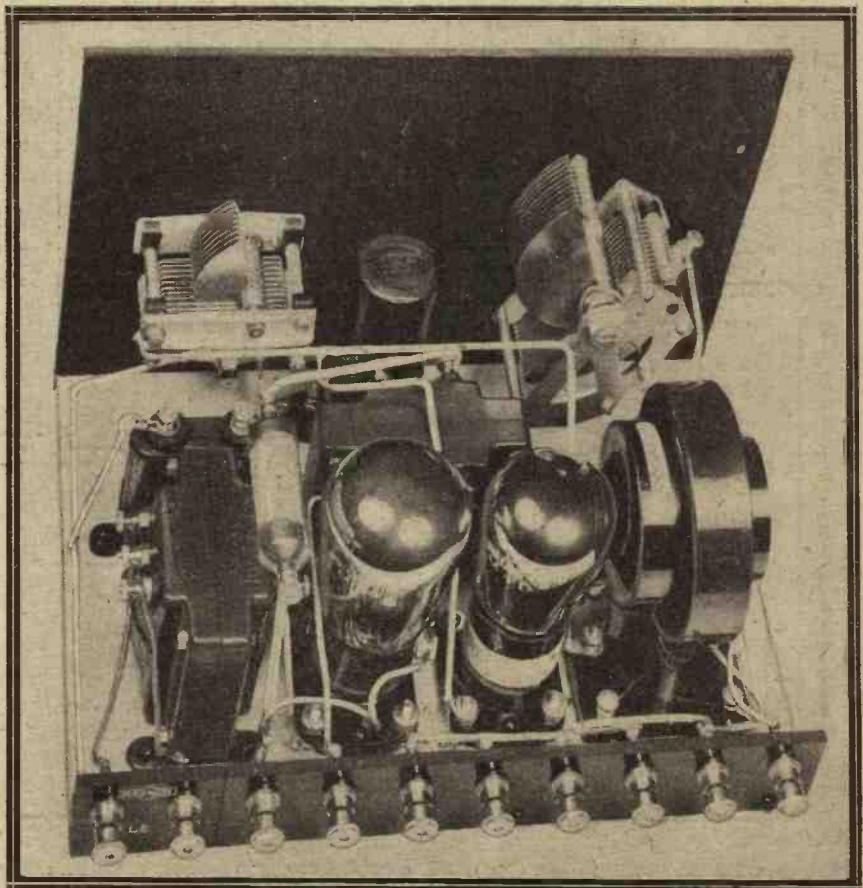

The flex lead going to the side terminal on the pentode can be seen above.

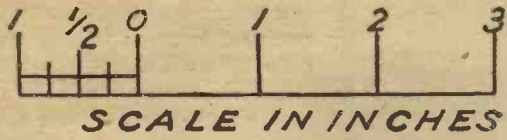

WIRING
DIAGRAM.

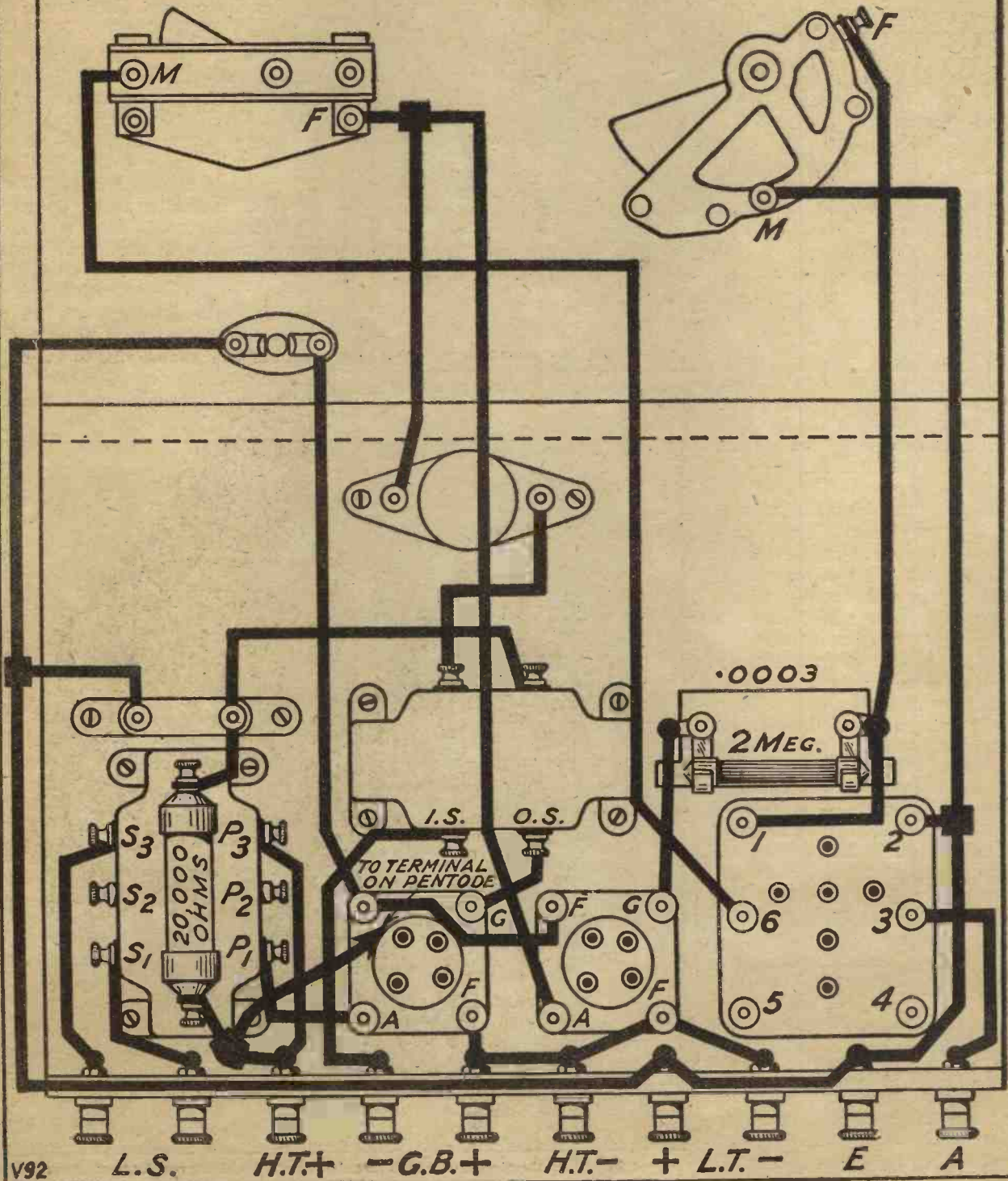

The "Pentwin"—continued

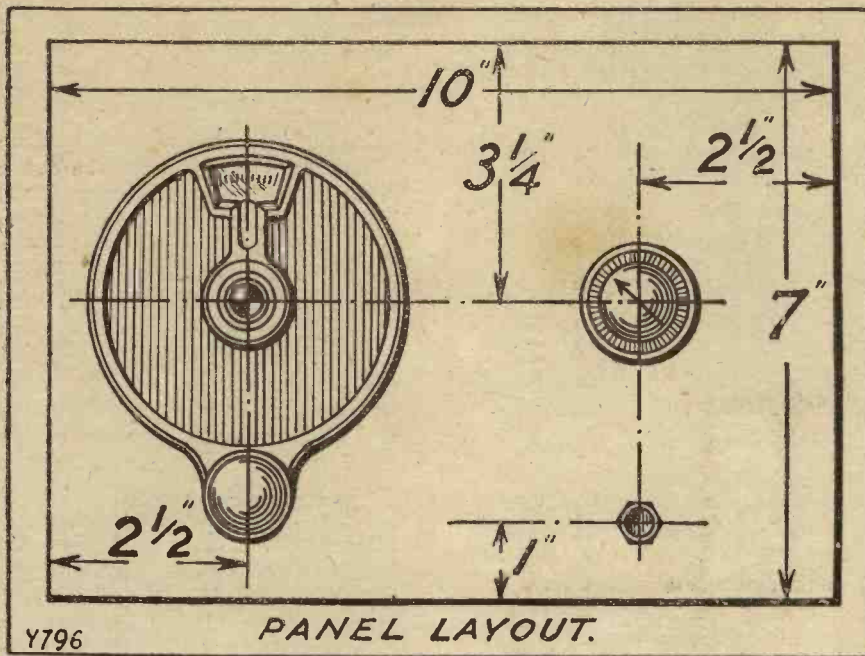

high-frequency transformer of the split-primary type the interchangeable coil can be the centre-tapped primary.

Interchangeable Windings

The advantages of this new coil, apart from its high efficiency, particularly on the longer waves, is that we can pick the reaction winding to suit our particular purpose, and when we use high-frequency transformers we can pick a primary to suit the degree of selectivity and the valve with which we are working. In the present case, however, we are using only an aerial coil, and to suit this receiver I have chosen a reaction coil No. 4, which suits our purpose excellently.

Using transformer and not resistance coupling, I find the reaction winding on an ordinary reaction coil too large, but by using a No. 4

(Continued on page 314.)

boating device, and prevents battery coupling and feed-back, which would in some cases spoil or impair the quality, and, thirdly, it is a very excellent safety device limiting the current drain from the high-tension battery should by any chance the plates of the variable condenser touch one another.

Even if we short-circuit the reaction condenser it can do little harm to the batteries, whereas if this resistance were omitted and the plates short-circuited there would be a "short" on the high-tension battery through the comparatively low-resistance winding of the transformer primary. True, this shorting effect could be prevented by the insertion of a fixed condenser in series with the reaction condenser, but by using the one resistance for three purposes we can dispense with the fixed condenser in question and thus save cost.

New Tuning Coil

This receiver will introduce WIRELESS CONSTRUCTOR readers to a new kind of coil, the Lewcos Super coil, which has certain distinct advantages. In the first place, it fits into the standard six-pin base, and in the second it has on its side three pins irregularly spaced which fit into sockets on a coil which is removable. In the case of an aerial coil, the removable coil can be the reaction winding, and in the case of a

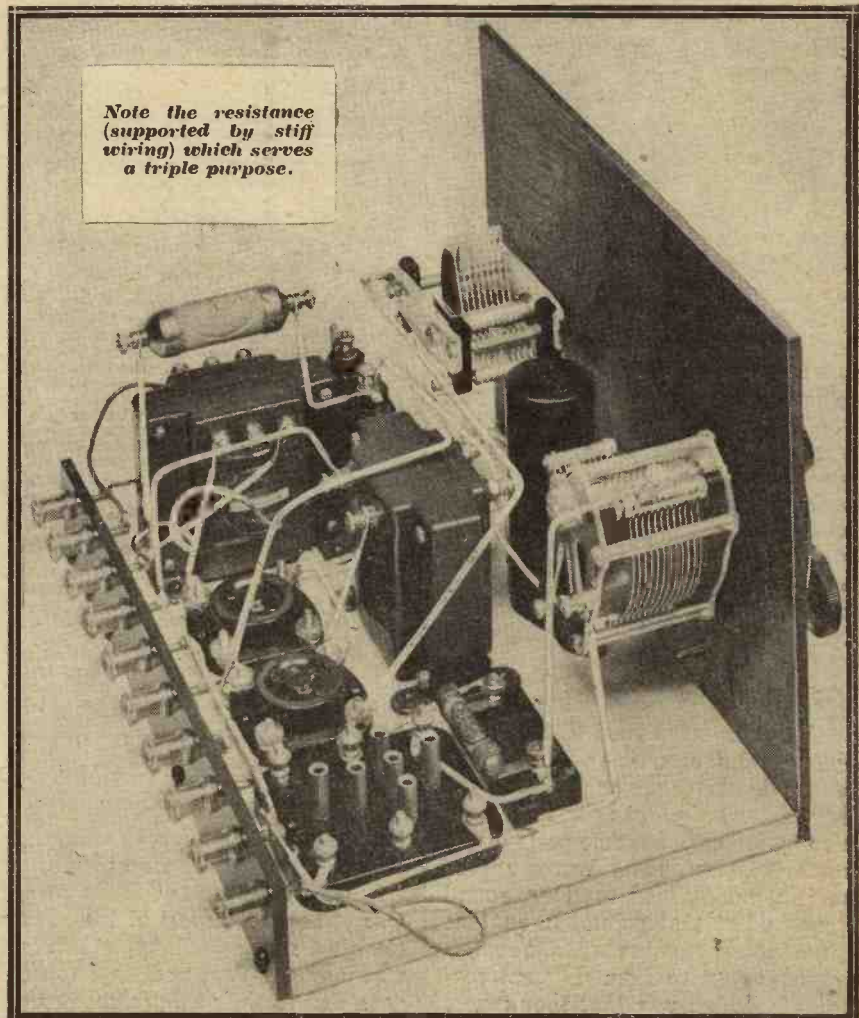



Some typical faults and remedies reviewed.

By P. R. BIRD.

Loud-Speaker Location

"IF a loud speaker is moved from one position in a room to another position, does this alter the tone of the reproduction?"

This question is very often asked and often hotly disputed, for at first sight it would appear as though the tone of any loud speaker would depend upon the loud speaker, and upon nothing else. But the word "tone" is capable of such a wide application that most people would apply it to the alteration in sound waves which takes place when they are reflected by different surfaces.

In any room the sound which reaches us comes not only from the loud speaker itself, but in the form of reflected waves which, originating in the loud speaker, are turned back to our ears from the various room-surfaces. The character of these reflected waves will appear to differ when reflected from a perfectly flat surface, such as a wall, as compared with when the surface is a "broken" one, such as a curtain or other soft furnishing.

Echo Effects

Moreover, apart from these surface differences, the *position* of the various walls, etc., gives rise to waves which have a marked effect upon the reception by the ear. In some parts of the room these secondary waves appear to join, and, added together, sound very loud at that point. In another place (possibly quite close) the sounds appear to arrive from different surfaces in such a way that they cancel each other out, and consequently there

is a sort of silent area there which could easily be mistaken for a change in tone. If during a long note, such as the tuning note, one ear is kept closed and the listener then moves slowly about the room, he will soon realise that the loud-speaker position is very important, and for perfect reproduction it must be carefully arranged.

THE TECHNICAL QUERIES DEPARTMENT

Are you in trouble with your set?

Have you any knotty little Radio problems requiring solution?

The WIRELESS CONSTRUCTOR Technical Queries Department has been thoroughly reorganised and is now in a position to give an unrivalled service. The aim of the department is to furnish really helpful advice in connection with any radio problem, theoretical or practical.

Full details, including the revised and, in cases, considerably reduced scale of charges, can be obtained direct from the Technical Queries Department, WIRELESS CONSTRUCTOR, Fleetway House, Farringdon Street, London, E.C.4.

A postcard will do: on receipt of this all the necessary literature will be sent to you free and post free, immediately. This application will place you under no obligation whatever. Every reader of the WIRELESS CONSTRUCTOR should have these details by him. An application form is included which will enable you to ask your questions, so that we can deal with them expeditiously and with the minimum of delay. Having this form you will know exactly what information we require to have before us in order to solve your problems.

"Faults" which are Not

Amongst the many puzzling things that may cause worry to the owner of a wireless set, there are a good many "faults" that are not faults at all. One of the commonest of these is an electric shock. Many set-owners who are quite unused to electrical gear find to their astonishment that when handling their sets they some-

times feel a distinct shock when touching the H.T. positive wiring. Generally, they realise that they were not harmed in any way, but in effect they would "like to know what is wrong, because whatever it is it ought to be put right."

Battery Shocks

In such a case, of course, there is nothing wrong (except the owner himself). It is perfectly normal, and indeed inevitable, for a battery to try and supply current whenever a resistance is connected across it, and if the set-owner places one hand on H.T. negative and the other hand on a wire which is carrying H.T. positive current he is quite likely, especially if his skin happens to be moist, to feel the tingling of the small current which the battery is trying to send through his body. (This, of course, applies more especially where the battery voltage is high.)

In such cases the fault lies not in the battery giving the shock, but in the listener placing his hands in such a way that he inserts his body as a resistance across the H.T. positive and negative.

Screening and Tuning

Now that the necessity for screening certain H.F. stages in sets has become generally realised, a good many people have been intrigued by the fact that they notice an alteration in tuning every time screening is brought near to a coil. This was particularly noticeable when copper screens were used to surround solenoid coils, but even with a standard square screening box it often happens that the tuning is noticeably affected when the lid is put on or taken off, and similarly the condenser readings will sometimes alter by several degrees according to whether a screening plate between coils is in position or is taken out of the set.

A Magnetic Effect

The point that seems to puzzle those with this peculiarity is how the presence of metal can affect wave-lengths, which they understood depended only on the capacity and inductance in circuit. A little consideration, however, will show that the effect of an adjacent copper screen upon inductance can be comparatively large, for the magnetic field of a coil often extends several inches from the coil itself, as we can notice if we remember how loosely coils may be coupled together in some circuits.

ADDING PUNCH TO YOUR SHORT-WAVER

"Real" H.F. amplification on the short waves can now be achieved, and in this article full details of a special short-wave H.F. unit are given.

By L. H. THOMAS (G 6 Q B).

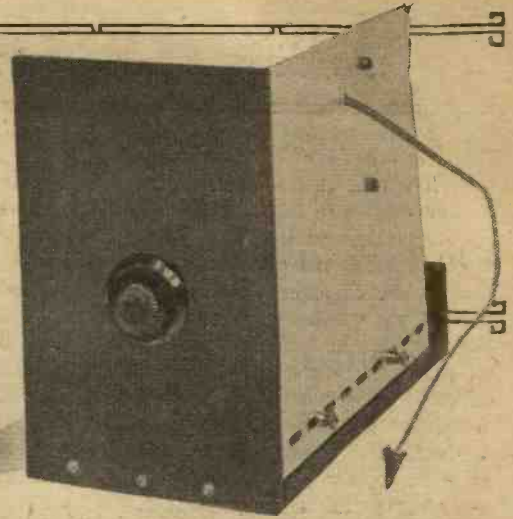

It has until recently been an almost proverbial belief among short-wave enthusiasts that, for all-round efficiency and satisfaction, nothing can beat the conventional "detector and note-mag." outfit.

COMPONENTS REQUIRED.

- 1 Ebonite panel, 4½ in. × 6½ in. (Any good make).
 - Baseboard, 8 in. × 4½ in.
 - Standard metal screen, 6 in. × 7 in. (Magnum). (Parex, etc.)
 - 1 Non-microphonic valve holder (Lotus). (Benjamin, Igranic, W.B., etc.)
 - 1 Short-wave H.F. choke (Magnum).
 - 1 5-mfd. condenser (T.C.C.). (Dubilier, Ferranti, Mullard, etc.)
 - 1 0001 mica condenser (T.C.C.). (Lissen, Dubilier, Atlas, Mullard, etc.)
 - 1 Base-mounting coil socket.
 - 1 Semi-adjustable condenser, maximum about 00015 (Formodenser).
 - 1 30-ohm rheostat, panel mounting (Igranic). (Lissen, G.E.C., etc.)
 - 1 Two-terminal strip and 1 four-terminal strip.
- Tinned copper wire, wood screws, etc.

I have, I admit, been guilty from time to time of saying things to this effect myself.

Simplicity and Short Waves

It is true that the old and unsatisfactory methods of H.F. amplification had little or nothing to offer the short-wave man, and the short waves possess such remarkable carrying properties that it was perfectly true that if a signal were "there" at all, it could be picked up straight away on the detector and any attempt at H.F. amplification was generally unwanted.

H.F. did, in fact, introduce a most serious disadvantage—the presence of another control and the corresponding increase in difficulty of

operation. This was a real hindrance from the point of view of the short-wave fan a year or so ago, since he spent most of his time searching round the various amateur wavebands logging signals from incredible distances—the more the better.

The "Buffer" Effect

With the advent and steady improvement of short-wave broadcasting, however, we have a new state of affairs, and the introduction of a new class of listeners, who are content to "sit still" for a while instead of being continually on the search for something fresh.

To them the introduction of another control is not so serious a disadvantage. H.F. amplification,

with modern valves and circuits, can prove distinctly worth while for this class of listener, and it was primarily for their benefit that I made the screened-grid unit described herewith. During experiments and tests I found, however, it could be so far simplified as to prove of distinct value to the other class of listeners—the "D.X.-hounds."

I myself belong to both classes, and until the introduction of something better, this unit, in front of a good two-valver, fulfils my needs perfectly, as regards ease of operation, all-round efficiency and consistency of results. The cost and trouble of construction are so small, and the performance of the unit so satisfactory in every way, that I am describing it in full

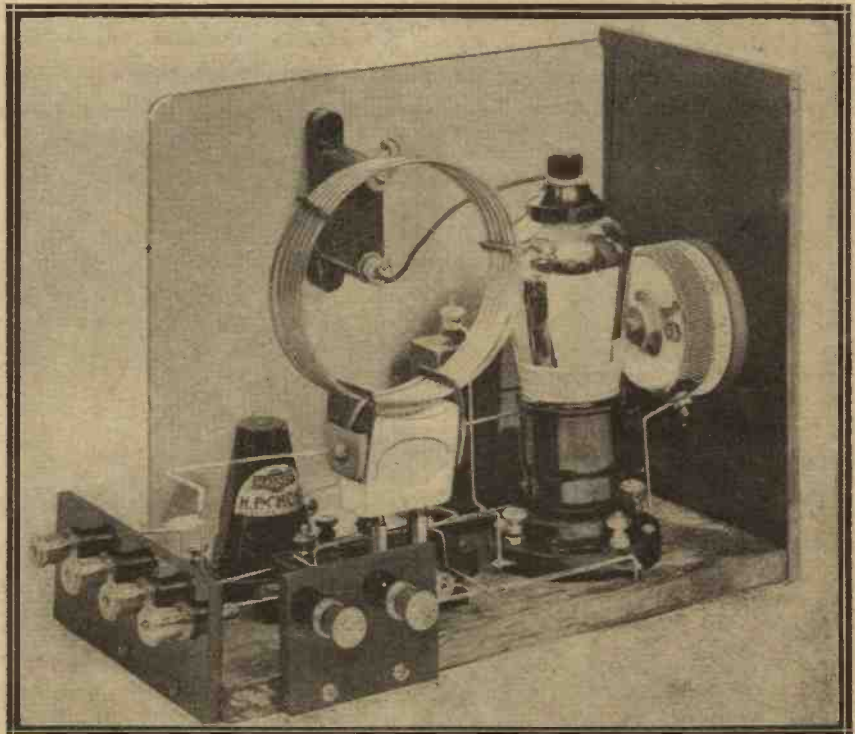

Very simple, isn't it? As you can see from the list of components, only a few parts are needed to build the unit.

Adding Punch to Your Short-Waver—continued

for the benefit of readers who feel that it would be useful to them.

As a matter of fact, I decided some time ago that such a unit would be worth placing in front of the average short-wave receiver even if no amplification whatever were obtained from it, for the sake of what I term, for want of a better name, the "buffer effect." A stage of H.F. between the aerial and the detector eliminates, for a start, all "dead spots" on the reaction control, due to resonance with the aerial or harmonics of the aerial circuit.

Improving Selectivity

This in itself is a great advantage, since the position of the reaction condenser now remains practically constant over the whole of the tuning range and simplifies tuning to an enormous extent. Then, again, it reduces the damping of the detector grid circuit somewhat (although this depends on the way in which the aerial circuit was coupled in the first place), with a consequent improvement in selectivity.

It also greatly reduces the effect due to a swinging aerial during high winds, and signals remain rock-steady although the aerial may be behaving itself very badly indeed.

It has been the fashion in some quarters recently to arrange a screened-grid valve as H.F. amplifier in front

of a short-wave set, and not to attempt to tune the grid circuit of the H.F. valve. Some prefer an H.F. choke, while others use a high resistance, to give this "aperiodic aerial" circuit. Needless to say, this greatly reduces the amount of amplification available, although it naturally eliminates any tendency to instability in the H.F. amplifier.

With a tuned-grid circuit, even a screened-grid valve will oscillate quite strongly at these very high frequencies unless it is neutralised in some way. I have effected a compromise between the two states by utilising what the Editor calls a "partially tuned aerial circuit."

All that this means is that the aerial circuit is tuned within reasonable limits of the wave on which one is working; the resulting amplification is very nearly equal to that obtained when the circuits are perfectly in tune, and much greater than that obtainable with a resistance or choke in place of the tuned circuit, while there is no tendency towards instability.

Small but Efficient

The grid circuit of the H.F. amplifier, therefore, comprises a plug-in coil and a "Formodenser." The latter is very seldom touched, but adjustment is occasionally useful, as will be mentioned at a later stage.

The very small size of the unit may be judged from the photographs. The ebonite panel holds only a filament rheostat and is, of course, really unnecessary. It has been incorporated purely for the sake of

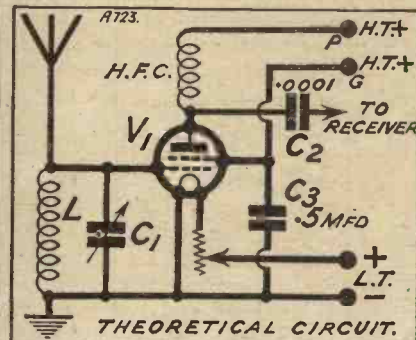

appearance, with a view to making the unit suitable for placing alongside an existing set without looking ridiculously out of place.

Naturally, if we were to make any attempt to tune this H.F. stage accurately to the wave on which we are working, we should find very soon that the screening was quite inadequate and that the whole thing was unstable and unworkable. Trouble would also most probably arise from the small size and the small amount of spacing between the components.

The "partially tuned" grid circuit is the solution of these difficulties, and I am inclined to think that on the whole it is just as good a solution as neutralisation, and one which involves less trouble.

Hand-Capacity Prevented

Regarding the anode circuit of the H.F. valve, shunt-feed has been employed, the necessary H.F. choke being incorporated in this unit. From the anode, through a .0001 fixed condenser, a lead is simply taken straight to the top end of the grid coil of the existing receiver, i.e. directly to the side of the grid condenser which is remote from the grid.

Thus the tuning control to which you have been accustomed on your existing set will still remain as the main control. The only other components in the unit are the valve holder, two terminal strips, and the by-pass condenser for the H.T. supply to the screening grid.

In my opinion it is practically essential to use shunt-feed for the plate supply to the H.F. valve, since

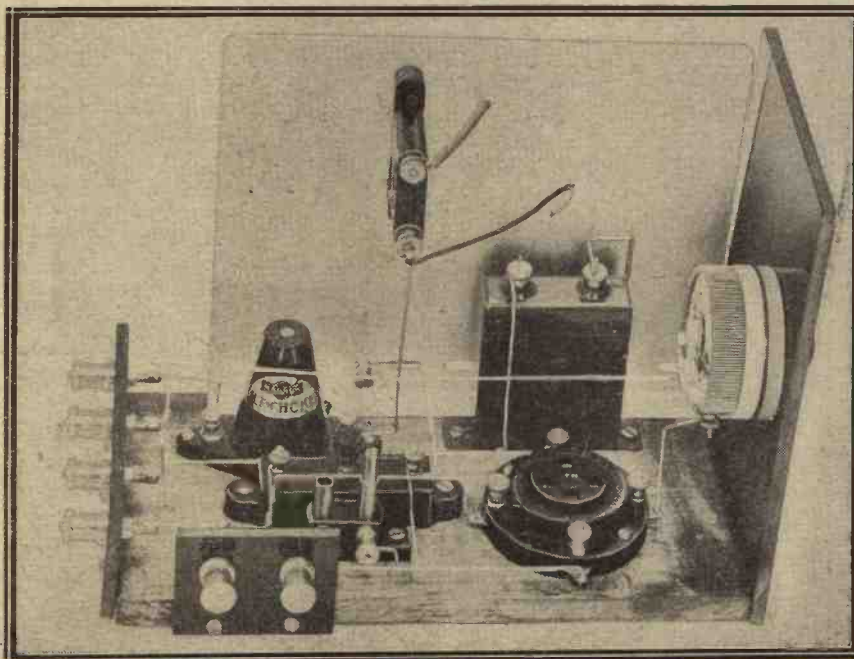

The simplicity of the wiring can be gathered from this photo of the amplifier with the screened-grid valve and the coil removed.

Adding Punch to Your Short-Waver—*continued*

it is most important in a short-waver to keep one set of plates of the variable condensers at zero potential.

This can, of course, be done in a straight tuned-anode circuit—the plates connected to H.T. positive are, theoretically, at zero H.F. potential, but one too often finds troublesome hand-capacity effects present. Shunt-feed usually overcomes any trouble in this direction.

Construction is Easy

On my own two-valve short-waver there is no metal screen of any kind on or near the panel, and yet one can bring one's hand up to the metal dial of the main control without so much as altering the beat-note of a station to which the set is tuned. There is no reason why this state of affairs should not be universal, since there is no difficulty whatever in obtaining it with a small amount of trouble.

Nothing more need be said about the theoretical aspect of the unit until we reach the operating notes.

Regarding the constructional work, no difficulty should be encountered here, since the photographs and back-of-panel diagram show all that there is to be seen. Looking from behind the unit, the two left-hand terminals are respectively H.T. + (plate) and H.T. + (screen). It should be remembered, of course, that the connections to the base of the latest types of screened-grid valves are altered—the anode of the valve is taken to the terminal on the pip, and the pin on the base which normally carries the anode connection is connected to the screen.

Mounting the Condenser

The actual anode is connected by a flex lead to the lower terminal of the .0001 coupling condenser (which is mounted on the screen itself), and a rigid connection is taken from this point to the H.F. choke, the other side of which is, of course, taken to the H.T. + (plate) terminal. From the top of the coupling condenser a flex lead is taken through a hole in the screen to the detector valve.

A condenser of the type used may conveniently be mounted on the screen, either by means of nuts and bolts or by two bolts of such a size that they tap themselves into the moulding material.

The screen itself is, of course, connected to L.T. — and earth.

No on-off switch for the H.F. valve has been incorporated, since it was found desirable to use a rheostat, and a good rheostat with an "off" position is sufficient in itself.

Connecting the Unit

And now as regards the operation of this unit in conjunction with the short-wave set which the reader has at his disposal. First, remove the aerial from the existing set completely.

If the set has a capacity-coupled aerial, remove the condenser and leave the grid circuit completely free. If the aerial is inductively coupled, as it probably will be in most cases,

remove the coupling coil completely. Also remove the earth from the set.

Place the unit beside the receiver, and connect the aerial and earth to their appropriate terminals. Also wire up the batteries (the batteries supplying the existing set may, of course, be used). Note that there is no H.T. — connection on the unit, since H.T. — will already be connected to one side or other of the L.T. on the receiver.

H.T. and L.T.

To the H.T. + (screen) terminal about 60 volts should be applied, while for the H.T. + (plate) terminal any voltage from 100 to about 130 is

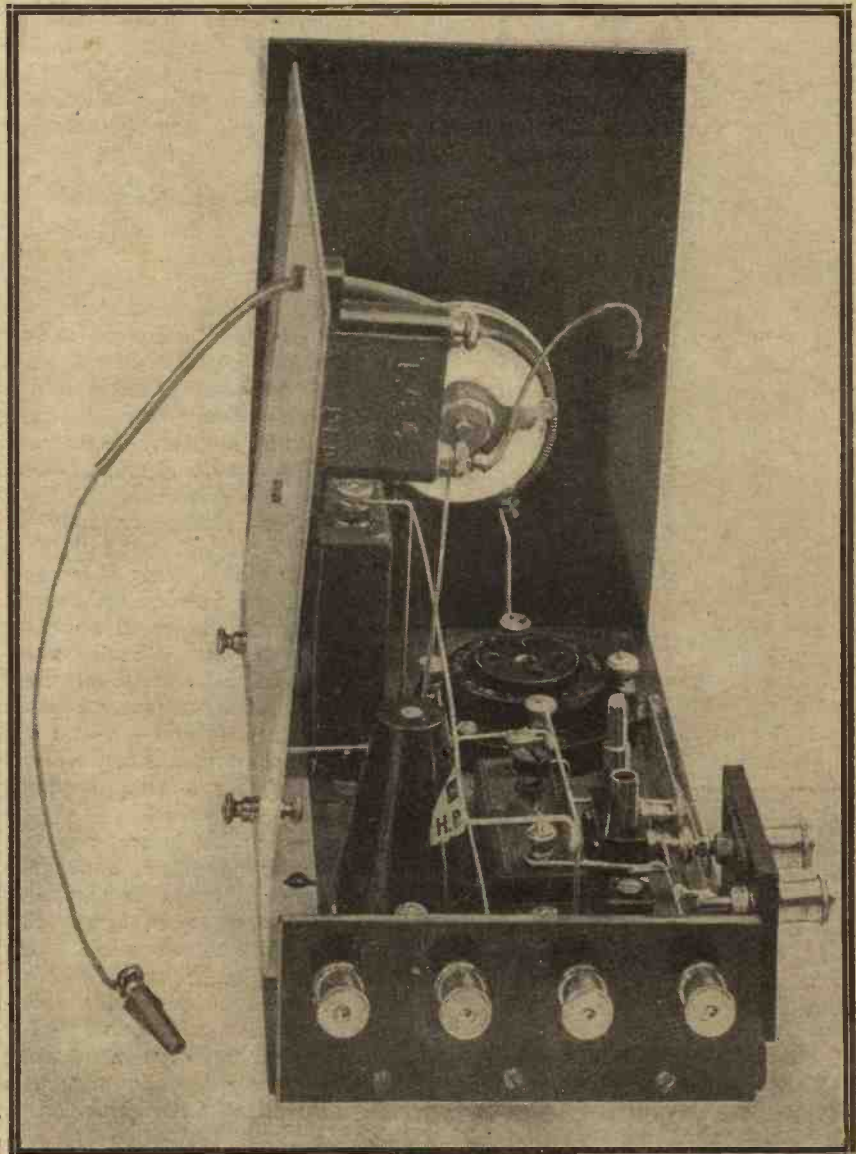

It is necessary to screen the short-wave amplifier, but this entails no difficulty.

Adding Punch to Your Short-Waver—continued

satisfactory. The L.T. voltage may, of course, be 2, 4, or 6, according to the type of valve used. This should naturally be chosen to suit those already in use in the receiver.

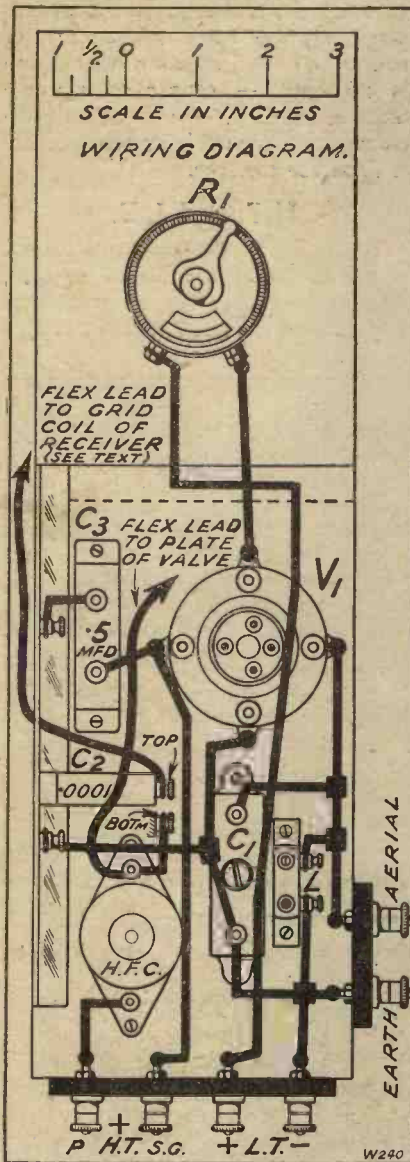

Connect the clip on the end of the flex lead coming through the screen, as already mentioned, to the top of the grid coil. In the coil socket on the unit insert a 6- or 9-turn coil. (This coil may be either home-made or a commercial product such as is turned out by Igranics or "Atlas.")

The Condenser Readings

I am not going to give any hints on short-wave operation, since it is presumed that the reader has already had a fair amount of experience with

his own set. If the latter has a capacity-coupled aerial in any shape or form, it will probably be found now that the calibration of the receiver has shifted only very slightly, if at all. If it is inductively coupled the condenser readings for any given station will now be slightly lower, depending chiefly upon the tightness of coupling formerly between the aerial and the detector valve.

If you are going to listen in the region of 40 metres to amateur work, use the 9-turn coil and screw the Formodenser fairly hard down. This should tune the aerial circuit roughly to a point just above the 40-metre band, which I have found to be the best position.

When listening on 20 metres to 2 X A D and the other broadcast stations in that region, tune the aerial circuit to a point just above the 20-metre band, by using a 3- or 4-turn coil and keeping the Formodenser near the "all-out" position.

Real H.F. Amplification

Incidentally, if you have a high-capacity aerial (whether on account of great length or poor height) you will probably find it beneficial to connect a small condenser between the aerial and its terminal. A series condenser was not included in the unit, as it was thought that it would not be used in many cases, and "floor space" was valuable. With the average short-wave aerial, direct coupling will almost certainly be satisfactory.

I use this unit in front of my own receiver, chiefly in conjunction with the transmitter, for rapid searching round the 20- and 40-metre wavebands, and I find that with one given position of the Formodenser a 4-turn coil for 20 metres and a 9-turn coil for 40 metres are satisfactory without the necessity for altering anything else.

The amateur bands are, after all, fairly narrow nowadays, and if the aerial circuit is tuned to something like 45 metres we can cover our band of 41.0 to 42.8 metres without any serious change in efficiency.

When one has tuned in a short-wave broadcast station to which one is probably going to listen for some time, it is worth while making a small adjustment of the Formodenser, tuning the grid circuit of the H.F. amplifier reasonably accurately to the

wave on which one is listening. The damping introduced into the amplifier grid circuit by directly coupling the aerial will almost certainly prevent self-oscillation. If there is any tendency to the latter effect when the

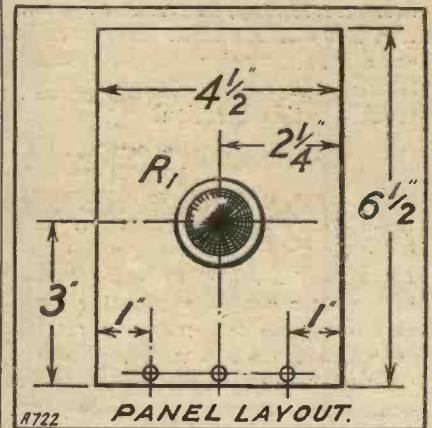

circuits are dead in tune, simply leave the grid circuit tuned slightly above the other.

I have often noticed an effect in a transmitter using the "tuned-grid tuned-plate" circuit—that greater efficiency is obtained, for some reason, when the grid circuit is tuned to a wave-length very slightly above that of the plate circuit, than one can obtain with the set completely in resonance. Whether this has any bearing on the fact that no noticeable loss of efficiency results in this H.F. stage when the grid circuit is tuned well above the plate circuit I do not know.

One evening recently I was listening on the usual two-valver and logged four or five signals from South African amateurs on or around 20 metres. The best signal was not stronger than R4. On connecting the unit in position and searching again for some twenty minutes, fifteen South Africans were logged, and one or two of the stations could honestly be described as R8.

Most Useful "Gadget"

On the whole, I am inclined to think that this unit has been more useful to me, personally, than any other set or "gadget" I have made up for short-wave work, and I can thoroughly recommend readers who are looking for a change to take up the screen-grid valve for a while. Results will amply repay all the time and trouble they spend.

LONG WAVES ON THE "NEW BUSINESS MAN'S FOUR"

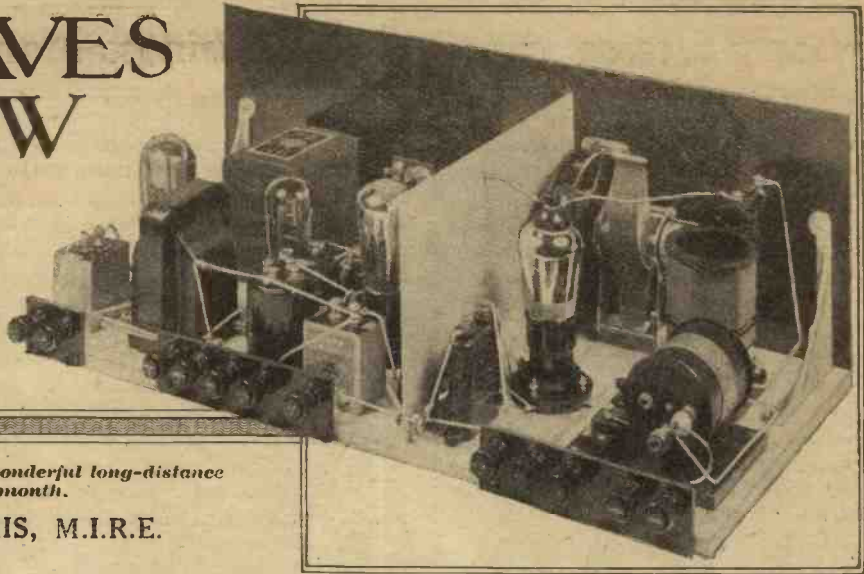

Some further practical details of the wonderful long-distance receiver described last month.

By PERCY W. HARRIS, M.I.R.E.

In our last issue a full constructional description was given of the New "Business Man's" Four—a receiver in which the scheme first introduced in the "Business Man's" Four of last year was further developed and simplified, the inclusion of a screened-grid valve improving enormously the sensitivity of the set. Furthermore, initial adjustment of

Furthermore, no recourse whatever was made to the reaction control in picking up stations, all being found by simply rotating the tuning dial.

Had use been made of the reaction knob the list could have been increased appreciably, but it was thought better to give a "constant reaction" test report on one evening rather than a test report spread over

a number of evenings with skilled operation of the reaction circuit.

On the long waves a special coil is needed for this receiver in order to get best results, although the standard long-wave Reinartz transformer can be used if desired. With this latter, however, the selectivity is not high enough for most people's requirements, and so I have found it best to take a standard Colvern Reinartz transformer and to remove 45 turns from the aerial winding. (This is very easily done with the Colvern coil.)

A FURTHER TEST REPORT.

Note.—On long waves all stations except Motala were received on the loud speaker in daylight. On shorter waves all stations were received within thirty-five minutes in the evening. No recourse was had to reaction adjustment, which remained at one setting throughout.

SHORT WAVES.

Nuremberg	Copenhagen
Cassel	London
Kosice (?)	Toulouse
Bremen	Hamburg
Cologne	Kattowitz
Belfast	Frankfurt
Breslau	Daventry Ex. (5 G B)

Bournemouth	Munich
Budapest	

LONG WAVES.

Hilversum	Daventry (5 X X)
Kalundborg	Radio-Paris
Motala	Woolf's Bureau
Zeesen	Eiffel Tower

The Long-Wave Coil

If it is examined the lead running from pin No. 1 will be seen to emerge from the ribbed former underneath the first groove from the bottom at the lower end, and that from lead No. 2 just above the fifth groove. In order to remove the turns, cut the

the instrument has been still further simplified so that it now represents by far the simplest long-distance receiver not only to operate but to build.

A 35-Minute Test

With it a large number of stations can be received at loud-speaker strength at any time on the average outdoor aerial, and by no means a negligible number on a small indoor arrangement. In the adjoining list twenty-five stations are given, seventeen on the short waves and eight on the long. The seventeen short-wave stations were picked up in thirty-five minutes—between 10 p.m. and 10.35 p.m. one evening—while the long-wave stations were, with the solitary exception of Motala, all picked up at loud speaker in broad daylight.

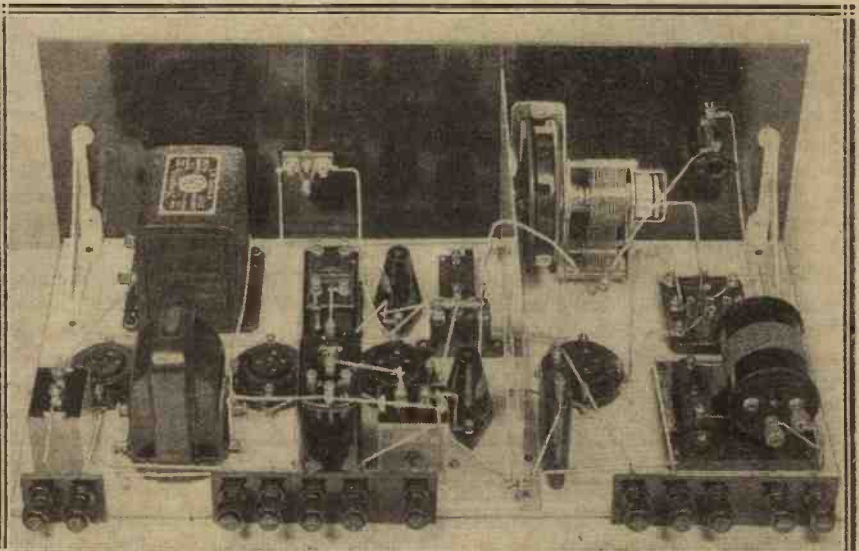

"It represents by far the simplest long-distance receiver, not only to operate, but to build."

Long Waves on the "New Business Man's Four"—continued

wire where it emerges from the hole above the fifth groove and unwind 45 turns.

This will leave about 30, which is quite sufficient for the coil. When you have taken off enough turns, bare the two ends of the wire (that coming through the hole, and the end of the wire remaining in the groove), twist them together and solder them. You will now have a long-wave coil for the new "Business Man's" Four which can be plugged into the receiver and the set operated as for the shorter waves.

Long-wave reception on any receiver is often made troublesome by

this particular circuit (although with many other circuits it will not operate so well). The trap consists of a No. 250 plug-in coil of good make shunted by a variable condenser of .0005 mfd. maximum.

The aerial is connected to one terminal of this condenser and a lead from the aerial terminal of the receiver to the other, so that this trap comes directly in the aerial circuit. The method of use is to tune the New "Business Man's" Four to 5 X X and then rotate the dial of the trap condenser until 5 X X comes in at its weakest.

It will then be found that 5 X X will

often gives an excellent alternative daylight programme.

The new "Business Man's" Four works perfectly with any good high-tension mains unit, and, of course, with the "Stedipower" L.T. Unit. In the tests described in the last issue and in this, two-volt valves were used throughout, although, of course, it will work the four- or six-volt varieties if desired, with slightly greater efficiency.

TRADE JOTTINGS
 * A brief review of recent issues of *
 * trade catalogues and literature. *

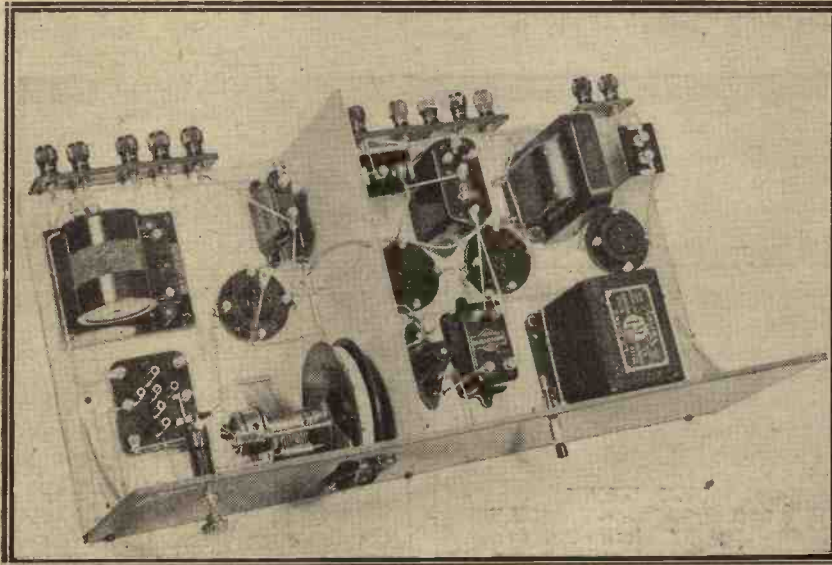

Although a drum type of variable condenser is shown in the original design, the ordinary type of condenser can be used if desired.

the fact that either 2 L O or 5 G B may seem to come through over the whole range. 5 G B is the greater sinner in this respect with some aerials, for the length of primary winding used on a long-wave coil is often just sufficient to tune the aerial to 5 G B.

Simple and Selective

With the removal of the number of turns as explained, this trouble will vanish, and while the coupling is necessarily weaker for this reason, the very high efficiency of the New "Business Man's" Four circuit on the long-wave more than compensates for this.

If the selectivity of the set is found to be still too low for a given set of circumstances, a very simple long-wave trap can be made and will be found to function efficiently with

occupy a very narrow tuning band and you will get no interference on Radio-Paris or other stations of nearby wave-lengths. Furthermore, the selectivity can be made so sharp with this arrangement that the new Zeesen station, which is extremely close to Daventry 5 X X, can be received with practically no interference from the latter.

The Colvern long-wave Reinartz transformer is particularly recommended for this set, not only because the removal of turns is made practical with simplicity, but because the particular coil covers a very wide band of wave-lengths and will enable the listener to receive not only 5 X X and Radio-Paris, but Woolf's Bureau and Eiffel Tower—two stations very rarely received on long-wave sets. At the lower end of the scale Hilversum is easily received, and

IN spite of many set-backs and handicaps, Britain's radio trade manages to keep doing the Old Man River stunt pretty thoroughly, and come fair or foul, it jes' keeps rollin' along.

One sign of the times is a note just received from Burne-Jones and Co., Ltd., saying that:

"Owing to the continuing growth of our business, further extensions have been acquired at 296, Borough High Street, accommodating Sales Counter, Showroom, Offices, Research Dept. and Assembling Shops, all under one roof.

"All correspondence should be addressed to Magnum House, 296, Borough High Street, S.E.1"—and if it's orders, well, so much the better!

All-from-the-Mains Two-Valver

The Philips' people have just introduced to the public a 2-valve all-electric receiver that looks like making a big name for itself.

This model has been designed to operate entirely from A.C. mains, the H.T., L.T. and grid bias requirements all being supplied.

Like the other Philips' receivers, the latest model incorporates unusual features which will undoubtedly appeal to radio enthusiasts. Although the receiver is primarily intended for local station reception, it can, under favourable conditions, bring in other stations. A special detector and pentode valves are incorporated, the price, complete with valves, etc., being £12 10s.

The tuning—by one control—is very simple, and there is a wave-length switch covering 200/400, 400/600 and 1,000/2,000 metres. Readers interested can obtain full particulars by asking the makers for leaflet 139.

What the Pentode Really Does!

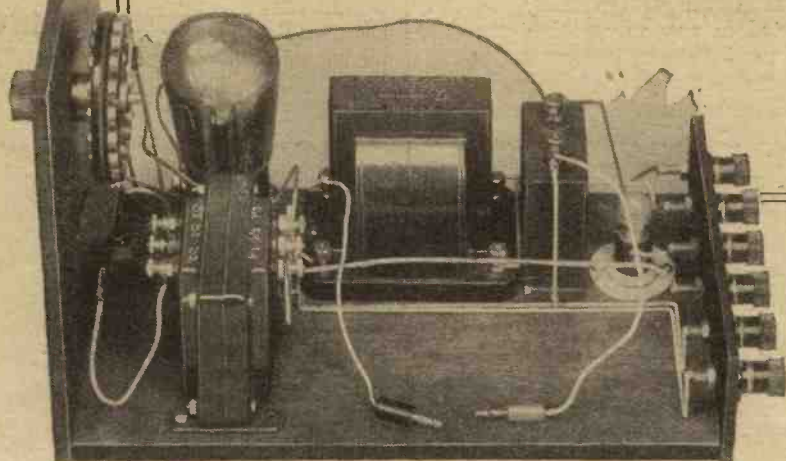

Little has been said about the Pentode, the new wonder valve which created such a stir at last year's Radio Exhibition, so the following clear explanation of what it does and how it does it will be welcomed by all readers.

By G. P. KENDALL, B.Sc.

WHAT about this new valve? Does it really give as much amplification as two ordinary stages? Has it any snags? It seemed to me, when I was on duty as "technical expert in attendance" on the WIRELESS CONSTRUCTOR, "Modern Wireless," and "Popular Wireless" stand at the Wireless Exhibition last October, that almost every other visitor came primed with such conundrums as these.

To judge from the remarks, often rather bitter ones, of our queries staff, it would appear that the problem is still worrying a large proportion of our readers as much as ever, so the Editor has asked me to do what I can to clear up the business. The matter is, frankly, a difficult one to present fully and lucidly in one short article, and I must confess that I tried to squirm out of the job, but the Editor unfortunately knew that the Research Department of which I am in charge (that of "Modern Wireless" and "Popular Wireless") had gone into the question very thoroughly, and he would take no denial.

Remarkable Properties

Here goes, then, to do the best we can, but I must ask the reader's indulgence if I make some of my points rather briefly, without going very far into theoretical "why's and wherefore's," because the subject is a large one. First and foremost, let me say right away that there ARE snags in the use of the Pentode. It is an entirely new type of valve to the ordinary listener, does not obey some of the rules to which he is accustomed, and must be treated accordingly.

Moreover, it has certain definite features which can only be described as drawbacks to the average user, which must be clearly understood, duly allowed for, and regarded as the price we must pay if we desire to take full advantage of its undoubtedly very remarkable properties.

We will take these awkward points in due course, and see just what they are, but first let us get a clearer idea as to what the Pentode is and what it will and will not do. Well, this

valve is of the multi-electrode type, with a decidedly complicated arrangement of bits and pieces inside, with which we need not concern ourselves too closely. The main point for the practical user is that one of these extra electrodes is connected to a special terminal on the valve cap, and to this we apply a high positive bias which is normally the same as the H.T. voltage on the ordinary anode.

High Impedance

The valve has a very high impedance, and it is here that we come up against its first breach of the rules as

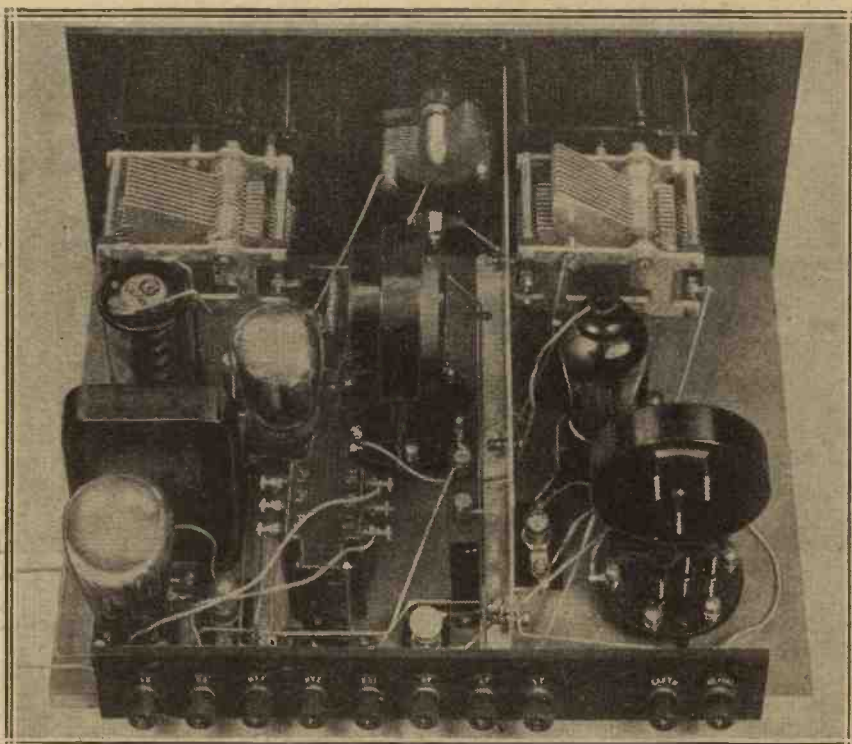

A small but efficient receiver which uses the screened-grid H.F. valve, detector, and a Pentode for the L.F. stage. Note the special output transformer (the one with six terminals on it).

What the Pentode Really Does!—continued

understood by the ordinary use for valves. All the ordinary valves with which we have to deal are of high D.C. resistance if they are of high impedance, i.e. high impedance types all pass quite a small anode current.

The Pentode, on the other hand, passes a definitely large anode current, despite its high impedance, for reasons into which we cannot enter here. It must suffice to point out that it DOES take a large current, quite as large as the ordinary super-power valve. This current will be, perhaps, from twelve to fifteen milliamps, according to the H.T. voltage, and this is the first apparent drawback which we must accept. Definitely, then, we must be prepared for a considerable drain on the H.T. supply, and if we use dry batteries, then we must see that they are really large ones if they are to have a proper life.

Reducing Current Consumption

It is true that the H.T. consumption can be cut down considerably by reducing the H.T. applied to the extra terminal to, say, half that on the anode, and this has been seriously proposed as a method of reducing the drain on the H.T. supply, but I do not find it advisable.

will find that the H.T. consumption comes down and quality is not affected in any way, which you can discover by ear unless you are trying to handle very powerful signals.

What you have done by adopting this expedient is to limit slightly the capacity of the valve in the direction of handling very strong signals. For ordinary domestic purposes I have found this quite permissible, for you can still get a large undistorted output before you reach the point of overloading and have to restore the grid bias to its normal value.

Obviously, whether or not this can be done in any particular case will depend upon a number of factors, such as the size of the room to be filled, the sensitivity of the speaker, and so on.

We have seen then that the high impedance of the Pentode does not mean that it is of correspondingly high D.C. resistance, in the sense that it passes a large current; and next we come to the question of the effect of the high impedance on the functioning of what is called technically the "output" circuit. This, of course, is normally the loud speaker when the latter is connected straight in the anode circuit of the last valve. Where

normal response of the loud speaker to different frequencies, and so the use of a Pentode is very apt to make the reproduction sound high-pitched and "edgy." To correct this high tone it has been suggested that a

One of the five-electrode, or Pentode, valves, now made by nearly all the large valve manufacturers. This is the version from the Cossor works.



fixed condenser of a capacity usually somewhere between '005 and '01 be shunted across the loud speaker.

A better way of balancing things up seems to be to raise the effective impedance of the output circuit to suit, and this can now be done by the use of one of the special output transformers produced to suit the Pentode. In passing, I should like to point out that the need for some correcting device of this sort has been considered to be so definite that no design for a set incorporating a Pentode was prepared for publication by my department until one was made available.

Output Transformers

The need is now being met, and an example of an output transformer on these lines is the new Marconiphone "Universal" type. By making suitable connections to the primary of this component (instructions will be found on the leaflet accompanying it) the necessary high output impedance is obtained. I understand that Messrs. Igranic are also producing a Pentode output transformer, but this I have not yet actually tested.

Just one final point in connection with the output circuit. Where the set incorporates an output filter it would appear desirable to disconnect this and place the output transformer direct in the anode circuit of the Pentode. The ordinary type of output filter is not quite suitable for use with this valve.

(To be continued.)

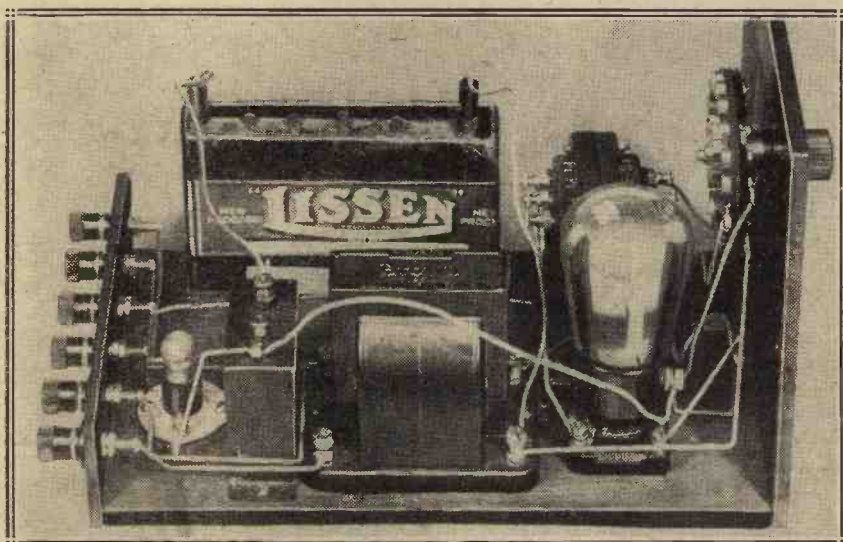

A Pentode amplifier. This little unit is capable of exceptional magnification.

A method which I do find helpful is to increase the negative voltage on the grid (i.e. the ordinary grid bias) about one third above that recommended by the makers. For example, if they specify 9 volts, try 12, for a particular H.T. voltage, and you

an output filter is used the "output circuit" comprises both the filter choke and also the loud speaker in series with a large fixed condenser.

Now, the use of a valve of an impedance much higher than that of the output circuit tends to upset the

THE "DC" FOUR

BY G.V. COLLE

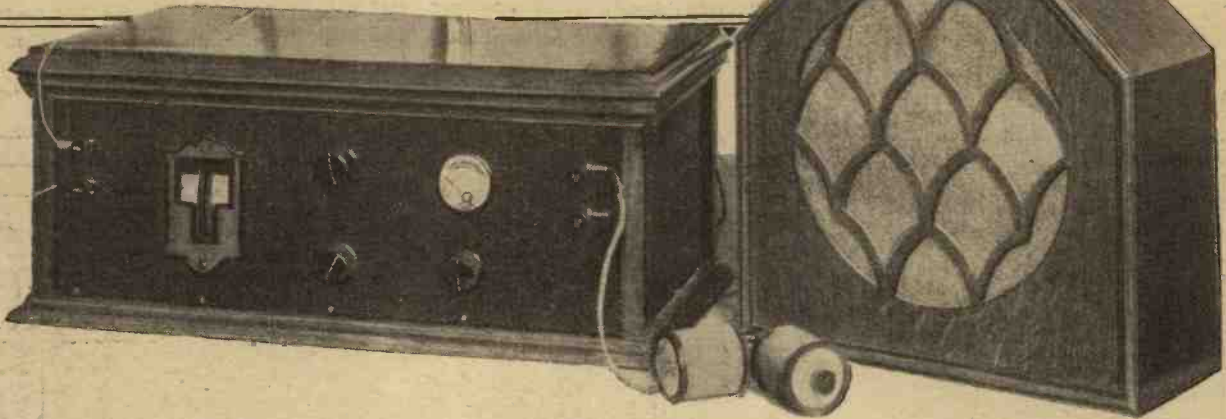

THIS month it is the writer's intention to describe in detail a four-valve receiver operating entirely from D.C. mains and possessing all the advantages of a good four-valver, less the battery troubles which invariably accompany the use of a multi-valve set. The circuit arrangement is based on that of the four-valve receiver given in an article by the writer in the December "Wireless Constructor."

Before attempting a description of the foregoing set it would be well, per-

An easily constructed and efficient four-valver which takes all its power from the mains, no batteries whatever being required.

haps, to give prospective constructors an idea of the results likely to be obtained, and likewise some cautions regarding the use of D.C. mains before and after connecting up the receiver.

One series sets out the running costs, the total cost of the component parts approximately, results to be

expected, etc.; and the other series of remarks consist mainly of "don'ts" and cautions on the maintenance of the outfit.

It would also be to the advantage of those interested to state now that the most difficult (if this misused term can be applied) part of the proceedings is the initial adjustments, and when these are mastered, after observing the simple instructions given elsewhere, then the rest is the acme of simplicity, and will continue so for as long as the set is in use.

YOUR SHOPPING LIST.

(Names in brackets are those of parts shown. Suitable alternatives are also given.)

- 1 Cabinet 21 in. × 7 in. × 12 in. deep, including baseboard (V. C. Bond). (Cameo, Caxton, Arcraft, Raymond, Bond, etc.)
 - 1 Panel 21 in. × 7 in. × $\frac{1}{8}$ in. or $\frac{1}{16}$ in., either plain or special figured finish (Ebonart, Moire). (Trolite, Radion, Ripault, etc.)
 - 1 0-300 milliammeter (That shown is a small model Weston. Other good makes can be used, such as Ferranti, Turner, Jewell, Hunt, Sifam, etc.).
 - 1 1,500-ohm resistance (A Centralab panel-mounting type is shown, and if not procurable in the value stated, one of 2,000 ohms can be substituted or else a 1,500 Truvalt). (Hamleys, Rothermels.)
 - 1 Twin-drum-drive Synchratune condenser, '0005 each section (Cydon).
 - 1 '0001-mfd. miniature variable reaction condenser (Dubilier). (Bowler-Lowe, Cydon, Peto-Scott, etc.)
 - 1 500,000-ohm potentiometer volume control (Any value up to 1 megohm may be substituted, although lower value preferable). (Frost Radio.)
 - 2 Six-socket bases (Lewcos, Colvern, etc.)
 - 4 Sprung valve holders (Those shown are the new cheap type Benjamin). (Lotus, Magnum, W. & B., Igranie, Godwinex, etc.)
 - 11 2-mfd. fixed condensers, Mansbridge type (Those shown are a combination of the standard 2-mfd. Lissen, Dubilier and T.C.C. Actual number of Lissen were 5, Dubilier 4, and T.C.C. new type 2. Any other good makes can be employed).
 - 2 28/14-henry L.F. chokes, shrouded type (R.I.-Varley).
 - 1 L.F. transformer, universal type (Marconiphone shown). (Ferranti, Lissen, R.I.-Varley, Mullard, Phillips, Igranie, Brown, etc.)
 - 1 30-ohm baseboard type rheostat to carry 100 m.a. (Igranie or any suitable makes).
 - 1 50-ohm baseboard type rheostat to carry 100 m.a. (Igranie or any suitable makes).
 - 2 400-ohm potentiometers, used as resistances, for baseboard mounting (Igranie shown. One carries 500 m.a. and the other 150 m.a.).
 - 1 '1-mfd. mica condenser, standard type (T.C.C., Hydra, Dubilier, Ferranti, Mullard, etc.).
 - 1 '0003 mfd. fixed condenser (Dubilier, Lissen, T.C.C., Magnum, etc.).
 - 1 '001-mfd. fixed condenser (Dubilier, T.C.C., Lissen, Mullard, etc.).
 - 2 Grid-leak holders, one being of the vertical type (Dubilier, Lissen, Mullard, etc.).
 - 1 2-meg. grid leak (Lissen, Mullard, Dubilier, etc.).
 - 1 .25-meg. grid leak (Lissen, Mullard, Dubilier, etc.).
 - 1 10 in. × 6 in. standard aluminium screen (Burne-Jones).
 - 1 Neutralising condenser, baseboard type (Peto-Scott, Gambrell, Magnum, etc.).
 - 3 Anode resistances and holders, two of the latter being of the vertical type. Values of the wire-wound resistances are 250,000, 100,000, and 10,000. If the mains voltage is between 230 and 250 a further resistance of approximately 5,000 ohms is desirable (see text) (R.I.-Varley, Lissen, Ferranti).
 - 1 Batten type standard lamp-holder and plug.
 - 4 Fully-insulated terminals as per diagram (Belling and Lee).
 - 1 H.F. choke (R.I.-Varley, Lissen, Dubilier, Bowyer-Lowe, Igranie, etc.).
- Quantity of No. 18 or 20 S.W.G. tinned copper wire and Systoflex, or, alternatively, Glazite.

The "D.C." Four—continued

In case any reader should get a false impression of what is meant by the "most difficult part of the proceedings," it must be explained that this simply refers to the adjustment of the grid-biasing resistances and the

controlling the grid bias to V_1 also being treated similarly.

When everything is adjusted, the mains are switched on, and the 1,500-ohm resistance on panel regulated until the 0-300 m.a. meter reads just

grid bias on the L.F. valves, while one of the L.F. smoothing chokes has been omitted and a slight re-arrangement made in the method of obtaining H.T. voltages.

In the first case, early practical

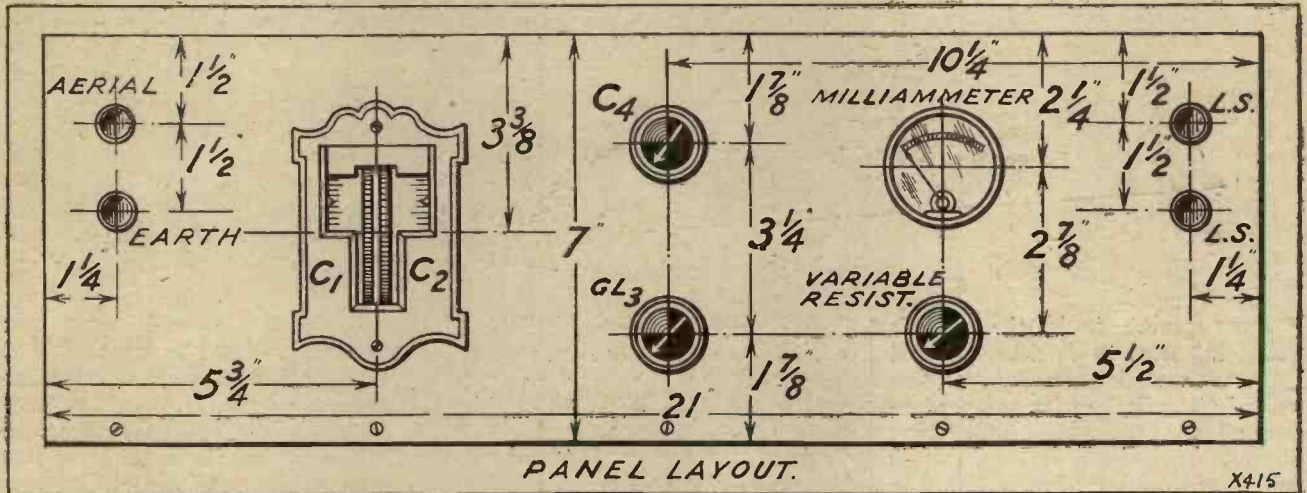

400 resistance (baseboard potentiometer used as a resistance with two connections only), which regulates the filament voltage to the 1-ampere valves (V_1 , V_2 and V_3). Actually the exact process is as follows: The valves are inserted in their respective valve holders, the 1,500-ohm resistance on panel set at maximum (so that all the wire is in circuit), the arm of the 400-ohm resistance on the baseboard set just over half-way round, and the 30- and 50-ohm biasing resistances according to the grid bias required, the 400-ohm resistance

under 150 m.a. As a matter of interest readers may take the adjustments of the resistances as shown in the photographs as being approximately correct, except the 1,000-ohm resistance, the regulation of which depends on the voltage of the mains.

The Circuit Employed

Referring now to the theoretical circuit of the set, it will be seen that in comparison with the one shown in the December issue of WIRELESS CONSTRUCTOR, resistances are shown in place of potentiometers for controlling

experiments indicated that the loss of voltage using potentiometers for grid bias and two smoothing chokes was too serious to be ignored, being roughly 39 volts across each of the latter and 75 volts across the 400-ohm potentiometer, passing .15 ampere. On 200-volt mains this meant there would be hardly 100 volts available for H.T., so that the writer decided to use the resistances, to allow all the available voltage for H.T. less the exact amount required for grid bias and L.T. purposes. Further, the change from potentiometers to resistances

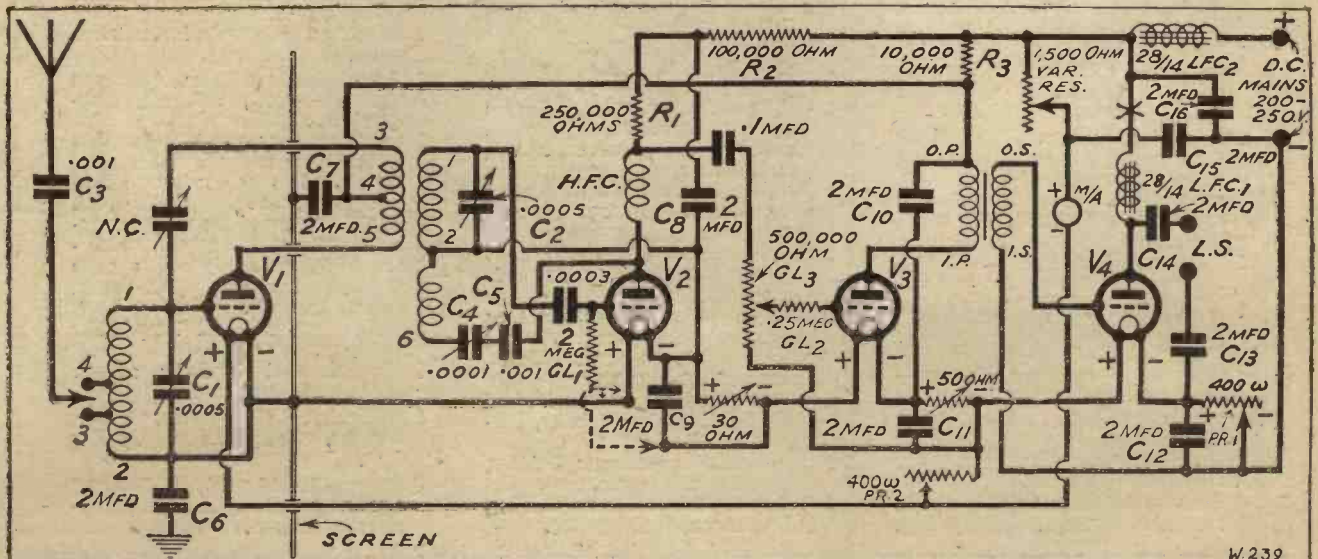

The "D.C." Four—continued

was rather welcome, since it obviated the necessity of converting 30- and 50-ohm resistances into something for which they were not intended.

In regard to the L.F. chokes, even one of these had to be sacrificed to obtain sufficient H.T. on the 200-volt

performs a further function—it gives extra smoothing as well as allowing the required voltage drop, 39 volts. In either case, it is the writer's intention to describe later an auxiliary smoothing unit, consisting of two special H.F. chokes and fixed con-

average D.C. mains, but unfortunately there are still certain supplies which are derived from rectified A.C., and these require special treatment. While on the subject, readers must clearly understand the receiver is not infallible, nor yet are the suggestions given by the writer, because there are a few D.C. mains which will not yield to treatment, despite elaborate smoothing circuits. However, there is little chance of many readers coming across such supplies, as most cities possessing power stations derive their current from modern generators, and these will usually be found reasonably constant and silent for radio purposes.

The Variable Condenser

Referring now to the actual constructional details, readers will find everything perfectly straightforward, and where large areas of ebonite have to be removed from the panel, suitable jigs are supplied by the manufacturers of the components requiring the areas so removed.

When the necessary drilling has been completed the components can be mounted in their respective positions and the panel attached to the baseboard by two screws, or more if desired. Do not insert all the screws, because a standard 10 in. by 6 in. aluminium screen has to be screwed to the baseboard, and between the

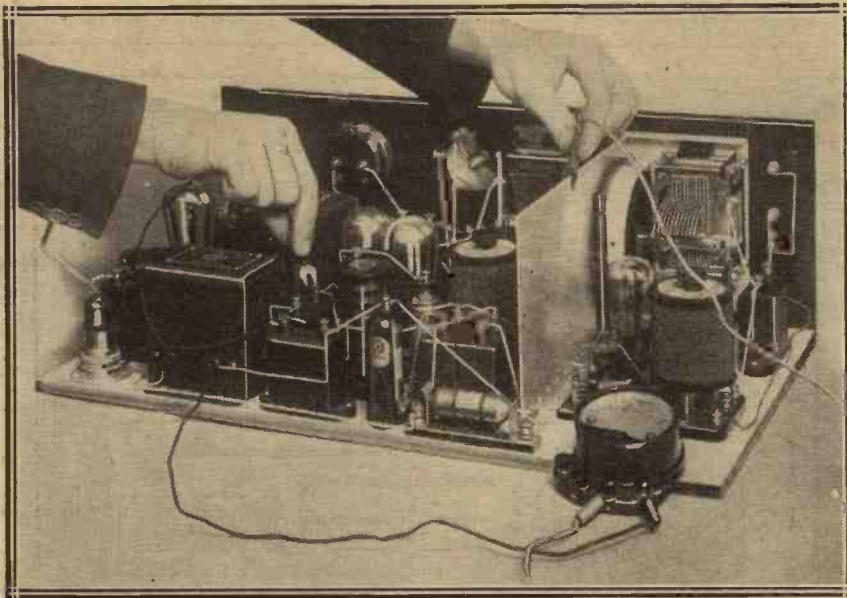

Testing the filament voltage of the detector valve. The method of doing this is explained in the text.

mains. As it is, using one only for smoothing, the H.T. voltage to the last valve is 140 volts, which is about sufficient for reliable L.F. characteristics and a reasonable grid swing. On 230- to 250-volt supplies provision must be made to include a fixed resistance at the point marked X on the diagrams, otherwise there will be a brave chance of the power valve being overrun and its emission spoilt. Most power valves of the .15-ampere type take 120 to 150 volts H.T., so that the only advice the writer can give constructors is to keep within the maker's limits and check the H.T. voltage by a reliable voltmeter of a high-resistance type, connected between the negative filament leg of V_4 and the plus H.T. side of the filter choke.

Smoothing Rough Mains

Failing the resistance, which can have a value of approximately 5,000 ohms or less (depending on the H.T. required and the mains available), a further 28/14-henry L.F. choke can be included in the negative mains lead outside the set. Probably the former method will appeal the most to constructors, although the choke

densers having a central earthing point, to cover cases where the actual D.C. supply is erratic and noisy. The amount of smoothing incorporated in the set has been found sufficient for

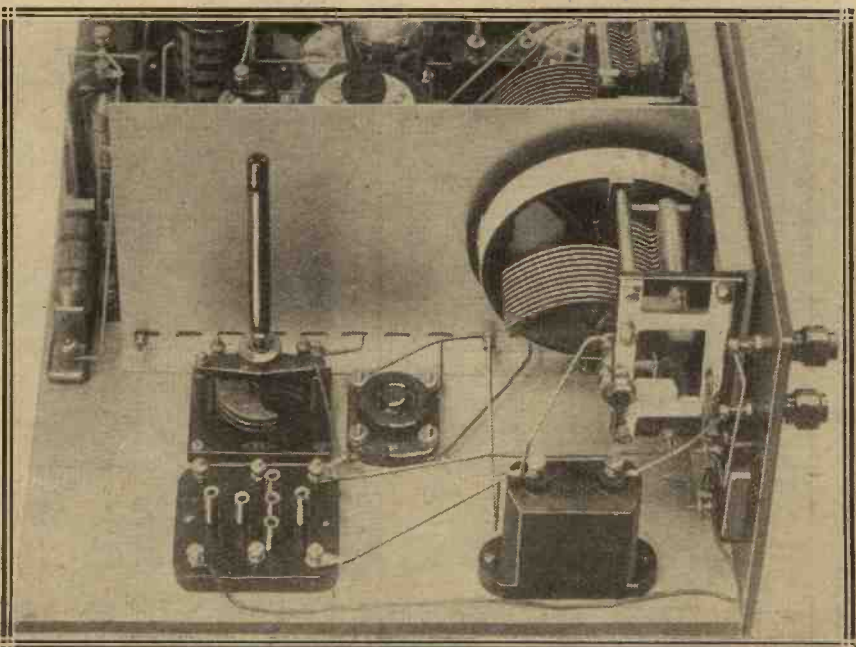

The H.F. end, showing the aerial section of the drum condenser, the neutralizing condenser and the six-pin coil socket.

The "D.C." Four—continued

two drums of the twin-gang condenser, and one of the screws holding the screen is situated under the drums. The correct procedure is to find a position for the screen so that it does not touch the drums, and, when found, mark the positions of the holes for the screen on the baseboard with a pencil, when the panel can be

removed and the screws inserted through the ledge on the screen.

Screen Omitted

Those readers who purchase the "Synchrature" gang condenser will no doubt observe that the small screen supplied with the unit has been omitted, and the reason put forward

is that the larger screen offers better opportunities of making a neater job. However, it must also be explained that the small screen can be utilised in conjunction with a standard one measuring 7 in. by 6 in., the two sheets of metal being joined together with a connecting wire and then wired as per diagram.

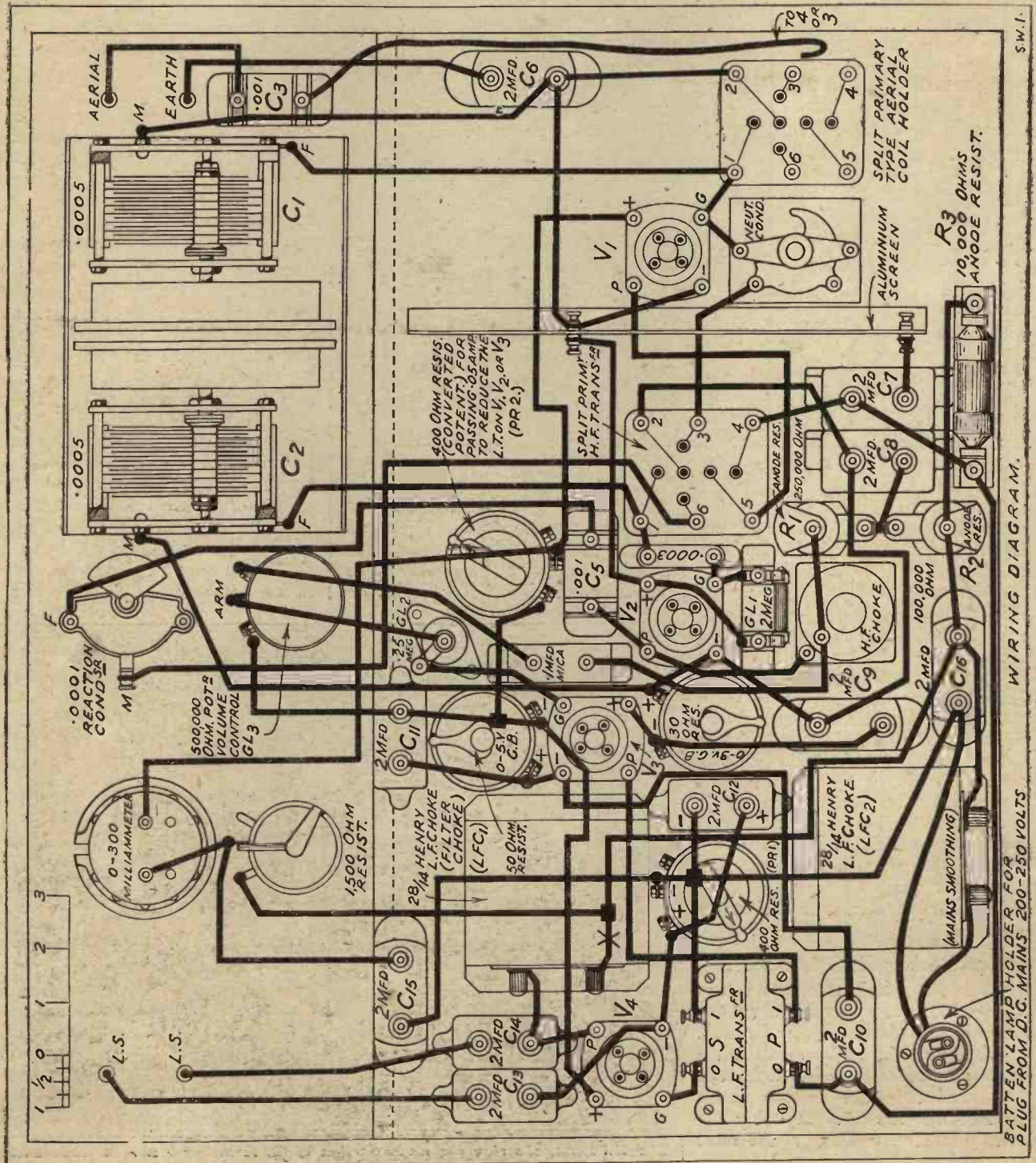

The "D.C." Four—continued

Baseboard components offer no difficulties and can be fixed in approximate positions to those shown in the photographs. It will be necessary to employ a vertical type of grid-leak holder for the "H.F. stopper" resistance in the grid circuit of V_3 , owing to the limited space available.

When everything is arranged to the satisfaction of the constructor and conforms generally to the layout shown, the wiring can be commenced. Bare wire must be absolutely ruled out, owing to the great risk of short-circuits, and only covered wire used, preferably Glazite or No. 18 or 20 S.W.G. tinned copper wire and thin Systoflex.

Careful Check Essential

With any mains set it is most important to check the completed wiring even more carefully than is usual, as any mistakes may result in paying an early visit to the nearest radio stores to replace valves that have suffered damage. Partially to safeguard against such a catastrophe, make it a practice of wiring the filaments and grid-biasing resistance first, and follow up by a careful check before fixing the remaining leads. If a further careful scrutiny, preferably by a second person, fails to bring any wrong connections to light, then it may be assumed all is O.K.

The writer made a special point of prefacing the constructional details with a summary of the adjustments to be made before the valves are inserted, so that constructors are advised to refer to these notes and the photographs of the baseboard layout before attempting further. In regard to the photographs, the positions of the arms of the various resistances controlling grid bias can be discerned, and it is hoped they will give the operator an approximate idea of where they should be placed, since they remain fairly constant for all mains voltages between 200 and 250.

A Peculiar Feature

A surprising point in regard to the choice of valves for this receiver, apart from their characteristics, is that theoretically any combination of 2-, 4- or 6-volters can be employed, providing the first three take 1 ampere and the power valve (V_4) 15 ampere. Actually the case is not

quite so simple, because tests have indicated that if, say, a 2-volt 1-ampere valve is used for the H.F. position and a 4-volt 1-ampere for the detector, with perhaps a similar valve for V_3 , then, with 1-ampere passing, the full 4 volts have not been developed across V_2 and V_3 , due to the filaments not quite conforming to the published characteristics. It is therefore advisable to choose valves of similar filament voltage and current, and, even more important, arrange to use the same make throughout, as one can then be reasonably certain the filaments possess the same characteristics.

A valve of 13,000 to 20,000-ohms

impedance can be used in the H.F. stage (V_1) and one of a slightly greater impedance in the detector circuit, but not exceeding 30,000 ohms. V_3 (1st L.F.) can be of the general-purpose type of approximately 7,000 to 15,000 ohms impedance, and should take 1 ampere, similar to V_1 and V_2 .

Low Impedance Valve

V_4 is a small power valve, taking 15 ampere at 2, 4, or 6 volts, according to those chosen to fill the first three positions. Its impedance can be as low as possible, since plate consumption is not a vital factor,

(Continued on page 316.)

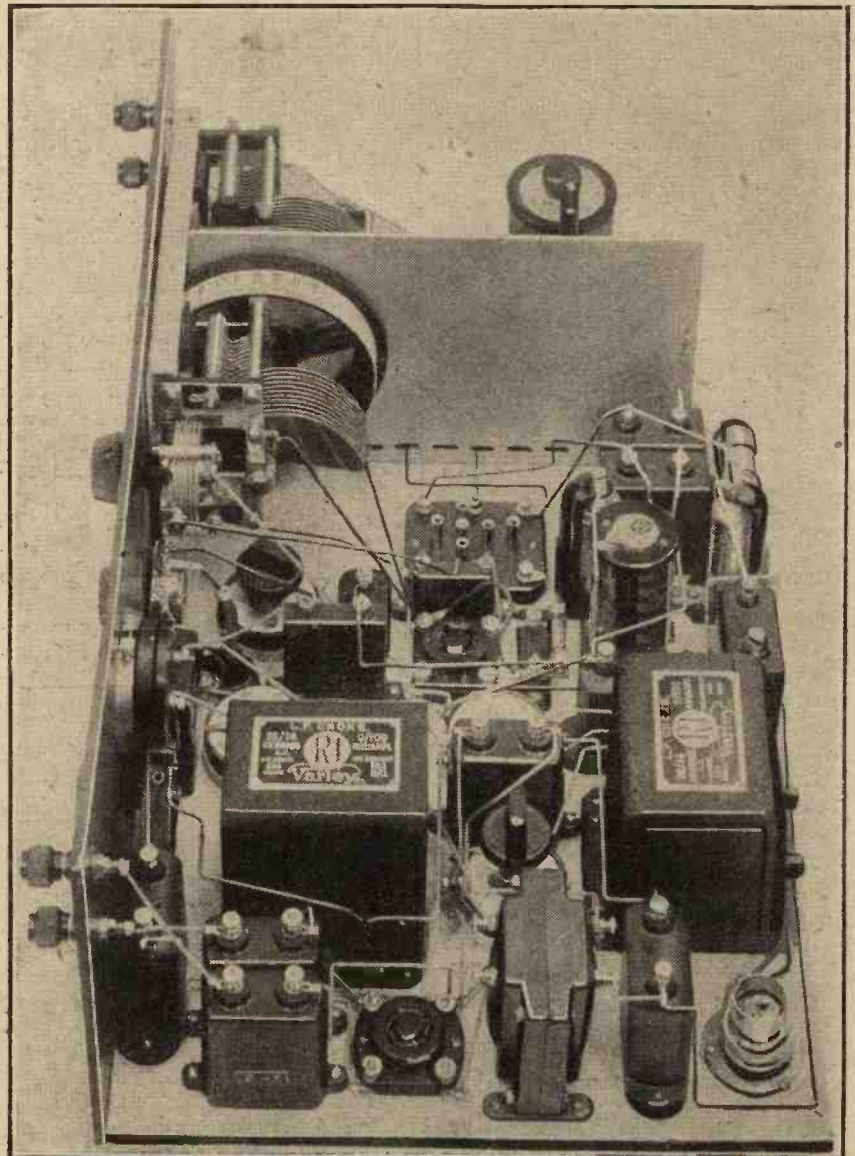

Though compactly arranged the components in the "D.C." Four are not overcrowded

RADIOGRAMPHONICS

A monthly article for the gramophone enthusiast.

Using a Pentode for gramophone amplification—Stopping motor-boating.

By A. JOHNSON-RANDALL.

THE use of a Pentode valve in gramophone amplifiers is likely to become popular. With a single ordinary L.F. valve, coupled up to a Pentode in the last socket, it is possible to obtain magnification equal to three stages using three-electrode valves.

For example, in the case of a three-valve set consisting of an H.F., detector, and a Pentode, one can get the necessary amplification by connecting the pick-up leads across the grid and filament of the detector.

I see that Messrs. Philips have just brought out an exceedingly neatly arranged two-valve amplifier utilising a Pentode, and designed specially for pick-up work.

Volume Control

The amplifier is transformer-coupled and a volume control is included. It is interesting to note that this control does not produce any change in the proportion between the high and low notes, hence volume is not controlled to the detriment of quality. The retail price of the amplifier is £6 10s., and we hope to be able to publish a test report in the near future. The price, incidentally, includes valves and leads.

The same firm have also produced a lightweight pick-up of compact design. I find that a number of listeners have a certain amount of trouble from low-frequency oscillation when they attempt to use a Pentode with a stage of transformer coupling.

In most cases this is due to a battery "coupling" effect which takes place when the H.T. supply has developed a high resistance.

Dry Batteries

With new dry batteries of suitable type, or with freshly charged accumulators, these troubles do not occur. If, however, the batteries happen to be a little below par, an increase in internal resistance takes place and this in turn produces a tendency towards instability in the amplifier. Whenever any trouble in this direction

is experienced the constructor should immediately investigate

the condition of his H.T. batteries. If these are of the dry-cell type the question arises of how long they have been in use, and whether the cells are of sufficiently large capacity to withstand the load. For example, it is quite useless to employ a small-capacity battery with a valve like the Pentode. It simply cannot stand up to a load of 12 milliamps or more, and its condition will in a very short time become such that howling or distortion is sure to occur.

A Useful Scheme

Then, again, take the case of H.T. accumulators. Directly the voltage of the cells begins to drop the internal resistance of the battery rises. Now this increase can be very serious if by chance one or more of the cells have, through neglect, become sulphated.

Again, there is the case of the mains eliminator. These units are very efficient, but it is very easy to strike the "coupling" snag with them.

For these reasons I strongly recommend the use of some form of "anti-

motor-boat" device with any Pentode amplifier, as a precautionary measure. The scheme is quite simple and generally speaking it is unnecessary to use more than one "stopper" in the average amplifier. Let us suppose that we are using a stage of transformer coupling followed by a Pentode output stage, as in the case of a straight three-valve set in which the detector becomes the first valve of the pick-up amplifier.

Our "anti-motor-boat" arrangement consists of a wire-wound anode resistance connected between the H.T.+ lead to the primary of the L.F. transformer and the transformer primary itself. That is to say, the H.T.+ lead is disconnected and instead taken to one side of the resistance. The other terminal of the resistance goes to the transformer terminal to which the H.T.+ lead was previously joined. This same transformer terminal also goes to one side of a 2-mfd. condenser, the other side of which is taken to L.T.—. The value of the anode resistance can be about 50,000 ohms.

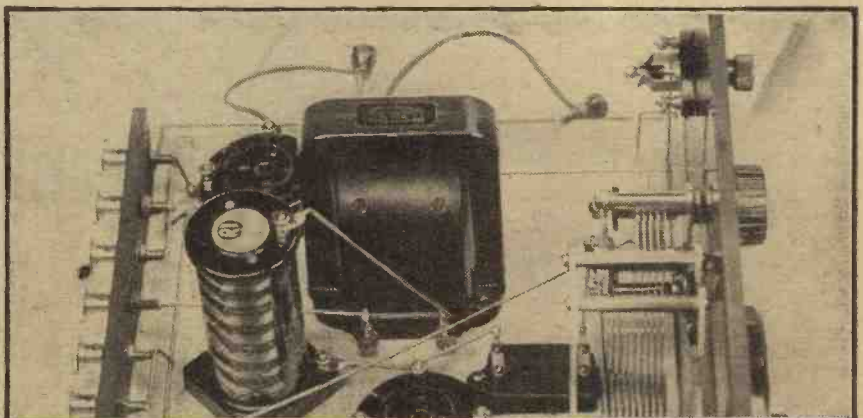

If "motor-boating" developed in a set of this type when using a Pentode, the lead (shown behind the H.F. choke) from H.T. + to the primary could be broken, and the resistance inserted as explained in the above article.



Transatlantic Tendencies

By THE EDITOR.

An interesting survey of the circuits used in the leading commercial receivers on the American market.

A GROUP of readers, interested in the why and the wherefore of their receivers, as well as in how to construct them, have asked me

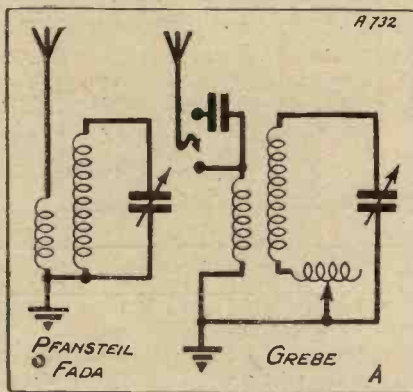

to explain to them how the average American receiver compares in design with ours, and how they are able to obtain the high sensitivity, great sharpness of tuning and simplicity of control which are such prominent features of their designs.

Unique Information

This, as might be expected, is rather a large order, but after a careful analysis of the circuits of a dozen or more well-known American receivers I have been able to get together what I think is the most complete data so far published in this country. In

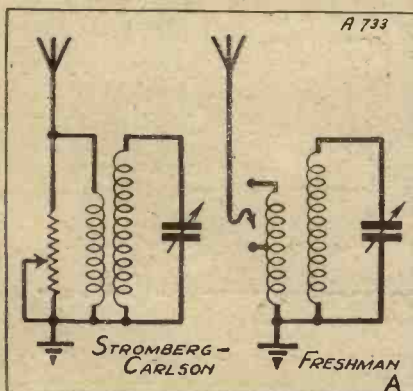

order that the maximum information may be given in a minimum of space, I am giving not complete circuits, but an analysis of the essential features of all of them, leaving out those conventional portions which are well understood.

"All-Electric" Sets

First of all a few general remarks. This year practically all the American set manufacturers have changed over to "all-electric" receivers, designed to run off alternating current mains (a few have D.C. models, but A.C. is practically universal in America), and with the required "power" units built in the complete instrument. A very well-known receiver—the Crossley—has already been described in these pages, and for the purpose of

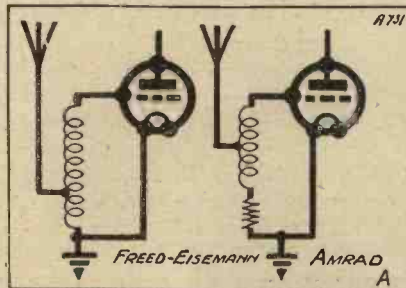

the present analysis I have taken the following makes (given in alphabetical order): Amrad, Bosch, Fada, Federal, Freed-Eisemann, Freshman, Grebe, Kolster, Pfausteihl, Splitdorf, Spartan, Stromberg-Carlson; while a number of other makes are mentioned for special points.

A Six-Valve Minimum!

In the analysis it should be noted that one receiver of each make has been dealt with, although practically all of the manufacturers named market a number of different models. It is significant that in the list given no set has less than six valves, and

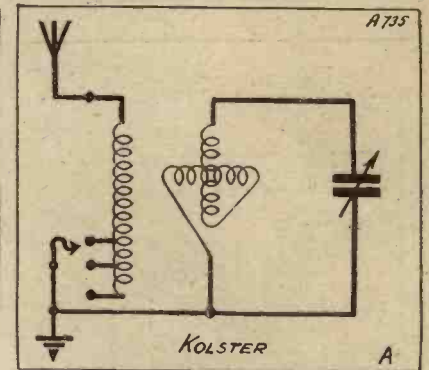

one—the Fada—has eight. Eight-valve models are also made by several other manufacturers.

An Enormous Improvement

Within the last year or two an enormous improvement has taken place in the quality of reproduction given by American receivers, particularly as the leading manufacturers have properly equipped laboratories where they are able to take overall reproduction curves and obtain something approaching "straight-line output." In the receivers listed all are transformer-coupled and all use super-power valves in the output. In the most expensive models of many makers "push-pull" is used in the output stage, but I have yet to find an American commercial receiver with the output valves in parallel.

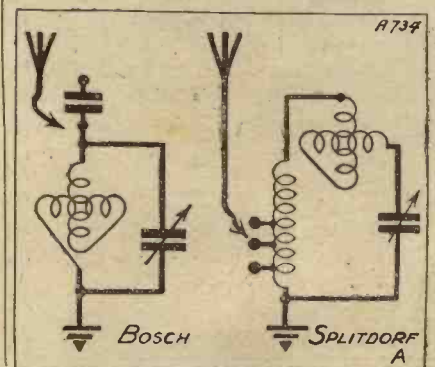

Transatlantic Tendencies—continued

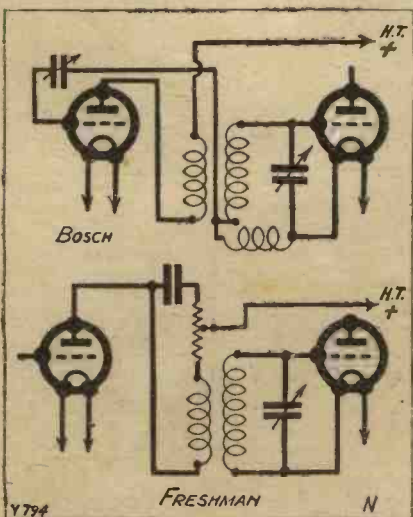
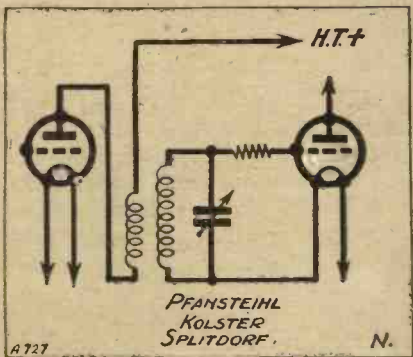
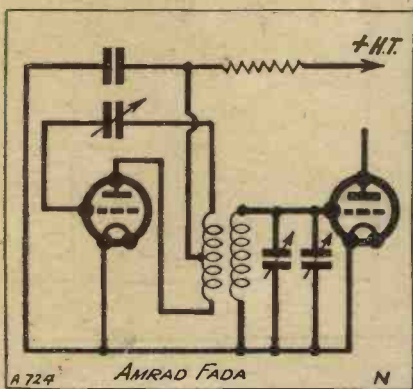
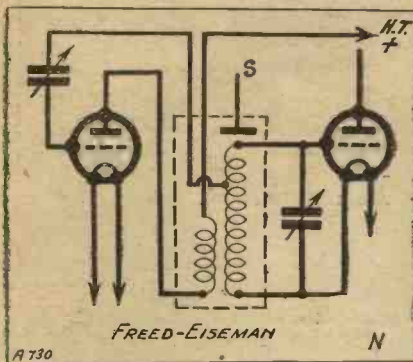

At the recent American Wireless Exhibition, 131 cabinet models were shown, 70 table models, and 17 combination radio and gramophone sets. Of 64 loud speakers exhibited, 35 were balanced armature, moving reed, and other sorts of electro-magnetic drive, while 29 were of the moving-coil variety.

So much has the American trade turned to the complete all-electric receiver than only ten firms were showing separate power units. I even notice that one firm, internationally famous for its dry batteries, has now turned to the manufacture of all-electric sets from the mains!

Shielding Practically Universal

In the receivers named none has less than three stages of radio-frequency, while Amrad, Fada, Federal and Freed-Eisemann all have four. Two stages of low-frequency is the rule, but the Fada has three, with a switch to cut out one when required. Grid-leak and condenser rectification is the rule, though the Fada and the Stromberg-Carlson use anode bend. Of the receivers on my list, only the Freshman, Grebe and Pfansteihl feed straight from the output valve to the loud speaker.

Splitdorf, Stromberg-Carlson, Federal, Fada, and Kolster have choke and condenser output, while Bosch, Freed-Eisemann and Amrad use transformer output. One of the receivers—the Stromberg-Carlson—has not only a choke-condenser output, but a special audio filter built into the output stage for the purpose of cutting off the very high frequencies such as occur owing to the beat-note of two stations working at 10 kc. separation.

Needless to state, shielding is practically universal, although in the case

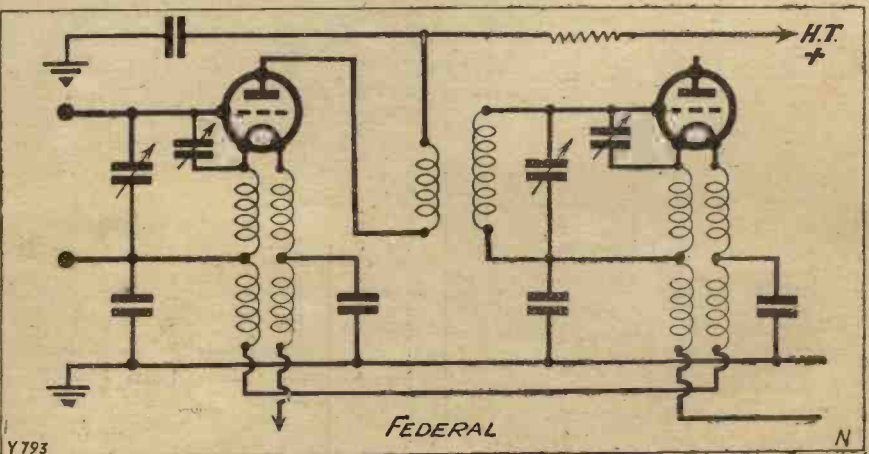
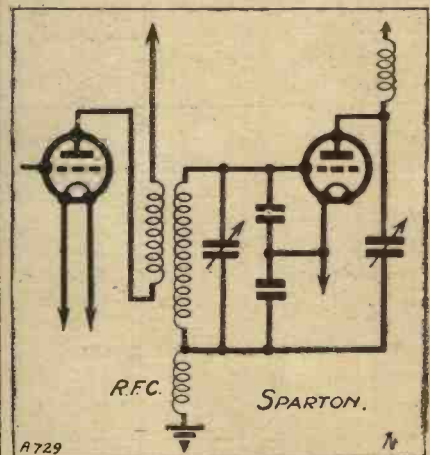
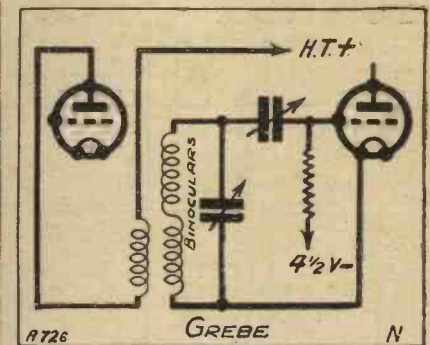
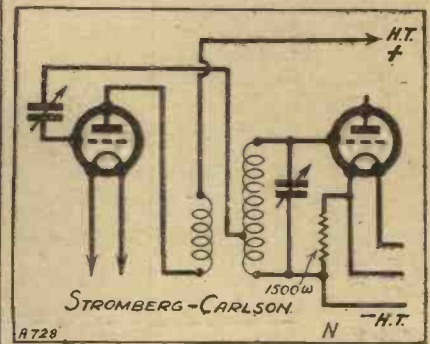

Transatlantic Tendencies—continued

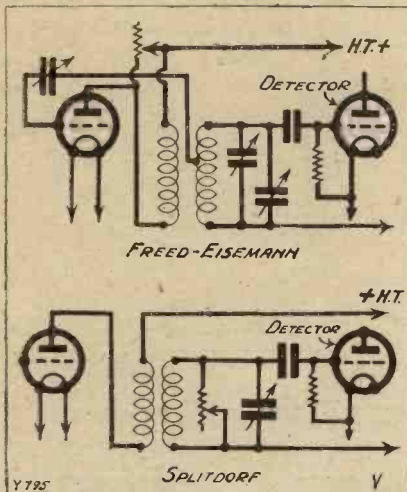

of the Grebe the use of binocular coils and very careful layout has cut down the amount of shielding necessary. In some cases the coils are separately shielded apart from stage shielding, and in other cases we have stage shielding alone. Single control is used

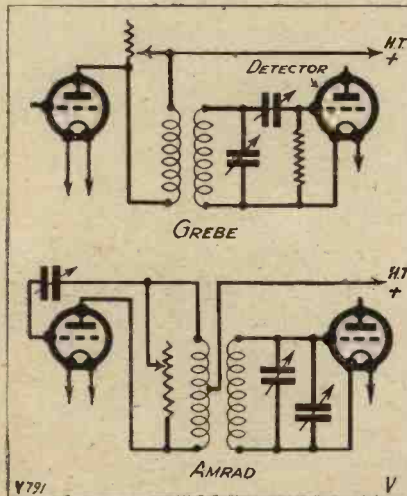

in all save Fada and Freshman, but in one or two of the others, although single-control shielding is apparently used, the provision of verniers enables a little finer tuning than is possible with gang control alone.

No More Dials

The external appearance of all the receivers is very much the same. In some cases the cabinets themselves are of metal, and in others the metal case is enclosed in a polished wood cabinet. In all the examples named, dials of the old-fashioned type have been abandoned, the majority having tuning indicators of the drum type, although in the case of the Stromberg-

Carlson and Splitdorf a disc-shaped dial is concealed behind the panel, so that only just the few degrees round about the indicator show.

The Fada set uses ordinary valves supplied from a power unit built into the set. This power unit uses a dry rectifier and electrolytic condensers on similar lines to my own "Stedi-power." The rest of the receivers use A.C. valves, either directly heated or indirectly heated, with the exception of the Federal, which uses ordinary valves with their filaments run in series.

"Tube" Troubles

All the receivers, without exception, use the "171A" type of valve in the output—that is, a super-power valve with a 5-volt $\frac{1}{4}$ -ampere filament with a plate resistance of 1,900 ohms and an amplification factor of 3:1. This valve is used on 5 volts A.C., with either a resistance across it and a centre-tap to prevent hum, or else a separate transformer winding with its own centre-tap. Incidentally the manufacturers in the States are having a great deal of trouble owing to the very short life given by these valves in A.C. receivers. The trouble here is that considerable variations in line voltage vary the filament voltage and therefore shorten the life.

So far as the power units are concerned, these are mostly of a conventional design, although the mixing up of different types of A.C. valve requires a number of different filament windings in such receivers. Practically all of the receivers use the valve type of double-wave rectifier (like our U5), and even in the Fada, although a dry rectifier is used for L.T., a full-wave valve rectifier is used for H.T. The sole exception to the filament type is the Federal, where the Raytheon type of rectifier is used. Here a high-power Raytheon tube is

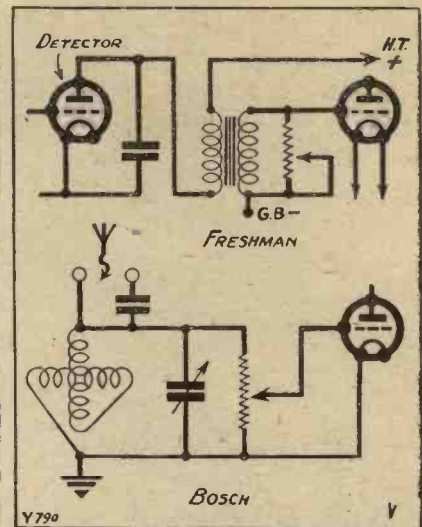

used to supply filament current to the valves, as well as H.T. Readers who have studied the articles in this magazine on power units will know how the H.T. units are made.

Comparative Details

And now for comparative details. Dealing, first of all, with the method of aerial coupling, the diagrams on the

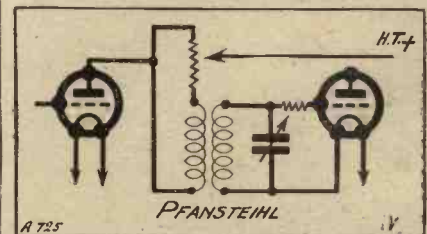

first page show how these are arranged. Pfansteihl and Fada use a simple method which is very popular over here, and Grebe has a modification of this method. It will be seen that the aerial can be placed either in series with the condenser and inductance or straight on to the inductance. This is to compensate for different lengths of aerials.

(Continued on page 320.)

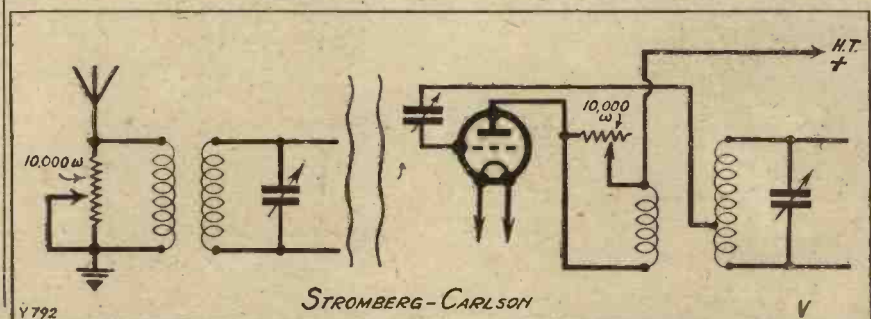

WHEN WE REACH THE REAL WIRELESS AGE

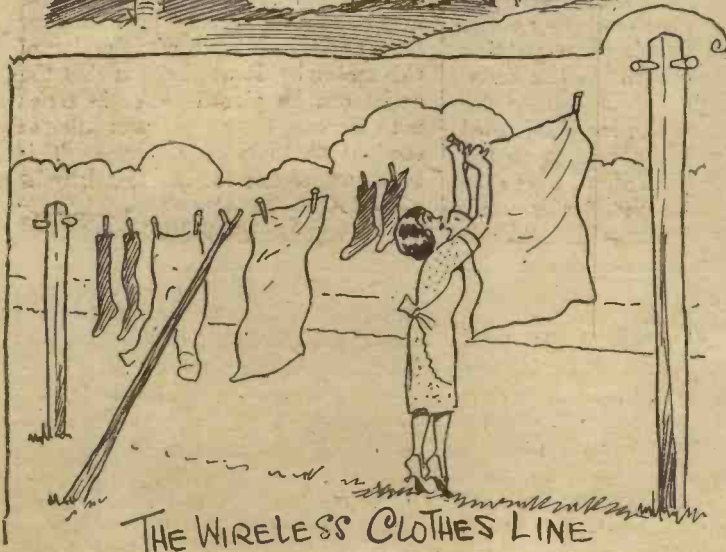
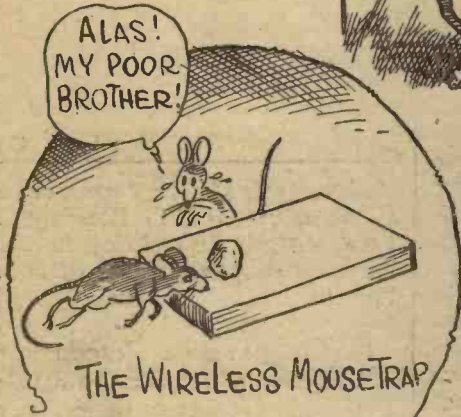
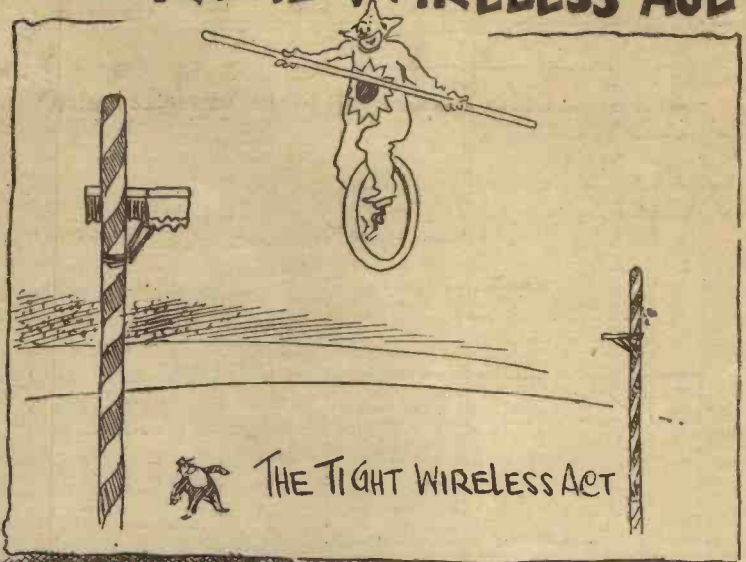
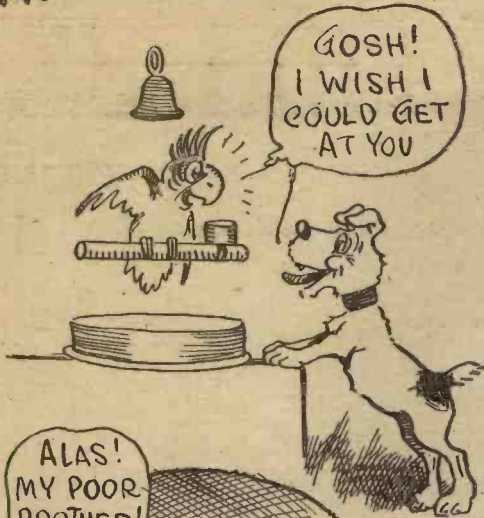

TON SHAW



HAPPENINGS AT SAVOY HILL

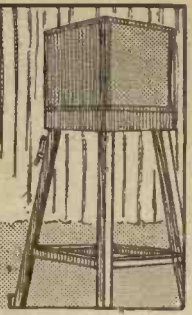

By OUR SPECIAL COMMISSIONER

WHEN, last August, the B.B.C. announced that relay stations would cease to originate local programmes in November, the reason given was that the inevitable transfer of relay stations to a national common wave, replacing the international common waves, would make it impossible to radiate local programmes. The programme changes were made according to schedule. The programme staffs at ten relay centres were either released or absorbed elsewhere in the B.B.C.

All this happened in November. But now, well on in January, there is still no sign of the inauguration of the heralded "single wave-length working." All that can be learned at Savoy Hill is that stations will be put on the national common wave gradually between now and the end of the spring—a period flexible enough to mean two months or four months. It follows that the whole of this wireless season will have been endured under the old conditions—regarded by the B.B.C. as "impossible."

Surely there was some grave miscalculation at Savoy Hill. Why penalise all the relay stations of their cherished local programmes a year ahead of the time when it was necessary?

Broadcasting House Problem

Although the B.B.C. has given its plans for Broadcasting House in unusual detail, no reference has been made to any allowance for picture broadcasting. Is it that there is still no intention to incorporate pictures in the service? If this is the case, the B.B.C. will fall behind the other enterprising broadcasters? Studio plans seem to be imaginative and comprehensive.

The super-studio, with room for an audience for 1,000, will be particularly welcome to listeners. I understand that there are ten thousand names on the Savoy Hill waiting list of people wishing to see broadcasting in a studio. The B.B.C. was not over-explicit about its plans for the financing of the new building. There

was a vague reference to a "syndicate." If Savoy Hill thinks that it can keep this dark for long it is labouring under a delusion. Parliament must be told all about a transaction of this kind.

No one presumes that it is unsound, but this withholding of information encourages unpleasant suggestions.

wider range of distinguished "talker" is being secured. On the other hand, there has been a depressing tendency to convert the studio into a lecture-hall. The intention to educate and improve is less unobtrusive than it was.

Talks are getting away from the entertainment side of the work. They

BROADCASTING HOUSE

The new premises as they will appear when finished. Broadcasting House will stand at the corner of Portland Place and Langham Street, near Oxford Circus, and probably the shift will be made to the new home in 1931. The building is expected to cost at least £400,000, probably £500,000. It will include nine studios, four of which will be more than twice the size of the largest studio at present in use at 2 L O. There will also be a super-studio, three storeys high, covering nearly 4,000 sq. ft. This will have a gallery and will be able to accommodate an audience of over 1,000 people, as well as a large orchestra. Work has already begun on the new building, and the site is rapidly being cleared.



By the way, why are all those buffets and restaurants being included? Is it possible that the B.B.C. is about to recant its temperance attitude and resume the use of strong drink?

The Evolution of Talks

Competent critics have remarked the gradual improvement of the individual broadcast talk during the past year. It is notable also that a

are being classified, organised, and made much too efficient. I am told that this has brought its own Nemesis, and that talks at Savoy Hill are being given a fresh orientation for next autumn and winter. There is to be a general scrapping of rigid methods, and a development of the impromptu natural treatment of interesting subjects by really interesting people.

Happenings at Savoy Hill—continued

Regional Progress

With regard to the construction of the new stations there is nothing very exciting to report. Brookman's Park appears to be going forward according to plan. There is unnecessary delay in the Pennines, and still a good deal of uncertainty about the others. There is a crumb of comfort, however, in the promise of transmissions from London this autumn.

Another point, too, deserves note. The Postmaster-General, when cornered in the House on matters relating to the B.B.C., falls back on the Regional Scheme as the potential cure of all present and future ills. This has more significance than it might appear to have. The P.M.G. up to a few months ago never mentioned the Regional Scheme. The Post Office as a whole regarded it with the deepest suspicion, and only sanctioned the construction of the London twin-

have any retiring pensions. The reason given was that the B.B.C. had a licence of only ten years, which was so short that it could not be recognised as a Department or taken seriously by regular Civil Servants.

It is also mentioned that, as the licence if renewed in 1937 will probably be for another similar period, the same objection will be brought forward to any subsequent application for pension rights or formal recognition. Incidentally, one highly-placed Treasury official was alarmed at the "swollen" salary list of the B.B.C., which he inspected in connection with the application for pensions. This is an entirely wrong attitude, and reflects gravely on the capacity and common sense of Treasury authorities.

Future of the Children's Hour

There are signs that the future of the Children's Hour is in the balance.

warmly resented by a particularly vocal and enthusiastic section of the listening public. The Children's Hour is one of the things the B.B.C. has learned to do well; it recruits many thousands of firm friends yearly, and is an important gatherer of new licences. Think again before dissipating lightly such an important asset!

Sir Thomas Beecham

So the permanent symphony orchestra under Sir Thomas Beecham, financed entirely by the B.B.C., has come to pass. It will be heard on the air for the first time during the first week of October, when it will inaugurate a series of special concerts which will be epoch-making in every sense. Sir Thomas, with characteristic enthusiasm, says it will be the best orchestra in the world. Savoy Hill, for once, agrees with him:

Sir John Reith's Future

A year ago now I gave it as my opinion that Sir John Reith might be leaving the B.B.C. at the beginning of 1929. I am glad to have been proved a false prophet in this respect. The able executive head of the B.B.C. remains at his post, and seems happier and more active than ever.

The task of Broadcasting House seems to have appealed particularly to him, and the chances now are that he will certainly see this through, and will probably stay the length of the licence, that is until the end of 1936. This is good news for all those who have at heart the quality and efficiency of the British Broadcasting service.

The Return of "Dick" Sheppard

Reassuring news about the restoration of the health of the Rev. H. R. L. Sheppard, C.H., revives speculation about his future activities. If he does get well enough to take up active work once more, it is almost certain to be at Savoy Hill. Before his last illness, he was known to be a regular reader in the Epilogue on Sunday nights.

B.B.C. News

Mr. Philip Macer-Wright asks me to state that the paragraph which purported to give his views on Broadcast News Bulletins was neither inspired, nor authorised, by him. This I do willingly.

CHANGING WAVE-LENGTH

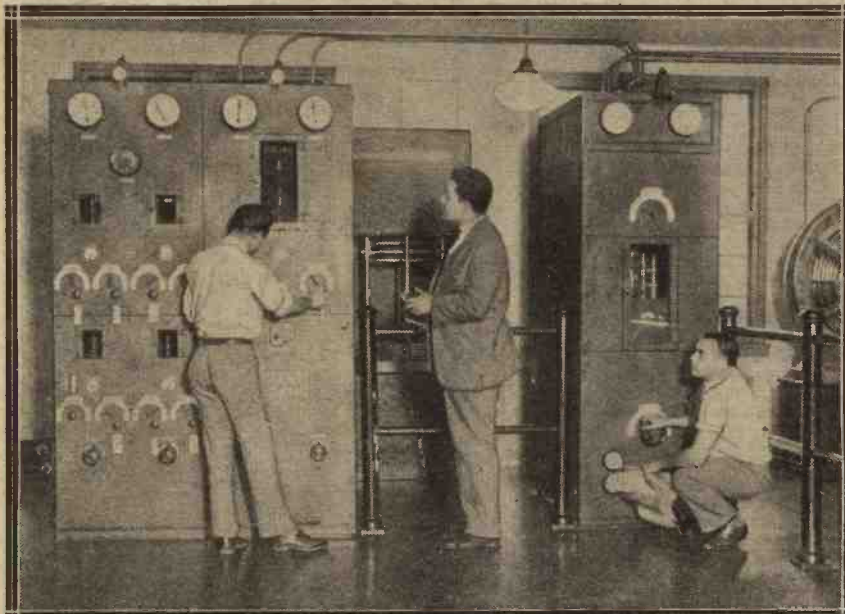

WEAF, America's super broadcaster, has changed its wave-length from 491.5 to 454.3 metres. The photograph shows three of the engineers busy checking up the transmitter by means of a wave-meter.

wave transmitter with misgiving and reluctance. Accordingly there would appear to have been a gratifying change of heart among the pundits.

No Pensions for B.B.C. Officials

It is known in Treasury circles that that Department has finally and irrevocably turned down the proposal that officials of the B.B.C. should

The resignation of Mr. C. E. Hodges (Uncle Peter) is believed to be significant of a decision at Savoy Hill to weaken and fade out this part of the programmes. If this is the case, then the B.B.C. is dallying with a first-class blunder.

Change of officials may or may not be a good thing, but any tendency to reduce the quality or scope of the Children's Hour programmes will be

HEAR REVELRY ON SUNDAYS!



from CONTINENTAL CABARETS

YOU will enjoy the kind of programme they broadcast on the Continent on Sundays—gay hours from the famous cabaret shows, music from the dance halls, and all the happy freedom of the Continental Sunday are brought to your home by the Lissen S.G.3 Receiver. Because, with this latest development of radio, distant stations come in all around the dials at full loudspeaker strength; the Lissen S.G.3 Receiver gives you a degree of selectivity, volume and purity of reproduction of Continental programmes such as you can get from no other receiver you have ever tried. The cost is moderate; you can easily build the S.G.3 Receiver yourself, or you can buy it completely assembled. If you build it yourself you save pounds.

FREE
Step-by-step
Chart and
Wiring
Diagram

To
LISSEN LIMITED,
26-30, Friars Lane, Richmond, Surrey.

PLEASE SEND ME THE FREE STEP-BY-STEP CHART OF THE S.G.3 RECEIVER.

NAME.....

ADDRESS.....

Please Mark Envelope S.G.3 in top left corner.

HOW TO START BUILDING IT!

There are only 6 steps in the building of the Lissen S.G.3 Receiver. Lissen have published a free STEP-BY-STEP Chart and Wiring Diagrams, which make every step absolutely simple. Lissen also provide a ready-drilled panel, baseboard with component layout marked, aluminium screens all ready to erect, and all the wires, terminals and sundries you require in an envelope, price 10s.

Go to your wireless dealer and ask for the Lissen S.G.3 Chart; on the back of it is a list of all the parts you require. Your wireless dealer will help you to choose these parts from his stock. Lissen do not tie you down to any particular make of valve, nor to any special cabinet; you choose these yourself, although Lissen advise a cabinet of polished wood so as to make the finished set a handsome piece of furniture.

10,000 RADIODEALERS

sell the parts for the Lissen S.G.3 Receiver, and any one of them will help and advise you. Get the free chart to-day, or send coupon below direct to factory for it.

YOU CAN BUY IT—COMPLETELY ASSEMBLED

If you prefer it, you can buy the S.G.3 Receiver completely assembled in finely finished wood cabinet large enough to hold batteries and accumulator, price .. **£8**
(Valves, batteries, accumulator and loudspeaker only excluded.)

But remember you save pounds by building it yourself

LISSEN LIMITED,
26-30 FRIARS LANE, RICHMOND, SURREY
(Managing Director: Thos. N. Cole.)



**REALISM
COSTS
ONLY
90
SHILLINGS**

FROM THIS MASCOT LOUD SPEAKER

IT would be quite natural if, when you heard this "Brown" Mascot Loud Speaker, you thought such realism would cost many, many pounds. Its faithful reproduction—so uncannily true-to-life that it creates the illusion that the artiste is in the

very room—is quite the equal of the performance of very expensive instruments. You will realise, then, that only the resources of the great "Brown" organisation could produce such a masterpiece for 90/-. Other models from 30/- to 15 guineas.

**MADE
BY**

Brown
BRITAIN'S PIONEER LOUD
SPEAKER MAKERS

Advt. S. G. Brown, Ltd., Western Ave., N. Acton, London. W.3.

 6442

LABORATORY NOTES

By the
Editor



RESISTANCE, which we often seek to lessen in wireless circuits, at times plays a very important part in our receivers. The little cartridge of paxolin or glass with metal ends and containing a substance which has a resistance of no less than 2,000,000 ohms, and which, with little respect, we call a "2-meg. grid leak," is really a vital link in the chain between the broadcaster and our ears.

The First Grid Leak

To the best of my knowledge the first grid leak was a lead-pencil-rubbing on a sheet of paper made in Dr. Lee de Forest's laboratory. It was then not so important in detection as it is now, for the valves were very soft and leaked themselves without much external aid, detection taking place with a grid condenser and the internal leak of the valve. But as valves improved and became "harder" it was found necessary to add an external leak, if this form of detection was to be used. Grid leaks are in such universal use that few listeners give much thought to their manufacture or construction.

The first grid leaks to be sold in this country consisted of strips of Bristol board dipped into Indian ink, dried, cut to a size, and sealed into a small tube which had metal ends. In order to render them immune to atmospheric influences, the tubes were later filled with paraffin wax. Millions of grid leaks of this kind must have been made and sold, and indeed many on the market at the present time are of similar manufacture.

Various Methods

They were manufactured so cheaply that no trouble was taken to make individual specimens to a particular value. When a large number had been

In this article Mr. Percy W. Harris discusses the question of grid leaks, their origin, design and construction.

manufactured they are sorted by means of measuring instruments to the $\frac{1}{4}$, $\frac{1}{2}$, 1, 2, 3, 4, and so on, megohms, an accuracy within 30 or 40 per cent of the rated figure being considered quite good.

Some grid leaks have been made of a composition of a kind of chalk powder, with graphite, well mixed and compressed into a small rod. Others have been made from a carbonised filament, while for experimental use a

piece of wet sewing cotton will function quite well (until it dries). Some of the best grid leaks are made by coating the inner surface of a glass tube with an extremely thin film of metal, and others by spraying a special composition on to a glass rod and sealing this glass rod (after contact has been made at each end) in an outer tube from which the air is evacuated.

Home-made Resistances

Still others have been made by rubbing lead pencil, or graphite, on the inner surface of an ebonite tube, and forcing plugs into each end to establish contact and to keep out the moisture. Indeed, it would take a

These two huge aerial towers, erected at a new radio station near Munich, Germany, are made entirely of specially treated wood.

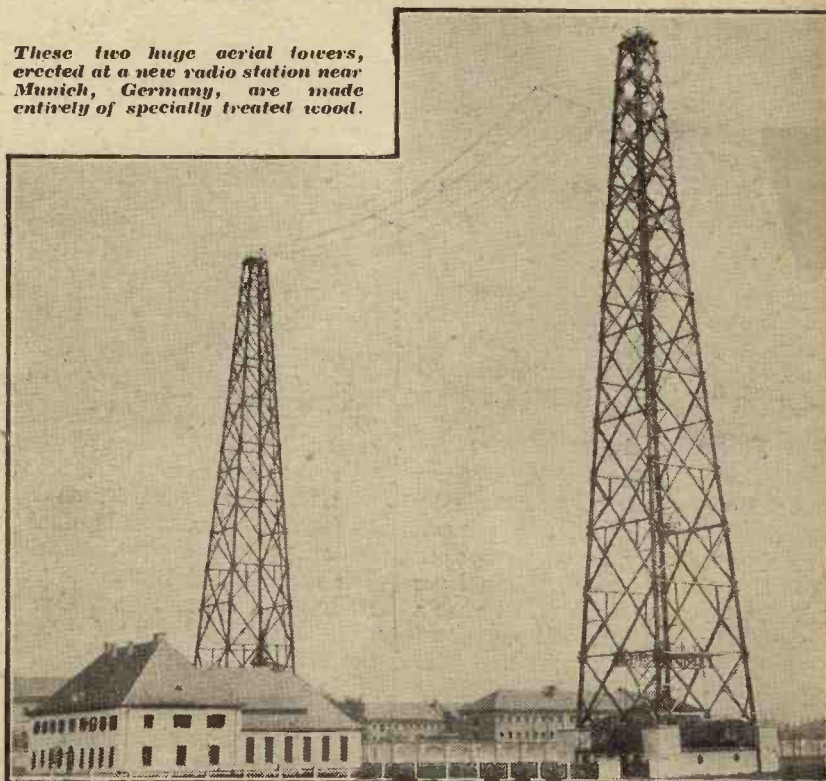

LABORATORY NOTES

—continued from previous page

long article to describe all of the methods which have been adopted.

The Editor recently undertook to produce for our weekly contemporary, "Popular Wireless," a three-valve receiver for a total cost of 7s. 6d. (excluding, of course, valves, batteries, and loud speaker!). In order to come within this figure—and it was successfully done—practically all the parts had to be home-made of very inexpensive material, and as the circuit chosen consisted of a detector followed by two resistance-coupled low-frequency stages, it was necessary to provide three grid leaks and two anode resistances of home-made pattern. Seeing that accurate measurement is not available to the average experimenter, a large number of experiments were undertaken with the object of finding a simple way of making both anode resistances and grid leaks for this receiver.

A Useful Rule

Now in a resistance-coupled amplifier it is not a bad plan to make the grid leaks four times the resistance of the anode resistances, and so it was decided to prepare a sheet of some high-resistance material which could be cut into strips so that the width of the grid-leak strips could be made a quarter of that of the anode resistances, thus having four times the resistance.

In order that reliable data could be obtained, the finished grid leak and anode resistances were left about for a month or six weeks in order to find what variation might occur. Different papers dipped into Indian ink were tried and these proved very satisfactory but lasted for a short period only, and if lead pencil rubbings were made on the top of this the results were still unsatisfactory, bearing in mind that it was not intended to seal them in tubes or airtight cases.

A Satisfactory Scheme

In the end a very satisfactory form of resistance material was made by taking a sheet of "P.W." paper and rubbing on it by means of a cloth covering the finger a very thin layer of Enameline stove polish, which is a graphite preparation. The paper used for the WIRELESS CONSTRUCTOR is of similar texture, and if the reader cares to take strips from the side of an unwanted page and spread the Enameline stove polish lightly on the

surface, using just enough to make the surface of the paper just jet black, he will find on cutting it up that a strip measuring 2 in. by 1/2 in. wide wound round at each end with silver paper, so that an inch and a half is left between the tinfoil, will measure on the average round about 150,000 ohms.

Excellent Results

A strip of the same sheet, measuring an eighth of an inch wide, will serve as a grid leak. The method adopted in the "Popular Wireless" receiver was to take a small piece of wood, lay the resistance prepared in this way on it, and pass a wood screw with a soldering lug beneath in each end through the foil. The three-valve set described enables not only 2 L O and 5 G B to be picked up on a loud speaker, but also Frankfurt, Cologne, and several other Continentals, the quality of reproduction being excellent.

In passing, it may be stated the only satisfactory way of measuring resistances of this kind is with a micro-ammeter and a low-voltage accumulator. The extremely high voltage given by a megger invariably does harm to such resistances.

* **RADIO-FREQUENCY** *
* **CHOKE TROUBLES** *

MANY strange troubles in wireless sets can arise from a faulty radio-frequency choke. If you have a set with one stage of high-frequency and reaction on the detector and you find, for example, that you fail to obtain reaction on the upper end of the lower wave-band, say between 500 and 600 metres, and the set refuses to oscillate even when the plates of the reaction condenser are "all in," it is ten chances to one that it is due to an inefficient or faulty radio-frequency choke.

Invariably a Cure

Similarly, if the set persists in oscillating even with the reaction condenser plates "all out" at some parts of the scale (usually on the upper part of the wave-band near Radio-Paris), then the chances are that your radio-frequency choke is unsuitable. The substitution of an approved and recommended make in either case will invariably cure the trouble. Some of the earlier radio-frequency chokes, made before the principles of their design were well understood, are very prone to give rise to troubles of the kinds mentioned.

* **"STEDIPOWER" NOTES** *

THE number of manufacturers who are making electrolytic condensers suitable for the Harris "Stedipower" L.T. Unit grows apace, and we are glad to see that the well-known firm of Dubilier are now marketing excellent electrolytic condensers which can be used interchangeably with those already specified.

A Higher Value

The Telegraph Condenser Co., the first condenser manufacturers in this country to market electrolytic condensers, have now raised the capacity of their models to 2,000 mid. each, the capacity being thus much larger than mentioned in the description of the "Stedipower" Junior. In this article, by the way, owing to the unfortunate omission of the word "or," it appeared that both T.C.C. and Tobe-Deutschmann condensers were necessary for this component, whereas, of course, an examination of the wiring diagram showed that the two makes were intended as alternatives.

The Tobe-Deutschmann Company are marketing both condenser blocks with two separate condensers joined in one casing, and also the condensers in individual units. The Tobe-Deutschmann Company are also marketing a complete "A" block, in which, in the one case, are included the two chokes and the necessary filtering condensers. This can be attached to any battery charger used for accumulator work, or to the trickle charger as explained in the article on the "Stedipower" Junior.

For Moving-Coil Speakers

In view of the large number of enquiries received, we would like to point out again that for energising the field of the moving-coil speaker designed to work from a 6-volt accumulator it is *not* necessary to make up a complete "Stedipower" Unit. All that is necessary is a step-down transformer and the dry rectifier, or, alternatively, a complete trickle charger, for the inductance of the field is so high that this alone is sufficient to smooth out any ripple which is present in the rectified current.

The very small trace of hum left is only noticeable when one stands quite close to the speaker, and then only when no programme is coming through.

Really powerful on distant Stations!

- LANGENBERG
- HAMBURG
- FRANKFURT
- BUDAPESTH
- BRUSSELS
- BRESLAU
- BERLIN
- MADRID
- ROME
- HILVERSUM
- PRAGUE
- RADIO PARIS



The Extra Valve
makes all the
difference

The Six-Sixty Mystery Receiver not only captures scores of European stations but presents them at full loud-speaker strength, with all the richness of their original tone maintained.

Such startling long-distance reception has only been made possible by the four matched Six-Sixty valves. Wonderful what a difference that fourth valve makes! Wonderful what a difference there is with valves that are *matched!*

Fill in this coupon and learn more about this marvellous Mystery Receiver. You will find it as easy to build as it is easy to use, and as easy to use as any Set could be.



Six-Sixty MYSTERY RECEIVER



SIX-SIXTY RADIO COMPANY, 122, CHARING CROSS RD., LONDON, W.C.2

To SIX-SIXTY RADIO COMPANY, 122, Charing Cross Rd., London, W.C.2

I am interested in this Set: send me all constructional details, please

NAME.....

ADDRESS.....

"BUY DUBILIER COMPONENTS



—and
you can
count the
cost as a
NON-
recurring
one!"

**DUBILIER
PRODUCTS**

"TOREADOR SCREEN GRID
FOUR."—This set incorporates the
latest developments in Receiver
design—full constructional details
free on request.



If not obtainable from your dealer write
to us giving his name and address.

*Dubilier
for Durability*

Advt. of Dubilier Condenser Co.
(1925), Ltd., Ducon Works, Victoria
Road, N. Acton, W.3.

©200B.



—the Speaker
that lives!

Whatever goes into the microphone, comes through absolutely naturally on the Blue Spot 49 Loudspeaker. No matter whether it is the top note of the piccolo, the deepest thunder of the organ or the middle register of the voice, you get unalloyed tone without distortion. Reproduction is perfect—and this amazing speaker, obtainable from all leading wireless retailers, costs only £2 2 0

The secret of its success is the Blue Spot 66Z Driving Unit, capable of handling great volume without distortion, and pleasing results can be obtained with low H.T. values. It can be obtained for home constructors as a separate unit, price 17/6

For those who own sets of 3 valves or more we recommend Blue Spot Speaker 59. Price £4 4 0, with 66K unit capable of handling any output. Price of unit alone, 25/-.

F. A. HUGHES & CO., LIMITED
204-6 Great Portland Street, London, W.1

Distributors for Northern England, Scotland and North Wales: H. C. RAWSON (SHEFFIELD & LONDON) LTD., 100 LONDON ROAD, SHEFFIELD; 185 PRINCESS STREET, MANCHESTER

"Ideal Blue Spot Cone Speakers are sold under full protection of the patents owned by Standard Telephones and Cables and the Hopkins and Lektophone Corporations."

EXPERIMENTING WITH THE THIRTY-ONE NEW CIRCUITS

BY THE EDITOR.

CIRCUITS Nos. 5, 6, and 7 are of the original Cossor "Melody Maker," the Mullard "Master Three" and the Ediswan "Threesome" respectively. These three circuits were put out by the respective manufacturers to foster the sale of their valves, and as full constructional details and wiring charts were provided, very large numbers of these receivers were built up. Each has its own special points, and although the first two have now been replaced by different designs, the circuits of the original sets will still prove the basis of much interesting experiment.

Circuit No. 5—the original Cossor "Melody Maker"—is particularly in-



The Ediswan "Threesome" comprises an assembly of compact units. Above is the L.F. transformer unit.

genious owing to the very special scheme of wave-change used in this set. It will be seen that the coil L_1 and L_2 is continuous, the portion L_2 being short-circuited when desired by the switch S_2 .

How Reaction is Used

The reaction coil L_3 is so arranged in the original design as to come on the same former as L_1 and L_2 , between L_1 and L_2 , and considerably closer to L_2 than to L_1 . Thus the separation of L_3 from L_1 being much greater than from L_2 , the reaction effect on L_2 was much greater than on L_1 . Arranged in this way the one reaction coil served for both short and long waves, and the change from short to

long waves was immediately effected by moving the switch S_2 .

The detector valve is resistance-coupled to the first low-frequency valve, this latter being transformer-coupled to the output circuit. It will be noticed that no radio-frequency choke is included in the circuit. The reader may wonder how reaction is obtained in such circumstances, but a few moments' consideration will show that the impedance of R_2 is much greater than that of the condenser VC_2 , and therefore the high-frequency currents pass to filament through the reaction condenser rather than through the resistance.

Inserting a Choke

The condenser C_5 (fixed) is placed in series with VC_2 , so as to prevent any short-circuiting of the high-tension battery should by any chance the moving plates of the reaction condenser touch the fixed. Although in many cases one can dispense with a radio-frequency choke here, it often happened in the original design that trouble was experienced due to high-frequency currents getting through into the low-frequency side, and personally, I much prefer a good radio-frequency choke included.

To insert the radio-frequency choke, break the connection where R_2 joins the plate lead and also disconnect the condenser C_4 where it joins the same lead. The radio-frequency choke is then inserted between R_2 and the plate lead, while the condenser C_4 is connected on the resistance side of the radio-frequency choke, the lead from the plate to the coil L_3 being left as before.

Circuit No. 6 of the Mullard "Master Three" also has one resistance and one transformer-coupled low-frequency stages, and was noteworthy for the use of a metal panel which considerably simplified the wiring. It will be noticed here that a radio-frequency choke is included as shown. Six-pin plug-in coils were used in place of a wave-change scheme, but although this is less convenient for the user it was considered by the designers that greater efficiency is obtained by using the separate coils.

The new model Mullard "Master Three" has a wave-change switching scheme which is very practical, while the new Cossor "Melody Maker" includes a screened-grid valve and only one stage of low-frequency.

Rearranged Coil Systems

It is interesting to note that while Mullards have changed over from interchangeable coils to a wave-change scheme, Cossors have gone back to the interchangeable coils!

The Ediswan "Threesome" was actually the first of what are generally called "valve makers' designs," although the circuit shown in this book, as mentioned, is an improvement on that originally published, and is that now circulated. It has two stages of resistance coupling, the idea here being to give very great purity, but it is now possible with an alternative design to include one stage of transformer coupling for those who like the greater magnification.

Circuit No. 8 is a special three-valver which has a selectivity far in excess of that obtainable with the previously mentioned circuits, and indeed much greater than many people believe possible without a stage of high-frequency.

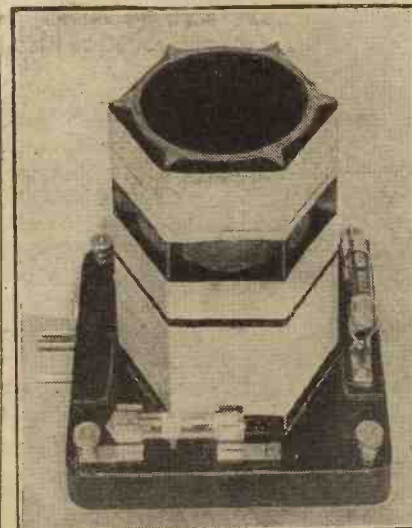

This is the inductance unit of the Ediswan R.C. "Threesome." The detector valve takes its place inside the coil.

A VARIABLE H.T. UNIT

An easily made gadget that will provide progressively variable voltages from mains sources of H.T.

By W. L. S.

THE little unit described herewith and seen in the photograph is another of those obvious little "gadgets" which are always useful once one has made them, and yet are never thought of until someone gives one the idea. Since the writer made up the unit it has been in incessant use, together with another of a some-

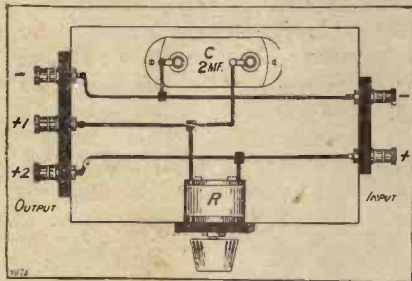

what similar type, and if it had only been made up a month or so before it would have saved endless "fiddling" and hasty rigging up of loose components.

Its original purpose was simply to provide an extra H.T. terminal when it was desired to use a four-valve receiver in conjunction with an eliminator which had only three tappings, or, of course, in the case of an eliminator with only one H.T. positive terminal to provide an extra terminal. A friend using D.C. mains for H.T. supply then wanted to borrow it and showed such reluctance to return it that it appeared to be useful to him!

Man Who Made Three!

He was using D.C. mains, through a suitable filter circuit for smoothing, which gave him a voltage of about 180 to play with, and since seeing the original unit he has constructed three of them, which give him three "tappings" on his mains, so that he has four H.T. terminals on his set, one giving him the full 180 volts for use on the last power valve, and the other three being variable from about 45 volts to 135 volts and being quite useful for all sorts of odd jobs.

Most sets operating from D.C. mains or on an eliminator which works from A.C. mains have suitable tappings provided for most requirements. It is, however, a distinct

refinement to have a smoothly variable tapping such as one can obtain by the use of a "Bradleyohm," "Clarostat," or similar variable resistance, and a little unit incorporating one of these and a large by-pass condenser is all that is necessary to provide the necessary variable H.T. terminal.

The unit seen in the photograph is probably the simplest possible form of this, but doubtless readers will think of modifications and alterations to suit their own requirements. Of course, if the eliminator to which it is connected has four or five H.T. terminals, the "input" terminals on the unit are taken to the negative and to the *highest voltage* positive terminal on the eliminator.

Suitable Variable Resistances

If D.C. mains are used, they will, of course, be connected to the set through a smoothing unit of some kind, and it is to the positive and negative terminals on the output side of this filter that the new unit should be connected.

If a Bradleyohm is used, types E5 and E10 are both suitable. Type E10 gives the greater voltage variation, but rather less current will be available than if E5 were used. A "Volume Control" type Clarostat is also suitable.

Useful Reaction Control

The 2-mfd. condenser is, of course, essential since we are inserting a resistance in the H.T. supply, and unless a suitable path is provided for any H.F. currents that may reach the

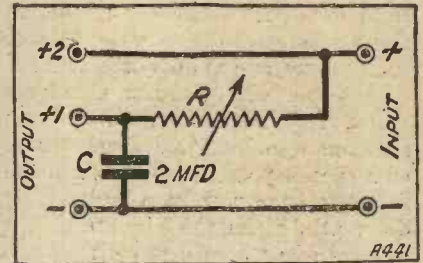

H.T. terminals of the set there will be trouble of the same kind that arises when an H.T. battery has run down and reached a very bad state.

As a matter of fact, when the extra terminal provided by one of these units (which is, of course, the "+1" terminal) is used for supplying the H.T. to the detector, the variation in voltage given by the variable resistance is sufficiently smooth for this to be used as a means of reaction control.

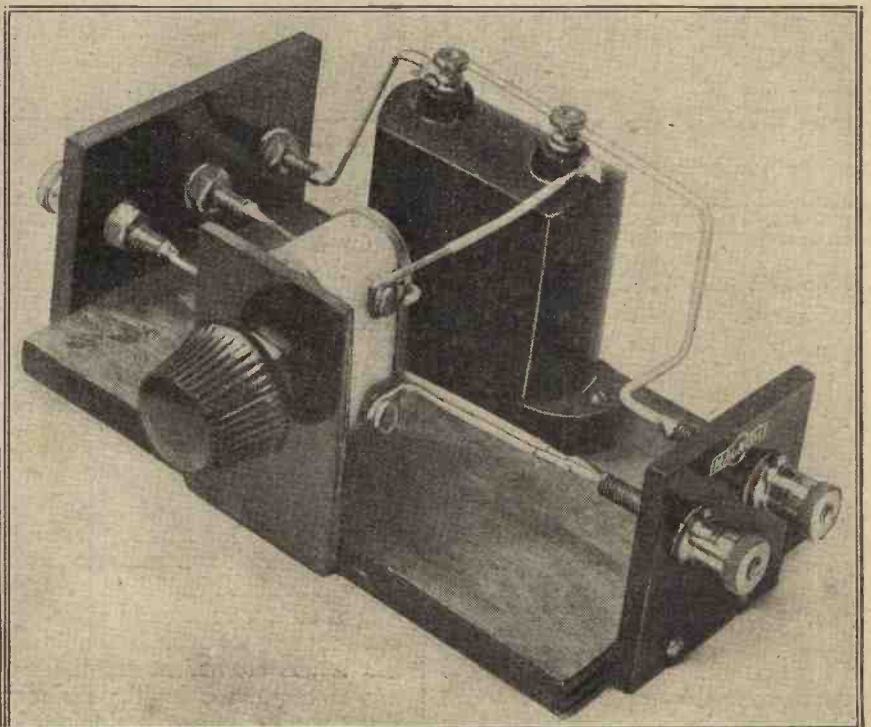

The complete H.T. unit, looking from the "input" end and showing the variable resistance and smoothing condenser.

PERFECT PRECISION COMPONENTS

ENSURE ULTIMATE SUCCESS!

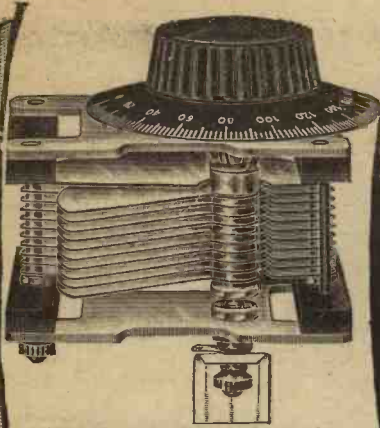

ORMOND LOW-LOSS CONDENSER. Capacities .00025, .0003, .0005, .001, with or without friction control. Prices from 6/6.

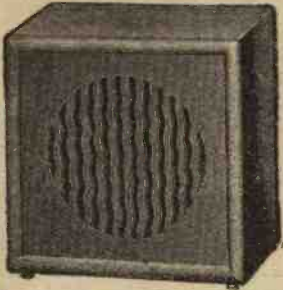

The **ORMOND LOUD SPEAKER** for quality and power. Supplied in Oak or Mahogany. Price £4-4-0.

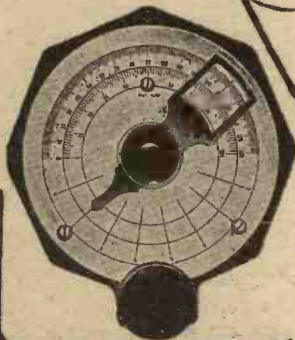

The Popular Ormond **SLOW MOTION DUAL INDICATOR DIAL** (Ratio 16-1), as illustrated, or in black. Price 5/-.



Fit the Ormond **BALL-BEARING TURN-TABLE** to your portable or frame Aerial Receiver. Price 6/-.

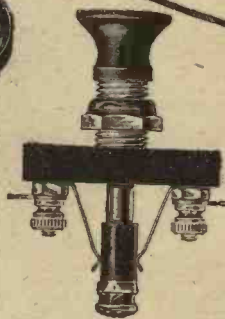

PUSH-PULL SWITCH. Two-point type, price 1/3; Three-point type, price 1/6 (one-hole fixing).

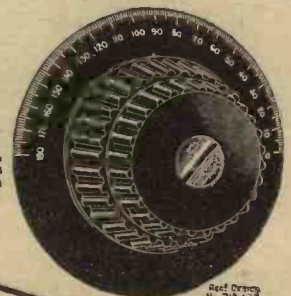

FRICITION CONTROL DIAL. 4 in. Dial, with direct drive and slow motion (Ratio 55-1). Price 7/6.

You will agree that makeshift methods never pay—carelessness in the construction of any set is the precedent of troubles galore. But has it occurred to you that the same truth is equally applicable to every component you use?

Why ask for trouble? Insist upon Ormond—the finest components made—and enjoy that security and satisfaction which none but the best can afford.

*All Good Dealers
Stock them!*

Leaflets and Booklets on request. Also details of our complete receiving sets



THE ORMOND ENGINEERING CO., LTD.
199-205, PENTONVILLE RD., KING'S CROSS, LONDON, N.1.

Phons: Clerkenwell 9344-6. Grams: "Ormondengi, Kinross."
Factories: Whiskin Street and Hardwick Street, Clerkenwell, E.C.1.
Continental Agents: Pettigrew & Merriman, Ltd., "Phonos House," 2 and 4, Busknull Street, New Oxford Street, London, W.C.1.

WIND YOUR OWN COILS

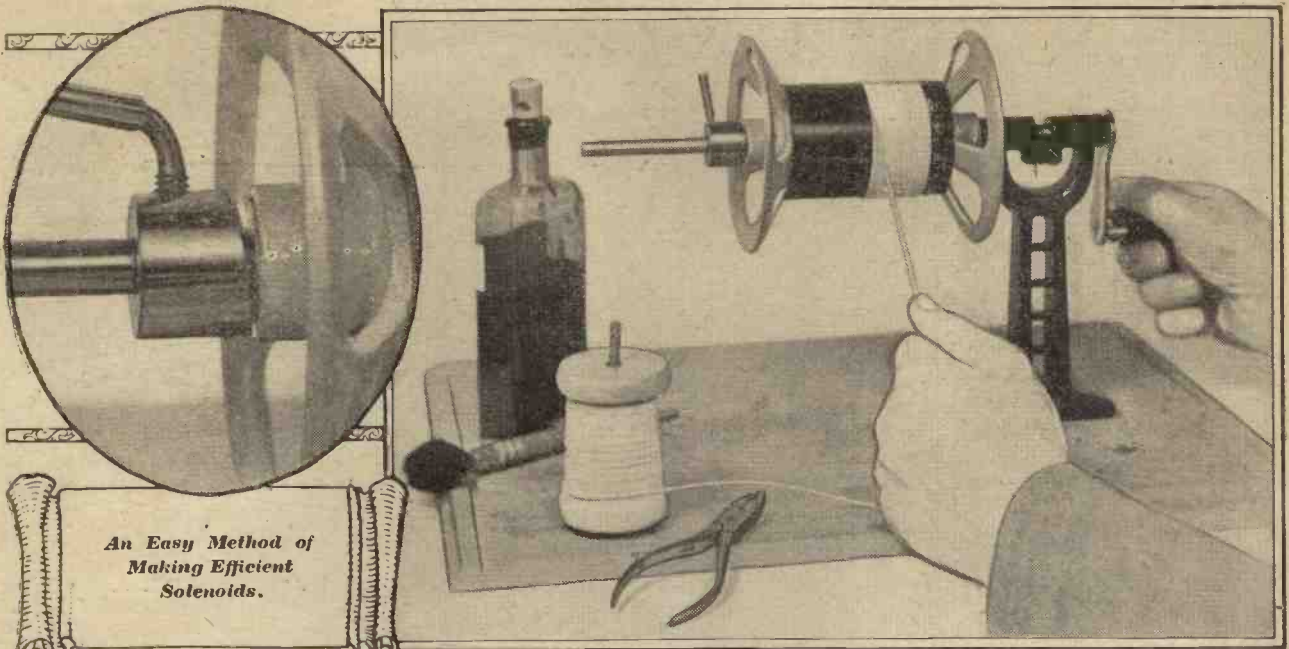

An Easy Method of Making Efficient Solenoids.

MANY readers who would like to wind their own coils are loth to attempt the task owing to the tediousness and inconvenience attending the process. Unless some special form of winder is used, the former must be slowly rotated in one hand while the wire is kept tight, turn by turn, with the other.

The WIRELESS CONSTRUCTOR, after careful investigation, has now found a coil winder, illustrated herewith, which is far superior to anything we have yet seen. It sells for £1, is known as the "Goodell-Pratt Coil Winder No. 695," and can be obtained from any wireless dealer who troubles to order it from his factor. It will take any size of former up to that used for winding the "Melody Maker" H.F. unit coil; the tube is immediately,

accurately and automatically centred when placed in position; a special gripping spring prevents the slightest slip of the former when the hand is taken off the handle (as needs to be done to straighten turns), and an ingenious fitting at one end provides that the slightest slip of the end cheeks is immediately transformed into a tightening pressure on the tube.

Winding single-layer or other coils with this machine is a sheer joy, and the device will save its cost to any serious experimenter in a very short time. Equipped with this winder, an assortment of coil formers, such as "Pirtoid" tubes, and a few pounds of wire, the real "fan" will find a whole field of new experiment immediately opened to him.

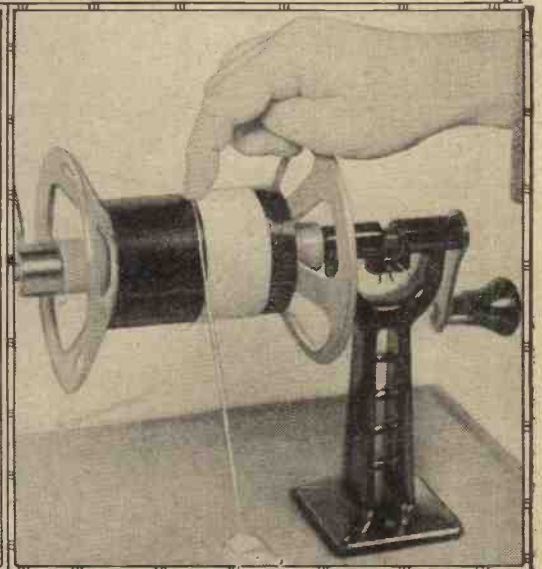
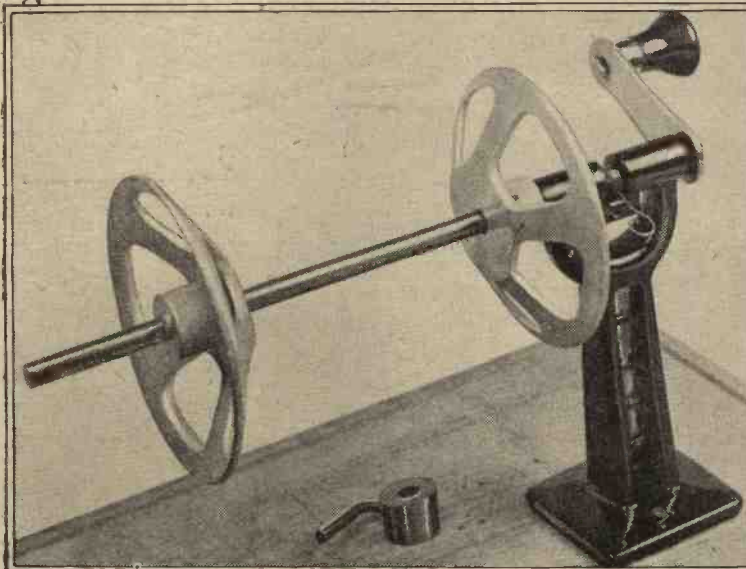

IN LIGHTER VEIN BY WIRELESS WAYFARER

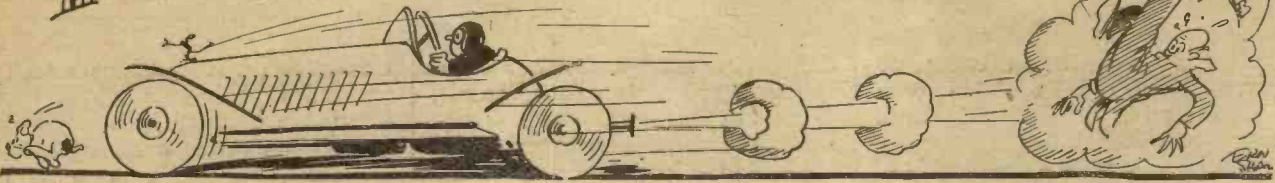

"HAS it occurred to you," asked Professor Goop, "that nobody has ever yet designed a receiving set for our sporty boys?"

I admitted that it had not.

"It's a crying shame," went on the professor. "The dear little fellows are well catered for by the motor-cycle firms who turn out gas wheels—I believe that is the correct technical term—with which a sleeping village can be awakened in the most amusing way during a midnight run. Many of the users, though, never get very far afield, for what could be more jolly than to roar up and down the high street of one's native place clad in the correct raiment and to divide

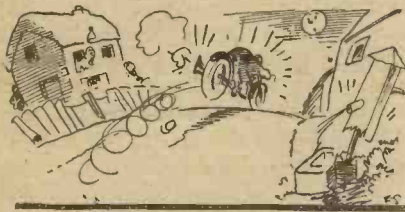

... A sleeping village can be awakened in the most amusing way ...

the population, as someone once put it, into the quick and the dead!"

Thoughtfully I rubbed the bump at the back of my head contracted that very afternoon when I had been only just quick enough to escape being dead.

"But—" I began.

"That," broke in the professor, "is exactly what they do. Why, only yesterday one of the dear fellows butted me, in a manner of speaking, from here to Thursday week. So much for the youthful motor-cyclist. The adolescent motorist is equally well catered-for with the super-sports car. Do you know what a super-sports car is?"

Quite Easy to Make

"Yes," I said, glad to be able to get a word in. "They are quite easy to make. You take an ordinary bus and begin by removing the bonnet fasteners. You hold the bonnet down by means of a long leather strap, but you must take care not to draw it too tightly, or you will suppress a delightful clatter. Then you

discard the existing steering-wheel, fitting in its stead one about as big as a grindstone. Next you slip off the silencer and substitute a conger-eel thing with a flattened spout. You pull out the seats, replacing them by cushions on the floor. The wings give way to flat strips of plywood. A smoke-screen-making appliance is added to the exhaust. You have a special dashboard provided with all the meters that you can think of. You make the speedometer read fifty per cent. fast, and there you are."

"You have only forgotten one point," said the professor, "and that is that to make the car into a real super-sports model the engine must be so adjusted that it is quite incapable of running either slowly or quietly when the car is standing still. Otherwise you have put it, if not in a nutshell, at any rate, in a sausage skin. Now what is the main characteristic of the bright things of the present generation?"

What is Wrong?

"It's freedom from parental spanking," I hazarded.

"No, no," smiled the professor. "It is something which concerns the other end. I think I can claim to be the first to discover exactly what is wrong—or perhaps I should say 'right'—with the rising generation. I hesitate to publish my discovery, for it would probably mean sending to the workhouse hundreds of novelists who earn their livelihood by trying to give to the great world explanations of what they call the modern spirit. No one, save myself, has yet discovered that flaming youth suffers from atrophy of the eardrums.

"It is for this reason that they cannot dance except to music that could be heard a mile away by normal people. This it is that makes them loathe the silencer, for when it is there they positively cannot hear whether the engine is working or not. It is this same sad affliction that causes them to demand what they call realistic volume from their loud

speakers; they have to talk at the top of their voices, or none of their friends would be able to hear a word. Similarly, they do not mind squeaky brakes, for youth must be served."

"And what," I queried, "do you propose to do about it?"

"I have designed," said the professor, "a super-sports wireless receiving set specially to meet the demand of the rising generation."

"Tell me more," I cooed. "Your tale interests me strangely."

The Super-Sports Set

"Let me describe it briefly," went on Professor Goop. "The circuit is my own adaptation of the super-heteroneuroregenerodyne. In the ordinary super-heterodyne, of course, you have a first detector followed by intermediate-frequency valves; then comes a second detector and one or more note-mags."

"Yes, yes," I breathed.

"In my super-sports model I don't do unsporting things."

"How do you mean?"

"Well, do you call it quite fair to step-down a frequency? As you probably know, with frequencies it is a case of the higher the friskier, and when you go stepping them down

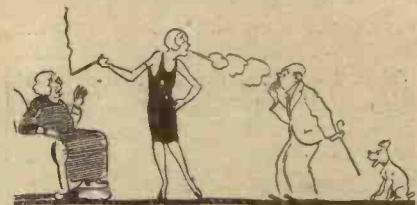

... It's freedom from parental spanking ...

you take all the life out of the poor things. Now I do exactly the reverse."

"Explain!" I cried, dithering with excitement.

"Instead of stepping-down frequencies, I step them up. My first detector is followed by a first-speed high-frequency; then comes another detector; then second-speed high-frequency; then a third detector and third-speed high-frequency; followed by the final detector. In case, by any chance, oscillations are not sufficiently lively by this time, I

In Lighter Vein—continued

provide also four reaction forward speeds, as well as an emergency reverse, which is used to calm things down in times of crisis, when the set looks like busting."

I begged for more details.

"The valves, of course, are of the overhead type, ignition being either by accumulator or by an incinerator worked direct off the mains. Where a battery is employed provision is made for the use of a super-charger."

"And what of the cabinet?"

"The cabinet is naturally fabric, finished with sliding roof, a broad leather strap being used to keep the lid in its normal position. I forgot to mention, by the way, that all high-

a voltmeter, an ammeter, a milli-ammeter, a micro-ammeter, a millivoltmeter and a gas meter. The last, I should explain, is a clock fitted with a special automatic arrangement for recording the length of speeches and the like. Above the dashboard comes a rack for spare dials, and beyond that, of course, is the panel of the set itself with its controls."

Hot Stuff!

"Pretty hot-stuff those controls, I should think."

"So much so that I have provided water-cooling for them. In order to introduce the necessary damping an ascending main is centre-tapped to

here again I have shown what I think I may style without undue modesty my genius.

"In the ordinary set slow-motion dials are employed. Anything slow is, of course, an anathema to sporty boyhood. My dials are therefore geared up instead of being geared down. This means that there is no need for any silly delay when foreign stations are being tuned in. Almost before the Langenberg orchestra has finished a bar you can be in Madrid or Oslo or Stamboul or Nice. In fact, by keeping the controls continually in motion by means of both hands and feet it is possible to hear a delightful pot-pourri from simply scores of stations."

"And what other controls are there?"

"In addition to the reaction arrangements already described we have a volume booster, a self-starter, a self-stopper, a super-screamer, an automatic panel-wiper, and last, but not least, one-shot lubrication."

"And how does that work?"

Complete Absence of Bass

"On setting the device into motion vaseline is immediately applied to the terminals of the accumulator, if there is one, whilst a special lubricant, which I propose to call Goopo, is fed to the bearings of variable condensers and all moving parts. Simultaneously, a brown liquid is poured into a cylindrical glass vessel, all froth being removed by means of my patent blower. An automatic lazy-tongs appliance moves the glass vessel towards the lips of the operator, whilst a special little device tilts back his head and tilts forward the glass container. A carefully designed piece of mechanism eliminates such parasitics as heel taps and the like. Even the most carping critic cannot say that my super-sports set fails to bring out the Bass."

I asked if I could try the set and was told that I could.

Curiously enough, my hands went straight to the one-shot lubrication dial.

"You press the button," smiled the professor, "and we do the rest."

I wasn't quite satisfied with my first test. I pressed again. I even suggested that the third time would mean real luck, but as he had brought the poker with him I pressed neither the point nor the button.

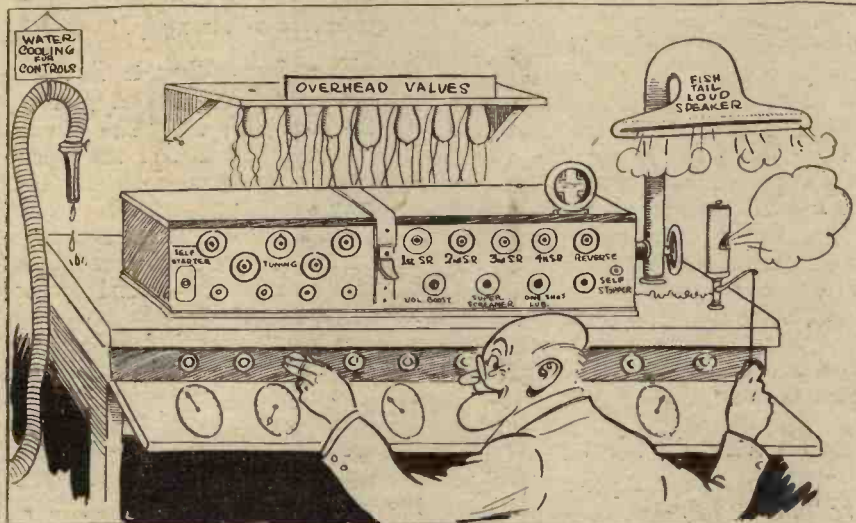

... In addition to the reaction we have a volume-booster, a self-starter, a self-stopper, an automatic panel-wiper, and one-shot lubrication ...

tension terminals are provided with shock absorbers. A fish-tail loud speaker goes with the set and a neat little contrivance makes it possible for this to project into the room dense clouds of evil-smelling gas when a topical talker is at work. On the base of the loud speaker is a licence holder, which in the case of the true sporty boy will invariably display a licence at least twelve months out of date. The set is supported upon a table but twelve inches in height, which enables the operator to sit, or rather to lie, in a semi-recumbent position comfortably upon the floor."

A Neat Dashboard

"And what is immediately before him?"

"A neat dashboard (I regret to say that in my experiments I frequently referred to it as a damboard) carrying

enable the requisite number of turns to be brought into play as required."

"Turns of what?"

"Turns of hose-pipe. One turns the tap—"

"I thought you said that it was the hose that was turned?"

"So it is. When the controls have been turned so furiously that they become red-hot."

"Here, steady on, I'm getting rather mixed up with all these turns."

"And I," said the professor, "am getting distinctly fed-up with your interruptions. It is"—and here he reached down for the poker—"a long worm that has no turning. Any more of your mutual obstruction—"

I hastily closed down.

"The controls themselves," the professor continued, "will be a sheer delight to the super-sporty. There are no less than nine tuning dials, and

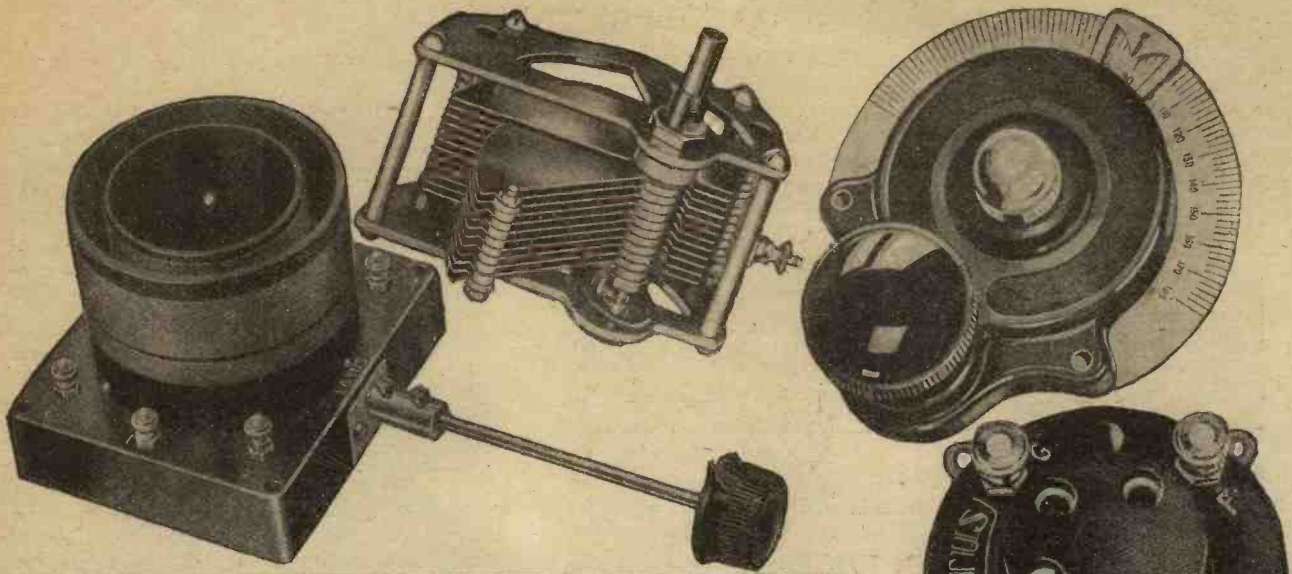

**FOR EVERY
GOOD
CIRCUIT
YOU NEED
LOTUS
COMPONENTS**

If you are building the Mullard "Master Three Star," Cossor "Melody Maker," or any other popular set, ask your dealer for Lotus Components.

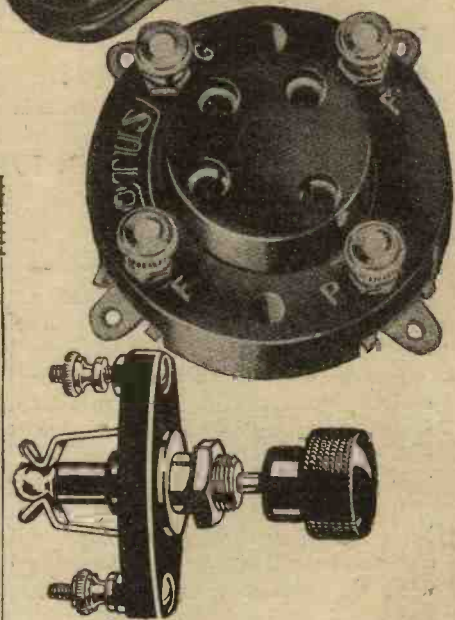

For your set choose—
 Lotus Dual Wave Coil, 15/-,
 16/6, 21/-; Lotus Vernier
 Dial, 4/9; Lotus Variable
 Condensers, from 5/-; Lotus
 Buoyancy Valve Holders, 1/3
 to 1/9; Lotus Jacks, Switches
 and Plugs; Coil Holders,
 Single Coil Holders, Lotus
 Remote Control for recep-
 tion in every room from
 any type of set.
 From all radio dealers.

Garnett, Whiteley & Co., Ltd., Broadgreen Road, Liverpool

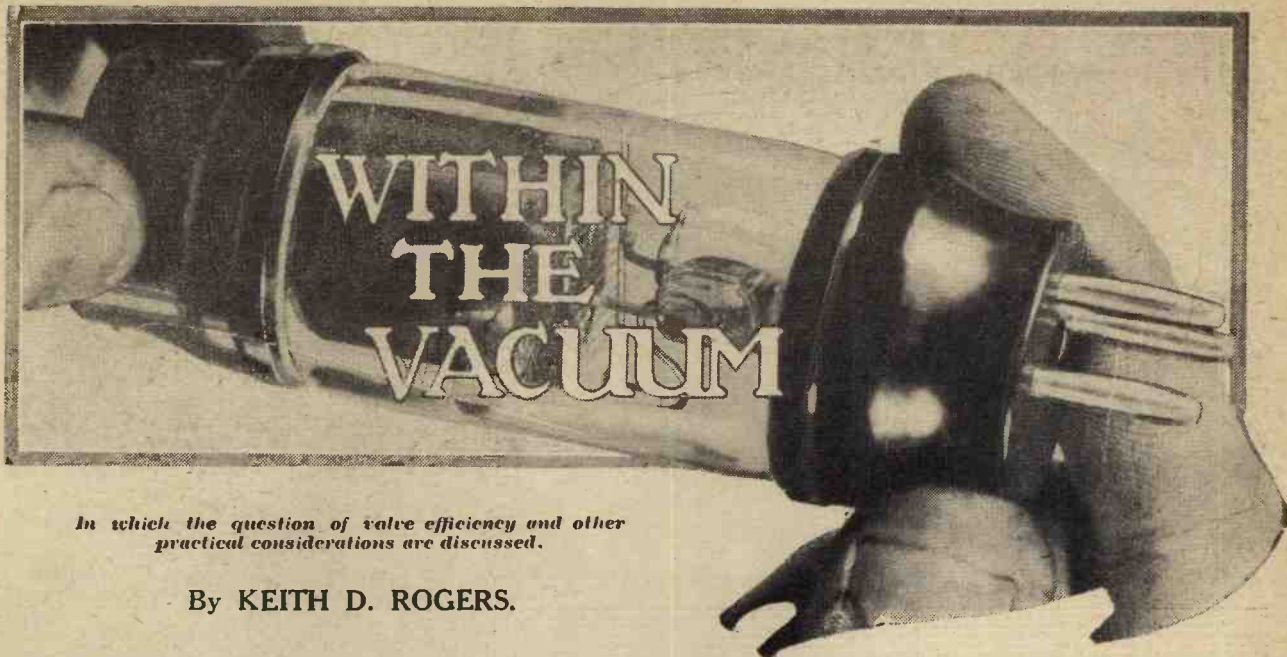

In which the question of valve efficiency and other practical considerations are discussed.

By KEITH D. ROGERS.

THIS month I want to answer one or two questions that have been asked by correspondents during the last month or so.

In the first place there seems to be a certain amount of doubt as to what is meant by the "slope" of a valve, and of what value is the so-called "steep slope."

Without going into technicalities, I might say that the "slope" is really a scientific efficiency factor showing what the valve will do. It gives an

and call the result the "slope," or "mutual conductance."

For instance, if a valve has an impedance of 10,000 ohms and a magnification factor of 10, we say its "mutual conductance," or "slope,"

$$\text{is } \frac{10}{10,000} \times 1,000 = 1.$$

While if it has a magnification factor of only 8, we find that its efficiency (compared with unity) is

$$\frac{8}{10,000} \times 1,000 = .8.$$

Obviously, then, if the mutual conductance of a valve is above 1, it is a more efficient valve than any having a figure equal to or below unity.

So far so good. But slope does not mean absolutely everything, as we shall see, although it means a good deal and is a ready way of comparing valves of the same class.

"Impedance" v. "Mag."

Suppose we want a valve for H.F. work. We naturally take one with as low impedance as possible and with high magnification factor. In other words, we take one with the highest impedance to magnification ratio, or slope.

We want low impedance so that we can design circuits that will give us the greatest amount of effectiveness from the valve. (The screened-grid valve has the drawback of high impedance, though its high magnification factor mitigates against this).

But when we come to L.F. work a different story is told, for though we want, as before, low impedance and high efficiency, we have to take into

effect another thing—the volume or input carrying property of the valve.

Unfortunately the valves with steep slopes are unable to carry as much input without being overloaded and causing distortion as are valves with less steepness, i.e. less magnification per 1,000 ohms impedance.

Super-Power Valves

So we have to compromise on the L.F. end and choose valves which, while giving us reasonable magnification, will carry a reasonable input from the previous stage.

Super-power valves usually have slopes of about 1 to 1.5 or so, but have to be of the large anode current consumption type if they are to carry



A 6-volt L.F. valve which has a slope of 1.5, its impedance being 10,000 ohms and the magnification factor 15. The curve of the valve is shown in column 3, whence it will be seen that although the magnification (variation of plate current for variation of grid volts) is high the valve will carry only a moderate grid swing, so obviously would be unsuitable for heavy inputs.

indication of the ratio between that unwanted factor "impedance" and the property that is aimed for, namely, "magnification."

We can look upon the impedance as a "fault," if you like, similar in its unwelcomeness to resistance, but the magnification we do want, and so we balance these up against one another

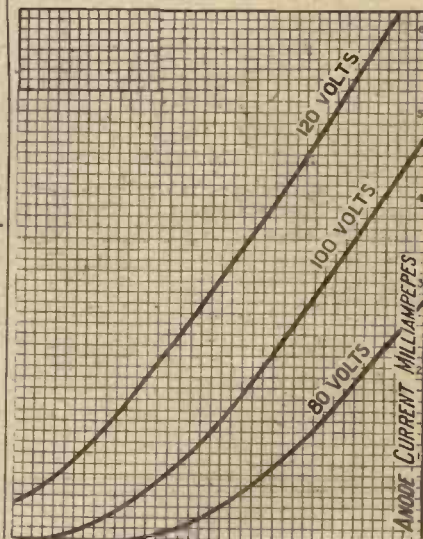

Compare this curve with the one overleaf which is drawn to the same scale, which is that of a super-power valve

Technical experts have long adopted CELESTION as their standard. The Technical Press leaves no doubt as to the merits of Celestion (*vide* the "Wireless World"—'The embodiment of all that is good in Loudspeaker design,' etc.). Eminent musicians are unanimously in favour of Celestion. All the leading national set manufacturers incorporate Celestion in all their models. Many, many thousands of satisfied users attest to its extraordinary realistic response.

EXCELLENT REASONS why you should consider Celestion as a most acceptable gift.

Your dealer will demonstrate without obligation. Or, call at our showrooms, one minute from Victoria Station, where you can also hear the finest sets.

Celestion is British throughout. Models range from £5-10-0. Write for new Booklet, and particulars of the Celestion-Woodroffe Gramophone Pick-Up, price £4-4-0.

SHOWROOMS:

106, VICTORIA STREET, LONDON, S.W.1.

Write for latest booklet "L"

Celestion, Kingston-on-Thames.

FIRST ON MERIT - ON DEMONSTRATION



Model C.14

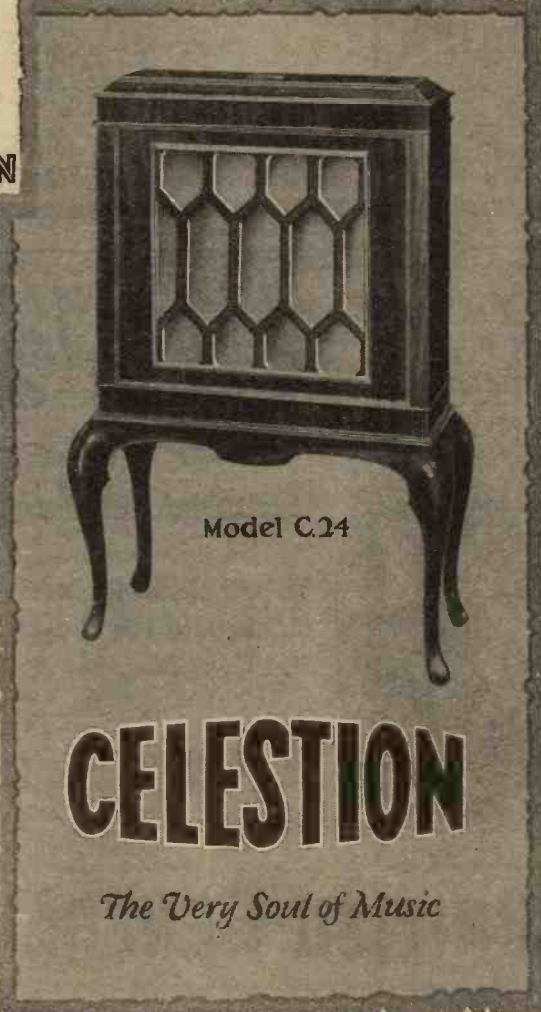

Model C.24

CELESTION

The Very Soul of Music



Model C.10



Model C.12

Made under licence.

A NEW

DIAL

WE have every confidence in placing before the Radio public a new and improved BurTon Micro-Log Dial, our latest product, illustrated herewith, is the result of several years' experience of the great weakness of Dial construction, together with our vast knowledge of what is required for superfine tuning. One point alone which will make this product an outstanding feature of the 1928-1929 Season is the special logging position, which is situated on the front of the Dial, enabling all stations to be logged clearly by means of the pointer upon the centre knob. This celluloid strip is situated free from any interference, can easily be replaced, and, further, any logging marks can be removed from this surface by being erased with india rubber in the usual manner, which is quite impossible with other logging devices.

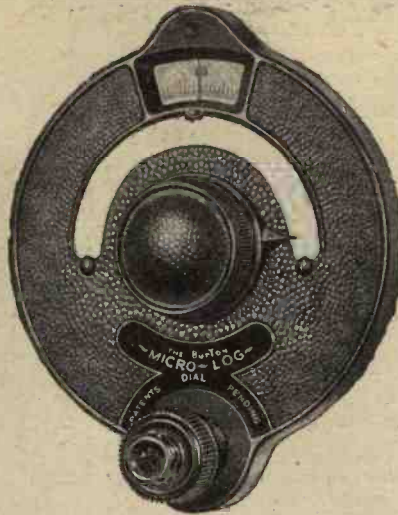

THERE are two models of this dial, one which gives slow motion only, and the other, which by the simple means of revolving one knob for the fraction of a turn frees the slow-motion device, enabling the centre knob to be moved quickly to any of the stations which have previously been logged on the celluloid logging strip.

We feel sure this new BurTon Micro-Log Dial will please you because of its graceful design, its ease of mounting to any condenser, its velvety smoothness, its freedom from back-lash, and finally, because it is the only Dial which gives you a practical solution to the logging problem.

Truly the product of master craftsmen who specialise in the production of Radio Dials.

The BurTon Micro-Log Dial, De Luxe Model

Registered Design. Patents pending.
Slow Motion only .. 5/6 each
With Fast and Slow Motion .. 6/- each



REGD. TRADE MARK.



REGD. TRADE MARK.

C. F. & H. BurTon, PROGRESS WORKS, WALSALL, ENG.

RUPERT COLLINS SERVICE.

NOW! ALL STATIONS FROM 250—2000 METRES WITHOUT CHANGING COILS

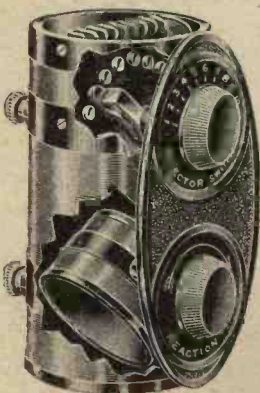

Note these Special Features:

1. Easy two-hole fixing.
2. No friction joints whatever.
3. Improved bakelised former.
4. Reversible dial to allow of upright or horizontal mounting.
5. Knobs fixed by means of grub screw on spindle.

BRITISH GENERAL

AERIAL TUNING UNIT

PRICE **18/6** From all wireless dealers of repute, or direct from **BRITISH GENERAL MANUFACTURING CO., LTD.,** Brockley Works, London. S.E.4.

EQUAL TO 3 ORDINARY BATTERIES

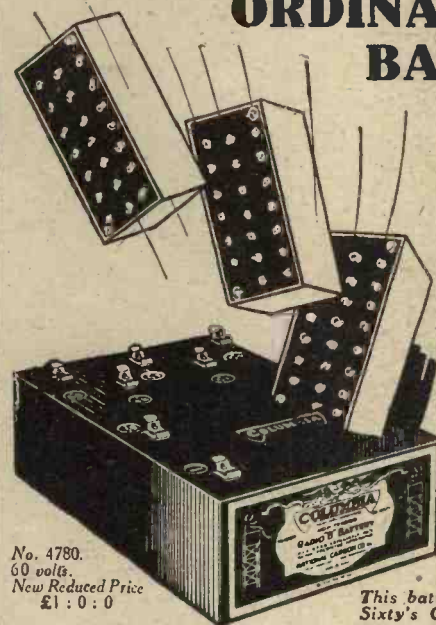

Not a battery but a **SUPER BATTERY**—that is the correct description of the Columbia No. 4780 Triple Capacity H.T. Battery. It possesses the emission of three ordinary batteries, the lasting power of three ordinary batteries, and the quality of three ordinary batteries.

For the man with the good Receiver, this Columbia battery is indispensable.

You are proud of the results yielded by your receiver—you'll be prouder still when you use this Columbia battery.

This battery is specified for "Six-Sixty's Great Mystery Receiver."

No. 4780.
60 volts.
New Reduced Price
£1 : 0 : 0

Columbia RADIO BATTERIES

J. R. MORRIS, Imperial House, 15, Kingsway, London, W.C.2
SCOTLAND—J. T. Cartwright, 3, Cadogan Street, Glasgow.

Within the Vacuum—continued

any big input and still have a steep slope.

It should not be imagined, however, that steep slope necessarily means high magnification; the magnification factor shows the possible amplification power of the valve, the other is only this factor in ratio with the impedance, and denotes the efficiency only.

“Slope” and “Amplification”

So we can get more amplification out of a valve of 20,000 ohms and a magnification factor of 30 (slope of 1.5) than we can out of a power valve with a magnification factor of 6 and impedance of 2,400 (slope of more than 2).

An example of this is the Pentode, which has a slope of less than 1, but is capable of giving enormous amplification.

And now I want to reply to a querist who asks: “Why, if the impedance of a valve should be low compared with its plate circuit impedance in order to get the maximum magnification of the valve, does the amplification drop off as we use valves of lower impedance?”



A modern screened-grid valve which is capable of tremendous amplification due to the high magnification factor. Owing to the peculiar construction it cannot be directly compared with the ordinary three-electrode valve, though the slope is below unity.

In this case our correspondent is forgetting two important facts. He is right in assuming that (he is discussing R.C. coupling) the higher the ratio between the external impedance and valve impedance the higher the proportion of the amplification factor of the valve that is used, but there are limits in practice.

Unfortunately, with low impedance valves we get a lower magnification

factor, and furthermore, the H.T. drop across the resistance becomes serious.

H.T. Voltage Drop

Take an example. If we have a valve of D.C. resistance (when correct grid bias is employed) equal to, say, 60,000 ohms (this is not the A.C. impedance, but a figure higher than that) and a resistance of 180,000 ohms, obviously the H.T. voltage is divided into the ratio of 180,000 to 60,000 across the resistance and valve, or 1 to 3. In other words, the drop is such that if 120 volts are applied, only 40 are used on the valve, the rest being lost across the resistance.

Now if we decrease the resistance of the valve by having one of much lower impedance, see what happens. Assume the D.C. resistance is now only 20,000 ohms when the valve is properly biased. The drop is now in the proportion of 20,000 to 180,000, or 1 to 9. The valve thus gets one-ninth of the applied H.T. instead of one-third, as in the previous case.

Have to Compromise

Therefore we not only get less effective H.T., but less magnification factor in the valve itself, so obviously down comes the magnification per stage.

In this, therefore, as in all wireless practice, we once more have to compromise in order to get best results.

NOVEL STEP-DOWN TRANSFORMER

THE sudden failure—without the usual month's notice in writing—of a step-down transformer recently forced me to use rather a novel component in a wireless set.

I had agreed, in blind ignorance, and without knowing what I was in for, to give a public demonstration of the possibilities of a three-valve set to a crowd of some fifty schoolboys. I arrived at the meeting-place late, due to some slight technical hitch with my car, and was somewhat at a disadvantage in consequence.

Nothing but Noise.

After the usual preliminaries, I turned to the set and attempted to coax music from it. Lord, what a

clatter! You all know the row a broken-down transformer kicks up in a powerful set, so there is no need for me to describe it. I switched off, apologised amid sniggers, and fussed round, endeavouring to locate the trouble. I got hot and bothered, flustered and flushed, messing about in front of a crowd of youngsters who didn't hesitate to express their opinions of my capabilities pretty freely, and it was some fifteen minutes before I located the breakdown—

This curve of a super-power valve looks “steep,” doesn't it? But mere glancing at curves is often liable to be misleading, for the geometrical “slope” of a curve means nothing at all—it is the figures on the axes that count, and these must be taken into consideration. As this graph is drawn to the same scale as the one on the previous page, it can be taken as a direct comparison, but if it were drawn to a different scale it would LOOK very different (though in reality it would be the same). There is no fixed scale for valve curves and so they are often misleading. The slope of the valve shown here is 1.95, and it is capable of a good grid swing, though not such a swing as is obtainable from valves of the same class but with less steep slopes.

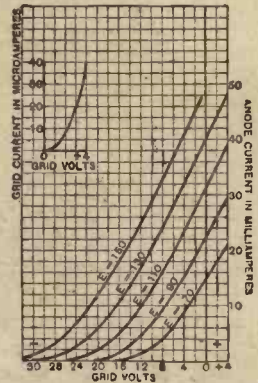

an intermittent open-circuit in the output transformer.

Here was a fine pickle! No spares, only low-resistance loud speakers to work with, and a collection of turbulent boys growing restless at the delay. Then came inspiration!

A Way Out

I excused myself for a few moments, went outside, disconnected the ignition coil from my car, was back in the hall with it in less than three minutes, and in less than five minutes had it fixed in place of the “dud” transformer.

I will admit that it didn't work perfectly, but then, schoolboys are not hypercritical, and although I even had to parallel the two low-resistance loud speakers, the rest of the evening went through splendidly.

J. B.

Read POPULAR WIRELESS
Every Thursday :: Price 3d.



Well-Made Valve Holder

A WELL-MADE and efficient valve holder of the non-microphonic type has been submitted by the makers of the Godwinex components. Unlike most valve holders, which are moulded in black, the present model is a pleasing dark red colour—what is known in the trade, we believe, as “natural bakelite colour.” In accordance with what we consider an excellent practice, a large proportion of the solid material has been removed from between the valve pins, laboratory tests showing that valve holders made on this principle have appreciably lower losses. The spring tension is adequate for the purpose for which it is designed, and we are glad to see that soldered and not merely press connections are made between each socket and the springs. The spacing of the sockets is accurate, serviceable terminals and soldering lugs are provided and altogether the holder is a thoroughly satisfactory product which can be recommended to our readers.

Airmax Coils

The plug-in type of tuning coil, the early death of which was prematurely foreshadowed by the too confident prophets several years ago, is still immensely popular, for its adapta-

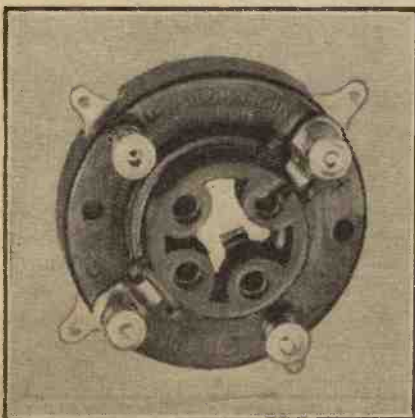

Unlike most valve holders the “Godwinex” is dark red in colour.

A MONTHLY REVIEW OF TESTED APPARATUS.

(Note: All apparatus reviewed in this section each month has been tested in the Editor's private laboratory, under his personal supervision.)

bility to the more complex as well as simple tuning circuits is a great convenience. Although many of the early plug-in coils were very inefficient devices, there have been great im-

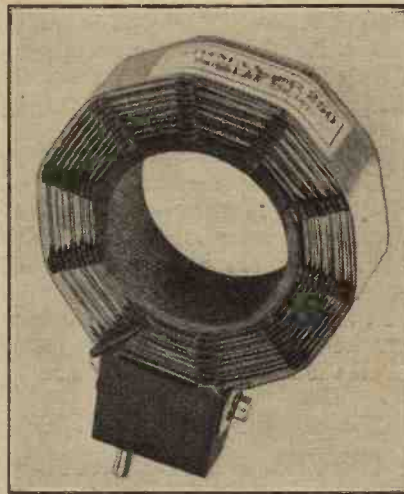

The Airmax plug-in coil.

provements in this regard recently, and the modern plug-in coil will be found to give very good service and high efficiency in a variety of ways.

The “Airmax” coils which have been submitted to us for test are mounted on good quality plugs, apparently cut from solid ebonite, and are layer-wound on a central ebonite tube, layers being well separated by spacers and the individual turns of each layer separated by a space approximately equal to the thickness of the wire. Such a method of winding is sound, and as in the present case the wire is bare, losses due to the absorption of moisture by such substances as bare untreated cotton are avoided.

Mechanically the coils are well made and can be quite roughly handled without damage, although in

our opinion all coils of whatever kind should be handled as gently as possible. The coil illustrated is a No. 250, and is thus suitable in a coupled circuit for tuning to the 5 X X-Radio-Paris band. Laboratory tests for high-frequency resistance, and practical tests in receivers, show that these coils are quite satisfactory for the purpose for which they are designed and are very distinctly superior to many submitted to us for test.

Ingenious Vernier Dial

Amongst several interesting products submitted to us by the manufacturers of the Harlie products, the vernier dial illustrated herewith is more than usually ingenious. In appearance it differs from the conventional vernier dial with a window, for a larger proportion of the scale than normally is visible, while two side windows enables calibration marks to be made when necessary. The feature which commends itself particularly to us is the fact that for rough tuning the centre knob turns the condenser quite freely, whilst for fine tuning pressing on and turning the lower small knob gives an accurate vernier motion without backlash. Fitting the dial to a panel is considerably simpler than with some dials we have handled, for the two

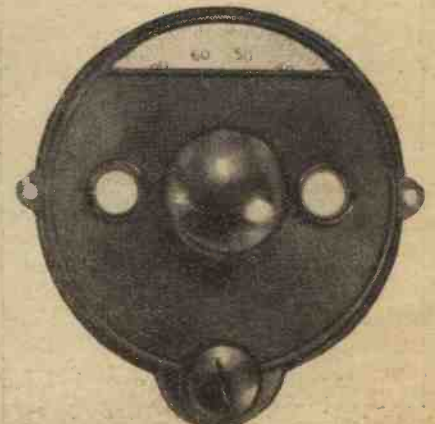

This is the ingenious dial referred to above.

A Message to the Home Constructor

FERRANTI

will issue shortly, simple Constructional Charts of
SCREENED-GRID RECEIVERS

wait for them!

These receivers, in addition to their extreme sensitivity, are capable of unusually good reproduction.

FERRANTI LTD.

HOLLINWOOD

LANCASHIRE

Nothing off the Quality



but 3d off the price
- Now 1/3

On January 15th, 1929, the well-known W.B. Antiphonic Valve Holder will be reduced in price to 1/3. On January 15th, 1929, the quality, workmanship and efficiency of this product will remain exactly as it always has been - extremely good.

WHITELEY, BONEHAM & CO., LTD.
Nottingham Road, Mansfield, Notts.

Manufacturers of the famous Whiteley Boneham Loud Speakers. Prices from 47/6.

High-grade

QUEEN ANNE STYLE FIGURED OAK CABINET

Height 3 ft. 3 ins. Depth 1 ft. 3 ins.
For Panels up to 21 ins. x 7 ins.
Baseboards up to 11 ins.

£5.5.0

Packed Free.
Carriage Paid.

Prices of other sizes in proportion. Manufacturer of all types of wireless cabinets and furniture of every description. Illustrated lists free.

GILBERT, CABINET MAKER, SWINDON.

Estimates Free.

Estd. 1866.



THE 100% Broadcast Receiver
BUILD and OPERATE in ONE EVENING



Screened Grid



Obtain a Broadsheet from your dealer and read why you should—
Completely Screen the Grid

EXTRACT FROM LETTER RECEIVED.

"I may add that I am very pleased with this set. It is the best I have ever handled and I intend to push it as the best Screened Grid yet. Anyhow, I am concentrating on it now and dropping the —"

The above is one of many UNSOLICITED TESTIMONIALS.

Send post card for **FREE FULL-SIZE LAYOUT PLAN** and wiring instructions

THE FORMO CO.,
Crown Works, CRICKLEWOOD LANE, N. W. 2

What's New—continued

projecting lugs with holes (see illustration) can be used as a drilling template *after* the dial is fitted over the condenser spindle. The fixing

instrument when sent out. On the front are two dials controlled by knobs, one at each end of the instrument, and a central lever which

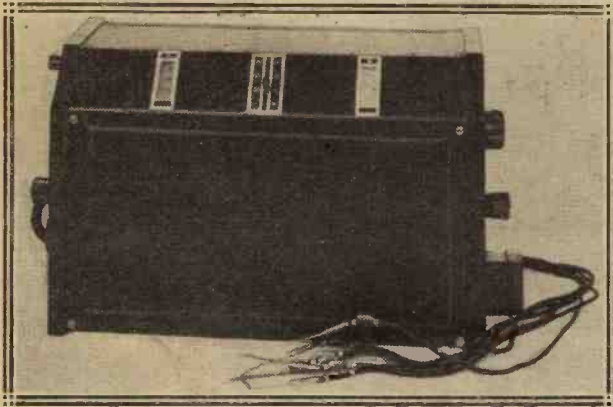

The Philips receiver shown here and in the photograph below employs a screened-grid valve and also one of the new Pentode type.

screws pass through the holes so made and easily fix in position by nuts on the back of the panel. Freedom in turning the larger knob is ensured by the fact that the vernier movement is out of engagement when this is done. It is a very useful component and should find a ready sale.

An Interesting Receiver

The Philips receiver, illustrated in the accompanying photographs, is a most ingenious and interesting set. Although several models are made, the particular one shown is designed to work from batteries, complete battery leads being attached to each

governs the wave-length range the receiver will cover, going from 200 to 2,000 metres in all.

The sharpness of tuning can be varied by placing the aerial in different sockets. A reaction control is provided; the set can be made to oscillate when desired, and owing to its special construction it is non-radiating and, therefore, will not cause interference with one's neighbours. Although small and compact, the instrument is remarkably sensitive, this being due to the fact that not only is a screened-grid valve incorporated, but also a pentode. Very high magnification is thus given both

on the high-frequency and the low-frequency sides.

The valves themselves are contained within the set, being tucked away as shown in our second photograph. The instrument is well made, with what appears to be moulded bakelite ends, the top, front and back being covered with a leather cloth of a pleasant dark-blue shade. Operation is extremely simple and the results on the loud speaker of excellent quality.

Useful Fuses

Although the flash-lamp bulb type of fuse has been used on a number of occasions to protect the filament circuits of valve receivers, the rather erratic behaviour of these bulbs often



The Micro-Fuse protects the valves from excessive voltages.

results in the emission of valves being destroyed before the bulb blows.

Messrs. Micro-Fuses, Ltd., are producing a particularly clever form of fuse made to fit in clips and replaceable in a moment. For general wireless receivers these fuses are made in the 100-milliampere type, although for other purposes, such as protecting meters and the like, they can be manufactured to "blow" as low as 25 milliamperes—in special cases even lower than this. They are made by a special process from pure gold, and are stated to carry 90 per cent of their load without undue heating. A number of the 100-milliampere fuses submitted to us all blew reasonably close to the rated figure and proved far more reliable than any of the bulb types that have so far come our way.

The average flashlamp bulb will carry four or five hundred milliamperes without fusing, so that the comparatively low fusing point of the Micro-Fuses makes them distinctly valuable. The price is 2s., with base and clip, and replacements are 1s. 6d. each. These are components which should prove most useful to wireless experimenters.

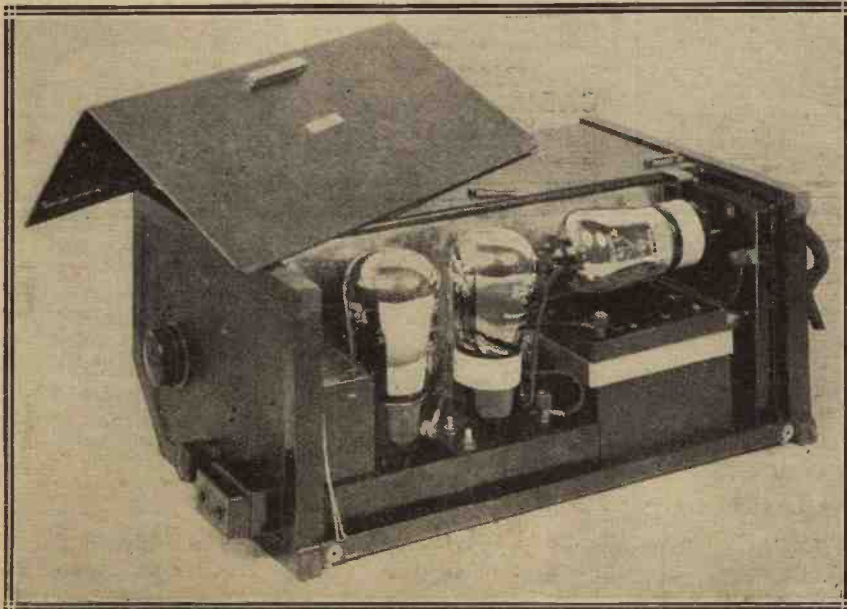

How the valves are fitted in the compact receiver described on this page.

**NO OTHER COILS
CAN GIVE THESE**

ADVANTAGES

AERIAL COIL

250-550 metres Price 10/6
1000-2000 metres Price 12/6

H.F. TRANSFORMER

250-550 metres Price 10/6
1000-2000 metres Price 12/6

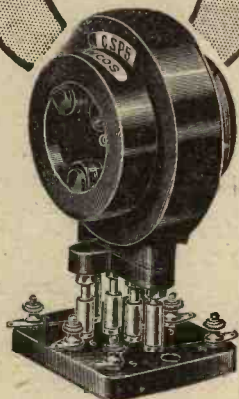

SUPER COIL
Pat. No. 285,723

**INTERCHANGEABLE
PRIMARIES**

P.4	250-550 m.	} 3/-
P.6	"	
P.8	"	
P.10	"	
P.12	"	
P.14	"	} 4/-
P.16	1000-2000 m.	
P.18	"	
P.20	"	
P.22	"	

1. STANDARD SHAPE AND SIZE—no need to buy a new coil-holder.
2. STANDARD PIN CONNECTIONS — no need for re-wiring.
3. AERIAL COIL has tapings for all degrees of selectivity required and provides for a detachable Reinartz Reaction winding—an absolutely unique feature.
4. H.F. TRANSFORMER has interchangeable primary windings to suit the new screened-grid or any other type of valve.
5. A COMPLETE RANGE OF PRIMARY WINDINGS is available, from the most selective to the largest types required by screened-grid valves.
6. ALL PRIMARIES ARE CENTRE-TAPPED, with plugs and sockets arranged so that wrong connection is impossible.

LEWCOS
REGD.

SIX-PIN SUPER COIL

(Please state Primaries required when ordering).

Obtainable from all dealers

**THE LONDON ELECTRIC
WIRE COMPANY AND
SMITHS, LIMITED,
Church Road, Leyton, E.10.**



**LEWCOS RADIO PRODUCTS
FOR BETTER RECEPTION**

Trade Counter and Cable Sales:
7, Playhouse Yard, Golden Lane,
E.C.1.



**THE MOST
EFFICIENT
SOLDERING
IRON
IN THE WORLD**
Guaranteed for One Year

**12'6
COMPLETE**

Ask your dealer. If any difficulty write to:
K.N. ELECTRICAL PRODUCTS LTD.
87 Wardour Street, London, W.1: 'Phone: Regent 4632

Centralab

GIANT POWER RHEOSTAT

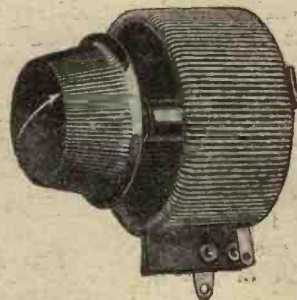

Small in diameter but large in capacity, this rheostat is constructed of heat resistant materials throughout. Wire is wound on a metal core insulated with asbestos. No fibre to warp or burn out. Large area for heat radiation. Will carry a continuous current load through the entire resistance of 70 watts at 375° Fahrenheit. This unit is ideal for primary control of "AC" receivers or L.T. power supply units to keep the line voltage a constant average and the secondary output well within rated limits. It can be used in any radio power circuit without any danger of burning out, since the fusion point of the wire is the limit of capacity.

Types, G.R.010. 10 ohms
" G.R.060. 60 "
" G.R.150. 150 "
" G.R.1,000. 1,000 ohms.
" G.R.2,000. 2,000 "
" G.R.8,000. 8,000 "

PRICE 8/6 each.

Write for the Centralab Circuit Booklet. It's Free.
SOLE DISTRIBUTORS:

The ROTHERMEL CORPORATION LTD.
24-26, Maddox St., LONDON, W.1.

Telephone MAYFAIR 0578. Telegrams ROTHERMEL, WESDO, LONDON.

CHATS AT THE WORK-TABLE

Many points of practical interest to all radio constructors are dealt with under this heading.

By R. W. HALLOWS, M.A.

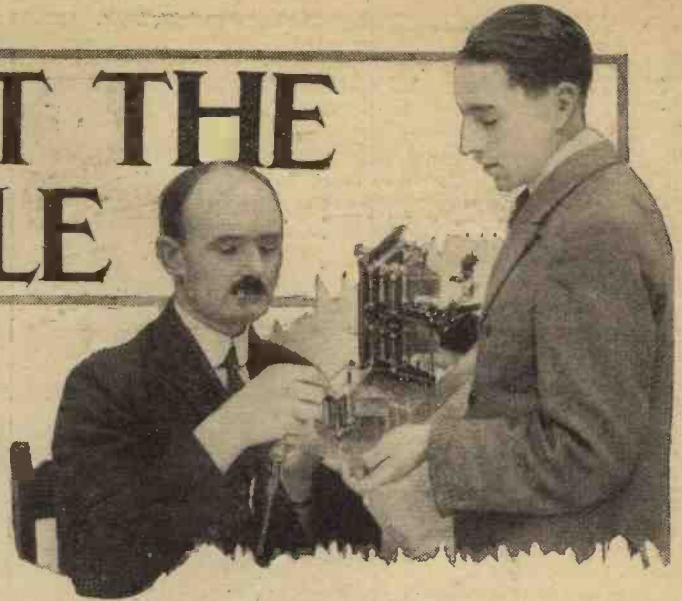

Easily-Made Frame Aerials

RECENTLY I required a frame aerial for a special purpose, and as none of those on the market was of quite suitable size, I decided to make one up myself. The process turned out to be so exceedingly simple that I shall certainly use it in future.

The materials are of the simplest. For the frame itself two pieces of hard wood $\frac{1}{2}$ in. or $\frac{3}{8}$ in. square are needed, whose length will depend upon the size of the frame. These are jointed together by means of the halved-in method as shown in Fig. 1, being held in position by means of a 4 B.A. bolt (with a washer under its head and on the far side) and a nut.

Mounting a Frame

The ends of the arms are prepared in the way shown in Fig. 2. A hacksaw cut is made in each some 2 inches in depth. Right through the end of the arm are drilled as many holes as there are turns of wire on the frame, the diameter of these being such that small wooden pegs (matchsticks will do perfectly well) are a good push fit.

The way in which the frame is mounted on its base is shown in Fig. 3. To the lower end of the upright a small piece of the same wood as that used for the frame is screwed. In the bottom of this is drilled a $\frac{1}{4}$ -in. hole, into which is inserted a standard coil plug, fixed by means of a screw.

The base is a piece of $\frac{3}{4}$ -in. wood of suitable size in the middle of which is mounted a standard coil socket. This can be done by drilling a $\frac{1}{4}$ -in. hole of the proper depth and driving the socket gently in with a mallet.

Winding

Now for the way in which the frame is wound. To the small wooden block provided with the coil plug a piece of ebonite about $\frac{1}{2}$ in. in width by $2\frac{1}{2}$ in. in length is attached. This may be held in place by the screws which hold the piece of wood to the upright.

In the ebonite two holes are drilled (or three if the aerial is to be centre-tapped) to receive terminals to which the ends of the windings are attached. Use No. 22 double-cotton-covered wire, which goes just nicely into the hacksaw cuts.

Attach the end of the reel to the "in" terminal and wind on the first turn. This having been done, push a peg into the lowest hole of each arm and put on turn No. 2. The same procedure follows for the remaining turns. Should a centre-tapping be required, scrape a bare place in the wire when half the desired number of turns are on, and take a turn round the middle terminal.

made it from Hobbies stripwood, which can be obtained in 24-in. lengths $\frac{1}{2}$ in. square.

This gives an aerial with approximately 16-in. sides. For a frame with 2-ft. sides the upright and cross pieces should be approximately 34 in. in length.

Further Hints

In order to prevent the wood from splitting under the tension of the wire it is as well to drive a screw through each of the arms just below the end of the notch cut with the hacksaw. The pegs may be fixed absolutely tightly if the holes made are a good fit for them, and if each before insertion is dipped in glue or smeared with Seccotine.

Instead of No. 22 D.C.C., either thin silk-covered flex or Litz wire may be used. It is not, perhaps, generally known that in addition to the ordinary rather thick flex with an inner covering of rubber and an outer covering of braided silk there

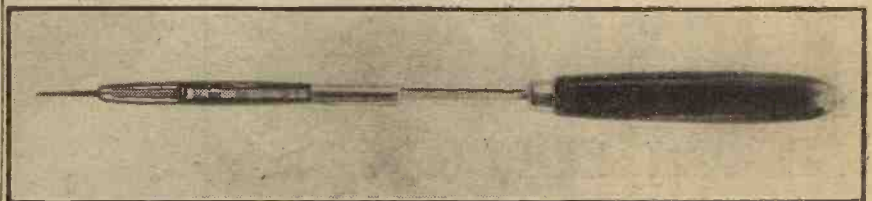

A ratchet type of screwdriver which was recommended by the author in his last article for use in the construction of wireless receivers.

When all the turns are on, cut the wire and attach the "out" end to the terminal provided for the purpose. The whole job can be done in an hour or so and the result is a very serviceable frame aerial costing next to nothing at all. I required mine for use with a super-heterodyne set, and

is a thin flex obtainable which has but a single covering of floss silk. This actually takes up very little more space per turn than No. 22 D.C.C. wire and it is exceedingly useful for the making of frames.

Litzendraht, made of twenty-seven strands of No. 42 wire, each separately

TRY POLAR Q.J. REACTION

THE LATEST THING SINCE

Screened Grid Valves

If successful results are to be obtained on distant stations, particularly on very short waves, reaction control must be smooth. If a set breaks into oscillation it is very difficult to obtain maximum sensitivity, even by careful reaction adjustment.

Polar Q.J.



SIZE
2½" x 2½"

THIS IS ONLY POSSIBLE WITH AN ACCURATE SLOW-MOTION CONDENSER.

·00025 ·0001
10/6 10/-

Obtainable from all dealers.

DIAGRAMS OF TYPICAL Q.J. CIRCUITS POST FREE FROM

WINGROVE & ROGERS LTD.
188, STRAND, LONDON, W.C.2.

GOOD NEWS FOR SET BUILDERS

In response to the urgent demand for first-class sets for family use. Mr. PERCY W. HARRIS, M.I.R.E., has now prepared the

Wireless Constructor Envelopes

The first two of this series are NOW on Sale, price 1/6 per envelope (by post 1/9).

Envelope No. 1.—THE RADIANO THREE (*Recently reprinted*). A famous loud-speaker set which you can build in an hour or so—no soldering necessary and a wide range of components to choose from.

Envelope No. 2.—THE CONCERT FOUR. Made of standard parts, all easily obtainable, this is a *highly-sensitive, long-distance set*, giving *powerful reproduction of wonderful quality*. Covering both long and short wave-lengths, with a switch for 3 or 4 valves, it is essentially a *set to enjoy* both in building and operation.

In each envelope you will find every detail of the set simply explained; photographic reproductions and diagrams are included, as well as a full-size Blue Print.

NOW ON SALE ————— Price 1/6

By post 1/9, from *Wireless Constructor Envelopes, The Amalgamated Press, Ltd., Bear Alley, Farringdon Street, London, E.C.4.*

CHATS AT THE WORK-TABLE

—continued from page 302

insulated, is, if anything, rather finer than No. 22 D.C.C., and if it is used the cuts in the arms may be made with a small tenon saw. Its resistance is considerably less than that of either flex or plain wire, and there is possibly

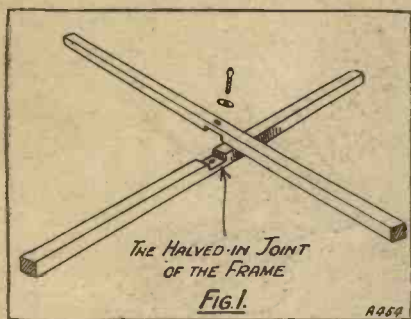

some advantage in employing it in a frame intended for use with a very sensitive receiving set.

The Terminals

As an alternative to the very simple coil-plug coil-socket mounting,

something rather more elaborate may be used in the Igranic heavy-duty plug and jack. The former is mounted upon the end of a small block of ebonite attached to the upright arm. The jack is fixed to a small ebonite panel let into the upper side of a hollow base.

Most electrical shops have in stock hollow bases intended for the mounting of switches and so on. One of these will serve admirably for the purpose and its cost is trifling. If the aerial is not to be centre-tapped the plug fixed to the upright arm may have both ends of the windings attached to it.

The Centre-Tapping

In this case the terminals may be mounted upon the base, a very great advantage, since the aerial may be rotated without moving the leads running to it from the receiving set. In the case of a centre-tapped aerial the same principle may be utilised, the centre-tapping being taken to a terminal mounted upon the upright.

Since in nearly all circuits the centre-tapping is earthed, the insulation here is of no great moment, and the terminal may be mounted directly

upon the wood. Using a plug and jack in the way suggested only one of the leads to the frame moves during the process of rotation. As a further refinement an old condenser dial may be mounted at the end of the piece of wood or ebonite attached to the

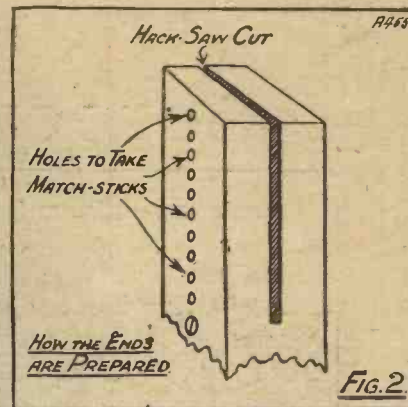

upright arm, the scale side, of course, being uppermost.

If a small pointer is affixed to the base the orientation of the frame is always easily established. A still better method is to attach a small compass to the upper side of one of the horizontal arms. The direction in which the frame is pointing when

(Continued on page 306.)

MAGNUM H.F. CHOKES



Recognised as the most efficient of their types. Made in two ranges. STANDARD, 50 to 3,000 metres. Price 7/6
SHORT WAVE. From below 10 metres up to 100 metres. Price 7/6

MAGNUM LOADING COIL, 7/6

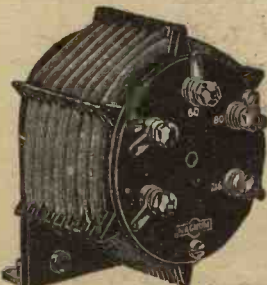

Catalogue and lists on application, including particulars of the "Pentwin," "Radiano" Four, "New Business Man's" Four, etc., etc.

MAGNUM UNIVERSAL THREE



A truly remarkable receiver giving 5-valve results. Employs latest S.G. and Pentode Valves. Perfect reception of the ultra short waves of 15-metres up to 2,000 metres. PRICE, including valves, coils, and Royalty £18
Free demonstration in your home within 50 miles of London. The ideal receiver for Overseas.

Note.—The above is supplied only ready wired and tested, and not as a constructional kit.



BURNE-JONES & CO. LTD.,
MAGNUM HOUSE
TELEPHONE: HOP 6257
296, BOROUGH HIGH ST. LONDON, S.E.1

L.T. and H.T. from A.C. Mains.
The "Stedipower" The "Stedipower"
L.T. Unit. H.T. Unit.
Ready wired and tested, and including a U.5 valve. Output 50 M.A. Two continuously variable and one fixed tapping is provided.
If you wish to build these units yourself, we supply the complete kits of components, including Cabinets, as follows:
L.T. Unit, complete kit of parts £8 17 0
H.T. Unit, complete kit of parts (less valve) £10 16 0

IGRANIC TRANSFORMERS IN YOUR SET

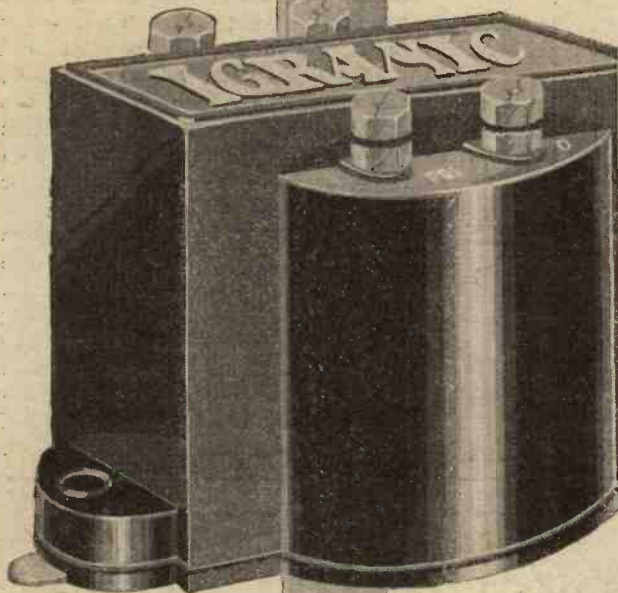

The first and best high-grade transformer to be sold at a popular price. Fit one in YOUR set. You will be delighted at the difference it makes.

Ratio } **PRICE**
3:1 } **17/6**
6:1 }

There is an Igranic Transformer for every purpose. Send to-day for illustrated list.

IGRANIC ELECTRIC CO., LTD.,
149, Queen Victoria Street, LONDON, E.C.4

Have you read "Radio, How It Works and How To Get The Best From It"? Price 6d. Send this coupon with your name and address and get YOUR copy FREE!

Name.....
Address..... J773

Weston sets the world's standard



Model 506 Pin Jack Voltmeter with High Range Stand, Measures High and Low Tension Voltages. The Weston free booklet "Radio Control" explains the uses of this and other Weston Radio Instruments. Write for your copy.
Price £2 10 0

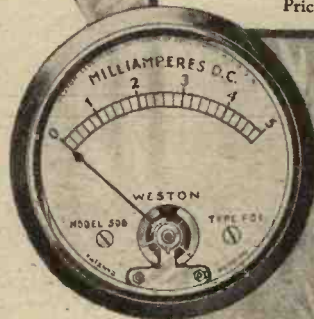

Model 506 Mil-Ammeter should be placed in the H.T. circuit of the valve to ensure correct operation and check distortion. Panel mounting type.

Prices
£1.15.0—£2.15.0

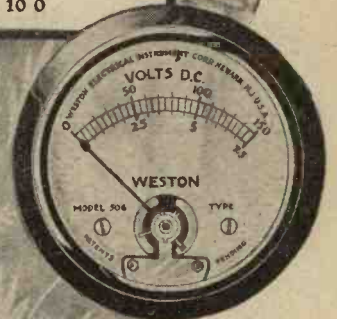

Model 506 Panel Voltmeters ensure permanent accuracy. With a high internal resistance of 125 ohms. per volt, they make practically no load on the batteries. Neat and compact.

Prices
£1.15.0—£2.15.0



Model 489 Double Range D.C. Voltmeter is a necessary portable testing instrument for every radio enthusiast. It is of great use

in tracing circuit troubles. Made in various ranges with different sensitivities. Similar instrument for A.C. Model 528.
Prices £3.15.0—£7.5.0

WESTON ELECTRICAL INSTRUMENT CO. LTD.
15 GT. SAFFRON HILL, LONDON, E.C.1

CHATS AT THE WORK-TABLE

—continued from page 304

any transmission is best received can then be found at once.

Stripped Terminals

Most of us, I suppose, have found to our horror at one time or another that a terminal screw of one's most coveted component was stripped. The first thing to discover is whether the screw itself or the nut which runs upon it is at fault. This can be done by the simple process of removing the milled nut and trying others in its stead.

Should the male thread be stripped it will always be impossible to tighten a nut, but if the original nut has suffered a substitute can be turned tightly home. What is to be done if it is found that all nuts tried are equally loose and therefore that the male thread is spoilt?

In the great majority of cases the thread will have been ruined quite close to its base. All that is needed, therefore, is to place one or two flat

washers between any lead that is to be attached and a securing nut. If, however, the screw is stripped over its whole length the case is still not hopeless:

Rub down the threads with a fine file, and then put a die one size smaller than the original over them. Thus a 4 B.A. screw may be re-threaded 5 B.A., and so on. With a fresh nut of the proper size connections can now be made that are thoroughly firm.

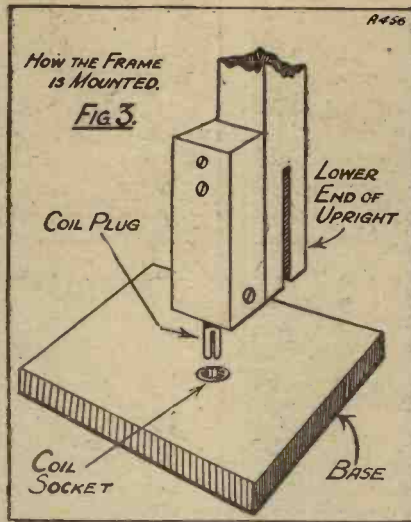

LOUD SPEAKERS AND THE WEATHER

MANY newcomers to radio complain that in some weathers their loud speaker gives very distorted reproduction. This is often due to the fact that in some atmospheric conditions the cone expands or contracts and causes the reed or other actuating mechanism to touch the magnet.

An adjustment which may be accurate on one evening can be quite unsuitable on another, particularly in foggy weather, and as most loud speakers have an adjusting screw, this should be turned slightly in one direction or the other when this trouble arises. Be careful not to turn the screw too far in either direction or you may damage the mechanism.

The results given by loud speakers vary considerably according to the conditions in which they are used. Even assuming that they are being fed with undistorted output from the receiver—and this is rather unusual on loud signals—the tone will sometimes be quite different in one part of the room from that given in another.

Now Available

Pentode (5 Electrode) Valves for 2 and 4 Volts.

Give greater volume whilst dispensing with one stage of L.F. and can be used with any type of loudspeaker.

The "priming grid" which is connected to a small terminal on the caps of the valve should be joined directly to a tapping on the high tension supply at 100-150 volts. Suitable grid bias values are 6-12 volts depending on the anode voltage in use.

PRICE:—25/- each.



5E. 225 SPECIFICATION
 Filament Volts ... 2
 Filament Current 0.25 amp.
 Max. Anode Volts. 150
 Priming Grid Volts. 100-150
 Amplification Factor 80
 Impedance 66,000 ohms.
 Slope ... 1.2 ma/o.

5E. 415 SPECIFICATION
 Filament Volts ... 4
 Filament Current 0.15 amp.
 Max. Anode Volts 150
 Priming Grid Volts 100-150
 Amplification Factor 50
 Impedance 27,000 ohms.
 Slope ... 1.8 ma/o.

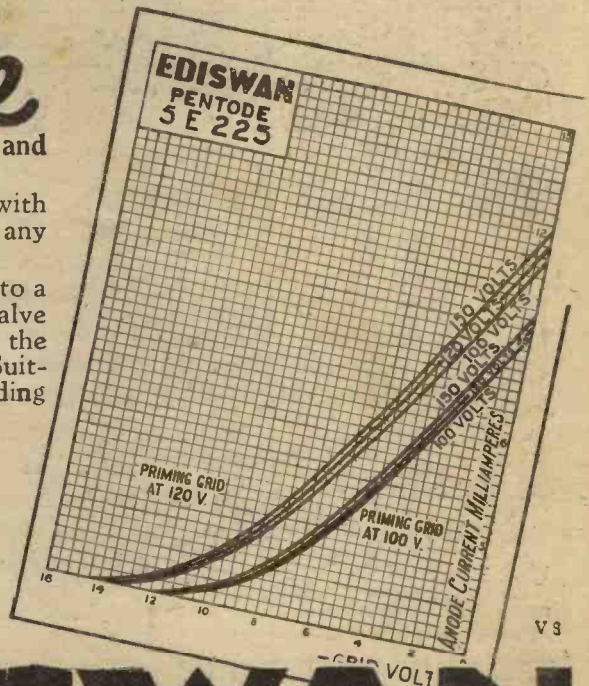

EDISWAN PENTODES

The EDISON SWAN ELECTRIC CO., LTD., 123/5, Queen Victoria Street, London, E.C.4.



DARIO

VALVES

—AND THE CHEAPEST WAY, TOO,

guaranteeing utmost satisfaction. Just look at the prices below—made possible by reason of the biggest valve output in the world. Radio without Dario can never be radio at its best. SUPERLATIVE FINISH - LOWEST CONSUMPTION

TWO VOLTS.		FOUR VOLTS.	
General Purpose, 05 amp.	5/6	General Purpose, 05 amp.	5/6
R.C.C., 06 amp.	5/6	R.C.C., 07 amp.	5/6
Super-Power, 18 amp.	7/6	Super-Power, 1 amp.	7/6
Super H.F. & R.C.C., 18 amp.	7/6	Super H.F. & R.C.C., 1 amp.	7/6
Pentodion 15 amp.	21/-	Pentodion, 15 amp.	21/-

From your dealer or direct:
IMPEX ELECTRICAL, LTD.
 (Dept. L),
5'6 538, **7'6**
 High Road, Leytonstone, E.11.

A Happy, No-Drudgery, Spare-Time Business for YOU



Here is YOUR chance to become a Master Man in a Spare-Time Business which is expanding enormously; one which is competing successfully against large combines.

Just sit down and think over this carefully. Our enormously successful Patents are in great demand everywhere. They have become tremendously popular, and as the Wireless and Electrical Business extends, which it will do, and is doing, to an unthinkable degree, this demand will increase proportionately. We will licence you to manufacture our articles under our own Patent Rights, so that you can participate in the Big Profits.

Profits Guaranteed!

We positively Guarantee your profits. Only a limited number of persons are allowed to manufacture. There is not the slightest chance of your market being overcrowded. If necessary we will purchase all your stocks—a fact which assures that you make PROFIT whatever may be the peculiarities of your own case!

No 'Plant' Needed.

No special knowledge or skill is needed, and you will find no difficulty about the manufacture. With our new and improved process, no expensive "plant" or machinery of any kind is required, and, even though you have not the slightest knowledge of Electricity or Wireless, you can commence to turn your spare hours into GOLDEN Hours! There is no drudgery. Indeed, the work is so simple and easy that you require no special accommodation—the kitchen or any spare room can be your work-room—and the whole of the family, including the children, can help you. The work is of fascinating interest, and your profit is only limited by the amount of time you have to spare.

Earn up to £300 a Year!

£300 a year EXTRA can easily be yours. New vistas will open out to you. It will smooth the way to Success and enable you to be independent of Employers and Industrial Upheavals. All those luxuries and necessities you have long desired will be yours. Let us hear from you NOW!

You are not asked to attempt to revive a "dud" industry, but are offered a Novel and Live Business—a *growing business which has now been established a decade!* Somebody is going to make a BIG PROFIT in your district, and that somebody can be YOU! Send the coupon AT ONCE, and Full Free Particulars will be forwarded. Any questions you ask will be answered fully. We have nothing to hide—no expensive "plant" to sell you. This is a plain, STRAIGHTFORWARD, MONEY-MAKING Proposition. As man to man, can you afford to let it pass by?

Send this Coupon NOW!

To Mr. V. ENGLAND-RICHARDS,
 THE ENGLAND-RICHARDS CO., LTD.,
 99, King's Lynn, Norfolk.

Sir,—Please send me at once, and FREE, full details as to how I can make Money at Home in my spare time. I enclose 2d. stamp for postage.

Print your name and address boldly in capital letters on a plain sheet of paper and pin this coupon to it.
 "Wireless Constructor," Feb., 1929.

OUR NEWS BULLETIN

*Some of the More Interesting Happenings
in the Radio World this Month.*

The Mystery Transmitter

PERHAPS by the time this issue of the WIRELESS CONSTRUCTOR is on sale the identity of the mystery broadcaster will be known. Every endeavour is now being made to find the location of the station, from which vulgar and obscene messages were transmitted a week or two ago.

Who is the Culprit?

Complaints have been pouring in to the B.B.C. and the Post Office, but nobody seems to have yet found who the culprit is. Whether this is a joke in bad taste, or whether some experimental transmitting station has been operating on a wave-length too close to 2 L O, is a matter for conjecture, but in any case the vulgarity which has been predominant in these transmissions is certainly to be deplored.

Tact Tactics

The row between Professor Andrade and Colonel Brand, the official host at 2 L O, has caused a good deal of amusement. There are, no doubt, a few faults on both sides, for everybody knows the effect of microphone fright, and everybody knows that the most tactful person in the world must sometimes relieve his feelings by being a little brusque.

Anyway, the correspondence which has passed between Professor Andrade and Sir John Reith in connection with the incident at Savoy Hill has certainly been amusing, but the matter seems to have ended when Sir John Reith replied to Professor Andrade: "I have told you as plainly as I can that Colonel Brand's reputation for tact and courtesy is sufficiently well established here for me to feel sure that he would not go out

of his way to insult you or your friend."

George Robey, Too

From personal knowledge of Colonel Brand, we can say that he is the model of tact and courtesy. Speaking to a newspaper man, Professor Andrade said: "I know that Colonel Brand was very civil to George Robey. Why shouldn't he be civil to men of science?"

The whole incident, which has unfortunately been ventilated in the Press, seems very childish.

Peter and Columbus

Mr. C. E. Hodges, who is better known to millions of kiddies as "Uncle Peter," has resigned from his post of Organiser of the Children's Hour at Savoy Hill. It is good news, however, to note that he will continue to contribute to the Children's Hour programmes, although his place as Organiser will be taken by Mr. Alan Howland, who is better known as "Columbus."

"Death of a Scientist"

I saw in the North Eastern Daily Gazette the other day a paragraph that Mr. Baird is working eighteen hours a day just now and "looking

(Continued on page 310.)



EXCELLENCE OF DESIGN

Look at the base of the Vibrolder; study its design from behind the scenes. Note the one-piece springs whose coils form the sockets for the valve legs—the self-aligning contacts; the transparent "window" which excludes all dirt and dust; the ready tinned soldering tags.

Next time say "Vibrolder" **1/6** and be sure of the best.

1,500,000 Benjamin valve holders are already in use



Sound Waves from Day's

- SETS**
Victory G.E.C. 3-valve set, including all accessories and batteries £8 10 0
- KITS**
Cossor Melody Maker .. £7 15 0
Igranikit .. 6 6 0
Mullard Master Three Star 6 18 0
Mullard Five Portable 12 10 0
- SPEAKERS**
M.P.A. Plaque £1 9 6
Celestion Speakers from .. 5 10 0
New Phillips 2 10 0
Mullard .. 2 13 6
B.T.H. Cone 3 0 0
Marconi Octagon .. 1 19 6
Lion 44 Amplion .. 6 0 0

- SPECIAL LINES**
SOLDOMETA Pocket Soldering Outfit for 2/6
Mogen H.T. Generator, 400 v. 200 m.a. output, from £22.
- PORTABLE GRAMOPHONES**
All the best makes in stock. Prices from £2 15 to £10.
- SMALL TABLE GRANDS**
All the leading makes always available for immediate delivery. Prices from £6 10 to £8 10, and other larger models.
- RECORDS**
H.M.V. 3/- to 10/-
Columbia 3/- to 12/6.
Zonophone 2/- to 4/-
Brunswick 3/- to 8/-
Parlophone 2/6 to 4/6.
Radio 1/3.
Duophone 1/6.

Write for our Radio or Gramophone Booklets free on request.

For the Best in Radio

WILL DAY LTD.

(THE BEST IN THE WEST)

19 LISLE STREET, LEICESTER SQUARE, LONDON, W.C.2.
Telephone: (2lines) Regent 0921 and 0922 Telegrams: Willday, London

BUILD THE PEERLESS "RESONIC 2"

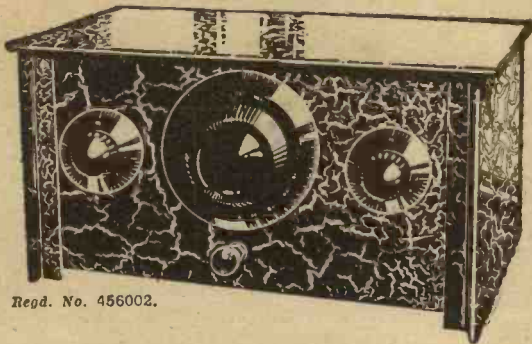

Regd. No. 456002.

Anyone can build this set in 60 minutes. No drilling. No soldering. All wires cut and bent. JUST ASSEMBLE and then immediately enjoy the radio entertainment which is of splendid tone and comes in at good loud-speaker volume. Circuit allows use of standard valves (1 H.F. and 1 Power).

Blueprint and easily followed Diagram of Connections included with every set. Cabinet and full Kit applied in carton.

COST ONLY £3 . 15 . 0 Obtainable from all dealers, or

THE BEDFORD ELECTRICAL & RADIO CO., LTD.,
22 Campbell Road, Bedford.

Scottish Office: 113 St. Vincent Street, Glasgow, C.2.



What About Your Future?

ARE you content with the position you occupy now—with the money you are earning, or do you wish for something better and something more?

Ask yourself these questions; then consider for a moment what you ought to do. Don't for a moment imagine that integrity, punctuality and length of service will of themselves carry you far. The one thing more than any other that enables a man to rise above his fellows and win a way into the better-paid jobs is a sound and practical technical training. He cannot possibly get such a training in the course of his everyday work.

The I.C.S. originated spare-time technical training by post 36 years ago, and is by far the largest institution of its kind in the world. It has teaching centres in eleven countries and students in fifty.

Write to-day for full information as to how the I.C.S. can help you in your chosen vocation. There are 360 Standard Courses, of which the following are the most important groups:—

- | | | |
|---|----------------------------|-----------------------|
| Wireless Telegraphy (Elementary and Advanced) | | |
| Accountancy | Draughtsmanship | Salesmanship |
| Advertising | Engineering (all branches) | Scientific Management |
| Architecture | French and Spanish | Showcard Writing |
| Building | General Education | Textiles |
| Commercial Art | Professional Exams. | Window Dressing |
| Commercial Training | | Woodworking |

There is a special booklet for each group, which will be sent free on request. Tell us the one you would like to see.

International Correspondence Schools, Ltd.
172, International Buildings, Kingsway, London, W.C.2.

WHATEVER THE CIRCUIT—Specify "WEILO"

POWER TYPE

as specified for Manchester Evening Chronicle "Distance Two" and also the Sir Isaac Pitman "All Europe 3."

MODEL 10
Price

11/6

Stocked by Harrods and all good class dealers. Send for illustrated and interesting catalogue describing Weilo and N.S.F. components. This catalogue is one of the most complete in radio—it is yours free on application.



HEAVY TYPE

Ideal for all general purpose work.

MODEL 3
Price

8/6

SEND FOR FREE CATALOGUE

THE SUPER VALUE TRANSFORMER.

Specify Weilo—you will be safe! There is no query as to Weilo's undoubted capacity and fitness for all circuit work. The experts know and have tested Weilo. It gives a cast iron efficiency of performance and a wonderful purity of maximum amplification. At the price the value of this super transformer is nothing short of amazing. High component prices are to go—Weilo sets a new standard of transformer value. Built by experts and guaranteed two years. Obtainable from your dealer or direct.

S. W. LEWIS & Co., Ltd., Dept. W.C.,
39, Victoria Street, London, S.W.1.

Indian Agents, Bombay Radio Company, Bombay and Calcutta.

THE LARGE Squire ALUMINIUM CRADLE FRAME AND CONE KIT 15/-

A Plywood Clamping Washer included with each complete set.

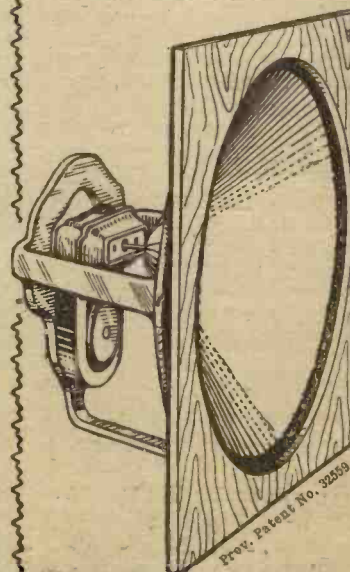

For Various Balanced Armature Speaker Units

The Frame is ready to take Blue Spot, Tritron, Bullphone and G.E.C. Units, &c., which are secured rigidly and DIRECT to ALUMINIUM CRADLE or CHASSIS. Setting remains constant and speaker will take full output from set without chatter.

CRADLE FRAME ONLY, ready to receive various units - **12/6**

Designed to give easy access to adjusting nuts on reed of unit.

CONE KIT, comprising 11½ in. Kraft Diaphragm (forming 9½ in. Cone), 4 Suedlin Segments, 1 Card Ring, all cut to size ready for **2/6** mounting

INSIST ON THE GENUINE SQUIRE CONE KITS, IN LABELLED ENVELOPES

Guaranteed Moving Coil Speaker Resemblance.

FREDK. SQUIRE 24, Leswin Road, Stoke Newington, London, N.16

OUR NEWS BULLETIN

—continued from page 308

more wan and dishevelled than ever."

According to the correspondent in the above paper, he is toiling behind closed doors on the improvement of his apparatus.

"Why on earth don't you go away for a rest?" he was asked.

"If I did," was his reply, "I should read in the papers the next day—'Death of a Scientist.'"

It appears that Mr. Baird's labours have their amusing side. Some time ago the Baird people tried to get hold of a horse for television purposes, but as the studios are up a flight of stairs the job was found to be more than the Baird people—or the horse—could manage!

This somehow reminds us of that old proverb about putting the cart before the horse.

One Hundred Players!

At the recent Radio Manufacturers' Association banquet, Sir John Reith mentioned the plans now in preparation for a great new orchestra of one hundred players, which may be formed next year in time for the autumn season.

The Big Four

It is understood that negotiations are progressing favourably between the B.B.C. and Sir Thomas Beecham, who will be jointly responsible for the formation of the orchestra. Members of the orchestra will be chosen from among the four big London orchestras—the London Symphony Orchestra, the Royal Philharmonic, the new Queen's Hall Orchestra, and the B.B.C.'s own orchestra.

At Last!

The orchestra will be a permanent one, and rehearsals will be thorough. Deputising among members of the orchestra will be forbidden, so at last it looks as though this country will possess an orchestra equal, if not better than, the great orchestras of other countries in the world.

For Concert-Goers

It is to the B.B.C.'s credit that it has already formed a National Orchestra of Wales, and also a National Chorus of more than two hundred and fifty voices. It is likely that when the B.B.C.'s new building is ready, and the giant studio for holding one thousand people, this big orchestra will be heard not only by listeners, but by regular concert-

goers, who will attend as they do now at the Queen's Hall.

From One Brighton to Another

A note appeared in the papers the other day to the effect that Brighton was endeavouring to arrange a broadcast programme to be sent out from Brighton, England, to the sixteen Brightons in the United States. Why only sixteen Brightons in the United States is a puzzle, for the "Gazetteer" mentions as many as twenty-six Brightons in the United States. But the English Brighton is certainly the biggest of the lot, for none of the United States' Brightons can pass the population figure of 130,000.

The Sound "Curtain"

It has been asked recently in the papers: Should broadcast concerts end with the National Anthem instead of closing down with the announcer's brief "Good-night!"?

It seems there is a varied opinion about this, and certainly the etiquette is different at various Continental stations. For instance, the broadcasts from Paris usually end with the Marseillaise, and from Germany with Deutschland uber alles. But it is very seldom we hear the B.B.C. band end

(Continued on page 312.)

MARCONIPHONES

What a difference

It's just as simple as switching on the light. Batteries are entirely dispensed with; recharges and renewals become unnecessary. The only requirement is a lighting socket and the Marconiphone Power Unit. The result—a generous, smooth flowing stream of power that is readily controlled; always available, and meets every demand with minimum cost.

All-Power Units for supplying H.T., L.T., and Grid Bias Current.
 Model A.C.4, All-Power Unit for A.C. Mains. With power supply costs only 2d. per week. Model B.1153 for 100-125 volts, and 200-250 volts, 40 cycles and over. Price, including valve and royalty, £4 15s. od.

Model D.C.4, All-Power Unit for D.C. Mains. Entails little or no alteration to existing circuits. Model B.1154 for 200-250 volts, £5 5s. od.

H.T. Supply Units.

Model A.C.2 for A.C. Mains. Supplies H.T. to receivers of almost any type. Output 40 milliamperes at 120 volts. Two models available for 100-125 and 200-250 volts. Price, including U.5 valve, £6 10s. od.

Model D.C.2 for D.C. Mains. Output 50 milliamperes at 120 volts. Tappings at 42 and 84 volts. Suitable for use on 100-250 volt mains, £4 2s. 6d.

For One- or Two-valve Receivers, Models A.C.3 and D.C.3. Model A.C.3 for A.C. Mains. For 100-125 or 200-250 volts. Complete with valve and royalty, 70/-. Model D.C.3 for D.C. Mains. For 100-125 or 200-250 volts. Price 35/-.

Write for Catalogue No. 453, mentioning WIRELESS CONSTRUCTOR.



Model A.C.4.

THE MARCONIPHONE CO., LTD.,

Dept. P.
 210-212, Tottenham Court Road, London, W.1.
 Showrooms: 210-212, Tottenham Court Road,
 W.1., and Marconi House, Strand, W.C.2.

POWER UNITS



**Why Worry
about buying a
new Set when
for 12/6 you can
make your present
Set as selective
as the most
modern receiver**

No matter what type of set or aerial you may have, the "HARLIE" WAVE-SELECTOR will definitely cut out the unwanted station, bring in stations—home and foreign—clearer and with greater volume, and also bring in stations hitherto unobtainable.

This ingenious device, which caused a sensation at the Manchester Exhibition, is selling phenomenally and is producing astounding results in all parts of the U.K. Numerous testimonials have been received and these can be seen on request.

4½" high, 3½" diameter. In finest grade black crystalline finish throughout.

NO ALTERATION TO SET—JUST PLUG AERIAL INTO SOCKET PROVIDED. FULL PARTICULARS ARE GIVEN.

£100 Guarantee.

If the "Harlie" Wave-Selector proves unsatisfactory, and is returned to us within 7 days of purchase, your money will be returned in full, providing it is purchased direct from us. A similar arrangement can be made with your dealer.

2 MODELS SUPPLIED

(a) Normal Waveband, 200-700 metres
(b) High Waveband, 700-2,000 metres.

Please state model required when ordering.

If unobtainable, either model will be sent on receipt of 12/6 or per C.O.D. upon receipt of postcard.

"HARLIE" WAVE-SELECTOR

Dept. E,

HARLIE BROS.,

Balham Road, Lower Edmonton, N.9.

RADIO in the NEW YEAR

is sure to go ahead. Developments will be occurring—new circuits discovered—better and cheaper methods will be available. To take advantage of every development you must

KEEP IN TOUCH!

Get the news while it is news—

Get reliable how-to-make articles—

Get dependable designs—

Get hints and tips—

Get busy and

Get

POPULAR WIRELESS

This fine Thursday-Threepenny-worth is well worth a small weekly subscription, because it offers the brightest and best radio reading every week. But there is more in it than that. Full of hints, tips, and practical how-to-make articles, "P.W." is

A SOUND RADIO INVESTMENT

Scores of readers have testified that one 3d. issue of "P.W." has saved them Pounds!

Every Thursday

Threepence

READY RADIO

SUPPLY COMPANY,

159, BOROUGH HIGH ST.,
LONDON BRIDGE, S.E.1.

3 Minutes from London Bridge Southern Rly. and
Tube Stations.

Telephone: HOP 5555 (Private Exchange).
Telegrams: READY.HOP 5555, LONDON.

BUILD THE "PENTWIN"

A Set for the Progressive Constructor.

Price List of ALL the CORRECT
Parts.

	£	s.	d.
1 Cabinet in solid oak or mahogany with baseboard (Ready Radio) .. .	12	6	0
1 10 in. x 7 in. panel (Ebonart) .. .	4	0	0
1 Variable condenser, '0005 mfd. (Lotus)	5	9	0
1 Miniature reaction condenser, '0001 mfd. (Bowyer-Lowe) .. .	5	9	0
1 On-and-off switch (Benjamin) .. .	1	3	0
1 Six-pin base (Lewcos) .. .	2	9	0
1 Super coil, C.A.C.5, with No. 4 primary (Lewcos) .. .	13	6	0
1 Super C.A.C.20 coil, with 10 or 12 primary (Lewcos) .. .	15	6	0
1 Terminal strip with 10 terminals .. .	3	0	0
1 Fixed condenser, '0003 mfd., and clips (Lissen) .. .	1	0	0
1 Grid leak, 2 megohms (Dubilier) .. .	2	6	0
1 Radio-frequency choke (Lissen) .. .	5	0	0
1 Low-frequency transformer (Marconi-phone Universal) .. .	16	0	0
2 Valve holders (Benjamin) .. .	3	6	0
1 Fixed condenser, 1 mfd. (Dubilier) .. .	2	6	0
1 Special pentode output transformer (Marconiphone) .. .	1	0	0
1 Wire-wound resistance with terminals, 20,000 ohms (Lissen) .. .	3	6	0
1 Vernier Dial (Indigraph) .. .	6	0	0
2 Valves: 1 Detector .. .	10	6	0
1 Pentode .. .	1	5	0
Total (including valves) .. .	£7	19	6

RECOMMENDED ACCESSORIES

	£	s.	d.
60 v. H.T. Batteries (Siemens) .. each	8	0	0
100 v. " .. .	13	0	0
2 v. 30 Accumulator (C.A.V.) .. .	11	0	0
6 v. 30 " .. .	1	13	0
2 v. glass accumulator, 20 amp. hrs. (C.A.V.) .. .	4	6	0
100 ft. aerial wire (Electron) .. .	1	8	0
1 Earth tube (Climax) .. .	5	0	0
1 H.T. Eliminator, A.C. (junior) .. . (Parmeko)	4	15	0
1 H.T. Eliminator, A.C. (senior) (Parmeko)	8	10	0
Trickle Charger (Marconi) .. .	2	9	6
Loud Speakers:			
Marconi Moving Coil (accumulator model)	10	10	0
Mullard "H" Model .. .	6	6	0
Ready Radio Cabinet (incorporating balanced armature driving unit) .. .	4	4	0

SCREENS.

STANDARD COPPER SCREENS
10" x 6" 2/6 7" x 6" 1/9
Any type of screen made to specification.

IMMEDIATE DISPATCH

OF ANY OF THE ABOVE SPECIFIED PARTS.

WE HAVE SATISFIED CUSTOMERS
ALL OVER THE WORLD.

CALL OR 'PHONE
WRITE OR WIRE.

COME TO US FIRST--
AND SAVE TIME.

Send for our 144-page General Catalogue. Price One Shilling. Free with all Orders if requested.

INLAND: All orders post free. OVER-SEAS: Consignments carefully packed and insured. Charges forward.

OUR NEWS BULLETIN

—continued from page 310

a programme with "God Save the King." The B.B.C. explains that this is on artistic grounds, and that "God Save the King" is only played on special occasions, when it is considered the anthem is far more effective.

For the Deaf

The National Institute for the Deaf will shortly carry out experiments to determine whether broadcasting can overcome deafness. Various experiments have already been tried, but it is believed that by multiple low-frequency amplification, in conjunction with the use of headphones, the volume of sound produced might be intelligible to persons whose hearing is badly affected.

An Interesting Experiment

Sir Oliver Lodge recently supervised a very remarkable test in this connection. A boy who had been deaf from birth was able to hear and enjoy music which, through over-modulation, was distorted so far as people with normal hearing were concerned out of all semblance to harmonious sound. But the boy quite clearly heard the music.

A Dramatic Ending

Another rumpus occurred the other day when Mr. George Bernard Shaw, the famous playwright, was speaking at the Royal Academy of Dramatic Art. His lecture was being broadcast by 5 G B, but after about twenty minutes 5 G B shut off the lecture in order to make way for a far more unimportant item on the programme. The B.B.C. admits that sometimes it allows an item to encroach on programme schedule time, but why on earth it cut off Mr. Shaw, who is so very rarely heard these days by wireless, it is hard to imagine, for a more interesting and more popular speaker would be hard to find.

The Effects of Aerials

A paper entitled "The Attenuation of Wireless Waves Over Towns" was read recently before the Wireless Section of the Institution of Electrical Engineers by Messrs. R. H. Barfield and G. H. Munro. The paper dealt with the effects of buildings, tuned aerials and transmitting aerial masts in attenuating the waves sent out by 2 L O. Using a receiver which was taken from place to place a very complete survey of the strength of 2 L O was made.

THE "JUNIOR" BELLING-LEE TERMINAL

(TYPE R)

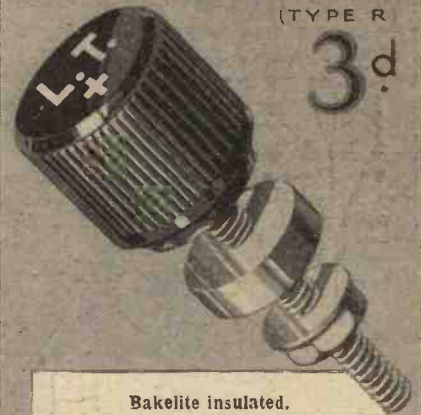

Bakelite insulated.
Non-detachable head.
Nickel-Plated Collar and 4 B.A. stem :: Perfect finish.

OTHER MODELS.

Type 'B.' Large, all-insulated de-luxe model with non-rotating name 6d. each.
Type 'M.' Metal model with non-rotating name, 4d. each.

BELLING-LEE
TERMINALS

Belling & Lee, Ltd., Queensway Works,
Ponders End, Middlesex.



MICROFU

Stocked by all first-class Dealers

2/- complete — Saves Valves

Refills 1/6 Microfuses embody an entirely new principle in fuse construction. This is a gold fuse—not wax. Absolutely reliable, 100 per cent. British.

MICROFUSES, LTD.
3, Finsbury Sq., London, E.C.2

SOLVE ALL H.T. TROUBLES

LONG LIFE

WET BATTERIES

TAYLEX

SILENT ECONOMICAL

SELF GENERATING



JARS (waxed) 2 1/2" x 1 1/4" sq. 1/3 doz.
ZINCS, new type 1 1/2 doz. 8AOS 1/2 doz.
Sample doz. (18 volts), complete with bands and electrolyte, 4/3, post 9d.
Sample unit, 6d. illus. booklet free.
Bargain list free.

AMPLIFIERS 30/- 3-VALVE SET £5
G. TAYLOR, 57, Studley Road,
STOCKWELL, LONDON.

Make
The DAILY SKETCH
YOUR Picture Paper

Keep on Saying
DARIO for Radio

See page 307

PLEASE MENTION "WIRELESS CONSTRUCTOR"
WHEN REPLYING TO ADVERTISEMENTS.

NOW YOU CAN STAND THEM UP OR LAY THEM DOWN!

A GAIN T.C.C. lead the way! T.C.C. Fixed Condensers now incorporate an ingenious bracket which permits them being mounted in either upright or horizontal positions. In modern Sets, space is at a greater premium than ever before. That is why T.C.C. Condensers are more than ever indispensable to Set constructors. Ask your Dealer for the new double-mounting condensers.

—a T.C.C. innovation that saves baseboard space



**BUT—
BE SURE
TO SAY:**

T.C.C.

CONDENSERS

Adv. Telegraph Condenser Co., Ltd., Wales Farm Rd., N. Acton, London, W.3.

CA 6764

THE ONLY BRITISH VALVE WITH A WRITTEN GUARANTEE AS TO PERFORMANCE AND LIFE.

Why Allow Profiteering? Why pay 10/6 when P.R. VALVES will give you equal service for 3/6?

WHAT OTHERS SAY of P.R. VALVES

NOW ONLY

3/6 C.O.D. Phone City 3789
Post 4d.

Type	Fil. Volts	Amp.	Imp. Ohms.	Amp. Fac.	
PR 1	2	.095	30,000	14	H.F.
PR 2	2	.095	28,000	13	Det.
PR 3	2	.095	15,000	8	L.F.
PR 4	2	.095	120,000	32	R.C.
PR 8	3.5.4	.063	23,000	15	H.F.
PR 9	3.5.4	.063	18,000	14	Det.
PR10	3.5.4	.063	10,000	8.7	L.F.
PR11	3.5.4	.063	88,000	40	R.C.
PR16	5.6	.1	19,000	13	H.F.
PR17	5.6	.1	18,000	17	Det.
PR18	5.6	.1	9,500	9	L.F.
PR19	5.6	.1	80,000	40	R.C.
PR20	2	.15	7,000	6	Power
PR40	4	.15	7,000	6	"
PR60	6	.1	5,000	6	"

POPULAR WIRELESS, Sept. 8, 1928: "Has quite remarkably good characteristics, and should appeal to those to whom the price of the usual British valve is still too high."
AMATEUR WIRELESS, 14/3/28, says: "The characteristics of this Valve compare favourably with many well-known makes."
"Unsurpassed for purity of tone and selectivity—the equal of any," is the opinion expressed in hundreds of letters from satisfied users—the originals can be seen at our offices.
Tell us your set—we will send correct Valves Matched Valves 1/- extra



7/6 Each. Post 4d. P.R. VALVES

All orders executed by return of post.
GUARANTEE. All valves despatched under guarantee of Money Back in Full if not satisfied. All valves are carefully packed and breakages replaced
17-40, Paternoster Square, LONDON, E.C.4.

A Cocktail of Laughter

LONDON CALLING is a bright paper for bright people—a real week-end tonic, sparkling with wit, bubbling over with humour. Live up-to-the-minute! Never dull. The newest jokes with brilliant drawings, humorous articles by foremost writers. Gossip of the week. Theatre Chat, Films and Novels reviewed. A Cocktail of Laughter to drive dull care away!

LONDON CALLING
Every Friday - 2d.

FREE LIST OF CABINETS



FOR ALL THE POPULAR CIRCUITS, MOVING COIL AND CONE SPEAKERS

Send this coupon for free copy.

To CARRINGTON MFG. CO., LTD.,
Cameo Works, Sanderstead Road, South Croydon
Telephone: Croydon 0623 (2 lines).

Please send me full details of the "Moving Coil" and other Cameo Cabinets.

NAME.....
ADDRESS.....

w c.

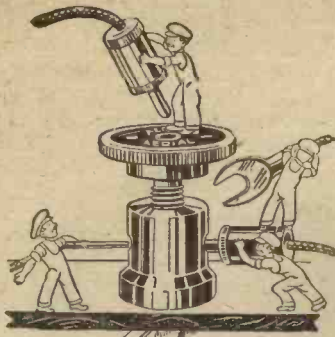

TREBLE-DUTY TERMINALS

Have multiple uses and cost from 2d. to 4½d. each, according to size and finish.

4½d. TERMINAL T2 LC as illustrated, nickel-plated, with choice of 40 indicating tops.

3d. TERMINAL T2 LN as T2 LC without indicating tops, with slightly smaller head.

2½d. TERMINAL T2 SN as T2 LN except smaller in size.

SPADES, PINS AND EYES

for use with BELEX TREBLE-DUTY TERMINALS—

EACH **2d.**

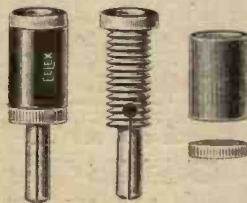

The above illustration shows a T14 Plug in parts. They are available in 6 coloured sleeves—red, yellow, black, blue, white or green—3d. each. Sockets 1d. each. Name Plates 1d. each.

Write for Booklet Y65, and learn all about the EEXLEY System of standardisation.

J. J. EASTICK & SONS,
Eelex House,
118, Bunhill Row, London, E.C.1

'Phone: Clerkenwell 9282-3-4.

THE "PENTWIN"

—continued from page 259

reaction coil on the Lewcos Super coil we get the necessary smooth reaction over the whole scale. A suitable reaction coil for the long waves is a No. 10 or 12.

The constructional work should be done systematically, and the two condensers and on-and-off switch should first be mounted on the panel, so that you can gauge the correct positions for the other parts on the baseboard.

The Output Transformer

Before proceeding farther I may state that any good makes of components can be used alternatively to those given in the list provided they do not occupy any more space. The special Marconiphone Universal output transformer should, however, be used in this case, as this is particularly suitable for the pentode.

The first L.F. transformer can be of any good make that will fit into the space available. The Lissen 20,000-ohm wire-wound resistance will be found particularly convenient, as it is to the best of my knowledge the only make fitted with terminals, thus not requiring a special stand, but any good 20,000-ohm wire-wound resistance can be used in this place, provided it fits in conveniently.

The high-frequency choke is placed next to the panel and is so arranged that neither condenser fouls at any portion of its travel. A flexible lead is taken from high-tension positive terminal to a spade which screws underneath the terminal on the side of the cap of the pentode. In making any changes for experiment, always disconnect the high-tension battery before you move the pentode, otherwise there is a risk of this high-tension lead falling on some other part of the circuit and causing trouble.

The Valve Holders

Owing to the necessity of getting a large number of terminals into a small space, it has been necessary to take the terminal strip the whole width of the baseboard, thus in some cabinets it may be necessary to remove a small portion of the wood at each end of the back. This, however, will be found to be quite simple with a small saw, or the maker will provide the cabinet completely cut, as required.

With regard to valve holders, the Benjamin new pattern have been chosen, as they occupy a very small

(Continued on page 315.)

SAFETY FIRST!

Why do most manufacturers of Eliminators employ HYDRA Condensers for their smoothing circuit—in spite of the fact that they are a foreign product?—Because they have proven thoroly dependable—and the manufacturer cannot risk his reputation in case the condenser fails. Benefit by the manufacturer's experience.

SAFETY FIRST

Do not accept a silver grey condenser without the HYDRA label. Others are imitations and we are not responsible in case of breakdown.



PRICES

2 mfd 4/- 1 mfd 3/-
Tested at 500 volts
A.C. Work voltage
240 A.C. at 50 M.A.

HYDRA CONDENSERS

Hydra Condensers are sold by all good radio dealers. In case of difficulty write **LOUIS HOLZMAN,** 34, Kingsway, London, W.C.2.

DON'T COVET

Your Neighbour's Wireless Set

BUILD YOUR OWN RECEIVER— BUT BE SURE to Buy on the Best Terms from THE P.D.P. CO., LTD.

EVERYTHING WIRELESS ON EASY TERMS

NEW COSSOR MELODY MAKER, MASTER THREE STAR, ETC.

BEST MONTHLY TERMS quoted by return for all Receivers and Components.

CASH ORDERS promptly executed

Goods sent C.O.D. by return.

Call at showrooms or post your list of requirements.

The P.D.P. Co., Ltd.

(Dept. C.), 121, CHEAPSIDE, London, E.C. 2.

'Phone: City 9846

HAND MADE CABINETS

(INDIVIDUAL ATTENTION TO EACH)

Prices are comparable and competitive with cheap makes. We pay our men over Trade Union rate of wages, thus assuring expert craftsmanship. Our prices range from £4 in Oak and £4.2.6 in Mahogany.

Our Specials to customers' own specifications are incomparable

H. COOK, Shopfitters, Height 3' 3" for Panels up to 21" x 7"

13, WANDLE ROAD, CROYDON Croydon 0488

Write for the New **DARIO Folder**
See page 307

PLEASE MENTION "WIRELESS CONSTRUCTOR" WHEN REPLYING TO ADVERTISEMENTS.

The New



RADIO FUSE completely PROTECTS RADIO CIRCUITS

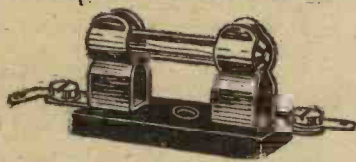

Now you can protect your radio circuit just as an ordinary electrical house circuit, with the ingenious Sifam Radio Fuse which, when connected in series ensures complete valve and meter protection from overload. Banishes the bugbear of burnt-out valves and costly meter repairs. A boon to all. Don't be without it.

Avoid burnt out valves and costly meter repairs
Fit this ingenious invention **2/6**

Price 50-500 M.A., 2/6. 1.5 to 4.5 amps., 2/-. Complete with clip.

The Sifam Electrical Instrument Co., Ltd., Dept. W.C., Bush House, Aldwych, W.C.2.

Obtain from your dealer or direct



NOW CONTROLS AND PROTECTS

M.R.

NEW COSSOR MELODY
Radiax Coils—the finest made, improve results on this set.

B.E.C. 15/-; Long Wave, 17/- pr. Any dealer can supply. Insist Radiax, refuse cheap rubbish. Mullard Master. Short 7/6, Long 8/6. Special Long improves long wave reception & selectivity, 10/6.

Easy Payments on Melody or any other Kit.
A. E. OAKLEY, 43, Carleton Road, London, N.7.

MONOTUNE 3.
The 40-station, single-tuning set by Allinson, Constructional Envelope, 1/2. List parts free. H.F. Screened Gridstage now ready. Comp. Kit & Cabt. 55/8.

DARIO Super H.F. means Super Radio

See page 307.

PLEASE be sure to mention "Wireless Constructor" when communicating with Advertisers. THANKS!

THE "PENTWIN"

—continued from page 314

space, but the Lotus, Bowyer-Lowe White Line, the Formo, and the Magnum Vibro are three small square-base valve holders which will fit in equally well.

In view of the small space it is well to use insulated wire for wiring up, although bare with Systoflex sleeving can also be utilised satisfactorily. The first valve should be one of the nominal high-frequency, or a Det.-L.F. type of valve will also function well here. The pentode, of course, goes in the second socket, as will be seen in the photograph; 120 volts should be used on the H.T. positive, from a good size of high-tension dry battery or a mains unit, or H.T. accumulator.

Do not use the small size of dry battery on this set, for although it is very compact and neat, the pentode valve requires a good deal of high-tension current, so that the consumption may rise as high as 25 to 30 milliamperes if a 4-volt pentode is used. With a 2-volt pentode the consumption is less, but it is still large.

Bright Reproduction

Operation of this set is of the simplest. Before switching on, the reaction condenser should be set at zero; aerial and earth, loud speaker and batteries all being joined up as shown on the terminal strip. Grid bias necessary for the pentode will depend on the particular make, but the leaflet supplied by the manufacturer with the valve will give the necessary information. It will generally be found to be somewhere between six and nine volts.

The local station can be tuned in at once and a trial of the reaction condenser will show that the set will pass smoothly into oscillation. Three degrees of selectivity are provided when using the Lewcos Super coil, and if the aerial is successively tried on terminals 3, 4 and 5, the best terminal for your particular aerial and condition will soon be found. The operation of the set will be found to be precisely the same as with the ordinary Reinartz detector and two low-frequency stages; but so far as the reproduction is concerned, if a good modern cone loud speaker is used, the reproduction of the higher frequencies, usually somewhat weak, will be found to be greatly improved. Indeed, with a pentode and the output transformer mentioned, a remarkably uniform

(Continued on page 319.)

K. RAYMOND

27 & 28a, LISLE ST., LONDON, W.C.2
Come to LEICESTER SQUARE TUBE

This address is at the back of Daly's Theatre. Phones: Gerrard 4637 and 2821

HOURS OF BUSINESS EVERY DAY 9 to 8
SATURDAY 9 to 9
SUNDAY MORN 11 to 1

C.O.D. SEND ORDER and PAY POSTMAN. We despatch within 24 hours where possible. C.O.D. U.K. only.

MULLARD MASTER 3*

LIST OF COMPONENTS:
3 Valve Holders, Lotus, at 1/3. Combined Wave Coil, 17/6. Ferracore Transformer, 25/-. Ollmax "L.F." Transformer, 25/-. Ollmax H.F. Choke, 7/6. Benjamin Battery Switch, 1/3. J.B. 0005 Log, 11/6. 00035, 10/6. Mullard 0003 and 2 meg, 5/-. Magnum Panel Brackets, 2/6. Mullard 0001 Fixed, 2/6.

Total £5 : 12 : 6 Carriage Free up to 150 miles

FOR 12/6 EXTRA
You can purchase a first class oak polished American type cabinet with hinged lid, carriage 2/-. Please add 3/6 to above price (total £5/16/0) and I will include: 2 Handsome S.M. Dials, Set of Connecting Links, 8 Plugs, 2 Spades, 4 Engraved Terminals, 2 Ebonite Strips, Twin Flex, Splendid Aluminium Panel, 18 x 7, drilled ready for use. 9-volt Grid Bias, Base (Super Power, 15/-).

MULLARD VALVES. 2 at 10/6. 1 at 12/6. (Super Power, 15/-). CAN BE SENT C.O.D., 1/6 EXTRA.

Always in Stock
C.O.D. by return
FINSTON



Q COILS

QA 15/-
QSP 21/-
QAM 21/-
JAMES 3

By using Finston Coils which are made exactly to Mr. Reyner's specification, you are guaranteed the best possible results. Coils cover a wavelength of 250-2000 metres. Complete with switch 25/- pr. (Star) 17/6 Lists Free

FERRANTI 3 (Screened Grid) KIT OF PARTS

£5 : 10 : 9
See "Popular Wireless," January 5 issue, or copy 3d.

Send for our 148-pp. Catalogue. Illustrated latest sets and components. Postage 3d.

LOUD SPEAKERS

Amplion, B.T.H., Celestion, M.F.A., and all good makes. **Wates' Combined Volt. Amp. & Milliamp. 8/6**

IF IT'S WIRELESS We have it!

BLUE SPOT UNIT 66K. 101. 25/-
Balanced Armature

THE SQUIRE

Alum'n Cradle Frame Post free 12/6 ready to use.

CONE KIT.

Kraft Diaphragm, Card Ring, and Segment, 2/6 (by post, 3/6). The above lot 15/- post free. Plywood damping washer free.

Copper and Aluminium Screens (all sizes) or made to order.
P.W. Screening Boxes, 12/6
P.W. Loading Coils, 7/6
Harlio Wave Selector, 12/6
Tunewell Dual 3 Star, 7/9
Combined Wave Q 3 Star, 15/-
Scott's All-Wave-Tuner, 13/6
DX Set 4 short wave, 7/6
DX L.F. Standard Ratio, 8/-
Wello L.F. Power, 11/6
Wello Standard, 8/6

LEWCOS C.A.C.5, 10/6;
C.A.C.20, 12/6; C.B.5, 10/6; C.S.P.20, 12/6; P4 to 14, 3/- each; P16 to 22, 4/- each. Touchstone Coils, 30/- pair, O.T. Coils, 3/6, 5/6. Q Coils: Q.A., 15/-; Q.S.P., 21/-.

ALL LEWCOS PRODUCTS.
CYLDON CONDENSERS
Triple Gang and Shields, 24. 17s. 6d.; Dual for "Furzehill," 25/6; Syn. crature for "Inceptor," 47/6. LISTS FREE.

SIX-SIXTY VALVES
Specified in all well-known receivers. Always in stock. Screened Grid, 2-volt, 22/6. R.C.H.F. Special Detectors, 10/6 each; Power, 12/6; Super Power, 15/- Post free, registered.

PLEASE MAKE OUT LIST FOR
Special Quotation if over 25/- in value.

COUPON W. Con. Feb.

ONLY ONE COUPON ON ANY ONE ORDER
If you spend 25/- or more you can buy for 3d. extra any one (only) of the following:
S.M. Dial, 100 ft. 7/22 Copper Aerial, 12 yds. Lead-in, Fuse and Holder, 12 Nickel Terminals, 60X Coil, H.F. Choke, Permanent Detector, Battery Switch, 0003 and 2-meg. Leak, 9-volt Grid Bias, Panel Brackets, 6-pin Coil Base, 30 ft. Insulated Aerial, Loud Speaker Silk Cord, 30 ft. Covered Connecting Wire, Ebonite Panel, 9 x 6, 12 yds. Twin Flex, 100 ft. Indoor Aerial, Cycle Rear Reflector. **OR we will Present you FREE with a New 10 in. Record, "Broadcast" or Edison Bell.** Send name of record required for coupon.



Specified for

MULLARD MASTER 3, MULLARD MASTER 5, AND SIX SIXTY

**LISENIN'S
FOUR
LATEST
TRIUMPHS**

- | | |
|-------------------------------|------------------------------|
| SIX-SIXTY
RECEIVER | MULLARD
MASTER 3* |
| 2 Spade Ends | 8 Wander Plugs |
| 3 Wander Plugs | 2 Spade Ends |

**MULLARD
MASTER 5**

- 4 Plugs and Sockets
2 Spade Ends

Also included in the *Cossor Melody Maker.*

Obtainable from all radio dealers. Look for the *Lisenin* showcase on the counter. Send for descriptive leaflet X1.

LISENIN

WIRELESS CO.,

1c, Edgware Road, London, W.2.

The Picture Paper with the MOST News

:: SUNDAY GRAPHIC ::

REPAIRS

Any make of L.F. Transformer, Loudspeaker or Headphones repaired and despatched within 48 HOURS—TWELVE MONTHS' GUARANTEE with each repair. 4/- Post free.

Terms to Trade.

TRANSFORMER REPAIR CO.,
Dept: "C,"

214 High Street, Colliers Wood, London, S.W.19

ARTCRAFT
RADIO CABINETS
BRITAIN'S BEST VALUE
New Catalogue Free
THE ARTCRAFT COMPANY
156, CHERRY ORCHARD R' CROYDON

THE "D.C." FOUR

—continued from page 273

especially as the grid bias can be increased to a voltage beyond that required. Naturally, the valves should have amplification factors as high as possible consistent with the impedances specified, and the better kinds of valves will combine comparatively low impedances with high magnifications.

Testing Filament Voltages

When suitable valves have been chosen, they can be inserted in their respective sockets and tests made to enable the filament voltages to be corrected as well as those developed across the grid-biasing resistances. The values of the latter can be determined by placing the leads from the voltmeter (if the triple-range Ferranti, as shown in photograph, it will be the 0-30-volt range) across each of the 2-mfd. condensers which are connected across each resistance. A small point to observe when carrying out this test is that the filament voltages are approximately adjusted beforehand, otherwise the meter readings will be in error. A photograph illustrating how a filament reading for the detector valve is taken accompanies this article, and shows how the aluminium screen becomes positive for this valve (V_2), while the negative connection is taken from the 2-mfd. condenser, which is joined to the grid-biasing resistance and negative filament leg of valve holder. The screen automatically becomes the positive filament connection for the H.F. valve, and it is essential the lead from the voltmeter to the screen is reversed when testing this valve, as will be the case for all stages.

Choosing the Coils

Choosing suitable tuning coils for this receiver will not prove difficult, if it is remembered the first is a split-primary type aerial coil and the second a "split-primary H.F. transformer," the tuning range being 250 to 550 metres for the broadcasting band, and 1,000 to 2,000 metres for 5 XX and equivalent high-wave stations, if so desired. Lewcos coils are illustrated, but, of course, other makes, such as Colvern, Wearite, Peto-Scott, etc., can be chosen at the discretion of the operator.

Our next step is to insert the coils in their six-socket bases and join the flexible lead from the .001 mfd.

(Continued on page 317.)

PERFECT CONTROL of H.F. & L.F.



THE NEUTROVERNIA

In those days of Screened Grid Valves the sensitivity of the modern circuits cannot always be used to the full owing to the local station or the nearest high power station causing interference.

By connecting the Neutrovernia in series with your aerial the selectivity of your receiver can be adjusted exactly to suit the prevailing conditions.

The construction of this condenser permits it to function perfectly as either a Neutralising or Balancing Condenser or Capacity Reaction Control.

Price 5/6

THE VOLUVERNIA

Here is a true volume control, one which does not create distortion. It gives you just the volume you desire and keeps your reproduction pure at all times.

The "Voluvern" gives perfectly smooth control from maximum to minimum for Radio Receiver or Gramophone Amplifier.

Price 6/9

From all Dealers. Write for Components Folder "C."

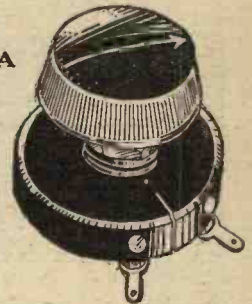

GAMBRELL RADIO, LTD.

6, Buckingham St., Strand, London, W.C.2.

DARIO

This week's best bargain
See page 307.

CASTLE RADIO CABINETS

We would like you to look through our New Wireless Cabinet List

E. FARNELL & SONS,
Cabinet Factory,
Birkenshaw, Nr. Bradford.



PLEASE be sure to mention "Wireless Constructor" when communicating with Advertisers. THANKS!

CLAROSTAT

VARIABLE RESISTANCES FOR VOLUME, TONE, DISTANT CONTROL, ELIMINATORS ETC.



As frequently specified by "The Experts."
• HIGH QUALITY • LOW PRICE •
New 20 Page Brochure free on request.
Many unique circuits.

CLAUDE LYONS LTD.
76, OLDHALL ST., LIVERPOOL.

REDUCED PRICES!

of the wonderful **STANDARD**

PERMANENT H.T. SUPPLY
REDUCED PRICES OF ELEMENTS

CELL.	ZINC		SAC	
	Old Price	New	Old	New
No. 1	11d.	10d.	1/2	1/2
No. 2	1/-	11d.	2/2	1/9
No. 3	1/7	1/3	4/-	3/-
No. 4	—	1/6	—	4/6

CELL.	COMPLETE CELL		CAPACITY	
	Old	New	Milliamp-Hours	
No. 1	41d.	41d.	2,500	
No. 2	6d.	51d.	5,000	
No. 3	9d.	71d.	10,000	
No. 4	—	10d.	20,000	

The Battery that lasts for years

THE BENEFIT OF AN AMAZING GROWTH IN POPULARITY. The tremendous and steadily maintained growth in the popularity of this wonderful permanent battery has led to what will be greeted as splendid news by listeners throughout the Radio World. The prices of the Standard Battery are NOW REDUCED—this includes all models of the battery and all spare parts. The Standard Battery lasts for years because it is positively self-regenerative and RECHARGES ITSELF OVERNIGHT. All that is necessary to maintain the voltage is replenishment of the elements at long intervals, beyond which little or no attention is needed. This wonderful battery greatly improves the quality of reception. It is

PROVED THE BEST SOURCE OF PERMANENT H.T. SUPPLY.

Its super cells maintain a constant pressure of unvarying current that banishes "background" and "ripple."

NOTE.—ANY VOLTAGE SUPPLIED. Listeners are asked particularly to note that any size of the battery is supplied from 1½ volts upwards. The larger cells, and especially the new model No. 4, are proving the most economical in the long run.

WRITE FOR BOOKLET NOW.

Sent free on receipt of card. The new booklet is entirely revised and contains valuable data that assists in the selection of a suitable battery, cost of upkeep, spare parts, lists, and new prices. Importers.—Kindly state whether you already possess a Standard Battery or not.

POPULAR MODEL "UNIBLOC" CABINET

96 volts, assembled complete, was 9/1 down, now cash £2/3/1, or 7/6 down and five monthly payments of 7/6. Obtainable from Halford's Stores, Curry's Stores, and all Radio dealers on cash or deferred terms.

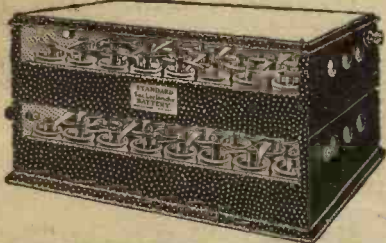

THE STANDARD WET BATTERY CO. (Dept. W.C.)
184-188, Shaftesbury Avenue, London, W.C.2
M.B.

11th YEAR — 12,000 SUCCESSES ENGINEERS!

The way to rapid advancement to a well-paid executive post in any branch of engineering is through the wonderful home-study courses of The 'Tech'.

Write TO-NIGHT to find out how The 'Tech' can help YOU! State your age and experience and mark your letter "Confidential Advice." (Moderate Fees—Easy Installments).



FREE BOOK.

"Everything about Engineering; how to become A.M.I.Mech.E., A.M.I.E.E., etc."—the greatest book ever published on Opportunities for the practical engineer.

The Technological Institute of Great Britain,
200, Temple Bar House, London, E.C.4.

PLEASE be sure to mention "Wireless Constructor" when communicating with Advertisers. THANKS!

THE "D.C." FOUR

—continued from page 316

series aerial condenser to the No. 4 terminal on the aerial coil base, this particular tapping point giving us loudest signals, but not the greatest selectivity. No. 3 terminal, when connected to the aerial lead, enables maximum selectivity to be obtained, but results in a diminution of signal strength.

Set the neutralising condenser to a point somewhat conforming to that shown in the illustration of the H.F. side of the receiver, and then attach the aerial, earth and loud-speaker leads. For the purposes of this test, after checking the filament current, voltage, and grid biasing, it is important to hear whether the set possesses a bad mains hum and, if so, to disconnect the earth lead and note the difference.

Adjusting the Set

Should positive mains be earthed, removing the earth lead often reduces the hum, simply because the mains voltage is not introduced across the series earth condenser and the accompanying fluctuations are not applied to the grid of the H.F. valve. With negative mains earthed the tendency to hum will not be so great, but in any case, if mains noises tend to become troublesome and removing the earth effects a cure, it will be in order to omit the lead permanently, because a direct earth is made via one of the mains leads, and results show the aerial tuning is not visibly upset, judging from the position of the tuning condenser C₁. It should be understood the grid leak of the detector valve is joined to L.T.+ of V₂ during adjustments.

The local station or any powerful transmission may be now tuned in, keeping reaction at minimum and the volume control half-way from maximum. Finer adjustment of the two tuning condensers can next be attempted and note taken of the positions of the two drums in respect to each other. Coils carefully matched will result in nearly similar dial readings, although our object here is to see whether the H.F. valve oscillates, using no intentional reaction.

Should no oscillation occur, an attempt can be made to tune in on a higher wave-length or on a weak station. Oscillation may still not occur, so that reaction can be increased carefully, keeping the two tuning

(Continued on page 318.)



ENGINEERING PRECISION.

Bestriding the Tyne like a Colossus, this inspiring new bridge leaps the great waterway in one span, a perfect example to Newcastle—and, indeed, the world—of the skill and precision to be found in twentieth-century engineering.

No less worthy examples of craftsmanship are to be found in the products of J.B. Infinite care and accuracy, and a flair for turning a good design into a perfect one have raised J.B. precision instruments to an unassailable position of good repute.

Here is their neutralising condenser—an example of J.B. Engineering Precision. So far ahead of all other models that it cannot go wrong. Extremely simple, and incorporating the best possible materials.

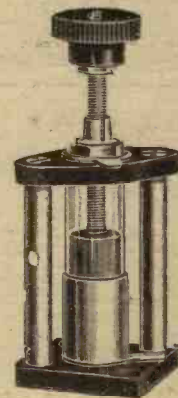

PRICE
3/6



PRECISION INSTRUMENTS

Advt. of Jackson Bros., 72, St. Thomas's St., London, S.E.1. Telephone: Hop 1837.



Readings
 Price **8/6**
 Fully Guaranteed

0-150 VOLTS
0-30 MILLIAMPS
0-6 VOLTS

Res. 5,000 OHMS.
 Crystallised Black finish.

Three readings on one dial—an amazing feature—that has completely swept away every preconceived notion of meter value. NOW, one instrument, and one instrument alone, the wonderful WATES THREE-IN-ONE TEST METER tells you all you want to know to ensure the accurate and efficient handling of your set. Experts and listeners alike are rapidly realising that accurate volt and amp-readings are the essentials that secure the superlative quality of reception that marks the perfectly controlled set. The Wates Meter is in every sense a precision job, and gives three accurate dead beat readings from one clearly engraved dial. No valve set user should be without it. Obtainable from your dealer or direct complete with explanatory leaflet. Stocked by Halford's Stores, Curry's Stores and all radio dealers.

THE STANDARD WET BATTERY CO. (Dept. W.C.),
 184-188, Shaftesbury Avenue, London, W.C.2.

WATES
three in one
VOLT-AMP
RADIO TEST METER

M.B.

**THE CONNOISSEUR'S
 CONE LOUD-SPEAKER KIT**
Recommended in November Issue.
REDUCED PRICES.

Complete Kit includes:—
 Type 66K Blue Spot, new light universal framework fitted with supports, all screws and MADE-UP Cone, ready for use, 39/-
 Fitted with "Hegra" unit 35/-
 New light universal framework to take Blue Spot, Hegra, Goodman, etc., etc., units, 12/8.
 Patented MADE-UP Cone, ready for use, 1/9, plus 8d. Post and Packing. Make your own Cone with Paper and Suedlin at 1/6, plus 2d. Post.
 Old Type heavy framework with machined ring, screws and supports, 17/6. Old Type rough casting, undrilled, 7/6.

THE CROMWELL ENGINEERING Co.
 181 OXFORD AVENUE, S.W.20.
 Usual Trade Terms. Tele.: Wimbledon 2012.

ALL APPLICATIONS for ADVERTISING SPACE in "WIRELESS CONSTRUCTOR" must be made to the Sole Advertising Agents, JOHN H. LILE, LTD., 4, LUDGATE CIRCUS, LONDON, E.C.4.

THE "D.C." FOUR

—continued from page 317

condensers still in tune. Increase reaction until oscillation begins to be audible, and then slacken off slightly by turning the reaction dial back. Now swing only the aerial tuning condenser drum backwards and forwards, and listen carefully to hear whether the set breaks into oscillation or not. If so, reduce reaction a tiny amount and try again. Persistent oscillation will indicate the H.F. valve is not fully neutralised, and further adjustments can be made to the neutralising condenser on the baseboard, the process of turning the aerial condenser drum being repeated until the swinging movement no longer causes oscillation.

Smooth Reaction Control

To make the neutralising more exact, reaction can be again increased slightly and the process repeated as above. When the H.F. valve is stabilised, the actual reaction control should be found smooth with no "lag" or overlap, and it should be possible to maintain the receiver on the point of oscillation for indefinite periods.

Finally, a word of warning in respect of the operation of the set. Under no circumstances consider the 1,500-ohm resistance on the panel an ordinary control. Once set, it should not be touched unless the milliammeter falls well under 150 milliamps, in which case it can be employed to correct the filament current. This rule does not hold, however, for the needle's position when a valve is removed, as the correct procedure in such a case is to switch off at the mains before removing one. The polarity for the mains to the receiver will be denoted by the position of the needle of the milliammeter; and, if correct, the needle will go on to the scale instead of tending to go off.

Interesting Points About the Set

Total cost, including cabinet and valves, approximately £20.

Current consumption, 0.15 amp., equivalent to the consumption of a 240-volt 36-watt lamp.

Always ready for use, and no batteries to be charged or replaced. There are exactly six leads to be connected, including those to the D.C. supply.

Performance equal to that given by usual four-valver, including split-primary neutralising for the

(Continued on page 319.)



LEAD TO LEAD

FOR PERFECT CONTACT

The advantages of using lead-plated Spade Terminals for accumulators are twofold. Firstly, they offer the least resistance for a steady flow of current; secondly, one not only secures a firmer contact, but such terminals are not easily affected by acid. The method of wire attachment is most simple. It leaves no exposed wires and ensures a safe and good connection. Made in two sizes for all types of screw terminals.

Price 2d. each.

Also supplied nickel-plated at same price.

CLIX-LOX

Does your wander plug fit your H.T. battery socket? If not, there is a danger of it jumping out and causing trouble! Not only that, but your reception will be marred by unpleasant noises due to bad contact. Fit a Clix-Lox Adjustable Wander Plug and there will be no more trouble or danger. It fits snugly into the socket of any H.T. Battery by a turn of the insulator. A further turn and it is securely locked into position.

Price 2½d. each.

The Clix Showcase, in addition to the above, contains six other aids to perfect contact. See it on your dealer's counter.



LECTRO LINX LTD.,
 254, Vauxhall Bridge Rd., London, S.W.1

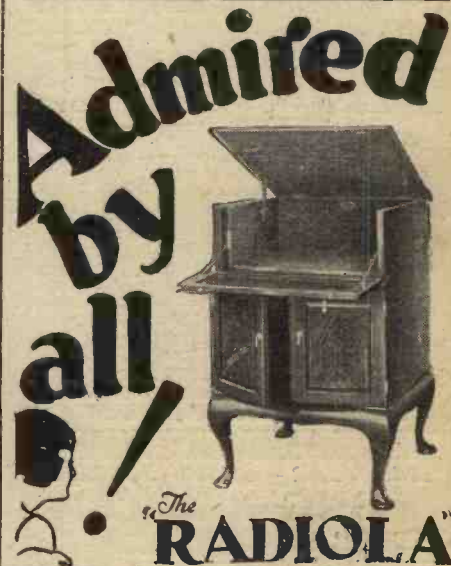

Wireless Bureau will be sent on 7 days FREE TRIAL to you, if you write now. Money back in full if not satisfied. Over 3,000 delighted users have bought RADIOLAS through the post at Makers prices—which are considerably less than shop prices. Strongly made and beautifully finished in oak or mahogany. A Wireless Cabinet and Writing Bureau combined. P.C. brings full particulars and prices of all models from 75/-

PICKETT'S
 Wireless Cabinets
 CONWORKS, BEXLEYHEATH, N.R. LONDON

THE "D.C." FOUR

—continued from page 318

H.F. valve, alternative means of rectification, resistance and transformer-coupled L.F. stages with safety choke filter output.

Before Connecting the Mains to the Set

Make certain the 1,500-ohm resistance controlling the filament current is at maximum resistance and turn on gradually when plug is inserted, until the 0-300 milliammeter registers slightly under 150 milliamps.

Adjust all the resistances on the baseboard for the required values of grid bias.

Do all further internal adjustments very cautiously, standing on a dry board or rubber mat, and only insert one hand in the set at a time.

Apply a voltmeter across the filament terminals on the last valve holder and note the reading.

For 2-volt valves the meter should read 1.8 or 1.9 volts, and for a 6-volt 15-amp. valve, 5.6 to 5.9 volts. When this valve is adjusted, take readings on any one of the other valves, and if not correct regulate by the 400 ohm resistance near the second variable condenser of the gang.

THE "PENTWIN"

—continued from page 315

range of tone is given on any good loud speaker.

The change from the lower to the upper band is simply performed by withdrawing one six-pin coil and substituting the other. Still higher selectivity can be obtained on either wave-band, if desired, by inserting a .0001 mfd. fixed condenser in the aerial lead, but, in general, the set will be found to function perfectly satisfactorily without such addition.

Tested on an average night on an aerial of average proportions, London, 5 G B and a dozen other stations were brought in at good loud-speaker strength within half an hour, while on the long wave-band, Hilversum, Radio-Paris, Kalundborg and, of course, 5 X X all came in extremely well. The set is admirably suited for those who require a very compact loud-speaker set capable of providing several alternative programmes with exceptionally good quality of reproduction, while the total cost of the set is quite reasonably low, as will be gathered from the component list.

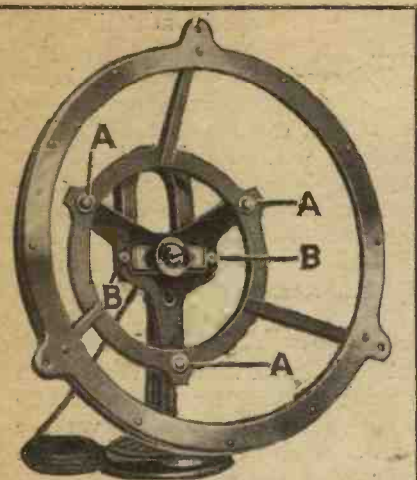

GET MOVING COIL RESULTS FROM YOUR "BLUE SPOT" UNIT BY USING THE "WHITE SPOT" FRAME.

The whole made of solid castings, and front ring highly polished. THE UNIT can be attached by two screws B, which are provided, in one minute, and centred by means of the three screws A.

Frame, complete with diaphragm assembled and suspended as in moving coil practice, price 16/-. This can be fitted to either a cabinet or baffle by means of the three lugs provided.

Frame only, complete with front ring and all screws, 12/6.

Stand extra to either of above, 2/6. All post free.

WOLVERHAMPTON DIECASTINGS CO., Great Hampton Street, WOLVERHAMPTON.

TRADE ENQUIRIES INVITED.

THE "ARTILLERY" ELECTRIC TORCH

measures 2 in. wide by 5 in. high, a convenient size for carrying in the pocket, and switch cannot be accidentally left on and run down the battery. Specially manufactured to Government Specification for use in the ARMY. It is therefore made with the very best materials and workmanship. The ends of the case are brass and the body is Zinc, which cannot rust. Fitted with a powerful Bullseye Lens, white unscratchable reflector, and bulb, new "Ever-Ready" two-cell batteries (No. 1626) of full strength, capable of 6 hours' intermittent light for months with ordinary care and use. These torches, being Surplus, we are able to offer a limited stock at the very low price of

Each COMPLETE 2/6 WITH ORDER
Packing and postage in the U.K. 6d. extra.
Refills 1/- each. Spare bulbs, 2.5 volt, 6d. each.
THE TORCH CASE ALONE COSTS MORE THAN THIS TO MANUFACTURE.

Model de Luxe

Multi-range

DIX-ONEMETER

INSTRUMENT 55/-
IN CASE

MULTIPLIERS EACH 6/6

COMPLETE RADIO
OUTFIT

£4 10 0

Mirror Double Scale. AN IDEAL GIFT.

Huge Govt. Surplus Sale now on. Send stamped envelope for printed Sale List.

ELECTRADIX RADIOS,

218, Upper Thames Street, E.C. Blackfriars Stn., Met. Riv. City 0191

COPPER PAREX SCREENS

For the "D.C." Four.

Standard Screen, highly polished & mottled, 4/6
Tween Fieldless H.F. Choke 6/6
Six-pin Base 2/-

From your dealer or direct from

E. PAROUSSI, 10, Featherstone Bldgs., HIGH HOLBORN, W.C.1.

A HIGH MAST IS EQUAL TO TWO EXTRA VALVES

Everybody knows that to have a high aerial is to get extra powerful signals. The difficulty of fixing up a high aerial is banished if you fit a

P.R. PATENT STEEL MAST

DAMP PROOF!

ROT PROOF!!

GALE PROOF!!!

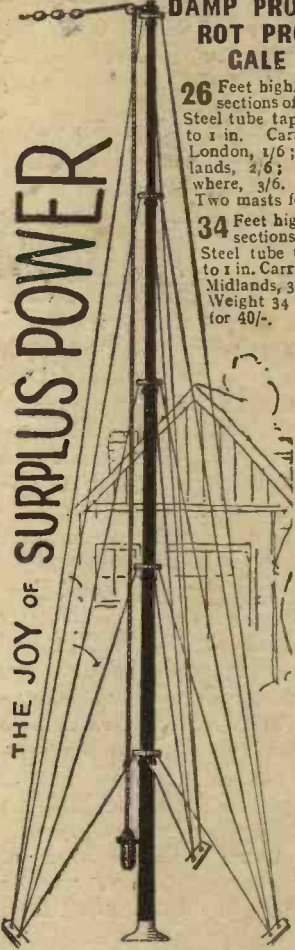

26 Feet high. In 3 sections of 1 1/2 in. Steel tube tapering to 1 in. Carriage, London, 1/6; Midlands, 2/6; elsewhere, 3/6. Weight 24 lbs. Two masts for 28/8.

34 Feet high. In 4 sections of 1 1/2 in. Steel tube tapering to 1 in. Carriage, London, 2/-; Midlands, 3/-; elsewhere 4/- Weight 34 lbs. Two masts for 40/-

The "Super" Mast.

42 Feet high. 29/6

In 5 sections of heavy 1 1/2 in. Steel tube tapering to 1 in. A real bargain. Carriage, London, 2/6; Midlands, 3/6; elsewhere, 4/6. Weight 46 lbs. Two masts for 55/-

P.R. MASTS

are made of British Steel in 9 ft. lengths, 10 m. 1 1/2 in., tapering to 1 in. and are supplied with cast-iron bed plate, steel ground pegs, stay rings, galvanised steel flexible wire stays cut to lengths, pulleys, bolts and fullest erecting instructions. No further outlay necessary.

NO HOLES TO DIG. ONE MAN'S JOB.

Any intelligent man can assemble and erect a P.R. Mast in a couple of hours. Our patent Mast being tapered. It is easy for anyone to raise it from the ground into position. Ordinary tubular Masts require several hands and difficult rigging to do this. To help you the wire rope is sent cut to size—a saving of endless worry. Imagine sorting out 500 ft. of rope in your back garden!

Minimum Radius 3 ft. 6 in.	GUARANTEE Money refunded without question if not satisfied.	The easiest Mast to erect.
----------------------------	---	----------------------------

PAINTING. Any protective coating applied before dispatch gets so damaged by the Carriers that it is essential to paint the Mast before erection. All P.R. Masts are sent out oxide-finished ready for painting. One coat of P.R. Colloid covering applied—a 10 minutes' job—to all parts of the Mast when ready to erect sets dead hard in an hour and protects it against all weathers.

PRICE OF ACCESSORIES. P.R. Colloid Covering sufficient for a Mast—with brush, 2/6. Halyard Log Line—Ryland's patent rot-proof; For 26-ft. Mast, 1/6; 34-ft., 2/-; 42-ft., 2/6. For 100 ft., 3/6. Note—Double length supplied to make lowering of Aerial easy.

A HIGHLY EFFICIENT AERIAL. P.R. Aerial is made of 14-28 High Conductivity Pure Copper Enamelled Wire—each strand insulated from its neighbour to give the highest signal strength obtainable. 100 ft., 4/3; 60 ft., 2/3.

17-42, PATERNOSTER SQUARE, LONDON, E.C.4. Opposite G.P.O. Tube.

P.R. MASTS
IF YOU USE VALVES it will pay you to write to us for particulars of the famous 3/6 range of P.R. valves. Each valve has a written guarantee of life and performance.

TRANSATLANTIC TENDENCIES

—continued from page 277

The point of considerable interest in the Grebe receiver is the adjustable inductance in series with the usual inductance in the grid circuit. By varying this the proportion of capacity to inductance can be adjusted for the particular conditions. Kolster utilises the same principle in a slightly different way, for there a variometer is used in the first grid circuit.

First Grid Circuits

Stromberg-Carlson uses a scheme similar to Pfansteihl and Fada, but here the volume control (a note on this is given later) is placed across the aerial inductance. Bosch adjusts the first grid circuit by means of a variometer, but this, it will be noticed, is directly in the aerial—or, rather, in some cases is directly in the aerial and in others joined to a fixed condenser as shown. Freshman taps the aerial coil in two places, while Splitdorf has a tapped direct-coupled scheme together with a variable inductance, so as to adjust the set for given aerial conditions.

The schemes used by Freed-Eisemann and Amrad are particularly interesting, as here, in the case of Freed-Eisemann, we have a tapped radio-frequency choke, untuned, in the first grid circuit, the first valve thus being only what may be termed a coupling valve. A similar scheme used in Amrad places a resistance in series with the radio-frequency choke.

Passing now to the methods of obtaining stability we have another series of interesting diagrams. Amrad and Fada use the scheme known in this country as the "split primary" high-frequency coupling.

Pfansteihl, Kolster, and Splitdorf, use a fixed resistance in each grid circuit to prevent oscillation, this value being in the case of the Kolster 800 ohms, and in the Splitdorf 600 ohms. Grebe now use a very interesting scheme in which a very small adjustable condenser is placed in each grid circuit, while, of course, the coils are binocular, as previously mentioned.

At one time the Grebe firm used the split-primary method of neutralising, but after an unsuccessful action with the Hazeltine Corporation they changed over to the present scheme.

Stromberg-Carlson and Freed-Eisemann use what is generally termed Hazeltine neutralising, although the Hazeltine patents cover a number of different methods, including the split-primary in some of its forms. The tapping is taken in a different place on the Freed-Eisemann from that of the Stromberg-Carlson, and for this reason the values of the neutralising condensers are somewhat different.

A Novel Scheme

The Bosch scheme is similar to that used in the Freed-Eisemann and Stromberg-Carlson, but instead of having a tap on one coil, two separate coils are used at right-angles to one another. The Freshman has a peculiar scheme using a combination of a resistance and a capacity as shown.

The Federal looks very strange and complicated, but it is less so when examined carefully. In this receiver the filaments are run in series and radio-frequency chokes are placed in each leg of each valve. It will be noticed that two small coils are also placed in the legs of the valves above the points where the fixed condensers are joined to them. These coils, in conjunction with the small condensers joined between the grid and the fila-

ment, form a special neutralised circuit.

This receiver is the only one in the list which works directly off a frame aerial built in the cabinet, although in the case of the Fada and others arrangements are made for the attachment of a frame when desired. In this series of diagrams I have included one showing the scheme used in the Spartan receiver.

Various Volume Controls

The control of volume is effected in a number of different ways. In the case of the Freed-Eisemann, a variable resistance is shunted across the primary of the last radio-frequency transformer, while in the case of the Freshman a variable resistance is shunted across the secondary of the first audio-frequency transformer. In the Splitdorf the grid circuit of the detector valve is similarly shunted, while in the Bosch the first radio-frequency valve can have its voltage varied as shown. The Stromberg-Carlson uses a rather elaborate scheme in which one volume-control knob simultaneously varies two separate 10,000-ohm resistances, the first being placed across the aerial inductance and the second across the primary of the last radio-frequency transformer.

In the Grebe a variable resistance is shunted across the primary of the last radio-frequency transformer, and a similar scheme is used in the Pfansteihl. In the Amrad a peculiar scheme is used, a variable resistance being shunted right across the winding, which serves both as neutralising and primary winding in the split-primary transformer. The effect of this is not to vary the plate voltage, but the radio-frequency voltage applied to the next valve.

In a further article a number of other features will be described in a similar way.

INDEX TO ADVERTISERS

	PAGE
Aircraft Co.	316
Benjamin Electric, Ltd.	308
Bedford Electrical & Radio Co., Ltd.	309
Belling & Lee, Ltd.	312
British General Mfg. Co., Ltd.	296
Brown, S. G., Ltd.	282
Burtou, C. F. & H.	296
Burne-Jones & Co., Ltd.	304
Carrington Mfg. Co., Ltd.	313
Celestion Radio Co.	295
Cook, H.	314
Cosser, A. C., Ltd.	252
Cromwell Engineering Co.	315
Day, Will, Ltd.	303
Dublilier Condenser Co. (1925), Ltd.	286
Eastick, J. J., & Sons	314
Electradix Radios	319
England-Richards Co., Ltd.	307
Edison Swan Electric Co., Ltd.	306
Farnell, E., & Sons	316
Forno Co., The	299
Ferranti, Ltd.	280

	PAGE
Garnett, Whiteley & Co., Ltd.	293
Gambrell Radio, Ltd.	316
Gilbert, J. C. (Cabinets)	299
Harlie Bros.	311
Holzman, Louis	314
Hughes, P. A., & Co., Ltd.	286
Igranite Electric Co., Ltd.	305
Impex Electrical, Ltd.	307, 312, 314, 315, 316
International Corr. Schools, Ltd.	309
Jackson Bros.	317
K.N. Electrical Products, Ltd.	301
Lewis, P. W., & Co., Ltd.	309
Lectro Liny, Ltd.	318
Lissen, Ltd.	281
London Elec. Wire Co. & Smiths, Ltd.	301
Lisenin Wireless Co.	316
Lyons, Claude, Ltd.	316
"London Calling"	313
Marconiphone Co., Ltd.	249, 310
Metro-Vick Supplies, Ltd.	Cover iii
Morris, J. R.	296
Microfuses, Ltd.	312
Mullard Wireless Service Co., Ltd.	Cover ii
Oakley, A. E.	315
Ormond Engineering Co., Ltd.	289
P.D.P. Co.	314
Pickett's Cabinet Wks.	318

	PAGE
P.R. Masts	319
P.R. Valves	313
Paroussi, E.	319
"Popular Wireless"	311
Raymond, K.	315
Ready Radio Supply Co.	312
R.I. & Varley, Ltd.	Cover iv
Rothermel Corporation, Ltd.	250, 251, 301
Sifam Electrical Inst. Co., Ltd.	315
Six-Sixty Radio Company	285
Standard Wet Battery Co.	317, 318
Squire, F.	309
Taylor, C.	312
Technological Institute of Gr. Britain	317
Telegraph Condenser Co., Ltd.	313
Transformer Repair Co.	316
Whiteley, Boneham & Co., Ltd.	299
Wolverhampton Die Castings Co.	319
Weston Elect. Inst. Co., Ltd.	305
Wingrove & Rogers, Ltd.	303
WIRELESS CONSTRUCTOR Envelopes	303

All communications concerning advertising in "Wireless Constructor" must be made to John H. Lile, Ltd., 4, Ludgate Circus, London, E.C.4 Telephone: City 7261.

METROVICATION

FOR ALL-ELECTRIC WIRELESS OPERATION

THE ALL ELECTRIC VALVE

If only valves would work without accumulators and without H.T. batteries!

Yet this is now actually possible with the Met-Vick All-Electric Valve which in combination with a suitable eliminator (like the Model 'B') enables everyone living in an electrically lit house to operate a wireless set straight off the mains like a lamp or other domestic appliance.

These amazing Met-Vick All-Electric Valves have solved the problem of mains operation. They are standardized by the leading set makers. They are so designed that they can be plugged into an existing battery set without altering the wiring, thus making conversion into an All-Electric set easy.

Met-Vick All-Electric Valves will improve a set out of all recognition. With these wonderful valves and All-Electric operation the H.T. never fades away, the L.T. is always just right.

Met-Vick All-Electric Valves are without doubt the most supremely successful valves obtainable.

Convenient hire purchase terms arranged if desired.

MET-VICK All-Electric Valves AC/G for all but last stage 15/-—AC/R last stage(power)—17/6.

Disc Adaptors, price 6d. enable MET-VICK All-Electric Valves to be fitted into existing Valve Holders.

Fully descriptive illustrated literature and name of nearest dealer on request.

MET-VICK VALVES-SETS-COMPONENTS

Metro-Vick Supplies Ltd., 155, Charing Cross Road, London, W.C.2.



The model "B" Eliminator connected to a wall plug or lamp socket provides heater current for the All-Electric Valves, five tappings for the H.T. supply, up to 180 volts 20 milliamps, and automatically regulated grid bias taps for the last stage. Price complete with Met-Vick Rectifying Valve for A.C. £8. For D.C. £7 2 6.



The Met-Vick 3 Valve All-Electric Mains Operated Set for Local, Day-entries & many Continental Stations. The extremely high quality reproduction is a special feature. It is very suitable for new Regional Scheme. Price complete with Valves, coils and Royalties, A.C. £12 17 0. D.C. £13 8 0.



The Met-Vick 4 Valve All-Electric is called the "All Necessary Performance" set, one H.F. stage, low loss coils and condensers, loose coupled Tuned aerial, it gets anywhere and everywhere at Loud Speaker strength. Price, complete with Valves, coils and Royalties A.C. £17 14 6. D.C. £18 7 6.



Met-Vick 5 Valve All-Electric. More powerful, of course, than the Met-Vick 4. In beautiful cabinet with cupboards for L.T. and large size H.T. Eliminators, 220 volts 35 milliamps. For A.C. or D.C. supply price complete with all accessories, except Loud Speaker, and including Royalties. In Oak £47 9 0. In Mahogany £50 19 0.



For Constructors: This Met-Vick combined Transformer furnishes current for the Met-Vick indirectly heated Valves and for the Rectifying Valve in Eliminator. Price, any voltage £1 17 6.

R.V. 136.

Real Choking Efficiency

The new SCREENED GRID Reactive Anode Unit

Bi-Wire



Duplex wound

In 1927, when we first marketed our Bi-duplex Wire-wound H.F. Choke, almost immediately it became universally popular because of its wide range of real choking efficiency. That range has now been increased to cover without a break all wave lengths from 30-4000 metres. This has been made possible largely as a result of the famous Bi-duplex winding, which in addition ensures negligible self-capacity with ample inductive reactance, and eliminates any pronounced resonant peak.

There is practically no external field with the R.I. & Varley H.F. Choke so that it can be mounted close to other components without fear of interaction.

Multi-Cellular H.F. Choke 9/6

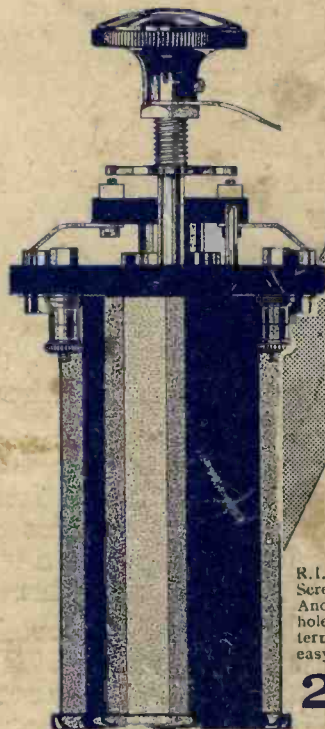

R.I. and Varley Screened Grid Anode Unit. One hole fixing. With terminals for easy connections.

27/6

R.I. and Varley components are always up to date. This year we have produced over thirty new components—all up to the usual R.I. and Varley standard.

The new Screened grid Anode Unit is a typical example. It provides correct values of inductance and reaction for efficient coupling after a screened grid valve. A change-over switch permits BOTH THE ANODE AND REACTION WINDINGS to be altered simultaneously so that the component covers medium wave lengths between 250 and 600 metres and long wave lengths between 850 and 2000 metres.



THE MARK OF BETTER RADIO

Kingsway House, 103 Kingsway, W.C.2 Telephone: Holborn 5303

