

# The Wireless Constructor

6<sup>D</sup>  
MONTHLY

EDITED BY  
**PERCY W. HARRIS, M. I. R. E.**  
VOL. VI. AUGUST, 1928. No. 22.

*Goldend*  
**Biggest Boon for Years!**

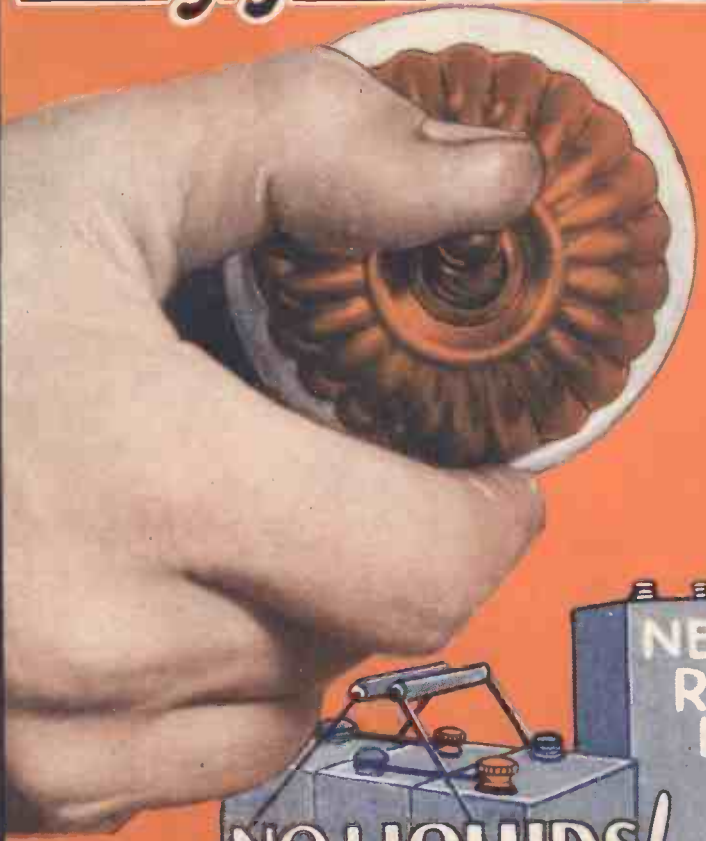

**BUILD THE  
HARRIS  
"STEDIPOWER"  
L.T. UNIT**

**REPLACES  
ACCUMULATORS  
ON A.C. MAINS**



**CHEAPER THAN  
CHARGING**

**NO LIQUIDS!**

**NEVER  
RUNS  
DRY**

*No Changes  
in your  
Set!*

My hearing, my pocket, and  
my commonsense tell me  
"Mullard every time"

If you like take them in rotation. **My hearing**—well the improvement in reception when using Mullard P.M. Valves is obvious without delving into curves of frequencies, there's definition about it, it's clear, and when long distance stations are in you haven't that feeling that you've only barely got them, and always in danger of losing them. Oh, no, Mullard valves improve the volume and reach of your set tremendously.

**My pocket**—Accidents will happen, and the toughness and robust construction of the Mullard P.M. Filament is a decided advantage; the time they last is amazing. Why, using your set 3 hours a day for 350 days makes hardly any difference to the efficiency of Mullard P.M. Valves, and their .075 amp. filament consumption gives the L.T. accumulator a chance to economise.

The range of Mullard products extends to-day beyond the most comprehensive range of valves on the market.

It comprises speakers, H.T. Units, and the latest is the Mullard "Permacore" Transformer with its silver winding.



One of the real good things that pack into small parcels.

A Mullard product commands attention, **my commonsense** tells me—Mullard every time.

# Mullard

## THE · MASTER · VALVE



# CONTENTS

	Page		Page
Editor's Chat . . . . .	219	More About the Seven-Valve Super-Het	247
The Harris "Stedipower" L.T. Unit	221	In the Wireless Workshop	248
Building the Harris "Stedipower" L.T. Unit	227	Loading Your Set for 5 X X	249
The B.B.C. Report	231	Happenings at Savoy Hill	253
Using the Thirty-one Tested Circuits	232	What's New	255
The "Output" Amplifier	233	In Lighter Vein	257
Within the Vacuum	237	Push-Pull	259
Queer Queries	238	Chats at the Work-Table	262
The "P.C." Three	239	For the Pick-up Enthusiast	266
Radiogramophonics	245	A Page for the Handyman	270
Results with the "Roadside" Four	246	Our News Bulletin	272

*As some of the arrangements and specialities described in this Journal may be the subject of Letters Patent, the amateur and trader would be well advised to obtain permission of the patentees to use the patents before doing so.*

EDITED BY  
**PERCY W. HARRIS, M.I.R.E.**

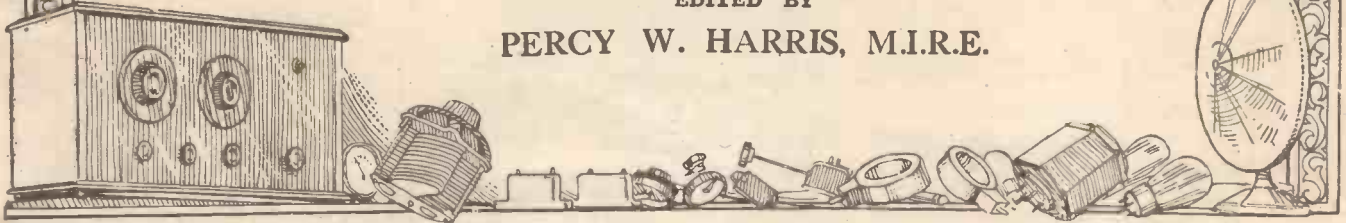

Accumulators Supplanted by the "STEDIPOWER" L.T. UNIT Operating from A.C. Mains



The "Stedipower" L.T. Unit represents one of the foremost achievements of modern times. No longer will it be necessary to have accumulators with all their attendant drawbacks of recharging, sulphation, poisonous fumes, and corrosive acid. In addition to these advantages the running and maintenance costs are almost negligible—no valves to burn-out and practically indestructible. Wherever A.C. supply is available this Unit will save you many pounds and avoid the dissatisfaction of missing part of the programme through exhaustion of the accumulator.

Price, Ready Wired and Tested .. £9 10 0  
A comprehensive range of lists, including several new Magnum products, will be sent on receipt of 1½d. stamp.

Wireless Constructor Envelopes are now available.

Price 1/6 each, by post 1/9 each.  
No. 1.—The "Radiano Three."  
No. 2.—The "Concert Four."  
These envelopes contain Blueprints and full constructional details. We specialise in the above and can supply all components as specified. Lists on application.

Construct the  
**"STEDIPOWER" L.T. UNIT**  
described in this issue by Mr. Percy W. Harris.

1 Oak Cabinet, with baseboard as described	2 s. d.
1 Ebonite Panel, 7 in. x 7 in., ready drilled	1 1 0
1 R.I. Special Transformer and 2 Chokes	0 3 8
1 Kuprox Rectifying Unit	3 3 0
1 Tobe Condenser, Type A	1 5 0
1 Sifam Voltmeter, 0-6 volts	1 10 0
4 Belling-Lee Terminals	1 5 0
1 Igranite-Pacnet Rheostat, 30 ohms	0 3 0
1 Igranite-Pacnet Rheostat, 10 ohms	0 2 6
2 Magnum Panel Brackets (small)	0 2 6
1 Tumbler Switch	0 1 6
Glazite and Sundry Screws	0 1 6
	£9 0 0

Any of the above parts supplied separately if required. Cabinet can be supplied in Mahogany at an extra cost of 2/-.

**BURNE-JONES & CO. LTD.,**  
**MAGNUM HOUSE**  
TELEPHONE: HOP 6257-8  
**288, BOROUGH HIGH ST.**  
**LONDON. S.E.1**

**"ROADSIDE FOUR"**  
PORTABLE RECEIVER

as described by Mr. Percy W. Harris in the May issue of "Wireless Constructor."

Total Weight 27 lb. Overall Size 17" x 17" x 8"

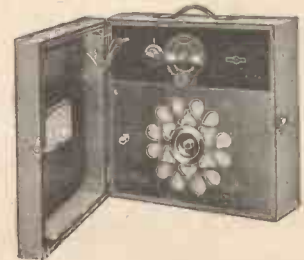

The ideal set for alternative programmes.

In spite of its low price this portable receiver is unquestionably one of the simplest and most efficient portables.

It is entirely self-contained and so simple that a child can operate it.

Price, ready wired and tested and including 4 valves and Extra Aerial for 5 X X

£17 0 0

Royalty £2 10 0

If you wish to build this set yourself we can supply the kit of components.

Price £13 6 0

# COSSOR brings them in



**COSSOR** Valves bring you the pick of Europe's broad-cast on the wonderful **Coscor "Melody Maker."** They give you purity of reproduction as well as distance. **Coscor** Valves bring success to any Receiver. Use them in yours.

**Post this Coupon Now!**  
To A. C. Coscor, Ltd., Highbury Grove, London, N. 5.  
Please send me your large constructional chart "How to build the Coscor "Melody Maker."

Name.....  
Address.....  
W. Cons. Aug.

**COSSOR VALVES**  
improve any Set

Adv. A. C. Coscor, Ltd., Highbury Grove, London, N. 5.

3098

Round the World  
with the  
**BROWN**



The "Brown"  
Q Loud Speaker  
Price £15 15 0



## In Japan (Land of the "Cherry Blossom")

All over Nippon broadcasting is enjoyed and, being artists to their finger tips, the Japanese will have the "Brown" Loud Speaker. Its faultless rendering of the truth charms east as well

as west. All the world over the "Brown" Loud Speaker is appreciated. Everywhere it is recognised as the standard of Loud Speaker reproduction.

They listen to the  
**Brown**

The Loud Speaker on which the sun never sets!

Adv. S. G. Brown, Ltd., Western Avenue, North Acton, London, W. 3.

4001



# The WIRELESS CONSTRUCTOR

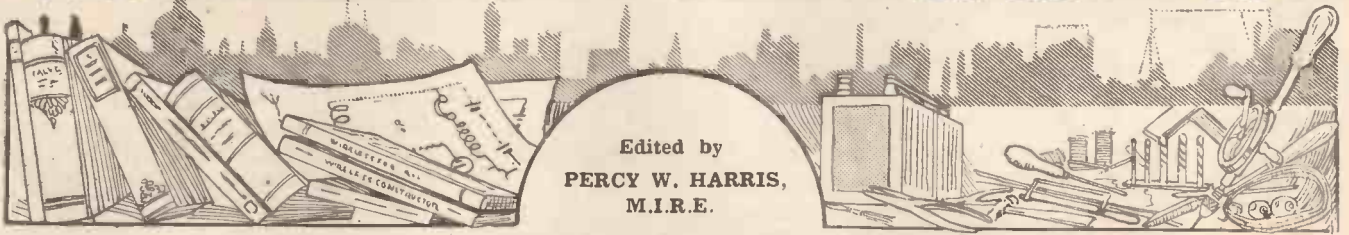

Published by the Amalgamated Press, Fleetway House, Farringdon Street, E.C.4

## THE EDITOR'S CHAT.

Percy W. Harris, M.I.R.E., the Editor of the "Wireless Constructor," announces the arrival of the Harris "Stedipower" L.T. Unit, which he considers to be "The Biggest Boon for Years."

It is with no little satisfaction that we are able to announce this month the Harris "Stedipower" L.T. Unit, on which work has been conducted for many months and which will prove such a boon to many thousands of wireless listeners.

The secret has been carefully kept, and it would have been possible to have published the results of our experiments a month ago, but it was decided that nothing should be announced until the most drastic tests had been conducted upon the unit to make quite sure that it would fulfil in every detail the demands likely to be made upon it. Every set so far published in the WIRELESS CONSTRUCTOR can be worked from this unit, including the seven-valve super-heterodyne described last month.

### A Technical Triumph

Readers of the WIRELESS CONSTRUCTOR are thus now in the unique position of being able to build marvellously sensitive and selective wireless equipment capable of being run entirely from A.C. mains and without exterior aerial or earth. To this end it is only necessary to construct the seven-valve super-heterodyne, the high-tension mains unit described in the last issue, and the new Harris "Stedipower" Unit.

No other British wireless journal has been able to provide such a service for its readers, having regard to the fact that no special and expensive A.C. valves are used, and that the L.T. Unit is capable of supplying current not only to this set but to any other receiver so far published in our columns.

That the new unit will come as a surprise to the more advanced student as well as the relative newcomer is evident by the fact that, as recently as May 24th, the well-inspired wireless correspondent of "The Times," written "Low-Tension Supply," stated: "As to the methods of filament heating which involves the rectification of the alternating current, it is found to be very difficult to smooth a low-voltage rectified alternating current

greater than a quarter of an ampere without either wasting a considerable amount of power or else allowing the smoothing apparatus to become too unwieldy and expensive. Consequently the most general practice has been to use the rectified current to charge accumulators." How the problem has been overcome is fully explained in the article which follows.

And now to thank the numerous readers who have so kindly responded

### BRITAIN'S RADIO PIONEER



Sir Oliver Lodge, F.R.S., at his country home near Stonehenge, where he recently celebrated the 77th anniversary of his birthday. It was Sir Oliver Lodge who, in the very early days of wireless, invented "tuning" for transmitting and receiving circuits.

## The Editor's Chat—continued

to our invitation to send in postcards describing the kind of sets they would like to see. Postcards have poured in from all over the country—England, Scotland, Wales and Ireland, and also from the continent.

Quite a number have asked for a super-heterodyne on the lines of that published last month, while a large section are asking for a set to specifications which the "Concert" Four—published as a constructional envelope—exactly fills. The "Concert" Four, as has been previously stated, is a four-valve set with one stage of high-frequency, and a switch for immediately changing from four to three valves when desired for local station reception.

### A Selective Set

It is very selective, gives admirable quality, and is very easy to handle. The Envelope contains not only very full constructional details with photographs and illustrations, but a full-sized blue print which greatly facilitates the wiring up.

It has been previously mentioned in these pages that, owing to the very large circulation of the WIRELESS CONSTRUCTOR, it is necessary to go to press well in advance of the publishing date, and the present issue is the first in which it has been possible to include sets built specifically in response to requests sent in.

### A Useful Amplifier

Many readers have asked for a separate push-pull amplifier which can be added to any existing set so as to give proper reproduction with a moving-coil loud speaker. For while the "Super-Quality Amplifier" already published is admirable for replacing existing audio-frequency units which may be imperfect, many

readers have sets which suffer only from the defect of giving not quite sufficient undistorted volume for a moving-coil speaker, and the neat little push-pull amplifier which Mr. Harry P. Wootton is describing in the current issue should meet their needs in every way.

### The "P.C." Three

The second set, the "P.C." Three, described by Mr. Kelsey, has also been planned to meet the stated requirements of a large number of readers, and is a particularly handsome receiver combining sensitivity with high quality of reproduction and a sharpness of tuning unobtainable with sets using a detector and two stages of low-frequency magnification.

The remarkable success which has attended the publication of the "Roadside" Four is again reflected in the correspondence published this month, and particular interest attaches to the letter from a reader in Germany who, together with a number of friends, has built it up and is obtaining very successful results.

\*\*\*\*\*  
 \* READERS' \*  
 \* "RADIO" RESULTS \*  
 \*\*\*\*\*

### "Radio" Short-Waver in India

SIR,—I am sure you will be pleased to hear that this morning at 5.30 a.m., Indian Standard Time, I received part of the programme from WGY, Schenectady, U.S.A., on the two-valve short-wave set described in the June, 1927, number of your valuable journal.

The coils used were: aerial 13, grid 5, reaction 7 turns respectively.

The reception of speech, the singing and the music rendered by the orchestra of a hunting scene was good and clear. I got the call-sign WGY during the performance. I am pleased to say that this is the best S.W. set out of quite a dozen that I have built during the past two years.

Yours faithfully,  
 E. CLIFT.

Bangalore, Mysore,  
 India.

### "Radiano" Three on Short Waves

SIR,—You will no doubt say that I am an aggressive correspondent in view of two previous letters on the subject of the "Radiano" Three, but with regard to the first, which you kindly published, I must apologise for my modesty in the claims I put forward for this set on the short waves.

I herewith append list of S.W. stations received in order of frequencies. In all cases marked (\*) the station has been definitely identified by call-sign.

- 7,963 k.c. Doberitz, A F K.
- \*9,375 k.c. Melbourne, 3 L O.
- \*9,554 k.c. Hilversum, P C J J.
- \*9,554 k.c. Schenectady, 2 X A F.
- \*10,000 k.c. Bergen, L G N.
- \*12,500 k.c. Chelmsford. 5 S W.
- \*13,661 k.c. Schenectady. 2 X A D.
- 18,726 k.c. Rocky Point, 2 X G.

In addition to these, dozens of Morse and telephony stations have been received.

In conclusion, what more can a radio enthusiast ask than the "Radiano" Three? I ask you!

All short-wave work is done on an aerial consisting of twin flex, 4 yds. long, slung across the room.

Yours,  
 H. RUSSELL.

S.W.19.





# THE HARRIS "STEDIPOWER" L.T. UNIT

FULL DETAILS OF THE  
BIGGEST BOON  
FOR YEARS.

*How the Filament Supply  
Problem has been solved at last.*

By PERCY W. HARRIS,  
M.I.R.E.



IT is with the greatest pleasure that I am able to present to readers of the WIRELESS CONSTRUCTOR this month a new unit which has been characterised by the experts who have seen it as the biggest advance in radio for many years.

Briefly it consists of a simply constructed unit which, when connected to A.C. mains, completely replaces the accumulator, giving with any set pure, hum-free D.C. current at a steady voltage and negligible cost of running, just so long as it is switched on.

Unlike all the previous schemes put forward (most of them of a makeshift variety) for the purpose of running valve filaments from the mains, no alterations whatever are required in the set to which this unit is connected, nor are special valves used.

## Immense Advantages

The results with this unit are indistinguishable from those given by a fully-charged accumulator in first-class condition, and once it has been simply adjusted to suit the particular set with which it is used it requires no more attention than to be switched on and off whenever the set is operated.

The WIRELESS CONSTRUCTOR is proud to be the first British journal to give such a design to its readers, and the article which follows gives full details for the complete constructional work. Nothing like it has ever been described before, and it has completely replaced accumulators in the WIRELESS CONSTRUCTOR laboratory for some time past.

A few minutes' thought will show the immense advantages of such a device. No longer is the wireless listener who has alternating current mains in his house faced with the problem of constantly taking his

accumulator to be recharged, or, if he charges it himself, disconnecting it from the set, putting it on charge, watching its voltage, making up for the evaporation of liquid by adding distilled water, and always risking burning holes in the carpet if the accumulator should be upset.

## And Saves Money

No longer will he be faced with the risk of an accumulator running down in the middle of the only interesting programme for many nights. No longer will there be the constant expense of charging—just a pure, hum-free, steady D.C. current from the unit at a cost which works out, when the unit is running a big set, at something of the order of a fortieth of a unit per hour! Taking the average cost of electric light and the

amount of use the average set is given, a rough estimate places the cost of running, at the outside, at a shilling a-month.

## Will Serve Big Sets

At the present time, if a continuous service is required with accumulators, two are needed, so that one can be used while the other is being charged. Furthermore, the high cost of accumulators and charging has caused many people, for economical reasons, to confine themselves to 2-volt valves, although it is known that the 6-volt types are superior in their performance—at least in the output stages.

The Harris "Stedipower" L.T. Unit, the name given to the new device, will operate 2-, 4-, or 6-volt valves equally well, and has a capacity amply sufficient to run a set with two

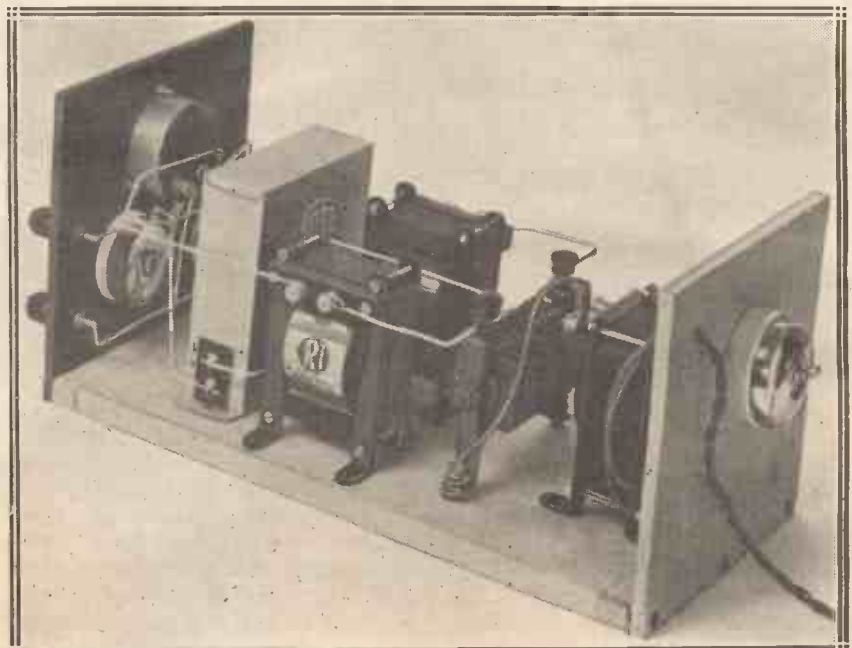

Here is the complete unit, with the on-off switch on the rear panel and rheostats and voltmeter mounted on the main ebonite panel. Note the Kuprox Unit, next to the two L.F. chokes.

## The Harris "Stedipower" L.T. Unit—*continued*

stages of high-frequency, a detector, and two stages of low-frequency, with two super-power valves arranged in push-pull in the last stage, on the assumption that the first four valves are of the .1-amp. variety and the two output valves each a quarter ampere. The total filament consumption in such a case being .9 amp. Similarly it will run the seven-valve super-heterodyne described in our last issue with a super-power valve in the output, as this set takes .85 amp.

to wear, and the only possible replacements, if any, will be required only after long periods, such as a year or two. Once installed and adjusted, it is switched on and off just like the electric light.

### A Real Boon

If at any time it is desired to connect this unit to some other and quite different set, a slight adjustment on one knob is all that is necessary to make the change. When it is con-

Perhaps the simplest way to explain the Harris "Stedipower" Unit is to consider how it came to be evolved in the WIRELESS CONSTRUCTOR laboratory. At the beginning of this year it was decided to begin experimental work with the idea of producing for the coming autumn a set which would operate entirely from the A.C. mains without batteries of any kind, and while this was immediately possible by using specially selected A.C. valves, the requirements of the WIRELESS CONSTRUCTOR set were rather stringent.

### Important Considerations

The technique that we have so carefully worked out in the last few years for our sets has been developed with existing types of valves, and while the special valves operating with interior heaters—e.g. Marconi-Osram K.L.1 type, and the Metro-Vick A.C. valves—were available, and will, when correctly used in properly designed sets, give good results, it was felt that it would be more satisfactory generally to devise a set which would use the existing and relatively inexpensive types of valves, so as to make as few changes as possible in the general design of the receiver.

Careful study of the problem showed that there were several ways of attacking it. It is possible, for example, to run certain of the valves in the set with raw A.C. on the filaments, while others require a smooth D.C. current for satisfactory operation. In all ordinary sets the valves are wired-up in parallel so that the larger the number of valves the greater the L.T. current, the voltage remaining the same for one or ten valves.

### Not a Satisfactory Scheme

By adopting series filament wiring the current consumed can be kept down to the maximum taken by any one valve, and as one increases the number of valves so the overall voltage correspondingly increases. To give actual figures we will take the case of a five-valve set with valves in parallel, 6-volt filaments being used. If all of these are .1-ampere valves, then we shall require half an ampere at 6 volts. If series wiring is used, then we shall require .1 ampere at 30 volts.

It is now possible to obtain satisfactory rectifying valves which will

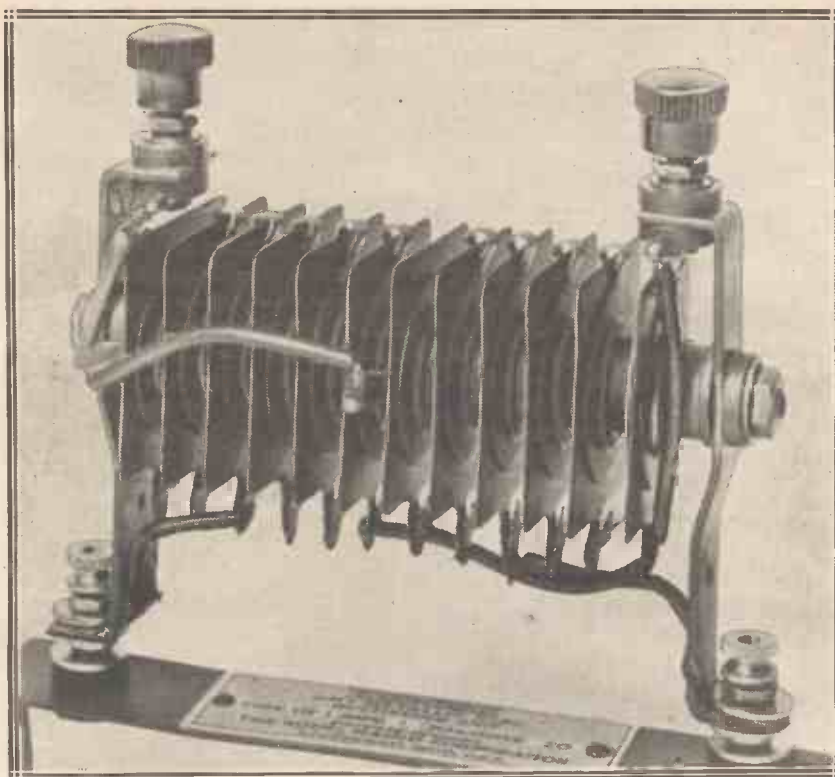

A close-up view of the Kuprox Rectifying Unit.

The unit itself has been constructed to give a maximum output of about one ampere, which is amply sufficient for all British sets, and it is not intended that the present model should run some of the more extravagant American sets which use  $\frac{1}{4}$ -ampere valves throughout, though it would be a simple matter, at slight additional expense, so to modify the unit that it would give up to 2 amperes.

### Dead-Silent in Operation

The Harris "Stedipower" Unit is dead-silent in operation, has no valves to burn out, no liquids to spill, no distilled water to be added, and, in fact, is dry throughout. There is nothing

considered the current taken to operate it is about half of that used by the average electric lamp used for illumination in the home, it will be seen that here at last we have the real boon for which we have been waiting.

To understand clearly the operation of the Harris "Stedipower" L.T. Unit the reader should have studied the articles which have been appearing in this journal dealing with units for giving high-tension supply from the mains. The first of these articles appeared in the March issue, and those readers who have not yet studied them carefully should take the first opportunity of reading them through, as it will help them greatly to understand the present device.



## The Harris "Stedipower" L.T. Unit—*continued*

pass a tenth of an ampere, and it is relatively simple to design smoothing systems for such a current, but the large size of the condensers and the losses which must be introduced in order to cut down the voltage make such a device both expensive to build and expensive to run.

### Series Wiring "Snags"

Furthermore, in general we like to have a super-power valve in the output of a good modern set if first-class quality is desired—even two, in either "push-pull" or parallel. Most of the super-power valves take a  $\frac{1}{4}$ -ampere filament current, although one, the Cossor Stentor Six, takes only 100 milliamperes. If series wiring is adopted to supply sets which have a  $\frac{1}{4}$ -ampere valve in the output, then those valves which did not consume a quarter ampere must be shunted and the total current taken by the whole will be a quarter of an ampere at a voltage equal to the voltage of the individual valves multiplied by their total number. It is not an easy matter to design a good rectifier and filter which will give a quarter ampere satisfactorily in the conditions in which such sets must work.

In investigations such as this it is always wise to set up before oneself an ideal and to endeavour to work up to it. The ideal in the WIRELESS CONSTRUCTOR laboratory was to produce a set working entirely from the mains which would derive its L.T. and H.T. supply from separate units, so that the design of the set itself could be made along lines which experience has shown to be thoroughly reliable and practical.

### Difficulties Appreciated

As we can supply high-tension current from the mains, it might at first seem simple to supply low-tension in a similar fashion so that a unit connected up to the L.T. terminals of the set would simply take the place of the accumulator, yet the more experience we have in wireless matters the more we appreciate the difficulties with which we are confronted when working along such lines.

Although at the time it did not seem practical to bring out a unit which would measure up to the ideal we have just indicated, an analysis of the problem was made to find just what would have to be done. It was

assumed, of course, that we should be working from alternating current mains, as these are widespread, and can be considered as the supply of the future.

### Analysing the Problem

To supply adequate filament current (up to, say, 1 ampere) at, say, 6 volts from A.C. mains, required the following essential apparatus.

(1) A transformer to step the voltage down from the high voltage of the mains down to one convenient to use in the set.

(2) A rectifier which will satisfactorily rectify (full-wave rectification if possible) current of at least 1 ampere.

(3) A smoothing system, to eliminate all ripple.

(4) Some means of adjusting the voltage on the output to exactly the figure we require (usually 6 volts, but sometimes 2 or 4).

Considering these items in detail, we find that (1) is immediately susceptible of solution, as it is a simple matter to design a low-frequency transformer which will step-down the

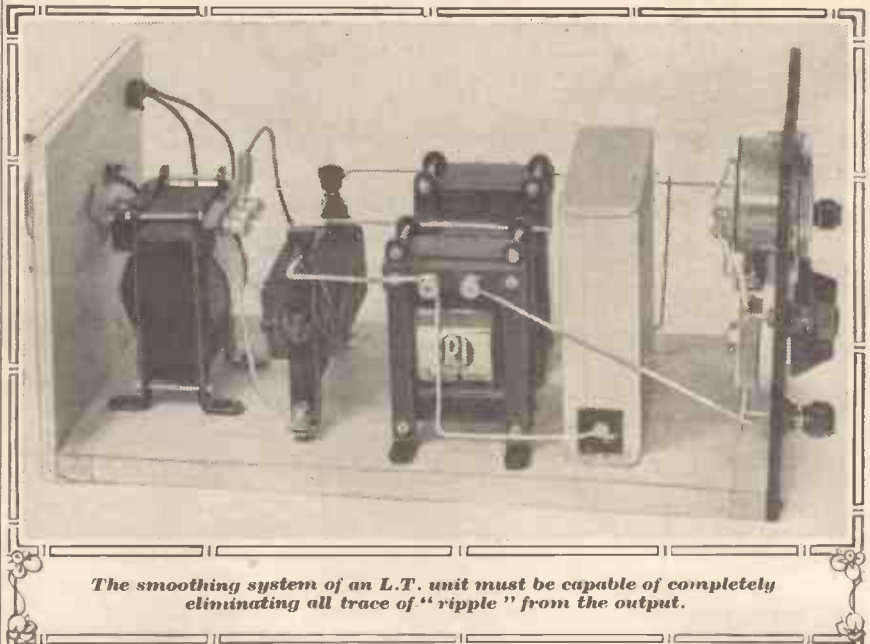

*The smoothing system of an L.T. unit must be capable of completely eliminating all trace of "ripple" from the output.*

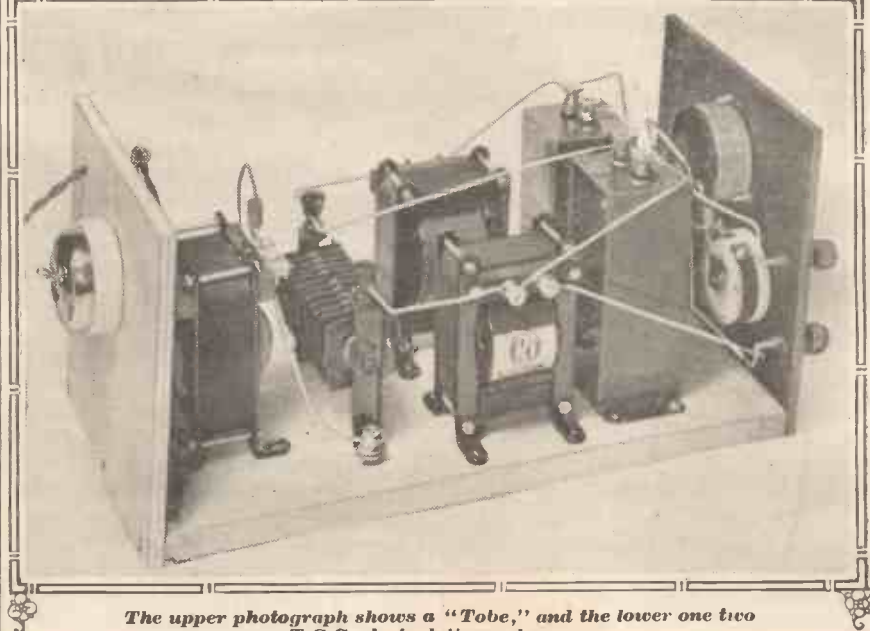

*The upper photograph shows a "Tobe," and the lower one two T.C.C. electrolytic condensers.*

## The Harris "Stedipower" L.T. Unit—continued

mains voltage. Point No. 2, concerning the rectifier, is not so simple of solution.

Previous articles have explained the various forms of rectifiers, and we know that we have the rectifying valve, the vibrating rectifier, the chemical rectifier and the relatively new "dry" or copper oxide rectifier. The ordinary types of rectifier valve such as used for high-tension supply units do not usually pass more than 50 or 60 milliamperes each, and if we want more current than this we must use these valves in parallel.

### Valve Rectifiers

In any case, it is not practical to use the ordinary types of rectifier valves to give an ampere of rectified current. Special types of valves,

Point No. 3 concerns the filter. Here we are "up against" certain very big problems. The general type of filter consists of chokes and condensers, the functions of both these having been explained in previous articles dealing with high-tension mains units (see WIRELESS CONSTRUCTOR for May, page 17).

It is, again, a fairly simple matter to design a choke which will carry the maximum of one ampere as desired, although as the current goes up the size of the choke also increases rapidly, owing to the additional thickness of the wire required, and the amount of iron needed to obtain the necessary inductance. When we come to the condensers, however, the case seems at first hopeless.

apparatus made to work on an artificial load for two or three days at a stretch, this being equal to several weeks of operation on a wireless set in average conditions; and it was found that the rectifying unit not only stood up and worked perfectly satisfactorily, but that it gave almost perfect rectification, the ratio of current in one direction to that in the other being about 150 to 1.

Incidentally, investigations on other rectifiers revealed the fact that with both the electrolytic and valve types the rectification was by no means always perfect, and there may be considerable irregularities in the shape of the half-wave form after rectification. While in such matters as battery charging such irregularities are unimportant, they make proper smoothing much more difficult. With the copper oxide rectifier used for this purpose, it was found that the shape of the wave form was very good and distinctly superior to most other rectifiers.

The current as supplied at this juncture was, of course, hopeless for filament operation, and when connected to a set gave a tremendously loud hundred-frequency hum due to the two half waves of the rectified fifty-frequency A.C. supply.

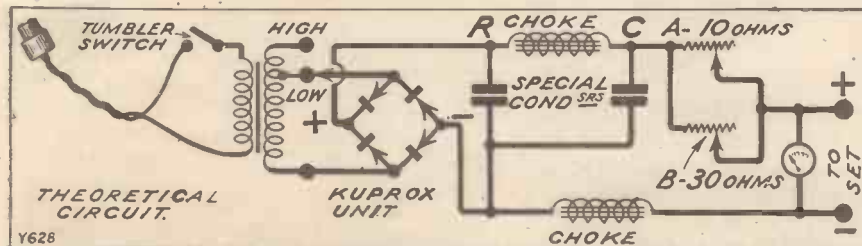

This theoretical circuit shows that the fundamental circuit is relatively a simple one.

such as those used for accumulator charging, will pass such a current—the Tungar valve will, for example, pass well over an ampere, but such valves have a relatively limited life and are not intended for continuous running, but only for intermittent use when charging accumulators.

Used in the latter way, they will last a long time, but one must not expect a long life from such a valve if it is used for several hours a day, every day. The electrolytic types of rectifier will handle the ampere we need, but are messy, and it is desired in our ideal set to dispense entirely with any liquid, either acid, alkaline, or neutral.

### Big Problems

No electrolytic rectifier I have yet handled can be left for long periods without attention, as they all need occasional topping up with distilled water. Vibrating rectifiers are noisy, frequently very useful for accumulator charging, but are unthinkable for use in such a unit as that we desired to build. The new dry rectifier, therefore, seemed to offer the best solution of our rectifier problem.

In order that really first-hand data should be acquired for the benefit of WIRELESS CONSTRUCTOR readers, special testing apparatus was built up for working out the problem. A transformer and chokes were designed, in collaboration with Messrs. Radio-Instruments, to meet my specification for the experimental gear, and a kind of "international search" revealed the fact that in America there was a form of full-wave dry rectifier, designed, as a matter of fact, as a replacement unit for a valve battery charger, which would give full-wave rectification and pass 1-ampere current without overloading.

Here the collaboration of the Rothermel Corporation was sought, and they kindly obtained for me the particular unit known as the Kuprox. The apparatus was then assembled with the transformer, rectifier, and chokes, and prolonged tests at a full load of an ampere given to find out whether this unit would satisfactorily give one ampere of rectified current (ignoring for a moment the smoothing) without faltering.

Meters were attached to all important parts of the apparatus, and the

### The Smoothing Condensers

Experiments were now made to find what amount of capacity was necessary to give smoothing; and whereas with the ordinary high-tension mains unit as previously described three condensers of 2, 2, and 8 mfd. respectively will give excellent smoothing with adequate chokes, even a 50-mfd. with the size of choke practical to use in such a unit not only did not smooth the current, but had not the slightest effect on the loudness of the hum. In fact, it was impossible to detect by ear when the capacity was switched on or off!

The reason for this will be clear when we consider what happens to the condenser and its charge. If, for example, we have capacity of a certain value and connected it to a 100-volt D.C. supply it will charge up, and the available energy contained in it will depend upon its capacity and the voltage to which it is charged.

If now we connect it to a 50-volt D.C. supply we shall get only half the



## The Harris "Stedipower" L.T. Unit—continued

previous charge into this condenser and at half the voltage, so that the power available is only a quarter of that of the 100-volt supply. Let us now come down to the region of 10 volts, and we shall find something in the neighbourhood of hundred times the capacity is needed to give the same smoothing.

Remember, too, that the current we want at the output is in the neighbourhood of one ampere maximum, whereas very few mains units for high-tension purposes are required to give even a tenth of this as high-tension current.

### Smoothing Difficulties

In a previous issue where we described the construction of a high-tension supply unit, we included chokes which would still have a good inductance value at 100 milliamperes, and these were fairly bulky components. A choke which would have, say, twelve henries inductance at one ampere would be very bulky and an expensive item, and outside the range of practical politics for such a unit as that which we desired to design.

It was therefore decided to have a choke of reasonable size, passing one ampere, and giving as large an inductance as possible for a reasonable cost.

The lack of smoothing in the choke would therefore have to be made up with additional capacity, although here we have a slight advantage with L.T. supply over the H.T. as the filaments of the valves retain heat to some extent, and the amount of ripple which would be audible on a high-tension unit as a bad hum would be inaudible with valve filaments. In any case, it would take too long to describe all the experiments in detail, and it is sufficient to say that after a time it was found that capacity in the neighbourhood of at least a thousand mfd. would be needed to give the smoothing required.

### The One Thing Lacking

With regard to control of the voltage at the output, this was a very simple matter to arrange. The position after two or three months' experiments was that we had ready a complete L.T. unit capable of taking current from the A.C. mains, rectifying it, and delivering this rectified but unsmoothed current at a value which suited any number of valve filaments up to nine at two or six

volts. The one thing lacking was adequate capacity at reasonable cost.

Of course, it would have been simple (if very unpractical!) to take, say, 250 4-mfd. Mansbridge condensers and join them all up in parallel, but the size and expense of such an arrangement would immediately rule it out of court. A careful watch was kept upon technical literature in all countries, particularly American literature, and later an announcement was found regarding a new form of electrolytic condenser, reputed to have a capacity of well over a thousand mfd., provided one did not use at an excessively high voltage.

### Success At Last!

Cablegrams were soon in transit across the Atlantic, and a rush order was then sent to the Tobe-Deutschmann Company in America, through Messrs. Rothermel, to despatch at once an advance specimen of their new dry condenser, especially for the benefit of the WIRELESS CONSTRUCTOR

readers. The condenser, straight from the factory, not even properly labelled, was despatched immediately, and in due course arrived at the WIRELESS CONSTRUCTOR laboratory. Data sent with it showed that it had a total capacity of 3,600 mfd., yet in spite of this the size of the unit was no more than  $1\frac{1}{2}$  in. by  $4\frac{1}{2}$  in. by 5 in.

Without delay this condenser was fixed into its vacant place in the WIRELESS CONSTRUCTOR unit and connected up at once to the seven-valve super-heterodyne described in the last issue.

I confess to considerable excitement when I switched it on. Would or would not the unit work? A few adjustments put the output voltage at six—and the result—complete freedom from hum and results indistinguishable from the accumulator!

Once this result was achieved a number of practical points had to be considered and the design of a complete unit undertaken. It must be

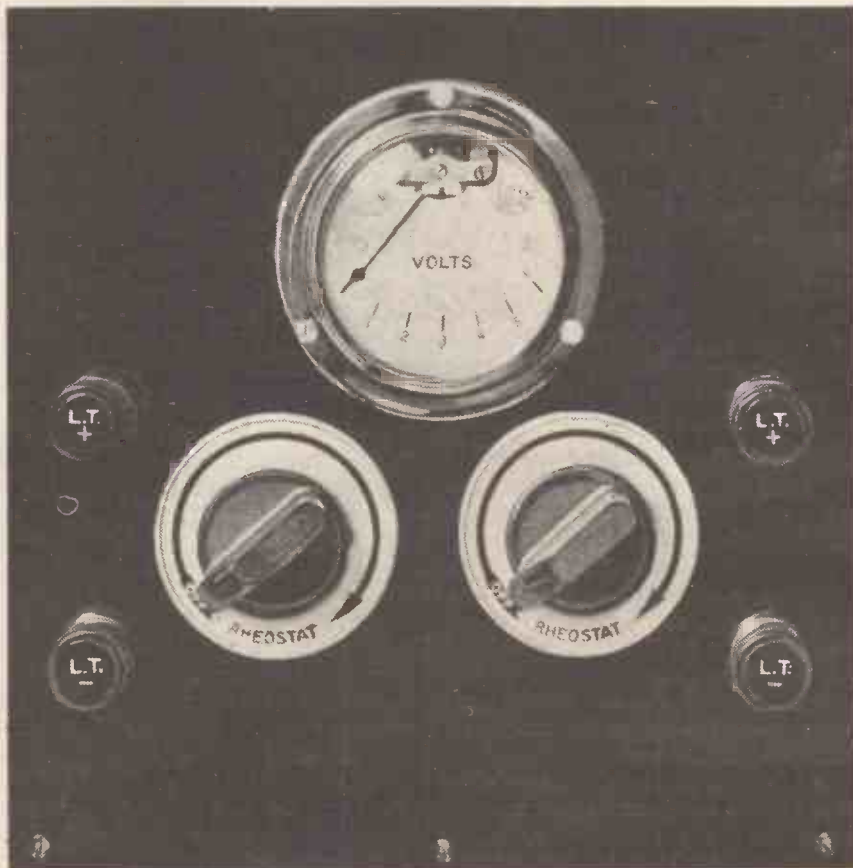

The arrangement of the panel-face is very straightforward. The hole for the voltmeter is easily cut out with a fretsaw or holes may be drilled round the edge of a circle, any inequalities being hidden later by the flange of the instrument.

## The Harris "Stedipower" L.T. Unit—continued

remembered that up to this point the apparatus was experimental, the values chosen were approximate, and the whole apparatus unsuitable for general use. The result desired, however, was achieved, namely, the production of steady, uniform low-tension current, exactly replacing the current drawn from an accumulator.

### Voltage Adjustment

The next step was to work out a practical piece of apparatus which would give the necessary control to suit all British conditions and having the highest efficiency possible from input to output. As we had already found in high-tension units, the output voltage was partly dependent upon the load, so that the larger the load the lower the output voltage—other conditions being equal.

The design of the voltage adjusting scheme required some thought, for obviously whichever device was incorporated in the set would have to carry a maximum of one ampere without undue heating.

There are comparatively few filament resistances which will carry this current satisfactorily, and the selection had to be carefully made. After many tests it was decided to incorporate the Igranac-Pacent Porcelain Rheostat—or, rather, rheostats, for two are used. One of these, the 10-ohm variety, will carry one ampere without overheating; and the other, the 30-ohm pattern, will carry half an ampere satisfactorily. These two are wired in parallel, and one or the other is used according to the load we have on the set. When one is used the other is at the off position, and, therefore, cut out.

### "With the Greatest Ease"

In this way we can take care of very wide variations of voltage. Furthermore, the output side of the transformer which steps the current down from the mains for the rectifier has two tappings, and by the choice of one or other of these tappings, and one or other of the rheostats, we can adjust the apparatus to suit any load from one valve up to the maximum with the greatest ease.

An examination of the photographs and diagrams of the set will show that the front panel, which measures only 7 in. by 7 in., carries two pairs of L.T. terminals and two rheostat knobs. The two L.T.

terminals are in parallel, and two pairs are given for convenience, according to which side one attaches the leads.

On the back of the unit is a simple on-and-off switch. A flexible lead goes from this to a plug which fits into the nearest electric lamp socket. The method of operation is quite simple, and will be explained in detail later. Meanwhile it may be stated that all one has to do is to connect the filament leads of your ordinary set to one or other pair of L.T. terminals on the "Stedipower" Unit, put both of the rheostats at the off position, turn the set on by its normal switch, and then switch on the power.

The next step is simply to turn one or the other of the rheostat knobs (which will be explained later), and watch the needle of the voltmeter. If we are using six-volt valves then the knob is simply turned until the needle of the voltmeter reaches the

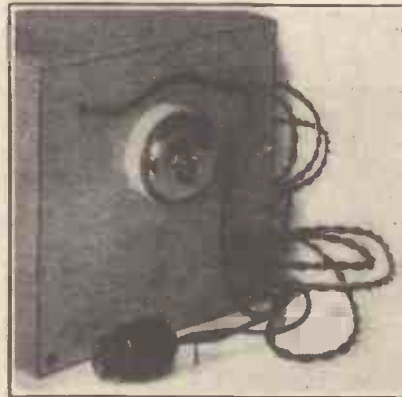

A strong feature of the "Stedipower" Unit is the ease of connection to the A.C. house wiring—just a plug, length of flex, and the tumbler switch.

figure six, when the set will be found to function exactly like an accumulator. Once this adjustment is found no further adjustment is required.

After the Tobc-Deutschemann 3,600-mfd. condenser had been despatched from America, but before it reached me, I learned that the well-known British condenser manufacturers, The Telegraph Condenser Co., Ltd., were already producing in their test laboratories experimental models of a similar type of condenser, and within an hour or two of receiving the American condenser the first T.C.C. condenser reached my hands.

The T.C. Company have also managed to get it in a remarkably

small space and experiments now being conducted indicate that their condenser will be equally suitable for the "Stedipower" Unit. The Tobc-Deutschemann condenser is really a pair of condensers made up in a block, the method of connection being as shown in the theoretical diagram. In the case of the T.C.C. arrangement the two condensers are separate, the total space occupied about the same, and connections very simply made.

### Free From Hum

A great deal of experimental work had to be done with the various components before the final design was achieved. My thanks are due to Messrs. R.I.-Varley, Ltd., for their hearty co-operation in producing for me a number of different experimental models of transformers and chokes to my specifications, in order that the best possible arrangement and values could be found by practical tests as well as by calculation.

After the second rough model had been worked out with correct values the unit was tried with a Rice-Kellogg loud speaker to check the freedom from hum.

By placing one's ear close to the diaphragm, it is just possible to hear a very slight hum when there is no transmission, but this is overpowered by even the weakest signal that can be heard on a loud speaker. Indeed, many observers who were invited to listen had failed to detect the hum at all, even when they had been told it was present.

Further tests were undertaken to test the whole unit for continuous running, and powerful sets were run from it for as long as three whole days and nights without a break, the results at the end of the experiment being just as excellent as at the beginning.

### A Final Hint

On heavy loads, such as three-quarters up to one ampere, it is found that the full voltage is not attained until the unit has been running a minute or two, but after this the unit settles down and maintains an absolutely constant voltage for as long as it is left on. For this reason I recommend users to run any set for five minutes before deciding on their permanent voltage adjustment in order that the unit may settle down to its work.



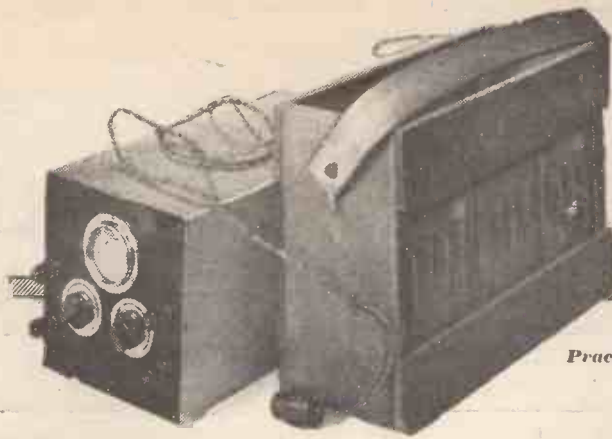

# BUILDING the HARRIS "STEDIPOWER" L.T. UNIT

Practical details for the construction of the Unit which completely replaces the L.T. accumulator.

By PERCY W. HARRIS, M.I.R.E.

Now for the actual constructional work in the "Stedipower" Unit. For this you will want a baseboard measuring 14 in. by 7 in., a piece

### COMPONENTS REQUIRED

- 1 Transformer and two chokes for Harris "Stedipower" Unit (R.I.-Varley, Ltd.). (State your mains voltage when ordering.)
- 1 Kuprox rectifying unit, type CR-1 (Rothermel Corporation, Ltd.).
- 1 Tobe-Deutschmann "A" condenser block (Rothermel Corporation, Ltd.), or
- 2 T.C.C. electrolytic condensers (T.C.C.)\* 1 Baseboard measuring 14 in. x 7 in. x 1/2 in. or 3/4 in.
- 1 Ebonite panel, 7 in. x 7 in. x 1/4 in. or 3/8 in. (Any good make.)
- 1 Wood panel, 7 in. x 7 in. x 1/4 in.
- 1 Good-quality moving-coil voltmeter, 0 to 6 volts (Sifam, as shown; Ferranti panel-mounting type RIFa, flush mounting, 0 to 7.5 volts; Weston 0 to 6 volts, moving coil, etc.). **SPECIAL NOTE.**—Do not use a cheap moving-iron instrument. If you try and save money by using an inferior instrument here you may ruin the whole design and, incidentally, may injure the valves.
- 1 10-ohm Igranite-Pacnet Porcelain rheostat, panel mounting.
- 1 30-ohm Igranite-Pacnet Porcelain rheostat, panel mounting.
- 4 Belling-Lee indicating terminals (2 L.T. +, 2 L.T. -).
- 1 Electric-light tumbler switch.
- 1 Plug adaptor with flex.
- Quantity of Glazite or similar wire for wiring up.
- Piece of perforated zinc measuring 16 1/2 in. x 7 in., for ventilating the top of the set.
- 2 Pieces of plywood, 16 1/2 in. x 7 in., for sides of box (see note below), or special cabinet (Camco).

\* Note: At time of going to press suitable T.C.C. electrolytic condensers for the Harris "Stedipower" Unit are not quite ready for the market.

given in the list above, and it should be noticed that at the present time you have not many alternatives. Later, other manufacturers will no doubt be producing parts for this, but at the present time I would recommend readers to obtain only those named.

### About the Parts

The transformer and two chokes made to my own specification for the Harris "Stedipower" Unit are obtainable as a complete set from Messrs. R.I.-Varley, Ltd. The Kuprox full-wave dry rectifying unit, type CR-1, has been specially chosen. It must not be confused with other Kuprox rectifying units of different type numbers.

Constructional work is particularly simple. First drill your panel and mount the meter, rheostats, and terminals as shown. The hole for the meter can be very easily cut with a fretsaw, or a circle can be scratched

the size of the drum of the meter and holes drilled round the edge so that the centre drops out, and the hole shaped suitably with a file. Per-

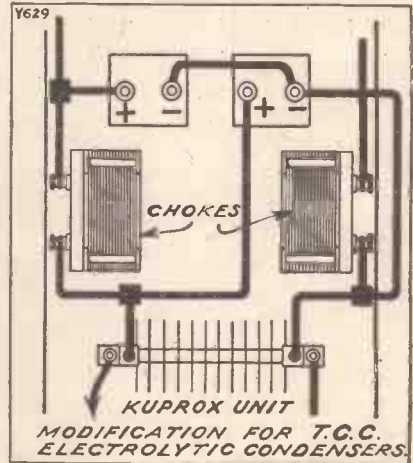

sonally, I always use a fretsaw for this purpose, as I find it by far the simplest way of cutting, and also neater.

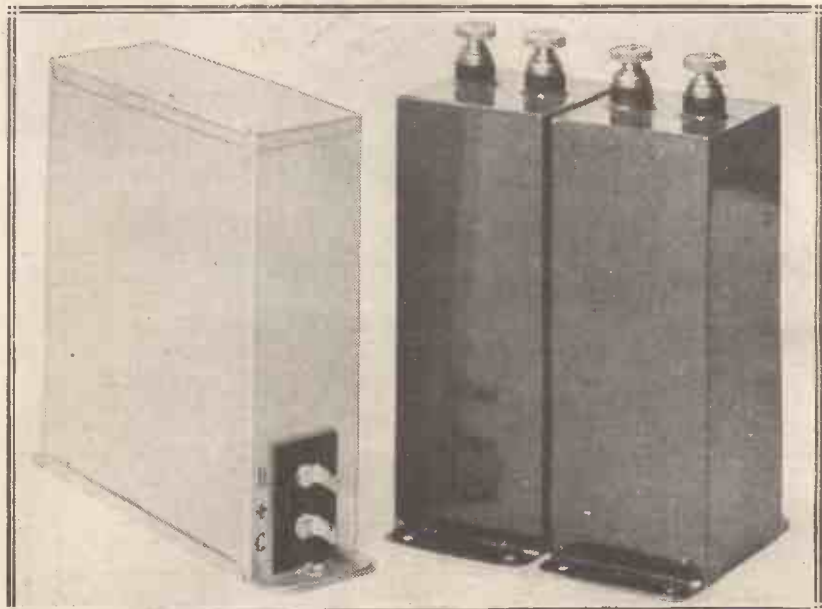

To the right are shown the T.C.C. electrolytic condensers, and on the left is the Tobe-Deutschmann condenser

of ebonite 7 in. by 7 in., and a piece of plain wood about 1/4 in. thick and 7 in. by 7 in. for the end which carries the on-and-off switch.

Choose the baseboard of fairly thick wood, say 1/2 in. or 3/4 in. The components you will require I have

## Building the Harris "Stedipower" L.T. Unit—continued

Full instructions for mounting the rheostats are provided in the cartons. Before screwing the panel to the front edge of the baseboard mount the other components in place, being very careful so to place the condenser block that its single terminal marked "negative" comes on the same side as the unit's negative terminal.

It should be noticed that the rectifying unit is removed from the base on which it is supplied, for, as mentioned earlier in this article, this particular unit was originally designed as a replacement unit for certain types of battery chargers.

### Mounting the Switch

After it has been detached from its metal base it is mounted by drilling two holes in the baseboard and passing screws from the underside and securing by nuts on the top. The whole idea is to make the wooden baseboard take the place of the metal strip on which the unit is mounted when you receive it, so be careful to keep the nuts and washers in correct order.

Now carefully mount the on-and-off switch on the wooden panel. To do this, unscrew the metal cap and this will reveal four holes. Two are for the wood screws which hold the switch base to the wooden panel, and

the other two are to take the wires which come through the back and are held in place by grub screws.

It will thus be necessary to drill the two holes in the correct positions, so

when you have drilled these in correct positions you can mount the switch over them and secure it by the two wood screws through the other pair of holes.

### RAPID GUIDE TO ADJUSTMENT.

No. of Valves.	Rheostat.	Tapping.	Approximate Dial Position.
<b>SIX-VOLT VALVES :</b>			
1 at .1 amp. . . . .	30	B	Just on.
2 at .1 amp. . . . .	30	B	Three-quarters on.
3 at .1 amp. . . . .	30	C	Half on.
4 at .1 amp. . . . .	30	C	Three-quarters on.
5 at .1 amp. . . . .	10	C	Quarter on.
6 at .1 amp. . . . .	10	C	Half on.
2 at .1 amp. and 1 at .25 amp. . . . .	10	C	Quarter on.
3 at .1 amp. and 1 at .25 amp. . . . .	10	C	Half on.
4 at .1 amp. and 1 at .25 amp. . . . .	10	C	Three-quarters on.
4 at .1 amp. and 2 at .25 amp. . . . .	10	C	Nearly full.
6 at .1 amp. and 1 at .25 amp. . . . .	10	C	Three-quarters on.
<b>TWO-VOLT VALVES (.1 amp.) :</b>			
2 . . . . .	30	B	
3 and 4 . . . . .	30	C	
5 and 6 . . . . .	10	C	

NOTE.—For one valve at 2 volts .1 amp. use 10-ohm rheostat across pair of L.T. terminals.

that the wires can be passed through the back of the wooden panel into position on the switch itself, and

A hole is now drilled at one corner of the wooden panel and the twin flex passed through this, leaving about six inches through the hole; tie a knot so that it will not pull back again and untwist the flex up to this knot. Bare one end of this flex and insert it in one of the holes of the switch itself, securing the bared wire in position by the grub screw on the switch. The other flexible wire is taken to one terminal on the input side (high voltage) of the transformer. The other terminal of the transformer is connected by a short wire to the other terminal of the switch.

When ordering your transformer and choke set do not forget to specify the voltage of your mains and do not forget that this unit will only work with A.C. mains and will not operate from D.C. mains.

### Rectifier Connections

The rectifier will be found to have four terminals, of which two (one on each foot) go to the transformer and the other two (fitted with insulated terminals on the top of the unit) go to the chokes as shown. Notice the positive and negative marks on the frame near the insulated terminals,

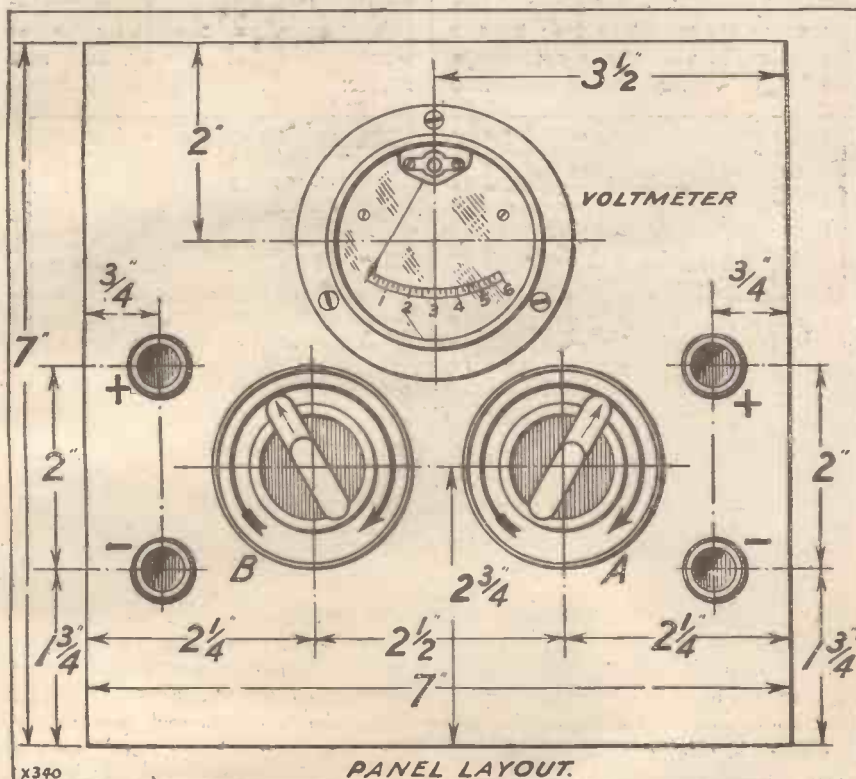



## Building the Harris "Stedipower" L.T. Unit—continued

and be sure, as indicated above, that the negative comes on the same side as the common negative terminal of the condenser block.

Now screw the wooden panel in position at one end, and wire up the ebonite panel as far as possible before attaching it to the other end of the baseboard. Next screw the ebonite panel in position and complete the wiring as shown. Notice that a flexible wire goes from one leg of the rectifying unit to one or the other of the transformer output terminals. Which you will use will be explained a little later.

### Do Not "Box" It

When the unit is operating, a fair amount of heat is generated in the rectifying unit, and for this purpose the unit is fitted with metal cooling fins, very much like the cylinder of a motor-cycle. The heat developed, however, is not great, provided space is left around the unit and it is not boxed in.

This is the reason for the fairly generous spacing of the unit and for the use of the perforated zinc top. Do not be persuaded for the sake of appearance to box the whole unit in. The simplest way is to make it as already explained, and then to attach two pieces of plywood of the dimensions indicated, one at each side. The piece of perforated zinc can then be secured in any convenient way over the top of the instrument, and this will allow of adequate ventilation.

And now for precise details of how to operate the unit satisfactorily. Bear in mind that the output voltage will depend to some extent upon the current drawn from the unit, therefore the adjustment which is correct for one set of valves is not necessarily correct for any other.

### Switching On and Off

When joining up your unit to an existing receiver you must first of all make sure that the mains switch is "off," and that the on-and-off switch on your receiver is "on." Once joined up to your receiver the switching on and off of your set should be conducted *entirely by means of the switch on the Harris "Stedipower" Unit* and not by means of the usual on-and-off switch on the set. The reason for this is twofold.

First of all, the output voltage of the "Stedipower" Unit on no load will rise to above the maximum figure of the voltmeter, and, secondly, the unit will use a little current even when no current is being taken from the output.

Having made sure that the mains switch is "off," and that both filament resistances on the "Stedipower" Unit are at the "off" position, consult the rapid guide in this article to find which filament resistance you will need to use, and which tapping

load, such as from .6 to .9 ampere, it is possible that the voltage will not read six at first, even when the filament resistance is turned to the "full-on" position.

### The First Five Minutes

This is due to the fact that it takes a minute or two for the unit to rise to its maximum voltage. In any case, watch the voltmeter carefully for the first five minutes, readjusting the knob of the filament resistance if needed, to see that the

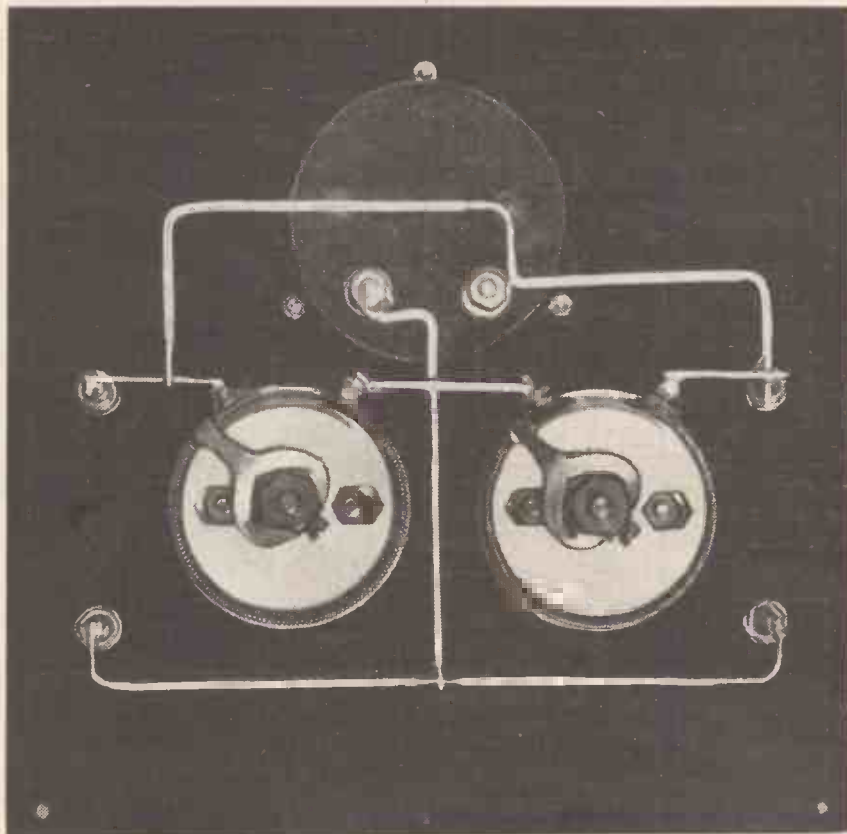

The back-of-panel wiring is simplicity itself.

on the transformer for your particular number of valves.

### Voltmeter Readings

Having set the transformer tapping to either B or C, switch on the unit and turn the knob of the particular resistance (right-hand knob for the ten ohms and left-hand for the thirty ohms) until the needle of the voltmeter reaches the voltage figure for your valves (two, four or six volts according to the types you use). If you are using a fairly heavy

voltage does not rise above two, four, or six, as needed.

After about five minutes the unit will have reached its maximum voltage and no further change of voltage nor any further adjustment will be needed so long as the set is left switched on, even if you leave it on for several days and nights on end. Make a pencil mark on the frosted metal plate of the filament resistance to indicate the correct position for your resistance knob once the unit has "settled down."

**Building the Harris  
"Stedipower" L.T. Unit—contd.**

The set can now be switched off when required by means of the "Stedipower" Unit switch. The next time it is switched on there will be no need to make any adjustment whatever on the "Stedipower" Unit, for while the voltage may not be up to the maximum in the first minute or two on load (the difference in voltage between first switching on and the settling down is very small, and will rarely be noticed, by results on the loud speaker) the unit will automatically adjust itself if left untouched, and after two or three minutes will reach exactly the voltage you have chosen on the first adjustment of the set.

**Low Upkeep Costs**

The whole receiver can thus safely be left in the charge of unskilled people, who have only to switch on either by the knob on the back of the "Stedipower" Unit or by a convenient switch on the wall. Do not forget, however, that if you should turn off the filaments of one or more valves in the set you will need to readjust the filament resistance on the unit to compensate for the difference in load.

There is no particular point in switching off individual valves with this unit, as the total consumption of the unit is extremely small, and no noticeable saving will be effected by switching off a 100-milliamper valve!

The unit is designed to be universal in its application, therefore you will find that in the rapid guide I have allowed for a single valve of the 2-volt variety! If you should want to use a single .1 2-volt valve it will be necessary to shunt an ordinary filament resistance across the spare pair of L.T. terminals so as to give a slight load to the unit in addition to that taken by the valve.

**Some Special Notes**

In all other cases, however, the filament resistances within the set will take care of any adjustment needed.

**SPECIAL NOTES.**—Do not forget to allow for the slight time lag in making your preliminary adjustments. Once you have found the correct position for a given set, and have put your resistance knob on this setting, then the difference between

the voltage when the set is switched on and the figure it reaches after the first few minutes will not be any different from that of an ordinary accumulator at the voltage which requires a recharge and the voltage when it is fully charged.

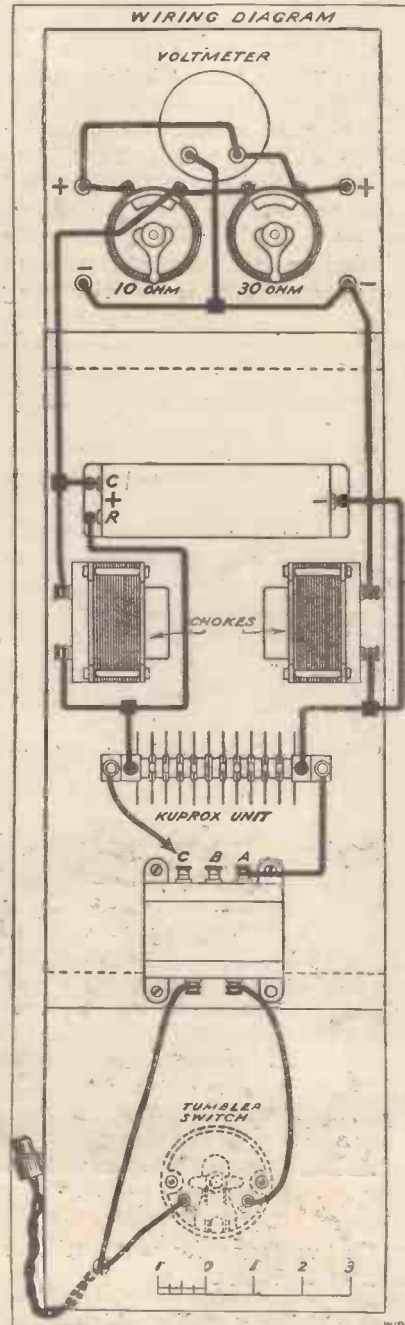

If you set the unit to give six volts, immediately it is switched on it will rise to a higher figure than is good for the valves, in the first five minutes.

Note that the T.C.C. condensers have terminals marked with red and black insulators. The black insulated terminal must be connected to the negative side. Reversal will ruin them.

\*\*\*\*\*  
\* **SUBSTITUTING R.C.** \*  
\* **UNITS FOR** \*  
\* **TRANSFORMERS** \*  
\*\*\*\*\*

A NUMBER of resistance-capacity coupling units are now sold fitted with four terminals corresponding to the four terminals on a low-frequency transformer. It is a simple matter to take out a low-frequency transformer and substitute a resistance-capacity-coupling unit for it, but when so doing certain points should be borne in mind.

For example, a valve which gives excellent results with a transformer may give very poor results from a resistance-capacity unit which requires for its best operation a valve with a fairly high impedance and magnification—either one of the H.F. valves having an impedance of 15,000 to 30,000 ohms and a magnification of fifteen to twenty-five, or, better still, in most cases one of the special R.C. valves.

Secondly, a high-tension voltage which is perfectly satisfactory for a valve in transformer coupling may be much too low for resistance-capacity coupling, and at least 100 volts should be applied to the H.T. terminal. (In sets where one voltage is used throughout, this voltage may be too high for some of the other valves.)

**Reaction and Grid Bias**

Thirdly, if the R.C. unit immediately follows the detector valve and an R.C. valve is used as a detector, you may find it much more difficult to obtain proper reaction effects. If the detector is fitted with reaction it will generally be found that a medium-impedance and magnification valve (such as now sold for high-frequency amplification) will give better results than the high-impedance type of valve specially designed for resistance-capacity coupling. In such cases, too, the anode-resistance value should not exceed 250,000 ohms, and is better at 100,000.

Finally, the value of grid bias will have to be altered if you change to resistance-capacity coupling. When using special R.C. valves in the anode of which a high-resistance is placed, the grid bias required will be very small—being generally not more than 1½ volts. Watch the maker's leaflet in this regard, for a grid bias which is perfectly satisfactory with transformer coupling may be so great as to cut out signals entirely with R.C. coupling.

H. P. W.



# THE B.B.C. REPORT

By a Special Correspondent



THE B.B.C. recently issued its first annual report—a document which covers the work of the Corporation for 1927. It is decidedly an interesting report, and one upon which the Governors of the B.B.C. may congratulate themselves.

The thing in the report which makes downright unpleasant reading are the facts relating to the "rake off" from licence revenue taken by the Post Office. That "rake off" is nothing more or less than a scandal.

## The Regional Scheme

Regarding finance for 1927 the report states that: "The Regional Scheme naturally bulked largely in the considerations involved. Estimates were drawn up to the probable income of the Corporation for some years ahead, the cost of erection and equipment of the proposed Regional Stations and of financing the scheme by borrowing, and the increased cost of programmes and engineering maintenance.

"It was seen that, if programme development took place immediately to the limit of income, the increased maintenance costs, and the sinking fund appropriations to repay borrowed capital, would reduce programme expenditure below its former level when the Regional Scheme began to operate. While the normal development of the service was not interfered with, income not thus absorbed was reserved to meet the cost of erecting and equipping Regional Stations, thus minimising future sinking fund charges, and making progressive expansion possible. It will certainly not be possible, however, to provide all the money required for the Regional Scheme out of income in advance."

## The Obsolescence Factor

The Report shows that the assets of the company were taken over, on January 1st, 1927, without payment, at a valuation of £174,938. The capital expenditure of the company had amounted to £334,788 6s. 11d.,

but in arriving at the former figure certain kinds of capital expenditure, such as alterations to premises, were written off altogether as having a non-realizable value, and plant was written down heavily in view of the high obsolescence factor inherent in wireless equipment. Other assets were depreciated at customary rates. Further capital expenditure on development and improvement of the service during the year amounted to £10,108 1s. 11d., and this sum was appropriated from revenue, in addition to a reserve for the Regional Scheme of £100,000.



Miss Beatrice Harrison, the celebrated 'cellist, who by playing in its woodland haunts induced the nightingale to broadcast.

The obsolescence factor and the anticipated replacement of existing stations determined the basis on which the reserve for depreciation of £26,350 was made. In the case of plant, depreciation was calculated at the rate of 20 per cent per annum, which allows for replacement in five years.

## Spending the Money

The total revenue expenditure is £773,289 16s. 8d., to which the expenditure under the various headings bears the following approximate percentages:

Expenditure on programmes ..	63-07
Maintenance of plant, power, etc. . . . .	16-95
Rents, rates, insurances, etc.	8-18
Administration expenses ..	6-58
Provident fund contribution	1-02
Governors' fees . . . . .	7-9
Provision for depreciation ..	3-41
	<hr/>
	100-00

The Report shows that the Post Office takes at present something like 30 per cent of the gross income from licences, and will take a higher proportion as the number of licences increases.

## What the P.O. Gets

A charge for issuing licences must be made and this is provided for by a general charge of 12½ per cent on the gross receipts. But, after this has been deducted, the Post Office takes, above and beyond, 10 per cent on the first million licences, 20 per cent on the second million, 30 per cent on the third, and 50 per cent on the fourth. It took altogether last year something in the neighbourhood of £350,000.

(Continued on page 284.)

## Using the Thirty-One Tested Circuits.

*In this, the sixth article of a series by the Editor dealing in detail with the "Thirty-One Tested Circuits" Booklet, presented free with the February issue of the "Wireless Constructor," the five-valve circuits are explained. This series of articles, together with the gift booklet, should be studied by every home constructor, and new readers are advised to obtain the back numbers through their newsgents.*

IN my booklet "Thirty-One Tested Circuits" I gave two five-valve arrangements: circuits H1 and H2, pages 25 and 26 respectively. H1 is what is known as a "split-primary" arrangement and H2 is a "split-secondary."

With properly designed high-frequency transformers, the circuit H1 is, in my opinion, the better of the two, but the circuit H2 is easier for the home constructor who wishes to make up his own H.F. transformers. Again, tuning is somewhat sharper on the split-secondary arrangement, but against this we must set off the fact that it is particularly prone to give bad hand-capacity effects unless due precautions are taken.

### Home-Made Transformers

Both of these circuits should be made up with screening to get the best results, or, alternatively, the aerial transformer and the two high-frequency transformers can be of the "fieldless" or "binocular" type. Readers who wish to make up their own high-frequency transformers for the circuit H1 can use the specification for a split-primary high-frequency transformer given by Mr. G. T. Kelsey in the "P.C." Three published in the current issue.

The transformers wound by Mr. Kelsey have been tested in the WIRELESS CONSTRUCTOR laboratory and found to be very suitable for the circuit H1, in addition to the set for which they were designed.

### Screening and Soldering

The screening can consist of single sheets of copper or aluminium of the height of the panel used with the particular layout, and of a length equal to the depth of the cabinet from front to back, minus about an inch to allow for the projecting shanks of the terminals on the terminal strip. Between the two screening materials there is in practice nothing to choose electrically, but copper has the advantage that one can solder directly on to it, whereas soldering on to aluminium is difficult, and,

indeed, impossible, with ordinary soldering methods.

The best way to make a sound electrical connection to the aluminium screen (this being necessary in order to earth the screen) is to drill a hole, insert a 4 B.A. or 6 B.A. metal screw, lock it tightly into position with a nut and then solder on to the shank of the metal screw. (Choose a cheese-head or round-head screw and not a countersunk one.)

In speaking of screening for five-valve sets, do not forget to take precautions against any wires which have to pass through the screen actually making contact with the screen itself. If the hole is too big

Do not fail to keep your booklet, for further articles from the Editor's pen discussing the various circuits included will appear from time to time.

you will spoil the screening effect by introducing an unwanted aperture, and if it is too small there is a chance that the sharp edge of the hole will cut through the insulation of the wire and make a dangerous short-circuit.

As a safety precaution I would recommend using, in addition to the ordinary insulated wire, a short length of valve tubing such as is used for bicycle-tyre valves. This can be slipped over the insulated wire and slid along to the correct position.

### Protection From Shorts

A part of the short length of this tubing can then project on each side of the screen. Only the radio-frequency stages will need shielding, the low-frequency side working perfectly satisfactorily without any form of shielding other than that given by the transformer cases themselves.

It will be noticed that both in H1 and H2 an additional resistance is

inserted in the grid lead of the first low-frequency valve to prevent the radio-frequency currents getting into the low-frequency side. Do not omit this resistance, for in many cases it will prevent several awkward troubles.

### The L.F. End

It will be noticed that circuit H2 has two transformer-coupled low-frequency stages, whereas the circuit H1 has one resistance and one transformer coupling. It is a perfectly simple and practical matter to combine the high-frequency circuit of H1 to the low-frequency side of H2, and vice versa, but if the detector valve of H1 is followed by a transformer coupling then a grid leak and condenser should be used as in H2. It will be noticed that in IH no grid leak and condenser are used, and the remarks on the detector circuit G2 (page 214 in the last issue) apply equally to H1.

H2 can be made up entirely with plug-in coils, the coils  $L_2$ ,  $L_4$ , and  $L_6$  being the ordinary centre-tapped variety obtainable from practically all of the leading coil makers. The advantage of this make-up is that experiments can be made with different sizes of coils for the primary windings  $L_1$ ,  $L_3$  and  $L_5$  respectively.

Owing to the rather extensive field of such coils it is essential here that adequate screening be used, and the coils themselves should not be placed too close to the metal screen or undue losses will occur.

### Push-Pull Possibilities

Both circuits are greatly improved by making the last stage "push-pull." The single-valve amplifier described by Mr. Harry P. Wootton in the current issue will give all the layout details necessary for this. To incorporate it it is merely necessary to stop at the fourth valve and make the last part of the receiver identical with the layout in Mr. Wootton's article.

Next month I shall have something to say on the subject of the screened-grid sets.



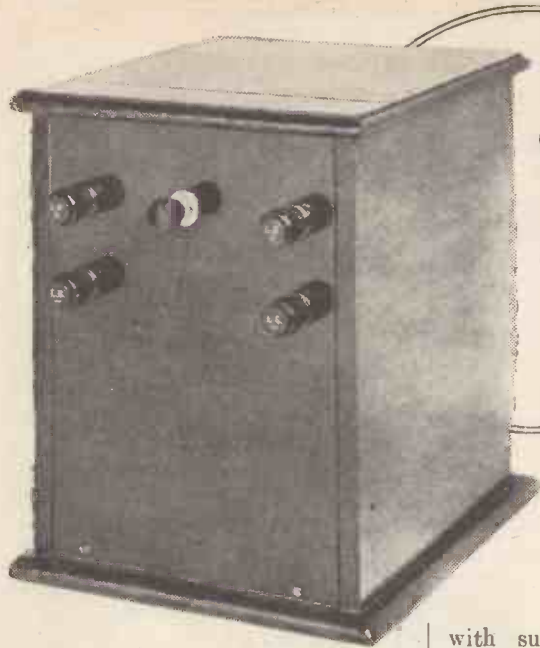

# The "OUTPUT" AMPLIFIER

by Harry P. Wootton

*A single stage of push-pull amplification which can be added to any set in order to develop great power for operating large speakers, more particularly of the moving-coil variety.*

A FEW months ago there appeared in this journal a description of how to make a super-quality amplifier which could be substituted for the low-frequency side of any existing set, not only assuring the excellent quality now obtainable from

with such speakers as the Rice-Kellogg, the Magnavox, the moving-coil loud speaker already described in these pages, and others which are easily assembled from lists of parts now marketed.

It is not the intention in the present article to go into the principle of push-pull working, and it is sufficient to say for the moment that one of its outstanding advantages is that, in an amplifier using two valves in push-pull, a plate voltage of 120 to 150 will give results which in an amplifier using a single valve connected in the normal fashion would require 200 to 300 volts to get the same undistorted output. The unit to be described is particularly compact (an examination of the photographs will show that it could scarcely be made smaller!) and the height of the panel has been made such that the small cabinet will match in height most existing sets when placed alongside them.

No alteration to one's present set is needed, the amplifier being connected to the loud-speaker terminals of your receiver on the one side and to the loud speaker on the other.

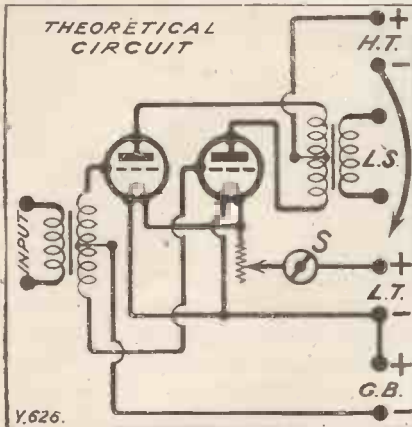

the audio-frequency side of a receiver, but giving at the same time sufficient power output to work a moving-coil loud speaker. Many readers of this journal already possess sets in which the low-frequency side is up to the best modern standard, but which are still not sufficiently powerful to operate the now popular moving-coil speaker.

### H.T. Required

It was suggested to the writer that if a single-stage push-pull amplifier were constructed, in such a way that it could be attached as an "output stage" to any existing receiver, it would fill a definite need and enable readers to take full advantage of the magnificent rendering possible

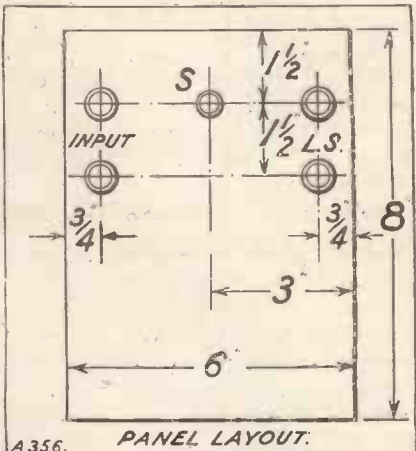

A356. PANEL LAYOUT.

While specifically designed for moving-coil speakers, it must not be imagined that these are the only kinds that can be used with the "Output" Amplifier, for the results obtainable with any modern cone-type of speaker will be definitely better with this amplifier than with an ordinary

### THE COMPONENT PARTS REQUIRED

- 1 Baseboard 7 in. × 6 in. ×  $\frac{3}{8}$  or  $\frac{1}{4}$  in.
- 1 Ebonite panel 8 in. × 6 in. (or 7 in. × 6 in. if you wish to match a receiver with a 7-in. panel).
- 1 Cabinet for same, in oak or mahogany to match existing set.
- 1 Terminal strip 6 in. ×  $1\frac{1}{2}$  in.
- 10 Terminals marked as shown in the illustrations (Belling-Lee, Ealex, Igranic, etc.).
- 1 On-and-off switch (Lo.us, Benjamin, Lissen, Duco, etc.)
- 1 Push-pull input transformer (Ferranti).
- 1 Push-pull output transformer (Ferranti).

NOTE.—Choose the output trans-

former ratio to suit your loud speaker (see article).

Any recognised good makes of push-pull transformers can be used, but the terminal arrangement will not necessarily be the same as those shown in the diagrams, and in the case of alternatives being used care should be taken to see that the correct connections are made and that space is available.

2 Valve holders (Benjamin, Lotus, W.B., Igranic, etc. Those illustrated are Benjamin).

1 Filament resistance for baseboard mounting, 10 ohms (Igranic, Lissen, etc.).

1 Spring clip.

Insulated wire for wiring-up.

## The "Output" Amplifier—continued

arrangement, unless this latter uses a much higher voltage than is adopted for the present scheme.

The circuit diagram shows that the input terminals are connected to the primary of a special transformer, the secondary of which has three terminals, two of these being connected to the extremities of the secondary winding and the third to an accurately placed centre tap. The two extremities of the winding are connected to the two grids of the valves and the centre tap to the negative terminal of the grid-bias battery, the output of the two valves going to a special second transformer which has three terminals on its primary winding.

### The H.T. — Lead

The two outer terminals are connected to the extremities of the primary winding, and a centre terminal to a centre tap on this primary. The two plates of the valves are connected to the ends of the primary winding, and the high-tension positive goes to the centre tap.

The secondary of this second transformer has but two terminals, these being connected to the output terminals on the amplifier and thus to whatever loud speaker is used.

A single filament resistance controls the filament current of the two valves, and an on-and-off switch is mounted symmetrically in a convenient position on the front panel. A terminal strip at the rear carries terminals for low-tension, high-tension and grid bias.

It should be noted particularly that

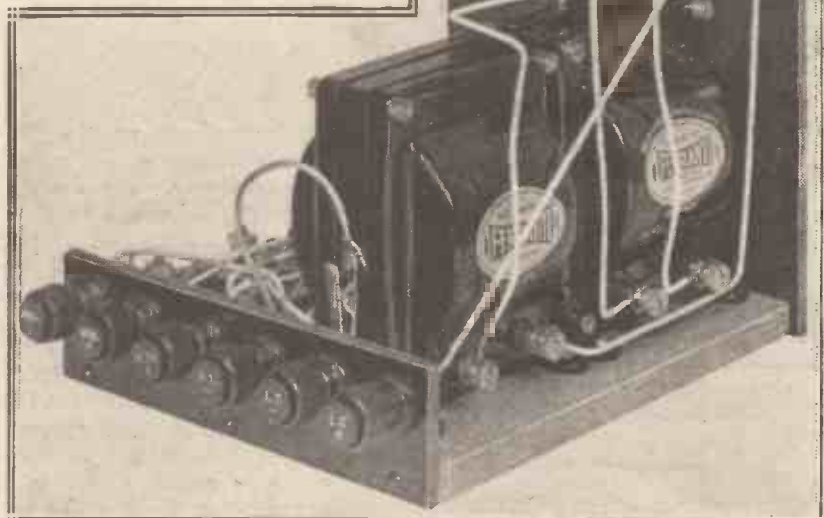

The connections both for the input and output are plainly to be seen in this photo.

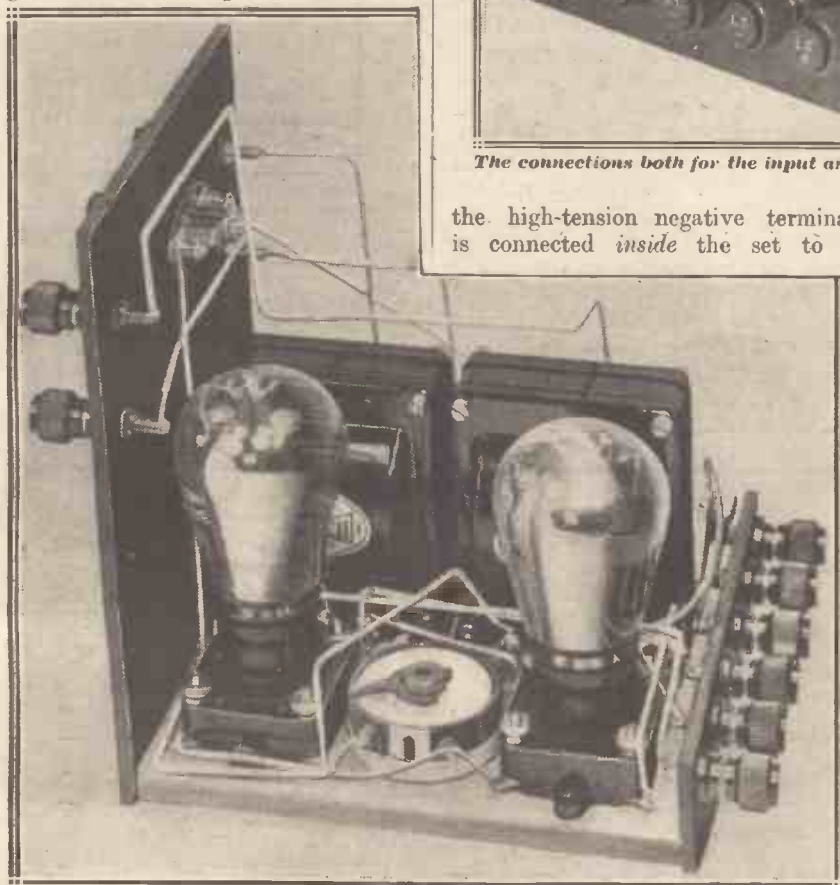

The filament resistance, which is of the baseboard-mounting variety, and which has a prominent position in the foreground of this photo, controls the filaments of both of the valves.

the high-tension negative terminal is connected inside the set to a

flexible lead which terminates in a spring clip. This spring clip can be connected either to low-tension negative or to low-tension positive. Which connection you make will depend upon circumstances to be explained later.

### The Valves to Use

To get the best results from this unit a pair of super-power valves must be used. Both valves must be of the same make. Valves actually tested and found to work very satisfactorily in this receiver are the following.

Note that they are placed in alphabetical order and not in any special order of recommendation!

Cosmos S.P.55R.

Cossor Stentor 6.

Marconi D.E.5A.

Mullard P.M.256.

Osram D.E.5A.

Six-Sixty S.S.625 S.P.

No special instructions are needed with regard to the construction of this unit, for the photographs and



## The "Output" Amplifier—*continued*

diagrams will give all the data needed. Owing to the small space, care will be required in wiring up, and if the shanks of the terminals project too far and tend to foul the output transformer, small portions should be cut off them, as they are awfully long enough in most cases.

### About H.T. Supply

Do not confuse the two transformers, and be sure to place the input transformer (that marked grid, grid bias, and grid respectively for the three secondary terminals) next to the panel.

As this amplifier will invariably be used with another set, the low-tension supply can be run off the same accumulator. As, however, the high-tension required by a push-pull amplifier of this type is fairly heavy, it is advisable to use either a mains unit, high-tension accumulator, or the special heavy-duty super-power battery which the leading dry-battery firms now supply.

If you are using dry batteries I would strongly recommend you to have a separate one for the push-pull amplifier, but, in any case, if you run this amplifier off a separate high-tension battery, then you must connect the clip joined to high-tension negative to either low-tension negative or low-tension positive (either can be used without any noticeable difference). If, however, you run this amplifier from the *same* high-tension battery as your existing set, then it is essential either that the high-tension negative should be left free (remember that high-tension negative is already connected to the low-tension battery in the other receiver) or else the clip should be connected to the same low-tension lead as the high-tension negative is connected in your existing receiver.

### The Transformers

For example, you may find in your present set that high-tension negative is connected to low-tension negative. If this is the case, join the clip in the output amplifier to low-tension negative.

Indeed, I would recommend the clip joined to the correct lead in place of leaving it free, or otherwise you may have trouble by the clip shorting or touching something else. Do not forget that the clip in the amplifier, if connected to the wrong low-tension

terminal, will short-circuit your accumulator.

When a separate high-tension battery is being used, unconnected to the high-tension battery on the set, it does not matter whether the high-tension negative goes to low-tension negative or positive.

The grid bias needed must suit the type of valve and the high-tension voltage used. So far as high-tension is concerned, do not use less than 120, and use 150 if you can. Do not exceed the figure given by the makers.

There is another very important point, and that is regarding the ratio of transformation in the *output* trans-

former. Two ratios are made, one to one and twenty-five to one.

The one-to-one output push-pull transformer is designed to work the ordinary loud speaker such as the various cones now sold. The twenty-five to one is made to work special low-resistance moving-coil speakers.

### Loud Speaker Resistance

All the moving-coil speakers are not of low-resistance winding; indeed, it is probable that the majority are arranged to connect to existing receivers without special step-down transformers. The B.T.H. Rice Kellogg loud speaker now being sold

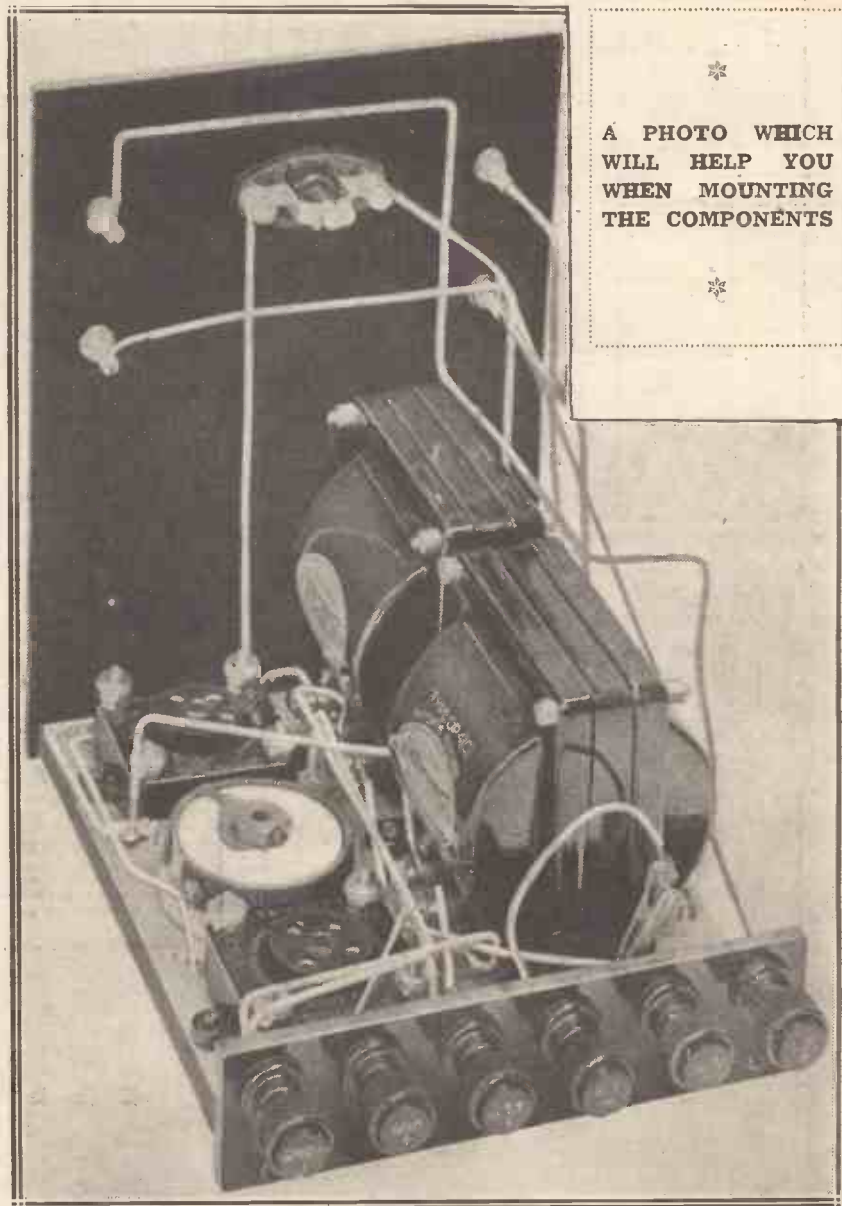

A PHOTO WHICH  
WILL HELP YOU  
WHEN MOUNTING  
THE COMPONENTS

The best use of a very small space is made in this ingeniously designed amplifier.

# The "Output" Amplifier—continued

at £9 10s. already has built into it a step-down transformer, so that for this you should have a one-to-one output transformer in your output amplifier.

Similarly, the Magnavox has its own step-down transformer, and here again you will use a one-to-one. If you have built the permanent-magnet moving-coil speaker already described

in this journal, then you should use a twenty-five to one output transformer. If you are not sure what transformer to use with the moving-coil loud speaker you intend using, the makers will tell you on application.

### Preliminary Adjustment

No skill is needed to operate this amplifier. The filament resistance

should be set near the full-on position, and is best adjusted by inserting both valves in their sockets and joining the accumulator without high-tension or low-tension. A good filament voltmeter should then be connected across the two filament terminals of one of the valve holders, and the baseboard resistance adjusted until the voltage across the two filament terminals is exactly that recommended by the makers for their valves.

### Switching Off

After this adjustment has been found it need not be touched again, as the amplifier is simply operated by joining up the input terminals to the existing loud-speaker terminals on the receiver and the output terminals to whatever loud speaker you use. Do not forget that when using this amplifier with a receiver you will have to switch on and off both the set and the amplifier.

Switching off the amplifier will stop the music, but it will leave the valves burning in the receiver itself. With some valves it is an advantage to insert a quarter-megohm resistance in each grid lead. Two of Pye's quarter-megohm leaks will serve excellently, and should be joined between each grid terminal on the transformer and the grid terminal on the valve holder, just as was done in Mr. Harris's super-heterodyne last month.

## THE "THREE FOR SPARE PARTS"

SIR,—I have constructed your "Three for Spare Parts," described in your March issue of the WIRELESS CONSTRUCTOR. As you can see by my address I am not more than three or four miles from the London station, but I am able to cut out London and get 5 G B too loud for our hearing. Of course, I have to cut London down a great deal. I have also received the following stations during the last two or three weeks. With London on: Hilversum, 5 X X, Berlin (Witzleben), and Langenberg. When London has closed down: Madrid, Dusseldorf, Hamburg, Zeesen, Radio Paris, Rome, and plenty more which I have been unable to identify.

Yours faithfully,

P. A. ROBINSON,  
Battersea Park, S.W. 11.

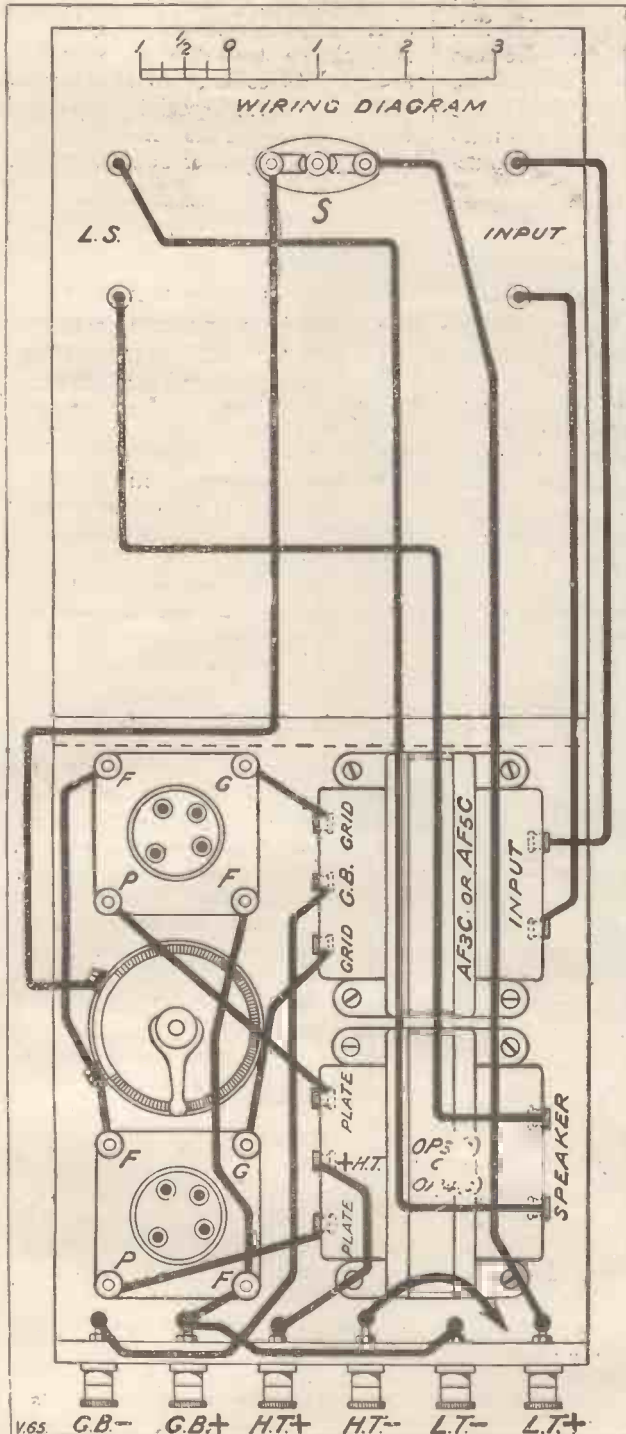

### POINT - TO - POINT CONNECTIONS.

The L.T. plus terminal is joined to one side of the switch. Remaining side of the switch is connected to one side of the filament resistance. Remaining side of the filament resistance to one filament terminal on each valve holder. The remaining filament terminals on the valve holders are joined together and taken to the grid bias plus terminal, and to the L.T. negative terminal. The H.T. negative terminal is connected to a flex lead with clip.

H.T. plus terminal is connected to the H.T. plus terminal on the O.P.3 (C) or O.P.4 (C). Grid bias negative terminal is connected to the grid bias terminal on A.F.3C. or A.F.5C. The two input terminals on the panel are joined to the input terminals on A.F.3C. or A.F.5C., and the two L.S. terminals on the panel are connected to the corresponding speaker terminals on O.P.3 (C) or O.P.4 (C). The grid terminal on each valve holder is taken to the corresponding grid terminal on A.F.3C. or A.F.5C. The plate terminal on each valve holder is taken to the respective plate terminal on O.P.3 (C) or O.P.4 (C). This completes the wiring.



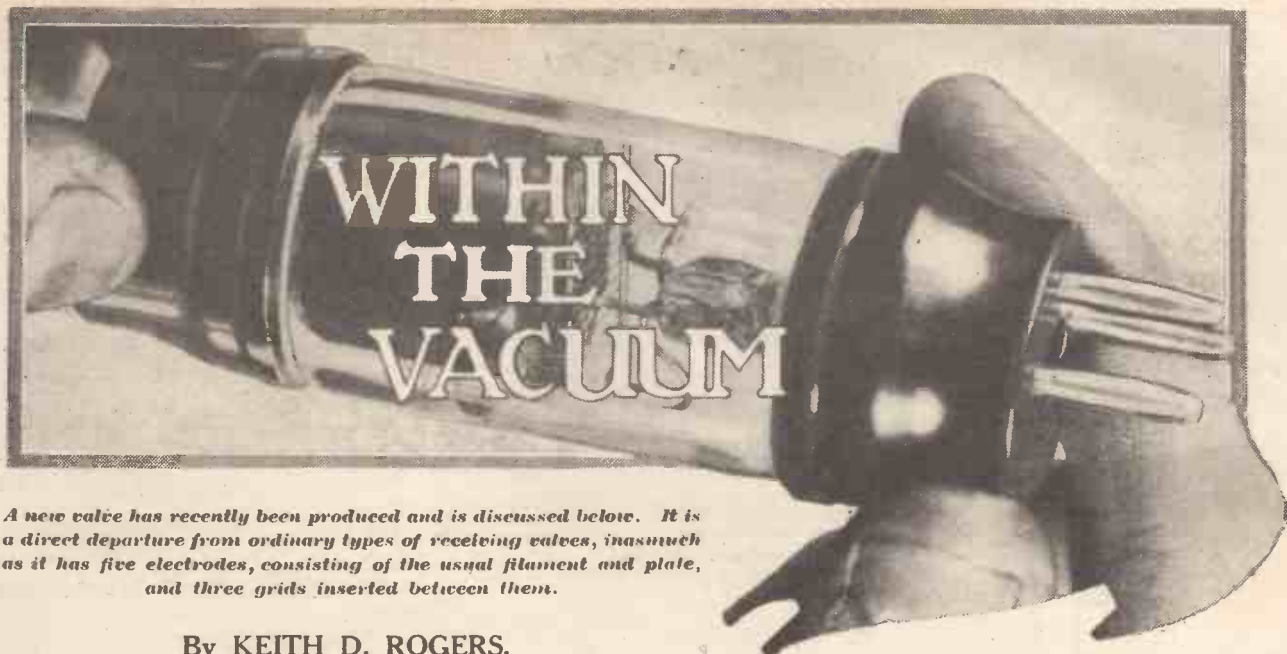

A new valve has recently been produced and is discussed below. It is a direct departure from ordinary types of receiving valves, inasmuch as it has five electrodes, consisting of the usual filament and plate, and three grids inserted between them.

By KEITH D. ROGERS.

I HAVE been carrying out some tests with the new Mullard "Pentone" valve which is likely to be released for public sale in the near future—possibly before you read these lines.

The valve itself is normal in appearance except that it has a terminal in the base in addition to the four round pins on the base itself.

That grid nearest the filament is the usual control grid; outside this is an auxiliary grid which is connected to the terminal on the side of the valve base, and which under working conditions is provided with a positive bias equal to that applied to the anode of the valve, while the third grid (nearest plate) is connected internally to one of the filament pins.

### High Amplification Factor

In use the valve can be plugged in to any set, its four pins in the base making contact with the usual plate, grid, and two filament sockets of the normal valve holder, while the extra terminal on the base of the valve is connected by a piece of flex to that H.T. + terminal which supplies the H.T. + to the anode of the valve.

The whole idea of the Pentone—which is to be marketed in two voltages (2 and 4)—is to provide a very high amplification factor so that with small inputs the valve is capable of a large output.

The electrodes are arranged so that a magnification factor of 62 is obtained in the case of the 4-volter and one of 82 in the case of the 2-volt valve. The only trouble accompany-

ing this is the fact that the impedance is also high in each case, being 28,600 ohms and 62,500 ohms respectively.

On test these figures were upheld within reasonable limits, and great magnification was obtained, though the question of a suitable plate-circuit impedance has yet to be settled. The makers intend the Pentone to take the place of the usual

CHARACTERISTICS		
2-volter :		
Fil. Volt. . . . .		2.0
Fil. Current . . . . .		0.3 amp.
Max. Anode Volt. . . . .		150
Anode Impedance . . . . .		62,500 ohms
Amp. Factor . . . . .		82
4-volter :		
Fil. Volts . . . . .		4.0
Fil. Amp. . . . .		0.15
Max. Anode Volt. . . . .		150
Anode Imp. . . . .		28,600 ohms
Amp. Factor . . . . .		62

last valve, but it must be realised that with the ordinary output valve an impedance of anything from 2,000 to 8,000 ohms may be used, and here the loud speaker can go reasonably well direct in the plate circuit, whereas in the case of the Pentone the impedance is 28,000 or 62,000 ohms, and then the loud speaker will obviously be of too low an impedance to be placed directly in the plate circuit if any reasonable degree of success is desired.

A special 30 to 1, or some such ratio, output transformer is really necessary.

There is another point. I have found, perhaps rather *expectedly*, that

the Pentone does not reproduce the bass notes to the same extent as the ordinary output valve of low-impedance type. It may be due to the non-matching of external impedances with that of the valve, but the fact remained. I should welcome results from readers as soon as they have had opportunities to test these new valves. In magnification they certainly do do their job.

They are not designed for heavy inputs, and so although they are to take the place of the output valve they must be used circumspectly.

### "A Real Saving"

It must not be thought that the P.M.22 and P.M.24 are merely *substitutes* for the super-power valves, because the Pentone's magnification powers make it such that, whereas it is now general practice to employ an L.F. stage between the detector valve and the output valve, the use of the Pentone in the place of this latter should enable one to dispense with the intermediate L.F. stage.

That is to say, that a detector and one Pentone would give the same *volume* as a detector, one intermediate L.F. and a super-power valve. Thus a real saving in valves, in current consumption—the 4-volt Pentone only takes 0.15 amp.—and in H.T. would result. It still remains to be seen whether output circuits really suitable can be devised—suitable to such an extent that reproduction will not suffer in any degree by the substitution of multi-grid valves for those of the ordinary types.



Some typical faults and remedies reviewed.

By P. R. BIRD.

### Faults in Flex

As most of the currents dealt with in wireless work are extremely weak ones, it might be suspected that bad contact anywhere in a wireless set would give rise to trouble. But just how bewildering that trouble may be, and in what a variety of ways it can crop up and cause confusion, is not generally realised.

Of all the various kinds of bad contacts, probably the most puzzling one is that in which the fault occurs intermittently. Flexible leads are a great source of danger in this direction, the worst offenders being comparatively long leads, such as those for telephones or the loud speaker.

I well remember my astonishment when visiting a friend one day, to see his mother—a charming old lady—wearing the telephones and sitting in a chair with her forehead on the table! At my entry she glanced up for a moment, smiled, and resumed her semi-devotional attitude, just as though it were a usual thing to listen-in like that!

### The Cause of Intermittent Contact

After a few minutes' interval (during which I felt as uncomfortable as she looked) she took off the telephones and explained matters. It appeared that she had particularly wanted to hear a certain item in the news bulletin, and she had accidentally discovered that she could hear about twice as well if she put her head upon the table. (This discovery had been made while bending down to pick up something which had fallen to the floor.)

Having determined to hear one particular item, and knowing that she could hear it better with her head on the table, she had assumed that position and stuck to it, for she is a lady of some character. But as she did not intend to bow the knee in this way every time she listened in, she demanded that I should tell her

### THE TECHNICAL QUERIES DEPARTMENT

Are you in trouble with your set?

Have you any knotty little Radio problems requiring solution?

The WIRELESS CONSTRUCTOR Technical Queries Department has been thoroughly reorganised and is now in a position to give an unrivalled service. The aim of the department is to furnish really helpful advice in connection with any radio problem, theoretical or practical.

Full details, including the revised and, in cases, considerably reduced scale of charges, can be obtained direct from the Technical Queries Department, WIRELESS CONSTRUCTOR, Fleetway House, Farringdon Street, London, E.C.4.

A postcard will do: on receipt of this all the necessary literature will be sent to you free and post free, immediately. This application will place you under no obligation whatever. Every reader of WIRELESS CONSTRUCTOR should have these details by him. An application form is included which will enable you to ask your questions, so that we can deal with them expeditiously and with the minimum of delay. Having this form you will know exactly what information we require to have before us in order completely to solve your problems.

for what reason her crystal set asked this homage.

Fortunately it was just a case of the kind referred to above—a matter of intermittent bad contact. The trouble was that the telephone leads were old ones, some of the strands were broken, and in order to restore good contact it was necessary to hold the telephones in a certain position just above the table.

In any other position the leads partially opened up and left a very imperfect connection to carry the signals to the telephone. The provision of a new pair of telephone leads restored good signals and allowed the listener to assume a much more comfortable position than the one demanded by the frayed 'phone cords.

### A Crystal Set Puzzle

Failure to get good results on a crystal set is very often attributed at this time of the year to the fact that summer reception is not so good as reception in the winter. This is true so far as it goes, but it is an undisputed fact that wireless sets and aerial-earth systems come in for a good deal of neglect in the summer-time, owing to the greater charms of tennis, cricket, etc.

I am inclined to think that a great deal of the bad reputation which summer has is due to the fact that some listeners persistently neglect to overhaul their sets during the summer. Quite recently, in dealing with a case of very poor reception of a crystal set, I happened to ask if, in the overhauling of the aerial-earth system, the actual joint of the lead-in had been examined.

This had not been done, and subsequently it was found that the point where the aerial connected to the lead-in tube had not received an atom of attention for about twelve months. Though still screwed up tightly, it was exposed to the weather and looked "rusty" and dirty. After the lock-nut on the lead-in tube had been undone, cleaned and screwed down again on to the aerial wire (which had also been thoroughly overhauled and reburnished) the strength of reception was doubled.

### Long-Distance Reception

It is true this was rather an extreme case, for in this instance the aerial was situated at about thirty miles from 2 L O, which consequently had never given very loud reception, although it was quite satisfactory when the lead-in connection was clean. It is in such circumstances, when a set is called upon to work over unusually long distances or under other handicaps, that the question of good contact becomes really vital. So listeners who live under the disadvantage of long distance from their local station or some similar disability should remember to be particularly on the look-out for trouble due to circumstances of this kind.



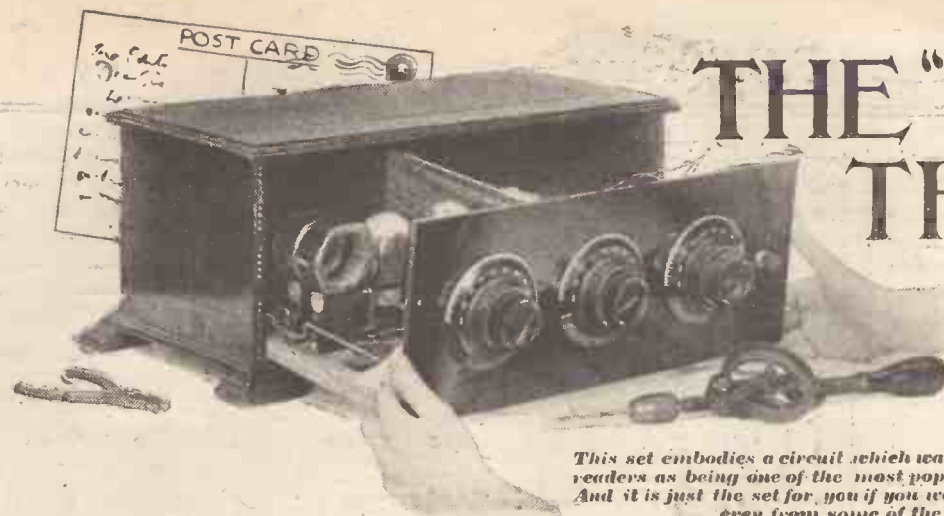

# THE "P.C." THREE

By  
**GEORGE  
T. KELSEY**

*This set embodies a circuit which was voted by "Wireless Constructor" readers as being one of the most popular arrangements of three valves. And it is just the set for you if you want first-class loud-speaker results even from some of the distant broadcasters.*

I WONDER how many of you have guessed it, and how near you are to being correct? I mean, of course, the reason for the strange title which has been chosen to adorn the top of this page. Is it to do with those postcards? Yes, you are quite right, it is!

The design of the receiver illustrated on this and following pages is one of the outcomes of those postcards which so many of you were good enough to send along to the Editor in response to his invitation for opinions.

## Consistent

### Loud Speaker Reception

The "Post-Card" Three—to give it an appropriate name—employs a circuit which was "voted" as being one of the most popular arrangements of three valves, namely, one neutralised H.F. stage, a detector and a stage of L.F. transformer-coupled.

Had I been asked to send in a card, I feel compelled to admit that I should certainly have registered my "vote" in favour of the above combination.

My reasons? Certainly. Bearing

in mind that it consists of only three valves, it is a circuit which can be relied upon for consistent loud-speaker

considerable number of the more powerful distant stations to be heard, many of them under average conditions

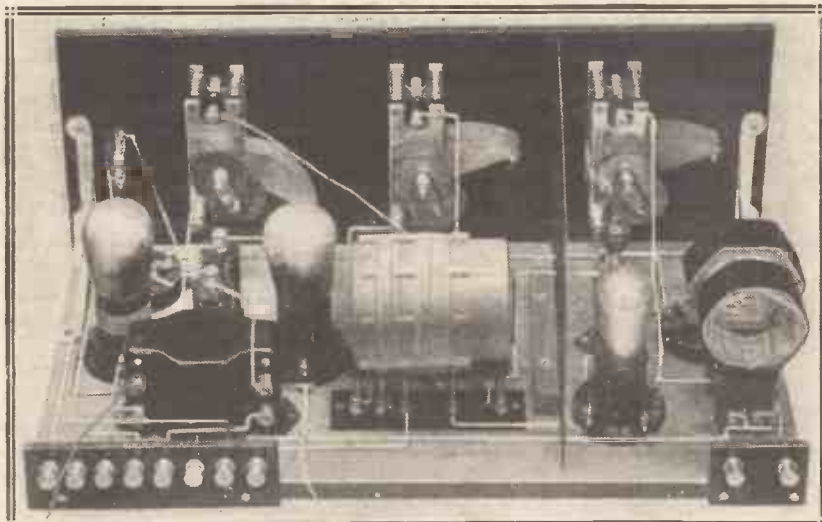

*In the early tests of this set an interesting experiment was carried out with an astatic H.F. transformer which, however, did not give such good results as the coil finally chosen. The photo above was taken as a matter of interest during this experiment.*

reception of the local station and the two Daventrys, and the provision of a stage of H.F. enables a con-

at good loud-speaker strength.

The operation of such a circuit to obtain satisfactory results is, I will

## COMPONENTS REQUIRED

- 1 Ebonite panel, 18 in. × 7 in. × ¼ in. (Red Triangle used for original. Any good branded material, Becol, Ebonart, Radion, Trelleborg, etc.).
- 1 Cabinet for above, and baseboard 8½ in. deep (Original by Caxton. This is a standard size, available from most cabinet suppliers, Aircraft, Bond, Cameco, Makerimport, Pickett, Raymond, etc.).
- 2 Slow-motion variable condensers, .0005 each, with dials (Jackson in original. Any good make).
- 1 Slow-motion variable condenser, .0003, with dial (see above).
- 1 L.T. switch, panel-mounting type (Lotus in original. Any good type, Benjamin, Bowyer-Lowe, Igranic, Lissen, etc.).

- 3 Anti-microphonic valve-holders, baseboard type (Lotus in set. Any good make, Ashley, Benjamin, Bowyer-Lowe, B.T.H., Burndept, Burne-Jones, Igranic, W.B., etc.).
- 1 Neutralising condenser, baseboard type (Jackson in set. Any standard make).
- 1 H.F. choke (Climax in set. Any good make, Bowyer-Lowe, Burne-Jones, Colvern, Cosmos, Igranic, Lissen, R.L.-Varley, etc.).
- 2 Single coil mounts, baseboard type (Lotus, or similar type).
- 2 Baseboard filament resistances (Lissen, or similar type).
- 1 5-pin base, as used in 1928 "Solydne" (Burne-Jones, Peto-Scott, etc.).

- 1 L.F. transformer (Sterling in set. Any good make).
  - 1 Copper screen, 8½ in. × 6 in.
  - 1 Grid condenser, .0003, and 2-meg. leak (T.C.C. in set. Any good make, Dubilier, Igranic, Lissen, Mullard, etc.).
  - 2 Panel brackets (Magnum, or similar type).
  - 1 Terminal strip with 8 terminals, and one with 2.
  - Tinned copper wire, Glazite, wood-screws, flex, etc.
- For the coil you will require:
- 1 5-pin plug to fit the special base (Peto-Scott, Burne-Jones, etc.).
  - Length of tubing, 2½ in. diam. × 2½ in. long (Pirtoid used for original).
  - ¼ lb. No. 24 D.C.C. wire. 1 oz. No. 34 D.S.C. wire.

## The "P.C." Three—continued

agree, a little more difficult than is the case with the more usual "det. and two," but even so, strictly speaking, there are only two dials to manipulate at once, the third which controls reaction only requiring occasional adjustment when a station has been found.

In the matter of coils for the H.F. inter-valve coupling, the cards revealed an overwhelming majority in favour of the home-made type, and accordingly the "P.C." Three has been designed incorporating a home-constructed split-primary H.F. transformer.

I think I have said all that need be said in regard to what the "P.C." Three really is, I have also indicated what may be expected from it, and so now to get down to the real business of the article by describing how it can be made.

### Easy to Build

At the outset it should be understood that the actual building of the set from the home-constructor's point of view is not what I should call difficult. There is, perhaps, need for a little care in regard to the screen and the wires that pass through it, and also in connection with the home-made transformers some difficulties will probably make themselves manifest; however, with the aid of the photographs and drawings, it is hoped in the article to clear up any difficulties which may arise.

For the convenience of readers, the components required are listed

together elsewhere, and although the makes of those used in the actual set are listed first, it should clearly be understood that any of the reliable makes are quite suitable provided

various makes. If the baseboard happens to be unstained, a very pleasing colour effect can be obtained by painting it with a solution of permanganate of potash and

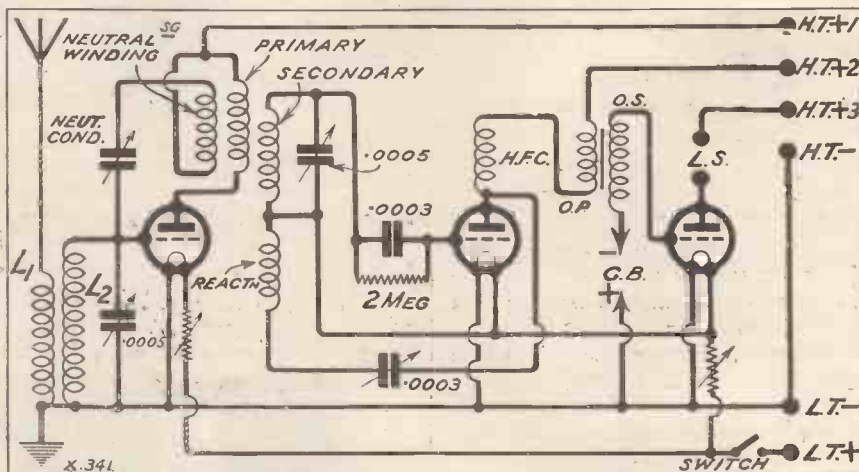

substitutions will not materially effect the layout of the set.

With the components to hand, the actual constructional work can be commenced in the conventional way with the fixing of the panel to the baseboard, having, of course, first drilled the panel.

The weight of three condensers was quite sufficient to justify the use of panel brackets, although on the panel layout diagram it will be noticed that the bracket holes are not dimensioned. These measurements were purposely omitted since there is no real standard in the distance between the two holes in

water. The stain, when first on gives a red appearance, but the red, after a few minutes, disappears and leaves an attractive brown finish.

It is desirable to fit the panel components first, and since a screen is placed between the first two condensers, careful attention should be paid to the angle at which these two are secured, otherwise there is a possibility that one set of moving vanes will foul the screen.

### Fixing the Screen

The positions of the holes in the screen through which wires pass cannot be determined with accuracy until all the components are in position, nevertheless it is best to fix it temporarily in place so that the positions of components on either side can be found.

There are several ways in which the screen can be secured, but in the writer's estimation the most simple is that used in the original set. A block of wood about  $\frac{1}{2}$  in. square and approximately 6 in. long was secured to the base of the screen. Holes were then drilled at right angles to those of the screws holding the screen, and the rest was easy.

It now remains to fit the rest of the baseboard components, not forgetting the two terminal strips, and all is then ready for the wiring which is the next job.

From the back-of-panel photographs it will be seen that the majority of the wiring was carried out with

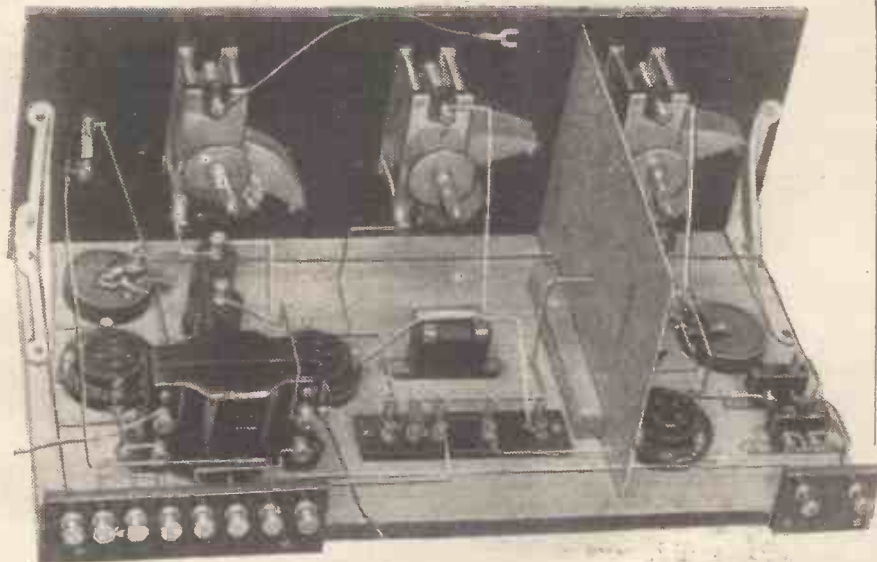

A general view of the finished receiver with coils and valves removed. The flexible lead at the top of the picture is joined to the reaction terminal on the H.F. transformer.



## The "P.C." Three—continued

square-section tinned copper wire. With this particular wire it is possible to make the finished set look extremely neat, but be very wary of "dry" joints.

For some reason or other, the square-section wire always seems to give more trouble in this direction than other kinds of connecting leads, but if you carefully tin each piece of

$\frac{1}{4}$  in. in diameter, and at a distance of about  $\frac{1}{4}$  in. from one end in each rod cut a V-shaped slot. Before the primary and neutralising windings can be commenced, it will be necessary to arrange for something to hold the spacing rods in position while the winding is done.

In making the original coil, the most convenient way of holding the

Having, therefore, secured the ends in fresh holes, commence the double winding as near as possible to the position shown in the drawing. A glance at Fig. 2 will give an idea of how the winding is done. It is very important to note that these windings must be in the same direction as the secondary, and the double winding should be carried on until sixteen turns in all are wound—that is to say, sixteen turns of each wire. As before, the ends should be secured in holes other than those holding the end of the secondary winding.

### The Coil Connections

It would, I think, be advisable to stress once again the importance of doing this winding carefully so as to avoid crossed wires. The best scheme is to feed the double winding through the thumb and forefinger of the right hand while holding the former in the other hand.

We now come to the use of the "V" slots. These are to accommodate the reaction winding, which consists of 8 turns of No. 34 D.S.C. wire, wound hank fashion in the slot and in the same direction as the secondary. The end of this last winding should be taken to a terminal mounted on the side of the former, as shown in Fig. 3.

With regard to the connections from the coil to the base, the diagram of Fig. 3 should clear up the difficulties in this respect. It now remains finally to secure the coil to the five-pin base, and all is then ready for the testing.

Place valves of the "H.F." type in the first two sockets, and a power or super-power valve in the last stage. In the 2-volt range, one or two of

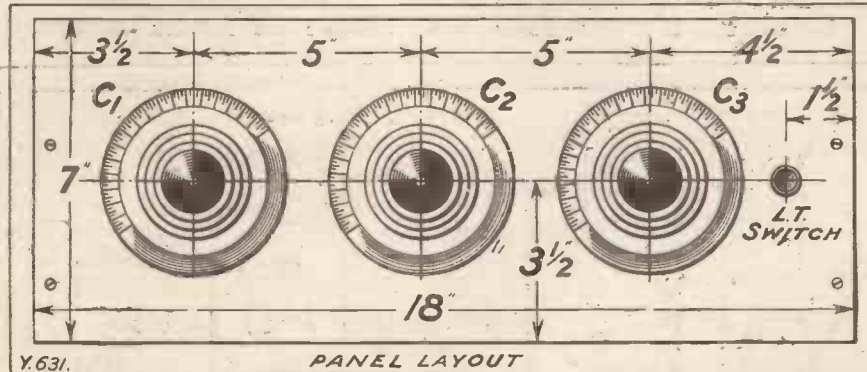

wire where a joint occurs, and test each connection when made, by giving it a "tug," there is nothing to worry about.

With the exception of the L.T.—to earth connection, which is actually soldered to the screen, all wires passing through the metal sheet must carefully be insulated. For these connections the reader cannot do better than use Glazite, since the covering on this wire has a very high insulation resistance.

To drill the holes in the screen, the positions of which can quite easily be determined with all the components mounted, it should be removed. It is advisable to cut the holes on the large size to prevent the possibility of chafing.

### Making the Transformer

The point-to-point wiring instructions, and the back-of-panel diagram, render it unnecessary for further details in this respect, and the next thing which calls for elucidation is the construction of the special H.F. transformer.

For this purpose, a  $2\frac{3}{4}$  in. length of Pirtoid, or similar tubing, with an external diameter of  $2\frac{3}{4}$  in., will be required. Commencing with the 24-gauge double-cotton-covered wire which is to form the secondary, wind centrally on the former 60 turns, tightly securing each end through holes drilled in the tube.

Next prepare eight round wooden rods about two inches long and

spacers in position was found to be by pieces of wire passing over the rods right round the former at each end.

### The Double Winding

We now arrive at the double winding, which operation probably calls for more care than anything else in the construction of the set. About 16 ft. of the No. 34 double silk-covered wire should be wound off on to another reel, and taking the two ends thus formed secure them to the same end of the former, as the start of the secondary.

It is not desirable to fix these ends through the same holes as the start of the first winding, on account of the possibility of "shorts" due to frayed insulation.

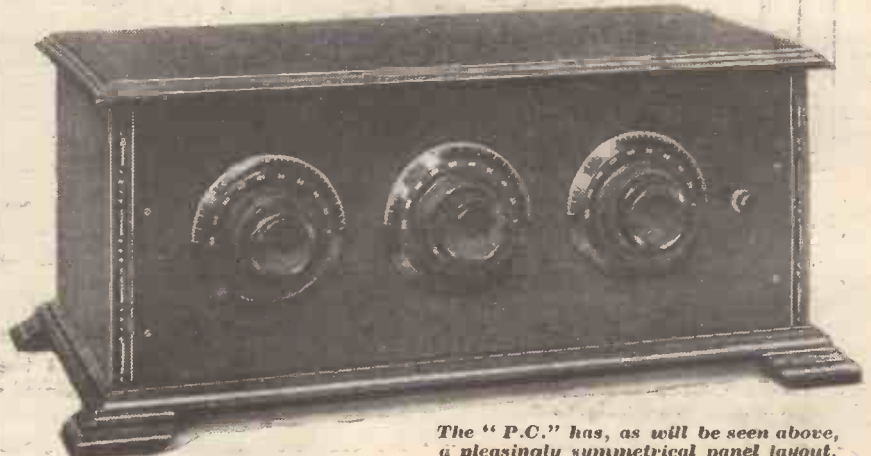

The "P.C." has, as will be seen above, a pleasingly symmetrical panel layout.

## The "P.C." Three—continued

the well-known makers recommend a valve other than the "H.F." for detection, and in this case the detector valve should be as advised. For the aerial circuit a No. 25-35 plug-in coil, depending upon the size of your aerial, will be required, and  $L_2$  should be a No. 60 or 75.

### Neutralising the Set

Assuming that you have joined up the aerial, earth, batteries and loud

sistor to the off position and once again join the aerial lead to the appropriate terminal. Now, by slowly rotating the two tuning dials and taking care to keep them in tune, it should be possible faintly to hear the local station. This being the case, the neutralising condenser should be adjusted until a position is found at which the signals fade right away.

Having made quite certain that the local station cannot be heard, the

eight or ten degrees should be sufficient to eliminate the local station, unless, of course, you are situated very close to it.

When the local station is out of the way, the best indication as to when the two circuits are in tune is to listen for a certain "liveliness" or hissing noise which will only occur under these conditions.

In searching for distant stations, advance the reaction condenser to

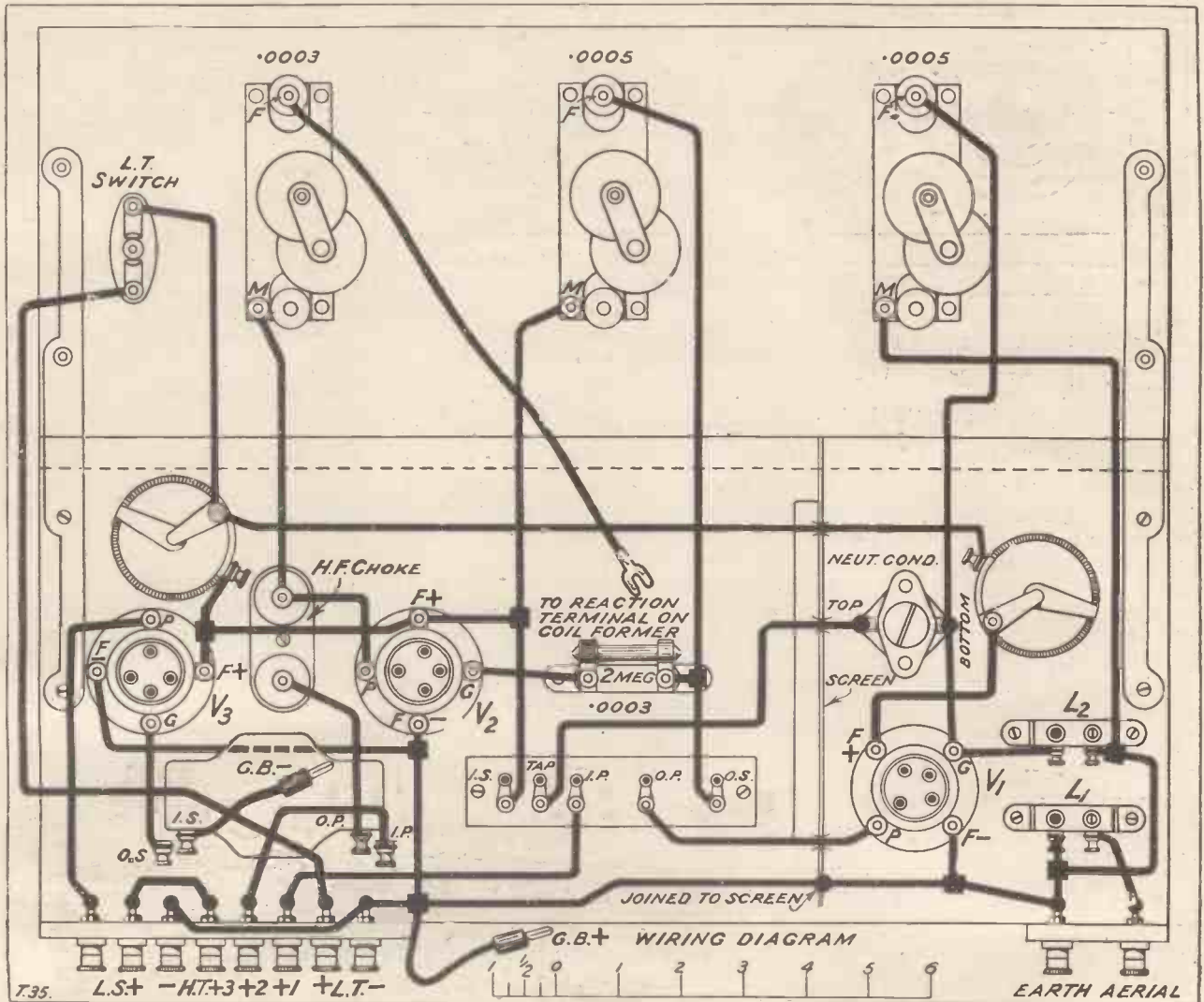

speaker, proceed to neutralise the set in the following manner.

Disconnect the aerial for a moment or two and rotate the two tuning dials until it will probably be found that with the neutralising condenser screwed right down the set commences to oscillate when the first two dial readings are approximately the same. Turn the H.F. valve's filament re-

H.F. valve's filament resistor can once again be placed in the "on" position and the set will then be neutralised and ready for use.

### Searching for Distant Stations

It is important to note that the two circuits should be fairly sharply tuned, that is to say, the simultaneous movement of the two dials over about

the point just before the set goes into oscillation, and move each tuning condenser a degree or so at a time, taking care so to adjust each one until the hissing noise is present. It should be pointed out that the setting of the reaction condenser to bring the receiver just below the oscillating condition will not remain constant over the whole range, and occasional



## The "P.C." Three—continued

readjustments should therefore be made.

You can take it as a general indication that the two circuits are out of tune as soon as the "hissing" disappears, and having once got the two circuits in tune, it is best to move the aerial condenser, say, two

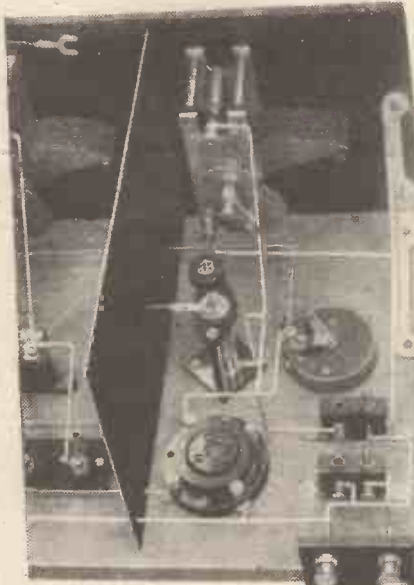

The H.F. side of the receiver is shown above. With the exception of the one in the extreme foreground, all wires passing through the screen must be insulated.

degrees, following it with a similar movement on the second condenser. By this method it should not be found difficult to hear several stations on the loud speaker after dark.

It is possible that you may hear one or two of the more powerful Continental stations during daylight, if you happen to be in a good spot for reception, but at this time of year it is not easy with any three-valve set to get consistent loud-speaker results from distant stations during daylight, with, of course, the exception of 5 G B.

### "Practice" Makes Perfect

In so far as operating goes, I am of the opinion that it is a case of practice makes perfect with a set of this type, and once you have got the "knack" of operating you will feel quite at home, despite the fact that there are three dials.

In the early tests of this set, several stations apart from London and 5 G B were heard at pleasing loud-speaker strength. Langenberg, who is usually

quite strong, was found a few degrees below the setting for 5 G B, while coming down the scale, Frankfurt, Hamburg, and Stuttgart, to mention a few, were all received on the loud speaker.

### Long-Wave Transformer

Full details for making an H.F. transformer for the long waves, together with a detailed test report, will be given in the next issue of the WIRELESS CONSTRUCTOR, meanwhile the set can be built and tested on the broadcast band.

In the foregoing operating instructions the method of neutralising known as the silent point was given, since this is the quickest and easiest way of stabilising the receiver.

When, however, you become a little more familiar with the handling of the set, there is another and, incidentally, more reliable method by which the set can be neutralised. This method is known as the reaction demand way, and the procedure is as follows.

### The Other Neutralising Method

Set the reaction control and likewise the neutralising condenser at minimum—that is to say, with plates all out. Now, on setting the tuning condensers so that the two tuned circuits are in step with each other it will probably be found that the set is oscillating. To test for oscillation, touch one or other of the sets of plates of the tuning condensers.

You will probably find that the set will only oscillate under the above

### WIRING IN WORDS.

Join earth to socket of  $L_1$  coil base, to pin of  $L_2$  coil base and to moving vanes of first variable condenser.

Join L.T.— to H.T.—, to one filament contact of  $V_2$ , to G.B.—, to screen, to one filament contact of  $V_1$  and to earth.

Join remaining filament contact of  $V_1$  to one side of first baseboard resistor.

Join I.S. terminal on five-pin base to moving vanes of second variable condenser, to remaining filament contacts of  $V_2$  and  $V_3$  and to one side of second baseboard resistor.

Join remaining side of first to remaining side of second baseboard resistor, and to one side of L.T. switch.

Join remaining side of L.T. switch to L.T. + terminal.

Join pin of  $L_1$  coil base to aerial terminal.

Join socket of  $L_2$  coil base to grid of  $V_1$  to one side of neutralising condenser and to fixed vanes of first variable condenser.

Join remaining side of neutralising condenser to "Tap" terminal on five-pin base.

Join I.P. on five-pin base to H.T.+1 terminal.

Join anode of  $V_1$  to O.P. on five-pin base.

Join O.S. on five-pin base to one side of grid condenser and leak and to fixed vanes of second variable condenser.

Join remaining side of grid condenser and leak to grid of  $V_2$ .

Join anode of  $V_2$  to one side of H.F. choke and to moving vanes of reaction condenser.

Join a flex lead to the fixed vanes of reaction condenser, the remote end of which lead should be equipped with a spade tag.

Join remaining side of H.F. choke to O.P. of L.F. transformer.

Join I.P. of L.F. transformer to H.T.+2 terminal.

Join O.S. of L.F. transformer to grid of  $V_3$ .

Join a flex lead terminating in a wander plug to I.S. of L.F. transformer.

Join anode of  $V_3$  to one L.S. terminal.

Join remaining L.S. terminal to H.T.+3.

conditions when the two circuits are in tune with each other, and this, as well as the liveliness mentioned previously, can be used as an indication. It is convenient to perform the operation at some point near the middle of the tuning range.

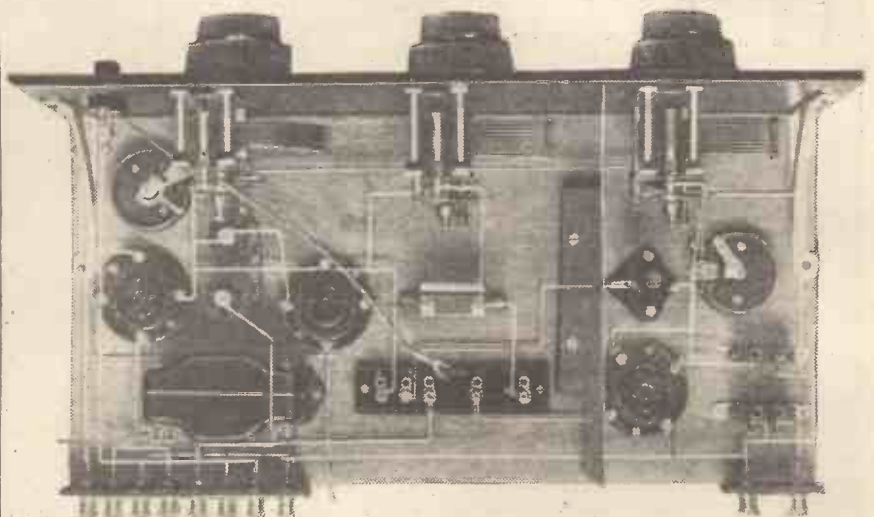

When laying out the components and during the wiring, reference to this photo will help considerably.

## The "P.C." Three—continued

Now, gradually increase the capacity of the neutralising condenser. (In the case of the one used in the original, this is done by screwing the plate downwards.) Test at intervals for oscillation as this is done, and you will presently find that the set has ceased to oscillate and will not recommence even when the tuning dials are slightly readjusted.

Now, increase the reaction condenser a little until the set once more oscillates, and again increase the capacity of the neutralising condenser until oscillation ceases. Slightly readjust the tuning condensers again to make sure that the set is completely stable once more.

### Final Adjustments

Proceed in this way until it is found that the correct adjustment of the neutrodyne condenser has been overshoot. Once this point has been passed it will be observed that further increases of the neutrodyne condenser setting no longer stop oscillation, but cause it to become stronger.

The object is to find such an adjustment of the neutralising condenser as will permit the greatest setting of the reaction condenser to be used without producing oscillation.

It will then be observed that when the two tuned circuits are in step and the set is brought to the verge of oscillation, a slight movement in either direction of the neutrodyne condenser will cause the receiver to break into oscillation.

### Twenty-One Stations Received

Little else need be said with regard to operation, for once the set is completely stable the constructor should not have much difficulty in finding stations.

In this connection, I am able to add as we go to press that, during a recent test of this receiver on a night when conditions were good, twenty-one stations were received on the loud speaker, some of them not very loud, of course, but on the other hand quite a fair number really worth listening to.

In the concluding article next month a list of some of the more important of these stations will be given.

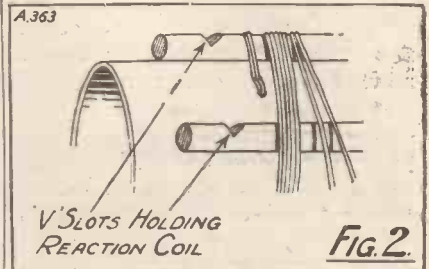

\*\*\*\*\*  
 \*  
 \* **A USEFUL** \*  
 \* **ACCESSORY** \*  
 \*  
 \*\*\*\*\*

A POUND of plasticine is a very useful investment for any wireless enthusiast. This material, as most readers know, is a form of plastic clay which does not harden on exposure to the air.

With aerial coupling, it is sometimes desired to support a coil at a particular angle and at a particular height near another. A small piece of plasticine can be shaped so as to give the necessary support to hold the coil at the correct angles. Another small piece will temporarily secure a couple of wires in the desired positions when they show a tendency to become tangled, or to short-circuit with others.

### A Short-Wave Makeshift

In short-wave work it is sometimes very convenient and effective to be able to make connections directly to the legs of the valve without using the conventional socket. Any valve can be securely supported upside down by pressing its bulb into a piece of plasticine, and there will be no risk of its falling over, as might happen with other types of temporary support.

On several occasions tips have been given in this journal for the use of black or coloured wax for filling up holes in ebonite panels. When these holes are large, precaution has to be taken to prevent the wax running out. The simplest way is to place a small piece of plasticine at the back of the panel so as just to cover the hole.

H. P. W.

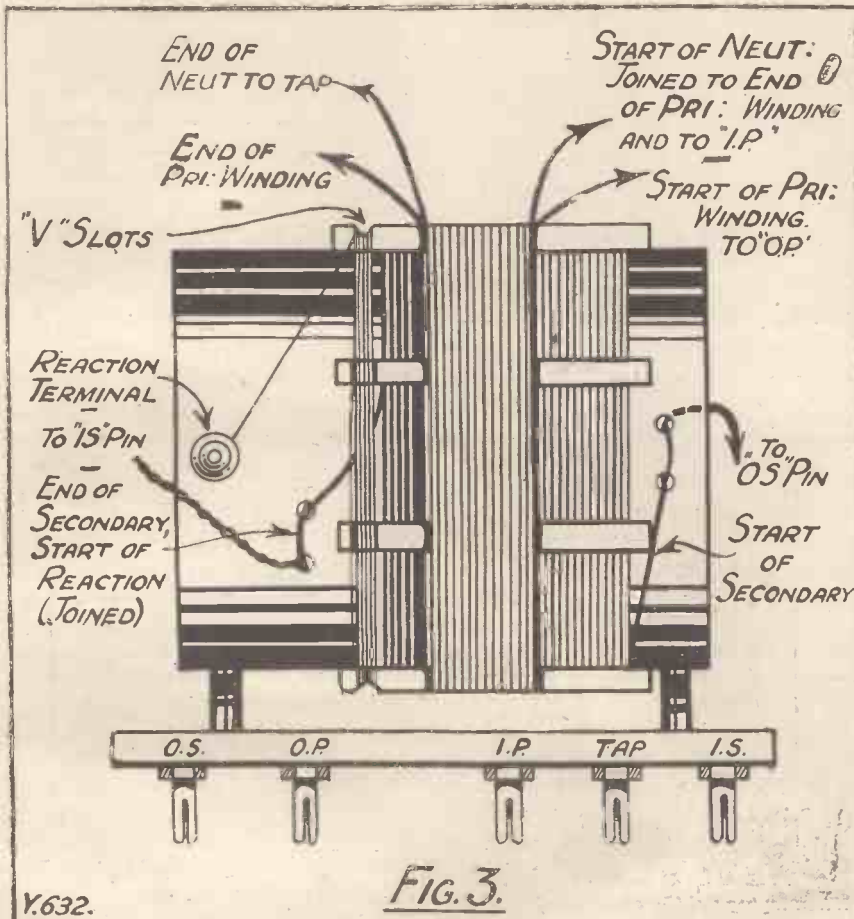



# RADIOGRAMPHONICS

*A monthly article for the gramophone enthusiast.*

*Pick-ups Tested—The Pick-up in Practice.*

By A. JOHNSON-RANDALL.

WE have received for test one of the new Loewe pick-ups. This device has been placed on the British market at the low cost of 18s. 6d.

It is of the permanent-magnet high-resistance type, and operates on a "semi-balanced" armature principle, that is to say, the armature is placed equidistantly between the two magnet poles. Every endeavour has been made to damp out resonance by providing stout rubber buffers at vital points. The pick-up is light in weight and exceedingly compact. The magnet assembly is well protected by a neat bakelite casing and the whole arrangement is sturdy and strongly constructed.

## Battery Consumption

On test the pick-up gave very good results and there was a marked absence of "dither," this tending to show how well the resonance has been damped out. In addition the higher frequencies were present in their correct proportion (aurally), and the device is certainly excellent value. It can be recommended to those who desire a good-quality pick-up at a moderate price.

This month I want to talk about the H.T. consumption of gramophone

amplifiers and H.T. batteries in general.

Now it is highly probable that the amplifier used is part of the ordinary domestic radio equipment. There are not very many readers who care to run separate amplifiers, this partly for economical reasons and partly because there is no difference between a gramophone amplifier and any other valve magnifier employed for the reproduction of music.

Hence my remarks on H.T. consumption will apply equally to the L.F. side of radio receivers.

Most gramophone amplifiers consist of either a combination of resistance and transformer coupling, or of pure resistance-capacity coupling.

Suppose we assume an ordinary straightforward two-stage amplifier, consisting of a resistance stage followed by an L.F. transformer. The anode current taken by the first valve will be quite small, because of the limiting effect of the resistance, and we can take it that it will not exceed half a milliampere. The second valve will have the primary winding of the transformer in series with the anode,

and if it is a good modern low-ratio instrument the plate current for this valve will not be greater than 3 or 4 milliamperes, owing to the effect of heavier currents on the transformer characteristic. The last valve will be a "super-power," and with 120-150 volts H.T. it is probable that the anode current will be in the neighbourhood of 20 milliamperes, or perhaps a little less.

Now, the sum of these currents will be, roughly, 24 milliamperes, and it is quite useless attempting to employ a small dry H.T. battery of the "Popular" type. These batteries are really intended for the smaller sets, and the current taken should not generally exceed 5 milliamps.

## Large-Sized Cells Required

If dry batteries are to be used economically for an amplifier designed to give high quality it is essential to choose those of the "super" type, which have large-sized cells. Apart from the fact that the smaller cells cannot stand up to a current "drain" of 20 milliamps or more, the internal resistance of a small-sized battery tends to rise very rapidly, and this in turn frequently causes low-frequency howling and distortion.

Those who have charging facilities will be much better off if they use H.T. accumulators, or, alternatively, they can employ the electric-lighting mains in conjunction with a suitable mains H.T. unit. In the case of H.T. accumulators, for currents in excess of 20 milliamperes it is preferable to choose the 5,000-milliampere-hour type of cell, since the smaller sizes will need rather frequent charging if the amplifier is in constant use.

(Continued on page 282.)

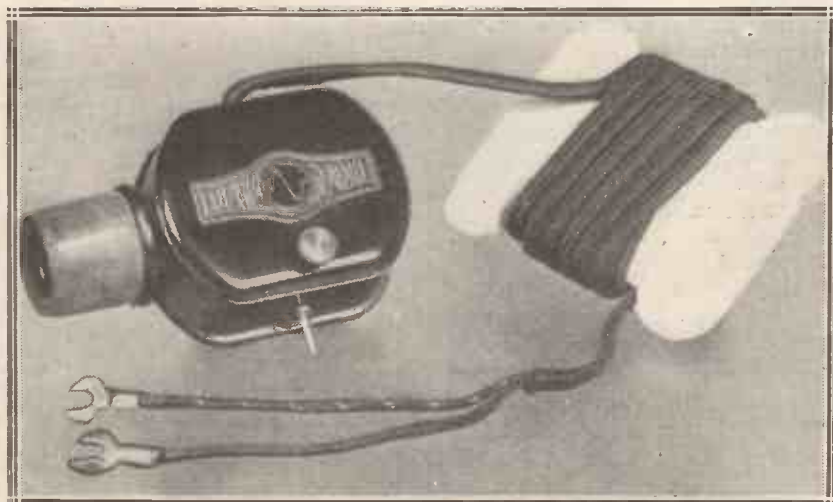

This is the Loewe gramophone pick-up which Mr. Johnson-Randall deals with above.

## Results With The "Roadside" Four

A selection from the many letters received from readers who built this set from details given in the "Wireless Constructor" last May.

### "Roadside" Four in Lancashire

SIR,—You have asked for results re the "Roadside" Four in the current issue of WIRELESS CONSTRUCTOR. I am listening to my version of the set now as I write this.

I am over thirty miles from my local (Manchester, 1.5 kw.) and am obtaining nearly full loud-speaker results, in broad daylight. Last night I got Dublin and Liverpool on the speaker, which is a 9½-in. cone, and built in the set according to your instructions.

### Foreigners on Loud Speakers

I have been using the set on outdoor aerial and earth with Gambrell coils ("B" for broadcast and an "E" for 5 XX) instead of frame, and they worked excellently. I had Hilversum, Berlin and another this morning at full loud speaker. These coils were the centre-tapped type, but were a trifle small in turns.

I am now waiting instructions re a frame for the 5 XX range, and I hope to get very good results indeed as I do most of my listening on that range. I obtained 5 GB this evening, but only very faintly on loud speaker, as this is poorly received up north, even on powerful sets, being subject to fading and distortion.

I think the "Roadside" Four will last me a very long time, and is likely to prove superior to some very expensive five-valve portables I have heard.

I will conclude with best wishes to you and your paper.

Yours truly,

L. EDWARDS.

Preston, Lancs.

### The "Roadside" Four in Germany

(TRANSLATION)

SIR,—In the search for a good circuit for a portable receiving set there came into my hands a copy of the May number of the WIRELESS CONSTRUCTOR, and I commenced to make up the "Roadside" Four.

I was a little sceptical as to whether I should make a success of it as the description being in English made it rather difficult for me to follow. However, every day I am more and more pleased with its performance;

whether in the town, on the highways, in a tent or on the water, the "Roadside" Four puts up a really remarkable performance.

As you will see from the accompanying photo my set only differs in make-up from yours in respect of the form of loud speaker, which I built myself from a "Gramor" self-coloured membrane made of Pertinax, an insulating material which is very commonly used in Germany for making loud speakers and which serves the purpose remarkably well. I now want to adapt the set for the 1,000- to 2,000-metre range. Besides myself there are from ten to twelve others who have built the "Roadside" Four on my recommendation, and they are all equally interested in this point.

With this improvement one will be able to get Daventry, Hilversum,

### "Roadside" Four in Germany



This "Roadside" Four, built by a Dortmund reader, picks up 5 GB in Germany.

Königswusterhausen and Zeesen on the "Roadside" Four.

With my apparatus I get Langenberg, Stuttgart, Leipzig, Frankfurt, Hamburg at pleasant strength for room reception on a loud speaker. On the headphones I get other stations, such as 5 GB. I am sorry to have to write you in German, but I could not make my meaning clear in English.

With radio greetings,

JULIUS LINDNER.

Dortmund,

Westfalen, Germany.

### Novel Use of "Roadside" Four

SIR,—I am using the "Roadside" Four; and have, in connection with it, a "gadget" that may be useful to other readers.

I am using the electric-light mains for an aerial. I have the usual

scheme of two fixed condensers between the aerial and earth terminals and the two mains leads.

One condenser is very much larger than the other. The one between the grid end of the frame and the mains being a neutralising condenser and, in my own arrangement, the other condenser is an R.C. unit minus its resistances.

### More Loud-Speaker Results

Incidentally, a neutralising condenser makes a very good coupling when using the ordinary outdoor aerial and earth with the "Roadside" Four, and it certainly has the advantage of simplicity. With this arrangement I can get upwards of twenty stations at good L.S. strength.

Apart from external aerials the set is satisfactory in every way, and I have permanently adopted it after trying several other circuits. I can get three foreigners at what would be good phone strength almost every night after dark. And, of course, its constancy of reaction is very reliable.

Thanking you for an ideal portable receiver.

I am,

Yours faithfully,

C. J. CARTER.

Bucks.

[EDITOR'S NOTE.—This scheme is most interesting, but readers should be careful not to connect the mains direct to the condensers mentioned. They should place a high voltage test Mansbridge type of about 1 mfd. in series with each mains lead for safety.]

### "Roadside" Four Amazing!

SIR,—"Roadside" Four just constructed. Amazed at results in Birmingham. 5 GB, 2 LO, and three others in daylight. Have used Trix tuning condenser, Ormond dial, unknown make of 0001, McMichael choke, Ferranti A.F.4, etc. Excellent quality noted by all, and ease of control.

Hearty congratulations and thanks!

BM/SNGR.

London, W.C.1.

## POPULAR WIRELESS

Is the Leading  
Radio Weekly

Price 3d.

EVERY THURSDAY



## MORE ABOUT THE SEVEN-VALVE SUPER-HETERODYNE

*Some operating details and further practical points about the powerful long-distance receiver described last month.*

By PERCY W. HARRIS, M.I.R.E.

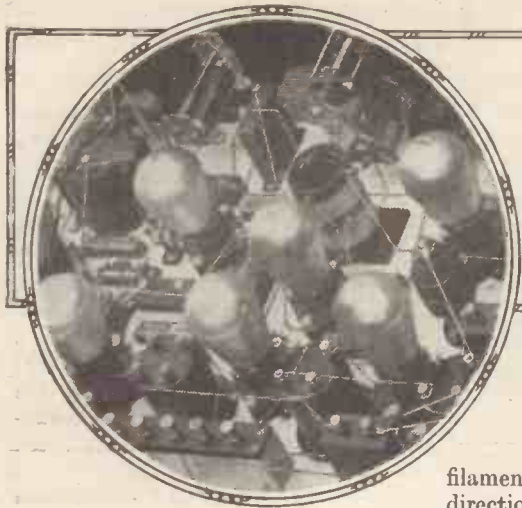

No receiver I have yet designed has given me so much pleasure and interest as the seven-valve super-heterodyne described in last month's issue. Visitors to the laboratory have, without exception, expressed surprise that such admirable quality is obtained with a type of receiver which is not generally distinguished by first-class quality, while the sensitivity is, of course, not the least fascinating of its virtues.

It is now invariably run from a Harris "Stedipower" L.T. Unit (as, indeed, are all the other receivers in the laboratory), and, of course, the attachment of a mains H.T. unit in conjunction with the "Stedipower" L.T. Unit converts it into an "all from the mains" receiver of first-class all-round performance.

### Increasing the Sensitivity

Readers who have already built the seven-valve super-heterodyne will by this time have become generally accustomed to handling it, and many doubtless will have added to the list of forty-five stations given in the test report last month. General operating instructions were given in the last issue, and here I am giving a few tips which will add still further to the sensitivity and sharpness of tuning.

It will be found that with practically all makes of valves the intermediate-frequency valves will oscillate slightly more freely when the filament resistance is adjusted to give a slight dimming of the filament. For example, we will imagine that with the filament resistance at the "full-on" position a station is tuned in, and the potentiometer adjusted so that the intermediate-frequency stages are just below the oscillating point.

Now move the sliding arm of the

filament resistance in a clockwise direction so as to dim the filament slightly, and it will be noticed that the intermediate-frequency valves will probably run into oscillation at once. Turn back the potentiometer knob until you are again just below the oscillation point, and repeat this process until you find a position on the filament resistance which, when the potentiometer is set at the correct position, gives the maximum sensitivity and selectivity.

### Coupling Coil Adjustments

There is also a best position, although it is not at all critical, for the coupling coil of the oscillator coupler, and sometimes slightly better results are obtained by rotating the oscillating coupler coil through a half circle so that the direction of winding is opposite to what it was

Be sure to follow out the instructions given for matching the valves in the intermediate stages (pages 161 and 162), for individual valves of the same make and type vary quite appreciably in their characteristics. It is one of the special features of our seven-valve super-heterodyne that the same type of valve is used in a number of different sockets, so that one can choose out of the total number the best valves for the intermediate stages.

The selectivity of a super-heterodyne is dependent upon, firstly, the sharpness of tuning of the frame-aerial circuit, secondly, the sharpness of tuning of the intermediate-frequency circuit, and, thirdly, the relative strength of the signal desired and the interfering signal. The maximum sharpness of tuning in the intermediate stages of this instrument are obtained

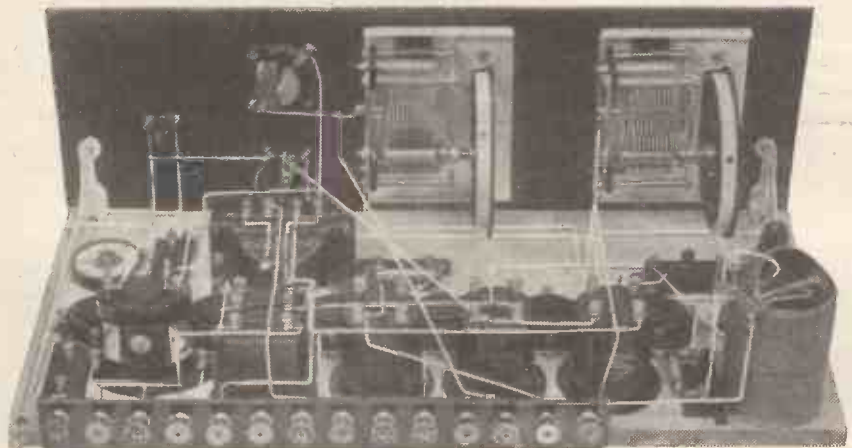

*The coupling coil of the oscillator will be seen to the right, and it may prove advantageous to readjust this as suggested in the above article.*

before. While there is a best voltage for H.T. positive 2 which supplied the oscillator and the intermediate stages, it is not at all critical, and the values given in the previous article can be varied 10 volts either way without noticeable effect.

when the intermediate valves are fairly near to the oscillation point, while skilful use of the small reaction condenser will greatly sharpen up the frame-aerial circuit.

In most cases, however, if the  
(Continued on page 280.)

# In the Wireless Workshop

A Novel Light—R.C. Coupling Condensers—Mounting Spare Meters.

## A Novel Light

EVERY experimenter or constructor at some time or other has had jobs to do in corners or awkward places where it is impossible to have a light.

Below is described a headlight which can be easily and cheaply made from material one finds in a scrap-box or, if parts have to be purchased, these can be obtained for less than 1s. 6d. The following parts are required:

### Few Components

Three-quarters of a yard of 1-in. elastic.

One 3.5 flash-lamp bulb.

One lamp-holder.

One 4.5 flash-lamp battery.

Approximately 12 inches of flex.

Two battery clips.

One hook and eye or patent clip.

The elastic is measured to the size of the head, and sewn. The surplus is not cut off, but formed into a loop which should be a trifle smaller than the size of the battery (this forms the battery carrier) and is fastened with a hook and eye or patent clip.

The lamp-holder is fixed to the elastic by means of stitching and connected to the battery (the wires passing over the top of the head). The lamp is screwed into the holder as far as possible—it will then be switched on. By giving a quarter of a turn in the reverse direction the lamp



The "headlight" in position, showing the method of fixing and wiring.

will immediately be extinguished; therefore it will be seen how simple is the operation. The above sketch will be helpful.

It will be noticed from the foregoing

that by having a light attached to your head both hands are released, which is a great asset. The light can be adjusted by moving the elastic up or down on the forehead, so that the full flood light can be centred upon what you are doing and, at the same time, there being no fear of fire.

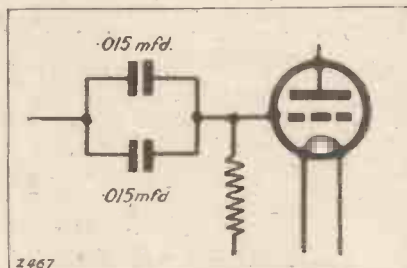

Using two condensers in parallel.

## R.C. Coupling Condensers

By using resistance-coupled stages for note magnification a high degree of quality is obtainable in reproduction. It is possible particularly to bring out the bass notes of music with their proper value, since with this form of coupling the anode impedance remains almost constant for all audible frequencies, and the amplifier, if well designed, thus gives a due response to both high and low notes.

It is not always realised, however, that these low notes cannot be properly heard unless the capacity of the grid condenser is large enough to ensure that no "cut off" takes place at the lower frequencies. Unfortunately mica dielectric fixed condensers with a capacity exceeding 0.15 mfd. are rather expensive, and there are considerable drawbacks to the use of paper dielectric condensers in the grid circuit of a valve.

## Solving the Problem

A simple solution of the difficulty is seen in the accompanying diagram. Fixed condensers of the clip-in type, with a capacity of 0.15 mfd., are obtainable quite cheaply, and two of these may be used in parallel to form the grid condenser. The total capacity is thus 0.3 mfd., which, as practical experiments show, is sufficient to allow the bass notes to be really well brought out. If the clips of a standard

holder are eased a little with a pair of pliers, no difficulty will be found in fitting into them two 0.15-mfd. condensers side by side.

## Mounting Spare Meters

THE wise experimenter usually keeps one or more meters on his bench free from regular service, so that he can have them handy for general testing. Now, if you use a meter flat on the bench, you have to bend over it to take a reading; you probably have to stand up to do your job. Meters fixed vertically, on the other hand, are awkward to read when you are standing, unless, of course, they are fitted on the wall.

The most convenient position for a meter is at an angle of 45 degrees, and you will find your testing work much easier to carry out if you set up your meters as shown in Fig. 1. Each meter is mounted on an ebonite panel just large enough to accommodate it. You can fit two terminals on the panel if the meter terminals are behind. The panel is screwed to a small baseboard with its front edge bevelled off at an angle of 45 degrees. You can read meters mounted like this from any position.

The average good moving-coil meter is practically unaffected by the angle, but before you mount a meter like this you should take a few readings, holding it at various angles, so as to see if there are any discrepancies.

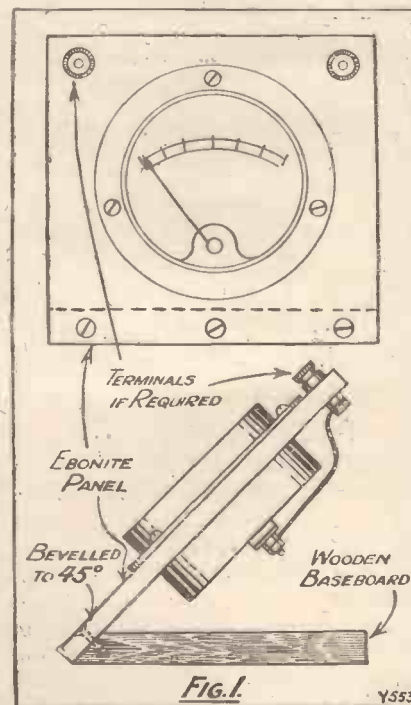

One of the best ways of mounting a meter is shown in this diagram.



# LOADING YOUR SET FOR 5 XX



By G. P. KENDALL, B.Sc.

*"Wave-change" sets are becoming more and more popular, and possessors of receivers of the older type are asking whether they cannot incorporate some of the new schemes in their own circuits. Here are some thoroughly practical notes which will show you exactly how it can be done in sets of the simpler type.*

THE long-wave Daventry station provides such a valuable programme in localities where reception is bad on the ordinary wave-lengths, as the result of bad local conditions, interference from shipping, or what not, that it will probably not have occurred to many

lengths, between 1,000 and 2,000 metres, and the lure of these stations, is irresistible to the average long-distance listener.

The result is that whenever a designer thinks out some nice new scheme, he is under the necessity of providing interchangeable coils or some other abomination to enable the set to receive long waves as well as the ordinary broadcast band, which often makes him think longingly of the conditions in America, where there are no long-wave stations to provide for, and the designers can concentrate upon securing the greatest possible efficiency on the relatively narrow band of waves from about 200 to 500 metres.

make such alterations in coupling between the various circuits (such as between the aerial and the secondary circuit, and so on) as will cause the receiver to function efficiently on the upper range.

At the same time, this must be done

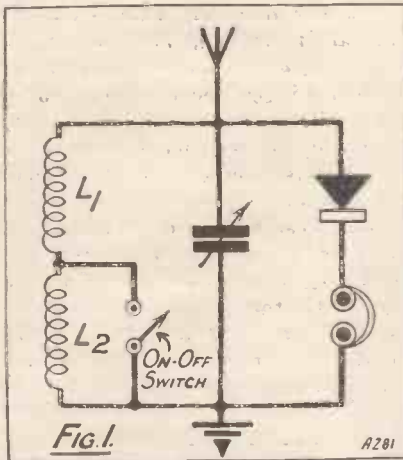

*The simplest way of "loading" a crystal set for 5 XX, with a switch for changing over.*

readers of the WIRELESS CONSTRUCTOR that there is, nevertheless, a section of the community by whom the 5 XX station is regarded as anything but a boon and a blessing. It is a fact, all the same, that the arrival of 5 XX upon the scene has done much to embitter the existence of the designer of wireless sets for home construction, to say nothing of the designer of commercial receivers.

## The Long-Wave Lure

The existence of an alternative programme on the longer waves would have been sufficient in itself to compel the making of provision for long-wave reception in practically every set designed, even though the station does not actually provide an alternative programme for the London area, but the matter does not end here, for some of the best and most easily received of the foreign transmissions are also on long wave-

## The Coil-Changing Nuisance

Of late there have been strong signs that another aspect of the long-wave problem is going to be added to those already perplexing the designer, and that is that the public is really getting very tired of this coil-changing business, and is demanding a set with a rapid and easy change-over from long waves to short by means of switches or some other scheme which dispenses with the business of pulling out one set of coils and inserting another in the dark interior of a set.

A good deal of useful work has been done on this problem, and some interesting schemes evolved, many of which have now been published in one journal or another. Some of the information which has been obtained is capable of application to existing sets, and it is proposed in this article to outline a few of these, showing how they may be applied to simple types of receivers in a way which it is hoped will show the reader how he can apply them to his own particular requirements.

Now, the problem is essentially this: We wish to insert in each of our tuned circuits such an additional amount of inductance as will cause that circuit to tune over the desired upper range of 1,000 to 2,000 metres, and in some cases we also require to

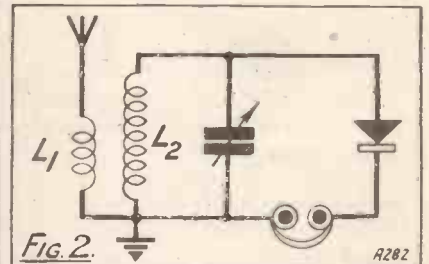

*A crystal circuit of the more selective type, which is a little more difficult to "load."*

by some simple form of switching which shall not introduce objectionable losses, and, moreover, the presence nearby of the long-wave coil must not produce objectionable effects when we are working on the short waves, with the extra inductance cut out. The simpler the receiver the easier it is to meet these requirements, as the examples which follow will show.

## Simple Circuits Only

As a matter of fact, in the larger and more complicated circuits the problem is at present really so

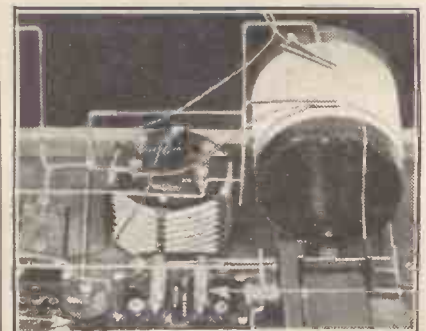

*The slot-wound inductance seen here is the new standardised loading-coil which is proving so useful in "wave-change" sets.*

## Loading Your Set for 5XX—continued

difficult that it can be taken that it is practically insoluble in a way which can be carried out by the average home constructor without considerable expense.

The first example which I have chosen is one of a perfectly plain and straightforward crystal receiver with a parallel tuned circuit, connected directly in the aerial-earth circuit. This is shown in Fig. 1, and you will see here that all we need to produce the desired effect is to fix a loading coil  $L_2$  in series with the tuning coil  $L_1$ , and to connect across  $L_2$  a simple short-circuiting switch which can be one of the better types of "on-and-off" switches used for the filament circuits of valve sets.

### Reducing Losses

Any switch of the type possessing well-insulated and well-separated spring contacts will serve this purpose quite well, and you will see that when the switch is closed it completely short-circuits the long-wave coil and thereby very largely minimises any loss effects, which can be further cut down to quite negligible proportions if the loading coil is not placed anywhere near to the ordinary tuning coil, or preferably at right angles. On the average aerial, the loading coil will require to be the equivalent of approximately a No. 100 plug-in coil, and there will be nothing difficult or complicated about this scheme.

It is when we come on to the slightly more advanced type of circuit in which there is a special arrangement of coupling between the aerial and the secondary circuits that we begin to come to the difficulties, as you will see from Fig. 2. This circuit is a very

popular type of crystal receiver with a so-called aperiodic aerial arrangement consisting of the untuned coil  $L_1$  fairly tightly coupled to the tuned circuit coil  $L_2$ .

Here the simplest way of loading the set with extra inductance for the reception of 5XX is to connect the loading coil  $L_3$  in the circuit as shown in Fig. 3; again with a simple on-and-off switch to short-circuit it when the ordinary waves are desired. This will certainly have the effect of enabling us to receive 5XX, but it will also upset the original scheme of functioning of the set, since it will now produce extremely tight coupling to the aerial and selectivity will be poor, with conse-

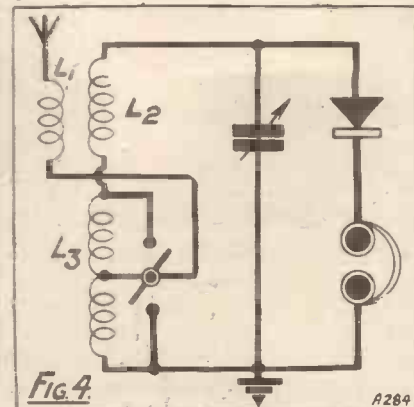

**Fig. 4.** A method of loading the Fig. 3 circuit so as to obtain higher selectivity on the longer waves.

three we can employ a better coupling scheme on the long waves also.

The centre contact of the switch is joined first to the lower end of the short-wave coupling coil  $L_1$  and also to a tapping point on the loading coil  $L_3$ , which tapping point will usually be located about one-third of the way up from the lower end. Then, when the switch is open, not merely is the coil  $L_3$  brought into circuit, but also the lower end of the aerial coupling coil  $L_1$  is connected to a suitable tapping in the circuit for producing a suitable degree of what is called "auto-coupling" on the long waves. Quite good selectivity can be obtained in this way, and good signal strength also.

### Suitable Switches

Fortunately, switches of this nature are quite easily obtained, and many of those sold for on-and-off switches fulfil these requirements perfectly. For example, there is the "Lotus" on-and-off switch, which consists of a central metal spindle working between two separately mounted spring contacts. In the "on" position this plunger touches both the side contacts and thereby makes connection to them, and, of course, at the same time connects each to the other, thus providing us with our three points which are connected together in the "on" position. The centre connection is made by gripping a wire under the metal fixing bush. In the "off" position the plunger is separated from the two side springs by an insulated sleeve of ebonite, whereupon all three points are separated from each other, giving us the desired "open circuit" arrangement for working on the long waves.

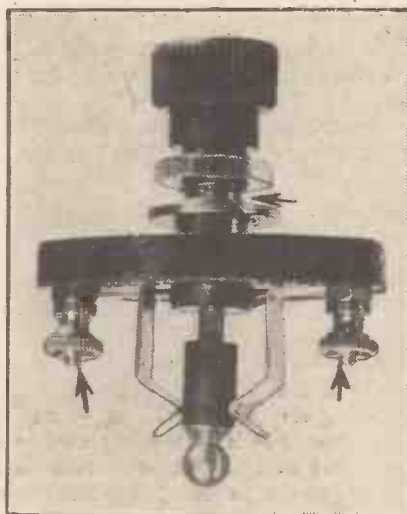

An example of the type of switch required for the Fig. 4 circuit (Lotus). The arrows denote the points to which connections should be made. Note: It is usually safer to solder a wire direct to the plunger knob rather than to depend on the contact through the fixing bush.

quent flat tuning and possible trouble on the long waves from shipping interference to coastal readers and interference from the local station in the main broadcasting centres. The loading coil can again be of the order of the No. 100 plug-in size.

The difficulty is at first sight rather a serious one, but by using a very slightly more complicated kind of switch it can be got over in a very efficient manner, which is illustrated in Fig. 4. Here we have a form of switch possessing three contacts, which are all joined together in the "on" position, and all separated in the "off" position, and you will see that by making use of these

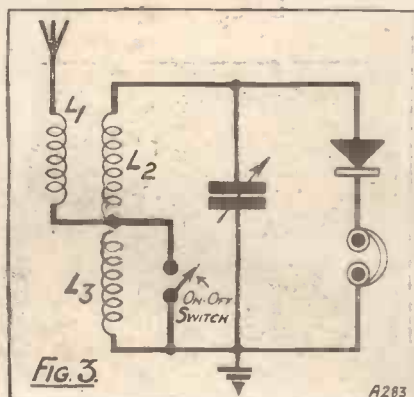
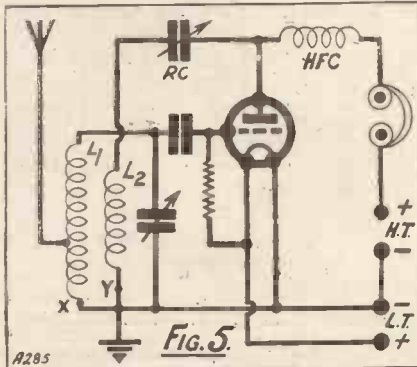

**Fig. 3.** A method of loading a crystal set of the more selective type with a coupled aerial circuit.



## Loading Your Set for 5XX—continued

There are several switches of this general type upon the market, and then, again, there is the "Lissen" two-way push-pull switch which can be made to serve the purpose quite well with a very slight modification. In this switch there is again a sliding central plunger having a contact and two separate side springs. The side springs in this case, however, are of



An example of the type of detector circuit to which wave-change switch may be added fairly easily. It is assumed that L.F. stages may follow.

unequal length, but by bending the longer by means of a pair of pliers it is quite easy to arrange that it shall make contact with the metal ring of the sliding plunger at the same point as does the shorter spring, thereby giving us exactly the same condition as before.

### A Useful Scheme

This is a very useful form of switching, and it can be applied in quite a variety of ways, as we shall see in a moment. For example, one switching scheme of the type illustrated in Fig. 4 can be inserted in the grid circuit of a set, while the same scheme can be applied to the intervalve coupling circuit, with a reaction winding and so on.

Turning now to valve circuits, where it may be expected that greater difficulty will be met with, we will take first the simple Reinartz single-valve receiver illustrated in Fig. 5. Here we have a tuned secondary circuit consisting of a coil  $L_1$  and a variable condenser, to which the aerial is auto-coupled through a portion of the main winding.

We shall require to insert a loading coil in this tuned circuit, presumably at the point marked X, but then, again, we must also obviously increase the size of the reaction winding  $L_2$ ,

when working on the long waves, or we shall not be able to obtain enough reaction. Evidently we shall also require to insert here an extra coil at the point Y, and preferably couple it to the loading coil at X. To achieve our end it is evident that we shall have to provide some means of shorting out these two coils when working on the shorter waves, and it will be very desirable to do this by means of a single push-pull switch.

### Altering the Reaction

A little "experimenting" on paper will soon show that the same kind of switch as used before will again serve our purpose, and will suffice to short out both the loading coil and the extra reaction winding. Just how it is done you will see in Fig. 6, where you observe that the same type of three-contact switch is used with the ends of the loading coil taken to the two side clips of the switch and the lower end of the reaction winding to the centre contact.

You will see that in the "off" position all the coils are brought into circuit, and the set will tune over the upper wave-range. On closing the switch both the extra reaction winding and the loading coil winding are shorted out, and the set will work

just in the ordinary way on the shorter waves and should not suffer any loss of efficiency provided that the switch contacts are kept clean and also that the coils are mounted well away from one another, with the long- and short-wave groups preferably at right angles to each other.

In this scheme we have still the drawback which was pointed out in circuit No. 2, namely, that the aerial coupling becomes decidedly tight on the longer waves, and consequent selectivity is not good. In the case of a single-valve reaction receiver, however, this is not such a serious matter, since the use of a moderate amount of reaction sharpens the tuning greatly and the selectivity will not be so very poor.

### Changing the Coupling

To get over the difficulty completely it will be necessary to shift the tapping point from  $L_1$  to a suitable position on  $L_2$  when working on the longer waves, and one can quite easily do this by means of a plug-and-socket connection. Such a change of tapping is an extra operation, but it is not recommended that you should attempt to do it by using a still more complicated type of switch, since by the time this is done the wiring would tend to become decidedly involved,

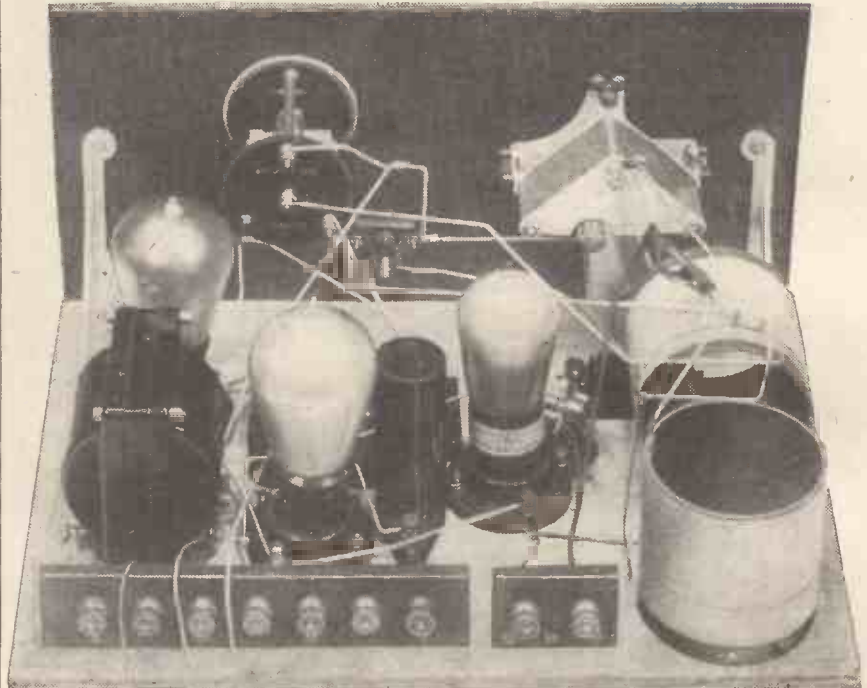

An example of one of the more recent wave-change sets. Note the careful placing of the coils.

## Loading Your Set for 5XX—continued

and there would be some risk of trouble unless it was properly worked out for you by a competent person. Considerable self-restraint is necessarily involved in cases of this type, since it is very easy to let one's enthusiasm for change-over switches run away with one and lead one into inefficient schemes.

### Where the Danger Lies

This last is a very important point, and one cannot too strongly warn the reader against the risk of too-much switching. Using switching schemes instead of changing coils is all very well within reason, but one must never lose sight of the fact that switches are dangerous things in wireless sets, and we must never run any risk of reverting to the days when people seemed to think that they could treat a wireless set like a telephone exchange, and wire up dozens of different points with yards of wire, rows of complicated switches, and so on, and expect to get good results. Good results will not be forthcoming!

Bearing these points in mind, you will see that, when it comes to more complicated types of sets than those which we have been considering, considerable discretion is called for if we attempt to use switching schemes for changing over from the long waves to the short. Thus one can take it as a general rule that it is not wise to adopt the use of a single switch to change over the wave range of both the grid and the anode circuits of a high-frequency valve, but it is far better to use entirely separate switches.

### Combined Methods

For example, if we have a screened-grid-valve set we could switch it by using the scheme illustrated in Fig. 4 for the aerial and grid circuits and the scheme illustrated in Fig. 6 for the tuned-anode and reaction circuits which follow on the plate side of the valve. On no account should one attempt to use something like a four-pole two-way switch to do both operations simultaneously. After all, it is quite easy to manipulate a couple

of little knobs on the front of the panel for the two separate switches indicated, simply pushing them in for the long waves and pulling them out for the short.

The whole subject of switching in the more complicated types of sets,

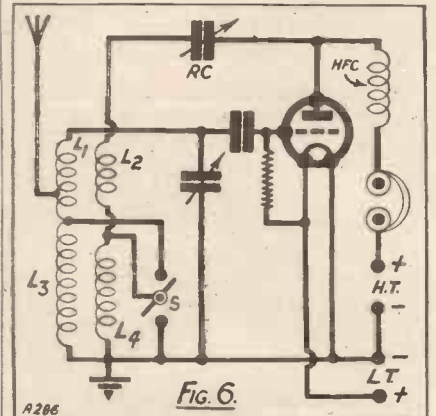

Here is the Fig. 5 circuit redrawn to include one of the latest systems of wave-change switching.

especially those containing one or more high-frequency stages, is a very large one and cannot profitably be dealt with in a general theoretical manner. It can really only be done satisfactorily in dealing with some particular practical working design, and it would be useless to do so here, where I have been attempting to give an outline of general methods which can be applied to the simpler types of sets which can be modified by the owners themselves. To do the same thing for larger and more ambitious sets is scarcely possible without detailed assistance from a competent adviser in each case, and there I must leave the matter.

\*\*\*\*\*  
 \* "Short-Wave Three" in \*  
 \* China! \*  
 \*\*\*\*\*

SIR,—Here are the results of your "Short-Wave Three." Last night (or rather, early this morning), between the hours of 2 a.m. and 7.30 a.m. I tuned in P. C. J. J. (Holland), 2 L. O. (London), 2 X. A. F. (New York).

2 L. O. \* came in very loud. Piano solo by Miss Robert (2), Welsh tunes, and National Airs are some of the pieces I tuned in.

Wishing your paper every success.  
 Yours faithfully,  
 H. CHARRINGTON.

Hong Kong, China.  
 \* Via S. W.

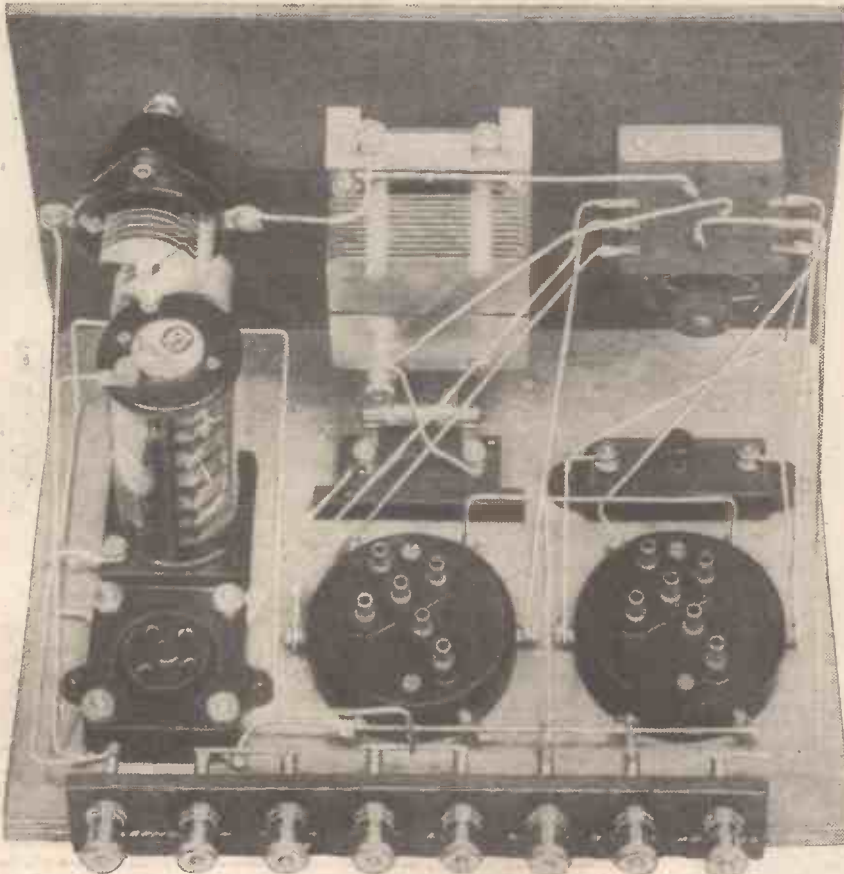

An example of one of the rather more elaborate types of wave-change switching in which permanent tuning adjustments can be made for a long- and a short-wave station.



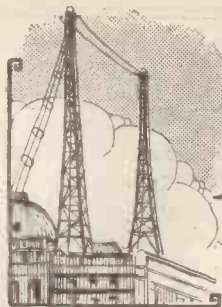

# HAPPENINGS AT SAVOY HILL



By OUR SPECIAL COMMISSIONER

## Summer Programmes

IT is easy to say "I told you so," but I feel that there is full justification for it in view of the failure of the B.B.C. to produce satisfactory summer programmes this year. It made a good start by cutting out a lot of the educational guff in the afternoons. Then we expected that the "serious" evening talks would give way to seasonably light substitutes. Not a bit of it.

Here we are, sweltering in mid-summer while Savoy Hill continues unashamed to pour uplift and education into the ether. The comparatively few "summery" programmes are very well done, which makes the situation worse, because it proves that all this business of "Foundations" of what-not is due to malice aforethought! I suppose that the right thing to do is to start agitating now for really light programmes next summer!

It might be worth while offering rewards to the chief programme officials. I would gladly start a subscription list for a presentation to Mr. R. H. Eckersley if I thought that would induce him to insist on more flexibility and adaptability in programmes.

## Big Autumn Changes

It appears that the relay station as a programme entity has not long to survive. The acuteness of the international wave-length muddle has forced the B.B.C. to take drastic steps considerably in advance of the establishment of the Regional Scheme.

One has heard a great deal about the efficacy of the Union Internationale dū Radiophonie at Geneva. But it seems unable to apply any of its schemes. *International common waves* are no longer of any value in this country. It is probable, therefore, that in October the B.B.C. will introduce "single wave-length working" with a central drive, for all relay stations, which will then operate on a *National Common Wave*.

This step will mean very much better conditions of reception in all the crowded centres which have

relay stations. It will also mean much better programmes. The B.B.C. has been unnecessarily anxious about the effect of the change on local opinion. There is no danger of unfavourable reaction.

The London programmes are relatively so much superior to anything that has been or can be done locally that the substitution will be universally welcomed. I notice that there is some modification contemplated during the afternoons, when "group" programmes may take the place of the "S.B." transmissions. It is a real consolation to look forward to some beneficial changes in B.B.C. distribution.

## That Permanent Orchestra

Mr. Roger Eckersley is stated to have reconsidered his intention to retire from the headship of B.B.C. programmes. The factor which has bulked most with him in this mind-changing is his overpowering desire to complete the work of establishing the B.B.C. permanent symphony orchestra, the idea of which was hatched by him in the spring.

I understand that fairly satisfactory progress has been made, but

the vexed question of a permanent conductor is still outstanding. Sir Thomas Beecham, Sir Hamilton Harty, and Sir Landon Ronald are all considered to be in the running.

It would appear as if the first-mentioned would have been appointed months ago if he would have allowed himself to come within the orbit of the organisation of the B.B.C. for purposes of discipline as well as for "pay and rations." But Sir Thomas insists on a free hand, which it is very difficult for the B.B.C. to concede.

Difficulties are not made less by the existence of strained feelings between the B.B.C. Music Advisory Committee and the B.B.C. Music Department. It is mainly to the solution of these intricate problems connected with the permanent orchestra that Mr. R. H. Eckersley will devote himself this autumn.

## Progress of 5 SW

It is good news that the recent move of the "Continentalists" at Savoy Hill to suppress 5 SW has not succeeded. The short-wave station continues its transmissions, which although still formally "experimental" are in practice providing a

## LISTEN WHILE YOU WAIT

*The Germans have been the first to realise that the tedium of waiting in the ante-room of the doctor's surgery is not wholly banished by the store of ancient periodicals that usually adorn the waiting-room table. Consequently radio has been called in, and this photo shows patients listening to broadcasting while waiting for the familiar "Next, please!"*



## Happenings at Savoy Hill—continued

much-appreciated service for Britons the world over.

Then there is the further point that some quite useful results have been achieved from the co-operative experiments arranged between Captain Eckersley and his opposite number in the United States, Dr. Goldsmith. But the chief objection at the listening end is the absence of news.

As soon as the time arrives for the news bulletins, 5 S W shuts up. This maddens listeners at the other side of the world. The reason appears to

be that the news agencies will not allow their copyright matter to be disseminated in this widespread fashion without special compensation. Moreover, the Press of the Dominions and Colonies is by no means keen on news bulletins being included in the 5 S W transmissions.

But, of course, the news must be included before very long. The money for it will have to be found from sources actually interested, such as for instance the Governments of the Colonies. The B.B.C. would not

be justified in spending British licence money on overseas news services.

### The B.B.C.'s Critics

B.B.C. criticism of music, drama, literature, and the film are now important parts of the programmes. It is complained in interested quarters that the B.B.C., being a monopoly, should not be allowed to exercise functions of artistic criticism analogous to those of the ordinary competitive newspaper.

Whatever may be the rights or wrongs of this contention of principle, the fact remains that criticism is now firmly established, and will not be disturbed. But there is more practical point in the objection that the same critic should not go on year after year.

Every professional critic is bound to have some angularities; but if the B.B.C. worked a roster of the leading members of the Critics' Circle for all branches of art, these angularities would tend to cancel out. I put up this suggestion in all seriousness, and hope it will receive consideration in time for next season.

Mr. Percy Scholes, in particular, needs a rest and a change. His voice has been in the programmes and his name in the programme journal far too much lately. He has done a lot of good work, and no doubt will do more, if he is laid off for a couple of years or so.

### The New 2LO

Work is in full swing at Brookman's Park, where the new 2 L O is in process of erection. Captain Eckersley and his assistants are fighting against time in order to defeat the prediction that the station will not be ready for service until next July.

It has been stated that the Postmaster-General has forbidden it to start until July, 1929, anyway. The apparent intention of the B.B.C. engineers is to get the place absolutely ready months ahead of this date, and then, if the P.M.G. remains recalcitrant, to seek the help of public opinion to force his hand.

They are right in presuming that there would be a tremendous outcry if the impression got about that the station was "standing-by" idly for months. Meanwhile, contrary to previous policy, the P.M.G. is understood to have given way about starting some of the other Regional stations.

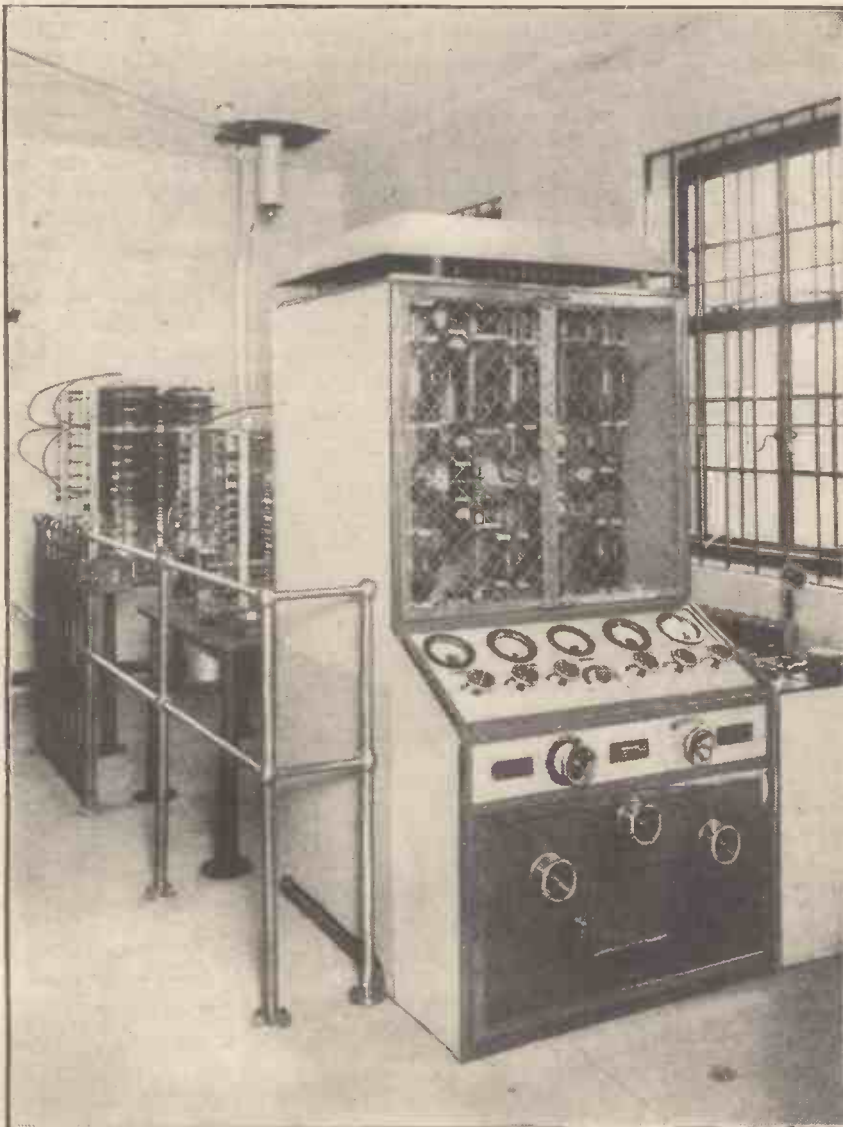

One of the four new Marconi 3-kw. aerodrome ground transmitters installed at the new wireless ground station at Croydon. These transmitters work on any wave-length between 800 and 2,000 metres, and transmit either telephony, continuous wave or interrupted continuous wave. They incorporate a drive circuit to maintain constancy of wave-length. The drive valve is totally enclosed in the screened lower compartment of the transmitter. The top part of the transmitter contains the main oscillating valve, rectifying valves and modulator valves. The controls and measuring instruments are on the sloping panel which is above the drive screening-box. (Marconi W.T. Co.)





**Dual Impedance Coupling Unit**

THE IGRANIC ELECTRIC Co., of Bedford, send us their Dual Coupling Unit consisting of two iron-core inductances and a coupling condenser conveniently sealed into a case very little bigger than a large modern low-frequency transformer. Four terminals on the top are marked quite clearly for connection.



A useful feature of the Dual Impedance Unit (Igranic) is the diagram of connections incorporated under the terminals.

The dual impedance method of coupling is likely to achieve considerable popularity here, as it has done in America, for the response curve of such a device is excellent when properly designed, at least equalling and often surpassing the finest resistance-capacity-coupling curve.

The dual impedance coupling method consists of using an iron-core choke in the anode of the valve to be coupled, a coupling condenser of a correct value as in ordinary choke-capacity coupling, and instead of the usual grid leak a suitable high-impedance iron-core inductance. While at first sight it might appear that with correct values the dual impedance coupling would function just like a capacity resistance unit, a few moments' consideration shows that it is possible to arrange the values of inductance and capacity so

**A MONTHLY REVIEW OF TESTED APPARATUS:**

(NOTE: All apparatus reviewed in this section each month has been tested in the Editor's private laboratory, under his own personal supervision.

as to adjust the shape of the reproduction curve to suit our purpose and to compensate for certain variations in amplification which would otherwise occur.

Actually, in the Igranic dual impedance unit the values have been chosen so as to maintain the amplification at low frequencies by making use of the resonance frequencies of the circuit formed. The makers claim that in measurements made on a complete amplifier, with one stage of resistance coupling and two stages of dual impedance choke coupling with choke output, the amplification did not fall below 10 per cent of the maximum at any point between forty and six thousand cycles per second.

Our own tests, using a single stage of dual impedance coupling in a complete receiver, showed that remarkably uniform amplification is obtainable, the quality of reproduction being up to the highest modern standard. So far as strength was concerned we

found that the dual impedance unit gave results slightly better than those obtainable with R.C. coupling, while a lower plate voltage could be used.

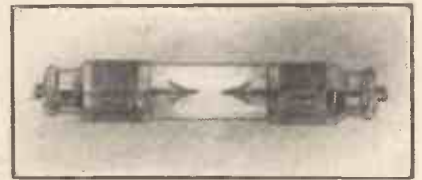

Positive or negative?—This Pole-Finder tells in a tick! (New Wilson Electrical Mfg. Co.).

**Rapid Pole-Finder**

An ingenious, useful and very efficient little instrument, the "Rapid" Pole-Finder, has been submitted to us by The New Wilson Electrical Manufacturing Co., Ltd., of London. This consists of a glass tube with metal ends fitted with terminals, containing a liquid in which are immersed two metal arrows as shown in the accompanying photograph.

When this device is connected to an electrical circuit, the arrow joined to the negative lead will immediately turn purple, the purple colouration disappearing in a few seconds after the device is removed from circuit. It is really most fascinating to use and gives a positive and perfectly clear indication with a single dry cell

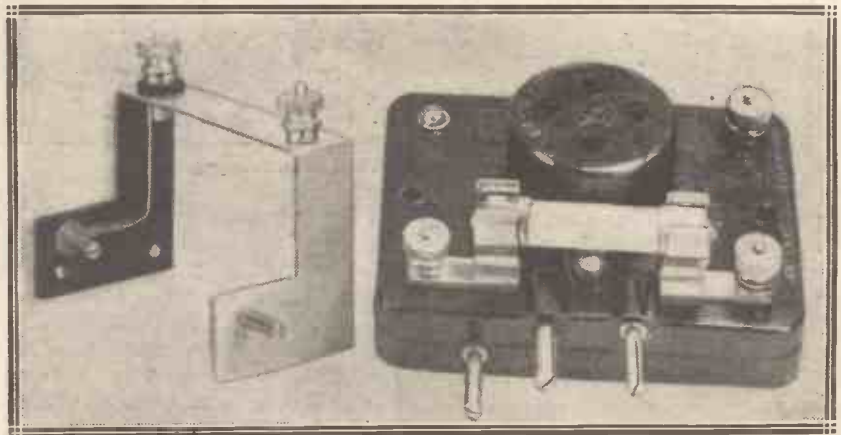

The ingenious H.F. Unit for the Ediswan Threesome.

## What's New—continued

or on 200-volt high-tension from a mains unit (the two extreme limits of our test).

Many uses for this device will suggest themselves, such as finding which is a negative lead at the end of a long accumulator lead, and the rather difficult task of identifying the positive loud-speaker lead at the end of a loud-speaker extension from one room to another. The price (4s.) is very reasonable and the device can certainly be recommended to every wireless experimenter.

### Adding H.F. to the Ediswan Threesome

Among what may be called "valve-makers' sets"—designs published by various valve makers to stimulate the sales of their particular valves—the Ediswan Improved R.C. Threesome has proved very popular.

The Ediswan Company are now supplying an additional unit which can be combined with the existing improved R.C. Threesome, converting it into a four-valve set with a stage of high-frequency preceding the detector. The additional unit sent to us for review and illustrated in the accompanying photograph is characterised by the same ingenuity of manufacture as the other units, and if the makers' instructions are carried out, the

Reaction is used on the detector as before. Owners of the new Ediswan R.C. Threesome should certainly try the new unit, which will greatly improve their receiver.

### Clarostat Devices

The American Mechanical Laboratories, Inc., of Brooklyn, New York, U.S.A., have sent for review a number of Clarostat Products, covering a wide range of uses. Three of these are shown in the accompanying photograph, and the whole series is most useful to the experimenter.

Briefly described, the Clarostat is an adjustable resistance device consisting of a metal shell, a movable piston on a finely-threaded shaft, and a suitable knob for operation. Inside the metal shell is special resistive material which can be subjected to varying degrees of compression, the resistance of the material being lowest at the maximum compression.

The important part—namely, the resistive material—appears to be a graphite compound, and with this is mixed a finely-divided insulating material of a resilient nature which helps to separate the particles of the conductive material after-compression is released. The case is hermetically sealed and the whole finish of the instrument is pleasing and efficient.

instrument the maximum resistance of which is five or six megohms with a current handling capacity of twenty watts (according to the manufacturers' claims), a power Clarostat in several ranges, one being 0 to 10



This handsome "Radiola" cabinet—as used for the "Business Man's" Four—is made by Pickett Bros., of Berleyheath.



A group of Clarostats referred to on this page.

addition of this high-frequency stage becomes a very simple matter.

The actual circuit used is of a neutralised high-frequency stage with parallel tuned-anode coupling, a half-megohm resistance being used in place of the more usual radio-frequency choke in the high-tension feed. This is, of course, a perfectly sound method of connection.

By correctly proportioning the parts of the Clarostat and selecting the material to suit particular uses, a wide range of application can be found. There is thus a grid-leak Clarostat having a nominal range of a tenth to ten megohms, a volume-control Clarostat with a resistance range of practically zero to half a megohm, a standard universal range

ohms filament control, and others from 25 to 500 ohms, and a third from 200 to 100,000 ohms.

The higher values are particularly useful in high-tension mains units. The volume-control Clarostat is also made in a table model (illustrated in the right of the photograph), and also there is a duplex Clarostat in which two are included in the one case, adjustment being made by a screw-driver.

### For Volume Control

All of these devices functioned satisfactorily on test, the table-size Clarostat being particularly useful for controlling the volume of a loud speaker. All are characterised by smoothness and silence in working and several turns of the knob are required to go from minimum to maximum—no mean advantage when accurate control is desired.

The devices can be recommended for the purposes for which they are designed. The English agents are Messrs. Claude Lyons, of Liverpool.

(Continued on page 279.)





THE coming of the warm weather made me feel, somehow, that I was overworked and needed a change. Unfeeling friends tell me that they have noticed the same symptoms in me at most times of the year, but you know the sort of things that friends do say. Anyhow, I rang up Mr. Wadgar Ellace and asked him to deputise as reporter of the doings of the Mudbury Wallow Wireless Club.

"Let me see," said Mr. Wadgar Ellace, "I have only two plays,



... The professor put the kitten in the empty grate and the coal-scuttle out of the window ...

a novel, and six short stories to do on Thursday. Yes, I can fit it in quite well on that day." And here you are.

THE TWIDDLER,  
OR  
THE MYSTERY OF THE  
BLOOD-STAINED KNOB.  
By WADGAR ELLACE.

CHAPTER I  
CRIME MOST FOUL

CRASH!

Like the sound of crockery hurtling town the back-stairs on a Saturday night when Maria Anne is out at the movies and the missus takes over to show how things ought to be done, the fell noise echoed through the house.

Professor Goop, somewhat startled, rose, placed the kitten in the fire-grate, emptied the coal-scuttle out of the French window, sat down again, and resumed his work.

Tingggggggg! went the telephone. "\*\*\*\*\* \$\$\$\$\$% %%% @@@!" breathed Professor Goop.

He picked up the microphone and placed it to his ear.

"Is that the Plate Tuner's Arms?" said a shaky voice.

"No!" bellowed the professor into the receiver.

"I thought not," went on the voice. "This is Tootle speaking. In less than two minutes I shall be no more. Tootle is now closing down. Good-bye, professor, good-bye!"

"What?" cried the professor. "Hi! Answer, can't you? I say, I say—"

"Number engaged," trilled a fresh voice.

The professor replaced the spout of the telephone, jiggled the lever thing up and down, and tried again.

"Police!" he called into the loud hearer.

There was a click which did in one car-drum.

\* \* \*

"Yerse?"  
"Is that the police?"

"Yerse."  
"Professor Goop speaking."

"Yerse."  
"Mr. Tootle has been murdered."

"Yerse."  
"Murdered, I say!"

"Yerse: How do you know?"  
"He has just told me so."

"Yerse. Was he alive when he told you, or had he already been murdered?"

"He told me that he was just going to be murdered, and then came two loud howls on my wireless set."

"Two loud howls?"  
"Yes."

"By gad! The Twiddler! That is his sign. I will come at once."

CHAPTER II  
THE UNDERWORLD

Meantime, in a loathsome den in the underworld of Mudbury Wallow, Bill the Snooper, Slugger Briggs, and One-eyed Pete were squabbling over the division of the evening's haul.

"That tizzy's mine, I tells yer!" snarled Bill, covering it with a hairy paw.

Slugger Briggs, drawing a knife from his pocket, pinned the hand to the table, and was about to remove the coin when One-eyed Pete caught him a saucy one on the knob with a life-preserver. He would have got clear away with the loot had not Bill the Snooper sunk his teeth into the calf of his left leg.

"Curse you, you copper's nark!" screamed One-eyed Pete.

At this moment the door opened, and a hand fung in a smoking bomb. In about two shakes bits of the underworld of Mudbury Wallow were being scattered all over the upper world.

CHAPTER III  
THE FLYING SQUAD

Such speed did the flying squad of Mudbury Wallow make that in less than two hours the professor's front-door bell was torn out by the roots, and P.-c. Mugglewump was ushered into his den.

"I will go at once," he cried, helping himself to a bottle of beer and sinking into the most comfortable arm-chair, "to the scene of this horrible crime. But first tell me all that you know."

The professor did so. As he went on with his story the constable's eyebrows were raised in astonishment, and his elbow in refreshment time after time.

When the tale was ended, Mugglewump seized the professor's hand.



... Just then a hand fung in a smoking bomb ...

"A dreadful fate," he said, "is brooding over Mudbury Wallow. The Twiddler, past-master of all crimes, is undoubtedly at the root of this, for those two howls are the sign that he always gives."

## In Lighter Vein—continued

"If I am right we shall find also yet another mark of his work: a blood-stained knob. Skilled though they are in the detection of crime, the police are helpless against this enemy of mankind. We must call in the finest amateur brain that we can find. There is only one man who can aid us."

"Who is that?" asked the professor.

"Mr. Wireless Wayfarer," answered the police constable, thoughtfully drawing another cork.

### CHAPTER IV

#### THE SLEUTH-HOUNDS

On arriving at Orpheus Villa, Mugglewump, Professor Goop and Wayfarer were shown by a frightened maid straight into Tootle's den, the scene of the foul crime.

"By gad!" cried Mugglewump.

"W-w-w-what's the matter?" chorused the others.

"THE BODY HAS DISAPPEARED!"

To make quite sure he looked under the cushions, examined the coal-scuttle, and turned the waste-paper basket upside down. There was no sign of Tootle's corpse.

"I will investigate first of all,"



... "Who is your witness?" "The corpse!" answered Wayfarer.

he told Wayfarer. "When I have done my best you shall follow and see what you can do."

Producing a magnifying glass, an inch tape, a pair of callipers and a millimeter, the constable carefully examined every inch of the room. His forefinger presently pointed shakily to the wireless set.

THERE WAS A BLOOD-STAINED KNOB.

"No other clue of any kind," he sighed at last. "Now, Mr. Wayfarer."

His handsome face glowing with enthusiasm, Wayfarer made a lightning dart behind the sofa.

"A clue," he cried, holding aloft

a lady's high-heeled shoe. "Size number twelve. There is only one female foot in Mudbury Wallow that it could fit. This is Miss Worple's shoe." From the top of the piano he removed a seaman's peaked cap. Captain Bucket's without a doubt.

Thrusting his hand into the loud speaker he pulled out a pair of trousers.

"These," he said, "are Professor Goop's."

"How do you know?" asked the constable in astonishment.

Wayfarer pointed to the condenser knobs fixed on with No. 18 D.C.C. which were doing duty as brace buttons. After a frenzied search through every pocket P.C. Mugglewump unearthed his whistle and blew a shrill blast upon it.

In a moment six inspectors, five detectives disguised as detectives, and fourteen constables had entered through doors and windows. Snapping the bracelets upon the professor's wrists, Mugglewump cried in a singing voice:

"Ebenezer Goop, I arrest you for the murder of Phineas Tootle. You had better come clean."

### CHAPTER V

#### BEFORE THE BENCH

The whole of the beauty and fashion of the town was assembled in the court some time before the Bench appeared. The Wireless Club sat in a solid phalanx in the two front rows. They had urgently petitioned to be allowed to broadcast the proceedings but permission had been refused.

The charge having been read, the prosecutor, Mr. Burpleson Bilger, K.C., rose to his feet and promptly began an impassioned speech of which no one could hear a word. The Bench settled down to slumber, waking with a start as the oration ceased.

After some consultation they found the prosecuting counsel guilty of arson and he was removed protesting to the cells. The handsome, cultured and charming Mr. Wayfarer then rose on behalf of Professor Goop.

"I ask the Court's permission," he began, "to call an important witness."

"Who is your witness?" queried the Chairman.

"The corpse," cried Wayfarer, in a voice of thunder.

Phineas Tootle, having entered the witness box and taken the oath, stated that to the best of his knowledge and belief Professor Goop was entirely innocent of having murdered him.

Amidst rousing cheers the professor was discharged without a



"Great godfather-in-law!" cooed Miss Worple.

stain on his character. Tootle, it appeared, had been indulging in a midnight shave, using the panel of his receiving set as a mirror, when he rang up the professor on that terrible night. He was wielding a safety razor invented by the professor, and it came so near to severing his head from his neck that he feared the worst. The knob that he touched with his bloodstained hand happened to be that of the reaction condenser, which explained the two hoots.

### CHAPTER VI

#### A GLAD REUNION

A glad reunion took place within an hour at Professor Goop's house.

"I have a little surprise for two of you," smiled Wayfarer, producing from his pocket a sheaf of papers and handing them to Captain Bucket. The captain flipped over the sheets, his eyebrows rising higher and higher. Then he beamed upon Miss Worple.

"Your dear mother," he gasped, "your dear mother, whom you never knew, was my beloved wife. She died within a week of our wedding day, and you, her posthumous child, was born just three years later."

"Father," cooed Miss Worple.

"Jemima," chortled Captain Bucket.

"Stay," yelled Tootle, pulling a sheaf of papers from his pocket. "These papers show that she is the grand-daughter twice removed of your godson's second wife."

"Great godfather-in-law," cooed Miss Worple.

"Jemima," chortled Captain Bucket.



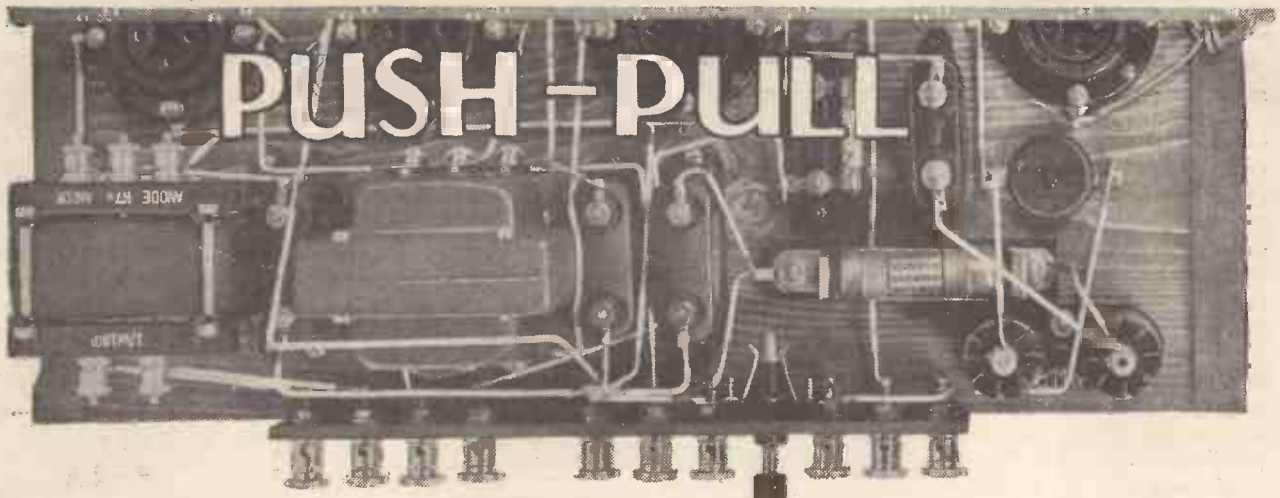

**A**LTHOUGH the push-pull system of connecting low-frequency amplifying valves is not very widely used in this country, and the difficulty of obtaining components has discouraged amateurs from experimenting with the arrangement to any great extent, the method of connection nevertheless possesses certain definite advantages.

With the advent of the moving-coil loud speaker, and the increasing appreciation of high-quality reproduction, there is among experimenters a tendency towards building more powerful amplifiers, this being evidenced by the rapid growth in popularity of the super-power valve.

It is probable, therefore, that the push-pull system of amplification will receive more attention in the future,

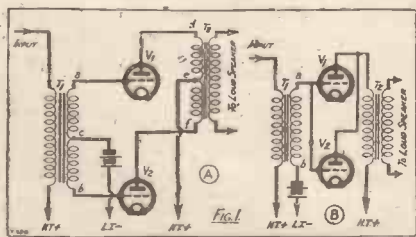

and, as there is a considerable diversity of opinion as to whether the system is worth while, it is proposed here briefly to outline its operation and advantages.

**How It Works**

For those who are entirely unfamiliar with push-pull, it may be said that the arrangement is one in which two valves are connected in such a way that the incoming signals are split up and divided equally between the grids, whilst the corresponding plate currents join and add together in the following transformer.

The system differs from that in which two valves are connected in

In the March issue the Editor introduced an amplifier design which enabled one to achieve "Super Quality With Any Set." It embodied "Push-Pull" and this article concisely brings forward the advantages of the system.  
By C. E. FIELD, B.Sc.

parallel, in that each grid receives only half of the signal voltage, whereas in the parallel circuit the full voltage is applied to each.

In Figs. 1A and 1B are shown simple push-pull and parallel circuits respectively, all filament connections and circuit details being omitted.

**Splitting the Input**

Referring to Fig. 1A, current from a detector or low-frequency amplifier passes through the primary winding of the transformer T<sub>1</sub>. This produces a voltage across the ends a and b of the secondary winding, but instead of this voltage being applied between grid and filament of one valve, it is applied between the grids of the two valves.

A lead is taken from a centre tapping of the winding to the grid battery, and thence to the low-tension negative.

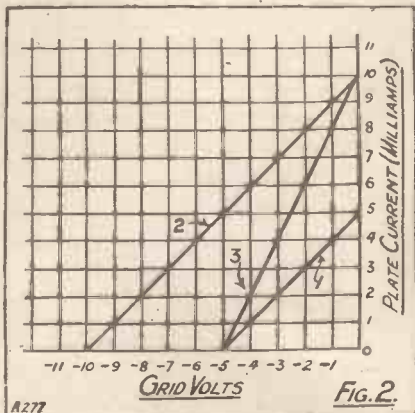

Then if, for example, the voltage across the points a and b is 4 volts, the potential of each point must be 2 volts different from that of the centre point c. One end will be

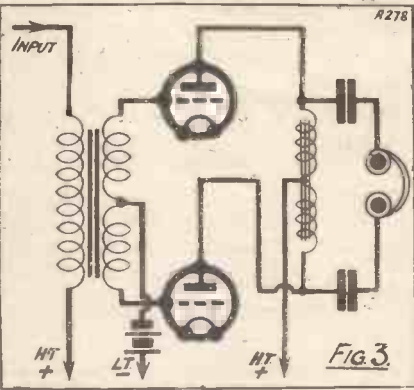

positive while the other end will be negative, so that there is, in effect, a voltage on the grid of V<sub>1</sub> of 2 volts positive relative to its own filament, and a voltage of 2 volts negative on the grid of V<sub>2</sub>.

In the parallel circuit shown in Fig. 1B, a difference of 4 volts between a and b would mean that both grids would be at a potential of 4 volts relative to their filaments, and both would be positive or negative at the same instant.

**Combining the Output Currents**

These examples, of course, disregard the voltage of the grid battery.

Reverting now to the push-pull circuit, the effect of two equal voltages of opposite polarity on the grids of V<sub>1</sub> and V<sub>2</sub> is to cause equal but opposite changes of plate current from the two valves. Thus, 2 volts positive on the grid of V<sub>1</sub> might produce an increase of 2 milliamps in its plate current, i.e. through the portion d e of the primary winding of the transformer T<sub>2</sub>, whilst 2 volts

## Push-Pull—continued

negative on the grid of  $V_2$  would produce a decrease of 2 milliamps of the winding  $f e$ .

Since the windings  $d e$  and  $f e$  are simply one continuous winding, all in one direction, tapped at the point  $e$ , the effect of these two changes of 2 milliamps is exactly the same as would be produced by a change of 4 milliamps flowing straight through from  $d$  to  $f$ , and a corresponding voltage is produced in the secondary winding.

In short, the plate currents have added themselves together, just as much as they did in the parallel circuit, even though each of the grids only received half the input voltage.

### Power Capacity

The difference between the two systems can be seen from the characteristic curves shown in Fig. 2, in which the bottom bends have been omitted, in order to simplify the diagram.

Curve 1 is assumed to be the grid voltage-plate current characteristic of one of the valves shown in Fig. 1.

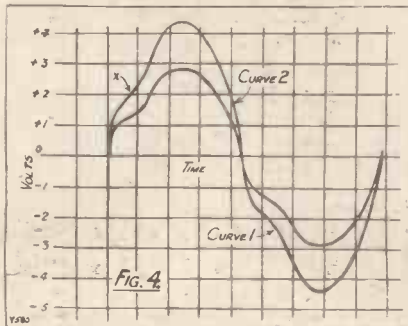

In the push-pull circuit, Fig. 1A, since the grid-input can be double, and will then double the plate current changes, the operation of the two valves can be represented by Curve 2.

In the case of the parallel connections, Fig. 1B, each grid receives the full signal voltage, and so the system cannot handle any greater input than if a single valve were employed. The plate current, however, is doubled for a given grid voltage, making the slope of the characteristic twice as steep, as shown by Curve 3.

### Push-Pull With Chokes

Summarising, the push-pull arrangement allows twice the input to be handled without over-running, but for inputs up to half the maximum is no better than a single valve, whilst the

parallel system cannot handle any greater signal strength than can a single valve, but for a given input provides twice as much plate current variation.

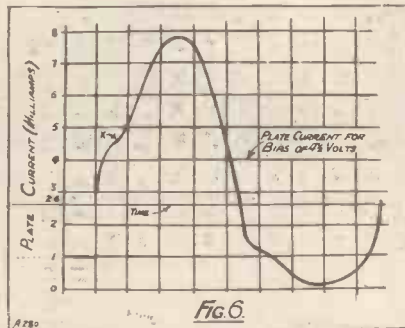

The push-pull system can also be applied to a choke-coupled output circuit, as shown in Fig. 3, the output choke consisting of two windings in series, both wound in the same direction on the same core.

There are two respects in which the push-pull arrangement offers definite advantages over the use of one super-power valve having similar characteristics, and these two may be found to outweigh the additional cost of the system now that push-pull components have become more readily available.

### Freedom From Saturation

Firstly, it will be seen from Fig. 1A that although the valve output currents add up in the primary transformer winding, the D.C. portion from the high-tension battery divides at the point  $e$ , and flows in opposite directions through the winding, and so produces no steady magnetic field through the core. Now, it is the superimposed direct current in the primary winding of a transformer, or of an output choke, which makes it

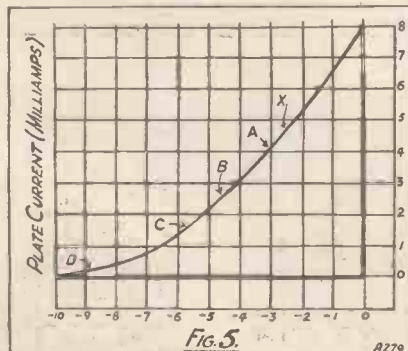

difficult to construct a high-inductance winding for use after a power valve, for the effect of the direct

current is to saturate the core, and reduce the inductance very considerably, giving rise to poor amplification of low notes, and peak voltages.

Consequently, a push-pull transformer or choke, in which no direct-current magnetisation occurs, will have a higher inductance than will a single winding of a similar number of turns and section of core.

The second respect in which push-pull scores is that each valve can be overrun so as to work a little way round the bottom bend of its characteristic, without introducing appreciable distortion.

### Reduced Distortion

The equation to a valve characteristic provides a simple proof of this, but an actual example will probably be more convincing.

Suppose that the speech wave which is being received is as shown in Fig. 4, Curve 1, and that it is being applied to the grid of a power valve, the characteristic of which is shown in Fig. 5.

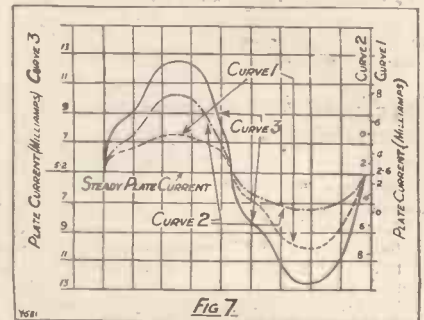

If we bias the grid of the valve at the point A, the maximum positive value of the speech wave, which is about 3 volts, will fall just short of the zero-grid-voltage mark on the valve curve, whilst the maximum negative value (3 volts more negative than the bias point A) will reach just to the beginning of the bottom bend, at the point C. The corresponding changes in plate current give a curve which is a replica of that shown in Fig. 4, and no distortion is introduced.

If, now, the speech input were increased to give a grid voltage curve as shown by Curve 2, Fig. 4, the valve would have to be biased with  $4\frac{1}{2}$  volts at the point B, in order to avoid the grid becoming positive when the maximum positive voltage was received. The maximum negative

(Continued on page 282.)





## Come on and dance— TO LISSEN'S NEW PORTABLE GRAMOPHONE

LISSEN has entered the gramophone trade—with a determination to make good in it. The first productions are two portable gramophones in different price fields. These are LISSEN'S first contributions to the gramophone buying public. LISSEN has got to make good in gramophones right from the very beginning, and you can be sure therefore that there is fine value for money concentrated in the two portable models illustrated on this page.

### TAKE A LISSENOLA PORTABLE WITH YOU ON YOUR HOLIDAYS

Do this year what you may never have done before—take a portable gramophone with you on your holidays, and be sure it is a new LISSENOLA portable. On the river, in the car, in your garden, use it indoors. You can take the LISSENOLA portable gramophone with you everywhere. The large model is better than many indoor table grands sold at double the price.

THE LISSENOLA portable will happily pass away many of your leisure hours, no matter where they may be spent. The range of tone reproduction is wider in the LISSENOLA than in any other portables sold at double the prices, because the horn in each LISSENOLA is longer than any portable horn, except the most expensive kind. There is a fine sound-box fitted to each LISSENOLA model. The motor is strongly made and silent running. Fittings are bolted on, not merely screwed in. They therefore do not come loose. Heavily nickel-plated fittings throughout. Case is covered in black morocco grain leather cloth. Every LISSENOLA portable is compact, easy to carry, light, handsomely finished. The lid of each machine carries eight 10 in. records. Each machine plays up to 12 in. records.

Should your music dealer be unable to give you prompt delivery ORDER AT ONCE DIRECT FROM FACTORY. Kindly give dealer's name and address. State machine required. Remittance may be sent with order, or the machine will be sent by return C.O.D. merely on receipt of your order on a postcard.

**7 DAYS' APPROVAL**

If you are not entirely satisfied with your LISSENOLA Portable Gramophone after trial you can return it to factory within 7 days of purchase, and your money will be willingly refunded in full.

# LISSENOLA

GRAMOPHONE

THE LISSEN TRADITION FOR FINE QUALITY AND BIG VALUE FOR YOUR MONEY IS FULLY UPHELD IN THESE TWO NEW LISSENOLA PORTABLE GRAMOPHONES.

**LISSEN LIMITED,**  
26-30, FRIARS LANE, RICHMOND, SURREY.  
(Managing Director: Thos. N. Cole)



LISSENOLA  
MODEL No. 1

12½" x 10½" x 6"

£2-2-0

LISSENOLA  
MODEL No. 4

14" x 11½" x 7½"

£3-7-6



# CHATS AT THE WORK-TABLE

Many points of practical interest to all radio constructors are dealt with under this heading.

By R. W. HALLOWS, M.A.

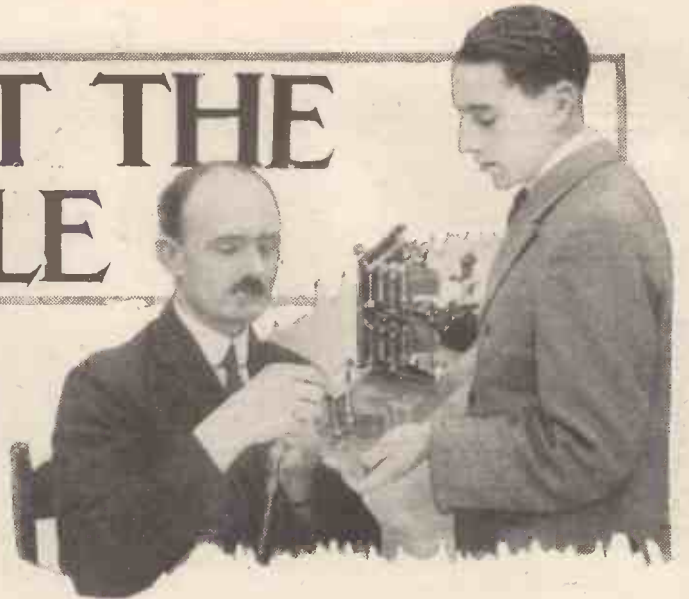

## Not A Jack Of All Trades

Too many amateur mechanics have in their workshop outfits simply a screwdriver. That this unfortunate tool has to deal with the largest and the smallest screws that they use means that unfair strains are put upon it; it is asked to do jobs that it cannot do properly, and the certain result is damage to screws (and possibly to fingers and ebonite panels) and work that is not altogether satisfactory.

The wireless constructor requires at least three screwdrivers for special jobs. Those that I use cost respectively 1s. 3d., 1s., and 9d., a total of 3s. The necessary outlay therefore is not very great. All of them have been in use for years, and a little periodic attention keeps them in as good condition as ever. I therefore have still my original three-shillings-worth.

Now supposing that I had only had one screwdriver, this would probably have been the middle one of the three, costing a shilling. If I had put it to all sorts of jobs its point would have been broken long ago; I should, in fact, have had to replace it at least three times in the period. I should, therefore, have spent four shillings and should now have probably a somewhat damaged shillingsworth to show for it. It pays then to have and to use a set of screwdrivers.

## The Ideal Outfit

My own outfit for wireless construction work is shown in one of the photographs. The largest screwdriver is  $11\frac{1}{2}$  in. in length overall and has a blade  $\frac{3}{16}$  in. wide. The medium one has an overall length

of  $6\frac{1}{2}$  in. and a blade  $\frac{1}{8}$  in. in width. The small one is of the type known as the jeweller's screwdriver. It is  $4\frac{1}{2}$  in. in length and has two interchangeable blades whose widths are  $\frac{3}{32}$  in. and  $\frac{1}{16}$  in.

The biggest screwdriver is used for 2 B.A., 3 B.A., and 4 B.A. screws as well as for the wood screws used for fixing panels and mounting com-

ponents upon baseboards. Its comparatively great length makes it a most handy tool for all kinds of jobs. The medium driver is generally employed for 6 B.A. or 8 B.A. metal screws and for small wood screws where no great force is required.

The jeweller's screwdriver is a most convenient tool for small jobs. One tip I would give to wireless constructors. Purchase a large, cheap screwdriver and leave this on your workshop bench, carefully hiding or locking up the others. Then when packing-cases arrive in your absence members of your family will fall eagerly upon what we may call the "bait" screwdriver lying before their eyes and will use it for levering up the lid and prising out the nails. Your own screwdrivers will then not suffer. Excellent bait screwdrivers are procurable for sixpence at Woolworth's.

## Some Cheap Tools

Speaking of Woolworth's reminds me that there are one or two extraordinarily cheap and really good tools for wireless constructional work to be obtained at their various shops. One that I bought the other day for sixpence will appeal to many readers. It is a 24-in. steel rule marked off into inches along one edge (sixteenths from 4 to 24, thirty-seconds from 1 to 3, and sixty-fourths from 3 to 4), and into centimetres along the other (half millimetres from 1 to 10 and full millimetres from 10 to 60).

This is just the very rule that one wants for marking out large panels and for preparing baseboards. Another very good sixpennyworth is a clamp which is most useful for fixing down work to a bench or for clamping

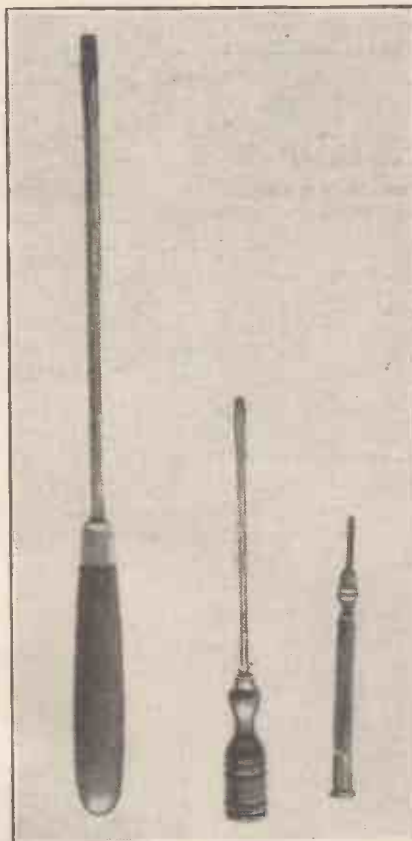

Three types of screwdriver which are essential for good radio set construction. The second size is invaluable for small baseboard screws.



# "EDISWAN Quality" 100% BRITISH AND 100% VALUE

## LOTEN DRY-CHARGED ACCUMULATORS

The particular superiority of the Ediswan Accumulator lies in the absolute purity of all of the materials used; the special construction of the grids which make shedding impossible under ordinary treatment, and in the special glass containers which render unnecessary the use of separators, often the means of inducing injurious foreign matter into the accumulator.

Loten accumulators are supplied dry-charged and only require filling with acid in accordance with the instructions on the glass boxes, when the accumulator is ready for service.

**Prices of LOTEN  
Dry-charged 2-volt  
Accumulators.**

- 10 amps. - 6/- each
- 20 " - 8/6 "
- 30 " - 10/6 "
- 45 " - 13/6 "

**Price of Type XG 282  
20 amps. - 10/6 each**

**Prices of 4 and 6 volt  
pro rata.**

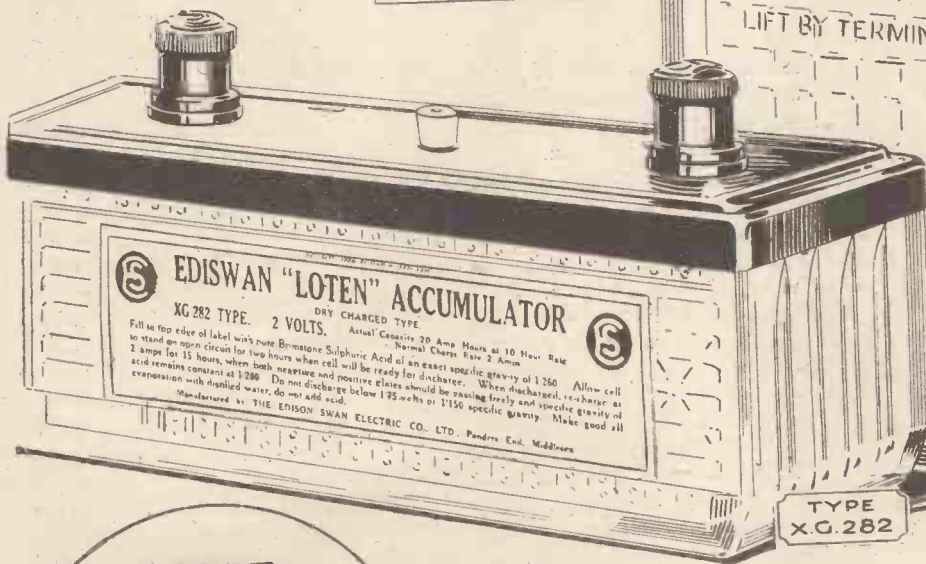

THE  
**100%**  
BRITISH  
ACCUMULATOR

Advt. of  
**THE EDISON SWAN ELECTRIC  
CO., LTD.**

Manufacturers of all types of  
Accumulators and Dry Batteries.

The  
capacity of all  
**EDISWAN**  
ACCUMULATORS is  
based on the  
10 hour rate  
of discharge

## Chats at the Work-Table—continued

down certain components when experiments are in progress. I should have mentioned that all my screw-drivers are magnetised (this is done very simply by stroking a large permanent magnet with the blades).

For fixing components to base-boards I always use copper-covered steel screws obtainable at the aforementioned shops. Owing to their copper covering the screws do not rust, and with a magnetised screw-driver one can place them easily in holes that would be inaccessible otherwise, or can recover them when they make their way into awkward corners.

### Soldering to Screens

If you use copper for screening purposes in your wireless sets you can solder to it leads, brackets, tubes for mounting screen-grid valves, and so on, without any great difficulty—provided that you know how to set about it. The great drawback to the use of aluminium is that ordinary soldering cannot be done with this metal. There are special aluminium solders, but they are by no means easy to use, and I do not particularly recommend readers to undertake such a task.

I was amused to read recently in a contemporary a constructional hint that involved the soldering of a steel wire to a piece of aluminium. A good deal of heated language was probably used by those who essayed to put



*Soldering on to metal screens is not an easy task unless the metal is perfectly clean and is reasonably hot.*

this precept into practice. The trouble with copper from a soldering point of view is that it is such a magnificent conductor of heat.

When we are dealing with a large surface such as that of a screen the copper draws heat with amazing rapidity from the bit of the soldering-

iron and radiates it into the air. The result is that, though the bit is heated up until the desirable green flames are seen about it, though the surface of the copper has been thoroughly cleaned, though a good flux is used, and though the solder is of a soft kind, one simply cannot make it flow.

A little solder is taken up with the bit, and is applied to the surface of the copper. It may refuse altogether to go on, but if it does adhere it is quite likely that the bit will stick to it. In any case, it is impossible in the ordinary way to produce on a largish sheet of copper anything like a smoothly tinned surface. What one generally manages to achieve is the adherence of a certain number of blobs, and when an attempt is made to run these together, the result is reminiscent of the surface of the moon as seen in an enlarged photograph.

The four requisites for making solder run and adhere properly are these:

- (1) The iron must be hot.
- (2) The iron must be clean.
- (3) The metal to be soldered must be brought up to a certain minimum temperature.
- (4) The metal must be clean.

Unless we take special precautions we can fulfil every condition except No. 3, for radiation from the copper defeats us here, and by doing so causes us to break condition No. 1.

The second photograph shows a way in which soldering to copper screens, no matter whether they are quite large, can be accomplished with a minimum amount of trouble. Close to a spirit-lamp place a block of wood whose height is somewhat less than that of the top of the flame. Rest one end of the screen on this and hold the other in a large pair of pliers.

Do not attempt to hold it in your fingers or you will have a practical proof of the fact that copper is a fine conductor of heat. Having cleaned the screen at the point to be soldered and dressed it lightly with flux, place it over the flame of the spirit-lamp and keep it there for a minute or two. Meantime heat up the iron, and when it is ready you will find that solder will flow on with the greatest ease.

If the job consists in soldering a lead or something of the kind to the

screen, two blocks of wood—one on either side of the spirit-lamp—may be used. One then has both hands free for the job.

### Tapping Straight

One is always being asked by beginners whether some golden rule cannot be found which will enable them to

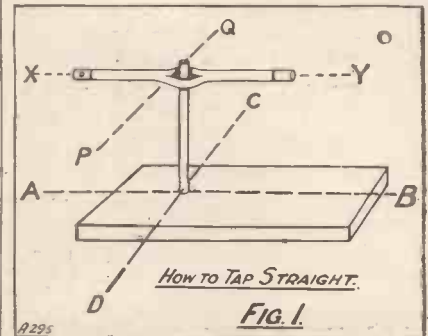

drive a tap, not slanting in this direction, or in that, into holes that have been made for its reception.

Here is a method which will, I think, make matters comparatively easy even for the most inexperienced. Having drilled a hole of the right size—place the work in a vice in such a position that the tap can be driven in horizontally.

Always use a second cut tap for ebonite. This is slightly pointed, and the presence of the point helps one very greatly to make a proper start. Stand right over the tap and turn it in until it just begins to bite, making every endeavour to keep it dead straight. As soon as you feel the tap cutting the ebonite take the work out of the vice and hold it up on a level with the eye, leaving the tap in position.

Turn it, first of all, so that you are looking along the line AB in Fig. 1. If you have anything of an "eye" you will see at once whether it is leaning at all in one direction or the other, and will be able to make the necessary correction. But do not be satisfied with looking at the tap only along this line. Turn the work so that you can examine it also along the line CD. Now make a further quarter turn and examine it again.

You will soon get the tap into its proper position, and it may then be driven through without any fear that the hole will not be threaded straight.



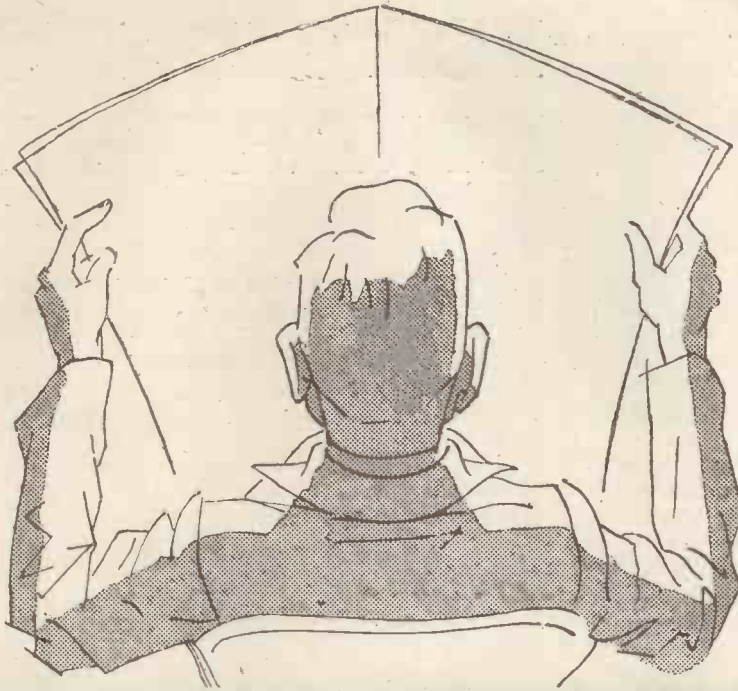

**AN IMPORTANT EXTRACT  
FROM THE  
"BRISTOL EVENING TIMES AND ECHO"**

Faithfulness of reproduction can only be obtained by the use of (1) good transformers; (2) good valves, and (3) a good speaker. The valves I was using were not very old—I purchased them at the National Radio Exhibition last year. I have since found them faithful servants, consuming very little indeed, and possessing all the qualities that good valves should possess. They were Six-Sixty valves.

WRITE TO US FOR GIFT BOOKLET

**SIX-SIXTY  
GLOWLESS VALVES**





# FOR THE PICK-UP ENTHUSIAST

*All gramophone owners who would like to make their own "wireless" programmes should read this interesting article.*

*By D. CHARLES.*

THOSE who are experimenting in the reproduction of gramophone records electrically are probably actuated by one of two motives. On the one hand there are the real music-lovers, and on the other the technical experimenters, keen on seizing and trying out any development that demonstrates the progress of radio.

## Improved Reproduction

There are plenty of gramophone owners, probably, who will be glad to take advantage of this new method for getting rather more quality from their records than has hitherto been possible. Among them will be a proportion who are not at all interested in radio for its own sake and may perhaps not realise that they are already in possession of a horn which is probably as good as, and in many cases even superior to, many existing forms of loud speaker.

There are, of course, on the market several "gramophone attachments" which consist of the electrical portion of a loud speaker constructed in such a way as to be easily attachable to the tone-arm of any gramophone. I propose to show, therefore, how by very simple means indeed the improved music rendered by the pick-up device can be translated by means of such an attachment.

## Pick-Up Easily Attached

This same idea will be even more attractive to the experimenter, since, employed in a different way, it will enable him to demonstrate the improved rendering of the pick-up, not only without removing the record from the machine but without the annoying interval rendered necessary by interchange of sound-box and pick-up.

There is nothing at all spectacular in the idea which I am offering. It consists merely in the addition of an

extra tone-arm to the gramophone, upon which the pick-up can be more or less permanently mounted. Such a tone-arm can be purchased at any gramophone stores for a few shillings.

It is sometimes possible, as in my own case, to attach this addition without making any new screw holes in the woodwork. One of the screws securing the motor-board was removed, inserted through one of the holes in the base of the new tone-arm, and replaced. Any injury to the french-polish which might show in case of subsequent removal was prevented by the insertion of a disc of blotting paper. The only precaution needed in choosing the position for the additional tone-arm is to so fix

insertion and removal of records (especially when using the normal sound-box and tone-arm), it becomes necessary to depart slightly from this ideal.

## Gramophone As Loud Speaker

One photograph shows the pick-up in use upon the added tone-arm with its flex arranged to allow of free movement whilst being electrically connected to the radio set, wherever the latter may be situated. In this picture the gramophone sound-box has been removed and one of the aforesaid loud-speaker attachments substituted. Used in this way, with the valves switched on, there is not the slightest difference in manipulation

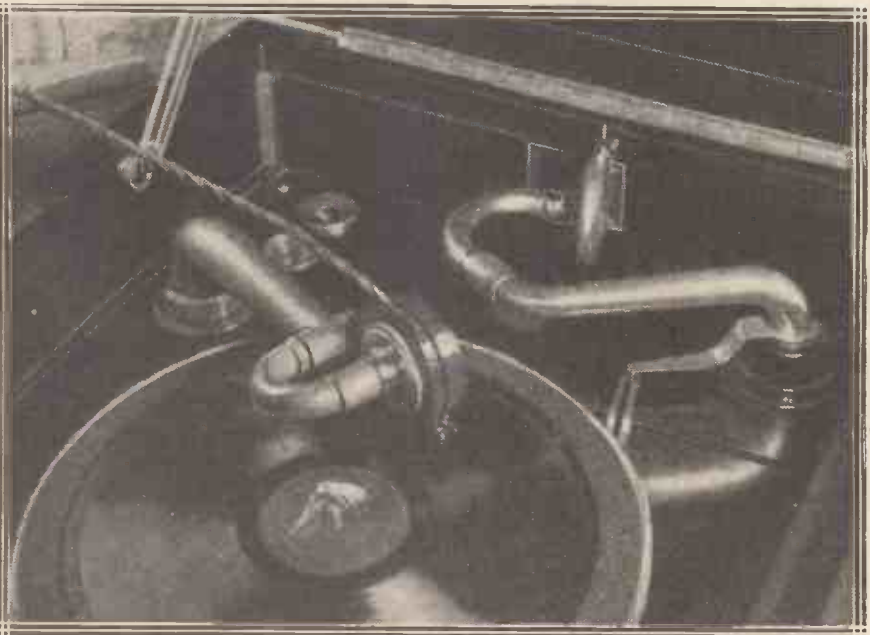

Fig. 1. The pick-up in use, with the flex arranged to allow of free movement.

it that the needle could, in swinging over, touch the central pivot of the turn-table. That is the correct theoretical position, but it may be found that to provide clearance for the

from the ordinary method of using a gramophone. The gramophone user carries on just in the way he has always been familiar with, making no variation whatsoever, and so



# THE HEART of the HARRIS STEDI-POWER UNIT

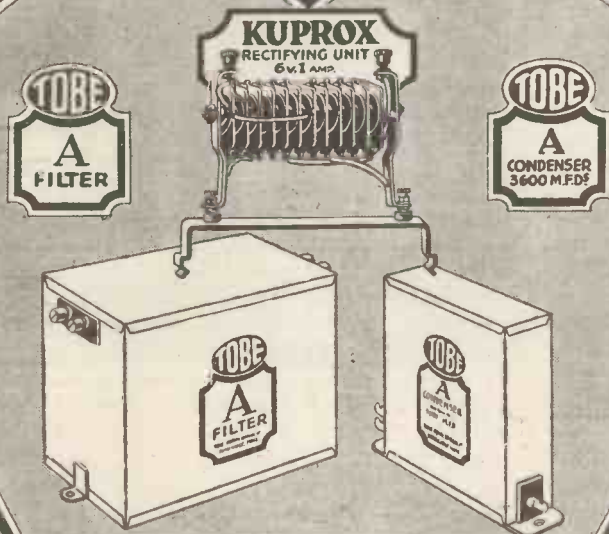

### TOBE "A" FILTER 80/-

Here is a completely wired-up filter unit containing two TOBE "A" condenser and two chokes of special design. The "A" Filter is more compact and obviates the purchase of either the individual "A" condenser or choke coils.

Capacity 7,600 mfd.

## HUMLESS - BONE DRY - CAREFREE - A.C. FILAMENT CONTROL

### KUPROX DRY METALLIC DISC RECTIFIER

Type C.R.1

25/-

The bone-dry rectifying unit giving a 6-volt 1-amp. output.

AS SPECIFIED.

### THE ROTHERMEL CORPORATION LTD.,

24-26, Maddox Street,  
London, W.1.

Telephone :

Mayfair 0578, 0579.

### TOBE "A" CONDENSER

25/-

Capacity 3,600 mfd.

Used in conjunction with two chokes of special design and Kuprox C.R.1 dry metallic disc rectifier.

AS SPECIFIED.

## For The Pick-up Enthusiast—continued

enjoys his improved reproduction without added complication or effort.

In the second photograph the gramophone will be seen in use as a gramophone, and the pick-up is swung back out of the way. If, while in this position, the pick-up with its set and a normal loud speaker are held connected up in readiness, it will be obvious that the change over from the employment of the machine, as shown in this photograph, to the arrangement shown in the next photograph (Fig. 3), where, with the sound-box out of the way and the pick-up in use, takes very much fewer seconds to effect than it has taken me to describe the operation.

### A Quick Change-Over

It becomes possible, with one winding of the spring, to listen first to the record reproduced by gramophone, and then with an interval which need not exceed two seconds to hear the same tune reproduced by a method which is at the present time making great strides into favour among those who either like good music for its own sake, those who like to experiment, and those again who value a combination of these two results because it gives them something worth dancing to.

better your amplifier and loud speaker, the better will be the results obtained by playing the records by means of the electrical pick-up. Further, if you have a volume control

With a volume control and a fairly powerful amplifier it is possible to vary the volume from a mere whisper to a strength sufficient for a concert hall. Generally speaking,

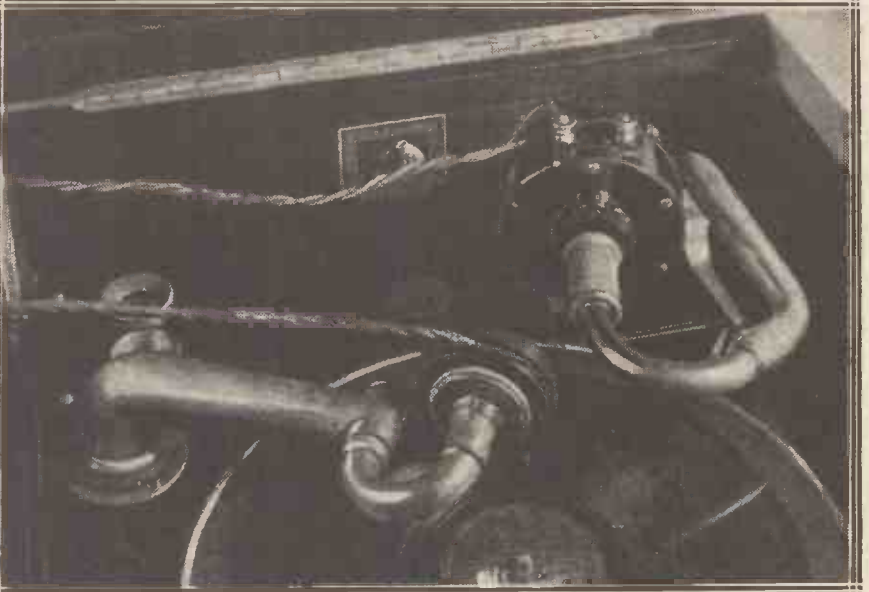

Fig. 3. The pick-up can be used and at the same time the gramophone may be employed as a loud speaker by utilising a reproducer unit on the tone arm.

on the set or pick-up, you can vary the degree of loudness to a nicety without that suppressed sort of effect

it is better to use a loud-tone needle and cut the volume down to the degree needed. This serves to reduce scratch, or, at least, the proportion of scratch, to that of the speech or music.



Fig. 2. When the gramophone itself is in use the pick-up is swung back out of the way.

Finally, then, we can recommend the electrical pick-up to all possessors of gramophones and wireless receivers which have efficient amplifiers. The

so often obtained when the doors of the gramophone are closed to decrease volume in the ordinary way.

\*\*\*\*\*  
 \* REDUCING A.C. HUM \*  
 \* \*\*\*\*\*

IF you use an A.C. eliminator for your H.T. or L.T. supply, you may be troubled with a slight hum, continually audible in the loud speaker. This should not be prominent with a well-designed eliminator, but the hum may also occur if your lighting circuit is A.C., whether you use it for supplying the receiver or not. This hum can be materially reduced, and even sometimes eliminated altogether, by lowering the value of the detector grid leak. Values down to about  $\frac{1}{4}$  megohm should be tried. The value of the grid condenser may also be varied with success. Here the capacity may be lowered to .0001 without seriously impairing the functioning of the receiver in other ways.

A. V. D. H.



# true to tone

—the first and final  
test of a speaker



What a loud-speaker looks like, how much it costs, even the volume of sound it produces—all these are secondary considerations. What does matter first, last, and always is the *quality* of its interpretation. By virtue of its remarkable four-pole drive and its absence of "natural frequency" the "Ideal 44" gives results that compare favourably with speaker performance at a much higher price. It is a speaker that musical people with a critical ear are hearing and buying. Never was a good speaker produced at such an attractive figure—the price has just been reduced to **37'6**

Ask your dealer to demonstrate an "Ideal 44" cone speaker. Notice its exceptionally crisp rendering of the "borderland tones" at either end of the scale.

The **IDEAL**  
CONE **44**  
SPEAKER

The Ideal Cone Speaker is supplied also at the same price in the form of a kit from which you can build up the identical model in your own home.

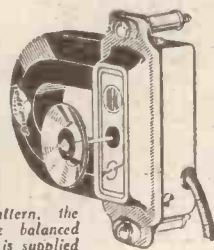

For home constructors wishing to build a cone speaker to their own pattern, the Ideal four-pole balanced armature Unit is supplied exactly as embodied in the "Ideal 44." Special steel used for the magnet gives high sensitivity. Each unit is supplied with full instructions and two padded washers on threaded spindle. 25/-.



**F. A. HUGHES & CO., LTD.** (Dept. W.4)  
204-6, GREAT PORTLAND STREET, LONDON, W.1  
MANCHESTER: 185, PRINCESS STREET.



## JEWELLED IN EVERY HOLE

**Y**OU can tell the quality of a watch by opening the case. If it is jewelled in every hole you'll know that it will keep good time. Without jewels the moving parts will suffer from friction, and its time-keeping qualities will be impaired.

But you can't open up a condenser to see whether it will give good service or even to see whether it is accurately made. You buy on trust. Therefore it will always pay you to buy a T.C.C. Condenser, instead of an unknown condenser, which may cost a few pence less. T.C.C. condensers have been on the market for 22 years; they have a reputation; they are accurately made and carefully tested; you can buy them with confidence.

Specified for the  
Cossor "Melody Maker"



# T.C.C.

To Telegraph Condenser Co., Ltd., Wales Farm Rd., N. Acton, London, W.3.

I enclose 1d. stamp. Please send a copy of "How to build your High Tension Eliminator for A.C. or D.C." to:

Name.....  
Address .....

W.C. August



## A PAGE FOR THE HANDYMAN

*Saving 10s. on a Set—A Simple Loud Speaker—A Wireless Use for Vacuum Cleaners—Topping-Up Accumulators.*

### Saving Ten Shillings on a Set

**T**HE cost of ebonite is often a serious handicap to some wireless enthusiasts.

The writer recently had occasion to build a set, and, unfortunately, it had to be built down to a price. Even after whittling down the component parts at the expense of quality, the price was still too high, and ultimately it was decided to dispense with the proposed ebonite panel (24 in. by 9 in.) altogether, and by vignetting a wooden one with scrap ebonite, quite a presentable job was made.

The only components on the panel were two variable condensers, one rheostat, and one low-tension switch. The wood panel was first cut to size, sand-papered, stained and polished, then two squares with 4 in. sides, and one rectangle 4 in. by 2 in., were cut out of it with a fretsaw.

The side of an old 6-volt ebonite accumulator was next attacked; to supply two pieces, 4½ in. by 4½ in., and one 4½ in. by 2½ in. These were then screwed to the back of the panel with short countersunk screws.

A little difficulty was encountered when mounting the condensers, since the ebonite was only ½ in. thick, allowing too much of the condenser spindle bush to project above the panel, and preventing the dials from screwing down. This was overcome by inserting celluloid washers (not



metal) between the condenser end-plates and the back of the panel.

A number of people who have seen the set since it was completed have expressed their admiration for this form of mounting, and it has the one

signal advantage of cutting down the price of the new panel to practically nothing.

Finally, I may say that when tested on a "Megger" the greatest leak found anywhere on the panel between individual components was 350 megohms, proving that this method of building a panel has no detrimental effect on the working of the set, except perhaps on ultra short-wave receivers.

### A Simple Loud Speaker

**A** VERY effective loud speaker of exceptionally good tone may easily be made in a few minutes by gluing a brown-paper cone to the diaphragm of a Lissenola, or similar unit, as shown in Fig. 2, the pull of the magnet being sufficient to hold the diaphragm in place. The cone, which is of stiff brown paper, is cut out as shown in Fig. 1, and may be of about 12 in. diameter and about 2 in. deep.

When I had made a trial with a Lissenola in this way, the results were so satisfactory that I decided to make a more permanent arrangement by soldering a small nut to the centre of the diaphragm so that the cone might be screwed on. A cardboard washer was glued on each side of the cone at the centre and a brass washer was put over each of these before passing the screw through. The screw was short enough to allow of its being

screwed up tight without its touching the diaphragm.

If it is desired to use the cap to hold the diaphragm more certainly than the magnet can, a circular hole must be cut in it, of course, so that the cone will clear it when in position.

The hole may be cut with a fretsaw, but this is not easily done as the material is very brittle; however, an accidental fracture may be repaired with shellac. (Here I may mention that the Lissenola reed, which may be fitted without damaging the cap, and is doubtless well suited to its purpose when used in the ordinary way, was quite unsatisfactory when used with this free-edge cone.) Finally, the Lissenola was fixed by its terminals to an upright strip of ebonite and this was screwed to a wooden base.

This loud speaker is decidedly more pleasing in appearance than one constructed with a cardboard horn, and, what is of greater importance, it reproduces the bass—drums, organ pedal notes, etc.—really well.

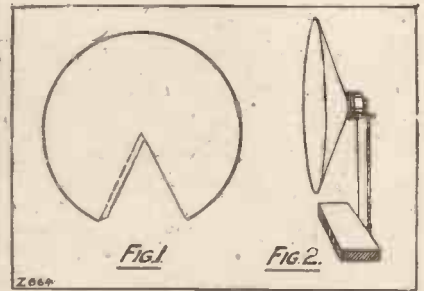

### A Wireless Use for Vacuum Cleaners

**M**ANY wireless-set users have a vacuum cleaner in the house, and while one does not usually think of running the vacuum cleaner over the wireless set, it should not be forgotten that practically all of these useful domestic instruments have a "blower" attachment by which a strong jet of air can be projected through a nozzle at the end of the tube. This jet of air is of great use in removing dust from a set and particularly for cleaning the spaces between the vanes of variable condensers.

### Topping-Up Accumulators

**D**O not succumb to the temptation of using tap water to top up your accumulators when the liquid has evaporated so as to expose the plates. You may not notice any ill-effects for several weeks and so be lulled into feeling that, after all, the use of distilled water is not necessary, but unless you live in a district where the water is particularly soft you will inevitably damage the plates sooner or later. Distilled water can now be obtained from practically any garage, as these premises all charge accumulators. A large bottle should be kept handy for topping up purposes.

*Instead of having one large ebonite panel, this home-constructed set has ebonite only where the controls are mounted, the rest of the front being made of wood.*



from THE OBSERVER

# FERRANTI

*"very best obtainable"*

Last week I mentioned that I was going to try the effect of two stages of transformer coupled note magnification. Well, I have done it, and I take back anything I may have suggested against transformer coupling—with the proviso that really good transformers must be used. The man who must build cheaply had best stick to at least a first stage of resistance-capacity coupling. If he wants to build his note magnifier very cheaply, he must use two stages of resistance capacity amplification and risk the serious attenuation of the higher frequencies that will follow unless he is a skilled designer. Into the set I built I put a leaky-grid detector; because a medium resistance valve must be used in front of the first transformer, and it is difficult to use such a valve to give good anode bend rectification. I followed it with a valve of about 8,000 ohms resistance, and ended with a stage of push-pull amplification for the output. I feed the plate of the detector valve from a dry battery, and the intermediate and pair of output valves from an accumulator battery. The current taken by these three valves, at 120 volts, is about 30 ma. The first transformer is a Ferranti AF3, followed by the same maker's push-pull transformers. With this receiver I have a choice of the 2LO or 5GB programmes at excellent strength, so that the softest passages can be heard all over a living room 25 by 20 feet, without the slightest strain—and the quality is wonderfully good. I have yet to determine whether an anode-bend detector and a resistance capacity stage will be better, but I think there will be very little in it. Please note, though, that the transformers used are the very best obtainable; there is no reaction in any form, and the set has been very carefully designed and built.

Radio engineers—*everywhere*—both professional and amateur, have expressed highest praise of Ferranti Transformers, and use them exclusively. They are by test the *World's best*. No other Wireless Transformers have such high primary impedances. Ferranti have over forty years' experience as designers and builders of all types of transformers. That vast experience coupled with scientific research is applied to Ferranti Wireless Transformers. Every foot of the miles of enamelled wire in each is *tested*. Before a completed Ferranti Transformer is marketed it is submitted to eleven special tests.

### PUSH-PULL TRANSFORMERS

These are similar to our standard A.F. and O.P. types. They are provided on their secondary and primary sides respectively with centre tapplings—and in consequence the windings of the Push-Pull O.P. Transformer have been suitably increased.

FERRANTI push-pull amplification enables better reproduction to be obtained than is possible by any other commercial means.

### AUDIO FREQUENCY

AF3c. Ratio 1-3.5 . . . . . Price 29/-  
 AF5c. Ratio 1-3.5 . . . . . Price 34/-

### OUTPUT TYPE

OP3c. Ratio 1-1 (up to 130 m/a) Price 25/-  
 OP6c. Ratio 1-1 (up to 50 m/a) Price 19/6  
 OP4c. Ratio 25-1 (up to 130 m/a) Price 25/-

These Transformers are now supplied fully licensed under the Push Pull Patent No. 275/1915 for use in Broadcast Receivers.

*Output Transformers of non-standard ratios can be supplied at an extra 4/- above the standard price.*

**FERRANTI LTD.**  
**HOLLINWOOD, LANCs.**

C.F.H



\*\*\*\*\*  
**OUR NEWS BULLETIN**  
*Some of the More Interesting Happenings  
 in the Radio World this Month.*  
 \*\*\*\*\*

**The Regional Scheme**

WE hear that there is considerable disagreement between the B.B.C. and Post Office engineers with regard to the Regional Scheme.

The Post Office people seem to be of the opinion that the erection of five high-power stations each transmitting two programmes will eventuate in increased jamming, and that the average listener's sets will not be able to separate the transmissions.

The B.B.C. engineers, however, maintain that the difference between the wave-lengths to be employed will be more than sufficient and listeners will not have to make any serious alterations to their sets.

The Potters Bar station will test these rival opinions—and the theory which proves right will decide, one way or another; the fate of the Regional Scheme.

**The Potters Bar Station**

It has been obvious for some time past that all was not well with the Regional Scheme—and lately it has become more and more obvious that Post Office official opposition to the scheme was growing, and that the B.B.C. was finding it difficult to get their plans officially sanctioned. The permission given for the erection of the Potters Bar station was not obtained without a good deal of trouble—and, no doubt, when the station has been in operation for a few months and reports from listeners come in, there will again be a long and tedious argument between the P.O. and Savoy Hill as to the feasibility of the scheme. Which side will win remains to be seen, but it is obvious that it will be a long time, in any case, before the Regional Scheme is completed.

**This Year's Exhibition**

September 22nd to the 29th will mark the opening and the closing of the National Radio Exhibition at Olympia this year. This year's show is likely to be the finest yet, for already applications for space for stands at the exhibition have exceeded all expectations.

Last year, 229 stands were taken. This year, 262 have already been booked.

There is little known as yet as to what will be the main attractions at Olympia this year. Manufacturers are working hard, however, and we hear of many surprises in store for amateurs. Probably the "Evening News" Wireless Correspondent was right when he wrote the other day that the outstanding features of the show will be coil-driven cone loud speakers and sets incorporating screened-grid valves. Chargers and eliminators will also probably be well to the fore, and, in any case, the exhibition shows every sign of being one of great outstanding interest.

**Political Broadcasting**

According to the "Daily News," a suggestion has been made that the B.B.C. should issue invitations to the  
 (Continued on page 274.)

Pat. No. 276,867.

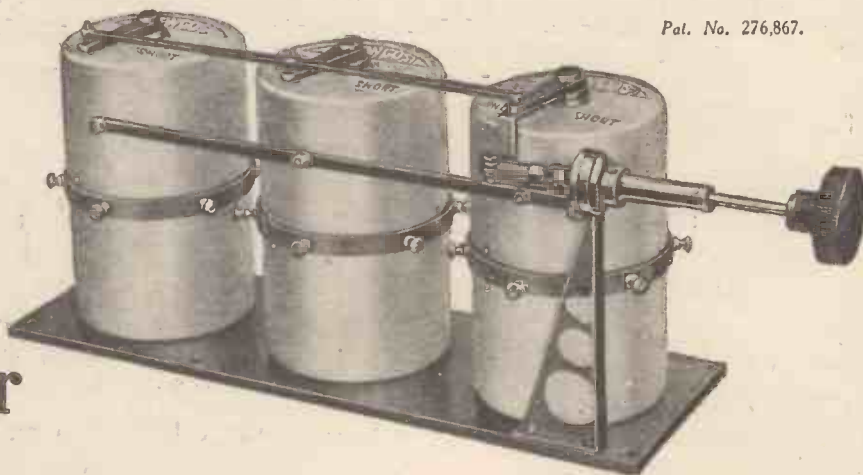

**Modernise**

**your**

**1926 "SOLODYNE"!**

This LEWCOS Dual Screen Coil improves reception and makes tuning easier. You have 250-550 and 1,000-2,000 wave-length range in one unit. Panel controlled, the set fits exactly into the space occupied by the old type of three separate coils and bases. Perfectly balanced. Obtainable from stock through all wireless dealers.

THE LONDON ELECTRIC WIRE CO. AND SMITHS LTD.,  
 Church Road, Leyton, E.10. Telephone: Walthamstow 2531.

Ref. No. DSP/3  
 One SP Aerial Coil  
 and two Split  
 Primary H.F.  
 Transformers, the  
 last with Reinartz  
 Reaction. Per unit  
**£5**

**LEWCOS DUAL SCREENED COILS**



**YOUR "MASTER THREE"**  
will be better still with the  
**J.B. TRUETUNING S.L.F.**

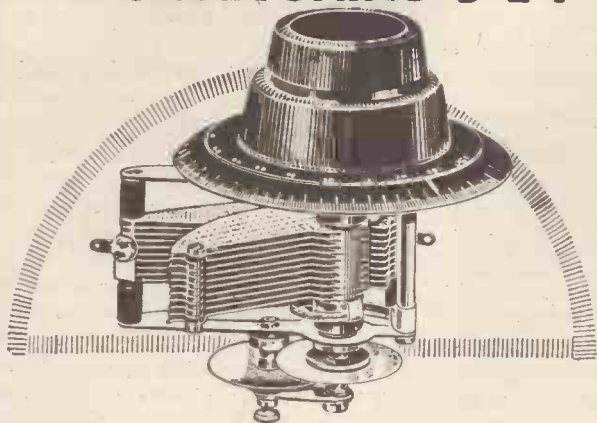

Make tuning really easy by fitting J.B. True Tuning Condensers to your "Master Three." Your original J.B. Condensers have, of course, rendered you superb service, but if you fit the True Tuning S.L.F.'s you will find that it is impossible to slip past any station on the wave band, as you are sometimes bound to do when your condensers are not fitted with slow motion devices.

Prices, '0005 mfd., 16/6 ; '00035 mfd., 15/6.

**JACKSON BROS**  
& POLAND ST-OXFORD ST  
LONDON - W.1  
Telephone  
GERRARD 7414



**A** Last!—A Battery Eliminator for Alternating Current at a Reasonable Price.

**HARRODS H.T. BATTERY ELIMINATOR £2.10**

For less than the price of Power Capacity Batteries you can now have H.T. supply from your alternating house circuit.

The Harrods Eliminator is silent and safe, it has no valves but a special rectifying unit (Prov. Patent 5599/26), it has 10 intermediate voltage tappings up to 120 volts, at 20 milliamps output, and is guaranteed for 12 months.

**HARRODS**

HARRODS LTD

LONDON SW1

In two Models:  
100-120 v.  
200-240 v.

Same price  
£2 10 0



Over 600 hours' use for 1 unit.

KEEP YOURSELF AND YOUR SET "IN TUNE"

with all the radio news and developments by reading

**POPULAR WIRELESS**

This fine Thursday threepennyworth is well worth the small weekly subscription because it gives the brightest and best radio reading every week—but there is more in it than that—

Full of hints, tips, and practical how-to-make articles "P.W." is

**A SOUND RADIO INVESTMENT**

Scores of readers have testified that one 3d. issue of "P.W." has saved them pounds!

So now they always ask for

**POPULAR WIRELESS**

The paper that made

**WIRELESS POPULAR**

Every  
Thursday

Price  
3d.

**OUR NEWS BULLETIN**

—continued from page 272

Prime Minister, Mr. Lloyd George and Mr. Ramsay MacDonald to speak before the microphone, leaving it to them, or any of them, to accept or reject the offer.

In any case, a strong effort should be made to end the political deadlock which has arisen over the question of broadcast political debates. The whole squabble is really rather petty.

**The European Conference**

A conference of the Council of the Union Internationale de Radiophonie, under the presidency of Admiral Carpendale, and a European Conference of Broadcasting Engineers have concluded their sittings at Lausanne. The Council ratified the admission of new members to the Union as follow: Radio Stanica, Zagreb; British East African Broadcasting Company, Nairobi; Société Roumaine de Radiophonie, Bucarest. The Council recommended that the identity of broadcasting stations should be stated as clearly as possible. Some twenty European countries were represented at the Engineers'

Conference, when discussions took place on the methods of eliminating interference with broadcasting by tramcars, lifts, and other electrical apparatus, and on the latest experiments in short-wave transmission. The technical conditions indispensable to the relaying of programmes over long distances by means of telephone lines and cables were also examined.

**"POPULAR WIRELESS"**

is the leading radio weekly and has a **GREATER CIRCULATION**

than any other journal of its kind. If you wish to maintain your keen enthusiasm in radio and keep abreast with all its modern developments you must read

**"POPULAR WIRELESS"**

Every Thursday :: Price 3d.

**Television Coming?**

A good deal of publicity has been given in the Press lately to the possibility of a television service starting the end of this year, and to the proposed service of broadcast pictures on the lines of an invention by Captain Fulton. The B.B.C. has been investigating both systems, but so far the comments from Savoy Hill have been very cautious and nothing is

yet definitely known as to what the B.B.C. intends doing.

Captain Fulton's system seems to be quite a practical proposition and would appear to stand a good chance of early adoption in this country—certainly a better chance than any known television system.

**The Fultograph Method**

The inventor of this development of broadcasting is Captain O. Fulton, who has been experimenting for the past 17 years. He has been operating his own experimental station in Vienna for the last 2½ years with such success that, starting on October 1st, R A V A G, the Vienna wireless station, will broadcast pictures by the Fultograph method, as Captain Fulton's invention is called, from Vienna. These regular picture transmissions will also be relayed from Graz, Klagenfurt, Innsbruck, and Linz.

**The Time Factor**

Interviewed the other day, Captain Fulton said:

"My apparatus transmits and receives photographs. The basic idea is the changing of light waves into sound waves. When these sound waves are picked up by my receiving

(Continued on page 276.)

**Coils for all circuits**

Gambrell Coils have proved again and again their superior efficiency for all kinds of circuits. Their Low-Loss properties, their rigidity and the fact that they are totally enclosed makes them eminently suited for sets in which screening is used.

Gambrell Coils are repeatedly selected by contributors of constructional articles to the technical papers.

Size	a2	a	A	B1	B	C	D	E1	E	F	G
Price	4/10	4/10	5/-	5/3	5/6	5/9	6/3	6/3	7/9	8/6	10/-
Approx. No. of turns	18	22	30	40	40	45	100	150	140	300	501



**The Gambrell Neutrovernia**

during the last few weeks has been used and specified by the designers of no less than twelve popular receivers.

This popularity is due to the remarkable efficiency, the construction and the usefulness of this condenser which can be used as either a

PRICE CAPACITY REACTION CONTROL,  
**5/6** BALANCING CONDENSER, or  
EACH NEUTRALISING CONDENSER.

Obtainable from all Dealers.

**GAMBRELL BROS. LTD.**  
**76, Victoria St., London, S.W. 1**



Illustration shows patented method of construction and winding which is responsible for their remarkable efficiency

**"The Quality is Perfect"**

"I have tried twelve different types of pick-ups but you will be pleased to hear that yours absolutely puts them in the shade. The quality in my opinion is perfect."

R.H.  
Wimborne, Dorset.



That is the opinion of an experienced experimenter who is so enthusiastic about the Igranic-Pacent Phonovox that he voluntarily writes us the above testimonial. And how could it be otherwise? The Phonovox has a patented needle suspension that gives it the straightest response curve of all pick-ups. Yet its price is one of the most reasonable on the market.

**THE IGRANIC-PACENT PHONOVOX**

Price complete with volume control and plug adaptor 50/-  
Send for List No. 3591 for full particulars.

149, Queen Victoria Street, London, E.C. 4

Works: BEDFORD



Branches: Manchester, Birmingham, Cardiff, Newcastle, Bristol, Glasgow, Leeds



**THIS SIGN IN A GOOD CIRCUIT INDICATES DUBILIER**

*Dubilier Components embodied in a set make all the difference between moderate results and results as good as the set is capable of producing. Though the circuit is good it requires to be built with efficient components if its best is to be obtained. And Dubilier Components are not only good to start with, but their efficiency is steadfast.*

The Type 610 Mica Condenser illustrated is made in 21 different standard capacities between 0.00005 and 0.015 at prices ranging from 2/6 to 4/6. They will take either the Parallel or Series Dumetohm Clips. Type 620 is the upright type of the same condenser.

If unobtainable from your dealer send direct to us giving his name and address.



Type 610.

*Dubilier built is better built*



Advt. of Dubilier Condenser Co. (1925) Ltd., North Acton, London, W.3

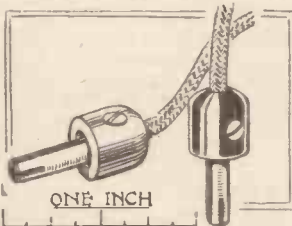

**ELEX NEW "MIDGET" WANDER PLUG**

Specially designed for use in sockets of varying sizes. The pins are made of hard spring brass and

have double slots. The ordinary wander plug projects  $\frac{3}{4}$ " above the level of the H.T. Battery, but this new plug only  $\frac{1}{8}$ ". Specially suitable for portable sets, where space above H.T. Battery is limited, and of paramount importance to users of H.T. Batteries of varying makes.

WANDER PLUG - Price 2d. each, in red or black.

WRITE FOR LIST V30.

J. J. Eastick & Sons, Ealex House, 118, Bunhill Row, E.C.1

SPAN FULLY OPEN  $3\frac{1}{2}$ "

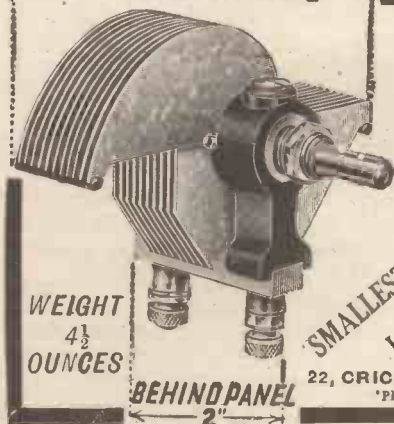

**FORMO "1928" LOG CONDENSER**

00035 **5/-** 0005  
Absolutely the **SMALLEST, LIGHTEST, and most EFFICIENT.**

22, CRICKLEWOOD LANE, N.W.2  
Phone: Hampstead 1787.

*Invaluable to EVERY Amateur and Constructor.*

The "POPULAR WIRELESS" **BLUE PRINTS** of TESTED CIRCUITS

"P.W." BLUE PRINT

- Number
1. DETECTOR VALVE WITH REACTION.
2. OUT OF PRINT.
3. 1-VALVE L.F. AMPLIFIER.
4. CRYSTAL DETECTOR WITH L.F. AMPLIFIER.
5. H.F. (Tuned Anode) AND CRYSTAL WITH REACTION.
6. H.F. AND CRYSTAL (Transformer Coupled, without Reaction).
7. 1-VALVE REFLEX WITH CRYSTAL DETECTOR (Tuned Anode).
8. 1-VALVE REFLEX AND CRYSTAL DETECTOR (Employing H.F. Transformer, without Reaction).
9. H.F. AND DETECTOR (Tuned Anode Coupling, with Reaction on Anode).
10. H.F. AND DETECTOR (Transformer Coupled, with Reaction).
11. DETECTOR AND L.F. (With Switch to Cut Out L.F. Valve).
12. OUT OF PRINT.
13. 2-VALVE REFLEX (Employing Valve Detector).
14. OUT OF PRINT.
15. OUT OF PRINT.
16. H.F. (Tuned Anode), CRYSTAL DETECTOR AND L.F. (With Switch for Last Valve).
17. CRYSTAL DETECTOR WITH TWO L.F. AMPLIFIERS (With Switching).
18. 1-VALVE REFLEX AND CRYSTAL DETECTOR, with 1-VALVE L.F. AMPLIFIER, Controlled by Switch.
19. OUT OF PRINT.
20. OUT OF PRINT.
21. THE 2-VALVE LODGE "N."
22. "THE GUARANTEED REFLEX."
23. THE 1-VALVE "CHITOS."
24. THE "SPANSACE THREE." Three-Valve Receiver employing 1 Neutralised H.F. Valve, Detector with Non-Radiating Reaction Control, and 1 L.F. Valve.
25. OUT OF PRINT.
26. A "STRAIGHT" 4-VALVER (H.F., Det. and 2 L.F.
27. OUT OF PRINT. with Switching).
28. A "MODERN WIRELESS" 5-VALVER (H.F., Det. and 3 L.F.).
29. AN H.T. UNIT FOR DIRECT-CURRENT MAINS.
30. A REINARTZ ONE-VALVER.
31. A STANDARD TWO-VALVER (Detector and L.F.).
32. THE "CUBE SCREEN" THREE (H.F., Det. and L.F.).
33. A "KNIFE EDGE" CRYSTAL SET.
34. AN H.F. AND DETECTOR TWO-VALVER.
35. THE "UNIVERSAL THREE" (Det. and 2 L.F. stages resistance-coupled).
36. THE "SPANSACE FOUR" (H.F., Det. and 2 L.F.).
37. THE "LONG SHORT" CRYSTAL SET.
38. A TWO-VALVE L.F. AMPLIFIER.
39. THE "SYDNEY" TWO.
40. THE "SUPER SCREEN" THREE.
41. THIS YEAR'S "CHITOS" ONE-VALVER.
42. THE "Q AND A" THREE. A simple set (Det. and 2 L.F.)
43. THE "INEXPENSIVE FOUR."
44. THE "ECONOMY FIVE." For long range loudspeaker work.

**ALL "POPULAR WIRELESS" BLUE PRINTS—6d. EACH**

All orders for these Blue Prints should be sent direct to the "Popula Wireless" Queries Department, Fleetway House, Farringdon Street, London, E.C.4, enclosing a stamped addressed envelope and a postal order for 6d. for each Blue Print ordered.



MODEL C.14.

## The Finest Gift

As a gift, "Celestion," most excellent of loud speakers, is without a peer, for all who hear it can share the great pleasure that it brings. Get your dealer to demonstrate "Celestion" for you. You will be amazed at its realism.

Embodied in "Celestion" are the six essentials of an excellent loud speaker:

They are:

**EVEN RESPONSE,  
EXTREME SENSITIVITY,  
ONE ADJUSTMENT,  
IMPERVIOUS TO CLIMATE,  
IMPROVEMENT WITH AGE,  
DISTINCTIVE APPEARANCE**

Moreover, "Celestion" is British made throughout.

*Made Under Licence.*

There are four "Celestion" models in oak or mahogany, ranging from £5 10s. Od. to £25. We shall be glad to forward to you our free illustrated literature giving full particulars, and of our "Woodroffe" Type Gramophone Pick-up. When ordering Pick-up please state whether adaptor is for H.M.V. or 7-in. size.

# CELESTION

*The Very Soul of Music*

Write to Dept. L.

**THE CELESTION RADIO CO.,**  
Hampton Wick, Kingston-on-Thames.

Showrooms:

33-35, VILLIERS ST.  
LONDON,  
W.C.2.

Associated Company:

CONSTABLE-  
CELESTION CO.  
PARIS.

## OUR NEWS BULLETIN

—continued from page 274

apparatus they are changed back to light waves.

"Anyone using the apparatus can see the photograph being reproduced on special paper on the cylinder.

"Depending on the strength or power used, a photograph takes about three or four minutes to develop.

### Suitable Sets

"The receiving apparatus, which is called the Fultograph, is simply attached to a wireless set. The system can be attached to any two-valve set, and, if the set is within a mile or so of a broadcasting station, a one-valve set could be used. The Fultograph will cost about £25, and produces a picture 4½ in. by 3½ in.

"Companies to work my invention in conjunction with wireless broadcast companies have been established in practically every country of importance in the world except England.

### A British Invention

"It seems strange that a British invention of such importance should be neglected in England when so much interest in it is shown by foreign countries. Before long, people in this country will be able to see a picture of some remarkable happening in a distant part of the world a short time after it has occurred."

### Plain Speaking

A recent issue of the "Electrician" had some interesting comments on television.

"We have nothing but admiration for the progress that has been made so far," says the "Electrician," when dealing with television, "but do not favour the publicity methods that are at present being employed."

Dealing with the "Berengaria" experiment, which was conducted by Captain Hutchinson, the business manager of the Baird Wireless Television Development Co., the "Electrician" says: "On such occasions where the results of the demonstrations are likely to be of genuine historical value, it is customary to invite the technical Press, or else to appoint some independent body so that the public may not hesitate in believing the results. On both these scientific occasions the only people present seem to have been with the Baird Co., or of them."

### Crude or Costly

Continuing, the "Electrician" says: "Now, although this kind of

thing may have publicity value, it is calculated to undermine the confidence of those who are looking for evidence of definite scientific achievement, and when the complaint is made, as we have recently seen it in print, that Mr. Baird's work is criticised in certain quarters, we feel that Mr. Baird has only himself to thank for having acted in a manner which provokes distrust. We do not think that commonplace home television can be expected for some considerable time to come. The systems of which we have knowledge appear to be either too crude to be of more than experimental interest, or else where some higher degree of success has been obtained by way of results the costs have been prohibitive."

### A Gentle Reminder

In conclusion, the "Electrician" says: "Every scientist who respects his reputation should take steps to

## "POPULAR WIRELESS"

is the Paper you ought to

### READ.

Bright in its outlook and appearance, it tells you the very things about radio that you want to

### LEARN.

And these articles are not written by condescending high-brows, but are in the form which you can

## INWARDLY DIGEST

Every Thursday. Price 3d.

ensure that what he puts on record regarding his scientific achievements shall not be distorted and exaggerated by others who may quote him. Even so far back as 1926, Mr. Baird made a statement to the Press that he anticipated that his televisors would be available to the public before the end of 1927, and at the Radio Exhibition last year went so far as to exhibit a number of boxes labelled 'Baird Televisors.' Good publicity, we agree, but in a form which can hardly be expected to inspire lasting confidence."

### Better Broadcasting?

Listeners have been commenting lately on the considerable improvement in the quality of broadcast programmes. According to a B.B.C. official, these improvements are due to the constant modifications of plant and replacements, including changes in design of the modulator panels which control the strength and quality of output.

(Continued on page 278.)





SYDNEY S. BIRD & SONS, LTD.,  
CYLDON WORKS - - - ENFIELD TOWN.

**SPECIAL NOTE FROM MR. PERCY HARRIS**

On page 227 of this issue Mr. PERCY HARRIS stresses the fact that a "Good Quality Moving Coil Voltmeter" is essential to the satisfactory functioning of his "Stedipower" Unit. The Weston Model 506 Voltmeter is recommended. Take the experts' advice—they know best—and that means

**WESTON**  
STANDARD THE WORLD OVER  
*Pioneers since 1888*  
WESTON ELECTRICAL INSTRUMENT CO. LTD.  
15, Gt. Saffron Hill, London, E.C.1

**GOOD NEWS FOR SET BUILDERS**

In response to the urgent demand for first-class sets for family use, Mr. PERCY W. HARRIS, M.I.R.E., has now prepared the

**Wireless Constructor Envelopes**

The first two of this series are NOW on Sale, price 1/6 per envelope (by post 1/9).

**Envelope No. 1.—THE RADIANO THREE.** A famous loud-speaker set which you can build in an hour or two—no soldering necessary and a wide range of components to choose from.

**Envelope No. 2.—THE CONCERT FOUR.** Made of standard parts, all easily obtainable, this is a highly-sensitive, long-distance set, giving powerful reproduction of wonderful quality. Covering both long and short wave-lengths, with a switch for 3 or 4 valves, it is essentially a set to enjoy, both in building and operation.

In each envelope you will find every detail of the set simply explained; photographic reproductions and diagrams are included, as well as a full-size Blue Print.

**NOW ON SALE ————— Price 1/6**

By post 1/9, from Wireless Constructor Envelopes, The Amalgamated Press, Ltd., Bear Alley, Farringdon Street, London, E.C.4.

**FORMO**  
TRANSFORMER  
Low Frequency  
Popular Shrouded Model  
1-3 **8/6** 1-5  
Send for complete Catalogue  
THE FORMO COMPANY,  
Crown Works, Cricklewood, N.W.2.  
Phone: Hamp. 1787.

**THE CABINET FOR THE HARRIS "STEDIPOWER" L.T. UNIT**  
MR. PERCY HARRIS specifies a CAMCO Cabinet for his "Stedipower" L.T. Unit described in this issue. Price complete  
Oak 21/- Mahogany 23/-  
Post this coupon now for full details and list of Camco Cabinets  
To CARRINGTON Mfg. Co., Ltd.,  
CAMCO WORKS, SANDERSTEAD ROAD, SOUTH CROYDON.  
Telephone: Croydon 0623 (2 lines.)  
Please send me full details of the Harris "Stedipower" and other Camco Cabinets.  
NAME.....  
ADDRESS.....



## Whatever kind of set you use

... look to the valve holders. If they are Lotus, they are best for your set. They will protect your valves from shocks, prevent irritating microphonic noises, and ensure pure, clear reception. Owing to the sockets being split, they expand on inserting the valve legs, and thus grip the legs throughout the whole socket depth. The valve cannot work loose.

Whether you buy your set or make it yourself, insist on Lotus Valve Holders.

From all radio dealers at 1/6 without terminals, 1/9 with terminals.



Made by the makers of the famous Lotus Remote Controls, Lotus Vernier Coil Holder, and Lotus Jacks, Switches and Plugs.

**GARNETT, WHITELEY & CO. LTD.,**  
Lotus Works, Broadgreen Rd., Liverpool.

## OUR NEWS BULLETIN

—continued from page 276

A great many alterations and improvements have also been made lately in valve filaments for transmitting gear, which now give purer emission than hitherto.

### Radio in the Foreign Office

Not many people know that the Foreign Office have installed receiving sets for official purposes, though reception has never been really good. At first a big multi-valve set was employed, but later on a three-valve set was installed. A new aerial has just been put up, and if you pass the Foreign Office to-day you will see a 30-ft. pole sticking up over the central arch. The Foreign Office people would probably find that a "Solodyne" or even a portable set like the "Roadside" Four would serve them better for the purposes they have in mind.

Buy Britain's  
Leading Radio Weekly  
**"POPULAR WIRELESS"**  
The paper that made  
**WIRELESS POPULAR**  
On Sale Everywhere.  
Price 3d. Every Thursday.

### The German Programmes

The authorities which control the Langenberg broadcasting station have established an extensive series of studios and transmitting stations. Langenberg has no studio of its own, but it broadcasts throughout the day the programmes sent out from studios at Dusseldorf, Elberfeld, Muenster, Dortmund, or Cologne. Muenster and Cologne studios form part of transmitting stations operating on their own special wave-lengths of 250 and 283 metres respectively. Dortmund and Elberfeld were at one time transmitting stations, but latterly they have acted as studios only.

### Buying the Beam

Rumours have now been current for some weeks past in connection with the Government's alleged negotiations in secret to hand over the successful Beam wireless system to a cable combine. But these rumours are likely to prove unfounded, as it does not seem possible that the Government would relinquish control of the Beam system. The Beam

system continues to work successfully, and it is most improbable that the Government would hand it over to private owners, said an official of the Post Office recently.

### Dramatic Criticisms

The question of broadcast criticisms of London stage plays is again exercising a good deal of controversy. There have been, of course, complaints from time to time, but in the fortnightly talks on the drama, plays have been badly criticised in the hearing of millions of wireless listeners, and this has reacted unfavourably on the Box Office. Managers naturally complain that the theatres regard wireless as one of their chief competitors and no dramatic critics are invited to attend plays on behalf of the B.B.C.

### Unwanted Opinions

Some weeks ago now, theatre managers heard the dramatic critic at the B.B.C. state that there were no good actors in London, and that listeners had better go to the Moscow Art Theatre Company for a lesson in acting. Naturally this aroused the ire of the theatre people, and it does seem rather ambiguous that the B.B.C., as competitors of the theatre, should broadcast unwanted and unasked for dramatic criticisms of the London theatres.

### The "All-Wave" One

In the description of the long-wave coils for the "All-Wave" One, it was stated (p. 104, WIRELESS CONSTRUCTOR, June issue): "The tap which is taken to pin 2 is the connection common to the large winding and the aerial section." The figure was a misprint, and the statement should have read pin 4, instead of pin 2.

\*\*\*\*\*  
\* "THE POWERFUL" \*  
\* THREE " \*  
\*\*\*\*\*

SIR,—As you frequently ask readers to send you reports on sets described in the WIRELESS CONSTRUCTOR, perhaps you will be interested in the following re "The Powerful Three" described about two years ago.

For volume and clarity the set is superb. I can always be sure of at least seven or eight stations on the loud speaker. I have not had a bit of bother with it ever since I made it about eighteen months ago.

Wishing the WIRELESS CONSTRUCTOR every success.

Yours truly,

J. PICKARD.

Bradford, Yorks.



There is still time to get your copy of

# MODERN WIRELESS

Amongst many other features, it contains full details of

## THE 'INSTANTO' ONE

A quick-change-over set by Percy W. Harris, M.I.R.E.

## THE 'ELECTRIC' TWO

An All - from - the - Mains quality receiver.

## THE 'AUSTRAL' THREE

Capable of superb short-wave reception.

## THE 'SUITCASE' FOUR

A practically perfect portable

And a Special 10-page

## RADIO GRAMOPHONE

### SUPPLEMENT

Etc. Etc. Etc.

# MODERN WIRELESS

Obtainable everywhere

July Issue - Price 1/-

## WHAT'S NEW

—continued from page 256

### Philips H.T. Unit

As this issue goes to press we have received for test examples of the Philips trickle charger, Model 3002 H.T. unit, and Model 3003 H.T. and G.B. unit, all for use on A.C. mains. Time has not permitted tests to be made on all of these for report in the present number, but one of them, the Model 3002 unit, has been tested and found to be a very satisfactory instrument indeed.

It is strongly constructed in a well-finished metal container, one end carrying a removable false cover to permit access to the rectifying valve (Philips No. 506), and to the connecting point for the mains. At the other end is a strip of insulating material recessed into which is a series of sunken sockets for the insertion of the large, robust tapping plugs.

These sockets and plugs are arranged with commendable care to ensure complete elimination of the risk of shock by touching exposed metal parts, and we could only find one small point to criticise, namely, that the grub screws for gripping the leads in the plugs are rather small.

The sockets themselves are sunk to an ample depth below the surface of the insulating material, and one cannot get a shock even by trying to insert one's finger in them.

On test the unit gave an excellent performance, the absence of hum being remarkable even when very heavy currents were drawn. The voltage available was found to be generous, that on the maximum tap being in the neighbourhood of 180 volts when moderate currents were drawn, and only falling to about 150 volts at a current of 30 milliamps.

The unit will evidently run quite large sets efficiently, and represents excellent value at the price of £8 10s., complete with rectifying valve.

### New Clix Accessories

From Messrs. Lectro-Linx, Ltd., makers of the Clix products, we have received two interesting little accessories both of which should prove of value to all set-users. The first is known as "Clix-Lox," and is a combination of an adjustable wander plug and a permanent locking plug. It consists of a metal plug with a polished insulator, close examination showing that the metal portion is different in form from any existing wander plug.

(Continued on page 280.)

## THE "CONCERT FOUR"

By Percy W. Harris, Editor, 'Wireless Constructor' Components as specified.

2 Ormond 0005 mfd. with S.M. Dials, 22/-; Panel Mounting, 0001 Var. Condenser, 5/6; Utility D.P.D.T. Lever Pattern, 4/-; 2 P.P. Switches, Ormond, 2/6; Copper Screen, 8 1/2 x 6; to stand on baseboard, 2/6; 4 Lotus or W.B. Valve Holders, 7/-; 2 Coil Sticks, 2/-; 4 Transformers and Bases (cartridge type), 10/-; Neutralising (Jackson), 3/6; 2 Lissen 0003 Fixed, 2/-; 0001, 1/-; 01 Mullard (Mic), 3/-; Lissen 2 meg. 1/-; Dubilier 1 meg. and Clix, 2/9; Lissen H.F. Choke, 5/6; R.I. Varley (Type A), R.C.C. Unit (important), 20/-; Geophone 4 1/2 L.F., 20/-; Lissen or Dubilier, 2 mfd., 3/6.

List Total **£5 17 9**

**FREE with above**

21 x 7, High quality panel (drilled); Strips, 8 x 1 1/2 and 2 x 1 1/2; Pair Brackets; 12 Engraved Terminals; Wood Screws and Connecting Wire; 5-ply Baseboard, 21 x 10 1/2.

Climax Autobot Transformer, 35/-; Heavy Mains Choke, 21/-; Pot Divider, 5/-; Special Choke, H.T., 10/6; H.F. Choke, 8/6. Igranic, L.F. Choke, Type G, 27/6; Smoothing Choke, 25/-; Indragrid Dial, 7/6; Universal High Resistance, 5/6; Patent Jacks from 2/-; Ask for List No. J.546. Lissen Electrical Pick-up, the finest at the price. Without adaptor, 16/6; 15/- with adaptor.

R.I. Varley Super-Power Resistances, for Battery Eliminators, various from 500 at 50 m/a to 3,000 at 20 m/a 12/9 ohms. Each ...

Mullard Permacore L.F. Transformers. Special Winding ... 25/-

Valves, all latest stocked, D. L.E., H.F., P. 10/6 & 12/6 each; D.U.10, 15/-; Mullard S.M.A.D. 12/6; Cossor, Mullard, Ediswan, Marconi, Osram, Six-sixty, Sifam New Model Rocket Voltmeter, H.E., 4,000 ohms heavy nickel case ... 9/6 R.C.C. Units, various, Lissen, 4/-; Cosmos, 8/6 (with V.H. 10/8); Magnium 7/6; Carborundum, 8/6; Marconi, "A" 7/3, and "B" 8/6; Dubilier 7/-.

Amplion Vivavox Gramophone Pick-up, with volume control plug, adaptor, and leads 50/-

Amplion A.C.13, cone unit assembly ... 50/-

Sifam Moving Coil milliammeter 0.50 25/-

## CABINETS

Large stocks of really useful cabinets kept or made to order. Solid Oak, American type, hinged lid, baseboard. Carriage 1/6. 12 x 8 x 9 ... 10/8 14 x 8 x 9 ... 13/6 16 x 8 x 9 ... 13/11 16 x 8 x 10 ... 15/11 21 x 7 x 9 ... 16/6 Also Cabinets in stock for P.M. Nelson, de Luxe, Raleigh, Mullard 3, Cossor 3, Britain's Fav. 3, do. 2. Cheap (good), also in expensive quality.

## LISSEN

Valve Holders, 1/-; Fixed Con., 1/6; Leaks, 1/-; Switches, 1/6, 2/6; Latest 2-way Cam Vernier, 4/6; Rheostats, 2/6; B.B., 1/6; Lissenola, 13/6; L.F. Batteries, 100-v., 100-v. H.T., 12/11; 60-v., H.T., 7/11; Coils, 60 X, 6/4; 250 X, 9/9; 60-v. H.T., 7/11; 100-v. 12/11; Sifam 60-v. 13/6; Grid Bias, 1/6; 4-5, 5d.

ALWAYS IN STOCK.

## C.U.D.

Orders despatched same day as received where possible. Send ORDER with instructions and pay the Postman.

Orders for abroad or outside U.K., additional carriage and packing, insurance, etc., must be included.

## WE ARE OPEN

ALL DAY SATURDAY  
ALL DAY THURSDAY  
ALL DAY EVERY DAY  
Hours: 9 a.m. to 8 p.m.  
Sat.: 9 a.m. to 9 p.m.  
Sunday morning: 11-1.

## Quotations for

all circuits.  
PRICE LISTS FREE  
State requirements.

## MULLARD MASTER THREE

No solder—only 20 wires to connect (all ready for use).

### SPECIFIED PARTS:

2 Strips .0005 J.B. Master 3 Coils  
1 Base .00055 J.B. 4 Named Terminals  
2 Brackets 3 Valve Holders R.I. Varley L.F.  
Climax Choke Fulgin Switch D.P.A.  
A.B.C. Links Mullard .0003 2-megohm Leak  
Snade Terminals Flex and Screws 8 Plugs  
and 3 MULLARD P.M. Valves (state voltage).

**£6 17 6 Carr. 2/6 U.K.**

**FREE with above kit.**

EXTRA quality aluminium Panel, 18 x 7, drilled (surface specially frosted); 9-volt Grid Bias; 100 volt H.T. (good make), OR you can have Oak Cabinet, 18 x 7, hinged lid, American type, instead of H.T. Battery.

## COSSOR MELODY MAKER

Watmel H.F. Choke now included. **£4 10 0 kit.**

### GENUINE COMPONENTS

2 Ormond 0005; 2 Do. S.M. Dials; 6 T.C.C. Condensers, 001, 002 two 0003, 004, 2 mfd.; 2 Grid Leak Chops, B.B., 1 Var. B.B. Rheostat; 3 Grid Leaks, 25, 3, 4 Meg.; 3 Lotus V.H.; 1 Ferranti A.F.3; 2 Panel Switches; 1 Cossor Melody Wound Coil; Terminals, Name Tabs, Glazite, 9-v. Grid Bias, Waxmel, American type. CARRIAGE 1/- U.K. (EXTRA ELSEWHERE).

**FREE with kit.**

Drilled High-grade 21 x 7 Panel, with Drilled Strip, Wood Screws.

## K. RAYMOND

27 & 28a LISLE ST., LONDON, W.C.2  
Come to LEICESTER SQUARE TUBE  
This address is at the back of Daly's Theatre.  
Phones: Gerrard 4637 and 2821.

# FOR CONVENIENCE SAKE

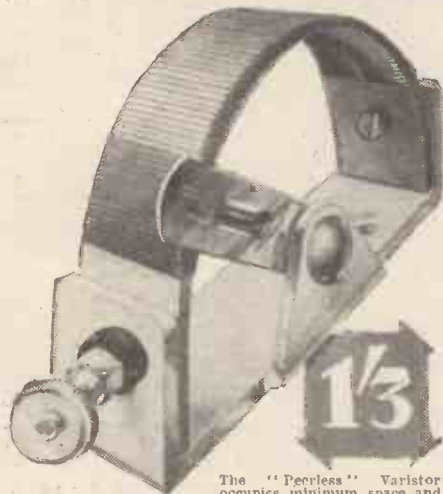

The "Peerless" Varistor occupies minimum space and stands clear of wiring.

making adjustment more convenient in every way. Best quality resistance wire is used for windings. Terminals are fitted in the most convenient position and the adjustable phosphor-bronze arm is easily accessible. Five types—5, 6, 10, 15, and 20 ohms. For efficiency and convenience use.

## PEERLESS VARISTOR

From all good dealers or—  
**BEDFORD ELECTRICAL & RADIO CO., LTD.**  
 22, Campbell Road, Bedford.  
 London: 21, Bartlett's Bldgs., Holborn Circus, E.C.4.  
 Glasgow: 113, St. Vincent Street, G.2.

### REPAIRS

Any make of L.F. Transformer, Loudspeaker or Headphones repaired and despatched within 48 HOURS—TWELVE MONTHS' GUARANTEE with each repair. 4/- Post free.

Terms to Trade.

**TRANSFORMER REPAIR CO.,**

Dept. "C."

214, High Street, Colliers Wood, London, S. W. 19.

When replying to advertisers please be sure to mention "Wireless Constructor."

## YOU WILL SAVE MONEY

by calling at

# ELECTRADIX HOUSE

for everything Radio-Electrical.

**ELECTRADIX RADIOS,**

218, Upper Thames Street, E.C.4.

Telephones: City 0191.

*Vitality in Reception!*

This depends on the correct feeding of H.T. current. The Watts Universal Test Meter, besides measuring H.T. and L.T. voltage, gives you the milliamps taken by your receiver. Simple to use, accurate and dependable. Its low price is repaid many times by its general usefulness. Full instructions supplied with each Meter.

**WET H.T. BATTERY CO.**  
 12-13 Brownlow St., High Holborn, London, W.C.1

8/6

POST FREE

8/9

## WHAT'S NEW

—continued from page 279

To use the plug one inserts the metal end in the socket of the high-tension battery or grid-bias battery, finds what kind of fit it makes, and if it is either too large or too small for the particular socket then a slight rotation of the insulator one way or the other will bring it to a size which will make a smooth fit into the battery.

The plug is again inserted and a half-turn will lock it securely. It is necessary when using Clix-Lox to read the instructions carefully, so that the fitting of the wire may be properly carried out, otherwise any attempt to adjust the plug to fit the socket may merely result in unscrewing the insulator from the metal portion.

Provided care is taken in the first fitting, the plug should give every satisfaction to those who want an adjustable or locking plug for their battery.

Another ingenious and useful component is the Clix accumulator knob, consisting simply of an insulated knob with a side hole into which a wander plug such as the locking plug just reviewed can be inserted.

If the battery leads are fitted with a couple of wander plugs the change of an accumulator can be carried out with ease and certainty even if it is dark. The knobs, which are non-corrosive and made to fit the standard accumulator thread, cost 10d. a pair and are, of course, obtainable in either red or black as required. An excellent and very useful little component.

## A Lewcos Announcement

To increase the efficiency of the service to customers, The London Electric Wire Company and Smiths, Ltd., are removing their sales, orders and accounts departments from Playhouse Yard to larger offices at Leyton. All correspondence with these departments should be addressed to Church Road, Leyton, London, E.10.

## Battery Eliminators

We have received from H. Clarke & Co. (M/cr.), Ltd., an advance copy of their new leaflet, No. 31, describing A.C. mains apparatus incorporating the Westinghouse Metal Rectifiers. In these instruments there are no valves to burn out, and copies of the descriptive leaflet may be had on application to the above firm at Atlas Works, Eastnor St., Old Trafford, Manchester.

## MORE ABOUT THE SEVEN-VALVE SUPER-HETERODYNE

—continued from page 247

sharpening process by reaction is carried too far, signals will begin to be distorted, and it is better to have a little sharpening of the frame circuit and a little of the intermediate circuit (the first being controlled by the reaction knob on the panel and the second by the potentiometer knob); rather than leaving the tuning on the frame-aerial circuit rather flat and doing all the sharpening by the potentiometer control.

## Frame-Aerial Reception

A great deal of nonsense has been written about the use of a frame aerial for obtaining selectivity (chiefly by people who are not experienced in handling one). To judge by some of the articles one reads in the non-wireless papers (and written by alleged "wireless experts"), we only receive a given station when the frame is exactly in line with that station, and one can pass from one station to the other by the simple process of turning the loop through perhaps 10 or 15 degrees.

This is sheer nonsense, for while one can get a fairly sharp minimum or zero point for a given station, very little difference in strength will be noticed when the frame is rotated through even forty-five degrees, and this very fact can often be utilised to give very considerable selectivity which would otherwise be difficult to obtain. The procedure is as follows.

## A Selectivity Tip

Let us imagine, first of all, that we are very close to a powerful station, and that the direction of the station we wish to receive is about forty-five degrees away from the interfering station. If now we set the frame exactly in line with the station we wish to receive we shall still get a very considerable "pick-up" from the interfering station, although that will be somewhat out of line with the frame.

If we now turn the frame so that it is exactly at right angles to the line joining us to the station we wish to eliminate, then we shall still be able to pick up the station we desire, although this, too, is not exactly in line with our frame. True, it will not be received quite as strongly as if we were placing our frame exactly in

(Continued on page 281.)





Complete battery as illustrated, cash price £1 6 6

## A FULL CAPACITY L.T. BATTERY THAT LASTS A LIFETIME

Every user of a two-valve set can, for a modest sum, banish for ever the bother and expense of recharging L.T. accumulators. This amazingly efficient permanent battery produces a continuous self-generated current, free from fluctuations and constant in voltage, resulting in greatly improved reception.

Mr. H. C. S. Colborne, the well-known wireless correspondent, says: "I am really very pleased indeed with the L.T. batteries sent me. I find two Cells work a 3-valve set admirably, and what really astonishes me is that there is a marked improvement in reception, for the 'background' is really quieter than when running low-voltage rates with an accumulator. In my opinion it is the best form of filament supply yet on the market for the average listener."



Write for free-leaflet describing everything you want to know about efficient L.T. supply.

The Standard Wet Battery Co. (Wet H.T. Battery Co.) (G), New Address: Head Office, Showrooms and Works, 184-186, Shaftesbury Av., W.C.1.

Stockists: Halford's Cycle Stores, Wireless Dealers, all units from Woolworths.

# STANDARD

Permanent L.T. Supply

M.B.

### The HOME for your WIRELESS SET

OUR STANDARD CABINETS

are DUSTPROOF and house the whole apparatus, leaving no parts to be interfered with. All you do is UNLOCK AND TUNE IN.

Made on mass production lines, hence the low price. Provision is made to take panel from 16" to 30" wide. Carriage paid and packed free England and Wales. Thousands supplied with full satisfaction.

**MAKERIMPORT Co.**  
Dept. 20,  
9, York Street, LIVERPOOL.

From £4 15 0. Write to-day for descriptive pamphlet and suggestions for adapting your receiver or panel in our Standard Cabinets. Immediate Delivery.

Make **The DAILY SKETCH** YOUR Picture Paper

## MORE ABOUT THE SEVEN-VALVE SUPER-HETERODYNE

—continued from page 280

line with it, but reception will be definitely better, as quite apart from the selectivity of the set itself as a factor in eliminating the undesired station, we shall have reduced the interference to practically zero.

### The Rustling Noise

Of course, normally the tuning of the set is sharp enough to eliminate an undesired station even when the station we wish to receive and the interfering station are in the same line; but the hint just given will enable readers to receive stations which differ only slightly in wavelength.

The best way of searching with this, or, for that matter, any other super-heterodyne, is to tune the frame-aerial circuit—the right-hand condenser—with one hand, starting at, say, 180 degrees, and then with the other hand to move the oscillator condenser backwards and forwards very rapidly—the potentiometer being adjusted to be fairly near the oscillation point. As we move this condenser backwards and forwards we shall hear a rustling noise as we pass a certain point.

This rustling noise, as previously stated, indicates that the set is in its most sensitive condition, and it is indeed the point which we want to find on the oscillator condenser. There will be a different position for this at every setting of the frame-aerial condenser, and it will thus be easy to keep the two condensers in proper step if we move one backwards and forwards so as to find the "breathing point."

### "Exceedingly Simple"

It is not very easy to suggest this procedure in words, but if the method is tried the reader will soon find the actual handling of the instrument to be exceedingly simple. The frame-aerial condenser can be calibrated and notes made of readings for the various stations, so that if it is desired to find a station on subsequent occasions, it is only necessary to adjust the frame-aerial condenser to the figure previously found and swing the oscillator condenser backwards and forwards to find this breathing-point or points—for there will be two for each frame-aerial setting.

(Continued on page 282.)

## Build your own Harris 'STEDIPOWER' UNIT

Something new in radio, bringing many advantages and savings to its users. Read full description of Mr. Harris's wonderful Eliminator for L.T. in the article in this issue of "Wireless Constructor."

Set of parts delivered on first payment of

# 12/6

Balance in Easy Instalments.

FOR YOUR COSSOR MELODY MAKER

## THE KEYSTONE SCREENED GRID H.F. UNIT

Increases range and selectivity. Necessitates no coil changing or alterations to set. Finished instrument complete with Valve and Royalty paid.

# £5 : 5 : 0

- Set of parts. Price of Components - - - - 49/-
  - Cabinet, Panel and Terminal Strip - - - - 17/-
  - Screened Grid Valve - - 22/6
- Free Blue Print. Send for details.

## GENUINE B.T.H. RICE - KELLOGG COIL-DRIVEN LOUD SPEAKER



Works off 6-volt Accumulator.

# 17/6

DOWN

(Balance in 11 monthly instalments of 17/6).

Write for List No. 650 which contains full details of Coil Driven Loud Speaker, Cabinets and Amplifiers.

**PETO-SCOTT Co., Ltd.**  
77, CITY ROAD, LONDON, E.C.1.

Branches at 62, HIGH HOLBORN, W.C.1 & 4, MANCHESTER STREET, LIVERPOOL.

# WHY KEEP CHANGING? FIX A HYDRA

Fit Hydra throughout your set. You will never want to change. Then receive the best reception and never go wrong.

**PRICES:**

Tested on 500 volts D.C. (working voltage 240 d.c.): 1 mfd. 2/6, 2 mfd. 3/6, 4 mfd. 5/3. Tested on 750 volts D.C. (working voltage 375 d.c.) equal to 500 volts A.C.: 1 mfd. 3/6, 2 mfd. 4/6, 4 mfd. 6/9. Inquire for prices of condensers tested at 1,000, 2,000, 4,000 and 6,000 volts D.C.

**LOUIS HOLZMAN,**  
34, Kingsway, W.C.2  
Holborn 6209

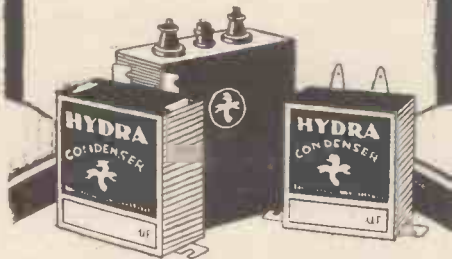

## The WHITELINE VALVE HOLDER

Mechanically and Electrically Perfect.

**Bowyer-Lowe**



## MODERNISE YOUR WIRELESS

The "RADIOLA" BUREAU

Costing no more than a Loud Speaker, quickly transforms YOUR SET into a Stately Drawing-Room Receiver.

Highest approval, Radio Press, leading experts — and over 3000 delighted clients.

FROM

£5.5.0

3 ft. high. Solid oak or mahogany. Beautifully polished



De Luxe Model

Sent ON APPROVAL in sizes for every set. Send for full particulars — FREE.

**PICKETT'S CABINETS**

W.C. WORKS, BEXLEYHEATH, KENT.

The Picture Paper with the MOST News

**:: SUNDAY GRAPHIC ::**

PLEASE MENTION "WIRELESS CONSTRUCTOR" WHEN REPLYING TO ADVERTISEMENTS.

## MORE ABOUT THE SEVEN-VALVE SUPER-HETERODYNE

—continued from page 281

The best way of adjusting the super-heterodyne for the local station is to have both condensers slightly detuned and *not* to have one accurately set for the station and the other detuned. Remember that with an enormously sensitive set loud signals from the nearby station will choke up the valves if the circuits are correctly tuned, and produce ghastly distortion. The strength of signal from the local station when both are slightly detuned will be more than enough for any living-room.

### Using Moving-coil Speakers

Readers who desire to work a moving-coil loud speaker to the best advantage from this super-heterodyne are advised to build up the push-pull amplifier described by Mr. Harry P. Wootton in this issue. It has been frequently used with this super-heterodyne to drive both a Magnavox moving-coil loud speaker and the new Rice-Kellogg £9 10s. unit, and, equally successfully, the permanent-magnet moving-coil loud speaker already described in these pages.

The reproduction on the moving-coil loud speaker of many of the continental stations when using this push-pull amplifier with the super-heterodyne has been truly remarkable and has been a revelation to visitors. At the same time, it should not be imagined that this super-heterodyne is not powerful enough to operate the ordinary loud speaker at full strength. It is merely a question of providing pure undistorted output for giving the best results with a moving-coil speaker.

### The Long Waves

Excellent results are, of course, obtained by connecting the moving-coil speaker directly to the super-heterodyne, but in this case the output valve cannot handle quite enough energy to give the pure undistorted output that is required for best production on this modern type of speaker.

Finally, it should be noted that this super-heterodyne is *not* designed to get the 5 X X—Radio Paris range of wave-lengths, as the alterations to do this, while not impossible, would have detracted considerably from the simplicity and low cost of construction, which are most valuable features.

## RADIOGRAMOPHONICS

—continued from page 245

Now, what about those amplifiers designed for large volume?

These will usually have three L.F. stages, and in most cases the last stage will have two low-impedance valves connected in parallel.

### Paralleled Valves

We can assume an average anode current of 5 milliamps for all valves excepting the two in the last stage. The paralleled valves may take anything from 30-50 milliamperes, according to the H.T. voltage, and in consequence it is hopeless to expect dry batteries to supply such a heavy current demand. In these cases accumulators or a mains unit are the only solution, and of the two there is no doubt that the mains unit is by far the more economical.

In choosing the mains unit it is as well to provide for a voltage of 200 or more if possible.

This is an easy matter with A.C. mains, but in the case of D.C. mains it is not practicable to step-up the voltage except by expensive means, and the constructor may be limited to 120 volts maximum. If very large volumes are required it may be worth while trying push-pull amplification when the H.T. voltage is limited.

## PUSH-PULL

—continued from page 260

voltage (4½ volts beyond the bias voltage), however, would now occur at the point D; which is well off the straight portion of the curve.

The resultant plate-current wave can easily be plotted by determining from Fig. 5 the plate currents corresponding to a number of voltages on the curve in Fig. 4, and plotting these on a base-line divided similarly to that in Fig. 4.

For instance, the point X on Curve 2, Fig. 4, representing a positive grid swing of 2 volts, is shown on the valve characteristic at X, which corresponds to a plate current of 4.7 milliamps.

A curve plotted in this way is shown in Fig. 6, from which it will be seen that the shape of the negative half of the wave is very much changed by the bend of the characteristic.

(Continued on page 283.)





# CONTROL

The flickering needle of the telegraph wavers... then like a live thing darts forward... the pulsing engines strain and throb... slowly the great ship gathers speed, to race on through the night... frantically the sensitive needle oscillates, then settles down... with a swirl the propellers whirl in reverse, the danger is averted... perfect control has played its part. Slowly the needle rises... 60... 70... 80... 82... then falls to 80... with uncanny purity the voice of a wonderful contralto is wafted into the room... the Browns settle back in comfort... their evening's pleasure is assured. Again control, symbolised by a Sifam Radio Meter, has played its part.



## RADIO METERS

See ad for "Detecting Distortion" free from (C) SIFAM, LTD., Bush House, Aldwych, W.C.2



SIFAM  
ELIMETER  
200-volt for  
Eliminators.  
30/-  
POCKET  
VOLTMETER  
120-volt. 4.000  
ohms Res.  
(Ill.) 9/6

**Real**

ACCUMULATOR HIRE SERVICE. H.T. OR L.T.

We lend you one of our fine wireless accumulators while we recharge yours. Or keep you continually supplied with our own fully-charged accumulators. Collection, maintenance and delivery free, anywhere within 12 miles of Charing Cross. Any voltage or capacity. Skilled service. The famous C.A.V. accumulators supplied for H.T.

Write for full particulars to-day:  
RADIO SERVICE (London) LTD.,  
105G, Torrington Avenue, Kentish Town, N.W.  
Telephone: North 0623-4-5.

**ARTCRAFT**  
RADIO CABINETS  
BRITAIN'S BEST VALUE  
New Catalogue Free  
THE ARTCRAFT COMPANY  
156, CHERRY ORCHARD ROAD, CROYDON

## PUSH-PULL

—continued from page 282

In practice, this would mean bad distortion.

Suppose, now, that we applied the same voltage wave to a push-pull stage comprising two valves each capable of handling only half the grid swing of that represented in Fig. 5.

### A Balanced Effect

Then, since each grid receives half the signal voltage, the plate current wave from each valve would be exactly similar to the distorted wave shown in Fig. 6. When one valve was giving the distorted negative half-wave, however, the other would be giving the undistorted positive half, and vice versa, as shown in Fig. 7, Curves 1 and 2, so that the total plate current half-wave in the output transformer would be given by the sum of a distorted and undistorted half-wave.

By adding the values at any instant of the Curves 1 and 2, therefore, we can get an idea of the plate current wave-form produced by the push-pull stage. This is shown by Curve 3, Fig. 7, which will be seen to be almost an exact replica of the original voltage wave in Fig. 4.

### Worth Careful Consideration

Under working conditions, of course, the valve curve would be considerably flatter than that shown in Fig. 5, but the static characteristic has been used here in order to show the effects of distortion more clearly.

It is evident from this example that, although we may replace a push-pull stage by one large valve having a similar characteristic, the former may be given a higher grid bias than the latter, and so will deal with larger inputs without serious distortion.

Finally, it may be advanced that the very extensive use of the push-pull system in America at least merits its careful consideration by experimenters who are desirous of dealing with very large volume with a minimum of distortion.

## "POPULAR WIRELESS"

is the  
WEEKLY RADIO JOURNAL  
that made

WIRELESS POPULAR

**NO SOLDERING**



One of the many outstanding advantages of the Belling-Lee terminals is that no soldering is required. The terminal is fitted with a transverse slot with clamping nut, which eliminates this tiresome task. Make your set distinctive by fitting Belling-Lee terminals. Made with 30 different engravings. Prices: Type "B"—Standard large insulated model. Polished black bakelite. 9d. each. Type "M"—As type "B" but smaller and with only the engraved top insulated. Rest nickel-plated brass. 6d. each. Type "R"—Cheap competitive insulated model with rotating name. 3 1/2d. each.

## BELLING-LEE TERMINALS

Belling & Lee, Ltd., Queensway Works, Ponders End, Middlesex.

# SIX-SIXTY CONE SPEAKER PAPER

IS BY FAR

THE BEST CONE MATERIAL

PRICES: 12" diameter 2/6 18" diameter 3/6

Ask your dealer or write us.

THE ELECTRON CO., LTD.,  
122-124, Charing Cross Road, London, W.C.2.

## FREE!

**DURING JULY AND AUGUST**

We are prepared to build and test any set desired free of charge, the customer paying only for components, accessories and royalties.

**EVERYTHING WIRELESS ON**

**EASY PAYMENT TERMS**

First Monthly Payment Secures Delivery. Call at our showrooms or send list of requirements. Best monthly terms quoted by RETURN. P.D.P. Co., Ltd., 121, Cheapside, E.C.2. Phone: City 9846.

When replying to advertisers please be sure to mention "Wireless Constructor."

**THE "RAPID" POLE FINDER (PAT. APPL. FOR)**

An Ingenious Instrument with many uses. Indispensable to all engaged in Electrical Work. For currents from 1 to 250 volts.

Send postcard to-day for descriptive list. 4/- (One-third actual size.) POST FREE

Arrow in contact with negative (-) wire of an electric circuit shows purple colour.

PATENTERS AND SOLE MANUFACTURERS:  
NEW WILSON ELECTRICAL MFG. CO., LTD.  
18, Fitzroy St., London, W.1. Museum 8974

\*\*\*\*\*  
**THE B.B.C. REPORT**  
 \* —continued from page 231 \*  
 \*\*\*\*\*

This amounts to a flagrant tax on entertainment, and we hope that Parliament will soon take notice of what is nothing more or less than a Post Office impost.

"If the contribution to the Post Office were reduced, the B.B.C. could avoid the reproach, so often levelled at it, that it underpays its artistes and talkers," says a writer in the "Evening Standard."

"There seems to be little room for economy in the administration costs, which amount to only a trifle over 6 per cent of the whole. There is, nevertheless, room for examination into the administration from another point of view.

**Too Many Cooks?**

"The B.B.C. is not technically a government department, but it is one in character and spirit, and, like all new departments, it has grown very rapidly and been staffed very lavishly. We had experience during the war of how that happened whenever a new Ministry was set up.

"My own impression of Savoy Hill is that officials there jostle one another like tadpoles in a pond, and I have heard complaints from artistes not only that they are underpaid, but that arranging for a performance takes up more of their time than the performance itself."

From our own knowledge we heartily agree with the above comments.

The Corporation states that it kept closely in touch with listeners by means of direct correspondence (it received during the year approximately 60,000 letters from them with reference to programmes), through the medium of the newspapers, and

various representative organisations. It maintained, in addition, the system of Advisory Committees, initiated by the company, both at headquarters and locally. The advice of these committees, and of representative individuals, was of considerable benefit to the Corporation in many branches of its activity, particularly in its religious, musical, and educational work.

**Alternative Programmes**

Alternative programmes, the report states, have for long been regarded as essential to the development of the service. The first step in this direction was the establishment of the Daventry Experimental Station 5 G B, which, from August, 1927, gave programmes contrasting with

**POPULAR WIRELESS**

IS THE LEADING  
 RADIO WEEKLY

Price: 3d.

EVERY THURSDAY

Daventry 5 X X, these latter being mainly derived from London 2 L O. Listeners within the service area of this station have therefore had a choice of two programmes. The addition of the new station gave an opportunity for experimental work on programmes in general.

Of over 60,000 hours' transmission the percentage of breakdown in 1927 was only '03. The stations were equipped early in the year with special devices to enable them to adhere to the frequencies, allotted under international agreement, and the listening post at Keston, Kent, was used as a checking centre for the stability of

frequencies by means of very accurate wave-meters.

The quality of transmissions improved as a result of experimental work on transformers, lines, transmitters, and amplifiers. Experimental work on acoustics gave rise to a novel method of studio construction whereby artificial echo was introduced, which considerably improved the quality of music broadcast. The new form of microphone introduced in the London studios in 1926 was put into operation for all outside broadcast work.

**Some Interesting Points**

For simultaneous broadcasting, new equipment was installed to correct the distortions introduced by land-lines, and a further repeater station was set up at Gloucester for correction, amplification and switching of programmes transmitted by telephone lines. Successful connections were made by undersea cable with Continental stations.

Other interesting points from the report are as follow:

The licences in force at the end of 1927 numbered 2,395,174, an increase of 217,000 in the twelve months.

Sixty thousand letters were received from listeners with reference to programmes, and 16,000 with reference to technical matters.

Of 802 S.O.S. messages broadcast, 340 were successful.

Four thousand schools were known to listen to the London and Daventry schools transmissions alone—double the number for the previous year.

The total revenue expenditure was £773,289 16s. 8d., of which £487,728 8s. 6d. was spent on programmes.

The income from licences was £800,959 5s., and from publications £93,686 10s. 1d.

The Sunday evening appeals on behalf of charities were known to have brought in subscriptions totalling £40,000.

**INDEX TO ADVERTISERS**

Artercraft, Co., The	Page 283
Bedford Electrical & Radio Co., Ltd.	280
Belling & Lee, Ltd.	283
Bird, Sydney S., & Sons, Ltd.	277
Bowyer-Lowe Co., Ltd.	282
Brown, S. G., Ltd.	218
Burne-Jones & Co., Ltd.	217
Carrington Manfg. Co.	277
Celestion Radio Co., Tho	276
Cossor, A. C., Ltd.	218
Dubilier Condenser Co. (1925), Ltd.	275
Eastick, J. J., & Sons	275
Electron Co., Ltd.	265 & 283

Electradix Radios	Page 280
Edison Swan Electric Co., Ltd.	263
Forno Company	275 & 277
Ferranti Ltd.	271
Gambrell Bros., Ltd.	274
Garnett Whiteley & Co., Ltd.	278
Harrods, Ltd.	273
Holzman, Louis	282
Hughes, F. A., & Co., Ltd.	269
Igranio Electric Co., Ltd.	274
Jackson Bros.	273
Lisson, Limited	261
London Elec. Wire Co., & Smith's, Ltd.	272
Makerimport Co.	281
Metro-Vick Supplies, Ltd.	Cover III
Mullard Wireless Service Co., Ltd.	Cover II
"Modern Wireless"	279
New Wilson Electrical Mfg. Co., Ltd.	283

Peto-Stott Co., Ltd.	Page 281
P. D. P. Co.	283
Pieckett's Cabinet Works	282
"Popular Wireless" and Blue Prints	273 & 275
Raymond, K.	279
Radio Service (London), Ltd.	283
R.I. & Varley, Ltd.	Cover IV
Rothermel Corporation, Ltd.	267
Sifam, Ltd.	283
Telegraph Condenser Co., Ltd.	269
Transformer Repair Co.	280
Wet H.T. Battery Co.	280 & 281
Weston Elect. Instrument Co., Ltd.	277
"Wireless Constructor" Envelopes	277

All communications concerning advertising in "Wireless Constructor" must be made to John H. Lile, Ltd., 4, Ludgate Circus, London, E.C.4. Telephone: City 7261.



**A Sigh of Relief!**

# No Batteries No Accumulators

AVOID all the annoying part of wireless by building the Met-Vick A.N.P. 4-Valve Set. Accumulators, H.T. and G.B. Batteries will then be unnecessary, as the valves can be fed with current from your domestic Electric Light Supply, both for the filaments and the plates. Cosmos A.C. Valves, which are used in this set, will work on alternating current from the domestic supply without smoothing. They have solved the problem of **Wireless Reception from the Lamp Socket.**

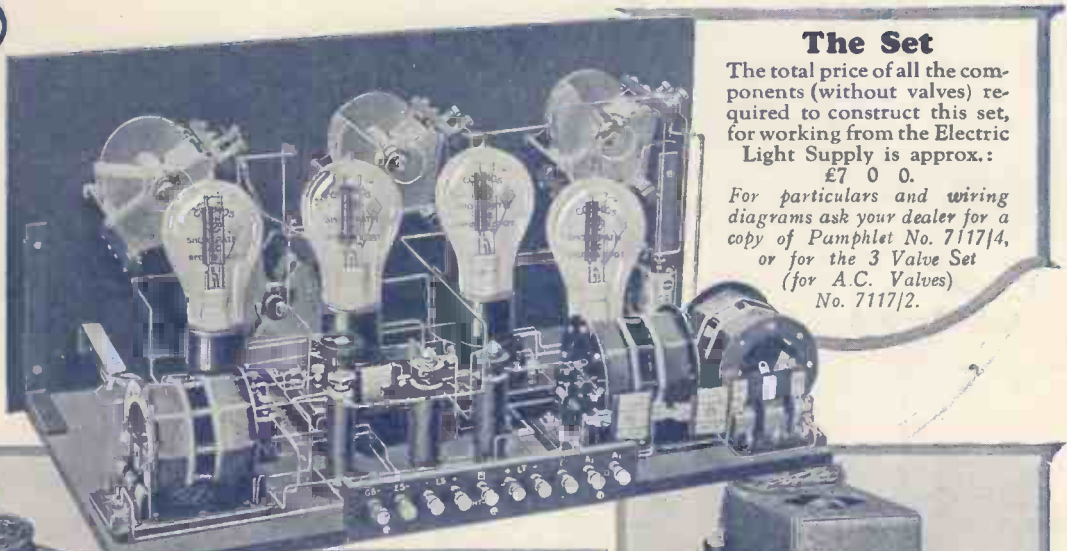

### The Set

The total price of all the components (without valves) required to construct this set, for working from the Electric Light Supply is approx.:

£7 0 0.

For particulars and wiring diagrams ask your dealer for a copy of Pamphlet No. 7117/4, or for the 3 Valve Set (for A.C. Valves) No. 7117/2.

### The Valve

"Cosmos" Shortpath A.C. Green and Red Spots 22/6 each.



### The Accumulator Substitute

"Cosmos" L.T. Eliminator for A.C. Valves—  
100 to 110 Volts } £2 10 0  
200 to 240 Volts }

This item can be made up from Component Parts. See Leaflet No. 4632. Price of Met-Vick Type 'A' Transformer and Potentiometer £1 14 0



### The H.T. Battery Substitute

"Cosmos" H.T. & G.B. Eliminator [A.C. Model] complete with Rectifying Valve 100 to 110 and 200 to 240 Volts. £11 10 0.

This item can be made up from Component Parts. See Leaflet No. 4633. Total price of Transformer Choke Coils, Resistances, Condensers, & Valve £7 0 0.

# MET-VICK

VALVES COMPONENTS & SETS

Metro-Vick Supplies Ltd., 155 Charing Cross Rd., London, W.C. 2

RP  
108

# Used by Mr Percy Harris IN HIS "STEDIPOWER" L.T. UNIT

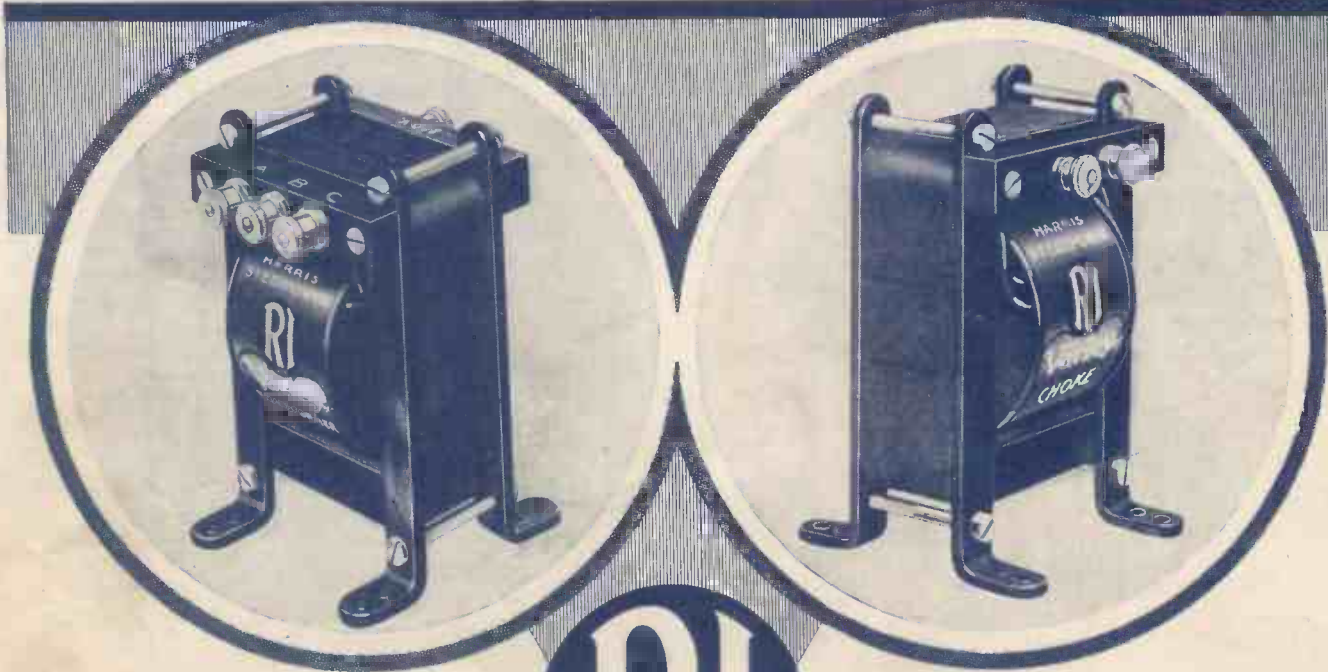

These new R.I. & Varley components have been chosen by Mr. Harris for his "Stedipower" L.T. Unit described in this issue. This is one of the finest radio achievements of modern times and Mr. Harris has used the components which ensure the best results.

Special "Stedipower" Choke  
(two chokes required) 21/- each  
Special "Stedipower" Transformer 22/6  
£3 3 0 the set of 3.



THE MARK OF BETTER RADIO



Kingsway House, 103, Kingsway, London, W.C.2.

Telephone: Holborn 5303.