

# The Wireless Constructor

**6<sup>D</sup>**  
MONTHLY

EDITED BY  
PERCY W. HARRIS, M.I.R.E.

Vol. II No. 2 DECEMBER 1925

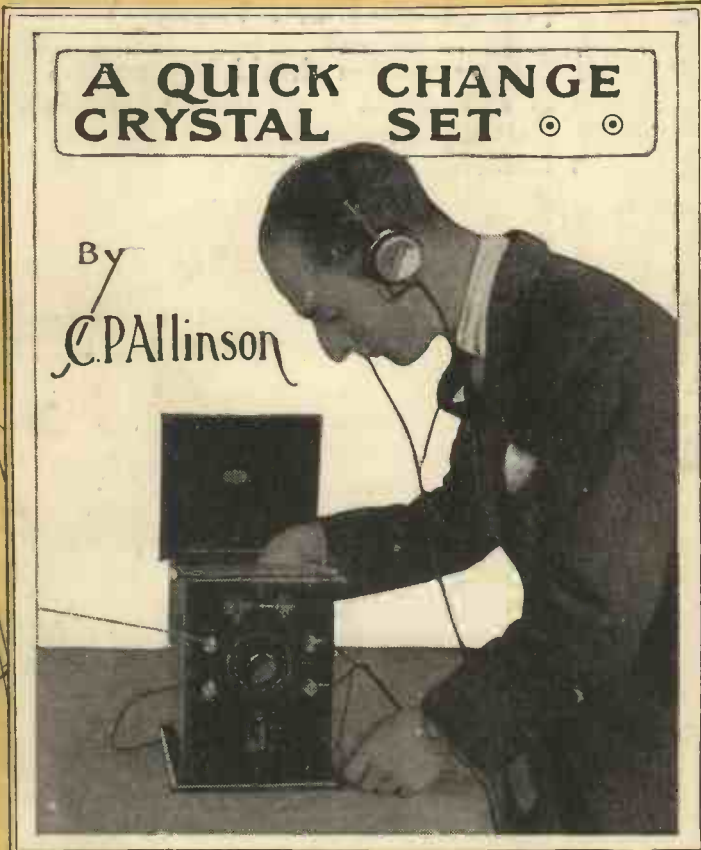

## Special Features :

**"My Own" Local Receiver—A Powerful 3-Valve and Crystal Set**

By Percy W. Harris, M.I.R.E.

**An Interesting Single Valve Receiver**

By A. S. Clark

**Adding Note-Magnifiers to the Low-Loss Crystal Set**

By G. P. Kendall, B.Sc.

**What to do with One Valve and a Crystal**

By Stanley G. Rattee, M.I.R.E.

**Fading—Its Causes and Mysteries**

By J. H. Reyner,  
B.Sc. (Hons.), A.C.G.I., D.I.C.



**FREE BLUEPRINT INSIDE**

# Every Tuesday

**2<sup>D</sup>**  
WEEKLY



## “WIRELESS” (The One-Word Weekly)

is just the paper you should buy to keep you in close touch every week with the latest news, views and developments in this fascinating pastime.

Every issue has much of interest for those desiring to build their own sets. There are also many other well illustrated articles contributed by technical experts and well-known writers, among whom are the following:

Lieut.-Commander the Hon. J. M. KENWORTHY, R.N., M.P.; JOHN SCOTT-TAGGART, F.Inst., P., A.M.I.E.E.; Capt. P. P. ECKERSLEY (Chief Engineer to the B.B.C.); WILLIAM LE QUEUX (the well-known Novelist); Major JAMES ROBINSON, D.Sc., Ph.D., F.Inst.P. (Director of Research and Chief Engineer to Radio Press, Ltd.); Earl RUSSELL; Capt. H. J. ROUND, (Chief of Research Dept., Marconi Co.); Capt. WEST (of the B.B.C. Research Dept.); and The Editor, PERCY W. HARRIS, M.I.R.E.

**EVERY TUESDAY A SPLENDID  
NEW ISSUE IS ON SALE**

Make sure you buy a copy regularly  
You, like thousands of others, will not only be satisfied,  
you will be delighted!



Obtainable from all Newsagents and Booksellers. If any difficulty in obtaining locally, send P.O. 13/- to Dept. W., Radio Press, Ltd., Bush House, Strand, London, W.C.2, and copies will be posted you every week for a year



*The*  
**WIRELESS CONSTRUCTOR**

— Edited by Percy W. Harris —

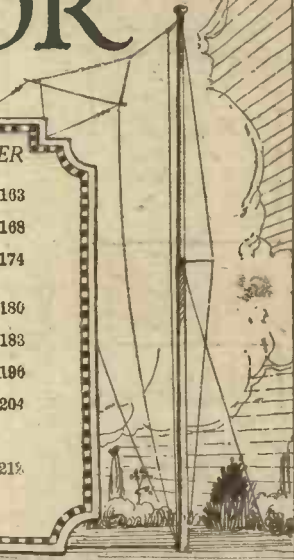
Vol. 11 No. 2	CONTENTS		DECEMBER
"My Own" Local Receiver .. 123 By PERCY W. HARRIS, M.I.R.E.	Broadcast Composers .. .. 103 By "CARRIER-WAVE."	103	
Fading—Its Causes and Mysteries .. 128 By J. H. REYNER, B.Sc., A.C.G.I., D.I.C.	Wood or Ebonite? .. .. 108 By A. V. D. HORT, B.A.	108	
A Quick-Change Crystal Set .. 131 By C. P. ALLINSON.	Are Long Waves Doomed? .. 174 By Major JAMES ROBINSON, D.Sc., Ph.D., F.Inst.P.	174	
Valves and How to Treat Them .. 134	A Wireless Medical Service .. 180 By SYDNEY WILDMAN.	180	
A Wireless Wanderer in Spain (continued) .. 137 By Capt. L. F. PLUGGS, B.Sc., F.R.Ae.S., F.R.Met.S.	Oscillation Control .. .. 183 Adding Note-Magnifiers to the Low-Loss Crystal Set .. 196	183	
More Practical Workshop Hints .. 153	How to Choose Components .. 204 By D. J. S. HART, B.Sc.	204	
An Interesting Single-Valve Receiver .. 157 By A. S. CLARK.	What to Do with One Valve and a Crystal .. 212 By STANLEY G. RATTEE, M.I.R.E.	212	

# The ROYAL Super Transformer is the ONLY Transformer which carries a **2 YEARS GUARANTEE**

## A SOUND INVESTMENT

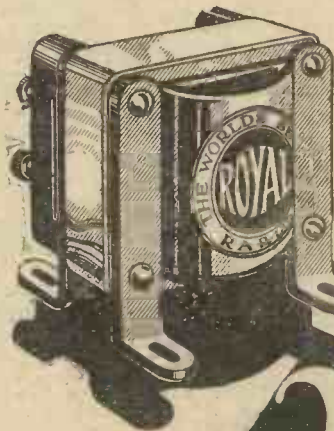

When you equip your set with Royal Super L.F. Transformers, you are assured of perfect reception, faithful reproduction of speech and music and, moreover, are given an unconditional guarantee for 2 years.

We shall be pleased for readers of Radio Press Journals to try out one or two Royals on the understanding that, if results are not satisfactory or better, we will refund purchase price in full.

STANDS ALONE FOR PURE TONE

This Transformer carries an unconditional guarantee for **2 YEARS** if defective during that period return to **ROTHERMEL RADIO CORPORATION** 24-26, MADDUX ST., LONDON, W.1.

**ROTHERMEL RADIO CORPORATION OF GREAT BRITAIN, LIMITED.**

24-26, MADDUX ST., REGENT ST., LONDON, W.1.  
Phone: Mayfair 578 & 579. Grams: "Rothermel, Wesdo, London."

20/-  
EACH



# Accumulator troubles are over!

With the introduction of the Sterling "Super Invicta" Battery it is no longer absolutely necessary to use accumulators for heating the filaments of radio receiving valves. This is a boon for those to whom the frequent recharging of accumulators presents difficulties. A further great advantage is, that the "Super Invicta" will continue to function satisfactorily even after an indefinite period of inactivity.

The "Super Invicta" is primarily intended for use with D.E.R. and D.E.3 type valves. It is

calculated that two "Super Invicta" cells will operate, for approximately ten months, a two-valve set employing D.E.R. valves and used for two hours daily, without further attention than the addition of water to the cells to counter any evaporation.

With D.E.3 valves the "Super Invicta" may be said to last indefinitely subject to replacement of water. The usual careful handling of these valves is necessary, however, in order that dethoriation may not occur.

## STERLING SUPER INVICTA BATTERY



# 30%

The "Super Invicta" Cell illustrated has an approximate capacity of 500 ampere hours when discharged at the rate of 1 ampere for 8 hours continuously per day. Its initial voltage is 1.4. It can be easily cleaned and recharged when necessary, and it will then be ready for a further period of service.

PRICE, per Cell 30/-

Announcement of  
**THE MARCONIPHONE COMPANY, LIMITED**  
 Registered Office: Marconi House, Strand, London, W.C.2  
 and 210-212, Tottenham Court Road, W.1  
 Sole Agents for THE STERLING TELEPHONE & ELECTRIC CO., LTD.

*Director of Research :*  
 Major JAMES ROBINSON,  
 D.Sc., Ph.D., F.Inst.P.  
*Scientific Adviser :*  
 Prof. G. W. O. HOWE,  
 D.Sc., M.I.E.E.  
*Advisory Editors :*  
 Professor  
 R. WHIDDINGTON,  
 M.A., D.Sc., F.R.S.  
 Prof. C. L. FORTESCUE,  
 M.A., M.I.E.E.

# The WIRELESS CONSTRUCTOR

*Staff Editors :*  
 E. H. CHAPMAN, M.A.,  
 D.Sc.  
 A. D. COWPER, M.Sc.  
 R. W. HALLOWS, M.A.  
 G. P. KENDALL, B.Sc.  
 A. JOHNSON-RANDALL,  
 STANLEY G. RATTEE,  
 M.I.R.E.  
 J. H. REYNER, B.Sc.,  
 A.C.G.I., D.I.C.

Vol. II. DECEMBER, 1925 No. 2.

## MY OWN LOCAL RECEIVER

By PERCY W. HARRIS, M.I.R.E., Editor

*Tastes differ, and one man's requirements are not those of another. This set is particularly designed to give loud-speaker reproduction of the greatest purity from the local station up to distances of 10 to 15 miles. It is also characterised by a great selectivity and simplicity of operation*

"WHAT can't you build me a set?" said my wife one day. "Something we can keep in the dining room and turn on and off when we want to without doing any damage!" There must be thousands of wireless enthusiasts who receive similar requests from time to time, for however much we ourselves enjoy listening to distant stations and grappling with the many problems of wireless reception, the non-technical members of the household are generally interested only in the local station. They want, in fact, the highest quality reproduction from the local station with "one knob control." The apparatus, furthermore, must be good looking, dustproof, foolproof, and without unsightly trailing wires. The instrument I am to describe this month covers, I think, all the aforementioned requirements, and possesses certain virtues in addition.

### Special Features

When completely closed the finished instrument resembles a small oak cupboard. When the front doors are open we see a



The handsome oak cabinet is provided with doors which completely enclose the set.

mahoganite panel carrying three knobs. The lowest of the three tunes the instrument, and once the best position has been found this knob need not be touched until such time as the local station changes its wavelength (not a very

frequent occurrence), or until it is desired to listen to Daventry instead of the local programme. Immediately above the tuning dial is the knob of the filament resistance, which controls the filament current of all three valves. This knob acts as an "on and off" switch, and over-running the valves is prevented by a small device I will subsequently describe. The third knob, which is situated immediately above the filament resistance knob, can be termed the "volume control." Turning it clockwise reduces the volume of sound and anti-clockwise increases it (within limits). Strength can thus be regulated without touching the tuning.

### After Tuning

Once tuned, the apparatus is brought into operation merely by turning the filament resistance knob as far as it will go, the wavelength adjustment and the volume control being ignored. The circuit, as shown in Fig. 1, consists of a



sharp-tuning circuit, across which is placed a crystal detector, this being followed by three resistance-coupled note magnifying valves.

**Valves to Use**

The receiver is primarily designed for the type of valve using .25 ampere filament current. The first two valves should be of the type designed for resistance capacity

Two .01  $\mu$ F fixed condensers, type 610 (Dubilier Condenser Co.).

Two .25 megohm gridleaks (L. McMichael Ltd.).

Three antivibration valve holders (Burne-Jones & Co., Ltd.).

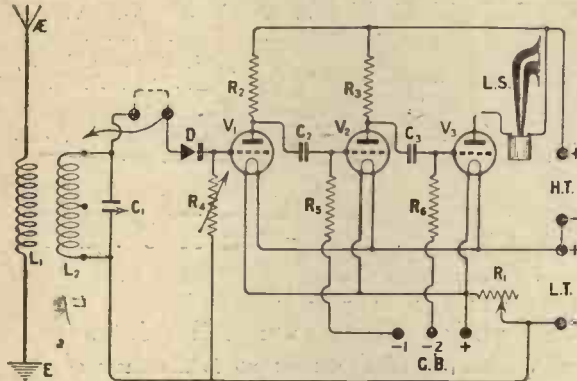
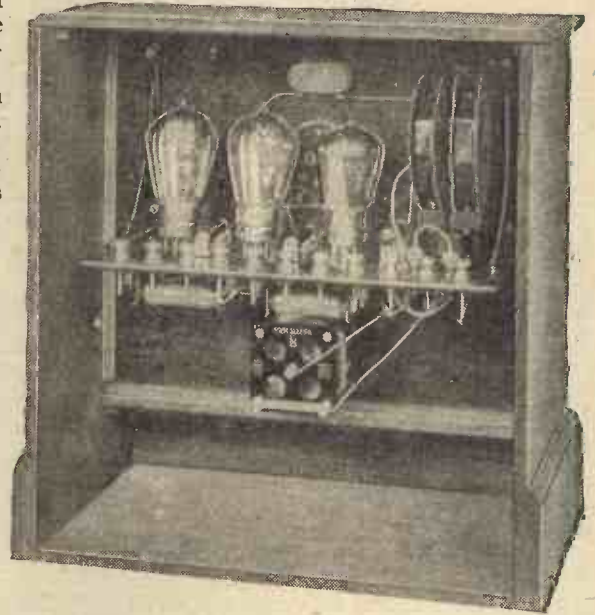

Fig. 1.—The circuit diagram.



The cabinet has a sliding back, which is here removed to show the interior arrangements.

amplification. The following are suitable: D.F.A.4, D.E.5B.

In the last socket any good valve of the D.F.A.1, D.E.5 or B.4 type should be used. If it is desired to run the set from dry cells, then the first two valves can be D.E.3B., and the last a D.E.3, D.F.A.3, B.5, or other similar type.

Three of the 1/4 ampere valves, or three of the .06 ampere dull emitters mentioned will run satisfactorily on the one filament resistance, but if the use of bright emitters is desired, three separate filament resistances should be used. The best results, however, will be obtained by using the valves mentioned.

**Components**

Below is a list of the components used in the instrument illustrated. In many cases different makes of components could be substituted without loss of efficiency but, following the usual Radio Press practice, the actual components used are named.

Ebonite panel, 14" x 12", Radion Mahoganite (American Hard Rubber Co., Ltd.)

Ebonite panel, 12" x 5 1/2", Radion Mahoganite (American Hard Rubber Co., Ltd.)

Cabinet to take 14" x 12" panel (Carrington Manufacturing Co.).

One .0005  $\mu$ F "Four square" variable condenser (Bowyer-Lowe & Co.).

Two 100,000 ohm resistances, with bases (Dubilier Condenser Co.).

Two panel brackets (Burne-Jones & Co., Ltd.).

One Transadapta (Gambrell Bros., Ltd.).

One "P.M." permanent detector (Radio Instruments, Ltd.).

One dual rheostat (Burndept Wireless, Ltd.).

One Bradleyohm resistance, 10,000-100,000 ohms (Rothermel).

Two Clix plugs and sockets (Autoveyors, Ltd.).

Eleven 4-B.A. terminals.

Radio Press panel transfers.

Glazite connecting wire.

**Constructional Work**

The front panel is of standard size, and can be purchased ready cut. The sub-panel supporting most of the components you can

cut yourself, or obtain ready cut from your dealer. The constructional work has been purposely made as simple as possible, and it will be found that practically everything is mounted on the sub-panel, with the wiring points so arranged that leads between them are very short. The free blueprint with this issue will show you just how to wire up the sub-panel, and when you have mounted the volume-control, filament resistance and variable condenser on the front panel, it is a very simple matter to join them up. In attaching the sub-panel to the front panel, I would suggest that first of all you wire up the sub-panel, next attach to it the brackets, and, finally, mark the holes for the

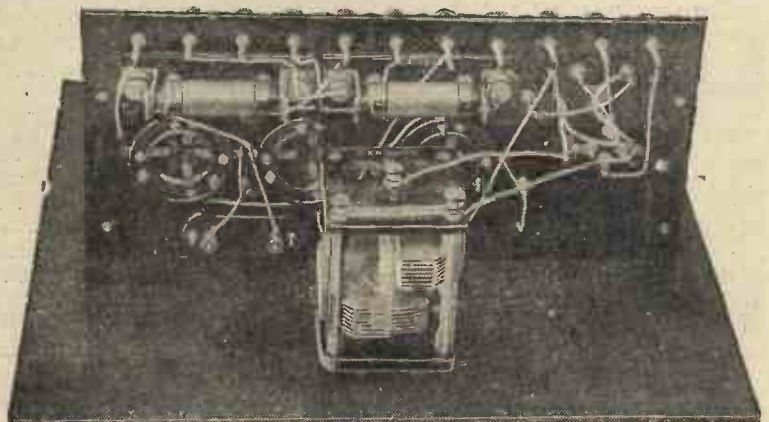

This photograph shows the underside of the shelf, and should be consulted in conjunction with the free blueprint.

securing screws on the front panel by using the brackets themselves as templates.

Notice that a flexible lead is soldered to one side of the detector. I will explain how this is used a little later. The special valve sockets and several other parts are mounted beneath the sub-panel.

**Operating the Circuit**

As soon as you have finished the set and placed the panel in the cabinet, short-circuit the grid-bias terminals by connecting all three together (this is a temporary expedient for a preliminary test), turn the filament resistance to the "off" position, connect up a 6-volt accumulator if you are using the quarter-ampere valves, or a 4-volt accumulator if you are using the .06-ampere valves. A high-tension battery should also be joined to the terminals marked. To get the best results with this set, you should use about 100 to 120 volts, for resistance amplifiers need a higher voltage than transformer amplifiers. Do not imagine, however, that the set will not function with a lower voltage—a 60-volt high-tension battery will give quite good results, but you will get much greater volume by using the voltage mentioned. Join up aerial, earth and loud-speaker.

**The Coils**

Now place the three valves in the sockets and turn the filament resistance knob almost all the way round for the quarter-ampere valves, or about half or three-quarters of the way through the fine wire portion for the .06-ampere valves. If the valves light satisfactorily, turn the filament

resistance to the "off" position again, place a small coil in the right-hand socket of the Trans-adapta (looking from the back)—a Gambrell "a" or "A," or in the numbered coils a 25 or 35 will do. In the left-hand socket I would suggest that you use a Gambrell C coil with centre tapping. This is a special coil that Messrs. Gambrell's have made at my suggestion, and which I am using in a number of special circuits.

It is not essential to this receiver, but it will give a great increase in selectivity if joined up in the way I am about to mention. If you use it, join the flexible lead to the screw terminal of the centre tapping, and leave the two Clix sockets open. The effect of this will be to place the crystal across only half the winding, an arrangement which proves very effective in this receiver.

**How to Tune In**

Now switch on the valves. You will probably hear nothing whatever with the loud-speaker, and may wonder whether the set is functioning. Carefully turn the tuning dial (first making sure that the volume control screw is turned in an anti-clockwise direction as far as possible), and you will suddenly find the local station.

The tuning is so exceedingly sharp that you are liable to miss it if you turn the knob quickly. Once you have tuned the local station, make sure that your crystal detector is properly set to give the best results, and if signals are too loud, turn the volume control switch inwards until the sound is reduced to the volume you desire.

**A Safety Device for the Valves**

Next experiment to find the best position of the filament resistance knob (burn the valves no brighter than will give good signals), and when this is found, disconnect the batteries (leaving the filament resistance knob in its best position), take out the valves and drill a small hole in the filament resistance boss just in advance of the arm. Into this insert a peg, which will prevent the arm rotating further. After

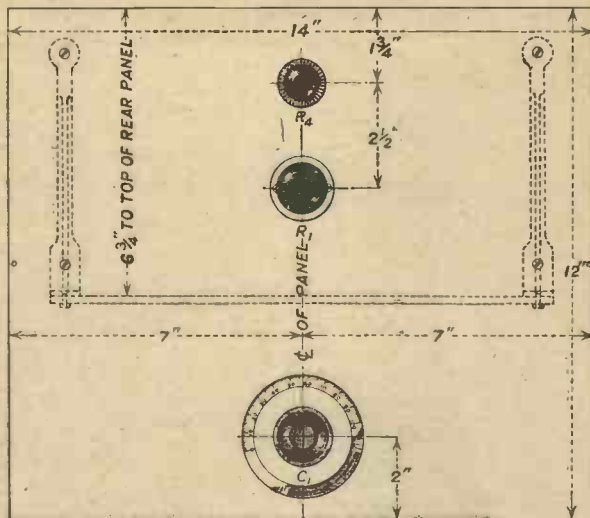

Fig. 2.—The front panel components are very simply arranged.

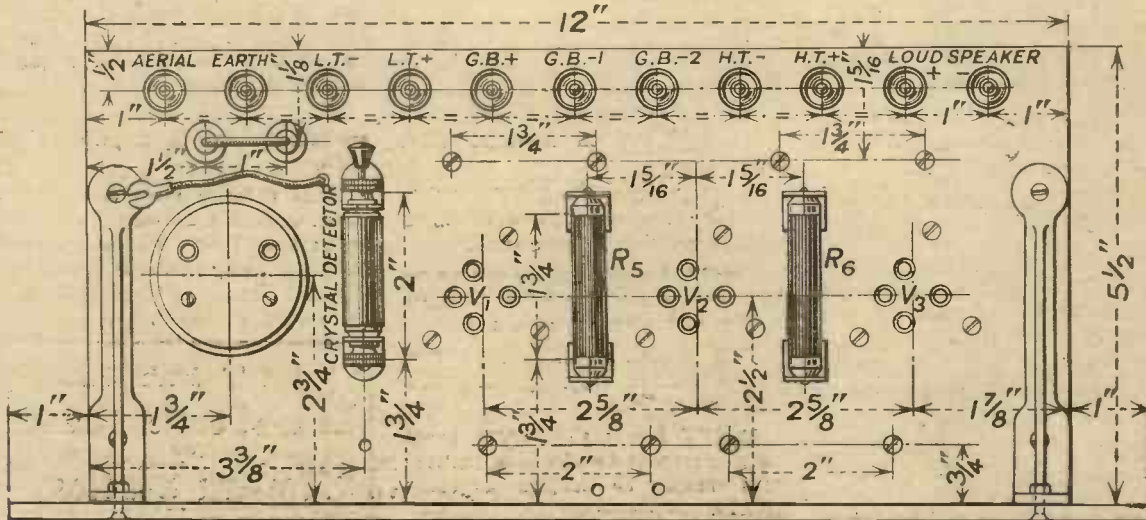
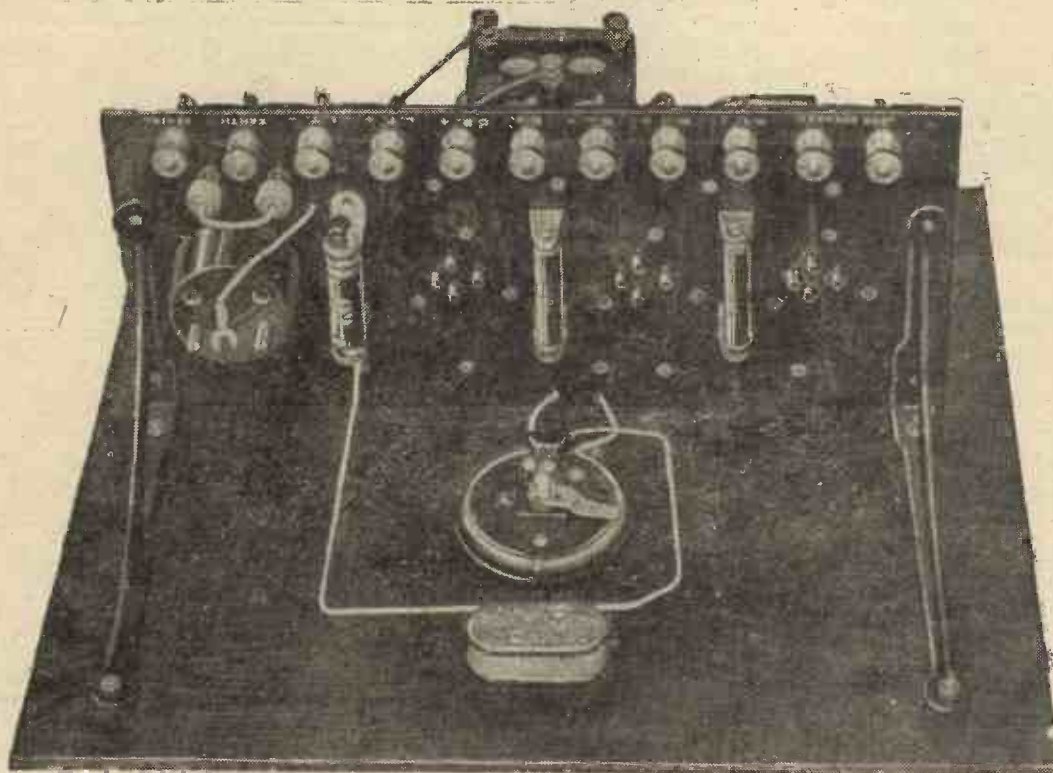

Fig. 3.—The lay-out of the shelf-panel. The free blueprint shows the wiring. R5 and R6 are the .25 megohm leaks.



This photograph shows the upper side of the shelf. Note the Clix plugs on the left, and the spade connector resting on the Transadapta.

this is done, you will not be able to turn the knob too far. You can now replace the valves and batteries and use the set for listening. I am sure you will appreciate the fine quality and purity of repro-

duction. If you are not using the special tapped coil, leave the flexible lead free and join the two Clix sockets with a link made of two Clix and a wire. A No. 75 coil can then be used in place of the tap-

ped coil. For Daventry, follow the same procedure, using a 100 coil in the right-hand socket (at back), and a 250 in the left-hand socket, the Clix sockets being joined together.

## Don'ts for Valve Users

DON'T overrun your valve, especially if it is a dull emitter.

DON'T employ a higher anode voltage than that for which the type of valve is designed.

DON'T forget that a power valve is advisable for good loud-speaker work.

DON'T throw de-sensitised dull emitters away, as sensitivity may frequently be restored.

DON'T forget that dull emitters can be used as bright emitters if sensitivity has been lost.

DON'T keep tapping your valve with your finger.

DON'T, if you want satisfaction, use a rather microphonic dull emitter as detector without a special valve-holder.

DON'T forget to clean valve-legs occasionally.

DON'T ignore the advantage to be obtained from separate H.T. tappings.

DON'T forget to use the valve specially designed to work in a certain position in the circuit.

DON'T forget that an old valve will make a useful weather forecast instrument. (See next issue.)

DON'T omit to use valves of low inter-electrode capacity for ultra short-wave work.

DON'T forget that valve bases may be removed and special mountings made to reduce capacity effects.

DON'T buy unnamed cheap valves if good results and economy are desired.

DON'T forget that many small receiving valves will function satisfactorily in small power transmission.

DON'T forget that valves can be run in series to limit the current consumption, where it is desired to use dry batteries for filament heating purposes.

DON'T pull valves out of their sockets by taking a grip on the bulb.

DON'T leave your valves lying about when not in use. Pack them up in their original containers and put them away in a safe place.

E. H. B.

DON'T MISS THE  
Xmas Double Number  
OF  
"Modern Wireless"  
OUT ON DEC. 1st  
Price - - - 1/6



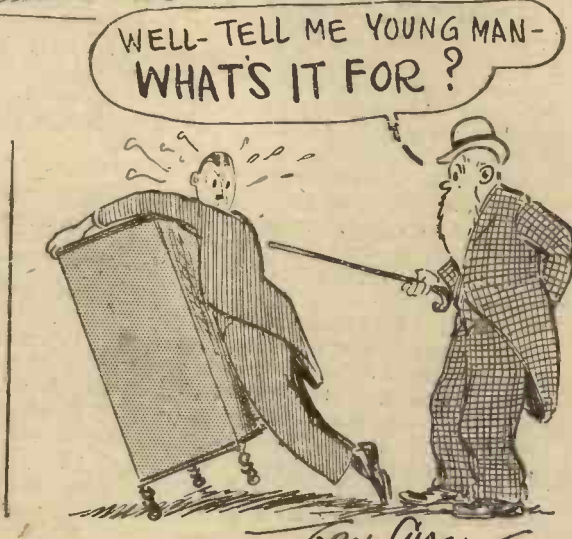
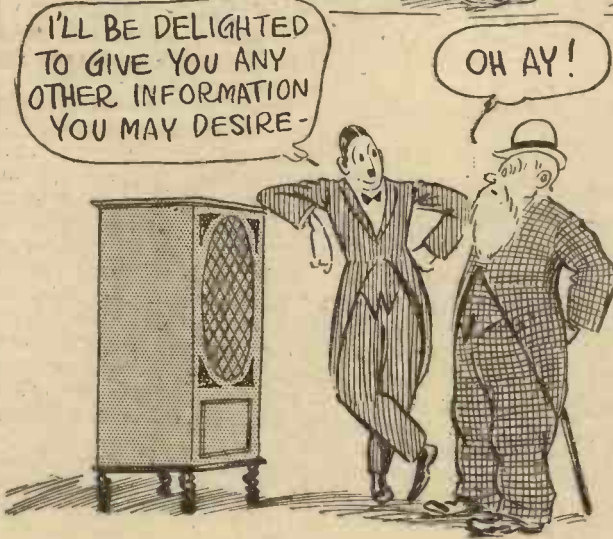
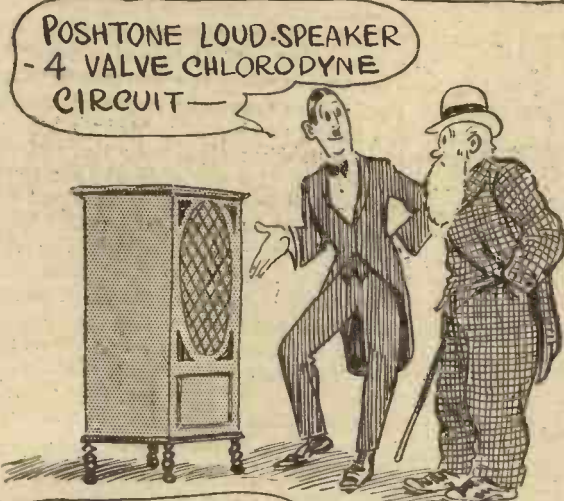
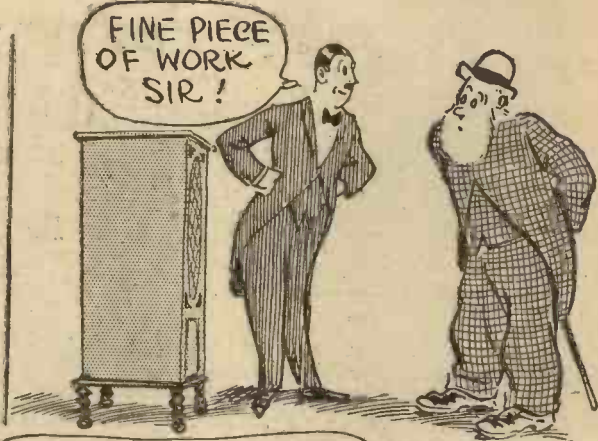
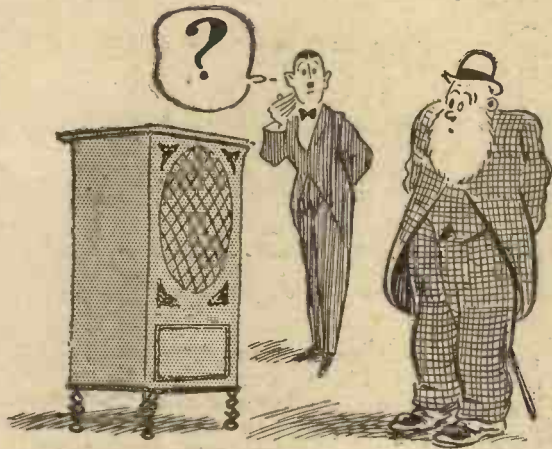

GEN SHAW

= WHAT SOME OF OUR POOR WIRELESS SALESMEN HAVE TO PUT UP WITH.



## Fading—Its Causes and Unexplained Mysteries

By J. H. REYNER, B.Sc. (Hons.),  
A.C.G.I., D.I.C., Staff Editor

ANY enthusiastic amateur who has listened to comparatively distant signals will have observed the baffling and sometimes somewhat annoying phenomenon of fading. Perhaps the signal strength when the station is tuned in is remarkably good and every word can clearly be understood. A short while afterwards the signal strength gradually decreases until it is perhaps impossible to distinguish a single word or even to distinguish what is happening. In extreme cases the signal strength may absolutely vanish and no trace of the station can be heard at all. Then, without any alteration to the adjustment of the receiver whatever, the signal strength will gradually commence to increase again until within a comparatively short time the signals are once again at their maximum value, as they were when the station was first tuned in.

### A Puzzling Phenomenon

If a station is tuned in and left, it will be found that this fading is rhythmic in its action. That is to say, the interval between the points of maximum signal strength is approximately the same in each case, and the signal strength will continue to wax and wane in this more or less periodic manner. It is only comparatively recently that any reasonable explanation has been forthcoming to account for these peculiarities. In the first place, fading is only noticed over comparatively long distances, that is to say, distances of about 50 miles or more, and this actually set the investigators on the track of the true explanation.

Prof. Appleton appears to have put forward the most satisfactory theory, which was developed in a paper presented before the British Association this year. Prof. Appleton and Mr. Barnett, at Cambridge University, have been experimenting for some time upon the fading which they obtained of the signals from 2L.O. They thought the matter out and worked upon a certain theory, on which they would expect to obtain certain results. It turned out that the results they obtained agreed with the theoretical expectations and they are therefore fairly confident that their explanation of the phenomenon of fading is correct.

### Two Waves at the Receiving Point

The explanation of the whole matter appears to lie in the fact that the receiver picks up the energy from two directions. There is, first of all, the direct wave

which travels from the transmitter, along the surface of the ground to the receiver. There is also, however, a second wave, which is radiated at the transmitting point away from the earth at an angle. This wave travels outwards until at some distance above the earth it encounters an electrified layer of gas known as the Heaviside layer. Now, wireless waves will not pass through a conductor, and as this electrified layer of gas is partially conducting, the waves cannot pass through it. They are in consequence bent round and caused to return to the earth again. (Fig. 1.)

The problem is somewhat similar to the reflection of light from a mirror. If a ray of light falls upon a mirror at an angle it will be reflected at an equal angle and so deviated from its original path. In a similar way the wireless waves reaching the upper atmosphere are reflected down to the earth again. At any particular point, therefore, provided there is some considerable distance from the transmitting point, there will be the two waves, one of which has arrived directly, travelling over the surface of the earth, and the other arriving at an angle by reflection from some layer of electrified gas in the upper atmosphere.

### Interference

Now, the fading can be shown to be due to interference between the two sets of waves.

The wave which arrives along the surface of the earth is more or less regular in character, but the wave which arrives by reflection from the upper atmosphere is subjected to a certain

twisting when it is reflected. It is not easy to explain exactly what happens without complicated theoretical discursions. Fortunately, however, it is easy to give a very simple mechanical analogy which will convey a fairly lucid idea of what is happening. The method I propose to describe is a development of my original pendulum experiments described in *THE WIRELESS CONSTRUCTOR*, Vol. I, No. 11.

We need for this experiment three pendulums, one to represent the receiver, the other two to represent the two waves arriving at the receiving spot. These three pendulums must be suspended from a triatic across the room as in the previous experiments. In this case, however, the triatic takes the form of a "Y." The point is illustrated in Fig. 2. A length A-B of stout cotton is stretched across between two convenient points in the room. At some point in the middle of this triatic a second length of cotton is connected, the other end of which is fixed to the wall

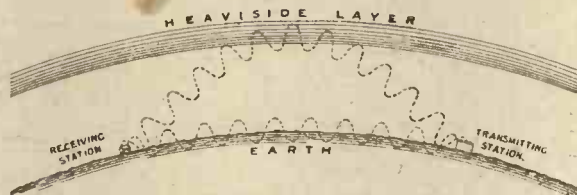

Fig. 1.—The wireless waves reach the receiving station in two ways.

in such a manner as to make an angle of about 45 deg. with the first cotton. At the junction of these two triatics, the point *C* in Fig. 2, one of the pendulums is attached.

The several pendulums are made up by cutting off lengths of cotton, about 3 ft. long, having fairly heavy weights attached at the bottom extremities. I myself used ordinary sewing cotton with 1½ oz. weights on the end. The triatics should not be stretched too tightly, but should be arranged so as to give about 2 in. without undue strain when pulled aside with the finger.

One pendulum, therefore, is attached at the meeting point of the two triatics. The other two pendulums are measured off equal in length, and are attached at points along the other triatics about four or five feet away from the meeting point where the first pendulum is attached. As in all these pendulum experiments, it is essential to have the lengths exactly the same within one-quarter of an inch or so, so that the times of swing are the same. This, of course, corresponds to the process of tuning in a wireless receiver.

#### Performing the Experiment

Now set all three pendulums at rest, then start *a* swinging (see Fig. 2) with an ordinary backward and forward motion at right angles to the triatic on which it is suspended. The pendulum *b* should then be set in swinging with a circular motion. That is to say, instead of pulling it aside and releasing it, it should be given a slightly circular movement in releasing it, which will cause it to swing round and round instead of simply to and fro. This motion will very rapidly degenerate into a to-and-fro swinging motion in a plane which is continually rotating.

Now these two pendulums represent fairly accurately the condition of affairs which we have in a wireless receiver at some distance from a transmitting point. The first pendulum represents the direct wave coming across the surface of the earth in which the vibrations are all in the same plane. The second pendulum represents the wave which is reflected from the Heaviside layer, and in which the vibrations are not consistently in one plane, but take place in a large number of different planes with a sort of rotating movement.

#### An Interesting Analogy

The effect of these two pendulums upon the third pendulum *c*, will be seen to be exactly similar to the effect on a wireless receiver. The pendulum *c* will shortly commence to swing and will build up to a comparatively large amplitude. After this the size of the swings will begin to decrease again until shortly the pendulum comes to rest. After this it will once again commence to swing and will continue in this manner, alternately building up to a maximum and then coming to rest again. This corresponds to the condition of affairs in a wireless receiver, where the signal strength builds up to a maximum, and then periodically dies away almost to nothing. This peculiar effect is due to interaction, which takes place between the impulses set up by the two pendulums. The impulses set up

by the first pendulum are all in the same plane, although alternatively backwards and forwards. The impulses produced by the second pendulum, however, are not in the same plane, but, as has been seen, occur first in one direction and then in a slightly different direction, and so on round the circle with a rotating motion. The combined effects of all these is that at times the two sets of impulses assist each other, and cause the third pendulum, representing the receiver, to build up to a good strong oscillation, whereas, at other times, the two impulses cancel each other out, and the effect on the third pendulum is nothing.

#### Minor Adjustments

The experiment is a very pretty one if properly conducted. It will be found to require a little trial before it can be made to work perfectly. There are one or two minor points which make a fair amount of difference. The distance of the two pendulums *a* and *b* from the centre of the "Y" should be approximately equal.

Another point is that the distance from the centre point should not be too small, as otherwise one pendulum may tend to exercise an undue effect. I have found a distance of between four and five feet quite satisfactory. Another important point is that the tension on the triatics must not be too great, or else the experiment will not work at all. Should any difficulty be experienced, therefore, the effect of loosening the tension on the cottons may be tried. A very convenient method of adjustment is to make the connection at the point *C* between the two lengths of cotton in the form of a slip-knot or suitable form of running knot, so that the point at which the second triatic joins the first will be varied. It will be found that as this point is moved

one way or the other so the tension on all three cottons is either increased or decreased, and a point can very soon be found at which the experiment works very well.

#### How are we to Overcome Fading?

To return now to the electrical problem, we see that fading is caused by interference between the two waves radiated from the transmitter. Prof. Appleton and Mr. Barnett have conducted experiments which show that the angle at which the reflected wave was arriving at Cambridge was about 60° on the transmission from 2L.O. From this and certain other observations which they made they were able to obtain some very valuable information concerning the Heaviside layer, which is responsible for this reflected wave.

It is certainly rather difficult to see, in view of this explanation, how we are to overcome fading. It is not as if the fading was due to any permanent tilting of the wireless wave, for in such a case as that we could overcome the effect of the fading by tilting our aerial to correspond. The effect, however, as we have seen, is due to an interaction between two sets of waves, and no arrangement of the aerial will overcome this effect. When we get to considerably greater distances than 100 or 200 miles we have further peculiar effects occurring, which I may refer to in future articles. I hope, however, that this simple experiment will help readers to understand the phenomenon of fading.

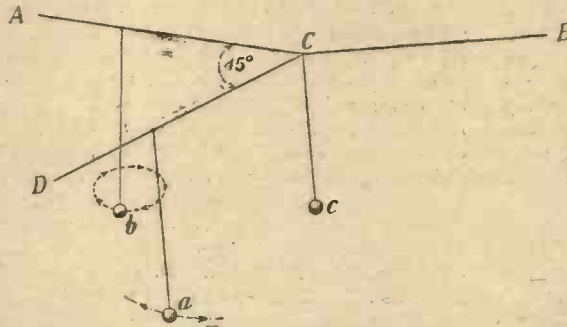
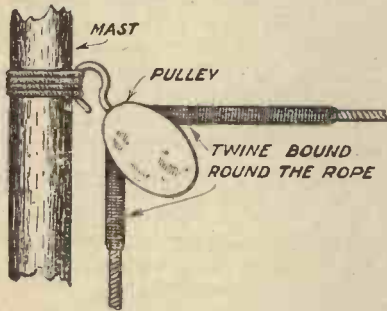

Fig. 2.—This shows clearly how the experiment is carried out.



## Protecting Aerial Halliards from Wear and Weather

ONE of the minor worries which beset the owner of an outdoor aerial is the maintenance of his rope halliards in good condition. The combined effects of rain and frost tend to break the fibres of which the rope is composed. Rain makes the fibres swell and shorten, making the rope taut, and putting a great strain on it if initially it happened to be hauled up tightly. The obvious remedy for the latter occurrence is to leave a few inches of slack when hoisting the aerial to its position on the mast, but this will not, of course, mitigate the rotting effect of the rain. The



Thin twine will prevent wear at the pulley.

effect of frost on a wet rope is to cause the moisture which has soaked into it to freeze, and so burst the fibres and greatly weaken the rope.

### How to Treat the Rope

Prevention is better than cure, and if water can be prevented from getting into the rope the latter will be far less liable to rot and give way in windy weather. Probably the best waterproofing substance is liquid tar—that strong smelling black treacly liquid beloved by sailors of the old type. Tar can be obtained quite cheaply, and a gallon or half-gallon can will suffice to treat many ropes of the kind used for aerial halliards. The rope should be placed in a can and covered with the tar, a lid being placed on the top to exclude rain.

After soaking for at least a week in the tar the rope should be removed, the tar adhering to it being well rubbed in with a pad of old rags held in the hand. Needless to say, an old suit, old gloves and well-soaped hands are necessary preliminaries to the operation.

### Advantages Gained

After "rubbing in" the rope should be stretched out between two posts, and allowed to dry in the open air for a week, when it should again be well rubbed to remove excess tar. The rope will now be practically rot-proof, and, in addition, the tar will act as a lubricant, and reduce friction, and consequent wear at the pulleys, cleats, etc. If liquid tar cannot be obtained, creosote or some kind of heavy viscous oil will prove to be fairly good substitutes. Ropes treated as above should last quite twice as long as untreated ropes.

### Protection from Wear

A rope frequently gives way at the portion which passes through the pulley. It can be protected against wear at that point by binding it round with strong twine, sewing on a "sleeve" of sail canvas, or in some similar way covering the section at which wear is likely to

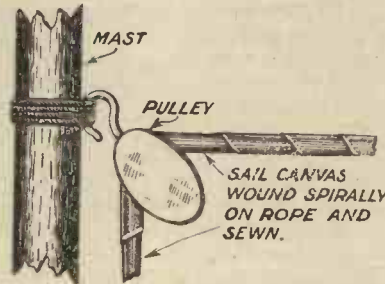

Protection is also afforded by a canvas "sleeve."

occur. The protective covering should be well tarred after it has been put on, and will then last much longer.

The above simple precautions will enable you to get long and trouble-free service from any ropes you may use in your aerial system.  
P. H. W.

## Fixing Variable Condenser Dials

THE engraved dials of many types of variable condensers are nowadays secured on the spindle by means of a grub screw in the knob. It not infrequently happens that, even when the grub screw is turned hard up against the spindle, the dial is still capable of turning independently of the spindle. This movement usually occurs when the moving vanes of the condenser reach the full maximum or minimum position, and it is very annoying to note dial readings for stations received and then to find that the dial has turned on the spindle and rendered them useless.

A simple remedy for this trouble is to file a small "flat" on the spindle at the point where the grub screw is to press on it. First, set the dial in the desired position on the spindle and screw the grub screw hard down. Turn it back again till the dial can be removed, when a small mark will be found on the spindle where the grub screw has pressed on it. With a small file make a narrow nick in the spindle at this point. When the dial is replaced, the point of the grub screw will bed into this nick, and it will be impossible for the dial to turn on the spindle.

A. V. D. H.

## The Simple All-Enclosed Receiver

SIR,—I have just constructed the "simple all-enclosed local or Daventry crystal receiver," described by F. English in the September issue of THE WIRELESS CONSTRUCTOR, and these are the results: I receive Newcastle (very good), Daventry (about the same) and Birmingham.

I am roughly 200 miles away from Daventry, and I think it seems rather a record for a crystal set. I have made several crystal sets described in THE WIRELESS CONSTRUCTOR, but this one seems to be the best of the lot. I consider I get a good sixpennyworth of wireless information from THE WIRELESS CONSTRUCTOR every month and wish your paper every success.

Yours faithfully,

RICHARD H. SHEARS.

West Hartlepool,  
Co Durham.

# A QUICK CHANGE CRYSTAL SET

By C.P. Allinson

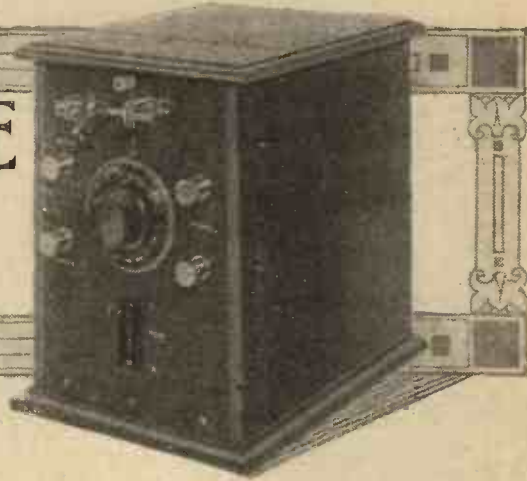

## A Multi-Crystal Receiver for the Local Station and Daventry

THE crystal receiver has many advantages which appeal to a large number of enthusiasts. Even the wireless enthusiast who possesses a multi-valve set is sure to have a crystal receiver with which he may receive local broadcasting. In one respect especially the crystal receiver stands pre-eminent, that is in the quality of reproduction which it gives. Especially when listening-in to music, such a set will enable the listener to distinguish the most delicate shades of light and tone, and pick out the various individual instruments without the slightest difficulty.

Another point which recommends it to many wireless enthusiasts is the fact that it costs nothing to run. There is no need to supply it with current from an accumulator, which therefore has to be re-charged periodically, nor is there any need to supply it with a high-tension battery. Furthermore, it is simple to handle, there are no difficult tuning controls, and the reception of broadcasting is merely a matter of adjusting one dial.

### A Multi-Crystal Device

There are very few listeners who are not within range of both the high-power station at Daventry and a local B.B.C. transmission, so that in order that they may have the choice of either of two programmes, two separate coils are incorporated in this receiver, by which either programme may be listened to. The change from one to the other is effected by a simple switch.

There are many opinions as to what are the best crystals to use, and in order that the listener may experiment for himself in this direction the crystal receiver which has been fitted to this set is of the type which allows different crystals

to be used by a very simple operation. If desired, further, a combination of two crystals may be used instead of the more usual cat-whisker and crystal arrangement. It is therefore an easy matter to make experiments comparing the selectivity and sensitivity of various forms of crystal detector, and decide for oneself just which arrangement it is that one prefers.

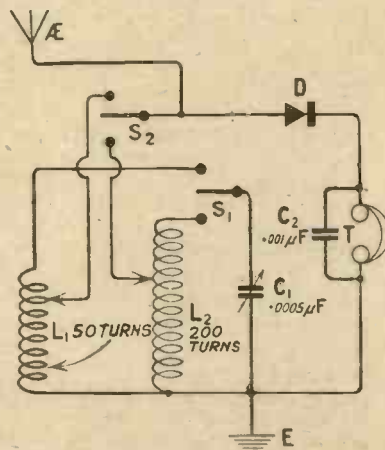

Fig. 1.—The circuit used.

### Circuit Novelties

The circuit diagram shown in Fig. 1 shows a further novel feature which has been incorporated in this receiver. This is the use of both auto-coupling and the proportional crystal tap together. In order to simplify the adjustment and operation of this receiver, the two taps have been combined, the aerial and crystal being connected to the same one. A double-pole, double-throw switch connects the variable condenser either across  $L_1$  or  $L_2$ , according to whether the local B.B.C. station or the high-power station is required, and at the same time it transfers the aerial

and crystal lead from the tap on the one coil to the tap on the other.

It will be seen from the photograph of this receiver that it presents a neat and symmetrical appearance. On the one side are two terminals for connecting to aerial and earth, and on the other are two to which the 'phones may be attached. The crystal detector is conveniently placed for adjustment, and the switch shown at the bottom of the panel is that which transfers the various connections from the short wave to the long wave coil. The whole receiver is contained in a handsome cabinet, and will not look out of place in any surroundings.

An examination of one of the photographs of the inside of the receiver shows that home-made coils have been employed. These present no difficulty at all to make, as they have been wound more or less on the hank principle, the whole operation not taking more than a quarter of an hour for the two coils.

### What You Will Need

The following components and materials will be required to build this set, and for the benefit of those who wish to duplicate the receiver exactly, we give the names of the actual components used. It is understood, of course, that other components will be perfectly suitable, as long as these are of good quality. You will need:—

One ebonite panel, 9 in. by 6 in. by  $\frac{1}{4}$  in. (Paragon).

One cabinet to fit this, with loose baseboard  $8\frac{1}{2}$  in. deep (Camco).

One  $0.0005 \mu\text{F}$ . variable condenser. (The one used is a Newey 4-point.)

One crystal detector, unmounted (Service Radio Co.).

One double-pole, double-throw switch, lever type (Utility).

- One 001 $\mu$ F. fixed condenser and mounting (McMichael).
- Two spring clips (Burndept).
- Four large acqured terminals.
- Half-pound gauge 18 d.c.c. copper wire.
- Quarter-pound gauge 24 d.c.c. copper wire.
- Quantity of square tinned wire and two short lengths of flex for connections.
- One set Radio Press panel transfers.

**Construction**

The construction of this receiver should present no difficulties at all, and the first step to be undertaken is the construction of the two coils. Coil  $L_1$ , which is the short-wave coil, consists of 50 turns of the gauge 18 copper wire, wound on a glass tumbler of about 2½ in. diameter, windings being taken at the 25th, 30th and 35th turns. The turns are wound on jumble fashion, and when slipped off are held together by means of a short length of string bound round it.

$L_2$ , the long-wave coil for Daventry, is wound on a cardboard former with a diameter of 2½ in. The 200 turns of gauge 24 wire are wound, more or less, in four sections, each being wound hank fashion close together. The windings are taken at the 50th, 100th and 150th turns.

The next step is to mount the components on the panel and, provided that guaranteed ebonite is used, the holes for mounting these may be drilled right away. Should there be any doubt, however, as to the surface insulation of the ebonite,

it should be carefully rubbed down on both sides with No. 0 glasspaper before mounting the components. The positions for these are given in the panel layout in Fig. 2; and the only point that is likely to present any difficulty is the cutting

cheese-head screws, soldering lugs being used for the connections. The small crystal cup which is used instead of the catwhisker when a double crystal detector is employed is mounted on the panel by means of a 6 B.A. screw, so that it is always at hand when required, and there is, therefore, little risk of its being lost when not in use.

**The Baseboard**

Next mount the panel on the baseboard, and having done this, the two coils and the fixed condenser may be affixed thereto. The method of mounting the coils is clearly shown in the photograph, but in order further to make it plain for the benefit of those who have not had great experience in the construction of receivers, an enlarged sketch giving the details is shown in Fig. 3. The short-wave coil, it will be noted, is fixed to the baseboard by means of a short length of ebonite, which has two holes drilled in it, one at each end. Two screws pass through this into the baseboard, and thus fix the coil firmly to it. The long-wave coil is placed on end, and a piece of screwed 2 B.A. rod is fixed tightly into a hole made in the baseboard. A short strip of ebonite, with a 2 B.A. clearance hole drilled in the centre, is then dropped over the rod, and a washer and lock-nut screwed down so as to fix the coil firmly into the baseboard.

**Wiring-Up**

The wiring-up of this receiver will be an easy matter, all the connections being shown in the

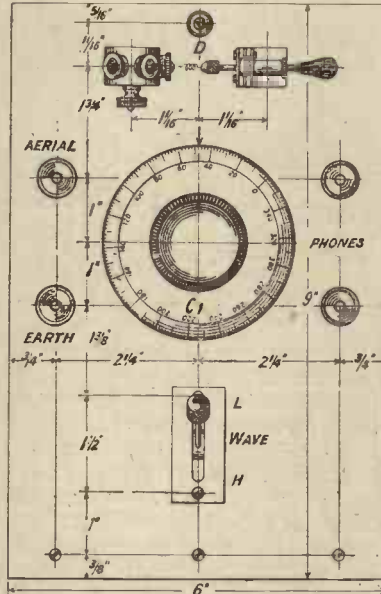
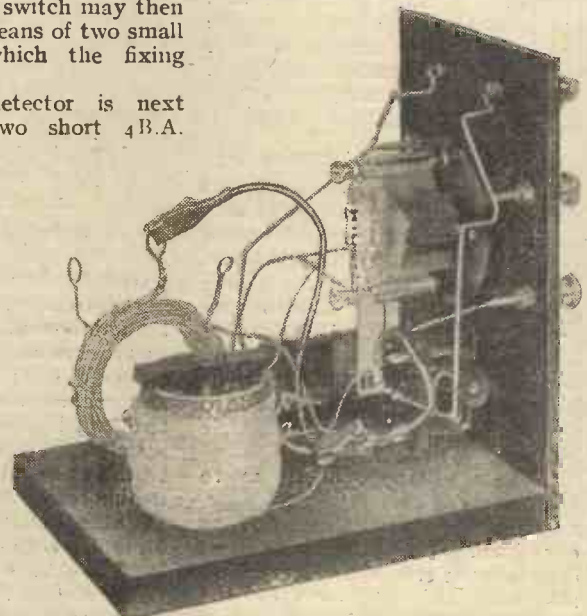
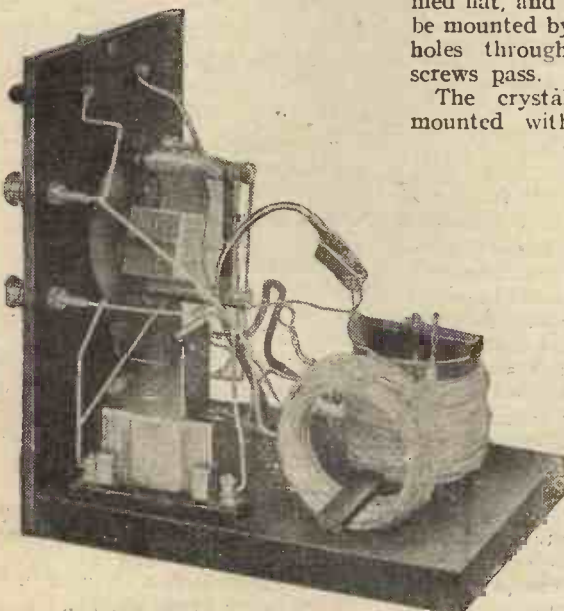

Fig. 2.—The panel lay-out is very simple and neat.

of the slot through which the lever of the wavelength switch works. This may easily be done, however, if the back of the panel be marked out with exact dimensions of the slot required. A number of 3/16 in. holes are then drilled and run together with a small file; the sides of the slot are then filed flat, and the switch may then be mounted by means of two small holes through which the fixing screws pass.

The crystal detector is next mounted with two short 4 B.A.



These two photographs clearly show how the components are arranged on the panel and baseboard.

wiring diagram in Fig. 4. A hot, well-tinned soldering iron should be used, and only a minimum of flux, for if too much flux is employed it will splutter and possibly spoil the insulation of the panel. Should any difficulty be experienced in tinning the ends of the flex leads which are connected to the switch and the spring clips they should be cleaned with a little glasspaper first, after which it will be found that they will take the solder quite easily.

**Operation**

There is probably no receiver so simple to operate as the crystal receiver, and the testing-out of this set should present no difficulties. The aerial and earth leads are connected to their respective terminals and the telephones are connected to the receiver. The wavelength switch is placed in the low or high position according to which station is most easily within range, and the aerial and crystal taps may be taken first to the centre of the inductance. A suitable crystal is placed in one of the cups of the revolving drum, a catwhisker fixed in the chuck, and the crystal detector adjusted in the usual manner. The dial of the tuning condenser is then slowly revolved from minimum to maximum, and if the station is not heard the crystal contact should be re-adjusted and the procedure with the condenser repeated. Once having tuned the station in to its loudest on the condenser the crystal detector may now be adjusted again until the best signals are heard.

Now try the effect of adjusting the aerial-crystal clip to another of the taps, after which, of course, it will be necessary to re-tune on

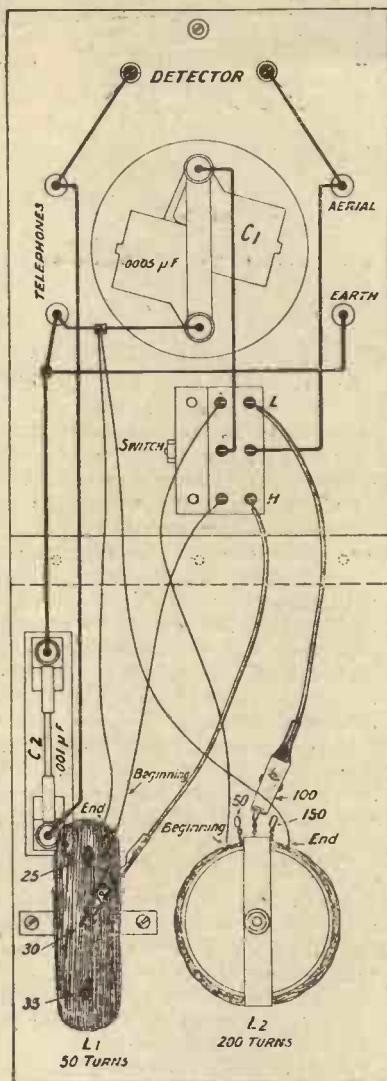

Fig. 4.—The wiring diagram. Note the switch connections.

the condenser. Once having determined which of the taps gives the loudest signals, the clip may be left fixed to it.

Having adjusted the receiver on the louder transmission, we may next try and receive the weaker one. Change over the wavelength switch, put the clip which goes to the tap of the other inductance on the centre tap, and if the crystal detector has been set at its most sensitive adjustment and the station is within range, it should now be heard by slowly turning the condenser dial.

**Interference**

Should the listener live within two or three

miles of one of the main broadcast stations, he may have difficulty in receiving the high power station at Daventry if he is at all distant from it, without the use of a wavetrap to cut out his local station. This occurred in the writer's case, and an ordinary type of wavetrap was connected, as shown in Fig. 5. The procedure in adjusting this wavetrap is as follows: Place the trap tuning condenser at zero degrees, and tune in the local station which you are wishing to get rid of as loudly as possible on the receiver. Next turn the trap condenser till a spot is found at which the local station becomes inaudible. You can now change over to the distant station and receive it without interference, provided, of course, that it is within your range.

**Results Obtained**

When tested upon a very small aerial within three miles of 2LO, this station was received uncomfortably loud in the headphones. With this aerial, which was only 20 ft. long, 2LO was received loudest with the clip connected to the 35-turn tapping. Tested with a wavemeter the tuning range was approximately from 300-600 metres.

On switching over to the long wave coils, it was found that as previously stated, interference from 2LO made its reception impossible. However, as soon as the wavetrap had been connected in circuit, London was completely eliminated, and the high power transmission received, certainly not very strongly but at reasonable strength in the headphones.



Fig. 3. This sketch shows how the tapped coils are made.

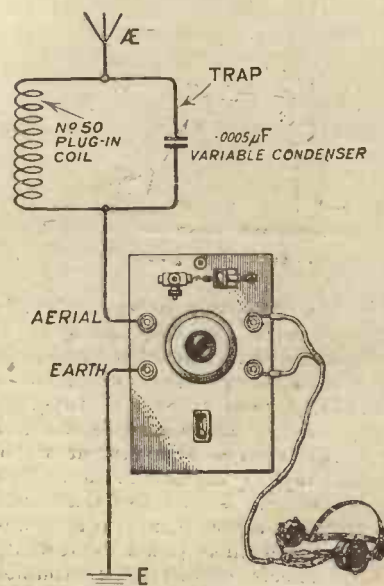

Fig. 5.—How to connect up the wavetrap mentioned

# Valves—and How to Treat Them

By AN IRRESPONSIBLE EXPERT

*Are you bringing up your valves properly? If not, train them in the way suggested by the Expert—but don't blame US!*

WHAT everybody seems to want to know is how valves can be made to last longer. There are several ways of doing this, one of the most certain being not to use them upon the wireless set, but to employ them tastefully as ornaments for the decoration of the wireless den. Another excellent scheme is to cut down your filament voltage to only half the rated amount. It has been amply proved by various famous writers, including myself, that if you raise the voltage to ten per cent. above the normal you cut down the life of your valve to little more than half what it ought to be. It follows that if you cut down the voltage to fifty per cent. below the normal you will lengthen the life of your valve twenty or thirty times. The fact that you hear little in the way of signals has to be faced, but this is relatively unimportant.

### Don't Coddle Them

On the whole, I think the majority of valves are terribly fragile things simply because they are coddled from their youth upwards. If you insist upon little



.....give it a good yank.....

Willie's always wearing his thickest vest when the weather is at all cool the child will suffer incessantly from a leaky nose; on the other hand, if you allow him to please himself, in which case he will probably never wear a vest at all, he will rapidly become immune from colds. It is just the same with valves. If you pamper the things, you spoil their power of resisting the effects of any little troubles, such as a fall downstairs or an accidental meal from the high tension instead of the low-tension

battery, and similar misadventures. To coddle a valve is to soften its constitution, and everyone knows that soft valves are short-lived. The reason in a few simple words is that where there is softness there also will positive ions be made when electrons go barging about. Some genius whose name is a household word, though for the life of me I cannot remember it at the moment, once stated that in size a positive ion is to an electron as St. Paul's Cathedral is to a pigeon. Just put yourself in the place of a filament, and think what it means to have several million St. Paul's Cathedrals biffing into you every second!

### Spartan Treatment

No, valves, if they are to last, must be hardened from the very beginning by Spartan treatment. Let them see from the moment that you first open the elegant boxes in which they are housed that you mean to stand no nonsense whatever. Wrench the valve out of its box, put it not too gently upon the table and allow it to roll about whilst you connect up the rest of the apparatus. When you are ready, stick it into a holder and let things rip with the rheostat. The valve will probably howl as a protest. Take not the least notice. One must often be cruel to be kind. By adopting the suggestion that I have just made you can frequently turn a dull emitter into a bright, and every expert is agreed that bright emitters are much the more constant of the two. When you remove the valve from its socket do not grasp it by the metal part as the pamperers recommend, seize it by the glass only and give a good yank. This will help you to discover any weakness in the attachment between the bulb and the thingmejig at the very outset. And then you can write to the makers the letter which they are so fond of receiving:

Dear Sirs,

*I am returning one of your valves*

*which I purchased yesterday. On removing the valve from its box I noticed that the cap was loose. I have used your valves for the last ten years and I am sure that you will not like me to adopt another make. Will you please replace the defective valve by return of post?*

*Yours faithfully,*

*S. Cronger.*

You may give them to understand, if you like, that yours is an outside in valve sets and that your annual consumption of valves is something considerable. Do not mention that it is a single-valver and that you took to wireless only a fortnight ago. That would not be tactful. Nor is it tactful to return defective valves to the same firm more than twice in the same week.

### Replacements

When carrying valves home after purchasing them it is most unwise to place them in the coat-tail pocket. Quite apart from the fact that the softest valve feels hard, for a fraction of a second at any rate, when you sit on it, there are few valves that are really up to



.....when you sit on it.....

weight. Talking of pockets, an excellent way of replacing a burnt-out valve free of charge is to place it in a top waistcoat pocket and then to go to see a friend who is simply brimming over with rude health and wants all the world to know it. We all have friends of this kind. You may be quite certain, if you lead the conversation carefully round to physical training and fitness, looking rather flabby yourself as you do so, that he will presently punch you playfully in



the ribs. If he gets you on the wrong side the first time, you must go on keeping the conversation on the same points until presently he lets out with the other hand and does the bulb in. The smile dies from his face as he hears the tinkle of glass. He does not know quite what the damage is, but he realises by that and by the pained look that you have assumed that he is for it. With a rueful glance, you pull from your pocket—it is best to keep your gloves on in anticipation of this moment—the mangled remains and gaze upon them sorrowfully. "My dear chap," says the Kruschen friend, "I am so sorry. I had no idea. . . . Quite unintentional, I assure you. . . . I hope that it was not a valuable valve?" I refuse to give any hints as regards the line that you should now take. I will only say that I generally come away either with his best dull emitter or his promise that he will order me a new valve, at his expense of course, and send it round on the next day. This is the best way of repairing a burnt-out filament that I know. One must, of course, be careful not to make use of the same friend on more than one occasion, and it is just as well to find out, as you can by leading the conversation round to regrettable minor accidents, that nobody else has been before you.

**Foiled!**

My friend Goosby, for example, had a very trying experience the other night when he was seeking to effect a valve repair in this way. Running over in his mind the list of suitable friends and acquaint-



..lets out with the other hand..

ances, he selected Slobbsmith, who lives on patent foods with curious names and takes on every health and strength course that comes out. After dinner, Goosby strolled round to see Slobbsmith, having carefully placed the damaged valve in his upper left-hand waistcoat pocket. Slobbsmith was quite glad to see him because he had just taken up wireless and wanted some advice. Goosby gave some excellent advice and tried for all he was worth to turn the talk into channels suited to his purpose. "How do you keep so wonderfully fit?" he

asked. "Oh, just by doing things," replied Slobbsmith. "But, tell me, what is the best value for the gridleak?" A little later in the evening, Goosby was giving Slobbsmith a lesson in tuning. "Turn that knob very gently with the right hand," he instructed, placing his own hand upon Slobbsmith's bulging biceps. "My word, what muscles you have! I wish I could be as fit as you are. Do tell me." "My dear chap," cried Slobbsmith, turning round so as to face Goosby, "it is as simple as A B C. You are not healthy because your chest is flat." Goosby became hopeful. Slobbsmith doubled his fist. Goosby became still more hopeful. The strong man's hand shot out, but it struck no blow. Instead, the fingers fumbled for a second in the top left-hand pocket of Goosby's waistcoat and withdrew the valve. Sighing a little, Slobbsmith held it up to the light, examined it carefully and then replaced it in the pocket. "I thought so," he said, wearily. "Gobblesfield came round at tea time and talked about physical fitness and pushed his mangy chest at me until I hit it. Then he produced a broken valve and I had to stump up a Fisher and a half-crown. Just before dinner Pottle blew in and led me on in the same way. Instead of hitting him on the chest, I ran my hand over its contours and felt the valve that was waiting for me. And now there is you." Goosby talked quite a lot about coincidences and the extraordinarily low standard of morality some people possessed and mentioned that it had been a habit in his family ever since the time of his great-great-grandfather to wear a dud valve in the top left-hand waistcoat pocket in order to ward off rheumatism. But this availed nothing at all, and when Slobbsmith had given a demonstration of his physical fitness by kicking him down the five front-door steps into the street, he realised that he must be very much more careful in future.

**An Alternative Method**

Another way of having your valves repaired when they have suffered is to send them to the repairers. These people are so skilled nowadays that they can repair a valve if there is anything left of it at all. Putting in a new filament is a very simple job to the up-to-date repairer. He will also re-bulb your valve should you have broken the glass, whilst it is not an expensive business to have it re-capped. My friend Tippleston

who is of a distinctly economical turn of mind, preserves any fragments that may remain of a valve that has suffered from the roughest treatment. The other day he sent the repairers a little parcel containing a plate, a grid and assorted supports. In a covering letter he said:—

*Dear Sirs,  
I enclose a damaged valve. I should be much obliged if you would kindly fit a new filament, a new pinch, a new bulb, a new cap and new pins. Please let me have it back by return of post if possible.  
Yours faithfully,  
T. Tippleston.*



.....kicking him down.....

In due course, though not by return of post, the repaired valve came back, and has given excellent service ever since. Yesterday I went one better than Tippleston, writing to an eminent firm:—

*Dear Sirs,  
Yesterday I had the misfortune to have my best valve run over by an express train. It fell from my pocket on to the railway line whilst I was waiting for my connection at a junction. If you would be kind enough to supply plate, grid and filament, to fit them into a pinch, to re-bulb, re-cap and re-pin, I should be very much obliged.*

*Yours faithfully,*

So far the repaired valve has not turned up—it could hardly be expected to arrive in so brief a space unless it came by telephone, telegraph or wireless—but I live in hopes. If, as I trust, I have discovered a firm of repairers who can rehabilitate at trifling cost a valve that was completely annihilated, I shall have solved one of the valve-user's greatest problems, and you may rely upon me to let you know.

**A Testimonial**

I have told the firm in question that they can count on me for an unsolicited testimonial should they be successful, and I think that they will deserve it. What we require now is other firms who will undertake the repairs of condensers, coils, transformers, rheostats and so on, returning the article as good as new, provided that you send them at least the knob or the terminals.



# “QSB”?



*In radio communication, the letters “QSB” followed by an interrogation mark mean “Is my tone bad?” If such is the case the station in reply sends “QSB,” “Your tone is bad” (no interrogation mark).*

## “Is my tone bad?”

**P**OOR tonal quality in radio reception is invariably directly traceable to a faulty low frequency transformer. Probably an instrument of inferior make purchased with a view to economy.

False economy truly, since tonal beauty necessarily depends upon the superiority of the audio transformer.

**MB** L.F. Transformers have always been synonymous with better reproduction and tonal quality.

The set that amplifies the **MB** way is a set that will reproduce each note and each intonation of the broadcasting artist purely and with exactitude.

Your friends in criticising your set, if it incorporates **MB** components, will never say “QSB.”

In any circuit  
**MB** COMPONENTS  
give *better* results  
Ask your dealer for



H. F. Transformers  
Tuned Supersonic  
Units  
Autodyne Units  
Filament Rheostats  
Potentiometers  
Fixed Condensers  
Grid Leaks  
Coil Holders

### **MB** L.F. TRANSFORMER

A high-grade and efficient Transformer of pleasing design for all intervalve purposes, possessing the best possible electrical characteristics. Provision is made in this model by the clips at the top to take an **MB** flat type condenser of suitable value. A point to observe in the design is that the fixing down lugs can easily be got at. Each one is tested to 1,000 volts.

PRICE (o8o) 21/-

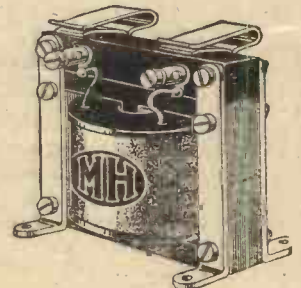

Head Office & Works:  
WEXHAM ROAD, SLOUGH  
BUCKS.

Telephone: SLOUGH 441 & 442  
TELEGRAPHIC ADDRESS: RADIETHER, SLOUGH.

## L.M. MICHAEL LTD

Manufacturers of Wireless and Scientific Apparatus  
WEXHAM ROAD, SLOUGH, BUCKS.

London Office & Wholesale Showrooms:  
HASTINGS HOUSE,  
NORFOLK ST. STRAND, W.C.2

Telephone: CENTRAL 8272  
CABLE ADDRESS: RADIETHER, SLOUGH

# A Wireless Wanderer in Spain

by *Cap<sup>tn</sup> L.F. Plugge, B.Sc., F.R.Ae.S., F.R.Met.S.*

(continued)



*In the November issue of THE WIRELESS CONSTRUCTOR Captain Plugge gave an account of his arrival in France with a 7-valve "Super-Het." on his car, and his entry into Spain. Below he describes his further experiences in the latter country*

ON leaving San Sebastian I decided to proceed to Bilbao, an important port of the north coast of Spain on the Bay of Biscay. Unfortunately it rained during the morning of my departure from San Sebastian, the only rain that I encountered whilst I was in this country, and my departure was only made after lunch. It was found impossible to reach Bilbao until considerably after dark, and we consequently halted for the night, and stayed at a typical Spanish village called Durango. The road between San Sebastian and Durango is very picturesque. It follows the coast line nearly the whole time, running up and down, round sharp corners, and in many cases passing through tunnels hewn in the rock.

## A Spanish Village

Arriving at night in a Spanish village by car with a wireless equipment attached proved to be somewhat of an ordeal. This small village possessed only two hotels, and the moment the car stopped such a huge crowd of onlookers surrounded it that it made it very difficult to move about either for getting in and out of the car or making any arrangements for the unloading of the luggage. It is certainly handy to have the luggage on the car when negotiating prices, as if one is not satisfied it is an easy matter to drive further on, and try the next competitor. This is what we did, to the great disgust of the proprietor of the first hotel, and we secured better terms at the second, which proved to be a very satisfactory place with reference to cleanli-

ness, the main thing to consider in Spanish village inns. I fortunately was able to secure the help of the one and only policeman of the village, who, with the aid of a stick managed with some partial success to beat off the crowds, composed chiefly of idle youths and inquisitive little boys. It gave one the real sensation of being in the wilds, and we were all slightly nervous that some of the luggage would be taken away. This feeling was unnecessary, however, I am happy to say, and, in fact, no luggage was mislaid or lost during the whole of the trip.

The wireless set was merely strapped to its platform by means of two wide and very solid leather straps. The frame aerial could similarly be slid out of its platform, and I always made a point of taking these valuable parts into my room, instead of leaving them in the garage where I was obliged to leave the car. This also enabled me to have the set next to my bed, and to be able to listen to some of the interesting transmissions from London and other stations before going to sleep.

## Daventry in Durango

In Durango, wireless had not yet been introduced to any great extent, and my wireless set caused a tremendous amount of interest among the crowds who watched the unloading of the car, and also among the staff of the hotel. The result was that I was kept up quite late that evening in my bedroom, which contained no less than four chambermaids, the hotel proprietor, his wife and their two daughters,

who, all in turn and simultaneously—I only had five headphones—listened to the Daventry station sending out the Savoy bands from London. The amazement on their faces was worth gold to watch. From here I tuned in several other stations, the Bilbao one being naturally the best. Union Radio Madrid also came in very well indeed, and seemed to interest my crowd of visitors more than the British station. Strangely enough this transmission appeared to be more extraordinary to them, probably because they understood better what was being said.

A very good principle when travelling abroad on unknown roads is to go to bed at dusk and get up at dawn, thus making full use of the beautiful sunshine and of the hours of daylight.

## In Bilbao

Our resolution to leave at dawn resulted in our leaving at 9.30 a.m., and we arrived in Bilbao at about eleven. Our first halt was in front of a Bank, which, as on all such trips, is a place very often required. Here we were greeted by a huge crowd, and also by several policemen who were necessary to keep it off. Bilbao is an interesting town and a very active one, as a great deal of trade is done with South America from this port. On a tour through the town I caught sight of a wireless dealer, the name affixed to the shop being "Casa Radio." On seeing me pass from the other side of the Plaza Elíptica, the pretty square on which the store was situated, several of the staff came to the door and

signalled to me to stop. They were all very interested in examining my installation, and they were furthermore enthusiastic when I gave them my card. They all said that they had heard of my name from my articles in "Radio Press" publications. It might be interesting to note here how much the "Radio Press" periodicals especially *Wireless Weekly*, *Modern Wireless* and *THE WIRELESS CONSTRUCTOR* are read in Spain. In all the large towns I visited I always noticed them on sale at the bookstalls and Spanish amateurs who go in for constructing sets generally refer to the circuits described in these magazines. There is no doubt that "Radio Press" publications, although printed in English, appear to have fostered interest in Radio and in many instances to have opened the market for British goods. The confidence which does not appear to exist in any other printed matter, even in Spanish, seems to exist in "Radio Press" publications, and if any circuit happens to be mentioned with reference to the purchase of any component parts, the Spanish dealer inevitably pulls up from under the counter some back number of *Modern Wireless* and discusses the circuit by means of the diagrams, which all Spanish constructors seem to understand as well as we do ourselves.

#### The Bilbao Station, EAJ9

The Bilbao broadcasting station is erected on the roof of a large hotel called the Carlton. This hotel is not yet in commission. It is a large and modern building which is at present unfurnished and undecorated, only the actual masonry part of the building being completed. When ready it will no doubt be a very spacious and luxurious hotel, occupying an entire block of its own on the Plaza Eliptica. I went up on to the roof to examine the aerial system, which consisted of a main aerial formed of a twin reach with spreaders and a counterpoise consisting of eight or ten heavy wires forming the earth system. The transmitting equipment was installed in two large rooms just underneath the roof. The gear is of French manufacture, consisting of a 500-watt L.L. panel. The station is run by Mr. Pina, a well-known solicitor of the town. Transmissions take place from this station every evening, and the wavelength used is 415 metres.

#### Enormous Crowds

My car had evidently caused some sensation in Bilbao, as when

I returned to it Mr. Cametle, the agent of the Paige Motor Company, was waiting to speak to me. He had been told of the presence in Bilbao of a Paige car equipped with a wireless receiving set, and he very kindly offered to make any adjustments my car may have needed. He also asked my permission to take some photographs in order to publish them in the local Bilbao press. Although I was in a great hurry to proceed further South I consented, and after having had some lunch several photographs were taken in Gran Via Lopez de Haro, the principal street of Bilbao. The help of the police was indeed necessary in order to take the photographs, as the crowd which surrounded the car was enormous, and threatened to stop the tramway

dusk began to set in before we had reached the summit of the 10 mile climb before us. We had to switch on the light, and during the last two miles of the climb we entered into a thick cloud. As on one side of the road there was a very steep precipice, some 2,000 ft. deep, and as after a certain time I began to realise that I could hardly see three yards ahead, I decided to stop and spend the night in the open before proceeding any further. We managed with the aid of our electric torches, which formed a very useful part of our equipment, to discover a small cart track going up into a field on the near side of the road, where, with a certain amount of difficulty, owing to the weight and very large wheel base of the car, we parked it away from the main



Captain Plugge's car and its equipment. Notice the frame aerial at the side of the bonnet.

traffic, which is fairly important at this spot. We took leave of Mr. Cametle and proceeded down South. The next important town on our itinerary was Burgos. Burgos is very famous for its Cathedral, which is reputed to be the most beautiful one in Spain. Some people consider it also to be the Cathedral of the purest Gothic style in Europe.

#### Climbing in the Clouds

There is a tremendous climb from Bilbao to Burgos, and indeed this climb exists anywhere in Spain when you go from the coastline to the interior of the country. Spain itself forms a huge plateau, rising suddenly from the sea. Owing to the various things we had to attend to in Bilbao we left rather late, and the consequence was that

road, and there in the chill of the cloud and right on the height of the mountain we prepared our evening meal.

#### A Night in the Mountains

We had carried a Primus Stove with us, and although in the word "primus" there is no doubt an indication of the word "first," the last event of that evening occurred when the Primus Stove caught fire by aid of our last match. However, it did light, and we had an excellent cup of tea, which was very much welcomed on all sides. Before we had finished, the cloud had drifted on. The August moon rose and threw into striking relief the rugged edges of these rocks of Old Castille, which with the intense silence created a

**LISSENIUM**

# Keeping the Grid at the right potential—

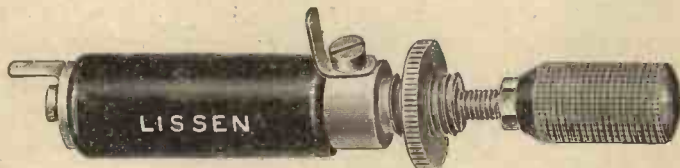

LISSEN VARIABLE GRID LEAK (patent pending) Lissen one-hole fixing of course, 2/6

**YOU** are often recommended to try your grid leak on L.T. negative as well as on L.T. positive. There is a difference in potential between these two points of about 6 volts (the E.M.F. of the accumulator). It is well therefore to be able to compensate for the effect on the grid which this difference in potential makes.

Every valve has different characteristics—every circuit its peculiarities. The fixed type of grid leak is largely used, but with a variable grid leak you have just that extra facility for

obtaining correct grid leak resistance which is often worth a good deal at a particular moment.

A variable grid leak should not of course be expected in every circuit to modify signals always, but with a Lissen Variable Grid Leak fitted you know you can always get any variation in leak resistance which you may think you ought to try. In some circuits, on the other hand, a Variable Grid Leak is essential.

**ASK FOR THE LISSEN VARIABLE GRID LEAK IN THE NICKEL FINISH — WE UNCONDITIONALLY GUARANTEE IT.**

LISSEN VARIABLE GRID LEAK (pat. pending) 2/6  
Lissen one-hole fixing of course

## Constancy in a Fixed Grid Leak—



**I**F you use a Fixed Grid Leak it must never change its resistance value. Much of the noise which develops in some receivers after months of use is directly due to the resistance of the Fixed Grid Leak altering. Once this happens the Grid Leak is useless. Make sure your **FIXED GRID LEAKS** are **LISSEN LEAKS**—they will not change. All resistance values one price **1/8 each.**



It is worth while fitting Lissen Fixed Condensers too—made with scrupulous care accurate to within 5%—they never leak—they never vary—they deliver all their stored up energy.

·0001 to ·0009	- -	2/-
·001 to ·002	- -	2/6
·004 to ·006	- -	3/-

Ask your dealer for a leaflet on LISSEN L.F. Chokes—or send direct. If the **TEXT BOOK OF LISSEN PARTS** is also needed, please enclose 3d. for postage.

# LISSEN LIMITED

LISSENIUM WORKS

26 - 30, FRIARS LANE, RICHMOND, SURREY

Phone: Richmond 2285 (4 lines). Grams: "LISSENIUM, Phone, London."

## BUILD WITH THE BETTER PARTS

# Superior Matched Tone Headphones

TRADE MARK

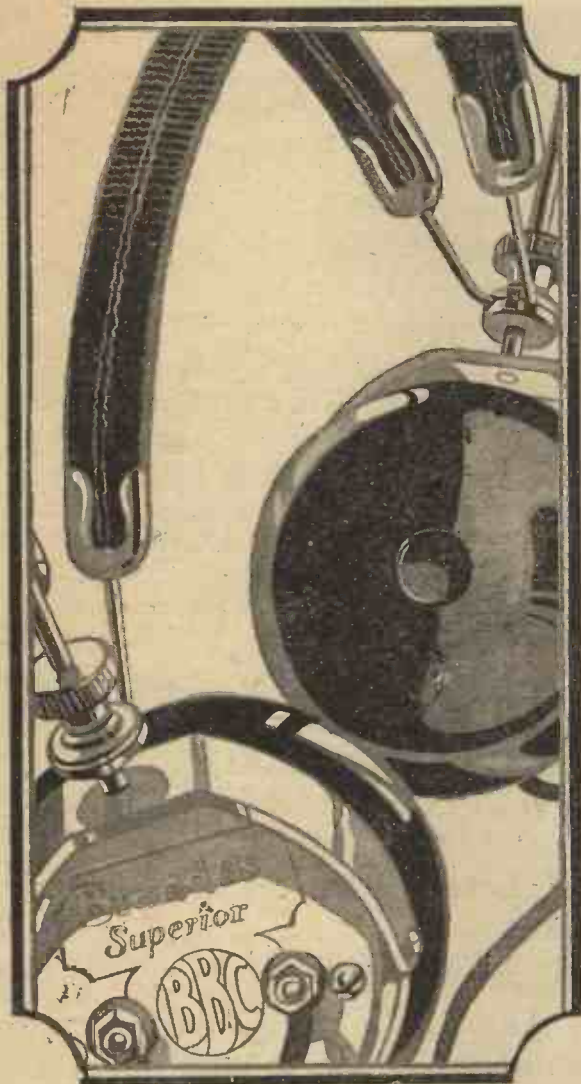

THE receivers of *Matched Tone* Headphones have no interests apart. Their whole existence is wrapped up in one another. Gently led into these paths of concerted effort by our *Matched Tone* apparatus they each give of their best to exactly the same degree. That is the secret of *Matched Tone*—team work. Obviously, this achieves a desired end. It removes any possibility of one receiver being half a tone lower than the other and the distinct risk that tone, sensitivity or volume may not synchronise in both receivers. Brandes receivers definitely capture these three essentials in perfect unison. Does not this mean redoubled excellence?

Ask your Dealer for Matched Tone

20/₳

Brandes Limited, 296 Regent Street, LONDON, W.1  
WORKS 1 Slough, Bucks

## Brandes

Experts in radio acoustics since 1908



Table-Talker  
30/₳

Audio Transformer



Ratio 1 to 5.  
17/6



The Brandola  
90/₳

scene of utmost grandeur and impressive beauty. One had the real impression of being lost miles away from everywhere. It is under these conditions that the wonders of broadcasting come more forcibly to one's mind. The mere turn of a switch with no further adjustments whatever, and there we were hearing the familiar voice of Rex Palmer telling us the latest London news. It was all so extraordinary, and yet it somehow seemed so natural. We all take so much for granted, and to many of us now life would appear impossible without this wonderful link which allows us to go anywhere and yet remain in touch with home.

#### Wonderful Scenery

In the morning when we awoke we found how really beautiful the



The party leaving San Sebastian, en route to Bilbao.

scenery was, and we were then able to realise what a great mistake it was to motor in the dark, and miss all the wonderful sights which were being passed. The cloud that we had gone through was clearly visible some 400 feet below, and for a long time I took it for a lake, owing to its beautiful mirage. As the sun rose, however, the mistake became evident, the cloud lifted, and spellbound I watched it lift. It gave the impression of what a geyser must be in New Zealand, the mirage gradually disappeared, and the lake seemed to rise in enormous waves. After getting breakfast, with the aid of a camp fire this time, we again proceeded on our journey, arriving at Burgos late in the afternoon.

#### Britons at Burgos

I saw no aerials at Burgos, and little or no interest seemed to be

taken in wireless locally. This, however, did not appear to diminish in any way the interest taken by the inhabitants in our car and its equipment, as we were again surrounded by a crowd when we stopped to ask our way or for any other reason. There is at present a large British colony in Burgos, as a British firm has secured the contract to build the Burgos-Santander railway. The work will last seven years, and the British staff are very cosily installed in a kind of garden suburb on the south side of the town. They have erected a very nice tennis club house, with two gravel courts, and have quite settled down with their wives and relatives, and are resigned to the fact that they will have to remain there for seven years. We visited the wife of the chief engineer in

in the middle of the road in order to make sure that anyone who subsequently looked at the print would not have any other object to distract his attention.

#### Warm Weather

The two men allowed us finally to proceed, but not before we had all shaken hands with both of them. We were very anxious to leave Burgos in order to reach Madrid as soon as possible, as it was late, and dusk was beginning to set in. We consequently decided to postpone our visit to the Cathedral till our return journey if we happened to pass by Burgos again. We set out, therefore, for Madrid, some 200 miles further south. We did not go far, however, as darkness completely set in, there is very little dusk in Spain, and the time between day and night is hardly perceptible. According to our decision to motor as little as possible by night, we decided to camp out again. At dawn we had a long stretch before us, and we decided to stop as little as possible in order to reach Madrid that same day. The heat soon became so considerable that we felt more and more uneasy, and the fast motion of the car through the warm air did not tend to cool us in any way. We had been travelling due south for over a week now, and that meant the sun shining in our faces and in our eyes nearly continuously. Fortunately we met a somewhat wide river which for some time followed a ravine below the road. The sight of the water gave us great delight, and although we were rushed for time we decided to devote a half hour of our schedule to a bathe. The water was beautiful and clear and above all, cool and wet.

#### Arrival in Madrid

Our arrival in Madrid had been announced by radio on the previous day by both the Union Radio Broadcasting Station on 430 metres and Radio Iberica on 392 metres. The result of these announcements was that the roads were lined to greet our arrival.

The heat in Madrid was not so excessive as we had anticipated, and, in fact, compared to that of the parts of country we had passed it might have been termed as mild.

A great amount of interest seems to exist in Madrid with reference to wireless, and during the three days our stay lasted in the capital the car and its equipment caused great enthusiasm amongst the enormous crowds which surrounded it whenever possible. We were never allowed to park or even stop for any

charge of the construction. She gave us tea, and it was the most delightful drink we had tasted since we left England.

#### The Civil Guard

A careful watch is no doubt kept on travellers entering or leaving Burgos, as some five miles outside the city we were stopped by the usual pair of the "Guarda Civil." They looked especially comic on this occasion, with their hats covered with grey-green dust flaps. After careful examination of our papers, which in this case lasted considerably longer than usual, they both overlooked the fact that the only paper I had in Spanish was not valid. Before allowing us to proceed, they asked if we would take their photographs and send them copies. This we did, and one of them even posed

length of time, as the police in Madrid are very quick at ordering cars to move. There is a law, however, that if a car is left outside a restaurant it can stay there for any length of time, so long as its owners are having a meal. This Madrid bye-law provided us with a great amount of amusement, as our meals were as a rule taken in one of the restaurants in the Via Grande, and leaving the car in full view of our table we could have our meal in peace and yet watch the crowds which gathered round and examined our equipment. The crowd was continually renewed by people coming and going as time went on.

**A Super-Het.**

As I said, everything is done in Madrid to increase the interest

Union-Radio and Radio-Iberica, the two leading broadcasting stations in the town, and I hope to be able to say more about these stations on some future occasion.

**Ancient Toledo**

From Madrid I proceeded further south to Toledo. Toledo, as no doubt my readers know, is reputed to be the oldest city in Europe. It was one of the first towns that the Moors built on this Continent, and certain vestiges of this ancient civilisation are still to be seen.

The Cathedral is one of the chief attractions of the city, and although the Cathedral at Burgos is reputed to be the most beautiful in Spain, the Toledo Cathedral is held by some to hold this title.



The arrival in Madrid, where crowds lined the streets to welcome the car.

taken in wireless. I even saw, one evening, in one of the leading cafés, a man walk in with a super-sonic heterodyne receiver under his arm; a soprano was singing at the time, and the effect was strange. He placed the instrument in front of each customer in turn, allowing each one to examine and listen. The local station was being received, and during the whole time the set, which was self-contained with frame aerial, battery and loud-speaker, was continually working.

The new Madrid station of Union-Radio also possesses a van equipped with four loud-speakers, which goes out nearly every night when this station is on the air, giving out their concert to the inhabitants of the suburbs and the outlying districts of Madrid. Whilst in Madrid I had the opportunity of visiting both

In any case, it is admittedly the richest Cathedral in the world, with the exception of St. Peter's in Rome. Its treasures which have accumulated during the past thousand years make its fame. They are enclosed in a special vault which is only opened at 3 o'clock in the afternoon, and for nobody except Royalty is it permissible for this vault to be opened at any other time of the day.

**80,000 Pearls!**

There are four different locks to the iron gates, each separate key of which is in the possession of a different priest. All four priests meet at 3 o'clock every afternoon, and the public are allowed for one hour to inspect these wonderful treasures, among which might be cited a Madonna covered with over 80,000 pearls.

*The "Midget" Set  
in South Africa*

SIR,—Just a few lines to tell you of my results with the one-valve "Midget" receiver, as described in the May issue of THE WIRELESS CONSTRUCTOR. Being unable to obtain a Lissenstat Minor, I had to use the usual type of rheostat (wire wound), which meant enlarging the panel.

Using an Ediswan "R" type valve and with an aerial from 15 to 20 ft. high I am able to get Johannesburg, Durban and Cape Town Broadcasting Stations clearly and loud. Each of these stations is from 500 to 600 miles away, and as this is my first set, I think it speaks well for the design and the clearness of the instructions for making the receiver.

Wishing THE WIRELESS CONSTRUCTOR every success,

I remain,

Yours truly,

C. MORRIS.

Port Elizabeth, S. Africa.

*An Appreciation*

SIR,—I am very pleased with THE WIRELESS CONSTRUCTOR, and wish to state that I agree with the diagrams giving the squared joints and straight cross lines, in place of the usual semi-circles, the new way being much easier to follow.

Yours faithfully,

F. H. CHRISTIAN.

Hove.

*Important Notice*

Owing to the numerous applications from our readers for back numbers of our publications, we have decided to make no extra charge on any of our periodicals for issues published within six months. The charges for back issues prior to six months will be as in the past



# Opinions of the Press

Throughout the country the Press has been unanimous in praise of the new GECOPHONE Condenser. A few illuminating extracts from Press reports are printed here.

Sold by all GECOPHONE Service Depots, Wireless Dealers and Stores.

## GECOPHONE

### LOW LOSS-SLOW MOTION VARIABLE CONDENSER

DUNDEE COURIER. Sept. 11th.

"A revelation to the exacting amateur who has been searching for a precision instrument which is capable of the finest tuning with an ease that is remarkable."

ELECTRICAL TIMES. Sept. 10th.

"With new stations opening almost daily and with wave-lengths within a very few metres of each other, there is greater and yet greater need for close tuning. That this close control is attainable with this new GECOPHONE condenser we are able to speak at first hand."

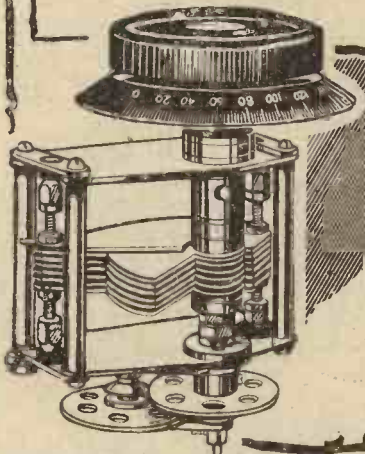

## GECOPHONE

### LOW LOSS-SLOW MOTION VARIABLE CONDENSER

POPULAR WIRELESS. Sept. 26th.

"... represents an achievement well worthy of its famous manufacturers. We found it to be robustly constructed and capable of standing up to hard work without developing mechanical faults. ... The movement is excellent and is absolutely positive, no backlash being present."

TALKING MACHINE NEWS. Sept.

"We are extremely gratified at the results obtained. On short wave lengths results are really wonderful. ... The new Low Loss Slow-Motion Variable Condenser is a 'Gecophone' triumph."

## GECOPHONE

### LOW LOSS-SLOW MOTION VARIABLE CONDENSER

Mr. Mark Potter in LEEDS MERCURY. Sept. 15th.

"What I like about it is that it is a good engineering job; it seems to be made with the accuracy of a chronometer. ... An excellent feature is the micrometer adjustment, which does away with the need to use the inefficient so-called vernier plate."

"The operation was perfectly silent, and there was no harshness or harshness, the 'feel' being truly velvety, as there are no cut gears and no spring is used."

## GECOPHONE

### LOW LOSS-SLOW MOTION VARIABLE CONDENSER

ELECTRICITY. Sept. 25th.

"The construction and finish of this instrument conforms to the high standard which characterises the whole range of GECOPHONE productions. ... We heartily recommend this condenser to our readers."

NOTTINGHAM JOURNAL.

Sept. 12th.

"In design, mechanical construction, electrical efficiency, and appearance, it is typical of the high quality products of the G.E.C. The G.E.C. engineers set out to design an ideal condenser. They are to be congratulated upon the result."

#### PRICES

·0002 mfd. ..	22/-
·00025 mfd. ..	23/-
·0003 mfd. ..	24/-
·0005 mfd. ..	27/6
·001 mfd. ..	32/6

## GECOPHONE

### LOW LOSS-SLOW MOTION VARIABLE CONDENSER

Advt. of The General Electric Co., Ltd., Magnet House, Kingsway, London, W.C. 2.

In replying to advertisers, please mention THE WIRELESS CONSTRUCTOR.

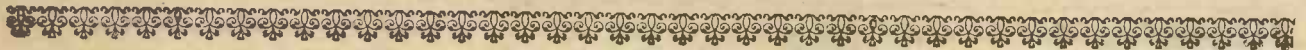

# Doing one thing ... and doing it well

A BASIC essential of fine craftsmanship is the whole-hearted concentration upon one special task. Those fine old craftsmen of the Middle Ages devoted their whole lives to the betterment of their craft. They possessed the right spirit.

The same understanding can be observed among the ivory carvers of Japan, the metal workers of India, and the watch-makers of Switzerland. They all carry on the traditions of their fathers for generation after generation. Truly they realise that doing one thing and doing it well inevitably spells success. Among wireless enthusiasts throughout the country the name Cossor has also been associated with the basic idea of doing one job and doing it well.

Cossor Valves are the *only* contribution to the wireless industry by A. C. Cossor, Ltd. And here again specialisation has brought success. For many years Cossor has been making valves—always experimenting, always aiming to effect

improvements. Each year has seen the standard of performance slowly—but surely—raised. Each year finds Cossor more determined to remain true to its self-imposed task.

Three years ago the research work on the Cossor hood-shaped Anode and Grid and the arched filament was completed. Its inventors were fully convinced that for increased sensitiveness, durability and tonal purity these principles possessed immense possibilities. And they resolved to concentrate upon their development.

What has happened has been wireless history. From a new valve with a sale of a few hundreds a week, the wireless industry has watched Cossor sales leap upward until today it enjoys the distinction of being by far the most popular British Valve.

Once again it has been proved that the public is always ready to recognise an honestly made article—and, once having recognised it, loyally continues its support.



**The Wuncell Dull Emitter**  
Voltage 1.8 volts. Consumption 3 amp.  
W1 for Detector and L.F. 14/-  
W2 for H.F. amplification. 14/-

**The Cossor Loud Speaker Valve W3**  
Voltage 2.8 volts. Consumption 3 amp.  
Price 18/6



Issued by A. C. COSSOR LTD., Highbury, London, N.5

Ref. A.1. 3697

## A Series Telephone Board

IT is often necessary to connect two or more pairs of phones in series, but if this is done by means of ordinary two-screw brass links there is always the possibility of at least one pair being cut out of circuit by the links accidentally touching. The little device described below will take up to three pairs of phones, and can be stood on a table or carried to any part of the room.

The materials required are quite inexpensive, and are as follows:—

One circular ebonite disc, 4 in. diameter, about  $\frac{3}{8}$  in. thick.

About 2½ in. of ebonite tubing.

A wooden baseboard, about 4½ in. square by ½ in. thick.

Eight ¼ B.A. terminals (preferably six telephone type and two ordinary W.O. pattern).

Four ¼ in. brass screws, and some connecting wire.

First drill eight ¼ B.A. clearance holes in the positions shown to take the four pairs of terminals and four further holes, which should be countersunk, to take the brass wood-screws. Fix the terminals in

position and wire up as shown. The ebonite tube should be cut into four equal lengths, each, say, ½ in. long, the screws slipped through the holes in the disc and through the pieces of tube and then screwed into the wooden base. The leads from the set are connected to the pair of ordinary terminals, and the phones in the unconnected "gaps" in the wiring. Any pair of phone terminals not being used must be shorted by means of a length of copper wire.

P. H. W.

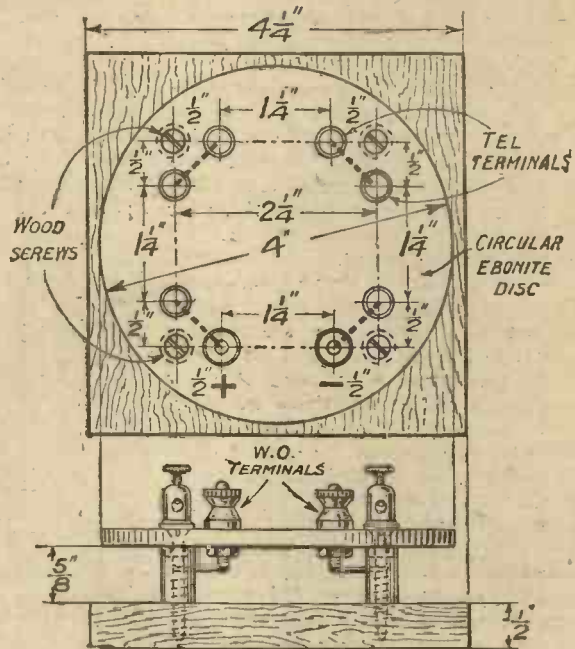

The board is made as above, the wiring being shown by the thick dotted lines.

## More Letters from our Readers

SIR,—I would like, if I may, to wish THE WIRELESS CONSTRUCTOR many birthday anniversaries and continued success. I started taking the paper a year ago and have obtained much pleasure from the monthly numbers and also most of my education in matters wireless.

After living abroad for nearly 20 years and in what was then practically a "non-wireless" country, I returned to England last year knowing very little more about wireless than its name. My small son had a very elementary crystal set given to him, and I fell a victim to wireless as a hobby. The first serious constructional work that I did was to make the Seven Circuit Crystal Set, by P. W. Harris, M.I.R.E., described in your December number of last year. This I did in an experimental way, using a whisky-box as a cabinet, but results were very good.

From that, having much time on my hands last winter, I proceeded to experiment on quite ignorant and amateur lines and eventually evolved my present set, which,

although somewhat different from the Seven Circuit set, is still its descendant by evolution.

This winter I am hoping to construct an amplifier to work off the above crystal set, and I am hoping that in one of your early numbers you will publish constructional details of a simple dull-emitter one-valve amplifier, and will include in the article some information as to the batteries to be used and how to work with them.

There must be many like myself who at present are nothing but crystal-set users, but who are thinking of going on a step. To me, at least, it is puzzling, after studying constructional details, to find such instructions as, "connect to batteries in the usual way."

Pray excuse me for being so lengthy, and accept again my best wishes for THE WIRELESS CONSTRUCTOR.

Yours faithfully,

H. E. ATKINSON.

Richmond, Surrey.

SIR,—It is with great pleasure that I am writing to inform you of my success with the "Powerful Three-valve Set," described by Mr. Percy W. Harris, in the April number of THE WIRELESS CONSTRUCTOR, Vol. I., No. 6.

I have now built two sets to this design, and the results are really extraordinary. London and Daventry come in at delightful volume and purity on the loud-speaker, the former being received at full loud-speaker strength, with merely 12 ft. of insulated wire slung across a ground-floor room as an aerial.

This is undoubtedly the set for those who wish to listen to the local station or 5XX at good strength and purity on the loud-speaker. It can also easily tune in Birmingham, if 2I.O is not transmitting.

Will you please allow me to wish you and your wonderful papers every success.

Yours faithfully,

W. F. MARTIN.

Wimbledon, S.W.19.

# A Neat Container for Your Drills

EVERYONE knows what a nuisance drills, particularly small ones, can be at times. If all sizes are kept together in a box on the workbench, one often has to rummage amongst them for quite a long time before the desired size can be found. With small drills kept in this way a still further waste of time occurs owing to the fact that the sizes are seldom marked upon their shanks owing to the small space available for figures. One has, therefore, often to make use of the gauge plate in order to discover the correct drill. Further, drills kept in this way do not last as long as they should, since their points are apt to become blunted by contact with one another when the box is shaken, as it is to some extent whenever it is moved.

Here is a handy little container for drills which can be made by any amateur in his own workshop in the course of a spare hour or two. It costs nothing, and it saves endless time and trouble, besides keeping the drills out of harm's way.

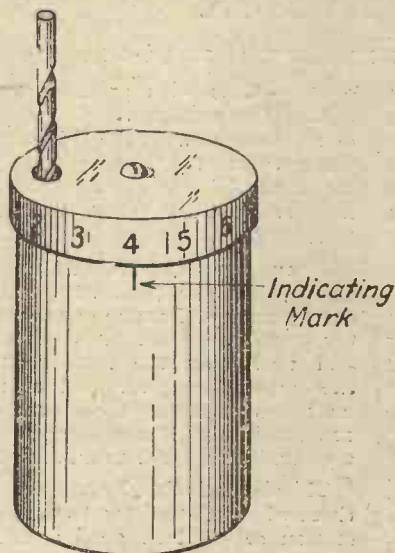

Fig. 1.—The finished container.

Fig. 1 shows the finished container, whilst in Fig. 2 is a section. The two together will serve to explain how the container acts. The drills are housed in pockets or recesses made in the wooden cylinder, which fills up the interior

of the container. The lid, which is held in position by a single central screw and is free to revolve, contains only one hole. When this hole is immediately over any pocket the drill within it can be

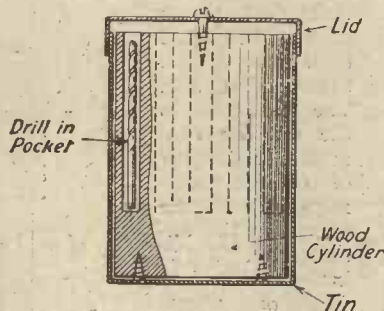

Fig. 2.—This sectional view will help the constructor.

obtained by simply canting the container, when it slides out into the hand. Upon the rim of the lid numbers are scratched corresponding to the drills in the pockets. On the body of the tin is an indicating mark, so arranged that when any particular number is immediately above it the hole in the lid coincides with the corresponding pocket. Thus all that one has to do when a drill of any size is required is to turn the lid until its number is in line with the mark, and then to "pour out" the drill. As the drills are kept point downwards in the wooden recesses they are well protected.

### Materials Required:

The materials required are an ordinary cocoa tin with a loosely fitting lid and a piece of round wood—curtain pole answers admirably—from which a cylinder can be cut to fit fairly tightly into its interior. We shall also need four screws. Cut your cylinder so that when it is placed inside the tin its top is flush with the rim. Trim both ends up carefully, and, having found the centre of one of them, draw with a pencil a circle whose circumference is about  $\frac{1}{2}$ -in. from the edge. Having decided how many drills you wish to house in the container, mark off the centres for the recesses at suitable intervals on the circumference of your circle. A cocoa tin of the

usual size should be used large enough for a single ring of from twenty to twenty-five drills, according to their diameter.

### Assembling and Marking

Next drill out the recesses, making them an easy fit for the drills which they are to contain. Thus, to house a  $\frac{1}{4}$ -in. drill, the recesses should be  $\frac{3}{8}$ -in. in diameter and about  $\frac{1}{2}$ -in. longer than the drill itself. When all the pockets have been made, fix the cylinder into the cocoa tin as shown in Figs. 2 and 3 by means of wood-screws driven into it through the bottom of the tin. In the lid drill a central hole for the pivot screw and another of suitable diameter in such a position that it coincides with the pockets made in the wood cylinder. Fix on the lid, tightening down the screw until it is so held that it does not turn too easily. With the scribe scratch an indicating mark on the body of the tin. Now turn the lid until the pocket containing the largest sized drill is immediately under the hole in it. Keeping the lid in this

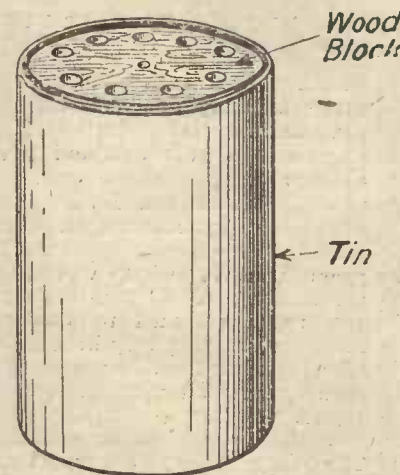

Fig. 3.—After drilling, the wooden cylinder is forced into the tin.

position, scratch the number or inch fraction size of this drill on the edge immediately above the indicating mark. Next turn the lid to the next size smaller, scratching in the size as before. Proceed in the same way for the remaining recesses.

R. W. H.



## Radio Components of Outstanding Merit

**F**ROM time to time there emerges from the maze of the world's efforts—things of outstanding quality.

In the radio world, there have emerged components so perfect in design, construction and practical efficiency that they have called forth the highest praise from radio enthusiasts the world over.

They are the **MH** COMPONENTS—as perfect in the essential details of efficient radio instruments as perfection has made possible.

If you would obtain better radio results, incorporate **MH** Components.

### **MH** Filament Rheostats

A distinctive type made for use with all types of valves.  
Bright Emitter Filament Rheostat 5/6 each; Dull, 8/6 each. Dual type (for either Bright or Dull) 7/6 each; Triple Rheostat 22/6.

### **MH** Grid Leaks

All values 2/6 each. Mounted on ebonite base 1/- extra.  
Grid Leak and Condenser Unit (mounted) 5/-.  
Anode Resistance, all values 4/6 each. (Each supplied with two clips).  
Mounted on ebonite base with terminals all values 5/6 each.

### **MH** Mica Fixed Condensers

Are of the permanent capacity engraved thereon  
Are instantly interchangeable

	PRICES	each
'0001 to '0009	...	2/6
'001 to '01	...	3/-
'015 to .04	...	4/-

(Two Clips are supplied with each Condenser)

Above, mounted on ebonite base, with terminals, any value, 1/- extra

### **MH** H.F. Transformers

"The Transformer that made H.F. amplification popular"  
Supplied in six ranges of wavelengths, covering 80 to 70 000 metres. Price 10/- each (with H.F. Damper, Price 12/-). Special Neutrodyne Units and Superheterodyne Couplers also supplied

No extra charge for matching, if requested when ordering

**MH** H.F. Damper, Price 2/-  
The H.F. Damper is a device which, when inserted in the central hole of the H.F. Transformer, stabilises a circuit which otherwise could oscillate.

OBTAINABLE FROM ALL DEALERS

Head Office & Works:  
WEXHAM ROAD, SLOUGH  
BUCKS.

Telephone: SLOUGH 441 & 442  
TELEGRAPHIC ADDRESS: RADIETHER, SLOUGH.

# L.M<sup>c</sup>MICHAEL LTD

Manufacturers of Wireless and Scientific Apparatus  
WEXHAM ROAD, SLOUGH, BUCKS.

London Office & Wholesale Showrooms:  
HASTINGS HOUSE,  
NORFOLK ST., STRAND, W.C.2

Telephone: CENTRAL 8272  
CABLE ADDRESS: RADIETHER, SLOUGH

# Something New from the B.T.H.



Standard Type



Standard with Vernier

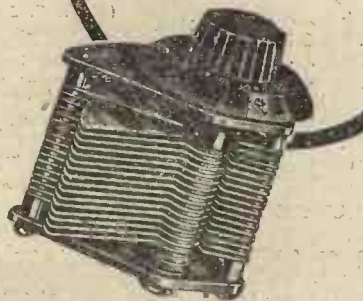

Square Law Type

**T**HE initials "B.T.H." on any piece of radio apparatus, as everyone knows, stand for perfect workmanship and design. This fact is exemplified in the three B.T.H. Variable Condensers illustrated, which are unsurpassed in mechanical and electrical efficiency.

The **STANDARD TYPE** is a very robust instrument, and the moving vanes are so rigidly set that they remain parallel to the fixed vanes throughout the whole movement. Constancy of calibration is therefore maintained. It is perfectly silent in operation.

The **STANDARD WITH VERNIER**, whilst retaining a perfectly rigid construction, provides a very delicate adjustment. Maintenance of calibrated capacities and silence in operation are important features. A definite stop prevents complete rotation. The vernier vane is actuated by a small knob mounted on the main dial.

The **SQUARE-LAW TYPE** has all the good features of the Standard with the addition that the wave-length variation is approximately proportional to the scale readings. It will therefore be found that the stations are spaced out, thus giving a greater degree of selectivity.

TYPE	CAPACITIES					
	.00025 m.f.		.0005 m.f.		.001 m.f.	
	s.	d.	s.	d.	£	s. d.
Standard .....	13	6	15	6	1	1 0
Standard with Vernier .....	17	0	19	6	1	6 0
Square Law .....	13	6	15	6	1	1 0

## B.T.H. VARIABLE CONDENSERS

*Insist on B.T.H.—the Best of All*

Ask your dealer for a demonstration, and for Leaflet No. R7430.



*Advert of The British Thomson-Houston Co. Ltd.*

# Do You Know—?

By C. P. ALLINSON

THAT a mica-dielectric condenser has a power factor nearly as low as that of one with air dielectric, but only if the mica used is the best grade ruby mica.

That experiments have been carried out to see in what way, if any, the activity of the Aurora Borealis has any effect on wireless reception. As yet no definite conclusions appear to have been reached.

That when split secondary tuning is used in a receiver, that is, the secondary or closed circuit coil is divided into two sections, one coupled to the aerial coil and the other to the reaction coil, two 50 coils in series in this secondary circuit are not equivalent to one 100. Tuned by a  $0.0005\mu\text{F}$  variable condenser their range may be from 300 to 600 metres.

That the wireless amateur and experimenter is largely responsible for the great attention that is now being paid by commercial concerns to short wave work. It was amateur transatlantic work, in the face of technical experts' disbelief in its possibility, that showed the potentialities of wavelengths of 100 metres and less.

That the best kind of carborundum to use for detection is the green waxy looking variety. When used with a steel contact with the right amount of pressure, in conjunction with a potentiometer and battery so as to apply a negative potential of about  $1\frac{1}{2}$  volts, its sensitivity is very little less than that of some of the synthetic "ites."

That aluminium always has a film of oxide on its surface, so great is its affinity for oxygen. That is why all precision variable condensers used for standards and substandards have brass plates. These are also frequently lacquered or gilt so as to prevent oxidation, with the resulting rise in H.F. resistance.

That many amateurs write out received messages directly on a typewriter. And not always a "noiseless," either.

That a pitch lens will refract wireless waves. It would need to be so very large, however, except when used in conjunction with the shortest waves, that its use would be impracticable.

That hard-drawn copper wire will stand about twice the tensional strain per unit area cross-section that soft wire will. The old South American Indians or Mayas, however, were able to temper copper to the hardness of steel. This art is now lost.

That ebonite is made of a mixture of sulphur and rubber. The proportions are usually about seven parts of rubber to three parts sulphur. Good ebonite should drill and machine without chipping, and yet should not be soft.

That notwithstanding the late arrival of England in the broadcasting game, this country was the first fully to develop simultaneous broadcasting and bring it to an efficient stage.

That when a multi-valve set is being used with general purpose valves, each valve should be tried in various positions to determine where it works best. For instance, one may function better as a detector than any of the others, another as H.F. amplifier, and so on.

That the ohmic resistance of an oscillatory circuit has an effect on the frequency to which it will respond, as well as the inductance and capacity contained in it.

That coils should not be placed in a receiver so that any metallic components, such as condenser vanes, filament resistances, or low-frequency transformers are included in the field of these coils. Serious losses will result if this rule is not adhered to.

That when two condensers are placed in parallel the total resulting capacity is equal to the sum of their separate capacities. Two inductances in parallel, however, have a total inductance less than that of either of them.

That when building Radio Press sets you should strictly follow the layout given by the designer. This has generally been arrived at after considerable experiment, and unless adhered to, the receiver may not give the same results as obtained by the author.

(To be continued.)

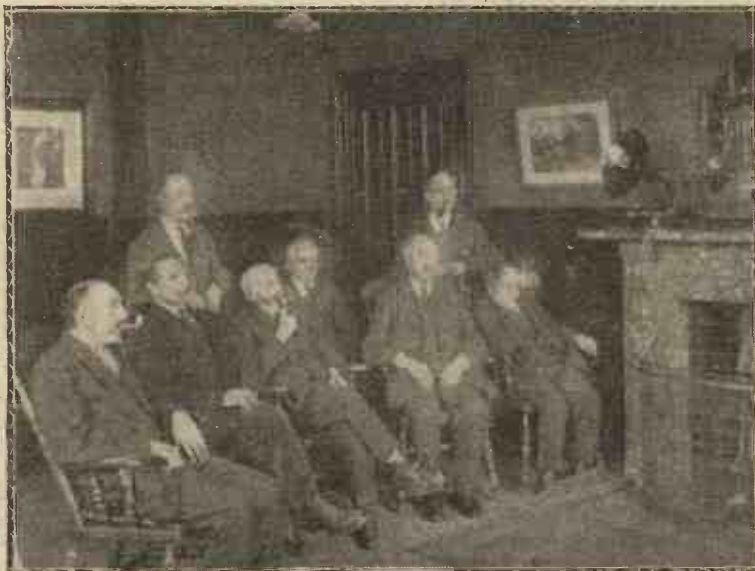

Inmates of Blind Institute, Bradford, enjoying music from a loud-speaker in their recreation room.



### AN INTERESTING VALVE-CRYSTAL RECEIVER

SIR,—I constructed the valve-crystal set described by Mr. John W. Barber in the August WIRELESS CONSTRUCTOR, and am very pleased with it.

Using the set at Boscastle, N. Cornwall, I received the high-power station at good strength on two pairs of phones in broad daylight, and in spite of the fact that the coils available made it necessary to use 180° of condenser.

I also received three other B.B.C. and two French stations at good strength.

The aerial used was about 40 ft. long, and in a valley badly screened by trees.

The earth wire was soldered to a water-pipe 20 ft. from the set, an inefficient arrangement, as the water main is not under the aerial by any means.

Mr. Barber does not mention in his article what coils to use for 5XX. I used D for  $L_1$ , F for  $L_2$ , F' for  $L_3$ , and although the results were surprising, I believe they will be much better when I have the proper coils.

Please, may I be informed what coils are most suitable.

Later I will send you a complete list of the stations I can get at good strength, and I believe it will include all the main B.B.C. stations.

Thanking you for evolving a circuit which, while giving the crystal user the advantages of L.F. amplification, also increases his range.

Yours truly,  
H. W. WARD.

Torquay.

NOTE—The coils this reader is using for 5XX will be quite satisfactory. In the numbered series of coils, Nos. 150, 250 and 200 respectively may be used.—J. W. B.

### AN ENCLOSED CRYSTAL SET

SIR,—In the September issue of THE WIRELESS CONSTRUCTOR a simple all-enclosed local or Daventry crystal receiver was described by F. English. The Sunday following this issue I constructed the set. I

can hardly say I followed the instructions, as I only had a panel previously drilled for a single valve set, so I had to mount the components where the drilled holes suited best. I used a very small glass-enclosed detector, and all connections were made with spade clasp connectors. My aerial is only 34 ft. long, four-wire sausage type, and considering I am situated about 150 miles from Daventry and the aerial is very low I consider the set acts wonderfully. I have only at present been able to tune in Daventry, the speech and music coming in very clear indeed. This evening (September 6), when the announcer announced Casando's Octet I could plainly hear the violins tuning up at the same time.

Wishing THE WIRELESS CONSTRUCTOR every success.

Yours faithfully,  
H. J. CREASEY.

St. Leonards, Sussex.

### TWO STAGE CHOKE AMPLIFIER

SIR,—Probably you are interested in results obtained by your readers, and I wish to report on the Two-valve Choke Coupled Amplifier, described by Mr. John W. Barber in THE WIRELESS CONSTRUCTOR for September.

I made it up on the "Omni" receiver, which I have, using the secondaries of the L.F. transformers as chokes. The large coupling condensers and the leak for the last valve are fixed outside the cabinet. The result is very good indeed. I had always refused to have a loud-speaker until I could obtain reception without distortion, which a transformer coupled amplifier never seemed to give. A big . . . loud-speaker was lent to me, and gave very good results, though not *entirely* pure. But I have now bought a . . . loud-speaker, which has a porcelain "horn," and distortion is non-existent, provided that reaction is kept in bounds. This is a new type of speaker, and certainly gives very good and loud reproduction, with excellent quality. The amplifier

seems quite free from any distorting tendency. As the Omni receiver has only three valves, I am obliged to use aerial reaction on the detector, but the amplification seems to be so good that I shall probably build it up with proper chokes and a separate unit, and will then be able to use an H.F. on the Omni, probably getting the more distant stations better. Cardiff (15 miles) and Daventry (100 miles) are very good; Bournemouth fair, but inclined to distort. On one night when conditions seemed specially favourable for reception I got 5NO, 2BE, and Madrid at very fair loud-speaker strength.

Valves, Ediswan A.R.D.E. for detector and first stage. Cossor two-volt power valve for last stage. H.T.—27 volts on detector and 100 on amplifiers—using Ever-Ready large celled batteries. Transformers are Igranic and Formo. Grid-bias is used on both valves, 4½ volts on first and 6 on second seem to be the optimum values; but I am not sure whether this improves the quality better than taking the lower ends of the leaks to L.T.—, but, perhaps, it lowers the H.T. amperage. Thanking you for a very excellent amplifier.

Yours faithfully,  
KENNETH ANDERSON.

Banwell, Somerset.

### THE MIDGET SINGLE-VALVE RECEIVER

SIR,—Having made up the "Single-Valve Midget Set" described by A. S. Clark in the May, 1925, issue of THE WIRELESS CONSTRUCTOR, with great success, I am writing to congratulate you on the circuit. I have made up many sets during my short career as a wireless enthusiast, but never have I seen such a circuit as this one-valve. My aerial and earth are certainly good, but, even so, the results are exceptional. My congratulations to the author, and wishing THE WIRELESS CONSTRUCTOR all success.—

Yours truly,  
M. FRENOLDS.

Alverstoke.



# The 'Polar' Cam-Vernier Coil-holder adds infinitely to the pleasures of fine tuning

No more useful or more popular device has been introduced for the simplification of *fine tuning* than the "Polar," the *original* Cam-Vernier Coil-holder.

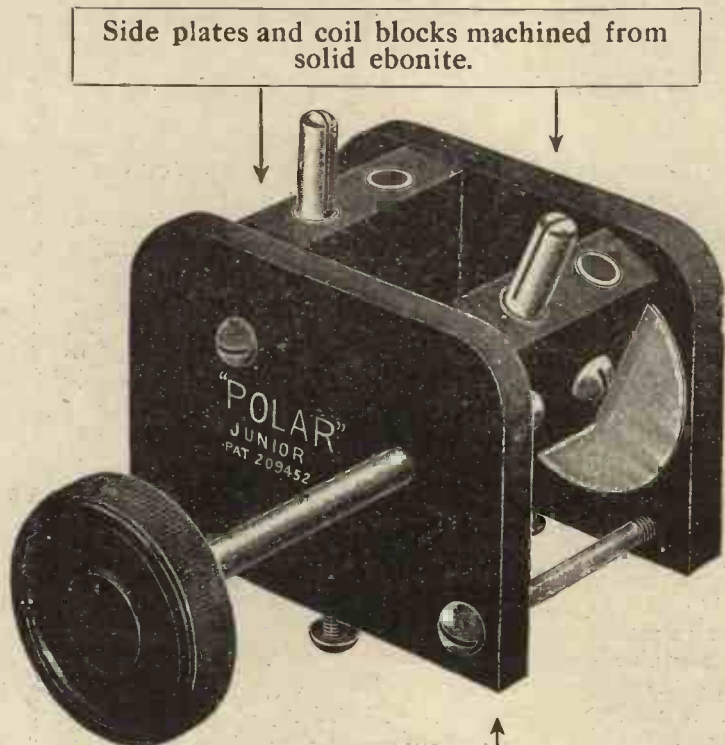

Side plates and coil blocks machined from solid ebonite.

The original Patent Cam-Vernier mechanism providing rapid positive drive followed by a most precise vernier adjustment for final delicate tuning.

An additional feature is, that at a central position in the vernier, movement, the mechanism can be locked by slightly withdrawing the knob, when the coil again moves solidly with the spindle. The vernier movement in either direction can then be immediately brought into operation once more, at any point, by simply depressing the knob.  
There are no gears to cause harsh or jerky movement.

A turn of this screw is sufficient to adjust the tension to accommodate the heaviest coil without danger of its dropping.

The movement is delightfully smooth and absolutely precise, enabling the most minute variation to be made without the tedious knob twisting characteristic of a Vernier Coil-holder operated by gears.

## The 'Polar' Cam - Vernier Coil-holder

Has no Gears

### The 'Polar' Cam-Vernier Coil-Holder

is made in three types: Type "J," the most popular, illustrated above, made of best grade ebonite, nickel-plated fittings; can be locked in positive drive by pulling knob outwards; two-way 6/-, 3-way 9/6. Type "N," has in addition a rotary movement as well as swing, giving extremely fine variations from close-coupled to right-angled loose position; 2-way 11/-, 3-way 17/-. Basket-coil Type—lighter in construction—2-way 4/6; 3-way 7/-. Backed by the well-known Polar guarantee and service.

Sold by all reputable Radio Dealers. In case of difficulty write to :

**Radio Communication Co., Ltd.**

34/35, Norfolk Street, Strand, London, W.C. 2.



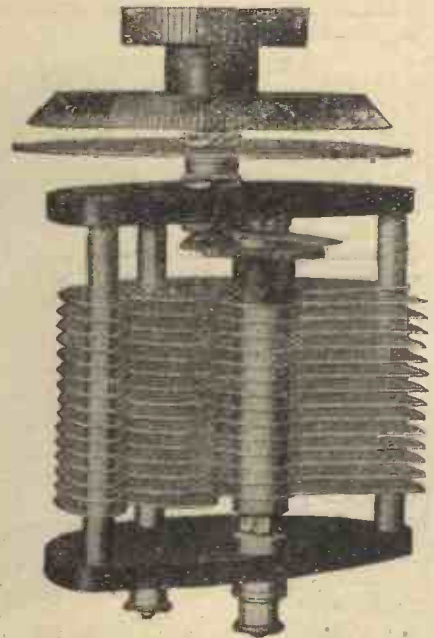
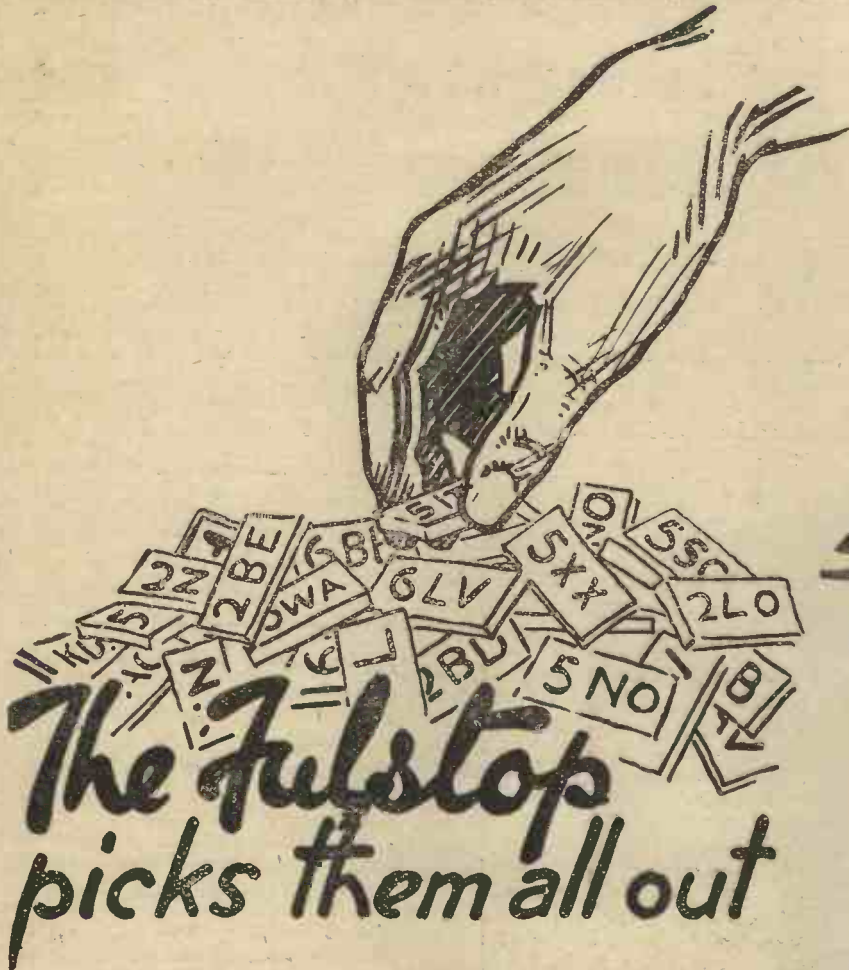

IT'S easy with a FULSTOP variable condenser to pick out stations which hitherto you had never been able to get. The FULSTOP guarantees to abolish all hand capacity effects and the increased audibility is very marked. In addition to being a square law condenser the FULSTOP is geared at 2 to 1 and therefore enables very fine tuning to be carried out with ease.

The only condenser made which guarantees the elimination of hand capacity effects.

Send for full descriptive leaflet. All FULSTOP condensers are guaranteed for 12 months.

**Fulstop**  
VARIABLE  
CONDENSER

Standard Fulstop Variable  
Condenser

PRICES:

STANDARD FULSTOP (Geared 2 to 1) Guaranteed to abolish hand capacity		PLAIN FULSTOP (No gear) Guaranteed to abolish hand capacity	
:0002	9/6	8/3	
:0003	10/3	8/9	
:0005	11/3	9/6	
:001	13/6	11/6	

SUPER FULSTOP  
Geared 2 to 1 and 125 to 1  
Patent clockwork gear

:00025	25/6
:0005	28/6
:001	30/6

Stocked by most Wireless Dealers

If any difficulty in obtaining, write us and we will send direct, post free

J. H. NAYLOR, LTD. - - - WIGAN



## More Practical Workshop Hints

*Dismantling an Old Set—Cleaning Terminal Shanks—Box  
Spanners—A Novel 6 B.A. Nut—Mending Celluloid Cases  
—A Useful Varnish*

### Dismantling

AT this time of the year hosts of wireless enthusiasts are engaged in re-making their receiving sets so as to have everything right up to the mark for the coming season. In order to rebuild you must first dismantle, and there is more in this process than might at first be thought. Careless dismantling amounts almost to scrapping—in fact, to judge from the results produced by some of my friends they might almost as well tackle the job with the coke hammer as with the more conventional screwdriver, pliers and soldering iron! If dismantling is carefully done nothing of any value should be lost, but every part should be capable of further use.

### Precautions Necessary

Here is the way in which I set about taking down a set, and I think that other amateurs may find it useful if they adopt it or something like it. The workshop bench is first of all cleared and the set is placed upon it. If it is of the American type it is slipped out of its cabinet, the latter being placed where it will come to no harm from scratching. When the set is horizontal its panel is removed from the cabinet by the drawing of the fixing screws. The screwdriver must not be used in a slap-dash fashion during this process or the ebonite will probably be scratched and the heads of the screws damaged. Just before lifting the panel off the cabinet the milled nuts or binding screws of all terminals are removed and placed in an empty tobacco tin. If this is not done they are liable to come loose by themselves and to be lost when the panel is turned over for work to be done on its underside. There should be several of these empty tins upon the bench for the reception of various small parts which are thus safeguarded. All

knobs and dials are also removed before the panel is turned over.

### Wire, Nuts, and Screws

The panel is next turned face downwards, after which all the wiring is cut away ruthlessly with end-nippers or side-nippers. At first sight this might appear to be a wasteful process, but it is not so really. If round wire is employed there will not be more than a few pence worth in the set, and the pieces cut away can be placed in a scrap wire box to come in useful when short pieces are required

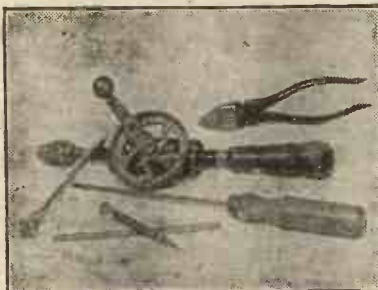

Every home constructor needs the tools shown.

later. Square rod, though it is more expensive than wire, is best scrapped, since it is not safe to straighten out right-angled bends in it with a view to future use. To be suitable for wireless purposes square rod must be stiff and if it is stiff it cannot be bent at right angles more than once in the same place with safety. Straight pieces of square rod may also find a home in the scrap wire box. Having got rid of the wiring we have, so to speak, cleared the decks for action and can get on quite quickly with the work of dismantling. Should connections have been made with nuts these should be removed with a box spanner, which is far and away the best tool for the purpose, since

it enables the work to be done quickly and does not spoil the nuts. I will describe in a later paragraph a home-made box spanner which is a very handy tool. When soldering has been done at the ends of screws or of terminal shanks the business is a little more complicated. The best way, I think, is this: Apply a little flux to the solder, grasp the short end of the wire that remains in the jaws of a pair of flat-nosed pliers and use a very hot soldering iron.

### Removing Solder

The wire will come away at once, but a certain amount of solder may be left at the end of the terminal or in the threads. Any blobs of solder can be cut away with the end-nippers, and if the nut which holds the terminal or screw in place is now removed forcibly with the box spanner the threads will be pretty well cleared by its action. Terminals and screws which have been soldered should be placed in a box by themselves for a further treatment to which we will come later.

### Components

Remove the variable condensers first of all if they are accessible, but should you have any difficulty in getting at them dismount first of all any components that are in the way. Put the condensers in a safe place so that they may not be damaged. Next tackle the big parts, such as transformers and coil-holders, and when they have been removed, take off fixed condensers and other small components. Great care must be exercised in unfixing rheostats, whose spirals, especially if they are of the open type not wound upon a core, may easily be damaged by careless handling. If the set is taken apart in this methodical way nothing is lost, or mislaid, and every component (provided, of

course, that it is electrically perfect) can be used again. The only part that will probably be of no use for making the new set is the panel, for it is most unlikely that the majority of the holes in it will be in the places where they are wanted. Still one is always requiring pieces of ebonite of various sizes for making up smaller sets, for mounting parts or for constructing gadgets. These can be cut out as required from the old panel, which should be wrapped in paper to prevent it from being scratched, and placed in the box devoted to ebonite scrap.

**Removing Solder**

And now for the treatment of screws and terminal shanks to which a certain amount of solder still adheres after dismantling. There are three ways of getting them quite clean once more. The first, which is rather a lazy one, can be used when screws and shanks are very long. It consists simply in cutting off the small piece to which solder is adhering and of trimming up the end with a fine file. The next, which is very satisfactory, is this. Trim off as much of the solder as you can, using an

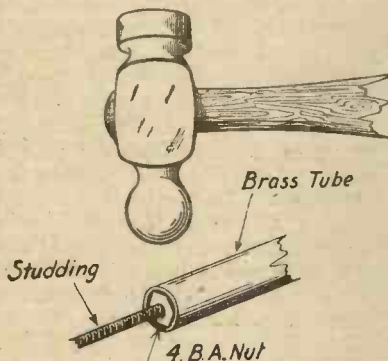

Fig. 1.—A useful box spanner is not difficult to make.

old file for the purpose. Do not use a good one since the solder will clog it and possibly spoil it. Now fix a 4 B.A. die vertically in the jaws of the vice and turn each screw and terminal into it. The die will remove all solder from the threads and nuts can be run on when required without any difficulty.

**A Third Process**

When a 4 B.A. die is not available or if you have such a die but wish to clean screws and terminals of a different thread for which you have not a corresponding die, I recommend the third process. Smear the solder-covered portion

of the screw or terminal under treatment with flux. With a pair of pliers hold it in the left hand and place its point in the flame of a spirit lamp or a Bunsen burner, keeping it there until the solder is quite liquid. Hold it with the end pointing downwards, so that the solder may not run up further into the threads. In the right hand have a thickly folded piece of rag. When the point under treatment is quite hot remove it from the flame and wipe it over with the rag. This will remove all the solder, except possibly for a thin tinning, which will not hinder the nut from going on and will greatly facilitate the process of making a soldered connection when the screw or terminal is used again.

**A Box Spanner**

Fig. 1 shows how very useful home-made box spanners may be turned out in the workshop. Obtain a piece of stout brass tubing with an external diameter of  $\frac{3}{8}$  in. Cut off a 4-in. length. Now take a standard sized 4 B.A. nut and insert into it the end of a piece of studding. Put the nut just inside one end of the tube as shown in the drawing, lay the latter upon the closed jaws of the vice or any hard surface and work all round with the round end of a hammer so as to shape it to the nut. Box spanners are very quickly made in this way and they last quite well. Should the jaws become slightly expanded after long use the spanner can always be re-shaped in the way described. Personally I always use a box spanner of this kind in the hand drill for dismantling purposes, in which case nuts can be run off in a trice and one's work is greatly speeded up.

**Adapting it for a Hand Drill**

To adapt the box spanner for use in a hand drill the jaws of whose chuck have a gape of  $\frac{3}{8}$  in., all that is necessary is to insert a plug of  $\frac{1}{16}$  in. brass rod into the unshaped end to prevent it from being crushed by the jaws. The plug should be held in place with a pin. A chuck which will not take a  $\frac{3}{8}$  in. drill will sometimes just manage  $\frac{1}{8}$  in. In this case the rod which forms the plug may be allowed to protrude for about an inch beyond the tube and this portion of the box spanner can be inserted into the chuck. Many drills, however, will not open wider than  $\frac{1}{4}$  in. and with them it is necessary to turn down the end of the rod as shown in Fig. 2. If you have not a lathe of your own

you can get this small job done at trifling cost by the handy man of a cycle repair shop or a garage. It is well worth while to make up one of these spanners, or even a set of them, for the breast drill, since they are of the utmost use not only in dismantling a set, but for constructional purposes. Owing to their length one can reach nuts in places which would otherwise be inaccessible, and thanks to the breast drill attachment nuts can be put on or taken off very rapidly.

**A Curious Problem**

The other day I found myself in rather a dilemma. I had to make use of a piece of apparatus pro-

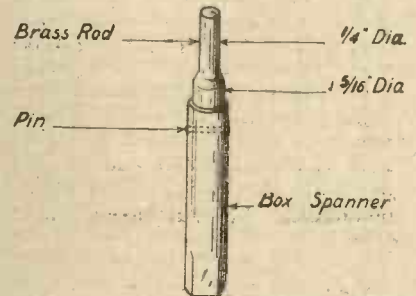

Fig. 2.—The spanner is easily adapted for use in the drill.

vided with two 6 B.A. terminals. The milled-headed nuts of these terminals were missing and I had no others of that size that I could use. Nor could the local shops help since they stocked nothing but 4 B.A.

**The Difficulty Solved**

On looking through the box in which I keep spare terminals I found that I had a few 2 B.A. milled nuts that were not of a very large size. Taking one of these I screwed into it the end of a piece of 2 B.A. studding which was then cut off with rather less than  $\frac{1}{16}$  in. protruding at either end of the nut. Both ends of the studding were then riveted down with a ball-pane hammer. The next process was to make a centre punch mark as nearly as possible in the centre of the studding and to run a No. 41 drill through it. This hole was then tapped 6 B.A. When the other nut had been treated in the same way the flat surfaces of both were cleaned up with a file and there was a pair of makeshift 6 B.A. terminal nuts which served quite well for the purpose for which they were required. This tip is quite a useful one at times since any 2 B.A. hole can be plugged with a piece of studding and subsequently

tapped 6 B.A. In the same way a 3 B.A. hole may be plugged with studding of that size and tapped 7 B.A., whilst a O.B.A. hole can be converted into a 4 B.A., or a 1 B.A. into a 5 B.A. A 4 B.A. terminal nut can also be converted without much difficulty to 6 B.A. In this case the process is first of all to run a No. 26 drill through the existing hole and to tap this 2 B.A. One then inserts the rod and proceeds as before.

**The Reverse Process**

The reverse process of converting 6 B.A. to 4 B.A. is very simple. Simply put a No. 34 drill through the existing hole and follow this with a 4 B.A. tap. Speaking of milled terminal nuts, it is not generally known that these can be purchased from tool dealers by the dozen or gross. I suppose that every one has a box containing a large number of terminals which are out of use because their nuts have been lost. These can be brought back into commission by purchasing nuts for them.

**Repairing Accumulator Cases**

It happens occasionally that the celluloid case of an accumulator

becomes damaged as the result of an accident, or that a small leak develops after long use. Not everyone knows that small holes or cracks in celluloid are quite easy to repair. Should the case of your accumulator require this kind of attention, here is the way of tackling the job. Obtain from any chemist a small bottle of acetone or amyl acetate—either is, I think,

and leave it for some little time to set.

**Strengthening Flimsy Cases**

Some accumulators of cheap make have rather flimsy cases, and these may be strengthened by bands of celluloid put on with the help of acetone or amyl acetate. A useful varnish which is lasting and quite waterproof may be prepared easily from either of the above-mentioned liquids and celluloid.

**How to Make the Varnish**

Into a small bottle three parts filled with the liquid drop sufficient little chips of celluloid to bring the liquid nearly to the top. Put in the cork, shake well and then leave until all the celluloid has dissolved, or at any rate, as much of it as the liquid will take up.

**Uses to Which it May be Put**

This varnish dries very quickly indeed and it stands a great deal of wear. I have found it useful for giving a top dressing to the windings of coils and transformers as well as for finishing off the whippings at the ends of flexible leads.

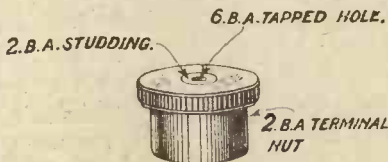

Fig. 3.—Showing how a 6 B.A. terminal nut can be made from one of larger size.

equally good for the purpose. Thoroughly clean the accumulator case round the place where the repair is to be made and paint on a little of the liquid with a brush. Its action will cause the celluloid to soften slightly and to become sticky. Prepare a patch of celluloid of the required size and treat this in the same way with the liquid. Apply the patch, press it well down

**Announcement**

**:: To the Trade ::**

**Our New Season's Catalogue is now ready**

and will be dispatched immediately on request to all bona-fide traders

This comprehensive volume embraces all and sundry of the Radio user's requirements, and is fully illustrated. *We are in an exceptional position to give the most efficient and prompt service.*

The  
**WHOLESALE FITTINGS CO., LTD.**  
23, 25 & 27, COMMERCIAL STREET,  
LONDON, E.1

65, Newington Butts, London, S.E.11  
78/80, High Street, Manchester  
14, North Street, Stokes Croft, Bristol

**Firm Fixtures in your Home for 3/6**

**IN every home there are dozens of articles which must be fixed securely and neatly. Only the Rawlplug method will ensure a permanent fixture to walls of any material—plaster, bricks, concrete, tiles, etc. The Rawlplug Outfit contains everything necessary to enable anyone without previous experience to do these jobs himself.**

*Obtainable from all Ironmongers, Electricians and Stores. A. 44*

**HOUSEHOLD OUTFIT**  
(No. 9 size)  
57 Rawl-plugs, Tool-holder and Bit, supply of Screws & Hooks with full instructions.  
**3/6**  
Refs No. 9 assorted size; Boxes of 50, 1/6; 10, 2/6

**BUY AN OUTFIT TO-DAY**

**RAWLPLUGS**

The Rawlplug Co. Ltd., London, S.W.7

**AMATEUR MECHANIC'S OUTFIT**  
(No. 8 size)  
100 Rawl-plugs, Special Tool-holder and two Bits, supply of Screws and Hooks with full instructions.  
**5/6**

# *It makes all the difference*



**WHAT'S** that, Sir? — Why am I so keen on the Harlie-Detector?

I'll tell you in a very few words.

*Firstly*, it embodies the most sensitive crystal yet produced.

*Secondly*, it does away entirely with the nerve-racking business of "crystal tickling."

*Thirdly*, it provides a contact that vibration and even hard knocks can't disturb.

*Fourthly*, it is so arranged that contact is always at the exact delicate tension required for perfect reception.

*Fifthly*, it is adjusted by simply turning the knob—in the dark as easily as in the light—and without disturbing the crystal, too—a great advantage when you want to adjust whilst others continue to listen-in.

There's a sixth reason. The Harlie-Detector has been officially adopted for use on Lifeboats and in the Mercantile Marine—and you can't do better than follow the experts.

*Harlie*  
SUPER-SENSITIVE  
**DETECTOR**

*There is no substitute!*

*If your Dealer does not stock, fill in this coupon and post to us with Postal Order for 5/6.*

**HARLIE BROS., 36, WILTON ROAD, LONDON, E.8**

Dear Sirs,

I enclose herewith 5/6 for one HARLIE-DETECTOR to be sent to me post free on the understanding that my money will be refunded, without question, if I return the Detector undamaged within ten days.

NAME.....

ADDRESS.....

15

**5/6**  
**COMPLETE**  
**WITH CRYSTAL**

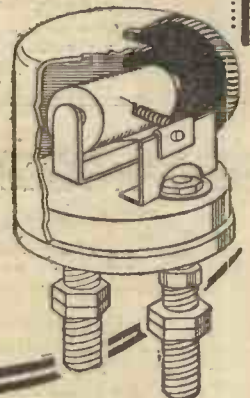

Merrill Service

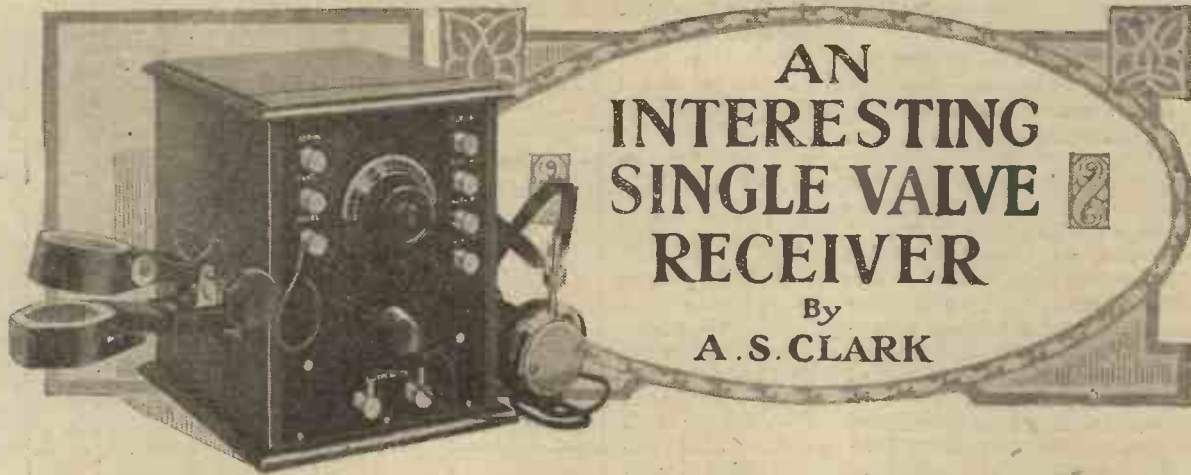

# AN INTERESTING SINGLE VALVE RECEIVER

By  
**A. S. CLARK**

*Why not get out of the rut for once? This anode-input set will give good results on the local station, and "feels" quite different from an ordinary receiver as regards tuning*

**T**HE set about to be described has two distinct advantages. Firstly, the tuning is quite sharp, and therefore it should be useful for working in cases where local interference from ships or other stations is inclined to spoil reception. Secondly, the signal strength on the local station is very good, and the set is particularly suitable where several pairs of

The circuit, which is shown in Fig. 1, is derived from those given by Mr. John Scott-Taggart, F.Inst.P., A.M.I.E.E., in his article on "Anode-Input Circuits," in *Modern Wireless* for September, 1925. Provision is made whereby either the whole or a part of the aerial coil may be included in the anode circuit. The aerial circuit is untuned; and Lissen X coils are employed when it is desired to use only a part of the aerial coil as the reaction coil.

panel, 6 by 8 by  $\frac{3}{8}$  in. (American Hard Rubber Co.).

.0005  $\mu$ F. low-loss variable square law condenser (Jackson Bros.).

Magnum "Vibro" valve-holder (Burne-Jones & Co., Ltd.).

Compression-type filament resistance (General Radio Co.).

.001  $\mu$ F. fixed condenser, mounted type (L. McMichael, Ltd.).

.0003  $\mu$ F. fixed condenser with grid-leak clips (Dubilier Condenser Co., Ltd.).

2 megohm grid leak (Dubilier Condenser Co., Ltd.).

Nine terminals.

One cabinet of suitable size (Camco).

### The Coupling Arrangement

The idea of the circuit is to use the primary  $L_1$  of a coupled aerial tuning arrangement, of which  $L_2$  is the secondary, as the reaction coil as well as aerial coil. In this way it is possible with two coils only to obtain more or less the same effect as on a receiver having 3 coils, all variably coupled.

The set is well worth while making up by the amateur who is out for something new, as the "feel" of it is entirely different to that of an ordinary single-valve reaction receiver.

### Components

As is the usual practice, a list of the components used in this receiver is given. The makers are also indicated, but it is not imperative that the constructor should definitely adhere to these, as there are many similar goods on the market which will give equally satisfactory results:—

Radion black

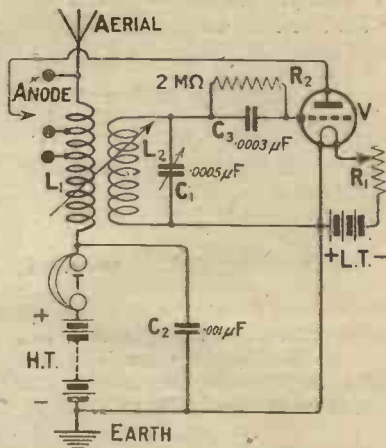
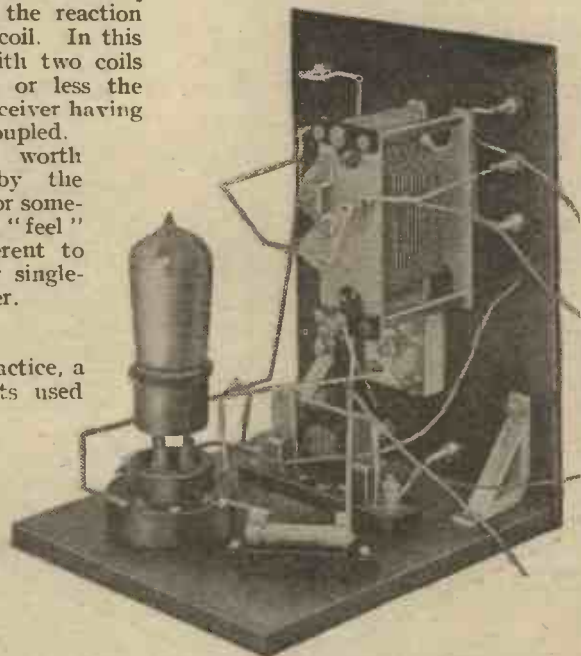

Fig. 1.—The anode-input circuit employed in the receiver.

telephones are to be worked, as when using this receiver it is unnecessary to keep quiet in order not to miss part of the programme.

### Some Notes on the Circuit

It is intended for reception from the local station, as reaction control is very peculiar, and no one but an expert could have much success on distant stations. But crystal users will probably find this receiver by itself more satisfactory than a stage of L.F. amplification after the crystal set.



This back-of-panel view shows that the components are well spaced.

Packet Radio Press panel transfers.

Two small angle brackets (Burne-Jones & Co., Ltd.).

Two-way coil-holder with round knob handle (Burne-Jones & Co., Ltd.).

It is best to collect all the components together before starting to make the receiver, as this will ensure that no holes are drilled in the wrong places. No valve-window has been used, as with the majority of valves to-day, especially dull-emitters, it is not easy to tell the brilliance of the filament when looking through a valve-window. If it is desired to examine the valve, this may easily be done by opening the lid at the top of the cabinet.

**Drilling the Panel**

The drilling of the panel is the first part of the construction to be undertaken. If a polished panel is employed, it must be laid on several thicknesses of tissue paper or other soft material while being marked out and drilled, so as to prevent scratches disfiguring the set when completed. Fig. 2 shows where the holes must be drilled. First of all mark out the panel with a scribe and after centre-punching all points to be drilled, make the holes with suitable-sized bits. The drilling of the panel should not take long, as the only components mounted on it are the variable condenser,

filament resistance and terminals. The hole below the terminals on the left-hand side is for a flexible wire, as explained later.

**Fitting the Angle Brackets**

A little care is necessary in fitting the angle-brackets. Before the holes in the panel which take the nuts and bolts which hold the brackets in position are made, the panel should be screwed to the baseboard with 3 wood screws at its bottom edge. The position of the panel holes can then be marked with the brackets held in position. Do not make any holes in the baseboard until the brackets are tightly fixed to the panel.

**Mounting the Components**

The panel should now be taken off the baseboard again, while the necessary components are mounted on it. But before doing this, it will be as well to fix the panel transfers, the positions of those required being shown in Fig. 2, the drilling diagram.

Having fixed the transfers, mount the terminals, filament resistance and variable condenser in this order. Then mount the three components that go on the baseboard. The positions for these may be obtained from Fig. 3. Before replacing the panel, all points to which soldered joints are to be made should be carefully filed clean and tinned.

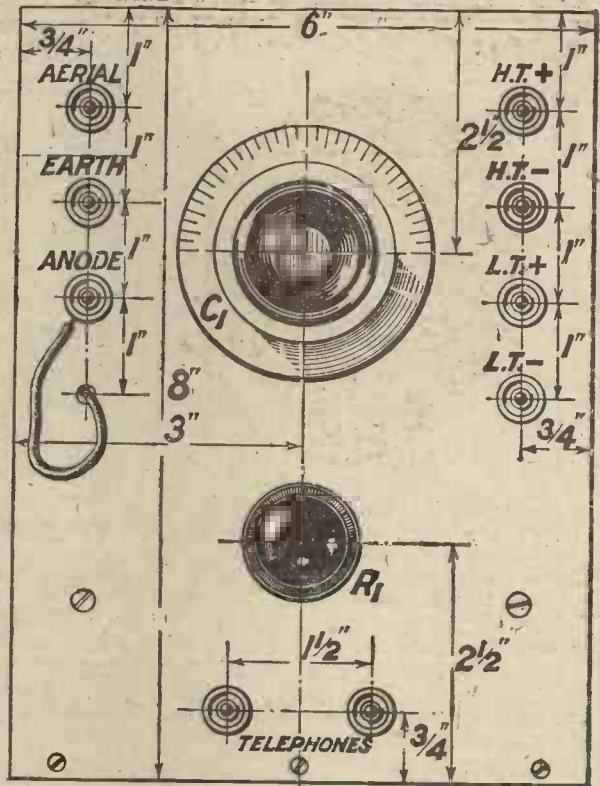
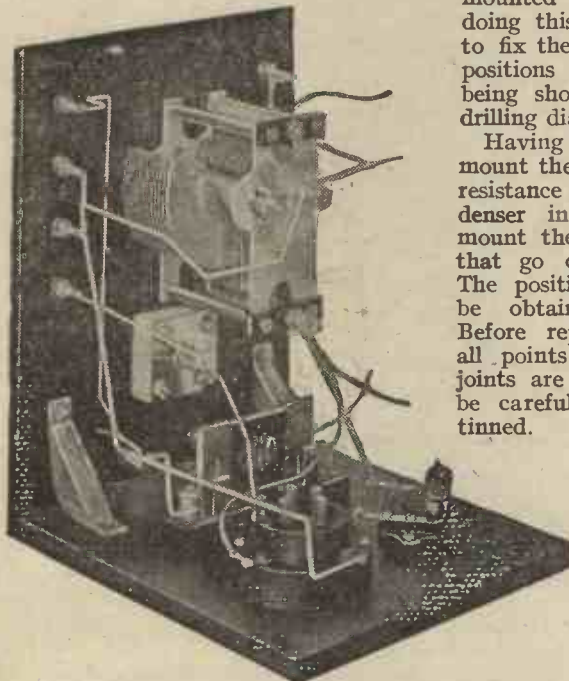

Fig. 2. The drilling of the panel should present little difficulty. Note the small hole for the flexible lead on the left.



Another view of the panel and baseboard, which slide completely out of the cabinet.

are connected first and the diagram carefully and correctly followed.

Having wired the receiver, replace it in the cabinet, and after fixing the coil-holder to the side of the case, take the flex wires through holes drilled for this purpose, and connect them to the coil-holder. It is immaterial which coil is made the moving one—it may either be the aerial coil or the grid coil, but it may be necessary, as is shown later, to reverse the connections to one or both of the coils.

**Testing**

First connect the batteries, aerial and earth to their respective terminals, and the telephones to the two telephone terminals.

Now plug a small coil, such as a No. 35, in the fixed socket, and with the coils at right angles, find the coil which, when used in the moving socket, tunes in the local station at the lowest reading. Then bring the coils towards each other, and if there is no reaction effect, try a size larger coil in the fixed socket. Should there still be no increase in signals on bringing the coils together, it will be necessary to reverse the connections to the fixed socket.

Signals were found to be loudest



# EXCEPTIONAL EFFICIENCY



GAMBRELL COILS		Nearest Size in Ordinary Coils	GAMBRELL COILS		Nearest Size in Ordinary Coils
Size	Price		Size	Price	
a/2	5/9	18	E1	8/9	150
a	5/9	25	E	9/6	200
A	5/9	30	F	10/3	300
B1	6/-	40	G	12/-	500
B	6/-	50	H	14/-	750
O	6/9	75	I	16/-	1,000
D	8/-	100	J	19/-	1,500

**GAMBRELL COILS ARE USED BY THOSE REQUIRING MAXIMUM RESULTS**

**Special Note re Tapped Coils**

Any Gambrell Coil can be supplied with a tapping at its electrical centre at an additional charge of 9d per coil.

**HAVE YOU TRIED THE TRANSADAPTA ?**

Used with Gambrell Coils for H.F. Transformers, Neutrodyne Circuits and other purposes. Compared with ordinary fine wire plug-in Units a remarkable increase in volume and selectivity is obtained.

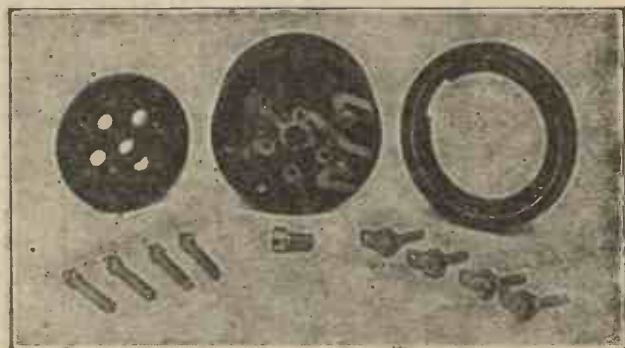

Showing the internal construction of the Transadapta with switching device. Price 6/6

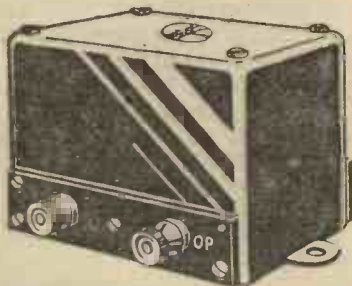

**L.F. TRANSFORMERS**

which are properly designed leave nothing to be desired from the point of view of purity and volume.

There is 30 years' experience behind Gambrell Transformers. Made in two models for 1st and 2nd Stages of amplification.

1st Stage - 27/6      2nd Stage - 27/6

**DON'T WASTE TIME !**

You'll pick up stations far more quickly by finding the correct settings of your controls with the **GAMBRELL WAV MEIER**. Accurate and simple to use.

Full instructions with each instrument. Each Wavemeter calibrated against N.P.L. Standards and supplied with hand-drawn charts.



**Q** Type "C" Wavemeter, 50 - 500 metres, £4 10 0.

Extra ranges, 20 - 7000 metres if required.

**CUT THIS OUT AND POST AT ONCE**

Messrs Gambrell Bros., Ltd.,  
76, Victoria Street, London S.W.1

Dear Sirs,

Please send the Leaflets marked with a x

- 1 RECEIVING SETS      Name.....
- 2 WAVEMETER            Address.....
- 3 COMPONENTS        /.....

TWC13

**GAMBRELL BROS., Ltd.**

76, VICTORIA ST., LONDON, S.W.1

'Phone - - - - - VICTORIA 9933

when the coil in the fixed socket was such that the set was just off oscillation with the coils almost at right angles.

**Using X Coils**

It may sometimes be found an advantage to use a Lissen X coil in the fixed socket. The set should be adjusted as just described, and then an X coil of about the same size as the fixed coil substituted for it. If on placing the flex lead on one of the tappings of this

coil instead of on the terminal marked "Anode," it is necessary to close the coils a little to obtain reaction, all is well. But if the coils have to be brought almost together, it will be necessary to reverse the flexible connections to both sockets. The set will then be adjusted for use with X coils or with ordinary ones.

**Reception**

The local station—London in this case—was received at very excellent strength on the set, as also should be other local stations. 5XX may be received with suitable coils, but the set is not primarily intended for the reception of Daventry unless the latter happens to be the local station.



The panel. The two-coil-holder is mounted on the left as shown in the left as shown in the heading on page 157.

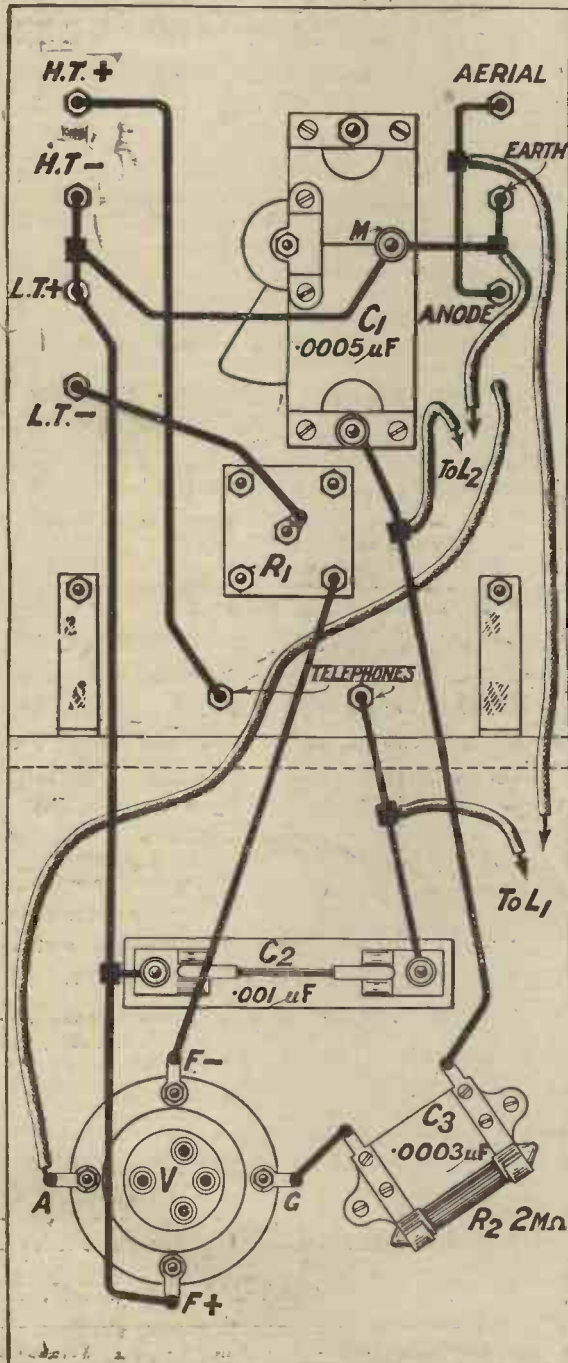

Fig. 3. The wiring diagram. Note that C<sub>2</sub> is not shunted directly across the phones.

**Radio Press, Ltd. v. The Radio Press Syndicate**

On Friday, October 16, in the Chancery Division of the High Court of Justice, before Mr. Justice Astbury, Radio Press, Ltd., sought an injunction restraining a company known as the Radio Press Syndicate from carrying on business under that name or any other name likely to lead the public to believe that the defendants' business was in any way connected with that of the plaintiffs, the publishers of this journal.

**An Injunction Obtained**

The result of the case was a foregone conclusion, the judgment being in favour of Radio Press, Ltd. An injunction, with costs, was granted restraining the defendants from carrying on business under the name of the Radio Press Syndicate or any other name likely to be confused with the name of the publishers of THE WIRELESS CONSTRUCTOR and our other authoritative wireless journals.

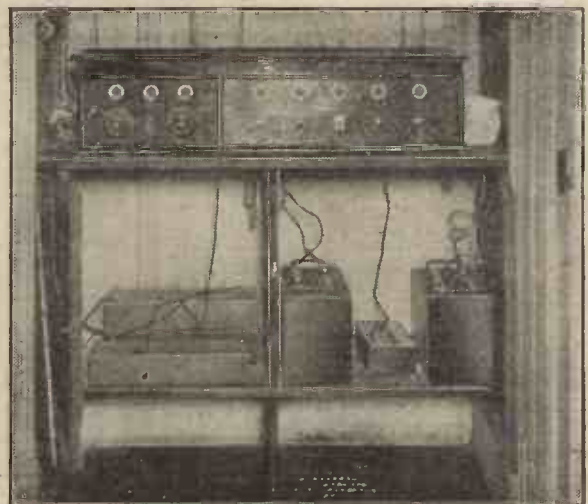

The wireless receiver at Moorfields Eye Hospital, where headphones are provided at every bedside.



**The New Duplex Terminal**

Patent applied for

WHILE it has not been found possible to improve the design of the T.C.C. Mansbridge Condenser, important alterations have been effected in the actual metal case. The new T.C.C. Mansbridge is fitted with Duplex terminals. A quick connection can now be made by means of the milled head. Soldering can still be carried out—a lug being fitted as shown.

One further improvement to be found in the use of a metal top instead of a pitch sealing compound. Thus the danger of heat affecting the Condenser during soldering is now completely abolished.

Once more T.C.C. demonstrates its ability to lead the way in condenser design—its 20 years' experience places it in a unique position for building *genuine* Mansbridge Condensers accurately and economically.

T.C.C. Mansbridge Condensers are now supplied in green metal cases in all values from .005 mfd. to 4 mfd. Your Dealer stocks them

Get the new T.C.C. Mansbridge



**T.C.C. Mansbridge Condenser**

Advertisement of Telegraph Condenser Co. Ltd., Kew, Surrey.

Gilbert Ad. 3728

In replying to advertisers, please mention THE WIRELESS CONSTRUCTOR.

**3 Famous Formo Products !**

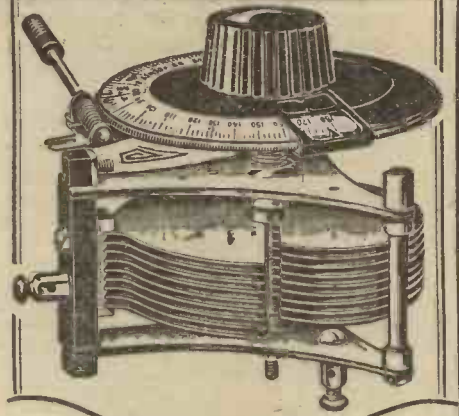

.0003μF .0006μF  
**FORMO - DENSOR**  
 complete with  
**FINE TUNING**  
**RECORDING DIAL**  
 17/6  
**FORMO - DENSOR**  
 without Dial  
 10/6  
**FINE TUNING**  
**RECORDING DIAL**  
 separately  
 7/6

The New Formo-Densor Straight Wave, Ultra Low Loss, with 200-1 Fine Tuning Recording Dial.

**SEPARATES STATIONS WITH HAIR-SPLITTING EXACTITUDE.** A condenser of advanced design, suitable alike for laboratory and general use, and for Super-Het., Neurodyne and other circuits designed for super-selectivity.

**GROUNDING ROTOR, INDEPENDENT SKELETON FRAME, JEWELLERS' METAL VANES, NO HAND CAPACITY STATIONS LOGGED ON THE DIAL.**

THE EVER POPULAR **FORMO**

**SHROUDED MODEL**

12,500 Turns

10/6 formerly 18/-



This Transformer is increasing in favour by leaps and bounds, and, at the new price of 10/6, is undeniably the utmost value in Radio that money can buy.

It is giving honest and faithful service to thousands of listeners in every quarter of the globe.

**THE FORMO PERFECTION L.F. TRANSFORMER**

Full, rich, mellow reproduction of voice or music, with the utmost fidelity. **ITS STRONGEST APPEAL IS TO THE MOST CRITICAL. ONE GUINEA.** 30,000 turns of wire. Correctly proportioned between the windings. On a core composed of the exact amount of iron.

Illustrated Descriptive Leaflets on Request:

The **FORMO COMPANY**  
 (ARTHUR FREEN & Co., LTD.)

CROWN WORKS,  
 CRICKLEWOOD, LONDON  
 N.W.2



MAKE SURE IT'S CLIMAX

UNDOUBTEDLY THE BEST FRAME AERIAL



**CLIMAX FOLDING FRAME AERIAL**

**30% Complete**

Prov. Pat. No. 26818/25

Constructed on an ingenious mechanical system by which it may be opened or folded in a few seconds. The wire folds into the frame or opens out to its final form without the least trouble.

The winding is arranged in two flat coils which are mechanically and electrically balanced. They combine the advantages of the pancake type of winding with the solenoid type. A centre tapping is provided for use with various special circuits. This frame aerial is very attractive in appearance, extremely efficient in operation, remarkably simple in construction, and is very easily folded into a conveniently portable form. The stand also folds. It is offered at a particularly attractive price.

MAKE SURE IT'S CLIMAX

For Crystal Set constructors, the

**CLIMAX POPULAR PLUG-IN DETECTOR**

is supplied fitted with the Climax Auto-micrometer Catwhisker and Superb Crystal.

Price 3/6 complete with sockets.

**THE CLIMAX AUTO-MICROMETER CATWHISKER**

combines an automatic pressure with a separate and completely independent hold-on pressure. The setting is easy, permanent and of maximum possible efficiency.

Price 1/-

Climax Superb Crystal, guaranteed natural galena, Price 1/- per box.

MAKE SURE IT'S CLIMAX

**CLIMAX AERIAL EARTH EQUIPMENT THE CLIMAX RADIO EARTH**

The Climax Radio Earth (Prov. Pat. 17693) — the low-loss direct tubular earth. Far better than the old-fashioned water-pipe or gas-pipe earth. The latest pattern is provided with flanges, which break up and help to fill in the earth around the tube, thereby preventing any rocking of the tube in the ground. In addition the projections on the surface of the tube provide water courses which make for perfect electrical contact. Ready for use. Easily fitted. Maximum efficiency. Length approx. 30 ins. Price 5/.

Climax Insulated Low-Loss Earth Lead, 20 ft. Price 1/8.

**THE CLIMAX INSULATED SHOCK ABSORBER SET** for aerial insulation de luxe. One pair of Climax Insulators linked with a Climax Shock Absorber at each end of a single span wire means perfect insulation, while the aerial wire is relieved from sudden strains due to mast sway or halyard rope shrinkage. Each Climax Insulator (Regd. design No. 708718) will stand four times the flash-over voltage of the ordinary insulator, while it has far less capacity to earth. It will stand a direct pull of hundreds of pounds. It is entirely non-hygroscopic. It cannot absorb moisture even if fractured. It insulates perfectly during rainfall. It is self-cleaning on all surfaces.

Price: One Climax Insulated Shock Absorber set comprising four Climax Low-Loss Insulators and two Climax Shock Absorber Springs 3/- per box. Climax Low-Loss Insulators, boxed separately, 1/- per box. Climax Low-Loss Aerial, 120 ft., 6/.

**THE CLIMAX LIGHTNING ARRESTER.** Made on the multi-gap quenched spark principle. Price 7/6 complete. Ready to fit.



**Metal for me!**

TAKE the advice of John the Blacksmith. "There's nothing like metal." He knows. All the hard jobs in this unfeeling world are given to metal. If it's hard service, or long service, or exact service, then the man who knows says at once, "Metal for me."



INSULATED HEAD FITS FLUSH ON PANEL PROTECTS THE VALVE; DECORATES THE PANEL

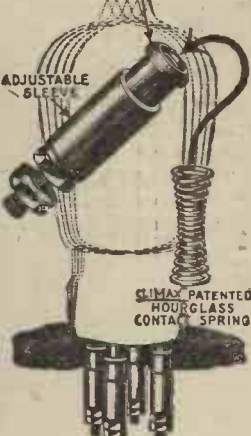

The Climax Metal-Cooled Rheostats and Potentiometer are metal wound on metal cooling cores. They employ no carbon, no sponite, no rubber. Except for the bakelite knob and terminal bar they are 100 per cent. metal. The Climax Anti-Microphonic Valve Sockets have anti-microphonic metal contact springs housed in metal sockets. They employ no rubber. Except for the insulating sleeves they are 100 per cent. metal.

**THE CLIMAX METAL-COOLED RHEOSTAT** (Prov. Pat. No. 220124/23) is wire wound on a solid metal rod, and insulated by high temperature vitreous enamel capable of standing over 2,000 volts. The cooling thus obtained far exceeds that of any other method, and keeps the resistance cool even on excessive overload. This method of construction is a Climax Patent. No other can be "just as good." Undoubtedly the best possible Rheostat at the lowest possible price.

Price: **CLIMAX METAL-COOLED RHEOSTAT**, 30 ohm universal pattern, for all D.E. or Bright Valves, 4/- each. 6 ohm, heavy duty pattern for one, two or three Bright Valves, 3/- each. **CLIMAX METAL-COOLED POTENTIOMETER**, 300 ohms, made on the same patented system 5/- each.

**THE CLIMAX ANTI-MICROPHONIC VALVE SOCKET** is made on an entirely new principle. The valve floats on metal springs. Each separate socket contains a patented hour-glass contact spring which is truly anti-microphonic and at the same time makes excellent electrical contact. The socket is provided with a circular rim for mounting flush on the panel, the upper surface of this rim being insulated to prevent accidental burning-out of the valve. The Valve Stem is supported on the Climax Patent Hour-glass Spring, the waisted portion of which makes excellent electrical contact and keeps the stem absolutely clear of all other parts of the mechanism. The use of Climax Anti-Microphonic Valve sockets is confidently recommended in place of the ordinary built-up valve-holder which has relatively high capacity, big dielectric losses and consequent low efficiency, particularly for high-frequency work.

Price: One set of four Climax Anti-Microphonic Valve Sockets, fitted with patent hour-glass contact springs, complete with nuts and washers, Prov. Pat. No. 17339/25 and 17340/25. Per Box 2/-.

**CLIMAX ANTI-CAPACITY VALVE HOLDER** for under panel mounting. One hole fixing. Price 1/6.

MAKE SURE IT'S CLIMAX

L.F. AMPLIFICATION

**THE CLIMAX DE LUXE TRANSFORMER** is constructed on a new method. The laminations of the iron core are at right angles to the usual direction. This construction enables a much shorter iron path to be employed, which means that a larger flux can be set up for a given magnetising current. It also cuts down the total weight of iron used and therefore reduces the possibility of loss by leakage and by hysteresis. The primary and secondary coils are sub-divided to reduce capacity effects and advantage is taken of this sub-division to bring out both primary and secondary circuits to two sets of terminals each. There are thus eight terminals altogether. The Climax de Luxe L.F. Transformer is therefore a multiple ratio transformer and can be connected to suit many different circuits and valves in a way not possible in the ordinary design. The workmanship and materials used are of the highest possible quality. The cores and windings are enclosed in a die cast aluminium case, giving complete mechanical protection and a handsome finish. The Climax de Luxe L.F. Transformer (Prov. Pat. No. 9549/23). Cradiform design. Multiple Ratio. Price 27/6. The Climax Popular L.F. Transformer, A highly efficient transformer for general L.F. amplification. Price 17/6.



**CLIMAX RADIO**

**"MAKE SURE IT'S CLIMAX"**

If you have difficulty in obtaining genuine CLIMAX productions, and are asked to accept inferior imitations, kindly send your order direct to us, enclosing P.O. or cheque to the correct amount, when immediate attention will be given to your instructions. **CLIMAX RADIO ELECTRIC, LTD.** Head Office and Works: QUILL WORKS, PUTNEY, LONDON, S.W.15 Telephone: Putney 2559. Showrooms: 257, High Holborn, London, W.C.1. Telephone: Holborn 2538. All communications to Head Office.

WRITE for the MAGAZINE CATALOGUE for FULL DETAILS of ALL CLIMAX RADIO COMPONENTS and SETS  
162 In replying to advertisers, please mention THE WIRELESS CONSTRUCTOR.



# Broadcast Composers

By  
"CARRIER-WAVE"

*Notes on some of the men—and women—whose musical creations reach millions via radio*

WITH the ever-increasing appreciation of classical music, the question must arise in many minds regarding the relative importance of composer and executant. Through the wide influence of the gramophone, to which, frankly, must be given first credit for giving the public better music, then the cinema—sneer at it as ye may—and at the present day "wireless," the great masses of the public have become familiar with compositions that twenty years back, or even less, were only heard at the most classical of concert halls. To-day our papers or our milk are no longer delivered to the tunes of "A Bicycle made for Two" or "Little Annie Rooney," but to the strains of fragments from Schubert's "Unfinished Symphony," Luigini's "Egyptian Ballet" and "The Song of the Volga Boatmen," often transformed into a musical melange of the whistler's own conception, but nevertheless unmistakable, and proving indubitably that, given the right material, there is a public that, knowing nothing of the composer himself or of his famous interpreters, yet has

taken to its heart the actual tune. The man therefore who said he would be content "to write the

performed; but Dame Smyth came into notice first with a quintet for strings, performed at Leipzig in 1884, where she had studied. Two of her works were heard later at the Crystal Palace in England, and a Solemn Mass at the Royal Albert Hall; but "The Wreckers" had to be taken to Leipzig for production before it was produced here. Her works have frequently been heard at all stations over the aether, including her other operas, "The Boatswain's Mate" and "Fête Galante."



Sir Frederic Cowen is also well-known as an organist.

### Off-heard Songs

Everybody knows the songs of Amy Woodforde Finden and the various song-cycles of Madame Liza Lehmann, particularly "In a Persian Garden" and its Indian companion "A Golden Garland."

We have had, too, the songs of Lady Dean Paul, best known to the musical world as Poldowski. A daughter of the great violin virtuoso Wieniawski, some of his fire and brilliance are reflected in her compositions.

Amongst the young composers

nation's songs" was not far wrong in his estimation of true fame.

### Feminine Composers

If we are to give "place aux dames," we must congratulate the British Broadcasting Company on their giving still wider fame to the gallant little band of women composers. Dame Ethel Smyth heads the list, and we have heard not only excerpts from her several operas, but also, late in July, the first performance of her latest work, "Entente Cordiale," performed by the students of the Royal College of Music and conducted by the composer herself. The public probably knows her best by her opera "The Wreckers," from which the famous prelude, "On the Cliffs of Cornwall," one of the finest pieces of spectacular writing, is so often



Sir Edward Elgar, the world's greatest living composer.



Frederick Delius, another Englishman who has achieved world-wide fame.

who have faced the microphone may be mentioned Miss Muriel Herbert and Miss Rebecca Clarke, the latter being the well-known viola player, and both writers of pleasant songs. Miss Dorothy Howell's works are on a more ambitious plane, mainly orchestral concertos, and she was hardly out of her teens when her first piano-forte concerto was performed at a



The Hallé Orchestra is inseparably connected with Sir Hamilton Harty.

Queen's Hall promenade concert, conducted by Sir Henry J. Wood, and so great was the enthusiasm evoked that a repetition was in the following week's programme—an unprecedented occurrence for a new work.

**British Composers**

A very long list now confronts the programme-maker, and no longer can the charge be made that British works of real musical value are conspicuous by their absence, for broadcasting has made their names household words.

Sir Landon Ronald, composer, pianist, conductor, and Principal of the Guildhall School of Music, has lent immense aid to the B.B.C., conducting their concerts in hall and studio. Although so many vocalists persist in believing that he has no other song to his name but "Down in the Forest," the number of song cycles and concerted works is beyond count. Sir Walford Davies is another of the noteworthy musicians who have taken immense interest in broadcast work, and he has recently conducted several concerts. Like so many of his profession, he was an organist, acting at Windsor Park Chapel Royal.

Most of his works, the Festival Overture; oratorio "The Temple," and songs and glees, have been performed throughout the kingdom.

A favourite composer, too, is Sir Alexander Mackenzie, who conducted a programme of his own works before the microphone. Late principal of the Royal Academy of Music for some 40 years, amongst his best-known works are the "Benedictus" and his opera "St. John's Eve."

**A Musical Editor**

Granville Bantock has conducted his own broadcast programme, and associated himself strongly with the wireless music. Not only has he a long list of musical triumphs to his name, best known being "Omar Khayyám," "Pierrot of the Minute," and "Lalla Rookh," but on the literary side he founded and edited the *New Quarterly Musical Review*, while later he became conductor of one of the Gaiety Theatre touring companies, which he accompanied through America and Australia. Later still he returned to become Professor of Music at the University of Birmingham, there succeeding Sir Edward Elgar.

**Elgar, German and Cowen**

Of Elgar's work so much has been written that further details here are not necessary. Probably, out of all his works, the one that will linger in popular fancy is his march from "Pomp and Circumstance," to which tune is set "Land of Hope and Glory."

The real English music-maker not nearly well enough appreciated is



Miss Dorothy Howell achieved success at an early age.

Edward German. The true spirit of English music lives in his work. It needs no "book" to make it "programme music," and it is not hard to believe that his music will go hand in hand with English folk-song history.

Sir Frederic Cowen's music also is often heard over the aether, the



Granville Bantock's music is familiar to most listeners.

best known of his productions being "The Butterfly's Ball" and "The Language of Flowers" suite.

**Chamber Music**

It is surprising how great a revival has taken place in the liking for quartets, trios and the old classics, as well as for the fresh works, and for modern chamber music the names that come first to one's mind are Frank Bridge, John Ireland, Joseph Holbrooke and Armstrong Gibbs.

Mr. Frank Bridge has composed many works, one of the best being a suite, "The Sea," performed at a Queen's Hall concert many years ago. His best-known song possibly is "Love Goes a-Riding."

The "Phantasy" trio is perhaps the best known of John Ireland's works, and the somewhat turgid "Variations on Three Blind Mice" that of Joseph Holbrooke. Better appreciated are Eric Coates with one of his dainty miniature suites, Gerrard Williams, a clever song-writer, and also Roger Quilter.

Cyril Scott is essentially a pianist, and accordingly his "Danse Nègre" appeals to actual players as well as listeners.

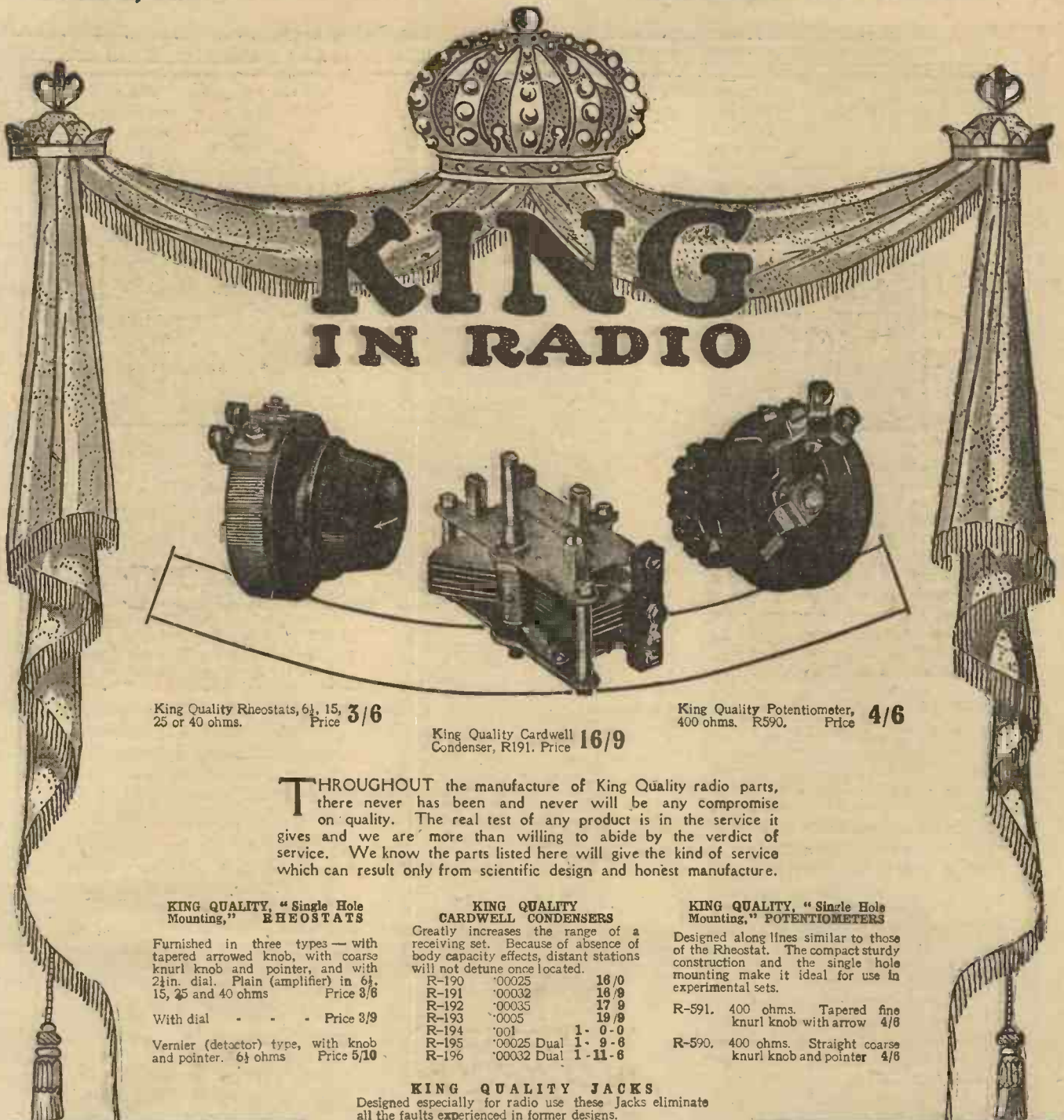

King Quality Rheostats, 6 $\frac{1}{2}$ , 15, 25 or 40 ohms. Price **3/6**

King Quality Cardwell Condenser, R191. Price **16/9**

King Quality Potentiometer, 400 ohms. R590. Price **4/6**

**T**HROUGHOUT the manufacture of King Quality radio parts, there never has been and never will be any compromise on quality. The real test of any product is in the service it gives and we are more than willing to abide by the verdict of service. We know the parts listed here will give the kind of service which can result only from scientific design and honest manufacture.

**KING QUALITY, "Single Hole Mounting," RHEOSTATS**

Furnished in three types — with tapered arrowed knob, with coarse knurl knob and pointer, and with 2 $\frac{1}{2}$ in. dial. Plain (amplifier) in 6 $\frac{1}{2}$ , 15, 25 and 40 ohms Price 3/6

With dial - - - Price 3/9

Vernier (detector) type, with knob and pointer. 6 $\frac{1}{2}$  ohms Price 5/10

**KING QUALITY CARDWELL CONDENSERS**

Greatly increases the range of a receiving set. Because of absence of body capacity effects, distant stations will not detune once located.

R-190	'00025	16/0
R-191	'00032	16/9
R-192	'00035	17/9
R-193	'0005	19/9
R-194	'001	1- 0-0
R-195	'00025 Dual	1- 9-6
R-196	'00032 Dual	1-11-6

**KING QUALITY, "Single Hole Mounting," POTENTIOMETERS**

Designed along lines similar to those of the Rheostat. The compact sturdy construction and the single hole mounting make it ideal for use in experimental sets.

R-591. 400 ohms. Tapered fine knurl knob with arrow 4/8

R-590. 400 ohms. Straight coarse knurl knob and pointer 4/8

**KING QUALITY JACKS**

Designed especially for radio use these Jacks eliminate all the faults experienced in former designs.

R-372a. Two springs, one break contact, frame insulated. Closed circuit. 2/9

R-374. Four springs, breaks two contacts. Double circuit. 3/3

R-375. Five springs, opens two and closes one contact. Double filament control. 3/9

R-377. Seven springs, opens three and closes one contact. Double circuit, double automatic filament control. 4/2

**KING QUALITY SWITCH LEVERS**

Constructed with an enclosed tension spring which ensures smooth operation and perfect electrical connection at all times. With fine knurl or coarse knurl, Bakelite knob.

Price 1/6

**KING QUALITY TERMINALS**

R-73. All Bakelite, knob and base. Per dozen 7/6

R-75. Bakelite knob. Black or Mahogany, nickel base. Per dozen 4/-

R-77. Bakelite knob, nickel grooved base. Per dozen 4/-

**KING QUALITY PRODUCTS, INC.**  
**GASTON E. MARBAIX, European Sales Manager, 27, Anning St., LONDON, E.C.2**

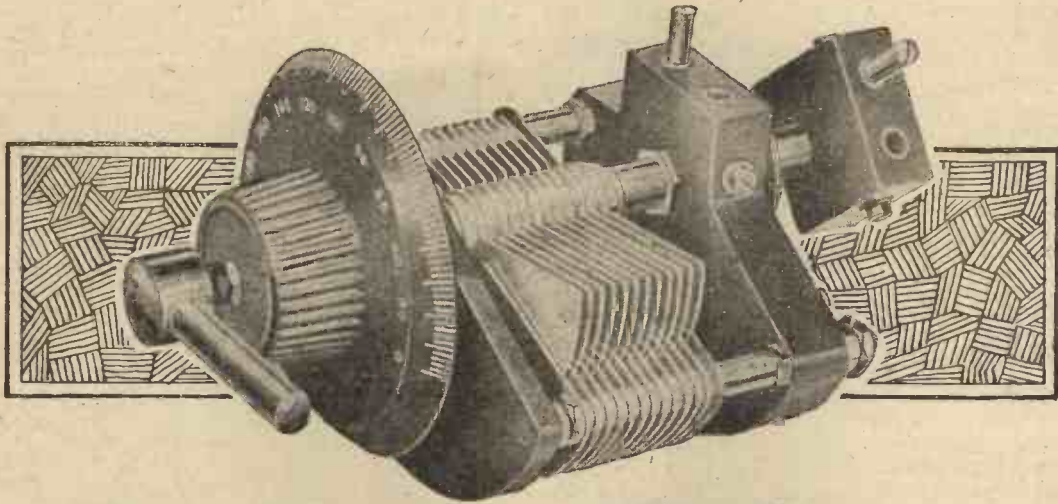

# Striking a Balance

**T**O balance a pole across a trestle a certain amount of see-sawing is necessary. You move it in one direction, and it over-balances; then you move it back a bit, and so on, until a perfect balance is found.



Tuning your set is very much like balancing a see-saw on a trestle. You add capacity by bringing up your reaction coil. The balance is upset and the receiver "howls"; then you dash across to the condenser dial, and reduce its reading, thereby reducing capacity. And so a balance may be struck by alternate adjustments, first on one dial and then on the other.



How much easier it would be to combine these two adjustments on one component, to introduce a

balance over our trestle, as it were. The Seamark Connode is the only instrument which does this. It allows capacity to be increased by the reaction coil, and decreased by the condenser, or vice versa, until a balance is obtained, without removing the hand from one dial to another.



Moreover, increase of capacity by the coil holder can be obtained in the same direction, as decrease is obtained by the condenser. If one adjustment introduces instability, a compensating readjustment may be made on the Seamark Connode without even altering the direction in which the hand is moving.



# 19/6

IF ANY DIFFICULTY IS EXPERIENCED IN OBTAINING

## The SEAMARK CONNODE

REGD

WRITE DIRECT TO THE

Sole Patentees and Manufacturers:

C. E. NEEDHAM & BRO. LTD., 10, MILK ST., SHEFFIELD



**The Song Writers**

Amongst those who have appeared before the microphone may be mentioned Stephen Williams, singer as well as composer, while the songs of Wilfred Sanderson, and the late Easthope Martin, with his "Come to the Fair," and the former's "Up from Somerset" and "The Company Sergeant-Major," are again known from Land's End to John o' Groats. Maurice Besley is a competent conductor as well as composer, and has conducted concerts at the Queen's Hall as well as for the B.B.C. A programme of Benjamin Dale's music was also greatly appreciated last year, while his cantata "Before the Paling of the Stars" was produced at Queen's Hall in 1913.

**Typically English Music**

Two composers who are invariably considered to be foreign, owing to their names, are Gustav Holst and Frederick Delius. Both are unmistakably English, Mr.



Sir Landon Ronald is a famous conductor of the Royal Albert Hall Orchestra.

Holst being born at Cheltenham, though of Swedish parentage, and Mr. Delius at Bradford, and their compositions are too typically English to be mistaken.

**Two Conductor-Composers**

Sir Hamilton Harty, conductor and composer, too, performed Delius' work "At Brigg Fair," at one of the Hallé concerts last year, and it was relayed to London. Of Sir

Hamilton's own works, "With the Wild Geese," and many symphonies stand to his name.

**A B.B.C. Conductor**

One more noted conductor, as well as composer, is Mr. Eugene



Miss Rebecca Clarke is a song writer and viola player.

Goossens, who conducted another symphony concert recently for the B.B.C. Gainer of many scholarships, and silver medallist of the Royal College of Music, he has composed many symphonies and quartettes, and conducted the principal orchestras in the kingdom.

**On the Lighter Side**

Perhaps best known of all, however, are the composers who give us the more "popular" melodies, and here according to our desires we have had such masters of their art as Rex Burchell and Albert Ketelbey, with his orchestral tone pictures.

It will be a long time before "In a Monastery Garden," "A Chinese Temple Garden," and others will be forgotten.

**Ballads and Fox-Trots**

For lovers of songs of the ballad type are Frederick Nicholls, Stephen Williams, and that ever popular member of the Savoy Bands, Billy Mayerl, who ran a whole pantomime when other boys are in school. His songs and fox-trots are heard now every night.

**Foreign Composers**

To try and give any idea of the immense work of foreign composers in a limited space would be useless. Best known from a wireless standpoint are Grieg, with his "Peer Gynt" and Lyric suites, pianoforte concerto, etc., and Saint-Saëns, writer of operas and songs innumerable, who was an organist in his youth, which possibly accounts for the wonderful scoring in his concertos. Debussy, Gabriel Fauré and Dvorak have all been made familiar names before the microphone, likewise Jean Sibelius, with his tragic "Valse Triste" and "Finlandia," the latter having such an effect when it was first produced that the Finnish Government forbade it to be played lest it led to open mutiny.

**"Rustle of Spring"**

Christian Sinding, who is known, alas! to this country apparently most by that trifle "Rustle of Spring," has conducted his own works over here, while we fancy



Humperdinck—the late composer of the popular fairy opera "Hansel and Gretel."

Humperdinck's fairy opera "Hansel and Gretel," known now to every child, young and old, was the second opera to be broadcast in this country.

Next Month :  
**SPECIAL XMAS NUMBER**  
 Out on December 15

## Wood or Ebonite?

Some notes regarding the use of wooden panels in the construction of wireless receiving sets

By A. V. D. HORT, B.A.

**M**OST experimenters have probably at some time assembled a temporary receiver on a wooden baseboard or panel, without using ebonite or any other insulating material in addition. They may have found that the set worked quite reasonably well for a time at any rate. On the other hand, perhaps, results were disappointing, though the cause of failure was not easy to discover.

### Modern Tendencies

At or below the frequencies used by the broadcasting stations, wood may be fairly satisfactory as an insulator, under certain conditions, and provided that it is properly used. Visitors to the Wireless Exhibitions this year can hardly have failed to notice that there is a tendency nowadays to reduce the amount of ebonite or similar material in receivers, especially in those which are designed to be attractive pieces of furniture, as well as efficient instruments for reception. In such receivers, however, it will often be found that the components and terminals mounted on the wooden panel are insulated from it with bushes of ebonite or similar insulating material; the wood, therefore, acts merely as a supporting medium, and not primarily as an insulator.

### For What Frequency?

There is a certain advantage in the reduction in favour of wood of the amount of ebonite used in a receiver, in the comparative cheapness of the former material. But a good deal depends on the frequency at which the receiver is intended to operate. At the higher frequencies, and especially at frequencies above about 15,000 kc. (20 metres), it is usually advisable to reduce to a minimum any masses of solid conducting or non-conducting material not actually concerned with the construction and operation of the receiver. Such parts as cannot be altogether eliminated, as, for instance, the supports for the variable condensers, tuning coils and so on, should possess good dielectric properties,

in order to reduce direct losses due to the presence of poor dielectrics.

In designing receivers for these high frequencies, therefore, it appears that wood is in general to be avoided. At the frequencies at which broadcasting is carried out, however, there is less objection to the employment of wood close to the component parts of a receiver, though its use as an insulator is still to be deprecated, unless it is specially treated. Unless special material is selected, even treated wood compares unfavourably with ebonite.

### A Few Figures

The main difficulty with wood is keeping it dry. A wooden panel may seem to be perfectly dry, while in reality enough moisture is present in its fibre to render it quite useless as an insulator for H.F. currents. As far as direct

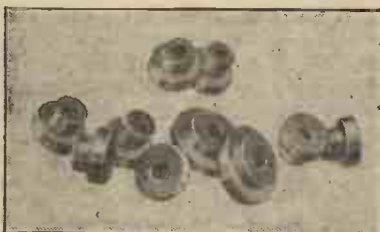

Ebonite bushes allow wooden panels to be used for mounting.

current resistance is concerned, untreated dry wood possesses an insulation resistance superior to that of vulcanized red fibre. Thus the insulation resistance per cubic centimetre for dry wood is about  $50 \times 10^6$  megohms, while the equivalent figure for red fibre is only about  $10 \times 10^6$  megohms. For purposes of comparison, it may be mentioned that the value for ebonite varies between  $4,000 \times 10^6$  and  $28,000 \times 10^6$  megohms per cubic centimetre.

### Some Interesting Points

Untreated dry wood will soon absorb sufficient moisture from the atmosphere to render it practically

useless as an insulator for wireless purposes in our climate. Suitable treatment of the wood is capable of raising its insulation resistance considerably, wood dried out and impregnated with paraffin wax showing a resistance of  $300 \times 10^6$  megohms per cubic centimetre. From these figures it is apparent that under proper conditions wood is not to be despised, at any rate as an insulator for direct current, the main points to be observed being the choice of a suitable wood and the correct preparation of it. Such prepared wood may also be found quite suitable for wireless apparatus, provided that generous allowances of space are made between conductors touching the wood, and so long as the frequency of reception desired is not too high. Generally speaking, hard woods are to be preferred to soft, since they are not so prone to pick up moisture from the atmosphere. Incidentally, they are more satisfactory to cut and drill than soft woods, and so more suitable for instrument mounting. Also they can be readily given a high polish, which adds to their usefulness as insulators, since a highly-polished surface will be easier to keep free of dust and more impervious to moisture than a rough one.

### Suitable Woods to Use

Teak is probably the most satisfactory material for general use, but it may be no better than any other wood unless it is properly treated. It must be very thoroughly dried, and then soaked in hot paraffin wax of good quality until it is impregnated right through. When the superfluous wax has been drained and scraped away from the surfaces, the latter may be polished by rubbing hard for some time with a dry soft cloth, it being assumed that they have been well smoothed before being soaked in the wax. If the polish is to last, this rubbing must be very thorough, as little free wax as possible remaining on the surfaces when the polishing is finished. It will be found that the wood will drill quite cleanly when it is thus impregnated with wax.

Among other woods which may be used are mahogany, beech and oak, mahogany being especially useful when thin panels are needed. Beech needs some care in working, as it is close-grained and extremely hard; holes have to be bored to the full depth for any screws to be put into it, in order to avoid shearing of the screws when they are driven home. This remark applies also to oak, and in this case steel screws are unsuitable, as the gallic acid in the wood would quickly rust them away.

**Use of Bushes or Inserts**

The precaution of soaking the wood in wax is only essential, of course, when metallic parts of the circuit are to be mounted direct on the wood. It is not so necessary if ebonite bushes or inserts of generous dimensions are let into the panel, the wood under such conditions acting merely as a mechanical support. This latter method of using wood for a panel will be found quite satisfactory, so long as the insulating bushes are large and all parts of the circuit are insulated from the panel in this way.

**Testing for Leakages**

If any anxiety is felt about possible leakages of current between,

for instance, the positive and negative terminals of the high-tension battery, a simple test will locate any faults in this respect. Connect one tag of a pair of head-phone leads to the negative wander-plug, and with the positive plug and the other phone tag touch various parts of the panel, taking great care to avoid bringing the tag and lead into metallic contact with each other. If the insulation is in order, no sound should be heard in the phones on tapping, for instance, on a terminal and a point on the panel an inch or so away. A slight or pronounced click when this is done will indicate that the insulation between the terminal and the panel is slightly or seriously at fault.

*A "Constructor" Set  
in the Transvaal*

SIR,—The New Crystal-Valve Set as described by Mr. John Scott-Taggart, F.Inst.P., A.M.I.E.E., in the March number of THE WIRELESS CONSTRUCTOR has given me great pleasure, and I wish to let you know how successful it is

here. Lately I used a crystal set which was all right while in Johannesburg, but when I moved out here, about 25 miles from J.B. (Johannesburg), I found it inadequate, so I looked around for a simple way of hearing J.B. clearly. A friend who had tried out the set told me of the wonders of it, which I took with a grain of salt. To make a long story short, I made one and now I get J.B. very loudly, Durban (600 miles) clearly, and even Cape Town (1,000 miles away) fairly well. Of course, atmospherics are bad in this country in the summer, which is now coming on, and Cape Town fades very much at times. To-night I could only get it after J.B. closed down. Nevertheless, I think it rather wonderful to get it at all on such a simple, inexpensive layout. I made it exactly as described and got my good results right away without any bother. Mr. Scott-Taggart wished to hear how this set acted, so I have written this letter to let you know it is possible to hear concerts in this country 1,000 miles away with the "New Crystal-Valve" set.

Yours faithfully,  
HECTOR C. MACKAY.  
Transvaal,  
S. Africa.



**Announcing**  
**A BOWYER-LOWE**  
**LOW LOSS CONDENSER**  
**FOR TEN SHILLINGS.**

**A Precision Condenser at a Popular Price**

This remarkable new instrument of precision comes as the result of a determination to give the amateur experimenter a thoroughly GOOD condenser at a price he can well afford. Test one yourself, and prove that its performance is worthy of the reputation of The Bowyer-Lowe Company who made it. Its ball-bearing rotor eliminates uneven bearings, harshness of control and uncertain tuning. Its low loss design ensures electrical efficiency and a wavelength range unusually great. Its compensated square law design ensures the availability of the whole dial for tuning. This condenser is guaranteed against faults for twelve months. If within that time it fails to give satisfaction through any cause it will be repaired or replaced FREE. The "Popular" is the condenser the amateur has long sought. Instal it in all your sets. It makes precision tuning possible for every wireless enthusiast. Buy it to-day. Descriptive leaflet free on application to The Bowyer-Lowe Co., Ltd., Letchworth.

**0003 M.F.**  
**10<sup>7</sup>**  
**0005 M.F.**  
**10<sup>6</sup>**

**The Bowyer-Lowe**  
**"POPULAR" Condenser**  
**BALL BEARING · LOW LOSS DESIGN · SQUARE LAW**

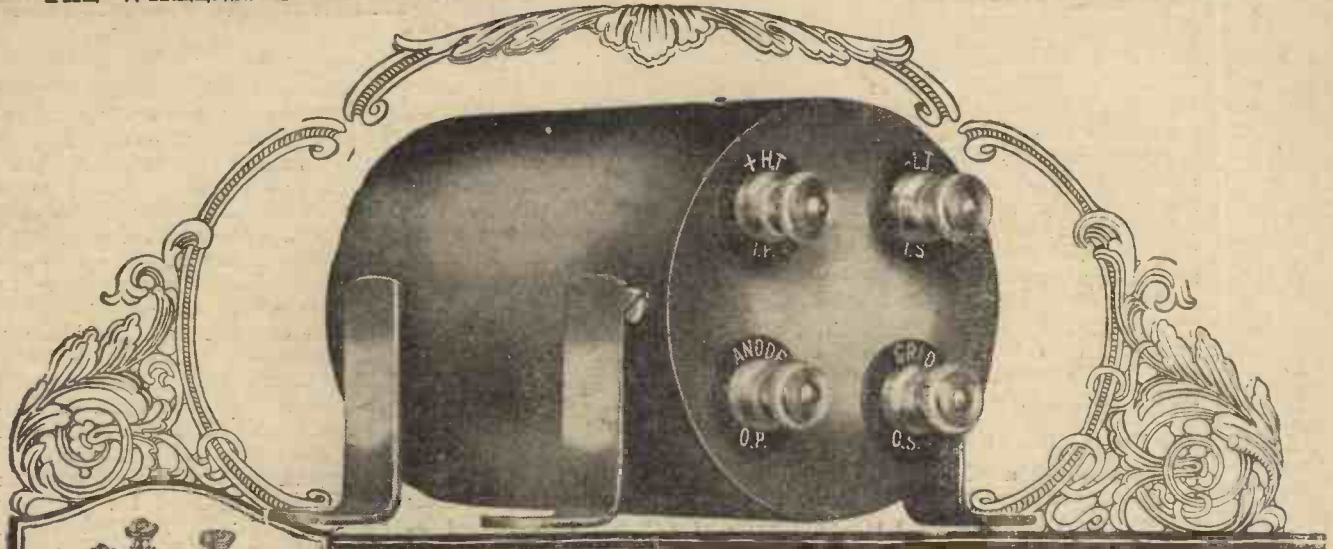

## After two whole years Eureka supremacy is still unchallenged

THE Eureka Concert Grand was the first high-grade Transformer to be made with a non-laminated core. It was the first to be made with the large amount of 2½ miles of wire. It was the first to be made with a coppered steel case which simultaneously prevented interaction, and hermetically protected its contents. And it was the first to be sold under a generous guarantee of instant replacement free of charge in the remote possibility of breakdown. Such pioneer work met with instant appreciation. Hundreds of thousands of wireless enthusiasts have realised the importance of using only the finest Transformer that money can buy or that Science can evolve—they have chosen the Eureka. Their choice has been a wise one.

Your L.F. Transformer is to your Set what an engine is to a motor car. You may select the finest looking car—its appearance may be most impressive. But if its power unit is inefficient, your money will have been wasted. So with your Set. You may spend

pounds on the other components—you may choose the most expensive panel, yet if your L.F. Transformer is inferior, the whole of your expenditure will be prejudiced.

Any Eureka Transformer is a veritable key to melody. Such purity of tone and volume as was never before believed possible is now within the reach of everyone. With its five

distinct models there is now a Eureka to fit every need at a price within the reach of the most modest experimenter.

### EUREKA REFLEX

The usual transformer is not pre-eminently suitable for reflex circuits. Special qualifications are needed, and here is the first Reflex Transformer built to measure up to true Eureka standards of quality and to conform to reflex requirements. Each ... 15/-

### BABY GRAND Nos. 1 & 2

For those whose purpose does not render the superlative Concert Grand a necessity, we can now offer the Eureka Baby Grand Nos. 1 and 2 for second stage. Incorporating all the recognised Eureka principles of design. Each ... 15/-

### EUREKA CONCERT GRAND

The Standard de Luxe Transformer ... 25/-

Eureka No. 2. For use as a second stage amplifier ... 21/-

From all Dealers.



RADIO

Portable Utilities Co., Ltd.

# EUREKA

PRODUCTS

Fisher St., London, W.C.1

Gilbert Ad. 3710

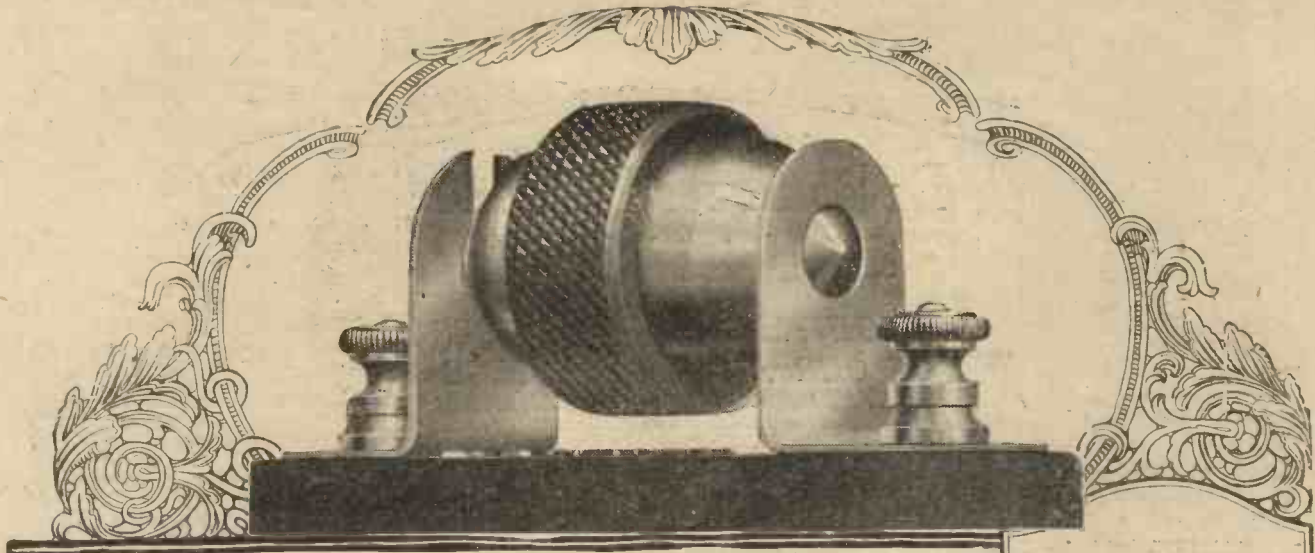

# Why the new Eureka Rotary is the last word in Detectors

*A permanent Detector is convenient but comparatively insensitive.*

*A catwhisker Detector is supersensitive but troublesome.*

*The Eureka Detector combines all the advantages of both and possesses the disadvantages of neither.*

FOR three years the world has been waiting for a Crystal Detector so foolproof that it can be set in the dark. One that is really sensitive to weak signals. One that is thoroughly adjustable. One that will never wear out. One that can be reloaded with a new piece of crystal in a moment. One that is proof against damage. One that will receive any type of Crystal. Many Crystal Detectors on the Market will measure up to one or two of these requirements, but until the Eureka Rotary appeared none could measure up to all.

The Eureka Rotary is totally enclosed, dustproof, and employs entirely new principles. It makes use of a series of phosphor bronze contact points made to rise and fall in contact with the

Crystal by means of a rotary cam operated by an external ebonite ring. The pressure of the point on the crystal can be varied from a gentle touch to a firm grip.

### THREE EUREKA EXCLUSIVE FEATURES.

1. Merely remove the Eureka Rotary Detector from its clips and it falls apart and releases the crystal for a complete change of facets. No unscrewing or troublesome fitting.
2. Any crystal can be used in the Eureka Rotary. No Special mounting required. Just drop it in and insert the Detector between its clips again.
3. Rotate the Eureka and you bring into operation a succession of sensitive spots. Stop rotating when you have obtained the loudest signals and adjust for pressure of contact.

From all Dealers.

Everyone knows that the fixed Detector—after a brief spell of fame—is falling rapidly out of serious consideration. No Crystal can remain sensitive in one spot for long. And a permanent Crystal Detector when insensitive must be thrown away. The Eureka lasts for ever. You can use any new crystal that is placed on the market. It is a handsome component which will enhance the appearance of any Receiver. If required it can be mounted direct on the panel by using the base

as a drilling template. Every instrument is covered by the generous Eureka guarantee.

**5/6**



RADIO

# EUREKA

PRODUCTS

Portable Utilities Co., Ltd.,

Fisher St., London, W.C. 1

Albert Ad. 371C



*An announcement of importance to all our readers*

**R**EADERS will be interested to hear that following upon the visit of the Editor to the United States to investigate the radio position there, Radio Press, Limited, have opened an American house, with offices in the heart of New York, thus enabling readers of our publications in this country to keep right up to date with all developments taking place in America.

#### **An Important Step**

The importance of this step to the British experimenter and home constructor can scarcely be over-estimated. No longer will it be necessary for the British enthusiast to view new experiments in America through American eyes. New apparatus, new circuits, new valves, and, what may be still more important, new tendencies which are showing themselves in radio design and developments, will all be reported upon immediately by a competent radio expert, fully acquainted with radio matters on both sides of the Atlantic.

#### **Our Representative**

It is with great pleasure that we introduce to our readers Mr. A. H. Morse, A.M.I.E.E., M.I.R.E., who has been appointed manager of the American House of Radio Press, Limited. Mr. Morse has for some years been actively concerned with the technical side of telegraphy in both its "wired" and "wireless" branches, and has held many important positions in radio both in England and America, and his practical acquaintance with the art dates back to the very earliest days.

It will be seen that Mr. Morse not only has considerable experience of administrative matters, but he has also a wide technical

experience of the art. This combination of administrative experience and technical knowledge is of no little importance, since the task of obtaining full information on technical matters is not easily performed. Mr. Morse's standing assures for him the entry into many places which are normally difficult of access, and his personal acquaintance and friendship with some of the greatest men in American radio will be of inestimable value to him.



Mr. A. H. Morse, A.M.I.E.E.  
M.I.R.E.

#### **With the G.P.O. and the R.E.**

In 1897 Mr. Morse entered the Telegraph Service of the General Post Office in London, and after three years there, left England in 1900 to serve in the Boer War, being attached to the Telegraph Section of the Royal Engineers. He was engaged in journalistic

work for a short time on his return to England in 1902, but again left this country in 1904 for West Africa, where he carried out the construction of the first telegraph line to Sokoto.

#### **Wireless in Canada**

On completion of his African work, Mr. Morse proceeded to Canada, entering the service of the De Forest Wireless Corporation as a consulting engineer in 1906, and had charge of the complete wireless telegraph service between the cities of Montreal, Ottawa and Quebec. He was made Superintendent of the Company in 1907, and had charge of five stations on the Pacific coast. Afterwards he was on the staff of the United Wireless Telegraph Co., and returned to England in 1910 to take charge of that company's European business.

#### **Further Wireless Work**

In 1912, Mr. Morse joined the Marconi Co. when that company took over the business of the Northern Wireless Telegraph Co., and three years later became wireless adviser to the Indo-European Telegraph Company. He accepted the position of managing director of Marconi's Wireless Telegraph Co., Ltd., of Canada, in 1919, but resigned this office in 1923 to go into business on his own account.

#### **Offices of the Radio Press, Ltd.**

The offices of our American house will be situated in the Bush Building, West 42nd Street, New York; an admirable position in one of that city's most famous thoroughfares, and we have no doubt that before long, Radio Press, Bush Building, New York, will become as well known as Radio Press, Bush House, London.

# Bowyer-Lowe Parts for Minimum Losses

EVERY time you put into your Receiver a component which reduces the losses incidental to wireless reception, you increase the power available for telephones or loud speakers. So that every time you buy a Bowyer-Lowe Component you know that you are making a contribution to the strength of your receiver and the purity of the signals it will yield.

**Every Component Guaranteed 12 Months**  
Put Bowyer-Lowe Low Loss parts into every set you build

## ANTIPONG LOW LOSS VALVE HOLDERS



Non-Microphonic, low loss and shock absorbing, this valve holder is the most efficient devised. It prevents all noises in Dull Emitters and protects ordinary valves from jars. Valve legs surrounded by air are mounted on phosphor-bronze springs and attached to a non-inflammable bakelite ring. Universal fitting. Screws provided. PRICE **3/-**

## MATCHED H.F. TRANSFORMERS

Every Bowyer-Lowe Transformer is individually matched against standards so that every one of a range is precisely like every other. No special selection for H.F. Stages is necessary. All ranges from 150 to 2,000 metres and up, and special Neutrodyne Unit, 300 to 600 metres, at uniform price. EACH **7/-**



ALL RANGES

*No increase in price has occurred since these Transformers were first offered*

## SERIES PARALLEL & STUD SWITCH PARTS FOR PANEL MOUNTING



Sold complete in boxes, these components comprise all parts necessary for building, including switch arms and knobs, studs and stops, screws, nuts, drilling template and instructions. The Stud Switch parts make any switch from 2 to 10 way. The Series or Parallel Switch is useful for every purpose where a double pole change over is needed.

Stud Switch 2 to 10 way **2/3**

Series Parallel Switch .. **4/-**

# BOWYER-LOWE TESTED COMPONENTS MAKE SUCCESSFUL SETS

Drop us a postcard now asking for a complete catalogue of reliable parts for every kind of receiver, from a Crystal set to a Super-Heterodyne

**BOWYER-LOWE CO., LTD. LETCHWORTH**



## "TANGENT" The Better Coil!

**BETTER—**

because the special method of winding allows a larger gauge wire to be used, which naturally offers a minimum resistance to high-frequency currents.

**BETTER—**

because there is ample air-spacing between the windings, reducing the self-capacity to a minimum.

**BETTER—**

because these windings are in no way interlaced and this absence of turn crossing turns is a factor of no small importance.

**BETTER—**

because the coil is a sound mechanical job, substantially built on a stout frame, each coil being a solid and compact unit not affected in any way by handling.

The tuning with the Tangent Coil is so sharp that the resulting selectivity is surprising and there is a complete absence of distortion at all frequencies. Made to fit all standard coil holders.

See Tangent - The Better Coil - Nov. Most good houses sell Tangent Fitments

Write for  
Booklet  
W.C. free  
on  
request.

RADIO  
**TANGENT**

FITMENTS  
**GENT & CO. LTD.**  
Established 1872

GENT & CO. Ltd. FARADAY WORKS, LEICESTER



Radio users will welcome the NEW NEUTRON products. These instruments set a very high standard in design, embodying all the outstanding features that science has as yet produced. The name of Neutron is in itself a guarantee of quality goods.

Write for fully illustrated Catalogue of  
**H.T. BATTERY ELIMINATOR**  
(to work off any direct current)  
**CRYSTASTAT Semi-permanent DETECTOR**  
**POCKET CRYSTAL SET**  
**LF. TRANSFORMER**

Sole Producers: **SENTINEL HOUSE, SOUTHAMPTON ROW, NEUTRON, LTD. LONDON, W.C.1. Phone: Museum 8340**

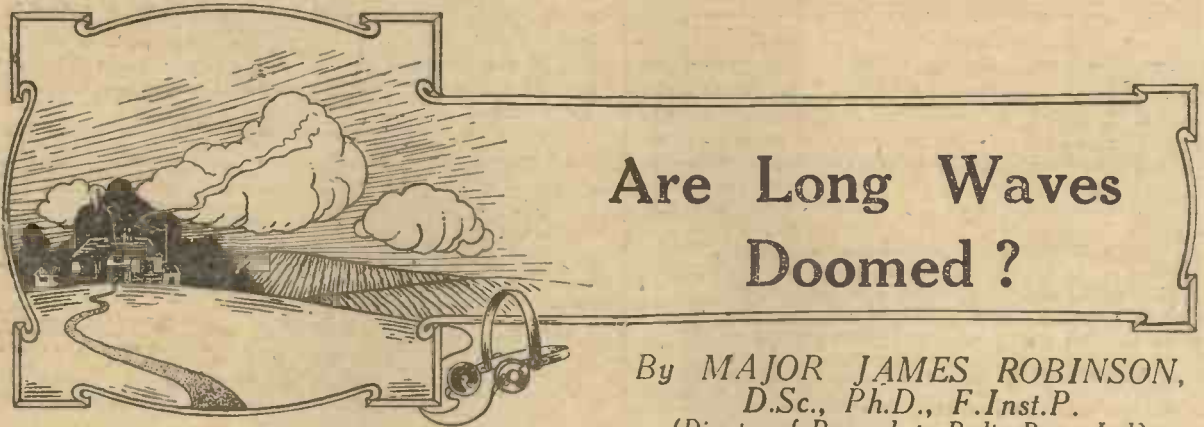

## Are Long Waves Doomed?

By MAJOR JAMES ROBINSON,  
D.Sc., Ph.D., F.Inst.P.  
(Director of Research to Radio Press, Ltd.)

*In this article Dr. Robinson discusses the increasing use of the higher frequencies in radio communication*

**W**IRELESS is a subject full of surprises, and probably the biggest surprise occurred within the last two years when it was discovered that it is not always essential to use very great power to send signals over very large distances. Wireless engineers were staggered because they had been developing for the last twenty-five years along lines which meant more and more power and higher aerials in order to guarantee reliable communication over long distances.

### Huge Stations Needed

They might well be staggered, for a typical transmitting station for long-distance communication, such as from England to Egypt, required masts from 500 to 800 ft. high, as many as six such masts being wanted, and an input of 250 kilowatts or more, with an aerial current of 200 amperes or more. In order to reach India from England in one stage it was considered that more and more power would be required, and so on to Australia. This phase of wireless development was employing frequencies of 15 to 75 kilocycles (wavelengths of 4,000 to 20,000 metres). Suddenly results began to appear, to a very large extent from amateurs, showing that it was possible to communicate with America at certain times of the day using a power of a quarter of a kilowatt, and with an aerial current of 2 or 3 amperes. Once this was known, other experimenters attempted to do the same and it was not long before we had a large number of such results, and now we hear quite regularly of communication between England and Australia, between America and Australia, between England and Iraq, and so on. The power of the transmitters being usually of

the order of  $\frac{1}{4}$  kilowatt. The difference between these two absolutely opposed results was in the frequency that was being used, these newer results being obtained on frequencies above 3,000 kilocycles (wavelengths below 100 metres).

### Early Experimenters

We may thus with good reason ask the question, "Are long waves doomed?" The early experimenters in wireless who still survive are also wondering why it is that they were deflected into the development of long waves 25 to 30 years ago. Senatore Marconi himself is now doing a considerable amount of work on short waves, and he has been devoting his time to this problem for the last 7 or 8 years. Actually in his case it is a return to a region on which he had already experimented in common with all investigators of 30 years ago.

### Marconi's Work

Hertz, Marconi, Sir Oliver Lodge, Hughes, Sir Henry Jackson, and other pioneers all experimented with short waves, but the reason why they were deflected into long wave development was the discovery by Marconi in 1895 that the earthing of a vertical aerial greatly improved the range of signalling as known in those days. This discovery of Marconi's was the basis of the commercial utility of wireless telegraphy, and although it appeared to be introducing a form of signalling which to scientists was not pure electromagnetic waves, yet it provided the necessary range for signalling, and thus wireless telegraphy was able to commence commercially, and the development of long waves was placed on a firm footing. Higher and higher

aerials were used, long wires were used horizontally at the tops of the aerials, and as the natural wavelength of an aerial is approximately four times its own length it is seen how the wavelength used soon became very long indeed.

### Modern Tendencies

It is interesting to study the reason for the tendency to return to short waves. After the war the development of wireless telegraphy was prosecuted with great vigour. The war period was almost entirely in the long wave phase of wireless development. After the war, however, amateurs became very pressing to be allowed to experiment, commercial services for wireless telegraphy began to multiply, and the rumours that wireless telephony had been used during the war began to excite people so that a demand for broadcasting was made. To satisfy all these services it was necessary to widen the band of wavelengths, and thus amateurs were forced down in wavelength. The commercial services were using waves longer than 300 metres, and amateurs were sent down in some cases to 100 metres, and though they resented this at the time, they attempted to make the best of what they considered to be a bad bargain, with the result that we have this remarkable discovery that short wavelengths enable us to economise on power for long-distance communication.

### Short Wave Developments

Amateurs cannot claim all the credit for these excellent results on short waves. Senatore Marconi, as already mentioned above, with his assistant, Mr. Franklin, began to develop short waves towards the latter end of the War. They used wavelengths of the order of 6 to



10 metres, and they actually obtained wireless beams with waves of this type. They first of all developed short wave work for navigational purposes, and one station has been installed at Inchkeith in the Firth of Forth for some time. Another station has recently been installed at the mouth of the Thames. The rotation of this wireless wave beam is equivalent to the rotation of a lighthouse beam, and signals can be heard only when the beam is pointing in the direction of the receiver, or within a few degrees of this direction. Special signals are sent for different points of the compass so that mariners know their bearing from the beam transmitting station according to which signal they hear.

#### Extending the Range

Mr. Marconi, after developing the beam for navigational purposes, attempted to extend the range of his beam system, and by lengthening the wave somewhat soon came to the conclusion that very large ranges could be obtained on frequencies above 3,330 kilocycles (wavelengths up to 90 metres). His transmitting station is usually at Poldhu, and he periodically makes voyages in his yacht "The Elettra" in order to discover what ranges he can obtain under different conditions, working on wavelengths below 100 metres. The enormous ranges that he obtained with comparatively small power was of such importance that a contract was entered into with the Imperial Government for Communications with the Colonies. This scheme has a great advantage, as the initial cost of erection and installation of a short wave beam station is very much less than that of a long wave high-power station.

#### The Beam System

One great advantage of the work which Mr. Marconi has done is that by the use of beam transmitters a considerable amount of secrecy in signalling can be maintained, for most of the energy can be concentrated in a very narrow beam, and signals can only be obtained within a very small angle of the direction of the beam.

#### A Drawback

There is one very great drawback to short wave communication at long distances, which is that no single wavelength has been determined below 100 metres which will guarantee communication at any time of the day or of the night. These short waves can be heard practically any time throughout the night, and at very great ranges

the strength of signals does not appear to fall off to any considerable extent. As soon, however, as day breaks, these long ranges immediately vanish. Below about 30 metres wavelength, certain daylight ranges begin to appear, but here again these are only obtained for a limited number of hours per day. This feature of short wave communication is very serious and it is one of the main reasons why there will be hesitation to adopt short waves in place of long waves universally.

#### Peculiar Phenomena

There is a very peculiar effect with short waves, which is that signals are often not heard within a distance of a few hundred miles of the transmitting station, but they only appear beyond this

distance. This refers particularly to the very high frequencies. This "skipped distance" has a peculiar effect, and it may have something to do with the fact that long-distance communication on short waves was not discovered previously because the experimenter normally attempted to communicate over short ranges before attempting longer distances.

Another serious effect of short waves is the phenomenon known as fading, where signals rise and fall in strength from time to time. The period of fading is sometimes fairly long, and sometimes it is comparatively short, the matter of a few seconds or even less.

#### Great Signalling Speeds

On the other hand, there is a great advantage of short waves,

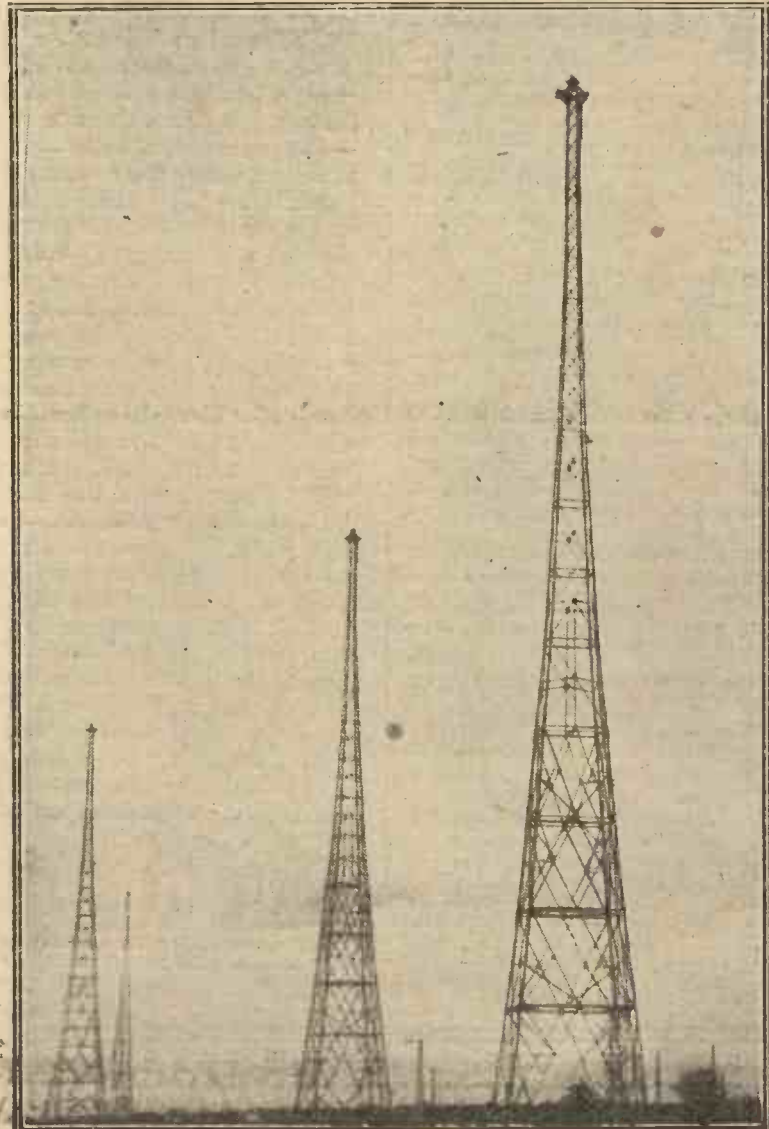

Long-wave stations require expensive equipment, including huge masts such as are shown in this photograph.

**The New S.T.100**

The wonderful 2-valve Reflex described in the first issue of *Wireless*. Complete Pilot Kit of Components, £6 4 0. Polished Cabinet, 20/-.. Best quality Panel, drilled, tapped and engraved, 11/9.

**The All Concert-de-Luxe**

One of the most popular of the *Modern Wireless* 3-Valve Sets. Complete Pilot Kit of Components, £4 12 3. Polished Cabinet, 17/-.. Best Quality Panel, drilled and tapped, 13/-.. Engraving (if required) 3/6.

**The Transatlantic V.**

The ideal 5-Valve Set for long distance reception. Complete Pilot Kit of Components, £5 4 0. Polished Cabinet, 17/-.. Best quality Panel, drilled and tapped, 15/-.. Engraving (if required) 3/6.

**The Single-Valve Reflex**

A 1-Valve Set which will amaze you for volume and sensitiveness. Complete Pilot Kit of Components, £2 13 0. Polished Cabinet, 4/6. Best quality Panel, drilled and tapped, 4/6. Engraving (if required) 2/6.

**The Puriflex**

Specifically designed for perfect Loud Speaker reproduction. Complete Pilot Kit of Components, £3 15 0. Polished Cabinet, 17/-.. Best quality Panel, drilled and tapped, 13/-.. Engraving (if required) 3/6.

**The 2-Valve All-Stations**

A splendid and economical Set for long distance work. Complete Pilot Kit of Components, £1 18 0. Polished Cabinet, 21/-.. Best quality Panel, drilled and tapped 6/-.. Engraving (if required) 2/6.

**The 3-Valve Dual**

An economical Reflex in which three Valves do the work of four. Complete Pilot Kit of Components, £5 16 0. Polished Cabinet, 27/6. Best quality Panel, drilled and tapped, 11/6. Engraving (if required) 3/6.

**The 4-Valve Transatlantic**

An economy long distance Set with two stages of H.F. Complete Pilot Kit of Components, £6 12 6. Polished Cabinet, 27/6. Best quality Panel, drilled and tapped, 11/6. Engraving (if required) 3/6.

**The Anglo-American Six**

The latest long distance Set with three stages of H.F. Complete Pilot Kit of Components, £9 11 6. Polished Cabinet, 63/-.. Best quality Panel, drilled and tapped, 25/-.. Engraving (if required) 5/-..

All the above Sets described and illustrated in *The Pilot Manual*

Where the Complete Kit of Components are purchased with Panel, a Marconi Royalty of 12/6 per Value Holder is payable, and must be remitted with order

**PETO-SCOTT CO. LTD.**

77, CITY ROAD, E.C.1

(For all Post Orders)

BRANCHES: 62, High Holborn, London, W.C.1  
Walthamstow: 230, Wood Street  
Plymouth: 4, Bank of England Place  
Liverpool: 4, Manchester Street



**George Williams builds his first Set**

LAST week-end I took a run over to see George Williams at his little cottage down in Surrey. A fine old-world place—300 years old, if a day—set in the most wonderful country surroundings. The cosiest house you ever saw—big Elizabethan fireplaces, timbered ceilings, panelled walls, winding staircases, massive oak doors and so forth. “Hullo, old chap, you are just in time,” he said, “to hear this 5-valve Set I have been building.” “I didn’t know that wireless was one of your hobbies,” I replied. “Well, to tell you the truth,” he answered, “it wasn’t—until last week.” “You don’t mean to say that you have built up this Set within a week and without knowing anything about wireless?” I asked in amazement, for the Set which George showed me would have been a credit to any wireless expert. “Yes,” he said, “eight days ago I couldn’t tell a rheostat from a condenser. Of course, you know

that I was never much of a mechanic, and I’m really indebted to my young nephew for this,” he said, proudly fondling a magnificent multi-valve Receiver resplendent with its dials and switches. “I thought there was a catch in it somewhere,” I said laughingly, “you mean that your nephew really built it and not you.” George was most indignant. “No,” said he, “my nephew merely put me on the easiest way for a duffer like me to build a good Set. He sent me a copy of a little book called the “Pilot Manual,” which told me all about it.” And then George explained to me what a splendid idea this Pilot scheme was. How the parts for any well-known Set are all supplied ready to fit together on the panel—how it is really only a matter of assembly and wiring up. I’m sure that if George can build up a 5-valve Transatlantic I can. Anyway, I’m sending for a copy of the “Pilot Manual” to-morrow.

Please send me a copy of the Pilot Manual, giving detailed working instructions and illustrations for building many of the well-known Radio Press Sets. I enclose 3d. to cover cost of postage, etc.

Name.....

Address.....

**Pilot Sets for Home Constructors**

which is that it is possible to use very great signalling speeds. The speed of signalling is one of the pressing problems of wireless telegraphy, and it is found that on the longer wavelengths which are commonly used at present the speed cannot profitably be raised above 30 words per minute. On the very short waves, however, it is possible to speed up the signalling considerably, and although there is a

In the case shown at (b) the oscillations only just reach their full value on the length of a dash, and the dots do not attain more than about half their full strength. On the other hand, (c) shows how the dots and dashes will come through on short waves. In this case there are very many oscillations of the waves in the period of a dot, and it will quickly "build-up" as shown by the curve. Hence it is possible to

for fading has a more serious effect on telephony, particularly if this fading is very rapid. We only need to refer to the attempts which have been made by the B.B.C. to relay KDKA to see how difficult the problem of telephony on high frequencies at long distances really is. For short distances there is, of course, no technical reason at all why broadcasting should not be good on short waves.

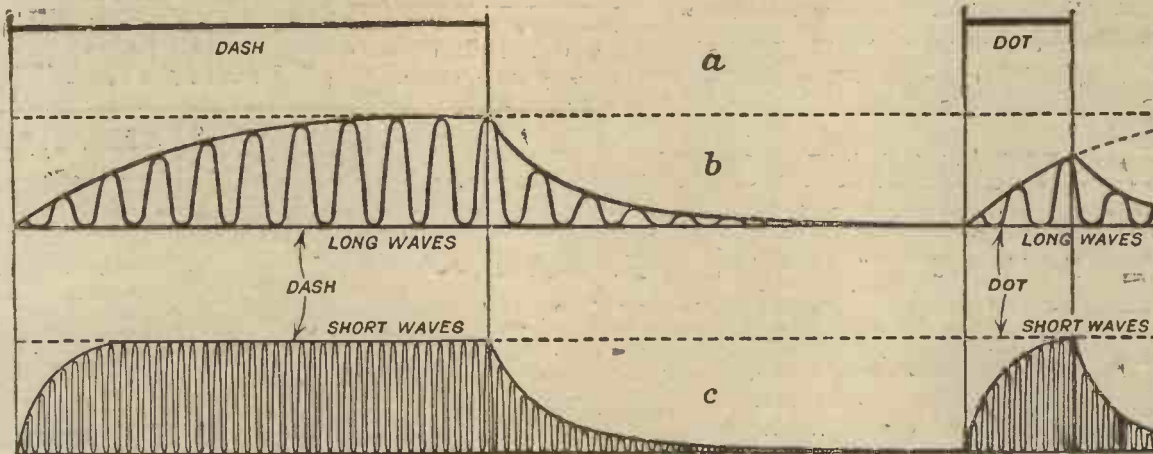

Fig. 1.—It is seen in (b) that when long waves are employed the dot is unable to build up to the necessary strength in the allotted time, whereas it will reach the required strength in the same period if short waves are used (c).

shorter available time in which the signalling can take place, it should be possible to get through the same amount of traffic.

**Speed and Frequency**

The reason why the speed of signalling depends on the wavelength can be seen from Fig. 1.

The high-frequency currents take a certain time to build up to their full value, the number of oscillations required before this full strength is attained depending on the constants of the circuit.

It will be seen from Fig. 1 that on long waves the length of the dots must be greater.

obtain the full effect of a dot in a shorter space of time, and the speed of signalling can be very much higher than in the case of long waves.

Atmospherics have different effects on different frequencies, and they are much worse on the lower frequencies than they are on the higher. This is conducive to more reliable signalling on the latter.

**Telephony—and the Future**

Most of the preceding remarks apply principally to telegraphic signalling. As regards telephony, the problem is somewhat difficult,

Some of the peculiarities of long and short waves have been enumerated, and as regards commercial development, we have seen that there is one instance of a commercial company committing themselves to short waves; that is in the case of the Marconi contract for Imperial Communications. There is no doubt that high frequencies will be used very considerably in the future for long-distance communication, but it will be a long time, if ever, before long wave stations will be completely displaced by short wave stations.

The Special Christmas Number of  
**THE WIRELESS CONSTRUCTOR**

will be published on 15th December

124 pages—6d.

Order your copy early

# K. RAYMOND

**7, GRAPE STREET,  
Shaftesbury Avenue, W.C.2**  
Back of New Princes Theatre.

**HOURS OF BUSINESS AT GRAPE STREET.**

9 to 7.30 Daily. Closed Thursday Afternoon.  
Open Saturday, 9 to 7.30. Closed Sunday.

All Post Orders from this Address.

POSTAL DEPARTMENT.

All Post Orders, Parcels or postal communications of any kind to be addressed to 7, Grape St., Shaftesbury Avenue, W.C.2.

All orders post free over 2s. U.K. Foreign orders extra postage, please.

## CUSTOMERS

who call at 27 and 27a, Lisle Street, are requested to see they enter my premises.

*Don't Forget the Name*  
**K. RAYMOND**

## SECOND HAND GOODS

Possibly you have some saleable goods you wish to exchange or sell. If you will post me a list of same, together with the price you expect, I will endeavour to make you an offer. Silence a polite negative.

### RADIO PRESS ENVELOPES

#### SETS OF PARTS

All Less  
Box, Valves and Panel.

2 Valve Amplifier De Luxe  
R.P.E. No. 7  
Author's Parts  
£4 16s. 6d.

Single Valve Reflex (No. 8)  
Author's Parts  
£3 2s. 2d.

"Simplicity"  
3 Valve (No. 3)  
Author's Parts  
£3 7s. 10d.

All Concert De Luxe (No. 4)  
Author's Parts  
£6 18s. 2d.

Efficient Single Valve  
Author's Parts  
£1 16s. 10d.

9 Valve Supersonic  
May, 1925, Modern Wireless.  
Author's Parts  
£18 5s. 0d.

4 Valve Family (No. 2)  
Author's Parts  
£6 15s. 0d.

Twin-Valve Loud-Speaker Receiver  
by Scott-Taggart  
Set of Parts  
£4 12s. 0d.

2 Valve Cockaday Set  
Nov. 1925, "Wireless Constructor"  
Set of Parts  
£3 17s. 6d.

Please Note Heading

## VARIABLE CONDENSERS

### SQUARE LAW

K. RAYMOND

"DE LUXE" LOW LOSS MODEL.



SQUARE LAW

High grade Ebonite ends, one hole fixing, knob and dial.

With Vernier.

001 .. ..	8/11
0005 .. ..	7/11
0003 .. ..	7/8

Without Vernier.

001 .. ..	7/6
0005 .. ..	5/11
0003 .. ..	5/6

Accurate, narrow spacing, splendid workmanship, high-class article. Clean cut signals. Many testimonials.  
Post, 3d. per set.

K. RAYMOND

American Type Low-Loss, skeleton ends, perfectly rigid, moving vanes and end plates are an earth potential. Each complete with dial and knobs. Square Law.



With Vernier	Without Vernier
001 .. 9/8	001 .. 8/3
0005 .. 8/9	0005 .. 7/9
0003 .. 8/8	0003 .. 7/6

Post, 3d. per set.

### Above Condensers SQUARE LAW.

G. ROBINSON, Esq.,  
4, Gladstone Street,  
DERBY.  
21/10/25.

"Have tested your Condensers and they are the best money's worth I have ever had. The workmanship is supreme and gives entire satisfaction."

G. GLAZE, Esq.,  
Coakway Road,  
Merry Hill, COMPTON.

"Goods splendidly packed, and thank you for the high quality."

### IGRANIC

Last word in Condensers.  
0005, 24/-; 0003, 21/-.  
Sq. Law with vernier.

### COLLINSON'S SELECTOR

"Low Loss" (geared)  
0005 21/-; 0003 20/-.  
Sq. Law with vernier.

### "ORMOND"

"Low Loss" American Type, Skeleton ends, knob and dial. 001 10/8; 0005 9/6; 0003 9/-.  
Above with vernier. Deduct 1/6 each if no vernier required. As with Ebonite ends, same price.

### JACKSON BROS. (JB) Condensers.

Low Loss	Geared	Square Law	Standard
001 .. 13/-	001 .. 17/6	001 .. 9/8	001 .. 8/-
0005 .. 10/8	0005 .. 15/-	0005 .. 8/-	0005 .. 7/-
0003 .. 9/-	0003 .. 13/-	0003 .. 6/9	0003 .. 6/9

Sq. Law with vernier: 001 14/-; 0005 12/6; 0003 11/6.

### Radio Micro Valves

06 Special

F.V. 3 to 3.5  
A.V. 40 to 80

12/6

2s. allowed for your burnt-out valve on this particular item.  
Post Extra

### MULLARD

PM 4  
LOUD-SPEAKER VALVE  
22/6

For use with 3 dry cells or 4 v. accu.  
Finest L.S. Valve on the Market.

### B.B.C. New British Headphones

4,000 ohms, equal to 20/- pair  
Limited Number at 12/6

### Dekko

VALVE WINDOWS  
Nickel .. 6d.  
KEYSWITCH - 2/9  
PUSHPULL - 1/6  
Post 2d. under 2/-

### "Matchless"

Duplex Coils

1 in. wide, airspaced  
25, 35, 50, 75, 100  
Highly Recommended  
Set of 5 .. 2/6  
Post Free.

### BOWERMAN'S SUPER POWER 'PHONES

Uniquely light in weight, first quality materials, craftsmanship perfect, true-tone, comfortable, 4,000 ohms, stator diaphragm, highly finished Duralum headbands. Each phone guaranteed. Reduced from 21/- NOW - - 12/6

### N & K. Headphones

Genuine (stamped on back of each case), very fine value. Comfortable leather headbands. 4,000 ohms.  
POST FREE - 13/11

### BENJAMIN Valve Holder

For good reception with Dull Emitter Valves, Benjamin Clearer Tone Anti-Microphonic Valve Holders are absolutely essential .. 2/9

### VAN RADEN

Accumulators guaranteed for 12 months. Send for List.

### PELICAN UNIVERNIER DIAL

Makes your Set Micro-selective.  
The 12 to 1 Reduction has been proved most efficient for selective control, AND the price! .. 6/-

### TELEFUNKEN

(New Model)  
Loud Speaker 18/11

### WATES MICROSTAT, 2/9

### APEX Anti-Cap Valve Holder

Baseboard Type, Nickel Screws, Soldering Tags  
1/8, Post. 2d.

### "BRUNET"

The old original phones, a little lighter in weight, very fine value, 4,000 ohms.  
Post free 12/11 pair  
Reduction to callers.

### TELEFUNKEN

In sealed boxes. Genuine Phones, 4,000 ohms. Adjustable magnets in sealed boxes. Many thousands sold without a complaint. Light as a feather. No need to try and find a better phone.  
Post free 18/- pair.  
Reduction to callers.

### "COMBINE"

Vernier Dial, 5/9.

### GENUINE DR. NESPER Loud-Speaker

Post Free 15/11

### BATTERY BOXES

ready for filling  
63 volts ... 5/3

### FLASH LAMP BATTERIES

for same 14 for 6/-

### T.C.C.

genuine green  
Mansbridge  
Condensers

2 mfd. ... 4/6  
1 mfd. ... 3/10  
25 .. ... 3/-  
etc.

Don't be bluffed by people trying to trade on their reputation.

HULL UP EVERYBODY!

K. RAYMOND

I ADVERTISE FOR OUR MUTUAL BENEFIT, SO SEE THE SHOPS YOU ENTER ARE THE ADVERTISED ONES BEARING THE NAME

RAYMOND

TWO SHOPS—so you will ALWAYS find one OPEN.

Still at old address

27 & 28<sup>a</sup> Lisle St.

Leicester Square, W.C.2 Opposite DALY'S Gallery Door.

AT THE BACK OF DALY'S

HOURS OF BUSINESS 9 a.m. to 8 p.m.

Saturdays 9 a.m. to 9 p.m.

Sundays 11 a.m. to 1 p.m.

BOWYER LOWE PARTS.—H.F. Transformers, 7/.

BURDETT PARTS.—Rheostat, 5/.

CRYSTALS (Best)—Neutron 1/6 Lustron, 1/6 Uralium, 1/3 Shaw's Genuine

DUBLIN CONDENSERS.—'0001 to '05, each, 2/6.

DORWOOD FIXED.—'01 to '008, 3/.

EUREKA TRANSFORMERS.—Concert Grand, 25.

EDISON BELL PARTS.—Ser. Par. Variometer or B.B.C. or 5XK, 16/6.

GOSWELL (QUALITY RADIO).—Coils, mounted 25, 1/6; 35, 1/8; 50, 2/.

GAMBRELL PARTS.—L.F. 1st or 2nd. Stage, 2/6.

H.T. VALVE HOLDERS.—"A," or "B," 1/9; O, 1/6.

HEADPHONES, BRITISH 4,000 OHMS.—B. T. H. Browns, Brindes, 20/.

HEADPHONES, GENUINE 4,000 OHMS.—Dr. Nesper Adjustable, 12/11.

IGRANIC PARTS.—L.F., 1st Stage, 2/.

"KAT RAY" DETECTORS.—Enclosed nickel fittings, trigger movement, 2/6.

LOUDSPEAKERS (Various).—Sterling "Baby," 50/.

LISSAN PARTS.—Anode or Variable Grid Leak, 2/6 ea.

MARCONI PARTS.—Potentiometer, 12/.

MICHAEL PARTS.—Rheos or D.E., 6/6.

MAGNUM (BURNE-JONES).—H.F. Transformers, 7/.

POLAR (RADIO COMM. CO.) 4,000 OHMS.—L.F. Trans.

LOTUS (GEARED)—2-way, 7/.

REFLEX RADIO COILS (Made under Burmlept Licence).

STERLING PARTS.—'00025 Square Law and V., 23/6.

SUCCESS GEARD & FITCH.—L.F. all black Super, 21/.

TRANSFORMERS (L.F.).—Peranti, 17/6; Pye, 22/6.

UTILITY (W. LEINS & WRIGHT).—Call Changing Unit, 7/6.

VALVES.—Bright, 8/ each Mullard Ors, Red or Green Ring, Marconi, R4, R5

WATMEL.—Variable Grid Leak, 2/6.

WOODHALL PARTS.—L.F. Transformer, 23/6.

SUNDRIES.—COIL STANDS 2-way Standard, 2/9.

COIL PLUGS (Ebonite).—Fitted Fibre, 1/6 pair.

ACCUMULATORS.—2 v. 40 amps, 15/11, 17/6.

ATHOL VALVE HOLDERS 13/; Aeronic, 1/6.

TERMINALS.—Complete, per Dozen, 9/6.

RHEOSTATS.—Raymond, 1/6.

AERIAL WIRE (100 feet).—Heavy, 7/22, 2/6.

FLEX (Twin), etc. (any length cut).

TOOLS.—Soldering Irons, 1/.

PHONE CORDS, etc.—6 ft. Rubber Insulated, 1/11.

COIL WINDERS (Honeycomb).—Westminster, 8/.

VARIOMETERS, Standard—3/11.

PANEL SWITCHES, Nickel SPDT, 1/.

IMPORTANT

Please read this column With each order for our own goods at full list prices of not less than £3 I shall be happy to present you with a really good pair of 4,000 ohm 'phones

FREE If purchasing £5 worth of our goods we will present you with a pair of Bowerman's, Dr. Nesper or Ericsson E.V. Continental phones, and over £6 a fine little Loud Speaker.

AS AN ADVT. If you buy 25/- worth of our goods you may purchase for another 5/- a really good pair of headphones, 4/00 ohms

Kindly make out a list of what you are requiring and I will quote you lowest inclusive prices at the earliest possible moment.

BURNT OUT VALVES

1 Burnt-out Valve accepted in part exchange for a new British Valve bought. Usable Valves purchased or exchanged. Second-hand Parts bought (callers can bring goods, but am under no obligation to purchase).

Dr. NESPER HEADPHONES

Genuine and adjustable, 4,000 ohms. Comfortable Leather Bands. Post free 12/11 pair

FRENCH THOMSON-HOUSTON HEADPHONES

Want's me beating 4,000 ohms for 12/11 nett.

S'EMENS

EBONITE.—Special sizes 3/16 in. id. per sq. in. id. per sq. in. Post extra

CALLERS (NETT PRICES) COLUMN ALL POST ORDERS FROM OTHER COLUMNS

VARI.—CONDENSERS.—Square Law or standard. Special Offer, '0005, with Knob, 3/11; '0003, ditto, 3/8.

ACCUMULATOR.—2 v. 40 amps, 8/6, 9/6; 4 v. 40 amps, 13/11, 1/11; 4 v. 80 amps, 17/1, 18/6; 4 v. 60 amps, 23/1, 25/;

Aerial Egg Insulators, 2 for 13d. Copper Foil, 3d. Shorting Plug and Socket, 4d. Valve Holders, 9/4d, 10/1, 1/.

SPECIAL—Wonderalite, 100 feet, 4/10. Best quality 3/.

Dr. NESPER HEADPHONES Genuine and adjustable, 4,000 ohms. Comfortable Leather Bands. Post free 12/11 pair

FRENCH THOMSON-HOUSTON HEADPHONES Want's me beating 4,000 ohms for 12/11 nett.

CALLERS. We stock everything you require.



# A Wireless Medical Service

By SYDNEY WILDMAN

Many people are under the impression that the uses of wireless are confined to broadcasting and S.O.S. calls. Below is an account of another object for which it is used

**T**O-DAY every large passenger ship of any importance carries one or more surgeons, and some of the larger liners have hospitals of their own, complete with operating theatres and everything necessary for emergencies.

Although the list of vessels carrying a medical officer may seem a large one, there are many, many more ships that do not carry a doctor. What of those small tramps which are found on every ocean, or those cargo vessels which sometimes take weeks on a voyage, and are out of sight of land for most of the time? Very often the captain or mate of such a vessel is also the acting "doctor," and, with his sometimes small knowledge of medicine, is able to attend to the minor ills of his crew.

### Obtaining Advice

Sometimes a case of serious illness or accident may take place on board a vessel many miles from land. If there is a doctor on board all may be well; but, should there not be one, wireless telegraphy is called to the aid of the sufferer. There is hardly a vessel sailing the seven seas which does not carry a wireless installation, and it is generally a simple matter to establish communication with another boat, from which the necessary information may be obtained. The

captain usually signs requests for medical advice, and he states as far as he can the symptoms or nature of the injuries. Within a short time the reply is flashed back, and those in charge are able to treat the sufferer. There have been cases where vessels have remained in wireless communication for days at a time, exchanging messages which in the end have resulted in the saving of life.

### The U.S.A. Service

In the United States, Central America, and in Scandinavia, there are certain wireless stations from which free medical advice may be obtained by any ship of any nationality.

The United States Public Health

Service, in co-operation with the Seamen's Church Institute of New York, provides a wireless medical service from five stations, four of which are on the Atlantic coast, and one on the Pacific coast. The stations are:—Chatham, Mass. (WCC), Siasconset, Mass. (WSC) New York City (WNY), Cape May, N.J. (WCY), and San Francisco (KPH). All these stations use a wavelength of 600 metres.

### A Private Company Help?

In addition to the above, there is also a service provided by a company known as the United Fruit Company. This company has several private hospitals of its own, and also has a number of wireless stations scattered throughout Central America and the United States.

Besides these finely equipped hospitals and wireless stations, the United Fruit Company runs passenger vessels from which any ship can obtain medical advice. Arrangements have also been made whereby ships' doctors can hold consultations by wireless with the ships and hospitals of the United Fruit Company. Any message prefixed "DH MEDICO" is given preference by this company over all other messages except the S.O.S. signal.



Deaf children at the De Paul Institute, Pittsburg, U.S.A., are taught to recognise sounds by the use of radio sets.

**European Stations**

In Denmark there are two stations giving a free wireless medical service, and in Sweden one. Blaavand (CXB) and Copenhagen (OXA) are the Danish stations, while Göteborg (SAB) is the Swedish station. Again, all these stations work on the 600 metre wave. In the case of a ship calling up Copenhagen, and asking for advice, the message would be at once passed on to the Seamen's Hospital in that city, from which the doctors would pass the necessary advice direct to the ship.

**How the Doctor Prescribes**

Imagine a vessel hundreds of miles out at sea; for many days no other ship has been passed, but the wireless operator has been in touch with several ships, which are miles and miles away beyond the horizon. Suddenly a passenger, or a member of the crew, is taken seriously ill; there is no doctor on board, and medical advice must be had at once. The captain writes a message, and in a very few minutes the wireless operator is calling one of the many ships he knows to be within range. He may call several ships before finding a

vessel with a doctor aboard, but in the end he is successful. The medical officer on the distant ship replies, giving carefully worded directions for treatment. These directions are always sent in plain language without any technical terms, so a layman has no difficulty in following them. For several hours the two vessels may exchange messages giving details of the patient's temperature and general condition. Should it be considered that the case is extremely urgent, the distant ship may change its course and later come alongside the vessel which has called for assistance. The doctor goes aboard, and in mid-ocean may carry out an operation in order to save the patient's life. Had there been no wireless a life might have been lost.

**For Isolated Districts**

Hardly a day passes without ships asking for medical advice, and instances have often been reported in the Press. Nevertheless, there are many cases which are not reported in the newspapers, and so the public do not get to hear of all those little dramas of the sea.

As far as I know, the British

Broadcasting Company has not yet been called upon to broadcast medical advice from a doctor or specialist to an outlying district where there are no telephones, or where telegraphic communication is bad. Some day they may be called upon to do so.

**International Service Wanted**

The importance of a wireless medical service must not be underestimated, and every country should have a service of its own. At conveniently placed points upon the coast there should be wireless stations from which a medical advice service could be obtained at any time, and by any ship, irrespective of nationality. Besides serving ships, it should be possible to serve isolated areas in the centre of great continents.

**A Medical "S.O.S."**

Every one has heard of the S.O.S. signal—the signal which brings immediate help to ships in distress. Why not create an international signal which would put ships and others needing help into immediate communication with a wireless station able to give medical advice from the best sources?

*Ah! this is a Real Gift!*

WIVES—A happy thought! Surprise your hubby this Christmas with the finest gift on earth—the gift of COMFORT!  
Buy him a Berkeley!

Long after Christmas has gone he will come home to his "fireside friend" to read or smoke in peaceful relaxation after the busy day's work. What a splendid gift for a man is the Berkeley—and what great comfort for so little cost! Huge production and a wonderful factory organization enable us to offer the Berkeley at a price never before dreamed of for an Easy Chair of such sound value and honest worth.

The **Berkeley**  
(Registered)

HAS THE LARGEST SALE OF ANY EASY CHAIR IN THE WORLD SOLD ON THE MONEY-BACK PRINCIPLE. Soon after receipt of First Payment with your order we send the Berkeley Chair Carriage Paid in England and Wales (Scotland 5/- extra). If upon examination it is not completely satisfactory, you may return it within 7 days at our expense and we will refund your money in full.

WRITE NOW FOR PATTERNS AND SELECT YOUR OWN COVERING—POST FREE  
**H. J. SEARLE & SON, Ltd.**  
Manufacturing Upholsterers,  
(Dept. W.S.) 70-78, OLD KENT RD.  
LONDON, S.E. 1

SHOWROOMS: 133, Victoria Street, Westminster, S.W. 1, The Arcade, High St., CROYDON, and 16, The Parade, WATFORD.



CASH PRICE **85/-** or 15/- with order and 5 payments of 15/- monthly

THE frame of the Berkeley is of well-seasoned birch, properly dowelled and strengthened. It is fitted with long coppered-steel springs in the back, seat, and front edge. The best fibre stuffing is used. The Berkeley has broad, upholstered arms with an extra deep seat and double-bordered front. Covered in hard-wearing tapestries, cretonnes, etc., of your own selection.

# The rejuvenation of wireless!

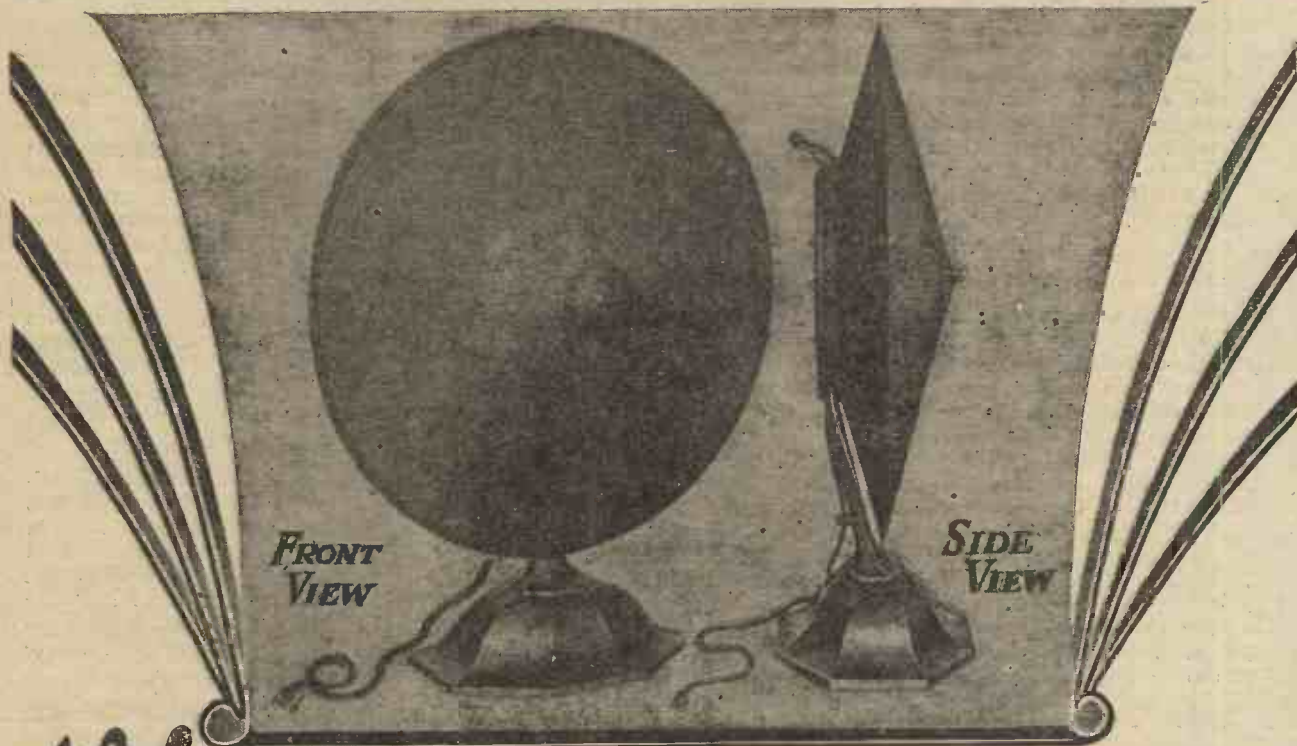

*The New*

## Kone Loud Speaker & Amplifier

HERE is the latest Loud Speaker that scientific research and experiment can offer, and which will prove a milestone on the road of advancement in the wireless art. Special characteristics of the "Kone" Loud Speaker are as follows:—

Freedom from distortion. Greater purity of tone than any other Loud Speaker at present on the market. Even distribution of sound over a wide area. Distinctive appearance.

Do not order your new Loud Speaker until you have heard a "Kone." You will save yourself disappointment. The "Kone" Amplifier gives really wonderful results used in combination with the "Kone" Speaker, or any other standard Loud Speaker of good design. Supplied as illustrated for inclusion in any existing furniture, or encased in a handsome mahogany cabinet as a separate unit.

### Standard Telephones and Cables Limited

GONNAUGHT HOUSE, ALDWYCH, LONDON, W.C.2

Central 7345 (10 lines)

WORKS:  
NORTH WOOLWICH  
NEW SOUTHGATE  
and  
HENDON

BRANCHES:  
Birmingham, Leeds,  
Manchester, Newcastle,  
Glasgow, Cardiff,  
Southampton, Liverpool  
& Dublin

Patent No.  
209345

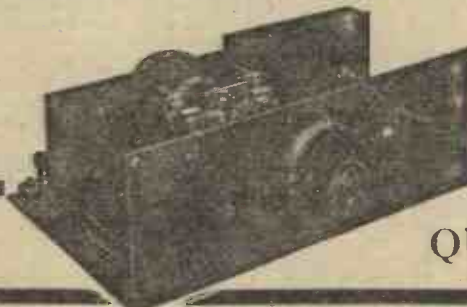

**Standard**

**QUALITY PRODUCTS**





Some sets will not oscillate—others are uncontrollable. Suggestions to overcome both these difficulties are given below.

**T**HERE are no doubt many amateurs who have been troubled with either or both of the following difficulties:—

- (a) Failure of a set to oscillate;
- (b) Inability to control oscillation with certainty;

and it is for their benefit that these notes are written.

It sometimes happens that after a set has been completed it has not been found possible to make it oscillate with the usual size reaction coil, and even a size or two larger may fail to produce the desired effect. If a larger coil does succeed it may be that the oscillating state is entered with a "plop," instead of smoothly. This, of course, comes under heading (b).

**Failure to Oscillate**

When, however, it has not been possible to get the set to oscillate

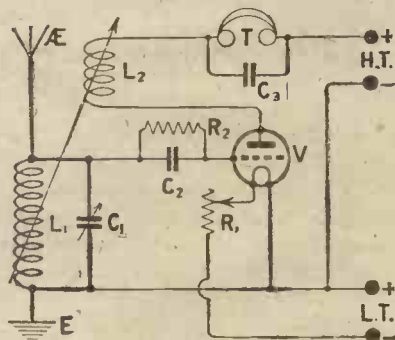

Fig. 1.—The usual straight circuit may prove unsatisfactory.

at all it may be due to one or more of several causes. The most usual one is due to excessive damping being applied to the grid circuit of the receiver owing to the aerial-earth system having a very high resistance. It is understood, of course, that the reaction coil has been tried connected both ways round, and that neither scheme of connections has succeeded in getting

the set up to the oscillating point, and that sufficient H.T. is being used, say, about 50 volts, with the usual general purpose valve.

A means of decreasing the effect of a "stiff" aerial is to employ:—

- (1) Loose coupling;
- (2) Auto-coupling; or,
- (3) Constant aerial tuning, or a series tuning condenser instead of a parallel one.

**Some Common Circuits**

Fig. 1 shows a conventional circuit using direct coupling, and it will be seen that the aerial is connected straight to the grid of the first valve, via the grid condenser. Loose coupling is shown in Fig. 2A, and it will be seen that not only the aerial, but also the earth leads are now brought to a coil that is not conductively connected to the grid coil. This coil may or may not be tuned by a variable condenser, C<sub>1</sub>. Very good results may be obtained without this condenser, provided that the coupling between the coils is fairly tight. The looser the coupling between the two coils L<sub>1</sub> and L<sub>2</sub>, the less is the damping applied to the grid circuit, and therefore the less reaction will be required to make the receiver oscillate. Fig. 2B shows the use of auto-coupling.

**Auto-Coupling**

Here only one aerial coil is used, but the aerial is connected to a tapping point which includes only a small portion of the coil in the aerial-earth circuit. This has a similar effect to loosening the coupling, and the less the number of turns common to both aerial and grid circuits the smaller the virtual coupling becomes. Not only is less reaction then required to make the receiver oscillate, but an increase in selectivity is also obtained. This increase in selectivity is, of course, also obtained with loose coupling.

Another method that may be

used is to employ either constant aerial tuning, probably known to all our readers as C.A.T., or a series-tuning condenser instead of a parallel one. These are shown in Fig. 3A and 3B respectively. Both these methods have the merit not only of lessening the damping applied to the grid of the first valve, but also of making tuning sharper.

All the above schemes may be employed whatever the first valve may be, either an H.F. amplifier or the detector, as shown. But there are still one or two other methods that may be tried which apply only when the first valve is an H.F. valve.

**Suggested Remedies**

The first point to note is to see whether the grid return is connected to L.T. - or L.T. +. If a potentiometer

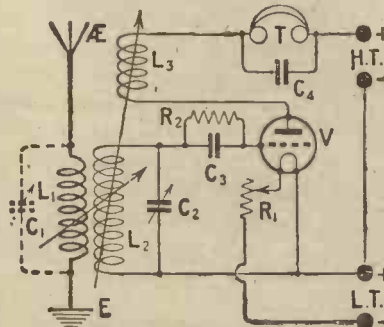

Fig. 2a.—Loose-coupling will facilitate oscillation.

meter is used make sure which end of the winding is negative and which positive, and mark the panel accordingly, so that you may always be certain what grid potential you are applying. If no potentiometer is being used, and you find that the grid return goes to L.T. +, transfer it to the negative lead. In many cases this alteration alone will be sufficient to get the set to oscillate

without the need of using some form of loose coupling. Another point that needs to be watched is that the filament of the H.F. valve is not too bright, and also that the H.T. applied to it is not too high or too low. Any one of these conditions may stop the set from oscillating in a large number of cases.

**Necessary Condensers**

Another case that is rather difficult to discover is when the set will not oscillate owing to no telephone condenser being used, or if a stage of I.F. is being added, when no condenser is shunted across the primary winding of an L.F. transformer, or, if such a condenser is fitted, its value is too small or is not that marked.

The substitution of a condenser of known accuracy will in the latter case show immediately whether this is the trouble.

We now can consider cases which come under heading (b), i.e., where oscillation is uncontrollable. By this is not meant that it is not possible to stop the set oscillating, but that, instead of the set going smoothly into and out of oscillation, this state is entered with a loud "plop" or "plonk." This condition is known as "backlash," and may be due to a variety of causes.

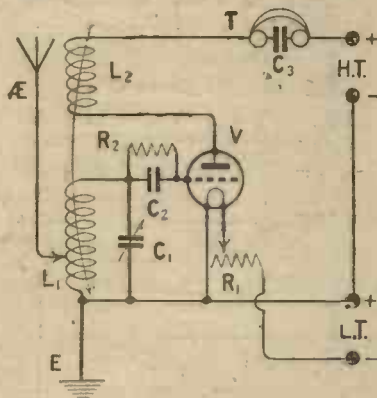

Fig. 2b.—Auto-coupling will give increased selectivity.

**Uncontrollable Oscillation**

We will first take the case where the valve is a detector. The first cause that comes to one's mind is that too large a reaction coil is being used.

If magnetic reaction is being used, the usual value for the reaction coil is a 50 or 75 on the broadcast wavelengths, and it is best to work with the smallest possible size reaction coil that will give oscillation over the whole of the wave band covered by the tuning condenser. When capacity reaction is

employed, the maximum value of the condenser may be between  $0.001\mu\text{F}$  and  $0.005\mu\text{F}$ ; a larger value should not be necessary.

**Grid Leak Adjustments**

The next reason that may be found is too bright a filament or too high a value of H.T. being used. If, however, the adjustment of

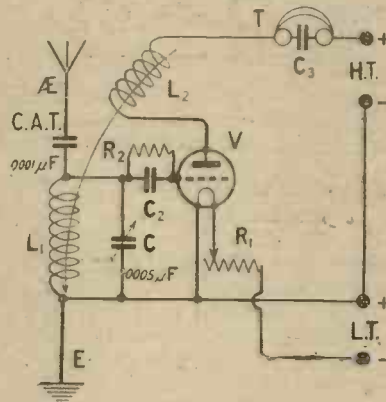

Fig. 3a.—The use of a C.A.T. condenser lessens damping.

these fails to produce any improvement without a loss in signal strength, the value and position of the grid leak should next be examined. In a series of experiments carried out by the writer it was found that connecting the grid leak between grid and positive I.T. gave the greatest signal strength, while this scheme of connections in use will frequently be found to eliminate backlash. If this still does not cure the trouble, the value of the grid leak may be altered, and in most cases it will be found that a higher resistance leak will do the trick.

**H.F. Amplification**

Where one or more stages of H.F. amplification precede the detector valve the problem becomes rather more difficult. All the foregoing expedients may be tried, but other methods may be necessary before the set will become perfectly controllable. The chief causes of uncontrollable oscillation in this case will probably be too low a filament temperature and incorrect H.T. These should therefore be carefully adjusted, and when the correct values have been found no further difficulty should be experienced.

**Capacity Effects**

The design of the set should next be considered, as to whether coils in the grid and anode circuits of the H.F. valve or valves are too close together, or are parallel to each other,

thus causing reaction effects to be present that prevent proper control. Capacity coupling may also occur between grid and anode tuning condensers, resulting in capacity reaction effects. Switches on the H.F. side should also be eliminated as far as possible, and all leads carrying H.F. currents spaced out carefully, while anode and grid leads should not be allowed to run parallel, and where they have to cross they should do so at right angles.

**Troubles Due to Bad Arrangements**

The writer has come across sets where very poor reception accompanied by bad self oscillation has been due purely to bad layout and wiring. The alteration of layout and wiring should not, however, be attempted by the inexperienced except with the help or advice of a skilled experimenter, or it may result in a case of "out of the frying pan into the fire."

**Short Wave Work**

Lastly, a few words may not be amiss with regard to short and ultra-short-wave work. It is frequently found difficult to get the set to oscillate at all. If magnetic reaction is being used, the trouble may be due to the reaction coil being the wrong size. It is fre-

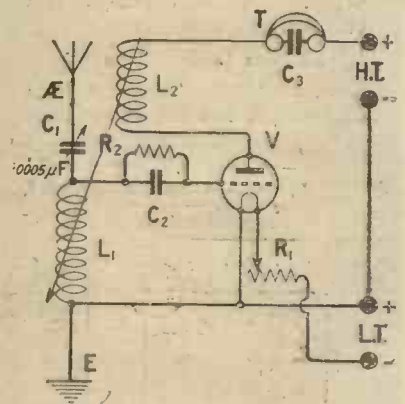

Fig. 3b.—A series aerial tuning condenser may be tried.

quently found that this is critical within one or two turns. The removal or addition of these one or two turns may make all the difference in the world. The best method to employ when making the reaction coil is to make it too big by five or ten turns, and then remove turns one at a time till the receiver will oscillate smoothly over the whole range. If Reinartz reaction is used, the choke in the plate circuit should not only be





## FOUR MILLION horse power under control

NIAGARA FALLS supply the energy for huge electric power stations—power that is used to drive electric trams in cities 250 miles away.

A button pressed, a lever moved, the turn of a knob; that is how things are done to-day—the result of inventive genius and modern engineering skill.

ORMOND PRODUCTS are typical examples, and the outcome of 25 years' British Manufacturing experience.

We specialise in turning Brass and Steel Screws and Machined Parts and Accessories of all descriptions

### ORMOND LOW LOSS CONDENSERS

(SQUARE LAW)  
(PATENT APPLIED FOR)

A new departure in British Condenser design, giving the following advantages:

1. Practically negligible losses.
2. One-hole fixing—one  $\frac{3}{8}$  in. diam. hole is needed to fix this condenser to panel.
3. Rigid construction—cannot warp; end plates of stout aluminium perfectly flat.
4. Fixed vanes supported by  $\frac{1}{4}$  in. ebonite strips.
5. Smooth action, spindle tension is maintained by a specially designed friction washer.
6. Moving vanes and end plates are at earth potential.
7. One-piece knob and dial—supplied loose. Secured by 4 BA Set Screw.

This condenser is fitted with optional soldering Tags, or Terminals, and can be supplied with or without Vernier as desired.

#### Supplied in the following sizes:

Size:	Price with Vernier	Price without Vernier
:00025 ...	8/-	6/6
:0003 ...	9/-	7/6
:0005 ...	9/6	8/-
:001 ...	10/6	9/-

Complete with Knob and Dial.

Ask your dealer to show you the "Ormond" Condensers—the best dealers stock all "Ormond" Products.

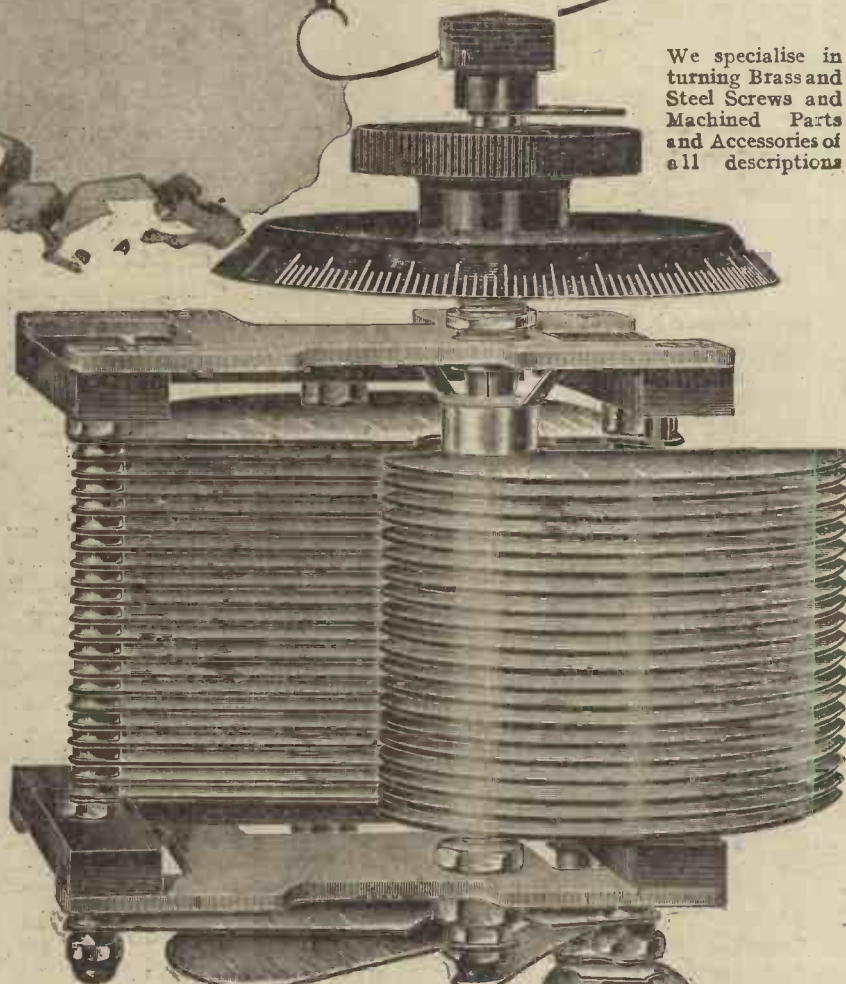

Trade Terms and New 1926 Catalogue on request:

199-205, Pentonville Road, King's Cross  
London, N.1

Telephone—Clerkenwell 9344, 5 and 6  
Telegrams—"Ormendeng", "Kincross"

Factory—Whiskin Street, Clerkenwell, E.C.1

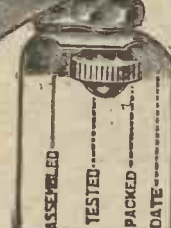

See the Inspection Label on every Condenser

**25 YEARS' BRITISH MANUFACTURING EXPERIENCE**

large enough, but it should also have a very low self capacity.

**Chokes in the Filament Circuit**

For ultra-short-wave reception it may also be necessary to place small chokes in each of the filament leads. Suitable inductances for this purpose may consist of 30 turns of 24 gauge d.c.c. wire wound basket weave fashion on a former 1 in. in diameter. It may also be found necessary to isolate the phones in a similar manner. If this is done it is important that a telephone condenser be used if magnetic reaction is being employed; a suitable value for this will probably be between .003 and .001  $\mu$ F.

C. P. A.

## An Inexpensive High-Tension Battery Box

A SIMPLE and neat case to contain pocket lamp cells used as high-tension supply may be made for a few shillings.

Of course the length of the case depends entirely on the number of cells one is using, so no measurements of the length will be given

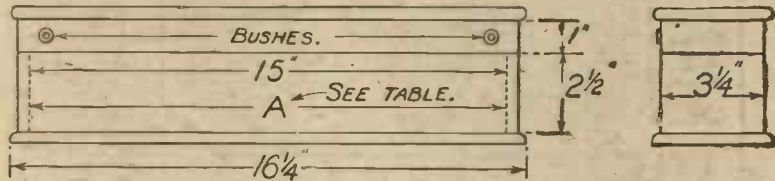

Fig. 1.—Constructional Details of a 17-cell box. Note the bushes in the deep lid.

### BROADCASTING IN THE UNITED STATES



Mr. John McCormack, the famous opera singer, at the microphone. He has broadcast songs from WEAf, at New York City.

in the description, but the reader will find a useful table at the end of this article from which he may work.

The letter A will be used to indicate the length of the inside of the box.

**Materials Required**

Two pieces of wood 2 1/2 in. by A by 3/8 in. Sides.

Two pieces of wood 2 1/2 in. by 3 1/4 in. by 3/8 in. Ends.

Two pieces of wood 1 in. by A by 3/8 in. Sides of lid.

Two pieces of wood 1 in. by 3 1/4 in. by 3/8 in. Ends of lid.

Two pieces of wood 3 in. by A by 1/2 in. by 3/8 in. Top and bottom.

Two ebonite bushes.

Two hinges and screws.

A number of 3/4 in. steel brads.

One bottle of good quality varnish stain.

The wood is cut and well sanded, then nailed together. Fig. 1 shows the construction. The edges may be rounded off with a plane.

The lid is also made, and the holes drilled in it for the bushes, through which come the leads to the battery.

The lid is then fitted with hinges, and the whole given one coat of the varnish stain, this being done with a fine brush.

Table from which A may be determined.

A.	Cells,	Approx. Volts.
7 1/2 inches	8	36
9 "	10	45
12 1/2 "	14	63
15 "	17	77
17 1/2 "	20	90
23 1/2 "	27	120



# Little IGRANIC Radio Devices that make a big difference

In Radio, as in any other pursuit, it is often "the little things that count," and upon the efficiency of the minor components and accessories may depend success or failure to achieve satisfactory results. Therefore, it behoves every Radio constructor who aims at obtaining a high standard of performance from his Radio receiver to exercise the utmost care in choosing these small components. There is the "VERNOB" VERNIER CONTROL KNOB, for instance, which enables a fine vernier movement to be imparted to any rotatable component which is not otherwise provided with means for vernier control. Pressing the Knob slightly forward gives a direct positive drive on the spindle for rapid adjustment, while rotation of the Knob in the normal position gives an exceptionally fine movement which makes a wonderful difference when tuning-in that elusive station.

So it is with all other IGRANIC RADIO DEVICES—they enable the best possible results to be obtained even under adverse conditions.

*Ask your dealer about them*



include: Honeycomb Duolateral Coils, Variable Condensers, Fixed Condensers, Filament Rheostats, Intervalve Transformers, Variable Grid-Leaks, Variometers, Vario-couplers, Coil Holders, Potentiometers, Combined Instruments, Vernier Tuning Devices, Switches, Valve Holders, etc., etc., also the Igranic Supersonic-Heterodyne Receiver Outfit. All carry the IGRANIC guarantee

Write for List Z813

**IGRANIC ELECTRIC CO., LTD.**  
149, Queen Victoria Street, London

Works: BEDFORD

Branches:

BIRMINGHAM: 73-74, Exchange Buildings; BRISTOL: British Dominions House, Tramways Centre; CARDIFF: Western Mail Chambers; GLASGOW: 50, Wellington Street; LEEDS: Standard Buildings, City Square; MANCHESTER: 30, Cross Street; NEWCASTLE: 90, Pilgrim Street.



**IGRANIC EARTHING SWITCH**

(Patent applied for)

A handsome fitment with contacts giving perfect electrical conductivity. Mounted on solid ebonite base with three fixing holes. Price 3/-



**IGRANIC TELEPHONE CONNECTOR**

(Pat. No. 223409)

A handsome and useful addition to any set. Provides connections for addition of four pairs of telephones. Automatic in action. Price 8/6

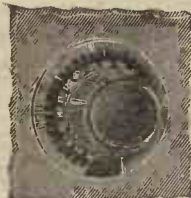

**IGRANIC COMBINED KNOB AND DIAL**

To enable you to make extremely accurate settings of rheostats, variable condensers, variometers, etc. Prices: 4" diam. 2/6 each; 3" diam. 1/3 each; 2" diam. 1/- each.



**IGRANIC RADIO SWITCH**

A self-contained, completely enclosed make and break switch. Recommended for use as a master switch in filament circuits. Price 2/6

## Our New Extended Guarantee Scheme

*How readers can safeguard themselves*

**H**ITHERTO the Radio Press guarantee has applied only to goods ordered direct from the manufacturers. We have pleasure in announcing that our guarantee now extends to all advertisers' goods bought from a local retailer, excepting only valves and H.T. batteries.

### What to Do

A reader, on purchasing any of the goods advertised in Radio Press publications, should fill in the details of his purchase on one of the enclosed postcards and send the card to the actual manufacturer concerned. If this is done, Radio Press, Ltd., will use every endeavour to obtain satisfaction for the purchaser should the apparatus prove defective or faulty in operation.

**Read the Directions on the Cards**  
Readers should note that the guarantee applies only to goods

advertised in our journals, and that the postcard *must* be filled up and sent direct to the manufacturers concerned. Full details will be found on the cards themselves.



An American portable super-heterodyne receiver in use.

## The "Double Purpose Two"

SIR,—I feel it is my duty to tell you of the good results I am receiving on Mr. D. J. S. Hartt's "Double-purpose Two-Valve Receiver," described in the July issue of THE WIRELESS CONSTRUCTOR.

Of course I pick up London and Daventry at good loud-speaker strength; and I also have picked up Manchester and Birmingham quite strongly while 2LO was on.

When 2LO is closed down I can receive other stations clearly on the H.F. circuit. I use a 50 coil for the aerial and a 75 for the reaction; my aerial is bad and screened by trees. I might mention that this set is the first that I have made entirely myself, and therefore shows how simple Radio Press sets are to follow. Also let me congratulate you on your excellent new paper *Wireless*. I am a faithful reader of your instructive papers.

Yours faithfully,

GEOFFREY M. AUSTIN.  
Streatham Common, S.W.16.

**IT'S A  
VERY  
SMALL  
WORLD  
—thanks to**

Indispensable to the "globe trotter" and a revelation to the man who wants purity and volume from the home station. The "ATLAS" Low-Loss Coil is an amazingly efficient radio engineering production, embodying all that is known of ultra-modern low-loss principles as applied to tuning. Makes unusually good results usual. Prices from 4/3 to 17/6

**CLARKE'S  
"ATLAS"  
LOW LOSS COILS**

Clarke's "ATLAS" Special  
DAV. NT. Y. COIL. No. 175  
Price 7/9 each

Only Manufactured by  
**H. CLARKE & CO. (Mer.) Ltd.**  
ATLAS WORKS, OLD TRAFFORD,  
MANCHESTER.

Patent No.  
215053.



PRICE  
**27/6**

The ULTRA works off two valves better than most Loud Speakers work off three.

Ask your Dealer for an **ULTRA**

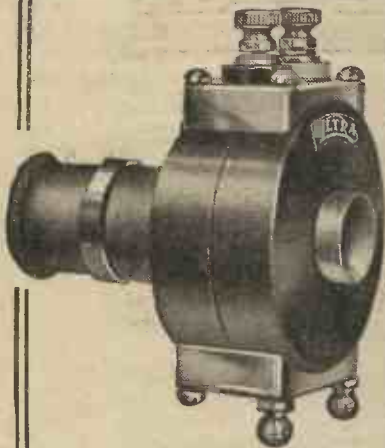

The New ULTRA Gramophone Attachment will convert your Gramophone into a magnificent Loud Speaker. Price 25/-

Should you have any difficulty in obtaining these lines, write direct to

**ULTRA ELECTRIC LTD.**  
ULTRA WORKS,

661-663, Harrow Road,  
LONDON, N.W.10.

Telephone: WILLESDEN 4544.

## Fixed Condensers and Their Uses

By E. H. BERRY

THE fixed condenser plays a large part in all wireless sets, and especially in the ordinary broadcast receiver, but the reasons for its actual inclusion are little understood.

As it is felt by the writer that a better understanding of the uses, sometimes optional, sometimes imperative, is desirable, the main uses of these "gadgets" are discussed below, without entering into the theory of their functioning.

### Its Uses

The most common uses to which the fixed condenser can be put are roughly divisible into three classes:

- (1) By-pass condensers.
- (2) Blocking condensers.
- (3) Reservoir condensers.

The first use is one of the most important, and the neglect of this is frequently the source of considerable trouble.

The function of the by-pass condenser is to provide an easy path for the passage of high-frequency currents.

It is a property of condensers that they will readily allow of the passage of high-frequency impulses; the higher the frequency the smaller need be the capacity of the condenser which will permit of its passage and, vice versa, the lower the frequency it is desired to pass the larger must be the condenser to enable the current to pass with comparative ease.

### An Illustration

To take an example. In the anode circuit of, say, a single-valve receiver there will be two variations occurring simultaneously—the radio frequency component, which is inaudible, and the audio frequency impulses, which are audible in the phones.

Now the telephones, while readily offering a path for the low-frequency impulses, offer a considerable impedance or resistance to the passage of the high-frequency impulses. In most cases it is essential that the circuit should offer as little resistance as possible to both the low and high-frequency impulses. Here, then, is a plain case for the inclusion of a fixed condenser. If we connect it across the phones this condenser will by-pass with ease the H.F. impulses while impeding the L.F. oscillations which then flow through the phones.

### Troubles with Reflex Circuits

In the case of some reflex circuits wherein one valve amplifies both high and low-frequency currents a condenser is necessary across the secondary of the transformer. In some cases one across the primary also is beneficial. If no condenser is included, "howls," buzzing, hums and other weird noises frequently result. If a transformer-coupled note-magnifying valve follows a detector valve a condenser should be placed across the transformer primary, especially where reaction is employed.



A typical reservoir condenser for H.T. battery use.

If a condenser is not used in this position the control of reaction is usually

very much more difficult. Many readers who have perhaps omitted this minor component in their sets, especially those who have found that it will work without it, will be well advised to fit one. The increased smoothness of reaction control will amply compensate them for the slightly extra cost. It will frequently be found that sets will operate without these by-pass condensers. This is due to the inherent or self-capacity of the telephones



Nearly every wireless set contains at least one fixed condenser. The uses of these indispensable components are briefly described below

or transformer windings, whichever are in circuit.

**Values to Use**

The value of by-pass condensers for the various positions cannot be stated dogmatically, but values between about .0003μF and .002μF are usual. The value of the condenser across the transformer primary in reaction circuits is usually about .001μF. Loud-speakers in the anode circuit of a power valve usually require values from about



Grid condensers are usually provided with clips for the leak.

.002μF up to as high as .1μF, good average values being about .006μF or .01μF.

**Blocking Condensers**

In many circuits a condenser must be included to prevent the application of the potential of the H.T. battery to undesired points, and the fixed condenser is admirably adapted to this purpose. For instance, in resistance-capacity coupling a condenser must be included in the grid lead to the following valve to prevent the potential of the H.T. battery being applied between the grid and filament.

**The Grid Condenser**

The blocking condenser, however, in the case of resistance-capacity coupling allows the L.F. impulses to be by-passed to the grid of the following valve. The value here indicated for the passing of the L.F. impulses is much higher than is necessary for the passing of H.F. impulses. Usual values for a condenser in this position are from .005μF up to .1μF, a general value being .01μF.

In the case of the grid condenser of a rectifier, a value of .0003μF has

been found to be the most generally useful.

Blocking condensers often perform the functions of by-passing and reservoir at the same time.

It will be apparent, after a little thought, that this occurs in the case of the grid condenser.

It by-passes the H.F. impulses, blocks the H.T. when following a high-frequency valve, and acts as a reservoir for cumulative grid rectification, as described by John Scott-Taggart, F.Inst.P., A.M.I.E.E., in *Modern Wireless* for October 1925.

**Reservoir Condensers**

The next use to which fixed condensers are usually put is as reservoir condensers. The usual position in the circuit for this purpose is across the H.T. supply battery. The battery charges up the condenser; the variations in anode current are then drawn from the condenser, the battery merely serving to maintain the charge on the condenser plates.

**Performing Several Functions**

The fixed condenser may perform two or three of its functions in one position. Take, for instance,

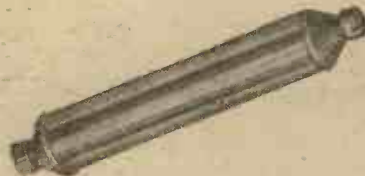

Condensers in "cartridge" form are now popular.

the telephone condenser in a single valve reaction receiver. Here the telephones are in a circuit in which both H.F. and L.F. variations are present. The condenser placed here by-passes the H.F. impulses, blocks the L.F. impulses, deflecting them, as it were, via the telephones. As the telephones, however, offer an impedance even to the low-frequency impulses the condenser charges and discharges through the phone winding. In this case, also, the one condenser is performing all three functions.

**MAGNUM**

**Construct**

"My Own Local Receiver"

as described in this issue by Mr. P. W. Harris

1 Radion Mahoganite Panel 14" x 12"	17 6
1 Radion Mahoganite Panel 12" x 5 1/2"	7 6
1 Bowyer-Lowe Four Square Condenser .0005 mfd.	1 10 0
2 Dubilier 100,000 ohms Resistances with bases	11 0
2 Dubilier Fixed Condensers .01 mfd. Type 610	9 0
2 McMichael .25 megohm Resistances	4 0
3 Magnum Antiphonic Valve Holders	15 0
2 Magnum Panel Brackets	3 0
1 Gambrell Transadapta	6 6
1 R.I. Permanent Detector	6 0
1 Burndept Dual Rheostat	7 6
1 Bradleyohm 10,000-100,000 ohms	9 6
2 Clix Plugs and Sockets	1 2
11 Terminals 4B.A.	1 10
1 Set Radio Press Transfers	6 6
Glazite Connecting Wire	2 4
	<b>£6 12 4</b>
Cabinet in Oak	£2 2 0
" in Mahogany	2 8 0

NOTE.—Where a complete set of components is purchased together a Marconi Royalty of 12/6 per Valve Holder is payable.

**New MAGNUM Components**



TERMINAL PANELS as used on several R.P. Sets. No. 1 (7 Terminals) 4/6; No. 2 (4 Terminals) 2/6; No. 3 (3 Terminals) 2/6

These Terminal Panels are drilled, engraved and fitted with Terminals ready for use.

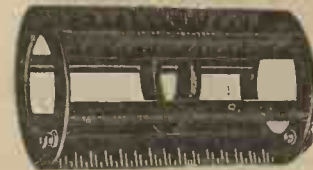

Kendall "3-Step" Low-Loss Former .. 10/- Or Ready-Wound .. 12/6

(As described in this issue) Low-Loss Former for Davenport .. 7/6 (As described by Mr. A. S. Clark in *Wireless*, September 26)

Magnum "Vibro" Valve Holder as used in sets described in this issue, 5/- each; Magnum Angle Brackets, 3/- per pair; Magnum Heavy Terminals, 5d. each complete.

**TAPPED ANODE COIL**

For the Simplicity-3 and T.A.T. Circuit designed by Mr. John Scott-Taggart 8/-

Send stamp for new Illustrated Catalogue, also Lists dealing with 15 Radio Press Sets and Magnadyne Super-Het

**BURNE-JONES & CO., Ltd.**

MAGNUM HOUSE

296, Borough High Street, London, S.E.1 Telephone: Hop. 6257

# New Range of Models

FROM THE HOUSE OF

## A.J.S.

(Sir Oliver Lodge's choice after Test)

**CERTAINTY** in Radio is one of the great advantages that the new A.J.S. Instruments confer upon you. Switch on a concert any time, any day, and you can always be certain that reception will be perfect—that is one of the reasons why Sir Oliver Lodge chose A.J.S. for use in his own home

### A.J.S. CHOKE UNITS

A carefully designed Choke when used with the correct valve will give equal volume to any transformer with very greatly improved tone quality over the whole range of audible frequencies. A.J.S. Choke Units, besides giving the utmost amplification with natural reproduction, eliminate or greatly reduce atmospheric and electrical disturbances.

(A very good selling line)

EVERY A.J.S. RECEIVER CARRIES WITH IT 12 MONTHS' WRITTEN GUARANTEE AND 12 MONTHS' FREE INSURANCE



**A.J.S. CHOKE UNIT (1st Stage)**

### A.J.S. FIXED CONDENSERS

Best ruby dielectric, moulded ebonite container. One hole fixing. In all capacities.

1/9 and 2/-

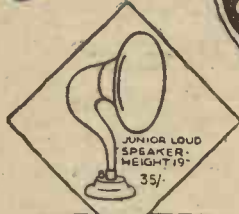

JUNIOR LOUD SPEAKER. HEIGHT 19". WEIGHT 35/.



CABINET LOUD SPEAKER £4.15



10/6 LOW LOSS VAR. CONDENSER



2-VALVE SET ACCESSORIES & LOUD SPEAKER £13.18.6

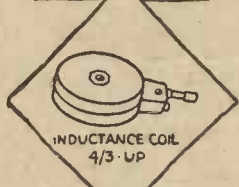

INDUCTANCE COIL 4/3 UP

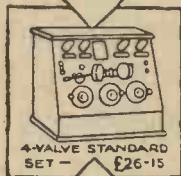

4-VALVE STANDARD SET £26.15



CHOKE UNIT 20/-

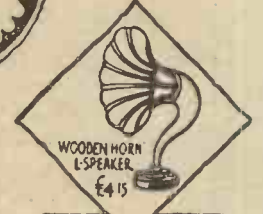

WOODEN HORN LOUD SPEAKER £4.15



2 VALVE AMPLIFIER (first model) £7.10



PEDESTAL LOUD SPEAKER £22.10.



CONCERT AMPLIFIER (first valves) £15.19



A.J.S. HEADPHONES 20/-



TABLE MODELS £20.10



PEDESTAL MODELS £52

GLASGOW: 240-250 Great Western Road.  
Phone: Douglas 3449.  
Grams: "Reception, Glasgow."

Choke Unit, 1st stage (as illustrated.) For use in Plate Circuit of Detector Valve. Combines Choke, By-pass and Grid Condenser and Grid Leak. £1  
Choke Unit, 2nd stage. For use in Plate Circuit of 2nd and subsequent stages of L.F. amplification. £1  
Choke. For inter-valve coupling. Can also be used for output units, transmitter modulation, etc. Price 15/-  
All these components are shrouded and finished in dull egg shell black, with best quality ebonite platform, and nickel plate terminals.

Full details of all A.J.S. sets and components and particulars of Free Insurance gladly sent on request.

**A. J. STEVENS & CO. (1914) LTD., Radio Branch, WOLVERHAMPTON**

Telephone: 1748 (7 lines)

Radio Call Sign: 5 R.I.

Telegrams: "Reception, Wolverhampton"

LONDON OFFICES & RADIO SHOWROOMS: 122/124, CHARING CROSS ROAD, LONDON, W.C.2

## Partially Variable 'Fixed' Condensers

THE small condensers described here can be easily made from scraps of copper foil and mica. These condensers have the advantage that should too much or too little capacity be incorporated, it can be instantly changed by just undoing three small screws.

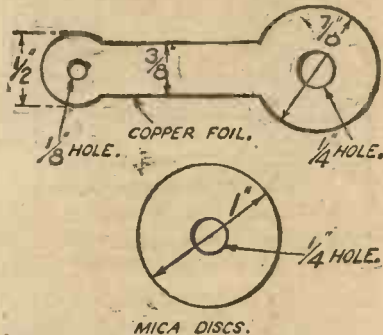

Fig. 1.—The foil and mica are cut to the dimensions shown.

It is advisable to cut a small cardboard shape as shown in Fig. 1, and to lay this on the copper foil, and mark round the shape with a sharp pointed instrument.

In Fig. 1 the dimensions of the mica discs are also indicated.

Two discs, the same size as the mica, of fairly thick brass, should be used as end plates.

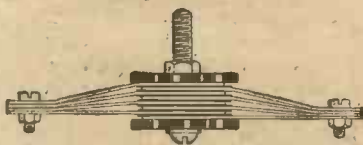

Fig. 2.—When assembling, the central screw must not touch the copper foil.

To construct the condensers, place a 1 in. 6B.A. screw through the hole in the brass end plate, then slip on a mica washer, then a copper foil, then a mica and so on until a sufficient number of plates have been used, finishing with a mica washer and the other brass end plate. A 6B.A. nut is placed on the screw, but before tightening up alternate copper foils are placed in convenient positions, and a 6B.A. screw passed through the small holes in their ends.

Fig. 2 shows the completed condenser.

## The Virtue of Simplicity

*Some notes on simplified control and pictorial diagrams*

IT is probable that one of the principal reasons for the disappointment sometimes experienced by beginners and relatively unskilled operators is to be found in the complicated nature of the sets which they have built. It seems that we are in danger of forgetting that operating a wireless set is really an art, and an art, moreover, which cannot be learned in a day. The experience of the Radio Press Service Department shows clearly that this is the main reason why constructors of limited operating proficiency are sometimes disappointed to find that they cannot equal the results obtained by the original designer, who is in most cases a skilled operator, of course. Local conditions may sometimes be at fault, no doubt, but in the great majority of cases it is purely a matter of the acquisition of a little skill in handling the set.

To produce a set whose controls have been so simplified as to enable any one to get really good results is no easy matter, but it has been done with remarkable success by G. P. Kendall (staff Editor of *Wireless Weekly* and of *Modern Wireless*) in the design of the "Simplicity" three-valve set. The tuning of this receiver is almost of the "one knob" variety, yet the set incorporates a stage of high frequency amplification of good efficiency and is capable of excellent results. In the hands of a user of only moderate skill a set of this type will often yield actually better results than those which the same user would obtain with a larger and more complicated set.

Everyone, therefore, who is considering the building of a good set for general purposes should make a point of obtaining Radio Press Envelope No. 3 (Radio Press, Ltd., 2s. 9d., post free) and considering the merits of the "Simplicity" receiver.

### Removing one of the Beginner's Difficulties

Not so very long ago one of the greatest difficulties confronting the beginner was that of reading a circuit diagram. What did those zig-zag lines mean? Why were arrows drawn through certain symbols at some times and not at

others? These, and a host of similar puzzles, were so baffling to the novice that until he had memorised all the symbols and acquired facility in reading diagrams he was unable to connect up and try a circuit unless he could obtain a wiring diagram.

He was thus debarred from one of the experimenter's chief joys, until the advent of the "pictorial" circuit diagram, in whose exploitation Radio Press was foremost, as ever. In these diagrams each component is represented by an actual sketch of the piece of apparatus itself, instead of by a conventional symbol, and the connections are shown in a manner resembling the actual wiring. It is consequently quite easy for even a beginner to wire up a set from one of these diagrams.

Pictorial diagrams are constantly appearing in this journal, but the beginner should make a point of obtaining also a copy of "Pictorial Wireless Circuits," by Oswald J. Rankin (Radio Press, Ltd., 1s. 8d., post free), which contains a most invaluable collection of good straightforward circuits, ranging from crystal to multi-valve examples.

### What a Reader Thinks about the Seven-Circuit Crystal Set

SIR,—Just a few lines to tell you that I have constructed the seven-circuit crystal set by P. W. Harris, M.I.R.E., in the December, 1924, issue, and that I consider it to be the finest set that has ever been issued.

I buy every book published to get the different circuits, but yours is equal to any one-valve set. I have just an ordinary aerial, but your system of plugs allows of stronger and stronger signals being obtained.

I well recommend the set to any reader who is thinking of building a crystal receiver.

Yours faithfully,  
T. H. MARTIN,

S. Norwood.

## High Frequency Transformers

IT is becoming more and more appreciated, both by the wireless public and manufacturers as a whole, that the type of high-frequency transformer usually used in Great Britain to-day is very far from 100 per cent. efficient. The information gathered by the Editor, Percy W. Harris, M.I.R.E., during his recent American tour shows that in the matter of H.F. intervalve coupling, America is ahead of Britain, although in most other respects we certainly lead the Americans.

In this respect, great interest will be created amongst wireless enthusiasts by the new five-valve receiver designed and described by Mr. Harris in the current number of *Modern Wireless*. "The Special Five," as it is called, combines extreme sensitivity with extreme selectivity, due mainly to the new pattern of high-frequency transformer incorporated in it, and to other novel features.

Some there are who prefer telephones for distant reception rather than the loud-speaker, and it is for these more especially that E. J. Marriott has designed and described "The Continental Two," which, like "The Special Five," makes use of the neutrodyne stabilizing method, using, however, plug-in coils variably coupled instead of the usual neutrodyne unit.

### Obtaining Stability

Experimenters are sure to be interested in P. W. Harris's series of articles appearing in *Wireless Weekly*, discussing the various methods of obtaining stability in wireless receivers by neutralizing the H.F. valves, and in view of the author's experience in this direction they cannot afford to miss reading this series.

A little off the beaten track is the "Anode Input Reflex Set," designed by J. H. Reyner, B.Sc. (Hons.), A.C.G.I., D.I.C., which is described in the current issue of *Modern Wireless*.

In the same magazine, A. Johnson-Randall (Staff Editor) describes a "Double-circuit Crystal Set" which he has designed, and whilst its sensitivity is of the order usually obtained with a good low-loss crystal receiver, selectivity is obtained to a remarkable degree.

Selectivity is, of course, very much in evidence on the very high

frequencies (short waves), but a receiver of this type must have strict attention paid to its design, and an interesting discussion on the lay-out of a short-wave receiver appeared in *Wireless Weekly*, Vol. VII., No. 5, whilst the description of a very efficient set designed for reception of the high frequencies will be found in the current number of *Modern Wireless*, contributed by D. J. S. Hartt, B.Sc. There are nowadays a great number of stations transmitting on low wavelengths, and A. V. Hooper, B.A., in the same publication, gives a list of some of those which can be heard.

Those who aspire to transmission in the high-frequency region will find much of interest to them in the constructional description of a 45-metre transmitter, which appeared in the November 4 issue of *Wireless Weekly*.

On the lower frequencies (higher waves), however, the aperiodic aerial arrangement has been relied upon to a large extent to obtain selectivity, and experimenters will read with interest Mr. Kendall's discussion, in the November *Modern Wireless*, entitled, "Is the aerial ever aperiodic?"

### Relaying America

Everybody, however, experimenters and listeners alike, will find much of interest to them in *Wireless*, the Radio Press one-word weekly. Apart from the well-known Radio Press authors, many well-known writers of outstanding ability contribute regularly to this journal.

"The Wireless Underworld," by William Le Queux, and "Relaying America this Winter," by Captain P. P. Eckersley, are articles which will command the interest of all interested in wireless, whether experimenters or only listeners.

A contribution which, perhaps, will be read with relief by worried householders is that entitled, "Safety First," written by Dr. Robinson in Vol. I., No. 7, which is a chat on aeriols and the danger of lightning striking them.

In each issue of *Wireless* also there appears full constructional details of a crystal and a valve receiver, which even the veriest novice will find within his ability to construct. The more advanced enthusiast, however, has not been forgotten, as is demonstrated by the article, "What is a Low-loss Coil?" by G. P. Kendall, B.Sc., which appeared in Vol. I., No. 6, of *Wireless*. Altogether, all interested in wireless, whatever their degree of skill, will find that they have been catered for.

## Mullard Double Ring DULL FILAMENT Valves

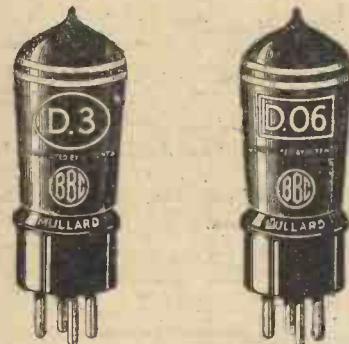

### DOUBLE WHITE RING FOR MASTER DETECTION

Mullard Double White Ring Valves have been specially selected for superior detection. They are made in two types:

Type D·3 for 2-volt accumulators - each	14/-
Type D·06 for 2 or 3 dry cells or 4-volt accumulators - each	16/6

### DOUBLE RED RING FOR H.F. AMPLIFICATION

Mullard Double Red Ring Valves are designed for real long-distance reception. They are made in two types:

Type D·3 for 2-volt accumulators - each	14/-
Type D·06 for 2 or 3 dry cells or 4-volt accumulators - each	16/6

### DOUBLE GREEN RING FOR L.F. AMPLIFICATION

Mullard Double Green Ring Valves are designed for real pure tone reception. They will operate small and medium-sized loud-speakers. Made in two types:

Type D·3 for 2-volt accumulators - each	14/-
Type D·06 for 2 or 3 dry cells or 4-volt accumulators - each	16/6

*Ask any dealer for leaflet V.R.26:*

# Mullard

**THE MASTER VALVE**

Advt.—The Mullard Wireless Service Co., Ltd.,  
Nightingale Lane, Balham, London, S.W. 12.

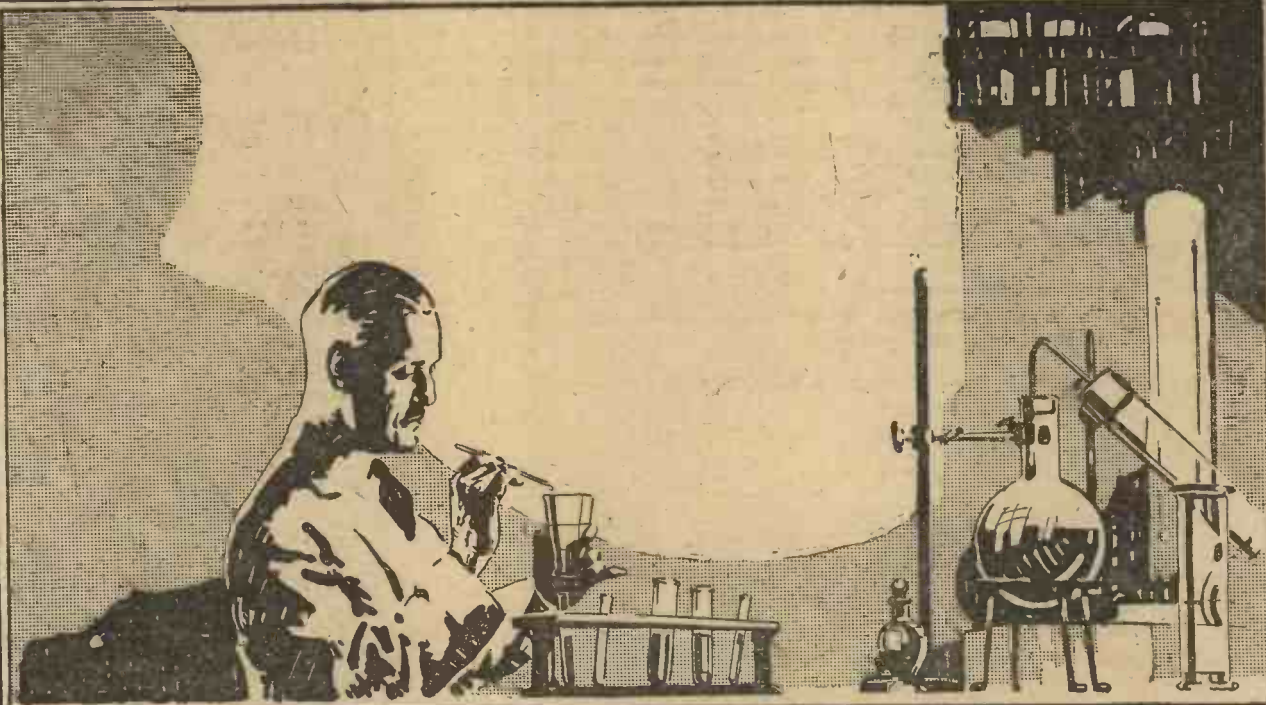

**Drops and Globules**

**M**ASTER Valves are not entirely the work of the electrical specialist. My beakers and solutions may provoke the mirth of those engineering demi-gods, but they know right well that the purity of their materials and the advantages of certain minerals are the results of my labours.

I am like all chemists—EXACT.

I want perfection in the materials for my valves . . . you want perfect reception . . . . . Then take the advice of a man who is *decidedly analytical* and ask for



**Mullard**  
**THE · MASTER · VALVE**



Ask any Dealer for Leaflet V.R.26 for complete range of Mullard Receiving Valves

Adv.—The Mullard Wireless Service Co., Ltd. (W.C.), Nightingale Lane, Balham, London, S.W.12

In replying to advertisers, please mention THE WIRELESS CONSTRUCTOR.

# Adding Note Magnifiers TO THE Low-Loss Crystal Set

By G. P. KENDALL, B.Sc., Staff Editor

An article for those who wish to obtain loud-speaker results from the crystal receiver described in our November issue



The Low-Loss Receiver with two stages of L.F. amplification added.

**T**HE results given by the simple low-loss crystal receiver which I described last month have been so pleasing that I imagine that many of the readers who built this instrument will wish to add valves to it in order to be able to work a loud-speaker.

If the same simple type of construction is adopted, the addition

can be made a very easy matter, and the whole of the work can be done in an evening. The object being simplicity, the method of mounting known to the American constructor as a "breadboard" assembly is adopted.

### The Base

The basis of operations is a wooden base-board 9 in. by 14 in.,

and anything from 3/4 in. to 1 in. thick. I should recommend that this be obtained from one of the firms of cabinet makers who specialise in wireless work, the thick five-ply wood which they supply for use as an internal shelf in a cabinet being very much to be preferred; this material is easily worked and does not warp.

The one which I used was supplied by the Carrington Manufacturing Co., and was left untreated. Some constructors will no doubt prefer to have it stained or stain it themselves.

### Method of Construction

The complete crystal set is fastened down at the right-hand end of the base-board, with the condenser dial facing forwards, as may be seen in the photograph. The set is easily secured by passing two small brass screws through two holes in the lower end ring of the "three-step" former.

The components which constitute the two-valve note magnifier are spread out on the base-board in suitable positions, the necessary terminals for connections being mounted on strips of ebonite,

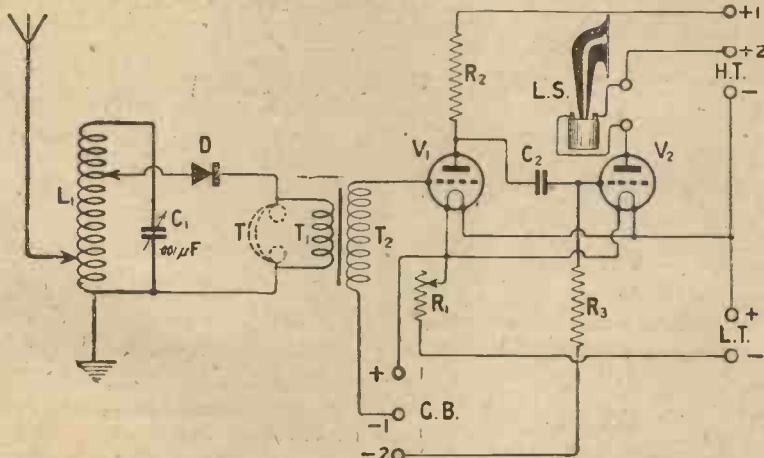

Fig. 1. The primary of the L.F. transformer is connected to the phone terminals of the original crystal set.

which are screwed to the edges of the base-board.

I used on the set which may be seen in the photographs two of the terminal strips with standardised markings supplied by Messrs. Burne-Jones. Although these markings do not refer to the terminals as I use them, the terminal panels in question save one a good deal of trouble.

**The Circuit**

To obtain really adequate loud-speaking it is necessary in most situations to add two "stages" of

risk of trouble from interaction between different parts of the amplifying circuit, and it is very uncommon for low-frequency howling to take place.

Less care is therefore needed in laying out the parts than is required when two transformers are used, while really good volume is obtained.

To render the construction as easy as possible, I have used one of the neat Polar units, which provide in one component the necessary anode resistance, grid condenser and grid leak. To this unit, which

and two terminals which are intended for grid-bias positive and negative, but which I have wired up to serve as terminals for the loud-speaker (Fig. 2).

The other panel carries three terminals, marked to serve as aerial, earth, etc., but actually used as grid-bias positive and two separate negatives. All these terminals, of course, can readily be re-lettered with the aid of some Radio Press transfers.

The arrangement adopted enables one to apply a different value of H.T. to the two valves (occasionally

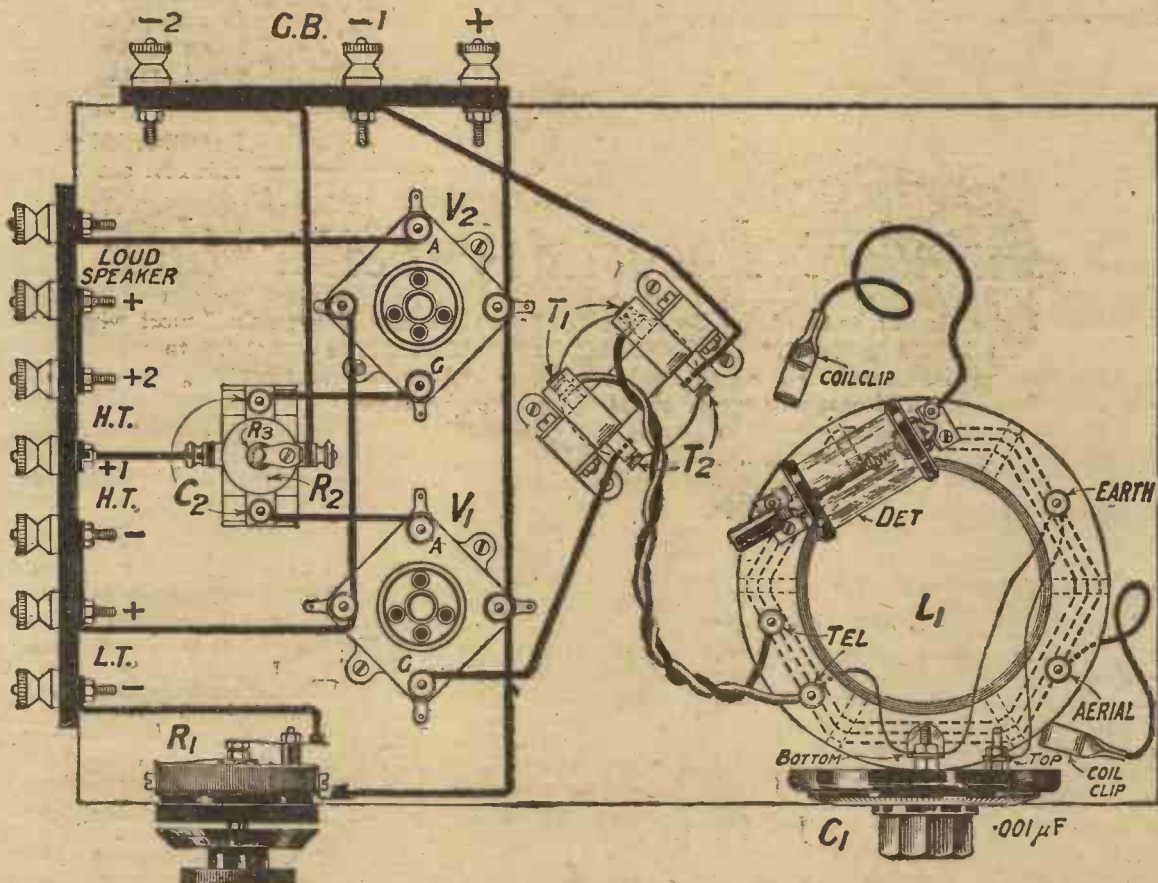

Fig. 2. The layout and wiring of the components on the base-board are shown here. No dimensions are given, since the size is optional to some extent.

low-frequency amplification—that is to say, to use two valves.

A variety of ways of coupling these valves in cascade is available, but the one which strikes me as most suited to the present case is to use an ordinary low-frequency transformer between the crystal set and the first valve and resistance capacity coupling between the first and second valves.

**Advantages**

This arrangement makes it easy to secure really good quality in the reproduction of speech and music. Moreover, there is usually little

desirable) and different values of grid-bias (practically always admissible). This will be considered in greater detail later.

**Components**

The actual components used in the original set are given below, the makers' names being quoted for the benefit of those who like to make an exact copy.

One I.F. transformer (L. McMichael, Ltd.),

One Polar resistance-capacity coupling unit (Radio Communication Co., Ltd.).

**Arrangement of Terminals**

The battery and output terminals are provided by two standard terminal strips as I have mentioned, and these are actually a "No. 1 panel" and a "No. 2 panel." One of these carries terminals for L.T. positive and negative, H.T. negative and two separate positives,

The Burndept method of one-hole fixing is unusual in that the pointer-knob will remain flush with any panel from  $\frac{1}{8}$  to  $\frac{1}{2}$  an inch in thickness. There is only one hole to drill and one nut to tighten.

The element is wound with thick wire, having high current-carrying capacity.

The brush moves over a flat surface with a very smooth movement and cannot work loose. The contact resistance is low.

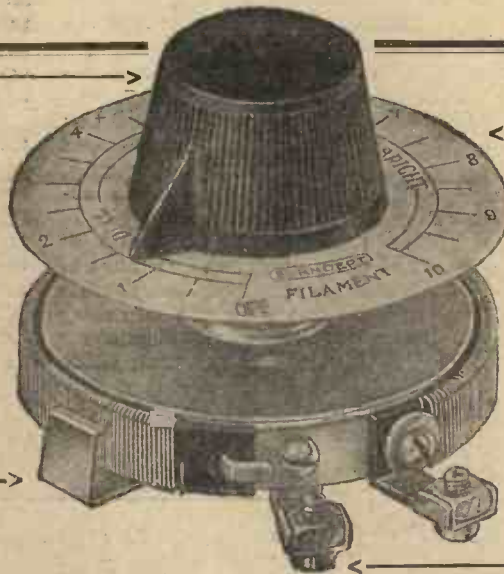

This neat scale saves one the trouble of engraving the panel. It is interesting to note that either the scale or knob will cover holes previously drilled for our old rheostats.

As these Rheostats are made almost entirely of metal, the heat dissipation is increased. On account of this and the fact that there is ample air-space between element and panel the ebonite cannot be damaged by heat.

Large-headed screws are provided for connecting wires.

## New Burndept Rheostats—better than ever

THOSE who already know of the Burndept reputation in the production of rheostats will take special interest in the new models which are constructed almost entirely of metal. They are a distinct advance both in appearance, efficiency and durability, and are very easy to fit. The movement is perfectly smooth and absolutely noiseless. Each rheostat is supplied with a scaled aluminium plate and a neat pointer-knob ready for mounting on any panel from  $\frac{1}{8}$  to  $\frac{1}{2}$  an inch in thickness.

The well-known Dual Rheostat, illustrated in its new form above, was first introduced by Burndept in December, 1923. We have gone a step further in this direction by producing a Super-Dual Rheostat, which enables one to use any valve, bright or dull emitter, with any battery up to 6 volts! It may truly be described as the "universal" rheostat. Two Burndept Potentiometers are now obtainable, with 250 and 500 ohm windings, the latter type being particularly suitable for use with dry batteries.

That these new Rheostats will meet with general approval cannot be doubted. In price, performance and appearance, they have no equal. Send the coupon below for Publication 281, giving full particulars of the various types, and a free copy of the Burndept Components Catalogue. Here are brief details of the eight models:



The special contactor-spring between spindle and body ensures perfect contact and complete absence of "frying-noises"

Price list of New Rheostats, supplied complete with Scale and Pointer-knob, ready for mounting on any panel.

- No. 754. Power Rheostat, 2 ohms, 3 amps. 5/-
- No. 756. Standard Single-Valve Rheostat, 7 ohms,  $1\frac{1}{2}$  amp. 5/-
- No. 757. Medium Rheostat, 15 ohms, 1 amp. 5/-
- No. 758. H.R. Rheostat, 30 ohms, 0.5 amp. 5/-
- No. 743. Dual Rheostat, 5-30 ohms 6/-
- No. 744. Super-Dual Rheostat, 10-60 ohms 7/6
- No. 760. Standard Potentiometer, 250 ohms, 0.1 amp. 6/-
- No. 759. H.R. Potentiometer, 500 ohms, 0.05 amp. 7/6

The Burndept Range includes everything for radio reception from components to complete installations.

— CUT HERE —

To BURNDEPT WIRELESS Ltd.  
Aldine House, Bedford Street, Strand,  
London, W.C.2.

Please send me Publications  
276 and 281

NAME .....

ADDRESS .....

DATE ..... *Wireless Constructor, Dec.*

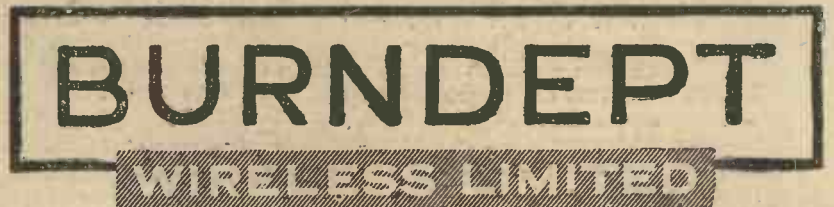

Head Office : Aldine House, Bedford St., Strand, London, W.C.2  
Telephone : Gerrard 9072      Telegrams : "Burndept, Westrand, London"  
BRANCHES at Belfast, Birmingham, Brighton, Bristol, Cardiff, Exeter, Glasgow, Leeds, Liverpool, Manchester, Newcastle, Northampton and Nottingham



Two valve holders (Benjamin Electric, Ltd.).

One dual filament rheostat (L. McMichael, Ltd.).

One No. 1 terminal panel (Burne-Jones & Co., Ltd.).

One No. 2 terminal panel (Burne-Jones & Co., Ltd.).

One piece of ebonite about 3 in. by 2 in. on which the rheostat is mounted.

**Construction and Wiring**

The actual arrangement and attachment of the parts will be found easy to manage, I think, with the aid of the photographs accompanying this article. The wiring up will also prove quite easy, since it is all readily accessible, and there are relatively few connections to make (Fig. 2).

All the connections, except two, can be made without soldering; those constructors who can solder, of course, are urged to do so in the case of all the connections, but those who cannot may yet make a sound job by bending loops in the ends of the leads and screwing them down under the nuts or terminals of the various components. The filament resistance is the only part which does not possess quite suitable nuts or terminals, and two soldered connections are desirable, though not essential here. (Most constructors possess a friend who will

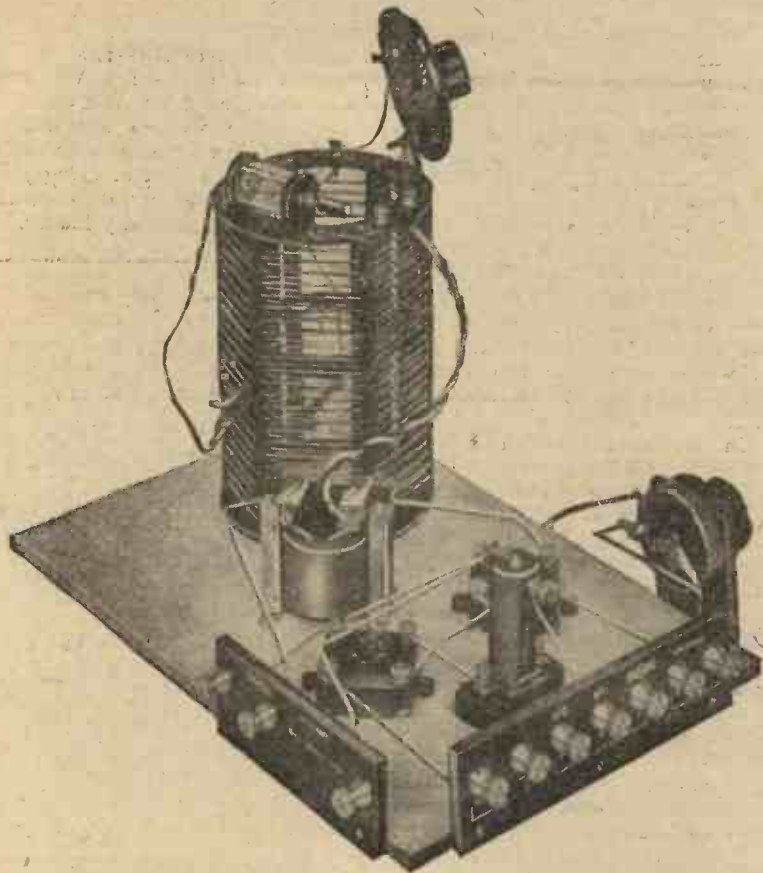

The above photograph shows the terminal strips, and the flex lead from the transformer to the crystal set.

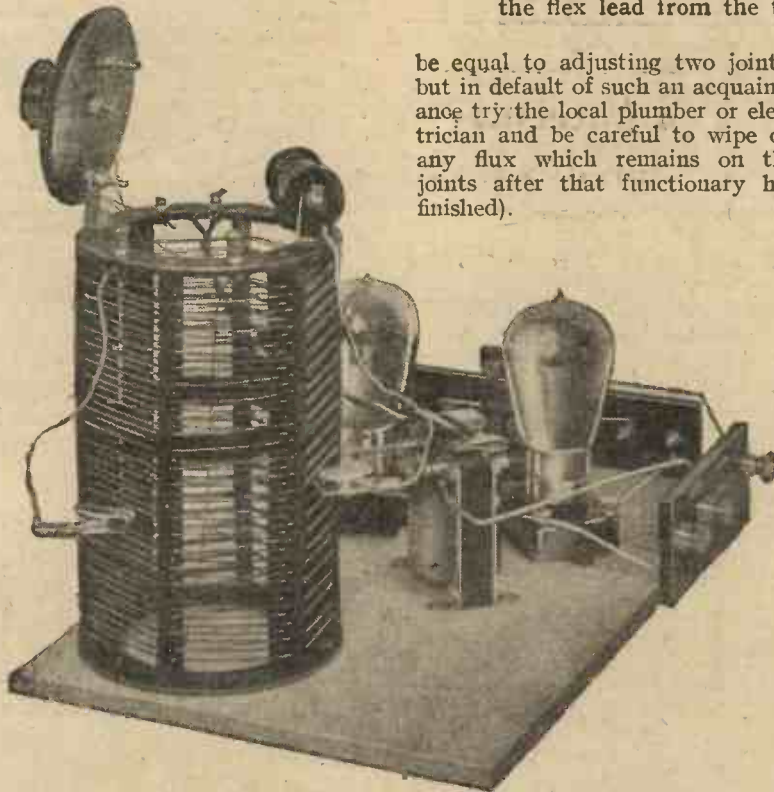

A view from the back with valves inserted. Note how the clips are attached to the low-loss coil.

be equal to adjusting two joints, but in default of such an acquaintance try the local plumber or electrician and be careful to wipe off any flux which remains on the joints after that functionary has finished).

**Connecting to the Set**

It will be seen that the connections between the primary terminals of the L.F. transformer and the telephone terminals of the set consist of a short piece of twin flex, and this is intended to enable the user to disconnect the L.F. valves easily and attach a pair of phones direct to the old terminals on the set, for tuning-in purposes.

The mounting of the filament resistance (which controls both valves at once) is the only other constructional point calling for mention. This component is mounted upon a piece of  $\frac{1}{4}$  in. thick ebonite, 2 in. by 3 in., and this piece of ebonite is attached to the edge of the base-board in the position seen in the photographs.

Probably the neatest job will be made if the wiring is done with stiff square wire; one of the easier methods can be adopted if desired, without any risk of ill-effects.

**Valves and Voltages**

Since really strong loud-speaker signals can be obtained with this set, and since one of the valves has in its anode circuit a coupling resistance, it is important that a

suitable type of valve be employed in each socket.

In making a choice it must be remembered that both the valves are controlled by one filament rheostat, and therefore they should be of types requiring equal filament voltages.

For example, a special valve of the resistance-capacity amplifier type is very desirable in the first socket (the one nearest the filament resistance); examples of this type are the D.E.5b. and D.F.A.4, both of which should be run from a six-volt accumulator and a suitable setting of the rheostat.

In the second socket a small power valve is best, and types which will run from the same filament voltage as the ones just mentioned and take about the same current (0.25 amp.) are the B4, D.F.A.I, D.E.5, and the L.525.

Another valve suitable for use in the first socket is the D.E.3b., which requires about 3 volts across the filament and takes .06 ampere. When one of these valves is employed one with similar characteristics of filament must be used in the second socket, and one may then be limited to one of the general purpose valves, taking .06 amp. filament current. Such a combination will usually only be resorted to when extreme economy of filament current is imperative.

**H.T. and Grid-Bias**

The values of H.T. and grid-bias to use will depend to a large extent upon the types of valves in use, but in general it may be taken that the higher the voltage the better on both valves, provided that the makers' specified maximum voltages are not exceeded, and that appropriate values of grid-bias are used.

The same value of H.T. may generally be applied to both terminals, but the grid-bias voltage will almost always require to be different. With the majority of

valves either 1½ or 3 volts negative will be best on G.B.-1, and 4½ or 6 volts on G.B.-2. Whatever valves are used try the effect of varying the voltage supplied to each grid-bias terminal, remembering that the object of using grid-bias is to ensure good quality, and not to make signals any louder.



The bases of huge aerial masts are pivoted to allow the masts to sway in the wind.

easily "reversible," that is, the substances which result from the change cannot be re-converted into their original form by passing a charging current through the cell in the reverse direction. Hence, when all the active substance has reacted with the exciting agent, the cell is "run down" and must be discarded.

A secondary battery, on the contrary, operates by virtue of a chemical change which can be reversed by passing a current through it in the opposite direction to that given out by the battery. The materials composing the cell are thereby restored to their original form, and will once more react and give out a current from the terminals of the battery. The battery can therefore be re-charged when it has run down, and the cycle of changes can be repeated almost indefinitely. Secondary batteries, of course, are commonly known as accumulators, though the name is something of a misnomer.

What is super-regeneration and how does it differ from ordinary reaction ?

When ordinary reaction is applied to a tuned circuit, a point is soon reached beyond which it is inadvisable to go because the receiving set then breaks into self-oscillation. It appears, therefore, that the very powerful effect of reaction could not be made full use of. Major Armstrong conceived the idea of applying reaction at full strength, but arranging that a kind of braking effect should be introduced with just sufficient rapidity to avoid the production of a noticeable audible note and to prevent continuous self-oscillation actually occurring.

**Two Interesting Queries Answered**

What is the difference between primary and secondary Batteries ?

A primary battery is one in which the chemical change which produces the electric current is not

**"WIRELESS"**

The One-Word Weekly  
Every 2d. Tuesday



The uses of a portable set are manifold !

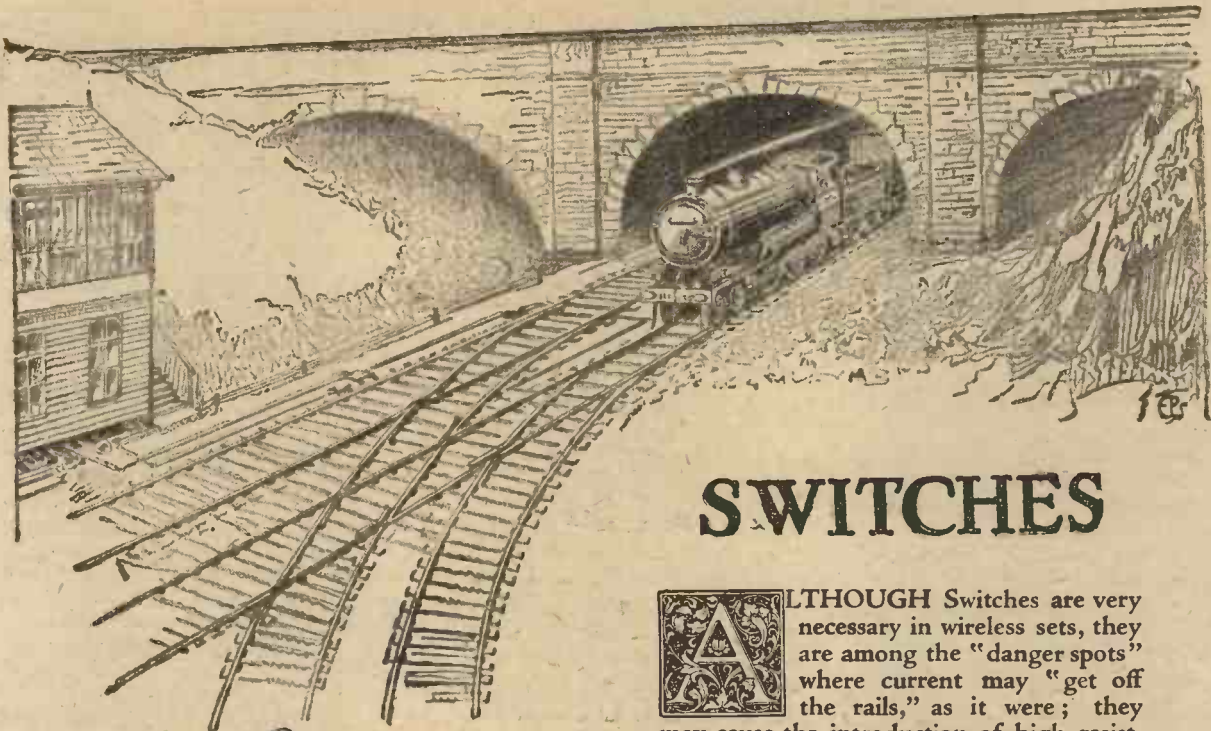

# SWITCHES

**A**LTHOUGH Switches are very necessary in wireless sets, they are among the "danger spots" where current may "get off the rails," as it were; they may cause the introduction of high resistance owing to faulty or dirty contacts, and in addition they may introduce very undesirable capacity effects between the opposing terminal strips.

When the Dubilier Minicap Switch was designed, these particular problems were solved—the first by the use of definite self-cleaning rubbing contacts, the second by a special arrangement of the terminal strips, as shown in the illustration. The terminals have substantial tags for soldering, and the frame is solidly constructed of a special metallic alloy.

The Minicap is a double-pole double-throw switch useful in all circumstances for general purposes.

Manufactured by the Dubilier Condenser Co. (1925) Ltd., in addition to the following:—Fixed Mica Condensers, Variable Air Condensers, Anode Resistances, Grid Leaks, the Dubrescon Valve Protector, the Ducon Aerial Adaptor, the Mansbridge Variometer. The Company are also sole concessionnaires for the products of the Mansbridge Condenser Co., Ltd.

Whenever any of these products are required, the wisest course is to

*Specify Dubilier.*

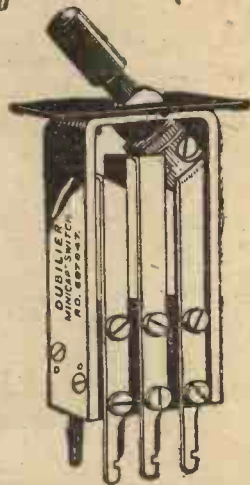

The Dubilier Minicap Switch.

8/-

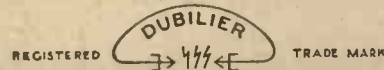

ADVERTISEMENT OF THE DUBILIER CONDENSER CO. (1925) LTD., DUCON WORKS, VICTORIA ROAD, NORTH ACTON, LONDON, W.3. TELEPHONE: CHISWICK 2241-4-3 E.P.S. 245

**Vibration-distant shocks - they are always here**

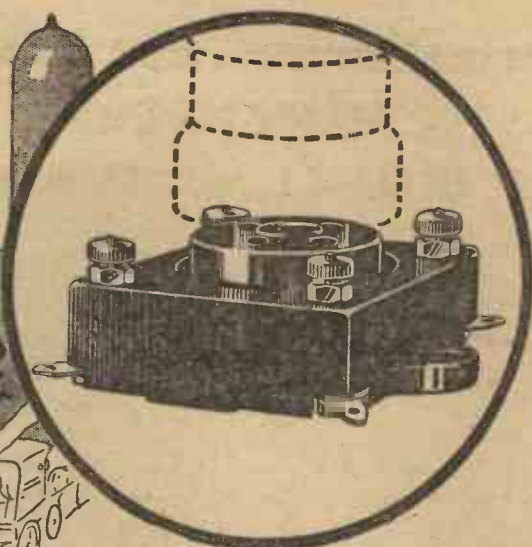

## Give your Valves the protection of this unique holder

Use the Clearer Tone Valve Holder and float your valves—secure from the ever-present tone-destroying vibrations caused by street traffic and the hundred and one common microphonic disturbances. So thoroughly does this new holder cushion the valve that foreign noises are completely dissipated.

The springs, though delicately adjusted, are immensely strong and the tightest valve can be inserted without fear of damaging them. EACH SPRING HAS ONE TURN ONLY. Bakelite construction of the body of the holder ensures high insulation, low capacity and sturdiness.

There are terminal connections for the experimenter and soldering tags for the permanent set. The Benjamin Clearer Tone Valve Holder is easily cleaned—little or no dust can collect in the sockets.

The springs themselves, as shown in the lower of the two diagrams, form the valve pin sockets. No soldered

joints—all one solid metal piece from tag to valve leg.

No flexible wire connections. The spring supports are not affected by stiff bus bar wiring. For Good Reception with Dull Emitter Valves Benjamin Clearer Tone Anti-Microphonic Valve Holders are absolutely essential.

2/9  
Each.

Sectional View of Holder

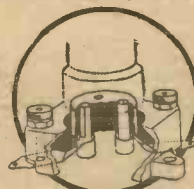

Detail of Spring Feature

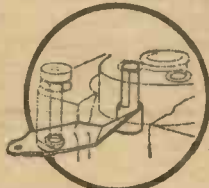

BRITISH **BENJAMIN** MADE

## CLEARER TONE VALVE HOLDER

Patents (ANTI-MICROPHONIC) Pending

From your Dealer or direct from:

**THE BENJAMIN ELECTRIC LIMITED**  
Brantwood Works, Tariff Road, Tottenham, N.17.

The Benjamin Battery Switch gives perfect current control, 2/- each.

## X Your Needs

in Radio Literature are fully met when you select & specify:

### Radio Press Books

	Post	Price	Free
	9d.	11d.	
1. Wireless for All... By John Scott-Taggart, F.Inst.P., A.M.I.E.E.			
2. Simplified Wireless By John Scott-Taggart, F.Inst.P., A.M.I.E.E.	1/-	1/2	
3. How to Make Your Own Broadcast Receiver By John Scott-Taggart, F.Inst.P., A.M.I.E.E.	1/8	1/8	
4. How to Erect your Wireless Aerial By B. Müttel, A.M.I.E.E.	1/-	1/2	
5. The Construction of Wireless Receiving Apparatus... By P. D. Tyers.	1/8	1/8	
6. The Construction of Crystal Receivers By Alan L. M. Douglas.	1/8	1/8	
7. How to Make a "Unit" Wireless Receiver... By E. Redpath.	2/6	2/8	
8. Pictorial Wireless Circuits By Oswald J. Rankin.	1/8	1/8	
9. Wireless Valves Simply Explained By John Scott-Taggart, F.Inst.P., A.M.I.E.E.	2/6	2/8	
10. Practical Wireless Valve Circuits By John Scott-Taggart, F.Inst.P., A.M.I.E.E.	2/6	2/8	
12. Radio Valves and How to Use Them... By John Scott-Taggart, F.Inst.P., A.M.I.E.E.	2/8	2/8	
13. 500 Wireless Questions Answered By G. P. Kendall, B.Sc., and E. Redpath.	2/6	2/8	
14. 12 Tested Wireless Sets By Percy W. Harris, M.I.R.E.	2/8	2/8	
15. More Practical Valve Circuits... By John Scott-Taggart, F.Inst.P., A.M.I.E.E.	3/6	3/10	
16. Home-built Wireless Components	2/6	2/8	
17. Wireless Sets for Home Constructors By E. Redpath.	2/6	2/8	
18. Tuning Coils and How to Wind Them By G. P. Kendall, B.Sc.	1/6	1/8	
21. Six Simple Sets... By Stanley G. Rattee, M.I.R.E.	1/6	1/3	
22. Switches in Wireless Circuits... By Oswald J. Rankin.	1/8	1/8	
24. Wireless Faults and How to Find Them... By R. W. Hallows, M.A.	1/8	1/8	
Elementary Text Book on Wireless Vacuum Tubes By John Scott-Taggart, F.Inst.P., A.M.I.E.E.	10/-	10/6	
Radio Engineering By J. H. Reynier, B.Sc. (Hons.), A.C.G.I., D.I.C.	15/-	15/9	

Radio Press Books are obtainable from all Newsagents, Bookstalls, your local Wireless Dealer, or direct from Dept. W., Radio Press, Ltd. For prompt and sure delivery when ordering direct from Radio Press, Ltd., please write your name and address in BLOCK LETTERS.

**RADIO PRESS, LTD.**  
Bush House, Strand, London, W.C.2

Barclays Ad.

## THE NEW VALVE WITH THE IRONCLAD GUARANTEE



*America's Foremost Valve  
made in  
Britain's newest Factory*

*C.T. 25 B. For resistance  
capacity coupled amplifier.  
Amplification Factor 20. 15/-*

### Perfect Service or instant replacement

Positive Performance or a new Valve. That is the Ironclad Guarantee. So long as there is light and life in a Cleartron this Guarantee holds good. No matter where the Valve is bought any Cleartron Dealer will replace it instantly without cost or question.

#### Make sure of your Valves.

Cleartron gives you increased volume, greater distance, purer tone, keener selectivity—and guarantees it up to the hilt.

## 12/6

Cleartron guaranteed valves consume less current, oscillate, detect and amplify.  
Types — C.T. c8,  
C.T. 15 at 12/6.  
American type  
C.T. 199 at 12/6

**CLEARTRON RADIO LIMITED**  
1, CHARING CROSS, LONDON  
AND BIRMINGHAM

\*Phone: Regent 22,31-2. \*Grams: Cleartron, Westrand, London

# CLEARTRON

BRITISH  MADE

## 15/=

Types C.T. 25,  
C.T. 25B at 15/-.  
American type  
C.P. 201A at  
15/-. If your  
dealer does not  
carry Cleartrons,  
order from us,  
with your  
Dealer's name  
and address

*All Cleartron Valves are Dull Emitters*

*Service Advertising*



## What to Look For When Buying Components

By D. J. S. HARTT, B.Sc.

*Choose your components with care—it will pay you in the end*

**M**OST readers of this journal when making up sets probably adhere fairly closely to the specifications given in the original design, but for the benefit of those who may make up sets from their own designs, or depart for some legitimate reason from the specification given by Radio Press designers, I propose to devote this short article to some of the essential things to consider when purchasing components.

### Inferior Components

First of all let me warn you against buying cheap or shoddy components; I know that this warning has been repeated many times, and some of you may be getting somewhat tired of it. You may argue that it is not always possible for you to purchase better-class components, but in such cases I would advise you always to purchase the best possible under the circumstances. Probably most radio enthusiasts pass through that period when they buy inferior components, but all in the end profit by their experience, and find that the only wise procedure is to purchase the best possible—but not necessarily the most expensive—in every case.

I will deal with some of the more important components first, such as variable condensers, coils, coil holders, and L.F. transformers. A few brief hints on the choice of accessories, such as H.T. batteries, accumulators, phones and loud-speakers, etc., will also be given.

### Variable Condensers

While the majority of variable condensers now on the market are of a fairly high standard, both electrically and mechanically, I can quite conceive that there may be some readers who are not even in a position to judge why any particular condenser is a good or a bad one. Look first at the insulation of the moving plates from the fixed vanes; there are several

ways of achieving this. First we may have the end-plate made of ebonite or some other insulating material such as bakelite, the spindle carrying the moving plates of the condenser being supported in metal bushes in these end-plates. Secondly, we may have metal end-plates with bushes in them which serve both as bearings and as insulation between the two sets of plates. Thirdly, we may have metal bearings in metal end-plates, thus making the end-plates in electrical contact with the moving vanes, the fixed plates being insulated and supported by a strip of insulating material attached to the frame.

### End Plates and Bushes

Modern practice seems to indicate that the last-named method is probably one of the best, since it is pos-

Further points to observe are that the clearance between the plates is uniform, thereby reducing the possibility of short circuit through the moving vanes touching those which are fixed; and that the mechanical strength of the whole condenser is adequate and that there is no "shake" or play in the bearings supporting the moving system.

### Geared Condensers

More recently we have had a number of condensers put on the market in which some provision is made for the fine movement of the moving vanes, either by some form of gearing incorporated in the actual condenser, or by means of some gearing embodied in the dial. If you should be choosing a condenser of this type (and they are very desirable in sharp tuning circuits or in short-wave sets), make sure that there is no backlash in the gearing movement and also that none is likely to develop during reasonable use of the condenser.

### Mounting and Connections

The question of the mounting of the condenser is also important. Much as everybody appreciates the convenience of one-hole fixing for components, this type of fixing is not always suitable for a heavy condenser, and some such scheme as a three-screw fixing is often desirable. It is also important to observe what type of connection is provided between the moving system and the soldering tag or terminals. Some type of positive contact is desirable here in all cases, but it is absolutely essential if the condenser is to be used at all successfully for short-wave reception. The use of a "pigtail" connection is the usual means of ensuring this positive contact, but do not imagine that any type of pigtail will be suitable. If the pigtail consists of a spiral of bare wire, the turns of which touch and scrape together as the moving vanes are rotated,



The filament rheostat is not the least important part of your set.

sible to have the insulating material well out of the intense electrostatic field, and dielectric loss is therefore minimised. In the case of ebonite bushes in metal end-plates, we may have a strong electrostatic field here, and unless these bushes are of adequate size and designed correctly, there may be fairly heavy dielectric loss, and also large leakage loss.

it may be found that the system will be noisy in operation on short waves. Personally I prefer a thin rubber-covered flexible connection between the moving vanes and the soldering tag in all cases.

**Fixing the Dial**

One could write a good deal more on the various points of excellence in variable condensers, but I must close my remarks on this type of component with a few words about the method of securing the dial. The method which consists in relying on the use of a lock nut on a threaded spindle, although it is extensively used, is not, in my opinion, always good. A properly adjusted set screw is much better, but this method of securing the dial raises yet another point. As usually employed this set screw passes through the actual knob of the dial, and in many cases when it is tightened up, the top of the set screw comes quite near the sides of the knob, which are gripped in the fingers. Since in most cases this set screw is in electrical contact with the spindle and the moving vanes, this is liable to make hand capacity effects more apparent. The remedy, of course, is to have a knob of fairly large diameter, and to use a short set

screw, so that when the latter is screwed down tightly on the spindle the top of it is well away from the sides of the knob; when this is the case its presence will not seriously increase the hand capacity effects.

**The Plug-In Coil**

In purchasing coils there are several important things to look for if one is to be sure of getting a good type. The purchaser must first decide whether he is going to use the conventional plug-in type, or whether he is going to use coils, say, of the single layer variety

which are designed upon low-loss lines. As a compromise between convenience and absolute efficiency the plug-in coil is hard to beat, and while modern tendencies seem to indicate that it will not in future be so extensively used in certain types of receiver, it is quite certain that this form of coil will always have a large number of supporters.

**Wire and Insulation**

The points to look for in selecting a good plug-in coil are, firstly, that it is well made mechanically; secondly, that there is



Radio dances are very popular this Winter. Here is a merry gathering with a loud-speaker "band."

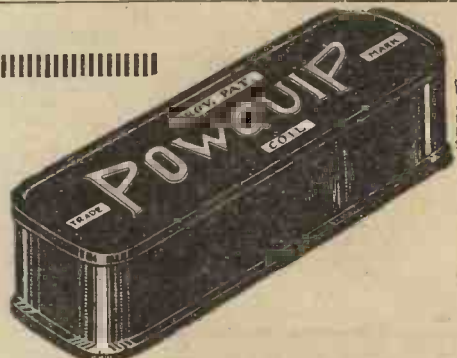

# A new - POWQUIP - Plug-in Coil

After nearly a year's research this entirely new form of single layer plug-in coil has been evolved. These Powquip Coils have ultra-efficiency and selectivity. The windings are entirely enclosed and therefore protected from damage. The dimensions of the coils are 4 3/8" long, 1 1/2" wide, and 1 1/4" deep, and they fit any ordinary standard coil holder.

*Prices from 4/3 each*

Write for descriptive booklet which explains how to use this unique coil

**The POWER EQUIPMENT COMPANY LIMITED**

KINGSBURY WORKS, THE HYDE, HENDON, N.W. 9

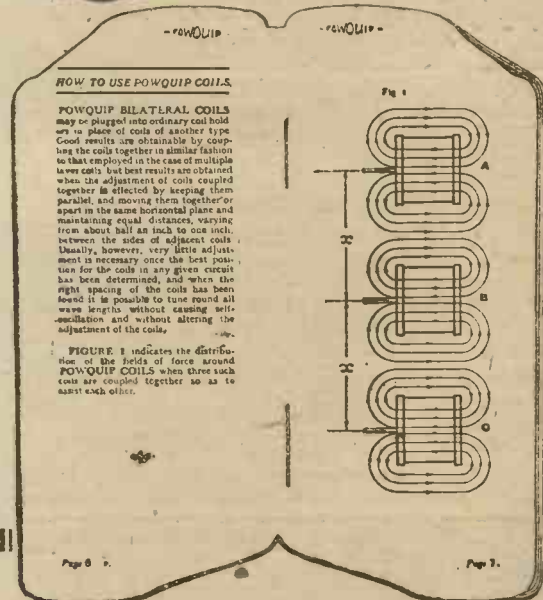

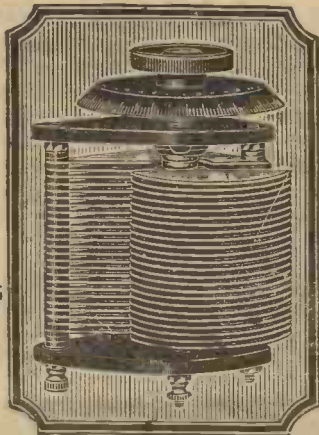

6  
points

of Superiority in the J.B. Condenser

SQUARE LAW.			
'001	.. 9/3	'0025	.. 6/9
'0075	.. 9/	'009	.. 5/6
'009	.. 8/	'001	.. 5/3
'009	.. 6/9	Vernier..	4/6
J.B. SQUARE LAW			
WITH VERNIER.			
'001	.. 14/	'009	.. 11/3
'009	.. 12/3	'0025	.. 11/3
STANDARD.			
'001	.. 8/6	'0025	.. 5/9
'0075	.. 8/	'009	.. 5/
'009	.. 7/	'001	.. 4/9
'009	.. 6/9	Vernier..	4/
Post. One 6d., Two 9d., Three 1/			

End plates guaranteed hand-polished abonite free of surface leakage and of low dielectric loss. The maximum capacity is guaranteed. A very low minimum capacity. Negligible losses 0.05 ohms. Specially designed spacers. Precision spindle and bearings, giving a delightfully smooth movement to the centre vanes. —details of tremendous importance, contributing to the high standard of efficiency for which the J.B. Condenser is famous. From all dealers.

**JACKSON BROS.**  
8, POLAND ST- OXFORD ST  
LONDON - W.1  
(First Floor)  
Telephone - GERRARD 7414

Barclays Ad.



AT YOUR  
DEALER  
6/-

WANT MORE STATIONS?

Like that elusive distant one you heard last night . . . Well, the cheapest, simplest way to get them is to replace your old dials with

**PELICAN  
UNIVERNIER**

CAHILL & CO., LTD., 64, Newman St., London, W.1

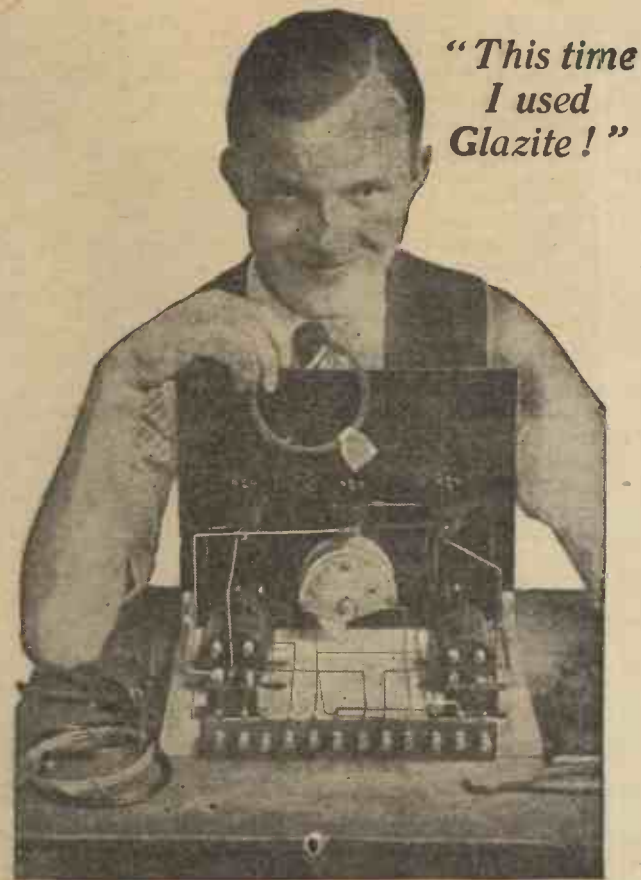

The more complicated the circuit, the more important it is to use

**GLAZITE**  
BRITISH MADE REGD.

COLOURED CONNECTING WIRE  
Red Yellow Blue Black

10 ft. Coils  
1/2 Per Coil  
1/18 SWG

2ft. lengths  
Per Packet 1/-  
4 Assorted Colours  
1/16 SWG.

Supplied by all Radio Dealers Write for Descriptive leaflet

Genuine Glazite bears this Seal which guarantees quality



Makers of Electric Wire for over forty years

THE LONDON ELECTRIC WIRE CO. & SMITHS, LTD.  
Playhouse Yard, Golden Lane, London, E.C. 1

Telegrams: Electric, London. Telephones: Clerkenwell 1388, 1389, 1390, 1391



preferably some amount of air space in between the various layers of the coil, and thirdly, that the mounting plugs are made of good quality insulating material. It is not always possible to tell whether this is so from a casual inspection of the mounting plugs, but if any doubt is experienced, I must ask you to bear in mind what I said at the commencement of this article—that is, buy only components made by makers of good reputation and which are generally acknowledged to be reliable.

#### Low Loss Principles

Other points to observe are: see that there is little solid dielectric in the support of the coil, and also guard against the presence of too much metal work. Coils which have closely-wound turns should have little impregnating material, as excess of this only increases the self-capacity of the coil, and tends to mar its efficiency; where the turns are air-spaced this question of impregnation is not so important. Mr. G. P. Kendall, B.Sc., has in recent issues of *THE WIRELESS CONSTRUCTOR* discussed the main points to consider in the design of the more strictly low-loss coils, so I will not enter into the question here.

#### Coil Holders

As far as coil holders for plug-in coils are concerned, the main point to consider is that the method of mounting is reasonable and simple, that the means of controlling the movement of the coil mount to be used for the moving coil is sufficiently fine and free to allow of a close regulation of the coupling between the coils without any jerky effects. Where one of the moving coils is to be used for reaction, some form of vernier movement on this coil mounting is extremely desirable. This movement should be free and sufficiently fine to allow one to make small changes in the movement of the coil with ease. A steady and rigid construction is desirable in all plug-in coil holders, and the moving portion should be such that even the largest sizes of plug-in coils will stay at any particular adjustment, without any tendency to drop or move, on account of their weight.

#### Interval Transformers

There are so many makes of low-frequency transformers on the market that it is not difficult to see why many amateurs are often

in doubt as to which particular makes to purchase. It is, of course, very difficult to decide whether any particular transformer is good or bad, merely by a casual inspection of the instrument. As a general rule (and this is not infallible) the weight of the instrument gives a fair indication as to what its performance will be. The making of a good transformer demands the use of a large amount of wire, and an ample iron core, and it is these factors which contribute towards the weight and size of the instrument. There are quite a number of transformers on the market which, I think, no reader would hesitate to purchase, but the obstacle in most cases is their price.

#### The Question of Price

It is, however, impossible to make a really good instrument

rheostats, potentiometers, switches, etc., and in the case of these, readers can do no better than accept the many specifications of Radio Press sets as a guide. If you will look through a few specifications you will find that large numbers of components such as these are used, and there is ample variety from which to choose.

#### Accessories

As far as accessories are concerned, I will deal briefly with H.T. batteries, accumulators, headphones and loud-speakers. With regard to H.T. batteries, while the usual small type gives excellent service with single, two or three-valve receivers, I would strongly recommend the users of multi-valve sets to employ batteries of a larger type, of which there are several now on the market which give good service. As an alternative a number of the smaller size batteries may be used with multi-valve receivers and so connected that each supplies the H.T. current for, say, two or three valves.

#### H.T. Accumulators

For large sets employing five or six valves, or for super-heterodyne receivers, the H.T. battery problem, if such sets are to be used extensively is a very serious one. If the purchaser can afford it, and if he has facilities for charging, one of the well-known makes of H.T. accumulators will give him good service with such multi-valve sets, and will ultimately be the cheapest supply.

#### Filament Batteries

As far as the choice of accumulators for lighting the filaments of your valves is concerned, you need have little doubt about purchasing any of the well-known and advertised makes, for any of these will give you good service provided it is treated as it should be. This latter point is of extreme importance, but unfortunately, I am afraid, most users of accumulators are at the mercy of the charging stations or garages. I do not wish to cast any reflections on the various well-conducted charging stations, but obviously if you are to secure long life and satisfactory service from your accumulators, provided you yourself treat them with care, it only remains for you to choose a good charging station.



A typical modern variable condenser of square-law type.

at a very cheap price, so that again we may say, as a rule, the price of the instrument is some criterion of its quality. This bears out my general statement regarding the choice of any component. Finally, in choosing any transformer, see that adequately-sized and conveniently-placed terminals or soldering tags are provided. These factors will not make or mar the performance of any transformer, but they are points which should be noted when convenience of wiring and construction is considered.

It would take too long to describe all the features of other components such as valve holders,

**Don't Misuse Your Phones**

In the purchasing of phones and loud-speakers, I am aware that you are confronted with a vast medley of different makes and sizes, and your ultimate choice, in the case of the loud-speaker, will depend on the purpose for which you require the instrument. Good phones can now be obtained at a fairly reasonable price, but no pair of phones will remain good unless they are treated with care. Do not, therefore, blame the maker or the dealer from whom you purchased them, if you find that after about a month's use, or should I say misuse, your phones have lost their sensitivity. Short of a break occurring in the windings, a pair of good phones will have a fairly long life, provided they are treated with care.

**Loud-Speakers**

A loud-speaker is somewhat more difficult to choose, and the most important thing to consider is the power of your set when you are buying this accessory. It is obviously too much to expect a loud-speaker of the small type to stand up to the overloading which would be produced by working it in conjunction with a multi-valve receiver near to a main broadcasting station. I have known people who have complained about the quality

produced by their loud-speaker when they were operating it under these extreme conditions of overloading; a slight detuning of the receiver and a few careful adjustments should demonstrate this point. Therefore, if you want good quality and large volume, and provided your set is as free from distortion as is possible, you must buy a good loud-speaker of large size. If you require only medium volume for a small room, then one of the many well-known makes of small loud-speaker will suit your purpose, but do not overload it.

**Spend Wisely**

There are many more minor points which could be raised to help the intending purchaser who knows very little of the subject of wireless, but I trust that these few hints have shown him some of the more important points to observe, and will prove of help to those who wish to spend their money wisely.

**"What to do with Three Valves"**

We regret that an incorrect circuit diagram appeared in the article entitled "What to do with 3 Valves" in the November issue of THE WIRELESS CONSTRUCTOR. The diagram in question was Fig. 4 on page 84, the grid leak and condenser being inadvertently omitted in the lead to the grid of the second valve. The correct circuit is given below.

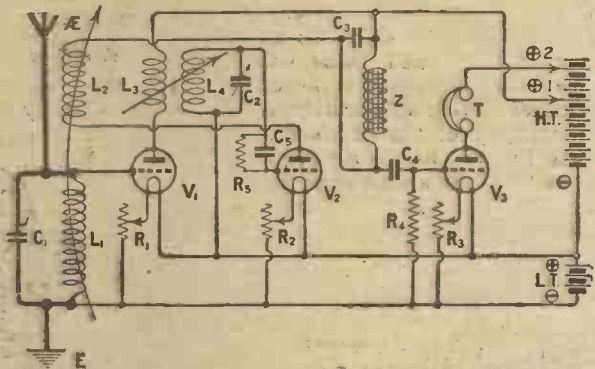

The corrected circuit diagram, with the grid leak and condenser,  $R_5$  and  $C_6$ , inserted.

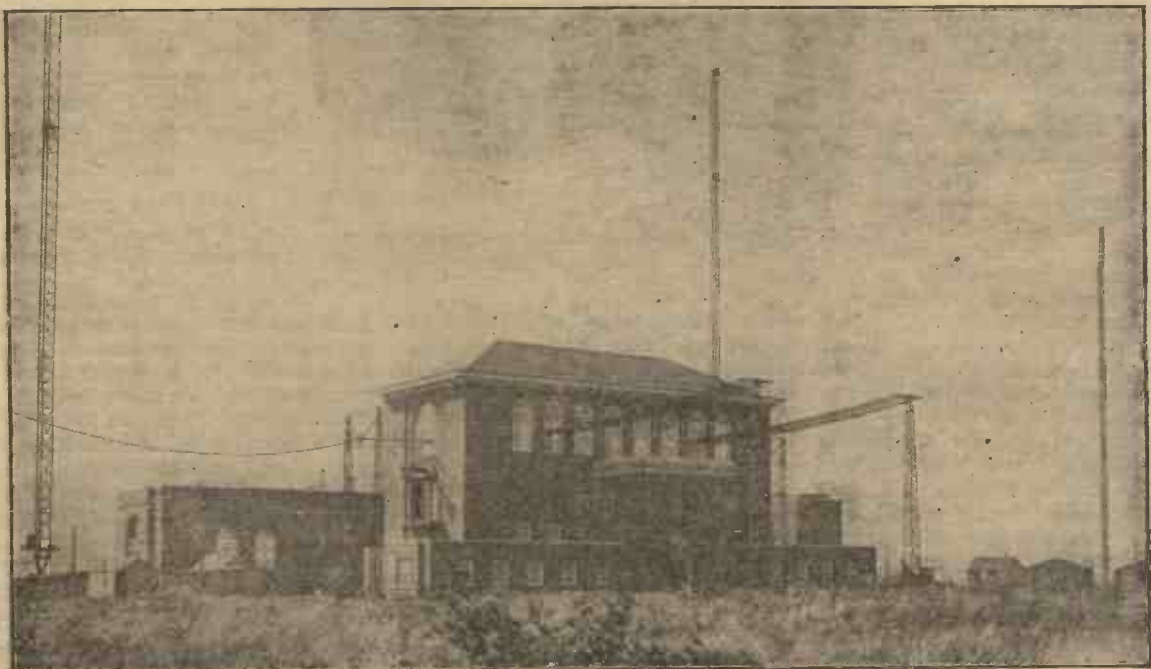

The great Post Office Station. The main building at the new Hillmorton Wireless Station, near Rugby. Note the masts, and on the left the lead-in.





MODERN WIRELESS  
THE LEADING SHILLING MONTHLY

## Every Reader

of The Wireless Constructor improves his knowledge month by month and is therefore on the look-out for details of new circuits and developments which are practically taking place daily.

To get further ahead, therefore, one should make a habit of buying MODERN WIRELESS each month. It always contains a big selection of interesting articles which you can grasp and enjoy, and scope is also given you to extend your knowledge and experiments in a manner both valuable and pleasing.

In the splendid issue the cover of which is here illustrated there is a selection of no less than six constructional articles, all fully illustrated, and a mass of valuable information and interesting reading matter.

### HERE ARE A FEW OF THE CONTENTS:

#### How to make

- THE "SPECIAL FIVE."  
By Percy W. Harris, M.I.R.E.
- A SINGLE VALVE SHORT WAVE RECEIVER.  
By D. J. S. Hart, B.Sc.
- AN ANODE-INPUT REFLEX SET.  
By J. H. Reyner, B.Sc. (Hons.) A.C.G.I., D.I.C.
- A TWO-VALVE POWER AMPLIFIER.  
By C. P. Allinson.
- A DOUBLE CIRCUIT CRYSTAL SET.  
By A. Johnson-Randall.
- THE CONTINENTAL TWO.  
By E. J. Marriot.

- HOW TO RUN YOUR RECEIVER DIRECT FROM D.C. WAI S.  
By Major James Robinson, D.Sc., Ph.D., F.Inst.P.
- WHAT VALVE SHALL I USE?  
By Captain H. L. Cronther, M.Sc.
- WHAT TO LISTEN FOR ON SHORT WAVES.  
By A. V. D. Hort, B.A.
- IS SELF-CAPACITY A BOGEY?  
By H. J. Barton-Chapple, B.Sc., A.C.G.I., D.I.C., A.M.I.E.E.
- REACTION CONTROL CIRCUITS.  
By J. H. Reyner, B.Sc. (Hons.), A.C.G.I., D.I.C.
- IS THE AERIAL CIRCUIT EVER APERIODIC?  
By G. P. Kendall, B.Sc.
- PICKING UP THOSE DISTANT STATIONS.  
By R. W. Hallows, M.A.

## BUY A COPY TO-DAY

Obtainable from all Newsagents and Bookstalls. If any difficulty in obtaining locally send P.O. for 15s. and copies will be sent you every month for a year. Address: Sales Dept. W, Radio Press, Ltd., Bush House, Strand, London, W.C.2

# Modern Wireless

Edited by JOHN SCOTT-TAGGART, F.Inst.P., A.M.I.E.E.

Barclays Ad.

THE FIRST WIRELESS LOUD SPEAKER WAS A BROWN



Greater volume and better tone than many costing twice as much.

TO those who have been accustomed to believing that a miniature Loud Speaker must, of necessity, be productive of little more than a whisper, this wonderful new Brown H.4 comes as a revelation.

Its generous volume and its unsurpassed purity of tone are due solely to the application of the famous Brown tuned reed principles of reproduction. Super-sensitive to a degree, it is the only miniature Loud Speaker capable of giving, at a comfortable strength, perfect reproduction at a price within the reach of all. The Brown H.4 will, for example, give a volume of sound adequate for the average small room from any 2-valve Receiver within 15 to 20 miles from a B.B.C. Station.

Although its price is so low, the H.4 is manufactured to conform to typical Brown standards of accuracy. Its handsome symmetrical appearance and its solidity of construction bespeak the quality product. Your Dealer can show you a complete range of the new Brown Loud Speakers at prices to suit all pockets—ask him for a demonstration. Afterwards you'll agree that the superb Brown has no competitor.

**The new H.4**

A miniature Loud Speaker 10-inches high. Finished in a rich brown colour and fitted with standard Brown tuned reed movement. Plated fittings. Resistance of 2000 ohms—

If the Trade have difficulty in obtaining Brown Wireless Instruments they should write to us without delay.

30/-

S. G. Brown, Ltd., N. Acton, London, W.3

Retail Showrooms: 19 Mortimer Street, W.1.  
 15 Moorfields, Liverpool. 67 High Street, Southampton.  
 Depots (Wholesale only): 13 Bushy Park, Bristol.  
 Cross House, Westgate Road, Newcastle.

BRITISH

**Brown**

THROUGHOUT

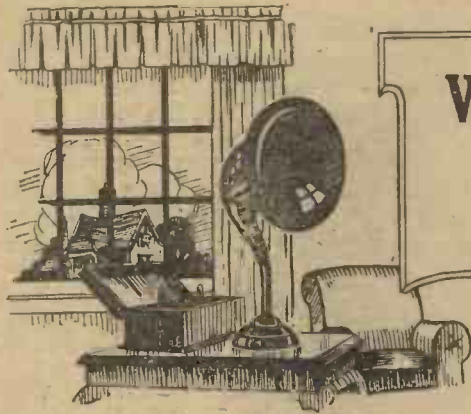

# What to do with One Valve and a Crystal

By STANLEY G. RATTEE, M.I.R.E.,  
Staff Editor

The article below will interest all those who think of "adding a valve" to their crystal detector

MANY users of crystal receivers are, no doubt, anxious either to increase their receiving range or to increase the volume of their present results; or, on the other hand, they may wish to perform both these operations. With these points in mind, the purpose of this present article is to show just what circuits may be tried using a crystal as a detector and a single valve either as a high- or a low-frequency amplifier. Condenser and coil values are given, so, beyond actual constructional details, sufficient information is supplied for readers to construct a receiver on their own design, or else the circuits may be tried as rough bench "hook-ups" to see the actual performance of each.

### L.F. Amplification

Probably the simplest form of crystal-valve circuit is that given in Fig. 1, which shows a simple crystal circuit, using a semi-aperiodic aerial coupling, followed

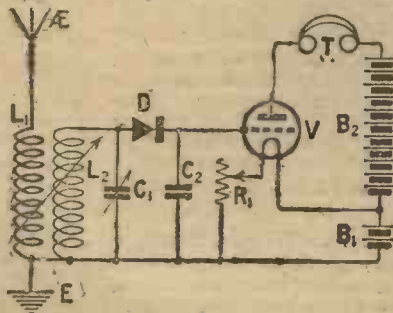

Fig. 1.—A simple and inexpensive arrangement.

by a valve acting as a low-frequency amplifier. It will be noticed that the conventional low-frequency transformer is omitted, and though the final results given

by this arrangement are not in any way as loud as those obtained when the transformer is included, the circuit possesses the merit of simplicity and is inexpensive to make up.

The coil  $L_1$  will usually be a

being used for the  $C_2$  condenser. For the reception of those stations working within the broadcasting belt  $L_1$  will be a No. 35 or 50 coil, with a No. 75 as  $L_2$ . In the case of 5XX  $L_1$  will again be a No. 150, with a No. 250 for  $L_2$ .

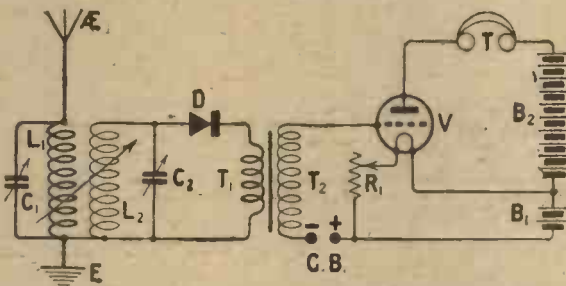

Fig. 2.—A more common circuit incorporating a transformer.

No. 25 or 35 for the broadcast band, with a No. 75, tuned by a  $.0005\mu\text{F}$  variable condenser for  $L_2$ . The condenser  $C_2$  is not critical in value, and may be of  $.0003\mu\text{F}$  capacity. The grid and filament of the valve are connected across the  $C_2$  condenser in the same way that telephones would be normally connected. For the reception of 5XX with this arrangement,  $L_1$  should be a No. 150 coil with a No. 250 as  $L_2$ .

### Transformer Coupling

The more conventional manner of adding a low-frequency valve to a crystal circuit is that shown in Fig. 2, where it will be seen that the transformer  $T_1$   $T_2$  couples the crystal circuit to the valve. In this case the primary of the transformer is connected across the crystal circuit, one side of the secondary going to the grid of the valve, while the other side goes to G.B. negative. In this circuit it will be noticed that the  $L_1$  coil is also tuned in addition to the coil  $L_2$ , the condenser  $C_1$  being one of  $.0005\mu\text{F}$ , the same value also

### Selectivity

In both this and the Fig. 1 arrangement the degree of selectivity required is given by varying the coupling between  $L_1$  and  $L_2$ , any alteration of coupling, however, necessitating the re-setting of the condenser  $C_1$  in the first circuit and the re-setting of both condensers  $C_1$  and  $C_2$  in Fig. 2. Readers will remember that in THE WIRELESS CONSTRUCTOR for November,

1925, Mr. G. P. Kendall described a crystal set using a "three-step" coil, and in Fig. 3 is shown how such a circuit may have a low-frequency valve added for further signal strength should it be desired.

So far we have considered only the adding of a valve to increase signal strength, with perhaps some

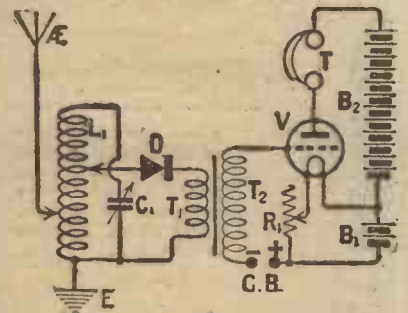

Fig. 3.—An L.F. valve added to a "3-step" circuit.

slight increase in range, therefore, in order that we may definitely increase the receiving range of the crystal, we will add a high-frequency valve.



**Built**  
by precision methods  
for perfect amplification

WHEN broadcasting first began Ericsson Transformers had already strongly established themselves as powerful amplifiers with a total absence of distortion.

In designing Ericsson Transformers an amplification ratio has been used which provides the utmost volume consistent with an absolute purity of tone.

They are made in no great size, which is a great help in constructing sets on the American enclosed cabinet style. Give one as a present to your constructor friends.

- D** Catalogue No. 0/0016. Ratio 1:4 Price 17/6
- D** Catalogue No. 0/1016. Ratio 1:2 Price 17/6

Should your phones or loud-speaker be of the 120 ohm resistance pattern we thoroughly recommend the Ericsson Phone Transformer for perfect coupling.

*Write us to-day for further information. Catalogue giving useful wiring hints, also full information on Components, Valve and Crystal Sets, Super-sensitive Telephones, Super Tone Loud-speakers, etc., sent free.*

The BRITISH L.M. ERICSSON Mfg. Co. Ltd.  
67-73 Kingsway, London, W.C.2



The **SUPER SUCCESS TRANSFORMER**  
gives volume with tonal purity

THE low frequency side of most radio sets receives but scant attention. L.F. Transformers are generally taken for granted—certainly not on their merits. You may persuade your set to give satisfactory results by considering the question of using transformers that give greater volume without robbing reproduction of good quality. Such a transformer is the SUPER SUCCESS, the result of constant research and experiment. In practical result, it gives ample amplification without distortion in either a straight or a reflex. Each instrument is tested to 1,000 volts between the windings and between windings and frame and is broadcast tested.

PRICE  
**21/-**

—a good transformer cannot be made for less

From all  
Dealers

The **SUCCESS FRAME AERIAL**

HERE is an ingeniously designed frame aerial. Constructed of thoroughly seasoned wood—stained black. It is collapsible, which obviously offers a distinct advantage to flat-dwellers.

The particular construction permits collapse without damaging the wires. When in use the wire is held taut.

A specially prepared braided covered insulated wire is used.

All metal fittings are heavily nickelled. The Success Frame Aerial presents a very desirable piece of apparatus for all Super Heterodyne owners.

Waveband covered with a .0005 mfd. Stated capacity 260 to 550 metres.

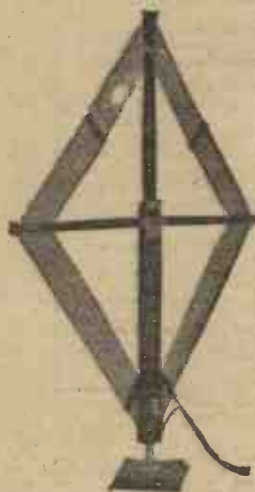

PRICE **£2 2 0**

**BEARD & FITCH, LTD.**

34, AYLESBURY ST., LONDON, E.C.4

Telephone Clerkenwell 8941

Also at 1, Dean Street, Piccadilly, Manchester

# Duodyne

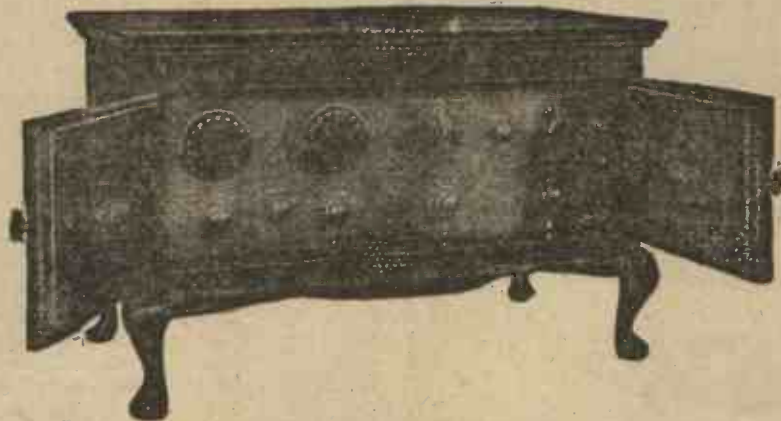

## A Record of Achievement

### THE CURTIS DOUBLE CIRCUIT "SUPER-HET. 8"

**LOUD SPEAKER RANGE.**—750-1,000 miles.

**SELECTIVITY.**—Unaffected by 2LO (London 3 kilowatts) 500 yards away.

**TUNING.**—Absolutely mechanical. The two condenser settings for all main B.B.C. and principal Continental Stations are supplied with each instrument.

**STABILITY.**—Entire freedom from all undesirable oscillation—thus ensuring

that silent background so essential for distortionless reproduction under normal atmospherical conditions.

**DOUBLE CIRCUIT.**—2 or 3 valves may be used for local station work and 7 or 8 valves only for long distance reception.

**CURRENT CONSUMPTION.**—Designed to operate with dull emitter .06 valves. Thus current consumption with all 8 valves is less than that of a single bright emitter valve.

**PRICE:** from **£40** according to Cabinet selected

So many unfulfilled "claims" and illusory "promises" have been made for Super-Heterodyne Receivers and parts therefor, that a practical demonstration is your only **GUARANTEE OF SATISFACTION**

#### BUILD YOUR CURTIS Double Circuit Super-Het

Treatise containing: Circuit Diagram, Wiring Chart, Schedule of Components and Hints 2/6

The only Super-Heterodyne circuit and components backed by the solid demonstrable efficiency of

**THE CURTIS SUPER-HET. 8** each in their respective categories **THE BEST PRODUCED**

**THE CURTIS SUPER HET. 8** for Super-selectivity

**THE DUODYNE V** for Long Range Reception

**THE DUODYNE REGENERATIVE** for Local Broadcasting

**THE DUODYNE PORTABLE IV** The most powerful self-contained Loud Speaker Receiver

Prices range from **£7 10s.** Write now for Catalogues

### DEMONSTRATIONS

can now be given by:

**HARRODS' STORES, LTD., LONDON**  
**C. H. BOOK, 19, John Bright Street, BIRMINGHAM**

**PETER CURTIS, LTD., 312, Deansgate, MANCHESTER**

**H. S. INGLEBY, 1, Albion St., LEEDS**  
**BROWN & CO., 116-118, West Nile Street, GLASGOW.**

Also at all leading London Stores and Wireless Dealers, as soon as existing orders can be fulfilled

All Communications to

## PETER CURTIS, LIMITED

Telegrams: **PARACURTEX 75, CAMDEN ROAD, N.W. 1** Telephone: **NORTH 3112**

Branches: **312, Deansgate, MANCHESTER, 47, Carrick Street, GLASGOW**

Sole Agents for Ireland: **DUBLIN: SOLOMON & PERES, 13, Chatham Street. BELFAST: SOLOMON & PERES, 83, Berry Street**

For Super-Het. Demonstrations only — Open until 9 p.m. every evening Monday to Friday



**High Frequency Amplification**

Unlike the low-frequency valve, which follows the crystal, the high-frequency valve precedes the crystal, amplifying signals before they are actually detected, as in the manner shown by the circuit Fig. 4. Here the coil  $L_1$  may be one of the ordinary plug-in types, or it may be, as shown, one of the tapped specimens, such as the Lissen X, tuned by a  $.0005\mu\text{F}$  variable condenser. The coil  $L_2$  is another plug-in coil tuned by a  $.0003\mu\text{F}$  variable condenser, the crystal and telephones being connected across this circuit  $L_2, C_2$ . The operation of the circuit is to tune

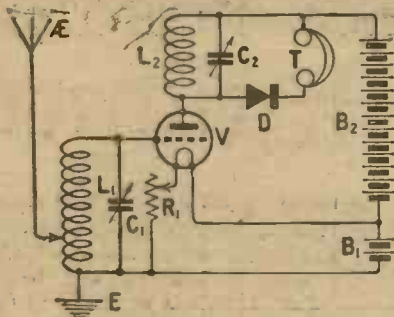

Fig. 4.—The H.F. valve precedes the crystal.

they are connected the right way round), a controllable reaction effect will be given, though alteration of the coupling will necessitate retuning upon both condensers. For the reception of the B.B.C. stations, excluding 5XX, the coil  $L_1$  will be either a No. 35 or 50, or a Lissen X 60 or 75, with a No. 60 or 75 for  $L_2$ . While for 5XX a No. 150 or Lissen

conventional plug-in H.F. transformer is used, then the operation becomes somewhat easier.

**Coil Sizes to Use**

The coils for  $L_1, L_2$  and the handling of that part of the circuit are the same as in the case of the Fig. 1 circuit, while if the plug-in transformer is used for  $L_2, L_4$ , then the remainder of the circuit is operated in the same way as the Fig. 4 circuit, namely,  $L_2, L_4, C_2$  operate as one circuit, and are brought into line with  $L_1, C_1$ . For the lower-wave B.B.C. stations the transformer should be of the 300-600 metres size, while for 5XX it should be of the approx. 273-130 kilocycles (1,100-2,300 metres) size, the coil sizes being as for Fig. 1.

Should the reader choose to use plug-in coils for  $L_2, L_4$ , then for the shorter-wave B.B.C. stations  $L_2$  should be a No. 35 or 50, with a No. 50 or 75 for  $L_4$ ; while for 5XX a No. 200 should be used for  $L_2$ , with a No. 250 for  $L_4$ . By varying the coupling between these two coils, a good degree of selectivity will be obtained over and above that given by the loose-coupled circuit  $L_1, L_2$ .

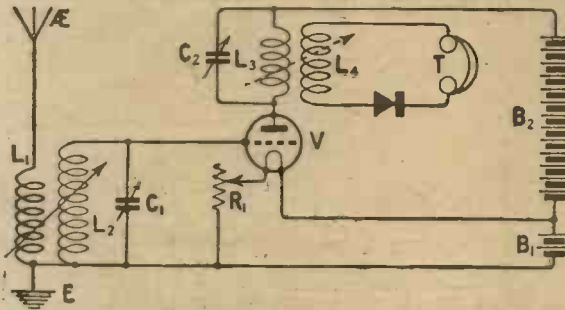

Fig. 5.—Transformer coupling is employed in this circuit.

the  $L_1, C_1$  circuit to the desired wavelength, and then tune the  $L_2, C_2$  circuit to  $L_1, C_1$ , whereupon the desired station will be heard in the telephones.

**Range and Reaction**

The range of such a circuit as this is considerably greater than that of a crystal receiver alone, though at the same time it must not be regarded as capable of receiving all the B.B.C. stations.

Should readers care to make the experiment, the coils  $L_1$  and  $L_2$  may be mounted in a two-coil holder, when, by bringing the two coils nearer to each other (provided

X 250 for  $L_1$  should be used with a No. 250 for  $L_2$ .

Fig 5 is a somewhat similar circuit to Fig. 4, except that we now employ an H.F. transformer  $L_2, L_4$ , and the aerial circuit is variably coupled to  $L_2$ .

With this arrangement the coils  $L_1, L_4$  may be one of the well-known types of plug-in H.F. transformers, or else they may

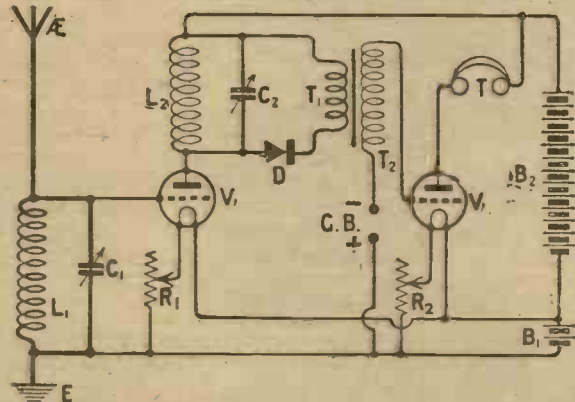

Fig. 5a.—The "straight" method of obtaining high and low frequency amplification.

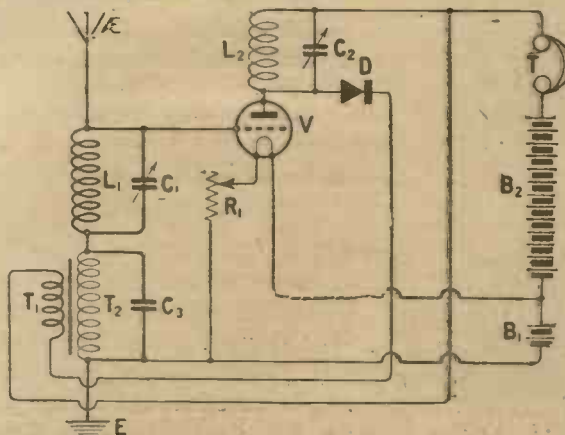

Fig. 6.—A popular form of reflex circuit.

be two plug-in coils mounted in a two-coil holder, the primary winding  $L_4$  being tuned by a  $.0003\mu\text{F}$  variable condenser  $C_2$ . The operation of this circuit, if  $L_2, L_4$  are to be plug-in coils mounted in a two-coil holder, is rather tricky if the best results are to be obtained, though at the same time it has much to commend it with regard to selectivity; if the

**The Reflex Principle**

We have now considered both low and high-frequency amplifiers added to a crystal for covering all the B.B.C. wavelengths; and though in some cases resistance-capacity coupling could be used, we will confine these circuits to the use of plug-in coils and transformers. It will be understood that any of the H.F. valve and crystal circuits may be followed by an L.F. valve, though perhaps the best way of making this addition is to use the reflex method. Ordinarily the L.F. valve would follow the crystal in the manner shown in Fig. 5a, but by placing the transformer  $T_1, T_2$  in the position indicated in Fig. 6,

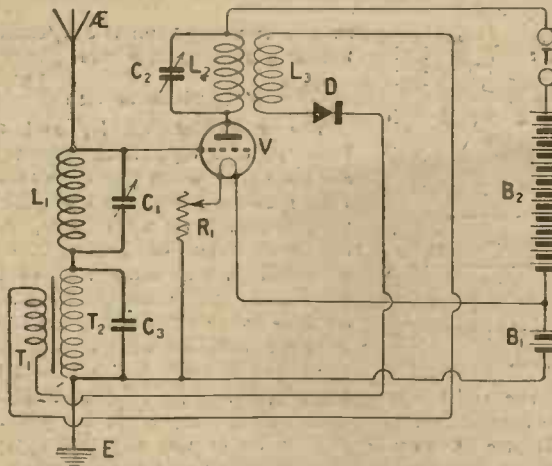

Fig. 7.—Here an H.F. transformer replaces the tuned anode coil of Fig. 6.

practically the same effect is obtained, with the advantage that only one valve is used. Here the valve first amplifies at high-frequency, the amplified signal being rectified by the crystal, the rectified signal being led via the transformer  $T_1 T_2$  to the grid of the valve, which now amplifies at low-frequency, the signal then being heard in the telephones. With this arrangement the coil  $L_1$  will be either a No. 35, 50 or 75 for the shorter-wave B.B.C. stations, with a No. 50 or 75 for  $L_2$ .  $C_1$  will be a  $.0005 \mu F$  variable condenser, and  $C_2$  a similar condenser of  $.0003 \mu F$ . The condenser  $C_3$  across  $T_2$  may be a  $.0003 \mu F$  fixed. The operation of this circuit is like that of Fig. 4, which it resembles. For the reception of 5XX  $L_1$  should be a No. 150 or 200 coil, with

the  $C_3$  fixed condenser may again be  $.0003 \mu F$ .

**A Third Reflex Circuit**

Still another form of single-valve reflex is given in Fig. 8, wherein it will be seen that between the secondary  $T_2$  of the transformer  $T_1 T_2$  and the grid of the valve a third coil is introduced. This coil  $L_3$  is a radio-frequency choke, and may quite conveniently be a No. 300 plug-in coil. The operation of

a No. 250 for  $L_2$ . In Fig. 7 is shown the transformer-coupling arrangement of Fig. 5, with the reflex action again applied. Here the remarks relative to Fig. 5 will again hold good, with the exception that the coil  $L_2$  will be a No. 35, 50 or 75 for the higher frequencies (lower wavelengths), with a No. 150 or 200 for 5XX, loose-coupling no longer being used; other values as for the Fig. 5 arrangement. The value of

this arrangement is exactly the same as that of the Fig. 4 circuit, and, furthermore, the variable-condenser values are the same.  $L_1$  should, for the higher frequencies of the broadcast wave band, be either a No. 35 or 50, while  $L_2$  will be either a No. 50 or 75. For 5XX  $L_1$  will be a No. 150 with a No. 200 for  $L_2$ . The fixed condenser  $C_2$  may be one of  $.0003 \mu F$ . When receiving 5XX better results may be obtained by increasing the size of  $L_3$ . Using the reflex circuits, the experiment of incorporating a telephone condenser of about  $.002 \mu F$  should be tried.

Though the circuits given do not in any way cover every possible way of utilising a crystal and a valve, they will, nevertheless, offer considerable scope for experiment.

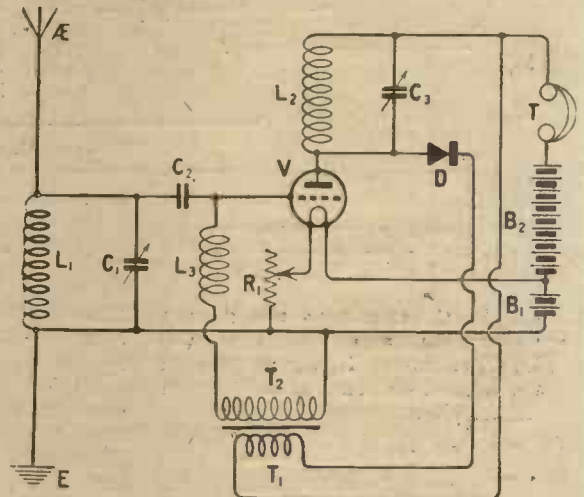

Fig. 8.—This reflex circuit employs a radio-frequency choke  $L_3$ .



Congo Natives attended at 2LO recently to provide African "effects" in the broadcasting of a play.

**Our Advertisers**

We regret that on page 100 of the last issue of THE WIRELESS CONSTRUCTOR an incorrect illustration was inadvertently inserted in the advertisement of Messrs. Autveyors, Ltd. The Autveyors condenser is correctly illustrated on page 224 of this issue.

Messrs. Peter Curtis, Ltd., advise us that the price of the booklets, etc., entitled "Hints to Constructors" and "Super Heterodyne Hints," in their advertisement on page 39 of the last issue, should have read 2s. 6d. each, and not as stated.

# ELECTRADIX RADIOS

Have opened a large City Showroom at 218, UPPER THAMES STREET, E.C.4, and are selling an enormous stock of Radio and Electrical Goods of the highest grade—Marconi, Siemens, Sullivan, Brown, Western Electric, at bargain prices. Send 4d. for illustrated catalogue and price list. The Stores at 9, Colonial Avenue, Minories, contain tons of goods at sacrifice prices to save removal. Callers only. Telephone: Avenue 4166.

"NEW WESTERN ELECTRIC LOUD SPEAKERS."  
Complete with Cord in Maker's Sealed Garton, 20/-  
*Cheaper than elsewhere*  
4,000 ohms, 22/6. 2,000 ohms, 20/- 70 ohms. 17/8



"The Catalogue that saves you pounds"

Its scope ranges from a 5s. pair of British Headphones to a 12s. 6d. Milliammeter to a 4,000 volt Generator, and covers all requirements.

If you cannot call and inspect goods in our showrooms between 9 a.m. and 6 p.m. it will pay you to send 4d. for our Catalogue at once. Goods promptly despatched all over the world.

ELECTRADIX RADIOS,

218, Upper Thames Street, London, E.C.4  
9, Colonial Avenue, London, E.1.

Phones: City 191. Avenue 4166.

Address: all Post Orders to City Showroom:

218, Upper Thames Street, London, E.C.4

## MICROMETER ADJUSTMENT

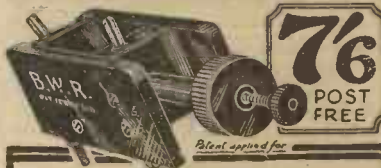

### B.W.R. "No 21" COIL HOLDER

This coil holder has distinctive features that fill a real want.

The most minute adjustment rapidly or slowly obtained without the use of unreliable springs. Absolute rigidity.

Mountable in any position (panel or cabinet) Matt or polished. Also in "Radion" (black or mahogany). Post free 7/6 each direct from manufacturers.

BUDGE, WARREN & RIDGLEY, LTD.  
91-92, Gt. Saffron Hill, London, E.C.1

Quotations given for all kinds of Ebonite work—large or small—repetition or hand made lowest prices.

## ORDER BY POST

### CABINETS for Wireless CONSTRUCTORS



Send for constructors list free  
PICKETT'S CABINET WORKS  
BEXLEYHEATH-S.E.

ESTIMATES & LISTS (W.C.). SEND SIZES



Model RS1.M., with mahogany cabinet and oxydised silver "grille." Price 8 gns.

## A Revelation in Radio Reproduction

THIS new RADIOLUX AMPLION represents an outstanding triumph in the art of Loud Speaker design, being totally different in appearance, in construction, and in results.

Louder, clearer, more sensitive and realistic in tone than any contemporary instrument, the RADIOLUX AMPLION is a revelation in every essential loud speaker quality.

Not only is the spoken word and the song of the vocalist true to life, but instrumental music is almost indistinguishable from the original studio performance. Outwardly resembling the English bracket clock—in itself a standard to the world—the cabinets possess that beauty of form and superlative finish which denote the masterpiece.

The RADIOLUX AMPLION is also available in a smaller size and in metal, oak and de-luxe finish at prices from £4.15.0

Patentees and Manufacturers:

ALFRED GRAHAM & CO. (E. A. GRAHAM),  
St. Andrew's Works, Crofton Park, London, S.E.4.



Demonstrations gladly given during business hours at 25, Savile Row, London, W.1; 79, High Street, Clapham, S.W.4; 10, Whitworth Street West, Manchester; and at the newly opened Scottish Depot: 101, St. Vincent Street, Glasgow

FOR THE FIRST TIME IN LOUD SPEAKER HISTORY  
SCIENCE AND ART GO HAND IN HAND

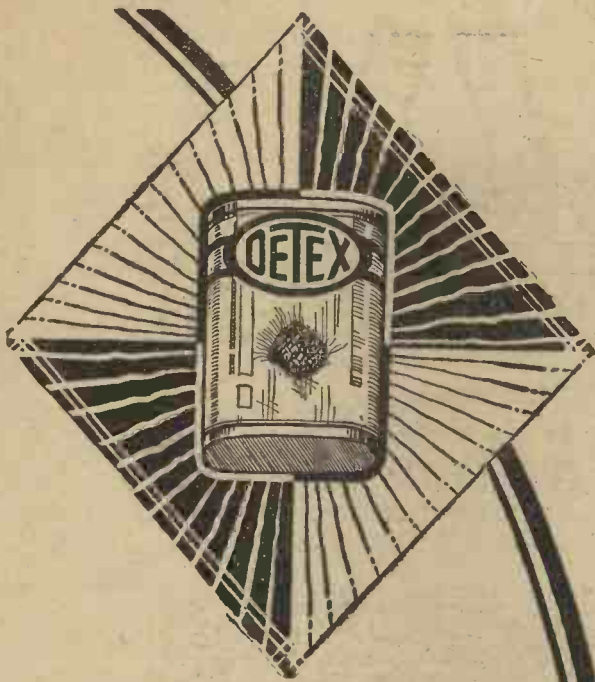

Reepham, Norwich, 14.10.25  
 The Detex crystal rectifier which I received from you some time back has given me great satisfaction. It has proved to be better than any other make I have tried.  
 (Signed) F. H. Durrant.

The word "DETEX" is all you need know about Crystals. It is a product of science and the outcome of many years of British Scientific research. Each piece of "DETEX" is contained in a specially constructed red transparent package, the colour and substance of which is a protection against all possible causes of damage and deterioration. Each package is sealed and should be intact when purchased.

Manufactured and guaranteed by:—  
**DETEX, LTD.**  
 59, New Oxford Street  
 LONDON W.C. 1

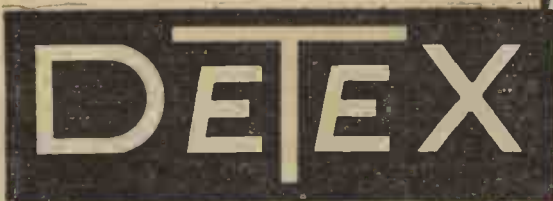

Obtainable from all Radio Dealers, or send P.O. for 1/6 (post free)

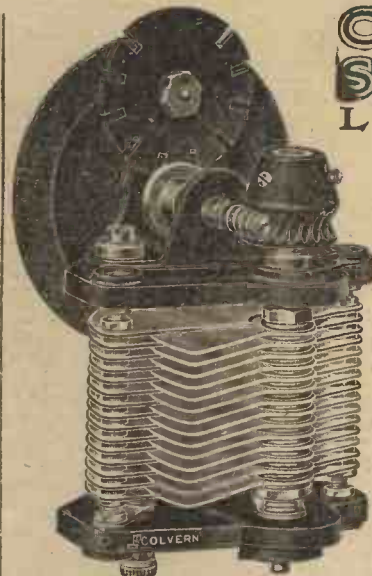

**COLVERN  
 SELECTOR  
 LOW LOSS**

Little experience is necessary upon any such super-sensitive circuits as the short wave side of the Super-Heterodyne or capacity-reaction circuits to self-demonstrate that distant work is an impossible pastime without a mechanical fine tuning device operating on the condenser

**IT'S WHEN YOU WANT TO CALIBRATE** your receiver to dead accuracy that the Colvern Selector proves its superiority as a fine tuning device. It is an instrument which will give the precise tuning essential to perfect reception, whether of local broadcast or weak distant transmission.

**The Colvern Selector Low Loss—**  
 Reading to 1/3,600th capacity  
 Capacity .0005 mfd. . . £1 1 0  
 " .0003 mfd. . . £1 0 0  
**Type F, without gear attachment—**  
 Capacity .0005 mfd. . . 15 0  
 " .0003 mfd. . . 14 0  
 One-hole fixing. Other capacities if required  
 Descriptive Folder upon request  
 Colvern Independent Vernier—  
 Price 2/6

Ask your dealer also for the Colvern Low Loss Coil Former—Price 6/-

**COLLINSON PRECISION SCREW CO., LTD.**, Provost Works, Macdonald Rd., Walthamstow, London, E.17. Telephone: Walthamstow 532

Barclays Ad.

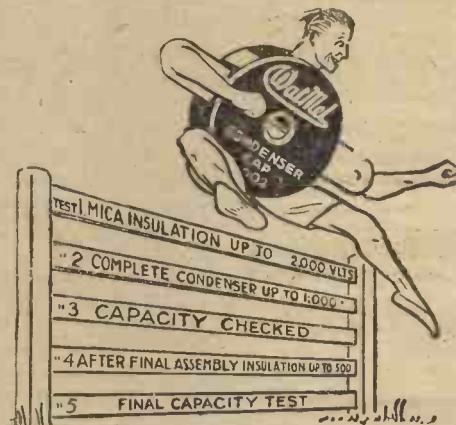

**PRICES:**  
 Capacities for Standard Grid Condensers .00005 to .0005 2/8 each  
 Standard Fixed Condensers .002 to .001 2/6 each  
 .0025 to .006 3/6 each  
 Combined Grid Leak and Condenser 3/- each

**AN EASY FIRST**

THE Watmel Fixed Condenser is quite a new-comer to Radio, yet its standard of efficiency has already elevated it to a foremost position amongst products of its type. The Watmel is distinctly different from other fixed condensers. First, in its unusual design, which being symmetrical ensures an even distribution of electrical charges and the reduction of edge losses to a minimum. In its construction no wax whatever is used. Wax being subject to dielectric losses and temperature changes with consequent results of noises and changes in capacity, it will be readily appreciated that the absence of wax in the Watmel is a vital improvement. Only the very best gauged ruby Mica is used for insulation, while the outer case is of high grade Bakelite. Each condenser is individually tested and is guaranteed to be correct within 5 per cent. From all dealers.

**WatMel**

**Watmel Wireless Co. Ltd**

332a, Goswell Road, London, E. C. 1

Agent for Lancashire and Cheshire—  
 Mr. J. B. Levee, 23, Hartley St., Levenshulme, Manch.





**The "COMET"**  
**LEVER PANEL SWITCH**  
 SINGLE HOLE FIXING  
 REG. NO 712462.  
 PRICE 2/- EACH  
 OBTAINABLE FROM THE TRADE OR  
 THE LONDON COMMERCIAL ELECTR. STORES LTD  
 13 FARRINGTON AVE  
 E.C.4

*big  
 bargains  
 for  
 Wireless  
 Dealers*

The Superlamp Net Trade List No. 9 contains hundreds of bargains in British, American and Continental Radio goods. Write for a copy today. Trade only supplied.

**SUPERLAMP**  
 ELECTRICAL AND WIRELESS ACCESSORIES LTD.  
 92-94, Paul St., Ct. Eastern St., London. E.C.2

**LIBERTY PERMANENT DETECTOR**

Prov. Pat. No. 10447  
 THE ORIGINAL ONE HOLE FIXING DETECTOR  
 50% More Efficient. 50% Lower Price

THE 100% DETECTOR



STOP FIDDLING WITH CATS WHISKERS!  
 The "Liberty" Detector gives more sensitive reception than a cat whisker gives temporarily. No hunting or that "special note" lost by the slightest vibration. The "Liberty" is entirely unaffected by vibration sensitive all over, and that loud spot cannot be lost.  
 RADARCEL CIRICAL Co. Ltd.  
 Bennett Street, LONDON, W.4

Fixing - one hole clips or by two pieces copper wire to existing detector terminals.



Price 3/6

TRADE DECKO MARK  
**BATTERY SWITCHES**  
 OUR USUAL HIGH CLASS FINISH  
 PERFECT CONTACT. FULL PUSH ACTION  
 OBTAINABLE FROM ALL THE BEST DEALERS.  
**A.F. BULGIN & CO**  
 9-11 CURSITOR ST.  
 CHANCERY LANE LONDON



PRICE 1/6 EACH IN CARTONS



By far the cheapest way to buy H.T.

USE a high-tension accumulator for half an hour and you will never go back to high-tension batteries. You will instantly appreciate the intense background of silence, the complete absence of crackling noises—so frequently mistaken for atmospheric—and the greatly increased power of your Receiving Set.  
 The cheapest H.T. supply you can buy is an Oldham H.T. Accumulator. Cheapest because it holds its charge longer—because it can stand idle for long periods without sulphation—and because it will last for years. When an H.T. dry Battery begins to fail—perhaps only a few cells are defective—it must be discarded. A multi-

valve set user will spend 35/- to 40/- per annum on H.T. Batteries and still have nothing to show for his money. Very little more than that sum will buy this fine Oldham 60-volt H.T. Accumulator, which will last for years.

This new Oldham is the first really portable H.T. Accumulator. Its 20-volt units, resting in tiers one above the other, can be tapped at each 2 volts. Instead of flimsy glass test tubes it utilises

stout rectangular glass boxes. Its plates are made throughout under the Oldham Special Activation Process with the same scrupulous care which attends the manufacture of all Oldham plates. And yet this Super H.T. Accumulator costs only 1/- per volt. At such a price it is a splendid investment.

- Five exclusive Oldham features**
1. The only readily portable H.T. Accumulator.
  2. Can be tapped at every two volts.
  3. Can remain idle for long periods without harm.
  4. Any voltage available in 20-volt units.
  5. Its glass cells are practically unbreakable.
- Prices:  
 20 volts, £1 60 volts, £3 100 volts, £5  
 40 volts, £2 80 volts, £4 120 volts, £6  
 Carrying handles, 1/6 extra.

OLDHAM & SON LTD., DENTON, MANCHESTER  
 London: Hazlitt House, Southampton Buildings, W.C.2  
 Glasgow: 120 Wellington Street

Special Activation Process  
**OLDHAM**  
 ACCUMULATORS

Gilbert Ad. 3718

# Until!



DON'T PUT OFF UNTIL TO-MORROW  
THE SERVICE YOU CAN GET TO-DAY

UNTIL YOUR SET IS EQUIPPED WITH THE

## PETO & RADFORD

### BULLDOG BATTERY IN "DAGENITE"

YOU HAVE NO REASON TO EXPECT THE HIGHEST SERVICE OF EFFICIENCY, ECONOMY AND RELIABILITY

PETO & RADFORD B.D. BATTERIES ARE ESSENTIAL FOR PERFECT RECEPTION, AND THEIR SPECIAL "DAGENITE" CONTAINERS, WHICH DO NOT LEAK, ROT OR CRACK, AND ARE IMPERVIOUS TO ACID, ENSURE ENTIRE ABSENCE OF WASTE, A COMBINATION WHICH GUARANTEES ESSENTIAL ECONOMY WITH THE HIGHEST STANDARD OF EFFICIENCY

Ask your Radio Dealer for details  
or write direct to us for latest lists

### PETO & RADFORD

Proprietors: PRITCHETT & GOLD and E.P.S. Co., Ltd.  
50, GROSVENOR GARDENS, VICTORIA, LONDON, S.W.1

## Protect your Valves from Shocks

The infinitesimal graduation of Resistance of the WATES

### MICROSTAT Filament Resistance

prevents that sudden shock to the filament, and the jumping from step to step so prevalent with the ordinary wire rheostat.

It helps your tuning enormously, and often means just the difference between getting and not getting that difficult station.

Fit a Microstat now and you will soon discard all other resistances.

Small underpanel space — One hole "Fastlock" fixing—Soldering unnecessary.

Suitable for PRICE  
Bright or Dull ONLY **2/9**  
Emitters.

Send at once for our New Free Illustrated Catalogue, which gives particulars of this and many other interesting specialities.

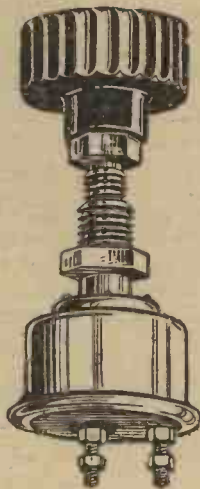

Insist on seeing Patent No. 21923 on each microscope.

## WATES BROS., LIMITED.

Head Office: 12/14, Gt. Queen Street, Kingsway, W.C.2  
Phone: GERRARD 575-573. Grams: "ZYWATESENG" Westcent  
Works: LONDON and BIRMINGHAM.

Where other coil holders miss the station

## The AERMONIC (Regd. Trade Mark) Puts you RIGHT THERE

There is no "plop" when going into or out of oscillation with this method of coil coupling, because this system gives far smoother and more gradual increase and decrease of reaction than any other. The movement is beautifully smooth and the construction is superb, also the scale ENABLES YOU TO KEEP A RECORD. This is essential if you want to log the stations.

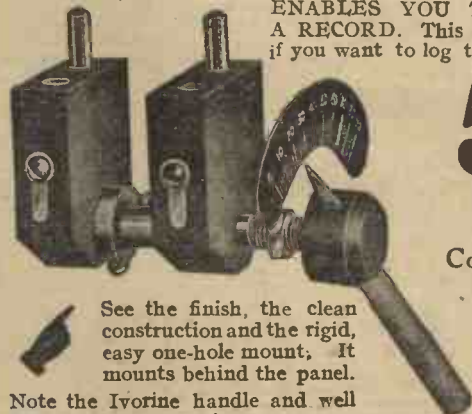

**5'6**

EACH

Complete as illustrated

Satisfaction Guaranteed

See the finish, the clean construction and the rigid, easy one-hole mount. It mounts behind the panel.

Note the Ivorine handle and well finished scale and pointer.

If your dealer cannot supply this coil holder write at once to us, enclosing remittance, and we will gladly supply

**JAS. CHRISTIE & SONS, Ltd.**  
246, West Street, Sheffield

**EVERY "Utility" Component is fully and unconditionally guaranteed. If for any reason it proves unsatisfactory in service, return it to us and it will be replaced by a new component by return of post.**

**"UTILITY" COIL CHANGING UNIT**

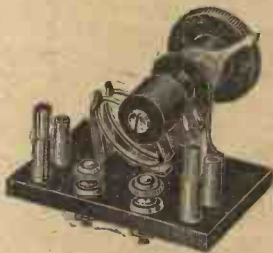

enables instant switching to be made from one station to another, e.g. from London to Daventry. It is fixed inside the panel by the usual "Utility" one-hole fixing and the coils are plugged-in in the ordinary way.

**PRICE**

Ref. No. W. C. 155 ... .. 7/6 each

**"UTILITY" LOW LOSS CONDENSERS**

are essentially low loss due to unique design. One end plate only is used, thus reducing end plate losses by half. All solid dielectric is external to the electrostatic field. The spindle bearing is of generous length, automatically takes up wear, and end play and end thrust are entirely eliminated.

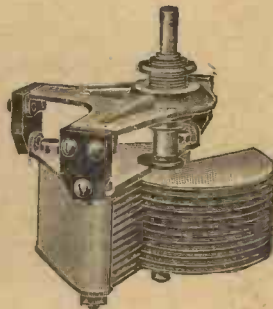

These condensers are immediately convertible to Vernier type, by fitting the "Utility" Vernier dial.

All Condensers have the usual "Utility" one-hole fixing.

**PRICES**

Ref. No.	Max. Cap.	Low Loss Type	Vernier Low Loss Type
W. C. 159	.001 Mfd.	... 14/9	19/9
W. C. 160	.0005 ..	... 12/6	17/6
W. C. 161	.0003 ..	... 10/-	15/-
W. C. 162	.00025 ..	... 9/6	14/6
W. C. 163	.0002 ..	... 9/-	14/-

**WILKINS & WRIGHT, Ltd., Utility Works**  
Kenyon Street, Birmingham

**Utility**  
**GUARANTEED**  
**COMPONENTS**

E.P.S. 4

**A Revelation in Selective tuning**

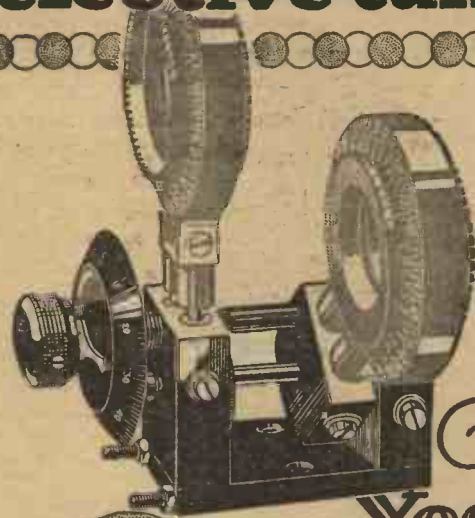

*The*  
**Yesly**  
**Ecliptic Coil holder**



PROV. PAT.  
No. 24,683

THE superiority of a tuning system that permits right angle adjustment in the relative positions of tuning coils can be readily appreciated by all who understand the theory of magnetic fields and the influence they have on each other.

Up to the present the more simple method of coil adjustment has been employed in the construction of the majority of coil holders, despite the wonderful improvement that can be obtained by direct cross flux adjustment.

In the new YESLY ECLIPTIC COIL HOLDER the adjustment of the coil is made so as to produce a perfect electrical combination between the coils by a gear cut "face to face" movement having a ratio of 6 to 1. The immediate increase in selectivity and resulting strength of signals is beyond that of all other coil holders on the market.

This unique coil holder can be fitted to either front, side or back of panel positions, and is thoroughly finished in highly polished ebonite. A knob and pointer assist tuning in conjunction with a fully graduated dial, and two additional fixing screws are supplied to prevent bodily rotation in the case of back of panel mounting. The high standard of Yesly Tuning has already created a premier position in the wireless field, and the ECLIPTIC COIL HOLDER will secure still better results for all radio amateurs.

PRICE  
**7/6**

**LOOK FOR THE NAME**

REGISTERED



Ask your dealer, or write direct  
**ENGINEERING SUPPLIES, Ltd.**  
235, Blackfriars Road, LONDON, S.E.1

# THE MOST EFFICIENT LOW LOSS TUNER YET!

Plug-in-coils are antiquated. Be up to date and FIT a SEAGULL LOW LOSS TUNER.

100% increased efficiency, much greater selectivity.

The only tuner that will cover efficiently the range of 30-2000 Metres. Increase YOUR range with this remarkable instrument. 1,000 miles on one valve easily accomplished.

Compact and neat, one hole fixing.

Guaranteed for one year.

Produced by the makers of the famous Seagull choke capacity coupling.



## SEAGULL

### LOW LOSS TUNER

Price 10/6	
Set of three low loss coils	
Long wave set	12/-
Set of three low loss coils	
Short wave set	7/6

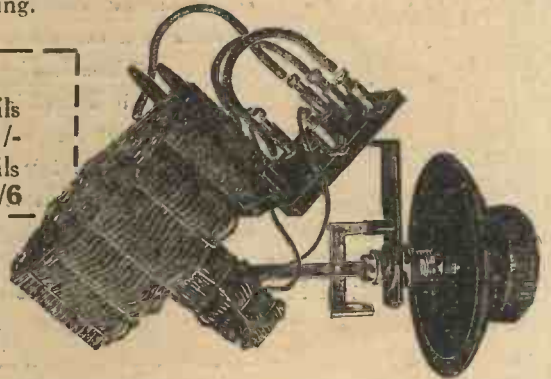

**SEAGULL LTD.**  
 REGENT HOUSE,  
 KINGSWAY, LONDON, W.C.2  
 Phone: Holborn 6380.

Crichton Ad.

**Soldering Joints**  
*made easy with the*  
**J.E.G. J.E.G.**

**SOLCLIPS**

Hitherto one of the most difficult and weakest parts in assembling a Wireless set has been the soldering of the joints.

**The J.E.G. Solclips**  
**Strengthen the soldered joint**

Perfect joints by simplest method. Ends soldering joint troubles. The old method of soldered joints was the weakest part of a set. By using the J.E.G. it becomes the strongest.

Samples free on request  
**1/- per box of 18**

Includes solder pellets, flux and instructions. Can be used for either 1, 2, 3, or 4 perfect joints, any angle required, without bending wire, which may be either square or round.

DALE FORTY & Co., LTD., BIRMINGHAM

*Selling Agents:*  
**COOKE & WHITFIELD WIRELESS LTD.**  
 ST. PAUL'S SQUARE BIRMINGHAM

*Britain's Best in Radios!*  
 THE LAMPLUGH  
**FILAMENT RHEOSTATS**

STRIP TYPE—A Rheostat possessing every feature for the correct control of Filament emission, fitted with special Buffer Contact, which ensures smooth and silent working. Strong Terminals and Winding, highly polished knob to match. Lamplugh Dial—Unbreakable. One-hole fixing.

No. 1059 6 ohms 3/- No. 1073 15 ohms 3/3  
 No. 1074 30 ohms 3/6

*This Mark is our Guarantee*



**RADIO LAMPLUGH PRODUCTS**  
**S. A. Lamplugh Ltd.**  
 KING'S RD., TYSELEY, BIRMINGHAM

**CABINETS CAMCO CASEWORK CABINETS**  
 Free Write at once

For our illustrated list, contains 100 VARIETIES, including many of the latest circuits described in WIRELESS CONSTRUCTOR, MODERN WIRELESS, etc., etc.

**THERE IS A CAMCO CABINET FOR EVERY CIRCUIT**

TRADE ENQUIRIES ESPECIALLY INVITED.

**THE CARRINGTON MANUFACTURING CO., LTD.**  
 18/20, Normans Buildings, Central Street, London, E.C.1  
 Telephone: Clerkenwell 6903



# WISDOM & WIRELESS

The wise wireless enthusiast always keeps a tin of FLUXITE close at hand. The set may be perfectly made, but that does not protect it from accidental jars and jolts which upset its delicate adjustment. With FLUXITE in the house these little things are easily put right.

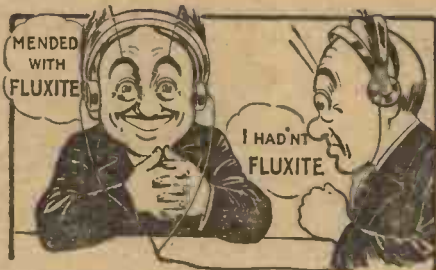

## FLUXITE SOLDERING SET

It is perfectly simple to use, and will last for years in constant use. It contains a special "small space" Soldering Iron with non-heating metal handle, a Pocket Blow-lamp, FLUXITE, solder, etc., and full instructions. Price 7/6. Write to us should you be unable to obtain it.

Price 7/6



## FLUXITE SIMPLIFIES SOLDERING

All Hardware and Ironmongery Stores sell FLUXITE in tins, price 3d., 1/4 & 2/8.

Buy a Tin To-day!  
 FLUXITE, LTD. (Dept. 330), West Lane Works, Rotherhithe, S.E.14.

ANOTHER USE FOR FLUXITE  
 Hardening Tools & Case Hardening  
 ASK FOR LEAFLET on improved methods



THOSE who have not tried a "6-60" have yet a great deal to learn of purity of reproduction and volume.

The Molybdenum-Thorium filament of this remarkable valve and the special construction of grid give volume without distortion, so that the valve can be worked always under ideal conditions. The "6-60" is a sensitive detector, as well as a high-efficiency amplifier. The Ideal Loud Speaker Valve.

Molybdenum and Thorium used for the filament of the "6-60" give remarkably High Electron Emission. Filament volts 1.5-2. Filament current 0.3 amps.

"6-60" works at low temperature—this means long life for filament and low current consumption.

Write for interesting literature giving full particulars of this amazing valve, and testimonials, which will be a revelation to you.

PRICE  
**14/-**

**SIX-SIXTY**  
 AMPLIFYING & RECTIFYING  
**VALVES**

Your dealer can supply. In case of difficulty write the Makers.

THE ELECTRON Co., Ltd., Triumph House, Regent Street, London, W.

# The Bretwood Products



## GUARANTEED FOR 3 YEARS

EVERY Bretwood Product is subject to stringent tests both for quality of material and practical radio efficiency before it receives the final O.K. Incorporate guaranteed Bretwood Components and be sure of best results.

### THE "BRETWOOD" ANTI-CAPACITY VALVE HOLDER

(Patent No. 213724.)

A valve holder constructed on new and scientific lines, combining the following advantages: Easy to fix; no capacity; no leakage; always perfect contact; saves panel space; back rft of pane. mounting; no soldering necessary. PRICE 1/9



### THE "BRETWOOD" VARIABLE GRID LEAK

(Patent No. 224955.)

The only reliable grid leak. The plastic resistance gives smooth, perfect control, and is absolutely constant in action. Gives accurate readings consistently from 50,000 ohms to over 1 megohms. PRICE 3/- With Condenser (as illustrated) .. 4/6



### THE "BRETWOOD" FILAMENT RESISTANCE

(Patent No. 22224.)

This instrument is the result of exhaustive experiment along new lines by Bretwood engineers. The Bretwood Rheostat takes up very small space on or behind the panel. It is extraordinarily smooth in action, effects perfect continuous contact, and does not depreciate through long use. It is capable of rough as well as a very minute Vernier adjustment, and is one hole fixing. Extremely well made. PRICE 5/-

### THE "BRETWOOD" ANTI-CAPACITY (Ball-Bearing) SWITCH

(Patent Pending.)

A first-class speciality of 100 per cent. efficiency, the principal features of which include absolute freedom from capacity; perfect contact; smooth action; practically no wear and tear; first-class finish and appearance; one hole fixing. PRICE 5/-



We are shortly putting on the market the following new and interesting Bretwood products:  
 Bretwood Super-Het. Transformer (Tunable).  
 Bretwood Super-Het. Oscillator.  
 Bretwood Variable Low Loss Condenser.  
 Bretwood Variable Low-Loss Condenser (Geared).

## BRETWOOD LIMITED

12-18, London Mews, Maple Street  
 LONDON, W.1

# The All-important Variable Condenser

And the Prestige behind the "Polar"

Not all variable condensers can be judged by appearance and price alone. It is unlikely that the condensers produced by any but long-established Radio Engineers can be fully efficient.

The "Polar" Junior Condenser



5/6

### All Capacities

Possesses all the characteristics of the well-known Polar "Straight-line-Frequency" condenser. Gives a straight line of frequencies, with an approximately even movement of dial in relation to change of wavelength. Low minimum self-capacity; one-hole fixing; 350 degrees dial; perfectly screened; remarkably compact; occupying minimum space behind panel.



### The 'Polar' Cam Vernier Variable Condenser

Compensated square-law design of vanes; this means that the Condenser functions in the square-law manner, not on the bench, but on your set. Its shape of vanes compensates for the inherent self-capacity of your coils and aerial, with the result that the figures on the dial indicate definite wavelengths. You can recognise the Cam-Vernier Variable Condenser, if by nothing else, by the specially engraved dial which commences at "26"—recognising that no aerial tuning system can have a zero capacity. It embodies the well-known Cam-Vernier device, giving 10 degrees of Vernier movement in any position; and the vernier readings register on the dial.

Prices:

- '0003 - - - 10/6
- '0005 - - - 11/6
- '001 - - - 12/6

It is, further, unlikely that nondescript, cheaply-assembled condensers will carry anything like the UNCONDITIONAL written GUARANTEE enclosed with every "Polar" Condenser. It is a guarantee against original defects, as well as against breakdown or the development of faults in ordinary use—for a period of ONE YEAR.

All constructors of Radio Sets have an appreciation of quality in appearance, as well as of quality in performance; yet not all are equally able to indulge in the expensive class of components. For this reason we have introduced the "Polar" Junior Condenser, at a price of 5/6 for all capacities—putting a product of high quality (backed by a great reputation) within the reach of all.

Buy the products of well-known Firms—disregard any may-be biased recommendations of "cheap" components—and depend upon the Manufacturers to "see you through."

# Polar Components for Sound Design

Sold by all reputable Radio Dealers. Ask your Dealer, or write to us, for the Polar Condenser Booklet.

Radio Communication Co., Ltd.  
34-35, Norfolk St., Strand  
London, W.C.2



Square Law—  
Low Loss.  
One-hole  
Fixing.

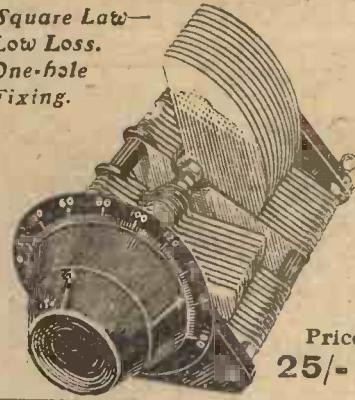

### The SINGLE/DUAL CONTROL

of the 2 movable electrodes provides the highest degree of sensitivity and selectivity.

### BRIDGE CONDENSER

Price 25/- '0003 and '0005 mfd.

THE NEWEST AND MOST EFFICIENT

### H. F. CONDUCTOR

Composed of hollow copper tube (= 16 s.w.g.) with highly polished internal and external conducting surfaces.



In packets (contents, six 2ft. lengths). In coils (12 ft. per coil.)  
2/- per packet.  
per coil.

Minimum H.F. Resistance.  
Minimum Capacity.  
Minimum Energy Loss.

Obtainable from all Wire'ess' Dealers or direct from the Patentees  
**AUTOVEYORS LTD., 84 Victoria Street, S.W. 1**



# RECO

The Rechargeable  
H.T. BATTERY



60 VOLT BATTERY ... 40/-

For particulars write to:

Radio Equipment Co., Ltd.  
5, Dyer's Buildings  
HOLBORN, LONDON, E.C.1



Barclays Ad.

VICTORIA PRODUCTS

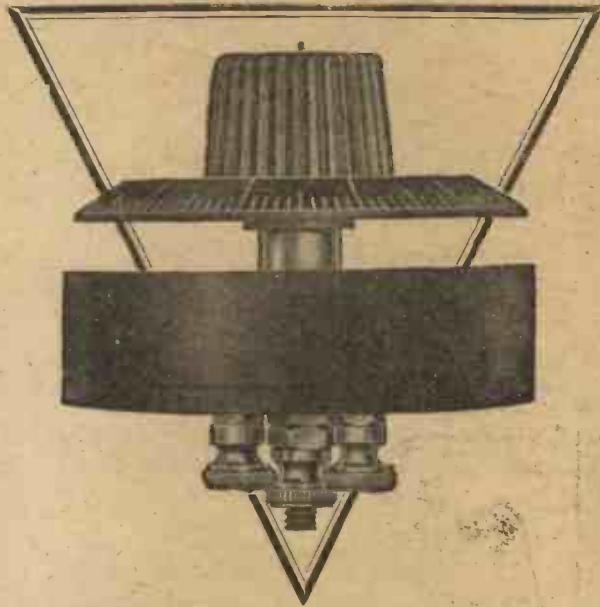

for better radio efficiency

THE VICTORIA VARIABLE GRID LEAK and VARIABLE ANODE RESISTANCE (illustrated above)

The exceptional features of this component make it superior to the many grid leaks now on the market.

It has a resistance variation of  $\frac{1}{4}$  meg. to 5 megs. obtained by a single rotation of a Dial engraved to present readings of variation of  $\frac{1}{4}$  megohms. Metal to metal contact. Wire wound. Resistance element always consistent and packing impossible. Positive contact. Self-capacity practically zero. It is one-hole fixing. Something entirely new. Price 7/6 each

VICTORIA LOW-LOSS CONDENSER

Observe these Points of Superiority

Lowest losses. Min. capacity: 4 micro-micro farads. Greater wavelength range obtained than in any other type. Spring contact. Ball bearings. Vanes insulated by ebonite supports outside the electrostatic field. Sturdily constructed. Highly finished aluminium end plates, nickelled supports and brass vanes. A really first-class condenser, particularly ideal for short wavelengths.

PRICES

.001, 16/- .00075, 15/6 .0005, 14/9 .0003, 14/- .0002, 13/6 Fitted with Vernier Dial and precision extension handle, as illustrated, 2/6 extra on prices quoted above.



For purposes of illustration section of panel is not shown in correct position

The VICTORIA VERNIER DIAL

You can obtain a micrometer variation of the whole condenser by using the "VICTORIA" VERNIER DIAL, which has a ratio of 300 to 1, obtained by a precision screw motion. No gears, therefore no back lash. Coarse and fine tuning provided for. Suitable for use with any standard condenser or variometer. Price 4/9

VICTORIA ELECTRICAL (Manchester) LTD. Victoria Works, Oakfield Road, Altrincham, Cheshire

Barclays Ad.

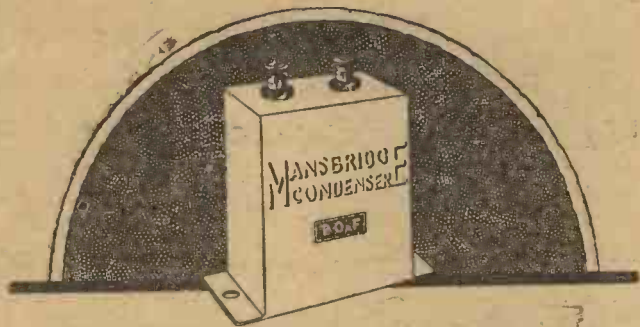

THE Mansbridge Condenser

WE have pleasure in announcing that the genuine Mansbridge Condenser, originated and designed by Mr. C. F. Mansbridge over 20 years ago, will now be manufactured by the Mansbridge Condenser Co., Ltd., under the aegis of Mr. C. F. Mansbridge, himself, and marketed with the full backing of the Dubilier Condenser Co. (1925), Ltd.

No Condenser of the "Mansbridge" Type is a genuine product of the Mansbridge Condenser Co. unless the words "Mansbridge Condenser" are plainly embossed on the metal case. The colour of the case is maroon.

The capacity is plainly marked and is accurate to within fine limits, and nickel plated screw terminals are provided for making connections.

In your own interest you should see that when you require condensers of this type you

Specify Mansbridge.

Prices and Capacities:

Capacity.	Prices.
0.05 mfd.	2/6
0.10 "	2/8
0.20 "	2/8
0.25 "	3/-
0.30 "	3/-
0.40 "	3/3
0.50 "	3/6
1.00 "	4/-
2.00 "	5/-



ADVERTISEMENT OF THE DUBILIER CONDENSER CO. (1925) LTD., DUGON WORKS, NORTH ACTON, W 3  
Phone: Chiswick 2241-2-3

E.P.82

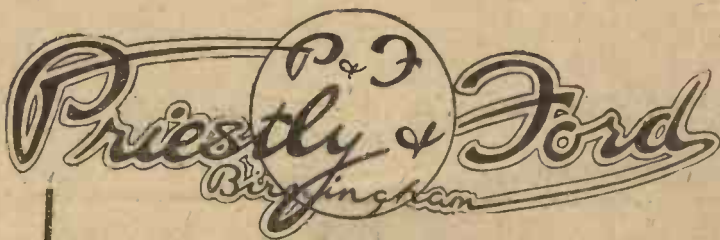

The Oldest and Largest Wireless Wholesalers in the Kingdom

If it's Good—we sell it!

EVERYTHING IN RADIO!

The P. & F. IDEAL TERMINAL

PRICE (Each) 6 D.

THE most useful terminal on the market, which anyone can fix in thirty seconds without tools or solder. Perfect contact and insulation—and there's no fumbling with screws! Tube A. Metal tube with red or black insulated top, containing thick insulating rubber bush. Clip B. Slips into rubber insulation of Tube A, holding wire tight, and makes perfect contact. Ring C. Will hold firmly on any existing terminal of any set. Clip B pushes into this as shown above. "D" The Assembled Terminal.

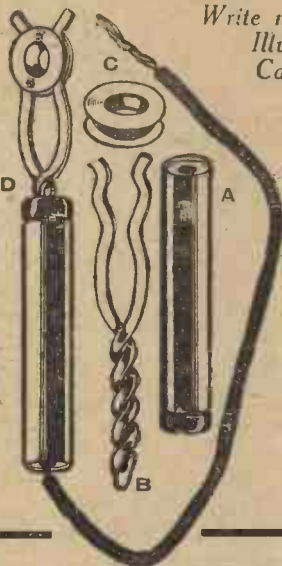

Write now for Illustrated Catalogue

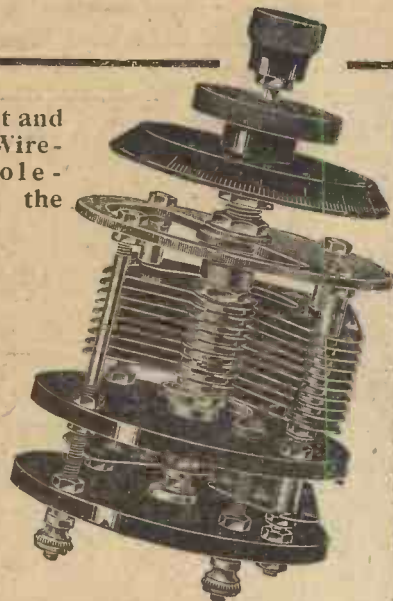

The P. & F. Square Law Condenser

The "P. & F." Square Law Condenser "A" Type, 12 white Enamel Plates; Permanent Contacts; One-Hole Fixing. An entirely British Product.

	PRICES:	
001 ..	12/6 ..	14/6 with Vernier
0005 ..	10/6 ..	12/6 ..
0003 ..	9/6 ..	11/6 ..
0002 ..	8/6 ..	10/6 ..
0001 ..	6/6 ..	Vernier .. 4/6

3 CARRS LANE, BIRMINGHAM  
Telephone: CENTRAL 2942 (Private Branch Exch.)  
Telegrams: "PEANEF, BIRMINGHAM."

YOURS FOR 20/-



Send 20/- to-day, together with your order for the "Tonyphone," and this wonderful set, which receives all B.B.C. Stations, will be sent on approval, complete with all accessories. You pay a further £1 each month, or 5/- each week until completed.

'Tonyphone' Super Two-Valve Set

Complete with Accumulator, H.T. Battery, Aerial, one pair of 4,000 ohms Headphones and two Valves—one High Frequency and one Detector. All Royalties paid

Send to-day and enjoy broadcasting NOW. Illustrate 1 Price List free on application  
BRITISH ENGINEERING PRODUCTS CO.  
(Battery Dept.), Windsor House, Victoria Street, London, S.W.1  
S.S.A.

SERVICE AND STOCK

Does your local dealer serve you right  
Has he always in stock every item you need  
Has he the Technical Knowledge to know the efficient components from the "junk" ?

If you feel uncertain, use the order form in this issue and deal direct with us. We offer you the finest Mail Order Service organised.

Do not improvise—just be wise.  
Our catalogue will convince you and it is post free for the asking—want one ?



4/- Per Dozen Trade Supplied

THE BRIGHTON RADIO STORES  
163 WESTERN ROAD - - - BRIGHTON

Something New in Detector Crystals

This new Crystal Detector, Kathoxyd, is ideal for reflex circuits. It will be found capable of withstanding high potential without the deterioration to which ordinary Crystals are subject.

Kathoxyd consists of a smooth metal plate in a brass mount, which fits your crystal cup. It is supplied with two contacts—one a ball of zinc iron, for local station use, the other a fine graphite point for long-distance work. Each contact is readily fixed in place of your ordinary cat's-whisker.

METAL PLATE  
KATHOXYD  
DETECTOR CRYSTAL

Is sold by most Wireless Dealers. If obtainable locally, send 1/6 and your Dealer's name and address to—

KATHOXYD, LTD.  
41, High Holborn, London, W.C.1  
Phone: Chancery 8542  
when the Detector will be sent by return post

1. The "Crystal"—A Metal Plate  
This consists of a brass holder, in which is mounted the specially prepared Kathoxyd metal plate.



2. The "General Purpose" Contact.

A zinc, ball-ended rod, held in a spiral spring, is merely dropped at any point on the Kathoxyd plate.



3. The "Long-Distance" Contact.  
Consists of a specially-pointed rod held in spring, for use in place of ordinary cat's whisker.

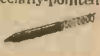

The Kathoxyd Element and two contacts are supplied in attractive cellophane-windowed carton at— Retail price 1/6

THE WORLD'S SIMPLEST PATENT FLEX CONNECTION

6 D. EACH



NICKEL PLATED INDICATING PLUGS & SOCKETS 1d. each extra



Ask for them of your Dealer or the Manufacturer:—  
E. A. WOOD, ASTON RD, BIRMINGHAM

**"You Won't Always Have A Fire"**  
 in the room where your set is fixed.

**A PHONEREEL**  
 will allow you to listen in, in whichever room you happen to have a fire, without the trouble of moving the whole set; just connect the terminals on end of flex to the set, hold the Phonereel by knob on base and walk to desired room allowing wire to unwind as you go along, always free from knot and tangles.

Each Phonereel carries four pairs of terminals and 12 yard good quality twin flex.

Price complete 15/- Trade enquiries invited  
 Any length of wire can be fitted up to 25 yds. at 3d. per yd.

Fit a PHONEREEL and listen in comfort.  
**J. MERRETT & Co.**  
 Trowbridge, Wilts.



**Mr. GUY BURNEY,**  
*late Managing Director of the Sterling Telephone and Electric Co., Limited*

begs to announce that he has opened Offices at Morning Post Building, 34, Strand, W.C.2 (Telephone: City 2373)

Mr. BURNEY is prepared to negotiate with inventors and owners of Mechanical, Electrical and other kinds of Patents with the view to developing them, or placing same upon the market. Communications, in the first instance, should be made by letter only.

**CABINETS**  
 QUALITY and ACCURACY.  
 Paragon Panels Ground, Drilled and Engraved.  
 SEND FOR LIST.

**CATTFERMOLE BROS.** *Specials Quoted for per Return*  
 PATTERNMAKERS,  
 17, WALLER ST., HULL

TRADE DECKO MARK

**DIAL INDICATORS**  
 SIMPLY DRILL ONE HOLE AND FIX AT ANY POINT OF DIAL BEAUTIFIES THE PANEL.  
 OBTAINABLE FROM ALL THE BEST DEALERS.

**A.F. BULGIN & CO.**  
 9-11 CURSITOR ST.  
 CHANCERY LANE E.C.4.

Price 9/- per Pair

**THE FREE CHARGE BATTERY CHARGER**  
 enables accumulators to be charged from any D.C. supply with no extra current cost. Before adopting any system of charging, write for FREE BOOK explaining all methods.

**THE CARPAX COMPANY, Ltd.**  
 312, DEANSGATE, MANCHESTER

**MAKE YOUR OWN CABINETS**

We supply the parts accurately cut ready for assembly. 9 x 8 in. sections only 3/6. Made up and polished 7/6. 10 x 12 only 6/- or same made up and polished 10/-. All carving paid. Sloping types 30% extra. Illustrated lists sent gladly.

**F. & J. FLETCHER**  
 Water Lane, HALIFAX

**VALVES Repaired Quick**  
 Let our valve making plant repair your broken or burnt-out valves efficiently and promptly (most makes). Amplification, radiation, and current consumption guaranteed same as new.

Bright emitters 5/- "D.E.s" (2 and 4 v. types) 7/6. **Radions Ltd.**, Bollington, nr. Macclesfield Ches. Largest Valve Repairing Firm in the world. List Free.

**RADION**  
 Reliable Repairs

**S. SMITH & SONS (M.A) LTD**

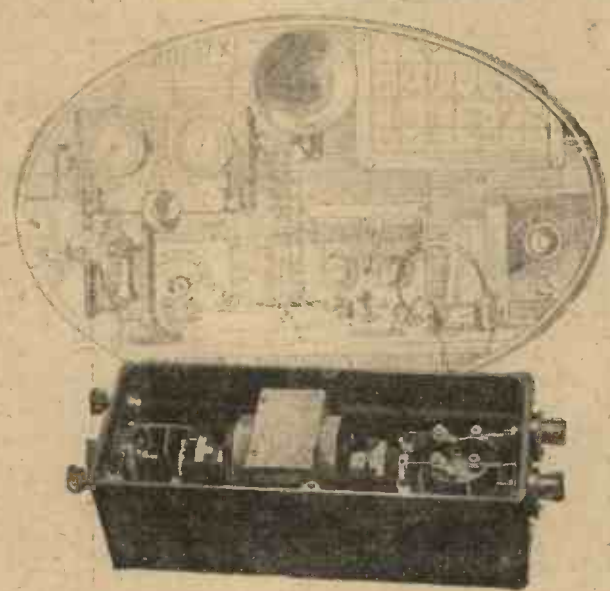

*The M-L anode converter*

**T**HE M-L Converter is designed to replace H.T. Batteries.

It consists chiefly of a small motor-converter, being fed from an accumulator through a controlling rheostat. The high-tension current is generated by a specially wound motor of high efficiency, and supplied at the output terminals free from any ripple or huff due to the machine. This is secured by smoothing circuits, which are incorporated in the complete converter.

The M-L Anode converter is particularly recommended for use with Power Amplifying Valves or Transmitting Valves where a smooth and constant supply of H.T. current of the order of 20 to 30 milliamps is required. The current consumption of the motor is extremely low owing to its high efficiency and it is absolutely silent and free from vibration in working.

Single Voltage Types:

Type B (6/120v. or 4/80v.)	£11 5 0
Type C (12/300v.)	£13 10 0
Type D (12/500v.)	£18 0 0

Two Voltage Types:

Type BX (6/120v. or 4/80v.)	£12 15 0
Type CX (12/300v.)	£15 0 0

We shall be glad to send full particulars of all M-L Anode Converters and auxiliary apparatus on request.



**S. SMITH & SONS (M.A) LTD.**  
 179-185 Great Portland Street, London, W.1  
 Telephone: Langham 2323

E.P.S.7.



ASK YOUR DEALER

FOR THESE

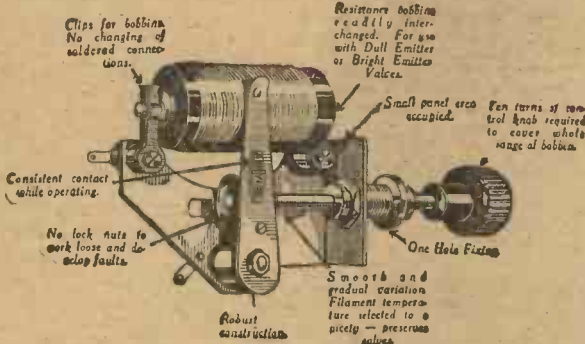

The **SERVICE** Micrometer Rheostat.

represents a complete departure in Rheostat design and adopts an entirely new principle of working. Owing to the fact that 10 turns of the control knob are required to cause the contact arm to travel over the range of the resistance bobbin, the variation of current is gradual and smooth, thus assisting the life of the valve. Resistance bobbins of different values to suit either Dull Emitter or Bright Emitter valves can be readily interchanged without in any way disturbing soldered connections. This Rheostat which is one-hole fixing and requires the small panel space of 1 1/4 in. by 3/4 in. is mechanically robust, and has no rotating lock nuts to work loose.

Retail Prices—6 ohms ... 3/9 20 ohms ... 4/-  
Interchangeable Bobbins—6 ohms ... 1/6 30 ohms ... 1/9

The SERVICE Potentiometer is exactly similar in design and size to the SERVICE Rheostat. The contact is consistent throughout its range, so that the point of resistance can be selected to a nicety.

Retail Price—400 ohms ... .. 5/-

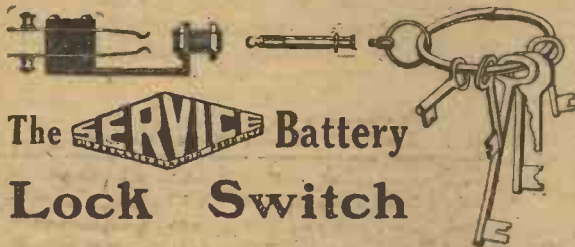

The **SERVICE** Battery Lock Switch

This switch protects a receiving set from unskilled or unauthorised usage by virtue of the fact that when the key plug is removed it is impossible to light the valves or put the batteries in circuit, and thus impossible to use the receiver. It is very useful when it is desired to close down for an interval, etc., without altering the setting of the rheostats which have already been adjusted for best results. The key plug, which is a detachable unit and can be carried on an ordinary key ring, is made in two parts, so that the plug is easily removable from its ring head when required for use in a receiver. It can be used to control both L.T. and H.T. batteries, and is one-hole fixing, occupying very little panel space. It is of robust construction in order that perfect contact shall be maintained, and is fitted with both terminals and soldering tags. Retail price, 2/6. Additional key Plugs, 1/- extra.

Write for fully illustrated Price List of all SERVICE Products.

SOLE PRODUCERS: **THE SERVICE RADIO Co., Ltd.** 67 Church Street Stoke Newington London - N. 16 'Phons - - Clissold 4931

THE PANEL

DE LUXE



IF after you have built up your Set you find that a component is unsatisfactory it can usually be replaced without much difficulty. On the other hand a leaky panel will render useless the work of many hours and necessitate the complete rebuilding of the Set. Be wise, therefore, and refuse to take risks. Don't ask merely for an ebonite Panel—ask for a Radion Panel and see that it bears the trade mark Radion.

Radion is available in 21 different sizes in black and mahogany. Radion can also be supplied in any special size. Black rd. per square inch, mahogany 1 1/2d. per square inch.

**RADION**

American Hard Rubber Company (Britain) Ltd.

Head Office: 13a Fore Street, London, E.C.2. Depots: 120 Wellington Street, Glasgow; 116 Snow Hill, Birmingham. Irish Agents: 8 Corporation Street, Belfast.

Gilbert Ad. 3722

**A GIFT FOR XMAS**

that you or anyone would be pleased to give or receive. A 5-VALVE SET COMPLETE WITH LOUD SPEAKER AND ALL ACCESSORIES FOR £18 : 10 : 0 (Note—Total L.T. consumption 1 Amp.) Requires no Aerial or Earth, can be used anywhere—in the House, on the Car or Motor Boat, on the Caravan, or in the Air. GIVES PERFECT RECEPTION. Demonstrations during Broadcasting hours at our Show Rooms or at your own home by appointment. "SALIENT FEATURES," our new 80-page List (price 6d. credited against first purchase) gives full particulars of this set and of many "Radio Press" constructive sets, together with a quantity of useful information, data, tables, etc.

**"S. A. CUTTERS," LTD.**  
18, Berners Street, London, W.1

Telephone: Museum 6273

Made of the finest low loss ebonite, is neat and well finished. Counter-sunk sockets provide ABSOLUTE SAFETY against burning out. Cap specially constructed to serve as drilling Template. Valve legs always make good contacts. Just the thing for experimenters as well as the amateur. Above all it's cheap, as well as good. Each one on card with instructions for simple fixing.

Export enquiries invited. From all Dealers, or in case of difficulty write to the Patentees MURRAY, SON & CO., 387a, HIGH ROAD, TOTTENHAM, N.17 'Phone: Tottenham 178 Postage one or two d., three or more post free. Pat. No. 15426/24



**MURRAY** The Finest Valve Holder Ever Produced!  
VALVE HOLDER 1/3



# "CROIX"

The World's greatest  
**TRANSFORMERS**  
over 500,000 in use



one year's guarantee

RATIO 5/1

9/-

RATIO 3/1

9/-

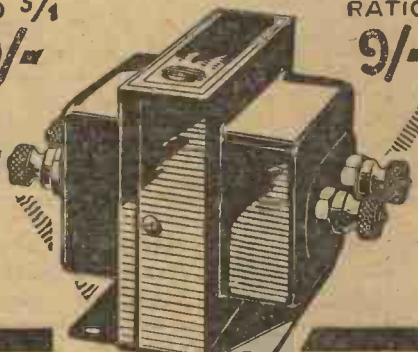

*an opinion.*

"VALVE," of "The Ilford Guardian" of April 24th, said:

"I put in a 'Croix' Transformer which cost 9/6 only, and although somewhat sceptical as to its power and purity, I was amazed at the results. The average price of good Transformers is quite double this sum; I have experimented with the best of them, but this little instrument stood up bravely and well to every test it was put to."

"The Manchester Evening Chronicle" of April 13th said:

**"CHEAP AND GOOD."**

"Tested in the family two-valve set a 'Croix' L.F. transformer, though small, gives tremendous amplification, with a complete absence of mush. Tested on the bench with other standard makes, it compared favourably with the best. It is a beautiful little instrument, and sells at a remarkably low price. It was sent by the Wholesale Wireless Co. of Farringdon Road, London."

### WARNING—"Croix" Transformers

This is to give notice that genuine "Croix" Transformers will in future be boxed in white boxes, with the Trade Mark "Croix" stamped in black and gold on each end, and will be numbered individually. These boxes are marked in English, and substitutes marked in French should be refused. No other Transformers are genuine or guaranteed by us, and the Trade and Public are warned against them.

FROM ALL WIRELESS DEALERS.  
SOLE DISTRIBUTORS, United Kingdom:

**THE WHOLESALE WIRELESS CO.**

103, FARRINGDON ROAD, LONDON, E.C.

Colonies and Dominions:

**A. VANDAM, WESTMINSTER, LONDON, S.W.**

## TUNING

Keen as a Razor!

Successful reception of distant radio demands the utmost tuning accuracy. Every radio enthusiast of experience appreciates this fact which accounts for so many having incorporated the Microhm Vernier Condenser into their receivers. They have proved it to be an instrument capable of sharp and accurate tuning always, with the greatest ease of adjustment. Until you have fitted the Microhm into your set, you cannot know what fine tuning really is. For a negligible outlay you can greatly improve upon present results. Remember it must be the—

24 turns of tuning adjustment. Single in. hole fixing. Maximum capacity .000015 mfd. Minimum capacity Negligible. Price 2/6.

### MICROHM VERNIER CONDENSER

For use in parallel with aerial and anode tuning condensers.

Indispensable for "Neutrodynes."

MICROHM ENGINEERING CO., VARSITY WORKS, COLLEGE ST., LONDON, E.9  
Phone CL1350LD 2887  
Scottish Agents: KEITH & IRWIN, 35, Robertson Street, Glasgow, C.2

Barclays Ad. 1316

## A REAL POWER VALVE

The New Pattern "FAMA"

Four reasons why every wireless enthusiast should have one

- (1) Fama Valves have been tested and found unsurpassed by any, irrespective of price
- (2) The Power Valve works on the low amperage of 3
- (3) Works on 4 or 6 volts accumulator
- (4) Less than half the price of any other Power Valve

POWER DOUBLE PLATE Fil. 4-6 Volts, 0.3 Amps Anode 100-200	10/6
0.06 Dual Emitters Fil. 1.8-3 Volts, 0.06 Amps. Anode 20-100	9/6
4 Volt Amplifiers and Detectors	4/6

Of all Wireless Dealers or Post Free from

**H. D. ZEALANDER & CO.**  
ST. JOHN'S HOUSE, MINORIES, E.1.

**absolute  
micrometer  
precision  
with  
rigidity**

British made in every detail

Price:  
**10/6**

These are the pre-eminent virtues of the new "Eclipse" Micrometer Coil Holder. You can make minute adjustments with the true micrometer screw action—no friction drive, but a positive mechanical movement. You cannot jar the coils from their adjusted position. Pigtail springs give perfect connection through moving blocks.

2-way holder only at present available. (3-way coming shortly.)

Ask your radio supplier to get it for you.

**Eclipse MICROMETER COIL-HOLDER**

P. & C. MANUFACTURING COMPANY, LTD.  
6, BATH STREET, CITY ROAD, LONDON, E.C.1



# CAXTON 4-VALVE CABINET

Made for Editor of Wireless Magazine for Set "As good as money can buy" described in issue February, 1925.

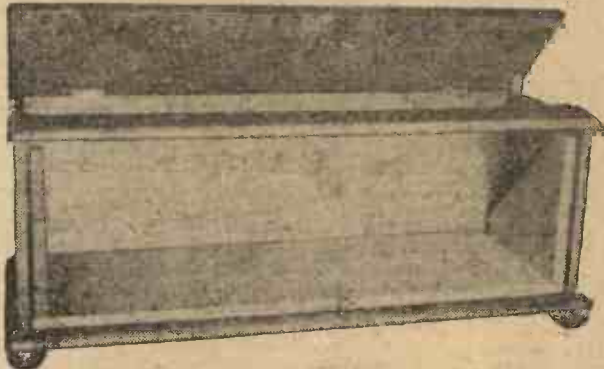

Cash with Order. Fumed Oak ... £1 5 0  
 or Real Mahogany polished ... £1 14 0

With detachable recess fitted Base Board to mount 21 in. by 7 in. panel to slide out of Cabinet front. Extra 10/- with two beaded front doors totally enclosing fitted panel. Cabinet overall length 22½ ins. Width 8½ ins. Height 9 ins.

Polished with the new enamel that gives a glass hard surface that cannot be soiled or scratched.

SENT FREE.—Catalogue of standard Wireless Cabinets in various sizes and woods. Special Cabinets made to customer's orders.

PACKED AND DELIVERED FREE IN U.K.

CAXTON WOOD-TURNERY CO., Market Harborough

## ACCURACY

*Guaranteed!*



## THE GRAHAM FARISH GRID LEAK & CONDENSER

Combined by the Patent Series and Parallel Connector



PRICE

**2'3**

COMPLETE

Grid leaks (all sizes) .. 1/3

Condensers '0001-'002.. 1/- '003-'006.. 1/9

Unique in design, the only grid leak and condenser admitting instant connection in series or parallel. Every model tested and supplied with written guarantee of accuracy. Sold by all leading dealers, or post free direct from the manufacturers. Liberal Trade Terms on application.

THE GRAHAM FARISH MFG. CO. WRAY WORKS, BROMLEY, KENT

Details of Free Gift Scheme in Every Carton



## Perfect Radio Reproduction

RADIO reproduction through the loud-speaker is not only a question of power, but of sensitivity to frequencies over the whole audio range—and clear amplification.

The U.S. Super Transformer owes its foremost position amongst L.F. Transformers to its uniformity of amplification. There is no marked "dropping off" in amplifying power when the broadcasting artist is singing or playing the lower notes, neither is there any jarring on the high notes.

The U.S. Super amplifies evenly over the whole musical register, low or high notes are reproduced with absolute fidelity.

The U.S. Transformer's success lies in the excellence of its design. The core, with no bolts through it, is packed with finest stalloy iron, allowing fullest amplification without hint of distortion; winding is done by experts; terminals are large and comfortable, with ebonite strips at top and soldering tags. —Ratios guaranteed 5-1 and 3-1.

PRICE

**18/6**

From all dealers or direct from the manufacturers

2 other U.S. Transformers of high efficiency

No. 1, suitable for first stage work . . . Price 14/6  
 No. 2, designed for following stages and power work Price 11/6

All U.S. Transformers are tested and guaranteed. Write now for a copy of the N.P.L. Chart showing the amplification curve of the U.S. Transformer.

A. D. Cowper, M.Sc., in "Modern Wireless," says of the U.S. Super Transformer:—

"The present instrument, if the high quality of the specimen submitted is an indication, can be heartily recommended, and indicates the vast strides that have been made recently in the design of really effective transformers for L.F. amplification."

THE U.S. RADIO COMPANY, LTD.

(Dept. 2)

Radio Works, Tyrwhitt Road, Brockley, S.E.4

'Phons: Lee Green 2404 Wires: Supertran, Lewis, London

Used in circuits published in MODERN WIRELESS



Used in circuits published in The WIRELESS CONSTRUCTOR

## SUPER TRANSFORMER

"U.S." Transformers are British throughout. The letters have no connection whatever with the words "United States"

# A REVOLUTION IN CONSTRUCTION —SOLDERED JOINTS SUPERSEDED!

Complete range of combined Nut-Connectors for easy and quick wiring-up of any set.

## “KRISCROS” (PATENT) CONNECTORS

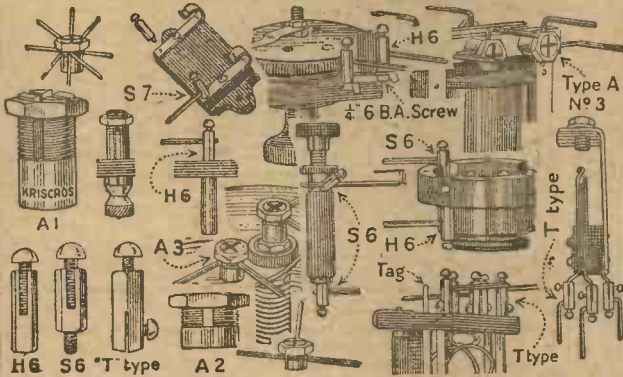

SIMPLE, NEAT. BETTER RESULTS SECURED THAN WITH SOLDERING.

A CONNECTOR FOR EVERY CONTACT, FOR EVERY COMPONENT AND EVERY PURPOSE

From 1/- to 3/- per doz. Send p.c. for list.

**KRISCROS CO.** (Retail Mail Order Depot)

50, GRAY'S INN ROAD, LONDON, W.C.1



## Experiment with your Fixed Capacities

No longer is it necessary to work in an awkward spot behind the panel with screwdriver or soldering iron when you want to change a capacity.

### The “K” TUBULAR FIXED CONDENSER

fits to the panel in clips, and capacities snap in or out—just like a gridleak. Thirty seconds only are required to change a capacity—an invaluable asset to the experimenter. Small underpanel space—no soldering necessary. Capacities are accurate.

Send for our New Free Illustrated Catalogue, which gives particulars of this and many other interesting specialities

PRICES	
·0002	} 1/9
·0003	
·0005	
·001	} 2/-
·002	
·003	
·006	} 2/6

**WATERS BROS., LIMITED**

Head Office: 12/14, Gt. Queen St., Kingsway, W.C.2  
Phone: Gerrard 575-576. Grams: "Zywateseng, Westcent." Works: LONDON and BIRMINGHAM

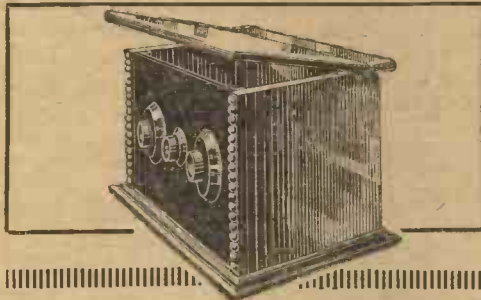

## The Artcraft Cabinet for Radio Receivers

Sizes of "Artcraft Popular Type" Cabinets		
Panel Size	Depth	Price in Oak / Price in Mahog.
9 x 6	6 x 6	8/0 / 8/0
10 x 8	6 x 6	8/0 / 10/0
10 1/2 x 8	6 x 6	8/6 / 10/6
10 x 9	7 x 7	10/0 / 12/0
12 x 10	8 x 8	12/0 / 14/0
13 x 6	7 x 7	10/0 / 12/0
14 x 10	8 x 8	14/0 / 17/0
16 x 6	8 x 8	14/0 / 17/0
18 x 10	8 x 8	16/0 / 19/0
18 x 12	9 x 9	21/0 / 27/0

All Cabinets Carriage Paid in England and Wales. Prompt delivery guaranteed. When ordering state if Base-board required.

ARTCRAFT Cabinets are made in either light or dark Oak or Mahogany, and are of very attractive and pleasing design.

Cabinets can be supplied for all sets described in Radio Press publications. If the special design you want is not listed we will quote price and deliver seven days after receipt of order.

Write for Illustrated Brochure of Standard "Artcraft" Cabinets

THE ARTCRAFT COMPANY, 156, CHERRY ORCHARD RD., CROYDON. Phone: Croydon 1981

RADION VALVES ARE GUARANTEED BRITISH MADE

## Save Money on Valves!



This Book, Free on request gives useful information and curves of RADION VALVES. Write to-day

**Radion D.E. ·06** A wonderful efficient 3-volt "very dull" filament valve. In two types: H.F. & L.F. **10/6**

**Radion D.E. ·34** A 2-volt dull emitter of fine performance. In two types: H.F. & L.F. **10/6**

**Radion G.P.** A 4-volt bright valve that only consumes 48 amp. **7/-**

**Radion Pyramid (1) Valve** The power valve de luxe. Can be used with largest loud-speaker without valve distortion. Filament robust; works at low temperature, ensuring long life. Special construction gives highest efficiency and mechanical strength. Fil. volts 5.5; Fil. amps. 34; Anode volts 50-100; Neg. Grid. Bias 3-9. Also supplied with 4 v. fil. if desired. **22/6**

Don't let any dealer try to sell you something dearer. There are no better valves; our curves PROVE IT. Buy RADIONS and save money.

A user writes: "I am really amazed at the result, they are the best valves I have yet come across. Let me thank you for executing my order so quickly, and when I require any more valves I will certainly send to Radions Ltd."

From Untied Dealers or direct Post Free from the Manufacturers:

**RADIONS LTD., Bollington, Nr. Macclesfield, Cheshire**

Send for our booklet; it describes valves, repair service, and gives useful hints. It's free. Write to-day.



Radion Pyramid Valve



**2/6 COMPLETE SOLDERING OUTFIT**  
with directions for Wireless Soldering  
Soldering Iron with Copper-bit of correct weight for wireless work : 12 Terminal Tags, Solder and Flux Useful Spirit Blow-lamp 1/3 extra  
**DARFX RADIO CO.**  
Standard Works, Forest Hill, S.E. 23

2/6

TRADE DECKO MARK  
**BAG OF PANEL VALVE HOLDER**  
PURE EBONITE, SAFETY SOCKETS N. PLATED ONE HOLE FIRING BOLT. OBTAINABLE FROM ALL THE BEST DEALERS.  
**A.F. BULGIN & CO.**  
9-11 CURSITOR ST. CHANCERY LANE E.C. 4.

PRICE 2/- EACH IN CARTONS

**2-VALVE AMPLIFIER, 35/-**  
1-Valve Amplifier, 20/-, both perfect as new; Valves, 4/6 each; smart Headphones, 8/6 pair; new 4-Volt Accumulator, celluloid case, 13/-; new 60-Volt H.T. Battery, guaranteed, 7/-; 2-Valve All-Station Set, £4. Approval willingly  
**C. Taylor, 57, Studley Rd., Stockwell, London**

MAKE YOUR OWN ELECTRIC LIGHT—These wonderful Dynamos light brilliantly 4 cv. lamps and are very easy to work. "De Luxe" model, 6/6 post. 6/1. (Usual price 7/6.) List free. GREENS (dept. E.H.), 65, Long Acre, London, W.C. 2

5/6



TRADE DECKO MARK  
**HEAVY GAUGE VALVE WINDOWS**  
MAKE & FINISH OF THE HIGHEST QUALITY, FOR SETS OF DISTINCTION. OBTAINABLE FROM ALL THE BEST DEALERS.  
**A.F. BULGIN & CO.**  
9-11 CURSITOR ST. CHANCERY LANE E.C. 4.

PRICE 6/- EACH N.P. P.D. OR BLACK IN PACKETS

**Spintite Wrenches AT REDUCED PRICES**  
Get your Spintite Wrench Set to-day  
Here are new prices—  
Set No. T 61 (hex) 24/- Single wrenches 1-6 B.A. 1/6  
" No. T 60 " 4/6 " " " " " 2/6  
" No. T 85 (round) 4/6 Phone Jack size 2/6  
Write for Folder C, which tells you all about them  
**Rockwood Co. Ltd., 147, Queen Victoria St., E.C. 4**

TRADE DECKO MARK  
**PANEL KNIFE SWITCHES**  
ASK TO SEE THE DECKO IN THE ORANGE COLOUR CARTONS OBTAINABLE FROM ALL THE BEST DEALERS  
**A.F. BULGIN & CO.**  
9-11 CURSITOR ST. CHANCERY LANE LONDON.

PRICE 5 S.R.T. 9 D.P.D.T. 1/6

**COUPON**

**QUESTIONS AND ANSWERS**

This Coupon must be accompanied with a 2/6 P.O. and stamped addressed envelope.

**"Wireless Constructor"**  
DECEMBER, 1925

25/-

25/-



*A careful experimenters' opinion*

**W**E find that the best way to advertise the M-L Transformer is the easiest: we glance through our file of letters from people who have bought the transformers, and pick out one at random.

The one we have lighted on this time is from an experienced and painstaking English experimenter. He says:—

*"After a large number of comparative tests with other makes, I have found the M-L Transformer to be entirely satisfactory. I find that it is absolutely silent in working, with practically no distortion, and that the amplification is quite high enough for all ordinary purposes. . . . There is no Transformer on the market that distorts less."*

Wireless experimenters will find that their own experience will be the same as this.

If you cannot get the M-L L.F. Transformer from your Wireless Dealer, write and let us know.

- The 1:6 ratio is used for amplification after a crystal rectifier.
- The 1:4 ratio is used for single stage L-F amplification.
- The 1:2.6 and 1:4 ratios are used respectively in the first and second stages of two-stage amplification.

**S. SMITH & SONS (M.A.) LTD.**  
179-185, GREAT PORTLAND ST., LONDON, W.1

**S. SMITH & SONS (M.A.) LTD**

**"EVERY CONDENSER A VERNIER FOR 2/-"**

**AND TWO HUNT'S CLEVER SWITCHES**

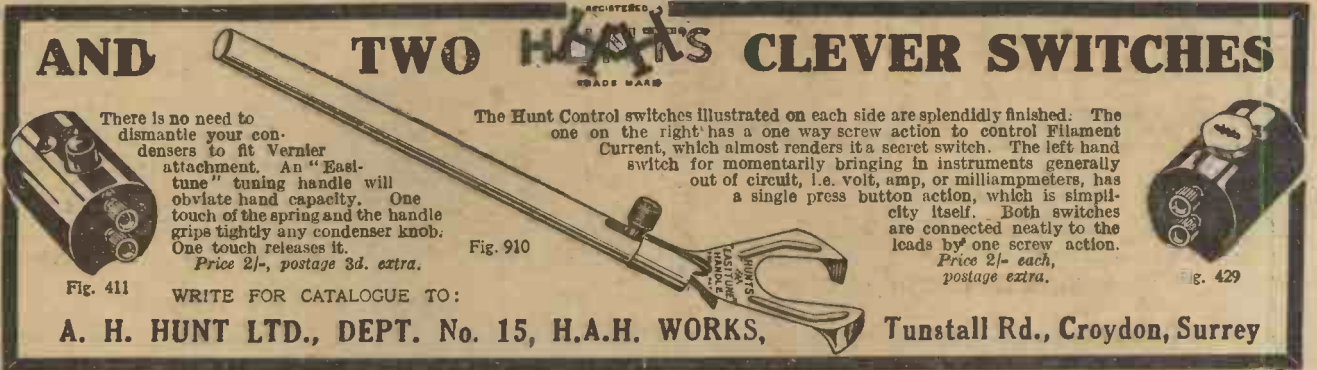

There is no need to dismantle your condensers to fit Vernier attachment. An "Easy-tune" tuning handle will obviate hand capacity. One touch of the spring and the handle grips tightly any condenser knob. One touch releases it.  
Price 2/-, postage 3d. extra.

The Hunt Control switches illustrated on each side are splendidly finished. The one on the right has a one way screw action to control Filament Current, which almost renders it a secret switch. The left hand switch for momentarily bringing in instruments generally out of circuit, i.e. volt, amp, or milliampmeters, has a single press button action, which is simplicity itself. Both switches are connected neatly to the leads by one screw action.  
Price 2/- each, postage extra.

Fig. 411 WRITE FOR CATALOGUE TO:  
**A. H. HUNT LTD., DEPT. No. 15, H.A.H. WORKS, Tunstall Rd., Croydon, Surrey**

WE SPECIALISE IN  
**SETS OF PARTS**  
AND  
**PARTS FOR SETS**  
WE SUPPLY  
**EVERYTHING WIRELESS**  
with Quick Service and  
Guaranteed Satisfaction

We Want Your Custom and Your Recommendation  
While your Local Dealer is thinking where to  
get your Supplies we despatch per return

**"OCTOPUS"**

Our Trade is known  
Mark all over  
**"OCTOPUS"** the world



REGD. TRADE MARK.  
No. 458314.

WRITE FOR FREE LIST  
**RADIO "STOCKS"**

(B. HAINE, Proprietor)

NOW REMOVED TO LARGER PREMISES AT  
**14, Rathbone Place, W.1**  
LONDON  
Phone: MUSEUM 3205.

**For Goodness Sake!**

**"ETHERPLUS"**

BRITISH MADE  
Permanent connection on rotor

FIT THESE  
**"ETHERPLUS"**  
Variable Condensers  
in your Set

The "Etherplus" Low-loss Brasted condenser with vernier, cost only 12/6 each in the "0005" and "001" capacities (without vernier 11/4). Yet you can have implicit confidence that whatever else may go wrong in your set, your condenser is all right.

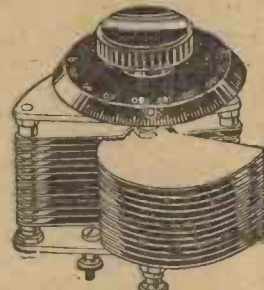

Without Vernier		
No.	Capacity.	Price.
W/53	.0025	10/-
W/54	.005	11/-
W/55	.01	11/-
W/56	.01	14/-
With Vernier		
No.	Capacity.	Price.
W/57V	.0025	11/6
W/58V	.005	12/6
W/59V	.005	13/6
W/60V	.01	15/6

If your dealer cannot supply: direct from

**MANDAW** 9-15, Whitecross Street, London, E.C.1

**WHY BUY ACCUMULATORS?**

and suffer the depreciation and many annoying inconveniences caused by unskilled charging

If you add depreciation to the expense and inconvenience of having your own accumulators unskilfully recharged, it costs you considerably more than our inclusive Hire Service.

WE SUPPLY and deliver a New Rotax Wireless Accumulator of suitable size for your set. We call and exchange it for another fully charged one weekly or fortnightly anywhere in Greater London for 13 weeks from 8s. inclusive.

If you have your own accumulators we give the same continuous service from 6s. per quarter—and if you have only one, lend you one of ours, alternate exchanges.

Radio Service Co.  
105, Torrington Avenue, Kentish Town, N.W.5

**REAL SERVICE—Hire or Maintenance**

WRITE FOR FOLDER "Z-5" or PHONE—NORTH 4161 & 4162



**"SCIENTIFIC" LOW LOSS SQUARE LAW CONDENSERS. ONE-HOLE FIXING**

As illustrated or with EBONITE END PLATES.

PRICES:

Maximum Capacity.	Without Vernier.	With Vernier.
.0010 mf. . . . .	7/6	11/9
.0005 mf. . . . .	5/6	10/9
.0003 mf. . . . .	4/9	9/3
.0002 mf. . . . .	3/6	8/-
5-pl. Vernier . . . . .	3/-	—
3-pl. Vernier . . . . .	2/3	—



**Scientific Low-loss Tuning Stand**  
With knobs or extension arms, 2-coil 19.3-coil 29.



**Combined Rheostat Valve-Holder**, one-hole fixing. Overhead or underhang 1/3  
**Combined Omnistar Valve-Holder**, one-hole fixing . . . . . 3/6  
All components postage extra.

**SCIENTIFIC SUPPLY STORES**, 126, Newington Causeway, London, S.E.1. Branches: 80, Newington Causeway, S.E.1; 7, St. George's Circus, S.E.1; 16, Mettett Street, Charing Cross Rd., W.1; 251, Edgware Rd., W.2; 84, Church Rd., Upper Norwood, S.E.23. Phone: HOP 4177.



**“THERLA”**

**A FAMOUS LABORATORY ISSUES THE GUARANTEE**

Faraday House—the famous Electrical Institution—tests every Therla Product. Affixed to every fixed Condenser and every Therla Grid Leak is the Faraday House Guarantee—a personally signed blue label signifying that the accurate testing instruments of this laboratory pass out the product within a narrow commercial limit of the stated capacity.

Think what this accuracy means to you. Better Reception, the elimination of mysterious faults—briefly, accurate condenser and leak values ensure the best results. For this accuracy you pay nothing. Therla products are manufactured to a high electrical standard, and are both accurate and reasonable in price. From all dealers.

THERLA GRID LEAKS		THERLA FIXED CONDENSERS		
Size	Price	Size	Price	
250,000 ohms	1/8	'0001 to '0015 mfd.	1.3 each	
500,000 "		'002 mfd. to '006 mfd.	2/- each	
1,000,000 "				
1 megohms				
2 "				
3 "				

Grid Condenser and Leak 3/-    Grid Condenser with Clips 1/3

*Sole Distributors:*  
**SEL-EZI WIRELESS SUPPLY CO., LTD.**  
 6 CREEK ST., LONDON, W.1, & 20, OLD HAYMARKET, LIVERPOOL  
 Telephone Regent 1140    LIVERPOOL Royal 1682

*Barclays Ad.*

20 Metres or 20,000  
 IT'S ALL THE SAME  
 TO THE

# EDDYSTONE

SQUARE LAW  
 LOW-LOSS CONDENSER  
 PATENT No. 240716

## WHY? BECAUSE



- 1—The 10:1 patent micrometer gearing gives hair splitting tuning. The fine helical cut gears prevent backlash.
- 2—Ordinary brass or aluminium vanes oxidise in time, which causes High Frequency resistance. The “EDDYSTONE” Brass Vanes are specially treated to prevent this.
- 3—There are no losses due to insulation, or unwanted metal in the magnetic field.
- 4—It has negligible series resistance since both Stator and Rotor Vanes are soldered to their separate supports.
- 5—A phosphor bronze permanent contact ensures silent working.
- 6—The fixed aerial vanes are of thinner metal to reduce high frequency resistance. The moving earth vanes are stout to prevent buckling.

The “EDDYSTONE” LOW LOSS CONDENSER is an instrument of precision, of handsome appearance, and is complete with large dial and knob. The end plates are of polished Duralumin for strength and lightness. One hole fixing; easy to mount and nothing to go wrong.

**FIT ONE TO-DAY AND GET PERFECT RESULTS**

Price: '0005 - 17/6 each  
 '0003 - 16/6 "

From all good class dealers. If any difficulty write direct.



**STRATTON & Co. Ltd**  
 BALMORAL WORKS,  
 Bromsgrove Street, Birmingham

ASK YOUR DEALER TO SHOW YOU  
 THE “EDDYSTONE” ABSORBOS  
 The Ideal Radio Set Mount.

## ACCUMULATORS RE-CHARGED FREE!

STANDARD MODEL    IN YOUR OWN HOME with the  
 “CHASEWAY” CHARGER



The “Chaseway” is a thoroughly practical electrical apparatus, designed specially to remove the re-charging bugbear. It can be connected by the merest amateur in any household having DIRECT (CONTINUOUS) CURRENT, and if used whilst current is in use for lights, irons, kettles, radiators, etc., costs nothing for the re-charging. Once fitted, it is there for life, requires no attention, and is a wonderful boon for all accumulator users.

No. 1 Model. For any installation of 100 to 250 volts. Size 9 in. by 3 1/2 in. 25/- complete.  
 No. 2 Model. For 25 and 50 volt systems and other special circumstances, 35/-; with special resistance lamp (2 amps.) or with special adjustable resistance (2 to 5 amps.), 40/-.  
 No. 3 Model. For Shopkeepers, Garages and others who can re-charge batteries for revenue—will charge several accumulators at once.

**A WONDERFUL VARIABLE GRID LEAK.**

The “Chaseway” Variable Grid Leak is the greatest advance yet made in gridleak manufacture. Reliable for all time and gives really wonderful results. One hole fixing and simple to fix. Remarkable testimony has already been received as to its efficiency.

ONLY **25/-**  
 DON'T PAY MORE

ASK YOUR DEALER FOR ONE  
 or send remittance direct if any difficulty.  
 Illustrated Catalogue of other “Chaseway” Specialities FREE on receipt of stamped envelope. Contains many novel necessities.

**“CHASEWAY”** 195, Archway Road,  
 LONDON, N. 6. 4/-  
 Mountview 6921    TRADE INQUIRIES INVITED.



# 40 metres & below !!

BUY A COPY  
EVERY WEDNESDAY

PRICE

**6<sup>D.</sup>**

Obtainable from all News-agents and Booksellers. If any difficulty in obtaining locally, send P.O. 32/6 to Dept. W, Radio Press, Ltd., Bush House, Strand, London, W.C.2, and copies will be posted you every week for a year.

“WIRELESS WEEKLY” is pre-eminently the journal for short-wave enthusiasts.

The remarkable developments in this field are fully reflected each week in both theoretical and practical articles.

All experimenters will find in its pages information and assistance of the greatest practical value. “Wireless Weekly” keeps you abreast of Radio development and progress. Every up-to-date enthusiast should buy it.

On sale each Wednesday.



# Wireless Weekly

EDITED BY JOHN SCOTT-TAGGART, M.C., F.Inst.P., A.M.I.E.E.

**UNIVERSAL TERMINAL**  
Takes all thicknesses of wire, spade or pin connectors.  
Price 4½d. each

**Nickel-plated Dial Indicators**  
3d. each

**Small nickel-plated push-pull switch** for single hole under panel mounting, 3/-

**Angle Brackets** for supporting mounting boards.  
Price 3/- pair

**'DEXTRAUDION' VALVES**

3-volt	06	14/-
2 "	35	12/6
2 "	4	16/6
3 "	12	21/-
4 "	4	6/6
4 "	06	14/-
4 "	12	21/-
5 "	3	21/-

**Combined Volt and Ammeters** 7/9

SEND TO-DAY for 44 PAGE RADIO CATALOGUE PRICE 3d. Deductable from first purchase

**ECONOMIC ELECTRIC, LTD.** Head Office: 10, FITZROY SQUARE, LONDON, W.1 Showrooms: 303, EUSTON ROAD, N.W.1

**IMPORTANT NOTICE**  
THE MAXEL WANDER-PLUG TERMINAL IS NOW ON SALE  
This is a fitting that should be on every set and battery where a quick change of connections is desirable  
**NON-CORROSIVE**  
Trade enquiries invited

Extract from "Popular Wireless" April 25th, 1925  
The tops of the terminals, which can be used in the ordinary manner if desired, form sockets into which standard wander plugs can be inserted similarly to an H.T. battery. This is an improvement which is decidedly a brain-wave, and one of those obvious little things which are overlooked until some genius brings it to light and then everybody wonders why everybody did not think of it.

**PROV. PAT.**

4<sup>d</sup>. POST EACH FREE

**The New MAXEL Accumulator**  
Specially designed for Wireless  
GUARANTEED TWELVE MONTHS.  
If you live too far away to call and see the Battery Mail your Order to us for the size you want. We will willingly return your money if you are disappointed.  
Now fitted with NON-CORROSIVE Wander Plug Terminal

	AMPS.			
	40	60	80	110
2 VOLT ..	7/6	9/6	11/9	14/6
4 VOLT ..	15/-	19 -	22/6	26/6
6 VOLT ..	22/6	27 9	33 6	39 -

Packing 1 - extra per battery

**H. T. BATTERIES 60 VOLT - POST 7/6 FREE**

*What Maxel users say!*

Maxel Electrical Co. Dear Sirs,  
I am not in the habit of writing firms in praise of their products but your accumulator and battery which I have received urge me to do so. I only wish to say that you, the Maxel Electrical Co. live up to every point you advertise. It is one thing to look at the advertisement of your accumulator and quite another to look at the article itself, and above all use it. It is then that one can appreciate all the smart points of the Maxel, and realise just what an accumulator should be. I shall recommend them to anyone I know who is wanting a battery. Yours etc., R. A. B.

**MAXEL ELECTRICAL CO.** 28, Clipstone Street, Great Portland Street, W.1  
Telephone: MUSEUM 708.

**You want the Best** when buying coil-holders. Ask for "Lotus" and you will get the best.

**"LOTUS" Coil-Holders** are made from Bakelite mouldings with nickel-plated fittings; they are an ornament to any set and they give the best results.

**TESTIMONIAL:**  
"I should like to take this opportunity of saying how glad I am that I fitted your coil-holder. I can now, without any other alteration in my set (Det. LF), receive six stations with comparative ease, where, before, tuning-in of three was an achievement."

**RETAIL SELLING PRICES:**  
Two-way ... 7/- Extended handles ... 8/-  
Three-way ... 10/6 Extended handles ... 12/6

The Vernier Movement is actuated by three sets of encased Precision Cut Gears, representing a reduction of 8 to 1.  
**MOVING BLOCK CANNOT FAIL**

**GARNETT, WHITELEY & CO., LTD.**  
Lotus Works, Broadgreen Road, Liverpool

**Two in One!**

The new Dual Rheostat—a "Peerless" product in every way. Specially designed to meet the demand for a resistance equally applicable to bright or dull emitters. It has two windings—one offering a resistance of 6 ohms, whilst a continuation of this is of 30 ohms resistance. The resistance element is wound on a hand fibre strip under great tension. One hole fixing is provided, and the terminals are placed in convenient positions. The contact arm has a smooth, silky action, and all metal parts are nickel-plated.

**3/9 PEERLESS 3/9**  
Retail  
**DUAL RHEOSTAT**  
Retail

Send now for full details

The Bedford Electrical and Radio Co., Ltd.  
22, CAMPBELL ROAD - - - BEDFORD

May we send you also details concerning our new "Resicon" Condensers? Precision Instruments—made to an ideal

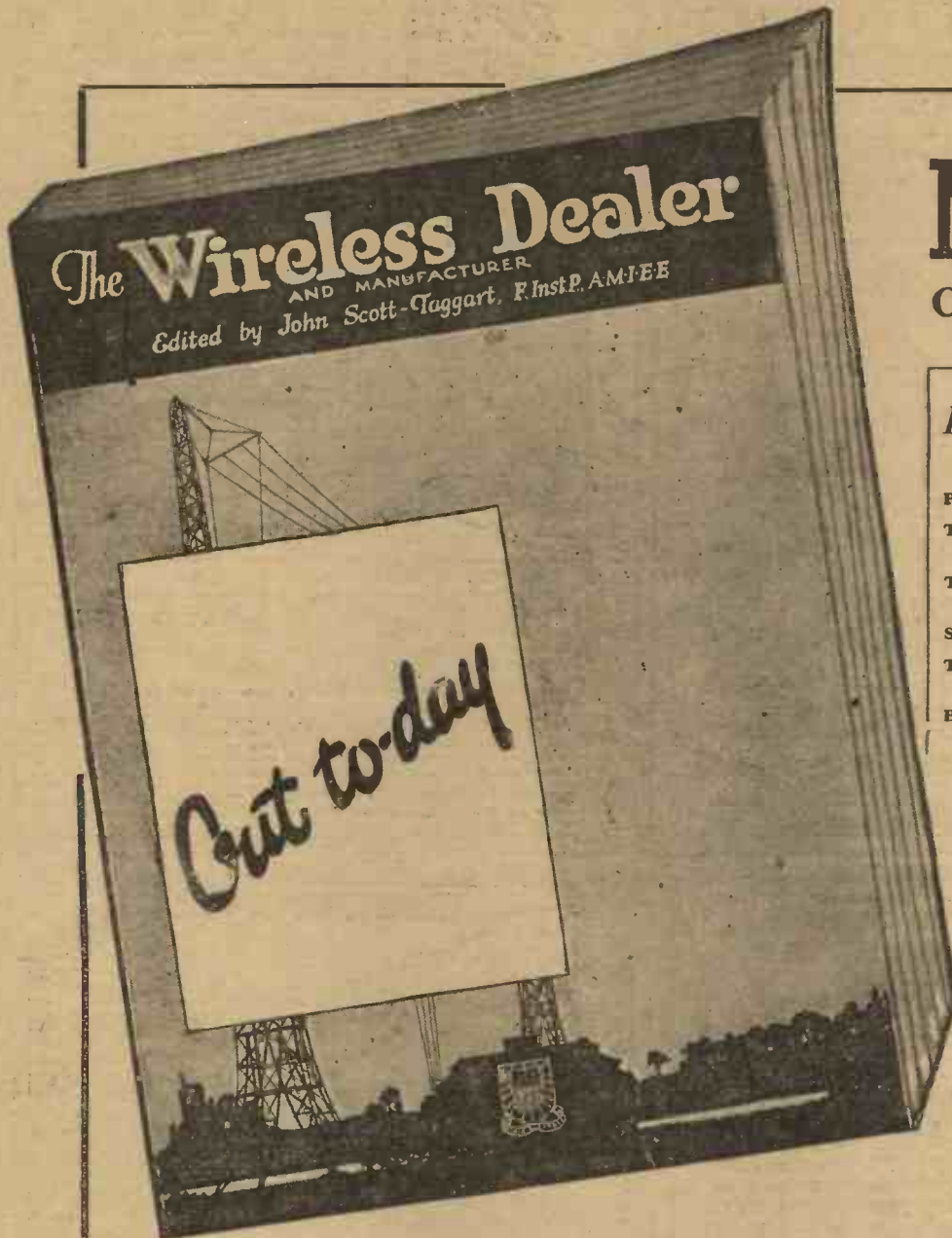

# No. 3

OUT TO-DAY !!!

*Important Articles*

*in this Issue on*

- PRICE CUTTING
- THE TREND OF WIRELESS DESIGN
- THE WIRELESS DEALER AND HIS ADVERTISING
- SALES METHODS
- TRADE CONDITIONS AT HOME AND ABROAD
- BRITISH AND FOREIGN EXHIBITIONS
- AND
- A SEARCHLIGHT ON THE V.M.A.

**HAVE YOU**  
sent in  
your  
**Subscription?**

There is no other source of information from which the Manufacturer & Dealer can secure such reliable advice and business building assistance

**FILL IN THIS FORM TO-DAY AND ATTACH IT TO YOUR LETTER HEADING**

*The Wireless Dealer is only supplied to bona-fide Manufacturers and Traders*

**SUBSCRIPTION ORDER FORM**

To RADIO PRESS, LTD., Sales Dept. W  
Bush House, Strand, London, W.C.2

Please enter my/our name for a twelve month's subscription to "THE WIRELESS DEALER" commencing with No. 1. Enclosed is remittance of 7/6 (10/- abroad)

NAME.....

ADDRESS.....







Index to Advertisers

PAGE		PAGE		PAGE	
American Hard Rubber Co. ...	228	Fluxite, Ltd. ...	223	Priestley & Ford ...	226
Autoveyors, Ltd. ...	224	Formo Co. ...	161	Radi-Arc Electrical Co. ...	219
Beard and Fitch, Ltd. ...	213	Gambrell Bros. ...	159	Radiax, Ltd. ...	239
Bedford Electrical and Radio Co. ...	237	Garnett, Whiteley and Co. ...	237	Radio Communication Co., Ltd. ...	151, 224
Benjamin Electric, Ltd. ...	202	General Electric Co., Ltd. ...	143	Radio Equipment Co., Ltd. ...	224
Bowyer and Co. (H.) ...	239	Gent and Co. ...	173	Radio Instruments, Ltd. ...	209, Cover iv
Bowyer-Lowe Co. ...	169, 173	Graham (A.) and Co. ...	217	Radio Service Co. ...	234
Brandes, Ltd. ...	140	Graham Paris Mfg. Co., The ...	231	Radio "Stocks" ...	234
Bretwood, Ltd. ...	223	Green (H. Cecil) ...	233	Radians, Ltd. ...	227, 232
Brighton Radio Stores ...	226	Harlie Bros. ...	156	Rawplug Co. ...	155
British Engineering Products ...	226	Hunt (A. H.), Ltd. ...	234	Raymond (K.) ...	178, 179
British L. M. Ericsson Mfg. Co., Ltd. ...	213	Igranic Electric Co. ...	188	Rockwood Co., Ltd. ...	233
B.T.-H. Co., Ltd. ...	148	Jackson Brothers ...	206	Rothermel Radio Corporation of Great Britain ...	121
Brown (S. G.), Ltd. ...	211	Kathoxyd, Ltd. ...	226	"S. A. Cutters," Ltd. ...	228
Bulgin (A. F.) and Co. ...	219, 227, 233	King Quality Products, Inc. ...	165	Scientific Supply Stores ...	234
Burge, Warren and Ridgley ...	217	Kriseros Co. ...	232	Seagull, Ltd. ...	222
Burndept, Ltd. ...	198	Lamplugh, Ltd. ...	222	Searle (H. J.) and Son ...	181
Burne-Jones and Co. ...	191	Lissen, Ltd. ...	139	"Sel-Ezi" Wireless Co. ...	235
Burney, Guy ...	227	London Commercial Electrical Stores ...	219	Service Radio Co., Ltd. ...	228
Cahill and Co. ...	206	London Electric Wire Co. ...	206	Smith (S.) and Sons (M. A.), Ltd. ...	227, 233
Carpax ...	227	London and Provincial Radio Co., Ltd. ...	209	Standard Telephones and Cables, Ltd. ...	182
Carrington Mfg. Co. ...	222	Lowenadler's (F. W.) ...	229	Sterling Telephone & Elec. Co., Ltd. ...	122
Cattermole Bros. ...	227	McMichael (L.), Ltd. ...	136, 147	Stratton and Co., Ltd. ...	235
Caxton Wood Turnery Co. ...	231	Makerimport Co. ...	229	Stevens (A. J.) and Co. (1914), Ltd. ...	192
"Chaseway" ...	235	M. and A. W. ...	234	Superlamp, Ltd. ...	219
Christie, Jas., and Sons, Ltd. ...	220	Maxel Electrical Co. ...	237	Taylor (C.) ...	233
Clarke (H.) and Co. ...	189, 239	Merrett (J.) and Co. ...	227	Telegraph Condenser Co., Ltd. ...	161
Cleartron Radio, Ltd. ...	203	Michrom Engineering Co. ...	230	Ultra Electric, Ltd. ...	190
Climax Patents, Ltd. ...	162	Mullard Wireless Service Co., Ltd. ...	194, 195	U.S. Radio Co., Ltd. ...	231
Collinson's Precision Screw Co., Ltd. ...	218	Murray Son and Co. ...	228	Vandervell (C. A.) and Co. ...	185
Cooke and Whitefield Wireless, Ltd. ...	222	Naylor (J. H.), Ltd. ...	152	Victoria Electrical (M/c.) Ltd. ...	225
Cossor (A. C.), Ltd. ...	144	Needham (C. E.) and Co. ...	166	Vokes (C. G.) and Co. ...	229
Curtis (Peter), Ltd. ...	214	Neutron, Ltd. ...	173	Wates Bros. ...	220, 232
Darex Radio Co. ...	233	Nibols, Ltd. ...	209	Watmel Wireless Co. ...	218
Davis (Walter) and Son ...	232	Oldham and Son, Ltd. ...	219	Western Electric Co., Ltd. ...	182
Detex Ltd. ...	218	Ormond Engineering Co. ...	186	Wholesale Wireless Co., The ...	230
Dixon (L.) and Co. ...	217	P. and C. Manufacturing Co. ...	230	Wholesale Fittings Co., Ltd. ...	155
Dorwoods ...	229	Peto and Radford ...	220	Wood, E. A. ...	226
Dubilier Condenser Co., Ltd. ...	201, 225	Peto-Scott Co., Ltd. ...	176, 240	Wilkins and Wright, Ltd. ...	221
Economic Electric, Ltd. ...	237	Pickett Bros. ...	217	Williams, Ellis and Co. ...	229
Electron Co., Ltd. ...	223	Portable Utilities Co., Ltd. ...	170, 171	Zealander (H. D.) ...	230
Engineering Supplies, Ltd. ...	221	Power Equipment Co., Ltd. ...	205		
Falk, Stadelmann and Co. ...	Cover iii				
Fletcher (F. and J.) ...	227				

# The New Low Loss H.F. Transformer

(Prov. Protected)

THIS H.F. Transformer represents an entire departure from all other existing designs, and its performance has been keenly commended upon by such well-known Radio Engineers as Mr. Percy W. Earle, M.I.R.E., and others. Its primary is aperiodic, and its exclusive design and shape make it the best word in low loss and efficiency. The secondary is air spaced on a grooved ebonite former, and each one is made to an exact standard, resulting in the condenser scale reading being practically identical in each successive stage of H.F. amplification. The main feature of this new Peto-Scott production is that the capacity coupling has been reduced to an absolute minimum, resulting in an exceptional degree of selectivity.

- No. 1 250 to 550 metres with base ... 15/-
  - No. 2 350 to 700 metres without base ... 15/-
  - No. 3 1,200 to 2,300 metres without base ... 15/-
- Base 2/- each

We wish to warn intending purchasers that these new Low Loss H.F. Transformers bear our name and none is genuine unless so marked.



The New Low Loss H.F. Transformer

## The new Low Loss Coil Former

This handsome Low Loss Former is made throughout of only the very best material, and carries a centre supporting ring, which can be moved along inside the former when winding the coil, to prevent the rods being bent inwards by the pull of the wire. Made in two sizes:

- 5" x 3 1/2" ... 6/-
- 7" x 3 1/2" ... 6/6

## PETO-SCOTT CO., LTD.

77, City Road, London, E.C.1

Branches: 62, High Holborn, London W.C.1. WALSLEY—230, Wood Street. PLYMOUTH—4, Bank of England Place. LIVERPOOL—4, Manchester Street.

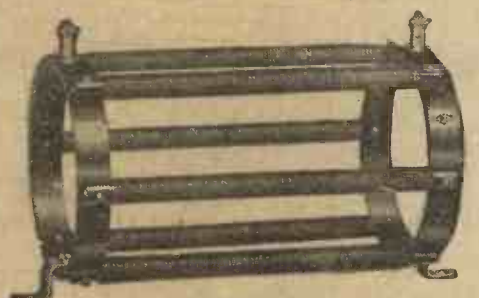

Low Loss Coil Former

P.S. 3715

# EFESCA

LOW FREQUENCY TRANSFORMER

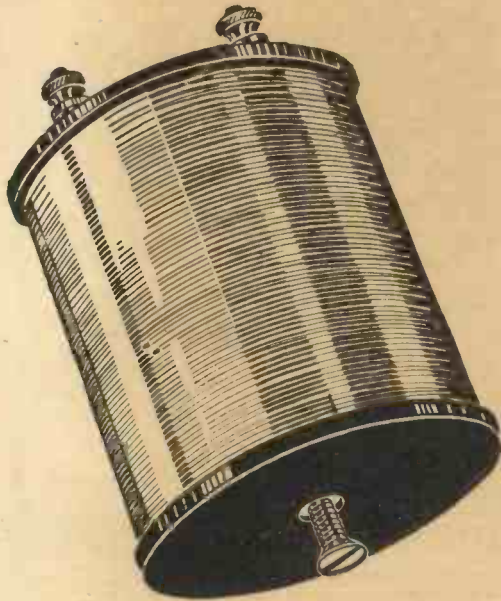

## CORRECT IMPEDANCE

is indispensable to a really efficient Low Frequency Transformer, and the correct impedance is that of the Valve.

### THE NEW MODEL TYPE "B" EFESCA FIRST STAGE LOW FREQUENCY TRANSFORMER

has been designed so that, while maintaining a 4 to 1 turns ratio—the accepted ratio for 1st stage low frequency amplification—the primary winding consists of such a number of turns as to produce an impedance at average speech frequency to match the average impedance of an "R" Type Valve.

The Secondary Winding is of the correct resistance to obviate the possibility of grid current flowing, thus ensuring freedom from breakdown, purity of reproduction and maximum amplification.

An important feature is the heavy insulation between the primary and secondary windings, every Transformer being tested to withstand 2,000 Volts.

The Transformer is enclosed by a polished brass screen, eliminating parasitic noises, while the windings are embedded in a wax compound to maintain an even temperature and give immunity from atmospheric humidity

*One Hole Fixing, price 21/- each*



# EFESCA

REGENERATIVE AERIAL TUNER

The Efesca Regenerative Aerial Tuner is the natural development of the extremely convenient series of Efesca One-Hole Fixing Tapped Coils. It is a specially designed form of Tapped Aerial Coil incorporating Aerial Reaction in a self-contained Unit.

Reaction is effected by means of a rotor revolving in a separately wound section of the Aerial Coil, thereby effecting maximum reaction over the whole wave band covered by the coil. Wavelength range 150 to 2,600 metres in conjunction with a .0005 variable condenser in parallel.

*Price, complete with Knob, Pointer and Scale. 32/- each*

Ask your Wireless Dealer or Electrician for

## EFESCA COMPONENTS

Write for Catalogue No. 559/4, describing and illustrating EFESCA Components and EFESCAPHONE Receiving Sets.

### FALK STADELMANN & Co., Ltd.

83-93, Farringdon Road, London, E.C. 1  
Also at Glasgow, Manchester and Birmingham

EFESCA  
POPULARITY  
COMPETITION

£200

IN

CASH PRIZES

Ask your Dealer  
for Entry Form,  
or write direct

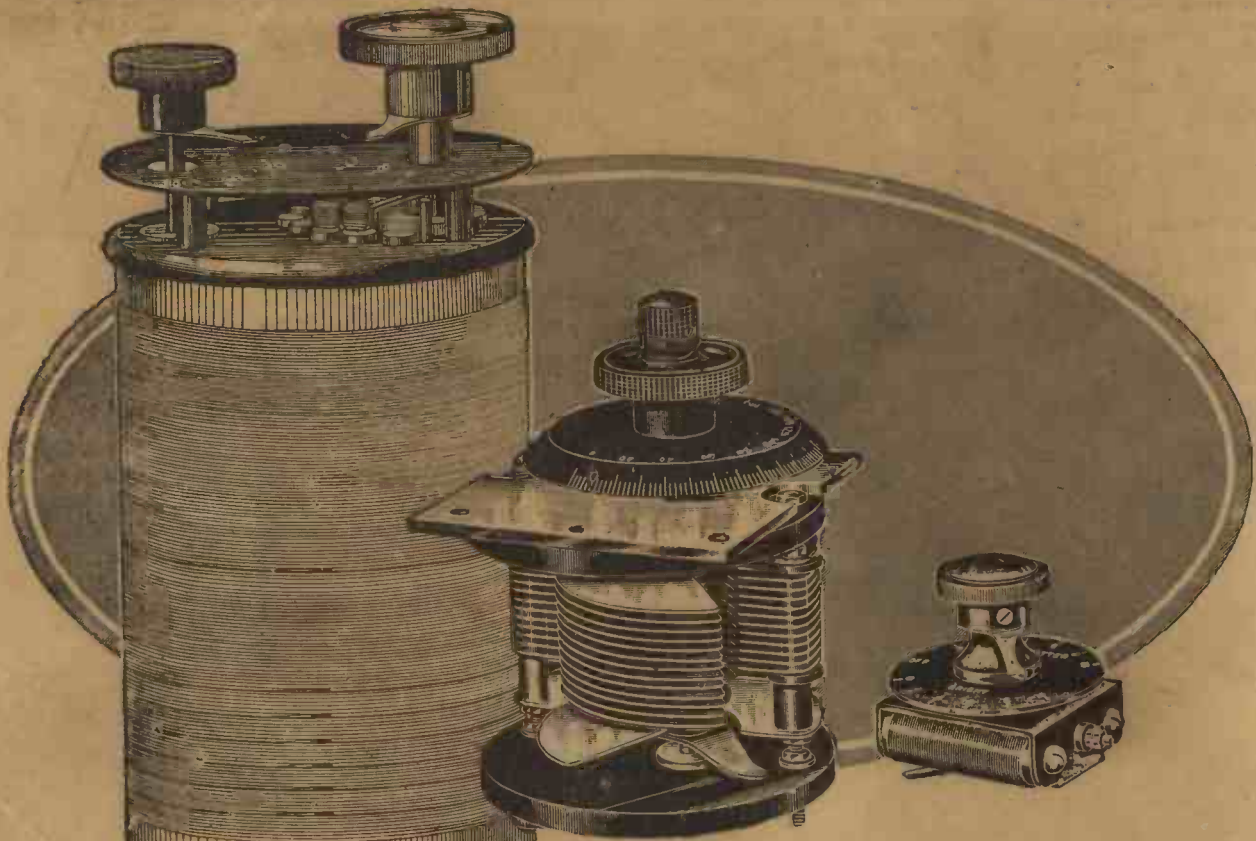

**P**ERFECT reception is the objective of practically every wireless enthusiast to-day. If you want to get perfect reception you must build your set with good components.

The Firm R.I., with 25 years' experience behind it, has built up a reputation for supplying only the best. You can rely on their products, and be sure of perfect wireless reception if your set is constructed with R.I. Components.

Look at The R.I. DUOSTAT, a component which marks the highest standard in valve filament current control. The special construction enables it to be used for bright or dull emitter valves. The contact is uniform and smooth in operation, eliminating all microphonic disturbances during the adjustment of the filament current and giving certain assurance of valve safety.. **Price - 7/6**

The R.I. SQUARE LAW CONDENSER is a striking example of perfect design and workmanship. It has been designed to give a straight line curve in the wavelength adjustment of a receiving set, resulting in increased range with the greatest precision in tuning. A vernier vane is provided, which is separately controlled by a small knob situated in the centre of the dial knob.. **Prices - .0005 mfd. £1 : 4 : 0**  
**.00025 mfd. £1 : 2 : 6**

The R.I. RETRO-ACTIVE TUNER is another R.I. Component which has met with universal approval. It carries the distinction of selective tuning over all wavelengths, and dispenses with the use of multi plug-in coils .. **Price - 39/6**

The NEW R.I., H.F. TUNED INTERVALVE COUPLING. This special anode unit for one-hole fixing, and covering a range of wavelengths from 200-4,000 metres has been designed to complete the series of components required to build either 2, 3 or 4-Valve Set.

The unit has five tapings, and the coil is wound on a grooved ebonite cylinder in such a way that the impedance of each tapping has been calculated to keep the reactance value approximately uniform for all the wavelengths. This method of radio frequency amplification was originally developed by our Research Director for reactance capacity, coupled with H.F. amplification, and has now been adapted as the standard of this country.

This component is beautifully made, and can be fitted to any set in a few minutes .. **Price - 25/-**

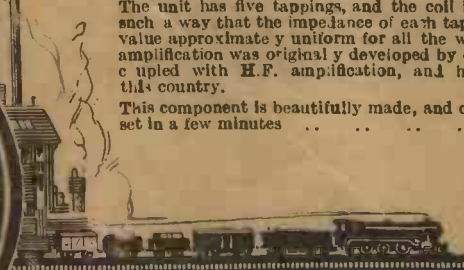

THE MARK OF BETTER RADIO

Write for the R.I. Blue and Gold Catalogue, free on application

Advt. R. I. Ltd, 12, Hyde Street, New Oxford Street, London, W.C.1

P.C.9

Published for the Proprietors, RADIO PRESS, LIMITED, Bush House, Strand, London, W.C.2, on the 15th of each month, and printed for them by Messrs. FLEETWAY PRESS, LIMITED, 3/9, Dane Street, High Holborn, W.C.1. Address for Subscriptions and Editorial communications:—Bush House, Strand, W.C.2. Advertisement Managers:—BARCLAYS ADVERTISING, LIMITED, Bush House, Strand, W.C.2. Phone. City 9911. Registered as a Magazine for transmission by Canadian Magazine Post. Subscription Rates:—3/6 per annum, 4/3 for six months post free. Sole Agents for Australia:—GORDON & GORTCH (AUSTRALIA) LTD. S.I. Agents for South Africa:—CENTRAL NEWS AGENCY, LTD—December, 1925