

The "America's Foremost Radiophone Review" December 25 Cents

WIRELESS AGE



This is a Radio Christmas

Cunningham TUBES



Assure Clearest Broadcast Reception

Nationally known for Super-sensitive Detector Action and Distortionless Amplification, Cunningham tubes are ideal for use in your home receiving set.

The results obtained from the best radio sets depend largely upon the vacuum tubes used. Cunningham Detector Tubes insure clear reception—maximum signal strength and an absolutely quiet receiver in the absence of incoming signals.

Cunningham Distortionless Amplifier Tubes perform a great service. In making possible the reception of distant stations and the use of loud speaking telephones, these tubes bring into your home the music of great concerts and the singing of famous artists, aiding in the cultivation of the musical side of home life.



CUNNINGHAM
TYPE C 300
PATENTED



The trade mark GE is the guarantee of these quality tubes. Each tube is built to most rigid specifications.

TYPE C-300
Super-Sensitive
DETECTOR
\$5.00

Amplifies
as it
Detects

TYPE C-301
Distortionless
AMPLIFIER
\$6.50

Patent Notice Cunningham tubes are covered by patents dated 11-7-05, 1-15-07, 2-18-08 and others issued and pending. Licensed only for amateur or experimental use in radio communication. Any other use will be an infringement.

E. J. Cunningham

Home Office:
248 First Street
San Francisco, Calif.

Eastern Representative:
154 WestLake St.
Chicago, Illinois

Increase the Range of your AERIOLA SR. with the new AC AMPLIFIER



AERIOLA AMPLIFIER
Model AC
Complete with 2WD-11A vacuum tubes
(without batteries)

\$68.00



**VOCAROLA LOUD-
SPEAKER**
Model LV
\$30.00

THE new AC Amplifier, to a considerable extent, increases the reception possibilities of the Aeriola Sr. With head telephones and the AC Amplifier reception ranges of one hundred to three hundred miles become possible for the owner of an Aeriola Sr., depending on local conditions. Used with the Vocarola loud-speaker, the Aeriola Sr. and AC Amplifier fill a whole room with music and speech received over distances of ten to thirty miles.

Anybody can make the simple connections required, including mother and the girls.

See this New Amplifier at Your Dealer

Radio Corporation of America

Sales Dept. Suite 2064
233 Broadway
New York City

District Office
10 South La Salle St.
Chicago, Ill.

Before buying radio apparatus, always consult the book "Radio Enters the Home." Price 35 cents by mail or at your dealer.



*This symbol of quality
is your protection*

THE WIRELESS AGE

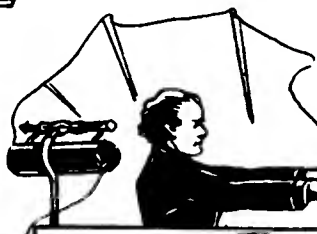

Volume 10

Edited by J. ANDREW WHITE

Number 3

December, 1922—Contents

Cover Design, <i>By O. J. Schulz</i>		An Ideal Amateur 5-Watt Radiophone Transmitter, <i>By Samuel C. Miller</i>	60
Editorials	17	Helpful Hints on Tuning, <i>By A. F. Van Dyck</i>	63
Pictorial Section	18	Experimental Tube Using 110-Volt A. C. on Filament and Plate	65
National Radio Week	26	Electrical Recording and Reproduction of Sound	67
A Non-Partisan Political Medium <i>By Maurice Henle</i>	27	Loud Speaker Circuits and Devices (First Prize) <i>By Clyde Fitch</i>	68
With an Opera and Radio Star in Europe <i>By Paul S. Gautier</i>	30	Loup Speaker Circuits and Devices (Second Prize) <i>By C. P. Bernhardt</i>	69
How Radio "Scooped" the Newspapers <i>By Glenn Scott</i>	31	Loud Speaker Circuits and Devices (Third Prize) <i>By Ray Dio</i>	70
Is There a Perfect Radio Voice? <i>By Marguerite White</i>	33	Amateur Activities in South Africa <i>By Wilfred J. Copenhagen</i>	71
Radio Triumphs Over Fire Peril at Sea <i>By Earl Ennis</i>	35	A. C. for Filaments and Plates of Receiving Tubes, <i>By Abraham Ringel</i>	72
A Saxophonist's "Swanee Smiles" <i>By T. J. Dunham</i>	39	Widening the Range of Variometer Receivers <i>By F. B. Ostman, 20M</i>	74
Ada May Weeks, <i>By Edwin Hall</i>	40	A Practical Super-Heterodyne Receiver	75
Radio Connects Ship and Shore Telephone <i>By Ward Seeley</i>	41	A 100-Mile Crystal Receiver, <i>By Carl Dreher</i>	76
Radio Brings Football to All the People <i>By Sam Laomis</i>	44	New Appliances and Devices	79
Listening In With the Home Folks <i>By Rosemary Clarke</i>	45	N. A. W. A.	81
The Boom Is On in Britain <i>By Milton S. Waldman</i>	47	Correct Use of the Soldering Iron <i>By J. A. Kimmey</i>	82
Humor	49	Radio Chronology	84
Cartoons	50	Queries Answered	87
Broadcasting Station Directory	52	Stations Worked and Heard	93
World Wide Wireless	54	Book Reviews	95
Modern Radio in Ancient Syria	57	Advertisers' Index	111
Broadcasting From Films	58	Amateur Radio Stations of the United States (Supplementary List)	112

PUBLISHED MONTHLY AT WIRELESS PRESS, INC., 326 BROADWAY, NEW YORK
GREAT BRITAIN, 12-13 Henrietta St., London. AUSTRALIA, 97 Clarence St., Sydney, N. S. W.

Yearly subscription in U. S. A., \$2.50—Outside U. S. A., \$3.00; Single Copies, 25 cents. Entered as second class matter Oct. 9, 1913, Post Office, New York, N. Y., under the Act of March 3, 1879. Copyright, 1922, Wireless Press, Inc. When subscription expires you will find a renewal blank enclosed. Return with remittance promptly. Notify us of any change in your address, giving both the old and new location. Edward J. Nally, Pres. J. Andrew White, Vice-Pres. L. MacConnach, Secy. George S. Desousa, Treas.

Because certain statements and expressions of opinion from correspondents and others appearing in these columns from time to time may be found to be the subject of controversy in scientific circles and in the courts, either now or in the future, and to sometimes involve questions of priority of invention and the comparative merits of apparatus employed in wireless signalling, the owners and publishers of this magazine positively and emphatically disclaim any privity or responsibility for any statements of opinion or partisan expressions if such should at any time appear herein. Printed in U. S. A.

"America's Foremost Radiophone Review"

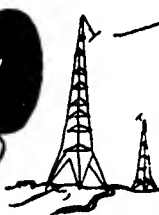



Make the most of Your Christmas Trade

Sell Crosley Radio Instruments

CROSLY Instruments and Parts will be your best sellers during the Christmas Season. They are what the consumer wants. A moderate priced instrument with all the good qualities of the more expensive sets.

The demand for CROSLY Instruments has been increasing by leaps and bounds. The reason is simple. All of our larger units incorporate one stage of Tuned Radio Frequency Amplification. We were the first to bring this feature on the market and we have developed it to its highest degree. This simplifies tuning, increases the range and clarity and eliminates interference. Crosley instruments are popular wherever they are tried.

Advertisements such as this and others of a similar nature will appear in all the leading Electrical and Radio Publications during December and the succeeding months. Combined with our previous national advertising, our continued publicity will create a demand for CROSLY APPARATUS such as you have never experienced before.

You cannot afford to be without a supply of CROSLY instruments during the Christmas Season.



Write for fully descriptive catalog and discount sheet

CROSLY
BETTER-COST LESS
RADIO

CROSLY MANUFACTURING CO.
Department W A 4
Cincinnati·Ohio

"This is a Radio Christmas"

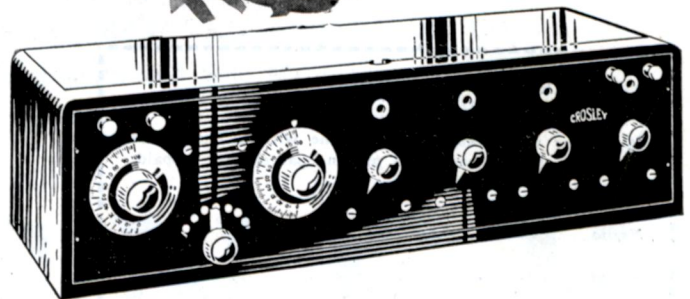

CROSLY RECEIVER MODEL X. A four tube outfit the same as shown in the above scene. It consists of tuner, one stage of Tuned Radio Frequency Amplification (the feature that has made our larger sets so popular), Detector and Two Stages of Audio Frequency Amplification in a beautiful mahogany finished cabinet. It will bring in distant stations loud and clear. Price without phones, batteries or tubes.....\$55.00

When writing to advertisers please mention THE WIRELESS AGE

Thoro-bred

RADIO PRODUCTS

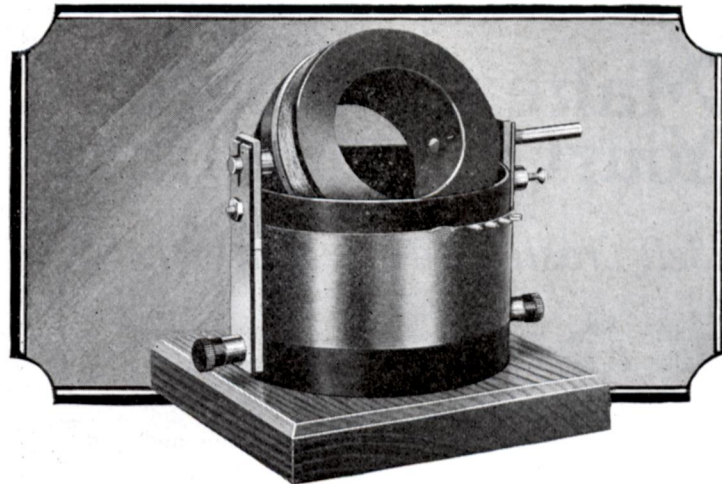

How to tune-in without the "birdies"

HISSING, sizzling and similar noises have been such a common experience of the radio amateur while tuning in that they have been nicknamed the "birdies." This nuisance can be eliminated. The Thoro-bred Vario-Coupler in addition to the usual services has the added feature of tuning in so closely that the "birdies" are driven away. Ordinary vario-couplers have a tap brought out for connection purposes only at every six or seven turns of the primary. The Thoro-bred Vario-Coupler has each of the first seven turns tapped one turn at a time and the balance

of the primary tapped every seven turns. This close-tuning feature scares the "birdies" away. It also saves you the expense of a variable condenser.

Each tap on the primary has a 3-inch lead insulated with cambric tubing. This permits making connections to contacts without using soldering iron. There is a directly positive connection to the secondary which eliminates all scratchy noises when in operation.

The Thoro-bred Vario-Coupler is molded. It is not subject to moisture as are the common wooden types. Distributive capacity is eliminated through the use of special green silk wire in both the primary and secondary. *For only five dollars* you can now buy the Thoro-bred Vario-Coupler from your nearest radio or electrical store. If for some reason your dealer cannot supply you, send the money direct and a Thoro-bred Vario-Coupler will be mailed you parcel post prepaid.

THE MARSHALL-GERKEN CO.
TOLEDO, OHIO, U. S. A.

THE MARSHALL-GERKEN CO.,
Toledo, Ohio, U. S. A.

My dealer was unable to supply me with a Thoro-bred Vario-Coupler. Please send me one parcel post prepaid. I enclose five dollars.

Name.....

Street.....

City.....

Dealer's Name.....

Why Magnavox is the Reproducer Supreme

OFFICIAL tests with the Oscillograph prove that the Magnavox electrodynamic receiver reproduces incoming wave forms with maximum accuracy.

The Magnavox can be used with any receiving set—the better the set, the more Magnavox can do for you.

When you purchase a Magnavox you possess an instrument of the very highest quality and efficiency.

R2 Magnavox Radio with 18-inch horn
(as illustrated)

This instrument is intended for those who wish the utmost in amplifying power: for clubs, hotels, dance halls, large audiences, etc. It requires only .6 of an ampere for the field. Price \$85.00

R3 Magnavox Radio with 14-inch horn

The ideal instrument for use in homes, offices, amateur stations, etc. Same in principle and construction as Type R2. Price \$45.00



3-stage

Model C Magnavox Power Amplifier

For use with the Magnavox Radio and insures getting the largest possible power input.

2-stage \$ 80.00
3-stage 110.00

Magnavox products can be had of good dealers everywhere. Write our nearest office for copy of new illustrated folder.



Make it
the GREATER Radio Christmas

THE gift of all gifts is Magnavox Radio, the Reproducer Supreme—the gift that will mean most to every member of the family—old and young.

Let Magnavox tell you the world's daily news and entertainment—so clearly that voice or music can be enjoyed by all, as though from your own phonograph.

The Magnavox Co., Oakland, California
New York: 370 Seventh Avenue



MAGNAVOX
Radio
The Reproducer Supreme



Registered Trade-Mark

DAY-FAN RADIO APPARATUS

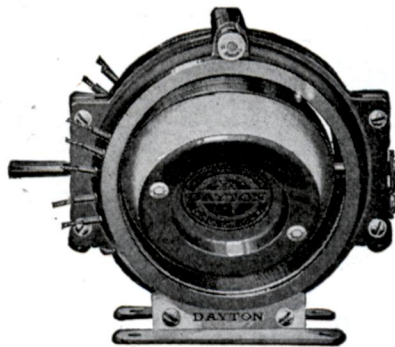

Variometers
Variocouplers
Audio
Transformers
Condensers
Rheostats
Knobs and Dials
Other units to
follow



The Market: Radio is decidedly a seasonal demand. Selling radio during the past months has been like selling electric fans in winter. The season is just opening and your recent sales give no indication of the coming demand. *Prepare for the season now.*

Move Your Present Stocks: Your customers are tired of seeing the same stock in your store that they saw last year and all summer. They believe that it is obsolete. You must put in something new to get the buyers into your store and then your old stock will go with the new. *Don't Save One Dollar and Lose Two.*

What to Buy: The development of Radio devices has been rapid and it has not yet slowed up. For that reason your manufacturer must have Engineers and plant facilities which will keep him ahead of these developments. Such manufacturers bring out new designs when others are copying their old ones. *Protect yourself against obsolete stocks* by buying DAY-FAN RADIO APPARATUS.

Manufactured by

THE DAYTON FAN & MOTOR COMPANY

Factory and General Offices

701 Day-Fan Block, Dayton, Ohio.

Established 1889



DAYTON MOTORS



DAYTON FANS



This sign means safety for you

LOOK for this sign in the radio or electrical dealer's windows before you purchase radio supplies. The words "Agency For Radisco Products" means far more than a place where you may purchase the various products of the Radio Distributing Company. They mean safety for you.

Satisfaction or money back

THE Radisco Agency Sign is your guarantee that the products sold within will positively do what they are intended to do. No ifs or ands. Should a Radisco Radio Product prove defective in material or workmanship the Radisco dealer will replace it with a new Radisco Part or he will return your money. You are guaranteed satisfaction or money back.

Reliable advice

EVERY one of the hundreds of Radisco Agents can be depended upon for responsible, perfectly reliable advice on Radio. They know their business. They would not be Radisco dealers if they had not measured up to the Radisco Standard.

In their stores you will find everything that is good, practical and reliable in radio. They carry a complete line of Radisco Radio Products which comprise everything in transmitting and receiving apparatus that the amateur need require. Just name your purpose. They'll do the rest.

Price reductions

IN line with the Radisco policy of selling the very best apparatus at the lowest possible prices, your Radisco dealer can now offer a large number of radio product at marked reductions in price. Ask him about it.

Mail this coupon now

MAIL this coupon for a copy of the Radisco Catalog (which lists all that you need to buy for the most complete type of radio set). Just leaf through it pages, pick out the set (or parts) you desire and go to your Radisco dealer. If you do not find a Radisco dealer in your own town, write us. Remember you get satisfaction or money back. Just fill out the coupon

NOTE: Dealers who believe they are qualified to become Radisco Agents will be given prompt, courteous attention. State in your letter the reasons why you believe you can uphold the Radisco Standards.

THE RADIO DISTRIBUTING CO.
Newark, N. J., U. S. A.

Gentlemen:—
Send me free of charge a copy of the Radisco Catalog of Radio Products.

Name

Street

City

Dealer's Name

RADISCO RADIO PRODUCTS

"Guaranteed Radio For Every Purpose"

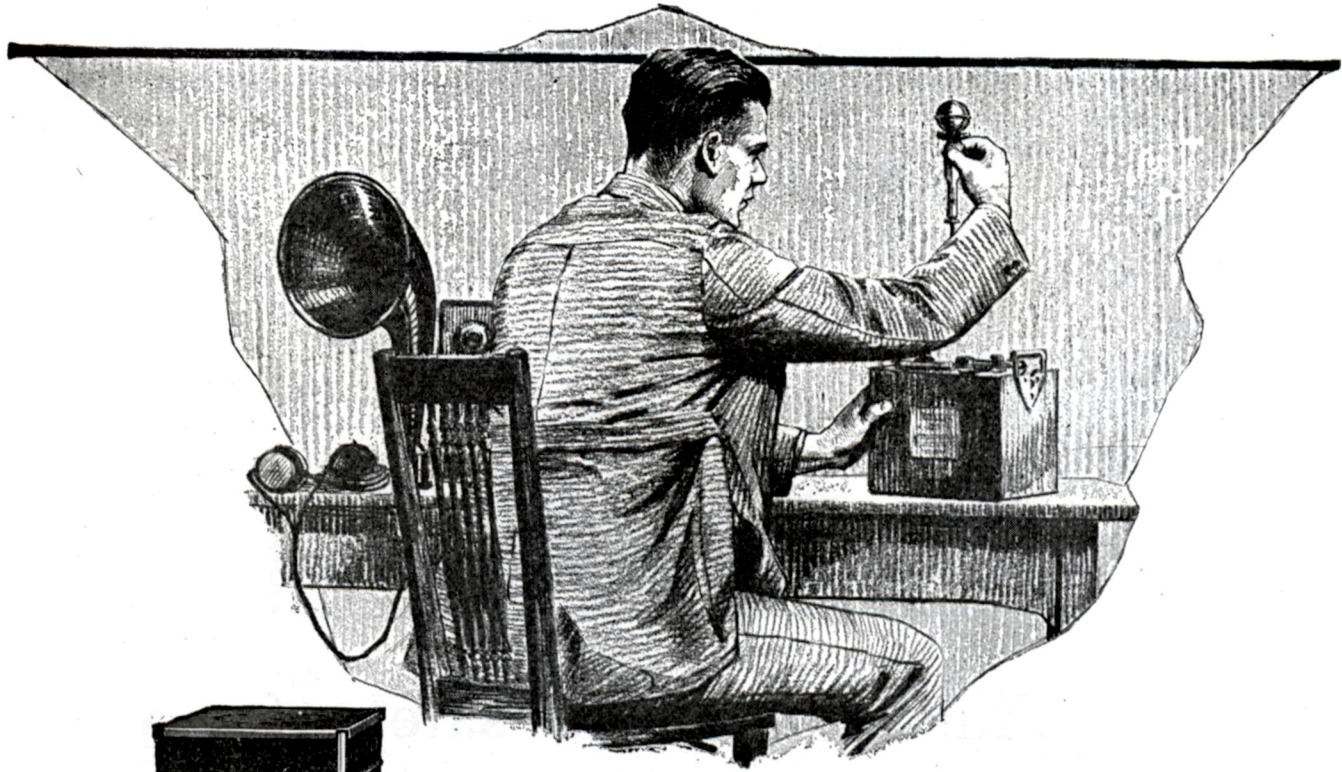

Tungar

BATTERY CHARGER

This enables you to keep batteries fit, right at home. With simple attachment, it will also charge "B" storage batteries.

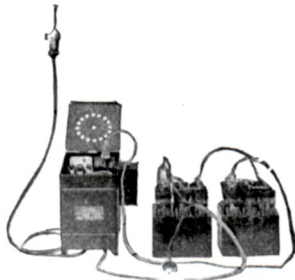

This is the way "B" Storage Batteries are charged with Tungar and attachment.

Your Battery Should be Kept Fit

The Tungar Battery Charger makes it a simple matter to keep your storage battery tuned-up and fit. With it you can recharge your battery at home—and at little cost.

Tungar is a small, compact rectifier, which can be connected with any a-c. lighting circuit. It is easy and safe to operate—in fact, requires no attention after starting. And when properly connected, the current can go only the one way, eliminating any danger of ruining the battery. There is no excuse for allowing your battery to run down and spoil the evening's fun. A Tungar doesn't cost much—and it charges the starting and lighting battery in your automobile also.

Send for our new booklet on Tungars for radio, if your dealer cannot supply you.

Address Merchandise Dept., General Electric Company, Bridgeport, Conn.

General  Electric
Company

General Office
Schenectady, N.Y. Sales Offices in
all large cities

35A-78

\$13.60 That's All for a Willard "A" Battery

Here's a Christmas present that will go big, you can be sure—with yourself or anyone else who has a radio set.

It's a genuine Willard "A" Radio Storage Battery at the lowest price for which a Willard Radio "A" Battery has ever been sold.

And when we say genuine Willard we mean just that, for this new battery is fit in every detail to bear the name. We are no less proud of having been able to produce such a good battery to sell at such a low price than of being the makers of the popular Willard All-Rubber Radio Batteries, the last word in radio battery construction.



Why This is a Real Willard

It is made in the same plant and by the same men who make the higher-priced Willard batteries for both radio and automobile service, and they bring to it the same care, skill and experience.

It has Willard quality plates, selected wood separators, tested rubber jars, acid-proofed container.

It includes such features as special terminals to insure easily-made and tight connections, special marking for positive terminal; patented rubber gaskets to prevent leakage; a convenient durable roller-type handle, and other advantages.

All Willard Radio Batteries, too, are shipped from the factory dry and fully charged, so that you always get a brand new battery and one that is ready for use just as soon as the acid solution is poured into it.

It's Made in 3 Sizes!

This new battery—the Willard FW—is of the 6-volt type and made in three sizes, 40, 80 and 110 ampere hour capacity. They are priced as follows: 40 a. h., \$13.60; 80 a. h., \$17.50; 100 a. h., \$22.00. A slight addition to these prices is made in the extreme South and West of the Mississippi.

Go to the nearest Willard Service Station or your dealer's today and see this new Willard Battery.

WILLARD STORAGE BATTERY CO., Cleveland, Ohio

Made in Canada by the

Willard Storage Battery Company of Canada, Limited, Toronto, Ontario

Willard STORAGE BATTERY

When writing to advertisers please mention THE WIRELESS AGE

*Result of
14 Years' Experience*

To hear the Music perfectly

Brandes *Matched Tone* headsets are the standard equipment of the receivers made by the leading radio manufacturers. The listener judges a radio receiver by what he hears. It follows that Brandes *Matched Tone* headsets must have the qualities that the radio manufacturer demands.

If your receiver is not equipped with Brandes *Matched Tone* headsets, you are not hearing the music perfectly. Send ten cents in stamps for the "Beginner's Book of Radio." It explains radio in terms that anyone can understand.

DISTRIBUTORS AND DISTRICT OFFICES:

Munsey Bldg., Washington, D. C.	709 Mission St., San Francisco, Cal.
33 S. Clinton St., Chicago, Ill.	76 Pearl St., Boston, Mass.
704 Granite Bldg., Pittsburgh, Pa.	802 Forsyth Bldg., Atlanta, Ga.
1220 Nicollet Avenue, Minneapolis, Minn.	

International Electric Company, Wellington, N. Z.

C. Brandes, INC.

"Matched Tone" Headsets

TRADEMARK REG. U.S. PAT. OFF.

237 Lafayette St., New York

Dept. W. A.

Made in Canada by Canadian Brandes, Ltd., Toronto, and distributed by Perkins Electric, Ltd., Montreal.

Make this a Radio Christmas

When writing to advertisers please mention THE WIRELESS AGE

RADIO AS A PROFESSION

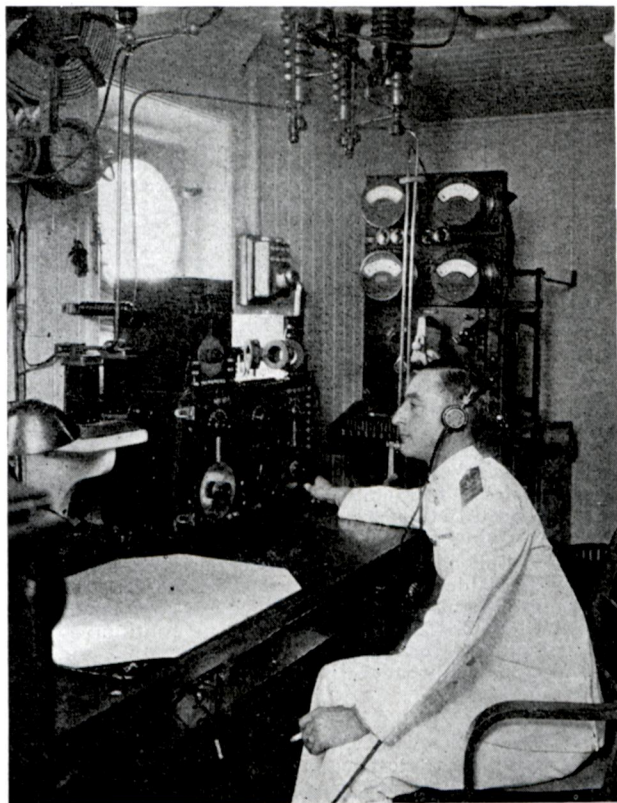

With the rapid development of radio—its vast expansion and world wide popularity—there is an open door to a profession that is unlimited in its possibilities, for those who are prepared. Even now, with radio in its infancy, there are men with a limited knowledge of this science posing as experts in the field, wholly on account of the shortage of well trained radio technicians. **RADIO NEEDS TRAINED MEN.**

Why not prepare yourself for a position in this fascinating and ever growing field of industry? Qualify yourself through the Radio Institute of America, an Institution of International reputation. Our instruction based upon thirteen years' experience is unquestionably the most sound and thorough being both practical and theoretical. Our laboratory contains a more complete assemblance of wireless equipment, for instruction purposes, than any other radio school in the United States.

HOME STUDY DIVISION

For the benefit of those who cannot attend our class room instruction we have organized a systematic **CORRESPONDENCE COURSE** including everything from the basic principles of elementary electricity and magnetism to com-

mercial apparatus—C. W.—I. C. W.—TELEPHONE—ARC and SPARK. Code instruction is taught by means of automatic transmitters of special construction. The Institute possesses all essentials necessary in giving the most efficient training.

There are two main points to be considered in choosing your school for radio instruction. First, the success of that school and the quality of its instruction. Second, the opportunities in the Radio Field after the successful completion of the course of training. It is well to bear in mind that it is NOT the number of students actually enrolled or taught by a school that denotes its quality of instruction but rather it is the

NUMBER OF SUCCESSFUL GRADUATES

The Radio Institute of America has actually graduated more than 6,000 students—over 6,000 individuals who have obtained commercial license certificates and fully 95% of this number have secured positions in the radio field. 90% of all the wireless operators in the employ of the Radio Corporation of America, on land and sea, are our graduates.

Owing to the close connection existing between the Institute and the Radio Corporation of America, our graduates enjoy a great and exclusive advantage.

Information regarding either the Residence or Home Study Division gladly sent on request.

Radio Institute of America

(Formerly Marconi Institute)

America's oldest and foremost radio school

326 Broadway

New York, N. Y.

BRANCH RESIDENT SCHOOL:

New Call Building, New Montgomery St., San Francisco

Please indicate whether information regarding Residence or Home Study Course is desired.
RADIO INSTITUTE OF AMERICA,
326 Broadway, New York.
Please send me information concerning your
HOME STUDY } course of instruction.
Name.....
Street.....
City or Town.....
State.....

**"This is a Radio Christmas"
COME ON IN, O. M.!**

"2ZL is open for you. No matter where you are, you can go through it in the comfort of your own home.

"I used to wish there were ten or me, so that I could help everybody who called and wrote to know how I got so much out of the glass bottles that had nothing in them and how they could do as well. Guess I did help a good many, at that, though I had to burn the midnight oil to do it. Then I decided to put the whole story in a book, so everybody could read it, saving time for myself and for them too. So I wrote my book, 'Modern Radio Operation.' All the dope is in it; how I have put through long-distance two-way voice communication, how I have transmitted across the Atlantic, etc., and a lot of kinks that many amateurs never even heard of before. Now I can say to everybody,

"Come on in!"

J. O. Smith

EVERY RECEIVING AMATEUR can profit by the experience of J. O. Smith. EVERY TRANSMITTING AMATEUR can learn from his unique experience. Those who have been privileged to go over his station, 2ZL, at Valley Stream, L. I., have understood how his utterly unprecedented results have been obtained, and have been able to get more out of their own instruments.

Mr. Smith's knowledge, his experience, his results, are available to everyone now. His book, "Modern Radio Operation," puts at everyone's command all the details of 2ZL, and of other famous continuous wave transmitters, such as 1ZE, 8ZG and 9ZG, and also the popular broadcasting stations WDY, WJZ and WGY.

With this book you can increase your knowledge, arrange your set in the light of the most modern and effective practice, save time and money in purchasing equipment, make your tubes last longer, increase the quality of your modulation and add many miles to your effective transmitting and receiving ranges.

Are you still wondering about the comparative merits of spark and CW transmission? Read "Modern Radio Operation," and your doubts will be dispelled by real facts and figures of actual operation, demonstrating conclusively the superiority of the tube in range, clarity of reception, ease of eliminating interference, and, what is to many the most important of all, low power consumption.

RECEIVING EXPLAINED—Chapter 4 is the most comprehensive yet published on receiving apparatus and is intended especially for those who are content to listen to the broadcast programs. It contains full details, with diagrams, of every type of set; crystal, honeycomb, regenerative with audio frequency amplification, and the radio frequency-detector-audio frequency set used on indoor loop antennas. There is even a summary of the super-regenerative Armstrong circuit, 100,000 times more sensitive than the usual hook-up.



HERE ARE THE CHAPTERS

1. The Radio Telephone.
2. Transmitting Equipment Used in Radio Telephony and Its Operation.
3. Typical High Power Broadcasting Stations.
4. Receiving Equipment for All Purposes and Its Operation.
5. Spark vs. Continuous Wave Transmission.
6. Vacuum Tube Fundamentals.
7. Operating Characteristics of Vacuum Tubes.
8. Methods of Obtaining Plate Potentials, and Types of Continuous Wave Transmitters.
9. Continuous Wave Transmission by Amateurs.
10. Tube Transmitters in Commercial Work.
11. Advantages of a Counterpoise Ground in Connection with Tube Transmitters.

150 PAGES
OVER 50 ILLUSTRATIONS

No Theory—No Mathematics—No Formulas

Just a straight story of the development and operation of the tube sets that made amateur history, written in everyday language that explains itself, by the man whose design and operation of 2ZL gave that station world-wide fame.

DO YOU KNOW

- the proper proportion of grid and plate currents in a transmitting tube?
- the proper proportion of plate current when not modulating to the normal full-load current when modulating?
- how to eliminate excessive plate current when no adjustment of the circuits will do it?
- the percentage of increase in output to be expected by the addition of one or more tubes to a transmitter?
- the advantages and disadvantages of transmitting circuits employing direct current on the plates; A. C., with half-wave rectification; A. C. with full-wave rectification, kenotron-rectified A. C.; and which type of circuit is the most economical and at the same time most efficient?

IF YOU DON'T—"MODERN RADIO OPERATION" WILL TELL YOU, and tell you in plain language that you will enjoy reading.

ORDER BLANK

WIRELESS PRESS, INC.,
326 Broadway, New York.

I enclose \$..... Please fill my order as checked below:

..... MODERN RADIO OPERATION and *THE WIRELESS AGE for one year, \$3.75 (outside U. S. 50c. extra)

..... MODERN RADIO OPERATION, \$1.75.

Name

Street

City State

*If new subscriber check here.....

NOW READY

"Modern Radio Operation" is now ready for distribution. It is the most up-to-date volume on amateur tube operation ever published, and should be in every station. It will save you time and money, tell you how to get the maximum results with the minimum power, how to save tubes and how best to use the power that is available in your locality.

Price \$1.75

At any dealer, or send order direct to the publisher—

WIRELESS PRESS, Inc.

326 Broadway

New York City

VERNIER Rheostat
Model 200

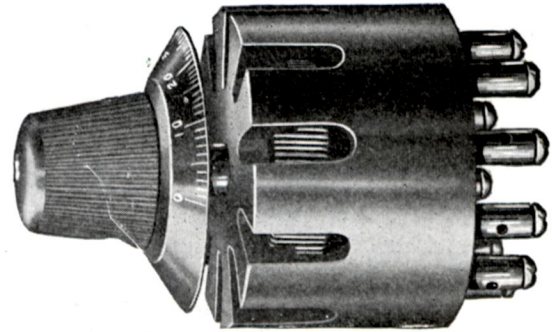
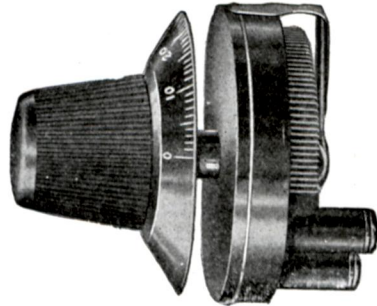

The AMPLITROL

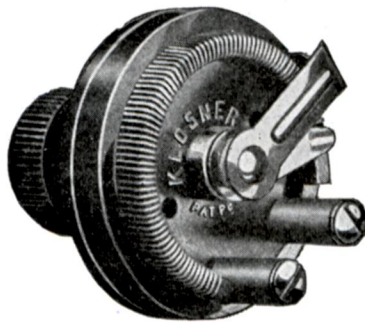

Model 100

**The ORIGINAL
VERNIER Rheostat**
\$1⁵⁰

*No Panel can be Up-to-date
without these Two*

**Only a Rheostat with a
Vernier can make your
set more sensitive**

It is impossible to tune out interference without perfect adjustment of your detector tube. No ordinary rheostat can give you the fine adjustment necessary.

The Klosner VERNIER Rheostat has a micrometer adjustment that permits getting EXACTLY on the very spot for perfect reception.

The Klosner operates both coarse and fine adjustments with ONE knob—a feature protected by broad patent claims. Wire-wound like all true electrical instruments.

And it has a graduated DIAL to show just where it is set. No guessing.

Condensite, phosphor bronze contacts, white graduations on black dial, \$1.80.

**Does away with plugs and
jacks—Makes tubes last
many times longer**

Now, for the first time you can have complete control and adjustment of each amplifier tube merely by turning a simple knob. Do away with all jacks, plugs, rheostats and switches. The Amplitrol knob switches on the plate circuit and adjusts the filament circuit at the same time. You turn on any stage of amplification at will.

Lengthens the life of the tube from one-third to one-half, as it absolutely prevents suddenly throwing a heavy current onto the delicate filament. With the Amplitrol, the current is turned on GRADUALLY.

Genuine condensite, white graduations on a black dial, phosphor bronze contacts. Highest grade. Complete with wiring instructions, \$4.00.

DEALERS

No instruments on the market surpass the Klosner in neatness of design or quality of material and workmanship. Show your customer a Klosner and any other kind—he selects the Klosner regardless of any difference in price. Order through your jobber.

If your dealer cannot supply you, don't make the mistake of accepting something "just as good." We will take care of your order direct.

KLOSNER IMPROVED APPARATUS CO.

Originators and Sole Manufacturers

2024 Boston Road

New York City

"This is a Radio Christmas"

KLOSNER



“This is a Radio Christmas”

HE'S ONLY A BOY

But when he installs a set—
IT WORKS!

WHY? Because, boylike, he's a human interrogation point. He wasn't satisfied to follow a diagram of connections. What's the condenser for? Why the tuning coil? He wanted to know the reason!

Are you a broadcast listener—one of the many bewildered ones who hear the radio programmes now clear, now fuzzy? Perfect tuning makes a big difference in the quality of music or speech. There's a wide gap between the results secured by the novice when compared with those secured by the radio fan who knows the function of each part and its relation to the other apparatus in a receiver.

2 Volumes
Size 3 1/8 x 5 inches
Flexible Leather Covers
Fully Illustrated
96 pages in each volume
Price 2 Vols. **\$1.00**

AN INTRODUCTION TO RADIO (The Title Tells the Story)

ANSWERS YOUR QUESTIONS—Every novice in radio always asks the same questions: What is a radio wave? How is it made? How long does it take to get to me from the broadcasting station? Is there any difference between the dot and dash waves and the music waves? What is a condenser for? What is a variometer? What is the difference between a variocoupler and a loose coupler? How are the ear phones made? What does the crystal detector do? How does a vacuum tube work? What is the grid leak for? Is there any danger that my antenna will be struck by lightning? How can I tune my set to get the loudest signals? What is the difference between radio frequency and audio frequency? What is a potentiometer for and how does it differ from a rheostat? And scores of other questions. All are answered in this book.

FOR THE BEGINNER—Make no mistake. This is an elementary book. All who can read English can understand it. Funny how hard it is for an expert to talk shop so everyone can understand—there are a number of good technical books, but this is the best book we have ever seen of the hardest kind to do well.

An introduction to Radio. That is just what it is. Mr. (Miss or Mrs.) Reader, we take great pleasure in introducing Radio. After a few hours you can meet the other members of the family and talk radio with them as you can't now.

If you were sailing for France you would study an elementary text book on the French language—here is your book for your trip to radio land, the most fascinating country ever discovered by modern science. Explore it knowingly, as thousands are now doing, with a receiving set and “An Introduction to Radio.”

In Two Volumes — Handy Pocket Size — For the Whole Family

What's In Them?

VOLUME 1

An Introduction to Radio
Radio Telephony
The Various Instruments
Used in Radio Transmitting and Receiving Outfits

VOLUME 2

Technical Terms Explained
How to Set up Receiving Outfits
Primer of the Vacuum Tube
How to Set up Radio Transmitters
International, Morse Code and Conventional Signals

“Great!” is what the first readers of this book said. Just what they had been looking for. Everything in plain language, all the facts you need to know. One thing leads right to another in this book, for it starts with the A, B, and C and goes on through to the end in the proper order. You understand everything because there's nothing left out, no illogical jumps from one subject to another.

Make “An Introduction to Radio” the foundation of your radio library, the basis of your real understanding of what radio is and how its wonders are done. Examine these two volumes. Go to your dealer and ask for them. If he hasn't them, ask him to order a supply, or, if you wish, pin a dollar bill or a check to the coupon and we will send the books on approval. Look them over for five days. If you are not wholly—100 per cent.—satisfied, return them and we will refund your money. Send for these books today. Pin a dollar to the coupon →

WIRELESS PRESS, Inc., New York

ORDER BLANK

A-12-22

WIRELESS PRESS, INC., Date
326 Broadway, New York.

Here's my dollar. Send me AN INTRODUCTION TO RADIO. If I don't like the books I'll return them in 5 days and get my money back.

Name

Address

City

State

SPECIAL OFFER

For \$3.00 we will send you these books and THE WIRELESS AGE for a year (outside U. S., \$3.50). This saves you 50c. If you want to grasp this opportunity check one of the squares below.

New Subscriber I am now an AGE subscriber

FOR BETTER RESULTS USE

EVEREADY

"A" and "B" BATTERIES
WITH YOUR RADIO SET



EVEREADY "A" BATTERIES

- No. 6810 - 50 Amp. Hrs. - \$15.00
- No. 6860 - 90 Amp. Hrs. - 18.00
- No. 6880 - 110 Amp. Hrs. - 20.00

Hardwood Box, Mahogany Finish—Convenient Handle, Nickel Plated—Rubber Feet, Protect the Table

Cannot Be Accidentally Short-Circuited

All Eveready "A" batteries are equipped with a 4 volt as well as a 6 volt terminal, making it possible to use either 6 volt or 4 volt vacuum tubes in your set.

EVEREADY "B" BATTERIES

Guaranteed to Be Absolutely Noiseless

No. 766 is the most popular size, and its use is recommended by most radio engineers and by experienced operators. The larger size of its 15 cells result in a much longer life, which far outbalances its increased cost over our No. 763. We strongly recommend the use of this No. 766 where ultimate economy is the important consideration. It is equipped with Fahnestock Spring Clip Binding Posts, giving variable voltages from 16½ to 22½ in 1½ volt steps. Dimensions: length 6⅝"; width 4"; height 3"; weight 3 lbs. 7 oz. Price, \$3.00



No. 763

Contains 15 cells of small size and enclosed in waterproof cardboard box. It is equipped with five brass strip positive taps ranging from 16½ to 22½ volts in 1½ volt steps, which covers the requirements of all present day soft detector tubes. Because of its limited capacity, due to its small cells, this battery is recommended for use only where light weight and small space are essential. Dimensions: length 3¾"; width 2"; height 2½"; weight 13 oz.

Price \$1.75

No. 767

Contains 30 cells of the same size as in No. 766. This battery was designed especially for use in connection with vacuum tube receiving sets employing a detector and one or more stages of amplification. In reality it is two No. 766's in one box. It therefore has the same desirable characteristics of economy and long life as the No. 766, and is recommended for use wherever 45 volts is required. It is provided with five positive taps ranging from 16½ to 22½ volts for detector tube control, and a 45 volt tap for the amplifier tubes. All terminals are of the Fahnestock Spring Clip Binding Post type. Dimensions: length 8"; width 6⅝"; height 3"; weight 9 lbs.

Price \$5.50

No. 746

Contains 72 cells of the same size as in No. 766, and gives a maximum voltage of 108. It is equipped with Fahnestock Spring Clip Binding Posts giving following voltages: 16½, 18, 19½, 21, 22½, 45, 108. This type of battery is frequently used in connection with loud speaking devices requiring high amplification. With the above arrangements of taps, it is possible to use the same battery to operate not only the loud speaker, but the radio receiving set as well. These taps also make this an ideal battery for those who wish to experiment with a Super-Regenerative Circuit. The battery is assembled in a wooden box of neat appearance and sturdy construction. Dimensions: length 17"; width 9"; height 3½"; weight 20 lbs.

Price \$15.00

Columbia Ignitor Six-Inch Dry Cells equipped with Fahnestock Connectors

Columbia Dry Cells are suitable for the filament or "A" circuit of Westinghouse WD-II Vacuum Tubes, which require one six-inch dry cell per tube

Visit our Exhibit—RADIO SHOW—Space No. 56, Grand Central Palace—New York

NATIONAL CARBON COMPANY, Inc.

Long Island City, N. Y.

Atlanta

Chicago

Cleveland

Kansas City

**A NATIONAL EVENT
A CALL FOR YOU**

You are wanted to take an active part in

National Radio Week

December 23 to 30 inclusive

and help popularize radio by joining the great demonstration to be made throughout the nation.

The entire radio fraternity, from broadcast listener to manufacturer, from amateur to publisher are cooperating in a national effort to interest the uninitiated in the entertainment and education to be obtained from radio.

The number of radio enthusiasts and listeners is approximately a million.

This number can easily be doubled during National Radio Week.

Plans to make NATIONAL RADIO WEEK one long, continuous, joyous festival for the radio listener, are going ahead swiftly. Special entertainment will be "put on the air" throughout the length and breadth of the country. Many of these programs will have national significance. That is, the big stations across the country will combine to form a chain through which to send a program into the most remote section simultaneously. National figures will broadcast and their voices will be heard everywhere. Local stations will join in the movement and will make special efforts to get the best there is for their listeners. The words "This is a Radio Christmas" will fill the air, will be on everyone's lips.

At a meeting in New York City some weeks ago an Executive Committee was formed to have general charge of the campaign. The names of the members of this Committee are listed below. They want your cooperation. They want you—the radio listener—to join the cause, to pledge to send suggestions as to how to make NATIONAL RADIO WEEK the greatest and most effective campaign, the most successful general nation-wide movement, this grand old country ever saw. And the Committee also wants you to pledge to get at least one recruit to the radio ranks. Find at least one person who up to this time has not taken an interest in radio. Just let him listen in on your set once. That will be sufficient to make him a regular radio fan. And then his chorus of approval will join the general acclaim that will fill the air for Radio during NATIONAL RADIO WEEK! For

"This is a Radio Christmas"

EXECUTIVE COMMITTEE

J. Andrew White, Chairman,
Editor, The Wireless Age

H. Gernsback,
Editor, Radio News

Arthur H. Halloran,
Editor, Radio

Roland B. Hennessy,
Editor, Radio World

Laurence Nixon,
Editor, Radio Dealer

Arthur H. Lynch, Treasurer,
Editor, Radio Broadcast

National Radio Week Headquarters, 326 Broadway, N. Y. City

When writing to advertisers please mention THE WIRELESS AGE

In Our Opinion

THE calendar unemotionally records the fact that the 31st of December ends the year. Yet, somehow, Christmas—that day of unrivaled richness in sentiment, for young and old—marks with most of us the actual high-tide of inspiration for the year's accomplishments.

In radio, this has been an unusual year. And as this, our Christmas magazine, goes to press we find irresistibly coupled with the glow of satisfaction over the forthcoming hour of retrospect, something uplifting in the vision the future holds.

Broadcasting has gone through its trial stages, and survived. The radiophone has become institutional, won for itself a definite place in the American home, and risen from the stature of a scientific toy to the proportions of a great force for good in both the fields of recreation and education. Amazing technical progress has linked arms with the genius that has guided the steady improvement in scope and quality of the programs of the air. Transmission of sound, as an art, has been vastly enriched by long-houred toil and deep concentration with the research workers.

A decade of progress has been crowded into a year.

And those who were accustomed to listening in the early months of 1922 have not alone the sense of obligation to patient engineers, but a debt of gratitude to those far-visioned toilers into the night, the program directors. Handicapped by technical limitations, harassed by the uncertainties of transmitter operation and embarrassed by lack of precedent in catering to public likes and dislikes in a wholly new medium of entertainment—their courage, unremitting energy and pioneering spirit blazed out a steadily ascending trail to program pinnacles of no mean altitude. No little significance may be attached to the official regulations governing class B stations which place a ban on mechanical music—this edict is nothing short of a tribute to the initiative and ability of program makers who progressed in the short span of a dozen months from haphazard selections making up an evening of canned music to presentations of elaborate programs comprehending the best in music, classical and popular, the most virile and valued of the gems of literature and oratory, the drama unfolded in championship sporting events, announcements and lectures of vast economic import—a wide and diverse field requisitioning the masters of interpretation to deliver in person their messages in music and speech.

And we, the radio listeners, heard them.

Now is our time to marvel at the wonder of it all. A revolutionary change has been effected within a few months, one which has been accepted in a manner that is perhaps too matter-of-fact. For even the broadest mentality may well be stunned at the realization that the isolation of culture is no more, that into the humble home, into the isolated community, radio has entered, bringing with it the great messages of words and music that for ages have been confined to a fortunate few.

A new era has dawned. Radio's mission has yet reached a stage of definition only; the working out of its destiny is, as it always has been, one of steady betterment of humanity, than which there is no more noble task, no one more monumental.

Unceasing inspiration and unparalleled anticipatory thrills are the stimulus behind the human element which is guiding radio. Barriers cannot long resist this spirit, nor present-day obstacles remain impassable. So as we glance ahead to the holiday season, to the day hallowed by memory and tradition for observance of good-will toward man, let us add a mental gift of gratitude for the new influence that has entered the very soul of the great American public; lodged there but a fragile bud now, it holds promise of bloom unrivaled, unapproached, in the garden of civilization's progress.

Truly, "This Is A Radio Christmas."

THE radio broadcasting station of I. B. Rennyson, New Orleans, La., WBAM, has been discontinued. The reason given is interesting. We learn that its owner considered that his station was interfering with others whose programs were better than he could offer the public. In voluntarily discontinuing the station, which was used as an adjunct to his real estate business, the owner stated that it meant considerable loss to him from an advertising standpoint.

Mr. Rennyson is deserving of substantial commendation for his broad-minded attitude. It would hardly be surprising to hear that his closing down resulted in a measure of good-will from his listeners exceeding whatever degree of past appreciation was registered during the period of broadcasting. Certainly, there will be widespread appreciation of his self-sacrifice in putting public interest ahead of selfish pride.

GOOD sportsmanship, courtesy and enthusiasm for the development of science insure that a period of silence will be observed by all American transmitting amateurs December 12th to 31st. while the trans-Atlantic tests are on.

A Period of Silence



— THE EDITOR



"HELLO, folks, this is Ada May Weeks," said a voice over the radio not so long ago. And here is the beautiful owner of that voice. The immensity of her radio audience staggered Miss Weeks, and on page 40 she figures out how long it would take—well, you read her story



CECIL ARDEN, Metropolitan opera star, recently completed a tour of Europe. Over there she was asked many questions about her broadcasting experiences. She tells of them on page 30 in an exclusive interview



IS there such a thing as a "perfect radio voice?" Does any particular type of voice carry over the air better than others? Miss Margnerite White, a young and talented concert singer, believes so, and in a special, signed article on page 33 she tells why



A SAXOPHONE laughs as heartily as any human being—at least if played by Nathan Glantz, phonograph and radio favorite. Mr. Glantz, famous through his laughing saxophone, tells radio fans, in an interview on page 39, of his early struggles



Truly Are Youngsters Living in a Wireless Age



This lad must be hearing an address on the League of Nations, or reparations, for he is rather serious

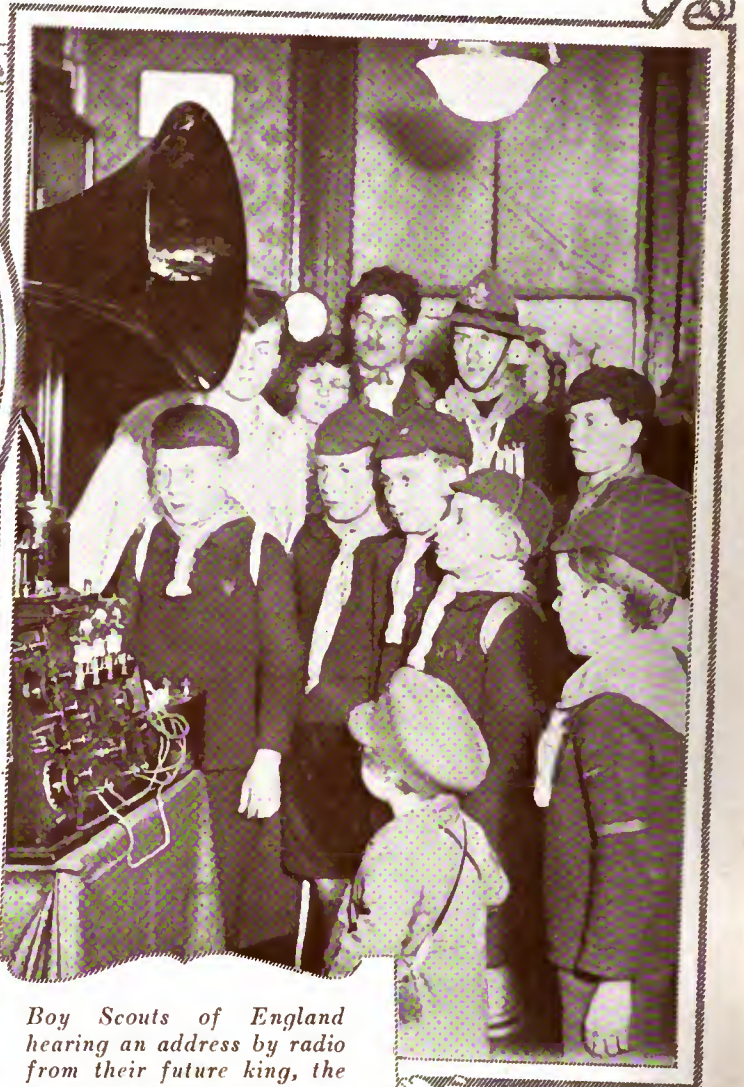

Boy Scouts of England hearing an address by radio from their future king, the Prince of Wales, who broadcast from his York House



Christmas time is coming and Janet, Dorothy, Betty and Merle Wick, of Belleville, N. J., seem to be all ready. This IS a Radio Christmas!

But here—oh, boy!—it is rather difficult to say just what is coming over, but there is no mystery left in that expression of childhood's wonder and delight



England and France Are Following America's Lead



Radio telephones have been installed in Parisian modiste shops for the amusement of patrons and also mannequins; two of the latter are shown above listening intently

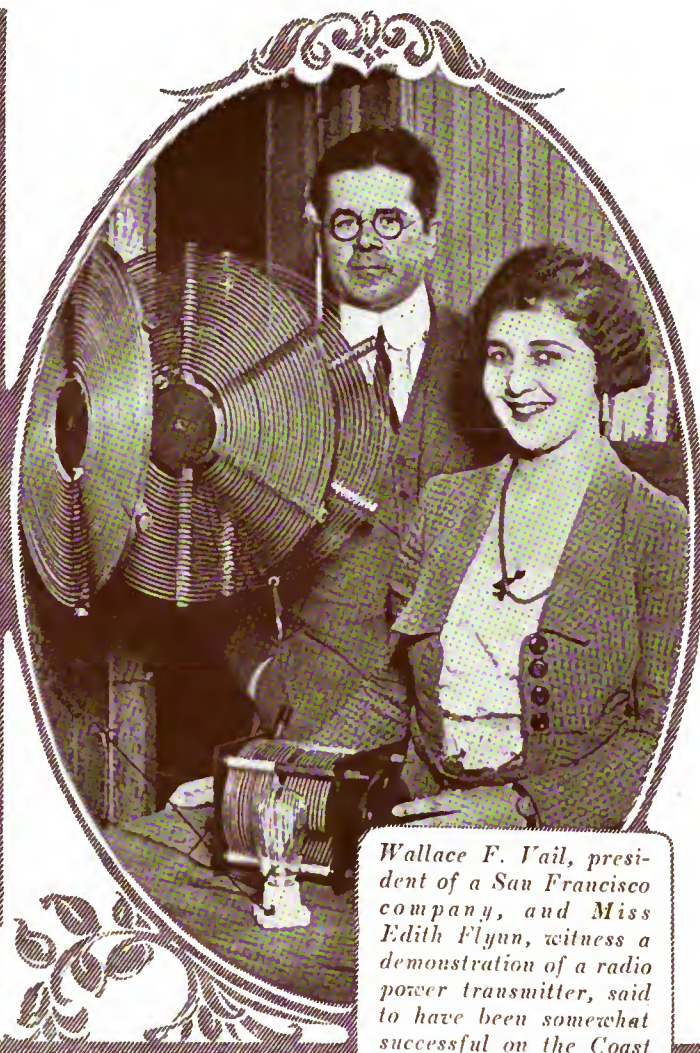

Wallace F. Vail, president of a San Francisco company, and Miss Edith Flynn, witness a demonstration of a radio power transmitter, said to have been somewhat successful on the Coast



A new game, La Tely, has come into vogue in England. The photograph above was taken at a wireless exhibition in London. A crime has taken place somewhere on the landscape depicted in the model. Clues consist of boot prints and bloodstains. A report of the offense is broadcast. A member of the police force is shown on the wireless telephone asking for details of the "crime." Even the ladies from far-off India look interested. The idea seems to be to make a reproduction of the scene from a description sent by radio, to aid the police in detecting the offender

When Stars of the Stage Bring Happiness to the Blind



Benny Leonard (left) lightweight champion and Raymond Hitchcock, comedian, co-starring in a production, broadcast in Philadelphia

The "sensation" of a New York radio fair was Madame Radora (kneeling on case) and her "radio-plasms" by which she "forecasts" the future

St. Dunstan's School for the Blind has installed a radio receiving set to the great pleasure of the afflicted soldiers there. Captain Ian Fraser (seated) entertains them daily

Random Shots on Radio's Activity in the Nation



When the Broadway Limited snorts her way westward, she does so to the strains of radio music, as this photo taken aboard during a journey reveals. Radio à la train is becoming commonplace these days

And here we see Luther Burbank, he who can turn a radish into a quince, talking with Nils E. Borch, of Oakland, Cal., on the relative merits of Mr. Borch's portable radio set, now mounted in an auto



Our Navy is up to date. It carried its own broadcasting plant and sent out on the ether results of the Maryland-Delaware SS football game



Leading summer and winter resort hotels have their radio rooms now. Mrs. Charles F. Thompson, of Washington, D. C., and Mrs. A. N. Fay, of Pittsburgh, listen in at the Greenbrier Hotel at White Sulphur Springs, W. Va. It's a recent acquisition at the hotel

The most popular feature of life at Camp Douglas for members of the Howitzer Company, 127th Infantry, Wisconsin National Guard, is the "radio hour." Guardsmen gather in a tent and listen to music from almost any section of the country, on their powerful set

National Radio Week

December 23 to 30

THE extraordinary value of radio broadcasting to the educational, religious and recreational life of our country is to be emphasized during NATIONAL RADIO WEEK, to be observed everywhere from December 23 to 30, inclusive.

The full significance of broadcasting, that marvelous new phase of community life, has been caught by multitudes. These are joining in a co-operative effort to present the virtues of radio to everybody from coast to coast, from Gulf to Lakes.

What is NATIONAL RADIO WEEK? Some few weeks ago, a group of editors of radio periodicals met at the Bankers Club, New York City.

They had in mind the utilization of the approaching holiday season as a time when the number of broadcast fans could be doubled, when the value of radio broadcasting would be brought home to all the people.

Thus NATIONAL RADIO WEEK was born. Before they left the meeting, the editors had decided upon the time. December 23 to 30 was chosen because all school and college students will be at home. The family circle will be complete and happy. During those days people are seeking for the unusual, are ever casting their eyes in this direction and that for something new and interesting to do or to listen to.

The movement will not die on the night of December 30. It is to be a permanent and annual affair.

During NATIONAL RADIO WEEK special programs are to be put on the air. Some will be national in scope. Others will consist of community programs. Many will be educational. Others will be first-class entertainment, musical and vocal.

One feature to be emphasized is the astonishing growth of broadcast grand opera music. We Americans are almost without knowledge of grand opera. Unfortunately opera has been confined to the few. A child of the middle classes in Europe knows as much about opera as an adult over here. These simple statements none will dispute who is familiar with the two continents.

And now radio comes along, with its broadcast of operatic arias, even of complete performances.

What is the result? In a few years of it, we Americans—and that includes everyone, and not only the privileged few—will be living richer lives, far richer, because of this wonderful music picked from the air. Well—that is what NATIONAL RADIO WEEK is going to do. Operas will be broadcast, the like of which never would have been dreamed of a year ago.

And there is the religious life of the country. What does radio mean to that? The life of this nation rests with its religious tolerance. Every creed has an equal chance. Of late years there has been a definite drift away from the churches, the cathedrals, the temples. Radio has not put the people back into the churches, but it has gone farther, and brought the churches to the people.

Radio listeners are hearing things they never heard before. They are thinking more because of it. And their store of knowledge is richer for it. Well—that is another thing that NATIONAL RADIO WEEK will reveal—the progress made in broadcasting spiritual services, educational and other addresses.

But do not get the idea that NATIONAL RADIO WEEK will be confined to operas and religious services. Jazz bands, solos by national stars, entertainments by famous comedians, instrumental playing that would soothe an angry lion—all this will come in addition to speeches by people whose names are national bywords.

That is why NATIONAL RADIO WEEK means so much to everyone. Listener and manufacturer will join hands to put it over, but the bulk of the responsibility for its success lies with the listener. It is estimated there now are a million of the latter. Let's double this number. If each one gets one convert to the cause of radio, it will be done—done overnight! All this magnificent preparation for these super-programs is for the listener, everything that is ever done in radio is for the listener. Ask your neighbors in tonight to learn what radio means to you.

And so, listeners, this NATIONAL RADIO WEEK is for you. And being for you, it is desired by the Executive Committee of NATIONAL RADIO WEEK, that you send in your suggestions as to how it can be more successful. Everyone has ideas. Uncork them. Let them come.

Let's make NATIONAL RADIO WEEK a whiz!

NATIONAL RADIO WEEK

326 Broadway

New York City

EXECUTIVE COMMITTEE:

J. Andrew White, Chairman,
Editor, *The Wireless Age*.
H. Gernsback,
Editor, *Radio News*.
Arthur H. Halloran,
Editor, *Radio*.

Roland B. Hennessy,
Editor, *Radio World*.
Laurence Nixon,
Editor, *Radio Dealer*.
Arthur H. Lynch, Treasurer,
Editor, *Radio Broadcast*.

A Non-Partisan Political Medium

Only One Radio Station Adopted a Biased Attitude in the Recent Elections When Campaigning Over the Air Became Generally Accepted As of Value to Candidates

By Maurice Henle



THE NEW WAY

Judge Silzer, successful in securing the Governorship of New Jersey, reveals the new way for candidates to reach the people. Alone in a studio, he is able to speak to hundreds of thousands, while over in the last column we see—



THE OLD WAY. Standing on the rear end of an auto truck this speaker, also seeking votes, gets his message across to exactly fourteen—count 'em—people. And moreover it is decidedly more uncomfortable to speak this way than in a warm studio

BROADCASTING stations and radio in general were baptized, politically speaking, in the recent elections. At the time of the 1921 elections politicians overlooked the few stations that then operated. But the sentiment that radio stations were valuable in campaigning had been crystallizing and gaining headway month by month until the 1922 elections found all the hand-shakers, backslappers and vote-seekers eagerly seeking to make their debut on the air. National and local figures, great and small, beat a tattoo on broadcasting studio doors.

But the politicians discovered a strange thing in their first contact with wireless. The campaigners, jolly good fellows all, were rosy with smiles as they rushed to get their voices on the air. But they did not always find a willing response. "Politicians Keep Out" was the sign to be read on almost as many studio doors as the "Welcome" that all had expected to find. The broadcasters neither kept all politicians at arms' length, neither did they gather them fondly to their breasts.

And in practically no instance was any single political party given exclusive use of the microphone.

We say "almost without exception."

A canvass was made by THE WIRELESS AGE of all broadcasting stations and in only a lone case, that of KZC, a twenty-watt station with an eighty-mile radius, at Seattle, Washington, was it said the privilege of broadcasting political speeches had been extended to a single party only, the Republican. The others were about equally divided between the policy of having no political speeches of any kind broadcast, and that of taking a strictly, even painfully non-partisan attitude.

To be exact, 53.333 per cent of the broadcasters observed a non-partisan policy, .016 per cent. was partisan, and 46.651 per cent refused to permit political matter of any kind to be broadcast through their stations.

If any conclusion may be drawn from the survey, it is that the development of broadcasting has brought into being an absolutely unbiased and impartial medium through which public expression may be given to subjects

AT A GLANCE

Non-Partisan Broadcasters	53.333%
Partisan Broadcasters	... 0.016%
Refusing All Politicians	... 46.651%
	100.000%

that have public interest, whether local, state-wide, national or international. The non-partisan stations are slightly more numerous than those refusing in the recent election to permit a political speech of any kind to be made.

This non-partisan group will grow. Recruits will come from the other faction. It is safe to predict that in the near future no station will be partisan, and few, if any broadcasters will close their doors to the politician.

It is interesting to note the reply telegraphed when the query as to its political broadcasting activities was sent to the St. Louis *Post Dispatch*, which operates class "B" station KSD:

Radio Station KSD of the St. Louis *Post Dispatch* first in the country to be licensed on four hundred meters does not permit the broadcasting of political speeches of any kind though it has been importuned by candidates to do so. It also forbids addresses on any controversial subjects. Two years from now when a president of the United States is to be chosen it is quite likely that station KSD will invite the principal candidates to speak in person so as to satisfy a natural curiosity as to their voices, manner of delivery and such other impressions as could be gathered by listening to them on a radio receiving set but it is difficult to foresee any other exceptions which could be made to the KSD policy.

The reason this telegram is so interesting to the broadcasting public is that the St. Louis *Post Dispatch* is owned by the Pulitzer Estate, which also owns the New York *World*, one of the hottest, strongest partisan papers in the country. Broadcasting has tamed the partisan Pulitzers!

The presence of broadcasting in the recent campaign brought out a number of peculiar instances, and new combinations of circumstances. For instance, who ever heard of a candidate for an office in New York State going into New Jersey to appeal for votes? Yet it was common for Empire State candidates to cross the Hudson River and appeal for support through WJZ in Newark, and from other stations in the Skeeter state as well.

Can one imagine a situation in which a speech by a candidate for office in New York is being read for him in New Jersey, while the candidate himself is making another speech in New York? That is exactly what happened. In another column Dr. Royal S. Copeland in a signed article tells of his experience.

The Westinghouse company, which operates three big stations, KDKA in East Pittsburgh, WJZ at Newark in cooperation with the Radio Corporation of America, and KYW at Chicago, in expressing their stand sounded the sentiment of most of the stations in the country when it said:

"Our officials, believing in satisfying the desires of as many of its invisible audience as possible, adopted a non-partisan attitude in the game of politics by radio. No matter how the officials may have felt and no matter what their attitude might have been as individuals, the company policy was formulated quickly in the interest of all voters, no matter what their political faith might have been, by the decision to make the broadcasting stations non-partisan participators in politics.

"Prior to this Fall, addresses were broadcast by candidates for mayor of various cities, candidates for Congress, the candidates for major county offices, candidates for the United States Senate and candidates for governor of several states. In the Spring campaign, which led up to the primary elections, the seekers for party nomi-



Governor Edward I. Edwards, of New Jersey, used WJZ to assist him in his successful fight for a place in the U. S. Senate

nations were given an opportunity to 'meet the voters of the state by radio and discuss with them personally, although unseen, the issues of the campaign.'

"The practicality of this new method of campaigning is best estimated by the fact that, wherever and whenever a candidate was given an opportunity to campaign by radio, he, or his campaign committee in his behalf, speedily accepted the proffer.

"The advantages of carrying the personality of the candidate and his campaign to the masses by radio cannot be estimated in a definite, concrete manner. But it is known that thousands of voters, in sections never visited by candidates, heard speeches of candidates for office for the first time in their lives and many of them, their interest in their rights of citizenship stimulated by radio, thereby were persuaded to cast their ballots and take advantage of their rights and duties as citizens to vote.

"It is known that the broadcasting of addresses by political candidates increased the size of the vote in isolated places where, prior to the advent of politics by radio, citizens were little, if at all, interested in the men who, as state or Federal officeholders, mould the destiny of the various states and the nation."

Among the expressions of those broadcasting stations adopting a non-partisan attitude were:

Our station is strictly non-partisan, no "Mud-Slinging" will be allowed and candidates must submit their speeches and secure acceptance before broadcasting. In addition candidates will be limited to 3 minutes and their speech must be snappy. Also each candidate's voice will be tested before broadcasting that corrections as to articulation, etc., may be made.

NIELSEN RADIO SUPPLY COMPANY
(KFCB), Phoenix, Arizona.

Our station has avoided partisanship. Among our candidates to speak is Attorney General C. A. Davis, candidate for U. S. Senator.

NEBRASKA WESLEYAN UNIVERSITY (WCAJ),
University Pl., Nebraska.

We are endeavoring to maintain a non-partisan attitude with respect to candidates and parties. Recently the governor of our state made a short address from our station. We have extended invitations to a number of candidates, and we have several talks by prominent men on our program.

COMMONWEALTH ELECTRIC CO.,
St. Paul, Minn.

KLZ is operating along non-partisan lines and is very glad to broadcast political speeches regardless of political parties. We believe this to be the best policy. On October 9th at 11.30 a. m., Mr. McAdoo talked from KLZ and was heard in all surrounding states giving KLZ a reliable daylight range of over 500 miles.

THE REYNOLDS RADIO CO., INC.
(KLZ), Denver, Colorado.

No candidate of any party speaks through the medium of this station. The broadcasting of the station is confined to concerts, weather, crop and market, and agricultural reports, with occasional lectures and addresses.

CLARK UNIVERSITY (WCN'),
Worcester, Mass.

The policy of this station, WEA, American Telephone & Telegraph Company, is non-partisan. The station is available for the use of candidates of any party since it is our endeavor to render a service to the public and we are desirous of serving them

By **DR. ROYAL S. COPELAND**
Senator-elect from New York

THE practical use of radio was demonstrated to me during my campaign when my speaking schedule was changed on almost a moment's notice, preventing me, to my disappointment from talking at WJZ in Newark, N. J. A messenger carrying my speech for the evening meetings hurried from campaign headquarters to Newark and there it was read. It has been brought to my attention that it was the first time a nominee for national office had his speech broadcast from one State to another.

My son, Royal, Jr., whom we affectionately call Buster, has an excellent outfit and he received the surprise of his twelve years one evening several weeks ago. I was speaking from the platform at Schenectady and Buster caught my voice. It is quite needless for me to say that he was somewhat excited. In fact, it was an important chapter in my young hopeful's life.

Imagine my great surprise and personal gratification when I received a telegram from my father and mother in Michigan, stating that they had heard my voice. That incident brings radio so close to my heart. Think of it! Hundreds of miles away and my dear father and mother in such intimate touch with me, actually listening to my voice. Had I even suspected that they were in my almost boundless audience, I surely would have said "Hello, Dad and Mother, how are you?"

in the best possible manner and without prejudice.

AMERICAN TELEPHONE & TELEGRAPH CO. (WEAF),
New York City.

I may state that it is generally considered, that this station being the property of the Missouri State Marketing Bureau, it will be non-partisan for reasons apparently obvious.

MISSOURI STATE MARKETING BUREAU (WOS), Jefferson City, Mo.

The nearest approach to political campaigns which we have been handling are the reports of the addresses of Secretary Wallace, and while these are running under the guise of information from the Department of Agriculture, there is no question but what they have a certain tendency toward Campaign Propaganda.

STANDARD RADIO EQUIPMENT CO.
(WEAB), Ft. Dodge, Iowa.

We are non-partisan. The only speakers so far are Col. Theodore Roosevelt and Hon. Simeon B. Fess, both Republicans.

YAHRLING-RAYNOR PIANO CO.
(WAAY), Youngstown, Ohio.

We are pleased to advise that our station is available free, of course, to political speakers of all faiths—in other words, our position is non-partisan. Governor Cox, Mayor Curley of Boston, and the Mayors of other Massachusetts cities, and candidates for the State Legislature, have either spoken from Amrad during the Primary Campaign last month, or during the Election Campaign this month.

AMERICAN RADIO & RESEARCH CORP. (WGI),
Medford Hillside, Mass.

The By-Laws of the Radio Broadcasting Society of America forbid members taking any partisan attitude in politics in so far as the use of their station is concerned. It is permissible for the members to allow political talks to be broadcast but only on condition that all views are presented. I know that WHN would want to exercise the closest supervision to see that nothing disloyal to our existing government, or anything seditious could be broadcast. There is no charge made at any of the stations to my knowledge. We expect to have the leading candidates from the Governor down speak from the Ridgewood Radiophone WHN Sta.

STATION WHN,
Ridgewood, L. I.

Please be advised that Mayor Fitzgerald of New Haven, the nominee for governor on the Democratic Party has already given a speech from this station. We have taken a non-partisan attitude regarding candidates; anyone who wishes to use our station for political publicity is at liberty to do so.

THE NEW HAVEN ELECTRIC CO.
(WGAH), New Haven, Conn.

We have had but one candidate for office speak from *The Star-Telegram*, that being in the Senatorial race. The opposing candidate was invited to speak but his schedule would not permit. We do not believe in much political speaking from broadcasting stations. The attitude of *The Star-Telegram* is strictly non-partisan, as far as our Radio Department is concerned. We believe

there is a real danger in lending radio to political campaigning, inasmuch as there would be a tendency to overload the air with political "hot air," which would be displeasing to our listeners.

FT. WORTH STAR-TELEGRAM (WBAP), Ft. Worth, Texas.

Other stations reporting a non-partisan attitude are:

- THE RHODES Co. (KDZE)
Seattle, Washington.
- CUTTING & WASHINGTON RADIO CORP. (WLAG)
Minneapolis, Minn.
- THE DOERR-MITCHELL ELECT. Co. (KFZ)
Spokane, Washington.
- HALLOCK & WATSON RADIO SERVICE (KGG)
Portland, Oregon.
- McARTHUR BROTHERS (KFAD)
Phoenix, Arizona.
- PORTABLE WIRELESS TELEPHONE Co. (KWG)
Stockton, Calif.
- J. C. DICE ELECTRIC Co. (WCAV)
Little Rock, Ark.
- THE MIDLAND REFINING Co. (WAH)
El Dorado, Kansas.
- THE DES MOINES REGISTER (WGF)
Des Moines, Iowa.
- ROUND HILLS RADIO CORP. (WMAF)
South Dartmouth, Mass.
- L. BAMBERGER & Co. (WOR)
Newark, N. J.
- LOUISVILLE COURIER-JOURNAL & TIMES (WHAS)
Louisville, Ky.
- Jos. M. ZAMOISKI Co. (WKC)
Baltimore, Md.
- SLOCUM & KILBURN (WDAU)
New Bedford, Mass.
- THE HECHT Co. (WEAS)
Washington, D. C.
- IOWA RADIO CORP. (WHX)
Des Moines, Iowa.
- NEVADA MACHINERY & ELECTRIC Co. (KDZK)
Reno, Nevada.
- THE DESERT NEWS (KZN)
Salt Lake City, Utah.
- KIMBALL-UPSON Co. (KFBK)
Sacramento, Cal.

Some stations did not allow any political speeches at all to be made through them. Some of their comments follow:

Allow no candidates to use this station for political purposes. We broadcast election returns only. Personally I have no party affiliation.

VIRGIN RADIO SERVICE (KFAY),
Medford, Oregon.

The Radio Station of the Mercantile Trust Company of California is absolutely non-partisan, and so far this company has not planned to use it for any political purpose whatever. On that account, it has not been placed at the disposal of any candidate, or used for broadcasting political messages by the supporters of any candidate. You will understand that the Mercantile Trust Company of California is a banking institution with wide connections, and as such cannot consistently be affiliated with any national political party.

MERCANTILE TRUST CO. (KFDB),
San Francisco, California.

We are absolutely refraining from entering into the political field in any shape or form. You can readily understand the situation of a State College receiving Federal aid through the Morrill Act. It would be

very unwise for us to go into this matter in any way, even were we particularly careful to be non-partisan.

NEW MEXICO COLLEGE OF AGRICULTURE & MECHANIC ARTS (KOB),
New Mexico.

We absolutely refuse to have any political propaganda transmitted from our Broadcasting Station.

INTERSTATE ELECTRIC CO. (WGV),
New Orleans, La.

The *Tribune* is a Democratic paper but it does not use its Broadcasting Station for politics in any way whatsoever. No candidate is allowed to use it for partisan purposes. THE TRIBUNE (KDYS),
Great Falls, Mont.

Radio Station WHA, of the University of Wisconsin, broadcasts will consist of agricultural information, educational lectures and musical educational matter only. Because of the non-partisan policy of the University with respect to the political elections, this station will not be employed for campaign purposes.

THE UNIVERSITY OF WISCONSIN (WHA), Madison, Wis.

The Detroit News has not been permitting its broadcasting station, WWJ, to be used for political purposes. Candidates for office have not been permitted to speak over it. The station is used exclusively for entertainment and civic service. The civic service includes household economics, health messages, university extension lectures, and addresses on good citizenship and public welfare. The leaders already elected by the people have been able to supply the public with a sufficient amount of civic matter by radio without our giving the station over to partisan politics.

THE DETROIT NEWS (WWJ),
Detroit, Mich.

BY ALFRED E. SMITH
Governor-elect of New York

A POLITICAL campaign is a movement to broadcast information to voters for the purpose of familiarizing them with the views of the candidates on the issues of the coming campaign, although it would be to the advantage of some of them to voice their opinions as little as possible on these issues.

I have just returned from a two weeks' tour upstate during which I have addressed audiences aggregating about 70,000 persons. To reach this number of persons I made 20 speeches in cities in various sections of the state.

In Schenectady the value of radio in campaigns was brought home to me when I addressed 300,000 persons all over the state through a radio microphone which was installed in the hall where I spoke to an audience of 2,000. The number reached through radio in one hour was over four times greater than the entire number of persons reached in my whole state tour. My own children told me that they had "listened in" in New York and heard me as plainly as if they had been in the audience in the hall.



On the other hand Senator William N. Runyon, New Jersey, speaking from the same station, was defeated for the office of governor

Our broadcasting station has not been used for partisan political broadcasting. Last spring it was suggested by the agent of a candidate that he broadcast a speech, but this being a retail store we thought best to avoid political speeches entirely.

STRAWBRIDGE & CLOTHIER (WFI),
Philadelphia, Pa.

The following stations also reported "no political broadcasting":

- ALABAMA POWER COMPANY (WSY)
Birmingham, Alabama.
- SOUTHERN EQUIPMENT COMPANY (WOAI)
San Antonio Texas.
- UNIVERSITY OF CALIFORNIA (KQI)
Berkeley, Calif.
- HURLBURT STILL ELEC. Co. (WEV)
Houston, Texas.
- H. C. SPRATLEY RADIO Co. (WFAF)
Poughkeepsie, N. Y.
- THE PRECISION EQUIPMENT Co. (WMH)
Cincinnati, Ohio.
- CITY DYE WORKS & LAUNDRY Co. (KUS)
Los Angeles, Calif.
- H. F. PAAR & REPUBLICAN TIMES (WKAA)
Cedar Rapids, Iowa.
- JOURNAL-STOCKMAN (WIAK)
Omaha, Nebraska.
- CORNELL UNIVERSITY (WEAI)
Ithaca, N. Y.
- ST. LOUIS UNIVERSITY (WEW)
St. Louis, Mo.
- ALDRICH MARBLE & GRANITE Co. (KHD)
Colorado Springs, Colo.
- THE ERNER & HOPKINS Co. (WBAV)
Columbus, Ohio.
- THE ENTREKIN ELEC. Co. (WCAH)
Columbus, Ohio.
- SHIP OWNERS RADIO SERVICE, INC. (WDT)
New York City.
- THE RADIOVOX Co. (WHK)
Cleveland, Ohio.
- THE SHEPARD STORES (WNAC)
Boston, Mass.
- ALTADENA RADIO LABORATORY (KGO)
Altadena, Calif.

And this speaks for itself:

We were quite active—many local candidates used our station last month with evident success as they were mostly all nominated. We have extended our privilege to Republican candidates only.

PUBLIC MARKET AND DEPARTMENT STORES STATION (KZC),
Seattle, Washington.

With an Opera and Radio Star in Europe

Cecil Arden, of the Metropolitan Opera Company, Found Europe Eagerly Seeking News of American Radio Activities

By Paul S. Gautier

EUROPEANS are viewing with astonishment the rapidity with which the radio telephone is developing in America. They regard it as a great giant that has suddenly loomed on the western horizon. They—the people themselves—do not know much about it over there, and that is why, when Cecil Arden, Metropolitan Opera star, toured Europe during the past Summer, they plied her with questions as to the whys and wherefores of it all.

They wanted to know:

1. The distance the voice can be heard.
2. Whether house-to-house conversations can be carried on?
3. What kind of programs are being given?
4. How much a receiving set costs?
5. What the government is doing in the way of regulations?
6. What an artist who has actually sent her voice through the air thinks of it?

These were but a few of the things they wanted to know. And answering the questions kept Miss Arden busy during her stay over there.

She found that Paris was the only city among those that she visited where radio is developed to any satisfactory degree. In the French metropolis many families are equipped to receive the concerts sent out from the Eiffel Tower, while shopkeepers and the boulevard cafés for which Paris is famous, have seized upon the radio telephone as a medium with which to increase their patronage.

But in other parts of the continent—she did not get to London—she found that the radio telephone did not exist. Word of the gigantic scale on which it is conducted in America had reached the people, but they had no first-hand experience of it.

"I found nothing but admiration for the energy and hustling spirit of America," she told me. "It seems they had heard in some way that I had broadcast. They asked me about it, indicating by their dubious manner that they expected me to give them a vigorous denial of the rumor. And when I not only confirmed it, but told them more wonderful things about broadcasting than they ever had heard, they marveled and decided to see that they



too were supplied with radio music.

"As a result, communities have banded together and are investigating the cost of transmitting sets and receiving apparatus. It will not be long, now, I think, until all Europe is listening in.

"The first thing they asked me, and they did it eagerly, was whether or not they would be able to listen to Americans speak and sing if they got receiving apparatus. I told them this would not be possible now, but undoubtedly it would be a development of the future.

"Imagine the results of a world's series baseball game being broadcast into

MOST grand opera stars and concert singers have "managers" who attend to details such as booking, tours, etc. But not so Cecil Arden, talented and beautiful Metropolitan artist.

It is "Management of Cecil Arden." She is the whole business, if anything of an artistic nature may be thus classified. And she has disproved the theory that opera stars are too temperamental to be good business men and women.

The happy thing about it is that she enjoys working out the financial details, the business arrangements. Which after all, probably is the secret for her success in it.

Her hustling spirit, as well as her rich, sweet voice are the marvel of the singing world.

the quiet, simple homes of the peasants of the Austrian fields, into the valleys of the Italian countryside, everywhere in Europe. How long do you think it would take for those people to understand what they were hearing? to sympathize with it? to swing into the excitement of it?

"I will answer that, for I know those people. It would not be long, I can assure you. Soon all Europe would be playing baseball. Soon all Europe would be doing the things we hustling Americans, whom they so greatly admire, are doing.

"And then what?

"Don't you see what radio will mean to this sorely stricken world? It is the one hope of ultimate peace on earth, of brotherhood among men. It will unite the people and give them a common interest. Radio is the guide that will lead them into Utopia or the Promised Land."

Cecil Arden, the opera star, stopped talking, and while the handsome clock on the table ticked solemnly for a full half minute, silence reigned in her apartment, which is located in New York's most exclusive residential district. I now knew why Cecil Arden was so rapidly endearing herself to the American people—her people. I had heard that the beautiful Cecil Arden was a "different" type, one anyone could immediately become sympathetic with, because of her great sincerity.

I could but admire as she spoke, for it seemed as if her whole soul were wrapped around the words she was uttering in a voice that sounded like the ripple of a brook and a happy child's laughter in the sunshine.

It was so real—and I just listened without an interruption, happy to be the one privileged to bring this wonderful woman's thoughts before the readers of THE WIRELESS AGE.

Of course, the reader will recall hearing Miss Arden on the air. That is, he will if he followed radio in the pioneering days of broadcasting. She is one of radio's most sincere friends, a friend who regards the science not alone in the light of an entertainment-giving instrument, but also as the best hope of mankind of welding the peoples of the world together in a common cause, with a common appreciation for the things that make for health and happiness.



While the flames were being fought, a description of the fire was broadcast

How

Radio "Scooped" the Newspapers

WSB, Atlanta "Journal," Broadcast Description of Fire That Threatened the City—Newspapers All Over Country Copied Report—Transmission Stopped Only When Flames Imperiled Studio

By Glenn Scott

ALL was merry and serene in the broadcasting studio of WSB, operated by the Atlanta *Journal*, a daily newspaper of that Georgian city. Entertainers had come and sung their songs into the microphone and the usual audience in many states had listened throughout the evening program, and were preparing to turn off their instruments for the night. But suddenly the song that they were hearing was stopped abruptly. All wondered what had happened.

And then a rather excited voice was heard through the air:

"Atlanta is threatened with its most disastrous fire; the whole city seems to be in flames."

There was a "long" pause of two seconds, during which the listeners heard only the crackling of the static in the air. It seemed an ominous silence. Instead of preparing to turn off their instruments and call it a night, all thoughts of sleep fled from their minds and they even roused out of bed

other members of the family who had become sleepy earlier in the night and were now in the Land of Nod.

And not only were thousands of family groups eagerly listening in for the next bulletin which was to come, but in distant cities newspaper editors of other periodicals were being given their first realization that radio was

THE fire described in this article was the most ravaging in Atlanta's history. It has come to be known as the "Million Dollar Fire," though damage to office buildings in the heart of the city amounted to a sum greater than that.

The blaze occurred late last September and raged for several days. In fact, as in the case of all big fires, the smoke-eaters still were pouring water on the smoldering ruins a week after the conflagration started.

"scooping the world" on the biggest news story that had come out of the South for many months.

If in the newspaper offices of these distant cities there was no receiving apparatus, then it so happened in almost every instance that a private station or a station owned by a club in that city eagerly telephoned a "flash" about the fire to the newspaper. No word had come from the regular press associations or their correspondents. The Morse wires were as silent as the well-known cemetery at midnight, and all thoughts turned toward the radio room which is so rapidly becoming a vital part of the daily newspaper.

And then the voice went on:

"The fire is sweeping through the central part of the city's business section. Our studio is only two blocks away, but we do not feel that the Journal Building is threatened and we will endeavor to carry through the radio program."

And then, wonder upon wonder, the

listeners heard the strains of an orchestra. It made them gasp in astonishment; or perhaps it was a gasp of admiration for the intrepid little group that they could picture excitedly trying to carry on in a broadcasting studio near the heart of the burning city with the light of the licking flames coming through the windows and playing upon the plush-covered walls.

The orchestra number stopped and then the voice went on.

"The flames are bright and light up the studio like sunshine. The heat from the flames that now rise one hundred feet above the Journal Building disturbs performers in the studio here. The flames are spreading and the streets are filled with people."

The program was carried through that night, and, between the numbers—and sometimes in the middle of them—bits of information as to the progress of the fire were put on the air.

Finally at 12.30 o'clock in the morning, like the words of a radio operator on a burning ship at sea, the voice said, "We must sign off. The whole city is fighting the fire. The heat is so great that we can operate no longer."

Of course the reaction from the daring enterprise of the *Journal* was great. The next morning in cities throughout the United States the front pages of newspapers were loud in their praise of the little band of persons in the Atlanta studio who, while the city blazed fiercely under them, figuratively outlined a new path for radio to travel,



pointing a way that must be followed in the future, showed the press of the country that even in the matter of disseminating big news events, while radio never can take the place of a newspaper, still it will be a power to be reckoned with, a power to be cooperated with, a power that will be constructive and for the general good of the people. Among the newspapers that used the radio bulletins were the Philadelphia *Enquirer* and the Kansas City *Star*, which shows the wide range of reception.

The paper was complimented by Chief William Cody of the Atlanta Fire Department, who said that the Department "was genuinely indebted to the paper for its radiophone service" and that he was now "strongly advocating that every man in the department equip his home with a receiving set in anticipation of similar emergencies in the future."

He said that the "Voice of the South," as he called the radio, had actually helped fight the million-dollar fire that menaced the entire city and almost made good its threat. A number of firemen off duty and at home, heard the first announcement of the fire through their radio sets and they immediately deserted their headphones and hurried to help their fellow smoke-eaters to fight the flames.

Radio has been used to report news events before, but probably this is the first time that it was called into action to tell the world about what is known in newspaper circles as a "spot" news story, that is a story that "breaks" suddenly without any advance notice. The feat of the Atlanta *Journal* will live long in the history of radio. Of that there is no doubt. It was a genuine contribution to the progress of broadcasting which is going ahead at such tremendous speed that its complexion seems to change every fifteen minutes.

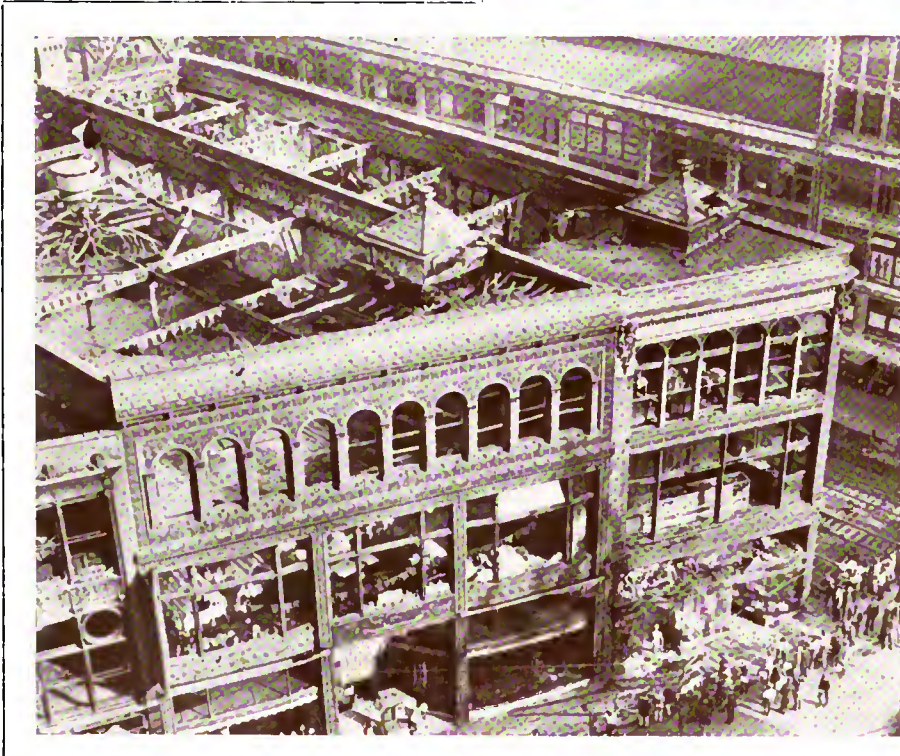

Upper right hand photo shows the Western Electric 1-A 500 watt transmitter, part of the equipment of WSB, operated by the Atlanta Journal. Walter W. Tison (right), operator, and George A. Iler (left), radio engineer, seem to be well satisfied with the station's success. Center shows Lambdin Kay, director of the station, who broadcast the eye-witness description of the fire, part of the ruins of which are shown immediately above

Is There A Perfect Radio Voice?

A Special and Exclusive Article by a Young Concert Singer, Contending That There Is

By Marguerite White

Marguerite White



RADIO? When first I was asked to "appear" for the radio telephone, I gasped. You see, although it was not so long ago, still broadcasting had only barely started. It was during the veriest infancy of the science. It was quite a brand new idea to sing by wireless.

And when I found myself in a studio before a funny little instrument, and was asked to sing to it, I gasped again.

I forget what songs I had chosen, but my program was such as I had been giving in all my regular concert appearances, coloratura folderol and embroidery as well as sweet, tender lyrics. When I had finished my first number, I looked over at the radio officials and said, "Was it loud enough?"

They laughed and one of them—the Editor of *THE WIRELESS AGE*, by the way—said, "Yes, I guess it was loud enough to be heard in Chicago."

I thought they were teasing me, but pretty soon the telephone rang and it was from Yonkers or Tarrytown or some place like that. They were hearing me! I didn't understand it at first, but since then I've been studying and observing very hard, and I've learned lots of things about acoustics and radio and music, and it's helped me with my singing. For instance I know now that it isn't how big your voice is at all.

Theoretically and practically, I have found that the best type of voice for radio transmission and reception is a high, clear, brilliant soprano.

Just remember the laws of vibration. The ear cannot hear all vibrations—only those within a certain radius. If there are too few vibrations there is no sound, presumably, for the human ear cannot detect them. On the other hand if the vibrations are too quick, the same thing happens.

Now examine the human voices. The sopranos and tenors have quicker,

shorter voice vibrations than have the contraltos and bassos. In an ordinary theatre, there is no trouble in hearing any of them, sopranos, contraltos, tenors, bassos. But enlarge the auditorium, deepen the voice, and some particularly low tones are lost at a very little distance. Their vibrations are dissipated quickly. The deep voices have long, slow vibrations, the high voices have quick, short swings. Have you ever tried to throw a football as far as you do a baseball? Or do you think with the same amount of impetus you can shoot a cannon ball as far as a bullet? The higher voices cleave the air with more velocity. There you have it. They are like fleet runners compared with clumsy elephants. This does not mean that soprano tones are necessarily lovelier than contralto measures.

We are speaking of acoustical matters. And sound is easy to understand when these elemental thoughts are analyzed. See how it works out. The contralto cannot take her great bulk of tone and hurl it very far. But the agile-throated coloratura has an easy time of it, when she wants to sing to the back rows of the theatre, or to the radio fans in San Francisco and New Orleans.

I imagined at first that a large fat contralto with a deep, sonorous voice would be heard further and more easily than I with my notes way up on the scale, and my voice not nearly so big.

I thought my fragile, delicate, top notes would be lost while the contralto's deep ones would be heard. But it isn't so at all.

It was like an experience I had recently, when Chamberlain Berolzheimer asked me to sing at Mayor Hylan's New York City concerts, in the open air. I had sung in the open air before that, but under the most favorable conditions with sound boards and all that. But this was to be at Prospect Park for twenty thousand people.

I went out with some slight fears. But my first note went whizzing through the air—and I could tell that it was reaching far. It is peculiar how

a singer can tell whether her tone is getting to the back rows or not.

Of course I understand it all very well now. It's just a question of science and acoustics. The contralto has to throw a great bulk of sound and I only have my fast-vibrating notes to worry about. Mine are way, way out before the contralto's have even started!

It gives a thrill comparable to nothing else I can remember, to sing to a radio audience. I can think of the big crowd out there before me. I actually almost see them.

Most of the audience at the radio concerts find the classic brand new. They get by radio their first real taste of a thing they have never known, a glimpse into a musical universe which they never saw before.

A searchlight is being turned on a darkened shore, and lo, the beauties become illumined and clarified. I know that every time I or any other artist uses the medium of the radio, a great clarion call of art is being sounded forth. I would do anything I can to help radio, because I think it is the greatest single aid to the development of musical art ever conceived. Yes, bigger than the phonograph—and I say that in no disrespect, or forgetfulness of what the talking machine has done for artists and listeners alike. But radio is supplying new buyers for the records, new audiences for the concert halls, more admirers in the opera houses, a greater attendance in the educational institutions.

Somewhere I have read in an article, "Thank God for anything which reaches into closed, dust-covered minds—even if it breaks up the old bric-à-brac—and lets in the sunlight." The radio telephone is doing this—it is breaking into the tenements of the mind and letting in the sunlight.

The future of radio is to my mind very understandable. The biggest artists and educators will employ this new medium to awaken interest in every worth-while idea before the world.

For myself, let me say here and now that I am ready for radio whenever radio seeks to call upon me.

Distant Broadcasting Stations Heard

Broadcasting fans daily surprise themselves and others by reaching out across hundreds of miles by a turn of the wrist. Often the most simple bulb equipment will produce astonishing results, as reported below. What have YOU done?

WALTER ODEIRO, Cleveland, O., using a single U V 200 tube and no amplification, heard in the first two months of operation 44 stations in 17 states. His list in part is as follows:

	Miles
KDKA	Pittsburgh, Pa. 125
WIP	Philadelphia, Pa. 370
WHAS	Louisville, Ky. 320
WOH	Indianapolis, Ind. 260
WLK	Indianapolis, Ind. 260
KYW	Chicago, Ill. 315
WDAP	Chicago, Ill. 315
WMAQ	Chicago, Ill. 315
NOF	Anacostia, D. C. 320
WEAS	Washington, D. C. 320
KSD	St. Louis, Mo. 495
WOC	Davenport, Ia. 470
WJZ	Newark, N. J. 410
WOR	Newark, N. J. 410
WAAM	Newark, N. J. 410
WEAF	New York City 425
WBAY	New York City 425
WGY	Schenectady, N. Y. 430
WHAM	Rochester, N. Y. 260
WHAZ	Troy, N. Y. 450
WNAC	Boston, Mass. 575
WBZ	Springfield, Mass. 490
WSB	Atlanta, Ga. 550
WGM	Atlanta, Ga. 550
WDAJ	Atlanta, Ga. 550
WKN	Memphis, Ga. 630
WBT	Charlotte, N. C. 440
WHB	Kansas City, Mo. 700
WDAF	Kansas City, Mo. 700
WOS	Jefferson City, Mo. 600
WGF	Des Moines, Ia. 630
WDAX	Centerville, Ia. 600
WLAG	Minneapolis, Minn. 650
WLB	Minneapolis, Minn. 650
WHAI	Davenport, Ia. 470
WBAP	Fort Worth, Texas 1,050

MARTON R. MILLER, College Corner, O., is 14 years old, and with a regenerative set of his own make has been able to hear local stations and also the following:

	Miles
WHAS	Louisville, Ky. 100
WJZ	Detroit, Mich. 200
KSD	St. Louis, Mo. 300
KDKA	Pittsburgh, Pa. 300
KYW	Chicago, Ill. 250
WOC	Davenport, Ia. 350
WSB	Atlanta, Ga. 450
WJZ	Newark, N. J. 600
WBAY	N. Y. City 600

H. R. THOMPSON, Phoenix, Ariz., has hardly been able to believe his ears this Fall, hearing many distant broadcasters on one UV 200 detector tube. He thought some strange freak was responsible for his records until he read the reports of others in THE WIRELESS AGE. Mr. Thompson's list is as follows:

	Miles
WGY	Schenectady, N. Y. 2,000
WJZ	Detroit, Mich. 1,600
WSB	Atlanta, Ga. 1,400
WOC	Davenport, Ia. 1,200
KYG	Portland, Ore. 960
KGG	Portland, Ore. 960
WDAF	Kansas City, Mo. 955
WHB	Kansas City, Mo. 955
WEAY	Houston, Tex. 875
WAAP	Wichita, Kans. 800
KFAY	Medford, Ore. 800
WFAA	Dallas, Tex. 775
WLAJ	Waco, Tex. 760

WMAB	Oklahoma City, Okla. 760
WBAP	Fort Worth, Tex. 750
WBL	Anthony, Kans. 750
WOAI	San Antonio, Tex. 725
KFDB	San Francisco, Cal. 600
KUO	San Francisco, Cal. 600
KFBK	Sacramento, Cal. 590
KWG	Stockton, Cal. 550
KLZ	Denver, Col. 550
DN4	Denver, Col. 550
KFAF	Denver, Col. 550
KZN	Salt Lake City, Utah 475
KDYL	Salt Lake City, Utah 475
KOG	Los Angeles, Cal. 310
KWH	Los Angeles, Cal. 310
KHJ	Los Angeles, Cal. 310
KYJ	Los Angeles, Cal. 310
KFI	Los Angeles, Cal. 310
KDPT	San Diego, Cal. 260
KYF	San Diego, Cal. 260

M. J. CLEARY, North Sydney, Nova Scotia, enjoys listening to American broadcasting these nights, in spite of interference from ocean steamers and the Marconi stations at Place.

	Miles
WBZ	Springfield, Mass. 550
WJZ	Newark, N. J. 625
WNAC	Boston, Mass. 500
WNAF	Dartmouth, Mass. 500
WOR	Newark, N. J. 625
WGY	Schenectady, N. Y. 550
WOO	Philadelphia, Pa. 600
WFI	Philadelphia, Pa. 600
WIP	Philadelphia, Pa. 600
NOF	Washington, D. C. 800

ALBERT BANNISTER, Hudson Falls, N. Y., reports hearing the following broadcasting stations:

	Miles
WLW	Cincinnati, Ohio 600
WVI	Dearborn, Mich. 500
WBAZ	Richmond, Va. 450
WOH	Indianapolis, Ind. 625
CKCS	Montreal, Canada 250

EARL C. ROSZELL, Indianapolis, Indiana, has never used amplifiers of any kind but is able to pick up from fifteen to thirty stations any night. Some of the stations he has heard are:

	Miles
WGY	Schenectady, N. Y. 650
KLZ	Denver, Col. 1,125
WGF	Des Moines, Ia. 375
WAG	Shreveport, La. 675
WEAY	Houston, Tex. 900
WBZ	Springfield, Mass. 700
WLAG	Lancaster, Pa. 525
WBAP	Fort Worth, Tex. 825
WFAA	Waterloo, Ia. 375
WHA	Madison, Wisc. 275
WOS	Jefferson City, Mo. 350
WOC	Davenport, Ia. 275
WKAM	Hastings, Nebr. 700
WGI	Medford Hillside, Mass. 800
WCK	St. Louis, Mo. 250
WIP	Philadelphia, Pa. 600
WOR	Newark, N. J. 600
NOF	Anacostia, D. C. 525
KLP	Los Altos, Calif. 2,100
WHB	Kansas City, Mo. 475
WLAC	Raleigh, N. C. 500
WTZ	Newark, N. J. 600
WOAI	San Antonio, Tex. 1,000
WSB	Atlanta, Ga. 450
WLAG	Minneapolis, Minn. 500
WPA	Fort Worth, Tex. 825
WDAF	Kansas City, Mo. 475
KDKA	Pittsburgh, Pa. 350
WKN	Memphis, Tenn. 350

JOHN V. N. BERGEN, 2GT, Port Jefferson, N. Y., has heard PWX at Havana. Here are some of his distant records between October 1 and 22.

	Miles
WJZ	Detroit, Mich. 550
WHAS	Louisville, Ky. 700
WOH	Indianapolis, Ind. 700
KYW	Chicago, Ill. 750
WVI	Detroit, Mich. 550
WOC	Davenport, Ia. 900
PWN	Havana, Cuba 1,400
KSD	St. Louis, Mo. 950
WTW	Cincinnati, O. 650
WHB	Kansas City, Mo. 1,200
WDAF	Kansas City, Mo. 1,200
WSB	Atlanta, Ga. 825

ROBERT P. CARR, Dayton, O., has listened to concerts from the following stations, using a single detector bulb, and in addition has been able to hear others for short periods.

	Miles
KHJ	Los Angeles, Cal. 2,010
WNAC	Boston, Mass. 740
WGI	Medford Hillside, Mass. 738
WBZ	Springfield, Mass. 650
WEAF	New York City 560
WJZ	Newark, N. J. 555
WOR	Newark, N. J. 555
WGY	Schenectady, N. Y. 605
WSB	Atlanta, Ga. 435
WDAJ	College Park, Ga. 435
WAAC	New Orleans, La. 790
WFAA	Dallas, Tex. 900
WEAY	Houston, Tex. 980
WLAJ	Waco, Tex. 960
WBAP	Ft. Worth, Tex. 920
WHB	Kansas City, Mo. 590
WDAF	Kansas City, Mo. 590
WOC	Davenport, Ia. 375
WOS	Jefferson City, Mo. 460

RICHARD R. MARTINDALE, Los Angeles, California, says that "there is certainly an art to tuning in long distance stations" and sends the following list to prove that he is an artist at it:

	Miles
KDN	San Francisco, Cal. 400
KDYL	Salt Lake City, Utah 600
KFAF	Denver, Col. 850
KFAN	Moscow, Idaho 900
KFAD	Phoenix, Ariz. 400
DN4	Denver, Col. 850
KFBK	Sacramento, Cal. 450
KFC	Seattle, Wash. 1,000
KFU	Gridley, Cal. 450
KGW	Portland, Ore. 900
KGY	Lacey, Wash. 1,000
KJJ	Sunnyvale, Cal. 350
KLN	Monterey, Cal. 350
KLP	Los Altos, Cal. 350
KLS	Oakland, Cal. 350
KLX	Oakland, Cal. 350
KLZ	Denver, Col. 850
KOW	San José, Cal. 350
KRE	Berkeley, Cal. 350
KSL	San Francisco, Cal. 400
KUO	San Francisco, Cal. 400
KVO	Sacramento, Cal. 450
KWG	Stockton, Cal. 350
KYG	Portland, Ore. 900
KZM	Oakland, Cal. 350
KZN	Salt Lake City, Utah 600
KZY	Oakland, Cal. 350
WBAP	Fort Worth, Tex. 1,200
WGL	Philadelphia, Pa. 2,300
WSB	Atlanta, Ga. 2,200

Trans-Atlantic Test Fails

THE attempted trans-oceanic transmission of the voice of Station WOR during the past October, was unsuccessful, despite newspaper publicity that the feat had been accomplished. An arrangement was made with the Selfridge Stores in London to attempt to pick up the voice sent out from Newark, New Jersey. Sir Thomas Lipton delivered the speech which it was hoped would be heard on the other side of the Atlantic.

Word received from London showed that the receiving apparatus used was a Tingey Five-Valve Receiver, using two radio frequency, one detector and two audio frequency tubes. WOR was listened for from 6 a. m. to 7 a. m. on the day the attempt was to be made. Observers in London informed THE WIRELESS AGE that "it was suggested that perhaps the carrier-wave was heard faintly at times," but beyond that there was nothing definite to report.

Radio Triumphs Over Fire Peril at Sea

Wireless Call from "City of Honolulu" Brings Quick Assistance and Not a Life is Lost—Radio Operators Heroic

By Earl Ennis

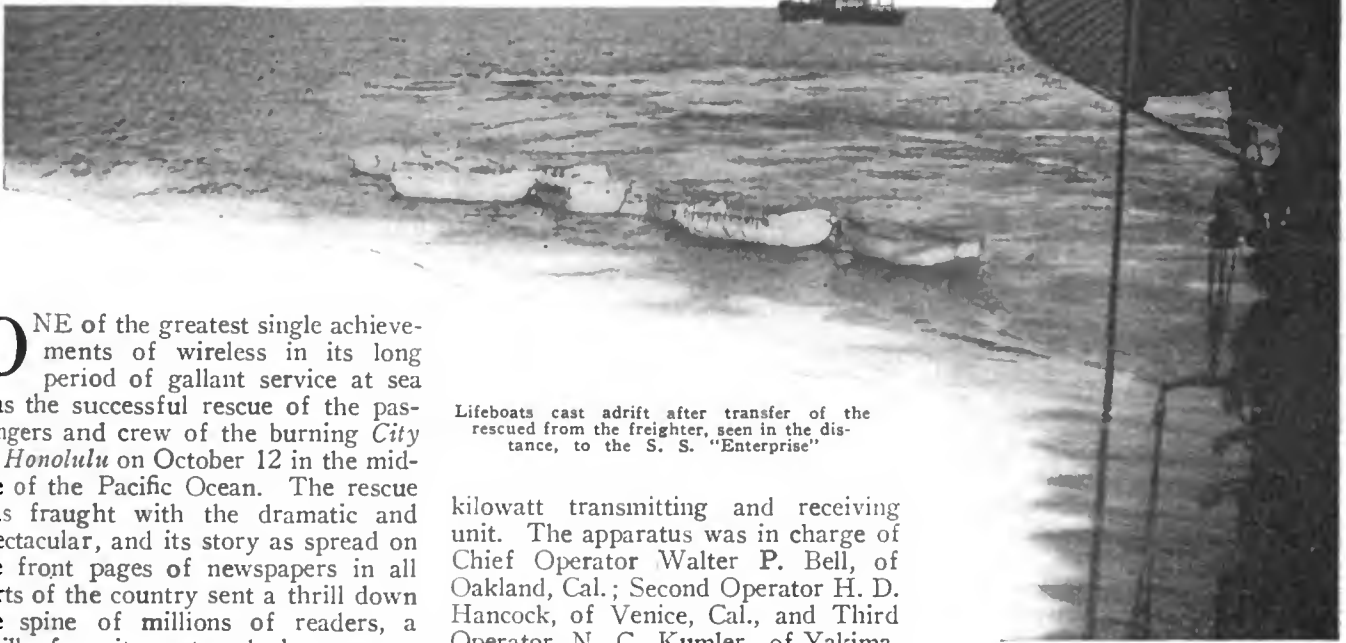

Lifeboats cast adrift after transfer of the rescued from the freighter, seen in the distance, to the S. S. "Enterprise"

ONE of the greatest single achievements of wireless in its long period of gallant service at sea was the successful rescue of the passengers and crew of the burning *City of Honolulu* on October 12 in the middle of the Pacific Ocean. The rescue was fraught with the dramatic and spectacular, and its story as spread on the front pages of newspapers in all parts of the country sent a thrill down the spine of millions of readers, a thrill of excitement and also a warm gratitude that the modern marvel of wireless should so safeguard life at sea. Two hundred and sixty-two men, women and children, the passengers and crew of the doomed steamer, reached land without a scratch, without even hardship. Thereby a new achievement of the wireless telegraph has been written down in marine history, and a bright page is added to the record of the Radio Corporation of America's invisibly protecting network thrown over the seas.

The rescue was effected more than seven hundred miles from land, within a few hours after passengers and crew had been forced to flee from the burning ship, and take to lifeboats in the open Pacific. The wireless call, far-flung into the night by operators who remained at their posts until driven forth by a creeping circle of flame, brought timely assistance. To the heroic work of the operators, the prompt responses from other ships and the shore, and the efficient system of which all are a part, is attributed the fact that not a single life was lost by the disaster.

The *City of Honolulu* left Los Angeles for the Orient on its maiden outbound voyage on September 23, in charge of Captain H. R. Lester. Its radio equipment consisted of a standard Radio Corporation Navy-type two-

kilowatt transmitting and receiving unit. The apparatus was in charge of Chief Operator Walter P. Bell, of Oakland, Cal.; Second Operator H. D. Hancock, of Venice, Cal., and Third Operator N. C. Kumler, of Yakima, Wash.

The outward voyage was made without incident. On October 7th, the *City of Honolulu* cleared from Honolulu for Los Angeles on her return trip with a passenger list of seventy-five persons and a crew of one hundred and eighty-seven, all told. There was comparatively little wireless work to be done, and the three radio operators, working in shifts of four hours on duty and eight hours off, anticipated a quiet trip.

Their expectations were fulfilled until October 12th, when they participated in the making of a dramatic chapter of Pacific marine and radio history that will remain long in the memories of those who are familiar with the graphic happenings of those few short hours.

Third Operator Kumler had the "dog watch"—the "trick" from midnight to 4 a. m. The sea was smooth with a barely perceptible roll and there was a slight haze in the air. The static was chattering in with the occasional "splurts" of intensity that are wholly familiar to those who have worked the ether lanes of the far Pacific under varying conditions. Kumler listened to Estevan Point in far Northwest Canada squabbling with a Japanese liner over a coaling place, while down off the Mexican coast a Norwegian

"mucker" hunted for a weather report.

He worked his way through his messages until there was but one more, for WMQ, the steamer *Manoa*.

"WMQ de KUSD!" he called, signing the call of the *City of Honolulu*.

The *Manoa* was listening. Her operator answered immediately.

"Go ahead," he said.

At the instant Kumler caught his acknowledgment, the silence of the operating room was broken by the sudden, quick jangle of the bridge telephone.

Kumler glanced at his clock. It was 5.41 a. m.—an unusual hour for a summons to come from the bridge. A quiver of presentment rippled up his spine. An old-time operator, familiar with shipboard usage, he sensed instantly that something was wrong aboard.

"KUSD—go ahead," snapped the *Manoa*, out in the dark.

"Min—wait a minute," Kumler replied.

He took off his receivers and reached for the bridge telephone, every nerve tingling.

"Hello!"

The voice of Captain Lester—cool, incisive—came down to him sharply.

"Wake the other operators and report to the bridge immediately!"

Kumler slammed the telephone back into place. As he did so, he became aware of something he had not noticed before—an odor of smoke, of hot varnish.

Chief Operator Bell slept in a stateroom adjoining the operating room. It was the work of a moment to run inside and touch him on the shoulder.

"Get up quick," Kumler snapped. "Something's happened!"

"All right," said Bell, scrambling out, instantly alert.

Leaving Bell jumping into his clothes, Kumler ran to the bridge. Outside, in the gangways, the smoke was thick, and the smell of burning wood was plainly distinguishable. He knew then that the fire must have been burning for some time.

At the bridge he found Captain Lester and the mates. The Captain whirled on him.

"Send out a general call to all ships to stand by for our position as we have a fire aboard!" he commanded.

Kumler wheeled in his tracks and ran back to the radio room. He found Chief Operator Bell already at the key, waiting.

"Well?" he asked, as Kumler entered.

The Third Operator repeated the Captain's instructions. Bell nodded. His hand darted to the key.

Kumler glanced at the clock. It was exactly 5.56 a. m.

"CQ-CQ-CQ," flashed the powerful spark, under the control of Bell's nimble fingers. Out dashed the general attention call that asks all to listen because the message to follow is everybody's concern.

"CQ-CQ-CQ from KUSD—fire aboard ship, please QRX (stand by) for position!"

From the bronze strands stretched taut between the vessel's masts the whisper of imminent danger and tragedy went hurtling through the early dawn. It beat a ghostly tattoo upon the giant antenna at Pearl Harbor. It flicked the aerial of the steamer *Enterprise*, many miles away, into sudden vibration. It drummed in the ear-caps of an operator's headpiece aboard the Transport *Thomas*. It reached a score of vessels in various parts of the Pacific, many of them out of transmitting distance.

At far-off Marshall, Cal., on the rock-strewn shores of Tomales Bay, where is located the control room for the main radio station of the Radio Corporation's Pacific system, at Bolinas on Point Reyes, it set the receiving apparatus to pulsating, and caused the operator on duty to straighten suddenly in his chair.

When the last faint echo had died

away, there came an answer, a reply, a response to this quick cry in the night. It was Marshall—KPH—whipping back with all the force of his powerful transmitter the information that the call had been heard.

"KPH—KPH," he tapped out, "have you any report for us, for San Francisco?"

"No, not yet," answered Bell.

He was waiting for word from the bridge.

KPH took immediate charge of the air. In his familiar bass, he broadcast a "QRT," a general order to all ships to "stop sending." Goat Island station, NPG, the West Coast listening post of Uncle Sam, came close on



The "City of Honolulu" as snapshotted by a passenger during the launching of the lifeboats

his heels with a similar order to all government boats. In the space of a few seconds, five thousand miles of busy waterway became as silent as a tomb while a score of operators waited for the *City of Honolulu's* position.

Aboard the burning vessel, Third Operator Kumler had dashed back to the bridge. He had been absent less than a minute. In that period of time, the mates had been figuring feverishly. The result was handed him on a slip of paper—a memorandum of the vessel's location. With this in his hand he retraced his steps to the operating room, through smoke that billowed and undulated like a deadly anaconda through the ventilators and air shafts.

Exactly two minutes from the time the CQ call was sent forth to a startled radio world, Chief Operator Bell transmitted the vessel's position.

"Lat. 31.07 North, Long. 131.40 West at 5.40 a. m.," it read.

Instantly came acknowledgments from four sources—from KPH, Marshall, Cal.; WMN, the *Enterprise*; WXM, the United States Army Transport *Thomas*, and from KOZC, the *City of Los Angeles*. Each vessel also gave its own position.

Connection with nearby ships having

been established by radio, there was nothing to do for the time but wait, wait for the results of the battle below decks where the courageous crew was fighting to quench a fire that had beaten them before they had discovered it.

In an effort to quench the blaze, water was pumped into the port side. This caused a ten-degree list. To stabilize the vessel, oil was pumped from the port tanks to those on the starboard side. Before the vessel could respond, a port-side comber rolled the ship to starboard and the water in the hold followed the oil. Under the double weight the *City of Honolulu* took a list thirty-five degrees to starboard, terrifying the passengers and making all fire-fighting efforts extremely hazardous.

Then there was nothing to do but get the passengers off and that quickly. Through it all, the radio operators stayed with their instruments. The operating table was pointed toward the floor of the ocean. A pencil or a pad, released, slid down the incline. Chief Operator Bell sent his final calls with one foot braced against the wall to keep from sliding out of his chair. These, however, are bits clipped from the final chapter.

At 7.30 a. m., with daylight outside and a pall of smoke creeping across the ocean from the vessel's incandescent vitals, the *City of Honolulu* received a call from far-off Marshall.

"Is the fire any worse?"

"About the same," reported Chief Operator Bell as he choked from the smoke.

At 8 o'clock, with the fire rapidly gaining headway, the utter hopelessness of the fight became evident. It was determined to abandon ship. Thirty minutes later, Chief Operator Bell sent across the Pacific the little three-letter call that freezes the marrow of the radio operator quicker than the icy touch of a Northern blizzard.

"SOS! SOS! SOS!" he called. "WMN—SOS!"

He followed this with the signature letters, KUSD, of the *City of Honolulu* and the vessel's position. WMN was the call of the steamer *Enterprise*. Instantly came back the answer from that vessel.

"Come to our aid at once!" flashed Bell.

"O. K.—we're coming!" answered the *Enterprise*, comfortingly.

Swinging about on its course, with its engines drumming under forced draft, the *Enterprise* started on a record run toward the burning sister ship.

With aid thus assured, the ship's officers gave their attention to the work of launching the lifeboats and getting the passengers safely into them. There was perfect discipline, and not a mis-

hap occurred. The passengers were permitted to take handbags containing personal belongings and in this way nearly all their valuables were saved. Some were excited, nervous, and were dressed in what first came to hand, but most of them were properly clothed. There was no panic.

Word filtered through the crowd that the radio operators had been busy, that help was coming, that all they had to do was be brave and patient. That seemed to steady them—**RADIO!**—that, and the confidence of the officers in an early rescue. They did not like the prospect of the open ocean and the lifeboats, but it was better than being burned alive. More than one face turned upward to the antenna wires high overhead. They were pinning their faith in them.

"Enterprise are you coming? Lowering boats now. Very bad fire."

Chief Operator Bell, sitting calmly at his key, flashed this message forth from a radio room filled with smoke, acrid with the odor of burning paint and varnish, with his table on a slant, with his foot braced against the wall to keep from sliding out of his chair, with the crackle of flames loud above the hum of the generator, with the knowledge that others were being carried to safety. He had no orders to leave, and so he remained at his post.

Three minutes after nine o'clock came another flash from his steady fingers.

"Leaving ship any minute now . . ."

Bell's sending was smooth and unbroken, as placid as though he was safe in a land station, instead of sitting over a crackling inferno at sea, where the decks were warping with heat, the companionways were black with smoke, and the flames growled and roared over the meal they were making of the ship.

The next hour was one of tense expectancy. The ship's officers saw that everyone was out of the staterooms, checked up on the crew, made sure that all were safe. Now and then a vessel far out on the Pacific, which had not heard of the tragedy, would start to call, only to be shut up instantly by another vessel or inland station. Minutes dragged interminably. Ashore and afloat, scores of operators sat silent, tense, listening, wondering what was taking place on KUSD.

Aboard the *City of Honolulu* the final chapter was being written. The ship had become utterly unsafe now. With every roll the vessel listed still farther to starboard, threatening any moment to capsize. Captain Lester and the ship's officers stayed until it was not humanly possible to remain longer. And in the radio room, alone, sat Chief Operator Bell.

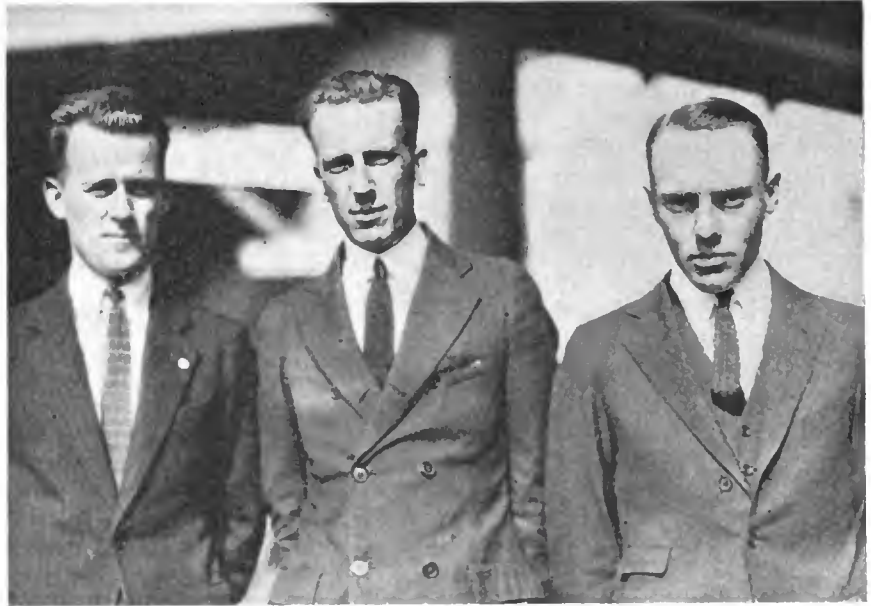

The radio operators of the "City of Honolulu"; from left to right, W. P. Bell, Chief Operator; H. D. Hancock, Second Operator, and N. C. Kumler, Third Operator

The station of second and third operators, when their usefulness as operators is over, is at the lifeboats. Hancock and Kumler were at their fire and shipwreck posts. Bell was on the key. No one else was needed there now. He would remain to the end. That was part of his job, of every radio operator's job. It is this sort of courage that has turned the profession into an Escadrille of the Ether.

At 9.58 he sent the waiting world another message, directed to the *Enterprise* and heard by KPH.

"All left but Captain, Chief Officer, Chief Engineer and myself!"

Like a fragment from some drama of history this terse message stood out against the background of the whole episode, bringing home to every listener the grave issues that must be met by the men who follow the sea for a calling. Was this to be the last message from the doomed ship?

While listeners still pondered this question, another land station, San Francisco, called the burning vessel and asked Bell to take a message. With death facing him, a sardonic sense of humor came to relieve the tenseness of the moment.

"Business before pleasure," he said, and he shot back: "Go ahead!" as he opened his circuit for reception.

Without a falter he took this last message, addressed to Captain Lester, and acknowledged it. The Captain was below, ready to leave. Bell had to fight his way through the billowing smoke to get to him. When he did, the Captain laid a hand on his shoulder.

"Do you think you can get back there to answer it?" he asked.

"I'll try it," said Bell, simply.

He disappeared in the murk, clinging to the rail, staggering along the

slanted deck, clawing at rings, ropes, anything to keep his balance, until he made the operating room. There he sent the last message from the doomed vessel, the Captain's reply, which was transmitted to KPH, the Radio Corporation station at Marshall.

When he finished, the operator at KPH reached for his key to ask a question, but even before he could form the words, came the farewell of the *City of Honolulu*, Chief Operator Bell's last message from the burning ship:

"Leaving ship now. . . . GB . . . goodbye . . .!"

That was all. He gave the last goodbye of the trained operator, and ran for the deck, for the boat. There was a squeal of pulleys, the figure of a man jumping. The last boat swung outward and down, and the roaring pyre that had once been a proud liner was left to meet her doom alone.

Twenty lifeboats rocked and teetered on the open Pacific, seven hundred miles from the nearest land, with over two hundred persons in them, and a pall of smoke settling down on all sides.

The passengers for the most part took the situation good-naturedly. There were plenty of supplies aboard the lifeboats. The steward, by some unexplained necromancy, had a pan of browned chicken in each, to go with the hardtack and water always kept in them for emergency. Also, he had managed to throw a package of cigarettes into each boat before it swung off, a thoughtfulness that salvaged many an overwrought nerve.

It was estimated that the steamer *Enterprise* could pick up the survivors not later than 4 a. m. the next day, so that at most there would be only sixteen hours to be spent in the life-

boats. Some became sea-sick, but the majority accepted the situation philosophically, and were thankful that the sea was smooth instead of tempestuous and stormy.

The hours passed. The burning *City of Honolulu* held all eyes. Some of the passengers stood up and photographed it as the flames licked up the cabins, the superstructures and the masts. Once the lifeboats drifted too close to each other and orders were issued to scatter for fear one would capsize another. At dark, they were to close in so none would become separated from the others.

Three o'clock. A mate in one of the boats glanced casually around the horizon. Suddenly his eyes grew tense. He stood up and peered for a moment. . . .

"A smudge of smoke . . . off there!"

Everyone followed his finger, stared and some cried out.

With tense faces they watched the smudge as it grew larger and darker. Finally a mast tip, a stack, then a hull. It was a freighter, whose operator had been off duty at the time of the SOS call. Later, on being heard by a shore station and asked for his position he was found to be a few miles from the burning liner, closer even than the racing *Enterprise*.

The *West Faralone*, for this was the freighter, with its draughts roaring in its engine-room and every ounce of steam on its gauges, came ploughing through the swells to the little group of lifeboats.

Half an hour later all the survivors were safely aboard the freighter. As the creeping shadows of the night closed down, the *West Faralone* turned about, leaving behind a pillar of fire that once had been one of the proudest liners on the Pacific Ocean.

At daylight the freighter spoke the Army Transport *Thomas*, which also had steamed toward the burning vessel under forced draught. The transport, unlike the freighter, had ample accommodations and facilities for the rescued party, and so in mid-ocean there was another transfer, from the *West Faralone* to the *Thomas*. Aboard Uncle Sam's craft, every comfort was given the survivors, every courtesy, every attention, as had been done on the freighter despite her limited facilities.

The passengers of the ill-fated *City of Honolulu* have given high credit to Captain Lester and his crew. But to Chief Radio Operator Bell and his assistants, and to the radio web whose far-flung filaments spanned the broad Pacific in a moment of need, has gone their fullest appreciation. To the work of these men, to the efficiency of the service, and to the alertness of the

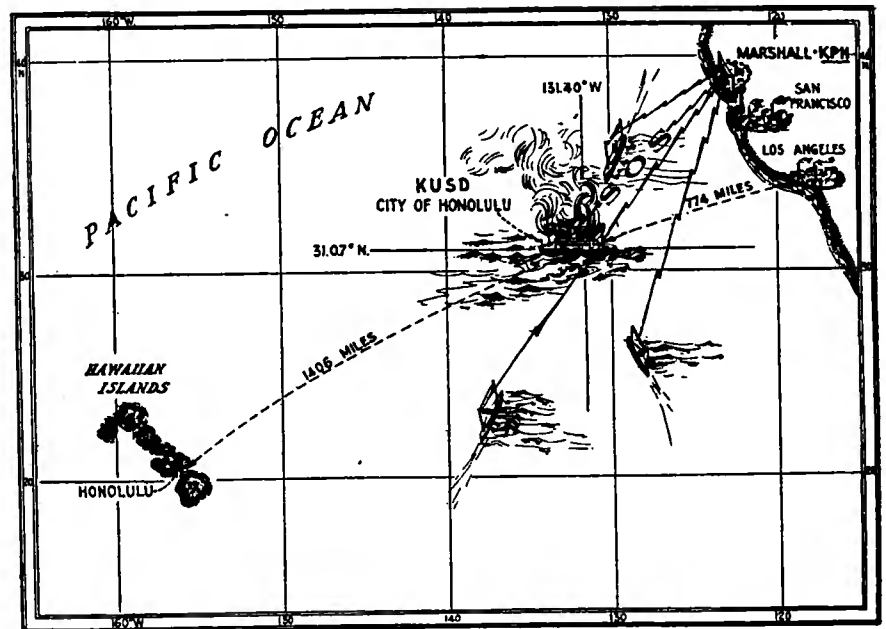

The "City of Honolulu" was 774 miles at sea when passengers and crew abandoned her and waited in lifeboats for the help that had been summoned by radio

ship and shore chain of the Radio Corporation and its operating personnel, goes full credit for the saving of the lives and property of the 262 passengers and crew of the late *City of Honolulu*.

Radio Tells How Youthful Welterweight Won

LIKE a hungry kitten loves its saucer of warm milk, so do radio fans joyfully listen to the blow-by-blow broadcast description of a boxing bout. Their usual enthusiasm for such events was surpassed on the occasion of the most recent, that of the Jack Britton-Mickey Walker bout, held in Madison Square Garden, New York City, a few weeks ago.

J. Andrew White, Editor of THE WIRELESS AGE, assumed his familiar rôle of ringside announcer, and judging by the letters that have come to him, to WJZ officials and to Madison Square Garden, the description of the blows that caused the welterweight title to pack its valise and move away from the House of Britton, was "alive," was "thrilling," and "complete," to quote only a few adjectives.

So eager were the fans to show their appreciation that many wrote their letters of thanks a few minutes

after the end of the bout, while WJZ was signing off.

In Mr. White's audience there was at least one telegraph operator to whom a description of a sporting event was an old story. Edward J. Monahan, of Brooklyn, wrote that he had "sent" descriptions of such events for hundreds of reporters, but none of them had ever compared with Mr. White's story from the viewpoint of "descriptive quality."

"Your voice and spirit was right in the action and no more lucid explanation could have been given," wrote Gustave T. Speckel, of Crestwood, N. Y. "We at home are not fight fans, but we thoroughly enjoyed the evening's entertainment and hope that it may be possible for you to broadcast other events of a similar kind."

And Kenneth Munroe, of Perth Amboy, N. J. added:

"My house becomes the center of the neighborhood on the evening of such contests."

Edward Bodmer, Jr. of Butler, N. J. said his wife listened in with as great pleasure as he did.

R. Bartholomew, in Garrochales, Porto Rico, heard Mr. White very clearly, every word being easily understandable. This was one of the distance records made by WJZ that night, the others being in the southwest, in Texas, where a number of broadcast listeners heard the description of the bout.

And so they all went on—in this same happy, joyous, hearty way. Every letter, with almost no exception, revealed the hope of the writer that the description of boxing bouts by radio will continue as long as boxing itself does.

And it probably will.



John R. Mansfield, Bondsville, Mass., says "Radio means a lot to me." He likes boxing bouts

THIS man made the ether waves chuckle with his laughing saxophone

A Saxophonist's "Swanee Smiles"

A Close-Up Study of Nathan Glantz, Famous Player of the Wind Instrument, and a Favorite With Radio Fans

By T. J. Dunham

BROADWAY in the twenties is purely commercial. It is a deep canyon, lined with tall and massive buildings that crowd each other for light and air. The sidewalks are thick with hustling merchants during the business hours, walking nervously this way and that, with set frowns of anxiety on their most serious faces.

A strange setting indeed in which to put one of the most famous saxophone artists in America today. But come and walk with the writer down this canyon of Broadway to a big building between 27th and 28th streets, get into the steel elevator with him and ascend to the sixteenth floor—the very top of the building. The farther up you go the less clearly do you hear the bustle and roar of the great commercial center below.

There, nestling on the top floor of this building, is an important part of the musical world, a phonograph recording studio in the place you would least expect to find it. As you reach the sixteenth floor and the operator opens the elevator door there bursts upon your ear the melody of an orchestra, and all thoughts of cloaks and suits, neckwear, socks and shoes flee from your mind, for lo and behold! you are in an atmosphere that is as foreign to this section of New York as the section itself would be in Central Park.

There you often may find Nathan Glantz, saxophone soloist, recording artist, for whom is claimed the distinction of being the first to make his instrument "laugh," who has broadcast his melodies through the air and has given the invisible radio audience the benefit of his complete mastery over the saxophone. My introduction to Mr. Glantz seemed to me to be rather dramatic. I have been in broadcasting studios many times when artists have been playing or singing. They stand in front of the microphone and sing or play each selection once. There is no test, and no note, once sung can be recalled. There is no applause save from the one or two persons who may be in the studio, and no one knows how the radio audience likes a per-



Maybe Mr. Glantz's extraordinary performance of "Swanee Smiles" is due to a sojourn along the smiling Swanee River

formance until the next day, when the letters begin to come in.

But here I was in a phonograph recording studio. Mr. Glantz was one of six artists. They sat in a rather untidy room, screened in. Before

MANY artists get a queer, shaking feeling in the vicinity of the knees when they play for the first time over the radio. They explain this apparent inconsistency in their theatrical make-up by the utter lack of a visible audience. Artists like applause. It is bread and meat to them. And when you take away applause they lose, nine times out of ten, their "pep."

But not so Nathan Glantz, the hero of this sketch, and saxophone player extraordinary. His first experience over the radio brought nothing from him but a great admiration for a new device through which to reach hundreds of thousands of persons without even seeing them.

Mr. Glantz has played so many times for phonograph records, which are universally used by the public, that standing in front of a horn with no audience to applaud, was an old story.

them were three horns, one large, the other two a bit smaller. Two of the players were seated in high-chairs like the kind in which you first sat at your home table. The horns extended through an aperture in the wall into another room, and there they connected with the recording device.

Suddenly a bell rang and all talking and practicing stopped. An electric bulb glowed redly, and then the six players burst forth with "Swanee Smiles" until it seemed that the very chairs in the room would dance from the irresistible harmony.

And when they were finished, Mr. Glantz, to whom this recording is an old, old story, took me into the room where the record had been made and there within five minutes we heard a reproduction of the selection that had been just played.

"It is a little different from playing over the radio," Glantz chuckled. "It is true that the visible audience we play to in the broadcasting studio is just as numerous as is the audience you see in the empty room here. But on the radio we do not know what impression we left. Here we do within five minutes."

Glantz likes to tell how difficult it was for a saxophone player to get a hearing in the days before the instrument was as widely known and universally liked as it is now. Few recording studios would give it any consideration. But once they did, success came so fast that it was difficult to keep up with the demand for saxophone records.

The saxophonist has broadcast from several stations. WJZ, WEAf and WVP audiences have been among those who have heard and enjoyed Mr. Glantz's genius. In each instance he gave his specialty, "the laughing saxophone," in which he makes the instrument emit weird, uncanny or almost human sounds that have the effect not only of making the saxophone laugh, but the audience as well.

Among the many phonograph companies for whom he has recorded, are the Okeh, Victor, Columbia, Paramount and many others.



Ada
May
Weeks

THE musical comedy star about whom we write has figured it would take six hundred and eighty-four years not to mention a few months and days in addition for her to meet personally each one of her radio audience, at the rate of one a day

An interview with Ada May Weeks

By Edwin Hall

"HELLO everybody, this is Ada May Weeks!"

These words rang cheerily through the air one evening not so long ago. It was a novel way to crash through the reserve that always exists at first between an artist and her audience, whether it be in a theater or over the air. It not only served to introduce the speaker—and incidentally the singer—but it did so in a way that brought a pleased smile to the listeners.

At least such were the comments I heard on the morning following Miss Weeks' success.

She is a unique maiden, of unique ways, and she always does the unusual and unexpected—as she proved by radio.

Her latest whim, or ambition, or craving, or whatever you wish to call it—besides, of course, her already gratified desire to be a smashing success on the musical comedy stage—is to meet, individually, the people who listened to her over the radio telephone!

The evening she broadcast was admirable for the purpose, being a night practically free of static, and the vast audience heard perfectly.

Now then, here is the task Miss Weeks has arranged for herself:

If she becomes acquainted with her radio audience at the rate of one person each day it will take just six hundred and eighty-four years, two months and seven days, including leap years, to complete the rounds! That is, supposing a quarter of a million persons heard her. Nobody knows how many she spoke to that night; it may be more and it may be less—a quarter of a million is an easy guess.

The guess is easy, and the task is hard, but Ada isn't discouraged. She says the first six hundred years will be the hardest and that the last eighty-four are at least something to look forward to. Besides she says she may be able to meet and get acquainted

with two people each day, which will cut the time necessary to meet her audience to a mere three hundred and forty-two years!

The women probably will come first in this lengthy reception line, to judge from her remarks over the air that night.

"Radio ought to be very popular with the women folks," said she, "because, just think: whatever you say by radio has to be listened to and the only thing you can do on the other end is to hold your tongue and listen. This ought to interest husbands greatly." A rather delicate suggestion, but as she did not explain why it will interest husbands, we do not feel it behooves us to take anything for granted.

Ada May Weeks is playing now in "The O'Brien Girl." When she spoke her company was in Newark, N. J., and her vivacious talk interested the folks from that state so much that they turned out en masse to see her perform and hear her sing—and get acquainted.

Her first success came with "Listen Lester," and as she says, when the people started to listen to Lester, there wasn't a word about radio in the air, and now in a brief time the entire world, or most of it, is listening in,

AS this edition is going to press, reports are coming in from various parts of the country of the great success Ada May Weeks is having in the titular rôle of "The O'Brien Girl."

Miss Weeks, so we understand, was so impressed by the response she received when she broadcast from Newark, N. J., that she has taken advantage of each opportunity that has arisen to "appear" before the radio audiences in the different states in which the production shows.

And as was the case in the East, those who heard her cheerful voice over the air make a special effort to see her in person in the play.

So that all in all, Miss Weeks has become a sincere and we might say, proud, friend of radio.

and it not only is a case of "Listen Lester," but everybody else besides "Les" is included.

"I like the radio and think it is a wonderful thing," she said. "Just imagine that I can be in Newark and people all over can hear everything I say."

And then she made a prophecy.

"I am sure there will be a definite connection in time to come between the stage and radio. One will help the other, and they will be mutually beneficial."

Miss Weeks, during her talk—which was followed by several songs from "The O'Brien Girl"—urged her audience to make themselves known when she "played" the towns in which they were living.

"I have the advantage here," she said over the air, "because I can talk to you, but you can't talk back. I want to say 'hello' to every one of you personally."

Later she told the writer that she was much awed by the thought of reaching so many persons at once, and that the very idea of it "thrilled her through and through."

But so were the listeners thrilled. They like to hear talented and happy dispositioned young women, such as the smiling Ada May Weeks happens to be. And it takes but a comparative few minutes for a girl, such as she, to make thousands of friends for life—friends who like her from an impersonal and professional viewpoint, not being able to know her more intimately.

But to get back to Miss Weeks' ambition—that of meeting her audience. The day for greeting the last one will fall on December 24, in the year 2606. It will be Christmas Eve, and the beautiful star says she won't give a performance that night, but will stay at home and listen in. And she will ponder upon the immensity of that audience to which she spoke from Newark, N. J., within the short space of thirty minutes!

Radio Connects Ship and Shore Telephone

Engineers Prove Practicability of Stateroom-to-Home Telephone Connection, Using Special Radio Transmitters and Ordinary Land Wires—Business Men Developing Arrangements

By Ward Seeley

“HELLO, give me Stagg 1234.”
“Get me Telegraph 5678.”
“I want Bowling Green 9012.”

Such are the telephone calls that may come from the middle of the Atlantic ocean some time in the near future, to be picked up by a radio receiving station connected with the land telephone system. Then it may be possible for voyagers on Atlantic liners to talk to Chicago, San Francisco, New York and any place in between. The ship-to-shore radio telephone, linked with the land telephone system, is an assured success. The tests with the *S. S. America*, which radio amateurs all over the eastern part of the country heard, have demonstrated that American radio engineering genius has been successful in overcoming the many obstacles encountered in conducting simultaneous two-way radio telephone conversation in conjunction with the land telephone.

How soon it will be before all ocean lines will be equipped with the necessary apparatus cannot be foretold. We only know that in time it will be possible for Mrs. Smith, in the middle of the Atlantic to call up the nurse in her home on Riverside Drive, New York, talk with her and ask how Willie's croup is coming along. Or Mr. Alexander may talk to his office in Los Angeles from his cabin on board ship, as easily as he would from his hotel room in New York City.

The millions of business and personal uses to which the land telephone is put daily, will be duplicated at sea. No longer will passengers have to write out their messages in a few condensed words for a radio operator to tick off into space. Instead, they will speak their messages directly to whom they please on land and hear the voice come back in reply.

This by no means contains any promise of the abandonment of the radio telegraph. The wire telegraph came before the wire telephone, and the sole effect of the telephone upon it was to increase its traffic by rendering the public more familiar with communication by modern means. The telephone on land served to develop new traffic for itself and for the telegraph as well, and it is predicted here



The *S. S. "America,"* on which the historic ship-to-shore radio telephone was proved a triumph for American radio engineering

that the sea telephone will follow the same course.

Its development has been by no means as simple as was that of the ordinary telephone, strange as that may seem. The engineering difficulties, which will be spoken of more in detail later, were of a character that the late Alexander Graham Bell, the inventor of the telephone, would have been unable to comprehend in the days when he was making his great contribution to modern life. They have been surmounted, however, by the cooperation of experts of several companies working together. It now remains for the business man to step in, unify the many commercial interests that are concerned, and place the sea telephone on all ships.

The actual apparatus that was necessary for accomplishment of the feat was developed by experts of the Radio Corporation of America, in conjunction with engineers of the Western Electric Company, the General Electric Company, and of the American Telephone and Telegraph Company.

There is an angle that the reader may not be aware of and that is the fact that the installation and maintenance of radio apparatus on foreign ships is done by foreign companies. In each of the European countries

there is a separate radio corporation, usually containing in its title the name "Marconi," as they all have license arrangements under the numerous Marconi patents, as has the Radio Corporation of America. These companies each take care of radio affairs in their particular countries, including ships of their own registry because it serves their national interests.

It can be seen that the installation of the ship-to-shore radio telephone on a broad scale presents difficulties of extraordinary magnitude from the business viewpoint. Were it a matter for discussion only between American companies it would be fairly simple, for our business men could easily get together around a table and half a dozen of them could, within a short time, arrive at a satisfactory basis for handling the new classes of business. But the presence of foreign ships upon the seas, and the necessity for securing agreements with a dozen or so of foreign companies, each operating under different nationalistic maritime laws, raises complications that probably will serve to delay considerably the advent of the sea telephone.

That it will come is assured. It is too big a thing for any obstacle to hinder for long. The technicians know how to build the necessary apparatus, and it only remains for the business man of the United States and of England and France, Spain, Italy, Germany, Norway, Sweden, Denmark and all the others, to get together with their steamship lines, their radio apparatus manufacturers, and their government or private telephone and telegraph systems, and make the sea telephone universal. In time to come passengers at sea will talk to America as they leave its shore, and as their voices fade away on one side they will begin to come in on the other, and they will talk to London, Paris, Rome and the other continental centers. The day is coming when no traveler will be out of telephone reach of the rest of the world.

Credit for the first experiments with the ship-to-shore radio telephone must be shared with the United States Lines. The *America* is one of the Shipping Board's vessels, and was selected for the installation of the test apparatus because she happened to be in New

York at just the time that the radio engineers were ready for ship experimentation. They had completed all the work they could do on land, and desired to make tests at sea. The United States Lines were approached, and Mr. T. H. Rossbottom, general manager, gladly gave his consent for the installation, and offered to provide transportation for the three or four engineers who desired to observe the tests.

The radio room was turned over to them, and the new apparatus was installed. The vessel sailed, and soon listeners on land began to hear her signals and then a voice came from over the waves—the *America* was talking to land by the radio telephone. In reply a voice went dashing back from land to the ship. The land replied by radio telephone. Two-way ship-to-shore radio telephone communication was established.

Mr. Rossbottom, sitting in his office some time later, told the caller about this marvelous development.

"We were only too glad to let the engineers use the *America*," he said, "for it was good publicity for us, and moreover if the apparatus should prove successful, as we all hoped it would, we would have a new asset for our line. The engineers put the apparatus on board the ship and one day they told me that probably within twenty-four hours they would make a test, linking the ship with the land telephone system of the American Telephone and Telegraph Company.

"Sure enough, one noon my telephone rang and the Radio Corporation asked me if I was ready to talk to the *America*. I held the line and in a minute or two I recognized Captain Rind's

voice. He was then some four hundred miles at sea and I was talking across that distance just as easily as I can talk across the street. The idea wasn't new to me, because as I say we had discussed it a great deal in advance, but to find myself actually doing it, talking here at my own desk telephone to the Captain at sea and hearing his voice come back to me just as clearly, was really marvelous.

"The Captain asked me several questions of a business nature that had come up since his ship had left the dock at New York. I was in touch with him by telephone every noon and night for four days, until his ship was too distant from this side to be heard by the radio telephone. One evening at home I listened in on my own radio receiving set, hearing the conversation in the air between the ship and the station at Deal Beach. The Captain always called me up every night at 7 o'clock and sure enough on the evening while I was listening via radio at about a minute to seven I heard the Captain say that he wanted to talk to Mr. Rossbottom at such and such a number, in Sound Beach, Conn. In about a minute my telephone bell rang and when I took off the receiver there was the Captain speaking to me through the air."

On the return trip the same thing was accomplished. Many passengers on both trips used the radio telephone to call up their friends and offices on shore. Most of these calls were of a personal nature, but on the return voyage the Captain used the telephone for business purposes, reporting certain details about his cargo and passenger list, and asking on which side of the pier he would dock in New York City.

"Then you think that radio telephony at sea is of a commercial value not only to the passengers, but also to the steamship line?" he was asked.

"Absolutely," was his reply. "At present every steamship line uses the radio telegraph to a great extent for service messages, but you know that a telegraph message isn't as satisfactory as the telephone, no written message ever is as good as conversation, especially in the complications that can arise when a big liner is coming in. The ship-to-shore radio telephone has exactly the same advantages over the radio telegraph that the land telephone has over the land telegraph."

Since those recent experimental days the apparatus on board the *America* has been shifted to another room, where more space was available. It still is in the experimental stage, though the radio engineers state that they have had sufficient experience with it to give them the information they desire. They know what they can do and are ready to do it when all the manifold interests concerned in the ship telephone have joined hands in order to make it a commercial practicability. At present the *America* is the only ship provided with this apparatus capable of carrying on a two-way conversation simultaneously.

When asked what would happen if it would be possible to offer the combined ship-to-shore telephone and telegraph apparatus tomorrow to all ships, Mr. Rossbottom said, "They would jump at it." He went on to say that its great commercial advantage would make it essential equipment for all the trans-Atlantic passenger lines, and that once the ship telephone became a part of the facilities offered the traveling public of any one line, all the others would have to follow. He pointed out that this applied particularly to the big trans-Atlantic steamers, which offer a fertile field for telephone development due to the fact that they carry large numbers of passengers whose purses usually are well lined, and many of them being active business men who make steady use of the radio telegraph and would use the radio telephone if they could have it. The fact that steamer routes from New York City swing northeastward, staying fairly close to land until about the second or third day, is greatly in favor of the radio telephone, as it permits contact with the shore for a longer period than would be possible if the steamers sailed due east.

Technically the development of the sea telephone represents a remarkable achievement. Heretofore the send-receive switch usually has been a part of all transmitters. An operator on ending transmission sends a conventional signal, the letter K, to signify



In the radio room of the "America," showing the operator, and in the background, J. Horace Porter, Marine Manager of the Radio Corporation of America, using the ship-to-shore radio telephone. Conventional telephone instruments in any part of the ship may be connected into the new system.

that he is finished. He then throws the send-receive switch to the receive side while the station to which he is sending throws its switch to the send side and transmits an acknowledgment of the message. In other words, by that arrangement it is impossible to both send and receive at the same time.

This now is possible, however, by recent developments. These new circuits are highly intricate—and absolutely effective. At the time this is written they are held secret, pending the securing of the necessary patent protection.

A general idea of the nature of the problem can be secured from the somewhat similar one encountered by the telephone company in its land lines. These lines had to be connected to two different radio stations of the American T. & T. Co., one for receiving only, at Elberon, N. J., and the other at Deal Beach, N. J., for transmitting only, while the land telephone instrument had to be connected simultaneously to both. To effect this double connection the telephone company used what is known as a "hybrid coil" and "balancing network," located in New York City.

Referring to the diagram the hybrid coil consists essentially of a transformer with three separate windings. These windings are arranged around an iron ring in the form of a toroid and are so carefully wound that their electrical characteristics balance one another with extreme accuracy. The balancing network is composed of resistances, inductances and capacities so arranged that the electric impedance of this network is as nearly as possible the same as the impedance of the telephone circuit joined to the other end of the hybrid coil.



Chief Operator Black of the "America" at the side of the transmitter

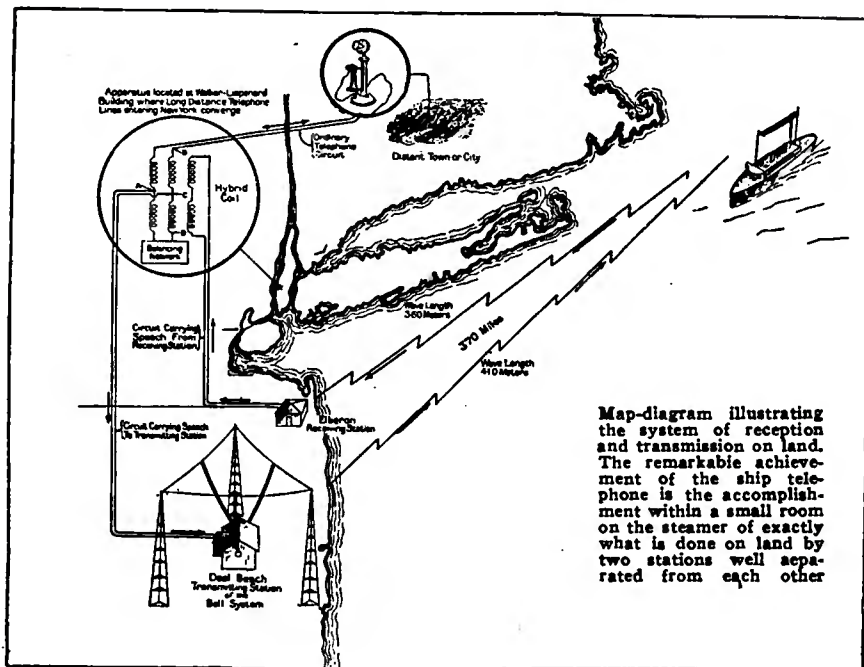

Map-diagram illustrating the system of reception and transmission on land. The remarkable achievement of the ship telephone is the accomplishment within a small room on the steamer of exactly what is done on land by two stations well separated from each other

To those of our readers who are familiar with the action of the Wheatstone bridge which is used for measuring resistances, capacities, etc., the action of the hybrid coil will now be apparent. Let us consider the case in which the ship is talking to shore. Voice currents are generated at the Elberon receiving station and pass out over the 2-wire circuit to the associated winding of the hybrid coil. Now the electrical impedance between the points C and B is exactly equal to the impedance between C and D; also the impedance between B and A passing around by way of the telephone instrument is equal to the impedance between D and A passing by way of the network. CB and CD, and BA and BD, therefore, constitute the four balanced arms of a Wheatstone bridge. Therefore, when the voice currents flow in the windings which are connected to the Elberon station they generate similar currents in the other windings of the hybrid coil which flow through the balancing network and the telephone instrument. But due to the balanced relation, voice currents flow in such a way that the electric potential of the points A and C are always equal to one another and hence no current flows in the circuit running between A and C and the Deal Beach transmitting station. On the other hand, when the telephone instrument on shore is spoken into, current does flow down to the Deal Beach station, but because of the balanced relation in the hybrid coil no current flows to Elberon.

Although the use of hybrid coils and balancing networks is relatively new in the radio art, it is a matter with which telephone engineers have long been familiar, as these are pieces of

apparatus which are made use of at every repeater station located at regular intervals along the long-distance lines of the country.

One interesting point in connection with the hybrid coil and balancing network remains to be mentioned. Many persons throughout the Eastern section of the United States who have "listened in" on the ship-to-shore tests between Deal Beach and the steamship *America* have noticed that they could tune their sets for Deal Beach and receive the ship although it was transmitting on quite a different wave length. Others with crystal detectors have recorded hearing the ship although several hundred miles out to sea. Also many have noticed that they could hear the ship only after a land connection had been established and that when this connection was broken, although they could still hear Deal Beach they did not get the ship's half of the conversation. These observations are each accounted for by re-radiation from Deal Beach due to a slight unbalance between the telephone line and the balancing network. As a result of this unbalance, the voice current coming to the hybrid coil from Elberon induces a certain small current in such a fashion that it flows down to Deal Beach where it is re-radiated into the ether.

On board ship, by reason of the fact that the transmitter and receiver have to be side by side, the simple device of the telephone company's land wires is ineffective, besides being unsuitable for handling high-frequency radio currents. New appliances had to be developed by the radio engineers, and they are the ones principally responsible for the perfection of the ship-to-shore radio telephone.

Radio Brings Football to All the People

Excited Broadcast Listeners Far Out-Number Tens of Thousands of Spectators in Vast College Stadiums—All Important Gridiron Battles Broadcast

By Sam Loomis

THERE has been just one big movement visible in collegiate football during the past few years. That has been the great and growing interest of the general public in the sport. It was not so many years ago that only college students and "old grads" were at all concerned in the gridiron struggles, some of which went down as glorious victories and defeats in college history.

Now all that is changed. The big college games fill the sporting pages with columns of scientific analysis of the opposing teams; front-page stories are printed describing an important contest, such as Yale-Harvard and Princeton-Chicago; thousands of men and women who never went through college—unless in one door and out the other—pay big premiums for the privilege of sitting in bleak stands under a cold November drizzle and watching a collegiate football classic. Football has changed from a college sport to a national one, and it is expected that in the near future the All-American Football Team, instead of being picked by sporting editors from comparisons of records, will be actually selected on the gridiron by a few games comparable to the World's Series in baseball.

What share is radio having in this great and important change that is coming over football? A big part, of course. All who owned receiving sets this Fall had the privilege of listening to nearly a score of broadcast football games, games broadcast directly from the field, with the yells and songs of the cheering sections plainly audible, as well as the voice of some sporting writer describing each play.

"HOLD 'EM, HOLD 'EM, HOLD 'EM, HOLD 'EM, HOLD 'EM!!!"

And through the din came the calm voice of the expert, "Chicago's ball on her own ten-yard line, third down, eight yards to go. . . . A forward pass is blocked by Princeton, which gets the ball on a fumble. . . ."

And in that particular game the ex-



Just about an eighth of the big Harvard Stadium before the Harvard vs. Dartmouth football game, which was broadcast by WGI. The two faint white lines near the top of the picture are supports for one of the microphones used to pick up the yells of the students

citement was as intense in thousands of homes as it was at the field in Chicago as Princeton, apparently defeated, though within a couple of yards of a winning touchdown that she apparently could not make, hit the Chicago line hard. "Is the ball over the line, is the ball over the line?" panted the voice of the announcer. "We can't tell from here, no one can tell, for it is buried far under a mass of piled up humanity. The referees are digging their way to the bottom. If the ball is over the line, Princeton has won. Is it over? Listen to them yell! Yes, it's over, it's over. Princeton has won. A touchdown has been made. Princeton has won the greatest football struggle I have ever seen, and that's that!"

Who could help succumbing to such contagious enthusiasm, to such evident suspense?



W. S. Flitcraft, sporting editor, who broadcast through WJZ the Saturday afternoon football games at the Polo Grounds, New York. This was taken during the Washington and Jefferson vs. Lafayette event

Today the football fields of a score of colleges have been much enlarged in order to accommodate the vast public. The Stadium at Harvard seats 53,000. The Yale Bowl at New Haven, and Franklin Field in Philadelphia; the Polo Grounds in New York, fields in Chicago, St. Louis, and San Francisco, all have been given the increased facilities demanded by the public.

But radio gives the public the greatest football field of all—the home. Every game of major importance was put on the air this Fall, in some case by two different stations at once. This was the case with the Princeton-Chicago battle, which was broadcast by KYW, the Westinghouse station in Chicago and at the same time by WEAJ, the American Tel. & Tel. station in New York City. The Princeton-Harvard battle, in which Princeton won for the fourth time in 30 years, was also broadcast by two stations, one the Amrad transmitter, WGI, and the other WEAJ. WJZ, the Radio Corporation of America-Westinghouse station at Newark, N. J., ran a regular schedule every Saturday during the Fall, reporting the games as played at the Polo Grounds in New York City. KDKA at Pittsburgh reported its local games. So it went throughout the country. In all, over twenty-four different games must have been broadcast, some of them by two transmitters at once.

In at least two instances the radio equipment of college laboratories was turned to broadcasting football reports. Union College, which operates WRL, put a number of play-by-play reports on the air each Saturday, and Yale College, at New Haven, Conn., did likewise.

Listening In With the Home Folks

Broadcasting Service That Lightens the Daily Household Tasks Has Aroused Enthusiasm Among the Women, Making Newspapers Secondary in Interest

By Rosemary Clarke

RADIO has entered the home. It is known there—is a welcome visitor to the hearthside. That has been the big accomplishment of radio broadcasting during the short two years since its very modest beginning.

Of course, it is nothing new for radio to enter the home, for ever since the first radio wave was created by man it penetrated willy-nilly everything within its range. Ever since radio telegraphy became a part of the commercial communication network of the world and was used for land and sea communication, radio waves have filled the ether in all parts of the globe. But only when the waves of the radio telephone commenced operating through the ether in all directions, carrying material that could be understood by anybody who can hear—only then did radio enter the home in the popular conception sense.

What is it doing there?

It is entertaining, amusing, instructing, brightening the lives, adding to the joys of millions of Americans. It is civilization's newest and most popu-



Mrs. Gilbert, of Washington, D. C., does her housework, sweeps, mends and cooks, by radio. As she prepares the evening meal she listens to concerts, market reports on the prices of foodstuffs, and lectures. She says radio keeps her up to date as she works

lar asset enjoyed by the entire family.

That is a generalization, and as broad as it is, it still falls far short of the actual truth, as anyone knows who has had occasion to talk to people in diverse walks of life who are receiving the broadcast radio telephone programs.

Everyone's experience with radio is different. Everyone gets slightly different advantages from it.

One man wants a receiving set for time signals and weather and market reports.

A woman values her instrument chiefly because it gives her music and

entertainment and household hints in the afternoon when her household work is done, and an hour or so of idle time hangs heavily on her hands.

The young man values his receiving set for the jazz music and popular songs that he receives over it, and for the descriptions of baseball and football games, boxing bouts and similar sporting events.

The kiddies are delighted with the bedtime story.

Father sits down beside the loud speaker or puts the headphones over his ears with a sigh of relief. He has read the evening paper on the way home and instead of just killing time until he grows sleepy, he listens and is grateful for the entertainment and instruction that come by radio.

Little Sallie Jones, the neighborhood object of charity, who never can stir from her wheel-chair, wears her headphones as a kind of crown, and the neighbors who used to worry over her unhappy lot and cudgel their brains for ways of relieving her tedium, now sit happily at their own receiving sets, content to know that here is the one great thing of modern life that Sally shares with them without her frail body setting up a single bar.

Mother and father discuss a simple little operation that needs to be done some time. "Let's do it now," says mother, "for I can take the radio set to the hospital with me. Won't that be fine? I can listen in while I am getting well."

The Blankville Radio Club decides that it is high time that it owned transmitting equipment as well as its re-

Grandma's imagination now takes a rest—she listens to the bedtime stories with her grandchildren around her just as they used to gather for her tales before the radio set arrived



ceiving apparatus. "Why, that is easy enough," says the president, Sam Brown. "Let us give some radio dances." And the club hires a local hall, sets up its loud speaker and gives a series of radio dances, to the great joy of the younger set, which dances to the music of the best metropolitan orchestras, received by radio. The radio club soon has its transmitter.

One could go on almost indefinitely with examples like these, drawn from one's own experience in meeting radio fans. There is a different story under every antenna. There is not an aerial wire stretching over a roof that does not bring the benefits of the radio telephone in a new way to somebody.

Mr. Edward Bok, the famous former editor of the *Ladies' Home Journal*, rendered radio a remarkable tribute recently when he persuaded Mr. David Sarnoff, vice-president and general manager of the Radio Corporation of America, to deliver an address before the Philadelphia Forum. The Forum is one of Mr. Bok's creations since he "retired," ostensibly to enjoy private life, but really to give full play to his genius for public-spirited work.

He realized the tremendous factor that radio now is in the home life of the nation, and desired to present a radio authority to the Forum, to further the cause of broadcasting in the city of homes.

Mr. Sarnoff gladly consented to speak on the "Commercial and Social Influence of Radio," and held an audience of 3,000 people silent with eager attention as he described how broadcasting is bringing new interests into the lives of the womenfolk of households all over the country, arousing their interest in many important civic, educational and cultural subjects of



Emily Exner keeps a typewritten record of all lectures on household matter that are sent by radio. She is an ardent radio fan and says that her knowledge of housekeeping has increased through her experience with radio

which previously they had been hardly aware. A striking demonstration of broadcast reception by means of a loud speaker illustrated Mr. Sarnoff's remarks.

DIVERSE EXAMPLES

"Dinah is so much happier since we bought another loud speaker and put it in the kitchen for her," says Mrs. Smith.

"My illness has not permitted me to walk for more than five months," said Mr. Pattengill. "You can imagine how I listened daily to broadcasting."

Mrs. Suburbantown decides that it is her turn to give a party. All her neighbors have done something unusual this season to make their evenings more than a mere night of games and talk. What shall it be? She sud-

denly remembers the radio set. George has been begging for a loud speaker. "Son," she calls upstairs, "if we bought a loud speaker could you have it working by Tuesday night?" "Sure I could," is the excited response. And out go the invitations for a radio evening. "Mr. and Mrs. Suburbantown are giving a musical party on Tuesday night. Paul Whiteman's orchestra will play, and songs will be rendered by Madame La De Dah, Signor Vermicelli and Señor Madrigo," says the local paper, and the local paper is right because that happens to be the radio program for that evening.

Si Hopkins, out on the farm, sticks another piece of wood in the old cast-iron stove, puts on his headphones, turns on the switch and listens. He

(Continued on page 48)



The radio world has heard of M. J. Caveney, the Canadian trapper to whom the radio telephone means so much. Here is his lonely cabin close to Sandy Falls, near Timmins, in northern Ontario. He not only has a receiving set over which he hears the broadcasting of Canada and the United States, but also operates a transmitter with which he telegraphs to amateurs over a wide territory

The Boom Is On In Britain

By Milton S. Waldman

WITHIN a few days of the time that this article appears in print the wireless telephone program in London will be in full swing. England will then be in the position that we were a year ago—with an important difference; here in the British Isles it will be no experiment; there will be no slow growth, then a sudden bang, and an almost equally sudden let-down. Everything has been carefully planned to make the whole business of broadcasting as perfect in every detail as is humanly possible, and to keep it a permanent thing.

I asked Mr. Gill, head of the Manufacturers' Committee, which had the matter in charge, to explain his ideas on the subject for the benefit of the readers of *THE WIRELESS AGE*. Mr. Gill had just spent several months in America investigating our system (in fact, we crossed on the same boat, but I didn't find out until the last day that he was one of the best posted men in England on broadcasting) and admitted freely that many of their plans were being laid over here on the basis of American successes and failures.

Among the latter he places the programs in a prominent position. While granting that the quality of entertainment had probably been lowered during the Summer months, still he expressed surprise that the American public would put up with so much canned music, third-rate singers and stereotyped lectures. He stated that his investigations had convinced him that the programs must be put on the same basis as theaters and vaudeville houses—in fact, Mr. Gill asserts that from the very beginning no attempt will be made to exploit the novelty side of the broadcasting, since that wears away and leaves the business in no better shape than before. It should be, he believes, a permanent form of high class entertainment with its own scope as definitely fixed as that of the moving pictures (the English are, by the way, taking up the word "movies" in place of "cinema" for that form of entertainment).

The means by which the funds to pay the artists are to be raised are twofold. In the first place, all the manufacturers of radio apparatus are formed into an association to further the art of broadcasting. Into this association they pay dues for the construction and upkeep of the stations and for the payment of artists. Secondly, the tax which the Post Office



A group of Boy Scouts visit the Marconi works at Chelmsford, England, to listen to the Prince of Wales address them by radio telephone from London

exacts from each owner of a receiving set will be divided in two, one-half to the Government, one-half to help pay for the broadcasting.

POST OFFICE IN CONTROL

The Post Office, which in England controls the telephones, is also the Government agency for control of broadcasting. They issue the licenses and keep the whole business within close control. It has been arranged that licenses will be issued only to the association, but the aspect of a monopoly is avoided by allowing all manufacturers to join on equal terms and to have equal voice in its affairs. It is thus expected that the unpleasant features of competition, conflicting hours and jamming, will be avoided.

Meanwhile, all London, at least the majority of the younger folk, are all agog over the imminence of broadcasting. All over London you may see aerials, of all sort and descriptions, from the elaborate cage antenna over the Admiralty Building in Whitehall to little single strand affairs over private houses. In the little tea shops which every afternoon between the hours of four and five are jammed with working people of all classes and descriptions, shoppers and visitors, you never fail to overhear snatches of conversation involving "damped waves," "valve amplifiers," "filament resistance," etc., etc. Shop windows of every description are crowded with apparatus, and five out of six passersby

stop to examine and discuss. The buying of parts is popular, and I should say that there are likely to be more amateurs here in relation to broadcasting listeners than in the United States. Of course, the tax makes some difference here, as Mr. Gill tells me that they are not likely to enforce it against builders of home-made sets.

The precise date of starting is still uncertain, although "a week or two" has been promised for some time. Mr. Gill hopes to start either in London or Manchester this month, and to add the other stations as rapidly as possible. Six are now planned, although the general opinion here and in America seems to be that eight are contemplated. This is not true, for the present at any rate.

WIDER BAND TO BE USED

The English stations will work on a wider latitude than our own. Their bracket will probably be 350-475 meters, and since each will have but a comparatively small geographical area to cover and will at the same time be comparatively far from the others, interference should be at a minimum. The value of highly selective receiving sets seems to be generally appreciated here, and the most complete sets will probably be of the single tube, two-circuit type.

Prices do not vary much from those in America. I have before me a catalogue of one of the largest electric supply houses in the United Kingdom, which offers such sets as already mentioned from about forty to sixty dol-

lars. A complete set, comprising tuner and three tubes (detector and two audio frequency stages of amplification), can be obtained for about \$75, without tubes, batteries or headphones.

I might add that electric stores have by no means a monopoly of the business here, talking machine shops carrying complete sets, hardware stores a supply of parts, and many other retail establishments going in for the new craze in some way.

The following abstract of a speech delivered by the Postmaster-General, Mr. Kellaway, whose position in regard to broadcasting is somewhat analogous to Secretary Hoover's in the United States, is of interest in that it discusses problems here that have or are agitating us:

Referring to the broadcasting of wireless telephony, Mr. Kellaway said that he was glad to be able to state that there was a reasonable prospect of broadcasting services commencing in the course of the next week or two. The delay had been disappointing in some respects; but if they succeeded in starting this new form of communication in this country on really sound lines, no one would regret the delay. He thought events would show that the Post Office and the Broadcasting Company had been well advised in not being in too much of a hurry.

He had made it a condition in his discussions with the Broadcasting Company that there must be nothing in the nature of monopoly in regard to the selling of receiving sets. Every firm in the country capable of producing cheap and efficient receiving sets must be allowed to become a member of the Broadcasting Company on reasonable terms. When the articles of association of the company were published, as they soon would be, he thought it would be seen that this condition had been amply guaranteed. This was the more essential since he had decided that licenses for receiving sets for use in this country should be confined to instruments made in this country. There had been some criticism of his decision in this matter and it had been described as rank Protection, but his decision had been taken without any regard to fiscal considerations. It was no use having a receiving set in your house unless there was some broadcasting service which it could receive. If he had allowed licenses to be issued in respect of any instrument, whether British or foreign, it was absolutely certain that there would be no British broadcasting service provided.

Those who demanded that foreign instruments should be licensed for broadcasting were in effect demanding that British capital should provide the service, whilst foreign manufacturers

secured the benefit. He had never had any doubt that the decision he had taken was the right one in the circumstances, and he was glad to know that he was supported by the principal wireless societies and by the overwhelming majority of the people and press of the country.

An agreement had been come to under which receiving sets would not be limited in respect of wave length. The result of this would be that the owners of receiving sets would be able to receive, not only the programs sent out by the Broadcasting Company, but matter broadcasted from any other center. This would add immensely to the value of the receiving sets.

A beginning would probably be made in London and Manchester. The seven other stations which were to cover the country would, he hoped, be ready for work in the course of three or four months. The building of these stations would provide an amount of useful employment.

Some anxiety had been expressed by the press as to whether the Broadcasting Company would be allowed to broadcast news. He had recently told a deputation that before permission was given to the Broadcasting Company to broadcast news, he would arrange for a meeting between these interests and the Broadcasting Company in the hope that they would be able to come to a friendly arrangement. It was obvious that the Broadcasting Company could not be allowed to take the property of the press and the press agencies, and he would see that these interests were properly protected in any arrangement made by the Broadcasting Company.

He was very glad to find that these important agencies took a long-sighted view. They realized, as he did, that they could not put a Chinese wall around this new form of communication and say that it should not under any circumstances be allowed to broadcast news. Such an attitude as that would be comparable to the short-sighted attitude of the men who opposed the use of machinery. If they were to make the fullest use of broadcasting it must not unreasonably be circumscribed or shackled. He had every hope that a meeting between the Broadcasting Company and the press interests would arrive at a settlement which was just to the press and was in the interest of this new form of communication.

Listening In With the Home Folks

(Continued from page 46)

hears the programs of the distant stations, giving the day's quotations on

the produce upon which Si and his farm depend for their existence. He hears the time signals and for the first time in his life his farm is run by a clock that is accurate.

He hears the weather reports and sometimes he hears an urgent warning of an impending storm, a warning that reaches him by radio in time for him to make all possible preparations that will minimize the damage and possibly prevent any injury at all being done by the approaching storm. Si hears lectures by leading government experts, and by professors of agriculture in his State college on the subjects in which he is interested. He hears the latest popular music. He hears the classics interpreted by artists who never would venture in person into the places where their voices now are spread by radio.

What is radio? Can anyone define it? It escapes analysis. It can't be limited, pinned down, blueprinted. There is only one frame big enough to hold a picture of even a part of it and that frame consists of the seas and boundary lines that form the limits of the United States. Only a portion of the picture is within that frame, which is not big enough for the whole, as radio dashes far over the boundaries of the United States.

And so it must be said that radio defies all attempts to analyze it, to make it fit in one single plan or scheme. Radio broadcasting is a combination of the many hundreds of broadcasting stations and of the many hundreds of thousands of broadcast receivers. The whole is enormously complicated and very great. Its greatness lies in the home.

The American home is a radio home. Radio shares its benefits with all who can listen. It is not niggardly, but spreads its talents to the four winds, and more and more are those who are fortunate enough to have receiving sets sharing them with others.

"This Is a Radio Christmas," one is told. Ah, there is more to be said for radio than that. Although it is true that this year as never before radio sets are being selected as Christmas presents, and radio programs are adding new life and vitality and joy and peace to the holiday season, still the phrase, "This Is a Radio Christmas" marvelously apt as it is, falls short of the real truth.

"This Is a Radio Christmas"—and it is also a radio age, a wireless age. These are radio days and nights and weeks and months and years. This is a radio century.

Radio's place is in the home.



Laughter on the Radio Wave

Our New Alaskan Station

(As heard in New York with the secondary 40 degrees below zero.)

7 p.m. (Tuning in.) Squirrrr-whoooliopp-pft-PING! Yroww grrrr-rr woof woof zinggg ffsstfsts Bow Wow. "This is station POW at Blip-blaah, Alaska. It gives us great pleasure to introduce to our radio audience Professor Iheposksh Blppuort, dean of the Ice Conservation Department, Eskimo University, who will speak on The Menace of the Equator. Professor Blppuort."

A voice: "Ladea-es and Gentle-lemen, Oogbob! Woof goof! Ujsuopw ueiot—"

Announcer (after lapse of three minutes): "That'll be enough; thank you, Professor. . . . Our radio audience will be interested in knowing that later on the wolves will be broadcasting, too. We will now listen while Wirjrposlrrku Hirujslpq talks on 'Why shouldn't an Eskimo eat pie?'"

Announcer: "He says he won't speak on that subject, but will choose, instead, 'Why sea lions like fish.'"

A Voice: "Ladies and Gentlemen, most of the fish-loving sea lions are in the zoological gardens just now. They prefer to be there because they not only can eat fish, but can look at them through the bars at the same time." Etc., etc.

Announcer: "We will now hear the applause of the sea lions. 'Ugh, Ugh!' Next on the program is a group of trained alligators demonstrating the latest and most improved methods of sleeping."

A pause of six months.

Announcer: "We hoped you liked that. Now, John Yueipwoeuryhf, mayor of Eskimoland, will talk on, 'Why Is An Iceberg?' He will ask questions, and you listeners are expected to answer."

A Voice: "My first question is 'What Sex Is An Iceberg?' If Mississippi don't know, Alaska. Those believing me will answer yes."

Announcer: "The last speaker left, angry because he didn't get any answers to his questions. We will end the evening's entertainment by singing the national anthem, 'Love Is Blind, But Oh! Bering Sea.'" M. H.

Wise Crack-les

RADIOPHONE transmitting stations will never reach the popularity attained by the receiving sets, in the opinion of the Amalgamated Order of Absentee Husbands.

A prominent Elk of Massachusetts recently was examining equipment of his local club house, when he picked up a call from his own sending station. It was his wife operating; and this is what he heard:

"John, come right home. It's 9:30." Not so good.

* * *

VARIETY THE SPICE OF RADIO

AN Englishman has invented an 18-inch phonograph record that takes an hour and a half to play, and it will be ready for the Christmas trade.—*News Item.* That settles it—broadcasting does not compete with phonographs!

* * *

NEW BED-TIME STORIES

A PHILADELPHIA station broadcasts setting-up exercises at 10.30 p. m.—*News Item.*

For the night-watchmen, probably. Or perhaps Philly citizens sleep in two shifts of twelve hours each.

A Cartoonist's Idea of Radio



IT'S A FAST AGE.
(Murphy in the Beattie "Post-Intelligencer")

"Abe Martin" Likes It

MANY famous humorists have cast quizzical eyes towards radio and given the world the benefit of their wisdom in the form of a laugh or two. The latest recruit is "Abe Martin," one of the funniest of the times. His specialty is "rural stuff" and he knows farmers and their thoughts as well as any expert on the subject. That is why his notes about the radio telephone are interesting, and needless to say, amusing.

In *Farm Life* he writes

"Fer years an' years th' most serious drawback t' farmin', next t' th' hard work an' element o' chance, has been that it isolates a feller an' keeps him out o' touch with th' affairs o' th' world.

"It wuz hard fer 'em t' remember who th' president o' th' United States wuz, an' they didn't know whether ther friends an' relatives wuz dead or alive unless a letter or newspaper wormed thro', or by chance they got t' town.

"We believe that next t' th' harvestin' machine an' a pump in th' kitchen th' best an' so fer th' cheapest thing that's happened fer th' farmer in many a day is th' invention o' th' radio phone.

"Th' radiophone's performances already have proclaimed th' end o' isolation. Th' farmer no longer has t' drive t' town, or entertain a house full o' hungry relatives, or depend on a day-old newspaper fer his news o' th' outside world.

"Th' farmer an' his family may now know when a car is stolen from in front o' th' courthouse, or when a schoolhouse is burnin' up, or when a treaty is signed, as soon as th' ether waves kin deliver th' news.

"After a hard day o' toil th' farmer, without even changin' his collar or rollin' down his sleeves, kin tune in an' take his pick out o' ever'thing in th' air.

"An' all about him sits his family t' hear what's goin' on in th' world in th' way o' news, singin', music an' oratory.

"If they tire o' th' 'Wabash Blues' they kin tune in a lecture on onion culture, or th' treatment o' hog cholera.

"It's no uncommon thing t' jest innocently tune in on a fine helpful sermon from Pittsburg or Wheelin', a' it's no trouble t' tune off o' it.

"But ther's no longer any excuse fer folks that are imprisoned on remote farms t' git behind on th' affairs o' th' world—not t' be able t' whistle th' latest airs, t' know when th' President misses a chance to play golf, t' keep track o' th' bonus bill an' all th' latest gossip about prosperity."

A Veritable Barrage of Humor Is Being Loosened By OUR OWN WEEKLY RAVINGS

BEATRICE NICNAC, FAMOUS EXPERT ON HOUSEHOLD MATTERS, GIVES AN ABSORBING TALK TO THE LADIES ON "HOW TO MAKE FUTE THINGS OUT OF YOUR HUSBAND'S OLD CLOTHES"



—New York Evening Mail

SNOODLES

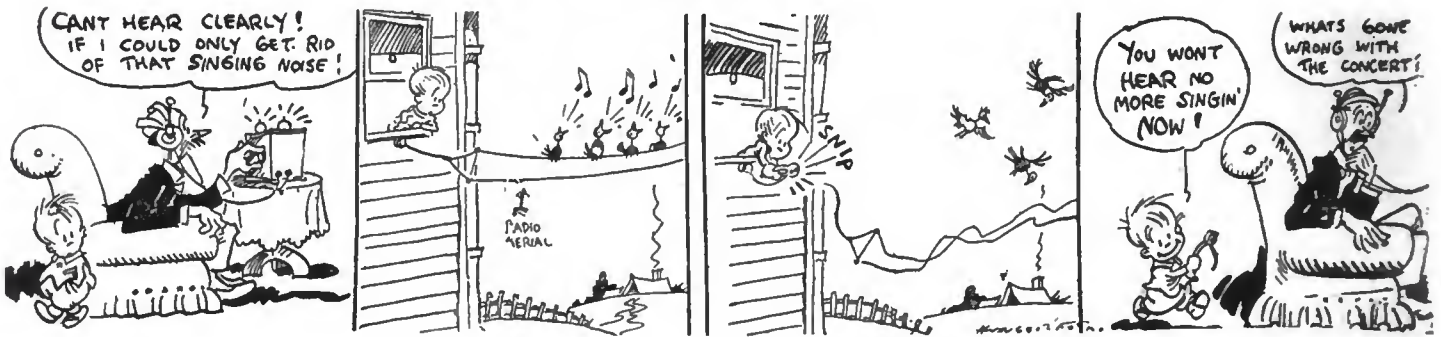

—New York Evening Mail

CICERO SAPP



—N. Y. World

HANDY MAN AROUND THE HOUSE



—N. Y. Tribune

Cartoonists of the Metropolis on Radio These Days

PETEY

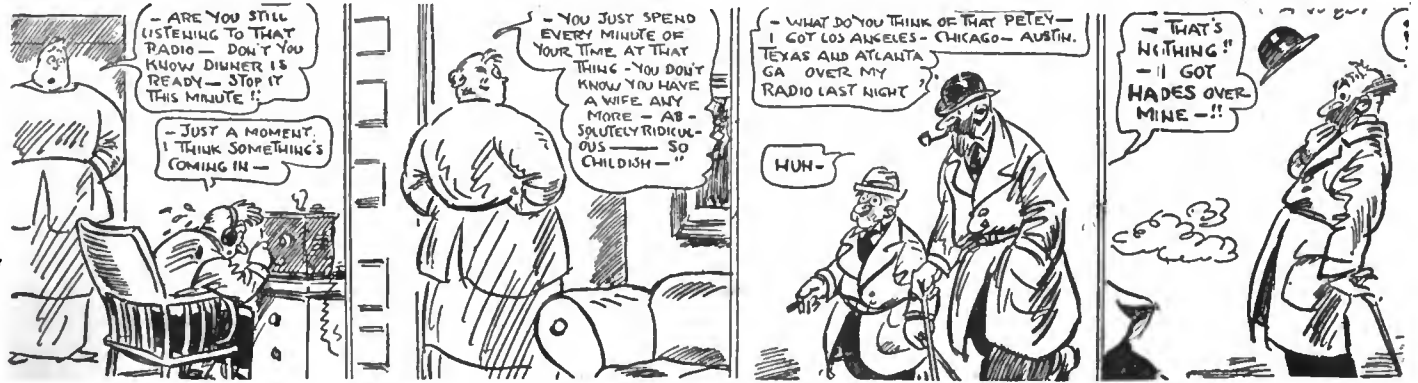

-New York Evening Mail

MUTT AND JEFF

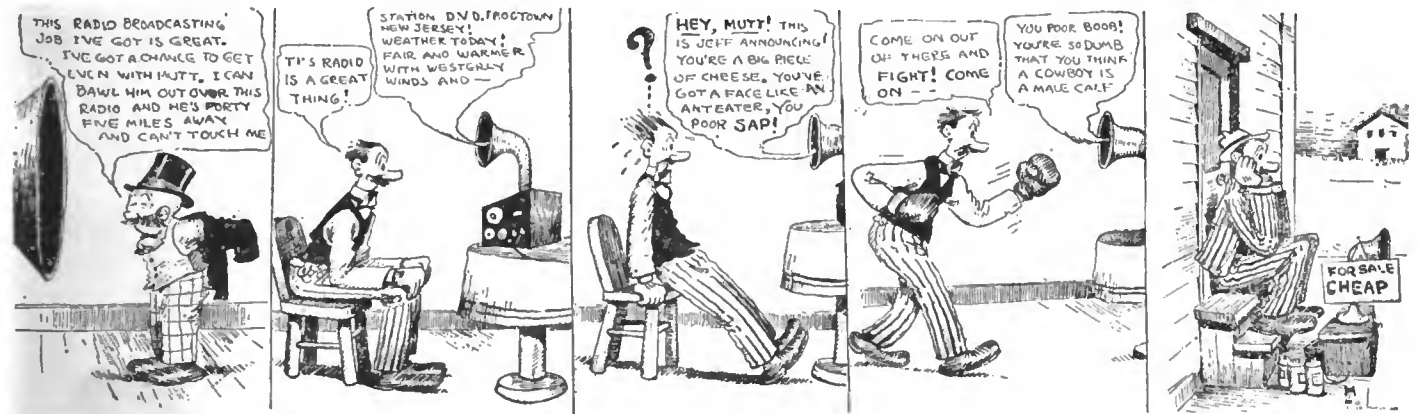

-N. Y. World

SIMEON BATTS

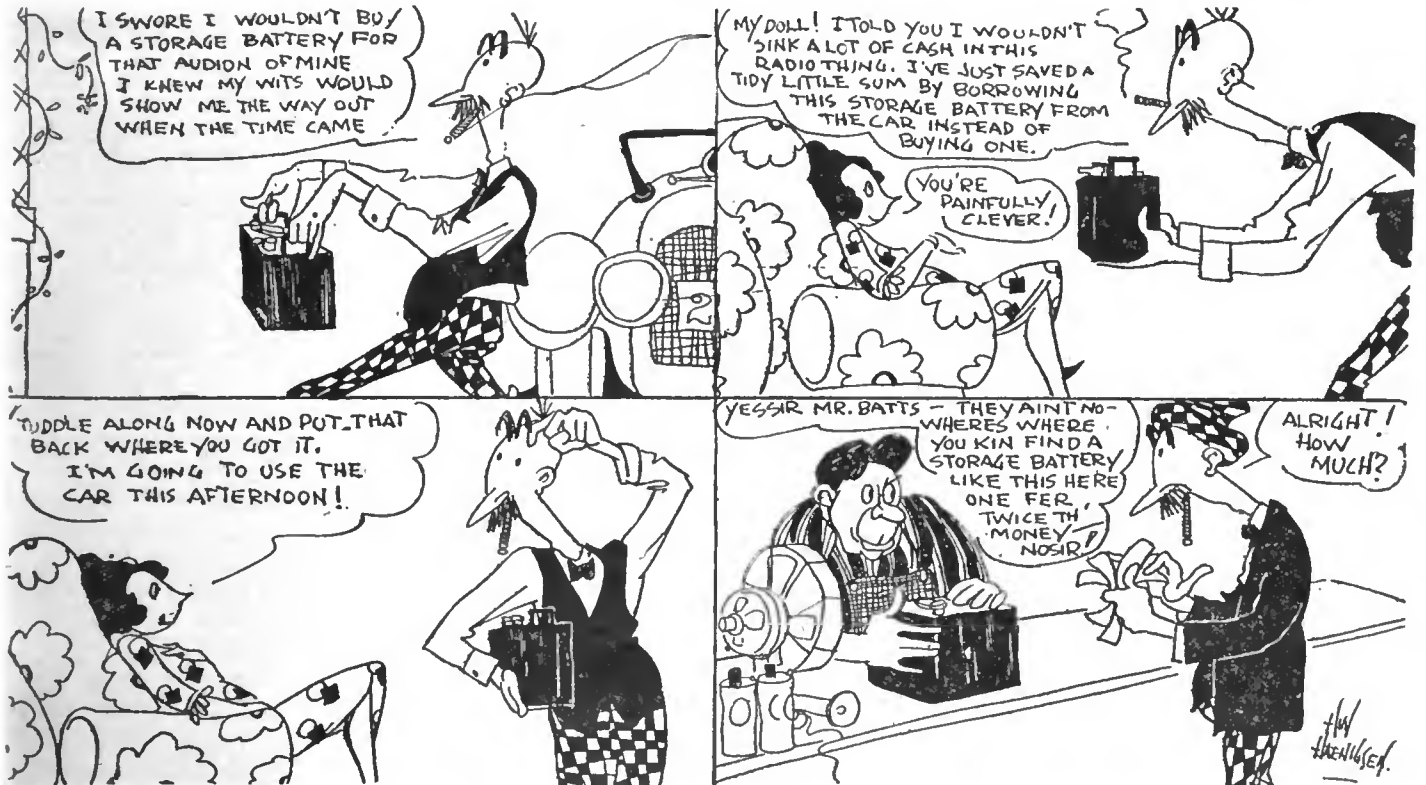

-New York Evening Mail

BROADCASTING STATION DIRECTORY

(Revised to November 25, 1922)

Class B stations, broadcasting on 400 meters, are designated by *

KAD	Young Men's Christian Association, Denver, Colo.	KFAQ	City of San Jose, San Jose, Calif.	WPD	United Equipment Co., Memphis, Tenn.
KDN	Leo U. Meyberg Co., San Francisco, Calif.	KFAR	O. K. Olsen, Hollywood, Calif.	WQX	Walter A. Kushi, Chicago, Ill.
KFC	Northern Radio & Electric Co., Seattle, Wash.	KFAS	Rene Motor Supply Co., Reno, Nev.	WRK	Doron Brothers Electric Co., Hamilton, Ohio
KFY	E. C. Anthony, Los Angeles, Calif.	KFAT	Dr. S. T. Donohue, Eugene, Ore.	WRL	Union College, Schenectady, N. Y.
KFV	Foster Bradbury Radio Store, Yakima, Wash.	KFAV	Independent School District, Boise City, Idaho	WRM	University of Illinois, Urbana, Ill.
KFZ	Theatre Music Co., San Diego, Calif.	KFAW	Cooke & Chapman, Venice, Calif.	WRR	Federal Institute of Radio Telegraphy, Camden, N. J.
KGB	Doerr Mitchell Elec. Co., Spokane, Wash.	KFAY	The Radio Den, Ashford & Whitia, Santa Anna, Calif.	WRP	City of Dallas (Police and Fire Signal Department), Dallas, Tex.
KGF	Wm. A. Mullins Electric Co., Tacoma, Wash.	KFBB	W. J. Virgin Milling Co., Central Point, Ore.	WRW	Tarrytown Radio Research Laboratory, Tarrytown, N. Y.
KGG	Hallock & Watson Radio Service, Portland, Ore.	KFBC	F. A. Buttrey & Co., Hays, Mont.	*WSS	Atlanta Journal, Atlanta, Ga.
KGN	Preston D. Allen, Oakland, Calif.	KFBD	C. W. Azbill, San Diego, Calif.	WSL	J. & M. Electric Co., Utica, N. Y.
KGO	Northwestern Radio Mfg. Co., Portland, Ore.	KFBE	Clarence V. Welch, Hanford, Calif.	WSN	Ship Owners Radio Service, Norfolk, Va.
KGU	Altadena Radio Laboratory, Altadena, Calif.	KFBH	Thomas Musical Co., Marshall, Idaho	WSV	L. M. Hunter and G. L. Carrington, Little Rock, Ark.
KGW	M. A. Mulrooy, Honolulu, Hawaii	KFBJ	Boise Radio Supply Co., Boise, Idaho	WSY	Eric Radio Co., Erie, Pa.
KWV	Oregonian Publishing Co., Portland, Ore.	KFBK	Kimball-Upton Co., Sacramento, Calif.	WSZ	Alabama Power Co., Birmingham, Ala.
KWY	Portable Wireless Telephone Co., Stockton, Calif.	KFBL	Lease Brothers, Everett, Wash.	WTG	Marshall-Oerken Co., Toledo, Ohio
KXY	St. Martin's College, Lacey, Wash.	KFBM	Cook & Foster, Astoria, Ore.	WTK	Kansas State Agr. College, Manhattan, Kans.
KXD	Aldrich Marble & Granite Co., Colorado Springs, Colo.	KFBN	Borch Radio Corporation, Oakland, Calif.	WTF	Paria Radio Electric Co., Paria, Tex.
KXH	Los Angeles Times, Los Angeles, Calif.	KFBS	Savage Electric Co., Prescott, Ariz.	WTP	George M. McBride, Bay City, Mich.
KXJ	Louis Wasmor, Seattle, Wash.	KFCB	Chronicle News and Oas & Elec. Supply Co., Trinidad, Colo.	WTP	Signal Corps, Radio's Island, N. Y. Harbor, N. Y.
KXK	Standard Radio, Los Angeles, Calif.	KFCV	Rishon N. S. Thomas, Laramie, Wyo.	WUB	Daily News Printing Co., Canton, Ohio
KXL	The Radio Shop, Sunnyvale, Calif.	KFCW	Clarence O. Ford, Colorado Springs, Colo.	WUC	Ford Motor Co., Dearborn, Mich.
KXN	C. O. Gould, Stockton, Calif.	KFCX	Nilsen Radio Supply Co., Phoenix, Ariz.	*WVJ	The Detroit News, Detroit, Mich.
KXR	Vincent I. Kraft, Seattle, Wash.	KFCY	Auto Supply Co., Wallace, Idaho	WVW	Lovola University, New Orleans, La.
KXS	Rible Institute of Los Angeles, Inc., Los Angeles, Calif.	KFCZ	Salem Elec. Co., Salem, Ore.	WVZ	John Wansmaker, New York, N. Y.
KLB	J. J. Dunn & Co., Los Angeles, Calif.	KFCF	Frank A. Moore, Walla Walla, Wash.	WAA	Vaidmar Jensen, New Orleans, La.
KLN	Norgie Electric Works, Monterey, Calif.	KFCG	Electric Service Station, Billings, Mont.	WAA	Tulane University, New Orleans, La.
KLP	Collin B. Kennedy Co., Los Altos, Calif.	KFCJ	Colorado Springs Radio Co., Colorado Springs, Colo.	WAA	Ohio Mechanics Institute, Cincinnati, Ohio
KLS	Warner Brothers, Oakland, Calif.	KFCK	Adrian Radio Store, Colorado Springs, Colo.	WAA	Chicago Daily Drivers' Journal, Chicago, Ill.
KLX	Tribune Publishing Co., Oakland, Calif.	KFCA	Mercantile Trust Co., San Francisco, Calif.	WAA	Shiloh Electric Co., Shreveport, La.
KLZ	Raynolds Radio Co., Denver, Colo.	KFDB	St. Michael's Cathedral, Boise, Idaho	WAA	Commonwealth Electric Co., St. Paul, Minn.
KMC	Lindsay-Weatherill & Co., Readley, Calif.	KFDD	The City of Taft, Taft, Calif.	WAA	Eastern Radio Institute, Boston, Mass.
KMD	San Joaquin Light & Power Co., Fresno, Calif.	KFDE	Meier & Frank Co., Portland, Ore.	WAA	Beulah Electric Co., Minneapolis, Minn.
KME	Lois Electric Co., Tacoma, Wash.	KFDF	Billings Polytechnic Institute, Polytechnic, Mont.	WAA	Omberl Brothers, Milwaukee, Wis.
KMI	T. W. Smith, Eureka, Calif.	KFEG	Midland Refining Co., El Dorado, Kans.	WAA	L. B. Nelson Co., Newark, N. J.
KMJ	Boswell Public Service Co., Boswell, N. M.	KFEH	D. & H. Radio Co., Anthony, Kans.	WAA	University of Missouri, Columbia, Mo.
KMK	Bullek's, Los Angeles, Calif.	KFEI	James I. Bush Store, Tucson, Ariz.	WAA	Radio Service Co., Charleston, W. Va.
KMN	North Coast Products Co., Aberdeen, Wash.	KFEJ	Midland Refining Co., St. Louis, Mo.	WAA	Otto W. Taylor, Wichita, Kans.
KMV	Radio Supply Co., Los Angeles, Calif.	KFEK	T. H. May, Inc., Newark, N. J.	WAA	New England Motor Sales Co., Greenwich, Conn.
KMW	Electric Lighting Supply Co., Los Angeles, Calif.	KFEI	Southern Radio Corporation, Charlotte, N. C.	WAA	Oroves-Thornton Hardware Co., Huntington, W. Va.
KMX	Y. M. C. A. College of Agriculture, Denver, Colo.	KFEJ	City of Chicago, Chicago, Ill.	WAA	Georgia Radio Co., Deatur, Ga.
KDB	Mechanical Arts, State College, N. Mex.	KFEK	Westinghouse Elec. & Mfg. Co., Springfield, Mass.	WAA	Athens Radio Co., Athens, Ohio
KDG	Western Radio Electric Co., Los Angeles, Calif.	KFEI	Findley Electric Co., Minneapolis, Minn.	WAA	Omaha Grain Exchange, Omaha, Neb.
KDN	Halwasser, Inc., San Diego, Calif.	KFEI	St. Albans, N. H.	WAA	Radio Service Corp., Crafton, Pa.
KDP	Detroit Police Dept., Detroit, Mich.	KFEI	Stir-Baker-Fuller Co., New Haven, Conn.	WAA	Yahrling-Rayner Piano Co., Youngstown, Ohio
KDQ	Modesto Evening News, Modesto, Calif.	KFEI	University of Texas, Austin, Tex.	WAA	Kelly-Vavter Jewelry Co., Marshall, Md.
KDR	Hale Brothers, San Francisco, Calif.	KFEI	Clark University, Worcester, Mass.	WAA	Yankton College, Yankton, S. D.
KDS	University of California, Berkeley, Calif.	KFEI	Detroit Free Press, Detroit, Mich.	WAA	Indian Pipe Line Corp., Princeton, Ind.
KDT	Bliss Diamond Electric Co., Hood River, Ore.	KFEI	Church of the Covenant, Washington, D. C.	WAA	Purdue University, West Lafayette, Ind.
KDV	Doubladay-Hill Electric Co., Pittsburgh, Pa.	KFEI	Ship Owners Radio Service, New York, N. Y.	WAA	Andrew J. Potter, Syracuse, N. Y.
KDW	Charles D. Herrold, San Jose, Calif.	KFEI	John O. Yesser, Jr., Omaha, Neb.	WAA	Sterling Electric Co. and Journal Printing Co., Minneapolis, Minn.
KDX	Stubbs Electric Co., Portland, Ore.	KFEI	James I. Bush Store, Tucson, Ariz.	WAA	Fred M. Middleton, Merristown, N. J.
KDY	Maxwell Electric Co., Berkeley, Calif.	KFEI	Benwood Co., St. Louis, Mo.	WAA	Diamond State Fibre Co., Bridgeport, Pa.
*KED	Post Dispatch, St. Louis, Mo.	KFEI	Midland Refining Co., Tulsa, Okla.	WAA	The Dayton Co., Minneapolis, Minn.
KEL	The Emporium, San Francisco, Calif.	KFEI	Hurlbut-Still Electrical Co., Houston, Tex.	WAA	Marshall-Oerken Co., Toledo, Ohio
KEM	Public Radio Lab., Los Angeles, Calif.	KFEI	St. Louis University, St. Louis, Mo.	WAA	Wireless Phone Corp., Paterson, N. J.
KEN	First Presbyterian Church, Seattle, Wash.	KFEI	Strawbridge & Clether, Philadelphia, Pa.	WAA	James Millikin University, Decatur, Ill.
KEO	The Examiner Printing Co., San Francisco, Calif.	KFEI	The Rike Kumlir Co., Dayton, Ohio	*WBA	The States Telegram, Fort Worth, Tex.
KEP	City Dye Works & Laundry Co., Los Angeles, Calif.	KFEI	Coe Radio Co., Wichita, Kans.	WBA	Republican Publishing Co., Hamilton, Ohio
KEQ	Coast Radio Co., Del Monte, Calif.	KFEI	American Radio and Research Corporation, Medford Hillside, Mass.	WBA	Erner & Hopkins Co., Cincinnati, Ohio
KER	J. C. Hoberg, Sacramento, Calif.	KFEI	Thomas F. J. Hewlett, Philadelphia, Pa.	WBA	Marietta College, Marietta, Ohio
KES	Los Angeles Examiner, Los Angeles, Calif.	KFEI	Atlanta Constitution, Atlanta, Ga.	WBA	John H. Stenger, Jr., Wilkes-Barre, Pa.
KET	Harold Publishing Co., San Francisco, Calif.	KFEI	Federal Tel. & Tel. Co., Buffalo, N. Y.	*WBA	American Tel. & Tel. Co., New York, N. Y.
KEU	Bread Corporation, Los Angeles, Calif.	KFEI	Interstate Electric Co., New Orleans, La.	WCB	Newburg News Printing & Publishing Co., Newburg, N. Y.
KEV	Radio Service Bur., Inc., Portland, Ore.	KFEI	General Electric Co., Schenectady, N. Y.	WCA	John Fink Jewelry Co., Fort Smith, Ark.
KFY	Alfred Harrell, Bakersfield, Calif.	KFEI	University of Wisconsin, Madison, Wis.	WCA	St. Lawrence University, Canton, Ohio
KFZ	Leo J. Meyberg Co., Los Angeles, Calif.	KFEI	Sweeney School Co., Kansas City, Mo.	WCA	Kaufman & Bear Co., Pittsburgh, Pa.
*KYA	Electric Shop, Honolulu, T. H.	KFEI	West Virginia University, Morgantown, W. Va.	WCA	Entrakia Electric Co., Columbus, Ohio
KYB	Westinghouse Electric & Mfg. Co., Chicago, Ill.	KFEI	Warren E. Cox, Cleveland, Ohio	WCA	Nebraska Wesleyan University, University Pl., Neb.
KYC	The Radio Telephone Sbp., San Francisco, Calif.	KFEI	Ridgewood Times Printing & Pub. Co., Ridgewood, N. Y.	WCA	Alfred P. Daniel, Houston, Tex.
KYD	The Desert News, Salt Lake City, Utah	KFEI	Stewart V. Seelye, East Lansing, Mich.	WCA	St. Olaf College, Northfield, Minn.
KYE	Wenatchee Battery & Motor Co., Wenatchee, Wash.	KFEI	Iowa Radio Corporation, Des Moines, Iowa	WCA	Villanova College, Villanova, Pa.
KYF	Atlantic Pacific Radio Supplies Co., Oakland, Calif.	KFEI	K. & L. Electric Co., McKeesport, Pa.	WCA	Sanders & Stayman Co., Baltimore, Md.
*KDKA	Westinghouse Electric & Mfg. Co., Pittsburgh, Pa.	KFEI	Continental Electric Supply Co., Washington, D. C.	WCA	Daily States Publishing Co., New Orleans, La.
KDY	Southern Electric Co., San Diego, Calif.	KFEI	Cine Radio Mfg. Co., Cincinnati, Ohio	WCA	Tri-State Radio Mfg. & Supply Co., Defiance, Ohio
KDZ	Telegram Publishing Co., Salt Lake City, Utah	KFEI	Richard H. Howe, Granville, Ohio	WCA	Akamo Radio Electric Co., San Antonio, Tex.
KD1	Barry Electric Co., San Diego, Calif.	KFEI	White & Boyer, Washington, D. C.	WCA	William Hood Dunwoody Industrial Institute, Minneapolis, Minn.
KD2	Great Western Radio Corp., Redwood City, Calif.	KFEI	Service Radio Equipment Co., Toledo, Ohio	WCA	South Dakota State School of Mines, Rapid City, S. Dak.
KD3	Carson & Simpson, San Diego, Calif.	KFEI	DeForest Radio Tel. & Tel. Co., New York, N. Y.	WCA	Philadelphia Radiophone Co., Philadelphia, Pa.
KD4	Oregon Institute of Technology, Portland, Ore.	KFEI	Radio Corporation of America—Westinghouse	WCA	J. C. Dies Electric Co., Little Rock, Ark.
KD5	Pasadena Star News Pub. Co., Pasadena, Calif.	KFEI	Landau Music & Jewelry Co., Wilkes-Barre, Pa.	WCA	University of Vermont, Burlington, Vt.
KD6	The Tribune, Inc., Great Falls, Mont.	KFEI	Joseph M. Zamolski Co., Baltimore, Md.	WCA	Kesselmeier-Drescoll Co., Milwaukee, Wis.
KD7	Herald Publishing Co., Klamath Falls, Ore.	KFEI	Riechman-Crosby Co., Memphis, Tenn.	WCA	Robert E. Compton, Carthage, Ill.
KD8	Cape & Cornwall Co., Salt Lake City, Utah	KFEI	Oklahoma Radio Shop, Oklahoma City, Okla.	WCA	Ward-Belmont School, Nashville, Tenn.
KD9	Smith Hughes & Co., Phoenix, Ariz.	KFEI	University of Minnesota, Minneapolis, Minn.	WCA	Illinois Watch Co., Springfield, Ill.
KD0	Star Bulletin Publishing Co., Honolulu, T. H.	KFEI	Hamilton Mfg. Co., Indianapolis, Ind.	WDA	Tampa Daily Times, Tampa, Fla.
KD1	Arizona Daily Star, Tucson, Ariz.	KFEI	Crosley Mfg. Co., Cincinnati, Ohio	*WDA	Kansas City Star, Kansas City, Mo.
KD2	Frank E. Siefert, Bakersfield, Calif.	KFEI	Arrow Radio Laboratories, Anderson, Ind.	WDA	Mine & Smelter Supply Co., El Paso, Tex.
KD3	KDZD W. R. Mitchell, Los Angeles, Calif.	KFEI	WMA Auburn, Me.	WDA	Hughes Electrical Corp., Syracuse, N. Y.
KD4	The Rhodes Co., Seattle, Wash.	KFEI	WMC Columbia Radio Co., Youngstown, Ohio	WDA	Atlanta & West Point B. R. Co., College Park, Ga.
KD5	Automobile Club of So. Calif., Los Angeles, Calif.	KFEI	WMD Precision Equipment Co., Cincinnati, Ohio	WDA	The Courant, Hartford, Conn.
KD6	Cyrus Peirce & Co., San Francisco, Calif.	KFEI	WME Doubladay-Hill Electrical Co., Pittsburgh, Pa.	WDA	Florida Times Union, Jacksonville, Fla.
KD7	Fresno Evening Herald, Fresno, Calif.	KFEI	WNJ Shotton Radio Mfg. Co., Albany, N. Y.	WDA	Weston Electric Co., New York, N. Y.
KD8	Electric Supply Co., Wenatchee, Wash.	KFEI	WND Wireless Telephone Co. of Hudson County, N. J.	WDA	Olenwood Radio Corp., Shreveport, La.
KD9	Kevador Radio Co., Eugene, Ore.	KFEI	*WDC Palmer School of Chiropractic, Davenport, Iowa	WDA	Automotive Electric Co., Dallas, Tex.
KD0	Excelsa Machinery & Electric Co., Reno, Nev.	KFEI	WDE Ruckey's Radio Service Co., Philadelphia, Ind.	WDA	Midwest Radio Central, Inc., Chicago, Ill.
KD1	Rocky Mountain Radio Corp., Orden, Utah	KFEI	WDH Halford Electric Co., Indianapolis, Ind.	WDA	Hartman-Riker Elec. & Mash. Co., Brownsville, Pa.
KD2	E. A. Hollingworth, Centralia, Wash.	KFEI	WDI Iowa State College, Ames, Iowa	WDA	St. Brothers, Philadelphia, Pa.
KD3	Newberry Electric Corporation, Los Angeles, Calif.	KFEI	WDK Arkansas Light & Power Co., Pine Bluff, Iowa	WDA	Florida Times Union, Jacksonville, Fla.
KD4	William D. Pyle, Denver, Colo.	KFEI	*WDD John Wansmaker, Philadelphia, Pa.	WDA	Weston Electric Co., New York, N. Y.
KD5	Bellingham Publishing Co., Bellingham, Wash.	KFEI	WDE Western Radio Co., Kansas City, Mo.	WDA	Olenwood Radio Corp., Shreveport, La.
KD6	Seattle Radio Association, Seattle, Wash.	KFEI	WDF Arrow Radio Laboratories, Anderson, Ind.	WDA	Automotive Electric Co., Dallas, Tex.
KD7	Western Radio Corporation, Denver, Colo.	KFEI	WDM WMA Auburn, Me.	WDA	Midwest Radio Central, Inc., Chicago, Ill.
KD8	Cope & Cornwall Co., Salt Lake City, Utah	KFEI	WDM Columbia Radio Co., Youngstown, Ohio	WDA	Hartman-Riker Elec. & Mash. Co., Brownsville, Pa.
KD9	Claude W. Oerdes, San Francisco, Calif.	KFEI	WDM Precision Equipment Co., Cincinnati, Ohio	WDA	St. Brothers, Philadelphia, Pa.
KD0	Oxid Tidings Tabernacle, San Francisco, Calif.	KFEI	WDM Doubladay-Hill Electrical Co., Pittsburgh, Pa.	WDA	Florida Times Union, Jacksonville, Fla.
KD1	Kinney Brothers & Sippell, Portland, Ore.	KFEI	WNJ Shotton Radio Mfg. Co., Albany, N. Y.	WDA	Weston Electric Co., New York, N. Y.
KD2	Pacific Radiophone Co., Portland, Ore.	KFEI	WND Wireless Telephone Co. of Hudson County, N. J.	WDA	Olenwood Radio Corp., Shreveport, La.
KD3	KFAE Glendale Daily Press, Glendale, Calif.	KFEI	*WDR W. R. Rambarger Co., Newark, N. J.	WDA	Automotive Electric Co., Dallas, Tex.
KD4	KFAF McArthur Brothers Mercantile Co., Phoenix, Ariz.	KFEI	WDU Metropolitan Utilities District, Omaha, Neb.	WDA	Midwest Radio Central, Inc., Chicago, Ill.
KD5	KFAE State College of Washington, Pullman, Wash.	KFEI	WDZ Palladium Printing Co., Richmond, Ind.	WDA	Hartman-Riker Elec. & Mash. Co., Brownsville, Pa.
KD6	KFAF Western Radio Corporation, Denver, Colo.	KFEI	WPA Fort Worth Record, Fort Worth, Tex.	WDA	St. Brothers, Philadelphia, Pa.
KD7	KFAJ University of Colorado, Boulder, Colo.	KFEI	WPE Central Radio Co., Kansas City, Mo.	WDA	Florida Times Union, Jacksonville, Fla.
KD8	KFAJ Electric Shop, Moscow, Idaho	KFEI	WPG Nushawg Poultry Farm, New Lebanon, Ohio	WDA	Weston Electric Co., New York, N. Y.
KD9	KFAF Standard Publishing Co., Butte, Mont.	KFEI	WPI Electric Supply Co., Clearfield, Pa.	WDA	Olenwood Radio Corp., Shreveport, La.
		KFEI	WPJ St. Joseph's College, Philadelphia, Pa.	WDA	Automotive Electric Co., Dallas, Tex.
		KFEI	WPM Thomas J. Williams, Washington, D. C.	WDA	Midwest Radio Central, Inc., Chicago, Ill.

WEAD Northwest Kansas Radio Sup. Co. Atwood, Kans.	WHAP Dewey L. Otta. Decatur, Ill.	WLAO Anthracite Radio Shop. Scranton, Pa.
WEAF Virginia Polytechnic Institute. Blacksburg, Va.	WHAG Semmes Motor Co. Washington, D. C.	WLAB W. F. Jordan. Louisville, Ky.
WEAF Western Electric Co. New York, N. Y.	WHAR Paramount Radio & Elec. Co. Atlantic City, N. J.	WLAQ Mike's Music Co. Kalamazoo, Mich.
WEAG Niacus-Hines-Bassett. Edgewood, R. I.	WHAS Courier Journal & Louisville Times. Louisville, Ky.	WLAR Hutchinson Grain Radio Co. Hutchinson, Kans.
WEAH Wichita Beard of Trade & Landers Radio Co. Wichita, Kans.	WHAT Yale Democrat & Yale Tel. Co. Yale, Okla.	WLAT Chas. G. Bosch Co. Burlington, Iowa
WEAI Cornell University. Ithaca, N. Y.	WHAV Wilmington Elec. & Supply Co. Wilmington, Del.	WLAV Electric Shop, Inc. Panama City, Fla.
WEAL University of South Dakota. Vermillion, S. Dak.	WHAW Pierce Electric Co. Tampa, Fla.	WLAW New York Police Dept. New York City, N. Y.
WEAK J. B. Abercrombie. St. Joseph, Mo.	WHAX Huntington Press. Huntington, W. Va.	WLAX Greenoast Community Broadcasting Station. Greenoast, Ind.
WEAM Borough of North Plainfield. North Plainfield, N. J.	*WHAZ Renneiser Polytechnic Institute. Troy, N. Y.	WLAY Northern Commercial Co. of Alaska. Fairbanks, Alaska
WEAN Shepard Company. Providence, R. I.	WIAA Waupaca Civic & Commerce Assn. Waupaca, Wis.	WLAZ Hutten & Jones Elec. Co. Warren, Ohio
WEAO Ohio State University. Columbus, Ohio	WIAB Joslyn Automobile Co. Rockford, Ill.	WLAB Radio Supply Co. Oklahoma City, Okla.
WEAP Mobile Radio Co., Inc. Mobile, Ala.	WIAO Ocean City Yacht Club. Ocean City, N. J.	WMAC F. Edward Page. Casewell, N. Y.
WEAQ Y. M. C. A. Berlin, N. H.	WIAE Mrs. Robt. E. Zimmerman. Venton, Ia.	WMAF Round Hills Radio Corp. Dartmouth, Mass.
WEAR Baltimore Am. & News Pub. Co. Baltimore, Md.	WIAF Gustav A. DeCortin. New Orleans, La.	WMAJ Tucker Electric Co. Liberal, Kans.
WEAS Heat Company. Washington, D. C.	WIAH Matthews Electric Supply Co. Birmingham, Ala.	WMAK General Supply Co. Lincoln, Nebr.
WEAT John J. Peary. Tampa, Fla.	WIAI Hoers Stores Co. Springfield, Mo.	WMAJ Drivers Telegram Co. Kansas City, Mo.
WEAU Davidson Brothers Co. Sioux City, Iowa	WIAJ Fox River Valley Radio Supply Co. Neenah, Wis.	WMAK Norton Laboratories. Leokport, N. Y.
WEAV Sheridan Electric Service Co. Bushville, Nebr.	WIAK The Stockman Journal. Omaha, Nebr.	WMAM Trenton Hardware Co. Trenton, N. J.
WEAW Arrow Radio Laboratories. Anderson, Ind.	WIAN Chronicle & News Pub. Co. Allentown, Pa.	WMAN Beaumont Radio Equipment Co. Beaumont, Tex.
WEAY T. J. M. Daly. Little Rock, Ark.	WIAP J. A. Rudy & Sons. Paducah, Ky.	WMAP Round Street Baptist Church. Columbus, Ohio
WEAZ Will Horwitz, Jr. Houston, Tex.	WIAB Chronicle Publishing Co. Marion, Ind.	WMAQ Utility Battery Service. Basco, Pa.
WEAZ Donald Raymond. Waterloo, Iowa.	WIAB Burlington Hawkeye-Home Elec. Co. Burlington, Ia.	WMAQ The Chicago Daily News. Chicago, Ill.
WEAF A. H. Belo & Co. Dallas, Tex.	WIAT Leon T. Neal. Terkto, Mo.	WMAJ Waterloo Electrical Supply Co. Waterloo, Iowa
WEAF Carl F. Woese. Syracuse, N. Y.	WIAU American Sec. & Sav. Bank. Le Mars, Ia.	WMAJ Paramount Radio Corporation. Duluth, Minn.
WEAF Superior Radio Co. Superior, Mich.	WIAV New York Radio Laboratories. Binghamton, N. Y.	WMAV Louisiana State Fair Association. Shreveport, La.
WEAF Watson, Weldon Motor Supply Co. Saline, Kans.	WIAW Saginaw Radio & Elec. Co. Saginaw, Mich.	WMAV Alabama Polytechnic Institute. Auburn, Ala.
WEAF Benry C. Spratley. Poughkeepsie, N. Y.	WIAW Capital Radio Co. Lincoln, Nebr.	WMAV Walpoleton Elec. Co. Walpoleton, N. D.
WEAF Radio Engineering Laboratory. Waterloo, N. Y.	WIAW Woodward & Lothrop. Washington, D. C.	WMAX K. & K. Radio Supply Co. Ann Harbor, Mich.
WEAF Electrical Supply Co. Port Arthur, Tex.	WIAW Electric Supply Sales Co. Miami, Fla.	WMAJ Kingshighway Presby. Church. St. Louis, Mo.
WEAF Hi-Grade Wireless Instrument Co. Asheville, N. C.	WIAW American Radio Co. Lincoln, Nebr.	WMAJ Mercer University. Macon, Ga.
WEAF Houston Chronicle Pub. Co. Houston, Tex.	WIAW Rodoli Co. Joplin, Mo.	WMAJ Park City Daily News. Bowling Green, Ky.
WEAF Times Publishing Co. St. Cloud, Minn.	WIAW Jackson's Radio Eng. Lab. Waco, Tex.	WMAJ Shepard Stores. Boston, Mass.
WEAF Hutchinson Elec. Service Co. Hutchinson, Minn.	WIAE Texas Radio Syndicate. San Antonio, Tex.	WMAJ Enid Radio Distributing Co. Enid, Okla.
WEAF Brown's Business College. Peoria, Ill.	WIAE Huse Publishing Co. Norfolk, Nebr.	WMAJ Rathert Radio & Electric Co. Smith, Iowa
WEAF Missouri Wesleyan College and Cameron Radio Company. Cameron, Mo.	WIAH Central Park Amusement Co. Rockford, Ill.	WMAJ Manhattan Radio Supply Co. Manhattan, Kans.
WEAF Hall & Stubbs. Sanford, Me.	WIAH Y. M. C. A. Dayton, Ohio	WMAJ Benson Co. Chicago, Ill.
WEAF United Radio Corporation. Fort Wayne, Ind.	WIAH White Radio Laboratory. Rockdale, Ohio	WMAJ R. J. Rockwell. Omaha, Nebr.
WEAF Daily Argus Leader. Sioux Falls, S. D.	WIAH Victor Radio Corporation. Portland, Me.	WMAJ Ideal Apparatus Co. Evansville, Ind.
WEAF Edwin C. Lewis, Inc. Boston, Mass.	WIAM D. M. Perham. Cedar Rapids, Ia.	WMAJ Syracuse Radio Tele. Co. Syracuse, N. Y.
WEAF University of Nebraska. Lincoln, Nebr.	WIAN Peoria Star & Peoria Radio Sales Co. Peoria, Ill.	WMAJ Wittenberg College. Springfield, Ohio
WEAF Miami Daily Metropolis. Miami, Fla.	WIAJ Kelly-Duluth Co. Duluth, Minn.	WMAJ Charleston Radio Elec. Co. Charleston, S. C.
WEAF Arthur L. Kent. Independence, Kans.	WIAJ The Outlet Co. Providence, R. I.	WMAJ C. C. Rhodes. Butler, Mo.
WEAF Daniels Radio Supply Co. Independence, Kans.	WIAJ Pittsburgh Radio Supply House, Pittsburgh, Pa.	WMAJ Texas Radio Corporation and Austin Statesman, Austin, Tex.
WEAF South Carolina Radio Shop. Charleston, S. C.	WIAJ The Union Trust Co. Cleveland, Ohio	WMAJ People's Tel. & Tel. Co. Philadelphia, Pa.
WEAF QBV Radio Co. Houston, Tex.	WIAJ Chicago Radio Laboratory. Chicago, Ill.	WMAJ Henry Kunsman. Knoxville, Tenn.
WEAF Orpheum Radio Stores Co. Brooklyn, N. Y.	WIAJ H. F. Paar & Republican Times. Cedar Rapids, Ia.	WMAJ Dakota Radio Apparatus Co. Ardmore, Okla.
WEAF Spanish Am. Schl. of Telegraphy. Enonada, P. R.	WIAJ Star Publishing Co. Lincoln, Nebr.	WMAJ Dr. Walter Hardy. Yankton, S. D.
WEAF Geller Radio Service. Tulsa, Okla.	WIAJ Charles Loof. East Providence, R. I.	WMAJ Valley Radio. Grand Forks, N. D.
WEAF New Haven Elec. Co. New Haven, Conn.	WIAJ W. S. Radio Supply Co. and Wm. Schack. Wichita Falls, Tex.	WMAJ Maus Radio Co. Lima, Ohio
WEAF W. H. Glass. Shenandoah, Iowa	WIAJ Edwin T. Bruce, M.D. Louisville, Ky.	WMAJ Friday Battery & Elec. Co. Sigourney, Iowa
WEAF Macon Electric Co. Macon, Ga.	WIAJ Planet Radio Co. West Palm Beach, Fla.	WMAJ Midland College. Fremont, Nebr.
WEAF Lancaster Elec. Supply & Const. Co. Lancaster, Pa.	WIAJ Fargo Plumbing & Heating Co. Fargo, N. D.	WMAJ Tyler Commercial College. Tyler, Tex.
WEAF Orangeburg Radio Equipment Co. Orangeburg, S. C.	WIAJ Okfuskee County News. Okemah, Okla.	WMAJ Adlio Theatre. San Antonio, Tex.
WEAF Cecil E. Lloyd. Pensacola, Fla.	WIAJ Gray & Gray. Orange, Tex.	WMAJ Southern Equipment Co. Parsons, Kans.
WEAF W. G. Patterson. Shreveport, La.	WIAJ Adam Breede, Hastings Daily Tribune. Hastings, Nebr.	WMAJ Penna. National Guard. Erie, Pa.
WEAF Southern American. Fort Smith, Ga.	WIAJ Alabama Radio Mfg. Co. Montgomery, Ala.	WMAJ Anderson & Webster Electric Co. Waco, Nebr.
WEAF Ray-di-co Organization. Chicago, Ill.	WIAJ Flint, Duffie Wilcox. Cranston, R. I.	WMAJ Pennsylvania State College. State College, Pa.
WEAF American Legion, Dept. of Nebr. Lincoln, Nebr.	WIAJ White Radio Laboratory. Lincoln, Nebr.	WMAJ Peterson's Radio Co. Council Bluffs, Iowa
WEAF Marcus G. Lumb. Wooster, Ohio	WIAJ Michigan Arri. College. East Lansing, Mich.	WMAJ Superior Radio & Tel. Equip. Co. Columbus, Ohio
WEAF Ernest C. Albright. Altoona, Pa.	WIAJ L. E. Lines Music Co. Springfield, Mo.	WMAJ Levy Bros. Dry Goods Co. Houston, Tex.
WEAF Radio Electric Co. Washington Courthouse, Ohio	WIAJ Frankfurt Morning Times. Frankfurt, Ind.	WMAJ Horace A. Beale, Jr. Parkersburg, Pa.
WEAF North Western Radio Co. Madison, Wis.	WIAJ Laconia Radio Club. Laconia, N. H.	WMAJ American Radio Co. Lincoln, Nebr.
WEAF South Bend Tribune. South Bend, Ind.	WIAJ Turner Cycle Co. Beloit, Wis.	WMAJ West Texas Radio Co. Abilene, Tex.
WEAF State University of Iowa. Iowa City, Ia.	WIAJ Wm. A. MacFarlane. Bridgeport, Conn.	WMAJ Jacob C. Thomas. David City, Nebr.
WEAF Clark W. Thompson. Galveston, Tex.	WIAJ Brenau College. Jacksonville, Ga.	WMAJ Americ Daily News. Americo, Tex.
WEAF Cole Brothers Elec. Co. Waterloo, Iowa	WIAJ North Carolina State College. Raleigh, N. C.	WMAJ Radio Sales Corporation. Scranton, Pa.
WEAF Marquette University. Milwaukee, Wis.	WIAJ Arvanetto Radio Supply Co. Hastings, Nebr.	WMAJ Clifford W. Vlek, Radio Construction Co. Houston, Tex.
WEAF Automotive Electric Service Co., Sioux City, Ia.	WIAJ Johnson Radio Co. Lincoln, Nebr.	WMAJ Agricultural & Mechanical College of Texas. College Station, Tex.
WEAF Radio Electric Co. Pittsburgh, Pa.	WIAJ Cutting & Washington Radio Corp. Minneapolis, Minn.	WMAJ Sanker Brothers. Waco, Tex.
WEAF University of Cincinnati. Cincinnati, Ohio	WIAJ Samuel Woodworth. Byrassau, N. Y.	WMAJ General Supply Co. Lincoln, Nebr.
WEAF J. T. Griffin. Joplin, Mo.	WIAJ Waco Electrical Supply Co. Waco, Tex.	WMAJ Woman Brothers. Laredo, Tex.
WEAF Radio Equipment & Mfg. Co. Davenport, Iowa	WIAJ Vermont Farm Mach. Co. Bellows Falls, Vt.	
WEAF Roberts Hardware Co. Clarkburg, W. Va.	WIAJ Tulsa Radio Co. Tulsa, Okla.	
WEAF Phillips, Jeffrey & Darby. Lansing, Mich.	WIAJ Morrow Radio Co. Springfield, O.	
WEAF School of Music, Rochester Univ., Rochester, N. Y.	WLAN Putnam Hardware Co. Houlton, Me.	
WEAF Southwestern Radio Co. Wichita, Kans.		
WEAF F. A. Hill. Savannah, Ga.		

*Class B. station broadcasting on 400 meters.

Canadian Broadcasting Stations

CFAC Radio Corporation of Calgary, Ltd. Calgary, Alberta	CHCB Marconi Wireless Telegraph Co. of Canada, Ltd. Toronto, Ontario	CJCH The United Farmers of Ontario, Toronto, Ontario
CFCA Star Publishing and Printing Co., Toronto, Ontario	CHCC Canadian Westinghouse Co., Ltd. Edmonton, Alberta	CJCI McLean, Holt & Co., Ltd., St. John, New Brunswick
CFCB Marconi Wireless Telegraph Co. of Canada, Ltd., Vancouver, B. C.	CHCF Radio Corporation of Winnipeg, Ltd., Winnipeg, Manitoba	CJCN Simons Agnew & Co., Toronto, Ontario
CFOD Canadian Westinghouse Co., Ltd., Winnipeg, Manitoba	CHCQ The Western Radio Co., Ltd., Calgary, Alberta	CJCS Eastern Telephone and Telegraph Co., Ltd., Halifax, Nova Scotia
CFCE Marconi Wireless Telegraph Co. of Canada, Halifax, Nova Scotia	CHCS London Radio Shoppes., London, Ontario	CJCY Edmund Taylor. Calgary, Alberta
CFCF Marconi Wireless Telegraph Co. of Canada, Ltd., Montreal, Quebec	CHCZ The Globe Printing Co., Toronto, Ontario	CJCC London Free Press Printing Co., Ltd., London, Ontario
CFCH Abitibi Power and Paper Co., Ltd., Iroquois Falls, Ontario	CHCJ B. L. Silver., Montreal, Quebec	CJNC Tribune Newspaper Co., Ltd., Winnipeg, Manitoba
CFCI Motor Products Corporation, Walkerville, Ontario	CHCK Canadian Westinghouse Co., Ltd., Hamilton, Ontario	CJSC The Evening Telegram., Toronto, Ontario
CFCN W. W. Grant Radio Ltd., Calgary, Alberta	CHCV Metropolitan Motors, Ltd., Toronto, Ontario	CKAC La Presse Publishing Co., Montreal, Quebec
CFCX The London Advertiser., London, Ontario	CHCX J. R. Booth, Jr., Ottawa, Ontario	CKCB T. Eaton Co., Ltd., Winnipeg, Manitoba
CFPC International Radio Development Co., Fort Frances, Ontario	CHCY Northern Electric Co., Montreal, Quebec	CKCD Vancouver Daily Province., Vancouver, B. C.
CFTC The Bell Telephone Co. of Canada, Toronto, Ontario	CJCB Dupuis Freres., Montreal, Quebec	CKCE Canadian Independent Telephone Co., Ltd., Toronto, Ontario
CFYC Victor Westworth Odium., Vancouver, B. C.	CJCA The Edmonton Journal, Ltd., Edmonton, Alberta	CKCR Jones Electric Radio Co., St. John, New Brunswick
CFZC Canadian Westinghouse Co., Ltd., Montreal, Quebec	CJCB James Gordon Bennett, Nelson, British Columbia	CKCS The Bell Telephone Co. of Canada, Montreal, Quebec
CHBC The Albertan Publishing Co., Calgary, Alberta	CJCC T. Eaton Co., Ltd., Toronto, Ontario	CKCZ Canadian Westinghouse Co., Ltd., Toronto, Ontario
CHCA Radio Corporation of Vancouver, Ltd., Vancouver, B. C.	CJCE Vancouver Sun Radiotelephones, Ltd., Vancouver, B. C.	CKCK Radio Equipment and Supply Co., Toronto, Ontario
	CJCF News Record, Ltd., Kitchener, Ontario	CKOC The Westworth Radio Supply Co., Hamilton, Ontario
	CJCG Manitoba Free Press Co., Ltd., Winnipeg, Manitoba	CKQC Radio Supply Co. of London., London, Ontario
		CKZC Salton Radio Engineering Co., Winnipeg, Manitoba

WORLD WIDE WIRELESS

High Power Stations for China

STEPS have been taken by the Radio Corporation of America for linking China directly with the United States by radio, and it is confidently expected that if the present plans are carried to a successful conclusion, at the end of two years regular radio service will be offered between the Pacific Coast and Shanghai. Tentative arrangements thus far made have progressed to such an extent as to lead to the formation of the Federal Telegraph Co. of Delaware by the Radio Corporation of America and the Federal Telegraph Co., which together plan to develop the new stations that will be erected in China, half the cost of which the Chinese government is to defray by issuing \$6,500,000 in bonds. R. P. Schwerin, president of the Delaware company, is now in China making final arrangements, accompanied by six radio engineers who are making the necessary preliminary technical surveys before work actually starts on the construction of the new stations.

Five stations are to be erected, the main one for trans-Pacific work at Shanghai. This will have 1,000 kilowatts of power, and present plans call for an antenna system using six steel masts at least 1,000 feet high. There will also be a 100 kw. transmitter at Shanghai, for the purpose of working with the other stations, located at Peking, Canton, and Harbin, the two former using 100 kw. transmitters, and at Harbin 200 kw. This will provide a comprehensive radio net linking the principal cities of China, and touching the edge of Siberia at Harbin in Manchuria. According to the present agreements in force, the new Federal Telegraph Company of Delaware is willing to take over the contracts and concessions which the Federal company has with the Republic of China, and, subject to obtaining certain modifications in these contracts, will immediately undertake to build the radio net just described.

The big station at Shanghai may be able to transmit its messages directly to the Pacific Coast, where it will work with the Radio Corporation of America's present stations. It will be able to reach all American radio stations in Pacific waters, including the R. C. A. station at Honolulu. Spanning the Pacific by a reliable radio ser-

vice, such as has been offered for a number of years between New York and Europe, will represent a new achievement in the art of wireless. At present it seems likely that the trans-Pacific service when ready will bridge the greatest distance to be crossed regularly by commercial radio. Present-day apparatus made the feat possible some time ago, and it only remains for business men and statesmen to reach the agreements that will make it possible for the constructional work to commence. About \$13,000,000 is the



During the recent airplane race around Great Britain the public was kept informed of the position of the pilots by radio telephone bulletins broadcast from Marconi House, London. The planes themselves reported by radio to London

estimated cost of the whole plant needed in China.

Great stress is laid on the importance of the new service. In bringing it thus far toward realization months of negotiations were necessary, involving officials of the Chinese government and the R. C. A. and Federal executives. The State Department at Washington likewise assisted in the work of arriving at the preliminary understandings, as it considered the new radio system of the highest importance. It will afford the first direct communication without the possibility of censorship or control by any other nation between China, where there are many important American interests. No American cable touches China, and communication by existing means is such that the State Department was compelled to ask the U. S. Navy to establish and operate Navy radio stations at Peking and other points in or-

der to secure quick and reliable transmission of official messages between Washington and the Legation at Peking. The system put in operation by the Navy, however, entails relays, messages being sent from Washington to San Francisco, from there relayed to the Philippines, and then again relayed to Peking. The new commercial service it is hoped will span the Pacific at a single leap.

RCA Sets "Letter" Rate

A "RADIOLETTER" service has been inaugurated by the Radio Corporation of America, which now offers a special rate of six cents a word for week-end messages to London and Germany. Messages taking this special rate may be filed any day of the week up to Saturday, and will be transmitted in time to reach their destinations on the following Monday morning. No minimum is set to the number of words, which is unusual in "letter" service, and thus it is possible for messages to be sent across the Atlantic for only a few cents more than the cost of a letter. A two-word address and a two-word message, without signature, for instance, would cost only 24 cents. Addresses may be in code, but the text of the message is restricted to plain language only. For the present the service is confined to London and Germany, and already it is being eagerly taken advantage of by business firms and private individuals.

New Marine Record at KPH

THE commercial station of the Radio Corporation of America near San Francisco, Cal., KPH, had a fine time last Summer breaking its hot-weather distance records with ships. The last one was made August 21, when it worked the S.S. *Maunganui* at a distance of 4,980 miles, when the ship was nearing Australia. The vessel was regularly worked every night from the time she left San Francisco until she was near Australia.

SAM Is Swedish

THE call SAM, which the uninitiated might think to be American, belongs to Sweden, and has just been assigned by that country to a new radio compass station opened at Hallo on the Skagerrak. The new station co-operates with SAB at Goteborg, in determining positions of vessels within a 150-mile radius, on 600 meters.

Chief of Staff A. E. F. to Be New RCA President

General James G. Harbord Elected to Presidency of Radio Corporation of America—Edward J. Nally, Takes Over Corporation's Foreign Affairs in Paris

MAJOR GENERAL JAMES G. HARBORD, Deputy Chief of Staff of the United States Army, becomes president of the Radio Corporation of America on January 1, 1923. His retirement from the Army, effective December 29, has been accepted by Secretary of War Weeks, who stated that the General will prove to be as great a leader in industry and commercial affairs as he has been in the military activities of the nation.

General Harbord succeeds Edward J. Nally who has resigned the presidency of the Radio Corporation to become its Managing Director of International Relations, with headquarters in Paris. Creation of this new office and the election of General Harbord took place November 17, when the RCA directors met to perfect the organization of plans of world-wide scope that have been maturing for some time. Mr. Nally, the retiring president, has been exceedingly active in the development of world-wide wireless, and his new position will give practically unlimited scope to his talents in that direction. RCA international relations have grown to such great importance as to necessitate the appointment of a responsible officer who will give his entire time to them, as well as develop them to a greater degree.

The new president, General Harbord, fills a post that is regarded as of vital importance to the government as well as to the public, since the Radio Corporation was formed at the suggestion of representatives of the United States Navy, in order that a single world-wide wireless communication company, free of foreign domination, might be built up under American ownership and control. The Radio Corporation, as is now well known, maintains reliable wireless communication with all the principal countries of the world, installs, maintains and operates radio apparatus on ships at sea, and develops and sells broadcast receiving sets for home use.

Radio, though highly developed, far beyond the dreams of the most far-sighted only a few years ago, is considered to be in its infancy, both in the domestic and foreign field, as is indicated by the appointment of two such strong executives as Mr. Nally and General Harbord to manage RCA affairs in these respective spheres. Mr. Nally has just returned from Europe, after several months' visit there, dur-

ing which he concluded arrangements with the great wireless concerns of England, France and Germany, by which the radio interests of the four great nations will act together in creating and operating international wireless communication with all parts of the world, but especially with South America.

The Radio Corporation of America has assumed the leadership of this consortium, which carries heavy responsibility to our own people and the world at large.

Mr. Nally, who has been in communication business all his life, has been a prominent figure in the development of radio in this country, and because of his familiarity with conditions abroad is especially qualified to represent the growing interests in the foreign field.

It is interesting to note that both Mr. Nally and General Harbord have risen from the ranks in their professions to positions of great responsibility, the one, from messenger boy for the Western Union Telegraph Co., and the other from a private in the U. S. Army. Both triumphed over early adversities and the difficulties of rising above the great mass of workers around them. Mr. Nally was born in 1859, the child of a successful and influential citizen, but only a few years later the failure of first his father's health and then of his business sent the young lad out to earn a living for the family. He had just one year's schooling. At sixteen he became a messenger boy for the Western Union in St. Louis. Coincidentally with his rise in this company went arduous study to make up for the lost schooling.

In 1890 he went to Chicago as assistant general superintendent of the Postal. Within a year he was made general superintendent. Five years later he was elected vice-president and director, and in 1907, vice-president and general manager, which position he held until 1913, when he retired.

Inactivity did not suit his energetic nature, however, and his far-sighted vision led him to accept the offer of the American Marconi Co. and become its vice-president and general manager in October, 1913, a few months later. This position he held until the Marconi Company was succeeded by the Radio Corporation of America, of which he was the first president.

General Harbord early aspired to a

military career, though he was unable to gratify his desire until 1899. He was born in Bloomington, Ill., in 1866, and was a farmer boy and then a country school teacher until, at the age of 23, he abandoned the school to enlist in Company A, 4th Infantry, U. S. A. From recruit he became private, corporal sergeant, and quartermaster sergeant, and in 1891 he was commissioned second lieutenant. He saw service in Cuba, Porto Rico and the Philippines. Some sixteen years of his army life were spent in foreign service, in which he won many distinctions.

He was appointed Lieutenant Colonel in 1917, and accompanied General Pershing to France as Chief of Staff, in which capacity he served during the period of organization of the A. E. F. When the time came for action he was assigned to the Marine Brigade of the Second Division, and commanded it in the Verdun sector and during the fighting in the Bois de Belleau and at Bouresches, during the stand of the Second Division near Château-Thierry, which stopped the German advance on Paris in June, 1918. He was promoted to Major General of the National Army July 14, 1918, assigned to the Second Division, and commanded it during the Soissons offensive, July 18 and 19. He returned to the United States November 11, 1919, and was assigned to the Second Division. He was promoted to Major General, U. S. A., September 8, 1919, and at the time of his retirement is the only officer of that rank on the active list who has risen from the ranks to become Deputy Chief of Staff, ranking next to General John J. Pershing.

U. S. Plans for Paris Conference

PREPARATIONS are being made in the United States for the forthcoming international communications conference, to be held next year in Paris. Each governmental department in Washington has been asked by the Department of State to appoint a representative to serve on an inter-departmental committee for the consideration of problems of international communication. The representatives so far appointed are: Post Office, Paul Henderson, 2nd Assistant Postmaster General; War, Major-General George O. Squier, Chief Signal Officer, U. S. A.; Commerce, P. E. D. Nagle; Navy, Rear Admiral H. J. Ziegemeier, Director of Naval Communications; U. S. Shipping Board, F. P. Guthrie. The State Department representative has not been named as yet. This committee will study the problems to be considered at the Paris conference, and an agenda and a policy will be worked out in detail.

Radio Makes a Desolate Island Useful

IT is no longer uncommon to hear that desolate places have been brought within the pale of civilization by the means of radio or that isolated people have been visited by the light of human understanding and sympathy by the same means. But the conquest of the island of Jan Mayen is the first instance in which radio reached out its arm into the region of the midnight sun, and subdued to usefulness an island that has for centuries stood in dangerous and forbidding aloofness.

Norway's action in placing a radio station on the Arctic island of Jan Mayen has converted that spot from a mere obstruction to Polar navigation into a meteorological point of importance. The west coast of Norway is open to particularly disastrous storms from the northwest. In past years, Norwegian shipping has suffered to an alarming extent, and a study of the character and origin of these disturbances led to the discovery that Jan Mayen was directly in the path of these "terrors" as they swept down from the north. The suggestion naturally was made that a wireless station on the island would serve the highly important mission of sending needed warnings to the shipping on the north coast of Europe.

The station as it now stands was delivered and erected in the summer of 1921 by the Norwegian Radio Company of Christiania. All the instruments, together with the masts and equipment for the complete installation of a motor generator outfit were transported with great difficulty from Norway. On August first, 1921, two vessels, the *Isfluglen* and the *Polarfront*, left Aalesund with the gear on board

and started on the five-hundred-mile voyage to Jan Mayen. It was rather late to approach an island so far north, for at that time of the year the sun is sinking below the horizon, and the winter of darkness rapidly setting in. The work of construction was rushed, however, and on September 17th of the same year, Radio Engineer Ekerold, in charge of the work, worked Norway for the first time.

The aerial masts were erected 200 feet apart, and the aerial of three wires suspended between them. It is 165 feet high, and the lead-in comes from the exact center of the span, making it a T type aerial.

The power house is separate, being situated 25 yards from the wireless station. The plant consists of one 8-horsepower gasoline engine with a 6-kw. D. C. generator, the converter giving 400 cycles alternating current. The transmitter is a 2½-kw. station of the Telefunken quenched spark system and gives 1½ kw. in the aerial. For transmitting a counterpoise is used, while the receiving instruments are connected with the ordinary earthed ground wires. The best transmitting wave length has been determined to be 1,000 meters, which gives 14.8 amperes in the aerial.

The receiver is the Telefunken type E-62 vacuum tube receiver, fitted with a two-tube, audio frequency amplifier. Traffic is mostly carried on with the Ingoy radio and the Fauske radio stations in Norway, and with the Reykjavik wireless station in Iceland. The normal range by day is five hundred miles.

English Planes Use Phone

RADIO telephony has come to be such an important part of the airplane lines connecting London with the Continent that a wireless telephone ex-

change has had to be established at Croydon, England, where the airplane hangars are located. The pilot of each airplane is now required to report his position by radio telephone every fifteen minutes to a traffic controller at Croydon.

New Japanese Radio Net

APPLICATION for sanction from the Japanese Government to establish a wireless telephone system has been made by the Daido Electric Power Co., of Nagoya, Japan, according to advices received by the U. S. Department of Commerce. The company proposes to operate this wireless system primarily for its own convenience in communicating with the various stations of its electric light and power system, but its use may be extended eventually to the general public if sufficient demand should arise.

As at present planned, the first wireless station will be built at Okuwa in Nagano Prefecture on the Central Japan Railway Line, from which point communication will be established through Nagoya and as far as Osaka, a distance of about 150 miles.

I. R. E. Awards

THE Medal of Honor of the Institute of Radio Engineers, which is awarded annually for pioneer work of recognized eminence in the radio field, is to be awarded for 1922 to Dr. Lee deForest. The basis of the award is his application of the grid element to the vacuum tube, thus improving a device which in its many uses has revolutionized radio communication, both in transmitting and receiving.

The I. R. E. also has made another award, for 1922, that of the Liebmann Memorial Prize of \$400 in cash, to Mr. C. S. Franklin, research engineer of Marconi's Wireless Telegraph Company, Ltd., for his investigations in connection with short wave directional transmission and reception. The Liebmann Memorial Prize is awarded for radio work of conspicuous merit.

2ZL Successfully Transmits to England on Schedule.

COOPERATING with the Manchester, England, Wireless Society, through W. R. Burne, 2ZL station, Valley Stream, L. I., transmitted signals on the night of Nov. 22, and the signals were received at Manchester, Mr. Burne reporting them as being "marvelous." This latest achievement of 2ZL stands out as a milestone of radio progress, for it is the first time in the history of radio communication that trans-Atlantic transmission by an American amateur station has been successfully accomplished at the first attempt on a prearranged schedule.

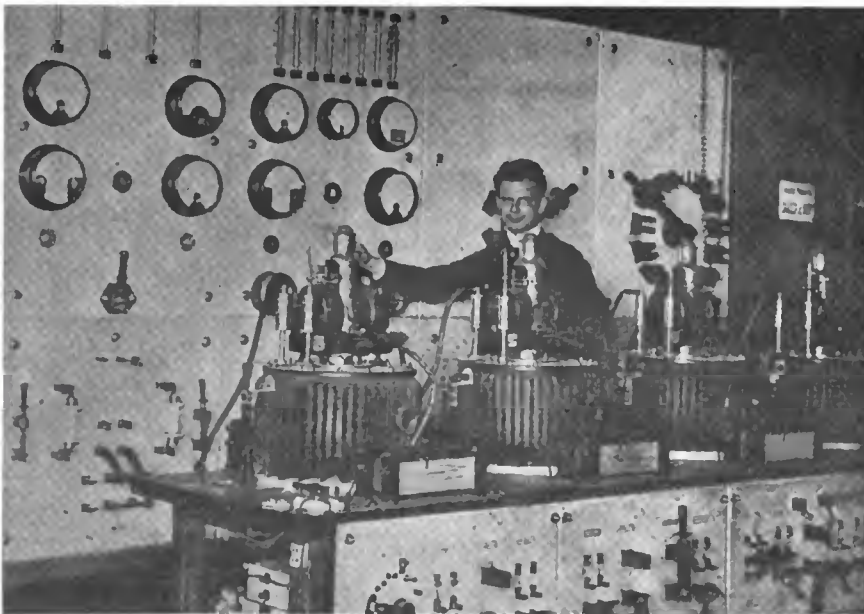

This is one of the first photographs ever made of the powerful transmitters high up in the Eiffel Tower, Paris, taken by permission of the French army. The switchboards are shown, and also a bank of mercury turbines

Modern Radio in Ancient Syria

New French Station at Beirut Connects a Remote and Historic Part of the World with Paris—Station Equipped for Duplex Operation, with Remote Control

WHEN Syria and Lebanon were placed under the French Mandate after the war, one of the first pre-occupations of the French High Commission to these two countries was to assure reliable communication with the rest of the world, and particularly with France. It was necessary that a communication system be devised that would be certain, rapid and independent.

In achieving this end one could not use the land wires which traversed Turkey in Asia and the Balkans, nor could one consider the submarine cable, already overloaded with traffic, which touches Alexandria and to which Beirut is linked via El Arich. A study was first made of a project of laying a submarine cable between Bizerta and Beirut. This would entail an approximate expense of 36 million francs, which the financial situation of France rendered very difficult. Moreover, one would have to count upon a delay of about a year and a half for manufacture of the cable, and upon a minimum time of two and a half years until the cable should have been laid and in operation.

The question of maintaining communication with the French Mandates in the Near East was at this difficult point when a French radio telegraph company proposed to install, at its own risk and expense, without subsidy of any kind, a radio station sufficiently powerful to afford regular communication with France. This offer, which relieved the state of a considerable expenditure, was quickly accepted and the work of construction started immediately.

The radio station was erected at Beirut and consists, as does every

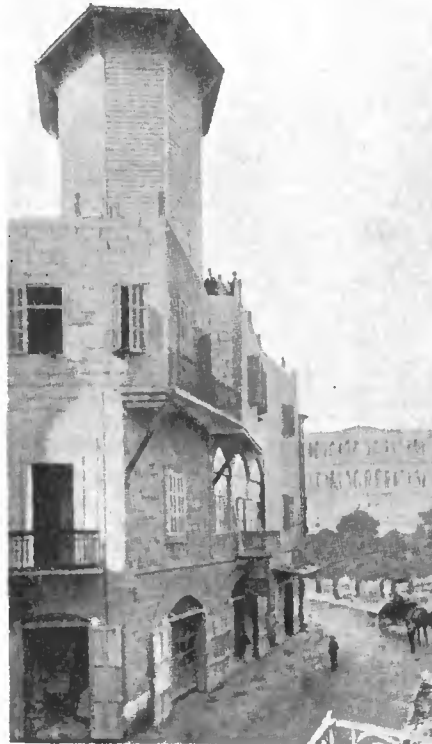

Central bureau of the radio station in Beirut, Syria

other modern installation of radio telegraphy, of three definite parts, each playing a particular rôle. These are the transmitting station, which produces high frequency energy; the receiving station, which receives the signals from other transmitters; and the central bureau, the brains of the whole, which exercises remote control over the two preceding elements of the system.

The transmitting station has been built at Khalde, 12 kilometers (7.2 miles) to the south of Beirut. This

situation on the east coast is particularly fortunate, as no obstacle hinders the propagation of the radio wave. The antenna is of the umbrella type, and is supported by a tower 250 meters high (820 feet) which is divided into four sectors, with two separate leads, with the necessary switches, making it possible to utilize the whole antenna for transmission, with one or two oscillators coupled electrically, or if necessary, the station may be operated duplex, with simultaneous transmission on two different wave lengths.

Special arrangements have been made in order to reduce the resistance of the antenna to the minimum with the result that an increase has been obtained in the antenna current over that realized in the first tests, giving greater efficiency on the same power. The radio frequency energy is produced by two alternators which place 25 kilowatts in the antenna, turning normally at 6,000 r.p.m. At that speed the frequency of the current is 32,400 alternations per second, corresponding to a wave length of 9,260 meters.

These machines are furnished with speed regulators permitting them to generate waves of any length between 9,000 and 11,200 meters. Both electrical and mechanical means are used for control of these alternators, maintaining the frequency with rigorous exactitude.

The electrical energy necessary for the operation of these alternators is produced at the same station by means of two semi-Diesel engines of 85 horsepower. Independently of the rooms containing the electrical machinery which has been mentioned, the transmitting station has a number of

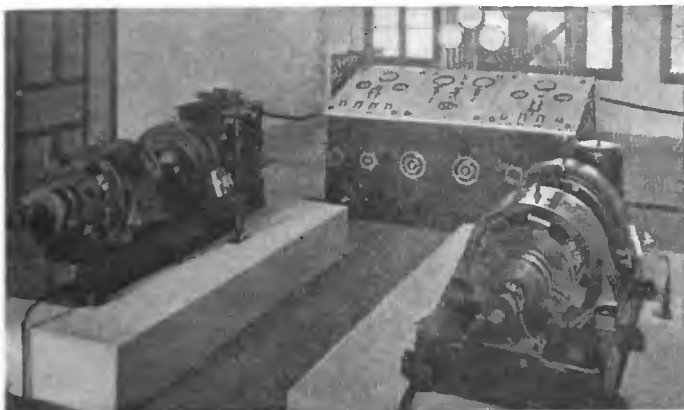

The high frequency apparatus in the Beirut radio station



General view of the transmitting station operated from Beirut



Map of the Near East, showing location of Beirut and relation of the radio station there to the railway through Syria

rooms reserved for the workshop, for the enormous storage battery provided for use in case of breakdown, for the electrical generator system, the control switch boards, the antenna inductances, the chief operator and for the personnel.

A special land wire connects this station at Khalde with the central office at Beirut, which is the actual operating office. This line comprises the necessary circuits for control and communication necessary for the operation of the transmitter by remote control.

A receiving station has been installed just outside the city of Beirut, two kilometers (1.2 miles) to the west, in the locality known as "Raz de Beirut." This station is able to receive under

all conditions, twenty-four hours a day, without suffering from any effects produced by induction from the electric light and power lines, and street car wires of the city of Beirut.

The receiving station has a main hall in which are installed the control panel and the various tuning elements. Another room is used at quarters for the operator in charge of the station, who thus lives next to his instruments. A small charging plant for the storage batteries completes the equipment of the station. No decoding of radiograms is done at the receiving station. The signals received are simply placed upon a special land wire going into the central part in the city. Methods are provided for sending these sig-

nals either in reversing (Wheatstone) current for recording at high speed, or in tone frequencies for reading by ear.

The line connecting the receiving station with the central office contains seven pairs of conductors in a lead housing, in a strong catenary suspension from a steel cable, hung from wooden poles. Special precautions have been taken in this cable in order to compensate for all induction effects between the circuits, and avoid too much loss of energy in the wires.

The central office is in the city of Beirut, facing the port, and in the very center of the business life of the city. Here radiograms are filed and delivered. The different offices are on the main floor, including the public waiting room and switch boards and relays connecting the office with the telegraph and telephone systems of Syria and Lebanon.

On the second floor are the control rooms, in which the actual operation of the transmitting and receiving station is carried out, including automatic transmission and reception of messages. A test receiving station is located on the roof, enabling the operators to listen in at any minute and observe the manner in which the transmitted signals are being sent out. A pneumatic conveyor system carries the messages between the traffic room and the distributing office.

The Beirut radio central is certain to have an ever-increasing importance in the Near East, in consequence of the assured economic development of Syria and Lebanon, and France well may take pride in having aided in that expansion by placing radio communication at the command of the population of those regions.

Translated by THE WIRELESS AGE from "Radioélectricité," of Paris.

Broadcasting From Films

Pallophotophone Has Many Important Applications—Additional Details Show Remarkable Quality of Reproduction

ADDITIONAL details have been received since the publication in the last number of *THE WIRELESS AGE* of the fact that film recording and reproduction of sound has been successfully accomplished by the General Electric Company. These new facts, while still reserving some of the essential technical details, demonstrate even more clearly than before the startling nature of the new invention, and the great usefulness that it is sure to achieve when it is made commercially available.

The extraordinary machine, known as the Pallophotophone, which is the invention of Charles A. Hoxie, of the engineering laboratory of the General

Electric Co. at Schenectady, N. Y., is considered to have as many as a dozen different applications. One of the most interesting and popular uses foreseen for it is that of the "talking movie." The Pallophotophone makes it possible to place a record of sound on the margin of the conventional motion picture film, thereby affording absolute synchronization of reproduced words and action.

The Pallophotophone has introduced into radio broadcasting an entirely new element—the possibility of making a master record of a speech and broadcasting it days or weeks later from scores of radio sending stations in every part of the country. This could

be done also in reproducing music, or for that matter, any kind of sound.

It can now be stated that the Pallophotophone is the answer to the little mystery which WGY, the broadcasting station of the General Electric Company, introduced into one of its programs a few weeks ago. Radio fans that evening heard the voice of Kolin Hager, the well known studio manager and chief announcer of WGY, saying the following words:

"The next selection is for the benefit of the Edison Convention, White Sulphur Springs, West Virginia, to which WGY sends greetings. These greetings are being transmitted by a new device, not a phonograph, con-

structed by the General Electric Company, and by means of which the voice has been recorded and is now being reproduced. We would like to get comments from our listeners, telling whether this last announcement came through as clearly as the other announcements on our evening program."

These words were actually spoken by Mr. Hager nearly a week before the radio audience heard them. What the radio listeners really listened to was the machine — the Pallophotophone — speaking to them in the voice of Mr. Hager; while Mr. Hager himself stood by in silence. He could have been absent entirely and yet, so far as the innumerable groups gathered around the receiving sets over hundreds and hundreds of miles of territory were concerned, his voice would have come to them as naturally and as distinctly as though he himself had spoken into the microphone in the broadcasting studio.

Many of those who listened in to this announcement, "transmitted by a new device," responded to the request to comment on the way it sounded. Invariably they reported that it was a noticeable improvement; they heard Hager's voice more distinctly than ever.

The "new device," it turned out, could talk over the radio even better than persons who spoke directly into the regular microphone transmitter. And it has a big advantage over the phonograph for this sort of work, in that it can record and reproduce speeches of long duration, or an entire concert program.

Preparations are now being made for a demonstration of the Pallophotophone in making and reproducing moving pictures for the purpose of making the actors in the picture speak.

The perfect talking movie has been sought for years, but until the Pallophotophone was developed there did not seem to be any very great prospect of early success. Now, however, a film can be made, the Pallophotophone working with the moving picture camera, and this film reproduced on the screen, the Pallophotophone being used with the moving picture projector to reproduce the sound of the actors' voices. The reproducing device of the Pallophotophone being mounted on the projector itself, the film, with both the picture and the sound record upon it, will then be projected in synchronization.

There are two distinct devices in the Pallophotophone. One of them is the device that records the sound and the other is the device that reproduces the sound.

The first of the two consists essentially of a tiny mirror, hardly bigger than the head of a pin, on which is re-

flected a beam of light. The mirror is attached to a most delicately adjusted vibrating diaphragm. When sound waves, originating with the human voice or any other nearby sound, reach the diaphragm, causing it to vibrate, the mirror oscillates, or moves, and the reflected beam of light moves with it.

This moving ray of light falls upon a strip of photographic film, which passes in front of it in a continuous motion. The film, upon being developed, shows a succession of delicate dark-up-and-down markings, on a clear background. These markings represent the oscillations of the reflected beam of light. That dancing beam is what gives the apparatus its name, for "pallo photo" are Greek words, that mean literally "shaking light!"

The record secured on the film is a marvelously faithful record of the sound because of the extremely small size of the little mirror and diaphragm, and their low inertia. These characteristics enable the dancing beam, or "shaking light" to produce a sound record on the strip of film that catches all the fine overtones, the delicate shadings of speech, the sibilant sounds, every trait that makes one voice different from another. Therein lies its salient triumph, for the sound record is more nearly exact than any record so far obtained in devices of this nature.

This recording device operates by mechanical principles, as distinguished from electrical. There is no essential electrical process involved at this stage of the procedure.

When the time comes to reproduce the record, which has been obtained in the manner just described, an entirely different contrivance, the reproducing device, comes into play. These two devices are so independent of one another that each can be removed from the

apparatus while the other is in use. This procedure has been followed by Mr. Hoxie repeatedly in his laboratory demonstrations of the Pallophotophone.

The reproducing device is electrical in mode of operation as distinguished from the mechanical principles employed in the recording device. The photographic film, on which the record of the sound has been made, is wound on a reel so that it passes in front of an extremely sensitive electrical apparatus. This apparatus consists of an ingenious arrangement of vacuum tubes.

Its particularly notable characteristic is that it responds to variations in the light falling upon it with such instantaneous speed that it can only be compared to the speed of light itself, or to the speed with which wireless waves travel through space. Consequently, when the film is moved continuously in front of this device, an electric current is created which corresponds with great accuracy to the original sound wave, as represented by the markings on the film. This electric current is then made to actuate a telephone, a loud speaker or to operate directly radio broadcasting apparatus without the use of a microphone or the other pick-up devices ordinarily used.

This shows how the Pallophotophone can be used to produce, at some central studio, a master film from an artist's concert number or a man's speech, this film later being copied and sent to broadcasting stations anywhere, to be sent out by radio. In addition, however, it might be used to make a record of a speech of any great figure in American public life on any memorable occasion, and to reproduce this speech, for future generations, in the true voice of the man himself.

(Continued on page 64)



C. A. Hoxie and an assistant operating the G. E. Pallophotophone in the laboratory of the General Electric Co., at Schenectady, N. Y.

An Ideal Amateur 5-Watt Radiophone Transmitter

By Samuel C. Miller

DUE to the technical difficulties with which the average amateur is confronted at the beginning of his experiences in radio even in the construction of a very simple receiving set, it cannot be hard to understand why he regards the building of a transmitter out of the question until he has been further initiated into the mysteries of the ether. By gradual steps he improves upon his first attempt which in the case of a crystal affair, is quickly discarded in favor of a tube set. The addition of steps of amplification is only a matter of time and then in succession he improves his receiving set, becomes acquainted with regeneration, tries radio-frequency amplification and at last constructs the latest in radio, a super-regenerative set. At this stage he is a dyed-in-the-wool radio experimenter, with a lot of experience gained in actual practise, plus the theoretical knowledge obtained from reading books on the subject, which has enabled him to grasp a firm hold on the basic principles of this fascinating art. He then becomes interested in building a transmitting set and it is important that one who has reached this stage should be put on the right track in regard to the kind of set that should be built so the needless expense in buying parts which will never be used, can be eliminated as far as possible. Also the experience and data that others have obtained in experimenting can be utilized by the newcomer in constructing his transmitter. This article deals with a radiophone transmitting set which was

developed and constructed along scientific lines of development and which is intended for and is ideal for the use of amateurs. The various stages in the choosing of circuits with their relative merits and the electrical and mechanical designs of the units will be taken up in order.

GENERAL OUTLINE

The radiophone apparatus here described is essentially a complete transmitting unit consisting of two 5-watt tubes (oscillator and modulator) and is shown in figures 4 and 5. It is designed to operate on any selected wave length between 160 and 350 meters when used with an antenna having the following characteristics:

Capacity, 0.00035 mfd.; resistance, 3 to 8 ohms; natural wave length, 120 to 150 meters. This set, however, can be used on antennas having capacities between 0.00025 to 0.00055 microfarad at correspondingly lower or higher wave lengths.

The choice of circuit and arrangement of parts of this set are specially selected for ease of operation, so that the entire manipulation for both receiving and transmitting is by a single switch on the front of the transmitter and a push button on the microphone transmitter. The switch when thrown to "start" position closes the filament circuits of the tubes and starts the motor generator unit in operation. When the push button is pressed a relay is operated causing the antenna to be connected to the transmitter and the plate and microphone circuits to close. If the proper adjustments are

made the set is then in operative condition. By releasing the button the plate and microphone circuits are opened and the antenna is thrown from the transmitter to a contact connecting the antenna to receiving set.

DESIGN OF CIRCUIT

A radio telephony transmitting station can be said to be divided into four parts with each having a distinct function toward the final radiating of telephonic signals. They are the microphone unit, the modulator unit, the oscillator unit and the radiating unit. The microphone unit is a system which changes the sound waves impressed on the diaphragm of the microphone transmitter into electrical impulses of the same variation. In the early stages of radio, the microphone was almost always inserted in the antenna circuit thereby causing the voice waves to be directly impressed on the radio output. This was a very poor method as the entire output passing through the microphone would heat this instrument to such extent that very poor modulation was obtained and in the majority of cases the microphone was rendered totally useless. Various air-cooled and water-cooled types were constructed with practically no gain towards successful operation. Only due to the great strides made in the field of vacuum tubes during the past five years has there been any development in radio telephony.

One of the principal reasons for the advance of the art is due to the extent which the modulating systems used today have been improved. If such a

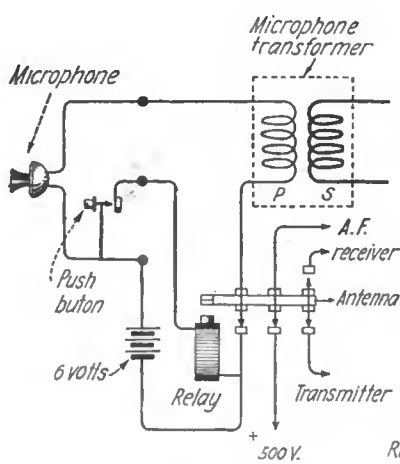

Figure 2

Details and controls of the microphone and modulation transformer

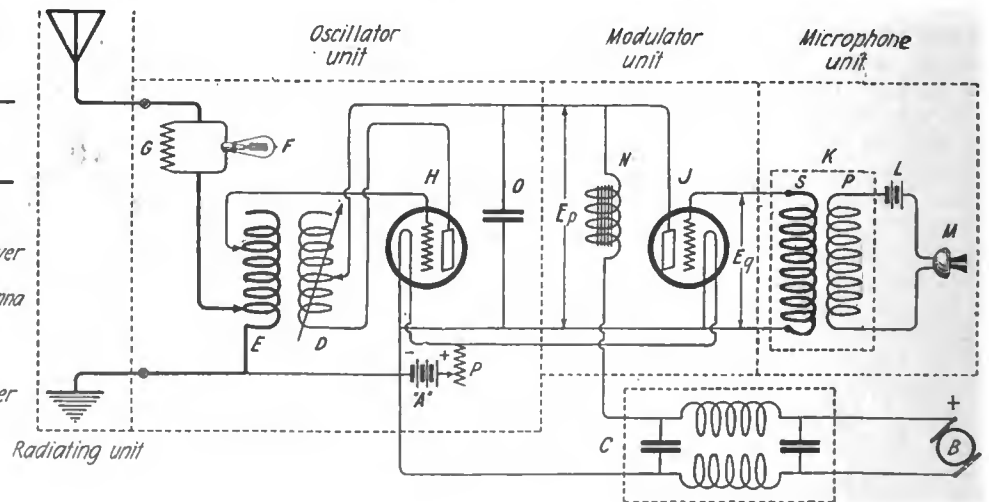

Figure 1

Diagram of 5-watt amateur phone transmitter especially suited for amateur use

modern system of modulation is used, the transmitting set radiates electrically, the exact reproduction of the sound waves impressed on the microphone transmitted. Of all these systems, the one invented by Heising and known as the Heising system of modulation is very largely used in the broadcasting stations of today, and was therefore used in the design of this 5-watt transmitter. This method can be explained as follows. When the sound waves strike the microphone transmitter, a mechanical vibration of the diaphragm is set up. This changes the resistance of the microphone circuit and causes a pulsating current to flow through the primary of the microphone transformer. As the transformer is a step-up type, there is induced into the secondary a variable voltage of considerably higher value, which is also impressed on the grid of the modulator tube. Due to this grid voltage variation, the modulator tube plate current will be varied accordingly. In series with the high voltage generator that supplies the plate current to the tubes, is an audio-frequency choke coil. If this coil has constants of the correct value, a difference of potential will be set up across it of plus or minus the generator voltage and will give perfect modulation. This is due to the change of the modulator plate current flowing through the coil. As the plate current through the oscillator coil is directly proportional to the voltage across its input the oscillator plate current will vary in the same manner thereby causing the output oscillations to be modulated.

The next unit to be investigated was the oscillating circuit. There are many forms in general use, but for short waves especially between 160 and 350 meters, the maximum efficiency was obtained from an oscillating circuit as shown in figure 1.

LIST OF PARTS

The complete transmitting set consists of the following parts:

- 1—Two U.V. 202 radiotron tubes.
- 2—Two tube sockets.
- 3—Antenna-grid inductance coil.
- 4—Plate coupling coil.
- 5—Change-over relay.
- 6—Start-stop switch.
- 7—Filament rheostat.
- 8—Wave length control switch.
- 9—Microphone, desk stand type.
- 10—Plate choke coil.
- 11—Radio frequency condenser.
- 12—Motor generator set.
- 13—Four ammeter jacks.
- 14—Microphone transformer.
- 15—Antenna current indicating lamp.
- 16—12-volt storage battery.
- 17—Filter circuit.

The above units are described in detail in order.

1. Transmitter tubes—The transmitter for results requires the use of two U. V. 202 Radiotrons having a

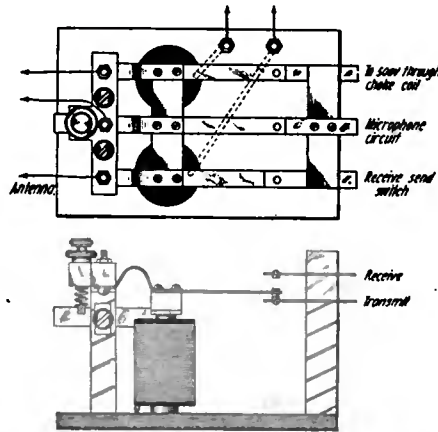

Figure 3—Plan and side views of the relay used as a send-receive switch

rating of 2.35 amperes at 7.5 volts. The circuit used requires the use of one tube as an oscillator and the other as a modulator.

2. Tube sockets—The sockets are standard Radido Corporation sockets. No spring or felt mounting for shock absorption is necessary.

3. Antenna-grid inductance coil—This coil consists of 28 turns of No. 18 S.C.C. copper wire wound on a



Figure 5—Back view of the complete transmitter as assembled, including two spare bulbs

dilecto form 4¾ inches outside and 6½ inches long (figure 6). The wire is wound in a small groove made by threading the dilecto form with a thread of 6 turns per inch. Taps are taken and brought to studs on a wave length control switch which also controls simultaneously the grid tap position. The proper turns from which taps are made is listed below:

Tap number—1 2 3 4 5 6 7 8 9 10 11 12.

Turn number—6 7 8 9 10 12 14 16 18 20 24 28.

4. Plate coupling coil—This coil consists of 40 turns of No. 18 D.C.C. copper wire, wound closely on a dilecto form 4 inches outside diameter and 3 inches long (figure 7). The complete coil is given a coat of shellac.

A total of 9 taps is taken off the coil and connected to a 9 stud switch at the end of the coil. The proper turns on the coil from which the above taps are taken are listed in the following table:

Tap number—1 2 3 4 5 6 7 8 9.

Turn number—20 22 24 26 28 31 34 37 40.

A variable coupling of this coil to the antenna coil is provided in order to make it possible to obtain maximum antenna currents on all wave lengths. The adjustment is made by mounting the plate coil on a slide which moves along a rod and after best coupling is obtained by indication of maximum antenna current and best modulation for a definite wave length, this coil is made fast by clamping it to the sliding rod. A square rod is recommended as a simple and reliable method of holding the coil in place.

5. Change-over relay—This relay is an electrically operated send-receive switch, and is shown in figure 3. Its operation is controlled by a small push button on the upright portion of the desk stand transmitter. The relay used is converted from an ordinary 4-ohm telegraph sounder. The functions of the change-over relay are as follows when the push button is pressed:

- a—Plate circuit of transmitter tubes is closed,
- b—Antenna is connected to transmitter,
- c—Microphone circuit is closed.

When the push button is released the above operations are reversed and the antenna is connected to the receiver.

6. Start-stop switch—This is a manually operated switch having an easy accessible handle on the front panel, and performs the following

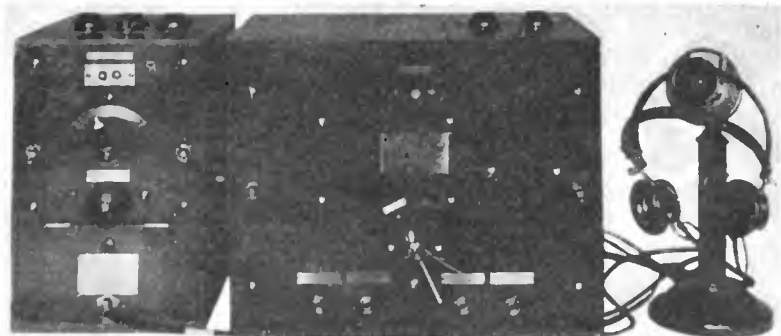

Figure 4—Complete phone transmitting and receiving sets. The four jacks at the bottom of the transmitter are for plugging in ammeters for testing the various circuits

functions: When the switch is thrown to "start" position, the line supplying the motor generator unit is closed and the filaments of the transmitter tubes are lit.

7. Filament rheostat—This is a Radio Corporation model PR-535 type rheostat and is used to control the filament current supplied to the transmitter tubes which are connected in parallel.

8. Wave length switch—This switch is to be located inside the set because when adjustments are once made no tinkering is required and the set can be started at all times to operate satisfactorily. It is shown in figure 6.

This switch is of such design that

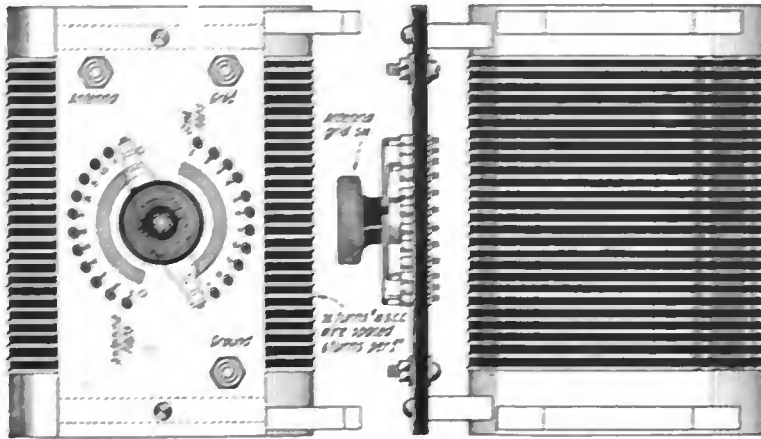

Figure 6—Front and side views of the tuning coil and switch

as the antenna inductance is increased for higher wave lengths the grid connection is simultaneously varied so as to maintain proper grid potential for maximum antenna current and best modulation at all wave lengths.

The grid switch, which is a part of the wave length control switch, has also a total of 12 studs. The first five studs are all connected together and then brought to tap No. 12 on the antenna side of switch, so that on antenna tap Nos. 1, 2, 3, 4 and 5 there will be 28 turns on the grid coil. Likewise the next three studs, 6, 7 and 8 are connected together and brought to antenna tap No. 9 and the remaining grid studs, 9, 10, 11 and 12 are connected together and brought to antenna tap No. 7.

9. Microphone, desk stand type—This is a standard desk stand microphone transmitter without the receiver hook, but provided with a push button which when pressed will close the circuit through the change-over relay. A schematic diagram of the microphone transmitter is shown in figure 2.

10. Plate choke coil—The plate choke coil used is the plate circuit re-

actor UP-415 made by the Radio Corporation.

11. Radio frequency condenser—This is a small condenser having a capacity of 0.003 microfarad which must be capable of withstanding a D.C. potential of 500 volts. This condenser is used to provide a low impedance path for radio frequency currents across the high tension supply leads.

12. Motor generator set—Any motor generator set that is capable of supplying a constant 500-volt D.C. to the plates of the tubes can be used.

13. Ammeter jacks—Four jacks are provided for plugging in ammeters to check up the antenna current, filament current, plate current and the microphone current.

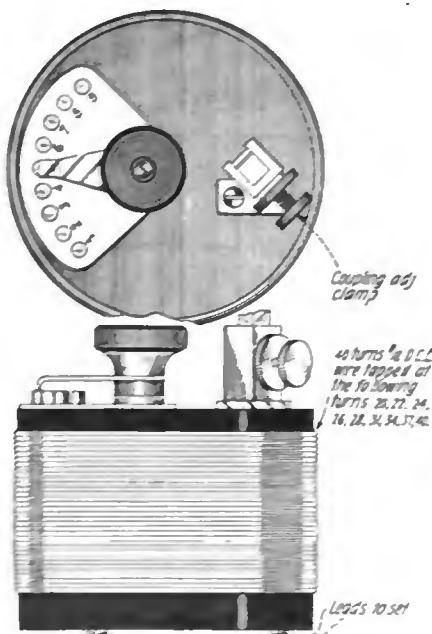

Figure 7—The plate coupling coil

14. Microphone transformer—The microphone transformer used is the UP-414 made by the Radio Corporation.

15. Antenna current indicating

lamp—This consists of a small 2 1/2-volt Mazda incandescent lamp and socket shunted with a resistance of 1.2 ohm, which is inserted in series with the antenna circuit to provide a reliable means of indicating the presence of current in the antenna circuit. It is shown in figure 8. This method is very convenient and after a little practice the antenna current can be readily guessed at by noting the brilliancy of the lamp.

16. Storage battery—A 12-volt 80-ampere-hour storage battery is very convenient for use with this set.

17. Filter circuit—This filter circuit is used across the 500 volts for filtering out with good results commutator ripples from the generator. It consists of two 1 mil. paper condensers, Western Electric type 21 AA, and two iron core chokes of about 1 henry each. The plate circuit reactor UP-415 (Radio Corporation) can also be used as chokes for this filter.

On the photograph showing the arrangement of parts inside the cabinet (figure 5), it is noticed that there are four UV-202 tubes. The two extra tubes are spares and are included inside the set so that a defective tube can be very readily replaced.

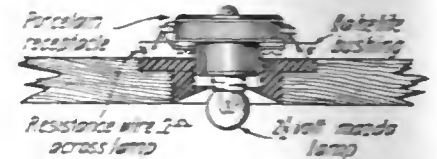

Figure 8—Detail of mounting of antenna indicating lamp

OPERATION OF TRANSMITTER

After the wave length switch is set at a definite wave length and the plate coupling coil is adjusted for maximum antenna current, the cover can be placed over the transmitter, as no other adjustments are necessary. The set is then operated by throwing the switch to "start" position and pressing the button on the microphone desk stand for transmitting, releasing it for receiving.

When the transmitter is in proper operation, the antenna current reading for 500-volt plate potential should be not less than 1.2 amperes. The average range is then approximately 30 miles radius.

Helpful Hints on Tuning

By A. F. Van Dyck

Radio Engineer, General Electric Company

THE basic rule to be followed for best results in the tuning of a radio receiver, is to understand what each control does, in a general way at least, and to use the controls in systematic, and not haphazard, manner. An understanding of the general principles of the set and its controls is necessary in order to obtain good results consistently. I assume that your apparatus is some good standard make, or if homemade, is constructed and connected in one of the standard ways; that your antenna system is properly

which is that they have definite frequency, or in other words, a certain number of them pass the receiving aerial in a second. The exact number is determined by the adjustment of the transmitter. Since these waves travel at a certain speed, they must be a certain distance apart, which is called the wave-length. So that instead of saying that a station sends out waves 360 meters apart, we could just as well, perhaps more clearly, say that it sends out 830,000 waves per second. These waves strike receiving aerials regularly

the electrical length of the antenna. This can be done easily by putting in the circuit some wire wound up into a coil, with some means provided for changing the number of turns which is used, for example by a switch, or with some means for varying the electrical effect of the turns without actually changing the number of them. The variometer is such a means, and is made by having the coil in two parts, one of which turns inside the other. Also it is found that if there are connected in the circuit two metal plates

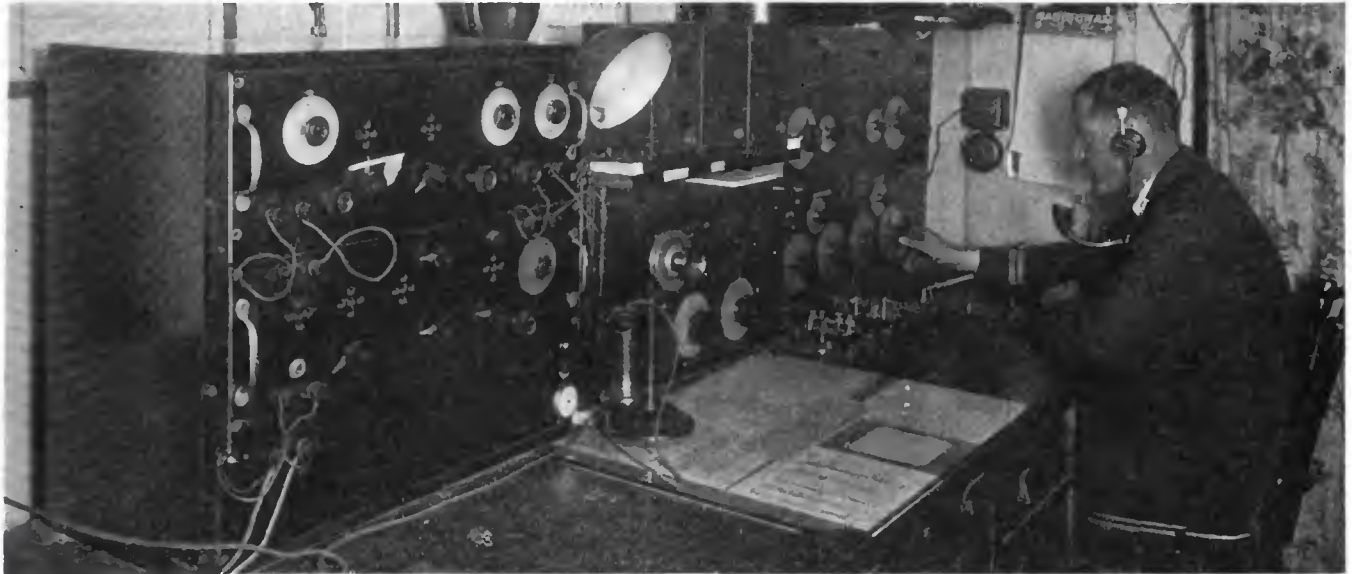

SS. "America's" receiving equipment with Armstrong superheterodyne at left, which is operated according to the principles given in this article—as is any well-operated receiving set

installed;—that the ground connection is a good one; that all electrical joints in the aerial and ground wires are soldered; that all connections on the apparatus are well made and the batteries in good condition. In general, one cannot be too careful or too thorough in the installation of a set, if it is expected to be able to operate it day after day without vexatious delays, hunting for troubles and correcting them.

Tuning, in the meaning of this article, is the process of adjustment of receiving apparatus to accord with a particular transmitting station, in order to obtain the greatest response to that station's waves, which when they strike an antenna, cause it to move, electrically. The tuning of the aerial is for the simple purpose of so adjusting the aerial wire that it can vibrate electrically to the greatest extent possible under the force applied to it by the radio wave.

There is an important thing to note about these traveling radio waves,

and evenly one after another, and we want to have them vibrate the aerials as much as possible.

Consider the analogy of a rope swing with one boy in it, and another boy trying to swing the first as high as possible. You know that the swing can be started and its motion increased each time it vibrates, even by very weak pushes, if the successive pushes are timed to occur exactly right, and one doesn't try to push the swing at the wrong instant. The receiving aerial corresponding to the swing works the same way, and the radio waves to the pushes.

The only difference is that in radio instead of changing the rate of the pushes to suit the swing, we adjust the length of the swing to suit the pushes. That is, we adjust the electrical length of the antenna to suit the frequency of the waves. Then the antenna will swing electrically as far as it can, depending upon the strength of the wave pushes.

Therefore, radio receiving sets have to provide some means for changing

which are placed near to each other, but not touching, and one of them is moved, that this changes the electrical length of the circuit. Such a device is called a variable condenser. Sometimes both condenser and adjustable coil, called variable inductance, are used.

There are two somewhat different ways of connecting up the tuning devices, which are in common use today. These are known as the single circuit tuner and the two circuit tuner. In the operation of a receiver based on either one of these tuning systems, adjustment of the tuner part is but half the problem. In addition to the tuning system, there is the detector, which is connected to the tuning part, and which changes the received high-frequency current into one with a form which will operate telephone receivers, which the high-frequency current itself cannot do.

There are two kinds of detectors in common use today—the crystal, or mineral detector, and the vacuum tube detector. So that there are four funda-

mental combinations in receiving apparatus—first, the single-circuit crystal type; second, the two-circuit crystal type; third, the single-circuit vacuum tube type; and last, the two-circuit vacuum tube type.

The single-circuit crystal receiver is of course the simplest to operate. In this there are only the tuning control and the crystal. The proper procedure in tuning this type is to set the detector in contact and slowly vary the tuning control until desired signals are heard, then adjust tuning and detector contact to maximum results. The most difficult part of this process is that if no signals are heard at first, it is impossible to tell whether the detector is in receptive condition or not. It is possible and very desirable to connect up a buzzer, a push button and a single dry cell battery so as to test the detector and set it in sensitive condition. Ways of doing this are shown in most radio textbooks. Also it very often happens in a house equipped with electric lights, that the switching on or off of a lamp makes enough electrical disturbance to hear on the radio receiver as a sharp click. This click is not heard if the detector is not in sensitive adjustment, so that the detector can be adjusted while some switch is being turned on and off until the clicks are heard most loudly.

Now just a word about the operation of detector vacuum tubes. Assuming that the proper accessories are used and are properly connected up, the adjustment of the tube to sensitive condition is done on most sets entirely by the filament rheostat, which controls the current through the filament, and therefore its temperature. Usually the tube will operate to some degree if the filament temperature is anywhere near right, but best signals will be obtained only after it is exactly right, which is accomplished after signals have been picked up.

The filament must not be burned brighter than necessary. If it is, its life will be greatly shortened. The correct brilliancy is one not quite as bright as the ordinary incandescent lamp filament, and care should be taken always to burn the filaments as dimly as possible.

Most sets using vacuum tube detectors have another feature added in connection with the tuner which is valuable. This feature is called regeneration and adds to the sensitiveness of the set enormously. It is governed usually by a coil whose electrical relation to the tuning coil can be adjusted. This coil is called the tickler coil, or the intensity coil, or the regeneration coil. When this is provided on a receiver, it gives one more adjustment to be made.

Consider a single circuit receiver

using vacuum tube and regeneration. We have three controls, the wave length tuning, the regenerative coil, and the filament rheostat. The proper method of procedure in operation is as follows: Set the filament to as near proper brilliancy as it is possible to estimate. On many tubes this point is easily found, (the tickler coil being set at zero during this adjustment) by increasing the brilliancy slowly until a hissing sound is heard in the telephones, and then turning down the filament just enough to stop the hissing. The next step is to vary the wave length control over its range very slowly, listening carefully for the desired signals. When they are heard, adjust the wave length control and the filament control to best results and then increase the regenerative or tickler control until signals are best, possibly slightly readjusting the wave length control, which may have been affected by the change of the tickler. If the tickler is increased too far, telephone signals will be spoiled, speech and music sounding mushy instead of being clear. Always take pains not to increase the tickler too far, because when this is done, the vacuum tube oscillates, or becomes a small generator of high frequency current, which goes out on the aerial and causes waves just like a sending station's, only not as powerful, and other receiving stations within a distance of one or two miles can hear it and will be interfered with by it. Whenever you hear on your set some whistling sounds which come and go, varying in pitch, you may know that some receiving stations near you are radiating in this way because their ticklers are turned up too far. This is an excellent opportunity for practising the Golden Rule—remember that whenever your tickler is increased too far, you are causing to other stations the same interference which they cause you.

The single-circuit receiver with its few controls, is quite simple to operate, and a little experience enables one to get results easily. This type of receiver is sensitive, but is not as selective as the two-circuit type, that is, it is more likely to let through undesired signals with the desired ones, resulting in confusion. On the other hand, the two-circuit receiver, especially if provided with regeneration, is more difficult to adjust. The major controls on a two-circuit receiver are the aerial circuit—called primary—tuning, the secondary circuit tuning, the coupling between these two, the tickler, and the tube filament rheostat. In short, there are five controls to adjust. The most important and most critical one of these is the secondary tuning. To pick up signals, set the coupling at or near maximum (primary and secondary

parallel) the detector filament at the proper brilliancy, and the primary tuning control at or near its lowest value. Then very slowly vary the secondary wave length control from zero to maximum. If signals are not heard, change the primary setting five or ten degrees and vary the secondary through its range again. This should be continued until signals are heard. If they are not heard, increase the tickler some and repeat. After a signal is once located, adjust all controls to best results, remembering that if it is desired to obtain selectivity, that is, freedom from interference, the coupling must be decreased toward zero, considerably. Do it in small steps so as not to lose the signal at any time. The decrease in coupling will decrease the strength of the desired signals, too, but not as much as the undesired ones.

Broadcasting From Films

(Continued from page 59)

If the Hoxie apparatus had been in existence in 1863, and had been taken to the Gettysburg dedication, the immortal Gettysburg address of Abraham Lincoln, in the very voice of the Great Emancipator, could be heard today by the millions who have been born long since Lincoln has breathed his last.

As an apparatus which may, and probably will, produce talking movies, and as the recorder of speeches, songs and whole concert programs, which can be broadcast by radio at any subsequent time, it is wonderful enough.

The Pallophotophone has other applications. It has the possibility of being developed into a film-phonograph for use in the home just as disc-phonographs are now used. It is an excellent telephone transmitter, for use in voice communication. It can be used to advantage in radio telegraphy in producing wireless telegraph signals. It can also be used in the electrical laboratory to do the work of the ordinary oscillator without the local interference commonly encountered in using the oscillator. And it can be used for audio amplification in wireless telegraphy. It is quite likely that other equally interesting applications may develop.

Mr. Hoxie, who has perfected this interesting apparatus, is an engineer engaged in special development work in the General Engineering Laboratory of the General Electric Company. He has always been interested in telephone developments, both wire and wireless, and is one of the original pioneer radio amateurs in the United States, having had an amateur radio receiving set as early as 1899.

Experimental Tube Using 110-Volt A.C. on Filament and Plate

DR. ALBERT W. HULL, of the Research Laboratories of the General Electric Co. at Schenectady, N. Y., has developed an altogether new form of receiving tube. This tube consists of a combined kenotron rectifier and ordinary three-element vacuum tube, with a heated metal thimble as the source of electrons instead of the usual filament. This thimble is heated by the filament of the rectifier, which is inside the thimble, and at the same time acts as the plate of the rectifier circuit. Alternating current is used on both filament and plate, without any resultant hum in the telephones. No hum is produced from the cathode, because it is in an equi-potential surface, that is to say, every point on the heated surface is at the same potential or voltage—no alternating current being directly applied to it. The voltage which is applied to the plates is practically direct—because it is rectified by the kenotron and then smoothed out by a suitable filter. All these functions are ingeniously combined in a single tube, which was facetiously called “equi-potential cathode-keno-plio-dynation,” at a recent meeting of the Institute of Radio Engineers, where Dr. Hull described its properties and characteristics.

plate is 5 to 6 micro-microfarads, which is practically the same as the UV-201 Radiotron—and at that rate, the radio-frequency amplification at 200 meters, using resistance coupling would be 4 or 5. With transformer coupling, even better results are obtained.

If the cathode of a tube is heated by some external source, instead of by the heating effect of the current passing through it, it would be an equi-

latter is bombarded by the stream of electrons coming off from the filament.

Dr. Hull makes use of this sort of cathode in his new tube. In addition, he uses this to serve as the rectifier for his plate supply. A grid and plate of the usual type are supplied. Thus the new tube, which is a combined rectifier and amplifier has four elements: (1) a filament heated by alternating current; (2) a cathode surrounding the filament and very close to it, so that it absorbs heat radiated by the filament and also acts as plate of kenotron rectifier, and is a source of electrons for amplification; (3) usual grid or control element (4) plate-connected to output.

PRINCIPLE OF NEW TUBE

The main features of the new tube are shown in the circuit of figure 1, where the tube is used as a regenerative detector. These operations are the same as in the ordinary tube. We are concerned only with the new features. The filament within the cathode is heated by alternating current obtained from the secondary of a step-down transformer. The cathode becomes a dull red and emits a copious stream of electrons, since it is coated with barium oxide. The cathode also acts as the plate of a kenotron rectifier, the filament inside functioning as the rectifier filament. The connections of the filter and rectifier are practically the same as if an ordinary tube were used with an external rectifier. A comparison will show the resemblance between this circuit and those described previously.

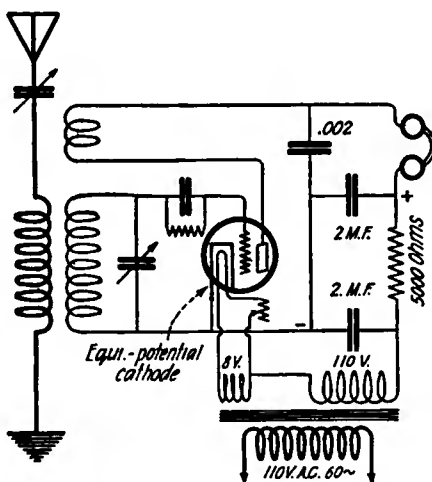

Figure 1—Use of A. C. for filament and plate. The cathode is equi-potential and is heated by filament inside of it; it also acts as the plate of the rectifier

potential cathode—that is, every point on the cathode is at the same voltage, and connecting the grid circuit to it would not cause any fluctuations in grid voltage. Such a cathode may be heated merely by its close proximity to a separate filament which is heated in turn by alternating current. In addition it may be further heated by applying a voltage between filament and the cathode surrounding it, and the

The tubes used by Dr. Hull have about five times the amplification of the ordinary UV-201's and about the same internal impedance. With the notoriously inefficient resistance-coupled amplifiers, voltage amplifications of the order of 20 or 30 are obtained at audio-frequency and voltage amplifications of 8 to 10 at 300 meters at radio frequency. The internal capacity of the tube between grid and

CHARACTERISTICS OF NEW TUBES

The grid voltage-plate current curve of the new tube is much steeper than that of the UV-201 and correspondingly greater amplification is obtained, because a given change in grid voltage on the new tube will produce a greater change in plate current than in the standard. The values for amplification constant, internal resistance, and mutual conductance for the new tube are respectively 27, 18,000 ohms and 1.5×10^{-8} mho.; and for the UV-201, these values are 6.0, 20,000 ohms and 0.28×10^{-8} mho. The new tube can thus give four to five times the amplification. The grid-voltage-grid-current curve is also very much steeper, and indicates that the detection coefficient is about 10 times as high as in the UV-201.

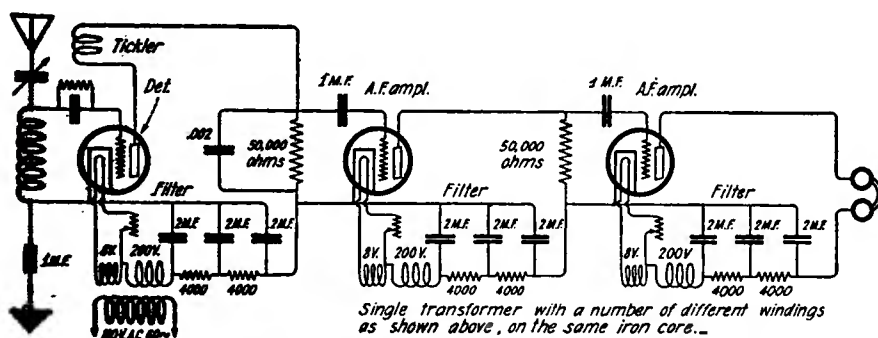

Figure 2—Use of the new tube in a receiver having detector and two stages of resistance-coupled audio frequency amplification. Different filament and plate transformer windings are required for each tube

The amplification factor is of especial significance. Not only are very high audio-frequency amplifications obtained, but it also seems to solve the problem of a good radio frequency amplifier. Using resistance coupling, at 300 meters, voltage amplifications

and one audio-frequency amplifier, it can be heard only when the telephones are pressed close to the ears. With two audio stages, it is quite noticeable, but still not objectionable. With several radio stages and a detector tube, the hum cannot be heard. Most of

primary winding. A separate filter is used with each tube. The detector and amplifier circuits are the usual types encountered with ordinary tubes.

Figure 3 illustrates a similar circuit with transformer-coupling between the audio frequency stages.

Figures 3 and 4 show combinations of radio and audio frequency amplifiers. In figure 4 the first two tubes act as a resistance-coupled radio frequency amplifier, with the third tube as a detector. In figure 5 we have a single-stage transformer coupled R. F. amplifier, a detector, and a single-stage transformer coupled A. F. amplifier. This circuit shows the use of a different form of filter, namely the choke coil condenser type. The choke coil should have an inductance of at least 1 henry,

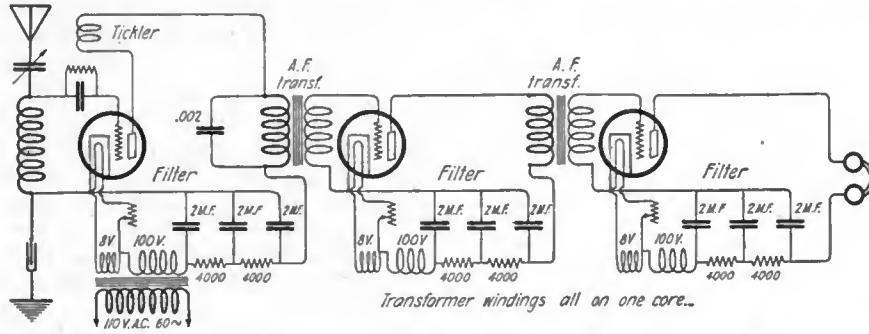

Figure 3—Use of the new tube in a transformer-coupled two-stage receiving set

of 8 are easily obtained, and at 360 to 400 meters, voltage amplifications of 12 to 15 are common. In many cases Dr. Hull has obtained a voltage amplification of 20 times at 360 meters—and this with resistance coupling—the most inefficient form of amplifier. Just a single radio frequency tube, using a good radio frequency transformer, will be better than four or five stages with existing tubes. It will be far superior to a super-heterodyne with existing tubes. At audio frequencies, the fact that with resistance coupling we get voltage amplification of 20 to 25 times is of great importance, in that two resistance coupled stages will be much better than two transformer coupled tubes with present UV-201's both in regard to signal strength and quality of music or speech received.

When used as a detector alone, the tube should give at least ten times as loud reception as a UV-201. This is of great importance when receiving distant stations, since, in present tubes, such signals are usually of the same magnitude as the tube noises and hence cannot be distinguished. In the new tube, the tube noises are practically the same, but the desired signal will be many times louder.

When a single tube is used, the hum cannot be heard at all. With two tubes in series, that is, one detector

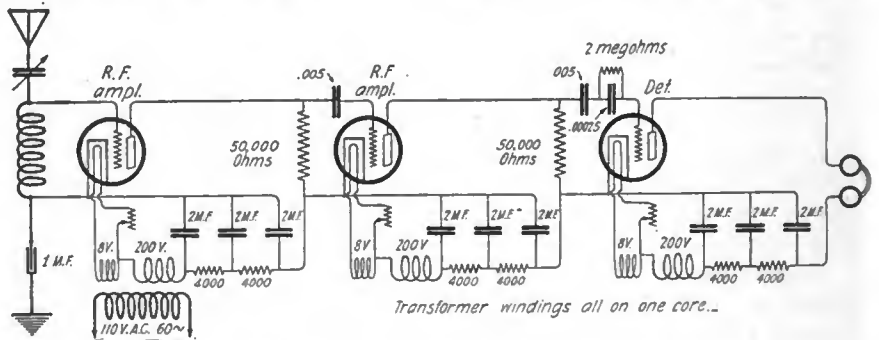

Figure 4—The new tubes also can be used for a resistance-coupled radio-frequency amplifier

this hum is caused by stray electric and magnetic fields and can be prevented by properly screening the various circuit elements.

CIRCUITS FOR USE OF NEW EQUIPOTENTIAL CATHODE TUBE

Figure 2 shows the application of the new tube to a detector and two-stage, resistance-coupled, audio-frequency amplifier. Note that separate transformer windings are used for each tube—one filament secondary of about 8 volts, and a plate supply secondary of about 200 volts. These need not be separate transformers; all are wound on a single core, energized from the power line by a single

and the condensers a capacity of 2 microfarads each.

Figure 7 illustrates an interesting circuit when using the 110-volt tube shown in figure 6. No transformers are used either for filament lighting or plate voltage supply—the latter being supplied directly from the power line. Thus the only additional equipment required with this tube is the filter, which consists of three 2-microfarad condensers and two 4,000 ohm resistances. The power line is also employed as the antenna for receiving the signals. This tube is still in the experimental stage, and as it is to be made the subject of further research and development work is not commercially available, and it is not known when it will be.

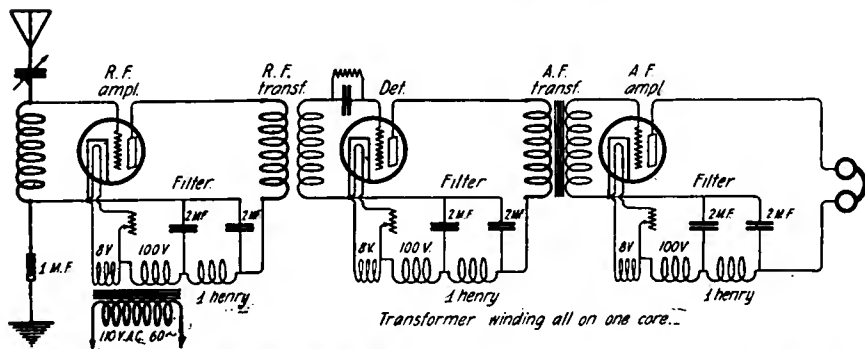

Figure 5—They likewise lend themselves to combination of radio and audio amplification, transformer-coupled

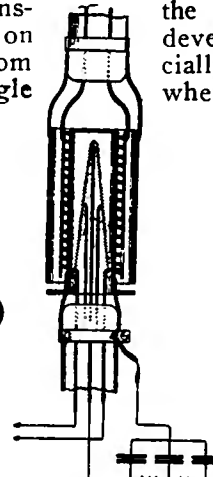

Figure 6—Section through the tube

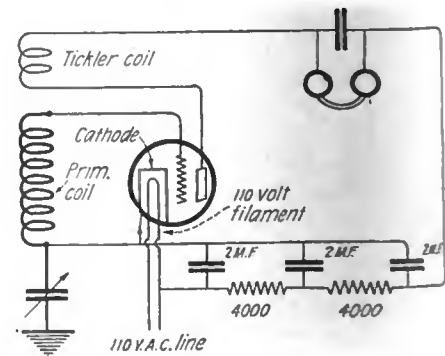

Figure 7—Circuit using the A. C. line as an antenna

Electrical Recording and Reproduction of Sound

ATACKLING the problem of voice recording in conjunction with motion pictures from an angle slightly different from other experiments, the Western Electric Co. has been successful in developing a device that operates to the satisfaction of its engineers and of those of the general public who have heard it in operation. The first showing of the new device was made recently in New Haven by E. B. Craft, chief engineer of the company. He displayed to an audience of 2,500 people a motion picture portraying the operation of the vacuum tube. The accompanying voice explanation was delivered by a group of loud speakers actuated by the reproducing mechanism, through which was run a record made some time previously.

Asked how it was done, Mr. Craft said that one of his engineers had prepared the lecture to go with the film and then delivered it into a transmitter, while he watched the film being shown. An ingenious synchronizing device kept the projector and the sound recorder in step. During the demonstration, several days later, the same device was used to synchronize the projector and the sound-reproducer, so that the speaker's words were heard at the proper stage of the film.

"There are five elements to be considered in the production of a talking movie," said Mr. Craft, "four physical and one psychological. It has been definitely established that the direct recording of sound by simple acoustic means is neither sensitive nor powerful enough. At present all phonograph

records are made by sending the sound waves into a horn which converges them onto a small diaphragm. This in turn moves a needle through the soft wax on a revolving disc or cylinder. Considering that all the power to move the needle comes from a speaker's voice, and that at best, the total power from his lips is exceedingly small, it is amazing that phonograph records get as much of the details of the voice as they do. Our researches into the nature of speech show that a true reproduction of the human voice—not merely an intelligible talk; but one that we can listen to with pleasure—requires the handling of tones of a very wide range, some of which are extremely weak. Many of these in the higher pitches the phonograph does not reproduce at all. As a concrete example, consider how poorly the sounds 's' and 'f' are reproduced on the average. In our talking movie, however, these sounds come out perfectly clear and distinct. Our recording equipment includes a high-quality transmitter coupled with vacuum tube amplifiers.

"The transmitter is so sensitive that it will pick up actors' voices at any point in a movie studio, and the amplifier supplies ample power to reproduce the sound as mechanical vibrations or in any other form we wish for recording purposes. All frequencies are preserved in the relative proportions of the original sound.

"For reproducing the record, several methods are available, according to the type of record used, but all ultimately produce an electric current in a wire

circuit. This current is then passed through vacuum tube amplifiers, and turned into sound waves by our loud-speaking projectors. The whole apparatus is a Western Electric achievement, and is one of the many by-products of the researches which are constantly being made in our Bell telephone laboratories.

"The two problems—recording and reproducing the speech—are still under development, and it would not be wise at this time to go into any details. I may say, however, that the method recently demonstrated gives such satisfactory quality that it can be considered one solution of the problem, although probably not the final one. Synchronizing the picture with the sound is a problem of electrical and mechanical design, which requires careful thought, but which has a satisfactory solution.

"Finally we come to the problem of projecting the sound to the audience. By the use of our public address system, a combination of vacuum tube amplifiers and loud-speaking sound-projectors, the sound can come from any point we wish, behind the screen, in front of it, or from one side in the case of an actor who is just about to enter the picture. We might even have projectors at opposite sides of the stage to use in dialogues."

One of the first applications of the new device will be in educational pictures, where a running story will not require the close co-ordination that a drama needs.

A Hornless Loud Speaker

By Beryl Dill

ASUITABLE loud speaker is often a problem for the amateur radio fan. This problem became of interest to R. H. Marriott, U. S. Naval Radio Aide at the Puget Sound Navy Yard in Washington, with the result that he bent his technical knowledge to the production of a novel speaker.

This speaker, upon which Mr. Marriott

seeks a patent, consists of a thin leaf-shaped spruce panel, supported on pegs with a little iron armature fastened to the board, not in the center but near the point, where the stem and leaf would join. The ear cap and diaphragm of an ordinary radio receiver are removed and the phone laid on the iron armature so that it sticks to the armature. A clamp in the frame is made to grip the phone case and a knob turned to pull the phone magnets slightly away from the armature. Then any currents passing through the phone change the magnetic pull on the armature and vibrate the spruce panel.

This panel is about ten inches long and about as wide, with irregular leaf-like edges. The spruce is carefully selected Washington wood, cut, braced, dried and waterproofed to produce the desired sound and prevent warping.

When the leaf is mounted in mahogany supports and placed on the library table or mantel it looks more like an ornament than a loud speaker and as the sound is given off by both sides of the board, there are no directional effects. The stranger is usually at

a loss to know from what point the sound comes.

A soft tone of most pleasing quality is obtained by operating the device with no more amplification than is necessary in a quiet room of the average parlor size. Any ordinary iron diaphragm type of telephone receiver, which can be heard loudly when used with a horn or sound box of a phonograph, will operate the device.

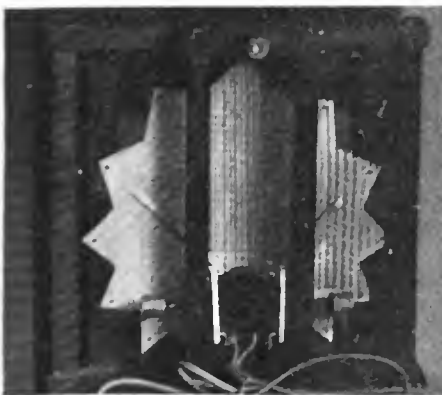

Back view of loud speaker showing single phone

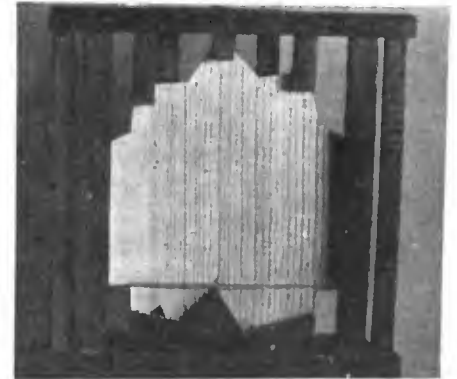

Front view of loud speaker using a spruce panel

EXPERIMENTERS' WORLD

Views of readers on subjects and specific problems they would like to have discussed in this department will be appreciated by the Editor

Loud Speaker Circuits and Devices

Loud speaker circuits and devices capable of reproducing the radio broadcast programs loud enough for large audiences in public halls or out of doors are being installed by many radio experimenters. To help those who wish to build their own equipment for this purpose, a brief description of the apparatus shown in the accompanying photographs will be given. This equipment was constructed by the writer entirely of standard radio parts now on the market, and has given excellent results.

The main purpose in the design of this set was to produce a complete receiving and amplifying set, in one unit, of neat appearance, compact construction, and simplicity in operation; so that the average person not familiar with radio can easily tune in the different broadcasting stations. Some of the refinements required for long-distance reception were sacrificed for compactness, but

By Clyde Fitch

(First Prize \$10.00)

Figure 2 shows the inside. This photograph shows everything in the set, which consists of a 1-step radio-frequency amplifier, detector, and 3-step audio-frequency amplifier.

It is well known that a 3-step amplifier is the practical limit for audio-frequency amplification, and if we wish louder signals we must resort to radio-frequency amplification. Many think that the results obtained from a radio-frequency amplifier are not worth the expense of installing one, but when a 3-step audio-frequency amplifier is used, even though the radio-frequency amplifier only doubled the signal strength input, it makes a great change in the output. It also elim-

inating the honeycomb coil, and connecting the secondary of a loose coupler to the terminals marked A and G and the antenna and ground to the primary of the loose coupler. Although signals are not quite as loud with the double circuit as with the single, the selectivity is much greater, and aids in tuning out local QRM. The single circuit arrangement using honeycomb coils makes a very flexible tuning system covering all wavelengths from the 200 meter amateur stations to the 15,000 meter government stations.

An iron core radio frequency choke coil is used for the radio frequency amplifier. This coil is shown in the grid leak base near the first tube, in the photograph, figure 2. Different size choke coils are used for covering the different bands of wavelengths.

The telephone jacks enable the operator to plug in one or two pairs of telephone receivers on the first three tubes. The switch

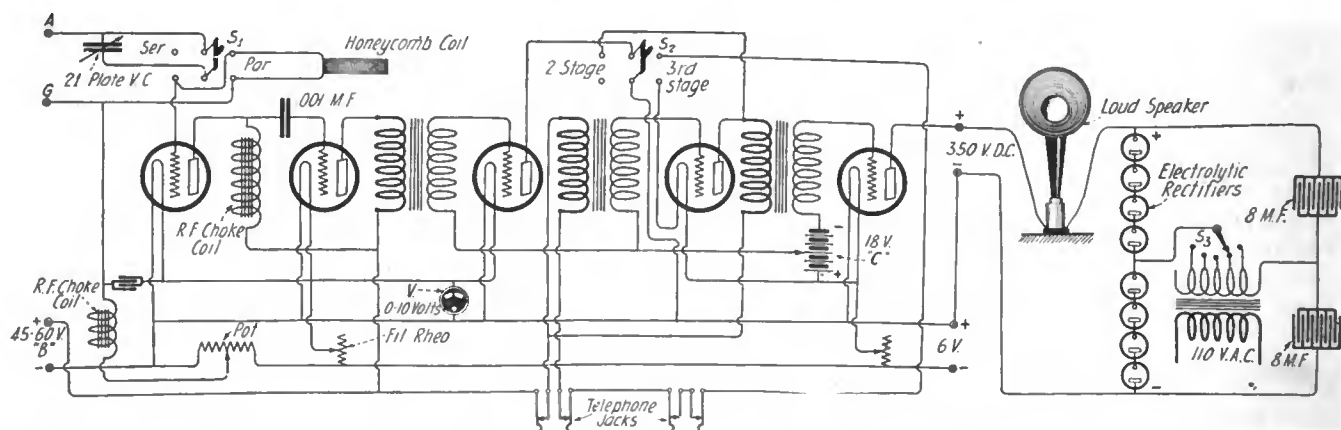

Figure 3—Circuit diagram of Clyde Fitch's receiver using one radio and three stages audio frequency amplification, with loud speaker operated by rectified A. C.

the main purpose of this set is to reproduce the radio programs of the nearer broadcasting stations loud and clear, and not to receive from extreme distances.

Figure 1 shows the complete set, with the exception of power supply, such as batteries, and loud speaker unit. This photograph shows the symmetrical arrangement of the tuning and control units, and also the compact construction of the set. The panel is only 6 x 12 inches and the cabinet is 7 inches deep, inside, making it ideal for portable use. The two metal dials control the variable tuning condenser, and potentiometer, or stabilizer. The two small knobs are power tube rheostats. One rheostat controls the filament current of the first three tubes in parallel, and the other rheostat controls the filament current of the last two tubes.

inates audio-frequency induction from nearby power lines.

Figure 3 shows the complete wiring diagram including high voltage supply for the last tube. Hard tubes such as the UV-201 are used throughout, even for the last step, using up to 500 volts on the plate. About nine tubes out of ten will stand this voltage. Although their life may not be as long as a 5-watt power tube, they are much more economical and convenient as regards filament current. A 5-watt tube may be used with A.C. on the filament on the last step only, without objectionable hum.

A single circuit tuning system is used by connecting the antenna and ground to the terminals marked A and G and throwing the switch S_1 to the series position. A double circuit tuner may be used by throwing the switch S_1 to the parallel position, remov-

S_2 connects in either 2 or 3 steps of audio frequency amplification. A "C" battery of 18 volts is used on the grid of the last tube, and a 1½-volt tap taken off to bias the grids of the third and fourth tubes. This "C" battery is important, as it operates the tubes on the straight part of the characteristic curve and prevents distortion so common in radio receiving sets.

Great care should be taken in wiring to insure tight connections. Connections should be soldered wherever possible. All grid connections, running to the grids of all the tubes, should be as short as possible. This prevents howling, as howling in multi-stage amplifiers is usually due to electrostatic feed back from the plate circuit of the last tube to the grid of the detector tube, and the smaller this grid lead is, the less chance there is of howling. The grid condenser should be mounted directly on the vacuum tube socket. Amplifying

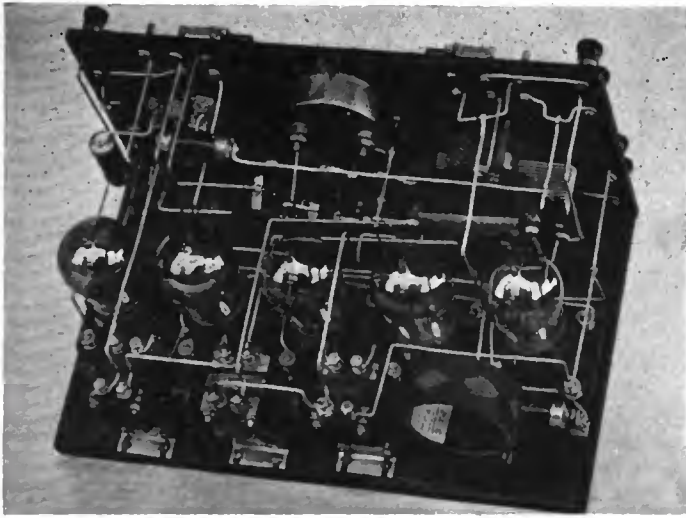

Figure 2—Showing how the apparatus is assembled in the five-tube receiver

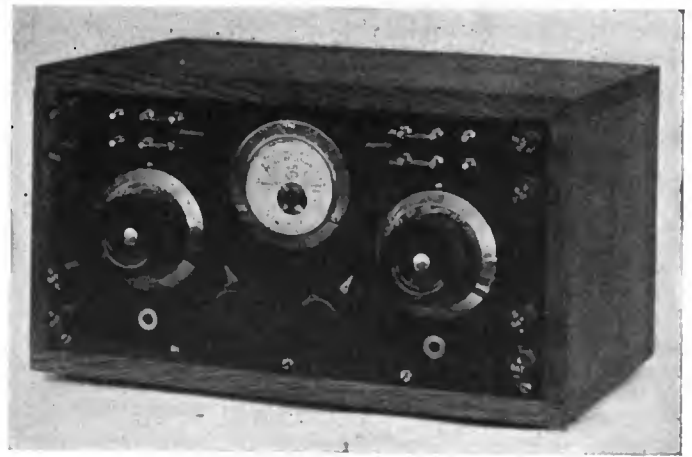

Figure 1—Front view of compact receiver and power amplifier used by Clyde Fitch for loud speaker operation

transformers having a ratio of turns of over 3 to 1 should have a one or two megohm grid leak resistance connected across the secondary winding.

The most important part of the power amplifier is the high voltage supply for the plate circuit of the last tube. Many experimenters have used "B" batteries up to 200 volts, but these are very expensive and become noisy with age. Others have used motor generators, but unless the commutator has a large number of segments and is in perfect condition, they are noisy no matter how many filter condensers are used. In this circuit, 60-cycle alternating current is used. This current is taken direct from the 110 V. socket, stepped up, rectified, and filtered, as shown in the diagram, figure 3. With the tubes lit full brilliancy, the hum is barely audible five feet from the horn.

The transformer consists of a 50-watt 110-volt 60-cycle transformer, with a 220-volt secondary winding. Several taps are taken off the secondary winding to give a variable plate voltage, which is very critical. At least 8 microfarads of condensers are used on each side, although more condensers are recommended. The electrolytic rectifier consists of eight 1x6-inch test tubes filled with a solution of sodium phosphate. About one teaspoonful of sodium phosphate to a cup of water is sufficient. The positive electrodes are of pure aluminum strip 1/4 inch

wide. The negative electrodes may be of tin, iron or lead. Before using, the switch S_2 should be connected to the lowest tap, and

In selecting a loud speaker, care should be taken to select one guaranteed by the manufacturers to stand voltages up to at least 350.

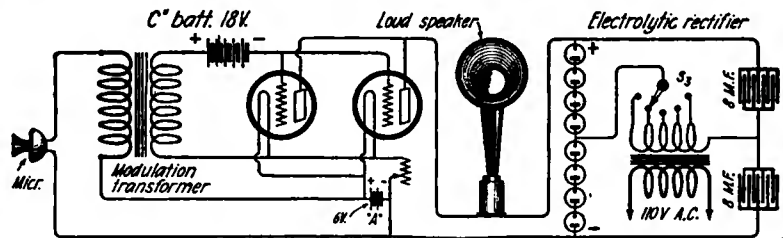

Figure 4—Circuit used for amplifying voice or music picked up by local microphone

the transformer connected to the 110-volt line for about ten minutes. This will form a rectifying film on the aluminum electrodes. This circuit doubles the maximum value of the alternating voltage. With the switch S_2 on the 220-volt or highest tap, the direct current voltage is 575 by actual measurement.

Before tuning in any stations, the last two tubes should be lighted and the "B" batteries, high voltage supply, and loud speaker, connected in the circuit. This is to test for noises caused by poor connections, old "B" batteries, or "A" battery. If everything is in good condition there should be no sound in the loud speaker except a slight hum caused by the high voltage supply:

With two tubes in parallel on the last step, and with an R2 Magnavox on the roof of the house, the concert from WGY about 50 miles distant, was heard over two miles in the opposite direction from which the horn was pointing.

Figure 4 shows the circuit used for amplifying speech, phonograph music, or other sounds. This circuit needs no explanation except that it is absolutely necessary that the telephone transmitter or microphone be shielded or located a great distance from the loud speaker, or the sound waves coming from the loud speaker will feed back into the microphone and cause a continuous howl.

Loud Speaker Circuits and Devices

By C. P. Bernhardt

(Second Prize \$5.00)

THERE are numerous types of loud speakers now in use, many of which are not being used as they were intended to be, and still others are not loud speakers, but "loud screechers." Loud speakers can generally be divided into two classes: (a) those intended for home entertainment; (b) for demonstration of public gatherings.

In the latter class the use of a loud speaker giving a large amount of volume is desired. This can be obtained by the use of types such as Western Electric, Magnavox and others of similar characteristics. With these the use of a power amplifier is a necessary requisite, and when so used good quality and volume may be expected.

We now come to the class of loud speakers which are in most general use, namely those

for home entertainment. In this class are generally—(a) the two receivers of the head-set arranged to clamp to a horn; (b) the use of a single phone, generally a Baldwin type "C"; (c) the Westinghouse phonograph attachment.

The first of these mentioned has the disadvantage in that distortion is present if any amount of volume is desired. The second type in the majority of cases consists of a type C Baldwin phone used in conjunction with a horn. A modification of this type giving greater volume and still retaining the good reproducing qualities of the type C phone may be had by the use of a Westing-

house Baldwin Phone. This device has a corrugated metal diaphragm eliminating any possibility of loose pins as is sometimes present in the type C. The third type mentioned, namely the Westinghouse Phonograph Attachment is essentially the Westinghouse Baldwin Phone provided with a socket to enable it to be fastened to the tone arm of the phonograph, thereby taking advantage of the superiority of the phonograph sound chamber as compared with that of the average metal horn.

It is generally not advisable to use more than two steps of audio-frequency amplification, where transformer coupling is used. However if two stages do not give the desired amplification the use of a third stage of resistance coupled amplification connected as shown in figure 1 will generally be more than

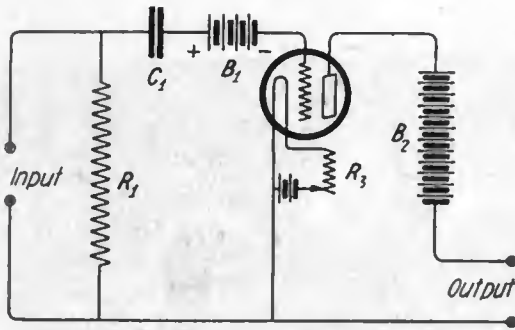

Figure 1—Resistance coupling for third stage of amplification to secure volume

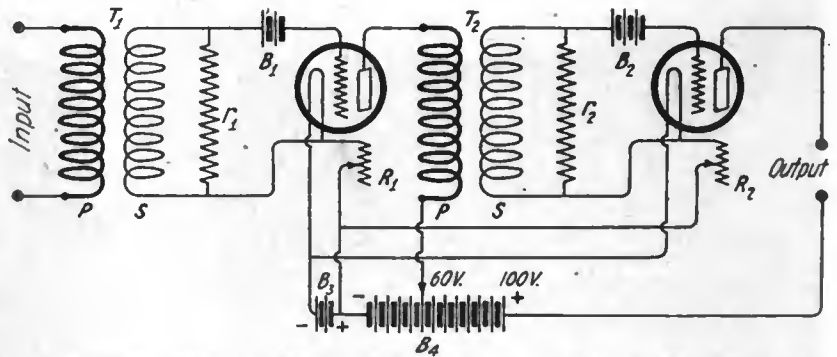

Figure 2—Wiring diagram of a two-stage transformer coupled amplifier

sufficient. Resistance coupled amplifiers are less noisy, cheaper, but do not give the overall amplification of the transformer coupled type.

For best results grid biasing batteries should be used on all amplifier tubes, the voltage depending upon the type of tube. For U.V. 201 Radiotron, 3 to 6 volts; VT 1, Western Electric, 3 to 6 volts; U.V. 202 Radiotron, 6 to 22 volts; VT 2, Western Electric, 3 to 12 volts.

The use of a shunting resistance across the secondaries of the amplifying transformers will generally improve the quality and re-

duce other noises to a minimum. This resistance can be of the order of 100,000 to 250,000 ohms and of the grid leak type. The complete wiring diagram of a two-stage transformer coupled amplifier is shown in figure 2. The use of a power tube in the last stage of the amplifier in connection with a plate voltage of 100 to 200 volts, and the proper grid bias battery is strongly recommended. Radiotron U.V. 202 or Western Electric V.T. 2s can be used for this purpose.

In receivers of the Baldwin phone type or Westinghouse phonograph attachment good results depend to a large extent upon the

proper direction of current flowing through the windings. This can be determined by comparing the quality and volume when the terminals of the speaker are reversed. The connection giving the best results is of course the one to use. In cases where the loud speaker blasts when a high note is sung the use of a fixed condenser of .005 to .01 mfd. capacity shunted across the terminals of the loud speaker will generally eliminate this.

It should always be remembered that in general the greater the regeneration the poorer the quality, and that good quality cannot be obtained when tubes are forced to their limit.

Loud Speaker Circuits and Devices

By Ray Dio

(Third Prize \$3.00)

THE Editor makes the very correct statement that "much distortion and noise heard at receiving stations originate at the receiving end" and I can truthfully say that I have done something toward increasing the quality of reception for myself and for many others by passing this information along to them:

"Simply sacrifice volume of sound or quantity for quality."

Very few owners and operators of stations have very much room for more to say after they get finished telling weird stories about how far from the phones or horn they were able to hear PXZ the other night—and always sign off with the disheartening tale of "how rotten PXZ's modulation was."

This is the whole story in a nut shell! Take it or leave it . . . but dem's my sentiments.

No matter what kind of horn or phones this type of operator owns he will continue to get distorted music and speech over the highest grade receiving apparatus on the market.

There is not much room for more loud speakers on the market as there is need of the use of a little plain horse sense in tuning.

Even though the crystal receiver is the poorest insofar as sensitiveness is concerned and it can only be used for the reception of local broadcasters, it is the life saver of true radio, simply because no human can succeed in pushing it to the straining point as many perfectly good distortionless receivers and loud speakers are. Many beginners using crystal sets marvel at the clarity of speech and music coming in on their receivers. Many more fortunate people (who happen to own vacuum tube receivers) are unfortunate

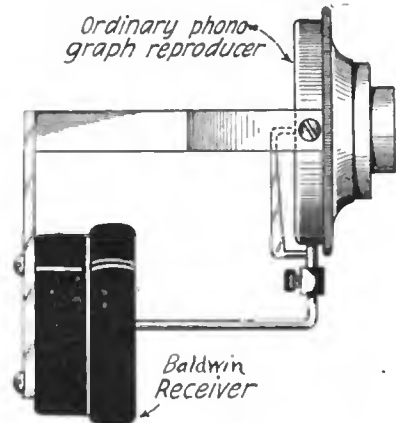

Method of connecting phone to ordinary phonograph reproducer

enough to own one and through their lack of common sense operating methods they turn good music into "tin pan stuff."

All loud speakers of the Magnavox, Callaphone, Western Electric, Vocarola and numerous other types are not placed on the market to jumble up music and speech to the point where it is not understandable. All horns are practically distortionless and the proper operation of any horn is entirely up to the operator.

I find one of the best methods of clarifying the music and speech and at the same

time eliminating many of the very low frequency extraneous noises in the amplifier is that adopted by the General Electric Company. They shunt the secondary of each audio frequency transformer with a 400,000 ohm resistance. This is the exact value employed, however a variable one reading from 200,000 to 2,000,000 will be found very valuable.

The author has had considerable success with the arrangement shown in figure 1; where a Baldwin telephone receiver was mounted so that the push and pull from the diaphragm (or vibrations) were imparted to the needle holder of the phonograph reproducer. The receiver functioned in a manner similar to the record groove in that it moved the needle backward and forward. With local stations the reproduction is fairly loud, however when distant stations are picked up one must place his ear to the horn of the phonograph. The weakness of the signal is due to the losses in the mechanical arrangement and the necessity of having considerable signal strength to operate the rod connecting the diaphragm to the reproducer.

The reproducer is placed in its ordinary position and the horn of the phonograph functions as usual.

The average experimenter is not going to perfect a crude model to take the place of the horns on the market today. However it is worth while working on and when a favorable device is produced some reliable manufacturer can take it up from where the inventor leaves off.

In the meantime let us be considerate and have faith in the horns we already have. Let us not ask too much in quantity, but rather have the quality.

Amateur Activities in South Africa

By Wilfred J. Copenhagen

AMATEUR wireless in South Africa, in its present form, dates from September 3rd, 1920, when a number of men who had been interested in amateur transmission and reception before the war, met and formed the Radio Society of South Africa. Shortly before this the Postmaster General for the Union of South Africa had resumed the issuing of amateur licenses for transmission, ending the long ban upon the amateur, resulting from the war. Since the formation of the society, the number of new radio enthusiasts have purchased and installed equipment and have secured licenses, although the number does not by any means approximate that which it is expected will be reached in the course of 1923.

The new society is modeled somewhat after the Wireless Society of London, and has its headquarters in the Argus Bldg., St. Georges Street, Cape Town. Its objects, as they are given in the society's official literature, are as follows:

(a) The furtherance of all matters and studies connected with radio science and

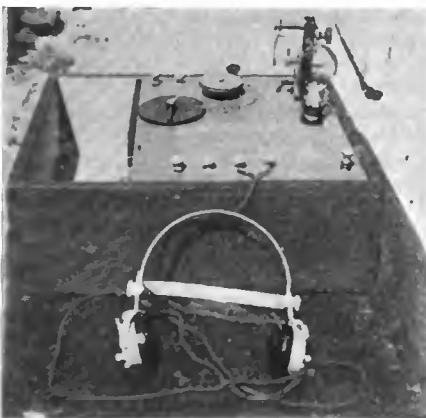

Simple English receiver combining tube and crystal

ban and in other important towns in South Africa. Johannesburg is the only large town which so far has not formed a branch. Kimberley, the famous diamond-mining center, has a branch of the society with fourteen members. At Port Elizabeth there is another branch with twenty members, and at Uitenhage there is still another with eleven members. This, with the ninety-eight members of the main organization, gives the society one hundred and forty-three men, exclusive of the Durban branch, which is still in the midst of its organization campaign, and which at last accounts had thirty-seven on its rolls.

As yet, there is no regular broadcasting being conducted in South Africa, but the



Cape Town and Table Mountain as seen from the harbor

ed in a great flood of correspondence from even the most remote sections of the Union, with demands for regular service.

In addition to the transmitter, the society has much radio apparatus at its headquarters, including testing instruments workbench and facilities for practice in sending and receiving code.

Monthly meetings are held, each meeting centering around a paper presented by an expert on some particular phase of radio work. Some of the papers presented during 1921 and 1922 were as follows:

Description of 7 and 5-Valve Amplifiers. Short and Long Wavetuners, Heterodyne Wavemeter, and an Audibility Meter, by Q. H. Bullard; The Length of the Tracks of Alpha Rays from Polonium, by C. W. v. d. Merwe; The Construction, Without a Lathe, of a 2-Valve Amplifying Receiver, and a 3-Valve Detector Amplifier, by J. E. Levyns; The Application of the Vacuum Tube to Recent Developments in Radio Communication, by H. J. v. d. Bijl; Electricity and Its



Another English combination tube and crystal receiver

allied subjects, and the promotion of intercourse and exchange of ideas between experimenters in radio science.

(b) To give members the advantage of collective representation and control in all matters of moment to radio experimenters, and to assist members with information and technical advice.

(c) To acquire and facilitate the obtaining of supplies on behalf of members individually and collectively.

The society has formed branches at Dur-

ban and in other important towns in South Africa. Johannesburg is the only large town which so far has not formed a branch. Kimberley, the famous diamond-mining center, has a branch of the society with fourteen members. At Port Elizabeth there is another branch with twenty members, and at Uitenhage there is still another with eleven members. This, with the ninety-eight members of the main organization, gives the society one hundred and forty-three men, exclusive of the Durban branch, which is still in the midst of its organization campaign, and which at last accounts had thirty-seven on its rolls.

Relation to Wireless, by H. E. Penrose; Modern Wireless Telegraph Transmitters, by Capt. W. G. H. Miles, R. M. L. I.; Wireless Telephony, by G. W. Heugh; Electro-Magnetic Waves and Their Application, by Dr. S. J. v. d. Lingen; Wave Motion, with Special Reference to Telephony, by J. Milne.

The officers of the society are: Chairman, Professor A. Ogg; vice-chairman, W. H. Perrow and J. Milne; treasurer, G. W. Heugh; secretary, G. H. J. Sadler, P. O. Box 43, Simonstown.

PRIZE CONTEST ANNOUNCEMENT

The subject for the new prize contest of our year-round series is:

ALTERNATING CURRENT FOR AMPLIFIERS

CLOSING DATE : : : : JAN. 15, 1923

Contestants are requested to submit articles at the earliest practical date. Prize winning articles will appear in the March, 1923, issue. All manuscript should be addressed to the CONTEST EDITOR OF THE WIRELESS AGE.

MANY amateurs and broadcast listeners are using rectified alternating current on the filaments and plates of amplifier tubes, also for operating loud speakers, to avoid constant recharging of storage batteries. If you have been successful in using A. C. for amplifying received signals our readers will be interested in your circuit arrangements.

PRIZE CONTEST CONDITIONS—Manuscript on the subject announced above is judged by the Editors of THE WIRELESS AGE from the viewpoint of the ingenuity of the idea presented, its practicability and general utility, originality and clearness in description. Literary ability is not needed, but neatness in manuscript and drawing is taken into account. Finished drawings are not required, sketches will do. Contest is open to everybody. The closing date is given in the above announcement. THE WIRELESS AGE will award the following prizes: First Prize, \$25; Second Prize, \$15; Third Prize, \$10.

A. C. for Filaments and Plates of Receiving Tubes

By Abraham Ringel

IN ORDER to obtain good results, amplifier tubes are usually run from storage batteries for filament lighting and blocks of "B" batteries for plate voltage supply. The "B" batteries are not particularly objectionable, except that they must be periodically renewed at intervals varying from six months to more than a year. The maintenance of the storage battery is generally a source of considerable annoyance. Its bulk and weight make it difficult to handle; it must be properly charged, the electrolyte must be tested for specific gravity, distilled water added every now and then; highly corrosive acids are likely to mar and spoil the woodwork or furniture unless proper precautions are taken. Thus, the development of some means of supplying filament and plate energy from alternating current power mains is of great importance.

The writer here traces a few steps in which alternating current is used first to supply plate voltage, then filament and plate voltage in ordinary amplifier tubes. It must be understood that these tubes cannot be used as detectors when the filaments are lighted by alternating current. The hum is so severe that it drowns out even the most powerful incoming signal.

USE OF RECTIFIED A. C. ON PLATE OF DETECTOR TUBE

Figure 1A shows a common form of three-circuit, regenerative receiver, in which filament and plate voltage are both supplied by batteries. Direct current generators may be used with equal effectiveness. Figure 1B shows the same circuit, except that rectified alternating current, sufficiently smoothed out by a filter, is used for the plate voltage. In the case of detector tubes, it has been found impossible to use A. C. for lighting the filaments, although it is quite successful on both audio and radio frequency amplifiers.

The 110-volt, 50-cycle alternating current is supplied to the primary winding of a special transformer. The primary is wound for 110 volts; there are two secondary windings: first an 8-volt winding which is used to light the filament of a rectifier tube; second, a 50-volt secondary for plate voltage supply. The rectifier tube is an ordinary UV-201 tube with grid and plate connected together. One terminal of the 50-volt winding is connected to the filament of the rectifier. The other is connected through the filter, telephones, tickler coil to the plate of the detector tube—and by means of the electron conductivity between filament and plate of the detector to the filament of the detector and thence to the plate of the rectifier. This constitutes a well-known half-wave rectifier where only one-half of the alternating current cycle is utilized in producing direct current. The terminals indicated would assume positive and negative polarity. If the filter were not used, a pronounced hum would be obtained, but the combination of capacities and resistance smooths and irons out the fluctuations in voltage which cause the hum, and the result is a very steady direct current. The larger the capacity of these condensers, the better the smoothing effect. For ordinary purposes an arrangement as shown is quite satisfactory. The condensers are each of 2 microfarads capacity, and the resistance is

approximately 10,000 ohms. A choke coil could be used in place of the resistance. The Radio Corporation's UP-415 plate circuit reactor, which has an inductance of 1 henry, is just right. An ordinary paper condenser of say 10 microfarads capacity could be used in place of the filter. A condenser of this magnitude is sufficient to keep the voltage quite steady. It is absolutely necessary to use some such means, otherwise we will have a series of uni-directional pulses instead of a steady, direct voltage.

USE OF ALTERNATING CURRENT TO LIGHT FILAMENTS AND RECTIFIED ALTERNATING CURRENT ON PLATES OF AMPLIFIER TUBES

Figures 2, 3 and 4 show the application of alternating current for both filament and plate supply in radio and audio-frequency amplifiers. In all these circuits, vacuum tubes cannot be used for detection and recourse must be had to the crystal detector for rectification of the radio frequency to audio frequency.

In figure 2 is illustrated a two-circuit tuner, using a crystal for detection. Instead of the customary telephones, we have the detector feeding the primary of an audio-frequency amplifying transformer, and thence to a two-stage amplifier. Both filaments and plates receive energy from the alternating current transformer, which must be specially wound to give the voltages indicated in the diagram. Both filaments are connected in parallel to the 8-volt secondary winding through a filament rheostat, which is used to adjust the current to the proper value. Two other windings are used as secondaries: one additional 8-volt secondary to light the filament of the rectifier tube and a 100-volt secondary to supply the plate voltage, which is made uni-directional by the rectifier and smoothed out by the filter. The effective plate voltage on the amplifier tubes is approximately 50 volts. The grid circuits of both amplifier tubes are connected to the slider of a potentiometer, which itself is across the filament leads. In this way, the A. C. hum is balanced out. In order to avoid having a positive bias on the grids because of this procedure, and thus kill a large proportion of the amplification, it is necessary to connect a bias battery in series with the grid circuits as shown in the diagram. Two or three small flashlight cells connected in series are about right to give a small negative voltage to the grids.

The rectifier and filter are essentially the same as described above—except that a higher voltage is used—and two tubes supplied instead of one. The rectifier tube may be an ordinary Radiotron (hard tube) with grid and plate connected together.

The circuit of figure 3 shows the use of A. C. for lighting the filaments, only, of an amplifier. There are two radio-frequency stages and two audio-frequency

stages. A crystal detector is employed for rectification of the signal. A separate "B" battery of the usual commercial type is used for plate voltage supply. The 110-volt, 60-cycle current is stepped down by means of a transformer to about 6 to 8 volts for filament heating. The feature worthy of note is the use of two potentiometers, one for the radio-frequency tubes and another for the audio-frequency tubes. Better amplification is obtained from the R. F. stages by using a .02 microfarad condenser, shunted by a 1-megohm grid leak resistance in series with the slider of the potentiometer. Better audio-frequency amplification is secured in the last two tubes by connecting a "C" or grid battery of three or four flashlight cells in series with the slider of the A. F. potentiometer. Only the second potentiometer is effective in balancing out the A. C. hum, the first being used to stabilize the R. F. amplifier and prevent oscillations in the transformers.

Figure 4 illustrates a circuit essentially the same as described in figure 3, except that rectified and filtered alternating current is used for the plate voltage supply, instead of the "B" battery. The main features have already been thoroughly described above and need no further mention. For supplying four tubes, an ordinary UV-201, with plate and grid electrically connected may be overloaded. In that case a kenotron rectifier, type UV-216, may be used with success.

DISADVANTAGES OF USING UV-201's ON ALTERNATING CURRENT

There are two objectionable features to the use of A. C. on ordinary tubes: first, a considerable amount of the hum is still present; second, a crystal detector must be used.

Theoretically, if a tube is symmetrical and has a perfect, straight-line characteristic, that is, plate current-grid voltage curve, there should be no disturbance from the 60 cycles when the potentiometer is balanced. Actually, however, tubes are slightly asymmetrical; even with very high impedance load in the plate circuit, the characteristic curve is not linear, but slightly parabolic; a sufficiently good balance cannot be made with the potentiometer unless it has a very high resistance (of the order of 1,000 ohms). Even under the best conditions, the hum cannot be balanced out; it is quite satisfactory where a loud speaker is used—the resulting hum cannot be heard above the speech or music; but weak signals would be badly interfered with.

In all of the foregoing circuits a crystal detector must be used for detection. It is absolutely impossible to use alternating current for the filament of a detector tube, as the A. C. hum would be loud enough to drown out the loudest signal that could be received.

Since the average radio-frequency voltage impressed between grid and filament of a detector tube is of the order of .01 and .001 volt, namely one hundred to a thousand times as great as the A. C. voltage, the signal after the detector tube will be 10,000 to 1,000,000 times as loud as the A. C. hum.

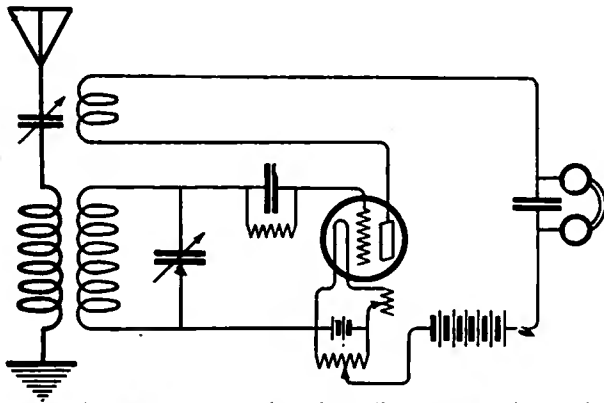

Simple rec circuit using direct current supply both for filament and plate voltage...

Figure 1-A

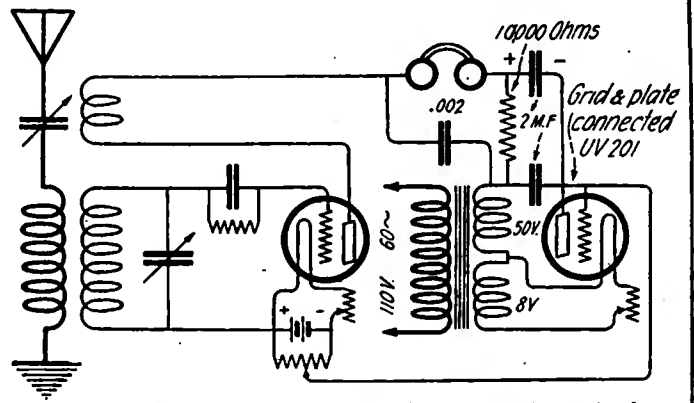

Simple circuit using alternating current supply for plate voltage only, employing rectifier and filter

Figure 1-B

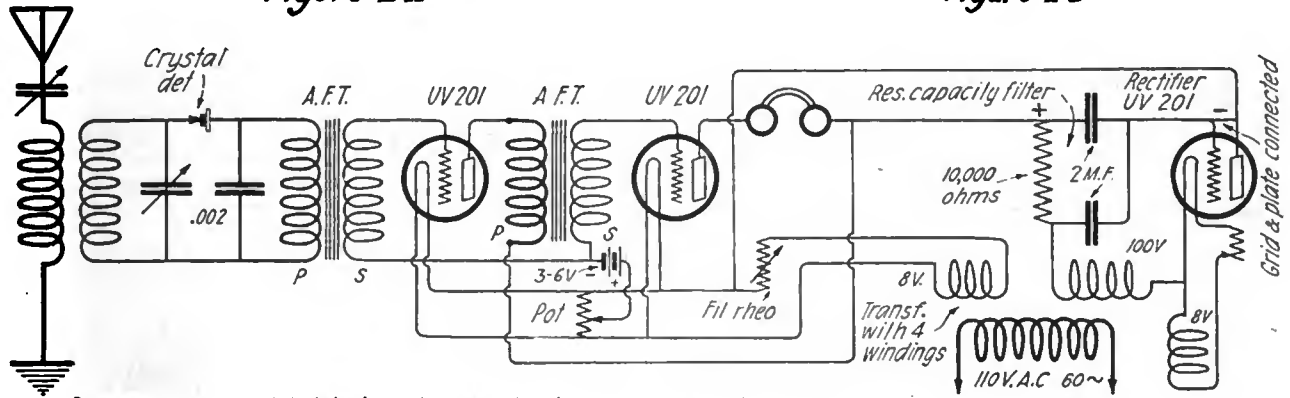

Receiver using crystal detector for rectification and two stage audio frequency amplifier. Filaments and plate supplied by alternating current...

Figure 2

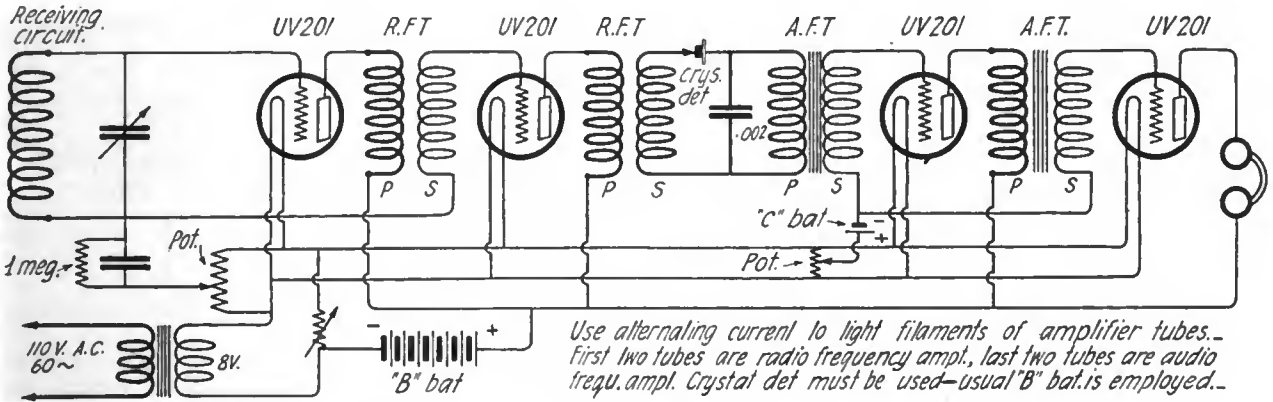

Use alternating current to light filaments of amplifier tubes... First two tubes are radio frequency ampl., last two tubes are audio frequ. ampl. Crystal det must be used—usual "B" bat. is employed...

Figure 3

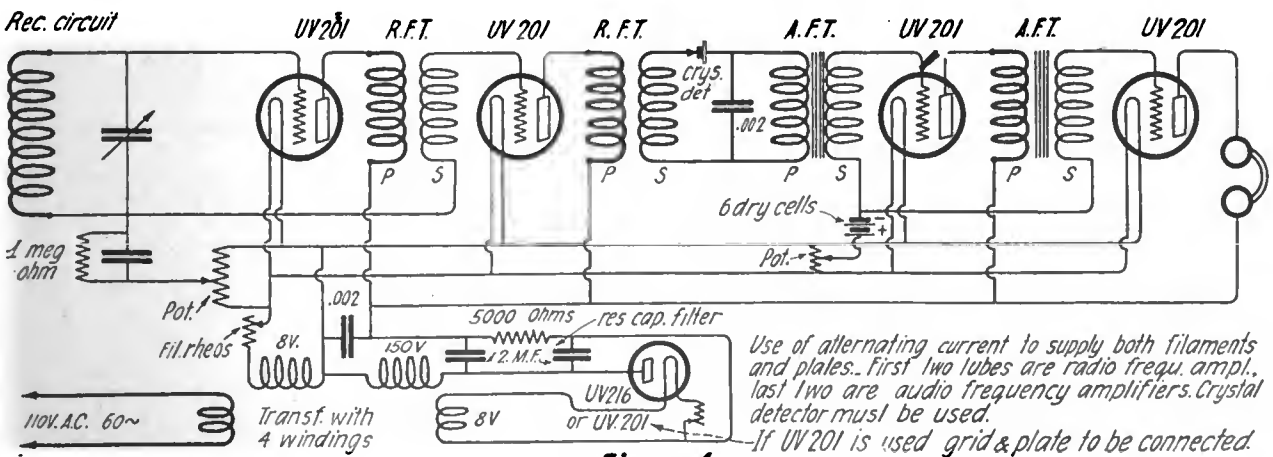

Use of alternating current to supply both filaments and plates... First two tubes are radio frequ. ampl., last two are audio frequency amplifiers. Crystal detector must be used. If UV201 is used grid & plate to be connected.

Figure 4

Various hook-ups showing the use of alternating current for filaments and plates of amplifying tubes

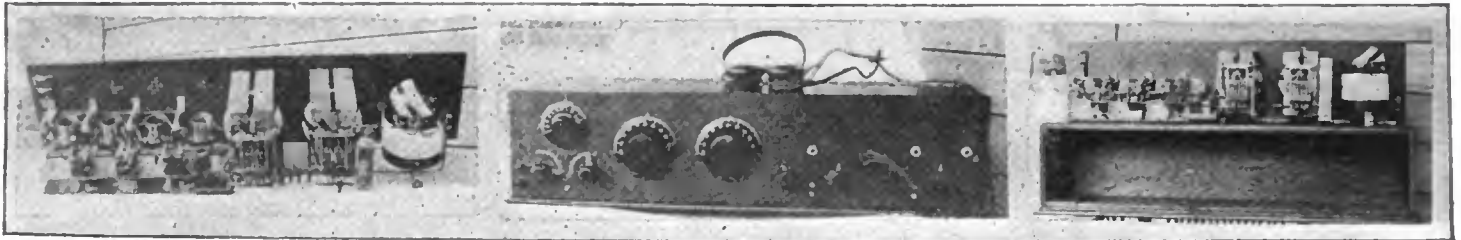

Widening the Range of Variometer Receivers

By F. B. Ostman 20M

MANY amateurs in order to secure efficiency on amateur waves around 200 meters, on broadcasting waves at 360 meters, and on ship and commercial stations from 485 up, have thought it necessary to buy or construct two and sometimes three separate receiving sets. This is not at all necessary, as the conventional vario-coupler and variometer receiver can be altered in such a way as to work efficiently over three over-lapping bands, from 140 to 1400 meters. The set now in use at 20M, at Ridgewood, N. J., has that range, and was awarded a \$50 prize at a recent radio show, since which time it has been much improved. The method used, essen-

They may be made to operate from the front of the panel, but mounting them as shown secures the very shortest leads. However it is necessary to raise one side of the cabinet cover to change the switch. In our case this is no trouble as the switch is mostly set in the parallel position for amateur waves.

For short waves, amateur length, the switch handles are thrown to the left. As can be seen in the diagram this connects

meters, amateur stations operating on a small band of wave lengths above and around 200 meters would all come in on one small section of the dial. This makes tuning very sharp and difficult, where with the parallel connection, practically the whole dial is used to cover the amateur range.

It has been found that to cover a certain wave band on the grid variometer with coils in series the grid variometer would have to turn from three to four times the distance to cover the same wave lengths when connected in parallel.

This is mainly for amateur work, where so many stations are operating on the band

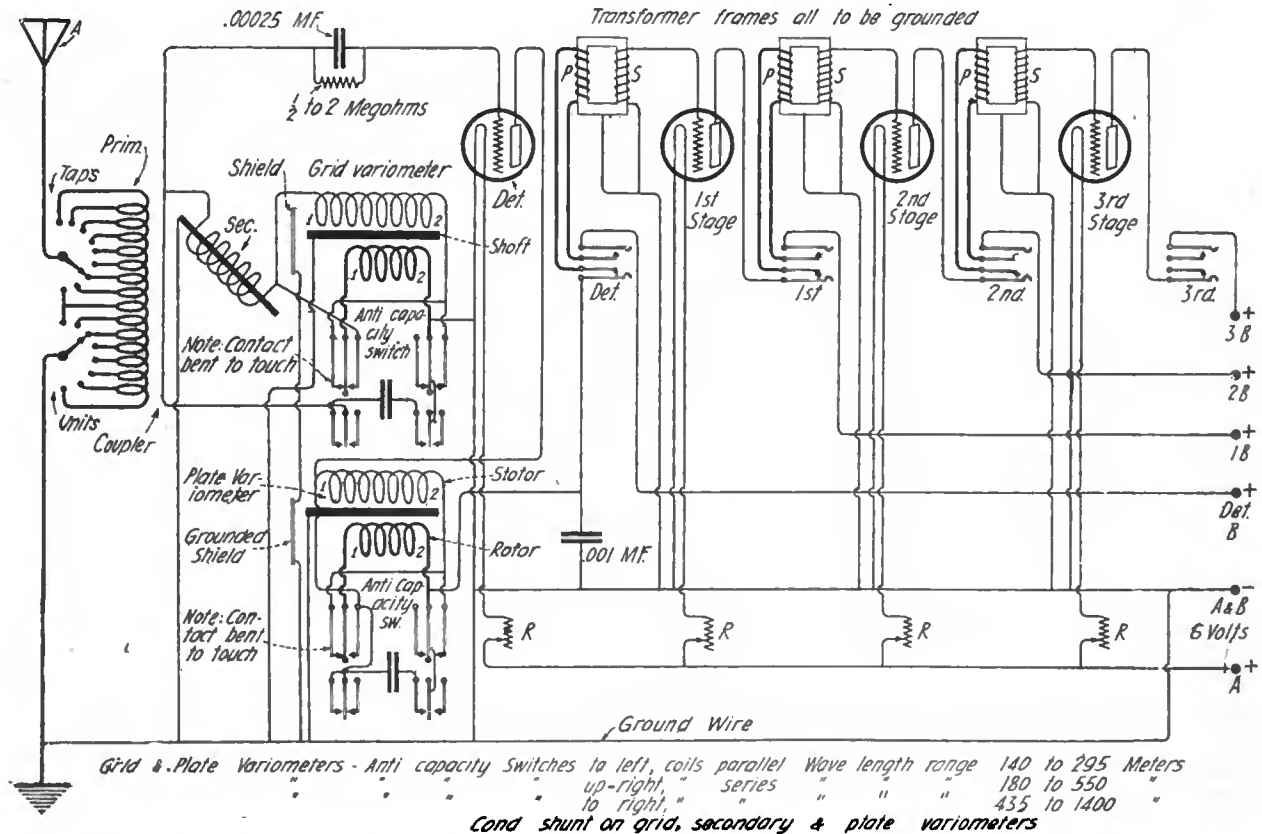

Diagram showing addition of condensers to conventional variometer and vario-coupler receiver for the purpose of spanning three different bands between 140 and 1,400 meters

tially, consists of switching the variometer rotor windings in series or in parallel with the stator windings, and in shunting fixed condensers across the variometers. When the coils are in parallel, the range is from 140 to 295 meters; in series, the usual 180 to 550 meters and in series with condensers shunted across, from 435 to 1,400 meters.

As can be seen in figure 1, two 4-circuit 3-position Federal anti-capacity switches are used, one mounted on the back of each variometer. These are used to make either series or parallel connections between rotors and stators and to shunt condensers across the variometers for receiving high waves.

the coils in parallel, which is ideal for tuning amateur stations. It is particularly desirable when tuning for C.W. stations many of which are so sharp that they are entirely skipped when tuning with the usual series connections in the variometer. The parallel connection allows better tuning on the lower waves which a large variometer with series windings cannot get down to at all. Also, the parallel connection in the plate variometer allows a more gradual control of regeneration.

It will be noted that with a series connection on a grid variometer having sufficient inductance to cover waves up to 600

of waves around 200 meters. A variometer of the usual size having a wave length range of 180 to 600 meters, when used in the regular series connection, is far from being efficient for amateur reception.

The coils in parallel cause the variometers to work at their maximum efficiency—because they are working over a particular wave band. The resistance of the circuit is reduced. The advantage however is purely a practical one giving much more selective tuning between points on the variometer dial—greater selective control—thereby giving louder signals.

(Continued on page 83)

A Practical Super-Heterodyne Receiver

THE desire of many amateurs interested in long-distance reception has been to possess a duplicate of the Armstrong superheterodyne receiving set used by Paul F. Godley at Ardrossan, Scotland, last year, when he recorded the signals of some twenty odd American amateur stations. In only a few cases, however, have these dreams come true, although many attempts have been made to build similar outfits.

In many cases failure resulted because of a lack of understanding of the principles involved, or because a lack of regard on the part of the amateur for correct values in assembling the various elements of the circuit or because it was difficult or impossible to secure parts of proper value. That the circuit is remarkably sensitive and selective, however, and that it can be readily assembled by anyone interested has been demonstrated at 2ZL station (also 2XAQ) located at Valley Stream, L. I., where a nine-tube transformer-coupled outfit of this type has been in operation for two months past, with unusual and unprecedented results—even for that station.

two coils L^1 and L^2 . These coils are shunted by variable condensers of .001 mfd. maximum capacity and tuned to the fixed difference of frequency and the frequency of H. It is the same principle as is followed in heterodyning by means of an oscillating detector tube in an ordinary regenerative circuit, except in that case the difference in frequency is an audible one, of 500 to 1,000 cycles. In the case of the heterodyne receiver used at 2ZL the difference in the incoming frequency in 136,360 cycles, or 2,200 meters. The two coils L^1 and L^2 are honeycomb coils L 300 which have a wave length between 1,500 and 2,500 meters, according to the value of the capacity shunted around them. By means of the two variable condensers it is possible to tune these coils exactly to the beat frequency, between D and H.

The amplification of the beat frequency at 2,200 meters is accomplished by means of L^3 and the four Radiotrons UV-201 and four radio-frequency transformers, UV-1714. The full winding of the transformers is used and as these transformers are very

the one step of audio-frequency amplification used are arranged in the usual manner. One lighting battery is used for all tubes and the negative side of all "B" batteries connected to the negative "A" lead.

METHOD OF OPERATION

The primary and secondary circuits of the receiving set are tuned in the ordinary manner to the wave length it is desired to receive, which, for example, may be 200 meters, or 1,500,000 cycles. The condenser, C^1 , should then be varied until signals are heard. This will occur at two points, one on each side of the incoming 200-meter wave frequency. It will be found that the point above the incoming wave frequency where signals are heard will give stronger signal response than the point below it. The frequency of the beat note obtained in this way will, of course, be determined by the constants of the D circuit, but if L 300 coils are used, shunted by variable condensers, the frequency will be in the neighborhood of 136,360 cycles, or, 2,200 meters.

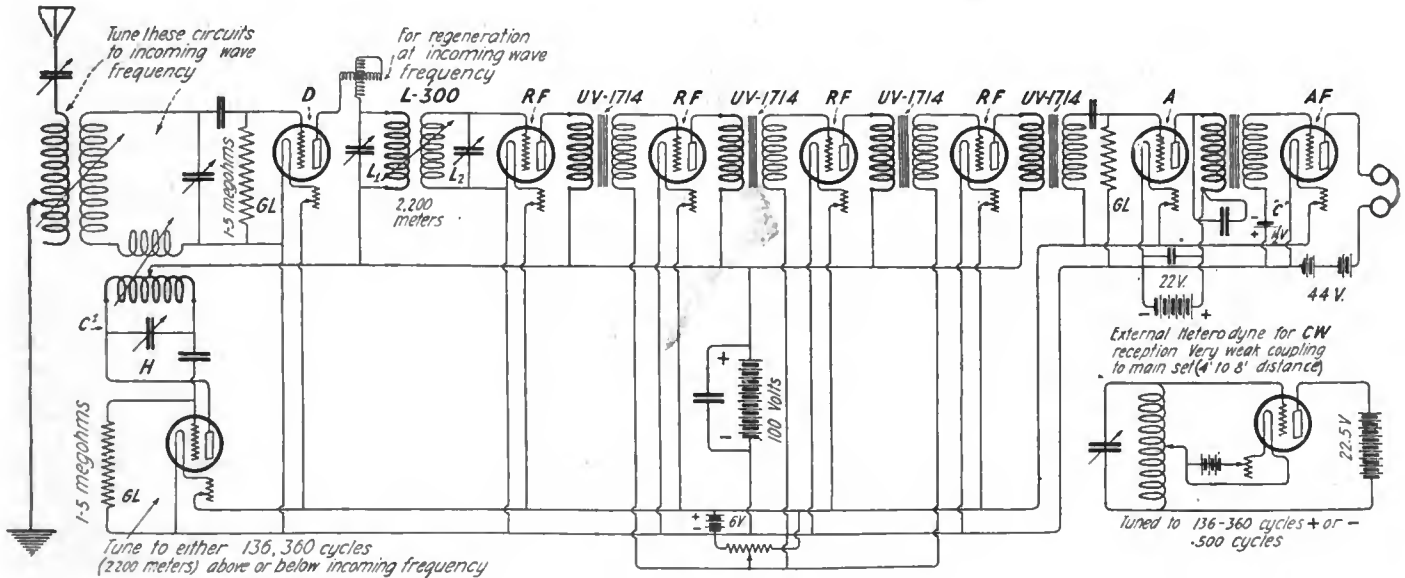

Practical super-heterodyne circuit using the full winding of radio-frequency transformers UV1714 for coupling between the radio-frequency amplifying tubes

The set has been used with a loop, with remarkable success. When used on the regular antenna of the station a standard receiver is employed, the primary and secondary circuits only, being used and tuned in the ordinary manner. The small coil in the filament of the first tube D, the radio-frequency detector, consists of 15 turns, on a 3/4-inch tube and by means of this coil energy from the tube shown directly below it, in the diagram, the oscillator or heterodyne, is picked up and a beat note, of any pre-determined frequency, is obtained. The heterodyne, H, is made to oscillate at any determined frequency, by means of a coil 4-inch diameter, of approximately 35 turns, shunted by a variable condenser of .001 maximum capacity and the difference in frequency between the frequency of the incoming signal and the frequency of H is the frequency which is transferred to the radio-frequency amplifier tubes and transformers, by means of the

effective at that wave length considerable amplification of the beat frequency is secured, resulting in a greatly strengthened signal. The radio-frequency amplification is not troublesome or as sensitive to capacity effects as the higher frequencies of low wave lengths and when the grid bias potentiometer has been set at a proper value it requires no further attention.

The unique feature of the set is, of course, the transformers, which supplant the resistances used in the Godley set. In a resistance-coupled radio-frequency amplifier these units must be of a definite value to obtain the best results from the particular tubes used. In addition such resistance units are frequently noisy so that the transformer-coupled radio-frequency amplifier is much more efficient and satisfactory.

The output of the last radio-frequency transformer is coupled to the detector tube grid through a condenser of .00025 mfd. and the balance of the detector circuit and

When spark or modulated C. W. signals (voice) are received they can be considerably strengthened by regeneration by means of the variometer in the plate circuit of tube D.

If it is desired to receive C. W. signals it will, of course, be necessary to use another tube to heterodyne the frequency supplied to the detector tube A, which is 136,360 cycles, or, 2,200 meters. The external heterodyne, should oscillate, therefore, at a period of approximately 500 cycles above or below the frequency impressed on the detector tube A.

An easy method for determining the period of the external oscillator is to insert a low-reading milliammeter, of a maximum range of 10 milliamperes, in the plate circuit of the tube and then operate a wave-meter in close inductive relation to the coil of the tube. As the wave-meter comes into resonance a sharp deflection will be noted in the ammeter.

A 100-Mile Crystal Receiver

By Carl Dreher

THE receiver described herein was designed, built, and tested for radio-telephone reception at Riverhead, L. I., in the early part of April, 1922. During about a week of occasional listening periods 2XJ, Deal Beach, N. J., 100 miles away, was heard with a good workable signal both day and night. The S. S. "America," KDOW, was clearly received in daylight when about 140 miles east of Riverhead. During the night WGY, Schenectady, N. Y., 150 miles, was picked up very consistently with more than understandable intensity. On one occasion KDKA, Pittsburgh, Pa., 400 miles, was heard after dark for a few minutes. This was clearly a case of freak reception, but is interesting as showing the possibilities of galena crystal reception with careful receiver design and a favorable DX receiving location.

Some time later the set was taken to New York City and tested in an unfavorable urban location. Here WGY, 150 miles, was also heard a number of times in the evening when local QRM lifted momentarily. It seems, therefore, that a consistent receiving range of 100 miles can be fairly claimed for this crystal set, with telephone stations, such as 2XJ and WGY, of somewhat above the usual power. Of course these results are possible only with a good crystal and careful handling of the receiver. It must be understood that crystal reception from the present order of broadcasting stations, over distances exceeding 25 miles, remains more or less of a "tour de force." For loud signals and consistent, easy long distance work tubes are of course indispensable. For those experimenters who find diversion in getting the most out of inexpensive apparatus, however, the following description of a crystal receiver may prove of interest.

Figure 1 shows the connection scheme, which presents no novel features. It will be seen that the receiver is a two-circuit affair with spiral inductances. Figure 2 illustrates the panel. The three knobs in a vertical line at the left are, from top to bottom, primary inductance control in steps of two turns, primary inductance control in steps of ten turns, and coupling variation between primary and secondary. The variable condenser, which is the only tuning element in the secondary, has its controlling knob at the right. Above it is the galena detector.

In figure 3 a back view of the apparatus is given. The tapped primary spiral is in fixed upright position at the right. The secondary spiral is in the inclined position, and the photograph shows how the coupling between antenna and secondary circuits is varied by the movement of the secondary pancake about a lower tangent axis. The variable condenser, switch points, and rear connection block may also be plainly seen.

The two circuit design was chosen because of the greater selectivity attainable with loose coupling. The primary spiral, having an inductance of 450 microhenries maximum, is designed to cover a range of from 200 to about 700 meters with an average amateur aerial of 0.0003 mfd. capacity. As a matter of fact there is considerable margin here and with most amateur antennas radio compass stations on 800 meters may be heard. The 40-



Figure 2—Panel of super-sensitive crystal receiver

turn secondary coil has an inductance of 200 microhenries, and with an 0.0005 mfd. (23-plate condenser) will go up to 600 meters, but without margin. With an 0.001 mfd. condenser, as used on the actual model, the range is about 800 meters. Clearly the design can be improved in this detail by the use of a 50-turn (310-microhenry) secondary spiral with 0.0005 mfd. capacity. This will give a range of 740 meters, which is ample, and at the same time a certain reduction in expense will result through the use of the smaller condenser. This change in the design is recommended and will be mentioned again in the course of the instructions for building the receiver.



Figure 3—Rear view of crystal receiver

Although the receiver was designed specifically for broadcast reception on 360 meters, the inclusion of 600 meters is an important feature in a crystal set. This highly congested ship-to-shore wave length is useful for adjusting the crystal, and, in effect, takes the place of a buzzer test. Furthermore, 600-meter ship and shore stations are generally more powerful than broadcasting transmitters, and hence more suitable for adjustment of a crystal detector. The best signal for this purpose is a medium one. A loud signal is unsuitable because the detector characteristic differs for very weak and very strong signals, and the best adjustment for strong signals is generally useless for broadcast reception. Adjustment on a very weak signal, on the other hand, is difficult

because the station is inaudible till an optimum point is touched. In practice I have always found it convenient to adjust the crystal on a ship station about a hundred miles out before hunting for telephone stations on 360 meters.

In constructing the receiver it is convenient to start with the inductances. These are of the spider-web spiral type, and the winding form is shown in the detail drawing, figure 5. It consists of nine 20 penny nails driven about $\frac{1}{2}$ inch into a $2\frac{1}{2}$ -inch curtain rod or other round wooden piece, a simple construction which is due to Mr. R. B. Bourne of 2BML. For the primary spiral, after the wire has been fastened to the small nail provided for this purpose, 50 turns are wound, a tap being taken off every 10 turns. This is accomplished by making a small loop, about $\frac{1}{8}$ inch in diameter, at the point where the tap is to be taken off, and twisting the wire once before continuing the winding. The wire is later skinned at this point and a soldered connection made to the switch lead. The same wire that is used for the winding of both spirals, number 24 D.C.C., should be employed for taking off taps. After 50 turns have been put on the form, a tap is taken off every second turn for fine regulation of inductance. If the taps are staggered somewhat, that is, not all placed on one radius of the spiral, the process of soldering leads later is decidedly facilitated.

The actual operation of winding is very simple and probably needs no description for a majority of readers. With the long end of the rod held in the left hand, the wire is wound around the core in a clockwise direction, being carried to the left of one nail, the right of the second, the left of the third, etc. One mistake that beginners make is keeping the right or winding hand too close to the form. This produces irregular crossings of the turns. If eight or ten inches of taut wire is kept between the form and the hand a neat symmetrical coil results.

When the winding is complete the end is secured with a thin strip of friction tape and the coil thoroughly painted with orange shellac of medium consistency. After 24 hours the dry shellac will hold the turns in place and the nails may be pulled out to permit taking the coil off the form. Care must be taken not to unwind the inside turns during this operation. When the coil has been detached from the form it is sometimes well to wind a narrow strip of friction tape around the wire at three places to reinforce the binding action of the shellac.

The size and number of turns of the two spirals, as shown in figure 5 are exactly as actually used in the model. They are so given because in reporting results with any piece of apparatus it is good engineering practice to give the constants used in the actual experiments. As has been stated, however, the original design can be manifestly improved by using a 50-turn secondary spiral. This will increase the diameter of the coil slightly, without necessitating any other changes in design. An 0.0005 mfd. condenser may then be used in the secondary to cover the range up to 740 meters.

The secondary coil has no taps and it is

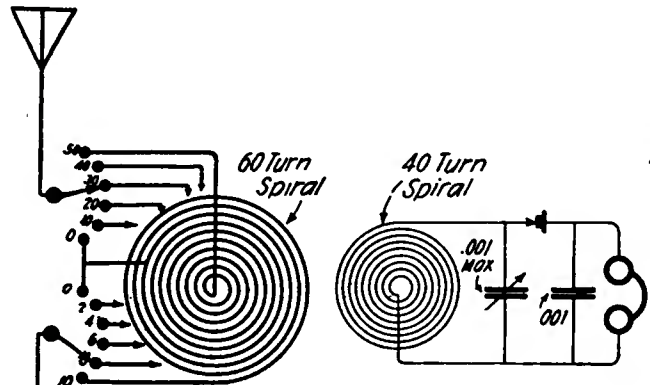

Figure 1

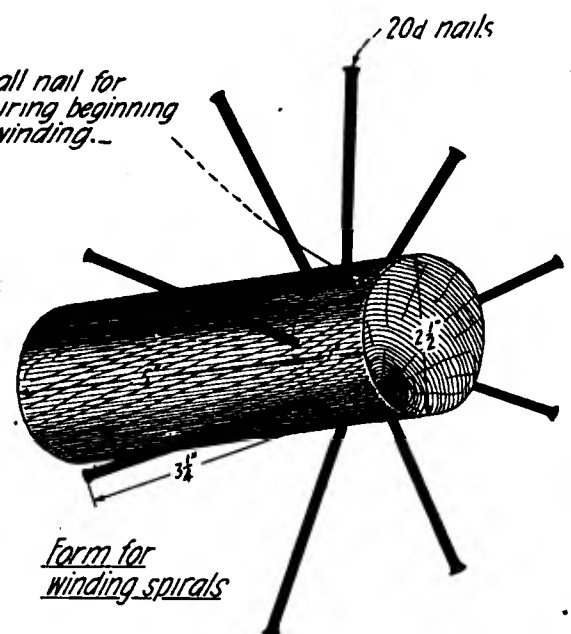
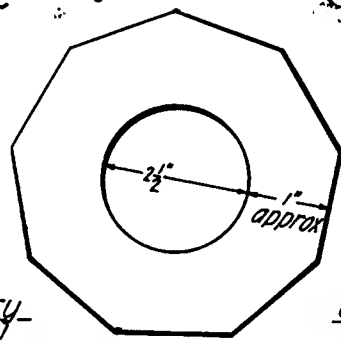
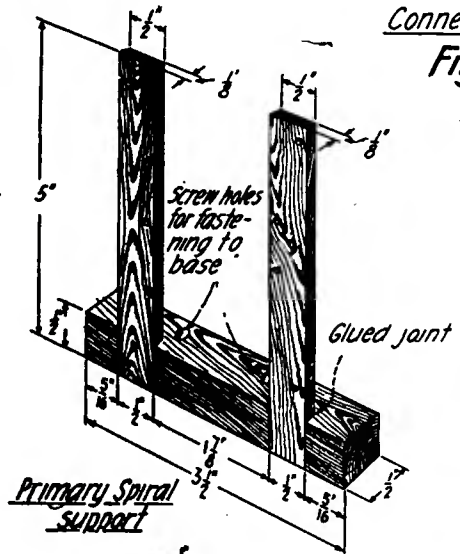

Figure 5-B

Note... use N° 18 drill if binding posts have #6-32 screws; N° 28 for #6-32



Connection Panel
Figure 5-C



Diameter of circumscribed circle, 4 5/8" approx
Taps, from inside, 0, 10, 20, 30, 40, 50, 52, 54, 56, 58, & 60 turns
60 Turns N° 24 D.C.C

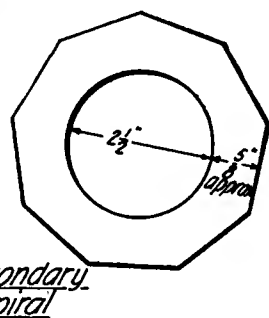

Diameter of circumscribed circle, 4" approx...
40 Turns N° 24 D.C.C.

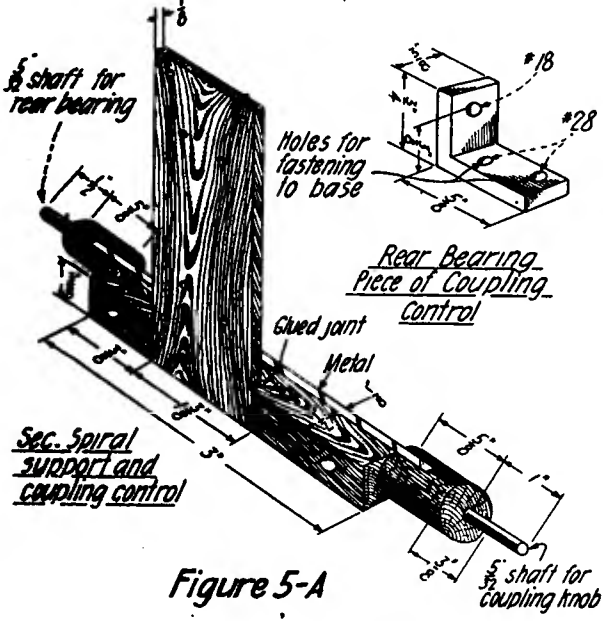
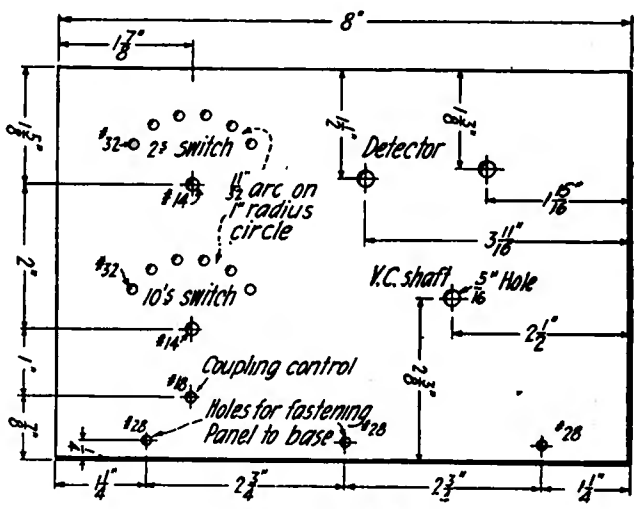

Figure 5-A



Constructional details and wiring diagram of the 100-mile crystal receiver

therefore well to wind it first if one has had no previous experience in making coils of this type.

Figure 4 shows the drilling of the panel, which is of 3/16-inch bakelite, formica, condensite, or other suitable insulating material. The panel is preferably bought cut to size and finished. The edges can, however, be finished in a home workshop by the use of a special tool made by grinding down one edge of a three-cornered file to knife sharpness on a grindstone, and using it in the finishing process with a swift drawing motion. At the same time that the main panel is cut and finished the small connection block shown in figure 5, of the same material, may conveniently be prepared. Two limitations on the mechanical design should be noted. The 11/32-inch arc between switch points is for points 1/4-inch in diameter, and if a larger size is used the distance should be increased. The connection block will not hold 6 binding posts conveniently if their diameter is over 3/8-inch.

The next step is the construction of the supports for the two spirals. The design is clearly shown in figure 5. The primary support consists of two thin wooden uprights set into a horizontal base member and glued into place. The piece must be held in a vise for about 24 hours to give the glue time to set. The secondary support and coupling control member uses the same principle, but the horizontal piece in this case, instead of being screwed to the base of the set, is fastened to a flat rotating arm between two collars. The parts as shown happened to be available and were accordingly used. Modification of this design is in order where different metal pieces of suitable construction are at hand. In my case the flat rotating member was of copper bus bar 3/8-inch by 1/8-inch and about 3 1/2 inches long. The ends were set into brass collars for 1/4-inch, as shown, and soldered. The same bus material was used for the rear bearing piece for the shaft. The purpose of the horizontal wooden piece is to separate the flat metal bar from the spiral and avoid the eddy current losses in the winding which would result if the metal were allowed to come close to the outside turns of the coil.

The method of fastening the spirals to their supports consists in drilling small holes in the wood and tying the spirals on with thin cord or heavy thread. The cord is then shellacked and in drying contracts and holds the coil tightly to the support. This seems a makeshift method, but electrically it avoids bringing metal into the radio frequency field; and from the mechanical standpoint, the coils of the model shown in the illustrations have now been held in this way for seven months without the least sign of loosening. The location of the small holes will vary with the dimensions of the spirals, which depend to some extent on tightness of winding. Hence they are not fixed in the drawings, but should be located in each case by putting the coil in place and spotting the holes. Each spiral will require cord at four points.

A neater and more compact means of mounting the spirals would be to wind them on a supporting form of insulating sheet about 1/16-inch thick, with radial slots cut to permit winding the wire in spider-web style, and using the sheeting for an upright by fastening it to the base or rotating mem-

ber. The reason why this mechanically superior construction was not used in the model is that the dielectric losses would be higher with insulating material instead of air in the interior of the double spirals, and it was felt that in the nature of the experiment—the object being to do maximum possible DX work on a crystal—no radio frequency energy could be spared. However, I have no definite data on relative copper and dielectric losses in spiral inductances of this type at 360 meters, and it may be that the added losses would be so slight as to warrant the use of the dielectric form. The number of turns in the spirals may have to be altered somewhat if this construction is adopted, as the inductive relation of turn to turn will be different. This is a good lead for experimentation and possible improvement of the receiver design.

With the panel drilled and all the parts constructed, the assembling of the receiver may be started. The first step is to fasten the panel to the base with three number 6 1-inch brass wood screws. The coupling mechanism may then be put together, the rear bearing mounted, and the primary spiral set up flush against the secondary coil

spotted. As the drawings show, two extra binding posts are provided for connecting a bulb to the set. An 0.001 mfd. paper or mica fixed condenser is connected across the phones. When all the connections have been made, including the taps to the primary coil, the set is ready for use.

The model from which the drawings were made used General Apparatus Co. switches, a variable condenser made by the same concern, and a Murdoch crystal detector stand. The latter came on a base and was adapted for mounting on a vertical panel by the substitution of a cup fashioned out of a fuse cap. Here again every experimenter will change parts and modify the panel drilling to suit himself. An enclosed crystal detector has several obvious advantages. The open type, however, is easier to adjust, since the usual method in practice is to raise the catwhisker by taking it between the fingers and letting it drop onto the crystal by spring action. Incidentally most of the detectors on the market have catwhiskers much too coarse for best use with galena. I never use anything larger than number 30 or number 28 copper. As for the switches, of course any make may be used, but the radius is

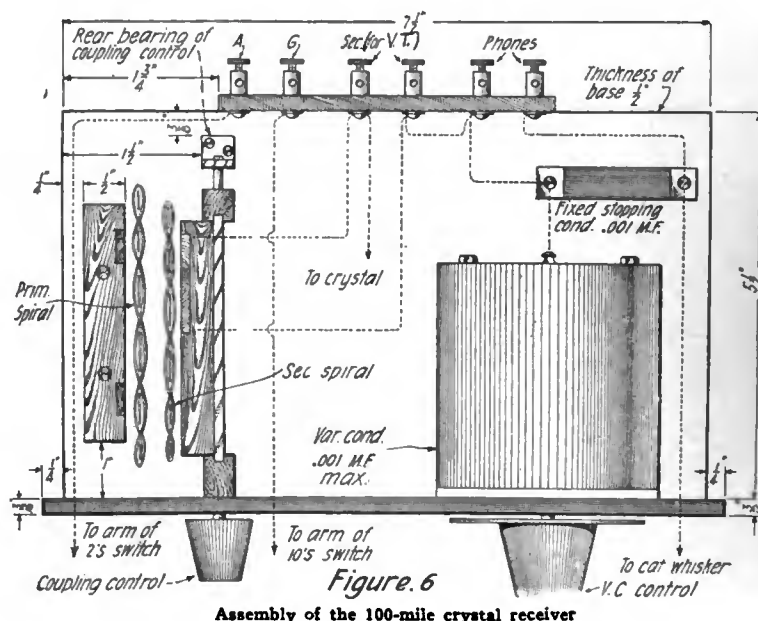

Figure 6
Assembly of the 100-mile crystal receiver

in its upright position and fastened down. The contact of the two coils acts as the close coupling stop. The loose coupling stop is easily made by means of a stiff copper wire, about number 12, an inch long, hammered flat at one end and fastened under the nearest of the three nuts compressing the stator plates of the variable condenser. The free end of the wire is bent so that the wooden support of the secondary spiral will strike it when the two coils make an angle of about 50 degrees. This affords ample coupling variation, and prevents moving the secondary so far back that it might strike the V. C. rotor at small capacities.

Figure 6 gives all needed data on the assembly of the set and the running of the connections. In the panel drilling the two holes for fastening the V. C. to the panel are not shown, inasmuch as condensers usually come with holes already tapped, and the clearance holes in the panel must be

restricted to not much over 1 inch in order to allow the design shown on a panel 5 1/2 inches high.

Two other details remain to be mentioned. One is the marking of the panel. The switch lettering and coupling scale may be scratched in with a sharp center punch or other improvised engraving tool, and filled with white crayon or powdered white chalk suspended in white shellac. If desired, the panel may be taken to an engraving shop and a neater job done at some additional cost. The other detail is in the leads to the movable secondary spiral and the method of holding the spiral in any given position. This is accomplished by means of spring braking between the face of the rear bearing and the collar on the shaft. An ordinary Fahnstock spring binding post may be used for this purpose, as shown in figure 2. For the leads any flexible strand-

(Continued on page 80)

NEW APPLIANCES AND DEVICES

Explains Use of Jewell Meters

"WHAT are all the meters for?" is one of the first questions asked by the radio fan when he sees his first transmitting set. The question is a natural one, for every well-behaved transmitter has anywhere from three to eight voltmeters and ammeters connected up, whereby the operator is able to tell at a glance at any time exactly what each circuit is doing. To answer the natural question of a man who gets his first glimpse of a metered set, the Jewell Electrical Instrument Co., of Chicago, has made up a special display board containing eight of its meters. These meters are mounted on the board with a painted wiring diagram, showing all parts of a transmitting circuit, thus both indicating and explaining where the instruments should be used in a transmitter.

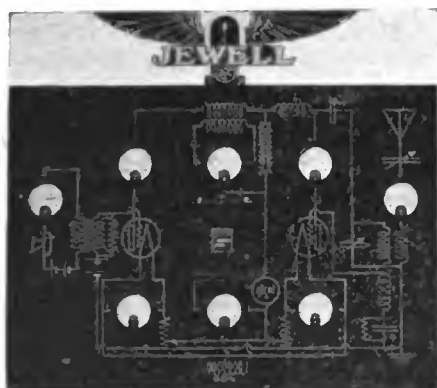

Jewell display board for exhibition use

Two alternating current voltmeters as shown are used across the filament terminals of the vacuum tubes, to show the voltage on the filaments. Two milliammeters are used in the plate circuit of these tubes to show the current flowing there, and a milliammeter is inserted in the microphone circuit. This use of a meter is growing more and more common among amateurs as it prevents the burning out of an expensive microphone by too high a current. The display board also contains a modulation meter reading in per cent and a radio frequency thermo-coupled ammeter in the antenna circuit to show the amperes being put into the antenna.

Radiobat Won't Spill

EVERY one who has ever spilled acid from a storage battery on the carpet, the floor, the clothing or the hands will appreciate the new Radiobat batteries being manufactured by the Multiple Storage Battery Corporation, New York City. These batteries have a solid electrolyte so that there is nothing in them to spill or leak.

They are operated just as other storage batteries, being charged in the conventional manner when discharged. These types are made suitable for all radio needs, for both A and B battery purposes. The Radiobat B battery is especially noteworthy among

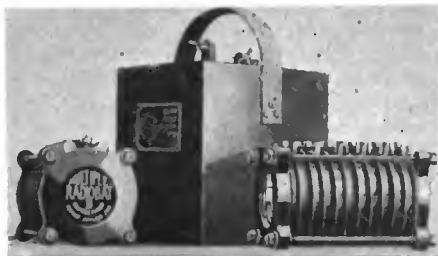

Radiobat A and B storage batteries

B batteries of the storage type for its compactness, being only 4 inches square by 7 inches long, or, in other words, it is little larger than a 45-volt B battery of the dry cell type. It has no glass jars to leak or liquid to leak and is noiseless in operation.

All-American Transformers

ONE of the audio frequency transformers that attracted much favorable comment at the recent Chicago Radio Show was the All-American, made by the Rauland Mfg. Company, of Chicago. The shielding of this transformer is so thorough as to make it possible to mount two or more of them in extremely close quarters without causing noises or distortion due to induction. This makes it possible to use the transformers in the compact sets that so many amateurs are constructing nowadays. The transformer is offered in three ratios, 3

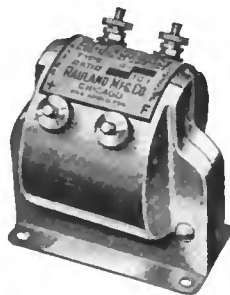

All-American audio-frequency transformer

to 1, 5 to 1, and 10 to 1, enabling the constructor to choose the one which suits his needs best. The price runs from \$4.50 to \$4.75. This is only one of the All-American products, the company making a wide range of radio apparatus, including radio and audio frequency transformers, sockets and condensers.

Uses Non-Metallic Diaphragm

TWO outstanding features mark the CIC head set made by the Connecticut Instrument Co., of Stamford, Conn. These are a non-metallic diaphragm of special composition, and an adjustable air cap for controlling the distance between the magnets and the vibrating metal. The use of the non-metallic diaphragm gives the head set a characteristic tone which is pleasing to users, while the adjustable feature makes it possible to get the best results from the head set under varying conditions of amplifications. The head set is also noteworthy in having large ear caps made of Condensite, thereby achieving considerable comfort. The cup is made of die-cast aluminum



The CIC headset

while the head band is a flat strap without covering and offering no points to catch on the hair.

New Radio Head Set

THE Globe Phone Mfg. Co., Reading, Mass., has been attracting considerable notice lately through its new radio head set, which has just reached the market. This set is highly sensitive to weak signals, and also produces pleasant results when used on the output of an amplifier. Tungsten steel is used for the magnets and every part that is susceptible to rust is treated to prevent oxidation. Brass is used for the shell, nickel plated, and the caps are of hard rubber.

New R. F. Bulletin

THE Federal Telephone & Telegraph Company announces that its new radio frequency bulletin No. 119-W is ready for distribution. This catalogue will be forwarded to anyone requesting it. It is practically a text book on radio-frequency amplification and also contains several circuit diagrams.

100-Mile Crystal Receiver

(Continued from page 78)

ed conductor will do. The leads should be given a loop through the wooden support of the secondary in order to avoid putting strain on the end turns of the spiral.

For 360 meters the primary tuning of the receiver is generally between 20 and 30 turns, depending on the aerial capacity. The procedure in tuning is to pick up the station at close coupling, and then to reduce coupling to the optimum value, making compensating changes in the primary inductance and secondary capacity. Loose coupling is the best just short of the point at which the intensity of the signal begins to drop off. When properly used the receiver is very selective and at Riverhead no difficulty was experienced in understanding Deal Beach, N. J., 100 miles away, above the QRM from the 600-meter spark station WSA at Easthampton, L. I., about 20 miles from Riverhead. WSA's very strong signal could be practically tuned out on 410 meters, the wave length of 2XJ.

In working good distances with a crystal set the prime essential, of course, is a sensitive piece of mineral. If the sensitivity does not extend over a number of sizable areas the search for a good point is tedious and discouraging. In my experience I have found the so-called iron-faced galena, which does not break along flat cleavage planes, but has striations and a granular structure, to be superior in the second requirement.

A somewhat more detailed account will now be given of the tests on the receiver. The antenna used was a 15-inch 6-wire T-type cage supported on wooden masts 60 feet high. The length of the flat top was 70 feet. This cage is the transmitting antenna of the noted amateur station 2BML at Riverhead, and I am indebted to Messrs. A. B. Tyrrell, R. B. Bourne, and E. M. Williams of the Radio Engineers' Club for allowing me to use it.

Riverhead, being the location of the Radio Corporation's high power receiving station, is admittedly a good receiving base. As stated previously, however, the receiver described also performed well in Manhattan, New York City, which is conceded to be a poor DX receiving location. At Riverhead the first station picked up was 2XJ. This was on April 6th from 3 to 6 p. m., and the audibility was so good that the music could be heard at times 2 to 3 inches from the phones (Western Electric P-11's). At 7.15 p. m., WGY was heard clearly by Mr. A. B. Tyrrell. On April 7th, 11 a. m., 2XJ and KDOW were both heard, 2XJ being somewhat louder, but both thoroughly understandable. KDOW was heard on his true 360 meter wave—not on 410 meters by re-radiation from 2XJ through imbalance in the Deal Beach-Elberon bridge system. (The latter phenomenon explains most of the distance records made by amateurs on KDOW.) 2XJ's modulated antenna power at this time was 1 KW. 2XJ and KDOW were heard again at 3 p. m., and the steamship gave her position as 140 miles out, which put her at about the same number of miles from Riverhead at 11 a. m. On April 10th at 8.11 p. m., a man's voice was heard talking about "industry"; "unemployment"; "wholesale prices," etc., badly broken up by static, and there was considerable fading and fluctuation in intensity. At 8.14 p. m.,

there was an announcement concerning some "Musical Club." The announcer then said, "This is KDKA signing off." In the absence of static this would have been a good workable telephone signal. From 8.28 to 8.45 p. m., there was a musical program. Inasmuch as KDKA had a talk scheduled by a "prominent person of Pittsburgh" at 8 p. m., and an entertainment by the Musical Club of Washington Seminary, Washington, Pa., there is little doubt that this station was actually heard. As for WGY, he was picked up regularly on succeeding nights.

In New York City the receiver was tested by Mr. A. H. Thomas on a two-wire aerial 85 feet long, with 35 feet lead-in, supported 20 feet above the roof of a five-story apartment house. WGY was heard, not only during the spring, but several times in the summer, always, of course, during the night. The chief obstacle to consistent reception of this station was the activity of the local broadcasters.

The cost of building this receiver, exclusive of time and labor, was \$12.50, last April, when prices were considerably higher than at present. This amount was distributed as follows:

1 3/16-inch Formica panel 8 inches by 5 1/2 inches, and connection block 4 inches by 1 1/2 inches.....	\$1.25
1 crystal detector stand.....	.70
2 switches at 65 cents.....	1.30
12 switch points at 4 cents.....	.48
1 indicating knob for coupling.....	.40
1 0.001 mfd. variable condenser.....	4.30
1 dial and knob for v. c. above.....	1.25
1 0.001 mfd. fixed condenser.....	.35
6 binding posts at 17 cents.....	1.02
1 galena crystal.....	.25
For number 24 D.C.C. wire, allow...	.70
For screws and miscellaneous small metal parts, allow.....	.50

Total\$12.50

In the present market the cost of the receiver should be well below \$10.00.

Boston Radio Exposition

THE second annual Boston Radio Exposition and combined New England Amateur Convention which was held at Mechanics Building, Boston, Mass., October 30 to November 4, inclusive, seems to have accomplished considerable advance in the manner of handling the many problems encountered in this form of exposition. The affair was very successful and Boston and New England generally, have experienced a renewed interest on the part of the public in radio as a direct result. The attendance was about equal to that of the same type of exposition held last May, but the buying interest was much more in evidence than in the Spring. Several retail dealers of Boston are authority for the statement that they experienced a considerable increase in business during the week following the show, and reported that the radio Christmas spirit was already beginning to manifest itself.

The great problem of interference between demonstrators at all affairs of this kind, was pretty well solved by the special regulations of the management, which adopted a system of one central antenna and a common filament battery; the various exhibitors who desired to demonstrate being given an opportunity to use the antenna and the battery on a definite prearranged schedule.

The Signal Corps demonstrated "line radio" for the benefit of the visitors and there were several compact reflex sets in operation as well as several super-regenerative sets, all of which attracted much attention from the visitors.

The program of eighteen lectures and talks were held in Talbot Hall and a special course of elementary talks for young people was given by Miss R. N. Thompson, the only woman teacher of radio in the Boston public schools. Paul F. Godley, of "Far Call" renown, was present and gave talks which were listened to with great interest.

An innovation which caused no end of favorable comment were the 4 x 6-foot cards containing circuits of a crystal receiver and an audion receiver with each part designated on the margin of the card with its name and symbol.

The visitors displayed great interest in the broadcasting studio which was located at the general information booth. The special feature was contributed by the members of the "Shuffle Along" company, whose music and songs were transmitted to the broadcasting station of the Shepard Stores of Boston, and then broadcasted in the usual manner. This broadcasting was then received at the exposition, and as both ends of the operation were within reach of the visitors, this special feature was given continual attention and aroused a great deal of enthusiastic interest.

The radio championship telegraphic contests were held in four heats; two for speed, one for "jamming" and one for ten-letter cipher code. J. C. Smyth, of the Western Union, won all of these events on average, defeating T. R. McElroy, the present holder of the world's record for code speed reception. C. C. Kolster, Radio Inspector, First District, with his assistants, and Lt. Milly, of the Charlestown Navy Yard, Communication Division, were the judges.

The exposition was under the general direction of Sheldon H. Fairbanks, who has been in charge of the previous expositions at Boston. The technical director to whom credit goes for many innovations, both educational and interesting was O. C. Roos, who is well known in radio engineering circles.

The Monthly Service Bulletin of the NATIONAL AMATEUR WIRELESS ASSOCIATION

Guglielmo Marconi
President

J. Andrew White
Acting President

H. L. Welker
Secretary

Founded to promote the best interest of radio communication among wireless amateurs in America

NATIONAL ADVISORY BOARD OF VICE-PRESIDENTS

Prof. A. E. Kennelly
Harvard University
Maj. Gen. George O. Squier
Chief Signal Officer, U. S. Army

Rear Admiral M. Johnston
Director of Naval Communications
Prof. Alfred N. Goldsmith
College of the City of New York

E. E. Bucher
Instructing Engineer
Prof. Charles R. Cross
Massachusetts Institute of Technology

HEADQUARTERS: 326 BROADWAY, NEW YORK

EXTENSIVE preparations have been made by the amateurs of England for possible two-way work with American amateur stations during December. American stations are being heard frequently these days in England, but whether or not English stations can be heard in this country is another question. Success or failure will depend a great deal upon how much interference is caused by American amateur transmission during the time the English stations are sending to this side of the ocean. It is of the utmost importance, therefore, that all American amateur stations not taking part in these trans-Atlantic tests shall be silent during the period of the tests. They are of great importance to the entire radio world and should not be interfered with by unnecessary transmission on the part of stations not directly concerned and which might prevent the epoch-making achievement of the reception of European amateur station signals on this side of the ocean.

△ △

IN addition to 2EL, Freeport, L. I., two other Second District stations were heard in England during the American Radio Relay League's preliminary tests, Oct. 25 to Nov. 3. These stations were 2ZK, George Cannon, New Rochelle, N. Y., and 2HJ, Harold Hasbrouck, Port Chester, N. Y. On Oct. 29 1CX, the station of R. S. MacArthur, Cambridge, Mass., was heard by an English amateur located near Manchester, England. It is understood that two other amateur stations of other districts were heard by English amateurs, but these reports have not been confirmed at this time.

△ △

THE increasing amateur radio activity in Australia at last affords the summer-pestered radio fan the opportunity to listen comfortably all the year 'round. He only has to set sail for Sydney in May, and for San Francisco in September. In that way he will spend all his days—and nights—in more or less static-less winter, and have the joy of fraternizing with ship operators twice a year. Now's the time to organize a radio cruise to the wintry southern hemisphere.

△ △

HARRY H. CARMAN, of Freeport, N. Y., the old-time spark advocate who finally junked his stone crusher recently for a 100-watt C. W. transmitter, as told in THE WIRELESS AGE for November, continues to be astounded at the range of his

new set. Late reports show that he has been heard in England and in Seattle, Washington, giving him a radius of 3,000 miles in each direction, over land and sea. The shack at 2EL radiates pride as well as performance these nights. Cards come pouring in so constantly as to arouse the interest of even the postman. He is having a hard time keeping up with the postals, which already, at the end of only about two months of operation of the new transmitter, stack up on the table to a third of the height of the treasured heap piled up by the 1 kw. spark set since the war. Carman's pockets bulge with cards; here are the first few of an average handful, besides, of course, the notification of being heard in England: 6AMT (Tucson, Ariz.), 4OI (Porto Rico), 5ACU, 5EK, 5XV, 5TC, 9BWE and 7IY (Vashon, Wash.).

Two-way trans-continental communication by amateur stations 2EL, Freeport, L. I., and 6XAD, Catalina Island, Cal., was maintained until all traffic both ways had been cleared, for a period of 25 minutes, 5.20 to 5.45 a. m., Eastern standard time, on the morning of November 15, last. The set used at 2EL was fully described in the November issue of THE WIRELESS AGE, the circuit used being the one on page 11 of "Modern Radio Operation." Owing to the fact that trans-continental work is not a regular occurrence, it is said that Major Mott at 6XAD had trouble at first in "getting" the figure "2" and 2EL had some difficulty, owing to lack of practice in making a good "6." The overland airline distance between the two points, one on the Atlantic and the other in the Pacific, is approximately 2,600 miles. A Grebe CR-3 receiver with detector and one step of audio-frequency amplification was used at 2EL station, and a Grebe CR-5 at 6XAD.

△ △

A WORLD'S record for long distance communication on short waves by amateur stations was established by C. J. Dow, well-known 6ZAC of Wailuku, Maui, on the night of October 29th, when he succeeded in exchanging messages with Lloyd Berkner, Sleepy Eye, Minnesota (9AWM), a distance of 4,000 miles.

This is a greater distance than the recently completed transatlantic amateur tests between the east coast of the United States and England.

"DW," as Dow is known to the radio fraternity, has a self-rectifying continuous wave radio telegraph transmitter rated at 100 watts, and in view of the power used

this is indeed a remarkable record.

A portion of Dow's letter to the Radio Editor is quoted here:

"6ZAC and 9AWM were excellent QSO from 5.40 a. m. to 6.40 a. m., Central Standard Time, on the morning of October 29. One message was sent to 6ZAC and two to 9AWM. At no time did the bad QRN (static) necessitate a repeat, and compliments and QRA were exchanged in the same manner."

△ △

THE annual convention of the Second District Executive Radio Council will be held at the Hotel Pennsylvania, March 1, 2 and 3. The roof garden and adjoining butterfly room will contain the exhibits and lecture room. It is planned that any of the radio clubs affiliated with the Council are to have booths at the convention, and historic radio sets will be exhibited. There will also be a museum of old-time apparatus, such as amateur operators used ten or twelve years ago.

Admission to the convention will be confined to licensed amateurs and their friends. Tickets will be distributed through the radio clubs. There will be twenty-four booths available, which will be open to bona fide radio manufacturers. Dealers will not be permitted to exhibit in order to avoid duplication of exhibited apparatus.

△ △

THE Union College radio station 2XQ, Schenectady, N. Y., will take an active part in the trans-Atlantic amateur tests during December. In preparation for the work, the organization is now completing a new transmitting set. There will be two G-E tubes of 250 watts each, with the current supplied by a 240-cycle alternator. Since the circuit has no filters, but is self-rectifying, the tone will be the same as a 240 cycle modulated C.W. equipment. With the completion of the changes there will be four or five experienced operators ready to make the tests. Long distance continuous wave transmission is the new field in radio work and this is the field which will be explored by the college radio men.

△ △

A G. KASTENMAYER, 2GK, Schenectady, N. Y., has received a card from 6ZAC, Clifford J. Dow, Wailuku, Maui, Hawaii, reporting hearing 2GK working 9AFN. The entire message was copied by Dow on one step of amplification on October 16 at 9.15 p. m. Hawaiian time, which corresponds to 2.15 a. m., Eastern standard time. The distance of about 5,300 miles

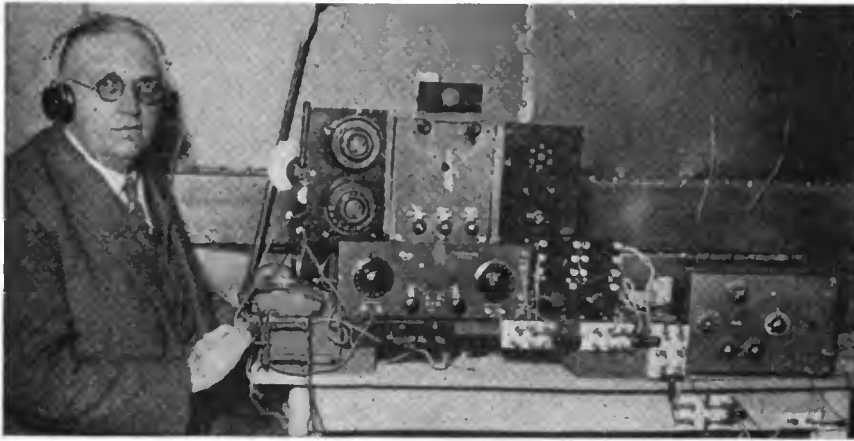

Dr. Franklin Leroy Satterlee and his one-tube non-regenerative set, shown at the extreme right, for which exceptional range is claimed in receiving

was covered by C. W., of course. The set at 2GK consists of two 50-watt radiotrons with 1,500 volts kenotron-rectified A. C. on the plates. The antenna current is normally 6.9 amperes in a cage antenna and combined counterpoise and buried earth ground.

△ △

THE radio call book published annually by the Department of Commerce, listing all amateur radio stations of the United States, is now ready for distribution and copies can be obtained of the Superintendent of Documents, Government Printing Office, Washington, D. C., at 25c each; remittance to be in the form of a money order, or cash by registered mail.

The new list of all commercial and government radio stations is also ready for



A small portable receiving set using an 18-inch loop installed in an auto brings in the broadcast programs

distribution, and copies can be obtained at 15c. each. This book lists both land and sea stations, including broadcasters.

Both books include all stations licensed up to and including June 30, 1922.

△ △

THE old familiar 2ZL call now has a brother—or maybe father would be the better term. Anyway, the famous station at Valley Stream, L. I., N. Y., has been assigned an experimental license, the call being 2XAQ. The additional license was allotted in order to give greater leeway for experimental work in transmission. The call 2ZL will be retained and will be used for message relay work, as in the past. The new call of 2XAQ will be used for experimental work.

Correct Use of the Soldering Iron

By J. A. Kimmey

AT the present time thousands of radio amateurs are building and rebuilding their radio sets and a few practical hints guiding them in the art of soldering—for truly it is an art—will no doubt be of considerable aid.

We all know that a radio set properly wired must have soldered connections, such as the taps on the inductance, lugs on instruments when so provided, and many other places. At times when we have difficulties in the functioning of the set it is certainly of value to know where not to look, as well as where to look; a well-soldered connection needs neither trying or tightening.

The successful use of the soldering iron in flowing soft solder neatly, is an extremely simple operation when a few fundamental and essential rules are observed. In all electrical work a perfect joint is required. It is well to realize the difference between a mechanical and an electrical connection. Two wires, or a wire and a terminal, may be mechanically secure and tight, but this does not constitute an electrical connection in the full and practical sense. The metal of the two parts must be intimately joined before we have a trouble-proof connection.

Too much cannot be said concerning the importance of neatness in assembling and

connecting the various parts that go to make up a dependable radio set. Outside the pride one takes in the appearance of the finished work, neatness has a practical value generally overlooked.

The chances of trouble are reduced to a minimum and when difficulties arise they are much easier to locate and remedy.

The first essential in soldering is scrupulous cleanliness; that is to say, we must start with a thoroughly clean surface, free from black oxidized spots and all traces of insulation or other foreign matter. This is easily accomplished by scraping or by the use of sandpaper or emery cloth—in the latter case being careful to wipe away the abrasive particles.

Next in order, the soldering iron, or soldering copper more properly called, must be entirely free from scales which forms when heating. After the end is "tinned," which will be described later, the copper can be kept clean by giving it a quick rub with a piece of hard cotton cloth each time it is removed from the source of heat, being always careful not to overheat as this burns away the "tinning," which must always be present to make solder flow.

The correct working heat is easily gauged by noting just when the copper commences to change color near the flame, and pris-

matic colors show about the edge. A little observation and practice will make this clear.

For ordinary work such as terminals and joining of wires, a fairly sharp iron is desirable; a blunt iron can be hammered to a point without much trouble and finished off with a coarse file, just slightly removing the sharp tip.

A few words should be said here concerning the flux to be used. Zinc chloride solution, formed by dissolving pure zinc in muriatic acid to a point of saturation is in general use for large work; this is not recommended for small work, especially in the case of electrical connections, as the acid spatters when heat is applied, and moreover, often spreads away from the point of soldering, making an easy path for electrical leakage as well as promoting corrosion. Rosin can be used where the parts to be joined have already been "tinned." The ideal flux to be used on radio work, and all electrical connections, is a good grade of soldering paste. Judiciously used, one could wish for nothing better.

The point of the iron, having been filed down to clean metal for a distance of at least one-half inch, can now be heated as described above, after which it is only necessary to touch the iron to the paste, and

then apply the solder. It will now be found that the solder has adhered to the cleaned end, provided it has not been overheated. When using paste, a good method is to use the top of the small can for tinning, by placing a small amount of paste and a small piece of solder in same, rubbing the end of the hot iron in the mixture.

Keeping the iron tinned is largely the secret of good soldering and must be observed. In this condition the tinned portion will pick up and hold a quantity of solder, depending on the size of the iron and the amount of surface tinned.

It is now only necessary to clean the parts to be joined, and apply a small amount of paste, preferably with a tooth pick or match for small work. Use wire solder when possible, melting only the amount you think you will need on the end of the iron. The parts to be joined must be held firm and steady, while the iron holding the solder is applied and held there up to the instant the solder has flowed well, but no longer. The longer it is held in contact, the further the solder flows as a result of the work being overheated. Judgment must be used here, giving special attention to holding the parts steady until the solder cools. With a little practice the careful novice can almost make the melted metal run up hill.

Sometimes where particularly neat work is wanted, and where the proximity of other parts make it difficult, it is recommended that the two parts to be joined be separately tinned first and then joined with a quick touch of the iron, holding a small amount of solder on the tinned portion.

As a summary by keeping the following points continually in mind, success is certain.

- Keep the iron clean and well tinned.
- Scrape the parts clean and bright.
- Use flux sparingly.
- Use as little solder as possible.
- Hold iron steady on work. Do not rub.
- Remove the iron from work the instant solder has flowed well.
- Hold work steady until the solder has cooled.
- Do not try to solder aluminum with soft solder and iron.
- Standard soft solder is one-half tin and one-half lead.

Widening the Range of Variometer Receivers

(Continued from page 74)

By throwing switches upright to neutral position the coils are connected in series.

Throwing switches to the right automatically shunts a small fixed condenser across the secondary and grid variometer and the plate variometer. This condenser is of high capacity—being made of two brass plates 1x5 inches, separated by a very thin mica washer. The wave-range of the set is thereby doubled. Although not very efficient on high waves, it certainly is a compact way to double the wave length range of the receiver.

More stable and quiet operation was obtained by shielding and grounding variometer shafts, bearings and variocoupler. The frames of the amplifying transformers and negative side of the filament circuit was also grounded.

NO OTHER CALL BOOK HAS

A large map, size 24x36 inches printed in two colors

showing location of every Broadcasting Station in United States and Canada; change of time area and location of each of the nine districts

CONTAINED IN

THIRD EDITION

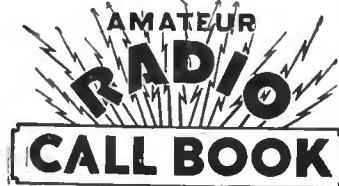

ALL UNDER ONE COVER

An Official List of all Amateurs, Special Amateurs and Broadcasting Stations of UNITED STATES AND CANADA

—ALSO—

How to Construct and Operate A Honeycomb Coil Set, Detector and Two-Step Amplifier

PRICE, \$1.00 COMPLETE
(DO NOT SEND STAMPS)

Order from your dealer—If your dealer hasn't them, send direct.

DEALERS WRITE FOR PROPOSITION

RADIO DIRECTORY & PUBLISHING CO.
45-B VESEY STREET NEW YORK, N. Y.

STATEMENT OF THE OWNERSHIP, MANAGEMENT, CIRCULATION, ETC., REQUIRED BY THE ACT OF CONGRESS OF AUGUST 24, 1912.

Of The Wireless Age, published monthly at New York, N. Y., for October 1, 1922.

State of New York } ss.
County of New York }

Before me, a Notary Public in and for the State and county aforesaid, personally appeared J. Andrew White, who, having been duly sworn according to law, deposes and says that he is the editor of The Wireless Age, and that the following is, to the best of his knowledge and belief, a true statement of the ownership, management (and if a daily paper, the circulation), etc., of the aforesaid publication for the date shown in the above caption, required by the Act of August 24, 1912, embodied in section 443, Postal Laws and Regulations, printed on the reverse of this form, to wit:

1. That the names and addresses of the publisher, editor, managing editor, and business managers are:

Publisher, Wireless Press, Inc., 326 Broadway, New York, N. Y.

Editor, J. Andrew White, 326 Broadway, New York, N. Y.

Managing Editor, none.
Business Managers, none.

2. That the owners are: (Give names and address of individual owners, or, if a corporation, give its name and the names and addresses of stockholders owning or holding 1 per cent or more of the total amount of stock.)
Wireless Press, Inc., 326 Broadway, New York, N. Y.
E. J. Nally (850 shares), 233 Broadway, New York, N. Y.

3. That the known bondholders, mortgagees, and other security holders owning or holding 1 per cent or more of total amount of bonds, mortgages, or other securities are: (if there are none, so state.)
None.

4. That the two paragraphs next above, giving the names of the owners, stockholders, and security holders, if any, contain not only the list of stockholders and security holders as they appear upon the books of the company but also, in cases where the stockholder or security holder appears upon the books of the company as trustee or in any other fiduciary relation, the name of the person or corporation for whom such trustee is acting, is given; also that the said two paragraphs contain statements embracing affiant's full knowledge and belief as to the circumstances and conditions under which stockholders and security holders who do not appear upon the books of the company as trustees, hold stock and securities in a capacity other than that of a bona fide owner; and this affiant has no reason to believe that any other person, association, or corporation has any interest direct or indirect in the said stock, bonds, or other securities than as so stated by him.

5. That the average number of copies of each issue of this publication sold or distributed, through the mails or otherwise, to paid subscribers during the six months preceding the date shown above is.....
(This information is required from daily publications only.)

J. ANDREW WHITE, Editor.

Sworn to and subscribed before me this 21st day of September, 1922.
(Seal)

M. H. PAYNE, Notary Public.

(My commission expires March 30, 1924.)

A Merry Christmas To All

Start the Season Right

ASK FOR CATALOG No. 103
COVERING 1923 MODELS

EXPERIMENTERS INFORMATION SERVICE

*Designers of the Highest Class
Radio Apparatus in the World*

220 WEST 42nd STREET 23rd Floor NEW YORK

NEW COPIES FOR OLD

For each copy of the following issues that you send us we will extend your subscription one month.

January, 1922

February, 1922

March, 1922

September, 1921

December, 1921

December, 1920

WIRELESS PRESS, Inc., Room 315, 326 Broadway, N. Y. C., N. Y.

Radio Chronology

Complied by General Electric Company

- 1883—Thomas A. Edison, discoverer of what is now called the "Edison Effect," a phenomenon occurring in a burning incandescent electric bulb, in that an electric current can be made to pass through space from the burning filament to an adjacent cold metallic plate. While not applied to radio at this early date, the discovery was later used in developing the vacuum tube, now a veritable modern Aladdin's Lamp, and the very heart of radio communication.
- 1885—Electric signalling through the air without connecting wires is started when an English experimenter stretches two lengths of wire one quarter mile apart, and by charging one with a local electric current is able to induce a response in the distant wire.
- 1887—Professor Heinrich Hertz, a German scientist, proves experimentally that electric waves are sent through space with the speed of light by the electric discharge that takes place when a spark is made by an induction coil or a static machine. These waves have since been called "Hertzian Waves."
- 1890—Prof. E. Branly of Paris develops the coherer, which considerably improves reception.
- 1894—British experimenters bridge a distance of 1¼ miles by means of improvements on the original induction system of 1885.

Kellogg Radio Equipment for Better Results



No. 69A

HEAD SETS

The value of extremely light and very small head sets in Radio receiving is most evident when using Kellogg head receivers, which, however, have proved as sensitive and thoroughly efficient as they are light in weight and small in size. The band, too, is especially adaptable and the simple receiver holders, which are held in place on the lower part of the head band by the spring tension of the metal, can be instantly adjusted so as to place the receivers over the ears for the best hearing.

No. 69A Head Set 2400 ohms, \$10.00; No. 69C Head Set 2000 ohms, \$8.00; No. 74A Head Set 1000 ohms, \$5.00



No. 74A

TUBE SOCKETS



All Bakelite tube socket. Takes all standard tubes. "The Standard Socket." No. 2, Ea. \$0.75

GRID AND PLATE CONDENSERS



Grid Condenser on Single Mounting No. 502

Kellogg Grid Condensers are 1 7/8 in. x 3/8 in. They are of the cartridge type, sealed in a moisture proof shell. Not affected by temperature changes.

Standard capacities, Ea. \$0.75



Grid Condenser on Double Mounting No. 503

PLUGS



The Kellogg plug fits all jacks. It is of strong construction and handsomely finished.

No. 501, Ea., \$1.00

We also manufacture microphones, spring jacks, choke coils, resistances, insulators, cords, variable condensers, variometers, dials, rheostats, variocouplers, transformers, etc., for radio work.

Only the highest grade material is used, which together with first class workmanship makes Kellogg radio apparatus stand out from other equipment both in appearance and performance. *Use Is the Test.*

KELLOGG SWITCHBOARD & SUPPLY COMPANY, Chicago, Ill.

Manufacturers of High Grade Telephone Equipment for Over 25 Years

When writing to advertisers please mention THE WIRELESS AGE

- 1895—Guglielmo Marconi proves that electric waves can be transmitted through the earth, air or water by means of sparks producing high frequency electrical oscillations.
- 1896—Marconi further proves that telegraph signals can be sent and received by means of the now famous Hertzian waves up to a distance of three miles.
- 1900—A. F. Collins bridges distances up to eight miles by means of his so-called electro static system of wireless signalling.
- 1901—Marconi, spurred by his early success, finally succeeds in bridging the Atlantic Ocean from Poldhu, Cornwall, England, to St. Johns, New Foundland, by sending the historical series of the letter "S," the distance being 1,800 miles.
- 1902—Prof. E. Ruhmer's photophone system of wireless covers a distance of 20 miles at Kiel, Germany.
- 1902—Wireless telegraphy is adopted on large trans-Atlantic passenger vessels, the test being on the American S. S. *Philadelphia*.
- 1902—Prof. J. A. Fleming of London, England, invents the two element thermionic valve detector for radio reception.
- 1906—Prof. R. A. Fessenden, an American experimenter, develops a high frequency alternator system, having a range of 20 miles.
- 1906—The Telefunken Arc system of wireless telegraphy is developed and covers a distance of 25 miles.
- 1906—Dr. Lee DeForest, an American radio expert, improves the Fleming original vacuum tube by inserting the third or control element, known as the grid.
- 1908—Prof. Poulsen perfects another arc transmitting system which covers more than 150 miles on first test.
- 1908—Marconi trans-Atlantic radio stations are opened to the general public for the transmission and reception of radiograms between Great Britain and Canada.
- 1908—Prof. Marjorana perfects an arc oscillating generator and liquid microphone system and bridges Rome with Sicily, a distance of 300 miles.
- 1911—The radio telephone covers a range of 350 miles between Nauen, Germany, and Vienna, Austria.
- 1912—The International Radio Telegraphic Conference approves regulations to secure uniformity of practice in radio services.
- 1912—E. H. Armstrong, an American, invents the now famous regenerative vacuum tube circuit while experimenting at Columbia University.
- 1913—The powerful radio station at Nauen, Germany, successfully bridges a practical telegraphing distance of 1,550 miles.
- 1914—Laws are formulated by foremost maritime nations requiring that vessels of certain sizes and grades carry wireless equipment and operators.
- 1914—The Marconi Wireless Telegraph Company of America inaugurates a new American trans-ocean wireless service by opening its California-Honolulu circuit.



This Panel Will Improve Your Set CONDENSITE CELORON

The best panel made is none too good for your set. Dependable insulation is vital because it has a direct bearing upon the clearness and sensitivity of both transmission and reception.

Every thinking radio enthusiast certainly wants the highest type panel he can obtain and the surest way to get it is to insist upon Condensite Celoron.

This strong, handsome, jet-black material is not merely an insulating material—it is a radio insulation made to meet high voltages at radio frequencies. That is why it will give you greater resistivity and a higher dielectric strength than you will ever need.

Make Your Next Panel of Condensite Celoron.—It machines readily, engraves with clean cut characters and takes a beautiful polish or a rich dull mat surface.

An Opportunity for Radio Dealers.

Condensite Celoron Radio Panels and Parts offer a clean cut opportunity to the dealer who is keen on building business on a quality basis. Write us today. Let us send you the facts. You'll be interested.

DIAMOND STATE FIBRE COMPANY

Bridgeport (near Philadelphia), Penna.

Branch Factory and Warehouse, Chicago.

Offices in Principal Cities.

In Canada: Diamond State Fibre Co., Ltd., Toronto.

The Radio Pathfinder

By Richard R. Ranger

¶ Here is a simplified, accurate treatment of the fundamentals of radio, written by an expert who has the happy faculty of writing interestingly and humorously of difficult scientific explanations.

¶ The author's odd characters, King Electron, the Positive Ions and the Negative Electrons, aided by the book's many illustrations, clearly create the "royal road to understanding radio."

"There is none of the shorter and more popular books more admirably suited to its purpose than this one," says the Syracuse Post Standard.

At all bookstores, price, \$1.50

DOUBLEDAY, PAGE & COMPANY

When writing to advertisers please mention THE WIRELESS AGE

ATWATER KENT

RADIO RECEIVING SET

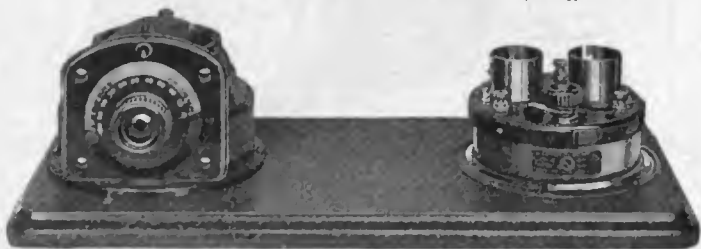

THE two instruments shown above comprise an excellent and complete receiving set. The Coupled Circuit Tuner and Detector Amplifier on the mahogany board present a beautiful appearance. Complete outfit as above, unwired, \$32.00.

ATWATER KENT MANUFACTURING COMPANY
4946 STENTON AVE. Radio Dept. PHILADELPHIA, PA.



JEWELL Lightning Arrester

Approved by Underwriters' Laboratories, latest Code. Carbon block types (not vacuum type) using a brown glazed porcelain case which can be installed inside or outdoors. Carbon block arresters have been standard in Railway signal and telephone protection for over 20 years. Ask your dealer or write us for special circular.

Price \$1.10

Jewell Electrical Instrument Co.
1650 Walnut Street Chicago

- 1915—The American Telephone and Telegraph Company, working in conjunction with the Western Electric Company, succeeds in telephoning by radio from Washington to Paris, a distance of 3,700 miles, and from Washington to Hawaii, a distance of 5,000 miles.
- 1917—Dr. E. F. W. Alexanderson, consulting engineer of the General Electric Company, develops a 200-kilowatt high-frequency alternator for use in trans-oceanic radio communication.
- 1918—Both radio telegraph and radio telephone conclusively prove their tremendous importance in warfare in the World War.
- 1919—Canada and England are linked by radio telephone for the first time, vacuum tube transmitters being used.
- 1919—The Radio Corporation of America is formed, taking over the interests of the Marconi Wireless Telegraph Company of America and the radio activities of the General Electric Company, to develop plans for a world-wide wireless system.
- 1920—The American Government returns the Marconi high-power radio stations, employed throughout the war, to the Radio Corporation of America.
- 1920—American radio amateurs reorganize their forces, now reinforced many thousands of times by war-trained radio men, and begin to turn their attention to amateur radio telephone development.
- 1920—An American-built and controlled station, to be known as Radio Central is conceived with facilities for simultaneous wireless telegraph communication to the entire world. To this end a tract of land covering ten square miles, is acquired on the north-eastern end of Long Island, near Port Jefferson, and construction work begins.
- 1921—Popular radio broadcasting begins.
- 1921—Twenty-seven amateur radio men make history by transmitting across the Atlantic from the United States to Ardrossan, Scotland. The power



The Only Knob and Dial Without A Set-screw



Patented June 20, 1922.

The unsightly and troublesome SET-SCREW is at last eliminated. No more splitting the head of the set screw or stripping of threads, perhaps ruining the dial.

To mount the TAIT-KNOB-AND-DIAL simply hold the dial with one hand and screw on the knob with the other, a few seconds does it. No tools are necessary. When fastened it is self centering and self aligning.

This beautiful patterned KNOB-AND-DIAL is made of the best grade of BAKELITE.

Prices—4" \$1.50; 3" \$1.00

To those building their own sets—Don't fail to use this dial, it is REVOLUTIONARY in its field and is the PEER of all KNOBS-AND-DIALS. If your dealer has

none, write us, and we will refer you to one who has.

Dealers—If your Jobber is not stocked up write us and we will refer you likewise.

We Sell Strictly To Manufacturers and Jobbers—whom we invite to write us for free samples and discounts.

TAIT KNOB & DIAL COMPANY, Inc.

11 East 42nd Street

Phone Murray Hill 0341

New York

When writing to advertisers please mention THE WIRELESS AGE

used in the various stations averaged from 50 to 1,000 watts.

- 1921—President Harding formally opens Radio Central by sending a radiogram addressed to the nations of the civilized globe.
- 1922—E. H. Armstrong announces his super-regenerative vacuum tube circuit.
- 1922—Dr. Irving Langmuir of the General Electric Company announces a 20-kilowatt vacuum tube, the most powerful ever made.
- 1922—Marconi demonstrates to an American audience his radio search-light, a means of directing radio waves.

Queries Answered

Answers will be given in this department to questions of subscribers, covering the full range of wireless subjects, but only those which relate to the technical phases of the art and which are of general interest to readers will be published here. The subscriber's name and address must be given in all letters and only one side of the paper written on; where diagrams are necessary they must be on a separate sheet and drawn with India ink. Not more than five questions of one reader can be answered in the same issue. To receive attention these rules must be rigidly observed. Positively no questions answered by mail.

Joseph Block, Brooklyn, N. Y.

Q. 1. I built a set using the diagram for a loop circuit shown on page 70 of the October issue of THE WIRELESS AGE. The diagram shows one stage of audio-frequency amplification, but I added another stage which does not give me greater volume. What is the reason?

A. 1. The wiring of your set is O. K., but you can obtain better results by substituting a variometer in the plate circuit for the DL 100 and .005 condenser. You do not need a condenser across the telephones. Your last amplifying transformer may be defective—the last tube may be defective. Try connecting a single dry cell in the grid circuit with the zinc (negative terminal) towards the grid. If this is ineffective, try a different tube here until you have determined whether the tube or transformer is out of commission.

Q. 2. Also kindly print diagram for 2 stages radio frequency, detector, 2 stages audio frequency, using the same tubes for radio and audio-amplification and a loop and variable condenser for tuning. Does using the same tube for radio and audio-amplification decrease the efficiency of the set or is it just as good as using separate tubes? Enclosed find diagram of my set.

A. 2. Below is diagram for reflex ampli-

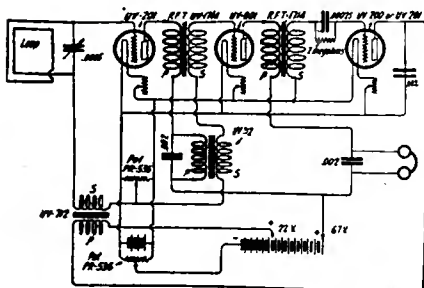

fier using 2 stages r.f. and 2 stages a.f. The efficiency of this set is not quite as good as when separate tubes are used, but that is a matter for experimentation.



QUALITY FIRST

The Roller-Smith loud speaker comprises two special receivers built permanently into a heavy cast aluminum horn. By matching the receivers as a pair and the pair to the horn we attain the quality of reproduction which characterizes a fine phone, combined with volume sufficient for any average room.

You will be surprised to hear the difference between it and the raucous shouter type, or it and the fish horn squawker.

- No batteries required.
- Handsome black crystalline enamel finish.
- Price, but eighteen dollars.
- Send for Bulletin No. AJ-20.

ROLLER-SMITH COMPANY
Electrical Instruments, Meters and Circuit Breakers

MAIN OFFICE
2129 Woolworth Bldg., NEW YORK

WORKS
Bethlehem, Penna.

Offices in Principal Cities in U. S. and Canada

A New Plug for 60c

HERBERT H. FROST
NATIONAL FACTORY DISTRIBUTORS TO THE ELECTRICAL-RADIO JOBBER
154 W. LAKE ST. CHICAGO, ILL.

Radio Department

HOPEWELL INSULATION & MFG. CO.

HOPEWELL, VA.

When writing to advertisers please mention THE WIRELESS AGE

Dealers

DISTRIBUTORS FOR
Radio Corp. of America
 Westinghouse
 General Electric

Frost Remior Fada Murdeck General Radio Brandes Baldwin Burgess Hippo Chelsea Heitzer Cabot	Clapp Eastham Kellogg Acme Homecharger Signal Pacnet Rhamsidine Connecticut Arkey Radio Service Tuska Brach
---	--

and other leading
manufacturers



Farmers Will Buy Sets and Parts

America's 25 million farmers—our largest single buying group—have been remarkably prosperous this year.

They have plenty of money and will spend it for Radio sets and parts, if you will but make an earnest effort for their business.

Tell them about the Aeriola Senior—which was designed particularly to meet the farmers' needs; it requires no storage battery, yet has a range of about 100 miles—tell them also about other sets.

If you are interested in getting the farmers' business, our Dealers Service Department will tell you how to go about it—write to them for their plan "How To Sell Radio To The Farmer."

How about your stock? We can take care of your orders for sets and parts at once.

Write for our new illustrated catalog 200E

LUDWIG HOMMEL & CO
 530-534 FERNANDO ST. PITTSBURGH, PENNA.

C. B. Adams, St. Joseph, Mo.

Q. 1. Can you give me working plans for crystal detector sets to be used without battery? Where can I get latest news pertaining to recent improvements on sets such as mentioned above?

A. 1. It is unnecessary to use any batteries with crystal detector sets. See the article "A Cheap Receiving Set With Spider-Web Coils," by E. F. Lake, on page 64 of the September issue of THE WIRELESS AGE.

* * *

H. C. Schermer, Houston, Texas.

Q. 1. Using 100 on primary, 75 on secondary, and 50 on tickler, should I not be able to get good results on the 360 meter, and the new 400 meter wave?

A. 1. Below is the hook-up you request. You should be able to receive the 360 and 400 meter stations with the coils you use. For the tickler coil, 35 turns are sufficient—50 turns would make the operation too critical. 75 turns on the primary is advisable.

Q. 2. Would 150 feet of insulated bell cord wire on the ceiling of a sleeping porch for the antenna, and a No. 14 insulated

FREE Radio Catalog



Describes and illustrates our large complete stock of Radio Equipment of all kinds. We can make immediate shipments of proven, reliable equipment. Protect yourself against disappointment by taking advantage of our experience and reliability.

Send \$5.00 for genuine Cunningham or Radio-tron Detector Tube. Free catalog sent on request.

Julius Andrae & Sons Co.
 In Business Since 1860
 124 Michigan Street Milwaukee, Wis.

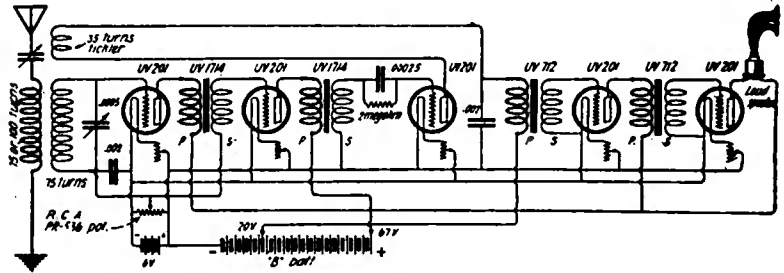

Amid health and wealth; in poverty, loneliness, joy and grief; at the side of the sick, the cripple, the shut-in; at bedside and fireside; in the drawing room, the attic, the barn; in city, suburb and crowded slum; in camp and mine and farm; mountain top and darkened valley; in the snows of the north and amid the flowers of the south—there radio brings cheer.

You who know what radio means, can enter into the true spirit of the holiday season by sharing the broadcast programs with your friends, for

"This is a Radio Christmas"

THORKITE

THE PERFECT RADIOPHONE DETECTOR

A new Silver-Copper-Bismuth Sulphide Crystal composed of some twenty-one chemical elements and rare metals of assay value over one hundred times that of galena. Vastly more sensitive—does not deteriorate but actually improves with use and lasts indefinitely.

Mounted in 1/2 inch nickeled cup. Can be attached direct to panel if desired. Special alloy used in mounting adds to the natural efficiency of this wonder crystal. Fully guaranteed. If you want the best radio reception, use THORKITE.

Price \$1.00 by mail postpaid
 Dealers' inquiries solicited

GILMOR-LAYNE CO.
 DISTRIBUTORS
 203 L. A. Railway Bldg., Los Angeles, Cal.

ground wire (20') be satisfactory for the above set?

A. 2. Wires strung along the porch would be quite satisfactory for nearby stations, but better results would be obtained on receiving distant stations by using a good outside aerial, approximately 50 feet high and 75 feet long. If this height cannot be attained, the aerial may be, for instance, 40 feet high and 85 feet long. Do not, however, exceed 125 feet total length from your receiving set to the far end of the antenna. An aerial of this size will give good results on 200 and 360 meters and also allow good selectivity.

* * *

Z. C. Falcon, La Plata—Calle 48 No. 1177, Argentine Republic, S. A.

Q. 1. What is the meaning of the letters "DCC" when with No. 24 wire? In this country there is wire of every nationality, so if I could know the diameter instead of the number of a particular standard, it would be quite simple for me and others to whom your magazine goes.

A. 1 The term DCC means "double cotton covered" and is used in specifying the insulation on the wire. SCC is the abbreviation for "single cotton covered," DSC and SSC are abbreviations for "double silk covered" and "single silk covered." Number 24 wire has a diameter of .020 inches or .51 millimeter.

Q. 2. Do I need the same voltage for American (hard to obtain here) German and French vacuum tubes?

A. 2. For American tubes, you need a 6-volt storage battery for filament lighting, and 22 to 66 volts obtained from block dry batteries, for plate potential. German and French tubes require 4 volts for filament and 56 to 88 volts for plate.

Q. 3. What are the dimensions of the two variometers shown? What size wire and how many turns?

A. 3. The dimensions of the variometers are given below:

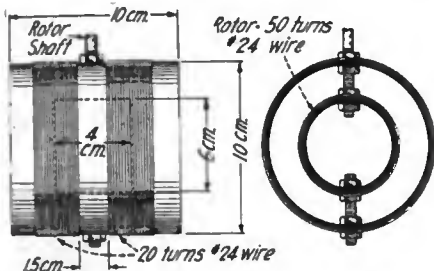

Q. 4. What are the dimensions of the variable and fixed condensers? I can easily make both of them. I have made a variable condenser of 15 fixed and 15 movable plates, separated 2 millimeters. The diameter of the movable plates is about 6 centimeters. How many plates would I need in order to obtain .0005 mf. I also have made as a tryout, a fixed condenser of 5 x 3 centimeters, (outside measure). How many tin paper plates would I need of 2 1/2 x 4 centimeters for the fixed condenser of the grid?

A. 4. You may use the condenser you have already built for antenna tuning. If you wish to make an .0005 condenser about 6 moving and 7 fixed plates are necessary. You need three sheets of tinfoil and two of paper for grid condenser.

* * *

Frank A. Rose, Two Harbors, Minn.

Q. 1. Can you furnish me with hook-up to use one or two stages of radio frequency with a Westinghouse R.C. set without making any material changes in the internal wiring of the set? I noticed that figure 3 in Mr. Ringel's article in the July issue seemed to be of the sort I would like, but I don't know just what changes I'd have to make and what apparatus I'd have to add in order to use it.

A. 1. Below is hook-up for addition of R.F. amplification to R.C. set.

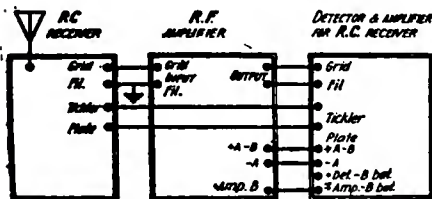

You need not add any additional apparatus, outside of the radio frequency amplifier.

Q. 2. At present I am getting WGY, KDKA, WSB, WDAF, etc., on the regular R.C. set, but am troubled by interference by Minneapolis stations at times. The Eastern stations are strong enough to let me get music just the same, but there is that weird interference howl in the background whenever a Minneapolis station near the same wave length sends. My idea is to use one or two stages of radio frequency and a loop to eliminate the stations I don't want. I could put the loop up in the air about 15 feet above the set if that would help. Am

"This is a Radio Christmas"

"COPPERWELD"
TRADE MARK REG. U.S. PAT. OFF.
(Made by the Molten Welding Process)
ANTENNA WIRE
50% Stronger Than Copper
Better than copper or strands for aerials. Doesn't stretch or sag.
The permanently welded copper exterior makes it ideal because of "skin effect" phenomena of radio currents. Standardized by the largest manufacturers of radio equipments.
Sold everywhere
100, 150 and 200 feet per carton
BUY IT IN CARTONS

COPPER CLAD STEEL COMPANY
NEW YORK SALES OFFICE: 30 CHURCH STREET, NEW YORK
CHICAGO SALES OFFICE: 129 S. JEFFERSON ST., CHICAGO
MAIN OFFICE AND WORKS: BRADDOCK P.O. RANKIN, PA.

"COPPERWELD"
THE IDEAL RADIO ANTENNA
COPPERWELD IS 50% STRONGER than Copper, can be strung taut, stays up when other wires stretch and break, and gives 100% electrical efficiency.
COPPER CLAD STEEL COMPANY
BRADDOCK P. O., RANKIN, PA.
Directions for Antenna construction on reverse side of carton

Milliken Radio Towers
Are justly famous in all parts of the world. Used at principal broadcasting stations. Constructed of galvanized steel, self-supporting standard types and heights. Reliable and Economical. Our Engineering Department is at your service.
Send for Complete Catalog
AGENTS WANTED
Milliken Brothers Mfg. Co., Inc.
233 Broadway New York, N. Y.
"This is a Radio Christmas"

STATION WVP
STATION WBZ
STATION 2 X J

NATIONAL RADIO WEEK
DEC 23 TO DEC 30 1922

When writing to advertisers please mention THE WIRELESS AGE

"This is a Radio Christmas"



"Can those shrieks"

HOW often have you sat helpless while some amateur Farrar has tried to hit "High C." But when your radio set starts in to show off its shrieking talent you need not go through another ordeal. Just drop in at your nearest radio store and order an Acme Audio Frequency Amplifying Transformer. Hook it up to your detector set and sit back easy. You'll be surprised how clearly and distinctly incoming sounds may be heard. Then, too, the tones are natural. Something usually so lacking in the ordinary set.

You will also want the Acme Radio Frequency Amplifying Transformer because this will greatly increase the range of your set whether it be vacuum tube or crystal detector. Both Acme Audio and Acme Radio Frequency Amplifying

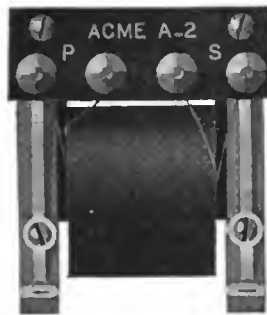

Type A-2 Acme Amplifying Transformer
Price \$5
(East of Rocky Mts.)

Transformers sell for only five dollars. Your set is not complete without them.

The Acme Apparatus Company (pioneer transformer and radio engineers and manufacturers) are also manufacturers of one and two stage amplifying units, detector units, detector and two stage amplifying units, the Acme Clear Speaker, the Acmehone. Acme C.W. and spark transmitting apparatus offer the amateur an opportunity to not only receive but send his own messages. For sale at radio and electrical stores or

write direct to the Acme Apparatus Company, Cambridge, Mass., U.S.A., or New York Sales Office, 1270 Broadway. Ask also for instructive free booklet on the operation of amplifying transformers, both audio and radio frequency types. You need it.

ACME

for amplification

When writing to advertisers please mention THE WIRELESS AGE

planning on using 5-watt transmitting tubes for amplifiers on the A.F. part of the set.

A 2. The only way you could get rid of the howl caused by two interfering stations is to have marked directional characteristics on the loop. This can be obtained only when the loop is remote from metal conductors. Another method would be to move your antenna so that it is in the direction of the stations you wish to hear. In such an aerial, in order to get good directional effects, the length should be about 15 or 20 times the height. It is unnecessary to use 5-watt tubes in the first stage of the A.F. amplifier—but it is advantageous in the second stage when the signals are very loud.

Here is the wiring diagram of the R.F. amplifier (2 stage).

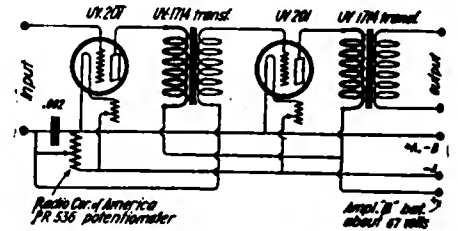

* * *

Thomas J. Walsh, Jr., Chicago, Ill.

Q. 1. Please give the hook-up for a detector and two-stage audio-frequency amplifier for use with a regenerative tuner, using automatic jacks and also having an extra jack by which the detector can be cut out and another set connected, so as to use only the amplifier (include values in diagram).

A. 1. Below is circuit for use of filament jacks:

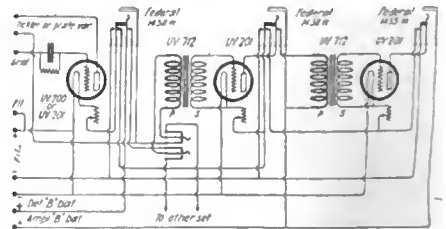

When dummy jack is in, other set is used, when jack is pulled out, above detector tube is used. For filament control jacks, use Federal No. 1438-W jacks. For changeover, a special two-circuit jack, or else an anti-capacity key of six prongs must be used.

Q. 2. What are the best transformers and tubes to use in the above circuit?

A. 2. The apparatus is shown in the diagram.

Q. 3. Does a three-tube super-generator give a greater range than a four-tube (not including local oscillator) super-heterodyne set?

A. 3. That is still being determined by experimenters.

Q. 4. Which circuit of all known has the greatest range and gives maximum amplification?

A. 4. Radio-frequency amplification gives greatest range. Super-regeneration gives loudest signals on nearby stations—its range is still being determined, although many amateurs are beginning to report distance.

Q. 5. Can a short-wave three-step R.F. regenerator be changed to a super-heterodyne set by the addition of a local oscillator and if so will any other changes be necessary? Can the same transformers be used and what will be the wave length of the set

(originally 200—600 meters)? Will the receiving range and signal strength be increased?

A. 5. There is no advantage in using a R.F. amplifier built for short waves on a super-heterodyne. In fact there will be a loss, in spite of the addition of the extra tubes. Long wave transformers such as Radio Corporation 5,000—25,000 meter transformers are useful here.

* * *

O. R. Welsh, Bakersfield, Calif.

Q. 1. Please advise me if the plan of a loop set with one stage of radio frequency shown on page 70 of your October issue of THE WIRELESS AGE is correct. If so, what kind of a transformer is used to allow filament current to go through its secondary without a large drop in potential as used?

A. 1. In the diagram on page 70, October 1922 WIRELESS AGE, the negative filament connection was accidentally omitted.

Q. 2. I am enclosing a sketch. Maybe you can aid me.

A. 2. In a circuit such as you use, each of the tuned elements must be accurately adjusted to the wave length desired. Try the following circuit, which has a few alterations.

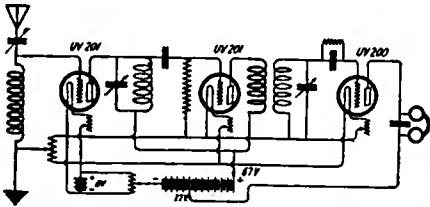

* * *

N. Demarest Campbell, Hackensack, N. J.

Q. 1. I have completed a radio-frequency set in accordance with the diagram which appeared in July 1922 of THE WIRELESS AGE, figure 6, page 73. I used Radio Corporation transformers Model UV-1714 for radio-frequency units and Acme transformers for audio frequency. I get nearby stations, such as Newark and New York City extremely loud on an inside loop, and can use Magnavox for both Newark and Tarrytown stations. What I am up against and do not understand is this: If I operate this set in the same room where two other sets are hooked up with an aerial I can increase volume of the set by adjusting the tickler and condenser of either or both of the other sets, and which are in no manner connected with the radio-frequency outfit. I also find that if I place a finger on the aerial switch, while using head phones, that the volume of the set increases to a considerable extent.

A. 1. You obtain better results on a loop which is located near metal structures such as antennas, overhead power wires, telephone wires, tin roofs and the like than when the loop is in an open field remote from all other wires. This is due to the fact that these wires are capable of picking up more signal energy than the loop and the resulting radio-frequency field is much stronger because this energy is re-radiated. If regeneration is used in tuning a nearby antenna, the resulting radio-frequency current is very much greater than if no regeneration is used, because of the feeding back of energy amplified in the plate circuit, and the re-radiation is very great. You will find that by cutting



M. P. M.
The World's Greatest Radio Crystal

M. P. M. is supersensitive, reproduces from every point on its surface and has record of receiving concerts over six hundred miles.

Ask your dealer for M. P. M. or send 50c for two M. P. M. Crystals, concert-tested and guaranteed.

M. P. M. SALES COMPANY
Dept. W
247 So. Central Los Angeles, Cal.



MADE FOR ALL PHONES ASK YOUR DEALER

THEY ARE GOOD Put Them on Your Phone
Slip out the metal disc and slip in the MICA-PHONE. Result—Clearer, better tone, all noises eliminated. Write for circular. Discounts to dealers and jobbers.
RADIO MICA PRODUCTS CO., 156 E. 43d St., N. Y.

The Radiovox Company

Distributors of Radio Corporation and Western Electric Radio Apparatus

Operating Cleveland Broadcasting Station "WHK"

5005 Euclid Avenue
CLEVELAND OHIO

Pick Up those Distant Stations

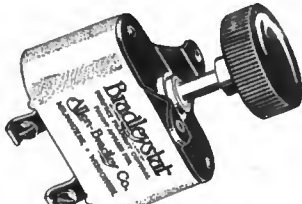

The tuning of detector tubes is such a critical operation that even the slightest movement of the ordinary rheostat knob will lose a distant concert or signal.

The Bradleystat, a guaranteed graphite disc rheostat, gives the most perfect vernier control with only one knob. Try one on your radio set. The improvement will be amazing.

Retail Price, \$1.85
P. P.—10c extra
For sale by leading radio dealers

Allen-Bradley Co.
Electric Controlling Apparatus
283 Greenfield Ave. Milwaukee, Wis.

Bradleystat

REGISTERED U. S. PAT. OFF.

PERFECT FILAMENT CONTROL

When writing to advertisers please mention THE WIRELESS AGE

"This is a Radio Christmas"

Have You Heard the New Radiola Grand?

No storage battery necessary; a complete and portable unit. Have your dealer order from us. We are also distributors of the famous Grebe products.



Trade-Mark Registered

PHILADELPHIA WIRELESS SALES CORP.

Formerly Philadelphia Wireless School of Telegraphy

Wholesale Department
1533 Pine Street

PHILADELPHIA

Retail Store
1326 Arch Street

GENUINE GERMAN MAUSER



Latest model 9 shot automatic. Shoots Standard cartridges — lies flat in the pocket — World's famous Luger 30 cal \$21.95 — Hand Ejector Revolver, swing out cylinder 32 cal. \$16.95, 38 cal. \$17.95. All brand new latest models — guaranteed genuine imported.

Pay Postman on Delivery **SEND NO MONEY**

Satisfaction guaranteed or money promptly refunded.
\$8.45 25 cal. Blue Steel Automatic — 32 cal \$10.45 — Officers automatic, 3 safeties, 25 cal \$11.95 — Military Trench Automatic — 32 cal. 10 shot, extra magazine FREE, \$11.65. — Imported Top Break Revolver 32 cal. \$8.65, 38 cal. \$8.95.
Universal Sales Co. 141 B'way, Dept. N-1 New York

SAVE YOUR "A" BATTERY BY A QUICK WEEKLY CHECK-UP WITH THE "CHASLYN" SINK-OR-SWIM BALL TESTER SET

Condition of acid instantly disclosed by the way the 3 balls of different colors and weights sink or swim.

Depth of acid tested by Depth Gauge.

Distilled water added neatly with air-controlled rubber-stopper.

Set of 3 as illustrated, \$1.00. Order from your Dealer. If he tries to sell you something else, send his name and address and your dollar. Set will be mailed postpaid.

CHASLYN COMPANY
4307 Kanera Ave.
Chicago, Ill.



out regeneration in the antenna and tuning it, it will absorb so much energy at that wave length that the signal from the loop will be weakened considerably. The energy picked up from an antenna depends on the amount of coupling to the loop. When you wear the phones and then touch the antenna switch, you increase the coupling (which is caused by the capacity between the telephone cords and your body) which is now a part of the antenna.

Q. 2. I have further found that by operating this set in another room removed from my other instruments and aerial switch that nearby stations come in properly, but distant stations while loud are very indistinct and it appears to be impossible to tune them in because the set commences to howl. I also find howling present if I come within two or three feet of the loop while the set is operating. I have changed all sockets as well as tubes with the idea in mind that the trouble was caused by one or the other being defective and have experimented with both Cunningham and Western Electric VT 1 tubes as detectors. I find the Western Electric to be the better of the two because it does not hiss but also find that it requires considerable less B battery than the Cunningham. All transformers are spaced three inches and the first audio-frequency transformer is fixed at right angles to its nearest radio-frequency transformer. I am also using Dubilier condenser and grid as shown before last radio transformer and detector tube, a Radio Corporation grid condenser and a Dubilier condenser in conjunction with potentiometer, all in the positions and of the respective capacities recommended in the above mentioned article. I have not, however, shielded each radio-frequency transformer and its accompanying tube from the others because of the difficulties attending such an operation. Furthermore, rather than have condenser attached to frame of loop I have installed it as a part of the set, between the potentiometer and input binding posts. When I use this set in conjunction with a tuning outfit, consisting of a condenser, two Amrad Variometers and an Amrad Variocoupler I have pulled in the radiophone station located at Tampa, Florida, without any trouble. When thus used I find none of the whistling and howling is present.

A. 2. The howling you experience may be caused by any number of factors. a. The set may be in a state of oscillation and the local oscillations superposed on the incoming radio frequency produce beat notes of audible frequency. You can determine whether such is the case by varying the tuning condenser. If howling is caused by local oscillators, this should change the pitch of the howl. They can generally be stopped by properly adjusting the stabilizer or potentiometer of the radio-frequency amplifier. b. The squealing may be produced by a number of different broadcast stations working at very nearly the same wave length—the audible beat note being due to the difference in frequency. Altering the tuning slightly should not change the pitch of the note. c. The audio-frequency amplifier may be howling, because of parasitic audio-frequency oscillations. Try grounding the filament battery—also connect the iron cores of both radio-frequency and audio-frequency transformers to ground. It is hardly necessary to shield the different stages.

PATENTS & FOREIGN RADIO & ELECTRICAL CASES A SPECIALTY

PROTECT YOUR IDEAS

Avoid Delays. Profit From Your Invention. Write today for free book "How to Obtain a Patent." Send Sketch or Model of your idea for preliminary examination and my report. Your rights will be carefully safeguarded and held in strict confidence. Highest references. Prompt Personal Attention to each case.

CLARENCE A. O'BRIEN **FREE**

Registered Patent Lawyer

500 Southern Building, Washington, D.C.

WRITE TODAY

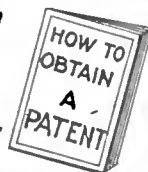

When writing to advertisers please mention THE WIRELESS AGE

STATIONS WORKED AND HEARD

Stations worked should be enclosed in brackets. All monthly lists of distant stations worked and heard which are received by the 10th of each month will be published in the next month's issue. For example, lists received by November 10th will be published in the December issue. Spark and C. W. stations should be arranged in separate groups.

2NE—A. H. Saxton, 211 Claremont Ave., Jersey City, N. J. (October.)

C. W.—Can 3bp, 1aby, 1ajp, 1aql, 1atj, 1azl, 1azw, 1bgf, 1bkz, 1bsj, 1bwj, 1cfi, 1cmk, 1fb, 1fa, 1gv, 1ii, 1jq, 1xm, 1xu, 1yk, 3bgt, 3bnu, 3cc, 3ei, 3pz, 4bq, 4bx, 4dl, 4ft, 4gh, 4nt, 5er, 5hl, 5ts, 5zl, 8ab, 8amm, 8anb, 8ato, 8atu, 8axb, 8axn, 8azd, 8azh, 8beh, 8beo, 8bnj, 8brl, 8bwa, 8cay, 8cdz, 8cf, 8ch, 8cko, 8csr, 8ij, 8kg, 8cw, 8qk, 8uk, 8vy, 8xh, 8xj, 8yd, 8zz, 9aap, 9afn, 9ajh, 9akd, 9aot, 9aps, 9awm, 9bds, 9bed, 9bhd, 9dr, 9dvn, 9ei, 9kp.

SPARK—1adc, 1aok, 1aw, 1ayo, 1gm, 1or, 5zl, 8azr, 8bda, 8uc, 8zy, 9cf, 8cp, 9dhe, 9dzy, 9of, 9tv, 9zn, 9amk, 9av.

VOICE—Ksb, wbp, wgy, wip, wmk, woc, woo, wsb, wwj.

2RA—R. R. Anders, 387 Autumn Ave., Brooklyn, N. Y. (October.)

C. W.—1gv, 1hk, 1iv, 1qp, 1xm, 1xp, 1ayz, 1bas, 1bjn, 1bq, 1bqr, 1bsc, 1cbj, 1cbw, 1cja, 3ex, 3jj, 3oe, 3pz, 3rf, 3vw, 3zo, 3afb, 3ajm, 3ajo, 3ava, 3bhl, 3bij, 3bnu, 3buc, 3bvl, 4bx, 4dc, 4ea, 4eb, 4en, 4ft, 4hw, 4jy, 4lj, 4sk, 5px, 5zap, 8bj, 8fm, 8gk, 8if, 8oe, 8ok, 8pj, 8qk, 8sb, 8sp, 8ue, 8yn, 8abn, 8ago, 8akm, 8akn, 8aol, 8apt, 8asl, 8asv, 8axn, 8bdu, 8brm, 8boz, 8btr, 8byt, 8bwa, 8bxh, 8cgb, 8cix, 8cko, 8ckx, 8cxt, 9cp, 9ei, 9ajh, 9anq, 9ark, 9awf, 9biz, 9cgl.

9DR D. C. Wallace, 1830 Stevens Ave., Minneapolis, Minnesota.

CW—1xu, 1yk, 1bko, 1cmk, 2fp, 2gr, 2kl, 2nz, 2qz, 2zk, 2brb, 3bz, 3fs, 3gk, 3lp, 3lr, 3pb, 3pc, 3zo, 3zw, 3afb, 3ajd, 3auu, 3auy, 3bhm, 3bnu, 3bvc, 4bo, 4dq, 4eb, 4ft, 4jk, 5ba, 5de, 5di, 5do, 5ek, (5ei), 5fb, 5he, 5je, (5kc), 5lb, 5ma, 5nc, (5nv), 5nk, 5px, 5qs, (5sf), 5sm, 5tj, 5uo, 5vm, 5xd, 5za, 5zh, 5acf, 5anu, 5cap, 5dak, 5zag, 5zaw, 5zaz, 6cp, 6cu, 6ea, 6en, (6ka), 6pv, 6abx, (6arb), 6asj, 6awt, 6bmn, (6bsa), 6cbr, (6xad), 7lu, (7sc), 7zb, 7zo, 7zu, 7afw, 7bwa, 8ab, 8an, 8ar, (8bo), 8cf, 8ft, 8ib, 8kg, 8ow, 8qi, 8qk, 8sp, 8vy, 8wa, 8xc, 8xh, 8yd, (8ze), 8zv, 8zx, 8zz, 8aer, 8afn, 8agc, 8aim, 8aio, 8aiw, 8ajp, 8ajv, 8akp, 8ame, 8anb, 8aoe, 8aoo, 8aou, 8asv, 8ati, 8atu, 8awp, 8awt, 8awz, 8axp, 8azb, 8bdo, 8bdu, (8bdv), 8bed, (8bfm), 8bke, 8bnj, 8bpl, 8bti, (8bux), 8bvr, 8bwa, 8bxh, 8bxx, 8cak, 8cay, 8cbc, 8cgm, (8cgp), 8cgv, 8cjh, (8cmi), 8cpv, (8ctp), 8cur, 8cuu,

ALKIRE Radio Frequency Receiving Set

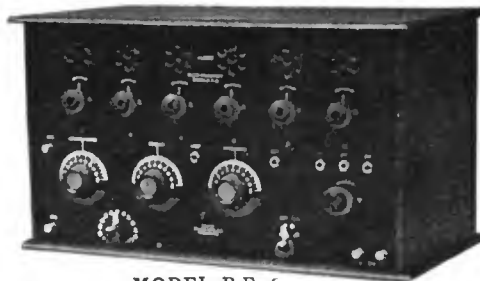

Super Sensitive

The Best for Appearance and Performance.

MODEL R.F. 6

Reduces static and interference

Easy to operate, no trouble with body capacity.

Mounted in handsome, highly polished mahogany cabinet with genuine bakelite panel.

All moulded parts are of genuine bakelite.

All sets are thoroughly tested for reception before shipped from factory and guaranteed with the Wells Iron Clad Guarantee.

JOBBERS: Good territory still open. Write for proposition.

The demand for Radio Frequency is tremendously assured.

Write for latest bulletin and proposition. Department R

WELLS MFG. COMPANY

FOND DU LAC, WIS.

GIVE YOUR FRIENDS A RADIO PRESENT



Give them something to make their set more efficient.

They will appreciate a set of

EBY BINDING POSTS

The post that guarantees a positive connection and the parts cannot become lost.

Commander "H"

Ensign "H"

Sergeant S. S.

Buddy

THE H. H. EBY MANUFACTURING CO., PHILADELPHIA, PA.

CITIZENS RADIO CALL BOOK

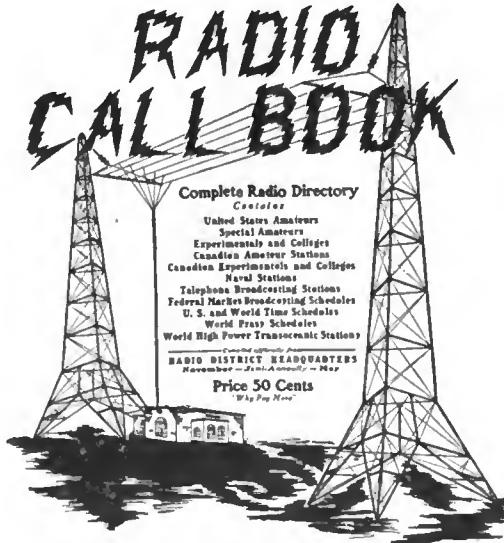

Actual Size of Book—9x12—128 pages. Covers printed in two colors. Absolutely best printed and best material used in any Call Book ever printed.

Citizens Radio Call Book

Fifty Cents

Why Pay More

November issue just off the Press

Contains all changes of address, Re-assigned Calls, Cancelled Calls—right up to date of issue—way ahead of any other Call Book at any price. Complete up to date Canadian list. Buy one—look it over—if it isn't the best you have ever seen, write us; money cheerfully refunded. At your dealer or direct from us. Postpaid.

Citizens Radio Service Bureau
406 S. Dearborn Street Chicago

Dealers, write for Guaranteed Sales Plan

When writing to advertisers please mention THE WIRELESS AGE

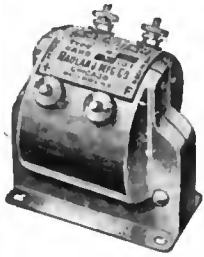

**To Strengthen Weak Signals
To Bring-in Distant Stations
To Get the Full Joy of Radio**

You will never know the full joy of Radio until you have hooked up to your set, a set of



"All-American" AMPLIFYING TRANSFORMERS

Our Radio-Frequency Transformer (Type R-10) brings in signals of 150 to 550 meter wave-lengths, and amplifies them many-fold, clear and sharp, largely eliminating static and other disturbances.

Our Audio Frequency Transformers simplify the detected signals, so that messages that would otherwise be audible only thru head-phones come in strong enough to be enjoyed by a roomful of people, thru a loud-speaker horn.

LIST PRICES (Radio and Audio Frequency)

R-10—Radio Frequency (150-550 meters).....	\$4.50	R-13—Audio Frequency (Ratio 10 to 1).....	4.75
R-12—Audio Frequency (Ratio 3 to 1).....	4.50	R-21—Audio Frequency (Ratio 5 to 1).....	4.75

Send for Bulletin No. 22.



RAULAND MFG. CO.
35 So. Dearborn St., Chicago, Ill.



8cvt, (8zac), (9cp), (9ex), (9gk), (9ii), (9iy), (9ps), (9uu), (9zc), (9zn), (9ahv), (9anq), (9aog), (9aqm), (9aqu), (9ays), (9bcf), (9bed), (9bhq), (9bji), (9bmn), (9bqw), (9bvy), (9bxt), (9ccb), (9ccs), (9cfi), (9cfw), (9cgg), (9ckm), (9dba), (9dcf), (9dHz), (9dky), (9dsm), (9dvw), (9zaf).

CAN—3co, 3ji, 4bv, 9aw.
SPARK—(5xac), (9abv).

6XAD—Major Lawrence Mott, Avalon, Catalina Island, Calif. (September and October).

1bbw, 1bka, 2brc, 3afv, 2kf, 2lt, 2apd, 2awf, 2byc, 2cin, 3jj, 3ot, (3bhm), 3bit, 3blf, (4bf), (4bv), 4fz, 4jy, (5el), 5hk, 5kc, 5fi, (5tm), (5uo), 5xv, (5za), 6bmy, 6zag, (7jf), 7lr, (7zu), (8ab), 8gp, (8hj), 8jp, 8se, 8vh, 8vq, (8vy), (8xo), (8zo), (8zy), (8agf), (8asv), (8aqf), (8aqz), (8awp), (8axm), 8axn, (8bcy), 8azd, (8bhe), (8bke), 8bmq, 8bnz, 8bum, (8bux), 8bzd, 8cak, (8caz), 8cef, 8cko, (8cpX), 8ctp, 8czn, 8yae, (9zaf), (9yaj), (9df), (9dl), (9dr), 9fk, 9fv, (9kp), (9ps), 9uc, (9uu), (9zl), (9zn), 9aap, (9afb), 9afn, 9ajh, (9ajm), (9aps), 9apw, 9aqr, (9awm), (9ays), (9xaf), (9xaq), (9ajs), (9amb), (9apw), (9awl), (9ayh), (9bed), (9bhd), (9bjv), (9bji), (9blc), (9dly), (9cns), 9bds, 9bkw, 9cdv, 9cvi, 9djo, 9dmh, 9dvl, 9dvw, 9dzy, 9dte, 9dtu, 9clz, 9ctr, (9xac).

CANADIAN.—3gn, 3ds, 4bv, 9al.

6XAD reported by H. E. Hansen, ship operator, to the effect that he heard 6XAD while his vessel was 60 miles off the port of Savannah, Ga.—in full daylight on Oct. 10.

"This is a Radio Christmas"

JOY-KELSEY CORPORATION
Manufacturers
RADIO EQUIPMENT
4021 West Kinzie St. Chicago Ill.

QST

A MAGAZINE DEVOTED TO AMATEUR WIRELESS

Official Organ: American Radio Relay League

New Developments, C.W. Transmission, Vacuum Tube Circuits, Regenerative Receivers, Underground and Loop Antennas, Radiotelephony, Relaying, Operating Department Work, all A.R.R.L. News, Humorous Stories by The Old Man. All these and many more are included in QST.

SPECIAL TRIAL OFFER

Regular price \$2.00 per year, 20 cents per copy. Introductory rate: 7-months subscription for \$1 and attached coupon.

PIN A DOLLAR BILL TO COUPON AND MAIL IT TODAY!

American Radio Relay League, Hartford, Conn.

Enclosed find \$1; please enter my trial subscription to QST for 7 months.

Name

Address

When writing to advertisers please mention THE WIRELESS AGE

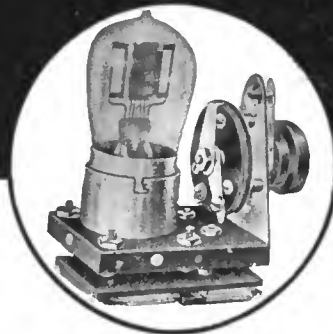

Use Radio Equipment of Proven Merit

Thousands of Amateurs have found Radio equipment manufactured by THE WIRELESS SHOP to be of the very highest quality. For more than ten years QUALITY has been the outstanding feature of our products. When you deal with this Company you do not experiment—all equipment manufactured in our plant has passed the severest test before it is offered to the public.

Note This DETECTOR UNIT for \$4.00

We are featuring, at this time, this complete No. 40 DETECTOR UNIT designed for back of panel mounting. By using this new Unit it is a simple matter for any Amateur to build up a Receiving Set. All that is necessary is to drill 3 holes in your front panel, mount Unit, and wire to Tuner. A complete Unit consists of socket for tube, rheostat, mica grid condenser and mica by-pass condenser, as well as knob and indicator. MAILED TO ANY ADDRESS UPON RECEIPT OF \$4.00.

If your name is not on our mailing list write today for our interesting folder "WA12". Invaluable to novices. Learn how you can save 20% on all Radio Equipment.

THE WIRELESS SHOP
A. J. EDGCOMB

1262 W. SECOND ST.

LOS ANGELES, CAL.

Book Reviews

New Edition of the Amateur Radio Call Book

A NEW edition of the Amateur Radio Call Book has been printed. The new edition is the most complete directory of amateur stations now available, and being corrected to November 1, is ahead of even the Government official directory of amateur stations.

Several improvements are noticeable in the new book over the last edition. A better paper is used, thus enabling the copy to stand the constant use that is inevitable. A more comprehensive introductory section is included, giving details of the construction of a honeycomb coil receiver, including a table of the sizes of honeycombs to be used for the different wave lengths.

In addition to the directory of American amateurs, which take up 121 pages, there is a complete list of broadcasting stations. Then follows a complete directory for Canada, both amateur and broadcasting.

The big feature of the book is reserved for the last, and is that indispensable item in every station, and one that is by no means always present, a large map of the United States. This is 20 by 30 inches in size, with a wide margin on which is printed a list of broadcasting stations, while on the map itself the calls of the various broadcasters are printed in red in the appropriate places. The directory is a favorite among amateurs, being the familiar com-

Twelve Reminders

When you give a year's subscription to

The America's Foremost Radiophone Review
WIRELESS AGE

for a Christmas present you do two things

You place in the recipient's hands the latest, most authoritative facts on the technical side of radio.

You open the way to a more personal, intimate knowledge of the stars who entertain over the air.

And you remind them every month of the fact that it's you who sought and found a year 'round way of saying

"This is a Radio Christmas"

Sterling

Radio Frequency Amplifying Transformer



Operate on any wave length. Pure amplification. Size 1 1/2" by 2" by 2 3/4" high.

List Price \$5.00

RADIO AND AUDIO FREQUENCY TRANSFORMERS

Long electrical engineering experience is the thing that counts in the making of a transformer, and 15 years of manufacturing devotion to this type of work is what accounts for the high esteem in which STERLING PRODUCTS are held.

PREFERRED FOR THEIR RELIABILITY

Sterling Amplifying Transformers are compact, neat little devices with all the care and attention put into their manufacture that Sterling has at its command.

OTHER STERLING RADIO DEVICES
Portable Rectifiers Filament Rheostats
Filament Ammeters and Voltmeters
Pocket Voltmeters for testing
"B" Batteries

Audio Frequency Amplifying Transformer



Magnetic circuit of closed core permeability shell type. Stray fields reduced. Size 1 1/2" by 2" by 2 3/4" high.

List Price \$4.00

THE STERLING MFG. CO. 2843 Prospect Ave.
Cleveland, Ohio
Over 2 1/2 million Sterling Devices in use today

"This is a Radio Christmas"

The Genuine and Guaranteed

"ALL WAVE" COUPLER

Trademark

WAVELENGTH 150 to 3000 meters
Flat and Bankwound

1. ELIMINATES the use of all Variometers, Variocouplers, and Loading Coils, as it performs in one compact unit the functions of all of these units combined.
2. BE PREPARED for the higher wavelengths that have been and will be allotted to various broadcasting stations because of their ever-increasing number.
3. FOR THE NOVICE—the six EFFICIENT HOOKUPS given free with each "ALL WAVE" Coupler enable the greenest novice to attain the same results attained by the expert in building the SIMPLEST, MOST COMPACT, and EFFICIENT Radio Receiving Set possible.



Patents Granted and Pending

Price \$9.00

BEWARE of imitations of the genuine "ALL WAVE" Coupler. Look for the trademark "ALL WAVE" on the rotor and the six efficient hookups in the box.

GUARANTEED with an absolute money back guarantee to operate as advertised.

Six efficient hookups sent upon receipt of 10 cents in stamps.

THOUSANDS OF SATISFIED USERS

CAPITOL PHONO LIER CORPORATION
58 Lafayette Street New York City

When writing to advertisers please mention THE WIRELESS AGE

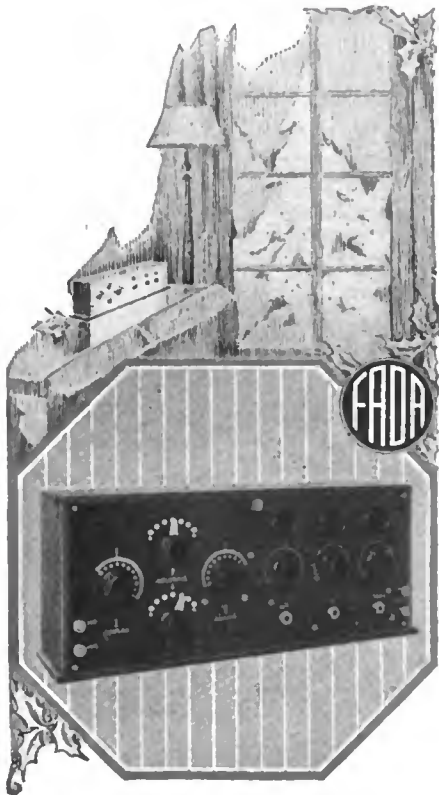

Make This A Radio Christmas

Extend Christmas cheer throughout the coming months by topping the family gift list with a Fada Receiver-Amplifier.

From the oldest to the youngest, every member of the household can easily operate and enjoy this master instrument, commanding as it does, entertainment from various broadcasting stations, bringing it, in true clearness of tone, to your own fireside.

Although a very simple instrument, the Fada receiver-amplifier, embodies those true refinements typical of all Fada equipments and parts.

F. A. D. ANDREA
1581-C JEROME AVE., N. Y. CITY

Manufacturer of Fada rheostats, tuners, switches, vario-couplers, sockets, detectors, condensers, audio frequency amplifiers, etc.

Write for the Fada Handbook enclosing 5c. to cover postage, mentioning your radio dealer's name and address. It's plumb full of things about radio you ought to know.



**Fada
Receiver-Amplifier**

panion of both "DX hounds" and the neighborhood spark coil devotee. The new edition makes even a greater appeal to the transmitting amateur and, more than that, will be eagerly welcomed by thousands of broadcast listeners who understand English, but not code, and are continually asking for the identities of distant broadcasters. The new directory should be in the hands of every transmitting amateur, and on the library table of every broadcast listener.

Amateur Radio Call Book, published by the Radio Directory & Publishing Co., 45 Vesey St., New York City. 144 pages, paper bound, with inserted map of United States. Price \$1.00. Can be obtained through The Wireless Press, 326 Broadway, New York City.

A Radio Wave Meter

EVER since the United States Government became critical of the wave length used by amateur transmitters there has been considerable interest in the design and construction of wave meters, the use of which has been necessary in order to make sure that the station is within the requirements of the law. Meters also are frequently used to calibrate receiving apparatus, making it possible to tune quickly and easily to any desired wave length. In view of these facts and the great growth of interest in radio meters, it is not surprising

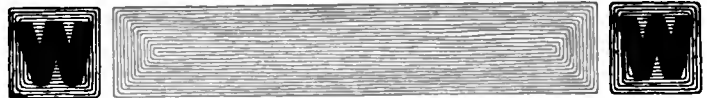

Stop Spoiling TUBES



Weston Filament Voltmeter

You're not a volt-meter. And GUESSING voltage doesn't "go" with vacuum tubes. That's why—nine out of ten of your tubes burn out prematurely. The Weston Filament Voltmeter

shows you at any time, the voltage your tubes require—(1) To assure 100% tube efficiency without danger of burnouts. (2) To duplicate results instantly. (3) To make exact tuning quick and easy.

Circular J describes this and other important Weston instruments for Radio use. Write for it.

WESTON ELECTRICAL INSTRUMENT CO.
27 Weston Ave. Newark, N. J.

Makers of Electrical Instruments since 1888

WESTON



"STANDARD" *The World Over*
**ELECTRICAL
INSTRUMENTS**

*An Indicating
Instrument for
Every Individual
Need and Industrial
Purpose*

When writing to advertisers please mention THE WIRELESS AGE

that the United States Bureau of Standards has just issued as letter circular No. 78, an extensive study of "The Design of a Portable Short-Wave Radio Wave Meter." The letter goes into considerable detail of the principles used in wave meters and is unusual in giving step-by-step instructions for building a meter with a range of from 100 to 570 meters. All the necessary data are given, including a circuit diagram, details of coil and scale, and a suggested arrangement of the units in a box. The letter is mimeographed and only a few copies are available so that unfortunately it is not offered to the general public; however, in all likelihood any radio engineers who have a need for the information will be able to secure it from Washington.

Let the Buyers of the Country see your Products at the

Permanent Radio Fair

(Under personal direction of R. F. Yates, Radio Editor New York Evening Mail.)

At the Hotel Imperial, New York

The Permanent Radio Fair is a centralized exhibit of reliable merchandise assembled for the benefit of buyers and the general public—the Bush Terminal Plan applied to the Radio industry. Following is a partial list of the space holders—

- Dubilier Condenser and Radio Corp.
- De Forest Radio Telephone and Telegraph Co.
- Radio Corporation of America.
- A. H. Grebe & Co., Inc.
- Multiple Storage Battery Co.
- Pacnet Electric Co.
- C. Brandes, Inc.
- Signal Electric Co.
- Jewett Mfg. Co.
- Horne Mfg. Co.
- Hopewell Insulation and Mfg. Co.
- Post Electric Co.
- Federal Telephone and Telegraph Co.
- Arrow Radio Co.
- W. E. Supply and Spec. Co.
- Victor Radio Corp.
- Mercury Radio Corp.
- Man-Day Radio Corp.
- Radio Laboratories of N. J.
- Radio Winding Corp.

Space rentals range from \$1.00 to \$3.00 per day. Wire or write for applications and literature. Space is not guaranteed to any applicant. Fair open in morning to buyers only. General public in afternoons and evenings. Runs from September 30th to May 30th. Minimum time one month.

PERMANENT RADIO FAIR, Inc.
HOTEL IMPERIAL
Broadway and 32d St. New York, N. Y.

You

will want a KENNEDY

*Regenerative Receiver
some day—why not now?*

Kennedy Regenerative Receivers, because of their superior construction and because they correctly apply the principle of inductively coupled circuits, are the standard by which all other radio receivers are judged.

*It is well to remember that it always
is safer and cheaper to buy the best.*

WRITE FOR OUR LATEST BULLETIN C-3
Address our nearest office

This Bulletin supersedes all others and illustrates and fully describes all Kennedy Radio Equipment.

*Kennedy Regenerative Receivers are licensed
under Armstrong U. S. Patent No. 1,113,149,
and are sold by good dealers everywhere.*

THE COLIN B. KENNEDY COMPANY

INCORPORATED

SAN FRANCISCO

U. S. A.

SAINT LOUIS

RUSONITE

CRYSTAL RECTIFIER

MULTIPOINT
(Patent Pending)

A synthetic CRYSTAL DETECTOR sensitive over its entire surface.

Eliminates all detector troubles. 50 per cent. increase in clearness and volume. Endorsed by Radio experts and press. Awarded certificates of excellency. Sets a new standard of efficiency. Price, postpaid, mounted, sensitiveness guaranteed, 50c. Dealers and Distributors Quoted Attractive Discounts. **RUSONITE PRODUCTS CORPORATION**
Dept. A, 15 Park Row, N. Y.



NA-ALD

Small Space
V. T. Socket
35c. each 3 for \$1.00

Moulded genuine condensite. Requires but small space for mounting. Readily accessible binding posts. No excess metal to interfere with efficiency. Unaffected by heat of bulbs or soldering iron. Phosphor bronze contacts. Nickel plated brass binding screws. Slash cut slot. Price possible because of large production.

Special proposition for dealers and jobbers
ALDEN-NAPIER CO.
Dept. A, 52 Willow St., Springfield, Mass.

When writing to advertisers please mention THE WIRELESS AGE



NATHAN GLANTZ
First and original
LAUGHING SAXOPHONE
on records

THE "LAUGHING SAX"

SENDS CHRISTMAS GREETINGS TO THE RADIO AUDIENCE

During the holidays when you play any of the records listed below remember to give a friendly thought to an artist who thoroughly enjoys his air-time concert work for you.

Records by
NATHAN GLANTZ

Birdie	Fox Trot.....	4684
Yoo-Hoo	" "	4438
Ti-O-San	" "	4418
One Sweet Smile	" "	4596
Somewhere in Naples..	" "	4475
Song of India	" "	4515
Valse—Ma Jolie.....	(Solo)	4561
Uncle Josh on the Radio.....		4686

(A Rural Skit introducing the Laughing Saxophone
By Nathan Glantz)

Romany Love	Fox Trot.....	Gennett Record
Meet Me Next Sunday.	" "	Edison Record

Okeh
Records

Appearances of Mr. Glantz at **WDY, WJZ, WVP, WEA**
all under auspices of

GENERAL PHONOGRAPH CORPORATION
MANUFACTURERS OF OKEH RECORDS—25 West 45th St., N. Y. C.

DAYTON RADIO PRODUCTS

Are the most complete and most accurate of any Radio apparatus made by one Company in America.

Dayton Variometers and Vario-Couplers are made in two types. Moulded and Tube of similar design.

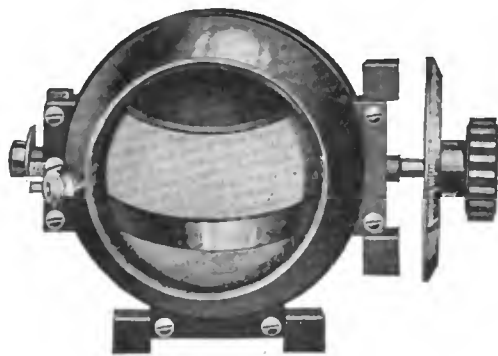

TYPE A VARIOMETER

Dayton moulded Bakelite Variometers Type A	\$6.75
Dayton moulded Bakelite Vario-couplers Type A	7.00
Dayton Bakelite Tube, Variometer Type B	4.25
Dayton Bakelite Tube, Vario-coupler Type B	4.75
Dayton Bakelite Tube, Vario-coupler Type C	3.75
Genuine Bakelite Knobs and Dials, Black or Brown, 2-inch.....	.75
Genuine Bakelite Knobs and Dials, Black or Brown, 3-inch.....	.75
Genuine Bakelite Knobs and Dials, Black or Brown, 4-inch.....	1.25

VARIABLE CONDENSERS IN 4 SIZES

	List Price
Type 9 P. C. S. Square and Round Plate .0003 Mf.....	\$3.00
Type 17 P. C. S. Square and Round Plate .0005 Mf.....	3.60
Type 31 P. C. S. Square and Round Plate .001 Mf.....	4.50
Type 45 P. C. S. Square and Round Plate .0015 Mf.....	5.30
Type 17 P. C. S. Condensers with Vernier attached.....	4.40
Type 31 P. C. S. Condensers with Vernier attached.....	5.30
Rheostats with Vernier, Licensed.....	1.75
Rheostat Plain, Licensed	1.10
Panel Switches 8 Points.....	.90
Phone Jacks65
Genuine Bakelite Knobs and Dials 3".....	.75
Insulating Rubber Tubing 10 ft. Package.....	.45
Radio Phone Receiving Sets.....	75.00
Amplifier Units	8.50

A complete illustrated Catalog will be mailed free upon request.

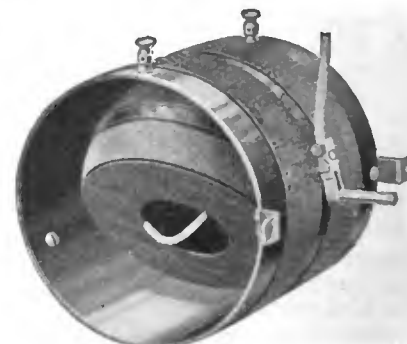

TYPE B VARIO COUPLER

THE A-C ELECTRICAL MFG. CO., DAYTON, OHIO
MAKERS OF ELECTRICAL DEVICES FOR OVER 20 YEARS

When writing to advertisers please mention THE WIRELESS AGE

If You Have a Radio Enthusiast in the Family—Put This on the Tree



If you buy a receiving set for a gift, be sure it is "PACENTIZED"

"This is a Radio Christmas"

PACENT TWINADAPTER

An ingenious device for providing two plug connections for a single jack. This permits the use of two sets of head phones, or one set of head-phones and a loud speaker. The radio experimenter will find many uses for the TWIN-ADAPTER. Price \$1.50.

PACENT Radio Essentials embody the highest radio engineering skill and over fifteen years practical radio experience. They are used and endorsed by experts and are standard equipment with leading set manufacturers.

The TWINADAPTER is just one of many PACENT devices for convenience and pleasure in radio. Ask your dealer to show you other members of the PACENT line, or

Write for Descriptive Bulletins (WD 104)

Don't improvise—"PACENTIZE"

PACENT ELECTRIC COMPANY INCORPORATED

Manufacturers and Distributors of Radio and Electrical Essentials
Executive Offices: 22 Park Place, New York, N. Y.

BRANCH OFFICES

Philadelphia, Bourse Building
Chicago, 33 So. Clinton Street



Washington, D.C., Munsey Bldg.
San Francisco, Sheldon Bldg.

Members, Radio Section Associated Mfrs. of Electrical Supplies

Canadian and British Licensees: Colonial Radio, Ltd., Hamilton, Can.



Get Better Radio Results With the NEW

BESTONE Condensite Vario-Coupler AND BESTONE Amplifying Transformer

Comparing elegance of design, quality of materials and actual performance, the new BESTONE apparatus illustrated represent the latest achievements in radio manufacture.

Catalog "W" Sent Free Upon Request.

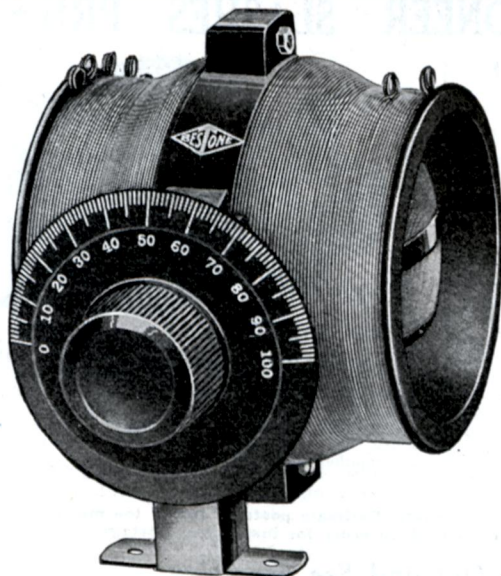

BESTONE CONDENSITE VARIO-COUPLER

This apparatus is constructed of genuine mahogany-colored condensite—the best known radio insulation.

By the unique design of this apparatus the primary and secondary coils take the same general outline within each other placing them in very close relation. The primary being divided into 16 taps enables very close tuning. Equipped with 3-inch Bakelite dial.

List Price \$7.00

Sold by the Best Dealers Everywhere.

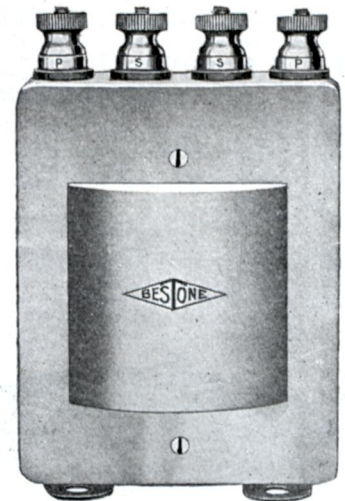

BESTONE AMPLIFYING TRANSFORMER

The use of this apparatus assures clarity and volume of tone as well as undistorted reception. This Bestone product is distinguished by superiority of design, excellence of materials and scientific construction. Fully enclosed by aluminum case.

List Price \$5.00

HENRY HYMAN & CO., Inc., Manufacturers

Executive Offices:
476 Broadway, New York

Branch:
212 W. Austin Ave., Chicago, Ill.

A Christmas Thought

Do You Have to Eat Raw Meat?

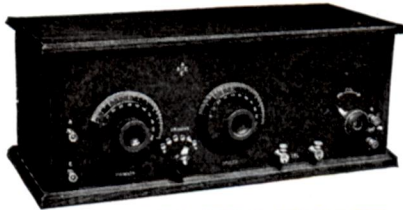

ACE RADIO BROADCAST RECEIVER

Licensed under Armstrong Patent No. 1,113,149

Neither do you have to be satisfied with distorted, unnatural reception of radio broadcasting.

Radio is wonderful—if the right equipment is used. Otherwise it can be repulsive.

In making your Christmas selection, purchase a scientifically constructed receiver, designed by RADIO engineers. In other words, an ACE radio broadcast receptor.

Address Dept. XA

THE PRECISION EQUIPMENT CO.

2437 Gilbert Avenue

Cincinnati, Ohio

Our little booklet, "Radio in Your Home," is convincing—may we send you a copy?

A HISTORICAL EPOCH IN RADIO — PIONEER SLASHES PRICES

Duck Instruments. The Leading Line Since 1909 At Prices to You Less Than Most Dealers' Cost

It was always the Duck policy to sell its own product direct—from factory to consumer. We have decided to continue this policy and pass on to the consumer, in reductions averaging 30%, our entire complete line of radio instruments. These prices simply cannot be approached by any house. Our tremendous good will and low manufacturing overhead makes these unusual prices possible. This shall be our future policy. Get catalog out and observe the reductions and the quality of the goods.

FREE PAMPHLET Mailed On Request Illustrating and Briefly Describing Many of Our Instruments with New Prices on Our Complete Line.

JUST A FEW OF THE MANY DUCK PRODUCTS AT REVOLUTIONARY PRICES:

- | | | | |
|---|--------|--|--------|
| Duck Bakelite Dial, 1/8" or 1/4"..... | \$0.55 | Duck Variocoupler | \$3.60 |
| Duck Positive Contact Socket..... | .70 | Duck Switch Parts for Variocoupler, pig-tail connections | 1.25 |
| Duck Filament Rheostat..... | .70 | Tuned radio frequency receiving set, with one step radio and detector..... | 29.75 |
| Duck Radio Frequency Potentiometer | 1.15 | Duck No. A204 Parts for Short Wave Receiving Set, in mahogany cabinet..... | 39.00 |
| Duck Moulded Plate or Grid Variometer, less dial | 4.65 | Duck No. A211 Parts for Short Wave Receiving Set | 24.95 |
| Duck Super-selective Mahogany Form Plate of Grid Variometer | 3.60 | Duck No. A212 Detector Panel | 5.25 |
| Duck Panel Type 43 Plate Condenser..... | 3.15 | Duck No. A213 One Step Amplifier Panel..... | 10.50 |
| Duck Panel Type 23 Plate Condenser..... | 2.50 | Duck No. A214 Two Step Amplifier Panel..... | 27.00 |
| Duck Panel Type Vernier Condenser..... | 1.65 | Duck, The Original Arlington Receiving Transformer | 9.75 |

Note:—Positively the very best variable condenser on the market. Pig tail connections; aluminum separators.

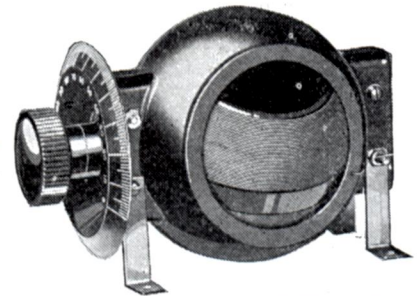

DUCK'S NEW MOULDED SUPER-SELECTIVE VARIOMETER LESS DIAL, \$4.65.

- Duck Navy Type Receiving Transformer..\$16.10
- Duck No. A220 One Step Radio Frequency Amplifier Panel
- Duck No. A221 Two Step Radio Frequency Amplifier Panel
- Duck No. A223 Three Step Radio Frequency Amplifier Panel

Postage or express extra on all goods. Estimate postage, and if too much, we will refund. We do not hold up order for insufficient postage.

Get Your Catalog Out and See Startling Reductions

Duck's Combined Radio Catalog and Text book No. 16—256 Pages

Continuously since 1909 Duck's radio catalogs have never been equalled for completeness and great wealth of radio data. Send 25 cents in coin, carefully wrapped, for your copy of this wonderful catalog—the most unusual and complete book ever put between two covers. Over 50 pages radio hookups and invaluable and up-to-date information on radio. Everything worth while in radio listed in this catalog.

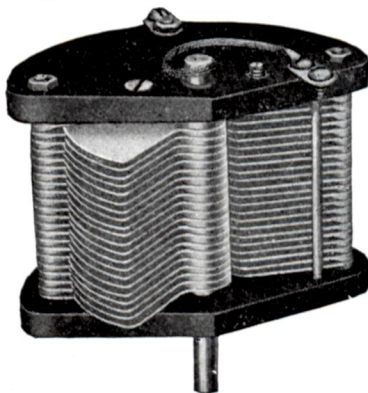
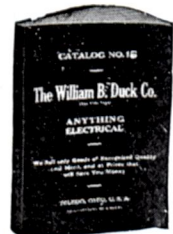

DUCK'S NEW PANEL TYPE VARIABLE CONDENSER

acclaimed by all that have seen it to be the peer of any on the market. Pig tail connections, i. e., no sliding contacts. Base and top moulded bakelite. Aluminum separators, i. e., even spacing and simple means of adjusting plates. Mounting screws furnished. Concealed by dial. Brass bearings: 3/4" shaft.

The WILLIAM B. DUCK CO., 239-241 SUPERIOR STREET TOLEDO - - - OHIO

BEST BY TEST

DX RADIO FREQUENCY AMPLIFYING TRANSFORMERS

DX TRANSFORMERS are used by U. S. BUREAU OF STANDARDS, U. S. NAVY ENGINEERS, LARGE RADIO MANUFACTURERS AND BY THREE OF THE FOREMOST CONSULTING ENGINEERS OF AMERICA.

(One of the latter, after most thorough comparative tests, states that DX TRANSFORMERS have the HIGHEST AMPLIFICATION of any Radio Frequency Transformer on the market.)

DX RADIO FREQUENCY TRANSFORMERS are used throughout the United States; they have proven BEST BY TEST, their superior qualities have earned for them a National Reputation.

An Attractive Proposition to Jobbers and Distributors

IT PAYS TO HAVE THE BEST

Send for Literature

RADIO
INSTRUMENT COMPANY, INC.
TRADE MARK REG.
WASHINGTON, D. C.

"This is a Radio Christmas"

If your dealer does not have DX RADIO Frequency TRANSFORMERS write us.



	Wave length Range	Price
DX-1	170—450\$8.00
DX-S	400—1200 8.00
DX-2	900—3000 8.00
Standard Plug Mounting	 1.00

MAKE THIS A RADIO CHRISTMAS

GREATEST
SELECTIVITY
 AND
 EXTREMELY
LONG RANGE

ARE CHARACTERISTICS OF THE

Federal

DX TYPE No. 58 R.F. RECEIVER

Unquestionably the most Sensitive Radio Instrument on the market today

IF YOU DON'T LIKE THE PROGRAM YOU ARE LISTENING TO—YOU MAY FIND ANOTHER MORE SUITABLE TO YOUR TASTE

We will be very pleased to mail—upon request—literature descriptive of RADIO FREQUENCY APPARATUS
 WRITE FOR BULLETIN No. 119-W

Federal Telephone and Telegraph Company
 MANUFACTURERS OF STANDARD RADIO EQUIPMENT

—BUFFALO, N. Y.—

DX TYPE No. 58



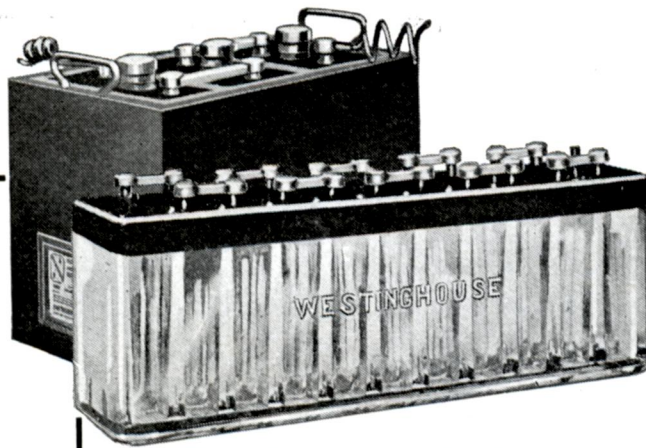

**Built by Westinghouse
—you know they're right**

Nothing about a radio set is so absolutely essential to satisfactory receiving as right batteries. Westinghouse Batteries are not only correct in design, but durable in construction and thoroughly dependable in performance.

WESTINGHOUSE "A" BATTERIES are full-capacity, low-voltage, slow-discharge, long-life batteries, built especially for radio work. Ten types—27 to 162 ampere hours' capacity; 4, 6 and 8 volts.

WESTINGHOUSE "B" BATTERIES. The new Westinghouse 22-MG-2 is a rechargeable 22-volt "B" battery and a marvel for steady, noiseless, full-powered service. Glass case; visible interior. Lasts indefinitely. Two other types.

*At your radio dealer's, or most any of the
2000 Westinghouse Battery Service Stations*

WESTINGHOUSE UNION BATTERY CO., Swissvale, Pa.

**WESTINGHOUSE
RADIO "A" and "B"
BATTERIES**



**NOVO
"B"
BATTERIES
FOR RADIO**

22½ - 45 & 105 VOLTS

**NOISELESS
DEPENDABLE
GUARANTEED**

ASK YOUR DEALER

NOVO MANUFACTURING CO.
424-438 W. 33rd ST.
NEW YORK

531 SO. DEARBORN ST., CHICAGO.

ANTENELLA
(No Antenna or Aerial Needed)

CHAS. FRESHMAN CO. Inc.
NEW YORK

ANTENELLA

PATENTS APPLIED FOR

At your dealer's—\$2.00

**MICON TESTED MICA
CONDENSERS**

"MICON"
TESTED MICA CONDENSER
CAP. .005 M. F.
PATENTS PENDING
MFG. BY
CHAS. FRESHMAN CO.
NEW YORK CITY

ALL CAPACITIES
Price 25c to \$6.00

At your dealers—otherwise send purchase price and you will be supplied without further charge.

Chas. Freshman Co., Inc.
97 Beekman Street New York City

"This is a Radio Christmas"

STILL IN THE LEAD—RIGHT UP TO DATE

Third Edition—Just Off the Press

Complete Up-to-date List of Broadcasting Stations in United States and Canada
Also
Map of Broadcasting Stations in Both Countries
Instructions for construction and operation of a honeycomb coil set and a two-step amplifier

Price \$1.00

Dealers send in your orders today

**AMATEUR
RADIO
CALL BOOK**

WIRELESS PRESS, Inc. **326 Broadway, New York**

When writing to advertisers please mention THE WIRELESS AGE

"IT'S TO BE A RADIO CHRISTMAS THIS YEAR!"

**A Receiving Station that
Anyone Can Operate**

For new beginners in radio—no less than for experienced radio "fans"—this is a Christmas gift that will outshine everything else the holiday brings.

These two Radak sets make a home receiving station that will not only bring in radio waves from amazing distances, but will amplify them hundreds of times, giving strong, clear, accurate reproduction.

Yet so simple, so free from confusing adjustments, that a mere child can tune and operate it as easily as a radio expert.

Radio and electrical dealers all over America are featuring Radak Receiving Sets for Christmas, because of the satisfaction they give in the home. If your dealer has not yet been supplied, his jobber will serve him promptly. Radio catalog, showing latest Radak equipment, 6 cents.



MODEL H. R.

Radak Receiving Set, the popular Christmas gift of the year. Handsome mahogany cabinet with dull black panel. \$40. (Licensed under Armstrong U. S. Pat. 1113419.)



MODEL H. Z.

Radak Two-Stage Amplifier. Popular companion gift with Model H. R. Radak Set, permitting the use of a loud speaker. Same size and finish. Price \$40.

CLAPP-EASTHAM COMPANY

Established 1906
America's Oldest Exclusive Radio Equipment
Manufacturers.
101 Main St. Cambridge, Mass.

Radak
Trade Mark Reg. U. S. Pat. Off.

Reliable Radio Equipment

New York Coil Company's Radio Products
The Leading Line of the Most Successful Jobbers and
Dealers in Radio

Our Amplifying Audio Transformers prove a revelation in true tone qualities. No distortion, no howling. Price \$4.00 each.

OUR STANDARD VARIO-COUPLER, VARIOMETER and AUDIO AMPLIFYING TRANSFORMERS (PRICED AT \$4.00 each) ARE THE BEST IN THEIR CLASS. OUR FAMOUS VARIABLE CONDENSERS

- | | | |
|----------|-----------------------|--------|
| list at: | 3 Plate Vernier | \$1.25 |
| | 11 Plate | 1.50 |
| | 23 Plate | 2.00 |
| | 43 Plate | 3.00 |

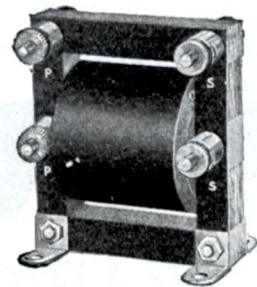

Mounted Vario-coupler for panel or table use, — but three holes in panel saves all laying out, drilling and soldering. — nothing else like it. Price \$8.00

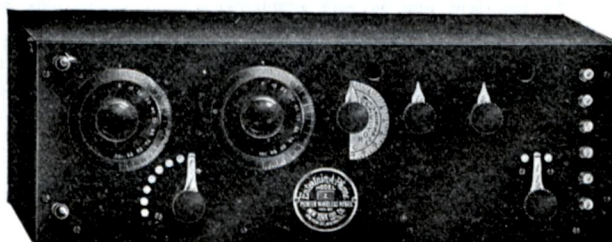

Entertain - a-phone Receiving Set No. 2 detector and two stages amplification. Price, \$50.00 Greatest value in radio.

NEW YORK COIL COMPANY, Inc.
338 Pearl Street
New York City, N. Y.

Instant—Positive—Noiseless

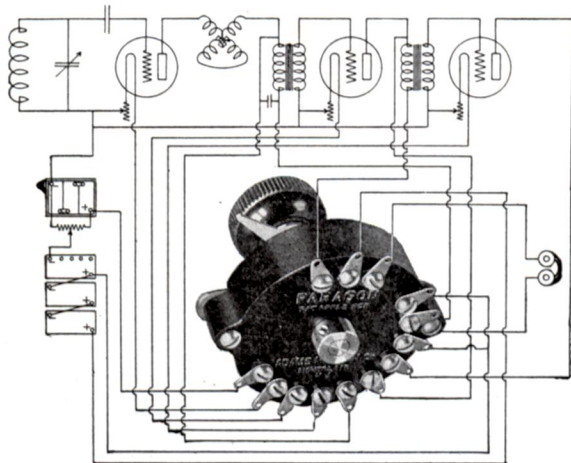

Paragon Stage Control Switch

Plugs and jacks are now obsolete. The PARAGON Stage Control Switch combines the functions of three multi-circuit jacks and the telephone plug. It controls, automatically and progressively, all the filament circuits, plate battery circuits and input and output circuits of the detector-two-stage amplifier.

Switching from stage to stage is instantaneous, positive, noiseless. All battery circuits are protected. The wiring of amplifier is simplified.

The wiring diagram, illustrated above, shows the method of connection when this new PARAGON switch is employed for control of detector and two-stage amplifier. The switch may also

be used for an unlimited combination of vacuum tube circuits. $2\frac{3}{8}$ " in diameter, $\frac{3}{4}$ " in thickness. Price, \$3.00.

Send for new illustrated catalogue of Paragon radio parts.

Also Manufacturers of
 PARAGON
 Radio Telephone
 Transmitters
 V. T. Control Units
 Rheostats
 Potentiometers
 V. T. Sockets
 Amplifier Transformers
 Detectors
 Control Dials
 Amplifiers
 Receivers
 Switches
 Variometers

ADAMS-MORGAN CO., 8 Alvin Ave., Upper Montclair, N. J.

PARAGON

Reg. U. S. Pat. Off.

RADIO PRODUCTS

CLICKERTY CLANK

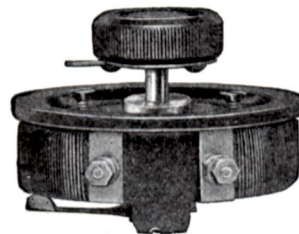

Does your rheostat go—"Clickerty-clank! BANG!" whenever you make an adjustment? It would not if it were General Radio constructed. When your tube is approaching the critical point, it is necessary that the adjustment be fine and introduce no extraneous noises in your head phones.

When you construct your set, you would not mount a toaster on the panel. Then why mount a rheostat that runs hot? The radiation surface of the General Radio rheostat is sufficient to permit the rheostat to be mounted in small enclosed spaces without fear of heat damage.

The base is real bakelite—no substitutes used. The switch blade is rugged phosphor bronze and polished nickel plated. The knob is convenient and attractive.

Made in two styles, Type 214-A for back-of-panel mounting, and Type 214-B for front-of-panel mounting or portable use. Also made in two sizes, for receiving tubes and for power tubes.

7 ohms, 1.5 amps. for receiving tubes
 2 ohms, 2.5 amps. for five-watt tubes
 PRICE, any style.....\$2.25

Similar in general dimensions and design to the rheostat is the 400-ohm potentiometer. This instrument is ideal for grid biasing.

PRICE, any style.....\$3.00

Send For Free Radio Bulletin 911W

GENERAL RADIO COMPANY
 MASSACHUSETTS AVENUE AND WINDSOR STREET
 CAMBRIDGE 39, MASSACHUSETTS

Do not confuse the products of the GENERAL RADIO CO. with those of other concerns using the words "General Radio." The General Radio Co. has been manufacturing radio and scientific instruments for many years. It has no affiliation with any other company.

Standardize on General Radio Equipment Throughout

"This is a Radio Christmas"

"This is a Radio Christmas"

"TUNING IN"

To the right tune is very simple when your connections are soldered with the

NEW "POST SOLDERING IRON"
 (The iron with the platinum heating unit)
 Removable Soldering Tip

Designed especially to cover every requirement for delicate work.

The smallest practical-efficient instrument on the market.

Attached to any socket, Universal Current.

Fully Guaranteed.

From your dealer, jobber or write,

"Awarded the Certificate of Excellency by the Radio Institute of the N. Y. Evening Mail"

POST ELECTRIC COMPANY, 30 East 42d Street, Room 509, NEW YORK

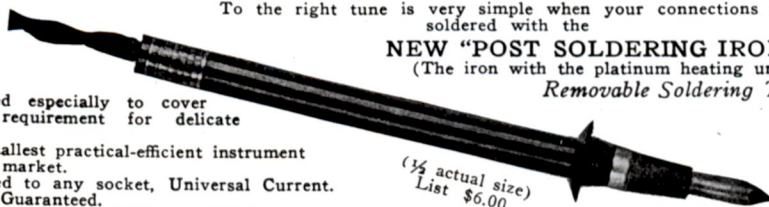

($\frac{1}{2}$ actual size)
 List \$6.00

GIVE YOUR EARS A TREAT!—USE

"RED-HEADS"

3000 Ohms

With Military Head-Band and Cord



Now \$6.50

At your dealer or direct on receipt of price.

A TRIUMPH IN RADIO RECEIVER DESIGN

The Newman-Stern Co. Newman-Stern Building Cleveland, O.

SIMPLEX

—that's your safeguard

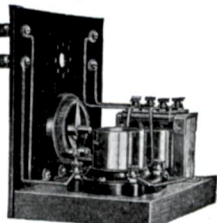
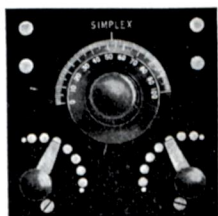

Simplex Vario-Coupler Panel Simplex Amplifier Panel

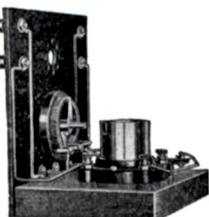
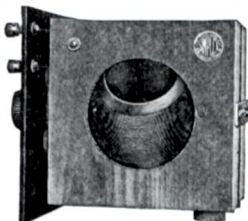

Simplex Variometer Panel Simplex Detector Panel

SIMPLEX PANEL UNITS make it possible to try out the many different hook-ups without disassembling panel, which is a decided advantage.

SIMPLEX RADIO CO.

1013-15 Ridge Ave. Phila., Pa.

"This is a Radio Christmas"

"EURACO" PRODUCTS

(Guaranteed)
Compact—Interchangeable—Most Efficient—Accurate.



60 Cents per Unit. 60 Cents per Unit.

MICA GRID CONDENSER
GRID LEAK RESISTANCE

Mica Condensers—Grid Leaks—Mountings.
Interesting Proposition for Dealers.

EUROPEAN RADIO CO.
1342 East 22nd Street Brooklyn, N. Y.

"This is a Radio Christmas"

BRACH vacuum RADIO PROTECTOR

The indispensable instrument wherever there is static interference with radio signals and voice currents.

Brach Arresters should last a lifetime unless hit by a direct stroke of lightning. Unscrupulous manufacturers of Air-Gap Arresters have made statements implying that Brach Vacuum Arresters lose vacuum. These statements are intended to mislead and are not founded on truth.



Listed by the Underwriters' Laboratories

L. S. BRACH MFG. CO.
NEWARK NEW JERSEY

Also Makers of Solderall—Best for Soldering Radio Connections

Coast Representatives
Pacific States Electric Co., San Francisco, Los Angeles, Oakland, Seattle, Portland, Spokane

HOMCHARGE

Your RADIO BATTERY for A NICKEL

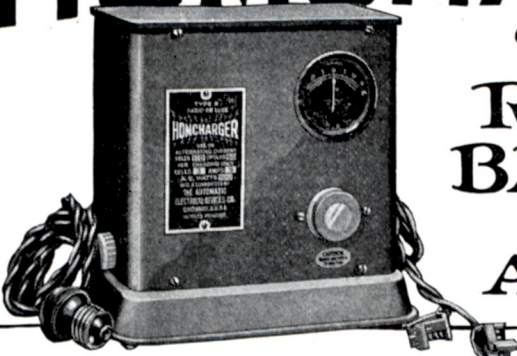

ENJOYABLE RADIO CONCERTS and maximum receiving range are obtained only when your battery is fully charged. Don't be bothered with the inconvenience and expense of taking your battery to a service station every few days for recharging. The

RADIO HOMCHARGER DE LUXE

has been designed especially for this purpose. It charges your "A" or "B" battery over night without removing from the living room—gives taper charge—cannot harm your battery in any way. Simplicity itself. Only two wearing parts, replaceable after several thousand hours use for One Dollar.

AN ORNAMENT FOR YOUR LIVING ROOM

Beauty has been combined with utility in the NEW RADIO HOMCHARGER DE LUXE. The body is beautifully finished in rich Antique Mahogany—the base and fittings in a handsome, dull gold. Equipped with rubber feet, it cannot mar polished surfaces. It harmonizes with the finest living room.

OVER 50,000 HOMCHARGERS IN USE

50,000 users have heartily endorsed the HOMCHARGER. Beware of imitations when buying and insist on obtaining the genuine which bears our registered trade name, HOMCHARGER. Furnished complete. No extras to buy. Price \$18.50 (\$25.00 in Canada) at all good dealers, or shipped prepaid upon receipt of purchase price. Booklet illustrating the NEW RADIO HOMCHARGER DE LUXE in actual colors is FREE for the asking. Send for your copy today. DEALERS - JOBBERS: Over 150,000 HOMCHARGERS will be sold this fall and winter. Send for your copy of "HOMCHARGER Business Builders" and see how you can get your share of this business.

CAUTION

When buying a Rectifier insist upon the following:

1. SELF-POLARIZING feature, otherwise your battery may be ruined through reverse charging.
2. AT LEAST FIVE AMPERE CHARGING RATE, otherwise it will require several days to fully charge your battery.
3. UNDERWRITERS' APPROVAL, otherwise in case of fire your insurance may be void.

The HOMCHARGER is the only Rectifier at any price which combines the above, three NECESSARY HOMCHARGING features.

The Automatic Electrical Devices Co.

119 West Third Street

Cincinnati, Ohio

Largest Manufacturers

of

Vibrating Rectifiers in the World

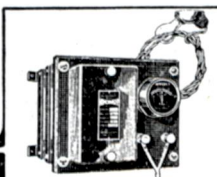

BRANCH OFFICES

New York Chicago Pittsburgh
Detroit Dallas
Philadelphia Los Angeles
Baltimore Minneapolis Atlanta
St. Louis Kansas City

TYPE "A" FOR WALL MOUNTING

OVER 50,000 IN USE

"This is a Radio Christmas"

EXPERIMENTERS

Build your Super-Regenerative Set from this new book and get it right

The Armstrong Super-Regenerative Circuit

By GEORGE J. ELTZ, Jr., E. E., A. I. E. E.

Complete description of each of Three Circuits Invented by MAJOR E. H. ARMSTRONG

How to Change a Regenerative to Super-Regenerative Circuit
52 Pages 21 Photos and Hook-Ups Price \$1.00

Dealers, Place Your Orders Now

WIRELESS PRESS, Inc., Distributors, 326 Broadway, New York

Static Defeated and Distortion Forgotten

Cotoco

TRADE MARK REG. U. S. PAT. OFF.

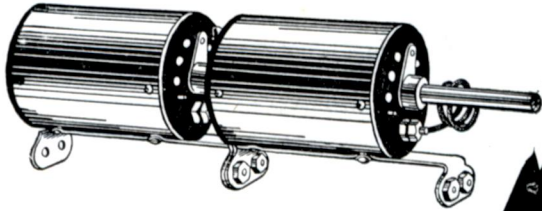

COTOCO Amplifying Transformer for Audio Frequency

Forget Distortion. The message or music that is amplified by this transformer of superior design and workmanship comes through either headphones or loud speaker clear and right.

COTOCO Tapped Type Amplifying Transformer for Radio Frequency has made the Loop Aerial available to all. It has practically overcome Static Troubles. When you adjust it to handle a certain wave length all others are excluded and most static with them.

Buy Radio by the Name Cotoco

Write for Cotoco
FREE
Connection Diagram
for Loop Aerial Sets

COTO COIL CO.
87 Willard Ave.
PROVIDENCE, R. I.

Other Cotoco Products

Coto Coils

Variable Air Condensers

Metal Insert Dials

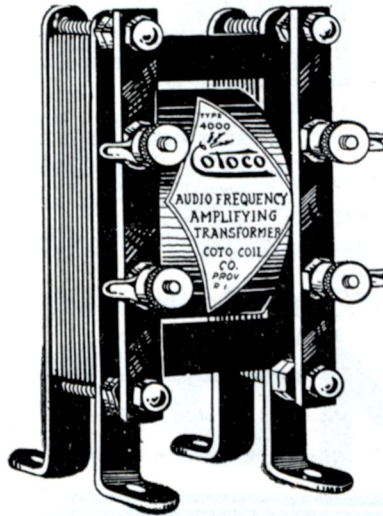

\$5.00



\$7.50

For perfect reception there is no phone like the "Royal-fone" King of All at either \$5.00 or \$7.50. Either phone will make an appreciated Christmas gift, something that anyone will cherish for a long time.

A "Royalfone" is a satisfied gift because it is guaranteed.

We will take care of you if there is no dealer in your vicinity.

ROYAL ELECTRICAL LABORATORIES
207 Market St. Newark, N. J.

Royalfone

"This is a Radio Christmas"

INTERFERENCE

Can be cut out with Knott Super-Vernier Condenser

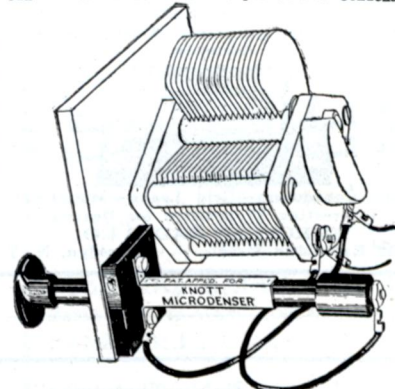

(Trade Mark Registered)
Showing how you connect to your condenser. Super accurate tuning. This Micro will stretch the critical tuning point on your variable condenser to two inches of adjustment. Send us \$3.00 and we will mail you one with connecting wires and wrench-screwdriver. Send 2c stamp for information about Knott instruments for selective and sharp tuning. Their performance will astonish you and you will brag about what they give you. Jobbers, our proposition will interest you.
E. R. KNOTT MACHINE COMPANY
1 Ellery Street Boston 27, Mass.

School of Radio Telegraphy

Complete course in Radio covering arc, spark and vacuum tubes. Enrollments now being accepted for both day and evening classes. Positions assured all graduates. Your first month's salary as a radio operator more than your entire tuition.

Instruction in Morse on the sounder if desired.

CALL, PHONE OR WRITE FOR INFORMATION

Y.M.C.A. RADIO SCHOOL

149 East 86th Street

TELEPHONE LENOX 6051

New York City

"The Best Radio School in the East"

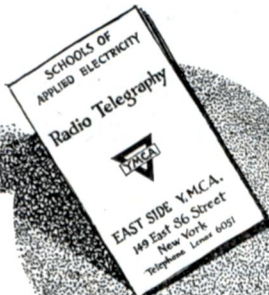

SEND FOR THIS BOOKLET TODAY

The Latest and most essential Part of an Efficient Tube Set

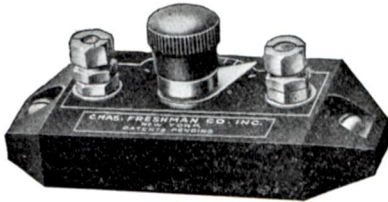

Variable Grid Leak and Micon Condenser Combined

Obtainable in an unbroken range from zero to 5 megohms—all intermediate points. Fixed capacity—.00025 M. F. Will improve your set wonderfully by

- Clarifying Signals
- Lowering Filament Current
- Increasing Battery Life
- Eliminating Hissing

Price only \$1

At your dealers—otherwise send purchase price and you will be supplied without further charge.

Manufactured by

CHAS. FRESHMAN CO., Inc.
97 Beekman St. NEW YORK CITY
Home of Micon and Antenella

DIALS



2 in. 20c. 3 in. 27c. 2 3/4 in. 25c.
With Brass Insert and Set Screw
Specify whether 3-16 in. or 1/4 in. Insert

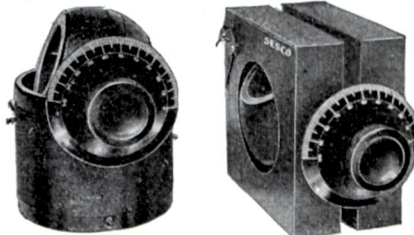

\$1.75 "SESCO" Variocoupler 600 meters
23 Plate Condensers \$1.90
Sockets (tube) 50c.
Standard Mod. 8 Phones, 2,500 Ohms, \$3.50
Half with order, balance C.O.D.

\$2.50 "SESCO" Variometer
Rheostats 60c.
43 Plate Condensers \$2.10

STANDARD ELECTRIC SALES CO.
843 BROAD STREET NEWARK, N. J.

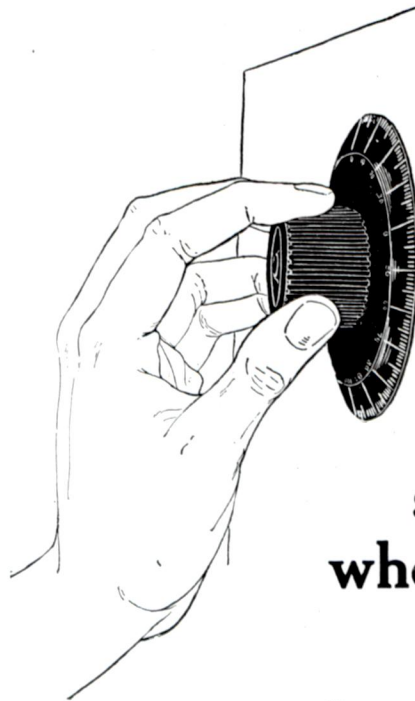

How to stop noises when you touch Dials

Have you ever found, after tuning in a distant broadcasting station, that when you removed your hand from the dial, there is a growling noise which makes it impossible to hear anything else?

This is usually caused by two things—too much current through your detector tube filament and dials made from compounds which, being comparatively poor insulators, cause body capacity to make proper tuning an impossibility.

If you are positive that the proper amount of current is flowing through your filament and these distracting noises still persist they can be overcome only by removing the dials at present on your set and replacing them with dials made of RADION.

Tests have proved time and again that RADION is without question the supreme insulating material for Wireless use. Secure a dial from your dealer today. Take it home and place it on your set and you'll notice the difference immediately. Also have your dealer show you a RADION MAHOGANITE panel—the most beautiful panel made—easy to saw and drill. It is also warp and chip proof.

If your dealer can't supply you write us direct giving us his name and we'll see that your requirements are immediately taken care of.

Insist on RADION

American Hard Rubber Company

11 Mercer Street -- -- New York

The Marvelous New **PLANET Loud Speaker**

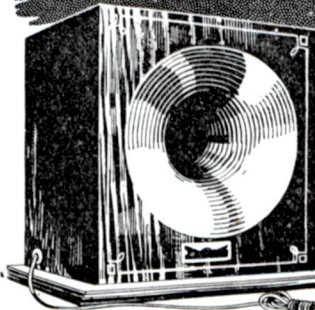

PERFECT SOUND REPRODUCTION

The Planet Loud Speaker marks the most advanced step in the perfection of Receiving Radio Broadcasting. Radio experts, "fans" and dealers, all are amazed at the remarkable fidelity with which the Planet fills a room with the exact tonal qualities of the human voice, musical instruments, etc. The Planet is a complete unit. Like a thing of magic it transforms the ordinary two stage amplified receiving set into a wonderful musical instrument. Beautiful design, richly finished mahogany case and polished emitter with gold or aluminum finish, make the Planet an ornamental attraction to any home. Loud, distinct, clear reproduction. Price \$40.00.

Illustrated folder on request—Order from your nearest distributor or write to

PLANET RADIO CORPORATION, 1223 South Wabash Ave., Dept. D-1, Chicago, Ill.
Dealers write for attractive proposition.

THE PLANET POWER AMPLIFIER

An essential unit for receiving sets that do not produce sufficient volume. Constructed so that a five-watt power tube or amplifying tube can be used depending upon the volume desired. An article of the highest grade. It is equipped with special units found in no other amplifier. With the Planet Amplifier you can greatly increase your volume without distortion. Every detail of construction shows the highest grade workmanship and materials.



Price \$27.50 (without tube)

DISTRIBUTORS
BOSTON—Beaudette & Graham Co., 915 Boylston St.
BALTIMORE—Jones Elec. & Radio Mfg. Co., 118-20 E. Lexington St.
DETROIT—B. E. Polozynski & Co., 304 Capitol Theatre Bldg.
GRAND RAPIDS, MICHIGAN—Wolverine Elec. Corp., 21 Division St.

KANSAS CITY, MISSOURI—Western Radio Co., 6 W. 14th St.
PEORIA—Diamond Elec. Sup. Co.
ST. LOUIS—The McGraw Co., 2018 Locust St.
NEW YORK CITY—Harold M. Schwab, Inc., 419 W. 42nd St.
NEWARK, NEW JERSEY—General Mfse. Co., 142 Market St.

A Michigan "Senior" Receiver



Assures You MANY HAPPY BROADCASTS OF THE DAY

Equipment of the Michigan "Senior" Receiver

Tuner, detector and two stages of amplification. Wave length 150-650 meters. Cabinet richly finished in brown mahogany, representing the highest standard of Grand Rapids cabinet work. Size 18 1/4" wide, 11 1/2" high and 7" deep. Weight, approximately 20 pounds. Vernier dial adjuster. Filament control jacks. Molded variometer wound with special green silk magnet wire. Binding posts located on rear sub-panel, not inside. Michigan Vernier rheostat for detector tube control. Michigan filament rheostats for amplifier tube controls. Radiation hard rubber panel (shield over entire panel) on which are mounted all instruments, including rear sub-panel. This arrangement permits immediate accessibility to all instruments and wiring, by removing four front panel screws.

The ease of operation and the wonderful performance of the Michigan "Senior" Receiver makes any amateur sure of obtaining satisfactory broadcasting.

An outstanding feature of the Michigan "Senior" Receiver is the Vernier Dial Adjuster. This means that a very fine adjustment may be made on each dial, which is necessary in tuning in on stations, located at great distances. Another superior feature is the Vernier Rheostat, which enables the operator to obtain extremely delicate adjustment of filament current on the detector tube. Quality is the hallmark of all "Michigan" products.

"Senior" Receiver \$125.00

A complete line of radio parts and accessories are manufactured in our own plant. Michigan "Junior" and "Senior" Receivers are not merely assembled sets, but are made complete by us. We are, therefore, enabled to guarantee, absolutely, everything we sell.

Dealers: A connection with this Company will prove pleasant and profitable for you. Send for our catalogue of high grade, first quality merchandise.

MICHIGAN RADIO CORPORATION GRAND RAPIDS, MICHIGAN

THE MATTATUCK VACUUM TUBE RECEIVER TYPE RP-1

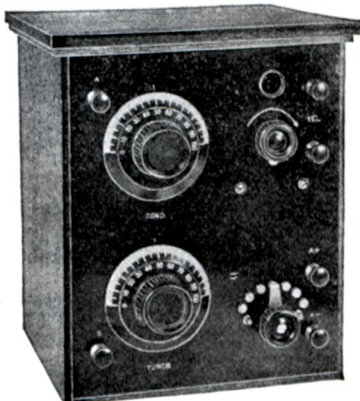

A QUALITY INSTRUMENT

A dependable receiver designed for clear radio telephone reception. Simplicity of operation and clearness of tone makes the Mattatuck a desirable instrument. Has a tuning range from 150 to 650 meters.

The cabinet is made from select mahogany, finished in its natural color. Condensate panel, beautifully finished, possessing high dielectric strength. Rotary type condenser, with aluminum plates, shielded from body capacity effects. Has compartment for B battery, finger ease knobs, rubber covered binding posts, etc.

Price \$35.00

With phones, tube and B battery \$50.00

MATTATUCK RADIO APPARATUS CO., 27 No. Elm St., WATERBURY, CONN.

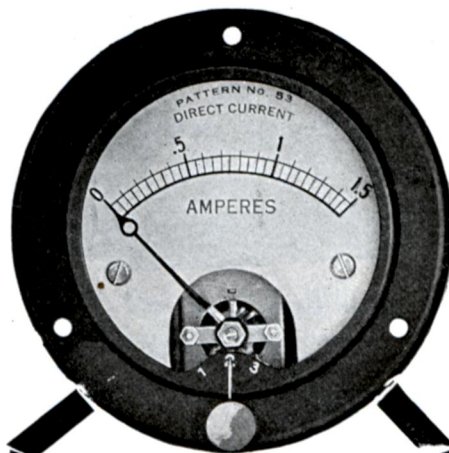

Triplex Filament Meter

Filament control by the use of proper instruments in receiving sets is the trend of the times. The Jewell triplex filament instrument, made as an ammeter or voltmeter, places on your panel the proper means for controlling the filaments of three tubes. It has a self-contained mechanism for switching to either tube and being of small size, can be accommodated on the most compact tube set.

Price \$10.00

We were the first to supply a complete line of miniature radio instruments of uniform size. Ask your dealer or write to us for complete radio circular.

Jewell Electrical Instrument Co.
1650 Walnut St. Chicago

Saves time, labor and is accurate
"PREPARED RADIO MEASUREMENTS"
By R. R. Batcher. Price \$2.00
WIRELESS PRESS, Inc. 326 Broadway, N. Y.

If you use Amplifying Tubes



you can make your Victor talking machine a RADIO LOUD SPEAKER, with a "Beeko" Radio-Phono attachment.

Sample by mail, 40c.
Liberal discount in quantities.

J.H. BUNNELL & CO.
32 Park Place, Dept. W
NEW YORK

American RADIO Exposition

The Official Exposition for American Manufacturers

with the endorsement of the

NATIONAL RADIO CHAMBER of COMMERCE

and sanction of the Radio Apparatus Section of the

ASSOCIATED MANUFACTURERS of ELECTRICAL SUPPLIES

Grand Central Palace
New York

December 21st to 30th

(Sunday excepted but Christmas Day included)

This first really comprehensive Exposition is to be staged in a manner worthy of a great industry.

The leading manufacturers have contracted for space. This opportunity to display Radio products to thousands of buyers during the holiday season is an unusual one. The exposition will be one of New York's big features in connection with National Radio Week.

For further particulars write or wire

AMERICAN RADIO EXPOSITION COMPANY
120 BROADWAY, NEW YORK
TELEPHONE JOHN 0009

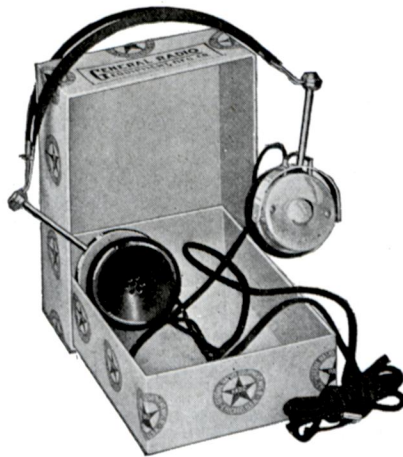

Red Star Head Phones

Why take a chance with your receiving set by using poor head phones, for after all your radio receiver set is no better than your head phones.

Red Star head phones speak up sharp and clear. Light in weight, they fit the head comfortably and do not tire; they are easily adjusted over the ears.

Protect your receiving set by buying good head phones—ask your dealer to show you Red Star phones. You will be surprised at the results you will attain.

Monocoil, 2,000 ohms, \$5.00

Long-distance, 3,200 ohms, \$8.00

Including head band and 6 ft. cord

General Radio Equipment Co.

1131 Diversey Parkway

Chicago

High Efficiency Head Receivers

LIST PRICES

\$6.00 to \$12.00



Made by a factory, with over 30 years' experience in manufacturing good receivers.

THE TEST TELLS

Ask for full data

American Electric

COMPANY

State and 64th Streets Chicago, U. S. A.



NA-ALD

genuine
Condensite Dial
The dial that runs true

Numerals engraved on bevel and knob so shaped that fingers do not hide them. Thin edge with clear graduation to make accurate reading easy. Concealed set screw in metal insert. Will not warp or chip. Finish and enamel permanent.

3-inch dial, 35c.

2-inch dial for rheostat potentiometer use, 35c.

3 7/8-inch dial, 75c.

Send stamps for literature

ALDEN-NAPIER COMPANY

52 Willow St. Dept. A Springfield, Mass.

RADIO "A" & "B" STORAGE Batteries CHARGED at Home For Few Cents With "PATENTED FULL WAVE" 100-130 Volt 60 Cycle A. C. Automatic Magnetic F-F RADIO RECTIFIER

Eventually You Will Buy An F-F RECTIFIER. Why Not Now? The Sooner You Buy It; The More You Save

It CHARGES All 6 Volt RADIO "A" & AUTO Batteries; & All RADIO "B" & LOUDSPEAKER Storage Batteries Up To 120 Volts In Series Inductively At Home Overnight. Disconnecting & Multiple Connections Unnecessary. Charging Circuits Separate. Nothing Like It Made. No Chance For Grounds Or Short Circuits. No Skill Required. AMMETER eliminates Guess Work. It Costs You Less To Buy An F-F RECTIFIER than To Be Without One. You PAY for ONE whether You Buy One Or Not, for It Costs An Average Of \$2. for Charging & Rentals Every Time An Auto Battery Is Charged By Others, but Only A Few Cents When You Charge Your Own From A Lamp Socket With An F-F Battery Boosting RECTIFIER. If You Have Never Known The Delightful Feeling Of Having Your Storage Batteries Always Fully Charged for RADIO & AUTO You Will Experience A New Thrill When You Have A RECTIFIER of Your Own Which Gives You A Fully Charged Battery Overnight At A Cost of A Few Cents & A Pleasant Feeling Of Things Well Done. Those Who Own Them Feel Their F-F RECTIFIER is Their Faithful Friend. It Charges Automatically & Being Clean Can Be Placed Anywhere. Nothing To Stop Over Be Filled Burn Out Need Attention Or Cause Trouble. Both Waves Are Rectified Thru Infusible Carbon Rectifying Brushes, Maintaining Constant Efficiency Uninterruptedly. While Its FULL WAVE Delivers The RAPID TAPER CHARGE recommended By All Storage Battery Manufacturers. The F-F RECTIFIER is A Complete Compact Portably Handy Charging Unit. Delivers Service Day & Night Automatically. Will Charge Dead Battery. Do Not Think Battery Is Dead & Worn Out Simply Because It Will Not Start Your Car. Buy An F-F RADIO RECTIFIER & Fill It With LIFE. IT SAVES MORE than Its Cost & Lasts A Lifetime. Leave Your Battery In Car, Or Where Ever It Is, Without Even Disconnecting It Screw RECTIFIER Plug In Lamp Socket, Snap RECTIFIER Clips On Battery Terminals; Turn Switch & Battery Will Be Charged In Morning At Cost Of Few Cents. Is It Not Gratifying To Be Ready For All RADIOPHONE BROADCAST Music Sermons & News When Friends Call? Never Having To Be Careful Of, or Tell Friends Your Batteries Are Dead & To Feel Your Car Respond Like A Greyhound, Spinning Engine With Power When You Throw In STARTER? Fully Charged Batteries By Starting Car Quick Require Fewer Expensive Replacements. INSIST on The F-F RECTIFIER. Built By A Master Of The Art In 7 Types. So Many Thousands Are Being Sold It Has Made Possible These POPULAR PRICES

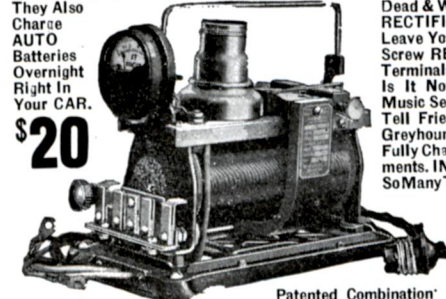

\$20

Patented Combination

CHARGES AUTO & RADIO BATTERIES
The Large TYPES are Recommended For Heavy Batteries, or Where Time Is Limited. SHIPPING WEIGHTS Complete With AMMETER & BATTERY CLIPS 11 to 15 lbs. Purchase From Your Dealer Or Mail Check for Prompt Express Shipment. If Via PARCEL POST have Remittance Include Postage & Insurance Charges, or WRITE us To Ship TYPE desired C.O.D. Other F-F Battery Boosters Charge Batteries From Farm Lighting Plants & D. C. Circuits & for GROUP CHARGING Economy Use Our 8 Ampere 12 Battery Capacity Automatic Full Wave F-F ROTARY RECTIFIER described in ROTARY BULLETIN 34A ORDER Now, or WRITE Immediately for FREE Descriptive RADIO & AUTO BOOSTER & ROTARY BULLETINS 34A & 34
General OFFICES & WORKS: CLEVELAND, OHIO, U. S. A.
Canadian Rep.: Battery Service & Sales Co., Hamilton, Ontario, Canada

FRANCE MFG. CO.

"G.-D." RADIO PRODUCTS

—Order by MAIL and save money. Postage paid on all our goods—any part of U. S. A.

G-D Radio Head Sets



3000 Ohms
\$4.25
Weight complete
12½ ozs.

—Every pair tested, matched and guaranteed as sensitive as \$8.00 to \$10.00 phones. Adjustable, headband, nickel plated; special feature.

SINGLE PHONE, five foot cord.
Price \$2.00.

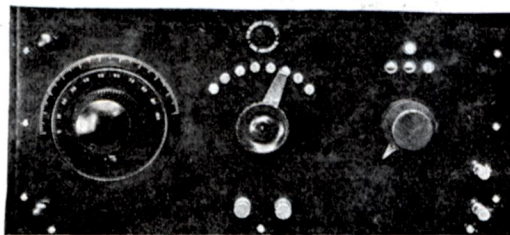

G-D No. 3 Audion Radio Set

—For the clear reception of broadcasting at a greater range—consists of twenty-three plate Variable Condenser—Eight tap tuning unit—Detector Tube—"B" Battery—Mounted on bakelite panel 5½"x12"—With G-D 3000 OHM HEADSET—Price complete, \$25.00. Without HEADPHONES, \$22.00.

G-D No. 2 Crystal Radio Set

—For Selective Tuning—consists of twenty-three plate Variable Condenser—Eight tap tuning unit mounted on bakelite panel, 5½"x9½", base of hard, non-warpable wood—G-D 3000 OHM HEADSET—Price Complete—\$15.00. Without Headphones, \$12.00.

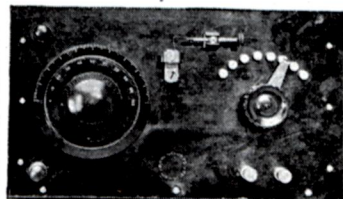

G-D No. 1 Crystal Radio Set

—Practical and efficient. Panel of bakelite 4" x 5½". Prices—SET \$6.00—With Supersensitive single phone, \$7.00—SET complete with 3000 OHM G-D HEADSET—\$10.00.

"Magnetite Radio Crystal"

It Magnifies—Substitute this new marvelous crystal for your old one and hear broadcasting louder and clearer. The most sensitive mineral on the world market. Unaffected by handling or moisture and will render efficient service for years. Price per crystal 50c.

Satisfaction Guaranteed or Money Refunded—Examine the goods we ship you. They must please you in every respect. If not satisfied with purchase return the goods at once and we will refund the price you paid.—Enclose money order or bank draft—currency by registered letter only. Catalogue on request.

GIBBONS-DUSTIN RADIO MFG. CO.

2859 WEST NINTH STREET

LOS ANGELES, CALIF.

SMALL ADS OF BIG INTEREST

A MEETING PLACE FOR BUYERS AND SELLERS

Space in this department costs only 65 cents a line. Minimum space seven lines. Payable in advance.

INVENTORS: Protect your invention through A. M. Wilson, Inc., Washington, D. C. Over 20 years of efficient, expert, confidential service. Skilled in Radio-Electrical, Chemical, and Mechanical fields. Our 1922 Illustrated Booklet, giving much necessary and very useful information which every inventor should know, will be sent free upon request. Prompt and careful attention. Highest references. Moderate fees. Send sketch or model for our careful opinion and preliminary advice. Write today to A. M. WILSON, INC. (Radio 3ARH), 314-19 Victor Building, Washington, D. C. (Successor to business established in 1891 by A. M. Wilson.)

"This is a Radio Christmas"

SALESMEN that have been or are calling on electric or radio trade, see Mr. Rice, 6311 N. Clark St., Chicago.

PATENTS—Send for form "Evidence of Conception" to be signed and witnessed. Form, fee schedule, information, free. Lancaster and Allwine, 289 Ouray Bldg., Washington, D. C.

LIGHTNING—STRANGE BATTERY COMPOUND startles the world. Better than sulphuric acid. Charges discharged batteries instantly. Gallon free to agents. LIGHTNING CO., St. Paul, Minn.



CONTINENTAL

"New York's Leading Radio House"

PARAGON RD—5

and WESTERN ELECTRIC LOUD SPEAKER

This Receiver is capable of amplifying speech or music with the highest degree of clarity and tone quality. Wave lengths from 160 to 510 meters. Paragon RD-5 includes a detector unit in the receiver cabinet. Careful distribution and proportioning of units affords selective and sensitive tuning.

Western Electric Loud Speaker consists of a curved horn and 2 stages of amplification. Three type 216-A vacuum tubes are used, one for the first stage of amplification and two connected on the differential principle for second stage.

"Modern Radio"—a two hundred and eight page catalog of our radio equipment, supplies and apparatus sent for 25 cents.

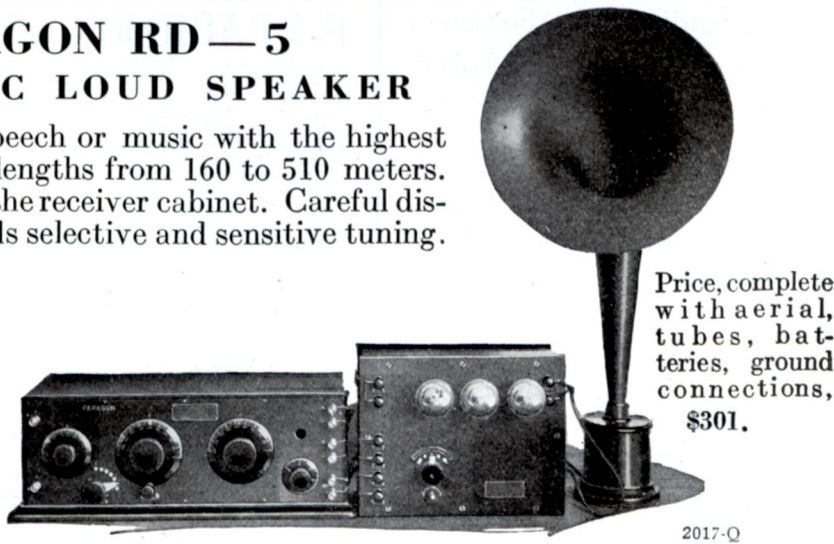

Price, complete with aerial, tubes, batteries, ground connections, \$301.

2017-Q

CONTINENTAL RADIO & ELECTRIC CORPN.

6 and 15 Warren Street

New York, U. S. A.

Advertisers' Index

A-C Electrical Mfg. Co., The.....	98
Acme Apparatus Co.	90
Adams-Morgan Co.	104
Alden-Napier Co.	97, 109
Allen-Bradley Co.	91
American Electric Co.	109
American Hard Rubber Company.....	107
American Radio Exposition.....	109
Andrea, Frank A. D.....	96
Andrae & Sons Co., Julius.....	89
Atwater Kent Manufacturing Company.....	86
Automatic Electrical Devices Co., The.....	105
Brach Mfg. Co., L. S.....	105
Brandes, C., Inc.....	10
Bunnell & Co., J. H.....	108
Burgess Battery Company.....	111
Capitol Phonoller Corp.	95
Chaslyn Co., The	92
Citizens Radio Service Bureau.....	93
Clapp-Eastham Co.	103
Continental Radio & Elec. Co.	110
Copper Clad Steel Company	89
Coto Coll Co.	106
Crosley Manufacturing Co.	3
Cunningham, E. T.	Second Cover
Dayton Fan & Motor Company, The.....	6
Diamond State Fibre Co.	85
Doubleday, Page & Co.	85
Duck Co., The William B.	100
Eby Manufacturing Co., The H. H.	93
European Radio Co.	105
Experimenters' Information Service	84
Federal Telephone & Telegraph Co.	101
France Mfg. Co., The	109
Freshman Company, Inc., Chas.	102, 107
Frost, Herbert H.....	87
General Electric Co.	8
General Phonograph Corporation.....	98
General Radio Co.	104
General Radio Equipment Co.....	109
Gibbons-Dustin Radio Mfg. Co.....	110
Gilmor-Layne Co.	88
Grebe & Co., A. H.	Fourth Cover
Hommell & Co., Ludwig.....	88
Hopewell Insulation & Mfg. Co.	87
Hyman Co., Henry, Inc.	99
Jewell Electrical Instrument Co.	86, 108
Joy-Kelsey Corporation	94
Kellogg Switchboard & Supply Co.	84
Kennedy Co., The Colin B.	97
Klosner Improved Apparatus Co.	13
Knott Machine Co., E. R.	106
Magnavox Co., The	5
Marshall-Gerken Co., The	4
Mattatuck Radio Apparatus Co.	108
Michigan Radio Corporation.....	108
Milliken Brothers Mfg. Co., Inc.....	89
M. P. M. Sales Company.....	91
Mydar Radio Company.....	Third Cover
National Carbon Co., Inc.	15
National Radio Week.....	16
Newman-Stern Co., The	104
New York Coll Co., Inc.	103
Novo Manufacturing Co.	102
O'Brien, Clarence A.	92
Omnigraph Mfg. Co., The.....	111
"O. S. T.".....	94
Pacent Electric Co., Inc.	99
Permanent Radio Fair, Inc.	97
Philadelphia Wireless Sales Corp.....	92
Planet Radio Corporation.....	107
Post Electric Company.....	104
Precision Equipment Co.	100
Radio Corporation of America	1
Radio Directory & Pub. Co.	83
Radio Distributing Co., The	7
Radio Institute of America	11
Radio Instrument Company, Inc.	101
Radio Mica Products Co.	91
Radiovox Company, The	91
Rauland Mfg. Co.	94
Roller-Smith Company	87
Royal Electrical Laboratories	106
Rusonite Products Corporation.....	97
Simplex Radio Co.	105
Standard Electric Sales Co.....	107
Sterling Manufacturing Co.	95
Tait Knob and Dial Company	86
True-Tone Radio Mfg. Co.	87
Universal Sales Co.	92
Wells Mfg. Company.....	93
Westinghouse Union Battery Co.	102
Weston Electrical Instrument Co.	96
Willard Storage Battery Co.	9
Wireless Press, Inc.	12, 14, 102, 105, 108
Wireless Shop, The	94
Y. M. C. A. Radio School	106
SMALL ADS OF BIG INTEREST	110

Burgess, the *Radio Battery* —construction fully patented

When you buy a Burgess "B" Battery you get more than long life, noiselessness, high capacity and moderate price. You get also Burgess special radio construction, perfected by wireless specialists and fully patented! This exclusive *radio* construction is found in no other battery on the market today.

Leading manufacturers of radio equipment specify "Burgess." Burgess "B" Batteries are handled by all progressive jobbers and dealers. "Look for the Black and White Stripes." And if your dealer doesn't handle Burgess "B" just address:

BURGESS BATTERY COMPANY Engineers—Dry Batteries—Manufacturers

Offices and Warehouses at:
CHICAGO, ILL., 111 W. Monroe St. KANSAS CITY, MO., 2109 Grand Ave.
ST. PAUL, MINN., 2362 University Ave. BOSTON, MASS., 136 Federal St.
NEW YORK, N. Y., 50 Church St. MADISON, WIS., Main and Brearly Sts.

In Canada: BURGESS BATTERIES, Ltd.
Winnipeg, Toronto, Montreal

BURGESS "B" BATTERIES "ASK ANY RADIO ENGINEER"



Learn the Code at Home with the Omnigraph

"Just Listen—The Omnigraph will do the teaching"

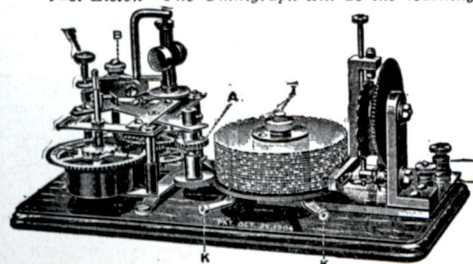

THE OMNIGRAPH Automatic Transmitter will teach you both the Wireless and Morse Codes—right in your own home—quickly, easily and inexpensively. Connected with Buzzer, Buzzer and Phone or Sounder, it will send you unlimited messages, at any speed, from 5 to 50 words a minute. THE OMNIGRAPH is not an experiment. For more than 15 years it has been sold all over the world with a money back guarantee. The OMNIGRAPH is used by several Depts. of the U. S. Govt.—in fact, the Dept. of Commerce uses the OMNIGRAPH to test all applicants applying for a Radio license. The OMNIGRAPH has been successfully adopted by the leading Universities, Colleges and Radio Schools. Send for FREE Catalog describing three models, \$14 to \$30. DO IT TODAY.

THE OMNIGRAPH MFG. CO.
16A Hudson St. New York City

If you own a Radio Phone set and don't know the Code—you are missing most of the fun

Amateur Radio Stations of the United States

Supplementary List brought up-to-date from November WIRELESS AGE

First District

- 1 AJI Alfred C. Blakeslee, 191 Main St., Terryville, Conn.
- 1 AJZ Rienzi B. Parker, 535 Beacon St., Boston, Mass.
- 1 AKD George W. Young, 36 Merrill St., Hartford, Conn.
- 1 AKX Max D. Kreidel, 176 Easton Ave., Waterbury, Conn.
- 1 AKY Stanley Herbeck, 124 Prospect St., Athol, Mass.
- 1 AKZ John W. Mackenzie, 524 June St., Fall River, Mass.
- 1 ALF Andrew Hurnanen, 62 A Street, Gardner, Mass.
- 1 ALH Mass. Electrical Laboratories, Inc., 127 Federal Street, Boston, Mass.
- 1 ALO Bertram F. Pierce, 188 Main St., Malden, Mass.
- 1 ANN James H. Jones, 94 Mass. Ave., Boston, Mass.
- 1 ANS Henry R. Wengen, 22 Armory St., Wakefield, Mass.
- 1 ANU Arthur W. Mayer, 7 Chestnut Square, Jamaica Plain, Mass.
- 1 ANV Edwin D. Rosenwald, 9 Supple St., Roxbury, Mass.
- 1 ANX Harold H. Swain, 78 First Street, Melrose, Mass.
- 1 BZD Earl C. Burdick, 47 Courtland St., Westerly, R. I.
- 1 MY William E. Drew, 324 Central St., Auburndale, Mass.
- 1 MZ Donald C. S. Comstock, 1622 Main Street, East Hartford, Conn.

CHANGE OF ADDRESS.

- 1 FA Harry E. Upton, 55 Chase St., So. Portland, Me.
- 1 FL Wm. A. Gordon, Charles River Rd., Cambridge, Mass.

Second District

- 2 CQC John A. Filkas, 133rd Co. CAC., Ft. Terry, N. Y.
- 2 CQD Winfield G. Beck, 145 Third Ave., Roselle, N. Y.
- 2 CQE Alec. A. Weiner, 2065 80th St., Brooklyn, N. Y.
- 2 CQF John A. Lucas, Fishers Island, N. Y.
- 2 CQG Alfred N. Laurence, Box 53, Laurence, N. Y.
- 2 CQH Richard F. Currey, Main St., Milburn, N. J.
- 2 CQI Frederick E. Dobson, 73 Trask Ave., Bayonne, N. J.
- 2 CQJ Frank Wolf, 145 E. 97th St., New York City
- 2 CQK Harry J. Simpson, 327 E. 158th St., N. Y. City
- 2 CQL Wyman N. Holden, 648 111th St., Rich. H., N. Y.
- 2 CQM Fredsch, J. Winsch, 7 Tossach Rd., Stapleton, N. Y.
- 2 CQN Edward Shepley, 5007 Ave., Brooklyn, N. Y.
- 2 CQO Harold M. Zimmerman, 26 Lyon Pl., Elizabeth, N. J.
- 2 CQP Harold W. Davis, 307 Lexington Ave., Clifton, N. J.
- 2 CQQ W. W. Nitschman, 38 Alexander St., Newark, N. J.
- 2 CQR John A. Schenck, Box 141, RFD No. 1, Glendora, N. Y.

- 2 CQS Clarence A. Glover, Southold, N. Y.
- 2 CQT Charles H. Prindle, South Highland Ave., So. Nyack, N. Y.
- 2 CQU Donald S. MacLeod, Compton St., Belford, N. J.
- 2 CQV Frank C. Bindewald, 31 Snowden Ave., Schenectady, N. Y.
- 2 CQW Charles A. Stay, Bayville Rd., Locust Valley, N. Y.
- 2 CQX Millard V. Everett, Wash. Ave., Highland, N. Y.
- 2 CQY Eric R. Osborne, Water Mill, N. Y.
- 2 CQZ Robert M. Morris, 827 Gross Ave., Elizabeth, N. J.
- 2 CRA Lawrence A. Tuna, 182 Madison Ave., N. Y. C.
- 2 CRB Joseph Goldstein, 1326 40th St., Brooklyn, N. Y.
- 2 CRC Fredk. B. Woodworth, 22 Spruce St., Bloomfield, N. Y.

- 2 CRD George F. Elston, 19 South 13th St., Newark, N. J.
- 2 CRE Fredk. Selmer Olsen, 298 17th St., Brooklyn, N. Y.
- 2 CRF Coleridge M. Hutson, 637 Clark St., Westfield, N. J.
- 2 CRG Chas. Ford Warren, 81 Pierrepont St., Bklyn., N. Y.
- 2 CRH Alfred Oldford, 223 13th St., Bklyn., N. Y.
- 2 CRI Emil H. Kolvenbach, 429 154th St., New York City
- 2 CRJ Edwin H. Ma Dan, 1856 85th St., Bklyn., N. Y.
- 2 CRK Lucien E. Bonduaux, Alex. H. Knights, 1115 Kelley St., New York City

- 2 CRL Joseph Morris, 304 Johnston Ave., Jersey City, N. J.
- 2 CRM William Ahlfeld, 35 West 25th St., Bayonne, N. J.
- 2 CRN Americo Beltrani, 319 East 70th St., N. Y. City
- 2 CRO John J. Escobar, 40 Fourth St., Ridgetfield Pk., N. J.
- 2 CRP Ronald B. Wehrly, 23 East 34th St., Bayonne, N. J.
- 2 CRQ Robert Lee Koerner, 60 W. 190th St., N. Y. City
- 2 CRR Geo. H. Webber, Jr., 1617 N. Y. Ave., Bklyn., N. Y.
- 2 CRS Lement U. Harris, Tuxedo Park, N. Y.
- 2 CRT Karl L. Myers, Wash. Ave., Schenectady, N. Y.
- 2 CRU Clarence George Montgomery, 609 1/2 Park Pl. Ave., Bradley Beach, N. J.

- 2 CRV Newburgh News Ptg. & Pub. Co., 40 Grand St., Newburgh, N. Y.
- 2 CRW Irving Gallagher, 646 Marshall St., Elizabeth, N. J.
- 2 CRX Philip Edgar Zitzmann, 80 Union Place, Ridgetfield Park, N. J.
- 2 CRY North Side Radio Club, John D. Sembler, Opp. Birch Hill Ave., Locust Valley, N. Y.
- 2 CRZ John De Giovanni, 648 Morris Ave., New York City
- 2 CSA Theodore A. Smith, 1011 Ocean Ave., Bklyn., N. Y.
- 2 CSB Edmund Fitz Patrick, 210 Buena Vista St., Yonkers, N. Y.
- 2 CSU Allen B. Du Mont, 60 Walnut St., Montclair, N. J.
- 2 CSD Paul Bernard King, Jr., Cedar Ave., Stony Brook, N. Y.

Third District

- 3 BN Smith, Sewall P., Wynderest Ave., Catsville, Md
- 3 CP Metropolitan Elec. Sup. Co., 45 No. 7th St., Phila., Pa.
- 3 CV Freund, Louis, 1634 N. Wolfe St., Baltimore, Md
- 3 DQ Porter, Martin J., 1628 Federal St., Baltimore, Md
- 3 EQ Frach, Raymond, 5019 Race St., Phila., Pa.
- 3 GA Trout, Clifford C., 533 S. 12th St., Reading, Pa.
- 3 GS Engnost, Milton H., 126 Highland Ave., Balto., Md
- 3 HK Thomas, David, 200 Bethlehem Pike., Ambler, Pa.
- 3 HV Lloyd, Blanchard J., 27 W. County St., Phoebus, Va.
- 3 IF Beacham, Rbt. J., Jr., 129 Linwood Ave., Balto., Md
- 3 IZ Thackeray, Saml. J., 6112 Tulip St., Wismoming, Phila., Pa.
- 3 IU Elliott, Richard G., 1 Red Oak Rd., Wilmington, Del.
- 3 NM Patterson, Robert M., Iona Ave., Linwood, N. J.
- 3 NP Leoser, Thos. S., 30 Altamont Ct., Morristown, N. J.
- 3 SE Deering, James M., River Road., Belvidere, N. J.

- 3 AEX Harbold, Geo. K., Lebanon High School, Lebanon, Pa.
- 3 AGB Reeser, Norman A., 238 E. Philadelphia St., York City, Pa.
- 3 AKV Towell, Richard, 24 N. New Hampshire St., Atlantic City, N. J.
- 3 ALA Stevens, Nelson G., S. Main St., Woodstown, N. J.
- 3 ALC Robbins, Robert F., 5244 Rising Sun Ave., Phila., Pa.
- 3 ALH Boyer, Roswell R., 28 Elcheberg St., Hanover, Pa.
- 3 ALI Thompson, John M., 1706 S. Ringold St., Phila., Pa.
- 3 AMJ Gilbert, Walter E., 125 Ansley St., Germantown, Pa.
- 3 AMN Torris, Samuel S., 1410 Moore St., Phila., Pa.

- 3 AMV Pratt, Horace B., 1918 Bellevue Road, Harrisburg, Pa.
- 3 AOC Rounsley, Kenneth, 2839 Penn St., Penbrook, Pa.
- 3 AOE Treptus, John, 3602 Richmond St., Phila., Pa.
- 3 AOH Geist, Henry J., 4419 Walnut St., Phila., Pa.
- 3 AOI Miller, Robert J., 428 Beall St., Cumberland, Md.
- 3 AOL Smith, Carl T., 1123 Grove St., Richmond, Va.
- 3 AOO Sengpiel, Clarence, 2408 Lehigh St., Phila., Pa.
- 3 AOP Kantro, Reuben, 718 S. 5th St., Phila., Pa.
- 3 AOQ Davis, John A., Jr., 108 N. Morris St., Richmond, Va.
- 3 AOR Werkeheiser, Harlan C., 2212 N. Natrona St., Phila., Pa.
- 3 AOU Graham, Donald W., Atlantic & Monroe Aves., Magnolia, N. J.
- 3 AOW Freidman, Benjamin, 901 S. Cecll St., Phila., Pa.
- 3 APC Fairbanks, Charles R., Monroe & Walnut Aves., Magnolia, N. J.
- 3 APJ White, Harry S., 19 General Green Ave., Trenton, N. J.
- 3 APN Warren, George F., Evesham Ave., Magnolia, N. J.
- 3 APR Owen, Clinton M., Broad Street, South Boston, Va.
- 3 AQC Corson, Harold, R. F. D. No. 1, East Main St., Penns Grove, N. J.

- 3 AQD Camp Roosevelt, B.S.A., Chesapeake Beach, Md.
- 3 AQJ Kieffner, Richard G., 835 Rittenhouse St., Washington, D. C.
- 3 AQM Mead, William N., Berwyn, Pa.
- 3 AQS Chessman, Marcus L., 108 N. Broad St., Penns Grove, N. J.
- 3 AQU Dorsey, Ernest E., 226 Cecelia St., Cumberland, Md
- 3 ARG Black, D. Arnold, 6105 Fourth St., N.W., Washington, D. C.
- 3 ATA Robinson, Samuel A., Coveseville, Va., Coveseville, Va.
- 3 ATP Vitsky, Meyer, 222 North 17th St., Richmond, Va.
- 3 ATI Clayton, Elias B., 1034 Butler St., Chester, Pa.
- 3 AVE Nutt, Stanley O., 2356 Nottingham Square, N. J.
- 3 BCC Banta, Edwin S., 4928 Chestnut St., Phila., Pa.
- 3 BCG Simon, Edward M., Cor. Gay & Walnut St., West Chester, Pa.
- 3 CCR Bewley, Lyburn, 2630 Atlantic Ave., Atlantic City, N. J.
- 3 CCS Farley, William J., 4019 Van Penseiler Ave., Atlantic City, N. J.
- 3 CCT Thornley, Anthony K., 1561 East St., Trenton, N. J.
- 3 CCU Strine, D. S., Emigsville, Pa.
- 3 CCV Morrow, John W., Wernersville, Pa.
- 3 CCW Hocker, C. Reese, 2708 Canby St., Penbrook, Pa.
- 3 CCX Noch, Horace G., 2200 N. Third St., Harrisburg, Pa.
- 3 CCY Thompson, J. Cox, Locust St., Camp Hill, Pa.
- 3 CCZ Rowland, James L., 78 Warren St., Pottstown, Pa.

- 3 CDA Denton, Earl T., 10 S. Church St., West Chester, Pa.
- 3 CDB Brown, Christian F., 413 Christian St., Steelton, Pa.
- 3 CDC Kern, Bertrose B., 361 Main St., Slatington, Pa.
- 3 CDD Durst, William H. K., 133 N. Fanson St., Phila., Pa.
- 3 CDE Geiser, W. Don, 704 Wingochocking St., Phila., Pa.
- 3 CDF Clay, Murray G., 606 Seventh St., Washington, D. C.
- 3 CDG Hersker, John & James, Gomer, 142 N. 50th St., Phila., Pa.
- 3 CDH Easton Radio Co., 404 Northampton St., Easton, Pa.
- 3 CDI Lenox, Robert F., 110 Virginia Ave., Trenton, N. J.
- 3 CDJ H. C. Roberts Elec. Co., 1101-5 Race St., Phila., Pa.

- 3 CDK Hooker, Samuel C., Jr., Mountain Road, Mendham, N. J.
- 3 CDM Willier, Herman, 4211 N. Seventh St., Phila., Pa.
- 3 CDN Stultz, Wilmer L., 636-36th St., Norfolk, Va.
- 3 CDO Lawrence, J. B., Dr., 204 Market St., Harrisburg, Pa.
- 3 CDP Griffin, Andrew G., Jr., 9 Railroad Ave., Penns Grove, N. J.
- 3 CDQ Zandouini, Elizabeth M., 3320 19th St., N.W., Washington, D. C.
- 3 CDR Keys, Thomas H., 323 11th St., N.E., Washington, D. C.
- 3 CDS Frederick, Russell W., 365 Schuyllkill St., Reading, Pa.

- 3 CDT Haus, Paul, Point Pleasant, Bucks Co., Penna.
- 3 CDU Furlong, Melvin, 906 S. Clinton St., Baltimore, Md.
- 3 CDW Huns, Stephen H., 15 Piney Point, Md.
- 3 CDX O'Brien, James W., 1922 Carey St., Phila., Pa.
- 3 CDY Jacobs, Edward M., 7 Mackey St., Cherrydale, Va.
- 3 CDZ Dickerson, Robert, 3122 Barton Ave., Richmond, Va.
- 3 CEA Hill, Harry, 428 Main St., Bedford, Va.
- 3 CEB Eubank, Robert N., 2920 North Ave., Richmond, Va.
- 3 CEC Morton, Russell S., Cor. Broadway & Market St., Salem, N. J.

- 3 CED Reed, Ezekiel C., 18 N. Sovereign St., Atlantic City, N. J.
- 3 CEE Fritsch, Daniel, 708 High St., Lancaster, Pa.
- 3 CEF Manning, Anthony, 2516 Jefferson St., Harrisburg, Pa.
- 3 CEG Kreider, George L., P. O. Box No. 856, Anville, Pa.
- 3 CEH Bekls, Andrew, 207 McKean St., Phila., Pa.
- 3 CEI Sawyer, John L., 211 E. Walnut St., Lebanon, Pa.
- 3 CEJ Fugazzi, Frank, 1389 Quincey St., N.W., Washington, D. C.
- 3 CEK Albright, Arthur W., 1314 L Street, N.W., Washington, D. C.

- 3 CEL Hammond, Gordon, Ashland, Va.
- 3 CEM Miller, John L., Jr., 535 Lemon St., Lancaster, Pa.
- 3 CEN Dolner, J. Paul, 411 W. Main St., Anville, Pa.
- 3 CEO Hautenschild, George, 15 Logan Ave., Audubon, N. J.
- 3 CEP Prosser, Roger D., 512 Madison St., Hackettstown, N. J.
- 3 CEQ Hastings, Laurence E., 1340 Fairmont St., N.W., Washington, D. C.
- 3 CER Breitenbach, Derek S., Tyler Ave., Ballston, Va.
- 3 CES Carmichael, Hilton T., Peddie Institute, Hightstown, N. J.
- 3 CET Westervelt, Edwin 2nd, Hillside Ave., Chatham, N. J.
- 3 BPS Radio Phone Sales & Serv. Co., 5501 Chestnut St., Phila., Pa.
- 3 BVV Bramble, Albert L., Jr., Boush St. & City Hall Ave., Norfolk, Va.
- 3 BTA Hartman, G. Ralph, 440 Mulberry St., Reading, Pa.
- 3 BVD Maciary, Robert W., 101 Washington St., Collingswood, N. J.

- 3 BSG Carl Dillman, 133 W. Lime St., Inglewood, Calif.
- 3 BI George E. Bourne, 859 Washington St., Dayton, Ohio

- 8 BW Samuel Greco, 623 12th Ave., New Brighton, Pa.
- 8 KC Werner K. Sauber, 2985 Coleridge Rd., Cleveland Hgts., Ohio
- 8 QO Robert J. Neff, Valley Pike., Medway, Ohio
- 8 QW W. Stanley W. Edgar, Jr., 347 N. Robert Blvd., Dayton, Ohio
- 8 QX Irving R. Groves, 71a Sheldon Court., Ithaca, N. Y.
- 8 RS Roland F. Meng, 2525 Pingree Ave., Detroit, Mich.
- 8 RW Ralph V. Wood, 1608 Dewey Ave., Portsmouth, Ohio
- 8 RY Arthur C. Bates., Burton, Ohio
- 8 SA Donald Carpenter, Cor. Spring & South Pk., Adams, N. Y.
- 8 SJ John Edw. Coleman, 649 Ridgedale Rd., Dayton, Ohio
- 8 SQ Edward M. George, 434 Earl Ave., Detroit, Mich.
- 8 SS Harry Reans, 1231 Hart Ave., Detroit, Mich.
- 8 SU William A. Hoffman, 7344 Dennison Ave., Swissvale, Pa.

- 8 SX Ralph Balazs, 9001 Buekeye Road., Cleveland, O.
- 8 TE George H. Wilhelm, 705 Fifth Ave., New Kensington, Pa.
- 8 TN Harry L. Wadsworth., Kilton, Pa.
- 8 TX Earl Schwenger, 1834 E. 101st St., Cleveland, Ohio
- 8 UB Frank J. Maslyk, Prospect St., Box 2, Elyria, Ohio
- 8 UI The Radiophone Corporation by Albert B. Allen, 5680 12th St., Detroit, Mich.
- 8 UL Harvey S. Dillenbeck, East Avenue., Avoca, N. Y.
- 8 UN Orland J. Calahrese, 6219 Van Dyke Ave., Detroit, Mich.

- 8 UT Harold L. Hargrett, 352 Walsh Ave., Wilmerding, Pa.
- 8 UU John Churay, 531 Vermont Ave., Glassport, Pa.
- 8 UV Myron Gould, 12542 Clifton Blvd., Lakewood, Ohio
- 8 UY Howard F. Hansell, 611 Yankee Rd., Middletown, O.
- 8 UZ Walter J. Brown., Red Rock, Pa.
- 8 VA Raymond J. Burke, 243 Chestnut St., Akron, Ohio
- 8 VF Clyde Hillman, 2800 Veteran St., N.S. Pittsburgh, Pa.
- 8 VM Justin H. Smith, 1113 N. Park St., Kalamazoo, Mich.
- 8 VP Cecil T. Hall, 423 Edgemont St., Pittsburg, Pa.
- 8 VV Ernest A. Munch, 105 Excelsior St., Pittsburgh, Pa.
- 8 WM Elwood Reese, 230 W. Main St., Plymouth, Pa.
- 8 WQ Harold Wengate, 36 Stone St., Oneida, N. Y.
- 8 WY Samuel W. Townsend, 179 Marvin Ave., Akron, Ohio
- 8 AA Robert L. Osborne, R. F. D. 4, Mt. Clemens, Mich.
- 8 AAE Westinghouse Elec. & Mfg. Company, 1535 6th St., Detroit, Mich.

- 8 AAF Wayne Mason, 421 High St., So. Brownsville, Pa.
- 8 AAP Robert C. Hodges, 917 Oak St., Columbus, Ohio
- 8 AAY George A. Cooke, 127 Gilman St., Marietta, Ohio
- 8 ABA John M. Staude, 119 Quincy Ave., Pittsburgh, Pa.
- 8 ABB John K. Swartz, 1135 Wisconsin Ave., Dormont, Pa.
- 8 ABE Benjamin C. Fidler, 631 Parrish St., Uhrichsville, O.
- 8 ABG Arthur B. Berresford, 116 Summit St., Ithaca, N. Y.
- 8 ABK James E. Terry, 1262 Beach Court., Lakewood, Ohio
- 8 ABL Anthony A. Kiedis, Jr., 1031 Hamilton Ave., Grand Rapids, Mich.
- 8 ABT Melven T. Spence, 202 Reynolds St., Charleston, W. Va.

- 8 ABS Belford C. Angle, Cummings Ave., R. F. D. 2, Conneville, Pa.
- 8 ABW Roy C. Barlow, 1018 Beech St., McKeesport, Pa.
- 8 ACK D. Wenger, 1076 Linden Ave., Dayton, Ohio
- 8 ACL William F. Agee, 829 Gallia St., Portsmouth, Ohio
- 8 ACT Fred E. Welsh 243 Crescent Ave., Buffalo, N. Y.
- 8 ADA Norman H. Gimmy, 13503 Emily St., E. Cleveland, Ohio
- 8 ADB William Buresch, 1726 Smith Way., Carrick, Pa.
- 8 ADC Carl J. Yeager, 225 Hunter Ave., Dayton, Ohio
- 8 ADF Thos. M. Johnston, Jr., 245 Arlington Ave., S.W., Canton, Ohio
- 8 ADJ Clarence H. Hoffmann, 1420 Auburn Ave., Cleveland, Ohio
- 8 AEB Don I. Barringer, 1347 N. Edwards St., Kalamazoo, Mich.

- 8 AED Stephen E. Callahan, 117 W. Patterson Ave., Columbus, Ohio
- 8 AEF Stanley E. Leach, 119-121 Main St., Hamburg, N. Y.
- 8 AEH William F. Lutes, 2709 Lena St., Flint, Mich.
- 8 AEI Frank Balbo, 24 Neff St., Pittsburgh, Pa.
- 8 AEL John H. Fraser, Perrysville Ave., Ben Avon, Pa.
- 8 AEM Arthur H. Denison, 1613 E. 75th St., Cleveland, Ohio
- 8 AEP Edward R. Hughes, 20 74th St., Cincinnati, Ohio
- 8 AFI Edgar Sadd, 1000 Davis Ave., Pittsburgh, Pa.
- 8 AFK William Gage, 155 Bidwell St., Battle Creek, Mich.
- 8 AGA Calvin P. Barie, 173 Washington St., Sharon, Pa.
- 8 AGO Joseph Lathrop, 613 Atkinson Ave., Detroit, Mich.
- 8 AGI Wm. A. Gehegan, Jr., 318 Westview Ave., Lockland, Ohio
- 8 AHC Benjamin T. Wehner, 5900 Margaretta St., Pittsburgh, Pa.

- 8 AHF Franklin A. Selberling, N. Portage Path, Allegheny, Pa.
- 8 AHM Robt. F. Wirsching, 36 Shaw Ave., Dayton, Ohio
- 8 AHN Samuel Calato, 13 Reed Park Ave., Roches, Pa.
- 8 AHO Frederick W. Sullivan, 292 W. Tupper St., Buffalo, N. Y.

- 8 AN Karl Niskanen, 12043 Cloverlawn Blvd., Detroit, Mich.
- 8 AT Eldridge J. Dickerson, 8129 Dexter Blvd., Detroit, Mich.
- 8 BE Jesse J. Francis, 14309 Brook Drive, Maple Heights, Cleveland, Ohio
- 8 BV Clyde W. Thorpe, Washington Ave., Cobleskill, N. Y.
- 8 IQ A. S. Baehel, 151 Garman Rd., Akron, Ohio
- 8 JX John Becker, 2662 E. Congress St., Detroit, Mich.
- 8 VL Raymond E. Deemer, 2806 York Ave., Cleveland, Ohio
- 8 AOR Harry I. Bastyr, 5th & Park Ave., Dunkirk, N. Y.
- 8 AQG Vincent C. Hemophy, 119 Garfield St., Rochester, N. Y.
- 8 ASH Warren L. Fisher, 738 Hazel St., Akron, Ohio
- 8 AXB Austin Hubner, 347 W. McMillan St., Cincinnati, O.
- 8 BXY George W. Fischer, Jr., 195 N. Front St., Cuyahoga Falls, Ohio
- 8 BFR Frank A. Nelson, 31 W. Grace St., Bedford, Ohio
- 8 BKX Clarence A. Ramsey, R. F. D. 4, Youngstown, Ohio
- 8 BLD Fred J. Gerber, 399 W. Delavan Ave., Buffalo, N. Y.
- 8 BMF Edgar H. Wilson, 1201 Bealle Ave., Wooster, Ohio
- 8 BOZ James M. Moran, 1532 Columbus Ave., Sandusky, Ohio
- 8 BPI Albert J. Kappes, Race St., Waynesburg, Pa.
- 8 BFL Samuel J. Hutchinson, Jr., 1914 Delaware Ave., Swissvale, Pa.

- 8 BVP Oscar Piletz, Jr., 11307 Fairport Ave., Cleveland, O.
- 8 CHI F. Eugene Maguire, 529 S. Huron St., Wheeling, W. Va.
- 8 CHP C. B. Delaney, 209 Spring St., Marietta, Ohio

Sixth District

Eighth District

- 8 BHP George E. Bourne, 859 Washington St., Dayton, Ohio

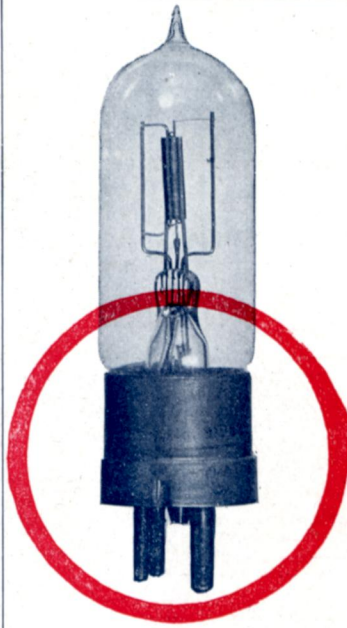

BURKE

SOCKET

ADAPTER

PATENT APPLIED FOR

FOR
WD-11 1½ Volt Tube

Takes but
three seconds
to attach

No change of
hook-up necessary

Fits any standard
open base socket with
flat contact springs

\$ **1** **00**
EACH

DOES NOT RAISE THE TUBE

Ask Your Dealer First

If he can't supply you send his name
and full remittance to



849 Broad Street

Newark, N. J.

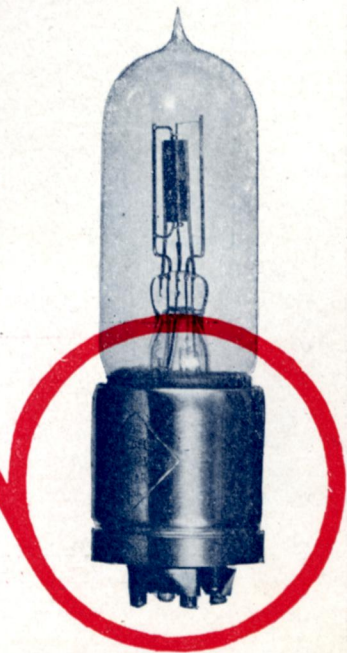



"Let the Instructed Lead the Way"
—Said Kang Hsi.

The Wise Radioist sets the example with
the Grebe Receiver.

Doctor Mu.

A New Record— Coast to Coast

FROM 5.20 to 5.45 A. M. Eastern Standard Time on the morning of November 15, 1922, Mr. Harry H. Carman, 2EL, Freeport, Long Island, N. Y., and Major Lawrence H. Mott, 6XAD, Catalina Island, Cal., maintained two-way radio communication. The air-line distance is approximately 2,600 miles and is *over land*.

We congratulate Major Mott and Mr. Carman upon their achievement. We are pleased to know that Grebe Receivers played an important part in this radio communication, station 6XAD being equipped with a Grebe CR-5 Receiver while the receiver at 2EL is a Grebe CR-3.

Ten Years' experience in satisfying the most critical radio buyers—the dyed-in-the-wool Amateurs—has taught us how to build Grebe Receivers.

Station 6XAD, Catalina Island, Cal., with GREBE
CR-5 Receiver

Station 2EL, Freeport, L. I., N. Y., with GREBE
CR-3 Receiver

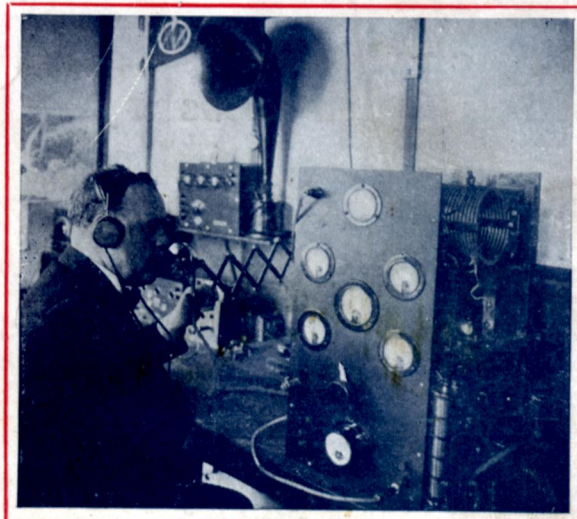
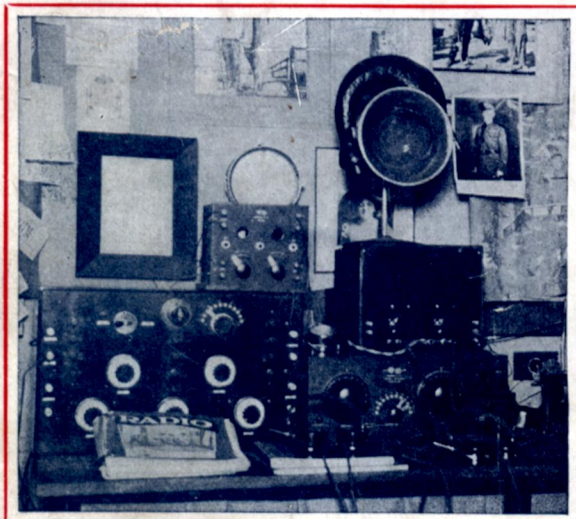

Get your copy of "Musings of Doctor Mu"—the interesting story of the development of Grebe Receivers.

Address Dept. W.

A. H. GREBE & COMPANY, Inc., Richmond Hill, N. Y.