

The "America's Foremost Radiophone Review" October 25 Cents.
WIRELESS AGE



What of Political Broadcasting?

THROUGH PRISON WALLS
 RULING INDIA BY WIRELESS
 BRIDGING THE GAP' FOR THE CABLES
 RADIO A GODSEND TO BLIND MEN
 HOW FRENCH STATION AIDS COMMERCE

HOW GOOD IS YOUR ANTENNA?
 WORLD WIDE WIRELESS NEWS ITEMS
 SUPER-REGENERATIVE CIRCUIT TUNING
 PLAYER BOARD FOR WORLD SERIES BASEBALL
 MOST POWERFUL VACUUM TUBE EVER CONSTRUCTED

Complete Directory of Broadcasting Stations

ART PICTURES OF BROADCASTING STARS—EXCLUSIVE INTERVIEWS—WIT AND HUMOR

Digitized by Google



RADIO

INSULATORS AND PARTS

ELECTROSE insulation, made in America and used throughout the world, and approved by the United States Government, Army and Navy and commercial operating companies.

ELECTROSE was the insulation selected for use in connection with the first high power transmitters employed in the Navy, the first high power radio traction employed on board a submarine, the first radio equipment to make a record in air craft, the first radio set to fly across the Atlantic, and the recent world's record of long distance commercial telephone transmissions carried out from the U. S. S. America.



No. 4501

No. 4500

No. 4502

No. 4507

No. 6902B
Dia. 1 1/2" length 19"



No. 6905
Dia. 1" length 12"

No. 6902A
Dia. 1 1/4" length 11 1/4"

No. 6906
Dia. 2" length 12 1/2"

No. 6907
Dia. 2" length 19 1/2"



No. 8358
Patented



No. 771



No. 703



No. 818

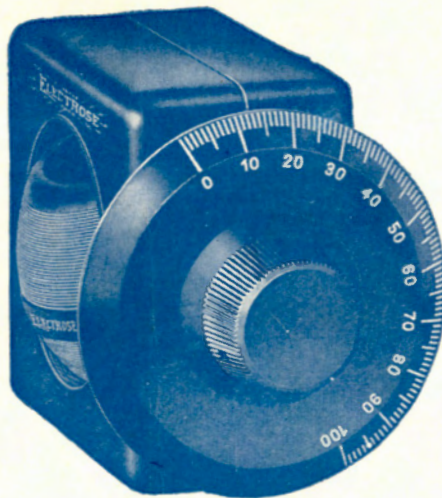

No. 209
Patents Pending



Oct. 1 1/2"
Patents Pending



T 1 3/16"



T 1 5/16"



T 1 3/4"



T 1 3/8"

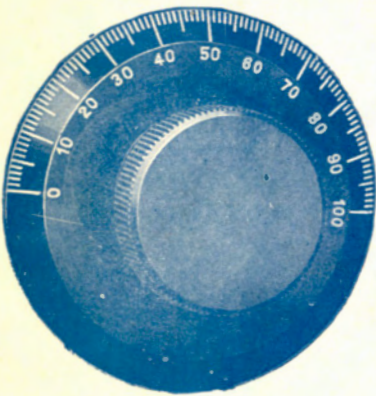

G-4"

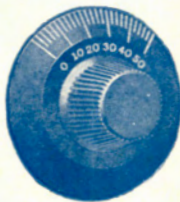

S 2"



L 3"
Patents Pending

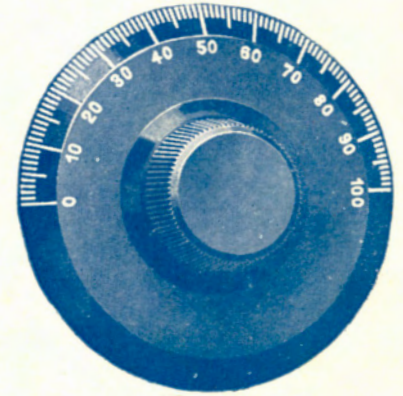

S 4"

"ELECTROSE" RADIO STANDARD PRODUCTS

Panels, sheets, bases, tubes, rods, dials, vacuum tube sockets, variometer rotors and stators, vario couplers, receiver shells and caps, condenser supports, antenna insulators, insulated connectors and bushings, horns, lightning switches, lightning arresters, transmitter key knobs, binding posts, switcharm knobs, dial knobs, and any other style of knobs.

SOLE MANUFACTURERS

ELECTROSE MFG. CO.

60-82 Washington Street
66-76 Front Street

27-37 York Street
1-23 Flint Street

BROOKLYN, N. Y., AMERICA

Globe Commercial Co., San Francisco, Cal., Factory Representatives on the Coast.

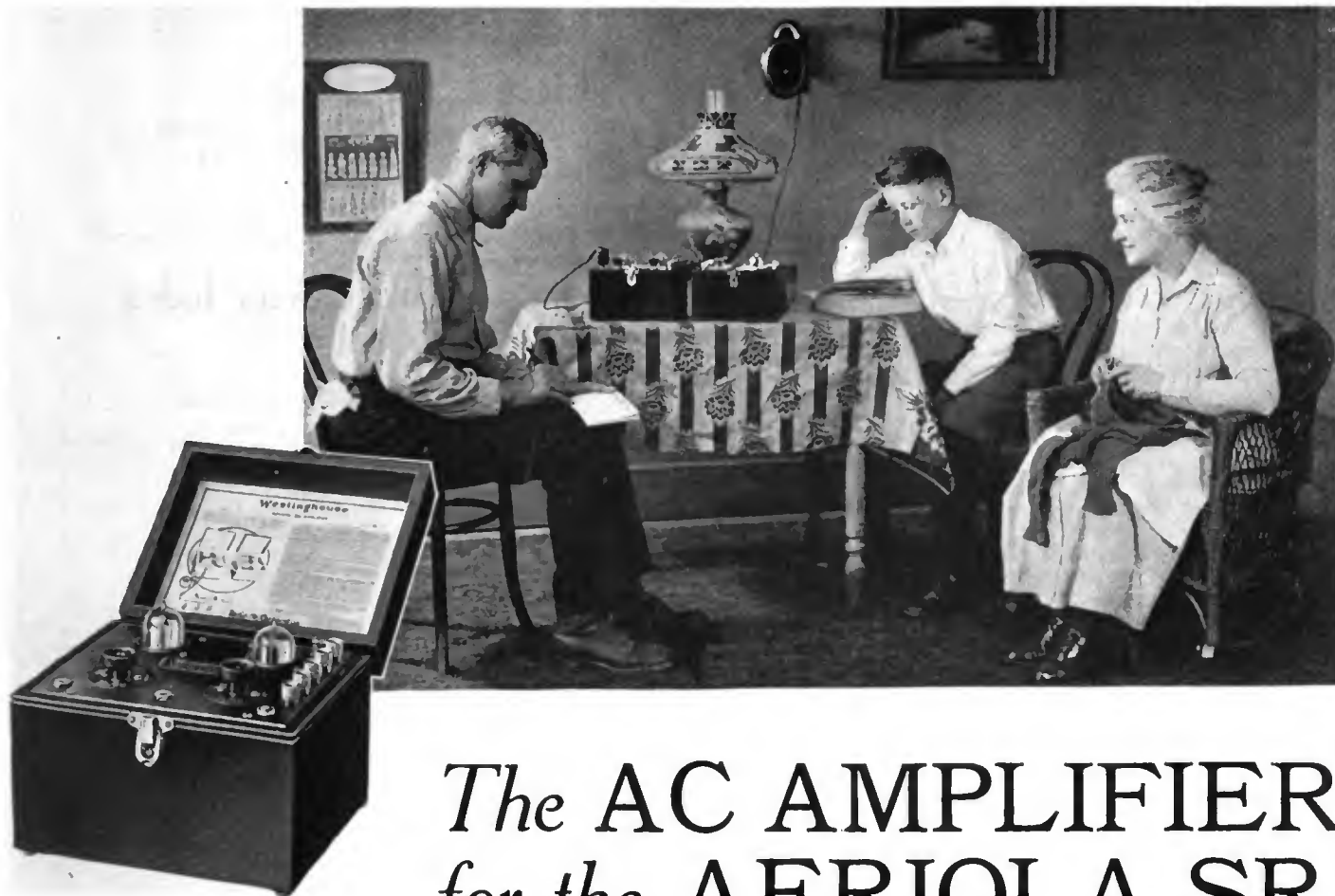

The AC AMPLIFIER for the AERIOLA SR.

AERIOLA AMPLIFIER Model AC

complete with two WD - 11 A
vacuum tubes (without batteries)

\$68.00

VOCAROLA LOUD- SPEAKER

Model LV

\$30.00



*This symbol of quality
is your protection*

*Before buying radio apparatus,
always consult the book,
"Radio Enters the Home."
Price 35 cents by mail.*

The Aeriola Sr., simplest and most efficient of all single-tube receiving sets, becomes still more efficient with the new model AC amplifier.

No storage battery is required. With only two dry cells, two tubes, and a 45-volt plate battery the model AC amplifier greatly increases the Aeriola Sr.'s range of reception. Used with the Vocarola loud-speaker, the amplifier connected with an Aeriola Sr., fills a whole room with concerts received over distances of ten to thirty miles.

Anybody can make the simple connections required, including mother and the girls.

Because there are no storage batteries to charge, because both the Aeriola Sr. and this new model AC amplifier are so light and handy, the combination is ideal for Boy Scouts and for campers.

Radio  **Corporation**
of America

Sales Department, Suite 2064
233 Broadway,
New York, N. Y.

District Office
10 South La Salle St.,
Chicago, Ill.

When writing to advertisers please mention THE WIRELESS AGE

Contents—October, 1922

Cover Design, by O. J. Schulz	
Editorial	17
Pictorial Section	18
Political Broadcasting	26
Radio Penetrates Prison Walls, by Maurice Henle	27
Aileen Stanley, by Edwin Hall	29
Dad Answers When He's Asked, by E. F. Lake	30
Ida Geer Weller, by Claire Burquo	31
Amelia Bingham, by Paul S. Gautier	32
Play Ball! Radio at the Bat!	33
Symphony Concerts on the Air, by St. John Martens	35
Gustave Langenus, by H. N. Lee	37
Japan's Response to Radio's Appeal	38
An Example of Service to the Blind, by Ward Seeley	39
WVP	41
Distant Broadcasting Stations Heard	43
Broadcasting Station Directory	44
New Class of Broadcasting Stations	45
Cartoons	46
Humor	48
World Wide Wireless	50
Radio Communication in India, by S. B. Banerjea	53
Filing Radiograms With Postal	55
The New French Radio Central	56
New Swedish Trans-Oceanic Station	57
Bridging the Gap for the Cables	58
100-Kilowatt Tube Developed Successfully	60
Radio Power Transmission's Improbability, by Dr. Charles P. Steinmetz	63
Short Wave Reception vs. Antenna Resistance, by Samuel Miller	64
A Convenient Change-Over Switch, by Edward W. Vail	68
Advantages of Radio-Frequency Amplification, by B. Bradbury	62
Miniature Warfare Direction by Oklahoma National Guard Radio	69
Good Work by IIV on 10 Watts	70
An Efficient Loop Circuit, by Clyde B. Gardenier	70
Operating Suggestions for Armstrong Super-Regenerative Circuit, by Burton S. Clark	71
December Trans-Atlantic Tests Announcement	71
French Amateur Station 8AB	72
Eliminating Capacity Effects	73
New Appliances and Devices	74
N. A. W. A.	76
Stations Worked and Heard	78
Queries Answered	79
Amateur Radio Stations of the United States (Supplementary List)	111

RENEWALS—When subscription expires you will find a renewal blank enclosed. Return with remittance promptly.

CHANGE OF ADDRESS—Notify us of any change in your address, giving both the old and new location.

PUBLISHED MONTHLY AT WIRELESS PRESS, INC., 326 BROADWAY, NEW YORK
 GREAT BRITAIN 12-13 Henrietta St., London. AUSTRALIA, 97 Clarence St., Sydney, N. S. W.
 SOUTH AMERICA, Florida 524, Buenos Aires, Argentina.

Yearly subscription in U. S. A., \$2.50—Outside U. S. A., \$3.00; Single Copies, 25 cents.
 Entered as second class matter Oct. 9, 1913, Post Office, New York, N. Y., under the Act of March 3, 1879.

Copyright, 1922, Wireless Press, Inc.

E. J. Nalty, Pres. J. Andrew White, Vice-Pres. L. MacConnach, Secy. G. S. DeSousa, Treas.

Owing to the fact that certain statements and expressions of opinion from correspondents and others appearing in these columns from time to time may be found to be the subject of controversy in scientific circles and in the courts, either now or in the future, and to some-times involve questions of priority of invention and the comparative merits of apparatus employed in wireless signalling the owners and publishers of this magazine positively and emphatically disclaim any priority or responsibility for any statements of opinion or partisan expressions if such should at any time appear herein.

Printed in U. S. A.

Advertisers' Index

Acme Apparatus Co.	81
Adams-Morgan Co.	4, 5
Alden-Napier Co.	100
Allen-Bradley Co.	8
American Association of Advertising Agencies	106
American Electric Co.	180
American Radio Exposition Company	105
Andrew, Frank A. D.	18, 11
Artistic Wood Turning Works	94
Atwater Kent Manufacturing Company	94
Audiotron Mfg. Company	114
Automatic Electric Company	105
Automatic Electric Devices Co., The	3
Bogert & Hopper, Inc.	94
Boston Radio Exposition	85
Brach Mfg. Co., L. S.	98
Braden, C. Inc.	108
Bunnell & Co., J. H.	102
Burgess Battery Company	106
Chaslyn Co., The	90
Clapp-Eastham Co.	103
Continental Fibre Co., The	Third Cover
Continental Radio & Elec. Co.	103
Copper Clad Steel Company	80
Coto Coll Co.	107
Crosley Manufacturing Co.	8, 7
Diamond State Fibre Co.	87
Ditagraph Products Corporation	15
Doubleday-Hill Electric Co.	95
Duck Co., The William B.	99
Eastern Radio Institute	90
Eby Manufacturing Co., The H. H.	92
Electrose Mfg. Co.	Second Cover
European Radio Co.	92
Experimenter's Information Service	98
Federal Telephone & Telegraph Co.	97
France Mfg. Co., The	92
General Electric Co.	89
General Radio Co.	98
General Radio Equipment Co.	83
Gilmor-Layne Co.	88
Globe Phone Mfg. Co.	82
Grebe & Co., A. H.	107
Hommell & Co., Ludwig	Fourth Cover
Hopewell Insulation & Mfg. Co.	82
Howard Radio Co.	102
Jenkins, J. E.	108
Jewell Electrical Instrument Co.	98, 102
Joy-Kelsey Corporation	88
Kennedy Co., The Collin B.	92
King Radio Mfg. Company	83
Kleener Improved Apparatus Co.	13
Knott Machine Co., E. R.	90
Magnavox Co., The	91
Manhattan Electrical Supply Co., Inc.	12
Marshall-Gerken Co., The	110
Milliken Brothers Mfg. Co., Inc.	80
National Cabinet Company	90
National Carbon Co., Inc.	15
Newman-Stern Co., The	103
New York Coll Co., Inc.	99
Novo Manufacturing Co.	100
Omnigraph Mfg. Co., The	106
Pacnet Electric Co., Inc.	94
Permanent Radio Fair, Inc.	102
Philadelphia Wireless Sales Corp.	90
Pinkerton Electric Equipment Co.	85
Pitts Co., F. D.	95
Post Electric Company	98
Precision Equipment Co.	78
Radio Corporation of America	1
Radio Distributing Co., The	101
Radio Institute of America	104
Radio Instrument Company, Inc.	88
Radio Laboratories of New Jersey, Inc.	88
Radio Mica Products Co.	88
Radio Shop of Newark, The	90
Radiophone Equipment Co.	90
Roller-Smith Company	84
Royal Electrical Laboratories	86
Rauland Mfg. Co.	83
Ship Owners Radio Service, Inc.	88
Simplex Radio Co.	92
Standard Radio Products	85
Systematic Printing Company	84
Tait Knob and Dial Company	88
Westinghouse Union Battery Co.	100
Weston Electrical Instrument Co.	79
Willard Storage Battery Co.	9
Wireless Press, Inc.	82, 84, 94, 98, 100, 106, 109
Y. M. C. A. Radio School	107
SMALL ADS OF BIG INTEREST	108



HOMCHARGE your Radio Battery for a nickel!

Enjoyable Radio Concerts and maximum receiving range are obtained only when your battery is fully charged.

Don't be bothered with the inconvenience and expense of taking your battery to a service station every few days for recharging.

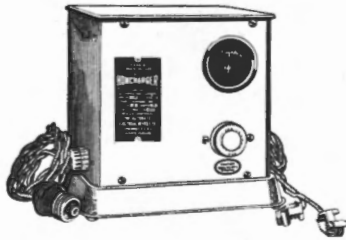

Type "R" (Portable)
Radio Homcharger De Luxe

RADIO HOMCHARGER DE LUXE

has been designed especially for this purpose. It charges your "A" or "B" battery over night without removing it from your living room. The Homcharger is silent and clean in operation—no muss—no trouble—no dirt—requires no watching.

Simplicity itself. Attach to any lamp socket and connect to battery. Fully automatic in operation—cannot overcharge or injure your battery.

Constructed of the best materials—moulded Bakelite Base—Jewell Ammeter—Oversize Silicon Steel Transformer. No castings to break—only the finest stampings used thruout.

SAFE—all parts entirely enclosed—no danger from fire—approved by Fire Insurance Underwriters everywhere. Unconditionally guaranteed—lasts a lifetime

An Ornament For Your Living Room

Beauty has been combined with utility in the NEW RADIO HOMCHARGER DE LUXE. The body is beautifully finished in rich Antique Mahogany—the base and fittings in a handsome dull gold. Equipped with rubber feet, it cannot mar polished surfaces. It harmonizes with the finest living room.

Over 50,000 HOMCHARGERS IN USE

50,000 users have heartily endorsed the HOMCHARGER. Beware of imitations when buying as *there is only one HOMCHARGER. Insist on the genuine which bears our registered trade name, HOMCHARGER.*

Furnished complete with attachment cord and plug, charging cable and battery clips. No extras to buy. Price at all good radio, accessory and electrical dealers, \$18.50, or shipped prepaid upon receipt of purchase price, if your dealer does not carry it.

Booklet illustrating the NEW RADIO HOMCHARGER DE LUXE in actual colors is FREE for the asking. Send for your copy today.

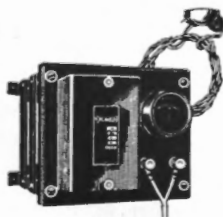

Type "W" Homcharger for
Wall Mounting
Over 50,000 in Use

The Automatic Electrical Devices Co.

119. West Third Street

Cincinnati, Ohio

Largest Manufacturers of Vibrating Rectifiers in the World

BRANCH OFFICES: New York - Chicago - Pittsburgh - Detroit - Dallas - Philadelphia
Los Angeles - Baltimore - Minneapolis - Kansas City - St. Louis - Atlanta.

Which Will You
Judge By—
Results or
Unproved Claims?

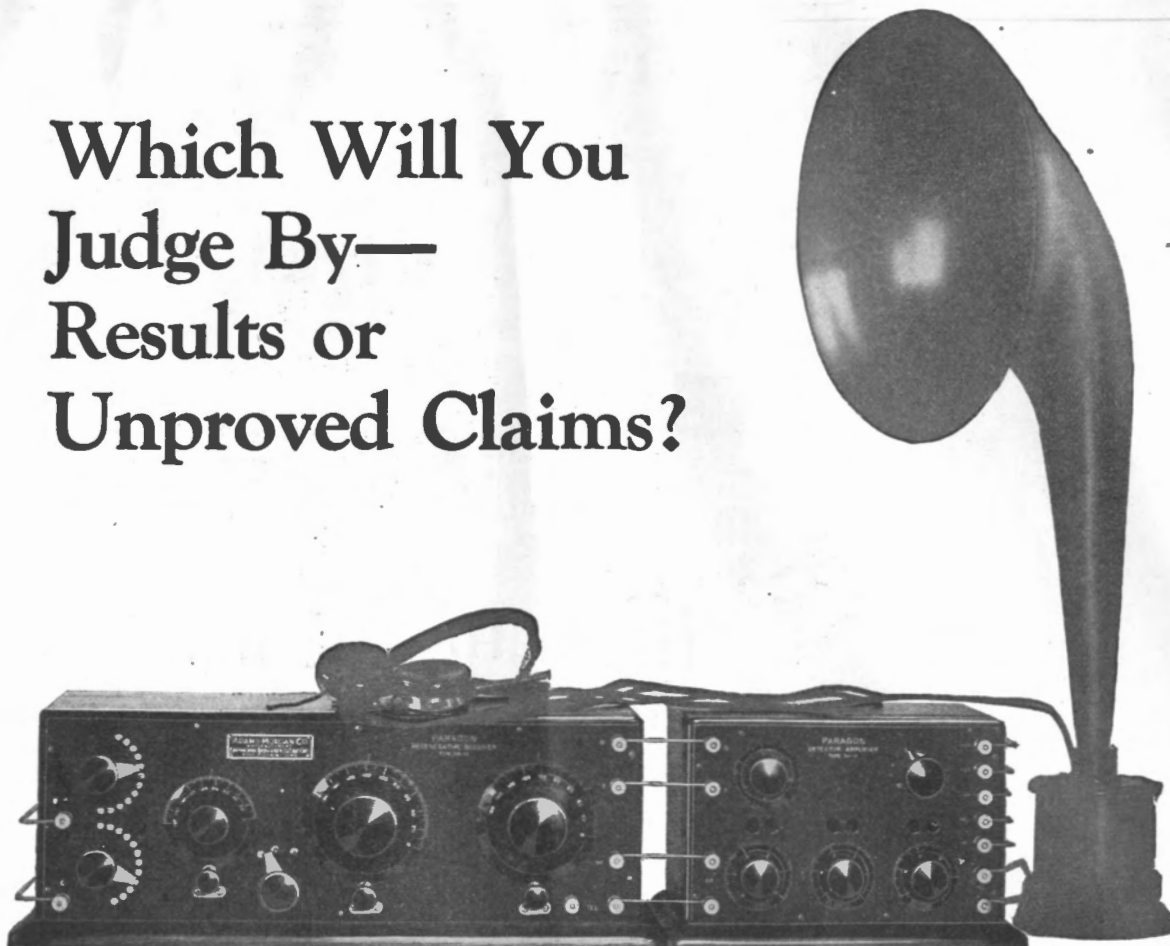

Type R-A-10 Receiver

Licensed Under Armstrong Patents

D-A-2 Detector-Amplifier

Also Manufacturers
of
PARAGON

Radio Telephone
Transmitters
V. T. Control Units
Rheostats
Potentiometers
V. T. Sockets
Amplifier Transformers
Detectors
Control Dials
Amplifiers
Receivers
Switches
Variometers

Paragon Stands on its Record

In 1915 the *first* regenerative receiver, Paragon, was manufactured.

In 1916 Paragon effected the *first* transcontinental reception (not prearranged) from New York to California.

In 1917-18 Paragon receivers, due to greater sensitivity and selectivity, proved superior to all others in interception of enemy signals by the U. S. Army and Navy.

In 1921 Paragon effected the *first* transatlantic amateur reception, registering signals from 27 American amateur stations at Ardrossan, Scotland, a distance of 3500 miles.

In 1922 Paragon Products are a safe investment in a market in which it is difficult to judge values.

Paragon needs no extravagant claims; but we guarantee our customers this:—that Paragon Products are reasonable in price, sound in design and thorough in workmanship.

If your dealer does not sell Paragon Products, send for our catalogue (free) and we will see that you are promptly supplied.

ADAMS-MORGAN CO., 8 Alvin Ave., Upper Montclair, N. J.

PARAGON

Reg. U. S. Pat. Off.

RADIO PRODUCTS

Distortion Kills Music The Curves Show Why

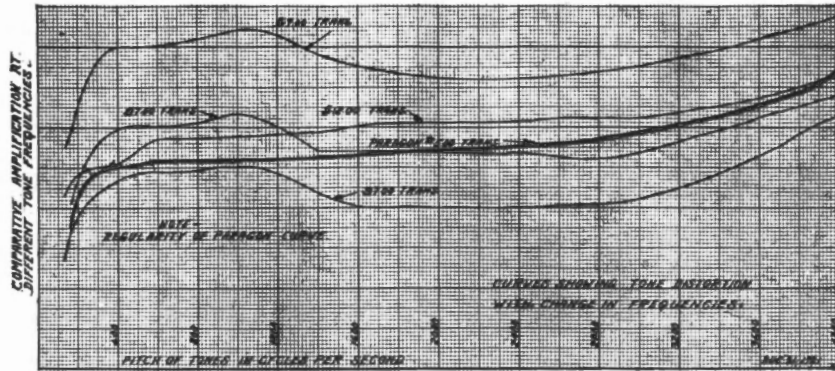

Curves Showing Tone Distortion with Change in Frequencies

Unless the Amplifier Transformer favors *all tones in exactly the same manner*, distortion will result.

Notwithstanding their high prices, some of the transformers

whose curves are shown above are totally unsuited to radiophone reception. When you build use **PARAGON**, the same as is used in the Famous Paragon DA-2 Amplifier.

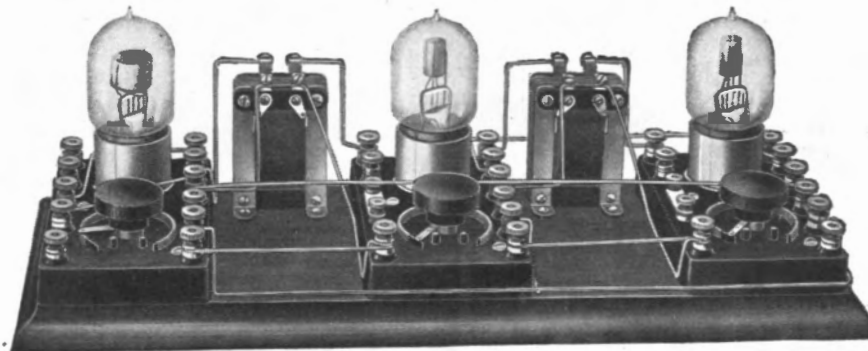

A Home-Built Paragon Amplifier

This illustration shows **PARAGON VT Controls** (Price \$6.00) and the **PARAGON Amplifier Transformer** (Price \$5.00) built into a Detector two step unit. The combination gives you a handsome high-grade instrument, low in price but highly efficient and absolutely without distortion.

PARAGON VT Controls (Patented) may be used to control vacuum tubes wherever they are used as detector, oscillator, transmitter, and in cascade for

radio and audio frequency amplifiers. An extremely useful and good looking unit. Comprises standard socket, famous **PARAGON** rheostat, grid condenser, provision for grid leak and all necessary circuit terminals.

If your dealer does not stock these Paragon Products, we will see that you are promptly supplied. Write for booklet which will tell you the many uses for this efficient and compact mounting.

ADAMS-MORGAN COMPANY, 8 Alvin Ave., Upper Montclair, New Jersey

PARAGON

Reg. U. S. Pat. Off.

RADIO PRODUCTS

When writing to advertisers please mention THE WIRELESS AGE

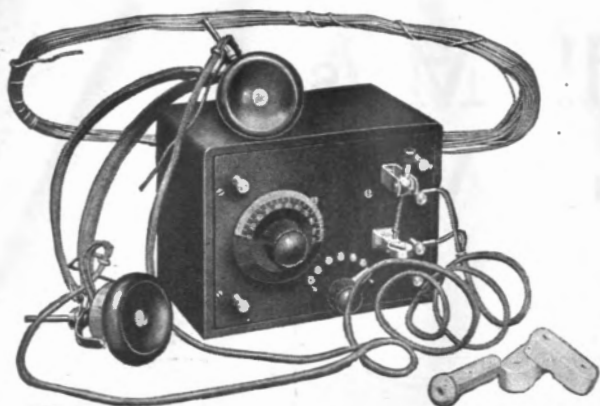

CROSLEY

Better — Cost Less



CROSLEY CRYSTAL RECEIVER MODEL 1. Complete with head phones, antenna and insulators, ready to install without additional equipment. Will receive wave-lengths from 200 to 600 meters and has a range of 25 to 30 miles. Has been known to receive up to 200 miles. Price, \$25.00.

CROSLEY AUDION DETECTOR UNIT is designed to be added to the Crosley Crystal Detector outfit Model 1 or any other type of tuner, eliminating the use of Crystal Detector. Will increase the range of the crystal outfit to about one hundred miles. One user in Minnesota hears Pittsburgh and Schenectady. The combination is equivalent to the Harko Senior. Price, \$7.50.

CROSLEY RADIO FREQUENCY TUNED AMPLIFIER. This unit can be used with practically any type of Audion Detector outfit, and is especially recommended for use with a combination of crystal receiver and audion detector, or Harko Senior Model V. It is the feature of all of our larger units. Being our own design, we are proud of it. The R. F. T. A. not only amplifies the signals before they reach the detector enabling it to work more efficiently, but also makes sharper tuning possible and eliminates interference to a wonderful degree. Will add at least six times the volume and range. Price, \$15.00.



CROSLEY TWO-STAGE AUDIO FREQUENCY AMPLIFIER. With this unit, two stages of audio frequency amplification can be added to any type of radio apparatus. This added to any set will increase the volume about one hundred times. Finished in Adam brown mahogany, it will match up splendidly with any of our other units. Price, \$25.00.



CITIZEN RADIO IS NEW. Few people realize the Manufacturer's problem in building production to take care of hysterical demand of last winter. While the **CROSLEY MANUFACTURING COMPANY**—an old established manufacturing concern—had been engaged in the production of Radio Apparatus for a year prior to the big rush, it was hard pressed to take care of the demand for its Radio Products.

IN SPITE OF THIS FACT, CROSLEY Radio Apparatus has been recognized as the standard of value at moderate cost. And with the aid of an efficient staff of engineers certain additional refinements of details have been effected.

CROSLEY RADIO APPARATUS and Radio Parts, with these refinements, are better now than ever. **CROSLEY** values are even more marked than heretofore, and are truly representative of the manufacturer, actuated by the highest ideals and a sincere desire to give the consumer the best for his money.

DEALERS and JOBBERS are requested to write for literature and booklets describing and illustrating our products in detail.



TAP SWITCH
30 cents

ON THE RIGHT IS SHOWN the assembly of the four above units. This arrangement is equivalent to the **CROSLEY RECEIVER MODEL X** shown on the opposite page. Under normal conditions this set should be able to pick up broadcasting stations over a thousand miles away, yet the combined cost is far below that of any other set of this size on the market.



With the exception of the **CRYSTAL RECEIVER MODEL 1**, the above prices do not include head phones. Nor do they include batteries or tubes.

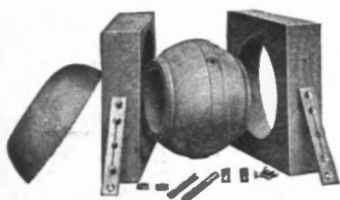

VARIOMETER PARTS
\$1.50 and \$1.75



VARIO-COUPLER PARTS
\$1.50



VARIO-COUPLER
With Knob and Dial
\$3.00

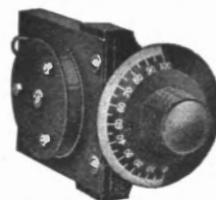

RADIO FREQUENCY AMPLIFYING TUNER
\$4.00



BINDING POSTS
No. 1 5 cents
No. 2 7 1/2 cents
No. 3 10 cents

Two Beautiful Pieces of Furniture

With one stage of radio frequency amplification, audion detector and two stages of audio frequency amplification

Model XX

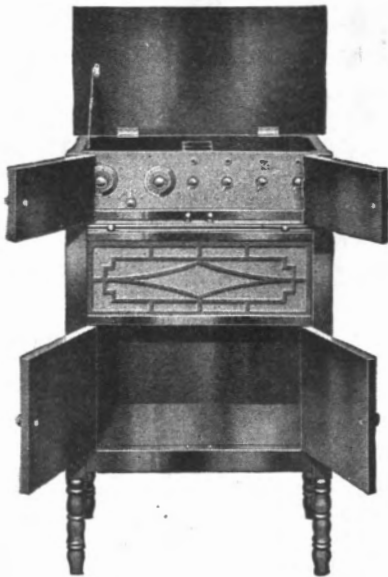

CROSLY RECEIVER MODEL XX. The last word in Radio Equipment design. Comprises a combination of the CROSLY RECEIVER Model X and a highly polished Adam brown mahogany cabinet with loud speaker and receptacle for batteries, charger, etc. Price, \$100.00.

CROSLY RECEIVER MODEL XV. Another wonderful combination. The same as CROSLY RECEIVER MODEL XX with loud speaker but without cabinet for batteries and constructed so that it can be set upon a table. Price, \$70.00.

Model XV

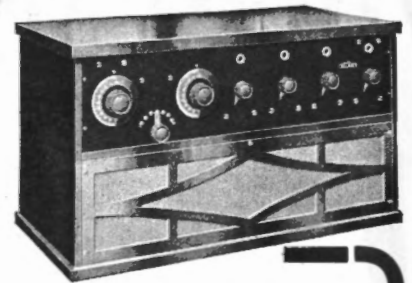

CROSLY HARKO SENIOR MODEL V. A combination tuner and Audion Detector. Will receive broadcasting stations up to one hundred miles. Under favorable conditions a user in Denver has heard Schenectady with this model. Price, \$20.00.

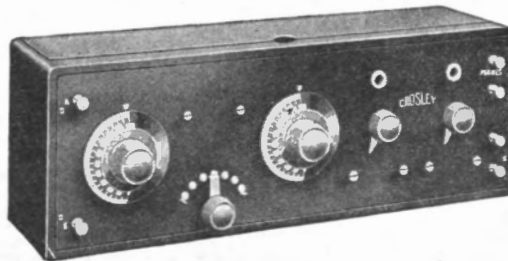

CROSLY RECEIVER MODEL VI. This unit has approximately six times the range and volume of the Harko Senior. It consists of one stage of Radio Frequency Amplification and Audion Detector. It eliminates static to a large extent and distant stations are brought in clear and sharply. Price, \$30.00.

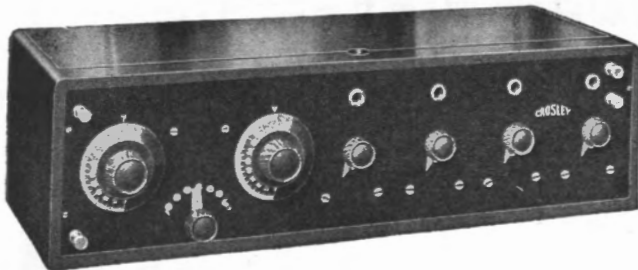

CROSLY RECEIVER MODEL X. In placing this receiver on the market we are offering you a unit whose range, volume and selectivity is remarkable. Nothing can be compared with it at double the price. Developed in the CROSLY laboratories, this unit combines one stage of tuned radio frequency amplification, audion detector and two stages of audio frequency amplification. It is the equivalent of CROSLY RECEIVER MODEL VI and CROSLY TWO-STAGE AUDIO FREQUENCY AMPLIFIER. Price, \$55.00.

Above prices are without head phones, batteries or tubes.

Attractive discounts to Jobbers and Dealers. Write for our new illustrated Booklets and Catalog just off the press.

CROSLY MANUFACTURING COMPANY

DEPT. W. A. 2 CINCINNATI, OHIO



MAGFON LOUD SPEAKER \$10.00

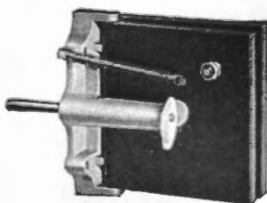

VARIABLE CONDENSERS
Model A.0005 Mfd. \$1.25
Model B.0005 Mfd. 1.75
Model C.001 Mfd. 2.25

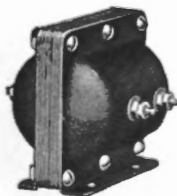

SHELTRAN AMPLIFYING TRANSFORMERS \$4.00

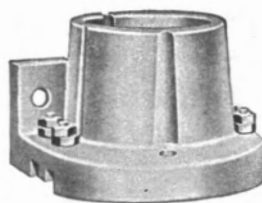

V-T SOCKET \$.50



RHEOSTAT \$.60



KNOB AND DIAL \$.40

Better Adjustment than any Vernier Rheostat

Says *Radio Editor Buffalo Eve. News*



Retail Price
\$1.85
Postage 10c extra



JOHN G. RIEGER
-RADIO EDITOR-

The Secret of Bradleystat Control

A single knob varies the pressure on the two columns of graphite discs.

The change of filament current is so gradual and smooth that no vernier rheostat can duplicate the noiseless Bradleystat. An internal switch protects the A-battery.

The Bradleystat brings louder reproduction, quicker tuning, and a greater range. The adjustment is permanent and precise.

Remember the one-year guarantee and the twenty years of experience behind the Bradleystat. Write for latest bulletin, today!

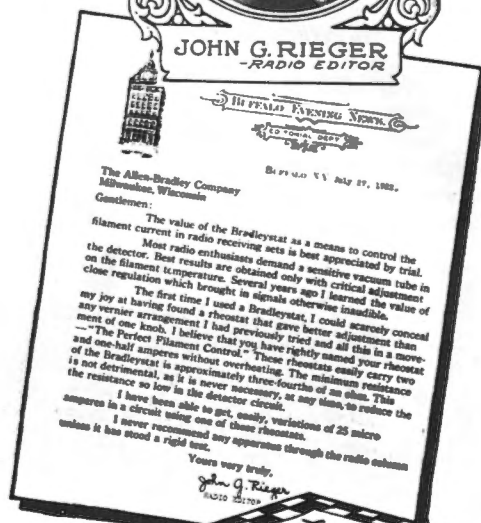

Allen-Bradley Co.

Electric Controlling Apparatus
283 Greenfield Ave., Milwaukee, Wis.

Member of the National Radio Chamber of Commerce



Bradleystat

REGISTERED

U. S. PAT. OFF.

PERFECT FILAMENT CONTROL

When writing to advertisers please mention THE WIRELESS AGE



The Willard Radio "B" Battery with glass jars and Threaded Rubber Insulation is the most practical insurance against leakage noises and leakage losses.

Why Gamble on "B" Batteries?

You're careful in soldering connections. You spend good money for additional stages of amplification. You give special attention to insulation of aerial and lead-in.

If you've gone that far, you simply can't afford to take a chance on having a leaky "B" Battery spoil it all with a bombardment of leakage noises. *You can't afford anything less than a leak-proof Willard "B" Battery.*

Every cell of a Willard "B" Battery is an individual glass jar. Jars are

well-spaced to prevent leakage from cell to cell. Threaded Rubber Insulation protects the plates and thus guards against inside leaks.

Because of the leakproof feature Willard "B" Batteries are unusually quiet and hold their charge for long periods.

Ask your radio dealer or the nearest Willard Service Station to show you the Willard 6-volt Radio "A" Battery and the Willard 24-volt Radio "B" Battery.

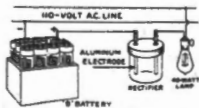

This rectifier will keep your "B" Battery charged at a cost of a few cents a month.

**WILLARD STORAGE BATTERY COMPANY
Cleveland, O.**

Made in Canada by the

Willard Storage Battery Company of Canada, Limited, Toronto, Ontario

Willard

THREADED RUBBER BATTERY

This Fada receiver meets the demand for dependable radio sets within the price range of everyone. Fada prices make it possible for "a radio receiver in every home."

\$35.00

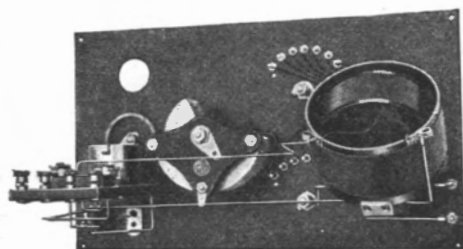
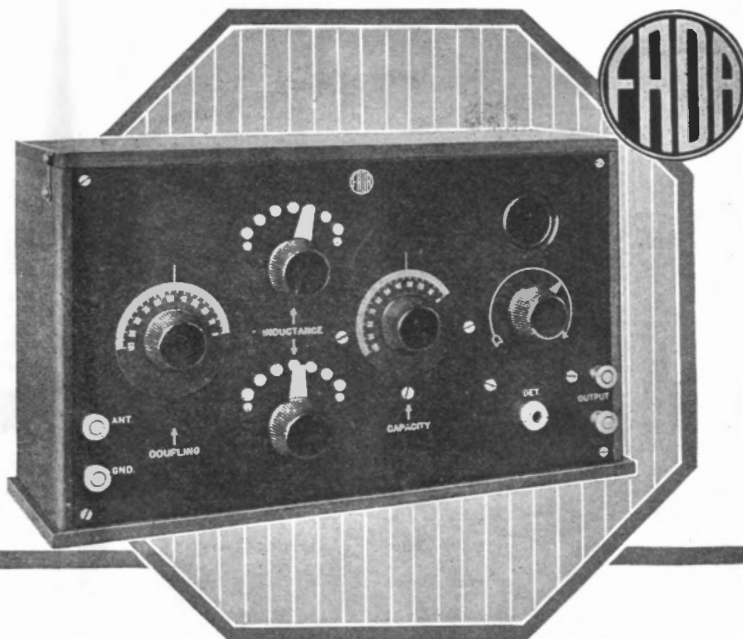

Interior of Fada Receiver

A Fascinating Recreation— Build Your Own Radio Set

That inherent instinct, within us all, to experiment, create and construct, influences many to build their own radio sets.

Fada equipment is so designed to give you the greatest possible reward for your creative efforts. All instruments and parts are definitely simple in construction and unusually easy to assemble into neat, dependable radio sets. Anyone, with the aid of the Fada handbook, can assemble Fada parts with greatest ease and assurance.

Fada detectors, mounted in cabinets with both one and two stage amplifiers hook up with any set, and increase your receiving range. The addition of Fada amplifiers in no way necessitates any change in your original construction. Fada rheostats, variable condensers, switches, vario-couplers, dials, etc. can be used with other equipment to make even a better radio set. Fada parts, if used exclusively in your assembly work, will give you a finished instrument of good appearance and highly satisfactory.

After you once use Fada equipment, you will take great pride in having Fada imprinted on every radio part you use.

Frank A. D. Andrea
1581-C JEROME AVE., NEW YORK CITY

**"Hook on
a Fada
Amplifier—
Increase
Your
receiving
range"**

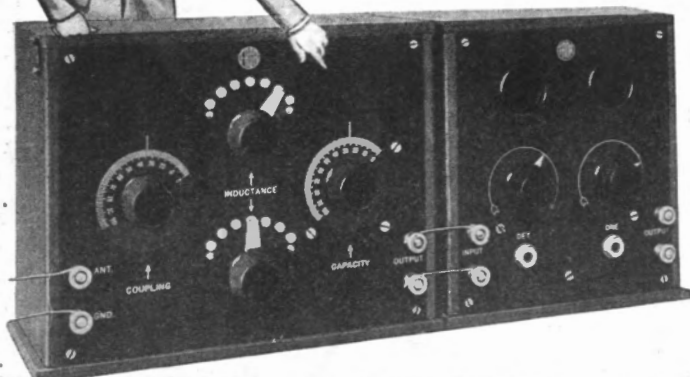

Now \$2.00



Now \$.75



\$4.00



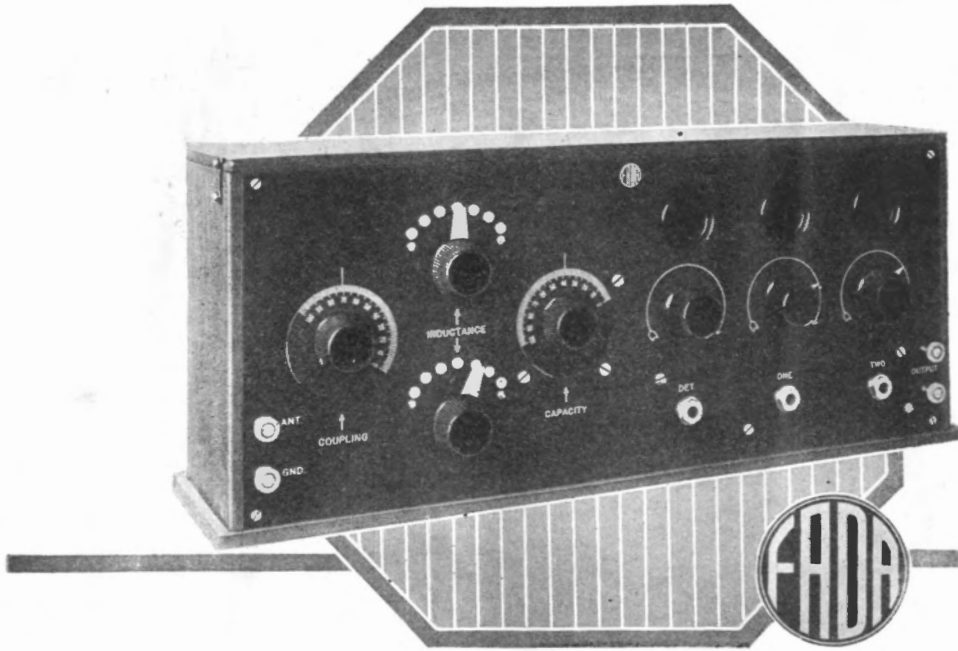

The Fada receiver, detector and two stage amplifier represents the highest type of cabinet construction. A fitting instrument for the finest home and instantly responsive to various receiving ranges.

\$80.00

An Ideal Home Entertainer

The Fada radio receiver, a result of the same perfection in design and construction that distinguishes all Fada products, is gaining popularity as an ideal home entertainer.

When it's radio time in your home, you can sit back in your favorite chair, among the family circle and command at your fingers' touch, the talent of such noted artists as May Peterson, Percy Grainger, Mme. Margaret Namara, or Lydia Lipkowska—Russian coloratura soprano of the Imperial Opera of Petrograd.

You marvel that their voices can come into your home with such depth of emotion and true personality. Music is an inspiration to everyone, it goes to the very soul of things and brings joy and happiness to all.

With a Fada radio receiver music can be made part of your daily recreation. And after the musical program there is broadcasted a digest of important world events. You can, with a Fada receiver, literally keep a jump ahead of the headlines in tomorrow's newspapers.

The new Fada handbook will be sent to you upon receipt of 5c. to cover postage. It's a How-To-Do-It book and you should have it.

Frank A. D. Andrea

1581-C JEROME AVE., NEW YORK CITY

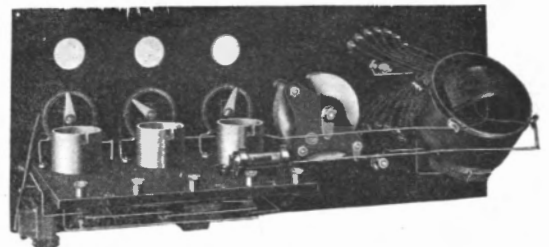

Interior of Fada Receiver, Detector and Two-stage Amplifier

"Let me send you this Fada Handbook."



\$2.00



\$.50



\$2.70



\$1.20

Battery Suitable For Every Use

Red Seal Battery Contest

Starts Nov. 1st Closes Nov. 15th

Battery Suitable For Every Use

All Radio Sets installed FREE in the homes of the winners anywhere in the U. S. A.



Cabinet Closed

1st Prize

This cabinet type complete Radio Receiving Set is one of the finest and most complete sets on the market. It is designed and manufactured by the Colin B. Kennedy Company of San Francisco and St. Louis, makers of the finest type of radio receiving sets. The cabinet is walnut and stands 58 inches high—a masterpiece of cabinet making. The receiving set is regenerative, having an effective range from 175 to 25,000 meters—400 to 600 miles on "broadcasting." Contained within the cabinet are all batteries, and a Magnavox Loud Speaker with special horn. Value complete, \$725.00.



2nd Prize

It consists of the Westinghouse R. C. Receiving Set and Western Electric Loud Speaker, "Tungar" Battery Charger, Storage Battery, 9 "B" Batteries, one Manhattan 2,000 ohm Headset, 3 vacuum tubes, 2 telephone plugs, and complete antenna equipment—a total value of \$408.50.

3rd Prize

A complete receiving outfit made up of the well known Grebe CR-9 Regenerative Receiver and 2 stage amplifier, Magnavox Loud Speaker, Storage Battery, "Homecharger" Battery Charger, "B" Batteries, one Manhattan 2,000 ohm Headset, 3 vacuum tubes, 2 telephone plugs, and complete antenna equipment—a total value of \$256.50.

50 Other Prizes

To 50 other contestants, whose answers the judges decide are most meritorious, will be given one of the famous Manhattan 2,000 ohm Radio Headsets. These headsets are built with the precision of a watch and have great sensitiveness and high amplifying qualities.

Win this \$725.00 Radio Set FREE

Only a rich man could buy it
but a poor man may win it FREE

SIMPLY obtain a free "Red Seal Battery" contest blank between November 1st and November 15th from stores that show the Window Display pictured below. Each contest blank gives full simple instructions to help you write your answer and full rules of the Contest.

Red Seal Battery "Finish-the-Sentence" Contest

The prizes will be awarded for the most appropriate answers for completing *in your own way* in not more than ten words, the following sentence:

- "The Red Seal Dry Battery is best
 (1) because it is the all-purpose battery and
 (2) because

Examples

Your answer may be descriptive of the Red Seal Dry Battery or it may describe some use. For example: "It never fails on land, air or sea." Another: "It never starts what it can't finish." Another: "It rings bells and buzzes buzzers."

Judges

The judges of the Contest are: Mr. Llew Soule, Editor of "Hardware Age," New York; Mr. Howard A. Lewis, Manager of "Electrical Merchandising," New York,

and Mr. Joseph A. Richards, President, Joseph Richards Co., Inc., Advertising Agents, New York.

Awarding the Prizes

Prizes will be awarded to those who conform to the rules of the Contest and whose answers, in the opinion of the judges, are most appropriate. In case two or more persons submit winning answers, prizes identical in character with those offered will be given to each successful contestant.

Announcing the Winners

As soon as possible after the judges have rendered their decision, the names of the prize winning contestants, will be announced in the Saturday Evening Post.

Contest Opens Nov. 1 — Closes
Midnight Nov. 15.

All answers must be written *only on contest blanks* supplied by dealers displaying Red Seal Battery Contest window display. Send as many answers as you like to:

Red Seal Battery Contest
Manhattan Electrical Supply Co., Inc.
17 Park Place
New York City, N. Y.



Look for this Window Display in Dealers' Windows Nov. 1 to 15. It identifies all stores that have free contest blanks.



MANHATTAN

ELECTRICAL SUPPLY CO., INC. NEW YORK
Makers of the Famous Red Seal Dry Batteries
and Manhattan Head Sets



When writing to advertisers please mention THE WIRELESS AGE

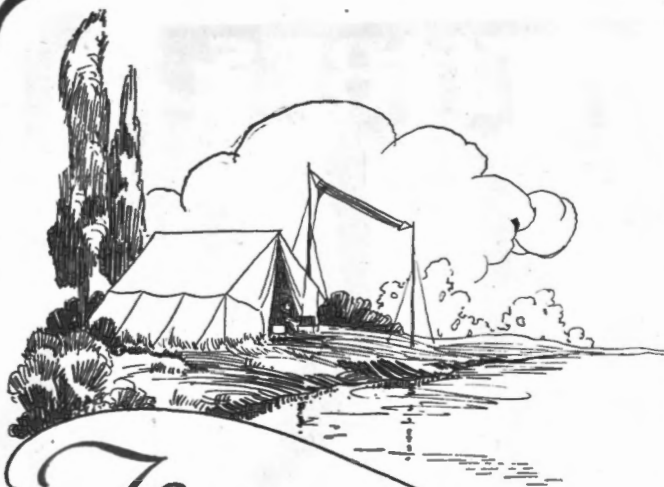

The ideal combination for VT control without the use of jacks or plugs.

We are the inventors and sole manufacturers of the famous Klosner Vernier Rheostat Model 100 still being sold for \$1.50.

Write for interesting literature on the "Amplitrol" and the Klosner Rheostats. Ask for Booklet OB.



Klosner Vernier Rheostat Model 200
PAT. PEND.

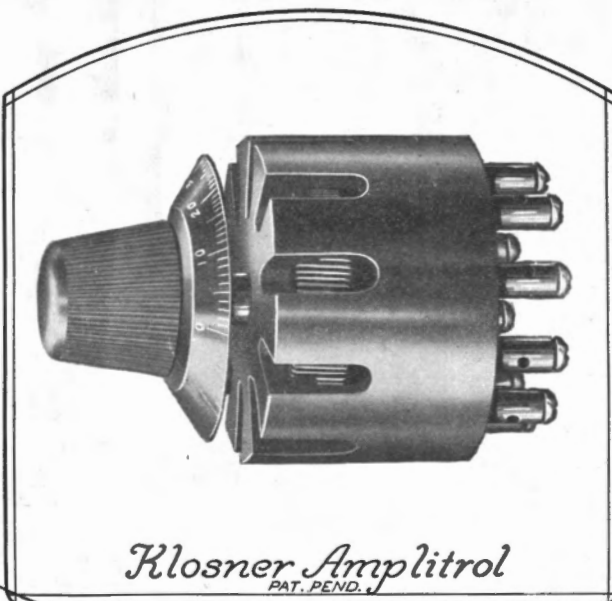

Klosner Amplitrol
PAT. PEND.

THE long looked for has at last arrived. The new Klosner "Amplitrol" fills that long felt radio want—that of controlling the vacuum tube circuit without the use of jacks, plugs or any additional switches. A real radio necessity. Each of your amplifier tubes deserves one. No more plugging in from one stage to the next. Simply attach your phones or loud speaker to binding posts and turn on any stage at will.

The "Amplitrol" not only adjusts the filament to its maximum efficiency, but it automatically controls the plate circuit at the same time, thus eliminating an extra operation. Unlike an automatic filament control, the "Amplitrol" does not put a sudden strain on your filament. It provides a gradual current increase for the filament, thus prolonging its life.

Made of moulded condensite. Contacts of phosphor bronze. Exposed metal parts highly nickel plated. New style tapered knob, and dial correctly numbered in white lettering. Price, \$4.00.

What the "Amplitrol" is to the amplifying tube, so the Klosner Rheostat is to the detector tube. The new improved Rheostat Model 200 embodies some vast changes and improvements. These are too numerous to list, but your inspection will immediately win your approval. The "Amplitrol" and the new improved Klosner Rheostat are the ideal combination for your vacuum tubes. Klosner Rheostat Model 200, Price, \$1.80.

The "Amplitrol" and the Rheostat do not employ the Graphite-Disk principle, but that of wire wound. This feature insures perfect contact at all times, making tuning quicker and louder and giving greater range. See them at your dealers or write for literature.

Klosner Improved Apparatus Co.,
2024 Boston Road
New York City

VACUUM TUBES CUNNINGHAM

*Built
To Give Maximum
Efficiency*

VACUUM tubes are used for two distinct individual purposes in a receiving set—as DETECTORS and as AMPLIFIERS. The qualifications of a tube for these two uses are so different that for maximum efficiency tubes of entirely different design must be used.

This point was one of the chief considerations of the research engineers who designed Cunningham tubes in the great laboratories of the General Electric Company. After years of research and experimental work, the Cunningham C-300, a SUPER-SENSITIVE DETECTOR, and the Cunningham C-301, a DISTORTIONLESS AMPLIFIER, were developed. These two tubes, now nationally recognized as standards for all types of receiving sets, are responsible for the highly perfected results obtainable in radio phone reception.

Amplifies As It Detects

**TYPE C-300
GAS CONTENT
DETECTOR**

\$5⁰⁰

**TYPE C-301
HIGH VACUUM
AMPLIFIER**

\$6⁵⁰

PATENT NOTICE

Cunningham tubes are covered by patents dated 11-7-05, 1-15-07, 2-18-08 and others issued and pending. Licensed only for amateur or experimental uses in radio communication. Any other use will be an infringement



E. J. Cunningham

Trading as

AUDIOTRON MFG. COMPANY

248 First Street
San Francisco, Calif.

154 West Lake Street
Chicago, Illinois

The trade mark GE is the guarantee of these quality tubes. Each tube is built to most rigid specifications.



Eveready "A" Batteries
 —hardwood box, mahogany finish
 —convenient handle, nickel plated
 —rubber feet protect the table
 —insulated top prevents short circuits
 —packed vent caps prevent spilling
 No. 6860—90 Amp. Hrs.—45 Lbs.—\$18.00
 No. 6880—110 Amp. Hrs.—52 Lbs.—\$20.00



Eveready "B" Battery No. 766
 Equipped with 5 positive voltage taps ranging from 16½ to 22½ volts. Fahnestock Spring Clip Binding Posts—an exclusive Eveready feature. Price \$3.00



Eveready "B" Battery No. 774
 Equipped with 6 positive voltage taps at 4½ volt intervals ranging from 18 to 43 volts. Fahnestock Spring Clip Binding Posts—an exclusive Eveready feature. Price \$5.00



For Better Results

USE

EVEREADY
 "A" and "B" BATTERIES

with your radio set

For sale by the better radio supply dealers everywhere

Send today for descriptive booklets

NATIONAL CARBON COMPANY, Inc., Long Island City, N. Y.

Atlanta

Chicago

Cleveland

Kansas City

San Francisco

At Last! *The Perfect* Radio Loud Speaker *for the Home*

Here is the Radio Loud Speaker you have been waiting for! Here is the Loud Speaker that gives you the world's supreme quality at an amazingly low price.

THERE is no other Loud Speaker like the DICTOGRAPH—made expressly for home use by the makers of world-famous Dictograph products—standard everywhere for the finest, most accurate and most sensitive sound-transmission and loud-speaking devices. No other organization in existence has the facilities, the skill, the experience of the Dictograph Products Corporation for producing a perfect Loud Speaker.

A beautiful instrument! Finely constructed, richly finished. Its handsome appearance harmonizes with any home. Highly burnished, French lacquered, eleven-inch spun copper bell horn attached to die cast black enamel tone arm, finished with nickel trimmings. Cabinet 6 x 5 inches base, 4 inches high, of solid, ebony-finished hardwood, mounted upon rubber knobs. Furnished complete with 5 ft. flexible cord. No extra batteries required.



Price
\$20

Complete with 5 ft.
flexible cord.

DICTOGRAPH Radio LOUD SPEAKER

Years of experience in producing the marvelously sensitive "Acousticon" for the Deaf, the Detective Dictograph and the Dictograph System of Loud-Speaking Telephones have made possible this wonderful Radio Loud Speaker that reproduces every sound—singing, speaking, instrumental music—in crystal-clear, natural tones, full volume, and FREE FROM DISTORTION AND NOISE.

The Dictograph Radio Loud Speaker gives perfect results with any vacuum tube receiving set. No alterations; no extra batteries—you simply plug in and listen.

And you pay even LESS for DICTOGRAPH quality than for an ordinary loud speaker. The tremendous demand of radio enthusiasts, volume production and Dictograph resources have made possible a REDUCTION from the price originally announced. Instead of \$25, the price is **ONLY \$20**—complete with 5 ft. flexible silk cord.

Ask for a FREE DEMONSTRATION of the Dictograph Radio Loud Speaker at any reliable radio shop. See why radio fans are so enthusiastic about it. Satisfy yourself that here at last is the perfect Loud Speaker for the home. Get DICTOGRAPH quality and still save money.

The Standard of the World

DEALERS

Order through your jobber or write
for names of authorized distributors



The Best Headset
at Any Price
3000 Ohms

PRICE
\$12.00

DICTOGRAPH Radio HEAD SET

THE Dictograph Radio Head Set has established a standard of quality impossible to secure in any other product. Its use on any receiving set, crystal detector or vacuum tube improves reception immeasurably.

Be sure you get the DICTOGRAPH Radio Head Set—the world's standard of supreme quality for super-sensitive and accurate sound-transmission. 3,000 ohms resistance. Price, \$12—the best Head Set in the world at any price. Regularly furnished as Standard Equipment with the leading Receiving Sets made.

DICTOGRAPH PRODUCTS CORPORATION

220 West 42d Street

Branches in all principal cities

New York City

Eng.
W. J. R.

In Our Opinion

DURING the summer the Newark "Sunday Call," an exceedingly progressive newspaper, which has done many constructive things for radio, undertook an investigation of broadcasting stations listed by the Department of Commerce.

Clarifying the Broadcasting Situation

Information was sought as to equipment, personnel, programmes and hours of operation. Reports were obtained from something like 150 of these stations, or approximately half, so the information furnished undoubtedly can be accepted as representative of the entire broadcasting list.

From the data secured, it is evident that preconceived notions of broadcasting are due for some upsetting.

It has been definitely established, for instance, that one-third of the broadcasting stations seeking to entertain the public throughout the country are endeavoring to do this with sets of a power of 10 watts, or less! Sixty per cent. use 100 watts or less. Only 9 out of the 150 reported power of 500 watts or more, which has recently been officially recognized as the standard power output of a well-conducted broadcasting station.

In many cases the station reported it had no fixed hours of operation, and no programme beyond "canned" music. In a large number of cases the operator was also the announcer and the "feature director."

Two points thus stand out for reflection. One, the inadequacy of personnel and organization to present features to the enormous audiences radio assembles. Second, that in the matter of power the greater proportion of broadcasting stations are inferior to the general run of amateur stations, yet these were prohibited by the Department of Commerce from broadcasting entertainment in favor of the 360-meter stations. There are many amateur stations throughout the country equipped with 200-watt transmitters, a large number of them use 100-watt transmitters, and an untold number—probably a thousand or more—use sets whose power output ranges anywhere from 20 to 50 watts. It is clear that a large percentage of so-called broadcasting stations, operating under the limited commercial station license, are really using only a fraction of the amount of power allowed amateur stations, and in a large number of cases are actually using less power than the amateurs themselves.

In issuing licenses for broadcasting stations previously, the Department of Commerce has apparently gone on the theory of equality, one applicant as good as the next, so long as the radio laws were complied with. As a general rule all applications for licenses for broadcasting were granted. So that today we have over 500 broadcasting stations in constant operation, with more or less resultant interference between them, with time allocation

schedules in effect in many places, the ether pretty well loaded with all kinds and qualities of speech and music—and the end is not yet in sight!

One hopeful indication of clearer insight into the problem of giving intelligent broadcast service to the public, however, appears in the step taken by the Department of Commerce in the creation of a new class of broadcasting stations, to be known as "Class B." A wave-length of 400 meters has been assigned to all in this classification, entry into which calls for compliance with a set of specifications.

These specifications require, among other things, 500 to 1,000 watts power output, with dependable, non-fluctuating power; special modulation; a non-resonant studio and a supervised programme. The use of phonographs or self-playing pianos is to be permitted only in an emergency or during an intermission in the programme.

It is further provided that when two or more stations in a given locality qualify for the new classification and each is contending for priority over the other, the matter will be put up to the listeners, and the Department of Commerce will recognize their opinion and give priority to the station most desired by the listening public.

In creating the new classification for broadcasting stations the Department of Commerce has taken a big step toward clearing up what had become an impossible situation. It is a certainty that the new arrangement is one which will receive the hearty endorsement and full co-operation of the radio industry and the public.

WHOLESONE regard, not unmixed with awe, characterized the first showing of the 250-watt tube, generally known as the "P" type, when it was developed, a few years ago. Only a few persons understood its uses and possibilities, and they held it in such reverence that even burnt-out or inoperative tubes of the "P" type were preserved as prize specimens, to be exhibited proudly and dilated upon whenever occasion offered.

Soon afterward a tube employing 15,000 volts on the plate, with an output of 20 K.W., was developed.

And now the radio world has been startled and amazed by the announcement of the development of a tube with an output capacity of 100 K.W.!

Kenotron-rectified alternating current is used on the plates of all these power tubes of large capacity and their output is evidently subject only to the limitations of the kenotron rectifier tubes, which have not been developed to handle voltages much in excess of 20,000 volts.

When the kenotron has been developed to handle higher voltages it seems reasonable to suppose that power tubes of 200, 300, or perhaps 500 K.W. will follow, with the result that the trans-oceanic transmitting stations of the future will consist of a couple of tubes, a transformer and a loop antenna with the directional properties so clearly demonstrated by Senatore Marconi on his recent visit to America.

There's a vision for those given to speculation about the course of future radio progress!

—THE EDITOR.

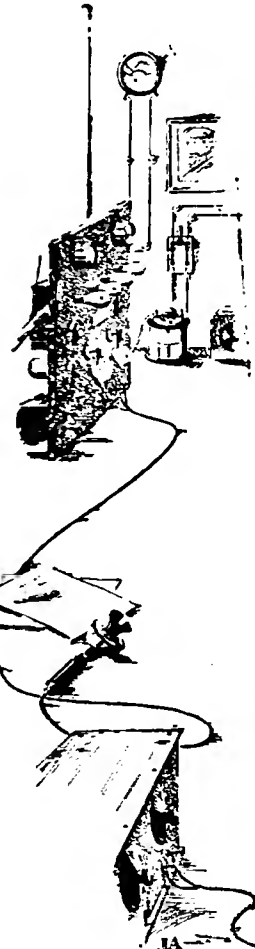



***PROGRESS**, says Aileen Stanley, vaudeville star, is like a big, massive moving Juggernaut—and Radio represents Progress. Her interview is on page 29. She makes many interesting observations*



A MELIA BINGHAM, one of America's most noted actresses regards the coming of Radio as particularly significant. On page 32 she comes deeply serious about Radio and makes comments all should read.



HOW good is "perfect?" And is there such a thing as "perfect transmission of music over the radio telephone?" Gustave Langenus, an accomplished clarinet player, has something to say about these subjects on page 37 of this issue



WHY radio will have a great effect on the children of today, is told on page 31, in an interview with Ida Geer Weller, a recital artist. Miss Weller's motto is "Be Yourself." She is concerned with the welfare of e

Views Showing Radio's Part in the National Life

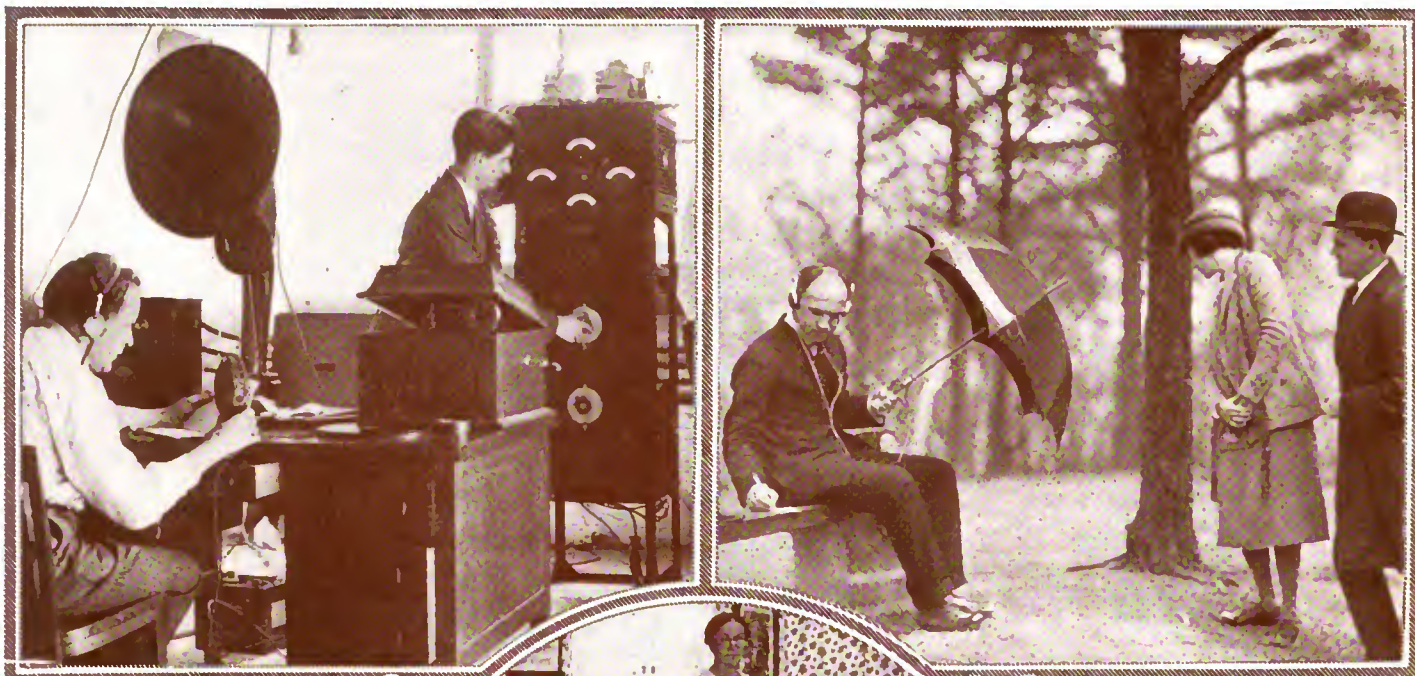

A broadcasting station is a necessary part of the equipment of the new \$5,000,000 Eastman theater owned and operated by the Rochester University, Rochester, N. Y.

Rain or shine, J. B. Taylor, consulting engineer of the General Electric Company, will make this radio umbrella serve a double use at the Mohawk Golf Club, located near Schenectady



The modern radio touch has been added to this famous New York City window display—to illustrate how farmers everywhere receive daily market reports by wireless telephone



Richard E. Williams (second from left) and Miss Valerin Driggers (standing next to him) will tell the world theirs was the first radio wedding. It took place in Tampa, Fla., on a palm-bedecked auto



Experimenting with the teletype, the most recent addition to the Navy Department. It's a wireless typewriter that transmits the written word through the air by punching a key and sending the dots and dashes

Giving Information by Radio to a Listening World

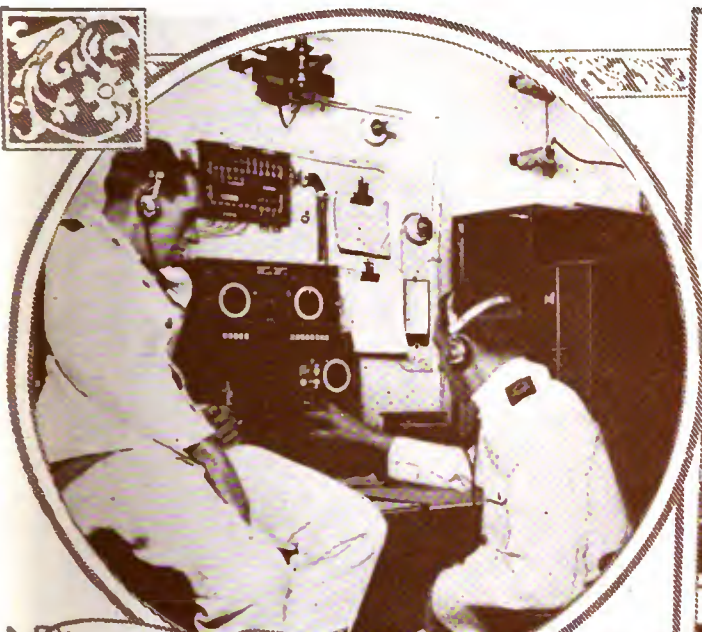

Officers aboard the "Empress of France" at Quebec are in touch with the world



In Washington, D. C., Clifford Grant, detective chief, transmits a daily list of stolen autos to get co-operation from nearby towns



Beth Weber, Chicago, discovered a radio way to play chess with her chum, Miss Rosalind Kendall (above), of New York. Rosalind uses a Jersey City transmitting station to talk back to her friend



Miss Nellie Stevens is helping the New York Police work out a plan to send fingerprints and photos by radio. She's an artist and experienced in visualization



"Little Drops of Water, Little Grains of Sand—"



The dance on the sands has become common to all beaches. It's made possible with radio music, as the photo shows

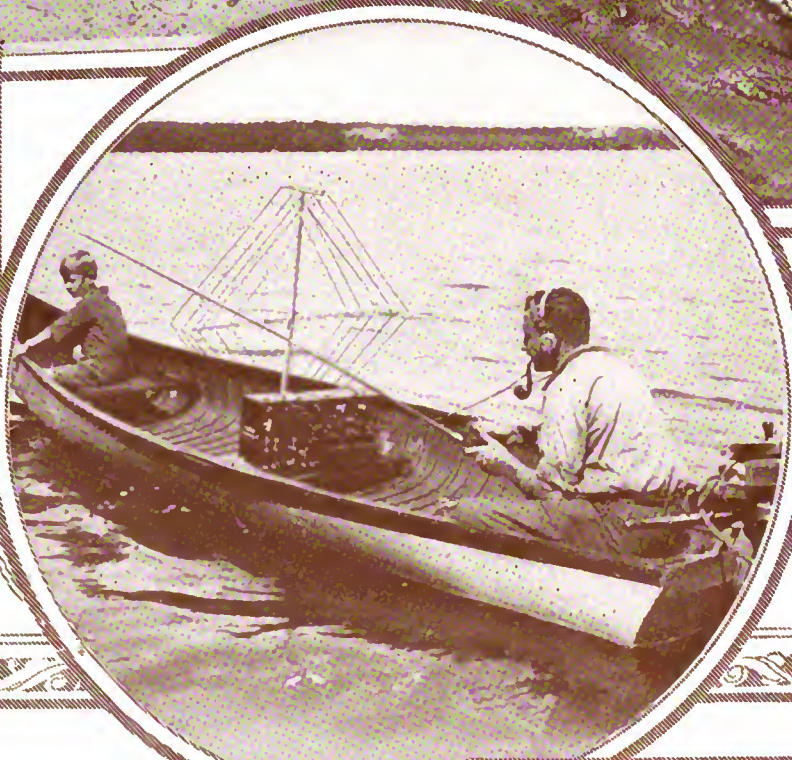

Miss Daisy Crossley tried out her "wireless buoy" at the beach. She says she obtained results, and that's quite enough for us

William Nigey went fishing on the Belgrade Lakes in Maine and added the "modern touch" to pass the hours when the fish were sleeping

Radio's Mystery Always Will Appeal to Children



When both children wanted to listen to the bedtime story, C. D. Wagoner, of the General Electric Co., removed the headband and gave each youngster a phone to hear with



The nine-months-old son of Mr. and Mrs. LeRoy Allain, Cincinnati, surely looks as though he's listening to the angels through the family's set

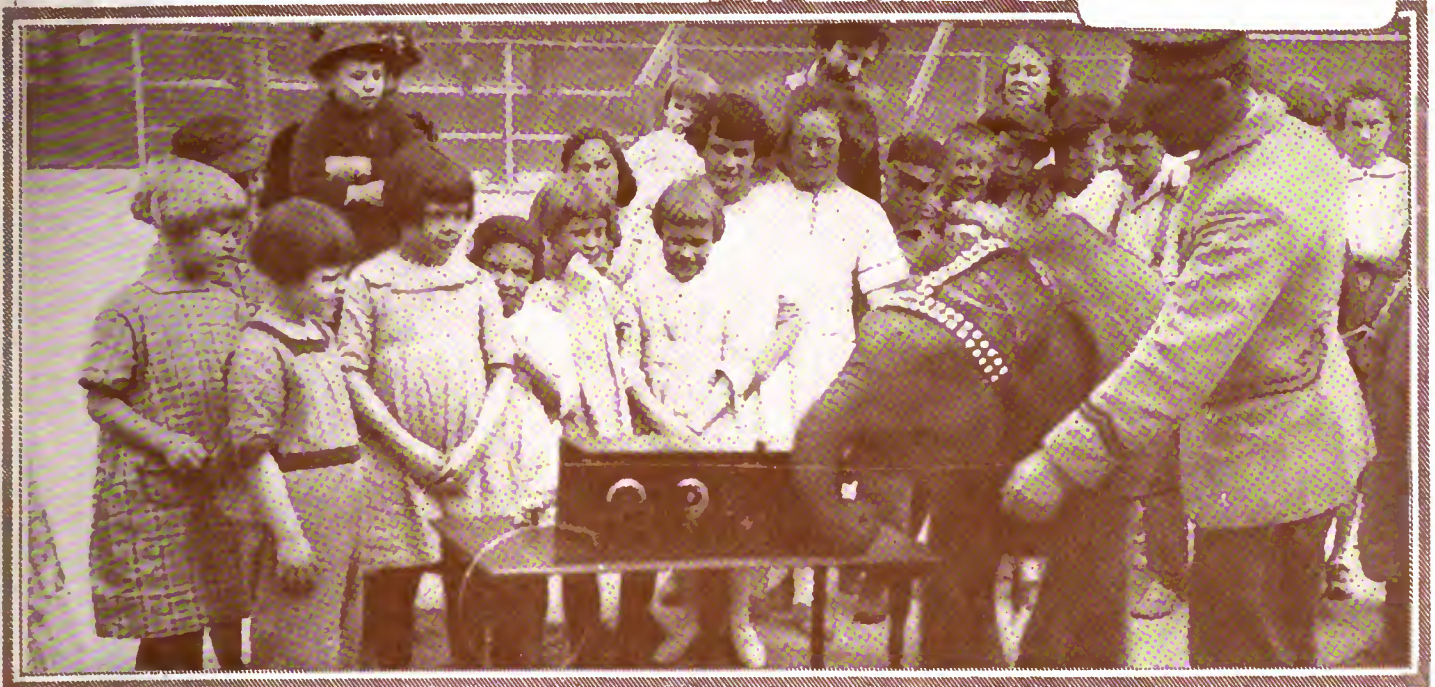

Even Tom Thumb, the baby elephant of Seattle, tried to tune in and catch the latest music and news. Surrounded by Seattle kiddies Tom performs, using his trunk to manipulate the knobs. We can't read his expression and thus don't guarantee that Tom recognized anything he heard. They say he was listening to the call of his mother—perhaps



Radio Makes Better Citizens

MRS. SMITH-BROWN says: "Politics is—or should I say 'are' tee hee—just too stupid for anything. One paper says its candidate ought to be elected, and another says the same thing about another man. I just can't read about politics at all."

How is Mrs. Smith-Brown—there are millions of women like her—to know what the real political issues are? How is her husband (millions are like him, too) to get his information, upon which the family's votes can be cast intelligently?

Just as they always have secured most of their information and formed most of their opinions—by word of mouth.

Nothing can replace the spoken word, the personal appeal. That is why President Wilson, campaigning for the League of Nations, made his tour of the country addressing enormous audiences.

If he had had the radio telephone at his service, he could have spoken to the majority of the voters, at no more effort than that required to talk into a telephone at the White House. He would have been spared the effort that brought on his physical collapse.

Equally, Senators Lodge and Borah and other Republicans opposed to the League, could have delivered their words directly into the ears of the same country-wide audience. And instead of partisan prejudice, as imperfectly reflected in the newspapers, the citizens, men and women, would have had the facts and opinions of each side direct from the mouths of the leaders.

No vital issue can be decided fairly in this country henceforth without the use of the radio telephone.

Radio can carry into the home nothing more important than the truth about those vital issues to decide which is to determine the course of this greatest of countries.

It has been claimed that Rome fell because her empire grew beyond reach of Roman methods of communication. It was too big for politicians to weld together by speeches, and there were no newspapers, because printing had not been invented and few people could read, anyway. There was no radio. If the radio telephone had existed in A.D. 200, perhaps we would all be Roman citizens today!

Instead, we are American citizens. The loss is Rome's and the gain ours.

Ours is the radio telephone, and ours the better citizenship that it makes possible.

Radio Penetrates Prison Walls

Sing Sing Chapel Now Equipped for Wireless Telephone Reception—Prisoners Show Enthusiasm—May Be Installed in Prison School

By Maurice Henle

"STONE walls do not a prison make
Nor iron bars a cage—"

THESE lines ran through my mind as I walked down the road beside the gray walls of Sing Sing prison, on my way back to the little railroad station at Ossining, New York.

I had just paid a visit to the famous penitentiary in order to ascertain what part, if any, the radio telephone was playing in modern prison life, and what its relation would be to such life in the future.

The prison itself, including its immense yard with its tennis courts, baseball field with grand stands, and walks, occupies approximately three acres of ground. It is well situated between the New York Central Railroad tracks and the Hudson River. So close is the river that were an inmate to scale the western wall he would almost drop into the water itself. On each of the four corners of the wall that surrounds the entire structure and grounds, there is a tower, and in each of these towers during every hour of the day and night sits a sharp-eyed sentinel with a rifle. Attached to the prison itself on the extreme southern end, is the home of the warden, General Lewis E. Lawes, and the lawn in front of his house is covered with a beautiful carpet of grass and flowers.

The whole aspect as seen from the outside seems to be utterly peaceful and only the iron bars of the grim prison buildings show that here is a place where society confines its outcasts.

RADIO IGNORES MAN'S LAW

It is a world apart, a world within a world, a world that watches every move of its residents, who, from the time of their admittance until they are discharged, are completely cut off from their fellow men with the slight exception of infrequent visits from relatives.

But the laws of nature recognize no man-made barriers and prison bars do not stop the messages sent through the air by the radio telephone. Music, speeches, and all the entertainment that is being enjoyed by hundreds of thou-



Read what joy the radiophone brought to one prisoner, as reported in the New York "Globe"

sands of free citizens penetrate the prison walls just as easily as they enter the homes of law-abiding people.

Radio re-establishes the contact between society and the prison.

Only within the past few weeks has the radio telephone made its bow in Sing Sing. A splendid set with radio and audio frequency amplification and a Western Electric loud speaker has been installed in the chapel of the prison, the immense room that seats at one time the entire prison population of 1,200 men.

Warden Lawes said that as yet radio activity in the prison is largely in the nature of an experiment.

"What the future will hold," Warden Lawes explained, "is difficult to predict. The radio telephone cannot be an instrument for anything but good and for that reason, if no other, every effort will be made to find its permanent place in prison life."

"I believe," he added, "its greatest value will lie along mass educational lines. The men hearing addresses made by prominent persons in many different parts of the country will gain valuable instruction. The music that is broadcast is of the better type and it, too, will enable the men to form a new viewpoint.

"After all, it is a human problem with which we are dealing. Prisoners are no different from other men, essentially. They have broken laws, that is all, and it is society's duty not only to punish by locking them away, but at the same time to prepare them during their incarceration for their return to the normal world. If the man lacks a knowledge of the better things of life, then it is society's duty to educate him to know and desire them."

The Sing Sing apparatus was installed shortly before the broadcasting of the Benny Leonard-Lew Tandler championship boxing exhibition in New Jersey, and although this was merely a coincidence, Warden Lawes eagerly seized upon the incident as a striking means of introducing radio to the prisoners.

PRISONERS "SOLD" TO IDEA

He utilized the boxing exhibition for many reasons. Primarily the radio telephone will be used, as he explained, for mass education. But he knew that only a small percentage of the men understood even the fundamentals of radio, or for that matter, had ever heard anything transmitted through the air. Here, then, was an opportunity of "selling" radio to the men, and selling it in such a thorough way that later on, when the sermons, music, and addresses came through the men would be eager to listen.

The broadcast boxing match, therefore, served not only as a prison recreation, but as an impressive introduction of radio to the prisoners, most of whom had been previously ignorant of the latest contribution of electrical science to modern life.

"Of course," concluded the warden, "when I say that in my opinion the radio telephone will benefit the prison primarily along mass educational lines. I do not mean to infer that this is the only use to which it may be put. For instance, I plan to give occasional radio concerts in the Death House, where the condemned prisoners await electrocution. Also within the prison we have a school, and how the radio telephone will find a place there may just as well be outlined to you by Mr. Henzel, who is the civilian in charge of that school."

Without question, the most important phase of Sing Sing's corrective work is the prison school. When a man is committed, officials soon find out exactly how much he knows. Many times a lack of proper education, or of any education at all, was responsible for the faulty step he took.

As Mr. Henzel, who is a very young man, said:

"It is believed that men who have pursued the course of instruction in Sing Sing faithfully will be in a position to sense some of the finer things of life.

"Possibly a few who were slaves of ignorance and impulse may become seekers after the light, and finally masters of their fate. Such is the aim of all true education, and, in the final analysis, the sole function of the prison school."

Mr. Henzel was interested, to say the least, in the subject of radio and its application to the school. He was, in fact, hungry after information, and the interviewer for *THE WIRELESS AGE* soon found himself in the role of the one being interviewed. At any rate it was a liberal exchange of views.

There are six "standards" in the school. A "standard" corresponds to the class year of an ordinary school, with the exception that it is but sixteen weeks in length. A permanent record is kept of the student's progress.

The syllabus of the first four standards is designed for an intensive course in practical English as distinguished from academic or cultural English. It aims to teach the fundamentals of speaking, reading and writing the language, so as to satisfy the student's immediate pressing daily needs.

To be able to communicate his thoughts in understandable English speech, to be able to write a simple and

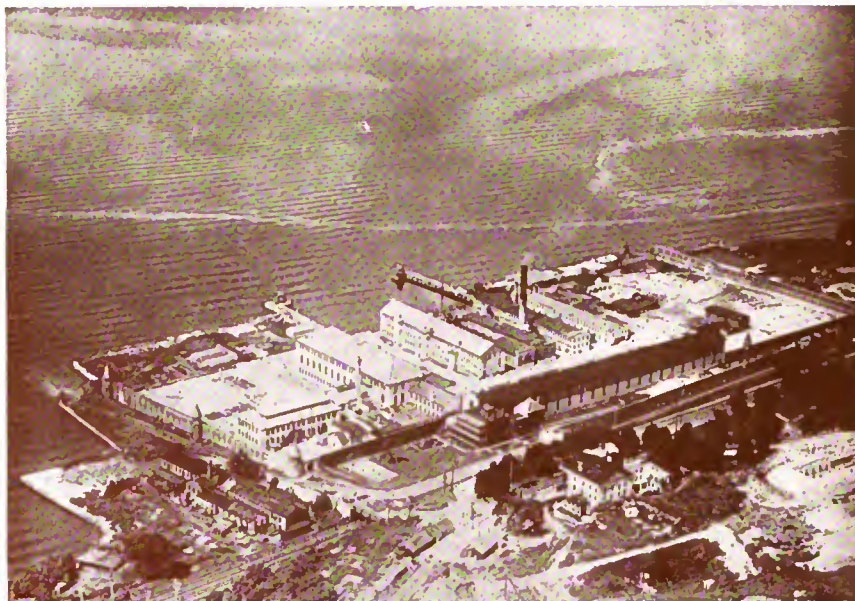

A birdman's view of famous Sing Sing Prison on the Hudson at Ossining, N. Y., the first large penal institution to install radio

clear letter, to be able to read signs and the daily newspapers—these are what the foreigner usually hopes to accomplish on coming to America. The prison school often gives him his first training in English.

In addition, a graduate of standard "four" should be versed in solving the ordinary arithmetical problems of buying and selling.

In the last two standards, five and six, the syllabus introduces subjects of a broader interest and appeal. Here the aim is formative. The creation and development of new and broader needs is sought. The student is taught the fundamentals of formal grammar, and he is given some notion of how the machinery of government works. In his reading he comes in contact with the lives of great Americans and traces the growth of this country through various stages of development.

He begins to sense the meaning of the world about him. In the last standard he "meets" well known authors, and for the first time takes note of literary expression. By this time he has also mastered fractions so that at the completion of this standard a student can take his place with the average man with an elementary school education.

This, in brief, sums up the work of the prison school. Of course, the work is only for those who lack such instruction. If an educated prisoner is brought in, he is not sent through this course. Other duties are found for him; he teaches a class room, for instance; or does clerical work; or works in the print shop.

Mr. Henzel agreed with Warden Lawes that the place for the radio telephone at the beginning was in the chapel. But he also sees a place for it in the class room.

"An educator in Chicago, or in Schenectady, or elsewhere, may be giving a lecture of particular interest to students in standard six. Why not be able to tune in," asks Mr. Henzel, "and give the prisoner-students the benefit of this supplementary work?"

"Many of them now take extension courses from Columbia University by mail."

Mr. Henzel also appreciates the value of good music as an educator. Music, he said, often awakens a longing for the better things of life.

"And music," he added, "appears to be the meat of the broadcast programs just now."

In the chapel of Sing Sing, which now hears radio music, all the prisoners gather periodically. Here they receive their spiritual messages from ministers of the various faiths. Here.

(Continued on page 42)



One of Sing Sing's schoolrooms. Receiving apparatus has been installed in the Chapel, but it is expected also to have it in the classrooms in the near future, when instructive broadcast addresses will be used to improve the minds of the men

“BEING a singer for the phonograph, I naturally wondered what effect my broadcasting would have on record sales. But it did not take long to discover that my radio work increased interest in my phonograph singing.”

An Interview with Aileen Stanley

By Edwin Hall

THE radio telephone means Progress—and please capitalize that last word!

When Aileen Stanley, vaudeville headliner, requests anything, it usually is a command, and so we hasten to instruct the printer to make it a capital “P.”

A performer’s ability to say or sing anything so that you just naturally swing into the tempo of it along with her, is called in stage parlance “putting it across.” Therein lies the Great Divide between the two classifications of vaudeville artists. Either they can “put it across” or they “don’t go over.” And if they don’t, you never hear of them, and if they do you do, and that’s why you have heard and you hear of Aileen!

And just as Aileen’s songs go over on the big time vaudeville stage, so do they go over on the phonograph and the radio telephone.

She sang first from the old WDY station at Roselle Park—that station whose triumphs still linger in the memories of those who followed radio broadcasting during its early introduction in the East.

Progress she believes, is like a Juggernaut, massive, irresistible, ever-moving, non-stop. Everything that contributes toward the good of mankind has a niche in the Juggernaut of Progress. And the innumerable parts make the whole. It is the old story of little drops of water and little grains of sand.

Her theories came without hesitation. I asked her to tell me more of her ideas of how radio fits in with the scheme of Progress.

“What I mean is, that nothing can stop the onward march of radio,” she replied, “that is, for long. And so instead of opposition or obstruction, such as every great invention has met, it would seem that the weight of constructive work and suggestion from the public and from professional

people, meaning entertainers, should be pitted strongly against any pessimistic onslaughts, so that those obstacles would be wiped away quickly.

“It has been said by some near-visioned people—or perhaps non-vision is what I mean—that the theatrical and music publishing businesses have suffered since the advent of radio. My own experience led me to doubt it. Even if it may be true in one or two instances, as in the case of other great inventions, those who suffer temporarily at the start are the ones who later profit—unless they allow their own prejudices to blind them.

“As an example, look at the phonograph industry. In the initial stages, it was fought by the theatrical interests, who thought that if a person were able to get an artist’s record he would not come to the theater and see the entertainer in person. Did that prove true? Does a cow give butter-milk? Caruso earned more on the stage after recording his voice than he did before he sang for the records, and needless to say his records were worth a mint, and still are, of course.

INCREASED RECORD SALES

“Being a vaudevillian, and phonograph artist, I naturally thought while broadcasting just what effect it would have on my record sales, and my value to the stage. But it did not take long to find out for in almost every letter I received by the radio public, the writer asked about by new records, and also spoke of desiring to see me in person when I played in his or her city, and in many instances people have come from small towns to nearby cities where I was playing, attracted by having heard me over the radio telephone.

“The fact that they came to the theater after hearing me by radio shows that although wonderful concerts can, are, and will be given



Aileen Stanley

over the wireless, still that one greatest asset—the artist’s personality or magnetism—is really not as forceful as it is on the stage itself, and instead of being satisfied with hearing the act through the air, it creates a desire in both the actor and the layman to meet each other in person.

“The layman comes to the theater, is captured by the artist’s personality and held by his magnetism; the artist gets his inspiration from the upturned faces and is rewarded by their applause.

“That is what I mean, when I say that instead of hurting anything that is here now, radio is bound to help. Eventually radio, music and stage will work in close harmony for the benefit and betterment of the only ones who count—the public.”

Aileen Stanley started out in the show business with her brother the two being known as “child workers.” At the start of the war, when the brother left for the army, Aileen attempted the “boards” alone, doing a “single” until now she has built up an enviable record, and is liked immensely by the public.

And as a post-script we might add that she has won a bathing beauty contest in Chicago, and is an enthusiastic airplane “fan,” being one of the first theatrical stars to make flights.

Dad Answers When He's Asked

It Was a Struggle Until the Radio Show and the Wireless Magazines Brought Father Up-to-Date

By E. F. Lake

THE Son brought home a galena receiving set one Saturday, put up an aerial and tuned in on a musical program that was being broadcast that evening. The first Detroit Radio Show was to start on the following Thursday and the papers were touting it to a fare-you-well. Son was up-to-date, you see.

With the arrival of the crystal set, Son treated Dad to more strange words than he had ever heard. Such words as antenna, condenser, amplifier, crystal detector, variometer, vacuum tube, frequencies, fading, etc., etc., came into constant use.



Dad knew what fading was in a pitched ball, because he had batted against such balls but seldom connected; also what interference meant in a foot ball game; further, Dad has been "undamped" since Volstead's reign. But the queerest of all was to call an electric lamp or globe, a vacuum tube.

When Son began to speak this strange language, Dad talked it too, but soon he saw he was exposing his ignorance before the family. That would never do. Therefore, he ceased until he could sneak into the library and study the dictionary and the encyclopedia. These did not seem to untwist the tangle and Dad then went to the Radio Show.

This event was a grand success, judging from the crowds, the way they were seeking for information, and the interest in the exhibits and lectures. Not idle curiosity, but very live interest, had drawn the multitude. There was much ignorance like Dad's, and everyone was seeking knowledge. It was like the first automobile show that Dad saw. In spite of its ignorance, the crowd seemed above the average in intelligence and asked all kinds of questions, for they came for the purpose of learning.

Detroit had awakened very suddenly to the possibilities of radio. Dad's

work as a metallurgical engineer takes him all over Detroit and as late as last January he does not remember hearing anyone mention radio. Today it is talked about on every street corner and in every home. Those with just a little knowledge are called "experts"—which flattery may inspire some of them to become really expert.

Some things at the show appeared funny to Dad. For instance, the first lecture he attended was entitled "Radio on the Farm." The young college professor who delivered this lecture started by saying that he had never been a mile out of a city and that he would not know a farmer if he saw one. He was well-informed on radio, however, and his lecture was very good, even though the farm part had to be a blank.

The most humorous part of the average radio show is the way some booth-tenders glibly answer questions on subjects they know nothing about. Usually their answers are so apparently wrong no one pays much attention to them and they do not confuse the interrogator as much as they might. "I don't know" seems to be the hardest thing for a man to say and when he is placed on public view in a demonstrating booth it seems impossible for him to utter those frank if fatal words. First-time shows gather together more men of this type than do exhibitions of older things as more has been proved and standardized by the older industries and their knowledge is more positive.

One demonstrator told Dad that a single wire 150 feet long made the best aerial; others said two wires, three wires and even four wires were the best if not less than three feet apart. This confusion seems foolish, for obviously the best type can be found experimentally, by erecting the several different kinds of aerials and switching a standard receiving set from one to the other. Outside aerials; aerials in the garret, or under the ceiling of a room; in phonograph bases, and even no aerials at all confuse the amateur, when this cheapest and simplest part of the radio set for home use could be standardized once for all.

Fortunately, there were a few real radio engineers at the show, men who gave all the information needed by the crowd. They also seemed glad of the

opportunity to answer all the foolish questions and to put men like Dad on the right path. Radio seems to be based on so much of the unknown that foolish questions will have to be answered intelligently for a long time to come.

Engineers and professors must be only students for a long time if radio does in the future all it now promises. "I don't know" is the answer that shows the most intelligence when such is the case, for it will not confuse the beginner nor start him on the wrong road. The beginner of today becomes the engineer, professor and expert of tomorrow in things of this kind.

The knowledge gained at the show enabled Dad to grasp the fundamental principles on which radio is based. He came home with a vacuum tube set to beat Son's galena set. He had made great progress in the six days following Son's purchase. Now radio magazines are coming to the house regularly, and another week may bring greater outfits, though Dad's ratio of increase, from a 25-mile galena set to a 500-mile vacuum tube set, can't be kept up for long. It would mean that if Son kept up this ratio, Dad would have only another week to jump to a 10,000 mile set.

The vacuum tube set plus the technicalities he learned at the show restored Dad's prestige at home. Now, however, that the radio magazines are arriving, it is nip and tuck between Dad and Son—the one who gets the latest copy first has a big advantage over the other. Dad insists to himself that he is not going to be beaten, and is thinking of sending in duplicate subscriptions, the extra copies to come to his office.

Mother has aroused great respect in the family by announcing that the wire frame in her hat is a perfectly good antenna, and that if any one wants to talk through her hat they can do so.



“CONSIDER the boy and girl of today. They get all this wonderful information and entertainment through the air. The world is smaller. Radio will have a marked effect on the people of tomorrow.”

Ida Geer Weller

An Interview With Ida Geer Weller

By Claire Burquo

THE motto explained it.

A plain, but neatly decorative and polished board hung from one wall in the cozy apartment of Ida Geer Weller on Riverside Drive, New York City.

On it were imprinted but two words: “Be Yourself.”

“It was Elbert Hubbard’s,” the mezzo-contralto said simply. “and it is mine.”

It certainly is.

In one of the breeziest interviews it has been my privilege to have, Miss Weller unbosomed a varied collection of thoughts about the radio telephone—a host of impressions and opinions that had been storing up since she visited WJZ to sing to the radio audience some months ago.

“I believe radio will have a marked effect on the people of tomorrow—the children of today,” she said.

“You recollect how skilful the American Indians were in living through their practical knowledge of nature’s secrets. The Indian could tell time by the sun. He knew when it was going to rain merely by observing the sky. He could hunt his own game, and manufacture his own fire. He knew countless other things, necessary for him to know if he were to exist.

“And what has our civilization—valuable as it is—done to us? Well, in the first place we made the watch and lost the art of reading the sun’s time. Do we look at the sky to find out if we are going to have clear weather tomorrow? We do not. We read the newspapers. I speak of the masses. And about our food. Do we know how to track it or do we buy it from the butcher? And our fire we get merely by striking a match.

“Now get this,—I don’t mean to say we have not progressed. But I do feel that by acquiring our civilization we lost valuable knowledge which it was not necessary for us to lose in acquiring our modern knowledge.

“And radio. How will it play its part in bringing back to us the lost gifts? Consider the boys and girls of today. Particularly those in rural, isolated communities.

“They get all this wonderful infor-

mation and entertainment through the air. The world is smaller. They are asking questions about the things they hear. They are learning. And especially are they learning about nature’s wonderful gifts—because of their realization that the voice and the music is coming to them absolutely without the aid of material means.”

The conversation—it was a free exchange of opinion rather than the usual question and answer interview—drifted into the possibility of rediscovering the “radio brain,” which Madame Olga Petrova discussed in these columns several months ago.

Miss Weller, too, believes it is highly probable that the radio brain will come with the future.

“It is all in the air,” she said, “the only fault lies with our ears. They cannot hear, because of their construction. That may change. Who can say it will not, and not put himself down as a modern bigot?”

And finally the thought turned to Miss Weller’s sphere—singing.

Right here is it well to digress and to give the reader an interesting tale about her, which the writer learned from a childhood friend.

One day in a little town near Smoke-town-on-the-Pennsylvania the wind lifted the roof off a house, and when the frightened mother and father ran upstairs to rescue their little one, they found her crowing with delight and—swallowing the raindrops as they fell from the sky.

An old superstition commands that drinking raindrops shall give a child a wonderful voice. The baby about whom we speak was Ida Geer Weller, of course, and that the ancient superstition in her case was borne out by fact is attested by thousands who yearly pay good American dollars to attend her recitals.

She started to sing at six years of age, and the musical training that followed included courses in dramatic work as well as study under the best voice trainers our country produces.



The singer comes from Revolutionary stock and prides herself upon being an American-trained singer of American blood.

But—we have been drifting.

“There is no question but that the future will develop broadcasting to a height of which we now have absolutely no conception,” she was saying. “I mean that it will grow into something vastly different in form than the present mode of broadcasting.

“The voice transmits perfectly over the radio-telephone. So that there remains but for those who guide the destinies of this new and powerful agency, to give the people the things they will get pleasure from hearing.”

When Mrs. Weller broadcast she did her best—successfully—in carrying out these ideas of her own. The audience will still remember the evening, by producing its collective memory a bit.

It was on the occasion of the last concert given from WJZ’s old studio, and was marked by a moment of excitement, unknown to the audience at the time. Miss Weller had finished singing, and a photographer was preparing to snap the picture you see reproduced in the art photograph section at the front of this issue.

He set off his flashlight—and poof!—the draperies of the studio caught fire.

Fortunately no casualties resulted, but friends of the singer to this day jokingly insist that her voice is “flamingly good.”

Amelia
Bingham



"It amazed me to discover the grip that the radio telephone now has on the people throughout the country. It exceeds in importance every other agency that makes a claim to educate."

Amelia Bingham

American Actress, Tells Paul S. Gautier
of Her Journeys

"YOU know, ingratitude is the very worst of all the sins." Amelia Bingham, one of the most talented actresses the American stage has produced, was talking. Her emphasis left no room for doubt as to the wisdom of her words.

We were chatting in the quiet of her Riverside Drive home. If you ever have visited the Big City you will remember the house. Rubberneck wagon criers point it out. It is situated on the Drive between 82nd and 83rd streets, and may be easily distinguished by the statuary before it.

The room in which we held our conversation was on the second floor at the front. Outside, motors were humming past. Across the way we could see a nurse girl taking her charge for a walk. It was a drowsy mid-afternoon scene, typical of the wealthier sections of the metropolis.

Within was a room that fascinated the visitor. Age-old curios and heirlooms met the eye everywhere. Costly draperies hung gracefully. The rich, full tones of Amelia Bingham's voice completed the charm of the quiet chamber.

Only a few weeks before, the actress had spoken from WJZ. She talked of patriotism, and how all should appreciate our country.

All those who listened know how eagerly she talked, how firmly she grasped the opportunity that had been given her.

And that was the theme of her first words when we met—the opportunity of radio.

Beyond even radio's power as an entertainer, is its mission as an instructor and educator, she believes. It surpasses the printed word in this regard.

"I have only just returned from a trip that took me into many small towns in Ohio and neighboring states," she began.

"It amazed me to discover the grip that the radio telephone now has on the people there. It exceeds in importance every other agency that makes a claim to educate.

"In days past these people could only be reached in a limited way. They read the papers—but they read only what they wanted to. If a man were interested only in sports, he would not read international news. If the drama held his attention, what chance had questions of labor?"

"I have found in my years of travel that people read only what they want to read. Unfortunately, we must admit that one's eyes are closed to subjects in which one is not interested. The laboring man can think of nothing but his problems. He is not interested in the terrible burdens of capital. He gets his pay each Saturday night and has practically no worries. And yet, despite the self-evident truth that it is the owner who depends entirely upon the profits of his business for a living who must worry about meeting his payroll, the laboring man, the salaried man, is bitterly prejudiced against him.

"That is the thing I have feared—the widening breach between the two groups, employers and employees.

"There is only one way to close this breach—to make the man in the street appreciate the real problems that confront the country and bring home to him that the safety of his land is dependent upon his understanding and co-operation. And that is education. He must be told. If the newspapers cannot force him to read, if the lecture platform cannot compel him to listen, then our hope must rest with the wonderful new agency—radio.

"It really was uncanny for people to tell me when I was traveling that they heard me speak from Newark. Folks who lived in little out of the way places that I would not ordinarily visit in a

lifetime were to all intents in the same room with me when I spoke by radio.

"Here then is the way to reach them. In that audience were probably 200,000 people. It would have taken me three years of constant traveling to make myself heard by those people. And it was accomplished in fifteen minutes of a single evening.

"I fear for a country in which the people do not appreciate its wonderful opportunities."

And then she repeated—said the words that appear at the beginning.

"You know, ingratitude is the very worst of all the sins.

"It is radio's mission to prevent the possibility of such ingratitude by educating the people. Only radio can reach them," she repeated.

"And what, to be specific," I asked, "do you mean by ingratitude of some of the people?"

She thought a moment, and then went on:

"I remember once going down on the crowded East Side of New York. I was asked to talk to a group of people whom I suspected of being disgruntled with society. They had no money. They were dissatisfied with their condition. I feared that I would not have a sympathetic audience. These people, you know, resent the words of those who, in their belief, are filled to overflowing with the material comforts of this life. They scowl when someone from Riverside Drive comes down among them. They resent their very existence. And in fact, they are the timber under which the red fires of the radical agitators are built.

"This was the type of audience before which I appeared.

"I could sense a feeling of not being welcome, even as I started to talk.

"Well, at any rate, I spoke to them in a way that they did not believe I would. I did not try to antagonize them. I merely tried to make them know things that were never told them before.

"You resent the gardens of the

(Continued on page 42)

Play Ball! Radio at the Bat!!

LAST year, radio for the first time entered the field of reporting the World's Series and again this year with the aid of broadcasting, baseball games are to be played in all the million or more of homes in all parts of the country that are happy in the possession of radio receiving sets.

At the moment that this issue goes to press, preparations are being made for broadcasting the World's Series games play by play, incident by incident. Many of the details still remain to be worked out, but this much is certain: the Series will be broadcast. The General Electric Co., whose broadcasting station WGY at Schenectady, N. Y., has been heard in many points in the United States and Canada, is getting set for the big games.

Other large broadcasting stations likewise will transmit the descriptions of the games, including WJZ at Newark, KDKA at Pittsburgh, and KYW

at Chicago. By radio every section of the country will be enabled to learn of every play only a second or two after it is made. In those cases where it is possible, the voice of the observer at the ball park will be put directly on the air; in this respect some remarkable accomplishments in broadcasting of long-distance telephone messages may be possible. Where conditions make it impossible to put the voice of the reporter directly on the air, an operator in the radio station will relay his words.

By radio the folks at home will be as well informed as will the crowds at the field, or the masses in front of the hundreds of animated score boards. Each home table can have its own radio player board—the one shown on this page, on which each play can be made as it is reported.

This board can be used for the whole series if a separate box score is kept, or it may be used once, filling

in the boxes shown below the diamond, and drawing another diagram like it each day. In each of the squares at the sides write the name and position of a player, then cut these squares apart, also cut out the baseballs. For convenience in handling, these may be pasted on cardboard.

When the first man is announced at the bat, place the square bearing his name on the home plate. If he makes a hit and is safe at first, move him there and mark the hit under the "H" in the box score. If one strike is called, place one of the baseballs over the first square under "Strikes." If a ball is called next, put a baseball in the first square under "Balls." Similarly, when one is out, place a ball in the first square under "Outs." If you want, you can use a baseball to represent the ball in play, moving it from the home plate to whatever part of the field it may be hit, just as is done in the complicated mechanical boards.

Play Ball!

National League

American League

Broadcasting Station in Rio de Janeiro

EASILY the most striking location for a broadcasting station in the Western Hemisphere is on the summit of Mount Corcovado, overlooking the colorful city of Rio de Janeiro, Brazil. Press reports from that city bear the information that the radiophone craze has at last struck the Brazilian Capital, and its music loving inhabitants are to be entertained by concerts, news reports and lectures by this newest addition to the broadcasting stations of the world. Whatever distinction the station on Mount Corcovado will eventually acquire, it has already the honor of being the first radio broadcasting station in all Brazil, although not in South America.

As yet little is known in the United States of the station as it now stands, but those who have lived in Rio and have taken the trip to the summit of Corcovado believe that it is not exactly a suitable place for a broadcasting station. There is apt to be a great deal of difficulty in finding a good ground for the instruments; for the mountain on which the station is said to be placed, is solid granite from base to peak, and a ground embedded in rock is not exactly efficient. The builders of the station in order to overcome this unfavorable feature probably will have to erect a counterpoise.

Then it is a difficult and inconvenient

task to get to the top of Corcovado. Every hour a Swiss Electric Mountain Climber leaves the base of the mountain, and laboriously climbs the cog railway to the summit. The ascent takes forty minutes. Upon arrival at the head of the railway, there is an arduous climb of some three hundred steps before the actual summit is reached, and once there, the climbers are exposed to whatever winds or rains that prevail. If musicians and singers are to go there to perform, this condition is unfortunate, to say the least.

Travelers hope that the station has been erected in Corcovado Hotel, which is on the side of the mountain, two-thirds of the way up, and accessible by street cars from the center of the city. Corcovado Hotel is 1460 meters above sea level, has a possible ground in the deep chasm over which it is built, and can tender some semblance of comfort and entertainment to the operators and performers. If, however, the station is on the summit, as the reports indicate, then it must be assumed that it is one of the show places of the Brazilian Centennial Exposition, and its builders are not taking its permanency into consideration.

This station is not the first that has been operated in South America. More than a year ago, in August, 1921, the Teatro Coliseo, an opera house in Buenos Aires, installed a radiophone outfit, and broadcast its nightly performances for the entertainment of its

small and select radio audience. Perhaps the Consejo may claim the distinction of being the first theatre to broadcast opera. It was mostly advertising, mixed with a creditable amount of enterprise, that prompted the venture, for at that time, radio work in the Argentine was of negligible proportions. The foreign ships in the harbor enjoyed the music more than the natives in their homes.

Even now, radio has gained such a small start that it has not yet been the subject of official "verbotens." The tariff on radio instruments is twenty-five per cent. of the total value, which sends prices soaring to almost double what we pay here, when the profits of all dealers are considered. Amateurs who might make their own sets are handicapped because there are no instruction books written in Spanish and no radio magazines. Under these difficulties, the radio situation in South America will be slow in improving.

Britain Solving Problem

GREAT BRITAIN will solve the interference problem in radiophone broadcasting by government control and regulation," according to A. P. M. Fleming, C. B. E., manager of the research and educational department of the Metropolitan-Vickers Electrical Company, Manchester, England. Mr. Fleming represented England at the international convention of the Institute of Electrical Engineers and the International Electro-Technical commission at Niagara Falls.

"We have learned many valuable lessons from the broadcasting experience of the United States," said Mr. Fleming.

"One of the things we have learned is to avoid the establishment of innumerable radio stations, with no plan of cooperation between them. Eight 1½ kw. stations are contemplated for England and some of these will probably be built this year."

Radio Slow in Germany

IN Germany radio transmitters and receivers both are required to be licensed by the government, and receiving sets are assessed a monthly fee ranging from 1,000 marks to 7,500. Hence amateur radio in Germany is practically non-existent.

The German Post Office Department keeps close control of the radio situation, both as to telephone and telegraph, and has made it so difficult and expensive for private individuals to enjoy the advantages of wireless that only the wealthy can afford to do so.

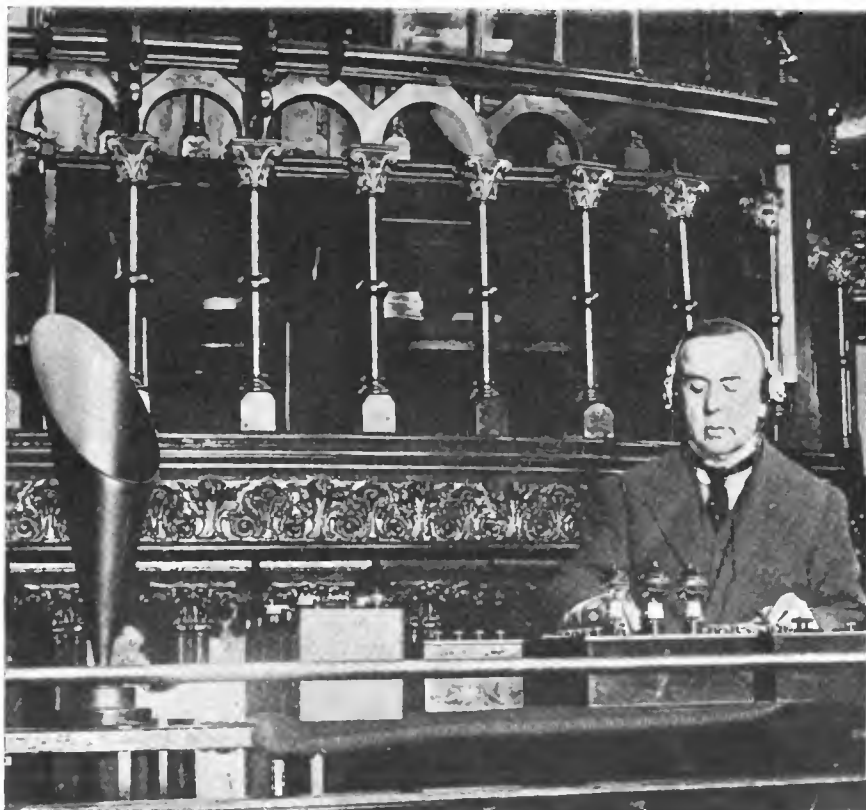

Dr. J. E. Boon delivered a sermon from Blackheath, England, to his congregation, the Peckham Christian Union Church, nearly seventy miles away. An audience of 300 persons were listening at the time this photograph was made

Symphony Concerts on the Air

Philharmonic Orchestra of New York is Heard over WJZ—Feat Marks New Era in Classical Music Field

By St. John Martens

NAPOLEON never "came, saw and conquered" more completely than did the successful efforts to broadcast the closing concerts of the New York Philharmonic Orchestra last August.

In years to come this feat will seem tame indeed. Others will follow that will rob it of its glory. They will be bigger and more far-reaching.

But to those of us who have receiving sets today and thus are privileged to follow the radio telephone, in its development, the broadcast concerts were extraordinary. They marked the apex of the summer's achievement, from an artistic viewpoint.

We are impelled by its triumph to review briefly the onward march of radio broadcasting since its beginning.

Starting with the sending of phonograph records, it swiftly introduced the individual artists themselves. Then public events came to be recognized as possibilities, and introduced to the public a new era in broadcasting—the sending of eye-witness accounts of sporting events.

So, in a way, the broadcasting fans were prepared for the announcements in the newspapers that four concerts of the Philharmonic Orchestra were to be put on the air. They came at a time when popular interest in indoor radio was suffering by competition from outdoor sports. And it served to remind us that radio was still on the job—still going forward.

During each summer the Orchestra entertains New York music lovers at the new Stadium, a magnificent structure seating 10,000 persons, with room for many more standees.

The fame of these annual summer offerings is not confined within the five boroughs of New York, and so, when the announcement was made that the programs were to be broadcast by radio, folk in the smaller towns within a radius of several hundred miles of the metropolis were just as eager to listen in as were the New Yorkers themselves.

Dotted about the Maine woods and in the Adirondack Mountains were



Part of the immense crowd in the Stadium on one of the nights the concerts were broadcast. The radio public may recall the voice that came over the air which advised those present at the concert that the flashlight was to be made

many camps, for the first time, these were equipped with outfits this year, and to them the concerts seemed to come from heaven itself. Hotels tuned up too, and even ships far out on the sea enjoyed the splendid music.

Standing before his orchestra, Willem van Hoogstraten, the conductor, was enjoying a new sensation. The conductor of an orchestra always is its most picturesque figure. Audiences like to watch the graceful swing of his baton.

But in a broadcast concert this is lacking. Sight plays no part, and the conductor, strange to say, simply is non-existent.

That is one reason why the writer sought Mr. van Hoogstraten to record his reaction to the achievement for

the readers of *THE WIRELESS AGE*.

The conductor was found at his hotel, The Wellington, and, between hurried calls to the telephone and interruptions from persons seeking a moment of his time—for the life of an orchestra leader is a busy one—he fired broadsides of admiration for the new science.

He summed up his acknowledgment of its power in replying to a question as to how he felt about the radio telephone:

"You call your magazine *THE WIRELESS AGE*," he said, with delightful accent, "well—that seems to me the answer. We are in the wireless age."

And then he went on:

"I am not entirely satisfied that the radio telephone can bring out all the little details, the fine nuances of the music. But I must admit that up to this time my experience has been entirely from the transmitting side—I have never heard anything come over the air. But I will today—yes, this very day.

"I am sure, however, that in a general way, radio music is entirely satisfactory. This holds true for what is known as the better music, such as our orchestra broadcast from the Stadium, as well as the lighter kind, that which you call jazz."

And then he showed himself to be completely human by paying jazz music and popular melody a pretty compliment.

"I like it," he said, with a smile.

To show the caliber of music that went out on the air, it might be well to recall a few of the selections. They included the overture to "Mignon" by Thomas; the "Entr'acte—music from Rosamunde" by Schubert; Three Movements from the "Rustic Wedding" Symphony by Goldmark, and



The conductor was Willem van Hoogstraten

the Dream Pantomime from "Haensel and Gretel" by Humperdinck. At the final concert the famous "Pathetique Symphony" of Tchaikowsky was transmitted.

The project was initiated by Kendall Banning, a progressive radio editor, who secured the co-operation of Adolph Lewisohn, donor of the Stadium and patron of the concerts. These preliminaries over, the engineering problem that faced the sponsors of the movement was solved with complete satisfaction.

It was fully described in the notice printed in the programs of the Philharmonic Society as follows:

"The suggestion of broadcasting the Stadium concerts was too good an opportunity to be disregarded. The Westinghouse Electric & Mfg. Co., which, with the Radio Corporation of America, operates the broadcasting station WJZ, was communicated with, executives of the American Telephone and Telegraph Company were consulted and radio engineers were called upon to study the technical problems involved. The thing was done.

"A special equipment makes possible the spreading of the actual music of the Stadium concerts over a territory that represents a population of 75,000,000 people, operating receiving sets roughly estimated at about 500,000.

"The music of the New York Philharmonic Orchestra is recorded by a special type of microphone developed by the Westinghouse Com-

pany. This device, in appearance a small black cylinder four inches long and four inches in diameter, is suspended in view of the audience about twenty-five feet in front of the platform and about twenty-five feet high. It is supplemented by a second microphone located just above the orchestra leader's platform for the purpose of recording any soloist. These microphones convert the music (as well as any applause) into an electric current of strength and character that varies in accordance with the character of the sound waves that impinge upon the diaphragm.

"This current is then transmitted over a special wire leased for the entire week. The wire extends through the various telephone exchanges to the broadcasting station at Newark, a distance of twenty-five miles from the Stadium. At the broadcasting station the electric current is amplified by means of special vacuum tube circuits; the amplified current is then impressed upon the modulator tubes of the transmitting set. These modulator tubes in turn vary the output of the radio transmitter in accordance with the same sound waves that are impressed upon the microphones at the Stadium.

"The music thus sent out may be picked up by any radio receiving set that tunes in to the prescribed wave lengths of 360 meters on which WJZ sends out its programs."

And, as we said at the beginning of this article, even this achievement in

broadcasting will seem tame at some time in the future—but that does not detract from the glory of the present.

Two weeks after the first Stadium triumph, concerts given in the big arena by the various city bands were broadcast. The organizations that "appeared" simultaneously to the audiences in the Stadium and the hundreds of thousands of listeners included the Fire Department Band, the Street Cleaning Department Band, and the Police Band.

During the season over 500 concerts were given by these bands in New York City parks and public places, giving every one of the more than 5,000,000 people in the metropolis a chance to hear the best band music in every section of the city. The broadcast concerts, however, were heard simultaneously by radio fans not only in all parts of the city, but over the Eastern part of the country, and far at sea as well.

Not on His Beat

"LIAR, liar!"

The words floated sharply from the window of A. H. Everest, of Pittsfield, Mass., recently.

A cop was passing the door. He took a good look at his badge, polished it with his sleeve, and made a dash for the house.

After demanding to know "what's the trouble," and being admitted, he found Mr. Everest calmly seated in his living room.

"Where's the fight?" asked the perplexed cop.

"In Schenectady," calmly replied Mr. Everest.

Then the officer discovered that he was listening to a fight scene of Eugene Walter's new play "The Wolf," being broadcast from Schenectady, N. Y. In the big scene of the play Hilda, a grossly misunderstood young woman, calls her papa a prevaricator. Mingled with her screams were the curses and shouts of rough men of the Canadian woods.

They came clearly through a loud speaker, and the cop sat down with Mr. Everest to enjoy, for the first time, a fight "on his beat," even though it was miles away.

Equip Foreign Mail Boat

THE New York Central Railroad is arranging for radio communication with the Government steamship *President*, used in transporting foreign mail from steamships arriving at Quarantine to the road's pier, West Thirty-second street. John H. Delaney, Commissioner of Docks, granted permission for radio equipment on the pier and similar equipment is being installed on the *President* by the Post Office Department.



Many difficulties had to be surmounted in making the microphone installation at the Stadium

Clarinet Transmits Perfectly

Gustave Langenus

Member of the Philharmonic Orchestra and Also of the New York Chamber Music Society Tells H. N. Lee That Tone Quality of Instruments Is Not Lost

IF the average man, without a knowledge of those refinements of musical technique upon which all true musical criticism is based, were to tell you a clarinet selection he heard over the radio telephone came over "wonderfully," you would be reasonably certain that there is "something to this radio stuff after all."

But if one of the country's very best clarinet players, one of its highest paid and most accomplished artists were to tell you that the instrument he plays transmits perfectly, you would be impressed.

Impressed you would have been if you could have been present when Gustave Langenus, member of the New York Philharmonic Orchestra, member of the New York Chamber Music Society, and super-instructor of the clarinet, told me of the clarinet's success by radio.

"I hear music daily over the radio, as it is called in the vernacular of our time. I enjoy it. The piano comes over clearly, every note; the voice floats from the loud speaker in a most mellow way; other music and speech likewise."

IT MUST BE SO

But I must confess that not until Mr. Langenus paid radio his emphatic and positive compliment was I convinced of the positive perfection of the radio telephone, as viewed from the angle of the professional musician.

That leaves no further room for discussion or argument. Mr. Langenus is too deeply wedded to his art to betray it with an idle remark.

Like many another artist who thinks in terms of what we call the "better kind of music," Mr. Langenus believes that radio's future will depend largely upon the caliber of entertainment the public gets.

But before you may gain the impression that he believes that only classical music selections should be put on the air, let me say that such is not the case. Mr. Langenus would give the public



Mr. Langenus and his daughter

the most varied entertainment. To do this properly he thinks that broadcasting in general should be controlled in the main by one organization, or combination of organizations, the biggest and most wealthy and accomplished of radio companies.

It would not do to have six or seven different telephone companies selling their service in each city; nor would it be to the best interest of the public to have many small companies unequipped either to get proper talent or to solve the engineering problems, competing to put entertainment on the air, he quite reasonably thinks.

DIVIDE THE NIGHT

He would divide the evening into units. Orchestra selections from a competent, high class orchestra built solely for use over the radio telephone, would give the public its type of music. Next would follow voice selections. And finally an hour or so of dance music and the lighter variety of melody.

Thus he would include everything—and at the same time maintain the highest standards in each class.

"Many musicians," he said, "are compelled to make a living by playing a lot of music that is distasteful to them.

This state of affairs is very regrettable because all musicians worthy of the name long to play good music. Until we have symphony orchestras in every city, the next best thing for the man to do who loves music for art's sake is to get together a few players and form a Chamber Music Club, from three to eleven members, according to the instrumentalists available.

"Don't you see how radio could fit in? Chamber music in my opinion, is the very highest type of music, bar none. I cannot be too emphatic. If the various communities were unable to have such Chamber Music Clubs, or symphony orchestras, their only salvation would lie in their ability to get it over the radio telephone, by radio clubs, if necessary.

BOOSTS CHAMBER MUSIC

"Chamber music in the future ought to become inseparably locked up with radio. It should, as it is the very highest expression of musical art, come to be expected from the transmitters of radio music. The pleasure and education derived therefrom will be very great.

"Already New York, Boston, Chicago, Philadelphia, San Francisco, and Los Angeles can boast of such Chamber Music Societies, but there should be a hundred of these instead of half a dozen.

"Yes, and furthermore, were the powers in the radio world to put Chamber music on the air, instead of a half hundred such organizations in the country, there would in reality be half a thousand and more. For the organization of such units of Chamber music in each town and village—even in each city—would become less of a necessity.

"The important thing, remember, is to get this music before the public. And there is no speedier way of doing so than by playing in a broadcasting studio with the motor of the generator whirring and the amplifiers doing their duty."

Japan's Response to Radio's Appeal

Flowerly Kingdom Taking Interest in Broadcasting—
Japanese Wireless Paper Now Caters to the Novice
Who Listens In—How "Wireless" Is Written in Japan

WILL the telephone talk Japanese?

That question, foolish as it now seems, was asked in all seriousness when Alexander Graham Bell first demonstrated his invention of the telephone. He secured two Japanese college students to prove that they could converse over wires as easily as could Americans.

Recently the Japanese have been asking themselves much the same question about radio. Can they talk by wireless? Tests have proved that they can, of course, and the Japanese public is taking great interest in the new art. Radio telephone history, as first revealed in the United States, is repeating itself in Japan.

The course of events in the Flowerly Kingdom is revealed in an issue of

"The Musen Times," which recently reached THE WIRELESS AGE. The first and last pages of this issue, No. 46, dated July 5th, 1922, are reproduced on this page. The publication is an old one, as wireless publications go, and for years has confined itself to wireless telegraphy. "Musen" means wireless. Now, however, it is giving great attention to radio telephony, and the issue in question devotes much space to it, including a long special article on "The Development and Future of the Radio Telephone in the United States." There also are articles on radio telephony in Europe, experiments with moving trains, opening of a new French high-powered radio telegraph station, radio communication between Canada and Australia, the design of the French Army's radio tele-

phone transmitter, design and construction of antennas for amateur radio telephone receiving sets, and a story of an operator's adventures. The diversification of the contents, and their careful selection, reminds one of THE WIRELESS AGE!

In the reproduction below, the first page is at the left. Japanese is read vertically and to the left, from the top of a column of characters to the bottom, then to the top of the column at the left. The pages are turned from left to right. The binding of the magazine when closed, therefore, appears at the right instead of at the left, as in Occidental publications.

On the front page the title appears

(Continued on page 40)



At the left, the front page of "The Musen Times" (The Wireless Times) of Japan, and at the right, the last page

An Example of Service to the Blind

Simple Receiving Set Brings Life Anew to Sightless Man Who Thought He Had Lost His World Forever—"Radio Is a Godsend to Me," He Says

By Ward Seeley

THIS is the story of Carlos F. Escalante.

You who read his name here will see it for the first time. This is not strange. Public fame is no gauge of the true worth of a man's efforts to make the world better for his having lived in it.

Until two years ago Mr. Escalante played his part in the world's drama, as traveler and business man. In 1920 he was attacked by a sudden illness, and the light of his eyes flickered and failed.

For a year and a half he sat in darkness, with his memories of travels and adventures in Europe, in Mexico, and in America. Inaction weighed heavily upon him. In the home where once he strode confidently he could but stumble uncertainly, with out-stretched arm. The world was far beyond his reach, forever—or so he thought. His fate seemed almost more than he could bear.

REVOLUTIONARY RADIO

Then a new thing came into his life and revolutionized it. Last Christmas an old friend, Charles Andrews, a member of a prominent stock brokerage firm, gave him a simple radio set.

"He sent a man up here," Mr. Escalante related, "and in less than two hours this wonderful thing was ready for me. I asked 'What do I have to do?' and he said 'Nothing but listen' and that is what I have been doing ever since.

"It is a Godsend to me. You cannot imagine what it is to sit day after day alone in the dark—I who had been so active, only to sit here in this apartment—" and his finely-modeled face showed an inner struggle with the insufficiency of words to express his emotions, while his sensitive hands seemed to reach out for new ways of expression.

"You cannot—no one can imagine what it is for a man to be stricken as I have been, and no more can you grasp what radio means to me. I had not thought that there could be such a blessing in the world. This—" he hesitated and then courageously pronounced the only word that fits: "This calamity I thought meant just the end of the world to me, and it did for quite some months. The people at the Lighthouse for the Blind have been very kind, and one of them comes here every Saturday. I have been learning to read the



Carlos F. Escalante

Moon type, the raised characters, but my hands aren't as steady as they might be and sometimes I slip from one line to another without knowing it. Still, the effort gives me something to do," and he slowly raised to his knee a thick heavy volume of the embossed print, to show how difficult it is to read.

BROUGHT THE WORLD BACK

"But the radio was the thing that brought the world back. I thought I had lost it for ever." The book slipped from his knees as his hands sought the headset on the chair at his side.

"Yes, there's music. Listen, isn't it wonderful?" he asked as he held the phones out. It was, indeed. The simple little crystal set was bringing in a piano solo from WJZ, clearly and sweetly.

"Oh, I hear so much over the radio," continued Mr. Escalante. "So much, so much. Do you know, I have heard complete operas, with the music, and very good descriptions of the story and the action. La Traviata, and Carmen, and La Bohème, and others. I have heard so many, and I thought I would

never hear an opera again because I cannot see any more. I have seen them all many times, but good music is always new, don't you think?

"And then, I like this lively new music, for dances, what you call—you know, that—"

"Jazz," I suggested.

"Yes, that's it. Jazz. I like that, too. It is a change, and it is full of life and it makes me happy. And the lectures are so interesting. Of course Mrs. Escalante reads to me a great deal, but she has a great deal to do and, well, you know how it is.

"I asked her to write to Mr. White and thank him for his description of the two bouts, the ones between Leonard and Tendler, and Britton. I heard them clearly. It was very exciting. Mr. White must be a remarkable man, isn't he? He has given me so much pleasure, and will you please thank him again for me?

"And then I have heard the concerts of the Philharmonic Orchestra, the best music. I hope they will do that again for I am very fond of orchestra music. WJZ is doing wonderful things, isn't it? I hear other stations, too, WOR, and WBAY, not so loudly, and sometimes WAAM, very faintly, and WEA. This new arrangement they have between the various stations has cut down WJZ's time, and that is the best station."

Again he sought the headset, and listened.

"You see now, there is nothing to be heard at all," he complained, putting the headset back on the chair and feeling the hands of a watch on the table in front of him. "It is twenty minutes after one, and you won't hear WJZ again until four o'clock. It used to be that each hour I could hear, but now I hear WJZ only from 9 to 9:15—" Mr. Escalante gave the entire schedule upon which WJZ worked. He knew it perfectly.

"Do you think WJZ will ever go back to the hourly system?" he inquired hopefully. "They say that there are other people sending out music, but I can't hear them, except, as I say, WOR and WBAY and that new station, WEA."

IS A NEW YORKER

"It means so much to me, I seem to have the whole city right here with me.

Do you know I am a New Yorker? Yes, I was born right here."

He explained that he was born in 1859, on 31st Street between Fifth and Madison Avenues, then an aristocratic section. He was the eldest child. When he was nine years old the family sailed for Spain, in order to give the children the benefit of a European education. When he returned, at 18, he had forgotten most of his English, but soon picked it up again. His command of Spanish proved invaluable in conducting business with Latin America. At the time of the Mexican revolution during which Madero was killed he had important business interests there, which he was forced to abandon, being glad to escape to New York unharmed. He then became connected with the Interboro Rapid Transit Co. in the treasurer's office.

"Would you allow me," I asked, "to send our photographer to take your picture? I would like to tell the readers of THE WIRELESS AGE of your experience with radio."

"Well, Mr. Seeley," he explained with a smile, "I really do not think I care for publicity. Let us ask my wife also what she thinks of it."

Mrs. Escalante was even firmer. She thought that her husband's blindness was a private matter. "We cannot thank you enough," she said, "for what your radio does for us, but I cannot see any particular advantage in any article such as you suggest."

"But, Mrs. Escalante," I protested, "there are thousands of blind people, and millions of fully-sighted people, who do not realize what radio means to the blind. You yourself did not until a friend gave you a set. My sole object in printing the story would be to help other blind people. Your story, told to the readers of THE WIRELESS AGE, should lead to many other blind persons enjoying the benefits of radio."

That triumphed over natural delicacy. "Radio is certainly the most wonderful blessing in the world for the blind," said Mrs. Escalante. "They all should have it, and if there is anything we can do to help, we want to do it. I hope our story will introduce radio to many blind people."

Coming Radio Shows

NEW YORK CITY will have a radio show December 21 to 31 next, in the famous Grand Central Palace, two floors of which have been taken by the American Radio Exposition Co., which also has an option on a third, if necessary to accommodate the exhibitors. The show, coming as it does just before and after the Christmas holidays, is expected to draw large crowds, and prove a feature of the holiday season. Sound-proof rooms are to be con-

structed for exhibitors wishing to demonstrate their apparatus, and there will be special educational motion pictures.

St. Louis, Mo., will be the radio center of the whole state during the week of October 6th to 11th, when the St. Louis Radio Association will hold its annual exhibition. The Missouri State Radio Association is co-operating with the St. Louis organization, and these two, with the Mid-West Division of the American Radio Relay League, will hold their conventions during the show week. The exhibition, therefore, will unite the radio amateur and broadcasting fan. Exhibits are to be made by leading manufacturers, jobbers and dealers, and many of the exhibits will proceed from St. Louis to Chicago, which has a radio show the following week.

Springfield, Mass., is planning a radio show for October 3d to 7th, inclusive, in the Auditorium, whose 350-foot tower will carry a receiving antenna and possibly also one for transmission. WBZ being located in Springfield, and having created thousands of radio fans in the immediate vicinity, it is expected that the show will be thronged.

Atlanta, Ga., is looking forward to its radio show from October 3d to 7th, inclusive, in the Auditorium. The event has been endorsed by the Atlanta Radio Club. Two newspaper broadcasting stations in the city have developed great local interest, and radio fans are numerous.

Boston, Mass., is to have its second radio show October 30 to November 4, in Mechanics building, under the auspices of the New England Executive Radio Council. Members of the American Radio Relay League in the First District are to co-operate, and the exhibition will have a flavor of both the transmitting amateur and the broadcast fan. The amateurs will have their dinner on November 4, closing the show. Careful plans are being drawn to prevent the presence of poor apparatus or fraudulent exhibits of any kind, and an advisory committee has been formed of representatives of leading manufacturers, including the American Radio & Research Corp., Radio Corporation of America, Clapp-Eastham Co., General Radio Co., Wireless Specialty Apparatus Co., and Wm. J. Murdoch Co.

Concerts for 'Bus Riders

AN Oakland, Cal., bus company has started experiments which it hopes will prove the practicability of installing radio equipment on each of the 85 busses running daily between that city and Sacramento. It was announced by

the company that concerts from San Francisco and Oakland were picked up by the vehicle on which the tests were made when it was on the road.

Japan's Response to Radio's Appeal

(Continued from page 38)

in the decorative panel in the upper right corner, and is read downward. The top character with four dots under it means "Nothing." The character under it is composed of two symbols, the one at the left standing for "Thread" and the right half meaning "White Water," in the sense of a flowing or bubbling spring. The two taken together mean "Wire." Thus, the first two complicated characters mean "Nothing Wire" or "No Wire" or "Wireless." This is Chinese ideography, or picture writing. The pronunciation of the first two characters is "Musen," and the meaning, "Wireless."

The next four and wavy zigzags are Japanese phonetic symbols standing for the sounds of the English word "Times."

The leading editorial, signed by the Editor-in-Chief, appears opposite the name of the paper, and is entitled, "Recent Appointment of a New Minister of Communications." In it the Editor expresses the hope that the new Minister will allow Japan to enjoy to the utmost the great facilities of the radio telephone. As in Japan the government is in complete control of radio, all development and use depends on the attitude taken by the authorities.

In addition to its reading matter, the paper contains in its ten pages a number of advertisements of such things as battery chargers, ammeters, and vacuum tubes, by firms in Japan, the United States, and England. In the reproduction of the last page, shown to the right of the title page, one such advertisement is to be seen. The name of the company, prominently displayed on each side of the trademark "NK" within a triangle is "Chino-Japanese Wireless Apparatus Manufacturing Company." The matter immediately above the advertisement, containing the names and call letters of many European stations, is the story of a radio operator's achievements.

Farm Market Service

PERFECTION of radio service of the State Bureau of Markets now enables the New Jersey farmer, whose home, farm, club or bank is equipped with a radio receiving outfit, to have actual up-to-the-minute information of prices which his crops, shipped into Newark, New York or Philadelphia that day are bringing.

How Uncle Sam Entertains

at

W V P

On Bedloe's Island, in New York Harbor, Which Transmits on 1450 Meters

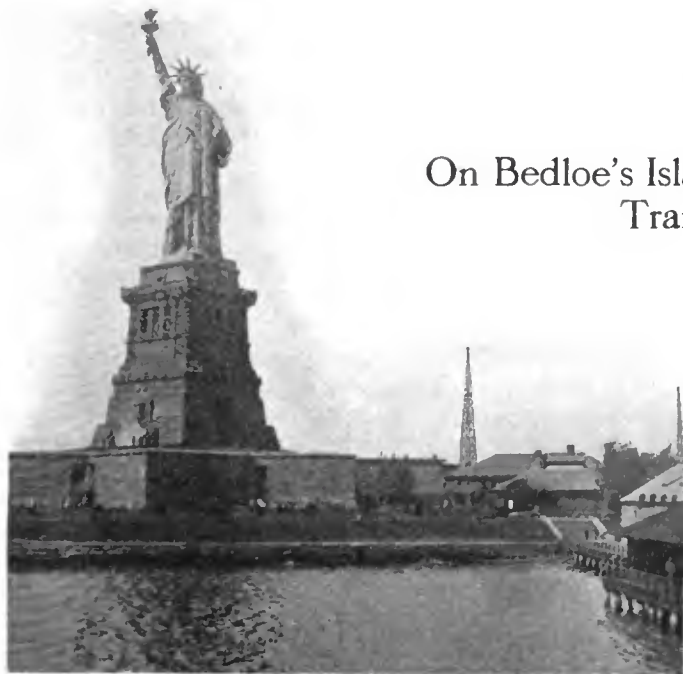

The army station is located on picturesque Bedloe's Island, the site of the Statue of Liberty, in New York Harbor. Its steel towers may be seen in the background.

WV P undoubtedly is a creature of circumstance. We say that advisedly—and we mean that it owes much of its popularity to its location on the same tiny island in New York Harbor as the Statue of Liberty.

Those who have crossed the harbor must have seen the steel towers and the antenna of WVP, one of the very few government wireless stations used to broadcast general entertainment,—speeches and music.

Hundreds of tourists every day take a small boat at the Battery—that landmark of the metropolis that was the inspiration of such entertainers of boyhood as Horatio Alger, Jr.—and after a slow, but pleasant twenty-minute ride, alight on the island.

The steel stilts towering 140 feet into the air are lost, for the moment, in the overpowering wonder of the Goddess of Liberty, to whom the tourists pay their respect, but the Grand Old Girl is an old story while WVP is new, and so we will confine ourselves to the station.

WVP broadcasts on a wave length of 1,450 meters. Therein, too, it differs from the other transmitters of air entertainment, who must confine their activities to 360 meters. But WVP has some influence in governmental circles, 'tis said. In fact, as Lieutenant H. S. Paddock said it *IS* the government.

Bedloe's Island is the official name of the garden spot in the harbor on which the station stands. It is in reality an army post, and one of the mightiest links in the radio net thrown by the Signal Corps over the country.

Its powerful signals are heard in the

most remote spots of each of the eight army corps areas in the country. Primarily the station is not an amusement dispenser. For twenty-three hours of the day crisp army orders leave the four wires on the high antenna for their given destinations.

Only during a single hour of the twenty-four, from 9 to 10 p. m., does the wary, official eye wink, and entertainment relieve the monotony of the day's routine.

Just about the time that January of this year took its place on the calendar Brig.-Gen. Edgar Russel, then Second Corps Area Signal Officer, conceived the plan of utilizing the station for a limited time during each day to broadcast entertainment.

It was not long before his plan became operative. He enlisted the aid of that body of young amateur operators,—the Amateur Radio Reserve—who, while not actually enlisted in the army, still are being trained in U. S. Signal Corps work. This body is growing rapidly, and was organized because of the experience the army had during the late war, when it required some little time to train men in army methods. Adding radio telephone broadcasting would give them new and invaluable experience, it was felt. Application was made to Washington which allowed the station to use the wave length of 1,450 meters for broadcasting.

It was not long before General Russel was transferred, and his work now is being carried on by Col. C. McK Saltzman, the present Corps Signal Officer; Lieutenant Paddock, Post Signal Officer; Captain Charles W. Chadbourne, Post Commander.

The set used to broadcast, which was built by the General Electric Company, is a powerful one— $3\frac{1}{2}$ K.W. Possibly it is most appreciated by men in government work itself, sailors within a radius of a thousand miles out at sea, and army posts scattered throughout

the country. The average broadcasting fan, who can tune only in a limited range on each side of 360 meters, does not hear it—which is a pity.

The studio itself is most modest. It is merely the adjoining room to that used as an office by Lieutenant Paddock. Besides its usual quota of government furniture, it holds a player piano, contributed by the maker, a phonograph—and a microphone.

A distance of some four or five hundred feet separate the studio and the small building or radio shack used to house the transmitting apparatus. The wires from the studio to the shack pass through an iron fence, the top-most pipe of which serves as a conduit.

The broadcasting transmitter consists of a $7\frac{1}{2}$ horsepower alternating current motor driving a 2,000-volt generator, which supplies the plate current for six 250-watt vacuum tubes. The motor also drives a 24-volt generator which acts as an exciter for the 2,000-volt generator. The filaments of the tubes are lighted from the alternating current power circuit through a step-down transformer. Three of the six vacuum tubes are used as oscillators and three as modulators, the constant current method of modulation being used.

The pick-up device at the broadcasting studio consists of a "Phonetron" in place of the usual microphone. The output of this device is passed through two stages of resistance-coupled audio frequency amplification before reaching the line which connects the studio with the radio station and the transmitting apparatus. This line is about 900 feet long and the conductors are thoroughly shielded throughout their entire length.

Before applying the voice frequency currents, generated at the studio, to the grids of the modulating tubes of the transmitter they are again passed through four stages of resistance-coupled audio frequency amplification, the first two of which utilize the ordinary amplifier tubes and the last two, five-watt power tubes.

A radiophone receiving set is installed in a room adjoining the studio and is used to check the actual transmitted sounds as to quality and proper operation of the transmitting set.

Talent has been plentiful at WVP.

Some "canned" music, records for the piano and phonograph are used, but for the most part singers and players "appear" in person from the station.

One evening each week has been given over to concerts under the direction of Charles D. Isaacson, of the New York "Evening Mail." More than a hundred artists have thus appeared, including Tom Williams, baritone; Harriet Cady, pianist, composer of Chinese music; The Misses Dale, operatic singers; Anca Seidlova, Czecho-Slovakian pianist; Isidore Greenberg, violinist, and a pupil of Leopold Auer; George O'Brien, American tenor; Elsie Reign,

This will serve to indicate the wide variety of talent that has entertained from WVP, the army signal corps station on the historic Bedloe's Island.

However, as has been indicated, broadcasting is but one-twenty-fourth of the work of the station. If you ever visit the island, or pass by it, you will see not one, but two antennae. The larger one—300 feet in length—is used for broadcasting, and for the inter-area communication work over the entire country. The smaller one carries government messages within the Second Corps Area.

It is also interesting to note that the

It will figuratively crumble the walls that keep him confined, while literally they remain firm. His body will remain where it is; his mind will expand and escape the bars, finding a new incentive to direct the body better when it once more is released and allowed to go its way in the world where all good people belong.

That the installation in Sing Sing had an immediate favorable effect is to be seen in a letter sent by one of the inmates to the Radio Construction Co., New York City, the day after the first radio concert.

"There was plenty of interest created, as we had heard plenty about it, but excepting the newer men, none of us has ever seen the practical working of the device that will undoubtedly be the greatest means of entertainment and education the world has known. Many lads in here, have plied me with queries as to how it works, how it is constructed, and how it is possible to receive just what you want to when the air is full of 'Broadcasts.' Perhaps you have some literature that you could send me that would explain these most natural inquiries.

"Most sincerely yours,
"Number 68777."

Amelia Bingham

(Continued from page 32)

rich,' I told them, 'and yet you have the most wonderful gardens in all the world available for a five-cent fare. The trees and cool grass of Central Park are yours. The park belongs to you. You resent the opportunity of the rich to possess art. And yet, for five cents you can fairly wallow around in the greatest collection of art in the world—the Metropolitan Museum. It is yours. Why, you are wealthy in the things that go to make life worth while! Just be patient, and use these opportunities that belong to you—the people—to improve yourselves.'

"The expressions on the faces turned up to me, changed from scowling distaste to interest, then understanding. That's what I mean by radio's opportunity—the educating of the people into an appreciation of our country."

The most remarkable thing about the rapid spread of the radiophone is that it has occurred without a law forbidding it.—Kansas City Star.

Flapper: "Whenever I comb my hair at night just before I go to bed, sparks jump and crackle. Can't you give me a lightning arrester or something that will keep the wireless waves out of my hair?"



Lieut. Paddock in charge of broadcasting in the operating room at WVP

contralto; Emily Roosevelt Chadderton, soprano; Andrew Haigh, pianist; Ruth Fried, soprano; Elsie Duffield, soprano; Schima Kaufman, violinist; Bartolo Vavatini, baritone; Willy Sauber, pianist; George Kanony, French baritone; Eugenia Jones, whistler.

Artists supplied by the Knabe Piano Co. also have appeared, as have those of the General Phonograph Corporation on the historic Bedloe's Island.

On one night a man appeared who demonstrated each instrument in a band. At another time a group of negro singers sang negro melodies.

government now uses wireless almost exclusively in the transmission of telegraph messages. Washington, D. C., acts as the mother station, as it were. From there most orders emanate. The Bedloe's Island station is operated by remote control from Governor's Island, across the harbor, in the transmission of such government work. Through this network of stations, the government has been able to cut its commercial telegraph bill to almost nothing. It saves, in the Second Area alone, from \$1,000 to \$1,500 a month in message tolls. Give this a thought when next you pay your income tax.

Radio Penetrates Prison Walls

(Continued from page 28)

too, they hear sermons preached in distant cities, transmitted and received by radio telephone.

It must not be mistakenly imagined that the introduction of radio into prison life will lay a path of roses for the prisoners to walk upon. They

must do their work now, and they will do it in the same way now that radio has reached the prison.

But the officials know that it will introduce a new element. It will constantly remind the prisoner, in a constructive way, of the outside world.

Distant Broadcasting Stations Heard

Broadcasting fans daily surprise themselves and others by reaching out across hundreds of miles by a turn of the wrist. Often the most simple bulb equipment will produce astonishing results, as reported below. What have YOU done?

Covers 1,450 Miles

EDWARD C. GILL, of Earlsyville, Va., reports that he is justly proud of himself and his U. V. 200 detector tube. His pride springs from the list of broadcasting stations he has heard with the single tube, without amplification, covering distances up to 1,450 miles. His list is as follows:

WGY	Schenectady	475	miles
WBAY	New York City	325	"
WWZ	New York City	325	"
WVP	New York City	325	"
WJZ	Newark, N. J.	315	"
WOR	Newark, N. J.	315	"
3XW	Parkersburg, Pa.	225	"
WEAS	Washington, D. C.	105	"
WPM	Washington, D. C.	105	"
NOF	Washington, D. C.	105	"
KDKA	Pittsburg, Pa.	205	"
WHK	Cleveland, O	320	"
WWJ	Detroit, Mich.	405	"
WHAS	Louisville, Ky.	425	"
WSK	Indianapolis, Ind.	405	"
KYW	Chicago, Ill.	565	"
KSD	St. Louis, Mo.	650	"
WSB	Atlanta, Ga.	465	"
WAAG	Shreveport, La.	945	"
WPO	Memphis, Tenn.	695	"
KFAF	Denver, Colo.	1450	"
WHA	Madison, Wis.	700	"
WCX	Detroit, Mich.	405	"

Mr. Gill also has heard faintly, a station on the Pacific Coast signing off, and his chief indoor sport now is trying to tune it in again.

2,300-Mile Broadcast Reception with Amateur Set

WHAT is believed to be a record for reception of a broadcasting station program with an amateur set was made on August 16, at Watertown, N. Y., when the music and news reports of Station KFC, the broadcasting station of the Northern Radio and Electric Company, Seattle, Washington, was clearly received by Henry B. Graves, Jr., of the Frank A. Empsall Co., an approximate distance of 2,300 miles.

A receiving set of the General Electric Company, Type AR-1300 and AA-1400 was connected to a makeshift antenna about 50 feet high and 150 feet in length. No earth connec-

tion was used, a loop composed of ten turns of No. 18 lamp cord on a 4-foot frame, being used as a counterpoise. When a Western Electric No. 7A loud speaker was attached to the receiving set in place of the head telephones, the music and speech from KFC could be heard 300 feet away.

Later in the evening the programs of stations WHAS, Louisville, Ky.; WOH, Indianapolis, Ind.; and KSD at St. Louis, Mo., were also brought in with exceptional volume and clarity.

The reception of the music and speech of Station KFC is undoubtedly a distance record for radiophone reception using an amateur type of set.

Hears Porto Rico

LUBIN PALMER, Schooley's Mountain, N. J., is doing some exceptional broadcasting reception work over long distances. Despite his proximity to WJZ at Newark, he has been able to hear broadcast programs from as far west as Kansas City, Mo., and has done even better distance work to the south, hearing the station at San Juan, Porto Rico, 1,225 miles away in an air line. His list of distant stations is as follows:

KSD	St. Louis, Mo.	875	miles
WHAS	Louisville, Ky.	625	"
WSB	Atlanta, Ga.	745	"
WOC	Davenport, Ia.	850	"
WHB	Kansas City, Mo.	1075	"
WBSQ	San Juan, P. R.	1225	"

WSB Heard on Pacific

PHILIP I. MERRYMAN, a commercial operator on the tug *Oneonta*, heard WSB, Atlanta, Ga., on July 29, while the tug was in Columbia Bay, off Astoria, Oregon. This is a distance of 2,300 miles, airline, from Atlanta.

Mr. Merryman picked up the Atlanta station at 9.43 p. m., meridian standard time, or 11.43 p.m., Atlanta time, just as WSB signed off for the evening. He was astounded to hear the voice announce itself as Atlanta. As Mr. Merryman remarked in his letter, "Boy, that's real DX!"

On One Bulb

JACQUES H. HERTS, of New York City, has an Aeriola Senior, and was surprised on September 12th to hear KDS, at St. Louis, 900 miles away. The same evening a slightly different adjustment brought in WHAS, at Louisville, Ky., 650 miles, and another, WWJ, Detroit, about 500 miles, airline distance. These three stations were all heard between 10 and 11 p. m. Mr. Herts uses no amplifier, and has a single wire 60 feet long, with a 50-foot lead-in.

Apartment House de Luxe

THE builder of a certain apartment house in Newark, N. J., is installing what is believed to be the most up-to-date set of radio equipment for this type of dwelling.

The building will have 72 apartments. A system will be installed with two complete Radiola receiving sets, each with a large loop or directional antenna, so that each may be pointed to a particular broadcasting station and receive concerts without interference from any other.

Each set will be equipped with two steps of radio and two steps of audio frequency amplification. The apparatus will be in a special room in charge of a licensed operator, and connections will run to each apartment, so that a tenant may plug in on whichever concert or program he likes best.

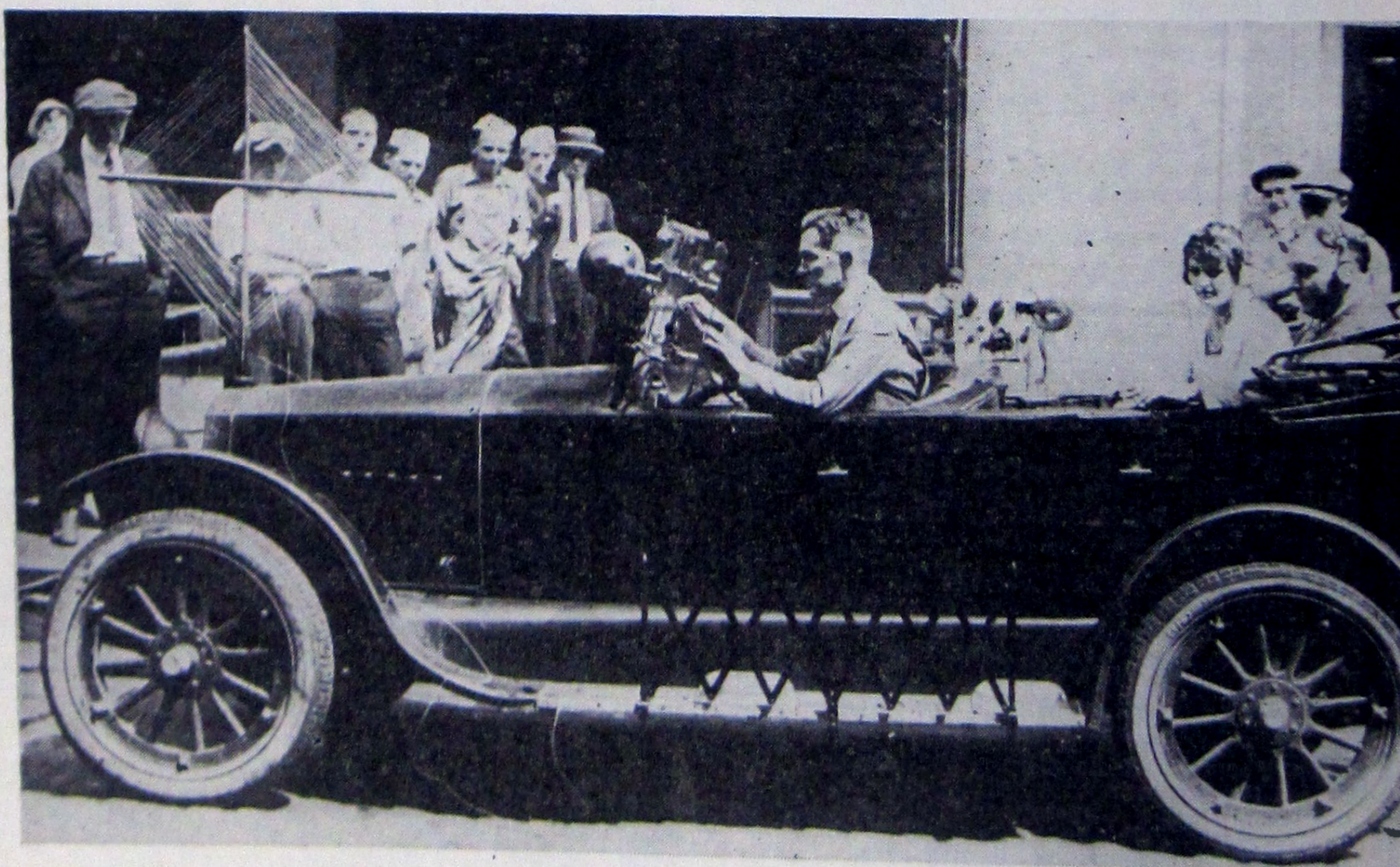

A touring car in Chicago equipped with radio telephone receiving equipment. Paul D. Coats, a fan, shown at the wheel, rides about the city's streets and hears concerts from as far away as Newark, N. J.

BROADCASTING STATION DIRECTORY

(Revised to September 16, 1922)

KAO Young Men's Christian Association Denver, Colo.
KDN Leo U. Meyberg Co., San Francisco, Calif.
KFC Northern Radio & Electric Co., Seattle, Wash.
KFI E. C. Anthony, Los Angeles, Calif.
KFV Foster Bradbury Radio Store, Yakima, Wash.
KFZ Doerr Mitchell Elec. Co., Spokane, Wash.
KGB Wm. A. Mullins Electric Co., Tacoma, Wash.
KGF Pomona Fixture & Wiring Co., Pomona, Calif.
KGG Hallock & Watson Radio Service, Portland, Ore.
KGN Northwestern Radio Mfg. Co., Portland, Ore.
KGO Altadena Radio Laboratory, Altadena, Calif.
KGU M. A. Muirony, Honolulu, Hawaii
KGW Oregonian Publishing Co., Portland, Ore.
KGY St. Martin's College, Lacey, Wash.
KHD Aldrich Marble & Granite Co., Colorado Springs, Colo.
KHJ C. R. Kieruff & Co., Los Angeles, Calif.
KHQ Louis Wasmer, Seattle, Wash.
KJC Standard Radio Co., Los Angeles, Calif.
KJJ The Radio Shop, Sunnyvale, Calif.
KJQ C. O. Gould, Stockton, Calif.
KJR Vincent I. Kraft, Seattle, Wash.
KJS Bible Institute of Los Angeles, Inc., Los Angeles, Calif.
KLB J. J. Dunn & Co., Pasadena, Calif.
KLN Noggle Electric Works, Monterey, Calif.
KLP Colin B. Kennedy Co., Los Altos, Calif.
KLS Warner Brothers, Oakland, Calif.
KLX Tribune Publishing Co., Oakland, Calif.
KLZ Reynolds Radio Co., Denver, Colo.
KMC Lindsay-Weatherill & Co., Readley, Calif.
KMJ San Joaquin Light & Power Co., Fresno, Calif.
KMO Love Electric Co., Tacoma, Wash.
KNI T. W. Smith, Eureka, Calif.
KNJ Roswell Public Service Co., Roswell, N. M.
KNN Bullok's, Los Angeles, Calif.
KNT North Coast Products Co., Aberdeen, Wash.
KNV Radio Supply Co., Los Angeles, Calif.
KNX Electric Lighting Supply Co., Los Angeles, Calif.
KOA Y. M. C. A., Denver, Colo.
KOB New Mexico College of Agriculture and Mechanical Arts, State College, N. Mex.
KOE Spokane Chronicle, Spokane, Wash.
KOG Western Radio Electric Co., Los Angeles, Calif.
KON Holzwasser, Inc., San Diego, Calif.
KOP Detroit Police Dept., Detroit, Mich.
KOQ Modesto Evening News, Modesto, Calif.
KPO Hale Brothers, San Francisco, Calif.
KQI University of California, Berkeley, Calif.
KQP Blue Diamond Electric Co., Hood River, Ore.
KQT Electric Power & Appliance Co., Yakima, Wash.
KQV Doubleday-Hill Electric Co., Pittsburgh, Pa.
KQW Charles D. Herrold, San Jose, Calif.
KQY Stubbs Electric Co., Portland, Ore.
KRE Maxwell Electric Co., Berkeley, Calif.
KSD Post Dispatch, St. Louis, Mo.
KSL The Emporium, San Francisco, Calif.
KSS Prest & Dean Radio Rsch. Lab., Long Beach, Cal.
KTW First Presbyterian Church, Seattle, Wash.
KUO The Examiner Printing Co., San Francisco, Calif.
KUS City Dye Works & Laundry Co., Los Angeles, Calif.
KUY Coast Radio Co., Del Monte, Calif.
KVQ J. C. Hobrecht, Sacramento, Calif.
KWG Portable Wireless Telephone Co., Stockton, Calif.
KWH Los Angeles Examiner, Los Angeles, Calif.
KXD Herald Publishing Co., Modesto, Calif.
KXS Braun Corporation, Los Angeles, Calif.
KYF Theatre Music Co., San Diego, Calif.
KYG Willard P. Hawley, Jr., Portland, Ore.
KYI Alfred Harrell, Bakersfield, Calif.
KYJ Leo J. Meyberg Co., Los Angeles, Calif.
KYW Westinghouse Electric & Mfg. Co., Chicago, Ill.
KYY The Radio Telephone Shop, San Francisco, Calif.
KZC Public Market & Mkt. Stores Co., Seattle, Wash.
KZM Preston D. Allen, Oakland, Calif.
KZN The Desert News, Salt Lake City, Utah
KZV Wenatchee Battery & Motor Co., Wenatchee, Wash.
KZX Atlantic Pacific Radio Supplies Co., Oakland, Calif.
KDKA Westinghouse Electric & Mfg. Co., Pittsburgh, Pa.
KDPT Southern Electric Co., San Diego, Calif.
KDYL Telegram Publishing Co., Salt Lake City, Utah
KDYM Savoy Theatre, San Diego, Calif.
KDYN Great Western Radio Corp., Redwood City, Cal.
KDYO Carson & Simpson, San Diego, Calif.
KDYZ Oregon Institute of Technology, Portland, Ore.
KDYR Pasadena Star News Pub. Co., Pasadena, Calif.
KDYS The Tribune, Inc., Great Falls, Mont.
KDYU Herald Publishing Co., Klamath Falls, Ore.
KDYV Cope & Cornwell Co., Salt Lake City, Utah
KDYW Smith Hughes & Co., Phoenix, Ariz.
KDYX Star Bulletin Publishing Co., Honolulu, T. H.
KDZA Arizona Daily Star, Tucson, Ariz.
KDZB Frank E. Siefert, Bakersfield, Calif.
KDZD W. B. Mitchell, Los Angeles, Calif.
KDZE The Rhodes Co., Seattle, Wash.
KDZF Automobile Club of So. Calif., Los Angeles, Cal.
KDZG Cyrus Peires & Co., San Francisco, Calif.
KDZH Fresno Evening Herald, Fresno, Calif.
KDZI Electric Supply Co., Wenatchee, Wash.
KDZJ Excelsior Radio Co., Eugene, Ore.
KDZK Nevada Machinery & Electric Co., Reno, Nev.
KDZL Rocky Mountain Radio Corp., Ogden, Utah
KDZM E. A. Hollingworth, Centralia, Wash.
KDZP Newberry Electric Corporation, Los Angeles, Cal.
KDZQ William D. Pyle, Denver, Colo.
KDZR Bellingham Publishing Co., Bellingham, Wash.
KDZS Seattle Radio Association, Seattle, Wash.
KDZT Western Radio Corporation, Denver, Colo.
KDZU Cope & Cornwell Co., Salt Lake City, Utah
KDZV Claude W. Gerdes, San Francisco, Calif.
KDZW Glad Tidings Tabernacle, San Francisco, Cal.
KDZX

KDZZ Kinney Brothers & Sipprell, Everett, Wash.
KFAB Pacific Radiophone Co., Portland, Ore.
KFAC Glendale Daily Press, Glendale, Calif.
KFAD McArthur Brothers Mercantile Co., Phoenix, Ariz.
KFAE State College of Washington, Pullman, Wash.
KFAF Western Radio Corporation, Denver, Colo.
KFAJ University of Colorado, Boulder, Colo.
KFAN Electric Shop, Moscow, Idaho
KFAP Standard Publishing Co., Butte, Mont.
KFAQ City of San Jose, San Jose, Calif.
KFAR O. K. Olsen, Hollywood, Calif.
KFAS Reno Motor Supply Co., Reno, Nev.
KFAT Dr. S. T. Donohue, Eugene, Ore.
KFAU Independent School District, Boise City, Idaho
KFAV Cooke & Chapman, Venice, Calif.
KFAW The Radio Den, Ashford & White, Santa Anna, Calif.
KFAY W. J. Virgin Milling Co., Central Point, Ore.
KFBB F. A. Buttrey & Co., Havre, Mont.
KFBC W. K. Azbill, San Diego, Calif.
KFBD Clarence V. Welch, Hanford, Calif.
KFBE Reuben H. Horn, San Luis, Gbiso, Calif.
KFBF F. H. Smith, Butte, Mont.
KFBH Thomas Musical Co., Marshfield, Ore.
KFBJ Boise Radio Supply Co., Boise, Idaho
KFBK Kimball-Upson Co., Sacramento, Calif.
KFBL Leese Brothers, Everett, Wash.
KFBM Cook & Foster, Astoria, Ore.
KFBN Borch Radio Corporation, Oakland, Calif.
KFBQ Savage Electric Co., Prescott, Ariz.
KFCB Nielsen Radio Supply Co., Phoenix, Ariz.
KFCB Auto Supply Co., Wallace, Idaho
KFCB Salem Elec. Co., Salem, Ore.
KFCB Mercantile Trust Co., San Francisco, Calif.
WAH Midland Refining Co., El Dorado, Kans.
WBL T. & H. Radio Co., Anthony, Kans.
WBS D. W. May, Inc., Newark, N. J.
WBT Southern Radio Corporation, Charlotte, N. C.
WBU City of Chicago, Chicago, Ill.
WBZ Westinghouse Elec. & Mfg. Co., Springfield, Mass.
WCE Findley Electric Co., Minneapolis, Minn.
WCJ A. C. Gilbert Co., New Haven, Conn.
WCK Stix-Baer-Fuller, St. Louis, Mo.
WCM University of Texas, Austin, Tex.
WCN Clark University, Worcester, Mass.
WCT Detroit Free Press, Detroit, Mich.
WDM Church of the Covenant, Washington, D. C.
WDT Ship Owners Radio Service, New York, N. Y.
WDV John O. Yelser, Jr., Omaha, Nebr.
WDZ James L. Bush, Tuscola, Ill.
WEB Benwood Co., St. Louis, Mo.
WEH Midland Refining Co., Tulsa, Okla.
WEV Hurlburt-Still Electrical Co., Houston, Tex.
WEW St. Louis University, St. Louis, Mo.
WEY Cosradio Co., Wichita, Kans.
WFI Strawbridge & Clothier, Philadelphia, Pa.
WFO The Rike Kumler Co., Dayton, Ohio
WGF The Register & Tribune, Des Moines, Iowa
WGI American Radio and Research Corporation, Medford Hillside, Mass.
WGL Thomas F. J. Howlett, Philadelphia, Pa.
WGR Federal Tel. & Tel. Co., Buffalo, N. Y.
WGU The Fair, Chicago, Ill.
WGV Interstate Electric Co., New Orleans, La.
WGY General Electric Co., Schenectady, N. Y.
WHA University of Wisconsin, Madison, Wisc.
WHB Sweeney School Co., Kansas City, Mo.
WHD West Virginia University, Morgantown, W. Va.
WHK Warren R. Cox, Cleveland, Ohio
WHN Ridgewood Times Printing & Pub. Co., Ridgewood, N. Y.
WHQ Rochester Times Union, Rochester, N. Y.
WHU William B. Duck Co., Toledo, Ohio
WHW Stewart W. Seeley, East Lansing, Mich.
WHX Iowa Radio Corporation, Des Moines, Iowa
WHY K. & L. Electric Co., McKeesport, Pa.
WIL Continental Electric Supply Co., Washington, D. C.
WIP Gimbel Brothers, Philadelphia, Pa.
WIZ Cino Radio Mfg. Co., Cincinnati, Ohio
WJD Richard H. Howe, Granville, Ohio
WJK White & Boyer, Washington, D. C.
WJL Service Radio Equipment Co., Toledo, Ohio
WJM Electric Equipment Co., Erie, Pa.
WJN DeForest Radio Tel. & Tel. Co., New York, N. Y.
WJW Westinghouse Elec. & Mfg. Co., Newark, N. J.
WJZ Westinghouse, Baltimore, Md.
WKC Joseph M. Zamoiski Co., Memphis, Tenn.
WKN Riechman-Crosby Co., Oklahoma City, Okla.
WKY Oklahoma Radio Shop, Oklahoma City, Okla.
WLB University of Minnesota, Minneapolis, Minn.
WLK Hamilton Mfg. Co., Indianapolis, Ind.
WLW Crosley Mfg. Co., Cincinnati, Ohio
WMA Arrow Radio Laboratories, Anderson, Ind.
WMB Auburn Electrical Co., Auburn, Me.
WMC Columbia Radio Co., Youngstown, Ohio
WMD Precision Equipment Co., Cincinnati, Ohio
WML Doubleday-Hill Electrical Co., Pittsburgh, Pa.
WNU Shotton Radio Mfg. Co., Albany, N. Y.
WNO Wireless Telephone Co. of Hudson County, N. J., Jersey City, N. J.
WOC Palmer School of Chiropractic, Davenport, Iowa
WOE Buckeye Radio Service Co., Akron, Ohio
WOH Hatfield Electric Co., Indianapolis, Ind.
WOI Iowa State College, Ames, Iowa
WOK Arkansas Light & Power Co., Pine Bluff, Iowa
WOO John Wanamaker, Philadelphia, Pa.
WOQ Western Radio Co., Kansas City, Mo.
WOR L. Bamberger & Co., Newark, N. J.
WOS Missouri State Mktg. Bureau, Jefferson City, Mo.
WOU Metropolitan Utilities District, Omaha, Nebr.
WOZ Palladium Printing Co., Richmond, Ind.
WPA Fort Worth Record, Fort Worth, Tex.
WPE Central Radio Co., Kansas City, Mo.
WPG Nushawg Poultry Farm, New Lebanon, Ohio
WPI Electric Supply Co., Clearfield, Pa.
WPL St. Joseph's College, Philadelphia, Pa.
WPM Fergus Electric Co., Zanesville, Ohio
WPN Thomas J. Williams, Washington, D. C.
WPO United Equipment Co., Memphis, Tenn.
WPQ Walter A. Kusch, Chicago, Ill.
WRK Doron Brothers Electric Co., Hamilton, Ohio
WRL Union College, Schenectady, N. Y.
WRM University of Illinois, Urbana, Ill.

WRP Federal Institute of Radio Telegraphy, Camden, N. J.
WRR City of Dallas (Police and Fire Signal Department), Dallas, Tex.
WRW Tarrytown Radio Research Laboratory, Tarrytown, N. Y.
WSB Atlanta Journal, Atlanta, Ga.
WSL J. & M. Electric Co., Utica, N. Y.
WSN Ship Owners Radio Service, Norfolk, Va.
WSV L. M. Hunter and G. L. Carrington, Little Rock, Ark.
WSX Erie Radio Co., Erie, Pa.
WSY Alabama Power Co., Birmingham, Ala.
WSZ Marshall-Gerken Co., Toledo, Ohio
WTG Kansas State Agr. College, Manhattan, Kans.
WTK Paris Radio Electric Co., Paris, Tex.
WTP George M. McBride, Bay City, Mich.
WVP Signal Corps, Bedloe's Island, N. Y. Harbor, N. Y.
WWB Daily News Printing Co., Canton, Ohio
WWI Ford Motor Co., Dearborn, Mich.
WWJ The Detroit News, Detroit, Mich.
WWL Lovola University, New Orleans, La.
WWT McCarthy Brothers & Ford, Buffalo, N. Y.
WWZ John Wanamaker, New York, N. Y.
WAAB Valdmar Jensen, New Orleans, La.
WAAC Tulane University, New Orleans, La.
WAAD Ohio Mechanics Institute, Cincinnati, Ohio
WAAE St. Louis Chamber of Commerce, St. Louis, Mo.
WAAF Daily Drivers' Journal, Chicago, Ill.
WAAG Elliott Electric Co., Shreveport, La.
WAAH Commonwealth Electric Co., St. Paul, Minn.
WAAJ Eastern Radio Institute, Boston, Mass.
WAAK Gimbel Brothers, Milwaukee, Wisc.
WAAL Minnesota Tribune Co. & Anderson Bemich Co., Minneapolis, Minn.
WAAM L. R. Nelson Co., Newark, N. J.
WAAN University of Missouri, Columbia, Mo.
WAAP Radio Service Co., Charleston, W. Va.
WAAP Otto W. Taylor, Wichita, Kans.
WAAR New England Motor Sales Co., Greenwich, Conn.
WAAS Groves-Thornton Hardware Co., Huntington, W. Va.
WAAT Georgia Radio Co., Decatur, Ga.
WAAV Athens Radio Co., Athens, Ohio
WAAX Omaha Grain Exchange, Omaha, Nebr.
WAAY Radio Service Corp., Crafton, Pa.
WAAY Yahrling-Raynor Piano Co., Youngstown, Ohio
WAAZ Hollister-Miller Motor Co., Emporia, Kans.
WAJT Kelley-Vawter Jewelry Co., Marshall, Mo.
WAJU Yankton College, Yankton, S. D.
WAJV Indian Pipe Line Corp., Princeton, Ind.
WBAW Purdue University, West Lafayette, Ind.
WBAB Andrew J. Potter, Syracuse, N. Y.
WBAD Sterling Electric Co. and Journal Printing Co., Minneapolis, Minn.
WBAE Bradley Polytechnic Institute, Peoria, Ill.
WBAF Fred M. Middleton, Morristown, N. J.
WBAG Diamond State Fibre Co., Bridgeport, Pa.
WBAH The Dayton Co., Minneapolis, Minn.
WBAJ Marshall-Gerken Co., Toledo, Ohio
WBAM I. B. Rennyson, New Orleans, La.
WBAN Wireless Phone Corp., Paterson, N. J.
WBAO James Millikin University, Decatur, Ill.
WBAP Wortham-Carter Publishing Co., Fort Worth, Tex.
WBAQ Myron L. Harmon, South Bend, Ind.
WBAU Republican Publishing Co., Hamilton, Ohio
WBAV Erner & Hopkins Co., Columbus, Ohio
WBAW Marietta College, Marietta, Ohio
WBAX John H. Stenger, Jr., Wilkes-Barre, Pa.
WBAY American Tel. & Tel. Co., New York, N. Y.
WBZ Times Dispatch Publishing Co., Richmond, Va.
WCAB Newburgh News Printing & Publishing Co., Newburgh, N. Y.
WCAC John Fink Jewelry Co., Fort Smith, Ark.
WCAD St. Lawrence University, Canton, Ohio
WCAE Kaufman & Baer Co., Pittsburgh, Pa.
WCAH Daily States Publishing Co., New Orleans, La.
WCAI Entreklin Electric Co., Columbus, Ohio
WCAJ Nebraska Wesleyan University, University Pl., Neb.
WCAK Alfred P. Daniel, Houston, Tex.
WCAL St. Olaf College, Northfield, Minn.
WCAM Villanova College, Villanova, Pa.
WCAN Southeastern Radio Telephone Co., Jacksonville, Fla.
WCAO Sanders & Stayman Co., Baltimore, Md.
WCAP Central Radio Service, Decatur, Ill.
WCAQ Tri-State Radio Mfg. & Supply Co., Defiance, Ohio
WCAR Alamo Radio Electric Co., San Antonio, Tex.
WCAS William Hood Dunwoody Industrial Institute, Minneapolis, Minn.
WCAT South Dakota State School of Mines, Rapid City, S. Dak.
WCAU Philadelphia Radiophone Co., Philadelphia, Pa.
WCAV J. C. Dice Electric Co., Little Rock, Ark.
WCAW Quincy Herald & Quincy Electric & Supply Co., Quincy, Ill.
WCAX University of Vermont, Burlington, Vt.
WCAY Kesselmen O'Drescoll Co., Milwaukee, Wisc.
WCBA Robert E. Compton, Carthage, Ill.
WCBB Ward-Belmont School, Portsmouth, Ohio
WCDB M. C. Sumner & Son, Springfield, Ill.
WCDC Illinois Watch Co., Lindsborg, Kans.
WCDD William Louis Harrison, Tampa, Fla.
WCDE Tampa Daily Times, Tampa, Fla.
WCDF Kansas City Star, Kansas City, Mo.
WCAG J. Laurence Martin, El Paso, Tex.
WCDA Mine & Smelter Supply Co., Syracuse, N. Y.
WCDA Hughes Electrical Corp., Syracuse, N. Y.
WDAJ Atlanta & West Point R. R. Co., College Park, Ga.
WDAK The Courant, Hartford, Conn.
WDAL Florida Times Union, Jacksonville, Fla.
WDAM Weston Electric Co., New York, N. Y.
WDAN Glenwood Radio Corp., Shreveport, La.
WDAO Automotive Electric Co., Dallas, Tex.
WDAP Midwest Radio Central, Inc., Chicago, Ill.
WDAQ Hartman-Riker Elec. & Mach. Co., Brownsville, Pa.
WDAU Lit Brothers, Philadelphia, Pa.
WDAS Samuel W. Waite, Worcester, Mass.
WDAT Delta Electric Co., Worcester, Mass.
WDAU Slocum & Kilburn, New Bedford, Mass.

WDAV Muskogee Daily Phoenix.....Muskogee, Okla.
 WDAW Georgia Railway & Power Co.....Atlanta, Ga.
 WDAX First National Bank.....Centerville, Iowa
 WDAY Kenneth M. Hance.....Fargo, N. D.
 WEAA Fallain & Lathrop.....Flint, Mich.
 WEAB Standard Radio Equipment Co.....Fort Dodge, Iowa
 WEAC Baines Electric Service Co.....Terre Haute, Ind.
 WEAD Northwest Kansas Radio Sup. Co., Atwood, Kans.
 WEAE Virginia Polytechnic Institute, Blacksburg, Va.
 WEAF Western Electric Co.....New York, N. Y.
 WEAG Nichols-Hineline-Bassett.....Edgewood, R. I.
 WEAH Wichita Board of Trade & Landers Radio Co.,
 Wichita, Kans.
 WEAI Cornell University.....Ithaca, N. Y.
 WEAJ University of South Dakota.....Vermillion, S. Dak.
 WEAK Julius B. Abercrombie.....St. Joseph, Mo.
 WEAM Borough of North Plainfield,
 North Plainfield, N. J.
 WEAN Shepard Company.....Providence, R. I.
 WEAO Ohio State University.....Columbus, Ohio
 WEAP Mobile Radio Co., Inc.....Mobile, Ala.
 WEAR Y. M. C. A.....Berlin, N. H.
 WEAS Baltimore Am. & News Pub. Co., Baltimore, Md.
 WEAT Hecht Company.....Washington, D. C.
 WEAT John J. Fogarty.....Tampa, Fla.
 WEAU Davidson Brothers Co.....Sioux City, Iowa
 WEAV Sheridan Electric Service Co., Rushville, Nebr.
 WEAW Arrow Radio Laboratories.....Anderson, Ind.
 WEAX T. J. M. Daly.....Little Rock, Ark.
 WEAY Will Horwitz, Jr.....Houston, Tex.
 WEAZ Donald Redmond.....Waterloo, Iowa
 WFAA A. H. Belo & Co.....Dallas, Tex.
 WFAC Carl F. Woese.....Syracuse, N. Y.
 WFAC Superior Radio Co.....Superior, Mich.
 WFAD Watson, Weldon Motor Supply Co., Salina, Kans.
 WFAF Henry C. Spratley.....Poughkeepsie, N. Y.
 WFAH Radio Engineering Laboratory.....Waterford, N. Y.
 WFAI Electrical Supply Co.....Port Arthur, Tex.
 WFAJ Hi-Grade Wireless Instrument Co.,
 Asheville, N. C.
 WFAL Houston Chronicle Pub. Co.....Houston, Tex.
 WFAM Times Publishing Co.....St. Cloud, Minn.
 WFAN Hutchinson Elec. Service Co.....Hutchinson, Minn.
 WFAQ Brown's Business College.....Peoria, Ill.
 WFAQ Missouri Wesleyan College and Cameron Radio
 Company.....Cameron, Mo.
 WFAH Hall & Stubbs.....Sanford, Me.
 WFAS United Radio Corporation.....Fort Wayne, Ind.
 WFAT Daily Argus Leader.....Sioux Falls, S. D.
 WFAU Edwin C. Lewis, Inc.....Boston, Mass.
 WFAV University of Nebraska.....Lincoln, Nebr.
 WFAW Miami Daily Metropolis.....Miami, Fla.
 WFAZ Arthur L. Kent.....Binghamton, N. Y.
 WFAZ Daniels Radio Supply Co.....Independence, Kans.
 WFAZ South Carolina Radio Shop.....Charleston, S. C.
 WGAB QRV Radio Co.....Houston, Tex.
 WGAC Orpheum Radio Stores Co.....Brooklyn, N. Y.
 WGAD Spanish Am. Schl. of Telegraphy,
 Ensonada, P. R.
 WGAH Goller Radio Service.....Tulsa, Okla.
 WGAH New Haven Elec. Co.....New Haven, Conn.
 WGAJ W. H. Glass.....Shenandoah, Iowa
 WGAK Macon Electric Co.....Macon, Ga.
 WGAJ Lancaster Elec. Supply & Const. Co.,
 Lancaster, Pa.

WGAM Orangeburg Radio Equipment Co.,
 Orangeburg, S. C.
 WGAN Ceell E. Lloyd.....Shreveport, La.
 WGAQ W. G. Patterson.....Pensacola, Fla.
 WGAR Southern American.....Fort Smith, Ga.
 WGS Ray-di-co Organization.....Chicago, Ill.
 WGAT American Legion, Dept. of Nebr., Lincoln, Nebr.
 WGAU Marcus G. Lumb.....Wooster, Ohio
 WGAU B. H. Radio Co.....Savannah, Ga.
 WGAU Ernest C. Albright.....Altoona, Pa.
 WGAX Radio Electric Co., Washington Courthouse, Ohio
 WGAY North Western Radio Co.....Madison, Wisc.
 WGAZ South Bend Tribune.....South Bend, Ind.
 WHAA State University of Iowa.....Iowa City, Ia.
 WHAB Clark W. Thompson.....Galveston, Tex.
 WHAC Cole Brothers Elec. Co.....Waterloo, Iowa
 WHAD Marquette University.....Milwaukee, Wisc.
 WHAE Automotive Electric Service Co., Sioux City, Ia.
 WHAF Radio Electric Co.....Pittsburgh, Pa.
 WHAG University of Cincinnati.....Cincinnati, Ohio
 WHAH J. T. Griffin.....Joplin, Mo.
 WHAJ Radio Equipment & Mfg. Co.....Davenport, Iowa
 WHAJ Bluefield Daily Telegraph.....Bluefield, W. Va.
 WHAK Roberts Hardware Co.....Clarksburg, W. Va.
 WHAL Phillips, Jeffrey & Derby.....Lansing, Mich.
 WHAM School of Music, Rochester, Unlv.,
 Rochester, N. Y.
 WHAN Southwestern Radio Co.....Wichita, Kans.
 WHAO F. A. Hill.....Savannah, Ga.
 WHAP Dewey L. Otta.....Decatur, Ill.
 WHAQ Semmes Motor Co.....Washington, D. C.
 WHAR Paramount Radio & Elec. Co.,
 Atlantic City, N. J.
 WHAS Courier Journal & Louisville Times,
 Louisville, Ky.
 WHAT Yale Democrat & Yale Tel. Co.....Yale, Okla.
 WHAU Corinth Radio Supply Co.....Corinth, Miss.
 WHAV Wilmington Elec. & Supply Co.,
 Wilmington, Del.
 WHAW Pierce Electric Co.....Tampa, Fla.
 WHAX Huntington Press.....Huntington, Ind.
 WHAZ Rensselaer Polytechnic Institute.....Troy, N. Y.
 WIAA Waupaca Civic & Commerce Assn., Waupaca, Wis.
 WIAB Joslyn Automobile Co.....Rockford, Ill.
 WIAD Ocean City Yacht Club.....Ocean City, N. J.
 WIAE Mrs. Robt. E. Zimmerman.....Venton, Ia.
 WIAF Gustav A. DeCortin.....New Orleans, La.
 WIAG Matthews Electric Supply Co., Birmingham, Ala.
 WIAH Continental Radio Mfg. Co.....Newton, Mo.
 WIAI Heers Stores Co.....Springfield, Mo.
 WIAJ Fox River Valley Radio Supply Co., Neenah, Wisc.
 WIAK The Stockman Journal.....Omaha, Nebr.
 WIAL Standard Radio Service Co.....Norwood, Ohio
 WIAN Chronicle & News Pub. Co.....Allentown, Pa.
 WIAP J. A. Rudy & Sons.....Paducah, Ky.
 WIAQ Chronicle Publishing Co.....Marion, Ind.
 WIAS Burlington Hawkeye-Home Elec. Co.,
 Burlington, Ia.
 WIAT Leon T. Noel.....Tarkio, Mo.
 WIAU American Sec. & Sav. Bank.....Le Mars, Ia.
 WIAV New York Radio Laboratories.....Binghamton, N. Y.
 WIAW Saginaw Radio & Elec. Co.....Saginaw, Mich.
 WIAZ Capital Radio Co.....Lincoln, Nebr.
 WIAZ Woodward & Lothrop.....Washington, D. C.
 WIAZ Electric Supply Sales Co.....Miami, Fla.

WJAB American Radio Co.....Lincoln, Nebr.
 WJAC Rodoll Co.....Joplin, Mo.
 WJAD Jackson's Radio Eng. Lab.....Waco, Tex.
 WJAE Texas Radio Syndicate.....San Antonio, Tex.
 WJAG Huse Publishing Co.....Norfolk, Nebr.
 WJAH Central Park Amusement Co.....Rockford, Ill.
 WJAJ Y. M. C. A.....Dayton, Ohio
 WJAK White Radio Laboratory.....Stockdale, Ohio
 WJAL Victor Radio Corporation.....Portland, Me.
 WJAM D. M. Perham.....Cedar Rapids, Ia.
 WJAN Peoria Star & Peoria Radio Sales Co., Peoria, Ill.
 WJAP Kelly-Duluth Co.....Duluth, Minn.
 WJAR The Outlet Co.....Providence, R. I.
 WJAS Pittsburgh Radio Supply House, Pittsburgh, Pa.
 WJAX D. M. Perham.....Cedar Rapids, Ia.
 WJAZ Chicago Radio Laboratory.....Chicago, Ill.
 WKA Landaus Music & Jewelry Co., Wilkes-Barre, Pa.
 WKAA H. F. Paar & Republican Times,
 Cedar Rapids, Ia.
 WKAC Star Publishing Co.....Lincoln, Nebr.
 WKAD Charles Loof.....East Providence, R. I.
 WKAF W. S. Radio Supply Co. and Wm. Schack,
 Wichita Falls, Tex.
 WKAG Edwin T. Bruce, M.D.....Louisville, Ky.
 WKAH Planet Radio Co.....West Palm Beach, Fla.
 WKAJ Fargo Plumbing & Heating Co.....Fargo, N. D.
 WKAK Okfuskee County News.....Okemah, Okla.
 WKAL Gray & Gray.....Orange, Tex.
 WKAM Adam Breede, Hastings Daily Tribune,
 Hastings, Nebr.
 WKAN Alabama Radio Mfg. Co.....Montgomery, Ala.
 WKAP Flint, Dutee Wilcox.....Cranston, R. I.
 WKAQ Radio Corporation of Porto Rico, San Juan, P. R.
 WKAR Michigan Agri. College.....East Lansing, Mich.
 WKAS L. E. Lines Music Co.....Springfield, Mo.
 WKAT Frankfort Morning Times.....Frankfort, Ind.
 WKAV Laconia Radio Club.....Laconia, N. H.
 WKAW Turner Cycle Co.....Beloit, Wisc.
 WKAX Wm. A. MacFarlane.....Bridgeport, Conn.
 WKAY Brenau College.....Janesville, Ga.
 WLAB George F. Grossman.....Carrollton, Mo.
 WLAC North Carolina State College.....Raleigh, N. C.
 WLAD Arvanette Radio Supply Co.....Hastings, Nebr.
 WLAJ Johnson Radio Co.....Lincoln, Nebr.
 WLAG Cutting & Washington Radio Corp.,
 Minneapolis, Minn.
 WLAH Samuel Woodworth.....Syracuse, N. Y.
 WLAJ Waco Electrical Supply Co.....Waco, Tex.
 WLAK Vermont Farm Mach. Co.....Bellows Falls, Vt.
 WLAL Tulsa Radio Co.....Tulsa, Okla.
 WLAM Morrow Radio Co.....Springfield, O.
 WLAN Putnam Hardware Co.....Houlton, Me.
 WLAO Anthracite Radio Shop.....Scranton, Pa.
 WLAJ W. V. Jordan.....Louisville, Ky.
 WLAQ A. E. Schilling.....Kalamazoo, Mich.
 WLAR Mickel Music Co.....Marshalltown, Iowa
 WLAT Chas. G. Bosch Co.....Burlington, Iowa
 WMAJ Radio Supply Co.....Oklahoma City, Okla.
 WMAK F. Edward Page.....Fernwood, Cazenovia, N. Y.
 WMAF Round Hills Radio Corp.....Dartmouth, Mass.
 WMAH General Supply Co.....Lincoln, Nebr.
 WMAH Beaumont Radio Equipment Co.....Beaumont, Tex.
 WNAC Shepard Stores.....Boston, Mass.
 WNAL R. J. Rockwell.....Omaha, Nebr.
 WOAI Southern Equipment Co.....San Antonio, Tex.

New Class of Broadcasting Stations

Government Creates "Class B" With Authority to Use 400 Meters for Such Stations as Can Comply With High Requirements Covering Equipment and Operation

CREATION of a new class of super-broadcasting stations has been authorized by the Department of Commerce, which has assigned a wave-length of 400 meters to the new classification. Stations using this wave-length will be known as "Class B" broadcasting stations. The new class will consist of only a few stations, well scattered over the country to prevent interference, and chosen entirely with regard to their capabilities, both as concerns radio technical matters and entertaining ability.

The new regulation establishing the special Class B station and defining it are as follows:

AMENDMENTS TO REGULATIONS
 To Radio Inspectors and Others Concerned:
 Regulation 57, page 55, amended August 8, 1922, to read:

CLASS "B" RADIOTELEPHONE BROADCASTING STATIONS
 A new class of radiotelephone broadcasting station license is hereby established to be known as Class "B."
 A license will not be issued for a station in this class which does not comply in every respect with the specifications hereunder.

Specifications covering the requirements governing the construction, licensing, operating and service of Class "B" radiotelephone broadcasting stations:

STATION
WAVE-LENGTH—The wave-length of 400 meters only will be assigned for the use of stations of this class which must be reasonably free from harmonics.

POWER—The power supply must be dependable and non-fluctuating. The minimum required will be 500 watts in the antenna and the maximum shall not exceed 1,000 watts in the antenna.

MODULATION—The system must be so arranged as to cause the generated radio frequency current to vary accurately according to the sound impressed upon the microphone system.

SPARE PARTS—Sufficient tubes and other material must be readily available to insure continuity and reliability of the announced schedule of service.

ANTENNA—The antenna must be so constructed as to prevent swinging.

SIGNALING SYSTEM—Some dependable system must be provided for communication between the operating room and the studio.

STUDIO—The radio equipment in the

studio must be limited to that essential for use in the room. The room shall be so arranged as to avoid sound reverberation and to exclude external and unnecessary noises.

SERVICE
PROGRAMS—The programs must be carefully supervised and maintained to insure satisfactory service to the public.

MUSIC—Mechanically operated musical instruments may be used only in an emergency and during intermission periods in regular program.

DIVISION OF TIME—Where two or more stations of Class "B" are licensed in the same city or locality a division of time will be required if necessary.

FORFEITURE OF 400 METERS PRIVILEGE

Licenses issued for the use of the 400 meters wave-length shall specially provide that any failure to maintain the standards prescribed for such stations may result in the cancellation of the license and requiring the station to use the 360 meter wave-length.

D. B. CARSON,
 Commissioner of Navigation.

Approved
 HERBERT HOOVER,
 Secretary of Commerce.

Cartoonists' Wit Amuses Radioists All Over The Country

CAN YOU BEAT IT?

METROPOLITAN MOVIES

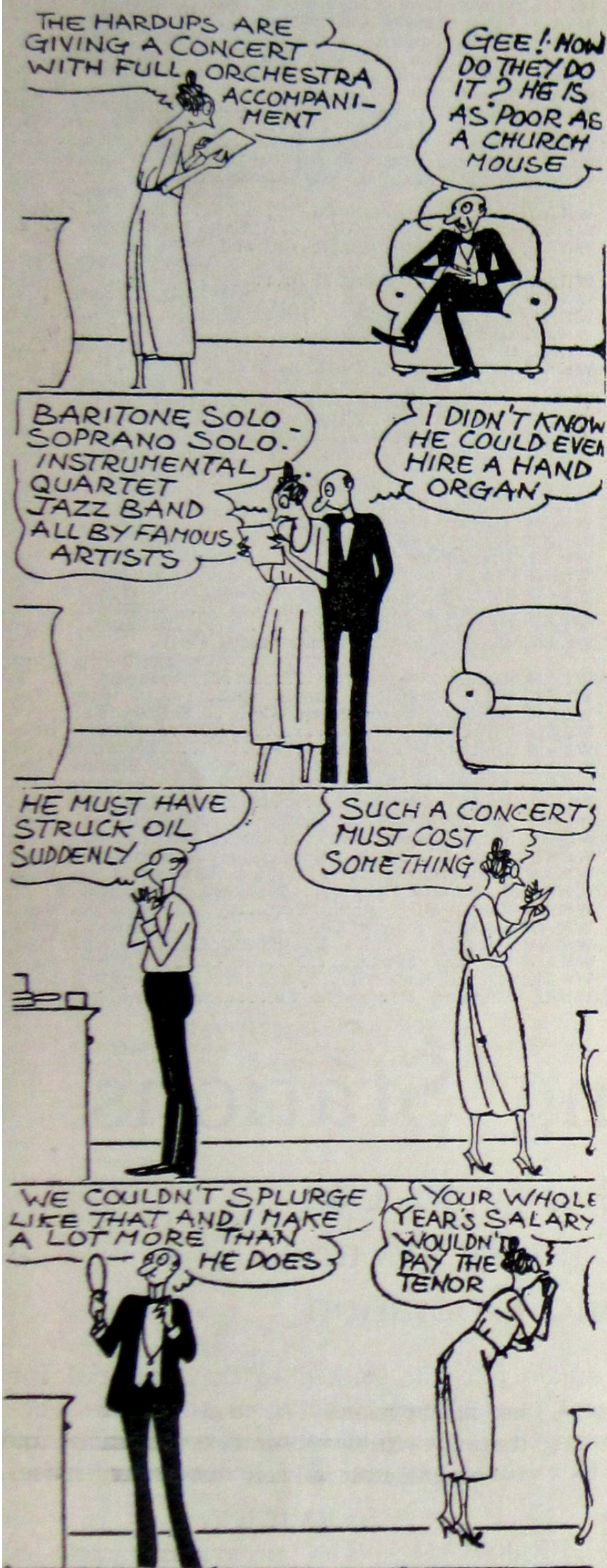

Copyright 1922 (N. Y. World) By Press Pub. Co.

"Is this the joint where they advertised for talent for a radio concert?"
 "Yes. What can you do?"
 "I'm a club juggler."

—N. Y. World.

LIFE ON THE RADIO WAVE



—Des Moines Tribune.



—San Francisco Chronicle.

As Famous Mutt and Jeff Become Ardent Radio Fans

JEFF IS THE ROBIN'S RAINCOAT AS A RADIO SALESMAN



—London Daily Express.

MISS SCHULTZ MUST HAVE A BROADCASTING STATION



—Cincinnati Times Star.

AS A RADIO OPERATOR, JEFF IS THE LIZARD'S LEGGINGS



N. Y. World.

IT'S NICE TO BE AN AUTHORITY ON SOMETHING



—N. Y. World.



When Ether Waves Run Wild

Con-structive Hints

Realizing that there is nothing like the home-made set, this department is dedicated to those who roll their own. Subscribers will have all their questions answered as they deserve until the time comes when they act like regular engineers and buy 'em tailor-made. In sending queries be sure to give complete diagrams, and a picture of yourself.

MR. EDITOR:

I enclose wiring diagram of my set, on which I have spent \$77.92 for materials and \$1,492.00 in time. It's a peach of a set, isn't it? I also show in the diagram the only kind of music I hear through it. Now, I undertand

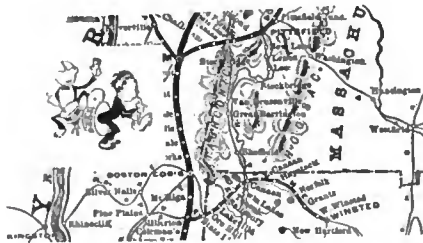

that speeches, songs, classical music, etc., are to be heard by radio. Why don't I hear those, too? **BIFF BAM.**

Answer: You put too many road houses in your set. Take some of them out and substitute two theaters, one opera house, sixteen concert halls, one pulpit, one college (Harvard or Yale), the Woolworth building, and a phonograph. You then will have no need for your radio set except on Monday, Tuesday, Wednesday, Thursday, Friday, Saturday and Sunday.

SIR:

As you can see by the enclosed picture, I have assembled my set complete except for the panel. Now what

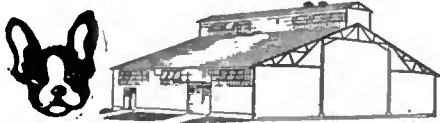

I want to know is, where should the panel be drilled? That is to say, what spots on the panel should I drill, and do you know anybody who will lend me a machine to do it with? My picture also enclosed. **SITTING BULL.**

Out Our Way



GRANDMA SUTTON SPENT TWO HOURS LISTENING IN ON RALPH'S NEW RADIO OUTFIT. BEFORE HE FOUND OUT THAT IT WASN'T CONNECTED UP.

—Danville (Va.) Bee.

Answer: It all depends. Some likes 'em that way' and some don't.

HEY, YOU:

I enclose a sketch of myself working on my radio set, which has absorbed my exclusive attention for 42 years. As you can see, I am now about to drive the last nail, and hope to hear something soon.



Please tell me: (1) Should the nail be driven in to the hilt? (2) Is gold a suitable material for it? (3) Would it be any better if President Harding drove it? (4) How can I improve this set?

D. CLASSAY.

Answer: We are much interested in this new and novel photograph. (1) Try a 1 megohm grid leak. (2) Yes, if you have any left. (3) Now you stop! (4) Scrap it.

Listen:

I've done my best to hook up a one-step amplifier but it won't work. There's no use sending you a diagram of the set, because, as I say, it won't work. What's the answer?

WAYSTEAD DAZE.

Answer: What you have is not a one-step; it's a stumble. Try a loud speaker according to the accompanying sketch. To operate, take loud speaker firmly in the left hand and twirl once every 24 hours. All you will hear will be "At Six O'Clock in the Morning." But can you expect more?—*W. S.*



Delirious Dave

(With 19 apologies to Bide Dudley—Continued from last month despite the bets and threats.)

AN elephant entered the store. He placed one foot on Dave's chest and recited, "I regret I have but one trunk to check with the American Express Company."

Dave came to. You will recall that he fainted a month ago, in these columns. But when he revived he was not in the columns any more.

He was in the Zoo.
"Yoo—hoo."

Where did he hear that voice before? It might have been his father, excepting that it was the voice of a little girl. Sure enough little Gertrude was looking at him through the bars of a cage.

"Why Gerty," flabbergasted Dave.
"Listen!" Gerty had spoken.

Radio music poured from the horn which had been erected in the drug store, following out Dave's idea as told to Proprietor Tracy. They listened to a prize fight, opera solo, and sermon, but before Gertrude could eat her fifteenth soda with chocolate ice cream, there was a noise.

A crowd of two thousand escaped convicts came through the trap door leading into the saloon.

A stranger entered. He whipped out a pistol and shot Dave, Proprietor Tracy and Gerty dead. Then he killed the two thousand convicts.

If not properly discouraged, the author of this thrilling story of love and two hearts may incline to the inclination to write still another serial brimming over with pathos and tense moments.



And Humor Fills the Ozone

Science or Invention?

A NEWSPAPER clipping comes to our attention—and holds it. In the article there is described a new invention, perfected by a 15-year-old boy, by which it is possible to transmit milk by radio.

This is by far the most advanced stage to which the science of wireless has progressed.

In the technical explanation we find that "the milk is passed through a vacuum and the spark going through the vacuum unites the atoms of the milk with the electrons and is carried out in the form of electric current. This applies to the sending of milk."

Of course, the article referred to sweet milk. But despite the fact that no reference is made to buttermilk, we have it on good authority that it is just as easy to send buttermilk from New York to Buffalo by radio as it is to send sweet milk.

The youthful inventor says that the sweet milk is received in the form of an ordinary message. It doesn't matter if the message happens to be a boxing bout description or a grand opera aria. We can see the complications that are liable to happen. Suppose Galli Curci is singing and instead of sending music, she by mistake transmits a couple of gallons of butter milk!

In the place of the phones, the inventor goes on, a condenser is used. When the condenser is filled to capacity it discharges. Atoms discharge easier than the electrons, says he, and therefore the atoms discharge and form the milk.

Try it on your cow.

Our informer says that scientists have even gone farther than this. Not alone sweet milk, and buttermilk, may be sent over, but cheese cake and gedampte kalbfleish as well.

Goodness only knows where this radio stuff will lead. The railroad company executives already are worrying.

In fact, we feel the time is not far distant when you, yourself, will be able to jump into a transmitter in Kokomo and come out of an Aeriola Sr. set over in Paris.

Necessity IS the mother of imagination!—M. H.

LIFE ON THE RADIO WAVE



—San Francisco Chronicle.

Wise Crack-les

As for that chap out in Spokane who said that static in his radio set sounded like a ton of coal sliding down the chute into his cellar, all we can add is that certainly his wish was daddy to his thought. He didn't say anthracite or bituminous coal, but either would be welcome.

* * *

We suggest that they install a gigantic broadcasting station up at Niagara Falls right over the falling waters. This will allow the roar of the great falls to be heard throughout the country and will save millions of dollars in honeymoons alone. All a young couple will have to do is tune in for Niagara, hold hands and let their gosh darn imagination run riot.

* * *

SHE'D BE A CURIOSITY

Asks a certain Nebraska daily: "If the old fashioned lady who wore a coil of wire around her waist and called it a bustle or around her hair and called it a rat, would attend a radio concert—would she be a broadcasting or a receiving station?"

* * *

WISDOM

Denby prohibits the use of navy radio for broadcasting Congressional speeches. Gosh, the man has sense hasn't he?—Nashville *Tennessean*.

* * *

AMENDING AN OLD SONG

The American youth's three R's are now: Readin', 'ritin' and radio.—Say the *Chicago Journal of Commerce*. "—taught to the tune of the vacuum tube" as one might say.

* * *

MEBBE, MEBBE!

Wonder if the radio craze will develop wireless wire-tappers.—Pittsburgh *Gazette-Times*.

* * *

Mother, buying a knock-down crystal set, after inspecting the lot of parts: "Never mind the cash, Tabby will never miss one hers."

Made for All

BY MARTHA HAWN BAKER

Pa says, "I think this radiophone Was surely made for me alone, For when I come home tired at nights The radio puts me to rights." Now Pa, he likes a first class show, But hates to have to dress and go, So now he sits back in his chair, A-listenin' in and smokin' there— And laughs and laughs; till he forgets All business worries, cares and frets. "This Radiophone, Oh yes sir-ee, Was just invented, Ma, for me."

And then Ma says, "That may be so, But I was thinkin' while ago How Radio helps me on my way By cheerin' me from day to day. And when I have so much to do, It seems to make me hustle through And get my mendin' for a rest And hear the latest news and jest. I tell you, Pa, it's quite a treat To darn the socks to music sweet! Yes, radiophones I'm sure have come To cheer the Mother in the home."

When Pa and Ma have had their say I tell 'em it's as plain as day That—though its concerts all enjoy— The radiophone is for the Boy! It gives us music, many kinds, Some jazz, and some to lift the mind; There's talks on how a boy should grow, And just the food he needs; and so,— The radiophone just can't be beat, For keepin' fellers off the street. So folks, I know you'll all agree, 'Twas made for boys, the likes o' me.

WORLD WIDE WIRELESS

Five New Stations to Link the Americas by Radio

THE Radio Corporation of America has received orders from the United Fruit Company and the Tropical Radio Telegraph Company for five radio stations, three for Central America and two for the United States, each with a sending radius of more than two thousand miles. The erection of these five stations will fill an important and essential gap in the radio communication system of the Americas.

The three Central American stations will be located on the corners of the triangle embracing Honduras, Nicaragua and Panama. They will be operated by the Tropical Radio Telegraph Co. and will be located at Managua, the capital of Nicaragua, and at Tegucigalpa, the capital of Honduras, the city designated as the capital of the new Central American Union. These stations will connect with the United Fruit Company's station at Almirante, Panama.

The terminals of this communication system in the United States will be at New Orleans, Louisiana, where the present station of the Tropical Radio Telegraph Co. is to be enlarged and new apparatus installed, and at a new station which the Tropical Radio Telegraph Co. will erect in the vicinity of Miami, Florida. Intercommunication between these five stations, and ship to shore communications with them, will open entirely new routes of communication between the Americas. The new stations will open a radio relay route between Bogota, Colombia, and the United States, a distance of more than two thousand miles.

Because of the layout of the three tropical stations, service from nearly all parts of Central America is practicable. In fact the system is designed to tie with North and South America in all points from southern Panama to the southern border to Mexico.

Equally as important as the land and overseas communication aspects of this new radio system is the announcement that the new tropical stations will be used for ship-to-shore radio service by vessels plying the waters of the Atlantic Ocean, Gulf of Mexico, Caribbean Sea, and the Pacific Ocean.

All the recent radical changes in the technical design of modern radio telegraph apparatus, the results of the combined efforts of the Radio Corporation of America and the General Electric

Company, will be incorporated in the apparatus used in this new inter-continent radio communication project.

Vacuum tubes of the latest design, and many times more powerful than any tubes heretofore used in sets for commercial service, together with the highly efficient multiple-tuned antenna, will be special features of these new stations. The wave-lengths used will range from 2,500 to 4,500 meters and



The most sensitive receiving apparatus ever installed on a merchant vessel is in the radio room of the S. S. Pan America, which carried Secretary of State Hughes to Brazil

the power actually delivered to the antenna at these wave-lengths will be equivalent to over 100 kilowatts.

It is worthy to note that in the case of the Tegucigalpa, Honduras, station the delicate radio apparatus, as well as the heavy steel members used in the construction of the 437-foot towers must be transported over an 80-mile mountain trail. It is expected that this station will be placed in operation in November of this year.

Radio Covers 7,000 Miles

THE U. S. Navy radio station at Cavite, P. I., now transmits its messages directly to the Pacific Coast, covering a distance of about 7,000 miles. At San Francisco the signals are picked up by a new "barrage" receiver, designed by the radio research section of the navy. Previously, messages from Cavite have been relayed by Pearl Harbor, Hawaii, which now is free to devote itself to its own traffic.

Need Radio for Foreign Trade Reports

USE of the radio telephone for broadcasting the numerous opportunities in foreign trade reported to it by its agents abroad is being considered by the Department of Commerce. A great mass of foreign trade information is received by the Department in Washington daily and is released to the press and also printed in the Department's various publications, but much of it fails to reach interested firms. Broadcasting it by radio would give it almost 100 per cent distribution, it is considered. The Department maintains 34 branch offices in all parts of the country, and at present it is planned to send foreign trade news by wire to them, for their local broadcasters. Eventually it is hoped to equip each branch office with a receiving set, enabling the matter to be transmitted by radio from Washington to all offices simultaneously, avoiding use of the wires.

Radio Exports Growing

AMERICAN exports of radio apparatus during last June were valued at \$547,364, or nearly half the total for the first six months of the year, \$1,164,514. This is in line with the trend of radio exports this year, which have been rising in value and number by leaps and bounds. Probably the greater portion of the material shipped abroad consists of commercial apparatus to be included in the equipment of big foreign transmitting stations, but there also is a rising flood of instruments and complete sets designed for amateur use. Accurate information on foreign markets for radio materials will be available during the winter, as a result of a survey being made by R. A. Lindquist, chief of the electrical equipment division of the United States Department of Commerce. He is now in Europe, and will visit England, Sweden and Germany during a period of three months.

Mexico Tries Lighthouse Sets

TWO wireless transmitting and receiving sets have been ordered by the Mexican Department of Communications for use on lighthouses. The order is an experimental one, and if the sets prove as valuable to the Mexicans as similar equipment have proved in the United States, all Mexican lighthouses will be given radio equipment.

Enlarged Radio Facilities on Oregon Coast

THE radio facilities at the entrance to the Columbia River, the port of Oregon and the outlet of the only water level grade through the Cascade or Sierra Nevada Mountains to the Pacific Ocean, are being enlarged and improved. The two big naval stations now existing there are to be enlarged, improved and co-ordinated, the control being vested in the stations at North Head, Wash., while the big Young's Bay plant, near Astoria, is to be operated solely as a transmitting station.

The work on the Young's Bay plant proper is already under way. It will include the erection of a fifth big steel mast and the installation of the machinery and equipment necessary for the operation of the increased size of the plant and for the remote control development. About six men will remain at the Young's Bay plant to maintain the instruments, but all operation will be done from the North Head station.

When the work of improving the Young's Bay plant is complete the mechanics and experts will shift their activities to North Head. There a new mast is to be raised, a new headquarters building constructed, a larger power plant installed and the whole station developed to handle the traffic included in the newer and larger scope planned for it. The underground cable, which runs from North Head to the cable crossing of the Columbia River, has been laid. This will serve effectively to do away with the delays and interruptions of communication due to wire trouble during storms.

Some time ago the Port of Astoria commission requested the Government to take steps to increase the efficiency and capacity of the stations serving the Columbia River, as the increasing traffic at that port was making insistent demands that the communication facilities be increased. Some time later the announcement was made that the Government expected to co-ordinate the two existing stations and so to increase their capacity as to accommodate all traffic on the river. This work is now under way earnest.

It is also understood that the Light-House Department expects within a few months to install a Kolster radio beacon on the lightship at the mouth of the Columbia, as well as to equip all other lightship property with radio position-locating apparatus. This will render the navigation of the river and the naval stations on the coast a more strict service.

It is also understood that the Light-House Department expects within a few months to install a Kolster radio beacon on the lightship at the mouth of the Columbia, as well as to equip all other lightship property with radio position-locating apparatus. This will render the navigation of the river and the naval stations on the coast a more strict service.

at mean low water, permits the radio compass stations to function principally in aiding vessels well off-shore and in speeding navigators in the work of handling their vessels.

Offers Free Radio Medical Advice to All

FREE medical advice by radio to ships of all countries is offered by the United Fruit Co., which has devised a system whereby messages asking for medical advice may be sent to any of its ships or land stations. The company operates a line of steamers between North American ports and Central America. In the past, medical advice given from its ships has been successful in saving life at sea, and so valuable has been the service that the company has given prominence to its policy of free radio advice in cases of



The radio slot machine has arrived in the United States. Dropping a quarter in the slot delivers the concert of the nearest broadcasting station. Hotels are expected to install these receivers

illness, in order that no one on the north Atlantic Ocean need suffer needlessly at sea. Requests for diagnosis and assistance may be addressed by radio to "Unifruitco," and sent to the company's hospitals at Santa Marta, Colombia; Port Limon, Costa Rica; Almirante, Panama; Tela, Honduras; Puerto Castilla, Honduras, or Puerto Barriaps, Guatemala. They may also be sent to any United Fruit ship.

Clifden Station Recaptured

AFTER a number of attempts, the Marconi wireless station at Clifden, Ireland, was recaptured from the Irish irregulars, and has been put into operation once more. It had been silent for several weeks, while in the hands of the irregulars, who did some damage to its equipment. The station, which is 43 miles northwest of Galway, is an important link in trans-Atlantic radio service, especially with Canada.

Report American Weather to France

EXCHANGE of weather reports between the United States and France has commenced by radio, and now daily meteorological data are transmitted from Annapolis to Bordeaux, and from Lyons to Bar Harbor. This information is especially valuable to Europe, as most storms progress from west to east, and storms along the Atlantic Coast, if of sufficient intensity, cross the ocean and affect the weather not only on European coasts but sometimes far inland. In France the local and American weather reports are collated by weather experts in Paris, and transmitted from the Eiffel Tower in the form of weather reports and predictions for western Europe. The reports from FL are received in all parts of Europe.

Fees for Canadian Licenses and Examinations

THE Department of Marine and Fisheries of Canada has announced an amendment to the Canadian Radio Regulations, by inserting the following rates of fees for station licenses and operators' examinations, as follows:

Fees for station licenses:

Limited Coast Station	\$50.00
Public Commercial Station	50.00
Private Commercial Broadcasting Station	50.00
Private Commercial Station	10.00
Experimental Station	5.00
Amateur Broadcasting Station	5.00
Amateur Experimental Station	1.00
Private Receiving Station	1.00
Technical or Training School Station..	5.00
Ship Station	1.00

Fees for operators' examinations:

Extra First-Class Certificate.....	5.00
First-Class Certificate	2.50
Second-Class Certificate	1.00
Third-Class Certificate	1.00
Experimental Certificate	2.50
Amateur Certificate50
Emergency Certificate, any class.....	5.00
Radiotelephone Certificate	2.50

Commends Navy Radio Man's Bravery

CHIEF Radioman Claude G. Alexander has been commended by Secretary of the Navy Roosevelt for bravery in rescuing the pilot of the airplane in which he was riding when it crashed to the ground. He was flying with Ensign Ralph R. Auerswald across the country in a Naval plane last July, when the plane crashed near Encinitas, Cal., bursting into flames. Alexander crawled out of his seat, released the pilot's safety belt and was lifting the unconscious man out of his seat when an explosion occurred. Alexander was thrown clear of the plane, while Auerswald fell beneath the plane. The radio operator dragged the pilot to safety from the midst of the flames.

Special Radio Sets for Hughes' Brazilian Trip

WHAT is the most sensitive receiving apparatus ever installed on a merchant ship is carried by the *Pan American*, operated for the U. S. Shipping Board by the Munson Line. This is the ship that carried Secretary of State Hughes to Rio de Janeiro for the opening of the Brazilian Centennial Exposition there, and the entire wireless equipment of the vessel was remodeled for the voyage. It was decided that constant and direct radio communication with the United States would be necessary during the entire trip. The receiving equipment consists of a three-stage radio frequency amplifier, detector, and two stages of audio frequency amplification. The amplifiers and tuning equipment have a range of from 150 to 30,000 meters. There also is a heterodyne circuit for reception by this method. A regenerative tuner is used, however, for wave-lengths up to 6,000 meters. This equipment gives the ship a receiving range of 10,000 miles.

The ship's transmitter also is a new one installed especially for the trip, and is an arc outfit whose signals are readable 5,000 miles. In addition, a 1 k.w. standard Navy spark transmitter, with a range of 1,500 miles, was installed. L. K. Meriweather is chief operator on the *Pan American*.

French Radio Regulations

ACCORDING to "Le Temps," of Paris, the departmental committee appointed by the French Under-Secretary of the Post Office to inquire into the regulation of wireless installations, has drawn its report. It is expected that rules based on its recommendations will shortly be issued.

The broad principle followed is that receiving apparatus may be freely used after formal registration, while trans-

mitting apparatus can only be installed by private individuals on the authorization of the Under-Secretary of State acting on the advice of a mixed committee of officials and experts. Transmitting installations will be divided into five classes—private stations, stations for financial news, scientific stations, mobile stations (ships), and amateurs' installations. There will be a limit of wave-length and power in the case of each class.

China a New Radio Field

CHINA is being regarded by the radio telegraph companies as a great field for expansion, the recent treaty restoring communication with China to the Chinese government operating to prevent foreign governments from handling commercial messages from China. For some years various countries have transmitted such business through their official stations. America, for instance, has handled much traffic through the Navy radio station at Peking, which relays its messages through Cavite, P. I. Formation of Chinese companies to operate radio systems is coming in the near future, and these, of course, will look to the Occident for their equipment and personnel.

Gambia Uses Radio

GAMBIA, the British colony in West Africa, has installed radio telephone and telegraph stations at Bathurst and McCarthy Island, 176 miles apart. The new stations are in daily use, giving instantaneous communication between the two centers. The colony has no organized wire telegraph or telephone system, and the radio stations already have proven of great value.

Honor for Senatore Marconi

SENATORE MARCONI, G.C. V.O., LL.D., D.Sc., has been elected a Vice-President of the Royal Society of Arts.

Army and Navy Training Air Operators

TRAINING of radio operators especially for airplane work is being carried out by both the U. S. Army and Navy, this being a recent development of both branches of the service. The Naval Bureau of Aeronautics at Pensacola, Fla., and the Army Air Service at Rantoul, Ill., so far have trained 60 men for aerial service, who now are in active flying duty. The men are selected from lists of promising radio students at the Naval Great Lakes Training Station, and transferred to the new school. Here they are given the same ground school work that is given to student aviators, after which they concentrate on radio work, including operation and repair of all types of transmitting and receiving apparatus. The course lasts for 12 weeks, the last three of which are spent with an air squadron for practical work. The Army's course is somewhat similar, and is given at Chanute Field, Rantoul, Ill., to those whose enlistments are accepted for the Army Air Service.

Rushing Belgian Station

WORK on the first Belgian radio station designed for international communication is progressing, and the new station is expected to be in operation before the coming winter. It is located at Bruges. Until it is in operation, Belgian wireless will continue to be confined to reception from stations in other European countries, and the relaying of messages, weather and market reports to all parts of the kingdom by land wire.

Radio in Life and Death

TO radio's achievements in saving life at sea must be added participation in funeral services. What is considered as the first contribution of wireless to a funeral at sea occurred early in September, when the S.S. *Canadian Trooper* asked the Cunarder *Carman* to transmit in full the ritual for burial at sea. One of the Canadian steamer firemen had died, and the captain, who called upon to read the service, that he had no prayer book. He asked his radio operator to get a prayer book from the nearest steamer.

Japan to Install Ship-to-Ship Radio Stations

THE city of Yokohama, Japan, has a radio station. It is the largest in the world, and has a capital of \$750,000. It is expected to give a service between the city and the steamer.



Among the U. S. Navy exhibits at the exposition at Rio de Janeiro, Brazil, is a model explaining the operation of radio fog signals and the radio compass

Radio Communication in India

New Regulations Provide for Licensing of Experimental, Limited Commercial and Broadcasting Stations—Existing Service to Be Expanded to Reach Now Isolated Sections—Public Demonstrations of Radio Telephony

By S. B. Banerjea

WIRELESS TELEGRAPHY is making slow progress in India, where there are not very many wireless enthusiasts; but I doubt not, if the advantages of wireless be clearly explained to the people, it will secure many enthusiasts—to the good of the country, maybe the world.

It is interesting to learn that the Marconi Company has applied to the Government of India for permission to erect a broadcasting station, either at Bombay or at Calcutta. The agents of this company have received several applications from Europeans and a few Indians for private apparatus. Most of the applicants hail from Bombay and the rest from Calcutta. The licenses are issued by the Director of Wireless Telegraphy, Simla, to whom all applications must be forwarded.

With the idea of popularizing radio and assisting in its use and development, the Indian States and Eastern Agency of Bombay will give demonstrations during October. Later on, demonstrations will be given in the

principal native states. Complaints having been made in the press that the Indian Government was not encouraging wireless enterprises, the Director-General of Posts and Telegraphs has announced that he is prepared to grant licenses for the erection, maintenance and operation of wireless telegraph stations in British India for the following purposes:—

(1) Non-commercial stations, that is, fixed stations established for research, experiment or instruction and which are operated by the licensee solely with a view to the advancement of wireless telegraphy.

(2) Limited commercial stations, that is, fixed stations established in connection with the business of the licensee or for carrying the private or business correspondence of the licensee.

The licenses will be valid for one year and may be renewed at the option of the licensee. A fee of ten rupees per annum will be charged for each

license. Licenses will have to be renewed on January 1st of each year.

In the case of limited commercial stations, an annual royalty will be charged, depending on the class of station, those maintaining a 24-hour service being in class I; not exceeding 16 hours in class II; and not exceeding 8 hours in class III. The royalties are, "rupees 440, 300, and 150 respectively for telegraph sets, and for sets equipped for telephony, rupees 550, 370, and 190. Stations outside the delivery radius of a Government telegraph office, which is usually five miles, may have their royalty reduced by 50 per cent."

The Government has announced that the above licenses will also cover the import into British India of the necessary apparatus, but separate import licenses are required when it is desired to import apparatus for sale. Import licenses are accompanied by a bond in a sum not exceeding twice the value of the goods imported, which must be executed by the licensee to guarantee



Modern Calcutta

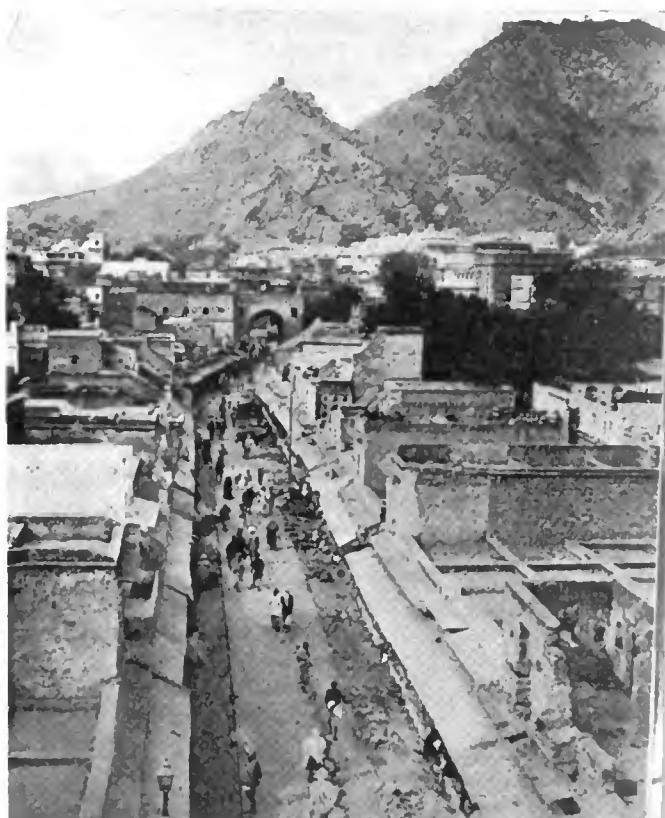

Ancient Lahore

LINKED BY RADIO

observance of the terms of the license. When stations for radio telephone broadcasting purposes are desired, a special license will be required for each such station.

Charges have been made in the past that the Government had done practically nothing to make wireless operation popular, or for developing the system in India. But the facts are otherwise; a big station is being erected in Madras for inland work and it is understood that this station is being converted into a high speed automatic plant for working inland and to Rangoon. The wireless apparatus at the Sandheads is being brought up to date. Malabar is to be connected by wireless, the necessary apparatus for which is being supplied by the Marconi Company. Arrangements are being made to have wireless for the tea districts of Assam, which will prove a veritable boon to the district which now is practically without communication.

Coastal stations are being maintained at Diamond Harbour, Port Mair, Karachi, Madras, Rangoon, Calcutta, Bombay, and Victoria Point. The inland stations are Allahabad, Delhi, Lahore, Nagpur, Patna, Poona, Quetta, Secunderabad, Peshawar, Mhow, and Maymyo. The Government of India will advise as to types of suitable feeder stations in any locality and will obtain, erect, maintain, and work the feeder stations on behalf of the local Government, in accordance with the local requirements. Rules governing the control of traffic on land and sea have been framed, as also rules regarding the transmission of wireless messages.

Commander Nicholson, the Director of Wireless in India, has issued a press communique, from which the further fact has been learned that arrangements have been made for broadcasting news, concerts, speeches, lectures, and other educational and entertainment programs to subscribers in certain areas, which may extend to 200 or 300 miles. Market quotations and other reports will also be broadcast to other subscribers.

From the above, it will be clear that the Government of India is moving with the times. The Government alone, cannot, however, move in every direction unless the public helps it in large numbers. A few people here and there will not be able to advance the cause of wireless communication in India. The broadcasting fever, or craze, which one will so put it, has not caught the people at all. Should a big demand show up, the cost of apparatus will go up. Even now, the price is not prohibitive. What the country needs is a number of enthusiastic workers to get things going. Wireless is no

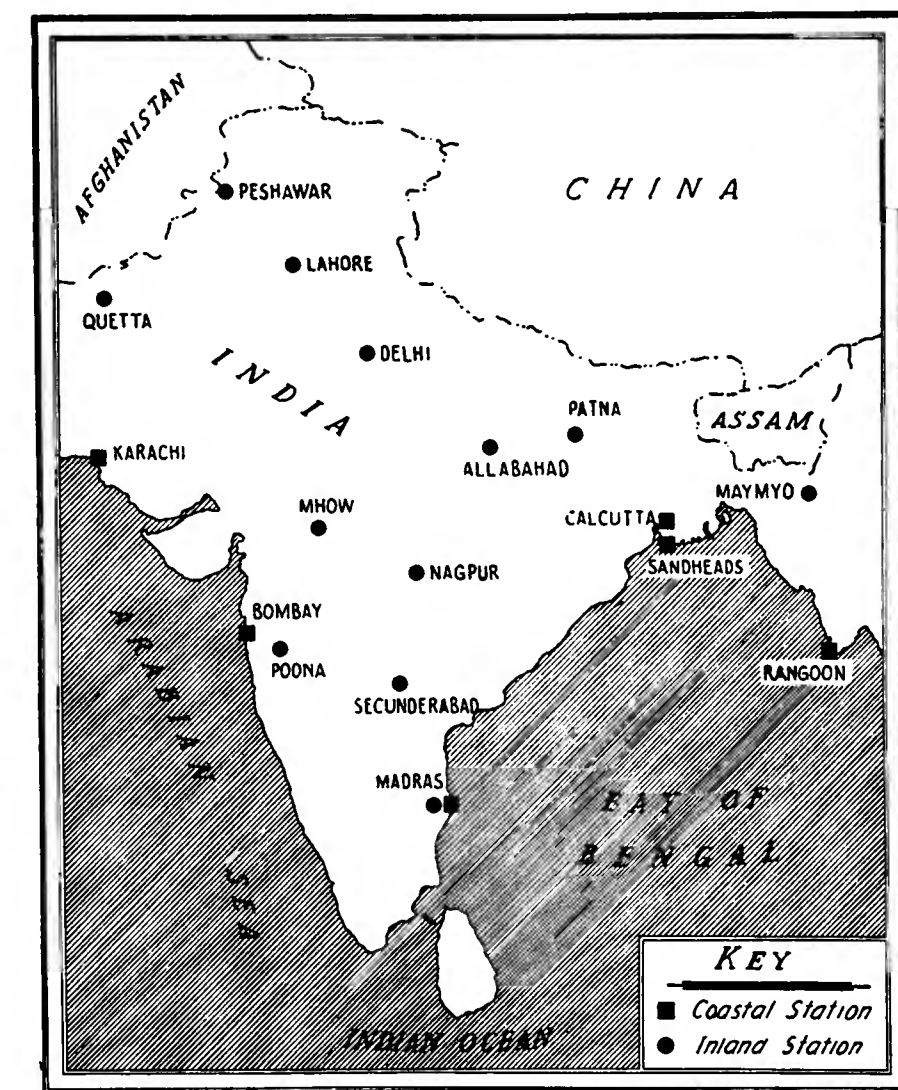

Radio map of India showing network of inland and coastal stations

longer a plaything, but a real benefactor of mankind.

Communication with the Malabar area will be by means of seven radio transmitters, just ordered by the Madras Government from Marconi's Wireless Telegraph Co., Ltd., of London.

This comes about logically as an outgrowth of the Moplah rebellion in that region, lasting from August to December last in its main phase. The Malabar section is heavily wooded and hilly, not to say mountainous, and is traversed only by footpaths and a few post roads. The work of the troops was greatly hindered by the destruction of all means of communication, telegraphic and postal by the rebels, a number of whom were returned soldiers with a clear idea of the value of such hampering tactics. The lines were promptly repaired only to be again torn down and no amount of watching could prevent their being destroyed by the rebels as fast as repaired.

Six armed camps have now been constructed at various strategic points each

to hold a company of police and each camp is to be provided with a wireless set of the type known as Duplex Telephone Installation. A charging plant is also being imported and the installations will be set up under the supervision of one of Marconi's experts. The aerial system employed will be simple, consisting of two masts 30 feet high and 200 feet apart, made of local materials. It is expected that the effective range, depending on conditions, will be from 30 to 50 miles, which will be sufficient for communication between the camps.

The Marconi Company is reported to be making an effort to push the employment of such stations throughout India and is arranging for a series of demonstrations among the various native States in the near future.

In conclusion I should like to add that the date from which the Indian Wireless Telegraphy (shipping) Act of 1920 shall have come into force has been postponed from August 1, 1922, to January 1, 1923.

Filing Radiograms With the Postal

Radio Corporation of America Makes Important Arrangement With Postal Telegraph-Cable Co. to Extend Radio Facilities to Whole Country

ANNOUNCEMENT has been made by Edward J. Nally, President of the Radio Corporation of America, that an agreement had been signed between his company and the Postal Telegraph-Cable Company whereby every office of the Postal Company in the United States becomes an agency of the Radio Corporation for the acceptance of radiograms for transmission across the Atlantic Ocean and for the delivery of radiograms received from overseas for points in the United States.

This important linking of radio and wire line services reflects the rapid growth of the Radio Corporation's overseas telegraph traffic since the return of its high power stations by the Government after the close of the World War.

These stations transmit and receive radiograms directly to and from England, France, Norway and Germany, and through connecting stations abroad, to and from all countries in Europe, Asia and Africa.

The Radio Corporation now maintains the only direct line of telegraph communication with Germany and Scandinavia; and additional direct service is planned for the near future with Belgium, Holland, Italy, Poland and Sweden, giving to those peoples the opportunity to communicate directly with their scattered brethren and nationals in all sections of the country.

Prior to the arrangement made by the Radio Corporation of America whereby it is enabled to use the extensive land line service of the Postal Telegraph Company, practically all the radiograms transmitted to transatlantic countries originated in New York City and Washington, D. C. The contract just signed gives to the inland commercial centers and the thousands of small points reached by the Postal system equal facilities with those now enjoyed by the eastern cities mentioned, the Postal Telegraph Company performing the same service for radiograms of the Radio Corporation of America as it does for cablegrams to be transmitted by submarine cable.

Mr. Nally pointed out that although heretofore radiograms received from Europe, destined to points inland in the United States, had been forwarded over telegraph land lines, the service

established by the agreement with the Postal Company insures prompt organized collection as well as distribution of radiograms at all points in the United States and gives to every section of the country the benefits of the phenomenal advances made in recent years in the radio art.

With the development of high speed wireless telegraphy to an even higher point than at present, the new arrangement will permit the Radio Corporation of America to carry out its plans for the inauguration of a low rate plain language Radio Letter service between the United States and Europe.

The Radio Corporation's present offices in New York, Washington and San Francisco for the reception and delivery of radiograms will be continued, and its plans for the opening of additional offices of its own in the more important centers from time to time will go forward as the growth of business warrants.

Radiograms coming over the land wires of the Postal Telegraph system from all sections of the country will be received at the Central Radio office at 64 Broad Street, New York City, where all the Eastern radio stations of the Corporation are controlled.

T. R. McElroy Sets New World Record for Code Reception

A RADIO Marathon was held Sunday morning, Aug. 6, at 10 A.M., in Congress Hall of the Pageant of Progress Exposition on the Chicago Municipal Pier. It was a speed contest for radio operators in receiving straight Continental Code, and simultaneously transcribing the message on regulation Western Union typewriters.

Contestants were present from other cities, and included T. R. McElroy of the Western Union Telegraph Company from Boston, holder of the present world's record of 56½ words per minute; B. G. Seutter of the New York Times Radio Department from New York; Benedict B. Brankey of the Western Union Telegraph Company, Chicago; and M. Swartz, assistant radio inspector, 9th district.

The test was conducted by Mr. Lawrence R. Schmitt, formerly United States Radio Inspector, ninth district.

The judges were Capt. Alfred Thomas of the Radio Corporation of America, Mr. E. A. Beane, U. S. Radio Inspector, ninth district, and Mr. Schmitt.

The starting speed was 40 words a minute. Succeeding tests were run for two-minute intervals, increasing the speed two words per minute at each test.

The rules for elimination provided that after a speed of 46 words a minute was reached, the contestant having the greatest number of errors was to be eliminated, and that this method was to be followed by successive tests at a higher speed. Brankey was eliminated at 46 words a minute, Swartz at 48. The contest was now on between Seutter and McElroy. Seutter was eliminated at 52 words a minute.

McElroy was presented with the solid gold diamond medal by Geo. E. Carlson, Commissioner of Gas and Electricity of the City of Chicago when he copied 52 1/5 words per minute, perfect copy.

To add interest for the spectators, the dots and dashes were sent through a loud speaker, and many of the audience expressed surprise that anyone could decipher the code at such speed.

After Mr. McElroy had won the main contest, Commissioner Carlson offered a prize of \$50.00 additional in case the world's record was beaten. McElroy established a world's record of 55 1/10 words per minute, perfect copy. Before awarding the prize, and to remove all doubt as to whether or not 55 1/10 words per minute perfect copy was superior to 56½ words per minute with four errors, which was the previous record, Commissioner Carlson obtained an opinion from a commission of five experts relative to this record.

Veterans Get Radio Jobs

A LARGE number of disabled veterans of the A.E.F. have been rehabilitated by giving them radio training, in which the Veterans' Bureau is particularly successful. Some of the new operators are on Shipping Board vessels, and others have been placed with different steamship lines through the "radio want ads" broadcast for the veterans through NOF, the government station at Anacostia. As more and more men are trained, the Bureau expects to be able to furnish men for service at land stations. So far, 100 men have been prepared for radio service at the Nola Radio School, New Orleans; 40 at the Loomis Radio School, Washington, and 70 at the Service Radio Institute, Washington. In New York City the famous Radio Institute of America has graduated 42 men who have obtained first-class commercial licenses. At the present time 282 are in training in all parts of the country.

The New French Radio Central

Powerful Station Near Paris Opened for Traffic Across the Atlantic, Europe and Asia—High Speed Transmission Successful on First Day

THE foundation stone of the wireless station of Sainte Assise, known as Paris Radio Central, was laid on January 9th, 1921, and

Since that date, observations from all parts of the world signify to the very high efficiency of the station. Sainte Assise was formally opened to

commercial traffic on August 17th, 1922.

Previously the wireless station of Croix d'Hins, near Bordeaux, which was opened at the end of 1920, has claimed the honor of being the most powerful wireless station of the world. The power of the new Sainte Assise station, however, eclipses that of Bordeaux, the Paris station being about twice as powerful.

The Compagnie Generale de T. S. F., which constructed and now operates the station, carried out the work on a large scale. The site of the station is on the plateau of Sainte Assise, about twenty-five miles from Paris. The ground is approximately level and the soil is sufficiently moist at all times to ensure an efficient earthing system. Many conditions were laid down by the French Ministry of Posts and Telegraphs when the erection of the station was sanctioned, and it was some time before a location was found which would comply with them all.



Main building of new French Radio Central at St. Assise, France

the first message was transmitted from this station on the morning of July 4th, 1922, at 11 o'clock G. M. T.

The station called Marion, U. S. A., on a wave length of 14,300 meters. Communication was immediately established and hand operation was then replaced by high speed automatic transmission.

During the afternoon, Senatore Marconi, from his yacht Elettra, at sea in the neighborhood of New York, reported excellent signals. A further telegram of congratulations after more detailed observations, was sent by Senatore Marconi on the following day, according to The Wireless World, London.

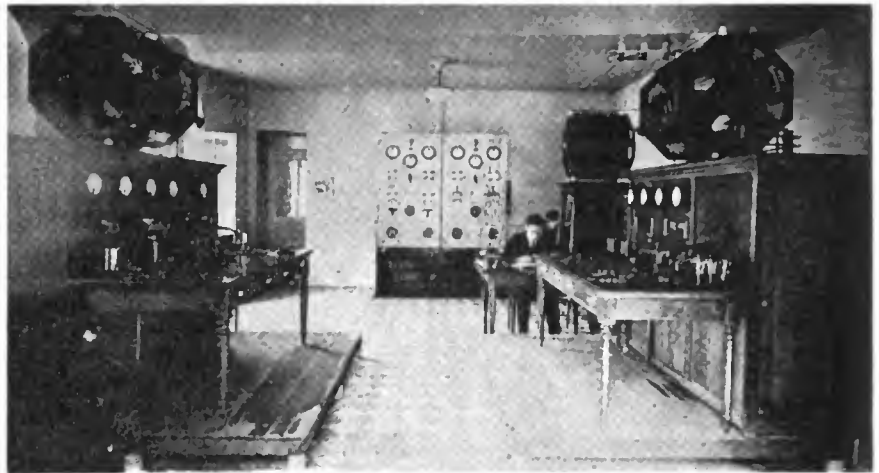

Receiving control room at St. Assise, showing duplicate equipment

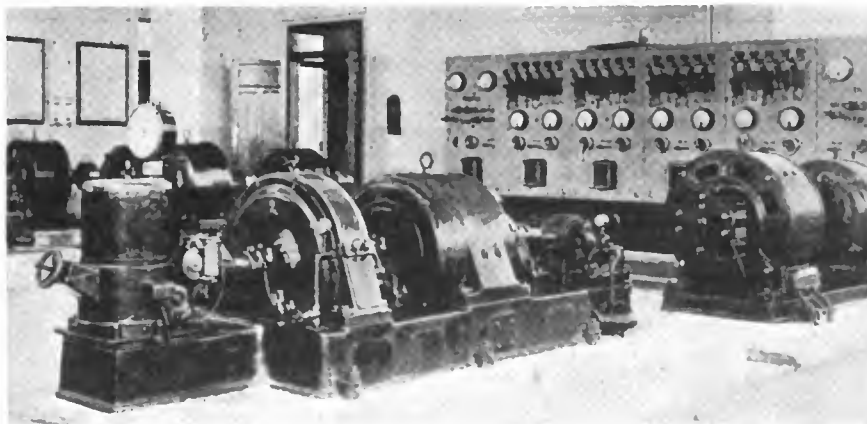

One of the 25 K. W. generator units supplying high frequency energy

There are two main buildings in which have been installed three transmitting sets as follows:

1. Two valve transmitters of 5 K. W. each, for short distance communication, the aerials being supported on a tower about 330 feet high.
2. A "Continental" station, consisting of four high-frequency alternators with an aerial input of 25 K. W., for European services.

The aerial, which is of the "double cone" type, consists of four independent networks and is supported by a single tower 830 feet in height.

3. An "International" station, consisting of two 500 K. W. high-frequency alternators and two of 250 K. W. each. In this case the aerial consists of a double network suspended horizontally by sixteen towers, each 830 feet high.

The earth system consists of 240 square yards of copper plates and ten miles of buried copper wires.

The four alternators with which the station is equipped can be run independently, or they can be used in combination to increase the output. They may also be used independently for duplex transmission.

Two sources of power supply are available, one a power distribution network, and the other an emergency installation of three Diesel engines each of 1,800 H. P. The station can transmit either with one machine of 250 K. W., or with two such machines coupled, or similarly with one or two machines of 500 K. W., or it may conduct two simultaneous transmissions.

The stations are all designed to handle traffic at a speed of at least 100 words a minute, so that with all six working transmitters at the same time, 36,000 words an hour may be transmitted.

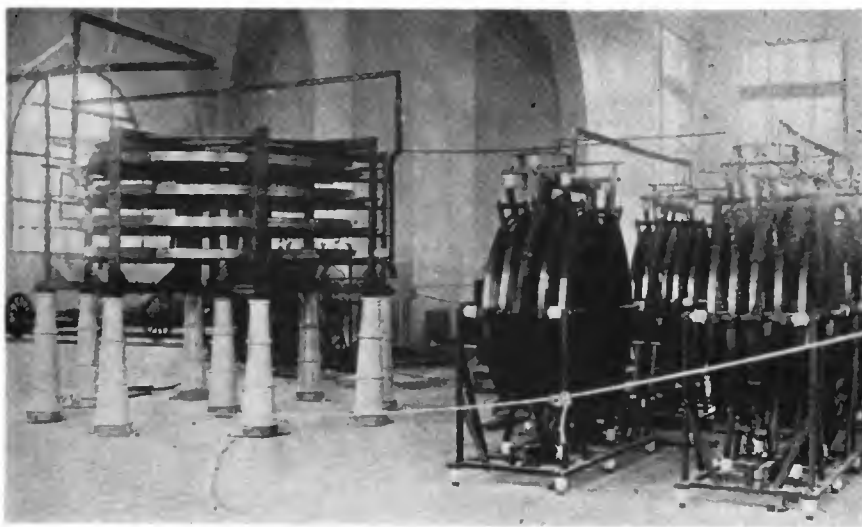

Large tuning inductances required to operate on long wave lengths

Both the transmitting and receiving stations are controlled from the Bureau Central Radioelectrique, Rue Montmartre, Paris, in the center of the business quarter. In addition this office is connected with the two principal Paris telegraph offices of the Bourse and Rue de Greville, by means of high speed Baudot and Hughes telegraphic apparatus. The recording apparatus for reception is all located

on the same operating tables and the arrangements are very similar to those at Radio House, London, from which the English trans-oceanic stations are controlled.

The receiving stations are distinct from the transmitting center, and are located at Villecresnes, 22 kilometers S. S. E. of Paris, at Essonnes 30 kilometers south of Paris, and Valenton, 18 kilometers S. S. E. of Paris.

New Swedish Trans-Oceanic Station

Radio Corporation of America to Erect \$2,000,000 Station Near Gottenborg—Two 200 K. W. Alexanderson Alternators Will Transmit Across Atlantic

COMPETING with English, French and German firms, E. F. W. Alexanderson, Chief Engineer of the Radio Corporation of America, has been successful in securing a contract with the Swedish Government for furnishing apparatus for a high power radio station to handle direct wireless communications between the United States and Sweden. The total cost of the station will probably be over \$2,000,000.

The new station will be situated in the vicinity of Gottenborg, which is on the west coast of Sweden, and the contract with the Radio Corporation of America calls for the installation of two 200 k.w. Alexanderson alternator equipments, which, when associated with the well known multiple-tuned antenna, will each deliver to the antenna a current of six hundred amperes. The equipment is similar to that which is being supplied to Poland by the Radio Corporation. The receiving equipment will consist of two complete and independent modern sets and the necessary amplifying apparatus and

will be used in conjunction with receiving aerials especially devised for the reduction of static disturbances.

At the time that the apparatus contract was signed a very important traffic contract also was signed, which assured the direct communication between Sweden and the United States for a long period of years.

The need of direct telegraph connection between Sweden and the United States was emphasized during the war and immediately thereafter. Internal conditions within Sweden demanded closer relationship with North America and therefore, more reliable and rapid communication facilities. Accordingly, as early as January, 1920, the Swedish-American Association submitted a report to the Royal Telegraph Administration setting forth the exact nature of the economic and political situation, with a recommendation that the subject of direct radio telegraph connections with the United States be investigated at once. The Swedish Government traced the trend of increasing influence and prestige

which had been established in other European countries to their tightly-woven international communication systems. A special committee then was appointed to investigate the possibilities of long-distance radio communication for Sweden.

According to the report of this committee, existing means of international cable communication via various European countries was a serious handicap to Sweden from a commercial, as well as political point of view, and this was especially true of the connections between Sweden and the United States.

It was also recognized that direct communication between the two countries would give a cheaper and freer service tending to bring about a closer relationship not only between the governments and their people but also between the commercial and financial interests of the two countries. Particularly would this be true in the field of international banking where there has long been felt a need for more direct contact. It was also pointed out in the

(Continued on page 61)

Bridging the Gap for the Cables

How Radio Central Saved the Day When the Irish Seized Cable Stations—Putting Into Operation Two New "Spare" Transmitters and Maintaining 24-Hour Transmission

WHEN the Irish forces during August seized and closed nine of the sixteen European cable stations they unwittingly did a favor to the business world in general and to radio in particular. By this action great congestion was caused in the remaining cables, and pressure of business forced hundreds of firms who never before had used radio in trans-Atlantic communication to avail themselves of the newer method of communication, thereby receiving their first and most impressive practical demonstration of its value.

What will be the ultimate effect of the sudden prominence of radio work across the ocean it is impossible to estimate, but it is certain that by its service in the emergency radio has earned a reputation even higher than it had before. Firms that at first despaired of their European messages getting across in time to be of any benefit, turned to radio. Not only in New York City, but in many other cities business houses, their cablegrams refused by the cable companies, resolved to "try radio." And then what was at first merely a hope became a mainstay.

Perhaps the most important educational work done for radio, by the cable congestion, in fact, was in cities other than New York, for in the metropolis radio long ago took its place beside the other methods of communication. In other parts of the country, due in part to certain difficulties of filing messages, radio was little used. In the weeks since August 7, however, thousands of messages have come to New York, by telephone, telegraph and even by mail, for dispatch across the Atlantic by radio.

The chief part in negating the effects of the cable interruption was played by the Radio Corporation of America, whose six circuits, already transmitting daily to Great Britain, Norway, France, Germany, and other European countries, were called upon suddenly to handle a tremendous increase in traffic. Almost instantaneously the traffic flowing into the New York control office at 64 Broad Street jumped to nearly twice its normal volume. The telephones rang incessantly, in fact there were not enough wires into radio headquarters to accommodate all those who wished to make inquiries as to service or to file urgent messages for transmission to the other side. On the morning that the news filtered over from England that the Irish had seized and silenced the cable stations there, it



Where radiograms are filed for transmission to foreign countries

became evident that industrial New York was demanding that radio take the place of the cable. By the next day, other cities took up the cry.

What happened at Radio Central when this deluge of traffic descended? Externally, nothing. The big operating room at 64 Broad Street hummed with activity, as usual. A few extra operators pounded typewriters for longer hours, and that was about all the change that could be seen. Fortunately, extra transmitting facilities were available at Rocky Point, N. Y., and New Brunswick, N. J., having been completed only about two weeks before, and these, consisting of two transmitters, originally designed to act as "spares," were put to work at once.

Most of the new traffic, of course, was bound for Great Britain, though there also were numerous messages for other European countries, which, formerly sent through the British cables, now went directly to their destinations by radio, without stopping in England on the way. Messages of the latter type, of course, are sent by the Radio Corporation of America direct to receiving stations in the various countries.

The greatest volume of traffic across the Atlantic, however, was to England, and the result was that the two spare transmitters worked mostly on messages to that country, which thus was able to receive three streams of radio messages simultaneously. In fact, at times the transmitters that normally work with other Continental countries were given British traffic. This oc-

curred only when they were clear of messages for the country to which they are assigned, which happened occasionally.

When some idle time developed for one of the transmitters, it was easy to turn over to it traffic from a congested circuit. The procedure was simplicity itself. The messages were simply handed to the transmitting operator for the circuit in question, after having advised England over one of its regular circuits to listen on the new wavelength. A signal "go ahead" from England, and the transfer was complete. A minute would be considered a long time for such a move, as it is customary to send a flash across the Atlantic and receive a reply in 15 seconds and less.

This flexibility of radio equipment is one of its most important features—and possibly its least dramatic. One man sits and works a typewriter keyboard on one side of a long table, perforating a tape that operates the automatic transmitter; another man sits at the other side of the table, transcribing a wavy line on a tape traveling in front of him. That is all.

But when one has punched a few holes in his tape, and the other, seconds later, has interpreted a wavy line into a few words, there has been performed an operation exactly equal to picking a cable line up from the bottom of the sea and moving it hundreds or even thousands of miles in a few seconds. The mythical Aladdin's Lamp and the Flying Carpet lose prestige when compared with the actual radio, especially for flexibility.

Picking the cable up and moving it around, in fact, was exactly the cure adopted by the cable companies. Cable ships were sent to the Irish coast, where they grappled for the cables whose land ends were dead, cut them, spliced on a new length, and reeled the additional cable around the Emerald Isle to England. About 400 miles of cable had to be connected in order to reach England, thereby giving the cable companies some severe problems. The new and increased length increased the resistance of the line so greatly that duplex operation, that is, sending of messages both ways, proved impossible, and at the time this is written these spliced cables are being operated simplex, or only in one direction. Achieving even this much by cable was a matter of days, almost as many

days as it took Radio Central in seconds to re-route its transmitters. Those were precious days during which that important part of American business that depends upon quick communication with Europe would have been starved, had it not been for radio.

The general public perhaps is not aware of the vital position of the cable and radio systems in the business of the world. Banks, brokers, exporters, manufacturers, steamship lines, all are constant users of wire and radio.

The banks need daily quotations on foreign exchange, and sometimes, when great and sudden changes in values are taking place, would pay large premiums for expedited service, if they could get it, so important do minutes and even seconds become on quickly rising and falling markets. Radio Central contains a number of direct telegraph lines to banking houses, over which messages are sent, saving the very few minutes required for delivery by messenger.

The brokers, both those dealing in foreign exchange and in bonds and stocks, need daily quotations of the prices on foreign markets, and also send hundreds of buying and selling orders by radio and cable to their correspondents abroad.

Manufacturers place buying orders for raw material likewise, and frequently conclude deals involving large sums by sending a few code words. Where large contracts are at stake a few minutes may mean the gain or loss of sums running into six figures or more.

In general, messages across the Atlantic are expected to lose no business

time. If filed before the addressee across the sea goes out for lunch, they are expected to reach him before he leaves for the day, and if given to the transmitter too late for that, they must be on the addressee's desk when he arrives the next morning.

This means that the five hours difference in time between New York and London works favorably to both sides. The Londoner, closing his desk at 5 in the afternoon, which is noon in New York, sees his outgoing radiogram to New York and knows that it will be delivered there before the close of the New York day. The New Yorker, getting his radiogram from London, knows that the day is done over there by noon, and when he too leaves at 5 o'clock by his time, taking a look at his radiogram in reply, he knows that his London correspondent will find it on his desk at 9 a.m., English time, or 4 a.m., New York time.

This is the consistent practice of firms in both countries who send daily messages to each other, so much so that the greater proportion of the messages sent abroad from each country are filed after 5 p.m. This gives New York the period from 5 p.m. to 4 a.m. to transmit its messages designed for receipt at the beginning of the new day abroad, while England has from 10 p.m. to 4 a.m., English time, to do the same thing.

Those messages that do not demand delivery under these conditions customarily are subject to being deferred, and carry a lower rate both by cable and by radio. During the cable congestion the cable companies abolished the deferred rate business, being unable to handle but a small part of the full rate traffic that was offered, but the Radio Corpor-

ation of America preserved its deferred classification. One of the results of the congestion, therefore, was continuous 24-hour transmission from Radio Central, which was one of the methods by which radio facilities were able to replace the service from the lost cables. In addition two new transmitters were placed in service.

This possibility of increasing the working hours, in fact, was important. As in the cable business, so in radio, the bulk of the traffic is filed at the close of the business day, and is gotten off during the night. Prior to the emergency both cable and radio transmitters had idle periods; their facilities were designed to carry the peak load, and anything over that, after being absorbed by such extra facilities as might be available, simply ran over into the previous idle time.

Though neither the cable companies nor the Radio Corporation of America make public any figures of their business, it is known that while the cables have been restored in part and are handling some business, the traffic by radio is holding up remarkably close to its high point. Firms that once used the cables exclusively now are filing by radio because they prefer the service.

It was during the first difficult days of the cable crisis that radio was called upon to carry its greatest burden, and when involuntary tributes to it were noted on all sides. Typical was the action of one of the important commodity exchanges in New York City, members of which need constant and very swift communication with London and Liverpool. One of the wire companies has sole right to maintain an office in this exchange, a privilege it guards jealously. However, when the cables were silenced, members called upon radio for help, only to find that radio messengers were barred from the floor. A hasty meeting of the board of directors was called, and after a heated debate it was decided that the contract in question was predicated upon the ability to give service, and could be disregarded as long as the service was unavailable. Radio messengers then flowed to this exchange daily in a steady stream, until the cables had been laid around Ireland and a semblance of service restored.

Still another evidence of the value of radio came to light in rather an amusing fashion shortly before the cable trouble. A New York business house, having beaten competitors by using radio, remarked how pleased it was with the service, and even put its commendation in writing—but it also let it be known that it would rather that other firms in its line were kept in ignorance of the radio facilities that had proved so valuable to it!

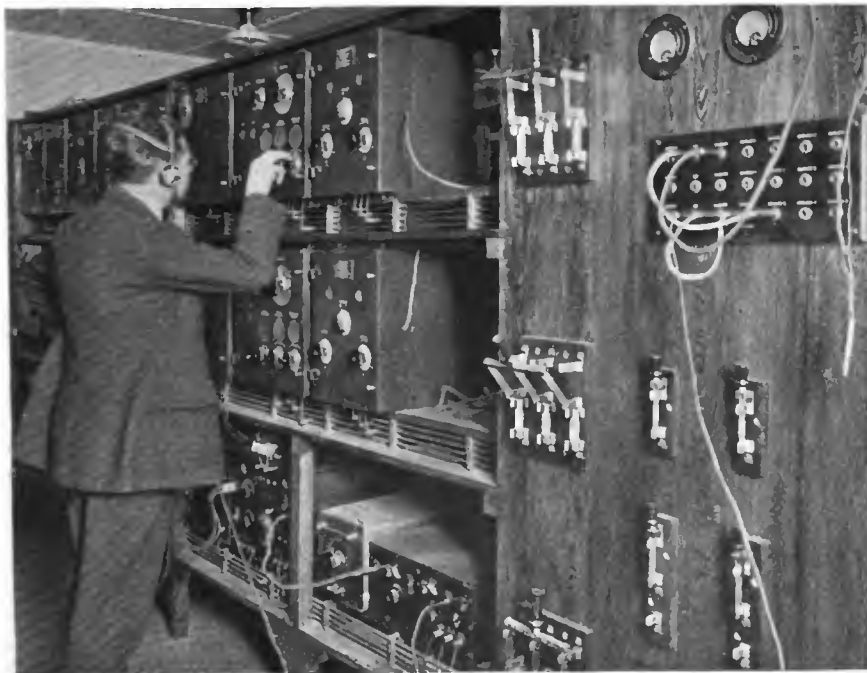

Interior of receiving room at Riverhead, N. Y., showing operator tuning to a station on the other side of the Atlantic

100-Kilowatt Tube Developed Successfully

Is Largest Ever Made. Development of New Copper-to-Glass Seals Rendered Extraordinary Accomplishment Possible. Few Stations Capable of Using Such Power

PRODUCTION of a vacuum tube of 100-kilowatt output capacity has been successfully accomplished within the last few weeks in the laboratories of the Bell Telephone System at the Western Electric Co., New York City. This is by far the largest vacuum tube ever produced. The new 100 k.w. tube has not been placed in commercial use, as comparatively few stations exist capable of utilizing such power. That it will be utilized in the near future, however, seems guaranteed by the possibilities of the tube, which are as remarkable as is its mere appearance.

The new tube contains one important addition to the art of making metal-to-glass seals. It was the solution of this problem, in fact, that did more than anything else to make the 100 k.w. tube possible, as the type of seal usually employed in vacuum tube construction fails under the high temperatures of large power. The new method is the invention of Mr. W. G. Houskeeper, who undertook the mechanical details of developing the tube, while Dr. M. J. Kelly concentrated upon the electrical design and process of evacuation. These special seals can be made in any desired size, and are capable of withstanding repeated heating and cooling over wide ranges of temperature, from that of liquid air to 350 degrees Centigrade, without cracking and without impairment of their vacuum holding qualities.

In an interview with Dr. William Wilson of the Western Electric Laboratories he stated that it is "no exaggeration to say that the invention of these seals has made possible the construction of vacuum tubes, capable of handling in single units, powers of any magnitude which may be called for in wireless telegraph and telephone transmission."

The underlying principle connected with the making of this seal consists in obtaining an intimate connection between the glass and metal, either by chemical combination or by mere "wetting" of the copper by the glass, when the latter has been softened by heat, and in so proportioning the glass and metal portions of the seal that the stresses produced when the seal is heated or cooled will not be great enough to rupture either the glass or the junction between the glass and metal.

The three principal types of seals developed by Mr. Housekeeper are known as the ribbon seal, the disc seal and the tube seal.



Mr. W. G. Houskeeper with the new 100 K.W. tube

If a copper ribbon is directly sealed through glass it is found that the glass and copper adhere along the flat faces of the seal but that ruptures occur along the edges. This is due to the fact that as the seal cools after being made, the glass in contact with metal is capable of resisting the shearing and tensile stresses that occur along the faces,

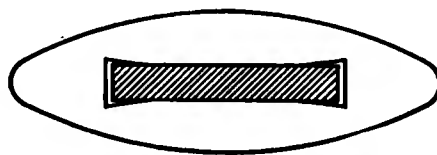

Rectangular seals result in cracking at the corners

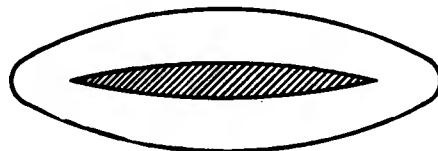

Sharpened ribbon design seal that solved the sealing problem

while the glass wrapping round the edges of the ribbon is called upon to withstand much greater tensile stresses and gives way. If the edges of the ribbon are sharpened, a tight seal results, the reason being that the forces of adhesion between the glass and copper acting along the flat contact faces are sufficient to stretch the thin copper at the edge and prevent its drawing away when cooled. There is a definite relation between the elastic properties of the metal and glass and the angle of edge that can be used for a successful seal.

By proper shaping of the metal ribbon, seals have been successfully made up to very large sizes, and capable of successfully conducting a current of several hundred amperes.

The principles involved in the making of the disc seal are the same as those involved in making the ribbon seal. If a metal disc is sealed wholly into glass the edges must be sharpened or the glass and copper break away from each other as in the case of the ribbon seal.

In the general use to which these seals are put there is no necessity for having the glass surround the circumference of the copper disc and the necessity for sharpening the edge is obviated by allowing the glass to adhere to the flat portion of the disc only, care being taken to prevent its flowing around the edge. It is necessary to have a ring of glass on both sides of the seal in order to equalize the bending stresses which would otherwise tend to break the glass and copper away from each other. Successful disc seals have been made with copper up to 1-10" thick. There is, of course, a certain maximum thickness that can be used for a seal of a given diameter and it is preferable to keep well below this limit.

The third type of seal and the most important in connection with the present problem is the tube seal. This furnishes the means of joining metal and glass tubes end to end and is used in the water-cooled 100 k.w. tube to attach the anode to the glass cylinder which serves to insulate the other tube elements. As in the case of the disc seal, it can be made either with the edge of the metal not in contact with the glass, or with the metal sharpened to a fine edge which is in contact with the glass. The glass may be situated either inside or outside of the metal.

The first thermionic tubes in which these seals were embodied were made of copper and were designed to operate at 10,000 volts and to give about 5 k.w. output.

The vacuum creating process in the case of these tubes at first presented considerable difficulty, chiefly on account of the large amount of occluded gas contained by the metal parts. This caused the time of pumping of the tube to be very long and dangerous warping of the internal structure developed owing to the fact that during exhaust the tube elements are maintained at a much higher temperature than they are sub-

jected to during normal operation. The trouble was overcome by heating the various parts of the tube to as high a temperature as possible in a vacuum furnace, prior to the final assembly, and thus getting rid of a large amount of the occluded gases. The anode was preheated before the glass seal was made and the whole filament grid assembly was preheated just before it was mounted on the glass stem. The preheating of the parts brought about an enormous reduction in the time required for pumping and gave a much more uniform product.

Although successful from the standpoint of operation, this tube had several undesirable features that it was thought well to eliminate. In the first place the welding of the bottom into the tube was not particularly desirable, and in general any troubles that occurred due to leaks in the metal could be traced to this point. Further, in the assembly of the tube there were a very large number of welds to be made which constituted points of weakness at the high temperature necessary for the evacuation of the tubes. It was, therefore, decided to go to a type of tube in which the anode would be drawn in one piece and in which as many welds as possible would be eliminated in the assembly of the internal elements. At the same time it was considered desirable to go to a somewhat larger type of structure in which high tension insulation could be more easily provided and a larger tube was, therefore, designed capable of delivering 10 k.w. to an antenna at a plate voltage of 10,000 volts.

In this tube all welds except those in the collar are eliminated, the assembly being bolted together. The drawing of the anode did away with the leaks that were troublesome in the older tubes and the manufacture of the tube can be carried out with certainty.

With this tube as much as 12 k.w. have been obtained in an artificial antenna working at 12,000 volts. This power was obtained at a frequency of 600,000 cycles corresponding to a wave-

length of 500 meters. The difficulties of obtaining this amount of power at this frequency when using a number of smaller tubes in parallel, are obvious to anyone who is acquainted with the problem. On a direct current test the anode was found to be capable of dissipating 26 k.w. when cooled with water.

The success which had attended the development of a tube of this high power capacity indicated the possibility of constructing still larger tubes and it was decided to proceed with the devel-

by a copper disc welded into the end, is 14 inches long and 3½ inches in diameter. The filament is of tungsten and is .060 inch in diameter and 63.5 inches long. The current required to heat it is 91 amperes, the total amount of power consumed in the filament being approximately 6 k.w. The filament leads are of copper rod one-eighth of an inch in diameter and are sealed through 1 inch copper disc seals. The grid is of molybdenum and is wound around three molybdenum supports.

The handling of the parts of this tube during manufacture presents a task of no mean magnitude and numerous fixtures have been devised to assist in the glass working. It has been found necessary for instance to suspend the anode in gimbals during the making of the tube seal owing to its great weight, and special devices have been made to hold the filament grid assembly in place while it is being sealed in, otherwise the strains produced by its weight cause cracking of the seal.

The significance of this development in the radio art cannot be overestimated. It makes available tubes in units so large that only a very few would be necessary to operate even the largest radio stations now in service, with all the attendant flexibility of operation which accompanies the use of the vacuum tube.

From the standpoint of wireless telephony the development of these high power tubes gives us the possibility of using very much greater amounts of power than have ever been readily available before. The filaments in these tubes have been made so large that the electron emission from them will easily take care of the high peak currents accompanying the transmission of modulated power.

The 100 k.w. tube by no means represents the largest tube made possible by the present development. There is no doubt that if the demand should occur for tubes capable of handling much larger amounts of power they could be constructed along these same lines.

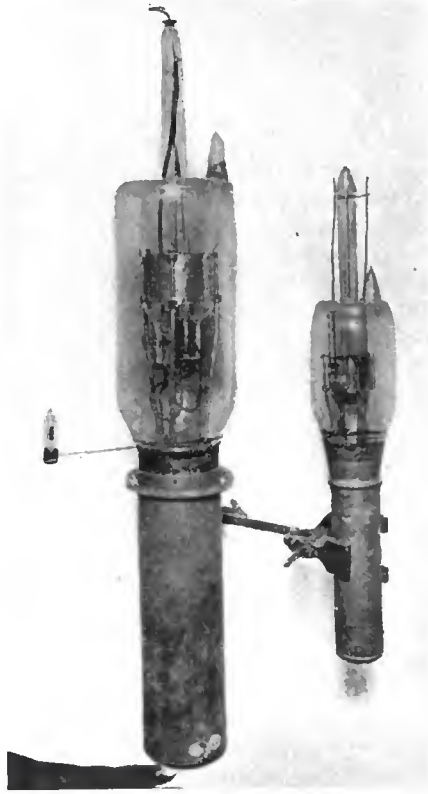

The 100 K.W. tube contrasted with a "peanut" tube and one of 10 K.W.

opment of a tube capable of delivering at least 100 k.w. into an antenna.

The development proceeded with a few minor alterations along the lines of the smaller tube, nominally rated at 10 k.w. and the 100 k.w. tube is now developed. The anode which is made of a piece of seamless copper tubing closed

New Swedish Trans-Oceanic Station

(Continued from page 57)

course of the negotiations that both countries would benefit tremendously by a rapid interchange of market quotations as certain articles of commerce which Sweden produces are greatly influenced by American quotations.

Feeling all these needs and desiring to control her own communications, Sweden therefore about two years ago sent missions to England, France and Germany and the United States to study the various wireless systems and types of apparatus in use. In 1921 the mission under the direction of Seth

Ljungquist, Head of the Royal Telegraph Administration of the Kingdom of Sweden, visited America to inspect the high power station of the Radio Corporation and to particularly see the Alexanderson alternators.

The Swedish Riksdag did not act upon the report of the mission and the tenders submitted by the competing companies last year for two reasons, one being the necessity of economy on the part of the Swedish Government itself, another, because of the fact that the Administration was undecided as

to whether the vacuum tube or the alternator should be used in the stations. But when the Riksdag met this year it sent a special legislative committee to study the subjects. After hearing its report, the Riksdag recommended the use of the Alexanderson alternator, and authorized the signing of the contract by the Telegraph Administration. The order is considered as especially gratifying because the Swedish engineers are considered among the most advanced in the electrical world in developing and manufacturing apparatus.

Advantages of Radio-Frequency Amplification

By B. Bradbury

Radio Engineer, General Electric Company

WHEN receiving very weak radio signals from distant stations it is found that amplification of the audible tones as heard in the telephone receivers is of little or no benefit, since the strength of tube noises, static, or other interference is increased in greater proportion than the signal strength. Under these conditions the most satisfactory signals will often be obtained directly in the output from the detector without additional amplification, since the signal, although weaker, is much more distinct in the telephones than when amplified.

To secure a louder signal with good quality, or to receive more distant stations, some other means of amplification must therefore be adopted. This other means is the amplification of the signal frequency as it is received on the antenna, before it reaches the detector. Detector efficiency decreases with a decrease in the energy received, so that if we can increase this energy before it reaches the detector, better efficiency will result.

One of the most common methods of obtaining radio frequency amplification is the utilization of regeneration in the detector tube itself. Since perfect rectification does not take place in the detector, a certain amount of radio frequency flows in its plate circuit, so that by coupling this circuit back to the grid or input of the tube, the amplified signal frequency is made to re-energize the grid and cause a still greater change in the variations of the plate current.

Regeneration may be accomplished by means of capacitive or inductive back coupling, or a combination of both. Short wave receivers are often constructed with a variable inductance in the plate circuit which can be tuned to the signal frequency. Sufficient voltage is thus built up across the plate circuit to feed a small amount of energy back to the grid through the capacity between the grid and plate within the tube itself. For long wave-lengths the tube capacity becomes insufficient for good regeneration, and some additional means must be provided, such as inductive coupling between the grid and plate circuits. This consists of placing a coil of wire in the plate circuit and coupling it back to the input or grid circuit of the tube.

Another method of obtaining radio frequency amplification is to use one or more vacuum tubes ahead of the de-

detector tube with suitable coupling between them to transfer the energy from one tube to the next at the signal frequency. As with audio frequency, the coupling between tubes may be resistances, inductances or transformers but they cannot, of course, have the same values as for audio frequency coupling. Just as it is somewhat of a problem to build a transformer which will transfer signal voltages uniformly over a wide range of audio tones, so it is difficult to build transformers which will operate well over a broad range of radio frequencies. Since there is such a great difference in the frequencies of the various wave-lengths in use, it is necessary to change transformers to receive all of the different classes of communication.

At short wave-lengths amplification is accompanied by more or less regeneration through the grid and plate capacities of the tubes, as mentioned in connection with detector regeneration. For some wave-lengths the back coupling is sufficient to cause oscillations in the amplifier tubes, and to overcome this tendency some special means must be provided, such as an adjustable grid voltage which can be made positive and thus secure stable operation.

Resistance coupling has the disadvantage of letting through tube noises and other audible frequencies, so that it is sometimes difficult to use it with advantage in addition to the regular audio stages following the detector. It has, however, the advantage of being effective over a wide range of frequencies and will therefore give uniform amplification over a broader wave-length band than inductive coupling.

Inductive or transformer coupling as previously mentioned, will transfer energy at a limited range of frequencies. For this reason inductances and transformers made for use in the amplification of the high frequencies of short wave-lengths will not transfer tube noises or disturbances which are limited to audible frequencies. Several stages may thus be connected in cascade to amplify the signal without distortion before it reaches the detector. Audio amplification may then be added as desired to obtain whatever volume of sound is found necessary.

Three or four stages of radio frequency amplification make it possible to use a loop antenna with good results.

For receiving broadcast signals a loop made by winding ten turns of wire, spaced three-eighths of an inch apart on a frame three feet square, is about the right size to use. There are now transformers on the market which will give good signals in conjunction with a loop and the construction of such a set will produce very gratifying results.

Improvements in Microphones

By MARK MEREDITH

MANY attempts have been made to improve the imperfect articulation resulting from the use of the carbon granule type of transmitter, but hitherto no successful substitute has been obtained, and the immense amount of telephone traffic going on every day is maintained by the earliest methods with very little modification. For moderate distances with wire transmission the solid back transmitter is quite satisfactory, but for long-distance working, and especially in radio-telephony, its performance is not so satisfactory. This is due to the fact that it is necessary to employ amplifiers, and imperfections which are unnoticed under ordinary circumstances are amplified as much as the desired variations, so that, although a large volume of sound can be obtained, the articulation is distorted and speech cannot be clearly understood.

Under the auspices of the National Institute of Inventors, England, a new type of transmitter has been developed, which is free from the disturbing elements associated with carbon transmitters. The variations in resistance accompanying the usual vibration of a thin diaphragm are accomplished by the movements of an electrode in glowing neon gas, which gives both an invariable value of the resistance when the vibration amplitude is zero and a large proportional change in resistance when vibration takes place. It appears that, owing to the nature of the conductor—an electron stream—there are no inertia effects, and the speech is transmitted with great clearness. This microphone should prove a service in radio-telephony circuits, for a more perfect modulating device is badly needed for this purpose. Meanwhile it has already been applied to the production of sound produced at the same time and synchronised with cinematograph films. A photographic record of light variations, produced by the use of the microphone and a vacuum tube is printed by the side of the cinema picture, and reproduction of the accompanying sounds obtained by selenium and a system of amplifiers.

Radio Power Transmission's Improbability

By Dr. Charles P. Steinmetz
Consulting Engineer, General Electric Co.

TRANSMISSION of power by radio is a very remote possibility. Yet it is true that in some respects, radio power transmission exists today, for the message which you receive by radio has been carried by the power of the electro-magnetic wave from the sending to the receiving station.

The sending station sends out electro-magnetic waves of a power of several kilowatts or even hundreds of kilowatts, but this power scatters in all directions and it may be only a fraction of a milliwatt which we receive; that is, less than a millionth part of the power sent out. This small power is sufficient, when amplified, however, to give us the message.

The problem of power transmission essentially differs from that of transmission for communication, for in power transmission most, or at least a large part of the power sent out by the generating station, must arrive at the receiving station, to make it economical to transmit the power.

Hence, the problem of radio power transmission is that of directing the radio waves so closely that a large part of their power remains together so as to be picked up by the receiving station. Much successful work has been done in directing radio waves and for instance our trans-Atlantic stations send out most of their power eastwards. But still, even as directed, the power scatters over the coasts of Europe from Norway to Spain, so that it is impossible to pick up any substantial part of it.

The limits of impossibility of concentrating a beam of radio waves may be illustrated by comparison with a beam of light. Light is an electro-magnetic wave, differing from the radio wave merely by having a wave length many million times shorter. While usually the light scatters in all directions, like the wireless wave, we can direct it in a concentrated beam by the searchlight. But there is inevitably a scattering of the light in the searchlight beam, and when the beam starts perhaps with a square yard section at the searchlight mirror, at 10 miles distance it has at the very best scattered to a diameter of 2,000 feet and at 100 miles distance the beams cover a section of 16 square miles.

If it were a beam of radio power, it



Dr. Charles P. Steinmetz

would thus require at 100 miles distance a receiving station covering 16 square miles—about four miles wide and, what is still more difficult, four miles high, to pick up a large part of the power.

The cause of this scattering is twofold. First, the inevitable imperfections of any apparatus. No matter how perfect a reflector, there are slight imperfections, and at 100 miles distance, they seriously count. Furthermore even with an absolutely perfect reflector, the beam of light would stay together only if the light came from a mathematical point. As it must however come from a small area, this causes an inevitable scattering, which at best gives an angle of scattering of about two degrees. This is about 100 times as much as would be permissible to transmit power economically a hundred miles by a direct radio beam.

Thus the probability of power transmission by directed radio is very small, except perhaps in very special cases where the distances are moderate and the efficiency of transmission of secondary importance.

The second possibility of radio power transmission—at least theoretically—is by resonant vibrations or standing waves.

Suppose we had a very large sending station sending out electro-magnetic waves not of hundreds, but of hundreds thousands of millions of kilowatts, and suppose we could find a wave length where the absorption in

the passage of the wave through space is sufficiently small so as to be negligible compared with the amount of power. Assuming, first, there were no receiving stations. Then the waves issuing from the sending station would circle the globe and return to the sending station and if the wave-length is adjusted so that the returning wave coincides with the outgoing wave, it would return its power, and little power would be required from the sending station to maintain such a system of high power standing waves, only enough to supply the losses—just as little power is required in a wire transmission system, to maintain the voltage wave, when no current is taken off.

Suppose now we erect a second station, tuned for the same wave length as the sending station. It would resonate with the standing electro-magnetic wave issuing from the sending station, thereby stop its passage by absorbing its energy. It would as we may say, punch a hole in the standing wave sheet coming from the sending station. Power would then flow into this hole; the sending station would begin to send out additional power to maintain the wave sheet, and this power would be received by the receiving station.

Any receiving station of suitable design would then be able to pick up power from the universal power supply carried by the standing wave sheet covering the earth. Also several sending stations might send out power. These might have different wave lengths, which then would not interfere, and the receiving station could be tuned to receive power from any one of the generating stations. Or—what would be preferable—all the generating stations would be tuned to the same wave-length, that is, the same frequency. Then they would have to be synchronized and operate in synchronism, just as electric generating stations on the same transmission line are operated in synchronism.

Theoretically, this is very interesting speculation, but whether it could ever become a possibility, would depend on the question whether a radio wave of such length could be found as to make the losses of power by absorption, etc., commercially negligible, and whether stations for such wave-lengths and power would be economically feasible.

Short Wave Reception vs. Antenna Resistance

Tests of Different Antenna Types Show Importance of Correct Installation—Weak Signals Due to High Resistance—Suggestions for Efficient Antenna Construction

By Samuel Miller

HIGH resistance in the antenna, caused by faulty installation, is responsible for the diverse and sometimes discouraging results achieved in the reception of radio telephone broadcasting and other short-wave signals. Since hundreds of thousands of antennas have been erected in all parts of the country by broadcasting fans, it has been observed that two amateurs, using identical receiving apparatus, may have at the headset or loud speaker signal volumes differing as much as 25 to 1.

In the hands of experienced radio men this state of affairs has been rectified in individual cases by a process of observation and trial and experiment. Given receiving apparatus of known worth, produced by capable manufacturers, the first move of the "radio trouble shooter" after testing batteries, bulbs and crystals, is to go over the antenna system, consisting of aerial and ground. It is there that the trouble often lies.

Faulty antenna installation has done more to give unsatisfactory results to the broadcasting amateur than any other single factor. In the vast majority of cases, high resistance in the antenna, resulting from hasty, thoughtless or ignorant installation, is the sole cause of poor receiving. Lowering the resistance by remedying the conditions often brings entirely satisfactory results.

The importance of low resistance in the antenna is obvious when it is considered that the flow of current in any circuit, voltage remaining constant, is inversely proportional to the resistance of that circuit. In other words, the less resistance there is in the receiving antenna, the more current will flow in it to and through the set. As the output of the set in volume of sound is dependent on the input of current, the importance of increasing the antenna current as much as possible is evident. It is, even under the best conditions, infinitely small, being only a millionth of an ampere or so, and there is an additional reason for making its path to the receiving set as easy as possible.

Astounding improvement frequently is realized by a rearrangement of the antenna in such a way as to secure less

resistance. Sometimes the mere matter of a soldered connection, or moving the lead-in six inches further away from the side of the house, or any one of a hundred simple changes, may increase the signal strength 100 or even 1,000 times.

The reason for this great improvement is obvious when it is considered that modern vacuum tube sets are capable of amplifying by a factor of many thousands of times. Consequently each drop in antenna resistance, with consequent increase in primary current flow, is multiplied by the amplifying factor of the set. It is a sort of compound interest, and at rates that would bankrupt the biggest bank in the country if forced to pay them for a single hour!

Here, then, is an investment of extraordinary profit for the receiving operator to make: go over the antenna, or have it gone over by an expert, and correct all conditions making for high resistance.

Just what such conditions are may be seen from the results of tests I have recently made on antennas of all types, in city and country, for the purpose of measuring their characteristics. The most obvious form of high resistance in the antenna circuit consists of imperfect contacts, which need solder. One particularly bad case, which I will report in detail later, showed a resistance of 100 ohms because the amateur had fastened his ground clamp about a pipe without taking the trouble to scrape off the paint. His results were unsatisfactory until the paint was removed, a perfect contact made, and the resistance thus lowered to 28 ohms. When it is considered that a circuit has a resistance of one ohm when it requires a pressure of one volt in order to force a current of one ampere through it, it is to be wondered at that any current at all went through the antenna with the 100 ohms of paint resistance. Cutting the resistance to almost a quarter of its

former value multiplied the output of the set many times.

During my investigations into antenna efficiency various other factors in resistance developed, such as nearness to grounded metal including pipes and roofs, proximity of the lead-in to the side wall of the building, and even the angle at which the lead-in enters the building. Practically every type of installation was the subject of accurate tests with a special, calibrated measuring set, which I carried about with me, making thorough examinations of each antenna, electrically and mechanically. Through the measuring apparatus I was able to measure directly the resistance, capacity and fundamental wave-length, and calculate the inductance from the last two factors.

Inasmuch as the facts observed and conclusions reached form guides for others who may have occasion to examine the efficiency of their own or others' antennas, I am giving here the details of each test. Measuring apparatus such as was especially developed for these tests is not easily available to the average man, but I believe that from the results and analyses published in this article, readers of THE WIRELESS AGE should be able to make material improvements in their antennas, with consequent surprising increases in signal volume, in those cases where high resistance is indicated by the present layout.

ANTENNA 1

The first antenna tested consisted of a single wire, No. 14 insulated copper, 125 feet long connected between two buildings over a grass ground. The ground connection was made to 11 copper strips spread fanwise and buried 18 inches in the ground. Within the house a lead-in 15 feet long went to the receiving set. This antenna showed the following excellent characteristics:

	RESISTANCE
300 Meters	12 Ohms
360 "	10 "
400 "	9 "
500 "	9 "

Apparent capacity at 625 meters, .00037 MF. Fundamental wave-length, 180 meters. Inductance, calculated, 24 microhenries.

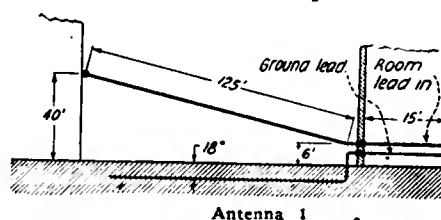

ANTENNA 2

Single wire, No. 14 insulated copper, 40 feet long, 10 feet high, connected between a tree and a building over grass. Ground connection made to steam radiator. On the broadcasting wave of 360 meters this showed a considerably higher resistance than the first antenna. The constants:

RESISTANCE	
250 Meters	22 Ohms
275 "	24 "
300 "	25 "
360 "	28 "
400 "	30 "

Apparent capacity at 625 meters, .0002 MF. Fundamental wave-length, below 125 meters. Inductance, calculated, less than 22 microhenries.

ANTENNA 3

This was the same antenna as number 2, but instead of the steam radiator ground a counterpoise was used, consisting of a single wire raised one foot from the ground under the aerial wire. This showed higher resistance than the previous arrangement, adding two ohms to the resistance at 360 meters, and cutting down the signal intensity from a broadcasting station on this wave to only 25 per cent of its previous value—a striking evidence of the importance of resistance. The constants:

RESISTANCE	
200 Meters	17 Ohms
250 "	22 "
300 "	27 "
360 "	30 "
400 "	32 "

Apparent capacity at 550 meters, .00011 MF. Fundamental wave-length, below 125 meters. Inductance, less than 22 microhenries.

ANTENNA 4

A single wire of No. 14 insulated copper. From the lead-in it runs vertically 80 feet to the roof, touching the building at different points, and then extends 50 feet from the cornice to a point 13 feet over the roof. The ground connection is made to a steam radiator. This showed a high resistance, due to the long stretch of wire touching the side of the building.

RESISTANCE	
300 Meters	39 Ohms
360 "	40 "
400 "	42 "
500 "	48 "

Apparent capacity at 600 meters, .00044 MF. Fundamental wave-length, 210 meters. Inductance, 28 microhenries.

ANTENNA 5

A single wire consisting of 7 strands of No. 22 phosphor bronze. It runs from the lead-in horizontally 30 feet at a height of 8 feet above grassy ground, and then back at an angle to the roof, a distance of 150 feet. The ground connection is made to a steam radiator.

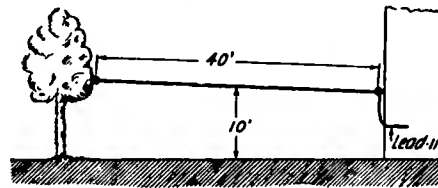

Antenna 2

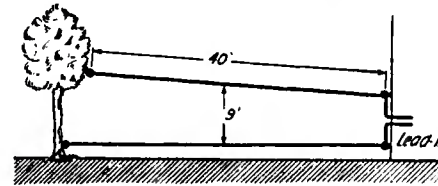

Antenna 3

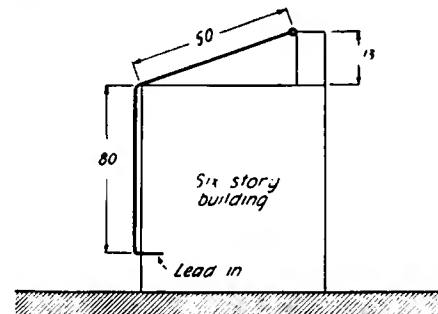

Antenna 4

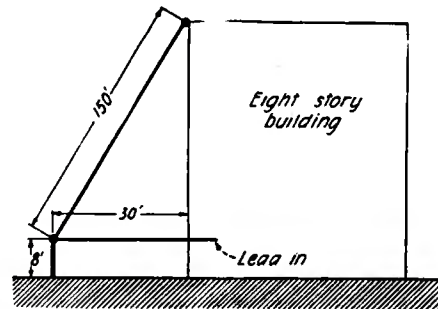

Antenna 5

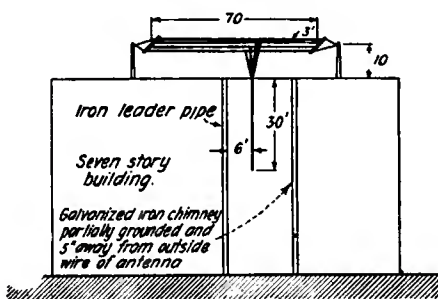

Antenna 6

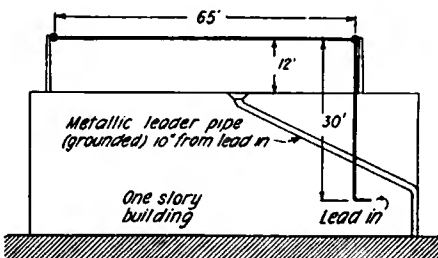

Antenna 7

(Antenna 5—Continued)

RESISTANCE	
360 Meters	10 Ohms
400 "	10 "
500 "	9 "

Apparent capacity at 650 meters, .00049 MF. Fundamental wave-length, 260 meters. Inductance, 39 microhenries.

ANTENNA 8

This is an ambitious-appearing four-wire T-type antenna, but showed a resistance that is relatively high. The wire is 7-strand No. 22 phosphor bronze. The horizontal portion is 70 feet long, 10 feet above the roof of a 7-story apartment house. The wires are three feet apart. The lead-in runs down to a point 30 feet below the roof, passing only one foot away from an iron leader pipe. There also is a galvanized iron chimney partially grounded, only 5 inches away from one of the outside wires of the antenna. The resistance shown is no doubt due in part to the proximity of the leader pipe and chimney.

RESISTANCE	
300 Meters	30 Ohms
360 "	22 "
400 "	20 "
500 "	19 "

Apparent capacity at 850 meters, .0007 MF. Fundamental wave-length, 240 meters. Inductance, 23 microhenries.

ANTENNA 9

A single wire of No. 14 bare copper. Located on the roof of a one-story building, 65 feet long, 12 feet above roof, with a 30-foot lead-in, running downward one foot from the side of the building. Ground connection to a water pipe. A metal leader pipe runs diagonally across the path of the lead-in, 10 inches from it.

RESISTANCE	
200 Meters	15 Ohms
250 "	15 "
300 "	18 "
360 "	23 "
400 "	26 "
500 "	26 "

Apparent capacity at 425 meters, .00008 MF. Fundamental wave-length, 145 meters. Inductance, 74 microhenries.

ANTENNA 8

A single wire of No. 14 bare copper. It stretches for a length of 100 feet from a pole 40 feet high to the cornice of a 2-story building, over a grassy ground. The lead-in is brought down vertically for 20 feet and at a distance of 6 inches from the building. The ground connection is made to the water pipe.

RESISTANCE	
250 Meters	13 Ohms
300 "	11 "
360 "	9 "
400 "	8 "
500 "	6 "

Apparent capacity at 550 meters, .00035 MF. Fundamental wave-length, 195 meters. Inductance, 30 microhenries.

ANTENNA 9

Two wire antenna, 7-strand No. 22

phosphor bronze. It stretches 135 feet across a courtyard to the top of another building, at a height of 14 feet above the roof. The wires are separate 3 feet, and the lead-in is connected to the flat top 15 feet from one end, running down an airshaft for 50 feet, 1½ feet from the wall. The ground connection is made to a water pipe. This antenna gave a classic example of high resistance, showing 100 ohms at 360 meters. Investigation revealed that the amateur had fastened his ground clamp over the water pipe without first scraping away the paint. This was corrected, and the following results obtained:

RESISTANCE	
360 Meters	28 Ohms
400 "	25 "
500 "	20 "
600 "	20 "

Apparent capacity at 850 meters, .00081 MF. Fundamental wave-length, 295 meters. Inductance, 11 microhenries.

ANTENNA 10

Single wire No. 14 insulated copper, stretching from the water tank of a 12-story building down an airshaft for 140 feet. Ground connection made to a steam radiator. Two sets of measurements were made here. The first were taken directly at the lead-in insulator, in other words, neglecting the lead-in, which was 50 feet long around the moulding of a room. This first test showed the following results:

RESISTANCE	
250 Meters	19 Ohms
300 "	15 "
360 "	13 "
400 "	14 "
500 "	15 "

Apparent capacity at 600 meters, .00039 MF. Fundamental wave-length, 205 meters. Inductance, 30 microhenries.

The second test was made at the end of the 50-foot lead-in, and gave much higher resistances.

RESISTANCE	
250 Meters	40 Ohms
300 "	25 "
360 "	27 "
400 "	22 "
500 "	22 "

Apparent capacity at 650 meters, .00041 MF. Fundamental wave-length, 195 meters. Inductance, 26 microhenries.

ANTENNA 11

Single wire of No. 14 bare copper, stretching from the roof of a 12-story building down and outward for 100 feet to the roof of a 4-story building. The antenna then turns inward and runs 55 feet to the lead-in insulator, 25 feet of this distance across the front of a building. The lead-in inside the room is 20 feet long. Ground connection is made to a steam radiator.

RESISTANCE	
360 Meters	25 Ohms
400 "	22 "
500 "	17 "

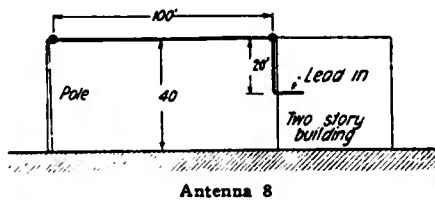

Antenna 8

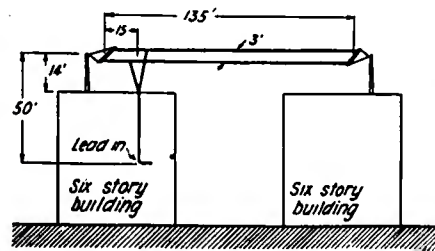

Antenna 9

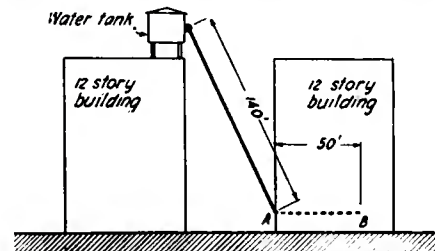

Antenna 10

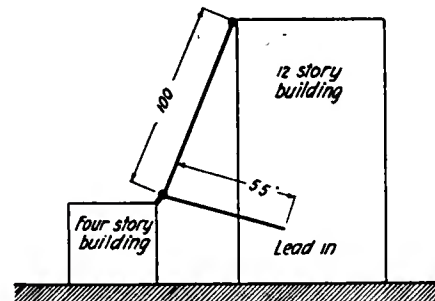

Antenna 11

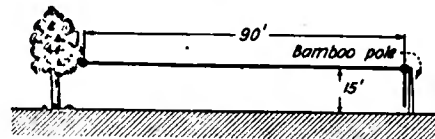

Antenna 12

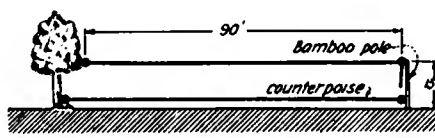

Antenna 13

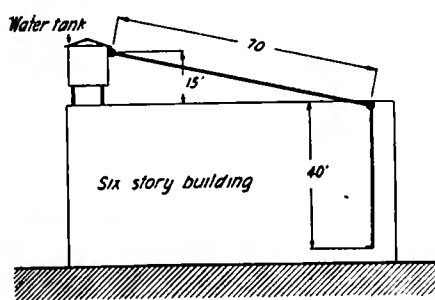

Antenna 14

(Antenna 11—Continued)

600 "	17 "
700 "	17 "

Apparent capacity at 800 meters, .00074 MF. Fundamental wave-length, 325 meters. Inductance, 40 microhenries.

ANTENNA 12

Single wire of No. 14 insulated wire, stretching between a tree and a bamboo pole for a length of 90 feet, at a height of 15 feet. The ground connection is made by driving a number of iron spikes in the earth to a depth of 10 inches. The soil under the antenna is very rocky.

RESISTANCE	
200 Meters	40 Ohms
250 "	50 "
300 "	50 "
360 "	90 "
400 "	80 "
500 "	80 "

Apparent capacity at 550 meters, .00026 MF. Fundamental wave-length, 135 meters. Inductance, 19 microhenries.

ANTENNA 13

This is the same as No. 12, but instead of the very poor iron spike ground, a single wire counterpoise of No. 14 insulated wire is used. This has the effect of cutting the resistance exactly in half at 360 meters, although the resistance at 200 meters was more than doubled.

RESISTANCE	
200 Meters	90 Ohms
250 "	50 "
300 "	50 "
360 "	45 "
400 "	45 "
500 "	45 "

Apparent capacity at 500 meters, .0002 MF. Fundamental wave-length, 180 meters. Inductance, 45 microhenries.

ANTENNA 14

Single wire antenna of No. 12 bare copper wire, fastened to a water tank on top of a six-story building, 15 feet above the roof, stretching downward at an angle for 70 feet to the cornice, whence it falls 40 feet, about one foot away from the front of the building. Ground connection made to a steam radiator. With this antenna the enormous resistance of 400 ohms was registered at 250 meters, as shown below. This was probably due to the fact that the radiator piping system before it is grounded to earth is in effect a loop which is resonant to 250 meters. At that wave length it absorbs a large amount of energy. A startling proof of this may be seen by comparing the figures below with antenna 15, the same installation, but with a water pipe ground.

RESISTANCE	
200 Meters	21 Ohms
225 "	55 "
240 "	190 "
250 "	400 "
275 "	160 "
300 "	44 "

(Antenna 14—Continued)

325	"	22	"
360	"	12	"
400	"	9	"
500	"	7	"

Apparent capacity at 650 meters, .00036 MF. Fundamental wave-length, 180 meters. Inductance, 25 microhenries.

ANTENNA 15

Same antenna as No. 14, but using a water pipe ground instead of the connection to the steam radiator.

RESISTANCE			
250 Meters	17	Ohms	
300	"	12	"
360	"	12	"
400	"	10	"
500	"	10	"

Apparent capacity at 650 meters, .00037 MF. Fundamental wave-length, 230 meters. Inductance, 40 microhenries.

ANTENNA 16

Single wire of No. 16 bare copper, running for a length of 60 feet horizontally across the front of a building, 1 foot from the wall. Ground connection to a steam radiator, which caused the same sudden increase of resistance at 250 meters as noted in the previous

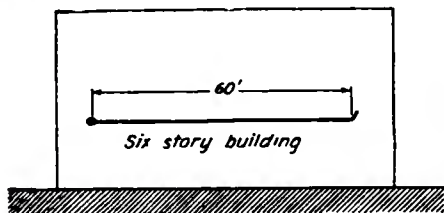

Antenna 16

case, with the same solving of the problem by using a water pipe ground.

RESISTANCE			
200 Meters	25	Ohms	
225	"	50	"
250	"	320	"
275	"	140	"
300	"	45	"
360	"	19	"
400	"	15	"
500	"	19	"

Apparent capacity at 550 meters, .00024 MF. Fundamental wave-length, 120 meters. Inductance, 17 microhenries.

ANTENNA 17

This is the same antenna as the previous one, but using a water pipe ground instead of the steam radiator, thereby revealing normal resistance.

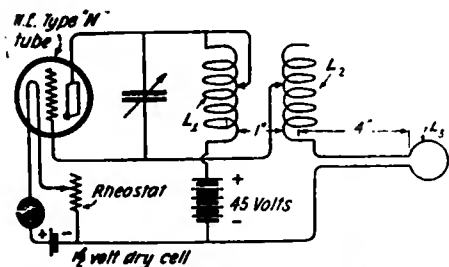

Figure 2—Oscillator wiring diagram

RESISTANCE

200 Meters	22	Ohms
250	"	20
300	"	17
360	"	17
400	"	17
500	"	17

Apparent capacity at 500 meters, .00024 MF. Fundamental wave-length, 180 meters. Inductance, 38 microhenries.

MEASURING OUTFIT

The instruments used for measuring the antennas consist of a calibrated oscillator with a wave length range between 150 and 800 meters and the measuring unit proper. The entire outfit has been so built that both units can be easily carried by one person to

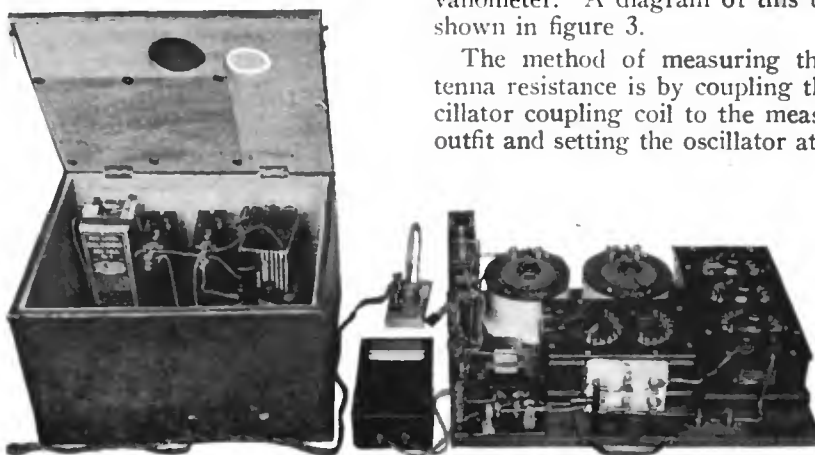

Figure 1—View of measuring instruments showing oscillator on left in shielded box, indicating devices at right

0.0007 microfarad. The coupling coil is 4" in diameter and is wound with 4 turns of annunciator wire. The leads to this coil are copper shielded as is also the box in which the entire set is placed. A wiring diagram of the oscillator is shown in figure 2.

The measuring unit can be used either for measuring the resistance, the apparent capacity or the fundamental wave-length of an antenna; the inductance is calculated from the apparent capacity and fundamental wave length. This unit consists essentially of a series tuning circuit and a dummy antenna circuit, the latter to be substituted for the antenna to be measured. In series with the antenna circuit is a units and tens resistance box, across which is placed a galena crystal detector in series with a galvanometer. A diagram of this unit is shown in figure 3.

The method of measuring the antenna resistance is by coupling the oscillator coupling coil to the measuring outfit and setting the oscillator at some

all parts of the city and country, thus enabling one to make the measurements of antennas under all conditions.

The oscillator is composed of a Western Electric Type "N" tube allowing the use of a dry cell for lighting the filament. A potential of 45 volts is required on the plate, which is supplied by two small "B" batteries. Both the plate and grid oscillating coils are tapped inductors of the General Radio Type 226A, the maximum inductance of each being approximately 280 microhenries. The tuning condenser has a maximum capacity of

definite wave-length. The series tuning circuit is varied until resonance is obtained by indication of maximum galvanometer deflection. By means of a throw-over switch the antenna is disconnected and the series tuning circuit is connected across the dummy antenna circuit, which in turn is tuned for the resonance by observing the galvanometer for maximum deflection. Resistance is then added in the dummy antenna circuit until the same galvanometer deflection is obtained as with the antenna in the circuit; the added resistance represents the antenna resistance. This comparison method of

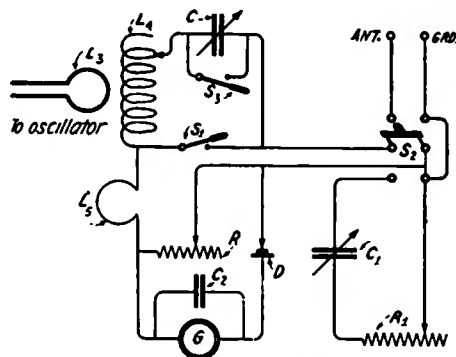

Figure 3—Circuit of the measuring unit

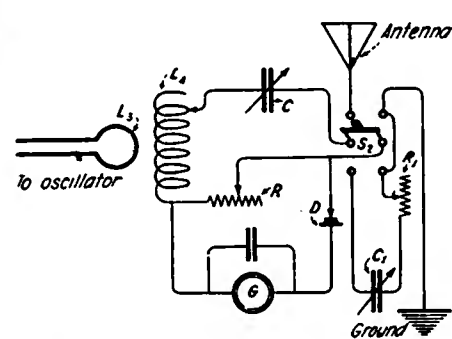

Figure 4—Circuit diagram of the method of measuring resistance

measuring antenna resistance has been checked and found reliable by laboratory investigations. Figure 4 shows the method of measuring antenna resistance.

The apparent capacity measured is practically the static capacity of the antenna, and is obtained by using the maximum inductance in the series tuning coil and varying the oscillator until

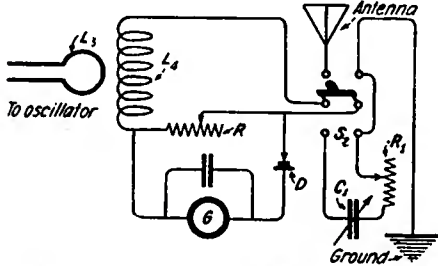

Figure 5—Circuit for measuring apparent capacity

resonance is had. In this measurement the series tuning condenser is short-circuited. By switching over to the dummy antenna circuit, the condenser in this circuit is then varied until resonance is again obtained, the condenser reading representing the apparent capacity. For convenience this instrument is calibrated directly in micro-micro farads. In figure 5 is shown the circuit used in measuring the apparent capacity.

For measuring the fundamental wave-length, the antenna is put in series with a single 4-inch loop to which is coupled the oscillator. The oscillator is varied until resonance is obtained by maximum deflection in the galvanometer. The wave-length is obtained from the oscillator condenser reading and a consultation of a calibrated curve sheet, made easily accessible by pasting on the inside of the box. Figure 6 shows the circuit used in making this measurement.

SUGGESTIONS ON ANTENNA CONSTRUCTION

In conclusion, a few precautions in construction details on the installation of an antenna are necessary.

1. Keep the flat top and lead-in away from metallic grounded substances.
2. Be sure that you have a ground connection as perfect as possible. Solder this connection, as the solder will not hold unless you have a clean surface. The water pipe should be used in preference to other grounded metallic pipes.
3. The dielectric losses are low, and hence the resistance is smaller for an antenna stretched across a grass ground than over a building.

4. In case of installing an antenna on an apartment house, keep the lead-in not less than one foot away from the building.

5. An ideal antenna to be used for reception on short waves is a single wire about 100 feet long and 50 feet high stretched over grass ground, the

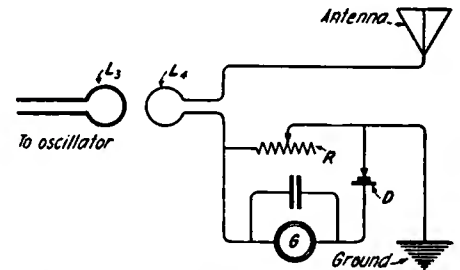

Figure 6—Circuit for measuring the fundamental wave length

lead-in coming into the building at as steep an angle as possible, and with a water pipe as a ground.

We may safely conclude from the measurements obtained, that at a wave-length of 360 meters, an average broadcast receiving antenna will have the following constants:

- Static capacity: 0.0004 microfarad.
- Resistance at 360 meters: 25 ohms.
- Fundamental: 200 meters.
- Inductance: 28 microhenries.

A Convenient Change-Over Switch

By Edward W. Vail

TO avoid unnecessarily using current from a storage battery on nearby reception or to listen in between selections when a loud speaker is used, it is very convenient to be able to receive on a crystal, to amplify the crystal reception, to receive with one tube or, as usual, with a detector tube and one or more amplifiers.

All of this may be done by using the switch shown in the accompanying diagram. The switch is simply one like those used for putting the primary condenser in series or parallel with the oscillation transformer, except that there are ten contacts for the ends of the switch arms instead of eight, and an auxiliary contact in one position. The connections are shown in the accompanying schematic diagram. In position (1) the detector tube is in circuit with the receiving phone socket P and the B battery. In position (2) the detector tube is connected with the B battery and the amplifying transformer. In position (3) the crystal is in circuit with the amplifying transformer, and in position (4) the crystal is in circuit with the phone socket P. These phone sockets receive the well-known two-pin phone plug.

The left-hand connecting strip of the control switch has an auxiliary spring contact as indicated by the inner arrow for making the return connection to the secondary transformer circuit when the crystal is connected with the amplifying transformer.

The above arrangement is fool proof and short circuits none of the batteries in passing from one position to another on the switch points.

Obviously one A battery may be used for the three tubes. The same series of circuit arrangements may be accomplished by a cylindrical switch, but the switch here

described, is simpler and takes up less room. The same switch may be adapted for use with a detector tube, crystal and with the new Armstrong super-regenerative circuit as well.

The switch is particularly useful in helping to locate loose connections or other "bugs."

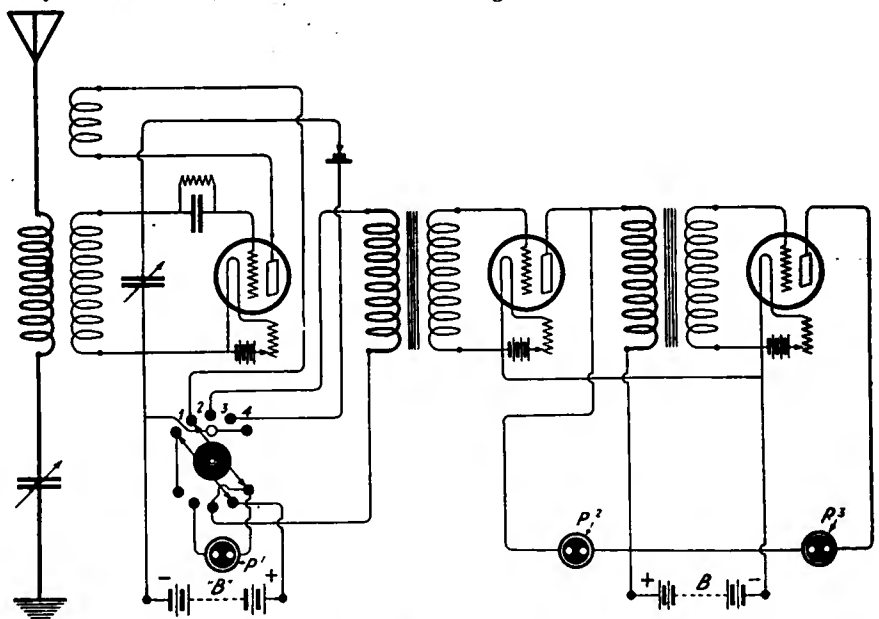

Hook up of change-over switch for selecting tube or crystal detector and putting output directly in phones or through amplifier



One of the field stations. Taken during testing of receivers before the "battle"



Two radio-equipped planes were used, one for code work and the other for telephone

Miniature Warfare Direction by Oklahoma National Guard Radio

The First National Guard Organization to Use Radio in Sham Battles and Other Military Maneuvers

IT remained for the Oklahoma National Guards to be the first national guard organization in the United States to use radio as a means for conducting sham battles and other maneuvers during their encampment.

While radio has been used to some extent in guard work, the Oklahoma organization added a radio unit to its organization during their encampment at Fort Sill this year and the success with which the new unit met and worked was demonstrated on July 28th when a sham battle was staged; the movements of the troops and all orders being delivered by radio.

The orders were received from Fort Sam Houston, Tex., over the radio at the central station DM6 at Post Field,

Okla., and were relayed from the central station, which was under the directorship of Lieut. Earl C. Hull, to the station located in the field, where the battle started.

Two loud speakers were placed on the field and the orders were heard by the entire regiment of infantry and artillery, who were on their toes to start the moment orders were received from Fort Sam Houston.

Two airplanes equipped with radio sets hovered over the battle field and four crews equipped with field radio sets progressed from the main field station following the troops.

During the entire engagement, which lasted for several hours, the radio worked without a hitch and the orders

could be heard and transmitted to the officers in charge above the roar of the cannons and the popping of the rifles.

Preliminary to the sham battle a school was conducted for two weeks by Lieut. Hull, to which every organization in the guard sent picked men. Lieut. Hull was a former instructor over seas with the A.E.F. and has been a student of radio for the past twelve years.

"Radio and the airships are going to be the biggest factors in the next war and in the civilian life of the American people and that is why I want the Oklahoma National Guard to be on their toes and up in radio work," said Col. J. P. O'Neil, senior instructor of the Oklahoma guards.



General view of the field of operations. The main transmitter was placed at the base of the steel tower shown in the center foreground

EXPERIMENTERS' WORLD

Views of readers on subjects and specific problems they would like to have discussed in this department will be appreciated by the Editor

Good Work by 1IV on 10 Watts

THE amateur station of C. H. Campbell, 66 Vine Street, Bridgeport, Conn., 1 IV, is one which is known by hundreds of amateurs throughout the eastern part of the country who have either worked with it or heard it.

The transmitter consists of two UV-202 radiotrons in a full-wave, self-rectifying circuit. High voltage is obtained from a 200-watt Acme transformer. The key is in the primary and a separate transformer is used to light the filaments. The antenna current is 2.5 amperes.

The receiving equipment consists of a Z-Nith regenerator, home made two-step amplifier, and Baldwin phones. With this receiver, amateurs' signals from all districts, except the sixth and seventh, and broadcasting stations as



Equipment at station 1IV, Bridgeport, Conn.

far as KYW (Chicago), have been heard.

The antenna is an inverted "L" of 4 wires, spaced 2 feet apart. It is 55 feet long and 40 feet high. The lead-in is a 6-inch cage. A counterpoise ground is used. It is fan-shaped and is directly under the antenna, 6 feet above the earth. It contains 9 wires 60 feet long. Both the antenna and counterpoise are electrose insulated and all joints are soldered. The antenna resistance is seven ohms.

Signals of 1 IV have been reported from 20 states and Canada. The station has worked amateur stations in 14 states and Canada, and was reported by a ship off Cuba last January, a distance of 1,280 miles. 1IV is an official relay station and handles considerable traffic.

An Efficient Loop Circuit

By Clyde B. Gardenier

EVERY amateur is interested in radio frequency, either to increase his range or make local broadcasting stations come in louder. It is invaluable to those forbidden the use of outdoor antennas. A combination of radio and audio frequency amplification and loop reception is the natural solution to these problems.

Since detector efficiency is directly proportional to the energy received, it is necessary to amplify the signal frequency as received on the loop, before it reaches the detector. Perfect rectification does not take place in the detector tube itself, a certain amount of radio frequency flowing in the plate circuit. By coupling this circuit back to the grid, the amplified signal frequency is made to energize the grid once more and cause increased variations in the plate current. This regeneration feature may be accomplished by a coil of wire in the plate circuit coupled back to the grid of the tube through a fixed condenser. Sufficient voltage is built up by this impedance to feed some back to the grid.

The accompanying diagram shows a circuit embodying these principles that is very efficient and at the same time extremely simple. The first tube is

made to perform the two functions of amplification at radio frequency and detection. One step of audio frequency amplification added produces sufficient intensity of sound to operate a loud speaker.

The inductive back coupling is obtained with a 100-turn honeycomb coil and fixed condenser of .002 mfd. capacity. The tube is a Radiotron No. 200 with 45 volts on the plate. Several of these tubes have been used in the circuit and it is found that they work efficiently with a plate voltage up to 50, with an increase in signal strength

in direct proportion to the applied voltage.

Amplifying at audio frequency is a simple undertaking, consisting merely of its transformer, Radiotron No. 201, and rheostat.

With 9 turns No. 18 lamp cord wire, $\frac{1}{2}$ inch apart, on a 3-foot loop, radio programs are received from WJZ, WBAY, etc.; the music being heard comfortably throughout a 5-room apartment; and without the static and other foreign noises accompanying the outdoor antenna. The loop is tuned to 360 meters with a 23-plate condenser at 64 degrees. Amateurs come in at 95 degrees, but for this class of work it is recommended to cut down the turns on the loop to six. The set has two controls and means to turn the loop.

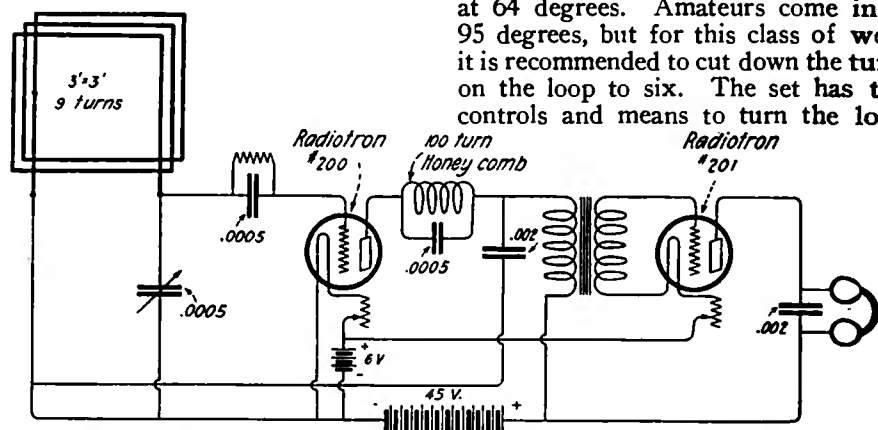

Simple two-tube regenerative loop circuit using radio and audio frequency amplification

Operating Suggestions for Armstrong Super-Regenerative Circuit

By Burton S. Clark

In the Boston Globe

TO those who have tried the new "super" circuit without really getting first-class results the following experiences that I have had with it may be of interest and benefit.

For the last two weeks I have been so fortunate as to do some experimenting on the new circuit with Prof. Newell in the electrical engineering laboratory at Worcester Polytechnic Institute.

It certainly works and the strength of signals is truly remarkable, but we did not find it very selective, especially on code. Eighth, 6th, 4th, 3d and 2d district stations came in and 1st district amateur stations were too numerous to mention. Music from Schenectady, Newark and other nearer broadcast stations came in splendidly when properly tuned, and this brings me to some of the real points of the circuit.

The circuit has to be very carefully tuned, a "hair" one way resulting in excessive regeneration—indicated by a rushing and hissing noise in the phones—a "hair" the other way and numerous harmonics result, as noted by the "canaries." There is just one place for the signal.

The regeneration is very critical to control in the first tube. A fine control over the filament current of this tube is essential for satisfactory operation. Changing the position of the lower lead from the loop and changing taps on the variocoupler, when this type of tuning unit is employed, may help in tuning.

The batteries, both filament lighting

and plate, should be kept up to normal, as the tubes, especially when putting the circuit into operation, must be burned brighter than usual. In the case of the low-frequency oscillator (second tube) it may be found that once oscillation has been established in it the filament current may be reduced considerably and still preserve the oscillatory state. This effect is more pronounced when L-1500 coil is shunted by a 0.0005 variable condenser.

I found that better results were obtained when the plate circuit of the oscillator tube was tuned instead of the grid circuit which contains the coil L-1200, placing a fixed capacitance of 0.002 microfarads across L-1200.

The best improvement noted in our experiments occurred when a choke coil and very small condenser were placed between the plate and grid of the oscillator in the two-tube circuit. This trap was used instead of the L-250 coil commonly employed. The condenser was of fixed value and its capacity was approximately 0.00025. The choke used was the primary winding of an audio-frequency amplifying transformer. The effect of this change was to stabilize the circuit and increase signal strength.

UV-201 tubes were used with marked success with a negative grid bias of $3\frac{1}{2}$ to $4\frac{1}{2}$ volts on the first tube and 9 to 10 volts on the grid of the oscillator. VT-1's were tried with good results. Fine results were obtained with "L" tubes, but these tubes require

more filament current and greater negative bias on the grids.

The "B" battery voltages employed varied between 65 and 120 volts. This potential did not appear to be critical when a value sufficient for operation of the tubes was obtained. The negative bias on the oscillator tube was found to be quite critical and different values should be tried.

When the two-tube circuit is working properly it is not advisable to wear the head phones, as there is sufficient energy available to satisfactorily operate a loud speaker. If phones are used they may be placed nearby on the table. We operated a loud speaker connected directly to the phone terminals in the two-tube circuit, which gave signals of very good audibility.

The circuit showing inductive coupling in the oscillator tube circuits is practical and can be nicely controlled when used in a two-coil mount. This circuit, however, is not as stable in operation as one employing capacity coupling and is consequently more difficult to adjust and tune. If the circuit employing inductive coupling is used, a variable condenser of 0.0005 microfarads may be connected across the plate inductance to advantage.

In conclusion, I may say that the super-regenerative circuit is a splendid one when carefully worked out, and those who have not as yet met with much success in operating it need not be discouraged, for excellent results can be obtained with it.

December Trans-Atlantic Tests Announcement

THE third series of trans-Atlantic amateur tests will be conducted by the American Radio Relay League in co-operation with the radio amateurs of England, France and Holland.

The tests will be conducted from December 12th, to December 31st, 1922, inclusive. During the first ten days of the tests, American and Canadian amateurs will transmit signals for reception by the radio amateurs of the European countries. Those of the American and Canadian transmitters making the best records as determined by reception reports from the European amateurs, will be used to transmit the results of reception by American and Canadian radio amateurs when the English and French radio amateurs are transmitting.

For the first time in the history of amateur radio, American and Canadian amateurs will have an opportunity to demonstrate their skill in receiving amateur signals from across the Atlantic. As a result of the success of the A. R. R. L. trans-

Atlantic tests of last December, when thirty radio amateur transmitters succeeded in bridging the Atlantic, the French Government has permitted the issuance of several amateur transmitting licenses, while the British Post Office Department has issued a special permit to the Wireless Society of Manchester to use a power of 1,000 watts of continuous wave energy for the express purpose of establishing amateur radio communication with the amateurs of the United States. The American and Canadian amateurs are highly optimistic in reviewing their chance of hearing the British amateurs using this amount of power, since several American amateurs using less than 500 watts of C. W. energy were heard by Paul F. Godley, who was at Ardrossan, Scotland, last winter.

Mr. Godley is arranging to establish his record breaking receiver at some point on the north Atlantic coast during the coming tests with the idea of copying signals from the European amateur stations.

A series of preliminary tests, for the purpose of determining what American and Canadian transmitters shall be given a place in the final tests with an individual schedule and code letters, will be conducted from October 25th to November 3rd inclusive. To qualify for the final tests a transmitter must cover a distance of at least 1,200 miles.

The preliminary tests will cover a period of two and one-half hours (9:30 P. M. to midnight, central standard time) each night, which is divided into ten periods of fifteen minutes each. Transmission will take place by inspection districts. One district will transmit at a time, all others remaining silent in an endeavor to copy as many of the transmitting stations as possible. After the tests each night, the receiving stations are to send a confirming record to all transmitters heard at a distance of 1,200 air line miles or over, and operators of transmitting stations must file at least one 1,200 mile record to be eligible for the trans-Atlantic tests.

French Amateur Station 8AB

This Experimental Station, the First of Its Kind in France and the First to Communicate With Amateurs in England—An Interesting Story of Development Which Many American Amateurs Will Appreciate

THE licensing of amateur experimental stations by the French Government last winter has already resulted in the achievement of some very interesting results in the way of communication between a French amateur station and several English stations. French amateur station 8AB, Nice, France, owned and operated by Leon Deloy, has been particularly successful in transmitting to English amateurs according to a description of the station in "The Wireless World" of London.

The aerial which was used in all the transmission experiments is an umbrella type, consisting of three bronze wires of two millimeters diameter (.078 inch) and 25 meters (82 feet) of ef-

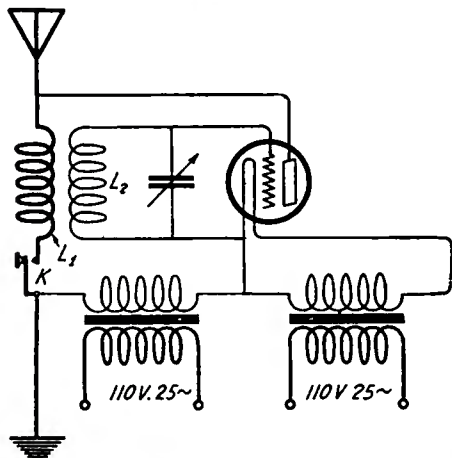

Figure 1. First tube transmitter at French 8AB

fective length. They are extended by insulated cables and suspended from their point of connection by an ebonite insulator attached to the lightning conductor of the house where the station is situated. The mean height of this aerial from the ground is about 20 meters, or 65½ feet. The lead-in wire, which is taken from the top of the aerial, is about 10 meters long (32.8 feet) to the point where it reaches the instruments; this is also a bronze wire two millimeters (.078 inch) in diameter.

As soon as the necessary authority had been received for conducting experiments in transmission, a valve transmitter was installed. The connections were those shown in the circuit diagram given in figure 1. The tube was an ordinary receiving tube, type T.M. Alternating current from the city mains was used for the filament, using a small tapped Ferrix transformer to step down the voltage. The coils used for

the primary and secondary were coils which had served in the construction of a heterodyne. They consisted of 300 turns of No. 24 wire for the anode and aerial coil, wound on a cardboard cylinder 15 centimeters (5.89 inches) in diameter, and for the grid coil 250 turns wound on a cylinder 12 centimeters (4.7 inches) in diameter. The condenser of the grid coil was an ordinary receiving condenser of a capacity of 0.00075 microfarad. The plate voltage was supplied by a Ferrix transformer giving 250 volts at the secondary.

The station was soon improved in the following manner. The key, instead of being placed in the earth lead, was placed in the primary of the high tension transformer, in order to avoid all possibility of shocks to the operator. The second improvement consisted in employing two tubes in parallel in place of one, and the signals of the station were at once heard at Cros-de-Cagnes at a distance of about 11 kilometers, or 6.8 miles. A high tension transformer was next installed which gave 500 volts at the secondary in place of 250. In these circumstances the plates of the tubes heated quickly, but for telegraphic transmission, where the signals are never of long duration, this did not constitute a serious difficulty.

With this circuit completed, a 4-volt lamp, with a carbon filament, was put in series with the earth lead, in order to indicate by its brilliance approximately the best adjustment of the apparatus, and to facilitate adjustments. With this addition the station was rendered more powerful by employing four tubes in place of two. The energy transferred to the aerial was then found to have been greatly augmented. The station's signals were heard on the first test at Antives, a distance of about 18 kilometers, or 11.16 miles. Up to this stage the earth connection had been simply to the water-pipe and now, with the assistance given by the lamp in the earth lead, it was found that by connecting the earth lead in turn to water, gas and central heating connections, and to the lightning conductor, the energy in the antenna was increased. The first transmission had been made on a wave-length of 1,580 meters. During tests made at a later period the wave-length was reduced to 960, then 725, and finally 525, employing other coils in the oscillating circuit. For 525 meters the same coils were employed which had been used for a long while in the

receiving apparatus. The plate and aerial coil consisted of 120 turns of bell wire coiled on a cardboard cylinder 75 millimeters (2.9 inches) in diameter and the grid coil 100 turns of No. 24 wire, coiled on a cardboard cylinder 55 millimeters (2.14 inches) in diameter.

At this stage the four receiving tubes were replaced by two 50-watt transmitting tubes, the connections being modified in the following manner. The transformer of 500 volts was replaced by a transformer of 1,000 and 2,000 volts. A fixed condenser was inserted in the plate circuit to allow the passage of H.F. currents, while a choke coil inserted between the secondary of the high tension transformer and the plates prevented the transfer of high fre-

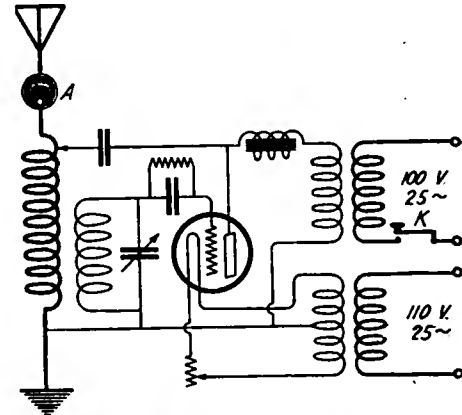

Figure 2. Present circuit arrangement used

quency currents into the secondary. A grid condenser shunted by a resistance was also inserted as shown in figure 2.

By earthing a receiving aerial which had before been left insulated during transmission, a considerable increase in aerial current was obtained.

The aerial coil and the grid coil were later replaced by an oscillation transformer, constructed in the following manner. The exterior coil was formed of a copper tube 7 millimeters (.283 inch) in diameter, wound in a spiral of 20 centimeters (7.8 inches) diameter, and consisting of about 30 turns spaced 7 millimeters (.283 inch) apart. With this coil two metallic clips were used which permitted connection to be made to the aerial and plate wherever desired. The grid coil was constructed of bronze wire three millimeters (.117 inch) in diameter, and consisted of 25 turns on a diameter of 17 centimeters (6.68 inches) a metallic clip allowing the required number of turns to be included in the circuit. An aerial ammeter was included and thereafter all

adjustments were made following its indications and with the successive improvements described, the antenna current gradually rose from one-tenth of an ampere to three amperes.

Later on, when the antenna current registered $2\frac{1}{2}$ amperes, the signals were heard at Bonifacio, about 300 kilometers (180 miles) distant.

The replacement of all the earth leads which went from the apparatus to water, gas and other connections, by strip, and the elimination of all unnecessary joints in the high frequency circuit, resulted in increasing the antenna current from 3 to 4 amperes. At the same time the wave-length was reduced to 360 meters in order to get away from interference caused by numerous stations working on 600 meters spark.

With 4 amperes in the aerial, the signals were received at Amiens, about 800 kilometers (480 miles) distance. At

this time the two 50-watt tubes were replaced by one 250-watt tube, the aerial current remaining at 4 amperes, but the valve was much less forced. At this stage tests were undertaken with the experimental station of Mr. Burnham, 2FQ, at London. Mr. Burnham was putting $2\frac{1}{2}$ amperes into his aerial, and had every hope of being received at Nice. Actually, after some days' unsuccessful efforts, his signals were received very strongly. Signals from Nice had been received regularly by another London amateur, at a distance of about 1,100 kilometers, or 660 miles. Then English 2FQ heard French 8AB and they were able to communicate very easily both ways several times in the evening.

The signals of 8AB were also received by an amateur in Aberdeen, Scotland, at a distance of 1,700 kilometers, or 1,020 miles. The station has also communicated with 2OM, another

amateur station in London, and has also received excellent signals from 2CV.

The arrangement of the circuit in use at present is shown in figure 2, the only difference being that two 250-watt tubes are now being used in parallel and the antenna current is normally from 4 to 5 amperes.

For the information of amateurs who may care to construct a similar station, the following dimensions of the principal pieces of apparatus not already described are given: The plate condenser is composed of 40 photographic plates 18 x 24 centimeters (7 x 9.4 inches) to separate the foils.

The grid condensed is composed of 10 glass plates 5 x 18 centimeters (1.9 x 7 inches) separating sheets of tinfoil. The grid resistance is of a special type not yet patented. The choke coil is composed of 250 turns of No. 24 wire on a cardboard cylinder 12 centimeters (4.7 inches) in diameter.

Eliminating Capacity Effects

IT is not the purpose of this article to treat with the phenomena of stray capacities further than necessary to explain to the reader the methods used to eliminate or counteract their effects in radio circuits.

The suggestions offered below are the result of extensive observation of radio apparatus both of amateur and commercial rating.

It is unnecessary to explain at length the effects of stray capacity. They are too obvious and are met with too often in much of the apparatus that is in use today. Often the expenditure of a little time in hunting them up and even less in correcting them would result in a much more satisfactory functioning of the apparatus in hand whether it be for reception or transmission. If the reader is constructing a set of either type a careful resume of the suggestions below will be advisable.

The first point that will be considered will be the antenna system. It is upon this that the whole station is dependent. Most of the things which have to do with capacity in this structure are brought out in the designing of a correct antenna, but sad to relate they are very rarely observed in practice and therefore they are emphasized here.

The "lead-in" must be as nearly stationary as possible. In shortwave C.W. transmission a swinging "lead-in" will cause a great deal of wave-length variation, especially if it is very near the side of a building. About

the only way to remedy this is to have your antenna as nearly taut as possible and then to stretch the "lead-in" from it to the "lead-in" insulator on the building.

Other points to be observed about the antenna system are: Keeping the resistance as low as possible, and if you use a counterpoise be sure that it is well insulated from the ground. Always make allowance when figuring your insulation for damp and rainy weather. Also use wooden supports for your counterpoise.

We will now take up one of the most troublesome of stray capacities; *i.e.*, body capacity. In using the ordinary vacuum tube "hook-up," the effects of body capacity are as a rule unnoticed, but with the regenerative tuner they are usually manifest to a most disagreeable extent. They are caused by the introduction of an imperfect dielectric, which is as a rule the hand, into the capacity field which surrounds the tuner. Often this field is of large extent and the movement of a person within several feet of the tuner when it is oscillating can be noticed. The best and only practical method of getting rid of this field is to line the whole box which incloses the apparatus with thin sheet copper and ground this lining. Care should be taken that no apparatus is in contact with it and moving parts should be placed at such a distance that in no portion of their rotation will they touch it. Sharp edges and corners should be avoided as much as possible in the construction of this lining.

The above method will admit of much variation according to the means of the designer. In place of using copper as a shield a fine brass mesh may be used or even the coating of the whole inside of the cabinet with tin-foil held in place with shellac. The same precautions that are taken with the copper lining are to be observed in this case, too, and care should be taken that each part of the foil is in contact with the adjacent portion. Often it is not necessary to shield the whole cabinet and a shield covering the inside of the panel will eliminate most of the effects due to body capacity.

Another method of eliminating body capacity, although in the strictest sense it is not elimination, is to use extended controls for the various adjustments to be made. Often this is not satisfactory due to one control interfering with another especially where the panel is rather crowded. If you desire to use this method, extension handles may be purchased from several well-known radio companies and they can be obtained equipped with a dial.

If your income is limited these extension handles can be made from glass rods or from hard rubber or bakelite rods. Convenient methods of attaching these handles to the apparatus for which they are intended should suggest themselves to the constructor. Verniers are especially desirable, equipped with these anti-capacity controls.

(Continued on page 77)

NEW APPLIANCES AND DEVICES

Amrad Radio-Frequency Transformer

THE American Radio and Research Corporation of Medford Hillside, Mass., has brought out a radio-frequency transformer, known as a "radioformer," for use with their line of Amrad receiving equipment. This radio-frequency amplifier is available in two types—No. 3071, particularly for use with Amrad short wave tuner No. 2596 and Amrad detector 2-Stage amplifier No. 2634; and No. 3045 for use with any of the Amrad units comprising the well-known Amrad unit system.

Amrad radio-frequency amplifier No. 3045 may also be employed with any tuner or detector units now available.

Both types are identical, except that No. 3071 is encased in a cabinet with rounded corners while No. 3045 is provided with square corners.



The Radioformer

Both radio-frequency amplifiers No. 3071 and No. 3045 permit use of different wavelength range radio-frequency amplifying transformers, or "Radioformers."

The unique design of Amrad "Radioformers," a product of Amrad research, has been carefully tested, assuring highest possible efficiency in the operation of either Amrad radio-frequency amplifier.

The two Radioformers, described, are inserted in specially molded sockets at the rear of the amplifier. They are as readily removable as a vacuum tube. As no radio-frequency amplifier is better than its transformer, great care should be exercised in the selection of this device. The Amrad radio-frequency amplifiers employ only "Radioformers" and have been designed for use with U.V. 201 Radiotron amplifying tubes.

Both Amrad radio-frequency amplifiers are encased in polished solid mahogany cabinets and mounted on standard engraved formica panels 10" x 5" in size. Two dial adjustments only are necessary. Complete operating instructions accompany each instrument.

Each radio-frequency amplifier is provided with an insulated switch for cutting out the radio-frequency amplification, thus permitting use of the detector together with any audio-frequency amplification with which the receiving set may be equipped.

New Type of Roller-Smith Galvanometers

THE Roller-Smith Company has developed and now offers two different types of galvanometers, one or the other of which will be found to meet practically any requirement.

These instruments were designed with the particular requirements of educational institutions and laboratories in mind. These galvanometers will also be of interest to anyone who is concerned in electrical measurements involving the use of a bridge network.

These instruments are offered with the assurance that every detail of design and workmanship is up to the exacting standard

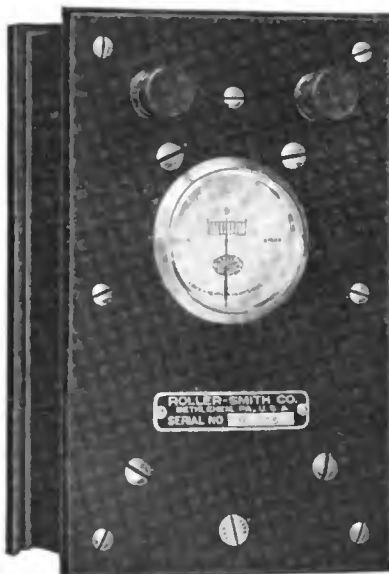

Roller-Smith Galvanometer

which the Roller-Smith Company has constantly before it.

The case of the Type KGD galvanometer, designed particularly for student use, is polished black walnut with highly finished hard rubber top. The binding posts have non-removable tops. A zero adjuster is conveniently located on the front of the case. The dial is pure white bristol-board. A knife-edge pointer is provided. The scale divisions are uniform with 5 divisions on both sides of zero. The instrument is well damped.

The case of Type LGD, designed for applications where sensitivity, accurateness and ruggedness are essential, is selected beautifully finished black walnut with heavy beveled plate glass front, which affords a complete view of the mechanism. A zero adjuster is conveniently located on the end of the case and the pointer can easily be adjusted to zero. The dial is pure white bristol-board. The pointer is of the knife-edge type. The scale divisions are uniform with 10 divisions on both sides of zero. These instruments are exceedingly well damped which insures quick readings.

The Radio Homcharger De Luxe

GOOD appearance has been combined with utility in the new Radio Homcharger De Luxe, a battery charging rectifier developed by the Automatic Electrical Devices Company, 119 West Third Street, Cincinnati, Ohio, especially for the home-charging of radio A and B batteries.

Finished in a dull mahogany and old gold, it harmonizes with the finest room furnishings, and permits the radio enthusiast to re-charge his battery after an evening's entertainment, without even disconnecting it from his set.

The Radio Homcharger De Luxe is constructed upon the same perfect operating principle used in the type A Homcharger, which has heretofore been the most popular battery charging rectifier in the radio field.



Radio Homcharger, de luxe type

Its working parts are entirely enclosed, eliminating all danger of shock and fire. It is constructed of the highest grade materials throughout such as—moulded bakelite base, Jewel ammeter, oversized silicon steel transformer. There are no frail castings to break, as all parts are made from highest quality stampings.

The Homcharger De Luxe can be operated by anyone. It is self-polarizing, so that the batteries may be connected either way and they will always charge. It gives a tapering charge, as recommended by battery manufacturers, and is guaranteed not to harm or injure the battery in any way. The above company has issued a booklet illustrating the radio Homcharger De Luxe in actual colors, which will be furnished upon request.

Thorkite, a New Crystal Detector Element

AN extremely rare bismuth-copper-silver-sulphide mineral, Thorkensonite, very rich in precious metals, has been placed on the market under the trade name "Thorkite." This mineral has been found to be a most efficient detector element for crystal radiophone receiving sets.

This mineral is known to occur in but one mine in America. Its value as a rectifier was unknown until recently, as few specimens of the mineral exist, and for this reason very little experimental work

could be conducted on this ore. The mineral as first broken from its silicious lime matrix is only an indifferent detector crystal, but after the surface has been exposed to the atmosphere, or artificially aged by means of an electric current, it becomes extremely sensitive as a rectifier for the high frequency radio waves. Continued exposure to the atmosphere tends to increased sensitiveness, the result being that this crystal lasts almost indefinitely and actually improves with use and age. This distinguishes it from many detector minerals which deteriorate to a greater or less extent when exposed to the atmosphere.

New Catalog of Jewell Instruments

THE Jewell Electrical Instrument Co. of Chicago, has recently added so extensively to its line of electrical measuring instruments that it became necessary to issue an entirely new catalog. This new catalog is now off the press and in addition to being an attractive piece of printing matter, it is indeed a most complete and valuable addition to electrical engineering literature. Each instrument is clearly illustrated and its applications, size, scale length, accuracy and general characteristics described in detail. In the back of the catalog detailed dimensional drawings are shown of each instrument together with full size scales and complete listing of readings and prices.

The sales department of the Jewell company is revising the entire mailing list and has asked all electrical engineers and users of electrical measuring instruments to send their names asking for a catalog. They are also preparing to send out their 1922-23 leather vest pocket "Jot-book" covers. The Jewell "Jot-book" or vest pocket memorandum pad with monthly calendars and filler pads has become an established and permanent feature of Jewell publicity.

The Jewell Electrical Instrument Co. has been adding new representatives and making changes in several of its territories. The line has developed and grown to such an extent that a more intensive selling program has been possible and many of the changes made were to enable the representatives to devote more time to the sale of Jewell instruments. Briefly enumerated, the territories and representatives affected by recent changes are as follows: New York by John Forshay, 45 Vesey Street; Philadelphia by L. B. Underwood, 139 N. Fourth Street; Buffalo by J. H. Burroughs, 70 Bloomfield Avenue; Cleveland by P. J. Burrill, 517 Bangor Bldg.; Dallas by F. T. Morrissey, 305-306 Slaughter Bldg.; Seattle by Messrs. Eicher & Bratt, 2107 L. C. Smith Bldg. All other territories and representatives remain as before.

The "Planet" Loud Speaker

A NEW loud-speaker, known as the Planet, has been put on the market by the Planet Radio Corporation, 1223 South Wabash Avenue, Chicago. The horn is a casting made of a patented metal known as Murphy bell alloy, which is claimed to have unusual properties for sound reproduction without distortion. It is built on the ram's horn principle. The scientific principles of the French horn have also been included in its construction. The Planet loud-speaker can be attached to any

amplified receiving set by using two or more stages of audio-frequency amplification.

New Pacent Products

THE new Pacent universal detector stand is dust proof, rust proof, and fool proof. Adjustment is easily made and held by the employment of a special universal joint. It has a moulded top and base, a substantial ground-glass covering. All binding posts and metal parts are carefully machined. It is extremely neat and has an appearance of precision which is very satisfactory to the radio user. This detector is now available through the Pacent jobbers and deal-

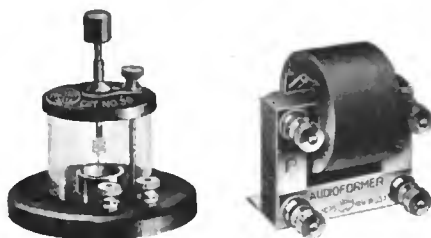

Pacent crystal detector, and Audioformer

ers, and is being put on the market at a price which will assure it the same general popularity which has been experienced by other Pacent Radio Essentials.

The Pacent company has also brought out a new amplifying transformer which has many distinctive features. The transformer occupies a space of only $1\frac{3}{4}$ by $1\frac{1}{2}$ inches. A laminated core is used, which is firmly clamped between heavy metal clamping plates. Secondary and primary windings have been carefully impregnated to prevent moisture absorption. The Audioformer, as it has been called, gives maximum amplification with minimum distortion. The voltage amplification is particularly high. The Audioformer is now available through the established Pacent dealers and distributors.

Combined Antenna Plug and Crystal Set

THE Globe Phone Mfg. Co., Reading, Mass., has placed on the market a complete radio receiving set to be attached to an electric light socket in the same way that one would attach an electric light bulb, electric iron, or a vacuum cleaner.

In a city where there is a radio telephone broadcasting station, the electric light wires

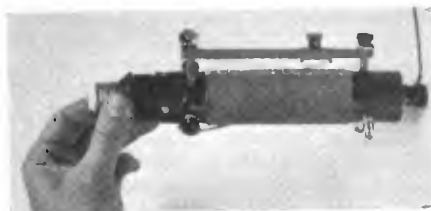

Globe crystal receiver

along the streets and in residences absorb the radio wave energy and in this way music, lectures, sermons, weather and stock reports can be received by using this compact receiving set.

This new receiving set can also be used with an outside antenna if desired. The instrument is seven inches long and one

and one-half inches in diameter, and contains the entire apparatus. No batteries are necessary with this set. No electric current is consumed by attaching the device to the electric light socket.

New Westinghouse Battery Charger

A NEW type of Rectigon, known as the "Radio-Type" Rectigon, designed primarily to charge 11 or 12 cell plate batteries, such as are used for radio receiving sets, but also suitable for charging 3-cell filament batteries or 3- and 6-cell automobile starting and lighting batteries, has been developed by the Westinghouse Electric & Manufacturing Company.

This type of Rectigon is similar to the private garage type, being portable, well finished, automatic in operation, and free from oil and grease. At the top of the transformer is a fuse block which is so arranged that, when the fuse is in the extreme left position, the Rectigon will charge an 11- or 12-cell battery and, when the fuse is at the right, will charge a 3- or 6-cell battery. Since only one fuse can be inserted at one time, there is no possibility of an incorrect connection.

After the fuse is in the proper position, the Rectigon can be started by clasping the battery clips over the terminals on the battery and turning on the current at the lamp socket. To stop charging, the current is turned off and the battery is disconnected.

Four Radio Is Formed

FOURAR Radio, Inc., has been organized, and now is functioning as a merchandising organization, handling radio apparatus made by the Radio Corporation of America, G. Brandes, Inc., Dubilier Condenser & Radio Corp., and the National Carbon Co. The president of the new company is Alfred Fantl head of a buying service for department stores all over the country, and the new radio jobber thereby secures at the start close contact with the department store trade. Arthur Wiesenberg, formerly research director of the National Dry Goods Association, is secretary and treasurer of the Fourar company, whose name means "Four R's," the letters standing for "Reliable Radio for Representative Retailers," descriptive of the company's policy. The officers of the company, besides those already named, are: first vice-president, William Dubilier, who is president of the company bearing his name; second vice-president, Frederick Dietrich, president of G. Brandes, Inc.; third vice-president, Maurice C. Rypinski, formerly of the Westinghouse Electric & Mfg. Co., now vice-president of the Brandes company.

A Vernier Rheostat

A NEW eastern manufacturer has recently placed on the market a new vernier rheostat, with a single knob for both the rough and fine adjustments. Its operation is quick, easy, and positive. The base and knob are made of highly finished condense, while the contact springs are made of phosphor bronze, with the metal parts nickel-plated. The diameter of the rheostat is $2\frac{1}{8}$ inches and it weighs about one pound.

The Monthly Service Bulletin of the NATIONAL AMATEUR WIRELESS ASSOCIATION

Guglielmo Marconi
President

J. Andrew White
Acting President

H. L. Welker
Secretary

Founded to promote the best interest of radio communication among wireless amateurs in America

NATIONAL ADVISORY BOARD OF VICE-PRESIDENTS

Prof. A. E. Kennelly
Harvard University

Rear Admiral M. Johnston
Director of Naval Communications

E. E. Bucher
Instructing Engineer

Maj. Gen. George O. Squier
Chief Signal Officer, U. S. Army

Prof. Alfred N. Goldsmith
College of the City of New York

Prof. Charles R. Cross
Massachusetts Institute of Technology

HEADQUARTERS: 326 BROADWAY, NEW YORK

B RIMFIELD Academy Radio Club, Springfield, Mo., was formed on May 8, 1922 with a membership of 27. It was organized by O. H. Benson, director of the Junior Achievement Bureau, Eastern States League.

The officers of the club are: President, D. Walker Cheney; vice-president, Everett Landen; secretary, Gladys Campbell; treasurer, Herbert Smith.

All the members of the club live in and around Brimfield and cover quite a wide area, including Brimfield, East Brimfield, South Warren, Holland, and Wales. The young people range in age from 14 to 20 and are enthusiastic and earnest workers. They are all members of the Hitchcock Free Academy.

The program of work for the club is to study the principles of electricity the radiophone and radio telegraphy; to purchase, set up and work a radio outfit for the Hitchcock Free Academy to be used by all the members as a broadcasting and receiving station.

Every member of the club during the year will learn to demonstrate some one phase of radio telegraphy so as to be able to pass on to others by way of public demonstrations the knowledge which they have acquired.

△ △

T HE Northern Indiana Radio Club of South Bend, Ind., is conducting a campaign for members and plans are making for many interesting club events. The club is exclusive only in that the members must be interested in radio. They must all be active members, and the club's activities will embrace all lines of endeavor which concern the operation and construction of radio sets.



Corner of interior of Chester County Club's radio motor bus

C AMP Ellis A. Gimbel, at Spring Mount, Pa., on the Perkiomen, has been equipped with a radio telephone outfit. The radio is proving popular among the hundreds of Girl Scouts.

M RS. Avery Lord of Elizabeth, N. J., reports that she recently picked up radio telephone messages from Chicago with a crystal set. The feat, the authenticity of which is unestablished, could be caused, radio experts assert, by freak air currents. Mrs. Lord said the conversation between Chicago and New York was regarding a boy in Montclair, N. J., whom the Chicagoan wanted to reach.



Chester County Radio Club's station installed in a motor bus

T HE Poughkeepsie (N. Y.) Radio Association has resumed its regular activities and has started a big drive for increased membership. The object is to obtain a permanent location for meetings and a club room if possible.

△ △

A RADIO club has been organized at Galveston, Tex. Clark W. Thompson, president of Fellman's was elected temporary president of the club and K. Warriner secretary. H. C. Sherrod also was temporarily chosen city manager. These three temporary officers and O. W. Chancellor, radio operator at Fellman's broadcasting station, will form a committee to draw up the constitution and by-laws of the club.

The object of the club, as announced at the meeting is to study innovations in the radio field, to keep in touch with all radio developments, and to instruct members in radio.

Part of the club's work in the city will be to watch the construction of all transmission sets and to see that all such sets are tuned in accordance with government regulations, so that they will not interfere with other sending stations.

T HE Milwaukee Amateur's Radio Club resumed its weekly meetings on Thursday, September 14th, in the Trustees Room of the Milwaukee Public Museum. At this meeting Radio conditions in general were discussed thoroughly by well known radio men.

△ △

T HE Cape Breton Amateur Radio Association occupied one of the booths at the North Sydney, N. S., Mercantile Fair held July 25th to Aug. 2nd. Exhibits were received from members in Sydney, North Sydney and Sydney Mines, and comprised all classes of apparatus from the home-made crystal set to the stately "tailor made" detector-amplifier sets.

Concerts were broadcast each evening from the home of the president, G. Arnold Edwards, whose station is licensed for club broadcasting on 250 meters under the call 7AA, and were listened to by hundreds of interested spectators at the fair, the receiving set comprising detector and four stages of audio-frequency amplification, with a loud speaker. Though only one 5-watt tube was procurable at the time, the music came through in great shape and was clearly audible, even through the usual QRM of such surroundings, at a distance of five or six yards from the booth.

The association will broadcast a regular weekly concert hereafter and will use 10 watts of power. Should local interest prove keen enough the power will probably be increased to 100 watts during the winter months. Mr. Edwards's private call is 1AW on 200 meters, using the same set and anyone hearing either C. W. or phone is asked to communicate with him at Box 155, North Sydney, N. S. The phone signals have been reported good up to 24 miles with perfect quality of modulation, but much greater range is expected when the new



Exhibit of Cape Breton Association at the Mercantile Fair, North Sydney, N. S.

age aerial and counterpoise with new panel set is brought into operation. So far as is known, this is the first association broadcast station to be licensed in Nova Scotia, and is purely for the benefit and entertainment of members and other listeners within range.

THE call of the amateur radio station of C. W. Vincent, Uniontown, Pa., has been changed from 8AYW to 8HM.

△ △

THE Egyptian Radio Bugs Association is composed of a number of radio clubs located in southern Illinois. The Marion, Ill., section meets every Wednesday evening in the Greater Marion Association rooms in the City Hall. A complete receiving set has been installed. The officers of the Marion section are: President, Le Roy Sul-lins, and secretary, Lloyd Williams. Other Clubs of the Association are located at Carbondale, Mt. Vernon, Johnston City and Herrin. The association will attend the St. Louis Radio Show, October 4 to 6.

△ △

GERMAN manufacturers of radio apparatus and equipment are not in a position to make extensive deliveries of their product, according to Vice Consul Nathaniel B. Davies, Berlin, in a report to the Department of Commerce. This is due to the fact that up to the present time the demand has not been sufficiently great to warrant the manufacture of radio instruments in large quantities.

Amateur radio work is not popular in Germany and stations are not numerous. Radio telephony in particular is almost an unknown science except to engineers, professional operators, and experimenters.

The principal reasons given for the lack of interest in radio on the part of the general public are that amateur stations are a luxury beyond the means of the average German, under present economic conditions, and official restrictions on their use.

All radio communication in Germany is under the control of the Federal Post Office Department, which operates the commercial stations. Private installations must ordinarily be made by the Department, but in exceptional cases private companies or individuals may be authorized to erect their own plants, but they must first obtain a license from the Post Office Department. The fee for such a license varies according to the size of the plant, with a maximum of 2,000 marks per annum.

△ △

UNITED STATES Civil Service Examinations for radio positions are listed below. Applications for these examinations may be had from the local secretary of the Civil Service Board at your Post Office, or, if not available there, may be secured from the U. S. Civil Service Commission, Washington, D. C. The examinations are held simultaneously on the dates given in several cities in each state, applicants presenting themselves for examination at the nearest examining office.

Junior Engineer, Radio, Bureau of Standards, salary \$1,200 to \$1,500 per year. Examination to be held November 22. Applicants must have been graduated with a degree from a college or university of recognized standing, showing at least 118 credit hours, or that he is a senior student in such an institution. His undergraduate work must include radio course as well as general courses in physics, chemistry and mathematics through calculus. On the same date will be held an examination for Junior Physicist, Radio, same salaries. Applicants must be college graduates or senior stu-

dents, with a course in mathematics through elementary differential equations, and also must show at least 18 hours of physics.

Junior Radio Engineer, to fill vacancies in the Signal Corps and elsewhere, at \$1,200 to \$2,000 a year. Examination to be held October 4. The applicant must show that he has been graduated from a college of recognized standing with at least 118 credit hours, or be a senior student. His studies must have included electrical engineering, physics, chemistry and mathematics through calculus.

△ △

EDWIN H. ARMSTRONG, inventor of the regenerative and super-regenerative circuits, has sailed on the Mauretania for a sojourn of several months in England and France. The purpose of his trip abroad is to seek rest and recreation. He will renew old acquaintances in London and Paris and will then go to the south of France to take a holiday.

Much importance is attached to Mr. Armstrong's visit abroad in engineering circles. He has frequently expressed his indebtedness to European inspiration for his radio discoveries, and has many warm friends in England and on the continent.

△ △

A MOST interesting installation has recently been completed for the Piedmont High School, Piedmont, California, involving a distinct improvement over present methods of inter-classroom communication. The installation consists of a central or master station and 25 receiving stations, each equipped with a No. LS-2 Magnavox Telemegaphone, the motor generator and

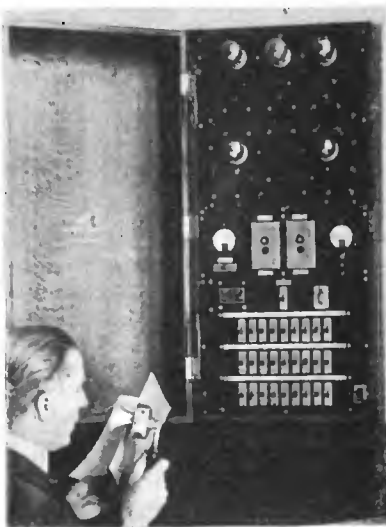

Piedmont High School principal talking to 25 classrooms at once by radiophone

battery being installed in a steel cabinet in the basement.

The master station is operated like an ordinary telephone as shown in the illustration. Talking into the Magnavox in ordinary tones, the speech is amplified in any or all of the 25 classrooms as desired, in sufficient volume to be distinctly audible to all the students. A novel feature of this particular installation also is the fact that, by means of a special switch, broadcasted radio lectures and concerts may be connected so as to be reproduced in any or all the classrooms by the same Magnavox Telemegaphones.

Eliminating Capacity Effects

(Continued from page 72)

I here wish to mention a word about this vernier control on apparatus. Its merits on the regenerative tuner are too well known to need mention and I would advise any amateur that can afford them to equip his apparatus in such a manner. A short time ago in one of the popular radio magazines there was a contribution explaining the use of a lead pencil as a vernier. The article explained how, by placing the "rubber" end of a pencil against one side of the dial and using it as a geared control, it was possible to obtain the same end that a regular geared control gives, but I find by using a lead pencil the introduction of a conductor; *i.e.*, the lead, will cause serious capacity effects which are very troublesome.

Should it be desired to use the above vernier control, I would suggest using a glass or hard rubber rod tipped with a rubber cap such as can be purchased for pencils, in a similar manner. Thus all the effects due to capacity will be eliminated.

Mechanical movements inside of the tuner are another thing to be considered. Often the relative movement of a variometer rotor or of the plates of a variable condenser will cause serious capacity losses. As a rule the effects on the circuit such as "howling" which are caused by them are under control but the losses due to capacity between the various parts are high. The use of lattice-wound coils and variometers will reduce coil capacity but shielding of each individual apparatus that has a variable factor is the only way to reduce variable, distributed capacity. Amplifiers, especially those designed for radio-frequency should be individually shielded and the shields grounded. This practice is, I believe, adopted by the Navy. Shields may be of copper gauze or if the amplifiers are in separate cabinets, using foil as above mentioned may be practiced.

Leads that lead to the cabinet often are a source of trouble. Those such as battery leads should be made as short as possible and should be fixed. Connections between two or more cabinets should be of a strip of copper and should be as short as possible.

Such leads as the 'phone cords can be obtained shielded with a copper braid which should be grounded. If you can not obtain them or do not care to go to the expense you can shield your own by braiding over them a shield of No. 40 bare copper wire. They then can be covered with another insulating braiding taken from an old cord. Be sure that the shield is not in contact with the tips at either end and that it is firmly fastened so there will be no contact.

\$50 in Prizes Monthly

IN order to stimulate interest and bring out the thousand and one good ideas which we know are of value to our readers, we have increased the amounts formerly paid for prize contest articles, as follows:

- First Prize\$25.00
- Second Prize 15.00
- Third Prize 10.00

The new arrangement, with the increased prizes, will go into effect with the January, 1923, issue.

Prize contest articles are judged and classified by the editors of THE WIRELESS AGE on points of originality, practicability and general utility. Literary ability is not required and neither are finished drawings. Ordinary sketches will do, so long as they are technically correct.

You do not need literary ability to win one of these prizes—the utility and practicability of the idea is what counts. It may take you an hour to prepare the article, but \$25, \$15 or \$10 for an hour's work is well worth while.

For full details of the contest see the announcement below.

STATIONS WORKED AND HEARD

Stations worked should be enclosed in brackets. All monthly lists of distant stations worked and heard which are received by the 10th of each month will be published in the next month's issue. For example, lists received by November 10th will be published in the December issue. Spark and C. W. stations should be arranged in separate groups.

IACU—P. D. Baldwin Groton Long Point, Conn. (August).

C. W.—1fw, 1gv, (1lv), (1oz), 1py, 1qn, 1sq, 1xm, 1xx, (1agh), lagi, (1ahm) fone, (1aip) fone, (1ajp), (1anq), lawb, (1ayq), (1azw), 1bkq, 1bqt, (1bsc), (1cbp), (1cja), 1cpn, (1cq), (2bg), (2fc). 2fz, 2hw, 2kl, 2rm, 2ts, (2aeh), (2aeq), (2aer), 2agc, (2ajw), 2auz, (2awh), 2aws, 2bdg, (2bdu), 2beb, 2beh, 2bfz, 2bgm, (2bir), 2bjo, (2blp), (2bml), 2bnz, 2bqu, 2brb, (2brc), 2byc, 2cbg, 2cbw, 2ccd, (2cei), (2ces), (2cgl), (2che), (2col), (2cox), (2cpl), 3as, 3cc, 3dt, 3fr, 3fs, 3gk, 3mk, 3ot, 3sm, 3tj, 3vw, 3zo, (3afb), (3anj), 3aqr, (3bgt), 3bjy, 3bit, (3bnu), 3bvc, 3bvl, 4bx, 4dc, 4ea, (4ft), 5hk, 5eh, (5sb), 5se, 5sp, 5ue, 5acf, 5afd, 5anb, 5aqo, 5bdu, (5bef), 5bfm, 5bfx, 5blx, (5bph), 5brc, (5bss), 5bxh, (5cdz), 5cjh, (5cjl), 5cko, 5ei, 5ii, 5io, 5arr.

Spark.—(1ava), (1bv), (1cdm), (2di), 2om, (2nf), (2aft), 3arm, 8uc.

Daylight, C. W.—(1iv), (1oz), (1agh), lagi, (1ahm), (1aip), (1ajp), (1anq), (1ayq), (1azw), (1bsc), (1cbp), (1cja), (1cq), (2bg), 2kl, (2aeh), (2aeq), (2ajw), (2awh), (2bdu), (2bir), (2bml), 2brb, (2brc), (2cei), (2che), (2cox), (2cpl), 3dt, 3ot, (3awh), (3bgt), 4ea.

5RE—Stuart Adcock, 2000 Washington Ave., Knoxville, Tenn., (July and August).

C. W.—2aaq, 2awf, 2beh, 2bjo, 2cbg, 2fp, 2nz, 3awo, 3bij, 3blf, 3bmn, 3by, 3bvc, 3bz, 3ca, 3cbm, 3fs, 3hl, 3jld, 3iw, 3ko, 3wj, 3ot, 3rv, 3vw, 3zo, 3zwl, 3zz, 3xw fone, 4aj, 4au, 4bl, (4bq), 4bx, 4dc, 4dq, 4ds, 4ea, 4eb, (4gh), 4gl, 4gx, (4hw), 4id, 4jh, 4jk, 4kb, 4kc, 4kf, 4lj, 4lp, 4ma, 4mw, 5aam, (5abm), 5amk, qra? 5da, 5di, 5do, 5ek, 5es, 5fv, 5la, 5nm, 5pl, 5px, 5qi, 5uk, (5wo), 5zwa, 8ab, 8abv, 8acf, 8afd, 8aim, 8hm, 8amo, 8awb, 8and, 8an, 8apt, 8aof, 8aqo, 8asm, 8asz, 8avd, 8ayt, 8awm, 8axb, 8azf, 8bbd, 8bcy, 8bdo, 8bdu, 8bef, 8bff, 8bfx, 8bjc, (8bke), 8bmf, 8bnu, 8bdx, 8bpl, 8bpu, 8brq, 8bvt, 8bwa, 8bwm, 8bun, 8bxh, 8bxv, 8bzf, 8bzp, 8cab, 8cay, 8cbf, 8cei, 8cef, 8cdz, 8cgm, 8ggw, 8cgv, 8cjh, 8cjl, 8ckk, 8ckd, 8coo, 8cur, 8czt, 8da, 8dak, 8ea, 8hh, 8ju, 8kf, 8kg, 8kh, 8kv, 8kr, 8oi, 8pt, 8sb, 8sp, 8ue, 8zae, 8zaf, 8zg, 8zz, 8xe, 8xv, 9aap, 9aon, 9aow, 9abv, 9ax, 9al, 9alb, 9als, 9aqj, 9ark, 9axf, 9akv, 9ami, 9blc, 9btt, 9bsg, 9bhd, 9bya, 9sba, 9cux, 9dcr, 9dex, 9dfb, 9djj, 9dky, 9dr, 9dtj, 9dug, 9dxn, 9ei, 9hw, 9ii, 9io, 9lq, 9lz, 9nu, 9oh, 9ox, 9uh, 9us, 9uu, 9ux, 9wa, 9xl, 9yaj.

Spark.—3bvc, 4fd, 4gn, 4ie, 5zl, 8baz, 8bda, 8ew, 8uc, 8zo, 9dmj, 9dwm, 9dzy, 9lf, 9ox, 9pd, 9uh, 9uv, 9zl, 9zv.

Prize Contest Announcement

The subject for the new prize contest of our year-round series is:

REDUCTION OF ANTENNA RESISTANCE

CLOSING DATE :: :: Nov. 1, 1922

Contestants are requested to submit articles at the earliest practical date. Prize winning articles will appear in the January, 1923, issue.

All manuscripts should be addressed to the CONTEST EDITOR OF THE WIRELESS AGE.

MANY operators of amateur transmitting and receiving stations have materially reduced the resistance of their antennas, and by doing so increased the output and strength of received signals. What have you done to decrease antenna resistance and how did you do it? How much did you gain in output and how much in received signal strength?

PRIZE CONTEST CONDITIONS—Manuscripts on the subject announced above are judged by the Editors of THE WIRELESS AGE from the viewpoint of the ingeniousness of the idea presented, its practicability and general utility, originality and clearness in description. Literary ability is not needed, but neatness in manuscript and drawing is taken into account. Finished drawings are not required, sketches will do. Contest is open to everybody. The closing date is given in the above announcement. THE WIRELESS AGE will award the following prizes: First Prize, \$25; Second Prize, \$15; Third Prize, \$10.

IF QUALITY counts, bear in mind that Ace equipment speaks for itself. An Ace type TRU Concert Receptor can be placed in your parlor, and is in a class with your piano or finest phonograph.

\$50.

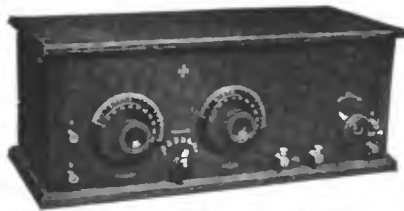

\$50.

Licensed under Armstrong Patent No. 1,113,149

For electrical efficiency we claim our TRU to be equal or superior to any similar equipment now on the market.

A very important point to be considered in purchasing a Concert Receiver is the proposed change of wave lengths of broadcasting stations. The majority of Radio receivers now on the market would be worthless should this change be effected. Our receiver is arranged for immediate adaptation to this change by even a most inexperienced person.

Better investigate—we have literature for the asking.

THE PRECISION EQUIPMENT COMPANY

2487-39 Gilbert Ave.

Cincinnati, Ohio.

When writing to advertisers please mention THE WIRELESS AGE

SZAE—B. P. Williams, 3220 Orleans St., Pittsburgh, Penna.

CW—(1agh), 1awz, 1anq, 1awb, 1bkq, 1cpn, 1cq, 1fb, 1gv, 1rd, 1xp, 1auz, 1aer, 1ayf, 1aja, 1awf, 1ajf, 1bdg, 1bdq, 1br, 1bqd, 1bg, 1cgj, 1cfs, 1cpd, 1fz, 1gk, 1hw, 1ry, 1auu, 1aah, 1aao, 1aqr, 1bz, 1bmg (1bnu), 1bvc, 1bij, 1bwt, 1blf, 1cc, 1ca, 1cbm, 1lr, 1zo, 1bx, 1ds, 1ea, 1ft, 1mw, 1do, 1ek, 1atu, 1awz, 1asz, 1amd, 1afy, 1avl, 1axn, 1afd, 1apt, 1amm, 1awm, 1bvt, 1bjv, 1br, 1bsj, 1bfm, 1bjy, 1bnu, 1bxt, 1blx, 1boz, 1cdz, 1caz, 1cye, 1ctp, 1cfb, 1cjh, 1cgp, 1brm, 1bjc, 1brw, 1ccx, 1bo, 1ctk, 1cur, 1cxk, 1bwa, 1bjs, 1bvr, 1bbt, 1cgm, 1ft, 1hj, 1lt, 1ml, 1nb, 1mf, 1ue, 1uo, 1uc, 1wi, 1sp, 1yu, 1xj, 1zaf, 1sb, 1zz, 1zg, 1zn, 1zq, 1zag, 1aap, 1ajh, 1al, 1aon, 1ami, 1arr, 1avn, 1aqm, 1bdb, 1bgh, 1bsg, 1bhd, 1ckg, 1cja, 1cp, 1dek, 1dzy, 1dtj, 1dfb, 1gl, 1ii, 1lz, 1nu, 1ox, 1uc, 1us,

Spark—2ahu, 2aje, 2bsc, (2om), 3acy, 3awf, 4fd, 5zl, 8ard, 8bep, 8bda, 8bxc, 8aib, 8uc, 8wz, 8zy, 8csi, 8fe, 8ckx, 9azf, 9aza, 9bws, 9dmj, 9uc, 9wx, 9uh, 9mc, 9lf, 9zn.
9DR—D. C. Wallace, 1830 Stevens, Minneapolis, Minn., (August).
 (Mostly CW). 2 fp, 4 bv, 4 kf, 4 mw, 5 aa, 5aar, (5di), 5do, 5dih, 5 ek, 5 hb, 5nv, 5 qi, 5rj, 5uk, 5za, 5zaw, 5zay, (6ea), 7lu, (8ab), 8aq, 8eh, 8ft, 8if, 8mq, 8uc, 8ue, 8ve, 8vy, (8wr), 8zo, 8zz, 8adn, 8aff, 8aiz, 8apt, 8apw, (8asv), 8asz, 8atu, 8bdo, (8bef), 8bft, 8bgo, (8box), 8bpl, 8brq, (8brt), 8bvt, 8bwa, 8bxh, 8cgn, 8cgh, 8dak, 8zwn, (9fk), (9hg), (9ja), (9na), (9nx), (9ox), (9xl), (9xt), (9zc), (9zn), (9aap), (9abd), (9aix), (9amb), (9ami), (9aon), (9aps), (9atu), (9baf), (9bcf), (9bgh), (9bkj), (9bqw), (9bmn), (9bsg), (9btt), (9ccs), (9cfi), (9dbi), (9dfb), (9dkz), (9dof), (9dvp), (9dsn), (9dyz), (9yaz), (9yak), (9zac), Can. 3ko.

Queries Answered
 Answers will be given in this department to questions of subscribers, covering the full range of wireless subjects, but only those which relate to the technical phases of the art and which are of general interest to readers will be published here. The subscriber's name and address must be given in all letters and only one side of the paper written on; where diagrams are necessary they must be on a separate sheet and drawn with India ink. Not more than five questions of one reader can be answered in the same issue. To receive attention these rules must be rigidly observed.
 Positively no questions answered by mail.

E. F. Waits, Corinth, Miss.
 Q. 1. I am enclosing hook-up with which I have been experimenting recently. As you see it is composed of a vario-coupler, two condensers and loop aerial. The loop has 12 turns No. 18 B & S wire, spaced 1/2-inch on 36-inch frame. From all the information I can get, a loop is supposed to work about twenty-five miles. With this arrangement I have a receiving radius of at least five hundred miles in the summer. There is very little static and the signals come in with much greater volume than with an out-door aerial 200 feet long and 100 feet high. Please advise if this is new, and if it can be improved.

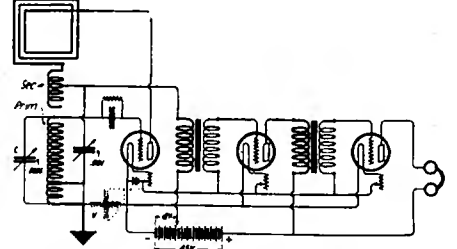

A. The hook-up which you enclose, although rather unusual, resembles the Reinartz tuner in some respects. We are surprised, however, that you get better results with the loop than with an antenna. Your antenna may be faulty. Possibly the loop is picking up the signals from a telephone or power line. It is well known that the latter are often very effective in picking up distant stations. See if moving the loop away from telephone or power lines has any influence and let us know of your results. You might improve your circuit to some extent by omitting the .0005 condenser C and substituting variometer V as shown.
 * * *

J. C. Thompson, Lemoyne, Pa.
 Q. On the evening of July 21 while listening in on my receiving set between the hours of 8:30 and 9:30 P. M. at Camp Hill, Pa., I had the peculiar experience of hearing what I think were weak signals from a very powerful broadcasting station. The conversation was in a foreign language and I was not able to interpret it as I believe it was either German, or Holland Dutch. This has occurred several times on good nights and I was wondering whether there would be some way of checking up this piece of transmission, and could determine whether one of the larger broadcasting stations in a foreign country was working during that particular time, or probably you could determine whether it was someone closer by. I was tuned to about 5,000 meters. I am using a three-step radio frequency detector and two steps of amplification, using Radio Corporation radio-

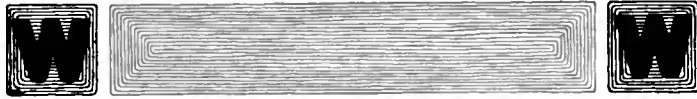

Essential for GOOD Reception



Weston Filmament Voltmeter

One of a Group of important Weston Radio Instruments

Gives you your proper voltage instantly—thus greatly simplifies exact tuning. Saves its cost over and over by eliminating hazardous guesswork and making it possible to get doubled or trebled life out of each tube. A premature tube "burnout" is practically an unknown occurrence with a Weston Voltmeter—if you use it properly.

Your dealer can supply you, or if he cannot, we will. Don't take a substitute if you want best results. Write for Radio Circular J.

WESTON ELECTRICAL INSTRUMENT CO.
 27 Weston Ave. Newark, N. J.
 Branch Offices in all Larger Cities.

WESTON
 "THE SUN NEVER SETS ON THE WESTON"
 "STANDARD" The World Over
ELECTRICAL INSTRUMENTS
 An Indicating Instrument for Every Individual Need and Industrial Purpose

When writing to advertisers please mention THE WIRELESS AGE

"COPPERWELD"
TRADE MARK REG. U.S. PAT. OFF.
 Made by the Molten Welding Process
ANTENNA WIRE
50% Stronger Than Copper
*Better than copper or strands for aerials.
 Doesn't stretch or sag.*
 The permanently welded copper exterior makes it ideal because of "skin effect" phenomena of radio currents. Standardized by the largest manufacturers of radio equipments.
*Sold everywhere
 100, 150 and 200 feet per carton*
BUY IT IN CARTONS

COPPER CLAD STEEL COMPANY
NEW YORK SALES OFFICE: 30 CHURCH STREET, NEW YORK
 CHICAGO SALES OFFICE: 129 S. JEFFERSON ST., CHICAGO
 MAIN OFFICE AND WORKS: BRADDOCK P. O. RANKIN, PA.



The A. B. C. of Wireless
 By **PERCY W. HARRIS**
 (Editor of CONQUEST, The British Magazine of Popular Science)
Price, 30c.
The BOOK for the "Man in the Street"

This wonderful little book has been specially prepared for those who are desirous of getting a good knowledge of Wireless without delving into intricate text books. No technical expressions to puzzle over. No mathematical formulae to be elucidated. No hard thinking to be done.

What is Wireless? How Does It Work?
THE A. B. C. WILL TELL YOU

An evening spent in reading this book will put you in a position to appreciate to the full the wonders of the latest and greatest of sciences

THE WIRELESS PRESS, Inc., 326 Broadway, New York

Milliken Radio Towers

Are being used for the principal broadcasting stations in different parts of the country. Built of galvanized steel, self-supporting standard types in heights up to 300 feet. Utmost reliability of service.

Send for new Catalog No. 16.

Milliken Brothers Mfg. Co., Inc.
 233 Broadway, New York, N. Y.

frequency transformers and audio-frequency transformers. I had the radio frequency transformers connected for the 5,000 meter range during the period these interesting signals came in. For tuning I was using .001 condenser in series with the antenna circuit, also a variocoupler with which I had added an inductance winding 276 turns bank wound on a 4" shell. I would certainly appreciate anything that you could do to help me along in determining where these mysterious signals are coming from.

A. The radiophone station you are hearing is probably some Dutch or German high power station experimenting with radiophone transmission. There are no regular broadcasting stations anywhere in the world on that wave length, for that band is assigned by international agreement for long distance transmission. It may possibly have been a Dutch battleship. Try to get the call letters of the station if you hear it again.

 Irving Fine, New York City.

Q. In the August issue of THE WIRELESS AGE, page 74, figure 9, you illustrate a combined, radio-audio frequency amplifier in which the tubes are made to do double duty. I would certainly very greatly appreciate the favor if you could let me know whether choke coils can be used in this hook-up instead of the transformers as shown. Instead of the audio-frequency transformer I would like to use iron core chokes; and in place of the radio-frequency transformers I would like to use radio-frequency choke coils. Kindly send me a hook-up for same, also data on how to build the radio-frequency chokes for this circuit.

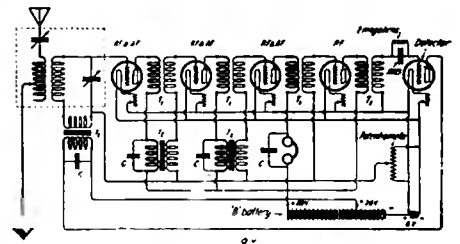

A. It is not efficient to use R. F. and A. F. choke coils in an amplifier where the tubes do double duty, and we therefore do not recommend it. We show herewith a hook-up using 5 tubes to give 4 stages of radio-frequency, detector and 3 stages of audio-frequency amplification, using transformers. We do not advise the use of more than 3 audio-frequency stages because of the howling they set up.

 W. H. Myers, Jefferson City, Mo.

The questions below refer to figure 1, page 65, of THE WIRELESS AGE, June, 1922.

Q. 1. What should be the capacity of the condensers, Nos. 1, 2, 3, and 4 respectively?

A. 1. The condenser 1, 2, 3 and 4 should have a capacity of .005 mfd. each. It is important to note that this resistance coupled amplifier is useful only on wave lengths above 1,500 meters.

Q. 2. What should be the voltage of the "B" battery?

A. 2. The "B" battery voltage should be quite large—say 150 to 200 volts.

Q. 3. What is the value, in ohms, of the resistance in the plate circuit?

A. 3. The plate resistance should be 50,000 to 100,000 ohms.

When writing to advertisers please mention THE WIRELESS AGE

G. T. Conner, Dallas, Texas.

Q. It is my intention to experiment with rectified 60 cycle, 110 volt lighting current for use on the filaments of receiving tubes. I understand there are vacuum tube rectifiers on the market which I could use, but I do not know just how to go about getting the current regulated to 6 volts. Should it be put through the rectifiers before or after being stepped down? If not, just how much should it be stepped down in order to give 6 volts D. C. after passing through the tubes? Will you kindly give, also, information as to how to hook up the circuit in order to secure advantage of both halves of the cycle?

A. 1. It is neither advisable nor necessary to rectify the 60 cycle current for use on the filaments of receiving tubes, since rectification would not be of material help in reducing the 60 cycle hum. The filaments should be run directly off the secondary of a step-down transformer—the hum being balanced out by means of a 200-ohm potentiometer connected across each filament. See diagram below.

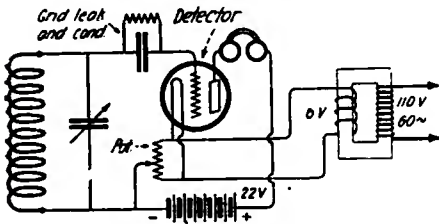

J. Van de Velde, New York City.

Q. 1. In the June issue of THE WIRELESS AGE I saw a hook-up of a set made by George R. Troxell, winner of the \$10 prize. I made the crystal detector set and it works first class. Now I want to make the set as illustrated in figure 5. Enclosed find a sketch of what the outside of my panel looks like. Please give me an idea of what it ought to look like when built like figure 5.

A. 1. The outside of your panel should be as shown herewith.

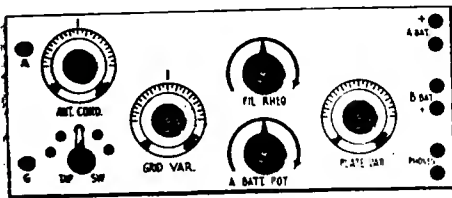

Q. 2. Is my cabinet large enough to hold all the other additional parts or will I need a larger one?

A. 2. Your cabinet is large enough to hold all parts.

Q. 3. How does one go about tuning the set?

A. 3. To tune this set (Figure 5, page 70, June, 1922, issue of THE WIRELESS AGE) proceed as follows: Set the plate variometer at minimum. Tune the antenna circuit by means of the tap switch and variable condenser. Then adjust grid variometer to obtain maximum signal. You may find it necessary then to slightly retune the antenna condenser. Adjust filament rheostat and potentiometer until best results are obtained. Tune with plate variometer until loudest signal is heard. It is necessary now



“Why the menagerie?”

YOU wouldn't stand for a young menagerie howling around the house. Why permit your radio set to act that way? It's unnecessary. For just five dollars you can add an Acme Audio Frequency Transformer to your set. This ends the howling and distortion so prevalent in the ordinary detector unit and at the same time it greatly increases the volume of incoming sound. Music and the human voice assume their natural tones. No more thin, squeaky voices and tiny elfin wails.

You will also want the Acme Radio Frequency Amplifying Transformer. You can use it with either a vacuum tube or a crystal detector set. It greatly increases the distance over which you can receive broadcasting programs. Just the same price as the Acme

Audio Frequency Transformer. Two stages of Acme Audio Frequency Amplification with two stages of Acme Radio Frequency Amplification will give you maximum range, volume and certainty of natural tone. Your set is incomplete without them.

The Acme Apparatus Company (pioneer transformer and radio engineers and manufacturers) also make detector units, detector and two stage amplifying units, the Acme Clear Speaker, the Acme phone, also C. W. and spark transmitting apparatus. Acme Apparatus is for sale at radio, electrical and department stores. If one is not close at hand, send money direct. Ask also for interesting and instructive book on Transformers. The Acme Apparatus Company, Cambridge, Mass., U.S.A. New York Sales Office, 1270 Broadway.

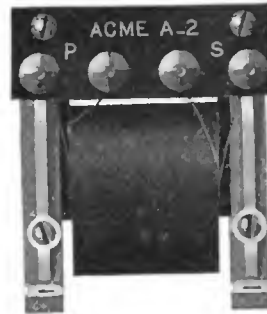

Type A-2 Acme Amplifying Transformer
Price \$5
(East of Rocky Mts.)

ACME

for amplification

When writing to advertisers please mention THE WIRELESS AGE



A Chain Is No Stronger Than Its Weakest Link

and

The best wireless set is no better than its insulators, for a poorly insulated antenna will cause dissatisfaction with the best of sets.

HOPEWELL INSULATORS

offer maximum insulation. Hopewell Patented Air Gap Insulators are made without metal. They do not absorb moisture. The air gap puts the electrical stress on the air, not on the material in the insulator; hence, it will not deteriorate.

Radio Department:

HOPEWELL → **INSULATION & MFG. CO.**
HOPEWELL, VA.

LEARN THE CODE

Get all the fun there is to be had from your wireless set. Learn to read the dots and dashes and double your pleasure.

The Marconi-Victor Records

Provide the ideal instruction.

SIX DOUBLE FACED RECORDS-TWELVE LESSONS

From the alphabet to press and code work. Actual operating conditions reproduced. Satisfaction guaranteed.

Price: \$5.00 per set

Wireless Press, Inc.

326 BROADWAY
NEW YORK



2200 Ohms
List Price
Only
\$9.00

"East and West, the Globe is Best."

GLOBE RADIO HEAD PHONES

Highly sensitive Matched receivers Natural in tone. Each receiver tested by radio. Light weight (11 oz.) Comfortable to wear. Specially designed adjustable headband. Will not distort signals when amplified. Articulation is perfect.

There are many types of head sets on the market but not too many good ones. The GLOBE RADIO HEAD SET incorporates a knowledge of acoustics not possessed by other companies. It embodies correct design with the best of materials.

THE GLOBE PHONES ARE FOR THOSE WHO DISCRIMINATE.
Ask about the Globe Antenna Attachment Plug for using electric light wire.

GLOBE PHONE MFG. CO.

EARL C. HANSON, Technical Radio Expert
Reading, Mass., U. S. A.

to again alter both the antenna condenser and grid variometer.

Q. 4. Would I hear concerts clearly if I used a King Amplitone as illustrated on page 97 of the June issue of THE WIRELESS AGE?

A. 4. A King Amplitone can be used only where the sound is loud enough to be heard all over the room—so that the phones need not be worn on the ears. You will not have much use for the Amplitone unless you use a two-stage audio frequency amplifier in addition; for the music you receive will be heard only with the head phones.

Q. 5. Could I hear Medford Hillside and Pittsburgh with set?

A. 5. In order to receive Medford Hillside and Pittsburgh in New York City, you must have a very good antenna. Otherwise you will be able to hear them only when atmospheric conditions are exceptionally good for radio transmission. Even then it is hardly likely that you will hear them, unless the numerous New York broadcasting stations stop transmitting for a while.

* * *

John M. Leete, Petersburg, Va.

Q. 1. Would too many turns on a tickler have the effect of making the bulb or vacuum tube too critical? I have about sixty turns, but it seems to oscillate on any position.

A. 1. Too many turns would make the adjustment of the tickler too critical, a slight increase in coupling causing the tube to go into oscillation. Try about half that number of turns, viz. 30 to 40, instead of 60 turns.

Q. 2. Does the addition of capacity raise or lower meterage? In other words, would the same amount of inductance have a greater meterage with a .0005 condenser or a .001?

A. 2. The addition of capacity across an inductance raises the wave length in meters. A .001 condenser would give a longer wave length than a .0005 condenser. If used in the antenna, a .0005 condenser is large enough.

Q. 3. I am using straight inductance varied by taps and a variometer, and am using detector and one-step. Is this circuit any more efficient on C. W. than on phone? Would it be any more efficient if I inserted a small series condenser? I have trouble in getting down to low enough meterages for phone reception.

A. 3. The addition of a series condenser in the antenna would enable you to get down to the lower wave lengths and should be added by all means. The circuit is equally efficient on C. W. or phone; the series condenser has nothing to do with efficiency.

* * *

E. D. Ames, Baltimore, Md.

Q. I have a receiving set consisting of the following: 2 variometers, 1 loose coupler, 1 large condenser, 23 plates, 1 small condenser, 23 plates, grid leak, grid condenser, radiotron tube, A and B batteries, 4 point double throw switch, 10 point switch for B battery, 3,000 ohms phones. My antenna is on roof and is 35 ft. long with a 100 ft. lead-in straight down to window. Now I want a hook-up for this, so I can talk to a friend two squares away. I have a microphone. Please tell me what else I

When writing to advertisers please mention THE WIRELESS AGE

will need. My hook-up now enables me to hear the radiation of my friend, who has two steps of audio in his receiving set. He sends by code by means of a key in his antenna circuit.

A. To talk to your friend several squares away, simply add a microphone in the ground lead of your antenna, tuning the plate variometer so that it is beyond the oscillation point. You can determine when oscillations are present by touching the grid terminal with a moistened finger and listening in the phones. On touching the grid a dull thump is heard, and on removal of the finger, a similar thump is heard. Better results are obtained with about 100 volts on the plate. Be sure, however, to obtain an amateur station transmitting license from your local radio inspector first and confine your enthusiasm to 200 meters. Below is hookup.

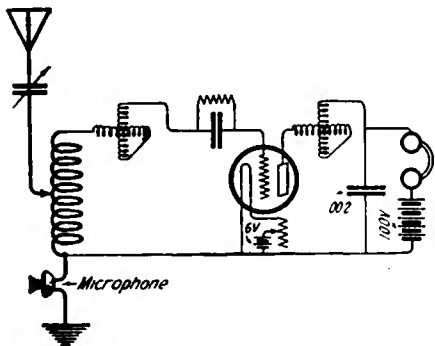

E. Bilgart, Chicago, Ill.

Q. I have thoroughly studied the "Supersensitive Receiving Set" described by Charles R. Doty on page 84 in your book known as "Practical Amateur Wireless Stations." I am building a set like this and would like to know if with this set I will be able to tune into the radio concerts broadcasted from station WJZ, Newark, N. J., and other distant places. Also is it possible to tune into these stations and tune out a local station? I do not clearly understand the construction of the coupler in this set. Is it a sliding coupler or is the primary and secondary wound on the same tube? Also what are the 3 F. S. W. for?

A. This "Supersensitive Receiving Set" is suitable only for receiving long waves, above 2,000 meters and cannot be used for reception of broadcasting on 360 meters.

* * *

Harold Unger, Morgantown, W. Va.

Q. 1. What is the standard diameter of the stators and rotors of the variometers and variocouplers?

A. 1. There is no standard diameter of stators and rotors of variometers or variocouplers. The stators have a diameter of the order of 6 in. and the rotors about 4 to 5 in. in variocouplers, and the stators of variometers are about 5 in. in diameter with the rotors 4½ in. In the case of the variometers, both windings are on spherical or ball shaped forms instead of on cylindrical forms.

Q. 2. How many turns of wire are taken on the stator and rotor of the variometers and variocouplers?

A. 2. In variocouplers, there are about 36 turns on both stator and rotor. In variometers there are about 30 turns on both stator and rotor.

Q. 3. How many taps are taken on the stator of the variocoupler and how many

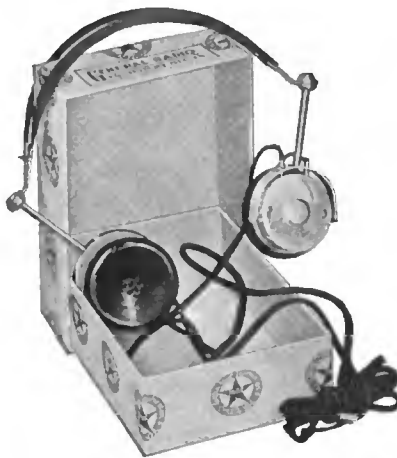

Red Star Head Phones

Why take a chance with your receiving set by using poor head phones, for after all your radio receiver set is no better than your head phones.

Red Star head phones speak up sharp and clear. Light in weight, they fit the head comfortably and do not tire; they are easily adjusted over the ears.

Protect your receiving set by buying good head phones—ask your dealer to show you Red Star phones. You will be surprised at the results you will attain.

Monocoil, 2,000 ohms, \$5.00

Long-distance, 3,200 ohms, \$8.00

Including head band and 6 ft. cord

General Radio Equipment Co.

1131 Diversey Parkway

Chicago



Na-ald Small-space V. T. Socket

35c. each. 3 for \$1.00

Moulded genuine Condensite. Requires but small space for mounting. Readily accessible binding posts. No excess metal to interfere with efficiency. Unaffected by heat of bulbs or soldering iron. Phosphor bronze contacts; nickel plated brass binding screws. Slash-cut slot.

Price possible only because of enormous production. Special proposition for dealers and jobbers.

ALDEN-NAPIER CO.

52 Willow Street, Dept. A., Springfield, Mass.

Buy Your Radio Receiving Set At Mfrs.' Cost

Buy your Radio Supplies at a large discount below the list or retail price. If a saving of \$15.00 to \$140.00 on a Radio Receiving Set or if a saving of 25% to 40% on Radio Supplies interests you, write or telegraph us today.

KING RADIO MFG. COMPANY
521 Penn Ave. Wilkinsburg, Pa.

"All-American" Transformers Radio and Audio Frequency

Radio and Audio frequency are day by day becoming more and more important. The days of sets with detector only, are gone.

To get the best results, you must use the best transformers. "All-American" Radio and Audio Frequency Transformers have given the best results to thousands of radio fans in all parts of the country and will give you the same results as soon as you try them.

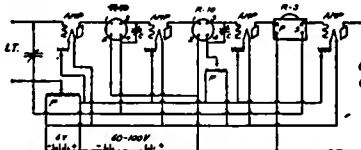

2 1/2" 100V TAPERS RAULAND MFG. CO., CHICAGO APR-10-'22
5 PLATE VARIATORS COND.

Try the hook-up illustrated, but be sure to use "All-American" Transformers or you will not be satisfied.

Ask your dealer

RAULAND MFG. CO.

35 So. Dearborn St., Chicago, Ill.



"All-American" Radio Frequency Type R-10—\$4.50



"All-American" Audio Frequency Type R-2—\$4.25
Type R-3—\$4.50

When writing to advertisers please mention THE WIRELESS AGE



SEND FOR THESE BULLETINS

Every person interested in "Radio" should have them.

No. AJ-10. 3½" ammeters, milli-ammeters, voltmeters, milli-voltmeters and thermal ammeters for all receiving and transmitting sets.

No. AJ-20. Telephone receivers.

No. AJ-810. Medium and large size ammeters, milli-ammeters, voltmeters, milli-voltmeters and current squared meters for all receiving and transmitting sets.

Distributors write for attractive proposition.

ROLLER-SMITH COMPANY
Electrical Instruments, Meters and Circuit Breakers

MAIN OFFICE
2129 Woolworth Bldg., NEW YORK



WORKS
Bethlehem, Penna.

Offices in Principal Cities in U. S. and Canada

EXPERIMENTERS

Build your Super-Regenerative Set from this new book and get it right

The Armstrong Super-Regenerative Circuit

By GEORGE J. ELTZ, Jr., E. E., A. I. E. E.

Complete description of each of Three Circuits Invented by
MAJOR E. H. ARMSTRONG

How to Change a Regenerative to Super-Regenerative Circuit
52 Pages 21 Photos and Hook-Ups Price \$1.00

Dealers, Place Your Orders Now

WIRELESS PRESS, Inc., Distributors, 326 Broadway, New York

SYSTEMATIC PRINTING COMPANY

"LISTEN IN"

We Carry in Stock at All Times, for Immediate Delivery, a Complete Line of Loose Leaf Binders, Ring Binders, Ledger Sheets, Indexes, Etc.

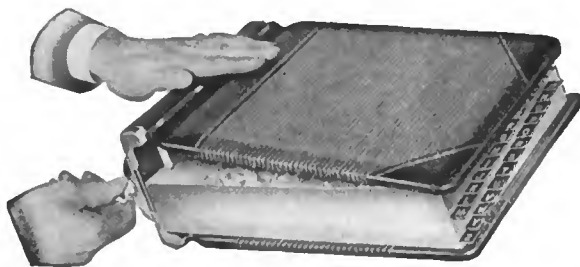

GET OUR PRICES BEFORE BUYING ELSEWHERE

WE specialize in printing "RADIO" forms of every description. We have done it for others in the trade and can save you money, too. A letter or phone call telling us your wants, will get us on the job.

SYSTEMATIC PRINTING COMPANY

Telephone Canal 4812

136 West Broadway, New York City

rounds to each? What are the number of meters to each tap?

A. 3. On the stator of the variocoupler taps are taken at every 6 turns, except for the first 6 turns, which are tapped at every turn. There is no definite wave length for each tap. That is determined by the capacity of your antenna and the setting of your antenna condenser.

Q. 4. How many rounds of wire are taken on the rotor of the variocoupler?

A. 4. There are about 36 turns on the rotor of the variocoupler.

Q. 5. What type of bulb detector is the best to use? Why cannot two B batteries be used in place of one B battery and storage battery to light the detector bulb?

A. 5. A UV-200 Radiotron makes a better detector than a UV-201. This tube is designed to operate with 18 to 22 volts on the plate and 6 volts on the filament. A higher voltage on the filament will burn it out and the tube will then be useless.

Q. 6. Would like a diagram of the hook-up of one variable condenser, two variometers, one variocoupler, and one bulb detector.

A. 6. Below is hook-up.

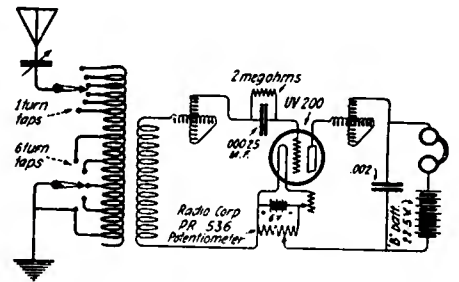

* * *

O. Ingmar Oleson, Ambrose, N. D.

Q. Will you please give exact specifications for building the Low Voltage Radiophone set mentioned on page 76 of the June number of THE WIRELESS AGE. Describe particularly the modulation transformer and the inductance coil. Would Ford coil work as transformer?

A. The modulation transformer used in the Low Voltage Radiophone Set described in the June, 1922, number of THE WIRELESS AGE was an ordinary bell-ringing transformer such as may be purchased from your electrical dealer. However, a Ford coil would make a much better transformer because of the greater ratio of turns (primary to secondary). But you must add a rheostat in the microphone circuit to prevent excessive current in the microphone. A very good modulation transformer may be built as follows: Add about 100 turns of No. 28 enamel wire, which you should use as a primary. Use the existing primary of the amplifying transformer as your secondary (this generally has about 4,000 turns of No. 40 enamel). The inductance coil contains 40 turns of approximate No. 14 bare copper wire, on a tube 5 inches in diameter, with the turns ½ inch apart, taps taken out at every turn.

* * *

W. Walter Filson, Audubon, N. J.

Q. Since I installed power spark transmitter I have been able to work without the least bit of trouble, stations north of me, and after one solid year I have only last week landed 8EW in Pittsburgh, Pa. I had a flat top L antenna for about six months, and then changed to a cage L using 4 wires in all. Antenna 65 feet and lead-in 35

When writing to advertisers please mention THE WIRELESS AGE

feet. Can you give me a solution to get away from this marked directionalism? Radiation is 2 amperes on 1/4 k.w. I think if I put my aerial east and west I would probably work as far west as I have gone north to Canada. Trans. 3/4 Thor. Dubilier condenser .008 Bell Gap (by the way, I can only use one side of the gap) Pan cake O. T. I would appreciate a solution.

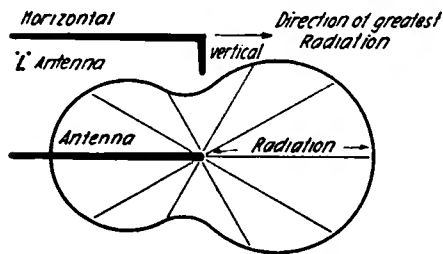

A. The inverted "L" antenna is known to possess certain directive properties. Generally better radiation is obtained in the direction of the antenna—greatest radiation being in the direction of the arrow.—See diagram. However, such directional effects are noticeable only when the horizontal part of the antenna is several times as long as the vertical portion. More uniform radiation is secured with a T antenna—the directive properties being practically nil. Changing the direction of your aerial may change the direction of maximum radiation. Much greater distance may be covered by increasing the height—and at the same time the directional properties would become relatively less important.

Harry S. May, Johnstown, Pa.

Q. 1. Please publish in your magazine a hook-up for 1 stage of radio-frequency amplification, using a Westinghouse Aeriola Senior detector with Type W. D. 11. Aeriotron tube style No. 319533, using 1.5 volts on filament 22 1/2 on plate, radio amplifier to consist of Murad type T 11. R. F. transformer, radiotron tube UV-201, Bradley-stat filament control 1,200 to 400 potentiometer, and a 0.5 MFD condenser and a .23 plate variable condenser. Also am using 2 stages of audio-frequency type RORK Serial 687 with 6 volts on filament, 90 on plate. Get good results with this, but would like to work some far stations.

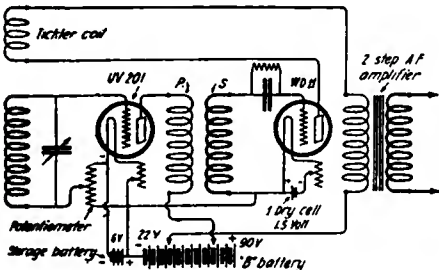

A. In adding one step of radio frequency to your Aeriola Senior, you will find it necessary to reverse the connections to the ticker coil in order to obtain regeneration. Herewith is wiring diagram requested.

The storage battery and B Battery are same as used with rest of apparatus.

Vernon Chaberd, Youngstown, Ohio.

Q. In connection with the article in your March and April issues entitled "Filament and Plate Current from A. C. Supply," I constructed a transformer, the specifications of which are given herewith on a separate sheet. I am having trouble with it heat-

KQV—Pittsburgh, Pa.—Broadcasting Stations—Washington, D. C.—WMU

Dependable Radio Equipment

All orders with remittance promptly delivered, Post or Express paid. Always a large and varied stock of most modern and reliable Radio Equipment and Parts.

(Immediate Deliveries on All Items Listed)



Stromberg-Carlson No. 2-A Headset

\$7.50

- Aeriola Senior Westinghouse Receiver.....\$ 65.00
- Aeriola Grand Westinghouse Receiver..... 325.00
- De Forest Radiohome Set DT 700 less Batteries, Bulbs and Headset..... 36.00
- De Forest 2-stage Amplifier DT 800 less Bulbs and Batteries 35.00
- Simplex Variometers 6.00
- King Amplitone Horns 12.00
- Holtzer-Cabot Headset 8.00
- UV 200 Radiotron Detector Bulbs, each.... 5.00
- UV 201 Radiotron Amplifier Bulbs, each.... 6.50
- No. 766 Eveready VT Batteries, each..... 3.00
- Gould 6 volt, 60-80 ampere Storage Batteries 19.00

Enclose Certified Check or P. O. Money Order with Orders.



R-3 Magnavox Loud Speaker

\$45.00

DOUBLEDAY-HILL ELECTRIC CO.

WASHINGTON, D. C.—Dealers Write for Discount—PITTSBURGH, PA.

PINK-A-TONE

DETECTOR OF THE AIR

MANUFACTURED BY
PINKERTON ELECTRIC
EQUIPMENT COMPANY



GENERAL SALES AGENT
NATIONAL SERVICE COMPANY

The Crystal Radio Receiver with the Seven Points of Superiority that has already achieved its success in New York City.

10,000 Sets Sold in Six Weeks

Executive Office 1834 Broadway New York City

BOSTON RADIO EXPOSITION

and

N. E. AMATEUR CONVENTION

Mechanics Building

Entire Week October 30—November 4

Covers New England with One Exposition

SPACE AVAILABLE NOW

Executive Offices: 5 Park Square, Boston, Mass.

When writing to advertisers please mention THE WIRELESS AGE

1500 OHMS
\$5.00 LIST.



2200 OHMS
\$7.50 LIST.

Dear Radio Fan:—

This is between ourselves, so I am going to get a little personal. Did you ever try a "ROYALPHONE" with your set? If you haven't, you are not getting the full benefits that radio affords you. A receiving set catches the sounds from the air; but a set of phones are required to translate the sounds so that they are understood. A good pair of phones will help your receiving a thousandfold.

The next time you are in a radio store listen in on the dealer's set with a "ROYALPHONE." You will experience a thrill that comes once in a lifetime. You will hear the messages and musical selections as if you were in the same room with the transmitter. The sounds will be natural and not distorted. The phones are so light and they fit so perfectly that you will not realize that they are on your head.

When you are through, examine the "ROYALPHONE" carefully. You will notice that all parts are of the best selected material and skillfully assembled.

After your curiosity has been satisfied, tell the dealer what you think of the "ROYALPHONE." If you will write me your opinion, there will be a surprise in store for you.



"ROYALPHONE" KING OF ALL.

Made by
ROYAL ELECTRICAL LABORATORIES
MANUFACTURERS OF
ELECTRICAL AND RADIO EQUIPMENT
181 South Street Newark, N. J.

We have attractive propositions for jobbers.

Royalphone

4000 MILES

Pick up that elusive long-distance broadcasting station.

An Illinois amateur, by using three stages of the **DX RADIO FREQUENCY TRANSFORMER** listens to Hawaii, Massachusetts, Georgia, California and Texas broadcasting stations regularly and hears broadcasting stations in sixteen different States.



Patents Pending

Using only two stages of **DX RADIO FREQUENCY TRANSFORMERS**, another amateur picked up 200 meter spark signals from fourteen different States in *two hours' time*. Make transcontinental reception a regular thing.

Use the Best Prompt Shipments in Quantity

RADIO INSTRUMENT COMPANY, INC.
WASHINGTON, D. C.

When writing to advertisers please mention THE WIRELESS AGE

ing up. After the transformer has been connected up for about 30 minutes, the windings and core are so hot that the heat is unbearable to the hand. This is with no load on the secondaries. This transformer consumes about 75 watts on open circuit, which certainly does not show a very high efficiency. There are no short circuits. The shape of the laminations, also their size, could not very well be changed. I could, however, build it up to any height required if advisable. Instead of using 320 turns for 80 volts in the plate secondary, I used 360 turns for 90 volts. I did this because I wished 45 volts for the plate of the amplifier tubes; as you know, only half of the secondary voltage is used. Do you think the rectifier would work satisfactorily on this voltage? Would a pint or quart mason jar cut in half be all right for the rectifiers? If so, what should be the dimensions of the plates? By what distance should they be separated?

Concerning the transformer, would you advise building the core up to a greater height? Or using fewer or more turns in the primary, with corresponding change in the secondaries to keep the correct ratio? Or having fewer turns per layer and thus build the windings up to a greater height?

A. Your transformer seems to be O. K. We cannot account for the heating up of the transformer, unless it is in the clamps that you use to hold the core together. They may be acting as short circuited turns, if they are of metal—and thus cause excessive currents in the primary. The rectifier will work satisfactorily on 45 volts. A pint mason jar is large enough. The rectifier plates should be about 3/4 in. wide, and immersed in the electrolyte about 1 1/2 in. and separated by 1/2 in.

* * *

John M. Saalwachter, Rochester, N. Y.

Q. My outfit consists of the following: 1 Variocoupler, one 15-plate variable condenser, 1 soft and 2 hard Radiotrons, 3 Ford spark coils, fixed condensers, 2 A batteries, 4 B batteries, 1 Type R-3 Magnavox, and pair of receivers. Kindly publish a hook-up using above parts with some additions if necessary, stating the sizes of the condensers and grid leaks.

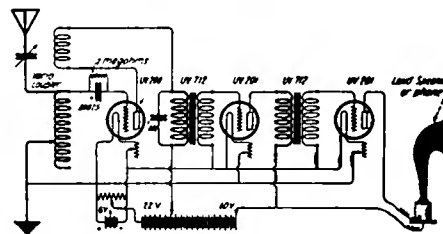

A. I. Herewith is a hook-up using the material you possess. You will find it necessary to buy 2 amplifying transformers, 3 rheostats, and one A battery potentiometer.

* * *

E. R. Haner, Flint, Mich.

Q. Where can I go to get more technical information on the process used by De Bernechi of varying the intensity of a beam of light by passing it through a photographic film which in turn alters the resistance of a selenium cell. This process was used in the electrical transmission of pictures.

A. We have no record of such experiments.

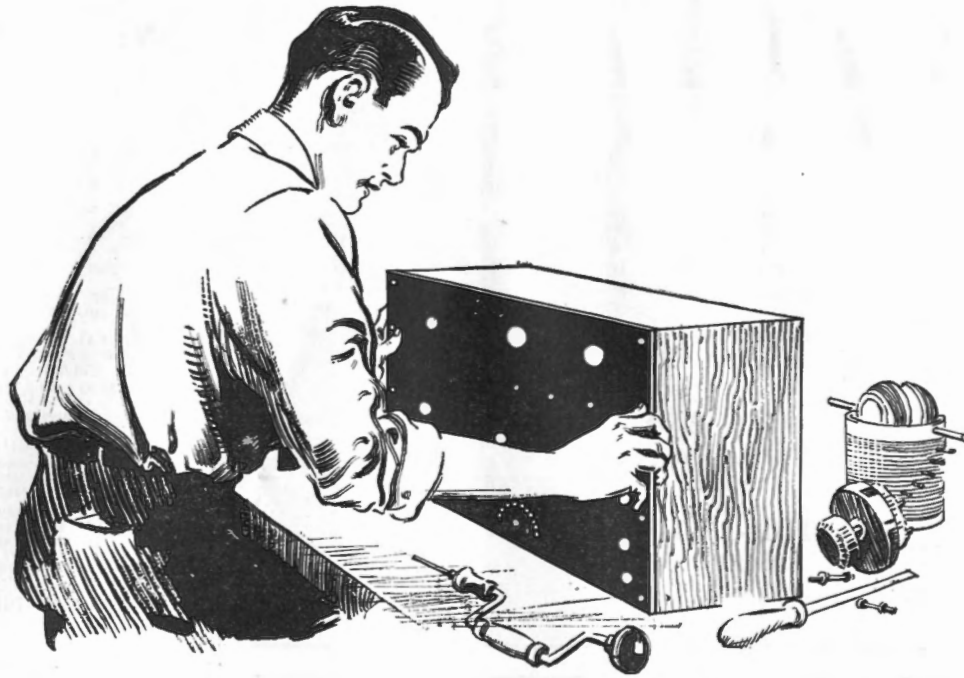

Improve Your Radio Set with a Panel of

CONDENSITE CELORON

The better the insulation the finer your radio set will perform. Keep your connections tight and your insulation right. This is a radio axiom. Here is another. Get the best panel obtainable.

The essential qualities of a radio panel are non-conductivity, strength and appearance. Condensite Celoron is a strong, hard, waterproof material that will give you surface and volume resistivities, and a dielectric strength greater than you will ever need. In addition to this, this material machines readily, engraves with clean-cut characters and takes a fine, natural, polish or a beautiful, dull, mat surface. Mount your equipment upon a Condensite Celoron Panel and note the improvement.

Are you a radio enthusiast? Step into your nearest radio supply store and get a Celoron Panel cut to the size you want. If by any chance that dealer cannot supply you, write us direct.

Do you make radio equipment? If you are not now using Condensite Celoron, let us give you the facts.

Are you a radio dealer? Send today for our special dealer's proposition covering Celoron Panels and Parts.

DIAMOND STATE FIBRE COMPANY

BRIDGEPORT (near Philadelphia), PA.

Branch Factory and Warehouse, Chicago

Offices in principal cities

In Canada: Diamond State Fibre Co. of Canada, Ltd., Toronto

THORKITE

THE PERFECT RADIOPHONE DETECTOR

A new Silver-Copper-Bismuth Sulphide Crystal composed of some twenty-one chemical elements and rare metals of assay value over one hundred times that of galena. Vastly more sensitive—does not deteriorate but actually improves with use and lasts indefinitely.

Mounted in $\frac{1}{2}$ inch nickeled cup. Can be attached direct to panel if desired. Special alloy used in mounting adds to the natural efficiency of this wonder crystal. Fully guaranteed. If you want the best radio reception, use THORKITE.

Price \$1.00 by mail postpaid
Dealers' inquiries solicited

GILMOR-LAYNE CO.

DISTRIBUTORS

203 L. A. Railway Bldg., Los Angeles, Cal.

The Condenser With a Conscience

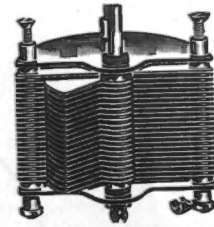

The "Standard" Condenser
The superiority of design and craftsmanship will instantly

APPEAL TO THE CRITICAL USER
Furnished from stock, fully assembled and tested, at

LESS THAN PRE-WAR PRICES.
11 plates \$2.35 23 plates \$2.85 43 plates \$3.00
Sent prepaid east of Mississippi on receipt of price. For Western States and to Colonias add 10c; for Canada, 25c.

FULLY GUARANTEED
Money back if not satisfied. Just return by insured Parcel Post within 5 days.

ALUMINUM HORNS
Superior in sound, ready for attaching to your RECEIVER—\$12.00 each, f. o. b. New York. We can also furnish in any desired quantity—Condenser Parts, Variometers and parts, Horns, Sockets 1-2-3 mounting, Switches, Jacks, Plugs. All of highest "standard" quality at the right price.

STANDARD RADIO PRODUCTS CO.
207 Fulton Street - - New York

WARNING!

While we try to adequately supply the newsstand demand for The WIRELESS AGE the safe way of getting your copy is to give to your newsdealer a standing order or place your yearly subscription with him. Now is a good time to do it.

JOY-KELSEY CORPORATION

Manufacturers
RADIO EQUIPMENT
4021 West Kinzie St. Chicago Ill.

VARIABLE CONDENSERS OF QUALITY



Designed correct and made to precision.

The condenser you need for good results with the Super-regenerator or the regenerative receiver.

Some manufacturers of high grade regenerative receivers have adopted these condensers for their sets.

Plates shaped to give a straight line increase in wave-length and very low minimum capacity.

Each condenser perfect and fully guaranteed.

41 plate .0011 M.F..... \$5.75 9 plate .00025 M.F.... \$3.25
21 plate .0006 M.F..... 4.75 Without knobs or dials.

RADIO LABORATORIES OF NEW JERSEY, Inc., GRANFORD N. J.

For
any
make

**PUT MICA
DIAPHRAGMS**

Ask your dealer or
send direct for free
illustrated circular
No. 21.

**ON
YOUR
PHONES**

LIBERAL DISCOUNTS Eliminate
TO DEALERS & JOBBERS Noises

CLEARER—BETTER—PURE TONE

Immediate delivery

RADIO MICA PRODUCTS CO.
156 East 43d Street New York City



The Only Knob and Dial Without A Set-screw

The unsightly and troublesome SET-SCREW is at last eliminated. No more splitting the head of the set screw or stripping of threads, perhaps ruining the dial.

To mount the TAIT-KNOB-AND-DIAL simply hold the dial with one hand and screw on the knob with the other, a few seconds does it. No tools are necessary. When fastened it is self centering and self aligning.

This beautiful patterned KNOB-AND-DIAL is made of the best grade of BAKELITE.

Prices—4" \$1.50; 3" \$1.00

To those building their own sets—Don't fail to use this dial, it is REVOLUTIONARY in its field and is the PEER of all KNOBS-AND-DIALS. If your dealer has

none, write us, and we will refer you to one who has.

Dealers—If your Jobber is not stocked up write us and we will refer you likewise.

We Sell Strictly To Manufacturers and Jobbers—whom we invite to write us for free samples and discounts.

TAIT KNOB & DIAL COMPANY, Inc.

11 East 42nd Street

Phone Murray Hill 0341

New York

Patented June 20, 1922.

When writing to advertisers please mention THE WIRELESS AGE



Run-down batteries need not be the reason for missing any broadcast programs

**No Concerts Missed
Because of Run-Down Batteries**

With a Tungar Battery Charger you can easily keep your batteries up to full voltage. It enables you to recharge batteries from any a-c. lighting circuit at your convenience and at a minimum cost. The battery doesn't have to be taken out of the house. "B" storage batteries, also, can be charged by means of a simple, inexpensive attachment.

The Tungar Battery Charger requires no attention while operating and is so designed that there isn't the slightest danger of injuring the battery. And its first cost is very low.

Tungar has kept other people's storage batteries in condition for years—why not yours? Of course, it is equally good for your automobile battery.

Our new booklet on the application of Tungars to radio batteries will interest you. Send to us for booklet B-3640, if your dealer cannot supply you.

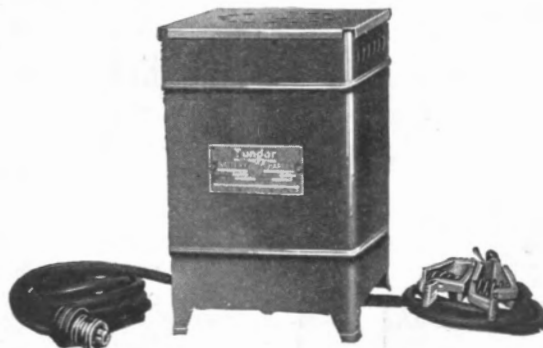

Tungar Battery Charger—saves disappointments and annoyance

Tungar
BATTERY CHARGER

General  Electric Company
General Office Schenectady, N.Y. Sales Offices in all large cities

35A-77

Attention Mr. Amateur!



Trade Mark Registered

We have a complete stock of the old line Radio Companies' experimental and measuring instruments and parts.

The famous Grebe Receivers and Amplifiers are our specialty.

We are the official Radio Corporation distributors.

Have your dealer order from us.

PHILADELPHIA WIRELESS SALES CORPORATION

Formerly Philadelphia School of Wireless Telegraphy

1533 PINE STREET

PHILADELPHIA, PA

KNOTT RADIO NAME PLATES



STYLE A	Antenna	A Battery—	Phone	
	Ground	B Battery+	Input	9 for 50c
STYLE B	A Battery+	B Battery—	Output	
Phones	2nd Step	Coupler	Parallel	
Off	3rd Step	Loading Coil	Variable Condenser	
On	Potentiometer	Detector Tube	+	
Increase Current →	Vacuum Tube	Grid Variometer	—	
Increase Current ←	Primary	Tickler	Microdenser	
1st Step	Secondary	Series	Microstat	
		Plate Variometer	Rheostat	

12 for 50c
Buy of your dealer, or we send direct upon receipt of price.
Made of sheet brass, etched, silver plated and lacquered.
They are of exceptional value and read above the binding post, the right place for them.
They greatly improve the appearance of a set and simplify the operations.
Send 2 cent stamp for circulars about Knott Sure Ground, Patent Stop Dia., Rheostat, Quodcoil, Cingcoil, Microdenser, Microstat.
Jobbers, write for our proposition, it will interest you.



E. R. KNOTT MACHINE CO., 1 Ellery Street, Boston 27, Mass.

EASTERN RADIO INSTITUTE
899 BOYLSTON ST.
BOSTON, MASS.

TEL
BACK BAY
5 9 6 4

You are urged to investigate the **ADVANTAGES** offered by the **EASTERN RADIO INSTITUTE**, New England's **OLDEST**, **LARGEST** and **BEST EQUIPPED** radio school. Successful graduates are found in responsible radio positions all over the world. Why not be one?

REMEMBER: Our **ORGANIZATION** with **YEARS** of **PHENOMENAL EXPERIENCE** and **SUCCESS** is behind every man who enrolls!

"Ask any man in Radio—he will tell you!"
Our illustrated prospectus for the asking.
F. D. PITTS, Director.

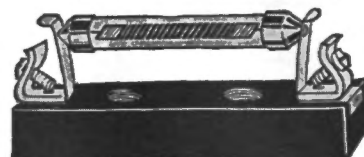

"PRECISION"
GRID LEAKS AND MOUNTINGS
Resistance Ranges from .05 Megohms to 5 Megohms. Accuracy Guaranteed.
Grid Leaks 75c
Mountings 50c
RADIOPHONE EQUIPMENT CO.
47 New St., Newark, N. J.

Chaslyn Patented
"Sink-or-Swim"
Ball Battery Tester

\$1.00

Specific gravity shown instantly by floating or sinking of colored balls. Accurate — Simple — Won't break if dropped. Tester, Water Filler and Depth Gauge.
All for a Dollar Bill
Send One Dollar and your dealer's name and address and set will be mailed you.

THE CHASLYN CO.
4307 Kenmore Ave.,
Chicago.



RADIO CABINETS

We build Cabinets for any size panel in Walnut, Oak or Mahogany. Will quote on one or one thousand. Send us your specifications for attractive prices.

NATIONAL CABINET COMPANY
Dept. R-10 Dayton, Ohio

DEALERS:—

WE are Jobbers for

Grebe Receiving Sets
Murdock Products
Baldwin Phones
Federal, Fada
and
Radio Shop Products

Write for our Special Proposition A

The Radio Shop
OF NEWARK

41 South Orange Ave.
NEWARK, N. J.

Unlimited resources of entertainment with the Magnavox Radio



IT is the Magnavox Radio which is invariably selected for demonstrations of technical or public interest. The two sizes of Magnavox Radio meet every requirement of volume and range—from the home gathering to the largest public audience.

R-2 Magnavox Radio with 18-inch horn . . .	\$85.00	Model C Magnavox Power Amplifier 2 Stage—AC-2-C . . .	\$ 80.00
R-3 Magnavox Radio with 14-inch horn . . .	45.00	3 “ —AC-3-C . . .	110.00

*The Magnavox products may be had of good dealers everywhere.
Our interesting new booklet (illustrated in 3 colors) sent on request.*

THE MAGNAVOX COMPANY, Oakland, California; N. Y. Office, 370 Seventh Avenue

MAGNAVOX RADIO

The Reproducer Supreme

KENNEDY EQUIPMENT

The Standard by which to judge Radio Equipment

SO careful has been the manufacture of Kennedy Equipment since its inception that radio enthusiasts everywhere proclaim it the standard by which to measure all radio receiving apparatus.

KENNEDY

Short-wave Regenerative Receiver Type 281



is a sturdy example of the quality which has made the name Kennedy synonymous with good radio equipment everywhere. Type 281 possesses selectivity and efficiency to a high degree, these features being insured by the correct use of inductively coupled circuits.

All Kennedy Regenerative Receivers are licensed under Armstrong United States Patent No. 1,113,149.

KENNEDY RADIO EQUIPMENT IS SOLD BY GOOD DEALERS EVERYWHERE

Write for Latest Bulletin C-3. Address our nearest office.

THE COLIN B. KENNEDY COMPANY

INCORPORATED

SAN FRANCISCO

U. S. A.

SAINT LOUIS

SIMPLEX

—that's your safeguard

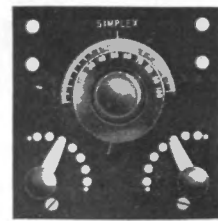

Simplex Vario-Coupler Panel

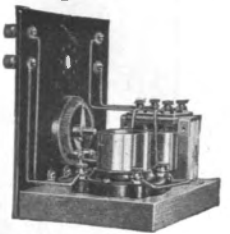

Simplex Amplifier Panel

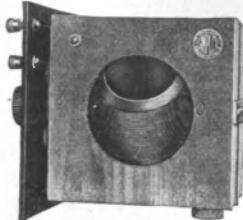

Simplex Variometer Panel

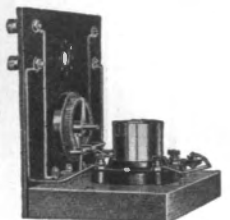

Simplex Detector Panel

SIMPLEX PANEL UNITS make it possible to try out the many different hook-ups without disassembling panel, which is a decided advantage.

SIMPLEX RADIO CO.

1013-15 Ridge Ave.

Phila., Pa.

"EURACO" PRODUCTS

(Guaranteed)

Compact—Interchangeable—Most Efficient—Accurate.

60
Cents
per
Unit.



60
Cents
per
Unit.

Mica Condensers—Grid Leaks—Mountings.

Interesting Proposition for Dealers.

EUROPEAN RADIO CO.

1342 East 22nd Street

Brooklyn, N. Y.

RADIO & AUTO STORAGE BATTERIES CHARGED FROM LAMP SOCKET At a Cost of a Few Cents With An F-F BOOSTER

\$15

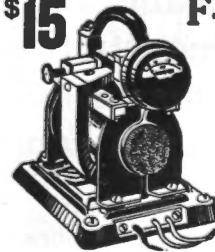

The Pioneer Charger. Is it not gratifying to feel Your Radio Batteries will never Fail and that you are Always Ready to Receive All Radio phone Broadcast Music, Sermons and News, never having to be careful of or tell Friends Your Batteries are dead? F-F BATTERY BOOSTERS Charge Automatically and Operate Unattended. Screw Plug in Lamp Socket. Snap CLIPS on BATTERY Terminals and see the

Charges Auto & Radio Batteries. gravity come up. Both Waves of Current are Rectified thru Adjustable and Easily Renewable Infusible Carbon Electrodes, which Maintain a Constant Efficiency and Last thousands of hours. Also Charges Batteries right in Autos. No Skill is Required. AMMETER shows Current Flowing, eliminating Guess Work. COMPLETE, COMPACT, SELF-CONTAINED, PORTABLE AUTOMATIC CHARGING UNIT. F-F BATTERY BOOSTERS are Full Wave Automatic Magnetic Rectifiers for 105-125 Volt, 60 Cycle A.C. Current. POPULAR PRICES: Type G charges Radio "A" 6 Volt Battery at 6 amperes \$15 Type B charges Radio "B" Batteries Up to 120 Volts \$15 Type A-B charges Both Your "A&B" Radio Batteries \$20 Type 12 charges 12 Volt Battery At 5 amperes..... \$15 Type 166 charges 6 Volt Battery At 12 amperes.....\$20 Type 1612 charges 12 Volt Battery At 7 amperes.....\$20 Type 1626 is a Combination of Both Types 166 & 1612 \$28 The Larger Types are for heavy Batteries, or where time is limited. Shipping Weights Complete \$11 to 15 Pounds. PURCHASE from Your Dealer, or Send Check for Prompt Express Shipment. If via Parcel Post have remittance include Postage and Insurance Charges. Or have us Ship TYPE desired C.O.D. Other F-F BATTERY BOOSTERS Charge Batteries from Farm Lighting Plants and D. C. Circuits. For GROUP CHARGING use our Full Wave, Automatic F-F ROTARY RECTIFIERS of 12 Battery, 8 Ampere Capacity. ORDER Now. Or WRITE Immediately for FREE ROTARY & RADIO-AUTO BOOSTER Bulletins 34 & 34A. The France Mfg Co. OFFICES & WORKS Cleveland, Ohio, U.S.A.

ATTENTION! RADIO AMATEURS

There's music in the air
A good electrical connection means clearer reception.

EBY BINDING POSTS

Guarantee both

Demand them of your dealer. They'll cost you less in the end. Look us up at the New York show.



Commander "H"



Ensign "H"



Buddy



Midget

THE H. H. EBY MANUFACTURING CO., PHILA., PA.

ARMSTRONG SUPER-HETERODYNE RECEIVER, RANGE 3,000 MILES.

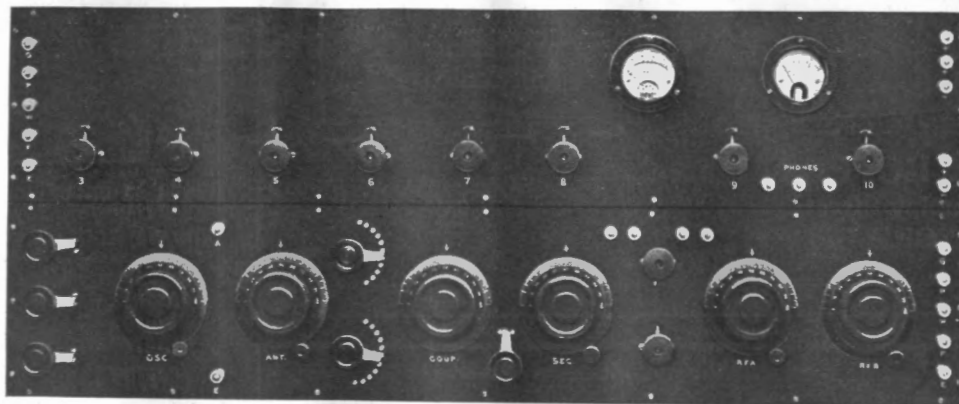

Contemporaries of Tomorrow's Models

are revealed in the

EXPERIMENTERS INFORMATION SERVICE

*presentation for 1922-1923
of RADIO*

RECEIVERS AND TRANSMITTERS.

ASK FOR CATALOG 98.

*EXPERIMENTERS INFORMATION SERVICE
DESIGNERS OF THE HIGHEST CLASS RADIO APPARATUS IN THE WORLD
23RD FLOOR 220 WEST 42ND ST. NEW YORK CITY*

RADIO CABINETS



Hard or soft wood, Mahogany or Walnut Finish, manufactured according to your specifications. Wooden parts for Radio Outfits, including Variometers and Couplers.

Send us Sample or Blue-print For Estimate

BOGERT & HOPPER, Inc.
65 Barclay Street
NEW YORK CITY

Telephone
Barclay 7416-7

NOW IN STOCK

Year Book Wireless Telegraphy, 1922

Price \$6.00

WIRELESS PRESS, Inc., 326 Broadway, New York

ATWATER KENT

2-STAGE AMPLIFIER

THE OUTSTANDING *Advantages* OF THIS INSTRUMENT are



- ¶ Excellence of reproduction.
- ¶ Amplification regulation by small steps.
- ¶ A complete instrument in itself.
- ¶ Compactness.
- ¶ Regulation entirely by knob, no jacks to equip.
- ¶ Transformers protected by steel housing.
- ¶ Short wiring connections eliminate capacity effect.
- ¶ Hermetically sealed, absolutely no moisture troubles.

THE LOW PRICE IS MADE POSSIBLE AS A RESULT OF 20 YEARS' EXPERIENCE IN QUANTITY MANUFACTURE OF SCIENTIFIC ELECTRICAL INSTRUMENTS

Price \$16⁰⁰ *An Excellent Merchandising Proposition*
ATWATER KENT MANUFACTURING COMPANY
4946 STENTON AVENUE Radio Dept. PHILADELPHIA, PA.

A New Member of the Pacent Plug and Jack Family

THE PACENT DUOJACK



This new Pacent Radio Essential, like all previous members of the Pacent Plug and Jack Combination, fills a definite existing Radio need. The Duo-jack enables

you to instantly convert an ordinary set equipped only with binding posts to a plug and jack set. It also facilitates connecting two pairs of phones or a loud speaker and headset to your receiver.

The illustration suggests many applications for this very ingenious device.

Cat. No. 53 Price \$1.50

The Pacent Duojack will be in production by October first, but dealers and jobbers are advised to place advance orders at the earliest possible date. Outline of the Pacent Sales plan upon request.

A device for every plug and jack need
Pacent Universal Plug
Pacent Standard and Automatic Jacks
Pacent Twinadapter
Pacent Multijack

Don't Improvise
Pacentize



Send for Descriptive Bulletins

Pacent Electric Company
INCORPORATED

150 Nassau St., CHICAGO
New York, N. Y. PHILADELPHIA
WASHINGTON

Artistic Variometer Parts

Wholesale only

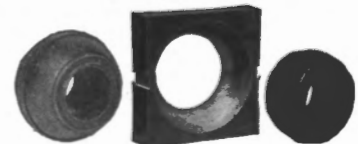

Variocouplers, Rotors, Winding Forms, Stators, in Genuine Mahogany. Quick Deliveries, write for prices.
Artistic Wood Turning Works
521 No. Halsted St., Chicago, Ill.

RADIO MERCHANDISE

F. D. PITTS CO.

Incorporated

219 Columbus Avenue, Boston, Mass., U. S. A.

Announces a Change of Policy
WHOLESALE ONLY



Distributors for

A. H. GREBE & CO. (New England)
 RADIO CORPORATION OF AMERICA
 GENERAL ELECTRIC COMPANY
 WESTINGHOUSE ELECTRIC & MFG. CO.
 WIRELESS SPECIALTY APPARATUS COMPANY
 MAGNAVOX COMPANY
 CLAPP-EASTHAM COMPANY
 WESTERN ELECTRIC COMPANY
 ACME APPARATUS COMPANY
 DeFOREST RADIO TEL. AND TEL. COMPANY
 FEDERAL TEL. AND TEL. COMPANY
 WM. J. MURDOCK COMPANY
 ADAMS MORGAN COMPANY
 PACENT ELECTRIC COMPANY
 CHELSEA RADIO COMPANY
 REMLER RADIO MFG. COMPANY
 FRANK A. D. ANDREA
 HERBERT H. FROST
 ELECTROSE MFG. COMPANY
 SIGNAL ELECTRIC MFG. CO.
 GENERAL RADIO COMPANY
 AMERICAN RADIO AND RESEARCH CORP.
 JOHN FIRTH AND COMPANY
 GENERAL APPARATUS CO.
 C. D. TUSKA COMPANY
 AMERICAN EVEREADY WORKS
 WIRELESS PRESS
 MURAD LABORATORIES
 DUBILIER CONDENSER COMPANY
 WESTON ELECTRICAL INSTRUMENT COMPANY
And Others

Dealers are urged to send for our latest stock sheets, listing desirable radio merchandise for immediate delivery at attractive discounts.

The Retail and Mail Order Business Formerly Conducted by The F. D. Pitts Co. at 12 Park Square, Boston, Mass., Providence, R. I., and Springfield, Mass., is Now Operated by the "Pitts Radio Stores, Inc.," at the Same Addresses

MODERN
RADIO OPERATION
J. O. SMITH

How Astounding Results Are Secured IN TRANSMITTING AND RECEIVING

EVERY RECEIVING AMATEUR can profit by the experience of J. O. Smith.

EVERY TRANSMITTING AMATEUR can gain a great deal through his new book, "Modern Radio Operation."

Practically all amateurs in America and many abroad have heard 2ZL and wondered how he gets his marvelous results. Those who have been privileged to go over this station, owned and operated by J. O. Smith, at Valley Stream, Long Island, have understood how the utterly unprecedented accomplishments of this station have been possible and have been able to secure greater efficiency from their own installations by operating them according to the principles used at 2ZL.

Mr. Smith's knowledge, his experience, his results, are available to everyone now. His book, just printed, places at everyone's disposal all the details of 2ZL, and of other famous continuous-wave transmitting stations, such as 1ZE, 8ZG and 9ZG (which were installed by Mr. Smith) and even of the well-known broadcasting stations WDY, WJZ and WGY.

J. O. SMITH knows how to put through long distance, two-way voice communication—he has done it. He knows how to get the greatest range in code work—he has been copied by many amateurs in Europe. Operating radio amateurs in all parts of the country have written him, by the hundreds, asking questions on one phase or another of tube transmission. They will welcome his new book, "Modern Radio Operation," for, until this book appeared, no one could ever profit fully by the work done at 2ZL. One could admire and wonder, and by mail or in person get a few pointers. Here, for the first time is the full

story, put into print so all can study it at leisure and use its data at will.

The book will increase every amateur's knowledge, enable him to arrange his set in the light of the most modern practices, save him time and money in purchasing equipment, and give him facts that will make his tubes last longer, increase the quality of his modulation, add many miles to his effective receiving or transmitting range. It discusses with particular clearness the comparative virtues of spark and CW transmission, and shows conclusively the superiority of the tube in range, clarity of reception, ease of eliminating interferences, and, what is to many the most important of all, low power consumption.

DO YOU KNOW

- the proper proportion of grid and plate currents in a transmitting tube?
- the proper proportion of plate current when not modulating to the normal full-load current when modulating?
- how to eliminate excessive plate current when no adjustment of the circuits will do it?
- the percentage of increase in output to be expected by the addition of one or more tubes to a transmitter?
- the advantages and disadvantages of transmitting circuits employing direct current on the plates; A. C., with half-wave rectification; A. C. with full-wave rectification, kenotron-rectified A. C.; and which type of circuit is the most economical and at the same time most efficient?

IF YOU DON'T—"MODERN RADIO OPERATION" WILL TELL YOU, and tell you in plain language that you will enjoy reading.

NO THEORY—NO MATHEMATICS NO FORMULAS

Just a straight story of the development and operation of the tube sets that made amateur history, written in everyday language that explains itself, by the man whose design and operation of 2ZL gave that station world-wide fame.

RECEIVING EXPLAINED—Chapter 4 is the most comprehensive yet published on receiving apparatus and is intended especially for those who are content to listen to the broadcast programs. It contains full details, with diagrams, of every type of set; crystal, honeycomb, regenerative with audio frequency amplification, and the radio frequency-detector-audio frequency set used on indoor loop antennas. There is even a summary of the super-regenerative Armstrong circuit, 100,000 times more sensitive than the usual hook-up.

LIST OF CHAPTERS

1. The Radio Telephone.
2. Transmitting Equipment Used in Radio Telephony and Its Operation.
3. Typical High Power Broadcasting Stations.
4. Receiving Equipment for All Purposes and Its Operation.
5. Spark vs. Continuous Wave Transmission.
6. Vacuum Tube Fundamentals.
7. Operating Characteristics of Vacuum Tubes.
8. Methods of Obtaining Plate Potentials, and Types of Continuous Wave Transmitters.
9. Continuous Wave Transmission by Amateurs.
10. Tube Transmitters in Commercial Work.
11. Advantages of a Counterpoise Ground in Connection with Tube Transmitters.

150 PAGES
OVER 50 ILLUSTRATIONS

ORDER BLANK

WIRELESS PRESS, INC.,
326 Broadway, New York.

I enclose \$..... Please fill my order as checked below:

..... MODERN RADIO OPERATION and *THE WIRELESS AGE for one year, \$3.75 (outside U. S. 50c. extra)

..... MODERN RADIO OPERATION, \$1.75.

Name

Street

City State.....

*If new subscriber check here.....

NOW READY

"Modern Radio Operation" is now ready for distribution. It is the most up-to-date volume on amateur tube operation ever published, and should be in every station. It will save you time and money, tell you how to get the maximum results with the minimum power, how to save tubes and how best to use the power that is available in your locality.

Price \$1.75

At any dealer, or send order direct to the publisher—

WIRELESS PRESS, Inc.
326 Broadway New York City

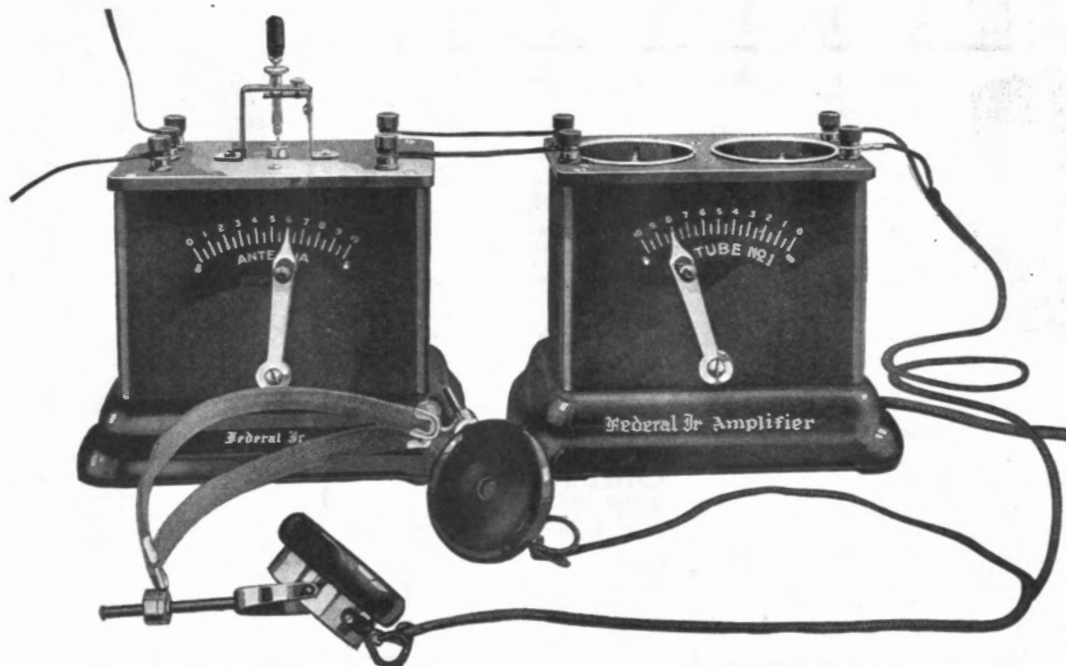

FEDERAL CRYSTAL RECEIVER

FEDERAL JUNIOR AMPLIFIER No. 20

Federal RADIO INSTRUMENTS ARE SUPERIOR

IN BEAUTY OF FORM AND FINISH, SIMPLICITY OF OPERATION, EFFICIENCY AND DURABILITY

THE **Federal** CRYSTAL RECEIVER, when used alone, is highly efficient for receiving radiophone programs in a clear—soft—pleasant tone, within a radius of 25 TO 30 MILES

With the addition of THE **Federal** JUNIOR AMPLIFIER this range is increased to 100 MILES

IF YOU HAVE A RECEIVER of any other type increase its efficiency by using

Federal HEAD TELEPHONES



YOUR RECEIVING SET IS ONLY AS EFFICIENT AS YOUR HEAD TELEPHONES

THE Federal BATTERY UNIT

is arranged to contain both "A" and "B" Battery in a most compact and convenient manner.

The metal container is beautifully finished—a style peculiar to

Federal APPARATUS and is in perfect harmony with ANY SETTING



FEDERAL BATTERY UNIT

The **Federal** Is a Name **Federal** Guarantee

Federal Telephone & Telegraph Co.

BUFFALO, NEW YORK

When writing to advertisers please mention THE WIRELESS AGE

PRICE REDUCTION OF TUBE SOCKET

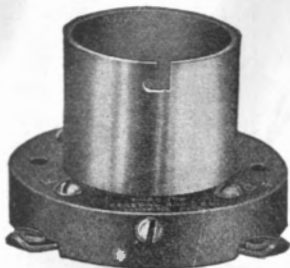

TYPE 156 SOCKET

The ever-increasing demand for our universal tube socket has enabled us to reduce the cost of manufacture and correspondingly the sale price. The same high quality of material and workmanship will be rigidly adhered to.

These sockets are adapted to any of the standard American four-prong transmitting or receiving tubes. They are adapted to the Western Electric VT-2 tubes, as well as to the Radiotron UV202 tubes. The contact springs are sufficiently rugged to carry the filament current of the five-watt transmitting tubes without arcing.

POSITIVE CONTACT SPRINGS
Rugged, Attractive, Reliable

PRICE \$1.25

Send for Free Radio Bulletin 911W

GENERAL RADIO COMPANY

MASSACHUSETTS AVENUE AND WINDSOR STREET

CAMBRIDGE 39

MASSACHUSETTS

Do not confuse the products of the GENERAL RADIO CO. with those of other concerns using the words "General Radio." The General Radio Co. has been manufacturing radio and scientific instruments for many years. It has no affiliation with any other company.

Standardize on General Radio Equipment Throughout

"TUNING IN"

To the right tune is very simple when your connections are soldered with the

NEW "POST SOLDERING IRON"

(The iron with the platinum heating unit)

Removable Soldering Tip



Designed especially to cover every requirement for delicate work.

The smallest practical-efficient instrument on the market.

Attached to any socket, Universal Current.

Fully Guaranteed.

From your dealer, jobber or write,

POST ELECTRIC COMPANY, 30 East 42d Street, Room 509, NEW YORK

(1/2 actual size)
List \$6.00

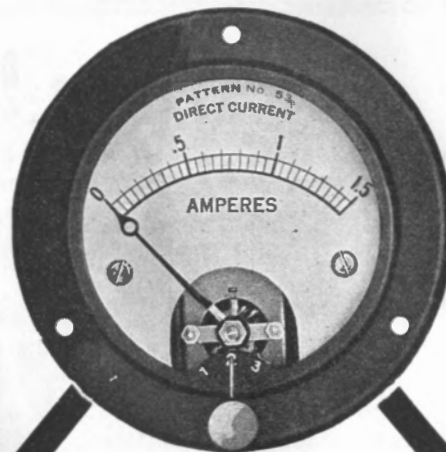

Triplex Filament Meter

Filament control by the use of proper instruments in receiving sets is the trend of the times. The Jewell triplex filament instrument, made as an ammeter or voltmeter, places on your panel the proper means for controlling the filaments of three tubes. It has a self-contained mechanism for switching to either tube and being of small size, can be accommodated on the most compact tube set.

Price \$10.00

We were the first to supply a complete line of miniature radio instruments of uniform size. Ask your dealer or write to us for complete radio circular.

Jewell Electrical Instrument Co.
1650 Walnut St. Chicago

BRACH vacuum LIGHTNING ARRESTER

The Highest Development in Radio Protection

Ordinary common sense will lead the average radio user not only to comply with the rules of municipal authorities to insure the safety of his radio equipment, but he will do it to make possible clear signals and enjoyable entertainment.

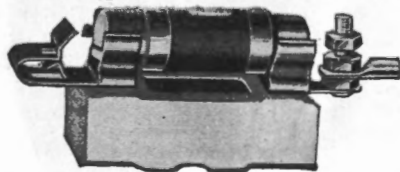

Indoor Type \$2.50

Listed by the Underwriters' Laboratories

L. S. BRACH MFG. CO., Newark, N. J.

MAKERS OF SOLDERBALL—Mends Metals; Connects Wires
COAST REPRESENTATIVES—Pacific States Elec. Co., San Francisco,
Los Angeles, Oakland, Seattle, Portland, Spokane.

The BRACH VACUUM LIGHTNING ARRESTER has demonstrated its superiority through over 16 years of service to the big railroad and telegraph companies, large fire alarm systems and the U. S. Army. It is built up to a standard—not down to a price.



Outdoor Type \$3

IT PAYS TO BUY Where You See This Sign—



find at shops displaying this sign.

Mr. Dealer:—Let us tell you about the Sorsinc Sign and how it will help you. Write us.

A COMPLETE stock; — a competent radio man in charge; — the Golden Rule in force— are what you

Ship Owners Radio Service, Inc.
80 Washington St.
New York
Wholesale Distributors

NEW YORK COIL COMPANY RADIO PRODUCTS ARE BUILT TO WORK—NOT JUST TO SELL

The leadership they enjoy is due to correct design, exceptional workmanship and eighteen years' experience in the manufacture of Wireless and precision electrical devices. There are no disappointments when these parts are used, that is why they are so much in demand with the builder, jobber and dealer.

Our Catalog will save you money. It's free

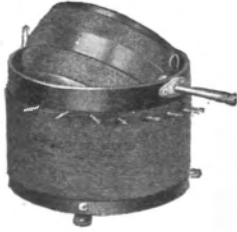

Price, \$4.00

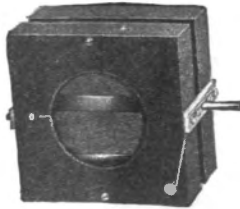

Price, \$4.00

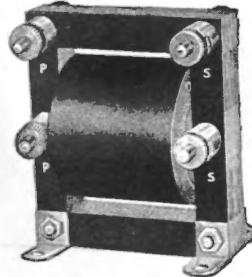

Price, \$4.00

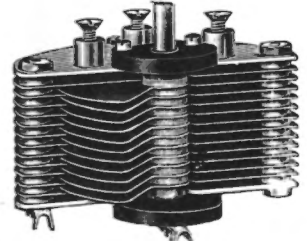

11 plate, price.....\$1.50
23 plate, price..... 2.00
43 plate, price..... 3.00
3 plate vernier..... 1.25

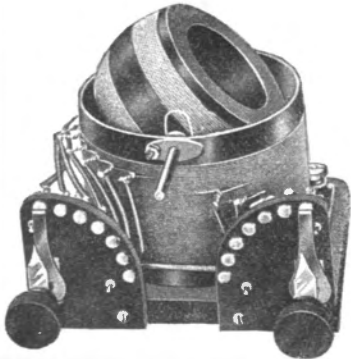

Mounted Vario-coupler for panel or table use, — but three holes in panel saves all laying out, drilling and soldering. — *nothing else like it.* Price \$8.00

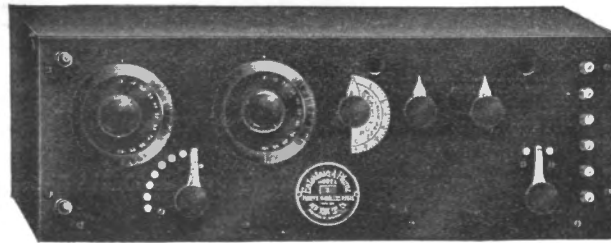

Entertain - a-phone Receiving Set No. 2 detector and two stages amplification. Price, \$50.00
Greatest value in radio.

NEW YORK COIL COMPANY, Inc.

338 Pearl Street

New York City, N. Y.

DUCK'S RADIO CATALOG No. 16 ²⁵⁶ PAGES

Continuously since 1909 Duck's Radio Catalogs have never been equaled for completeness and great wealth of radio data

Send 25c in coin carefully wrapped for your copy of this wonderful book, the most unusual and complete catalog ever put between two covers. Not sent otherwise. Enormous cost and tremendous demand prevent distribution at a less retainer.



Never in the history of radio has there been such a catalog. The radio data and diagrams embracing upwards of 50 pages give the experimenter more valuable and up-to-date information than will be found in many text-books selling for \$2; and \$1 could be spent for a dozen different radio catalogs before you could gather together the comprehensive listing of worth-while radio goods found in this great catalog.

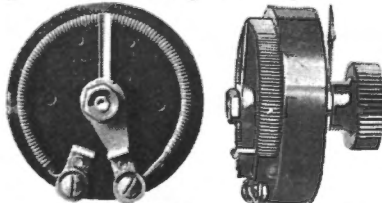

Our new No. A650 Duck Rheostat (shown above) has just the necessary amount of resistance to take care of the drop in voltage from the battery when fully charged to the battery at its minimum working voltage. The base is of moulded composition. The resistance element is wound on a black fibre strip, the element being securely fastened in a slot in the base. Contact arm is of phosphor bronze of the proper tension to insure perfect contact and smooth operation. Adjustable to any thickness panel up to 3/8 inch, 2 1/4 inches in diameter. An exceptional Rheostat at a most popular price. No. A650 Duck Rheostat, \$1. Shipping weight 8 oz.

No. A666 Duck's Positive Contact Bakelite Tube Socket (at right) is beyond doubt the most advanced tube socket on the market today. To our knowledge there is no other type of tube socket that cannot be forcibly criticized from some angle. Either the receptacle does not easily accommodate the varying diameter of the bases of bulbs, or the notch on receptacle is not just right, or the receptacle is easily subjected to breakage, or connections are in an inconvenient place, or, and most important of all, the type and style of the contacts do not insure positive, certain contact without considerable manipulation.

In our new socket all these defects in other bulbs are overcome. No. A666 Duck's Bakelite Tube Socket, \$1. Shipping weight, 1/2 pound.

Over 50 pages of latest hook-ups (wiring diagrams) and invaluable and up-to-date data and information on radio. Not only a catalog, but a wonderful text book on radio.

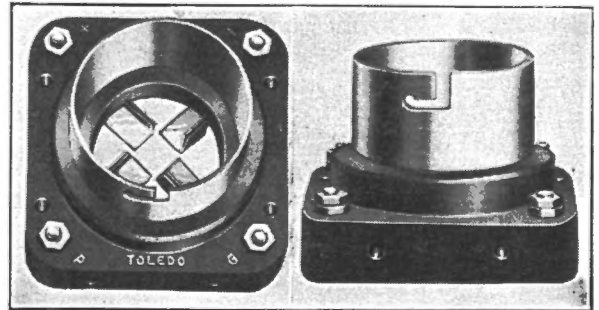

Our new moulded variometer (at right) speaks for itself. For a comprehensive description of the design and radio thought back of our variometers, we invite your attention to our exhaustive description in catalog. In prettiness of design, compactness and lightness of weight, we have not seen any variometer that we believe compares with ours. The forms, unlike many others, *positively will not warp.*

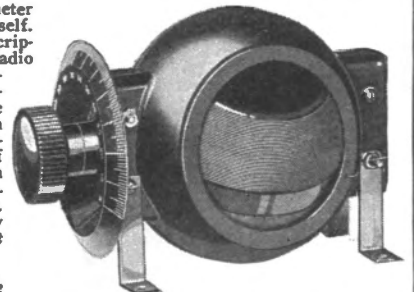

Duck's New Moulded Variometer

No. A900 plate variometer, with knob and dial, \$7.25
No. A901 grid variometer, with knob and dial, \$7.25

Note: If knob and dial are not desired deduct 75c.

There are many Duck products that completely dominate all competitive types. Duck Products have stood the test of time.

1909-1922

The largest line in America—62 COMPLETE INSTRUMENTS—58 PARTS.

DEALERS

We want live, responsible dealers in every city and town in the United States, both for the sale of our extensive line of radio apparatus and all other worth-while lines of radio goods, on all of which we can quote attractive dealers' discounts. We can offer you facilities and advantages that no other radio house can offer.

The WILLIAM B. DUCK CO., 239-241 Superior St., Toledo, Ohio

Give Your Radio Set the Advantage of
WESTINGHOUSE
 RADIO
BATTERIES

Westinghouse "A" Batteries are especially built for the peculiar requirements of radio work. They deliver a constant, dependable flow of low voltage current. They are built to give long, low-cost service. They demand a minimum of attention.



In the Westinghouse "B" battery you have a storage battery for "B" work—the latest development in radio practice. It has all the reliability and dependable performance of a storage battery and none of the disadvantages of a dry cell. The Westinghouse "B" gives a steady, continuous, noiseless service. It lasts indefinitely. When exhausted it is easily recharged. The first cost is the last cost.

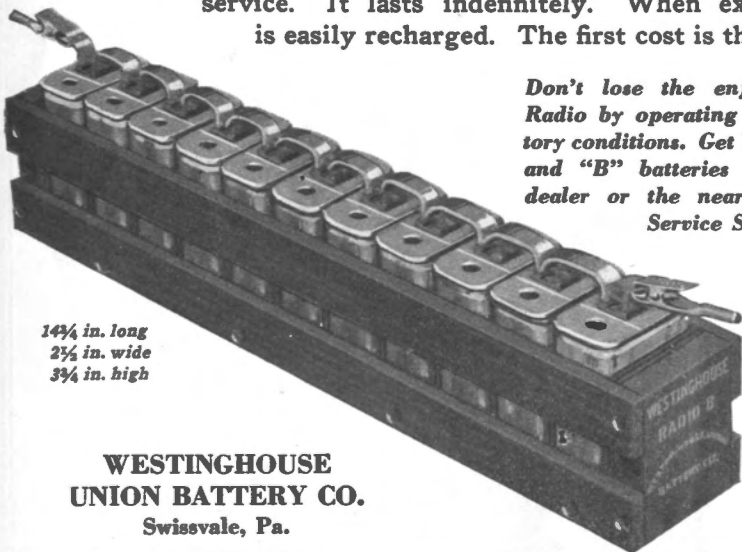

14 1/4 in. long
 2 1/2 in. wide
 3 1/4 in. high

WESTINGHOUSE
 UNION BATTERY CO.
 Swissvale, Pa.

Don't lose the enjoyment of your Radio by operating under unsatisfactory conditions. Get Westinghouse "A" and "B" batteries from your radio dealer or the nearest Westinghouse Service Station.

"The best Westinghouse can build."

NOVO
 "B"
BATTERIES FOR RADIO
 22 1/2 - 45 & 105 VOLTS

**NOISELESS
 DEPENDABLE
 GUARANTEED**
ASK YOUR DEALER
 NOVO MANUFACTURING CO.
 424-438 W. 33RD ST.
 NEW YORK
 531 SO. DEARBORN ST., CHICAGO.

35c. each 3 for \$1.00

Na-ald
Genuine Condensite Dial
The Dial that runs true

Numerals engraved on bevel and knob so shaped that fingers do not hide them. Thin edge with clear graduation to make accurate reading easy. Concealed set screw in metal insert. Will not warp or chip. Finish and enamel permanent.
 Low price with this quality only possible through automatic production methods.
 Special dealer and jobber proposition—an opportunity.
ALDEN-NAPIER CO.
 52 Willow Street, Dept. A., Springfield, Mass.

Head Receivers Keys Jacks
 Micro-Phones Plugs Etc.

**HIGH GRADE
 WIRELESS APPARATUS**
American Electric
 COMPANY
 State and 64th Streets, Chicago, U. S. A.

**AMATEUR
 RADIO
 DIRECTORY**
 AND CALL BOOK

2nd Edition Now Ready for Delivery

A complete UP-TO-DATE list of American Amateur Stations.
 A complete UP-TO-DATE list of Broadcasting Stations and Special Stations.
 Notes on Construction of Receiving Set and Calibration of Receiving Set without the use of Wavemeter.

Price \$1.00

Dealers write for prices

WIRELESS PRESS, 326 Broadway, New York



4 People for \$5

THAT'S what the Radisco Phonoscope means to your radio receiving set. Four people can listen in on a crystal or audion set, where only one could before with ordinary head phones. Since head phones cost from \$5 to \$15 each, the expense for phones to let the whole family listen in would be from \$20.00 to \$60.00 or more. The Radisco Phonoscope allows four people to listen in as easily and clearly at a cost of only \$5. Briefly, this is the way it works. A receptor is provided into which one receiver of your present head set can be automatically inserted.

The signals received by your head set will then be transmitted through pure para rubber tubing to the four listening ends of the Phonoscope itself.

Sold by the Radio Distributing Company and its agents throughout the country. If your dealer cannot supply you, send money direct with name of dealer. Money gladly refunded within 15 days if you are not perfectly delighted with the results you secure. 10 cents to cover mailing charges will bring you a copy of the new Radisco Radio Catalog. The Radio Distributing Company, Newark, N. J., U. S. A.

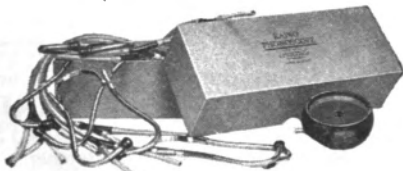

Radisco Phonoscope
Price \$5



Radisco Heliophone (Pocket receiver)
Price \$5

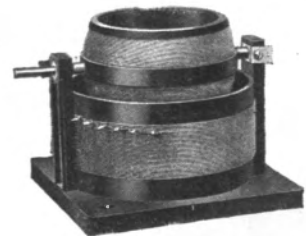

Radisco Vario-coupler
Price \$6.50

RADISCO RADIO PRODUCTS

When writing to advertisers please mention THE WIRELESS AGE

The Latest Developments

HOWARD MICROMETER ADJUSTMENT RHEOSTAT

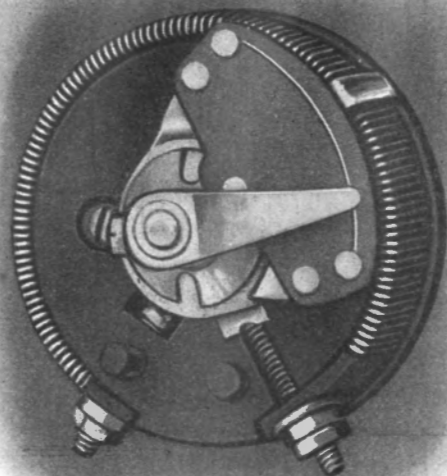

PATENT PENDING

Rheostats are used in many different ways—but for the user for radio purposes we have just what he has longed for—a MICROMETER adjustment RHEOSTAT with ONE KNOB CONTROL and INSTANTANEOUS ADJUSTMENT of the micrometer portion as well as the coarse adjustment.

Less than one turn of the knob gives complete control of the main as well as the micrometer portions of the rheostat. The delicate balance so necessary for the most efficient operation of gas content detector tubes is therefore readily obtained. PRICE, \$1.50.

Micrometer Attachment

(Patent Pending)

As shown on the rheostat above has been so designed that it may be placed on our regular rheostats now in service. PRICE, 50 CENTS.

Special Micrometer Rheostat Dial

(Patent Pending)

We manufacture a special dial for use with the micrometer rheostat and attachment which indicates the resistance in the circuit. PRICE, 25 CENTS.

HOWARD MULTI-TERMINAL TELEPHONE RECEIVER PLUG

(Patent Pending)

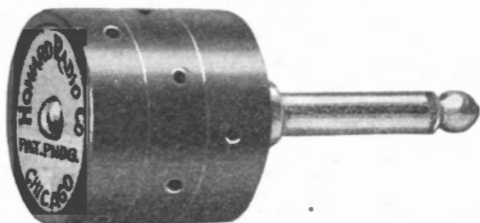

This new plug provides positive connections for standard receiver terminals instantly. From one to six pairs of receivers may be accommodated in such a manner that the maximum electrical efficiency is assured. Series, parallel, and series parallel combinations are instantly available without the use of tools. PRICE, \$2.00.

ASK YOUR DEALER

Liberal Discount to the Trade

HOWARD RADIO CO., Manufacturers and Jobbers 4248 North Western Ave., Chicago, Ills., U.S.A.

Let the Buyers of the Country see your Products at the

Permanent Radio Fair

(Under personal direction of R. F. Yates, Radio Editor New York Evening Mail.)

At the Hotel Imperial, New York

The Permanent Radio Fair is a centralized exhibit of reliable merchandise assembled for the benefit of buyers and the general public—the Bush Terminal Plan applied to the Radio industry. Following is a partial list of the space holders—

- Dubilier Condenser and Radio Corp.
- De Forest Radio Telephone and Telegraph Co.
- Radio Corporation of America.
- A. H. Grebe & Co., Inc.
- Multiple Storage Battery Co.
- Paent Electric Co.
- C. Brandes, Inc.
- Signal Electric Co.
- Jewett Mfg. Co.
- Horne Mfg. Co.
- Hopewell Insulation and Mfg. Co.
- Post Electric Co.
- Federal Telephone and Telegraph Co.
- Arrow Radio Co.
- W. E. Supply and Spec. Co.
- Victor Radio Corp.
- Mercury Radio Corp.
- Man-Day Radio Corp.
- Radio Laboratories of N. J.
- Radio Winding Corp.

Space rentals range from \$1.00 to \$3.00 per day. Wire or write for applications and literature. Space is not guaranteed to any applicant. Fair open in morning to buyers only. General public in afternoons and evenings. Runs from September 30th to May 30th. Minimum time one month.

PERMANENT RADIO FAIR, Inc.

HOTEL IMPERIAL

Broadway and 32d St. New York, N. Y.

Saves time, labor and is accurate

"PREPARED RADIO MEASUREMENTS"

By R. R. Batcher
Price \$2.00

WIRELESS PRESS, Inc.
326 BROADWAY NEW YORK

If you use Amplifying Tubes



you can make your Victor talking machine a RADIO LOUD SPEAKER, with a "Beeko" Radio-Phono attachment.

Sample by mail, 40c.

Liberal discount in quantities.

J.H. BUNNELL & CO.
32 Park Place, Dept. W
NEW YORK



JEWELL Lightning Arrester

Approved by Underwriters' Laboratories, latest Code. Carbon block types (not vacuum type) using a brown glazed porcelain case which can be installed inside or outdoors. Carbon block arresters have been standard in Railway signal and telephone protection for over 20 years. Ask your dealer or write us for special circular.

Price \$1.10

Jewell Electrical Instrument Co.
1650 Walnut Street Chicago

Radak Parts are leaders in their lines

Trade Mark Reg. U. S. Pat. Off.

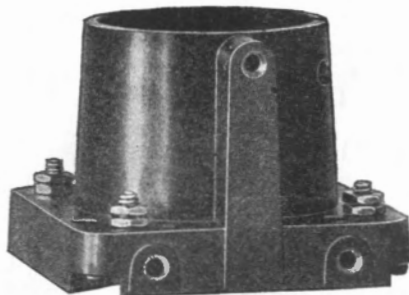

Type HT

RADAK UNIVERSAL TUBE SOCKET
Moulded in One Piece

Made of condensite, without the usual objectionable metal tube. Designed to mount easily on back of panel, requiring neither shelf nor brackets. Quickly screwed to any flat surface. Binding posts on base. Also holes outside each contact spring for using soldered connections. Fills a great need of the amateur.

Price complete, \$1.00

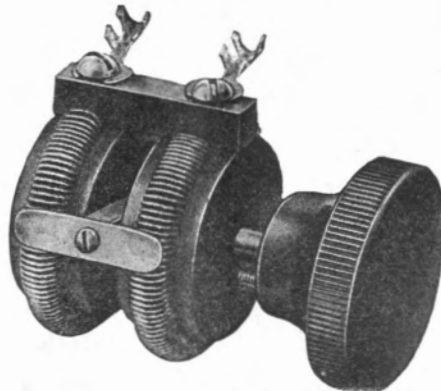

Type H400

RADAK FILAMENT RHEOSTAT
Economizes Panel Space

Unique Clapp-Eastham twin-construction design, insuring economy of space and freedom from tube noises. Current conducted from two sliding contacts—rather than through bearings—going direct to ends of wire attached to terminals. Requires space of only 1 1/2 in. diameter by 1 1/2 in. depth.

Price complete, \$1.35

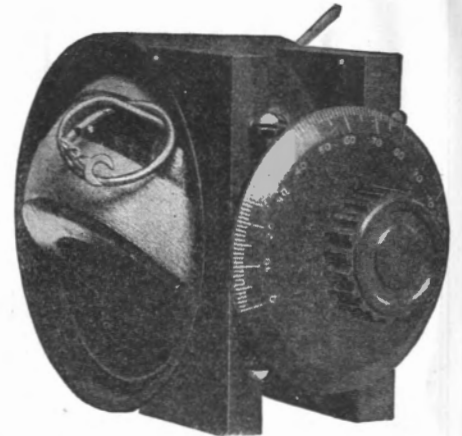

Type H. R. V.

RADAK VARIOMETER
Cuts Down Dielectric Losses

Ball of hollow moulded hard rubber; outer shell of bakelite. Inner winding firm on ball. Outer winding formed in section of sphere. Clearance small, giving wide range of wave-length. Dielectric material reduced to minimum. Unusually long inductance range for size of instrument. May be rotated continuously without breaking contact. Furnished with 3 in. dial and knob.

Price complete, \$6.50

Each of the parts shown separately here is one good reason why Radak Receiving Sets are giving such satisfaction. Each embodies the long experience of the Clapp-Eastham Company, and is a unit used in Radak

sets. Sold separately for the benefit of amateurs who construct their own sets. A Radio Catalog showing other parts, as well as the latest Radak Receiving Sets, 6 cents.

CLAPP-EASTHAM COMPANY, OLDEST AND LARGEST MAKERS OF RADIO EQUIPMENT EXCLUSIVELY. ESTABLISHED 1906
101 MAIN STREET, CAMBRIDGE, MASS.

'RED-HEADS'



A Triumph in Radio Receiver Design

3000 ohms, complete with cord and military head-band.

—NOW
\$6.50

At the new price of \$6.50 per pair, "Red-Heads" represent today's biggest value in radio headsets

"Red-Heads" Will be the Popular Receivers This Season

For sensitiveness, for mechanical perfection and for durability, "Red-Heads" easily surpass any 'phones ever offered at anything like the \$6.50 price. Their genuine merit has created a country-wide demand for "Red-Heads." The new low price will vastly increase their popularity everywhere.

The Newman-Stern Bldg.

The Newman-Stern Co

Cleveland, Ohio

N.B.

Have you observed how the Teagle line of radio products is coming to the front? "Demonstrated merit" is the reason. We are the producers of Teagle Rheostats, Sockets, Condensers, Detectors, Crystal Receivers, Adaptafones, etc. Like Newman-Stern "Red-Heads," they give the utmost for the money and the maximum of satisfaction. They must. For like our "Red-Heads," they're fully guaranteed.



SPECIFICATIONS

EACH "Red-Head" receiver is wound to 1500 ohms (3000 ohms per pair) with highest quality electrolytic copper on accurately ground pole pieces attached to the best magnet steel procurable for the purpose. Machine-finished aluminum backs with strain posts and nicked binding posts. Ear caps of scientific design, moulded from our special red-brown composition, comfortably fitting the ear. High quality, fully adjustable military type head-band with seamless tape binding. Green mercerized cord. Careful workmanship and distinctive appearance. *Fully guaranteed.*

It's a Fact That—

"RED-HEAD" 'Phones at \$6.50 are the lowest priced, high-grade, 3000-ohm aluminum cup receivers on the market. The new price is possible only because of greatly increased production and cleverly improved facilities. *Not one iota of quality has been sacrificed.*

"NAA" Detector Crystals

"Known and used the world over"

THESE are the original tested detector minerals. There are many imitations, but they only mean "interference" with good results. The genuine "NAA" are distinguished by their tested sensitiveness—remember that!—and by the name "J. S. Newman" on each box.
"NAA" Galena, Silicon or Goldite,
per crystal 25c
Mounted, set in Woods metal in brass cup, per crystal..... 40c

RADIO INSTITUTE OF AMERICA

(Formerly Marconi Institute)

America's Foremost School

Devoted to the Practical Science of Wireless Telegraphy and Telephony

RESIDENCE SCHOOL

A systematically organized course of instruction on radio apparatus of all types and models—SPARK—ARC—C.W.—I.C.W. and telephone. The Radio Institute of America is the most completely equipped of any radio school in the United States and offers sound practical training at the smallest cost.

The Radio Institute of America has been an established and successful institution for over fifteen years. It has trained over 6500 men, 95% of whom have successfully engaged in this new branch of science and industry.

Afternoon and evening classes are conducted throughout the entire year.

Prominent executives in the radio field are former students of the Institute. The Radio Corporation employs thousands of men in its executive departments, its factories and laboratories in addition to those employed as wireless operators on shipboard. A large percentage of these men are graduates of the Institute.

HOME STUDY DIVISION

The home course of radio training which has been developed for the benefit of those who cannot attend the Institute personally, is the same course used at the Institute. It includes everything from basic principles of electricity and magnetism to actual operation of commercial radio equipment, including arc and tube transmitters. It also includes the same text books used in the Institute classes, as well as a buzzer set of greatly improved design with a variable automatic transmitter for code practice. A three weeks Post-Graduate course in the New York Residence school is given without extra charge to students of the Home Study Division.

The graduates of the Radio Institute of America enjoy a great and exclusive advantage in the close connection existing between the Institute and the Radio Corporation of America, the world's largest radio manufacturing and commercial radio company.

You, too, can be successful in this new field if you properly train yourself by means of the Course given by the Institute. Qualified radio men are assured of an unlimited opportunity for future advancement.

Information on either the Residence School or Home Study Division will be gladly sent upon request. Address all communications to Director—

RADIO INSTITUTE OF AMERICA

326 BROADWAY

NEW YORK, N. Y.

BRANCH RESIDENT SCHOOL

New Call Building, New Montgomery Street, San Francisco, Cal.

\$10⁰⁰

At **FIRST CLASS DEALERS**



\$11⁵⁰

WITH **PLUG ATTACHED**

The perfected product of a scientific organization with over 30 years' outstanding leadership in the telephone world.

Automatic Electric Head Sets are designed with a powerful single pole electro-magnet, and a complete soft iron magnetic path. Both weak and strong signals are reproduced with maximum clearness and entirely without distortion or foreign noises, whether used with crystal, V. T. detectors or multi-stage amplifiers.



The Automatic Electric Head Sets are made only in one style and resistance—the very best! Resistance has been subordinated to a definite scientific design which gives the best results under all conditions

It is safer to patronize the dealer who handles the Genuine Automatic Electric Head Sets

Automatic Electric Company

ENGINEERS, DESIGNERS & MANUFACTURERS OF THE AUTOMATIC TELEPHONE IN USE THE WORLD OVER
HOME OFFICE AND FACTORY: CHICAGO, U. S. A.

Let Your Apparatus Speak for Itself

AMERICAN RADIO EXPOSITION

- A national exposition for radio manufacturers, dealers, inventors and amateurs, covering the entire field of radio.
- A complete exhibition of apparatus, accessories and materials.
- Daily demonstrations, broadcasting, lectures, orchestral concerts, Grand Opera artists in person—motion pictures illustrating practical uses of radio and the principles of its operation.

To be held at

Grand Central Palace

46th St. to 47th St. & Lexington Avenue

- The heart of the great terminal zone, close to the busiest shopping districts.

NEW YORK CITY

DECEMBER 21st to 31st, 1922

- Schools and colleges will be closed, making it convenient for young folk to attend. To these young people the magic of radio makes a specially strong appeal.

Manufacturers and dealers should contract for space now
Address inquiries as to rates, etc., to

AMERICAN RADIO EXPOSITION COMPANY

120 Broadway, New York City

Telephone, John 0009

Educational and Interesting

Burgess, the *Radio Battery* —construction fully patented

When you buy a Burgess "B" Battery you get more than long life, noiselessness, high capacity and moderate price. You get also Burgess special radio construction, perfected by wireless specialists and fully patented! This exclusive *radio* construction is found in no other battery on the market today.

Leading manufacturers of radio equipment specify "Burgess." Burgess "B" Batteries are handled by all progressive jobbers and dealers. "Look for the Black and White Stripes." And if your dealer doesn't handle Burgess "B" just address:

BURGESS BATTERY COMPANY
Engineers—Dry Batteries—Manufacturers

Offices and Warehouses at:

CHICAGO, ILL., 111 W. Monroe St. KANSAS CITY, MO., 2109 Grand Ave.
ST. PAUL, MINN., 2362 University Ave. BOSTON, MASS., 136 Federal St.
NEW YORK, N. Y., 50 Church St. MADISON, WIS., Main and Brerly Sts.

In Canada: BURGESS BATTERIES, Ltd.
Winnipeg, Toronto, Montreal

BURGESS

"B" BATTERIES

"ASK ANY RADIO ENGINEER"



LEARN THE CODE AT HOME WITH THE OMNIGRAPH

"Just Listen—The Omnigraph will do the teaching"

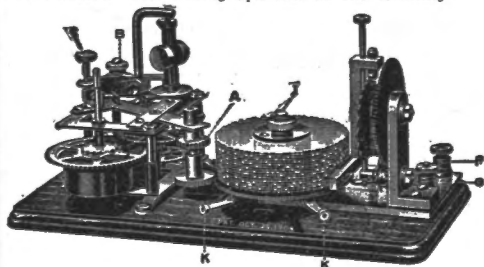

THE OMNIGRAPH Automatic Transmitter will teach you both the Wireless and Morse Codes—right in your own home—quickly, easily and inexpensively. Connected with Buzzer, Buzzer and Phone or Sounder, it will send you unlimited messages, at any speed, from 5 to 50 words a minute.

THE OMNIGRAPH is not an experiment. For more than 15 years it has been sold all over the world with a money back guarantee. The OMNIGRAPH is used by several Depts. of the U. S. Govt.—in fact, the Dept. of Commerce uses the OMNIGRAPH to test all applicants applying for a Radio license. The OMNIGRAPH has been successfully adopted by the leading Universities, Colleges and Radio Schools.

Send for FREE Catalog describing three models, \$14 to \$30. DO IT TODAY.

THE OMNIGRAPH MFG. CO.
16A Hudson St. New York City

If you own a Radio Phone set and don't know the Code—you are missing most of the fun

"Is the Product Right?"

It is a maxim of advertising that a poor product cannot be successfully advertised. It may flash upon the scene with brilliance, become the talk of the hour, and to all appearances be destined to set new records, but unless it is and does what is claimed for it, no amount of printer's ink and artist's colors can give it permanence.

Once in a while some article of merchandise will appear to defy this rule, but not for long. Public response, at first, perhaps, quick and active, becomes slower and slower. Sales fall off. The business grows sick, and in a few months or a few years, the very name of the product is forgotten.

Advertising men know this so well that today the first question upon which they must be satisfied before they will recommend advertising to any manufacturer is—Is the product right?

And merchandise that is right—merchandise that will satisfy in service—merchandise that will bring customers back for another purchase is the first requirement of the jobber and the retailer who expect to endure and flourish.

* * *

There is no better assurance of this kind of merchandise than an advertising pledge to the public.

[Published by THE WIRELESS AGE in cooperation with The American Association of Advertising Agencies]

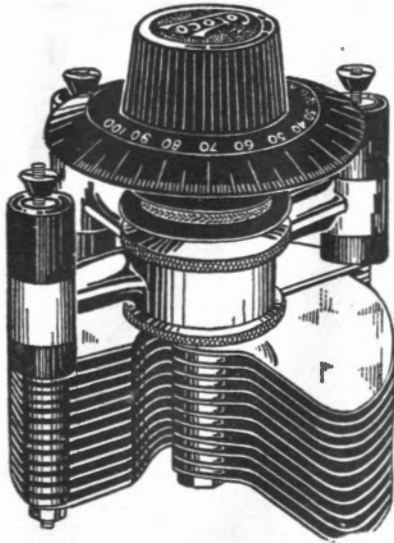

Cotoco

TRADE MARK REG. U. S. PAT. OFF.

Variable Air Condenser

Made by the originators of the Honeycomb Coil and of the Tapped Type Amplifying Transformer for Radio Frequency that has just about eliminated Static troubles. As superior in operation as it is in appearance.

Buy Radio by the Name Cotoco

Static Defeated Loop Aerials Available to All

Cotoco Tapped Amplifying Transformer for Radio Frequency has exceeded all expectations in overcoming static. Write for FREE Connection Diagram for Loop Aerial set giving name of your dealer.

Ask for it. It's Free.

Coto Coil Co.

87 Willard Ave. Providence, R. I.

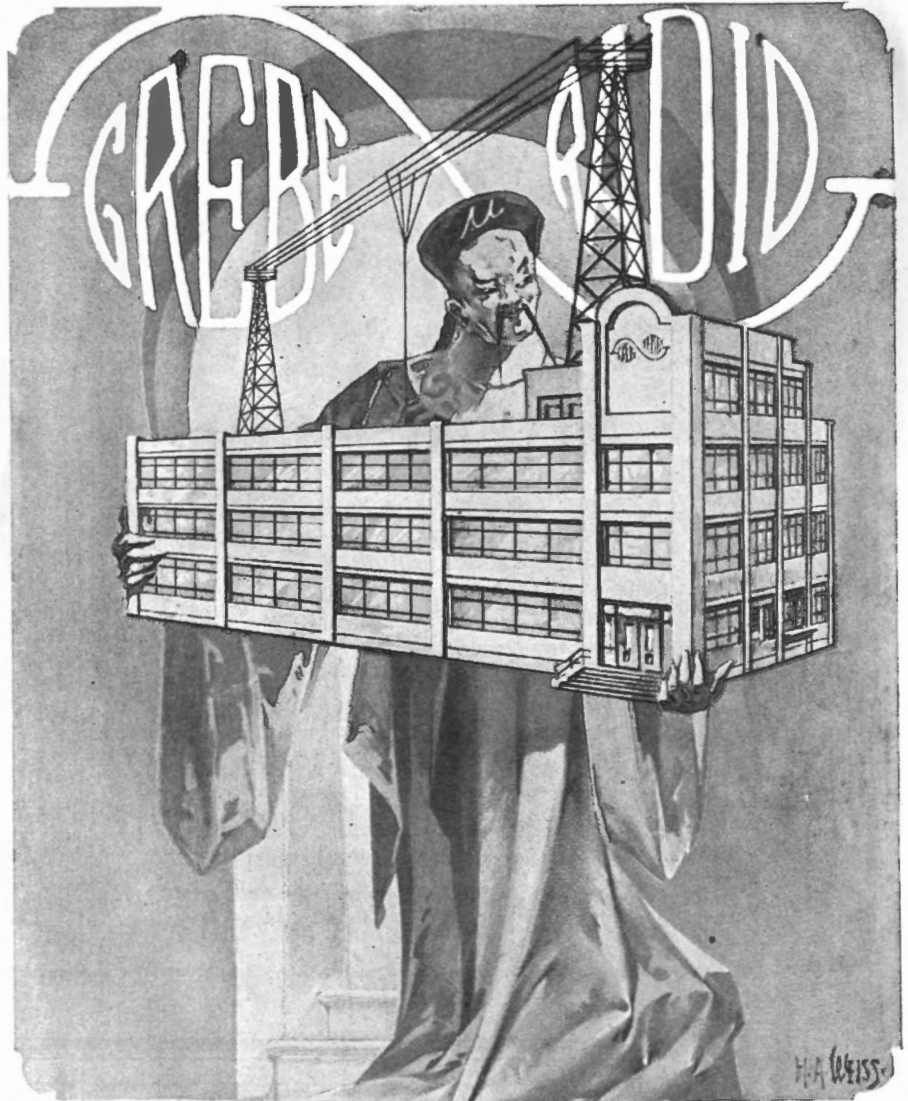

"TREASURES OF GOLD AND JADE SAID LAO TZU, DESERVE A PROPER DWELLING!"
"GREBE RADIO IS NOW HOUSED IN A MANNER BEFITTING ITS EXCELLENCE."

Doctor Wu



SEND FOR THIS BOOKLET TODAY

Radio a Profitable Profession

On ships radio operators get good pay, have wonderful opportunities for travel and are treated as officers. On land there are an increasing number of good positions open to trained men as operators or with companies manufacturing and selling radio apparatus.

We have trained thousands of successful men for jobs like these. Let us train you. Complete course covering

ARC, SPARK and VACUUM TUBES

Y. M. C. A. RADIO SCHOOL

149 East 86th Street

New York City

"The Best Radio School in the East"



Result of 14 years' experience

"As good as Brandes"

ONLY if a headset bears the name Brandes can it be "as good as Brandes." And genuine Brandes *Matched Tone* headsets cost no more than less sensitive and less rugged imitations.

Send ten cents in stamps for the "Beginner's Book of Radio," which explains radio in terms that anyone can understand.

Distributors and District Offices:
 Munsey Bldg., Washington, D. C. 76 Pearl St., Boston, Mass.
 33 S. Clinton St., Chicago, Ill. 709 Mission St., San Francisco, Cal.
 International Electric Company, Wellington, N. Z.

C. Brandes, INC

Matched Tone Headsets

237 Lafayette St., New York

Made in Canada by Canadian Brandes, Ltd., Toronto
 Distributed by Perkins Electric, Ltd., Montreal

SMALL ADS OF BIG INTEREST

A MEETING PLACE FOR BUYERS AND SELLERS

Space in this department costs only 65 cents a line. Minimum space seven lines. Payable in advance.

INVENTORS: Protect your invention through A. M. Wilson, Inc., Washington, D. C. Over 20 years of efficient, expert, confidential service. Skilled in Radio-Electrical, Chemical, and Mechanical fields. Our 1922 Illustrated Booklet, giving much necessary and very useful information which every inventor should know, will be sent free upon request. Prompt and careful attention. Highest references. Moderate fees. Send sketch or model for our careful opinion and preliminary advice. Write today to A. M. WILSON, INC. (Radio 3 ARH), 312-18 Victor Building, Washington, D. C. (Successor to business established in 1891 by A. M. Wilson.)

LIGHTNING—Wonderful new Electrolyte charges discharged batteries instantly. Eliminates old Sulphuric Acid method entirely. World has waited half a century for this invention. One gallon, retails \$10.00, free to agents. LIGHTNING CO., St. Paul, Minn.

Jenkins Vernier Rheostat



Indispensable for adjustment on Radio Frequency and Detector Tubes. Patent instant cut-off switch.

\$1.75

Write for folder.

Liberal Discounts to Dealers and Jobbers

J.E. Jenkins Not Inc.
 59 E. Van Buren St.
 CHICAGO



THE SYMBOL OF SERVICE

CONTINENTAL

"New York's Leading Radio House"

For the Wireless Sage of the Wireless Age

THIS CLAPP-EASTHAM SET



Consisting of a Type HR Regenerative Receiver and a Type HZ Two Stage Amplifier. Uniform in size, polished mahogany. Strong, clear tone, simple tuning, utmost reliability. Complete with Federal Telephone Head Set, Magnavox Loud Speaker, Antenna Equipment, all Tubes and Batteries, \$177.50. Glad to write or show you all about it.

"Modern Radio"—a new two hundred and eight page catalogue of our wireless equipment, supplies and apparatus sent for thirty-five cents.

2006-Q

CONTINENTAL RADIO & ELECTRIC CORPN.

6 and 15 Warren Street

New York, U. S. A.

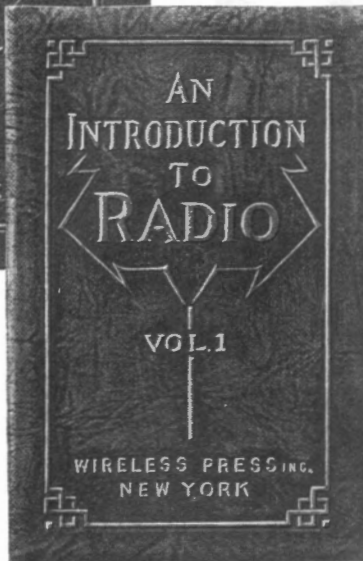
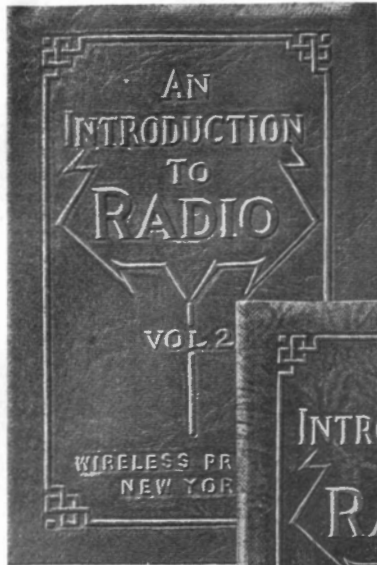

2 Volumes
 Size 3 1/8 x 5 inches
 Flexible Leather Covers
 Fully Illustrated
 96 pages in each volume
 Price 2 Vols. **\$1.00**

Personally Selected Books for the Beginner

When the Radio Craze swept the country manuscripts for beginners' books, hastily prepared, were submitted to us by the score.

None Met Our Standards

Some obviously were written by authors of too little knowledge. Others were incomplete or written in language too technical for the novice.

We rejected all manuscripts until

An Introduction To Radio

was offered to us

Here at Last Was a Real Book for the Beginner

J. Andrew White, Editor of the WIRELESS AGE, read it through page by page. He liked it—the language was not too technical—the illustrations were carefully selected—the diagrams right—and the information was really comprehensive. He passed it on to me—I felt just as he did, and then—he put it up to J. O. Smith, of "2ZL" fame, for his

opinion. "J. O." came back with an emphatic endorsement of the book. He said, "this is the manuscript we have been waiting for. It is what thousands of beginners have been waiting for and it's up to us to give it to them." Then we tried it out on some of our novice friends and they said it was easily understandable.

So Here Is the Book—In Two Volumes—Handy Pocket Size

List of Chapters: Chapter 1—An Introduction to Radio. Chapter 2—Radio Telephony. Chapter 3—The Various Instruments Used in Radio Transmitting and Receiving Outfits. Volume 2. Chapter 4—Technical Terms Explained. Chapter 5—How To Set Up Receiving Outfits. Chapter 6—Primer of the Vacuum Tube. Chapter 7—How To Set Up Radio Transmitters.

Your Money Back If You're Not Pleased

I want you to examine these books because I know they are what you want. Pin a dollar bill or check to the attached coupon. If the books are not just as represented return the books within 5 days and we will send your money back at once. Or go to your dealer and have him order them for you.

DEALERS—Get Your Order In Quick

J. H. Weeks
 Sales Manager

WIRELESS PRESS, INC., New York City

ORDER BLANK

WIRELESS PRESS, INC., Date
 326 Broadway, New York.

Here's my dollar. Send me AN INTRODUCTION TO RADIO. If I don't like the books I'll return them in 5 days and get my money back.

Name
 Street
 City
 State

SPECIAL OFFER

For \$3.00 we will send you these books and THE WIRELESS AGE for a year (outside U. S., \$3.50). This saves you 50c. If you want to grasp this opportunity check one of the squares below.

New Subscriber I am now an AGE subscriber

THE THORO-BRED DIAL, Type CD-5. This "raised axis" keeps the edge of the dial 1-64 in. from your panel at all times, effecting easy operation and no scraping of panels. Combining all features essential to perfect operation without friction and other difficulties. One of the indispensable trio. Price 90c.

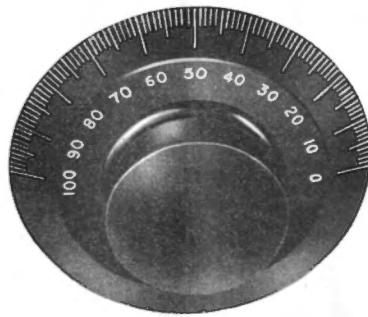

THE THORO-BRED RHEOSTAT Type R-90. Has a resistance of five ohms. No vernier adjustments necessary. Adaptable for either table or panel mounting. Silver plated, highly polished. One of the indispensable trio. Price \$1.10.

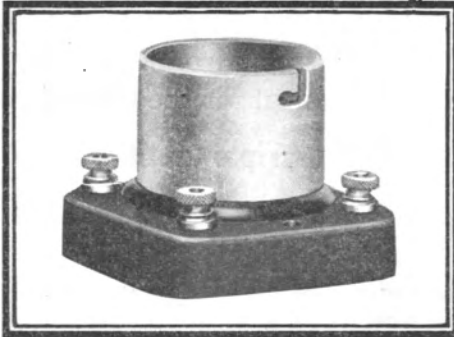

THORO-BRED TUBE SOCKET, Type S-12. Base of molded bakelite which, unlike ordinary shellac compositions used, reduces leakage to a minimum. Price \$1.00.

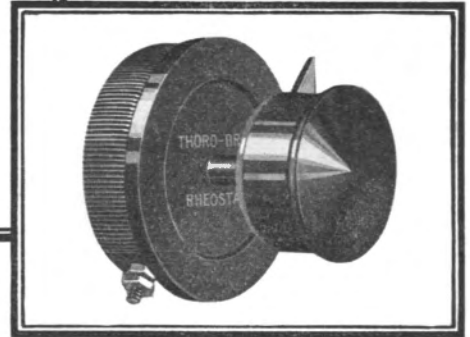

The Indispensable Trio

THE Thoro-bred Rheostat, Dial and Vacuum Tube Socket are an indispensable trio for every tube set. Without these three you will not know the best results your receiving set can give. Here's why.

The Thoro-bred Rheostat

enables you to secure the maximum detector action through its extremely close adjustment of the filament control. It has a resistance of five ohms, which eliminates the use of a vernier adjustment, since the resistance of one of its turns of wire on the resistive element is so small that the effect is not noticeable on the tube. All metal points are silver plated. It is adaptable for either table or panel mounting. Molded parts are of Bakelite. Knob is supplied with pointer and is of the same design as the dial. Patent applied for. Price \$1.10.

The Thoro-bred Tube Socket

is the second of this indispensable trio. The tube insert is of brass, heavy nickel plated with

high polish. The base is of molded bakelite, making it possible to withstand high heat. The leakage from the grid to the filament is reduced to a minimum. Bakelite used in the Thoro-bred Socket does not absorb the moisture or cause the leakage as in other sockets employing the common shellac composition. It gives a better appearance and holds the original finish. Price \$1.00.

The Thoro-bred Dial

was the first genuine Bakelite dial to be offered with both Clock-wise and Counter-Clock-wise Readings. This dial was also the first to introduce the popular "raised axis" which eliminates all panel scraping and friction and permit easy operation. The brass insert employed, does away with any wobbliness that might otherwise develop. Patent applied for. Price 90c. The indispensable trio can be obtained at your nearest dealer. If, for some reason he is not already supplied, send us his name and your money direct.

THE MARSHALL-GERKEN COMPANY
TOLEDO, OHIO, U. S. A.

Thoro-bred

RADIO PRODUCTS

When writing to advertisers please mention THE WIRELESS AGE

Amateur Radio Stations of the United States

Supplementary List brought up-to-date from September WIRELESS AGE

First District

RE-ISSUED.

- 1 AEA Joseph A. Sjogren, 33 Malthy Pl., New Haven, Conn.
- 1 AEC R. B. Brown, Jr., 7 Winslow St., Plymouth, Mass.
- 1 AFB Nathaniel H. Colby.....New London, N. H.
- 1 AFQ F. W. Steitz, 18 Jackson St.....Holyoke, Mass.
- 1 AFT Greeman A. Bedley, 75 Howard St., Reading, Mass.
- 1 AFU R. C. Lincoln, R. F. D. 3, Box 132, Attleboro, Mass.
- 1 AFW R. R. Noble, 48 Laney St.....Pittsfield, Maine
- 1 AFX A. Whitman, 73 Payne St.....Quincy, Mass.
- 1 AGF John H. Braun.....Branford, Conn.
- 1 AGP T. J. Gridley, 63 Hollywood St., Springfield, Mass.
- 1 AGV M. H. Allen, 21 Highland Ave., Watertown, Mass.
- 1 AGX Urie E. Doval, 72 Russell St.....Worcester, Mass.
- 1 AHH Joseph May, 23 Stowe Ave.....Milford, Conn.
- 1 AHI D. R. Holbrook, 101 School St., Cliftondale, Mass.
- 1 AHK John B. Whitelaw, Windfield Farm, No. Stonington, Conn.
- 1 ARM Henry B. Joy, "Treasure Hill".....Watch Hill, R. I.
- 1 AHS J. J. Lefevre, 33 Linden St., Springfield, Mass.
- 1 AHV C. W. Koehler, 960 Main St., Holyoke, Mass.
- 1 AIA John C. Phipps.....Christmas Cove, Maine
- 1 AIC L. V. DeVine, Hatfield St., Northampton, Mass.
- 1 AIK Charles W. Gamage, Maple St.....Lynn, Mass.
- 1 IBB Lloyd C. Kenfield, 374 Massachusetts Ave., Boston, Mass.
- 1 CHQ Eugene Ronson, State Road.....Scotland, Conn.
- 1 CQW George N. Rang, 82 Mill St., Newport, R. I.
- 1 VV J. G. Barrett, Jr., 674 E. 2nd St., So. Boston, Mass.

CHANGE OF ADDRESS.

- 1 AAO Reginald F. Chase, 1289 Massachusetts Ave., Arlington Heights, Mass.
- 1 AUW S. O. Need, 366 Townsend Ave., New Haven, Conn.
- 1 AYD C. B. McKeen, Amherst Ave., Waltham, Mass.
- 1 AYQ A. C. Reeve, 1355 Fairfield Ave., Bridgeport, Conn.
- 1 BAD C. W. Smith, 29 Devens St.....Greenfield, Mass.
- 1 BBS Wm. Bibby, 342 Nash Rd.....New Bedford, Mass.
- 1 BHW K. B. Warner, 282 Fern St.....Hartford, Conn.
- 1 CCE John A. Moran, Jr., 12 Burrige Pl., Malden, Mass.
- 1 CQP R. E. Cushing, 25 Dover St.....No. Adams, Mass.
- 1 FA H. E. Upton, 225 Westbrook St.....Portland, Me.
- 1 IL R. Nystrom, 336 Elm St., W. Springfield, Mass.
- 1 MO F. H. Schnell, 282 Fern St.....Hartford, Conn.
- 1 SE Earl G. Holbrook, 58 Pearl St., Attleboro, Mass.

CANCELLED.

- 1 BBU Leslie S. Williams, Cherry St.....Salem, Mass.
- 1 BCD Earl B. Ely, 337 Windsor Ave., Hartford, Conn.
- 1 CHQ Albert W. Watkins.....Merrimack, N. H.
- 1 CQW Russel E. Thomas, 32 Mill St.....Newport, R. I.
- 1 VV W. N. Holden, 84 Parrot Ave., Bridgeport, Conn.
- 1 ABP Charles G. Spalding, 6 Court St.....Windsor, Vt.
- 1 AUI Wm. C. Harris, Camp Chewink, Wiscasset, Maine
- 1 AUJ Jack H. Johnson, 21 Valley Road, Medford, Mass.
- 1 AUK W. B. S. Clymer.....Harrisville, N. H.
- 1 AUM C. MacDonald, 168 Leyden St., East Boston, Mass.
- 1 AUP Raymond L. Perkins, 79 Lawton Ave., Lynn, Mass.
- 1 AUR Winslow Eddy, Stearns School, Mont Vernon, N. H.
- 1 AUX Ralph J. Liedel, Lincoln Park, Hills Grove, R. I.
- 1 AUZ G. F. Wilkinson, 584 Putnam Ave., Cambridge, Mass.
- 1 AVA T. W. Cummins, Potomac Ave., Greenwich, Conn.
- 1 AVB J. L. Spiane, 107 West St.....Worcester, Mass.
- 1 AVC F. L. Simons, 51 Lonsdale Ave., Pawtucket, R. I.
- 1 AVF Max S. Johnson, R. F. D. 3.....Jericho, Vermont
- 1 AVJ Charles S. Slight, South St.....Agawam, Mass.
- 1 AVL Harold Bissell, 45 Asectney St.....Windsor, Vt.
- 1 AVM Harold V. Wyman, Main St.....Hopkinton, Mass.
- 1 AYP Clifton H. Luce, Front St.....Marion, Mass.
- 1 AVT R. D. Seed, 10 Gertrude Ave., Worcester, Mass.
- 1 AVU Ansley Newman, 517 Beacon St.....Boston, Mass.
- 1 AVV James J. Macdonald, 110 West Broad St., Stamford, Conn.
- 1 AVW Carlton Weidenhammer, 1274 Park Ave., Bridgeport, Conn.
- 1 AVX Donald B. Lee, 20 Prospect St., West Haven, Conn.
- 1 AVY G. D. Rogers, 39 Winsor St., New Bedford, Mass.
- 1 AWC Curtis Crowell, 180 Davis St.....Quincy, Mass.
- 1 AWH Wm. A. Hall, 31 Park Ave.....Wakefield, Mass.
- 1 AWJ Hilton T. Carmichael, 595 Whitney Ave., New Haven, Conn.
- 1AWN F. J. H. Wallace, 12 Second St., Cliftondale, Mass.
- 1AWP R. W. Pratt, 130 Main St.....Hingham, Mass.

- 1 AWQ Donald Cole, 5 Jacob St.....Windsor, Vt.
- 1 AWT Carl W. Phillips, 13 Horace St.....Malden, Mass.
- 1 AWU Oakes Ames Spalding, Mill Rd.....Falmouth, Mass.
- 1 AWY F. C. Justice, 148 Tremont St.....Newton, Mass.
- 1 AWZ Fred L. Hauck, 24 Second St.....Norwalk, Conn.
- 1 AXH R. H. Bird, Jr., Crafts St.....Waltham, Mass.
- 1 AXL L. P. Birnie, 21 Highland Ave.....Barre, Vt.
- 1 AXN Robert S. Dearborn.....Sanbornton, N. H.
- 1 AXO James A. Treanor.....Lanesboro, Mass.
- 1 UQ H. W. Castner, 25 Forest St.....Portland, Maine

Sixth District

- 6 BNN R. B. Lohry, 1921 Irving Ave., Oakland, Calif.
- 6 BNO Paul E. Clark, Mt. Tamalpais, Mill Academy, San Rafael, Cal.
- 6 BNP D. Mayhew, Box 215.....Willows, Calif.
- 6 BNQ M. Schilling, Box 297.....Beaumont, Calif.
- 6 BNR P. Schulz, R. F. D. No. 6, Box 354, Stockton, Calif.
- 6 BNS L. Stauffer.....Mendon, Utah
- 6 BNT W. C. Meddock, 225 Willard St., San Francisco, Cal.
- 6 BNU D. H. Atkins, 25 Glen Alpine Rd., Piedmont, Cal.
- 6 BNV Unassigned
- 6 BNW S. D. Baker.....Hilo, T. H.
- 6 BNX P. E. Riopel, 2542 Beachwood Drive, Hollywood, Cal.
- 6 BNY G. V. Hailock, 224 W. Florida St., Hemet, Calif.
- 6 BNZ Ed. Walsh, 4585 Berington Ave., Los Angeles, Cal.
- 6 BOA R. L. Erikson, University Campus.....Tucson, Ariz.
- 6 BOB E. B. Finseth.....Placentia, Calif.
- 6 BOC C. A. Steele, 5th St.....San Rafael, Cal.
- 6 BOD T. H. Woekel, 726 N. El Molino Ave., Pasadena, Calif.
- 6 BOE K. R. Unger, 119 Edith Ave., Salt Lake City, Utah
- 6 BOF T. T. Strickland.....Quincy, Calif.
- 6 BOG C. Crandall, Jr., Colomat Hotel, Honolulu, T. H.
- 6 BOH A. W. Martin, Jr., 894 Waller St., San Francisco, Calif.
- 6 BOI D. C. Kirk, 402 1st Nat. Bank Bldg., Bakersfield, Cal.
- 6 BOJ Whittier College.....Whittier, Calif.
- 6 BOK W. Munter, 718 Clement St., San Francisco, Calif.
- 6 BOL Taft High School.....Tart, Cal.
- 6 BOM M. L. Armstrong, 17 N. First St., San Jose, Calif.
- 6 BON A. Humberg, 195 Santa Teresa St., Santa Clara, Cal.
- 6 BOO R. O. Forsblad, R. F. D., Carrier B, Kingsbury, Calif.
- 6 BOP D. J. Balbontin, 103 Waller St., San Francisco, Cal.
- 6 BOQ Unassigned
- 6 BOB W. Bomheim, 2191 Pine St., San Francisco, Calif.
- 6 BOS D. Nilseker, 1153 Oakland Ave., Piedmont, Calif.
- 6 BOT C. M. Vonder Heider, 1037 Fillmore St., San Francisco, Calif.
- 6 BOU G. Arton, 116 23rd Ave.....Oakland, Calif.
- 6 BOV Unassigned
- 6 BOW Edw. Flynn, 3346 Liberty St.....Fresno, Calif.
- 6 BOX F. L. Whitesley, 539 12th St.....Richmond, Calif.
- 6 BOY Boy Scouts of America, Propl. Richmond, Standard Ave., Richmond, Cal.
- 6 BOZ W. Drinock, 452 10th St.....Richmond, Calif.
- 6 BPA J. F. Wilcox.....Redwood City, Calif.
- 6 BPB E. N. Willis, 1254 10th St.....Santa Monica, Calif.
- 6 BPC L. C. Brand, Mountain and Grand View St., Burbank, Calif.
- 6 BPD J. Rodrigner, R. F. D., Box No. 485, Richmond, Calif.
- 6 BPE C. H. Tringham.....Pleasanton, Calif.
- 6 BPF W. Delp, 2503 E. 16th St.....Oakland, Calif.
- 6 BPG J. P. Cunningham, 6391 Dana St., Berkeley, Calif.
- 6 BPH C. S. Fleisher.....Graton, Calif.
- 6 BPI B. Goldwater, 710 N. Central Ave., Phoenix, Ariz.
- 6 BPJ R. G. Burke, care of Pine Knot P. O., Big Bear Lake, Cal.
- 6 BPK H. Green, Box 602.....Prescott, Ariz.
- 6 BPL R. Kinkad, 212 Fulton Ave.....Palo Alto, Calif.
- 6 BPM P. Merrill, Box 403.....Pina, Arizona
- 6 BPN A. Stafford, 1721 Appleton St., Long Beach, Calif.
- 6 BPO F. W. Adams.....Flanagan, Nevada
- 6 BPP H. E. Thomas, 780 Guerrero St., San Francisco, Cal.
- 6 BPQ Unassigned
- 6 BPR E. Livezey.....Lihue, Kauai, T. H.
- 6 BPS H. L. Hackley, 714 80th St.....Sacramento, Calif.
- 6 BPT U. McLaughlin, 2024 16th St., Sacramento, Calif.
- 6 BPU E. K. Fogus, 214 Judah St.....Roseville, Calif.
- 6 BPV C. F. Willie, 320 Fair Oaks St., San Francisco, Cal.
- 6 BPW C. W. Mason, 4223 Latona Ave., Los Angeles, Cal.
- 6 BPX H. Ludgren, 1160 Spence St., Los Angeles, Calif.

- 6 BPY J. J. Signie, 1021 Cole St., San Francisco, Calif.
- 6 BPZ S. H. Lurtwiler, 414 Crumshaw Blvd., Los Angeles, Calif.
- 6 BQA B. Sano, 855 S. Birch St., Los Angeles, Calif.
- 6 BQB G. A. Wahlander, 1918 18th St., Sacramento, Calif.
- 6 BQC G. W. Schlaib, 1629 Vineyard Ave., Los Angeles, Calif.
- 6 BQD R. Sherman, 4517 W. 17 Drive, Los Angeles, Calif.
- 6 BQE J. Wardell, 301 N. Cedar St., Los Angeles, Calif.
- 6 BQF E. S. Walsh, 1998 Woolman Ave., San Diego, Cal.
- 6 BQG M. Petter, 1878 23rd St., Los Angeles, Calif.
- 6 BQH E. Champron, 2507 E. 1st St., Los Angeles, Calif.
- 6 BQI M. H. Anderson, 1840 63rd St., Berkeley, Calif.
- 6 BQJ N. S. Fairweather, 182 Grattam St., San Francisco, Calif.
- 6 BQK Unassigned
- 6 BQL A. M. Snell, 575 21st Ave., San Francisco, Calif.
- 6 BQM G. G. Budwig, 890 Central Ave., Glendale, Calif.
- 6 BQN E. Lousdale, 420 N. Harrison St., Stockton, Calif.
- 6 BQO D. S. Harsley, 1202 Fairfax Ave., W. Hollywood, Calif.
- 6 BQP P. Caspar, 1928 Crumshaw Blvd., Los Angeles, Calif.
- 6 BQQ G. G. Budwig, 890 Central Ave., Glendale, Calif.
- 6 BQR J. C. F. Turrill, 1738 Appleton St., Long Beach, Calif.
- 6 BQS C. F. Turrill, 1738 Appleton St., Long Beach, Calif.
- 6 BQT H. Hall, 1408 E. Ocean Ave., Long Beach, Calif.
- 6 BQU B. F. Elliott, 320 N. Lake Ave., Pasadena, Calif.
- 6 BQV G. Kaller, 411 E. 25th St., Los Angeles, Calif.
- 6 BQW S. Monsen, 167 Colorado St., Pasadena, Calif.
- 6 BQX L. W. Young, 2246 Pentucket St., San Diego, Calif.
- 6 BQY S. Thompson, 3101 Grand Ave., Los Angeles, Calif.
- 6 BQZ K. B. Stoddard, 1912 W. 23rd St., Los Angeles, Calif.
- 6 BRA L. Shapiro, 3711 Barbee St., Los Angeles, Calif.
- 6 BRB I. A. Moon, 3607 Mission Road, Los Angeles, Calif.
- 6 BRD G. J. Stewart, 1261 Victoria Ave., Los Angeles, Calif.
- 6 BRD C. J. Smith, 1525 W. 23rd St., Los Angeles, Calif.
- 6 BRE H. Kaufman, Mt. Tamalpais, Mill Academy, San Rafael, Calif.
- 6 BRF N. R. Winner, 2143 Branden St., Los Angeles, Cal.
- 6 BRG H. M. Fink, 1708 W. 23rd St., Los Angeles, Cal.
- 6 BRH W. G. Baffinger, 1444 Norton Ave., Los Angeles, Cal.
- 6 BRI W. Seitz, 620 N. Zeyor St., Anaheim, Calif.
- 6 BRJ A. P. King, 805 Athens St., Pasadena, Calif.
- 6 BRK G. Whetstone, 262-A, Euclid Ave., Long Beach, Cal.
- 6 BRM T. Erdmann, 3686 Georgia St., San Diego, Calif.
- 6 BRN I. C. Dietze, 136 Griffin Ave., Los Angeles, Calif.
- 6 BRN C. J. Wolf, 4532 40th St., San Diego, Calif.
- 6 BRO C. A. Hall, 936 Fedora.....Los Angeles, Calif.
- 6 BRP W. C. Poole Mills.....P. O. Mather Field, Calif.
- 6 BRQ C. C. Cocke.....Compton, Calif.
- 6 BRR C. R. MacCulloch, 1122 Baueroff Pl., San Diego, Calif.
- 6 BRS Venice High School.....Venice, Calif.
- 6 BRT A. G. Goldschmidt.....4740 88th St., San Diego, Cal.
- 6 BRU A. E. Wood, Rt. 5, Box 163-B, Watsonville, Calif.
- 6 BRV Y. H. Everton, 1721 Grove St., Berkeley, Calif.
- 6 BRW F. W. Hicks, 506 Liberty St., San Francisco, Cal.
- 6 BRX W. B. Rhodes, Thacher School.....Ojai, Calif.
- 6 BRY R. Gillespie, 1113 Charlevoix St., Los Angeles, Cal.
- 6 BRZ Alex Gempfert, 6140 Mesalve, Los Angeles, Calif.
- 6 BSA W. M. Forster, 2915 Otis St., Berkeley, Calif.
- 6 BSB G. Furtruy, 453 Center Ave.....Pomona, Calif.
- 6 BSC D. Hutton, 807 Cauhuenga St., Los Angeles, Calif.
- 6 BSD A. C. Packard, 140 W. 12th St., Claremont, Calif.
- 6 BSE H. L. Drake, 671 W. Myrtle St., Los Angeles, Cal.
- 6 BSF E. Norton, 830 W. Redondo Ave., Inglewood, Calif.
- 6 BSG C. Dillman, 133 W. Line St., Riverside, Calif.
- 6 BSH G. E. Breakeridge, 2055 Sarah St., Fresno, Cal.
- 6 BSI C. H. Cole, 752 E. 4th St., Pomona, Calif.
- 6 BSJ D. Bardin, 414 Churd St., Salinas, Calif.
- 6 BSK D. Bardin (Portable).....Salinas, Calif.
- 6 BSL G. E. Martin.....4410 Mettler St., Los Angeles, Calif.
- 6 BSM C. C. Sansom, 7513 Whitsett Ave., Los Angeles, Cal.
- 6 BSN H. R. Green, 1814 S. Vermont Ave., Los Angeles, Calif.
- 6 BSO Clayton Bane and Mill Muller, 619 Castro St., San Francisco, Calif.
- 6 BSP G. Brown, Jr., 205 E. 48th St., Salt Lake City, Utah
- 6 BSQ I. Pinkerton, 225 Sonora St., Nogale, Arizona
- 6 BSR W. L. Krance, 1025 Coronado Terrace, Los Angeles, Calif.
- 6 BSS Amateur Radio Shop, 15 Napa Rd., Vallejo, Calif.

6 BST Pasadena Council, B. S. A., Stanton Bldg., Pasadena, Calif.
 6 BSU K. Zuit, Rt. 2, Box 520, San Gabriel, Calif.
 6 BSV F. G. Somers, 675 So. 6th St., San Jose, Calif.
 6 BSW Unassigned
 6 BSX J. M. Dotson, 868 Miller Ave., South, San Francisco, Calif.
 6 BSY A. K. Branson, 3623 1/2 Grove St., Oakland, Calif.
 6 BSZ W. T. Smith, Adams St., San Lorenzo, Calif.
 6 BTA E. G. Trout, 1239 Royal Court, Los Angeles, Cal.
 6 BTB I. W. Sawyer, 115 Brown St., Napa, Calif.
 6 BTC G. Myers, 1023 Gerfield St., So. Pasadena, Calif.
 6 BTD L. G. Kent, 4956 Fairfax Ave., Oakland, Calif.
 6 BTE T. L. Mayes, Box 622, Coalinga, Calif.
 6 BTF H. B. Beals, 5423 Virginia Ave., Los Angeles, Cal.
 6 BTG W. H. Haines, 213 W. Lomita Ave., Los Angeles, Calif. (Portable)
 6 BTH K. Zachewitz, Box 541 Rt. 2, Santa Cruz, Calif.
 6 BTI J. D. McCarty, 1418 Adeline St., Berkeley, Calif.
 6 BTJ W. H. McAuley, Martin St., Monterey, Calif.
 6 BTK P. Casper, 1928 Crenshaw Blvd., Los Angeles, Calif. (Portable)
 6 BTL C. S. Pratt, 1347 La Brea St., Hollywood, Calif.
 6 BTM J. E. Wright, 514 Locust St., Visalia, Calif.
 6 BTN R. Wooden, Exeter, Calif.
 6 BTO V. F. West, 213 Cedar St., Glendale, Calif.
 6 BTP B. Stewart, Heath St., Santa Cruz, Calif.
 6 BTQ A. Wheeler, Box 7, Orange Ave., Patterson, Calif.
 6 BTR C. Stevenson, Clement, Calif.
 6 BTS H. D. Squires, 142 West Amerigo St., Fullerton, Cal.
 6 BTT Unassigned
 6 BTU J. W. Smith, 157 61st So. St., Murray City, Utah
 6 BTV Arroyo Sanatorium, Livermore, Calif.
 6 BTW M. L. Short, 216 E. 7th St., Hanford, Calif.
 6 BTX J. E. Regalle, E. Alum Rock Ave., San Jose, Cal.
 6 BTY R. D. Nagle, Van Nuys High Schools, Van Nuys, Calif.
 6 RTZ D. Luena, Sidds Landing Rock, Willows, Calif.
 6 BUA J. R. T. Knight, R. R. T., Box 25, E. Wood St., Willows, Calif.
 6 BUB F. E. Juvinal, 521 Highland St., Monrovia, Calif.
 6 BUC B. L. Holden, R. 4, Box 200, Turlock, Calif.
 6 BUD H. M. Hucks, 413 Court St., Woodland, Calif.
 6 BUE C. R. Gehr, 929 Winona St., Pasadena, Calif.
 6 BUF W. W. Case, Forestville, Calif.
 6 BUG W. Campbell, 261 River St., Santa Cruz, Calif.
 6 BUH F. Bowman, 438 D. St., Salt Lake City, Utah
 6 BUI R. Biddulph, 711 N. 1 West, Provo, Utah
 6 BUJ O. E. Adams, R. 2, Box 219, Pomona Ave., Chico, Calif.
 6 BUK G. G. Ma Canomy, 123 S. Cedar St., Glendale, Calif.
 6 BUL H. C. Richards, 1625 Cimarron, Los Angeles, Calif.
 6 BUM A. L. Weesels, 1100 Standley St., Ukiah, Calif.
 6 BUN C. E. Stuart, 4066 Leeward Ave., Los Angeles, Cal.
 6 BUO J. H. Humbreck, 1344 Mariposa Ave., Los Angeles, Calif.
 6 BUP H. E. Lewis, 1699 Everett St., Alameda, Calif.
 6 BUQ L. B. Platt, 2663 Pasadena Ave., Los Angeles, Cal.
 6 BUR L. E. Smith, 340 N. Painter Ave., Whittier, Calif.
 6 BUS W. Eilers, 12717 Prairie Ave., Hawthorne, Calif.
 6 BUT L. D. Andelin, Richfield, Utah
 6 BUU W. A. Oksone, Presidio St., Monterey, Calif.
 6 BUV A. Sellinger, 709 Hermosa St., So. Pasadena, Calif.
 6 BUW W. Dek Leffingwell, Box 176 Rt. 3, Pasadena, Calif.
 6 BUX A. E. Harris, 156 E. Santa Barbara Ave., Los Angeles, Calif.
 6 BUY J. D. Holmes, 2732 Prince St., Berkeley, Calif.
 6 BUZ Robt. Richardson, 2750 Prince St., Berkeley, Calif.
 6 BVA W. O. Pochstein, San Marcos, Calif.
 6 BVB G. E. Yeung, 2246 Pentucket St., San Diego, Calif.
 6 BVC San Francisco Radio Club, 173 Dolores St., San Francisco, Calif.
 6 BVD Paul Carpenter, 1902 Orange Ave., Long Beach, Cal.
 6 BVE L. L. Watson, 516 Baker St., Beal, Calif.
 6 BVF Leonard Obert, 1445 Mohawk St., Los Angeles, Cal.
 6 BVG C. F. Wainwright, Delta St., Los Angeles, Calif.
 6 BFH C. E. Huff, Orange, Calif.
 6 BFI C. E. Fernald, 1155 21st St., San Diego, Calif.
 6 BFJ F. Ahlin, 5575 Marshall St., Oakland, Calif.
 6 BFK J. G. Duncan, 1601 Ohio Ave., Long Beach, Calif.
 6 BVL H. G. Latta, 2158 Woolman Ave., San Diego, Calif.
 6 BYM Whitney Lewis, 1820 W. 43rd Pl., Los Angeles, Cal.
 6 BYN V. F. West, 213 N. Cedar St., Glendale, Calif.

9 CNS T. C. Shipley, Rushville, Nebr.
 9 CNT Leonard M. Border, 601 Meyer Ave., Connersville, Ind.
 9 CNU Theo. R. Border, 601 Meyer Ave., Connersville, Ind.
 9 CNV Wilmer M. Oelschlaeger, 1513 Bunton Ave., Ft. Wayne, Ind.
 9 CNW Eugene H. Bacon, 5843 Bartmer Ave., St. Louis, Mo.
 9 CNX Kenneth Meyer, 369 5th Ave., S. St. Cloud, Minn.
 9 CNY F. P. Watts, 512 Fourth St., Independence, Kans.
 9 CNZ Carl F. Anderson, 1126 Gibbs Ave., St. Paul, Minn.
 9 COA W. W. Brown, 416 8th Ave., S. E. Minneapolis, Minn.
 9 COB Theo. Wang, 3546 Wilton Ave., Chicago, Ill.
 9 COC C. T. Wall, 4227 Abbott Ave., S. Minneapolis, Minn.
 9 COD R. M. Planck, 615 W. McClure Ave., Peoria, Ill.
 9 COE Phil W. Sayles, 1219 Knoxville Ave., Peoria, Ill.
 9 COF F. W. Niskern, 613 First Ave., St. Cloud, Minn.
 9 COG E. A. Hopbin, 5658-A Cotterbrillianta St., St. Louis, Mo.
 9 COH Elmer G. Leachman, R. R. No. 3, Livia, Ky.
 9 COI Max R. Shepherd, 617 E. 14th St., Kansas City, Mo.
 9 COJ Harold R. Neger, Webster, S. Dak.
 9 COK Donald Lee, 111 E. 13th St., Harper, Kans.
 9 COL Quentin Swigart, 836 Ave. A., Galesburg, Ill.
 9 COM Edwin W. Landgraf, Pocatontos, Mo.
 9 CON Wm. W. Roper, 410 E. Bryan St., Hopkinsville, Ky.
 9 COO M. B. Webb, 946 S. Third St., Louisville, Ky.
 9 COP Freeman & Gabbert Radio Co., Clay Center, Kans.
 9 COQ C. J. Bartling, 1101 W. Poplar St., Taylorville, Ill.
 9 COR James L. Woods, Jr., McGregor, Iowa
 9 COS Florian J. Harriman, 903 Perry St., Appleton, Wisc.
 9 COT George S. Banks, 3829 Fourth Ave., S., Minneapolis, Minn.
 9 COU Wm. J. Mueller, 522 E. Boonville St., Sedalia, Mo.
 9 COV F. Raymond Linda, Jr., Gore Ave. and Glendale Rd., Webster Groves, Mo.
 9 COW Joseph L. Turre, 706 18th St., Denver, Colo.
 9 COX James H. Bell, 2821 Prairie Ave., Mattoon, Ill.
 9 COY James C. Banbow, Hubbard, Iowa
 9 COZ Fred Post, R. F. D. No. 3, Box No. 2, North Rd., Auburn, Ill.
 9 CPA Corda DeLong, 2217 Shelby Ave., Mattoon, Ill.
 9 CPB Ray E. Norene, 2404 Crown Point Ave., Omaha, Nebr.
 9 CPC H. J. Nemece, 816 14th St., Cedar Rapids, Iowa
 9 CPD Leo Manger, 819 Rudd Ave., Canon City, Colo.
 9 CRE Earnest A. Kamp, 701 Locust St., St. Louis, Mo.
 9 CPF W. Harry Jennings, 1020 First Ave., Cedar Rapids, Iowa
 9 CPG V. K. Reeder, 4901 Fletcher Ave., Indianapolis, Ind.
 9 CPH Kenneth I. Waughtal, 1319 Elm Drive, Mason City, Ia.
 9 CPI Gallen C. Mirick, Chelsea, Ia.
 9 CPJ C. G. Pelton, 420 Independence Ave., Waterloo, Ia.
 9 CPK Herschel O. Stoner, Fairfax, Mo.
 9 CPL D. E. Wilson, 1438 Newberry Ave., Marinette, Wisc.
 9 CPM Merlin A. Freeland, R. R. No. 1, Dalton City, Ill.
 9 CPN Joseph F. Riley, Jr., R. F. D. No. 6, Park Ave., Attica, Ind.
 9 CPO Norton H. Schensted, Broton, Minn.
 9 CPP Claudius R. Creever, St. Joseph, Minn.
 9 CPQ H. M. Hanson, 110 McKenzie St., Luverne, Minn.
 9 CPR Cecil E. Rhode, 123 N. Main St., Eureka, Kans.
 9 CPS Victor Marlowe, Cass Lake, Minn.
 9 CPT Glen F. Franz, 524 Bluff St., Beloit, Wisc.
 9 CPU Louis J. Schnell, 1014 Regent St., Boulder, Colo.
 9 CPY Harold A. Sears, Eureka, Kans.
 9 CPW J. E. Cook, R. F. D. No. 5, Box 154, Independence, Mo.
 9 CPX Everett L. Ware, R. F. D. No. 1, Stanford, Ky.
 9 CPY Elmer A. Scheer, 4453 Margaretta St., St. Louis, Mo.
 9 CPZ Geo. R. Call, 1529 Grandview Blvd., Slou City, Ia.
 9 CRA Victor Sierpinski, 1506 4th Ave., Milwaukee, Wisc.
 9 CRB Cornell Colaker, Mount Vernon, Iowa
 9 CRC R. B. Remnaker, R. F. D. No. 3, Converse, Ind.
 9 CRD Leo Manger, 819 Rudd Ave., Canon City, Colo.
 9 CRE Ernest A. Kamp, 701 Locust St., St. Louis, Mo.
 9 CRF Westinghouse Electric & Mfg. Co., 32 S. Peoria St., Chicago, Ill.
 9 CRG C. B. Phillips, 405 Lincoln Ave., Hot Springs, S. Dak.
 9 CRH A. M. Garrett, 301 1/2 Main St., N., Maryville, Mo.
 9 CRI Ted Johnson, 2419 South St., Lincoln, Nebr.
 9 CRJ Lewis W. Bear, Newton, Ind.
 9 CRK E. W. Stone, 1107 E. Harrison St., Springfield, Mo.
 9 CRL George C. Wallace, 2508 Taylor St., N. E., Minneapolis, Minn.
 9 CRM Bernard F. Piper, 307 W. 1st St., West Plains, Mo.
 9 CRN Carl J. Madsen, Mermer, Nebr.
 9 CRO D. R. Gordon, 1634 Ludlow Ave., Indianapolis, Ind.
 9 CRP K. O. Botnen, Hqrs. Co. 1st Bn., 3d Infantry, Ft. Snelling, Minn.
 9 CRQ Erwin M. Vardon, 702 Cottage Grove Ave., South Bend, Ind.
 9 CRR John M. Stevenson, Tarkio, Mo.
 9 CRT Geo. V. Horne, 711 Goodfellow St., St. Louis, Mo.
 9 CRS Geo. A. Scherer, 117 N. McCann St., Komo, Ind.
 9 CRU Edgar W. Stewart, Fairfax, Mo.
 9 CRV Arthur Hosler, 517 5th Ave., Milwaukee, Minn.
 9 CRW Thos. M. Edmunds, 3017 10th Ave., S., Minneapolis, Minn.
 9 CRX John H. Bruning, 111 E. Adams St., Havana, Ill.
 9 CRY J. H. Millus, Jr., 302 Wadsworth Ave., Collinsville, Ill.
 9 CRZ A. E. Olson, 54 W. American St., Freeport, Ill.
 9 CSA Walter J. Muir, 1831 W. Park Ave., Chicago Ill.
 9 CSB J. V. Butterfield, 1614 Main St., Knoxville, Iowa
 9 CSC W. N. Lambert, 1910 Washington St., Columbus, Ind.
 9 CSD Charles V. Meth, Arthur, Nebr.
 9 CSE Charles S. Powell, 714 Locust St., St. Louis, Mo.
 9 CSF William Nassour, 825 N. Nevada St., Colorado Springs, Colo.

9 CSG Radio Apparatus Co., Inc., 1625 Howard St., Omaha, Nebr.
 9 CRE R. E. Burchard, 6505 Hobart St., Wellaton, Mo.
 9 CRI Leo A. Hilde, 201 Adams St., Oconto, Wisc.
 9 CRJ R. Schlegel, 2524 Portland Ave., Minneapolis, Minn.
 9 CRK Harry G. Crofts, St. Paul, Minn.
 9 CRL William Kennebeck, Maple Ave., McHenry, Ill.
 9 CSM Edward J. Bromley, Jr., LaGrange, Wisc.
 9 CSN Burr W. Deal, 816 W. 10th St., Owensboro, Ky.
 9 CSO Cyrus W. Williams, P. O. Box 182, Cave City, Ky.
 9 CSF R. R. Boorman, E. F. D. No. 1, White Bear, Minn.
 9 CSB Herman Asmus, 5902 Peters Ave., St. Louis, Iowa
 9 CSB Harold L. Olesen, 922 N. St. John's Ave., Highland Park, Ill.
 9 CSS H. H. Guthmann, 2816 S. Park Ave., Chicago, Ill.
 9 CST L. B. Greene, 4224 Harrison St., Kansas City, Mo.
 9 CSU Frederic A. Tull, Lapel, Ind.
 9 CSV Victor Stones, 571 Harper Ave., Webster Groves, Mo.
 9 CSW H. McMaster, 824 E. Thompson St., Taylorville, Ill.
 9 CSX E. Platten, 218 Oakland Ave., N. Green Bay, Wisc.
 9 CSY G. B. Hise, 4309 Pleasant St., Des Moines, Iowa
 9 CSZ F. H. Schubert, 4011 Magnolia St., St. Louis, Mo.
 9 CTA J. Joe Graham, 703 W. Court Ave., Winterset, Ia.
 9 CTE Floyd N. Newton, 303 Martin St., Muncie, Ind.
 9 CTF A. H. Edgerton, 1115 N. 11th St., Springfield, Ill.
 9 CTD A. and H. E. Pohl, 310 Linn St., Boone, Iowa
 9 CTE E. T. P. Niespodziyeni, 2118 W. Kenwood St., South Bend, Ind.
 9 CTF Bobt. F. Allen, 309 Indiana Ave., Mandota, Ill.
 9 CTG E. I. Nowak, 1010 S. 18th St., St. Joseph, Mo.
 9 CTH Lajoze Wenkster, Ellendale, N. Dak.
 9 CTI The Lake View Radio Shop, 1604 Belmont Ave., Chicago, Ill.
 9 CTJ Victor E. Loufck, 1212 Bank St., Keokuk, Iowa
 9 CTK Charles Savage, 2103 "G" St., Granite, Ill.
 9 CTL Eugene Hermann, 3570 Delmar Blvd., St. Louis, Mo.
 9 CTM Lawrence Bever, 818 S. 13th St., Centerville, Iowa
 9 CTN Harry M. Ward, 1337 13th St., N., Fargo, N. Dak.
 9 CTO Sylvan H. Frase, 2641 Hennepin Ave., Minneapolis, Minn.
 9 CTP H. C. Barrett, 702 Anthony Ave., Anthony, Kans.
 9 CTQ R. C. Faullin, 203 Armory Ave., Champaign, Ill.
 9 CTR Fred Feuerborn, 4270 Clarence Ave., St. Louis, Mo.
 9 CTS Finley Peacock, 915 Howard St., Green Bay, Wisc.
 9 CTU W. A. Hayward, 6639 Normal Bldg., Chicago, Ill.
 9 CTU E. A. Willis, Tates Creek Park, Lexington, Ky.
 9 CTV Marquis H. Ervin, 509 Central St., Peoria, Ill.
 9 CTW C. Lee Herron, 937 Central Ave., LeMars, Iowa
 9 CTX M. K. Goetz, 518 N. 25th St., St. Joseph, Mo.
 9 CTY Burkham Gossett, 514 Garfield Ave., Topeka, Kans.
 9 CTZ A. W. Breyer, Jr., 1222 Norfolk Ave., Norfolk, Nebr.
 9 CUA Joel C. Livingston, 402 W. Lynn Springfield, Mo.
 9 SUB Tom North, 1510 Laurel Ave., St. Paul, Minn.
 9 CUC G. E. Johnson, 2419 South St., Lincoln, Nebr.
 9 CUD F. W. DeZonia, 1924 W. Logan St., Murphysboro, Ill.
 9 CUE Robert F. Gephart, R. E. No. 1, Edinburg, Ind.
 9 CUF Floyd E. Norwine, Jr., 737 Maple St., Maplewood, Mo.
 9 CUG M. Welhoelter, 4250 Athlone Ave., St. Louis, Mo.
 9 CUH G. P. Hixenbaugh, West Church St., Dallas, Ia.
 9 CUI Glenn H. Libbing, 2223 California Ave., Ft. Wayne, Ind.
 9 CUJ Herbert S. Wilhelm, 1817 Kansas Ave., E. St. Louis, Ill.
 9 CUK Henry J. Ranson, 321 Adams St., Jefferson City, Mo.
 9 CUL Cyril H. Smith, 1713 S. 4th St., Madison, Ill.
 9 CUM Sam. F. Bassett, 5427 Delmar Blvd., St. Louis, Mo.
 9 CUN Michael Ebinger, 4931 Gresham St., St. Louis Mo.
 9 CUO John D. Holmes, Lena, Ill.
 9 CUP Wallace T. Hunsler, Bancroft, Nebr.
 9 CUQ James B. Pollard, 2951 E. 11th Ave., Denver, Colo.
 9 CUR Francis J. Fox, 3501 11th Ave., Minneapolis, Minn.
 9 CUS R. G. Loeffel, 25 Sarah Ave., Webster Groves, Mo.
 9 CUT Frank E. Brass, Delavan, Minn.
 9 CUU Claude H. Ervin, 1809 Broadway, Parsons, Kans.
 9 CUV Charles H. Humes, 1408 Cuyler Ave., Chicago, Ill.
 9 CUW Virgil Spear, Melcher, Iowa
 9 CUX C. C. Baines, 24 S. 8th St., Terre Haute, Ind.
 9 CUY P. E. Huston, 3946 Guilford Ave., Indianapolis, Ind.
 9 CUZ H. L. Secrest, Castle Hill, Iowa
 9 DG CALLS REINSTUD
 C. B. Harrison, 502 S. Jackson St., Belleville, Ill.
 P. E. Thurman, care of T. & H. Radio Co., Anthony, Kans.
 9 TX Colorado Springs Radio Co., No. 29 N. Cascade St., Colorado Springs, Colo.
 9 VJ Palmer Nelson, 1405 First Ave., Fargo, N. Dak.
 9 AQH Fred C. Soper, M.D., Dalworth, Minn.
 9 AVZ H. W. Wilson, 800 E. Capitol Ave., Pierre, S. Dak.
 9 DFK W. Collins, 156 Franklin St., Valparaiso, Ind.
 9 DZI L. J. Gates, 507 Winona St., Winona, Minn.
 9 DG CALLS CANCELED
 Elizabeth A. Berner S. H. Academy, Lincoln and Washington Sts., Springfield, Ill.
 C. R. Dally, 824 Platte St., Colorado Springs, Colo.
 E. Emil Schmidt, 5831 Kildar Ave., Chicago, Dak.
 Robert Jackson, 5511 Sangamon St., Chicago, Ill.
 Thos. D. Cunningham, 404 Price Ave., Columbia, Mo.
 St. Joseph Valley Radio Assn., 1330 Leeper Ave., South Rend, Ind.
 9 PV Mangan & Hillard, 6828 Leffin St., Chicago, Ill.
 9 CCB W. V. Newell, 307 E. Stafford St., Stafford, Kans.
 9 DJM Sherman Brose, 100 Benton St., Clear Lake, Iowa
 9 IU Paul C. Patterson, 320 W. 12th St., Anderson, Ind.
 9 DJT Forrest G. Eakman and J. Ernest Gray, 11th St., Keltshurs, Ill.
 9 DKZ O. W. Nelson, 1528 E. 76th Place, Chicago, Ill.
 9 DAV Ira Paul Price, LeRoy, Kans.
 9 DGA Eric B. Hierpe, 936 W. Losey St., Galesburg, Ill.
 9 DKP Wm. W. Daniel, 347 Hill Ave., Owensboro, Ky.
 9 DUU T. F. Anderson, 606 S. 9th St., Aberdeen, S. Dak.
 9 DUE Wayne Sappenfield, 410 Parrett St., Evansville, Ind.
 9 DWF S. D. Park, 2001 S. Lincoln Ave., Springfield, Ill.
 9 DFR Merritt C. Haigh, 1224 Pleasant View Drive, Des Moines, Iowa
 9 DXV John G. Bain, 130 Coleman Ave., Clayton, Mo.
 9 DWJ John L. Siegle, 302 Thornwood Ave., Davenport, Ia.
 9 PB H. D. Barton, 1742 Ingraham St., Indianapolis, Ind.
 9 DY Homer U. Bishop, 210 E. Forest Ave., Neenah, Wisc.
 9 DY B. W. Nestlerode, 309 S. Walnut Ave., Freeport, Ill.
 9 YZ C. W. Krieman, 29 Greenbrier Rd., Ft. Mitchell, Ky.
 9 DKB L. H. Weeks, 908 Washington St., Detroit, Minn.
 9 VR O. M. Smith, 5837 Forest Ave., Kansas City, Mo.
 9 DXT Frank Schachtely, 642 75th Ave., West Allis, Wisc.
 9 DUC Kenneth LeRoy Clark, 105 E. Fourth Ave., Denver, Colo.
 9 KP J. A. Goodrich, 2316 Clybourn Ave., Chicago, Ill.
 9 AWS George E. and Frank J. Zempel, 406 Buchanan St., Minneapolis, Minn.
 9 AUR John Henry Boos, Jr., 4527 Washington Ave., St. Louis, Mo.
 9 AMY Stuart Gates, 2535 W. Market St., Louisville, Ky.
 9 CEC Hilbert R. Moore, 1802 Paris Road, Columbia, Mo.
 9 YZ E. J. Belfer, 837 E. 24th St., Milwaukee, Wisc.
 9 AMR Harvey D. Matteson, 334 W. Roosevelt St., DeKalb, Ill. (9 AMR)
 9 AIU W. H. Hatjaway, 414 Joliet St., Crown Point, Ind.
 9 BVZ J. T. Hood, 1344 W. 34th St., Indianapolis, Ind.
 9 ABA Don I. Shepherd, 316 N. West St., St. John, Kans.
 9 ALK Telford H. Smith, 2811 N. 68th St., Omaha, Nebr.
 9 AMQ Lee Frank Dechant, 16 Evans St., Oshkosh, Wisc.

Ninth District

9 CNC James E. Coram, Deering, N. Dak.
 9 CND Earl L. Pickett, 503 N. 2d Ave., Marshalltown, Iowa
 9 CNE Bert Worster, Jr., North Liberty, Ind.
 9 CNF H. F. Paar, 1444 Second Ave., E., Cedar Rapids, Ia.
 9 CNG Keitz LaBar, 3207 E. 27th St., Kansas City, Mo.
 9 CNH Peerless Electrical Company, 227 S. Fifth St., Minneapolis, Minn.
 9 CNI D. M. Perham, 322 Third Ave., W., Cedar Rapids, Ia.
 9 CNJ William Kavanaugh, Jr., 219 W. Chestnut St., Louisville, Ky.
 9 CNK Geo. A. Hawkins, 360 S. Corona St., Denver, Colo.
 9 CNL H. A. Stewart, 506 Division St., Indianapolis, Ind.
 9 CNM Sinalair T. Peaster, 319 E. 10th St., Topeka, Kans.
 9 CNN R. L. Jensen, 1205 S. 4th St., Forest City, Ia.
 9 CNO C. B. Putnam, 1246 N. Meade St., South Bend, Ind.
 9 CNP O. C. P. Connely, 1302 E. Main St., New Albany, Ind.
 9 CNQ Burten E. Briar, R. F. D. No. 2, Virginia, Ill.
 9 CNR N. H. Willis, 224 Hartwell St., Waukesha, Wisc.

Absolute Insulation

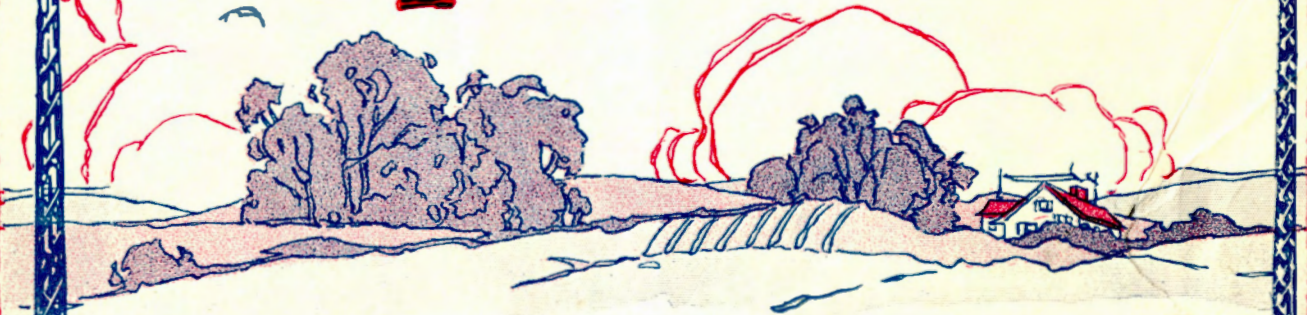

*Professional Smartness
for Your Home-Made Set!*

bakelite-dilecto

Beautifully sleek black surfaced, astoundingly hard and tough panelling, testing supremely high in dielectric (insulational) strength, in tensility, in volume resistance, and in **LOWEST** dielectric losses. Approved by eight years' grueling use in U. S. Navy and Signal Corps. Proof against heat, water and mild acids. Bakelite Dilecto (grade XX) has **EVERYTHING** the advanced amateur wants in a panel! And it is so reasonably priced!

**"A LAMINATED
PHENOLIC
CONDENSATION
PRODUCT."**

Machines admirably engraves clearly without roughing, and is made in sheets, rods, tubes, and other shapes for many sorts of radio fittings. Write us to know where to get it near you.

**The Continental Fibre Company
Factory at Newark, Delaware**

Serviced from:

New York City.....233 Broadway	Pittsburg.....301 Fifth Ave.
Rochester, N. Y., 85 Plymouth Ave., S.	San Francisco.....75 Fremont St.
Chicago.....332 S. Michigan Ave.	Los Angeles.....411 S. Main St.
Seattle.....	91 Connecticut St.

HOMMEL

EVERYTHING FOR RADIO

Immediate Shipments

ON SETS OR PARTS

DISTRIBUTORS FOR
Radio Corp. of Amer.
Westinghouse
General Electric

Frost	Kellogg
Remler	Acme
Fada	Brach
Murdock	Homcharger
General Radio	Signal
Brandes	Pacent
Baldwin	Rhamstine
Burgess	Connecticut
Hipco	Arkay
Chelsea	Radio Service
Holtzer-Cabot	Tuska

Clapp-Eastham
and other leading
manufacturers

DEALERS! Keep your radio customers in good humor by being able to give them everything they want when they want it.

That's why we keep such a large reserve stock of everything applying to radio. Place your orders with us and be sure of prompt service. For ordering, see our new illustrated price list No. 200 E.

A post card will bring it



Wholesale Exclusively

LUDWIG HOMMEL & CO

530-534 FERNANDO ST.



PITTSBURGH, PENNA