

# The WIRELESS AGE

Practical Courses

in

Aviation

Navigation

Wartime Wireless

Military Signaling

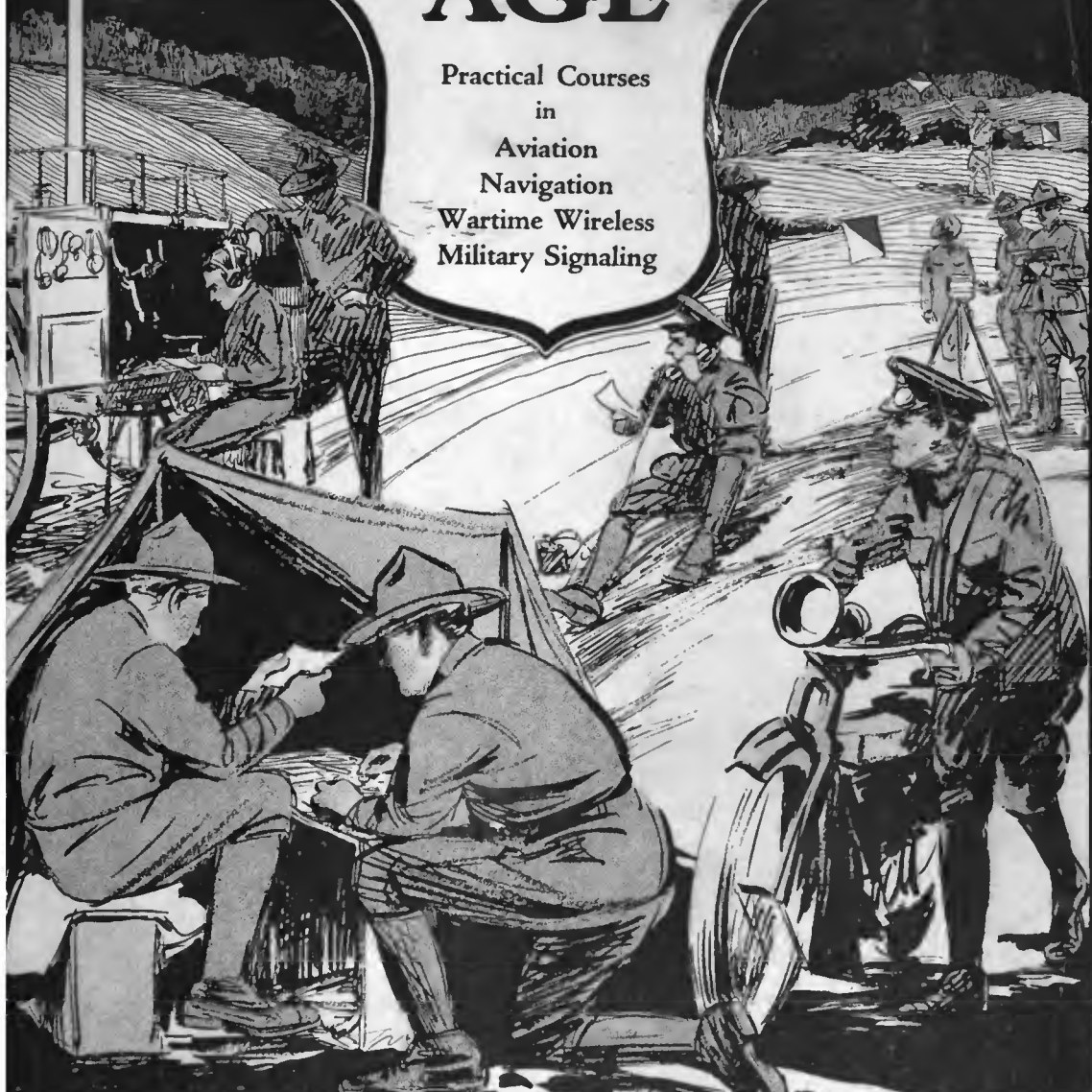



INSULATION  
 "MADE IN AMERICA"  
 LOUIS STEINBERGER'S PATENTS

**LIGHTNING-PROOF INSULATORS**

1,000 TO 1,000,000 VOLTS

INSULATORS ARE STANDARD WITH  
 UNITED STATES NAVY AND ARMY

AND WIRELESS TELEGRAPH AND TELEPHONE COMPANIES



No. 9802

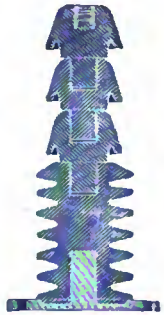

No. 7870



No. 6815



No. 4500



No. 4502



No. 4507

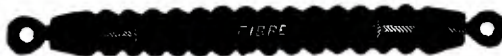

No. 4518



No. 6833



No. 7122



No. 7379



No. 6285



No. 6277



No. 7375



No. 159

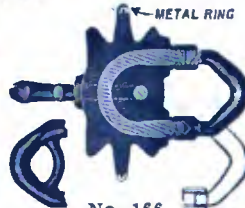

No. 166



No. 7163



No. 7878



No. 5568



No. 6805

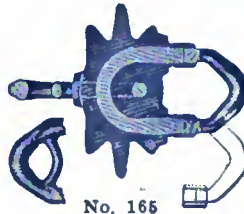

No. 165

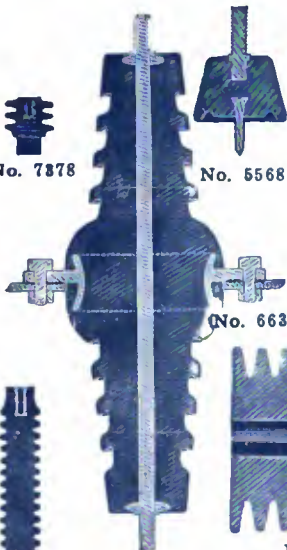

No. 6634

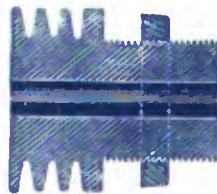

No. 6207

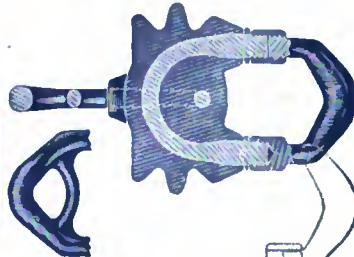

No. 172



No. 7489

SOLE MANUFACTURERS



66-82 Washington St.  
 66-76 Front St.

27-37 York St.  
 1-23 Flint St.

Brooklyn, N. Y., America

No. 7487

# DUBILIER MICA CONDENSERS

For any voltage and capacity. .004 mf Units to fit all Standard Racks.

**Used by the Marconi Company**

## MICA SELF HEALING

Protective Devices for all size equipments from  $\frac{1}{4}$  to 500 K. W.  
Protect your Motors and Generators from burning out.

**Up to further notice only U. S. Government Equipments  
will be supplied**

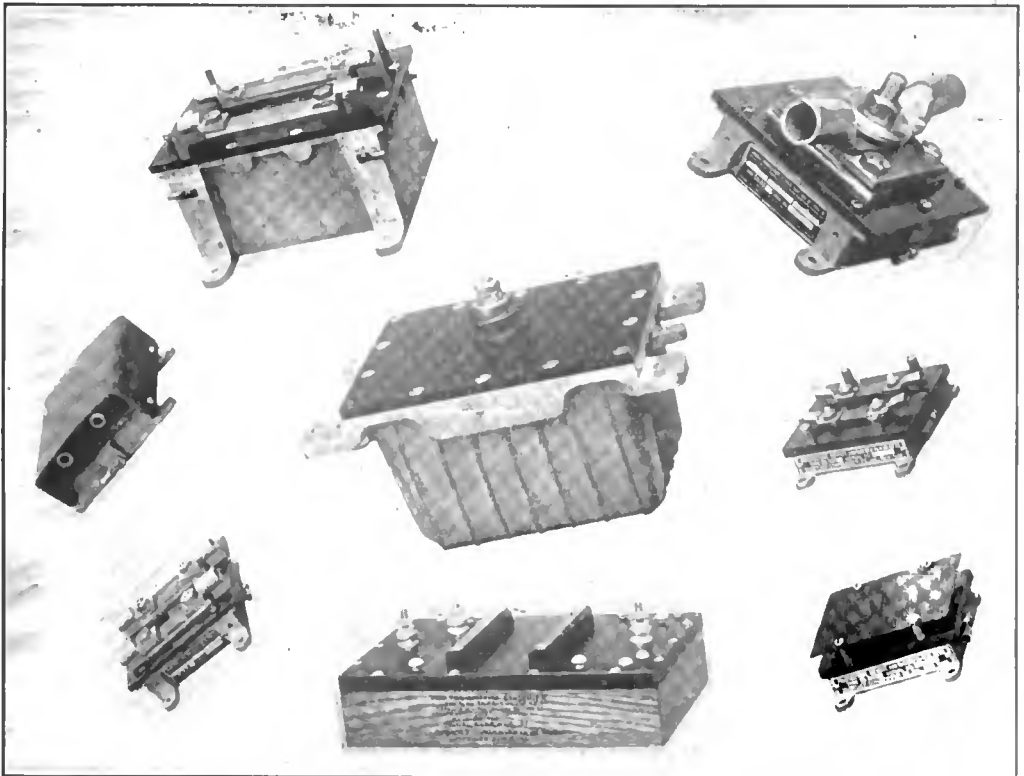

**DUBILIER CONDENSER CO., Inc.**  
**217 CENTRE STREET** **NEW YORK**

When writing to Advertisers please mention THE WIRELESS AGE

[www.americanradiohistory.com](http://www.americanradiohistory.com)



(C) Press III, SVCC.

*With a million and a half men under arms, the United States is directing every energy to prepare its new army for immediate service on the western front. This photograph of a training camp shows an advance through trenches in the face of a gas attack, special interest attaching to the new type of gas mask and the bends in the trench line to prevent effective enfilade fire when attacked on the flanks*



# THE WIRELESS AGE

## WORLD WIDE WIRELESS

### Remarkable Achievement in Italian Link with U. S.

THE announcement that Italy and the United States have recently been connected by wireless telegraphy deserves more notice than it has received. This achievement probably makes a back number of the great wireless station at Nauen, near Berlin, which has been so useful to Germany, and which, when the war broke out, claimed to be the most powerful in the world, with an effective range of between 5,000 and 6,000 miles. From the nearest point in Italy to the United States trans-Atlantic station at Arlington, near Washington, is not less than 6,200 miles, and to send an intelligible message across that distance might be more than even Nauen could accomplish. Owing to the hostility between the ether waves which carry wireless messages and sunshine, it is always easier to send messages long distances in northerly latitudes than in those more south, and the power required to cover a given distance increases with nearness to the equator. The wireless route between Rome and Arlington is for a good part of the way at least 800 miles nearer the equator than that between Nauen and the United States, which fact considerably adds to the achievement of the Italian and American experts.

### American Marconi Company's Service in Year of War

THE annual report for 1917 of the Marconi Wireless Telegraph Company of America is the record of the adaptation of the corporation's resources to the nation's war needs. All the radio stations, including the high power stations in the United States, were immediately taken over by the government and used exclusively for government communication under the direction of the Navy Department.

In spite of this condition, the company reports an exceedingly successful year. According to John W. Griggs, president of the company, the net profits for the year, after utilizing \$162,819.75 for reserves, amounted to \$617,772.69 against \$259,888.80 in 1916, or an increase of 138 per cent. This sum has been added to the surplus, increasing that amount to \$1,419,549.01, and the reserves set aside for depreciation amount to \$573,461.32 additional. The gross earnings from operations for 1917 were \$1,229,467.55, compared with \$796,290.39 for 1916.

In lining up its resources for the government, the Marconi Company faced these three major needs, according to the report:

"First—Facilities and trained experts for the manufacture of the new wireless equipment for the large number of vessels built and commandeered by the United States Shipping Board and the Navy Department.

"Second—A constant supply of capable, licensed wireless operators, for service on the rapidly increasing merchant marine.

"Third—Trained construction men to install wireless apparatus on the vessels, and engineers capable of coping with the many problems of wireless communication and production.

"To meet the first need, the company has built two large additions to its factory in Aldene, N. J., and is now engaged in building a third addition, which will soon be completed. This has resulted in more than trebling the capacity of its works, which are operating two shifts of mechanics a day, with a steadily increasing force of engineers, in the manufacture of wireless apparatus for government use.

"In order to meet the second and third needs, the company has increased its school facilities for the training of wireless operators, and is financing the training of a force of junior engineers to deal with the many problems of wireless communication and production."

Through the organization of the Pan-American Wireless Telegraph and Telephone Company, plans were laid for the erection of a chain of high power stations which will connect up the United States with Mexico, the West Indies, Central and South America for commercial wireless communication. Work will begin in the Argentine as soon as plans can be prepared.

A 5 per cent. dividend was declared by the Board of Directors at a meeting held April 9th, 1918, payable August 1st, 1918, to stockholders of record July 15th, 1918.

### **Enormous Benefits Seen in Pan-American Wireless Project**

**T**HE recent organization of the Pan-American Wireless Telegraph & Telephone Company, in New York, is the most practical step yet taken to develop and extend the trade and general relations of the countries of the Western Hemisphere. In order to convey an adequate idea of the importance and value of this enterprise, it is necessary to describe its objects and to indicate the advantages that will follow their attainment.

The main purpose of the Pan-American Wireless Telegraph & Telephone Company is to connect the United States with all the countries of South and Central America, and the West Indian Islands, by wireless telegraphy. It will begin with Argentina, where the arrangements with the Government have been concluded and its technical experts are arranging for suitable sites, so that the high power stations and their necessary equipment can be completed and ready for actual working service within the next twelve months.

Commencing with Argentina, the work will be taken up in Brazil, and then in Uruguay, Paraguay, Chile, Peru, Ecuador, Colombia, Bolivia, and Venezuela successively, and as rapidly as the necessary arrangements can be made. Also, Mexico, together with the Central American Republics and the principal West Indian islands, will be included in the system.

Wireless stations, more powerful and complete than any heretofore constructed, will be erected in each of the principal trade centres of the various countries, and will be able to carry on a twenty-four hour commercial telegraph service with New York. Messages intended for Europe will be sent either directly or through the transatlantic wireless service of the Marconi Wireless Telegraph Company of America, making connections with Great Britain, France, Spain, Italy, Russia and Scandinavia, and from the Pacific Coast—San Francisco, California—wireless connections will be made, through Hawaii, with Japan and the Orient.

In the United States, the system will connect with the landlines of the Western Union Telegraph Company—with over 25,000 of that Company's stations—in every state of the Union.

And all of this greatly improved service will be done with such a substantial reduction of rates that business men of the Americas will not only find themselves effecting a saving of their present cable expense, but will be enabled to

send much longer and more frequent messages, and make use of the telegraphy in fomenting and carrying on their business to an extent hitherto undreamed of.

The fulfillment of this comprehensive program will be greatly facilitated by the adoption of the latest inventions in wireless telegraphy, including the patents and improvements of the American and English Marconi Companies and the Danish Poulsen-Pedersen system. These developments ensure the highest efficiency in speed, economy and accuracy.

The new company is in a very strong financial position with abundant resources for the carrying out of its great undertaking. No stock is offered for sale.

The President, Edward J. Nally, who has devoted a lifetime to the development and advancement of the commercial telegraph, telephone and cable business, and who is well known as having held high executive positions with the foremost landline companies of the United States, is also vice president and general manager of the Marconi Wireless Telegraph Company of America, which is the chief wireless company of the new world, not only with respect to its transatlantic and trans-pacific commercial service, and its many ship and shore stations, but also in that it is the largest manufacturer of wireless apparatus and equipment in the United States.

The Chairman of the Board of Directors is the Honorable John W. Griggs, former Attorney General of the United States, and ex-Governor of the State of New Jersey. The other officers are: Vice-Presidents: Dr. Washington Dodge, and David Sarnoff; Secretary: C. J. Ross; Treasurer: John Bottomley.

In addition to the Honorable John W. Griggs, other members of the Board of Directors are: Mr. Nally, Messrs. James R. Scheffield, Edward W. Harden, David Sarnoff, Frank N. Waterman, Dr. Washington Dodge, George Pope and Nathan Vidaver.

The entire official and technical staff of the Pan-American Wireless Telegraph & Telephone Company, is made up of men who are thoroughly experienced and qualified for the practical working out of their plans, and they are, as well, men of vision and imagination, who have long been studying the question of how best to bring into closer harmony the ideas and ideals of North and South America. Their conclusion that the lack of a cheap and rapid system of telegraphic communication is the most important factor among the hindrances to such better international understanding, was authoritatively corroborated during the sessions of the Pan-American Financial Conference held in Washington in May, 1915. At that conference, which was attended by the President of the United States and members of his Cabinet, as well as by the most influential representatives of all Latin-American countries, there was hardly a speech or report of an individual or group which did not contain some reference to the urgent necessity for improved telegraphic service between the two Americas.

These reports not only express with high authority the true needs of the prevailing situation, but they also assure the hearty support and co-operation of all American Governments in the furtherance of the work undertaken by the new company. Every one of the points urged by the Conference is embraced in the plan proposed, including the offering of special rates and inducements to newspapers and press associations so that they will send and distribute reports and despatches of greater length and greater frequency than is possible under present conditions.

Another service, which has proved very popular in trans-atlantic and trans-pacific wireless business, will be the transmission of night and week-end letters at reduced rates.

Every one knows what wireless telegraphy and its great inventor, Marconi, have accomplished in the interests of humanity. In the conduct of the war now raging in Europe, it has been a potent factor in the field, in the air, and on the waters, and the improvements that have resulted from the forced stimulation

have brought the art forward by leaps and bounds. When the war is over and normal activities of the world are resumed, wireless telegraphy will take its place as one of the most important arts in the progress of humankind, and the organization of the Pan-American Wireless Telegraph & Telephone Company offering every moral and material guarantee for the fulfillment of its objects will be recognized as an epoch-making event.

It is earnestly to be hoped that not only the Governments but the business men, both individually and through their Chamber of Commerce and other organizations, in all the countries of Latin-America, will actively co-operate and offer their aid to the fullest extent possible, so that there may be no unnecessary obstacles placed in the way of the speedy consummation of this plan for an all-American system of wireless stations which, by linking the countries from Alaska to Cape Horn, will so materially advance the interests of every one concerned.

### **Improved Equipment for Nauen**

**T**HE German Government's wireless station at Nauen has been greatly improved since the outbreak of the war, according to the *Frankfurter Zeitung*. Instead of a single transmission tower 300 feet high it now has ten towers ranging in height from 360 to 890 feet, while the distance through which messages can be transmitted has been extended to 6,200 miles.

### **Brazil to Have New Link to Rubber Section**

**T**HE Brazilian Government has authorized the expenditure of a sum not to exceed 200,000 milreis (paper milreis — about 27 cents) for the erection and installation of a wireless telegraph station at Boa Vista do Rio Branco, State of Amazonas. The State of Amazonas, which has an area of 1,894,724 square kilometers and a population of 379,000 inhabitants, is the largest State in Brazil. Manaus, the capital of the State, where a Marconi station has been in operation for several years, is a thoroughly progressive city of more than 100,000 inhabitants, with fine public buildings and a theater which rivals in beauty of architecture, arrangement, decorations, and equipment the principal theaters of the world. This State is the center of the great rubber section of Brazil, and the city of Manaus, its capital, is nearly 1,000 miles from the mouth of the Amazon River.

### **Using Wireless to Measure Sea Distances**

**P**ROFESSOR J. JOLY, of Dublin, has suggested a method of measuring distances by wireless. He relies on the fact that disturbances travel with different speeds in different media. Sound travels eleven hundred feet or more a second in air and about forty-seven hundred feet a second in water, while wireless or light signals travel at equal speeds. Thus, if a shore station sends out these different signals at the same time, they will not be received by the ship simultaneously; there will be an interval of time between them that will increase as the distance of the ship from the shore increases. If a mile from the station, a ship would receive a sound signal in air 4.5 seconds later than a sound signal in water, and an air sound 5.5 seconds, or a sound in water 1.2 seconds, later than a wireless signal. Therefore, with a knowledge of the interval which elapses between the receptions of any two of these different signals, it is a comparatively simple matter to calculate the source from which they have been sent.

### **To Paris by Relay from New Station at Guadeloupe**

**I**T is announced that the wireless station at Destrellan will soon go into operation. Its equipment is sufficiently powerful to permit of communication with the most remote of the West Indian islands and with all vessels coming from



Europe, the United States, or South America. It can also receive messages from the Eiffel Tower, but cannot send messages through to Paris direct. However, by using the intermediate stations of Dakar and Bizerte, the Guadeloupe plant will probably be able to forward radiograms to Paris. The Destrellan station is owned by the colonial government, but, it is said, will be open to the public.

### Unique Buzz of the Familiar Radio "Bug"

REMINISCENT of the days before the booming guns of war cut off wireless experimentation and its queer twists and claims of self-admitted inventors is the recent occurrence in Reno, Nev., when a man who gave his name as James Dillon walked into the Mount Rose Hospital and in a matter of fact way requested that he be given an anaesthetic and killed. He stated that it was absolutely necessary that he die if the present complication of world affairs were to be properly adjusted.

Questioned as to his antecedents by the examining physicians Dillon stated that he wasn't born at all but "sprung up" in Montana and that he was raised by Indians until he was 15 years old, when he took up the study of wireless telegraphy and became the greatest wireless man in the world, not even excepting Marconi.

"I am able to send a wireless message to heaven or hell, and have 523 fairies in my employ who work in receiving stations at both places," he announced.

Dillon said that he was in Germany when the war broke out but that he left Europe because the big guns made such a noise that it completely disrupted his wireless system. Since then, according to his wanderings, he has traveled all over the world, trying to get in connection with his staff of sprites, but unsuccessfully.

Despairing of being able to conduct further research in the heavens or the nether regions and thinking that this was a punishment for some great sin he had committed, he said that he had determined to end his life in order that the bells might stop ringing in his head and that all might be well with the world.

He was thereupon ceremoniously interned in the state lunatic asylum.

### A New Cuban Station in Isle of Pines

WORK has commenced on the new wireless telegraph station at Nueva Gerona, Isle of Pines. The building in which the installation will be made is about completed. This building is constructed of concrete blocks, villa style, with tile floors, two bed-rooms, a sitting room, kitchen, and bath and an office, estimated to cost \$16,000. The station will be installed as soon as the building is ready. In addition to the building referred to, a tower 251 feet high will be erected at a cost of \$13,000. It is intended to open the station to public use.

### Navy Has No Room for Radio Women

WOMEN telegraphers who wish to render their country a patriotic service can best do so by accepting employment with a telegraph company, thereby releasing a man for military duty. This is the advice of naval authorities to women seeking to enlist as Navy radio operators. It is land-wire telegraphy, rather than radio, say the Navy authorities, that women should now study.

Women radio operators are not being enlisted in the Navy nor enrolled in the Naval Reserve Force for radio telegraphic duties, according to a statement made by the Naval Communication Service. At the outbreak of the war several women were enlisted as radio operators, but their employment in this capacity was found to be, generally speaking, impracticable. The Navy is supplying merchant ships as well as naval vessels, quarters on both being provided for men only.

Instructors in Navy Radio Schools must be radio electricians with actual shore and sea experience, hence women will not be accepted for this duty.

### Six German Wireless Plants in Mexico

**G**ERMANY is in direct daily touch with military developments in the United States. Her widespread espionage system in this country has an open road of communication to Berlin through no less than six powerful wireless stations in Mexico.

This is the statement of William W. Canada, for twenty-one years United States Consul at Vera Cruz. He has just returned from Mexico. He said:

"I have notified the State Department of these wireless stations. It is a matter of record at Washington. One of the stations is at Mexico City. We located another in the northern part of the State of Vera Cruz just before I left. It was built on the highest peak in the section. There are three or four others. Any one of them is powerful enough to transmit messages to Germany.

"Mexico is overrun with German agents. Many come from the United States, and others from South America, some by way of Honduras. German propaganda is being carried on in wholesale fashion. Several important newspapers have been subsidized. The German agents supply them with white paper, among other things. We have proof of this.

"Germany has a complete line of communication from Washington to Berlin by way of the wireless stations in Mexico. German agents are spending money lavishly in Mexico, and they are overlooking no opportunity to poison the minds of Mexicans against the United States. They are meeting with some success in their efforts."

### California Naval Radio School Extended

**T**HE United States' government is planning the expenditure of \$50,000 at the Chollas Heights wireless station, near San Diego, Calif., in order to make provision for a class of 100 or more wireless operators, who will be trained there permanently.

Gunner H. L. Rodman, U. S. N., who is located at the station, explained the future plans of the government, to make the Chollas station a great training school for wireless operators.

According to his statement, the government expects to spend about \$50,000 at once in new equipment and in living quarters for the men.

### The World Scope of Governmental Air Messages

**W**IRELESS words, which Gilson Garner characterizes the new war weapon, are interestingly dealt with in recent correspondence from him in Washington.

He asks that Americans think of the world as a great silent globe, the sky enclosing it, on which are creatures with a miraculous power to throw their voices across the ether. Think of these creatures talking to one another, interrupting one another, drowning out the talk of one another. There you have a mental picture of what is taking place daily and nightly in what might be termed the war of the wireless.

It is a war of words. It is literally a struggle of words carrying propaganda—all the official statements of all the world in regard to the war.

The wireless station at Arlington, Va., sends out messages which are taken at Nauen, near Berlin. The Nauen towers send out messages which are heard at Southampton, England; at the Eiffel Tower in Paris; at the Arlington station here, and in Cuba and in Mexico. They get to Russia. They are sent to the world in all languages—often from Germany in English, and from England in French, German and Russian.

The wireless has made the world literally a whispering gallery. The governments have taken the wireless for war purposes, and every wireless station is the mouthpiece of a government.

∨ In the old days ambassadors carried carefully written state communications, messages and letters from one government to another, bearing seals and red tapes. These were the voices of one nation to another whether at war or at peace.

Today the ambassadorial function is gone. Nations, at war or at peace, cannot but hear one another's voices. They are in daily, nightly, and hourly communication with one another through the air.

Germany puts out peace feelers. Our state department complains at Germany's announced terms. But they come through the air and cannot be checked. Whatever the kaiser or the reichstag, or Von Hindenburg wants said is said through the air. Also whatever Lloyd George or Woodrow Wilson wants said.

Lately a long dispatch floated in from Berlin telling exactly where American troops are located on the French front; just how many there are; what their physical condition is; comments on their morale; statements about orders issued by Pershing against visiting Paris.

Also came from Berlin an account of the Bigelow kidnapping near Cincinnati, with the declaration that tar-and-feathering was becoming common in the United States.

Communications between nations which are official and secret go in code. Of course many of these codes are ultimately deciphered and information leaks, but the codes are changed almost daily.

The wireless has made international communication simple and absolute. There is no room any longer for misunderstanding by reason of failure to receive messages. If language can convey it the governments of the world can adjust their ideas one to the other.

### Negroes for Army Signalmen

**PLANS** are under way for the forming of colored classes in wireless telegraphy to meet the demand being made on wireless operators by the War Department. To be eligible for admission the applicant must be registered under the draft act, but he cannot be enrolled if he has been called by his local board.

Through the activity of Emmett J. Scott, special assistant to Secretary Baker, the War Department realizing the expediency of the plan has authorized Adjutant-General H. P. McCain to issue orders for the organization of wireless telegraphy classes of colored registrants in Richmond, Virginia.

The orders issued by the Adjutant-General read as follows:

"The Federal Board of Vocational Education, which is handling the training of draft registrants as operators at Armstrong for the signal corps, has been notified that it is the desire of the chief signal officer to have a class started under the supervision of the Federal Board for High School, Richmond, with the view of furnishing operators for the Three Hundred and Twenty-fifth Field Signal Battalion (colored)."



*Dispatches from France telling of the excellent assistance rendered by Portugal's army in resisting the German drive, make this view of the cart wireless station of this minor Republic's field forces of unusual interest. The equipment shown is similar in type to the American cart stations and is said to be of great flexibility and power*

# Radio Science

## Weagant's Method for Group Frequency Tuning

**E**XPERIMENTS have shown that when the local circuit of a radio receiving system is fitted with a group frequency or audio frequency tuning circuit a diminution of the strength of signals results. A system has recently been disclosed by Roy A. Weagant, chief engineer of the American Marconi Company, wherein group frequency tuning is possible without the usual loss of signals. The connections are shown in figure 1. The primary and secondary

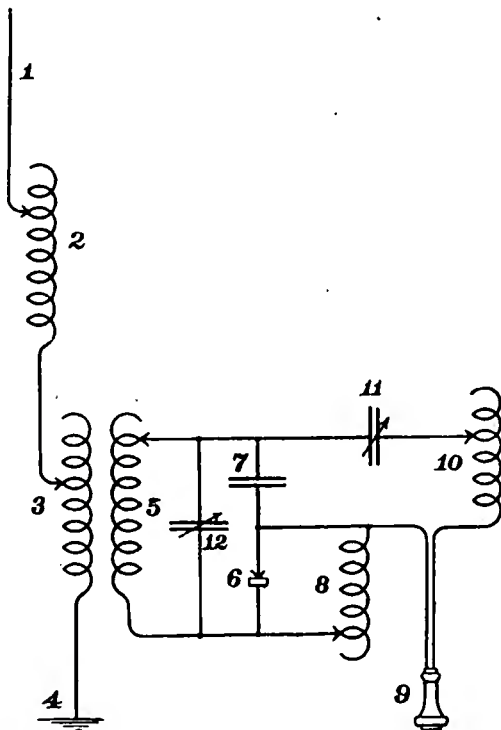

Figure 1—Weagant circuit for group frequency tuning

windings of the receiving tuner are indicated at 3 and 5, respectively, the shunt condenser at 12, a solid rectifier at 6, and a series condenser at 7. The group frequency tuning circuit includes condenser 7, a variable condenser 11, a variable inductance 10, and the head telephone 9.

Detector 6 is shunted by a coil 8, which has the effect of maintaining the signals in the telephone 9, at the strength which would be secured were the group frequency tuner removed. The principle of operation is somewhat

as follows: The detector 6, while permitting the passage of impulses in one direction, tends to prevent their passage in the other direction, and thus interferes with the oscillation of the circuit. By placing an impedance in shunt with the detector, however, a path is provided for the passage of oscillations in both directions, thus improving the operation of the circuit. The impedance 8, being of relatively high value, does not, however, interfere with the operation of the detector in the case of high frequencies. Mr. Weagant states that the best results are obtained when the inductances 8 and 10 are substantially of the same order, each of them being about 1,000 times the inductance of the secondary 5.

### An Amplifying Receiving System

IT is a well known phenomenon that if a coil of wire without shunt capacity (external condenser) is excited by a transient E. M. F. it will oscillate at a frequency determined by the inductance and the distributed capacity between turns. If such a coil is earthed at one end, its period of oscillation will be decreased and a loop of potential will exist at its free end. This is well illustrated in the action of the Oudin resonator. An amplifying receiving system based to some extent upon this phenomenon has recently been devised by E. E. Bucher.

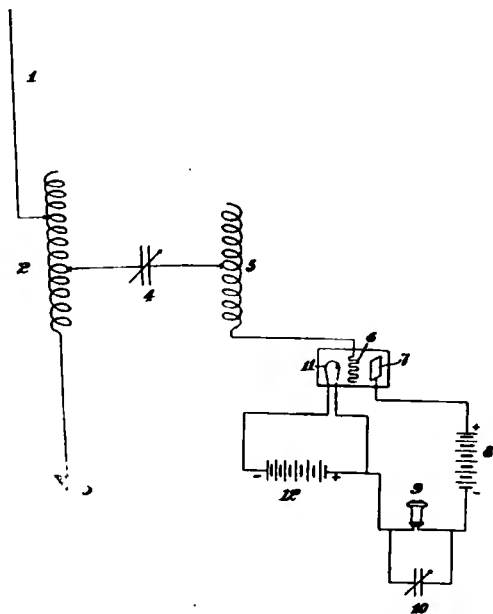

Figure 2—Amplifying receiving system devised by Bucher

Three practical circuits are shown in figures 2, 3, and 4. In figure 2 the antenna inductance is represented at 2, and the secondary inductance at 5, the coils being coupled together by the variable condenser 4. Coil 5 terminates in the grid element of a valve. The plate circuit of the valve includes the battery 8, the telephone 9, the shunt variable condenser 10, and the filament heating battery 12. Coil 5 is of such dimensions that the complete circuit, from the grid 6 through coil 5 through condenser 4 through coil 2 to the earth 3, has the same natural frequency as the incoming oscillations. During the reception of signals a very high E. M. F. exists at the free end of the coil 5,

which varies the electronic current flowing from the filament to plate. In other words, a circuit of this type impresses upon the grid a much higher E. M. F. for a given group of oscillations than would be obtained from the usual secondary circuit.

By shunting the plate circuit with inductance and capacity, this circuit is applicable for the reception of undamped oscillations, and will give strong signals.

A slight modification of this system is shown in figure 3, where the antenna inductances are shown at 2, and the circuits of the grid 6 of the vacuum valve leading from a contact point on the upper end of coil 2, through the inductance 5 to the condenser 4. Inductance 5 is shunted by a small variable condenser 13. It is found that by varying the capacity of condenser 13, the tuning of the receiving circuit becomes more sharply marked, aiding in the elimination of undesired signals. The use of this conductor is not recommended, however, under all conditions, as, for instance, in the reception of very long-wave lengths a small capacity has a certain utility.

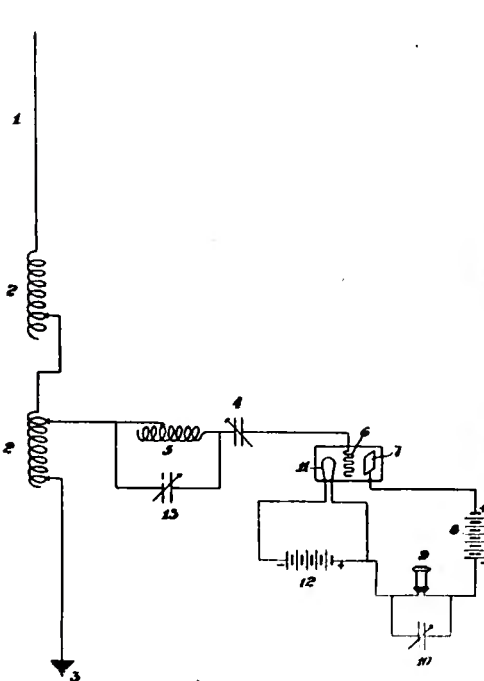

Figure 3—Receiving circuit to eliminate undesired signals

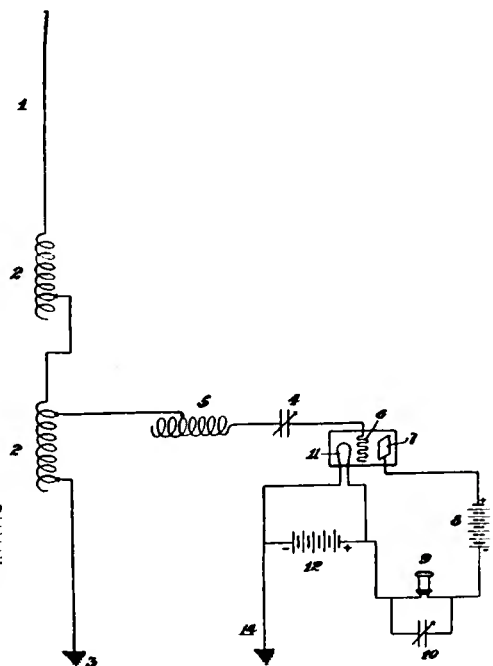

Figure 4—Receiving system with open circuit oscillator

A further modification is shown in figure 4, where the circuit including the coil 2, coil 5, series condenser 4, and the grid 6 is adjusted to the frequency of the incoming oscillations. In this circuit the valve is grounded at 14, but this does not affect the radio frequency tuning of the circuit. It, however, eliminates certain local disturbances, such as electrostatic induction from nearby alternating current power circuits. But as far as the tuning of the radio frequency circuits is concerned, removing the earth connection will have no effect whatever.

It has been reported that by means of this open circuit oscillator several oscillation detectors have been connected to the same antenna circuit, each

tuned to a different frequency of oscillation. The detectors functioned without interference.

Mr. Bucher states that by the term "open circuit" is meant a circuit which oscillates as an open circuit or linear oscillator after the manner of the Oudin coil, and which is of such high inductance and low distributed capacity as to cause a great rise of voltage at the end terminating in the detector. In this sense, such a circuit remains operatively an open circuit even if the filament of the valve detector connected thereto is grounded. In other words, it is a circuit in which a great rise of potential occurs, but no current flows in a closed path; rather, there is merely the surging of the charging current incident to the rise of the oscillating voltage at the end terminating in the detector.

### Constant Pressure Solid Rectifier

THE imperfections of spring contacts used with rectifying elements have been generally recognized. It has been difficult to obtain with the best spring arrangement the correct pressure for maximum strength of signals, and if, after a given transmitting period, the operator is required to immediately adjust his receiving apparatus to sensitiveness the chances are one in ten that he will be able to find the required adjustment in the brief period at hand before the reply is received from the distant transmitting station.

A recently devised detector holder in which the pressure of the rectifying element is secured by a balance device, instead of a spring, is shown in figure 5. In this drawing, balance lever L has secured to it a brass pin, over which is slipped a brass holder to take the brass contact-point. Contact 7 rests upon a rectifying element such as carborundum silicon, molybdenite or boronite. The crystal is held in the containing cup C, the cup being fastened

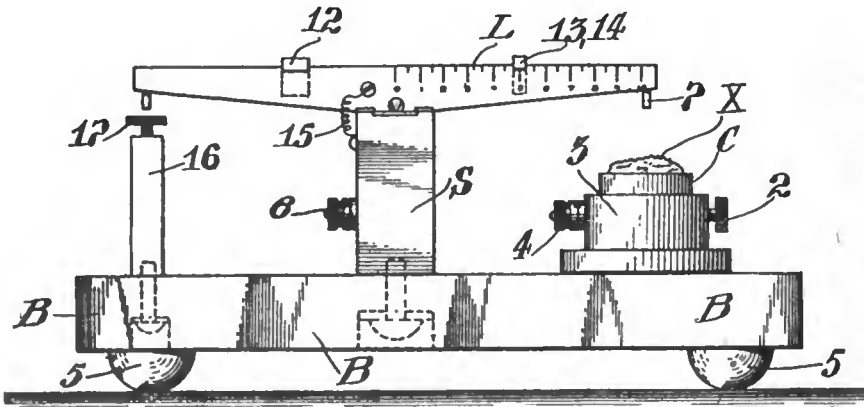

Figure 5—A detector holder with balance device

rigidly by the thumb screw 2. The base B is provided with soft rubber feet 5 to eliminate mechanical shock.

In order that the device may be operated with various samples of each of various rectifying solids, say for purposes of measurement, an adjustment consisting of varying weights 13, 14, operating on lever L along the graduated scale which extends from the knife-edge support to the center of pin 7. Weights 13 and 14 may be of one gram of aluminum and 10 grams of brass, respectively.



A conducting lead 15, figure 5, connects L and S in shunt to the knife-edge support to insure good circuit connections. This lead should be of fine copper wire in order to have a minimum of resistance.

If a device of this kind is intended to be used exclusively in a commercial way, by operators, it is recommended that no weight adjustment be permitted, provided that the operators are furnished with cups C containing a given solid rectifier of constant sensitiveness. The device should then be set to the pressure determined in the laboratory by a control instrument so that the optimum sensitiveness for a standard material can be readily obtained.

The great advantage of this holder, according to the inventor, is that there is practically no adjustment to the device. It is always ready for use provided the contact point 7 has the proper predetermined pressure. In the event that the operator's testing buzzer shows that the device has for some reason become inoperative, as to the particular surface point of crystal X in contact with P, it is permissible for him to move holder 3 slightly to obtain a new surface contact. This, however, will seldom be required if the rectifying material is properly selected. But should inoperativeness occur, as it may in the midst of a message, when it is essential for the operator to be able to restore the detector to sensibility, instant restoration is possible with this apparatus, for the contact pressure is automatically maintained constant, irrespective of the movements of holder 3 and of the consequent varying elevations of X, thereby caused to engage with contact point P.

### Novelty in the Construction of Quenched-Spark Gap

**W**HETHER or not the quenched-spark discharger which George Seibt has recently devised is commercially practical is an open question.

Gaps of this type heretofore consisted of a number of copper plates separated by insulating gaskets; these were mounted in a frame and tightly

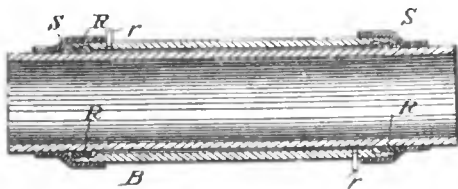

Figure 6—Section of quenched spark gap

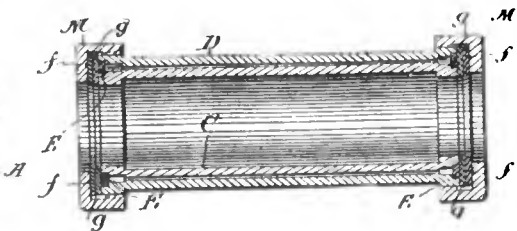

Figure 7—Modified construction of spark gap

clamped together, but Seibt declares that they were difficult to cool. Moreover, their construction did not permit the admission of the gas to the discharge surfaces which has been found to effect a marked increase in efficiency.

In Seibt's quenched-gap, shown in figures 6, 7, and 8, the spark occurs between two concentric cylinders, with an air space of the requisite separation, say  $1/100$  of an inch.

In figure 6, the gap element comprises the inner tube or electrode member A, and the outer tube or electrode member B, the former being mounted concentrically within the latter with both ends extending beyond the ends of the outer section B. The exterior diameter of the inner section is slightly less than the interior of the outer section, so that when they are assembled concentrically or with their geometric axes coinciding, a spark gap space of uniform thickness is formed. These sections may, of course, be maintained in axially centered relation in any convenient manner. Packing rings R interposed between the sections at their ends have been found to form a suitable insulating material.

It is important that provision be made to exclude air from the spark gap space between the sections. This obviously may be accomplished in several different ways. The packing R may be made to serve the purpose, but the inventor has shown other means. For example, if it is desired to fill the spark gap space between the sections A and B with a suitable gas, a short pipe section r, may be tapped or otherwise inserted through a transverse hole formed through one of the sections, as B. This pipe delivers into the space between the sections. Gas may thus be supplied to the spark gap space and when it is sufficiently filled, the section r may be closed up.

In figure 7, a slightly modified construction of the spark gap is shown. In this figure the inner and outer sections C, D, are substantially of equal length, and are held assembled concentrically by means of cap rings or nuts M, applied over the ends. The sections C, D, are separated or spaced apart from

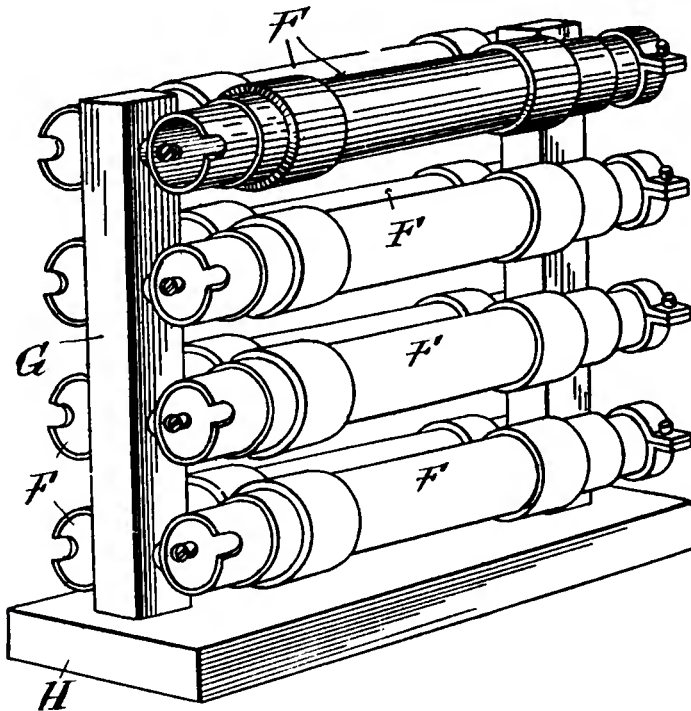

Figure 8—Complete spark gap with units assembled

each other and held in coaxial relation by means of the separating rings E, at their ends. Packing rings or disks g, of rubber or other suitable material, serve to exclude air from the space between the sections, while the caps or nuts M, are insulated from the inner section C, by means of the insulation indicated at f.

The complete spark gap is shown in figure 8, where a number of units are indicated at F. When assembled they may be held or supported preferably in parallel relation by the supporting standards G, on the base H.

By employing tubular sections for the units, and then setting these into a vertical position, a chimney or smoke-stack effect is produced. That is, the heat developed creates a natural draft of air through the bore of the inner tube, thereby absorbing and carrying off the heat. This cooling may be increased, of course, by artificially maintaining a draft of air through the bore of the inner tube.



(C) Press Ill. Svce.

*The close relationship between Italy and the United States, further fostered by the new wireless link across the Atlantic, has acquainted Americans with the amazing resourcefulness of this nation and its remarkable army. The howitzer shown in the picture is one set down in a public square of a village on the Piave, a powerful weapon of great range, whose firing is directed by wireless from observation stations nearby*

# THE DYNATRON

## A Vacuum Tube Possessing Negative Electric Resistance\*

By **ALBERT W. HULL, Ph.D.**

(RESEARCH LABORATORY, GENERAL ELECTRIC COMPANY, SCHENECTADY, NEW YORK)

### 1. Definition

The dynatron belongs to the kenotron family of high vacuum, hot cathode devices which the Research Laboratory has developed. Two members of this family, the kenotron rectifier and the pliotron, have already been described.<sup>1</sup> The fundamental characteristic of kenotrons is that their operation does not depend in any way upon the presence of gas.

In construction, the dynatron resembles the kenotron rectifier and the pliotron. In principle and operation, however, the three are fundamentally different. Each utilizes a single important principle of vacuum conduction. The kenotron rectifier utilizes the uni-directional property of the current between a hot and cold electrode in vacuum. The pliotron utilizes the space charge property of this current, which allows the current to be controlled by the electrostatic effect of a grid. The dynatron utilizes the secondary emission of electrons by a plate upon which the primary electrons fall. It is, as its name indicates, a generator of electric power, and feeds energy into any circuit to which it is connected. It is like a series generator, in that its voltage is proportional to the current through it, but it is entirely free from the hysteresis and lag that are inherent in generators and in all devices which depend upon gaseous ionization.

### 2. Construction

The dynatron consists essentially of an evacuated tube containing a filament, a perforated anode and a third electrode, called the plate. The essential con-

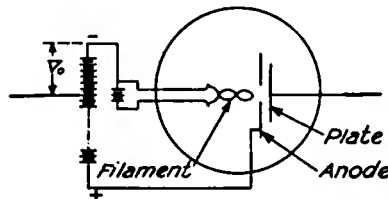

Figure 1

struction is shown in Figure 1. The plate must be situated near the anode, in such a position that some of the electrons, set in motion by the anode voltage, will fall upon it. A battery is provided for maintaining the filament at incandescence and for maintaining the anode at a constant positive voltage of 100 volts or more, with respect to the filament. This voltage is not varied during operation, and the anode plays no part in the operation of the tube except to set in motion a stream of primary electrons, and to carry away the secondary electrons from the plate; that is, to supply the power.

\* Reprinted by permission from the Proceedings of the Institute of Radio Engineers.  
1 "Proc. I. R. E.," September, 1915.

Figure 2 shows the construction of one of the practical types of dynatron that have been developed. The plate has been bent into the form of a cylinder (Figure 2, a) in order to utilize more fully the electron emission from the filament, and the anode has been provided with a large number of holes, instead of one. This is accomplished by using a perforated cylinder (Figure 2, b), or spiral of stout wire (Figure 2, c), or a network of fine tungsten wires (Figure 2, d). The filament is a spiral of tungsten wire (Figure 2, e). The filament may be further provided with a heavy insulated wire along its axis (Figure 2, f), or surrounded by an insulated spiral grid (Figure 2, g), making a "four member" tube, which is called a *pliodynatron*. The characteristics of the pliodynatron are discussed in Section 8.

### 3. Characteristics—Negative Resistance

Electrons from the filament  $F$  (Figure 1) are set in motion by the electric field between  $F$  and the anode  $A$ . Some of them go through the holes in the anode and fall upon the plate  $P$ . If  $P$  is at a low potential with respect to the filament, these electrons will enter the plate and form a current of negative elec-

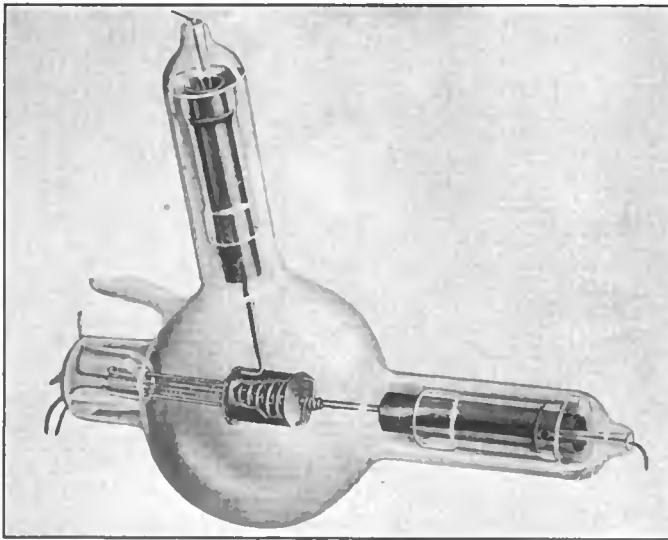

Figure 2—The dynatron

tricity in the external circuit. If the potential of  $P$  is raised, the velocity with which the electrons strike it will increase, and when this velocity becomes great enough they will, by their impact, cause the emission of secondary electrons from the plate. These secondary electrons will be attracted to the more positive anode  $A$ . The net current of electrons, received by the plate, is the difference between the number of primary electrons that strike and enter it and the number of secondary electrons which leave it. The number of primary electrons depends on the temperature of the filament and is practically independent of the voltage of the plate. The number of secondary electrons, however, increases rapidly with the voltage difference between plate and filament, and may become very much larger than the number of primary electrons; that is, each primary electron may produce several secondary electrons, as many as twenty in some cases.

The result is the characteristic voltage current relation shown in Figure 3. The abscissas represent voltages of the plate with respect to the negative end of the filament. The ordinates represent current in the plate circuit, reckoned positive for electrons passing from filament to plate, i. e., in the direction that is equivalent to positive electricity flowing from high potential to low across the vacuum. It is seen that for low voltages, the current is very small, since only those electrons which come from the most negative end of the filament are able to reach the plate. As the voltage is increased, the current increases rapidly, and at about 25 volts, the plate is receiving the full primary current from the whole filament. For all higher voltages, this primary current remains essentially constant. When the voltage is raised above 25 volts, however, the second factor becomes important. The primary electrons strike the plate with sufficient energy to cause the emission of secondary electrons, and this emission increases rapidly with the voltage, hence the *net* current to plate decreases rapidly. At 100 volts

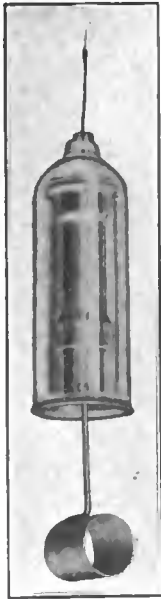

Figure 2, a



Figure 2, b

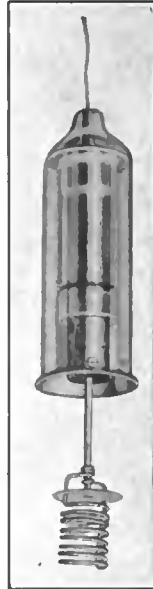

Figure 2, c

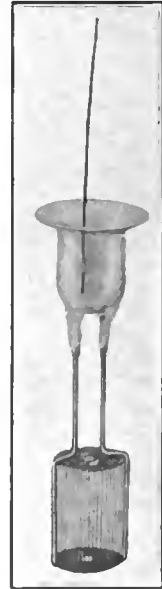

Figure 2, d

the number of secondary electrons leaving the plate is equal to the number of primary electrons entering it, so that the net current received by the plate is zero. As the voltage further increases, the number of secondary electrons becomes greater than the number of primary electrons, and the plate suffers a net loss of electrons; that is, the current is in the opposite direction to the impressed voltage. When the voltage is still further increased, a point is reached at which the anode is no longer sufficiently positive to carry away all the secondary electrons from the plate, and the current to the plate again becomes zero, and then rapidly rises to a value corresponding to the number of primary electrons.

It is evident from Figure 3 that over the range *A* to *C*, that is, between 50 and 150 volts in the case here represented, the current in the dynatron decreases

almost linearly with increase of voltage, and obeys the equation  $i = \frac{E}{\bar{r}} + i_0$ ,

where  $i_0$  and  $\bar{r}$  are constants,  $\bar{r}$  being negative. Since the constant  $i_0$  does not affect the variable part of the current in any of the applications for which the

dynatron has been used, it is convenient to characterize the dynatron by the constant  $\bar{r}$ , which will be called its *negative resistance*. The justification for this name is that the behavior of the dynatron in any circuit containing resistance, capacity, inductance and electromotive force can be accurately calculated by treating the dynatron as a linear conductor with negative resistance  $\bar{r}$ . Examples of such calculations are given below.

The term  $i_0$  in the above equation disappears if the dynatron is connected in

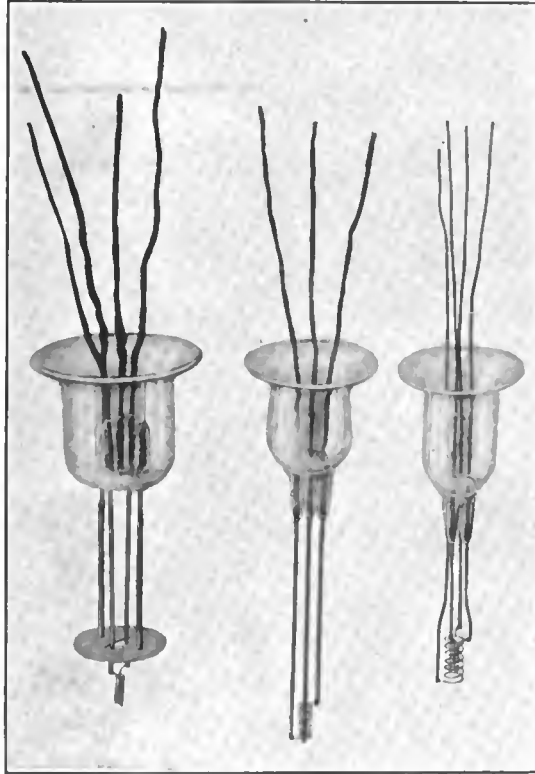

Figure 2, e

Figure 2, f

Figure 2, g

series with a battery, of voltage equal to that at which the dynatron current is zero (point  $B$ , Figure 3). The combination is a *true* negative resistance, for

which  $i = \frac{E}{\bar{r}}$ . For example, if the dynatron of Figure 1 be put, with its bat-

teries, in a box, and two wires be brought out through the box as terminals, one from the plate  $P$  and one from a point  $V_0$  of the battery corresponding to the point  $B$  of Figure 3, this "negative resistance box" would behave in all respects like a conductor with negative resistance, over the range of voltage, positive and negative, represented by  $BC_0$  and  $BA_0$  in Figure 3.

The magnitude of the negative resistance, which is the slope of the current voltage curve, Figure 3, and the range of voltage  $A_0 - C_0$  over which it can be used, depends upon the anode voltage, the temperature of the filament, and, to some extent, on the shape and material of the electrodes. The effect of varying

anode voltage alone is shown for two different types of tube in Figures 4 and 5, and the effect of varying filament temperature in Figure 6. It is seen that the effect of varying anode voltage is, in general, to shorten or lengthen the range of the negative resistance part of the curve, without changing the value of the

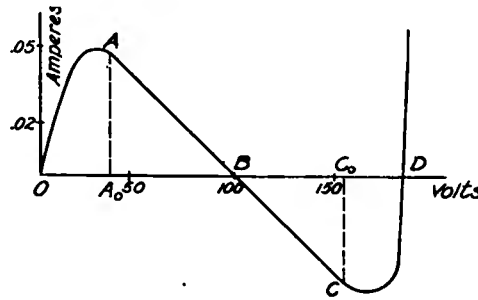

Figure 3

negative resistance. A slight shift in the voltage  $V_0$  at which the curves cross the axis is, for one tube, to the right with increasing voltage, and for the other, to the left. It is therefore to be anticipated that with proper construction, this shift could be made accurately zero, and the operation of the tube be independent of the value of anode voltage over a wide range. Varying the filament temperature, on the other hand, changes the negative resistance only, without affecting the range or the value of  $V_0$ . This affords a simple means of adjusting the negative resistance to any desired value, but at the same time imposes a condition upon

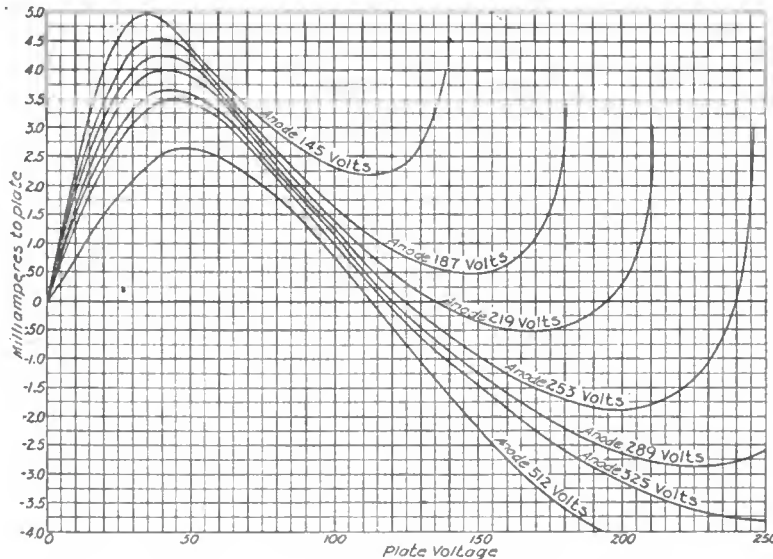

Figure 4

the uniform operation of the tube, namely, that the temperature of the filament be kept constant.

It will be noticed that the negative slope of the curves in Figure 4 is less straight than those of Figure 5. This is a disadvantage where exact balancing of positive and negative resistance is desired, but for some of the purposes of radio work to be described later, it is an advantage. The degree of curvature depends upon the construction of the tube, and may be made anything that is desired.



**4. Dynatron in Circuit Containing Positive Resistance A. Series Connection. Circuit with Zero Resistance**

If the dynatron is connected in series with a circuit containing positive resistance, the total resistance of the circuit is the algebraic sum of the positive and

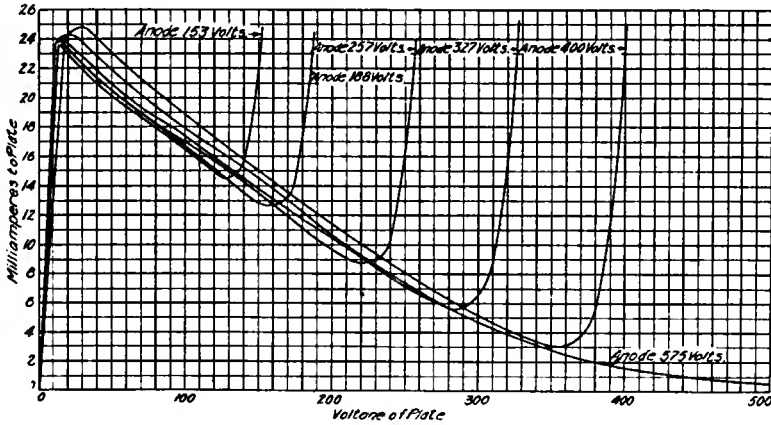

Figure 5

negative resistances, and may be made as small as desired by making the positive and negative resistances nearly equal. Such a circuit has very interesting properties. For, while the total resistance of the circuit is very small, that of its parts,

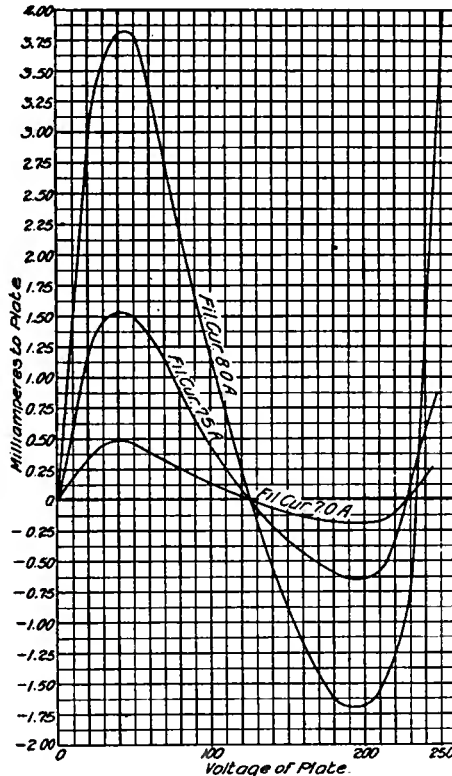

Figure 6

individually, is not. Hence a small change in the e.m.f. applied to the whole circuit will cause a comparatively large change in current, and therefore in the  $iR$  drop across each part separately; i. e., the circuit acts as a voltage amplifier.

(To be continued)

# Finding Your Way Across the Sea

A Practical Instruction Course in Navigation

By CAPTAIN FRITZ E. UTTMARK

## CHAPTER VI.

(Copyright, 1918, Wireless Press, Inc.)

### The Sailings

IN reference to a ship's position at sea relative to any other position, either one that has been left or one which the vessel is bound to, or the difference between any two positions, five terms are involved: The course or direction, the distance, the difference in latitude, the departure and the difference of longitude. The solutions of the various problems in which the mutual relations of the above terms are involved are called *Sailings* and are as follows:

*Plane Sailing.* In which we consider the earth as a perfectly flat surface or plane. In this sailing we can only consider the course, the distance, difference of latitude and departure. If two or more courses are involved, these are combined and the method is called *Traverse Sailing*.

*Spherical Sailing.* Whenever difference of longitude is involved the earth must be considered in its spherical form and therefore these sailings are called spherical sailings and include Parallel Sailing, Middle Latitude Sailing, Mercator Sailing and Great Circle Sailing.

### Plane Sailing

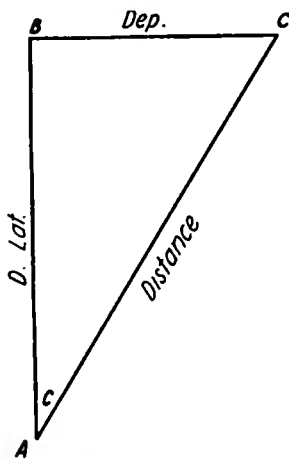

Figure 1

As said before, in plane sailing we take no consideration of the curvature of the earth but the problems are solved by considering the sides and angles of a plane triangle. Let in the triangle, figure 1, the angle BAC or C represent the course or rhumb line, the side AB the Difference of Latitude (D. Lat.), BC the Departure (Dep.), and AC the Distance from A to C. We have thus:

$$\sin C = \frac{\text{Dep.}}{\text{Dist.}}$$

$$\cos C = \frac{\text{D. Lat.}}{\text{Dist.}}$$

$$\text{Tang } C = \frac{\text{Dep.}}{\text{D. Lat.}}$$

From the above equations the following formulæ are derived and cover all the plane sailing problems:

<i>Given</i>	<i>Required</i>	<i>Formulas</i>
Course and Distance	Diff. of Lat. D. Lat. = Departure Dep. =	$\text{Dist.} \cos C. \log \& \text{Lat.} = \log \text{Dist.} \log + \text{Cos } C.$ $\text{Dep.} = \text{Dist.} \sin C. \log \text{Dep.} = \log \text{Dist.} \log + \sin C.$
Diff. Lat. and Departure	Course Distance	$\text{Tang } C = \frac{\text{Dep.}}{\text{D. Lat.}} \log \text{Tang } C = \log \text{Dep.} - \log \text{Diff. Lat.}$ $\text{Dist.} = \frac{\text{Dep.}}{\sin C} \log \text{Dist.} = \log \text{Dep.} - \log \sin C.$
Course and Diff. of Lat.	Distance Departure	$\text{Dist.} = \frac{\text{D. Lat.}}{\cos C} \log \text{Dist.} = \log \text{D. Lat.} - \log \cos C.$ $\text{Dep.} = \text{D. Lat.} \text{ tang } C. \log \text{Dep.} = \log \text{D. Lat.} + \log \text{Tang } C.$
Course and Departure	Distance Diff. of Lat. D. Lat. =	$\text{Dist.} = \frac{\text{Dep.}}{\sin C} \log \text{Dist.} = \log \text{Dep.} - \log \sin C.$ $\text{D. Lat.} = \frac{\text{Dep.}}{\text{tang } C} \log \text{D. Lat.} = \log \text{Dep.} - \log \text{tang } C.$
Dist. and Diff. Lat.	Course Departure	$\cos C = \frac{\text{D. Lat.}}{\text{Dist.}} \log \cos C = \log \text{D. Lat.} - \log \text{Dist.}$ $\text{Dep.} = \text{Dist.} \sin C. \log \text{Dep.} = \log \text{Dist.} + \log \sin C.$
Distance and Departure	Course Diff. of Lat. D. Lat. =	$\sin C = \frac{\text{Dep.}}{\text{Dist.}} \log \sin C. = \log \text{Dep.} - \log \text{Dist.}$ $\text{D. Lat.} = \text{Dist.} \cos C. \log \text{D. Lat.} = \log \text{Dist.} + \log \cos C.$

In the above table we have included all the various problems which may be solved by plane sailing but the two first mentioned are most frequently used.

The problems may be solved either by plane trigonometry, by construction or by the use of the Traverse Tables No. 1 and No. 2 Bowditch. The latter method is by far the most convenient and will therefore only be considered in this series. Table No. 1 contains the Difference of Latitude and Departure corresponding to distances not exceeding 300 miles and to courses for every quarter point of the compass. Table 2 is of the same nature with this difference that the Difference of Latitude and Departure corresponds to every full degree of the compass and the distances extend to 600 miles.

*Example.* A ship sails NW by W  $\frac{1}{4}$  W true a distance of 120 miles.

Required the Difference of Latitude and Departure made good.

Enter table 1 with the course  $5\frac{1}{4}$  points taken from the bottom of the page and refer the distance 120 miles to the distance column. Opposite 120 you find the Diff. of Lat. to be 56.6 miles and the Departure 105.8 miles.

*Note.* If you take the course from the bottom you must also read the names Lat. and Dep. from the bottom of the pages.

### Traverse Sailing

When the ship sails on various courses the ship's track will be irregular or zig-zag. This is called *Traverse*, and the method of *Traverse Sailing* consists of finding the difference of latitude and departure corresponding to the several courses and distances and combining them so as to reduce them to the equivalent of one single course and distance. This is done by determining the distance to North or South and to East or West made good on each course; then adding all the Northings also all the Southings; subtracting the lesser from the greater and calling the remainder Diff. of Lat. made good. Then add together all the Eastings and all the Westings; again subtract the lesser from the greater and call the remainder Departure made good.

*Example.* A ship sails the following true courses and distances: S by E  $\frac{1}{4}$  E, 25 miles; E  $\frac{3}{4}$  S, 50 miles; SW by W, 75 miles; W  $\frac{1}{4}$  N, 100 miles; NW  $\frac{3}{4}$  W, 125 miles.

Required Latitude and Departure made good; also course and distance made good.

SOLUTION

True Course	Distance	Diff.		Departure	
		N	S	E	W
S by E $\frac{1}{4}$ E.....	25		24.3	6.1	
E $\frac{3}{4}$ S.....	50		7.3	49.5	
SW by W.....	75		41.7		62.4
W $\frac{1}{4}$ N.....	100	4.9			99.9
NW $\frac{3}{4}$ W.....	125	74.5			100.4
		<hr/>	<hr/>	<hr/>	<hr/>
		79.4 N	73.3	262.7 W	
		73.3 S		55.6 E	
		<hr/>		<hr/>	
		6.1 N		207.1 W	
		Course Made Good.....	N 88°	W	
		Distance Made Good.....		207 miles	

To find the course and distance made good: Look in Table 2 for the difference of latitude in a latitude column and turn the pages over until you find the amount of departure to agree as near as possible. The exact amount is seldom found. If the *Diff. of Lat.* is greater than the *Departure* the course will be found at top of page, but if less than *Departure* it will be found at the bottom of page and the distance in the column immediately to the left hand side.

**Parallel Sailing**

In the foregoing the earth has been considered as a plane surface and its spherical form has not been taken into consideration. The Longitude or Difference of Longitude has therefore not been possible to consider.

Parallel sailing is the simplest form of spherical sailings. It is the method of converting the Departure into Diff. of Long. or the reverse; used when the ship sails on a due east or west course, or when the direction between two places is direct East or West.

In the figure No. 2, let A and B represent two places of the same latitude, P the adjacent Pole, AB the arc of the parallel of latitude through the two places; DE the corresponding arc on the equator intercepted between the meridian PD and PE; AB is the departure on the parallel whose latitude is BFE = CBF, and whose radius is CB.

Let Diff. of Long. represent the arc of the equator DE, which is the measure of DPE, the difference of longitude of the meridians PD and PE; R the equatorial radius of the earth, FE and FD; r the radius CB of the parallel AB; and L, the latitude of that Parallel.

Then, since AB and DE are similar arcs of two circles, and are therefore proportional to the radius of the circle s, we have:

$$\frac{AB}{DE} = \frac{CB}{EF}; \text{ or } \frac{\text{Dep.}}{\text{Diff. Long.}} = \frac{r}{R}$$

From the triangle FCB,  $r = R \cos L$ ; hence

$$\frac{\text{Dep.}}{\text{Diff. Long.}} = \frac{R \cos L}{R}; \text{ or } \text{Diff. Long.} = \text{Dep. sec } L;$$

$$\text{or } \text{Dep.} = \text{Diff. Long. } \cos L.$$

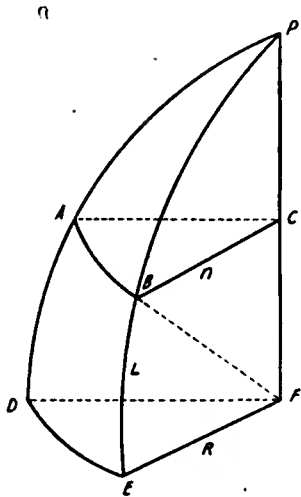

Figure 2

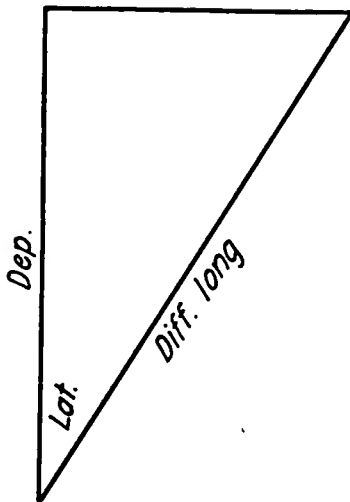

Figure 3

The above expresses the relations between *minutes* of Longitude and *miles* of departure.

Parallel sailing involves two cases: First where the difference of longitude between two places on the same parallel is given, to find the departure, and second, where the departure is given to find the difference of longitude.

The solutions may be found by computation using logarithms, but the Traverse Tables are used to greater advantage as they are more convenient.

The tables are based upon the following formulæ:

D. Lat. = Dist. cos C, and Dist. = D. Lat. sec C, we may substitute for the column marked *Lat.* in Table 2 the *Departure*, for that marked *Dist.* the *Difference of Longitude* and for the courses at top or bottom of the page, the Latitude. Figure 3.

The tables then become convenient for making the required conversions.

*Short Rule*, for finding Diff. Long. when the departure is given. Enter table 2 with the Lat. as a course, select the amount of departure from a Lat. column; find the Diff. of Long. corresponding thereto in a Dist. column.

For finding the departure, when Diff. Long. is given, enter Table 2 as before, take the amount of minutes of longitude into a *Dist. column*; find the Departure in a *Lat. column*.

*Example.* A ship in latitude 40° 50' North sails west 350 miles. Required the Diff. of Longitude.

*Solution:* Enter Table 2 with 41° (this being the nearest full degree) look for 350 in a Lat. column (you will find 350-2, this being the nearest) in the corresponding dist. column will be found 464; this is your minutes of Diff. Long. and = 7° 44'.

*Example.* A ship sailing on the parallel of Latitude 36° has changed her longitude 5° 10'. How many miles has she sailed?

*Solution:*  $5 \times 60 = 300' + 10' = 310$ , this being the Diff. of Longitude in minutes. Turning to 36° in Table 2 we find against 310 in the Dist. column; 250.8 in the Lat. column, this is the Departure or miles the ship has sailed in order to change her Long. 5° 10'.

*Note.* With miles in these articles, unless otherwise stated, we mean *nautical miles* or knots which have the same length as a minute of latitude or 6080 feet.

(To be continued)

# New Navigation Plotting Chart

Invented by Capt. F. E. Uttmark

Marc St. Hilaire Method of finding a ship's position at sea is extensively used in the U. S. Navy and gaining in popularity in the Merchant Marine. It is one of the best ways of finding the ship's position by employing the intersection of the Sumner lines.

At night, dawn or twilight when the stars and planets, or the moon is visible and the horizon clear, we can always select two conveniently situated heavenly bodies from which observations may be taken and position plotted on the chart, thus enabling us to fix the ship's position at any desired moment. In day time we have often the sun and the moon visible at the same time, and occasionally the planet Venus is in such a position that we can observe it when it crosses the meridian and the sun is in the Eastern or Western sky, thus obtaining Latitude by the Meridian Observation and the ship's position by intersection of the Sumner lines. When the Sun alone is visible we need two observations with an interval of time.

The point of intersection of two Sumner lines may be found by computation or by plotting the lines on the chart; the latter method is by far the more simple.

We have had specially designed charts for plotting purposes but the drawback has been the inconvenience of their bulk. To cover the latitude from the Equator to 60° a set of twelve charts (scale 4 inches to one degree of longitude) which is about the smallest scale that can be used for accurate results has been in use for many years, and contains over 200 square feet of paper.

This trouble is now over and by the use of the newly invented Uttmark's Plotting Chart which covers all Latitudes from 60° North to 60° South and all Longitudes, although less than *one square* foot in area, has a scale of 6 inches to one degree of Longitude; that is to say, 50 per cent. larger than the scale on the plotting chart published by the U. S. Hydrographic Office. The new plotting chart which is illustrated in the present issue of the "Wireless Age," I trust will be of help to the navigator and to the student of St. Hilaire's popular method.

The chart may be used for plotting ship's position by any method using the Sumner lines.



Uncle Sam's new five thousand ton concrete ship Faith, ten times larger than any constructed up to the present time

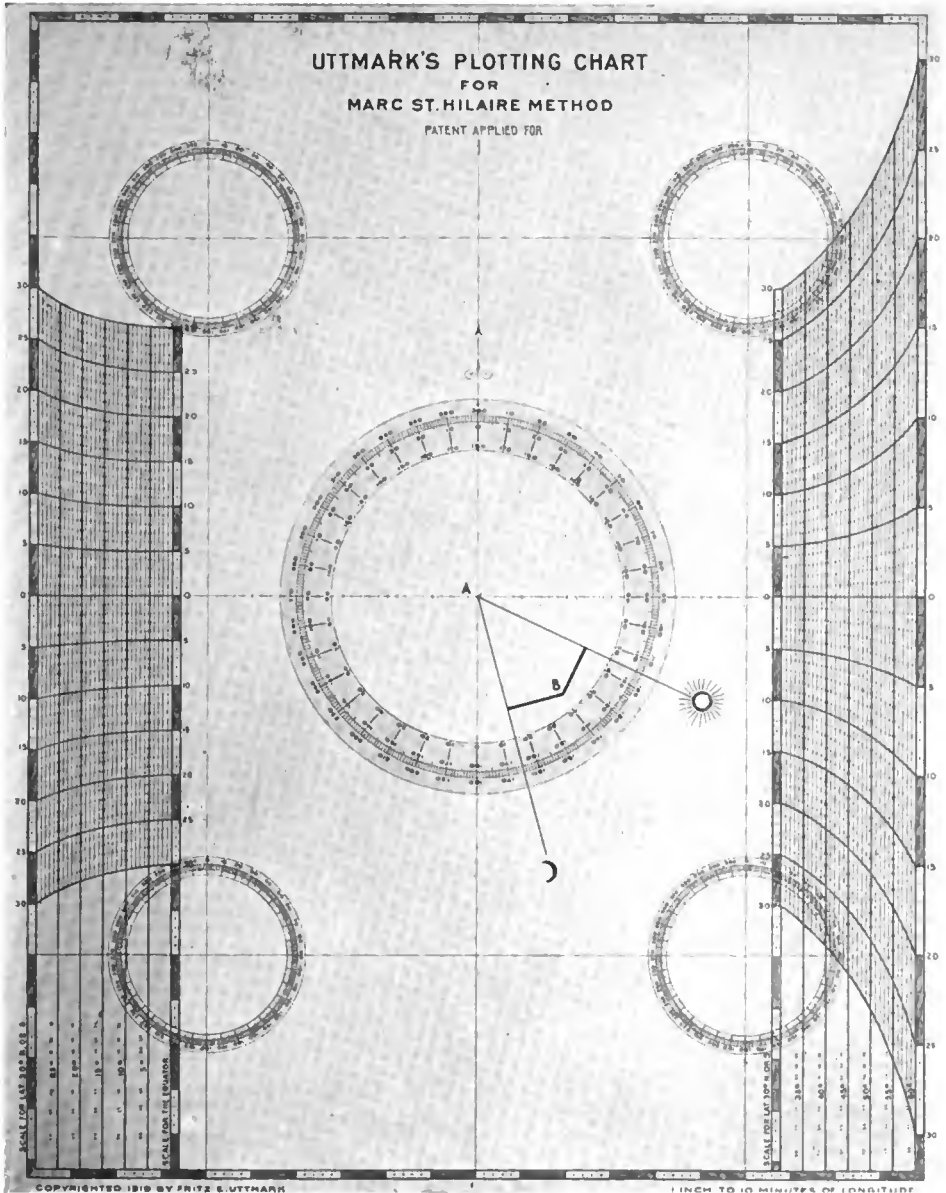

A. Ship's position by Dead Reckoning. B. Ship's correct position

**Directions for the Sun, Moon, Planets and Fixed Stars**

This chart can be used for all Latitudes from 60° North to 60° South and for any Longitude.

In North Latitude read the Azimuth from North to South over East or West according to the bearing of the celestial body. In South Latitude read the Azimuth from South to North over East or West, according to the bearing of the celestial body.

The center of the large compass diagram may generally be considered the ship's position by Dead Reckoning, and used in all Latitudes and Longitudes for which Mercator's Chart is constructed. The small auxiliary compass diagram may be used in extreme cases with an exceptionally long run between two solar sights.

The miles or minutes of Latitude are to be taken from the corresponding Latitude scale on the sides of the chart. For Longitude use the scale at top and bottom or center line of chart.

Although this plotting chart is specially designed for Marc St. Hilaire Method, it may be conveniently used for any other method when Sumner Lines are employed for finding the ship's position.

**NOTE.**—Lines of position or the Sumner Lines are always at right angles to the bearing or Azimuth of a celestial body.

(Patent applied for.)



(C) Press III Stce.

*One of the largest naval training stations in the country is located at Pelham Bay Park, near New York, where this picture was taken of advanced students manipulating portable wireless apparatus and vacuum tube receivers*



# Navigation News

This question has often occurred to men in the shipyards, particularly volunteers from inland communities:

**Shipbuilding Primer for Beginners** "How can they expect us to build ships, when some of us never saw a ship?"

It is a pertinent and natural question, and the Industrial Service Department of the Emergency Fleet Corporation has answered it by means of the book prepared by A. W. Carmichael, Assistant Naval Constructor, U. S. N.

This book is a primer on shipbuilding. It tells the man in the shipyard what he is to do; why he is to do it, and how he should do it. A child can read it and become fairly familiar with the technical terms common to the seafaring man.

The ordinary landlubber may know what a mainmast and a smokestack and bridge on a ship are. He may even know what the rudder and stern and propeller and their functions may be, but not many will understand when you talk to them about the cargo booms, the bulwark, boat deck, poop deck or forecastle. Imagine his mystification when you ask such a man to describe a shell plating!

By reading this book, which is called "Shipbuilding for Beginners," the volunteer worker will not only know what these things are, but he will know why they are and how they are made.

The little volume should be a valuable asset in every shipyard in the country.



A new chapter has been added to the romance of modern engineering, a story already replete with thrilling tales of man's triumph over the elements. An investigation conducted under the observation of the Emergency Fleet Corporation, involving construction of a large cargo-carrying concrete ship, opens up a new field that has possibilities of the most far-reaching importance. Success may mean a marked step toward victory over the German submarine.

In a shipyard at San Francisco has been launched the first large concrete vessel ever built in America, and, in fact, the largest ship of that construction ever built anywhere. This ship is an experiment, in so far as its size is concerned. There have been concrete ships built abroad, notably in Norway, but they were not so large. The vessel at San Francisco is of 5,000 tons.

If this ship is able to resist the strain of ocean traffic, which, it appears, is the big



*The bridge of ships to France*

factor of doubt connected with the experiment, experts say that it will be the forerunner of many more concrete ships.

It is confidently predicted that, with concrete shipbuilding an established, practical and economical accomplishment, the Fleet Corporation will be able to build many such vessels and that they will go far to solve the problem of re-establishing American prestige on the high seas.

The vessel will be put to sea with a cargo before her builders will call the test complete. If she successfully passes the first tests to which she will be subjected, and so demonstrates the practicability of the experiment, it is quite likely that more ships of similar construction and size, or even larger, will be built.

Another concrete vessel, smaller than the one in the San Francisco yard, is being constructed by the corporation in a private yard at Brunswick, Fla. The Fleet Corporation rented one of the shipways in the yard and began building a 3,500-ton concrete ship.

The work is being done under the direction of the Department of Concrete Ship Construction, of which R. J. Wig, formerly of the Bureau of Standards of the Department of Commerce, is head. Mr. Wig went to San Francisco to witness the launching of the vessel built there.

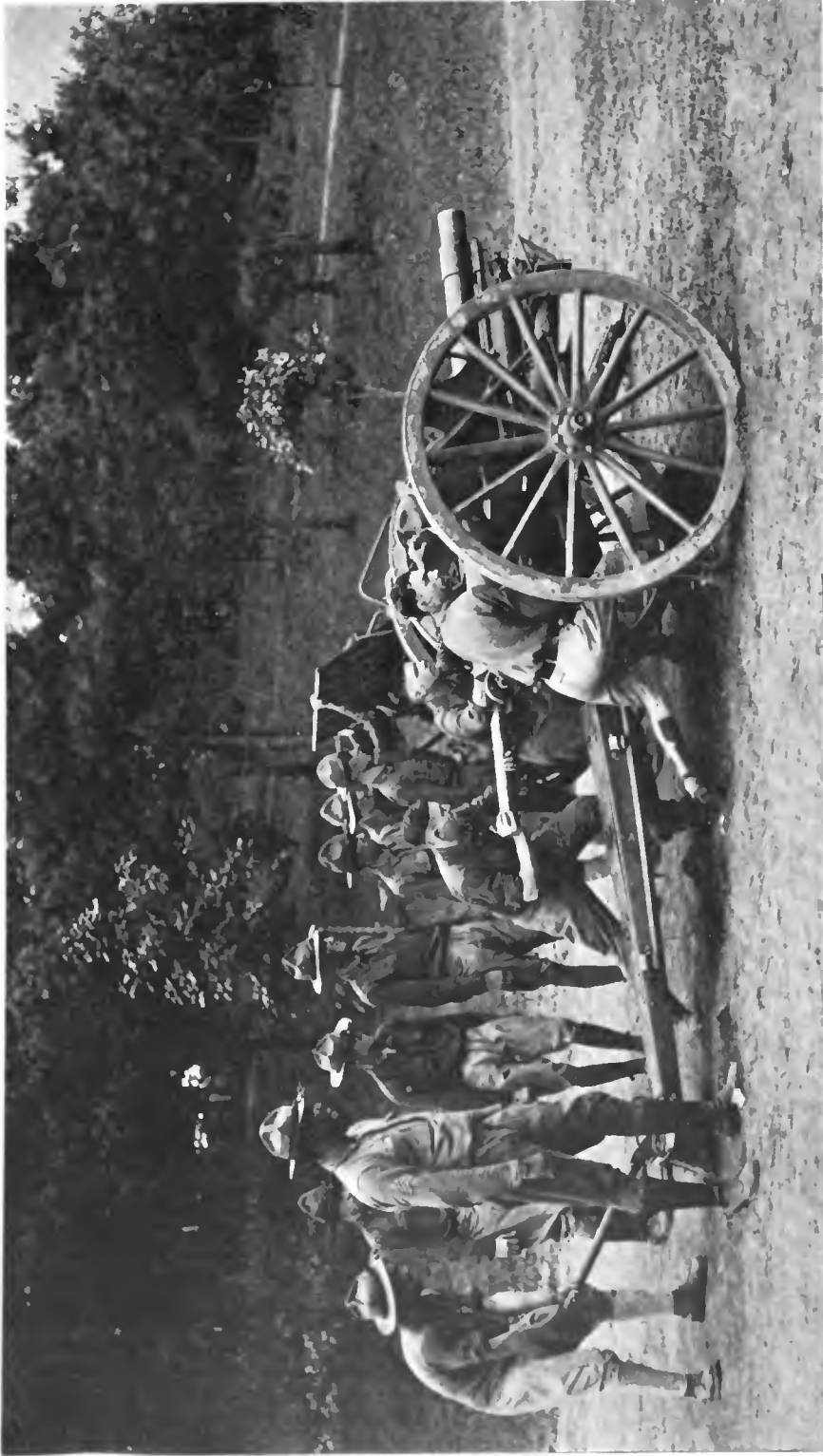

*Fire control by radio is one portion of the training of field artillerymen which is receiving special attention in the cantonments. The battalion radio officer responsible for accuracy of transmission of firing data is a second lieutenant, who receives advanced instruction. The photograph shows the 3-inch piece, correctly aimed in 20 seconds*

# Liberty Must Fight

AMERICA, entering a war for which her chief antagonist spent forty years in preparation, finds herself confronted with the necessity of a quick mobilization of every force within her industrial fabric including her man power. She can only meet Hun preparedness with industrial mobilization movements of a quickness, an intensity and of a size never before known in the history of the world.

Such a gigantic and necessary mobilization is the Third Liberty Loan, the campaign for which began on April 6.

Any man, woman or child who can read or listen while others are reading the authentic news prints of the day cannot escape the real conviction of the absolute necessity to civilization, to the United States and to each individual of our citizenship of the Third Liberty Loan.

The Hun has prepared the world and himself for conquest and a very definite extension of his Kommandanturs and Kultur throughout the world.

Readers of THE WIRELESS AGE know how thoroughly the forces of one of the newest arts and sciences have been utilized by the Hun in furtherance of a debasing of all the civilized world has held sacred. Officials of neutral countries and of peoples supposedly free have been corrupted for the purpose of allowing the establishing of wireless stations and the adjuncts to such stations which include secret service departments, poisoning squads, spreaders of germ diseases, and other practices which in a more primitive form have characterized barbarian warfare always.

We are told on the authority of perfectly authenticated observers in Belgium and North France that the German system there is perfect not only for repressing forcibly all manifestations of a national spirit but for actually attempting to win Belgians and French to German kultur.

Even the newspapers which were formerly published by the French in occupied parts of France have been taken over by the Germans. They are still published in French but with German editors who unceasingly attempt to point out to Frenchmen that they would be far better off under German barbarism.

There is ample evidence that such propaganda was long prepared under the direction of a department in Berlin and that the outbreak of the war found the German editors, with French educations, not far from the first forces which moved into Belgium and France.

Such preparedness can only be combated through the medium of Liberty Loans. America must be completely mobilized industrially, for not only must she fight for herself and take the place of Russia in the great struggle but she must also feed and in large part materially equip her Allies.

If every man followed the rare example of the man who will not buy Liberty Bonds there would be no world in which the non-purchaser could live—only a No Man's Land with a German Kommandantur to which the unhappy remnant of a once great nation would be compelled to report his every act.

The full duty of every American at this time is not only to buy Liberty Bonds, but to talk them. The addresses of Four Minute Men are helpful to the cause, but after all, the really effective speech, the speech that brings the biggest results is that employed in convincing the individual.



(C) Underwood & Underwood

*Aerial observers transmit their information by buzzer line and wireless to operators below. Wireless receiving sets of easy portability, such as shown in the illustration, being established at numerous points within the lines. With aircraft over the enemy positions sending while in rapid flight, the receiving task is no light one, requiring considerable skill on the part of the men engaged in this work*



# Military Preparedness

## Signal Officers' Training Course\*

A Wartime Instruction Series for Citizen  
Soldiers Preparing for U. S. Army Service

TWELFTH ARTICLE

By MAJOR J. ANDREW WHITE

Chief Signal Officer, American Guard

(Copyright, 1918, Wireless Press, Inc.)

### The Heliograph

THE heliograph is an instrument designed for the purpose of transmitting signals by means of the sun's rays.

#### DESCRIPTION

The service heliograph equipment of the Signal Corps consists of:

A sole-leather pouch with shoulder strap containing—

1 sun-mirror,  
1 station mirror. } Inclosed in a wooden box.

1 shutter, 1 sighting rod, 1 screw driver.

A small pouch, sliding by 2 loops upon the strap of the larger pouch, containing 1 mirror bar.

A skeleton leather case containing 2 tripods.

The mirrors are of plate glass, each  $4\frac{1}{2}$ -inch square, supported by sheet brass and cardboard backings, and mounted in brass retaining frame. The sun mirror has a paper disk covering the unsilvered spot in its center. The mirror frames are carried by brass supports provided at the bases with conical projections accurately turned to fit the sockets of the mirror bar and grooved at the ends to receive the clamping spring. Each support is fitted with a tangent screw and worm-wheel attachment functioned to control the motion of the mirror-frame about its horizontal axis.

The mirror bar is a bronze casting provided at the center with a clamp threaded to fit the screw of the tripod. By releasing the clamp the bar may be

\* The articles in this series are abstracted from the complete volume, "Military Signal Corps Manual," by the same author.

moved independently of the screw and adjusted to any desired position. Conical sockets for the reception of the mirror supports are provided at the ends of the mirror bar. These sockets work freely in the bar and, being actuated by a tangent screw and worm-wheel, serve to regulate the motion of the mirror frame about its vertical axis. Clamp springs, for engaging and securing the ends of the mirror-frame supports, are attached at each end of the bar.

The shutter is  $6\frac{1}{2}$  inches square, six segments or leaves being mounted in such a way as to form a shutter. The leaves are designed to turn through arcs

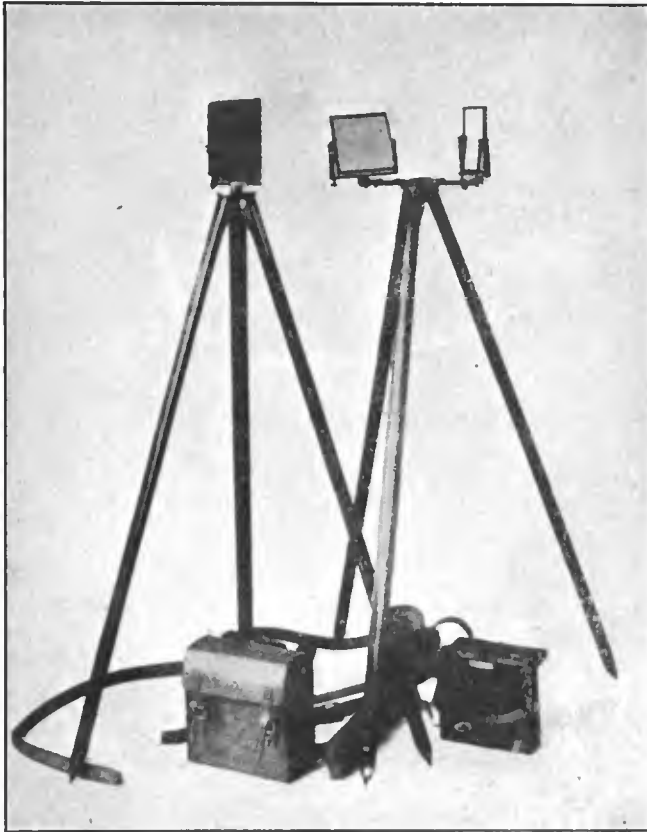

*The Heliograph assembled*

of 90 deg. on horizontal axes, unanimity of movement being secured by connections made with a common crank bar. The crank bar is operated by a key and retractile spring which serve to reveal and cut off the flash. A set screw and check nut at the lower edge of the screen frame limits the motion of the crank bar and the opening of the leaves. A threaded base support furnishes the means of attaching the screen frame to the tripod.

The sighting rod is a brass rod  $6\frac{1}{2}$  inches long, carrying at the upper end a front sight and a movable disk. About the rod is fitted a movable bronze collar, coned and grooved to take the socket and clamping spring of the mirror bar. A milled-edge bronze washer serves to clamp the collar to the rod at any desired point.

The tripods are similar in all respects, the screw of either threading into the mirror bar or shutter frame. Each tripod is provided with a hook at the base of the head, allowing the suspension of a weight when great stability is required.

## ASSEMBLING

There are two ways of assembling the heliograph, and the position of the sun is the guide in determining which of the two should, in any given case, be employed. When the sun is in front of the operator (that is, in front of a plane through his position at right angles to the line joining the stations) the sun mirror only is required; with the sun in rear of this plane both mirrors should be used. With one mirror the rays of the sun are reflected directly from the sun mirror to the distant station; with two mirrors, the rays are reflected from the sun mirror to the station mirror, and thence to the distant station.

*With one mirror:* Firmly set one of the tripods upon the ground; attach the mirror bar to the tripod; insert and clamp in the sockets of the sun mirror and sighting rod, the latter having the disk turned down. At a distance of about 6 inches, sight through the center of the unsilvered spot in the mirror and turn the mirror bar, raising or lowering the sighting rod until the center of the mirror, the extreme point of the sighting rod, and the distant station are accurately in line. Firmly clamp the mirror bar to the tripod, taking care not to disturb the alignment, and turn up the disk of the sighting rod. The mirror is then moved by means of the tangent screws until the "shadow spot" falls upon the paper disk in the sighting rod, after which the flash will be visible at the distant station. The "shadow spot" is readily found by holding a sheet of paper or the hand about 6 inches in front of the mirror, and should be constantly kept in view until located upon the disk. The shutter is attached to a tripod and established close to, and in front of, the sighting disk in such a way as to intercept the flash.

*With two mirrors:* Firmly set one of the tripods on the ground; clamp the mirror bar diagonally across the line of vision to the distant station; clamp the sun mirror facing the sun to one end of the mirror bar and the station mirror facing the distant station. Stooping down, the head near and in the rear of the station mirror, turn the sun mirror by means of its tangent screws until the whole of the station mirror is seen reflected in the sun mirror and the unsilvered spot and the reflection of the paper disk accurately cover each other. Still looking into the sun mirror, adjust the station mirror by means of the tangent screws until the reflection of the distant station is brought exactly in line with the top of the reflection of the disk and the top of the unsilvered spot of the sun mirror; after this the station mirror must not be touched. Now step behind the sun mirror and adjust it by means of the tangent screws so that the "shadow spot" falls upon the center of the paper disk on the station mirror. The flash will then be visible at the distant station. The shutter and its tripod are established as described in the single mirror assembling.

*Alternate method with two mirrors:* Clamp the mirror bar diagonally across the line of vision to the distant station, with the sun mirror and the station mirror approximately facing the sun and distant station, respectively.

Look through small hole in sun mirror and turn the station mirror on its vertical and horizontal axes until the proper disk on the station mirror accurately covers the distant station.

Standing behind sun mirror, turn it on its horizontal and vertical axes by means of the tangent-screw attachments until the "shadow spot" falls upon the paper disk on station mirror.

## ADJUSTMENT

Perfect adjustment is maintained only by keeping the "shadow spot" uninterruptedly in the center of the paper disk, and as this "spot" continually changes its position with the apparent movement of the sun, one signalman should be in constant attendance on the tangent screws of the sun mirror. Movement imparted by these screws to the mirror does not disturb the alignment, as its center (the unsilvered spot) is at the intersection of the axes of revolution. Extra care bestowed upon preliminary adjustment is repaid by increased brilliancy of flash. With the alignment absolutely assured and the "shadow spot" at the center of the disk, the axis of the cone of reflected rays is coincident with the line of sight

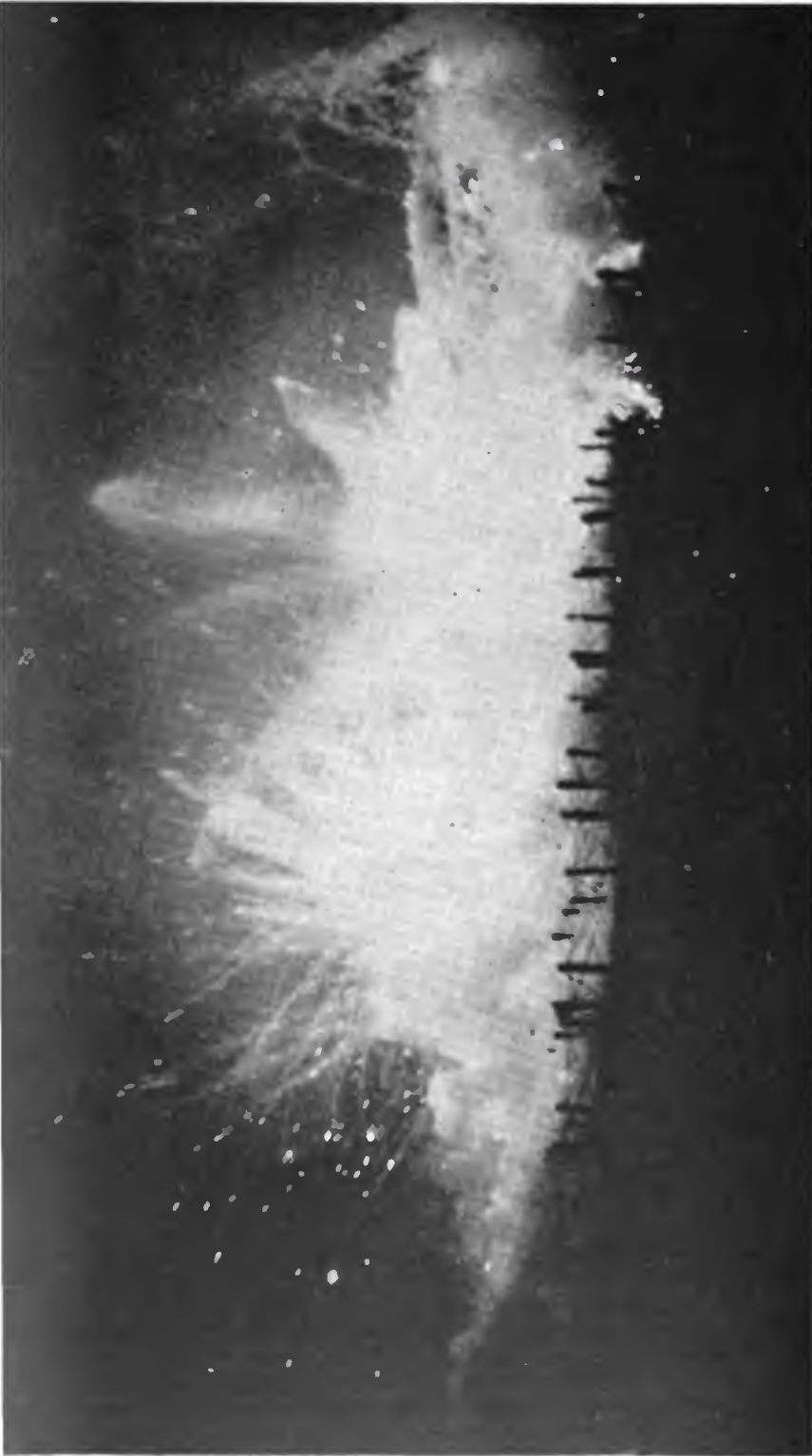

*This death-dealing pyrotechnic display is that which the Signal Corps man in the first line trenches faces in the long night preceding an attack at dawn. The remarkable view of No Man's Land given here graphically portrays the barrage fire which words cannot adequately describe*



and the distant station receives the greatest intensity of light. Remember the distant observer is unquestionably the better judge as to the character of the flash received; and if, therefore, adjustment is called for when the "shadow spot" is at the center of the disk, the alignment is probably at fault and should be looked after at once. In setting up the tripod always see that the legs have a sufficient spread to give a secure base, and on yielding soil press firmly into the ground. Keep the head of the tripod as nearly level as possible and in high wind ballast by hanging a substantial weight to the hook. See that the shutter completely obscures the flash; also that the flash passes entire when the shutter is opened. This feature of the adjustment is partially regulated by the set screws attached to the shutter frame. The retractile spring should sharply return all the leaves of the shutter to their normal positions when the key is released. Failure to respond promptly is obviated by strengthening or replacing the spring.

#### OPERATION

It is of the utmost importance that uniformity in mechanical movement of the shutter be cultivated, as lack of rhythm in the signals of the sender entails "breaks" and delay on the part of the receiver. Dark backgrounds should, when practicable, be selected for heliograph stations, as the signals can be most easily distinguished against them.

To find a distant station, its position being unknown, reverse the catch holding the station mirror and with the hand turn the mirror very slowly at the horizon over the full azimuth distance in which the distant station may possibly lie. This should be repeated not less than twice, after which, within a reasonable time, there being no response, the mirror will be directed upon a point nearer the home station and the same process repeated. With care and intelligence it is quite probable that, a station being within range and watching for signals from a distant station with which it may be desired to exchange messages, this method will rarely fail to find the sought-for station.

The exact direction of either station searching for the other being unknown, that station which first perceives that it is being called will adjust its flash upon the distant station to enable it when this light is observed to make proper adjustments. If the position of each station is known to the other, the station first ready for signaling will direct a steady flash upon the distant station to enable the latter to see not only that the first station is ready for work, but to enable the distant station to adjust its flash upon the first station.

Smoked or colored glasses are issued for the purpose of relieving the strain on the eyes produced by reading heliograph signals.

#### CARE OF APPARATUS

Minor parts of the instrument should be dismounted only to effect repairs. Steel parts should be kept oiled and free from rust. Tangent screws and bearings should be frequently inspected for dust or grit. Mirrors should invariably be wiped clean before using. In case of accident to the sun mirror, the station mirror can be made available for substitution therefor by removing the paper disk. If the tripod legs become loose at the head joints, tighten the assembling screws with the screwdriver.

#### POWERS AND LIMITATIONS OF THE HELIOGRAPH

Portability, great range, comparative rapidity of operation, and the invisibility of the signals, except to observers located approximately on a right line joining the stations between which communication is had, are some of the advantages derived from using the heliograph in visual signaling.

The principal disadvantage results from the entire dependence of the instrument upon the presence of sunlight. The normal working range of the heliograph is about thirty miles, though instances of its having attained ranges many times greater than this are of record. The heliograph can be depended upon to transmit from 5 to 12 words per minute.

### The Acetylene Lantern

The signal lantern is an instrument designed for the purpose of transmitting signals by means of intermittent flashes of artificial light. It is the standard night visual signaling equipment furnished by the Signal Corps and depends for its illumination upon the combustion of acetylene gas.

#### ACETYLENE

Acetylene is a pure hydrocarbon gas, producible in various ways, the commoner of which are: (a) By dropping calcium carbide into water; (b) by dropping water upon calcium carbide. This gas gives, when burning, high penetrative power, and was first described by Mr. Edmund Davy, professor of chemistry, to the Royal Dublin Society, in 1836.

#### CALCIUM CARBIDE

In the manufacture of calcium carbide for commercial purposes the best quality of coke and quicklime are used. These two substances are powdered thoroughly, mixed in proper proportions, and then placed in an electrical furnace. Under the action of the intense heat (5,500 deg. F.) these two refractory substances unite and form calcium carbide. Calcium carbide is of a grayish-white color, crystal in appearance, and is nonexplosive and noncombustible, being, except for its affinity for water, an absolutely inert substance.

When calcium carbide is brought in contact with water the following occurs:

As is known, the principal components of water are oxygen and hydrogen, and calcium carbide is calcium and carbon. When brought in contact, the oxygen in the water decomposes the calcium in the carbide, and in this decomposition the hydrogen in the water is liberated and unites with the carbon of the carbide, forming a hydrocarbon gas, which is acetylene. It gives a pure white light of intense brilliancy and high candlepower. The spectrum analysis of acetylene shows that it is almost identical with sunlight, and in consequence delicate shades of color appear according to their true value as under the light of the sun, consequently it penetrates fog to a greater distance than other lights. Acetylene is like other gases—explosive when mixed with air in proper proportion, confined, and ignited—and the same precautions should therefore be taken in its use as would be in the handling of coal or water gas, gasoline vapor, etc. As acetylene is very rich in carbon, it will not burn in its pure state without smoking. To avoid this, burners have been constructed so that the gas is mixed with the proper proportion of air at the burner tip, to insure perfect combustion. The burners for acetylene are different from those for other gases. In order to get a flat flame, the gas is brought through two perfectly round holes at an angle which causes the two flames to impinge upon each other and thus form a flat flame.

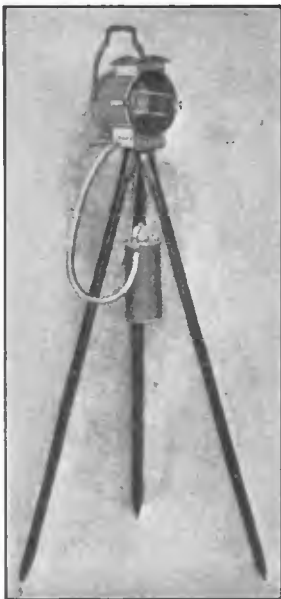

*Signal Lantern assembled*

#### METHOD OF GAS GENERATION

The method employed for producing acetylene in the signal lantern is by bringing water into contact with the calcium carbide. The disadvantage of this method is that when the water is not in excess and does not entirely surround and touch each piece of carbide the heat of generation will so change the chemical properties of the gas that combustion at the burners is not satisfactory.

This change is technically known as "polymerization," or the breaking up of acetylene into other hydrocarbons, such as vapors of benzine, benzole, etc. These form a tarry substance which is apt to condense at the burner tip and clog the openings. Also they deposit carbon on the burners, as they require more air for perfect combustion than does pure acetylene. Another disadvantage of this system is that after the carbide and water are in contact, generation of gas will continue until all the water is absorbed. Where, however, portability of the generating apparatus is desired and resort to this method is necessary, the objections are not important, if the apparatus is well constructed and care is taken in its use.

### DESCRIPTION

This equipment consists of a signal lantern with cartridge generator attached. The lantern is fitted with a special aplanatic lens mirror, 5 inches in diameter and about 3 inches focus. The lantern is packed complete in a wooden case with shoulder straps and the following extra parts are included, each part having its own receptacle in the case: 2 burners, 1 cover glass, 3 cartridges of calcium carbide of 5 ounces each, 1 pair of gas pliers, 1 tube white lead, 1 extra filter bag, 1 screwdriver.

The lantern is made of brass, all parts of which are riveted. The burner is of the double tip form. The lantern is fitted with a hood to provide proper ventilation and at the same time to prevent the flickering of the light by the wind. The front door of the lantern is hinged and fastens with a spring clasp; it is so arranged that it can be entirely removed if necessary. The cover glass is made in three sections and is not affected by the expansion and contraction of the metal due to changes in temperature. The glass is fastened by the aid of a spring wire, so that it can be readily removed if it is necessary to replace a broken section. In the base of the lantern is a key and the adjustment for regulating the height of the flame. The key is so arranged that when not depressed but little gas is admitted through to the burner, which gives a bright flash. At the back of the lantern there is an adjustable handle, so that the equipment can be used as a hand lantern if desired. This form of lantern can be used with the regular heliograph tripod, the generator being either attached to the back of the lantern or suspended, as shown in the photograph. When practicable it is better to attach the generator to the lantern, as shown in the smaller view. The candlepower of this lantern is about 1,900.

### THE GENERATOR

The generator used is known as "the cartridge generator," and while constructed on the water-feed principle, the disadvantages incident to this method are eliminated as far as possible. It is constructed of brass and has a removable top. Attached to the inside of the top is a flexible frame with a spring latch, the spring latch being hinged. At the top of the frame is a tube or cylinder, the bottom of which is conical in shape and covered by a rubber plug. At the bottom of the frame is a hollow tube, which is the water inlet. The cartridge proper consists of a tin cylinder having an opening at either end. A small cylinder of wire mesh extends from and connects these openings. The carbide lays around this mesh on the inside of the cartridge. The rubber plug before mentioned fits into the upper opening and the water tube into the lower opening. Inside the tube, at the top of the frame, is a filter, the function of which is to remove the dust and moisture from the gas. The outlet from this chamber is by a brass bent tube having a stopcock attached thereto.

The drawing gives a sectional view of the generator with the cartridge in place. *D F G H* represent the valve frame and *I* the cartridge attached. The reservoir *A* is filled with water, and when the frame is immersed, with the valve *R* closed, the air contained in the cartridge and tubing cannot escape, the water seal preventing, while the confined air prevents the water from rising in the tube *N*. When the valve at *R* is opened and the air is allowed to escape, part of the water from the reservoir rises into the tube *N* and then out through the small hole *O* to the carbide. Gas is immediately generated, the pressure of which prevents further ingress of the water from the tube *N*, and the generation of gas is suspended.

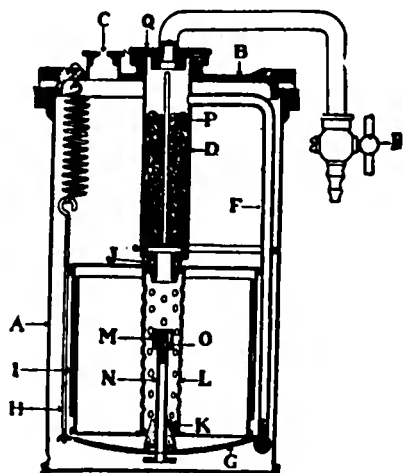

Signal Lantern Generator

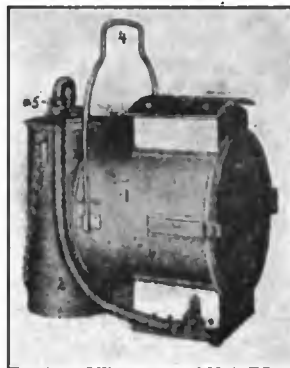

Signal Lantern with cartridge generator attached. The lantern is fitted with an aplanatic lens mirror and has a candlepower of 1900

As the gas passes out through the valve at *R* the pressure decreases, permitting the water to again rise in the tube and flow through *O*. Gas is again generated, which at once exerts its pressure and cuts off the supply of water. This is the automatic action by which water is brought in contact with the calcium carbide. Thus it will be observed that the use or escape of the gas regulates the generation by the simple device of the rise and fall of a water column. There is a cap *M* screwed over the tube *N*. This is used to deflect the course of the water downward, so that the carbide in the lower part of the cartridge is first attacked. There is a needle inside of cap *M*, which can be used for cleaning the hole *O*. When the gas is generated it passes through the filter *D* on its way to the burner through *R*. This filter consists of a tube loosely packed with ordinary nonabsorbent cotton, which should never cover the escape pipe leading to the valve *R*. In passing through this cotton filter moisture and dust are removed from the gas. In the latest model a felt filter is used instead of cotton.

The escape pipe *F* provides a means for the escape of gas generated and not used, or generated more rapidly than consumed. Should an excess be generated, it passes down through the tube *F*, and, finding its way through some small holes in the bottom of this tube, escapes through the water seal and the opening at *C*. It will be noted that if escaping gas at *C* should become accidentally lighted, the flame cannot strike back into the filter and cartridge because of the water seal. The principal things to observe in the operation of this generator are the following:

- (1) To see that the rubber plugs *fit tightly* into the openings of the cartridge.
- (2) That the tube *N*, the cap *M*, and water hole *O* are not stopped up.

- (3) That the cotton in the filter is changed frequently.
- (4) That the *stopcock R* is closed before inserting the frame in the water.

If this latter instruction is not complied with, it can be readily seen that the water will have free access to the carbide and excessive generation will occur.

When the charge is exhausted the entire cartridge is taken out and thrown away. This eliminates the handling of carbide and the disagreeable task of cleaning out the residuum after the gas has been extracted.

Connection is made from the stopcock *R* to the hose connection on the lantern proper, and this is the passageway of the gas from the generator to the burner. As soon as the stopcock is opened the water rises through the tube and flows to the carbide. The advantage of the cartridge being submerged in the water is to reduce and absorb as much of the heat liberated by generation as is possible.

#### POWERS AND LIMITATIONS OF THE ACETYLENE SIGNAL LANTERN

As conditions are usually more uniform at night than in the daytime, the signal lantern is probably with the exception of the searchlight the most reliable of all means of visual signaling. The advantages of this apparatus are its portability, speed of operation, and comparatively great range. The principal disadvantages are due to the interference caused by rain, fog, and moonlight. The speed attainable with the lantern is about the same as that attainable with the heliograph. In emergency, and for distances not exceeding  $\frac{1}{2}$  to  $\frac{3}{4}$  mile, the lantern can, on dark or cloudy days, be employed for day signaling. These lanterns have been tested up to a distance of 10 miles with the naked eye; and under favorable conditions can be used over a range somewhat in excess of this. With a 30 power telescope, the flash can be read at 30 miles.

#### Technical Equipment of Personnel

The technical equipment for men of a field company, Signal Corps, is as follows:

- (a) Each enlisted man carries on the person one electrician's knife, one pair of 5-inch pliers.
- (b) *Chiefs of sections* carry, in addition to (a), 1 field glass, Type D, a wrist watch, map case and map, a field message book, a pencil and a compass.
- (c) *Operators* carry, in addition to (a): Of wire sections—1 field buzzer (when not carried on the wire cart), 1 connector, buzzer, 1 ground rod, 1 wrist watch, 1 field message book, and 25 message envelopes, 2 pencils, 1 small roll of tape, 1 cipher disk. Of wireless stations—1 wrist watch, and also field message books, 25 message envelopes, 2 pencils, cipher disk and tape in the pack chests.
- (d) *Linemen* carry, in addition to (a), 1 wire pike, 1 cavalry buzzer, 1 connector, buzzer, 1 ground rod, 1 carrier with buzzer wire, 1 small roll of tape. The pike is not carried at ceremonies except at mounted inspection.
- (e) *Messengers* carry, in addition to (a): Of wire sections—1 field message book, 1 pencil, 1 small roll of tape, 1 box of wind matches, and, when not carried on the wire cart, a lantern, 3 candles, and box of wind matches. Of wireless sections—1 field message book, 1 pencil.
- (f) *Horseholders (dismounted: line guards)* carry, in addition to (a): Of wire sections—1 small roll of tape, and, when not carried on the wire cart, a lantern, 3 candles, and a box of wind matches.

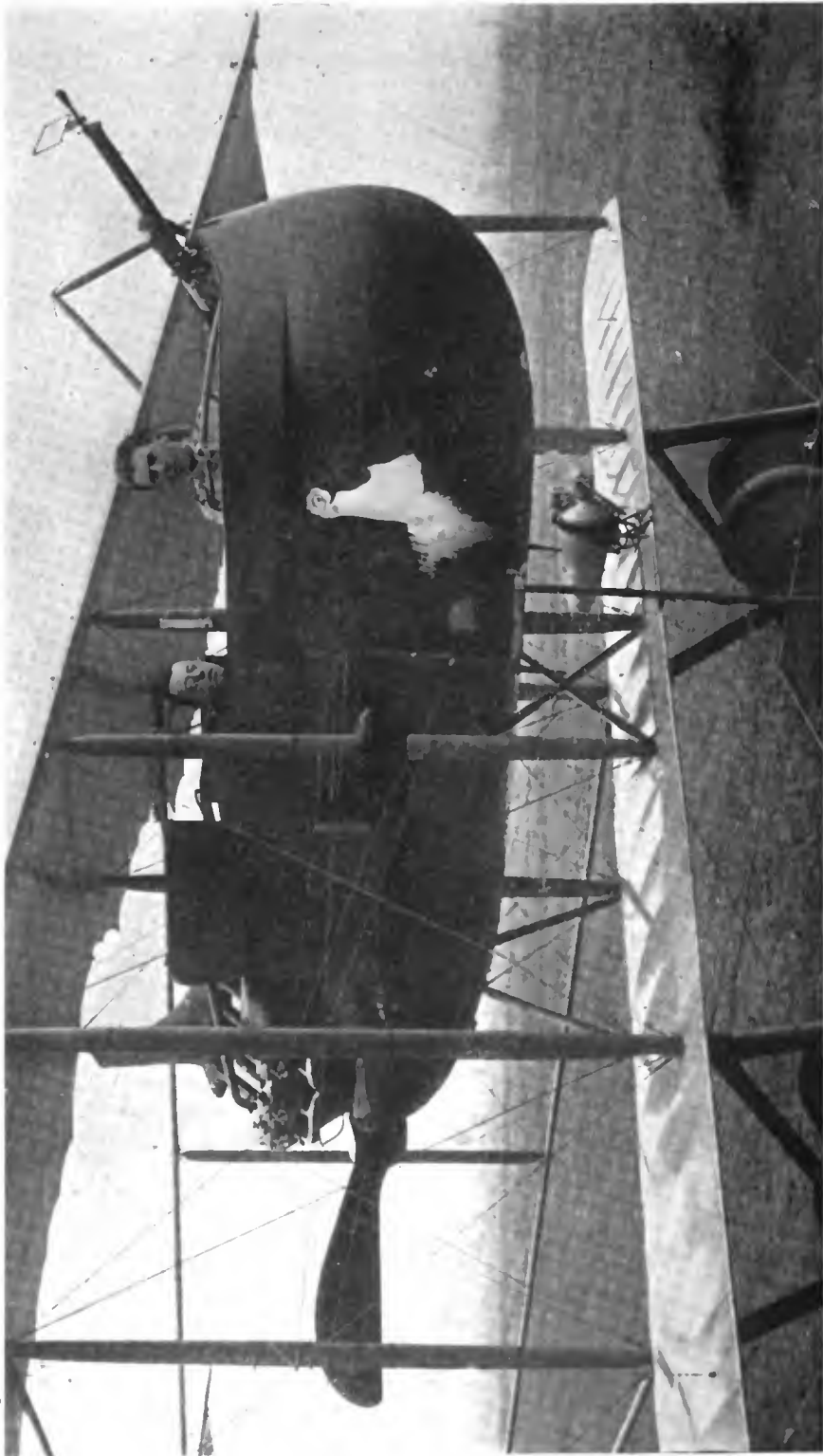
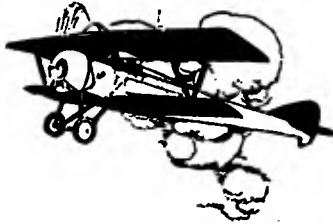

Photo Kadet & Herbert

*A French observation plane, showing the location of pilot and observer in the nacelle, the mounting of the machine gun and, on the lower wing, the generator for the wireless set rotated by wind action against the miniature propeller*

# How to Become an Aviator

The Tenth Article of a Series for Wireless Men in the Service of the United States Government Giving the Elements of Aeroplane Design, Power, Equipment and Military Tactics



By **HENRY WOODHOUSE**

Author of "Text Book of Naval Aeronautics"

(Copyright, 1918, *Wireless Press, Inc.*)

**C**ONTINUING the subject of aviation engines, a few considerations may be noted, preliminary to the study of pistons, valves and carburetors. First, is the refinement of design necessary for aeronautical work. The aviation engine, unlike those of motor cars, ordinarily uses 75 per cent. of its horsepower, as against one-quarter usage in motor cars. A second consideration of design is the necessity for building an aviation engine as light as possible, yet the punishment of material within the engine structure is about fourteen times as severe as in the motor car. The effect is demonstrated in the respective lives of both types. A motor car engine generally runs up to a mileage of 25,000, at a maximum average speed of 25 miles per hour, or completes 1,000 hours operation before overhauling is necessary. The aviation engine, with a speed of 100 miles per hour, requires a complete overhaul in about 50 flying hours, a total of 5,000 miles, or one-fifth of the motor car's period of operation.

These comparisons broadly illustrate the relative severity of the two types of engine service. But although it is required that the aviation engine be of light construction, strength must not be sacrificed in vital parts. While light weight is the aim in designing the crankshaft and crank case, main bearings, crank and piston bearings, strength is maintained by very careful selection of materials.

An aeroplane required to make climbs of 20,000 feet must necessarily have perfect reliability of operation. The structure of the aircraft is obviously sensitive to vibration and an engine which does not function smoothly materially impairs flight efficiency. Irregular impulses of the engine also affect its light structure and uniform explosions are a requisite. This uniformity is gained only through perfect distribution of gas to the cylinders.

The student should keep these conditions in mind as the study of vital parts of the engine is continued.

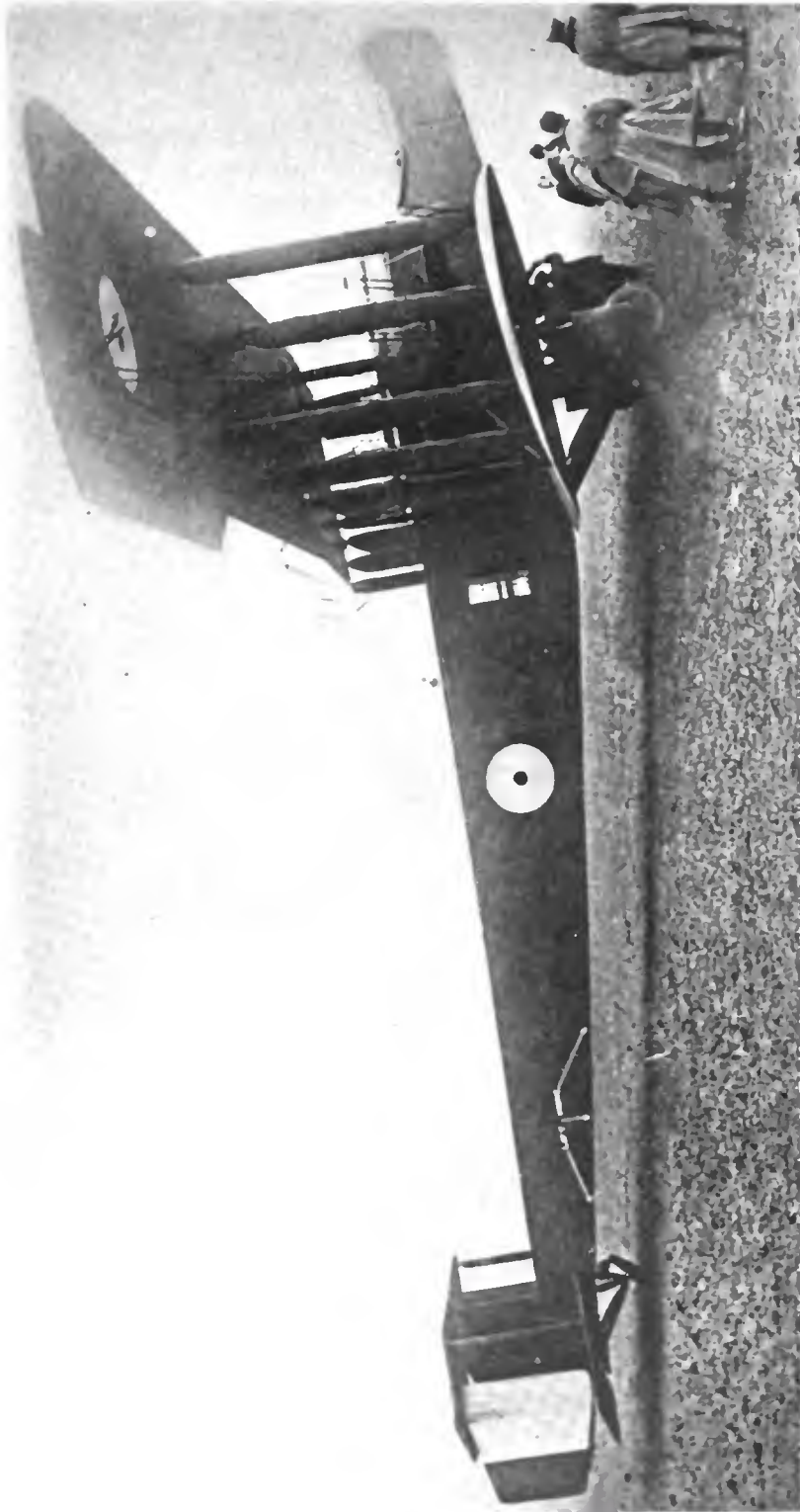

Photo Central News

*Interest in American aircraft production centers about the announcement that the Handley Page heavy bombing plane, here illustrated, has been adopted. This leviathan of the air carries as many as six men and eight machine guns*



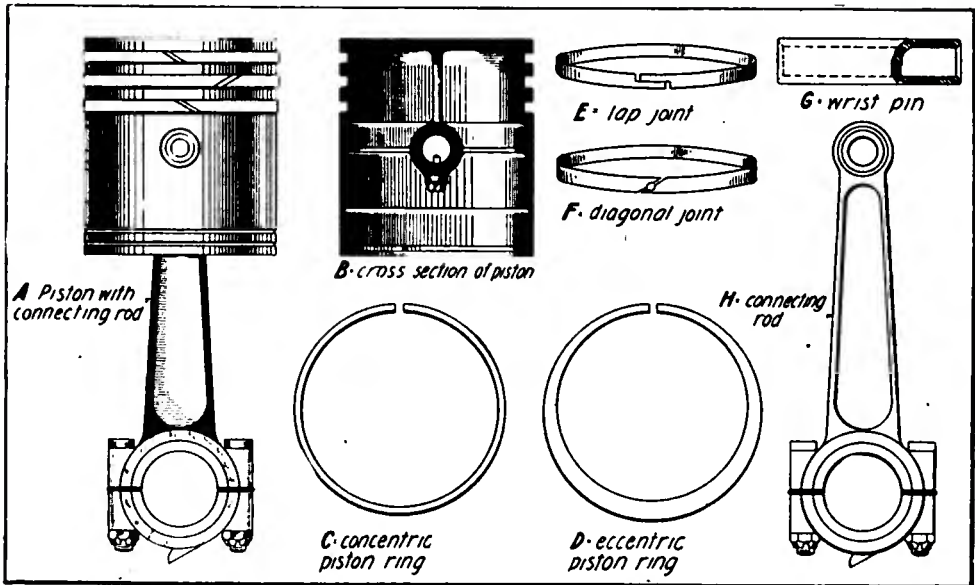

Figure 53—Details of the piston and connecting rod

## PISTON

Although one of the simplest parts of the aeroplane motor, the piston is one of the most important, as it receives the full force of the explosion and transmits the gas combustion into power.

In construction, it shows only slight variations in the numerous types of engines; the most common form of construction is shown at A and B in figure 53. The piston is made usually of cast iron, steel or aluminum, machined to fit the cylinder diameter with a clearance of .005 to .010 of an inch to compensate for the expansion of heat and permit lubrication between it and the cylinder walls. The clearance varies with the designed speed of the motor, increasing for the higher speed motors in which greater friction is created. Channels are cut in the outer face of the piston wall, near the top; in these the piston rings are placed.

## PISTON RINGS

These are split rings of cast iron, sprung so as to bear tightly against the wall of the cylinder to prevent leakage of gas from the combustion chamber and the passage of lubricating oil into the explosion area. Two types are shown at C and D in figure 53, and the common forms of expansion joints at E and F.

## CONNECTING ROD

The connecting rod joins the piston to the crankshaft and transmits the motion to the latter as the piston travels up and down. It is usually made of drop forged steel, I-beam construction.

A typical connecting rod is shown at H in figure 53, which indicates the two bearings, the upper, of bronze, connected to the wrist pin, and the lower bearing, through which the crank shaft passes, usually split and made of a bronze base with babbitt metal carefully scraped to exact clearance.

## WRIST PIN

This fitting, also known as the gudgeon or piston pin, joins the piston to the connecting rod. As shown at G in figure 53, it is a simple cylindrical element, usually made of steel and fitting the bosses closely.

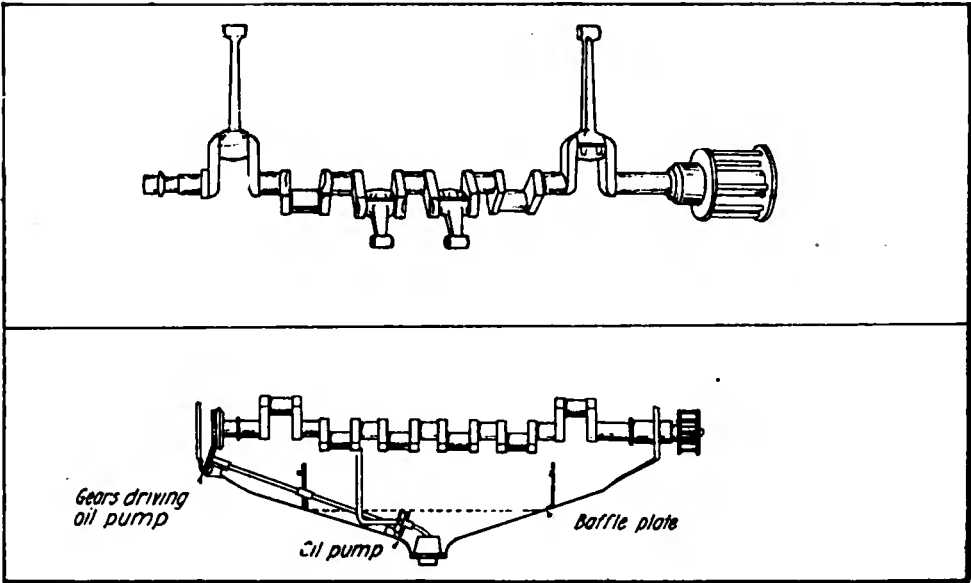

Figure 54 (upper)—Crankshaft of 6-cylinder engine

Figure 55 (lower)—Lower section of crankcase with shaft in position

## CRANKSHAFT

As the main drive shaft of the motor, the crankshaft is subjected to greatest strain; it is therefore ordinarily made of high tensile steel, drop or machine forging. It is constructed as a bar having U-shaped offset arms, or crank-throws, one for each cylinder for attachment to the connecting rods. It is usually drilled for oil ducts and hollowed to reduce weight, yet is of requisite strength to withstand the continuous shocks it sustains.

A crankshaft for a 6-cylinder engine is shown in figure 54, connecting rods being indicated and the propeller hub and flange shown at the right end. The opposite end carries a gear which meshes with a system of gears to transmit motion to the crankshaft, magneto, oil pump and other auxiliary parts.

In the illustration provision is made for mounting the propeller on the crankshaft for direct drive, in which case a flywheel would not ordinarily be used. Because the speed of the motor is generally considerably higher than the most efficient number of revolutions per minute of the propeller, reduction gears are commonly introduced at the propeller end of the crankshaft where the motor speed exceeds 1,400 revolutions per minute.

## CRANKCASE

The crankcase is usually made of aluminum alloy, in two parts, the upper, to which the cylinders are bolted, and the lower containing the crankshaft and lubricating oil. It contains the crankshaft bearings, or seats in which the center line of the crankshaft is supported. These mountings are usually made of babbitt or other high anti-friction metal.

Figure 55 shows the lower half of a typical crankcase for a 6-cylinder engine, the shape of the case conforming to the type of the motor in each instance.



(C) Comm. Pub. Info.

*Student aviators of the U. S. Signal Corps closely examining the assembly of the carburetor on an aviation engine*

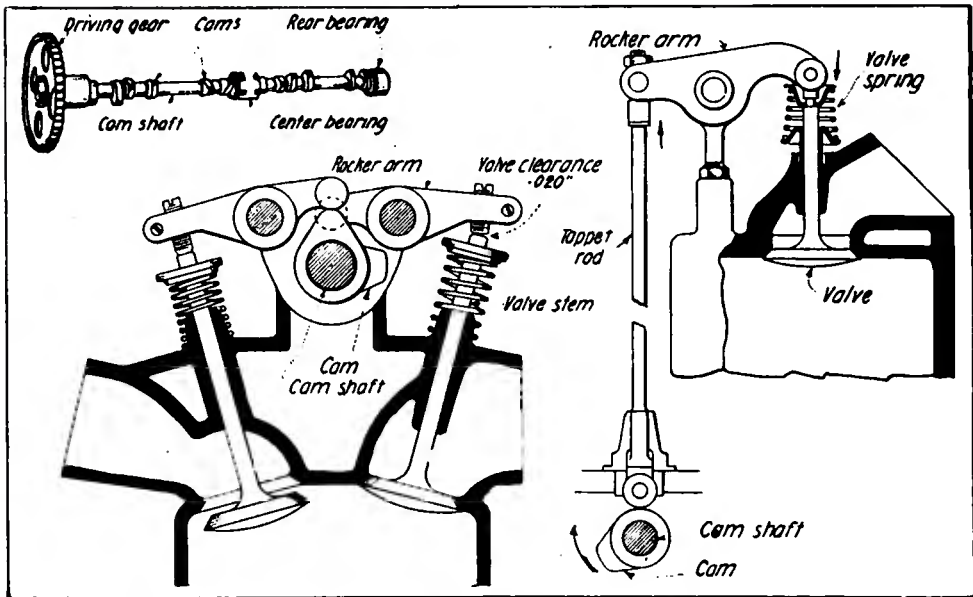

Figure 56 (upper left)—Camshaft, showing the driving gear and cams  
 Figure 57a (lower left)—Valve operating mechanism for overhead valves  
 Figure 57b (right)—Valve operating mechanism where camshaft is at base of motor

## CAMSHAFT

The shafts for operating the cams, or irregularly curved lugs, which operate the valve mechanisms are known as camshafts. The material generally used is open hearth or drop-forged steel; the bearings are of bronze. Camshafts are drilled to reduce weight.

Two methods of driving or rotating the camshaft are employed, the most common being by means of gearing, a simple spur gear such as shown at the left of figure 56 being employed when the camshaft is horizontal, or parallel to the crankshaft, from which it obtains its motion at half-speed.

Operation through use of a chain drive in the form of link belts over toothed pulleys, is the second method, recently come into some favor through its use in foreign engines.

## CAMS

A cam is a lug cast integrally on the crankshaft and machined to a form resembling a circle, with an approximately triangular projection at one point. It is this projection which acts on the valve mechanism as the shaft rotates.

Figures 57 a and 57-b show cams operating on overhead valves, the former acting direct on rocker arms and the latter through the medium of a tappet rod. Both intake and exhaust valves are operated by the same camshaft in general practice, although many exceptions are made in engines which have separate camshafts for intake and exhaust valves.

## VALVES

In almost every instance, aviation motors have valves placed in the head of the cylinder, or overhead valves, thereby gaining increased power. The valves are opened by the mechanism operated by the camshaft and closed by springs.

## VALVES AND VALVE MECHANISM

### EXHAUST VALVE

Exhaust valves are generally made of tungsten steel, which has the necessary high resistance to the heat of the exploded gases which pass through the exhaust. The disk and valve seat are beveled and ground so that the valve is gas-tight when seated.

Theoretically, the exhaust valve is opened only during one of the four cycles or phases of the engine's operation, that is on the upward exhaust stroke. In practice, however, it is usually opened as soon as the piston has moved downward through about seven-eighths of its power stroke, or  $\frac{1}{2}$  inch from bottom dead center. It closes exactly at the finish of the exhaust stroke, or in some cases it is allowed to remain open until the piston has moved down about 1-20-inch on its intake stroke, so that all exhaust gas has a chance to escape.

The exhaust ports are of proper dimensions, varying with type of engine, to insure rapid and complete expulsion of the burnt gas. Exhaust-manifolds are seldom used as they retard this expulsion, but short pipes are common, permitting the gas to exhaust into the open air but carrying it away from the aviator's face, and reducing the danger from fire.

### INLET VALVE

High nickel steel or cast iron are the materials generally used for inlet valves. The construction of valve and seat is identical with the exhaust valves, usually beveled and always ground so as to be leak-proof when closed.

It is timed to open as the piston has descended about  $\frac{1}{8}$ -inch on its intake stroke and remains open until the piston has traveled about  $\frac{1}{8}$ -inch up on the compression stroke. This permits the cylinder to fill with gas, the downward drive of the piston creating a suction which will remain stronger than the slight upward pressure created during the 200th part of a second in which the valve remains open as the upward compression stroke begins.

### VALVE OPERATING MECHANISM

Valve-in-the-head motors gain flexibility by offering no resistance to the entrance of gas into the combustion chamber, or impediment to straight exhaustion. But the valve opening mechanism is somewhat more complicated than that used in T-head or L-head cylinders. In place of the direct push rod action from the cams employed by the latter, the valve in the head motor secures its opening of valves by the system of rods and rocker arms illustrated in two forms, respectively in figures 57-a and 57-b.

In figure 57-b, the camshaft is located at the base of the cylinders, or at the crankcase, being rotated by bevel gears at half speed from the crankshaft. The cam pushes up the tappet rod, raising the rocker arm at one end which pushes down the valve attached to the other.

Figure 57-a shows a form of construction which places the camshaft above the cylinders, where it is driven by bevel pinion and gear drive by a vertical countershaft from the crankshaft. This form of construction is being adopted by many American aviation engine manufacturers, since it does away with the tappet rods and simplifies the engine construction.

All valves are closed by the action of the spring, as clearly indicated in the drawings.

### VALVE CLEARANCE

Space must be left between the valve stem and the actuating means, the amount of clearance depending upon the design of the engine. The clearance is indicated as .020 inch in figure 57-a, where the valve stems are long; in the Curtiss OX2 engine the clearance is .010 inch, or half, the variation being due to the amount of valve area which becomes heated and expands in length when the engine is running.

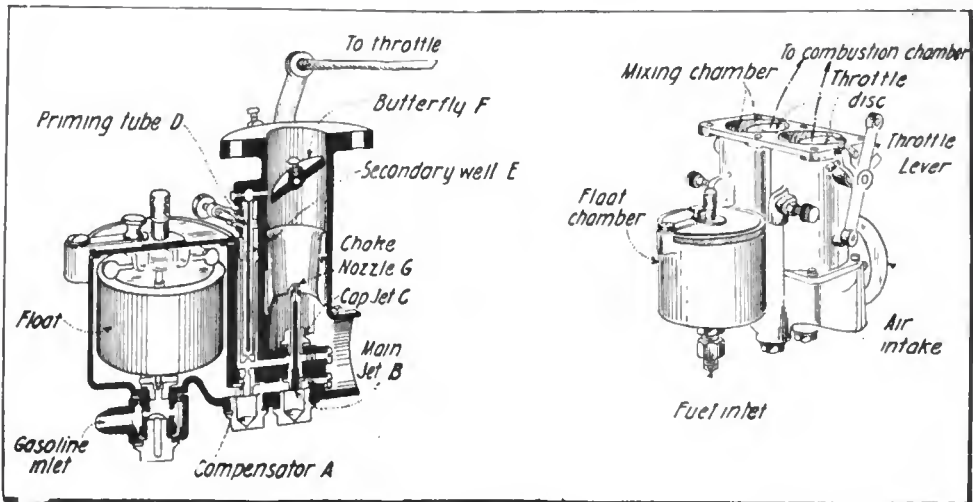

Figure 58 (left)—Sectional view of carburetor showing details of the compound nozzle and compensator

Figure 59 (right)—The duplex carburetor for multiple cylinder engines

## CARBURETION

Gasoline will not burn unless it is mixed with air. To burn with great rapidity and heat, or to "explode," as required by the internal combustion engines of aviation, the air must be in correct proportion to the gasoline vapor; these proportions range from 18 to 20 parts of air to one of gasoline. The vapor is produced by exposing the liquid to the air, generally by spraying into a mixing chamber.

## PRINCIPLE OF THE CARBURETOR

The device in which the vaporizing of gasoline is performed is termed a carburetor. There are numerous types used on aeroplanes, but the standard construction calls for: (a) a float chamber to maintain the gasoline at a constant level, (b) a mixing chamber where the gasoline is sprayed through a nozzle and mixed with incoming air. In the form of vapor it is then drawn through the inlet valve into the cylinder by the suction of the down stroke of the piston. The throttle valve, or butterfly, generally placed above the spray nozzle in the mixing chamber, regulates the amount of gas entering the cylinder; this valve is controlled by a lever near the pilot's seat. The speed of the engine increases with the opening of this throttle and decreases accordingly as it is closed. A float with a needle valve cuts off the flow of gasoline when the engine is not running.

## CONSTRUCTION OF THE CARBURETOR

Figure 58 is a sectional view of the Zenith carburetor, selected as typical of the best construction and widely used in American aviation engines. By a compensator and compound nozzle principle, this carburetor maintains a constant ratio of air and gasoline at the most efficient combustion mixture.

The advance in design here represented is the elimination of variable air valves or moving parts. The construction is clearly indicated in figure 58. Gasoline from the float chamber is admitted at compensator A into the priming tube D, extending into the secondary well E, and opening at the priming hole uncovered by the action of the butterfly valve F. The suction at the priming hole is powerful and with the butterfly partly open the well full of gasoline is drawn into the cylinders, effectively priming the motor. At high speeds with the butterfly opened further the priming well ceases to operate and the compound nozzle drains the well. It is this feature of the Zenith carburetor which counteracts the defects of the vaporization at the nozzle of the conventional carburetor when the engine is operating at low speed. To illustrate: In the conventional single jet carburetor the gasoline enters by suction through main jet B, spraying from nozzle G in the path of air entering through the inlet at the lower right of the drawing, figure 58. As the speed of the motor increases, the air flow increases, but the law of flow of liquid bodies makes the flow of gasoline from the jet increase faster, giving a mixture which increases the percentage of gasoline, or becomes richer. By the introduction of the secondary well E, the gasoline is fed through the compensator A and is not affected by the suction, since the well is open to atmospheric pressure. The flow of gasoline is therefore made constant at all speeds, it being obvious that as the air intake increases with greater speed, the mixture becomes poorer. The combination of the two results in a carburetor giving a constant mixture.

## DUPLEX CARBURETOR

For multiple cylinder aviation engines, arranged in V form, which will be discussed later, it was found that the strong cross suction in the inlet manifold made good carburetion difficult with a single carburetor. The development of the duplex carburetor, shown in figure 59, followed. It provides two separate mixing chambers, fed by a common float chamber and permitting each set of cylinders a separate intake.

## MANIFOLDS

As the gas mixture passes upward and out of the mixing chamber it reaches the cylinders by way of pipes divided into branches built to accommodate the model of motor, and termed manifolds. The branches of the manifold are of the same dimensions, so as to obtain the same results for all cylinders and are free from sharp bends or obstructions which might retard the progress of the gas to the cylinders.

# MILITARY AIRMEN



---

**CAPT.**  
**JAMES C. McCOY**

---

Prominent Balloonist and Former Militia Officer Whose Knowledge of Aeronautics Antedates the Use of Airplanes Now in Army Service.

**W**ITH the outbreak of the war, James C. McCoy was one of the first aviators to place his knowledge of aeronautics at the disposal of the Government. Recognizing the value of his long and varied experience, he was commissioned Captain in Aviation Section, Signal Corps. He had previously served in the Militia of the State of Colorado, where he held the rank of major.

Captain McCoy was among the first to take up ballooning in the United States, long before the days of heavier-than-air craft. He purchased one of the first aerostats to be used in the international races, and soon distinguished himself for his skill and fearlessness. Among the many thousands of men holding air pilot licenses today, Captain McCoy has the unique distinction of having been granted the first Spherical Balloon Pilot Certificate issued by the Aero Club. He is a charter member of the Aero Club of America, served on the Contest Committee for many years, was its president in 1908, and afterward a member of the Board of Governors.

More than ten years ago Captain McCoy, accompanied Lieut. Col. Charles de F. Chandler, U. S. A., when he won the Lahm Trophy. The flight, which lasted twenty hours and fifteen minutes, starting from St. Louis, covered 473 miles, the landing being made in West Virginia. He entered the second Gordon Bennett International Balloon Race in 1907, and afterwards ordered the best balloon that could be built, to be called the "America II," with which he entered the third Bennett race held in Berlin in 1908. This balloon was loaned to E. W. Mix, who entered it in the fourth international race which started from Zurich in 1909, winning the contest with a flight of 698 miles.

This famous balloon, which continued to be the personal property of Captain McCoy, was afterwards loaned to Allan R. Hawley, president of the Aero Club, who won the national balloon race, starting from Indianapolis in 1910; and afterwards the Fifth Gordon Bennett race, starting from St. Louis, when it made the remarkable record of 1,172 miles. The balloon was left in the wilds of Canada where it came down, but was afterwards rescued and participated in subsequent balloon races. Captain McCoy is not only one of the pioneers in the science of aeronautics in America, but has kept pace with its rapid development.



# Aviation News

The Board of Education of New York City has started classes in repair work for the aviation service. The **New York Trains Draft Men in Aero Repair Work** work is under the auspices of the Evening Schools, of which Henry E. Jenkins is in charge. The men will be taught how to reproduce, repair and assemble various parts of the airplane.

Only drafted men of Class 1 and 2 and who have had at least one year of experience in a mechanical trade necessary for aircraft work are qualified.

Ten classes to reproduce and repair the wooden parts necessary for an airplane have been organized. Two hundred and fifty men are taking this course. Six classes in engine repair work are now in operation, and several classes have also been organized in canvas work.



The Signal Corps has authorized the following statement:— Ten thousand machinists, mechanics, chauffeurs, mechanics, and other skilled workers are needed at **10,000 Skilled Men Needed by the Aviation Section** once by the Aviation Section, Signal Corps.

The present call for 10,000 men is to fill an immediate need and may be regarded as the precursor of others as the service is being built up. Even at that the actual strength of the service to-day is over one hundred times what it was on April 1st last year.

Men registered in the draft may be inducted into this service by applying to their local draft board. Men not registered may enlist at any recruiting office. Further information may be had by applying to the air division, Personnel Department, Washington, D. C. In either case they will be sent to San Antonio, Tex., for segregation by trades, followed by a brief course of instruction at the flying fields or at various factories and organized into squadrons mostly for service over-seas.

The present call is especially for machinists, auto mechanics, engine repairmen, gunsmiths, chauffeurs, carpenters, blacksmiths, tinsmiths, cabinetmakers, electricians, coppersmiths, sheet-metal workers, propeller makers, wireless operators and constructors, tailors, tentmakers, sailmakers, truck masters, vulcanizers, welders, and makers, repairers, and installers of mag-

netos, ignition systems, cameras, watches and clocks, instruments, and typewriters.



While the Signal Corps is not giving out the exact organization of the Aero Squadron, the Army and Navy **Aero Squadron Organization in U. S. Army** Journal publishes a tentative scheme, which outlines in a general way, the composition and organization of an Aero Squadron.

The squadron consists of Headquarters, Flying, Supply and Engineer divisions. Its officers are a major, captain and fourteen lieutenants, and an enlisted personnel of approximately 140 men.

The major is the commanding officer of the squadron, and it is not necessary that he should be a flier. He has an aid in the Headquarters Division, a lieutenant, who is in charge of all paper work, and who, in the absence of the major, takes command. The captain is in immediate command of the Flying Division, consisting of eleven lieutenants. He should be an expert flier and have a thorough knowledge of motors, planes and air currents. He designates the fliers for special duties and is responsible to the major for the planes.

The Supply Division is in charge of a lieutenant, who must not only look after all supplies for the squadron, but must attend to the transportation. Under the lieutenant in charge of supplies there is a mess officer. The Engineer Division officers must be experts in repair of planes, cars, trucks and cycles. They must keep a report sheet of all men under them, and a memorandum of parts needed to replace stock used. The enlisted force is made up of a sergeant major, a first sergeant, photographer, chauffeur, three corporals, besides dispatch carriers, a motor truck driver and two privates. The supply section has two clerks, a truckmaster, his assistants, a mess sergeant, supply sergeant, mechanic, a corporal, cooks, ten privates (first class, and privates) for general work. The enlisted men of the Engineering Section are four master signal electricians, four mechanics (sergeants, first class) and five sergeants (second class), three corporals and three privates (first class). In the Flying Section of the squadron are one mechanician (sergeant, first class), one mechanician (sergeant, second class) for each two planes,

six corporals (one for each two planes), twelve corporals (drivers of motor trucks) and four privates (second class).

It is probable that there may be one or two more lieutenants than the number mentioned—at least one in the Engineer Division and perhaps two instead of one in the Supply Division. The full number of privates is not given. In addition to the planes there are motor trucks, an automobile for the headquarters, motor cycles, repair trucks, developing room for photographs, apparatus for signaling and other vehicles and devices.



A motor car distributor of Chicago has arranged to sell aircraft as well as road craft. He is the first motor car dealer to handle aircraft on a commercial basis.



Official denial that the government has been placing orders for silk for use in the manufacture of airplane wings has been issued by the Aircraft Production Board. Rumors that heavy purchases of silk were contemplated have been circulated and many offers have come to the purchasing department from manufacturers whose material was said to be satisfactory for airplane purposes.

It is true, however, that silk has been considered. In fact, all fabrics have been experimented with, and the Bureau of Standards has been working under the supervision of the Aircraft Production Board, endeavoring to find the best material for wings. In addition many experiments are being made by private individuals and manufacturers.

Out of all the fabrics placed under these tests cotton proved to be the most satisfactory. A new way of spinning this material was devised and this method is closely guarded as a valuable military secret. Roughly compared with the usual process of cloth production, its description is covered by the term "spinning backward."

This new process cotton is said to surpass the stoutest linen and has passed the most rigid tests. Early experimenters thought it had an admixture of linen, but when unraveled it was found to be "pure cotton." It is understood the fabric has worked out so satisfactorily that the British Government has ordered several million yards for airplane purposes. It has also been found to be desirable for tentage.

A newly designed coupling, adaptable to all magnetos, generator or pump shaft drives, is similar in construction to the Oldham type, excepting that it has an automatic spring takeup for wear and to prevent noise.

The center piece consists of a ring two inches with  $3/32''$  wall; riveted solidly to the inside of this ring are two triangular shaped steel blocks. These rivets do not carry any load.

Placed midway between the two solid blocks are two similarly shaped blocks, loosely riveted and impelled inwardly by means of small coil springs. Regularly constructed shaft end members, each with two projections or jaws opposite each other, are inserted between the blocks, thus forcing the loose blocks outwardly from their inner rivet heads by deflecting the springs.

Due to spring pressure, these loose blocks hug the jaws at all times and will take up any wear. This squeezing action of the loose blocks does away of course with all looseness, rattle and back lash. The drive is meant to be taken on the solid blocks, but the spring tension is such that the loose blocks withstand a pressure of 34 pounds before they will squeeze outwardly.

About twenty-five of the largest motor car, truck and motor manufacturers have been testing this coupling for several months with satisfactory results in every case. Allowance is made for  $1/32''$  wear, but tests covering from 25,000 to 30,000 miles have shown a wear of less than .005.



In the month of January, says an official statement issued by the British War Office on March 4th, the Germans dropped 1,482 bombs in the area occupied by British troops in France. In the same period British aviators dropped 7,653 bombs in enemy areas.

The Germans dropped only 221 bombs in the daytime, the statement adds, while the British dropped 5,000 between sunrise and sunset.



The Air Board of Great Britain is issuing instructions to manufacturers of aircraft regarding efficient methods of cutting aircraft lumber. Diagrams are circularized showing the correct way of sawing up planks of various grains.



*That the terrible Turk, ally of the Hun, is using modern warfare methods under his master's tuition, is indicated in this view of the operation of the combined field buzzer and telephone*

# Wartime Wireless Instruction

## A Practical Course for Radio Operators

### ARTICLE XIII.

---

By **Elmer E. Bucher**

*Instructing Engineer, Marconi School of Instruction*

*(Copyright, 1918, Wireless Press, Inc.)*

---

**EDITOR'S NOTE**—This is the thirteenth installment of a condensed course in wireless telegraphy, especially prepared for training young men and women in the technical phases of radio in the shortest possible time. It is written particularly with the view of instructing prospective radio operators whose spirit of patriotism has inspired a desire to join signal branches of the United States reserve forces or the staff of a commercial wireless telegraph company, but who live at points far from wireless telegraph schools. The lessons to be published serially in this magazine are in fact a condensed version of the textbook, "Practical Wireless Telegraphy," and those students who have the opportunity and desire to go more fully into the subject will find the author's textbook a complete exposition of the wireless art in its most up-to-date phases. Where time will permit, its use in conjunction with this course is recommended.

The outstanding feature of the lessons will be the absence of cumbersome detail. Being intended to assist men to qualify for commercial positions in the shortest possible time consistent with a perfect understanding of the duties of operators, the course will contain only the essentials required to obtain a Government commercial first grade license certificate and knowledge of the practical operation of wireless telegraph apparatus.

To aid in an easy grasp of the lessons as they appear, numerous diagrams and drawings will illustrate the text, and, in so far as possible, the material pertaining to a particular diagram or illustration will be placed on the same page.

Because they will only contain the essential instructions for working modern wireless telegraph equipment, the lessons will be presented in such a way that the field telegraphist can use them in action as well as the student at home.

Beginning with the elements of electricity and magnetism, the course will continue through the construction and functioning of dynamos and motors, high voltage transformers into wireless telegraph equipment proper. Complete instruction will be given in the tuning of radio sets, adjustment of transmitting and receiving apparatus and elementary practical measurements.

This series began in the May, 1917, issue of *THE WIRELESS AGE*. Beginners should secure back copies, as the subject matter presented therein will aid them to grasp the explanations more readily. If possible, the series should be followed consecutively.

## RECEIVING APPARATUS

## PROBLEMS OF THE RECEIVER

(1) When a wireless aerial is set into oscillation, there is radiated into space a wave motion termed, **electric or electromagnetic waves.**

(2) These waves are composed of magnetic and static lines of force which are propagated at the rate of 186,000 miles per second (or 300,000,000 meters per second).

(3) The aerial at the **receiving station** is acted upon by both the electrostatic and electromagnetic fields, which cause the antenna system to oscillate at the same frequency as the transmitter.

(4) In order that the received energy may reach its maximum value the transmitter and receiver aeri-als must be carefully tuned to resonance, that is, they must possess the same natural frequency of oscillation.

(5) Resonance between the transmitter and receiver aeri-als is established when  $L \times C = L' \times C'$ ,

where  $L$  = the total inductance of the transmitter aerial;  
 $C$  = the total capacity of the transmitter aerial;  
 $L'$  = the total inductance of the receiving aerial;  
 $C'$  = the total capacity of the receiving aerial.

No matter how large or how small the values of  $L$ ,  $C$ ,  $L'$ ,  $C'$ , so long as  $L \times C = L' \times C'$ , the two systems oscillate in electrical resonance.

(6) Aeri-als having the same natural frequency of oscillation obviously if set into excitation would radiate waves of the same length. This is simply another way of stating the fact that the receiving aerial is accurately tuned to the transmitter when, if set into oscillation, it radiates a wave of the same length as the transmitter aerial.

(7) The condition is rarely encountered in practice where  $L \times C$  for the transmitter aerial =  $L' \times C'$  for the receiver aerial. That is, these aeri-als rarely possess the same physical dimensions or the same values of distributed inductance and distributed capacity.

(8) Because of this dissimilarity, the circuit of the receiving aerial must contain **tuning appliances** so that its natural frequency of oscillation can be made equal to that of the transmitter.

(9) These tuning devices are known as:

- (1) the **aerial tuning inductance;**
- (2) the **short wave condenser.**

Both are connected in series with the circuit from the aerial to the earth.

(10) From the simple equation for the natural wave length of an oscillation circuit,  $\lambda = 59.6 \sqrt{L/C}$ , it is easily seen that an increase of  $L$  or  $C$  will increase the natural wave length, or a decrease of  $L$  or  $C$  will decrease the natural wave length.

(11) By connecting a coil of wire in series with the antenna system at the base, its natural wave length is increased, and hence, as a receiving aerial it will respond to **long waves**. On the other hand, a series condenser connected in series with the receiving aerial reduces its capacity and therefore, as a receiving aerial it will respond to waves below the fundamental wave length.

(12) When the receiving operator tunes the receiving apparatus to a given transmitter, either by variation of inductance or capacity, he obtains the condition where the reactance of the antenna circuit to the incoming signals is zero. That is, the reactance of the inductance equals the reactance of the capacity for a given impressed frequency. Hence, the amplitude of the current flowing in the receiver circuit is governed by the impressed E. M. F. and the ohmic resistance (including other losses in the circuit).

## PHENOMENA OF THE TELEPHONE RECEIVER

(1) Vibrations in excess of 20,000 per second are practically inaudible to the human ear.

(2) If a 10,000 cycle current flows through the windings of a magnetic telephone, the diaphragm will vibrate 20,000 times per second. These vibrations are inaudible to the average ear. If the frequency of the impressed E. M. F. is reduced, the vibrations of the telephone diaphragm become more and more audible, the maximum sound being secured (for a given E. M. F.) at frequencies near to 500 cycles per second.

(3) The telephone diaphragm vibrates with the greatest amplitude when the frequency of the impressed E. M. F. equals the mechanical frequency of the diaphragm. That is, if the telephone diaphragm is deflected, and released, it will oscillate at a frequency determined by its mass and elasticity. Obviously, the greatest sound, as just remarked, will be produced when the frequency of the currents equals the natural frequency of the diaphragm. For the average receiver, the natural frequency of oscillation is around 1,000 vibrations per second.

(4) Currents above 10,000 cycles per second are inaudible, but those below this value become increasingly audible. Hence, an audio frequency current is one whose frequency is less than 10,000 cycles per second. A radio frequency current is one whose frequency exceeds 10,000 cycles per second.

(5) The frequencies employed in commercial wireless communication range from say 18,000 to 1,000,000 cycles per second, and since the ear will not respond to a rate of vibration so high as this, it is clear that we must supply some device at the receiving station which will change the incoming radio frequency current to an audio frequency current.

(6) Devices which effect this conversion are termed oscillation detectors.

(7) Among the simplest of oscillation detectors are, the solid rectifiers such as *cerusite*, *carborundum*, *galena*, *silicon*, *molybdenite*, etc.

(8) Possessing the property of rectification, these elements will convert a radio frequency current into a uni-directional pulsating current.

## COUPLED RECEIVING SYSTEMS

(1) As in the transmitting apparatus, coupled circuits are generally employed in connection with the receiving apparatus; that is, rather than connect the oscillation detector in series with the antenna, it is placed in a special closed circuit in inductive relation to the antenna system.

(2) The detector circuit may be coupled to the antenna system,

(1) inductively,

(2) conductively,

(3) electrostatically (inductive or conductive).

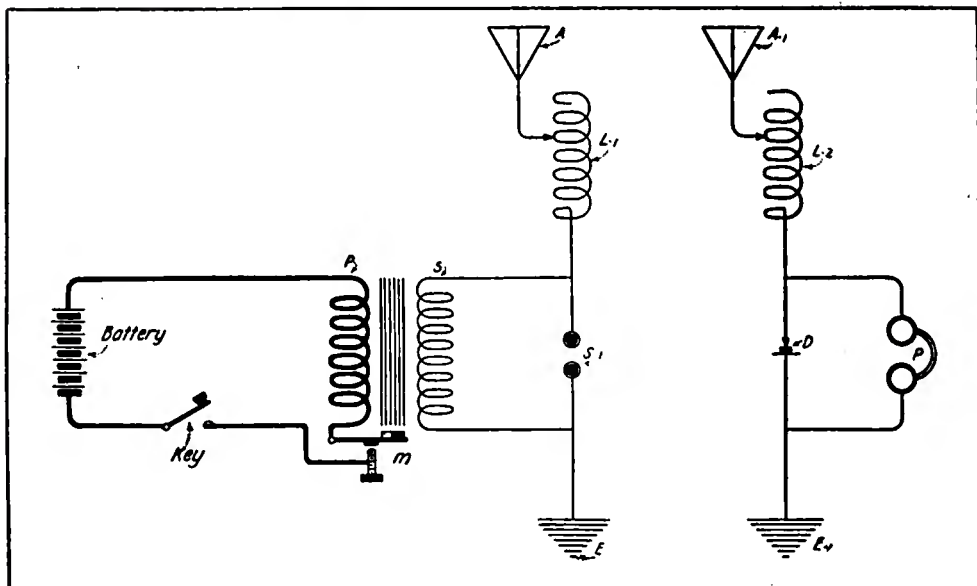

Figure 118

### OBJECT OF THE DIAGRAM

To show the circuits of the so-called "plain aerial" transmitting and receiving system.

### PRINCIPLE

An aerial wire (or group of wires) or any elevated capacity (preferably connected to earth at one end) possesses a certain value of distributed inductance and distributed capacity. If excited by a transient electrical charge, the aerial circuit will oscillate at a radio frequency determined by the magnitude of the inductance and capacity.

These oscillations set into motion groups of electrical waves which induce similar groups of oscillations in the receiving aerial.

The oscillations induced in the receiver circuits are of the same frequency as those of the transmitter. Direct response cannot be obtained in the head telephone, for reasons already explained. But if a rectifier be connected in series with the receiving aerial system, the incoming radio frequency currents are converted to direct current pulses which occur in groups following the spark of the transmitter. Each group impulses the telephone diaphragm once. The note of the spark discharge at the transmitting station is therefore reproduced in the receiver.

### DESCRIPTION OF THE DIAGRAM

The antenna system at the transmitting station comprises the aerial wires A, the loading inductance or antenna coil L-1, the spark gap S-1, and the earth connection E. Across the spark gap is connected the secondary winding of the induction coil S which has a primary winding P with the magnetic interrupter M.

The receiving station comprises the aerial wires A', the loading inductance or antenna coil, L-2, the rectifier D, the shunt telephone P, and the earth connection E',

## OPERATION

When the induction coil is placed into operation, the aerial is charged periodically at a rate determined by the frequency of the interrupter. For each charge given the antenna system, a spark discharges across the gap S-1 during the life of which a series of radio frequency oscillations flow in the complete antenna system. These radiate into space electromagnetic and electrostatic fields, which charge and cut through the receiving aerial wires A', inducing therein oscillations of similar frequency. By tuning the complete aerial system A' through the loading coil L-2, the currents in the receiving system will be built up to their maximum amplitude. Owing to the one way conductivity of the rectifier D, a series of direct current pulses flow through the telephone P, that is, each spark in the transmitter will send a decaying E. M. F. through the telephone which will produce one "click."

## SPECIAL REMARKS

(1) If aerials A and A' have the same electrical dimensions, coils L-1 and L-2 are not required to establish resonance (provided all other conditions are equal). But if, for example, aerial A' is considerably shorter than aerial A, turns must be added at L-2 to establish resonance with the transmitting station.

(2) Similarly, the length of the wave radiated by the transmitting station, can be increased or decreased by the inductance L-1, that is, if turns are added at L-1, the antenna will radiate a long wave, and if they are taken out, the antenna will radiate a wave determined by its distributed inductance and capacity.

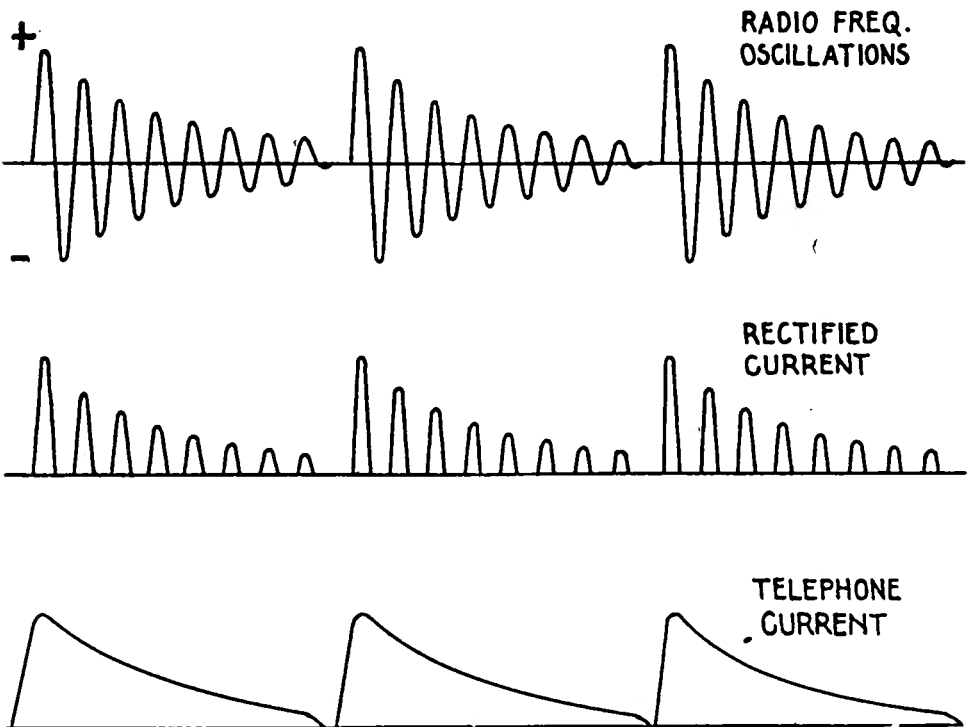

Figure 119.—Showing graphically how incoming radio frequency oscillations at the receiving station are converted into direct current pulses which actuate the telephone diaphragm. The oscillations on the upper line indicate those incoming at a given receiving station. Three groups are shown. A 500 cycle synchronous spark transmitter, for example, would induce in the receiving system 1,000 such groups. Their frequency is too great for response in the telephone, but when a rectifier is connected in the receiving circuit, one-half of each cycle is practically suppressed and the circuit is traversed by pulsating direct current as shown on the middle line. The frequency of the individual pulses is too great to obtain audible response from the telephone diaphragm, which responds to an average effect as shown by the lower line. Thus, 1,000 sparks at the transmitter will impulse the telephone diaphragm 1,000 times.



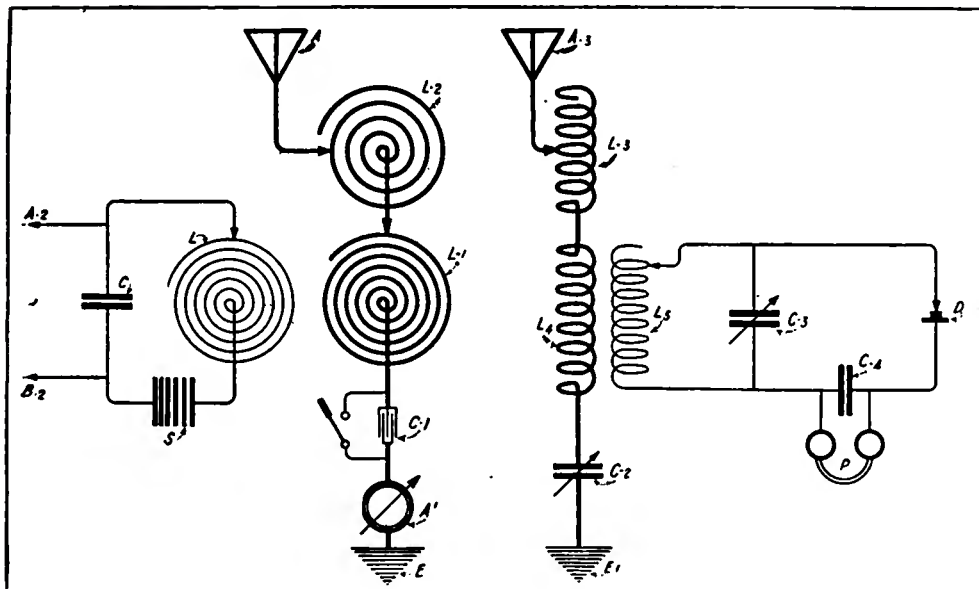

Figure 120

## OBJECT OF THE DIAGRAM

To show the complete radio frequency circuits of an inductively coupled transmitting and receiving system, i. e., a diagram representative of modern apparatus for the production of damped oscillations.

## PRINCIPLE

Powerful oscillations may be generated in a closed oscillation circuit from which energy can be transferred to the aerial wires by inductive coupling. Greater selectivity is obtainable at the receiving apparatus with inductive coupling because the character of the radiated wave can thus be closely governed. Similarly, the provision of inductive coupling at the receiver permits the operator to discriminate between stations that is, to prevent interference.

## DESCRIPTION OF THE DRAWING

The closed oscillation circuit of the transmitter is indicated by condenser C, inductance L, and spark gap S; and the open circuit by the aerial wires A, the antenna loading inductance L-2, the secondary winding of the oscillation transformer L-1, the short wave series condenser C-1, the aerial ammeter A', and the earth connection E. Connections A<sub>2</sub>, B<sub>2</sub>, extend to the secondary coil of a high voltage transformer, one giving from 15,000 to 20,000 volts.

The receiving system is represented by the aerial wires A<sub>3</sub>, the antenna loading inductance L-3, the primary winding of the receiving transformer L-4, the short wave variable condenser C-2, and the earth connection E'. The secondary or closed circuit of the receiving system comprises the tuning coil L-5, the shunt condenser C-3, the telephone condenser C-4, the crystal rectifier D, and the head telephone P.

## OPERATION

If the closed and open circuits at the transmitter are carefully tuned to the same natural frequency of oscillation, and moreover, if the coupling is adjusted so that the antenna system radiates a pure wave\*, the conditions of a modern transmitter are fully satisfied.

Oscillations flowing in the circuit of the aerial wires A, radiate electromagnetic waves which act inductively upon the receiving wires A<sup>1</sup>.

Radio frequency oscillations flow through coil L-4 setting up a magnetic field which acts inductively upon the coil L-5. The circuit L-5, C-3, is tuned to the given frequency of the incoming oscillations by the shunt condenser C-3. Condenser C-3, may, however, be eliminated, the requisite shunt capacity being found in the turns of the coil.

The oscillations in the secondary system are rectified by the crystal D, and a series of direct current pulses charge the condenser C-4. C-4 discharges through the head telephone P in one direction creating a single sound for each group.

## SPECIAL REMARKS

(1) The diagram of figure 120 indicates the fundamental circuits of Marconi's famous four circuit tuning patent.

(2) The closed and open oscillation circuits of the transmitter are carefully tuned to electrical resonance. Resonance adjustments may be found by a hot wire ammeter shown at A<sup>1</sup>. The circuits may be tuned to a definite wave length by means of a wavemeter. Similarly, the open and closed circuits of the receiving apparatus must be tuned to the frequency of the transmitter, that is, circuits A<sup>1</sup>, L-3, L-4, C-2, E, must be tuned to circuit L-5, C-3.

(3) The tuning appliances shown in the diagram of figure 120 are in general all that are required in modern wireless systems employing damped oscillations.

---

\*A single wave of decrement less than 0.2 per complete cycle.

# A Digest of Electrical Progress

Automatic Headlight-Dimmer for Automobiles—  
The Problems of Iron Wire Transmission—Checking  
Up Synchrosopes for the Paralleling of Alternators—  
A Mercury Vapor Pump for the Production of High  
Vacuum—The Regulation of a Series Single-Phase  
Motor.

## Automatic Headlight-Dimmer for Automobiles

IT has been customary for automobile drivers, as a matter of courtesy, to dim their headlights as they pass another automobile. In territories otherwise unlighted, this is a wise precaution. Now, through a recent invention of Victor Olson, the automobile operator is saved the trouble of shifting his headlights from bright to dim, leaving him free to tend to the driving mechanism of the automobile.

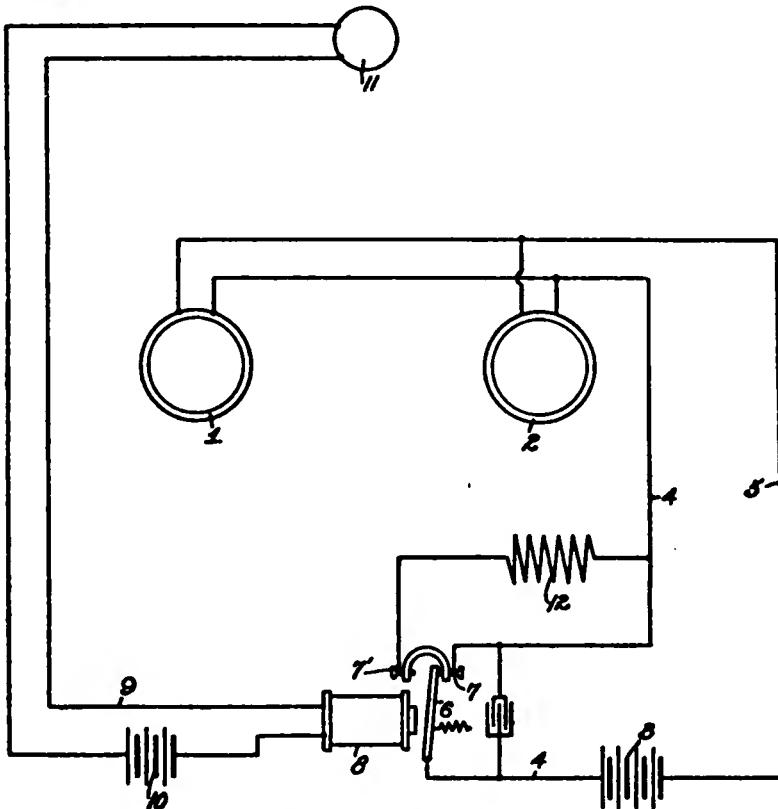

Figure 1—Circuit for Automatic Headlight-Dimmer for Automobiles

The invention is made operative immediately the rays of a distant automobile are played upon the headlights of an auto approaching in the opposite direction, a selenium cell being acted upon which closes a magnetic relay in the automobile and automatically dims the light until the automobile coming in the opposite direction has passed.

The circuits of this system are shown in figure 1, where the headlights of an automobile are indicated at 1 and 2, a small relay at 8, with the lever 6 and the contact point 7; a shunt condenser at 4, the local battery at 3, and a dimming resistance at 12. The selenium cell is indicated at 11, its battery at 10, which is in series with the relay 8.

When the light rays of a distant automobile fall upon the selenium cell 11, its resistance drops, energizing the magnet 8, and drawing over the lever 6. This throws resistance 12 in series with the headlight circuit, dimming the lights.

### The Problems of Iron Wire Transmission

**T**HERE was published in the September, 1917, issue of this magazine a report of investigations made by L. W. W. Morrow, of the University of Oklahoma, concerning the use of iron wires for transmission of electric power. The writer was conservative in his general conclusions, but he remarked that conditions as to cost of copper, power to be transmitted, voltage, etc., would determine the advisability of using iron instead of copper wire, and also would determine the type of iron wire which should be used.

M. D. Leslie, in a recent issue of the *Electrical World*, describes two power transmission lines employing iron wire which originate in Dodge City, Kansas. One of these lines is 31 miles in length, extending to Bucklin, Kansas. It consists of three No. 6 E. B. B. iron wires spaced four feet apart horizontally on Bates steel poles set 300 feet apart. The other line, which goes to Minneola, Kansas, is 22 miles long and consists of three No. 6 B. B. iron wires spaced triangularly 40 inches apart on Franklin steel poles set 375 feet apart. The first line has no transposition, but the second has three, 7, 14, and 21 miles from Dodge City. Both of these circuits operate at 22,000 volts.

An important factor observed was the high charging current of the line. The calculated charging current on the Minneola circuit was 13 amperes on the 2,300 volt side and 21 amperes on the Bucklin line, but in practice the ammeter indicated about 18 amperes per phase from the 2,300 volt side with very little change of variation of load (from the 31-mile line). When the 22-mile line was added, this was run up to about 33 amperes per phase, but was later reduced by the installation of two 15 kva. transformers near Dodge City on the 31-mile line. The transformers are seldom loaded and furnish some lagging current. The current on the two wires is now about 30 amperes per phase. The writer remarks:

It appears that the heavy current experienced produces a leading power factor, although it is possible that it is lagging, owing to the high reactance of the iron wire and the low power factor of the transformers under such light loads. The first indication that this current was leading was observed during Christmas week under severe overload conditions, when it was found that a higher voltage could be maintained in Dodge City with the Bucklin line connected than was possible without it.

In view of experience obtained with this circuit, the writer concludes that long, light-loaded iron wire transmission lines on steel poles require a heavy charging current in proportion to the load that they are supposed to carry. A distinct disadvantage enters into the case at this point because large capacity ammeters, automatic switches and transformers are required for a relatively small load. This may prove expensive. In addition, it is a disadvantage to the line that it operates at a high line loss irrespective of the load that is carried.

The writer summarizes:

Apparently more inductive load at the delivery end of line would improve the situation. It would be necessary for this load to be on the line continuously, but this does not appear to be practicable.

One thing is certain, and that is that the suitability of iron wire for transmission purposes where light loads are to be carried considerable distances is dependent on the charging current and not on the load current to be carried. This statement should not be taken as a serious argument against iron wire in a general way, but as one of the difficulties encountered. In the operation of these lines it has been found that they return a fair average rate on the investment. None of the lines built or contemplated would pay if copper wire were used at the present prices.

**Checking Up Synchrosopes for the Paralleling of Alternators**

**H**OW to check up and put into operation a synchroscope is interestingly described in an article by C. Otto Von Dannenberg in a recent issue of the Electrical World. A diagram representative of conditions usually encountered in practice and which indicates only the necessary connections is shown in figure 2.

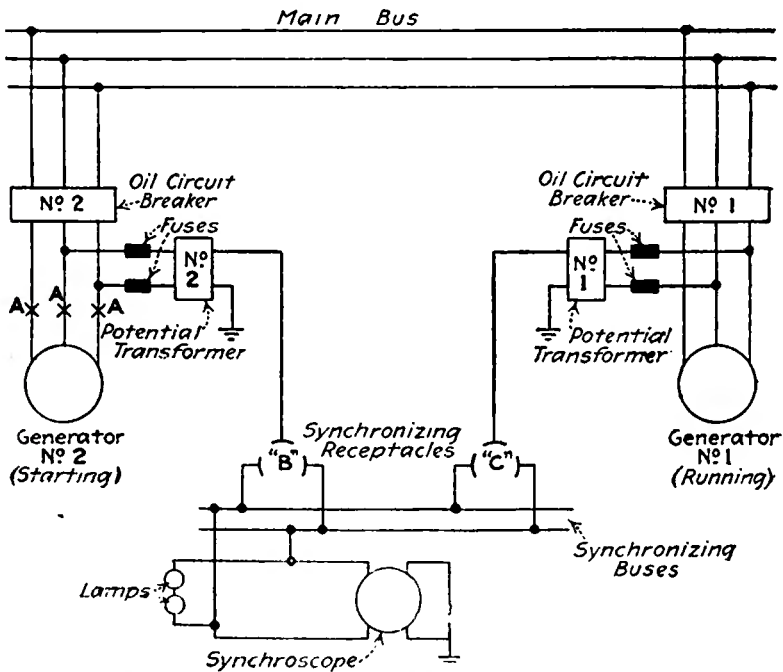

Figure 2—Diagram of connections for checking up synchrosopes in the paralleling of alternators

In this diagram, it is assumed that two three-phase generators are about to be connected in parallel and that the phase rotation has been found by test to be correct. The generated voltage is assumed to be of such value as to require the use of potential transformers to step down to the operating voltage of the synchroscope.

By way of preliminary explanation, the writer remarks:

With the connections as indicated and the "machine starting" and "machine running" plugs inserted in receptacles B and C, respectively, it might be assumed in general that the oil circuit breaker of the "starting machine," generator No. 2, could be closed when the lamps were dark and the synchroscope pointer was at rest just over the mark at the upper part of top of its scale. This would be in accordance with the general method in use in the United States. It so happens, however, that it is not

an unusual or exceptional occurrence to find potential transformers, even of the same make, with terminals wrongly marked for polarity or leads wrongly brought out of the case, so that the connections of the different transformers would not be symmetrical. This condition would give crossed connections which would cause the lamps to be bright at synchronism and the synchroscope pointer to take a position exactly 180 degrees from its correct location, so that closing breaker No. 2 with the lamps dark and the pointer at the top of the scale might cause serious damage to either or both generators, or at least a considerable disturbance on the system, since it is seldom, except in the smallest stations, that one finds generator breakers set for automatic operation.

A difficulty of such nature may be obviated with positive assurance of the correct connection by first disconnecting the leads of generator No. 2 at the terminal board, or at a point such as A, and then closing the oil circuit breaker No. 2. The conditions then existing will be the same as at synchronism, and the lamps will either glow brightly or darkly and the synchroscope pointer will assume either an upper or a lower position.

Should the pointer come to rest in the lower position with the lamps bright and it is desired that they be dark, the leads of the potential transformer of generator No. 2 should be reversed; if, however, the lamps are required to burn brightly at synchronism, the pointer of the synchroscope may be loosened on its shaft and shifted to its upper position. The switch of generator No. 2 may now be opened, the leads reconnected and the machine put in service.

The writer remarks, that while lamps nowadays are seldom used as a permanent synchronizing arrangement, they are usually an adjunct to a synchroscope, and the method described applies obviously as well when lamps alone are used for this purpose.

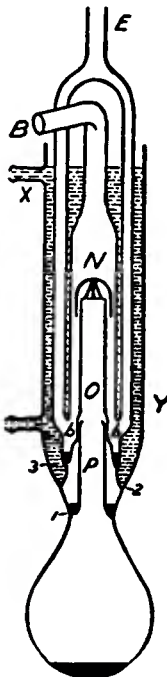

Figure 3—Diagram of high vacuum mercury vapor pump

### A Mercury Vapor Pump for the Production of High Vacuum

The molecular pump of Gaede has given stimulus to the design of several high-vacuum pumps. In a past issue of the "Physical Review," Charles T. Knipp has described a pump made wholly of glass which, he believes, possesses improvements over those heretofore produced. Diagrammatically the pump is shown in figure 3. The tube E is attached to the rough pump while the bulb to be exhausted and trap are fused to B. The mercury vapor rises from the lower bulb, which is heated in a sand or heavy oil bath, streams up through the short tubes P and O and is deflected downward through an annular throat by an umbrella N. The mercury vapor at once condenses on the water-cooled surface of the enveloping tube, and the gas that comes from B is forced mechanically downward from the lower edge of N along the cooled surface of the condensing chamber. The gas thus accumulated flows through the lateral tubes bb, which unite at the top and form the exhaust tube E. These are enveloped by the water jacket XY. This design tends to keep the mercury, which collects at the ring-seal 3, cool, and thus removes the objection that mercury vapor having an upward velocity would enter the annular condensing chamber. To prevent the hot mercury vapor streaming up from the boiler from con-

densing on the surfaces at 3, the short tube P is inserted to act on the shield. The upper end of P telescopes loosely into the lower end of O, while the lower end is secured by the ring-seal 1, having also a small valve opening in it through which the mercury passes back into the boiler.

If the upper end of P is conical, condensed mercury vapor is caught in the annular space formed and automatically seals the space PO from the cavity just outside of P. This construction simplifies the problem of the glass-blower, since the tube throughout the process is kept symmetrical.

### The Regulation of a Series Single-Phase Motor

**A** WRITER in the Electrical Review has described a method whereby a series single-phase alternating commutator motor will maintain a constant speed similar to a direct current shunt motor while running.

The connections are shown in figure 4. A, is the motor armature, F, the field winding, R, a resistance capable of carrying 1/10 normal full load line amperes, R<sub>0</sub> is a resistance capable of carrying continuously full load current.

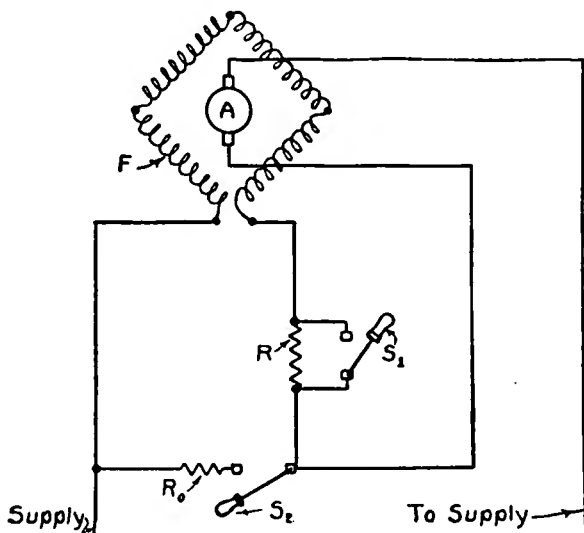

Figure 4—Diagram of connections to secure constant speed in a series single-phase motor

The operation is as follows: To start the motor close the switch  $S_1$ , and open switch  $S_2$ . Then connect the motor supply circuit. After starting, close the switch  $S_2$  and open switch  $S_1$  simultaneously. This operation can be much simplified by a specially constructed controller switch. The resistance  $R$  should be of such relative value to  $R_0$  as to cause seven to ten per cent. of normal full load field excitation in the motor field. Resistance  $R$  should be so proportioned as to allow the armature to take full load current and will be approximately equal to the series field resistance.

# From and For those who help themselves

Experimenters' Experiences.



## FIRST PRIZE, TEN DOLLARS

### A Compact and Efficient Rotary Spark Gap

OF the many new wireless telegraph instruments introduced within the last decade, very few, with the exception of the amplifying detector, have played such an important role as the rotary spark gap. Since its general adoption some five or six years ago this instrument has been growing in favor, until to-day it is employed in the majority of successful stations.

Although developed to a high state of efficiency as regards operation, the

rotary gap of to-day still retains most of the earmarks of the old-fashioned design incorporated in the pioneer gaps of this type. This statement does not of course apply in the case of enclosed and quenched gaps combined in the construction of certain rotary gaps of the present.

In order to develop a rotary gap which will embody the stability of design which is displayed by most of the other instruments used in connection with wireless telegraphy, it will be found necessary to depart somewhat from the usual line adhered to. Perhaps the easiest way in which to introduce a radical change in the general outline of any instrument is to change its principal axis of operation from vertical to horizontal, or vice versa. This the writer has done in an attempt to originate a rotary spark gap of sturdy design.

It will be noted from the accompanying drawings that particular attention has been paid to obtain the best mechanical and electrical construction possible, with the least expenditure of money and time. The gap is suitable for any range of power up to about  $\frac{1}{2}$  kw.

The novel features claimed are: the manner in which the motor is mounted and attached to the rotating member, through a flexible coupling; the use of several small phonograph records to form a heavy insulating member for the vital part of the gap; and the manner in which the various parts of the instrument are held together and adjusted, permitting very accurate construction.

From the partial cross-sectional elevation, figure 1, it will be noted that

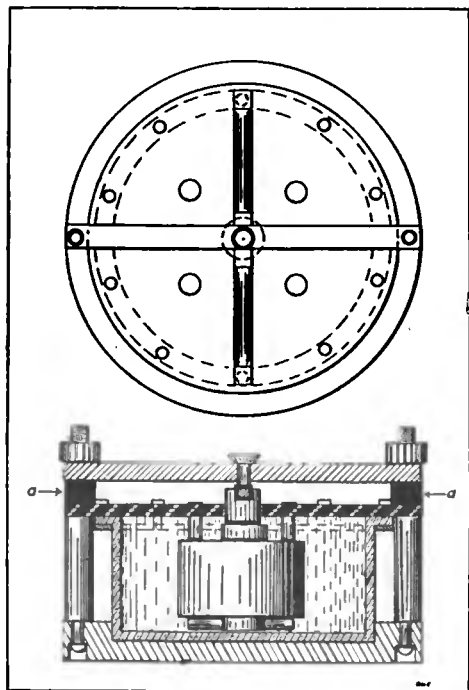

Figure 1—First Prize Article



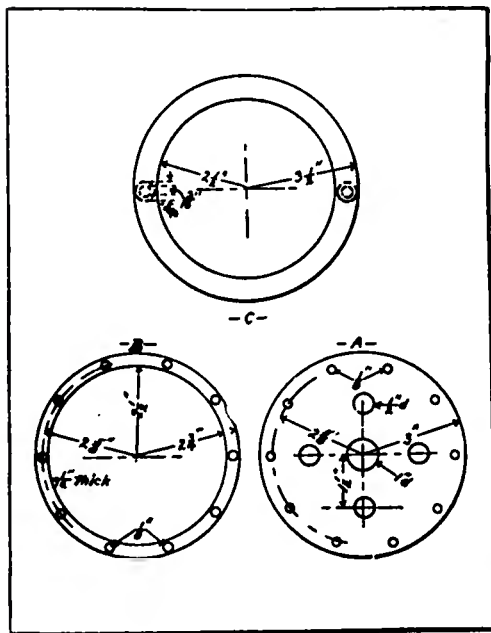

Figure 2—First Prize Article

the motor is enclosed in a round glass case which fits into a hollow space in the round wooden base. The case is held in position by the pressure exerted upon the composition top, through the soft rubber cushions, *a-a* which in turn form a part of the round fibre uprights which connect the ends of the top brass cross-rod and the wooden base.

The motor is hung from a composition top made up of several small disk records such as are sold for ten cents each. The small bolts which clamp these together near the periphery also secure this top to the glass case by means of the thin brass ring held in position by the glass shoulder around the top of the case. In this manner the bolts, which are to act as sparking points, must always remain in line because of their connection with the glass shoulder which will not warp. In connecting the gap for use, one wire is run to this ring and the other to one of the bolts passing through the fibre supports.

The rubber cushions mentioned make it possible to adjust the length of the gap by simply turning the insulated nuts on the top of the brass bear-

ing rod, the rubber providing sufficient spring to prevent the nuts from becoming loose through vibration.

Having studied the gap from the standpoint of general composition and operation, the actual construction of the various parts which enter into its make-up can now be dealt with more fully.

The first requisite is a round glass jar about 5 inches in diameter and from  $2\frac{1}{2}$  to 3 inches deep, with a narrow shoulder located near the top. A heavy glass butter jar of this size should be readily obtainable. A jar with slanting sides can be used if the round style is hard to find, provided the slant is outward at the top.

Having obtained a glass jar of the proper size it is only necessary to file a few small nicks at various points around the top, for the admission of air to cool the motor; and one large indentation about  $\frac{3}{16}$  of an inch deep, to be used as an exit for the motor wires. This completes the work on the jar.

A small electric motor of about  $\frac{1}{40}$  h.p. suitable for running in a vertical position is sufficient for any size of gap up to about  $\frac{1}{2}$  kw. capacity. This motor should be capable of being mounted by means of the bolts which hold the field pieces together somewhat after the manner shown in figure 1.

Three or four disk phonograph records are needed to form the top, which can be clamped together and drilled with several holes to be placed in positions similar to those at *A*, figure 2. These records should be large enough to overlap the top edge of the glass jar on all sides by about  $\frac{1}{2}$  inch in case the dimensions given are not closely followed.

A brass ring should now be made after the pattern of the one shown at *B*, figure 2. The holes in this are, of course, intended to coincide with those near the circumference of the disks, which are to form the top. A metal ring of the type desired can be made from brass stripping wound edgewise, or better, may be cut from a solid piece of sheet brass.

A plan view of the base is shown at

C, figure 2. This is best made of mahogany. No separate elevation or cross-sectional view is given, as the general idea can be obtained from figure 1.

The rotating member, its shaft, and the metal support for the same are pictured in figure 3 at C, B, and A, respectively. From this drawing it is patent that the rotating member is nothing more or less than brass rod, square in cross-section at the center and ends, and filed to a semi-stream-line form at all other points. This rod is supported in the center by a short, flat-headed steel bolt, which is tightly screwed into threads made in the rod, and riveted in place to prevent its coming loose. This is done with the bolt in place in the hole in the brass supports, A.

A few small steel balls are fitted between the short shaft and the wall of the enlarged hole at the top of the brass support, in the center. These take care of the strain and wear due to the weight of the rotating member, while the lower part of the hole acts as a guide to prevent the shaft from rocking, at the same time providing a good electrical connection to the rotating spark arm. No oil is used in this bearing.

Two round fibre supports or uprights, with brass bolts and insulated nuts are required. These should be similar to the ones illustrated in figure 3 at D. These, in conjunction with two pieces of soft rubber—one of which is shown at E in the same sketch, and the brass cross-rod previously mentioned—serve to hold the gap together as already described.

Ten or more sparking points can be made from brass bolts, which may either be fitted with short round ends such as are used for switch points, or with ordinary brass nuts. These pieces are not shown except in figure 1, as their size and style may be varied considerably in any manner desired.

No special provision has been made for the binding posts, which can be attached for taking off leads in the manner previously mentioned. It will also be noted that no detailed sketch for the motor supports is in evidence.

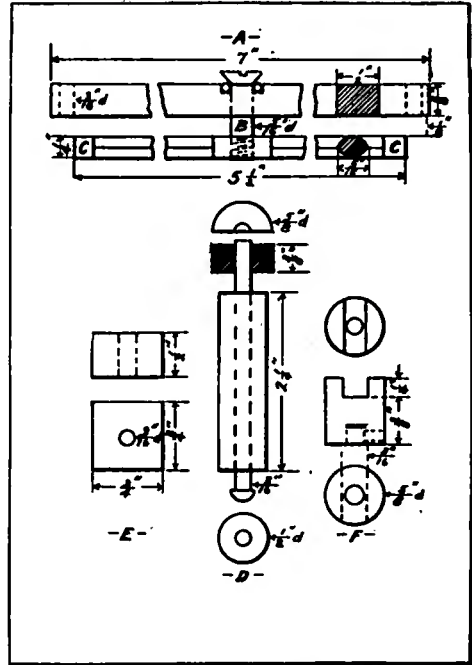

Figure 3—First Prize Article

These parts, as in the cases of the sparking points and binding posts, can be varied through such a wide range that no separate description is deemed necessary.

The various parts which have been described can now be assembled after the manner depicted in figure 1. The first step should be to bolt the motor to the several disks, after first securing to the long end of the shaft the fibre coupling shown in figure 3 at F. When this has been done the disks should be bolted to the ring near the top of the jar, using the spark point bolts, and after placing a round piece of felt in position for the jar to rest on, the latter can be set in place in the wooden base.

The completion of the instrument is now easily accomplished, and the adjusting of the gap a matter of personal supervision. The motor bearings can be oiled when necessary through the small holes in the composition top, through which the air to cool the motor is drawn by the rotating of the metal arm.

The cost of constructing a gap on the lines which have been laid out by the

writer should not exceed \$6.00 for materials, including the motor. In appearance it will equal many expensive instruments of lower efficiency.

In order to completely enclose this form of rotary gap it is only necessary to place a large inverted glass jar over the instrument and supply the lower edge with a felt ring to cut down the noise. This, however, decreases the

heat radiation, and is not considered advisable.

The main attraction of a rotary spark gap of the type outlined lies in the compactness and high insulating qualities incorporated in the design submitted, and to those who appreciate symmetrical design this gap should appeal very strongly.

R. U. CLARK, 3RD, *Massachusetts.*

## SECOND PRIZE, FIVE DOLLARS

### A Home-Made Insulator for Aerials

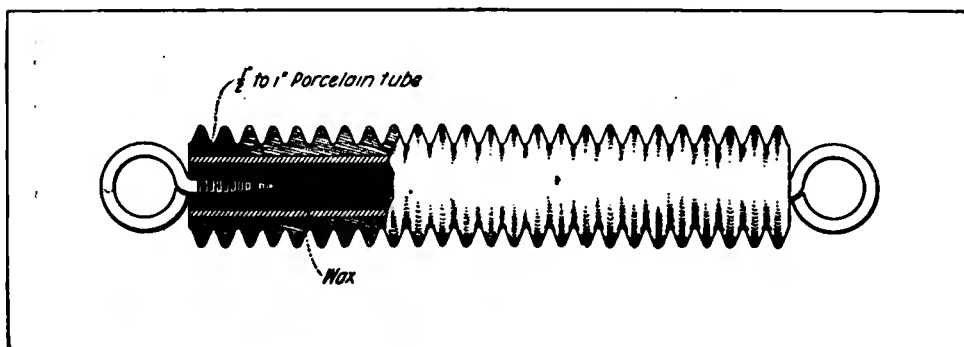

Figure 1—Second Prize Article

Because of the limited supply of tools and materials, the amateur finds it difficult to construct an efficient aerial insulator. High grade insulators such as may be purchased in the open market are too expensive to be considered.

I have had a disagreeable experience with imperfect insulators and therefore I decided to perfect an improved insulator for amateurs—one which the experimenter who hasn't a first-class workshop can easily construct.

The general method of construction follows:

Take the stick of an old mop or broom with a screw end. Saw off the handle from the screw as in figure 1. Keep the threaded part and bore or drill a hole large enough to permit the insertion of a 6 inch to 10 inch porcelain tube  $\frac{1}{2}$  inch to 1 inch in diameter (the ends

of which are to be cut out if you buy tubes with ends). Next coat the inside wall of the bored hole with melted wax or glue. Insert the porcelain tube in the hollow. Pour melted paraffine or melted beeswax until full; then allow it to partially harden, but before it completely crystalizes, imbed therein two eye-screws, one to two inches in length, as shown in figure 1. Then lay aside until hard. Coat the spiral or corrugated insulator with a good grade of beeswax, and over this put one or two coats of waterproof paint. Asphaltum has been found excellent for this purpose. Further details of construction appear in the drawings. This insulator has the appearance of commercial insulators. The corrugations serve to reduce the surface leakage in damp weather. This is an important feature.

STEPHENS MURANDE, *New York.*

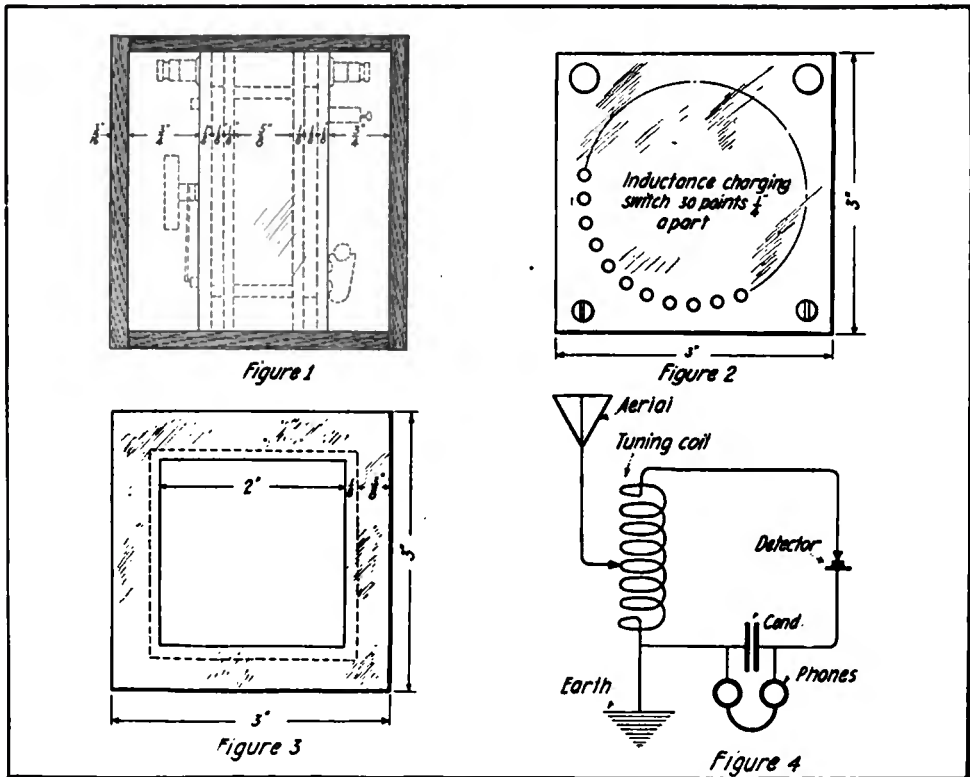

Third Prize Article

### THIRD PRIZE

#### A Small Portable Receiving Set

In Signal Corps field work a small light receiving set is often required. The receiving set herewith described meets all requirements and will give response over fair distances.

The oscillation transformer, which, by the way, is a single tuning coil, is wound on the wooden form shown in figure 4. It has five hundred turns of No. 26 cotton-covered wire, with leads brought out every sixteenth turn. The switch for changing the primary inductance, figure 2, has thirty  $\frac{1}{8}$ " x  $\frac{1}{8}$ " contacts mounted on a bakelite panel  $\frac{1}{8}$ " in thickness. This panel is fastened to small blocks of wood glued to each of the four corners of the frame on which the wire is wound. Binding posts can be located on two of the corners for the aerial and ground connections.

The condenser, which consists of ten

sheets of tinfoil 2" x 2", separated by wax paper, is placed in the hole inside the tuning coil and the panel on which the detector is mounted is placed over it and screwed down. The complete assembly is shown in figure 1 and the diagram of connections in figure 4. It is to be noted that a fixed number of turns are used in the detector circuit, the tuning being effected by the antenna connection above.

The case can be made of any strong wood and the covers may be hinged so as to open, allowing the set to stand upright. A set of this kind was tried out at my station before the United States entered the war. Excellent results were obtained. With a loading coil and a standard size aerial it was possible to receive Arlington very clearly.

JOHN B. COLEMAN, *Pennsylvania.*

# The Monthly Service Bulletin

## of the

# NATIONAL AMATEUR WIRELESS ASSOCIATION

Founded to promote the best interests of radio communication among wireless amateurs in America

J. ANDREW WHITE, Acting President GUGLIELMO MARCONI, President ALONZO FOGAL, JR., Secretary

### NATIONAL ADVISORY BOARD OF VICE-PRESIDENTS

Prof. A. E. KENNELLY  
Harvard University  
Maj. Gen. GEORGE O. SQUIER  
Chief Signal Officer, U. S.  
Army  
Commander D. W. TODD, U.S.N.  
Director Naval Communica-  
tions  
Major WILLIAM H. ELLIOTT  
Junior American Guard

Prof. ALFRED N. GOLDSMITH  
College of the City of New  
York  
Capt. W. H. G. BULLARD,  
U. S. N.  
E. E. BUCHER  
Instructing Engineer  
Prof. SAMUEL SHELDON  
Brooklyn Polytechnic Insti-  
tute

Prof. CHARLES E. CROSS  
Massachusetts Institute of  
Technology  
Colonel SAMUEL REBER  
Signal Corps, U. S. Army  
WILLIAM H. KIRWIN  
Chief of Relay Communica-  
tions

Headquarters, 25 Elm St., New York

**A**N amateur recently remarked: "What have you that is new to present to amateur experimenters in event they are allowed to work their stations after the war?"

The tone of the remark indicates that the experimenter doubted that any progress had been made in the wireless art since the closing of his experimental station. If he knew of the new inventions that have developed since the beginning of the war! They are astounding.

Of course, war safety measures do not permit us to speak more in detail but let it be said emphatically that never will there be such a wealth of material available for experimenters' use than after the close of the European conflict.

Various types of receiving apparatus which the experimenter may imitate when he again is permitted to construct wireless telegraph equipment are described from month to month in the Radio Science department of this magazine. Members of the Association are earnestly advised to follow this section closely and to retain their copies for future use.

Radio telephony will, in the future, play an important part in amateur communication. A small-sized vacuum

tube connected for the production of undamped oscillations will permit radio telephonic conversation to be carried on over distances of one to three miles, thereby opening up an entirely new field for the amateur experimenter in radio. Wireless telephone investigators have heretofore employed the arc system for generating the requisite radio frequency current; the expense of this construction was beyond the means of the experimenter. It is known now that a single vacuum tube works with greater efficiency and can probably be had at a much less initial expense. Also, it is simple to operate.

The use of open circuit oscillators in connection with vacuum tubes will amplify radio signals to a marked degree. These circuits, which have been described in the Radio Science Department of this magazine, are equally applicable to crystal rectifiers. Surprising results are in store for the experimenter who has not employed one of these circuits.

According to published newspaper reports there still remain throughout the country amateur experimenters who have taken down their aerials, but have failed to dismantle the trans-  
(Continued on page 702.)

STATEMENT OF THE OWNERSHIP, MANAGEMENT, CIRCULATION, ETC., REQUIRED BY THE ACT OF CONGRESS OF AUGUST 24, 1912,

of The Wireless Age, published monthly, at New York, N. Y., for April 1, 1918.  
State of New York, County of New York, ss.

Before me, a Notary Public, in and for the State and county aforesaid, personally appeared J. Andrew White, who, having been duly sworn according to law, deposes and says that he is the editor of The Wireless Age, and that the following is, to the best of his knowledge and belief, a true statement of the ownership, management, etc., of the aforesaid publication for the date shown in the above caption, required by the Act of August 24, 1912, embodied in section 443, Postal Laws and Regulations, printed on the reverse of this form, to wit:

1. That the names and addresses of the publishers, editor, managing editor, and business managers are:

- Names of— Post Office Address—
- Publishers.. Wireless Press, Inc.,  
25 Elm St., New York, N. Y.
- Editor.. J. Andrew White,  
25 Elm St., New York, N. Y.
- Managing Editor—None.
- Business Manager—Alonzo Fogal, Jr.,  
25 Elm St., New York, N. Y.

2. That the owners are: (Give names and addresses of individual owners, or, if a corporation, give its name and the names and addresses of stockholders owning or holding 1 per cent or more of the total amount of stock.)

Wireless Press, Inc., 25 Elm St., New York, N. Y.  
John Bottomley (85; shares), 233 Broadway, New York, N. Y.

3. That the known bondholders, mortgagees, and other security holders owning or holding 1 per cent or more of total amount of bonds, mortgages, or other securities are: (If there are none, so state.)

None.

4. That the two paragraphs next above, giving the names of the owners, stockholders, and security holders, if any, contain not only the list of stockholders and security holders as they appear upon the books of the company but also, in cases where the stockholders or security holder appears upon the books of the company as trustee or in any other fiduciary relation, the name of the person or corporation for whom such trustee is acting, is given; also that the said two paragraphs contain statements embracing affiant's full knowledge and belief as to the circumstances and conditions under which stockholders and security holders who do not appear upon the books of the company as trustees, hold stock and securities in a capacity other than that of a bona fide owner; and this affiant has no reason to believe that any other person, association, or corporation has any interest direct or indirect in the said stock, bonds, or other securities than as so stated by him.

J. ANDREW WHITE,  
Editor.

Sworn to and subscribed before me this 10th day of April, 1918.

(Seal) WILLIAM J. KINDGEN,  
(My commission expires March 30, 1920.)  
Bronx County, No. 29. Certificate filed in New York County, No. 198 Register, No. 10,159.

Queries Answered

Answers will be given in this department to questions of subscribers, covering the full range of wireless subjects, but only those which relate to the technical phases of the art and which are of general interest to readers will be published here. The subscriber's name and address must be given in all letters and only one side of the paper written on; where diagrams are necessary they must be on a separate sheet and drawn with India ink. Not more than five questions of one reader can be answered in the same issue. To receive attention these rules must be rigidly observed.

Positively no Questions Answered by Mail.

J. M. B., New South Pittsburgh, inquires:

Ques.—(1) Please publish a diagram showing the connections of a regenerative receiver, employing a loose coupler, loading coil, grid condenser, and variable condenser for use with the three-element vacuum valve.

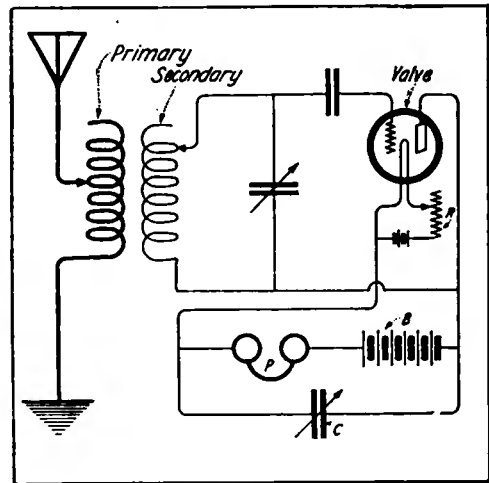

Figure 1

Ans.—(1) A simple diagram of connections is shown in figure 1, where the grid and plate circuits are electrostatically coupled through the coupling condenser shunted across the head telephone. Other diagrams of regenerative receivers appear in the textbook "Practical Wireless Telegraphy" and in the book, "How to Conduct a Radio Club" copies of which can be purchased from the Wireless Press, Inc., 25 Elm Street, New York City.

\* \* \*

C. L. W., New York City, inquires:

Ques.—(1) If the leads from the primary and secondary of a long wave tuning transformer are five inches in length, would this have any effect upon the signals?

Ans.—(1) These leads would do no harm.

Ques.—(2) What range could I expect from a 1 kw. transformer coil in connection with a 110 volt 5 ampere D.C. generator, under favorable conditions?

Ans.—(2) We assume that you are referring to an induction coil to be operated with a magnetic or electrolytic interrupter. If so, you should be able to transmit 20 to 30 miles in daylight and from 200 to 600 miles after dark during the favorable months of the year. You are, of course, aware that experimenters are not permitted to operate or construct wireless apparatus during the period of the War.

Ques.—(3) Is there any circuit available at the present time for the reception of undamped waves which gives better results than the Armstrong regenerative circuit?

Ans.—(3) This circuit seems to fulfill all requirements for long distance telegraphy, but of course stronger signals can be obtained from a far distant station by means of a radio frequency amplifier; i.e., by connecting a number of valves in cascade for the amplification of radio frequencies.

Ques.—(4) What experience is necessary to get the best results from a single step multi-audio-fone, to get it in working order? I had one with everything connected properly, yet I could not obtain as loud signals with the audio-fone as without it.

Ans.—(4) We have never been able to secure the details of construction of this device, nor have we information concerning its circuits. Consequently, we can offer you no advice.

\* \* \*

L. A. R., Seattle, Wash., inquires:

Ques.—(1) Where can I obtain a diagram showing how the vacuum valve is connected up for the production of radio frequency currents?

Ans.—(1) Such a diagram is shown on page 276 of the textbook, "Practical Wireless Telegraphy." The plate and grid circuits are shunted by inductance and capacity. They are usually magnetically or electrostatically coupled, so as to transfer energy from the plate circuit into the grid circuit. This keeps the valve in a state of oscillation.

Ques.—(2) What do you consider the most simple cascade amplification system for the amateur's use?

Ans.—(2) An audio frequency amplifier is perhaps the most satisfactory, simple iron core transformers being used in the plate circuit of each valve to transfer energy to the grid circuit of the next valve. The primary windings of these transformers may have inductance of 20 henries and the secondary from 75 to 100 henries. An iron core is generally used. The most efficient results and the greatest ease of operation are secured by cascade radio frequency amplification, that is, the plate and grid circuits of successive valves are coupled through a simple radio frequency transformer.

Ques.—(3) I have been told that great care must be used in the design of a receiving tuner to be employed in connection

**WHERE TO BUY**

<b>Aerial Spreaders</b>	PAGE
Jersey City Ladder Co., Inc.....	696
<b>Automatic Transmitters</b>	
Omnigraph Mfg. Co.....	701
<b>Blue Print Paper</b>	
New York Blue Print Paper Co.....	696
<b>Books</b>	
John Wiley & Sons, Inc.....	698
The Baker & Taylor Co.....	697
Wireless Press, Inc.....	698, 703, 704
<b>Bronze and Aluminum Castings</b>	
Fischer-Sweeney Bronze Co.....	II.
<b>Condensers</b>	
Dubilier Condenser Co., Inc.....	VII.
<b>Electrical Supplies</b>	
Charles F. Campbell.....	IV.
Manhattan Electrical Supply Co., Inc .....	701
The Newman-Stern Co.....	699
The William B. Duck Co.....	699
<b>Indicating Instruments</b>	
Weston Electrical Instrument Co..	I.
<b>Instruction</b>	
Dodge's Telegraph, Ry. & Wireless Institute. ....	699
Eastern Radio Institute.....	694
Graceland Radio Institute.....	699
International Correspondence School	694
Marconi Institute.....	II., 700
National Aero Institute.....	698
Uttmark's Nautical Academy.....	702
Y. M. C. A. Radio School.....	697
<b>Instruction Records</b>	
Marconi-Victor Records .....	705
<b>Insulation</b>	
Electrose Mfg. Co.....	Inside Front Cover
The Continental Fibre Co.....	V.
<b>Metal Signs</b>	
Premier Metal Etching Co.....	697
<b>Motors</b>	
Crocker-Wheeler Co.....	Back Cover
<b>Patents</b>	
Watson E. Coleman.....	698
<b>Silver</b>	
Handy and Harman.....	695
<b>Storage Batteries</b>	
Miller-Reese-Hutchison, Inc.....	Inside Back Cover
The Electrical Storage Battery Co..	II.
<b>Switches and Controllers</b>	
Industrial Controller Co.....	IV.
<b>Tools and Supplies</b>	
T. P. Walls Tool & Supply Co., Inc.	IV.
<b>Wireless Magazines</b>	
The Wireless Press, Ltd.....	695
<b>Wireless Telegraph Service</b>	
Pan-American Wireless Telegraph and Telephone Co.....	706



# WIRELESS

The Gov't and Merchant Marine need thousands of trained operators now, the demand far exceeding the supply. Men are needed urgently for the Naval Reserve, Aviation Signal Corps, Marconi Co., etc.

*Pick your rating before you are drafted*

Special short code courses, Day or Evening, for Gov't Service. Students from all over the country. Classes now forming. Send for LATEST prospectus, just out.

The Eastern Radio Institute is endorsed by the U. S. Government & Marconi Co.

**Eastern Radio Institute**  
899C Boylston St., Boston, Mass.



with the vacuum valve, particularly in respect to the disposition of the various connecting leads.

Ans.—(3) At the least, the set should be designed so that change in any of the elements of the circuit will not change the capacity to earth of the various coils. For example, the free end of the secondary winding generally has the maximum potential, but if a device placed near to it does not remain in the same position it will change the tuning of the circuit. It is desirable in any receiving set that circuits which have no direct relation be placed at right angles to one another. In short, the usual precautions taken in the design of tuners suffice for the vacuum valve.

In order that the capacity effect of the body of the manipulator may not interfere with the tuning of the circuits, the entire receiving set can be covered by a gauze screen and connected to earth.

\* \* \*

D. A. L., Washington, D. C.

Regenerative amplification circuits may be connected to a battery of vacuum valves in cascade, but sufficient amplification is obtained without the use of these transformers. However, when a single bulb is employed, some advantage is derived in employing regenerative couplings, particularly at radio frequencies.

\* \* \*

H. P. H., Highland Park, Mich., inquires:

Ques.—(1) Referring to the description of a ½ kw. 500 cycle generator in the December issue of THE WIRELESS AGE, are the field coils wound for 110 volts D.C., and if so, about what current should it draw?

Ans.—(1) The field is wound for 110 volts D.C. and will take about ½ ampere.

Ques.—(2) In order to get the same results, what size wire and number of turns should be used for six to eight volts to be furnished by a generator?

Ans.—(2) You will see from the answer to query No. 1, that since the field winding contains 13,000 turns at ½ ampere there are 6,500 ampere turns. This is for the same density in the gap and the same pole face area. A good off-hand formula for determining the number of ampere turns in the field is:

$$AT = \frac{11 \times A \times B \times 2g}{30}$$

where A = the area of the pole face;

B = the field density in the gap;

and g = the length of the air gap in inches.

Ques.—(3) The area of the pole faces in the above machine is 1.5 sq. in. If this is reduced to .625 sq. in. and the machine in general reduced in the same proportion except the air gap which is to be .006" instead of .030", is it safe to assume that the output will be slightly in excess of ¼ kw?

Ans.—(3) Off-hand, yes. In this connection we would state that a machine with a laminated structure and .006" air gap would be an instrument of precision that could be put on exhibition.



"Never Mind How Strong You Are—"

## What D'ye KNOW?"

Today it's a battle of wits—and brains win. Muscle and brawn don't count so much as they used to. The great question now is "What do you know?" It draws the line between failure and success.

What do you know? Have you special ability? Could you "make good" in a big job right now?

For 25 years the International Correspondence Schools have been training men for better work and bigger salaries. They can train YOU, no matter where you live, what hours you work, or how little your education. Mark and mail the coupon and find out—it won't obligate you in the least.

\*TEAR OUT HERE

INTERNATIONAL CORRESPONDENCE SCHOOLS, Box 6018, Scranton, Pa.

Explain fully about your Course in the subject marked X:

- |   |   |                                       |
|---|---|---------------------------------------|
| <input type="checkbox"/> Electrical Engineering | <input type="checkbox"/> ADVERTISING      | <input type="checkbox"/> CHEMISTRY    |
| <input type="checkbox"/> Mechanical Engineering | <input type="checkbox"/> Salesmanship     | <input type="checkbox"/> Illustrating |
| <input type="checkbox"/> Mechanical Drafting    | <input type="checkbox"/> Commercial Law   | <input type="checkbox"/> Farming      |
| <input type="checkbox"/> Civil Engineering      | <input type="checkbox"/> Bookkeeping      | <input type="checkbox"/> Poultry      |
| <input type="checkbox"/> Stationary Engineering | <input type="checkbox"/> Stenography      | <input type="checkbox"/> French       |
| <input type="checkbox"/> Mining Engineering     | <input type="checkbox"/> Civil Service    | <input type="checkbox"/> German       |
| <input type="checkbox"/> Architecture           | <input type="checkbox"/> Ry. Mail Service | <input type="checkbox"/> Italian      |
| <input type="checkbox"/> Architectural Drafting | <input type="checkbox"/> AUTOMOBILES      | <input type="checkbox"/> SPANISH      |

Name \_\_\_\_\_

Address \_\_\_\_\_



Ques.—(4) What size wire should be employed in the armature coil in view of the fact that the output is to be reduced?

Ans.—(4) For a small machine at a frequency of 500 cycles allow 1,000 circular mils per ampere. If the machine is to generate 3.5 amperes, 3,500 circular mils will be required. No. 14 double cotton covered wire (4,106 circular mils) should be employed. The use of stranded wire is advised.

Ques.—(5) Should the number of layers and turns per layer be the same as the ½ kw. generator in order to get the same voltage?

Ans.—(5) If the area of the pole is reduced more turns will be required on the stator pole for the same voltage.

Ques.—(6) About what per cent will a cast iron rotor decrease the efficiency?

Ans.—(6) It is difficult to state off-hand; in fact, the use of cast iron is not recommended.

Ques.—(7) I failed to state that I am increasing the poles from 9 to 10, mainly to facilitate measuring the diameter while grinding and turning. I intend to run the machine at 3,000 r.p.m.

Ans.—(7) You should take into consideration that the condensive reactance of the condenser, the reactance of the transformer primary and secondary, and the reactance of the generator are closely connected in radio design, and any change in one of the units calls for a corresponding compensation in either or both of the other units. Moreover, this state of affairs may call for a fourth change, namely, a reactance coil. This has been pointed out by Mr. H. E. Hallborg in the proceedings of the Institute of Radio Engineers, and by many writers in other publications.

\* \* \*

H. M., Kiel, Wis.:

The diagram of connections for the beat receiver given in the book "How to Conduct a Radio Club" will inform you how to wire up the apparatus described, shown on page 347 of the February, 1917, issue of THE WIRELESS AGE. With the information given therein and that published in previous issues of THE WIRELESS AGE, you should have no difficulty in connecting up a receiving set of this type.

The high voltage condenser for your Thordarson transformer should consist of four plates of glass, 14 inches by 14 inches, covered with tinfoil, 12 inches by 12 inches. If the glass will not withstand the potential of the secondary you should make up sixteen plates, putting eight plates in parallel in a bank and connect two banks in series.

\* \* \*

L. D., Wisconsin:

The majority of three-element vacuum valve detectors which are not highly exhausted are more or less erratic in action and require frequent readjustment. It is difficult to state just what is wrong with your particular bulb, but it is quite probable that it is

# SILVER

FOR

## Spark Gaps or Contacts

WE CAN FURNISH immediately: Pure silver for sparking purposes on quenched spark gaps. Sterling silver for contacts on sending or relay keys. Pure granulated silver for coatings on Leyden Jars.

*Ask for our prices*

---

HANDY AND HARMAN

NEW YORK PLANT

29 GOLD STREET

NEW YORK

---

## DO YOU READ THE WIRELESS WORLD?

In it you will find articles relating to the PRACTICE of Radioteleg-raphy as well as to the THEORY.

The QUESTIONS and ANSWERS SECTION is open to YOU for the SOLUTION OF YOUR DIFFICULTIES.

INSTRUCTIONAL ARTICLES for Home Study WRITTEN BY EXPERTS.

REVIEWS OF BOOKS useful to Wireless Students. The interests of Operators are well catered for.

WRITE for a Specimen Copy, post free to

**THE WIRELESS PRESS, Ltd.**

Marconi House, Strand, London, England

"WIRELESS WORLD," \$2.25 per annum for America. Single Copies, 25c Post Paid

## Service and Quality

Drawing Materials  
Surveying Instruments  
Sensitized Papers

Quality products delivered when you want them.

Try our Gold Seal blue print paper—100% pure—100% satisfaction.  
Working samples on request.

**New York Blue Print  
Paper Co.**

102 Reade St., New York City

*Write for Catalog W*

## Aerial Spreaders Flag Poles Ladders Spars

When in need of **Aerial Spreaders**, get in touch with us. We manufacture all kinds of **spars** and **flag poles**, from the largest to the smallest. **Ladders** of all descriptions.

We have supplied the Marconi Wireless Telegraph Co., of America with **Aerial Spreaders**, and various other kinds, since 1912.

**Jersey City Ladder Co., Inc.**  
677 Montgomery Street  
Jersey City, N. J.

*Telephone, Bergen 1988*

exhausted to that degree where the adjustment is extremely critical. It may be, however (from your explanation) that at certain adjustments, this valve is set into oscillation; therefore it distorts the spark note of the transmitting station and since the bulb does not remain in stable oscillation the signals are interrupted.

\* \* \*

B. R. K., Nashville, Tenn.:

Telegraph relays have been connected in the local telephone circuit of the vacuum valve and have been employed to operate calling apparatus, but obviously the bell would ring during atmospheric discharges as well as during the reception of radio telegraphic signals. Hence such an arrangement would be of little value for the purposes you require.

The coherer is used in the power stations of the New York Edison Company for determining the nearness of a thunder-storm. When lightning discharges become rather frequent, even when not in sight of the power stations, the coherer will actuate a recorder or call bell, and the increasing violence of its action will determine the probable distance of the storm.

\* \* \*

R. M. P., Fort Smith, Ark.:

We do not know the constituents of the "Lenzite" detector.

\* \* \*

K. V. R. L., Worcester, Mass.

We have no absolute record of the longest distance covered by an amateur set, but we have had reports that 1,400 miles have been covered during the night hours at the wave-length of 200 meters. It is not possible to consume 1 K. W. at the wave-length of 200 meters efficiently; in fact with a well designed set, owing to the restrictions of the closed circuit condenser, the transformer would not consume more than  $\frac{1}{2}$  or  $\frac{3}{4}$  K. W.

We have no data on multi-layered windings, such as you require, but you can easily determine for yourself the correct number of layers or turns for a given station by listening in to some station the wave-length of which is known. With the present war restrictions, you will be required to discontinue your experiments until peace has been declared.

We do not advise the use of No. 36 wire for the secondary winding of a receiving tuner except in connection with a vacuum valve detector. In practically every case No. 32 S. S. C. wire is preferred.

\* \* \*

E. T. D., Toronto:

A wiring diagram of the Marconi 5 K. W. transmitting set is not available for publication.

\* \* \*

R. J. M., Green Park, Pa.:

The three-element vacuum valve is generally considered the most sensitive of all receiving detectors.



*Detectometer—A combination of detector and indicator*

**A Novel Wireless Instrument**

The accompanying illustration shows a unique and interesting wireless device known as a Detectometer. It is a combination of a detector and a meter or indicator and can be used in place of any detector in connection with wireless telegraph or wireless telephone apparatus. It may be assumed that for given crystals the pressure for the most sensitive spot is practically uniform. During readjustment the correct pressure can be secured by noting the reading of the dial. When adjusted the detector will stand up under the most severe shocks, such as gunfire on board ships. During actual tests the instrument has held its adjustment for six months and probably would remain so indefinitely if properly protected from the local transmitter.

The crystal holder and points are easily replaced should the occasion arise to do so. This instrument has been tested on ships as well as on land by the U. S. Government. Many operators have given it their thorough approval.

**PREMIER  
METAL  
ETCHING  
Co.**

NAME PLATES, BRASS SIGNS,  
CLOCK AND METER DIALS,  
ADVERTISING NOVELTIES.

LONG ISLAND CITY, N. Y.

**RADIO OPERATORS NEEDED**

Government Service Merchant Marine  
Special course for men subject to draft  
Complete concentrated course under  
experienced teachers

**SETTING UP MACHINE GUNS**

Theory and Practice taught by experts—Com-  
plete Equipment—Low Rates—Individual  
Instructions—Dormitories

**START TODAY**

Write for Illustrated Booklet

**Y. M. C. A. Radio School**

161 E. 86th Street New York, N. Y.  
BEST RADIO SCHOOL IN NEW YORK

SCIENTIFIC BOOKS OF ALL PUBLISHERS  
—INCLUDING TECHNICAL MANUALS FOR  
EVERY BRANCH OF GOVERNMENT SER-  
VICE—ALSO THE PUBLICATIONS OF THE  
WIRELESS PRESS. OUR SERVICE IS CON-  
DUCTIVE TO ECONOMY OF TIME AND EF-  
FORT.

THE BAKER AND TAYLOR Co.—  
WHOLESALE DEALERS IN THE BOOKS  
OF ALL PUBLISHERS—354 FOURTH  
AVENUE—NEW YORK CITY.



## LEARN AVIATION

SEND FOR THIS  
FREE BOOK!

OPPORTUNITY is hammering at your door. The world is calling for millions of men, trained in the science of Aviation, Designers, Builders, Assemblers, Repairmen, Instructors, as well as "Flyers," and offering to pay them big wages! The first step is to send for our BIG FREE BOOK, THE SCIENCE OF AVIATION. It tells how you can learn the basic principles, the "ground work" of this great profession at home under our corps of eminent instructors, among them, Walter L. Brock, winner of the Great London-Paris Race, and others equally famous in aeronautics. The course is prepared so the layman can easily master it—QUICKLY TOO. THERE'S NO TIME TO LOSE. WRITE TODAY.

Dept 1215 NATIONAL AERO INSTITUTE  
Morton Building, Chicago, Ill.

Be a Marine Officer!

## NAVIGATION

By GEORGE L. HOSMER

Associate Professor of Topographical Engineering, Massachusetts Institute of Technology, points out the way in a clear and simple manner, in 214 pages (4½ by 6½). Illustrated, including signal codes in color. Cloth, \$1.25, postpaid.

JOHN WILEY & SONS, Inc.  
424 Fourth Avenue, New York

### Books for Men

Wireless, Signal Corps, Aviation, Navigation. Best books on these subjects. Let us know your book needs. We are in close touch with all publishers. Our own publications are authoritative in their field. Orders promptly shipped.

WIRELESS PRESS, INC.

25 Elm Street New York City

## PATENTS

THAT PROTECT AND PAY  
Books and Advice Free

If you want to sell your patent, take it out through my office. HIGHEST REFERENCES. BEST RESULTS.

WATSON E. COLEMAN, Patent Lawyer  
624 F. Street, N. W. Washington, D. C.

### Earn Spare Time Money

Represent us in your community. Complete line of wireless literature for amateurs and professional operators, Signal Corps men, Naval Radio operators and men who expect to enter the Service. Liberal commissions. Active agents wanted.

WIRELESS PRESS, INC.

25 Elm Street New York City

### A Code Practice Set for Continuous Service

Now that the amateur cannot work on account of the war he has a good opportunity to brush up on his sending and receiving without getting into trouble with the authorities. This he can do by means of the usual key and buzzer set, but it is not a very satisfactory method.

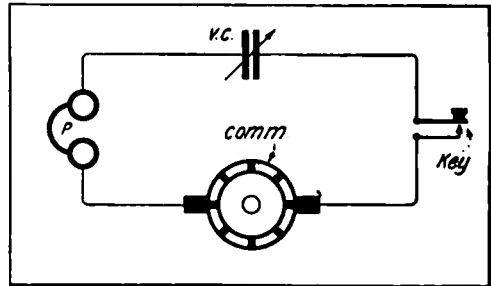

Figure 1

While experimenting to reproduce radio signals I hit upon the following plan which the average amateur can duplicate with the apparatus at hand.

Using the ordinary 110 volt A. C. high speed rotary gap motor, connect a pair of telephones in series with a key and variable condenser across the brushes of the motor. By varying the capacity of the condenser the intensity of the signals in the telephones may be increased or decreased, and by connecting a variable resistance in series with the motor the pitch of the signals may be varied at will.

By using several keys and telephones in parallel and mounting the whole on a long table a suitable apparatus for teaching the code may be had. Three or four amateurs "sitting in" on a set of this sort can carry on conversation as they were wont to do before the closing of their stations by the government.

Editorial Note.—The use of a motor for energizing a code practice circuit was first adopted by the Marconi Institute many years ago. By proper adjustment of speed and by the employment of a 2 microfarad condenser in series, a perfect imitation of a 500 cycle transmitter is secured.

**A Unique Micropho-Detectograph**

The accompanying illustration shows a novel micropho-detectograph transmitter which is said to be a super-sensitive microphone. It has been used by wireless operators and experimenters for the amplification of incoming signals.



*A supersensitive microphone*

It is pointed out that at no time in the history of American achievements has the nation been so stirred as by the remarkable exposures made in public and private life by the use of ingenious detective devices of sound-reproduction. As the word "Micropho-Detectograph" implies, it is the unseen detective. It hears everything—the slightest sound or whisper—and transfers the information to a receiving telephone connected in the circuit at a distant point.

This super-sensitive instrument may be concealed in the walls, behind a picture or desk, or in any article of furniture. The transmitter or sound collector is 2¼ inches in diameter, ½ inch thick, and weighs only two ounces.

One or more pairs of receivers can be used, according to the number of witnesses required for corroborative evidence. These receivers are so constructed that the vocal tones of persons are retained with all individual and identifying characteristics. Transmitter, earpieces, two standard dry cell batteries, regulator cord and case, complete the circuit. A room may be

**DUCK'S**

**BIG 300 pp. ELECTRICAL and WIRELESS CATALOG**

Mailed upon receipt of 8c. in stamps or coin which may be deducted on first dollar purchase. Catalog contains 160 pages of wireless instruments and 140 pages of electrical supplies. No bigger or better values are obtainable elsewhere. We have a complete stock of everything listed in this catalog. Wireless orders promptly filled.

**THE WILLIAM B. DUCK CO.**  
239-241 Superior St. TOLEDO, OHIO

**WIRELESS** for the man who is interested in the best instruction under most favorable conditions.

**GRACELAND COLLEGE** offers you an opportunity to fit yourself for expert radio service in either the Army or Navy. Course for registered men under supervision of Chief Signal Officer of the Army.

**RADIO SUMMER SCHOOL** begins May 6th and continues fifteen weeks. Intensive training in radiotelegraphy and Signal Corps work military drill, signaling by telegraph, heliograph, radio and service buzzer, telephones, wigwag and semaphore. Experienced instructors, modern complete equipment. Expansive, cool campus; splendid environment. Tuition, \$40, reasonable expenses. Enroll now or ask for illustrated booklet.

**WRITE TODAY** **GRACELAND RADIO INSTITUTE** **LAMONI, IA.**

**LEARN TELEGRAPH**

Morse and Wireless—R. R. Accounting (Station Agency) also taught. Tremendous Demand—much greater than supply—Permanent Positions Secured. Big Salaries—recently raised. Ideal Working Conditions—short hours, vacations with pay sick and death benefits, etc.—prevailing.

**Great Opportunities for Advancement. Women Operators** also greatly desired by Railways and Western Union. Tuition and largest school—two large school buildings, investment exceeds \$25,000.00—established 43 years. Endorsed by railway, Western Union and National Telegraph officials. Large illustrated catalogues free. Correspondence courses also. Write today. Enroll immediately.

Dodge's Telegraph, Ry. & Wireless Institute  
Green Street, Valparaiso, Ind.

**Wireless Instructor WANTED AT WASHINGTON**

One of the leading and fastest growing wireless schools in the country has a splendid opening for a competent experienced instructor; knowledge of latest modern apparatus required; must be able to send and receive 25 words of Continental Code and if possible have knowledge of Morse telegraphy. Good salary with splendid chance for advancement into an executive position to right man.

*Address Box 25, care of Wireless Age.*

**POCKET BOOK OF ELECTRICITY**  
**SPECIAL WAR EDITION FREE**

Distributed as a supplement to our big Handy Book during temporary government suspension of wireless. Lists new things to experiment with. Also contains: flashlight, telegraph apparatus, puzzle, magic outfit, books, athletic goods, chemical sets, fishing tackle, novelties. Handy, interesting. For every boy in America. Free on request.

THE ELECTRO-SET CO., 4000 BROADWAY  
THE NEWMAN-STERN COMPANY, Dept WA-29 Cleveland, Ohio

**Man Wanted**

in your community to earn money. Men about to enter the Signal Corps or Naval Radio divisions need our magazine and books. Big sellers wherever shown. Represent us and earn liberal commissions.

**WIRELESS PRESS, INC.**  
**25 Elm Street** **New York City**

## YOUR Opportunity to Secure a Practical Home Study Course in Wireless

THE Marconi Institute Extension Training Course and Service is a systematic, time-saving means of furnishing to students in the war camps, homes or local radio clubs, orderly and scientific training through literature prepared by the leading exponents of the art.

It is indispensable to experimenters or students who desire a thorough working knowledge of *wireless*. This service already has been subscribed to by 8,000 men.

It is planned primarily for those who are progressive and alert and who look ahead to the future.

Wonderful expansion in every department of scientific development and industrial application is assured. Students and experimenters who use the opportunities presented to them through the Institute Extension Course and Service, will never regret the time given to such study.

It is not essential that students have a college or technical education, but one thing is necessary: they must have a serious purpose and be willing to devote a reasonable portion of their spare time to study and practice.

The Institute Training Service for Schools and individuals comprises the following publications:

<i>Wireless Age, yearly subscription</i>	\$2.00
<i>Practical Wireless Telegraphy..</i>	1.50
<i>How to Pass U. S. Government</i>	
<i>Wireless License Examination</i>	.50
<i>Radio Telephony .....</i>	2.00
<i>Military Signal Corps Manual..</i>	1.50
<i>Victor Records for Code Practice (12 lessons) .....</i>	5.00
<i>*Key, Busser, Head Telephones and Condenser for Code Practice .....</i>	9.00

These items may be ordered *separately*, as required, or *in combination* at a discount of 10 per cent. on the magazine and text books, but not on the Records and Apparatus.

\*Price subject to change.

Extension Service Department

**MARCONI INSTITUTE**  
25 Elm St. - - New York City

Local and County Representatives Wanted to present this course to wireless amateurs and others looking forward to enlistment in the Signal Corps or Naval Radio service. Liberal terms.

equipped with micropho-detector in a moment's time by anyone. It does not require any technical knowledge to operate it. Full instructions as to how to install and operate it are included with each outfit. Conversation carried on in an ordinary tone is taken up by the concealed micropho-detector sound collector, magnified and conveyed over wire to a stenographer.

It is stated that by its use the stenographer or listeners at the receiving end, which can be in the adjoining room or some distance away, are enabled to hear every audible sound made in the room where the transmitter is concealed, without any suspicion on the part of the suspects. The micropho-detector is used in many government, state, county, and city offices and by the railroad corporation, banker, manufacturer, and in fact, to all who at any time have need to secure information or evidence. Many bankers' desks and directors' rooms are fitted with the micropho-detector in order that a record by a stenographer may be made of any important conference.

Railroads use the detectagraph to guard against attempts of blackmail or perjury in offering testimony in damage suits. Insurance companies utilize the device when contests arise over payments of insurance policies. Jails and penitentiaries may have a number of cells equipped with this detector, and thus record conversation between convicts and friends.

The originator of the micropho-detector modern detective devices has for many years been actively engaged in secret service work. The inventor has used these detective devices in securing corroborative evidence in an attempt to blackmail a railroad corporation of \$75,000. He saved a prominent insurance company \$150,000 in an attempt to collect upon a policy and in numerous other instances has successfully exposed trickery and fraud. He claims that this instrument clearly and distinctly reproduces sound however faint and correctly transmits it so that any person may hear the conversation of others without detection or interference.

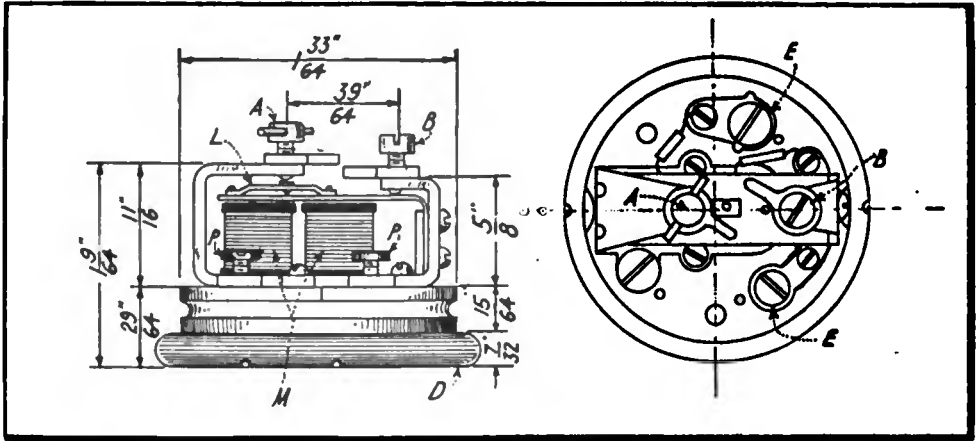

Figure 1

### Signal Corps Model High Frequency Buzzer

An electrical supply house has recently placed on the market a high frequency buzzer especially designed for Signal Corps use. A plan and side elevation are shown in figure 1. Two magnet coils M are mounted on a composition base, such as bakelite. A brass arm holds the adjustable contact A, and another arm the plate tension adjusting tube B. The contact S on the armature F is attached rigidly by means of

two rivets. Mounting the contact on the armature in this way permits a very high pitched note to be obtained.

By adjustment of either A or B, the tone of the buzzer may be varied over a wide range of frequency. These buzzers are applicable to code practice or to the testing of oscillation detectors, or for any purpose where shock excitation of a radio frequency circuit is desired.

"THERE'S MONEY IN IT"

AT HOME **LEARN TELEGRAPHY** AT HOME  
MORSE AND WIRELESS

**TEACH YOURSELF**

in half usual time, at trifling cost, with the wonderful Automatic Transmitter, THE **OMNIGRAPH**. Sends unlimited Morse or Continental messages, at any speed, just as an expert operator would. Adopted by U. S. Government. 4 styles. Catalogue free.

**OMNIGRAPH MFG. CO., 89-C, Cortlandt St., New York**



FOR IGNITION  
HIGH AMPERAGE  
**RED SEAL**  
DRY BATTERY  
PROPERLY CHARGED  
FRESH  
OPEN CIRCUIT WORK

## Red Seal Dry Batteries Are Guaranteed

to give absolute satisfaction for Automobiles, Motor Boats, Gas or Gasoline Engine Ignition, Medical Batteries, Telephone, Door Bells, Annunciators, Wireless Apparatus or any other open circuit work.

**ASK YOUR DEALER**

*Send for Our New Edition of Our Catalog N28 Now on the Press—  
Ready for Distribution At An Early Date*

It will be pocket size, 8x4 1/2 and will contain 248 pages with over 1,100 illustrations, describing in plain, clear language all about Bells, Push Buttons, Batteries, Telephone and Telegraph Material, Electric Toys, Burglar and Fire Alarm Contrivances, Electric Call Bells, Electric Alarm Clocks, Medical Batteries, Motor Boat Horns, Electrically Heated Apparatus, Battery Connectors, Switches, Battery Gauges, Wireless Telegraph Instruments, Ignition Supplies, etc.

**SEND FOR A COPY NOW**



SOMETHING  
ELECTRICAL  
FOR  
EVERYBODY  
**MESCO**  
MANHATTAN ELECTRICAL  
SUPPLY CO., INC.

**MANHATTAN ELECTRICAL SUPPLY COMPANY, Inc.**  
NEW YORK, 17 Park Place CHICAGO, 114 S. Wells St. ST. LOUIS, 1106 Pine St. SAN FRANCISCO, 604 Mission St.

### An Efficient Receiving Detector

I have shown in the drawing, figure 1, a detector of the ball and socket type which has the adjusting arm in a vertical position. I have found it to be an

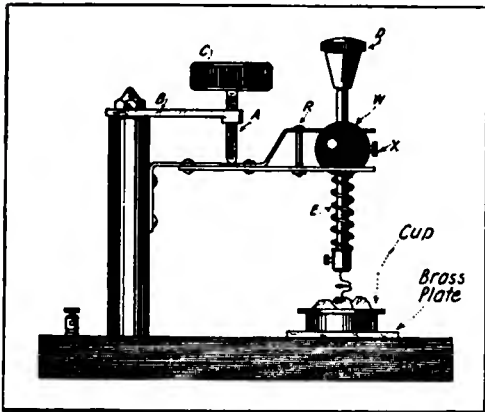

Figure 1

efficient one and particularly easy in point of adjustment. It will be noticed from the drawing that the vertical adjustment arm has the spring key which holds the sharp point in a state of tension against the crystal. It will be ob-

served that the movement of the ball may be regulated by the set screw R, which holds the piece of spring brass or phosphor bronze W in close contact with the ball. The additional material required is a  $\frac{3}{8}$ -inch square rod, an  $\frac{8}{32}$  brass bushing A, a piece of  $\frac{1}{8}$ -inch brass B, the knobs C and D, and a  $\frac{3}{16}$ -inch brass rod E. The length of the rod E may be adjusted by the set screw X, and coarse adjustment of the contact point made by means of the knob C, which places a tension on the spring.

J. G. STELZER, Michigan.

(Continued from page 691.)

mitting and receiving apparatus in such a way that it cannot be quickly connected up. Certain well intentioned enthusiasts have thus been left open to unnecessary suspicion, and placed in a most uncomfortable position.

The Government orders on this point must be strictly observed. *The aerial wires must be taken down, the apparatus dismantled and sealed up, i. e., it must be sealed in such a way that it cannot be readily connected for working.*

LICENSE PREPARATION  
FOR MASTERS, MATES  
AND PILOTS

WARRANT OFFICERS,  
PETTY OFFICERS AND  
SEAMEN IN THE U. S.  
NAVY PREPARED FOR  
THEIR EXAMINATIONS

## Uttmark's Nautical Academy

FORMERLY PATTERSON'S NAVIGATION SCHOOL  
ESTABLISHED 1882

8 STATE STREET, NEW YORK  
FACING BATTERY PARK

CAPTAIN FRITZ E. UTTMARK

PRINCIPAL.  
PROFESSOR IN NAVIGATION AND  
NAUTICAL ASTRONOMY

PRACTICAL NAVIGATION  
FOR YACHT-  
OWNERS AND OFFICERS  
OF THE PATROL  
SQUADRON AND  
NAVAL MILITIA. COM-  
PASSES ADJUSTED



Facing South and overlooking the Bay, in a quiet place, the building offers for students the very best facilities for studying. Observations of the heavenly bodies will be taken from the bridge on the roof, which is being equipped with compasses, pelorus, and other instruments, and practical use of same will be demonstrated, also practical sextant work will be done and position found by observations taken from the bridge.

This academy has the reputation of being the oldest and best equipped navigation school in the United States and is up-to-date in every respect. All our instructors are experienced teachers and able to up-hold the excellent reputation which the school has attained by many years of efficient work.

The new school building is most conveniently situated at No. 8 State Street, opposite the Berge Office at Battery Park. It is within two minutes' walk of Bowling Green and South Ferry subway stations, all the elevated trains, South Ferry, Staten Island Ferry and Atlantic Avenue Ferry. The Custom House, where the Board of Local Inspectors holds the examinations for masters, mates and pilots is just around the corner. In other words this school forms the hub or center of everything connected with shipping and shipping interest.

You and your friends are cordially invited to visit the school and inspect the new equipment. You will receive a hearty welcome. Please tell your friends about it.



# MILITARY SIGNAL CORPS MANUAL

By Major J. Andrew White

Chief Signal Officer of the American Guard, Member Institute of  
Radio Engineers, Acting President National Wireless Association

This manual, the first of its kind and the only complete work on the broad subject of army signaling, is indispensable to those responding to the call to the colors. Primarily prepared for Signal Corps men, it is a necessity for the proper understanding of apparatus and the tactical employment of troops and equipment.

Officers of infantry and artillery will find the volume of great utility, a proper conception of the enormously enlarged Service of Information being indispensable to all commissioned men.

Its contents include administration and government of military units—tactics of the division on the march, at rest and in engagement—function and operations of the Signal Corps and its relation to the line of the army—drill instruction, mounted and dismounted, for telegraph companies, radio and outpost companies, and battalions of Signal Corps—signaling by telegraph, heliograph, night lantern and flags, radio and service buzzer—camp and field telephones and their uses—radio apparatus of the Signal Corps—scouting, patrolling and tactical employment of field lines.

*Prepared with the full co-operation and approval of the Chief Signal Officer, U. S. Army.*

## CONTENTS

### Part I.—Organization

The Signal Corps, An Auxiliary Branch of the Army. The Signal Corps' Relation to the Line of the Army. Aircraft. Government and Administration. Military Courtesy. Personnel. Proficiency Test for Companies of Signal Troops.

### Part II.—Drill Instruction

General Principles. Definitions. Commands and Signals. School of the Soldier. Physical Training. School of the Squad. Instruction with Arms. The Company Dismounted. The Soldier Mounted. Elementary Collective Instruction Mounted. Field Signal Troops. The Wire Company. The Radio Company. The Outpost Company. The Field Battalion. Telegraph Signal Troops. The Telegraph Company. The Telegraph Battalion. Base Line Signal Troops. Depot Signal Troops. Ceremonies. Reviews. Inspections. Funeral Escort. The Standard. The Guidon. Manual of the Saber.

### Part III.—Technical Instruction and Apparatus

Telegraphy and Telephony. The Voltaic Cell, Ohm's Law, and Primary and Secondary Batteries. The Camp Telephone and the Buzzer. Induction Telegraph Set. Radio-telegraphy. Radio Apparatus of the Signal Corps. Visual Signaling Equipment. Flag Kits. The Heliograph. The Acetylene Lantern. Technical Equipment of Personnel.

### Part IV.—Transmission

Transmission of Military Information. General Instructions for Army Signaling. The American Morse Code. The International Morse or General Service Code. Instruction in Garrison. Visual Stations. Telegraphy. Visual Signaling in General. Signaling by Flag, Torch and Lantern, or Beam or Searchlight (without Shutter). Signaling with Heliograph, Flash Lantern, or Searchlight, (with Shutter). The Ardois System. Signaling by Two-Arm Semaphore. Signaling by Hand Flags. General Instructions for Locating and Operating Visual Stations. Letter Codes. Telegraph Code Books and Ciphers. Conventional and Preconcerted Signals with Rockets, Bombs, Small Arms and Guns. Flag Signals by Permanent Hoist. Emergency Signals. Conventional Telephone Signals.

### Part V.—Field Service

Signal Troops in the Field. Reconnaissance, Patrolling and Scouting. Military Map Reading. Signal Troops in Field Service. Field Lines. Camps. Company Guard Mounting. The Signal Corps and General Coast Defense. Coast Defense Information in War.

**Cloth. 588 pages. 260 illustrations. Price \$1.50 net.**

Specialists in  
Wireless Literature

Wireless Press, Inc. 25 ELM ST.  
NEW YORK, N. Y.

**IN STOCK—READY FOR DELIVERY**

[www.americanradiohistory.com](http://www.americanradiohistory.com)

# RADIO TELEPHONY

By Alfred N. Goldsmith, Ph. D.

Fellow of the Institute of Radio Engineers  
Member of the American Institute of Electrical Engineers  
Director of the Radio Telegraphic and Telephonic Laboratory  
of the College of the City of New York

This complete text on radio telephony is intended for radio engineers, radio electricians in the Navy, men in the Signal Corps and especially men in the Aviation Service who handle radio equipment. Amateurs and others who desire to be clearly informed concerning this newest and most interesting branch of electric communication will want this book.

It is written in clear style, and presupposes very little knowledge of radio. The text deals largely with the practical aspects of radio telephony and its future. It is copiously illustrated with wiring diagrams and previously unpublished photographs of "wireless telephone" apparatus.

IT IS THE ONLY BOOK TREATING THE SUBJECT OF RADIO  
TELEPHONY IN ALL ITS ASPECTS.

Among the unusual features of the book are a description of how radio telephony was carried on over a distance of more than 5,000 miles; an illustrated description of an airplane radio telephone set; an illustrated description of a large ship radiophone set; numerous illustrated sections on smaller ship "wireless telephone" transmitters; land station radio telephone sets of all sizes.

Another noteworthy feature is a description of the method of transmitting a radio telephone message to a ship at sea, or across continent or ocean, including the number of persons involved. This material is in dialogue form and so worded as to require no previous knowledge of the subject.

Among the topics treated are: the construction and operation of the Armstrong oscillating audion circuits; the construction and use of bulb amplifiers; the construction of the great alternators of the Alexanderson and Goldschmidt systems and how they are controlled, especially for radio telephony.

The book is very complete, practically every aspect of radio telephony being covered in detail. There are over 400 separate topics listed in a carefully prepared index.

8vo. 256 pages. 226 illustrations.  
Full cloth, stamped in gold. Price \$2.00 net.

Specialists in  
Wireless Literature

Wireless Press, Inc. 25 ELM ST.  
NEW YORK, N. Y.

IN STOCK—READY FOR DELIVERY

[www.americanradiohistory.com](http://www.americanradiohistory.com)

# *Solve the problem of self-instruction in the International Morse Code*

BY USING THE NEW

## MARCONI-VICTOR

### Wireless Code Instruction Records

*The Marconi Institute  
in collaboration with  
The Victor Talking  
Machine Company*

has prepared a complete set of Code Instruction Records for private study.

A series of progressive lessons provides elementary and advanced instruction for men in all divisions of Government and commercial service.

Records made by a *code expert* of years of practical experience.

Officially approved by The Marconi Wireless Telegraph Company of America.

#### *Brief Summary of Records*

Lesson No.	Title
1	International Morse Code and Conventional signals.
2	International Morse Code, etc., continued.
3	Easy sentences and periods.
4	Easy sentences and periods.
5	Marconi Press, South Wellfleet station.
6	Messages with static interference.
7	Press with static.
8	Messages with erasures, etc.
9	Press with interference from second station.
10	Groups of figures.
11	Ten-letter dictionary words.
12	Ten-letter code words.

A set of six double-faced *Victor Records*, complete in a container with instruction manual, specially priced at \$5.00.

**WIRELESS PRESS, Inc.**  
25 Elm Street, NEW YORK CITY

# Pan-American Wireless Telegraph and Telephone Company

EDWARD J. NALLY, President

233 Broadway

New York City

**T**HE main purpose of the Pan-American Wireless Telegraph and Telephone Company is the closer linking of the Americas by means of the modern and economical method of communication—Radio Telegraphy and Telephony.

Q A connection with the Marconi Wireless Telegraph Company of America extends its wireless telegraph facilities to Europe and the Orient.

Q High speed duplex working and reduced rates will be features of the new competitive service of the Pan-American Wireless Telegraph and Telephone Company.

## Pan-American Wireless Telegraph and Telephone Company

233 Broadway

New York City