

# Electronic Engineering



INCORPORATING ELECTRONICS, TELEVISION AND SHORT WAVE WORLD

## PRINCIPAL CONTENTS

Sir Ambrose Fleming  
Beam Tetrode Theory  
Circuit Diagrams  
Cold Cathode Counter Control  
A Bridge Stabilised R.C. Oscillator

**2/- JUNE, 1945**

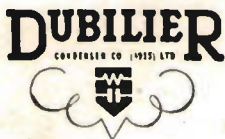
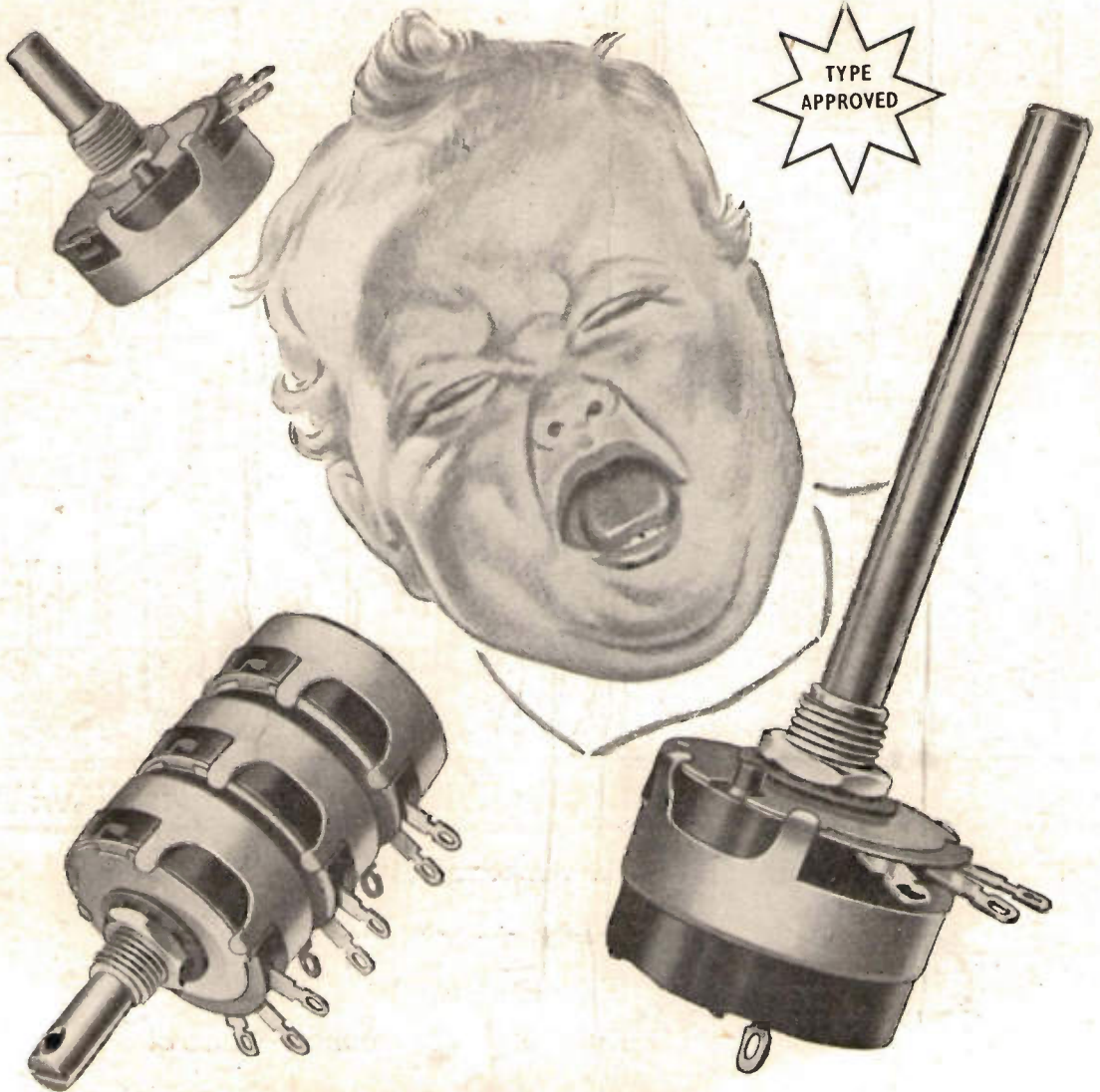

**VOLUME CONTROL.** We don't really claim that Dubilier Volume Controls will deal with *that* problem. Nobody's found an answer to crying babies yet. But for all radio and electronic circuits they are probably both mechanically and electrically the most reliable volume controls produced. Small but robust, they cover ratings from  $\frac{1}{2}$  to 2 watt. There is also a model TYPE CT, specially designed for tropical conditions.

*The name is . . . Dubilier*

C.R.C.P

The fact that goods made of raw materials in short supply owing to war conditions are advertised in this magazine should not be taken as an indication that they are necessarily available for export.

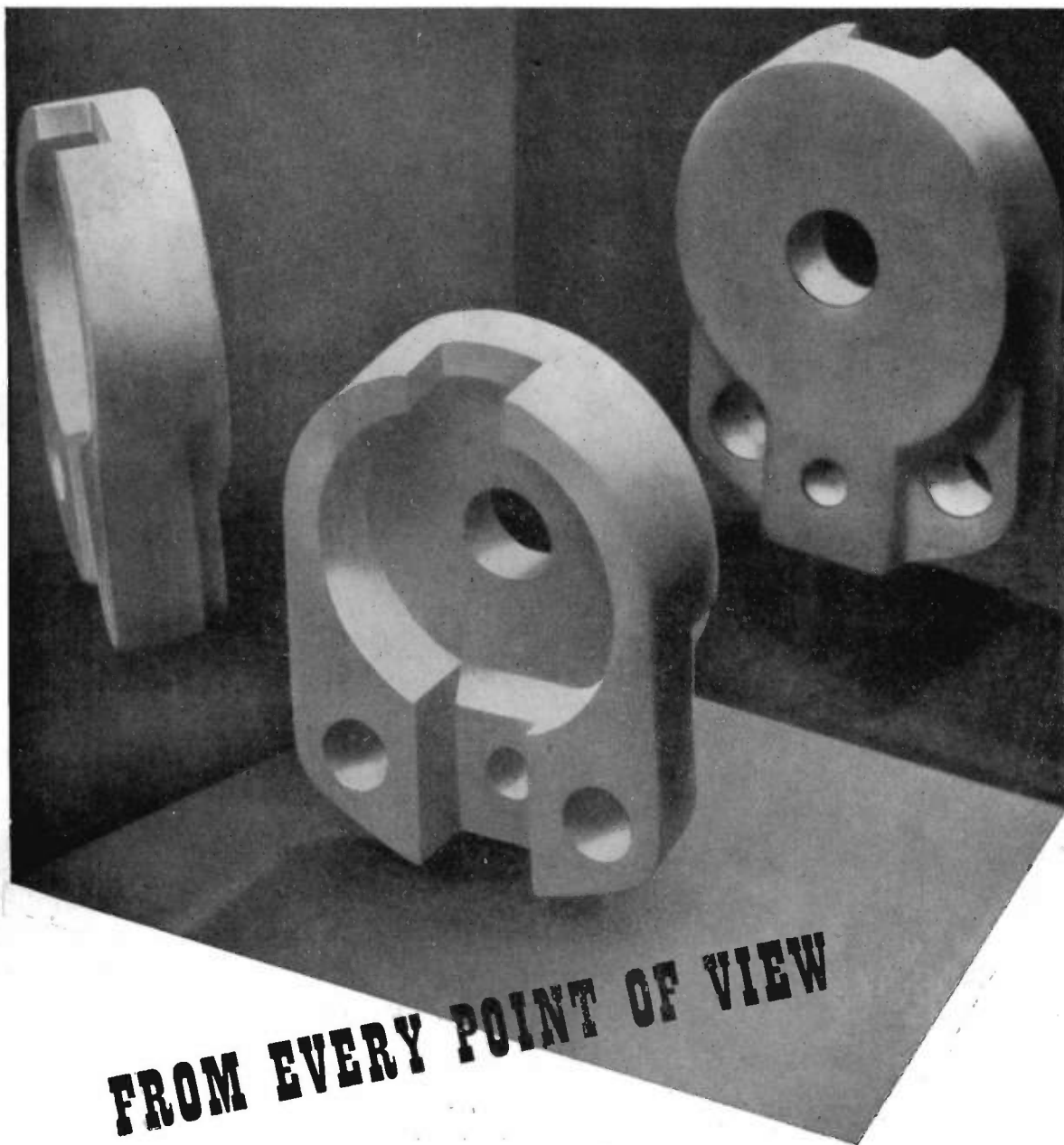

**Frequentite** is the most suitable insulating material for all high frequency applications. Ten years ago we introduced the first British-made low-loss ceramic, and consultation with us before finalising the design of new components is a wise precaution.



# **STEATITE & PORCELAIN PRODUCTS LTD.**

Head Office: Stourport-on-Severn, Worcester.

Telephone: Stourport 111.

Telegrams: Steatins, Stourport

S.P.31

# ELECTRONICS



Many OSRAM valves now on the secret list will be available, when priority production ceases, to meet the needs of electronic designers in every sphere.

## made it possible!

*Hullo, Red Section, tanks at nine o'clock — follow me* — and as one well-knit unit the flight goes hurtling down to its target, tied together with an invisible electronic link. Close command in the air depends on radio communications, and at the heart lies the electronic valve.

OSRAM VALVES have been in the forefront of electronic development during the war, and will bring to the pursuits of peace many well tried electronic devices to speed, smooth and make safer our way of life.

**Osram**  
PHOTO CELLS

**G.E.C.**  
CATHODE RAY TUBES

**Osram**  
Valves

*Going one better*

**IN COMMUNICATIONS**

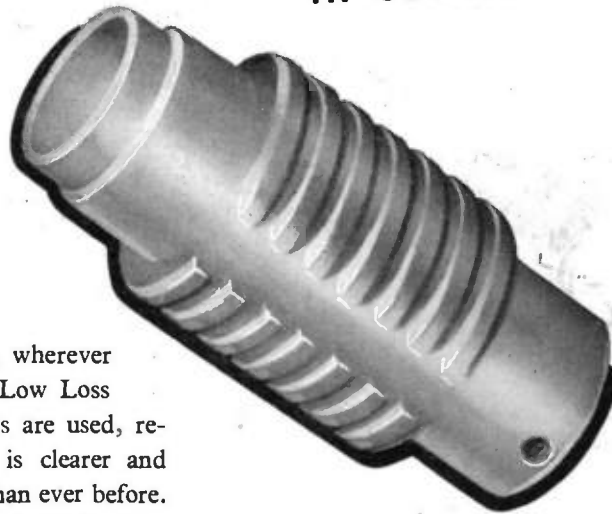

To-day, wherever Bullers Low Loss Ceramics are used, reception is clearer and better than ever before.

Years of research in Bullers Laboratories have developed these materials to such a high level of efficiency that Dielectric Loss is virtually eliminated. Bullers Ceramics are now playing a vital part in maintaining communications under all conditions.

**BULLERS LIMITED**

THE HALL, OATLANDS DRIVE, WEYBRIDGE, SURREY

Telephone : Walton-on-Thames 2451  
Manchester Office : 196 Deansgate, Manchester

**Bullers**

**LOW LOSS CERAMICS**

**Made  
in Three  
Principal  
Materials :**

**FREQUELEX.** An insulating Material of Low Dielectric Loss. For Coil Formers, Aerial Insulators, Valve Holders, etc.

**PERMALEX.** A High Permittivity Material. For the construction of Condensers of the smallest possible dimensions.

**TEMPLEX.** A Condenser material of medium permittivity. For the construction of Condensers having a constant capacity at all temperatures.



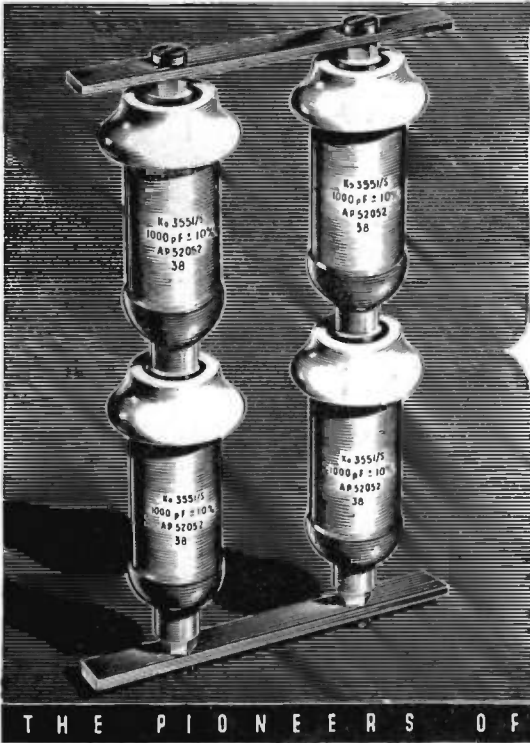

## CERAMIC *Pot* CAPACITORS

IN SERIES/PARALLEL COMBINATION  
 extend the useful range of voltage,  
 load and current . . . . .

FOR RADIO COMMUNICATION, BROADCASTING,  
 TELEVISION, NAVIGATION . . . and  
 HIGH FREQUENCY EQUIPMENT FOR INDUSTRIAL,  
 MEDICAL, & SCIENTIFIC PURPOSES . . . . .

Full details on request

UNITED INSULATOR CO. LTD., 12-22 LAYSTALL ST., EC1  
 Tel: Terminus 7383 (5 lines) Grams: Calanel, Smith, London.

THE PIONEERS OF LOW-LOSS CERAMICS



# TELCON CABLES

for  
**HIGH  
 FREQUENCY  
 TRANSMISSION  
 and RECEPTION**

Full particulars of all Telcon Products from:  
**THE TELEGRAPH CONSTRUCTION  
 & MAINTENANCE CO. LTD.**  
 Head Office: 22, Old Broad Street, London, E.C.2  
 Telephone: London Wall 3141

## "UNO" STENCILS

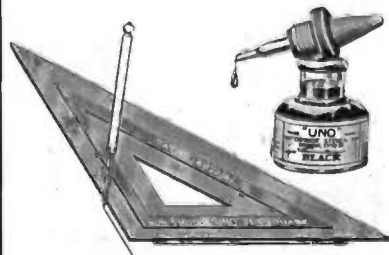

6 Stencils of  
 Electrical Symbols  
 6/- each

**A. WEST & PARTNERS, LTD.** 36, BROADWAY  
 WESTMINSTER, S.W.1

PROPRIETORS :

HULTON PRESS, LTD.

# Electronic Engineering

EDITOR

G. PARR.

EDITORIAL, ADVERTISING AND PUBLISHING OFFICES, 43-44, SHOE LANE, LONDON, E.C.4

TELEPHONE:  
CENTRAL 7400

Monthly (published last day of preceding month) 2/- net. Subscription Rates :  
Post Paid to any part of the World—  
6 months, 13/- ; 12 months, 26/-.  
Registered for Transmission by  
Canadian Magazine Post.

TELEGRAMS :  
HULTONPRES, LUD  
LONDON.

## Victory

IT would not be seemly to allow IV-month to pass without reference to the all-important part that electronics and radio have played in bringing about the victory in Europe and the victory to come in Asia.

From the start of hostilities this has been referred to as a radio war, and we have had ample evidence of the superiority in design and invention which has enabled us to go one better than the enemy in nearly every application of science to warfare.

Among the army of technical workers and scientists who have contributed to victory it is invidious to single out any one class for special praise, but there are two examples that may be cited for tribute.

First, there are those who, knowing nothing of radio or engineering at the outbreak of war, acquired by intense effort over a period of months or even weeks sufficient knowledge of the subject to operate some of the most intricate apparatus that has been devised, and who in many cases progressed so far in this

### IMPORTANT NOTICE End of Volume

This Journal changed its style and title in May, 1941, with the result that the end of the volume was thrown "out-of-step" with the end of the year.

Thus, Vol. XIV covered the 12 issues from June 1941, to May, 1942, and so on.

During the war period it has not been thought desirable to make a change, but with the prospect of increased paper supply next year it is better to regularise matters while the bound volumes can be kept reasonable in thickness.

**Accordingly, the current volume (XVII) will continue to December, 1945, and will contain 18 issues. The next volume (XVIII) will start in January, 1946, and will contain the usual 12 issues.**

Until conditions are more stable, a standard binding cover will not be available, but "self-binders" holding 24 copies can be obtained from the Circulation Dept., price 3/6, post free.

Binding covers for *Electronics, Television & Short Wave World*, as this journal was formerly known, can be obtained price 2/3, post free.

Orders should be accompanied by a cheque or P.O. and should be addressed to: Circulation Dept., Hulton Press, 43, Shoe Lane, E.C.4.

new sphere that they were able to instruct newcomers in the work.

We hope that their new-found interest in the science will not leave them at the end of their service, but that they will continue to study it with the keenness that they brought to it originally and reap the reward of their trouble in peace-time applications.

Secondly, there are those who at the outbreak of war dropped the career that they had chosen and put all their energy into solving the special problems that were set them—often without a clear indication of the immediate use of the work on which they were spending so much time and trouble.

The lucky ones have seen the results of their work in improved weapons, better navigation aids, safer flying conditions.

With the war over, they are now returning gradually to pick up the threads dropped six years ago, and if they reflect they may feel with justifiable pride that there are many walking about to-day—soldiers and civilians—who literally owe them their lives.

# Ambrose Fleming

## —His Early Electrical Work and the Discovery of Magnetic Focusing

By J. T. MACGREGOR-MORRIS, D.Sc. (Eng.), M.I.E.E.

Professor MacGregor-Morris was one of Sir Ambrose Fleming's first students and later became his personal assistant at University College in 1894



**M**Y first introduction to Fleming was at his opening lecture on Electrical Technology at University College, London, in 1891, when my brother (the late Dr. D. K. Morris) and I entered the college.

It was a breathless affair, for the rate at which he spoke made it extremely difficult for us to take notes. Usually he showed a few experiments and his enthusiasm about the whole subject was certainly infectious. This was the only course of lectures he gave each session for many years.

I well remember a lecture he gave after his return from the famous Frankfurt Exhibition, 1891. It was on delineating alternating current waves. At that time the only reliable method was that of the Joubert revolving contact. After describing this, he passed on to tell how he had seen at the Exhibition the waveform of speech waves by the use of a Bell telephone receiver. A very small mirror was fixed to the diaphragm about half-way along a radius, and a powerful beam of light falling on the small mirror was reflected on to a rotating mirror. When there was no speech current in the receiver, the image seen in the rotating mirror was simply a straight line, but when speech currents flowed, the straight line broke up into a jagged trace, especially when consonants were being transmitted. I can still vividly remember his ardent enthusiasm about the whole business, though it is now more than fifty years ago.

We have to remember that at that time neither the Duddell oscillo-

graph nor the reliable cathode-ray oscillograph has been produced.

### Laboratory Equipment and I.E.E. Transformer Tests Paper

The equipment of his laboratory was meagre in the extreme; in fact I have heard him say on more than one occasion that all that was provided for him by the authorities was a room with a blackboard and a piece of chalk! Practically all the apparatus available was lent by firms.

The first minor piece of research which he asked my brother and me to carry out had the object of showing experimentally that the hysteresis loop for an iron wire was only dependent on the net number of ampere turns in the magnetising coil, e.g., whether 40 A.T. or 420-380 A.T. were used. (The application of this to A.C. transformers is obvious.) We found no difference, except a slight temperature effect due to the extra  $I^2R$  loss when the large number of turns were used. This was in 1892 when he was engaged on an important I.E.E. paper, "Experimental Researches on Alternate Current Transformers."

In those days, the Institution discussions were adjourned from week to week if need be, and in this case it lasted six weeks. All the transformers tested were of the closed magnetic circuit type—with the one exception of a Swinburne hedgehog type. Mr. (now Sir James) Swinburne had constructed a workshop wattmeter with no metal in it save the windings, and then when it was put through the shops a fine instrument making job of it was made, including the addition of two lacquered brass cheeks for the current carrying coil. The rather disturbing result was found by Fleming that though this instrument measured the open circuit losses almost correctly of all the closed type transformers, when used on a Swinburne (hedgehog)

transformer it indicated that the losses were only about one-third of their actual value.

This result was obtained in perfectly good faith by Swinburne, but I can well remember how Fleming demonstrated incontrovertibly the facts about this rather partial wattmeter before his large audience.

### Popular Scientific Lectures in the Provinces

During the period from 1894 to 1898 when the present author was Fleming's private assistant, Dr. Fleming gave a number of highly successful popular scientific lectures in the provinces, including those for the Gilchrist Trustees. Most of his experiments were in the form of mechanical slides for the sake of portability.

On one occasion he told me jokingly that he had given a lecture to a large audience at the Crystal Palace entitled "Magnets and Electric Currents" which included a lantern slide of a group of nine pivoted little magnets. A good lady the next day was asked what she thought of the lecture. She replied, "It was about Maggots and Currants and he showed creeping things on a sheet!"

One of the nearest shaves he had was in the early days of X-rays, when he was lecturing to a crowded audience of nearly 2,000 in the Portsmouth Town Hall. During the lecture it was my duty to ask a member of the audience to come up on to the platform, and take an X-ray shadowgraph of his hand. This had been done, and on my return from developing the plate, I saw at once that something was wrong. The limelight was failing and I immediately noticed that Fleming was putting in padding (for I knew the lecture from end to end). He hastily said to me under his breath, "Morris, see if you can do



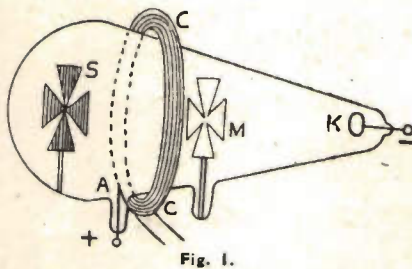

anything!" I at once went to the back of the hall, and together with an electrician got on to the top of the boarding of the entrance (which was thick with dust) and there we collected a discarded electric arc and rapidly wired it up while Fleming held the fort. I shall never forget the continuous thunderous applause which greeted the appearance on the screen of the X-ray shadowgraph of the man's hand taken during the lecture, thus converting what might have been a rather dismal ending to his lecture into a first-class success.

#### Magnetic Focusing of Cathode Rays

One morning in December, 1896, at the end of the term, I well remember Dr. Fleming coming with his quick step into his laboratory at University College, and after his usual "Good morning" he said, "Morris, I want you to try out an experiment on the effect of an axial field upon the discharge in a vacuum tube." For this purpose, he produced a Crookes' tube having a Maltese cross near one end, and I was to use his 10-in. spark coil and a strong bar magnet about a foot long.

The bar magnet applied axially at the end of the enlarged end of the tube was expected to reduce the voltage necessary to excite the tube, and also produce some changes in the shadow.

Having got the apparatus working, Professor (then Mr.) Clinton joined me, and Dr. Fleming (as he was always called by staff and students) had to hurry off and did not reappear until the late afternoon.

Clinton and I found a slight effect on the voltages required to excite the tube, but we were much more interested in the effect produced on the Maltese cross shadow by the magnet. It was apparently most erratic, and seemed to require great precision in centring the magnet, and in getting it accurately aligned with the axis of the tube.

Continuing the account in the words of Dr. Fleming's letter to

*The Electrician* (January 1, 1897):—

"Mr. Morris and Mr. Clinton, who were experimenting with it, finally were led to try a coil traversed by current, placed round the tube as shown in Fig. 1, as a substitute for the magnet.

"The following striking effects were then noticed. When the coil embraced that part of the vacuum tube between the metal cross and the end wall on which the shadow is formed, and when no current traversed the coil, the shadow of the cross was a dead-black shadow on an apple-green phosphorescent ground and was strictly the shadow of the cross defined by cathode rays as in Fig. 2. When the embracing coil had a current passed through it, the shadow rotated clockwise or the reverse according to the direction of the coil current, and the arms of the shadow were a little distorted or twisted round so as to resemble Fig. 3, the leading edge of the shadow being rather sharper than the trailing edge. Moreover, the shadow was altogether smaller than in the first case. As the current through the coil was increased, the shadow cross twisted itself more round, and got still smaller as in Fig. 4; and finally as the coil current was still more increased the cross shadow

was further rotated and diminished until it vanished . . . at this stage the coil current was increased still more, and a new and larger cross shadow made its appearance. This shadow was not so well defined, and the background less uniformly green; but it too, as the coil current was still more augmented, screwed itself round very slightly. This second shadow had its arms more sickle shaped than the previous one. . . ."

It will be noticed that at the time we performed the experiment, no mention was made of "focusing the cathode rays," but now this system is extensively used in connexion with all kinds of cathode-ray tubes to focus the beam sharply on the screen.

His unflinching enthusiasm for scientific research continued right up to the end of a remarkably long life, and indeed is expressed in an almost pathetic way in his last letter to the author, dated a few days before his 95th birthday. A portion of this is reproduced below.

That he laid the foundations for electrical engineering in such men as the late Sir Joseph Petavel, the Earl of Mount Edgcombe, the late Roger T. Smith and J. W. Meares, to name only a few, is sterling tribute to the quality of his work.

*in this work. As for myself, I shall be 95 years ~~of~~ old on Nov 29th and am past the age at which one can do much active work, as a result of bodily defects. But I wish you every success in your work*

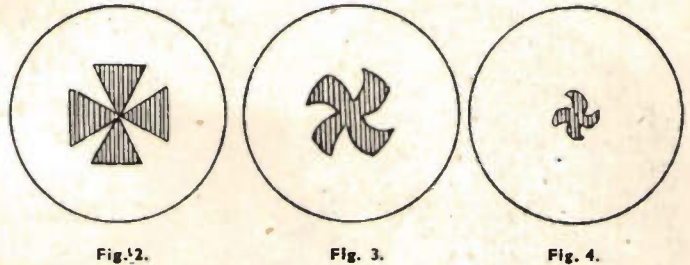



## Tropic-Proof Radio Apparatus — Part 2 By W. J. TUCKER

**U**NPROTECTED power transformers and chokes with high voltage windings are extremely susceptible to breakdown after limited periods of exposure to humid conditions and tropical temperature gradients.

Almost all of the breakdowns which occur are attributable to the penetration of moisture into the windings, although a limited number of failures are caused by the corrosive effects of chemicals used in protective impregnating solutions and varnishes.

Moisture penetrating to the coil of a transformer causes one or more of the following sets of conditions to arise:—

The paper used for interleaving is attacked, and water-soluble salts start electrolytic action on the enamelled wire. The corrosion proceeds rapidly until shorting across adjacent turns occurs or the coil is short-circuited. The use of varnished paper is only a partial solution since the varnish cracks during the winding operations. Impregnated paper gives better results but it has been found more economical and practical to aim at sealing the coil after winding has been completed.

The presence of moisture leads to a serious drop in the insulation resistance between windings and from windings to the iron core. Open-ended windings are particularly susceptible to failure due to breakdown through the wire covering to the adjacent iron core.

The collection of moisture on terminal strips increases the risk of tracking and flashover which in humid air occurs between points with a comparatively low potential difference between them.

Table 1 gives two sets of figures

for comparison between the performance of an untreated and a treated transformer, after both samples had been exposed to 95 per cent. humidity at 25° to 40° C. for the periods stated. The treatment consisted of impregnating the completely assembled transformer with varnish, and then applying a finishing coat of a dip compound.

The varnish impregnation method of protecting transformers has been in use for some time, but there is now sufficient evidence to show that only a limited degree of protection can be obtained by this method.

To prevent the ingress of moisture the varnish must form a complete seal around all absorbent surfaces and act as a barrier against moisture percolating to the crevices between adjacent turns of the inner winding. The smallest pinhole will allow a breathing action to take place, and exposed fabric sleeving such as is often used for lead out wires, being absorbent acts as a wick and draws moisture right inside the coil.

It will be recognised that it is almost impossible to guarantee a pinhole-free coating, and since all varnishes tend to be brittle cracks can easily develop as a result of vibration and shock.

An overall coat of bitumen compound applied after varnish impregnation partly overcomes the above disadvantages because the bitumen provides a thicker and more durable protective coat, but tests have shown that on power transformers, fully reliable protection can only be obtained if the impregnating and dipping is carried out and inspected to laboratory standards.

One quite common cause of trouble is corrosion set up by the solvents

used with the impregnating varnish. When a coil is impregnated it is at present necessary to use a varnish which is made as free flowing as possible by use of a solvent. By drying processes the solvent theoretically is evaporated before the varnish coating sets hard. In practice, however, it is extremely difficult to evaporate all traces of solvent before the varnish coating begins to set, and as hardening commences on the outer surfaces of the coil there is a grave risk of free solvent being trapped right inside the coil. Certain solvents attack the enamel in the wire and after a few months breakdown occurs. The development of a solventless varnish would solve this production problem but apart from claims made with respect to an American product, known as Fosterite, no developments of this nature have been given publicity.

The practice of varnish impregnation with a subsequent dip-coating of bitumen is regarded as a satisfactory method of sealing small transformers such as inter-valve and microphone types, but for larger power transformers tests have shown that unless the transformer is running continuously and thus generates heat to drive off moisture, the only reliable method to adopt is to hermetically seal the transformer in a metal can or neoprene bag.

A hermetically sealed, metal-enclosed transformer made by Applied Electronics Ltd. is illustrated in Fig. 1.

The makers of this transformer took a standard coil and lamination assembly and placed it in the metal can, subsequently filling the can with bitumen compound under pressure. The connexions are brought out

through ceramic seals which are soldered to the top plate of the transformer.

A transformer of this type will stand up to the worst possible conditions of humidity almost indefinitely.

Neoprene bag transformers are also very satisfactory the general method of construction being to enclose a normal transformer assembly in the bag which is filled with oil and then sealed. The expansion of oil when hot is greater than that of bitumen but the flexibility of the neoprene bag takes care of the increase in volume.

One important point to note in connexion with totally enclosed transformers is that the dissipation of heat is more difficult. It is as well, therefore, to consider designing on more generous lines so as to keep the heat generated down to a minimum. If space is a limiting factor, high permeability iron cores should be used.

The temperature rise in a sealed transformer when measured by the standard resistance method should not exceed 35°-40° C. The measurement should be made after the transformer has been running for a few hours.

Polythene and polyisobutylene mixtures have also been used experimentally as moulding compounds for totally enclosing small transformers. The high shrinkage rate of polythene however is a disadvantage in this application because the bulk of material is large, and shrinkage usually manifests itself by a breakaway of the polythene from the metal work of the transformer assembly.

Fig. 1. An experimental hermetically sealed transformer adapted from an existing mains transformer, filled with bitumen compound under pressure.

—Applied Electronics, Ltd.

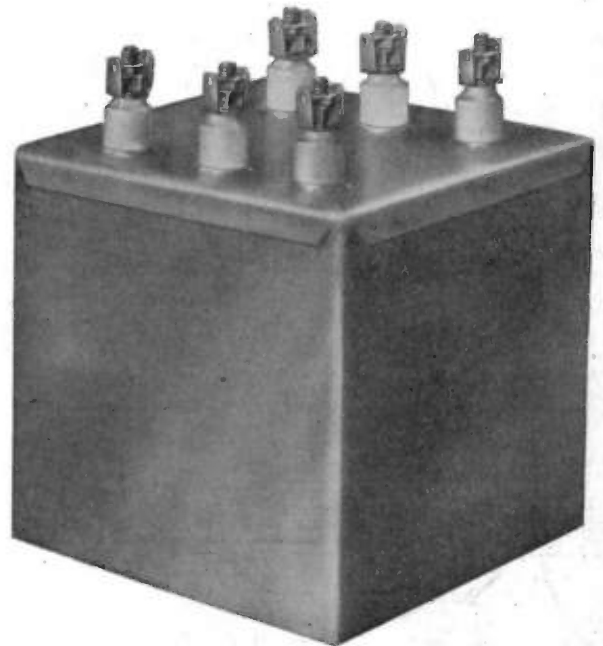

**Meters**

Meters are not used very extensively on normal domestic radio equipment but are usually fitted on special purpose and test apparatus. The delicate nature of a meter mechanism makes it very susceptible to deterioration and breakdown.

Meter failures are usually attributable to one or more of the following defects:

- (a) Corrosion on the pivots, pole-pieces, and pointer.
- (b) Disintegration of the paint on the scale plate. This paint flakes off and causes a seizure on the moving coil and pivot. (See Fig. 2.)

(c) Defective sealing of the glass window. Glass windows are also affected on the outside by the growth of fungus which etches the glass and impairs visibility. When fabric sleeving is used to insulate internal connexions fungus grows on this sleeving and spreads over all the meter mechanism.

The most effective way to overcome all these troubles is to hermetically seal the whole movement in a metal case, and the meter industry is already engaged in developing prototype sealed meters. Fig. 3 shows a meter recently developed by Messrs. Elliott Bros.

**TABLE I. Tropical Test on Treated and Untreated Mains Transformers**

(Insulation Resistance in Megohms measured at 500 V D.C. between each winding and all windings connected to core)

Period of Exposure to test Conditions	Primary 200-250 volts		H.T. Secondary 350-0-350 volts		L.T. Secondary 1 6.3 volts		L.T. Secondary 2 5 volts	
	Sample A	Sample B	Sample A	Sample B	Sample A	Sample B	Sample A	Sample B
Before test ...	9,000	8,000	10,000	9,000	8,000	8,000	10,000	9,000
5 days ... ..	300	7,500	700	2,000	600	4,000	700	700
10 days ... ..	200	5,000	—	500	200	500	150	350
15 days ... ..		500		350		500		350
20 days ... ..		200		250		150		10
40 days ... ..		150		100		70		

Sample A. Protected by a surface coat of varnish only. Sample B. Varnish impregnated and dipped in bitumen. Test prior to above cycles of tropical conditioning = Flash test on all windings to core at twice rated voltage + 1,000 V (50 cycles, A.C.). Check tests = Normal operation for 5 hours every 50 hours. Sample A broke down on H.T. secondary after 6 days' test. Humidity and temperature cycle = 25° C. — 40° C. at 95 per cent. relative humidity (10 hours at 25° C. — 10 hours at 40° C. — 2 hours each rise and fall).



Fig. 2 (left). A standard commercial meter, after 6 weeks' tropical test. (Temperature 25°C.—40°C. continuous cycle. 95 per cent. Relative humidity.) Note the almost complete obliteration of the scale markings, and disintegration of pointer. The rest of the mechanism on this model is cadmium plated, and has stood up well to the test. Meters with a less satisfactory finish, corrode very badly.

Performance can be improved by applying a more durable anti-corrosive finish to all parts of the mechanism paying particular attention to the pointer, the pivots and the scale.

It is worth noting at this stage that tests have shown that highly polished steel surfaces are far less susceptible to corrosion than surfaces left rough, and the surfaces of pole-pieces and magnets should be as highly polished as possible.

For scale painting and marking, the quality of the product used should be such that it will adhere firmly to the metal plate even after long exposure to humid conditions. Almost every meter examined after extended damp heat tests has to be rejected as unsuitable for tropical use because, quite apart from any other faults which have developed, the painted surface of the scale peels off.

When meter mechanisms are housed in moulded cases a good deal of the corrosion which occurs is caused by ammonia released from the moulding compound. Phenolic moulding materials of certain types give off free ammonia when exposed to damp and



Fig. 3. Special glass-cased hermetically sealed meter for tropical use.

—Elliott Brothers, Ltd.

Fig. 4 (right). A standard commercial lever operated "on-off" switch after 6 weeks' tropical test. Note extensive corrosion of spring, which eventually failed to operate. The moulded housing also swelled due to moisture absorption, and prevented the switch arm from moving freely.



heated atmosphere and this ammonia attacks all brass parts of the assembly.

### Switches

Unless they are completely enclosed or built on generous lines both toggle and rotary switches are liable to give trouble in the Tropics.

The contact clearances in toggle switches for radio use are of necessity very small, and unless precautions are taken water will collect very quickly between the contacts and cause a short-circuit.

From the many types tested and examined after being in use for a few months the conclusion has been reached that totally enclosed types are quite reliable even when they are not hermetically sealed, and that the useful life of other types can be prolonged if care is taken to protect the spring and operating mechanism adequately from corrosion. More detailed reference will be made to the subject of anti-corrosive finishes for metals under a separate heading. The finishes adopted for toggle switches, however, call for special comment because so many switches are rendered unserviceable by the failure of the "quick make and break"

mechanism to operate. Very often it is impossible for the operator to be sure that the switch is off or on by referring to the position of the operating lever or knob. The operating mechanism of a standard commercial switch not intended for tropical use is shown in Fig. 4. This was exposed to tropical conditions for six weeks. After this period the switch seized up completely and it will be obvious from the photograph that it could have been made suitable for tropical conditions if the metal parts had been more adequately protected.

Rotary switches as used for wave-band changing give trouble when moisture collects on the surface of the insulation between contacts, and when the insulation resistance of the wafer material is lowered by the effect of absorbed moisture. The cut edges of inferior grades of laminated sheet allow moisture to penetrate into the material and switches made up with such material are useless for tropical use.

Quite apart from the loss of electrical efficiency which occurs when moisture is absorbed by inferior laminates, mechanical distortion also takes place which interferes with the correct operation of the switch. Only best quality sheet materials are suitable for tropical applications and for high frequency applications, switches with glazed ceramic wafers are preferable. The service life of all components made with laminated sheet material can be extended by the application of Bakelite varnish on all cut edges. The use of varnish is not necessary if the correct tropical grade of material is chosen.

The stop mechanism on rotary switches if allowed to corrode will render the switch inoperative for two reasons. The mechanism is bound to seize up and the corrosion will scale off and settle in between moving and fixed contacts causing short-circuits and wrong switching sequences. It is therefore essential to ensure that all metal parts are adequately protected.

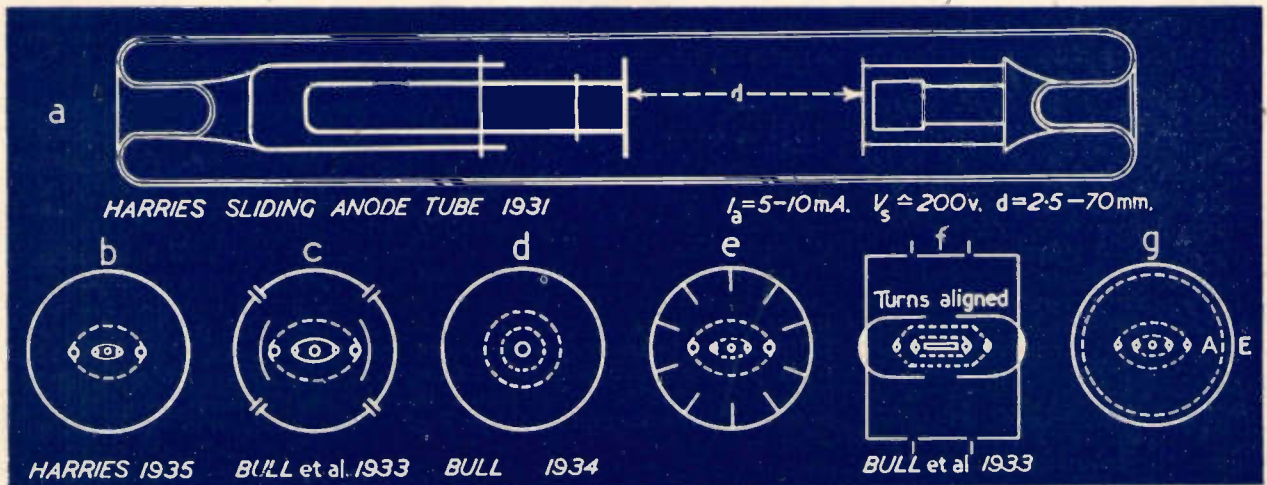

Fig. 2. Various forms of beam tetrode design.

# Space Charge and Electron Deflections in Beam Tetrode Theory

By S. RODDA, B.Sc., F.Inst.P.\*

## I. Introduction

IN this paper the name "beam tetrode" is used to denote a member of the class of valves known variably as output tetrodes, beam tetrodes, kinkless tetrodes or beam power valves.

As in the conventional pentode, the object of beam tetrode design is to prevent the passage of secondary electrons from the anode to the screen when the anode voltage is below the screen voltage, and from the screen to the anode when the anode voltage is greater than the screen voltage. In S.G. valves with low anode voltages, although the full number of primary electrons may be incident on the anode, the loss of secondary electrons from it causes a marked reduction in the net current registered in the anode circuit—indeed the apparent anode current may reverse in sign. The effect gives rise to the well-known "dynatron"  $I_a, V_a$  characteristic, and as a result the anode voltage cannot swing below the screen voltage without distortion in the output. In terms of power efficiency this is not serious if the screen voltage can be maintained at a small ratio of the mean anode

voltage, but then the mean anode current will be small compared with the anode current obtained by operating at a high screen voltage. It is seen, therefore, that if the passage of retrograde secondary electrons can be avoided very marked advantages will accrue. One way of suppressing the effect would be to find some conducting material for the anode which did not emit secondary electrons when bombarded by primaries, but although the value of  $\gamma$ , the ratio of secondaries emitted per primary, is sometimes small, it is theoretically a forlorn hope to expect  $\gamma$  to be zero. Practically, the situation is worse than this because of the evaporation of barium oxide and of barium from the cathode during the life of the valve, so that any initial surface becomes changed in its secondary emitting properties.

The pentode is characterised by the introduction of another grid, between the screen and the anode; the additional grid, known as the suppressor, is maintained at a low potential and is usually joined directly to the cathode inside the

It is a straightforward solution of the problem and has the additional advantage of providing extra screening between the anode and control

grid which is important for high-frequency operation—although the "duplex screen" of the old Mazda AC/SG screened grid valve had the same virtue.

The difference between the S.G. and the pentode or tetrode  $I_a, V_a$  characteristics can be seen from Fig. 1. Due to the presence of the low voltage suppressor grid in the pentode, secondary electrons emitted from the anode will have to overcome a voltage drop  $\Delta V$  before they can enter the suppressor grid to screen space, and it is only the electrons which are emitted with sufficiently high velocities which can do this. This action does not extend down to zero anode voltage, since at some critical anode voltage  $\Delta V$  vanishes and at lower anode voltages the field between anode and screen directs the secondary electrons back to the screen (*Jonker*).<sup>1</sup> However, the critical voltage is so low that the dynatron kink is entirely removed.

In both tetrodes and pentodes the  $I_a, V_a$  curves are characterised by having a rising portion when the anode voltage is increased from zero. At some anode voltage, designated the "knee voltage," the characteristics flatten out more or less abruptly. In order to permit the anode voltages to swing to low values it is desirable that the knee voltage should be as

\* The Cosmos Manufacturing Co., Ltd.  
MS. received Feb., 1944.

low as possible. In this survey relatively much attention is given to the problem of the steeply rising initial portion of the  $I_a, V_a$  characteristic, because of its fundamental physical interest, and in spite of the fact that in normal operation this domain must be excluded from the working range. The anode voltage in the course of its swing will reach low voltages when the control grid is most positive, and in this region the deleterious effects of secondary emission must be removed.

2. Methods of Suppression

In beam tetrodes also the annulment of secondary emission effects is achieved by ensuring in the screen-anode (S.A.) space a sufficient depression in voltage  $\Delta V$  below the anode. There are two methods which may be employed:—

1. Space charge suppression.

The presence of negative charges, viz., the electrons projected into the S.A. space, will reduce the potential at any given point in the space.

2. Electrostatic field suppression.

In the parts of the S.A. space not traversed by primary electrons the potential reduction due to space charge will be insufficient; or again, if the density of negative charge in the beam is too small it may become necessary to supplement the voltage depression due to space charge with the voltage depression due to additional electrodes maintained at a voltage lower than the anode, e.g., by an earthed plate system.

We may look on the S.A. space as forming an enclosure, which may contain electrodes to which potentials are applied. Electrons are projected into the enclosure forming regions of negative space charge density. In principle, one can calculate the distribution throughout the given enclosure from a knowledge of

- (1) The potentials of all parts of its boundary surfaces and electrode surfaces within the enclosure.
- (2) The density of charge at all points throughout the volume.
- (3) The Green's function for the enclosure.

The relevant expression for potential  $V_P$  at any point P is

$$V_P = \iint V \left( -\frac{\partial G}{\partial n} \right) dS + 4\pi \iiint G \rho d\tau \quad (1)$$

where  $G$ , Green's function, is the potential at the volume element  $d\tau$  if a positive charge  $1/4\pi$  were located

at P, with all boundary and electrode surfaces at zero potential.

$V$  is the potential applied at the surface element,  $\left( -\frac{\partial G}{\partial n} \right)$  is the normal intensity at the surface due to a charge  $1/4\pi$  at P.

$\rho$  is the actual space charge density in the volume.

The first integral in this expression gives the potential due to the electrodes, the second integral gives the potential due to space charge. Since  $G$  is positive throughout the enclosure, and since  $\rho$  for electrons is negative, there is some voltage depression everywhere due to space charge; but if P is well outside the beam,  $G$  will be small inside the beam, and therefore the second term will be small.

Fig. 2 shows various forms of tetrodes which have been proposed. The first tube (a) was described by Harries in Pat. Spec. 385,968, and later in the *Wireless Engineer*.<sup>1</sup> It was a sliding anode tube which was used to demonstrate how the desired tetrode characteristics could be obtained by changing the screen to anode gap; with gaps greater than a certain "critical distance" secondary emission suppression could be ob-

tained. The Harries Hivac tetrode is shown diagrammatically in Fig. 2b (*Wireless World*, 1935).<sup>2</sup>

Two forms of tetrode with earthed side plates proposed by Shoenberg, Bull, and the author<sup>3</sup> are shown in Fig. 2c and 2f. It was recognised that in a valve of normal construction, with grid and screen support rods, it is impossible to avoid regions where space charge is absent. These regions are in line with the supports and may be termed "shadow areas"; as shown above, within the shadow areas the depression of voltage due to space charge in the beams is relatively feeble, so that secondary electrons emitted at oblique angles from the anode are not prevented from traversing these areas and arriving at the screen. By dividing the anode into sectors as shown in Fig. 2c, earthing the side sectors to cathode and also inserting earthed side plates near the screen supports, a relatively low potential is obtained in the shadow areas, sufficient to act as a barrier to secondary electrons.<sup>4,5</sup>

If the field near the suppressor grid wires of a pentode is determined it will be found to be very non-uniform. Now if a voltage depression  $\Delta V$  is sufficient to inhibit the passage of secondary electrons, is there any advantage in having non-uniform barriers? With regard to the transport of secondary electrons across the barrier, the answer must be that a potential distribution going down to zero voltage must be, if anything, an advantage, but it is offset by the fact that primary electrons which are directed at the suppressor grid wires must themselves be reflected back towards the screen. It was realised therefore that the tetrode construction would eliminate this effect. The direct capture of primary electrons by the screen can be minimised by the correct alignment of screen and control grid wires; therefore in a tetrode with aligned grids the screen to anode current ratio can be reduced to very low values indeed.<sup>3a</sup>

In Fig. 2d is shown a cylindrical form of construction suggested by Bull and Keyston.<sup>7</sup> In this valve a "supportless" grid and screen construction is employed; thus the "shadow areas" have been avoided, and it is now no longer logically necessary to introduce earthed electrodes into the screen to anode space. Moreover, by using a cylindrical construction in which the ratio of anode radius to screen radius is

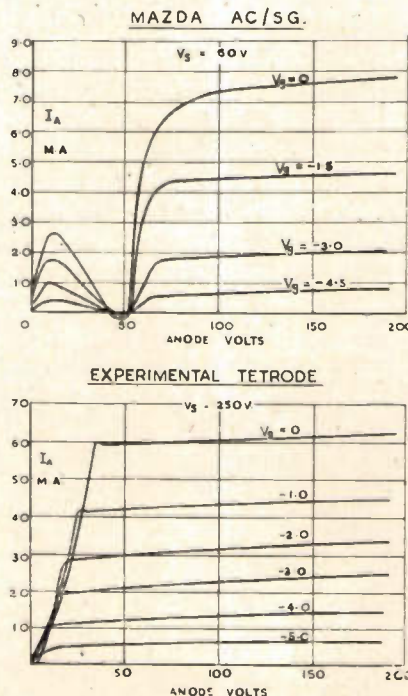

Fig. 1 (a).  $I_a, V_a$  characteristics of S.G. showing secondary emission loss if  $V_a < V_s$ .  
Fig. 1 (b). Characteristics of tetrode. Pentode usually has more rounded knee.

fairly large the field strength at the anode becomes small—in the purely electrostatic case the intensity at any point between concentric cylinders is inversely proportional to the radius.

Wing and Young, in the *Proceedings of the Institute of Radio Engineers*, Jan., 1941, have described an interesting U.H.F. high voltage beam tetrode in which an aligned grid and screen structure of vertical slats is utilised, without additional electrostatic suppression.

Fig. 2e shows a slatted anode structure which was an early suggestion for suppressing secondary emission. Even with the anode voltage well below the screen voltage the field within the partial enclosures formed by the anode and its slats is very small; also, a proportion of secondary electrons will be intercepted by the sides of the slats. On the other hand, the field strength along the inner edges of the slats is intense so that secondary electrons will easily leave the edges and reach the screen.

In Fig. 2g is shown an experimental tube, suggested by the author, in which the earthed electrode consists of a cylinder closely surrounding a gridlike anode. If the anode is made positive each anode wire will bear a positive charge, so that the potential diminishes in all directions from the wire. An emitted secondary electron will therefore be attracted back to the anode wire.

**3. Concerning Secondary Emission**

So far we have accepted the thesis that if in the screen to anode space a voltage depression is established below the anode voltage, then a fairly high fraction of the secondary electrons will be returned to the anode. This statement would cease to be true, for example, if the secondary electrons were projected directly back towards the screen with initial velocities as high as leaving the anode as they possess on striking it—or, in fact, if they have velocities greater than that acquired by an electron in falling through a potential  $\Delta V$  volts. It has, however, long been known that for small velocities of bombardment a relatively large number of "full velocity" secondary electrons are returned, so that the primary electrons merely appear to be "reflected" without loss of velocity at the target. (Lenard, *Historisches zur Elektronenreflexion*.)<sup>12</sup>

A method for determining the total secondary emission ratio  $\gamma$  is shown

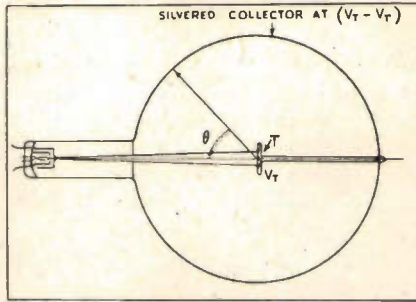

Fig. 3. Method of determining total secondary emission.

in Fig. 3. A primary beam of narrow divergence is projected at a target T, maintained at a fixed voltage  $V_T$  above the cathode potential. A higher positive potential is applied to the spherical collector, so that all the secondary electrons are drawn away and collected. If  $i_s$  is the current in the collector and  $i_T$  the current measured in the target circuit, then

$$\gamma = \frac{i_s}{i_T + i_s}$$

since  $i_T$  is the difference between the incident primary current and the emitted secondary current. The experimental results for  $\gamma$  show the following general features:—

1. The value of  $\gamma$  increases with increasing target voltage, passes through a maximum at voltages of the order of hundreds, and at still higher target voltages it gradually diminishes.
2. For metals, the bombarding voltage at which maximum secondary emission is obtained is approximately proportional to the square root of the density of the metal.
3. Secondary electron emission is greater for oblique angles of incidence on the target. (Kollath, 1937; see L. M. Myers, *Electron Optics*, p. 304.) These general results are understandable if one supposes that the faster primary electrons penetrate deeper into the target, so that the secondary electrons they liberate from atoms within the metal have a smaller chance of leaving the surface owing to collisions and scattering on the way out. Obliquely incident electrons will not penetrate deeply, but will liberate electrons from near the surface.
4. The value of  $\gamma$  is very susceptible to surface conditions, e.g., adsorbed gas, and for complex layers it may reach high values, over 15.

For nickel anodes in valves  $\gamma_{max}$  is of the order of 1.5—2, and  $\gamma_A$  can be represented approx. by  $0.03V_T^{0.7}$  up to 200 volts or so.

In addition to a knowledge of the total secondary emission at a given bombarding voltage  $V_T$ , a full description entails a determination of the distribution-in-velocity and the distribution-in-direction of the emitted secondary electrons. A large spherical collector does not discriminate in regard to the angle of ejection; if, therefore, its potential is negative with respect to the target it will collect all the secondary electrons which have a sufficient velocity of emission to overcome the potential drop between the target and the collector. With a plane electrode arrangement, the resolved velocity along the axis must be sufficiently great. In a cylindrical system, with the collector of smaller radius than the target, it can be shown that the collector potential may have to exceed the target potential by a considerable degree before all the secondary electrons are captured. In this case by no means all of the fast retrograde secondaries will be transferred across the potential barrier formed by a potential minimum, but some will return to the anode because of their oblique angles of emission. (Fig. 4.)

**4. The Potential Distribution in the Screen to Anode Space in the Absence of Space Charge**

If the enclosure forming the screen to anode space is sufficiently long the potential distribution simplifies to a two-dimensional problem, obeying Laplace's equation:—

$$\frac{\partial^2 V}{\partial x^2} + \frac{\partial^2 V}{\partial y^2} = 0$$

Solutions appropriate to a given electrode arrangement, when the electrode potentials are given, may be determined in several ways:—

1. By calculation for various simple electrode systems.
2. By step-by-step mathematical methods.<sup>9, 10</sup>
3. By using a "rubber drum" method in which a rubber membrane is stretched over a model of the electrode system.<sup>11</sup>
4. By plotting with the electrolytic trough.<sup>12, 13, 14</sup>

As an example of (1) the potential distribution in the cylindrical system

depicted in Fig. 2c may be represented by an expansion.

$$V = c + a_0 \log r + \sum_{n=1}^{\infty} \left( a_n r^n + \frac{b_n}{r^n} \right) \cos n\theta$$

where the coefficients  $a_n, b_n$  are found by Fourier analysis. They are such that the boundary conditions around the screen and the anode are satisfied.

By selecting only a few terms in the expression, new equipotential shapes can be determined which will give almost the same potential distribution in the region occupied by the beam.

It is possible to transform any given electrode arrangements in a two-dimensional system by using a conformal transformation. Let  $x$  and  $y$  be the Cartesian co-ordinates of a point in the first system, and  $X, Y$  of the second; then if in general

$$(X + jY) = f(x + jy)$$

where  $j = \sqrt{-1}$  the point  $(X, Y)$  corresponds to the given point  $(x, y)$  and it can be shown that the potential at  $(X, Y)$  will be the same as at  $(x, y)$  when the corresponding electrodes have the same potentials. If the potential distribution in one system can be found, by any means, the result can be transferred to get the potential distribution in the new system.

**5. The Potential Distribution due to Space Charge**

When electrons are projected through a screen into the screen to anode space the negative charges produce a potential depression in the space, but the problem of calculating the potential distribution is difficult except for the plane-parallel and cylindrical electrode arrangements with the earthed plates omitted. The potential distribution for the plane-parallel system was obtained by Gill in 1925,<sup>16</sup> and by Bricout<sup>18</sup> in 1926, who also treated the cylindrical case. These results have been amplified by various authors with special reference to beam tetrode systems—for example, by Plato, Kleen and Rothe, and by Salzberg and Haeff.<sup>17-22</sup> The simplest system to consider is the plane-parallel arrangement with a "beam" of infinite lateral extent so that there are no edge effects. Let the screen plane be maintained at an effective potential  $V_1$ , the anode at a potential  $V_2$ , with the gap  $x_a$  cm. (Fig. 5).

Assume that electrons are normally projected with uniform velocity through the screen plane into the screen to anode space.

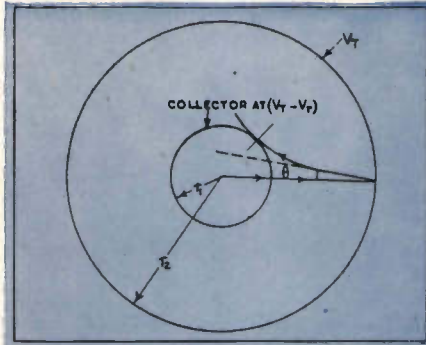

Fig. 4. Collection by a cylindrical collector.

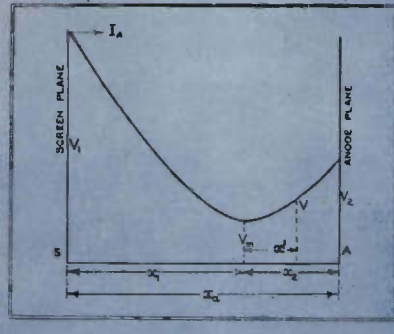

Fig. 5. Potential distribution between screen and anode planes.

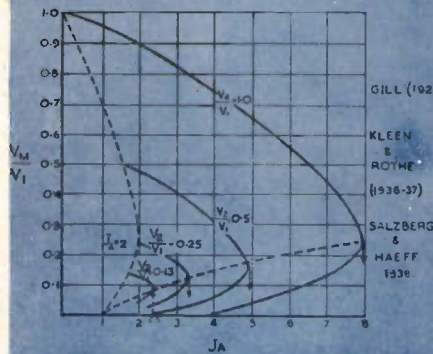

Fig. 6.  $\frac{V_m}{V_1}$  as a function of  $J_a$  keeping  $\frac{V_2}{V_1}$  at fixed values.

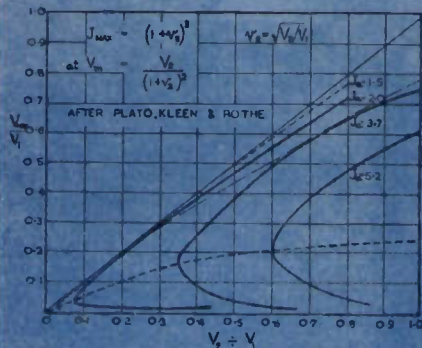

Fig. 7.  $\frac{V_m}{V_1}$  as a function of  $\frac{V_2}{V_1}$  keeping  $J_a$  at fixed values.

The derivation of the potential distribution depends on Poisson's equation

$$\frac{d^2V}{dx^2} = -4\pi\rho \quad (1)$$

$\rho$  is evaluated from the condition that the current density  $I_A = -u\rho$ , where  $u$  is the velocity of an electron at the plane where the potential is  $V$ .

$$\text{Now } u = \sqrt{\frac{2e}{m}} \sqrt{-V} \text{ if } V \text{ is the potential above cathode (ESU).}$$

Hence

$$\frac{d^2V}{dx^2} = \frac{4\pi I_A}{\sqrt{-2e/m} \sqrt{-V}} \quad (2)$$

This equation can be integrated, and the conditions imposed that  $dV/dx = \text{zero}$  at some potential minimum  $V_m$ .

Suppose that the origin is taken at the potential minimum position, then the solution can be written

$$J_A^{1/2} \frac{x}{x_a} = (v + 2v_m)(v - v_m)^{1/2} \quad (3)$$

$$\text{where } v = \sqrt{\frac{V}{V_1}}, \quad v_m = \sqrt{\frac{V_m}{V_1}}$$

$$\text{and } J_A = \frac{I_A}{I_D}$$

$I_D$  is equal to the current density which flows in a plane-parallel diode of gap equal to the screen to anode gap, with its anode potential equal to the tetrode screen voltage. Let the potential minimum to screen distance be  $x_1$  and the potential minimum to anode distance  $x_2$ .

$$\text{Then } J_A^{1/2} \frac{x_1}{x_a} = (1 + 2v_m)(1 - v_m)^{1/2} \quad (4)$$

$$J_A^{1/2} \frac{x_2}{x_a} = (v_2 + 2v_m)(v_2 - v_m)^{1/2} \quad (5)$$

so that on summation, since  $x_1 + x_2 = x_a$

$$J_A^{1/2} = (1 + 2v_m)(1 - v_m)^{1/2} + (v_2 + 2v_m)(v_2 - v_m)^{1/2} \quad (6)$$

It may happen, however, that the apparent position of the potential minimum lies beyond the anode—this applies when the current density is too low to give a real potential minimum between the screen and anode.

$$\text{In this case } x_2 - x_1 = x_a, \text{ so that } J_A^{1/2} = (1 + 2v_m)(1 - v_m)^{1/2} - (v_2 + 2v_m)(v_2 - v_m)^{1/2} \quad (7)$$



The justification for writing  $I_A$  in terms of  $I_D$  as the unit of current density appears in the relative simplicity of Equation (6). This unit  $I_D$ , which might be called "the diode unit," is in practical measurements equal to

$$\frac{0.234 V_1^{3/2}}{x_a^2} \text{ mA/cm.}^2$$

when  $V_1$  is expressed in volts and  $x_a$  in mm. It is important to understand that in practice  $I_A$  will be given, so that the valve designer has to adjust  $I_D$  to get the appropriate value of  $I_A$ .

Finally, if  $V_m$  is ascertained from Equation (6) we can go back to Equation (3) and solve for  $v$  explicitly in terms of  $x$ . The solution is:—

$$v = \left\{ \left( v_m^3 + \frac{I_A x'^2}{2x_a^2} \right) + \sqrt{\frac{I_A x'^2}{x_a^2} + \left( v_m^3 + \frac{I_A x'^2}{4x_a^2} \right)} \right\}^{1/3} + \left\{ \left( v_m^3 + \frac{I_A x'^2}{2x_a^2} \right) - \sqrt{\frac{I_A x'^2}{x_a^2} + \left( v_m^3 + \frac{I_A x'^2}{4x_a^2} \right)} \right\}^{1/3} - v_m \dots (8)$$

where  $x'$  is the distance from the potential minimum.

In Fig. 6 are shown the values of  $V_m/V_1$  plotted against  $I_A$  for various values of  $V_2/V_1$ .

Several remarkable conclusions can be drawn from these curves:—

(1) For a given current density there are in certain ranges two possible values of  $V_m$ , and so two possible potential distributions, which will allow that current density to be carried in the screen to anode space, e.g., if  $I_A = 6.5$  units, the valve can be either 0.5 or 0.1 (in both cases the full current density is transported across the space, so that the two cases cannot be distinguished by readings of anode current). It must be borne in mind that the solutions are steady-state solutions. The conditions for switching from one  $V_m$  to another must be examined under transient conditions, in which the instantaneous total current is no longer equal to the electron convection current, but includes the time dependent displacement current.

(2) For given values of  $V_1, V_2$  there is a maximum value of current density which can be transported across the space.

This value is got by differentiating Equation (8) with respect to  $V_m$ . The possible  $I$  is a maximum when

$$v_m = \frac{v_2}{1 + v_2} \text{ and is equal to } (1 + v_2)^3 \text{ units.}$$

This raises the question as to what occurs when this maximum current

density is exceeded, as although there is this limitation on the current which can be transported, there is clearly no restriction on the current which can be projected into the screen to anode space.

(3) In order to ensure the existence of a potential minimum over the whole range of anode voltage it is necessary that  $I_A$  should exceed 2 diode units. The actual value of  $I_A$  which just forms a potential minimum is easily found. At low current densities there will be no potential minimum, but the potential will continuously rise from the anode to the screen; then as the current density is increased a potential minimum will appear just at the

space charge depression is the more important factor. It should be emphasised that Gill's equations tell us nothing about the shape of the rising portion of the  $I_A, V_2$  characteristic—the theory applies to the full transport conditions, and can only indicate the lowest value of  $V_2$  at which full transport is possible, a value which we can tentatively assume might be the "knee voltage"  $V_k$ . If this is so it can be shown that

$$W_k = [J_r^{1/3} - 1]^2 \dots \dots (9)$$

where  $W_k$  is the ratio  $\frac{V_k}{V_2}$ .

(To be continued.)

anode plane, and will just equal the anode voltage. The corresponding value of  $I_A$  is obtained by putting  $V_m = V_2$  in Equation (8).

In Fig. 7 are shown the values of  $V_m/V_1$  plotted against  $V_2/V_1$  for several constant values of  $I_A$ . For comparison purposes a straight line of unit slope is drawn passing through the origin—its ordinate gives the value  $V_2/V_1$ , so that the difference of any curve from this straight line is a measure of the voltage depression. For  $I_A = 5.2$  the depression is large in value, but the curve does not extend below  $V_2/V_1 = 0.6$ . For  $I_A = 2.0$  the depression vanishes when  $V_2/V_1 = 0.25$ . For  $I_A = 1.5$  (shown in short chain line) there is a slight depression at low values of  $V_2$ ; over the range  $V_2/V_1 = 0.1$  to 0.5 there is no potential minimum at all, while above 0.5 there is voltage depression again.

The long chain line also shown indicates the typical effect produced by earthed side plates, in the absence of space charge. Below some critical anode voltage, lower than the screen voltage, there is no potential minimum; above the critical anode voltage the potential depression becomes increasingly large, so that when  $V_2 = V_1$  electrostatic suppression is the important factor, i.e., in the region where the secondary emission loss in the S.G. valve is most severe. At low anode voltages,

**Bibliography**

- 1 Jonker, *Wireless Engineer*, June, 1939, p. 174, July, 1939, p. 344.
- 2 Harries, Brit. Spec. 380,429/1931.
- 3 Harries, Brit. Spec. 385,968/1931.
- 4 Harries, *Wireless Engineer*, April, 1936, pp. 100-109.
- 5 Harries, *Wireless World*, Aug., 1935, p. 105.
- 6 Shoenberg, Bull. Rodda; Brit. Spec., 423,932/1933.
- 7 Bull, Keyston; Brit. Spec. 441,840/1934.
- 8 Warren, G.E.C. Journal, 1937, p. 190.
- 9 Shortley & Weller, *J. App. Physics*, May, 1938, Vol. 9, No. 5, p. 334.
- 10 L. F. Richardson, *Phil. Mag.*, 1908, 15, p. 237.
- 11 Kleynen, *Philips Technical Review*, Nov. 1937, pp. 338-345.
- 12 Fortescue & Farnsworth, *Proc. A.I.E.E.*, 1913, 32, p. 757.
- 13 Gabor, *Nature*, 1937, 130, p. 373.
- 14 Langmuir, *Nature*, 1937, 139, p. 1066.
- 15 Gill, *Phil. Mag.*, May, 1925, 49, pp. 993-1005.
- 16 Bricout, *Comptes Rendus*, 1926, 183, p. 1269.
- 17 Calpine, *Wireless Eng.*, Sept., 1936, 13, p. 473.
- 18 Plato, Kleen, Rothe, *Zeits. für Physik*, 1936, Vol. 101, p. 509.
- 19 Kleen, Rothe, *Zeits. für Physik*, 1937, Vol. 104, p. 711.
- 20 Salzberg, Haeff, *R.C.A. Rev.*, Vol. 2, No. 3, Jan., 1938, pp. 336-374.
- 21 Fay, Samuel, Shockley, *Bell System Technical Journal*, 1938, Vol. 17, p. 49.
- 22 Grank, Hartree, Sloane, Ingham, *Proc. Phy. Soc.* 1939, Vol. 51, p. 952.
- 23 Tonks, *Phys. Rev.*, Oct., 1927, pp. 501-511.
- 24 Harries, *Electronic Engineering*, Jan., 1942, p. 586.
- 25 Strutt & Van der Ziel, *Physica*, Oct., 1939, No. 9, p. 977.
- 26 Below, *Zeits. für Fernmeldetechnik*, 1928, Vol. 9.
- 27 Harries, Rodda, *Wireless Eng.*, June, 1936, 13, p. 315.
- 28 Rodda, *Science Forum*, June, 1943.
- 29 Gabor, *Nature*, Dec. 5, 1942, p. 650.
- 30 Davison & Calbick, *Phys. Rev.*, 38, 1931, p. 585.
- 31 Davison & Calbick, *Phys. Rev.*, 42, 1932, p. 580.
- 32 Lenard, *Ann. d. Phys.*, 40, 1913, pp. 393, 424.
- 33 Klemperer, "Electron Optics," p. 99.

# Circuit Diagrams

By

L. H. BAINBRIDGE-BELL

The increasing complexity of modern circuits makes their operational diagrams correspondingly difficult to follow.

In this article the author suggests some rules for laying out diagrams to show as clearly as possible the the operation of the circuit.

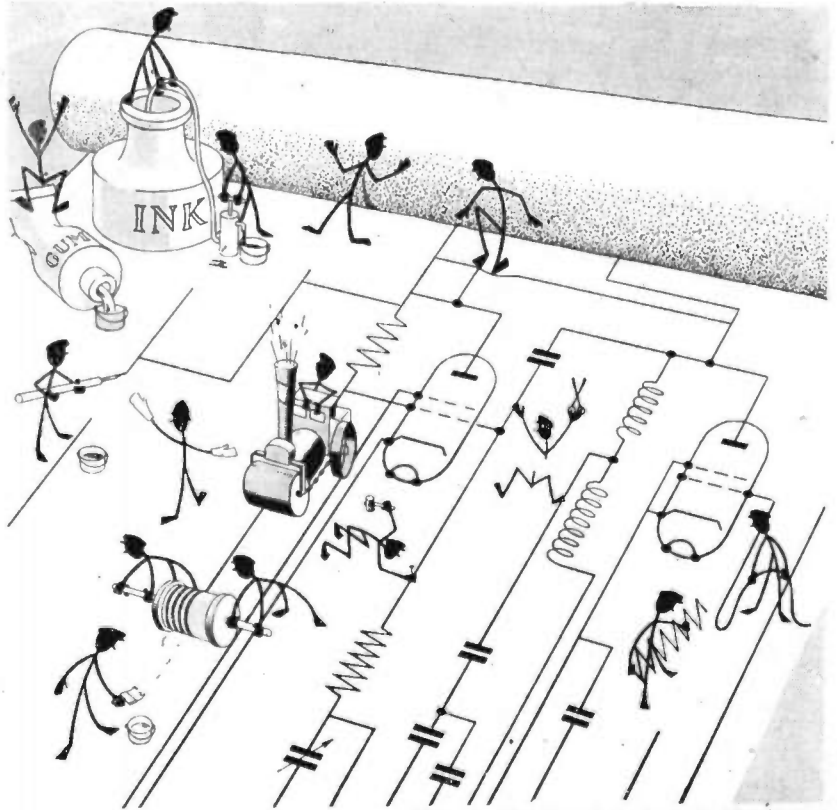

With acknowledgments to the Pye Radio Advertisement

THE circuit diagrams, which accompany the textual descriptions in technical handbooks on radio apparatus, need careful preparation if they are to present a correct *visual* impression of the working of a circuit. The importance of this need is realised in some American organisations, where a "Delineator" plans and appends his signature to the diagrams.

The following notes, intended as guides to the delineator, are the result of considerable experience of the planning of circuit diagrams.

The object of a circuit diagram is the explanation of the operation of the circuit. Attempts to make the diagram fulfil the additional rôle of a wiring diagram, or of a diagram showing the relative positions of components, usually result in obscuring the electrical operation of the circuit.

This principle has been followed for many years by telephone engineers who do not attempt to draw contacts near to the relays which operate them, but use, instead, the system known as the "detached contact" system, in which the contacts are put near to the circuits which they open or close.

If a knowledge of the physical position of a component will help the understanding of the circuit, the delineator of the circuit diagram is faced with two alternatives. He might either place the component in its proper *functional* position, and add a note explaining its *physical* position, or he might place the component in its physical position and draw (possibly) long leads from the component to the proper part of the circuit. *The first alternative is always to be preferred.*

## Connexions

The next principle concerns the arrangement of connecting wires in the diagram.

The underlying idea is that the eye follows smooth curves easily and that the direction of flow of *effects* can be suggested by imagining that the wires are roads along which fast-moving vehicles are intended to travel in one direction as easily as possible. The planner of roads will avoid sharp corners and bends, he will make an easterly road fork to the north by joining the north to the east road by a curve, he will make a road between two places follow as far as possible the direct route. Conversely,

smooth runs of lines which are *not* the path of "cause" to "effect" are misleading.

The delineator of diagrams should try to follow similar methods. Examples will be given later.



If the delineator confines himself to the use of straight lines (possibly radiused at the corners and bends), the following examples will show what the writer means by his reference to the "road planner."

1. A common path dividing into two or more should be shown:—

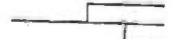
thus  and not

 or 

2. A common current feed should be shown:—

 and not 

If the diagram is complicated, the "reader" who wants to find the direction of the source from which A is fed is guided to the left by the preferred drawing.

The use of curved lines must be treated with judgment, but if the rule is observed that no two "incidents" must occur at the same place (for example, there must not be a sudden change of direction in one wire at the point where two wires cross) it is surprising how easy it is to follow by eye the run of a smoothly curved wire among a number of intersecting wires.

The qualification "by eye" in the above sentence needs some explanation and introduces the next important principle.

*A diagram should be drawn so that the run of every connexion can be followed by a reader whose hands are tied behind his back.*

In other words, it should not be necessary to trace leads with pencil or finger.

The following suggestions are made with this object in view:—

1. The equal spacing of more than four wires (so "admired" by some draughtsmen) should be avoided. The wires should be broken up into groups which are functionally related; the wider space on each side of the group should be preserved along the *whole run* of the group:—

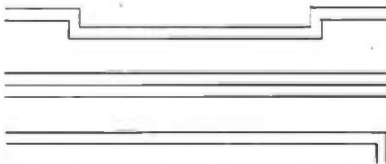

2. The use of coding marks should be encouraged. These enable different "services" to be distinguished, and can well consist of various "arrow" shapes, which can perform a second function: the indication of the direction of the flow of the "cause" to the "effect."

For instance, if two channels are to be distinguished, they can be shown

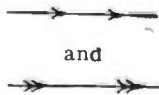

3. It will be found that the use of curved lines, as described in the previous section, will be of considerable assistance.

**Conventions of Direction**

The reading of circuit diagrams is facilitated by the adherence to certain logical conventions which can be classed as *conventions of direction*.

**1. Left-to-Right Conventions**

The *main* flow from *cause* to *effect* should be from left to right. This does not necessarily mean the conven-

tional *current* flow, or the increasingly used *electron* flow. In doubtful cases the ambiguity can be resolved by considering what would happen if a connexion is broken, and the question is asked "does the apparatus to the right or left of the break cease to function?" If the answer is "to the right," all is well.

In certain cases where there is a flow in two directions (e.g., a multivibrator) the convention must be broken. This involves a subsidiary convention.

1(a). "If the above convention cannot be adhered to, arrows must be used to indicate the direction—*cause* to *effect*." NOTE.—That the *main* flow is referred to; it will usually be sufficient to adhere to this convention as regards the more difficult functions of a circuit.

(For example, the synchronising e.m.f. to a multivibrator would come from the left, but the H.T. from the power-pack might well come from the right without confusing the diagram.)

**2. Up-and-Down Conventions**

In dealing with circuits carrying D.C. the more positive potential should be indicated by going "up" the paper, and *vice versa*.

For example: A conventional cathode-ray oscilloscope with amplifier would be drawn with the anodes of the amplifying valves *above* the earth line, and the filament of the C.R. tube (at, say, -2,000 volts) *below* the earth line.

2(a). As an appendage to this convention, components in which there is *no* distinctly high-potential terminal should be drawn with their terminals in a horizontal line.

**Conventions for Indicating that Wires do or do not make Contact at Crossings.**

From time to time much discussion has taken place with regard to the method to be employed for distinguishing between the facts that wires (shown as crossing on circuit diagrams) make contact or do not make contact. The use of the "bridge,"



to show that leads do not make contact at a crossing, is subject to a sharp difference of opinion. Some circuits make use of a straight crossing for "non-contact" and a dot at the crossing for "contact." Others use a bridge for "non-contact" and show "contact" either by a straight

crossing or, more usually, by a dot.

The sight of a bridge for "non-contact" may make the reader think that the straight crossing of the first method is a "contact," and the opposite significance of the two "straight" conventions may cause confusion.

If one or other convention were *universally* used, no confusion would occur. Failing this, an organisation could ensure that all its recruits were drilled in the use of the method used by that body. Owing to the wide variety of sources of information on radio and thermionic circuits, and to the variety of educational experiences of those who have to use circuit diagrams, no single convention can be imposed. It should therefore be the aim of the designer of circuit diagrams who realises these facts to see that the conventions used by him do not confuse the readers who are accustomed to *either* of the conventions.

The writer here submits his solution, together with the reasons for his decision.

**"Non-Contact"**

(1) In circuits showing a number of groups crossing which have a *similar function* (e.g., a lead crossing ten leads coming from a multipoint switch) no confusion can arise if the "straight" convention is used. This situation often arises in telephone circuit diagrams.

An example is appended. Here it is clear that no one could think that the A leads shorted all the B leads. It is fortunate that confusion cannot occur, as this diagram would be very difficult to follow if bridges were used.

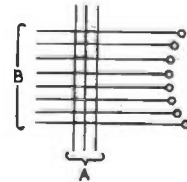

(2) In circuits showing a number of *isolated* crossings of leads with different functions (as in a radio receiver) the "bridge" is used.

In this case there is nothing to suggest that "contact" is unlikely; attention is drawn, therefore, to the "non-contact" condition by using a bridge.

**"Contact"**

(3) With the above conventions in use, it might be thought that a dot on the crossing would be satisfactory;

the writer suggests that *there is no need* to draw two leads which make contact in the form of straight lines crossing at an angle (right angle or otherwise).

An examination of circuit diagrams showing "contact" crossings will show that these are rare, and that they are, in most cases, *accidental*. An example will show what is meant by this expression.

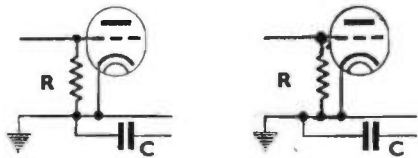

R is the grid leak of a valve. C is connected to earth. Due to convenience in drawing or to a mistaken idea of economy in "dots," C and R are taken to the *same point* in the earth lead and so produce a "contact" crossing. If the circuit is re-drawn

as in the right-hand sketch, the "contact" crossing has disappeared.

In the left-hand sketch the "contact" crossing has two disadvantages:—

(a) It might be a carelessly drawn or *badly printed* "non-contact" cross which had become blurred at the crossing.

(b) It can give a misleading *visual* impression that R and C are functionally connected, *i.e.*, that R is connected to C for some particular reason.

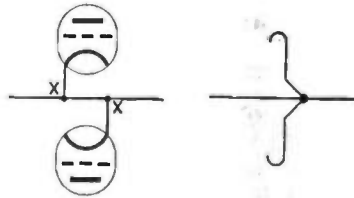

Suggestions for avoiding straight-line "contact" crossings."

The push-pull cathodes form a "staggered" cross-road junction.

The separation of the points x x is sometimes impossible, as it may be necessary to emphasise that two leads are connected to the *same point* in the earth lead.

The sketch shows the recommendation. The diversion should be quite marked in order to avoid confusion with a bridge.

Finally, in view of the perpetual controversy which the subject arouses, it is interesting to note the result of a census recently carried out by the author on British and American periodicals and text-books.

Half the number of periodicals examined used the "bridge" in circuit diagrams, and in the books the proportion of "bridges" to "straights" was as high as 4 to 1.

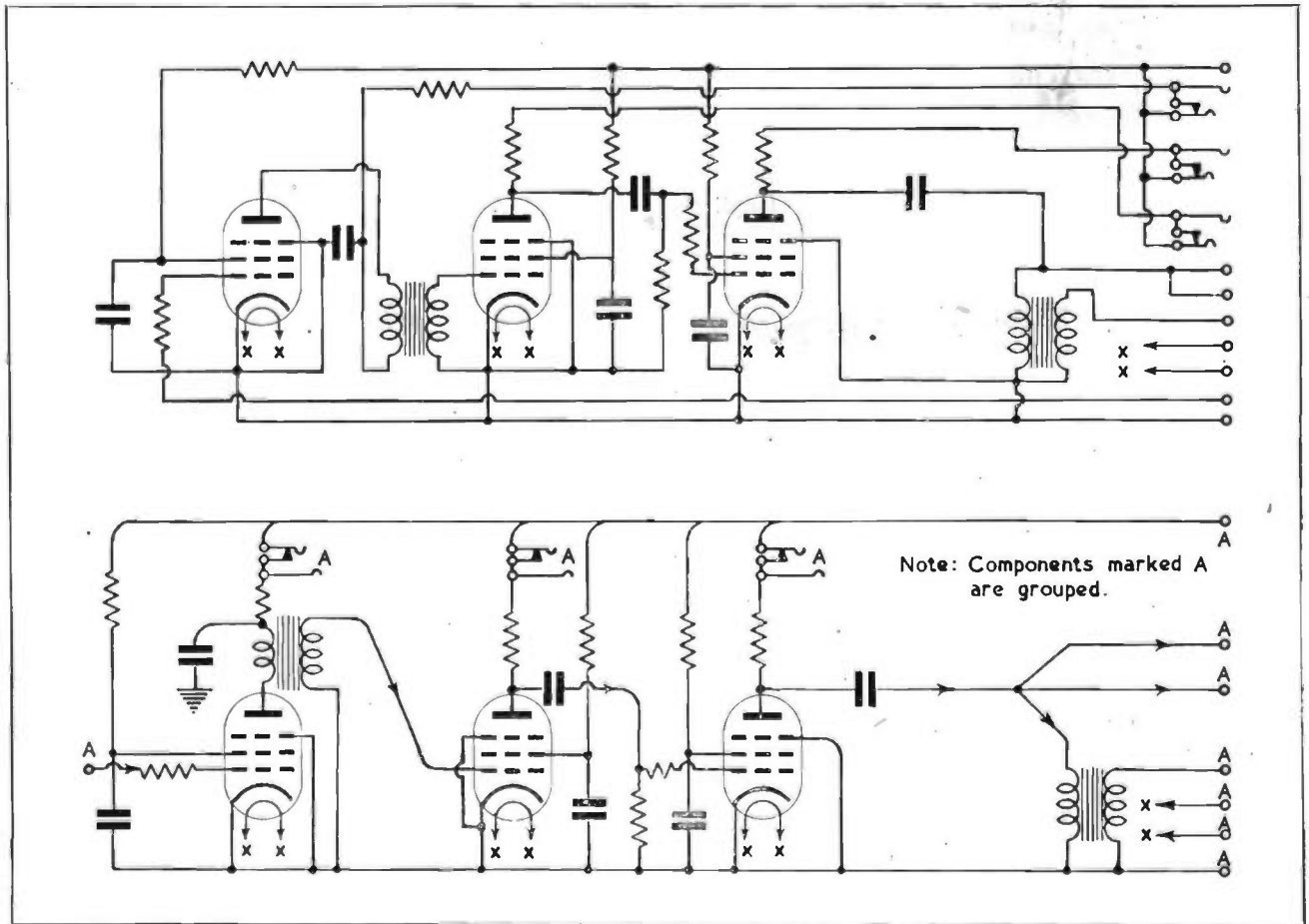

A circuit diagram drawn in a conventional way, and according to the author's recommendations

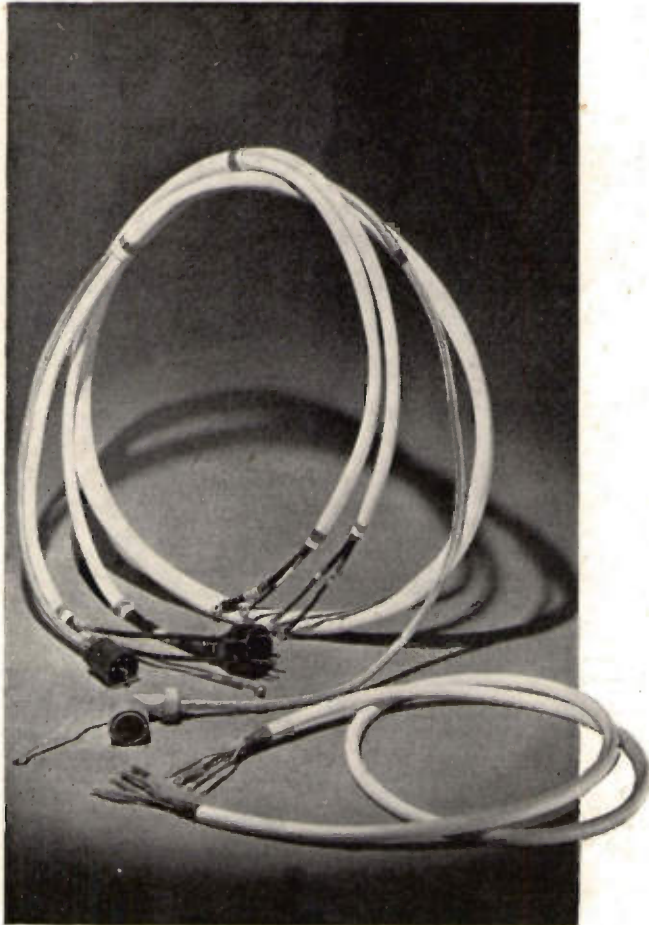

## Don't mention it!

WHY say "polyvinyl chloride" when all you need say is "BX P.V.C."? That is, if you are needing a plastic material for cable and wire covering and conduit tubing made to Specification G.D.E.S. No. 18 1944.\*

BX P.V.C. has many advantages. It is tough and non-inflammable; resistant to chemical attack and corrosion. It can be supplied in black or colours for various needs as an extrusion compound and in calendered flexible sheets or rolls up to 36 inches in width.

WE will gladly tell you more about BX P.V.C. and discuss its unlimited post-war possibilities, which will extend in every direction as Controls are relaxed. Why not make an appointment for one of our technical experts to meet you at our Exhibition Rooms, 6 Hanover Square, London, W.1. Just telephone Larkswood 4491.

*\* This material can only be obtained on allocation from Plastics Control.*

# **BX PLASTICS LTD.**

## **LARKSWOOD WORKS, LONDON, E.4.**

Principal Graphical Symbols adopted as Standard by

AERIAL		CIRCUITS		EARTH		LAMP	
- Transmitting		- Conductor		Conductors crossing		- Illuminating	
- Receiving		- Alternative		FUSE		- Indicating	
- Transceiving		- Tappings		Galvanometer		LINES	
- Dipole Vertical		- Common meeting point		GENERATOR		- Screened	
- Dipole Horizontal		- Jumper		- D.C.		- Alternative	
- Frame		- U-Link		- A.C.		- Multi-core	
- Frame Balanced		- Boundary		HEADPHONES		Link	
BARRETTTER		CONDENSER		- Alternative		Open	
Battery		- Fixed		INDUCTANCE		LOUDSPEAKER	
Bell		- Variable		- Iron cored		- General	
Buzzer		- Three-Terminal		- Dust cored		- Condenser	
- detailed		- Differential		- Variometer		- Moving coil (Energised Field)	
CELL		- Preset		Interruptor		- Moving coil	
Chassis		- Electrolytic		JACK		- Piezoelectric	
Counterpoise		- Non-polarised		KEY		METER	
		Crystal		- Morse		with appropriate letter inserted:	
						Voltmeter	V
						Ammeter	A
						Ohmmeter	Ω
						Frequency	f
						Wavemeter	λ
						MOTOR	
						D.C. - A.C. ~	
						Motor - Generator	

Important Note : These symbols have been extracted from the Handbook of Inter-Services those already in use by the Service and from the B.S.S., 530 (1937) to meet the needs of present Symbols, the Glossary of which is at present undergoing revision. These symbols are published

# the Services for use in Telecommunication Circuits

<b>MICROPHONE</b>		<b>RELAY COILS</b>		<b>Electro-dynamic</b>		<b>Beam Tetrode</b>	
General							
- Carbon		- Slow-releasing			<b>Thermo-couple Indirectly heated</b>		
- Condenser		- Slow-operating			<b>Directly heated</b>		
- Electro-dynamic		- With two windings			<b>THERMIONIC TUBES</b>		
- Crystal		<b>RESISTOR</b>			- Diode		
Micro-telephone		- Variable			- Triode		
<b>PICKUP</b>		<b>SCREEN</b>			- Triode Indirectly heated & metal coated		
- General		<b>SOCKET</b>			- Tetrode		
- Electromagnetic		- Screened			- Pentode		
- Crystal		<b>SWITCH</b>			- Heptode		
<b>PLUG</b>		- Alternative			<b>Variable-mu</b>		
- Standard 3-point		- Double-pole					
- Multi-pin see Socket		- Wafer type Rear view					
Press button Press to make		<b>TELEPHONE RECEIVER</b>					
Press to break		- Condenser					
<b>RECORDER</b>		- Thermal					
Relay							

Standard Graphical Symbols, by permission of the Symbols Committee. They have been selected from requirements. It should be pointed out that they do not necessarily agree with the British Standard for the convenience of Service readers who require them in a convenient form for reference.

Made to  
measure

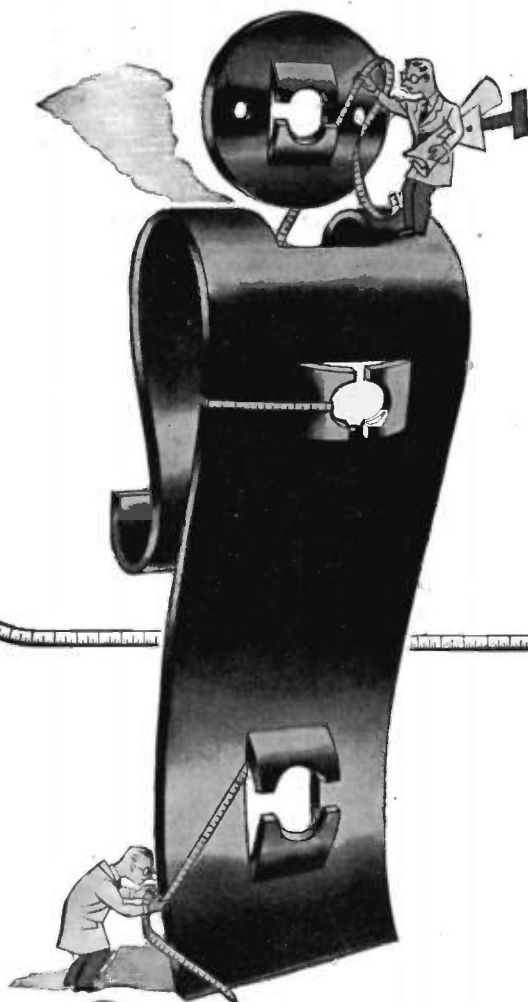

The standard Spire nut is only one form, and the most elementary form at that, of fixing by the Spire method. There are already over 300 special Spire designs, each of which has been "made to measure," for some particular job. In most of them no separate nut or washer is needed. The Spire fixing is part of the component itself. It is pretty safe to say that Spire can simplify *most* assembly jobs. Send us along any ordinary assembly-parts or drawings. We'll see if we can't cut out some of the bits and pieces and reduce the operational time by designing a Spire assembly. No charge for this. If it works we'll get your order. If it doesn't we'll tell you so and there's no harm done.

**THAT'S Fixed THAT! NP 1506.**  
Aircraft manufacturers and coachwork builders employing stressed skin construction are saving time and money and material by the use of this simple Spire fixing. It serves to hold the tack bolts in position until riveting of skin sections has been completed. It is quicker to use than the usual square pressed nut and is easily removed for further use when its 'holding job' is done.

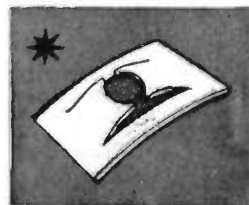

Spire

\* **A BETTER way of fixing**



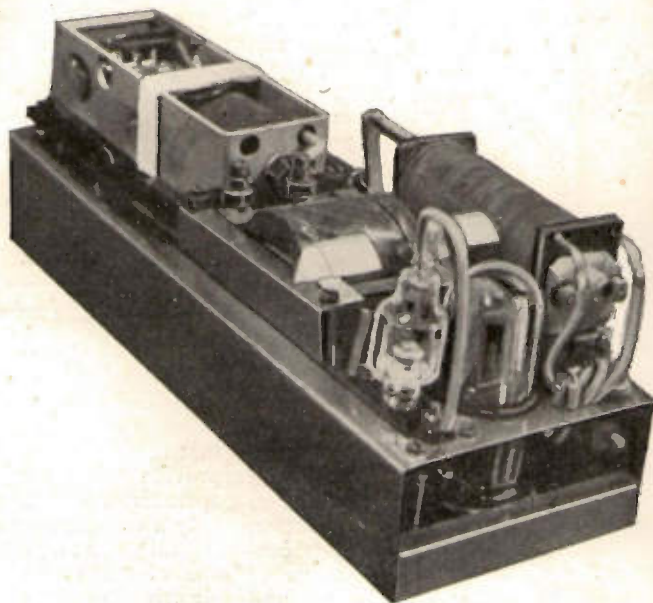
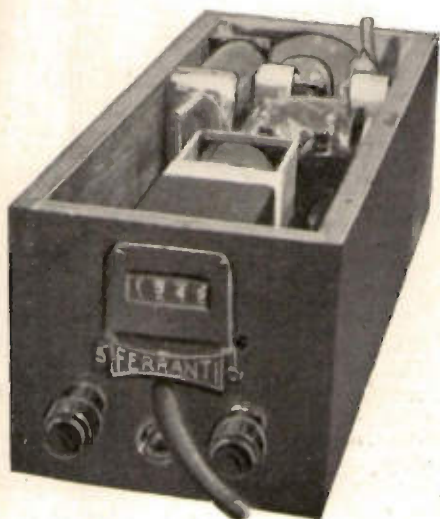

Fig. 4 (above). Finished unit.

Fig. 3 (right). View of chassis.

## Cold Cathode Counter Control

By L. ATKINSON\*

IN the rapidly developing field of industrial electronic apparatus there is and has always been a demand for a relay operated by a small signal such as that from a photo-cell or other source of small power capacity; up to the present time this demand has been partially satisfied by the numerous thermionic amplifiers which have been placed on the market, both in this country and the United States. However, there exists a prejudice against electronics which has gained support from the fact that while it is relatively easy to conjure up an electronic device to perform almost any intricate function, it is not easy to design the device so that it can be relied upon to operate satisfactorily, through long periods of unattended service. The majority of these electronic controls have had one fundamental weakness which has helped to foster the idea that electronic apparatus requires the constant attention of a skilled engineer if it is to give satisfaction; this weak link is the hot cathode tube which is used in these controls.

In every case where a hot cathode tube is used it is necessary to make allowance for one or both of the following factors:

- (a) The cathode must be maintained at or near normal operating temperature at all times.
- (b) There is a delay period when the tube is first switched on; this is necessary to allow the cathode to reach normal temperature.

In the majority of relay applications the active time is only a small fraction of the passive "alert" period, yet the cathode has to be continuously heated in order to be ready for any impulse which may arrive; consequently the valves are deteriorating even though they are inactive; and to reduce the possibility of failure a routine replacement programme has to be employed. Despite the relatively long life of modern valves it is not uncommon for failure to occur after only short periods, although the average life may be of the order of 3,000 hours; this failure is usually due to fracture of the filament or heater. The question of starting delay is not usually serious, but there are a few instances where it is necessary to arrange delayed switching so that a machine cannot be put into operation before its associated control unit is operative.

It will be evident that there exists

a large market for a device which is inherently free from these defects. The first and obvious step towards a solution is to find a substitute for the hot cathode tube without introducing other faults. For several years a number of trigger relays with cold cathodes have been available. In these tubes the emission is obtained by the use of an ionised discharge in an inert gas and a low work function surface on the cathode. It is not possible to substitute a cold cathode directly for a hot cathode since there are several vital differences in the characteristics. The two main factors to be taken into consideration are that the cold cathode tube has only a small difference in breakdown value for positive and negative voltages, and that while the grid can initiate current flow between anode and cathode it is normally unable to control the discharge when once it has started, unless the circuit is so designed that the anode voltage is momentarily reduced to zero or driven to negative values. A simple and reliable circuit has been developed which allows the grid to start and stop the current, this circuit is based on the well tried time-base generator used in cathode ray sweep circuits.

\* Ferranti, Ltd., Hollinwood.

It is well known that a condenser connected across the anode and cathode of a gas-filled tube may be used as the basis of an oscillator, the frequency of oscillation being controlled by the capacity of the condenser and the value of the series resistance in the charging circuit; if the gas-filled tube is a triode it is possible to start and stop the oscillation at will by variation of the grid voltage; and by interposing a suitable electro-magnetic relay in the anode circuit the change in grid voltage may be converted into a switching sequence. Fig. 1 shows this basic circuit which forms the foundation for the control units to be described later. It will be obvious that when used as a control the frequency of oscillation must be selected so that it is not so low that the relay contacts chatter, nor so high that the grid loses control; for most purposes a range of from 10 to 50 c/s. has been found suitable, the value being determined mainly by the telephone relay characteristics.

The cold cathode triode is essentially different from high vacuum hot cathode tubes in that the grid voltage required for triggering is positive and usually not very much less than the anode voltage; this means that if the grid is connected to a tapping on a potentiometer across the anode supply the tube can be triggered by variation of this tapping point, this variation being achieved by mechanical or electrical means. It will now be apparent that by combining the oscillator-relay circuit with a suitable impulsing means we have a new type of control with many uses; to illustrate this, two typical control units will be described.

The class of control in most com-

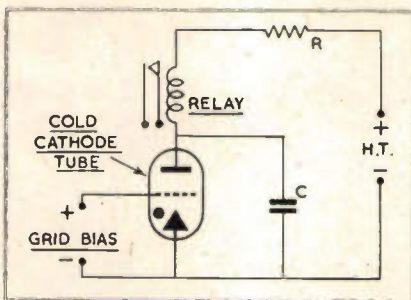

Fig. 1

mon demand and for which this circuit was expressly developed is that in which a ray of light is used to provide the trigger pulse which operates some device; this may be only a counter or may be a motor performing some operation; in fact, any one of the many and varied photo-electrically operated equipments. Fig. 2 is a circuit diagram of a cold cathode unit designed for this class of service. The light beam, which is furnished by a small car type lamp, is focused on to the photo-cell  $V_2$  and as a result the potential of the grid of the cold cathode tube  $V_3$  is maintained at a low positive value determined by the resistance of  $V_2$  relative to  $(R_1 + R_2)$ ; this voltage is below that required to trigger  $V_3$ . When the light beam is interrupted the photo-cell resistance increases with the result that the grid voltage rises until the triggering potential is exceeded;  $V_3$  then commences to oscillate and the relay contacts close. These contacts are arranged to do two things; first, one set of contacts removes part of the photo-cell load resistance  $R_1$ , this is equivalent to a locking action and prevents false

operation of the relay when the beam is interrupted by slowly moving objects. Second, the other pair of contacts are connected to the switch S in order that the unit may be used as a self-contained counter or may control external equipment. In one position of the switch, operation of the relay discharges the condenser  $C_2$  through an electro-magnetic counter; in the other position the relay may control any external device, as, for instance, the trip coil of a motor starter. In order to make the unit independent of hot cathode tubes the H.T. supply is derived from a metal rectifier  $V_1$ , there are thus no components which suffer serious deterioration during stand-by periods.

Using standard telephone type relays and counters this circuit will easily record up to 15,000 pulses an hour and yet it is equally capable of operating at intervals of days or weeks depending on the duty which it is performing. The life of the unit is determined by the point at which the cathode of  $V_3$  has become so denuded of active material that the tube refuses to trigger. A minute amount of material is removed from the cathode at each flash, the amount is proportional to the current in the discharge and its duration. The rated life of the cold cathode tube used in this equipment is 300 mA/hours, and by designing the circuit so that the current and time of each flash are reduced to minimum values, the life of the tube can be reckoned in hundreds of thousands of flashes; hence it will be seen that for all practical purposes the unit has unlimited life.

The overall size of the complete unit in cabinet is only 10 in. x 4 in. x 4 in., which includes the counter; Fig. 3 shows the chassis removed from the

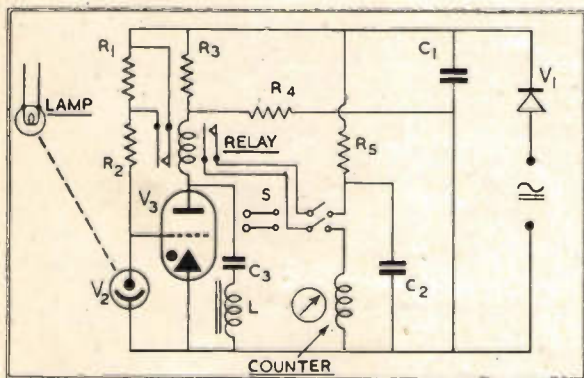

Fig. 2

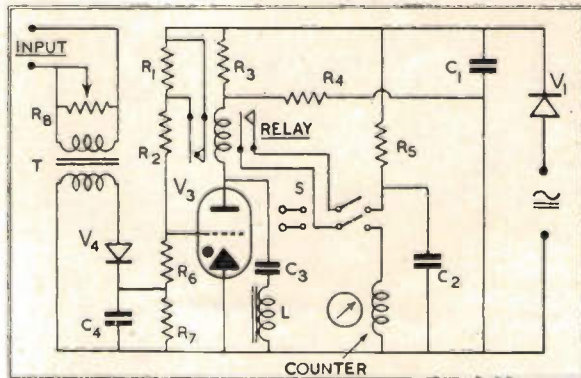

Fig. 5

cabinet, while Fig. 4 shows the finished unit.

Although the unit was primarily intended for photo-cell operation other types of input circuit may be used to suit the needs of the particular controlling function required. For some purposes it is necessary to have a record of the number of times that the load in a circuit exceeds a predetermined value; it is possible by a slight modification to the control unit of Fig. 2 to arrange for this; the altered circuit is shown in Fig. 5. In order to operate the unit it is necessary to convert the load current changes into voltage differences; this is conveniently arranged by inserting a small resistance in one of the supply leads and connecting a small transformer and metal rectifier as shown. The voltage output of the rectifier is proportional to the current in the lead and to the value of  $R$ , hence by adjusting  $R$ , it is possible to arrange for any specified current to trigger the cold cathode tube. Thus if a number of units are connected to the driving motors of machines (*e.g.*, power presses) in which the load varies between idling and working strokes, it is possible to obtain a record of the actual working operations of each machine in a central record office. This record shows the number of working strokes, the number of idle strokes and the time when shut down.

This circuit can be used in most applications where there is necessity to record or control a variable quantity from which a voltage pulse may be derived; naturally it is of greatest use in remote unattended operation where maintenance would be difficult or expensive. To the two uses described there may be added the following short list to illustrate the versatility of the circuit:—

- (1) Automatic door opener.
- (2) Automatic speed indicator.
- (3) Automatic weighing.
- (4) Maximum safe load indicator for cranes, etc.
- (5) Safety fence and burglar alarm applications.
- (6) Water level remote indicator.
- (7) Radio frequency pulse remotely operated devices.
- (8) Factory chimney smoke control.
- (9) Pinhole indicator in strip production.

#### Acknowledgment

The writer wishes to thank the management of Messrs. Ferranti, Ltd., for permission to publish this article.

# A Note on Audiometry

By C. J. GOLLEDGE, F.R.E.S.\*

**A**CCURATE diagnosis in otology depends upon more than one hearing test. The advent of the electric audiometer is not in itself an argument for discontinuing the use of the tuning-fork tests; rather must it be regarded as a supplementary test and as a time-saver. Audiometric tests aim to determine how much the listener can hear, not how well the examiner can run the instrument nor how quickly he can record results. The manufacturer is not an otologist and he need not understand the clinical interpretation of the results; but the more he is aware of the great variations which may be secured in audiometric tests, the more critical he will be and the more valuable his services. One of the principle uses of the audiometer is to determine whether the acuity of hearing is changing and to do this it must be possible to know how accurate are the results in repeated tests when no real change has occurred. The development of the audiometer has made possible the very important standardisation of records, the lack of which is a great disadvantage of the tuning-fork tests.

The usual instrument enabling measurements to be made both on normal subjects and on persons suffering from any degree of deafness short of complete loss of hearing comprises a tone source of continuously variable pitch, the output from which is fed to a high-fidelity head-telephone ear-piece through an adjustable attenuator. The apparatus is primarily intended for measurements by air conduction, but arrangements are made for measurements by bone conduction methods to be made over a more limited range of pitch and intensity. The tone frequency range used is from 100 c/s. to 10,000 c/s. Such an instrument is made by Marconi Instruments, Ltd. (TF 444A).

There has recently been published a book† which embodies the experience of twenty-five years of research and teaching in psychology and physics, and in otolaryngology, which though of special value to the otologist should interest the instrument manufacturer. The first three chapters deal with the tuning-fork

test, the modern audiometer, and the technique of the audiometric tests. The sound-proof room and its construction and use, conductive-type deafness, and perceptive-type deafness are each accorded a chapter, and Chapter VII deals with the use of the audiometer in selecting a hearing aid. Then follows discussion of the use of the residual hearing, with case-audiograms. The final chapter is an historical account of the development of the audiometer, and there is a bibliography of 114 titles. A tentative standard procedure for evaluating the percentage of useful hearing loss in medico-legal cases is appended. This is based on threshold measurements of acuity of hearing for air-conducted sound. "The following decibel losses, as measured by an accepted standard audiometer, represent 100 per cent. loss of useful hearing:

128	256	512	1,024	2,048	4,096	c/s.
65	80	85	95	95	90	db.

Percentage losses corresponding to measured decibel losses in the octave intervals are shown on a chart."

The following quotation from p. 175 should act as a challenge to British science and manufacturers alike:

"A brief search through the literature is sufficient to convince one that the greater part of the present-day studies in audiometry has originated in America. However, several reports have recently come from England. One outstanding study by Bárány has recently come from Sweden. He states, 'In Europe, electrical audiometers and bone-conduction receivers have not yet come into general use even as research tools and only a few non-clinical papers using them for bone-conduction work have been published.' Another study, also from Sweden, by Holmgren, appeared recently. He presented an audiometer which produced all tones from 62 to 15,000 cycles, reading in one-decibel steps, from the threshold of acuity to an intensity of 125 decibels. With existing conditions in Europe, it cannot be expected that many scientific studies of this type will be forthcoming from these countries for some time. A careful perusal of the American journals will for the most part keep the student informed of the progress in this field."

\* Marconi Instruments, Ltd.  
† Clinical Audiometry. By C. C. Bunch. (St. Louis, C. V. Mosby Co.; London, Henry Kimpton, 1943.) 21s.

# The Harmonic Analysis of Distorted Sine-Waves

By R. C. de HOLZER, D.Sc.(Tech.)

**Summary :-**

1. A table is given for the calculation of the first and third harmonics from two measured ordinates in which the ratio of these harmonics can be read at a glance.
2. From an assumed equation for the harmonic spectrum of continuously converging waveforms, formulæ are derived which make it possible, without measuring more ordinates and without any calculation, to read in a diagram the odd harmonics up to the seventh. Four examples (triangular, rectangular, sinusoidal and pulse-wave) show a maximum error of 2 per cent.
3. In cases where even harmonics are present a simple method is given for such calculations up to the fourth harmonic.

THE following methods of analysis will be found useful in cases where only the percentage content of a few sub-harmonics needs to be calculated.

If the ordinates of the wave at 45° intervals are measured, it is possible to calculate the fundamental and third harmonic (if even harmonics are present, also the constant term, and the second and fourth).

If the wave is symmetrical to ordinates of 180° interval, it contains only cosine-terms. If in addition the x-axis becomes an axis of symmetry after one half-wave is displaced for 180°, the wave contains only odd cosine-terms.

But in these stated compositions it is assumed that the zero-ordinate is one of the axes of symmetry and for the twofold symmetry curve that the x-axis is halfway between the curve maximum and minimum.

**1. Wave containing odd Cosine-Terms only. (Ordinates at 45° Interval.)**

After making sure that the above-stated symmetries are present, measure the ordinates at 0° and at 45° (at 90° the ordinate is zero). If possible, modify the scale so that the 0° ordinate is equal to 100 or a submultiple.

For example, suppose

- the 0° ordinate .....  $d_0=50$
- the 45° ordinate .....  $d_1=23$

Calculate the per cent. ratio of

$$\text{these two ordinates } d'_1 = 100 \frac{d_1}{d_0} \dots (1)$$

in this example

$$d'_1 = 46 \text{ per cent.}$$

Find in Table 1 in the column headed  $d'$ , the value calculated. The two amplitudes are in the same line (for  $d'$ , positive read downwards, for  $d'$ , negative read upwards).

In this example

$$B'_1 = 82.5 \text{ per cent.}$$

$$B'_3 = 17.5 \text{ per cent.}$$

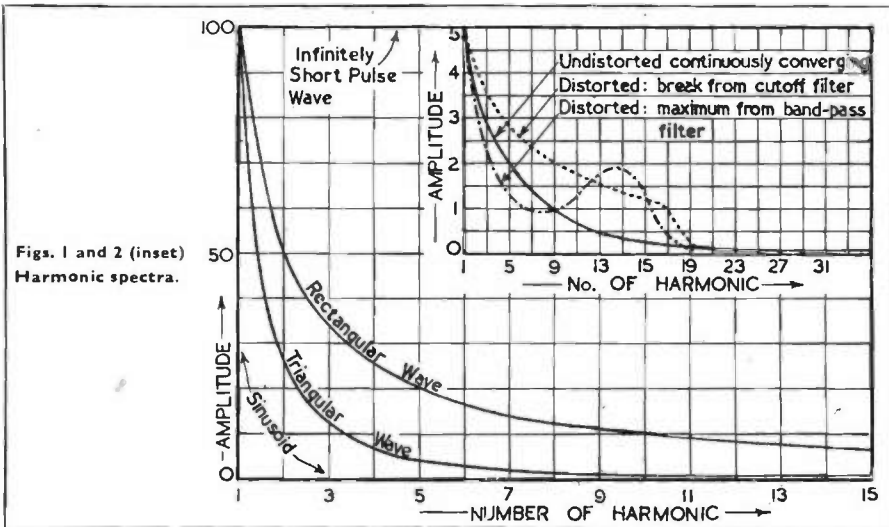

Figs. 1 and 2 (inset) Harmonic spectra.

thus the curve contains 82.5 per cent. of the fundamental and 17.5 per cent. of the third harmonic.

These values presuppose an 0° ordinate of 100, thus the real values of the amplitudes are

$$B_1 = \frac{d_0}{100} \cdot B'_1 \dots (2)$$

$$B_3 = \frac{d_0}{100} \cdot B'_3 \dots (3)$$

or in this example :-

$$B_1 = 41.25$$

$$B_3 = 8.75$$

**2. Correction of the Calculated Amplitudes (estimation of the fifth and seventh).**

In the preceding calculation all harmonics above the third have been ignored. But if such harmonics are present the values of the amplitudes of fundamental and third harmonics found by this method will be erroneous. Theoretically, oscillations when they are generated or distorted by electronic or other physical devices always contain higher har-

monics than the third. Generally, the harmonic spectrum converges continuously and attains zero at very high (theoretically infinite) harmonics. Only cases where, artificially, by means of a cut-off filter all frequencies above a certain value are practically eliminated, will the curve of the harmonic spectrum have a break.

In the case of a band-pass filter or of certain current generators, some high harmonics will be predominant; and the curve of the spectrum has there a maximum. Fig. 1 shows these three kinds of spectra.

Below is shown a method which for the generality of cases (i.e., when the harmonic spectrum converges continuously to zero) corrects the errors of the harmonic analysis for the fundamental and third harmonic, and makes it possible to find the fifth and seventh harmonics without measuring more than two ordinates.

Four examples calculated with this method prove that the resulting error

is less than 2 per cent., thus it can be considered negligible.

Any curve of a continuously converging harmonic spectrum can be approximately represented by the equation

$$y = 1 - e^{-k/x} \dots\dots\dots (4)$$

where

$$y = \left| \frac{B'_n}{B'_1} \right| \dots\dots\dots (5)$$

$$x = \frac{n - 1}{2} \dots\dots\dots (6)$$

$B'_n$  ..... amplitude of  $n$ th harmonic

$n$  ..... number of odd harmonic

$c$  ..... 2.71828

$k$  ..... constant determining the convergence

As examples the following four curves will be taken:—

(a) The sinusoidal wave, as the extreme case of the smallest convergence.

(b) The infinitely short pulse-wave as the extreme case of the largest convergence. (Thus assuming that

all spectra considered here must lie between these two.)

(c) The triangular wave representing a peaked curve.

(d) The rectangular wave representing a flat-topped curve.

Fig. 2 shows the spectra of these four curves.

In Table 2 are compared for these four curves the exact values of the ratios of the amplitudes with those calculated from Equation (4). The values of  $k$  have been determined from the third harmonic with Equations (7) and (8).

TABLE I

For $d'_1$ positive						For $d'_1$ positive					
1	1	2	0	1	2	0	1	2	0	1	2
$d'_1$	$B'_1$	$B'_3$	$d'_1$	$B'_1$	$B'_3$	$d'_1$	$B'_1$	$B'_3$	$d'_1$	$B'_1$	$B'_3$
0	50.0	50.0	50	85.4	14.6	70.0	99.5	+ .5	90	113.6	- 13.6
2	51.5	48.5	1	86.1	13.9	.2	99.6	.4	2	115.1	15.1
4	52.9	47.1	2	86.8	13.2	.4	99.8	.2	4	116.5	16.5
6	54.2	45.8	3	87.5	12.5	.6	99.9	+ .1	6	117.8	17.8
8	55.7	44.3	4	88.2	11.8	.8	100.1	- .1	8	119.3	19.3
10	57.1	42.9	55	89.0	11.0	71.0	100.2	- .2	100	120.7	- 20.7
2	58.5	41.5	6	89.7	10.3	.5	100.6	.6	2	122.2	22.2
4	59.9	40.1	7	90.4	9.6	72.0	100.9	.9	4	123.6	23.6
6	60.3	39.7	8	91.1	8.9	3	101.6	1.6	6	124.9	24.9
8	62.7	37.3	9	91.9	8.1	4	102.3	2.3	8	126.4	26.4
20	64.1	35.9	60	92.4	7.6	75	103.0	- 3.0	110	127.8	- 27.8
2	65.6	34.4	1	93.1	6.9	6	103.7	3.7	2	129.3	29.3
4	67.0	33.0	2	93.8	6.2	7	104.4	4.4	4	130.7	+ 30.7
6	68.3	31.7	3	94.5	5.5	8	105.1	5.1	6	132.0	32.0
8	69.8	30.2	4	95.2	4.8	9	105.8	5.8	8	133.5	33.5
30	71.2	28.8	65	96.0	4.0	80	106.6	- 6.6	120	134.8	- 34.8
2	72.7	27.3	6	96.7	3.3	1	107.3	7.3	2	136.3	36.3
4	74.1	25.9	7	97.4	2.6	2	108.0	8.0	4	137.7	37.7
6	75.4	24.6	68.0	98.1	1.9	3	108.7	8.7	6	139.0	39.0
8	76.8	23.2	.5	98.5	1.5	4	109.4	9.4	8	140.5	+ 40.5
40	78.3	21.7	69.0	98.8	1.2	85	110.1	- 10.1	130	141.9	- 41.9
2	79.8	20.2	.2	98.9	1.1	6	110.8	10.8	2	143.4	43.4
4	81.2	18.8	.4	99.1	.9	7	111.5	11.5	4	144.8	44.8
6	82.5	17.5	.6	99.2	.8	8	112.1	12.1	6	146.1	46.1
8	84.0	16.0	.8	99.4	.6	9	112.8	12.8	8	147.6	47.6
50	85.4	14.6	70.0	99.5	.5	90	113.6	- 13.6	140	149.0	- 49.0
$d'_1$	$B'_3$	$B'_1$	$d'_1$	$B'_3$	$B'_1$	$d'_1$	$B'_3$	$B'_1$	$d'_1$	$B'_3$	$B'_1$
0	2	1	0	2	1	0	2	1	0	2	1

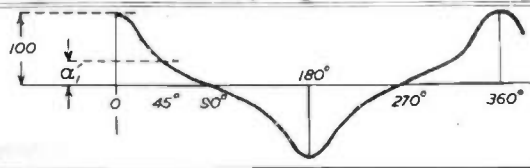

Table Values :

$$B'_1 = 50 + .707 d'_1 \quad B'_3 = 50 - .707 d'_1$$

- $L_n$  ..... exact value of amplitude-ratio.
- $L'_n$  ..... amplitude ratio calculated from (4).
- $\Delta$  ..... error in per cent.

The amplitude-ratio is  $L_n = \frac{B_n}{B_1}$

The deviation between calculated and real amplitudes ( $\Delta$ ) is thus less than 2 per cent. (2 per cent. about represents the accuracy with which the ordinates of a curve is normally measured).

Supposing

$$e^{-k} = r \dots\dots\dots (7)$$

the ratios ( $L'_n$ ) of the amplitudes, calculated from (5) and (6) (ignoring the algebraic sign), are:—

$$\left. \begin{matrix} L'_1 = 1 \dots\dots\dots \\ L'_3 = 1 - r \dots\dots\dots \\ L'_5 = 1 - \sqrt{r} \dots\dots\dots \\ L'_7 = 1 - \sqrt[3]{r} \dots\dots\dots \end{matrix} \right\} \dots\dots\dots (8)$$

where

$$L'_n = \frac{B'_n}{B'_1} \dots\dots\dots (8')$$

If an harmonic analysis is made, for which only two ordinates have been measured (at  $0^\circ$  and  $45^\circ$ ) the two amplitudes

$$B''_1 \text{ and } B''_3$$

will be found.

If an analysis of the same curve is made for which four ordinates are measured ( $0^\circ$ ,  $22\frac{1}{2}^\circ$ ,  $45^\circ$  and  $67\frac{1}{2}^\circ$ ) the four amplitudes

$$B''_1, B''_3, B''_5 \text{ and } B''_7$$

will be found.

It is obvious that the first two results of the second calculation differ from those of the first (if  $B''_3$

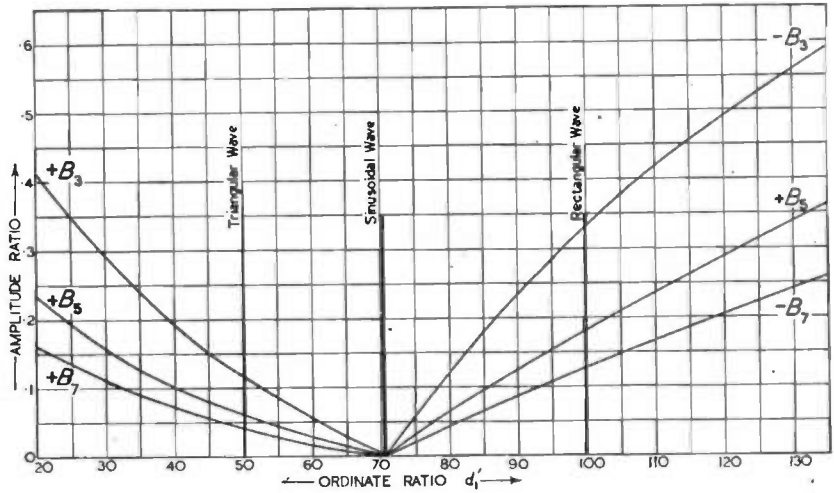

Fig. 3.

and  $B''_7$ ; are not zero); but it can be proved that

$$\left. \begin{matrix} B''_1 = B''_1 + B''_7 \dots\dots\dots \\ B''_3 = B''_3 + B''_5 \dots\dots\dots \end{matrix} \right\} \dots\dots\dots (9)$$

Supposing that the results of the harmonic analysis with four measured ordinates are identical with the result of the Equations (8) and (8') we can substitute  $B''_n$  of (9) for  $L'_n$  of (8) if all amplitudes are positive.

$$\begin{matrix} B''_1 = B'_1 (2 - \sqrt[3]{r}) \\ B''_3 = B'_1 (2 - r - \sqrt{r}) \end{matrix}$$

or

$$\frac{B''_3}{B''_1} = \frac{2 - r - \sqrt{r}}{2 - \sqrt[3]{r}} \dots\dots\dots (10)$$

if the algebraic signs of the amplitudes change alternately, i.e.,

$$\begin{matrix} B''_3 \text{ and } B''_7, \text{ are negative} \\ B''_1 = B'_1 \sqrt[3]{r} \\ B''_3 = B'_1 (\sqrt{r} - r) \end{matrix}$$

$$\frac{B''_3}{B''_1} = \frac{\sqrt{r} - r}{\sqrt[3]{r}} \dots\dots\dots (11)$$

Thus from the two measured ordinates, the values of  $B''_1$  and  $B''_3$  can be found (in Table 1). With the Equations (10) and (11)  $r$  can be calculated and then from (8) the four amplitude-ratios.

The real values of the four amplitudes ( $B'_n$ ) can be calculated from the relations

$$d_0 = B'_1 + B'_3 + B'_5 + B'_7 \dots\dots\dots (12)$$

and if

$$\frac{d_0}{B'_1} = \delta_0 = 1 + L'_3 + L'_5 + L'_7 \dots\dots\dots (13)$$

then

$$B'_n = \frac{d_0}{\delta_0} \cdot L'_n \dots\dots\dots (14)$$

Table 3 shows the waves chosen as examples for the accuracy of the result.

In Fig. 3 the ratios between the third, fifth and seventh harmonics and the fundamental can be read directly as a function of the ratio between the  $45^\circ$  and the  $0^\circ$  ordinate. After having calculated with the slide rule the ordinate ratio  $d_1/d_0$  in per cent., find  $L'_3$ ,  $L'_5$  and  $L'_7$  on the vertical line which corresponds to this ratio;  $L'_1$  is always unity.

TABLE 2

k	Sinusoid			Pulse wave			Triangular wave			Rectangular wave		
	$L_n$	$L'_n$	$\Delta$	$L_n$	$L'_n$	$\Delta$	$L_n$	$L'_n$	$\Delta$	$L_n$	$L'_n$	$\Delta$
		$\rightarrow 0$			$\rightarrow \infty$			.118			.405	
1st	1	1	0	1	1	0	1	1	0	1	1	0
3rd	0	0	0	1	1	0	.111	.111	0	.333	.333	0
5th	0	0	0	1	1	0	.040	.057	1.7	.200	.183	1.7
7th	0	0	0	1	1	0	.020	.039	1.9	.143	.126	1.7

TABLE 3

	Triangular wave				Rectangular wave			
	Harm. analysis	Corrected value	Theoretical value	Differ. in %	Harm. analysis	Corrected value	Theoretical value	Differ. in %
$L_1$	1.000	1.000	1.000	0	+ 1.000	+ 1.000	+ 1.000	0
$L_3$	.172	.115	.111	.5	-.172	-.330	-.333	.3
$L_5$	—	.060	.040	2	—	+.184	+.200	1.6
$L_7$	—	.040	.020	2	—	-.128	-.143	1.5

# MULLARD

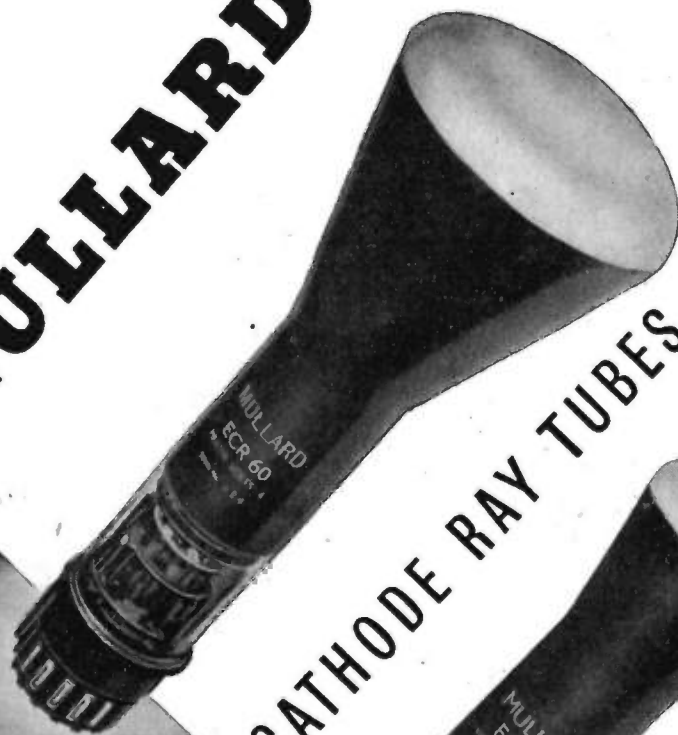

## CATHODE RAY TUBES

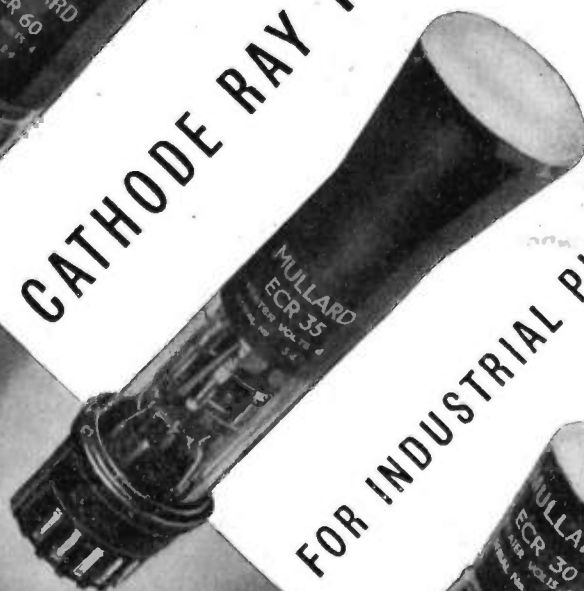

## FOR INDUSTRIAL PURPOSES

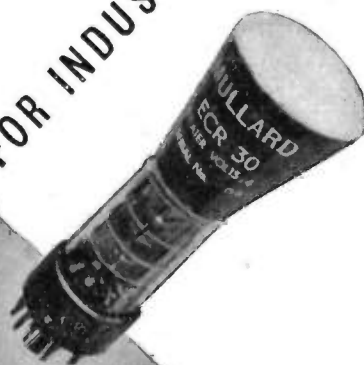

TYPE	SCREEN DIAMETER	LIST PRICE
ECR. 60	6"	£7. 7. 0
ECR. 35	3½"	£6. 6. 0
ECR. 30	3"	£3. 3. 0

## BOOK REVIEWS

### Hyper and Ultra-High Frequency Engineering

Sarbacher & Edson. John Wiley and Chapman & Hall. Price 33s.

The great and growing practical importance of microwaves is beginning to be reflected in the publishers' lists, particularly in the U.S.A. This is a healthy state of affairs since war-time conditions have, quite properly, forced most scientists to concentrate on operational needs rather than on an orderly development of this new science. This concentration has led to the existence of a large body of young research workers who have a vast practical knowledge of microwaves but very little theoretical knowledge. The situation is rendered more difficult by the fact that the basic theoretical foundation of microwave technique was laid by followers of Hertz and Maxwell around 1900 when the properties of resonant cavities and lines were first investigated. Since the whole emphasis of physical theory shifted first to Relativity and then to Quantum Mechanics this knowledge was lost sight of until around 1935 when Barrow at M.I.T. and Southworth at Bell Laboratories started their investigations on waveguides.

The need for a thorough theoretical approach is therefore great and the title of the book under review raised great expectations.

The book falls into two sections, the first, of rather over 400 pages, dealing with the derivation of Maxwell's Equations from the empirical laws of electricity and applying them to the theoretical analysis of waveguides, lines, and cavity resonators and horns. In addition to this some practical applications and measurement techniques are briefly described and many experimental results, taken from pre-war publications, are included. This section of the work should prove very valuable. It starts off from basic principles which are familiar to every physicist and engineer and the symmetry of electrostatic and magnetic relations is well displayed. Vector analysis is introduced in such a way as to make its advantages obvious, and the most important results are given in vector and in long notation. The theory is

then applied to the physical system. No steps are left out in the mathematical derivations which may be a help to some readers but makes the reading somewhat tedious. This section should be of the greatest value to students or researchers who wish to bridge any gaps in their theoretical knowledge.

The remaining 200-odd pages deal with video amplifiers and microwave generators. The section on video amplifiers is rather long and quite out of place. The space could have been used in bettering the section on generators. It is clear that the authors have attempted to give an abstract of the literature in this field and the picture they give is very unreal. Quite apart from material which may have had to be omitted on security grounds a much more critical attitude should have been adopted, and students should have been told that valve theory is not nearly as pat as the authors make out. The chapters on magnetrons and velocity modulation tubes are particularly deficient in this respect. For example, in spite of the fact that Brillouin's paper on the Magnetron published in the *Physical Review* appears in the bibliography, several of the figures show incorrect electron paths. One of Kilgore's photographs obtained using gas to make similar paths visible is reproduced without comment on the possible effects of gas. Again, one finds that the Webster analysis of klystron bunching appears in part but is cut short by deriving a very approximate value for the catcher current. This in spite of the fact that the necessary mathematics is no more complicated than that used freely in earlier parts of the book. No calculation of the efficiency is given. Active workers in these fields will find something to criticise on nearly every page of this part, and one wonders whether it is not actually

misleading. It should be possible to give a clear physical picture of transit time valves even under present conditions by using material already published and mentioned in the really excellent bibliography.

The book could have been wholeheartedly recommended if it had been limited to the first part; as it is, one can only say that gratitude is due to authors who can write as good a book in war-time, and wait for a good book on transit time electronics.

A. H. B.

### The Radio Amateur's Handbook

(Twenty-second edition — 1945), by the Headquarters staff of the American Radio Relay League. 728 pages, 1,278 illustrations, 133 charts and tables. Price \$1.00 U.S.A., \$1.50 elsewhere. American Radio Relay League, West Hartford, Conn., U.S.A.

The new 1945 Handbook is a comprehensive digest of the older, familiar phases of radio theory and practice with which has been combined material covering the more advanced techniques of the future. While the basic treatment of the theory section has not been materially changed, many of the latest phases of radio have been covered in completely new additions to the text, thus paving the way for the post-war amateur development with its new techniques.

The ten chapters under Equipment Construction contain practical information on the design and construction of all types of amateur receivers, transmitters, associated equipment and antennas. This portion of the handbook includes complete details covering all types of tested amateur communication equipment. The designs shown represent the best possible arrangement for their respective jobs.

Another feature of previous handbooks retained in this edition is the topical index, found in the rear of the book, containing some 2,300 items and comprising practically a glossary of radio terms as well as a means for readily locating every topic discussed in the text material.

**Books reviewed on this page  
or advertised in this Journal,  
can be obtained from**

**H. K. LEWIS & Co. Ltd.**

136 Gower Street, W.C.1

**If not in stock, they will be obtained  
from the Publishers when available**



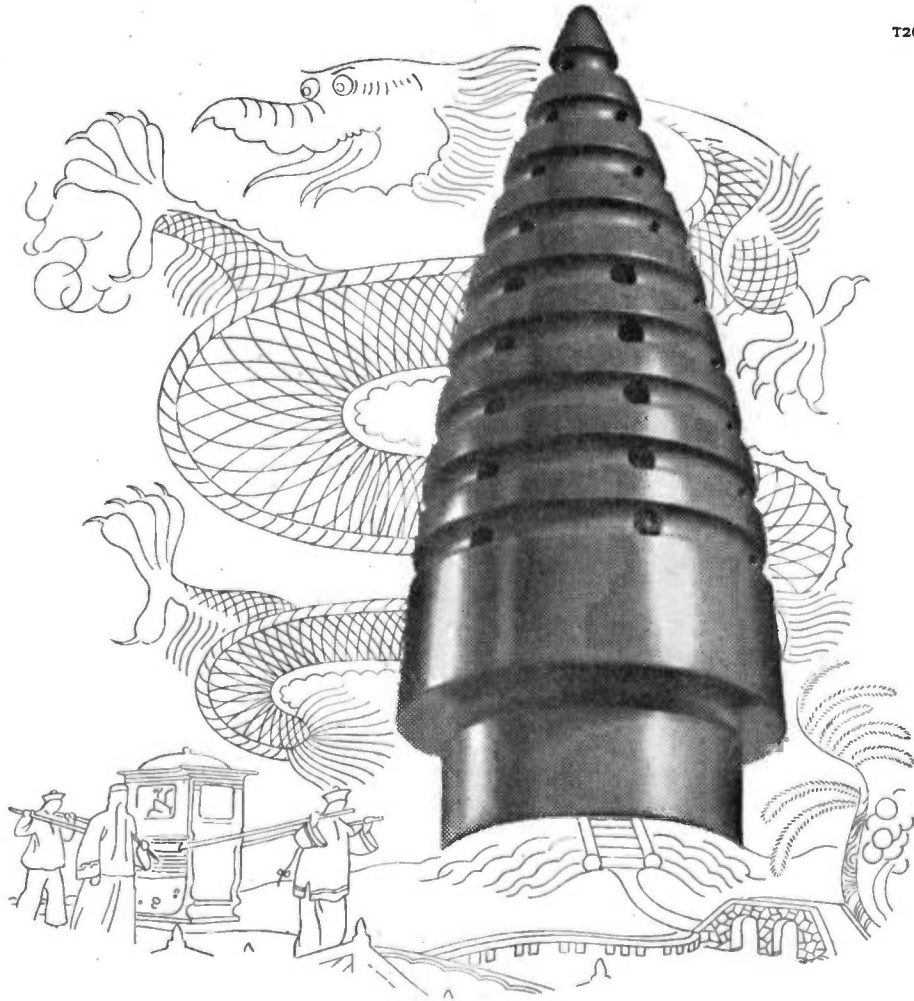

T26

## CLEVER PEOPLE, THESE CHINESE . . .

though in the case of *this* imposing object the dexterity belongs to two firms on these small islands, to wit, Bakelite Limited who made the Bakelite Laminated and Messrs. J. Burns Ltd. of Chadwell Heath who so skilfully machined it. The pagoda-like result is in reality a gauge for measuring the internal accuracy of shell noses, one of the many war products being made from Bakelite Laminated.

TREFOIL  
**BAKELITE**  **PLASTICS**  
 REGD. TRADE MARKS

*Pioneers in the Plastics World*

BAKELITE LIMITED, 18 GROSVENOR GARDENS, LONDON, SW1

# ABSTRACTS OF ELECTRONIC LITERATURE

## C.R. TUBES

### Improved Electron Gun for C.R. Tubes

(L. E. Swedlund)

Cathode-ray oscilloscope tubes with improved operating characteristics have recently been designed. The improvement is achieved by the use of a modified electron gun which requires no first-anode current and gives sharper focus. The beam is also less subject to stray fields capable of causing variation in spot brightness. Several constructional advantages are inherent in the design of the electron gun.

—*Electronics*, March, 1945, p. 122.\*

## CIRCUITS

### Notes on the Stability of LC Oscillators

(N. Leo)

The paper deals with the problem of the stability of LC oscillators, largely from the point of view of the development engineer, and is based on the author's experience within a limited field.

Some familiarity with the art is presumed, though references are given to a number of the more important publications.

Sections are devoted to the two fundamental oscillator components, namely, the amplifier and the resonator.

Methods of thermal compensation are discussed and the importance of humidity is emphasised, a diagram for the permittivity of moist air being included.

The paper concludes with a description of the performance of the Franklin oscillator and with experimental oscillators which have been built.

—*Jour. I.E.E.* (to be published).

### Zero Phase Shift Amplifier Design

(L. R. Malling)

Equations and circuits are given for the design of wide-band amplifiers having extended frequency ranges of flat phase and amplitude response. Negative feedback between successive stages is shown to be simpler and as effective as conventional shunt inductive and capacitive compensation.

—*Electronics*, March, 1945, p. 136.\*

### A Balanced and Repeating Time Base of Novel and Compact Design

(F. O. Mason)

A balanced time base using thyatrons, and capable of repeated operation at speeds up to 200 times per sec., is described. Several useful features are incorporated in the design, including sweep times varying from about 1  $\mu$ sec. to 3,000  $\mu$ sec., sweep voltages ranging from 250 V to over 2,000 V, beam trapping and modulating voltages and provision for beam positioning on both the  $x$  and  $y$  axes of a cathode-ray oscillograph. The characteristics of the circuit used and the effect of changes in circuit constants on the operation of the unit are also described.

—*Jour. Sci. Inst.*, Vol. 22 (1945), p. 87.

## MEASUREMENT

### Supersonic Measurement

(W. S. Erwin)

A supersonic instrument is described for rapidly measuring the thickness of metal sections in the approximate range 0.02–0.40 in. with a maximum error of less than 2 per cent. It requires contact with only one surface of the object to be measured. The simplicity of the instrument is due to the fact that it measures the frequency at which the work is set into resonant vibration. Since this resonant frequency in the plates of a given metal is directly related to the thickness, the measurement of frequency determines the thickness.

—*Steel*, 5/3/1945, p. 131.\*

### Dielectric Constant Meter

(F. C. Alexander)

Simple method for measuring dielectric constant by utilising the plate current characteristic of a crystal oscillator as it is tuned through its oscillating range. The meter can be made automatic for industrial applications or it can be used to measure capacitance.

—*Electronics*, Vol. 18, No. 4 (1945), p. 116.

## INDUSTRY

### Induction Heating—A History of its Development

(F. T. Chesnut)

Induction heating has emerged far from the developmental stage and induction furnace equipment of a total installed capacity exceeding 300,000 kw. is in use. This article gives an account of the early development of the process, commencing with the initial work done by Dr. Edwin F. Northrup in 1916. The first high frequency generators were spark gap oscillators; motor-generator sets came into commercial use about 10 years later and vacuum tube oscillators in the period between. The author traces the work of the Ajax Electrothermic Corporation as a pioneer company in induction heating applications and points out future possibilities for this type of heating.

—*Iron Age*, 22/4/1945.\*

### An Oscillographic Method for the Photometry of Photographic Flash Lamps

(T. H. Projector and L. E. Barbrow)

A method for the photometry of photographic flash lamps with a cathode-ray oscilloscope is described. The circuits required to obtain curves of luminous flux versus time on the oscilloscope are given. Accurate timing is obtained through the use of beam modulation. Some of the precautions necessary to assure accuracy are discussed.

—*Rev. Sci. Inst.*, Vol. 16, March, 1945, p. 51.

### Symposium on Cellulose and Cellulose Plastics

A symposium of six papers on Cellulose and Cellulose Plastics, presented before the American Chemical Society in New York, is included in this issue. The titles of the papers are: Recent Progress in Cellulose Chemistry; Weather Resistance of Cellulose Ester Plastic Compositions; Cellulose Moulding Compounds; Interchain Order and Orientation in Cellulose Esters; Impact Testing of Plastics; and Paper-Base Laminates.

—*Ind. and Engg. Chem.*, March, 1945, p. 226.\*

\* Abstracts supplied by the courtesy of Metropolitan Vickers Electrical Co. Ltd., Trafford Park, Manchester

# MOULDINGS

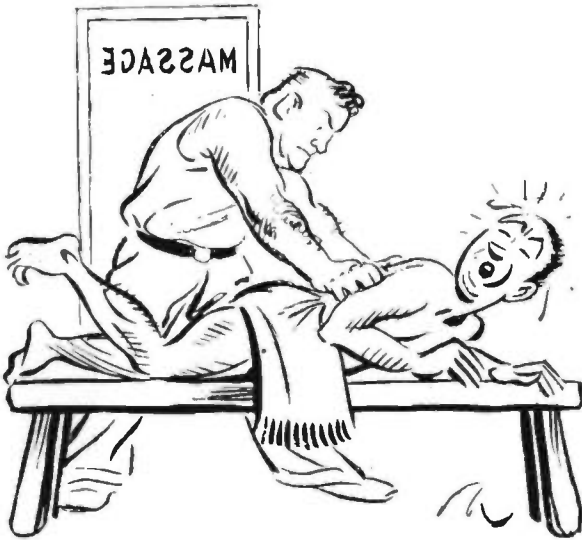

Much to our customers' relief we do not go in for this type of moulding, but we do make all kinds of Mycalex mouldings. So why not send us your enquiry?

- 
- Accurate
  - Rigid
  - Low Loss
  - Heat Resisting
  - Metal Inserts
  - Non Absorptive
- 

*Send for illustrated brochure*

**MYCALEX COMPANY LIMITED • CIRENCESTER • GLOS.**

MY9



Measurement has become a science in itself. In electrical communications it must encompass the globe, yet remain accurate to very much less than a hairbreadth; it must daily serve the communications engineer yet anticipate the trend of development and research.

Thus to describe measurement in communications is equally to define the function of Marconi Instruments, Ltd., makers

of the highly specialised equipments which have reduced once complicated testing problems to the level of routine operations.

We spare just a moment to review with satisfaction our endeavours of recent years—the tasks of to-day are no less vital and the expectations for to-morrow no less momentous in a world where communications will spread the truth to the far corners of the earth.

**MARCONI  INSTRUMENTS, LTD.**

**ELECTRA HOUSE . VICTORIA EMBANKMENT . LONDON . W.C.2**

## JUNE MEETINGS

**NOTE.**—In general, visitors are admitted to the meetings of scientific bodies on the invitation of a member, or on application in writing to the Organising Secretary at the address given. In certain cases (marked \*) tickets may also be obtained on application to the Editorial offices of this Journal.

### Institute of Physics

#### Electronics Group

Date: June 9. Time: 2.30 p.m.  
 Held at:  
 Fyvie Hall, The Polytechnic, 309  
 Regent Street, London, W.1.  
 Discussion on:  
 "Glass-to-Metal Seal Design."  
 Opened by:  
 W. J. Scott, B.Sc.(Eng.), M.I.E.E.  
 and  
 Discussion on:  
 "High-Vacuum Pumps."  
 Opened by Dr. R. Witty.  
**Group Secretary:**  
 A. J. Maddock, M.Sc., F.Inst.P.,  
 Messrs. Standard Telephones and  
 Cables, Ltd., Oakleigh Road,  
 London, N.11.

#### Bradford Electronics Society

Date: June 7. Time: 7 p.m.  
 Held at Bradford Tech. College.  
 Lecture:  
 "Construction and Manufacturing  
 Technique of Radio Receiving  
 Valves."  
 By N. McAdam.

### Institution of Electronics

#### North-West Branch

Date: June 1. Time: 6.30 p.m.  
 Both meetings held at:  
 The Reynolds Hall, College of  
 Technology, Manchester.  
 Lecture:  
 "Design of Electron Guns of  
 Radial Symmetry."  
 By:  
 Dr. H. Moss.  
*Note: This is a joint meeting with  
 the Manchester and District Branch  
 of the Institute of Physics.*

Date: July 27. Time: 6.30 p.m.  
 Lecture:  
 "Rectifiers and Inverters."  
 By:  
 Dr. R. Feinberg.  
**General Secretary:**  
 L. F. Berry, 105 Birch Avenue,  
 Chadderton, Lancs.

#### London Branch

Date: June 4. Time: 5.30 p.m.  
 Held at:  
 The Royal Society of Arts, John  
 Adam Street, Adelphi.  
 Lecture:  
 "Principles of Triode Design."  
 By:  
 J. H. Fremlin, M.A., Ph.D.  
**The Secretary:**  
 64 Wijnfred Road, Coulsdon,  
 Surrey.

#### The Association for Scientific Photography\*

Date: June 30. Time: 2.30 p.m.  
 Held at:  
 Alliance Hall, Westminster, S.W.1.  
 Lecture:  
 "Make the Photograph Tell a  
 Story."  
 By:  
 H. White, F.I.B.P., F.R.P.S.  
**The Secretary:** A.S.P., 34 Twyford  
 Avenue, Fortis Green, London, N.2.



## ENERGY REGULATORS

Our Publication R.12/16 describes this important technical development—an instrument that varies continuously any electric load from zero up to its rated capacity, giving closer control than the resistance method. Energy Regulator Control is used successfully for hot plates, mufflers, furnaces, drying rooms, etc. Write to-day for your copy of the above technical publication, free on request.

**SUNVIC CONTROLS LIMITED,**  
 STANHOPE HOUSE, KEAN STREET, LONDON, W.C. 2.



## "Post-War" Television

In the post-war period, backed by the Technical advances that have resulted from the war years, **TELEVISION** will again spring to life and offer opportunities, as never before, to the trained man.

Now is the time to prepare for this new "market." Our Home-study "Television" Course is comprehensive, up-to-date and suitable both for the amateur and experienced Radio Engineer.

We definitely guarantee  
**"SATISFACTION—OR REFUND OF FEE"**

You are advised to send for details of this special Television Course immediately, to investigate its possibilities. Details will also gladly be sent of A.M.I.E.E. and A.M.Brit.I.R.E. Examinations, and other courses in all branches of **WIRELESS ENGINEERING**, including particulars of our special **SHORT WAVE** and **RADIO SERVICE COURSES** which are in such demand—Free.

**BRITISH INSTITUTE OF ENGINEERING TECHNOLOGY**  
 337, Shakespeare House, 17/19, Stratford Place, London, W.1

## BRAY CERAMIC INSULATORS

for L.F. and H.F. Components; also capacitor dielectrics



made by  
**GEO. BRAY & CO., LTD. LEEDS, 2**  
 Established 1863 Phone Leeds 20981

Technical Reasons Why

★ **ERSIN**  
**MULTICORE SOLDER**

Is the Finest Cored Solder in the World

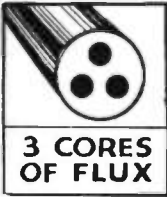

3 CORES OF FLUX

Three Cores of Flux ensure flux continuity. No lengths without flux are wasted. Consistent high quality joints are obtained with comparatively unskilled labour. Exactly the correct proportions of solder to flux are provided. Separate fluxing operations are obviated and no extra flux is required. The three cores of flux being evenly distributed over the cross section of the solder provide thinner solder walls than otherwise. This gives rapid melting and speeds up soldering. The flux does not tend to run out of the cores ; so there is always a supply available for the next joint. The utmost economy of solder and flux is achieved.



Ersin, contained in the three cores of Ersin Multicore Solder, is the fastest non-corrosive flux. Possessing all the non-corrosive advantages of rosin, it enables joints to be speedily made on oxidised or "difficult" surfaces such as nickel. Ersin not only avoids oxidation during soldering but removes surface oxide already present—this is particularly advantageous in respect of materials that have been in stock or apparatus that is being serviced. The use of Ersin Multicore, with correct soldering technique, avoids "HR" or dry joints.



10 SWG

22 SWG

Double actual size.

Ersin Multicore Solder is made in most gauges between 10 and 22 S.W.G. (-128—028") (3.251—7109 m/ms). For general radio and electrical production and maintenance 13 and 16 S.W.G. are in most demand.



Virgin Tin & Lead

Five alloys of Ersin Multicore Solder, made from virgin metals, are available—all antimony free. Under present circumstances 45% tin and 55% lead is the most widely used alloy.

Technically, Ersin Multicore Solder is far superior to any other cored solder. A practical laboratory or production test will demonstrate this and show you that it is the most economical solder to use. The majority of British and overseas manufacturers already enjoy the advantages of Multicore. If you do not, and are engaged upon Government contracts, write for further technical information and free samples.

Single reel rate nominal 1 lb. reels.

13 SWG - 4/10

16 SWG - 5/3

Above prices subject to usual trade discount.

½ cwt.—ton lots at bulk rate. 6d. cartons for home use, available at most good radio and electrical dealers, ironmongers, etc.

**MULTICORE SOLDERS LTD.** Commonwealth House, New Oxford St., London, W.C.1 Tel.: CHAncery 5171-2

**P. X. FOX, LTD.,**

HORSFORTH, YORKSHIRE

FOR STANDARD OR SPECIAL TYPES OF—

**TOROIDAL POTENTIOMETERS**



**Dainite**  
MOULDED RUBBER PARTS  
As soon as the war is won we hope to offer our usual "DAINITE" Service for Moulded Rubber Parts. In the meantime, enquiries for permitted essential lines will receive every attention.

THE HARBORO' RUBBER CO. LTD., MARKET HARBOURGH

Great Possibilities for Technically Qualified Engineers  
KEY MEN IN WARTIME AND AFTERWARDS

The finest posts and the majority of posts in this war are technical and when the war is over, the immense increase in technique and mechanisation created for war purposes will be applied to reconstruction and commerce. An age of great possibilities for qualified engineers is here. Study at home with The T.I.G.B. and take a Recognised Engineering Qualification such as C. & G., A.F.R.Ae.S., A.M.I.Mech.E., A.M.I.E.E., etc. In which examinations T.I.G.B. Students have gained 35 FIRST PLACES and hundreds of passes. Write now for "The Engineer's Guide to Success"—200 Courses—covering all branches—Aeronautical, Telecommunication, Mechanical, Electrical, Chemical, etc. etc.



World's best choice of Courses in Engineering

**THE TECHNOLOGICAL INSTITUTE OF GREAT BRITAIN**  
160, Temple Bar House, London, E.C.4.

**TRANSFORMERS**

POWER, AUDIO, INPUT AND OUTPUT TRANSFORMERS available from Stock

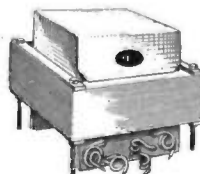

Type K450 (as illus.)  
450-0-450 v. 200 ma., 0-4-5 v. 4 amp. 47/6  
and 6.3 v. 6 amp. ct. ....  
Our OP12K, multi-ratio, 50-watt output unit is excellent for large amplifiers. We supply driver transformers to suit OP12K... 49/6

Send 2½d. stamp for List "EE." It gives details of our full range of Transformers and Chokes.

**RADIO INSTRUMENT Co.**  
294 Broadway, Bexleyheath, Kent  
Telephone: Bexleyheath 3021

just because they give no trouble—  
don't forget

# DALY ELECTROLYTICS

DEALERS—Don't pay more than 2/9  
for your DALY 8 M.F. 500 P.V.

**DALY (CONDENSERS) LTD.**  
Condenser Specialists for over 20 years  
West Lodge Works, The Green, Ealing, W5  
Telephone: Ealing 4841



Designers & Manufacturers of

## RADIO AND ELECTRONIC DEVICES

---

### TRANSMITTERS · RECEIVERS

---

Specialists in

### HIGH SPEED TELEGRAPHIC EQUIPMENT

---

**ROMAC RADIO CORPN. LTD**  
THE HYDE · HENDON · LONDON N.W.9

**THE PYROBIT  
TESTER**  
pat. appl. for.  
For Wireless  
Engineers. An in-  
dispensable Tool  
for Continuity  
Test, Earth Con-  
nection, Leakage,  
Polarity, etc.

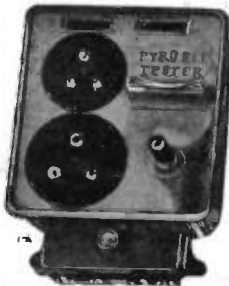

**THE AGRU ELECTRIC TOOL MFG. Co. Ltd.,**  
123, Hyde Road, Manchester-Ardwick  
Tel: Ardwick 4284.

## DUAL TESTSCOPE

This New  
Dual Model  
Indicates 2 to 30  
volts and 100.750  
volts. Send for interesting leaflet  
L 24 on "Testing."

**RUNBAKEN-MANCHESTER-I**

### CLASSIFIED ANNOUNCEMENTS.

The charge for miscellaneous advertisements on this page is 12 words or less 4/- and 4d. for every additional word. Box numbers count as four words, plus 1/- extra for replies. Remittance should accompany advertisement. Cheques and P.O.'s payable to Hulton Press Ltd., 43 Shoe Lane, E.C.4. Press date—15th month for following issue.

#### FOR SALE

**IN STOCK, Rectifiers, Accumulator Chargers, Rotary Converters, P.A. Amplifiers, Mikes, Mains Transformers, Speakers of most types, Test Meters, etc., Special Transformers quoted for.**—University Radio, Ltd., 22, Lisie Street, London, W.C.2. Ger. 4447.

**PHOTO-ELECTRIC CELLS, SeTe on gold-alloy, super-sensitive to light, gasfilled, permanent, operate relay direct or with valve amplifier, perfect reproduction of speech and music, etc., from sound track of films; large tube 3½ in. from glass top to valve pin base, 1 in. dia., 38/-; medium size, 2½ in. long, 35/-; small tube, 2 in. from top to terminal base, ½ in. dia., 30/-; miniature cell, 1 in. overall glass top to cap base, ½ in. dia., thin flex leads, 28/-; all cells operate on 40-100 volts. Connections diagrams free.**

**PRECISION OPTICAL SYSTEM, producing knife-edge line of light from any car headlight bulb, for scanning sound track of film direct into photo-cell, brass tube 2 in. long, ½ in. dia., ½ in. focus, 52/-; full instructions free, goods by return.** CEFA INSTRUMENTS, 38a, York Street, Twickenham, Middlesex. Phone: PO PEsgrave 6597.

#### LOUDSPEAKERS

**LOUDSPEAKERS**—We carry on. Sinclair Speakers, 12, Pembroke Street, N.1.

**LOUDSPEAKER repairs, British, American, any make, moderate prices.**—Sinclair Speakers, 12, Pembroke Street, N.1.

#### MISCELLANEOUS

**WE WILL BUY at your price used radios, amplifiers, converters, test meters, motors, pick-ups, speakers, etc., radio and electrical accessories.** Write, phone or call, University Radio Ltd., 22, Lisie Street, London, W.C.2. Ger. 4447.

**WEBB'S Radio Map of the World enables you to locate any station heard. Size 40' by 30' 2 colour heavy Art Paper, 4/6, post 6d. Limited supply on Linen, 10/6, post 6d.**—Webb's Radio, 14, Soho Street, London, W.1. Phone: GERrard 2089.

**MORSE Practice Equipment for Class-room or Individual Tuition. Keys, Audio Oscillators for both battery or main operation.** Webb's Radio, 14, Soho Street, London, W.1. Phone: GERrard 2089.

**RADIO-ELECTRIC PATENTS.** Well known London Radio Component manufacturers are open to consider patents or designs for post-war period. Write: Progress c/o Alfred Bates and Son, Ltd., 130, Fleet Street, London, E.C.4.

**TELE-RADIO (1943), LTD.**—for brand new good quality components at manufacturers' list prices. Suppliers to British and Allied Services and Government Departments, professional constructors and amateurs who want only the best.

Weston meters 0-1 mA, £2 10s., 0-500 micro amps, £3. 0-100 micro amps, £3 15s. 0-50 micro amps, £4 10s. 1 mA instrument rectifiers, 12s. 6d. "Spot-on" wire wound precision resistors plus or minus .05 per cent., 5s. 6d. each (up to 50,000 ohms only). Single pole 12 position switches, 3s. 6d. each, 4 pole 3 way, 3s. 6d. each. Cathode Ray Tubes, G.E.C., 1½ in., £2 15s. Cossor 23D, 2½ in., £3 6s. Cossor 26D, 4½ in., £6 10s. Cossor GDT4B gas filled triode, 24s. 4d. High voltage rectifiers and condensers. Potentiometers carbon, 4s. 6d., with switch, 6s. 6d., wire wound, 6s. 6d., all usual values. Crystals 100 Kc., 45s. 0d. (P.O. Permit). Rothermel crystal pick-ups, £3 13s. 6d., and £3 18s. 9d. (High fidelity Red Label, 10s. extra). Celestion, Goodman and Vitavox speakers. Wearite P. coils and I.F. Transformers. Wavechange switches, variable condensers and trimmers, etc. Comprehensive stocks of British and American valves. Steel racks, chassis, panels and cabinets—any specification (callers only). Unlimited resources for technical information to callers. Postal inquiries acknowledged same day. Cash or C.O.D. orders, if in stock 24 hours service. Postage and packing extra on all goods.

**TELE-RADIO (1943), LTD.,** 177a, Edgware Road, London, W.2 (Corner of Edgware Road and Sussex Gardens). Phone: Pad. 6116. Telegraphic address: "Goahead," Padd., London.

### Classified Announcements (Contd.)

**BE SURE AND WRITE NOW** for our latest large Mail Order List. Included in the hundreds of bargains and "short-supply" lines available at once from stock are the following: Instrument type Cabinets in 18 gauge steel. Chassis, panels, complete racks. Condensers, coils, volume controls, heavy duty chokes, etc. Send now for Mail Order List "E," 24d. post paid. **WAVEBAND RADIO, LTD.,** 63, Jermyn Street, London, S.W.1.

**BERRY'S (SHORT-WAVE), LTD.,** for prompt delivery of Quality RADIO AND ELECTRONIC COMPONENTS including: C.R. Tubes, 1½ in., 55/-; 2½ in., £3 6s.; 4½ in., £6 12s. I.F. Transformers, 7/6. Crystal mikehead, 75/-; Crystal Pick-up, 78/9. 0-1 Meters, 59/6. 8-1 Slow motion drive, station named dial, escutcheon and glass, 8/6. Metal cabinets, finished crackle black with hinged lids, chassis and panels, 30/6 and 63/-. Speakers, 2½ in., 27/-, 3 in., 30/-; also 6 in. to 12 in. Jacks and Jackplugs, 2/6 each, also Crystal filters, Ceramic tuning, reaction and differential condensers, trimmers, standoffs; Ceramic Amphenol, Paxolin and Bakelite valve bases (all types). For detailed Catalogue send S.A.E. for List "E," to Berry's (Short-Wave), Ltd., 25, High Holborn, London, W.C.1. Telephone: Holborn 6231.

**THE TECHNICA CAMERA CO.,** 21, William IV Street, W.C.2, consulting photographic engineers to H.M. Government Departments, undertake the solving of photo-electric and other problems.

#### SITUATIONS VACANT

**A.M.I.E.E., City and Guilds, etc., on "NO PASS-NO FEE" terms.** Over 95% Successes. For full details of modern courses in all branches of Electrical Technology send for our 112-page handbook—FREE and post-free. B.I.E.T., (Dept. 337B), 17 Stratford Place London, W.1.

**REQUIRED, TECHNICAL ASSISTANT** for Commercial Department of Radio Valve Works, North London district. A good knowledge of radio-engineering is essential and some commercial experience is desirable. No offer of engagement can be made until regulations permit. Applications with details of qualifications, age, experience, etc., to Box No. 731, "Electronic Engineering."

**CONSULTANT ELECTRONICS ENGINEER** required. A firm in West of London engaged in the application of high frequency heating would like to retain consultant electronic engineer for advice on problems connected with above and other electronic matters. Box No. 728, "Electronic Engineering."

#### SITUATIONS WANTED

**ENGINEER.** Experience: Administration, organisation, research, development and patents in radio, television, valve, C.R.T., telecommunications and industrial applications. Wants post with scope. Now under E.W.O. Box No. 729, "Electronic Engineering."

**DEVELOPMENT ENGINEER** with industrial electronic experience wishes to contact a progressive firm with view to employment. London area desirable. Box No. 730, "Electronic Engineering."

**YOUNG MAN** in University, physics and radio training, and considerable experience in miniature electronic research (particularly hearing aids), desires technical post in England or abroad. Box 732, "Electronic Engineering."

**ELECTRONICS.** Sales Engineer desires contact live concern interested in industrial electronics. Wide commercial experience; extensive connections numerous industries. Box 733, "Electronic Engineering."

#### WANTED

**WE OFFER cash for good modern Communication and all-wave Receivers.**—A.C.S. Radio, 44, Wildmore Road, Bromley.

## HILL & CHURCHILL

Booksellers

**SWANAGE, DORSET**

ENGLISH & AMERICAN  
BOOKS IN STOCK ON

RADIO AND  
TELECOMMUNICATION

Catalogue on Application



For the past 15 years we have devoted our energies exclusively to the manufacture of Transformers and Chokes. Although we continue to be very active in the field of Research and Development, we are nevertheless giving much of our attention to increasing our range of mounting facilities.

Illustrated above is one of the varied range of styles shown in our Catalogue (Price 1d.) which is now in preparation. If you would like a copy, please write to us and we will send you one immediately it is ready.

Telephone:  Abbey 2244  
**PARTRIDGE**  
**TRANSFORMERS LTD**  
 76-8, PETTY FRANCE. LONDON, S.W.1.

## ANNOUNCEMENT

**LOW-LOSS  
 CERAMICS  
 OF ALL TYPES**

*Manufactured by*  
**TAYLOR  
 TUNNICLIFF  
 & CO., LTD**

Head Office: Eastwood, Hanley Staffs.  
 London: 125, High Holborn, W.C.1.  
 Factories at Hanley, Stone and Longton,  
 Staffs. Telephone: Holborn 1951-2  
 and Stoke-on-Trent 5272-4.

TAS/TT.50

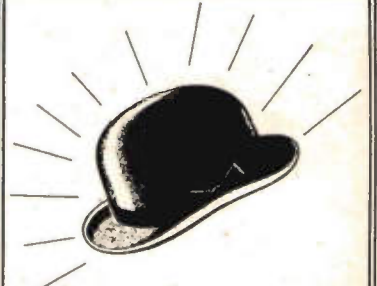

**BOWLER  
 HATTED**  
*we hope shortly  
 to serve in peace  
 as in war . . .*

**RELIANCE**  
 Manufacturing Co. (Southwark) Ltd.  
 Sutherland Rd., Higham Hill,  
 WALTHAMSTOW - E.17

Telephone : Larkwood 3245

*For*  
**Reliability**  
**SOUND**  
*Trust*  
**TRIX**



**Quality Equipment** **SOUND**

AMPLIFIERS FROM 5 to 500 WATTS  
 FOR PRIORITY WORK

**THE TRIx ELECTRICAL CO., LTD.**  
 1-5, MAPLE PLACE, TOTTENHAM CT. RD.  
 LONDON W.1.  
 TELE: MUSEUM: 5817 GRAMS & CABLES: TRIxRADIO, WESDO, LONDON

### RADIO RECEIVER CIRCUITS HANDBOOK

Containing practical notes on the Operation of Basic Modern Circuits. By E. M. Squire. A useful guide to circuits for members of the radio industry, and radio amateurs. By dealing with the receivers in stages the author has achieved the utmost clarity and conciseness. The text is liberally illustrated with circuit drawings and other diagrams. Third Edition. 6s. net.

### EXPERIMENTAL RADIO ENGINEERING

By E. T. A. Rapson, A.C.G.I., D.I.C., etc. Assisted by E. G. Ackermann. This book sets out a number of experiments and methods of measurement suitable for a three or four years' course in radio engineering at a Technical college. A few of them require rather specialised apparatus, but the majority may be carried out with standard laboratory equipment. Third Edition. 8s. 6d. net.

### RADIO SIMPLIFIED

By John Clarricoats. Provides a useful background of fundamental radio knowledge. There are many clear, interesting diagrams and chapters dealing with such subjects as Series and Parallel, the Measurement of Current, etc. Second Edition. 4s. 6d. net.

*N.B. Paper rationing means a shortage of books. Those you want may be temporarily out of stock.*

## PITMAN

PITMAN HOUSE, Parker St., Kingsway.

**EDDYSTONE**

# RADIO PRODUCTS

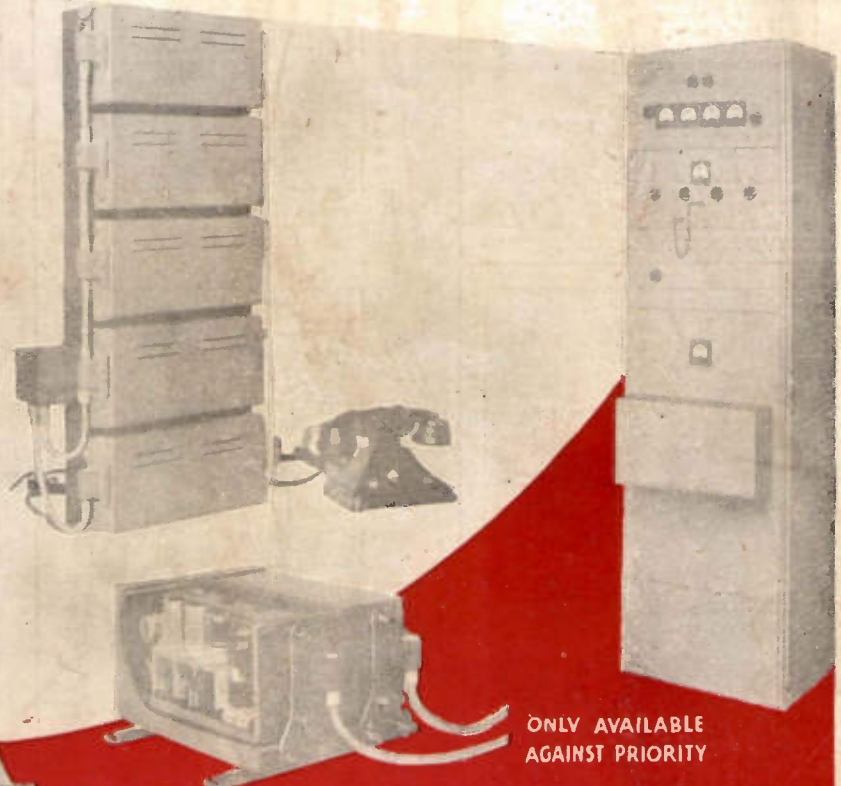

ONLY AVAILABLE  
AGAINST PRIORITY

*Manufactured by*  
**STRATTON & CO., LTD., EDDYSTONE WORKS**  
**BIRMINGHAM. Tele: PRIORITY 2231 Cables: STRATNOID' BIRM'm**  
*London Agents*  
**WEBB'S RADIO, 14 SOHO STREET,**  
**LONDON W.1. Tele: GERvard: 2089**