

Electronic Engineering

INCORPORATING ELECTRONICS, TELEVISION AND SHORT WAVE WORLD

PRINCIPAL CONTENTS

A Cathode-Ray Universal Flight Attitude Instrument

L.F. Amplification — Part 1

The Royal Signals

Design for Beat Frequency Oscillator

Magnetic Materials — Part 3

2/- NOV. 1944

GE CALLOY

RADIO CORES

An All-British product — the result of continuous research and development during the last 16 years. Made by the largest manufacturers in the industry of magnetic powders and dust cores.

*Send for
New List 1944
and let us
quote you*

SALFORD ELECTRICAL INSTRUMENTS LTD.

PEEL WORKS, SALFORD, 3. Telephones : BLAckfriars 6688 (6 lines). Télégrams and Cables : "Sparkless, Manchester"
PROPRIETORS: THE GENERAL ELECTRIC Co. Ltd., OF ENGLAND

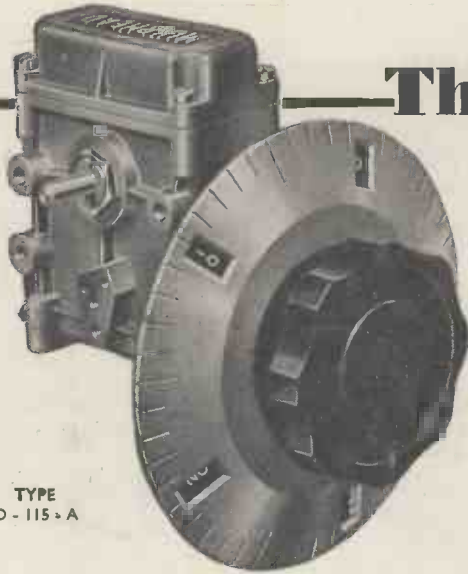

TYPE
D-115-A

These dials will interest you :-

DIALS & DRIVES

TYPES D-115-A & D-20-6A

Type D-115-A employs a 20 : 1 worm reduction gear providing a right-angle drive for two components.

Type D-206-A employs a 20 : 1 spur reduction gear providing a single in-line drive.

Outstanding features :-

- High reading and setting accuracy by means of a dial embodying an adding mechanism—effective scale length over 12 feet with 500 divisions.
- Gears spring-loaded to reduce backlash.
- Rugged die-cast construction and substantial bearings for long and continuous service.
- Shafts : $\frac{1}{4}$ in. diameter and $\frac{3}{8}$ in. projection.
- Finish : gunmetal with engraving filled white.
- Weight : 2 $\frac{1}{4}$ lbs.

Full description in Bulletins B-532-A and B-556-A

MUIRHEAD

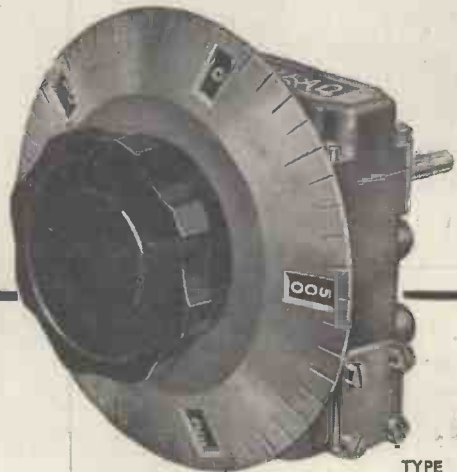

TYPE
D-206-A

MUIRHEAD & COMPANY LTD., ELMERS END,
BECKENHAM, KENT • BECKENHAM 0041 - 0042.

FOR OVER 60 YEARS DESIGNERS & MAKERS OF PRECISION INSTRUMENTS

**NICKEL-CHROME
& EUREKA (Regd.)
RESISTANCE
WIRES
AND
TAPES**

also
**MOLYBDENUM
WIRES, TAPES
& RODS
for
ELECTRIC
FURNACES,
LAMPS AND
VALVES**



**VACTITE
WIRE CO., LTD.**

19 QUEEN ANNE'S GATE
WESTMINSTER S.W.1

Telephone : WHITEHALL 2552

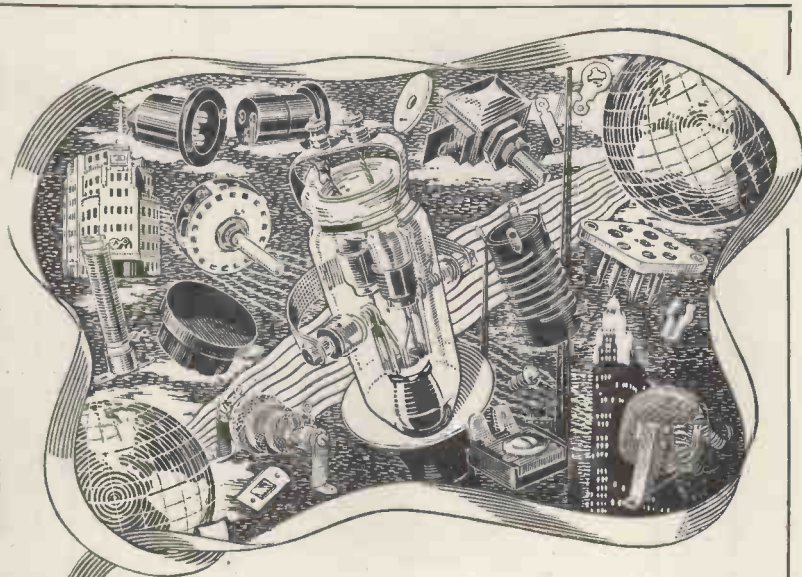

The World of Tomorrow.

JUST as the Reliability and Ingenuity of BULGIN Radio Products have been proved in the stress of War, so in the World of Tomorrow Industry can safely trust us with their Component Problems and Requirements.

The Return of Peace will find us ready to ease a large part of your production difficulties. Our Technique, with a back-ground of 21 years of experience solely devoted to the Manufacture of Essential Components, will safeguard your trade-mark.

"The Choice of Critics"

BULGIN

Regd. Trade Mark

A. F. BULGIN & COMPANY LTD.,
Radio and Electrical Component Manufacturers,
BYE PASS RD., BARKING, Essex.

Tel.: RIPPLEWAY 3474 (5 lines)

So much depends on them



"AVO" Electrical Testing Instruments are actively engaged on the fighting and factory fronts, sharing a great responsibility with a proud sense of duty and high confidence in the future.



It will therefore be appreciated by our numerous trade friends that we can only accept orders which bear a Government Contract Number and Priority Rating.

Sole Proprietors and Mfrs.: AUTOMATIC COIL WINDER & ELECTRICAL EQUIPMENT CO., LTD., Winder House, Douglas St., London, S.W.1

'Phone VICToria 3404-8

WODEN

"SOUND" BUSINESS

**OFFER
TWO UNSURPASSED
PUBLIC ADDRESS AMPLIFIERS**



WODEN "JUNIOR"
15-watt

Totally enclosed, solidly built instrument giving full 15-watts undistorted output. Impedance 8 and 15 ohms. Input for gramophone and moving coil microphone. A.C. operation.

WODEN are naturally engaged chiefly on war products, but welcome enquiries now, where licences and priorities permit, for Amplifier Equipment, Replacement Transformers, Special Power Packs etc.

WODEN "CLASSIC"
50-watt

An extremely robust and well designed totally enclosed amplifier. Gramophone and moving coil microphone inputs. Output: 5, 15 and 250 ohms. The ideal amplifying system for A.R.P. purposes, dance bands, works, and all public address uses.

PLAN YOUR POST-WAR REQUIREMENTS FOR SOUND BUSINESS WITH WODEN NOW

**WODEN TRANSFORMER CO. LTD., Commonwealth House
New Oxford Street, London, W.C.1. Phone: CHAncery 6451 (3 lines)**



BEAT FREQUENCY OSCILLATORS

**LELAND
INSTRUMENTS LTD**

—for priority requirements only, at present. Write for particulars stating frequency range required.
21, JOHN STREET, BEDFORD ROW, LONDON W.C.1
TELEPHONE: CHANCERY 8768

Miniature I.F. Transformers

DESIGNED FOR MAXIMUM GAIN AND SELECTIVITY IN THE SMALLEST DIMENSIONS

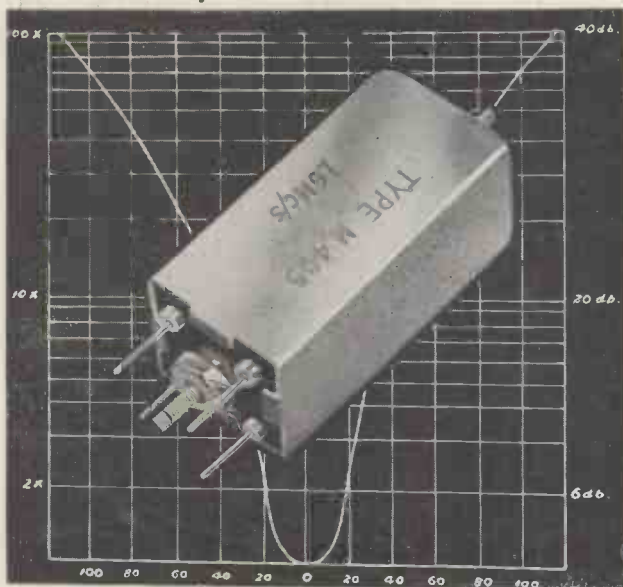

The coils are contained in enclosed pot-type iron dust cores, tuning adjustments being obtained by means of adjustable iron dust centre cores.

Fixed tuning condensers are contained inside the screening can.

Units are made with a number of variations in windings and coupling coefficients for certain circuit conditions, but five Standard types are recommended for general use.

Wartime restrictions prevent our accepting orders other than those covered by priority numbers

The illustration shows the actual size of the Unit which is provided with one hole fixing, the terminal wires being fed through insulated bushings which, in turn, prevent movement of the transformer when mounted in position.

Telephone : TOTtenham 3847-8-9.

WRIGHT & WEAIRE LTD.
HIGH ROAD, TOTTENHAM, N.17.

HIVAC

THE SCIENTIFIC VALVE

BRITISH

MADE

Specialists in

MIDGET VALVES

HIVAC LIMITED
Greenhill Crescent,
Harrow on the Hill, Middx.

Telephone: Harrow 0895.

Constant Voltage

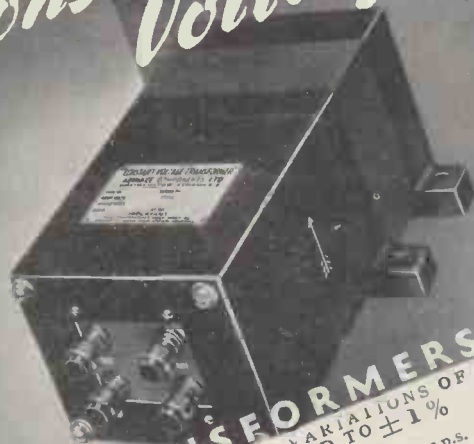

TRANSFORMERS
LINE VOLTAGE VARIATIONS OF
 $\pm 15\%$ REDUCED TO $\pm 1\%$
TYPICAL SPECIFICATION
Input Voltage ... 190-260 v. 50 c.p.s.
Output Voltage ... 230 v. $\pm 1\%$
Max. load ... 150 watts.
Input power factor over 90%
Prices on application. Write for details

ADVANCE COMPONENTS LTD.

BACK RD. SHERNHALL ST., WALTHAMSTOW, E17. PHONE: WARKWOOD 4663

WESTALITE

Rectifiers

For
D.C. POWER SUPPLIES

to operate all electronic devices requiring a steady and reliable supply of direct current from an A.C. source.

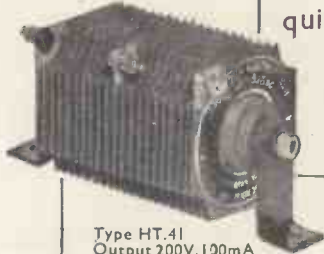

Type HT.41
Output 200V.100mA

Available with outputs from microwatts to kilowatts, there is a suitable



metal rectifier to meet the demands of any electronic application, including such purposes as H.T., L.T. and G.B. supplies to amplifiers, receivers, transmitters, oscilloscopes, etc.

WESTINGHOUSE BRAKE & SIGNAL CO., LTD.
Pew Hill House · Chippenham · Wilts.

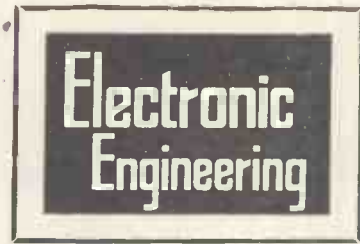

NOVEMBER, 1944

Volume XVII.

No. 201.

CONTENTS

	PAGE
Editorial—Post-war Jobs	227
Frontispiece—Valve-Makers' Delight ...	228
A Cathode-Ray Universal Flight Attitude Instrument	229
Flash-over at High Altitudes	235
Low Frequency Amplification—Part I ...	236
The Royal Signals	239
Magnetic Materials—Part 3... ..	248
Design for a Beat Frequency Oscillator ...	252
November Meetings	256
The Admittance Coefficient... ..	257
Notes from the Industry	260
X-Ray Crystallography (Summer School)	262

SOLON
INDUSTRIAL
ELECTRIC APPLIANCES

SOLON ELECTRIC
SOLDERING IRON

SOLON
ELECTRIC
INSULATION
STRIPPER

SOLON ELECTRIC
SOLDER POT

SOLON Industrial Electric Appliances are designed for practical use under factory conditions. They are robust and efficient.

The Soldering Iron illustrated is representative of a range which includes models with various types of bits suitable for a wide variety of jobs.

The Insulation Stripper provides a quick method of severing insulation neatly without damaging the conductor, by means of an electrically heated wire.

The Solder Pot maintains 1/2 lb. solder at working temperature.

Please write for Folder Y9.

W. T. HENLEY'S TELEGRAPH WORKS CO., LTD
MILTON COURT, WESCOTT, DORKING, SURREY.

CONDITIONS OF SALE—This periodical is sold subject to the following conditions, namely, that it shall not without the written consent of the publishers first given, be lent, re-sold, hired out or otherwise disposed of by way of Trade except at the full retail price of 2/- and that it shall not be lent, re-sold, hired out or otherwise disposed of in a mutilated condition or in any unauthorised cover by way of Trade, or affixed to or as part of any publication or advertising, literary or pictorial matter whatsoever.



If *your* set is fitted with Mazda Valves that do not as yet reveal the 'signs' and portents of old age — that's *fine*.

But should hard use, grim 'overtime', shocks, jolts and jars have interfered at long last with their functioning, you'll be glad to know the Government have made available, in spite of heavy Services' demands, more MAZDA Valves (of many types), viewing the maintenance of broadcast news as an essential service.

Remember, it's cheaper — and saves man-power — to have your old set 'put right again'.

Your Dealer has all details of available types, but in case of difficulty please write direct to us.

MAZDA

RADIO VALVES

PROPRIETORS :
HULTON PRESS, LTD.

Electronic Engineering

EDITOR:
G. PARR.

EDITORIAL, ADVERTISING AND PUBLISHING OFFICES, 43-44, SHOE LANE, LONDON, E.C.4

TELEPHONE :
CENTRAL 7400

Monthly (published last day of preceding month) 2/- net. Subscription Rates :
Post Paid to any part of the World—
6 months, 13/- ; 12 months, 26/-.
Registered for Transmission by
Canadian Magazine Post.

TELEGRAMS :
HULTONPRES, LUD
LONDON.

Post-War Jobs

IT is generally accepted that the radio industry will provide a large share of the opportunities for post-war employment, not only on account of the expansion of broadcasting and television, but also on account of the growth of allied fields of electronics. High frequency engineering, electro-medicine, super-sonics, electron microscopy, cinematography are only a few of the specialised branches which have their root in the thermionic valve.

These ramifications of radio should be remembered when considering the possibilities of a new career, as there is a tendency to confine the idea of radio to the manufacture and selling of large numbers of domestic receivers.

While this field is attractive, a little reflexion will show that it has its limitations. First it is an obvious one and therefore likely to attract all those who do not mind doing the obvious. Secondly, it has been open for many years before the war, and while there is always room at the top the old established ones have a good start. There are also economic questions which need not be elaborated here.

On the other hand, the allied fields offer far more tempting prospects. They are new and as yet have not been completely explored. Success depends more on the individual effort, and in many cases there may be little or no competition.

Some of the opportunities for development in the science of cinematography were mentioned by Mr. A. G. D. WEST in his Presidential Address to the British Kinematograph Society last month, and it is noteworthy that these are all connected with the electronic side of motion picture technique.

The problems requiring investigation include theatre acoustics, uniformity of sound reproduction, uniform screen brightness, maintenance of quality in recording, and improvements in miniature (16 mm.) film.

MR. WEST also visualises the future for all-electronic equipment in theatres showing large-screen television and an increase in electronic methods of measurement and control.

The cinema industry will require capable designers, research engi-

neers, and high-class technicians, from cameramen to projectionists, to do justice to the improved equipment which will be available ten years or so after the war.

This is quoted only as an example of one of the fields which will be open to Service people who have had their interest stimulated by contact with radio equipment during the war, or who perhaps contemplated radio as a career before the war altered their future.

It is not without significance that the Wireless Section of the Institution of Electrical Engineers recently altered their title to the Radio Section, and stated that all aspects of radio and electronics were within their scope.

Radio is not just the business of making, selling and servicing broadcasting equipment. It is an industry which may soon outstrip its parents—electrical engineering and physics. It is many years since the electrical engineering profession was mainly concerned with bells and telegraphs and the radio engineer nowadays can be something more than an expert in receiver design.

Valve-Makers' Delight

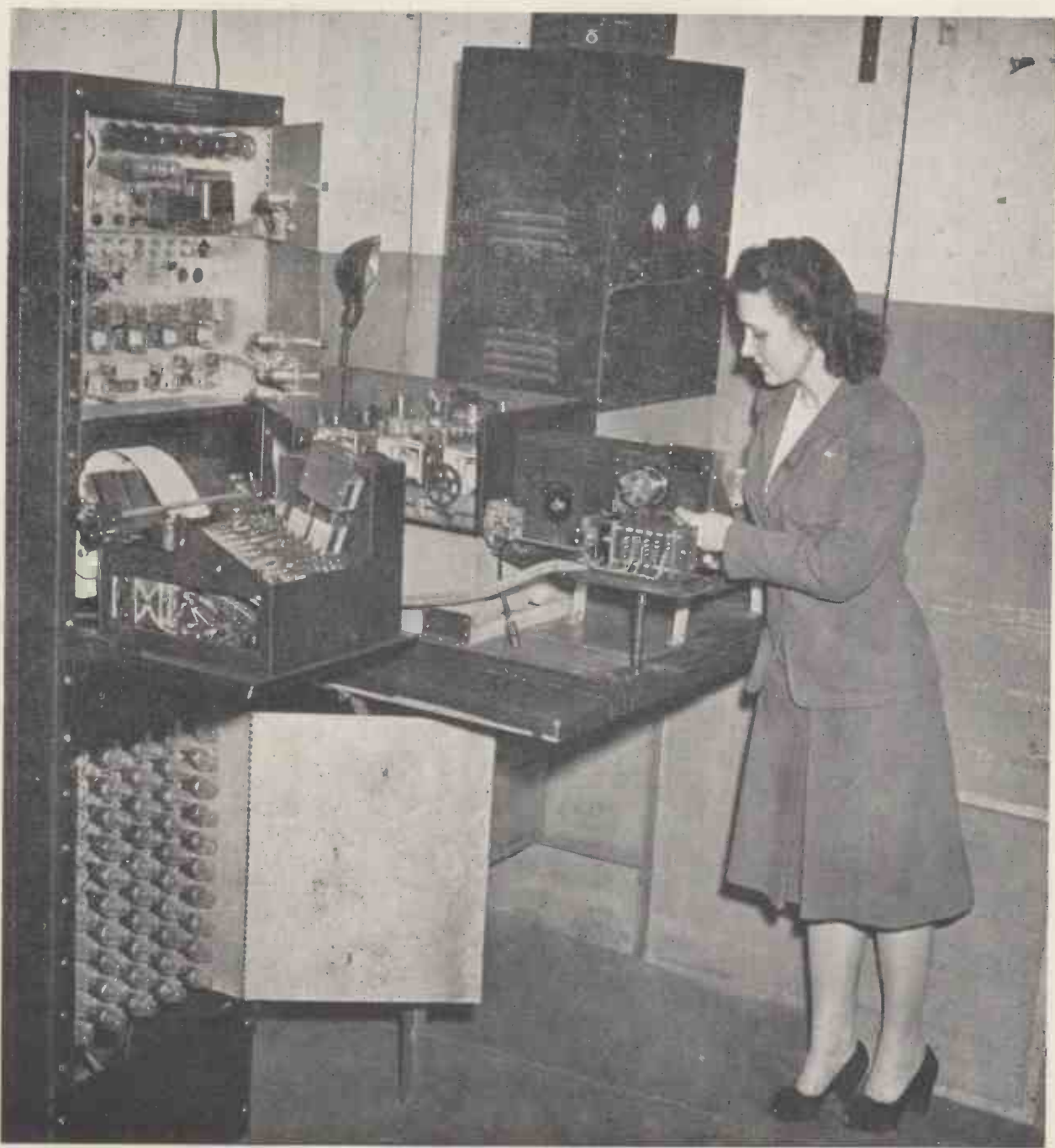

AN automatic frequency calibrator, designed by the Philco Corporation of America. It supplies a source of standard frequencies against which a frequency meter is calibrated. The dial of the frequency meter is continuously driven and a sharp pulse is generated each time the zero beat occurs with the standard signal. The dial readings are automatically recorded and tabulated. The equipment requires no less than 126 valves and has reduced the production cost of one type of apparatus by nearly £300,000.

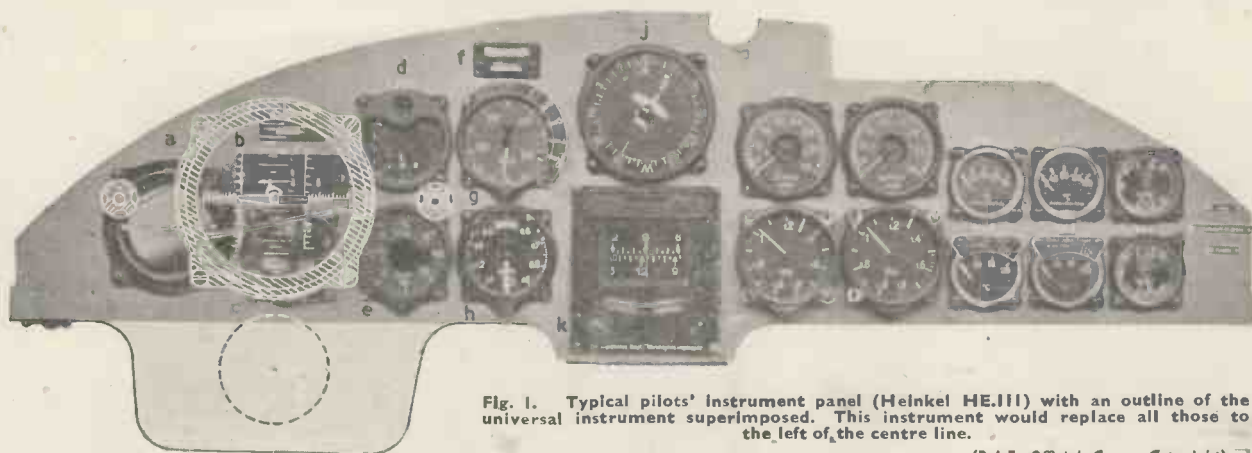

Fig. 1. Typical pilots' instrument panel (Heinkel HE.III) with an outline of the universal instrument superimposed. This instrument would replace all those to the left of the centre line.

(R.A.F. Official Crown Copyright).

A Cathode-Ray Universal Flight Attitude Instrument

By F. POSTLETHWAITE, Ph.D., M.Eng.

A proposal for a novel form of electronic aircraft instrument which would simplify civilian flying.

UNLIKE so many articles prepared at the present time, this does not deal with a device possessing potential war value, but attempts a prophecy in the post-war realms of civil aviation; describing a possible method of simplifying aircraft instrumentation. During the war years aviation has made gigantic strides, and inevitably instrumentation has become more and more complex. In the aircraft flown in the 1914-18 war, instruments were conspicuous by their absence, and pilots claimed that they flew by instinct and by the seat of their trousers. They flew, however, only on certain days when the weather was ideal, whilst flying under conditions of poor visibility was practically unknown and was considered extremely hazardous. In a modern aircraft the fighter pilot is faced with a bewildering array of instruments, switches, warning lights, etc., whilst in large aircraft attempts are being made to reduce the demand made on the pilot, and only those instruments, directly connected with flying the aircraft are placed on his instrument panel; all others dealing with the various services, engine speeds, booster air pressures, coolant temperatures, etc., being situated on the flight engineer's instrument-panel. Some idea of the complexity of a pilot's instrument panel can be

gathered from Fig. 1 which shows a panel taken from a Heinkel H.E.III; a twin engine type of aircraft. The flight instruments, reading from left to right and from top to bottom, are:—

- (a) An Artificial Horizon of the Sperry type.
- (b) An Indicator of the magnetically operated shutter type, for showing that the automatic steering circuit is made.
- (c) A Steering Indicator.
- (d) A Bank and Turn Indicator.
- (e) A Rate-of-Climb Indicator.
- (f) An Indicator similar to (b) which shows when the pressure-head heater circuit is switched on. (The pressure-head is an essential part of the Air Speed Indicator.)
- (g) An Air Speed Indicator.
- (h) An Altimeter.
- (j) A Compass Repeater.
- (k) A Directional Gyroscope.

The other instruments to the right of the centre line are not directly concerned with the flight attitude of the aircraft, being, port and starboard engine tachometers and boost gauges, engine oil and radiator temperature indicators, and combined fuel and oil pressure gauges. The flight instruments shown are by no means complete since they do not include indicators for the wing flaps and the retractable

undercarriages, fuel contents gauges or low level warning devices, or indicators for giving warning when ice forms on the leading edges of the wings.

In the development of most machines it seems that a period of complication alternates with one of simplification. The boom of civil aviation that must come in days of peace will certainly require some simplification of present day aircraft instrumentation, but the owner-flier will certainly demand the same all-weather performance that he has grown accustomed to with his car, and this cannot be obtained by omitting essential flight instruments; it can only be achieved by conveying the same flight intelligence to the pilot with fewer instruments. One of the most useful instruments, particularly under conditions of poor visibility, is the Sperry Artificial Horizon, and it is considered that a universal flight attitude instrument might be constructed on somewhat similar lines capable of conveying much more flight intelligence.

The Sperry Artificial Horizon

This Artificial Horizon is essential for blind flying, and it is in universal use. It is unique in that it has no pointer or graduated scale; its information being conveyed by pictorial representation. It is a well known fact

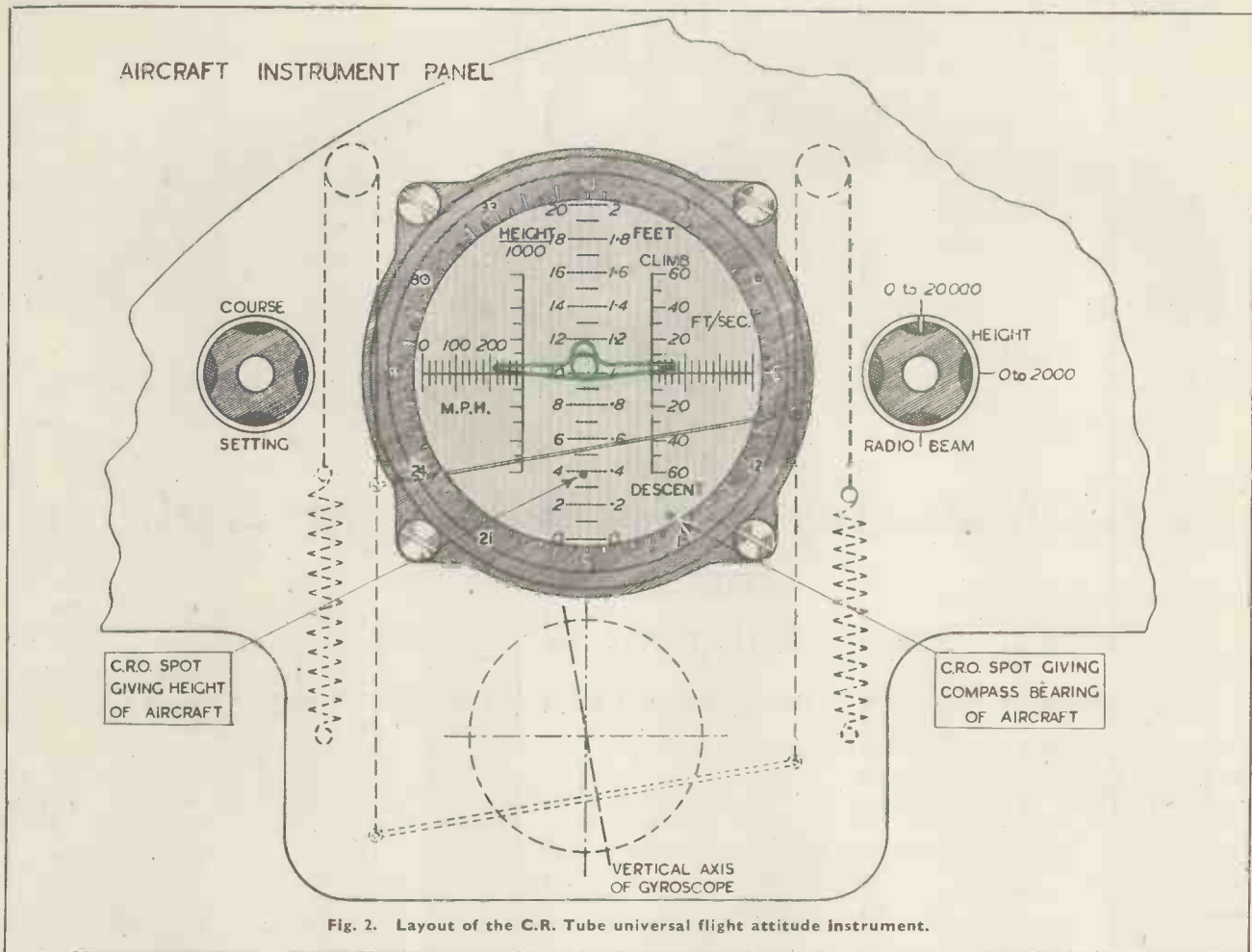

Fig. 2. Layout of the C.R. Tube universal flight attitude instrument.

that pictures convey the maximum intelligence with the minimum of effort on the part of the observer. Owing to its importance, the instrument is always placed in a prominent position on the instrument panel, usually directly in front of the pilot. One location is shown in Fig. 1, whilst its mechanism is shown in simplified form in Fig. 4. An outline or silhouette of an aircraft occupies a central position on the horizontal diameter of the cover glass. The instrument contains a vertical gyroscope carried in suitable gimbals; its erection being affected by the action of gravity. When the aircraft nose moves up or down the axis of the gyroscope remains truly vertical whilst an horizon bar situated behind the cover glass moves up or down in sympathy but in the opposite direction. Also, when the aircraft banks either to right or left the horizon bar appears to tilt in sympathy the opposite way; this effect being due to

the horizon bar being held at right angles to the vertical axis of the gyroscope under all conditions.

Perhaps the easiest way to understand the operation of the device is to imagine that its dial is a circular hole cut in the instrument panel, and that the horizon bar is actually the real horizon visible through the hole. It must further be imagined that the aircraft silhouette is a view looking on the rear of the machine being flown by the pilot. He then manipulates his controls so that the silhouette lies along the horizon bar. It will therefore be seen that the Artificial Horizon indicates whether the nose of the machine is pointing up or down, and also whether the aircraft is flying level or banked.

The silhouette does not change its shape or position on the dial; if it could be made to perform these functions then the new instrument

could be made to carry more flight intelligence than the one now in use. Before the war the technical press stated that the Sperry Co. were developing a new flight instrument making use of a cathode-ray tube and called the "Flightray." The writer of this article does not know any details of this instrument, and therefore the suggestions made in this note are believed to be original. The use of a cathode-ray tube to present a picture of the aircraft flight attitude is attractive in many ways, and one advantage accruing from the war will be the breaking down of the prejudice against the use of electronic apparatus in aircraft.

Advantages of the Cathode-Ray Tube

It is a comparatively simple matter to produce either an outline or a silhouette of an aircraft on the screen of a cathode-ray tube, and, further, when it is once produced it can readily

be moved to any part of the screen. The size of the picture is easily controlled and further detail can be added to the picture at will. To accomplish these ends both alternating and direct voltages can be fed to the deflector plates, and use can be made of spot modulation. At the present time an instrument panel is a complicated tangle of electric, hydraulic, and pneumatic instruments and their cables and pipes. It is not easy to find positions for all the instruments required, and due to the difficulty of making all connexions flexible the spring mounting of the instrument panel necessary to guard delicate mechanisms against aircraft vibration presents many problems. With a cathode-ray tube as the universal flight attitude indicator the matter is much simpler since its operation depends solely on electrical signals which can be fed along a small multi-core cable.

The cathode-ray tube can be mounted in a convenient position on the instrument panel, as shown in Fig. 1, and the ancillary apparatus can be located at more convenient positions in the aircraft where, if necessary, they can be insulated against the effect of vibration. When an automatic pilot is incorporated in the aircraft it duplicates in its mechanism many of the flight instruments required on the pilot's panel, and thus with suitable modification this device could be made to supply much of the flight intelligence to the cathode-ray tube. If an automatic pilot is not fitted it would be necessary to use a master unit containing many of the instrument mechanisms at present placed on the panel. Such a master unit possesses advantages over the present method since it would be more economical to make and more convenient to service. Since the various pieces of intelligence would be picked off by electrical devices it would not be necessary as at present to use systems of levers to obtain relatively large displacements; it would be more convenient to use electronic amplifiers.

A further advantage of the cathode-ray tube is the ease with which it can be used to indicate the reading of a distant instrument. At the present time use is made of moving coil instruments and repeaters, but these require skilled workmanship for their construction and they are relatively expensive to make. It would of course not be economical to replace each of these by a cathode-ray tube, but in the present proposal it is only intended

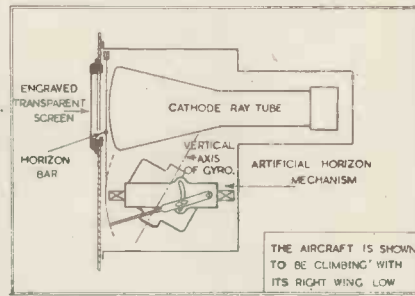

Fig. 3. Side view of the proposed C.R. Tube flight instrument.

to use one tube to perform many functions.

Proposed C.-R. Tube Universal Flight Attitude Instrument

The proposed instrument is shown in Figs. 1, 2, and 3. It will be seen that a somewhat larger dial is shown than for any of the instruments in Fig. 1. It is not proposed to make the instrument perform the functions of the instruments not directly concerned with the flight attitude of the aircraft. As already explained, these are looked after by the flight engineer on large machines, whilst for the owner-flier type of aircraft used after the war thermostats and other automatic devices could replace them. Figs. 1 and 2 show the cathode-ray spot tracing out the outline of an aircraft. A method of producing this outline, and also the production of a picture or silhouette of an aircraft, will be detailed later. As shown, the aircraft has its undercarriage retracted and its landing flaps in the up position. The part of the apparatus used to produce the aircraft outline would include means for adding either the flaps or undercarriage or both to the outline shown. Switches could be fitted near the flaps and undercarriages and arranged to function automatically when these parts of the aircraft are operated.

An Artificial Horizon mechanism is shown placed below the C.R.O. with a second horizon bar arranged to move between the cover glass of the universal instrument and the cathode-ray screen. With the aircraft outline method suggested in this article it is very convenient to arrange this mechanism close to the tube as shown, but if use is made of television technique the mechanism would be located in the master unit, and the horizon bar would form part of the picture on the screen. Otherwise, the mechanism would function exactly as it does in the standard Sperry instrument.

If the air-speed device is made to vary the gain of the outline signal amplifiers the size of the outline on the screen would vary with aircraft speed. It fits better into the scheme to arrange for an increase in speed to produce a smaller diagram than to arrange for the converse. The current air-speed indicator functions in conjunction with a pressure head. It suffers the drawback that it measures air and not ground-speed. Ground-speed instruments have been suggested, making use of a radio beam and the Doppler effect, and such a device would be ideal to incorporate in the flight attitude instrument under consideration.

Although the position of the horizon bar gives some indication as to whether the aircraft is climbing or descending it gives no measure of the rate at which it is doing one or the other. The Rate-of-Climb instrument measures this vertical velocity by virtue of the changes in atmospheric pressure; it could also be obtained from an attachment to the Altimeter. An electrical pick-up unit and amplifier could convert the output of this instrument into a biasing voltage, which when fed to the vertical deflector plates of the C.R. tube would move the aircraft outline in the appropriate vertical direction with the displacement being a direct measure of the vertical velocity of the aircraft. A suitable scale could be engraved on the cover glass as shown in Fig. 2. If the cover glass were illuminated around the edge the engraved impressions could be made to scatter light and they would then stand out as clearly as the aircraft outline.

Unless an aircraft is banked when it makes a turn it will tend to skid, and unless the bank is the correct one the pilot will tend to move sideways in his seat. The Bank and Turn Indicator is used to enable perfect banked turns to be made. The part of the indicator dealing with the bank consists of a metal ball contained in a curved transparent tube, and for a correctly banked turn the ball remains in its central position. A gyroscope with its axis horizontal is used in the turn section of the indicator. In a turn the case of the instrument moves relative to the gyroscope thus transmitting an indication of the deflection of the gyroscope axis to the pointer. Control is effected by means of a light spring attached between the gyroscope frame and the front disk on the gimbal ring. Rheostat type pick-up units could easily be incorporated in these movements to operate the universal instrument. By the application of suitable biasing

voltages to the horizontal deflector plates of the C.R.O. the aircraft outline could be made to move either to the right or left according to the direction of the turn. It is not necessary to measure this sideways movement since indications of the direction and rate of turn are sufficient. A little ingenuity must be used to indicate a correctly banked turn, but the convention used must be such that the indication appeals immediately to the imagination. The inclination of the horizon bar will already show if the aircraft is banked, but it will not indicate whether the machine is under or over-banked. It is suggested that a deliberate distortion of the aircraft outline can be made to supply this missing information. Thus if the bank is correct the two wings would be the same length, but if the aircraft were under or overbanked the wings would be of different lengths, and therefore the centre of the aircraft would appear to move in the sideways direction sensed by the pilot. A simple method of introducing this distortion will be described later in the article.

It is still necessary to indicate the height of the aircraft and its compass bearing. Since the demand on the C.R. spot in tracing out the aircraft outline does not compare with the demand made on it in depicting a television picture, it is a comparatively simple matter to make it trace out two indicating spots in addition to the outline. One of these spots would be used to indicate the height of the aircraft on a vertical scale running up the centre of the cover glass, whilst the other would lie on a circle near the edge of the screen and indicate the compass course of the aircraft by its position relative to the circular scale surrounding the screen. In many aircraft the magnetic compass is situated near the tail of the aircraft where the earth's magnetic field is comparatively free from distortions due to the many ferrous parts such as engines and retractable undercarriages, and due to stray fields from the many electrical devices, and the aircraft heading is transmitted to devices on the instrument panel. With the new instrument the compass could transmit the heading to the C.R.O. The heading and height spots are shown in Fig. 2, and a knob is shown for setting the course.

The height of an aircraft is generally obtained with the aid of an Altimeter; an instrument which measures the prevailing atmospheric pressure. Unless the barometric pressure at the

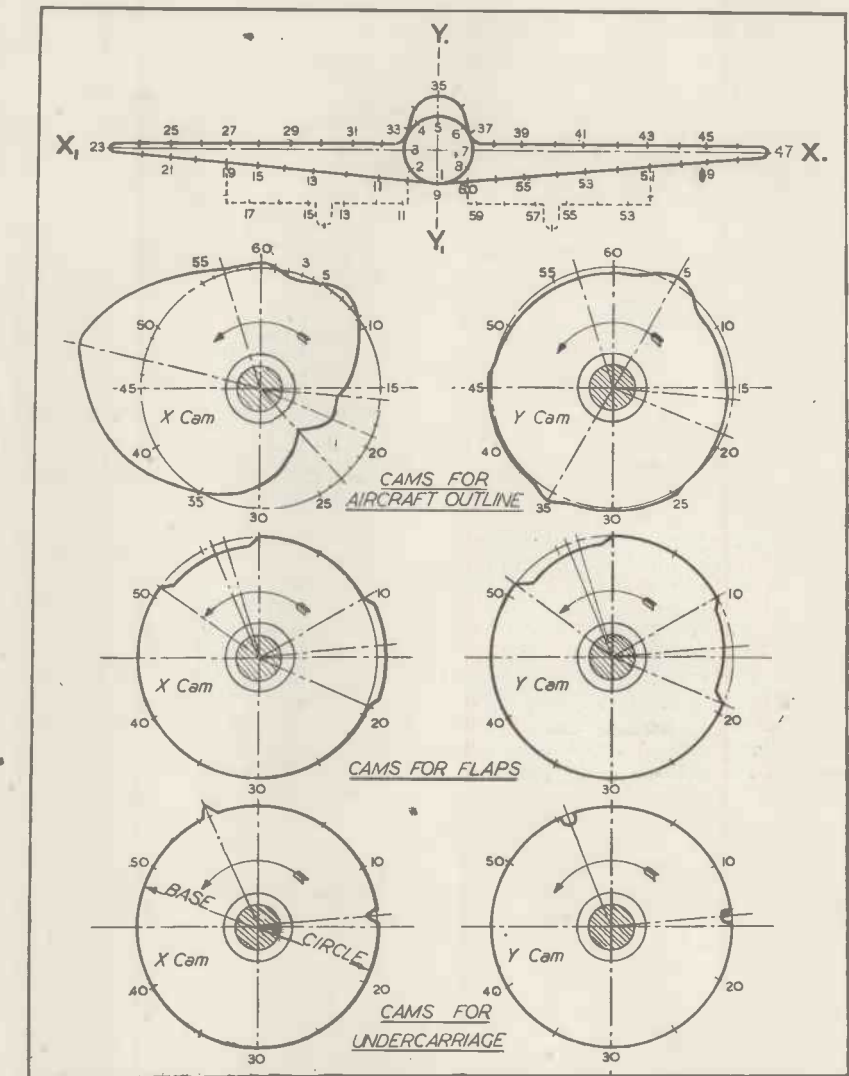

Fig. 4. Cams required for producing the aircraft outline.

aerodrome is known considerable errors may result at low altitudes, where accuracy is desirable. Radio altimeters have been suggested since they can be made inherently more accurate than the current instrument, and there is no doubt that these will be in wide use after the war. A radio altimeter, probably working on radio reflexion, would fit in well with the general scheme for the universal flight attitude instrument. The second knob on the right of Fig. 2 is intended to enable two sensitivities to be used for the altimeter, whilst the third position of the knob could enable the aircraft outline to be used with a blind approach system such as the Lorentz. For this system the position of the outline on the screen could indicate the actual position of the aircraft relative

to the landing beam. If the outline were in the middle of the screen the aircraft would be heading down the beam on the right contour of signal strength.

So far, all the flight intelligence required has been catered for in an easily understood manner without using modulation of the C.R.O. spot, but later in the article two suggestions are made for making use of this modulation, namely for warning of ice accretion on the wings and for warning that only a limited amount of fuel is left.

Means for Producing the Aircraft Outline or Silhouette

Perhaps the obvious way to produce a picture of an aircraft on the screen of the C.R.O. would be to make use of

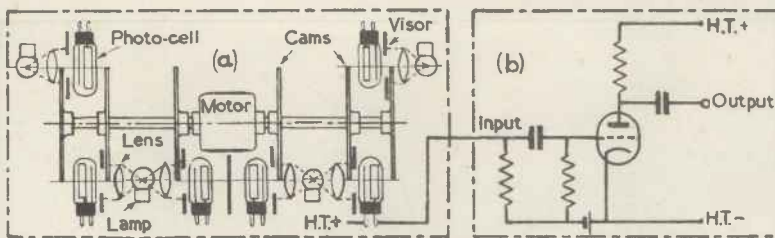

Fig. 5. Cam and circuit arrangement for producing the aircraft profile.

existing television techniques. It would be necessary to scan a silhouette in order to show a picture of an aircraft on the screen of a C.R.O. Movement of the picture up, down, and sideways could be produced either mechanically by moving the silhouette in the appropriate directions, or electrically by the application of suitable biasing voltages to the deflector plates of the tube. The size of the aircraft on the screen could be controlled by varying the scanning voltages applied to the tube, or by arranging to scan a shadow of the silhouette; in this method the size of the shadow would depend on its distance from a lamp. It would be relatively easy to arrange for the horizon bar of the artificial horizon to come within the scanned area, but the introduction of flaps and undercarriages to the silhouette would present some difficulty. In effect this method would require the use of a model aircraft complete with moveable flaps and retractable undercarriages for the purpose of scanning. It is considered, however, that there is a much better method of producing a picture of an aircraft on the screen than one based on television technique.

A preferred method consists of means of making the C.R. spot trace out an aircraft outline on the screen. This outline would be brighter and more distinct than one produced by spot modulation and scanning. If suitable variations of voltage are applied to the deflector plates it is possible to trace out any desired outline. The problem thus resolves itself into the production of the appropriate voltages. A suitable aircraft outline is shown in Fig. 4, from which it will be seen that position of the spot is determined by two dimensions, namely the Y ordinate and the X abscissa. If the spot is made to move around the outline at constant speed the diagram will possess the same brilliancy at all points. One method of producing the required deflecting voltages is shown in Fig. 5. A series of cams suitably shaped rotate and control the amount of light passing from the lamps past the visors to the photo-cells. Fig. 5 (a)

shows the arrangement of the cams and photo-cells, whilst Fig. 5 (b) gives the circuit diagram for one of the amplifiers. These diagrams are self-explanatory, but perhaps some comments are required regarding the shaping of the cam profiles shown in Fig. 4. Six cams are required; two for producing the aircraft outline; two for adding the flaps, and two for adding the undercarriage wheels. The aircraft outline has been divided into sixty equal lengths and each cam had been divided into sixty equal angles; each position being numbered for easy reference. The radial distances measured from the base circle of each cam varies as the horizontal distance of that position from the YY_1 axis for the X cams, and as the vertical distance of the position from the XX_1 axis for the Y cams. In operation the outputs from the cams are added arithmetically to produce the deflector plate voltages necessary for tracing out the required aircraft outline on the screen.

The aircraft outline is distorted to introduce bank by the use of a pentode for the amplification of the signal produced by the X cam of the pair required for the aircraft outline. Use is made of third harmonic distortion as illustrated in Fig. 6. If the aircraft is correctly banked the ball of the bank indicator is in its central position and the pentode is biased as shown in Fig. 6 (b). If, however, the aircraft is under

or overbanked the bias on the valve is altered due to the ball of the bank indicator being displaced from its central position, and the conditions shown in Fig. 6 (a) and (c) are produced. It should be noted that the distortion shown in Fig. 6 (a) holds for both an overbanked turn to the left and for an underbanked turn to the right, but no confusion results since the position of the horizon bar shows clearly which way the aircraft is banked. A side slip of the aircraft causes the same distortion as an incorrect bank, but this causes no confusion since the aircraft is not turning during this manoeuvre and hence the aircraft profile is not displaced to either side of the screen.

The Complete Cathode-Ray Tube Flight Attitude Instrument

A block diagram of the complete instrument is shown in Fig. 7. The output from the magnetic compass will consist of two potentials which when fed to the C.R. tube will position the spot near the scale surrounding the screen. The aircraft profile apparatus and the modified automatic pilot equipment have already been discussed in sufficient detail for their functioning to be understood. The rotary switch is required so that the various signals to the C.R. deflector plates are fed one after the other, *i.e.*, the aircraft outline is first traced out on the screen in a position fixed by the bias voltages applied to the plates, then the spot jumps to indicate the compass bearing, and finally the spot moves to indicate the height of the aircraft. The sequence of operation is sufficiently fast to cure flicker. When ice forms on the leading edges of the wings a simple device can be used to increase the brilliancy of the spot as it traces out the upper surfaces of the wings, and if necessary the spot can be dimmed as it traces out the lower edges

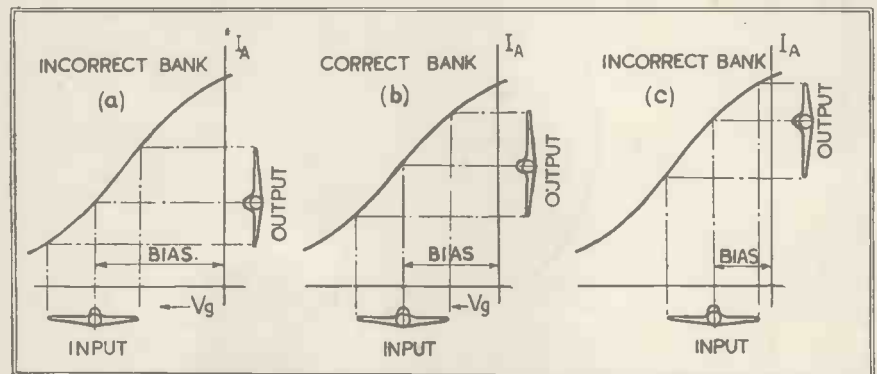

Fig. 6. Means of introducing "bank" to the aircraft profile.

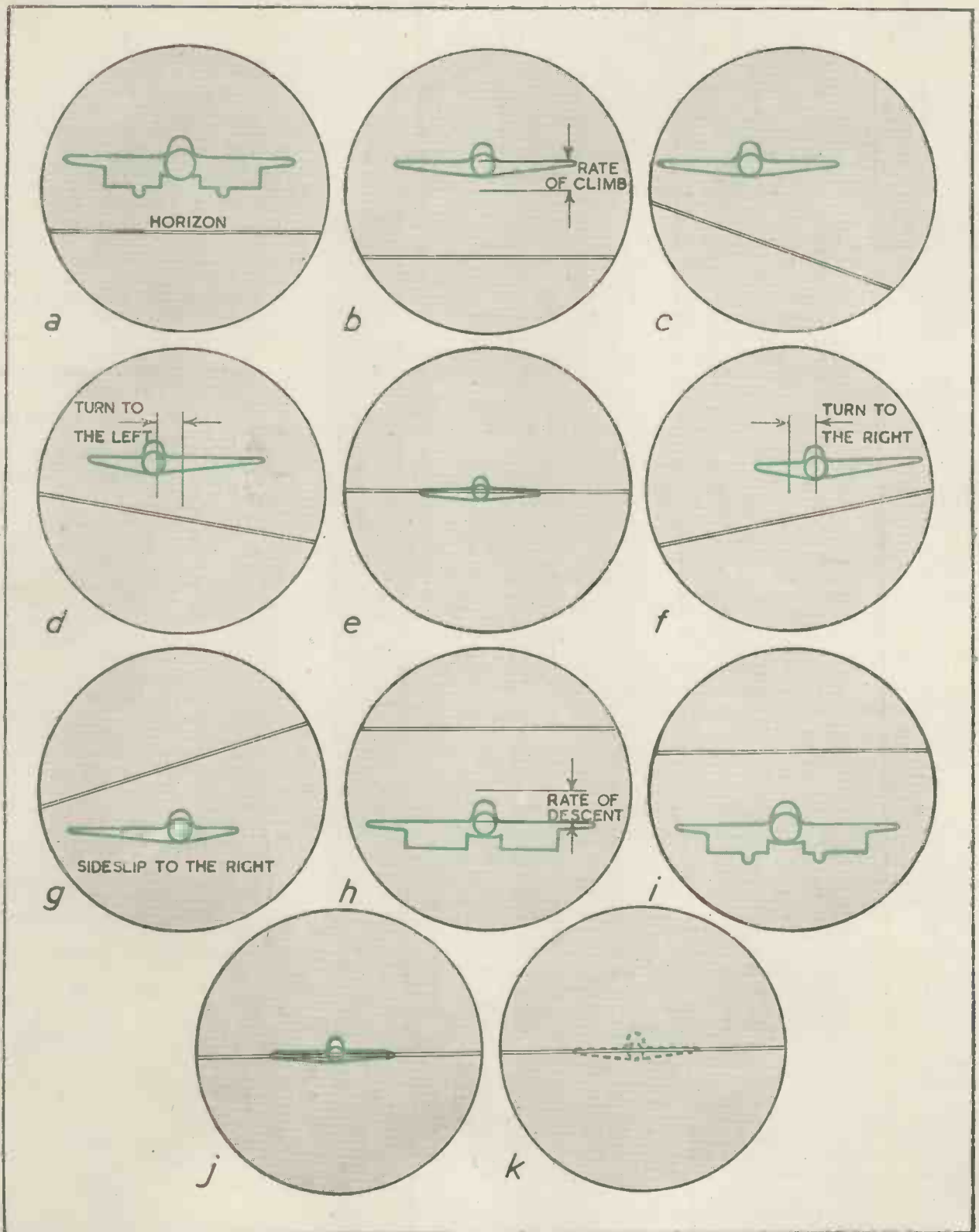

Fig. 8. Various attitudes and conditions of flight of aircraft.

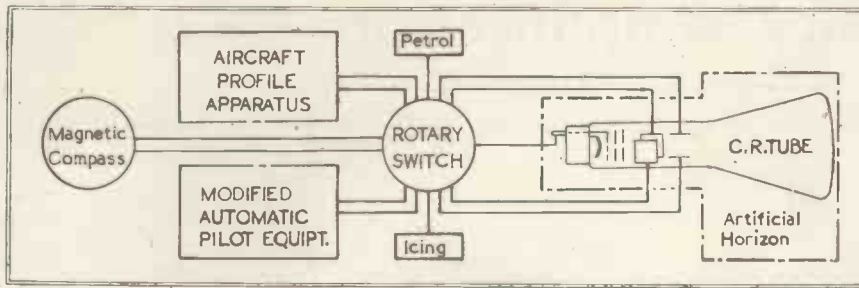

Fig. 7. Block diagram of the C.R. Tube universal flight attitude installation.

of the wings. The diagram can also be made to appear as a number of dots if a low level warning device fitted to the fuel system is made to switch the output of an oscillator to the modulating grid of the cathode-ray tube.

Typical Indications shown by the Instrument

A typical series of indications minus the indications of heading and height are shown in Fig. 8. They are as follows :—

(a) Aircraft flying straight ahead with flaps and undercarriages lowered. The aircraft is flying at a com-

paratively slow speed, and climbing at a rate which can be read off a scale. Further, the nose of the aircraft is inclined upwards, but the wing tips are parallel to the horizon.

(b) The aircraft speed has increased, probably due to the flaps and undercarriages being raised. It is flying straight ahead and climbing, but the inclination of the nose has increased.

(c) As well as climbing with the nose of the aircraft inclined, a correctly banked turn to the left is being executed.

- (d) The aircraft is performing the same manoeuvres as for (c) but the pilot has overbanked the machine.
- (e) The aircraft is flying level and on course at a comparatively high speed.
- (f) As well as climbing with the nose of the machine inclined, the aircraft is making an underbanked turn to the right.
- (g) The nose of the machine is pointing down while descending at a rate which can be read off a scale. The aircraft is also side-slipping to the right.
- (h) The aircraft has lowered its flaps and is descending.
- (i) In addition to performing the same manoeuvres as for (h) the undercarriages have now been lowered.
- (j) In addition to the conditions for (e) ice is forming on the wings.
- (k) In addition to the conditions for (e) the petrol has reached a low level.

The writer wishes to thank the authorities for permission to publish this article, but accepts full responsibility for all the ideas expressed.

Flash-Over at High Altitudes

The Influence of Atmospheric Conditions on the Insulation Strength of high voltage systems particularly at high altitudes

Translated abstract from "Archiv. f. Electrot." Vol. 36 No. 11. p. 629.

THE flash-over voltage of insulation and point spark gaps depends on the type of electrical stressing (i.e., low frequency A.C. voltage, impulse voltage, transients with superposed medium frequency A.C. voltage, etc.) together with the relative density and absolute humidity of the air at the gap. Taking these two factors separately, it is found that the A.C. flash-over voltage and impulse voltage of relative long duration vary directly as the relative density. For short-time impulse voltages, however, the density variation is less rapid.

If $k=1$, V/V_0 varies directly as the density. The flash-over voltage also increases with increase in the absolute humidity of the air. Taking 11 gm/m^3 as the standard moisture content, the relative flash-over voltage decreases by about 6–17 per cent. for dry air, depending on type of gap and kind of stress.

Similarly, if the moisture content is increased to 20 gm/m^3 , the flash-over voltage increases by 4 to 13 per cent. For short flash-over times, these effects are, however, considerably reduced.

For normal altitude conditions, the flash-over A.C. voltage and impulse voltages with discharge times of the order of $10 \mu\text{s}$ is decreased to .87, .76 and .67 times the ground level value for altitudes of 1,000, 2,000 and 3,000 m. respectively. These values can fluctuate by as much as ± 11 per cent. at ground level, leading to a corresponding variation at altitudes. Thus, at 3,000 m. for example, the

ratio of the A.C. flash over to normal ground level value which normally amounts to .67 as given above may vary from .6 to .8 with abnormal weather conditions.

Both the normal and range of flash-over, at high altitudes are lower if the flash-over period is short enough. Thus with $\tau=1 \mu\text{s}$, the total decrease in the flash-over voltage from standard ground level value is less than 5 per cent. for an altitude of 6,000 m., the range due to abnormal weather conditions being only ± 2 per cent.

It appears that the decrease in flash-over voltage associated with altitude can be allowed for in present day apparatus for altitudes up to 3,000 m. by fitting insulators belonging to the next higher supply voltage series (as tabulated in the standard specification).

Parallel spark gaps fitted to apparatus will have to be adjusted so that the minimum 50 per cent. flash-over impulse voltage rating at present required for ground and 1,000 m. operation is increased by $7\frac{1}{2}$ per cent. for each 1,000 m. in excess of this altitude.

If V_0 = flash-over voltage at ground level (relative density $\delta=1$).

V = do. at relative density:

we have

$$V = [1 + k(\delta - 1)]V_0$$

where k is a function of the flash-over time τ and is given in the following table:—

τ (μs)		1	2	3	6	8
Impulse wave	1/50 μs	.25	.45	.60	.90	1.0
do.	1/5 μs	.25	.35	.45	.50	.50

Low Frequency Amplification—Part I

By K. R. STURLEY, Ph.D., M.I.E.E.

Introduction

THE range of frequencies, which must be faithfully reproduced by a low-frequency amplifier, depends on the purpose for which the amplifier is to be used. For satisfactory audio frequency reproduction a range from 50 to 10,000 c/s. is adequate though for high fidelity reproduction a range from 30 to 20,000 c/s. is required. It is claimed that by extending the frequency range down to 20 c/s. increased realism is obtained, but the degree of improvement will also be determined by the characteristics of the loudspeaker, which must have a large diaphragm, adequate baffle area and free suspension. An output transformer with a high primary inductance (its reactance at 30 c/s must be at least ten times the reflected impedance of the speaker speech coil across the primary) is also an essential. For television reception the amplifier following the vision signal detector requires a range from about 15 to 2,000,000 c/s. Assuming that the D.C. component is restored at the output, low-frequency distortion requirements are more stringent in a vision frequency amplifier than in an audio frequency amplifier because the shape of the input wave must be faithfully reproduced at the output. As long as the amplitude ratios of the frequency components in the output wave are very nearly equal to the ratios in the input wave, the shape of the output from an A.F. amplifier need not correspond exactly with that of the input. When designing an amplifier with particular reference to very low frequencies, we may not be able to ignore the effect on high frequency response of the large physical dimensions of the coupling capacitances which may be needed. Large dimensions mean a large stray earth capacitance and this limits the high frequency response. Limitation of high frequency response causes distortion of input voltage transients having very steep leading or trailing edges. An example of this is provided by the television transmission of the half-white, half-black picture of Fig. 1a. The voltage wave corresponding to this has a fundamental frequency equal to a line frequency (10,120 c/s. according to English pre-war standards) and a square shape as shown in Fig. 1b. Theoretically, it has an

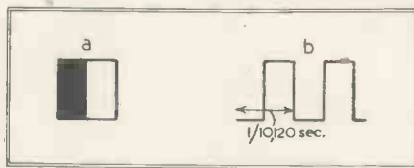

Fig. 1. A half-black half-white television screen and the waveform of the voltage produced.

infinite number of harmonic frequency components, but in practice the square wave shape is sufficiently closely approached by distortionless amplification up to the 20th harmonic, *vis.*, 202,400 c/s. Fine picture detail calls for the amplification of still higher frequencies, and stray capacitance, which causes loss of amplification and phase shift of the higher frequency components, must be reduced to its lowest possible value.

Amplification of very low frequencies is needed for certain types of electromedical apparatus, thus an amplifier for electrocardiographs⁶ needs to have a satisfactory response from about 5 c/s., and for electroencephalography⁷ a frequency range from 1 c/s. is required. Fortunately this type of apparatus need not, as a rule, have a very extended high frequency range so that low frequency design can be carried out without the stray capacitance limitations imposed in the case of amplification of the vision signal of a television programme. In many instances when very low frequency response is required the high frequency range of this type of apparatus is deliberately curtailed so as to avoid noise and possible self oscillation of the amplifier due to high frequency feedback. D.C. amplification can be employed, but A.C. amplification is preferred in spite of the problems caused by loss of voltage and phase shift in the coupling and self-bias capacitances. The disadvantages of D.C. amplification are that a more complicated H.T. system results, and stability of performance is much more susceptible to supply voltage variations.

The purpose of this series of articles is to discuss the characteristics needed of an amplifier with special reference to low frequencies down to 1 c/s., not forgetting, however, the effect which the low frequency design may have on the performance at high frequencies.

The Characteristics Required of a Low Frequency Amplifier

The most important characteristic required of a low frequency amplifier is that it shall reproduce faithfully at its output the shape of the input wave without adding noise or hum voltages. This statement may be qualified in the case of an audio frequency amplifier to "shall reproduce at its output the component input frequencies (and no others) in the same amplitude proportions as exist for the input signal." The undesirable hum voltages are generally associated with the valve heater and H.T. supply, and they can be reduced to negligible proportions by adopting special forms of heater and electrode construction, and by careful smoothing of the H.T. supply. In special cases when the input signal is very small and considerable amplification has to be employed, the H.T. supply may be stabilised by using a gas-discharge valve to preserve constant output voltage, and the heaters of the first or first and second valves in the amplifier may be supplied from smoothed rectified A.C. or from an accumulator. The latter is undesirable and should be avoided because of maintenance troubles. H.T. and L.T. dry batteries may be employed when portability is essential, but care must then be taken to ensure that the batteries are in good condition; fluctuations of H.T. or L.T. voltage (due to faulty or run-down cells), which are too small to show on a D.C. voltmeter, can cause appreciable noise in a high gain amplifier. Noise voltages are generally due to thermal agitation of the electrons in the conductors forming the first circuit, and also to shot noise from the valve. The former are reduced by having a low resistance input circuit to the amplifier and by preventing excessive temperature rise of the conductors; the latter are reduced by having the highest possible ratio of mutual conductance to anode current, and anode to total current, *i.e.*, the valve should have a high mutual conductance and anode current cut-off at a low negative bias, and it should be a triode, unless other considerations, such as high grid input impedance at high frequencies, demand the use of a tetrode. Both types of noise are reduced by restricting the range of frequencies covered by the amplifier to

only that absolutely necessary for satisfactory reproduction. Distortion of the output wave shape from a low frequency amplifier may be of four kinds, attenuation (variation of amplification for the individual frequency components of the input signal), harmonic or amplitude (involving the production of frequencies harmonically related to the input frequency components), phase (a variation in the time delay of the individual frequency components of the input signal from input to output terminals), and transient distortion. The latter is caused by damped oscillations following upon shock excitation of the amplifier by a steep-fronted signal. In illustrating the

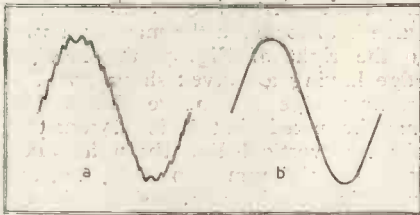

Fig. 2. An example of high frequency attenuation distortion: (a) Input wave shape, (b) Output wave shape.

effects of the various types of distortion produced by an amplifier we shall in most instances consider a square wave input shape because this contains a large number of sinusoidal components, and distortion is very quickly evident in the output wave shape. As a general rule an amplifier, which produces satisfactorily a square shaped input signal, will amplify faithfully any other shape of wave whose frequency components cover the same practical range.

Attenuation distortion results from the unequal amplification of the different frequency components of the input signal, *i.e.*, for zero attenuation distortion the frequency response of the amplifier over the range it is desired to accept should be flat. A reasonably sharp cut-off with considerable attenuation (outside the required range) is desirable as this assists in removing interference, hum, or noise voltages from the output. An example of attenuation distortion is given in Figs. 2a and b; the first figure shows the input wave shape and the second the output from an amplifier, which amplifies the high frequency components to a much less extent than the low frequencies.

In an audio-frequency amplifier; attenuation distortion resulting in loss of low frequency response causes reproduction to be unnaturally bril-

liant, whilst high frequency attenuation produces a muffled (sometimes called mellow) tone with reduced intelligibility for speech. If high and low frequency components are attenuated, reproduction is intelligible but lacks naturalness. An exception to the rule calling for a flat frequency response is provided by tone control, which allows adjustment of the amplification of the high and low frequency components relative to the middle frequencies (1,000 to 3,000 c/s.). Tone control may be used to compensate for deficiencies in the frequency response of apparatus associated with the A.F. amplifier. For example, attenuation of the high frequency modulation sidebands in the R.F. stages of a receiver can be counteracted by a corresponding increase in the high frequency response of the A.F. amplifier. Alternatively, greater attenuation of the high frequencies in the A.F. amplifier may be used as an aid to selectivity. Control of low-frequency amplification may be included to give a better frequency balance when interference requires severe attenuation of the high audio frequencies. Furthermore, the characteristics of the ear are such that a change in average sound level causes an apparent change in the balance of the frequency components, a reduction in volume leading to an apparently greater reduction in the low and high frequency components of the A.F. range as compared with the middle frequencies. Discrimination in favour of the high and low frequencies enables the balance to be retained as volume is reduced.

Loss of low frequency response in television reception affects the background intensity of the picture, *e.g.*, a transmitted all-white screen is reproduced as a screen gradually shading from white to grey, or *vice versa*, from top to bottom. Attenuation of the high frequency response mars the fine detail of the picture and a blurred out-of-focus image results.

The effect of low frequency attenuation distortion is illustrated for a square-wave input voltage in Figs. 3a and 3b. In Fig. 3c there is severe low frequency attenuation and the original character of the wave is completely lost. High frequency attenua-

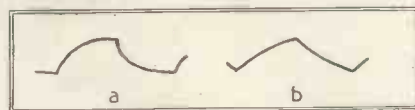

Fig. 4. High frequency attenuation of a square wave input: (a) Partial h.f. attenuation, (b) Severe h.f. attenuation.

tion distortion for the same input wave is shown in Figs. 4a and 4b, and with the severe high frequency attenuation shown in Fig. 4b, the original character is lost, the shape tending towards triangular.

Amplitude or harmonic distortion is caused by variation of the instantaneous amplification over the cycle of the input voltage. It may be introduced by the valve, its associated circuits or a combination of both. The valve produces amplitude distortion because of a non-linear $I_a E_g$ relationship, or because grid current flattens the positive tip of the input voltage wave. The first causes flattening of the negative peak of the anode current

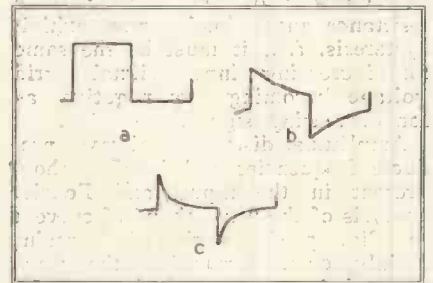

Fig. 3. An example of low frequency attenuation of a square wave: (a) Input, (b) Output with l.f. attenuation distortion, and (c) with severe attenuation distortion.

wave (see curve 1, Fig. 5), while the second causes the positive peak of anode current to be flattened (see curve 2, Fig. 5). Owing to curvature of the $I_a E_g$ characteristic as I_a approaches zero, the best operating grid bias voltage is always less than half the cut-off grid bias voltage; it is generally about 0.4 of this voltage. The positive peak of anode current may be flattened even though the input voltage is insufficient to draw grid current, and this is due to the anode load resistance causing a turnover or top bending of the $I_a E_g$ characteristic as shown by the dotted curve B of Fig. 5. Triode valves seldom have this type of characteristic, but with tetrodes it is quite apt to occur, particularly if the load resistance is high. This feature will be discussed in detail in a later article. Amplitude distortion from a valve having a resistance anode load is caused by incorrect biasing and/or too large an input signal. Curve 1 (Fig. 5) shows the result of over-biasing, and distortion could be appreciably reduced by changing the bias point from C to D. Curve 2 indicates overbiasing, together with too large an input signal. It may be noted that both curves are symmetrical about a vertical line drawn

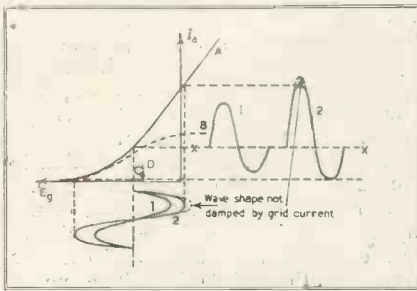

Fig. 5. Amplitude distortion due to $I_a E_g$ characteristic and grid current.

through maximum or minimum amplitude. This, of course, was to be expected because the operating $I_a E_g$ characteristic of the valve with a resistance anode load cannot exhibit hysteresis, *i.e.*, it must be the same for increasing input signal (grid voltage becoming less negative) as for decreasing signal.

Amplitude distortion always produces frequencies additional to those present in the input, and Fourier analysis of the wave shape of curve 1 in Fig. 5 shows that it contains mainly even harmonics, the wave shape being asymmetrical about the datum line XX' ; curve 2, on the other hand, contains mainly odd harmonics, the wave shape being almost symmetrical about XX' . Figs. 6a and 6b show that the addition of a second and third harmonic frequency respectively to the fundamental results in wave shapes similar to those of curves 1 and 2 in Fig. 5. As a general rule the input voltage wave to a low frequency amplifier does not consist of a single sinusoidal frequency but of a number of such components, and amplitude distortion may cause intermodulation frequencies to appear in the output as well as harmonics of the original frequency components. These intermodulation products are sum and difference frequencies (note that modulation of one frequency by another produces an upper sideband equal to the sum of the two frequencies and a lower sideband equal to the difference) formed by combining the original frequency components or their harmonics. Thus for an input of two frequencies, f_1 and f_2 , the output may contain fundamental and harmonic frequencies of f_1 , nf_1 , f_2 , and mf_2 , and also intermodulation frequencies of $nf_1 \pm mf_2$ and $mf_2 \pm nf_1$, where m and n are integers. Intermodulation frequencies generally have an inharmonic relationship to the original constituent frequencies and are consequently an unpleasant form of distortion in A.F. amplifiers,

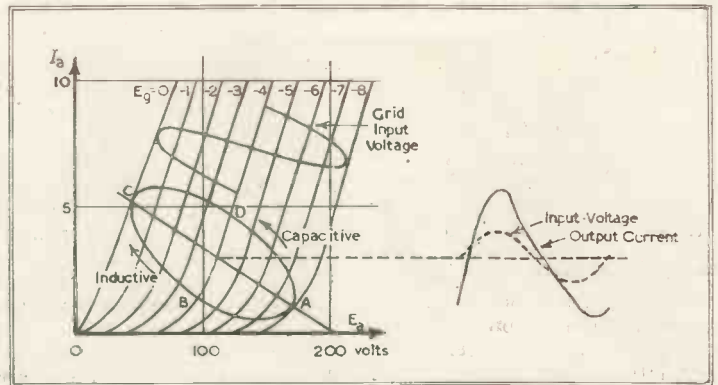

Fig. 7. Amplitude distortion due to capacitive anode load.

causing harsh and discordant reproduction. Harmonic distortion is relatively unimportant in television reception.

A valve, which may not produce amplitude distortion of a given input signal with a resistance anode load, may however distort with a reactive anode load. The locus of operation of a resistance anode load is represented on the $I_a E_g$ characteristics by a straight line such as AC in Fig. 7, but for an inductive or capacitive anode load it takes a form rather like a sheared ellipse* as shown by ABCD in Fig. 7. The part AB of the

(a) (b)

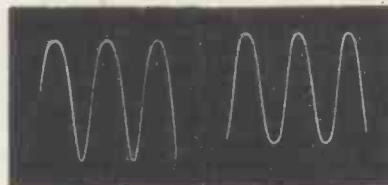

Fig. 6. (a) Addition of 2nd Harmonic to fundamental to give shape similar to curve 1, Fig. 6, (b) Addition of 3rd harmonic to fundamental to give shape similar to curve 2 of Fig. 5.

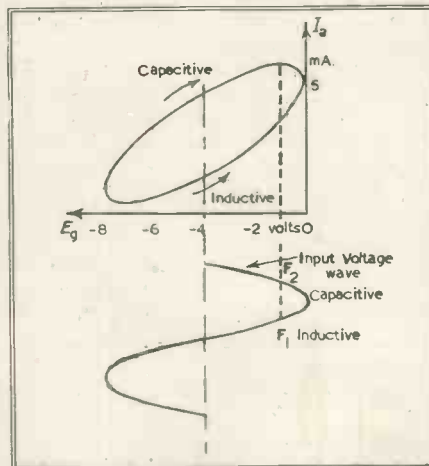

Fig. 8. $I_a E_g$ locus curve for a reactive anode load.

“ellipse” enters the cramped non-linear part of the $I_a E_a$ curves and amplitude distortion results. The wave is distorted in the manner shown to the right of Fig. 7, the leading edge having a convex shape and the trailing edge a concave shape. It may be noted that it is asymmetric about a vertical line through maximum or minimum amplitude, *i.e.*, the operating $I_a E_g$ characteristic is no longer the same for increasing as for decreasing signal amplitude but is somewhat similar to an iron B-H hysteresis loop as shown in Fig. 8. The lower curve of Fig. 8 represents the condition of increasing (positively) input voltage reducing negative grid voltage—and the upper decreasing input voltage when the anode load is inductive. Conditions are reversed for a capacitive anode load, the upper curve representing increasing signal input (positively). It should be observed that maximum input voltage amplitude (minimum negative grid voltage) does not produce maximum I_a , it occurs later in the cycle (point F_1) if the anode circuit is inductive, or earlier (point F_2) if it is capacitive.

Amplitude distortion may also be produced in the circuits associated with the valve; for example, an iron-cored coil may act as a non-linear† impedance, its inductance varying with the current through it because of a non-linear relationship between the magnetic flux and the current. Distortion of a symmetrical input wave by non-linear action of an iron-cored inductance usually results in an asymmetrical output wave owing to

(Continued on page 247.)

* The method of drawing the “elliptical” locus line for a given reactive anode load is treated in detail in Chapter 2, Part 1, of the author's book “Radio Receiver Design” (Chapman and Hall).

† A linear impedance consists of an inductance, capacitance or resistance; whose value is constant and independent of the amplitude or frequency of the voltage applied to it or of the current passing through it.

The Royal Signals

An account of the work and training of one of the most important branches of the Army in the Field.



THE Royal Corps of Signals was formed in 1920 to take over from the Royal Engineers the responsibility for providing inter-communication within the Army.

The scale of communication has grown enormously since the days of R.E. Signals. In 1918, for instance, there were 250 officers and men in a divisional Signals unit; to-day there are three times that number. In 1918 a division might

have used 12 wireless sets; there are 1,500 wireless sets in an armoured division to-day.

There are other striking differences. The army in this war has not been able to rely upon convenient civil telephone and telegraph systems in the rear areas. It has fought most of its battles thousands of miles from home and sometimes a thousand miles from the nearest base, with the result that the Royal Signals have had to provide their own vast trunk telephone and telegraph network.

It will probably be an eye-opener to most readers to know that there were ten thousand Royal Signals in the Eighth Army during its advance from El Alamein to Tripoli, and the number in Western Europe to-day must be very much greater.

On D-Day and days immediately following, a Command cross-channel radio telephone net was manned by two Staff Officers and an Officer and two operators of the Royal Signals.

The approach of H-hour was a period of tense interest and suppressed excitement for all Signals personnel. There was no means of testing cross-channel communications until the moment when they were urgently needed, because until H-hour wireless silence was imposed. All wireless sets at Command H.Q. were on listening watch from midnight. The U.S. H-hour was earlier than the British and the first signal from cross-channel on Army links was on the U.S. Air Support link at 0635 asking aircraft to stop laying smoke screens.

On British command links wireless silence was broken at 0723 when Radio telephone communication was established. Signals were 'R5'—maximum strength—from the start and communication was uninterrupted. The two operators on the link were Sigmn. Morton and Sigmn. Pinfield of War Office Signals. Both had been specially coached for this most important task of ensuring that the Staff Officers could carry on conversation across the channel without difficulty or interruption.

There was considerable anxiety to hear from the Airborne Troops, and at 0732—two minutes after the general breaking of wireless silence—the 6th Airborne Division came on the air to 21 Army Group.

The telephone and teleprinter services provided on this side of the channel for mounting the invasion were the most comprehensive ever constructed for any single enterprise, civil or military. Most of the construction and installation was carried out by the G.P.O. under Service directions, and over 2,000 miles of wire were used.

Training

The normal function of Signals is to provide communication from every headquarters to the immediate lower formations. This is a big enough task

in itself, but many further demands have been made upon the Corps. A special network has been devised, for instance, for the summoning of air support. Wireless communication has also had to be provided for the Royal Engineers, and for the recovery, repair, medical, and supply services. Much the greatest additional commitment has been to provide all land-line communications for the R.N. and R.A.F. overseas.

The long line communications and

Repairing damaged wires under service conditions. The repair party are testing for mines as they go forward from pole to pole.





the wireless links from the United Kingdom to distant theatres of war have meant using equipment not hitherto used in the army and have greatly added to the difficulties of obtaining suitable personnel.

Behind all this operational work there has had to be created, therefore, a vast training organisation capable of turning out competent operators, linemen, instrument mechanics and linemen mechanics after a technical training of only six months or under. No one will pretend that the training is as thorough as can be given in peace-time, but few would deny the enthusiasm and ingenuity which the trained nucleus of officers, NCO's and men have put into their work.

The main Signal Training Centre is in Northern Command and the following pages describe some aspects of the work which has been carried on there continuously throughout the war and is likely to continue for a long time to come.

With the exception of certain administrative personnel, the Royal Corps of Signals consists entirely of trained tradesmen, who are respon-



AREA — LOFC COMNS — LI

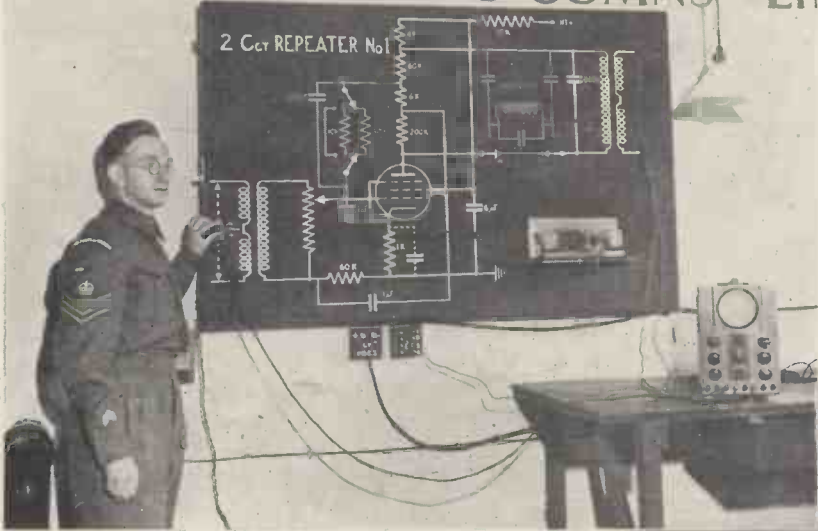

Page 240 (top). Boys undertaking instruction in teleprinting.

Page 240 (below). In the teleprinter room. A repair class at work.

(Left) Demonstrating the action of a repeater circuit by means of the cathode-ray oscillograph.

(Below) Testing a voice frequency telegraph unit under the instructor's supervision.

sible for the maintenance of the Army's systems of communications. It is the task of the five training battalions of the 1st Signal Training Centre to train suitable recruits in Signals Trades in order to maintain a steady output of skilled technicians. Recruits on arrival from Primary Training Centres are interviewed and allotted for training according to their capabilities in one of the twelve trades for which training facilities exist.

- Electrician Signals "A" Trade
- Instrument Mechanic "A" Trade
- Lineman Mechanic "A" Trade
- Operator Wireless and Keyboard ... "A" Trade
- Operator Keyboard and Line ... "B" Trade
- Operator Wireless and Line ... "B" Trade
- Clerk ... "C" Trade
- Draughtsman ... "C" Trade
- Driver Operator ... "C" Trade
- Lineman ... "C" Trade
- Operator Switch-board ... "C" Trade
- Despatch Rider ... "D" Trade
- Driver Mechanic ... "D" Trade
- Loftman ... "D" Trade

The "A" Trade is the highest paid and "D" Trade the lowest.

The 1st Operators Training Battalion handles the training of Operators,



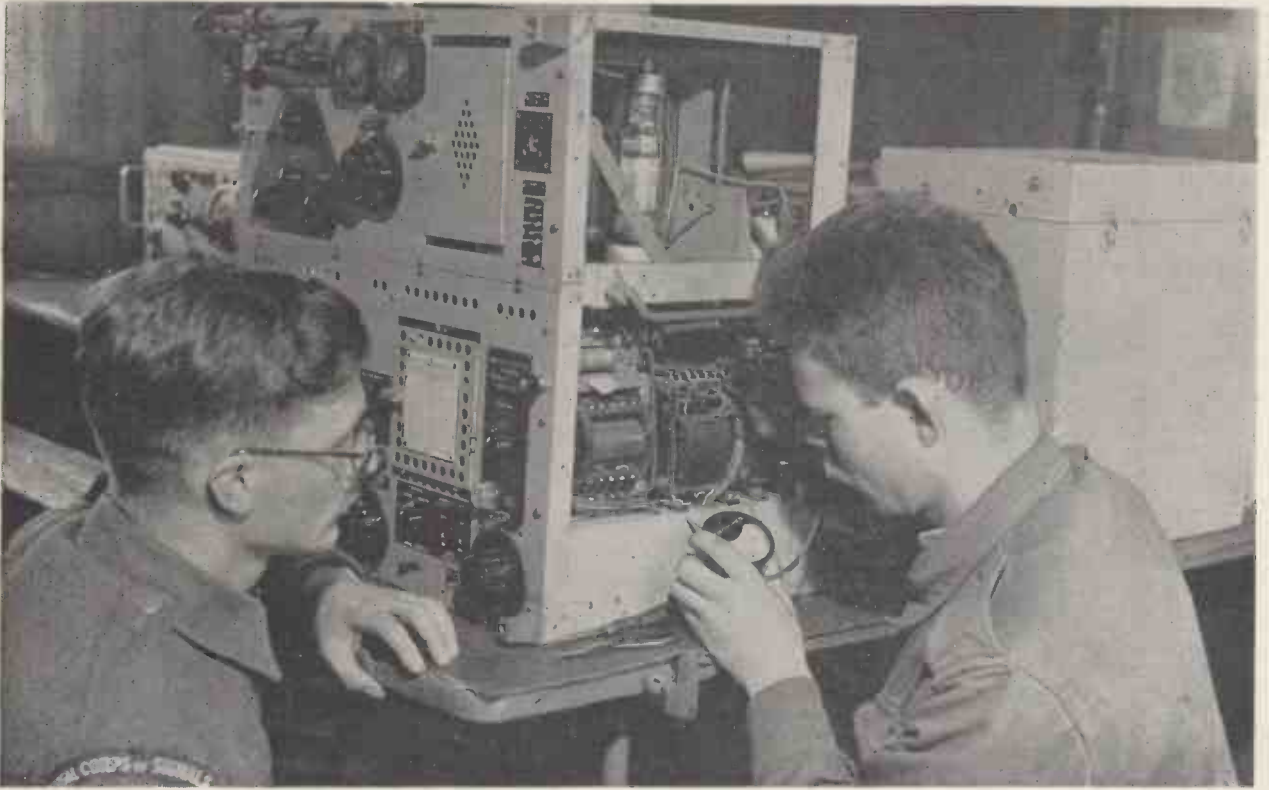

Student mechanics check over a medium power wireless transmitter.



View of the training workshop in which apparatus is repaired and made up.



Class being instructed in valve theory. The walls are covered with diagrams illustrating every part of the work.



Class room for practical work on Army sets.

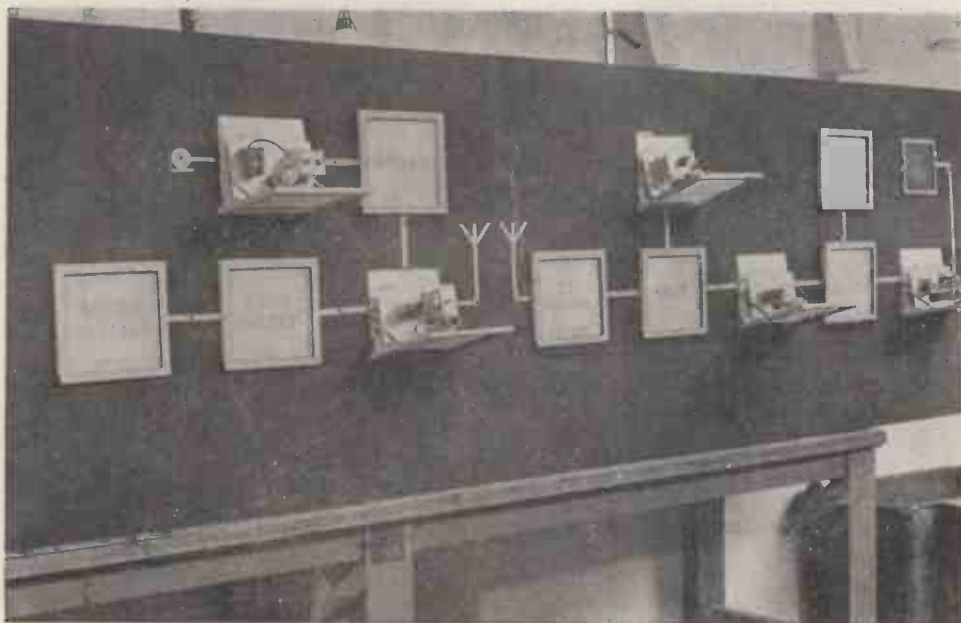

Circuit demonstration board assembled in the Signal Training Centre workshops. Each unit can be tilted forward to show details.

Wireless and Line. This type of operator must be prepared to man any type of wireless set, telegraph instrument, or telephone. Besides being able to pass messages by morse code or word of mouth under the most difficult conditions, he has to know enough about the instruments he is likely to use to be able to maintain them in working order and remedy at any rate the simpler faults that may occur. In the training of operators much stress is laid on the vital necessity for security in operating communications. The enemy uses every possible means of collecting information, and even momentary carelessness on the part of an operator may have disastrous results. For example, messages must be transmitted quite impersonally in case an individual trait on the part of the operator may lead to his identification and hence the identification of a unit. In the later stages of the training, exercises in vehicles equipped with wireless prepare operators for conditions which they are likely to encounter in mobile warfare.

Three other types of Operator are trained by the 2nd Operators' Training Battalion. For operators, Keyboard and Line, there is a twenty-one weeks' course in teleprinter operating and maintenance, and sending and receive-

ing morse. The course concludes with two weeks' training in a model Signal Office, where active service conditions are simulated as far as possible. The best men from the above two trades are selected for training as Operators, Wireless and Keyboard, and are employed on fixed high-speed wireless stations operating in a world-wide chain. Their duties include reading undulator slip, typing messages received on the headphones, perforating tape, and handling of high-speed automatic transmitters. They receive a further 16 weeks' training, which includes the erection of special aerial arrays. Operators, Switchboard, are taught in six weeks to become quick and efficient operators of the two main types of Army telephone switchboards, with a final grounding on a 200-line (restricted) multiple board, including use of dialling facilities. They deal with all types of call, from the mere "local" call to the distant "trunk" and complex conference calls.

Instruction

Although the method of instruction may vary in detail according to the subject taught, the same general principles are observed in all four training units. Instruction is carried out by N.C.O. instructors under the general supervision of section officers.

The trainees are divided into squads according to their week of training, each squad progressing normally from subject to subject until the syllabus is completed. However, if any member of a squad is found to be weak at a particular subject, he is "relegated" and works at that subject for a further period before continuing the course. Men with previous electrical knowledge and experience, e.g., G.P.O. Men and University Science students, may not need the preliminary lessons of a course and are then "accelerated" according to their qualifications.

In some units trainees take their own notes under the guidance of the instructors; in others printed notes are issued, illustrating the main points of a particular course. Whichever method is adopted, as much of the training as possible is of a practical nature. Trainees in workshops trades, for example, spend part of their time learning the use of various tools and tracing and repairing faults in electrical apparatus. They are encouraged to puzzle out unfamiliar equipment for themselves, so that they may gain confidence in tackling in the field equipment which may be introduced after they have left the Training Centre.

All units make extensive use of

Back view of demonstration board in assembling, showing flexible connexions between each unit.

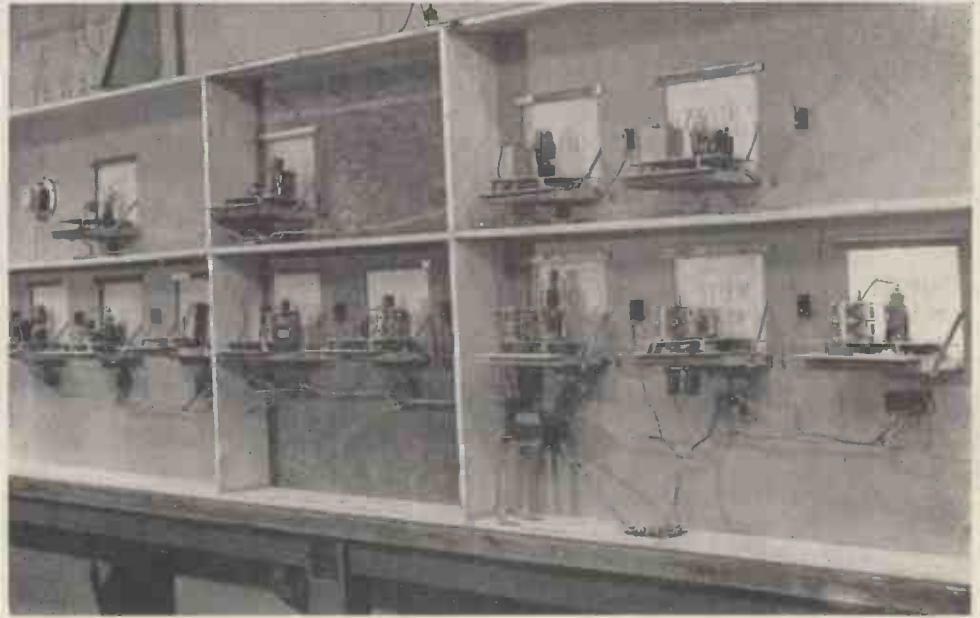

visual aids to learning. Models illustrating the working of various types of equipment are a feature of many classrooms. Wall panels are painted with effective training slogans or pictures which "tell a story." A variety of training films is also available. Some show how a particular piece of equipment works, whilst others give the trainees an idea of the type of work they will have to do when their training is completed.

It is evident that the technical training provided in the S.T.C. will be of value to many on their return to civil life. G.P.O. men and Wireless Service men cannot fail to benefit by the work. Opportunities will occur in civil communication organisations for skilled operators and maintenance engineers. Drivers and Driver Mechanics will be fitted for jobs with civilian transport firms and haulage contractors. Moreover it is likely that many who were previously engaged in unskilled commercial occupations will find an opportunity for taking up electrical or radio engineering as a career when they leave the Army.

It is appreciated that the trainees who are going through the mill can often give a helpful suggestion. In order to tap this source of ideas there are regular training conferences of an

entirely informal nature at which suggestions and difficulties are discussed with the C.O.

The Boys' Company, Royal Signals

The Boys' Company is not a wartime innovation. It was part of the peace-time Royal Corps of Signals, and its object is, in effect, to apprentice boys to R. Signals just as in ordinary life boys are apprenticed to civil firms.

In the spring and autumn of each year entrance examinations are held. Boys have to be between the ages of 14 and 15 and they must undertake to join the regular army for the normal 12 years engagement when they complete their Boys' training. Full particulars of the examinations are published in the Press and can also be obtained from Recruiting Officers. Boys who pass the qualifying examination sufficiently high to secure a vacancy are sent to join the Boys' Company in February and September for a 3-years' course.

During their final year, the boys specialise on whatever trade they are going to follow in the Army proper. Some specialise at Wireless Operating, others on Teleprinting (and the like) and some again in Servicing Electrical Instruments. Whatever their trade is to be, however, all receive a first-class basic electrical training.

During all the time, the boys attend school daily and continue with their normal education, the object being to gain at least a first-class army certificate of education before the boy passes into the ranks.

At present 15 per cent. of the boys also get a special Army Certificate which is the recognised equivalent of matriculation. The language the boys take for this exam is either French or German.

There are three terms each year like an ordinary boarding school, and parents are sent a report on their son's progress at the end of each term. A heavy bill does not accompany the report as with the usual boarding school!

The boys, of course, are fed, housed and clothed, free, and paid 10s. to 14s. 6d. weekly according to their seniority.

There are two weeks holiday at Christmas, two weeks at Easter, and a month's leave in the summer.

Our thanks are due to the Commandant, Brig. G. L. Pollard C.B.E. and the Staff at the Training Centre for facilities for taking the photographs illustrating this article, and to the Signals Directorate, War Office, for the information, which is published by permission of the War Office and M. o. I.



The simplest form of flexible coupling for transmitting rotary movement is shown above.

The Metalastik rubber-to-metal weld permits the transmission of heavy loads, with a torsional cushioning effect which extends over an appreciable angle. Note the 'V' section which gives uniform stress.

These couplings are used for many purposes and can be supplied with natural or synthetic rubber of various degrees of flexibility; and in any ordinary metals, including light alloys.

Other Metalastik couplings shown are — on the left, the 'ZPU' type; on the right, the 'ZVS', both have vanes which give a positive drive beyond a certain deflection and are capable of accommodating angular and parallel mis-alignment.

All these patent couplings are of great value in damping out torsional vibrations, in fact many of them are used expressly for this purpose where all other expedients have failed.



METALASTIK

METALASTIK LTD., LEICESTER

Low Frequency Amplification—continued from p. 238

the hysteresis loop of the B-H curve.

Phase distortion occurs in an amplifier when the frequency components of the input wave suffer differing time delays in passing through the amplifier. Examples of the change in shape produced by varying the time delay for fixed amplitudes of a fundamental and third harmonic frequency are shown in Figs. 9a, 9b and 9c. In Fig. 9a the two frequencies start from zero amplitude and rise together; in Fig. 9b the fundamental wave is delayed by 30° of its own cycle (alternatively 90° of the third harmonic cycle) compared with the third harmonic, *i.e.*, the delay in time is $\frac{30}{360f} = \frac{1}{12f}$ seconds, where $f =$ the fundamental frequency in c/s. Fig. 9c shows the result when the fundamental time delay is $\frac{1}{6f}$ seconds (60°).

Despite the difference in wave shape, the ear is unable to detect any noticeable difference between the character of the sound waves corresponding to the wave shapes shown in the figures. This applies also to frequencies not harmonically related, so that we can neglect phase distortion in A.F. amplification unless the time delay becomes very much larger than is usually encountered in practice. In apparatus for which the eye acts as an interpreter, phase distortion must be reduced to small proportions. This is especially true of television reception, for the light values conveyed by the signal in Fig. 9a are vastly different from those of Fig. 9c. Phase distortion at low frequencies is produced by the reactances in the coupling, de-coupling and self bias circuits, but at high frequencies stray capacitance across the coupling circuits is the major factor. High frequency phase distortion¹ in television reception leads to a plastic relief type of image, a white or black vertical line being preceded or succeeded by a black or white margin respectively. Low frequency phase distortion¹ tends to produce a variable background to the picture, a half-



Fig. 9. Addition of fundamental and 3rd harmonic with different phase displacements due to time delay through the amplifier.

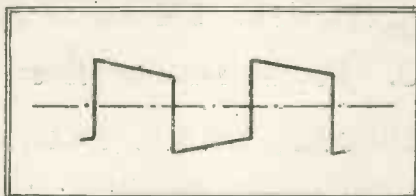

Fig. 10. Phase distortion of a square wave input with almost no attenuation distortion.

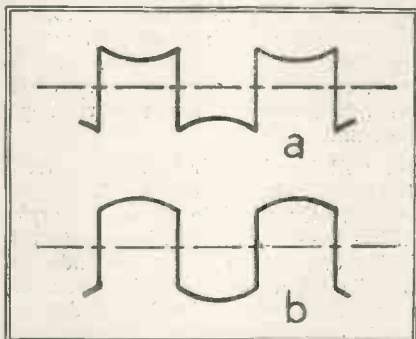

Fig. 11. Zero phase distortion with attenuation distortion, (a) l.f. attenuation, (b) l.f. intensification.

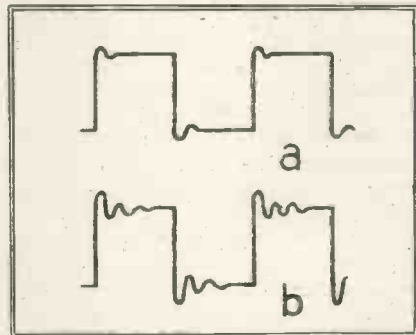

Fig. 12. Examples of transient distortion, (a) Peak to average ratio, 1 db., (b) Peak to average ratio, 6 db.

white, half-black picture showing a variation from white to grey and black to grey with possibly a dark streak in the white half and/or a white streak in the black half. The effect (on a square wave input) of low frequency phase distortion due to the coupling capacitance between stages is illustrated in Fig. 10 (attenuation distortion is negligible).

Phase and attenuation distortion do not necessarily become zero together but in many types of apparatus a flat

frequency response gives also a negligibly small value of phase distortion. Zero phase distortion accompanied by marked attenuation distortion is generally only encountered when phase distortion in one part of an amplifier is corrected by deliberately introducing distortion in the opposite sense in another part. The effect of correcting phase distortion at the expense of low frequency attenuation is shown for a square wave input in Fig. 11a. Increase in low frequency response with zero phase distortion is illustrated in Fig. 11b.

Transient distortion can occur in an amplifier if the latter contains a tuned circuit or its equivalent, *i.e.*, has a frequency response peaked over a comparatively narrow band of frequencies. A steep-sided pulse causes shock excitation of the tuned circuit or its equivalent, and a train of damped oscillations follows each sharp edge of the pulse. The decay of these oscillations is determined by the degree of damping on the tuned circuit, which is measured by the height of the peak above the average frequency response level in the vicinity of the peak. Transient distortion can generally be ignored if the peak-to-average frequency response is less than 1db, provided that a peak in one section of the amplifier is not being compensated by a dip in another. The effect of different degrees of transient distortion due to a peak of approximately 1 and 6db respectively in the frequency range at a frequency nearly 5 times greater than the fundamental of the square wave pulse is shown in Figs. 12a and 12b. If the peak occurs at a higher frequency, the frequency of the damped oscillation is increased. In A.F. amplification large transient distortion produces blurring; it is rather like playing a piano with the loud pedal always pressed down. With television reception it causes a rippled effect on the picture immediately following a sharp transition from black to white or *vice versa*.

- 1 Phase Distortion in Television, R.G. Shiffenbauer, *Wireless Engineer*, January, 1936, p. 21.
- 2 Some Notes on Video Amplifier Design, A. Preisman, *R.C.A. Review*, April, 1938, p. 421.
- 3 The Interpretation of Amplitude and Phase Distortion in Terms of Paired Echoes, H. A. Wheeler, *Proc. I.R.E.*, June, 1939, p. 359.
- 4 Network Testing with Square Waves, L. B. Argimbaum, *General Radio Experimenter*, December, 1939, p. 1.
- 5 High Quality Audio Transformers, L. E. Packard, *General Radio Experimenter*, December, 1939, p. 6.
- 6 The Electrical Amplifying Stethoscope and Phonocardiograph, G. E. Donovan, *Journal I.E.E.*, Part III, June, 1943, p. 21.
- 7 Amplifying and Recording Technique in Electrophysiology, G. Parr and W. G. Walter, *Journal I.E.E.*, Part III, September, 1943, p. 129.

(To be continued.)

Magnetic Materials

3. Recent Developments

By F. BRAILSFORD, Wh.Sch., Ph.D., A.M.I.E.E.*

2. Cold Rolled Steels

THE directional magnetic properties of single crystals have already been described. It is experimentally observed that the easy direction of magnetisation for iron or silicon-iron is along a cube edge or [100] crystallographic direction. When this magnetisation curve is compared with that for a sample of the ordinary polycrystalline material it is seen that the knee of the former curve lies considerably higher than that of the latter. In the case of a transformer the alternating flux in the core material is directed along one direction, in the material only, except, of course, for a fraction of the core near the corners. Also the highest working flux density which can be employed is limited to a value near the knee of the magnetisation curve, since beyond this point the transformer magnetising current increases at a very rapid rate and also then introduces undesirable harmonics into the primary current and output voltage. If, therefore, the shape of the magnetisation curve of a transformer steel, for the working direction of the sheet, could be made more like that for a single crystal

in the [100] direction, this would clearly be an advantage, leading to higher permeability if the same working flux density were adhered to, or alternatively allowing a higher working flux density, and therefore a smaller core for a given output, if the magnetising current were kept the same.

It will be clear that this improved shape of magnetisation curve is theoretically possible for a polycrystalline sheet if the constituent crystal grains can in some way be induced to take up a parallel alignment, or "preferred orientation," so that a [100] crystallographic direction in each grain lies along a particular direction, say the rolling direction, of the sheet. The greater the degree and accuracy of this preferred orientation then the nearer will the magnetisation curve of the sheet in the rolling direction approach that of the [100] single crystal direction, and the nearer will the knee approach the saturation value of the steel.

With certain nickel-iron and silicon-iron alloys it has been found possible, by carrying out suitable processes of cold-rolling and annealing, to induce a high degree of preferred grain orientation of the re-

quired kind in the finished sheet. Fig. 11 shows the magnetisation curves measured for three different directions of a sheet of 3 per cent. silicon steel made by a cold-rolling process. The resemblance between the shapes of these three curves measured for the rolling direction of the sheet, at right angles to this direction and at an angle of 54.7° ($\tan^{-1}\sqrt{2}$) respectively, and the curves for a single crystal of iron or silicon iron in the [100], [110] and [111] directions respectively will be clear by referring back to Fig. 6. The correspondence between these curves for the sheet and for the single crystal suggests that a proportion of the grains in the sheet are aligned with [100] in the rolling direction and the diagonal [110] plane in the plane of the sheet, and this conclusion has been verified by X-ray examination of the sheet and by the method described in the next paragraph. The magnetisation curve of a typical 4 per cent. silicon transformer steel, made by the normal hot-rolling process and whose magnetic properties are only slightly directional, is also shown in Fig. 11 and may be compared with the improved curve for the rolling direction of the cold-rolled steel.

* Metropolitan Vickers Electrical Co., Ltd.

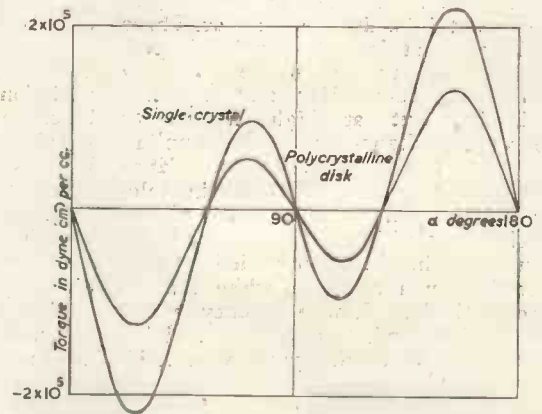
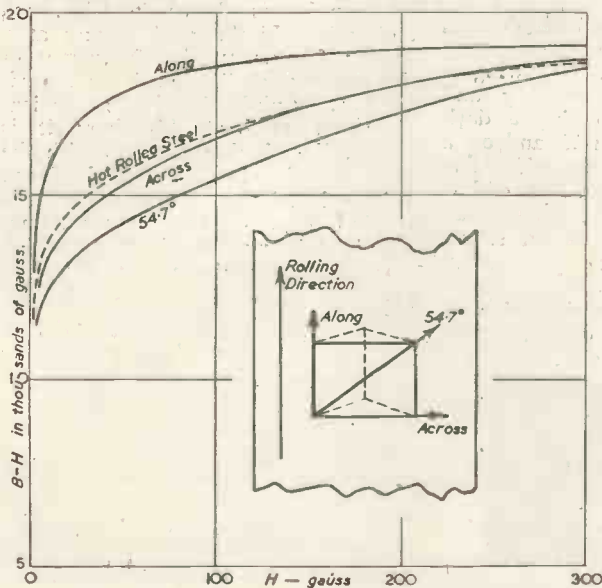
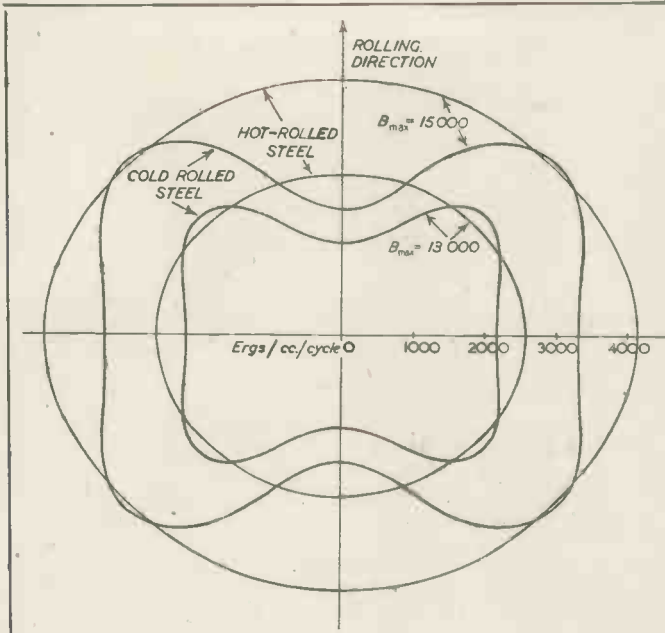

Fig. 11. Magnetisation curves for different directions in a 3% Silicon Cold-rolled Steel.

Fig. 12. Comparison of Torque curves for single crystal and for a sample of polycrystalline cold-rolled silicon steel. α is the angle between [100] and field for a single crystal, and between the rolling direction and field for cold-rolled sheet.



It is possible to determine approximately the kind and degree of the preferred orientation in a cold-rolled steel by a quick and simple torque test. The theoretical torque curve for a disk cut from a single crystal in the (110) plane and rotated about an axis perpendicular to the direction of a high saturating field is given, as already described, by equation (7) of the previous section. This curve with values of the constants K_1 and K_2 appropriate to a 3 per cent. silicon steel is plotted in Fig. 12. The torque curve experimentally obtained for a disk cut from a 3 per cent. silicon cold-rolled steel is also plotted. On comparing the two curves we deduce from the similarity in shape that the type of preferred orientation of the grains in the sheet material is that already mentioned, that is with [100] in the rolling direction and (110) planes in the plane of the sheet. We further deduce from the relative amplitudes of the two curves that about 58 per cent. of the grains have this particular average orientation the remainder being on the whole randomly arranged. While such a simple torque test cannot give exact information of the spread of the grain orientations about their preferred positions, as may be obtained from a laborious X-ray examination, the method is very useful in examining these materials and in fact becomes more precise the higher the degree and perfection of the parallel alignment of the grains.

3.2. Hysteresis Losses

The author has shown elsewhere how direct measurements of the hysteresis loss in a sheet material may be made on small disk samples, by observing the torque required to rotate them slowly in a magnetic field. The methods adopted enable curving when the flux rotates in the plane of the sheet, to be measured. They further enable the alternating hysteresis loss to be determined for any direction of the flux in the sheet on the same small sample. Measurements made in this way on cold-rolled silicon steel show that the direction of high permeability in the sheet is also the direction of low hysteresis loss. The variation of the hysteresis loss for an alternating flux in different directions of the sheet for a 3 per cent. silicon cold-rolled steel is shown in Fig. 13 for $B_{max} = 13,000$ gauss and $B_{max} = 15,000$ gauss. The results of similar tests on a 4 per cent. silicon hot-rolled transformer steel are also shown. The variation of loss with direction in the latter is not more than about 15 per cent., but a maximum variation of about two to one occurs with the cold-rolled steel. The relative values of hysteresis loss for the rolling direction in the two sheets will also be noted.

The rotational and alternating hysteresis loss curves similarly obtained for a hot-rolled steel with 1.91 per cent. silicon are shown in Fig. 14, together with the magnetisation curve. These three curves show

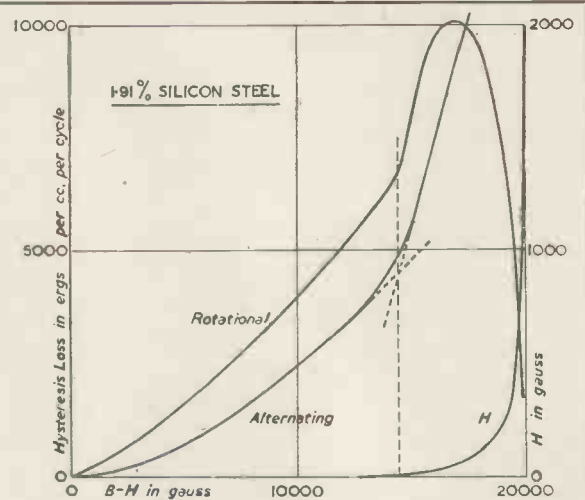

Fig. 13. Polar diagrams in the plane of the sheet, showing how alternating hysteresis loss varies with direction in the sheet for cold-rolled and hot-rolled silicon steels.

Fig. 14. Relation between rotational and alternating hysteresis loss and illustrating two mechanisms of magnetisation.

a discontinuity at the knee of the magnetisation curve corresponding to the transition between the two mechanisms of magnetisation previously described. It is interesting to note that while the well-known Steinmetz law holds, approximately, for the lower part of the alternating hysteresis loss curve, the upper portion approximates closely to a straight line.

3.3. Effect of Impurities

The way in which internal strains lead to reduced permeability and increased hysteresis loss has already been described. Such strains produce a deformation of the atomic lattice, one cause of which lies in the discontinuity existing at the boundaries between grains where neighbouring differently-oriented crystal lattices meet. The hysteresis loss might therefore be expected to decrease as the grain size increased since the proportion of strained grain-boundary material is then reduced; and this is, in fact, experimentally observed.

One of the most important sources of internal strain, however, is that due to impurities. "Interstitial impurities," like carbon or sulphur in small quantities, introduce lattice distortion by squeezing themselves in between the regular layers or atoms. "Other elements, such as silicon or manganese, called "substitutional," substitute themselves in place of the parent atoms, but even in this case, also cause a deformation of the regular pattern.

An exhaustive study of the quantitative effect of the common impurities in iron and silicon iron has been made by Yensen. According to his results carbon and sulphur are very harmful to magnetic properties, and particularly the former.

When the impurities are reduced to small amounts remarkable magnetic properties are attainable. Cioffi found that prolonged annealing of iron in hydrogen at a temperature just below the melting point, led to a reduction of the amount of the interstitial impurities present to about one-tenth of that in ordinary commercial dynamo sheet, the substitutional impurities present not being greatly changed. The treatment also gave a large grain size in the specimens. Fig. 15 shows hysteresis loops and permeability curves obtained for a sample of Cioffi's iron before and after treatment. The hysteresis loss was reduced to less than one-twentieth of that of a commercial material and the permeability raised by about fifty times. Another sample was reported with a maximum permeability of 340,000 while a single crystal specimen of hydrogen treated iron was found to have a maximum permeability of 1,430,000 for the direction of easy magnetisation. These remarkable figures may be compared with a maximum permeability of about 6,000 for commercial dynamo iron sheet.

3.4. Cooling in a Magnetic Field

If a ferromagnetic material is raised to a sufficiently high temperature it loses its ferromagnetism but regains it on cooling down through the Curie temperature as already described. Thus it is only as the metal cools through this temperature that the domains are formed. If a steady field is applied during the process the domains will tend to form with their magnetisation and their internal magnetostrictive stresses acting along, or near to the field direction. If these internal stresses can relieve themselves during cooling, it may be expected that the domains will tend to set with their preferred directions for the spontaneous magnetisation in the general direction of the field. Thus, when the field is removed and the material is subsequently demagnetised, there will be a relatively high proportion of domains with their spontaneous magnetisation, either forward or reverse, lying along one direction of the material. Now since boundaries between two domains in which the magnetisation is oppositely directed may be moved by an applied

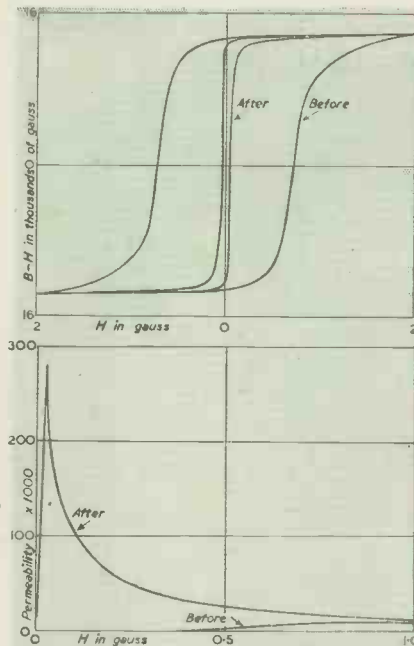

Fig. 15. Cioffi's hydrogen-treated iron, before and after treatment.

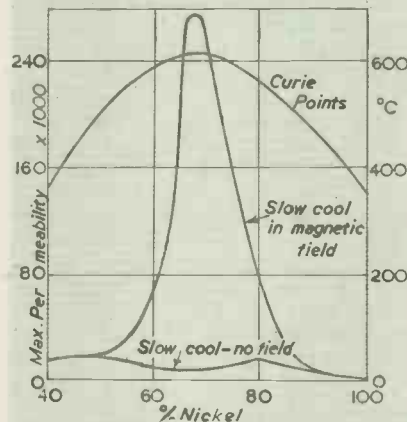

Fig. 16. Showing high permeability obtained for certain nickel-iron alloys by slow cooling in a magnetic field.

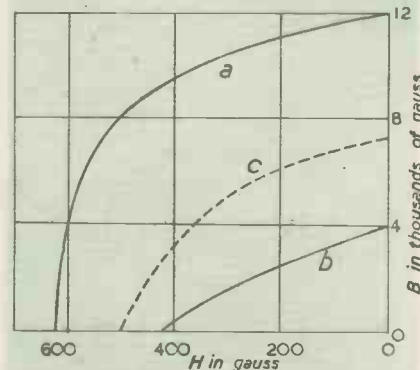

Fig. 17. Showing the effect of cooling in a magnetic field on certain permanent magnet materials (a) and (b) are the same material cooled in a strong field—(a) In the direction of the field, and (b) in a lateral direction. (c) : similar material heat-treated without field.

field more easily than those between domains in which the magnetisation is mutually at right angles, for in the former case no magnetostrictive change in length is involved, we would thus expect that the permeability, and also the remanence, would be higher for that direction of the material in which the field was applied during cooling than for a lateral direction.

The application of this process to iron or silicon iron alloys has not met with very remarkable success. This is attributed to the complicated magnetostriction characteristics of these materials, for in the case of iron, the magnitude and sign of the magnetostriction varies with direction in the crystal as already shown. Fig. 16, due to Dillinger and Bozorth shows the effect of a magnetic field applied during cooling for a range of nickel-iron alloys and it will be seen that for certain compositions a remarkable increase in maximum permeability is obtained.

An important commercial development of magnetic annealing has recently occurred in the permanent magnet materials known under various trade names such as Ticonal, Alcomax and Alnico V. In this case the permanent magnet alloy, of suitable composition, is cooled in a strong magnetic field and both the remanence and coercivity are greatly increased for the field direction and decreased laterally. The demagnetisation curves for one of these materials for two directions at right angles are shown in Fig. 17. The big difference in properties in the two directions and the improvement over ordinary Alnico are clear from the curves.

3.5. Conclusion

The main factors affecting the magnetic properties of commercial materials may now be said to be fairly well known and some of these have been described in these articles. It is known how improvements may be brought about, such as reducing hysteresis losses, raising permeability and, in the case of transformer steels, improving the shape of the magnetisation curve. The introduction of improved materials in the future will depend, not only on further technical developments, but also on the cost of production of the materials. It is, however, fairly certain that even on the basis of present scientific knowledge, the best quality economically possible has not, in general, been reached and that steady future improvements may be expected.

Callender

RADIO FREQUENCY CABLES



We are fully engaged on war production and are manufacturing all types of low loss and low capacity cables for use at high frequencies.

We shall be pleased to make available the experience of our extensive research and technical organisations in connection with special cable problems directly related to the war effort.

CALLENDER'S CABLE & CONSTRUCTION CO. LTD., HAMILTON HOUSE, VICTORIA EMBANKMENT, LONDON, E.C.4

All over the World

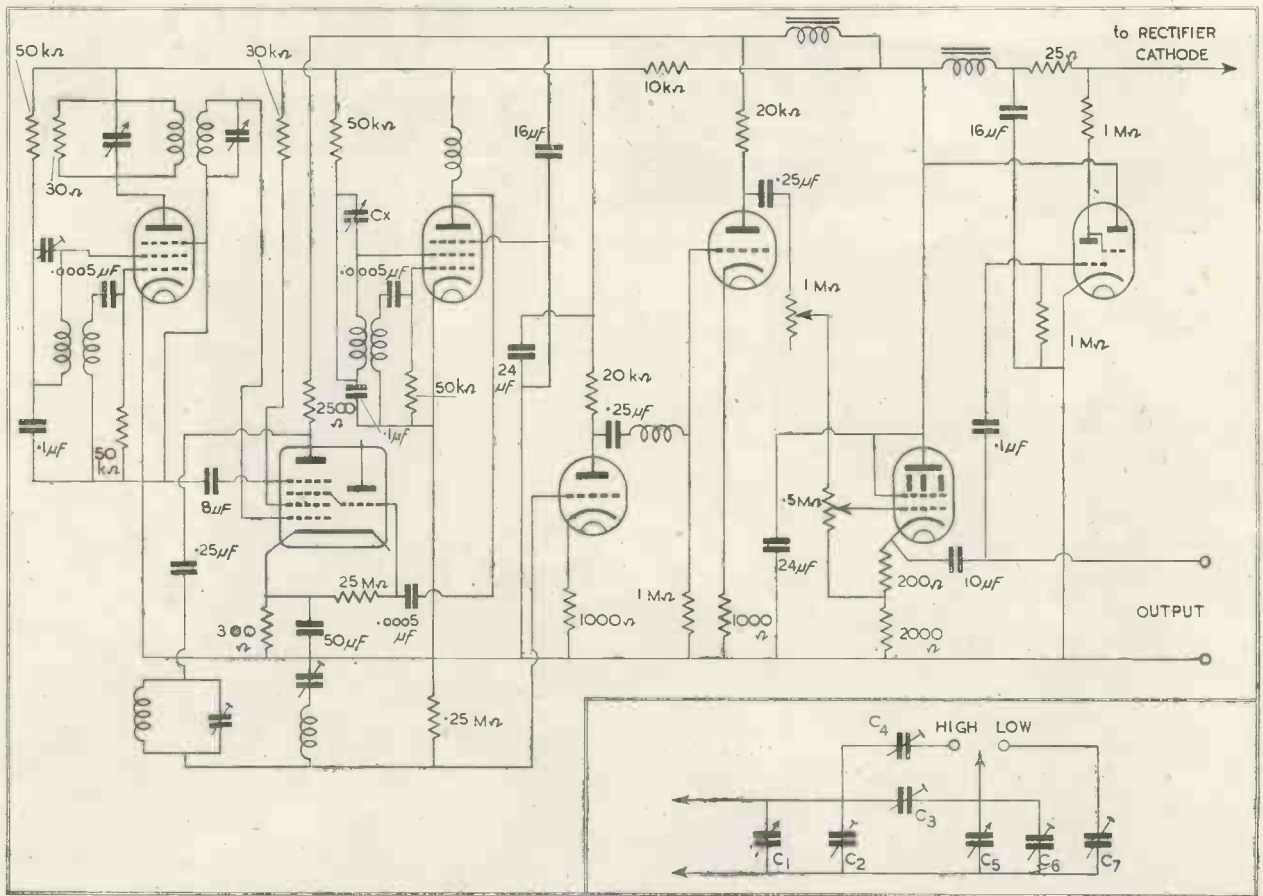

Design for a Beat Frequency Oscillator

By C. E. COOPER*

THESE are certain well accepted principles for the design of a beat-frequency oscillator. The most important of these is that, to secure good output waveform, one of the two beating signals must be free of harmonics. It is not necessary that both beating signals should be free of harmonics, since providing one of them is, all the intermodulation products, with the exception of the desired beat tone, will be of radio-frequency, and may therefore be filtered from the output waveform by the same circuits as are used to filter out the two beating signals.

For example, consider that the beating signals are of 100 and 102 kc/s. frequency. The beat will then be of 2 kc/s., and if both the signals contain a second harmonic component, the various other beats produced

will include one of 4 kc/s., *i.e.*, the second harmonic of the desired beat. If, however, only the 102 kc/s. signal included a second harmonic component, then the only beats possible would be

$$102 - 100 = 2$$

$$102 + 100 = 202$$

$$204 - 100 = 104$$

$$204 + 100 = 304$$

Of these, only the desired beat tone falls within the audio-frequency band.

One of the most serious difficulties is to avoid frequency drift with temperature variation. Apart from possible change of the frequency scale law, it is a considerable nuisance to have to readjust the zero set control every few minutes.

This drift may be minimised by arranging that the two beating oscillators are identical in every way, so that any unavoidable drift occurs to an equal extent in both oscillators, and

so cancels in its effect upon the beat tone. To secure this equal drift, all components in the two oscillators must be identical. Thus it would not be sufficient if the two tuning coils had the same inductance but a different shape, since this latter is likely to provide them with differing temperature co-efficients.

It is obviously also essential that the two oscillators should be so situated that they receive the same temperature variations, such variations being kept to a minimum by mounting the oscillators as far away as possible from the heat-dissipating components, such as the power rectifier.

If the two oscillators are made identical, and one of them carefully filtered to remove harmonics, then the output of the one so filtered is likely to be made very much smaller than

* Radio Manufacturers' Service.

the other in its passage through the filter.

This difference in amplitude between the two signals will assist in the avoidance of distortion in the detecting device, where this has a linear law, as is desirable. To minimise detector distortion, the amplitudes of the two signals should be in the ratio of 10 to 1 or more. If, for any reason, the two signals are to be fed to the detector in approximately equal amplitudes, a square law detector will provide the best waveform.

The actual frequencies of the two beating oscillators are a compromise between two conflicting requirements. The higher the frequencies used, the easier it will be to filter them away from the desired beat tone. On the other hand, the higher the frequency, the worse will be the problem of zero drift. A given temperature change will cause a certain percentage drift in oscillator frequency, and the higher the frequencies used, the greater the number of cycles represented by that percentage drift. The best compromise is usually to set the fixed oscillator to a frequency ten times higher than the highest audio-frequency required, and for the variable frequency oscillator to operate above the frequency of the fixed oscillator.

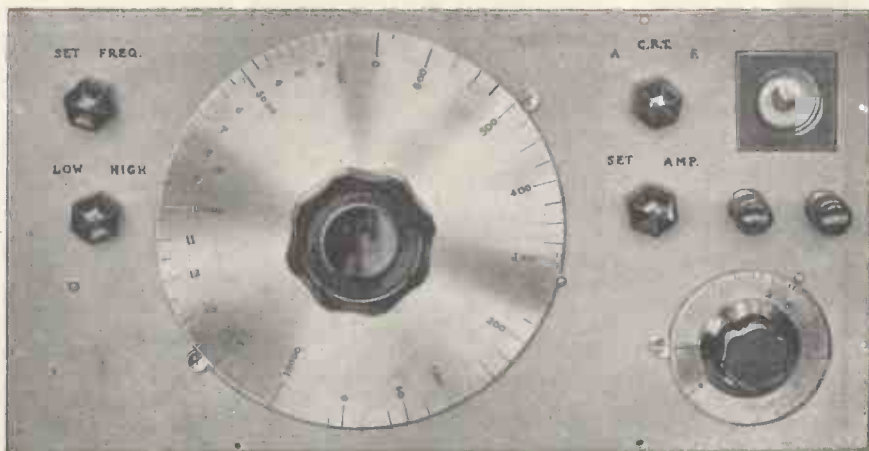

Panel View of B.F. Oscillator showing open scale.

To maintain the audio-frequency output from the detector at constant amplitude over the whole of the band, the amplitude of the variable frequency oscillator should remain constant. This is achieved by arranging that the variation of tuning capacity is a small fraction of the total tuning capacity, so that the L/C ratio does not change appreciably. The use of a large tuning capacity also tends to minimise the effect of variation of valve inter-electrode capacities as the apparatus heats up.

Where the apparatus is required to

produce very low audio-frequencies, say below 50 c/s., the utmost care must be taken to avoid coupling between the two oscillators, otherwise their tendency to synchronise with each other may prevent the lower frequencies being obtained. In any case, such tendency to synchronisation of the two oscillators tends to make the zero set adjustment rather indeterminate. If such tendency cannot be avoided, it will be better to make the initial adjustment at some frequency other than zero, 50 cycles being convenient, since it enables the adjustment to be checked against the mains.

A Typical Design

In the circuit shown, electron-coupled oscillators are used to minimise possible interaction between them, this being further ensured by applying the two signals to different electrodes in the detector-mixer valve. Separate decoupling to the two screens of the oscillators prevents interaction *via* the H.T. supply.

Oscillations are generated by cathode, grid and screen of each valve, that part of each valve's electron stream which passes through the screen to reach the anode being modulated at the oscillation frequency.

The fixed frequency oscillator has its output filtered by the double-tuned transformer before being fed to the control grid of the triode-hexode detector-mixer. The 30-ohm resistance across the transformer primary is required to reduce the amplitude of output to a value which can be handled without distortion by the triode-hexode.

The variable frequency oscillator has its output fed *via* a small condenser to the injection grid of the triode-hexode, the triode section of this



Chassis of B.F. Oscillator described in text.

valve not being used. The hexode section provides the most satisfactory mixing device available. Although it would be possible to use the triode section as the variable-frequency oscillator, such an arrangement causes greater tendency to "pulling" between oscillators, and makes it more difficult to keep frequency drift low. The injection grid of the hexode is auto-biased by the flow of grid current.

The load impedance for the hexode anode circuit is a 2,500-ohm resistance, this low value being used so that the necessarily high shunt capacities of the succeeding filter should not cause appreciable loss of amplification at the higher audio-frequencies. The cathode bias and screen bypass condensers are considerably larger than is usually expected in a triode-hexode circuit, owing to the fact that this valve is here required to deal with difference frequency components down to a few cycles per second.

From the anode circuit of the hexode the signal is taken to the first audio-frequency amplifier via a low-pass filter. This filter must produce negligible and constant attenuation over the required A.F. range, but must provide fairly complete rejection of the two original signals, which will be present at fairly large amplitude in the hexode anode circuit. The filter must also reject any intermodulation products other than the desired beat.

The filter consists of two tuned circuits in series to form a potential divider, both circuits being resonant at the central frequency of the small range covered by the variable frequency oscillator. One is arranged as a parallel circuit, which has high impedance to signals at its resonant frequency, and the other as a series circuit, with low impedance to signals at its resonant frequency. Thus the undesired radio-frequency signals are developed across the parallel circuit, the feed to the next stage being across the series circuit. To signals within the A.F. range, the inductance of the parallel circuit provides negligibly low reactance, while the condenser of the series circuit has high reactance at these frequencies, and so almost all of the A.F. output from the hexode is coupled on to the next stage. The resistance across the series circuit is merely to complete the grid circuit of the first A.F. stage. It is positioned inside the filter screening can to minimise hum pick-up.

Between the first and second A.F. amplifiers is another simple filter, comprising merely an H.F. choke, which works in conjunction with the

input capacity of the second amplifier.

Both these stages have the usual cathode by-pass condenser omitted, providing negative feedback which tends to maintain amplification constant over the range of frequencies covered.

Coupling to the output stage is via two gain controls. The first is a pre-set adjustment, and is set to provide 15 volts output when the second control is at maximum. This second control is then calibrated for output voltages less than 15.

The output stage is a triode connected output pentode, used as a cathode follower to provide the lowest possible output impedance without the use of a transformer, the cathode load being a 2,000-ohm resistance. The output impedance is approximately 150 ohms.

A magic eye tuning indicator is used for zero setting, or to provide checks against the mains frequency at multiples of 50 c.p.s. up to about 500 c.p.s. The triode anode of the indicator takes its H.T. direct from the rectifier cathode, with a 25-ohm resistance between this point and the reservoir condenser. The waveform of the ripple which is here superimposed on the H.T. supply contains numerous harmonics of the mains frequency.

The audio-frequency output of the cathode follower stage is fed to the control grid circuit of the magic eye, so that the anode current of this valve contains a beat at the frequency of the difference between the A.F. output and the nearest 50 c.p.s. harmonic. When this difference is only one or two c.p.s., it causes the shadow on the magic eye target to flicker visibly.

With the frequency dial set to 50 c.p.s. the set zero adjustment is moved until the shadow flicker is reduced to a very slow movement. The harmonics present on the indicator H.T. supply are sufficiently strong to enable 50 c.p.s. intervals to be checked up to about 500 c.p.s.

The wide range of frequency covered cannot conveniently be calibrated on to a single dial, unless the condenser controlled by that dial has an approximately logarithmic capacity law, necessitating vane shaping not normally obtainable.

The standard capacity law available is such as to give a linear law of wavelength, and even when the A.F. range is divided into two, such a condenser causes inconvenient cramping of the lower frequencies. To minimise this cramping it is desirable to use padding condensers in con-

junction with the main tuning condenser.

With a variable and a fixed condenser in parallel, the fixed condenser having a capacity of about one-third that of the variable condenser's maximum, then the per cent. change of capacity will be only slight for the first part of the travel of the variable condenser as it is increased from minimum. When the variable capacity approaches and exceeds that of the fixed condenser, total capacity will have a much more rapid per cent. increase.

The addition of a small series condenser can reduce the total capacity to any required value, and will not change the capacity law, providing the series capacity is appreciably less than the minimum of the parallel combination.

The inset to the circuit diagram shows the capacity network used to provide the best possible scaleform on each of two ranges. C_2 forms the major part of the total tuning capacity for the variable frequency oscillator. The very small condenser C_1 is in parallel with C_2 and is used for zero adjustment.

C_3 is the main tuning condenser, with a maximum capacity of 1,000 pF and a minimum of about 50 pF. For the high A.F. range it is in parallel with C_6 , of a maximum capacity of 100 pF. The two are then in series with the parallel combination C_3 and C_4 , of which C_4 is much the larger, and is set to cause the main tuning condenser to cover the required A.F. range.

With the range switch moved to the low A.F. range, covering up to 550 c.p.s., C_7 , of a maximum capacity of 350 pF, is switched into parallel with the main tuning condenser, and, simultaneously, C_4 is switched out of circuit. The remaining series condenser C_3 , has very low capacity, and so considerably restricts the range now covered by the tuning condenser.

The final adjustment of the various pre-set condensers is made to cover the desired frequency ranges and to arrange that the same zero setting holds good on both ranges. On both ranges, but more particularly on the low frequency range, the commencement of the scale is appreciably opened out from that which would be obtained without the padding.

Although this circuit shows the various pre-set condensers as single condensers, in actual fact all but C_3 consist of a fixed condenser in parallel with a variable one, with the majority of the capacity formed by the fixed condenser.



It isn't . . . isn't what? isn't a watt!
It's the c.g.s. unit of energy.

WHAT'S "ERG"?

ERG is the trade mark identifying a line of products that will be available when we've finished the biggest job of all.



ERG
RESISTORS LIMITED
1021a, FINCHLEY RD., LONDON, N.W.11
Phone : Speedwell 6967

GA

Have you heard this one?



The above heading is just to catch your attention. We (that is PARMEKO LTD. of Leicester) only want to remind you that we do make very good TRANSFORMERS either in small or large quantities or in single special designs - and if you have a job where a transformer has really got to do its stuff well we would rather like to have a crack at it.

One of our pet sales points is that all PARMEKO transformers are vacuum impregnated . . . this advantage, combined with special materials, makes certain that they operate under tropical conditions.

We have a large research department engaged on war work but we can at least discuss your problems—or are you not interested in post war planning?

PARMEKO LTD., LEICESTER Makers of Transformers.



STATIC TWO-DIMENSIONAL visual delineation of any recurrent law:

RELATIVE TIMING OF EVENTS and other comparative measurements with extreme accuracy.

PHOTOGRAPHIC RECORDING of transient phenomena.

SIMULTANEOUS INDICATION of two variables on a common time axis

INDUSTRIAL INDICATING and TESTING afford increasing scope for the Cathode Ray Tube as the only device with the above inherent features, of which the last is unique in the Cossor DOUBLE BEAM Tube.

The Model 339 Cossor Oscillograph thus equipped is invaluable on all problems of research, production or operational testing, when the effect examined is applied as a voltage. When recurrent, the traces are studied visually and when transient are recorded photographically, using Model 427 camera.

A. C. COSSOR Ltd.,

INSTRUMENT DEPT.

Cossor House, Highbury Grove, London, N.5

Phone: CANonbury 1234 (33 lines).

Grams: Amplifiers Phone London.

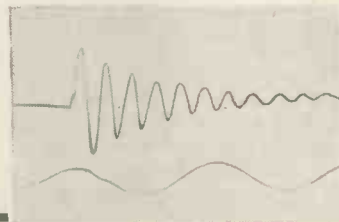

VALVE VOLTMETERS

Furzehill Valve Voltmeters are designed by engineers for engineers, attention being paid to the small details which save time.

For example, the zero does not need resetting when the range is changed. The reading is unaffected by the inevitable changes in mains voltage which might otherwise invalidate a whole series of figures. The scales are specially chosen for easy reading, etc., etc.

Two types are in current production, viz. :—

TYPE 281 Diode Voltmeter, reading from 0.1 volt to 150 volts in five ranges, suitable for all frequencies from 50 c/s to 50 Mc/s. Only 3 scales, the top three ranges having a common scale.

TYPE 378 Feedback Voltmeter (incorporating high gain stabilised amplifier) reading from 1 millivolt to 100 volts in five ranges. Accurate over the range 50 c/s to 250 kc/s. Only one scale for all ranges,

Both types mains operated.

Write for detailed particulars.

FURZEHILL
LABORATORIES LTD.
BOREHAM WOOD
HERTS
TELEPHONE . ELSTREE 1137

NOVEMBER MEETINGS

*NOTE.—In general, visitors are admitted to the meetings of scientific bodies on the invitation of a member, or on application in writing to the Organising Secretary at the address given. In certain cases (marked *) tickets may also be obtained on application to the Editorial offices of this Journal.*

Institution of Electrical Engineers

London Section

All meetings of the London Section will be held at the Institute of Electrical Engineers, Savoy Place, Victoria Embankment, London, W.C.2.

Radio Section

On November 1, at 5.30 p.m., two papers will be read as follows: "Theory and Performance of Corner Reflectors for Aerials," by E. B. Moullin, M.A., Sc. D.; and "The Measured Performance of Horizontal-Dipole Transmitting Arrays," by H. Page, M.Sc.

On November 21, at 5.30 p.m., the meeting will take the form of a discussion on "New Aspects of Post-War Interference Suppression" and will be opened by P. R. Coursey, B.Sc.

The Secretary: The Institution of Electrical Engineers, Savoy Place, Victoria Embankment, London, W.C.2.

Students' Section

At 6.30 p.m., on November 7, an address will be given by the Chairman (Mr. C. C. Barnes) entitled "Notes on the Design and Manufacture of Impregnated Paper Insulated Power Cables."

Section Secretary: R. G. Stefanelli, 19 Effingham Lodge, Surbiton Crescent, Kingston, Surrey.

Institute of Physics

A meeting of the above will be held on Friday, November 3, at 5.30 p.m., at the Institution of Electrical Engineers, Savoy Place, London, W.C.2. A lecture will be given by E. F. Relf, F.R.S., A.R.C.S., F.R.Ae.S., Superintendent of the Aerodynamics Department of the National Physical Laboratory, on "Air and Fluid Motion."

Hon Secretary (London and Home Counties Branch): South-West Essex Technical College, Forest Road, London, E.17.

Association of Scientific Photography *

The subject of the next meeting will be "Electron Micrography," and will take the form of an Introduction and two papers as follows:—

Introduction: "The Electron Microscope," by G. Parr, A.M.I.E.E.

1. "Photographic Materials for use in the Electron Microscope," by E. M. Crook, Ph.D., and L. V. Chilton, M.A., F.Inst.P.
2. "Applications of Electron Micrography in Textile Research," by D. G. Drummond, Ph.D., F.Inst.P.

This meeting will be held on November 25, at 3 p.m., at 16 Princes Gate, London.

The Secretary: Association of Scientific Photography, 34 Twyford Avenue, Fortis Green, London, N.2.

British Kinematograph Society

The next meeting of the above will be held on November 1, at 6 p.m., at the Gaumont-British Theatre, Film House, Wardour Street, London, W.1. A paper will be read by E. Lindgren on "The Work of the National Film Library."

Organising Secretary: R. H. Cricks, Dean House, 2 Dean Street, London, W.1.

Bradford Electronics Society

On Tuesday, November 7, at 7 p.m., a meeting will be held at the Technical College, Bradford. The lecture will be given by G. Parr, A.M.I.E.E., entitled "Electronics in Medicine and Medical Research."

Hon. Secretary: G. N. Patchett, Technical College, Bradford.

The Television Society *

A meeting will be held at the Institution of Electrical Engineers, Savoy Place, W.C.2, on Tuesday, November 28, at 6 p.m., when a paper on "Some Aspects of Large Screen Television," will be read by T. M. C. Lance (Cinema Television).

Lecture Secretary: G. Parr, 43 Shoe Lane, E.C.4.

The Admittance Coefficient

By J. H. OWEN HARRIES, A.M.I.E.E.

THE usefulness of any formula connecting current and voltage by means of a quantity termed the "admittance" (which may be a complex number) is well known. The present paper sets out this idea from a generalised conception up to its application to problems other than the relations between current and voltage. An application of this is exemplified in the case of the ultra-high-frequency deflection of a beam of electrons in a cathode-ray tube or deflection valve. It is also extended briefly to those cases in which a circuit "constant" is sinusoidally varied whilst an E.M.F. is applied.

Definition

The admittance of an electric circuit is that familiar quantity by which the voltage is multiplied to obtain the current.

For the purposes of the present paper, however, a mere general definition will be posed as follows:—

"The Admittance Coefficient of a device is the quantity by which a voltage or E.M.F. function is multiplied to obtain a desired operating condition or operating function of the device."

Particular derivations of this are:

Case (a). The Admittance is the quantity by which the E.M.F. or voltage function applied to it is multiplied to obtain the current flow function. (Thus $I = E \times K$, and K is the admittance).

Case (b). In the case of an electric circuit one of the constants of which is varied, the Admittance Function of an electrical circuit is the function (usually of time) by which the E.M.F. or voltage function applied to it is multiplied to obtain the current function.

Case (c). The Deflection Coefficient of a cathode-ray tube is the quantity by which the E.M.F. or voltage function applied to the deflection plates is multiplied to obtain the "beam deflection function,"

Let the admittance coefficient be represented by Z ; it will in general have real and imaginary parts A and jB respectively, and a phase angle (or argument) of $\tan^{-1} B/A = \phi$.

The magnitude of the admittance coefficient is $\sqrt{A^2 + jB^2}$.

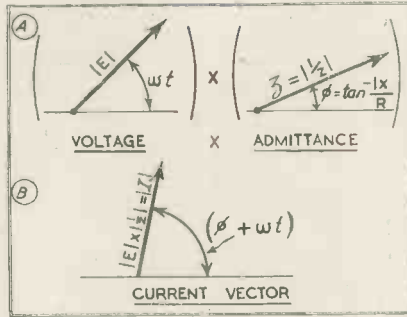

Fig. 1.

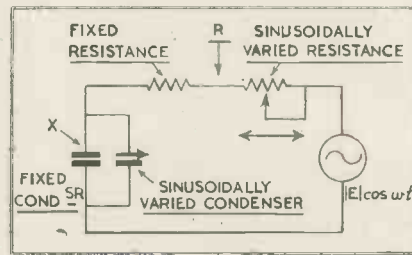

Fig. 2.

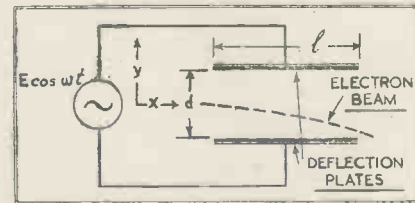

Fig. 3.

Let the "operating function" be indicated by a vector O .

Let the modulus of a vector V be indicated by $|V|$.

Simple Voltage and Current Relationships: Case (a).

Let the alternating current vector $I = EZ$ (1)

Here $E = |E| (\cos \omega t - j \sin \omega t)$ (2)

The accepted convention is that the instantaneous value of the voltage or E.M.F. is given by $e = |E| \cos \omega t$ (3)

that is, by the real part of the voltage vector. The phase angle of the current is therefore reckoned with respect to this real part.

The familiar conventional symbols are such that

$$Z = \frac{I}{E} = \frac{I}{R} + j \frac{I}{X}$$

when R and X respectively represent the resistance and reactance of the circuit.

The idea may be represented graphically by vector diagrams.

In Fig. 1a the rotating independent variable (or "cause factor") is the voltage or E.M.F. vector E , and the admittance coefficient is also a vector quantity $1/Z$ (or Z) which has a fixed phase angle

$$\phi = \tan^{-1} X/R.$$

To find the current function these vectors must be multiplied together as indicated.

The result of this multiplication is shown in Fig. 1b. The new vector is that of the current. Its maximum magnitude is $|E| \sqrt{R^2 + X^2}$ and occurs when $\cos \omega t = 1$ and $\omega t = 0, 2\pi, \text{ etc.}$

It has a phase angle of θ with respect to the voltage vector, and its real and imaginary parts are of corresponding relative magnitude.

Thus, for example, if $\omega t = 0$, the real part of the voltage vector is unity, and the imaginary part is zero. The current vector is θ in advance.

It is unnecessary to point out the usefulness of this familiar artifice for the study of current and voltage in any circuit. It is set out here for the sake of clearness and completeness.

Voltage and Current in a Circuit having Variable "Constants" Case (b).

In this case Z is itself a function of some variable; usually it is time. In practice only a part of the reactance or resistance is likely to be varied by some such means as are sketched in Fig. 2. Then the "admittance function" is

$$Z = A (1 + k_1 \cos pt) + j B (1 + k_2 \cos qt)$$

where $k_1 =$ the fraction of the resistance which is varied, and $k_2 =$ the fraction of the reactance which is varied, or $1/Z = (1/R) (1 + k_1 \cos pt) + j (1/X) (1 + k_2 \cos qt)$ (5)

The current vector is therefore

$$|I| = |E| \left\{ (1/R) (1 + k_1 \cos pt) + j (1/X) (1 + k_2 \cos qt) \right\}$$

and the instantaneous value of the current is

$$i = |E| \cos \omega t \left\{ (1/R) (1 + k_1 \cos pt) + j (1/X) (1 + k_2 \cos qt) \right\} \dots (5.1)$$

By ordinary trigonometry the current splits up into five components:

$$\begin{aligned}
 i_1 &= |E| \cos \omega t \left(\frac{1}{R} + j \frac{1}{X} \right) \\
 i_2 &= |E| \cos (\omega + \rho) t \left[\left(\frac{1}{R} + j \frac{1}{X} \right) \frac{k_1}{2} \right] \\
 i_3 &= |E| \cos (\omega - \rho) t \left[\left(\frac{1}{R} + j \frac{1}{X} \right) \frac{k_1}{2} \right] \\
 i_4 &= |E| \cos (\omega + q) t \left[\left(\frac{1}{R} + j \frac{1}{X} \right) \frac{k_2}{2} \right] \\
 i_5 &= |E| \cos (\omega - q) t \left[\left(\frac{1}{R} + j \frac{1}{X} \right) \frac{k_2}{2} \right]
 \end{aligned}
 \tag{5.2}$$

New admittances (in square brackets) exist for components 2 to 5; as well as that in round brackets for the applied frequency component.

The "Displacement Coefficient" of a Cathode Ray Tube or Deflection Valve Case (c).

The preceding cases are simple: in certain instances, however, a difficulty arises. On some occasions the "operating function" (see the general definition in sec. 1) is represented by a function of E' , and of some other factors such that $f(O)$ cannot readily split into two factors E and Z .

Such a state of affairs will be found when considering the following application.

It is often desired to study the magnitude and phase (with relation to a deflecting voltage) of the deflection of a beam of electrons in a transverse alternating deflecting field (Fig. 3).

It may be shown by successive integration of the equations of motion that the deflection is equal to

$$y = \frac{e|E|}{\omega^2 dm} \left\{ \cos \omega t - \omega \tau \sin \omega t_0 - \cos (\omega t_0 + \omega \tau) \right\} \dots\dots\dots 6)$$

where $|E|$ = the maximum value of the deflecting voltage,

d = the distance between the plates,

t = the time.

t_0 = the time of entry into the plates.

τ = the transit time through the plates: $\tau = t - t_0 = e/v_x$

where v_x = the velocity of the electrons past the plates.

Now equation (6) cannot be written directly in the form of a product of $E \cos \omega t$ and a Z value.

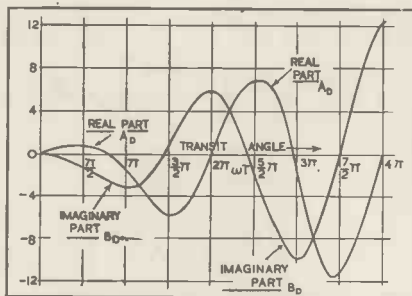

Fig. 4.

The difficulty may be overcome as follows:

To obtain (6) the usual acceleration equation

$$\frac{d^2 y}{dt^2} = \frac{|E| \cos \omega t}{dm}$$

was successively integrated between the limits of t_0 and t .

Instead, express the acceleration in terms of vector notation. Then

$$\frac{d^2 y}{dt^2} = \frac{|E| e^{j\omega t}}{dm} \dots\dots\dots (7)$$

Integrating this equation results in a vector displacement

$$y = \frac{e|E|}{\omega^2 dm} \left\{ \exp. (j\omega t) + j\omega \tau \exp. (j\omega t) - \exp. (j\omega t_0) \right\} \dots\dots\dots (8)$$

and this may easily be changed unto the desired form. It can be written as:

$$y = \frac{e|E| \exp. (j\omega t)}{\omega^2 dm} \left\{ \exp. (-j\omega \tau) + j\omega \tau \exp. (-j\omega \tau) - 1 \right\}$$

because $t - \tau = t_0$.

The deflection coefficient, Z_D is then:

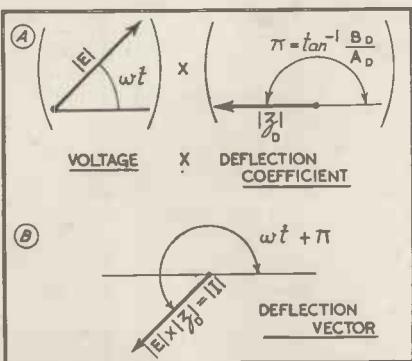

Fig. 5.

$$Z_D = \frac{e}{\omega^2 dm} \left\{ \exp. (-j\omega \tau) + j\omega \tau \exp. (j\omega \tau) - 1 \right\} \dots\dots\dots (9)$$

The real and imaginary parts of the deflection coefficient may be written, respectively, in terms of circular measure; and if the volts are in practical units, we have:

$$A_D = \frac{5.274 \times 10^{17}}{\omega^2 d} \left\{ \omega \tau \sin \omega \tau + \cos \omega \tau - 1 \right\} \dots\dots\dots (9.1)$$

$$B_D = \frac{5.274 \times 10^{17}}{\omega^2 d} \left\{ \omega \tau \cos \omega \tau - \sin \omega \tau \right\} \dots\dots\dots (9.2)$$

$$\text{and } \theta_D = \tan^{-1} \frac{B_D}{A_D}$$

The "maximum" magnitude of the deflection is

$$y = |E| \sqrt{A_D^2 + B_D^2}$$

Clearly both the real and imaginary parts go through successive positive and negative values as the transit angle $\omega \tau$ is increased from zero (Fig. 4). By altering $\omega \tau$ (i.e., by altering either the frequency, or the velocity of the electrons, or the length l of the plates), the phase and magnitude of the deflection may be given desired values.

For example, $\omega \tau = 3/2\pi$ the deflection coefficient is wholly real and negative. The deflection at the end of the plates is then exactly 180° out of phase with the voltage, i.e., this part of the beam moves towards the most negative of the two plates.

Fig. 5 illustrates this. In Fig. 5a the voltage vector is rotating at an angular velocity ωt and is multiplied by the "deflection coefficient" vector which is chosen by reference to Fig. 4, to be wholly real and negative, i.e., to have a phase angle of $\pi = 180^\circ$ (because if $B_D = 0$, \tan^{-1}

$$\frac{B_D}{A_D} = \pi). \text{ The product of the two}$$

vectors is shown at Fig. 5b, and is the deflection vector. It is always advanced 180° on the voltage vector. Therefore, the deflection is always negative, i.e., towards the negative deflection plate.

REDIFFUSION Radio Heating



This is the Rediffusion R.H.2, delivering more than 250 watts of radio frequency power. Only 18 x 15 x 12 inches, it is very simple to instal and control. The matching unit shown on the bracket may instead be coupled to the set through a 6-ft. screened cable.

A screened heating cage 12 x 12 x 12 inches can be supplied for laboratory work on moulding powders and other small specimens.

At present deliveries can only be made for high priority work, but we illustrate this as an indication of Rediffusion advance development.

REDIFFUSION LTD

A Subsidiary of
Broadcast Relay Service Limited



Designers and manufacturers of Radio Communication and Industrial Electronic Equipment

VICTORIA STATION HOUSE • VICTORIA STREET • LONDON • S.W.1 (PHONE VICTORIA 8831)

Ensure the most successful results



USE

B.I. CONDENSERS

BRITISH INSULATED CABLES LTD.,

Head Office PRESCOT, LANCs.

Telephone: PRESCOT 6571.

NOTES FROM THE INDUSTRY

Colour Code for Fixed Resistors

The Inter-Service Components Technical Committee decided earlier in the year that in order to avoid confusion with the interchange of equipment and spares between the Allies, the resistor colour code in this country should be in agreement with that in the United States. Accordingly, the tolerance coding has been altered to conform with the American standard as follows:—

- ± 5 per cent. Gold band or dot.
- ± 10 per cent. Silver band or dot.
- ± 20 per cent. No colour.

The former British practice was to use no colour for the 10 per cent. tolerance and silver for the 20 per cent. tolerance. Intending users of resistors in which the tolerance is important should see whether they are coded to the new or old convention. Service equipment was all changed to the new code on July 1.

Radio Components for Service Equipment

The British Standards Institution has issued a series of War Emergency British Standards and Specifications which have been prepared by the Inter-Services Components Committee. These include Guides (Codes of Practice), Specifications and Test Schedules, and Preferred Lists of Working Schedules, covering all types of radio components (except valves). Separate sheets relating to individual components are obtainable on request from the B.S.I., 28 Victoria Street, S.W.1.

It would be interesting to know why the specifications have been printed the length way of a foolscap sheet. Are the binding cases standardised? We doubt it.

B.S. 156 Standard for Enamelled Wires

A new grade of enamelled wire has been introduced into the specification B.S.156, a revision of which has been published by the British Standards Institution.

This new grade has a heavier coating of enamel, and the original grade and the new grade are not designated "normal covering" and "thick covering" respectively, the latter being sometimes referred to in the trade as "double enamelled wire."

Copies of this revised Standard (B.S.156-1943) may be obtained from British Standards Institution, 28 Victoria Street, London, S.W.1, price 2s., post free.

The British Kinematograph Society

Theatre Division

A step of great importance to the film industry is the formation by the British Kinematograph Society of a Theatre Division, whose function it will be to watch over every technical aspect of the cinema.

The primary function of the new Division will be to serve the exhibitor and the projectionist, and its policy will be shaped by them in conjunction with the renter and with the manufacturers of supplies and equipment.

Membership of the B.K.S. and of the Theatre Division is open, in the Associate grade, to any person who for more than a year has been actively engaged in the film industry, or in the many industries catering for its needs. Particulars of membership of the Society and of the Division may be obtained from the Organising Secretary, 2 Dean Street, London, W.1.

Post-War Prospects in Canada

The Hamilton Bridge Co., of Ontario, have issued a brochure on Post-War Prospects "addressed to business men and industrialists interested in the manufacture of metal products who have not yet considered the advantages of Canada as a manufacturing and marketing centre." The Hamilton Bridge Co. have had over 80 years' experience in the manufacture and erection of machines and is ready to discuss proposals for manufacturing in Canada. Copies of the brochure can be obtained from the Company at Hamilton, Ont., or the Canadian Government Trade Commissioner, Canada House, S.W.1.

War-Time Civilian Receivers

The maximum retail prices of war-time civilian receivers are as follows:

A.C. Mains £12 3s. 4d., inclusive of Purchase Tax.

Battery £10 19s., inclusive of Purchase Tax.

Renting agreements are terminable at one month's notice on the part of the customer, and the monthly rent must not exceed 13s. 6d. for any of the first 30 months. Battery sets may not be rented.

Correction

Dr. W. Sommer writes to point out that the B.S.S. relating to symbols is 423 and not 403, as mentioned in last month's Correspondence column.

Metro-Vick Research

It is announced that Mr. G. B. Churcher, M.Sc. has been appointed Manager of the Research Department of the Metropolitan-Vickers Electrical Co., Trafford Park.

Mr. Churcher, who is well-known to many in the electrical and radio industry for his work on acoustics, joined the British Westinghouse Co. in 1910 and was actively concerned in developing the Research Laboratory into its present form as one of the largest industrial research organisations.

He was Chairman of the N.W. Section of the I.E.E. at the beginning of the war and has read many papers on the various subjects investigated by his department.

Sinclair Speakers

Change of Address

Messrs. Sinclair Speakers have moved from their address at Copenhagen Street, N.1. to 12 Pembroke Street, N.1 in the same neighbourhood.

A Universal Tester

The Acru Tool Mfg. Co. (123 Hyde Road, Manchester 12) have produced a universal mains testing device for electrical apparatus. Known as the "Pyrobit" tester, it indicates continuity and insulation to earth of all kinds of electrical equipment and is fitted with 5 and 15 amp. 3-pin sockets for plugging in apparatus directly. Price £2 10s., with testing spikes 9s. 6d. extra.

Electricity for Schools

The U.S. War Department have prepared an outline course in Electricity and Magnetism for use in Pre-induction Training Courses, and the book has been issued and written by the staff of Science Service in collaboration with the Westinghouse E. & M. Co. The lessons are simply written and the experiments can be done by an intelligent youngster without any difficulty.

An interesting point is that stress laid on procuring materials for the experiments from the salvage heap: "Many dry cells are found on shores near boat landings where they are thrown out each fall . . . if you need binding posts and screws you can get them here!" Writers of school textbooks on electricity could follow some of the practical suggestions with advantage.

ELECTRICAL CONTACTS IN PRECIOUS METALS OR PRECIOUS METAL ALLOYS

JMC electrical contacts are in demand for war service in all types of electrical equipment in all theatres of war, but we endeavour to maintain our advisory service to customers and give the benefit of our wide experience in the application of precious metals and their alloys to all kinds of contact requirements.

SILVER. PLATINUM SILVER-COPPER
GOLD. GOLD-SILVER PLATINUM-IRIDIUM
PLATINUM-GOLD-SILVER PLATINUM-RUTHENIUM
AND OTHER ALLOYS
PALLADIUM-SILVER
PALLADIUM-COPPER

Enquiries should be headed "Contact Enquiry" and addressed to Head Office.

JOHNSON, MATTHEY & CO.
LIMITED.

73/83, HATTON GARDEN,
LONDON, E.C.1

Users of electrical contacts who do not possess a copy of our earlier reference booklet No. 112, are invited to apply for a copy of the abbreviated war-time edition illustrated reference No. 114

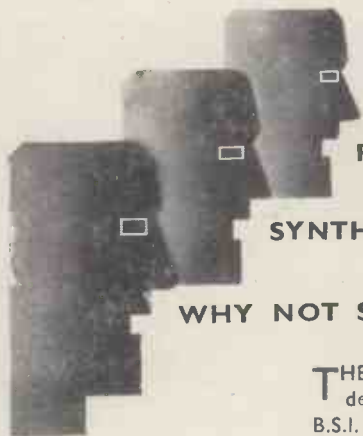

PHENOL BOARD

SYNTHETIC RESIN BONDED BOARD

WHY NOT SAY **DELARON** ... IT'S QUICKER AND BETTER !

THERE are a host of varying terms and descriptions to identify what is known to the B.S.I. as "Synthetic Resin Bonded Paper—(Fabric)—Sheets." And "DELARON" is the name that has been given to that made by De La Rue Insulation Ltd. But it is more than just a name—it is your guarantee that the whole of the vast resources both in research and manufacture, of the De La Rue organisation are enlisted in its production. Our Technical

and Development Departments will gladly co-operate with you in determining the most suitable grade of "DELARON" to meet your needs either for insulation or mechanical purposes. Fullest details, samples and prices gladly sent on request.

DELARON
LAMINATED PLASTIC

De La Rue
IMPERIAL HOUSE
84 REGENT ST. W1

Insulation

Limited
Telephone
REGENT 4901

Summer School in X-Ray Crystallography

Report of Cambridge Meeting

THE second Summer School of X-Ray Crystallography, held at Cambridge from September 4th to 15th, was highly appreciated by all who attended. The School was opened by the Cavendish Professor of Physics, Sir Lawrence Bragg and the nineteen lectures, followed by sessions of practical work, were shared by Miss A. M. B. Parker and Drs. N. F. M. Henry, H. Lipson, D. P. Riley and W. A. Wooster. The organisation and syllabus of the course were similar to those of last year.

The application of X-rays to crystallographic problems of industrial importance has made dynamic advances, but remains a young science still largely cradled in the Universities and similar academic laboratories. Many of the senior technical men attached to industrial organisations have had no opportunity to acquire more than a superficial knowledge of the subject and its possibilities, while graduates just entering industry, though they may have received some training in X-ray methods, can hardly be expected fully to appreciate their application to practical technology. A

gap clearly exists which it was the purpose of the School in some measure to bridge; to quote the syllabus of the course "the chief aim is to give scientists and technicians a training in the fundamentals of the subject, to bring them into touch with the wide range of methods used, to teach them the newest techniques, and to indicate the many types of industrial problems in which this work can be used with advantage." There is no doubt that these aims were admirably fulfilled.

During the first week attention was confined to the more fundamental aspects of the subject, In the second week the knowledge so acquired was applied to the study of polycrystalline

aggregates by means of "back-reflexion" and "powder" photographs and the essentially practical nature of the course emerged. Familiarity was gained with such matters as the accurate determination of lattice spacings, the identification of crystalline substances and of the phases present in alloys; the assessment of preferred orientation, internal stress and grain size in metals and the study of imperfect forms of crystals such as those occurring in rubber, textile fibres and plastics.

An important aspect of the more advanced work was the pains taken by the lecturers to point out the limitations of the methods at present available, to indicate the probable lines of future progress, and, in a word, to share with the students the fruits of their own experience. It is such personal contact which makes a course of this kind so valuable to one who, like the writer, had nothing previously but a smattering of text-book knowledge.

E. VOCE,

*British Non-Ferrous Metals
Research Association.*

H. K. LEWIS & Co. Ltd.

A twelve page list giving details of reproductions of German technical publications issued under the authority of the Alien Property Custodian in Washington has just been prepared; a copy will be sent on application.

LONDON: 136 GOWER STREET, W.C.1



War to the
NIFE

SERVING THE COUNTRY
WITH ITS
Life

NIFE All-Steel Alkaline Batteries are now in use wherever the Services require — **MAXIMUM RELIABILITY.** After the War, they will be available for peace-time radio requirements.

ALL STEEL ALKALINE BATTERIES

NIFE BATTERIES LTD. • HUNT END • REDDITCH • WORCESTERSHIRE



through

MIP LTD

Manufacturers of

Switchboard and Portable Pattern Microammeters,
Milliammeters, Ammeters, Voltmeters, Wattmeters
and Testing Sets.

MEASURING INSTRUMENTS (PULLIN) LTD.
ELECTRIN WORKS, WINCHESTER ST., ACTON, W.3



RESEARCH

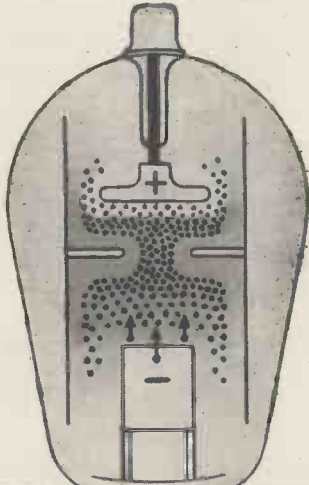

ELECTRONIC CONTROL

BTH Research has carried out pioneer work in all branches of electronic science and has been responsible for many of the major technical developments and applications.

BTH

THE BRITISH THOMSON-HOUSTON CO., LTD.
CROWN HOUSE, ALDREYCH, LONDON, W.2



A3456 N



5 mmf/ft
NEW LOW LEVELS in capacity and attenuation of CO-AX Cables mean new possibilities in electronic equipment design both for the war effort and for the post-war electronic age.

Write for characteristics

**BASICALLY BETTER
AIR-SPACED**

CO-AX-LOW LOSS CABLES

TRANSRADIO LTD. 16 THE HIGHWAY BEACONSFIELD 6-BUCKS.



*—now potential users of
High Frequency Equipment
should write for full
particulars of—
"Tenaplas"
Co-Axial Cable*

TENAPLAS

LIMITED

PIONEERS IN PLASTICS

7 PARK LANE, LONDON, W.1

You'll remember

DALY

for

**ELECTROLYTIC
CONDENSERS**

Condenser Specialists for over 20 years

Daly (Condensers) Ltd.,
West Lodge Works, The Green, Ealing, W.5.
Telephone: Ealing 4841

INSTRUMENT SOLDERING IRON
IDEAL FOR DELICATE
RADIO PRODUCTION
& REPAIRS



ONLY 5/0Z Send for List L28
RUNBAKEN-MANCHESTER-1

TRANSFORMERSto customers' specifica-
tions or in accordance
with standard list.**W. BRYAN SAVAGE LTD.**

Westmoreland Road, London, N.W.9. Colindale 7131

**Bargains in Radio, Electrical and
Scientific Apparatus.**

SEND YOUR ENQUIRIES TO DEPT. E.E.

ELECTRADIX RADIOS,

214, Queenstown Rd., Battersea, London, S.W.8

**LAMINATIONS & SCREENS
RADIOMETAL · PERMALLOY
SILICON ALLOYS****Electrical Sound & Television Patents Ltd.**
12 PEMBROKE ST., N.1**SHELL TYPE
CERAMIC INTERNATIONAL
VALVE HOLDER**HIGH Ω
LOW INTER-ELECTRODE CAPACITY
HIGH INSULATION
INTERCHANGEABLE
TYPE APPROVED

For Technical Data:

OXLEY DEVELOPMENTS Co., Ltd.
ULVERSTON, LANCs.

Tel: 486

CLASSIFIED ANNOUNCEMENTS.

The charge for miscellaneous advertisements on this page is 12 words or less 4/- and 4d. for every additional word. Box numbers (4 words) plus 1/- extra. Remittance should accompany advertisement. Cheques and P.O.'s payable to Hulton Press Ltd., 43 Shoe Lane, E.C.4. Press date—15th month for following issue.

FOR SALE

IN STOCK, Rectifiers, Accumulator Chargers, Rotary Converters, P.A. Amplifiers, Mikes, Mains Transformers, Speakers of most types, Test Meters, etc., Special Transformers quoted for.—University Radio, Ltd., 238, Euston Road, London, N.W.1. Ger. 4447.

BULL for rare and popular Valves, presenting also equivalent charts, 1/7, American Midgits, 2/7, Flick-O-Disk patent device reading volts, ohms and watts, 6/9, Electric Soldering Iron (state voltage) 13/6, "Testoscope," the vest pocket instrument, enables 20 tests AC/DC complete with search lead, 37/6. J. Bull and Sons, (Folio E.E.), 246, High Street, Harlesden, N.W.10.

LOUDSPEAKERS

LOUDSPEAKERS—We carry on. Sinclair Speakers, 12, Pembroke Street, N.1.

LOUDSPEAKER repairs, British, American, any make, moderate prices.—Sinclair Speakers, 12, Pembroke Street, N.1.

MISCELLANEOUS

WE WILL BUY at your price used radios, amplifiers, converters, test meters, motors, pick-ups, speakers, etc., radio and electrical accessories. Write, phone or call, University Radio Ltd., 238, Euston Road, London, N.W.1. Ger. 4447.

WEBB'S Radio Map of the World enables you to locate any station heard. Size 40" by 30" 2 colour heavy Art Paper, 4/6, post 6d. Limited supply on Linen, 10/6, post 6d.—Webb's Radio, 14, Soho Street, London, W.1. Phone: GERrard 2089.

MORSE Practice Equipment for Class-room or Individual Tuition. Keys, Audio Oscillators for both battery or main operation. Webb's Radio, 14, Soho Street, London, W.1. Phone: GERrard 2089.

BERRY'S (SHORT WAVE) LTD., can offer in addition to the usual radio accessories, a most complete range of U.H.F. and other precision components, such as CERAMIC Short Wave variable and screwdriver condensers from 25 mmfd.; 4 and 5 pin Ceramic valve-holders at 1/3; 6 pin and IR5 Ceramic at 2/-; Ceramic Octals 2/-; 2 1/2" Cathode Ray Tubes 13/6/-; Rothermel Crystal Pick-ups 73/6 and 78/9; Wearite "P" Coils 2/3 and 2/6; Brown's Headphones 22/6; nearly all types of English and American Valves at list prices. Speakers in all sizes: Ceramic formers, insulators, couplers, etc.; Jacks and Jackplugs, Fuseholders and the latest Radio Manuals. Send rd. stamp for List "E" to BERRY'S (SHORT WAVE) LTD., 25, High Holborn, London, W.C.1 (Tel.: Holborn 6231).

AMPLIFIER SPECIALIST offers Hi Gain 10 and 30-watt amplifiers of exceptional quality £20 and £30. Complete radio and staff locating installations undertaken. Radio Feeder Units. Sefton, 49, Clifford Avenue, London, S.W.14.

SITUATIONS VACANT

ELECTRONIC ENGINEER, French, Austrian, Czech, etc., required for research work. Priority job with peace-time prospects. Box No. 691, "Electronic Engineering."

LEADING MANUFACTURERS in light electrical engineering require a number of first-class Radio and Television Engineers, preferably with engineering degree, for post-war development. Applications will be considered from persons available at the cessation of hostilities. Write stating age, full details of previous experience and salary required, to Box No. 694, "Electronic Engineering."

HEAD FOREMAN required for development and semi-production of electronic tubes. Applicants must be fully conversant with the manufacturing and processing of transmitting tubes. Write giving full details of experience etc., to Box No. 696, "Electronic Engineering."

A.M.I.E.E., City and Guilds, etc., on "NO PASS-NO FEE" terms. Over 95% Successes. For full details of modern courses in all branches of Electrical Technology send for our 112-page handbook—FREE and post-free. B.I.E.T., (Dept. 337B), 17 Stratford Place London, W.1.

R. K. Dundas
LIMITED

are the manufacturers of

THE MICROTIMER

—an instrument for accurate measurement of short time intervals ranging from one millisecond to one second—and all other types of electrical apparatus.

Enquiries welcomed.

THE AIRPORT, PORTSMOUTH

Telephone: 74874

LONDEX for RELAYS

The wide range of Londex Relays includes a Variety of TYPES APPROVED

by
**AIR MINISTRY
& M.A.P.
ADMIRALTY**

Ask for details
and leaflet SPN/EO

Multiple contact
Relay LF

**LONDEX · LTD**

MANUFACTURERS OF RELAYS
207-ANERLEY ROAD · LONDON · S · E · 20
PHONE: 3708/1-2

Classified Announcements (Contd.)

A BRITISH COMPANY manufacturing special scientific instruments propose to expand their Research and Development facilities.

The new Department will be required to carry out Research and Development work connected with problems in Mechanical Engineering, Electrical Engineering, Aeronautical Engineering, Electronic Hydraulics and Physics, as applied to scientific instruments.

The following personnel are required:—

- Chief Research Engineer to co-ordinate and control the activities of the Department. Salary up to £1,500 per annum.
- Research Engineers to control sections dealing respectively with Mechanical Engineering, Electrical Engineering, Aeronautical Engineering, Electronics, Hydraulics and Physics. Salaries £750 to £1,000 per annum.

Applications are invited for the above posts, which offer unlimited scope immediately and in the post-war period. Essential qualifications are a University Degree and current research experience in the particular field for which the application is made. Write Box 1508, c/o White's, Ltd., 72, Fleet Street, London, E.C.4.

SITUATIONS WANTED

DESIGNER with ready plans for post-war development, radio-communication and test gear, seeks work with scope. Box No. 692, "Electronic Engineering."

PHYSICIST, several qualifications, 22 years' practical experience electronics and vacuum technique, several patents and original developments, wants responsible position. Write Box 1557, c/o White's, Ltd., 72, Fleet Street, London, E.C.4.

GRADUATE (Hons). Electrical, Mechanical and Radio Engineer (26), with qualification in Television, seeks engagement in Radio or Electronic industry. Box No. 695, "Electronic Engineering."

WANTED

ENGINEERING COMPANY in Hertfordshire will be glad to receive particulars of patents and inventions for post-war development, especially instruments or articles of light engineering character. Ample financial technical and manufacturing resources available. Box No. 693, "Electronic Engineering."

"After the War" Television

With the coming of Peace, and backed by the Technical advances that have resulted from the war years, TELEVISION will again spring to life and offer opportunities, as never before, to the trained man.

Now is the time to prepare for this new "market." Our Home-study "Television" Course is comprehensive, up-to-date and suitable both for the amateur and experienced Radio Engineer.

We definitely guarantee
"SATISFACTION—OR REFUND OF FEE"

You are advised to send for details of this special Television Course immediately, to investigate its possibilities. Details will also gladly be sent of A.M.I.E.E. and A.M.Bric.I.R.E., Examinations and other courses in all branches of WIRELESS ENGINEERING, including particulars of our special SHORT WAVE and RADIO SERVICING COURSES which are in such demand—Free.

BRITISH INSTITUTE OF ENGINEERING TECHNOLOGY
337, Shakespeare House, 17/19, Stratford Place, London, W.1

Great Possibilities for Technically Qualified Engineers KEY MEN IN WARTIME AND AFTERWARDS

The finest posts and the majority of posts in this war are technical and when the war is over, the immense increase in technique and mechanisation created for war purposes will be applied to reconstruction and commerce. An age of great possibilities for qualified engineers is here. Study at home with The T.I.G.B. and take a Recognised Engineering Qualification such as C. & G., A.F.R.Ae.S., A.M.I.Mech.E., A.M.I.E.E., etc. in which examinations T.I.G.B. Students have gained 35 FIRST PLACES and hundreds of passes. Write now for "The Engineer's Guide to Success" — 200 Courses — covering all branches — Aeronautical, Tele-communication, Mechanical, Electrical, Chemical, etc.



World's best choice of Courses in Engineering

THE TECHNOLOGICAL INSTITUTE OF GREAT BRITAIN
160, Temple Bar House, London, E.C.4.

"UNO" STENCILS

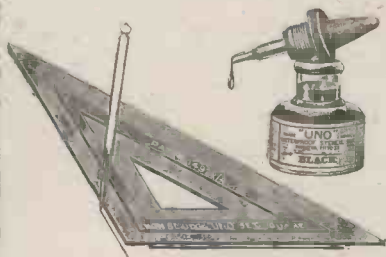

6 Stencils of
Electrical Symbols
6/- each

A. WEST & PARTNERS, LTD 36, BROADWAY
WESTMINSTER, S.W.1

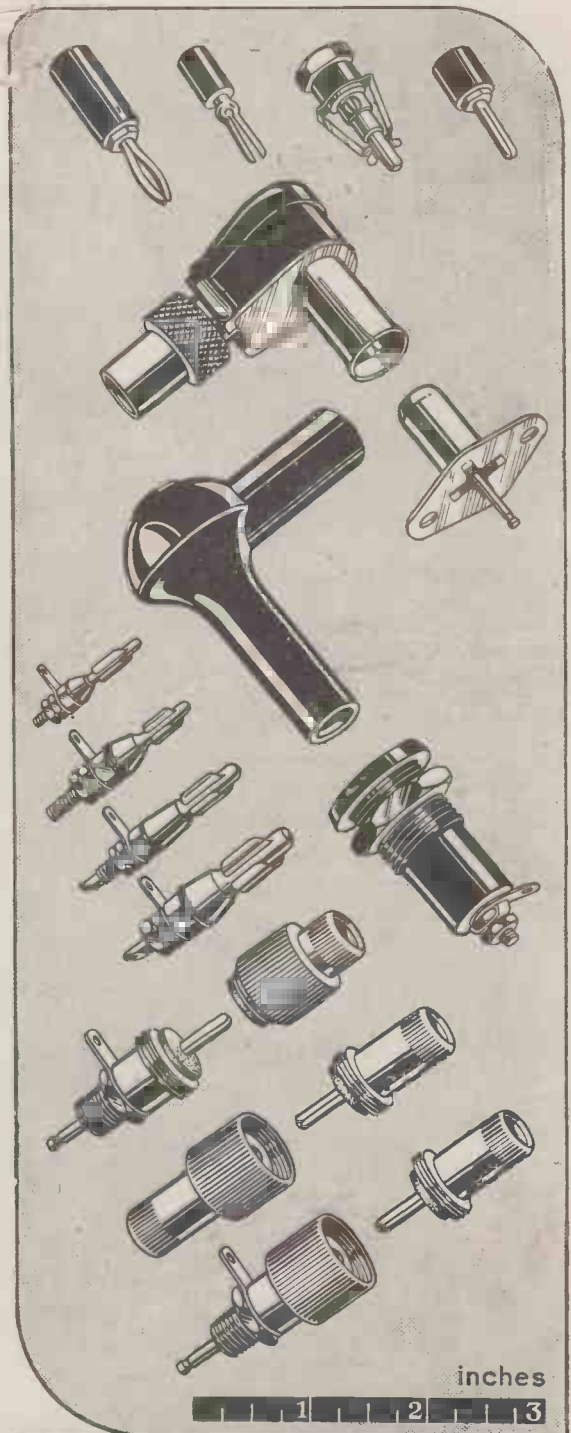

BELLING & LEE LTD
CAMBRIDGE ARTERIAL ROAD, ENFIELD, MIDDXX

GA

EDDYSTONE

RADIO TELEPHONE EQUIPMENT



Operates like your ordinary telephone; two-way voice communication between moving vehicles, or from fixed to mobile stations.

LONDON AGENTS

WEBB'S RADIO

14, SOHO STREET
OXFORD STREET, LONDON, W.1.

Telephone: GERRARD 2089

Manufactured by

STRATTON & CO., LTD.

EDDYSTONE WORKS

B I R M I N G H A M

'Phone PRIORY 2231. Cables: 'STRATNOID' Birmingham.