

Vol. 4 OCTOBER 1931 No. 44

SIXPENCE MONTHLY

TELEVISION

**TELEVISION IN
PROGRAMME
HOURS AT LAST**

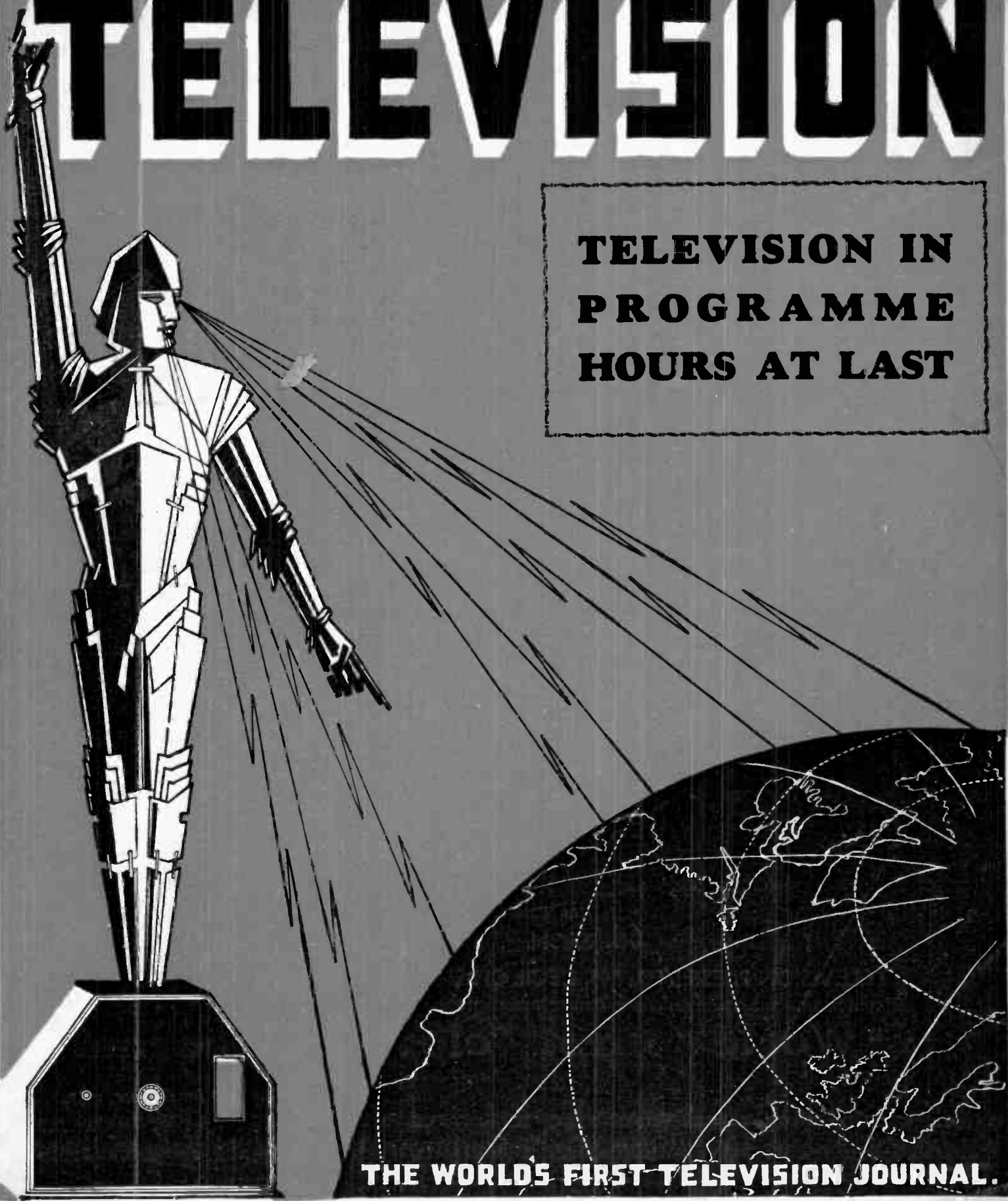

THE WORLD'S FIRST TELEVISION JOURNAL.

The World's First Television Journal

The best possible works of reference
for those interested in Television are

BOUND VOLUMES OF "TELEVISION"

Handsomely bound in rich brown
imitation leather, Morocco finish,
lettered in gold on front and spine,
complete with Index.

VOLS. 1, 2 & 3 **12/6** EACH
POST FREE

SELLING ^{VOLUME} **3** RAPIDLY

HAVE YOU YOUR COPY?

For those who wish to have their
own copies bound there are

BINDING CASES

in brown cloth, lettered in gold on
front and spine, with Index.

EACH **4/6** POST FREE

INDEXES

For Volumes 1, 2 and 3

6d. EACH. POSTAGE **2d.**

TELEVISION PRESS LTD., 505, CECIL CHAMBERS, STRAND, LONDON, W.C.2

The World's First Television Journal

TELEVISION

TELEVISION PRESS, LTD.

Editorial, Advertisement and Publishing Offices :

505, CECIL CHAMBERS, STRAND, LONDON, W.C.2

Telephone : TEMPLE BAR 8169

SUBSCRIPTION RATES:
 7/6 PER ANNUM, POST FREE.
 3/9 SIX MONTHS, POST FREE.
 AMERICAN RATE:
 \$2.50 PER ANNUM, POST FREE.
 \$1.25 SIX MONTHS, POST FREE.

MSS. AND OTHER MATERIAL FOR EDITORIAL
 CONSIDERATION SHOULD BE ACCOMPANIED
 BY A STAMPED ADDRESSED ENVELOPE, AND
 SHOULD BE TYPEWRITTEN.

PRINCIPAL CONTENTS

	PAGE
THIS MONTH'S CAUSERIE	283
INTRODUCING THE NEW TELE-RADIO RECEIVER <i>By H. J. Barton Chapple</i>	284
THE FERNSEH A.G. TELEVISION EXHIBIT	288
LOOKING-IN TO LONDON <i>By R. Bocchi</i>	289
THE GENIUS OF MICHAEL FARADAY <i>By L. P. Dudley</i>	293
NEON LAMPS FOR TELEVISION PURPOSES	294
FACING THE FACTS <i>By William J. Richardson</i>	295
STANDARD FREQUENCY TRANSMISSIONS	298
THE ENTHUSIAST SEES IT THROUGH	300
FROM MY NOTEBOOK <i>By H. J. Barton Chapple</i>	305
TELEVISION AT THE BERLIN RADIO EXHIBITION <i>By Dr. A. Gradenwitz</i>	310
SCOTTISH NOTES <i>By W. Barrie Abbott</i>	313
TRADE NOTES OF THE MONTH AND APPARATUS TESTED	314
TELEVISION AND EDUCATION	319
LETTERS TO THE EDITOR	320

INDEX to ADVERTISERS

	PAGE
"Armchair Science"	297
Baird Television Ltd. iii (Cover) and	309
Bapty, S. Lee	291
Bound Volumes ii (Cover)	
"Discovery"	303
Dossett, A.	292
Dubilier Condenser Co. (1925) Ltd.	307
"Irish Radio News"	299
Leaman, L.	285
Mullard Wireless Service Co., Ltd.	282
Oates, W. H.	315
Frank Pitchford & Co., Ltd.	287
Salter, J.	320
"Television To-day and To-morrow"	iv (Cover)

ORDER FORM

CUT THIS OUT AND HAND IT TO YOUR NEWSAGENT.

To Mr. _____, Newsagent.

Address _____

Please deliver to me at the address given below a copy of **TELEVISION** for November, and monthly thereafter until countermanded.

Name _____

Address _____

P.M.1A

Here are 3 valve types from the Mullard 2-volt range, supreme in their performance.

The P.M.1A is for use as a Detector, or as a High or Low Frequency Amplifier, in circuits where Resistance Capacity Coupling is employed.

Price 8/6

Mullard

P.M.2A

The P.M.2A is a high efficiency output valve of the Power type for use where moderate output only is required.

Price 10/6

THE MASTER VALVE

P.M.202

The P.M.202 is a new and highly economical "super-power" valve, combining large output and perfect reproduction, for a current consumption no greater than that of an ordinary power valve.

Price 13/6

Advt. The Mullard Wireless Service Co., Ltd., Mullard House, Charing Cross Road, London, W.C.2

TELEVISION



THE OFFICIAL ORGAN OF THE TELEVISION SOCIETY

SYDNEY A. MOSELEY, *Managing Editor.*

Consultants { H. J. BARTON CHAPPLE, Wh.Sch.,
B.Sc.(Hons.), A.C.G.I., D.I.C., A.M.I.E.E.
C. TIERNEY, D.Sc., F.R.M.S.
W. J. JARRARD, B.Sc., A.R.C.S., A.I.C.

VOL. IV] OCTOBER 1931 [No. 44

THIS MONTH'S CAUSERIE

IT is with great pleasure that we are able to announce this month the completion of arrangements between the Baird Company and the B.B.C. for a development of broadcasting facilities for television.

As we stated last month, a portable transmitter was recently installed in the B.B.C. No. 10 Studio, and a number of very successful transmissions have been made with this apparatus.

* * * * *

It has now been arranged that experiments shall be carried out by the Baird Company in conjunction with the B.B.C. engineers to ascertain whether the land-line link can be used to convey the television signals in sufficient strength and purity to enable the North Regional station at Slaithwaite to repeat the television transmissions of Brookman's Park.

* * * * *

If these experiments prove satisfactory it will be possible for owners of "Televisors" in the North to obtain very much better reception of the television broadcasts than they have had up till now.

* * * * *

The most important advance, however, is in connection with the midnight transmissions. At long last the B.B.C. have agreed to admit television within the recognised programme hours, and, commencing

early in October, there will be a broadcast from a B.B.C. studio at 10.30 one evening each week. This will be of an actual B.B.C. studio subject, to make it possible for owners of "Televisors" to see on their television screen some of their favourite wireless artistes.

It is hoped to make Jack Payne and his B.B.C. Dance Orchestra the first subject of this weekly feature series.

* * * * *

On another page will be found an announcement of the increase in price of the TELEVISION Magazine to one shilling as from the November issue. This will not come as a surprise to our readers, because it is a matter which has been discussed in these pages quite recently. Before taking this important step we took the precaution of obtaining the views, not only of the newsagents, but also of a great number of our regular readers, and, in almost every case, the opinion expressed was that this course was a wise one, and that we could rely upon the continued support of all who have in the past found this magazine of use as well as interest. Of course, we are not simply asking readers to pay one shilling for what they have previously had at sixpence. The size of the magazine is to be increased, and it will include articles by some of the world's most famous scientists.

*Entire Contents of this Journal copyright in the U.S.A., 1931, by Television Press, Ltd.
Foreign Translation Rights Reserved.*



Introducing the New Tele-Radio Receiver

DESIGNED AND DESCRIBED BY
H. J. Barton Chapple,
Wh.Sch., B.Sc. (Hons.), A.C.G.I.,
D.I.C., A.M.I.E.E.

FOR some months past readers will have noticed that the bulk of my experimental and constructional articles have been devoted to the vision wireless receiver and auxiliary apparatus appertaining thereto. After all, this is really one of the most important sides of the problem. At present the only means that can be adopted successfully to introduce television signals into the home is via wireless transmissions.

on to the vision apparatus for translation into images to delight the eye.

Fascinating

This question of radio reception has always fascinated me, and during the past few years I have carried out innumerable tests with different sets, both commercial and those of my own design. The knowledge that has been accumulated has proved invaluable, and as I am anxious to give every assistance to the experimenters, both potential and existing, I have come to the conclusion that the best purpose will be served by presenting to readers an "all-in" design. By this I mean a complete wireless set for receiving the vision signals, together with the vision apparatus and loud speaker, etc., all combined in one unit in a cabinet.

I know this is an ambitious scheme, and one that cannot be dismissed in a single short article, but I feel confident that the idea will commend itself to readers of this magazine, and be welcomed by all. With the all-round reduction in prices, especially as far as television components are concerned, the time is very opportune to deal with the project.



A dual vision and sound wireless receiver, housed in a "table" cabinet and working in conjunction with an early type "Televisor," which employed the circuit referred to as Fig. 1.

An All-mains Drive

In addition to the experimenter who is not happy unless he has all manner of oddments joined together with a maze of wires which he only can understand, there are others who are keen to build up an outfit which will harmonise with the furnishings in the home and yet work efficiently. The Tele-Radio Receiver I have in mind will, I trust, serve this purpose.

If the reader reflects on the series of articles I wrote recently on "Attention to the High Tension," it will be remembered that, taking all things into consideration, the house mains form the best source of voltage and current to meet all demands economi-

That being the case, it does not matter how perfect is your vision apparatus it will remain useless unless you have a wireless receiver for amplifying and rectifying the received signals, and passing them

cally and efficiently. The receiver will in consequence have an "all-mains" drive throughout; that is to say, the high-tension, low-tension, and grid-bias voltages will be furnished from an eliminator of appropriate design housed inside the main cabinet.

Will Readers Assist?

There is one point on which I am a little doubtful

other hand, I am intrigued with the idea of this "all-in" policy, and the extra cost will be comparatively small, for if previous experiments of mine are any guide, there will be no difficulty in making the eliminator furnish all the power. I have discussed the question with several people, and they all favour the dual receiver scheme, but I should welcome readers' opinions on the point at issue.

For the benefit of those readers who have missed

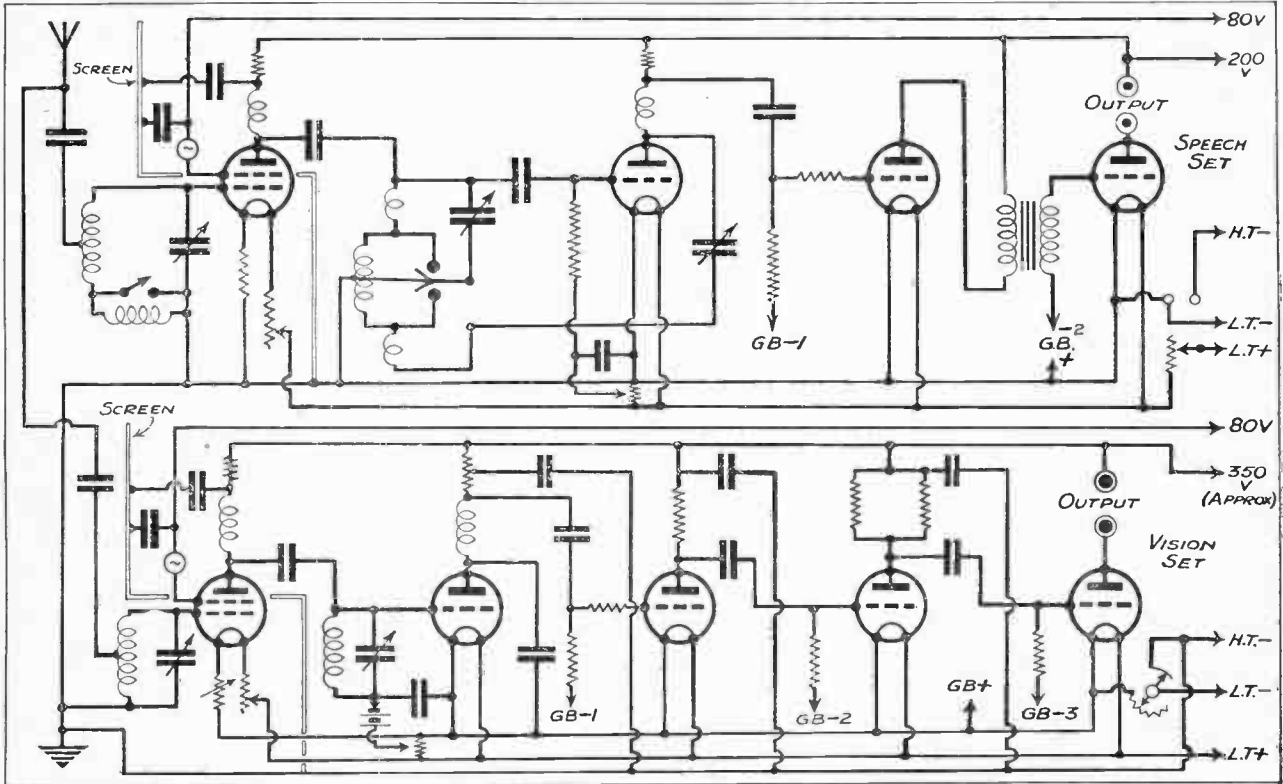

Fig. 1.—Working two wireless receivers (one for vision and one for sound) from the same aerial, H.T., and L.T. sources is not a difficult proposition provided suitable precautions are taken.

at the moment, and perhaps readers will assist by writing to me, care of the magazine, expressing their own personal feelings on the matter. I refer to the question of whether it is advisable to include a sound wireless receiver together with the vision wireless receiver.

There are many points in favour of this policy. The present transmissions of television which are broadcast daily by the Baird Company through the Brookman's Park stations are of a dual character; that is to say, both sound and vision are transmitted simultaneously on the two separate wavelengths of 261 and 355 metres respectively. Furthermore, as far as entertainment value is concerned, one without the other creates an erroneous impression.

A Previous Circuit

The point at the back of my mind, however, is that most constructors have a speech set already which will serve for receiving that side of the broadcast and have no wish to duplicate it. On the

my previous brief notes on the subject of dual receivers, I reproduce, as Fig. 1, a complete circuit showing how I have worked two wireless receivers (one for vision and one for sound) from the same aerial, H.T., and L.T. sources. This is drawn for a battery drive, but the same circuit was modified for mains working, and functioned daily for the reception of the dual broadcast and gave no trouble.

L. LEAMAN
 97, NORTHFIELD AVENUE
 WEST EALING, LONDON, W.13
 For Radio and Television
 DEMONSTRATIONS
 DURING TELEVISION TRANSMISSIONS
Baird Components Supplied
 PHONE: EALING 5394 (MEMBER, TELEVISION SOCIETY)

While this is by the way, it emphasises the value of undertaking the task as a whole and not resorting to separate and distinct designs.

Interesting Tests

Just recently I have been undertaking some very interesting tests to ascertain the suitability of reputable commercial wireless sets for television reception, and the work has revealed some very illuminating facts. It is overlooked repeatedly that while the higher frequencies give the intimate detail to a television image, it is the lower frequencies which are essential and bring about the pleasing or pictorial effects. In broadcast receivers these very low frequencies usually are not important, and in consequence the frequency characteristic of the set

Reaction in the majority of cases should be avoided. Experience has shown that unless handled carefully the reaction control is a notorious agent for introducing distortion, and for the best television images distortion at any cost must be avoided. To counterbalance the loss of reaction, I feel it advisable to incorporate two stages of screened-grid high-frequency amplification. This will give all the amplification required prior to handing on the signal to the detector stage, and, furthermore, will produce that degree of selectivity which is so essential to meet the modern conditions of separating the high-powered broadcasting stations.

Tuning

The tuning circuits must not be too sharp, other-

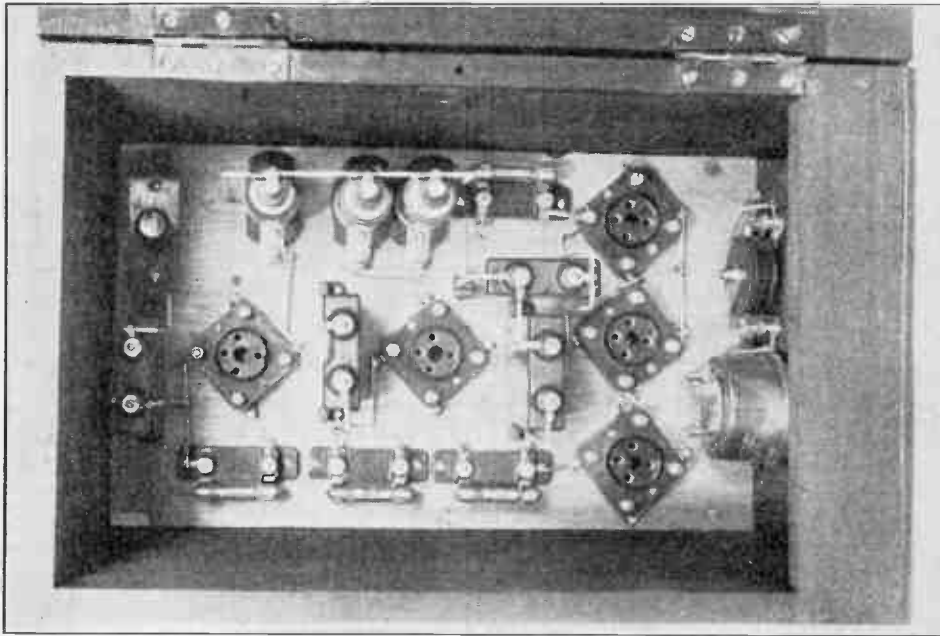

As example of a very fine three-stage resistance-capacity coupled amplifier, together with a separate synchronising valve, which on test has given excellent television images.

in many cases drops rather badly at the lower end of the frequency scale. This point was emphasised by my own tests and must be watched carefully if the best results are to be secured from our work.

The Detector Arrangement

It is as well at this juncture to deal briefly with the other items which have to be considered. First of all, what is the best type of detector arrangement to use? I think we can limit our choice to the three methods represented by grid leak and condenser, anode bend, and power grid. On previous occasions I have dealt very fully with the pros and cons of the first two methods, and shown quite conclusively that anode bend is to be preferred and perhaps I may be excused for referring the reader to *Television To-day and To-morrow*, where the subject is discussed at length. Subsequent tests have in no way made me reverse my opinion, but I intend to give the power-grid scheme a full trial before coming to a final decision.

wise the higher frequencies will be cut off and the image detail will suffer thereby. In order to simplify control, ganged tuning will be adopted if this is at all possible, for undoubtedly the value of any form of entertainment sent to us through the ether is lost if there are too many knobs to adjust in order to bring in the station with volume compatible with quality.

Now what of the low-frequency side? Presuming for argument's sake that the high-frequency and detector sides of the receiver have functioned according to plan, we have an audio-frequency current available to hand on to the low-frequency amplifier. To avoid distortion, the amplification here must be carried on in such a manner that the increased signal differs only from the original in that it is greater in magnitude.

Secret of Success

The real secret of success lies primarily in the choice of suitable valves and components, and the

problem is not an easy one. I find it is preferable to aim at a somewhat lower stage gain than normally required and increase the number of stages than to attempt to achieve the required output in one or two stages alone. So far the best images have accrued with three stages of resistance-capacity coupling, and this is also recommended by the Baird Company in their instructional leaflets, and at the moment I see no reason for the departing from this practice.

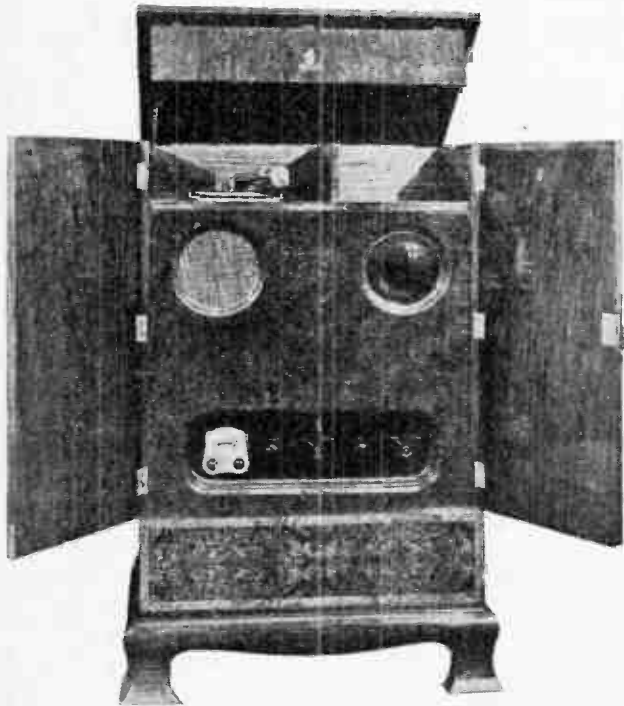

A receiver combining radio, gramophone and television, and for which our readers were asked to suggest a name some time ago.

Output Power

Speaking of output, a great deal of misunderstanding still exists as to the power required to make the vision apparatus function satisfactorily. Many people run away with the idea, even in these enlightened days, that the output signal must be of such a magnitude that if translated into terms of sound the result would fill a hall when handled by loud speakers. Of course, this is a long way from the mark.

We merely require to operate a neon lamp which, in the case of the Baird flat-plate type, takes a working current of 25 milliamperes to make it glow. The recommended undistorted output in the case of a Baird "Televisor" is 1½ watts, and although this is somewhat higher than is desired in the more usual "home" receiver, it is obtained quite easily from super power output valves and in consequence presents no difficulty.

Spoiling the Image

If any attempt is made to pass on too strong a signal to the vision apparatus, it will defeat its own

ends by bringing about "overcooking." Just as in wireless phraseology we refer to an overloaded loud speaker, meaning an excess of "quantity" to the detriment of "quality," so in the case of television we shall be rewarded with an image having too great a contrast between the light and shade, and all detail will be lost.

This big contrast will make the image somewhat resemble a silhouette, or it may be that the image will be broken up completely into light and dark patches which bear practically no resemblance to the features or objects being transmitted.

Proper types of volume controls will guard against this, and every precaution will be taken in this receiver to see that overloading does not arise.

Outstanding Merit

Readers will learn from this that the Tele-Radio Receiver promises to be a design of outstanding merit which, for performance, satisfaction and appearance, will bridge the gap which has existed for a long time. The individual parts of the design will be sectionalised and full constructional details given. By spreading the work over in this way, and then finally assembling the whole in a cabinet it will prevent any mistakes occurring and ensure that nothing is overlooked.

HAVE YOU GOT YOURS?

EVERYBODY'S USING IT

DIAMETER
9½ INCHES
TWO-SIDED

GIVES

"At-a-Glance"

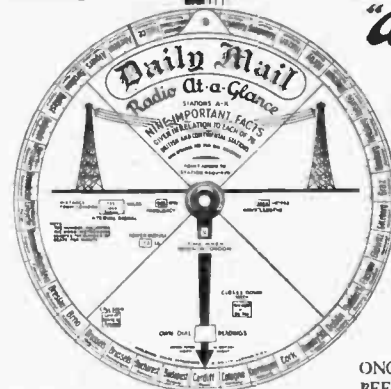

INFORMATION THAT HELPS YOU TO IDENTIFY FOREIGN STATIONS AS THEY ARE TUNED IN.

76 BRITISH & CONTINENTAL RADIO STATIONS

IN COLOURS

1/- EACH

ONCE THE STATION HAS BEEN LOGGED ACCURATELY, RECORD YOUR OWN DIAL READINGS IN THE SPACE PROVIDED, AND ANYBODY CAN THEN SWITCH IN TO ANY FOREIGN STATION REQUIRED WITHOUT ETHER SEARCHING.

DAILY MAIL RADIO

ON SALE AT ALL WIRELESS DEALERS, BOOKSELLERS, STATIONERS, ETC., OR WRITE DIRECT TO FRANK PITCHFORD & CO. LTD., WELL STREET, LONDON, E.C.1

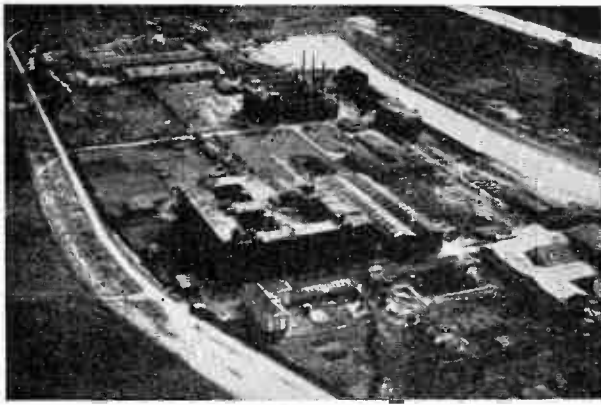

An aerial view of the Goerz Works at Berlin-Zehlendorf, this being the headquarters of Fernseh A.G.

The Fernseh A.G. Television Exhibit

THE Fernseh A.G., as last year, took part on the occasion of this year's Greater Berlin Wireless Exhibition, in the special "Television" Exhibition of the Reichs Central General Post Office. Transmitting as well as receiving apparatus were demonstrated.

The Fernseh A.G. has, during the past year, concentrated its efforts in the sphere of development associated with increasing the number of picture points, and augmenting the brightness of the controlled light source. Through special equipment they have succeeded in producing perfect spiral-holed discs with 90 and more holes, which for example in a disc having a diameter of about 500 mm. only, conforms with the side length of the six-sided hole of the nine-hundredth part of a millimetre. For the production of undistorted images it is necessary to undertake the division of the angle with a precision of 0.2 arc minutes.

With the increase in the number of holes in the disc (which, by the way, retained the same diameter) the size of the television images was also increased, and it thus became necessary to give up the glow lamp and use an entirely new method for obtaining the source of light. While, for example, the light strength of the plate glow lamp used up till now was 0.5 to 2 HK, the newly developed source of light has a light power of between 40 to 60 HK. With the help of this it is possible to fulfil all the requirements to such an extent that the present television image is brighter with 90 lines, corresponding to 10,800 picture points, and the normal cross-formation of 3:4, than it was last year with only 1,200 to 1,300 picture points.

At the exhibition a "Fern-Tonkinosender" (distant-sound film transmission) was worked in conjunction with a sound-film projector of the Zeiss-Ikon A.G. The picture frequency was 25 per second, and the transmitted images were made up of 90 lines, or 10,800 picture points, their size in the spiral-holed disc receiver being about 9 by 12 cm. (cross formation).

The Fernseh A.G. also exhibited a light-spot scanning transmitter with the receiver appertaining thereto. This scanning transmitter is for the purpose of transmitting living people and scenes. The

transmitted pictures (high formation, 3:4) were composed of 80 lines, corresponding to 4,800 picture points, while the picture frequency was 16 2/3 per second, and the size of the picture about 12 by 16 cm.

Apart from this the Fernseh A.G. exhibited this year a Nipkow disc projection receiver for pictures with 4,800 picture points and 25 picture changes per second. This construction was only made possible by the use of the bright light source mentioned earlier, as the projection of the Nipkow disc picture is direct on to the matt disc through a simple projection objective. The receiver emits

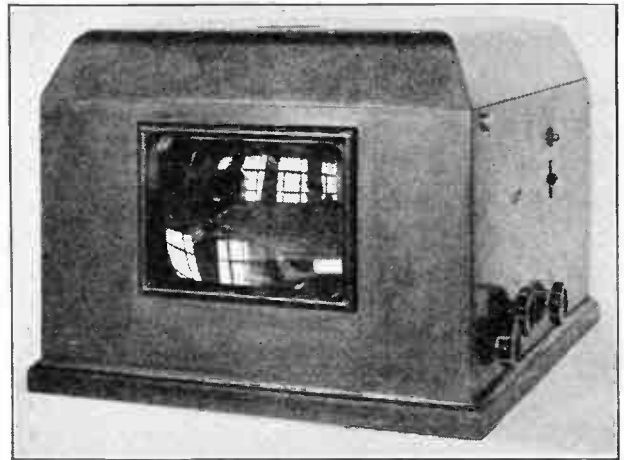

A disc-projection television receiver, designed for 4,800 picture points and which gave very bright pictures, was one of the Fernseh A.G. exhibits.

brighter pictures than a mirror-drum receiver of the same value with spot-light lamps. This is a very interesting experiment, to produce a projection image with the simple Nipkow disc and an ordinary surface light. The Fernseh A.G. has made this their aim, to produce a working receiving apparatus with the simplest means, evading complicated light sources and implements for assembling the pictures.

As last year, the Fernseh A.G. again showed a kit of single parts for the amateur, which were intended for the reception of the Witzleben television transmissions.

Looking-in to London

By R. Bocchi

IT may interest those people who have read previous reports of the reception of the Baird Television transmission in Rome to hear how experiments carried out during the months of May and June have progressed. Before, however, telling them of this I must first express my thanks to Messrs. Baird Television, Ltd., for their kind courtesy, assistance, and advice which has, I can assure them, proved most helpful to me and to others who are equally interested in the science of "Seeing from Afar."

Fading: Not troublesome.

This Night's Experiment.—The comparative merits of two vision sets constructed identically on the Baird principles.

Receiver Used.—A Philips 2531 Model.

Result of Experiment.—Both sets gave satisfaction, though the neon of one was more satisfactory than that of the other. Cause of this due to the fact that one had sustained loss in efficiency due to continual changing of striking voltage applied to it for its operation on the output of various receivers.

⊗ ⊗ ⊗

The translated programme, giving the artistes for the week and issued by the Baird Co., is always to be seen in the window of Messrs. G. Capuani in Rome.

⊗ ⊗ ⊗

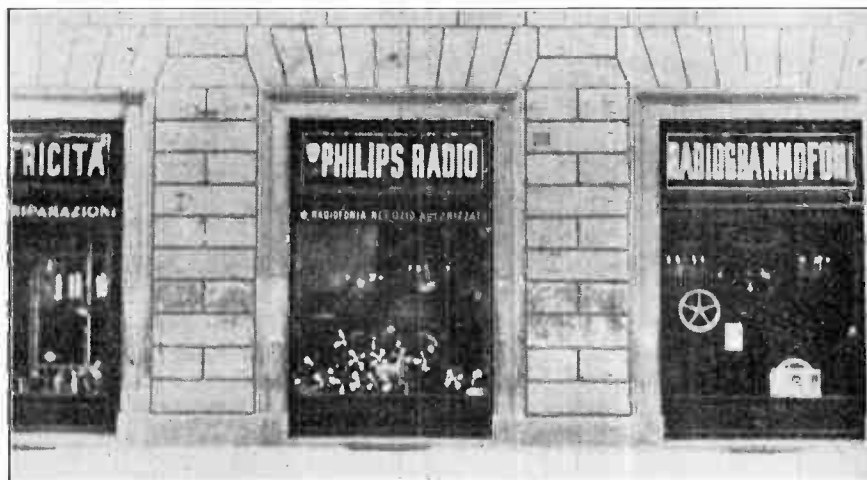

Reverting to the question of what has been done during the period mentioned, I may say that it has passed very usefully, for while another experimenter here, Mr. Giuseppe Capuani, of 32 Via Lucrezio Caro, Rome, has controlled the "Seeing-in," I have been free to experiment with various receivers and all kinds of material. The objective of these experiments may be described as a double one: the first to gain general experience and proficiency, and the second to endeavour to design a receiver suitable for television reception from afar that would prove both efficient and less expensive than a factory-built set.

Perhaps the most interesting manner in which to present the work carried out would be to give extracts from my television log.

Tuesday Night, May 5th, 1931.

Weather: Fair, somewhat unsettled.

Statics: Heavy and bad.

Interference: Nothing very exceptional.

Items of the programme seen were quite satisfactory.

Friday Night, May 8th, 1931.

Weather: Good.

Statics: Little.

Interference: None.

Fading: Scarcely any.

General Observations.—Reception on this night was quite good, and signal strength satisfactory.

Items Clearly Seen—The Announcer. Image of lady talking or singing. Image of gentleman moving and putting something on his head and apparently removing it.

All these figures mentioned were of head and shoulder size. This was followed by a small scene, composed of a table with a cloth upon it (folds in cloth particularly distinct). On the table there seemed to be certain objects the exact nature of which were not discernible. A gentleman in evening dress was seen to enter, and appeared to move

to and fro about the table, doing something to the objects thereon. He also sat down. The remainder of this item was lost by the transfer to another receiver.

A gentleman then appeared in fancy costume either talking or singing. At least 15 per cent. of the programme was lost in passing from one receiver to another. Furthermore it must be mentioned that no sound receiver was utilised in order to simplify matters.

N.B.—It may be stated here that at this distance all close-up images are received most satisfactorily, whereas full and three-quarter scenes are only obtainable with considerable difficulty, the resulting

thunderstorm with its centre in the close vicinity of Rome.

Statics: Bad.

Interference: Of no importance in such a setting.

Fading: No note was taken of its characteristic on this night.

The Experiment.—The utilisation of a single detector of regenerative type (specially built for test purposes) coupled to a two-valve L.F. amplifier.

Result.—The fact of attempting to see with a thunderstorm in full swing rendered this reception exceptionally interesting. (Possible danger due to aerial discharge was duly avoided by the insertion of a neon discharge valve in the aerial and earth system.)

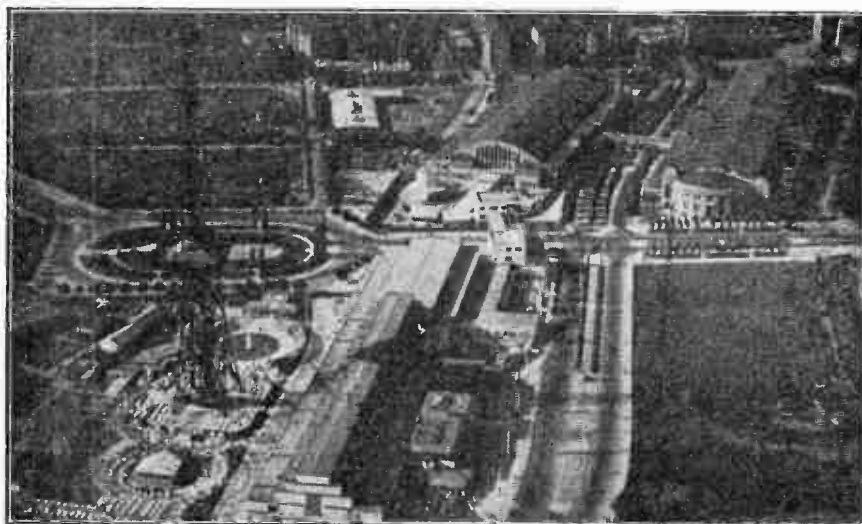

⊙ ⊙ ⊙

The Berlin Wireless Exhibition and the Witzleben Tower as seen from the air. Reference is made in the article to the reception of television signals from the Witzleben Station.

⊙ ⊙ ⊙

reduction in the size of the image causing indistinctness and loss in detail.

Tuesday Night, May 12th, 1931.

Weather: Not good. Stormy and overcast.

Statics: Extremely bad.

Fading: Annoying.

Interference: Bad both from telegraph station and a local oscillator.

Upon this night it was not possible to work with any satisfaction as the interference was such as to render all efforts useless, it being worst in the region of 358 and 360 metres approximately, which, upon the not too selective set in use, spread over the 356 metres in a disappointing fashion.

Friday Night, May 15th, 1931.

Weather: Warm and stormy.

Statics: As on the previous Tuesday, bad.

Fading: Fair, bearable.

Interference: Bearable, though telegraph station still annoying and the local oscillator still industrious in his disturbance of the ether.

Result.—Unsatisfactory.

Tuesday Night, May 19th, 1931.

Weather: Worse than ever. From 12.5 to 12.30 a.m. (B.S.T.) reception was spoilt by a violent

It is interesting to note that notwithstanding the effects of the storm which were manifested by: (1) Erratic and uncontrollable motor in vision apparatus due to jumps and failures in the mains in sympathy with each lightning flash. (N.B.—Power is brought to Rome by overhead cable across country from Tivoli in the hills about twenty miles from this city.) (2) Variations in the H.T. voltages and currents due to same cause. (3) Complete disintegration of anything appearing in the vision apparatus with every flash, it was possible on this night to faintly perceive two images which very much seemed to be male.

Under such conditions to be able to get even the shadow outline of an image coming from so far away as London is from Rome is not too bad. However, this kind of receiver is not advisable out of the laboratory, for it needs careful handling in order to avoid it oscillating "supersonically," which causes great inconvenience to other listeners.

Friday Night, May 22nd, 1931.

Weather: Warm and good.

Statics: Very troublesome.

Fading: Bearable, only three fades being noticed in the half-hour.

Interference: Absent.

The Experiment.—Conversion of a three-valve

S.W. receiver by change of inductance, bringing the set up on to the broadcast band of wavelengths.

Result.—Though this set provided very satisfactory synchronisation lines of narrow undistorted nature, nevertheless it proved unsatisfactory, images received being indefinite, shadowy, and bleached.

Tuesday Night, May 26th, 1931.

Weather and Statics: Very good, though warm.

Here an interesting physical note appears in the log to the effect that from 12 midnight to 12.15 a.m. (B.S.T.) statics became intensely annoying.

Fading: On this night fading gave scarcely any trouble.

The Experiment.—A second study of the behaviour of the arrangement used on the previous Tuesday for receiving purposes; this with the object of ascertaining causes of deficiencies.

Result.—As before, images seen were indistinct and shadowy. What was visible was something animated and in rapid movement. The trouble diagnosed with this set appeared to centre in the det. valve and its grid-leak rectification, the value of the grid resistance being too high and the condenser also unsatisfactory in value (which goes to prove that the anode-bend rectification is the best system for television).

An interesting note was made to the effect that during the reception the synchronisation lines seemed to spread and encroach upon the picture space twice. This was not due to the receiver, as the fact was noticed by G. Capuani situated at another address.

Tuesday Night, June 2nd, 1931.

Weather: Good and cool.

Statics: Negligible.

Fading: Practically non-existent.

Interference: None.

The Experiment.—(1) The utilisation of Philips 2511 Model as receiver. (2) The comparison of a U.S. neon valve with a European valve. The U.S. valve was a Raytheon.

Results.—It was most enthralling to observe that the Philips 2511 Model, composed of two screen-grids, a det., and transformer coupling to a L.F. pentode output stage, rendered an excellent account of itself by surpassing the 2531 Model, being more selective without being too much so, and therefore subject to less interference, whilst with a more powerful output better service is rendered by the neon. It is pleasing to be able to state that the programme in the shape of Miss Eleanor McDonald, monologue artiste, and Mr. Aleck Hardy was duly seen; whilst Miss Marie Mackie at the piano came in very well indeed.

With regard to the comparison of valves. It was found that the U.S. neon gave beautiful luminosity with very little striking voltage, only 90 to 100 volts being required to make it function. This is quite an important matter, for with such a valve only a small battery eliminator is required; and further

voltage can also be, as it were, reduced on the plate of the last valve, which means better functioning for less powerful sets, and an approach therefore to the general pocket of the man in the street. The European valve proved much more insensitive, less luminous, and with far greater inertia compared with its U.S. rival. Would there had been more than half an hour for the testing; and also that there had been to hand a "Baird branded neon" to be entered in the lists, for I am sure it would have proved the best of all.

Tuesday Night, June 9th, 1931.

Weather: Distinctly hot.

Statics: Very bad.

Interference: Very fair, but more prominent than usual.

Fading: Not too pronounced.

The Experiment.—The try-out of the receiver which should have been tested on the previous Tuesday.

Result.—A nasty failure through insufficient output strength to properly actuate the neon, it being only possible to apply 200 volts to the pentode plate. The writer however has a firm conviction that if this receiver had been in London the additional signal strength would have permitted "seeing." To be able to work at a considerable distance is by no means easy, and again is proved the advice in *Television To-day and To-morrow* that a three- or four-valve receiver must be used for really satisfactory results.

EXPERIMENTERS'

SCANNING DISCS

STANDARD - 20 $\frac{1}{2}$ -INCH

ALUMINIUM - 30-HOLE

BRASS-BUSHED

12/6

When ordering, please remit sufficient to cover postage; also please state size of motor spindle.

TRADE ENQUIRIES WELCOMED

S. LEE BAPTY

60, CRAVEN PARK ROAD, N.W.10

WILLESDEN 7084

Consult us regarding—

AUTOMATIC MOVEMENTS

EXPERIMENTAL WORK

STAMPINGS

PRESSINGS

CASTINGS

ELECTRICAL MACHINES

Friday Night, June 12th, 1931.

Weather: Very hot.

Statics: Bad.

Interference: None.

Fading: Somewhat pronounced.

The Experiment.—Further investigation on the relative merits of the U.S. and European neons.

Results.—A confirmation of previous data secured, which has already been mentioned.

The programme from London came in very well, the best being an entertainment by Mr. J. Stewart in the shape of conjuring tricks, and the demonstration by Mr. E. B. R. Benson of "Seaman's Knots."

Here must be mentioned that this particular night proved exceptional, inasmuch as upon London closing down, by mere chance, the writer landed on the Experimental Transmission of Television sent out by Berlin. With a great risk of disjointing necks, for owing to the difference in scanning system used



Showing the Model 2511 Philips receiver which Mr. Bocchi used in some of his experiments.

in Berlin, images appear in vision apparatus horizontally instead of vertically as from London, it was possible to make out a head being televised. It is a pity that the signal from Berlin is much inferior in quality to that received from London. It is terribly erratic, and subjected to slow persistent regular fading of a truly terrible nature, as complete disappearance of the signal takes place. It is not possible to work on such signals, and thanks are therefore offered to the powers that be that London comes in so well as it does. Unless mistaken, the writer assumes that the signals coming in this night were on 418 metres, the wavelength of Witzleben, Berlin. This transmitter has only 1.7 kW in its aerial and therefore, taking into consideration the distance from Rome to the transmitter, it is no wonder it is not possible to do much with it.

Here I think it is opportune to break off the report, but before so doing I would call attention to the fact that as it is most interesting in any special reception, be it only radio, or be it television, for a note to be taken of the weather conditions prevailing at the moment of reception, much is to be learnt in accurate observation of atmospheric

conditions. This explains why my log for television always mentions such factors as statics, fading, and general conditions of the weather. In fact, it will be remarked that generally when the weather is warm or hot, there is a distinct increase in the static disturbance. Therefore, to all experimenters, I would counsel them invariably to watch physical conditions, as they have a vitally important reflection on the quality of their reception.

In bringing this account to a close, I hope I may be pardoned for its lengthiness, it being borne in mind that such is the outcome of much endeavour. All that I do hope is that if this activity has been followed, then I trust sincerely that it will be rewarded in the shape of having stimulated the interest of yet another amateur to such an extent as to abandon the part of *reader* to enter the army of *practical workers*, who under the banner of Mr. John L. Baird are ready to march steadily behind him on the road he has with genius hewn in the face of obstacles and difficulties.

BOOK REVIEW

FROM TELEGRAPHY TO TELEVISION, by Lieut.-Col. Chetwode-Crawley, M.I.E.E., published by Frederick Warne & Co., Ltd., at 6s. net., is a story of electrical communications. Readers will no doubt remember the interesting series of articles which appeared in our columns written by Lieut.-Col. Chetwode-Crawley, and in the Foreword due acknowledgment is made to this journal for permission to make use of his articles.

We found the book both a captivating and picturesque narrative, for the story of electrical communications has been traced from the most primitive form of the telegraph to present-day television. He gives a bird's-eye view of telegraphy and telephony and their branches, showing their history, development, attainments, and future possibilities.

The evolution of wireless and the new science, television, is simply and clearly set before the reader, with an avoidance of such technicalities as can only be comprehended by the initiated. We do not know of any other book in which the whole range of electrical communications has been presented within the compass of two hundred pages.

The chapter on television shows clearly how the discovery was first made, and points out quite correctly how the first demonstration of true television was given by Mr. Baird early in 1926. No attempt is made to discuss details of the different types of apparatus, the whole question being dealt with on general lines.

We can confidently recommend this book to readers, as the story is well told and at no time proves uninteresting.

A. DOSSETT, Commercial Artist and Draughtsman for all technical diagrams, illustrations and layouts.—HAZLITT HOUSE, Southampton Buildings, Chancery Lane, London. Holborn 8638.

The Genius of Michael Faraday

By *Leslie P. Dudley, Grad. I.E.E.*

TO Michael Faraday, the son of a humble blacksmith, the civilised world owes an eternal debt of gratitude. It is not too much to say that his work has had a greater influence on modern engineering practice than that of any other individual scientist. The use of the giant alternators, to-day distributed over the world, of vast numbers of small electric motors for domestic purposes, and of electric lighting may be traced to Faraday's discovery of electro-magnetic induction. The brilliant experiments by which Faraday exhibited this phenomenon made possible also every system of electric traction and many other uses of electricity on a large scale, including radio-telegraphy and telephony.

Faraday was born at Newington Butts, London, on September 22nd, 1791, and at the age of thirteen entered the service of a bookseller. Always in search of knowledge, he appears to have read practically every good book that passed through his employer's shop. In the year 1812 he attended a course of lectures given by Sir Humphry Davy, of which he took notes. After re-writing these with great care and binding them, he sent the volume to Davy, offering his services as an amanuensis. Davy granted him an interview, and on March 8th, 1813, he was appointed assistant at the Royal Institution laboratory.

Here he quickly showed his genius as an experimenter and original observer, eventually becoming a director of the laboratory. In 1825 Faraday produced the hydrocarbon benzene, the foundation-stone of our modern artificial dyestuff industry. On August 29th, 1831, he made his fundamental discovery rendering possible the conversion of mechanical energy into electrical energy. He observed that if a ring of coiled wire or a metal disc were rotated between the poles of a magnet, currents were excited in the ring or disc, travelling in one direction during half a revolution and in the opposite direction during the other half.

In addition, he found an electric current to be induced in a coil of wire at the moment of passing a current from a battery through an adjacent similar coil, a current flowing in the reverse direction when contact with the battery was broken. From these experiments came the motor and generator of to-day.

In 1833 Faraday was made Fullerian Professor of the Institution for life, and in the same year he proved electricity from different sources to be iden-

tical. The following year came his discovery of equivalents in electro-chemical decomposition.

Almost every year saw some brilliant discovery on the part of this genius, through which he could, had he cared to do so, have become rich and famous. He preferred, however, to give the results of his researches freely to the world.

In the year 1838 Faraday announced the results of his researches on electrostatic induction, and also showed the relation between magnetic and electric

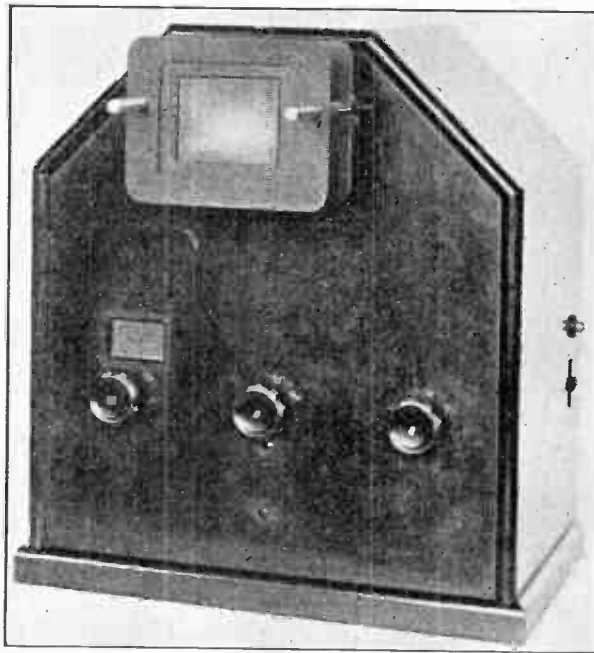

A projection-type television receiver made up by the Fernseh A.G., and suitable for 4,800 picture points. This receiver was displayed at the German Radio Exhibition in August 1931.

forces. In 1845 he published a paper on the properties of diamagnetic bodies, and in the following year a treatise on magnetic rotary polarisation.

He remained at the Royal Institution until he retired in 1858.

Michael Faraday, one of the most brilliant experimenters ever known, died on August 25th, 1867, at Hampton Court, where he had occupied one of Queen Victoria's houses. He will never be forgotten.

Neon Lamps for Television Purposes

THE neon lamp, when used in combination with the perforated disc, forms perhaps the cheapest method of building up a television image into a complete picture. On the other hand, we all realise that the neon lamp has the drawback that the luminosity is comparatively small and the disc only utilises a fraction of the total cathode surface. A certain amount of attention has therefore been directed to the problem of increasing the surface luminosity of the neon lamp, and we understand that good results have been obtained from polishing the cathode surface.

New Current Density

For example, the neon lamps of the Deutsche Glimmlampen-gesellschaft of Leipzig are characterised by the employment of a highly polished cathode of special material, with the result that the lamp, even under extremely low currents of the

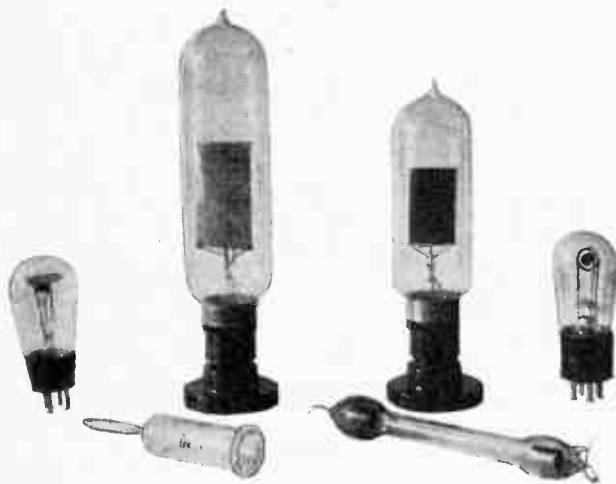

From time to time several different types of neon lamps have been employed during the course of television experiments, and the small group above are representative of some of these.

order of 0.3 mA. per square cm., will show a full and unbroken glow surface. The contraction and movement of the glow point, which is otherwise noticeable at a low load, it is claimed has been eliminated in the new lamp, with the result that a long, straight-lined and useful characteristic is secured.

The picture surface on the standard type neon has a size of 3 cm. by 4 cm., the anode being in the form of a frame. The mean working voltage amounts to 200 volts, while the load can be increased up to about 5 mA. per square cm., that is with the plate size just mentioned a current of 60 mA. In addition, this same company has designed a point neon lamp for working in conjunction with a simple mirror-drum. With these lamps it is essential that they should concentrate their entire luminosity on the smallest possible surface in point form.

A Point Lamp

In contrast to the perforated disc the mirror-drum will, however, utilise the entire light which is yielded by the point neon lamp, with the result that under certain prearranged conditions the pictures or the images secured show a greater luminosity.

There are some point neon lamps which have been made with a glow cathode. These have excellent electro-optical qualities, but require a separate source of heating current, and this, in many cases, is looked upon as a drawback. In the case of the firm previously mentioned, the anode of the lamp is arranged in a small chamber. This has been taken from the cathode, which is employed with a quartz jacket, and the light channel is connected up with this chamber.

Automatic Discharge

It is no doubt due to this construction that the automatic discharge commences with such low luminosity values that it is claimed that the lamp can be utilised almost to the point of extinction without any change in brightness. If the voltage rises the light channel is filled from the rear with a reddish glow light, which is finally augmented with the whitish light of the positive column.

In spite of this it is stated that the luminosity has a straight-lined dependence on the current strength. The surface on which the glow light of the point neon lamp can be concentrated has a diameter of 1.2 mm., while the mean working voltage amounts to 180 volts, the current varying between 6 and 150 mA. For photographic purposes it is important that the spectrum shall show the lines of the mercury vapour in addition to those of the neon and helium.

Facing the Facts

By *William J. Richardson*

WHEN you come to study things, don't you find invariably that the mind of the public in general is a short one? Something of importance happens, headlines appear in all the morning papers, and it becomes the topic in every conversation. The subject, however, once it has lost its glamour, joins the other nine-day wonders which have been equally short-lived.

This Generation

I suppose this course of events is a natural one. We rather live from hand to mouth, and seldom do we pause and take stock or endeavour to bring our minds to bear correctly on the problems which surround our everyday life. Certainly this generation has managed successfully to dovetail miraculous inventions into the everyday life, and withal a bountiful science continues daily to add to our already rich possessions. But are we content, do we appreciate to the full what science has done and what science will continue to do?

No, we are growing up too sceptical. The speed with which many indulge in their work and pleasures has warped their minds, and living so much on the surface, they fail to probe into the future. Their imaginations become stunted, and their mentality would expect any new invention to be perfect before it has had time to develop. They would expect George Stephenson's "Rocket" to put up the same performance as the "Golden Arrow," and Wilbur Wright's first aeroplane to be capable of competing successfully with machines used for the Schneider Trophy.

What we owe to Science

Why am I prompted to write in this strain? Because on so many sides I find that while we owe so much to science there are many who fail to acknowledge their indebtedness, and furthermore never calmly and impartially look ahead and discuss scientific gifts to civilisation or ruminate as to how these gifts can be made of commercial value. Until perfect they despise them or pour scorn on imperfections, and in this way endeavour to stunt growth and development.

One can point to so many evidences of this, that for the moment let me confine my remarks to one outstanding item—television. I do not propose at this juncture to prognosticate *indiscriminately*—that does untold harm. So also does the cynical and biased criticism of those who rely on hearsay and take no steps to investigate for themselves. There

are none so blind as those who *will not see*, or whose conceptions are warped and cannot expand to embrace the idea of television in its basic and concrete form.

Constant Touch

Man's natural instincts are such that he cannot live alone; he must be in touch constantly with his fellow creatures. Communication between indi-



Mr. J. L. Baird sitting before one of his early "Noctovision" transmitters. All visible light was filtered out by means of an ebonite screen.

viduals and nations has ever been foremost in his thoughts. Telephonic, telegraphic, and wireless devices have made distance no object, but whereas the ear has been served so well, the appeal to the eye has been kept within a narrow compass.

Television seeks to broaden this, not in a haphazard manner but with one definite object in view, namely to strengthen both home, national, and international ties. Wireless and the telephone have satiated the desires of one of our senses, hearing, but complete intelligence will never be conveyed until

both the senses of sight and hearing are harnessed and move together. Witness the almost complete subjugation of the silent film now that talking films have become perfected. Are we not bound to find the same thing happen with dual sound and vision transmissions, provided the vision side, that is the younger science, has meted out to a meed of praise and encouragement.

An Accomplishment

To-day the transmission of sight by radio is a matter of accomplishment, not speculation. When developed upon well-thought-out lines it will prove a welcome stimulant, a pleasant tonic to all the en-

Individual Portrayal

Television signals to be receivable in every home have to be broadcast by wireless, and have therefore to keep within the nine kilocycle sideband separation imposed for sound broadcasts. Technically this means that the extent of the scene available for those who "look-in" is at present somewhat limited. In spite of this the present Baird transmissions give extended scenes of two or three artistes acting in a sketch, dancing, demonstrations of sport, etc., and this is in addition to the close-up views of single individuals, that is head and shoulders, which come over wonderfully well within this frequency compass.

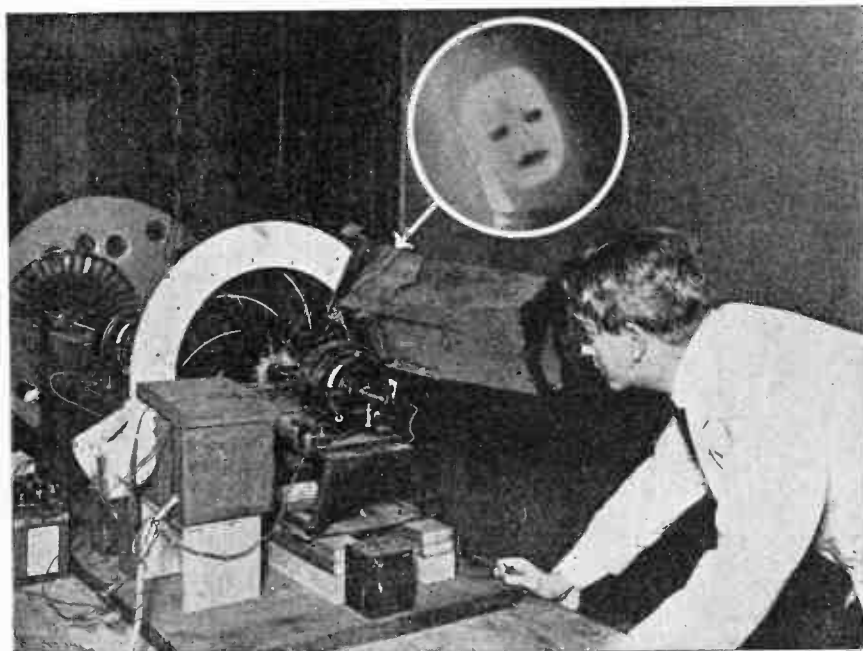

⊗ ⊗ ⊗

Observations being made by Mr. Baird at the receiving end of one of his first Television transmitters. The apparatus shown was demonstrated at Selfridges in 1925, when outline images were sent between two separate machines by wireless. The inset shows an outline image transmitted by this early apparatus.

⊗ ⊗ ⊗

tertainment arts. It will not repress present services, but supplement them. History in the scientific world can confirm the fact that the creation of a new service for the public does not result in the elimination of an older service, provided each has something of its own to give.

It was only in 1926 that John Logie Baird gave the world's first demonstration of television in a crude form, and yet the mention of the word "television" to some people has in many cases made them think that they are to see immediately big scenes both indoor and outdoor. In arriving at that conclusion, however, they have failed to appreciate that any commercial developments must perforce conform, in the initial stages, to standards which have been drawn up before the new invention was born. Laboratory demonstrations must be justified by results which will stand the test of commercial application.

To my mind this individual portrayal, instead of a group scene, has a great advantage. First of all it can be undertaken with simple apparatus handled without any difficulty. But there is something of greater importance. If you attend a public function—the return of Malcolm Campbell after his record-breaking feats, the King's drive through the London streets to open Parliament, the sermon of a great preacher from the church pulpit—you do not go to see the crowd but the *individual*. It is the central personality which is the attraction, and yet in the crowd you perhaps only obtained a fleeting glimpse. How much better to have watched this man or woman in the comfort of your own home by means of television, so that you can get the close-up denied to you amidst the jostling of others. Think of the saving of time and the complete independence of the weather conditions which a fickle Nature chooses to impose.

PLEASE MENTION TELEVISION WHEN REPLYING TO ADVERTISERS

Become Television-minded

Television even in its present stage of development gives you this, so why complain? Enjoy the fruits of this work while it is young, and then as developments take place you will appreciate what science has given to you. To stand outside and criticise only betrays your ignorance; see what has



No doubt readers have heard of the great Rockefeller project for a huge amusement centre in New York to include television. Here we see an air view of the proposed building.

been done, appreciate to the full this new aspect of life, and you will become television-minded and be prepared for the bigger developments which must inevitably follow.

To use the words of a well-known speaker, when television becomes a vital factor in the field of entertainment it will give new wings to the talents of creative and interpretative genius, and will furnish a new and greater outlet for artistic expression. When you consider the matter carefully, the potential audience in television in its ultimate development may reasonably be expected to be limited only by the population of the earth itself. New forms of artistry will be encouraged and developed. Variety and more variety will be the demand of the day. Whereas the ear might be content with the oft-repeated song, the eye would be impatient

with the twice-repeated scene. The service will demand, therefore, a constant succession of personalities, a vast array of talent, a tremendous store of material, and a great variety of scenes and background.

The Financial Question

The outlook far exceeds what we have become accustomed to associate with sound radio, but there is an important point which must not be overlooked. From what source is to come the money required to bring this state of affairs to fruition? Do you remember what happened in the early days of radio? Why, the various manufacturers associated with the industry became shareholders in the British Broadcasting Company. The money thus obtained was used to build up a small organisation which gave a service of broadcasting, and the manufacturers concerned reaped their reward in the sale of wireless parts and receivers. From this "sapling" grew the powerful B.B.C., which is now Government controlled instead of being a private concern, and for the service you obtain, an annual licence at the ridiculously small sum of just over 2d. a week is paid.

Could not something of a similar nature be done for television? It is most gratifying to record that the B.B.C. are exhibiting a closer working co-operation with the Baird Company in the matter of broadcasting television, and undoubtedly this will lead to

(Continued on page 308)

ARMCHAIR SCIENCE

ONE SHILLING — MONTHLY

YOU will enjoy reading this popular, brightly illustrated magazine dealing with curious and interesting discoveries and events throughout the world. Each month there is interest and instruction for every member of the family.

A FEW CONTENTS OF THE OCTOBER ISSUE ARE—

Does Sex Control Human Health? by Sir W. Arbuthnot Lane—How the Eye Sees, by Prof. D. F. Fraser-Harris, M.D.—A Scientific Bubble, by Rev. Desmond Morse-Boycott—Slumber Pills for Colds—Playing with Three Million Volts—Fish that Help to Fight Disease—Commonsense Slimming—Plant Forcing by Electricity—Medical Miracles—Blanchmange from the Sea—Mud Packs, Ancient and Modern, etc., etc.

NOW ON SALE : ORDER FROM
YOUR NEWSAGENT

SUBSCRIPTION TERMS. Posted direct to your door on the first day of each month. One year, 14/-. Half-year, 7/-. Post Free.

Send 3d. in Stamps for Free Specimen Copy.

ARMCHAIR SCIENCE, LTD.,
SUBSCRIPTION DEPT.,
56, VICTORIA ST., LONDON, S.W.1.

Standard Frequency Transmissions

ACCURATE WAVEMETER CALIBRATION

IN connection with the work of the Radio Research Board of the Department of Scientific and Industrial Research, waves of accurately known frequency have been transmitted for some years past from the Wireless Station at the National Physical Laboratory for checking the calibration of wavemeters and other apparatus.

Up to this year the frequencies employed have been suitable for commercial purposes, but com-

This standard frequency transmission is made on a frequency of 1,785 kilocycles per second (i.e. 168.6 metres), and is transmitted on the first Tuesday in March, June, September, and December, commencing at 9 p.m., G.M.T.

The standard transmission is preceded by the announcement "CQ de G5HW" repeated several times, followed by standard wave transmission on 1,785 kilocycles. The announcement is followed by a continuous dash, the whole lasting 10 minutes.

This procedure is repeated six times, i.e. at 21.00 (9 p.m.), 21.10, 21.20, 21.30, 21.40, and 21.50.

By the use of this standard frequency transmission a very accurate calibration of wavemeters or transmitters can be made, although, as is the case in all accurate measurements, a certain degree of skill is required. The method detailed below is that suggested by the Post Office for utilising this standard frequency transmission to obtain the greatest accuracy with the apparatus usually available at amateur transmitting stations.

The apparatus required to check a crystal-controlled transmitter or to calibrate a crystal wavemeter by means of this transmission is: firstly, a receiver, the settings of which can be accurately determined, having a range from 1,785 kilocycles to the highest calibration frequency required; secondly, a calibrated oscillator having a range of 200 to 1,785 kilocycles. If the receiver is not of the self-oscillating type, it will be necessary to employ a separate heterodyne in conjunction with it.

Dealing first with the case of a crystal-controlled transmitter working on the 42-metre band and which utilises a wavemeter of the absorption or resonance type.

The receiver is first set to the silent point of the standard frequency transmission—that is, to 1,785 kilocycles.

The output from the oscillator is then closely coupled to the receiver (which is assumed to self-oscillate), care being taken to ensure that there is no frequency interaction between the receiver and oscillator. The oscillator is then set to oscillate on 1,785 kilocycles by varying its frequency until the silent point of its oscillation is obtained on the same setting of the receiver as that obtained for the silent point of the standard wave transmission. Leaving the oscillator unchanged, the receiver is next

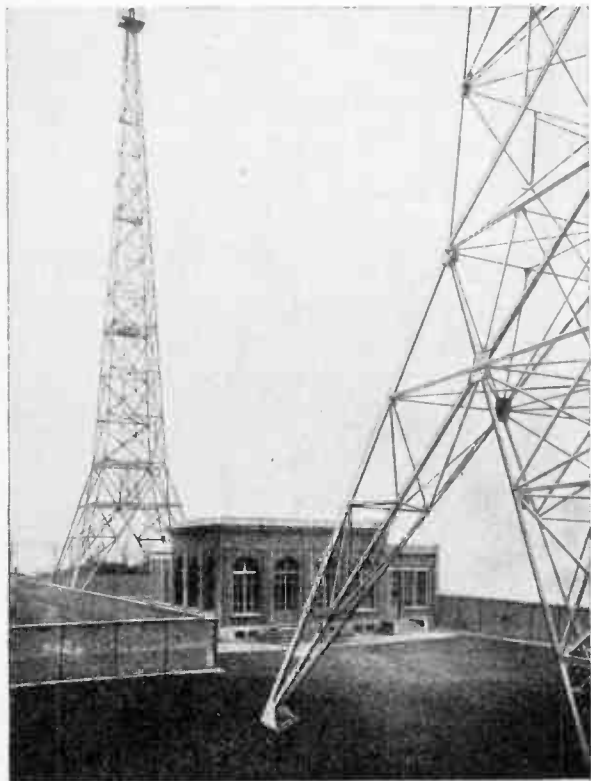

The new Radio Vitus Station, which is now complete and will start tests shortly, appears dwarfed beside the businesslike aerial masts.

mencing on March 3rd last, at the request of the Post Office, arrangements have been made for a standard frequency transmission to be sent out which enables owners of amateur experimental transmitting stations to enjoy the same facilities.

tuned to the 4th harmonic of the oscillator—that is, 7,140 kilocycles per second, or the mid-point of the 42-metre band.

The oscillator is then stopped and the transmitter made to self-oscillate and its frequency adjusted to the same setting as the receiver—that is, 7,140 kilocycles per second. The wavemeter setting for this frequency is then obtained by measuring the transmitter frequency in the normal way. It is desirable that this setting should correspond with the middle of the wavemeter scale.

To obtain a calibration curve of the wavemeter on this band, points are required separated by a smaller frequency interval than 1,785 kilocycles from the mid-point calibration already obtained, a separation which would be obtained by taking the 5th and 3rd harmonics of the previous oscillator settings.

To obtain two further points which will be less widely separated, the receiver is set to the silent point of the calibrated wave transmission and the oscillator frequency is decreased until its 5th harmonic corresponds with this setting of the receiver—that is, 1,785 kilocycles. The fundamental of the oscillator will therefore be 357 kilocycles per second. The receiver is returned to the setting previously obtained for 7,140 kilocycles, and the 20th harmonic of the oscillator will then be heard on this setting. The tuning of the receiver is then slowly varied until the 21st harmonic of the oscillator is heard—that is, 7,497 kilocycles per second. The transmitter is then tuned to oscillate on this frequency and the wavemeter reading again obtained. In a similar way the 19th harmonic of the oscillator may be tuned in and the process repeated, giving a third point on the wavemeter at 6,783 kilocycles per second.

To obtain accurate measurements, the wavemeter range should be such that the three calibration frequencies are respectively near the minimum, mid-point, and maximum of the scale.

Even greater accuracy may be obtained by utilising the 6th or 7th harmonic of the oscillator in place of or in addition to the 4th, thus obtaining check points with less separation.

A similar procedure is adopted to obtain checks on the 20-, 10-, and 5-metre bands, as it will be found that the mid-points of these bands correspond with an harmonic frequency of 1,785 kilocycles per second. It is not, however, necessary to employ such a high-order harmonic of the oscillator for obtaining check points, and harmonics should be selected to suit the range of the wavemeter used.

For example, in the 5-metre band it may be found satisfactory to set the oscillator to 3,570 kilocycles per second, and to utilise the 15th, 16th, and 17th harmonics, corresponding to frequencies of 53,550, 57,120, and 60,690 kilocycles per second.

To calibrate a non-crystal-controlled transmitter, which in consequence uses a crystal-controlled wavemeter under the regulations relating to amateur transmitters, the procedure is similar to that already described, except that the transmitter is calibrated instead of the heterodyne wavemeter, and this calibration is used to check the crystal wavemeter.



THIS
SAMPLE

COPY

F R E E

From experience we find those interested in Television to be THE real Radio ENTHUSIASTS. Everyone who is enthusiastic will naturally be interested in IRISH RADIO NEWS, and accordingly, if you drop us a line with your name and address, we will gladly send you a specimen copy FREE.

Irish Broadcasting is particularly interesting to those who are really keen on Radio. Hear Sponsored Programmes within the British Isles.

Edited by JAMES KITCHEN, A.M.I.R.E.

PUBLISHED EVERY FRIDAY

Regular Contents include :

OFFICIAL IRISH AND B.B.C.
PROGRAMMES FOR THE WEEK
"BROAD TUNING," by A.Z. (Gossip)
HINTS FOR CONSTRUCTORS
GRAMOPHONE NOTES
NORTHERN IRELAND NEWS
Special Articles, News, Photos, Etc.

Why Not Become a Subscriber ?

One Year, Post Free . . . 7s. 6d.
Six Months, Post Free . . . 3s. 9d.

**Irish
Radio News**

Editorial and Publishing Offices :

179 PEARSE STREET, DUBLIN

'Phone : DUBLIN 43236

ENGLISH BRANCH :

RICHMOND HOUSE

NORTHBROOK ROAD, LONDON, S.E.13

'Phone : LEE GREEN 1059



The Enthusiast Sees it Through

RECENT developments in television have stimulated interest in that science all along the line, and we are sure that this coming winter season will see big advances made in every direction. The enthusiastic readers of this magazine, if we are to judge from past experience, will be ready to meet this, and we know that these columns will bear witness to the efforts they have made individually and collectively to further the good work.

We are pleased to be able to print further interesting experiences from our readers in this issue and extend congratulations to them on their efforts.

Ready for the First Television Transmission

In furnishing us with details of his television receiver, Mr. F. Mander, of 43 Egerton Road, Stamford Hill, N.16, points out that he has been a regular reader of our journal since the first issue and had his receiver ready to tune in the first Baird television transmission. This surely is an achievement of which our reader can justly feel proud, and, as others will gather from the very detailed information which he has supplied concerning his apparatus. Mr. Mander has spared no time or expense in building up his material to the greatest advantage. We trust he will continue with this work and still further improve his results. He writes as follows:

"I have been a regular reader of TELEVISION and the book showing in the illustration is the first issue. I am also enclosing the circuit with which I receive the television programmes. This was built and ready for the first transmission, and from the illustrations you will observe it is laid out in such a manner as to facilitate the easy changing of resistances, valves, grid bias, varying plate voltages, etc.

"There are two sets, one being built on a base-board preceded by a single-valve short-wave adaptor, and these components are hidden from view by a six-inch ebonite panel on which can be seen the con-

denser dials, etc. The two neutralised H.F. stages are in their own partitioned compartments and screened. A similar six-valve circuit is seen above,

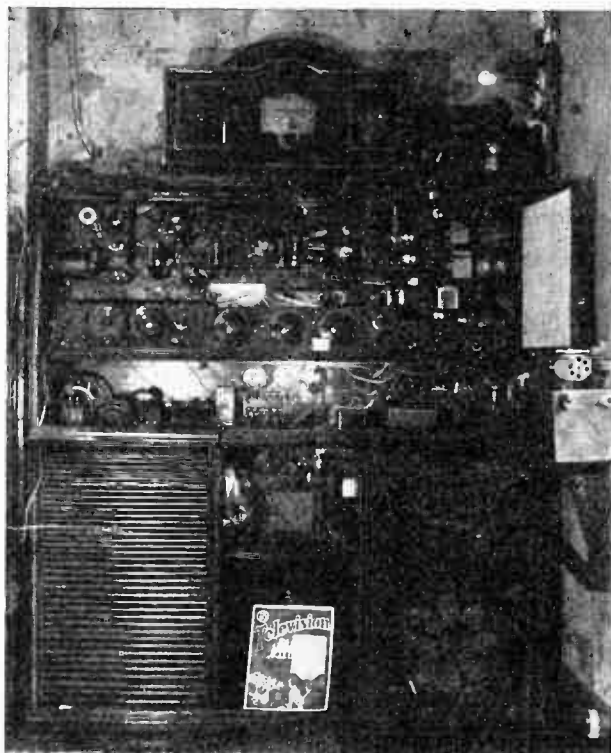

Mr. Mander refers quite proudly to the fact that he had his apparatus ready for receiving the first Baird television transmission from the B.B.C. station.

along the back facing, and both sets can be used for television, alterations from one set to the other being carried out easily.

"Of course, to receive television all this apparatus

is not necessary. Since the set is built to carry out various experiments, for the television transmission I just connect the two leads from the 'Televisor' to the phone terminals, switch on the mains, then the H.T. supply and motor, and finally switch on the set (having first cut out the two H.F. valves and connected the aerial to aerial 2 marked in the circuit, this making a 4-valve push-pull circuit). Then I decrease the variable resistance until the neon has sufficient current, and the motor speed soon steps into synchronism and is maintained with little attention throughout the programme. I am able to stand ten feet away and see and hear the artiste or whatever is being transmitted. *The results are perfectly satisfactory.*

"I was once troubled on the midnight transmission by the vibration of the electric trams which pass my house on their way to the depot. This caused the pictures to run away, upsetting the synchronism of the motor. Finally this was overcome by placing rubber cushions under the 'Televisor' and using special anti-vibratory devices for the detector valve. I have interested many by demonstrating the beehive neon lamp flashing from one set and hearing the same station on the other, meanwhile explaining how television is accomplished, since the times of actual television transmissions are not always convenient to show actual programmes. All who have seen the results are amazed and realise that we can now see by the Baird process, but the lack of longer and better hours is a decided setback.

"The push-pull part of the circuit was taken from

the September 1929 issue of TELEVISION, and for the B.B.C. programme I increase the resistance, cutting down the current.

"The panel with a cut-out on the right of the set is a Magnavox mains speaker and beneath is a 'pot' moving coil (Goodman's). The mains are 240 D.C. and a 6-volt accumulator is used to supply the filaments, this being kept charged from the mains, the room lighting being in circuit. If there are any further particulars your readers would care to have I shall be only too pleased to give same. Wishing you every success."

A Temporary Pause

We can readily sympathise with Mr. Foord, of 143 Denzil Road, Willesden, N.W.10, in his explanation that for the past six months activity with regard to television has not been very pronounced. This has arisen from the changing of his electric light mains from direct current to alternating current and necessitated a new motor for driving the television disc and also a complete rebuilding of the H.T. eliminator. However, our reader is in no way daunted and is tackling the problem in characteristic manner. He has been good enough to furnish us with details of his receiver, and we are sure readers will welcome this information.

"My activities in the direction of television have been practically nil for the past six months owing to a rather disastrous change of the electric mains from

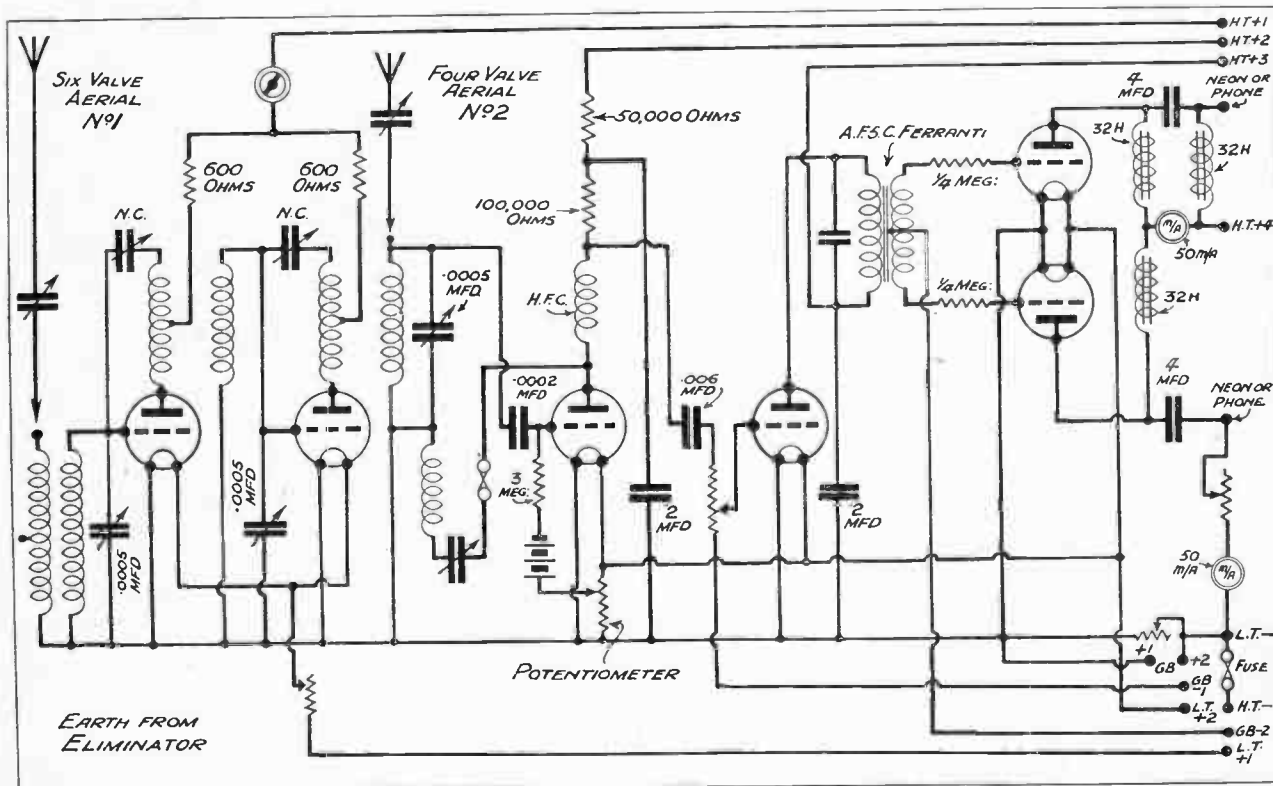

The six-valve experimental receiver used by Mr. Mander for his work in connection with television reception. Normally only the last four valves are employed when tuning-in the signals.

D.C. to A.C. This has necessitated the acquiring of a new motor, and a complete rebuilding of the H.T. eliminator, thus entailing a considerable ex-

circuit. The neon lamp, an ordinary Philips lamp with the resistance in the base short-circuited, is fed with a steady current of 20 milliamperes, and the

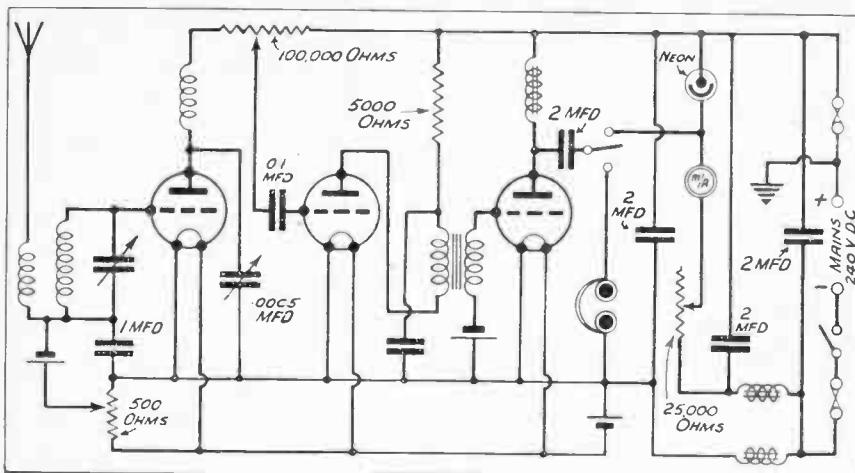

Three valves are employed for the reception of the television signals in the district of Willesden. Note the choke-capacity coupled output.

penditure. The expense involved, especially as I have been engaged on some electro-chemical researches, accounts for the rather long period of inactivity with regard to television.

"I have nearly completed the construction of my A.C. eliminator, which is part of a more ambitious receiver I propose to build with a view to obtaining images of better quality and larger size. With this object in view I am turning attention to the problems of mirror-drum scanning, which, personally, I think will be the ultimate method of scanning for pictures of a reasonable size.

"For your further information I will give a description of my receiver as it stands at present pending the resumption of experiments on A.C.

"The receiver used is as described in my last communication—namely, a three-valver consisting of an anode-bend detector followed by one stage of

signal superimposed on it in accordance with the circuit shown. Incidentally I note that this method of feeding the neon is essentially that described in the letter from Messrs. Meadway & Gill in the September issue, but I would like to point out to

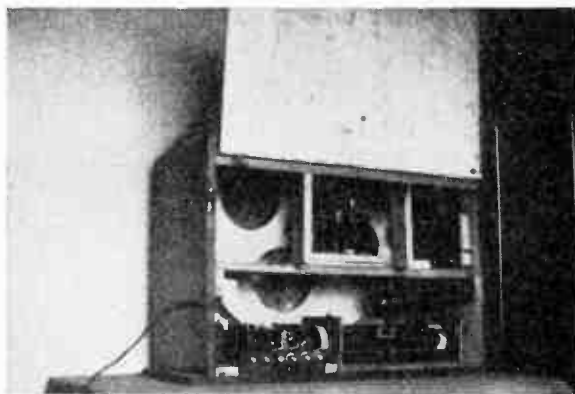

Looking at the back of the vision apparatus used by Mr. Foord.

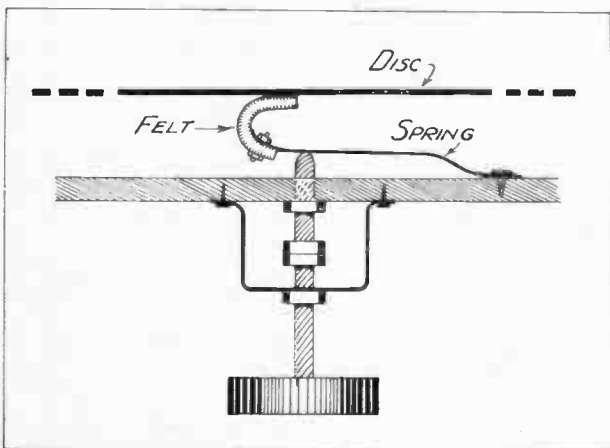

An idea for a friction brake used quite successfully by our contributor.

R.C. and one stage of transformer-coupled L.F. amplification. The output is choke-capacity coupled, first to the loud speaker for tuning in the signal, and then by means of a two-way switch to the neon

them that the impedances in the neon circuit are best grouped together as shown in my diagram, in order to obtain the maximum effect from the signal. A further advantage of this method is that if negative images are obtained it is necessary merely to reverse the position of the neon lamp and the impedances.

"For the reception of sound I have used a completely separate receiver, having had some difficulty in constructing a satisfactory dual receiver to work off D.C. mains, but it is hoped to overcome these difficulties on A.C.

"The mechanical portion is mounted in a cabinet fitted with a 5-inch short-focus lens for viewing the image, the image being built up by a 20-inch scanning disc of thin zinc with square holes giving a picture length/breadth ratio of 7 : 3. An additional viewing tunnel was incorporated at the top of the cabinet for the reception of the German transmissions, but cannot of course be satisfactorily used for this purpose owing to the use of a 4 : 3 ratio in Germany. The

eliminator and choke output are housed in this cabinet.

"The motor controls are mounted on the front of the cabinet, together with a knob which operates a friction brake which has been used for the purpose of holding the image in synchronism, and concerning

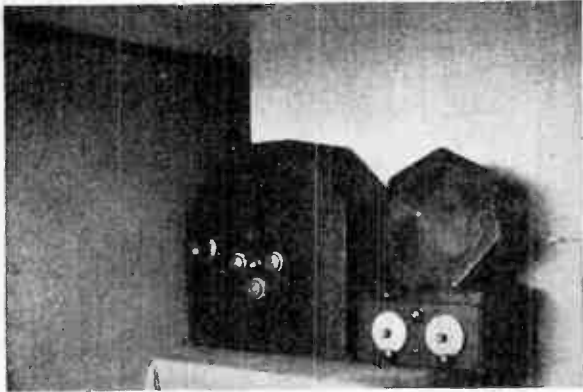

The complete apparatus made up by Mr. Foord is particularly neat and workmanlike.

which I enclose a diagram. A bell push in the motor circuit allows the disc to be run up to speed in a few seconds by short-circuiting the 60-watt lamp used as part of the series resistance. the bell push being released the moment the image comes

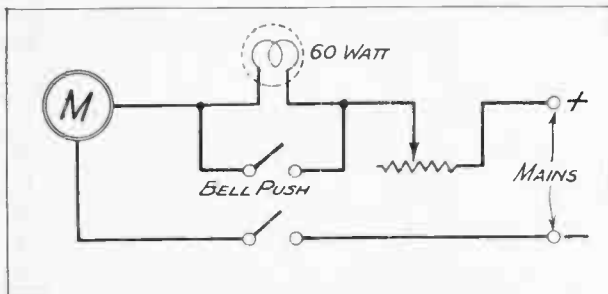

To allow the disc to run up to speed quickly a bell push short-circuits the 60-watt lamp.

into view. This device, suggested to me by Mr. Vaughan-Jones, of Eastbourne, at a recent exhibition of the Television Society, is a great improvement on the normal slow exponential increase of speed which may take several minutes to run up to the requisite speed.

FORTHCOMING LECTURE

The opening address to the Bradford Radio Society in conjunction with the Bradford Dyers' Association Staff Guild Radio Society is being given by Mr. H. J. Barton Chapple.

VISITORS WELCOMED.

To be held at Cambridge House, 65 Little Horton Lane, Bradford, on October 6th.

Subject: "TELEVISION — YESTERDAY, TO-DAY, AND TO-MORROW."



DISCOVERY

FOUNDED 1920

for everyone interested in

SCIENCE

NEVER TOO TECHNICAL
NEVER TOO POPULAR

BUT

AUTHENTIC ARTICLES
BY LEADING EXPERTS

THE CONTENTS OF THE
October British Association
Centenary Number

include the following:

SCIENCE, THE NEW FACTOR IN
HUMAN DESTINY

By General the Rt. Hon. J. C. Smuts

PERSONAL RECOLLECTIONS OF
FARADAY

By Michael Grabham, M.D., LL.D.

THE PEOPLES OF EARLY PALESTINE

By Sir Flinders Petrie

THE NEW PHASE IN CANCER
RESEARCH

By a Medical Correspondent

PRICE . . 1/- MONTHLY

ANNUAL SUBSCRIPTION 12/6

SEND FOR FREE SPECIMEN COPY
NOW TO

"DISCOVERY,"

Bouverie House, Fleet Street,
LONDON, E.C.4

Announcing the Shilling

TELEVISION MAGAZINE

Starting with the November issue the price of the
Television Magazine will be raised to 1/- monthly

SIZE INCREASED

Many new features will appear in this number including:

The Truth About Television
by J. L. Baird

The Nature of Light
by Sir Ambrose Fleming

A Striking Article from the Pen of
Sydney A. Moseley

Constructing the New Tele-Radio Receiver
by H. J. Barton Chapple

Readers' Query Page

Workshop Hints, etc.

Place an order with your Newsagent immediately to avoid disappointment,
or place a six months' or annual subscription direct with us

From My Notebook

By *H. J. Barton Chapple*
Wh.Sch., B.Sc.(Hons.), A.C.G.I.,
D.I.C., A.M.I.E.E.

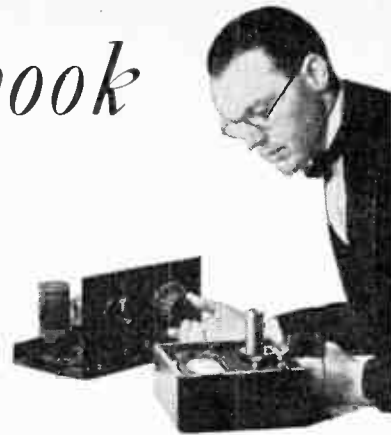

Manufacturers—Please Note

AS I carry out quite a good deal of experimental and constructional work, it is very natural that I should employ a number of radio components of varied types. Generally these are well packed in cardboard cartons, but when it

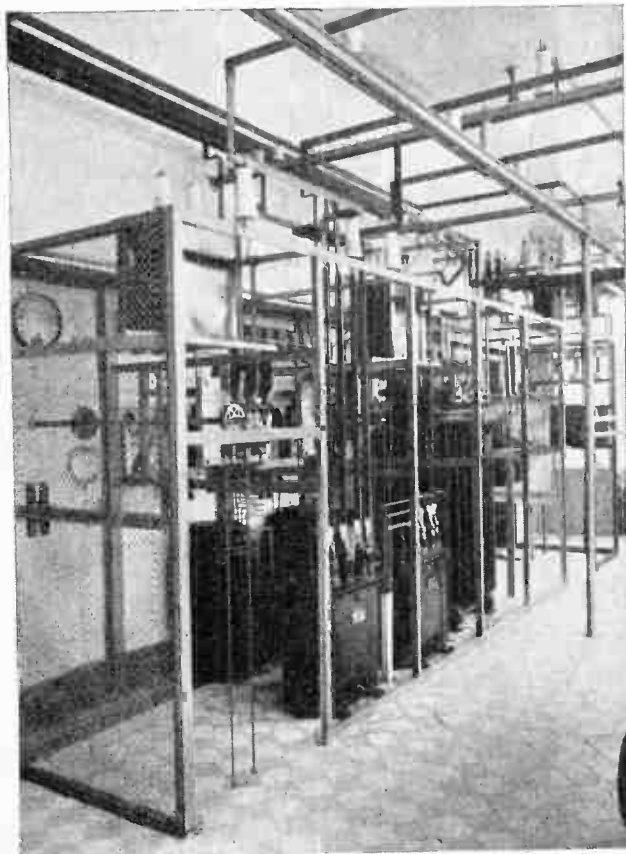

Inside the Radio Vitus broadcasting station, showing the contact breakers and voltage regulators.

comes to mounting them on baseboards for wiring up, frequently I have cause for annoyance and I know that other constructors share the same feelings.

These are given rise to by the fact that, owing to the varied types of bases and screw holes, screws of differing lengths and sizes are required in order to hold each component in place. Now, although the constructor and experimenter keeps a fairly well-stocked screw-box, he finds invariably that some of the sizes required are missing and makeshifts are called into service. These are either too short or too long, and in the case of the latter this means filing off the projecting points which have passed right through the baseboard.

My point is this. Would it not be a simple matter for all manufacturers to follow the lead of the few and include in the carton the necessary two, three, or four holding-down screws as the case may be? The extra cost to them would really be trifling and be amply repaid by the complete satisfaction of the constructor using the goods. The most popular baseboard thickness is $\frac{3}{8}$ inch, and this thickness could be allowed for when packing the screws.

Another detail is the omission of soldering tags. While this item does not worry those who prefer not to use a soldering iron, it is annoying to the others, who find that they have temporarily run out of the 4, 6, or 8 B.A. tags which may be required. In many cases manufacturers include these soldering tags under the terminal nuts, but to those who do not follow this practice may I suggest that it would help matters considerably if they did so.

Applause to Order

When station WOR radiates its special Sunday evening radio revue the programme is performed in a music-hall and not in the studio. The public is admitted free of charge, as it plays a most important part in the production.

Half an hour before the broadcast is timed to commence the audience is addressed by the stage manager, who instructs it how and when it shall laugh and applaud. Anybody who laughs out of place is promptly turned out.

During the performance a man stands at the side of the stage and with a white baton signals the audience when they must applaud. If the applause is insufficient he makes a funny face.

These drastic measures are to ensure that the listening public will not be mystified by applause due to some action it cannot of course see and appreciate.

Photo Cell unmasks Bogus Medium

A Philips photo-electric cell recently played an important part in the unmasking of a bogus medium who, operating in darkness, had succeeded in deceiving many psychic experts. The medium's performance was to move or cause to be moved objects on a near-by table, while he remained securely bound.

Convinced that there must be some trickery somewhere, investigators secretly fitted a Philips photo-electric cell between the table and the chair, and focused an invisible beam of infra-red light on to the cell aperture in such a manner that any movement on the part of the medium in the direction of the table would interrupt the beam.

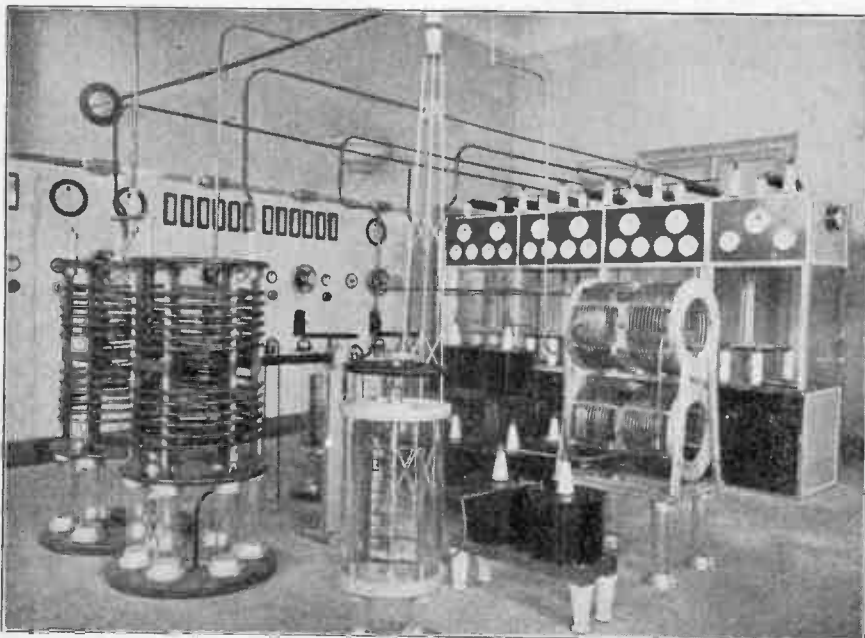

Any interruption would cause the photo cell to operate a relay, which in turn caused a quantity of magnesium powder to be ignited and a photograph taken. At one seance the device operated and the resulting photograph clearly showed the medium, who by some method had released his fetters, about to move objects on the table by hand.

Using Aluminium

It has been estimated that upwards of twenty-four million wireless sets are now in use all over the world. It is hardly necessary to emphasise, therefore, that competition in this rapidly developing trade is keen, and that manufacturers have to consider more than ever all the factors which may lead to a better technical performance, a reduction in manufacturing costs, or an improvement in selling characteristics. Among these factors is the choice of the material to be employed for certain components and purposes, and a noticeable feature is the

growing use of aluminium in a number of special directions.

It is the lightest of the metals commonly used, but has a strength and rigidity which are adequate for wireless constructional purposes. Then, again, we must not lose sight of the fact it is excellent for television disc construction, No. 32 S.W.G making up into a first-class disc for purposes of this character.

Screening

Perhaps one of the most important applications in receiver work is in connection with screening. Broadly speaking, screens are used in wireless sets for three purposes: firstly, to eliminate the possibility of picking up electro-magnetic waves from a distant source; secondly, to prevent interference from local low-frequency electro-magnetic oscillations present in the set itself; and thirdly, to give

Readers will see that the high-frequency room of the new Radio Vitus Station has been planned with an eye to great efficiency. Elaborate insulating precautions have been taken as judged from the size and the height of the insulators shown.

protection against local high-frequency oscillations.

For the first purpose it can be shown that the permeability of the metal is of small account, the screening efficiency depending chiefly on the low resistance of the metal, and from this point of view aluminium is much superior to iron.

As regards the second reason for screening, a ferrous metal of sufficient thickness would appear to be ideal. This statement, however, is modified by an important practical consideration. Space is a factor in most sets, and it follows that coils must often be quite near their screens. Elementary considerations indicate that the effective resistance of a coil will be appreciably increased if it is in juxtaposition to a ferrous metal of high resistivity. From this point of view, therefore, it is advisable to use a non-ferrous screen of low resistivity.

In the third application of screening also, the conductivity of the screen is again the chief factor, and in fact a high permeability, as in a ferrous metal, is definitely a disadvantage.

It will be seen, then, that aluminium fulfils the requirements from the technical point of view in all the above cases. No other metal can provide the requisite conductivity with the same lightness and with the same cheapness. It is considerations such as these that have led manufacturers to select aluminium sheet not only for small screens and screening boxes, but for the complete chassis in transportable sets.

An Interesting Visit

I spent a very interesting afternoon a few days ago, for I paid a visit to the Celestion loud-speaker factory, situated in London Road, Kingston-on-Thames. This company has been established in the loud-speaker market for many years now, but frankly I was surprised and not a little impressed with the results I heard. For one thing, they have produced an M.12 chassis suitable for building into a cabinet or fitting on to a baffle. The movement is very simple in design, but I was astonished at its efficiency when fitted with a reinforced diaphragm. The quality of reproduction was of the highest order, and, being priced at a figure of 35s., this product is sure to make an appeal to all who value good music.

I then participated in a very thorough and searching test of their two permanent magnet models, R.P.M.8 and R.P.M.12. The first named is the baby, but it is a very lusty infant when judged from its ability to handle great volume without distress. This is coupled with a good tonal range and a high degree of sensitivity, and I listened to almost every type of music but failed to detect any boominess or pronounced resonance. The same remarks apply to the larger model, and the volume of realistic music, song, or speech that it could handle left no doubt as to its quality.

A tour round the works satisfied me that, as far as Celestions are concerned, their loud speakers are instruments of precision and maintain the highest of reputations.

Swiss Broadcasting Develops

Determined efforts are being made in Switzerland to increase the number of radio fans. The erection of two powerful transmitters (Radio Suisse Romand and Beromunster) has definitely placed Switzerland in the front ranks of European broadcasting. The progress of Swiss broadcasting is amply illustrated by the following figures:

From 155 listeners in 1920 and 980 in 1923, the number increased to 17,000 in 1924, when the Zurich transmitter opened. By 1929 the figures had increased to 82,000 and by 1930 to 101,000.

New Radio Invention guides Air Pilots

Pilots flying on the Kansas City—Los Angeles air route have the benefit of a new radio invention to help them keep their course. In most direction-finding systems it is necessary for the pilot to wear headphones which sometimes can be a handicap. The new system, however, gives the pilot visible in-

AN ADDITION TO A FAMOUS RANGE OF DUBILIER CONDENSERS A 4 mfd. Type BB

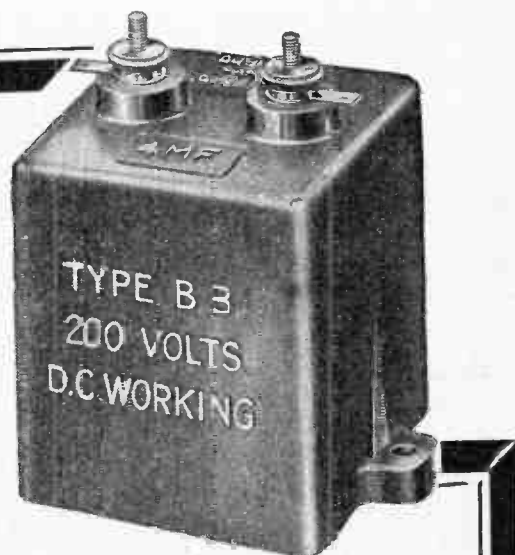

With the addition of this new 4 mfd. model the need for paper condensers suitable for wireless receivers can now be met from the range of Type BB Dubilier Condensers.

This range of condensers has already been used by many thousands of constructors of wireless receivers with entire satisfaction. They are built with all that precision which ensures unfailing reliability in any Condenser bearing the name Dubilier.

PRICES (Type EB):

1 mfd. - 2/6 2 mfd. - 3/6 4 mfd. - 6/3
(Working Voltage 200 D.C. Tested at 400 V.D.C.)

NORTHERN
NATIONAL RADIO
EXHIBITION
MANCHESTER
Oct. 7th to Oct. 17th
we are exhibiting at
STANDS 46 & 60

DUBILIER

CONDENSER Co. (1925) Ltd.

DUCON WORKS, VICTORIA RD., N. ACTON, LONDON, W.3

dication through a special instrument, the needle of which informs him how much he is off his route—either to the right or to the left.

True Radio Reproduction

The ethics of true radio reproduction unfortunately are very often misunderstood, and any means whereby knowledge on this subject can be added to should not be overlooked by the amateur experimenter and constructor who puts a high premium on that much-abused term "quality."

I therefore welcomed the opportunity of reading through *The True Road to Radio*, which has been

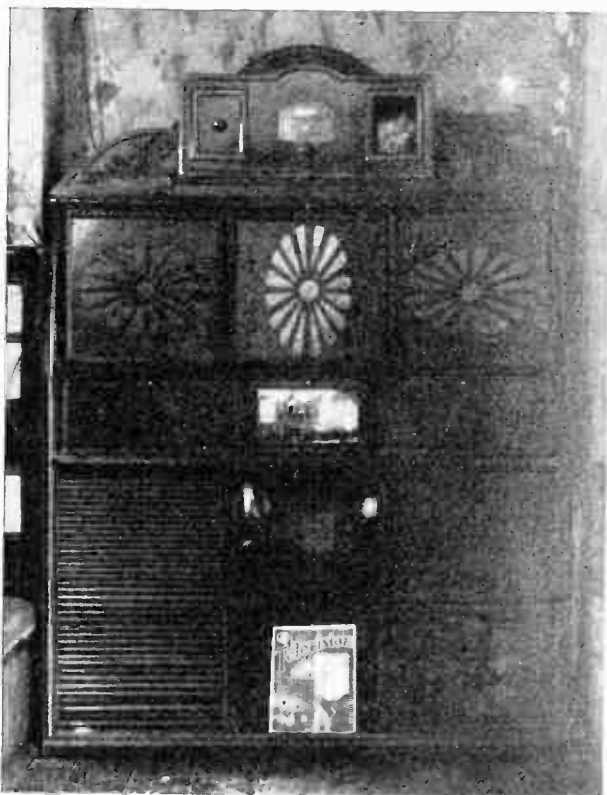

The outside appearance of Mr. Mander's receiver to which reference is made in the Enthusiast series.

produced by Messrs. Ferranti, Ltd., and of which there have been two previous editions. I understood that there have been numerous requests for a third edition of the book, and the author, Mr. A. Hall, in his activities designing commercial sets for Messrs. Ferranti, Ltd., has collected an enormous amount of useful information, a good deal of which is quite original. This has been compiled into a popular consecutive story illustrated by line-blocks and half-tones for the majority, while, in addition, there is a more detailed technical portion filled in as separate sections to help the growing number of amateur constructors and technical men interested in the science.

Outstanding Interest

I have found the book of outstanding interest, but Messrs. Ferranti quite rightly point out that, in

its present form, the book is a relatively costly production and, in consequence, they have decided to publish it at the price of 5s.

It has been made available to the public through the usual wireless dealers, and, failing that, a copy may be obtained from the Publicity Department of Messrs. Ferranti at Hollinwood, post free, on receipt of the 5s. remittance.

Quite frankly, this is one of the best investments I have made for quite a long time, and I unhesitatingly recommend it for the earnest consideration of all interested in radio, whether it be applied to sound reproduction or the television aspect.

Facing the Facts

(Concluded from page 297)

better hours and facilities. That does not answer the financial side, however, and as an expression of a personal opinion, I am sorely tempted to say that perhaps the American idea would solve the difficulty.

Income from Advertisers

I saw the other day that the two largest American broadcasting companies—the National Broadcasting Co. and the Columbia Broadcasting Co.—received during the first quarter of 1931 upwards of £1,672,000 as fees from advertisers for the broadcasting of sponsored programmes. This figure shows an increase of 36 per cent. on 1930 figures, 42 per cent. on 1929, and 83 per cent. on 1928. It is confidently anticipated that the total advertising revenue which these two companies alone will receive in 1931 will be £7,000,000, while the total revenue expected from this source by the 600 American broadcasting stations will be £15,000,000.

There is evidence that these advertisers are preparing to grasp the television performance as they have radio. It will permit demonstrations, and the audience will not have to imagine what a product looks like or how it operates. A new model motor-car, or even a domestic utensil, can be placed before the transmitter, and this will enable it to be introduced immediately to everyone looking into the television receiving apparatus. It has been said that one picture is worth more than a thousand words.

Again, if this sponsored programme idea gained impetus, we should see a revival of those advertising characters which have been displayed on cartons and in the daily press. With television in the home, however, the advertiser would have to see that at no time was he an unceremonious guest.

I wonder whether other readers have suggestions to offer. Perhaps they will make use of the correspondence columns and air their views on the subject, for I regard it as a most absorbing and important one.

ORDER NEXT MONTH'S "TELEVISION"
 IN ADVANCE
 An Outstanding Number!

TELEVISION

AT PRICES WITHIN REACH OF ALL

BAIRD TELEVISION LTD.

have pleasure in announcing

BIG PRICE REDUCTIONS



A happy family group enjoying television reception in the comfort of the home

"TELEVISOR" COMPLETE	£18 18 0
EXPERIMENTER'S KIT	7 12 6
COMPLETE KIT OF PARTS for the Home Constructor ..	12 12 0
Comprising—	
Motor and Synchronising Gear	£5 5 0
Motor Bracket, Clamping Bolts, etc.	1 0 0
Lens, large	13 6
„ small	7 6
Lens Box Assembly	1 0 0
Neon Lamp	1 5 0
„ Holder	1 6
Disc	£1 1 0
Zenite Resistance and Supports	17 0
Resistance with Bracket and Control Knob ..	6 3
Spindle Assembly with Control Knob	5 9
Terminal Board	7 6
T.C.C. Condenser	2 0

Any parts may be obtained separately

BAIRD TELEVISION LTD.

133 LONG ACRE, LONDON, W.C.2

Telephone: TEMPLE BAR 5401



Television at the Berlin Radio Exhibition

by
Dr. Alfred Gradenzwitz

TELEVISION has been a regular feature of Berlin's yearly Radio Exhibition even since 1928, when Dénes von Mihály came forth with a first crude attempt at shadowgraph transmission, while Prof. Karolus, in conjunction with the Telefunken Company, had a somewhat more elaborate apparatus to show. A distinct step forward was made the following year when the Baird Company, under the name of Fernseh A.G., incorporating, as is well known, three of the foremost German concerns in the fields of optics, radio, and motor construction respectively, stepped in, showing for the first time actual television, *i.e.* the electrical transmission of moving persons and animated scenes.

This year marks a distinct change in two respects. First of all, two of the men whose names have been intimately connected with German television work were absent from the show. Mihály seems to have given up all personal work in the field, though his Company, the Telehor people, in conjunction with the Tekade firm, of Nuremberg, still survives, and Prof. Karolus, after developing his apparatus to a point of fair efficiency, has temporarily withdrawn from the contest, though his return may be expected at a later moment.

A new-comer in the field is Manfred von Ardenne, the well-known pioneer in wireless work, who, in conjunction with the Loewe radio firm, has his cathode ray television to show. The other change relates to the quality of television images. Inasmuch as no permanently satisfactory results can be expected from German standards (12 picture cycles per second, 1,200 picture elements), all exhibitors made a point of showing what could be effected with pictures showing a greater wealth of detail. The numbers of elements of all television images exhibited were therefore kept intermediary between 5,000 and 11,000.

The first modest show of television, in 1928, took place under the auspices of the German Post Office. This, as readers are aware, has ever since been patronising and controlling all television work in Germany, and, at its experimental department (*Reichspost-Zentralamt*), has set apart a special

section for experiments on these lines. The Television Show of the Berlin Exhibition, accordingly, comprised samples of this official work side by side with the exhibits of private firms and experimenters. It is significant of present tendencies in Germany that the Post Office experimental station should quite recently have taken up cathode ray television, and should, in the space of only about a month, have obtained fairly good results in this connection.

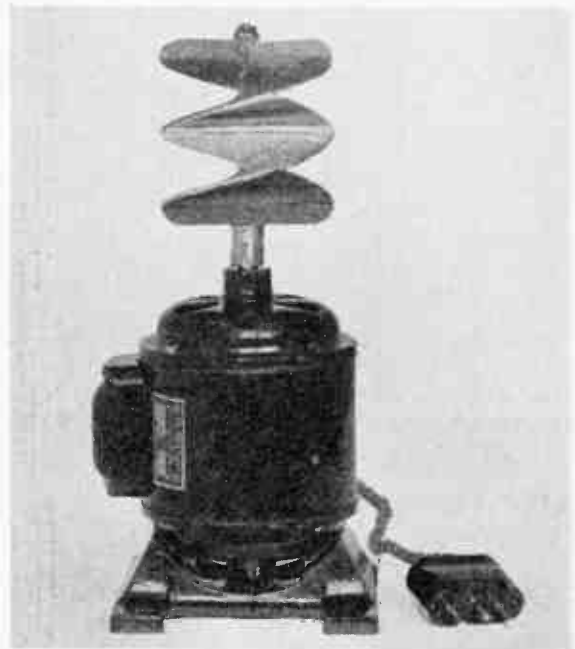

A mirror helix design containing 84 sections and coupled to a 25-watt commutatorless motor.

However, the cathode ray is made use of only at the receiving end, the transmitter being of the usual mechanical-optical design with a Nipkow disc or mirror wheel to scan the picture or scene to be televised. Synchronism is obtained by impulses sent along with the television signals.

The Post Office also exhibited mechanical-optical

television on similar lines to the Fernseh A.G. and, further, by a series of synthetic tele-cinema films, showed, or endeavoured to show, the influence of the number of picture elements on the clearness of television images. The impression actually produced by television pictures, of course, is much more favourable than could be inferred from an inspection of these artificial products.

The Fernseh A.G. has, during the last year, been intent upon increasing the luminosity of the lamps controlled by the television signals. Whereas the luminous intensity of the glow lamps so far used was 0.5 to 2 Hefner candle-power, those recently developed will give as much as 40 to 60 Hefner candles. At the same time, this firm, by employing special devices, have succeeded in preparing excellent Nipkow discs having as many as 90 holes or even more, which, in the case, *e.g.* of discs only about 50 centimetres in diameter, corresponds to hexagonal holes with a side of about 9/100ths millimetre. In this connection, to ensure undistorted images, the angular accuracy had to be raised to 0.2 minute of a degree. In spite of the increase in the number of holes, the diameter of the discs has to be kept unaltered. The size of the television images was increased, while the luminous intensity of the glow lamps, as above stated, was augmented. The new 90-line images, corresponding to 10,800 picture elements, with the standard horizontal size of 3 : 4, are more luminous than last year's pictures of only 1,200 to 3,000 elements, and, moreover, can be readily inspected in a bright room.

A tele-talkie transmitter, consisting of a talking film projector of the Zeiss-Ikon A.G., was exhibited, synchronising being effected from the mains, the same as during last year's wireless receiving tests from Doerberitz. The frequency of the pictures was 25 per second; transmitted images comprising 90 lines or 10,800 elements, their size in the Nipkow disc receiver being about 9 by 12 cm. (horizontal).

A moving-spot transmitter and receiver were further on show, this being used for television proper, *i.e.* the transmission of persons and scenes. The pictures transmitted were vertical, with ratio 3 : 4, and comprised 80 lines, corresponding to 4,800 elements; the frequency of the images being $16 \frac{2}{3}$ per second, and the size of the images about 12 by 16 cm.

The Fernseh A.G. also exhibited a Nipkow disc projection receiver for images comprising 4,800 elements, with a frequency of 25 per second. Its construction was made possible by the use of the bright glow lamps referred to above, the Nipkow disc image being projected by a simple optical system directly upon a frosted glass plate. In fact, the receiver gives brighter images even than an equivalent mirror-drum apparatus and point lamp. It is an interesting attempt at producing a directly projected image by means of a simple Nipkow disc in conjunction with an ordinary surface lamp, in accordance with the Fernseh A.G.'s general policy of providing suitable receivers with the most simple means, avoiding any complicated sources of light and image-reproducing devices.

In addition to these mechanical-optical receivers

the Fernseh A.G. also had a cathode ray tube receiver on show, which, however, was not exhibited in operation. Moreover, there was a collection of branded parts destined for the construction of receivers for television transmissions from Witzleben.

The Tekade Company, of Nuremberg, had an interesting novelty to show, viz. a helical mirror receiver (Telehor system). This is made up of lamella mirror sections, helically distorted, and directly mounted on the axis of the driving motor. The motor and helical system thus have a common vertical axis, and are used in connection with a lengthy glow lamp installed outside the vision apparatus proper.

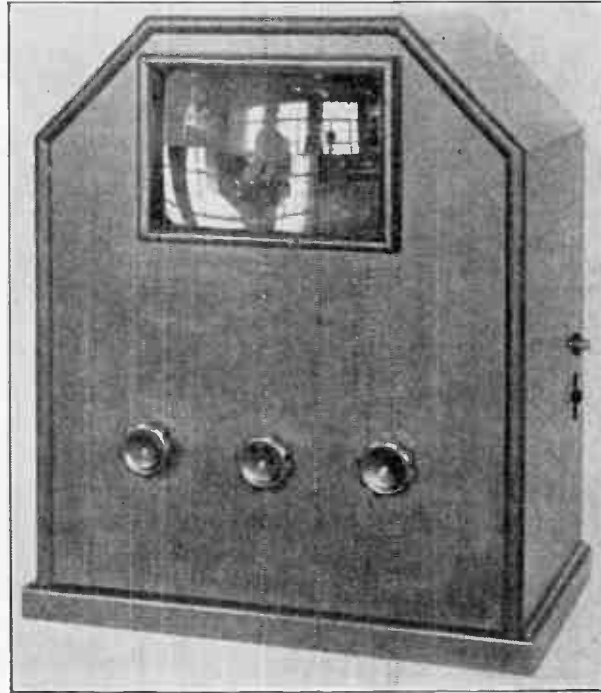

The Fernseh A.G. exhibited the receiver shown above. It is suitable for 10,800 picture prints and gave very brilliant images.

The advantages claimed for this arrangement are the compact design of the apparatus, a great luminosity, and the large dimensions of images. In fact, these are viewed without any magnifying lens, and are visible to a considerable number of persons at a time.

The helical mirror receivers shown at the exhibition were designed for 84 lines and 25 pictures per second, corresponding to 105,000 elements per second, the size of the images being about 100 by 100 millimetres. However, this, without any technical difficulties, can be doubled, nor should there be any objection to receiving up to 300,000 picture elements per second, corresponding to about 150 lines. These receivers are fitted with built-in moving-coil loud speakers, for receiving tele-talkies. The driving motor is a simple type of commutatorless 25-watt induction motor.

Both the loud speaker and motor are connected up to the alternating current mains direct, it being thought that satisfactory tele-talkie transmissions, on account of the broad frequency band, will in actual practice be effected only with ultra-short waves, the range of which is not much in excess of that of local lighting mains. The transmitter and receiver are synchronised simply by connecting them to the same mains. However, there is no objection to synchronising the helical vision apparatus by television signals.

Apart from the television section proper, at their stand in Hall IV of the Exhibition, the Tekade firm had on show their sets of branded parts destined

picture elements, thus enabling the picture to be scanned and reproduced by purely electrical means without the aid of any parts moved by mechanical means, such as motors and Nipkow discs. Another advantage of such an arrangement is the fact that cathode rays, being devoid of any inertia, will enable any number of image elements and any frequency of images to be obtained, thus supplying relatively bright pictures visible simultaneously to many persons at a time without resorting to any complicated apparatus expending much energy.

Though this sounds quite simple in principle, a number of special problems had to be solved before obtaining with the cathode ray tube any images of

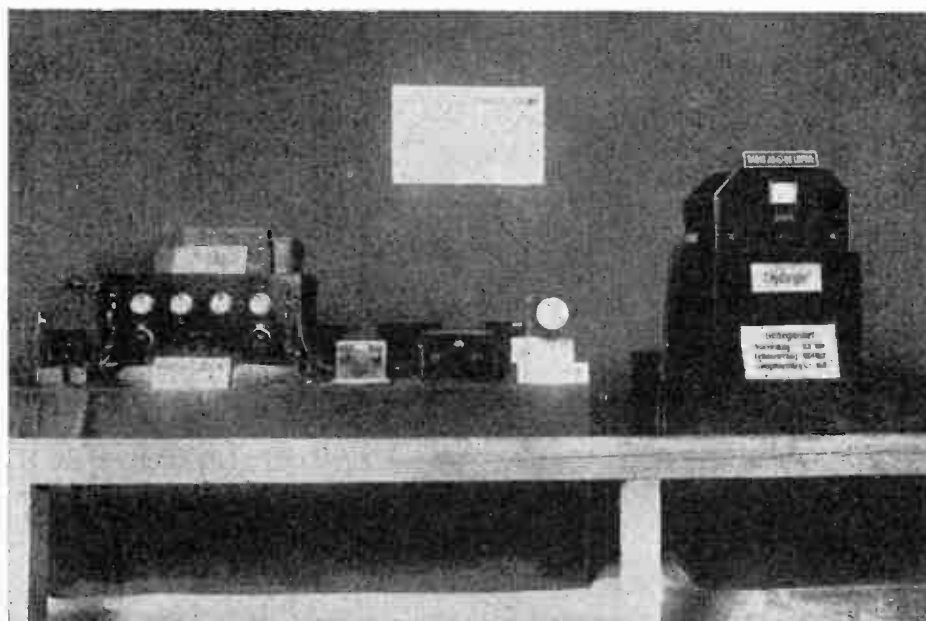

⊗ ⊗ ⊗

Some of the cathode ray tube apparatus specially adapted for television and produced by Manfred von Ardenne.

⊗ ⊗ ⊗

for amateurs, schools, etc., and by means of which vision apparatus suitable for receiving both the English and German transmissions can be built. Each such set comprises a detailed, fully illustrated description and is designed on the most up-to-date lines. While being destined for transmissions on the present television standards of the German Post Office—1,200 elements per image and 12.5 images per second—they may as well be used for higher numbers of elements and greater frequencies, another Nipkow disc being substituted and the arrangement of connections altered accordingly.

Manfred von Ardenne, in conjunction with the D.S. Loewe Radio Company, for the first time showed his cathode ray television. The main advantage claimed for this, apart from a great simplicity of apparatus, is the possibility of adapting a given apparatus to any improvement of the transmitter as obtained by an increase in the number of elements.

Cathode ray tubes are used both at the transmitting and receiving ends. These are large glass bulbs, having at one end a circular viewing surface coated with a phosphorescent material. A cathode ray produced in the bulb is deflected electrostatically in accordance with the number and luminosity of the

a quality comparable to that of mechanical-optical television images. Some of these are enumerated in the following:

Television pictures as produced by M. von Ardenne's cathode ray tubes comprise about 20 to 25 images per second, each of which is composed of about 12,000 elements. This figure is likely to be raised to 30,000 in the near future. In fact, the cathode ray moving within the glass bulb has to reproduce several hundred thousand picture elements each second. In order to realise the difficulty of such a task, it should be remembered that the low-frequency amplifier of a high quality radio receiver at best reproduces 8,000 to 10,000 oscillations per second. Entirely new amplifiers, nay even new amplifier valves, had therefore to be provided. Again, on account of the high number of image elements, the use of standard radio waves was out of the question, and ultra-short waves had to be resorted to, which in turn involved the problem of transmitting television pictures composed of oscillations varying in speed from the lowest to the highest figures by means of ultra-short waves.

After thus enumerating the various types of tele-

(Continued on page 318)

Scottish Notes

By *W. Barrie Abbott, B.L., C.A.*

We are always delighted to throw open our columns to those who are qualified to express opinions on any matter appertaining to television. We should like to point out, however, that the printing of any article does not necessarily imply that we endorse the views and opinions expressed by our contributors and correspondents.

THE number of television experimenters in Scotland is at present limited, chiefly owing to the fact that the existing B.B.C. stations do not provide the requisite power or facilities. We are therefore looking forward eagerly to the completion of the new station near Falkirk, which it is hoped will give Scotland a fair chance of receiving television. That there is a great deal of enthusiasm for television in Scotland admits of no doubt, and the granting of proper facilities by the B.B.C. will translate that enthusiasm into action. *Even now the B.B.C. could cater for Scottish requirements by arranging facilities for television through the North Regional Station.*

While Scottish enthusiasts appreciate the measure of co-operation hitherto given by the B.B.C. to television and are aware of the technical difficulties involved, they cannot help thinking that there is some force in the B.B.C. that is determined to give only grudging support to this new British industry. It is possible that in the early days of television lack of foresight on the part of some television officials helped to create this grudge. It takes two to make a quarrel, and there would be faults on both sides. But the past should be allowed to die, and that august body, with the name "British" proclaiming its patriotism, the B.B.C., which for weal or woe holds an undisputed and autocratic monopoly of the ether, should rise above all petty considerations and stand forth as the champion of British television as well as of British wireless.

We in Scotland, understanding that the Director-General of the B.B.C., and also the Scottish Regional Director, are both lovers of their country, are disappointed with their strange silence on the subject of television. One must try to be fair, but we are not aware of their ever having publicly given a word of praise to the inventor of television, and we have some reason to believe that they have never actually been in the Baird laboratories. We cannot help noting that whenever television establishes a milestone on its progress (e.g. the televising of the Derby), the B.B.C. adopts a policy of hush-hush.

These notes are being written just after the first broadcast of television from the B.B.C. studios has taken place, and again we note the complete silence on the part of the B.B.C. on the subject. What game are they playing? Can it be that they so abhor commercialism that they shrink from doing anything that may help the British television company financially?

Vested interests have tried hard and long to delay

television in the hope that the resources of the pioneering British concern will be exhausted, and so many prophecies have been made in this direction, that *amour-propre*—that most deadly disease of inferior minds—is trying to make these prophecies come true. Although the programmes now being put forward by British interests are greatly improved—only recently I saw group dancing and vaudeville by television—still the unreasonable times granted by the B.B.C. continue, and the B.B.C. demand payment for every facility given.

Experimenters all over the country want decent hours within the normal programme. Only then can one honestly say whether the public want television or not. But here, in the opinion of many Scottish enthusiasts, lies the key to the problem. The B.B.C. have a monopoly of which they are exceedingly jealous. So long as they can keep television at the experimental stage and outside the normal programme, they can ask payment for everything. The moment they admit that television programmes have commercial value, and show them to take place within normal hours, from that moment they will have to face the question of paying for television.

Instead of facing this problem justly and fairly, they appear to shelter under a smoke screen of horror at the idea of "boosting" shares or dabbling in what they call commercialism! While they are quite willing to pay all other artists who contribute to their programmes, they seem to be astounded at the thought of paying anything for television. We in Scotland are not deceived by the excuses they put forward, nor by their attempts to discredit a great achievement by a British inventor. We regard it as a shame and scandal that in these days of unemployment in our country that anybody, no matter how influential, should be allowed to "throttle" what, if properly encouraged, would be a vital British industry. In this crisis in our country's history, it is intolerable that matters should continue as they are; and if I, as the representative of Scottish enthusiasts, am allowed to do so, I shall continue to refer to this aspect of television from time to time until justice prevails.

There is no question of unfriendliness or ill-feeling on my part. I praise the B.B.C. for the wireless treats they continually give to the public, and in private discussions I have defended them many times. In this matter of television, however, their conduct up to the present has, in the opinion of many Scotsmen, been distinctly anti-British, and quite below the B.B.C. reputation for fair-play.



TRADE NOTES OF THE MONTH

REPORTS ON APPARATUS TESTED

Announcing a New Speaker

WE learn from Messrs. Whiteley Electrical Radio Company, Limited, that they are introducing at Olympia, a new "W.B." Permanent Magnet Moving-coil Loud Speaker Model P.M.3. This will be retailed at the remarkably low price of 45s., a tapped transformer being available at an extra cost of 7s. 6d. For those de-

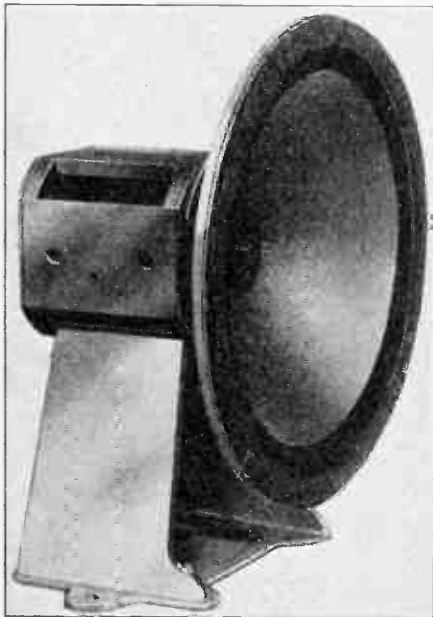

⊗ ⊗ ⊗

The new P.M.3 loud-speaker chassis of "W.B.'s," is robust and a real workman-like job. It retails at the low price of 45/-.

⊗ ⊗ ⊗

siring the speaker chassis housed in a cabinet, an extra 30s. meets the cost of one in attractive oak.

As readers of this journal are well aware, Messrs. Whiteley Electrical Radio Company, Limited, have

made permanent magnet speakers a great feature of their manufacturing activities during the last two years. They are one of the pioneers in this field, and their latest achievement is due partly to their close co-operation with the Sheffield manufacturers of cobalt steel magnets.

We understand that, despite the low price, this new P.M.3 Model is exceedingly sensitive and gives true moving-coil reproduction from any two- or three-valve set, and it is hoped to include a test report on this speaker in our next issue.

Another interesting item of news is that new low prices have been fixed for the range of W.B. Valve Holders and Switches. The fact that over a million W.B. Valve Holders have been sold is an indication of their appeal to constructors.

Journal of the Television Society

We have received from the Television Society, Part II of Volume I of their journal, which is published three times yearly. In this particular issue two of the lectures are described in full as well as a résumé dealing with the Society's Third Annual Exhibition and a report on the Third Annual Business Meeting. Under normal circumstances, payment of the annual subscription entitles fellows and associate members to one copy of each number of the Journal issued during the period of membership. Student members may obtain copies and ordinary members may obtain extra copies at one-half the published price, which is five shillings.

Price Reduction of Magnet Wireless Batteries

We learn that in view of improved methods of manufacture and the increasing demand for Magnet

wireless dry batteries, the General Electric Co., Ltd., has decided to reduce the prices of the whole range of its products falling within this category.

While the quality and capacity of all the batteries have been considerably improved, the triple-capacity type possesses an outstanding new feature in the method employed for insulation purposes, this eliminating any possibility of leakage or creeping and so ensures a longer life.

The new prices of the batteries, compared with the old prices, are tabulated below.

	Old Price.	New Price.
60-volt Standard Unit Cells	7/11 each	7/6 each
99-volt " " " " " " " " " " " "	12/- "	11/6 "
100-volt " " " " " " " " " " " "	12/11 "	12/- "
120-volt " " " " " " " " " " " "	—	14/6 "
60-volt Triple-capacity Type.	13/6 "	12/9 "
6-volt Grid Bias	1/- "	10½ "
9-volt " " " " " " " " " " " "	1/6 "	1/3 "
16½-volt " " " " " " " " " " " "	2/9 "	2/3 "

Cossor Empire "Melody Maker"

Messrs. A. C. Cossor, Ltd., sponsored their first "Melody Maker" in the year 1927 and, since that date, they have introduced annually a "Melody Maker" of advanced design when compared with its predecessor. This year they have evolved the Model 234 receiver, and we have recently had an opportunity of testing out this set.

We note with pleasure that many new features are incorporated. First of all this Empire "Melody Maker" is offered in kit form for easy home assembly. This has always been an outstanding feature of the Cossor series, but in order to simplify still more the work of construction, a metal base plate is supplied with every hole drilled, this ensuring automatically that the components are mounted in their correct positions. Two coils are employed, being separately housed in metal containers to eliminate instability through interaction, and also prevent direct pick-up when the set is used near a powerful station.

Another feature to which attention must be drawn is the ganged switching which has been introduced. This is effected by operating the switch in the end of the cabinet; push in for long, pull out for short.

With the extension of the B.B.C. Regional Scheme and the large increase in power of many foreign stations, adequate selectivity is a vital point with any receiver. To meet this the Cossor Empire "Melody Maker" has a series aerial condenser and, in addition, further selectivity is secured by properly controlling the filament current of the screen-grid valve in conjunction with a judicious use of the reaction condenser. These two last-mentioned controls appear on the front of the cabinet immediately below the push-pull on-off switch.

We found that the assembly of this receiver was quite an easy matter, and one which can be undertaken by anyone even if they have never previously built a set.

The circuit is a conventional 3-valve screened-grid arrangement, the first valve being the Cossor 220SG, which is coupled by means of a tapped tuned anode of suitable ratio to a Cossor 210HL,

acting as a leaky-grid detector. The detector is coupled by means of a Cossor transformer to a 220P output valve, which permits considerable volume to be handled without the least trace of distortion.

We tested the set within about six miles of the Brookman's Park station and, since each battery lead is plainly marked with the voltage to which it should be connected, no difficulty was experienced in putting the set straight into commission. A few minutes only were necessary to become familiar with all the

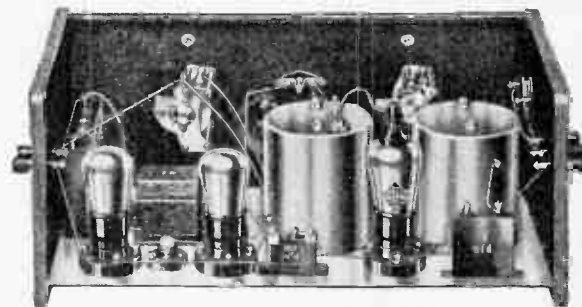

Very simple to construct and easy to operate, the Cossor Empire "Melody Maker" is a set giving remarkably good results.

controls, two tuning condensers being used in conjunction with the reaction and volume controls and series aerial condenser previously mentioned.

We feel that no good purpose would be served by mentioning individually the stations which were heard. A receiver's performance depends so much upon situation (apart, of course, from the skill of the operator), but we might add that both the London National and London Regional stations were separated with ease and, in addition, we were treated to good reception of both music and song in several foreign languages; a dozen stations were logged in half an hour.

We tender our congratulations to Messrs. A. C. Cossor, Ltd., on producing such a receiver at a relatively low price, namely £6 15s., complete with valves and a good quality cabinet, and, bearing in mind the range, good selectivity, first-class quality of reproduction and simplicity of operation, which we proved to our own satisfaction, we are sure that this receiver will experience a good demand from the radio public.

W. H. OATES

COMPLETE TELEVISION SERVICE

Our Depot affords unique facilities to those interested in Television. Our own transmitting apparatus enables us to give callers demonstrations upon request.

DEMONSTRATIONS
BETWEEN 9 A.M. AND 6 P.M.

THE **BAIRD** "TELEVISOR," ALSO HOME
CONSTRUCTOR'S "TELEVISOR" KITS,
SUPPLIED FROM STOCK.

Only genuine Baird components are supplied by us. We
have a full range available of parts and accessories.

195, HAMMERSMITH ROAD,
LONDON, W.6. RIV. 3342.

Henry E. Taylor's Position

There appears to be some misconception in the trade in regard to the position of Messrs. Henry E. Taylor, Ltd. This Company is not a reconstruction of Burndept Wireless (1928) Ltd., and no liabilities of the Burndept Company have been taken over by them. We have been asked to point out that they have agreed to purchase the goodwill, patents, trade-marks, stock of parts, and the "Merrymaker" series of receivers of Messrs. Burndept Wireless (1928) Ltd., which offer has been accepted. These receivers will be on show at the Radio Exhibition, and it is the object of the Company to maintain the name of Burndept by all the means in their power.

New Mullard Indirectly Heated Three-electrode Output Valve

A notable addition to the Mullard range of A.C. Indirectly Heated Mains Valves is announced. It is type 054V, an indirectly heated output valve of substantial output. Like all other members of the Mullard indirectly heated range, it is fitted with the standard 4-volt 1 amp. heater. The valve is rated for a maximum anode voltage of 200, its impedance is 1.250 ohms, amplification factor 5, and mutual conductance 4 mA per volt.

The 054V is stated to give ample output for operating a large moving-iron or moving-coil speaker, and can be recommended for use as an output valve in receivers where the degree of amplification in previous stages provides a grid swing sufficient to operate a valve of this type.

Mullard Multi-Mu Valve, Type MM.4V

This valve is of the "Multi-mu" class, that is to say, it is so designed that, by a simple adjustment of the operating conditions, the effective amplification of the valve can be varied, thus providing a simple yet efficient method of volume control.

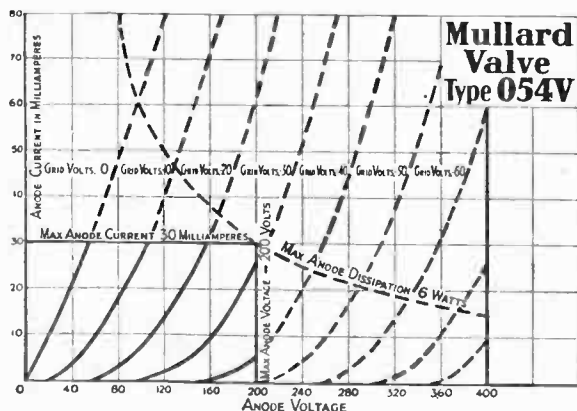

The static characteristic curves of the Mullard 054V valve which has a very large output.

The Mullard MM.4V gives a long grid base, yet has a high working slope at zero grid volts, as will be seen in the curve reproduced herewith.

The MM.4V is a modification of the screened-grid valve and gives smooth and efficient volume control by variation of the grid bias. For weak signals the grid bias is so adjusted that the valve is operated on the steep portion of the characteristic, thus obtaining maximum sensitivity, while for strong signals the grid bias is adjusted for low slope working.

The MM.4V valve is of the "multi-mu" class, it being possible to obtain a smooth and efficient volume control by variation of the grid bias.

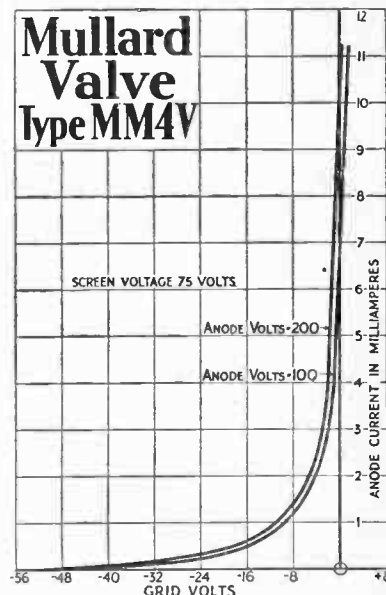

Not only is the volume control exceptionally smooth, but it has the effect of minimising rectification due to the curvature of the normal screened-grid valve characteristic, and thus avoids, to a large extent, cross-modulation.

The complete data on the MM.4V is as follows:

Max. Heater Voltage	4.0 volts
Heater Current	1.0 amp.
Max. Anode Voltage	200 volts
Positive Screen Voltage	75-100 volts
Mutual Conductance	(a) 3.0 mA/volt (b) 0.01 mA/volt

(a) At Anode Volts 150; Screen Volts 75; Grid Volts Zero.

(b) At Anode Volts 150; Screen Volts 75; Grid Volts -40.

Cossor Valves

We have received a full list of Cossor valves, together with a special leaflet on metallised valves and pentodes. A perusal of this list shows that there are nearly seventy types which make the selection of a valve for every type of set possible. Special attention is drawn to the 220SG which has the record low inter-electrode capacity of the order of .001 micro-microfarads; the 210DET and 210HL, which are available, either with metallised or plain bulb, both give the advantages of 7-point filament suspension, which entirely eliminates microphonic noise. Several power valves and two pentodes are available, and mention is made of the 230XP which,

with a slope of 3, permits a large output with a sensitivity not usually found in a valve of such low impedance; and also to the 220P/A, which has a mutual conductance of 4, and permits exceptional output stage amplification while retaining power-handling capacity suitable for all average needs.

The mains valves are noteworthy for their values of mutual conductance, for example—the MSG/LA has a slope of 3.75 under actual working conditions measured with $1\frac{1}{2}$ volts grid bias. Two good detector valves are the MIIH and MII, which have slopes of 4.5 and 4 respectively. These valves make power grid rectifiers and are also suitable for other methods. The 41MP and 41MXP have high slopes in this class of valve, the figure being 7.5 in each case. At the same time, the value of undistorted output is exceedingly high, permitting heavy output for driving moving-coil speakers from a relatively small input.

The Osram New Music Magnet Four

The G.E.C., Ltd., have this year sponsored a new and improved model of their "Music Magnet" in the form of kit of parts for home assembly. For the last two years this Company has made a speciality of this side of their business, and this, their third model, shows very marked improvements on the early ones.

It consists of two screened-grid I.F. stages, a detector, and a power unit stage, it being felt that this combination was capable of receiving all the stations worth listening to under normal home conditions.

A very large chart is supplied with the kit which, together with diagrams and photographs, gives very complete assembly and operating instructions in step-by-step stages. At first sight the instructions for assembly look rather complicated, but if they are read through carefully there is no reason at all why a single mistake should be made in the construction. Two evenings' work is sufficient to have the set in full working operation, and everything is provided for down to the smallest screw and nut.

There was only one small point which was not mentioned clearly, and that was in the case of assembling the wave-change switch. It was stated that the slide rod should be passed through the holes in the three supporting brackets, and then you were told to place a collar on each end inside the brackets. Obviously what was meant was that the collars should be placed on while the rod is being pushed into position.

There is no drilling or soldering to be undertaken, the baseboard being supplied in the form of a metal chassis complete with every hole drilled. The cabinet is made up in a very simple and straightforward manner, and when complete the set in every way rivals a commercial model produced under factory conditions. The wave-change and reaction controls appear on the right-hand side of the receiver, while the slow-motion drive for the ganged tuning and the series aerial condenser knob are accommodated on the left-hand side of the receiver.

In the centre of the front panel is the drum dial, while below this is the on-off switch. The operation of trimming the ganged condensers is explained in a very straightforward manner, and when connected up to the various battery supplies recommended we were frankly amazed at the performance.

As far as the circuit is concerned, there appears to be nothing of outstanding merit to bring about the range and selectivity obtained. As was expected, the set is far more sensitive and selective than the more popular three-valve combinations, and in this way is suitable for long-range work without having to resort to a critical control of the reaction knob. The amplification was very high while perfect stability was secured.

Both on the medium waveband and on the long waveband it was possible to tune in a considerable number of stations with absolute ease, no undue dependence on the skill of the operator being necessary.



The G.E.C. "Music Magnet" has a very prepossessing appearance and gives results which reflect great credit on the designers.

The G.E.C. Company furnish a very imposing station chart, showing the condenser settings where one may expect to tune in the various stations, but, of course, the actual number received depends largely on the situation at which the set is worked. We will therefore refrain from giving a list of stations received, but would point out that every worth-while European broadcasting station was heard during the course of our test.

There was not the slightest difficulty in assimilating the operating instructions, for the G.E.C. have gone to great pains to make these very simple. This will add considerably to the popularity of the set, for so often is the value of a receiver lost through complicated working instructions.

Undoubtedly the Osram "Music Magnet" is a receiver which can be recommended with every confidence and, when worked in conjunction with a good loud speaker, the quality of reproduction is of the first order. The price of the complete battery kit, with cabinet and valves, is £10 15s., and, since the finished receiver is very attractive in appearance and most efficient in operation, we have no doubt that it will prove one of the most popular sets of the season.

At-a-Glance Chart

A clever and ingenious article, of immense use to all listeners, is the "Daily Mail Radio At-a-Glance" Chart, which, by the simple movement of a pointer, answers nine of the most frequently asked questions concerning each of the 76 British and Continental broadcasting stations.

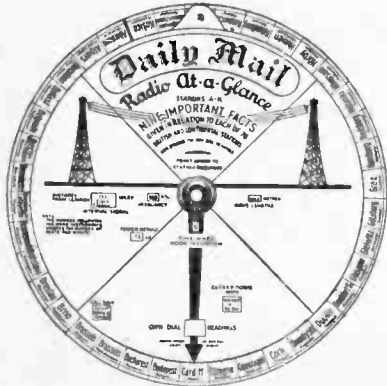

⊗ ⊗ ⊗

*The ingenious
At-a-Glance Chart
supplies you with
information to help
you to identify
foreign stations.*

⊗ ⊗ ⊗

If you are often puzzled as to what stations come through on your wireless set—if you want a record of your own dial readings for finding identified stations at will, then the "Daily Mail Radio At-a-Glance" Chart meets your needs.

This clever chart adds considerably to the interest of listening-in. It costs only 1s., and is on sale at all radio stores, booksellers, stationers, etc., or direct from the publishers, Frank Pitchford & Co., Ltd.

Osram Wireless Guide

The G.E.C. have forwarded to us a copy of this season's *Osram Wireless Guide*.

This little vest-pocket publication is not only a guide to the correct use of Osram valves, and a list of such valves, but will be found to contain a host of informative matter which will help wireless-set owners to get the best out of their sets, without confusing them with technical details.

The G.E.C. will be pleased to send a copy to any of our readers who care to write for one.

"Square Peak" Mains Receivers

In view of the big success of the Varley "Square Peak" Coils, the catalogue of the new Varley "Square Peak" Mains Receivers and Radiograms should be of interest to our readers, who are invited to write for a copy to Messrs. Varley.

The tuning of these "Square Peak" Sets and Radiograms is based on the Varley "Square Peak" principle. Selectivity is of a very high order indeed and quality of reproduction exceptional. All have built-in moving-coil speakers, a point worthy of notice.

Television at the Berlin Radio Exhibition

(Concluded from page 312)

vision apparatus exhibited at the Berlin Radio Show, I wish in a few words to summarise my personal impressions of what I have seen.

Cathode ray television, though an interesting alternative system, does not possess any superiority over the mechanical-optical types. In fact, at its present stage of development, it is still inferior to the latter in the quality of performance, and although further developments may be anticipated in the near future, there does not seem to be any reason why the mechanical systems should not in turn be developed to the highest standards of perfection. Again, although the various tele-cinema and tele-talkie transmissions were quite interesting and, in part, approaching remarkable perfection, a really fascinating impression was produced only by the Fernseh A.G.'s actual television transmission, showing a young girl seated in front of the transmitter and rendering her voice along with the visual reproduction. This, of all the various demonstrations, was the only one coming out on the screen with plastical effects and appealing to the imagination of the looker-in.

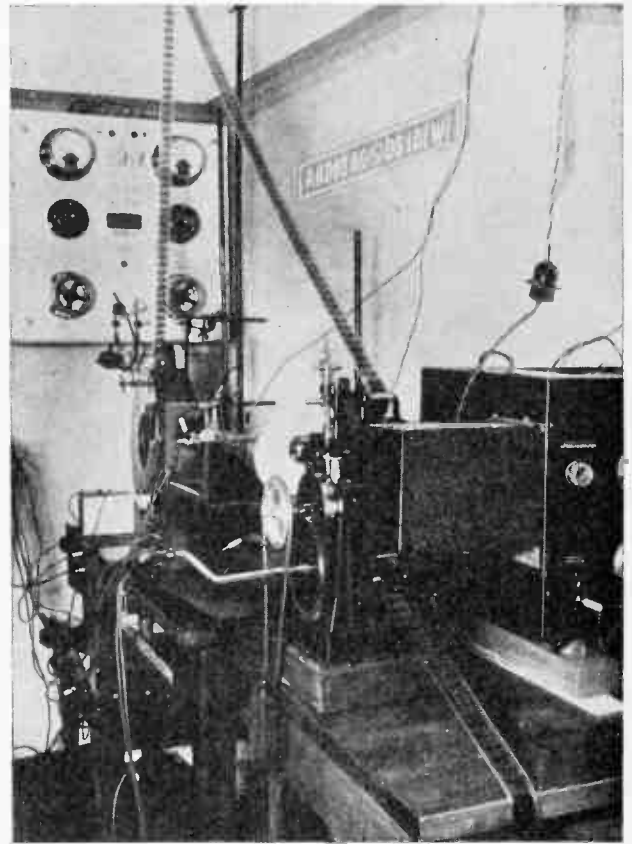

A tele-cine transmitter worked in conjunction with a cathode ray tube and shown at the Berlin Radio Exhibition.

Again, considering the excellent results recently obtained in England with extended-view transmissions of actual events in the open air and of broadcasting artistes from a B.B.C. studio, with barely half the number of elements used at the Berlin Exhibition, it would seem that English television can claim not only priority but at the present time a distinct advance over any performance abroad.

Television and Education

THE BAIRD MODULATED ARC AT THE BRITISH ASSOCIATION

AT the British Association Meeting; opening on September 22nd, in the section devoted to mechanical aids to learning, many novelties are to be seen. Since this magazine closes for press before the opening day of the exhibition, we are unable to furnish our readers with details of all the interesting exhibits, but have learned that in the television classes it is hoped to show to education experts, and to members of the general public who are interested, how objects may be seen about which a lecturer is speaking on the wireless.

Essential Principles

As all readers of TELEVISION are aware, the essential principles involved in televising an object are:

1. To scan the object with a beam of light spot by spot.
2. To convert the light reflected from each spot into electric currents of varying intensity.
3. To amplify and transmit these electric currents to the receiving end.
4. To reconvert these currents of varying strength into a light whose intensity varies according to the strength of current.
5. To build up this light of varying intensity by the aid of a Nipkow disc or mirror drum into a picture of the original object.

We are here only concerned with item No. 4, namely, the conversion of an electric current of varying intensity into a light whose intensity varies in like manner.

Apart from such devices as the Kerr cell, which acts on a steady light and so varies its intensity, the only form of light hitherto used for television purposes, which is modulated by the electric current itself, is the neon lamp. While this is very satisfactory on a small scale, it is useless for producing large pictures, as the intensity of the light given by a neon tube is so low, and in the Kerr cell something like 80 per cent. of the light is absorbed by the Nicol prisms and solution.

The most intense light-source known being the electric arc, this form of illumination immediately suggests itself; but when one tries to put it into practice, it is found that the ordinary arc lamp is not capable of varying its intensity with anything like sufficient rapidity for television purposes. The work

of Duddell and Ruhmer in connection with varying the light of an arc in proportion to speech currents from a microphone is, of course, well known, but it has remained for the staff of the Baird Television Laboratories to modulate an arc over a sufficiently wide frequency band, and with the necessary consistency and accuracy to make it satisfactory for television purposes. This has now been attained, and it is possible with the modulated arc to obtain a



Television offers excellent facilities for illustrating talks with actual objects which may form the subject-matter of the address.

brilliantly illuminated picture on a very large screen. This new development will be shown publicly for the first time at the British Association Meeting in the Exhibition of Mechanical Aids to Learning section accommodated in the Institute Français in Cromwell Gardens. It reflects the greatest credit on the engineers of the Baird Company, and we heartily congratulate them on performing a feat which was considered to all intents and purposes impossible.

PLEASE MENTION TELEVISION WHEN REPLYING TO ADVERTISERS

LETTERS TO THE EDITOR

The Editor does not hold himself responsible for the opinions of his correspondents. Correspondence should be addressed to the Editor, TELEVISION, 505, Cecil Chambers, Strand, W.C.2, and must be accompanied by the writer's name and address.

NORTHERN ENTHUSIASM

To the Editor of TELEVISION

DEAR SIR,—I am very glad to see that, according to to-day's *Daily Mail*, the B.B.C. is slowly but surely warming up to television, and I shall look forward to the weekly half-hour broadcasts at 10.30 p.m. What, however, is very much more interesting to me and the Northern television enthusiasts is the promise of a broadcast from the North Regional stations, and I very much hope that this is not premature but will soon be an actual fact.

Yours faithfully,
T. PAYNE.

7 ST. ANDREW'S BUILDINGS,
GALLOWGATE,
NEWCASTLE-UPON-TYNE.
September 10th, 1931.

*Announcing the Opening Lecture
of the Television Society*

MODERN DEVELOPMENTS IN TELEVISION

By H. J. BARTON CHAPPLE,
Wh.Sch., B.Sc.(Hons.), A.C.G.I., D.I.C., A.M.I.E.E.

to be given on

WEDNESDAY, OCTOBER 14
at 7 p.m.

AS KEEN AS EVER

To the Editor of TELEVISION

DEAR SIR,—I should like to assure you that I am just as keenly interested in television as ever, and I still look forward to the monthly appearance of your excellent journal as I have done since the first issue. I only wish I could see some hope of longer and more conveniently timed transmissions of television.

I have not been able to forward to you any further details of my experiments, owing mainly to

pressure of business. However, I have evolved a very successful magnetic corrector which is fairly easy to construct without the use of a gear cutting machine, the toothed wheel being assembled from laminations. I have also in mind a simple form of mirror wheel which I hope to construct at the first opportunity. I will gladly forward you details when I have had time to prepare photographs and drawings, as of course I am very anxious to help in my small way the cause of television.

Yours faithfully,
A. R. KNIFE.

P.S.—I should like to say how greatly the Baird transmissions have improved of late, especially the great step forward of extended vision.

5 SOUTHSEA AVENUE,
LEIGH-ON-SEA.
September 6th, 1931.

IS THIS A RECORD?

To the Editor of TELEVISION

DEAR SIR,—It will probably interest you to know that yesterday morning my daughter, a schoolgirl of sixteen years of age, succeeded in tuning in, at my home, some very good television pictures.

She informs me that she could plainly discern the necklaces and ear-rings of the ladies who were performing.

My daughter has had very little preliminary tuition in the tuning-in of a television picture, and this was her first attempt.

I think that this must, in a way, be something in the nature of a record, particularly so far as the North of England is concerned.

Yours faithfully,
T. PAYNE.

7 ST. ANDREW'S BUILDINGS,
GALLOWGATE,
NEWCASTLE-UPON-TYNE.
September 8th, 1931.

SCANNING DISCS, complete with motor boss, Spoked arms, black rim, 12/6 each. Experimental work of all kinds. Patents developed and placed on the market.—JOHN SALTER (Established 1896), Featherstone Buildings, High Holborn, London, W.C.1.

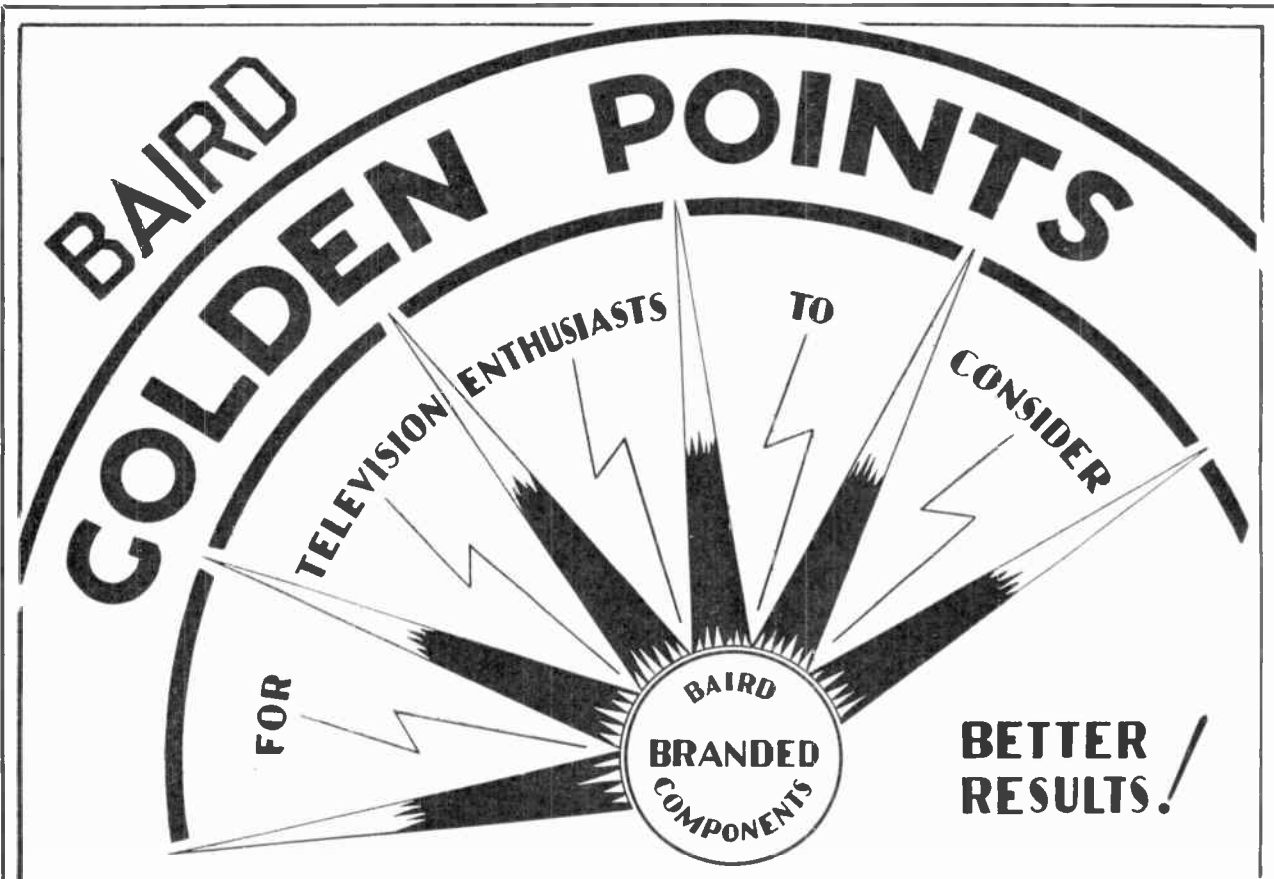

BAIRD

**B
R
A
N
D
E
D**

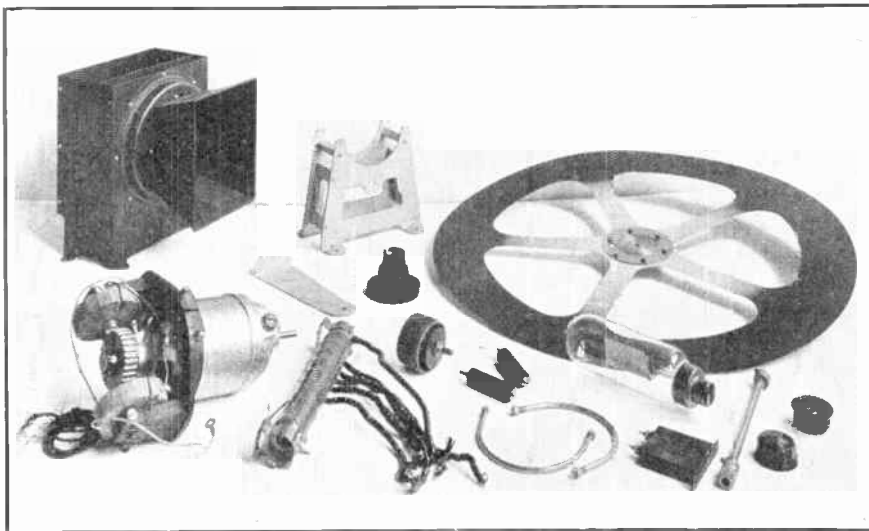

**P
A
R
T
S**

OBTAINABLE FROM ALL FIRST-CLASS RADIO DEALERS

BAIRD TELEVISION Ltd., 133 Long Acre, London, W.C.2

TEMPLE BAR 5401

**2ND
EDITION**

**2ND
EDITION**

**THE FIRST
EDITION OF
"TELEVISION
TO-DAY AND
TO-MORROW"
HAS SOLD OUT
IN RECORD TIME!**

**THE SECOND EDITION
WHICH IS
NOW ON SALE
IS THE
MOST UP-TO-DATE
BOOK OF ITS KIND**

All the big developments which have occurred in the Television World since this book was first printed are fully described in the New Edition. Every advance of the science is dealt with. The Second Edition is a veritable mine of the latest information.

"TELEVISION TO-DAY AND TO-MORROW"

By

SYDNEY A. MOSELEY

AND

H. J. BARTON-CHAPPLE

B.Sc. (Hons.), A.M.I.E.E.

**TELEVISION PRESS, LTD.
505, CECIL CHAMBERS
STRAND, LONDON, W.C.2**

**7/6
POSTAGE
6D. Extra**

**7/6
POSTAGE
6D. Extra**

Printed by HAZELL, WATSON & VINEY, LTD., London and Aylesbury, and published for the Proprietors, TELEVISION PRESS, LTD., 505, Cecil Chambers, London, W.C. 2, by THE ALDINE PUBLISHING Co., LTD., Crown Court, Chancery Lane, London, W.C. 2. Address for advertisements, "TELEVISION" ADVERTISEMENT DEPT., 505, Cecil Chambers, London, W.C. 2. Sole Agents for America, THE INTERNATIONAL NEWS COMPANY, LTD., 131. Varick Street, New York, U.S.A. Registered for transmission by Canadian Magazine Post. Entered as Second Class Matter, March 15, 1929, at the Post Office at Boston, Mass., under the Act of March 3, 1879 (Sec. 397, P.L. and R.)