

Germany First to Broadcast Baird Television Daily

6^D
MONTHLY

Television

The Official Organ of the Television Society

VOL. 2 JULY 1929 No. 17



THE POWER BEHIND GERMAN BROADCASTING

Secretary of State, Dr. Ing. Hans Bredow, who, on behalf of the German Post Office, controls the broadcasting situation in Germany. (See Sydney A. Moseley's article on page 244.)



THE WORLDS FIRST TELEVISION JOURNAL

THE TELEVISION SOCIETY

The Television Society was founded on September 7th, 1927.

The Society makes its appeal to those who desire to share in the responsibility of furthering this new branch of applied science.

THE OBJECTS OF THE SOCIETY

may be summarised as follows :

- (a) The Study of Television and its application in applied science and industry.
- (b) To afford a common meeting ground for professional and other workers interested in current research relating to Television and allied subjects and to afford facilities for the publication of reports and matters of interest to Members.
- (c) To encourage the formation of *Local Centres* of the Society in the Provinces, so that by social intercourse and discussion among members these aims may be more fully realised.

The present register indicates a world-wide membership.

ORGANISATION.

The Society consists of one Honorary Fellow, Fellows and Associates, and the management is vested in a Council of Fellows, including the President, three Vice-Presidents, and Ordinary Fellows.

FELLOWS.—Ordinary Fellows must be elected by the Council. Candidates for the Fellowship must be proposed by two Ordinary Fellows, the first proposer certifying his personal knowledge of the candidate.

ASSOCIATES.—Any person over 21 interested in Television may be eligible for the Associateship without technical qualifications, but must give some evidence of interest in the subject as shall satisfy the Committee.

STUDENT MEMBERS.—The Council have arranged for the entrance of persons under the age of 21 as Student Members.

SUBSCRIPTIONS.—The annual subscription for Ordinary Fellows is 20s., with an entrance fee of 10s. 6d. ; and for Associates 10s., with an entrance fee of 5s.

The annual subscription for Student Members is 5s., entrance fee 2s. 6d.

LIFE MEMBERS.—Life Membership may be secured at a fee of £10 10s.

MEETINGS.—The ordinary meetings of the Society are held in London at the Engineers' Club, Coventry Street, W.1, at 8 p.m., on the first Tuesday of the month (October to May inclusive). Notices of meetings are posted to all members about seven days before the meeting.



Full-size reproduction of the new Television Society Badge, which is available to accredited Members, and may be obtained from the Head Office, price 1s.

The official organ of the Society is "Television," published monthly by the Television Press, Ltd., 26, Charing Cross Road, W.C.2.

A memorandum for the guidance of members wishing to form a Local Centre of the Society may be obtained (gratis) on application to the Joint Hon. Secretaries, 4, Duke Street, Adelphi, W.C. 2.

Television

THE WORLD'S FIRST
TELEVISION JOURNAL

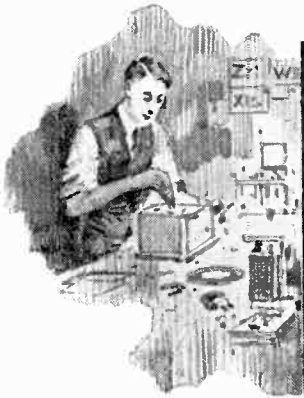

WIRELESS

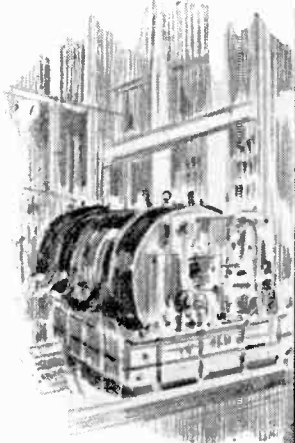

ELECTRICITY

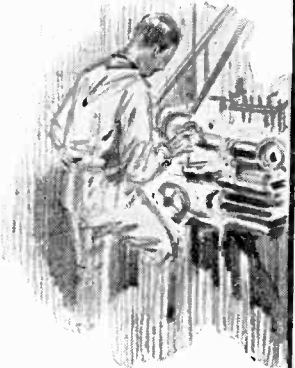

MECHANICS

Vol. II JULY, 1929 No. 17

| | PAGE |
|---|------|
| EDITORIAL | 219 |
| SOME NOTES ON SCANNING | 221 |
| <i>By Ronald R. Poole, B.Sc.</i> | |
| THE STORY OF ELECTRICAL COMMUNICATIONS | 225 |
| <i>By Lt.-Col. Chetwode Crawley, M.I.E.E.</i> | |
| ATMOSPHERICS AND INTERFERENCE IN WIRELESS | 229 |
| <i>By R. L. Smith-Rose, D.Sc., Ph.D., A.M.I.E.E.</i> | |
| REFRACTOMETERS OF THE CRITICAL ANGLE TYPE | 231 |
| <i>By Professor Cheshire, C.B.E., A.R.C.S., F.I.P.</i> | |
| RECENT WORK ON SELENIUM | 233 |
| <i>By E. E. Fournier d'Albe, D.Sc., F.Inst.P.</i> | |
| THE PROSPECT | 235 |
| <i>By Noel Swanne.</i> | |
| DISTORTION — SOME CAUSES AND CURES | 236 |
| <i>By William J. Richardson.</i> | |
| LIGHT: THE ESSENTIAL OF TELEVISION | 239 |
| <i>By Cyril Sylvester, A.M.I.E.E., A.M.I.Mech. E.</i> | |
| THE CONSTRUCTION OF EXPERIMENTAL TELEVISION APPARATUS | 241 |
| <i>By A. A. Waters.</i> | |
| SYDNEY A. MOSELEY WRITES FROM BERLIN | 244 |
| SOME NOTES ON EXPLORING DISCS—AND THEIR CONSTRUCTION | 247 |
| <i>By W. C. Fox.</i> | |
| LIVING PICTURES | 250 |
| <i>By Charles Jones.</i> | |
| THE STORY OF CHEMISTRY | 252 |
| <i>By W. F. F. Shearcroft, B.Sc., A.I.C.</i> | |
| PHOTO-ELECTRIC CURRENTS IN A VACUUM | 254 |
| <i>By H. Wolfson.</i> | |
| A QUANTITATIVE ANALYSIS OF TELEVISION | 259 |
| <i>By J. H. Owen Harries, A.M.I.R.E.</i> | |
| A REVIEW OF COMMERCIAL TYPES OF PHOTO-ELECTRIC CELLS | 261 |
| HOW THE FRENCH POLICE PROVED PHONOVISION | 266 |
| <i>By Derek Ironside.</i> | |
| INVENTION AND DEVELOPMENT | 270 |
| THE BEST LETTERS OF THE MONTH | 271 |
| TELEVISION SOCIETY | 272 |

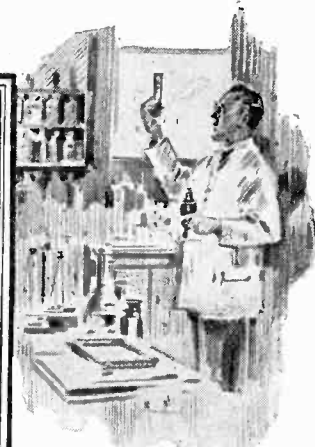

CHEMISTRY

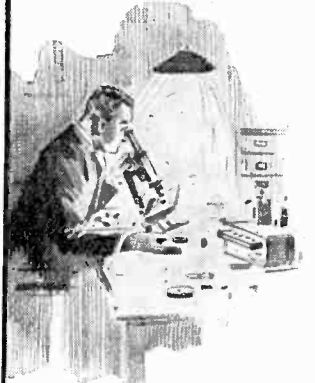

OPTICS

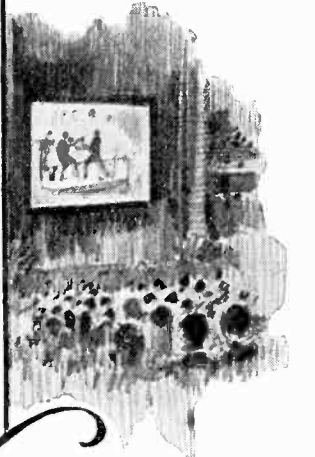

CINEMATOGRAPHY

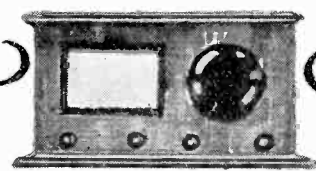

BOUND VOLUMES

are preferable to a loose collection of well-thumbed and worn individual copies of a magazine.

WE CAN NOW SUPPLY
“TELEVISION”
VOL. I

Handsomely Bound in rich brown imitation leather, morocco finish, lettered in gold on front and spine, complete with index

PRICE 12/6 post free

This is a unique opportunity for you to obtain a *handsome* and *permanent* record of the first volume of the

WORLD'S FIRST TELEVISION JOURNAL

ALSO AVAILABLE for those who wish to have their own copies bound :

Brown Cloth Binding Cases, lettered in gold on front and spine, and index

PRICE 4/6 post free.

Apply NOW to TELEVISION PRESS, LIMITED
 26, CHARING CROSS ROAD, LONDON, W.C. 2

Mention of "Television" when replying to advertisements will ensure prompt attention.

Television



THE WORLD'S FIRST TELEVISION JOURNAL

The Official Organ of The Television Society

Edited by A. DINSDALE, A.M.I.R.E.

Consultants: Dr. C. TIERNEY, D.Sc., F.R.M.S.; W. J. JARRARD, B.Sc. (1st Hons. Lond.), A.R.C.S., A.I.C.

Technical Editor: J. C. RENNIE, B.Sc., A.M.I.E.E.

Vol. II]

JULY 1929

[No. 17

EDITORIAL

IN our last issue we gave our readers the latest available information concerning television developments in Germany, which was to the effect that the Baird Company's representatives had been very cordially received by the German Government, before whom some very successful demonstrations had been given.

* * *

ELSEWHERE in this issue we give further information about the situation in Germany, from which it will be seen that events have moved with commendable rapidity. Since Mr. Moseley's article was written the daily press of this country has recorded the fact that negotiations between the Baird Company and German interests have successfully culminated in the formation of a powerful German company.

* * *

IMMEDIATELY the German Government became convinced of

the great superiority over other systems of the Baird system of television, Captain Hutchinson, the Managing Director of the Baird Company got in touch (with the cordial assistance of Dr. Loewe) with three well-known firms which he believed should co-operate in the development of the Baird system in Germany. These three firms are Bosch, Loewe Radio, and Zeiss. The first of these, famous for magnetos, would appear admirably suited to develop electric motors for driving television

scanning discs. The second firm, which specialises in multiple valves, may be expected to devote itself to the wireless and amplifier sections of television work, while great developments on the optical side may be expected from the Zeiss Company.

* * *

THE name of the new company is Fernseh, A.G., with headquarters at the Zeiss works in Berlin. It will, it is understood, devote itself to effecting improvements in the apparatus, and to manufacturing and distributing Baird televisior receivers for the German market. With three such important firms directing their attention to the subject, many important improvements may soon be expected.

* * *

MEANWHILE, television transmissions are being broadcast daily from Witzleben, Berlin, and have been very successfully re-

Editorial, Advertisement & Publishing
Offices:

The Television Press,
Limited,

26, Charing Cross Road,
London, W.C.2.

Telephone: Regent 6437.

SUBSCRIPTION RATES, 7/6 PER ANNUM,
POST FREE.

MSS. and other material for Editorial
consideration should be accompanied
by a stamped addressed envelope, and
should be typewritten.

Entire contents of this Journal copyright in the U.S.A., 1929, by Television Press, Ltd.

Foreign Translation Rights Reserved.

ceived at the Baird Company's laboratories in north London. It is understood that television transmissions will very shortly be broadcast from Koenigswusterhausen, a much higher powered and longer wave station, which can easily be picked up anywhere in the British Isles.

* * *

Germany First.

THUS Germany, enterprising and go-ahead, has established a lead over this country, and snatched from us the honour of being the first country in Europe to broadcast television regularly. This is a bitter pill for the country which produced the genius who translated the long-contemplated dream of television into a practical reality.

* * *

THERE is a striking contrast, too, between the attitude of the Runfunk Gesellschaft (the German B.C.C.) and that of the B.B.C. when representations were first made to them to broadcast television. The distinctive factors are that the Baird people went to Germany *at the express invitation of the German Government*, and that broadcast transmissions were made, and are still being made, at no cost to the Baird Company.

* * *

Hastings pays Tribute.

PROPHETS proverbially have no honour in their own country, and outstanding men of genius seldom receive due recognition until either they are too old and embittered to appreciate it, or have long been dead and buried.

It is refreshing news, therefore, that the town of Hastings has decided to put up a tablet to Mr. John L. Baird on the walls of the house at No. 8, Queen's Arcade. It was to that address that Mr. Baird retired in 1921 after a serious breakdown in health following his activities in various lines of business not even remotely connected with television.

* * *

IT was during this enforced retirement that Mr. Baird's mind once more began to occupy itself with the problem of television. He had contemplated it for many years previously, and made certain experiments, but it was not until he went to Hastings that he tackled the problem really seriously and with the determination to solve it. When he returned to London in 1924 Mr. Baird had broken the back of his task, and was not long in achieving complete success.

* * *

Helensburgh Next ?

NOW that Hastings has led the way, may we expect further interesting developments from Helensburgh, the town at the mouth of the Clyde, where the inventor first saw the light of day?

* * *

The British Association Meeting.

LAST year the annual meeting of the British Association was held in the imposing precincts of the University of Glasgow. Members of the Association who attended the meeting had the opportunity of witnessing demonstrations of Mr. Baird's latest scientific achievements, stereo-

scopic television, and television in colours.

* * *

THIS year the meeting is being held in South Africa, at Cape Town and Johannesburg, and in response to the invitation of the South African Committee of the B.A., the Baird system of television will be demonstrated in both cities to the visiting scientists. A delegation, headed by Lord Angus Kennedy, Vice-President of the Television Society, will have charge of the demonstrations. By the time this issue reaches our readers, this delegation, together with a large number of British scientists who are attending the meeting, including Dr. Tierney, Chairman of the Society, will have sailed for South Africa on the *Llandoverly Castle*.

* * *

A Correction.

OUR attention has been called to the fact that in our Editorial last month, and in the heading of Sir Ambrose Fleming's article entitled "Comparative Tests of Television Apparatus," we stated that Sir Ambrose pointed out errors in Mr. J. H. Owen Harries' thesis on "A Quantitative Analysis of Television," which appeared in our May issue. On closer examination of Sir Ambrose's article we find that these remarks are not justified by the facts, and we therefore have pleasure in withdrawing them and correcting the false impression which we created. Sir Ambrose's actual wording is quoted in a footnote to another article by Mr. Harries which appears elsewhere in this issue.

SOME NOTES ON SCANNING

By RONALD R. POOLE, B.Sc., *Fellow of Television Society*

At the May Meeting of the Television Society, Mr. Poole gave a very interesting talk, illustrated by most convincing experiments, on the subject of image scanning.

In the following article he elaborates his theme.

THE general principles of scanning are well known, but the details of operation and the disposition of the various parts appear to be less generally understood, and with the object of demonstrating these points to a small gathering of the Engineering Society of University College, London, a rough apparatus was constructed. This apparatus, with one or two additions and alterations, was shown at the May meeting of the Television Society.

Apparatus Used.

It consists essentially of a motor-driven disc with interchangeable systems of holes, by means of which a brightly illuminated lantern slide is explored, and the image, or succession of images, projected upon a screen. The arrangement of the model is shown in Fig. 1. The slide *S* is illuminated by an intense beam from the lantern *L*. The disc *D*, in which a series of holes is drilled, rotates close in front of the slide, at a speed which can be varied from zero to about 3,000 r.p.m. by a rheostat in series with the motor.

A direct-reading speed meter *T* is mounted on the motor spindle. A lantern projection lens combination *P* receives light through the scanning holes, and focuses it on the screen *A*, which is of squared tracing paper. Adjustment is provided so that a sharp focus may be made on the screen of either the surface of the slide or the edges of the scanning holes. The purpose of this adjustment will be explained later.

Using the former focus, there appears on the screen a small part of the view of the slide, bounded by the slightly blurred edge of the hole. As in the Baird system, the

disc is perforated with holes disposed in a uniform spiral, such that the radial pitch is equal to the width of the hole, which in this case is round.

It is clear, therefore, that if the disc is rotated slowly we will see on the screen the spot of light describing a series of curved paths, each one showing a narrow strip of the picture viewed continuously from top to bottom. Successive strips are, or should be, exactly contiguous, so that no portion of the picture is unexplored.

In the model shown only 16 holes are used, a diameter of $\frac{1}{8}$ inch being chosen. Consequently, a picture 2 inches wide could be explored, and a height of about 2 inches is taken. This height is limited mainly by the curvature of the path of the holes, which in this case has an outer radius of $6\frac{1}{2}$ inches. Fig. 2 indicates this limitation and shows the way in which the picture is divided up.

If now the disc is rotated at a speed of, say, 16 revolutions per second, the picture will be completely traversed an equal number of times a second, and will appear more or less free from flicker, since each point is momentarily illuminated once every one-sixteenth of a second; and persistence of vision lasts somewhat more than this time, even for weak or very short illuminations.

On setting the disc in rotation, the strips, at first apparently disconnected and only one at a time, are seen to succeed each other with increasing speed, until finally the picture grows clear and steady, showing only faint lines across it where the holes either overlap or do not quite meet.

Application to Practical "Televisors."

Let us now consider the application of this principle to a television transmitter. Fig. 3 shows the essence of the model stripped of all lenses so

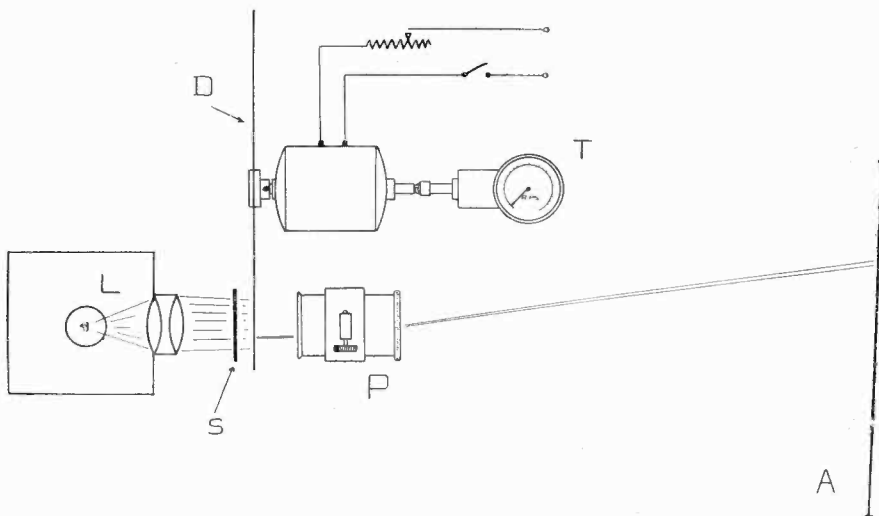

Fig. 1.
Showing the general arrangement of the apparatus. L is the projector lamp, S the slide to be explored, D the disc, P the projection lenses, and A the screen.

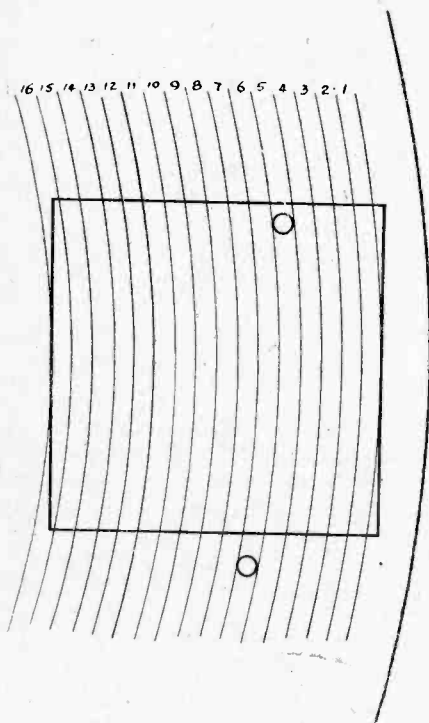

Fig. 2.

This represents a portion of the disc. The concentric arcs show the paths of the holes across the field of view which is bounded by the square. A small part of this square is seen to be cut off, due to the curvature of the strips.

that the light rays all travel in direct lines. The light, starting from the point source *L*, throws simply a shadow of the slide *S* on to the screen *A*. The perforated disc *D* explores the slide strip by strip and the final result is much as before, the lenses only being included to obtain stronger illumination and sharper definition.

If we substitute for the screen *A* a well-illuminated picture of the same size, take away the slide and put a photo-electric cell in place of the light source *L*, we have the essentials of a transmitter. All optical phenomena are perfectly reversible, and therefore light from points on the picture will pass through the holes in the disc, only the light from one particular point falling on the photo-electric cell at a time. Thus the picture will be scanned or explored, successive strips of it being, as it were, shown to the cell from end to end.

The receiver is a similar device, in which an identical disc is driven synchronously with that of the transmitter, and some form of lamp placed in the position corresponding to that of the light-sensitive cell. The brilliance of this lamp is made

to vary with the photo-electric currents, and hence with the varying light and shade of the subject.

The light from this lamp, being projected on to the receiving screen, will correspond in intensity and location to that from the original picture, or subject, which will thereby be reproduced with a detail, or lack of it, depending on the nature of the scanning holes, and the design of the amplifiers and intermediate apparatus.

Transmission of Detail.

With regard to the transmission of detail, and the sharpness of definition, about which some sense and much nonsense has been written, some ideas may be gleaned from an examination of one of the strips or bands projected on the screen by the model. Let the lens be focused so that a sharp image of the hole is projected on the screen. Then the circular spot is found to have an almost uniform intensity of illumination corresponding to the average density of the particular tiny spot of the slide under view, and while the spot is stationary all detail smaller than itself is lost.

If the disc is moved the slightest amount, the average density will be altered, since a new detail with a different light value will come in on one side of the hole, while an old one passes out the other, and this variation will be of a continuous

nature. So, then, if we plot a graph of average illumination of the hole against distance along the strip, we will get a continuous curve whose changing contours will be a measure of the changing details. The amplitude of the curve at any point measures the intensity of the light at the corresponding point in the strip, and the slope represents the rate of change in intensity, which is a measure of the fineness of detail or definition.

If the hole is large compared with the details it is to reproduce the sudden introduction of a small detail will not greatly affect the average illumination over the hole, and the response of the cell to this change will be correspondingly small. Hence the steepness of the curve under this condition will be reduced. Conversely small holes will generally give better reproduction.

Mr. Owen Harries has recently given us a valuable starting-point on which to base a quantitative treatment of this subject, and a good deal of mathematical work of fundamental importance has been done both in this country and America, with a view to determining optimum scanning speeds and sizes of holes.

From a purely qualitative point of view, however, if practical considerations limit the number of holes in the disc, it would appear that the best shape would be a slit with its greatest length along a radius. This

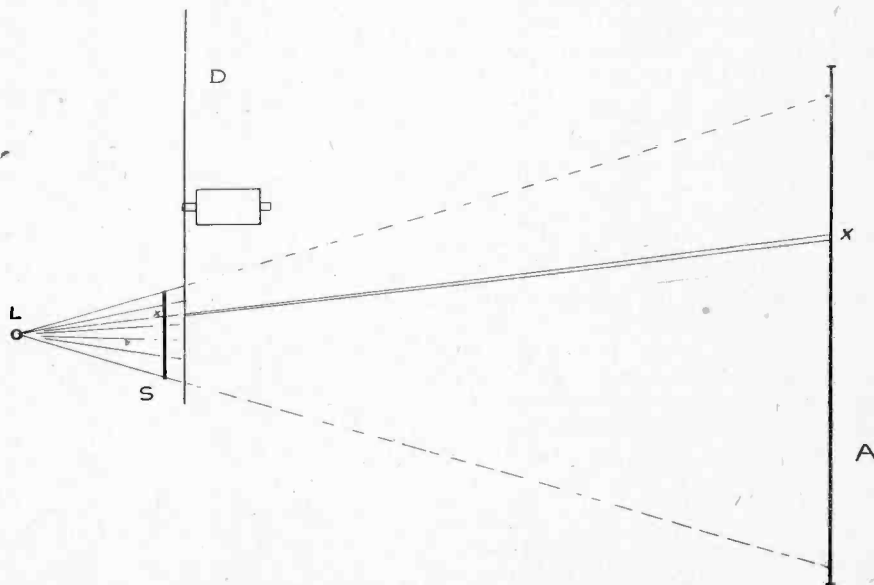

Fig. 3.

Skeleton arrangement of the model used as a shadowgraph.

shape would result in greater variations in the average illumination over its area for small changes in picture density along its path.

Side Band.

If the curve of light intensity against distance along the strip is analysed into its complete Fourier series of sine waves, it will be found to consist of an almost infinite number of components starting with very low frequencies, and running up to exceedingly high ones. The arrangements and amplitudes of these will, of course, be constantly changing in different parts of the curve.

It is evident that for rapidly changing detail the curve will be peaky or jagged, and this represents proportionately greater amplitudes among the higher frequency harmonics. It may so occur that a considerable part of the average height of the curve is due to frequencies of an order outside the range which it is desirable to transmit. That is to say, definition finer than a certain degree gives rise to these high harmonics, and we are therefore obliged to sacrifice this fineness of definition, not because it cannot be followed and reproduced, but because it is not worth the extra complication to our amplifiers and the extra width of side band, the latter being taken to mean the maximum frequency superimposed on the carrier wave.

It should be borne in mind that fineness of definition, in this connection, depends not so much on the actual size of small details, but on the abruptness of their contrasts. Thus it would be more difficult to reproduce with absolute fidelity a fine pen-and-ink drawing than a fairly soft photograph, though the latter might well be more detailed; and a vividly contrasting scene in a strong light would, in practice, lose much of its hardness, since the very high frequencies on which the contrasts depend, must be sacrificed at any rate while transmission takes place on comparatively low frequency carrier waves.

If television transmission were made on, say, 10 metres with a 1 per cent. side band, we would then have available modulation frequencies up to 300,000, as against the 20,000 or so imposed by present limitations.

If we are to limit our side band to this latter frequency, we have two ways of cutting off the surplus harmonics. The more obvious one is by electrical filtering; and this is more or less arranged for us by the fact that most amplifiers will pass very little above 10,000 cycles per second. The other way is by enlarging the scanning holes, or slits, so that the rates of change of light

results, the size depending on the tangential speed (speed of traversing). A few experiments with the model disc indicate that a traversing speed of about $6,000 \times$ (circumferential width of hole) per second, is a good practical figure, giving fair definition with a top frequency of 10,000 cycles per second.

This means that with a disc of mean radius of 6 inches, and the disc revolving at the minimum speed of 10 r.p.s., the holes should be 0.06 inch square. If a square picture is required, this would give 24 holes, and the field would be $1\frac{1}{2}$ inches square.

The above figures are entirely empirical, and are by no means ideal, but they give a workable arrangement for experimenting.

Linear Distortion of Moving Pictures.

The accurate reproduction of objects in rapid motion presents certain difficulties both in television and in cinematography. In the latter, the main trouble arises from the fact that if an object moves more than a certain amount between successive exposures, a pronounced jerkiness of motion or flicker becomes apparent. It is estimated that this flicker is seen if the movement per exposure subtends at the observer's eye an angle greater than about 0.01 radian, and for perfect continuity of apparent movement this angular movement must be reduced to about 0.003 radian per exposure.

In television we have not only this difficulty to contend with, but the further fact that the movement is not made by the object as a whole but is seen progressively from strip to strip, so that portions of the object in successive strips undergo a slight displacement relative to each other. If the movement is in the direction of the length of the strip, this displacement will result in a cornerwise distortion as shown in Fig. 4A. If the motion is across the strips, the effect will be less noticeable, resulting only in a slight breadthwise distortion, a widening or narrowing of the object. For this reason, it is better to employ vertical scanning in preference to horizontal, since in an ordinary moving scene the greater part of the motion is from side to side, and there is rarely much up and down movement.

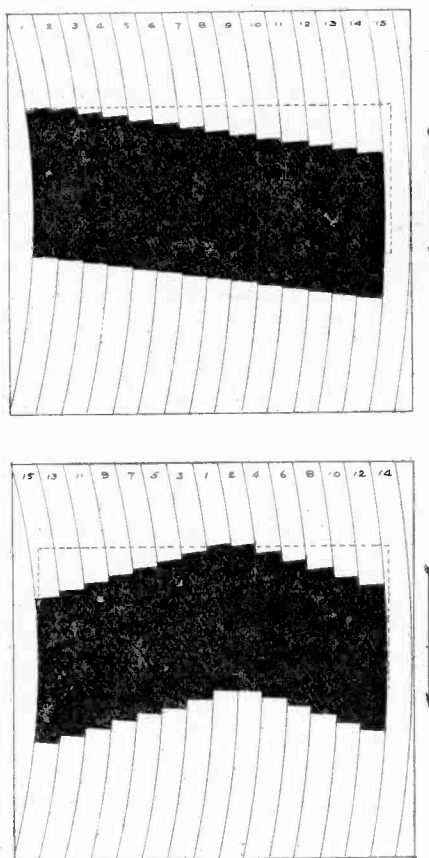

Figs. 4a and 4b.

Illustrating the distortion of a rectangle when moved in the direction of the arrows at the sides. The height of each step, measured between the mid points of each strip, is the distance moved in the time interval between adjacent strips, which, in 4a is $\frac{1}{250}$ th second, and in 4b $\frac{2}{250}$ th second. Notice that the ends of the strips are square, i.e., radial to the disc. The figures along the top refer to the order of viewing of the strips.

intensity become lower. This second method should always be adopted in conjunction with the first, since the larger the aperture the more light falls on the photo-electric pick-up, with consequent gain in efficiency.

The optimum size and shape of hole has been calculated for various conditions of operation, but for general experimental purposes a square one appears to give the best

The effect of this distortion is shown very clearly in the model, by moving a small object, a key or a screwdriver, behind the spinning disc, and observing its shadow on the screen. In some cases the vertical displacement between adjacent strips amounted to more than the width of the object itself.

A fundamental cure for these troubles in either television or cinematography is to speed up the rate of viewing, so that the movement between successive strips or exposures is imperceptible. This is exemplified in the latter art by the use of the ultra-rapid camera, or "slow motion," but the application of this principle to television would put a further strain on that already tender point, the side band.

Some Experiments with the Model.

Mr. Cameron Rennie, in his very interesting and suggestive paper to the Television Society in April, asked the question: Would the same visual impression be obtained if the picture were examined in non-consecutive strips? For instance, referring back to Fig. 2, what would be the result of viewing the strips in the order 1, 16, 2, 15, 3, 14, etc., instead of 1, 2, 3, 4, etc.?

To test this the disc with the simple spiral set of holes was replaced by a double disc in which one plate could be rotated slightly relative to the other, so as to cover or uncover various sets of holes. Three sets of 16 holes were drilled, the first in a simple spiral, the second in the order mentioned above, and the third in

an entirely haphazard order, taking care only that each hole covered a different strip. The three arrangements are sketched in Fig. 5.

On starting up the disc from rest, with the second set of holes uncovered, a rather confusing array of disconnected strips is first presented, and owing to the absence of continuity of view, it is difficult to get any idea of the nature of the whole picture. As the speed increases, however, the effect approximates to that of the uniform spiral; each half consisting of an opposite spiral of double the circumferential pitch and a radial pitch equal to the diameter of one hole.

Hence, so long as the time of scanning is less than that of visual persistence, continuity will be as good as that obtained by the ordinary method. Experiment shows that the results of the two systems are indistinguishable from each other as far as still pictures are concerned. The only difference lies in the fact that the band displacement due to movement in the direction of the scanning lines is now modified, the greatest displacement being in those strips viewed last, i.e., in the centre, the outside strips being viewed almost simultaneously. The total displacement at the centre will be the same as that between opposite sides in the former case, and as may be seen from a comparison of Figs. 4A and 4B there is little to choose between the two systems on this account.

The effect of the third set of holes could be inferred from the foregoing experiment, and is found to give perfectly good reproduction when

run at the normal 16 traversals per second. The displacement of the bands is, of course, quite irregular, and in some cases this may be rather troublesome, since adjacent bands may be widely separated in time, and so undergo a large relative movement. The actual value of this movement is clearly the product of the speed of the object and the time interval between the successive strip exposures.

Secrecy of Transmission.

One of the more or less unconsidered possibilities of television is the transmission of cinema film to be re-recorded and subsequently shown in the ordinary way, the radio channel being used only for speed of transport (and incidentally to complicate the task of the Customs collectors). This applies principally to news films from other countries, and it is evident that secrecy of transmission is essential, in view of the keen competition in this line. With a fair choice in the number of scanning lines, and the enormous number of possible arrangements in the order of such lines, eavesdropping is almost impossible.

Exactly the same argument applies to ordinary transmission of news items, such as sports or weddings or accidents, for simultaneous showing in the television theatres of the future. Rival news suppliers will require mutual protection against eavesdropping, which will provide ample incentive to the development of automatic disc-changing devices and other aids to exclusive presentation.

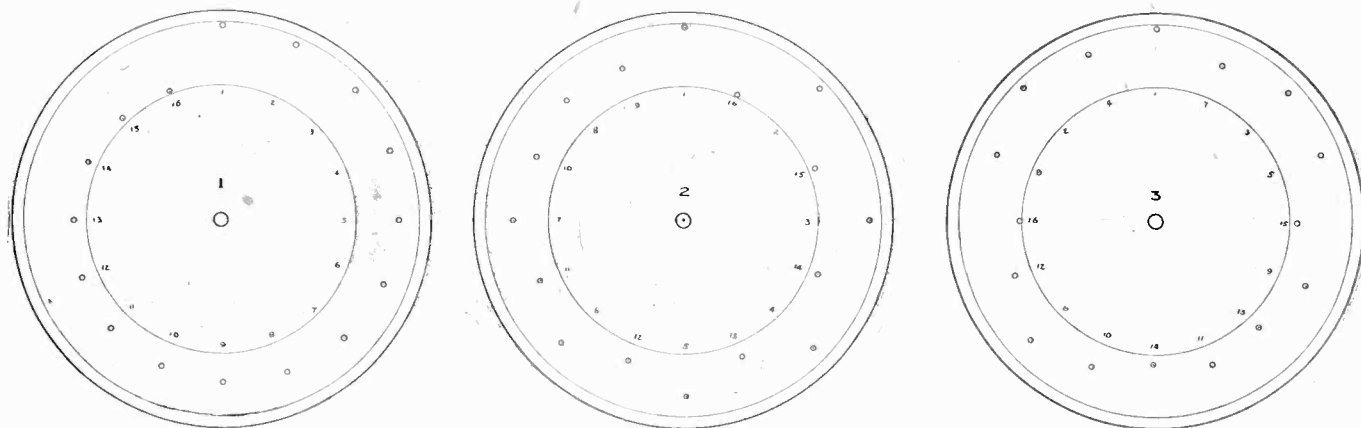

Fig. 5. The three different sets of holes used in the experiment.



The Story of Electrical Communications

by

Lt. Col. CHETWODE CRAWLEY, M.I.E.E.
(Deputy Inspector of Wireless Telegraphy, G.P.O.)

Part VII.—THE BIRTH OF WIRELESS.

IN 1811, the German scientist, S. T. Sommering, whom we have already mentioned as one of the great pioneers of line telegraphy, used water instead of wires to conduct an electric current for telegraphic purposes. This was the first time that a practical method was employed for sending telegraph messages by electricity without wires, though other scientists, notably William Watson, of England, in 1747, had suggested the use of earth currents for purposes of communication.

Conductive and Inductive Methods.

In 1842, Samuel Morse, of America, the great telegraph pioneer, by sinking metal plates in the water on both sides of a river was able to transmit signals across; and at the same time James Bowman Lindsay, of Scotland, was carrying out similar experiments in this country. Many other experimenters, including Willoughby Smith, in England, followed on along the same lines, and others tried using earth currents, but with less success. Many experimenters, too, devised systems of signalling through space without wires by means of electro-magnetic induction. Most prominent amongst these were William Preece in this country, and John Trowbridge in America. These experiments culminated when Thomas Alva Edison installed a technically satisfactory system of induction for signalling

with trains on an American railway in 1887, but after the novelty had worn off, the arrangement was found to be in little demand, and the apparatus was dismantled.

David Hughes.

All these methods of wireless signalling were based on either conduction or induction, but, in 1879, experiments were made for the first time in utilising what are now called wireless waves. These experiments, which extended from 1879 to 1886, were carried out by David Edward Hughes, of England, whom we have already noted as a pioneer in telegraphy and telephony. Hughes found that an interrupted current in a coil produced, at each interruption, some form of electric waves which could be detected by a telephone in a circuit which included a loose metallic contact, such as the microphone which he had previously discovered.

Between 1879 and 1888 several leading scientists witnessed these "aerial transmissions," as Hughes called them. Preece, Crookes, and Dewar were amongst them. A small coil was used for transmitting, and reception was carried out with a semi-metallic microphone, the results being heard on a telephone receiver. The transmitter and receiver were in different rooms, about 60 feet apart.

Hughes was not satisfied with 60 feet, but later he was able to obtain a range of 500 yards by setting "the transmitter in operation and walking up and down Great Portland Street with the receiver in my hand and with the telephone to my ear." History is silent on what people who met Professor Hughes in Great Portland Street thought about him.

A Discouraging Report.

On the 20th of February, 1880, Mr. Spottiswoode, the President of the

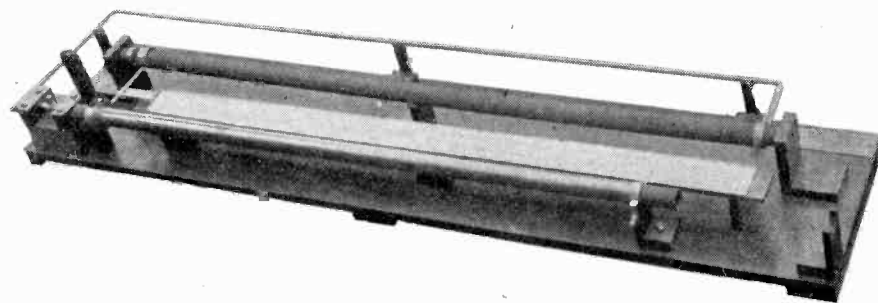

THE FLEMING CYMOMETER.

This is the instrument to which we referred in Editorial of our last issue. It was designed by Sir Ambrose Fleming, and was one of the earliest forms of wavemeter. As such, it was used in the early days of wireless.

Royal Society, with the two secretaries, Professor Huxley and Sir George Stokes, came to see the experiments, and after three hours' demonstration announced that they could not agree with Hughes' theory that the results were due to electric waves, as they could all be explained by the laws of electro-magnetic

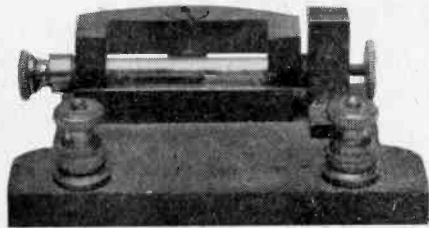

Mercury-Iron Detector used by Marconi. (The Castelli Coherer.)

induction. Hughes was so discouraged by this report that he refused to write a paper for the Royal Society until he was better prepared to demonstrate the existence of these waves. Orthodox science had closed the door on the invention of wireless telegraphy, as it has so often attempted to do in the cases of other important inventions.

Present-day workers on television will be interested to read what Sir Oliver Lodge has written of Hughes :

"He was a man who thought with his fingers, and who worked with the simplest home-made apparatus — made of match-boxes and bits of wood and metal, stuck with cobbler's wax and sealing wax. Such a man, constantly working, is sure to come upon phenomena inexplicable by orthodox science. And orthodox science is usually too ready to turn up its nose at phenomena which it does not understand, and so thinks it simplest not to believe in."

The Death of Hughes.

Hughes died in 1900, and left some £400,000 (which he had made by his inventions) to the hospitals of London. He was a great experimenter, and a great man.

There is no doubt that Hughes did not realise that he was using the very waves that had been predicted by James Clerk Maxwell, of Scotland, in 1864, and there was, indeed, another who had similarly used these waves in 1875, Elihu Thomson, of America. Thomson had used the waves and detected their presence at a distance of 100 feet, but he failed to grasp the significance of his experiments, and turned his attention to other investigations.

Clerk Maxwell.

James Clerk Maxwell, whom Sir Oliver Lodge has described as "one of the essential founders of wireless communication," was born in Edinburgh in 1831. He went up to Cambridge, graduated as Second Wrangler, was elected a Fellow of Trinity in 1855, and carried out his great life work at Cambridge. He was steeped in the work of Faraday, and what he set out to prove, and did prove, was that light and electric waves are identical in nature; in fact he founded what is known as the electro-magnetic theory of light.

In 1873 he published his epoch-making "Treatise on Electricity and Magnetism." He died in 1879 when he was engaged on a second edition of this work, which has placed him amongst the greatest mathematical physicists of all time. Clerk Maxwell has been described as "a man loved and honoured by all who knew him." His work was by no means confined to the particular line of research which has earned him undying fame, but it is

Neither he, however, nor any of his brilliant assistants, was able to give experimental proof of the existence of these waves.

The new theory was received coldly by orthodox science; even so far-seeing an authority as Lord Kelvin refused to accept it, and it was not until 1888 that the theory was experimentally confirmed in Germany by Heinrich Rudolf Hertz, in one of the most brilliant series of experiments that has ever been made.

Heinrich Hertz.

Hertz was born at Hamburg in 1857. He became a pupil, and later an assistant, of the great scientist Helmholtz. In 1883 he became professor of physics at Kiel, where he began a study of Clerk Maxwell's theory, and probably became aware of the fact that Fitzgerald, of Ireland, at a meeting of the British Association in 1883, had suggested that electric waves might be produced by the oscillatory discharge of a Leyden jar. In 1885 Hertz was appointed professor of physics at Karlsruhe,

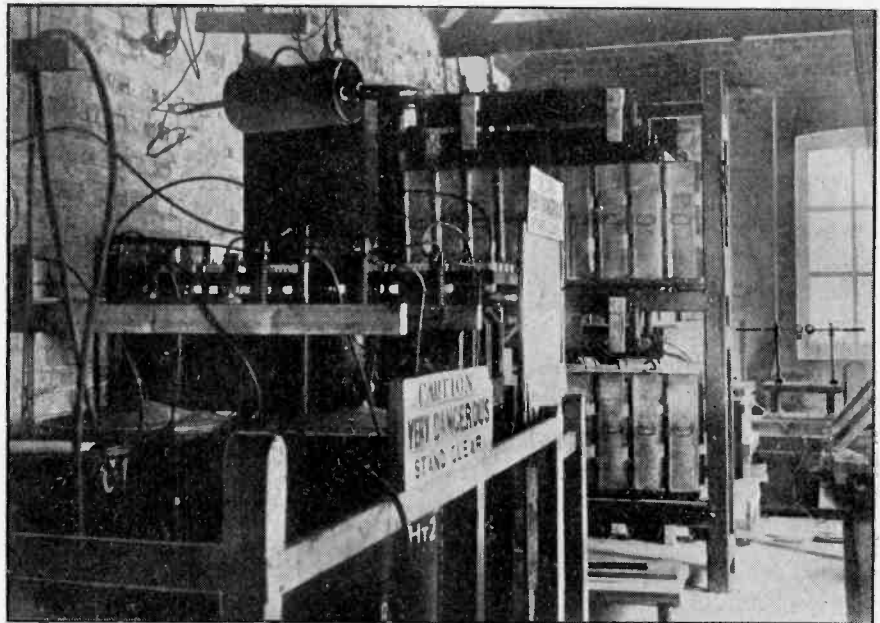

MARCONI WIRELESS STATION AT POLDHU, CORNWALL.

Early wireless apparatus used at Poldhu wireless station about the time of Senatore Marconi's transatlantic wireless experiments in 1901. On the extreme left are the transformers. The condensers are carried in metal containers on the wooden rack; and on the extreme right is the spark gap consisting of two steel spheres mounted on insulating rods.

outside our scope to mention his other brilliant discoveries. He not only worked out the properties of these unknown waves, but he gave measurements of their wave-lengths and he predicted that they would travel with the velocity of light.

and it was there that he carried out his famous series of experiments.

His apparatus was extremely simple. It consisted of what he called "the exciter" and the resonator. The exciter consisted of a spark gap, with metal plates

connected to each spark ball by metal rods. At first, the rods were connected to a Leyden jar, and, later on, to the secondary terminals of an induction coil, by which means a spark was caused to pass between the spark balls.

The resonator consisted of a wire bent in the form of a circle, but leaving a small gap fitted on each side with metal balls. He sent out waves with the exciter, and detected their presence by observing the spark which passed across the balls of the resonator. With this simple apparatus, impossible as it may appear, Hertz completely confirmed all that Clerk Maxwell had predicted, and published his results in a remarkable series of papers, between November, 1887, and December, 1889.

It was at once suggested to Hertz that these newly found waves, which have since been called Hertzian waves, might be used for communicating across space without wires, but Hertz did not know of Hughes' microphonic receivers, and did not know that his own receiver was far too insensitive to be of commercial use, so he, too, passed on to other investigations, and the development of wireless signalling was left to other hands.

Sir Oliver Lodge has said that "the enthusiastic admiration for Hertz's spirit and character, felt and expressed by students and workers who came in contact with him, is not easily to be exaggerated." He died at the early age of 37, but to quote Sir Oliver again, "he had effected an achievement that will hand his name down to posterity as the founder of an epoch in experimental physics."

Edouard Branly.

As we have seen, any adaptation of Hertz's work to practical signalling depended primarily on the invention of a sensitive receiver, and it was not long before this was available in the "coherer" which was invented by Edouard Branly, of France.

The principle of cohesion had first been observed in 1850 by Guitard, of France, when he observed that dust particles in electrified air tended to cohere together. Sixteen years later S. Varley, of England, rediscovered the principle, and applied it practically in the construction of lightning protectors. Hughes again used the principle for detecting waves in his experiments in 1879,

and in 1884 Oliver Lodge and J. W. Clark applied it for clearing rooms of smoke and other fumes.

In the same year, Calzecchi Onesti, an Italian professor, published the results of some experiments in which he had observed that a heap of copper filings between two brass plates became conductive when subjected to the electrical discharge

foresaw that such apparatus might be developed for commercial signalling purposes, as it afterwards was by Marconi, and it has even been claimed that, in May, 1895, he demonstrated the first practical system of wireless telegraphy. Little more, however, was heard of his work until after Marconi's initial successes in practical signalling.

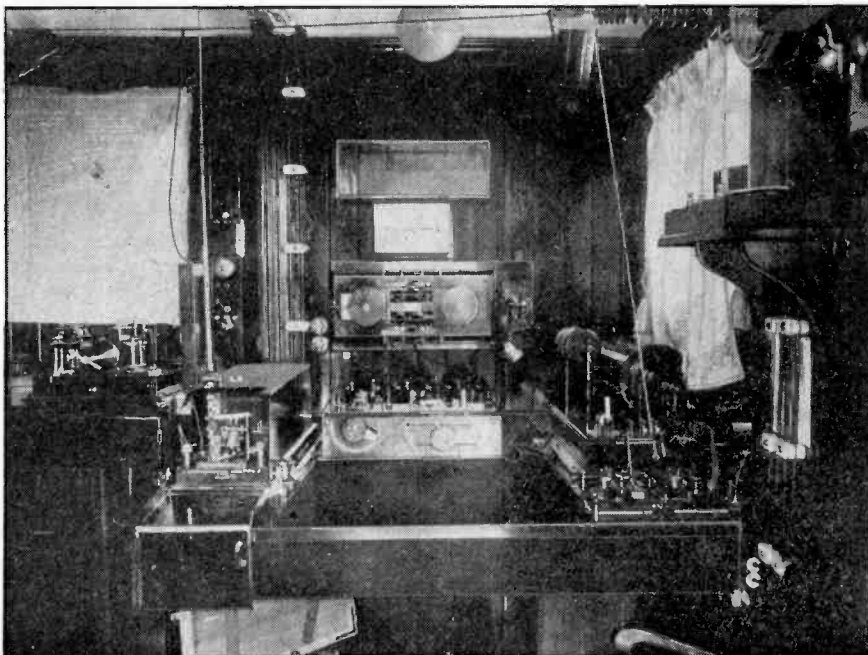

MARCONI SHIP SET, EARLY TYPE.

A photograph, about 22 years old, of a ship's wireless cabin, showing coil emergency transmitter, right (1½ K.W. main transmitter in separate silence cabinet not shown); multiple tuner and magnetic detector (centre), triple node X-stopper (left), coherer receiver, and morse inker (extreme left).

from an induction coil. About this time, Branly was investigating similar phenomena, and found that the conductivity produced in metallic filings by an electric discharge continued for a considerable time, but would at once disappear if the glass tube containing them was tapped.

Branly published these results in 1891, and probably he did not then realise that the effect was produced by the waves which Hertz had discovered a few years previously. Lodge, however, was quick to grasp the great significance of Branly's work, and in 1894 he repeated all Hertz's experiments with a Branly coherer as detector.

Popoff and Lodge.

In 1895 Alexander Popoff, a Russian professor, used an aerial wire, connected to a Branly's coherer and a Morse printer, to record lightning flashes. He undoubtedly

In this country, Lodge continued his experiments, and in 1894 signalled by Hertzian waves over distances up to 150 yards, but as he wrote many years later: "I was too busy with teaching work to take up telegraphic or any other development. Nor had I the foresight to perceive, what has turned out to be, its extraordinary importance to the Navy, the merchant service, and, indeed, to land and war service, too."

In the United States of America, Hertz's discovery was not followed up so quickly as it was on this side of the Atlantic, but as soon as Marconi had demonstrated practical signalling, the American pioneers joined up in the front rank, led by Nikola Tesla (an Austrian by birth), Lee de Forest, and Reginald Aubrey Fessenden.

(The author is indebted to Marconi's Wireless Telegraph Co., Ltd., for the illustrations in this article.)

BIRMINGHAM & MIDLAND INSTITUTE TELEVISION SECTION.

(President: J. B. Kramer, M.I.R.E. Hon. Sec.: F. H. Lane.)

The Birmingham and Midland Institute, with which is incorporated the Birmingham Wireless Association, is a scientific society which was first founded in 1873 and reconstituted in 1895. It has recently formed a Television Section, the first Progress Report of which we have pleasure in publishing below.

PROGRESS REPORT No. 1.

FROM MARCH 8TH TO APRIL 30TH,
1929.

1. Four meetings held during this period: March 8th, 22nd, April 12th, 26th. Average attendance 16.
2. Three books obtained for the use of members. Two copies of Dinsdale's "Television." One copy of Lerner's "Practical Television."
3. Reports issued: Technical Report No. 1 on "The G.E.C. Potassium Copper Cell."
4. Apparatus received: One K/Cu cell from the G.E.C., one neon lamp from the G.E.C., one chain drive from the Coventry Chain Co., one Pointolite lamp and resistance from the Ediswan Electric Co., one selenium cell on loan from the Radiovisor Co., one amplifier and batteries on loan from the G.E.C.
5. Laboratory.—Up to the present date most of our experiments have been done in the Photographic Section's dark room, but we hope soon to have space definitely assigned to the section.
6. General.—The chief feature of the period was Mr. Kramer's lecture, given to the Scientific Society, on the

"Principles Underlying Television," at which over a hundred people were present.

Experimental Work Done. (A) With the Photo-electric Cell and Amplifier.—A series of experiments were done with the K/Cu cell, the results being summarised in Technical Report No. 1. Work was also started on a complete televisior and receiver in connection with Mr. Kramer's lecture. This machine consists of two Baird discs on separate parallel shafts, connected by a chain. The discs have in them 35 holes 1 m/m diameter, arranged in a spiral of 1 m/m pitch circles. The P/E cell, in a light-tight box, was fixed behind one disc and the neon lamp behind the other. The area of the plate of the neon lamp is 2 square inches. The distance between the shafts is 2 feet 8 inches.

A choke-coupled 4-valve amplifier is connected to the cell as shown in Fig. 1, with the neon lamp in the output circuit. This arrangement will respond only to changes of light intensity. A light flashed on the cell causes a flash in the neon lamp, but a steady light does not cause a glow. The source of illumination used

when trying to use the discs was a Pointolite lamp of 100 candle power, with a concave mirror behind it to project a beam of light. The sitter was arranged about 12 inches away from an optical system which focussed his image on the P/E cell.

Unfortunately no response could be obtained from the cell in this way, due to the low intensity of the light which passed through the 1 m/m holes. Even direct illumination through the holes would give no effect. Up to the present no satisfactory method has been devised which will operate the cell, and until this part of the apparatus is working properly very little can be done on the receiving side of the machine.

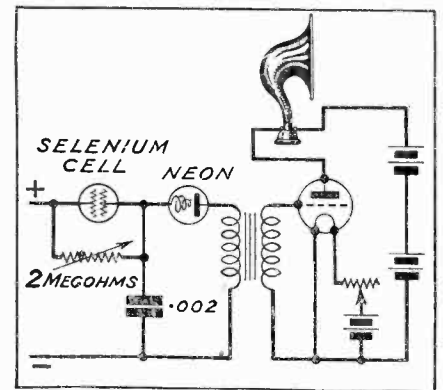

Fig. 2.
Diagrammatic representation of apparatus used by Mr. Kramer during his lecture.

Experimental Work. (B) With Selenium Cells.—The following apparatus was used during Mr. Kramer's lecture (see Fig. 2). It consists of the usual neon lamp flasher circuit, in which the fixed resistance is replaced by the selenium cell, shunted by a high variable resistance—a grid leak.

The oscillations produced are amplified and rendered audible by a one-valve amplifier coupled up through a transformer. When the cell is in the dark the value of the resistance in circuit is so high that the period of oscillation, if any, is about two or three seconds. When light falls on the cell, say, from a flash-lamp 20 or 30 feet away, the resistance falls and the circuit oscillates. The brighter the light the higher the note.

Experimental Work. (C) Synchronising.—Experiments are in progress with a view to getting a motor to run at a perfectly constant speed from D.C. mains, but as much work has to be done on this, descriptions will appear later.

F. H. LANE, Hon. Secretary.

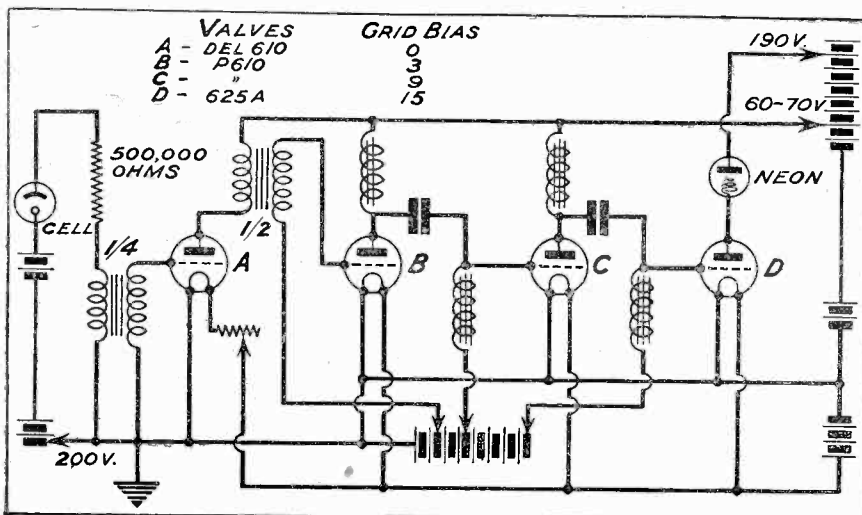

Fig. 1.
Diagram of the choke-coupled 4-valve amplifier, showing connection to neon tube.

ATMOSPHERICS AND INTERFERENCE IN WIRELESS.

By R. L. SMITH-ROSE, D.Sc., Ph.D., A.M.I.E.E.

In the following article the writer describes the nature and origin of that bugbear of wireless reception, "atmospherics." He also draws attention to the effects which they will have on a received television image.

ONE of the greatest difficulties met with in modern wireless communication is that of interference. Almost every day a new wireless transmitting station is set up somewhere and begins to launch forth its waves in an already congested ether, and it has truly been said that the main difficulty of modern wireless reception is not to receive a signal but to keep out unwanted signals.

Interference in wireless is broadly divisible into three classes: atmospheric, unwanted signals—either morse or telephony—and our old friend "oscillation." At about this season of the year listeners to broadcast programmes begin to renew their acquaintance with the crashing, rattling, and hissing noises produced by atmospheric.

Effect on Television.

In the reception of wireless pictures and in television the atmospheric also makes its presence felt by the production of irregular streaks or smudges upon the field of the picture. While these atmospheric may spoil otherwise perfect reception from a nearby station, it is in long distance working that the effect of atmospheric interference is experienced at its worst. In many parts of the world the intensity and frequency of these atmospheric disturbances are so great that many commercial wireless operators are unable to wear head telephones, and automatic recording apparatus is rendered inoperative for several hours a day during certain portions of the year.

As may be gathered from the name which was given to this type of interference many years ago, the origin of these electrical disturbances is intimately connected with the atmosphere. Scientific research on the subject of recent years has

shown that they arise from a discharge between separate accumulations of positive and negative electricity in the atmosphere, or between one such accumulated charge and the earth's surface. While it is not necessary that such a discharge



A lightning flash photographed several years ago in mid-Atlantic by the Editor of "Television."

should be either audible or visible it is commonly known to our senses in the form of thunder and lightning.

Tests at 1,000,000 Volts.

Some idea of the order of interference to be experienced from a lightning flash has been obtained recently in laboratory experiments with a high-voltage electrical discharge apparatus. Using a plant capable of generating appreciable power at pressures up to 1,000,000

volts, spark discharges were produced over a string of insulators about 6 feet long, the potential difference between the terminals prior to breakdown being about 850,000 volts. At the frequency of 50 cycles per second employed, the current through a maintained arc discharge was about 0.5 ampere.

Effects on Receivers.

Observations carried out on various wireless receivers operating on different wave-lengths between 7.5 and 1,600 metres showed that, while the interference effect of the spark discharge was very serious at short distances it decreased, very rapidly as the distance was increased. Thus, within 50 yards of the spark the strength of the interference was approximately equal to the strength of signals from the London broadcasting station, 2LO, some 10 miles away. As the receiver was moved away from the spark, however, the interference decreased rapidly until at distances greater than half a mile it was quite inaudible on the most sensitive receiver. In the case of all the experiments no audible effect was detectable before the occurrence of the spark discharge, and this result would tend to support the view that all atmospheric in wireless communication are due to actual lightning flashes.

On first consideration it might be thought that the effect of a lightning flash would only make itself felt over a small area, and that ordinary observation shows that insufficient flashes are normally experienced to account for all the atmospheric received. It must be pointed out, however, that natural lightning is an electrical discharge on an enormously greater scale than the relatively puny discharges which we can produce artificially.

10,000 Amperes !

For instance, the average length of a lightning flash is of the order of 10,000 feet as against the 6-foot spark employed in the above experiments; also, the current in the lightning flash has been estimated at about 10,000 amperes as against the half ampere mentioned above. From such figures it can be shown that the radiation from a single lightning flash is from 2,000 to 10,000 times as strong as that from the Daventry high-power broadcasting station. It is thus small wonder that the effects of such a flash are detectable as an atmospheric on all sensitive receivers within a radius of several thousand miles.

As to the frequency with which lightning flashes may occur, we are accustomed in the British Isles to look upon thunderstorms as of comparatively rare occurrence and practically limited to the summer months. As a result of statistics collected over a number of years from 3,000 observing stations, it has been shown that on an average thunder is heard in these latitudes on from eight to ten days per year. In tropical regions, on the other hand, thunderstorms are experienced on from 33 to 60 days per year.

1,800 Thunderstorms Always in Progress.

The complete analysis of this world study of thunderstorms actually observed shows that on an average there are in progress, at any one moment, about 1,800 thunderstorms in different parts of the world. Actually, of course, at any one place, the storms are of more frequent occurrence in the summer than in the winter months. In association with these storms it is estimated that lightning flashes occur at an average rate of 100 per second. When regarded on this basis one begins to understand the possibility of all the numerous atmospherics heard on a wireless receiver being attributable to lightning flashes as their origin.

With the aid of direction-finding and recording apparatus, investigations have been carried out in this and other countries with a view to locating the source of origin of atmospherics at various hours of the day and night. The general result of these investigations (which are

still in progress) is to indicate that the majority of atmospherics originate in land areas and particularly in tropical mountainous districts such as South Africa and South America, where it is possible that the convection of large masses of air with subsequent cooling at the upper levels causes the separation of electrical charges which is a necessary predecessor of the lightning

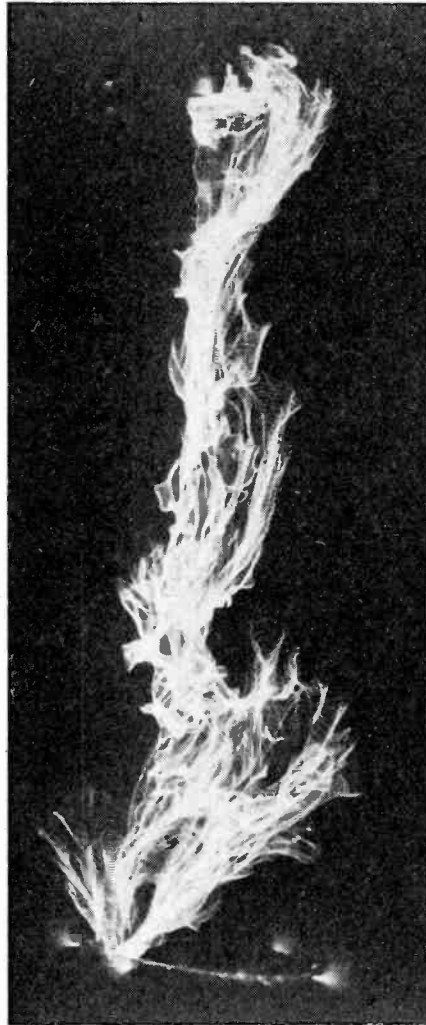

A photograph of a high-voltage electrical discharge about seven feet long. Artificial lightning flashes of this type were employed in connection with the experiments on radio interference referred to on the previous page.

flash. All observers appear to agree that large stretches of sea, such as the Atlantic and Pacific Oceans, are seldom the source of atmospherics.

Atmospheric Elimination Impossible.

In addition to research into the origin of atmospherics, many workers have tackled the problem of devising aerial systems and circuit arrange-

ments which will render the receiver immune from the effect of atmospherics. Although some of these are very successful in reducing the undesired effects without disturbing the required signals, there is as yet no known means of entirely eliminating the atmospheric disturbance from wireless receivers; in fact, at the present time, many experts are of the opinion that atmospherics, like the poor, will always be with us.

A Mighty Broadcast.

How the Americans do it.

The thunderous roar of Niagara Falls, and a description of the world's greatest lighting spectacle by aeroplanes, bombs, and billion-candle-power searchlights above the giant waterfall, was broadcast from coast to coast of the United States over the National Broadcasting Company System on the night of June 15.

Microphones in the Cave of the Winds and on the Falls View bridge, above the Niagara gorge, picked up actual sounds of the international "Festival of Lights," and relayed a vivid description of the scenic spectacle.

Graham McNamee and Phillips Carlin headed the corps of radio announcers familiar to American and Canadian listeners, and were posted at points of vantage.

The entire broadcast occurred as a feature of the General Electric Hour, which broadcast a sixty-minute programme from Niagara Falls on that night. It was the 250th anniversary of the discovery of the falls by Father Hennepin.

McNamee was on the bridge, midway between Canada and the United States, and described the scene lighted by a battery of 1,300,000,000 candle-power searchlights, aerial bombs, and electrically-lighted aeroplanes. Carlin was stationed in the Cave of the Winds beneath the actual waterfall, and broadcast the booming "voice" which primitive Indians worshipped.

In the Niagara hotel, beside the upper rapids, the Third Battalion Band from Toronto, Ontario, was stationed for musical interludes.

A nationwide network of stations in the NBC System, headed by WEAf, New York, broadcast the programme.

* * *

What a subject for Television !

Refractometers of the Critical Angle Type.

Part XII

By Professor CHESHIRE, C.B.E., A.R.C.S., F.I.P.

IN the article which appeared in the June issue of TELEVISION, we dealt briefly with prismatic refraction methods of determining the refractive indices of glass for the various colours of the Spectrum.*

An important instrument for this purpose depends essentially upon the measurement of the critical angle at which light is totally reflected from a plane surface separating two refractive media.

Critical Angle of Refraction.

In Fig. 1, let S represent a section of the bounding surface between, say a piece of glass, with a refractive index n , and air. A ray AO , striking this surface normally will pass through without deviation into the glass below, but if the ray be rotated in the clockwise direction about the point O , the ray passing into the glass will be more and more deviated until, when AO , has been rotated through a right angle into the position BO , the refracted ray will pass through the glass making an angle of refraction α with the normal AA' .

Now we know that the refractive index n is equal to the ratio of the sines of corresponding angles of incidence and refraction, so that when the angle of incidence is equal to 90° and its sine, therefore, is unity

$$\sin \alpha = \frac{1}{n}$$

This particular angle of refraction is defined as the critical angle, because if we reverse the direction of the light rays in Fig. 1, it is the

greatest angle of incidence at which a ray in the given medium, such as glass, can pass out into air, so that the refractive index of any medium in air is equal to the reciprocal of the sine of the critical angle—a relationship of which the optician makes great use, as we shall see.

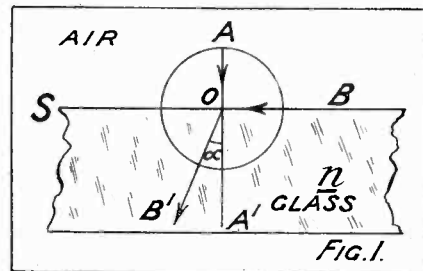

Refraction at the Critical Angle.

In the table below the critical angles for a number of important refractive media are given:—

CRITICAL ANGLES OF REFRACTION (α). FOR LIGHT IN VARIOUS MEDIA IN AIR.

| Medium. | Ref. index(n) | Critical angle(W) |
|------------------------|-------------------|-------------------|
| Water | 1.33 | 48°7 |
| Crown glass .. | 1.51 | 41°5 |
| Canada Balsam | 1.53 | 40°8 |
| Quartz (ord. ray) | 1.54 | 40°5 |
| Flint glass .. | 1.65 | 37°3 |
| Diamond | 1.71 | 35°8 |
| Monobromnaphthalene .. | 1.66 | 37°0 |
| Methylene iodide | 1.74 | 35°1 |

When the angle of incidence of a ray in the denser medium is greater than the critical angle it cannot emerge, but is totally reflected in accordance with the usual laws of reflection. In Fig. 1, as an incident ray $A'O$, in the denser medium is swung about the point O in any

direction, it passes out into air with some small loss by reflexion until it reaches an angle of incidence, in the case of crown-glass, of about $41^\circ 5$. Beyond this angle no light emerges through the point O , but it is totally internally reflected.

In the case of water the critical angle has a value of $48^\circ 7$, so that light from a complete hemisphere of sky passing into water through a small hole would be compressed into a cone with a semi-apical angle of $48^\circ 7$. A fish, therefore, swimming in the water outside this cone could not see anything through the hole by which alone the light is assumed to pass into the water; or, put in another way, a fish in an open pond would see a hemisphere, or 180° , of sky compressed into an arc of less than 100° , "precisely as if the water were covered with an opaque roof with a round hole directly overhead."

Angles of Incidence.

Fig. 2 shows rays at various angles of incidence falling upon a surface of water from a point O , in the water. The ray OA , has an angle of incidence greater than the critical angle so that it cannot emerge, but is totally internally reflected. The ray OB , falls upon the surface S , at a little less than the critical angle, so that, upon emergence, its angle of refraction is practically a right-angle, so that it grazes the surface S .

All rays, therefore, with angles of incidence less than the critical angle emerge in part, and are in part reflected, whilst those rays incident at an angle greater than the critical angle are completely reflected. The field of view of the fish we have mentioned is shown in dotted lines.

So far we have considered the critical angle, only in the case of a refracting medium immersed in air, or a vacuum more strictly, in many cases,

* A correspondent, Mr. D. J. Mynall, has kindly pointed out two slips in the article on "The Optical Specification of Optical Glasses, etc." in the June issue of TELEVISION, on p. 199, $\theta = d/p$ should be $\theta = d/M$, as a reference to the drawing shows, and the Equation on p. 200 should be $\eta = \frac{\sin \frac{1}{2}(\alpha + D)}{\sin \frac{1}{2}\alpha}$

however, as in the case of the spectrometer of the kind depending upon the measurement of a critical angle, we have, as shown in Fig. 3, two dense

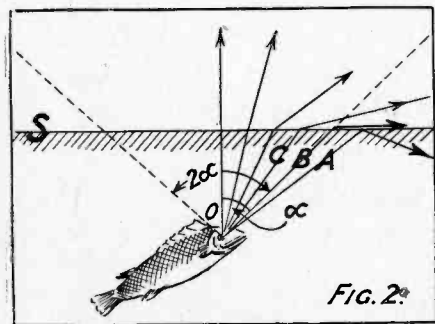

Critical Angle in Water.

media separated by a common plane surface *S*. A ray *CO*, strikes this surface at the critical angle and is reflected in the direction *OB*. A ray *BO* in the first medium, incident at an angle of 90° nearly, would traverse the lower medium in the direction *OC*. This diagram assumes that the ref. index n_1 , of the upper medium is less than n_2 , that of the lower medium.

Snell's law of refraction tells us that when a ray falls upon the plane bounding surface of two refracting media at an angle of incidence *i*, and passes into the second medium at an angle of refraction α , then n_1 , and n_2 , being the ref. indices of these media we have

$$n_1 \sin i = n_2 \sin \alpha$$

and when $i = 90^\circ$, as in Fig. 3.

$$n_1 = n_2 \sin \alpha$$

so that knowing n_2 and measuring α , the ref. index n_1 could be determined.

This is the principle upon which refractometers of the type under consideration work. It will be noticed that whilst the absolute indices for the two media are n_1 , and n_2 , respectively the relative index is n_2/n_1 and this index is equal to the reciprocal of the sine of the critical angle— $n_2/n_1 = n_1/\sin \alpha$.

Portable Spectrometer.

Figure 4 shows in section a small portable refractometer made by the firm of Carl Zeiss, primarily for the determination of the refractive indices of gem stones, but which may be used for other purposes.

A hemisphere *H* of a dense glass is mounted so as to be free to rotate about a vertical axis. The gem stone

K, or glass plate, to be examined, is placed with one of its flat facets resting on the flat surface of the hemisphere, near to its middle. Optical contact is secured with a drop of an immersion fluid, such as monobrom-naphthalene, ($n=1.66$); or in the case of very highly refractive gems methylene iodide ($n=1.74$) may be employed. In any case the refractive index of the immersion medium must be greater than that of the gem under examination, otherwise the reading will give the index of the medium and not that of the gem.

Obtaining Refractive Index.

Light, preferably that of a sodium lamp, is directed upwards towards the centre of the hemisphere *H*, by a mirror *M*. The light reflected by the

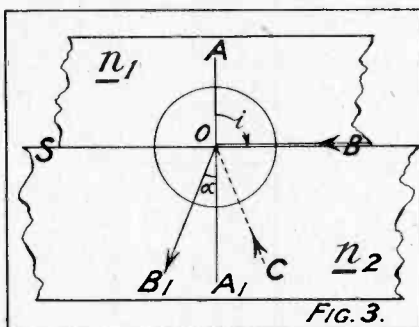

Critical angle in the case of two dense media.

surface of the gem in contact with *H* is collected by the hemisphere acting as a lens, and after reflexion by a prismatic reflector *P* is brought to a focus on the scale *Sk*, which is empirically divided to give the refractive index, directly and without calculation, of any gem or glass under examination.

A magnifier *OK*, is pivoted about a point *A*, the image of the centre of the hemisphere *H*, in the reflecting surface of *P*. In practice, when the necessary adjustments have been made, a horizon line, similar to that seen between sea and sky at the seashore, is seen crossing a vertical scale. The reading at the crossing point, after it has been brought into the centre of the field-of-view of the magnifier, gives the required refractive index.

In an earlier form of the instrument a half-cylinder of glass was used instead of the half-sphere *H*. By directing the sodium light at glazing incidence along the upper flat surface of the hemisphere *H*, and using a specimen cut with a 90° dihedral

edge, greater accuracy is realised. In ordinary use the first and second figures after the decimal point of a ref. index are read off directly, and the third can be estimated.

The advantage of the type of spectrometer we have described is that it gives results quite accurate enough for many of the needs of an optician and, at the same time, dispenses with the necessity in other methods for accurately ground prisms. A few square millimetres of flat surface on the gem or plate to be examined is all that is required.

Refractive Index of a Powder.

It is sometimes required to find the refractive index of a transparent medium which can only be obtained in the form of a powder. This can be done in the case of glass, for example, by immersing the powder in a mixture of benzol and carbon bi-sulphide, and altering the proportions in which the liquids are mixed until the powder becomes invisible.* The refractive index of the liquid, which is in these circumstances the same as that of the glass, can now be determined in any one of the usual ways.

Difficulty sometimes arises, when using white light, owing to the different dispersive powers of the glass and liquid, but this may be overcome by the use of monochromatic light, such as the sodium flame.

* A glass stirring rod disappears from view in an almost startling way when dipped into a bottle of Canada balsam.

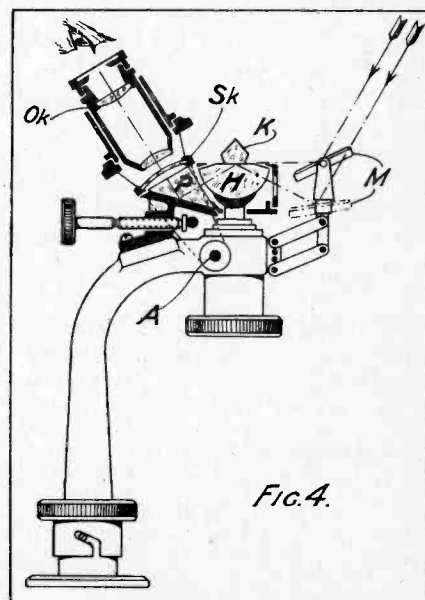

Pocket Refractometer.

Recent Work on Selenium

By E. E. FOURNIER D'ALBE, D.Sc., F.Inst.P.

Dr. Fournier d'Albe is known as a pioneer of the modern theory of selenium and the inventor of the "optophone," a selenium instrument which enables the blind to read books and newspapers printed in ordinary type. He is Consulting Physicist to Radiovisor Parent, Ltd., manufacturers of light-sensitive apparatus.

THE light-sensitive property of selenium was discovered fifty-seven years ago, at the Valentia Island transatlantic cable station in Ireland. The news of the discovery created a profound sensation in scientific circles, for they realised the far-reaching possibilities contained in a substance capable of "turning light into electricity."

Inventors soon got busy trying to turn that marvellous property to account, and fascinating projects of automatic lighthouses, unmanned boats, burglar alarms, and even television were soon put forward. Unfortunately, these early inventors did not trouble to study the properties of selenium very closely. They asked it to do impossibilities, and when it refused, their inventions naturally fell through.

To-day, selenium has many rivals. Not only have similar light-sensitive properties been found in the natural sulphide of antimony, in thallium oxy-sulphide and other compounds, but an entirely new phenomenon, that of photo-electricity, has been discovered in the alkali metals and utilised in the photoelectric cell.

The sulphides and similar substances have no advantage over selenium, and being compounds instead of elements, they suffer gradual disintegration by electrolysis.

The photo-electric cell, on the other hand, has the advantage that its action is instantaneous. In some processes where very quick action is essential, as in television, this property is very precious, and probably will give the photo-electric cell a permanent advantage in that field.

But it is worthy of note that the only cell which can claim the advantage of instantaneous action is the vacuum cell, where the alkali metal

—potassium, sodium, rubidium, or caesium—is mounted in a vacuum, instead of in a gas, which retards the action, though it greatly intensifies it.

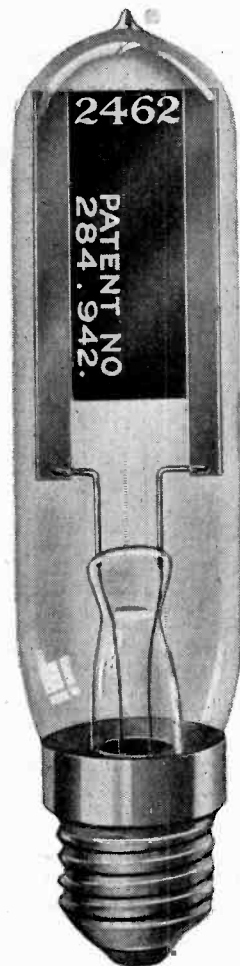

The Radiovisor Selenium "Bridge."

Selenium is by far the most efficient agent for producing a current from a given quantity of light. It yields in milliamperes what the vacuum photo-electric cell yields in microamperes. It also responds to the whole of the

visible spectrum, to the ultra-violet and to the infra-red up to a wavelength of 15,000 Angstrom units. When illuminated by any terrestrial source, it appears to be chiefly sensitive to the red rays, but that appearance is due to the fact that these rays are the chief carriers of energy in the spectrum. The response per unit of energy is the same throughout the visible spectrum.

Recent researches have gradually unravelled the mechanism of the light-action in selenium. The theory of this action is now generally based upon the conception of ionisation, or the splitting of the atoms and molecules of the substance into oppositely charged ions. The negative ions in the case of a solid like selenium would be free electrons, which move freely within the solid in obedience to electric forces until they are reabsorbed by positively charged atoms. The conductivity at any moment depends upon the number of electrons which have been liberated by the light and have not yet been reabsorbed.

Now the number of electrons liberated in a given time is proportional to the light absorbed by the selenium surface. The number of ions recombined is proportional to the square of the number of free electrons. This is best expressed by the equation

$$dN/dt = C - BN^2$$

where N is the number of free electrons, t the time, C a measure of the light energy, and B a constant called the coefficient of recombination.

Equilibrium is reached when the production of new ions by the light equals the number of ions reabsorbed in the same time, that is to say, when $C = BN^2$. This may also be written

$$N = \sqrt{C/B},$$

from which it follows that the value

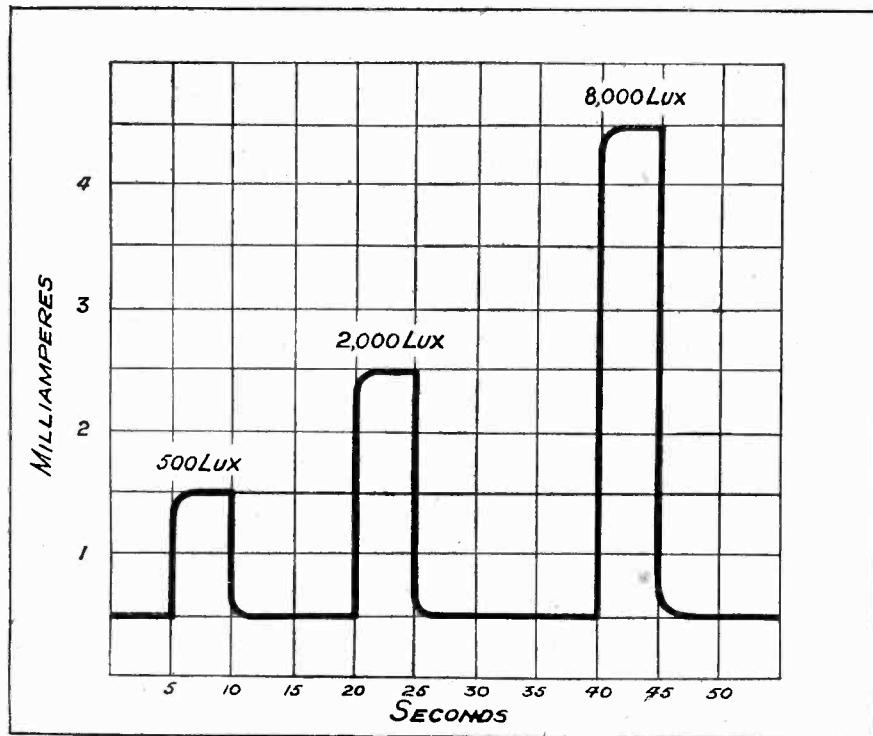

Fig. 1.
SELENIUM UNDER STRONG ILLUMINATION.
The current is proportional to the square root of the illumination.

attained by the conductivity of the selenium—and, therefore, also the current obtained with a given battery—is proportional to the square root of the illumination.

This explains why the response of selenium increases more slowly than the light intensity, and why selenium is comparatively inefficient in a very strong light. It also accounts for its marvellous efficiency under feeble illuminations. If, for instance, it gives a current of 1 milliampere under an illumination of 100 "lux" (100 candle-power at 1 metre), it will still give a current of 100 microamperes at 1 lux, and 1 microampere under illumination of 1/10,000th lux.*

Hand-in-hand with the theoretical advances in our knowledge of the properties of selenium there has been a development of practical applications. The automatic street lamps at Barnes are a matter of common knowledge. They are controlled by

* The complete equation to the light-action curve of selenium is

$$N = C/B \tanh(t\sqrt{BC}) + k\sqrt{B/C},$$

from which any curve for a given illumination can be traced. See the author's paper on "The Efficiency of Selenium as a Detector of Light," in the *Proceedings of the Royal Society, A*, 89, pp. 75-90, 1913.

volts for months on end without suffering deterioration. The same company is producing a complete system of automatic signalling for railways, and also an invisible-ray burglar alarm, which was put into very effective use at the recent exhibition of old silver at Seaford House.

A remarkable property of these new selenium cells is their capacity to follow oscillations of light, and give audible notes up to frequencies of 8000 cycles.

The Radiovisor Bridge.

The bridge consists of a thin glass surface on which a gold grid is fused by a special process, and on this the thin layer of selenium is spread.

This grid consists of a pair of interdigitated combs which form the electrodes, and on this the thin layer of selenium is spread. This forms the actual sensitive surface, and can vary considerably in size for special purposes; the standard bridge having a surface of 27 mm. x 50 mm. The effect of the thin layer of selenium spread on a transparent base is to make the utmost quantity of the material accessible to light, and to leave the smallest quantity to act as an inert shunt to the active portion;

Radiovisor selenium bridges, which can be exposed to several hundred

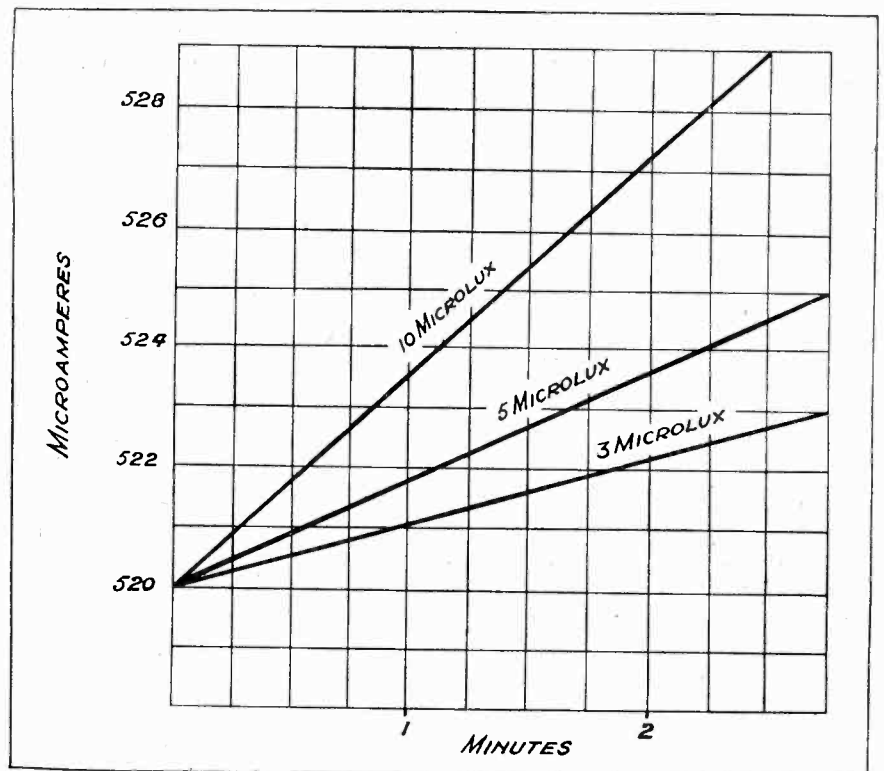

Fig. 2.
SELENIUM UNDER VERY FAINT ILLUMINATION.
The rise of the current is directly proportional to the illumination.

so that the ratio of light to dark current is as high as possible. The rigidity of the electrodes is also one of the great factors making for efficiency and permanence.

This sensitive surface, after the appropriate careful and special process of annealing, is held in clips making contact with the gold electrodes, and the whole is enclosed in a glass container with chemically treated gases, and mounted up with an ordinary Edison screw socket. The Radiovisor Bridge thus prepared is permanent, reliable, and is capable of standing up to high voltages—up to a thousand volts. It can be made of any resistance from about half to ten megohms or more, and will pass, in darkness, a current of from 1 up to 250 microamperes, if necessary.

A standard bridge of about 4 megohms will give a change between current in darkness and in light of the order of 100–150 microamps. On any given voltage the curve representing the increase of conductivity with illumination will rise rather steeply at first, and then become a straight line in which change of current is strictly proportional to increase of light, so that the greatest sensitiveness is with weak illumination.

The general law of the response to light of varying wavelengths is that it varies with the curve showing the energy contained in various parts of the spectrum. It is thus sensitive to the infra-red, and this property can be made practical use of. Naturally, the current passing through the resistance of the bridge causes a slight rise in temperature, and for this reason, to avoid injury, a maximum energy dissipation of .01 watt per sq. cm. of surface should not be exceeded for permanent working; the applied voltage and maximum illumination being considered in this respect.

From the above it will be seen that this bridge can be used directly on any commercial voltages, and can directly work a sensitive relay without magnification. It is capable of being efficiently used in all acoustic applications, so that in the reproduction of music or speech (as for example, from a film), it compares very favourably with any other device.*

* Through the courtesy of Messrs. Radiovisor Parent, Ltd., we recently had the pleasure of attending a highly successful demonstration of the ability of the Bridge in this direction.—ED.

THE PROSPECT

By NOEL SWANNE

TING-A-LING-A-LING!

"Yes, yes; all right; I know," I said, and turned over and went to sleep.

Hammer! Bang!! Smash!!!

"It's gorn 'arf parst eight, sir."

"Yes, yes; I know," I said, and turned over and went to sleep. I dreamed that a B.B.C. announcer turned into a Polar bear, seized me by the shoulder and shook me . . . and shook me again . . . and again . . .

"Do you know it is nearly ten o'clock!" said Marjorie.

"Yes, yes; I . . . What? . . . Ten! Good Lord! Why didn't you wake me up before?" I demanded.

"We did, several times," she replied.

"Ten o'clock! Phew! It's a funny thing that . . . Ten you said, didn't you?"

Marjorie nodded.

"Ten! Well . . . that's a morning wasted."

"Not if you bustle up a bit, dear," suggested Marjorie.

"Yes . . . no . . . Of course not . . . yes . . . well, here goes . . . just toddle along and warm up the bacon . . . and . . ."

I yawned as she shut the door, and turned over. Anyhow, a morning in bed never did anyone any harm. It is good for you. Some doctors order a morning in bed, once a week. Besides, will it be possible in the future to stay in bed at all? What with wireless and television one never knows what may happen . . . Dear me . . . I suppose I ought to get up . . . I must get up . . . I will get up . . . soon . . .

* * *

7.30 a.m.—Central chronometer hitches up with Long Acre, streams of electrons leave the ceiling and fall on bed clothes. Active influence comes into play in corners of room, and bed-clothes whisked off.

7.31 a.m.—Sleeping in dressing gown only.

7.35 a.m.—Loud speaker sings "Come into the Garden, Maud."

7.36 a.m.—Death of loud speaker.

7.40 a.m.—Six pips. Picture of bathing belles appears on wall-screen. I spring out of bed, and cut my foot on broken pieces of loud speaker.

7.50 a.m.—Construct long wire rod out of sponge rest while sitting in rapidly cooling water. Use same to switch off televisor, and then get out of bath.

8.2 a.m.—Spill coffee on news-screen. Wipe it up hurriedly, and upset synchronisation, hence top-half shows picture of Winston changing his coat as usual, and bottom half states the Derby was won by two lengths, and the loser was counted out on a foul in the rock garden.

8.5 a.m.—Realise what time it is, and feel *very* ill.

8.6 a.m.—Violent ringing from televisor in study. Find angry face on screen. Put my tongue out at it. Loud speaker splutters. "Why the . . . where the . . . when the . . .!" Still feeling ill, switch the whole lot off.

8.10 a.m.—Jones on the Visor-phone. Just going off to Walton for a round of golf. "Lordy man, you do look sick," he says. Tell Jones exactly what I think of men who a few minutes after 8 a.m. look like he does. Switch off the whole thing.

8.15 a.m.—Violent booming in basement. Fall down the cellar steps. Angry looking official on emergency-screen. Why have I switched off. Several visorgraphs waiting to be sent. Tell him the time, and switch him off too.

8.16 a.m.—Small girl from next door to say that I am wanted on their screen. Seize an egg and two pieces of buttered toast, and streak for garage. Make a dash for the open country.

8.20 a.m.—Portable set in back seat calls—"Swanne, Swanne . . ." I glance behind. Stern face appears on screen. "You are wanted immediately . . ."

8.21 a.m.—Commit suicide.

* * *

"Are you going to get up this morning at all?" said Marjorie.

"Yes! yes!" I shouted, "and I am never going to bed any more!"

Distortion—Some Causes and Cures

By WILLIAM J. RICHARDSON

The majority of wireless receivers in use to-day give unsatisfactory reproduction, due to faults of design, adjustment or operation, which give rise to distortion in a more or less acute form. It is not possible for the average broadcast listener to alter the design of his set, but he can do much to eliminate distortion by adjusting and operating his receiver intelligently. The hints given in the following article will materially assist the broadcast enthusiast to this end. The information given below applies equally to receivers intended to pick up television signals.

NO doubt all of you at some time or another have experienced the very doubtful pleasure of being invited to a friend's house to listen to the latest acquisition—a home-made wireless set—and been recompensed by hearing a painful travesty of that true quality music which is so often spoken about but found in a surprisingly small number of cases. If you are like me, your fingers must have itched to get at the set and its accessories to put matters right, but in order not to offend, diplomatic tactics have to be adopted so as to point out quietly but firmly where the enthusiast has erred. In the earlier days of wireless most of us were content to be in a position to receive *any* signals, no matter of what quality or type, even unintelligible morse dots and dashes were as a tasty meal to a hungry man, but times have changed.

The Perfection of Details.

From the point of view of the transmission and reception of speech and music, nothing of a revolutionary character has taken place of late. Wireless engineers and manufacturers have been devoting their time and attention to the perfection of details, and rightly so, with the result that there is no valid excuse for anyone possessing a wireless receiver and its attendant auxiliary apparatus which should not be able to delight the ear.

Yes, I know you will say that pure undistorted reception and reproduction is a pleasure denied to the average individual on account of cost, but I beg leave to differ. While granting that the man who is prepared to lay down, say, fifty pounds for his installation should reasonably expect to get the nearest approach

to perfection, *almost* the same result can be achieved by anyone who is prepared to give a little time and attention to his set. This costs nothing and will bring about a pleasing return for the time so spent.

To cover all the possible causes of distortion and propound cures for them is beyond the scope of one

errors that occurred with sound reception. Rather let us profit by previous mistakes, and not try to deceive the eye in the same way as we have been wont to deceive the ear.

Difficult to Dogmatise.

It is somewhat difficult to be at all dogmatic in diagnosing the greatest cause of distortion, but I am inclined to give shoddy components "pride of place." Penny wise and pound foolish is an old adage, but it strikes a very true note where wireless is concerned, so whether your set is used for receiving television or sound signals, do not on any account use parts of doubtful origin. It is better to economise on the total number of intervalve coupling stages, and expend the money saved on good quality components.

Cheap valves, for example, may appear to function all right at first, but they soon begin to lose their emission, while if placed in the detector position they invariably prove to be super microphonic. Nothing is worse than a microphonic howl, and great care should be paid to this point. Then, again, cheap loud speakers veritably "speak for themselves," and the best of efforts directed towards improving the set itself and overcoming distortion frequently are offset by coupling it up to a sound reproducing device to which it is painful to listen.

A Neglected Item.

Keeping for the moment to the question of false economy, there is one item amongst a wireless set's accessories which is so often neglected, and that is the high tension battery. Even in these enlightened

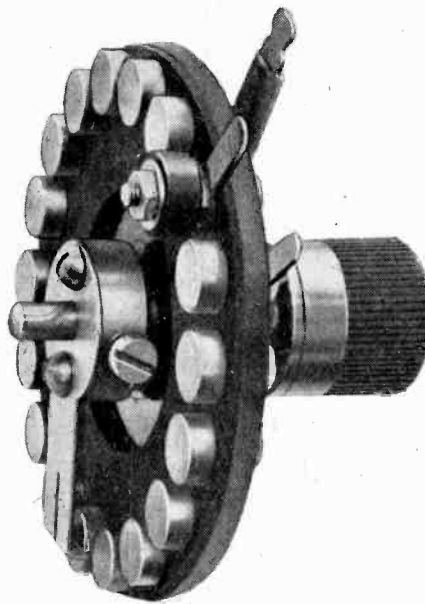

(Photo by courtesy of G.E.C.)

AN EFFICIENT VOLUME CONTROL.

Our illustration shows the new "Gecophone" potentiometer, which is designed to act as a volume control, a most useful adjunct to an L.F. amplifier. By means of 17 tapings a very fine variation of resistance is effected in a positive manner.

article, so rather let us focus our attention on the most important. We are on the threshold of a new phase of wireless, now that the broadcasting of television has been promised to us, so do not make the mistake of encountering all the past

days we come across people using flashlamp batteries in series because they say it is cheaper to replace one or two faulty ones when they are run down before the rest. It must not be forgotten that the small $4\frac{1}{2}$ volt battery units were never designed for standing up to steady current drains. They are essentially flashlamp cells, as their name implies, and will give good service if used for short periods at a time.

Large Batteries Best.

H.T. battery renewal is a problem which has got to be faced, and it is a step in the right direction towards the cure of distortion if batteries are chosen of high capacity and ample voltage. The initial expenditure is proportionately higher, but they stand up to heavy plate current demands and, of course, their life is much greater than those of their smaller brothers.

During the course of some experiments I have been conducting recently I have drawn anything from 50 to 80 milliamps from large capacity H.T. batteries of a well-known English make. At the end of six months' use the battery voltage had fallen from the original 108 volts to 80 volts, which speaks volumes for the robust construction of the cells. Can you picture what would have happened if small H.T. batteries had been in use? Undoubtedly they would have crumpled up after the first night.

The best solution to the high tension problem assuredly lies in the use of a mains eliminator, whereby the household electricity supply is pressed into service. Here, again, the initial installation may seem rather expensive, but running costs are negligible, and renewals in the form of rectifying valve replacements (where A.C. is in use) are quite infrequent.

Important Points.

Let us now focus our attention on the receiving set itself, for it will be appreciated that a large proportion of the distortion introduced is the direct outcome of our efforts to amplify the original impressed aerial signal. With high frequency circuits too sharply tuned, or a surplus of H.F. stages, we are likely to lose our sidebands and thus cut off frequencies which should be present if perfect reproduction is desired, or, alterna-

tively, if a really high-class television picture is aimed at.

Turning to the low frequency side, we take for our basis the fact that distortion is avoided if the increased signal from the output stage differs from the original only in being greater in magnitude. As was pointed out in an article appearing in last month's issue, as far as any low frequency amplifying valve is concerned, the output current in the plate circuit must be directly proportional to the input grid voltage. To ensure this important detail, the total input volts grid swing to each valve must operate well within that part of the straight characteristic situated on the negative side of the "curve." By following this principle it will also prevent the grid from assuming a positive charge. This factor must be rigidly guarded against and calls for a careful study of each valve's characteristics, so that adequate plate voltages are applied to the anode of the valve together with the appropriate grid bias, neither too much nor too little.

In Passing.

In passing, it is as well to note here that the H.T. voltages actually applied to the set itself do not represent the true plate voltages. There is always some form of impedance present in the plate circuit, and this will account for a certain voltage drop, small in the case of

inductive impedances but large when using resistance capacity coupling, and the actual anode voltages differ therefore from that applied to the set terminals.

In choosing the correct negative grid bias it is the *true* plate voltages which must be worked upon and not the battery voltage, and to ascertain what these anode voltages are it is a good proposition to purchase a reliable high resistance voltmeter. Do not employ a cheap low resistance instrument, otherwise you will get fallacious readings, and your money had better be kept in your pocket.

A Question of Design.

It is generally accepted that if an amplifier can be made which does not deviate more than 10 per cent. from the ideal (the ideal being one in which every frequency is amplified to the same extent, and hence gives a horizontal straight line if amplification is plotted against a frequency base), then the acutest ear or the sharpest eye would be unable to detect any difference. If an iron cored transformer is used in the plate circuit, then we are faced with the fact that theoretically the impedance changes with every change of frequency. Furthermore, the magnitude of the impedance is dependent upon the mean plate current flowing through the valve. Can we, therefore, expect to approach straight line amplification?

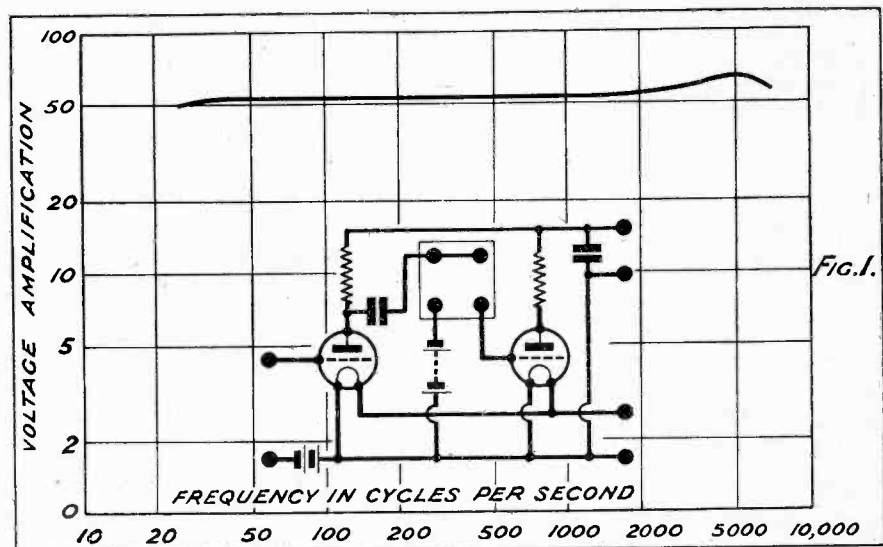

FIG. 1.
Voltage Amplification—Frequency curve of the R.I. "Hypermu" L.F. transformer. The first valve in the recommended circuit is a DEL 610; the second a Cossor Stentor Six. The first plate resistance is 30,000 ohms; the second 3000 ohms, non reactive. The coupling condenser between the plate of the first valve and the transformer has a value of 1 mfd. The condenser across the H.T. terminals is 5 mids.

Fortunately, the answer is in the affirmative, due to the fact that our low frequency transformer is not quite such a simple instrument as one at first imagines. One of the main features in the design of this transformer is to keep the impedance of the primary winding as high as possible at the low frequencies consistent with small self capacity at the high frequencies.

By careful design and bearing in mind that in addition to the inductance of the primary and secondary windings we have present a leakage inductance, primary and secondary resistance, and primary and secondary winding self capacities, it is possible to produce a component which gives a reasonably steady amplification value throughout the whole range of audible frequencies. Obviously, a cheap transformer cannot be designed to approach this degree of accuracy, and hence distortion takes place; so to avoid any trouble in this direction choose a reputable make. Actual bulk is not always a criterion, owing to the improvements which have been effected in the iron used for the core, and in this connection it is interesting to see the published N.P.L. curve of the latest R.I. transformer, the "Hypermu." The evenness of response at all frequencies is particularly good (see Fig. 1), and yet the transformer is relatively small in size.

R.C. Coupling Desiderata.

To achieve the best results in amplifiers for television work where the frequency range to be covered for amplification exceeds that of the audible frequency range, it is found that resistance capacity coupling meets the case in a really excellent manner. To avoid distortion here, it is necessary to note that the real secret of success lies primarily in the selection of suitable valves and component values. Empirical formula are available for those who wish to work out the values for themselves. If we consider the anode resistance alone, we have

$$\text{Amplification} = \mu \frac{R}{R + R_0}$$

where

- μ = Magnification factor of valve.
- R = Resistance in plate circuit.
- R_0 = Impedance of valve.

If a curve is plotted for this formula it will resemble that of Fig. 2,

and we can see that for most purposes the resistance in the plate circuit need not exceed about four or five times the valve impedance. While it is admitted that because grid bias is applied to a low frequency valve to accommodate the grid swing, and that this makes the A.C. working impedance of the valve much higher than those issued by the makers, since these are given for maximum anode volts and zero grid bias, the formula quoted will serve for most general purposes.

The Grid Leak and Coupling Condenser.

Coming now to the grid leak, we can consider this component as being

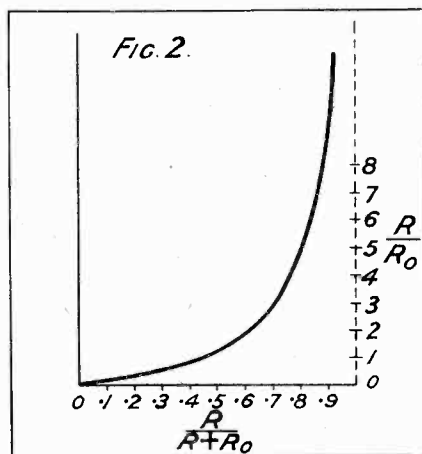

Curve plotted for the formula given at the foot of column 1 on this page.

virtually in parallel with the anode resistance, and in consequence it must be much higher in value. About four or five times the value of the anode resistance will suffice, and be sure and choose a grid leak of well known make, or trouble will occur. If the R.C. stage precedes a valve of the super power class, a wire wound resistance of from 100,000 to 250,000 ohms is advisable.

With reference to the coupling condenser, be sure that the insulation of the dielectric is above reproach, and to this end mica condensers are preferable. To calculate the coupling condenser value the following formula should prove useful:—

$$C = \frac{\mu_0}{6.28R_0 \times f \sqrt{1 - \mu_0^2}}$$

where

- R_0 = Grid leak value in ohms.
- f = Lowest frequency to be amplified.

C = Capacity in farads.

μ_0 = Fraction of maximum amplification desired at f .

Thus, if the grid leak is to be half a megohm with a plate resistance of 100,000 ohms, and μ_0 is .9, then, at a frequency of 50, C should be about .015 microfarad.

Note that when using more than one stage of R.C. coupling it is necessary to use somewhat larger coupling condensers if the same percentage of amplification of the lower frequencies is to be maintained. In the case quoted, μ_0 should be $\sqrt[3]{.9}$ for two stages, $\sqrt[4]{.9}$ for three stages, and so on. The condenser capacity values calculated are the minimums, and it is useful to use larger values if it is desired to be absolutely on the safe side.

Overloading.

Due attention to these details of R.C. coupling should remove any trouble likely to arise from distortion, and demands of space preclude further examination of other interesting points which arise in this connection. Before closing, however, there is one fruitful source of faulty wireless reception in both speech and television sets which must not be overlooked, and that is valve overload distortion due to the use of unsuitable valves. It is generally in the last stage that this occurs, although the possibility of similar defects in preceding stages must not be lost sight of.

One of the most reliable indicators of distortion is a milliammeter. If placed in the plate circuit of the last valve the needle will take up a certain steady position when no signals are being received. Any appreciable movement of the needle from this value, even when the strongest signals are being received, indicates overloading due to an unsuitable valve, insufficient high tension or incorrect grid bias. The capability or otherwise of a valve to deal with definite grid inputs was dealt with in this journal last month in an article concerning power valves, so the facts need not be reiterated, but remember that a good meter is indispensable in this connection.

At a later date the writer hopes to give actual practical results of some tests on distortion as applied to sets used for receiving television, as this is of particular importance to readers.

Light: The Essential of Television

Part X.

By CYRIL SYLVESTER, A.M.I.E.E., A.M.I.Mech. E.

The following is the concluding article of the series on light which our contributor has been writing month by month. In this article he deals with methods of artificially illuminating subjects or scenes to be televised.

IN this, the last of this series of articles on the importance of, and the effect of, light upon subjects which will come under the "eye" of the Televisor, there remains very little for me to do but to deal with a few essential points which may be said to be of a general character; which could not be discussed among the essentials of light and its effects alone.

A scene under normal daylight will be witnessed in clearness according to the quality of the light by means of which it is seen. With high intensities of light, the intensity for various subjects may be too high. This is not a serious fault since, through the medium of filters, the intensity may be decreased until it reaches the correct value for broadcasting. It will, however, be very difficult to "build up" the intensity of normal daylight. This is a question for those versed in optics to consider.

It should be remembered that the relation between the televisor and the camera ceases to exist at this point. That is, under low intensities of light the time of exposure for a camera can be varied so that the effect is a picture which, to all intents and purposes, may have been taken under much higher intensities. In Television, when an animated scene is being broadcast, all movements occur over a certain period of time. This instant of time cannot be varied.

Another important factor to be considered, and this applies equally to artificial light, is that the angle from which a scene is accepted must be correct from an illumination point of view. To describe this briefly it may be said that the light source must be behind or high above the television transmitter. The reason for this can best be explained by saying that "a bright light source in the line of vision reduces one's ability to see." It may,

therefore, be said that if the eye cannot clearly define a scene, the chance of successful transmission is very remote.

I will discuss this from various viewpoints.

In Fig. 1 is illustrated a white screen, A, upon which it is assumed some letters or figures are printed in black ink. In this illustration, L is a light source; it is to be assumed that the eye is looking at the screen. Brief consideration of this illustration will serve to show that the light rays from L are intercepted at two points; by the screen and by the eye. The letters on the screen are seen only by the light that is reflected from the screen, so that we have two

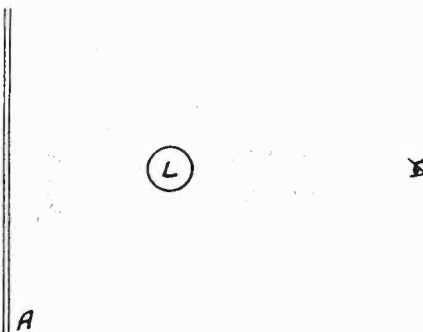

Fig. 1.

conditions of light entering the eye; direct light from L and reflected light from the screen.

Only a small pencil of light enters the eye from L, so that, from a vision point of view, the retina of the eye is blurred by a bright spot. The intensity of the reflected light is much lower than that of the direct light, so that the latter predominates and the portion of the retina occupied by the spot becomes blind. In this way a certain portion of the lettering upon the screen cannot be seen.

By raising the light source, as illustrated in Fig. 2, practically the whole of the light received on the

retina is reflected light of not too high intensity, so that the whole of the lettering will be seen.

In normal daylight the sun in a clear sky may, under certain conditions, be considered as a bright light source. From a Television point of view the best results will be obtained if a scene is accepted in such a manner that maximum advantage is taken of the light rays reflected from the various objects in the scene.

To illustrate this let us consider an important sporting event which would be broadcast under normal daylight—the English Cup final at the Wembley Stadium. This would be accepted by the Televisor from either ends or sides and, since the whole of the playing ground would be included, from the roof of the stands. The sun appearing over the top of the stands immediately opposite the point from which the scene was being accepted would considerably affect the reception; a portion of the transmitter would be, in effect, blind. The alternative is, of course, to accept the scene from the opposite side—with the sun behind the transmitter. In this way the whole of the light received from the various fixed objects, and the players moving about on the field, will be reflected light, and they will be clearly seen.

I have dealt to some extent with the design of lighting units which may be used to obtain certain effects under artificial light; directional effects which will enable objects to be seen in their three dimensions. I would now say a few words about the necessity for general illumination. A scene or setting must be illuminated in a general way before the directional effects are produced. That is, considering a drawing-room scene, a general system of illumination will enable the shape of tables, chairs, sideboards and lamp standards, etc.,

to be determined. Their decorative features, however, will not be revealed. The method of providing the general illumination will depend, of course, upon the size and character of the scene.

Ordinary lighting units are useless for this purpose. In the first place

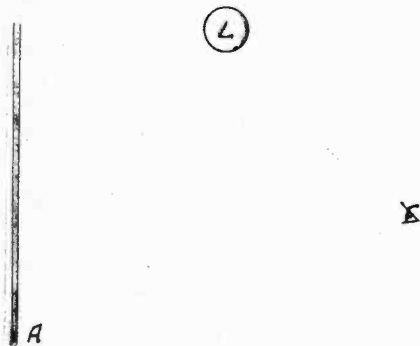

Fig. 2.

the intensity must be high; it must also be well diffused. It must not produce shadows which cannot be eliminated or reduced to correct value by means of directional lighting units.

In Fig. 3 is illustrated a lighting unit which will illuminate a large setting. It consists of a number of tungsten filament lamps accommodated in a square or rectangular type of reflector. The unit is made up of $\frac{1}{16}$ in. sheet iron lined with polished aluminium. This is much better than mirror glass, since the light will be more diffused. The lamps should have a 1000 watt rating, and should be fitted in appropriate Goliath holders of the porcelain backplate pattern. The distribution of light, or the area which can be illuminated with this unit, can be more or less controlled by raising or lowering it as the case may be. It may be said, in fact, that the quality of the illumination can be controlled by fixing the unit at a suitable height.

Let us assume, for instance, that with the directional lighting units in position the effect of light and shade is not quite what it should be. It should be remembered that the directional light must pierce (or neutralise) the downward directional light. This can be done in two ways. By increasing the intensity of the directional lighting units, or by decreasing the intensity of the general lighting unit. The intensity of the directional lighting units can be

increased by using more concentrating type reflectors, but the area illuminated is diminished.

If, therefore, a section of a setting is just covered by illumination from a directional lighting unit, using a more concentrating type unit will not assist matters at all. It will, in fact, cause distortion so that the true shape of the setting cannot be identified. By raising the general lighting unit the intensity is decreased; this in proportion to the square of the distance of the unit from the objects illuminated. The decreased intensity permits the effect of the directional lighting units to be emphasised so that the general effect is, relative to the general lighting, an increase in the intensity of the directional lighting units without any alteration to the area illuminated.

I would say a few words with regard to the illumination of countryside settings under artificial light. I have pointed out that the spectrum of normal type gasfilled lamps is very much different to that of normal daylight. If the illusion of a scene is

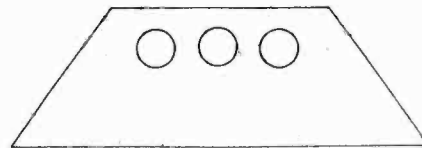

Fig. 3.

to be complete the spectrum must be rectified. Artificial sunlight, for instance, can be obtained by using colour filters of amber glass. The green on trees can be emphasised by projecting green light upon the branches through the artificial sunlight rays. In the same way the red bricks of the front of a house can be made more prominent by projecting red light upon it. This light filtering and projection must be carefully carried out or the general effect will be bad; that is, the light must be perfectly controlled. There must be no overlapping of colour. If the front of a house, for instance, is to be illuminated with red light, a green door, if receiving some of the light, would appear reddish-black. This can be controlled by the use of several small units with red colour filters with the angles of cut-off between lamp and reflector edges adjusted to obtain the correct beam spread. There is no reason why red light

should fall upon the door. A square type of unit fitted with a green colour filter will effectively illuminate the door.

In the same way artificial moonlight can be obtained by using a colour filter of the correct quality; not by decreasing the voltage applied the lamps terminals. The construction of a unit suitable for producing either artificial sunlight or moonlight is illustrated in Fig 4; for artificial sunlight the reflector is gilded and the face covered with amber coloured frosted glass. For artificial moonlight the reflector is of mirror glass and the filter is of deep blue frosted glass.

In conclusion I would say that all gasfilled lamps should be run at their rated voltage; this not from an economic point of view but from considerations of colour quality. It is, indeed, better to over-run the lamps; that is, from a colour quality point of view a 200 volt lamp will give better results if used on 220 volts. The light will be much more white and the spectrum will be nearer to that of normal daylight. The lamps' lives will be decreased, but the expense of colour rectification will also be decreased.

I would advise readers of this series of articles who are experimenting in the broadcasting of Television under artificial light to make several reflectors, and to obtain suitable lamps and colour filters. The filters are ordinary gelatine sheets which may be obtained from any firm who market stage-lighting equipment. Light control, and the effect of coloured light upon coloured material, is an interesting

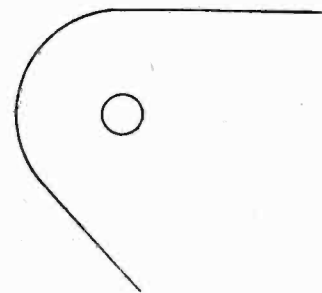

Fig. 4.

science, a science which must be understood by all Televisionists.

If any reader experiences any difficulty in his experiments I will be pleased to help him.

THE CONSTRUCTION OF EXPERIMENTAL TELEVISION APPARATUS

Part II

By A. A. WATERS

Mr. Waters, in collaboration with Captain F. Wilson, recently demonstrated before the Television Society a Shadowgraph Transmitter and Receiver which they had designed and constructed.

The following is the second of a series of articles which Mr. Waters will write for "Television," giving constructional details and information of value to amateurs.

IN the preceding article of this series we dealt with the tools required to make a simple piece of apparatus for use in television research work.

of a little paraffin oil on the cutter as a lubricant.

Next, lay the material on a flat surface and hold the point of the

trammels firmly in the centre, and, with the right hand, proceed to cut by applying light pressure. This operation should be repeated on both

Construction of Scanning Discs.

We will now consider the construction of scanning discs, such as were used by Captain Wilson and myself in our experiments with shadowgraph transmission and reception. The first disc tried was one with a double spiral of 24 holes, as shown in Fig. 1. Improved designs of disc were devised later, but I suggest that the beginner should start with this one, as it does not offer any serious constructional problems.

The material required for making it can be obtained from a sheet metal stockist, and care should be taken to see that the piece selected is flat. The particular metal used in our experiments was aluminium and was purchased from Messrs. Braby & Sons, Ltd., of Euston Road, the size being 24 in. square and the thickness 20 SWG (standard wire gauge).

Cutting the Disc.

We must now consider the method adopted to cut and mark off the disc. One requires, of course, a suitable tool for this job; the tool we use is a pair of trammels with one end ground to a small cutting edge, as illustrated in Fig. 2.

First, find the centre of the material and drill a hole $\frac{1}{16}$ in. dia. This is done to prevent the point of the trammels from slipping out of the centre when cutting. The actual cutting should be done with the aid

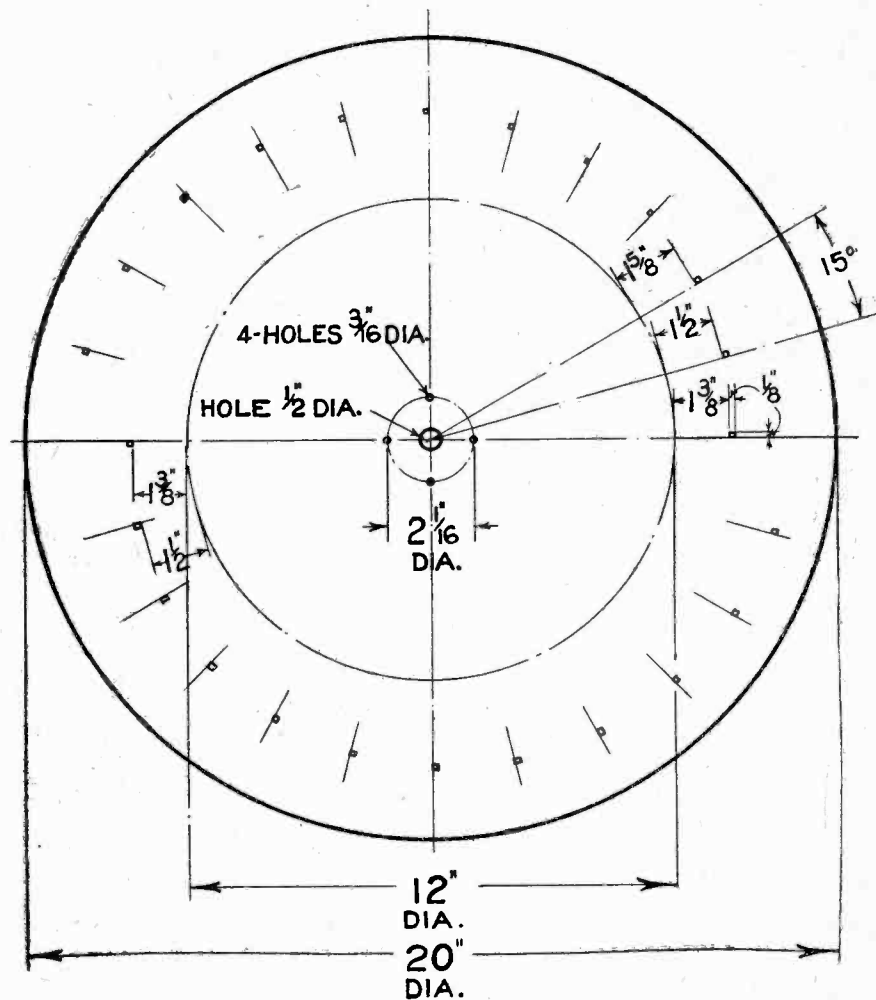

Fig. 1. Layout of a double spiral 24-hole disc.

sides of the material alternately until the cutter begins to break through, the time necessary to complete the job being usually not more than ten to fifteen minutes. Care should be

until the corresponding holes on both spirals have been marked off. After drilling these holes with an $\frac{1}{8}$ in. drill, the next step is to square them with the aid of an $\frac{1}{8}$ in. square file,

This arrangement proved of great value in our experiments with various sizes of apertures and spirals.

A 30-aperture single spiral disc with $\frac{1}{10}$ in. square holes is shown in Fig. 5. You will notice that the marking off is accomplished in a similar way to that described for the previous disc, except that the number and size of apertures are different.

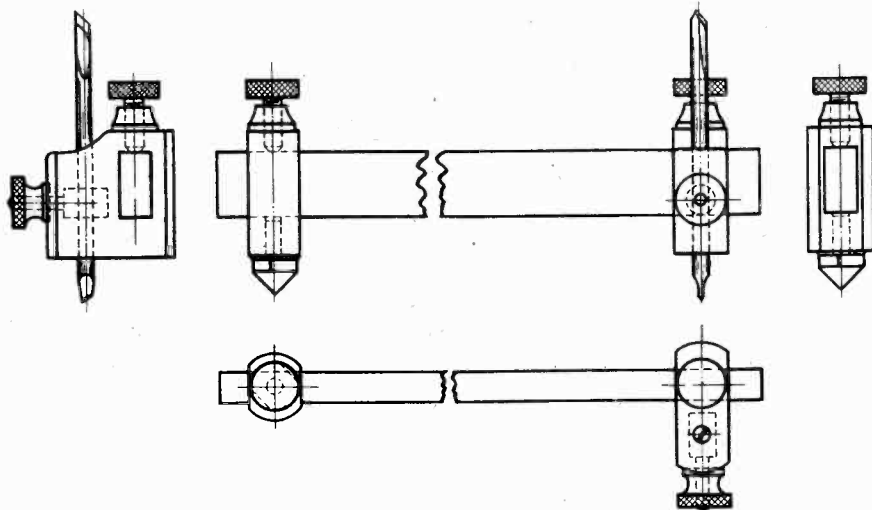

Fig. 2.

A pair of trammels, with one end ground to a small cutting edge, for cutting out discs.

taken when breaking the outer metal away from the disc, otherwise distortion of the material will result and the disc will not run true when mounted for use.

The Marking Process.

We will now consider the "marking off" process, and as there are several ways of doing this, I will describe the method which I consider the most simple. A pair of dividers is necessary for this operation, and I would advise the experimenter to make sure that the points are quite sharp.

You will notice that there are three circles in the diagram (Fig. 1); the object of the 12 in. dia. circle is to simplify the process of marking out the positions of the spirally arranged square holes. We measure radially from the circumference of this circle, and not from the centre of the disc, thus avoiding the necessity of using dividers of exceptionally wide span.

Set the trammels to scribe a 12 in. dia. circle, and divide it into 24 equal parts by scribing a series of equally spaced radial lines on the disc. From the points where these radii cut the circumference of the 12 in. circle set the dividers and mark as shown in the diagram.

Drilling the Holes.

The disc being of the double spiral type the dividers should not be moved

and finally with a drift, details being given in Fig. 3.

The drift should not be used until the apertures have been squared with the file, thus leaving very little metal for the drift to remove.

The results obtained from this disc were remarkably good, as, when it was running at a slow speed, one could actually see how the shadow-graph built up into small squares. When trying for improved results a double spiral disc having 30 apertures was used. This is described later.

Mounting the Discs.

We have next to consider the mounting of the disc on the motor

Testing for Accuracy.

After a disc is constructed, it is advisable to test the spiral for accuracy. This is best done by securing a piece of white paper to a flat surface, drawing a line across the paper, and laying the disc upon it so that it can be rotated about a fixed point. Turn the disc until the line appears in the centre of the first aperture and then mark the shape of the square on the paper. Repeat this until all twelve squares are marked: you will then have a row of squares the position of which will show the accuracy of the marking out.

To obtain the best results both spirals, of course, should be identical.

Separate Transmitter and Receiver Discs.

Having gained experience with the single-disc transmitter and receiver we can now turn our attention to the construction of pairs of discs, for use where separate discs are employed for the transmitter and the receiver respectively. It is immaterial what spiral one uses, provided that both discs are identical. When making the apertures, therefore, the discs should be clamped together.

When carrying out our first ex-

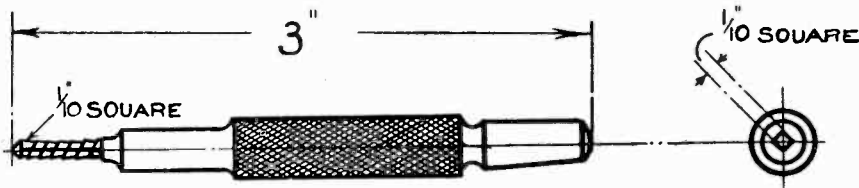

Fig. 3.

Details of the drift used for making square holes.

periments with a separate transmitter and receiver the question of synchronisation naturally engaged our foremost attention. If the experimenter has an A.C. mains supply the problem is fairly simply solved by the use of two synchronous motors. In our case, 200-volt D.C. was the only supply available, and

performs the function of a spindle. The mounting itself is turned from brass or steel and details are given in Fig. 4. The principal object of this mounting is to permit of discs being interchanged, and this is effected by taking off the four securing screws, the $\frac{1}{2}$ in. dia. hole in the disc registering with the mounting.

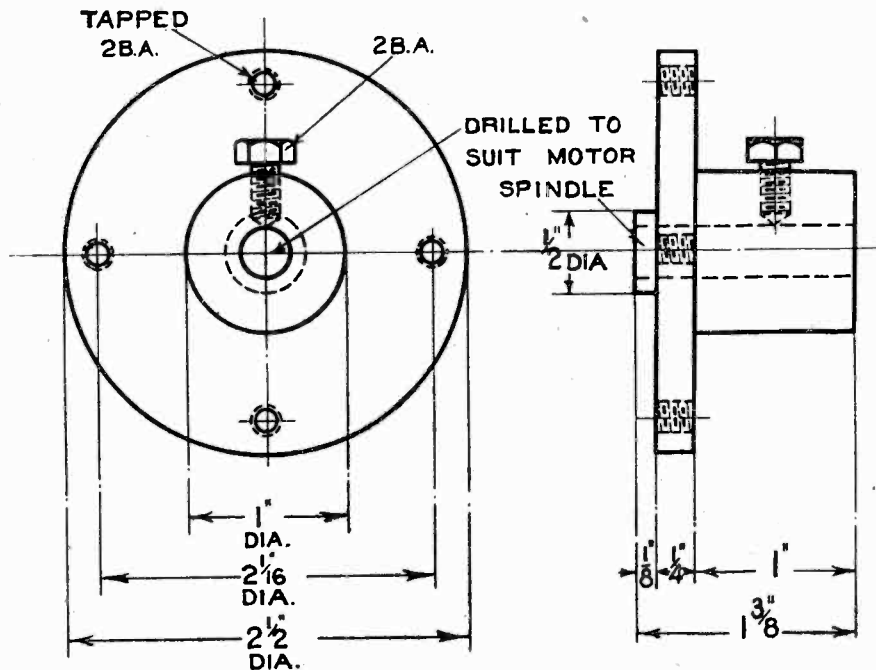

Fig. 4.
Details of the disc mounting.

to convert this to A.C. would have meant considerable expense. After carefully studying the matter we decided to experiment with the D.C., and find out if it was possible to keep two D.C. motors in synchronism with the aid of resistance control.

Synchronisation.

The first experiments were tried with two cheap motors, the current being supplied from a 12-volt accumulator. Failure, however, resulted, owing to bad brushes and to the bearings becoming warm.

Two better motors had, therefore, to be obtained to complete our experiments, and these unfortunately proved rather expensive. We had, however, the satisfaction of achieving what we set out to accomplish. The motors were of the Universal type made by the G.E.C., and are rated at 200-220 volts, 1/40th H.P. They can be used with A.C. as well as D.C.

To control the speed of these motors it was found that the resistances should be very smooth in action, so it was decided not to attempt to make them ourselves. Very good ones, however, are obtainable from Isenthal & Co., Ltd., of North Acton, London, W.3, the Type No. being J.C. 0.3 amp., 1100 ohms.

Magnetic Control.

The results obtained from the "separate" receiver and transmitter will undoubtedly open up further

lines of research to the experimenter. In the receiver used by Captain Wilson and myself we found it desirable to add a magnetic control. This consisted of a horseshoe magnet placed so that the disc ran between its poles. On the outer periphery of the disc were four steel rivets, evenly spaced. When the magnet is energised with current controlled by a small resistance it reduces the speed at which the disc is rotating. Therefore, if the speed of the receiver disc should happen to be slightly greater than that of the transmitter disc the magnetic brake can be brought into action, very smooth control resulting.

Supply Voltage.

This method is, of course, experimental only: much, too, depends upon the steadiness or otherwise of the mains supply voltage. I will, however, leave the constructor to judge of its merits for himself. I do not think he will be disappointed.

In my next article I will give details of the various light sources that were used in our experiments, with information as to how to construct the apparatus employed.

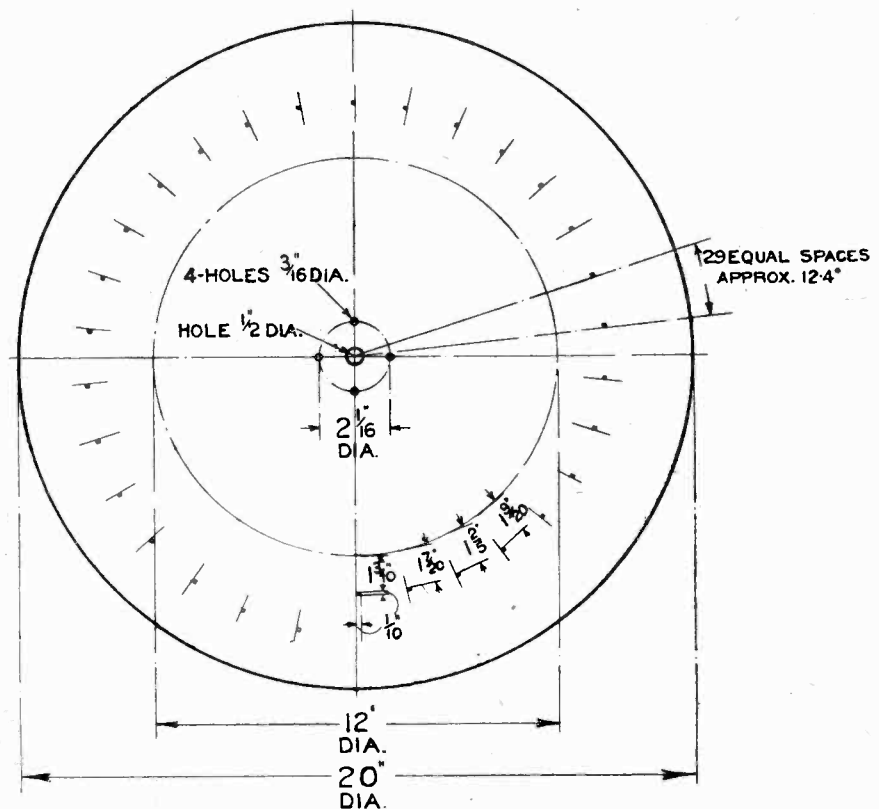

Fig. 5.
Layout of a single spiral 30-hole disc.



Sydney A. Moseley

Writes from Berlin

MY DEAR EDITOR,—So you are athirst for more news from this interesting centre. I imagined somehow that on receipt of my first letter your appetite would have been sharpened.

*The fact is that, since I wrote to you last, considerable developments have occurred which should please every reader who has followed the fight for the recognition of the Baird system of television in England and abroad.

In my last letter to you I referred to the officials of Germany as being enterprising.

They have been exceedingly charming as well.

Both State-Secretary Dr. Bredow (see cover illustration) and President Kruckow have feted us and given us every possible help. Dr. Bredow is the ruling spirit of the Rundfunk, while President Kruckow is in charge of the Reichspostzentramt—a huge organisation housed in one of the most wonderful buildings I have ever seen.

I enclose a photograph of it, the first ever published, which the President was good enough to give me; but this gives no conception of the originality and beauty to be found in the interior.

While being futuristic, it is eminently practical, and one is gaping at its outlines even though one has an urgent errand with the President!

From another photograph I enclose one gets some idea of the personality of the man who rules over this huge establishment. The president is chief in fact as well as in name.

In company with Mr. Hutchinson, Managing Director of the Baird Television Company, we were shown the up-to-date methods which characterise the working of this government department, and when (later) John Baird himself came over he was enthralled with the excellent workmanship of the radio and television apparatus in the Post Office. To be perfectly truthful, there was nothing of a revolutionary character, but the great pains exercised in the making of even the smallest gadget and the thorough organisation, typical of all German undertakings, won our unanimous approbation.

Baird Apparatus in German G.P.O.

All the more pleasing is it, therefore, that for the first time in history *the Baird apparatus has been installed in this building* so that the Baird engineers and our German friends will co-operate in further developments. The German authorities openly expressed wonderment at Mr. Baird's latest achievements. They had never seen anything like the extended view scenes and were so amazed at what they had seen that one of my best friends in Germany suggested, rather shamefacedly, afterwards, that perhaps what he had seen was not direct television but a film! He was very much relieved when I was able to assure him that what he had seen was really television.

The lunch that State-Secretary Dr. Bredow gave to Mr. Baird, Mr. Hutchinson and myself was some-

what historic, and I make no apologies for referring to it. Besides Dr. Bredow, Mr. Hutchinson, Mr. Baird and myself there was President Kruckow, Dr. Magnus, managing director of the Rundfunk, Dr. Reisser, chief engineer of the German B.B.C., and Dr. Bannietz of the G.P.O.

The result of all these interesting conferences has been the formation of a company in Germany whose main object will be the development and broadcasting of television with governmental blessing. The underlying purpose is purely scientific, although, of course, in order to further science it must have some commercial basis. This important Company is made up of the Baird Television Company, the



President Kruckow, of the German Central Post Office.



An aerial view of the vast building which houses Germany's Central Post Office in Berlin. In this building the Baird apparatus has been installed.

Bosch Magneto, the Zeiss Co., and Loewe Radio Co.—all names of eminence not only in Germany but the world over. It is satisfactory to know that these epoch-making arrangements were put into effect with every dispatch and with every desire to forward the main aim, which is to give Germany the best television system in the world.

Germany made further history in television by giving the Baird Company *permission to transmit for the first time in history a daily broadcast from 9-10 a.m., sometimes between 1 and 2 p.m., and after midnight.*

Televising to London.

Attempts have been made to pick up these pictures in London. At the time of writing, however, I do not know how successful this has been. (Probably it may be dealt with elsewhere in this magazine.) Strangely enough, the young Hungarian inventor Mihaly told me he had picked up the Baird transmissions on several occasions.

In view of my activity in Germany I have been somewhat out of touch with what has been happening in London. I had the opportunity, however, of flying over for a few days and although I find that the position is progressing normally so far as transmission in England is concerned, I must confess that it is impossible to refrain from comparing the wholeheartedness with which the German authorities have co-operated with us with the niggardly manner in which

the British inventor has been treated in his own country. There is a good deal I could write on this matter even though "Peace has been declared" and "flags are unfurled" and "everything in the garden is rosy."

Writing from Berlin in a totally different atmosphere I cannot refrain from an expression of impatience with what has been happening in London. I should really like to tell the whole history; may be I shall one day.

Before this reaches print, however, I may be back in your midst—particularly if there is to be any further fighting!

Congratulations.

I cannot help congratulating the pioneers of television on the remarkable progress made, not only here in Germany, but in different parts of the world. I read with great interest in the last issue of TELEVISION of the happenings in other parts of the world. Surely it is the first time in history that such enterprise has been exercised on behalf of a big British undertaking.

In Germany they would be the first to encourage such endeavours, but old England is known everywhere as conservative and rather stick-in-the-muddish. Despite this incredible aloofness, television has come into its own! What remarkable endurance, what a miracle, what a chance for the historian to tell of this up-hill fight in



TELEVISION IN BERLIN.

This photograph was taken on the occasion of the Baird Company's first demonstrations of television transmission and reception in Berlin. Bottom row (left to right)—State Secretary, Dr. Bredow; Under-Secretary of State, Dr. Feyerabendt; Herr President Kruckow of the Post Office research department. Top row (left to right)—Mr. Sydney A. Moseley; Dr. Banneitz of the German Post Office; Managing Director of the Rundfunk Gesellschaft, Herr Giesecke; co-Chief Engineer Schäffer of the Rundfunk Gesellschaft; Commander Jacomb, Chief Engineer of the Baird Company; Capt. O. G. Hutchinson, Managing Director of the Baird Company; Dr. Reisser, co-Chief Engineer of the Rundfunk Gesellschaft.

a country that is always calling out for efforts on behalf of its men and refuses to accept such service when it is offered. I frankly admit a sort of satisfaction that Germany should have been the first to broadcast television daily.

From the beginning, when Dr. Bredow, accompanied by his chief engineer, Dr. Reisser, came to London, one saw that here was a country that was go-ahead and was not going to permit personal jealousies, intrigues or red tape to interfere with progress. Since my stay in Germany I have come to understand the German people very well, and since science has no boundaries, I am well content. It is up to those readers who are disappointed that England has not been so enterprising to write to the new Postmaster-General and ask him what about it.

Auf Wiedersehen,

SYDNEY A. MOSELEY.

Phonovision Foretold.

PHONOVISION, the storing of televised scenes in records such as are used for the gramophone, was visualised by Mr. H. G. Wells in 1899. In his book, "The Sleeper Awakes," Mr. Wells pictures London in 2099. Books, as we know them, have disappeared, and instead there are pieces of apparatus which picture the story, and speak it at the same time.

Here is the description :

"The hero observed one entire side of the outer room was set with rows of peculiar double cylinders inscribed with green lettering on white that harmonised with the decorative scheme of the room, and in the centre of this side projected a little apparatus about a yard square and having a smooth white face to the room. A chair faced this. He had a transitory idea that these cylinders might be books, or a modern substitute for books, but at first it did not seem so.

* * *

"He puzzled over a peculiar cylinder for some time and replaced it. Then he turned to the square apparatus and examined that. He opened a sort of lid and found one of the double cylinders within, and on the upper edge a little stud like the stud of an electric bell. He pressed this and a rapid clicking

THERE MUST BE A REASON

Why the vast majority of the thousands who listen-in prefer Celestion.

DESIGNED WITH MARKED DISTINCTION CELESTION

LOUD SPEAKERS

The Very Soul of Music

The only sure proof of our Statement is to hear Celestion yourself. You can do so without obligation at any good Wireless Dealers, or at our Showrooms. Models range from £5.10.0 in oak or mahogany. British throughout. Made under Licence.

The new Celestion Booklet is free and gives you briefly and interestingly all particulars. Mail the coupon below for your copy now!

CELESTION LTD. (DEPT. T.V.), KINGSTON - ON - THAMES.

Visit our Showrooms :

106, VICTORIA STREET, LONDON, S.W. 1.

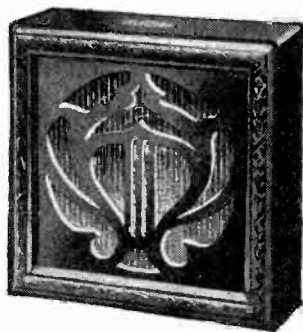

Model C10 £5 10 0

WHEN A BETTER LOUD SPEAKER IS MADE—CELESTION WILL MAKE IT.

Please send me a copy of the New Celestion Booklet. Post to Celestion, Ltd. (Dept. T.V.), Kingston-on-Thames.

NAME

ADDRESS

began and ceased. He became aware of voices and music, and noticed a play of colour on the smooth front face. He suddenly realised what this might be and stepped back to regard it.

"On the flat surface was now a little picture very vividly coloured, and in this picture were figures that moved. Not only did they move, but they were conversing in clear small voices. It was exactly like reality viewed through an opera-glass and heard through a long tube. His interest was seized at once by the situation, which presented a man pacing up and down and vociferating angry things to a pretty but petulant woman. Both were in the picturesque costume that seemed so strange to Graham. 'I have worked,' said the man, 'but what have you been doing?'

"Ah,' said Graham. He forgot everything else and sat down in the chair. Within five minutes he heard himself named, heard 'when the Sleeper awakes' used jestingly as a proverb for remote postponement, and passed himself by, a thing remote and incredible. But in a little while he knew those two people like intimate friends.

"At last the miniature drama came to an end and the square face of the apparatus was blank again."

* * *

Here, except that the gramophone disc has taken the place of the phonograph cylinder, is a description of what may well be looked for in the near future, thanks to the genius of Mr. J. L. Baird. The printed word will still be necessary for many things, but thrillers, shockers, and other inhabitants of the libraries will be scenarioed by the author and phonovised by the publisher.

So every house may be the home of a theatre.

E. P.

Gecophone Adjustable Reed Cone Movement.

The new Gecophone adjustable reed-cone movement, made by the General Electric Company, Ltd., and retailing at the popular price of 15s., is now fitted with a cone anchoring attachment at no extra cost. This small addition simplifies the attachment of the cone diaphragm to the armature reed and will thus be greatly appreciated by constructors.

Some Notes on Exploring Discs— and their Construction

By W. C. FOX

In the following article our contributor gives a few hints on the construction of scanning discs, and how to balance them when made. He also has some interesting suggestions to make concerning the thickness and weight of the sheet metal employed.

TELEVISION, probably more than any other invention of recent years, calls for a very wide knowledge of science and its application, for it is primarily a combination of several branches.

Not only does it demand an advanced knowledge of wireless, but optics, electrical engineering and mechanics all have their part to play. For this reason the "experts" who have condemned it have nearly always been wrong. Expert perhaps in their own particular line, they were quite at sea when going outside it.

In no particular has this been more patent than in the case of the exploring disc.

Despite the allurements of the inertia-less cathode ray and the work put in on it, the rotating disc does its job and has not burst as one expert predicted, or failed to go fast enough, as others declared.

Simplicity of the Disc.

By reason of its very simplicity the disc succeeded where oscillating mirrors and other complicated devices failed. However, a good exploring disc is a very nice piece of workmanship and calls for some skill in its making.

For these reasons, these brief notes on making them are offered. As everyone knows, to move any object any distance requires force, even though the movement may be merely round and round a given point. The amount of force required, too, depends on the weight, or mass—whichever term is preferred—of the object moved. Similarly, as the speed of movement is increased more and more power is required, not in direct ratio, but of the order of four times the power for double the speed.

These considerations applied to the disc indicate that, unless finance is

not a consideration (and finance in this case means ability to use as much power as is necessary), it is advisable to make it of as light a material as possible. Every increase in weight means a more powerful motor and greater current consumption.

In this connection it is surprising how little power an $\frac{1}{8}$ h.p. motor

takes more pulling up or accelerating than a lighter one. With a heavy disc the synchronising device, whether controlled by hand or by some other means, will have to "hunt" for a much longer period, and there will be more difficulty in finding the exact speed, than with a light disc, which will enable the motor to give very prompt response to any speed control.

Aluminium Best.

With regard to a suitable material, very thin aluminium sheet or untinned thin steel sheet known as "taggart" are suitable. They are easily cut, and have sufficient strength to stay flat when at rest. For discs up to about 18 inches in diameter black paper or thin celluloid can be used. When running centrifugal force will make them lay out quite flat. If nothing else is available, ordinary stout brown paper or drawing paper blacked with Indian ink where the holes come can be used.

Making one's disc of the lightest possible material is only half the battle. There is next the very important question of balance to be considered, i.e., the equal distribution of the weight of the disc, armature and commutator of the motor, etc., about the centre of rotation. This may seem a trifling point, but those who have followed racing motoring will know how very careful all successful motorists are to balance everything that rotates on a racing car. Even the tyre valves and the joint in the inner tubes on the road wheels are balanced. Or again, in aeroplane practice rotary engines are most carefully balanced, and an engine that shows even $\frac{1}{64}$ inch wobble about its centre when running is returned to the shops to be re-balanced.

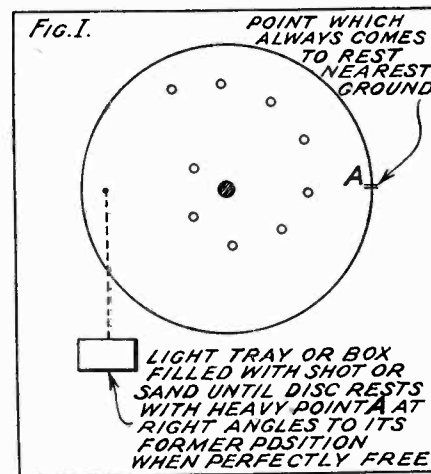

gives. It will barely turn a cardboard disc three feet in diameter with twenty, two-inch, lenses, mounted on its periphery, the whole running on a three-foot length of $\frac{7}{8}$ in. shafting directly coupled to the motor shaft.

Therefore, when planning a disc, particularly if it is desired to run it up to speeds of 2,000 or so revolutions a minute, it should be made as light as possible, for at such a speed with a 2-ft. to 3-ft. disc about $\frac{1}{8}$ h.p. or more will be necessary.

Even with discs of smaller diameter there is nothing lost by making them of the lightest possible material, particularly where they are to be used in a receiver. On this service it is necessary for some form of synchronising device to control the disc speed, and a heavy rotating wheel

While such a high degree of balance in an exploring disc may not be essential, the nearer one can get it to perfection the better, for at speed it plays an important part in the results secured. A disc much out of balance will not run at a steady speed or respond evenly and regularly

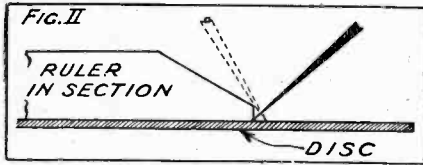

Fig. 2.

The solid and dotted outlines show two extreme positions of the scribe which are possible when marking out.

to any desired increase or slowing up that may be asked for.

Testing for Balance.

Having made the disc and mounted it on the motor shaft, it can be tested for balance by removing the brushes from the motor to get rid of their friction, and spinning the whole assembly. It will come to rest with some point on the edge of the disc nearest the ground. If during a succession of spinings the same point on the disc always stops when nearest the ground, that part of the disc is heaviest, and therefore out of balance. If the disc is pronouncedly heavy at that point, it will be quickest to weigh it and remove or add metal accordingly

The weighing process is done as follows, and is illustrated in Fig. 1.

Opposite the point which always comes to rest nearest the ground (marked A in the diagram) and about half way between the centre of the disc and its edge is drilled a small hole.

Through this a piece of string or thread carrying a small pan or box is fixed, either with a knot or by tying a nail or piece of wire in it.

Then sand, shot, or even tinctacks are dropped into the pan until it just, and *only* just, pulls the disc up to the position indicated in Fig. 1.

The quantity of material that has been put into the pan, not forgetting the weight of the pan and string, will give one a guide as to whether it is best to drill holes in the heavy portion of the disc wherever convenient near point A, or add weight on the opposite side of the disc in the region of the small hole drilled.

Correcting Lack of Balance.

When this initial correction has been carried out, the disc is spun

again, and if it is still found to be heavy at one point further correcting is done by removing or adding weight until when spun by hand the disc never comes to rest over a series of times with the same point nearest the ground.

If a disc is but slightly heavy it is best to correct it by filing a trifle off its edge on the heavy side, or if this is not practicable, add weight by putting small blobs of sealing wax or a small nut and bolt on the light side. In any case, go carefully and a little at a time. Furthermore, having balanced a disc on a motor shaft *don't* remove it unless you can replace it *absolutely* in the same position, because in all probability you have balanced inequalities in the armature of the motor and its commutator assembly, and to replace the disc in a position different to its original one will accentuate these.

The success of any disc, however well balanced and synchronised, depends entirely on the way it has been marked out and made. Carelessness in this operation will turn a good television transmission into a featureless blob.

Marking Out.

Marking out is a tedious job calling for care and the observation of one or two precautions, but it is not beyond the skill of any careful amateur.

Having selected the material and marked the centre of the disc, the next point, if metal is being used, is to mark out the circle of its full diameter. This will be scratched on the surface of the metal. Inside it will come the circles locating the radial position of the holes. These should be marked out with the utmost care as any irregularities in their position will cause white lines or black bands in the received image.

This part of the work is best done with a large firm pair of dividers. It is a decided advantage to have them with hinged legs, which can be bent to stand at right angles to the surface of the work, even when marking out the largest circles. Better than a large pair of dividers is a pair of trammels of heavy construction, with a metal beam.

Having marked out the circles fixing the radial position of the holes the next point is to draw the radial lines which locate their circumferential position.

It is here that the greatest inaccuracies are likely to occur. For dividing the circle, the largest protractor that one can secure is the best, and it can be taken as a maxim that the larger the protractor the smaller will be the error. The next point to watch is in ruling the lines. However good the ruler and scribe it is possible to rule parallel lines without moving the ruler, simply by reason of the thickness of the edge of the ruler.

Parallax Error.

Figure 2 shows a section, enlarged, of a ruler and scribe illustrative of this point. If you doubt your ability to hold the scribe invariably in the same position when marking a line, it is best to make a simple bridge form of carrier that will hold it in one plane at right angles to the surface of the metal. Figure 3 shows such a bridge made out of any suitable piece of metal bar that may be handy. Approximate dimensions are given. In use, the bar is kept as nearly as possible at right angles to the edge of the rule with the scribe up against the edge. Although one can tilt the scribe backwards and forwards *parallel* with the edge of the rule, it cannot be inclined to or from it (see Fig. 2), which causes the inaccuracies in marking out.

On cutting out a disc, particularly if it is a large one, *don't* try to follow the circle all round with one continuous cut. You will, even in the

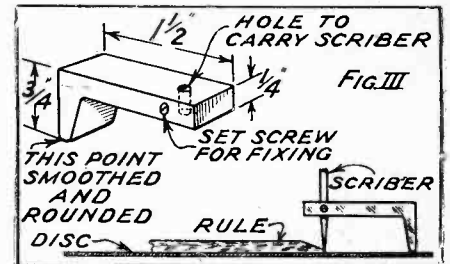

thinnest metal, get tied up and probably distort the disc, not to mention the chance of cutting your fingers.

Up to this point it has been assumed that it is known how to mark out a disc for any particular given ratio and number of scanning holes.

For the benefit of those who are just starting to explore the fascinating field of television, the following brief details are given of how to arrive at marking out measurements of a disc from supplied data.

The diameter of a disc controls the size of the picture, irrespective of all other considerations, and the disc need not necessarily be of the same diameter as that in use at the transmitting station. On the other hand the size of hole used for scanning determines the diameter of the disc for any given set of details.

A Hypothetical Specification.

In all probability, some such statement as the following will be given to describe a disc: "It is 60 scanning lines wide and 70 units high."

Such a statement means, first, that a disc of 60 holes is used and that the picture is $1\frac{1}{6}$ times as high as it is wide.

To mark out a disc from such information, one considers first the number of scanning lines wide and the smallest hole, square preferably, one can cut in the material decided on for the disc.

Suppose $\frac{1}{10}$ of an inch is decided on as the size of the hole, then, as every one of the scanning lines has to just touch its neighbour, sixty $\frac{1}{10}$ ths of an inch placed side by side make a line 6 in. in length, which will be the width of the picture. As it is 70 units high, it will be 7 in. high.

The next point is to arrive at the diameter of disc which will give a picture 7 in. high by 6 in. wide.

As there are 60 scanning holes they will have to be placed on 60 equally spaced radii of some circle.

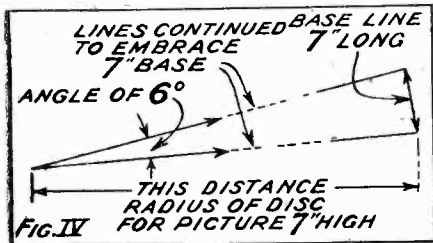

On a large sheet of paper, towards one side, draw a straight line, and with this as base, draw another line at an angle of 6 degrees to it. Six degrees is $\frac{1}{60}$ of 360 degrees, making the complete circle. These two lines will have to be continued to such a distance that an isosceles triangle of 7 in. base can be made, the angle at the apex being 6 degrees. The length of either of the long sides then gives the radius of a disc which will give a picture of the ratio being considered. For constructional purposes the radius would have to be a little greater, because it is not desirable for a hole to be on the extreme

edge of a disc. This is shown diagrammatically in Fig. 4.

Determining Disc Dimensions.

For an angle of 6 degrees a very large disc would be required to give a picture 7 in. high.

Alternatively, if the diameter of disc that can be used is fixed, one can determine the other details to conform to the 60 scanning lines wide by 70 units high as follows:

Assuming the disc is $24\frac{1}{2}$ inches in diameter, the angle of 6 degrees is drawn on a sheet of paper, each line this time being made 12 inches in length, $\frac{1}{4}$ in. less than the radius, for the reason already given above. Two such lines forming an isosceles triangle with an apex angle of 6 degrees require a base of $1\frac{1}{3}$ in.

This distance of $1\frac{1}{3}$ is therefore the height of the picture 70 units high, and has to be divided into 70 equal parts, which works out to .02 in. approximately as the diameter of the holes.

Drilling Small Holes.

Such a sized hole, although small, is quite easily drilled. Morse twist drills are best for such a job, and can be purchased as small as $\frac{1}{64}$ in. in diameter. Use the smallest and lightest brace obtainable and don't press hard on it. Very light pressure and high speed will drill the hole far more quickly than pressure which nearly bends the drill, coupled with slow speed. If in such a case metal of any thickness is being used for a disc, it will pay to countersink the hole each side of the disc, leaving only the smallest thickness of metal carrying the actual hole.

In any case thick metal for a disc is a mistake, because, quite apart from the load it will put on the motor and the expense of driving it, it will not permit one to view the image from as wide an angle as will a very thin disc.

This is illustrated diagrammatically in Fig. 5, where equal sized holes in thin and thick plates are shown.

The dotted lines indicate the extreme width over which light passing through the hole can be seen.

When making a disc it is best to do the whole of the marking out first, then drill, cut to diameter, and cut out the necessary holes in the centre for mounting purposes. Unwanted metal in the centre of the disc is next removed, and finally the disc is balanced on its shaft.

It may appear from what has been said that making a disc is a long and tedious process. It is not so really, but if one does not feel like taking care, it is merely a question of balancing one's ability to put up

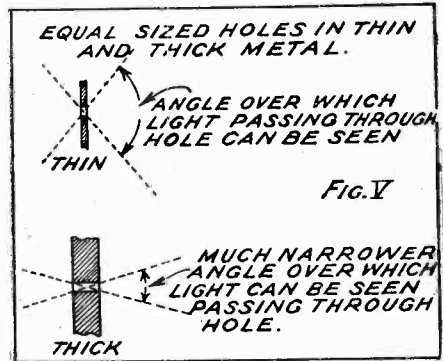

with a faulty reception of a good image against one's inclination to use a little care and thought in doing well the job that plays a most important part in television reception. Your reception depends finally on you.

Television and the Empire.

Mr. W. M. Hughes, the former Australia Premier, has just published a new book entitled "The Splendid Adventure" (Ernest Benn, 21s.). On page 277 of this book Mr. Hughes sums up the importance to the outposts of our Empire of rapid communication, and his words reveal the fact that he is by no means unacquainted with the vast possibilities of television. The passage in question reads as follows:—

"Wireless is to the people of the Empire a veritable gift from the gods, and daily new and wonderful developments are manifested; broadcasting and direct beam wireless telegraphy and telephony, which within a very short period will be operating between Britain and the Dominions, and later, television will bring the peoples of a world-Empire as intimately together as the inhabitants of Britain itself were twenty years ago."

"CAN FREQUENCY AND PHASE-CHANGE MODULATION REDUCE INTERFERENCE?"

Read this most interesting article by J. H. OWEN HARRIES, A.M.I.R.E., in our next issue.

Order your copy NOW.

LIVING PICTURES

By CHARLES JONES

IT is my good fortune to have business among farmers. They are a good race of men, deriving mostly from hereditary stock, and even now somewhat aloof from the scurry of events. They escape all the fussy regimen and purposeless hurry of a "well-ordered life," and having shouldered the whole burden of Adam's curse, retain also some fragrant memories and an occasional glimpse of Paradise.

As a result they are terribly conservative. It takes more than the scheduled results of agricultural college experiments to convince them that a balanced, synthetic fertiliser can make the ear that was forty-fold bring forth in its turn, grain an hundred-fold. They trust the bounty of the mother earth they know, rather than the chemical factory they wot not of.

"Because They Cannot See."

Perhaps it is because they cannot see the good work of the colleges and the actual results of scientific tillage, that they refuse to sink money in a grey powder, which, they are persuaded, would heal the sick field, and like a magic potion, add tons to the crop. Even fairy godmothers are unconvincing, if they stop short of demonstration.

Be that as it may, in early June (just before turnip sowing) I mounted my bike, and rode away, out of the village, to the farmsteads among the hills, armed with figures and invincible arguments.

Of the glory of the season; of the bright aspect of the plaided fields like crazy mantles laid upon the slopes; of the plumed copses, and monstrous-patterned sky, I must reckon nothing here, except to say how these things make for gladness, and sweep away idle doubts, if one has them, like the vision of a visible god. Where men raise a roof they often exclude much that is assured and sane, and they argue greatly as though life were full

of menace. But the open spaces, swept by the breath of Heaven, are not a challenge to the mind, but an embrace. Men of parts are bred in them, under the ægis of friendly skies.

Towards the end of the day I rode into the rickyard of the last farm; a farm tucked in the outermost ridge of the downs, like a babe's head in the folds of a great counterpane, and giving out upon the sea.

I dismounted amongst a crowd of heedless hens, with no idea of one-way traffic, and snuffed the sea-fume and the pungency of new-cut hay in one spicy breath. I glanced right and left, and at the second glance saw a freckled boy sitting astride the high ridge of a hay-stack, with withy thongs in his hand. He looked at me as a country boy does, mutely, and smiling. When I made no remark, he stabbed a thong deftly in the straw and bound down a wisp of wind-torn thatch.

"Hey!" I called, "Mr. Darke at home?"

The boy flung his leg over the rick, and slid quickly down the high-pitched side. He shot from the edge, eight feet above ground, at an appalling speed, and landed on his toes with marvellous precision, between two scared hens. Laughing with a gurgling sound, he pushed a school cap back on his head, and said:

"I think he's in house. I'll see."

The Joy of Youth.

He led the way through the yard to the farmhouse. It was a joy to follow him, to watch the jacket crinkling on his muscular young back, and the easy swing of his scratched legs, still in schoolboy shorts. He dived into the house, and ran back in the space of a breath swinging his cap in his hand.

"Dad can see you. . . . in yonder, Sir." He pointed through the dark door.

In a moment he was gone. But I hesitated at the door, strangely



A general view of the Baird Company's research laboratory in North London.

chastened, just for a moment of time. His voice was young and clear, his eyes healthy and clean. But beyond that, beyond the attributes of innocence which make their own appeal to the heart, his face had a radiance not of light or health, something of inexpressible purity for all that it was a freckled face with hayseeds caught in the eyebrows, and no little mischief betided in the eyes. But why bother with the indescribable?

My business with the farmer was done in half an hour. To clinch it, he laid a cheque on the closed lid of a pianoforte in the dim farm parlour. As I picked up the cheque and folded it I glanced up, and saw on the wall, not one, but a dozen certificates to one Ernest Darke, for proficiency in pianoforte playing, for harmony and counterpoint, of several grades, rounded off with an A.R.A.M. Perhaps I looked too long.

Repressed Pride.

"My boy," said the farmer, with the uncertain tremor of repressed pride.

"What! The lad outside, who showed me in?"

"No! Not that young rascal," answered Darke with a laugh. "He couldn't play the bones. He's all for the pencil, that one."

"It's jolly interesting," I said, for lack of anything more explicit to say.

"Like to see some of the young scamp's playthings?" he asked. As I murmured vaguely he brought a brown paper portfolio from a side table and laid it before me. On the outside, in illuminated printing, I read, "Ronald Darke. His Drawings." I turned over the cover, and on top of the sheet found pencil drawings of a daisy, perhaps a hundred. There was a tight-folded daisy bud like a lump of knotted twine: a daisy with petals shot out like a dozen tongues: a daisy just spreading, with a look of dew on it: a daisy like a spread parasol, gulping sunlight: a daisy with bent, afternoon head on a straight stalk: a daisy, sagging, twisted towards an invisible sinking sun, with languorous leaves and curving stem, full-fed and tired. Not just a daisy, but a daisy living its life, intimate and complete.

I searched the many sheets, some of which were better and some worse. There were a hundred studies of birds. A snail, in all his score of attitudes: at home and snug, or with palpy foot outspread and exploring antennae,

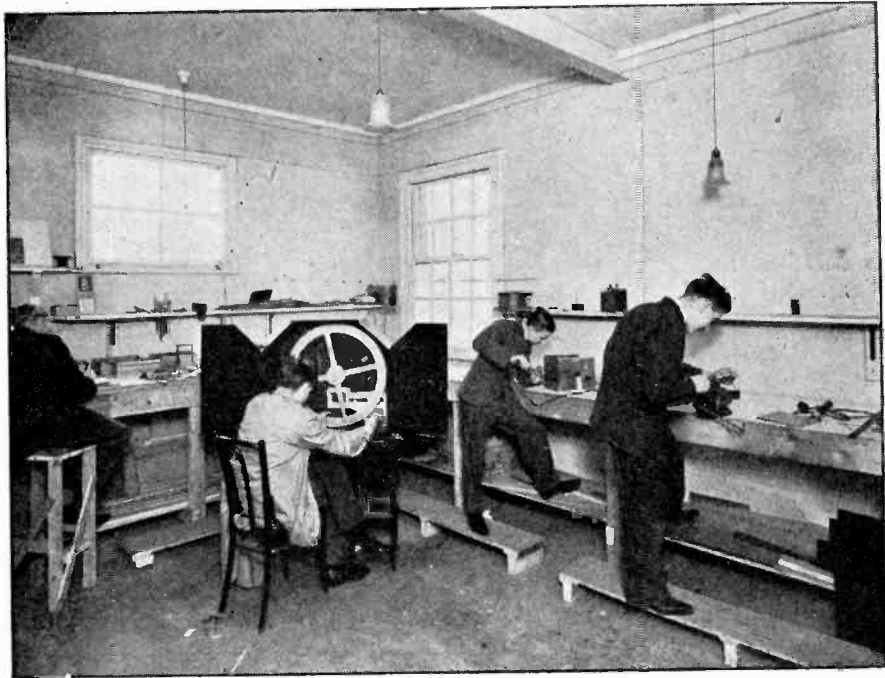

Assembling and testing Television Receivers at the Baird Company's laboratories.

rounding a perilous thorn with amazing elasticity, or feasting at ease upon a veined leaf. Further in there were little landscapes, an attempt or two in colour, and endless studies of waves breaking upon a sandy shore. There were designs and illustrations, but limited in scope.

Profound Observation.

I looked up at the farmer, who was twisting his moustache and grinning.

"Some kiddie, this," I said, with conviction. The drawings had that apt and sure quality of line which can only be won by profound observation, and an untiring struggle against the natural inertia of nerve and flesh. There was the patience and urge of love behind them.

"Never get his living at that," commented Farmer Darke, whose eyes nevertheless showed he had not missed the travail of his boy's spirit.

"No," said I, "but he'll live on it."

With a mute understanding on this somewhat sententious point we parted, and I made my way out through the rickyard thinking about the brace of boys in the farmer's household, each with his separate star, so far removed from the point of orientation of his forefathers. I wondered over the quaint and almost irrelevant way in which Nature throws up her shrewder and more sensitive humanities; those mutations of the intellect which she

flings up in the race as inconsequently as she builds flowers from the foulings of the earth.

I had a glimpse of the tall hayrick, and noticed that the thatch was rebonded. The boy was on the gate swinging his legs. He thrust the weight of his body forward, and opened it for me.

"You're fond of Art?" I asked, as I passed through.

He stared at me uncomprehendingly.

"Fond of drawing?" I explained, feeling shy under the bright gaze of a boy on whom no thin, wordy deception can be practised.

"How d'you know, Sir?" he asked.

"Your father showed me."

"Oh that!" he replied. "That's only practice."

"Looking for bigger things?"

"Some day."

"What About Television?"

"What about television? That will open your eyes when it comes your way."

He was walking beside me now, as I pushed my bike over a field path.

"I think my eyes are open," he said with a boy's fine confidence.

"But what is television?"

"Television? Oh, the science of sending living pictures by wireless."

He looked full at me.

(Continued on page 258.)

The Story of Chemistry

Part X

Isotopes

By W. F. F. SHEARCROFT, B.Sc., A.I.C.

WE have seen that Prout's brilliant speculation, that all the elements were composed of aggregates of hydrogen atoms, had to be abandoned owing to the experimental evidence against it. The atomic weights of certain elements were so definitely fractional, taking into consideration all possible experimental errors. Still, the idea persisted, and through the following century we see attempts to reconcile facts with theories.

One interesting speculation was that, during the hurly-burly of atomic life, some of the atoms became somewhat "worn out," and thus accounted for their weights being fractional and not whole numbers. It has to be remembered that in all the chemical methods of measuring atomic-weights, specimens of the element concerned, which contain many, many millions of atoms, have to be used. The results are, therefore, *average* values. There is always the possibility of variation in the individual atoms, although, as the average values are constant, there must be order in the variation, which could hardly be postulated for "worn out" atoms.

Chemical Families.

We have previously mentioned that the chemical elements may be grouped into families which show similarity in properties. Sometimes this similarity is very close indeed. With the group of elements known as the *rare earths* it is so close that considerable experimental difficulty occurs in attempts to separate the elements or their compound.

When dealing with the radioactive elements still closer likenesses were found. Thus an element ionium

was known, and its compounds when mixed with similar ones of thorium were found to resist all attempts to separate them. By all the chemical tests known, ionium and thorium were identical. They differed, however, in their radioactive properties, in such a way as to make it perfectly clear that they were two distinct elements. Chemically they were identical.

Identical Elements which are Different!

Here is a new conception—two identical elements which were different! It is only possible to assume that the difference is due to

differences in internal structure. This may concern the planetary electrons or the nucleus, a mixture of electrons and protons. So alike are the chemical properties of these elements that it is difficult to see how the outer arrangement of planetary electrons can be altered, without such alteration being manifested by chemical difference. This suggests that the real difference lies in difference of nucleus.

Now the proton is the part of the atom which is weighty. An electron has a mass of about $1/1845$ of that of a hydrogen atom, and so only contributes a very small share to the weight of the atom, even in those atoms which have many electrons. A



PORTABLE TELEVISION!

The above illustration shows a Baird portable television receiver (resting on running board) undergoing tests in the country. The broadcast television impulses are picked up by a portable wireless receiver, the output of which feeds the portable television.

change in the nucleus would entail, therefore, a change in the atomic weight. In the case of ionium and thorium, therefore, we seem to have two identical elements with different atomic weights.

Isotopes.

Further work with radioactive elements revealed other similar cases, and such elements were called *isotopes*. For some time isotopes were only known among the elements with high atomic weights which were radioactive.

The next step in the process came from another line of research. When a radioactive substance disintegrates, we have explained that it shoots out certain particles. In some cases the particles are positively charged and have been identified as helium atoms bearing positive charges; that is, helium atoms which have lost some of their planetary electrons. In some cases the radioactive atoms emit electrons. This will leave a particle bearing a positive charge.

Canal Rays.

Goldstein, in 1886, noted the existence of what he called "canal rays" when an electrical discharge was passed through gasses at low pressure. Wien, in 1898, showed that these rays could be deflected by a magnetic field, and J. J. Thomson carried out a detailed study of such rays, called them *positive rays*, and showed that they were positively charged particles. They are produced by the process which we now call ionisation. In gasses, under low pressures and the influence of an electrical field of about 50,000 volts, electrons are torn from the atoms, and positively charged residues are left.

Thomson investigated the charges and the mass of these particles by means of a method known as the "parabola method." The streams of positive particles were passed along a very narrow tube, and the very narrow beam so obtained was acted upon by electrical and magnetic fields, which deflect the rays from their paths. The deflection depends upon the mass and the velocity of the particles, and Thomson obtained a photographic record, shaped like a parabola, from which he was able to make the necessary calculations of the mass of the particles.

The Mass Spectroscope.

A marked step in advance was made by Aston, who considerably improved the method of positive ray analysis. He invented the mass spectroscope. The positive rays to be investigated are passed through two very narrow slits, and passed between two charged plates, which spread them out much in the same way that a prism of glass spreads out a narrow beam of light. Part of this electrical spectrum is then passed through a strong magnetic field, which causes a further deflection, and finally results in the bringing to a focus of all the particles having the same mass. These are made to impinge on a photographic plate and make a record upon it.

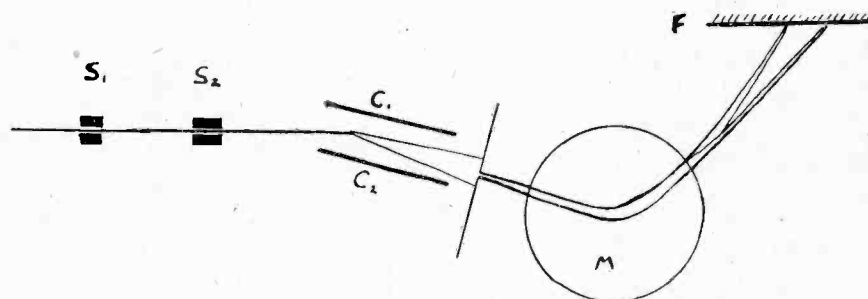

DIAGRAMMATIC REPRESENTATION OF A MASS-SPECTROSCOPE.

S_1, S_2 Slits.
 M Magnetic Field.

C_1, C_2 Charged Plates.
 F Photographic Plate.

If a mixture of particles of varying mass is passed through the instrument, then the particles will be sorted out and caused to make records at different points on the plate, according to their mass. If the atoms of an element are ionised, that is, converted into positive particles, then if they are all of the same weight they will make but one record on the plate, if of varying weight then they will indicate this fact when they are sorted out. By choosing some element as a unit, comparisons of the mass of the atoms can be found.

From a study of such mass spectrographs Aston was able to show that the lighter elements not known to be radioactive, also exist as isotopes, and that the weights of the atoms were always whole numbers. The fractional values obtained by the chemical methods were due to the mixture of different atoms, which were dealt with in bulk. Thus, for example, Aston found that the element chlorine was a mixture of atoms whose weights were 35 and 37, with a probable one, weighing

39. Further, he was able to estimate the proportions of these atoms in a sample of the element and his results showed that the mixture would have an average atomic weight of 35.46, the result which is obtained by the chemical determinations.

Return to Simplicity.

We now know the weights of the atoms, as distinct from the chemical atomic weights. We know that an element apparently homogenous, as far as all our chemical tests can indicate, may consist of mixtures of atoms varying in weight, but having the same chemical properties, that is, consisting of isotopes. Further, it has been demonstrated that the weights of the atoms are

all *whole numbers*, and thus the original objection to Prout's hypothesis is removed, and we may return, with some slight modifications to be noted later, to the fascination of simplicity—a universe made up of one primordial substance, hydrogen. Certainly we no longer fancy the atoms of the elements as simple hydrogen atoms packed together. There is more than simple packing in it.

Experiment has demonstrated the possibility and the existence of isotopes, and it remains to explain the theoretical aspects of these interesting discoveries. Possibly a concrete example will help. Lithium is an element found in nature, which has a definite set of chemical and physical properties, by which we recognise it. Its atomic weight determined by chemical means is 6.94. This element, as found naturally, Aston has shown to consist of two isotopes, the weight of the atoms of which are 6 and 7. They are mixed in a proportion such that

(Continued on page 258.)

PHOTO-ELECTRIC CURRENTS IN A VACUUM

By H. WOLFSON.

Readers who have been following Mr. Wolfson's series of articles on the photo-electric effect, and various types of photo-electric cells, will recall that last month he dealt with "Photo-electric Currents in Gases." This month he goes further back and outlines the various phenomena which led early observers to recognise photo-electric effects. These effects were first observed in free air. Later, experiments led to the production of the effects in a vacuum.

LAST month we considered in detail the various factors affecting the emission of photo-electrons when the sensitive substance was placed in a vessel containing a gas. We saw how an alteration of gas pressure, and of the nature of the gas exerted a marked influence on the photo-electric current which could be obtained from the cell.

In this article we have a number of equally important problems which arise when the cell is of the vacuum type. Many cells at present in use are evacuated, in preference to being gasfilled, and for certain purposes are preferable to the latter type, though they give a much smaller current than the gasfilled types.

We shall consider first the work which led up to the investigation of the emission of photo-electrons in a vacuum, since it was most natural to work with the substance in the air, as did some of the earlier workers.

Method Adopted.

Perhaps one of the most valuable lessons to be drawn from the present article is the *method* which was adopted by each different worker, and it is possible to trace a gradual refinement of both method and apparatus, without which many anomalies would have remained unexplained.

Hertz's apparatus was definitely of the cruder kind, yet it served its purpose admirably in that it led up, quite accidentally, to the discovery of photo-electricity. He used two sparks, *A* (see Fig. 1), serving to excite the primary oscillation, was

obtained from the ordinary discharge of an induction coil, while *B*, which served to measure the action set up in the secondary circuit, belonged to the induced secondary oscillation. The spark *B* could be enclosed in a light-tight case at will. When the spark *B* was so screened its length was less than in the unscreened condition.

A convenient arrangement of apparatus for the investigation consists of two induction coils *A* and *B*, Fig. 1, arranged with their primaries

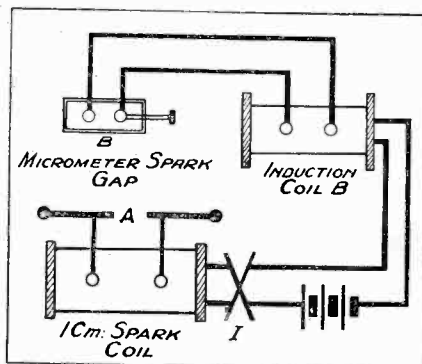

Fig. 1.
Hertz's apparatus, demonstrating the photo-electric effect.

in series with the common battery, and worked by the common interrupter, *I*. The coil *A* gives a spark about 1 cm. long, while the length of spark *B* is only 1 mm.

The spark gap at *B*, which is fitted with micrometer adjustment, is arranged of such a length that sparks can just pass when it is subjected to the action of the spark *A*. If a plate of metal or of glass is interposed between the two parallel gaps, the

spark at *B* at once ceases, and reappears as soon as the plate is removed. The action increases as the distance between the sparks is diminished.

Effect of Oxidization.

Hertz also found that the effect was either diminished, or else entirely absent, when the terminals became dull, tarnished or corroded. The effect was found to be transmitted in straight lines, by the usual type of experiment with slits and screens. A number of substances both solid, liquid and gaseous, were found to hinder or prevent the action, and by combining all the evidence quoted and carrying out further experiments dealing with the reflection and refraction of the light from the longer spark, it was possible to prove conclusively that the active portion of the light belongs to this ultra-violet portion of the spectrum.

Confirmation of this hypothesis was sought by the early experimenters, who employed a number of different light sources to bring about the effect. The electric arc, which is the richest in ultra-violet light, was capable of producing the effect up to a distance of four metres, and magnesium ribbon produced quite an appreciable effect. All the experiments as to the propagation, absorption, reflection, refraction, etc., were repeated, and the results were in strict agreement with those already obtained when working with a powerful spark as the source of illumination.

Hertz had recorded the fact that the action of ultra-violet light on the smaller or passive spark seemed to take place near the poles, and more especially near to the negative pole or cathode. Wiedemann and Ebert investigated the point more completely, and found that the true seat of the action was definitely the cathode.

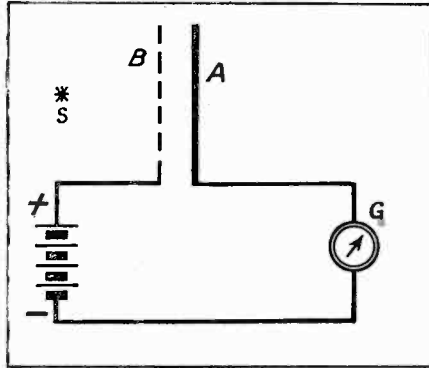

Fig. 2.
Stoletow's arrangement for demonstrating that a metal plate emits electrons under the influence of light.

Chief among these early investigators was Hallwachs, who sought for other phenomena of a similar nature by which he could explain the results of Hertz, and in this way was led to examine the action of light on electrostatically charged bodies. A polished zinc plate was connected to a sensitive electroscope, and was carefully charged, in one set of experiments negatively, and in another, positively.

Hallwachs' Experiments.

The plate was then illuminated by light from an arc lamp. In the case of the negatively charged plate, the leaves of the electroscope began to collapse as soon as the illumination was allowed to fall on the zinc plate, but in the other case, no effect was produced. The same results were obtained by using burning magnesium ribbon as the source of light, and Hallwachs concluded that the effect was due principally to ultra-violet rays, which conclusion had been reached previously by Hertz.

The light was shown to have no action on the surrounding medium, in this case air, and the effect was traced to the metal surface. This result was confirmed by the discovery that the activity of the metal plate was nearly fifty times as great when the plate was freshly polished as when it was old, or tarnished.

Experiments carried out with a view to determining the relative activities of various metals showed that aluminium was more active than zinc, while iron was less active than either of these metals.

Conclusive Proofs.

Hallwachs concluded that when a negatively charged metal plate is illuminated, negatively charged particles travel away from it, following the lines of force of the applied electric field. He also stated that "metal plates become electrostatically charged when irradiated with the electric light," and this view was confirmed by his later experiments.

He suspended a metal plate inside a rusty iron cylinder, and connected the plate to a Hankel electrometer. The contact potential against the plates to be examined was always negative, and it is only in this case that a rise of potential could be explained without any doubt, since, had the plate been negative to the case, a rise of negative potential would have occurred, as a result of the transport of negative electricity by the illumination.

With the plate positive, however, an increase of potential could only be explained by saying that positive electricity was produced on the plate. This production of a positive electrification is consequent upon the removal of electrons, or particles of negative electricity, from the plate, which disturbs the neutrality of the atoms of which it is composed, leaving them with a nett positive charge.

Experiments with a number of metals gave this same result, and it is interesting to note that the potential produced in the case of zinc was well over one volt, while brass gave one volt, and aluminium half a volt.

Stoletow and Righi.

Hallwachs' experiments had been followed with great interest by a number of other workers, and Stoletow and Righi, in 1888, working independently, devised a novel method of studying the discharge of bodies previously charged to a low potential. Both used the idea of a metallic grating or gauze placed a few millimetres from, and parallel to, the metal plate with which they were experimenting.

Stoletow's apparatus is shown diagrammatically in Fig. 2. A is a metal plate which is connected in series with a very sensitive high-resistance galvanometer, a battery and the gauze screen B. The grating is made positive to the plate. On illuminating the plate, the galvanometer indicates a current, but if the connections are changed round, no deflection is produced on the galvanometer. This, then, would suggest and confirm the view that the plate emits electrons under the influence of light.

Elementary Photo Cell.

The later editions of Stoletow's experiments employ a quadrant electrometer in place of the galvanometer. Stoletow constructed what might be described as an elementary type of photo-electric cell, which would cause an electric current to flow in an external circuit, by allowing ultra-violet light to pass through the openings in a perforated plate, and then fall upon a second plate. The active plate must be made of the less electro-positive metal, in order that the contact potential difference can drive negative electricity from the active illuminated plate to the perforated one.

Righi placed a vertical disc of metal A (Fig. 3), not far from the parallel gauze net B, arranged so as to be connected to the opposite pairs of quadrants of the electrometer M, that pair which is connected to B being earthed. A can

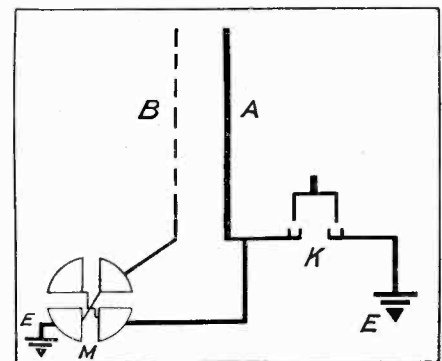

Fig. 3.
Righi's Apparatus.

also be earthed by means of a plug switch K. After momentarily earthing A, the illumination is turned on, and a deflection is obtained on the the electrometer, this reaches its maximum in a time which is less the nearer the source of light, and the

larger the metal surfaces. *A* was made of zinc, and *B* of brass. The arrangement of plates may be termed a simple photo-electric cell.

Elster and Geitel, in 1889, only two years after Hertz's original discovery, showed that electro-positive bodies, like the alkali metals, sodium, potassium, rubidium, etc., exhibit photo-electric activity when

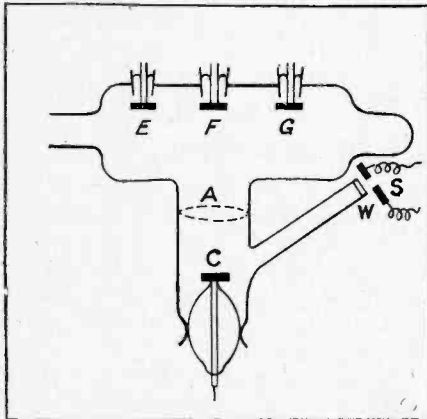

Fig. 4.
Merritt and Stewart's apparatus for the identification of photo-electric rays.

exposed to light of the visible spectrum. The most electro-positive of the alkali metals will lose a negative charge when the source of light is a glass rod heated to redness. Freshly prepared surfaces of less electro-positive metals, such as zinc and aluminium, exhibit an activity much smaller, it is true, when exposed to bright sunlight.

An Enclosed Cell.

In 1904, Hallwachs made the discovery that a plate coated with black copper oxide, preserved in an airtight chamber, showed a photo-electric activity which was remarkably constant over long periods of time. He actually used this type of cell in photometry, to compare the intensity of two sources of light.

Later Elster and Geitel suggested the use of potassium cells filled with some inert gas, such as argon, for ultra-violet photometry.

In 1890, Elster and Geitel made the important discovery that the application of a transverse magnetic field diminishes the photo-electric current, if the cell contains inert gas at a low pressure. These results suggest that photo-electric carriers in a vacuum or low pressure inert gas are identical with cathode rays, and this conclusion, fully substantiated by experiment, gave for the

first time a clear understanding of the nature of the corpuscles which act as carriers in photo-electric phenomena, and which we term photo-electrons.

Photo-electric and Cathode Rays.

The question of the identity of photo-electric "rays" and cathode rays is of such far-reaching importance that a closer study of the work which was done by the earlier workers should not be overlooked, although we are so accustomed to taking it for granted, that we are apt to lose sight of the fact that it did not immediately occur to the pioneers, nor was it accepted without most rigorous experimental proof.

In 1889, J. J. Thomson carried out measurements of the ratio of the charge carried by the particles to the mass of the particles. Within the usual limits of experimental error, the results for the value of the ratio e/m were in good agreement with those already determined for cathode ray particles. The value of the charge of the photo-electric particles was found to be the unit charge already known from measurements in connection with electrolysis.

The experiments of Lenard and of Merritt and of Stewart are of great interest and importance, and a short account of the method employed by the latter investigators is representative of the work which was done in this connection. The apparatus employed by them is illustrated in Fig. 4.

Merritt and Stewart's Experiments.

The cathode *C* is a zinc plate, which is maintained at a potential of 1000 volts by means of a dry pile. This is placed at the bottom of the tube, while the anode, *A*, is an aluminium ring. The side tube is fitted with a quartz window *W*, through which light from a spark between zinc terminals can pass and illuminate the cathode. The three electrodes, *E*, *F*, *G*, are fixed at the top of the tube, and the rate of change of potential at each of these electrodes was measured by means of a Kelvin quadrant electrometer.

When there was no applied magnetic field, the instruments showed that the middle electrode, *F*, received a negative charge. If the applied magnetic field was at right angles to the plane of the apparatus as shown,

and in a direction away from the observer, the negative charge was received by the right hand electrode *G*, either wholly or in part, according to the strength of the field. On reversing the field, the bulk of the charge appeared at *E*, the middle electrode receiving the same fraction of the total charge as in the previous case, this fraction depending only on the strength of the field.

Effect of Magnetic Field.

Merritt and Stewart found it necessary to regulate the strength of the applied field between narrow limits, in order to obtain sharply marked effects. Their results show that photo-electric rays are magnetically deflected, in the same way as cathode rays. The amount of deflection of the photo-electric rays which is produced depends on the potential of the cathode, since the effect of increasing the potential of the cathode speeds up the rays, or makes them "harder."

These two workers also formed the opinion that there were present, in addition to the ordinary photo-electric particles, heavier and slower moving particles, probably ions. These they attributed to ionisation of the residual gas in the tube, and we have seen that this view was borne out by later experiments, while studying the effect of a gas on the photo-electric effect. This served to explain discrepancies in J. J. Thomson's work which he had attributed to experimental error.

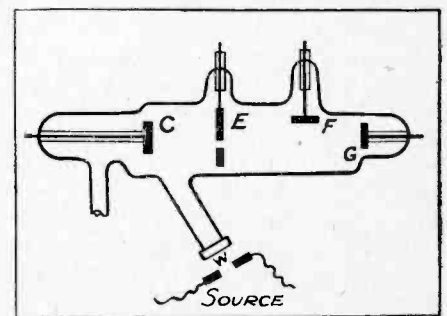

Fig. 5.
Lenard's apparatus for investigating and measuring the velocity of photo-electric particles.

Lenard went a step further than Merritt, by determining the velocity of the particles. His apparatus, shown diagrammatically in Fig. 5, consists of the aluminium cathode *C*, illuminated through the quartz window *W* by light coming from a spark between zinc terminals. The earthed

electrode, *E*, had a central aperture, 5 mm. wide, through which the rays passed. The subsidiary electrodes, as in Merritt's apparatus are shown at *F* and *G*. In a similar manner to

nated plate was of aluminium coated with turpentine black. Two velocity distribution curves are shown in Fig. 6. The continuous line refers to the charge leaving *C*, obtained by

4. The field now becomes an accelerating one, of small value, and the two curves practically coincide.

5. The accelerating field is now so large that the value of the current becomes almost constant, as is shown by the curves becoming nearly horizontal.

Complications arise from the reflection of light from *C* to *E*, where a secondary electron is produced. One must ascertain the fraction of light reflected, and this depends, of course, on the surface of the electrode *C* and the source of light. This fraction known, the curves can be corrected. There will be a null point in this curve, and it has been calculated that for a potential difference of 1 volt, the velocity of the electrons may be taken as 5.93×10^7 cm. per sec.

Space Charge.

In a previous article, we referred to the anomalies which arose through the confusion of "space charge" with other phenomena. In this work, too, numerous attempts were made to explain certain behaviours by saying that electrons were reflected from the electrodes, or from the walls of the apparatus. These things can be better explained on the basis of "space charge," i.e., the accumulation of electrons in the space between the electrodes. There is no doubt now, that electrons are reflected from metal surfaces, in much the same way as waves, as is shown by the work of Davisson and Germer. This would lead us to believe that the

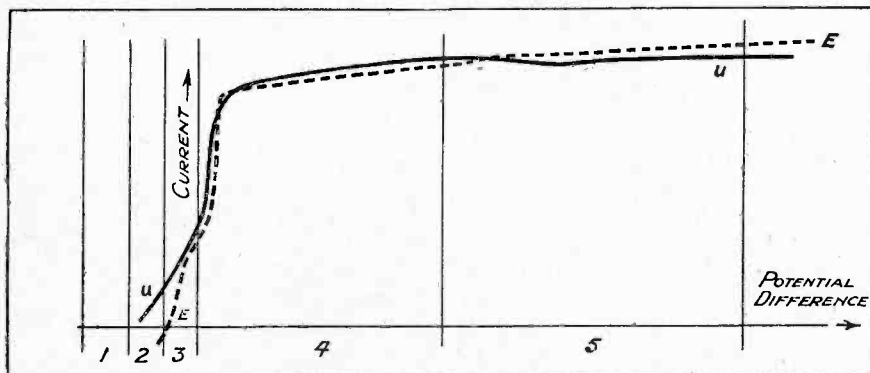

Fig. 6. Velocity distribution curves obtained by Lenard.

that already described, the photoelectric rays were shown to be cathode rays moving down the tube from *C*.

Determining Velocity of Particles.

If *P* is the potential of the cathode *C* (measured in E.M.U.) v_0 is the initial velocity of the particles, and v the final velocity due to the electric field.

Then difference in kinetic energy $= \frac{1}{2}m(v^2 - v_0^2)$, which we know to be equal to the product of the potential and the charge on the particle, i.e., $= Pe$.

Also, the initial velocity of the particles can be determined from the equation $P_0 e = \frac{1}{2}mv^2$, where P_0 is the positive potential which must be given to the cathode *C*, to cause the particles to return to it. The value of this potential has been found to be 2.1 volts. Re-writing the equation as $v_0 = \sqrt{2P_0 e/m}$, we obtain for the value of the initial velocity v_0 of the particles 10_8 cm. per sec.

This experimental determination of the particle is incomplete, in so far as it only gives us information about the fastest moving particles. Those whose velocity is less than the maximum will return to the illuminated electrode under the influence of a potential less than +2.1 volts. Lenard himself realised this, and set about determining what is called the velocity distribution curve.

He determined the quantity of electricity discharged per unit time (per second) when the applied potential was varied. The illumi-

applying a potential to accelerate the electrons leaving *C*, and the dotted curve the electric field tending to drag the particles back, gives the charge reaching *E*.

The curves can be divided into five stages, as shown, which are:

1. The retarding field is large, and any electrons leaving *C* are dragged back before they have gone very far from the plate. Both *C* and *E* are negative, due to reflected light causing a small discharge from *E* to *U*.
2. Here the retarding field is less, and electrons do manage to escape from *C*, but are unable to reach *E*. Thus *E* has a fractional negative v value, and *C* a small positive value.

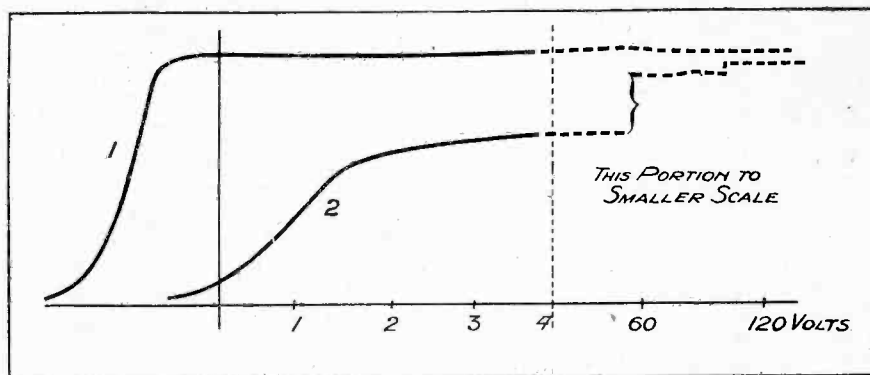

Fig. 7. Velocity Distribution Curves.—Curve 1: With charged gauze. Curve 2: Without charged gauze.

3. At this stage, the retarding field is so small that some electrons manage to reach *E*, instead of being stranded on the glass walls of the vessel. *E*, therefore, becomes positive in value.

electron is in the nature of a wave, or at least, that it has associated with it what is termed a "phase-wave," though this need not concern us here. In order to overcome any difficulties arising from electron

reflection a perforated screen and an auxiliary field was used by O. v. Baeyer. This prevents any reflected electrons from reaching the plate under test. Fig. 7 shows the effect of cutting out "reflected" electrons. Curve 1 was obtained with the electrified gauze screen, and curve 2 without the screen. It might be pointed out, in passing, that the negatively electrified gauze is not a perfect screen, there being a stray field through the apertures of the gauze.

Another Source of Error.

In 1912, Compton drew attention to yet another source of error in estimating the true value of the potential difference for a velocity distribution curve. I refer to the existence of a contact potential, since the electrons will be acted on by any potential difference due to this cause, while moving between the two plates.

There is much more interesting work both on this subject and on a number of others, which might be included under the heading of "early experiments," but it is necessary to keep this article within reasonable bounds. This seems a convenient place to pause, and I would certainly recommend my readers to study the foregoing very carefully, as an example of *method*, if nothing else.

Living Pictures.

(Concluded from page 251.)

"Is it being done?"

"A start has been made. Listen, Ronald! Would you always draw flowers and birds if you could see with your own eyes the fretted lattices of Cairo, the seven domes of St. Anthony of Padua and the turrets of Milan, the little flowery garden of Gethsemene, the Pagodas of the East and the gate of the Taj Mahal?..." I paused for breath.

"You have travelled a lot," he said.

"Only in the realms of gold," I answered, shamefacedly, "I shall be as glad to see them as you will."

"Oh, I don't know," he drawled unconcernedly, stooping to see better a little bloom of blue speedwell like a sapphire in the grass.

"They will be able to transmit whole evening programmes soon," I urged. "Perhaps a great artist will teach drawing and painting now and then, and illustrate as he speaks."

"Could he do that?" asked the

boy with an air of polite interest rather than credulity. "An artist stayed here for six months once. He taught me a bit. That is why I do it."

I had one foot on the pedal. The boy looked at me full again, and for the second time I felt the strange influence of personality, the impression of a limpid and exquisite purity.

I gave a tentative push.

"You coming this way again?" he called.

"Next month," I said over my shoulder.

"Tell me some more about the living pictures," he cried, cupping his hands.

He scuttled back over the field, and I took the road, soberly.

Truly a little rascal; truly of the country, and slow to give in. But I had captured him for all his seeming indifference.

Wireless for Yachts

The latest addition to yachts fitted with wireless is Sir William Berry's motor yacht *Sona*, which is equipped with a comprehensive Marconi wireless installation, including a broadcast receiver.

For telegraphic communication over a very wide range the latest type of Marconi valve transmitter with a power of $1\frac{1}{2}$ kilowatts is installed. This has been designed to transmit, in accordance with the recommendation of the Washington Conference, or interrupted continuous waves between 600 and 800 metres. In addition, an extra channel of communication is provided for transmission on continuous waves between 1800 and 2600 metres. The valve receiver for the telegraph service covers a wave length range of from 320 to 27,000 metres. This makes it possible to receive on one instrument all weather and navigation reports, news bulletins, time signals etc., in addition to the normal telegraphic traffic from local and long distance stations. In the event of failure of power, valve or battery trouble, or other emergency, a small quenched spark transmitter and a crystal detector are carried.

A four valve broadcasting receiver working from a separate aerial, and with a number of loud speakers will provide entertainment for those on the yacht. The loud speakers will be ranged where required, leaving the receiver in a central position.

The Story of Chemistry.

(Concluded from page 253.)

those weighing 7 are in the preponderance, and give an average value of 6.94.

Composition of Lithium Atom.

The lithium atoms contain three planetary electrons, and on their number and arrangement we believe that the chemical properties of the element depend. Thus, the two isotopes must also have three planetary electrons, because they are indistinguishable chemically.

If there are three planetary electrons, then the nucleus must have three *free* positive charges, that is, three *free* protons, to balance them and leave the atom electrically neutral. A proton is a hydrogen nucleus with a weight of 1. The weight of the electrons being negligible, the isotope of lithium weighing 6 must have six protons. With these must be associated in the nucleus three electrons, leaving three free protons to balance the three planetary electrons.

Similarly the isotope with weight 7 will have, in the nucleus, seven protons and four electrons, again leaving three free protons and three planetary electrons. Both atoms will have the same properties in virtue of the planetary electrons, but will have different weights.

Further Research Required.

Prout and his immediate followers thought of a simple packing of hydrogen atoms. This, however, will not meet the case. The mass of the hydrogen atoms is 1.008, and not unity, on the scale which fixes the weight of the oxygen atom as 16. Therefore, in the building up of the other atoms there appears to be a loss of mass.

The next lightest atom is that of helium, weighing 4 exactly. If this obtained by the uniting of four hydrogen nuclei to form the new nuclei, then there is a loss of 0.032 to be accounted for. Considerable speculation has taken place on the structure of the nucleus of atoms. One theory, supported by radioactive phenomena, is that the nuclei of the heavier atoms consist of helium nuclei. Another view directly opposes this, but further work will be necessary before a definite decision can be reached.

A Quantitative Analysis of Television

Some Extensions of the Theory and a Reply to Criticisms

By J. H. OWEN HARRIES, A.M.I.R.E.

Some extensions of the theory given by the author in the paper which appeared under the above title in the May issue (pp. 105-112), and a reply to various criticisms of the thesis.

I WISH first to thank all those who have replied to my request for opinions on my work, and particularly Sir Ambrose Fleming for the honour of the comments of so distinguished a scientist as himself.

It is especially gratifying for me to note that Sir Ambrose makes no criticism of the correctness of my methods of analysis.* His remarks may be summed up as (a) that further undiscovered factors are needed to produce a complete system of quantitative measurements, and (b) that therefore my work is "yet premature."

In reply to (a), since much of the very phenomena to be eventually measured has probably not yet been invented, one cannot imagine anyone disagreeing with Sir Ambrose here. His test card method is of great interest. As it seems possible that this might become a standard measure of overall experimental results, it may be of historical interest in the future to draw attention to the fact that the Baird Co. has used large type for some considerable time for demonstration work in connection with "telereading," i.e., printed messages are held up before the transmitter and legibly reproduced on the screen of the receiver.

Dr. Ives and his colleagues have used a tapering line test card (Fig. 1) and a diamond pattern (Fig. 2) for various purposes.†

* In his article in our June issue Sir Ambrose Fleming said:

"Mr. Harries deserves a compliment on his effort to bring this new art within the dominion of mathematical analysis. There are, however, some factors in it which I think have been overlooked in his attack on the problem, and to which I should like to direct attention."

† Bell System Technical Journal, Vol. VI, October, 1927. Pp. 582 and 649.

But, referring to (b), with all due respect to my distinguished critic, I cannot for one moment admit that, because the practical work of invention in a new branch of engineering is by no means complete, quantitative work is, therefore, premature. I have no space to enlarge on this, but I submit that one has only to study the history of science to see that quantitative theory has gone hand in hand with experiment, each helping the other on from first to last, in evolving any of the great engineering achievements in the world.

Sir Ambrose Fleming's Valuable Work.

Of all the branches of engineering, that of wireless perhaps shows this best. For example, Sir Ambrose's own early quantitative work, in collaboration with Senator Marconi's inventive genius, was not premature, and led to many essential inventions, despite the fact that then (and to a great extent now) the only final criterion of success was the experimental results aurally observed at the receiver.

(Needless to say the relative importance of this classical work of Sir Ambrose's, and that of my attempt to give a quantitative basis to, and an interpretation of, television research,* has nothing to do with the argument.)

Then, surely, unless my methods of analysis are proved to be incorrect, my claim is substantiated that any experimentally found factors in the future must be complementary to, and not antagonistic to, those I have given.

I make no more detailed claims for the usefulness of my theory at the moment, but merely confine myself to suggesting that readers should try the method in their work and, if possible, publish the results—"the proof of the pudding is in the eating."

In the meantime, if the example of its practical working given below is compared with any ordinary attempt to describe a televisor the result will be found, I think, to be illuminating.

* See the introduction to the original paper.

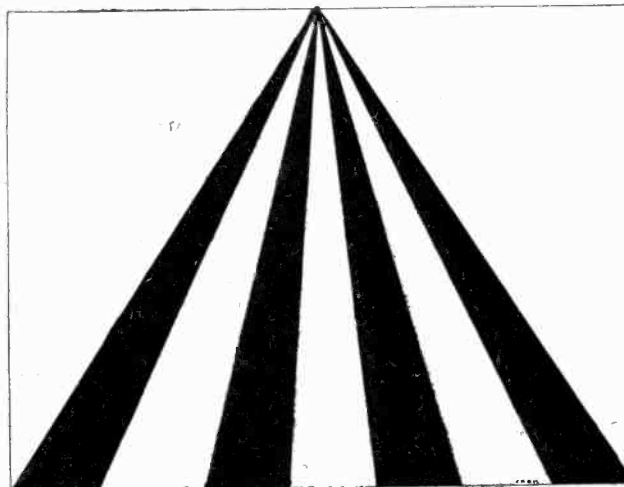

Fig. 1.

A Test Card used by the A.T.T. Co. of New York. The distance from the apex of the converging triangles at which they are resolved is a numerical over-all measure of "clearness." This card avoids errors due to the observer unconsciously guessing the words or letters on a type test.

Extensions of the Theory.

As I stated at the informal discussion before the Television Society,* previous to seeing Sir Ambrose's article, I had no time when I wrote my original paper to pursue the matter further than was required for my own work then; but that the basic formula—

$$R = \frac{A}{f_{max} t}$$

and the analysis expresses general relationships from which many extensions may be made.

I will repeat a few of these extensions now, as from the practical viewpoint they are perhaps more interesting than the formulæ at which the first paper stopped.

It is as well to remark first that (*H*) in the original analysis only referred to the lengthways definition.

Where a unit of breadthways tolerance is needed we have—

$$H_b = \left(\frac{A}{A_o} \right) - 1 \dots (9)$$

where

*A*_o = the area of maximum definition of the system employed.

A = the area used in practice.

For comparisons to be valid *A*_o must always be calculated from the standard value of β, and not found by observation, when variations in the acuity of the observers' eyes, and other effects, would cause inaccuracy.

In comparing "televisors" I suggest finding the answers to the following questions:

1. What is the value of the area of maximum definition of the system to be assessed?

2. What is the value of—

$$\frac{f_{max}}{t} = L_e \dots (10)$$

That is, what is the efficiency of lengthways definition;

These units, we must note, do not measure the amount of detail we can actually see, but that which is transmitted. What we can see depends on practical considerations, e.g., the tolerance ratio, etc.

3. Under what conditions does the designer intend his system to be used?

(The tolerance ratio and other points which are of interest.)

*Proceedings of the Television Society, June, 1929.

5

Fig. 2.

Another Test Card used by the A.T.T. Co.

Applied especially to studying fading and "ghost" images.

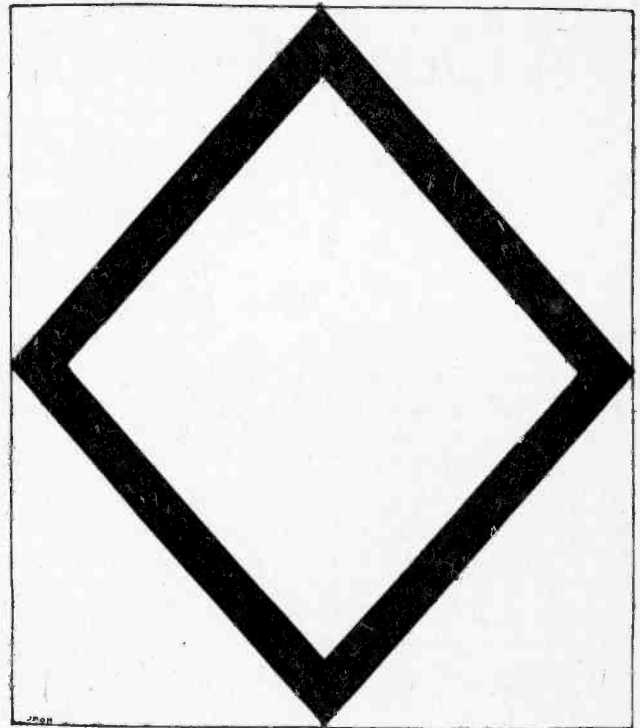

5

I will now give an imaginary report on a system such as might appear in a technical journal.

A Practical Example.

"Mr. Jones' new scanning disc is so much of an improvement that the area of maximum definition of his system is now 0.01 rad². This is double the previous best of Mr. Green's of 0.005 rad². Both are calculated with the usual standard value for β of 0.00065 to 0.0007 rad.

"Mr. Jones uses a top frequency of 40,000 cycles and a picture rate of 16 a second. The lengthways efficiency of analysis is therefore—

$$L_e = \frac{40,000}{0.06} = 6.66 \times 10^5$$

"This is an advance due to a new transmission system.

"Regarding the working conditions, Mr. Jones uses a breadthways tolerance of 4 times, which gives the working area *A* = 0.01 × 5 = 0.05 rad². We then have for the working scanning ratio *R* = 20 × 10⁶. Reckoning the standard scanning ratio to be 0.57 × 10⁶ as usual, we have for the lengthways tolerance *H* = 34—rather a high value—but Mr. Jones is nevertheless to be congratulated on his work."

And so on.

A point of interest is that *f*_{max} is more properly defined as the cut-off

frequency of the whole system. The radio band-width is probably as good a measure of it as any, however, as at the present state of the art it is the main limiting factor here,

The values, for the two examples of television systems given in the first paper, of the new units introduced at the discussion are given in the table appended.

| | <i>H</i> _b | <i>L</i> _e |
|-----------------------------|-----------------------|------------------------|
| Mr. Geloso's system | 0.73 | 3.75 × 10 ⁴ |
| Dr. Alexander-son | 9.3 | 15 × 10 ⁴ |

We may note that Dr. Alexander-son's lengthways working definition is very much better than Mr. Geloso's, but that the breadthways is very much less. Taking into account the results reported in the main paper, we may note that the extra efficiency in the one dimension has made up for the large tolerance in the other.

Referring to the letters contained in the June issue of "TELEVISION," perhaps I may point out to Mr. T. M. C. Lance, and others, that the standard is not necessarily the "ideal"; but merely what it is called—a standard of comparison—so one
(Continued on page 272.)

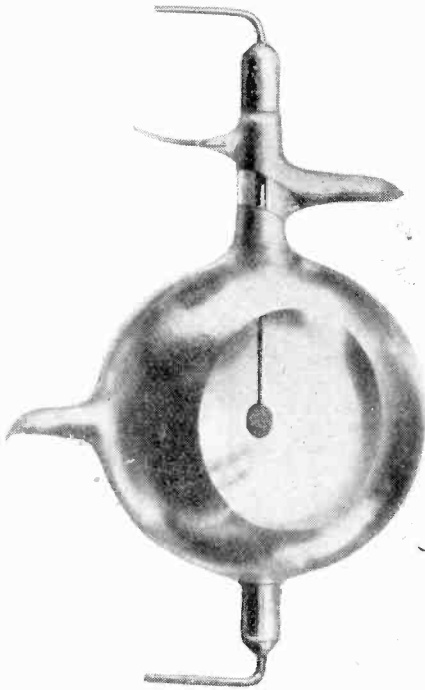

A Review of Commercial Types of Photo-Electric Cells

The performance of photo-electric cells has received the attention of at least one big Electrical Company in this country in recent years, and their Research Department has now succeeded in producing a cell which is sensibly stable in operation. This cell has now been put on the market. The following notes will, therefore, prove of considerable interest to our readers.

Choice of Photo-Electric Cells.

PHOTO-ELECTRIC cells may be classified according to (1) the size and geometrical form of the bulb and the electrodes; (2) the material used for the cathode; (3) the gas-filling.

Vacuum and Gas-filled Cells.

In a vacuum cell the current is that carried by the electrons directly liberated from the cathode by the light; in a gas-filled cell this primary current is magnified by the production of secondary electrons when the primary electrons travel through the gas.

Vacuum cells, containing no gas-filling, are preferable in everything but sensitivity. If accuracy is required, efforts should be made to use lights strong enough to give the requisite current in a vacuum cell, and to use the current to the best advantage, so that only a small current is required. But for most industrial purposes, and especially in television work, where sensitivity rather than accuracy is the first requisite, gas-filled cells are necessary. The choice of the nature and pressure of the gas requires care; but this is a problem for the manufacturer, not the user. Osram photo-cells are actually filled with argon to a pressure of about 0.15 mm.

The Material of the Cathode.

The primary current is proportional to the amount of light falling on the cathode; the constant ratio of the current to this amount of light is called the emission. The emission varies very greatly both with the material of the cathode and with the quality of the light.

The light-sensitive metal used for the cathode may be potassium, sodium, rubidium or caesium. Sensitivity curves for most of these metals will be found in the June issue of this magazine, p. 209, Fig. 1.

The cathode known as "potassium-on-copper" consists of a very thin film of potassium deposited on an underlying layer of copper by a process developed by the General Electric Company. The other cathodes consist of thick layers of the metals named, "sensitized" by a well-known process involving the use of an electric discharge through hydrogen.

The materials differ enormously both in the absolute values of their emission, and in its variation with the wavelength of the light. Further, it varies very considerably with the manner in which the material is prepared, and with its treatment after preparation.

Size and Form of the Cell.

In a vacuum cell the size and the

form of the bulb and electrodes have no effect upon the current obtained with a given amount of light incident on the cathode; but, of course, if the cell is exposed to diffused light, the larger cathode will give the greater current, because it receives more light. But a cell in which the cathode is not part of the wall of the bulb is more regular in action; and this form of construction is adopted in vacuum Osram photo cells.

In gas-filled cells, on the other hand, the size and form may make considerable difference to magnification of the primary current by the gas-filling. The effect of various possible changes in size and form are too complex to be discussed here in detail. The standard gas-filled Osram photo cell has electrodes which are approximately parallel planes contained in a bulb about 5 cm. in diameter. It is believed that this is the best construction if the object is to obtain as great a current as possible, approximately proportional to the illumination, when the amount of light falling on the cell is between 0.01 and 1 lumen. The "plane" form has also important advantages in connection with the special circuit for amplifying photo-electric currents described later.

For the detection of very minute lights, such as are important to astronomers and other scientists, but

not to most industrial users, another form of cell has advantages. This consists of a very small anode at the centre of a spherical bulb 6 cm. in diameter, the wall of which forms the cathode, apart from a window for the admission of light. A cell of this form is the "spherical" Osram photo cell, and is illustrated at the head of this review.

Voltage-Current Characteristics of the Standard Osram Cell.

The standard Osram photo cell (Fig. 1) has a cathode of potassium sensitised by the discharge in hydrogen, and is filled with argon. The cathode is a layer deposited on the silver coating on the bottom of the cell; the anode is the ring, covered with gauze, parallel to it. Potassium is the cathode most suitable for use with any light that is *roughly white*, that is to say, light from sources used for general illumination, such as the sun or incandescent electric lamps. The purpose of the argon filling is to magnify the primary photo-electric current, which consists of a stream of electrons emitted from the cathode when light falls on it; these electrons travel through the gas under the attraction of the positive potential on the anode, ionise the molecules of the gas, and set free other electrons which are added to the primary stream. The amount of this

magnification depends greatly upon the voltage applied between cathode and anode; a careful consideration of this matter is, therefore, necessary.

Fig. 2 shows the voltage-current characteristics of a typical cell under different illuminations. The ordinates are the currents through the cell plotted on a logarithmic scale; the abscissæ are the voltages between cathode and anode. The meaning of the second row of horizontal numbers will appear presently. The numbers marked against each curve are the amounts of light incident on the cathode, measured in lumens, the so urce being a 200-volt 100-watt Osram gas-filled lamp.

If L_0 is the number of lumens emitted by the source and r its distance from the effective cathode, of which the area is S , the number of lumens incident on the cell is given by

$$L = L_0 S / 4\pi r^2,$$

r is here supposed large compared with the largest dimension of the source. If there is no obstruction between source and cell the effective cathode is the actual cathode; if a screen with an aperture is interposed, which cuts off some of the light from

the cathode, the effective cathode is this aperture; if a simple lens is interposed to concentrate the light on the cathode, it is the aperture of the lens.

If the illumination on the cathode is I foot-candles or metre-candles, then the lumens incident upon it are IS , where S is measured in square feet or square metres respectively.

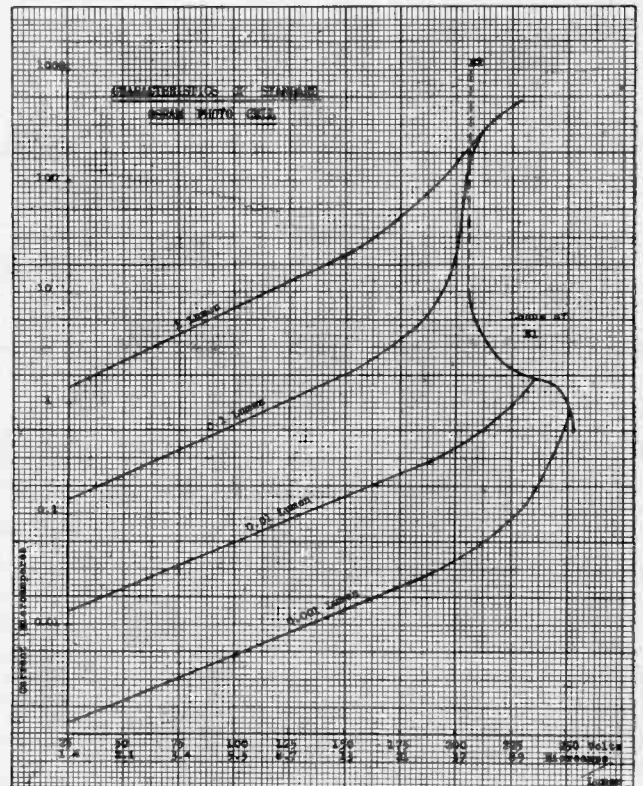

Fig. 2. Characteristic curves of standard photo-electric cell.

A gas-filled lamp may be taken as emitting 12 lumens per watt of electrical energy consumed. If sources giving light of a different colour are employed a correcting factor must be applied to the lumens marked against the curves. Thus 1 lumen of daylight is equivalent in its photo-electric effect to 6 lumens from the gas-filled lamp, and 1 lumen from a vacuum incandescent lamp to 0.75 lumen from the gas-filled lamp.

Adjustment of the Voltage.

Let us now consider the effect of varying voltage at constant illumination, which we will take first to be comparatively small. The current increases with the voltage at an ever-increasing rate, until the characteristic cuts the lower part of the thick line on the right of the diagram (Fig. 2).

At this voltage (the glow potential E_1) a discharge passes through the cell, which becomes filled with a purple glow; the current rises suddenly and enormously to the value corresponding to the point on the upper part of the thick line for the same voltage; it is now independent of the light and will not stop when

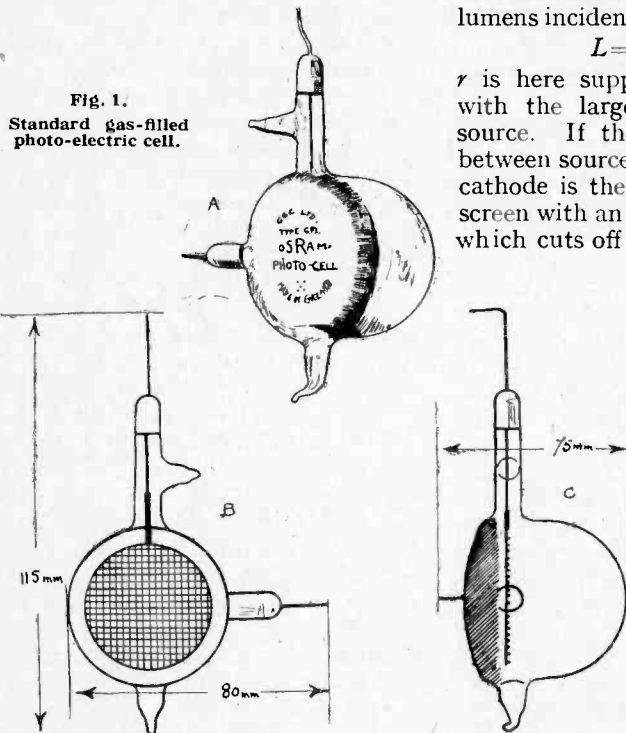

Fig. 1. Standard gas-filled photo-electric cell.



[Photo by courtesy of G.E.C.]
A type of Osram cell.

the light is turned off. If the voltage is now decreased, the current will fall along the upper part of the thick line until the vertical portion is reached at the stopping potential E_2 ; then the glow discharge ceases and the current falls back on to the original characteristic.

On the other hand, when the illumination is comparatively large, the characteristic merges slowly into the upper part of the thick curve. When it reaches this curve the current again becomes independent of the illumination, but there is no sudden increase of current. Whether the glow potential has been reached can be ascertained only by turning off the light and seeing whether the current stops.

If the greatest possible current is required for a given light a voltage just below the glow potential must be used. But the glow potential varies with the light and is lower the greater the light (unless it is very great). The greatest voltage that can be applied is the glow potential for the largest light that is to fall on the cell during use. The general rule for obtaining the greatest output is therefore to throw on the cell the greatest light to which it will be subjected; raise the potential till the glow discharge starts; reduce it immediately till the glow ceases; and then raise it to a value slightly (say 5 volts) below the glow potential. In order that the cell shall not be damaged by the discharge it is most important that a protecting resistance of not less than 10,000 ohms should

be placed in series with it; and it is not advisable to allow the discharge to continue for longer than is necessary to observe that it has started.

If the cell is to be exposed to very strong lights (e.g., full daylight) the greatest value of the voltage that can be used is the stopping potential E_2 . This can be determined by raising the potential with the cell in darkness until the glow discharge starts, and then lowering it until it stops. If the voltage is now lowered another two volts a safe value will be obtained at which *the glow will never start, however much light is thrown on the cell*, and yet a good output is obtained. The makers recommend the adoption of this voltage, unless it is important to obtain the very greatest output from very small illuminations, or unless the current has to be accurately proportional to the light at large illuminations.

Next we have to consider the variation of the current with light at constant voltage.

The necessary facts can be obtained by drawing vertical lines in Fig. 2 at the constant voltages, and plotting the corresponding ordinates against the lumens marked on each curve. If the intersections of the vertical line with the curves are equidistant, the current is proportional to the light; *it will always be so proportional if the light is sufficiently small*. We may therefore mark against each voltage the ratio of current to light for small lights; this ratio, in microamperes per lumen, is given by the lower horizontal row of figures in Fig. 2.

At greater illuminations the current increases more rapidly than the light, and the illumination at which deviation from proportionality begins is less the greater the voltage. If the voltage is E_2 , there is a range over which the current increases enormously rapidly with the light; namely, where the vertical line passes from intersecting the curves that meet the lower part of the thick line to intersecting those that meet the upper half. If it is desired to obtain the greatest possible current from the cell from a limited amount of light, and proportionality of current to light is not important, an effort should be made to secure light sufficient to fall in this range; it should be about 0.1 lumen.

Variability of Photo-electric Cells.

There are two kinds of variability to be considered—that in the same cell according to its previous history, and that between different cells of the same type.

If the directions for adjusting the voltage of the cell are followed each time it is taken into use the cell will always start at its maximum sensitivity. The emission for the cathode is greatest just after the glow discharge has passed; after a rest of 24 hours it will drop to about one-third of this maximum value. If a comparatively large current is passed through the cell in use, obtained with a large light and a large voltage, the emission will keep at or near the maximum value; but if small lights or small voltages are used, it will fall gradually to the minimum value. If small lights are to be used, and constancy of the response over a space of an hour is important, care must be taken not to pass the glow discharge.

Again, the glow potential changes somewhat when the discharge is passed for the first time after a long interval. In adjusting the voltage according to the instructions, it is therefore well to start and stop the

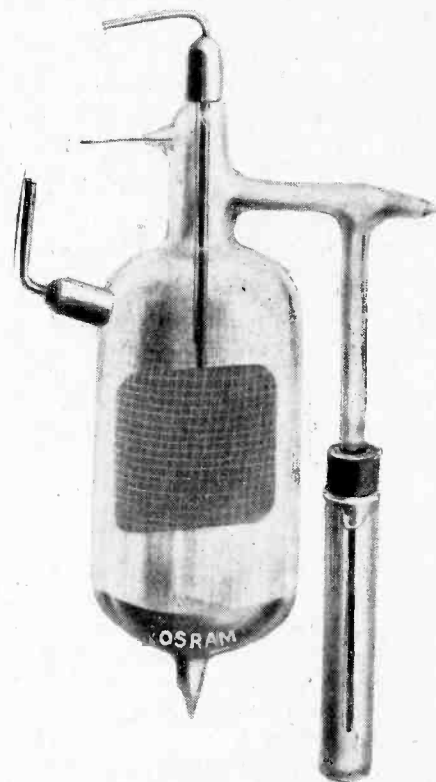

[Photo by courtesy of G.E.C.]
Another type of Osram photo cell.

discharge several times before taking the final value.

Next, it is impossible to make cells all of which have identical characteristics, and Fig. 2 must be regarded as representing only a typical characteristic. Other cells may differ from it in three ways.

1. The primary photo-electric current excited by a given light may be different. The effect of a change in this primary current is to shift the whole set of curves parallel to the vertical axis, or (for this is equivalent) to multiply by a constant factor all the numbers marked against the curves. In extreme cases this factor may lie between 0.7 and 1.3. It may even vary between these limits

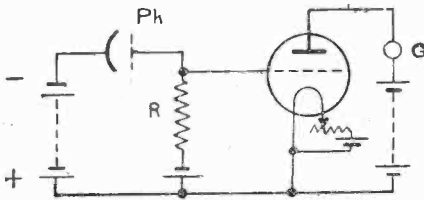

Fig. 3.
The fundamental amplifier circuit for photo cells.

over the surface of the cathode of a single cell.

2. E_1 and E_2 may be different. The effect of this change will be roughly to change the scale of the abscissæ. E_2 may lie between 210 and 150 volts. In Fig. 2 it is shown at 205 volts; if it lies elsewhere the diagram will be roughly correct if all abscissæ are changed in the ratio $E_2/205$.

3. The form of the thick line may change somewhat. The chief effect of this change is to alter the illuminations at which the current ceases to be proportional to the light, and the illumination at which, when the voltage is E_2 , the very great increase occurs in the current when the light is increased. These limiting illuminations may change in a ratio of about 3 to 1.

VALVE AMPLIFICATION

The Fundamental Circuit.

Although the current through a photo-electric cell increases when the light incident on the cathode is increased, the current obtained with such light as is usually available does not exceed a few micro-amperes, and is often very much less. In the laboratory such small currents can easily be measured with galvano-

meters and electrometers, but for most industrial purposes, and particularly when the changes of light have to operate automatically, some mechanism or further electrical circuit, the currents must be amplified. The increasing use of photo-electric cells in recent years is due largely to the development of thermionic valves, which make amplification possible.

The fundamental circuit, from which all others may be regarded as derived, is shown in Fig. 3. But the exact arrangement of Fig. 3 is seldom the best; the modifications of it appropriate to particular purposes must now be considered.

Detection, Burglar Alarms, &c.

First the cell may be wanted merely to detect the presence of light and operate a relay when light falls on it. The resistance R may then be omitted. In its absence, when no light falls on the cell, the grid of the valve is insulated and takes up a potential such that there is no grid current. If a power valve is used, for instance an Osram P.625 with 150 volts on the anode, the corresponding anode current will be about 20 ma.

When light falls on the cell the current from it charges the grid negatively; this negative charge

cannot escape from the grid through the valve, except in the form of "backlash" carried by the positive ions in the valve; consequently, if the photo-electric current is greater than the backlash, which is of the

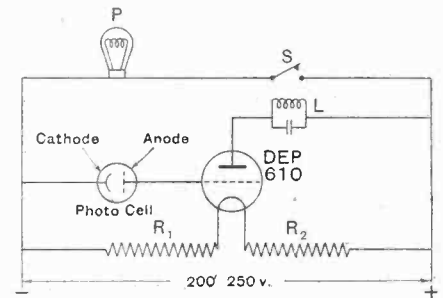
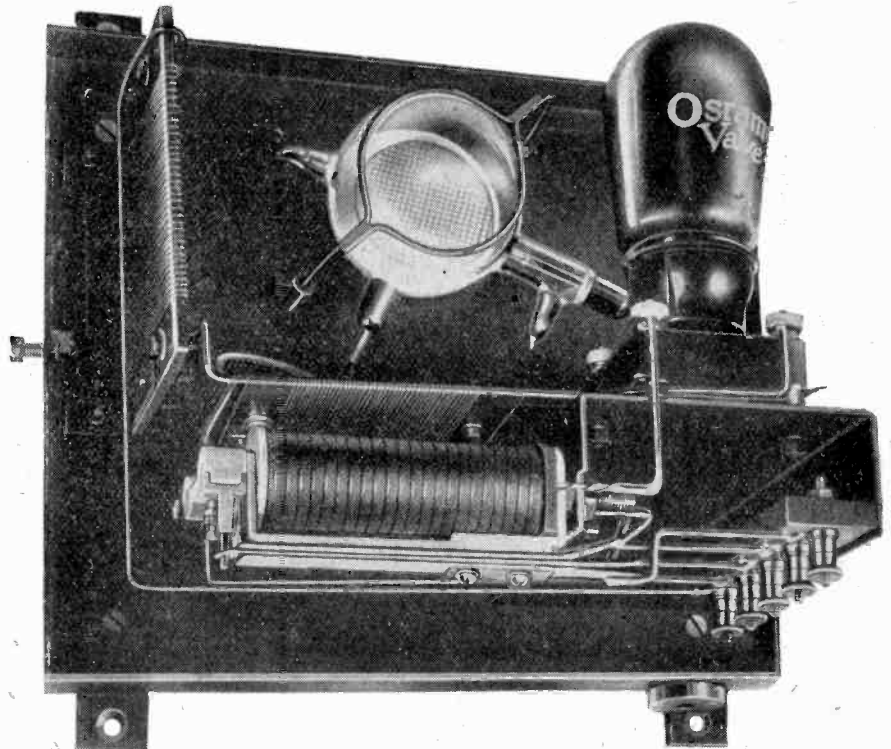

Fig. 4.
The circuit of the new Osram photo-cell amplifier, shown in Fig. 4a.

order of 10^{-8} amperes, the negative potential of the grid increases until it is equal to that applied to the cathode of the cell. If this potential is more than 30 volts, the anode current will cease entirely. Accordingly the effect of light is to stop the current in G . In this and all other arrangements, the insulation of the grid must be good, in order that it shall not pass any current comparable with the small photo-electric current. Some valves may have to be rejected on the ground of insufficient insulation.



[Photo by courtesy of G.E.C.]

Fig. 4a.
The new Osram photo-cell amplifier, a complete self-contained unit comprising one-valve amplifier, standard Osram photo-cell and 50 ma. relay. The amplifier is designed to work off the mains.

If mains are available giving 200 volts or more, a further simplification is possible, shown in Fig. 4. The cathode voltage of the cell, the anode and filament voltages of the valve are all derived from the same circuit. The resistances R_1 and R_2 are adjusted so that the correct current flows through the filament and the correct voltage to the anode; the difference between this anode voltage and the voltage of the mains is applied to the cathode of the cell. Thus, if the mains give 200 volts, and a P.625 valve is used with 150 volts on the anode, R_1 and R_2 should be 200 and 600 ohms respectively. If the supply is A.C. a condenser of about 0.0005 mfd. should be inserted across the cell.

When no light falls on the photo-cell, a current flows in the anode circuit of the valve. As soon as light falls on the cathode of the photo-cell the grid of the valve assumes a negative charge, and the anode current of the valve is stopped.

This change of current through the operating coil of the relay closes the secondary contact S, and lights up the indicating lamp P. The change in current through the relay-operating coil is about 10 milliamps. The secondary contacts will carry about 50 milliamps. Larger currents can be dealt with by a further relay circuit in place of the lamp P.

If the photo-electric current is as great as 0.1 microampere the circuit

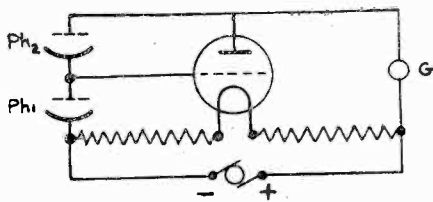

Fig. 5.

An indicator circuit using two photo cells.

will operate in a very small fraction of a second when the light is turned on; but the restoration of the anode current when the light is turned off will not be so rapid, because only the small backlash is available to restore the grid to its original potential. Speed may be increased by inserting a grid leak of several megohms, through which the negative charge can flow away; but sensitivity is thereby sacrificed. A better plan, which often has subsidiary advantages, is to employ a second photo-electric cell, as shown in Fig. 5, on which is thrown a constant illum-

ination. The anode current will now flow if the photo-electric current in Ph_2 is greater than that in Ph_1 , but will cease if it becomes less. If both cells are illuminated by the same source, the lights on them can be adjusted so that a very small

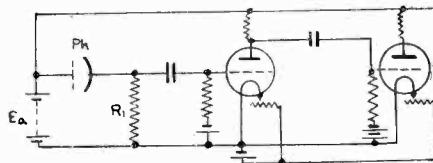

Fig. 6.

A resistance-capacity coupled amplifying circuit.

decrease in that falling on Ph_1 , due to the introduction of absorbing matter before it, stops the anode current; the amount of absorbing matter required will be almost independent of variations in the light sources.

Fluctuating Lights.

In the application of photo-electric cells to such purposes as picture telegraphy, talking films, or television, variations of light occurring with frequencies up to 10,000 per second have to be translated into corresponding variations of amplified current. Here the problem is very similar to that of audio-frequency amplification in radio-reception. The coupling between the cell and the first valve need no longer be conductive as in Fig. 3, it may be effected by capacity or inductance, which transmit only the variable component of the current, and the difficulties discussed in the preceding section may be avoided. Coupling by a condenser is usually employed, and if it is employed also in the subsequent stages of amplification, the whole circuit becomes a normal arrangement of resistance-capacity coupling (Fig. 6).

The choice of the resistance R_1 is the only matter requiring special consideration. The greater R_1 , the greater will be the variation of the grid potential of the first valve produced by a given photo-electric current, and the greater, therefore, the sensitivity. But a limit is set by distortion at the higher frequencies. The cell possesses a finite capacity C. If the frequency n of the photo-electric current is so high that $2\pi nCR_1$ is comparable with 1 there will be loss of amplitude and apparent time-lag in the operation of the cell. In order to combine as far as possible

sensitivity and absence of distortion, C must be made as small as possible; the cell should be as close as possible to the first valve, in order that the capacity of the leads may be reduced to a minimum; but even then R_1 should not usually exceed 2 megohms.

And here a word may be added on the question, so often raised, of time-lag in photo-electric cells. There is absolutely no measurable time-lag in the primary photo-electric current. Some time-lag may possibly enter in the magnification of this primary current by ionisation by collision in a gasfilled cell, but there is no evidence that it is appreciable in well-made cells properly used at any audio-frequency. What appears to be time-lag usually arises from the presence of a capacity which the small photo-electric current takes an appreciable time to charge and discharge.



[Photo by courtesy of G.E.C.]

Still another type of Osram cell.

How the French Police Proved Phonovision

By DEREK IRONSIDE

JACQUES MOULHAIN, Chief Inspector of the Sûreté at Marseilles, waved a hand dramatically towards the massive television receiver in the far corner of the room. His subordinate, Sergeant Duprez, turned a slightly bored but respectful countenance in the direction indicated.

"*Tiens, mon enfant,*" ejaculated the inspector enthusiastically. "At last our office is equipped with this latest scientific aid in our ceaseless conflict with crime. You've no idea how difficult it was for me to convince headquarters that Marseilles was more important than Bordeaux, and that we should be the first to be fitted with this apparatus. But I made them see my point of view. Bordeaux will have to wait a month to get their receiver."

"And what are the precise functions of this—er—apparatus?" inquired the Sergeant, regarding the receiver with a fascinated look such as an Australian aborigine might cast upon a typewriter. "I concede that television is an absorbing hobby and an interesting means of entertainment—I spent an evening last week at the Marseilles Television Theatre and saw a broadcast of the Folies Bergères from Paris—but I fail to see its possibilities as regards our own profession."

The Chief Inspector snorted impatiently. "I'll explain, Duprez." He crossed over to the receiver with swift steps. "The uses of this instrument are manifold. It is of the type known as a transmitter-receiver-recorder. With this red-knobbed switch pushed over to the left—*comme ça*—the apparatus is ready to transmit. With the switch over to the right, it becomes a receiver.

"Now, should you wish to record either something actually received from another station or events occurring in this room, you depress this blue-knobbed switch. It occurs to me, for example, that a record of

some of the little interviews which take place here from time to time with our friends of the underworld might be of inestimable value when the friends in question come before the examining magistrate. But this seems to alarm you, Sergeant."

"I was merely wondering, sir, whether it would really be advisable to take such records. The possibility of a magistrate observing too closely our methods of evidence-extraction—sometimes called the 'third degree' by the vulgar populace would rather cramp my style here."

"That is certainly a point, my practical and cautious Duprez. But to continue. Our mobile televisor, in charge of a skilled mechanic of the Sûreté, is available for setting up at any point in Marseilles, and can be hidden behind an upper-storey window, in a tradesman's van or in any other place of concealment. Sitting snugly here, we shall be able to make most useful observations.

"In addition, secret televisors are being established at the quay, the railway stations and at the aerodrome, in conformity with a general plan of the Minister of the Interior, who is anxious that the arrival of persons from abroad shall be closely controlled. As a further refinement, hidden televisors are also being fitted in the cabins of passenger aeroplanes and seaplanes. The pilots have instructions to switch on their televisors when fifteen kilometres from Marseilles, whereupon a buzzer will sound here, and on our moving the red switch to the receiving position a view of the interior of the cabin will be seen on the screen. Should any of the passengers prove to be undesirable, we act according to our discretion."

"You said, sir," interjected Sergeant Duprez, "that it is possible to take a permanent record of a scene. How is this done?"

"It is done, my dear and stupid Duprez, by means of what is called a phono-visual attachment. The

disintegrated light impulses are converted by the photo-electric cell of the receiver into electric impulses, which are in turn changed into sound-waves and recorded upon a sort of gramophone disc. You don't understand this, of course, but all you have to do is to depress this blue switch and the machine will do the rest. If . . ."

The Chief Inspector stopped short. The buzzer inside the receiver had begun to sound.

"Somebody is calling us, you see, Duprez," explained the inspector. "Now, I move the red switch over to the right. The screen immediately becomes animated. We are looking at the face—rather too life-like and large to be actually pleasant—of our mutual friend, Inspector Levois, of the Moroccan section of the Sûreté at Casablanca. You will observe that he has not yet had his weekly shave. In a moment he will commence to speak."

Surely enough, at that moment the loud-speaker concealed inside the cabinet began to function: "Sûreté, Casablanca, calling Sûreté, Marseilles. Please give the 'Understood' signal."

The Inspector touched another switch on the cabinet.

"Your 'Understood' signal received, Marseilles. This matter is extremely urgent. Pierre Duvalier, serving seven years penal detention at Bou Haima Penitentiary, has escaped and is believed to be heading for Algiers. Can you send a man to Algiers to intercept him? I am short-handed here—half my men have dysentery."

"I know Pierre Duvalier, Inspector," ejaculated Duprez excitedly. "I have an old grudge to settle with him. Let me go to Algiers."

"*Volontiers, mon ami,*" agreed the inspector. He threw the switch over to 'transmission.' "Hallo, Levois! Moulhain, of Marseilles, speaking. Am sending Sergeant Duprez, who knows Duvalier, by

the first seaplane bound for Algiers." "So you know Duvalier," said the inspector curiously when he had switched off. "And your acquaintanceship was not pleasant, since you owe him a grudge."

recognising him. My inspector was furious, and only the merest chance saved my career from a drastic termination. But next time, inspector, I shall not miss him. He can come disguised as an Arab, a Levan-

died somewhere in the desert, but had his doubts whether this explanation would altogether satisfy his chief.

The engines of the seaplane were already roaring when the cabin door opened and another passenger was admitted. From force of habit, Duprez shot a swift glance at the newcomer—not without hope that by mere chance it might prove to be the fugitive. But the most casual glance was sufficient to set any possible doubt at rest. The new passenger was a rubicund, cheery curé, doubtless proceeding on holiday from some comfortable Colonial mission. The two men exchanged greetings, but for the major part of the journey, whilst the seaplane flew over the sparkling blue waters of the Mediterranean, they scarcely spoke again. The curé was busy writing letters, whilst Duprez, too moody in any case to engage in conversation, glowered at the sea below him. Presently, however, the curé laid aside his writing and became sociable.

"It will be pleasant, m'sieur," he remarked, "to get back to France again. Five years in Morocco at a stretch are enough for me."

Duprez laughed. "You look as though Morocco has agreed with you, monsieur le curé."

The reverend gentleman flourished his hands deprecatingly. "Physically, yes, but spiritually, no. My heart has remained in France. We are so much out of things in Morocco. Everything is so primitive. There is not a single television theatre in the whole country, you know. And I have always been interested in television. Five years ago, in Paris, I used to experiment with a rather primitive set, modelled on Baird's earlier patents, and pick up the transmissions sent out after the usual broadcasting hours. But since those days, I understand, television has become a world-wide industry."

"That is true," agreed Duprez, "we use it even in my business."

"How interesting. It would perhaps be impolite to ask what that business is and how you apply television to it."

"Well—er—I'm afraid I'm scarcely at liberty to disclose details, monsieur le curé. You see, my firm is a limited company, so that I have a duty towards my shareholders."

"Oh, exactly. Pray excuse my



Recognition was sudden and mutual. Even as Duprez's hand flashed to his revolver pocket the Curé leapt upon him.

"Duvalier nearly got me discharged from the Sûreté, inspector. He was one of the cleverest mechanic-crooks in Montmartre when I was stationed in Paris some years ago. I knew him very well and had warned him that one day I should have to arrest him. He was, incidentally, a master of disguise, with curiously plastic features that enabled him to adopt a fresh face almost at will. Nevertheless, I was sure that I could always get him when I wanted him. He had a peculiar habit of twitching his shoulder when excited or spoken to suddenly.

"One day, however, I was ordered to arrest him on a charge of robbery under arms, and he fooled me completely. I actually passed him in the Rue Lamarck as he was tottering along in the guise of an enfeebled old man. This was bad enough, but worse was to follow. He was accidentally arrested as a suspect by an officer in another *arrondissement*, and his true identity revealed. Out of sheer malice he broadcast the fact that I had brushed past him earlier in the day in Montmartre without

tine, a Maltese pedlar or an old Indian hag, but I'll get him and send him back to the hell from which he has escaped."

"You are sure you would know him again?" asked the inspector suavely. "Men alter considerably at Bou Haima, I have heard. Some have been known to prefer Devil's Island."

"I shall know him," affirmed Duprez savagely. "I'll leave by the noon seaplane for Algiers, inspector."

* * *

Nevertheless, a month later, a disappointed and disgruntled Sergeant Duprez sat in the cabin of a big seaplane at Algiers, waiting for it to commence its flight back to Marseilles. He was, apparently, to be the only passenger. He was not looking forward to his pending interview with the inspector at Marseilles, since his quest for Pierre Duvalier had been entirely futile. No trace of the man had been discovered since he had escaped from Bou Haima Penitentiary. Duprez had decided that the man must have

rudeness in pressing you. Hallo, we're fairly close to Marseilles now—the coastline is becoming quite clear."

Duprez noticed that the curé's voice was curiously excited. There was certainly no doubt that he was really eager to get back to France. Duprez stared at him dully, then, despite himself, the blood surged to his temples.

The curé's shoulder was twitching spasmodically. Suddenly conscious that Duprez was staring at him, the curé turned swiftly.

Recognition was sudden and mutual. Even as Duprez's hand flashed to his revolver pocket, the curé, his pleasant expression changed to one charged with ferocity and hatred, leapt upon him.

At the same instant, ten kilometres away, Inspector Moulhain, of the Marseilles Sûreté, was staring in horror at the television-screen, to which he had been called by the buzzer a few minutes earlier.

* * *

The court was crowded. Everybody was excited and perspiring, from the presiding judge downwards. Already the case had attracted enormous attention. The disappearance of a member of the Sûreté from a seaplane en route from Algiers to Marseilles was unusual enough, but for his fellow-passenger—a curé of the Church—to be arrested on arrival on the charge of murdering him added a further sensation to the extraordinary affair.

There was a general feeling, however, that this time the Sûreté had overreached themselves. The seaplane pilot had seen nothing of the alleged affray, whilst the curé had already declared on oath that Sergeant Duprez had gone suddenly mad, and despite his efforts to restrain him had flung himself out of the cabin door into the sea. There were no evidences of an affray within the cabin, and everybody agreed that the Sûreté would have a very hard task in proving their charges.

The Public Prosecutor opened the case well, but obviously made the fullest use of his imagination. His description of the curé, who sat genially in the dock between two gendarmes, as "this desperate miscreant," created laughter in court by its obvious absurdity. Anybody could see that this curé was a jolly

young fellow. The case was not going to last long. They would all be able to leave very soon and have an apéritif in the Café de la République, which happened to be so conveniently near the court.

"I propose to call only one witness," concluded the Public Prosecutor. "His evidence, I think, will be decisive. We are, of course, all desirous of concluding the case as quickly as possible."

Inspector Moulhain was called.

"On June 5th last," he affirmed, "I received a wireless message from Sergeant Duprez that he was leaving Algiers by the 10 a.m. seaplane for Marseilles. He had been searching North Africa for an escaped convict named Pierre Duvalier. At 5 p.m. a buzzer in my office at Marseilles announced that the seaplane was about fifteen kilometres distant.

"It is not a matter of common knowledge that in the interests of the State, all aeroplanes arriving at Marseilles are fitted with televisors

while the other, with whom he was chatting in a friendly fashion, was this gentleman now in the dock. I had scarcely been watching them for more than a minute, however, when an argument seemed to arise and the two men grappled in a desperate and violent conflict. By sheer bodily strength, the curé overpowered Duprez and, dragging him to the door of the cabin, hurled him into space. It was all the work of seconds. I accuse this curé of the foul murder of my colleague."

The curé's counsel rose and appealed to the presiding judge. "I protest against such evidence being allowed. What proof has the inspector that he saw such an occurrence on the screen of his television receiver?"

Inspector Moulhain faced the court stiffly. "I have the proof here. Our television apparatus can be adjusted to take a permanent record of anything it receives. The electrical impulses constituting the pic-

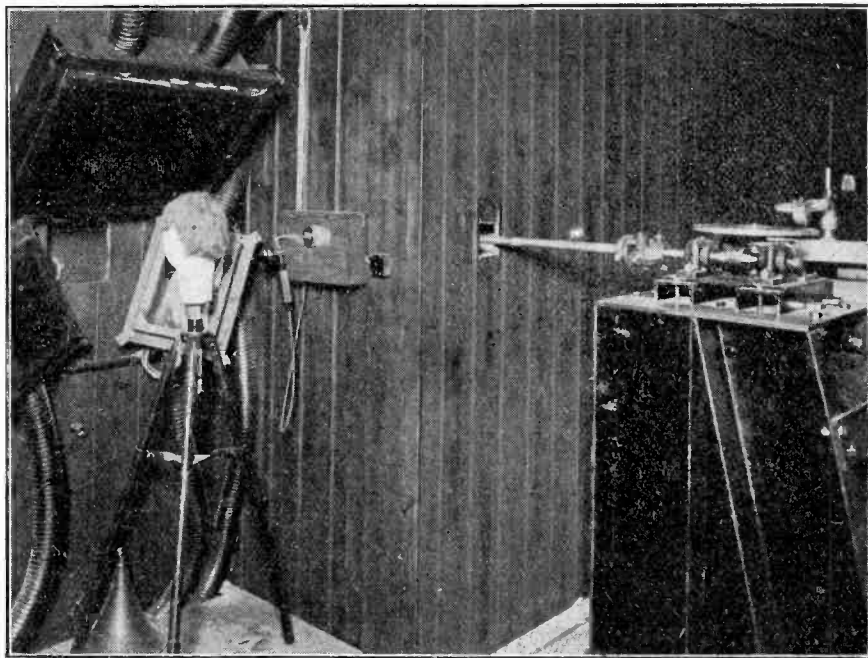

The noctovision transmitter (left) and the phonovision recording mechanism (right) in the Baird laboratories.

tures received are converted into sound-waves and recorded upon a sort of gramophone-disc, this process being well known to experts as phono-visual reception. To reproduce the picture, a gramophone pick-up is used in conjunction with a television-receiver. The necessary apparatus is actually here in the

which are put into operation at a certain distance from the port, so that the Sûreté may secretly examine the passengers. At 5 o'clock, therefore, I was accordingly watching the two passengers in Seaplane No. F-BMXY.

"One of the passengers I recognised as my own Sergeant Duprez,

body of the court, and I have here in my hand the sound-record of the scene which occurred in the cabin of Seaplane No. F-BMXY at 5 p.m. on July 5th. May I request that the court be darkened?"

Throughout the court the ushers extinguished the lights, and in a minute, save for a faint glow upon the judge's bench and in the dock, where the gendarmes guarded the accused man, the place was in darkness. A moving picture flashed into animation on the radiant screen of the inspector's apparatus.

As though spellbound, judge, counsel, the accused and the mass of spectators gazed at that living screen. There was almost complete silence save for the faint scratching of the twirling disc.

Upon the screen there had become visible the luxurious interior of a seaplane cabin, within which two men, their forms outlined against the glare of the windows, sat talking. One of the men, wearing a broad ecclesiastical hat, was obviously the accused man, whilst those who had known Sergeant Duprez had no difficulty in identifying him as the burly companion of the curé.

Suddenly the curé was seen pointing at some object outside the cabin, probably a landmark, and apparently addressing his companion rapidly and excitedly. Instead of gazing in the direction indicated, however, Duprez riveted his eyes on the curé himself, as if something about him had arrested his attention. The next moment the curé had turned, his eyes blazing with suspicion, and in a moment the two men were locked in a hideous embrace, rolling over and over on the floor of the cabin as each attempted to gain the mastery.

Within the court a profound stillness reigned as all gazed at the reproduction of that sinister tragedy that had occurred above the Mediterranean many weeks earlier. A sort of paralysis seemed to grip the silent watchers, but the spell was rudely broken by a scream from the dock that echoed uncannily in the darkness.

"*Mon Dieu*, switch it off. I'll confess everything." The curé's voice rang out dramatically through the darkened hall. There was the sound of a scuffle as the gendarmes pushed the accused man down once more into his seat.

On the screen the curé had now gained the mastery of his surprised opponent and was furiously dragging him towards the door of the cabin. Duprez seemed to resist grimly, but presently he vanished from sight. The curé, panting with his exertions, staggered into a seat.

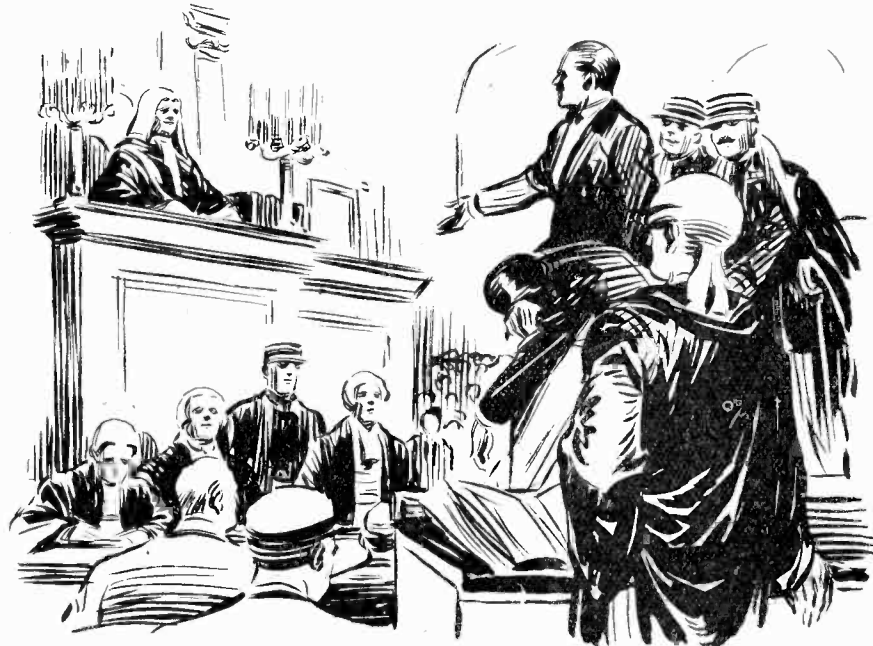

The prisoner had fallen forward. The gendarmes and a little fussy man in black—apparently a doctor—were feverishly trying to revive him. Then the little man in black rose slowly, and addressed the presiding judge: "*Monsieur le Juge*, it is futile to proceed. Pierre Duvalier is beyond the reach of human justice."

The excitable French audience broke into a storm of execration. Pandemonium reigned for a full five minutes, and riff-raff from the docks demanded that the curé should be lynched out of hand. But presently the ushers and police restored order, and quiet ruled once more.

"And now," came the inexorable voice of the inspector, "I propose to show a slow-motion picture of the first stages of the fight between the two men. We shall be able to analyse the causes of the dispute. Ah, you see. They are talking, as you can observe, in quite a friendly fashion. The curé is pointing out of the window, apparently at some landmark which indicates that the seaplane is very close to Marseilles. The idea of Marseilles seems to excite and agitate him. He has a peculiar habit, apparently, when excited, of twitching his shoulder. You can all observe this peculiar habit. Sergeant Duprez also observes this action. It fascinates him—as well it might.

"Note how intently he is staring at that shoulder. He has been searching North Africa for a month past to find a man with that particular habit. Ah, now the curé realises that he had been recognised. He is leaping upon Duprez before the Sergeant can draw his revolver.

I think we have seen enough, so I will stop the apparatus. But who is this man with the twitching shoulder? It is not a curé on leave from Morocco. It is an apache of Montmartre, Pierre Duvalier, the man with the plastic features, the man who escaped from Bou Haima Penitentiary. I accuse Pierre Duvalier, now in the dock, of the murder of Sergeant Duprez."

The lights in the court room went up in a sudden blaze of brilliance, and all eyes were turned towards the dock, around which there was a distinct stir. The prisoner had fallen forward. The gendarmes and a little fussy man in black—apparently a doctor—were feverishly trying to revive him. Everybody stared in futile astonishment. Then the little man in black rose slowly, shrugged his shoulders despondently, and addressed the presiding judge:

"*Monsieur le Juge*, it is futile to proceed. Pierre Duvalier is beyond the reach of human justice."

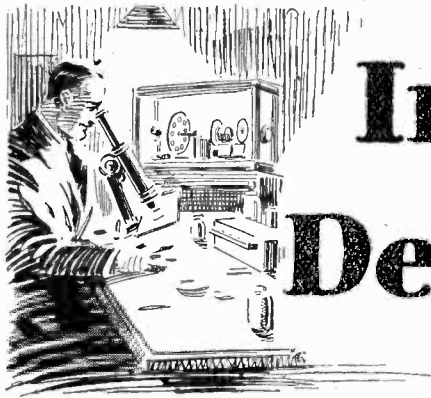

Invention and Development

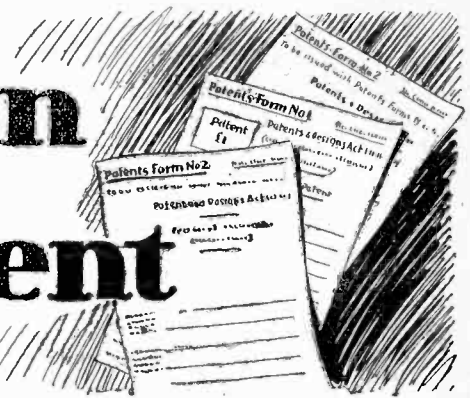

The following abstracts are prepared, with the permission of the Controller of H.M. Stationery Office, from specifications obtainable at the Patent Office, 25, Southampton Buildings, W.C.2. Price 1s. each.

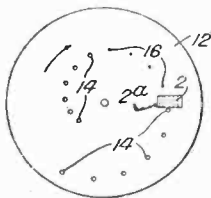

FIG. 1.

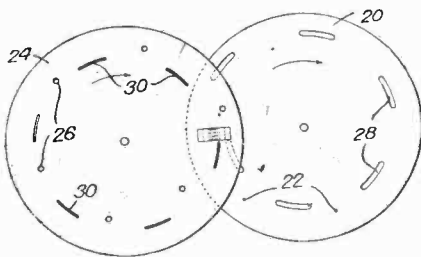

FIG. 2.

Patent No. 303771, granted to J. L. Baird and Television, Ltd.—A “graded-zone” system of exploring and utilising the known characteristic of the human eye (which sees extended scenes in greater detail at the centre) is described in this Patent specification. Fig. 1 shows an exploring disc (12) having large holes (14) with comparatively large radial spacing at one (or both) ends of the spiral, the remaining holes being small with small radial spacing. The picture area can be shifted so that the close spaced exploring lines (2a) occur at any part desired of the picture. Another arrangement is shown in Fig. 2, where the whole picture is explored in broad lines by holes (26) in one disc (24), and a certain zone of the picture is additionally explored in fine lines by holes (22) in the disc (20). The slots (28) (30) are provided to prevent interference. The distance between the centres of the discs may be varied so as to alter the location of the finely divided explored region in relation to the rest of the picture. Synthesising, or building up of the received picture, can be effected by the same means.

Patent No. 308277 (Convention date (U.S.A.) March 20th, 1928), British Thomson-Houston Co., Ltd.—The layout of a two-colour television system is indicated in Figs. 3 and 4. Interlacing lines of

the picture (5) are explored by the two sets of spirally arranged holes (6) and (7) in the rotating disc (4), a source of light (1), and the disc (3) consisting of two coloured sectors (9) and (10). This disc (3) is geared to the disc (4), and has the effect of providing the holes (6) with light of one colour, and the holes (7) with light of another colour. Light reflected from the picture (5) is converted into electrical impulses by photo-electric cells (13). At the receiver, shown in Fig. 4, the exploring disc is identical with that of the transmitter, the two sets of holes being illuminated by two different coloured lamps (16) and (17), the current impulses from the

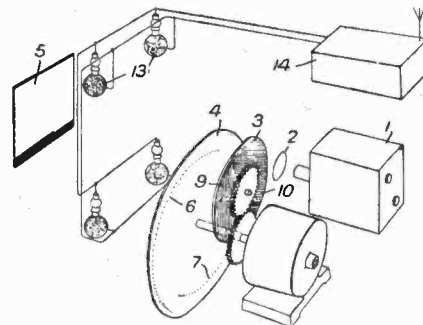

FIG. 3.

receiver being directed to the appropriate lamp through a commutator (20) mounted on the same shaft as the disc (18).

Patent No. 309224, granted to The General Electric Co., Ltd., and N. R. Campbell.—This Patent is an addition to No. 306996 (described in June issue of

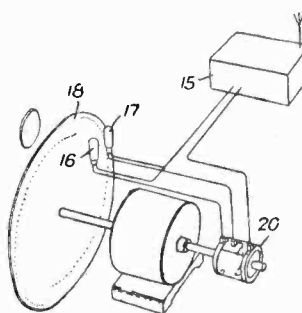

FIG. 4.

TELEVISION, page 214). Constancy of the hydrogen filling may be secured by providing a palladium tube in the cell. The support for the sensitive film is of a metal other than silver or platinum, and is pre-

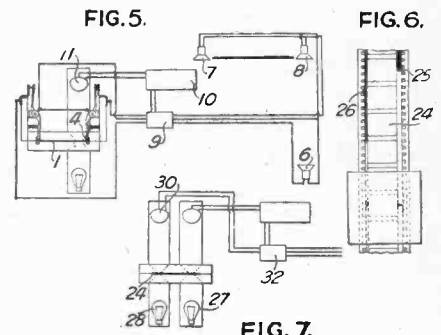

FIG. 7.

ferably copper or zinc. A preliminary layer of silver, formed on the bottom of the cell, is washed, dried, and heated to 100° C. for 15 minutes. The cell is then supported with the silvered coating vertical, and is filled with a coppering solution. A current of about 2 milliamps. per sq. cm. is passed through the solution for about 15 minutes, with a copper wire as anode and the silvered coating as cathode. The copper surface is then a matt chocolate brown colour. The cell is now washed, dried, and baked for a few minutes at 300° C. so as to oxidise the surface of the copper. The film of potassium is formed as described in Patent No. 306996, and hydrogen is then admitted.

The coppering solution is formed by preparing freshly-precipitated copper carbonate by adding a solution of 400 grams of crystallised copper sulphate in 2 litres of water to a solution of 100 grams of anhydrous potassium carbonate in 1 litre of water. The mixed solution is allowed to stand for one hour, and the precipitate is filtered off and washed. The precipitated copper carbonate is gradually added in excess to 60 grams of acid potassium tartrate dissolved in 1 litre of boiling water. The solution is filtered and allowed to stand for several days until the deposition of a blue precipitate ceases or becomes very slow.

Patent No. 309208, granted to S. K. Wilson and De Forest Phono-Films, Ltd., whereby arrangements are described for localising the sound effects in the auditorium in accordance with the topic treated in the film; for example, the sound appears to issue from the roof in the case of a film depicting aeroplanes. In Fig. 5

(Continued on page 272.)

THE BEST LETTERS OF THE MONTH

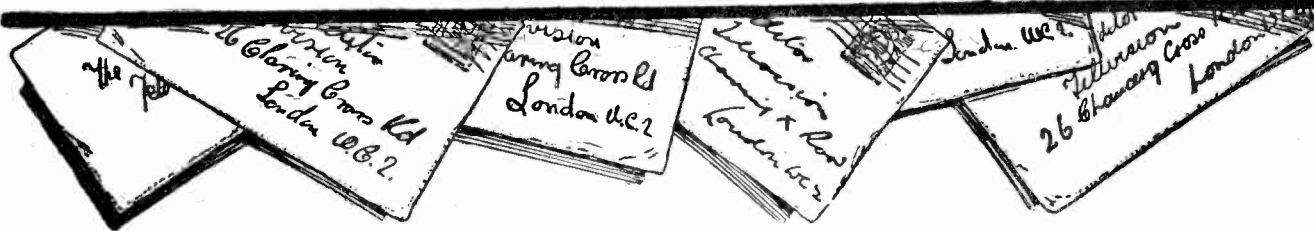

The Editor does not hold himself responsible for the opinions of his correspondents. Correspondence should be addressed to the Editor, TELEVISION, 26, Charing Cross Road, W.C. 2, and must be accompanied by the writer's name and address.

MECHANICAL FORCE OF LIGHT.

THE GREENS,
CARNWATH, LANARKSHIRE.

May 21st, 1929.

THE EDITOR,

"TELEVISION."

DEAR SIR,

I have followed with great interest the ideas put forward by Mr. E. P. Adcock and others in the correspondence columns of your journal TELEVISION.

While offering no comment as to the utility of these schemes, I would like to draw the attention of your readers to a phenomenon which, I think, might be utilised to advantage for television purposes.

This phenomenon—namely, "The mechanical force exerted by light on being reflected"—is quite well known, and is clearly demonstrated by the small daylight machines often exhibited in opticians' windows. I put forward no suggestion at the moment as to how this force could be utilised, but I will be very interested indeed in any opinion on this subject put forward by those gentlemen (and of course ladies) who are interested in the advancement of this great new science.

Trusting this matter is of interest.

I am, Sir,

Yours faithfully,

ROBERT CADZOU.

LAG OF SELENIUM.

HYLTON VILLA,
WESTFIELD, REDCAR,
YORKSHIRE.

June 14th, 1929.

THE EDITOR,

"TELEVISION."

DEAR SIR,

The "Lag" in a selenium cell, which formed the subject of Mr. C. M. Adcock's

letter in your June number of TELEVISION, has been investigated during the past two years or so.

It was found that provided the selenium layer was thin enough to be penetrated by the incident light, i.e., provided the thickness did not exceed .01 cm., and that the cell was dry, the lag was negligible.

The explanation given was, I believe, that the light liberated electrons which at once recombined when the light was removed. If, however, a thick layer of selenium was used this state of affairs was only true for the thickness of the selenium penetrated by the light, the remainder suffering a secondary ionisation by the photo electrons. It is this "ionisation at a distance" which gives rise to the well known lag.

The cure for lag is obvious, if this is correct, and experiments seem to confirm this statement.

The true cause of change of conductivity of selenium is not yet fully understood, and I would point out that from the Quanta view point the electrons liberated and energy of incident light do not fully agree.

I am, Sir,

Yours faithfully,

R. NEVILLE GRAY.

ELECTRO-MAGNETIC WAVES

SYDENHAM, S.E.26.

1st, June 1929.

THE EDITOR,

"TELEVISION."

DEAR SIR,

My letter to you, Sir, in your May number of TELEVISION had its origin in a sentence in Sir Ambrose Fleming's article in the April number.

It was not intended to provoke an elementary lecture on Physics from your correspondent in your June number, a lecture that might have been of service to me sixty years ago, but does not

directly deal with the question, while it shows evidence that my letter has not been very carefully read, nor does your correspondent fully realise the position Dr. Einstein takes up now.

I had no intention when I wrote you of opening a discussion but of stating a series of opinions arising from Sir Ambrose's question on page 56 in your April number. May I be permitted to leave the matter there? While thanking you for your courtesy in affording me so much of your valuable space.

I am, Sir,

Yours faithfully,

A. HAYWOOD.

Lt. Col. (retd.)

RIANT MONT,

LA ROSIAZ,

LAUSANNE.

April 29th, 1929.

THE EDITOR,

"TELEVISION."

DEAR SIR,

Mr. Wolfson's letter in your April issue was considerably interesting, and I have taken a few pains and time to see what his idea really is, but at the present moment, unfortunately, I am at loss for a correct interpretation. I can only trace, if he will excuse my saying so, a contradiction of ideas. Moreover, I can find nothing to support Mr. C. M. Adcock's idea.

As far as I can make out λ depends on the atmospheric conditions. Under two separate distinct conditions it is in my opinion possible to have too light waves of the same frequency but different wavelength. It is therefore evident that the speed of light cannot be an universal constant, as otherwise the action of the prism in separating light would be inexplicable.

Light is a subject that interests me, and I should be much obliged if Mr. Wolfson would kindly give me the titles of the books from which he obtained his

information, as it would be beneficial to examine this question more deeply.

I feel that I must, however, thank Mr. Wolfson for his somewhat unnecessarily severe criticism, as it is leading to a deeper investigation, and I fancy that he really has a good idea if only it can be isolated.

If he would allow me to refer to his formula $Q=i$, which is perfectly correct, I would point out a slight misinterpretation. Quantity of electricity is effectively measured in amperes, as from the formula it is readily visible that $1 \text{ ampere} = 1 \text{ coulomb per sec.} \left(\frac{Q}{t} \right)$ and one coulomb is not equal to the ampere per second as he would have me assume.

I would advise him to be rather more careful when applying a differential law such as Kirckhoff's, for, although the integral of the law can be verified experimentally, it does not hold that the differential law is exact, as the integrating constant is always to be remembered.

Finally, can any reader recommend me a reliable text-book where the laws of

electro-magnetic radiations, and in particular those of light, are expressed as a function of all dependent variables, such as pressure, temperature, medium, etc.? It is important to know as well exactly on what the colour of light depends, or rather what are the factors to which our sense of colour reacts, and what is the minimum variation we can appreciate.

From this it will be a simple matter to corroborate any of Mr. Wolfson's, Mr. C. M. Adcock's, or my own statements. In fact I should be much obliged for any really reliable information on the subject, for I feel that in the future television will depend to a much more important extent on an exact and precise knowledge of the nature of light, including its laws; this perhaps explains in a measure why television has not progressed as rapidly as might have been anticipated.

I am, Sir,

Yours faithfully,

E. P. ADCOCK.

Invention and Development.

(Continued from page 270.)

the record film (1) is notched or cut away along the sides so as to control spring contacts (4), which, in turn, actuate a relay (9), thus causing the sound reproduced by a photo-electric cell (11) and amplifier (10) to be localised by the loud-speakers (7) and (8), or alternatively by the loud-speaker (6) as desired. The film may have perforations instead of edge notches and move between clip contacts. Volume control as well as locality may be controlled by the same means.

In a modification the selection or control may be effected by markings (26), Fig. 6, on the film record, and these markings may conveniently be on the opposite edge of the film from the sound record. Light from a source (28) in Fig. 7 is projected through such markings on to a cell (30), which controls a relay (32) acting in the same manner as in Fig. 5. The two lamps (27) and (28) may be replaced by a single lamp and two refracting prisms, which direct the light through slits on to the sound record and on to the selecting markings respectively. Alternatively, the selecting means may operate in such a way that it brings into operation another sound record, and it may also control resistances to vary the volume or control different emission orifices from one reproducer.

A Quantitative Analysis of Television.

(Concluded from page 260.)

need not be discouraged by calculations with it.

Mr. W. H. Hebdidge seems to have missed a somewhat essential difference between the area of maximum definition and the working angular area. This also applies to Mr. S. Goldstein's first point. I must refer these gentlemen to the definitions already given, and in particular to the paragraph in the paper headed "Resolving Power of the Eyes," as space is too limited here to give a more detailed explanation.

Taking Mr. Goldstein's second point, the data for "pictures" also applies to the use of a three dimensional object; for in neither case, obviously, do we transmit the object itself, but only a two-dimensional (or flat) optical image.

I do not quite follow Mr. Goldstein's last point. The optical image at the transmitter is imagined to be of infinite detail. What we wish to measure is the result of transmitting this to the receiver. Therefore the "picture clearness" refers to the received "picture" or optical image.

Errata.

Two clerical errors unfortunately crept into the original paper. These were: "10 inches" should read "about 5 inches" beneath Fig. 2, and the second part of the caption should be deleted. Also the bracketed part of the formula in the footnote on page 110 should read

$$\left(\frac{R}{R_0} \right) \text{ and not } \left(\frac{R_0}{R} \right)$$

and this expression should be numbered (5.1).

Special American Broadcasts for Europe.

For the purpose of providing Europeans with an American radio programme at a convenient hour, W.G.Y.'s short wave station W2XAF of Schenectady has inaugurated a series of afternoon broadcasts on two different frequencies, daily except Saturday and Wednesday. These programmes also afford engineers of the British Broadcasting Company an opportunity to carry on experiments in reception and rebroadcasting of trans-Atlantic programmes.

The afternoon schedule of W2XAF, effective at once, follows: Sunday, 2.30 to 5.30 p.m., 15,340 kilocycles; Monday, 2.0 to 4.0 p.m., 13,660 kilocycles; Tuesday, 2.0 to 3.0 p.m., 15,340 kilocycles; Thursday, 2.0 to 4.0 p.m., 13,660 kilocycles; Friday 2.0 to 3.0 p.m., 15,340 kilocycles. All time references are eastern daylight-saving time. (Five hours behind British Summer Time.)

Television Society.

Having concluded a most successful session, the Society settles down to vacation. During the months of June and July outings have been arranged, to visit the G.E.C. laboratories at Wembley and the studios of British Talking Pictures, both meetings being filled to capacity. Already a complete list is arranged for the Autumn Lectures, due announcement of which will be made in our next issue.

Change of Address.

In order to be more centrally placed the address of Headquarters of the Society has been changed to 4, Duke Street, Adelphi, W.C. 2.

EXPERIMENTAL work. Inventors' models. Scanning discs any size to drawings. JOHN SALTER, Scientific Instrument maker. Established 1896. Featherstone Buildings, High Holborn, W.C. 1.

ORDER FORM.

To TELEVISION PRESS, LTD.,
26, Charing Cross Road, London, W.C.2.

I enclose herewith { Postal Order
Money Order } for 7/6 in respect of
Cheque

one year's subscription to "Television," commencing
with the.....issue.

Name.....

Address.....

Postal and Money Orders should be crossed & Co. and Cheques
should be made payable to Television Press, Ltd.

All Communications
respecting
ADVERTISEMENTS
should be addressed to
"TELEVISION"
Advertisement Dept.,
26, Charing Cross Road,
W.C.2.

Telephone : REGENT 6437

TELEVISION SOCIETY.

MEMBERSHIP APPLICATION FORM.

JULY, 1929.

Please send me particulars and conditions of membership of the Television
Society.

Name.....

Address.....

I desire to enrol as.....(Fellow, Associate or Student
Member) and submit qualifications :—

Academic Qualifications.....or

Scientific Pursuits.....

THE SECRETARY OF THE TELEVISION SOCIETY,
4, Duke Street,
Adelphi, W.C. 2.

[Stamp enclosed.]

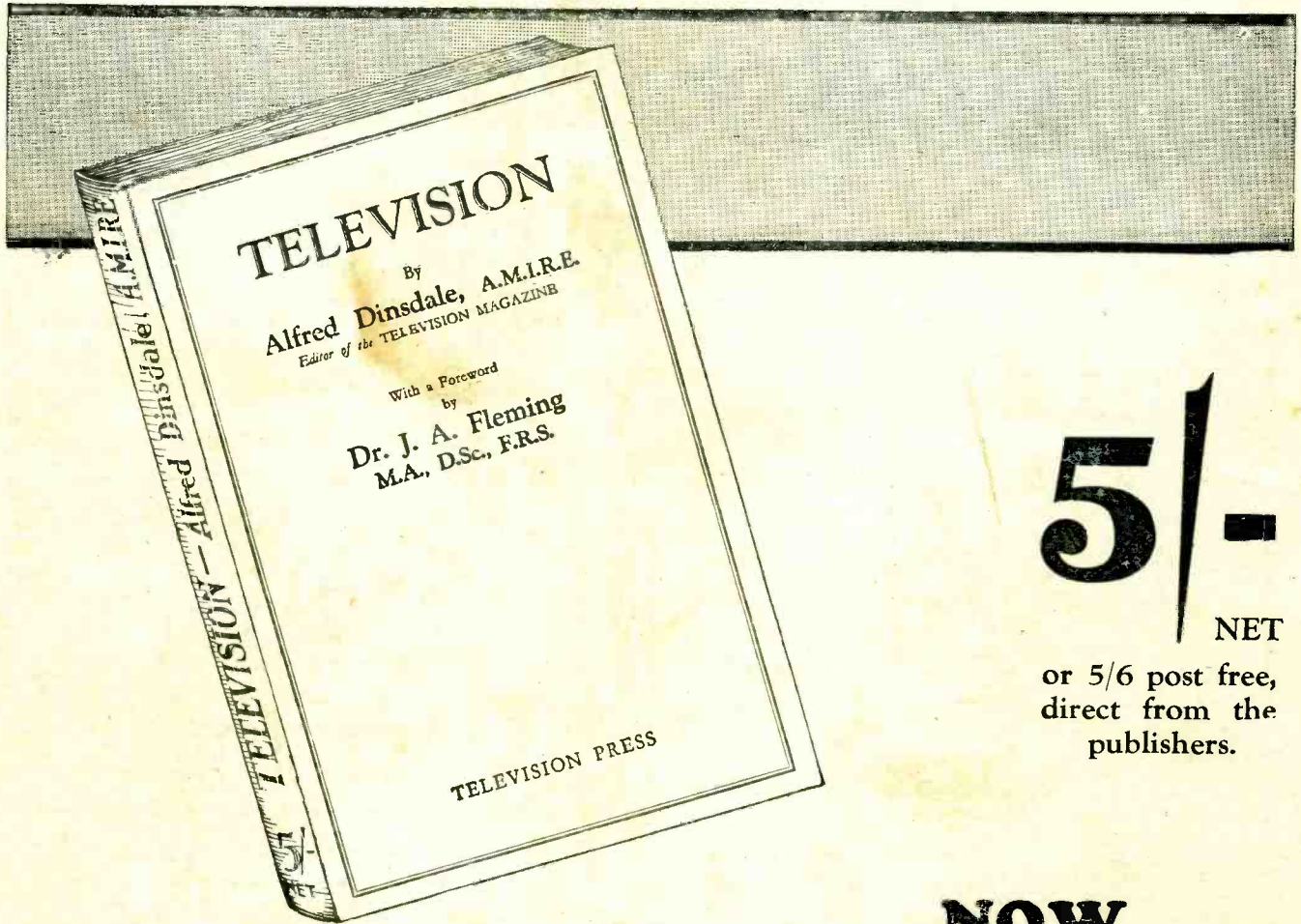

5/-
NET

or 5/6 post free,
direct from the
publishers.

**NOW
READY**

“TELEVISION” by Alfred Dinsdale, A.M.I.R.E., the greatest book on Television ever published—comprehensive, authentic and written in language you can understand. Contains, in addition to 200 pages of text, 36 diagrams and 33 full-page plates. Crown 8vo, bound in cloth with jacket.

The Foreword is written by
Dr. J. A. Fleming, F.R.S.

To Television Press, Ltd., 26, Charing Cross Road, London, W.C.2.
 Please send me, post free, a copy of Television by Alfred Dinsdale, A.M.I.R.E., for which I enclose a postal order to the value of 5/6.

Name

Address