

1/6

The
SHORTWAVE
Magazine



**EXCLUSIVELY FOR THE
SHORT WAVE LISTENER
EXPERIMENTER AND
TRANSMITTING AMATEUR**

VOL. IV No. 3 MAY 1946

COMPONENTS FOR THE DISCRIMINATING EXPERIMENTER

... all
carrying

WEBB'S

Unconditional Guarantee of Satisfaction

RACK MATERIAL

Relay Rack assembly, to International dimensions and drilling, finished black, comprising heavy base, channel uprights, back stays and assembly bolts :

3½ in. panel space	... £2 2 0
63 in. panel space	... £2 12 9

Panels, black crackle, drilled and slotted for International racks. All 19 in. wide, 16 gauge steel :

3½ in.	4 6
7 in.	5 6
8½ in.	6 6
10½ in.	7 6

Rack chassis, 16 gauge steel, smooth black :

17 in. × 10 in. × 2 in.	8 9
-------------------------	--------	-----

Brackets, smooth black, for mounting chassis to panel, per pair 4 6

SPECIAL 52½ in. RACK ASSEMBLY

in matt grey finish. Complete assembly including heavy fender, channel uprights, extended back stays for improved rigidity, five 10½ in. panels with brackets and five chassis 17 in. × 10 in. × 2 in. Chrome hexagon front bolts give finish to an efficient and attractive assembly.

£7 15 0

(Carriage 10, - extra)

SHIELDING CABINETS

robustly made, finished externally in black crackle, smooth black inside. Each size has hinged top-lid, removable front panel and internal chassis.

8½ in. wide, 9½ in. high, 9½ in. deep	£2 2 6
17½ in. wide, 9½ in. high, 9½ in. deep	£2 12 6
6½ in. w.de, 7 in. high, 6 in. deep	£2 10 0

DURALUMIN TUBE

for receiving and transmitting aeriels. The 8 ft. 6 in. length covers five and ten metre requirements for both radiators and reflectors. The 10 ft. 6 in. length is popular for television work.

NOTE : CALLERS ONLY FOR THESE TUBES

Duralumin tube ¾ in. outside diameter.

8 ft. 6 in. long	4 6
10 ft. 6 in. long	5 6

CRYSTALS

—plenty of frequencies available from stock—Specify and we supply, exact or within a kilocycle or two either way.

Q.C.C. type P5 (modified power type) from 7000 to 7500 Kc/s and 1.8 to 2.00 mc.s. In standard interchangeable mount £1 12 6

PLUG IN COILS

Complete range of famous Eddystone 6-pin ready wound coils now available covering 9 to 2,000 metres in nine types.

Directivity of signals by WEBB'S MAP OF THE WORLD

Drawn on Azimuthal scale the map distorts areas and is not recommended for class-room work. BUT it does show true directivity of any point in the world centred from London.

On paper	4 6
On linen with rollers	10 6

CO-AXIAL CABLE

Impedance 80 ohms, stranded conductor. Polythene insulation, metal braided with protective outer covering Diameter 0.45 in.

Price per foot 6d.

EDDYSTONE MICRODENSER

Special non-standard offer. Capacity 1 to 5 pF., 3,500 volts spacing. Suitable for U.H.F. tuning, neutralizing, etc. 1 6

Write, phone or call—

Our shop hours are 9 a.m. to 5 p.m.
(Saturdays 9 a.m. to 1 p.m.)

WEBB'S

RADIO

14 SOHO ST. LONDON, W.1

Telephone: GERRARD 2089

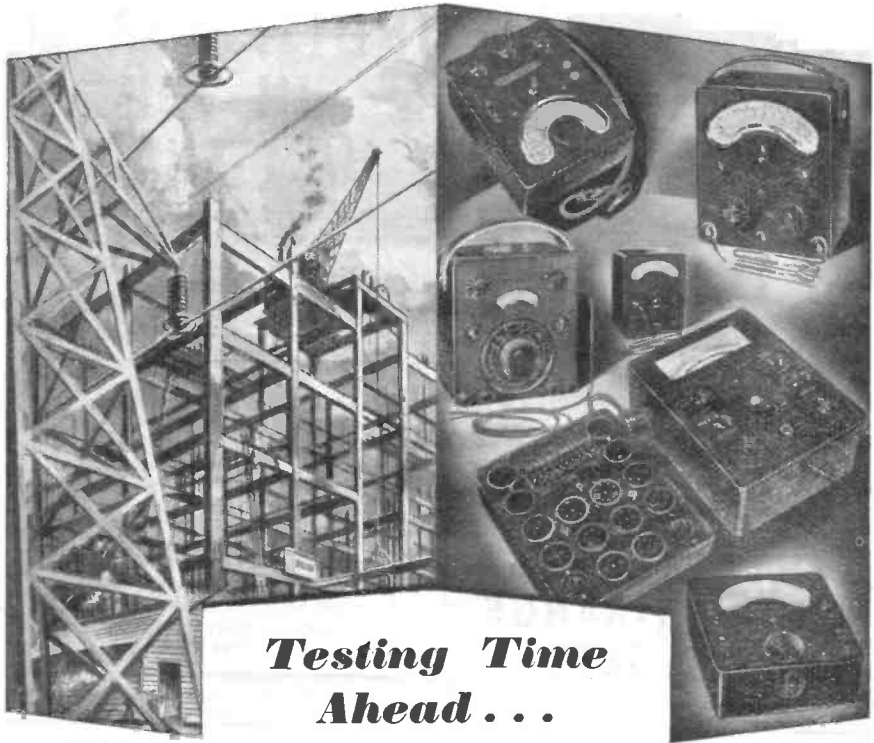

Testing Time Ahead . . .

RECONSTRUCTION, as we now know too well, means something other than enjoyment of the non-existent fruits of victory. The amenities of a world at well-earned peace are not for us until we have replaced the ravages of war with the necessities of life and the realities of universal peaceful intent for victors, victims and vanquished alike.

That is speaking collectively. . . . For ourselves, we learned much and progressed far in the six years of ceaseless toil, urged on by dire necessity and peril. We are not resting now. We are still pressing on, pressing into the service of those engaged in rebuilding the body and soul of a whole world the knowledge gained, the advancements perfected, the skill and craftsmanship that outmatched the efforts of our enemies.

"Avo" Electrical Testing Instruments set standard by which other instruments are judged.

- THE UNIVERSAL AVOMETER
- THE "AVO"
- ALL-WAVE OSCILLATOR
- "AVO" VALVE TESTER
- "AVO" TEST BRIDGE
- UNIVERSAL AVOMINOR
- THE D.C. AVOMINOR
- "AVO" LIGHT METER
- "AVO" EXPOSURE METER, ETC., ETC.

Catalogues on application.



Regd. Trade Mark

PRECISION ELECTRICAL MEASURING INSTRUMENTS

Sole Proprietors and Manufacturers:

The AUTOMATIC COIL WINDER & ELECTRICAL EQUIPMENT Co. Ltd.
 Winder House, Douglas Street, London, S.W.1

Phone: VICtoria 3404-8

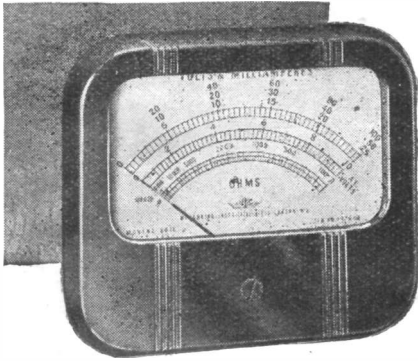

FOUNDATION INSTRUMENTS & MULTI-RANGE TEST SETS

Address all correspondence to Dept. K., Phoenix Works, Gt. West Rd., Brentford, Middx. Ealing 0011

INDISPENSABLE IN THE HAM SHACK

This attractive $3\frac{1}{2}$ " scale instrument has separate coloured scales for resistance, and 10v. A.C. ranges. All components can be obtained to build this modern multi-range testmeter. Price (1 ma. movement) - £4.9.0

Obtainable only from our authorized distributors:

A.C.S. RADIO LTD.,
44, Widmore Rd., Bromley, Kent.
CUSSINS & LIGHT LTD.,
King's Square, York.
HOLIDAY & HEMMERDINGER LTD.,
74-78, Hardman St., Manchester. 3.
RADIO-MART G5NI (B'ham) LTD.,
48, Holloway Rd., Birmingham, 1.
TELE-RADIO (1943) LTD.,
177, Edgware Rd., London, W.2
C. WEBB LTD., Carrs Lane, Birmingham
WEBBS RADIO, 14, Soho St., London, W.1
WELWORTH WIRELESS & ELECT. CO.,
8, Withy Grove, Manchester, 4.

Electradix Bargains

METERS. Switchboard type D.C. moving coil meters, 0-30 amps, $4\frac{1}{2}$ in. 1/C, 55/-; 60 amps C.Z., 60/-; 250 amps with external shunt, 60/-; 50 amps, 7 in. dia., 55/-; 1/C Voltmeters 0-30, 55/-; 0-250v., 70/-; Flush panel meters, moving coil D.C. 0-1mA, $2\frac{1}{2}$ in. dia., bakelite case, 55/-, 4 in. dia. 0-1mA, 75/-; Westinghouse metal rectifiers 1mA, 10/6; Precision M.I. meters AC/DC $3\frac{1}{2}$ in. dia., flush panel 0-60 volts, 45/-; M.I. 2 in. flush panel meters 0-5 amps D.C., bakelite case, 12/6.

RESISTANCES. Variable resistances 5 kW and down; surplus stock at special low prices, send us your enquiries. Special line Westinghouse 110 ohm 1 amp vitreous tube with two sliding clips, 10/-.

MOTORS AND FANS. Large D.C. 110 volt Fan Motors, enclosed type by Verity, ball bearing, 30/-, D.C. Table Fans 110 and 220 volts, with stand, 12 in. blade and guard, G.E.C., 35/-, Oscillating type 45/-.



CONDENSERS. Variable. Ultra short wave variable air Condenser, 16 m.mfd., Trolitul insulation, ball bearings, new, 5/-; .0005 or .0003 mfd. solid dielectric, 3/6 each; .0005 differential, 3/6.

FIXED CONDENSERS. 1 mfd. 1,000v. 4/-, 4 mfd. 1,000v., 10/- ea., 8 mfd. 1,000v., 15/- ea., .05 mfd. 16,000v. D.C., 25/-, .25 mfd. 10,000v. mica, 10/-.

DIMMER RHEOSTAT SWITCHES. 1 ohm to 0 and off up to 3 amps., for regulation of 6 v. AC/DC. Charger subcircuit regulators. Model speed control, etc., 1-hole fixing and extra bracket for rack. Hollow knob has base for miniature bulb to glow when "ON"; new Aetna Co., U.S.A. Price 2/6 each. Postage 6d.



SEND-RECEIVE Hand Coms. All-metal Field Hand Coms. for portable or fixed stations. The famous No. 16 Govt. tpe, used in field telephones; mike and earpiece with damaged finger switch easily repaired, 7/6. (No cords supplied).

MORSE KEYS. The British-made American type "Speed" Key, new, swan neck, 9/6. Key on bakelite base, 5/-, Model B.2 on wood base, 9/6.

SPARK COILS. Ex-G.P.O. spark coils $\frac{1}{2}$ in. to $\frac{1}{4}$ in. spark from 6v. accumulator, for model control and experimental work, 25/-, Spark transmitter units with coil, spark gap and helix, 55/-.

LABORATORY AND TEST GEAR. Gambrell Universal Shunt Box, 10,000 ohms, £5. Gambrell Resistance Box, 10-20-20-50-100-200-500 ohms, as new, £4. Tinsley Res. Box, four 125-ohm coils with terminals, 45/- We have a number of these resistance boxes, some less plugs, at special prices. Write for list. Wheatstone

Briggs, 100 ohms to sub-divided ohms, £5 10s. P.O. pattern, 10,000 ohms, £10. G.P.O. Resistance Box, 8,000 ohm by 10 ohm steps, switch and plug type, £4 15s.

PARCELS. 7 lb. parcel of useful oddments for your junk box, all clean and dismantled from Government and other apparatus. 7/6, post free.

When ordering, please mention the "S.W.M."

ELECTRADIX RADIOS

214 QUEENSTOWN RD., LONDON, S.W.8.

Telephone MACaulay 2159.

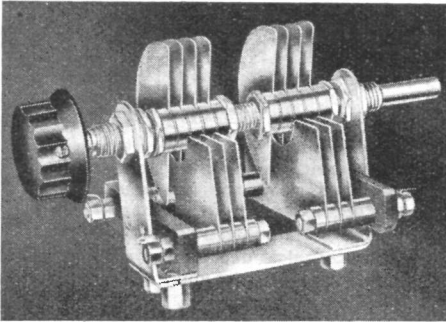

EXCEPTIONAL
RESULTS DEMAND
COMPONENTS
SUCH AS
THESE

Type RFCI

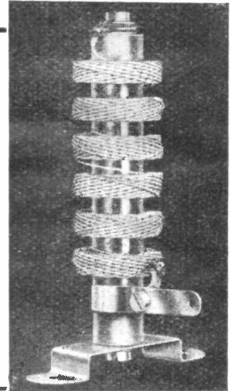

Type C50/50

**EXPERIMENTAL TRANSMITTING
GEAR** *Manufactured to*
INSTRUMENT STANDARDS
BY **LABGEAR**

Tele: 2494 (2 lines) Willow Place, CAMBRIDGE
Grams: Labgear, Cambridge
Manufacturers of Transmitting Equipment to G.P.O. and Government Depts.
and High-class Test Equipment

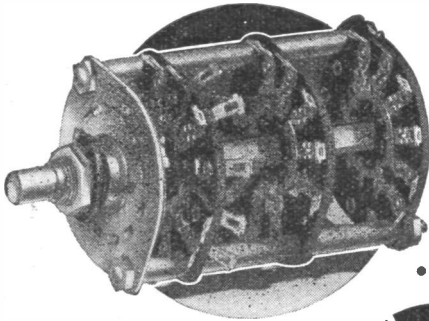

for
SWITCHES
... the name is

OAK

BRITISH N.S.F. CO. LTD.

KEIGHLEY • YORKS • *Phone: Keighley 4221/4*
Grams: Enesef, Keighley

SOLE LICENSEES OF THE OAK MANUFACTURING CO. LTD., CHICAGO
British N.S.F. Sub-Licensees: Plessey Co. Ltd., A.B. Metal Products Ltd.

Other British N.S.F. Products include **PAPER CAPACITORS,
SILVERED MICA CAPACITORS, WIRE WOUND RESISTORS
AND VOLUME CONTROLS** — *Write for full details.*



LASKY'S RADIO

FOR
ELECTROLYTIC CONDENSERS
MIDGET ALUMINIUM CANS
500 volts working.

8 mfd. ... 3/- 8- 8 mfd. ... 5/6
16 mfd. ... 4/9 8-16 mfd. ... 6/9

MIDGET TUBULAR CARDBOARD
500 volts working.
8 mfd. ... 3/6 4 mfd. ... 2/10

HIGH-VOLTAGE OIL-FILLED
CONDENSERS

mfd.	Volts working				
8	1,000	12/6
8	600	7/-
10	600	7/-
10	400	6/-
4	1,000	9/6
4	450	3/9
1	1,000	6/-
1	750	3/6
0.5	5,000	12/6
0.1	6,000	10/-

ALL WITH FIXING CLIPS

ELECTROLYTIC BLOCK
CONDENSERS

mfd.	Volts working				
16+16...	350	7/-
8	500	4/-
24	650	12/6
4	350	3/6

ALL TYPES OF BIAS AND BY-PASS CONDENSERS IN STOCK

0.1, 0.01, etc.,

25 mfd., 25 volts ; 50 mfd., 12 volts, etc.

SEE
PREVIOUS ADVERTISEMENTS

Send Id. for latest current List

NOW IN PRINT

Terms : C.O.D., pro forma and cash with order.

Everything for the Home Set Constructor Ham, and Serviceman.

Trade Enquiries Invited.

LASKY'S RADIO

370 Harrow Road,
PADDINGTON, LONDON, W.9

(Opposite Paddington Hospital).

Tel. : Cunningham 1979.

THE PARTRIDGE ORGANIZATION

is again at your service.

For six years we have been supplying the Services with our iron cored components. We are now once more accepting orders for ordinary commercial and domestic needs.

Our technical department will again be pleased to assist you in your transformer problems.

We look forward to hearing from our old friends, and welcome enquiries from newcomers.

May we send you our 1946 price list ? This details a comprehensive range of components that can now be despatched from stock.

Telephor.e:

Abbey 2244

PARTRIDGE
TRANSFORMERS LTD

76-8, PETTY FRANCE, LONDON, S.W.1

TOM THUMB A small compact amplifier, using 6F6's in push-pull, with new linear phase changing circuit. 15 watts output with ordinary magnetic pick-up. Complete in case, 9x8x6½ inches. (As illustrated).

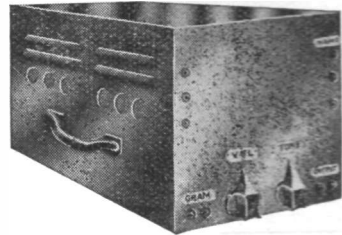

Ready to assemble, £8 18 0 (Carriage 2/6)

Assembled complete 20/- extra.

SPEAKERS. 10 in. and 12 in., 15 ohm. Suitable for use with TOM THUMB Prices on application

Call on your local dealer or write for illustrated literature

Microphones and Stands. Every conceivable transformer or component is available from us—Specialists in the design for Home Construction.

RADIO INSTRUMENT Co.,

294 BROADWAY, BEXLEYHEATH, KENT

**In the interests of Greater Production
in Loud Speakers for the New Season**

Rola-CELESTION

make an Important Announcement to the Radio Industry

In order to meet the demand for Loudspeakers by the Radio Industry, BRITISH ROLA LIMITED have arranged to purchase the shares of CELESTION LIMITED as at the 31st July, 1946.

By pooling the resources of the two Companies they feel confident that *a substantial increase in deliveries by both Companies will be achieved.*

It must be emphasised that the Designs and Technical Development of both Companies will proceed Independently so that each will retain its Individuality under the New Arrangement.

BRITISH ROLA LTD.,
Georgian House, Bury St., St. James's, S.W.1.
Factories: Thames Ditton & Devizes.

CELESTION LTD.,
Kingston-upon-Thames, Surrey.

Radio Communication!



Type "A"

One can say without exaggeration that the transmission of instructions in code and plain language played an all important part in winning the war. It, too, was essential that highly sensitive and robustly constructed Headphones should play their part. In this important sphere, S. G. BROWN Headphones gave reliable service under all conditions of use.

The excellent service they rendered in winning the war is now available to all radio enthusiasts.

YOUR LOCAL DEALER CAN SUPPLY

Type "A." Adjustable Reed Movement 57/6
Type "F." Featherweight, 23/- Type "D1," 32/6

S.G. Brown, Ltd.

Interesting technical details of all types of S. G. Brown headphones are given in Brochure "S.W." Free on request.

VICTORIA RD., NORTH ACTON, LONDON, W.3 Phone: ACOrn 5021

A.C.S. RADIO

Here is a selection from our ever increasing range of

RADIO COMPONENTS & ACCESSORIES

- MEICO 5A Amplifier, 5 watt output, in carrying case ... £16 10 0
- Meico Radio feeder Unit, 3 Pretuned Circuits ... £14 13 4
- WOODEN Junior Amplifier, 15 watt, in carrying case ... £24 10 0
- G.L. A23 Amplifier, 26 watt, complete ... £15 10 0
- GOODMAN 12 in. PM Speaker unit, 15 ohm ... £6 15 0
- Goodman 3½ in. PM Speaker unit, 2.3 ohm ... £1 10 0
- ERICSSON High resistance Headphones ... £1 5 0
- STANDARD TELEPHONES TX VALVES, 4074/A, 30/-; 4061/A, 40/-; 5B/250A 30/5; 2V/400A, 27/6; 5C/100A, £7 5s.
- PULLIN Meters, 2½ in. Round Dial, 1mA £2 15s; 10mA, £2 5s.; 100 mA, £2 5s.; 500 mA, £2 5s.; 100 microA, £3 10s.; 500 microA, £3 3s.; 3½ in. Square 1mA, £4 9s.;
- AVO-MINOR Universal £8 10s.

All items above in stock at time of going to press. Our new List "S.W." contains hundreds of items of interest to Transmitting Amateurs and Short Wave Listeners. May we mail you a copy?

44 WIDMORE RD BROMLEY, KENT
Phone RAVensbourne 0156

USE **Varley** TRADE MARK PRODUCTS

for **QUALITY and RELIABILITY**

Mains Transformers

A.F. Transformers

Smoothing Chokes

Thermal Delay Switches

Power Resistances

OLIVER PELL CONTROL LTD. TELEPHONE WOOLWICH-1422
CAMBRIDGE ROW, WOOLWICH, S.E.18

QUARTZ CRYSTAL UNITS

FOR YOUR TRANSMITTER

TYPE 2 LOW TEMPERATURE COEFFICIENT PLATES

3.50/3.75 Mc/s or 7.00/7.50 Mc/s for the 30 Mc/s band.
 3.66/3.75 Mc/s or 7.32/7.50 Mc/s for the 60 Mc/s band.

PRICES:—

Random frequency in either band . . . £1 - 10 - 0
 Specified frequency in either band . . . £1 - 16 - 0

AVAILABLE FOR IMMEDIATE DELIVERY



FOR YOUR FREQUENCY STANDARD

TYPE JCI/200 LOW TEMPERATURE COEFFICIENT BAR

Frequency . . . 100 Kc/s
 Accuracy . . . ± 0.1 %
 Price . . . £2 - 15 - 0

Vacuum mounted for optimum stability. A high precision unit of extreme stability, the crystal being nodally mounted on fine wires soldered to the bar.

DELIVERY FROM STOCK



SALFORD ELECTRICAL INSTRUMENTS LTD.

PEEL WORKS, SALFORD 3

Telephones: BLAckfriars 6688 (6 lines).

Telegrams and Cables: "SPARKLESS, MANCHESTER"

Proprietors: THE GENERAL ELECTRIC Co. Ltd., of England

A Great Team!

T. R. McELROY -

President of McElroy Manufacturing Corporation, U.S.A., and the World's high-speed Morse champion. Full facilities of his laboratories and technicians are available to this new Anglo-American Company.

H. R. ADAMS (G2NO) -

well known in England and abroad for his long association with the radio trade. Just released from special Army radio position he has held for 4 years.

THE HALLICRAFTERS -

produced during the War more apparatus for the United Services than any other American manufacturer. An entirely new range of communication receivers and transmitters will shortly be released.

THE McELROY-ADAMS GROUP has been organised in England to produce all types of telegraphic and communication equipment. **Extensive plans** covering a very wide field including police, marine and **amateur apparatus** are being prepared.

SPECIAL PRODUCTS DEPARTMENT. We will entertain the production of equipment to meet your special requirements. **We regret that the large and increasing Export demand may temporarily restrict supplies for the Home market.**

ALREADY IN PRODUCTION. 50 watt transmitter-exciter. **Rack-mounting power packs. Receiver Converter Unit for VHF, amateur bands.**

HALLICRAFTERS SERVICE DEPARTMENT is fully organised, and ready to accept alignment, calibration and general service on all Hallicrafters models.

Register your name so that we may advise you as new communication equipment becomes available.

EVERY MEMBER OF OUR STAFF HAS SERVED HIS COUNTRY DURING THE WAR

Issued by **McELROY ADAMS GROUP**

IMPERIAL BUILDINGS, KINGSWAY, LONDON, W.C.2

Cables : REGADAM, LONDON.

Telephone : HOLborn 3908

SHORT WAVE MAGAZINE

FOR THE RADIO AMATEUR AND AMATEUR RADIO

Vol. IV.

M A Y 1946

No. 3

C O N T E N T S

	<i>Page</i>
Editorial	139
Five Metres, <i>by A. J. Devon</i>	140
Principles of Short Wave Reception, Part III, <i>by A. A. Mawse</i>	145
Transmitter for Five, <i>by Austin Forsyth, O.B.E. (G6FO), Editor</i>	151
Break-in, Single-Channel, <i>by L. H. Thomas, M.B.E. (G6QB)</i>	154
The Cathode-Ray Tube, Part III	158
The Other Man's Station, (1), (G6OI)	162
Automatic Change-Over, <i>by N. P. Spooner, (G2NS)</i>	163
DX Commentary—On the Amateur Bands, <i>by H. A. M. Whyte, (G6WY)</i>	164
Calls Heard	170
Looking Back, <i>Conclusion, by G6QB</i>	172
Tidy Paper Work, <i>by J. Hum, (G5UM)</i>	175
G9BF Calling	176
Making Up Split Stators, <i>by D. H. Jones, (G3BO)</i>	177
Some Letters to the Editor.....	178
On the Market.....	179
New QRAs	181
The Month with the Clubs, <i>from Reports</i>	182

Editor : AUSTIN FORSYTH, O.B.E.

Advertising Manager : P. H. FALKNER

Published on the first Wednesday in each month at 49 Victoria Street, London, S.W.1
Telephone : Abbey 2279. Annual subscription : Inland 20s. Abroad 22s. post paid.

AUTHORS' MSS.

Articles submitted for Editorial consideration must be typed double-spaced with wide margins, on one side only of quarto sheets, with diagrams shown separately. Photographs should be clearly identified on the back. Payment is made for all material used, and a figure quoted in the letter of acceptance. A large stamped addressed envelope should be enclosed for the return of MSS. not found suitable for publication.

EVERYTHING FOR THE AMATEUR

AVO
Test Equipment

BELLING LEE
Components

B. & I.
Cables and Electrolytics

BRIMAR
Valves

BULGIN
Components

BULLER
Ceramics

CELESTION
Valve Holders

CLIX
Components

COLVERN
Wire Wound Potentiometers.

COSSOR
Oscilloscopes and C.R. Tubes

CYLDON
Transmitting Condensers

DENCO
Coils and R.F. Chokes

DUBILIER
Condensers and Resistors

GRELCO
Terminal Blocks

IGRANIC
Plugs and Jacks

MEASURING INSTRUMENTS (PULLIN)
Meters

MORGANITE
Resistors and Potentiometers

MUIRHEAD
Dials and Drives

MULLARD
Valves

N.S.F.
Oak Switches

EXHIBITION OF RADIO COMPONENTS AND AMATEUR COMMUNICATIONS EQUIPMENT

Every Week

9 a.m. to 6 p.m.

(Thursdays 1 p.m.)

177 Edgware Rd., London, W.2

(Near corner of Edgware Road
and Marylebone Road)

Staffed by

G3AD	A. N. Simmons
G8ZD	E. P. Appleby
SPIHH/SP2HH	M. Kasia

OSRAM
Valves

PARTRIDGE
Transformers and Chokes

PRECISION RESISTORS
LTD.
Wire-wound Precision Resistors

PYREX
Insulators

Q.C.C.
Crystals

ROTHERMEL
Crystal Pick-ups and Microphones

SANGAMO WESTON
Meters

S.T.C.
Transmitting Valves

TELE-RADIO (1943),
LTD.
Transmitters and Receivers

T.C.C.
Condensers

T.M.C.
Condensers (High Voltage)

T.C.M.
Mu-metal Sheet and Screens

U.I.C.
Ceramic and Silver Mica Condensers

UNITED
COMPONENTS, LTD.
Coil Packs

VITAVOX
High Fidelity Loudspeakers

WELWYN
Heavy Duty and Precision Resistors

WESTINGHOUSE
Rectifiers

All the above manufacturers' latest products are always well represented at what is now recognised as the finest display of new components in London, and are usually available for immediate delivery.

Operation "NEW CATALOGUE" nearly completed.



TELE-RADIO (1943) LTD.

177 EDGWARE ROAD, LONDON, W.2

Telephone: PADDINGTON 6116



EDITORIAL

Service

There is a well-founded belief, and good reasons why there should be, that Service reserve organisations may be formed with the idea of attracting those interested from the field of Amateur Radio.

The general idea for any such reserve organisation, where the matter has been given any thought at all, seems to be that it should be on the lines of the old R.N.W.A.R. and the C.W.R. In fact, that these formations should be revived.

It is at this point that we break away from those who wish to see things as they were. We consider that any future Service reserve organisation, to be effective, must be based on the situation as it is now, and not as it was. Before 1939, the general knowledge and experience of the amateur transmitter fitted in quite well with the Service conception of the communications problem. Broadly speaking, it was on the level of hand-keying and point-to-point working.

For anyone with recent experience in the Services, particularly of technical administration and planning, it will be obvious that an Amateur Radio reserve scheme based upon the fundamental idea of hand-keying will be practically useless for any future Service requirement. It is neither necessary nor desirable to discuss the reasons for this here. Suffice it to say that there have been tremendous advances in communications technique, which in some respects are quite as remarkable as the developments in radar. What it means is that the Service approach to communications problems is now far in advance of anything that can be offered by the radio amateur, or is likely to be achieved in Amateur Radio within the foreseeable future. Nevertheless, it is still true that the radio amateur will be able to absorb these advanced ideas far more quickly and more easily than anyone without his particular kind of experience.

Hence, any future radio reserve organisations will have to be designed on lines very different from the old R.N.W.A.R. or the C.W.R. They will have to be more technical, provide much better real training facilities, and cast their nets far wider than before the war. On these grounds, it seems to us that if the talent and ability latent in Amateur Radio are to be successfully enrolled in these Service reserves—which in the general interest are necessary, not to say essential—then the approach must be much more liberal and efficient than it was before 1939.

It is on such points as these that we have misgivings as to the future of Service reserves recruited from the ranks of the radio amateur. We are impressed by the fact that on the one hand there is no clear realisation of the Service requirement, and on the other an incomplete understanding of what the radio amateur can offer.

Arthur G. K. C. H. O.

Five Metres

*G5BY/G6CW Establish 233-mile inter-G Record—
G5MQ/G6VX/G6YQ Receive over 184-mile Path—
Birmingham (G2AK, G5LJ) Works Liverpool (G5MQ,
G6YQ)—G6CW/G6YQ QSO over 72 miles*

By A. J. DEVON

WELL, this has been a remarkable month for 58 mc, and we could add a lot more to those heading lines. But they contain the highlights, with G5BY (Thurlestone, S. Devon), G6CW (Nottingham) and G6VX (Hayes, Kent) as the outstanding performers.

With some 25 excellent reports in hand covering the month's activity, we can give only the main outlines this time; never before in the history of 58 mc in this country have there been so many well-equipped stations putting in so much time on the band. They have had part of their reward. And it is only something to be going on with, as it is quite clear that a few more periods with conditions of temperature-inversion, which causes the effect on VHF known as "ducting," will result in many more records being made and broken. That is, provided we get activity which is sufficiently well distributed, not only over this country, but in Europe and the Middle East as well.

It all started on the evening of Sunday, April 7, when at 2235, G5BY and G6FO (Penn, Bucks) obtained two-way contact over the 168-mile path, RST-339 both way. G5BY had already been heard in the South London area (by G2MR and G6OH), and the G5BY-G6FO contact was followed the next evening, April 8, by a good two-way between G5BY and G6VX (Hayes, Kent) at 2215, over 184 miles. On that same evening, at 1950, G6VX had worked G6CW (Nottingham, 125 miles); G2MR (Surbiton) had heard G2XC (Portsmouth, 56 miles), and at 2245, G6VX/G2XC worked over 65 miles.

So much for the South, for the moment. Now look at G6CW's log. After his contact on April 8 with G6VX, he had no less than *eighteen* QSO's at 100 miles distant or over; these include G2MV (Coulsdon, 123), G4CI (Kingston, 117), G2NH (New Malden, 116), G5MA (Ashted, 127), G2WS (Shortlands, 117), G6FO (Penn, 100) and G5BY (Thurlestone, 233); several of these, of course, being worked more than once.

The last, the inter-G record now standing, was made on April 16 at 2122, with 'BY 449 and 'CW 339.

G5BY's Log

This, as always, is a model of detailed information, and from it we extract the following:—April 7, G6FO; April 8, G6VX, opening on CW at 1745, with 'VX's 'phone just readable later at S2; April 9, G6VX, 339/549; same evening at 2115, G5MA at 339/449. April 10, G6VX again with a chancy contact; April 13, 'phone with G5MA and G6VX; April 15, G4NR (G3NR ?) heard at 2145, 'NR too weak to copy; April 16, G2NH at 2045, 229/549, and G5MA again at 2105, 549/549. This was followed by the contact with G6CW.

On April 20, G5BY had three QSO's with South London (G6LK twice, and G5MA again), making in all thirteen two-way contacts over 150 miles distant between April 7 and 21! **Brilliant work**, and much of it was on 'phone!

G6VX's Log

This shows some 30 stations worked two-way on 58 mc, with five more heard, and for real inter-G DX in-

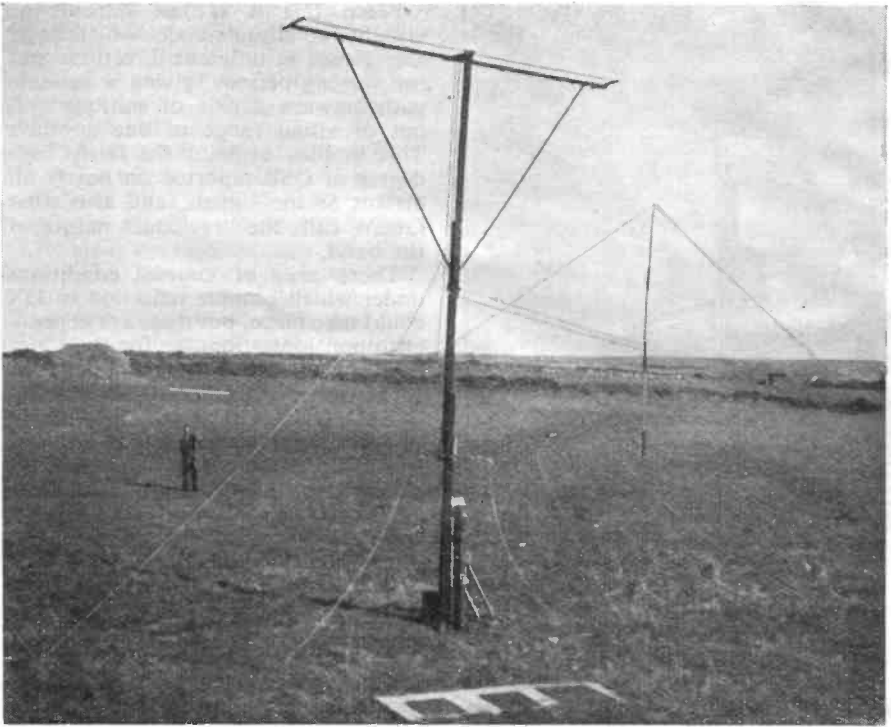

G5BY checking up with the field strength indicator. Part of his aerial system at Thurlstone, S. Devon; in the photograph are the W8JK beam and, in the background, the inverted rhombic. The 8JK is doing very well on 58 mc, having produced contacts with G6VX (184 miles) and G6FO (168 miles)

cludes G5BY, G6CW, G5MQ and G6YQ (both Woolton, Liverpool), G2AK (Birmingham) and G5LJ (Sutton Coldfield).

G6VX also remarks that stations signing GM5YX and SU1 have been heard; the latter may very well be SU1RD, who is on 58 mc, but the former is *not* genuine. The Editor has confirmed this with GM5YX, who is not yet active on 58 mc, nor is he transmitting on 28 mc—so the possibility of a harmonic must be ruled out.

Late Flash: On April 28, contact G5MQ-G6VX was established over the 184-mile path Hayes-Liverpool; time 2315, with 'MQ S4 and 'VX S5.

The Midlands

G2AK (Great Barr, Birmingham) has been putting out a 'phone signal

well received by stations to the North, South and East. He has worked G6VX (112), G5MQ (66) and G6CW (40), all on two-way 'phone and all over the period April 10-14. G5LJ at Sutton Coldfield has worked G5MQ (66), G6YQ (66), G6CW (38) and G6VX(112).

In the Lancashire area, the results of G5MQ and G6YQ (within 150 yards of one another at Woolton, Liverpool!) have already been mentioned. They both report steady activity in the district, a handful of stations (calls appear in the Activity List) coming on regularly. GW6OK (Colwyn Bay) is also active on 58 mc, and he hopes soon to be joined by the indefatigable GW6AA, whose 5-metre exploits will be remembered by all pre-war readers of this column.

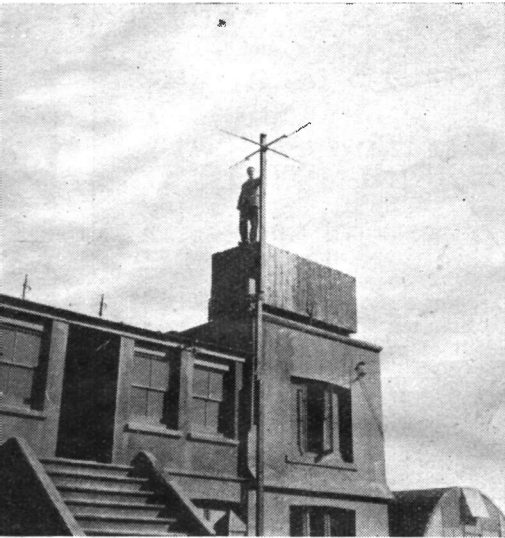

Station G5BY. The window on the right looks into the operating room. G2DYM is standing beside a quarter-wave ground-plane aerial for 58 mc.

Conditions—Ducting

A note or two on how all this happened. Quoting G6DH and G5MQ: "There is no doubt that recent contacts were *not* due to ionosphere bending; they would be of the lower-atmosphere or tropospheric type, and due to temperature inversion". The weather lately has been particularly suitable for this condition—warm, clear days followed by clear, cold and still nights. During the period April 11-13, a temperature inversion took place at a height of about 4,500 ft., with a change in temperature of some 13 deg. F.; the peak effect was on April 12, and is believed to be the greatest ever recorded."

As mentioned here earlier, this phenomenon produces the effect called "ducting," which was thoroughly investigated during the war in connection with some very unusual and unexpected radar ranges obtained in the Mediterranean and, to a lesser extent, over the North Sea. The theory arrived at is that ducting bends the radiation over the earth's surface, and given the right degree of ducting, can easily produce contact between stations not in visual range.

From this it is not difficult to visualise conditions under which ducts are formed in different directions and for varying periods, giving a variable path between a pair of stations well out of visual range of one another. This in turn explains the fairly high degree of QSB reported on nearly all distant 58 mc signals, and also what G6CW calls the "regional" nature of the band.

There are, of course, conditions under which genuine reflection to DX could take place, but these are dependent upon ionisation—as for the lower frequencies—rather than on temperature inversion effects.

G6DH comes in again here, with the point that he expects some summer short-skip 58 mc DX with Europe, perhaps starting in May. He checks MUF at Clacton daily and whenever the signs are propitious, starts up the auto test sender. This is a good idea, which is also adopted by G5BY.

Equipment in Use

Now for some quick notes on how all this has been done; and here we should explain that the 58 mc stations are, in every case, strictly observing the 25-watt power limitation. This is no more than need be expected, as nearly everybody taking a serious interest in the band is a responsible operator of standing in the world of Amateur Radio. So far as our observations go, and judging from all the reports received, the newcomers feel the same about it. We only make the point at all in case the casual reader should imagine that this DX is being worked with colossal power—it is not.

G5BY runs 355 volts at 70 mA, and gets his results with a good receiver (which we shall shortly be describing) and a wide variety of aerial systems, planted out over an extensive acreage of ground. The 58 mc DX has been worked on an 8JK, helped out by a four-element rotary beam, close-spaced.

G6CW has 500 volts at 50 mA in an 815, with 3.5 mc ECO drive, and the receiver is a 954 RF, 954 mixer, 955 oscillator, 10 mc IF, into an HRO.

The aerial is six half-waves in phase, stacked, and rotatable through 340 deg. His location is not good in the accepted sense, as he is covered by ground rising to 400 ft. to the West and North-East.

G6VX puts 400 volts at 60 mA into an 807, which is plate-and-screen modulated by a pair of 6L6's; this feeds an all-metal 4-element array 50 ft. high, coupled through 100-ohm line. His receiver is a home-built superheterodyne with 2 RF(956), 954 mixer with cathode injection, and 955 oscillator, with the IF on 1.7 mc and three stages using 6SG7's.

Up in Birmingham, G2AK has an 829 in the final, with 300 volts at 80 mA, feeding a 10 half-wave aerial, coupled at the centre with a 600-ohm line and Johnson-Q matching system. His receiver, on loan from G2FXK, is a VHF job with acorns in the RF stages.

G5MQ runs 24 watts in an 815, with a three-element rotary beam, his receiver being an HRO preceded by a converter unit using 954 mixer and 955 oscillator. G6YQ has an RK-34 in the final, and the receiver is a superhet with acorns in front and three IF's on 155 kc. His aerial is entirely indoor, consisting of a rotary three-element beam, horizontal, with folded dipoles.

G2NH also has a 3-element rotary in the roof-space, which beats the long-wire when lined up in the desired direction. The beam is a reflector - radiator - director arrangement, with a home-made 100-ohm feeder consisting of 16-gauge enamelled wire loosely tied together with silk. The elements are of duralumin tube, 5/16 in. diameter, and the whole thing is supported on a wooden frame. The spacings are: Director-radiator, 20 in.; radiator-reflector, 30 in. The director is 93 in. long and the reflector 103 in. The radiator itself consists of three 100-in. lengths of duralumin tube, spaced at 3-in. centres, with the feed taken to the middle element, across a 1-in. break. All elements are carried on -small stand-offs. We describe this aerial in detail because it

SECOND 58 mc ACTIVITY LIST

Call	Location
G2AG	Norwich.
G2AK	Great Barr, Birmingham.
G2OA	Liverpool.
G2BB	Yateley, Hants.
G2BMZ	Teignmouth.
G2DP	Thornton Heath, Surrey
G2FWA	Croydon, Surrey.
G2NM	Bosham, Surrey.
G2TA	Catterick, Yorks.
G2XC	Portsmouth, Hants.
G3BY	Ashton-u-Lyne, Lancs.
G3CU	Tooting, London.
G3HW	Teignmouth, Devon.
G3PD	Oldham, Lancs.
G3PV	Berkhamsted, Herts.
G4OS	Chester.
G5AS	Kingston, Surrey.
G5FK	Footscray, Kent.
G5LJ	Sutton Coldfield, Warks.
G5LT	Medstead, Hants.
G5MP	Hythe, Kent.
G5MQ	Woolton, Liverpool.
G5SY	Torquay, Devon.
G5TD	Chester.
G5TP	Henley, Oxon.
G5UI	Ryde, I. of W.
G5WH	Wolverhampton.
G6DH	Clacton.
G6DP	Fordsham, Lancs.
G6HX	Banstead, Surrey.
G6HY	Nottingham.
G6JI	Walthamstow, London.
G6LK	Cranleigh, Surrey.
GW6OK	Colwyn Bay, N. Wales.
G6OU	Basingstoke, Hants.
G6RA	Regents Park, London.
G6VX	Hayes, Kent.
G6YP	Forest Hill, London.
G6YQ	Woolton, Liverpool.
G8DV	Farnham, Surrey.
G8GS	Woking, Surrey.
G8JB	Havant, Hants.
G8RS	Reading, Berks.

LISTENERS

BRS-3003, Coulsdon, Surrey.
 F. H. Clarke, Newbury, Berks.
 (QRA's in "Calls Heard")

58 mc QRA's WANTED
 G2LC, G3IC, G3OO, G4CR, G4IG, G6RO

is an easy one to build, and it is certainly giving results.

G8RS (Reading) has a nice rig which will in due time be bringing him the DX, judging by the quality of his signal at ranges up to 50 miles or so. He has 400 volts on a 1614 power doubler, feeding an aerial very similar to that at G2NH, except that it is outside—but only 13 ft. above ground. His receiver is a three-stage converter (6AK5 RF, 1852 mixer, and 9002 oscillator) into an AR-77.

G6FO puts 42 mA at 550 volts into a KT8c; the aerial is a 12 half-wave, 35 ft. high, and the receiver a battery-driven converter using Mullard RL7 (EF54) valves. This can be run in conjunction with a variety of lower-frequency superheterodyne receivers.

Calls Heard

Elsewhere in this issue will be found what we hope will be a useful selection of calls heard on five metres—some good ones are not included for want of space. It is proposed to make a feature of 58 mc Calls Heard, so that we should be very glad to have logs from readers of these notes; it will be a great help if the logs are set out in the form shown, with distances in brackets. A great deal of work is otherwise involved.

Acknowledgment

Many stations have reported this month who are not mentioned; as they will fully appreciate, this is only because the DX news has topped the bill. In the ordinary way, we would have used much of this material, which consists in the main of individual activity reports and local news. We hope they will not feel that their efforts are not of interest because they cannot report DX—it is simply that we have already run over the allotted space, as there has been so much record-breaking news to discuss.

Second Activity List

This appears on the previous page and covers every new 58 mc station (callsigns *not* included in the First Activity List) reported to us

from any quarter up to April 24. A good spread of 58 mc activity is indicated, but there is still plenty of room for more, particularly in the isolated districts. We are still without authentic news from Scotland, Northern Ireland and the West.

Test Periods

We have not attempted to discuss in detail results during the April 14-16 Test Period, since much of the DX working reported took place while the Test Period was on. A careful listening check was kept for activity during the arranged times, and several new callsigns were logged; they have been entered in the Activity List herewith.

For May/June, 58 mc Test Periods are as follow:—May 17-20 inclusive, evenings 1830-2000, 2100-2300; Saturday, May 18, 1500-1630; Sunday, May 19, 1100-1230, 1500-1630. June 1-4 inclusive, evenings 1830-2000, 2100-2300; Saturday, June 1, 1500-1630; Sunday, June 2, 1100-1230, 1500-1630. All times BST.

Reports

Please post these by May 21 and June 5 to A. J. Devon, *c/o Short Wave Magazine*, 49 Victoria Street, London, S.W.1. A few nice, clear photographs would also be very welcome.

TARGETS

The following records are claimed for the bands mentioned—all American, all two-way, and all confirmed by *QST*, A.R.R.L.:

- 56 mc : W1EYM/W6DNS, 2,500 miles, July 22, 1938.
- 112 mc : W1BJE/W3FYB, 355 miles, September 6, 1945.
- 144 mc : W6OIN/W6UID, 100 miles, January 10, 1946.
- 224 mc : W6IOJ/W6LFN, 135 miles, August 18, 1940.
- 400 mc : W6IOJ/W6MYJ, 60 miles, September 14, 1941.
- 5,250 mc : W2LGF/W7FQF/2, 31 miles, December 2, 1945.

Some of these are going to take a lot of beating, and will depend (for G's) on much more Continental activity on the VHF bands than we used to get before the war.

The Principles of Short-Wave Reception

Dealing with Superheterodyne Converters and Receivers —Some Notes on Communications Receiver Design

PART III

By A. A. MAWSE

IN the first part of this short series—of which this is the concluding article—it was stated that three main types of receiver are suitable for short-wave use. Of these, it was agreed to deal with the “straight” and the superheterodyne, but to ignore the super-regenerative arrangement because of its many disadvantages.

Having considered various types of “straight” circuit, the superhet can now be examined. This type of receiver is slightly more complicated than are those already explained, but has very many important advantages. In fact, the advantages are so great that there are those who would go so far as to say that the superhet is the *only* circuit for serious work. There is no doubt that it is inherently more selective than the other types; it is also more sensitive. Although it is often necessary to employ two separate tuning condensers (ganging is not very satisfactory unless one has more than the usual facilities for aligning the circuits) the operation is actually somewhat easier than is the operation of a simpler receiver on short waves, where reaction is so critical. Because of the greater sensitivity and better inherent selectivity, results with the superhet are not quite so dependent upon the skill of the user.

It is quite easy, with a few figures, to prove that the superhet is more selective than other types, but it is not proposed to do so here. If the reader is not already familiar with the reasons, he is asked to accept the fact as stated. The enhanced sensitivity is due to the fact that radio-frequency amplification is greater at lower than at higher frequencies. Whereas RF amplification

is very difficult at, say, 60 mc, good amplification can readily be provided at a frequency in the region of 1.6 mc, which is that generally employed in the IF amplifier of a short-wave superhet.

The easier operation results from the fact that critical reaction control is obviated in the superhet. If reaction control is used at all—and it is not required unless CW reception is called for—it is by no means sensitive, and adjustment of reaction does not affect tuning.

Superhet Principles

Many readers may like to refresh their memories on the superhet technique before considering actual circuits. The underlying principle of the superhet is that a signal at the normal RF signal frequency is picked up, which beats with a CW oscillation generated within the receiver. As a result of the beating together of the two sets of oscillations, a variety of oscillations at several differing frequencies is produced. Of these, the most important is the one which has a frequency equal to the difference between the signal frequency and the locally-generated oscillation.

That difference frequency, known as the intermediate frequency or IF (an unfortunate name in many ways) is passed to an RF amplifier and thence to the normal detector and AF stages. What has just been referred to as a radio-frequency amplifier is known as an intermediate-frequency amplifier in a superhet. There might be a radio-frequency amplifier in addition, but if so it precedes the first detector and frequency-changing stages.

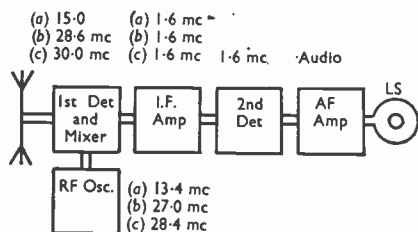

Fig. 1. This block diagram shows the essentials of a superhet receiver, and gives examples of the frequencies encountered at different parts of the circuit.

Fig. 1 shows in block diagrammatic form the essential parts of a typical superhet of the type under consideration. It will be seen that the first detector and RF oscillator are shown as separate units; in practice, the two functions are often combined in a single frequency-changing valve of the heptode, octode or triode-hexode type. It is the last-mentioned which is generally found most suitable in a short-wave superhet when a separate oscillator is not employed.

It will have been gathered that the frequency at which the IF amplifier operates is the same irrespective of the frequency of the signal being received. That in itself constitutes an important advantage, for it means that all IF circuits can be pre-tuned and that the usual variation in amplifier characteristics over any given frequency range are not involved.

Converter or Receiver ?

There are two principal methods of constructing a superhet: One is by building a complete receiver, usually with four or more valves; the other is by making a converter unit, comprising only a frequency-changer, which can be used in conjunction with a normal T.R.F. receiver. The RF amplifier of the receiver serves as an IF amplifier, while the detector stage is used as a second detector. The AF amplifier, of course, performs its normal function.

The converter has obvious advantages from the point of view of

economical construction, but is inclined to be in the nature of a compromise. In addition, by using a converter with a standard broadcast receiver, use may have to be made of an intermediate frequency which is not the most suitable. An IF of 1.6 mc (1,600 kc) is becoming standardised for short-wave work, but the average broadcast receiver will not usually tune quite as high as this; the highest frequency reached is generally just under 1,500 kc.

In passing, it should be mentioned that a converter can be used in conjunction with either a "straight" or superhet receiver tuned to a fixed frequency of between 1.5 and 2.0 mc. When a superhet is employed it will be seen that frequency-changing is carried out twice: once in the converter, and again in the receiver itself. This is not a disadvantage, and is actually to be preferred from some aspects when receiving on frequencies above about 15 mc.

Triode-Hexode Converter

The circuit of a fairly standard type of converter is given in Fig. 2. It will be seen that a triode-hexode valve is used as combined first detector and RF oscillator. These two functions are often referred to under the name of "mixer," but that term may prove rather confusing, as will be seen later.

Those who are accustomed to building superhets for broadcast use may ask why a triode-hexode is specified in preference to a heptode, octode or similar type of valve. The reason, in very simple terms, is that the oscillator portion of the triode-hexode is less likely to "pull" the first detector off frequency, and applies a smaller load to the first detector, than is the case with the other types of double valve. This is particularly the case on short waves, for which heptodes and the like cannot be recommended except when they are used in conjunction with a separate oscillator.

In looking at Fig. 2 it will be seen that the tuned circuit in the anode of the first detector is marked "B.C." This is intended as an abbreviation for "broadcast coil." Thus, the coil used

may be a normal aerial coil tuning to the same frequency as the highest range of the receiver employed. The primary winding of the coil, provided for aerial and earth connections, is used as the secondary and is connected to the aerial and earth terminals of the receiver. An alternative method of connecting the converter is to take a lead from the anode end of the tuned winding, through a 100 μF fixed condenser, to the aerial terminal of the receiver. In that case, an earth connection should be made to the receiver as well as to the converter. Such a connection is often desirable in either case, to prevent the receiver from being "up in the air."

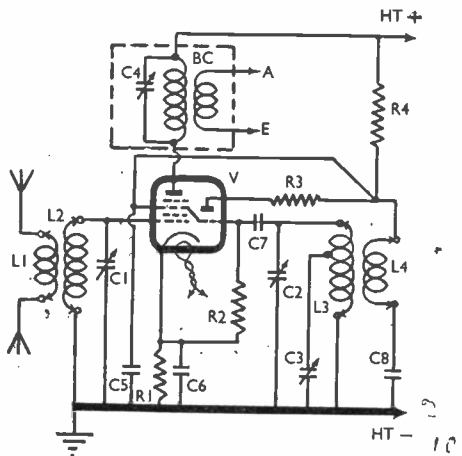

Fig. 2. Circuit of a triode-hexode superhet converter suitable for use on frequencies between 3 and 30 mc, with four pairs of plug-in coils.

Suitable component values are as follow: C1, 100 μF ; C2, 100 μF ; C3, 25 μF ; C4, 200 μF preset; C5, 0.1 μF ; C6, 0.1 μF ; C7, 50 μF ; C8, .001 μF ; R1, 300 ohms; R2, 100,000 ohms; R3, 50 ohms; L1, L2, L3 and L4, see table; B.C., see text; V, Osram X65 or similar, or American 6K8 (mains), Osram X24 or similar (battery).

Practical Data

The converter represented by Fig. 2 is intended for use on frequencies up to 30 mc, but it is not suitable for 60 mc. It can be constructed along the same lines as those described for the corresponding "straight" receivers in the last article of this series. Condensers

C1 and C2 may have normal drives, as they are provided principally for band-setting, although C1 is also used for final trimming. But the band-spread condenser marked C3 should have a good, slow-motion drive. It is this condenser which will require to be set most critically, and on which most of the tuning will be carried out.

Octal-base plug-in coils are recommended, and these can be made as explained last month, using standard formers of 1 1/4 in. diameter. Windings L2 and L3 should be in 22 SWG enamelled wire, with L1 and L4 in 30 SWG. In the case of the coils for the two lower frequency bands, windings L1-L2 and L3-L4 should be separated by about 1/8 in. on the former. For the two higher ranges the small coupling windings are interwound—that is, the turns are placed in the centre of the spaces between the turns of the tuned windings.

The following table gives winding data for the coils.

Band (mc)	L1 (turns)	L2 (turns)	L3 (turns)	Tap (turns from E end)	L4 (turns)
3.75	7	45	22	15	6
7.5	6	30	15*	7	4
15.0	5	14*	7 1/2*	3	3†
30.0	4	7*	3*	1	2†

Note: * Indicates that winding is spaced to fill 1 1/4 in. length on former.
 † Indicates that winding is interwound with tuned winding.

Oscillator Screening

It is desirable that the two coils should be screened from one another, and that the oscillator coil should be screened sufficiently to minimise radiation from it. This could be done by mounting the oscillator coil beneath the chassis, but there would then be the objection of turping the set upside down each time the coil had to be changed. A far better method is to construct an aluminium box, mounted

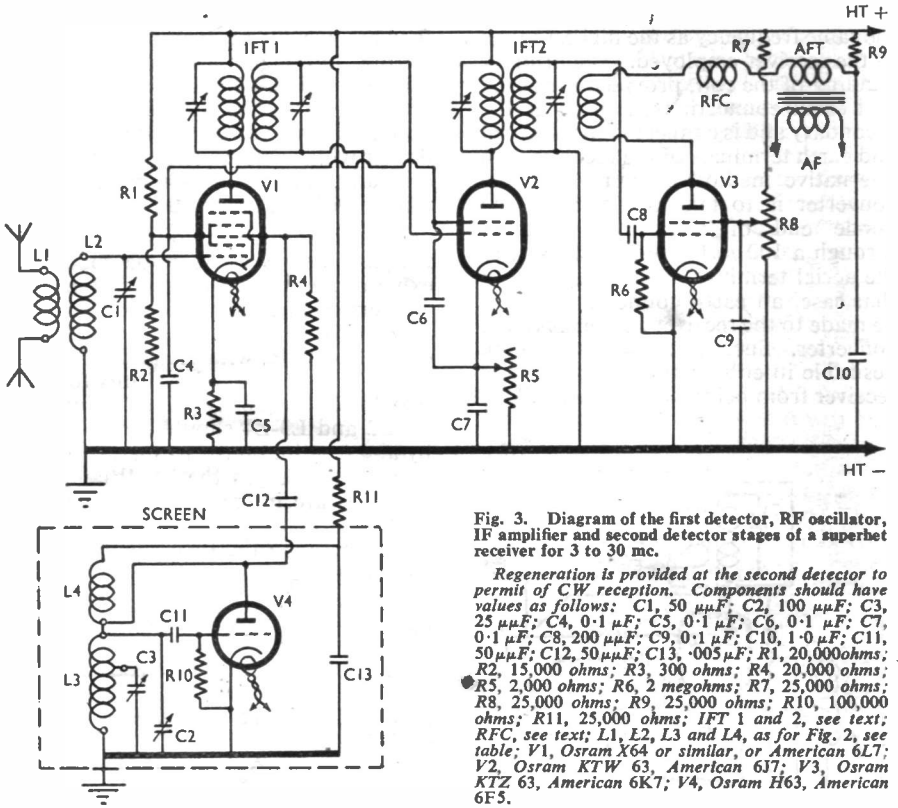

Fig. 3. Diagram of the first detector, RF oscillator, IF amplifier and second detector stages of a superhet receiver for 3 to 30 mc.

Regeneration is provided at the second detector to permit of CW reception. Components should have values as follows: C1, 50 μ F; C2, 100 μ F; C3, 25 μ F; C4, 0.1 μ F; C5, 0.1 μ F; C6, 0.1 μ F; C7, 0.1 μ F; C8, 200 μ F; C9, 0.1 μ F; C10, 1.0 μ F; C11, 50 μ F; C12, 50 μ F; C13, .005 μ F; R1, 20,000ohms; R2, 15,000 ohms; R3, 300 ohms; R4, 20,000 ohms; R5, 2,000 ohms; R6, 2 megohms; R7, 25,000 ohms; R8, 25,000 ohms; R9, 25,000 ohms; R10, 100,000 ohms; R11, 25,000 ohms; IFT 1 and 2, see text; RFC, see text; L1, L2, L3 and L4, as for Fig. 2, see table; V1, Osram X64 or similar, or American 6L7; V2, Osram KTW 63, American 6J7; V3, Osram KTZ 63, American 6K7; V4, Osram H63, American 6F5.

complete on top of the chassis and to contain the oscillator coil as well as condensers C2 and C3. The screening box will require a lid, and this should be a very good fit and properly earth-bonded. An alternative is to fix it by means of screws passing through clearance holes round the lid and into tapped holes in the box itself. In that case, it would be most convenient to make a hole in the lid through which the coils could be passed, and to provide a pivoting aluminium "door" to cover the hole.

There is scope for a certain amount of ingenuity in the design of the screening arrangements, but sufficient has been written to give the reader a line on which to work.

Separate RF Oscillator

Fig. 3 shows the circuit for a complete superhet suitable for use on frequencies up to 30 mc. A separate triode oscillator is used in conjunction with a special heptode mixer. It should be noted that this is a mixer valve purely and simply and differs from the heptode designed for use as mixer and self-oscillator. As far as is known, there is no suitable valve available in the battery-operated range; that is why only mains-type valves are specified in the caption.

This type of frequency-changer is even better than that shown in Fig. 2, but calls for the use of an extra valve. In constructing it, the coils required are

exactly the same as for the circuit previously described. As a separate valve is used as oscillator, the complete oscillator circuit may be screened, as indicated by broken lines, by mounting all the components in an aluminium or copper box mounted on top of the receiver chassis.

Intermediate Frequency

The IF transformers should be of the type designed for operation at about 1.6 mc; the more usual 465 kc transformers are not recommended, but will serve. A minor modification is required to the second IF transformer if the receiver is to be suitable for CW reception. About 30 turns of wire, say 30 SWG enamelled, are wound round the normal transformer windings, or round the former adjacent to the windings. This serves as a reaction or beat oscillator winding, and the most suitable number of turns will have to be found by trial, as it is obviously dependent upon the characteristics of the particular transformer employed. Alternatively, a separate beat oscillator (BFO) can be provided, injecting a fixed frequency signal into the grid of V3.

Reaction is controlled by varying the voltage applied to the screening grid of the tetrode V3 used as second detector—by adjustment of the potentiometer marked R8.

The receiver as illustrated can feed into any AF amplifier or into a pair of phones. Details of the RF choke in the anode circuit of the second detector are as given last month.

Using the Superhet

Operation of both converter and complete superhet is similar, after the IF stages have been aligned. When using a converter, alignment will already have been carried out in the receiver, so it is necessary only to tune the output circuit of the converter to the same frequency as that to which the broadcast receiver is tuned (the highest frequency that can be reached on the medium-wave band).

The method of aligning the IF circuits will not be described here, for it is

rather outside the scope of this article. It will suffice to say that the procedure is exactly the same as with a superhet broadcast receiver, and that a signal generator which will tune to the intermediate frequency is desirable, if not a practical essential.

It will soon be found that although tuning of the oscillator circuit is critical, aerial-circuit tuning is relatively flat. In using the circuit of Fig. 2, the first step is to set the band-set condenser C2 and then to bring C1 into line, tuning until background "hiss" is at a maximum. Searching can then be carried out on the band-spread condenser C3. When a signal has been found, slight re-adjustment of C1 will probably be required. The procedure should be repeated when working at different settings of the band-set condensers.

A 58 mc Unit

Fig. 4 shows the circuit of a frequency-changer, suitable for either a converter or complete receiver, for use on the 58 mc band. A separate oscillator is again used, but this time in conjunction with a pentode first detector-mixer. The general principles of unit are the same as those already explained, the only important difference being in connection with the component values and the coils employed. The latter should be made in the same way as those described last month for use in a T.R.F. receiver intended for the 58 mc band. It will be remembered they are more or less self-supporting, $\frac{3}{4}$ in. inside diameter, and wound with wire not thinner than 16 SWG. Following are details of the windings: L1 4 $\frac{1}{2}$ turns, tapped 2 $\frac{1}{2}$ turns from E end, L2 3 turns, L3 3 $\frac{1}{2}$ turns, tapped 2 turns from E end L4

Communications Receivers

There is no doubt that a good communications type of receiver is the best that can possibly be used for short-wave work, but the construction of this sort of set is generally beyond the scope of the amateur. In addition, it would be very difficult at the present time to obtain a suitable kit of parts for such a

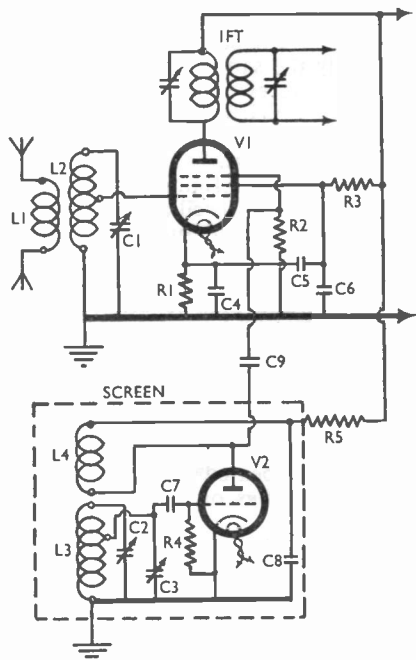

Fig. 4. Details of a frequency-changer for use on the 58 mc band. A unit with this circuit could be used as a converter or as the first stage of a complete superhet receiver.

Following are suitable components value: C1, 35 μF ; C2, 25 μF ; C3, 15 μF ; C4, 300 μF ; C5, 300 μF ; C6, 300 μF ; C7, 50 μF ; C8, 300 μF ; C9, 50 μF ; R1, 250 ohms; R2, 100,000 ohms; R3, 100,000 ohms; R4, 50,000 ohms; R5, 20,000 ohms; IFT, see text; L1, L2, L3 and L4, see table; V1, Osram ZA2 or similar, or American 7G711232; V2, Osram HA2 or similar, or American 7A4.

set; if the parts were available, some rather tricky design work would be called for and a fair amount of test gear would be necessary in lining up and making initial adjustments.

Communications receivers follow a fairly standard plan, but vary enor-

mously in actual design and construction. All have a superhet circuit, generally with an RF stage before the first detector. They use a separate RF oscillator, usually two or more IF stages, a second detector with AVC and BFO, and generally a noise-suppression circuit. Special IF transformers with three or more tuned circuits are usual, and there is frequently provision for bringing into circuit a crystal gate in the IF system. A selector switch, operating in conjunction with the crystal, gives five or six different band widths or degrees of selectivity. Other controls include one for variation of RF gain, another for AF input or volume, a tuning knob for the beat-frequency oscillator (used for CW reception) and a switch for putting the BFO into or out of operation.

The various RF and oscillator circuits are usually ganged, whilst there is a system of band-spreading, either by means of a separate band-spread condenser or by the choice of a very slow motion condenser drive. Most communications receivers cover a number of frequency ranges without coil changing and give continuous tuning from about 550kc to 30 mc.

From these very sketchy details it will be understood why home construction is extremely difficult, and why the price of a communications receiver (if one can be found these days) is high. All except those lucky ones who possess a set of this type will therefore have to make the best of the simpler receivers such as those described, for another year or so. But, in conclusion, it should be pointed out that excellent results and invaluable experience will be gained by making and operating one of the receivers of which details have been given in this short series of articles.

(Conclusion)

Mention the Magazine when writing to Advertisers—
It Helps You, Helps Them and Helps Us.

Transmitter for Five

Design for Three Valves—No Neutralisation— 25 Watts. Straight PA Output

By AUSTIN FORSYTH (G6FO), *Editor*

THESE are many different circuit arrangements which can be designed to give output on 58 mc. These range from the objectionable self-excited oscillator type—why is it that we always tend to start work on our highest frequency bands with the most unstable and ineffective kind of equipment?—to elaborate multi-valve rigs involving seven or eight tuned circuits.

Recently, some experimental work has been undertaken with a view to determining a reasonably simple circuit design, using the minimum number of valves, for getting satisfactory operation on 58 mc within the present power limitation, and with the final stage working as a PA and *not* as a power doubler, so called.

The fruits of these labours can be summarised in the circuit shown here, which is now giving excellent results on five metres. The main advantages of this arrangement are (1) Only three valves are required, (2) No neutralisation is necessary, (3) The third stage is a straight amplifier on 58 mc, (4) The set can be operated on 28 mc and makes an excellent exciter for a full-power PA on that band. If and when we get increased power allowed on 58 mc, it will easily drive a 5-metre RF amplifier of the pentode (PT15, PV1-35 or 4052A) type.

At the moment of writing, this transmitter is being rebuilt from its original "haywire" state to a finalised form of construction which will be described and illustrated in the next issue. Hence, no photographs or tables of operating data this time, since it is proposed to prepare these on the model as finally completed.

But sufficient information is given here to enable the transmitter to be

started, or its ideas applied to an existing design. The values are quite critical; nor should the valve types be changed (though similar valves of different makes may be substituted), while in regard to components, any parts of good make can be used successfully.

The Circuit

The valve line is tetrode-double triode-tetrode, the tuning sequence being: 7.35 mc crystal, 14.7 mc, 29.4 mc in the plate of the first half of the twin-triode, and 58.8 mc in the second, with the third valve as an unneutralised straight amplifier on 58.8 mc. This sequence is shown in the circuit diagram. Since the twin-triode is operated as a double-doubler, no neutralisation is called for, and it is avoided in the PA by careful attention to layout.

There are one or two circuit points of particular interest. Direct coupling is used as far as the PA; but circuits L4, L5, are inductively, *not* link, coupled, which is found to be more efficient at these frequencies. Direct coupling is not satisfactory at 58 mc, though with care it can be made to work if plenty of power is available on the driver side. Link coupling can of course be used between L4 and L5, but its adjustment is more critical than when these two circuits are inductively coupled, if only for the reason that there are two link coil ends to get properly set up. In the experimental version of this transmitter, the physical separation between L4 and L5 is 2½ in.; this is the setting for critical coupling and gives sufficient grid drive into V3 to push it well over 25 watts.

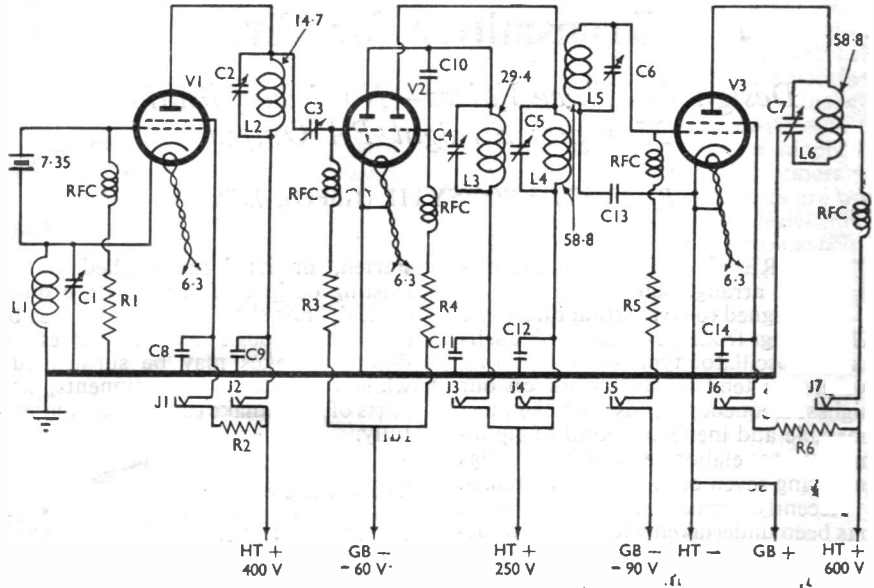

The other point is the excitation control condenser C3. Having set up the transmitter for maximum transfer of RF into the aerial, the power input can be smoothly and conveniently controlled merely by adjusting C3; any change in the setting of C3 will naturally react on the tune of C2/L2, so that unless the adjustment is a very small one, C2 must be reset to resonance after any alteration of C3.

Though jacks are shown in all HT leads and in the grid of V3 (J5), those actually necessary are only J2, J3, J4, J5 and J7, since the transmitter cannot be properly adjusted without metering at these particular points. The values of the series resistors R2 and R6 will automatically give the correct screen voltage (for the values of HT suggested) and need not be changed unless actual HT voltage varies by more than about 15 per cent. either way in the case of V1 and 10 per cent. for V3.

Layout and Construction

For anyone proposing to get on with the design, perhaps by adapting existing equipment, without waiting for the finished version as constructed for the

Showing the circuit and tuning sequence for a practical 58 mc transmitter, using KT8's and a DET19 twin-triode (V2). No neutralisation is necessary and keying in J4 produces a clean steady signal. Values are given in the table and all other details discussed in the text.

Magazine, the best advice that can be given is "Watch your layout, especially after V2." Juggle a little with the positions of RF components in order to get leads as short and direct as possible. All tuned circuits as far as C5/L4 can be put close together physically; since they are all doublers, but C6/L5 and C7/L6 must be kept separated, otherwise V3 may spill over.

In regard to RF chokes, those on the grid and plate sides of V3 should each consist of one of the VHF type in series with a normal short wave transmitting choke. The fixed condenser values are important, and it should be noted that the heaters of V2 and V3 are earthed. Take care to earth the same pole if feeding the valves from a common LT supply, otherwise it will be subjected to a dead short.

Tuning and Operation

To anyone with experience of 28 and 58 mc transmitters the tuning of this one should present no difficulties what-

ever. The first point to watch is that the correct harmonic (14.7 mc) is found on C2; then, with C3 at half-mesh, get 29.4 mc on C4/L3, checking both circuits with the absorption wavemeter. The 58.8 mc doubler (C5/L4) may be a little tricky in that careful adjustment of C5 will be necessary. The next move, with a meter at J5, is to adjust the distance and tuning of L4 and L5 to obtain grid drive. Start with a separation of two inches, and bring C6 to resonance. This will react on C5/L4, so that C5 will require readjustment. Then increase or decrease the coupling between the coils until the separation for maximum grid drive—up to about 4 mA—is obtained. Each change in coupling will involve retuning on both C5 and C6. When the correct setting has been found, the coupling can be left fixed, any further variation in drive being obtained by adjustment of C6.

The final tuning motion is to bring C7 into resonance, having first checked that swinging that condenser about the resonance point does *not* affect grid current reading (with HT off V3, of

course), nor the plate current in the 58.8 mc doubler.

Keying

The best point for keying the transmitter is in J4, though it can be keyed in J1 or J3. However, by keying in the plate of the 58 mc doubler, a good clean note results, free of any chirp or spacer.

The aerial matching unit into which the transmitter is at present feeding is a variation of the Collins coupler, as described by the writer on p. 12 of the February 1939 issue of the *Magazine*, and is known as the Matched End-On. This tuner is link-coupled to L6, but only as a matter of convenience; inductive coupling would be better. The aerial itself is $12 \frac{1}{2}$ -waves in length at 59 mc.

Results obtained so far have been good—see "Five Metres" in this issue—but it cannot be too strongly emphasised that since getting results depends upon a number of factors, of which the type of transmitter used is only one, DX worked can never be a direct measure of transmitter efficiency.

Table of Values

C1, C2	= 60 μ F.	L2	= 11 turns, self supporting, No. 12 SWG bare copper, $1 \frac{1}{2}$ in. diameter, turns slightly spaced to $1 \frac{1}{2}$ in. length.
C3, C10,		L3	= 7 turns, as above.
C13	= 100 μ F.	L4, L5	= 4 turns, as above.
C4	= 40 μ F.	L6	= 4 turns, self-supporting, No. 12 SWG bare copper, $2 \frac{1}{2}$ in. diameter, turns spaced to $1 \frac{1}{2}$ in. length, centre-tapped.
C5, C6	= 25 μ F.	Valves	
C7	= 25 μ F per section, split-stator.	V1, V3	= Osram KT8c, Standard 4B/250A, Mullard PVO6-25, 807, RK25.
C8, C9, C11,		V2	= Osram DET19, Standard 4074A, RK34.
C12, C14	= .001 μ F, mica.		
R1	= 50,000 ohm, 1 watt.		
R2	= 10,000 ohm, 3 watt.		
R3, R4	= 20,000 ohm, 1 watt.		
R5	= 20,000 ohm, 3 watt.		
R6	= 50,000 ohm, 3 watt.		
RFC	= Standard RF chokes at all positions, with VHF chokes in series for grid-plate circuits of V3.		
Coil Values			
L1	= 8 turns No. 18 enamelled on standard ($1 \frac{1}{2}$ in.) former.		

(Note.—Valves mentioned first are those used in design. Others given are equivalents and may be substituted.)

Break-In, Single-Channel

Remedy for Relieving Congestion—Working BK with ECO—Details of a Practical System

By L. H. THOMAS, M.B.E. (G6QB)

THE chief problem confronting the radio amateur of the future is the packing of a very large number of stations into a very small space. The amount of mutual interference arising from this is going to call for a high degree of skill in operating, for the use of efficient and modern apparatus, and for a large amount of patience and tolerance on the part of all concerned. It is no good waiting for the real trouble to start—far better to get down to it right away. What can be done *now* to ease the situation on our congested bands?

Take 28 mc for a start. Here we have had enforced on us, by the American allocation of CW and telephony areas, an extremely narrow portion of the band which is crammed with CW stations. In passing, we might mention that between 28,000 kc and 28,100 kc there are two "pirate" commercials, whereas the band 27,700 kc to 28,000 kc is virtually empty—that is just one of those things. But the CW band (by which we mean roughly 28,000 kc to 28,150 kc) is more than uncomfortably full at week-ends and whenever conditions are good. It is rapidly approaching the old unhealthy state of a scramble to be nearest the edge, on the assumption that anyone making a CQ call will start listening at the extreme LF end.

Fundamentals of "BK"

How does break-in operation help us? Let us examine what "break-in" is capable of doing. The term implies ability to listen, anywhere on the band, when your own key is not actually

down, and on quite a lot of the band when it is down. This means, to begin with, that you can continue to listen on the frequency of the man you call. Therefore, if you send the signal "BK," and he is similarly enlightened, he need not wait for you to finish calling, but can chip in and tell you that he has heard you. This reduces QRM by shortening your own call. And if all the other stations calling him have the same facility, it means that they also will stop when they hear him reply to you. Thus, the basic amount of QRM caused by one "incident"—i.e. a CQ call by a DX station and the consequent babel of replies—can be reduced considerably, to the benefit of those participating in other "incidents" at the same time.

So far there is nothing to lose. If the other man does not know what "BK" means, he will simply hear your call through to the end and then reply. And if any of the others calling him would normally have given longer calls than yours, they will know when to stop, by hearing him come back to you.

This is simply normal break-in procedure, as practised (even if without co-operation) by several of the best stations to-day, and for years before the war. But it is possible to take it further by using what will be known as "single-channel working." This simply implies the use of a variable frequency oscillator (of the electron-coupled or better variety) in place of a crystal, and the understanding that if you call anyone you will do so *on their own frequency*. This means that you are listening on your own frequency when you are calling, so your break-in technique must be perfect.

Pros and Cons of Single-Channel

Let us examine the credit and debit side of this transaction. On the credit side you have the fact that once the procedure is accepted, anyone calling CQ will automatically listen first on his own frequency; on that spot he will probably hear someone calling him and effect a QSO. Only one frequency is used up by this "incident." On the debit side you have the fact that if he is a rare DX station he will, in an extreme case, have so many people calling him on his own frequency that he will not be able to decipher any of them. Arising out of this—and also on the debit side—is the fact that the would-be "breakers-in" may also hear a welter of stations calling the same station that they are after, and if the number is large and the distances of the stations very varied, they may well succeed in blotting out the original caller if he *does* come back to anyone. And, to be pessimistic, we may add yet another snag—if he *does* return to you, some of the others, mutually blotting out his frequency among themselves, may not hear him and may go on calling after you have succeeded in starting a QSO!

Well, obviously single-channel working has its pros and cons, but it is one of those things that must be tried out thoroughly. One big advantage is that it can still be tried out if only a few people do the trying. Once the technique is known, and the fact is accepted that after calling CQ it is worth listening first of all on your own frequency, then the converse will also apply—that when you hear someone calling CQ it is worth your while to reply on their own frequency. Those who do not adopt the idea will get on just as well as before for a while, but will gradually find that they are being a little less successful until the truth dawns on them.

Having described the system, now to give some pointers towards its adoption. First of all, obviously, some form of stable variable-frequency oscillator has got to be designed and used instead of crystals. That is fundamental. The

rest of the points all arise from the problems of ordinary "break-in," leaving the single-channel technique out of the matter.

Working BK

There are two basic problems in break-in work. First—how much noise does your transmitter make when the key is *up*? (The answer should be "none.") Secondly, how much when the key is down—both on and off your frequency? (The answer to this cannot possibly be "none!") To secure the happy state of no noise with the key up, it is essential to key the oscillator, whether CO or ECO. This can easily be done by the back-bias method, an example of which is shown in Fig. 1. Here the CO functions normally with the key down, but receives full negative bias on its grid when the key is released. This is a very successful method and virtually clickless. But when the CO is biased off—what of the rest? If battery or external mains-supplied bias is used, every meter in the transmitter should drop to zero when that key is released. The doublers are easy to deal with—they normally do behave like

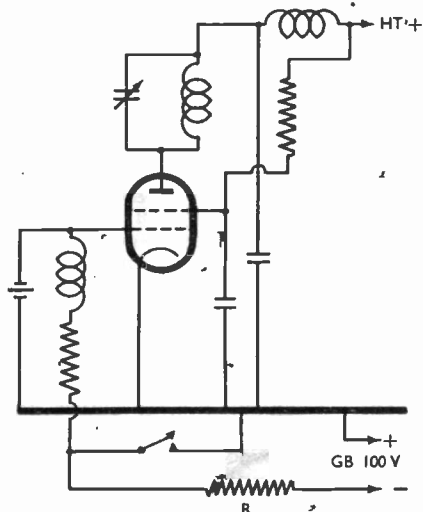

Fig. 1. Back-bias keying of a crystal oscillator. R is 1 megohm. Current drain on bias supply source is negligible.

that if they are correctly biased—but if the PA is prone in the slightest to parasitics, you will now find out all about it. There is no excuse for such unwanted oscillations, and break-in does a good turn by helping to show them up.

Parasitics in the PA

If the PA stage tends to go into a TP-TG type of oscillation, either it is improperly neutralised (if a triode is used) or the layout and screening are bad (if it is a tetrode or pentode). Watch, also, the old bugbear of grid and anode chokes starting a TP-TG type of oscillation. If, on the other hand, it is blameless in this respect but still makes noises, it is probably going into parasitics at a very high frequency, and will have to be cured by “stoppers,” chokes, and the usual devices for dealing with these things. A very useful stopper for anode or screen circuits is a small RF choke wound over about a 100-ohm 10-watt wirewound or vitreous resistor. One of the less bulky types of such resistor, wound with about fifteen turns of 16-gauge wire, is a good stand-by.

On the other hand, the writer found that a parasitic in a push-pull 807 stage was cured by two minute chokes in the grid leads, consisting of fifteen turns on a short piece of $\frac{1}{4}$ in. diameter paxolin rod.

Separate Rx Aerial

Another obvious requirement is the use of a separate receiving aerial. This needs to be as far away from the transmitting aerial as is conveniently possible, and it is an advantage to use a dipole with twisted or concentric feeder, so that the latter, where it is in the station, does not pick up too much RF from the transmitter, its aerial or feeder.

The sketch in Fig. 2 shows the arrangement adopted by the writer, which has proved very successful. If a good communications-type receiver is used, the whole problem is simplified somewhat. If a home-made “straight” receiver is concerned, you will probably have very little success in quietening it

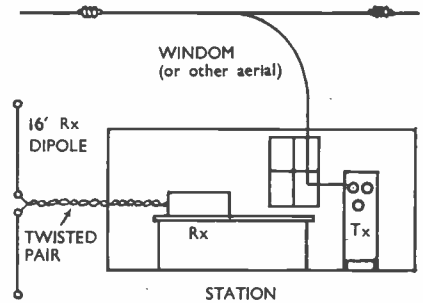

Fig. 2. Block layout for separate Rx and Tx aeri-als.

with the key *down*; but “key-up” is really the important feature, and there is no reason why a straight receiver, with loose coupling to a twisted pair and a dipole, should not prove a good all-round receiver for break-in.

Curing Other Noises

Various miscellaneous points come to mind—chiefly concerned with keeping the transmitter quiet in the “key-up” position. The mains feed may profitably be taken from a different point from the receiver feed. The receiver feed may be equipped with a filter consisting of two RF chokes with a pair of condensers across each outside end, the centre points being earthed (Fig. 3). The keying leads themselves should not be long; in other words the CO end of the transmitter should be at the end nearest to the receiver, so that a short flex lead can be brought straight out to the keying position. If long leads appear to be inevitable, it will be worth while to key with a relay. Remember that the ultimate goal to aim at is this: You should be able to tune your receiver to the weakest signal you can find on the band; then switch on your transmitter (key up and all ready to call him) without making the slightest sound in the receiver.

We all know how transmitters sometimes become prone to making noises of the “elephants on the gravel path” variety. Some of these extraneous noises are very difficult to find, but usually emanate from the power pack.

All such unwanted visitors must be found and removed. There is no short cut to this; if such faults are present, then they *are* just faults. The fact is that by equipping your station for efficient break-in you are really doing all your gear a good turn. Parasitics, stray TP-TG oscillations, unruly frying noises, and so on—none of these should really be there. And they *must* all be cleared up before your break-in is satisfactory.

Working Single-Channel

Now if you are going to attempt single-channel working—which will mean tuning your ECO to the frequency of the station you intend to call—you will naturally have to make sure that your receiver gives a good clear beat-note with the ECO. Even a straight receiver should be capable of doing this, because your ECO (of which more next month) will be well screened, of very low power, and

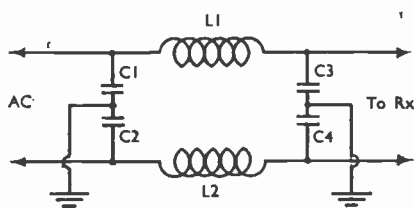

Fig. 3. RF filter for Rx power supply. For 28 mc operation, L1, L2, are 40 turns No. 16 SWG, 1 in. diameter, and C1, C2, C3, C4, .01 μ F, 250-volt wkg.

merely delivering a harmonic on the frequency to which you are listening. If your present rig uses a 40-metre crystal, two doublers and a PA, the suggestion is that you should eventually use an 80-metre ECO, feeding into your CO, which will then become a doubler. The keying, of course, will have to be transferred to the ECO. Then, merely by holding down the key without switching the transmitter itself on, you can flash your ECO round the band, sit on the frequency you want, and be all ready to start up on a call without disturbing everyone else who

is listening to your man. If you are only concerned with the CW band of, say, 28,000 to 28,150 kc, you will probably not have to touch anything in the transmitter except the final tank condenser after you have swung your ECO on to the required frequency.

One more point arises—keyclicks. Since you must listen on your own frequency (to see if your man comes back), it will be an advantage to develop a system of keying which is as clickless as possible, just to save wear and tear on your own nerves and ears. It will be no good turning the receiver gain right back while you are calling, or you will never hear the other fellow interrupt you (if he does!). So, the back-bias method already described is strongly recommended. This gives “bumps” rather than clicks. Further, it has been found a great help to keep the lead to the headphones as short and direct as possible. A long twisted lead from the receiver out to a jack-point somewhere else on the bench has been found to pick up a large amount of noise and to give the impression of bad key-clicks and severe hum when, in fact, neither was present to any extent.

To summarise, then, we have the following important points:

- (1) The transmitter *must* be perfectly silent when the key is up.
- (2) A separate receiving aerial (preferably a dipole) is necessary.
- (3) For single-channel working a good ECO with an easily accessible frequency control is essential.
- (4) The receiver itself should not be too prone to pick up unwanted noises (*via* phone leads, mains wiring, etc.).

By looking after points (1), (2) and (4) you can work efficient break-in with a crystal oscillator, quite apart from the ultimate aim of single-channel working. Next month further details will be given about a suitable electron-coupled drive oscillator.

The Cathode-Ray Tube

PART III

Amplifier Design

WHILST the cathode-ray tube offers an ideal means of recording visibly an extremely wide range of electrical phenomena, it presents a disadvantage in that it has a comparatively low deflection sensitivity. Dealing with a particular type of tube, for instance, in order to produce on the screen an image of 1-in. height, it may be necessary to apply an AC potential of about 45 volts RMS. For the examination of normal AC mains phenomena, such as phase measurement under various load conditions, etc., the low deflection sensitivity is of no importance, since the mains voltage itself is sufficiently high or can be readily stepped up.

When working with higher frequencies, however, an amplifier is often needed, and such an amplifier must comply with special requirements. It should be linear over the complete range of frequency it is desired to examine; that is to say, it should amplify equally at all frequencies within this range, its amplification must be sufficiently high, and its manipulation should be as simple as possible. For this purpose it is essential to employ resistance coupling, since it is not easy to construct a transformer capable of complying with the necessary standard of linearity. The question of power does not arise; what is needed is pure voltage amplification, the deflector circuit operating with negligible power consumption.

Design Points

The chief cause of non-linearity in resistance-coupled amplifiers is the stray capacity existing between leads and the unwanted capacity shunted across the coupling resistance, formed by anode capacity, grid-cathode capacity of the next valve, etc.

Fig. 21a shows the coupling elements with their capacity against earth. The various stray capacities may be considered as a total capacity C in parallel with coupling resistance R in Fig. 21b.

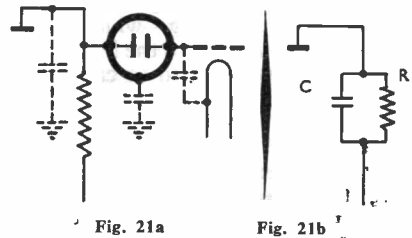

Fig. 21a

Fig. 21b

In order to examine the effect of this capacity in detail it will be assumed that C in Fig. 21b is $50 \mu\mu\text{F}$ and R is 50,000 ohms.

At 10 cycles the capacitive impedance is $\frac{1}{wC} \cdot 3.2 \times 10^8$ ohms;— at 1,000 cycles it is 3.2×10^6 ohms, and at 10,000 cycles it is 320,000 ohms. Now an impedance of 3.2×10^8 or 3.2×10^6 shunted across 50,000 will make no appreciable difference to the effective load, but a capacitive impedance of 320,000 which is obtained at 10,000 cycles will, when shunted across a resistance of 50,000, give a resultant impedance of approximately 44,640 ohms which is about 11 per cent. less than at 10 cycles. Going still further, at a frequency of 100,000, the resultant impedance of $\frac{1}{wC}$ shunted across the same 50,000 ohm resistance gives a resultant of approximately 26,315 ohms, which is approximately a 50 per cent. drop.

If several such stages were connected in series the difference between ampli-

fication at low and at high frequencies would be correspondingly greater.

Now, on the face of it, a frequency range of 10,000 cycles would appear to be a reasonable response for a number of purposes, but the following point must be borne in mind. It is frequently necessary to examine impulses of irregular or non-sinusoidal waveform, as for instance a saw-tooth waveform, or a rectangular waveform, and it can be shown mathematically that such impulses can be considered as consisting of a fundamental sine wave and a number of harmonics.

Achieving Linearity

If therefore such a voltage, at say a frequency of 10,000 cycles, is applied to the input side of the amplifier, the harmonics will be amplified less than the fundamental sine wave, and hence the original characteristic of the impulse will be distorted. Another consequence of the capacity shunted across the load resistance will be that the higher harmonics will have a different phase-shift from that of the fundamental and this, again, will entail further distortion.

From the above example the following conclusions can be drawn. In order to obtain as linear an amplification as possible, all stray capacities shown as C must be kept to an absolute minimum, and the value of R must not be made too high. Whilst with a smaller value for R the overall amplification will be less, there will, on the other hand, be greater linearity, since with a smaller R the influence of C will be less. It follows, therefore, that to obtain the highest possible amplification with a low value of R, valves must be used having as high a mutual conductance as possible. As a matter of interest it might be mentioned here that the development of special amplifiers having stringent requirements in the direction of the frequency characteristic has led to the use of secondary emission valves for this purpose, which valves have considerably higher mutual conductance than the normal type of valve.

Before leaving the subject of amplifier response at the higher frequencies a few words regarding the input impedance will not be amiss.

The same considerations apply regarding stray capacities as in the case of inter-valve coupling, and Fig. 22a shows the input circuit together with the possible stray capacity to earth whilst Fig. 22b shows the resultant circuit.

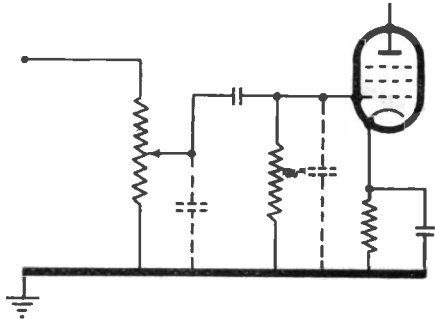

Fig. 22a

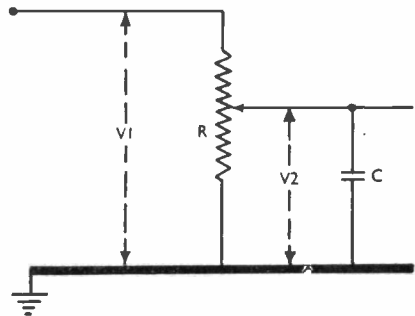

Fig. 22b

Now for the purpose of examining certain circuits the value of R must be high; for instance, for IF circuit examination R should generally be not less than 1 megohm, and it will be assumed that C is 22 $\mu\mu\text{F}$.

If C were zero and R were wound linearly then the ratio of voltages V1 and V2 would remain constant irrespective of frequency, but the shunting effect of C varies with frequency so that at any position of the

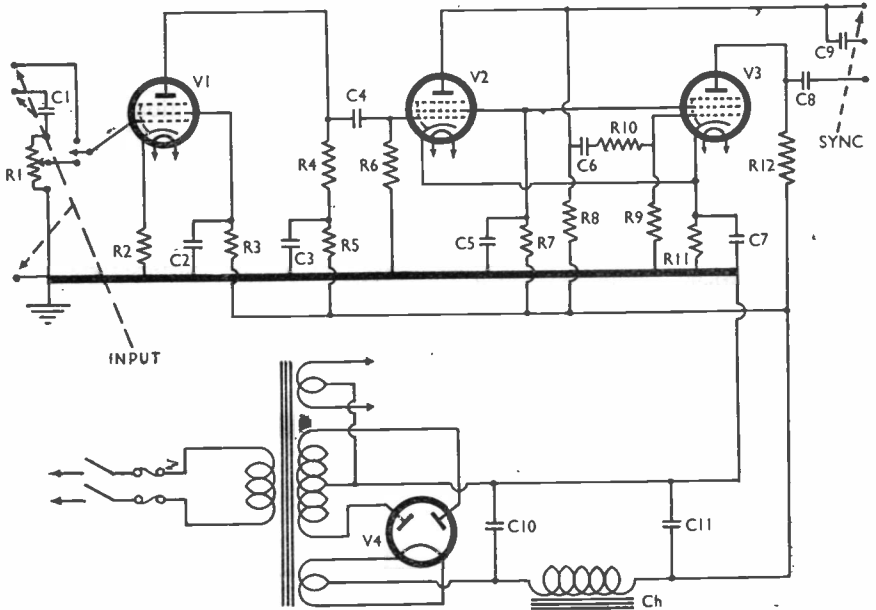

Fig. 23. Amplifier for Cathode Ray Oscilloscope. Values are: C_7 , $0.1 \mu F$; C_1 , C_4 , C_6 , C_8 , C_9 , $0.5 \mu F$; C_2 , C_5 , $4 \mu F$; C_3 , C_{10} , C_{11} , $8 \mu F$; R_1 , 1 megohm; R_2 , 400 ohms; R_3 , 150,000 ohms; R_4 , 8,000 ohms; R_5 , 15,000 ohms; R_6 , 700,000 ohms; R_7 , 20,000 ohms; R_8 , R_{12} , 6,000 ohms; R_9 , 40,000 ohms; R_{10} , 500,000 ohms; R_{11} , 350 ohms. Ch , 25-henry at 75 mA. V_1 , SP4B; V_2 , V3, PenA4; V_4 , DW2. These are Mullard—similar types of other makes can be substituted.

gain control, excepting at maximum gain where $V_2 = V_1$, the actual voltage applied to the first valve will decrease as the frequency increases, resulting in a falling characteristic.

Taking the values shown, for instance, and assuming that the slider of the potentiometer is in the mid-position, the voltage V_2 across grid and cathode of the first valve would vary between $.5$ of V_1 at 1,000 cycles to less than $.02$ V_1 at 1 megacycle. It will therefore be seen that it is of the utmost importance to keep the stray wiring capacity of the input circuit down to the absolute minimum by short leads and careful layout.

Another point to remember is that in connecting the amplifier across a tuned radio frequency circuit, the

input capacity may very seriously affect the circuit conditions by the addition of this capacity to the normal tuned circuit capacity.

In order to minimise this effect the coupling between the amplifier and the tuned circuit should consist of a capacity sufficiently small to have negligible effect on the external circuit, but in this respect a compromise must be made depending upon the available amplification, because too small a coupling will of course result in an image on the cathode-ray tube of inadequate dimensions.

An Amplifier Circuit

With careful construction the amplifier circuit shown at Fig. 23 should give linear amplification up to radio frequency, and the gain, measured at 100 cycles, is about 1,200.

The input to the amplifier may be taken either on to the potentiometer or directly to the grid of the first valve by means of a change-over switch. As an input valve a high gain pentode type V_1 is used which is coupled to two pentodes in push-pull. It will be noted

that whilst the first valve V2 receives the full output from the previous valve, only part of the amplified voltage is passed on to the second pentode, V3.

The grid circuit of this valve consists of a potential divider arrangement in which the resistance valves are such that both V2 and V3 deliver exactly the same output voltage which is symmetrical about earth.

When using the amplifier with the switch direct to the first valve it is of course essential that some form of grid-cathode return circuit be embodied, unless the circuit under examination itself forms such an arrangement.

Synchronising

In order that the phenomena under observation may be visible as a steady image a synchronising voltage is taken from the anode of V2 and should be fed via a small condenser to the grid of the gas triode in the time base.

The actual value of the synchronising coupling condenser will depend upon the frequency under examination, and it should be the minimum value necessary to produce positive synchronising.

For power supply a rectifier valve is used, which is required to deliver a voltage of 450 volts at a current of 75 milliamperes.

(To be continued)

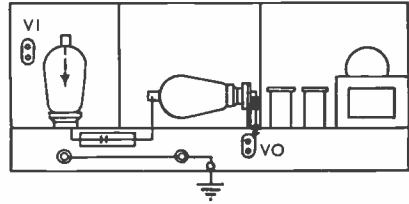

Fig. 24

A sectional drawing of a commercial amplifier chassis showing screening of amplifier units and separate section for power supply, V1 being input and V0 the output.

Sufficient has been said in previous articles to indicate the general principles underlying the design and operation of cathode-ray tubes and cathode-ray oscillographs, and with this information the experimenter should be in a position to apply the cathode-ray tube to the investigation of numerous problems associated with the maintenance and satisfactory operation of transmitting and receiving apparatus.

Apart from the ultimate usefulness of a complete cathode-ray oscilloscope, the experimenter may derive very considerable interest and experience from designing and building the various units which go to make up the complete equipment.

The Short Wave Magazine covers the whole field of Amateur Radio

SOURCE OF SUPPLY

It is probably unnecessary to remind readers not to ignore Woolworth's when looking round for useful bits and pieces. Our local has a very good selection of plugs, sockets, crocodile clips, covered wire, insulating connectors, miniature bulb-holders and similar oddments. And all of good quality. On the tool and ironmongery counters will usually be found strip brass (à la curtain-rail), also letters and numbers which can be used for making up one's call sign. In the half-inch size these look neat on the transmitter.

SMALL ADVERTISEMENTS

Space available is divided into two sections—Trade insertions and Readers' small advertisements. *Trade Advertisements*, 9d. per word, minimum charge 12s. *Readers' Small Advertisements*, 3d. per word, minimum charge 5s. Add 25% for bold face (heavy type) insertions in either section. All charges payable with order. No series discounts. Advertisements of radio interest only accepted. All copy to be in hand by the 15th of the month previous to publication. Apply The Advertisement Manager, *Short Wave Magazine*.

The other man's station

G6OI

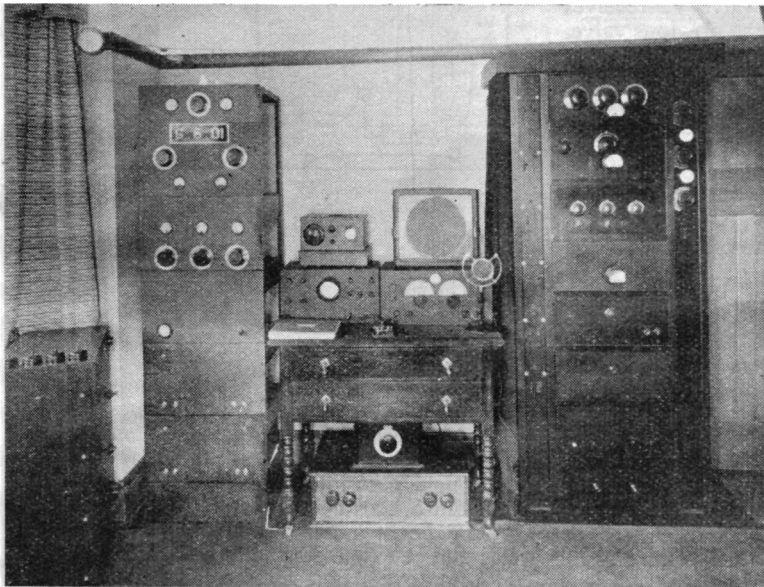

Before the war, this was a regular Magazine feature which was always popular. About a score of amateur stations from all parts of the country and abroad were described in their turn. It was not necessary to be either high-powered, good looking or clever with DX to get a showing as the "Other Man's Station." All we asked for were one or two good photographs and a general description of the equipment, the line of activity and the results obtained. The writing of the story round all this was a staff job.

Now we are open for business again in this section, and would be very glad to see what readers have to offer; contributors can expect a small reward for their efforts and any photographs used will be returned if required.

ILLUSTRATED HERE IS G6OI, Major J. Timbrell, B.Sc., Englefield House, Kinver, Staffs, President of the Stourbridge and District Radio Society, who has been on the air since 1924. His station is of particular interest in that all the equipment—with the exception of course of the RME-69—is home-built, even down to the racks and most of the chokes and transformers. There can be few amateurs nowadays who would attempt the latter feat—nor, unless one has a taste for it, is there any need to, since such equipment is easy to obtain and comparatively inexpensive. Nevertheless, it is always a creditable achievement to design and build one's own apparatus, besides being most satisfying to the ego.

The left-hand rack assembly houses a complete 28 mc rig, including modulator and power packs, and on the right is the transmitter for the other LF bands, which at present is operated only on 1.8 mc, for obvious reasons. The station is under oscilloscope observation (sitting on the table to the left of the RME-69) and general control equipment includes modulation and frequency meters.

G6OI is another of those whose main interest is not DX, which has always been incidental to his chief activity—the training of young operators. In this respect, he can lay claim to a remarkable record. Over a hundred beginners, most of them now with their own calls, learnt their radio at G6OI

and were licensed as additional operators of the station. We can well believe, as he says, that their collective war record makes most interesting reading, and it must be a source of pride and gratification to G6OI that he fathered so many amateurs who sub-

sequently went out to make their mark in the country's service. Many of them will, no doubt, also make their mark in Amateur Radio. Major Timbrell mentions that he would be very glad to hear from any ex-operator of G6OI whose eye should chance to fall on these lines.

AUTOMATIC CHANGE-OVER

Useful Suggestion

By N. P. SPOONER (G2NS)

A key-operated delayed-action system may commend itself to those who want break-in working without being tied to keying the crystal oscillator stage. While the arrangement described does not afford full break-in, in the sense that the receiving end can stop the sender whenever desired, it nevertheless contributes considerably towards the intelligent operating standard demanded by present-day conditions. It allows frequent automatic listening pauses during which the receiving station can indicate whether or not interference has sprung up.

The Circuit

To accomplish this a separate triode valve, run off the transmitter HT because of the extremely small current consumption, has a relay placed in its cathode circuit and a delay network in its grid. To actuate the cathode relay, bias is applied to the valve by means of a small battery and one pair of auxiliary contacts fitted to the key. The main contacts are free to key any desired stage of the transmitter. Not being concerned with the formation of "dits and dahs" this application of bias can also be made by a bug-key if two pairs of auxiliary contacts are fitted to an upright of insulating material held by the paddle-screw. In operation the initial closing of either straight or bug-key causes the cathode relay to actuate a second relay that switches off the receiver HT, swings the headphones from receiver to monitor, and switches on the transmitter. If during transmission a pause is then made with the key open, the relays automatically reverse the whole process back to the "Receive" position.

Push to Talk

For telephony the system can be manually operated if a push-button is wired across the auxiliary contacts. Additional

relays, made quite easily and cheaply from old car cut-outs, can be included if it is also desired to change the aerial system over and mute the receiver.

Finally, there appears to be no reason why one single relay in the valve anode or cathode circuit should not control the entire transmitter, receiver and headphones switching.

It should be added that the items and values listed with the circuit diagram were used solely because the junk-box disgorged these particular pieces.

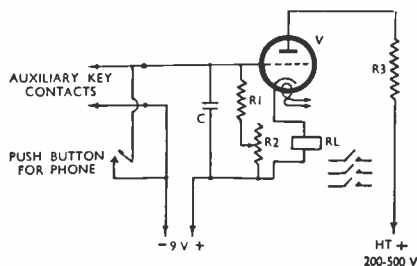

Circuit for the semi-automatic change-over device suggested by G2NS. The relay can be chosen to carry out as many switching operations as may be necessary.

V = Triode.

C = 0.1 μ F.

R1 = 0.5 megohm.

R2 = 1 megohm.

R3 = 50,000 ohms.

RL = P.O. type "B" relay (movements may be increased, or additional relays used.)

DX COMMENTARY

ON CALLS HEARD, WORKED & QSL'd

By H. A. M. WHYTE (G6WY)

OUR prophecy that East-West 28 mc signals would fade out by the middle of April seems to have been fulfilled right on time. The log shows that the week-end April 12-13 saw the end of regular reception of Asiatics. U.S.A. signals disappeared sooner, as is usually the case, and were last worked on April 8. We looked up our logs and found some most interesting data. Regular 28 mc contacts with U.S.A. started in October, 1935—prior to that year the band had produced very little DX. One recalls that the autumn of 1929 was a great time for W's, when they were heard at good strength, though few in number. Many of them just called "CQ Europe" with automatic senders and listened every half-hour! In 1936, W's disappeared after March 22; in 1937, April 11 was the last day; in 1938, April 4 was the finish; while in 1939 they faded out somewhat earlier on March 25. So it will be seen that April 8 this year has kept to the usual rule.

Summer Conditions on 28 mc

What can we expect in the way of DX during the summer? By past experience, the answer is very little! At the time of writing, ZS's are still coming through in the afternoons, but they fade in and out in a most elusive manner, while an occasional South American suddenly appears and equally suddenly disappears.

These erratic conditions may occur at any time during the months of May, June and July, but are not so likely in June and July. In fact, even with much greater occupancy, we cannot predict very much DX at all for the summer. The F-layer will not play in the Northern Hemisphere on 28 mc, but contacts with European countries are possible due to sporadic E reflection.

Some truly amazing signal strengths may be expected from countries as near as France, Germany and Scandinavia, but such results are not likely to occur on a regular day-to-day schedule. Inter-G contacts due to this sporadic E reflection are an interesting possibility, and already there are signs of these short skip effects. On March 13, at 0745, G5BJ (Birmingham) was worked by G6WY (Beckenham) at S5 both ways.

As soon as the shortest day is past, the effect of the sun's rays on the F-layer decreases daily in the Northern Hemisphere, beginning to increase again after the longest day, and the following dates for the reappearance of 28 mc U.S.A. signals will no doubt be of interest. They are the first days on which W signals were heard and worked and are taken from our logs: 1935, October 19; 1936, September 18; 1937, September 8; 1938 was an unusual year, as W4FT was worked on July 29, but U.S.A. was not heard or worked again until August 21, though August 14 produced four VU's and VQ3TOM. We have no records of 28 mc reception before September 3, 1939.

Apropos last month's comment about the Dellinger effect, G6DH (Clacton), who is an authority on the ionosphere, takes us to task for giving a misleading impression as to what actually happens under Dellinger conditions. It is that excessive ionisation occurs, especially at low levels, and the reason signals are not heard at DX is that they are returned within ground-wave range. G6DH quotes March 28 as an excellent example of this. Below 25 mc there was a complete fade-out for an hour or two, but on 28 mc G's at 50 miles and some nearby Europeans

were being reflected. Thanks, G6DH, for sorting this out.

Next 28 mc DX Season

From the dates given above we are prepared to prophesy that East-West signals will reappear during August, so that U.S.A. may be expected again during the last fortnight of August.

Many amateurs have been heard expressing the thought that DX conditions on 28 mc have behaved in a strange and unpredictable way this year, but from the data given above, we do not share this view. What *has* made the band appear unusual is the large

band—and not so local either with the D4's using 500 watts! G6ZO/I in Italy has also been on. Generally, however, Scotland is the aim and object of the more DX-minded and some very nice GM signals have been heard in the South. We understand that the Post Office is watching us very closely on 1.8 mc, as some firm opposition was put up by unfriendly interests to the amateur use of this band again. Do not yield to the temptation to use more than 10 watts, even though the D4's are doing it and thereby prejudicing the whole position. If the Editor agrees, it is hoped to run a Magazine

ON THE AMATEUR BANDS

number of American amateurs operating in strange parts of the Pacific with 500-watt Army sets. These areas obviously had no amateur occupancy before the war; VK was, however, quite a common country in 1938 and '39, coming through far more consistently than this year. Conditions have been poor on the whole, and variable when the F-layer was only just turning DX back to earth. We predict that next DX season will be far more consistent and reliable for 28 mc.

More Bands

Good news again! It is confidently expected that generous portions of both the 7 and 14 mc bands are to be given to us by June 1. This will supply many starving DX men with an opportunity of chasing some new countries! No doubt there will also be something to say about the necessity for faultless operating on 7 mc 'phone! So, taken by and large, if 28 mc is dead, we have only a little time to wait. Let it be spent in further rebuilding so that when we can radiate on 7 and 14 mc (legitimately) we shall be able to do so with reasonable signals.

The Top Band

There is still plenty of room for more occupancy on this ever-popular local

1.8 mc Contest in October or November. Such contests have always been well supported, and we believe that this would be a popular move.

Further to the DX details given in last month's Editorial article "The Top Band Again." John L. Hall (Thornton Heath, Surrey) heard W1, 2, 3, 4, 8 on CW on 1.8 mc during the winter of 1940/41. This was probably the peak year for DX on 1.8 mc.

Slow Morse Practice Transmissions

G5UM, 9 Windermere Avenue, St. Albans, Herts, is prepared to give slow Morse practice transmissions at 2115 every Thursday, on 1850 kc. If you are interested, please write to G5UM and tell him so. Reliable reception for listeners within a 30-mile radius, and possibly more, should be obtained.

Operating Procedure

By and large, operating has been good on 28 and 1.8 mc. There is a tendency, however, for operators to omit the letter "G" from their call signs, even when in contact with overseas stations! This is very poor practice and a direct contravention of the licence conditions. Some of the calls heard without the prefix would probably be found to belong to R.A.F. D/F stations. We have also

noticed a tendency for newcomers to ask for QRS, which is sound common sense if you cannot copy 18 w.p.m. One particularly bad case has been heard of an Englishman working a KA on 'phone and interspersing his remarks with numerous Americanisms; we did not get the impression that the KA fully appreciated the "humour," either. When will some of these lads learn that the British have one way of speaking and the Americans another? We have yet to hear an American trying to speak like an Englishman—so why do it?

28 mc DX

EPIC on 'phone was operated by W9SAJ (QSL to St. Joseph's, Missouri) on an American airfield near Abadan, South Persia. He has now left. It is understood that EP1W is also active in the same area. PJ3X is genuine in Curacao (QSL to Box 81) and is an American with permission to operate from the Dutch authorities. VS3JH (VS5JH) is on Labuan Island, British North Borneo, and has been giving some of the CW lads a new country; send cards to 2 Parkhill Road, Chingford, E.4. LI3JU has packed his equipment and is on the way home, leaving no one else to carry on in Libya. QSL to his home address, F/Lt. S. G. Abbott, 3 Dundonald Road, Ramsgate, Kent. YV5AP has been putting in a very healthy signal, while PK4DA has worked quite a number of G's and claims to be in Sumatra. KA's have given us some fun, and the following have been on regularly: KA1AA, 1AB, 1AC, 1AE, 1AF, 1AK, 1AW, 1AZ, 1JM, 1SS, 1ZU and 3TF, on 'phone or CW. ZD4AC in Accra has been worked by some G's, but has been very difficult to hear by others.

G2LT (Sheffield) reports hearing amateur 'phones from the following countries: ZB1, CE, EQ3, J5, K6, OQ, CT2, EP, KA, KB6, PY, SU, SV, XZ, ZC6, ZS, W, ZD4, VP6, FA, XU, YR and K4. In the same period he worked SV1EC, XACR (operated by W2JRP), XACD, W6NFL/J5 (Okinawa), ZS5B, SU1KE, W9WUG/KB6

(QSL to HQ, 20th Airport, A.P.O. 234, c/o Postmaster, San Francisco), W8WUE/KB6, KA2BA (operated by W5HPC, QSL to 2958 Russell Avenue, Abilene, Texas), EP1C, XACW, and KA1SS (QSL to Signal Corps Training School, A.P.O. 75, c/o Postmaster, San Francisco). G2LT uses a T20 in the P.A. with 45-50 watts. XACD (ex-G6WD, 67 Station Parade, Harrogate, Yorks) does not wish to be confused with GM6WD, the present holder of his old call.

From a very good 'phone/CW log sent in by BRS-3003 (Coulsdon) we extract in particular VE5AJV/VPS, the R.C.N. cruiser *Uganda* off the Falklands, heard at 1628 on March 27; other 'phones logged by him include VP3LF, CE3FG, HK4AF, and several PY's. Some of his CW entries appear in the Calls Heard section.

Continental News

We learn from our old friend HB9T that HB9BB has been very active on 28 mc working SU1USA, W8QKB/KB6; G6CU/ZC2, W2KQT (Guam), several ZS's and many W's. If you have cards for PA please send them to V.E.R.O.N., Postbox 400, Rotterdam, Holland. Remember, there is as yet no officially organised British QSL bureau, and G's are requested to forward their cards as best they can. Cards for U.S.A., and the Americans spread over the world may be sent to the A.R.R.L., 38 La Salle Road, West Hartford, Conn. U.S.A.

Nice Work

From March 15 to April 1, conditions on 28 mc remained unchanged at G6QB (Bexhill), with the Far East coming in every morning and afternoon. Australians were also heard in the mornings, and South Africans during the entire day.

One new phenomenon to emerge, however, was that kind of day on which no U.S.A. signals were heard except W5's—and Texans at that. These conditions held until about 1800 GMT, when one of two things would happen—the band would go stone dead, or W6's would begin to come in, peaking shortly afterwards.

Among G6QB's more interesting contacts during the month were: *Far East* VS5JH (now 3JH), Labuan; W2LRI,

W6QKB, W9WUG (all Guam) ; W6PUZ (Tinian), W9HJW (Saipan), PK4DA (Sumatra), VS6DY (Hong Kong). *Oceania* Many VK's, also ZL3AF and ZL3LB : the ZL's arrived on the morning of April 7. *South America* VE4AFT/VP8, R. C. N. cruiser "Uganda" near Falkland Is., also operated by VE5AJV, as mentioned elsewhere in these notes. CE2CE, with several LU's and PY's, were also worked, and CX has been heard.

The burst of freak conditions from March 24-29, when sporadic-E propagation was prevalent, produced many 28 mc contacts with Europe and within U.K. GI6TK (Belfast) was S6 in Bexhill on occasions. After it seemed that conditions had reverted to normal, there was one freakish day (April 5), when VK and ZL

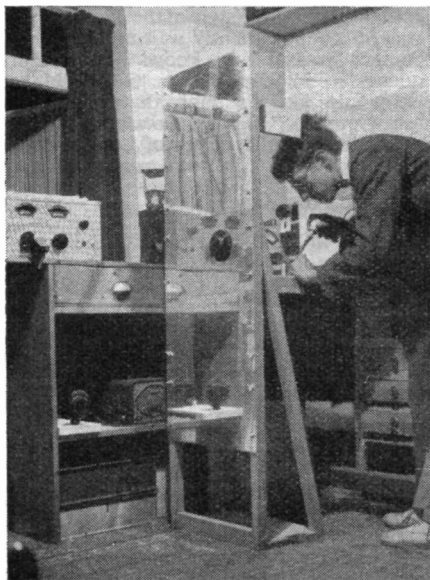

G2FMV (Grouville, Jersey, C.I.) at work on the Tx.

were heard at 2200-2300 GMT, working South Americans ; they were obviously coming over the "long way round." In the same way, several mornings have been noted when G's had that unmistakable DX ring on their signals.

For G6QB, other new countries coming up at odd times have been Bahrein (VU7BR) ; Kenya (VQ4ERR) ; British Somaliland (VQ6MI—reported by several) ; Iraq (YI2XG) ; Persia (EP1C) ; and

Macao (CR9AG). The latter station is run by ex-VS6AG from Hong-Kong.

'QB rounds it all off with a note regarding contacts on 1.8 mc with G6ZO/I in Caserta, Italy, some D4's and D2's, and LA5XY. All very nice work, as we see it.

1.8 mc Again

Two-way QSO's with LA5XY are also reported by G2NM (Bosham, Surrey) and G2TA (Catterick), who regards LA5XY as dubious. Any other opinions on this ? G2TA reports very briefly a point of great interest—a 3.5 mc schedule was arranged, via ten, with W4DCQ, who was to listen on 1.8 mc and report on 3.5 mc. Several other W's came in on the listening end, and though at the moment results are not fully known, one W who could not be identified was heard calling G2TA, G6BY and a D4, so it looks as if these two G's got across. The test was carried out at 0400-0700 GMT, April 7 ; a little late in the year, as G2TA remarks. But it gives us a very good idea for next season's 1.8 mc trans-Atlantic Tests, even if the W's can not transmit on the top band.

It is very nice to welcome to this column G2NM, the Old Timer as he calls himself and the G.O.M. of Amateur Radio as he is. G2NM mentions a queer bird on 28 mc, worked on 'phone on March 12, who announced himself as "KC5C in the Balkans". Is this a clean one, or is it G9BF again !

GC for Jersey

G8NO, up at the College, reports that amateurs on the Island are now using GC as their prefix ; it seems that GC2CNC finds his a bit cumbersome ! GC8NO runs a fairly regular schedule with G6ZO/I on 1.8 mc, which is good going. He reports growing interest and activity in Jersey, with a new club in action, of which GC4LI is chairman.

Speedy WAC's

GI6TK (Belfast)—who turns in a fine log which we shall hope to print next month—now steps forward with a claim for the fastest WAC ; on April 3, between 1238 and 1308, he worked W9WUG/KB6, YR5P, FA8JD, ZC4C, HK1AE and W5GSJ ; all in 30 minutes ! He had already WAC'd in one hour 30 minutes, on March 8, when ZC4C was also in the list. GI6TK uses 75 watts in a pair of 807's, with a three-half-wave aerial.

The *earliest* WAC 'phone is modestly claimed by G2TA (Catterick) who knocked off W4YA, ZS6BG, W8VOK/KA6, W4DCQ, W4HVT/PY7 and a local G before 1200 on February 10. He has 70 watts to P/P 807's, with a two-element rotary on a 70 ft. steel tower (sounds nice), the receiver being an AR88. Up to April 20, he had 48 countries worked in the log, with 70 heard; he has also worked all W, 1-0, on 28 mc 'phone.

Anyone else breaking WAC or WBE records? Those mentioned so far (this month and last) are pretty good.

On 1.8 mc, G6ZH (Devizes), another of the old hands, has worked a total of 106 stations, with another 47 heard. This was all between April 7-21!



The 2FBG (Welwyn Garden City) Rx position during the war

14 mc DX

It seems that it will be a good thing when we get our 14 mc permits through. G2HKU (Sheerness) reports hearing HK4AF, CX1CK, ZP1X on CW and CX2CO on 'phone. Besides these, there are dozens of the more common PY's and LU's. P. J. Masterson (Derby) has received CO8MP, EPIC, PR1AA, TR1T, SU1USA, CO2LY, PY2HV, LU6AJ on 'phone. John L. Hall (BSWL-2333, Thornton Heath, Surrey) heard (CW) CE3AG, 3DG, CR9AG, EL4S, HK4AF,

HZ2YY, OQ5AA, 5AC, 5AQ, OX1AA, PY2HT, 2HW, 5QF, 7AD, VS1X, VS7QB, W6QEU/VS2, W2MBC/KA, W9TZB/VS6, W1LHC (at sea off China), Y12AD, YV5AN, 5ABX; and on 'phone, EK1IND (W2IND in Tangier), EPIC, YV5ABQ, 5ABX, 5ABY, and 5AE.

QRP

We hear from G6SG (Chingford) that G4HQ (Woodford) using 25 watts worked a station in Okinawa on two-way 'phone and held him for an hour. The aerial used was $\frac{1}{2}$ -wave long and 15 ft. high. This will not make much sense to the experts, but it shows what *can* happen on "ten!" While we congratulate G4HQ on an excellent bit of work, we feel that to hold such rare DX as Okinawa for an hour rather cramped the style of the queue which was no doubt patiently waiting for a first contact! And you know how patient queues are in these days! G6SG thinks we would like to know that "X2DY," heard on 7mc, publicly proclaimed himself to be "45 miles north of London."

Another New One

Whilst in QSO with SV1EC the other day, he reported that VQ6MI is operating in Berbera, British Somaliland, on 28 mc 'phone: the signal has been heard by BRS-3003 (Coulson). VQ6MI is ex-G5MI, and is looking after a broadcast station out there.

Calls Heard Section

This has been restarted, largely as an experiment and to see whether it actually serves any useful purpose. There are some very interesting logs, but the work involved in setting them out readably has been considerable. We particularly ask that readers' logs should be made out in the form now being used in the Calls Heard section; they can then be inserted under the appropriate heading without more work than is necessary to make them legible to our compositors!

We should like to have comments from readers on the practical value of *printing* Calls Heard; they are, of course, always useful for reference when writing this column. The SLP logs are in a rather different category, and we consider them useful. However, there is doubt in the Editor's mind about "Calls Heard" in general.

Set Listening Periods

These are finding support again, and some of the logs received appear in the Calls Heard section. SLP's on 1.8 mc not only give us a chance of testing receivers, but also transmitters have an opportunity of coming on when they can be sure there will be good occupancy of the band. We propose laying one on for 1.8 mc each month, so please try to make use of them. Receiving and transmitting logs should be sent in *immediately* following the period (we are still trying to catch the first Wednesday of each month for publication) and the best of those received will be published. So if you want to know if you are getting out on 1.8 mc, come on during an SLP, and you will be heard and logged. For May, the date-time period is

May 18, 2100-2359 BST, 1.8 mc.

SLP's will be arranged for other bands as they are released to us in the same way. Incidentally, it would be a very good thing if, as suggested by G3HS (Faringdon) greater use was made of 1.8 mc during daylight hours—not just after dark in the evenings; agreed. He would like reports on his 1.8 mc 'phone and CW signals.

Address all correspondence for, "DX Commentary" to H. A. M. Whyte, G6WY, c/o the *Short Wave Magazine*, 49 Victoria Street, London, S.W.1.

Reorganisation—U.S.A. Call Areas

Following hard on the announcement of alterations in the Canadian call areas, we now learn that the U.S.A. is also in the throes of a big change. It is expected that although actual call signs will be issued from the United States to such places as Porto Rico (K4), Virgin Islands (KB4) and Alaska (K7), these calls will be preceded by the normal internationally agreed prefixes, and *not* by W, as some may think at first glance.

Here is the new organisation:—

W1—The six States of New England.

W2—The States of New York and New Jersey.

W3—Pennsylvania, Delaware, Maryland and District of Columbia.

W4—Virginia, North and South Carolina, Georgia, Florida, Alabama, Tennessee, Kentucky, Porto Rico and Virgin Isles.

W5—Mississippi, Louisiana, Arkansas, Oklahoma, Texas and New Mexico.

W6—California, Hawaii, and all Pacific Island Possessions (other than Alaska).

W7—Oregon, Washington, Idaho, Montana, Wyoming, Arizona, Nevada, Utah, Alaska and Adjacent Islands (Aleutians).

W8—Michigan, Ohio, West Virginia.

W9—Wisconsin, Illinois, Indiana.

W0—Colorado, Nebraska, North and South Dakota, Kansas, Minnesota, Iowa, and Missouri.

Later

From April QST, it seems that prefix "K" will be allotted to new stations on the mainland of America when "W" is played out. But it is also the plan that any outlying American territory or possession should be recognisable instantly by a suitable prefix, so it has been decided to issue the following forthwith to all *newly* licensed amateur stations in these areas:

KB6	Baker, Howland, American Phoenix Is.
KG6	Guam.
KH6	Hawaii.
KJ6	Johnston.
KL7	Alaska.
KM6	Midway.
KP4	Porto Rico.
KP6	Palmyra Group, Jarvis.
KS6	American Samoa.
KV4	Virgin Is.
KW6	Wake Group.
KZ5	Canal Zone.

Existing stations will continue to use their old calls in full until their licences come up for annual renewal. So, temporarily at least, two different prefixes—the new and the old—will emanate from the same quarter. It looks as if it will be quite a year to eighteen months before all this American callsign tangle is unravelled and tidied up.

Join Your Local Radio Club

CALLS HEARD

Please arrange all logs strictly in the form given here, in numerical and alphabetical order and on separate sheets under appropriate band headings, with callign or SWL number and address on each sheet.

GENERAL

1.8 mc CW

G5MU, 9 Windermere Avenue,
St. Albans, Herts.

GM3VB, 3RL, GW2HIR, 4CC,
LA5XY.

BSWL-2333, 21 Howberry Road,
Thornton Heath, Surrey.

GM3VB, 6JH, GW6AA.

G6ZH, 4 Eastcourt Street,
Devizes, Wilts.

D2KI, G2AAW, 2AOP, 2BI,
2BJF, 2BJY, 2CIW, 2DF, 2DVP,
2FIX, 2HNO, 2HRX, 2LC, 2NM,
2PA, 2WQ, 2YI, 2YY, 3HS,
3JO, 3LP, 3MI, 3MT, 3NZ,
3PL, 3PZ, 3UB, 3VM, 3VO,
3YZ, 4DC, 4FB, 4KZ, 4LQ,
4LV, 4MF, 4OM, 5BM, 5BQ,
5HH, 5HN, 5HS, 5KJ, 5KT,
5LO, 5RY, 5SU, 5UM, 5US,
5XD, 6BO, 6BQ, 6BX, 6DX,
6HA, 6JC, 6KR, 6NW, 6QA,
6UJ, 8CT, 8CZ, 8KH, 8LG,
8OM, 8QI, 8RF, 8RQ, 8VP,
GM3BZ, 3RL, GW5OD, LA5XY.

G8UO, 13 Chandos Street,
Keighley, Yorks.

G2ATU, 2AUZ, 2BK, 2BQ,
2BOO, 2CPF, 2DF, 2FIX, 2FM,
2FMF, 2FZR, 2HAP, 2HW,
2IF, 2NM, 2QM, 2QV, 2RB,
2SU, 2TA, 2VO, 3CF, 3HA,
3HS, 3JK, 3KF, 3MU, 3PD,
3RY, 3VO, 3WU, 4AK, 4IN,
4JB, 4LQ, 4LV, 4MC, 5BM,
5HB, 5HH, 5KJ, 5KT, 5NN,
5PR, 5RI, 5RY, 5UA, 5XD,
5XF, 5ZT, 6AX, 6BX, 6DV,
6MC, 6NM, 6RQ, 6ST, 6UC,
6UT, 6ZH, 8KH, 8ML, 8OM,
8RO, 8RQ, GW2HIR, 3VB,
4CC, 8CT, 8WS, GM6XI.

3.5 mc 'Phone

BRS-3003, 122 St. Andrews
Road, Coulsdon, Surrey.

W1HXN (0132), 2A1F (0115),
2CIS (0105), 8LWA (0027),
8QEM/CT2, VE1KN (0120),
VO2KJ (0029, Gander, NFD).
April 1-7; all times GMT.

3.5 mc CW

BSWL-2333, 21 Howberry Road,
Thornton Heath, Surrey.

E17FF, F8FA, HB9AP, I1RD,
LA5X, 9P, OE1XZ, 2AM, 2FC,
OH1XX, ON4F, OY1A, OZ5QE,
7K, 9QQ, PAØDL, SM4KL,
4NK, 5KE, 6KT, 6OE, 6OR,
6QP, 6YZ, 7JP, 7SE, 7SZ,
7TH, U1XA, YR5BF.

28 mc CW

G2VD, 12 Tudor Drive, Watford,
Herts.

CE2CE, CX1FB, F1DK, K4ESH.
KA1AF, KZ5AA, LI3JU,
LU3DH, 7AZ, OQ5BQ, PJ3X,
PX1B, PY1AJ, 2OE, SU1KX,
2GV, 7BR, VE5AJV, VK2TI,
3KX, 4GE, 5BR, 6AJ, 6FL,
6RU, 6SA, VQ2PL, 3EJT,
3TOM, VU2AA, 2BG, 2WP,
W9DPZ/KB6, XU1YV, Y1ZXX,
ZC6NX, ZL3AF, 3LB, ZSAX,
1BZ, 1CX, 2AL, 2AW, 2P, 2X,
4H, 5AJ, 5B, 5BZ, 5CK, 5EQ,
6AM, 6DH, 6DW, 6HS, 6J,
6RS.

MAGAZINE SET LISTENING PERIODS

1.8 mc

April 13, 2100-2359 BST

G5FB, 15 Cowper Street, Ipswich,
Suffolk.

G2BK, 2HIL, 2NK, 2NM, 2YY,
3PD, 4DL, 4LA, 4LH, 4LQ,
6HA, 6NM, 6TR, 6UJ, 8LX,
8TR, 8PX.

BRS-3003, 122 St. Andrews
Road, Coulsdon, Surrey.

G2AMJ, 2AX, 2BJY, 2DPQ,
2FWA, 2FZR, 2HNO, 2JL,
2LC, 2NK, 2NM, 2OU, 2PL,
2QV, 3KP, 3LM, 3UB, 4CC,
4DC, 4FZ, 4LV, 5HN, 5IU,
5KT, 5XD, 6GM, 6HD, 6KP,
6NM, 6QB, 8JG, 8LG, 8PX,
8QZ, 8RN, GW8CT.

BSWL-1400, 1 Briar Crescent,
Northolt, Middlesex.

G2DF, 2HR, 2LC, 2NM, 3MI,
3VM, 4DC, 4PX, 5HN, 5HS,
5RU, 6UC, 6ZH, 8RN.

1.8 mc,

April 14, 1830-2100 BST

G3HS, Lindsey House, Coxwell
Street, Faringdon, Berks.

G2NJ, 3JO, 4AK, 5BC, 5TZ,
6UT, 6ZH, 8OM, 8VP, GM8VG

G5FB, 15 Cowper Street, Ipswich,
Suffolk.

G2AMJ, 2BJY, 2CP, 2DF,
2YY, 3LA, 3VM, 4AU, 4LV,
5KT, 5JZ, 5PR, 5UM, 6ZH,
8OM, 8QZ, 8RQ.

FIVE METRES

(Heard or worked; distances in
miles, in brackets.)

G6CW, St. Ann's, Bramcote
Lane, Wollaston, Notts.

G2AK (43), 2MR (117), 2MV
(123), 2NH (116), 2WS (117),
4CI (117), 5BY (233), 5LJ (38),
5MA (127), 6FO (100), 6GO (33),
6VA (127), 6VX (125). All QSO's.

G8DV, Crow Holt Cottage,
Echo Barn Lane, Wreccles-
ham, Nr. Farnham, Surrey.

G2MR (26), 2NH (28), 2XC (25),
3CQ (50), *3NR (31) 4CI (29),*
5MA (23), 5OJ (16), 6FO (30),
6OH (16), 6VX (38), March 10-
April 10; Heard.*

BRS-3003, 122 St. Andrews Road,
Coulsdon, Surrey.

G2FWA, 2MV, 2NH, 2WS,
4CI, 5FK, 5MA, 6FO, 8DV,
8JR. Test Period, April 14-16, only.

J. H. Clarke, 136 Andover Road,
Newbury, Berks.

G2AK,* 2BI, 4CI, 5MA, 6CW,*
6FO, 6VX, 8DV, 8GS, 8LY,
8RS, 8UA. April 10-15 only;
DX stations.*

G8RS, 26 Shinfield Road,
Reading, Berks.

Worked: G2MC, 2MR, 2NH,
4CI, 5MA, 5RD, 5TP, 6FO,
6OH, 6VX; Heard: 2AK,*
2NM, 3NR, 4CG, 5BY,* 5OJ,
6LK, 6OU, 8JR. DX stations.*

G2MR, 3 Waverley Avenue,
Surbiton, Surrey.

Worked: G2DP, 2FWA, 2MC,
2MV, 2NH, 2UA, 2WS, 3CQ,
3CU, 3FU, 3NR, 3OO, 3PV,
4CI, 4CG, 4IG, 5AS, 5CD,
5FK, 5KH, 5MA, 5OJ, 5RD,
6AU, 6CW,* 6FO, 6LK, 6NA,
6OH, 6RA, 6VA, 6VX, 8DV,
8JR, 8RS, 8SK; Heard: 2AK,*
2CY, 2LC, 2XC,* 3IC, 5BY,*
5DT, 6DH,* 6HX, 6JI, 6YP.
DX stations.*

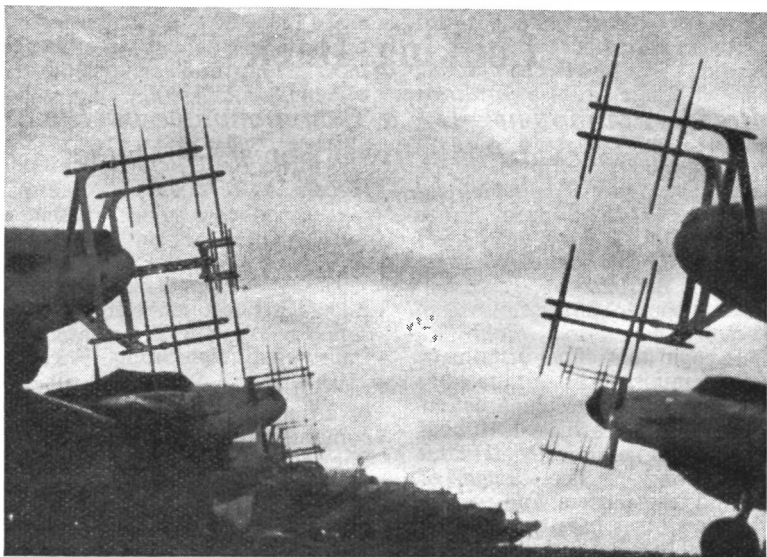

Puzzle Picture. *What is it? Answer on p. 185.*

NEW MULLARD VALVE

If there is one type more than another we should like to have seen in the British range of small transmitting valves, it is a double-tetrode, on the lines of the American 815. We are therefore pleased to be able to mention the Mullard QV04-20, which is just such a valve, and now available.

Brief details are: Double-tetrode RF amplifier for VHF, heater 12.6 v., 0.8 amps. in series or 6.3 v., 1.6 amps in parallel connection, maximum operating frequency 400 mc, 44 watts output with 400 volts on the plate (145 v. screen) at 125 mc. In fact, just the thing for that 58 mc PA, and we shall have one in a suitable design very shortly.

The price is 62s. 6d. Write Transmitting Valve Department, Mullard Wireless Service Co., Ltd., Century House, Shaftesbury Avenue, London, W.C.2.

WANTED

Someone who can cartoon G9BF—we feel he is almost worth it. Read the stuff (p. 85, April, and this issue), and send us your impressions.

SOME QSL'S—NOTE FOR SWL'S

From the current *QST* we gather that in the office of the A.R.R.L. QSL manager for the W6 district there are no fewer than *twenty thousand* unclaimed foreign cards! The American system depends, for its effective internal working, upon expectant recipients keeping a stock of stamped self-addressed envelopes on hand with their district QSL manager. If they fail to do it, the cards are simply not forwarded.

Since similar experience in this country fifteen years ago shows that the worst offenders are usually the busiest stations, the rule for SWL's seems to be—QSL direct, or do not QSL at all.

*The Short Wave Magazine
has the best information
on the latest news*

CONTACT

K. E. Clare, 9 Sunray Avenue, would like to get in touch with Amateur Radio activities in the West Drayton area, and T. W. Carney, G4QC, 9 Gladeville Road, Liverpool, 17, with G8AU.

Looking Back

Better Equipment—DX a Commonplace by 1932 —Unexpected Publicity—Contests—Whither Amateur Radio?

CONCLUSION

WE begin this—final instalment of reminiscences—in the early 1930's, a time when Amateur Radio had already achieved (fundamentally speaking) practically all that it has done to-day. The design of receivers and transmitters, and even of aerial systems, was not so efficient technically as it is now, but the fact remains that on all bands down to 28 mc the amateur had the entire world at his command on CW or 'phone, with a power of 50 watts or so. Present-day licence-holders who feel complacent occasionally would do well to remember that unless they do something *very* unusual, it is highly probable that it was done by someone else fifteen years ago!

What, then, has Amateur Radio been doing with itself all this time? I think the answer is that it has been choking itself to death in one way, while busily unstrangling itself in another. The number of stations on the air increased enormously between 1931 and 1939, but the state of the bands continued tolerable because of the steady improvement in receiver design—and most of all because of the crystal-gate super-heterodyne. In the early 1930's I used to hear and work most of the world with the aid of a single-valve receiver (which brought much derision pouring in on me from some quarters). Nowadays, I would only claim to do that when conditions are fairly bad. When they are good, the 28 mc band is so tightly packed with signals that a receiver of "post-1930" design is an essential.

Improved Equipment

With the appearance on the market of an efficient and moderately cheap communications receiver came another boon for the amateur. By this I refer to the appearance of the high-efficiency pentode and beam-tetrode. In spite of the heroic exploits of valves like the LS5 in the early days, I doubt whether anyone would to-day build a 1.8 mc transmitter using an LS5B as CO with an LS5 as PA. The odds are at least fifty to one that a 6V6-6L6 combination would replace them.

I remember, some time in 1933-4, saying a pathetic farewell to my LS5's and somewhat sceptically building a new exciter unit using 59's—one of the early pentodes. I was almost disappointed when it proved to be better than its predecessor. Then the RK20 caused more than a little interest. Here was a valve which really did not need driving; you just blew gently on the grid and the anode was red-hot! Gone was the excuse for "Goyder Lock." If anyone had an exciter unit big enough to lock a 50-watt oscillator, it was more than big enough to drive one of these pentodes. The 6L6 achieved immediate popularity, but the phenomenal 807 or KT8 type did not arrive until later.

Our present-day experience proves that if anything could have made efficient 28 mc transmission simple it was the 807. These valves—and many other bigger ones of similar type—can almost be driven from a No. 8 battery; their anode efficiency is high right up to 60 mc; they are cheap, and two of them will handle 100 watts indefinitely.

But not so in 1932 ! My 28 mc transmitter then used a de-based DET1 as a locked oscillator, and it was quite a job to produce enough 28 mc power from the exciter unit even to lock it. It had to be closely monitored all the time the transmitter was on, in case overheating made it creep out of lock, with the usual disastrous results to neighbouring amateurs and even broadcast listeners. But the fact remains that such good DX was worked then even on telephony, and I distinctly remember getting S9 plus from the U.S.A. on many occasions. You can't do better than that even now !

Press Blurbs

The years from 1932 onwards saw an intensely competitive spirit entering into Amateur Radio. There were the annual ARRL Contests, the BERU, the 1.7 mc Contests—in fact contests on every band. It became obvious that the good operator with a sufficiency of technical common-sense could rule the roost as far as publicity went, and for a time Amateur Radio was news. Frequent splashes in the popular dailies informed us that an amateur in Oswaldtwistle had communicated with his brother in India, using less power than an ordinary electric light bulb (as if we could not do that sort of thing most days). I even had a little more publicity than I wanted myself. Three of us from South London spent a day on top of the Crystal Palace tower with a five-metre outfit, and succeeded in working quite a number of stations up to ranges of 180 miles or so. For some unknown reason one of the big dailies appeared next day with headlines reading “Atmospheric-free Radio at Last.” “Experimenter's New Discovery.” “The Scientists Didn't Believe It.” And so on. At all events, Amateur Radio was going through some growing pains, and we are still not quite sure what will emerge. But we do know that the band of amateurs, whether they were scientists or DX-hunters, did their fair share during the war, and amply justified the allocation of a few narrow frequency-bands for their exclusive use. And it was obvious

that the amateur would still be officially fostered after the war, just in case. . . .

The years 1931-5 appear to have been almost dead for 28 mc. The chief DX bands were 14 mc and 7 mc (the latter only at times when all the 'phone-hounds were between the sheets). Apart from the developments already mentioned, the only progress appears to have been the steady exploitation of the 56 mc band. Unfortunately this started off on the wrong foot. Everyone had the impression that it would make an excellent band for local “rag-chew” and duplex work, so the vicious habit of using non-stabilised transmitters and super-regenerative receivers grew up. This was all very well for portable work, but it was obvious from the first that it would never enable us to make any serious use of the band for longer distances. It took some years for crystal-controlled transmission and superhet reception to force its way through, and as soon as it did, the band was revealed in its true colours. You can read about this elsewhere, so I will not expand on it. Sufficient to say that many British amateurs denied themselves the pleasures of DX on other bands and spent many very lonely days and nights on “five.” Most of them, eventually, were fitly rewarded by reliable contacts over distances that were not previously thought possible.

28 mc Reopens

In the autumn of 1935 the 28 mc band staged a come-back. My log shows the first “live” date as November 11, and from then until April 1936 the band was as lively as it has been this year. All continents were worked in one day, time and time again, and more and more stations appeared on the band (but never as many as are on the air this evening !) The behaviour was much the same—East Coast and Central U.S.A. from noon onwards, tailing off westwards towards dusk, with the W6's and W7's coming in about one night in three ; South America there most of the time, and South Africa all the time ; India and such other Asiatic stations as were active, in the mornings ; Australia and New Zealand occasionally, either

at 0830 or 1130 according to conditions. It is surprising how the log for 10 years ago gives an indication of what to expect this year ; so far it has been very reliable. There were even those queer days when the only Americans coming through were W4's and W5's—we still get them.

The 28 mc band went dead in April 1936 and opened up again in September. The winter of 1936-7 was better than the previous winter, and again the band remained open until the end of April. Probably this year things will be very different ; there are enough active stations, in all parts of the world, to keep the band alive to some extent throughout the summer.

About the period 1937-39 I can personally say very little. For the first time I was forced to give up Amateur Radio for a while, owing to a trip overseas. I sold all my old gear at a never-to-be forgotten auction sale in the shack, and when, to my surprise, I returned home late in 1938, I had to start all over again without even a terminal or a piece of ebonite ! But the only time spent on the air during 1939 was on 80 metres, and nothing eventful happened there. Then, of course, came the fateful day when we all discovered the Civil Service meaning of the word "determined"—as applied to our licences ; and the events of the next six years hardly come within the scope of this story.

Amateurs Never Die !

There were times when I thought I had become immunised to the bug of Amateur Radio ; but as soon as word got round that licences were to be restored I found, to my dismay, that I was still badly infected. So much so, in fact, that on the day my licence arrived (January 26, 1946) and long before my gear was returned by the GPO, I worked my first W. My first post-war contact—and it had to be a W3 ! The new station was built up entirely of junk left behind by the GPO, the only purchase being a pair of 807's. It was more haywire than anything I had ever used before, and unfortunately it has worked so well that it still remains in that state. Long experience has taught

me that it is fatal to tidy up a rig that works well !

What has happened since then we all know. The brightest part of it is that countries that have never even been heard before are now being worked regularly, and that the band has never really closed up during the whole spring. There are many days when the East Coast Americans vanish entirely owing to longer skip, but such days reveal the interesting stations that were buried before. Guam, Okinawa, China, Tinian and Saipan come in on all but the exceptionally poor mornings ; Australia practically every morning ; South Africa every day and all day long ; and, to cap everything, on the day before writing this I heard a VK and a ZL at 2130 !

Look to the Rx

There still seem to be many people who say conditions are poor when the band is not full of hundreds of Americans at S9 ; but I have more than a suspicion that such people need a receiver. Judging from conversations on the air, some amateurs have not the slightest suspicion of the interesting things that are going on every day. They may be a bit weak, but they are there ; and throughout the entire history of Amateur Radio it has been the weak signals that have been the interesting ones. This is unfortunate, perhaps, but it will always be the case.

And now we have the 1,800-2,000 kc band as well. This seems to be packed with more signals than I ever heard up there in the pre-war years, obviously owing to the lack of licences for 7 mc. Fortunately the signals remain fairly weak by day on 1.8 mc and we shall never have the pre-war 40-metre Sabbath Morn Phenomenon up there ! (And if you don't know what this was, ask an old-timer when you have two or three hours to spare, and he will begin to tell you.)

The title of this article doesn't allow me to write of the Future. That would be an interesting subject, but it is one with which many other articles will deal.

And never forget—what it holds is up to you.

G6QB

Tidy Paper Work

Useful Notes on "Admin" for the Amateur Station

By J. HUM (G5UM)

WHEN one visits amateur stations one comes to the conclusion that though most of them are good generators of RF energy rather fewer of them keep detailed records of what that RF energy does. The amateur logs, as his licence tells him he must, the fact that he worked Okinawa or Cocos. But if you ask him a few months later for details of the contact—or even the date—he may be quite at a loss to find them.

Accurate paper work is as important in Amateur Radio as it is in any other organised activity. In wartime no fighting Service would keep its records on odd scraps of paper, lacking any indexing or "reminder" system. To the radio amateur of peacetime the same thing applies with equal force.

Now, it is not intended to persuade you to go from the one extreme of the "scrap of paper" to the other where organisation is carried to such a degree that it leaves little time for operating. No, there is a happy medium in this as in most things. The system to be described results from some 20 years' experience of Amateur Radio, and while being detailed is not time wasting.

The Log

There are almost as many variants of station log as there are of stations. Experience has shown that one of the simplest methods of keeping the log while at the same time being able to check back on any contact, is to rule it off into the following columns :

Date, time, station called, calling frequency, system (whether CW or telephony), whether contact is effected (the fact is noted by writing "called and worked G7XYZ" and underlining those words).

It will be found that by using this method actual contacts made stand out

prominently from the remainder of log entries and can easily be picked up if it is desired to check back in subsequent months.

This main column for calls and contacts is some 4 in. wide on an 8 in. page, permitting scale readings to be included against stations when they are desired, or complete messages to be written in. Or if the messages conform to the all too frequently stereotyped exchange of reports and best wishes, then this main column need contain nothing more than the station called and contacted, underlined, followed by the words "my RST" and "his RST." If you want to be really fancy you can include such superfluous things as "the handle," or a note that a QSL has been despatched.

In close association with the log should be two very important documents. One of them is a list of international Q signals and RST signals, and the other is the calibration chart of the station frequency meter or variable frequency oscillator. These might very well be pasted into the front and back covers respectively for ease of access.

Record of Contacts

Merely to log station activity as required by the law is hardly a sufficient record for the conscientious amateur. It is very useful to be able to know whether you have contacted a certain station before. Here is the system to adopt for giving you this information :

A loose-leaf book is started with a separate page for G2, G3, G4, G5, G6 and G8 (with a page or two extra for any new G numbers that may start in the future). Other pages are allocated for each of the U.S.A. and Canadian districts and further separate pages for each overseas country.

After each contact the call sign of the station worked and date are entered in the correct numerical order in the loose leaf book.

The man at the other end is frequently startled when you tell him that you last worked him on August 1936 and may first of all tell you what a good memory you have. You reply by telling him what a good indexing system you have got!

Many a QSL has been lost because the man at the other end was told "Glad to meet you, OM" instead of "Glad to see you again OM!"

QSLs

This brings us to the subject of the filing of QSL cards—the value of them we will not venture to discuss now. Accurate log keeping and indexing as already described renders the receipt of a QSL almost unnecessary (except for claiming the various trophies that amateur organisations put up). Nevertheless, QSL cards will continue to arrive and it is therefore a good idea to preserve them in a filing cabinet in numerical order under their respective countries of origin.

If it is still desired to display a few, undoubtedly the best thing to do is to put up one from each call sign district (where such exist) and one for each country worked.

Technical Notebook

So much for the recording of actual station activity.

A final document that can be usefully maintained is a "technical-gen book." In fact two such books are useful. One should consist of a fairly large notebook or even a ledger for recording all experiments (their results and meter readings) that are conducted. A book with an alphabetical thumb index is useful here so that all information can be recorded under such headings as "coils," "keying systems," "crystals" and almost any other technical heading that is found convenient.

The second consists of a small pocket size notebook into which tit-bits picked up at amateur meetings should be written, or circuits lifted out of other people's magazines!

Such a record was kept by many amateurs during their years in the Services, when much information for putting into practice in peacetime was set down (not too much of it we trust being labelled "secret").

* * *

So there you have Amateur Radio recording made easy . . . the maximum of information and the minimum of writing. Any ideas to improve upon that ratio will be gratefully received.

G9BF Calling

(Our unwanted contributor has crept in again.—Ed)

DUE remarkable popularity my DX article last month (two letters saying didn't know G9's now licensed and one signed G9BF accusing *me* using someone else's callsign) have decided to become regular contributor. Editor making difficulties about this, but only because my fan-mail larger than his. Readers need someone on this paper with plenty experience Amateur Radio, particularly DX, for which I have been famous ever since starting to use call KZ7LX.

Believe I have competition from other G's on 40, notably X2DY or some call like that, but have set GPO vans on him as he uses more than 100 watts legal power.

Will not hesitate take similar action in all other cases brought to my notice.

Well, to resume where I left off last time. Put out fire in power pack with jug of water, but house lights went; fuse gone somewhere, of course (always look for simple fault first). Found fuse and repaired with good piece copper wire, as cannot tolerate constant breakdowns due mains trouble. Whilst at it, replaced thin, soft wire in all other fuses with copper wire capable carrying several amps. This should prevent fuses blowing again.

Decide to rebuild power pack and make proper job of it. Try screwdriver across HT xformer secondary to test for spark.

No joy, dratted thing burnt out. But LT side seems OK by same test so get as far as rewiring valve-holder while wondering how to get HT when have sudden bright idea. If two metal knitting needles driven into windings at both ends of secondary make contact with good turns, should get juice if breakdown is at outside end of winding, as is usual. Congratulate myself on this and decide to write short article for *Magazine* explaining my method. Try method.

Wake up feeling very queer with burn across hand and throb in head. Find time is three a.m. and realise caught packet from knitting needles. Feel pleased that I am alive but wonder why; this shows voltage on xformer secondary much lower than rated 1000. Decide to write safety first article for *Magazine*. Readers must be warned take care with high voltage.

Next day buy new xformer and rebuild pack. Take plenty precautions while testing on Tx—one hand behind back, stand on rubber mat, use insulated screwdriver and place foot on main switch. Finally get about my usual 150 watts on 14 meg PA.

Put out snappy CQ, sending call once only in case GPO QRX. Hear G sending "QRX?" Answer him; back he comes with very slow sending "Ur sigs RST-574 vy fb pse QRA?" Give him RST-569 and say "Hr QRA ship in Med." He says "OK fb OM can u QSL?" I give him "Sure QSL ob pse wait for card."

This QSL business always problem when working with calls like mine. Have not yet worked out idea how to get cards safely. If *Magazine* had QSL bureau *That's enough.—Ed.*

MAKING UP SPLIT STATORS

Idea By D. H. JONES (G3BO)

In view of the comparatively high price of split-stator condensers suitable for VHF, this tip—which is not claimed as original—may be of some interest. It is a method of making up a split-stator condenser from a pair of the lower-priced single-section variety, which can nowadays be obtained for 4s. or 5s. each.

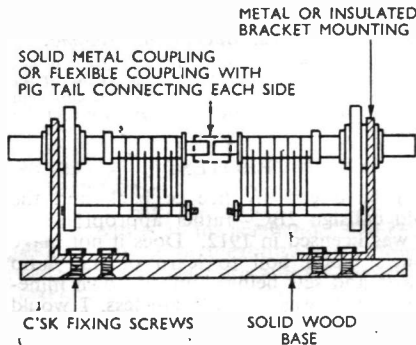

Sketch shows application of G3BO's idea. Any pair of single-bearing condensers, matched for capacity and of the type having an extended rotor shaft, can be made up in this way. Capacity value and plate spacing should be chosen for the job in hand.

The sketch is self-explanatory as regards construction. If a wooden base is used, the mounting brackets for the two sections should be of insulating material; alternatively, use brackets of thin metal strip cut,

and drilled to the correct dimensions, on a paxolin or polystyrene base. The important points to watch in construction are to make the two mounting brackets exactly the same size and to get the condenser assembly correctly lined up on the base before fixing the brackets. Over-size holes for the fixing screws, so that the brackets can be moved a little before tightening down, are a help in this respect.

Any two condensers of the same capacity range and make will be sufficiently well matched for the construction of this split-stator type, but they must be correctly chosen as regards capacity-per-section and plate-spacing. Some of the small receiving designs are unsuitable for transmission even with low power—the safe minimum spacing between rotor and stator plates for circuits using up to 500 volts on the anode is .06 in. Correct capacities per section are 5-15 $\mu\mu\text{F}$ for 58 mc and 10-25 $\mu\mu\text{F}$ for 28 mc.

Error Crep' in Dept.

April issue, p. 82, Fig. 3. This would be a good circuit if V2 got some HT. The lead from the junction of R6/R7 to the base-line should have in series a 500 $\mu\mu\text{F}$ fixed condenser. Sorry!

April issue, p. 127, bottom right-hand quarter-page advertisement. Add to top line under "secondaries": 500-0-500 volts, 200 mA. Sorry again!

We hope there will be no more.

SOME

Letters

TO THE EDITOR

ADVICE

I would like very much to see the *Magazine* as successful as it was before the war. But please do not make it into one of those highly technical books that very few amateurs can understand, as it would be of no use whatever to the young short-wave listener. He wants to learn the game as an amateur; he wants easy-to-understand articles on how to make something that works, and gives him satisfaction in constructing.—*H. J. Seagood, G6SG, 57, Whitehall Gardens, Chingford, Essex.*

Please remember those of your readers who are just out of the Services and starting from scratch as far as equipment is concerned, and give us plenty of constructional articles utilising available material to enable us to "get our feet under the table" again.—*E. A. J. Miles, 16 Russell Place, Cheltenham, Glos.*

(Both these letters express precisely what we have in mind.—*Ed.*)

SUGGESTION

May I offer a suggestion. Is it not possible in circuit diagrams to show the valve connections, either by numbering the pins or giving a separate base-diagram? For beginners, and quite a few old hands, it would save time and trouble, especially in view of the complications of the new valves.—*T. Orr, G3IV, Radio Station, St. Erth, Penzance, Cornwall.*

There is one thing I should like to see in the *Magazine* in the near future; that is a communications-type receiver for AC, described stage by stage with circuit and details for construction, so when the final stage is reached, the whole assembly can be mounted in a suitable container and lined up, and off we go.—*E. W. Wiskin, BRS-4384, 25 Meadows Road, Upminster, Essex.*

(The first is being adopted forthwith, but the second is not so easy, because we question whether there are many people who really want to build a modern superhet for the amateur bands. Some of the practical difficulties surrounding such an undertaking are explained by A. A. Mawse in this issue. We can run the articles all right, but from the point of view of readers we are a bit doubtful about the "off we go" part!—*Ed.*)

DEMAND

We want to know officially what conditions were like generally for the previous month. We want the latest information concerning the building of receivers and about the latest components. We want a *Magazine* which does not cater simply for the 17-year-olds or for the man who loves the mathematical side. Steer a middle path.—*A. E. Read, 7 Blakemere Road, Welwyn Garden City, Herts.*

(Don't shoot. We're doing our best.—*Ed.*)

REQUEST

This is a letter from a fellow quite unknown to you. Let me first explain how I got your name. A British M.P. gave me a copy of your *Magazine* and there I found it. During the war I was a local leader of the resistance and I offered and lost my radio parts in building small CW transmitter for the information service, oversea in England.

As long as money is not stabilised here we cannot send to England to buy parts and papers. So you see here a beggar. But a poor one, not having done so ever before. Will you ask your members if they can send me some wireless papers. We have nothing here. Perhaps one or two will inspect their "tube rack" and send me an AC tube, or other spare parts. You may trust me. For civil life I am a teacher. Those who can do so I will write to first.—*Jan D. Stob, Prins Maurits Park 12, Apeldoorn, Holland.*

(This letter reached us from a reader; it has been very slightly edited, but the sense of the original has been fully retained. See the comment "Amateur Radio in Holland" elsewhere in this issue.—*Ed.*)

PROTEST

I have got my licence back and the old callign 2BC—rather appropriate, as I was licensed in 1912. Does it not make one's blood boil to learn of the radio parts and sets being dumped down mine-shafts; it was not all valueless, I would wager, and things so difficult to buy—*D. F. Owen, G2BC, T8 Western Road, Flixton, Nr. Manchester.*

(Yes, but there are so many aspects of this particular problem of the disposal of surplus that it is hard to argue the case without knowing all the facts. It is said that in this instance the gear was unserviceable aircraft equipment. The answer is, of course, that it could have been stripped down for parts—if labour were available to do it. To give it away would start a black market; even if sold cheaply, few people would be found to buy, and the expenses of marketing would probably exceed the return. Colossal quantities are involved. Not really a very easy problem.—*Ed.*)

ON THE MARKET

The items received for discussion this month are of more than usual interest, and between them cover a wide field. As for other *Magazine* features, space for "On the Market" is limited, so our selection is confined to equipment of immediate application in Amateur Radio.

Most manufacturing concerns are still faced with considerable difficulties in regard to labour and material; the supply of certain raw materials remains very bad, and many factories are working on short stocks, so cannot accept forward orders with any guarantee of delivery. Due to the interlocking of trade and industry, it is surprising how far the effects of a shortage of one particular commodity can be felt. The current difficulty is said to be with ceramics, which obviously has wide repercussions on the radio industry.

Eddystone.—The specification of the 1946 "504" Communications Receiver, the price of which (between £40 and £45) will be announced shortly, has now been released. It is a high gain superheterodyne in a 9-valve circuit, designed with the amateur communications requirement well in mind.

The valve line is: Two RF, FC, two IF, combined AVC detector and first audio, noise limiter, BFO and audio output, with rectifier. All valves are international octal, and the AF output of the receiver is in excess of 3,000 milliwatts.

Tuning range is 600 kc to 30 mc, in five overlapping bands, with switched wave-change. Single control illuminated extra-slow-motion is provided, with a vernier scale and 140-1 reduction; the effective scale length is 36 in. per band. The IF is 450 kc, using permeability-tuned transformers, and special precautions have been taken to maintain accurate IF alignment.

An S-meter and crystal filter are incorporated; the latter gives a selectivity of 30 db down at 500 cycles off resonance, and 50 db at 2 kc off. The selectivity with crystal out is 30 db down at 5 kc off. The S-meter is calibrated S1-S9, and in db above S9, each S-unit corresponding to a change in carrier-level of 6 db. The meter is in circuit under all conditions, and zeros automatically (instead of going the other way, as is usual) if the RF gain control is turned back from maximum. The image ratio varies from 35 db down at 20 mc to 75 db down at 2 mc.

NEWS from the Trade and NOTES on Equipment

There are ten panel controls, including BFO note and stand-by switch, and the output end is arranged to match either a speaker impedance of 2.5-3.0 ohms or a high impedance headset. The aerial coupling is designed for co-axial feed, but can be adapted to other types of aerial connection.

The finish of the set is grey, with a blue panel; fittings are chromed, and the general construction is strong and rigid. We expect to be giving a detailed Test Report on this receiver in an early issue.

Labgear.—Their new list prices a number of useful items, including several different types of inductances for single-ended or push-pull output stages, ranging in cost from 5s. for the 28 mc single-ended coil to 20s. for a double-ended 28 mc 150-watt PA inductance with a controlled adjustable link coupler. Coils are plug-in and can be obtained with bases for interchangeability.

There are two types of low DC resistance transmitting RF chokes—1 mH at 5s. 6d. and 3 mH at 6s., each capable of carrying 350 mA and with self-capacities of 3 and 4 $\mu\mu\text{F}$ respectively. Other components include a variety of transmitting condensers, single section and split-stator for voltages up to 4,000 V, and two types of neutralising condenser, 4 and 10 $\mu\mu\text{F}$ maximum capacity respectively; they cost 10s. 6d. and 12s. 6d.

Labgear also have a 1,000-volt, 250 mA, power pack which can be tapped down to 750 volts. This is complete with valve and smoothing circuits, and can be supplied either in a cabinet or for a 19-in. rack at £14.

Wireless Supplies Unlimited.—We are glad to notice the useful line in aluminium chassis, very reasonably priced, which is being offered by this firm. These chassis are strong, well made and finished bright. The prices range from 3s. 9d. for the 7 in. by 7 in. size to 5s. 9d. for a chassis 17 in. long by 10 in. wide; they are all made 2 in. deep and represent good value for money.

Tele-Radio (1943).—Here are two views of a miniaturised 100-watt transmitter-modulator assembly now in production. The transmitter valve line is: 6V6-6V6-P/P 807, and the modulator 6SJ7-6J5-P/P 6L6. Both units incorporate power packs, using an 83 for the 400-volt 200 mA modulator supply, and an 83 and a 5Z3, giving 300 and 600 volts at 250 mA, for the RF unit. The RF input power ranges up to 100 watts and the bands covered—selected by plug-in coils—are 7, 14, 28 and 58 mc.

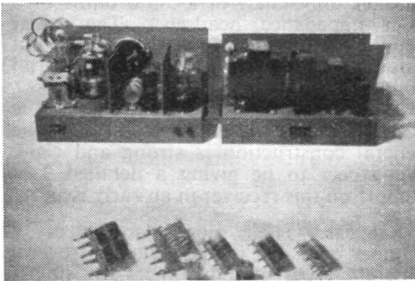

Rear view of assembly, with band-change coils in foreground

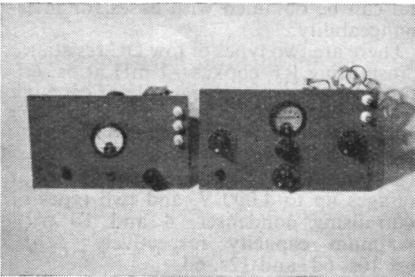

Front view of transmitter and modulator

These units are extremely well constructed and so compact as to be smaller than the average communications receiver. A switched meter is fitted for checking in the various stages of the transmitter. The coupling between buffer-doubler and PA is inductive, and on the RF output side, variable link coupling is provided. PA tuning is by means of split-stator condensers on both grid and plate sides.

Altogether, a very neat and attractive rig, as the photographs suggest.

Ferranti.—Their 2½-in. panel type meters have been known and used by amateur transmitters for at least twenty years, and have decorated the panels of many famous stations. A very wide variety of instruments is available, covering moving-coil, moving-iron and rectifier types, in all current and voltage ranges from one milliamp, microamp or millivolt up to 750 mA, 200 microamps and 500 volts. These meters can be supplied in either flush or projecting patterns, and can be adapted for portable (bench) work by the addition of a special moulded base.

T.C.C.—We have recently examined a number of fixed condenser types from their current range. Probably the most interesting from a wide selection are the "Picopack" and "Micadisc" designs. The former is a midget dry electrolytic, in capacity ranges from 1.0 to 20 μF, the size of which is only 1.56 in. long by 0.34 in. diameter. The wiring lugs increase the overall length to 2.38 in.; these condensers are, of course, small enough to be mounted in the run of the wiring.

The "Micadisc" types are made for transmitting and receiving applications and are of stacked-foil construction, contained in a circular plated brass case. This design results in very low inductance, and the receiver type is thus particularly effective in VHF circuits.

Birmingham Sound Reproducers.—One of the pieces of apparatus in their new catalogue is a vibrator power unit which gives 310 volts at 130 mA for an input loading of 6.35 amps. at 12 volts—the answer for those isolated locations where there are no mains, but heavy LT's can be kept charged from a wind-driven generator or some similar source of amps. The regulation curves for this unit are straight-line from 470 v./30 mA to 310 v./130 mA output, and for input to output, from 2 a./30 mA to 6.35 a./130 mA.

Parmeko.—This firm has for long been well known for a quality product in power transformers and smoothing chokes. They offer a wide range of well-designed and finished units, covering every possible need. The types listed include, as well as the usual HT and LT designs, auto-wound step-up step-down, cathode-ray, filament and relay transformers, and on the AF side, models for driver, input, line microphone and output applications. The chokes include types for filter and smoothing positions, and also swinging chokes for maintaining good output regulation.

NEW QRA's

Only those which have changed since the appearance of the September, 1939, issue of the Call Book, or were not included in it for fully licensed operation, or are now licensed for the first time, can be published here. All that do appear in this column will automatically be included in the new Call Book, now in preparation. The number of QRAs we can print each month depends upon space available. QRAs are inserted as they are received, up to the limit of the space allowance. Please write clearly and address to QRA Section.

G2AAM	J. S. Gingell, 21 High Street, Swanwick, Derbyshire.	G3IV	T. Orr, 31 Grange Park Avenue, Sunderland, Co. Durham.
G2AK	C. H. Young, 42 Stanford Avenue, Great Barr, Nr. Birmingham.	G3NQ	W. J. Barker, Woodside, Radfall Hill, Chestfield, Nr. Whitstable, Kent.
G2ATK	T. O. G. Talboys, 6 Bramley Croft, Shirley, Nr. Birmingham.	G3PS	S/Ldr. W. McCann, 39 Somerhill Avenue, Sidcup, Kent.
G2CYV	B. R. Meredith, 8a, Loughborough Park, Brixton, London, S.W.9.	G3VM	F. W. Fisher, Keppel, Dereham Road, New Costessy, Norwich, Norfolk.
G2DDR	L. Dale, Ashfield House, Ponsharden, Nr. Penryn, Cornwall.	G3YM/I	Major L. W. Richards, 2 GHQ Signals, C.M.F., Caserta, Italy.
G2DSV	W. A. E. Holl, 10 Raeburn Road, Edgware, Middlesex.	G4CW	H. L. Overton, 6 Lower Station Road, Crayford, Kent.
G2FDF	W. F. Limehouse, 84 Cottimare Avenue, Walton - on - Thames, Surrey.	G4FP	W. A. Lawson, 16 Marina Crescent, Netherton, Liverpool.
GM2FHH	L. Hardie, 530 Holburn Street, Aberdeen, Scotland.	G4GT	L. J. Groves, 19 Vernon Close, St. Albans, Herts.
G2FKS	G. D. N. Wilcock, 15 Ravensbourne Park, Catford, London, S.E.6.	G4IV	H. Carter, Greystones, Mount Hawke, Truro, Cornwall.
G2FMV	E. Chapman, The Grange, Roseden, Grouville, Jersey, C.I.	G4KV	Maj. R. Lansley, 41 Dawes Avenue, Wallisdown, Bournemouth, Hants.
G2FPP	F. H. North, 31 Burnt Oak Lane, Sidcup, Kent.	G5FB	K. R. Wootton, 15 Cowper Street, Ipswich, Suffolk.
G2FWA	S. E. James, 73 Kimberley Road, Croydon, Surrey.	G5UM	J. Hum, 9 Windermere Avenue, St. Albans, Herts. (Tel.: St. Albans 2109).
G2FZO	C. J. Hine, 4 Fairview Terrace, Moreton-in-Marsh, Glos.	G5UQ	P. H. Trafford, 1135 Alcester Road South, Kings Heath, Birmingham, 14.
G2HAP	B. L. Simpson, Estate Office, Lakes Road, Dukinfield, Ches.	G6BC	C. Pemberty, Crowlas, Penzance, Cornwall.
G2HCZ	E. S. G. Fish, 11 Melbourne Road, Ilford, Essex.	G6MU	W. J. Munt, 62 Seely Road, Tooting, London, S.W.17.
G2HHV	J. Spivey, 25 Alfred Place, Dewsbury, Yorks.	G6OH	G. S. Samways, Farthings, Earleydene, Sunninghill, Berks.
G2HNO	L. J. J. Morgan, 45 Parkwood Road, Bournemouth, Hants.	G6QB	L. H. Thomas, M.B.E., Heather Bank, Pear Tree Lane, Bexhill, Sussex.
G2JL	R. V. Allbright, Greenacre Cottage, Lidden, Penzance, Cornwall.	G6VX	L. D. Mason, 16 Abbotsbury Road, Hayes, Kent.
G2JN	J. G. Stonestreet, Pilot's Lodge, Lower Hardres, Canterbury, Kent.	G6XT	A. C. Edwards, c/o Stratton & Co., Ltd., Eddystone Works, Alvechurch Road, West Heath, Birmingham, 31.
G2NL	K. Middleton, Stoneycroft, Hayle, Cornwall.	G8DV	G. P. Morgan, Crow Holt Cottage, Echo Barn Lane, Wrecclesham, Nr. Farnham, Surrey.
G2PV	A. M. Stimpson, 74 Western Road, Leicester.	G8NO	R. Postill, Victoria College, Jersey, Channel Isles.
G2VD	L. F. Viney, 12 Tudor Drive, Watford, Herts.		
G2WW	D. J. Beattie, Suffolk House, Lidden, Penzance, Cornwall.		
G3FG	J. R. Davidson, 10 Stanley Square, Carshalton, Surrey.		

For more Enjoyment of your Hobby, read the Short Wave Magazine regularly

THE MONTH WITH THE CLUBS

FROM REPORTS

For this month, we are very pleased to see activity reports from fifteen Club secretaries though one or two of them only just caught the mail in time! As explained in March, the closing date for material for this column is the 20th of the month *latest* for appearance in the following issue. The printers get restless shortly after the 20th, by which time the Editor is shouting for copy. Your earnest scribe has nobody to kick, and so can only ask Club Secretaries to remember him on the 18th of the month.

Of the fifteen clubs whose activities are covered, six are here for the first time, and one is quite new, in that it is in process of formation. This is a very good sign and we wish Hounslow every success in the future, also hoping that readers in the locality will become members.

Here are the reports, with secretaries' names and addresses in the panel at the foot of this column.

Hounslow and District Radio Society.—This is a new society, just being formed, for those in the district interested in Amateur Radio and kindred subjects. Readers in the area are asked to get in touch with the secretary.

Birmingham and District Short Wave Society.—They meet at the "Hope and Anchor," Edmund Street, at 8.0 p.m. on the first Monday of each month (not in August—date of this meeting yet to be fixed), and secretary G. Hodgkiss mentions that Morse classes have been started and are being well supported. A 'Phone DX competition is to be held in July; we shall look forward to hearing more about this when the conditions have been arranged.

Swindon and District Short Wave Society.—This is a well-known pre-war club which has just re-formed, and is now getting under way again. It has eight active transmitting members, several of whom are giving lectures on Amateur Radio subjects. Morse classes have also been started here, too. Future talks are to cover VHF frequency measurement, aerial and feeder design, frequency modulation, receiver and transmitter design, and crystal grinding.

Swindon's meetings are held fortnightly on Saturdays at the Clifton Street School, and they hope for plenty of local support.

Bradford Short Wave Club.—Very active before the war with its own callsign (G3NN), like many other clubs, Bradford had to suspend operations when the majority of its members joined the Services. Now revived with a membership of about 30, the club has among its officers G2SU (President), G2CQY (Chairman), G2BYC (Secretary), and on the committee are G3KB and G3KF. As soon as permanent quarters have been secured, Bradford will be recommencing transmitting activities.

Reading and District Radio Amateurs' Club.—This club, started two years ago, now has about 50 members; since its inauguration they have had over 150 visitors. The lecture and discussion meetings are every last Saturday in the month at Palmer Hall, West Street, from 6.30-9.30 p.m., and include talks on matters of Amateur Radio interest. On the second Saturday in the month, the time is devoted to the building of club equipment, discussion of members' difficulties, and inspection of any apparatus they care to bring along. As secretary R. J. Nash remarks, this feature is found to be particularly helpful to the non-transmitting members.

The programme of activities also includes visits to radio and engineering works, and the BBC. Recently, on the initiative of G4NT, a very successful joint meeting of the Reading Club with amateurs from the Slough and High Wycombe districts was held at Messrs. Turners Electrical Instrument Works at High Wycombe; an attendance of about forty thoroughly enjoyed G4NT's hospitality.

The next Reading meetings are on May 11 and 25, June 8 and 29, and July 13.

Liverpool and District Short Wave Club.—Meeting every Wednesday, 8.0 p.m., at St. Barnabas Parish Hall, Penny Lane, Liverpool, 15, they run Morse classes and auction sales, and are planning the club

transmitting station. Members are active on 28 and 58 mc, and four more are due to take the qualifying examination for full tickets this month. Among the officers are G4NH, G4QC, and 2FZM; they have the assistance of G5MQ, who has given a talk on "Five and Ten."

Stockport Radio Society.—With nearly 70 members, Stockport is going from strength

The secretaryship is passing from BRS-11306 to G2AZI, on the former's departure to Hull; he will be a loss, as since December, when he undertook to start Stockport, membership has risen from 19 to 70! Good work.

Midland Amateur Radio Society.—The attendance at the meeting on April 16 was 47, with G3AY in the chair; an open

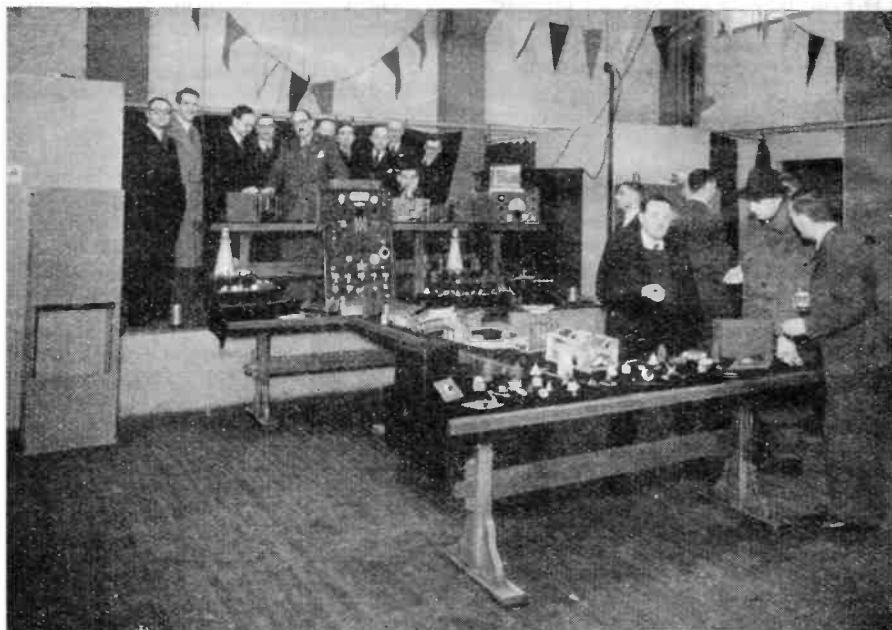

Looking over some of the Eddystone equipment, on view in Birmingham on March 23. To the right rear is their new "504" communications receiver, the specification of which is given in "On the Market," this issue.

to strength. The new officers are S. A. Mills, Esq., (Chairman), G2ARX (Treasurer), BRS-11306 (Secretary), and on the committee are G2AZI, G2ZF, G2DUD and G2BJT.

Three local contests have been organised for the summer—(1) Greatest number of DX stations confirmed on 28 mc, (2) The same for 58 mc, (3) Best piece of equipment built by a member. This will be followed by an exhibition of club members' gear, which it is hoped will also be supported by the Trade. Field Days are planned, with visits to the BBC. Altogether an attractive programme, which shows that the club is being run well and enthusiastically.

discussion on aerial design and coupling brought out many useful and interesting points, 2BKZ, G4MJ, G5AK, G5IQ and G6DL being the chief contributors. The next meeting is on May 21, the subject being 58 mc converters, to be opened by G5BJ. M.A.R.S. always welcome visitors to their meetings at the Chamber of Commerce, New Street, Birmingham.

Southend and District Radio and Scientific Society.—For the time being, the secretaryship has passed from G6CT to G5XI, who reports that the Sale and Exchange section—mentioned last month—has made an excellent start. They have had two very useful and interesting meetings,

on valve manufacture and D/F operation, and are looking forward to the summer programme.

Slade Radio.—Here again, a big influx of new members is reported, and secretary L. A. Griffiths remarks that, judging by their enthusiasm, Slade are in for some lively meetings. The next is on May 24, a talk and demonstration on moving-coil pick-ups, and on June 28 there is to be a D/F night, with a lecture on procedure, methods and circuits. These take place at the club premises at Broomfield Road, Slade Road, Erdington, Birmingham.

Watford and District Radio and Television Society.—Twenty eight members came in for the April meeting, and heard a very interesting lecture by G8CK on aerial design. This was so successful that another is to be arranged for the near future. After G8CK's lecture, a junk sale was held and much useful equipment changed hands. The next meeting—at Carlton Tea Rooms, Queens Road, Watford, 7.30 p.m. on May 7—will be devoted to a discussion on receiver design.

Grafton Radio Society.—By all accounts, Grafton has got away to a flying start. The first meeting on April 12 drew an enthusiastic attendance, when the aims and objects of the society were unfolded. Application is to be made for a transmitting licence, and Morse classes have commenced; no effort will be spared to turn out efficient operators. Members are encouraged to bring their own components and take advantage of the excellent workshop facilities that are available, and arrangements have been made for the safe custody of uncompleted apparatus.

Many interesting letters have been received from Service readers who intend joining Grafton as soon as they are out. A section for VHF enthusiasts is being formed within the society, which it is hoped will attract the support of returning ex-radar personnel and enable them to maintain their technical interest in this field. A very good idea which we cannot commend too highly. One of the society's objects is to foster ex-Service camaraderie, which we also applaud.

Grafton meets every Thursday and Friday, 7.30-9.30 p.m., at the Grafton L.C.C. School, Eburne Road, Holloway, N.7. (Go to Nag's Head Junction.) The society is fortunate in having as secretary W. H. C. Jennings, of whose keenness and energy we have heard from several readers.

Romford and District Amateur Radio Society.—We were in error last month in reporting that G2FLK had succeeded G3FT as the secretary; the latter, of course, remains in office and is doing a great job. The mistake arose because G2FLK reported to us as "publicity secretary," which is his particular function in the Romford organisation. Apologies all round for the mistake.

On April 10, the Romford, Ilford and Southend societies held a preliminary meeting to discuss the future of Joint Field Days and it was agreed that when the GPO can reissue portable licences, they should be continued on the basis of the very successful pre-war events. We also hope that portable facilities will be forthcoming before the summer is out, as there is much useful and interesting practical work to be done.

Edgware Short Wave Society.—With 50 members, Edgware is going strong. Recent events have been very successful, particularly the lecture by G2DZ, of Standard Telephones, on valves; this was attended by an invitation party from the Royal Signals depot at Barnet, in which was included no less than 15 amateurs. At the junk sale on April 11, £20 worth of business was done, some good gear being offered at surprisingly low prices. The Edgware dance on April 20 was also a great success.

Subjects for the next few meetings include lectures on crystals and the theory of waveform, and the semi-final of the "Constructors' Award" competition.

City of Belfast Y.M.C.A. Radio Club.—The club transmitter GI6YM is on the air again, making world-wide contacts, and it is hoped to join in on 1.8 mc very shortly. Recent visitors have been VE4LV and ON4WD, and membership is still soaring. A series of fortnightly lectures to be given over the next three months includes Oscillators for Amateur Use (GI5SJ, May 22), Crystals Grinding (GI5QX, June 19), and DX Working (GI6TK, July 3). These talks commence at 8.0 p.m. at the City Y.M.C.A., Wellington Place.

Amateurs visiting Northern Ireland during the summer months will be specially welcomed and are asked to contact the secretary, GI6TK, as members are always glad to meet amateurs from across the water.

Following are the names and addresses of the secretaries of the clubs mentioned this month. They will be pleased to give every assistance to prospective members.

- BELFAST.** F. A. Robb, G16TK, 60 Victoria Avenue, Sydenham, Belfast.
- BIRMINGHAM.** G. Hodgkiss, BSWL-1938, 30 Towyn Road, Moseley, Birmingham, 13.
- BRADFORD.** V. W. Sowen, G2BYC, 6 West View, Eldwick, Bingley, Yorks.
- EDGWARE.** P. A. Thorogood, G4KD, 35 Gibbs Green, Edgware, Middlesex.
- GRAFTON.** W. H. C. Jennings, 82 Craven Park Road, Stamford Hill, London, N.15. (Tel. : Stamford Hill 3891).
- HOUNSLOW.** A. H. Pottle, 11 Abinger Gardens, Isleworth, Middlesex.
- LIVERPOOL.** T. W. Carney, G4QC, 9 Gladeville Road, Aigburth, Liverpool, 17.
- MIDLAND.** W. J. Vincent, G4OI, 342 Warwick Road, Solihull, Birmingham. (Tel. : Solihull 0413.)
- READING.** R. J. Nash, BRS-4573, 9 Holybrook Road, Reading.
- ROMFORD.** R. C. E. Beardow, G3FT, 3 Geneva Gardens, Whalebone Lane North, Chadwell Heath, Essex.
- SLADE.** L. A. Griffiths, 47 Welwyndale Road, Sutton Coldfield, Birmingham.
- SOUTHEND.** B. C. Leefe, G5XI, 16 Carlton Drive, Leigh-on-Sea, Essex.
- STOCKPORT.** G. Wood, BRS-11306, 121 Garners Lane, Davenport, Stockport, Cheshire.
- SWINDON.** P. Greenwood, G2BUJ, 49 Western Street, Swindon, Wilts.
- WATFORD.** J. C. Warren, 29 Market Street, Watford, Herts. (Tel. : Watford 5988).

AMATEUR RADIO IN HOLLAND

Before the war, Holland supported no less than three distinct and separate Amateur Radio societies—the N.V.I.R., N.V.V.R. and V.U.K.A. When war came, they sank their differences and co-operated to give valuable and much-needed technical assistance to the Dutch resistance and underground movements. Many well-known Dutch amateurs—among them PAØQQ, PAØGA, PAØXL and PAØRW—sacrificed their lives in this cause.

Immediately after the liberation, a new merger society, V.E.R.O.N., was formed which already has a membership of over 3,000 and its own monthly publication, *Electron*. V.E.R.O.N. is recognised by the Dutch Post Office as the official body representing Amateur Radio in Holland. The PA's are now being licensed and becoming active on 28 mc with 100 watts and on 58 mc with 50 watts; the other bands will be released to them under the same conditions as apply elsewhere in Europe.

But the difficulties of our Dutch confrères are still considerable. The enemy confiscated all the radio equipment he could find, particularly in the way of VHF gear, and the amateurs in Arnheim and Rotterdam lost everything they possessed. Very little apparatus is available in Holland, and in the words of PAØAD, secretary of V.E.R.O.N., what is to be had is "crying expensive."

OBTAINING YOUR COPY

Due to current difficulties of supply and distribution, which apply equally to all publications while paper remains closely controlled, our wholesalers cannot guarantee even and regular supplies of the *Magazine* throughout the country. We only retain sufficient copies for posting to the direct subscribers, with a very small margin for counter-sales.

The point of all this is that our general correspondence makes it abundantly clear that many potential regular readers are unable to get news-stand copies because we cannot meet all trade orders in full. Most have to be cut by fifty per cent.

As we are anxious that the *Magazine* should reach everyone to whom it is of value and interest, the solution is to place a direct subscription order with us. This costs you twenty shillings and will bring a copy by post each month for twelve months, starting with the issue you specify; direct subscribers' copies are posted *en bloc* on the day of publication. Write the Circulation Manager, *Short Wave Magazine*, 49 Victoria Street, London, S.W.1.

Puzzle Picture (p. 171). *Graveyard of the German night fighters, showing the A.I. (Aircraft Interception) radar installation used for finding targets by night. The larger array is the SN2, operating on frequencies in the neighbourhood of 100 mc, and giving practically all-round looking for general search. The smaller system, mounted within the SN2 on the aircraft in the left foreground, was used in conjunction for the final homing on an individual target; the frequency was 490 mc and the beam very much narrower than with the SN2. These aerial systems all consisted of four radiating elements with directors, the aircraft itself acting as a reflector. There was a long and bitter struggle between aircraft of Bomber Command and the German night fighters, and in the field of radio countermeasures considerable effort was devoted to neutralising the enemy radar and communications systems in order to secure free passage for the bombers.*

WODEN *... the Hall-mark of a Good Transformer*

MULTIMATCH MODULATION TRANSFORMERS

Woden engineers have developed a special range of Multimatch modulation transformers for Amateur Transmitting use, details of which are given below. The transformers are vacuum impregnated and fitted in compound-filled steel pots giving reliable and silent working.

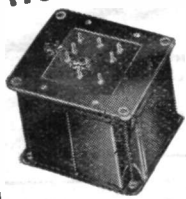

Primary Impedances, 2,000/18,000 ohms. Secondary Impedances, 200/20,000 ohms.

TYPE U.M.1. Suitable for 30 watts Audio. Max. Sec. current, 120 m/a 35/-
 TYPE U.M.2. Suitable for 60 watts Audio. Max. Sec. current, 200 m/a 46/9
 TYPE U.M.3. Suitable for 125 watts Audio. Max. Sec. current, 250 m/a 67/-

Larger sizes to order.

DE LUXE TYPE TRANSFORMERS AND CHOKES

This entirely new range of transformers and chokes housed in streamlined die-cast cases enable equipment to be constructed setting a standard not hitherto attained. Full details are given in our lists and a representative range is given below.

MAINS TRANSFORMERS

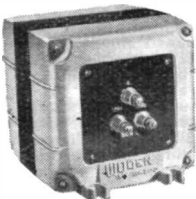

D.T.M.11. 250-0-250 60 m/a 29/9	D.T.M.16. 650-0-650 200 m/a 62/2
D.T.M.12. 275-0-275 120 m/a 42/11	D.T.M.17. 750-0-750 250 m/a 90/3
D.T.M.13. 350-0-350 120 m/a 46/3	D.T.M.18. 1250-1000-0-1000-1250 300 m/a 137/6
D.T.M.14. 425-0-425 150 m/a 53/8	D.T.M.19. 1500-0-1500 350 m/a 155/2
D.T.M.15. 500-0-500 150 m/a 53/8	D.T.M.20. 2000-0-2000 350 m/a 176/-

FILAMENT TRANSFORMERS



D.T.F.11. 2.5 v. 5 amp. C.T. 24/9	D.T.F.17. 7.5 v. 5 amp. C.T. 28/2
D.T.F.12. 2.5 v. 10 amp. C.T. 31/11	D.T.F.18. 5 v. 3 amp. C.T. 29/2
D.T.F.13. 4 v. 10 amp. C.T. 33/7	D.T.F.19. 4 v. 4 amp. C.T. 29/2
D.T.F.14. 5 v. 4 amp. C.T. 24/9	D.T.F.19. 4 v. 2.5 amp. C.T. } 29/2
D.T.F.15. 6.3 v. 4 amp. C.T. 24/9	D.T.F.19. 4 v. 6 amp. C.T. } 29/2
D.T.F.16. 4 v. 6 amp. C.T. 24/9	D.T.F.20. 10 v. 10 amp. C.T. 47/4

SMOOTHING CHOKES

D.C.S. 11. 12 Hy 60 m/a. D.C. Resist. 550 ohms 16/4
D.C.S. 12. 12 Hy 150 m/a. D.C. Resist. 190 ohms 22/11
D.C.S. 13. 12 Hy 250 m/a. D.C. Resist. 180 ohms 47/4
D.C.S. 14. 12 Hy 350 m/a. D.C. Resist. 60 ohms 86/11
D.C.S. 15. 12 Hy 500 m/a. D.C. Resist. 80 ohms 94/8
D.C.S. 16. 12 or 60 Hy 100 or 50 m/a. D.C. Resist. 250 ohms or 1,100 ohms 22/11

Obtainable from Messrs. Webbs Radio, Soho Street, London, W.1, or direct from
WODEN TRANSFORMER CO., LTD · BILSTON · STAFFS
 Phone: Bilston 41959

NEW DUAL TESTSCOPE



Ideal for High and Low Voltage Testing; 1/30 100/850 A.C. and D.C. Allowance made on old models. Send for interesting leaflet L34 on Electrical and Radio Testing, from all Dealers or direct.

RUNBAKEN-MANCHESTER-I

H.A.C.

Short-Wave Equipment

Noted for over 15 years for Short-Wave Receivers and Kits of quality

One Valve Kit, Model "C" Price 20/-
Two " " " " "E" " 43/-

These kits are complete with all components, accessories, and full instructions. The prices are inclusive of postage and packing. Send stamped addressed envelope for descriptive catalogue

A. L. BACCHUS, 109 Hartington Road, London, S.W.8

Short Wave Coil Unit

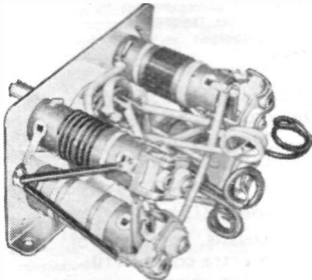

30/-

Complete (as illustrated)

4 COILS already wired and switched, each coil consists of aerial, grid and reaction windings. Ranges covered with 160 mfd. tuning condenser.

SWR 1. 9-83 metres to 24 metres. SWR 2. 18-7 metres to 45-4 metres. SWR 3. 38-4 metres to 95 metres. SWR 4. 92-3 metres to 206 metres.

Coil Unit complete with blue-print of 2 valve (Battery) S.W receiver for above Unit 30/-. Blue-prints only, 1/6. Individual coils 3/3 each.

Also available : S and 10 metre Tank Coil, R.F. Chokes, Aerial. Oscill. and H.F. coils for all wavebands.

AMATEUR RADIO PRODUCTS
50 GLASSLYN ROAD, CROUCH END,
LONDON, N.8. 'Phone :-Mountview 4745.

PREMIER RADIO

(MORRIS AND CO. (RADIO) LTD.)

ALL POST ORDERS TO : JUBILEE WORKS' 167, LOWER CLAPTON RD., LONDON, E.5. (Amherst 4723)

CALLERS TO : 169, FLEET ST., E.C.4. (Central 2833)

1946 LIST now available ; hundreds of new lines. Terms of Business : Cash with order or C.O.D. over £1. All enquiries must be accompanied by a 2½d. stamp.

BRAND NEW GOVERNMENT SURPLUS, Etc. MANY ITEMS AT PRE-WAR PRICES.

ELECTROLYTIC CONDENSERS. 8 mfd., 500 v.w., 3/-; 8+8, 500 v.w., 3/11, 50 mf., 12 v.w., or 25 mf., 25 v.w., 2/3; 50 v., 50 v.w., 3/-; 500 mf., 12 v.w., 4/6.

MIDGET RADIO KITS. Complete with drilled chassis, valves and loudspeaker, only cabinet required, medium and long wave t.r.f., size 10 x 6 x 6, 4 valve, inc. rect., tone control, AC/DC operation, 200/250 v. Circuit and Constructional Details supplied. Price including tax £6/17/6.

MOTOR GENERATORS. Input 6 v. DC. Output 220 v. DC, 50 mA, with smoothing. £3/10/0.

ROTARY TRANSFORMERS. DC to DC. Input 12 or 18 volts. Output with 12 v input; HT 200 v. 60 mA, and 8 v. 2 a, with 18 v. input; HT 300 v., 70 mA and 12 v. 2 a, £2. Smaller model, input 12 or 18 volts, with 12 v. input HT 180 v., 30mA. LT 4 v. 3a, with 18 v. input; HT 300 v., 30 mA; LT 6.5 v. 3 a., 10/-, Input 24/28 v. Output 1,000-1,200 v., 70 mA, £2.

VIBRATOR POWER UNITS. Input 6 v. Output 120 v., 15 mA. £2/0/0. Input 12 v. Output 240 v., 100 mA, 6 v. 10 a., £3/10/0.

CO-AXIAL CABLE. Super quality, single screened, weatherproof, 1/6 yd.

SUPER QUALITY OIL-FILLED PAPER (MANSBRIDGE TYPE) CONDENSERS 2 mfd., 1,000 v.w., 2/6 each or £1 per doz.; 2 mfd. 600 v.w., 1/3 each or 10/- per doz.; 1 mfd. 600 v.w., 1/- each or 8/- per doz.

LOUDSPEAKERS. Rola 5in., P.M., 21/6; 6½in. P.M., 22/6; 8in. P.M., 24/-; 2½in. P.M., 25/-; 3½in. P.M., 30/- Goodman's 10in., 6-watt. 15 ohm. V.C., P.M., 47/6.

SUPERHET TUNING KIT, comprising 9 midget coils for H.F., Aerial and Osc. covering 16-47, 200-557 and 700-2,000 m., suitable switch, all padders and trimmers, 38/10. Worth double. Also available a suitable 3 gang condenser with complete S.M. drive and dial, 30/-.

FIRST-GRADE METERS. 3½in. diameter, 1 milliamp, £2/12/0; 500 microamps, £2/18/6. 4½in., 1 milliamp, £3/5/0; 500 microamps, £3/11/6. Westinghouse Meter Rectifier for either type, 10/- Multiple shunts, 10, 100, 500 mA, 10/- Any value multiplier, 2/6 each.

SUPER QUALITY AC/DC 15 W. AMPLIFIER. 3-stage, high gain, push-pull, in steel cabinet, £15/15/0.

AC/DC AMPLIFIERS, 5 watts output, high gain, three-stage feedback, £8/8/0.

PLAYING DESKS. A super quality electric gramophone motor with magnetic pick-up and automatic start-stop. Mounted on a substantial metal base 200-250 v. A/C, £6/17/6.

MAINS TRANSFORMERS, 300+300 v., 60 mA, three 4 v. 2-3 a. windings, 25/-; 350+350 100 mA, 5 v., 2 a., 6.3 v., 2-3 a., 29/-; 350+350 100 mA, three 4 v. 2-3 a. windings, 29/-; 350+350 150 mA, 4 v., 2-3 a., 4 v. 3-6 a., 4 v. 1-2 a., 4 v. 1-2 a. windings, 39/-; 350+350 150 mA, 5 v. 2 a., 6.3 v. 2 a., 6.3 v. 2 a., 36/-; 500x500 250 mA, 5 v. 3 a., 6.3 v. 2 a., 6.3 v. 4 a., 65/-; 425+425 200 mA, 4 v. 2-3 a., 4 v. 2-3 a., 4 v. 3-6 a., 47/-; 350+350 150 mA, 4 v. 1-2 a., 4 v. 2-3 a., 4 v. 3-4 a., 36/-; 500+500, 150 mA four 4 v., 2-3 a., LT windings, 47/-.

8 VALVE "WALKIE - TALKIE"

CHASSIS COMPLETE WITH CASE !! **35/-**
 BRAND NEW! UNUSED!
 TROPICALLY PACKED

(carriage 1/6 extra)

DIMENSIONS 14" X 6 $\frac{3}{8}$ " X 5 $\frac{3}{4}$ "

Limited quantity only

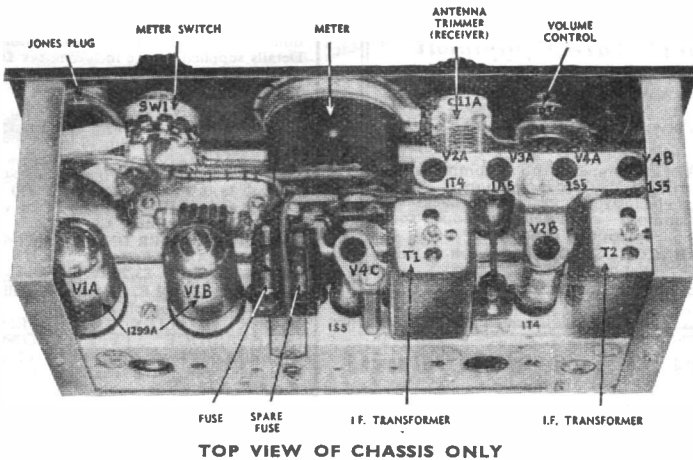

TOP VIEW OF CHASSIS ONLY

Receiver consists of a 5-valve superhet comprising one stage r.f. amplification, mixer and oscillator, one stage i.f., second detector and an a.f. stage. Transmitter consists of a master oscillator circuit followed by a single power amplifier working on the second harmonic of the output frequency of the oscillator. Frequency range 6-9 Mcs.

Contains a host of perfect and scarce components worth £15!

A complete set of 8 miniature type valves for this chassis, consisting of 2 IT4, 3 IS5, 1 IR5 and 2 3D6/1299A is available at an extra cost of 110/-. Individual valves of these scarce types also available at list prices.

A set of Aerials in Webbing case, comprising a 103" Telescopic type, and a 16 section Copper Tubing Aerial, also available at 15/- per set. Postage 8d.

S.A.E. will bring you copy of our new Summer price list of components.

TERMS :

C.W.O. Post orders only.

ENQUIRIES :

for any equipment welcomed.

M.O.S.

MAIL ORDER SUPPLY CO.,
 24 NEW ROAD, LONDON, E.1

STEPNEY GREEN 2760

RADIO CAREERS AN IMPORTANT GUIDE

"Engineering Opportunities" indicates clearly how all engaged in the Wireless industry can equip themselves for safe and highly-paid posts despite the keener competition which will come with a return to peace-time conditions.

This modern guide contains 112 pages of highly useful information. It gives full details of our very comprehensive series of modern WIRELESS COURSES, including General Wireless, Short Wave, Wireless and High Frequency, Talking Picture Engineering, Television and Radio Servicing, etc.

TELEVISION AND RADIO SERVICING
There is no doubt about it that there will shortly be an enormous boom in Television and unlimited opportunities for trained men. Our special TELEVISION and SERVICING Courses are fully described in the handbook.

"ENGINEERING OPPORTUNITIES" also explains the most efficient way of preparing candidates for such recognised Examinations as A.M.I.E.E., A.M.Brit.I.R.E., City and Guilds, etc.

**WE DEFINITELY GUARANTEE
"NO PASS—NO FEE"**

The Wireless industry is alive with possibilities. In your own interests you should write for your copy of "ENGINEERING OPPORTUNITIES" to-day. It will be sent FREE, and the book is bound to indicate many opportunities which otherwise you might miss.

**BRITISH INSTITUTE OF
ENGINEERING TECHNOLOGY**
149 Shakespeare House,
17/19 STRATFORD PLACE, LONDON, W.1

IN SEARCH OF QUALITY

We are pleased to announce an addition to the service we are providing for Amateurs. In the April issue of this Magazine, we gave details of some of the power equipment we can supply, and invited enquiries regarding special transformers, chokes, etc.

We now give below a few examples of the high quality audio apparatus we can now provide, and again invite enquiries.

MODULATORS

"Super Fifty" Modulator, 50 watts output. Response of 30 cps. to 15000 cps. within $\frac{1}{2}$ db. Under 2 per cent. distortion at 40 watts. Electronic mixing for microphone and gramophone of either high or low impedance. Top and bass controls. Complete with incorporated power supply and metal cabinet. Output valves matched and multi-ratio secondary fitted to modulation transformer.

Price (complete, including cabinet) £30 19 6
Price of complete chassis only £27 16 6

Modulation Transformers.

Made in two models, having identical electrical characteristics but differing power ratings.
60 watt model £2 5 0
100 watt model £3 3 0

Frequency response of 200 to 10000 cps. within $\frac{1}{2}$ db. Primary centre-tapped for 10000 ohms tapped at 8000, 5000 and 3000 ohms. Secondary 10000 ohms tapped at 8000, 5000 and 3000 ohms. Supplied fully shrouded, and fitted with tagged distribution panel.

The above apparatus is being specially constructed for us by Messrs. Vortexion Ltd., who are recognised as experts in the production of high quality audio apparatus.

AMATEUR WIRELESS SUPPLIES
11 Church Road, Upper Norwood, London, S.E. 19

Sound Understanding

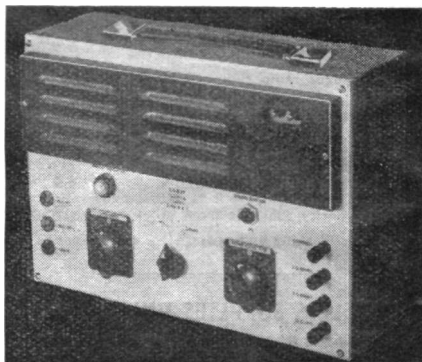

THE P.A.10 PORTABLE AMPLIFIER

A portable 10 watts A.C. operated Amplifier, with inputs for one crystal or moving coil microphone and one pickup. Output impedance 2.5, 7.5 and 15 ohms. Ideal for Hotel paging systems, Dance Bands, etc.

All B.S.R. amplifiers are built to a scientific standard, by pioneers in the art of Sound Reproduction.

SEND
YOUR
ENQUIRIES
TO

BSR

BIRMINGHAM SOUND REPRODUCERS LTD.

CLAREMONT WORKS, OLD HILL, STAFFS. TEL.: CRADLEY HEATH 6212/3
LONDON OFFICE: 116 GOWER STREET, W.C.1 TEL: EUSTON 7515
M-W-67

AMATEUR CHASSIS

The following are of aluminium ; very light in weight, very rigid, very easy to work. Fitted with stout steel straps (plated) for extra rigidity, and tapped 2 B.A. for cabinet fixing. All undrilled, perfectly plain.

- 7 in. by 7 in. by 2 in. deep 3/9
- 5½ in. by 9½ in. by 2 in. deep 4/-
- 11 in. by 7 in. by 2 in. deep 4/9
- 17 in. by 10 in. by 2 in. deep 5/9

Also midget radio type, 10 by 5½ by 2 in., punched for 6½ in. speaker and seven valves (or five valves and two IF transformers)... 5/-

Also steel (plated) 12 by 9 by 3 in. deep, undrilled 6/6

Any quantity available from stock, despatch at once. Packing and postage 1/- each extra.

WIRELESS SUPPLIES UNLIMITED

264-266 Old Christchurch Road,
BOURNEMOUTH, HANTS.

MORSE CODE TRAINING

There are Candler Morse Code Courses for **B**eginners and **O**perators

SEND NOW FOR FREE

"BOOK OF FACTS"

It gives full details concerning all Courses.

THE CANDLER SYSTEM CO.
(S.M.), 121 Kingsway, London, W.C.2.
Candler System, Co. Denver, Colorado, U.S.A.

LONDEX for RELAYS

AERIAL CHANGE-OVER RELAY

for Radio Frequency
Type A.E.C.O. 4.

3 V.A. Coil Consumption, especially designed for Transmitters, High Frequency Heating, Amateur Stations, etc. Ask for leaflet 112/SW.

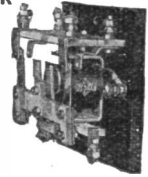

LONDEX · LTD

MANUFACTURERS OF RELAYS
ANERLEY WORKS · 207 ANERLEY ROAD · LONDON S.E.20 · PHONE SYDNEY 6250/9

If you use solder it will cost you no more to use

ERSIN MULTICORE

The **FINEST** Cored Solder in the World

Contains 3 cores of extra active Ersin Flux. No extra Flux required.

The solder that was used for making high precision soldered joints in radar and other vital equipment. Nominal 1 lb. reels and 6d. cartons available from most electrical shops and ironmongers.



SIZE 2 MULTICORE CARTONS 6d.

Each carton contains sufficient Ersin Multicore Solder to make over 200 average joints on radio and electrical equipment.

NOMINAL 1 lb REELS HIGH TIN CONTENT PRE-WAR QUALITY

Catalogue Reference No.	Alloy Tin/Lead	S.W.G.	Approx. length Nominal 1-lb. reel	Price per nominal 1-lb. reel.
16014	60/40	14	64 feet	6/-
16018	60/40	18	178 feet	6/9

Samples free of charge upon request.

MULTICORE SOLDERS LTD.

MELLIER HOUSE, ALBEMARLE ST., LONDON, W.1

Tel. : REGENT 1411 (P.B.X. 4 lines)

BARGAINS! SELECTION! QUALITY!

JUST READ DOWN THIS LIST

CONDENSERS AND RESISTORS

A special "buy" enables us to offer you the following at very competitive prices:

Block Types Paper.—4 mfd., 500v. w. 1,000v. test, 4/6; 2 mfd., 400v., 3/3; 1 mfd., 1,000v. w., 3/6; 0.25 mfd., 2,000 v. w. 4/-.

Tubular Types.—0.02 mfd., 750v., 10d.; 0.025 mfd., 350v., 7d.; 0.05 mfd., 1,000v., 11d.; 0.05 mfd., 500v., 8d.; 0.1 mfd., 1,000 v., 1/3; 0.25 mfd., 750v., 1/4; 0.5 mfd., 500v., 1/6; 0.5 mfd., 500v. (aluminium case), 2/6. Mica types: .001 mfd., 2,250v. test, 1/-; 0.05 TCC mica metal case, 1/8.

Resistors.—150, 220, 270, 1,000, 10,000, 15,000, 20,000, 27,000, 93,000, 40,000, 100,000, 1/2 meg., 1.8 meg., 1/2 watt, 4/- doz.; 600, 25,000, 50,000, 2 watt, 10d. All are Eric and brand new stock.

Meters and Test Equipment.—If it is available we have it; only best makes handled. Present stocks include: Record Insulation Tester, £11 2s. 3d.; Hunt's C & R Bridges, £18 18s.; Millard C & R Bridges, £15 15s.; Taylor C & R Bridges, £14 14s.

Valves.—Every conceivable type of valve which is available can be supplied, including PX4, PX25 (matched pairs if necessary), and many other types which are in short supply. Let us have your valve wants.

Load Speakers.—All sizes from 2 1/2-in. to 12-in. from stock. All best makes including Rola, Goodman, Wharfedale, BTH, Celestion, etc. If you want a good quality speaker chassis we have it.

Mains Transformers.—We specialise in mains transformers for every purpose. Here are just a few of the types we can offer from stock. Type MT/E 350-0-350v., 100 m.a., 4v. 2a., 4v. 5a., CT, 33/9; type MT/A 350-0-350v., 100 m.a., 5v. 3a., 6.3v. 4a., CT, 33/9; type MT/EA 350-0-350v., 100 m.a., 4v. 3a., 6.3v. 4a., CT, 33/9; type MT/E150 350-0-350v., 150 m.a., 4v. 3a., 4v. 3a., CT 4v. 5a., CT, 42/9; type MT/A150 350-0-350v., 150 m.a., 5v. 3a., 6.3v. 5a., CT, 41/3; type MT/6 450-0-450v., 250 m.a., 4v. 3a., 4v. 3a. CT, 4v. 3a. CT, 4v. 6a., CT, 51/9; type MT/7 450-0-450v., 250 m.a., 5v. 3a., 6.3v. 3a. CT, 6.3v. 5a., CT, 50/3; type MT/8 500-0-500v., 250 m.a., 4v. 3a., 4v. a. CT, 4v. 3a. CT, 4v. 6a. CT, 52/6. Mains Transformers built up to your own specifications.

Output Transformers.—To meet all requirements. Ranging from the small general purpose type to large types of high wattage rating. Here are a few of our standard stock lines. AMT Ratios, 57/1 and 32/1 for primary loads of 8,000 and 2,500 ohms to 2 or 3 ohm speakers, 6/- BM/T Ratios 80/1 and 42/1 for primary loads of 15,000 and 22,000 ohms and 3,000 to 5,000 ohms to 2 or 3 ohm speakers, 6/-. MR/15, rating 15 watts max. 18 watts. Ratios available, single-ended or push-pull, 13, 16, 18, 20, 22, 27, 33, 40, 52, 66 and 80/1. Primary loading, 2,000 to 16,000 ohms. Secondary impedance, 1 to 30 ohms. Maximum primary current for single-ended stage 90 m.a. for push-pull stage, 100 m.a. in each half of primary, 39/9. MR30, specification as above but rating 30 watts, maximum current in each half of primary 170 m.a., 40/6. Full instructions with each transformer.

NOW send your orders and enquiries for our prompt attention. C.W.O. or C.O.D., whichever best suits you. If you send C.W.O. please include sufficient for postage and packing.

VALLANCE'S

The Short Wave Specialists

144 BRIGGATE, LEEDS, I.



Q.C.C. TYPE P5 QUARTZ CRYSTAL UNIT

This unit uses the well-known Q.C.C. Power type crystal, which is undoubtedly the most rugged and active crystal cut available for amateur use. The crystal is mounted in our type U dust proof holder, with standard 1/2 in. pin spacing, as illustrated above.

The P5 unit has a temperature co-efficient of 20 cycles per megacycle per degree Centigrade temperature change. Used with a 6V6 or 6L6 type beam tetrode, it will give up to 5 watts r.f. output on the fundamental frequency, and approximately 3 watts on the second harmonic in the Tritet circuit.

Available in the 1.8 to 2.0 Mc. band for fundamental use, and in the 3.5 Mc. band and 7 Mc. band for frequency multiplying to the 28 and 58 Mc. bands.

An official certificate of calibration is sent with each P5 unit, giving the frequency under stated operating conditions to an accuracy of 0.025%.

PRICES: Ground to your specified frequency in the above bands ... £1.17.6

Or ground to a frequency not specified by you but taken from our stock ... £1.12.6

Please note that all the leading dealers in amateur equipment now carry stocks of the P5 crystal unit. THE QUARTZ CRYSTAL CO., LTD. (Directors: E. A. Dedman, G2NH., N. H. R. Munday, G5MA., W. J. Thompson, G2MR.), 63/71 Kingston Road, New Malden, SURREY. Telephone: MALDEN 0334

UNSURPASSED for SHORT WAVE WORK



Ericsson Supersensitive Telephones simply annihilate distance. Perfect in tone. Really comfortable in wear. British made. All good dealers 25/- or direct

Ericsson

**SUPERSENSITIVE
TELEPHONES.**

56 Kingsway, London, W.C.1

HOLborn 6936

"Cylodon" Transmitting Capacitors

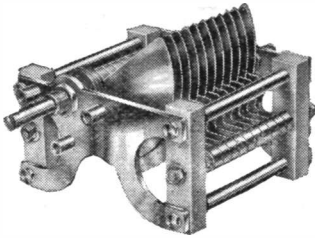

TYPE T.R. — SQUARE LAW

Max. Capacity	List Price	Max. Capacity	List Price
100 pF.....	19/6d.	300 pF.....	27/6d.
150 pF.....	20/-	350 pF.....	30/-
200 pF.....	22/6d.	400 pF.....	32/6d.
250 pF.....	25/-	500 pF.....	35/-

SYDNEY S. BIRD & SONS, LTD.
Cambridge Arterial Road, Enfield, Middx.

BROOKES CRYSTALS LTD.

PRESENT A NEW

SELECTOR UNIT

DESIGNED TO HOUSE FOUR OF OUR STANDARD CRYSTAL HOLDERS, THUS GIVING AN INSTANT CHANGE TO ANY OF FOUR FREQUENCIES IN ONE BAND OR A QUICK CHANGE OF BANDS WHEN USED WITH COIL SWITCHING. ANY SEQUENCE OF FREQUENCIES MAY BE ARRANGED.

Frequencies from 50 kc/s. to 10 mc/s. In all the usual cuts and accuracies to within 0.01% (or 0.001% if required).

1.8 and 7 mc/s. £1.12.6, and £2.0.0 from stock.
1.8 and 7 mc/s. £1.17.6, and £2.7.6. to order.
100 kc/s. reference units, £2.10.0.
100/1000 kc/s. Dual freq., £3.0.0.

Electronic apparatus made to order.

All enquiries are welcomed to :—
51/53 Greenwich Church Street,
London, S.E.10. 'Phone Greenwich 1828.

Amplifier Kit sets, 2 watts £5. 15 watts £8 18s. and £10 6s., 26 watts £14. Rack mounting panels and trays 8/6 set. 7 mc crystals, 22/6. 6 in. feeder spreaders 7d., ceramic valve holders 1/3. Vol. control with SW, 5/7; 8 in. PM speakers, 25/-; multi-ratio speaker trans., 7/4; Mains trans, 350 volt, 250 volt, 4 or 6-3, 27/-, 350 v. 300 m/a, 25/-; Wooden Mod. trans. 30 watts, 32/-, 60 watts 42/6, SM Micro dials 8/6, Morse speed key 9/6; Pyrex ant. insulators 9d.; toggle switches 2/6; tinned copper 16 to 22 SWG 2-1/2 lb; BPL Multi test meter £8 16s.; TX ant. wire, 12 SWG, plastic covered 7/6 100 ft.

Raymart and Hamrad stockist. Send S.A.E. for full list, carriage paid over £2.

DRURY & BEARDOW, GJFT, G3CQ,
45 Wangey Road, Chadwell Heath.

SMALL ADVERTISEMENTS

SOUND AMPLIFYING EQUIPMENT available from stock fully guaranteed for one year. Modulators, Portable Dance Band Amplifiers, 12 watt AC/DC £8 10s., Cinema type 50 watt, 45 gns. Full range of Radio Tuners, Speakers, Microphones, also Communication Receivers and mobile equipment, 6v-28v and 100 volts DC UHF receivers 90-156 mcs at 40 gns. complete. Catalogues on request.—United Electronics, 156 North End Road, West Kensington, W.14. FULHAM 5577/8.

T.R.F. BATTERY 3 Pentode Receiver. Stages screened, ganged. Received 280 Americans, 10 meter, 95s.—15 Belgrave Close, Chelmsford, Essex.

SALE.—14 mc Xtal in holder, 25s. Battery CO-PA TX, 56 mc RX, offers. TX valves and components. —G2YZ, 32 Onslow Drive, Sidcup, Kent.

COMMUNICATION Type Receiver, 10 valves, PX4 push-pull, bass and treble boost, 16-100 metres, medium and long, RF and IF stages, B.F.O., magic eye. Gram input. Built for R.A.F. Quality speaker.—Full particulars, Hitchcock, 8 Gladstone Road, Wimbledon, S.W.19.

HOME BUILT 8 tube superhet, plug-in coils, variable selectivity, BFO, etc., £12. 0-1 mc m/a, 2 1/2-in. fixing, 35s. 350 V.80 m/a Vibrapack, 6 V. DC in, £3 10s.—W. J. A. Carlton, G2CPX, Sycamore Farm, Sycamore Road, Farnborough, Hants.

SEVERAL power type 3.5 Mc/s crystals in plug-in dustproof holders, £1 each. All in harmonic relationship with other bands. Also much good surplus gear, cheap. Let me know your wants.—G8UA, 469 Higher Brunshaw, Burnley, Lancs.

FOR SALE.—Hammerlund Super Pro, latest model, 18 tubes, 2 RF, 3 IF, 540 kc/s. to 20 mc/s. Only few hours' use. Best offer over £70 or consider exchange really good receiver covering 30 mc/s.—Richards, 'phone Western 8096.

WANTED.—Complete file clean pre-war *Short Wave* magazines. State price.—F. Ambrose, 1 Albert Road, Southend-on-Sea.

NATIONAL HRO senior rack mounting, excellent condition, 4 coils, 1-4/30 mc/s table power unit HRO. Brand new Taylor capacity bridge 110 A. Brand new valves, 2-813, 2-TZ40, 2-866, 1-803, 9003's 9002's. What offers?—J. Holden, Brackenhurst, Graham Street, Penrith.



THIS *Double Beam* TETRODE

will be popular
with Amateurs

HERE is a valve with ideal characteristics for amateur transmitters. Low anode voltage and high frequency of operation are outstanding features. It is one of a complete range of Mullard transmitter valves available to amateurs.

QV04-20 DOUBLE BEAM TETRODE	
V _f	6.3 or 12.6 V.
I _f	1.6 or 0.8 A.
V _a	400 V.
V _{g2}	145 V.
V _a	2 x 10 W.
W _o (CW)	44 W.
Driving Power	0.23 W.
Max. Freq. for full ratings	125 Mc/s.
Max. Freq. for reduced ratings	200 Mc/s.

Write for details of Mullard Transmitting Valves for Amateurs.

MULLARD



NO BOMBASTIC CLAIMS

JUST A PLAIN STATEMENT OF OUR POLICY

To supply brand new goods only of best quality and up to specification

CATHODE RAY TUBES

Cosstor 23D. Screen 2 $\frac{1}{2}$ "	£3 6 0
G.E.C. 4103. Screen 1 $\frac{1}{2}$ "	2 15 0
Mullard ECR30. Screen 3"	3 3 0
Mullard ECR35. Screen 3 $\frac{1}{2}$ "	6 6 0
Mullard ECR60. Screen 6"	7 7 0

TRANSFORMERS

A large range of all types of Mains and Filament Transformers always in stock, including special types, such as:

0-1,000-1,500-2,000 v. at 5 mA, 4 v. 1.5 A, 4 v. 2A, 2 v. 1.5 A	63/-
450-0-450 v. 60 mA, 800 v. at 5 mA, 4 v. 1.1 A, 4 v. 4 A, 4 v. 2.5 A, 2 v. 1 A	59/6
350-0-350 v. 150 mA, 6.3 v. 2.5 A, 6.3 v. 2.5 A, 5 v. 4 A	59/6

HIGH VOLTAGE CONDENSERS

These are brand new T.C.C. and not ex-Government, and are a few of our many types.

0.1 mfd. 3,000 volt	19/3
0.25 mfd. 800 volt	5/6
0.5 mfd. 1,000 volt	8/-
1 mfd. 1,000 volt	8/-
2 mfd. 1,200 volt	15/6

STEEL CABINETS AND RACKS

Cabinets, hinged lid, louvred sides complete with handles, chassis and panels (Black Ripple or Grey).
 19" x 10", 67/6. 12" x 7", 45/-.
 Standard Racks, complete with chassis panels, etc.
 31" high, 5 gns. 63" high, 7 gns.

MIDGET I.F. TRANSFORMERS

460 Kcs. and 1.6 Mc/s 10/6 each

PRECISION RESISTORS

± 1% Carbon RESISTORS 2/- each
 ± 5% Vitreous, 10 watt, 3/6-4/9. 20 watt 6/6 each

OSRAM Transmitting Valves.

KT8C, 31/6 PT15, 32/6

CRYSTALS

A variety of frequencies are available from stock.
 I.F. Filter Crystal Units. 465 Kcs. or 1,600 Kcs. 32/6
 465 Kc. Band Pass Units. 300 cycles for CW and 2,500 cycles for telephony... 45/-
 100 Kcs. Crystal, for use in amateur frequency sub-standards 45/-
 Amateur Band Crystals. 1.7 Mc., 3.5 Mc. or 7 Mc. bands. X cut 32/6
 AT & BT cut 40/-

SHORT WAVE KITS

In response to numerous enquiries, we have brought out the following Kits:—
 A high performance 6 valve A.C. Superhet covering 880 Kcs. to 34 Mcs. (10 to 345 metres) in 5 bands, having an EF50 high- μ low noise RF stage.
 An All-dry 1 to 4 valve Short Wave receiver, utilising Plug-in coils from 11 metres to 250 metres.
 Circuits of either of the above... 3/6 each
 Other kits in course of production.

AMERICAN PUBLICATIONS

From time to time numerous American publications by Sufferin, Hicks, Fink, Watson, Welch, Eby, etc., are available. Please ask for special list, or better still—call.

COMPONENTS, ETC.

Polystyrene SW coils, Wearite "P" Coils, Single and Double Ceramic trimmers; VHF Ceramic variables; Split stators; Slow Motion Dials, 2" Circular nickel dials, all markings; Carbon and Wirewound Potentiometers; Speakers from 2 $\frac{1}{2}$ " to 12"; Thermal Delay Switches; Yaxley Switches; H.F. and L.F. Chokes; Ceramic Valve Bases, including EF50, Buton and Acorn; Polystyrene rod, sheet and tube; Test Prods; Plugs and Sockets; Signal Lamps; Jacks, Jackplugs; Single and double Fuse-holders; and Glass Insulators.

NOTE:

Send 3d. stamps for our 20 page Catalogue "S.M."

BERRY'S

(SHORT WAVE) LTD.

25 HIGH HOLBORN, LONDON, W.C.1
 (Opposite Chancery Lane) Telephone: HOLborn 6231