

1/3

of the

SHORT WAVE LISTENER



DEVOTED EXCLUSIVELY TO
SHORT WAVE RECEPTION

OCTOBER 1947
VOLUME I · NUMBER II

Here It Is!



The Radiovision PRESELECTOR

You really must have this highly efficient RF amplifier ahead of your receiver. The results will amaze you.

2 High Gain stages using EF50's with regeneration. Iron cored coils. 5 switched bands 9-90 metres. Direct reading dial. Built-in power pack.
Illustrated Brochure from And the price—Only £13.13.0 (less valves).

RADIOVISION (Leicester) LTD.
58-60 RUTLAND STREET, LEICESTER

Phone : 20167

THE **BUSH** MODEL AC71 ALL-WAVE **5 VALVE A.C. SUPERHET**

AGAIN WE OFFER THE MONTH'S BEST VALUE FOR MONEY!

We have been able to secure a very limited quantity of this first-class receiver, specification as below. Order now, or you will be disappointed

- ★ 3 Wavebands—16-5-51 metres, 195-560 metres and 850-2,000 metres.
- ★ Complete and ready for use on 110-240v. A.C. mains.
- ★ Valve line up : Mullard ECH33, EF39, EBC33, EL33, and AZ31.
- ★ Internal Aerial provided for use on local stations.
- ★ Provision for gramophone pick-up and extension speaker (without having internal speaker working).
- ★ **BUSH "TELEFLIC"** Logging Device for short wave stations. Makes retuning short wave stations an easy matter once they have been received.
- ★ Solid cabinet of best Bush quality. A fine piece of furniture as well as the best in receivers.
- ★ Full working Instructions provided.
- ★ Brand new and unused in maker's sealed cartons.

OFFERED AT THE SPECIAL LOW PRICE OF £17.17.0

(carriage and packing, 10/-)

M.O.S.

MAIL ORDER SUPPLY CO.
24 NEW ROAD, LONDON, E.1
STEPNEY GREEN 2760, 3906

THE SHORT WAVE LISTENER

A MONTHLY MAGAZINE FOR THE LISTENING AMATEUR

VOLUME I

OCTOBER 1947

NUMBER II

Conducted by the Staff of
The Short Wave Magazine.

EDITORIAL

Published on the third Thursday
in each month by The Short
Wave Magazine, Ltd., 49 Vic-
toria Street, London, S.W.1
(ABBey 2384).

Single copy, 1s. 3d. Annual
Subscription (12 issues) 16s.
post free.

All editorial and advertising
matter should be addressed to
The Short Wave Listener, 49
Victoria Street, London, S.W.1.

Payment at good rates is offered
for articles of short wave listener
interest.

Radiolympia

This year's Radio Show at Olympia, London—
the first since the war—will be held during the
period October 1-11.

It will be well worth a visit by all who are
interested in any branch of communications,
radar or television. This time Radiolympia is
on a more ambitious and comprehensive scale than
the exhibitions held in the immediate pre-war
period. The 1947 Show will cover, as it should,
the whole field of radio and many developments of
the war-time years will be disclosed for the first
time.

We who are concerned with a particular aspect
of wireless should always remember that the
British can lay claim to great achievements in the
world of radio: The development of the ther-
mionic valve itself, from which all else springs; the
short-wave beam system, which revolutionised
long-distance communication; television tech-
nique—and we are still the only country in the
world providing a regular television programme
service; the invention of radar; the magnetron,
to radar the counterpart of the thermionic valve,
making possible most of the more important radar
applications; and the pulse navigational aid
systems.

All these were originated and developed in this
country by British scientists and technicians.
Though the credit for much of this work has been
attributed, mistakenly, to America, the indisputable
fact remains that the British not only produced the
ideas but led the way in their application.

Though it cannot be said that radio alone won
the war, what is now clear beyond all doubt is that
without this vast radio effort and its application to
all our warlike operations, we certainly would not
have come within even measurable distance of
winning.

CONTENTS

OCTOBER 1947

Editorial	321
Amateur Transmis- sion For The Beginner, Part 1	322
European Journey	326
Have You Heard?	332
Calls Heard	338
"Pse QSL"	342
DX Broadcast	344
Broadcast Station List, Revision 19- 31 metres	352

AMATEUR TRANSMISSION— FOR THE BEGINNER

A SERIES FOR THE GUIDANCE OF SWL's

PART I

by

THE OLD TIMER

(These articles are intended to help the experienced SWL whose thoughts are now turning to the possibility of obtaining a transmitting licence. To give text-book information is not the object here; rather, the aim is to make a practical approach to the subject on the assumption that the reader can follow a circuit diagram and has already built himself simple apparatus.—Ed.)

THE Editor recently passed me a letter reading as follows: "As an SWL with an eye to a G call in a year or two, but with not much time to learn the theory of low-power transmission, I would be grateful for an article presenting concisely the general range of knowledge which it is necessary to cover, not merely to pass the GPO test, but also to ensure that your SWL becomes a competent transmitter who can get out, or, if he cannot, will know why not; and who is not liable to be mistaken for an I or an F if he comes on 'phone. In other words, what knowledge is it necessary to have to enable one to become a credit to Amateur Radio—which too many G's, as well as other Europeans, are not?"

This letter, you will understand, was passed to me for action—not merely information! And, as such, it becomes what our American friends are so fond of calling "a tough assignment," for space is limited. I hope, however, to be able to cover the subject in an essentially practical manner in a series of four or five articles, starting now.

It will have to be assumed that you, the reader, are a competent kind of short wave listener, well versed in the goings-on of the amateur transmitters, and well enough up in theory to know all about how a receiver works. If you know this, the understanding of a transmitter is surprisingly simple.

As with any other branch of radio, a sound understanding of the functioning of a thermionic valve is more than half the battle; and if you know your receiving technique it is safe to say that nothing fundamentally new will come your way when "learning" a transmitter.

Take a straightforward superhet re-

ceiver of the type almost universally used for short-wave reception to-day; in it you will find diodes (one for mains rectification, perhaps one for detection, perhaps another as a noise limiter); triodes (as oscillator and BFO); pentodes (for RF amplification); and probably a tetrode (as output stage). If you can deliver a convincing little talk to half-a-dozen friends on how each of these types works, you can practically design a transmitter on your own!

The RF portion of the average transmitter consists of an oscillator, one or more frequency-doublers and a power amplifier. The oscillator may well use the same type of circuit employed for the BFO in your receiver; the power amplifier is merely an RF amplifier stage; and frequency-doublers, though perhaps strange to you at the moment, are, curiously enough, the simplest and most trouble-free stages of all. More of them later.

The Oscillator

So let us boldly take the plunge and talk about oscillators. An oscillator can be a complete transmitter (remember the days when broadcast reception was ruined by someone with an oscillating detector swooping round the band? That was just a nice little transmitter—unlicensed!) In these enlightened days one must put out a stable type of transmission—one that stays very firmly on the frequency for which it is adjusted; and a stable transmission is impossible without a stable oscillator.

The most stable type of all is a crystal oscillator, but many other types of oscillatory circuit are used. The Hartley, Colpitts, "Tuned-plate Tuned-grid" and the electron-coupled varieties are exten-

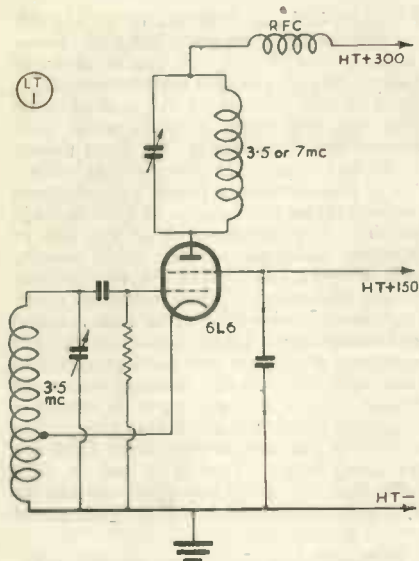

Fig. 1. The electron-coupled oscillator, which can be made very stable.

Note: In Figs. 1-4, the HT end of the plate coil should be by-passed to earth through a fixed condenser.

sively employed for different purposes, and the well-known VFO (variable-frequency oscillator) used by many amateurs to-day is very often of the electron-coupled type. Fig. 1 shows such a circuit. The actual oscillatory circuit consists of the grid/cathode and screen/cathode sections of the valve, and power is taken from the anode circuit, which may be tuned either to the same frequency as the oscillatory circuit or to a harmonic of it. When the latter process is used, we have an oscillator and frequency-doubler combined in the same stage.

If the tuned-circuit is of the high-Q variety (in other words, if its factor of "goodness" is high), such a stage can be very stable indeed.

When a crystal oscillator is used, the stage is rigidly tied to the fundamental frequency of the crystal (or a harmonic of it), and to understand its functioning you must regard a quartz crystal, with its piezo-electric properties, as a resonant circuit. Imagine a "tuned-plate tuned-grid" oscillator; take away the tuned grid circuit and substitute a quartz crystal, and there is your crystal oscillator or CO (Fig. 2). Imagine, for convenience, that the crystal has a fundamental frequency of, say, 3,505 kc. Then if you tune the

anode circuit to 3,505 kc the whole stage will go off at that frequency; and if the valve is big enough, and the HT is high enough, you can probably put some ten watts into that valve, and draw 5 or 6 watts of RF energy from its anode circuit. Whether you regard it as a transmitter capable of delivering 5 watts of power into an aerial, or merely as a stage capable of driving another one depends upon whether you are going to think in terms of high, normal or low power, and nothing else.

By using what is known as a "Tri-Tet" circuit you can combine the functions of CO and frequency-multiplier in the one stage; it becomes more like the electron-coupled oscillator. But the crystal forms the grid circuit; the cathode circuit is tuned to a higher frequency, and the anode circuit can then be tuned to a harmonic of the crystal. In other words, with your 3,505 kc crystal you can now extract, from the anode circuit, some energy at 7,010 kc (or even, in smaller amounts, at 14,020 kc). Fig. 3 shows a typical "Tri-Tet" arrangement; the rather misleading name suggests that the valve is combining the functions of a triode and a tetrode, which is not really true.

The Power Amplifier

Now imagine that you have your Tri-Tet CO working—crystal on 3,505 kc, output circuit tuned to 7,010 kc. You want to transmit on the latter frequency. We have already implied that you can just couple that anode circuit to some suitable

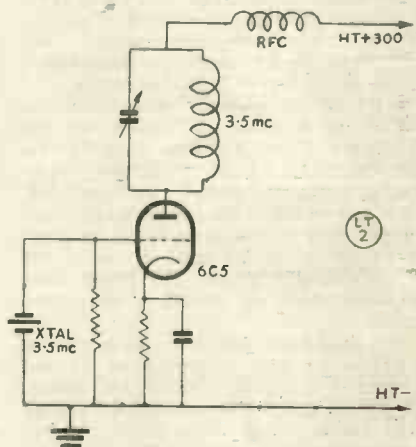

Fig. 2. The straight crystal oscillator.

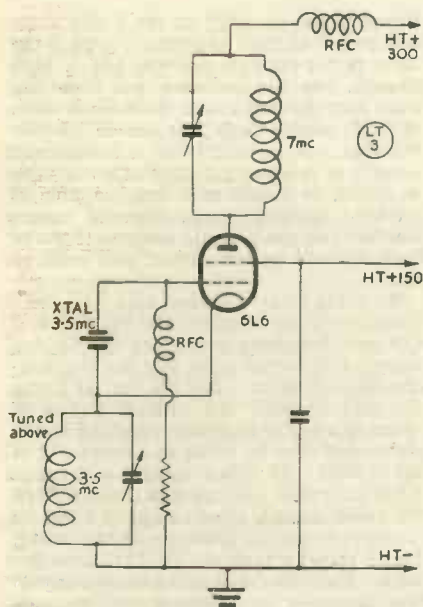

Fig. 3. The triode, or frequency doubling crystal oscillator. Power at twice (and sometimes four times) the crystal frequency can be taken off the plate circuit, or "tank." The cathode coil is tuned above the crystal in frequency.

aerial system, and off you go. But the power will be very low; how do we go about increasing it? Not, as the ingenious ones might suppose, by using a bigger crystal, a bigger valve, thicker wire in the tuned circuits and lots more HT! That *might* produce the desired effect, but it is not the most convenient method. We simply use an RF amplifier—hereinafter known as the power amplifier or PA.

A PA simply consists of a valve, the grid circuit of which is "driven" by the RF output of our previous stage (in this case the CO); with a suitable valve, whether triode or tetrode, sufficient DC power can be fed to the anode (and screen, if applicable) to enable us to derive from the anode or output tank circuit of the PA considerably greater RF power than that with which we started in the crystal oscillator.

As a spectacular example, we might use an 813, which with 2,300 volts of HT and an input of about 400 watts of DC power, will give us about 270 watts of RF energy in its anode circuit for a driving power from the previous stage of 2 watts! So you may be thinking, at this juncture, that

a 6V6 or 6L6 CO, followed by an 813 PA, constitutes a complete 250-watt transmitter; and if you are, you're perfectly right. But let us come back to something more closely resembling the sort of outfit that you will build yourself when your licence bears the words "an input power, to the last stage of 25 (twenty-five) watts."

For this amount of power you will need nothing larger than, say, a 6L6, or perhaps an 807. For the moment we will talk of tetrodes, although a triode could equally well be used. A 25-watt PA on the lines we are discussing is really simplicity itself. It consists merely of a valve with a tuned grid circuit and a tuned anode circuit, well separated physically and perhaps screened from each other. For what is known as Class-C operation, the valve is biased a long way below cut-off point, and driven as hard as possible by the output from the preceding stage. That is to say, if -30 volts bias will hold the plate current to zero mA, or cut-off, this bias is increased two or three times.

Remembering the accent on the *practical* nature of this series, let us describe a typical PA stage, using an 807. The circuit will look like Fig. 4. The stage will be on a metal chassis, probably with the 807 mounted horizontally through a vertical screen. At the left-hand end is the grid circuit, with a link-coupling back to the CO anode coil; at the right-hand end is the anode circuit, coupled by any appropriate method to the aerial system.

On the anode of our 807 will be about 400 volts; on the screen about 250; and the grid will have a negative bias of about 90 volts. Now this is how the PA will behave, if it is correctly set up. When the heater and HT are switched on, it will draw no plate current at all. When the CO is running, the PA's grid circuit is tuned to the correct frequency; this operation will show a grid current of about 3 or 4 mA in the grid lead and simultaneously the anode current meter will show a reading—probably a pretty high one.

The anode or output circuit is now tuned to resonance, indicated by a steep dip in the meter reading. When it is in resonance the current may be as low as 5 mA; when it is out of resonance it may be as high as 100 mA—which is not good for the valve. With the anode circuit correctly tuned, the aerial load may be adjusted, and this will cause the current to rise again, the impedance of the tuned circuit being considerably reduced by the effect of the load.

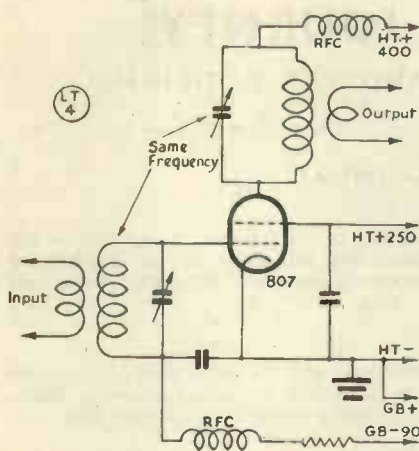

Fig. 4. A simple un-neutralised PA or RF power amplifier. Under some conditions, it might be necessary to neutralise the anode-grid capacity of the valve in order to prevent self-oscillation—but not on 1.7, 3.5 or 7 mc with an 807.

So here, with a crystal controlling an oscillator, and the oscillator driving an amplifier, and the amplifier transferring power to an aerial system, we have a transmitter. Not merely a simple one, but one that will satisfy all the requirements for low-power amateur communication. All we want is a method of *keying* it, for Morse operation, or of *modulating* it, for telephony. But these are both stories which must be left for a later instalment of the series.

Frequency Multipliers

You will remember that we started with a 3,505 kc crystal, and that by using a Tri-Tet oscillator we managed to operate on 7,010 kc with only the two stages in the transmitter. Now suppose it is necessary to work on the other bands—14 or even 28 mc? This is where we have to revert to the question of frequency-doublers. I have already said that the FD is perhaps the simplest kind of stage with which we shall have to deal. I have, in fact, already described one! Re-read the description of our 807 PA; give it a 7 mc grid circuit and a 14 mc anode circuit, and there you have a frequency-doubler. By over-biasing such a valve, and driving it hard, you can produce a very considerable second-harmonic (or even fourth-harmonic) output in the anode circuit and simply “winkle out” this energy by using a tuned

circuit at the right frequency. Of course you will not derive as much 14 mc second-harmonic power from your 807 anode circuit as you were obtaining at 7 mc, but you will get more than enough to drive another similar stage set up as a PA. One FD is very like another, the only difference being the frequencies to which the input and output circuits are tuned, so that you may now visualise a transmitter with a whole chain of FD's all using small valves operating at low power inputs until the desired frequency is reached.

A typical amateur-station layout consists of a 7 mc CO or VFO, doubler to 14 mc, second doubler to 28 mc, PA on 28 mc. The CO is perhaps a 6V6, the first doubler a 6L6, the second doubler an 807 and the PA a larger valve or perhaps two 807's in push-pull, which will handle 100 watts on 28 mc.

Fig. 5 shows various alternative combinations of stages for covering the various frequency-bands. The whole affair is so flexible that it is up to you to choose your own arrangement from personal preference—they all work!

Next month I propose to take time off from valves and to discuss aerial systems—how they work and why; they are a very fascinating and very important aspect of Amateur Radio, and, surprisingly, one about which the average amateur never seems to know enough.

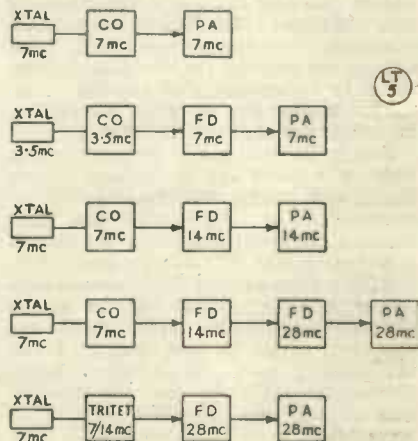

Fig. 5. Various CO-FD-PA combinations. The object should always be to operate the final stage, the PA, as a straight amplifier rather than as a frequency doubler.

EUROPEAN JOURNEY

MY TRIP TO ENGLAND AND THE CONTINENT

by

DOROTHY HALL (W2IXY)

(All readers will be interested in W2IXY's intimate account of her recent visit to this country and Europe. Those privileged to meet her will know her as a charming person, a well-informed American, and an amateur transmitter of great ability and experience.—Ed.)

ALMOST every Amateur Radio operator with leanings towards DX has a secret desire to meet the operators of these distant stations. During all the years of my own activity I wanted to take a trip abroad—to G-Land in particular—and meet my contacts in person.

On August 1, 1947, this ambition was realised when I arrived at Heathrow Airport. Not too many hours before, I had left from La Guardia Field. The flight was the first long-distance one I had ever attempted. Leaving New York at 5 p.m. we arrived at Gander, Newfoundland, at 10.45 p.m.—Gander Time. Immediately upon my arrival there I asked a man in charge of the Post and Telegraph Bureau if I could put through a 'phone call to the U.S. coastguard station which also had an amateur station. He told me that it would take at least two hours! The idea was abandoned—because we passengers had been warned the take-off for the Atlantic hop would be 45 minutes after arriving. It so happened that due to heater trouble on the 'plane our stay was 2½ hours.

Finally we got going—it was to be a flight of 7 hours and 29 minutes. I was scared stiff during the crossing but my reaction now is: If you make that flight no other can ever bother you. We arrived in Shannon, Eire, at 1.45 p.m. Irish Time.

After a delay of over two hours we took off for London. Barely had we gained altitude than someone tapped me on the shoulder. Upon looking around I saw two smiling men. In Amateur Radio formal introductions are unnecessary. One of the men identified himself as Scott Magness, W2AOJ, ex-W4JSS, connected with the American Embassy, and explained that he had gotten on the 'plane at Shannon. The other chap, in airline

uniform, was the radio operator. Across the Irish Sea we talked Amateur Radio and had a perfectly wonderful time.

Arrival

Heathrow was the culmination of my ambition. I was in England. My feelings were a mixture of sheer joy and tears. Friends Mr. and Mrs. Arthur Holden whom I had never met before in person but had known through the medium of radio were waiting for me. Customs cleared I got on my way. I had arrived to visit amateurs in England. It was Bank Holiday and my host and hostess—ardent short-wave listeners—had invited some friends over for an informal gathering on the following day. The call letters will strike a responsive note to many a DX'er. The guests at this first party were ON4AD, Belgium—who had lived at my shack when he was in the States; G6YF, ex-ZL2JQ, of New Zealand—who when he visited the States in 1938 had talked home to Napier, New Zealand from my station; G8IG, G2IG and G6VX, ex-ZL2CJ; Charles Cheffins, secretary of the B.S.W.L., Ron Baker, and their respective XYLS. It was really "old home week." G8IG invited me over to his station—off we went and in a very short time we had a QSO with my home, manned by some W friends of mine. The contact was perfect—you will never know the happiness you can get from talking back home until you actually do it!

On August 3 Arthur Woolven, active SWL and friend of G6AG, arrived and we went to G6AG's station. Several W contacts were made and I fell in love with Mac's receiver; I am yet to see or hear a better one. Designed and built by the operator it has a magnificent dial and is accurately calibrated—a feature rarely noted in amateur circles either here or



W2IXY operating G8IG, Bromley, Kent. *She had several contacts, rom here with her own home station.*

in the States. G6AG has a ship-shape station, complete in every detail.

My host and hostess had planned a quiet day for me for August 4 but G6VX popped in and scheduled me for a visit to his station. We arrived there and "real DX" was waiting for us in the person of ZS6GX, ex-ZF2TIR, ZS1BZ, radio operator on a South African 'plane service. G6VX had made a recording of my initial QSO with my home station via G8IG and this he played for us. Then we went on five meters where for the first time I heard the British five meter band. A contact was established with G6FO who I had worked many times on 14 mc from the U.S.

The next morning I left for Cambridge—with host Arthur Holden as my guide. Upon arrival in this very beautiful city G3BGQ met us at the train. We drove to his home where Dorothy Jeapes (XYL of G2XV) and G5BQ arrived in a short time and we were off to the American Military Cemetery. We detoured over to the house of G2PU. I made out a QSL card for him and G5BQ went up a ladder and threw the card in G2PU's shack window!

Cambridge Hamfest

Back in Cambridge we toured the University and then made preparations for the evening festivities. The Cambridge

amateurs had arranged a banquet at the Milton Arms, the first English "pub" I had ever been in. G2XV, who was in the chair, was delayed and telegraphed asking G5JO to take over. After a delightful dinner, toasts were offered, speeches (short but effective) were made. Then the party broke up and G5JO told me "the night is yours." I quickly decided I wanted to see the shacks of the operators with whom I had had many QSOs. We did the rounds—G2XV, G2PU, G5JO. It was the wee' sma' hours of the morning before we "pulled the big switch" and all of us "modulated the mattress." August 5 will always be a red letter day in my life and Cambridge will always be a port of call for W2IXY.

To The North

The morning came and I left under my own steam for Sheffield—via Kettering. This was to be the first of many trips made by myself. G2MF had been informed that I was *en route*. The L.N.E.R. performed beautifully and arrived on time, 3.13 p.m. G2MF, G2HQ, G3FA and ZC6MF of Palestine (whose identity I refuse to divulge) were awaiting me. Off we went to G2HQ's shack for tea and a look-see at his very extensive equipment and marvellous antenna array. Then G2MF, G3FA and ZC6MF and myself

set off to see a castle as this was one of the things I wanted to do. A round of shacks completed a glorious day.

On August 7 I was back home (Orpington) and I left next day for Bournemouth and G3BM. We did that town and Poole. G3DO was holidaying there with his family and I left with them the next day for his home town. We drove *via* New Forest, Winchester, Oxford, Banbury and Warwick, stopping at Kenilworth for dinner. G8WL stepped in to say "Hello" to us at the King's Arms, where we were dining. We started off on the last lap of our journey, but I detoured to see some short-wave listener friends of mine at Shirley. I was then delivered to the shack of G3DO. What a beautiful location! Ham paradise! And a room 22ft x 46ft—wall completely hidden by QSL cards and certificates of merit in radio activities. I had my first experience at local contacts on your 80-meter band.

Birmingham Meeting

Arrangements had been made for members of M.A.R.S. to convene at the Imperial Hotel, Birmingham, the following morning. We arrived at 11 a.m. and G5PP started swapping pictures at the door. There was also a representative group from C.A.R.S., Coventry, present. After introductions and informal chatter I was presented with honorary life membership in the M.A.R.S. and C.A.R.S. The former club gave me a beautiful plaque with the Mars insignia. Personally I do believe I am the only ham who belongs to both rival groups! When we arrived back at G3DO's, G5BJ popped in and G6XR came over to the house and a wonderful day was brought to a close when I took the 4.50 p.m. train back to London.

Doings in Denmark

August 11 found me at Northolt Airport, leaving for Denmark. A perfect flight and my thoughts were varied—in England I felt at home—now I was going to the Continent. What? I need not have been concerned because as we came down the steps I saw a hand waving in the crowd and in the hand was a QSL card—OZ2EA. What a lift that gave me! Customs difficulties overcome and cleared I walked out to meet the owner of the hand that held the QSL, his XYL, OZ3MB and OZ3U, the first OZ I had ever contacted many years ago. We drove to OZ2EA's shack. I shall clarify a situation. OZ2EA and OZ3EA are one and the same person—when he operates from home it

is 2EA, while from his radio and electrical supply shop he is 3EA.

The Copenhagen division of the E.D.R. held a meeting at The Tempo and over two hundred OZ's were present, representing all OZ districts. I met OZ9YL—a licensed operator who told me that she was in the throes of building a CW rig! After the meeting was adjourned and we had had some rag-chewing (washed down by R9 Danish beer) a group took off for The Tivoli, piloted by OZ7KG—nineteen made up the party which became gayer as the night advanced and when the Tivoli management gave us the QRT signal by flashing the lights on and off, we went over to 3EA's shack and on the air! Several G contacts were made—with 3EA's low-powered but efficient gear—and a gay time was had by all.

The next day was devoted to shopping and a tour of Copenhagen fire service, in which I was vitally interested due to my position as radio operator with the New York Fire Department. That night we embarked again to the Tivoli where OZ7KG, OZ3D and XYL were awaiting us. We did the Tivoli and in State-side parlance "and how." August 13 saw me to lunch at the Scandia where OZ7NJ plays the piano. He joined us over coffee and the inevitable glass of Danish Schnapps, known locally as V3! That night, as guest of OZ3U we had a real Danish dinner and party. OZ7R, OZ3MB, OZ7KG, OZ5TZ, OZ4L, OZ2EA were all there. OZ3U, whose present rig is a confiscated German 5-watter, went on eighty meters and we had a QSO with OZ6AA who came over the next morning to deliver his QSL.

Holland and Belgium

On August 14 I left for Holland, arriving at Skiphof airdrome. PAØFB, PAØBB and friends of theirs were awaiting me. We drove to The Hague and I dropped anchor at PAØFB's shack. We went on the air—had a QSO with OZ3EA who had been monitoring the band to hear of my safe arrival.

The days I spent in Holland were devoted mainly to sight-seeing with only a short stop at the shack of PAØBB where we had several contacts with G's. His station is perfectly arranged, the receiver being the German version of an HRO. Then a personally conducted tour of PCJ by world-famous Ed Startz, with a trip out to the rotary beams utilized for world coverage; a look-see at the site of the transmitting shack that was blown up



The dinner given in W2LXY's honour at the "Milton Arms," Cambridge. G5JO is standing on her left and others in the picture are G3BDQ, G5BQ, G8PB, G2DT, G2PU, G5IG, GAAZ and G5DQ.

when the German hordes overran the country, made very deep impressions. As an American and souvenir-conscious, I took a piece of the concrete with me!

On August 17, we were waiting for the bus to take us to the airport where I was to leave for Belgium. Two men walked up to me and introduced themselves as PAØLU and G2SA—the latter was visiting in Holland. We all got in the car and had a four-way QSO to the airport. It was the highlight of my Holland trip.

Arriving in Belgium, ON4AD (who I knew from New York and London) his XYL and two juniors were awaiting me. We trammed and trained it to Ghent. August 18 and 19 were devoted to shopping, but on the 20th a group of amateurs came over to ON4AD's, bringing flowers and a message of greetings from the U.B.A. (the Belgian National Amateur Radio organisation). ON4DX is very Americanised from a trip to the States; ON4L owns a radio repair shop near the Cathedral in Ghent, while ON4GH has his private 'plane and extended to me an invitation to fly as his guest to Southern France and then to England. ON4RD, an official of the U.B.A., drove us next day to Bruges and the coast. He is a marvellous artist and drew for me a pen-and-ink picture of the world-famous Bruges Town Hall.

On August 22, I returned to England

via the Ostend-Dover boat and the train through to London, arriving in Orpington unannounced. Detouring from Amateur Radio for a few words, the British customs at Dover informed me that my *visa* to England had been cancelled when I went to Denmark and they debated whether to send me back to Belgium! I had a mental picture of spending the rest of my life on the boat, as my Belgian *visa* was cancelled when I left that country. I talked fast and gained entry into England as a transient *en route* to U.S.A. I cleared away the immigration technicality by a visit to the Aliens' Section in London. W2IXY nearly became "mobile marine!"

Back in England

August 24 found me *en route* to Reigate to visit a very dear radio friend of mine, G5LK. They met us at the train and G2YL, Nell Corry, was the one who spotted the call letters on my jacket. We went on the air and worked several G's on 80 meters. G8HH, who was my last British contact on July 31 before I left for England, arrived in person, and we exchanged QSL cards. Then the crowd began to arrive. The hams greeted me in a body, followed by six car-loads who had been visiting at G2YL. What a wonderful time we did have! Ham radio, the

American dollar, high power *versus* low power were among the subjects discussed. The East Surrey Radio Club presented me with a sterling silver napkin ring duly inscribed. My meeting G5LK was something we had often discussed over the air and on this day we had made it come true.

On August 25 I made London and a luncheon with G5ZJ with whom I had had many perfect contacts. This was followed by a trip to Marlow and a personal QSO with G6FO, Editor of the *Short Wave Magazine* and *Short Wave Listener*, and his wife. A delightful place, far removed from the noise of the City, making this quiet spot ideal for our intimate conversation over dinner. "The Compleat Angler" nestling on the side of the Thames, swans quietly going their way, are something I shall always associate with the expression an "English countryside."

Another day in London and then home to Orpington and a visit from G3CKL, an old-time ship's radio operator. I was driven over to G8IG's shack as I wanted to talk to the States. I was suffering from a slight attack of homesickness—not having heard about my two dogs. We were not very long with G8IG before I had pulled myself out of the "blueness." Amateur Radio to the rescue once again!

August 27 at 5 p.m. was the time to be at Alexandra Palace for the 9 p.m. television performance. After formal introductions G2DVH, who is on the technical staff of the B.B.C., stepped up and identified himself; he had learned through the "grape vine" of Amateur Radio that I would be at the studio. He took us in hand—piloted us hither and yon—and made my visit to Alexandra Palace extremely interesting. Laughingly I told him that I was to complete one of my life's pet ambitions that night. Listen to Big Ben strike midnight from Westminster Bridge and that several hams were also to be there. G2DVH was game and after I had been parboiled under the lights used for televising we all took off for London. Under the cynical eye of a bobby we gathered together to hear midnight. Counting heads there were ten of us. G2DHV, G8IG and XYL, G6AG and XYL, G8KZ, Arthur Holden, Arthur Woolven and XYL. This was to me one of the most impressive moments in my radio career. For years I had listened to the B.B.C. broadcast the striking of Big Ben — during the war the sound gave confidence to everyone listening in. I am a confirmed SWL!

August 28 was devoted to a tour of the National Fire Service London Region Headquarters, where their two-way radio was of tremendous interest to me. H. C. Broxup, radio officer, ex-amateur again bitten by the bug, showed the radio gear available which is far superior to any I have ever seen for commercial purposes. That evening we took in a thoroughly British West End show. Rarely have I enjoyed anything so much.

Impressions

From the above the reader will quite easily see that I have had the pleasure of meeting hundreds of amateurs and visiting scores of ham shacks. Naturally I have arrived at some conclusions about overseas activities. There are many things that strike me, as a W, quite forcibly. One is the utter disregard of the potential danger of electrical apparatus. I have seen amateurs tune up a rig with both hands in the transmitter—make drastic changes with the mains on; pull a switch while someone else was tuning the final tank! My heart was more often in my mouth than in my chest!

Another item of interest was the lack of simple relay arrangements. Antenna change-over relays seem a "must" in the States, mainly because they are considered a necessary precaution to save "wear and tear" on receiving equipment. Many amateurs here throw their transmitters on; monitor the signal *via* the receiver, check the frequency the same way, block reception with their own power, rarely realising the damage caused by feeding RF into the receiver. In the States replacements are a matter of a trip to "Radio Row," but here it may mean the receiver will be inoperative for a long time.

Personally, I think the amateurs on this side of the Atlantic do a splendid job with the available equipment. They get every ounce of energy from their gear. I do think more thought to the preventing of over-modulation might make things happier, as I found only a limited number of amateurs had calibrated modulation meters available.

The backbone of Amateur Radio is typified not by the "Glamour Boys" who work the world, but by the chaps with low power plodding ahead. This is true in all the countries I visited.

Once I thought all radio widows were in the States. I find they are all over the world. I hesitate to sympathize with them—being a transmitter myself!

As a SWL turned amateur, I was

vitaly interested in tuning methods. Almost everywhere the receivers were tuned on full blast and the volume control ignored. Any successful SWL will agree that weak signals are killed by this sort of thing. You must keep noise level at a minimum. Every operator I visited with a real DX QSL collection had started his radio life as a SWL. Frankly, I feel that the best amateurs are graduates of the hard and trying school of SWL.

We all have the same problems over here and over there. Do not feel that your radio problems and arguments are limited locally—it is universal. Subjects never discussed in QSO were aired at any amateur gathering I attended, but hams have a high degree of honour and never let each other down. Where there is unity there is strength—pull together must be our motto all over the world.

Amateur Radio made my trip to England and the Continent something always to remember and I shall cherish

every thought. My trip was not a "tour." Indeed, I did see castles, cathedrals and paintings, but I was happiest in the company of a group of amateurs and short-wave enthusiasts. We all spoke the same language.

In what other field of endeavour is neither class, colour nor creed considered? Radio-minded people are the true exponents of democracy in its highest term. When I arrived anywhere it was "Hello Dot"—hands were clasped and the seeds of friendship, planted in a QSO, bloomed under the warm sunshine of international friendship.

Within a few days of writing this I shall be on my way to New York and in a few more hours I shall be home. Let me take this opportunity of thanking each and every one of you for your hospitality, friendship and regard. I shall never forget you. Look for my CQ call on 14,244 kc. I will always be there to work the G's.



An impression of W2IXY operating her own station at Springfield, Long Island, New York.

Have you heard?

THE month of October is nearly upon us, and with it the autumn DX season, which can be counted on to provide good listening over a long period. Not that the months of August and September have been dull—far from it! As a matter of fact September has been outstanding for real DX reception. But we have not yet had those days when the 14 and 28 mc bands have simply been packed full of DX signals, with no padding in the form of I's, UA's and others within the 1,000-mile circle.

The SLP's at the end of August were very well "attended," as usual, and some extremely interesting lists appear in the Calls Heard pages. The 28 mc period produced everything except W's; AR8AB, OQ5BA, W6VKV/16, ZD2KC and the others gave several of the participants some nice new countries. The 14 mc period, by contrast, was not so exciting, although no one could call it a failure.

Zoned Listening

Last month we announced the start of "Zoned Listening" on the 14 mc band, and, accordingly, all the 14 mc Calls Heard this time, apart from the SLP lists, conform to the suggestions we made. During the early mornings Zones 30, 31 and 32

AMATEUR BAND COMMENTARY

counted on, and VR2, VR5, KB6 and ZM6 have also been heard on rarer occasions.

O. A. Good (Oswestry) has performed what your Scribe considers the outstanding feat of logging 37 Zones and 99 Countries during the month of August (32Z and 64C on 'phone). He accordingly puts up the suggestion that a *monthly* HAZ Contest would be something to consider. We have been thinking of it, too, but we don't want the *whole* of the space taken up by tabulated results! What we have decided upon is to announce it every so often, and to see what the boys can do at short notice.

According to O.A.G. the high spot of August was the profusion of signals from VU—he heard nine different VU's on 'phone. One of his most interesting loggings, though, was J9CRP on Kwajalein Atoll (Marshall Is.), on August 5 at 1705-1730 and 1800-1815 GMT—S9 'phone at times. Peak conditions seemed

BY THE DX SCRIBE

have been providing plenty of sport, and in the evenings Zone 22 (India and Ceylon) seems to have attracted a good deal of attention. There is a surprising disparity between the various lists sent in, probably due to the amount of listening that various people have had time to do; after all, you can miss an awful lot of good stuff by just happening to be off the air on one single day when conditions are good.

We hope this Zoning experiment is going to be successful; letters on the subject comment on it in the proportion of roughly five in favour to one against.

Throughout the month 14 mc has been almost uniformly good in the mornings and evenings. Even the afternoons, from about 1400 GMT onwards, have provided their share of Far Eastern DX. In the mornings a fair number of W6, W7, KL7, KH6, VK and ZL stations could always be

to reach Oswestry on August 23. One query from O.A.G.—is CT3A genuine? A station was using that call on 14070 kc on August 22. If he's real, we presume he is in Madeira.

R. A. Hawley (Goostrey) doesn't like the cutting down of 14 mc General lists, but nevertheless sent in a very nice zoned effort. He has also been spending more time on 28. His collection of Maritime Mobiles on the two bands now includes W2OMU/MM (Eastern Mediterranean), W5NDG/MM (Atlantic) and W2VJW/MM in Alexandria. The latter is bound for the States *via* Palestine, Syria, Turkey and Greece, and is the s.s. *Greeley Victory*.

A. H. Onslow (Hove) was pleasantly surprised to find that he has cards from 32 Zones; one of which he is proud is from W6OGM, heard on the 3·5 mc band.



The well-equipped station of VU2CQ, Bombay, India.

One from CPIAX was accompanied by a bank-note!

D. W. Bruce (Eltham) has turned in some exceptionally good Calls Heard lists this month, and has heard a few "rarities" like KB6AB, KM6AA, J8's in Korea, MD7RH (Cyprus) and LU1ZA (South Orkneys). D.W.B. is one of our youngest regular correspondents, being only 16.

MD Prefixes

Speaking of MD7RH reminds us that the MD calls now run as follows: MD1, Cyrenaica; MD2, Tripolitania; MD3, Eritea; MD4, Somalia; MD5, Suez Canal Zone; MD6, Iraq; MD7, Cyprus. That MD9 that various people have heard remains a mystery. As he doesn't give a QTH he's probably not far from England!

N. S. Beckett (Lowestoft) is all in favour of zoned listening, and suggests that the SLP's must be becoming the most popular feature of all. Long may they live, he says. He suggests that MD1A (see p. 301, September *Short Wave Listener*) is probably not a pirate; he rather thinks he is a South African amateur flying between London and Benghazi for Transport Command, and that when he slipped up he was merely using his home call-sign from force of habit. He gave his QTH, at all events, and it is in the list herewith.

A. E. Hardman (Manchester) asks who "YO" is. We have heard the prefix being used by Rumanians, but whether YO5WZ is a phoney we don't yet know. He has a

similar query about YA1AB, regarded with a certain amount of suspicion. A.E.H. comments on the number of mis-read calls that one can detect in most lists of Calls Heard. (We know—we spot them as we do the editing, but we purposely don't correct them, hoping that those who mis-read them will peruse the other lists and discover their own mistakes!) He wonders whether he himself mis-read PK6SA, seeing that N. A. Phelps logged PK6HA. Well, we know PK6HA is all right—his card is on the wall here—but there's no reason why there shouldn't be a PK6SA as well.

J. M. Graham (Glasgow) remarks on the way 28 mc opened up for the U.S.A. on the evening of August 29. (Actually it was wide open also on the 22nd and 24th, but the 29th was certainly outstanding.) But since then it has gone dead again for East/West transmission, although it remains very lively at all times for South Africa, South America, and sometimes Asia and Australia. J.M.G. has a query (nearly everyone has, nowadays!). His is VS9K, heard on 14 mc 'phone—can anyone enlighten him?

L. Shearlaw (Camberley), writing in for the first time, took the receiver along on his holiday. It must have done it good, for on his return home he logged three new zones in the first twenty-five minutes! L.S. has had an interesting card and letter from C7TS, which confirms that SWL's can be of real use in the world—it was the first report C7TS had ever received! (We recently had a rather similar one from C6HH, enclosing a set of unused stamps

ZONES HEARD LISTING

How They Stand

Listener	Post-war Zones Heard	Post-war Countries Heard	All Time Zones	All Time Countries
'Phone and CW				
N. A. Phelps (London, N.10)	40	172	40	179
O. A. Good (Oswestry)	40	163	40	163
L. N. Goldsbrough (Wirral)	40	152	40	160
K. Callow (Mansfield)	40	111	40	111
M. A. Preston (London, S.W.12)	39	176	39	186
C. S. S. Lyon (Liverpool)	39	144	39	144
A. E. Hardman (Manchester)	39	140	40	165
T. Burton (Birmingham)	39	137	40	180
A. Baldwin (London, E.11)	38	150	38	150
G. Curtis (South Harrow)	38	137	38	137
D. W. Bruce (Eltham)	38	132	38	132
R. A. Hawley (Goostrey)	38	129	39	141
A. W. G. Boulton (Faringdon)	38	129	38	129
W. J. C. Pinnell (Sidcup)	38	125	38	125
G. P. Watts (Norwich)	37	133	37	140
A. Frost (Thornton Heath)	37	132	37	132
Dr. T. B. Williamson (St. Albans)	37	116	38	131
G. V. Haylock (London, S.E.13)	37	111	39	113
M. D. Lipscombe (Seaford)	37	104	37	115
H. Owen (Tafo, Gold Coast)	36	119	36	119
F. A. Herridge (London, S.W.12)	36	110	36	110
D. L. Courtier-Dutton (Herne Bay)	35	105	35	105
B. Case (Ipswich)	35	98	35	111
L. Tombs (Swindon)	35	94	35	94
R. Twidale, (Scunthorpe)	34	97	34	97
N. S. Beckett (Lowestoft)	34	91	36	106
Rev. D. D. White (Toller)	32	81	32	85
B. Hayes (Bletchley)	31	66	31	66
'Phone Only				
A. J. Slater (Southwick)	36	135	37	141
D. Heaton (Bradford)	36	130	36	130
A. H. Onslow (Hove)	36	126	36	126
D. W. Bruce (Eltham)	36	124	36	124
R. A. Hawley (Goostrey)	36	121	36	136
C. G. Tilly (Bristol)	36	119	37	138
M. Harrison (Darlington)	35	127	35	127
G. P. Watts (Norwich)	35	119	35	126
L. N. Goldsbrough (Wirral)	35	115	35	129
D. L. McLean (Yeovil)	35	114	35	125
M. C. Pavey (London, S.E.6)	35	108	35	108
T. W. Jones (Birmingham)	35	105	35	105
O. A. Good (Oswestry)	35	103	35	103
M. D. Lipscombe (Seaford)	35	101	35	112
G. Hare (Leadenham)	34	108	34	108
L. Tombs (Swindon)	34	90	34	90
W. B. Harrald (London, S.E.21)	33	81	33	81
L. Shearlaw (Camberley)	32	81	32	81
C. S. S. Lyon (Liverpool)	31	100	31	100
J. Crunden-White (Chorley Wood)	31	98	31	98
R. S. Craig (Llanely)	31	82	34	89
O. R. F. Mason (Southend)	30	59	30	64

and saying that our own QSL was the first foreign one *he* had ever received.) L.S. asks whether one can explain the loud rushing sound which occasionally comes up on the DX bands. Well, assuming that it is *not* due to any kind of local interference, it is almost certainly "solar hiss"—quite a well-known phenomenon which, of course, has a connection with the sun-spot condition. It generally coincides with a spell of unusually poor receiving conditions.

W. J. C. Pinnell (Sidcup) comes along with a very fishy one—AC4BR, heard at 2130 on August 4. No one else seems to have logged him, judging by the absence of enquiries, so we are afraid he is a phoney. (Fancy choosing "AC4" for a prefix, anyway! Guaranteed to make *anyone* suspicious.) But, against this, W.J.C.P. can claim ZP2AB, FM8AD, J9ANL and US64 (the latter working from a DC4 flying over Arabia). J9ANL, by the way, with the other J9's on Okinawa. The Zone list, it is true, gives J9 as Formosa, but this is wrong now. Okinawa, which used to be J5, is now J9—and is, of course, in Zone 25. Last query from W.J.C.P. concerns "HAC" claims—he asks whether Central America and the West Indies count as North or South America. The answer is that the actual continent of Sth. America is the only thing that counts there; everything the other side of the Panama Canal, and all the West Indian islands, count as North America. D. L. McLean (Yeovil) comments on the spectacular bursts from the U.S.A. on 28 mc, and

adds that on August 30 the African stations were coming in as early as 0730 GMT. He has a few words to say about QSL's: He is pleased to find that he gets nearly 50 per cent. back, but is amazed at the number of W5 and W6 "kilowatt" stations who QSL and are obviously very pleased to get reports, while some of the real DX never bothers.

Comparing Ten and Twenty

M. Forrest (Laverstock) sings the praises of 28 mc very ably. He says, "If you turn on the set on 'ten' at any time of day you can usually find about two or three interesting signals, but nothing else, with the result that I have hardly heard anybody QRM'd at all. I would much rather hear a few interesting signals in the clear than the mush and squalor of '20'." He mentions that VU2BJ was heard to say that he was in Pakistan, so he counts as a new country. Other interesting ones logged on 28 mc have been VU7AB, ZE1JB, PK1MK, ZC6RG, ZB1S, CX5AP and a number of MM's. On 14 mc M.F. also heard "US64" (previously mentioned).

M. H. Preston (London, S.W.12), who now has the enormous post-war total of 176 countries (but no 40th Zone as yet!) has heard XU6GRL and anxiously enquires whether he is in Zone 23 or 24. Well, when we last heard of him he was in Chungking, so the answer, unfortunately, is Zone 24.

T. W. Jones (Birmingham) sends a colossal list of 14 mc Calls Heard, but it was too late for last month and not suitable for this. Interesting "bags" mentioned by him during August were XZ2AJ "sandwiched between numerous South Americans," C1CH, heard most evenings, VR6AA most mornings, and ZD6DT, PK2EJ, J8AAA and KG6AG, all between 1740 and 1950 on August 9. Then he added two zones, with KL7 and UA9.

A. Baldwin (Leytonstone) queries the whereabouts of KX6USN and KN8BQ.



R. Hoermann is an active SWL at 401, Alliance, Ohio, U.S.A. His receivers are SX-17 and SX-32.

We know the former—Bikini Atoll—but have never heard of the KN prefix. R. J. Randall (Herne Bay) logged LA2UA (Skymaster flying from Tunis to Geneva at 8,500 ft).

Interesting queries in a letter from the Rev. D. D. White (Toller) include one concerning a French-speaking station on about 14400, with a "DX flutter," calling "Appelle général de la station Cayenne . . ." and he thinks the call-sign was FY8AN. FY8, of course, is correct for French Guiana; has anyone ever heard an FY8 before, particularly on 'phone? Then comes our old friend YO5WZ, on CW (probably Rumanian) and lastly MD9KM, also on CW. The last is distinctly fishy, we feel, but would like to know more about him if possible. D.D.W. is off to Argentina, whence we hope to receive regular reports from him, especially as he is taking his V55R with him!

A. J. Slater (Southwick) reports a lack of enthusiasm during August. You missed some good stuff, A.J.S. ! In spite of this he heard VZ5FR, VP5PU, ZD2KC, W6VRF/KG6 and VP3LF, among many other less rare birds.

F. A. Herridge (London, S.W.12) regrets that in future he will have less time for listening, owing to pressure of work, but he is justifiably proud of having stuck to 28 mc for so long, as his score, for that band only, is 33Z and 81C

DX QTH'S

AR8AB	P.O. Box 293, Beyrouth, Lebanon.	
ET3Z	Box 1636, Addis Ababa, Ethiopia.	
HZ2HV	Box 14, Medina, Saudi Arabia, or via ARRL.	
J2AJA	A.P.O. 226, c/o P.M., San Francisco, Calif.	
LF2K	via N.R.R.L., Post Box 698, Oslo.	
MD1A	c/o Wireless Troop, Cyrenaica Signals Regt., Benghazi, MELF.	
MD1D MD1E MD1F	} c/o Signals, RAF El Adem, Cyrenaica, MEF 7.	
MD2A		Radio Officer P. Joubert, Albergo Del Mehari, Tripoli, Libya.
MD2C		c/o B.O.A.C., Tripoli, Libya.
MD5AK	Capt. V. H. Thomas, 2050 (Maur) Co., R.P.C., MELF.	
MD5HJ	RAF Spinney Wood, Ismailia, Egypt, MELF.	
OQ5BR	Box 400, Leopoldville, Belgian Congo.	
OX3BC	68 New Street, Aabenraa, Denmark.	
OX3GE	A.P.O. 859, c/o P.M., N.Y.C. U.S.A.	
PK2RK	Radio P.T.T., Solo, Java.	
PY7QG	Box 4353, Rio de Janeiro.	
TG9JK	J. W. Knoth, Box 118, Guatemala City.	
VE9BW	W. Holland, Kokopo, via Rabaul, New Guinea.	
VP4TU	A.P.O. 869, c/o P.M., Miami, Fla.	
VQ2DH	D. C. Hilton, Box 93, Livingstone, N. Rhodesia.	
VQ2WR	Box 121, Luanshya, N. Rhodesia.	
VQ5WCF	W. C. Puttick, P. & T. Dept., Kampala, Uganda.	
VS1AQ	Capt. L. K. Ayre, Engineer Branch, GHQ, SEALF, GPO, Singapore.	
VS7DR	205 Sqdn., RAF Ceylon.	
ZC6RG	RAF Aqir, British Forces in Palestine.	
ZD2KC	G. F. Keen, P. & T. Dept., Lagos, Nigeria.	

D. F. Willies (Holt) has logged two unusual ones: IIAHL (Sardinia) and SM1MM on the island of Gottland. He also mentions that he sent a QSL to ZA1A in Tirana, Albania, and has now received a registered letter in French from Radiodiffusion Centrale d'Albanie, thanking him for the report! And finally he brings up the subject of UR2KAA (Estonia) and asks if he is genuine. No doubt of that, D.F.W.—card on the wall! He is in Tallinn.

D. Heaton (Bradford), a high scorer in the 'Phone Only list, comments on the peculiarity of short-skip conditions on 14 mc, and says he has frequently heard G's, VE, VS2, J2 and J9, all coming in together. He, too, has collected J9CRP on Kwajalein. D.H.'s score of 36 Z and 130 C is entirely on 14 mc 'phone with the single exception of CR9AG, heard on 28 mc.

C. S. S. Lyon (Liverpool) sends the full QTH of MD7RH, which duly appears in the list. He comments on the great improvement in ZC1AL's transmissions recently—he is now S9 plus with good quality—and was interested to hear him working LA2UA/Airborne. C.S.S.L. has heard the notorious ZA1A—another registered letter on the way?—and PK2RK (Solo, Java), both on 'phone. On CW he has captured UA1PA (Amderma, Arctic Coast), UD6AG, EP3D and VP9E.

P. D. Roberts (Swansea) bemoans the fact that he has heard nothing out of the ordinary on 14 mc, which, he says, seems to be rapidly becoming a "local" band. This we are inclined to interpret as the result of listening on a day when short-skip has been prevalent; and listening only to the loud signals, for the band has been full of DX for the entire month! Gather up some of those weaker ones, P.D.R. He queries LF2K (Trondhjem). He, so far as we know, is in order. Norwegian amateurs have been heard using the prefixes LA, LB, LH and LJ, so why not LF?

A. W. G. Boulton (Faringdon), putting in a nice score of 38Z and 129C, asks if an extra country may result from UW5JB, heard on CW on August 12. We just don't know this one, and no one else seems to have heard him.

M. Harrison (Darlington) approves of zoned listening, and wants to know why we haven't done the same thing for 28 mc. But how does anyone know which zones to expect on that band? If he'll tell us, we'll try it! Meanwhile, one feels like saying "Zones 1 to 40 only"! M. H. thinks that I4LL, mentioned last month,



The trawlers are coming in well this evening. Edith.

should be I4LLF; and he, too, has heard that "US64." He asks whether anyone knows of any active 'phone stations in Zones 17 or 18.

R.S. Craig (Llanelly) puts in a plea for more statements of the times at which rare DX has been heard. Not in Calls Heard—this makes them too untidy—but in any odd remarks about real rarities. Your Scribe heartily agrees, and will willingly publish times in brackets after any choice pieces mentioned. It should be a great trouble-saver for the DX-chasers.

Calls Heard—Blitz!

It is now your Scribe's painful duty to announce that the standard of Calls Heard lists has been falling off lately—not the quality of the entries, but the notice taken of the rules! If you have a copy of the March/April issue, full details were given on p. 139; briefly, they amount to this: For 28 and 14 mc, omit *all* Europeans, and *all* W1, 2, 3, 4, 8, 9 and *all* VE1, 2 and 3. Most of the other instructions now appear in small type underneath the words "Calls Heard"—so please read them. Quite a few lists had to be thrown out this month. When setting out your lists, print the letters and figures as neatly as possible and, above all, give yourself *space*! Cramped lists in microscopic writing are just the end when it comes to trying to get them into print. The golden rule is to prepare your lists *exactly* as you see them in Calls Heard.

Next month's "14 mc—General" lists will again be on a zoned basis. Those who listen in the mornings are asked to cover Zones 1, 2, 3, 6 and 29-32, as before; those who listen in the evenings are asked to go to town with Zones 7 to 13 and 33 to 39 only—and let's have some stiff competition.

Set Listening Periods—September

September 27, 2100-2300 GMT—14 mc 'Phone only.

September 28, 1600-1800 GMT—28 mc 'Phone and CW.



General view of J3WGT, one of the QRO American J's. D. W. Bruce, London, S.E.9, got this with J3WGT's card.

And we must ask you to get them in early this time, because even your Scribe needs a holiday. The absolute deadline will therefore be first post on October 1; and please hold up only the SLP logs until this date, as general letters, logs and HAZ claims would be appreciated earlier still. *Please* keep those HAZ claims out of letters and put them separately on a post-card. Address everything to the DX Scribe, *Short Wave Listener*, 49 Victoria Street, London, S.W.1. Meanwhile, Good Hunting—and don't overlook 28 mc!

QSL direct whenever you can. Do not QSL at all unless you are sure a report will be useful. If you do not know the full QTH of the DX station, consult the foreign QSL Bureaux List on p. 244 of the July issue of the "Short Wave Listener."

MORSE CODE Training



There are Candler Morse Code Courses for

BEGINNERS AND OPERATORS

Send for this Free

"BOOK OF FACTS"

It gives full details concerning all Courses.

THE CANDLER SYSTEM CO.

(Dept. S.L.) 121 Kingsway, London, W.C.2.
Candler System Co., Denver, Colorado, U.S.A.

CALLS HEARD

Please arrange all logs strictly in the form given here. Note, in particular, that the prefixes must be in alphabetical order, and that the number but not the prefix must be repeated with each call sign (e.g., WIAZ, 1BCR, 1CQL, 2DY, 2EF, etc.). The call signs, after the number, must also be in alphabetical order. Where listening has been on more than one band, a separate list should be sent for each band, under the appropriate heading. In other words, study the layout of the lists below, and make yours exactly like them.

SET LISTENING PERIODS

28 mc

August 31, 1400-1700 GMT

J. Crunden-White, Ecclesbourne, Chorleywood, Herts.

'Phone: AR8AB, MD5KS, OQ5BA, SUIHF, 1WS, W2VJW/MM, W6VKV/16, ZC6JP, ZE1JZ, ZS1P, 1T.

CW: VQ3EDD, ZS2GY.

A. J. Slater, 72 Underdown Road, Southwick, Sussex.

'Phone: AR8AB, CE1AH, CX1DD, KP4BM, LU8ER, NY4AB, OQ5AR, 5BA, 5BL, PY1JY, 5AQ, 7AY, 7QP, PZ1A, SUIHF, 1WS, VP4TV, VQ3EYE, VS9AB, W2VJW/MM, 6VKV/16, ZC6JP, ZE1JZ, ZS1AX, 1B, 1DH, 1P, 1T, 2CI, 5CI. (Receiver: SX 24.)

G. P. Watts, 62 Belmore Road, Thorpe, Norwich, Norfolk.

'Phone: AR8AB, CE3DW, KP4DR, LU4DJ, OQ5BA, 5BR, PYS4Q, 7CP, SUIHF, 1WF, VP4TT, 6ZL, VS9AB, XZ2KM, ZC6JP, 6JT, ZE1JZ, ZS1AX, 1DH, 1P, 1T, 2AZ, 6BV, 6DY, 6EK, 6FN, 6IK, 6U.

CW: ZS2DY. (Receiver: Hallcrafters S.20 & Eddystone 5/10 Converter.)

R. S. Craig, New Road, Llanely, Carmarthenshire.

'Phone: AR8AB, CE3DW, LU3DH, 4DJ, MD5DX, PY2NX, 7AY, 7CT, PZ1A, SUIHF, 1WS, VS9AB, W2VJW/MM, ØWSV.

R. Masters, 62 Battenburg Avenue, North End, Portsmouth.

CN8AB, FA8AB, MD5PS, SUIHF, 1WS, W2VJW/MM, W6VKV/16, ZC6JP, ZS6DW.

L. Shearlaw, Kaduna, Frimley Rd., Camberley, Surrey.

'Phone: AR8AB, OQ5BA, SUIHF, 1WS, VQ3VYE, VS9AB, W2VJW/MM, 6VKV/16, ZC6JP, ZE1JZ, ZS1AG, 1AX, 1FD, 1P, 1T, 5U, 6FC. (Receiver: R208.)

F. A. Herridge, 95 Ramsden Road, Balham, London, S.W.12.

'Phone: CE1AH, CX4CS, LU3DH, MD5AG, 5DC, PY1JY, 2CK, 2QK, 9AT, SUIHF, 1WS, VS9AB, WSAXI/MM, ZC6FP, 6JF, ZD2KC, ZS1P.

CW: PY1GJ, ZS2AL. (Receiver: 0-F-0.)

A. Frost, 18 Beechwood Avenue, Thornton Heath, Surrey.

'Phone: AR8AB, CX1DD, KP4DR, LU3DH, 4DF, 4DJ, OQ5BA, PY2CQ, 2DS, 2MX, 7AY, 7CP, SUIHF, 1WS, VS9AB, 2VJW/MM, ZC6JP, ZS1AX.

CW: KP4KD, LUTAZ, PY2DS. (Receiver: Eddystone 504.)

R. A. Hawley, Torview, Brookfield Crescent, Gostrey, Cheshire.

'Phone: AR8AB, MD5DS, OQ5BA, SUIHF, 1WS, VS9AB, W2VJW/MM, ZC6JP, ZE1JB, ZS1P, 1T.

CW: VS9AN, VU2LW, ZS2DY. (Receiver: Eddystone 504.)

14 mc

August 30, 2000-2200 GMT

R. A. Hawley, Torview, Brookfield Crescent, Gostrey, Cheshire.

'Phone: CX2CO, EL5B, PY1HB, 2AY, 4IE, VQ6J, VP4TJ, 9F, VU2BK, 2LS, WSNDG/MM, ZB1AH, ZC6JL. (Receiver: Eddystone 504.)

A. H. Onslow, 10 Egmont Road, Hove, Sussex.

CX2CO, EA9AI, EL5B, HK3DD, MD5PC, OX3GG, 3MG, PY1HP, 2AY, 4BL, 4IE, 7AD, TF3EA, VK2AGU, VP3LF, VP4TJ, 9F, VS2BV, VU2BK, 2LS, W6PFC, ZC1AL, 6JL, ZL1HY.

M. Harrison, 36 Southend Avenue, Darlington, Co. Durham.

'Phone: CN8BA, FA3JO, HK1FQ, KP4BU, LU7BU, 7CK, OX3GG, 3MC, PY1HV, 2AY, 7AD, VK4VD, YO6F, VP4TJ, VU2BK, 2LS, YV5ABE, 5AV. (Receiver: R-1155.)

J. Crunden-White, Ecclesbourne, Chorleywood, Herts.

'Phone: CN8ABA, OX3MG, PY1HP, 7AD, TF3EA, VP9F, YV3AL.

J. R. Killeen, 101 Derby Road, Hinckley, Leicestershire.

EL5B, LU6AJ, 6LD, 7BU, OX3GG, PY1DC, 1HP, 1MK, 4BI, 4IE, 7AD, 7QG, T2HB, UA1BE, VK2AGU, 4VD, VP4TJ, YV3AL. (Receiver: R1116A.)

A. Frost, 18 Beechwood Avenue, Thornton Heath, Surrey.

'Phone: EA9AI, HK1FQ, LU6LD, OX3GG, PY1MK, 4IE, 7AD, VK2AGU, VP4TJ, VU2BK, 2LS, YV3AL, ZB1AH, ZC1AL, 6JL.

CW: OX3BC, PY1FH, 6AC, 6AW, VK3ML, 4ZB. (Receiver: Eddystone 504.)

L. Shearlaw, Kaduna, Frimley Road, Camberley, Surrey.

'Phone: CN8MB, LU6LD, 7BU, OX3MG, PY1HB, 4BI, 7AD, TF3EA, VP4TJ, VU2BK, 2LS, YV3AL. (Receiver: R208.)

T. W. Jones, 56 Cuckoo Road, Netchells, Birmingham.

'Phone: CN8BA, 8MB, LU6LD, 7BU, MD5PC, PY1GU, 1HP, 1MK, 2AY, 4HE, 4IE, 7AD, VK2AGU, 4VD, VQ6J, VP4TJ, 9F, VU2BK, ZC6JL. (Receiver: V55R.)

R. Masters, 62 Battenburg Avenue, North End Portsmouth.

CO2JV, KP4BO, LU7BU, MD5DC, OX3GG, 3MC, PY2CK, 7AD, VK2AGU, VO2RM, 6J, VU2BQ, XAFX, ZB1AH.

D. W. Bruce, 39 Dunkery Road, Eltham, London, S.E.9.

'Phone: CN8MB, CX2CL, HK1FQ, J2ACW, LU4CN, 5WA, 7BU, OX3GG, PY1DC, 1HP, 2AY, 4BL, 4IE, 7AD, TF3EA, VK4VD, VO2RM, 6J, VP4TJ, 9F, VU2DG, 2LS, YV3AL, ZC6JL.

CW: LU1ZA (South-Orkney Is.) (Receiver: 0-V-1.)

N. S. Beckett, 26 Grosvenor Road, Lowestoft.

'Phone: LU5WA, 7BU, MD5PC, OX3GG, PY1AC, 2AY, 4IE, 7AV, TF3EA, XZ2AA, YV3AL, ZC6JL.

CW: LU1ZA, OX3BC, W5SF. (Receiver: 5 valve Superhet.)

A. E. Hardman, 14 Burtinshaw Street, Cross Lane, Gorton, Manchester, 18.

CW: EP3D, KV4AB, LU9EV, MD5DA, NY4CM, OX3BC, PY1AZ, 1FH, 1HX, 4AB, 6AC, 6AW, VE4KU, 8NW, VP4TL, YOSJ. (Receiver: Battery 1-V-1.)

M. J. F. Harrison, 53 Goring Way, Goring-by-Sea, Sussex.

PY1HB, 7AD, TF3EA, ZB1AH. (Receiver: 0-F-1.)

D. H. G. Tyrrell-Lewis, Claremont, Fernlea Avenue, Ferndown, Dorset.

EA9AI, HK1FU, LU6LD, 7BU, MD2C, 5PC, PY1HP, 2AY, TF3EA, YV3AL, ZB1AH. (Receiver: Modified Sagar AR18.)

G. P. Watts, 62 Belmore Road, Thorpe, Norwich, Norfolk.

'Phone: CX2CO, LU6LD, OX3GG, PY1HP, VP4TJ, ZC6JL. CW: EP3D, MD5DA, PY2OE, VE4KU, YO5J (?). (Receiver: Hallcrafters S.20.)

A. J. Slater, 72 Underdown Road, Southwick, Sussex.

'Phone: CN8BA, CX2CO, EL5B, HK3DD, LU6AJ, 6LD, 7BU, 7CK, MD5PC, OX3GG, 3MC, PY1ACN, 1DC, 1GU, 1HP, 1MK, 4BI, 4IE, 7AD, 7GF, TF3EA, VK2AGU, VP4TJ, 9F, VU2BK, 2LS, YV3AL, 5AV, ZC1AL, 6JL. (Receiver: SX.24.)

W. J. C. Pinnell, 40 Melville Road, Sidcup, Kent.

'Phone: CN8MB, EA9AI, FA9GG, HK3DD, PY4BI, T12HB, 2RC, VP9F, VU2BK, 2BQ, 2LS, YV3AL, ZC6JL, ZS1BV. CW: CN8MZ, MD5DA, PY4AE. (Receiver: V55R.)

D. Garrard, 17 Hill House Road, Ioswich, Suffolk.

'Phone: CX2CL, HK1FO, LU7BU, MB9AD, CX3GG, PY1HP, 2AY, 4BI, 4IE, 7AD, TF3EA, VC6J, VP4TJ, 9F, YV3AL. (Receiver: BC-342-N.)

GENERAL

14 mc

Zoned Listening

R. S. Craig, New Road, Llanelly, Carmarthenshire.

Zones 1, 2, 3, 6, 29-32 only, 0600-1200 GMT.

'Phone: VE7PR, 7AJA, VK2JU, 2TC, 2TE, 2ADE, 2ADG, 2ADJ, 2AGU, 2AHA, 3IA, 3IG, 3JW, 3MC, 3ND, 3TF, 3TN, 3YH, 3AUX, 4VD, 4ADT, 7TR, 7ZN, VR6AA, VU2BQ, W6ASZ, 6HCY/W7, 6NBD, 6OEZ, 6QNH, 6VFR, 6WNH, 6WPU, 6WUI, 7GJ, 7CHZ, XE1A, 1AC, 1CQ, ZL2BE, 2II, 4AR, 4FO.

M. Harrison, 36 Southend Avenue, Darlington, Co. Durham.

2000-2130 GMT.

'Phone: Zone 22: G3BMJ/V57, VU2BK, 2BQ, 2BV, 2DG, 2DS, 2HQ, 2PL, 2RV. Zone 26: XZ2AA, AJ, AT, WD. Zone 28: VS1AN, 2BU, 2BV. Zone 30: VK2AGU, 2II. Zone 37: VQ4ERR. Zone 38: ZS1T, 2AX, 6DW, 6LF.

0500-0630 GMT.

'Phone: Zone 3: VE7AIE, 7AJN, 7GQ, 7ZZ, W6BZE, 6BZF, 6CQZ, 6EQU, 6EPZ, 6ESH, 6FTU, 6GF, 6IKQ, 6KSE, 6LLQ, 6LSO, 6LXA, 6MBD, 6MHL, 6MLG, 6NO, 6OGM, 6RO, 6RSO, 6VFR, 6WNH, 6WUI, 7CHZ, 7DL, 7DV, 7EYW, 7GUI, 7HIA, 7HRV, 7HTB, 7JUO, 7JVV, 7VT. Zone 6: XE1AC, 1BC, 1CQ, 1CX, 1FU. Zone 20: VK2ABU, 2AGU, 2AHA, 2DW, 2JU, 2TE, 3HG, 3IK, 3VO, 3YH, 4KH, 4VD, 7NC. Zone 31: KH6AW, 6CT. Zone 32: VR6AA, ZL2FF, 4FO.

N. S. Beckett, 26 Grosvenor Road, Lowestoft.

0400-0700 GMT.

'Phone: Zone 3: W6EQZ, 6EVR, 6IKQ, 6LXA, 6PF, 6VFR, 6WNH, 7DET, 7DV, 7GDE. Zone 6: XE1BC, 1CQ. Zone 30: VK2AG, 2TC, 3MC.

1800-2100 GMT.

Zone 2: VO6J. Zone 22: VU2BQ, 2KM. Zone 25: J2NR, 5AAJ. Zone 26: XZ2AA. Zone 27: KA1AI. Zone 28: VS2BU. Zone 30: VK2AG, 4JP. Zone 37: VQ4ERR. Zone 38: ZS6FN, 6GR. (Receiver: 5 Valve Superhet.)

R. A. Hawley, Torview, Brookfield Crescent, Goostrey, Cheshire.

0630-0730 GMT.

'Phone: Zone 3: W6LHY, 6MBD, 6MLY, 6OEZ, 6OKO, 6PDB, 6RO, 6RYI, 6SMF, 6WNH, 7GC, 7HTB, 7KHQ, 7VT. Zone 6: XE1AC, 1CQ, 1I. Zone 30: VK2ADT, 2GU, 2JU, 2NO, 2RR, 2TE, 3HG, 3KX, 3MC, 3YH, 4KH. Zone 31: KH6AW, 6CT, 6GF, 6GH, 6JQ. Zone 32: VR6AA, ZL2BE, 3GX.

1930-2100 GMT.

'Phone: Zone 22: VU2BQ, 2DX. Zone 25: J5AAJ. Zone 26: XZ2AF. Zone 27: KG6AG. Zone 28: PK3EJ, VS1AM. Zone 30: VK2AGU. Zone 38: ZS1CN.

D. W. Bruce, 39 Dunkery Road, Eltham, London, S.E.9.

2000-2100 GMT.

'Phone: Zone 22: G3BMJ/V57/MM, VU2AN, 2BQ, 2BV, 2CN, 2DG, 2DS, 2DY, 2LR, 2RS, 2RV. Zone 24: J9ABX, 9CRP. Zone 25: J2AAT, 2ACQ, 2AHA, 2AJA, 2DON, 4AAS, 5AAJ, 5AAL, 5AAM, 8AAA (Korea), 8ASC (Korea). Zone 26: XZ2AA, 2AG. Zone 27: KA1ABM, 5KUG, KG6AG, 6AI, 6AU, 6SC (Saipan), W6WGN/KG6 (Saipan). Zone 28: KG6AV/VK9, PK3EJ, 6HA, VS1AN, 1BA, 1BG, 2BV. Zone 30: VK2AGJ, 2AGU, 2II, 2NO, 2TE, 2XG, 3KX, 3MC, 3XD, 3YH, 4EC, 4KH, 4VD. Zone 31: KB6AG, KH6GF, KM6AA. Zone 32: VR2AO, 5AJ, ZL4AO. Zone 37: VQ4ERR, 4RAW, ZD6DT. (August 1-30. Receiver: 0-V-1.)

G. P. Watts, 62 Belmore Road, Thorpe, Norwich, Norfolk.

0630-0830 GMT.

Zone 1: LK7BA, 7IB, 7IY, VESAW, 8OG, 8OI. Zone 3: VE7SR, 72M. Zone 6: XE1A. Zone 30: VK2AIZ, 2ALG, 2ANJ, 2ASM, 2DA, 2EK, 2EO, 2OU, 2IV, 2JT, 2SA, 2VA, 2VQ, 2WU, 3ASK, 3CN, 3LN, 3MC, 3NC, 3PG, 3ST, 3VJ, 3VQ, 3XK, 4EL, 4QA, 4RF, 5AJ, 5BZ, 5FL, 5ID, 5JE, 5JS, 5NR, 5QI, 7CW, 7LZ, 7NC. Zone 31: KH6IJ, 6IV. Zone 32: ZL1BQ, 1DI, 1LQ, 1MR, 2CU, 2CX, 2GL, 2GS, 2LB, 2QM, 2SR, 3BJ, 3GE, 3HC, 4CK, 4GL, 4IH.

1900-2200 GMT.

Zone 22: VU2WW, VS7IT. Zone 24: C4RK. Zone 27: KA1ABV. Zone 28: VS2BJ, 2BZ, VK9OU. Zone 30: VK2ACX, 2AIG, 2HW, 3ML, 4CG. Zone 37: ZD6DT, ET3Z. Zone 38: ZS1DA, 2DY, 2F, 6DL, ZS3D, 3F. (Receiver: Hallcrafters S.20.)

D. L. McLean, 9 Cedar Grove, Yeovil, Somerset.

0600-0730 GMT.

Zone 1: KL7KR. Zone 3: W6BZF, 6ELW, 6LSM, 6MBD, 6NO, 6RO, 4WNH, 6WUI, 7GC, 7GUL. Zone 6: XE1AC, 1BC, 1FU, 1I, 3D. Zone 29: J6GDF. Zone 30: VK2ABD, 2ABU, 2ADE, 2AGJ, 2AGU, 2AHA, 2AHJ, 2BZ, 2FJ, 2MK, 2II, 2JU, 2QR, 2TE, 2TI, 2TC, 2WH, 3ASV, 3IK, 3MC, 3TS, 3VO, 3XD, 3YH, 4HA, 4KH, 5LK, 7TR. Zone 31: KH6CT, 6GF, 6JQ. Zone 32: VR6AA, ZL1CD, 1KJ, 2BE, 2GX, 4FO, 4GM. (Receiver: AR88 and S.20.)

O. A. Good, 1 Western Drive, Oswestry.

0500-1000 GMT.

CW: Zone 1: KL7DM, 7IY, 7LL, 7UM, WÖPNQ/KL7, VE8BJ.

'Phone: Zone 3: VE7AIE, 7AJN, 7VP, W6GWY, 6MLJ, 6RO, 6WNH, 7BVO, 7DET, 7EVR.

CW: W6GRL, 6QVN, 6UOF, 7BXL, 7JKG.

'Phone: Zone 6: XE1CQ.

'Phone: Zone 29: VK5FL.

CW: VK5FL, 5JS, 5NR, 6AA.

'Phone: Zone 30: VK2ADJ, 2TE, 3BC, 3BZ, 3IK, 3SB, 3XD, 3YH, 3YX, 7TR.

CW: VK2ANX, 2BA, 2DA, 2DI, 2NO, 2OI, 2TR, 2VN, 2VQ, 2WH, 3AJB, 3BZ, 3CN, 3EK, 3JA, 3JE, 3KR, 3LD, 3LN, 3MC, 3NC, 3VJ, 3XU, 4AP, 4CS, 4EL, 4ER, 4QA, 4TY, 7DH, 7JH.

CW: Zone 31: KH6BM, 6GF, 6IJ.

'Phone: Zone 32: VR6AA.

CW: ZL1BQ, 2GH, 1MR, 1NG, 2BT, 2CU, 2OH, 2GL, 2LB, 2QM, 2RZ, 3BJ, 3CC, 3CX, 3GU, 4CK, 4HS.

1600-2100 GMT.

'Phone: Zone 22: VU2AS, 2BK, 2BQ, 2BV, 2DG, 2EC, 2PG, 2QS, 2RV.

CW: VS7IT, 7NX, VU2BG, 2CV, 2KM, 2RW, 2WG.

'Phone: Zone 24: CICH, 1YP.

CW: W7ANN/C1, W6YOT/C6, VS6AA.

'Phone: Zone 25: J2AJA, 2JCQ.

CW: J2AHI, 3AAD, 4AAK.

'Phone: Zone 26: XZ2AA, 2WD.

'Phone: Zone 27: KG6AG.

CW: KG6AL, 6BA.

CW: Zone 28: PK1MD, 1RI, 3JK, VS1AX, 1BA.

CW: Zone 29: VK5BZ, 5FL, 5JS, 5NR.

'Phone: Zone 30: VK2AGO, 2NO, 2XG, 3SB, 3VJ, 4VD.

CW: VK2ADV, 2PX, 2SA, 2XU, 2YL, 3EG, 3VJ, 4EL.

'Phone: Zone 31: J9CRP (Kwajalein, Marshalls).

CW: Zone 32: ZL3GU.

'Phone: Zone 37: VO4ERR.

CW: G3ZJ/16.

'Phone: Zone 38: ZS2AZ, 6AJ, 6DW, 6FT.

CW: ZS1CZ, 1DY, 1FE, 1M, 2G, 3D, 3F, 5DF, 5GL, 6CH, 6CY, 6FN, 6GF, 6GL, 6HH.

T. W. Jones, 56 Cuckoo Road, Nechells, Birmingham.

0600-1200 GMT.

Zone 1: KL7GO, 7KR. Zone 3: VE7GQ, 7ZM, W6FOH, 6IKQ, 6KBP, 6PF, 6RO, 6RSD, 6VFR, 6WNH, 6WUI, 6GMF/W7, 7CHZ, 7FLD, 7HIA, 7HRV, 8YEZ/W7. Zone 6: XE1AC, 1CQ. Zone 30: VK2ADE, 2AGU, 2AHA, 2BZ, 2GU, 2JU, 2NO, 2TE, 3YH, 4DC, 4KH, 4SU, 4UD. Zone 31: KH6AW, 6CT, 6GF. Zone 32: ZL2BE, 2GX, 4AO, 4FO, VR6AA.

2000-2300 GMT.

Zone 22: VU2BK, 2BQ, 2RV. Zone 24: CICH, 1YT. Zone 25: J8AAA. Zone 26: XZ2AA, 2AJ. Zone 27: KG6AG. Zone 28: VS2BV. Zone 30: VK2AGH, 2AM, 2NO, 2SQ, 2XG, 4VD. Zone 32: ZL2GX, 4AO. Zone 37: ZD6DT. (Receiver: V55R.)

28 mc

M. Forrest, Queen Manor Farm, Laverstock, Salisbury.

'Phone: ARRAB, CX4CS, 5AP, LU3DH, PK1MK, PY1JX, SUIHF, 1WS, VK5NR, VU2AJ, 2BJ, 2LR, 7AB, W3MJZ/MM, 5BSY/MM, QWV/MV/VU7, XZ2DN, ZB1S, ZC6RG, ZD2KC, ZE1JB, ZS1CN, 1DH, 1P, 1T, 2AF, 5P, 5Q. (Receiver: Eddystone 504.)

3.5 mc

D. W. Bruce, 39 Dunkery Road, Eltham, London, S.E.9.

'Phone: VE1LR, 1PX, 1RF, 2AC, 3AHF, WIABY, 1AW, 1CGB, 1FFS, 1IXO, 1JQO, 1PUD, 2HS, 2IUL, 2QRI, 4IYC, 4OIX, ØAU, ØKIF. (August 8 and 9, 0500-0600 GMT. Receiver: 0-V-1.)

7 mc

W. J. C. Pinnell, 40 Melville Road, Sidcup, Kent.

'Phone: CT1OZ, YR5QS. CW: CN8FT, COSFL, UR2KAA, VE1GT, WIHUL, 1KJO, 1OFT, 2GJE, 2KJP, 2OAV, 2SUC, 2TVH, 2TYU, 2UMA, 2UUT, 2VDR, 2VBQ, 3BZS, 3HD, 3JEJ, 3KBT, 3MLJ, 3MYQ, 4AFV, 4HTR, 4JLN, 4KYQ, 9JSD, 9PPE. (0015-0430 GMT, August 4. Receiver: V55R.)

1.7 mc

D. L. McLean, 9 Cedar Grove, Yeovil, Somerset.

'Phone: G2AAW, 2DGB, 2IK, 2ZG, 3AZT, 3MT, 5UH, 5YK, 6GU, 6HU, GW2BG, 3ALE. (Receiver: AR88 and S.20.)

DX FORECAST FOR SEPTEMBER/OCTOBER (ALL TIMES GMT)

	7 mc	14 mc	28 mc
NORTH AMERICA			
East and Central	2300-0700	1600-0800	1300-1800
West Coast	0500-0700	0800-0300	1500-1700
CENTRAL AND SOUTH AMERICA	2200-0600	2000-0700	1000-1600
AFRICA:			
North of Cancer	1400-1000	All day	0800-2200
South of Cancer	2100-0800	1500-2300	0800-2100
ASIA:			
West of 75 deg. E.	1800-0500	0600-2300	0800-2000
East of 75 deg. E.	2000-0700	1300-2200	0900-1600
OCEANIA:			
VK, ZL, ZK, ZM, etc.	0400-0800	0600-1200 1900-2300	0800-1300
PK, KA, KG6, etc.	2000-2300		1300-2000

NOTE.—The times given above are the most likely periods during which signals may be expected from the parts of the world indicated. Under unusual conditions, signals may be heard outside these times.

SENSATIONAL OPPORTUNITY—

EX GOVERNMENT STOCK



(A) Moving Coil Headphones. Made to stringent Government specification by World Famous Make.

Low resistance with ear-pads and headband. Per pair 15/- post free, or 3 pairs 40/- post free.

Post Free
15/-
PER PAIR
3 Pairs
40/-
Post Free

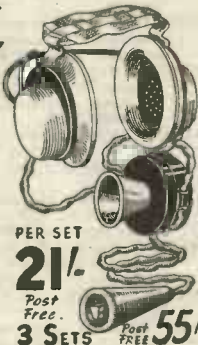

(B) Moving Coil Headphone and Moving Coil Microphone Sets, by set 21/- post free, three sets 55/- post free.

PER SET

21/-
Post Free.

3 SETS **55/-**
Post Free

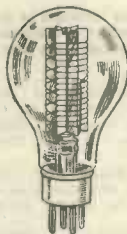

Dummy Load Lamps, 4-pin valve holder contact pins, 20/10/50 ohms, 3/6 each, post free, 6 for 18/- post free.

Metro-Vick Moving Coil, 0 to 1 ampere meter, 3 1/2" dial. New and unused in maker's sealed carton, 30/- post free.



Rotary Convertors, 11/200 volts, 70 milliamperes. New and unused in maker's cartons, 17/6 post free.

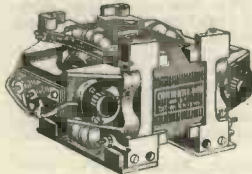

WIRELESS INSTRUMENTS (LEEDS) LTD.

54-56 THE HEADROW, LEEDS, I.



G.P.O. MIKE INSETS for Home Broadcasting. Metal clad, 2/6. Transformer, 4/6.

MICROPHONE BUTTONS. The G.P.O. Button 1" dia. provides interesting experiments for outside Listeners, sound transmission, etc., 3/6 each. Special H.R. Transformer, 4/6.

TRANSFORMERS. Double wound for Models and experimental use 230v. 50 cy., input 4 volts C.T., 7 1/2 amps output, 17/6, postage 1/6 extra. Large B.T.H. Transformers, 75 volts 6 amps, with 15 taps and 2 volts 20 amps, 70/-.

MICRO MOTORS. Totally enclosed precision made motors, weight 10 oz., 2" x 1 1/2" dia. A.C./D.C. Ball bearings, laminated fields, small vee pulley fitted on shaft. Centrifugal relay speed.

Governor on shaft, removable for second shaft drive. Will run on three 4 1/2 v. pocket cells for boat or models and up to 25 volts. 21/ each.

MAGNETS. D.C. Electric Magnets, weight 10 oz., lift on 2 volts, 1 1/2 lb.; 4 volts, 3 lb.; 6 volts, 4 lb., new surplus, 7/6 each. Permanent powerful flat bar magnets, 2 1/2" x 1" x 1/4", drilled 2 holes each end, for any pole pieces, 2/- pair. The wonder Midget magnets, Alin perm steel disc; 3/8" dia., 3/8" thick, with 3/16" centre hole, 3/6 each. Large stock of Horseshoe magnets. Send for special Magnet Leaflet "S.L."

TERMINALS.—Brass or plated Belling type with nuts and washers, 6d. each, 5/- dozen. Insulated Belling, 1/- each, 10/- dozen.

ELECTRAX RADIOS
214 QUEENSTOWN RD., LONDON, S.W.8
Telephone: Macaulay 2159

—1155 OWNERS—

The best of sets break down, and as there is no firm from whom you can buy spares for 1155's we suggest that to buy a parcel of 25 spares, including I.F. Transformers, Coils, B.F.O. Coil, H.F. Chokes, etc., etc., is a sound idea. We can offer such a parcel for 26/6 post free, e.g. less than the cost of the I.F. Transformers. We are able to make this offer because we bought a big stock of new parts which were not needed when the Air Ministry contract for 1155 receivers was completed. All parts are new and exactly as used in your Set. Order now to avoid disappointment.

COMMUNICATIONS RECEIVERS. At the time of going to press, we have stocks of the following:—R.1155, £14/10/-; R.208, £12/10/-; M.C.R.I., £6; BC.342, £18/10/-; BC.312, £18/10/10; R.109, £6/15/-; R.107, no second-hand models left, but a few new ones at £22/10/- each; R.102, £8; R.3515, £7/10/-; C.R.100, £24/10/-; H.R.O., £27/10/-; No. 18, £1/15/-; R.103 (Truck Radio) £18/10/-; B.19, 29/6; W.S., No. 9, £5/5/-; R/T/22, £7/10/-. NOTE: To these prices must be added carriage charges and packing case deposits.

OTHER GEAR. Practically all items as per our Summer List are still available. Have you had your copy?

BULL'S

"EX-GOVERNMENT" DEPOT
42-46 Windmill Hill, Ruislip Manor, Middx.

PSE QSL

The operators listed below have informed us that they would like SWL reports on their transmissions, in accordance with the details given. All correct reports will be confirmed by QSL card. To maintain the usefulness of this section, please make your reports as comprehensive as possible.

- CN8BF** *Villa Tanistler, Rue Damremont, a Oujda, Fr. Morocco.* CW and 'phone on 7050 kc, CW on 14100 kc and 'phone on 14300 kc. Operating 'phone from 1400 BST and CW from 0800 BST and after midnight.
- D2GU** *E. G. Styles, P. & T. Branch, TZA, 120 HQ, CCG, B.A.O.R.* Reports requested on signals heard in 3-5, 7 and 14 mc bands; all correct reports acknowledged.
- F9CH** *30-bis, Rue Nationale, Boulogne-Billancourt, Seine, France.* CW on 3525 kc, operating Sunday mornings 0530 BST onwards.
- G2APW** *Lamorna, Pant, Oswestry, Salop.* Report wanted on CW and 'phone transmissions on all bands, especially 58 mc.
- G2BJX** *1 Briaranna Avenue, Luton, Beds.* Operating CW on 1820, 1893, 7021, 7100 and 14042 kc, week-days 0700-0730 and 1900-2300 BST. Also during week-ends. 100 per cent. QSL station.
- G2BYN** *43 Pettitts Lane, Romford, Essex.* 'Phone and CW on 7 and 14 mc, 1900-2330 BST daily; reports wanted from outside London area.
- G2FLC** *73 Farmers Corner, Cheveley, Newmarket, Suffolk.* 'Phone and CW on 28100, 28300 and 28406 kc, operating 0900-2200 GMT. 100 per cent. QSL station.
- G2HIQ** *61 Raleigh Street, Walsall, Staffs.* VFO-controlled 'phone and CW on 3-5, 7, 14 and 28 mc bands, operating week-day evenings.
- G2HKU** *27 Unity Street, Sheerness, Kent.* CW and 'phone on 1820, 1880, 7021, 7090, 14042 and 14180 kc. Operating periods, 1-7 mc Wednesdays 2000 GMT and Sundays 0800-1200 GMT; 7 mc, alternate days 0330-0430 GMT; 14 mc, alternate days 0330-0430 GMT and week-ends 0500-0800 GMT. Reports on 7 and 14 mc outside U.K. only, please.
- G2KC** *82 Hatherley Road, Winchester, Hants.* Operating CW and 'phone on various frequencies in 1-7, 3-5, 7, 14 and 28 mc bands. Operating periods, 1-7 mc, 2000-2200 GMT daily; 3-5 mc, 1700-2000 GMT daily; 7, 14 and 28 mc, operating times irregular. 100 per cent. QSL station.
- G2RI** *90 Rowmay Road, Leicester.* Operating 'phone and CW on 59 mc, 2000-2359 BST daily. 100 per cent. QSL station.
- G3AOC** *10 Tunley Road, Balham, London, S.W.17.* CW on 14020, 14132 and 14148 kc, operating 0600-0800 and 1800-2100 GMT, also 28 mc 'phone at times. Reports wanted from East and Far East only.
- G3BJF** *Gwenmore, Kent Road, Quinton, Birmingham, 32.* CW on 14124 kc, operating 1600-2300 BST daily.
- G3BMM** *25 Wykeston Street, Burton-on-Trent, Staffs.* CW on 14024 and 14140 kc, operating periods irregular.
- G4QK** *39 Manor Way, South Croydon, Surrey.* Long-term reports wanted on VFO-controlled 3-5 mc CW from (a) Devon-Cornwall area, and (b) Buckingham-Bedford-Northampton area.
- G5HH** *29 Newcastle Road, Reading, Berks.* Reports wanted from outside Europe on 3-5 and 7 mc CW transmissions only.
- G5RZ** *Holmeside, Heath Road, Leighton Buzzard, Beds.* Overseas reports requested, especially from LU, PY and VU areas, on CW transmissions in 14000-14150 kc band.
- G5SI** *7 Burcott Gardens, Addlestone, Surrey.* Operating CW and 'phone on 3-5 mc band and on 7018, 14036 and 28072 kc, during period 2100-0100 GMT daily.
- I1LI** *Via Baracca 2, Desio, Milano, Italy.* CW on 7040 and 14080 kc, operating 0700-0830, 1300-1430 and 2100-2200 GMT.
- KP4BX** *116 Benitez Castano Street, Santurce, Puerto Rico.* VFO-controlled 14 mc CW and 28 mc 'phone, operating periods irregular.
- MB9AG** *3 Squadron, 8 Army Signal Regt., Klagenfurt, South Austria.* VFO-controlled 'phone and CW in 3-5, 7 and 14 mc bands, operating 2000 BST onwards.
- OH2NL** *Mlnna Canthink 1, Helsinki, Finland.* VFO-controlled 'phone and CW on 14 and 28 mc bands, operating 1700-2359 GMT daily.
- OK1ZW** *Delnicka 1431/42, Prague VII, Czechoslovakia.* CW on various frequencies in 7 and 14 mc bands, operating 0500-0900, 1800-2100, and 0001-0300 BST.
- ON4RA** *4 Avenue des Casernes, Etterbeek, Brussels, Belgium.* Operating 'phone and CW on various frequencies in 7 and 14 mc bands, mornings and afternoons.
- OZ4N** *Selroged 18, Aalborg, Denmark.* On 3-5, 7, 14 and 28 mc CW and 'phone at various times during period 1800-0001 GMT.
- PAØDX** *V.E.R.O.N., Box 400, Rotterdam, Holland.* CW and 'phone on 58612 kc, 2100-2300 GMT daily, also on Sundays 1000-1800 GMT.
- PAØHQ** Details as for PAØDX above but frequency 58620 kc.
- PAØXP** *Schalkburgerstraat 27, Hengelo(o), Holland.* CW on 3-5, 7 and 14 mc bands, irregular operating times.
- PY6QM** *Rua Buquin 77, Aracaju, Sergipe, Brazil.* CW and 'phone on 14060, 14150, 28300 and 56400 kc, during periods 0900-1100, 1500-1700, and 2130-2359 BST.
- SM6EQ** *Timmermans 21, Halmstad, Sweden.* VFO-controlled CW on 3-5 and 7 mc bands, operating 0500-0600 and 1700-2200 GMT daily.
- VE7SR** *1809 East Georgia Street, Vancouver, British Columbia, Canada.* CW on 14020 or 14099 kc during periods 0600-0900 BST and 1700-2100 BST. Also operating on 28040 kc when conditions right for working G's. 100 per cent. QSL station.
- VK3JI** *12 Camden Street East, St. Kilda, Victoria, Australia.* CW at LF ends 7, 14 and 28 mc bands, operating 1000-1400 BST four days a week.
- VK3YT** *16 Grant Street, Ballarat, Victoria, Australia.* CW on 28002, 28048, 28095 and 28108 kc, operating periods irregular. 100 per cent. QSL station.
- W3FGB** *417 Jones Street, Phoenixville, Penna., U.S.A.* VFO-controlled 'phone and CW on 14 mc band, operating 0050-0200 BST.
- W4GCW** *Route 2, Easley, South Carolina, U.S.A.* 'Phone and CW on 3-5, 7, 14 and 28 mc bands, operating 1100-1400 BST at LF ends, and 1000-1300 BST at HF ends.
- W4TMM** *P.O. Box 1418, Jackson, Tennessee, U.S.A.* VFO-controlled CW and 'phone on 14 and 28 mc bands, operating 1600-2200 BST daily. 100 per cent. QSL station, IRC's not required.
- W5LRE** *1003 East 6th Street, Russellville, Arkansas, U.S.A.* 'Phone on 14 mc band, VFO-controlled, and with spot frequencies 14203 and 14280 kc, operating 0600-1000 and 0001-0300 BST.
- WØFWW** *2111 K Street, Lincoln (8), Nebraska, U.S.A.* VFO-controlled transmissions in CW section 14 mc band, from 14002 kc. Operating periods 1400-1500 and 0400-0600 BST.
- ZS1DY** *9 Avenue Marina, Sea Point, Capetown, South Africa.* CW on 7019, 14038, 14061, 28076 and 28122 kc, operating 1900-2200 BST daily.
- ZS6BV** *103 Fifth Avenue, Melville, Johannesburg, South Africa.* 'Phone and CW on 3542, 3626, 7085, 14170 and 28340 kc, operating on Tuesdays and Thursdays 1800-2300 BST and also over week-ends.

A.C.S. RADIO

SPECIALISTS IN SHORT WAVE and High-Class Broadcast equipment, offer a wide range of components for the constructor and enthusiastic amateur.

IN ADDITION to our range of equipment bearing the well-known trade marks of Eddystone, Raymart, Hamrad, Labgear, etc., we have a large and varied stock too numerous to detail in the space available. For example we are usually able to offer Communications Receiver, tested and re-aligned in our workshops, including such well-known types as the NATIONAL H.R.O., R.C.A. AR88, etc. Your enquiry for any particular item will receive our careful attention. In P.A. Equipment we can offer a complete outfit comprising A.C. operated Amplifier with Push-Pull D.A.100 output, two 12" P.M. Speakers in Cabinets with detachable horns and stands, Mixer Panel, Gramophone Turntable and microphone. Complete outfit £75.

For the Short Wave Amateur we stock several types of transmitting and receiving valves including the EIMAC 100TH at £6, S.T.4074A(RK34) at £2, 5C/100A(813) at £7/15/-, Mullard RG1/240A M.V. Rectifiers at 20/-, V.H.F. receiving types include 9002, 12/10; 9001, 6AK5, 15/-, V.F.O. Units, 20-80 mc/s, new and tested, built by R.G.D. 807 in final stage, complete with A.C. Power Supply, at £16/16/-.

OUR NEW Component List, "S.L." and List "L" of Second-hand equipment will be sent on application to **A.C.S. RADIO**—

44 WIDMORE RD BROMLEY, KENT

Phone Ravensbourne 0156

FROM RADIOLYMPIA TO OUR RADIO BOOK DISPLAY

(No. 27 bus, door-to-door)

FOUNDATIONS OF WIRELESS

By M. G. Scroggie 7s. 6d.

RADIO SERVICE TEST GEAR

By W. H. Cazaly 6s.

THERMIONIC VALVES IN MODERN RADIO RECEIVERS

By A. T. Witts 10s. 6d.

THE CATHODE-RAY TUBE HANDBOOK

By S. K. Lewer 6s.

WORKED RADIO CALCULATIONS

By A. T. Witts 6s. 6d.

RADIO RECEIVER CIRCUITS HANDBOOK

By E. M. Squire 6s.

NEWNES SHORT-WAVE MANUAL

By F. J. Camm 6s.

WIRELESS COILS, CHOKES AND TRANSFORMERS

By F. J. Camm 6s.

THE WIRELESS WORLD VALVE DATA

2s.

Postage 4d. extra per Book

WE HAVE THE FINEST STOCK OF BRITISH AND AMERICAN RADIO BOOKS. COMPLETE LIST ON APPLICATION

THE MODERN BOOK COMPANY

(Dept. L) 19-21 Praed Street, London, W.2

EX-GOVERNMENT BARGAIN OFFER

ADMIRALTY CELL TESTERS

Comprising 0.3 amp high grade Moving Coil Ammeter $4\frac{1}{2}$ " scale.

0-80 ohm wire-wound variable resistance.

2 Perspex panels, size $5\frac{1}{2}$ " x $5\frac{3}{4}$ ".

Housed in an excellently made oak case with leather carrying handle.

Size $6\frac{3}{4}$ " x $6\frac{3}{4}$ " x 8".



OFFERED AT A FRACTION OF THE COST OF MANUFACTURE

PRICE

22/6 each

Carriage paid
C.W.O.

These were manufactured for the Admiralty by Messrs. Multhead & Co., Ltd.

LIMITED SUPPLY ONLY—SEND NOW TO:—

GRAHAM MARTIN TRADING CO. LTD.,
57 ONTARIO STREET, LONDON, S.E. 1

All times given in this article are GMT, except where stated. Add one hour for BST.

DX

broadcast

World-wide reception of Short Wave programmes

Thanks to the co-operation of Mr. Arne Skoog, mentioned last month as DX Editor of Sweden's biggest newspaper, we are to have a special broadcast for all readers of the *Short Wave Listener* from the Swedish Radio. Judging by the excellent reception of Swedish stations generally in this country, it seems certain that all readers will be able to enjoy every minute of this broadcast. And now for the dates and times!

The first broadcast will be on Sunday, October 26 from 1600 to 1700 GMT, and the transmission will be repeated the night following from 0200 to 0300 GMT. The two transmitters allocated for this special programme will be the same for both broadcasts, namely: SDB2 10780 kc, 27.83 m.; SBT 15155 kc, 19.80 m.

Swedish Radio would appreciate as much publicity as possible in connection with this particular broadcast, so be sure to tell your friends about it, and for your part, send as accurate a report as possible to Swedish Radio, Stockholm 7, Sweden,

programme continued with some recordings of Mozart's music.

Radio Australia's broadcasts to the British Isles are being as well received as ever. In the mornings you will hear well-chosen musical recordings at 0645 on VLA6, 15200 kc (19.74 m.) and VLB8, 21600 kc (13.89 m.); VLC9, 17840 kc (16.82 m.) comes on the air with the same transmission at 0645. The afternoon session begins at 1500 and the following transmitters are in use: VLC9, VLA6, VLA8, 11760 kc (25.51 m.) and VLB4, 11810 kc (25.40 m.). There is another session during the evenings, commencing at 1745; on this occasion the channels used are VLA8 and VLB, 9540 kc (31.45 m.).

On August 24 (Sunday) Radio Australia was logged at 0900, giving news in English, with an excellent signal in the 19-metre band, (VLA6).

GENERAL COMMENTS

Australasia

There is news from Wellington, New Zealand, that the new short wave broadcasting service there will be in regular operation before the end of the year. There are to be two ten-kilowatt transmitters operating on channels in the 19, 25 and 31-metre bands and these will primarily be beamed on Australia.

When conditions are favourable for DX signals, it is not unusual to find broadcasts from the lesser-known Australian stations popping up at unexpected times. Quite recently, whilst listening on the 31-metre band at 0720, the writer heard the following direction: "You are tuned to the A.B.C. National Service; you are listening to 3LO and VLR, short wave." VLR, located at Lyndhurst, operates on 9530 kc; on this occasion the

Asia

A few weeks ago the writer had the good fortune to log a test transmission radiated by the Middle East Land Forces Broadcasting Service, Jerusalem, then operating on 7250 kc (41.27 m.). The time was 2000 and despite relatively high QRM, it was possible to identify the station by the following announcement: "You are tuned to a test transmission from No. 1 Forces Broadcasting Service, Jerusalem." A prompt reply to the writer's report on this transmission indicates that these test broadcasts have now ceased.

However, the usual frequency of 7220 kc (41.55 m.) is in use for relays of Jerusalem 1, the normal medium-wave transmission of the Forces Broadcasting Service on 377.4 metres; Jerusalem 2, which is an

Monthly Comment by R. H. GREENLAND, B.Sc.

alternative medium-wave transmission on 315.6 metres, radiates a programme of a more serious nature than that of Jerusalem 1, consisting mainly of classical music and plays. The short wave transmitter is located at Beit Jala near Jerusalem, some 3,000 feet above sea-level, and operates with a power of $7\frac{1}{2}$ kW; the aerial system is a horizontal half-wave, 0.4 wavelength above the ground level. The normal service area is Egypt, Cyprus and other Middle East countries, and the identification of the station is by direction only: "This is your Forces Broadcasting Service, Jerusalem." The times of transmission are given later in this article.

In Iran there are outlets in use for broadcasting, namely EQD, 6155 kc, operating periods 0330-0415 and 1430-

1900, and EQB, 15100 kc operating 1030-1245. The English broadcast from Teheran can be heard from 1215 to 1230, and one in French is radiated from 1145 to 1200. There is an additional French broadcast on Fridays only from 1600 to 1630.

On several occasions reference has been made in these articles to another Iranian transmitter working on 12180 kc from Tabriz during the early evening. Elsewhere it has been logged on 11985 kc at 1330.

Asiatic broadcasting stations can in fact be heard at almost any hour of the day. On August 2, VUDI0, Delhi, 17830 kc (16.83 m.) was received at 0315 with a programme summary in English. Transmissions from Burma are, unfortunately,

PROGRAMME PERIODS

I. BST 0700-0830.

- 0700 COHI Havana, Cuba, 6450 kc (46.51 m). End of News in Spanish. Closing directions in Spanish and English.
- 0730 KOFA Salzburg, Austria, 7220 kc (41.55 m). U.S. Armed Forces Radio Service—Light music.
- 0745 VLA6 Shepparton, Australia, 15200 kc (19.74 m). Australia and Your Future. Programme for Intending Migrants.
- 0800 KCBF Los Angeles, California, 11810 kc (25.4 m). News Headlines followed by News at dictation speed of 55 minutes' duration.
- 0815 HER5 Schwarzenburg, Switzerland, 11865 kc (25.28 m). Home News from Switzerland.

II. BST 1300-1400.

- 1300 VUD8 Delhi, India, 21510 kc (13.95 m). Native music.
- 1315 EQB Teheran, Iran, 15100 kc (19.87 m). Home and Foreign news in English, followed by musical recordings.
- 1330 VLA6 Shepparton, Australia, 15200 kc (19.74 m). News in English, followed by recordings of Sports Commentaries, e.g. Wrestling. (Programme intended for Allied Forces in the Pacific sphere.)
- 1345 VUD11 Delhi, India, 15290 kc (19.62 m). News in English.

III. BST 1600-1800.

- 1600 VLA6 Shepparton, Australia, 15200 kc (19.74 m). Afternoon broadcast to British Isles, commencing with "Australians on Records."
- 1630 VUD2 Delhi, India, 9590 kc (31.28 m). News in English.
- 1700 WCBX New York, 17830 kc (16.84 m). Signing on with Sousa's Stars and Stripes March.
- 1715 CKNC Sackville, Canada, 17830 kc (16.83 m). Feature Programme, e.g. Visit to Canadian National Exhibition at Toronto.
- 1730 WGX Schenectady, New York, 17880 kc (16.78 m). Commentary on the News.

- 1745 PMA Batavia, Dutch East Indies, 19350 kc (15.50 m). "Marching Thru' Georgia" preceding Radio Batavia's broadcast to the British Isles.

- 1750 B.F.E.B.S. Singapore, Malaya, 15300 kc (19.61 m). News in English, closing announcements, and "God Save The King."

IV. BST 1830-2030.

- 1830 ETAA Addis Ababa, Ethiopia, 15060 kc (19.92 m). Assorted musical recordings.
- 1845 VLA8 Shepparton, Australia, 11760 kc (25.51 m). Musical box version of Waltzing Matilda, call of the kookaburra, announcements and musical interlude.
- 1900 OTC5 Leopoldville, Belgian Congo, 17770 kc (16.88 m). Interval signal—beats of tom-tom, followed by Flemish programme.
- 1910 PCJ Hilversum, Holland, 9590 kc (31.28 m). Postscript after news in English, e.g. Talk on the Dutch Tree Fellers in the Black Forest of Germany.
- 1930 HNF Baghdad, Iraq, 6780 kc (44.23 m). Arabic music.
- 1955 FZI Brazzaville, French Eq. Africa, 9440 kc (31.76 m). World Sports news in English.
- 2015 HER5 Schwarzenburg, Switzerland, 11865 kc (25.28 m). Switzerland calling England with a commentary on World news.

V. BST 2130-2300

- 2130 VLG7 Lyndhurst, Australia, 15160 kc (19.79 m). Children's Morning Half-Hour in Australian National Service.
- 2145 FZI Brazzaville, French Eq. Africa, 11970 kc (25.06 m). News in English.
- 2200 WNBI New York, 15150 kc (19.80 m). Baseball commentary.
- 2215 WLWR Cincinnati, Ohio, 15130 kc (19.83 m). Call in English, followed by Italian programme.
- 2230 CKNC Sackville, Canada, 17820 kc (16.84 m). Broadcast to Denmark, including dance music.
- 2300 HCJB. Quito, Ecuador, 12455 kc (24.08 m). English programme. News, pianoforte solos, followed by "Evensong."

PREMIER RADIO

MORRIS AND CO. (RADIO) LTD.,

All Post Orders To: **JUBILEE WORKS, 167 LOWER CLAPTON RD.**
LONDON, E.5. (Amherst 4723)

Callers To: **169 FLEET STREET, E.C.4 (Central 2833)**

OUR 1946 LIST IS NOW AVAILABLE. All enquiries must be accompanied by a 24d. stamp.

MIDGET RADIO KIT. Build your own midget radio. A complete set of parts, including valves, loudspeaker and instructions. In fact, everything except cabinet necessary to build 4-valve Medium and Long Wave T.R.F. radio operating on 200-250 v. mains, A/C or D/C. Valve line-up, 6K7, 6J7, 25A6, 25Y5. Wavelengths covered 200-557 and 700-2,000. Size 10x6x6in. Completely drilled chassis. Price, including tax, £7 7s. 6d.

SUPERHET MIDGET RADIO KIT. A complete kit of parts for a 5-valve superhet. Covers 16-50 and 200-557 metres, AC/DC 200-250 v. 6K8, 6K7, 6Q7, 25A6, 25Y5. Size, 10x6x6in. Completely drilled chassis. Price including tax, £8/5/-.

An attractive brown bakelite cabinet can be supplied for either kit at a cost of 25/-.

ROTARY TRANSFORMERS. Input 12 v., output 180 v., 30 mA. 4 v. 2-3 a. with 19 volts input, output is 50 per cent. higher. May be used on D.C. mains as L.T. Charger. With small conversion could operate as D.C. Motor. Original cost over £5. Employ powerful ring magnet. Price 10/- each.

ALUMINIUM CHASSIS. Substantially made of bright aluminium, with four sides, 10 in. x 8 in. x 2½ in., 7/-; 12 in. x 9 in. x 2½ in., 7/9; 16 in. x 8 in. x 2½ in., 8/6; 20 in. x 8 in. x 2½ in., 10/6; 22 in. x 10 in. x 2½ in., 13/6.

MAINS TRANSFORMERS. Available in "Drop through" or above chassis mounting. Input 200/230/250 v., 50 cycles. Output 350/350, 250 mA., 4 v. 3-5 a., 6-3 v. 5-7 a., 6-3 v. 1-2 a., 35/-.

FIRST GRADE OIL FILLED PAPER CONDENSERS, with miniature stand-off insulators and fixing clips, 2 mfd., 1,000 v.w., 2/6 or 20/- per dozen; 2 mfd., 600 v.w., 1/9 each or 14/- per dozen.

SHORT WAVE CONDENSERS. High-grade Ceramic insulation. Super Midget type. Single-gangs available in 10, 20, 50, 75, 100 p.f. (75 p.f. has double spindle for ganging). Price 2/6.

2 GANG, in 4-8, 9-6, 27-1, 50, 75 p.f. Price 5/-.

2 GANG. Full-size, 160 p.f. Price 5/-.

500 MICROAMP METERS. Moving coil, 2 in. diameter, flush mounting, available by the following manufacturers: Met-Vick 500 ohms. Ferranti 79 ohms. Western 116 ohms. Either type 21/-.

Special quotations for quantities. The following accessories are available to convert the above meter into a multimeter. Five multipliers plus/minus 2½ per cent. to read 10/50/100/250/1,000 v., 7/6 the set. Bridge type meter rectifier, 10/-.

OSCILLOGRAPH POWER UNITS. Consist of a complete kit of parts for a 1,000 volt power unit with a 6-3 v. L.T. winding, includes transformer, voltage doubling metal rectifiers and smoothing condensers. Price 20/-.

METERS. All meters are by the best makers and are contained in bakelite cases. Prices are about one-quarter of original cost.

Range.	Diam.	Res.	Fitting.	Type.	Price
300 v.	3½ in.	15K	Flush.	M.I.A.C.	7/6
500 mA.	3 in.	—	Proj.	M.C.D.C.	12/6
250/250	mic/A.	2 in.	100	Flush M.C.D.C.	7/6
40 v.	2 in.	8 K	Flush	M.C.D.C.	7/6
2½ a.	2 in.	—	Flush	Thermo. H.F.	7/6
4 a.	2½ in.	—	Proj.	H.W.H.F.	3/6
3 KV.	3½ in.	1 meg.	Flush	M.C.D.C.	20/-
20 a.	2 in.	—	Flush	M.C.D.C.	7/6
40 a.	2 in.	—	Flush	M.C.D.C.	7/6
25 a.	3½ in.	—	Flush	M.C.D.C.	7/6
25 a.	3½ in.	—	Proj.	M.C.D.C.	7/6
25 a.	3½ in.	—	Flush	M.I.D.C.	7/6

VALVES. Brand new guaranteed military surplus EF50 (VR91) 6/-, RL16 (VR137) 12/6, RL7 (VR136) 7/6, EA50 (VR92) 5/-, V872 (VR116) 5/-. EB34 (VR54) 5/-. VU120 (SU220A) 12/6.

MAINS TRANSFORMERS. Input 230 v. 50 cycles. Output 1,500-0-1,500 v. 120 mA. 4 v. 3 a. twice. £2.

TRANSFORMER CARCASSES. Excellent for rewinding. 200 watts. 15/-.

as elusive as ever, but my July copy of *Bama Athan*, the programme pamphlet issued by the Burma Broadcasting Service, gives the latest schedules. The channels in use are 9542 kc (31.44 m.) and 6035 kc (49.71 m.).

From China, XGOY, Chungking, transmits in English to the United States at 1240 on 15165 kc, and at 1445 on 7152 kc. The latter frequency is used for the English broadcast to Europe from 1455 to 1545.

XGOY is reported also on 15345 kc at 0930, whilst XGOA, Nanking, 15170 kc, has been heard at 1500.

Africa

Portuguese broadcasting stations in Africa continue to provide good DX news. CR7BV, 4915 kc, has been logged by the writer at 2015 with the playing of "The Lost Chord" and followed by the now familiar direction: "You are listening to Radio Mozambique, Lourenco Marques, for Happy Listening in the 60- and 85-metre bands."

A new Mozambique station is CR7IB, 7155 kc, located at Beira. Its schedule is: Weekdays, 0945-1045 and 1800-2000: Sundays, 0900-1800, and the address is: P.O. Box 3, Beira, Mozambique.



Close up of the main operating console for control of the various sets in the CBC transmitter hall at Sackville, New Brunswick.

On Africa's western coast, Portuguese Angola broadcasts over CR6RL (medium-wave), CR6RA (9470 kc) and CR6RN (15900 kc), the latter two being operated in parallel. The station is located at Luanda, but its present schedule is unfortunately unknown.

The writer has found that signals from the short wave stations of the Sudan Broadcasting Service, in Omdurman fluctuate considerably. Generally, the 13320 kc frequency is the more consistent, though recently the 9970 kc (30.09 m.) channel was well received one Friday at the

commencement of the weekly English broadcast at 1730.

One station which has not yet been identified is to be found on exactly 12000 kc in the evenings. On August 3 we heard "The Golliwog's Cake Walk" foxtrot at 1940 and five minutes later came native instrumental music. Perhaps this is Asmara, Eritrea, which has been reported to be working around this frequency, and which appears to close down at 2000.

Referring to ETAA, Radio Addis Ababa, Ethiopia, which has certainly been

working on 15060 kc, the following schedule for this station has been advertised by Radio Australia, 1200-1405; 1825-2005.

From our own observations the evening session commences earlier than the stated time, and normally ETAA closes down promptly after a very brief English announcement at 2000.

South America

This continent has not a great deal to offer this month, though some Peruvians and Ecuadoreans have been logged, though mainly on higher frequencies than are normally noted in connection with those countries.

OAX4J is quite regular on 9330 kc (32.15 m.) with carioca and other typical dance tunes around 0600. This Spanish direction was heard as late as 0620: "OAX4J, Radio Colonial, en Lima."

On 9765 kc a good signal has been observed with Latin American dance tunes at 0315, and the station identified by a distinct Spanish announcement before the close at 0350. This is OAX4K, Radio Goicochea, 9765 kc (30.72 m.) which finally fades out during the playing of a rumba. On August 8 it was heard until 0500.

A new Ecuador station whose call letters have as yet evaded us has been logged by the writer on 4650 kc at 0355 with a baritone song, and with tangos after announcements in Spanish at 0400. A station direction was given at 0415, but in so rapid a fashion as to make identification impossible. Several frequencies were mentioned, this being apparently one in an extensive network of stations. It closed down at this time after the playing of the Ecuadorean National Anthem.

On August 2, HC4EB, Radio Manta, 6870 kc, was an excellent signal (S9) at 0405. Its Spanish announcements indicated that it is a commercial short wave

broadcasting station; you will hear the following direction on the hour: "Radio Manta en la Republica de Ecuador, America del Sud." Dr. T. B. Williamson (St. Albans) mentions HC4EB and YV5RU, 4880 kc, in Caracas, capital of Venezuela. He has logged the latter at 0330 with an S6 signal.

North America and West Indies

YNAO, Masaya, Nicaragua, on 7420 kc is quite consistent, if you are up early enough to search for him. On August 2 signals were marred by severe Morse interference and it was not possible to read the final directions given as the station closed down at 0310. On the other hand, YNDG's closing announcements in English were again clearly heard at 0400; on August 5, however, YNDG closed down with the Ted Lewis "Goodnight Song" at 0317. This broadcaster, which is situated at Leon, Nicaragua, operates on 7660 kc (39.16 m.).

Radio Managua, Nicaragua, 8350 kc, is usually observed around 0400, but again Morse frequently spoils reception of this otherwise prominent station. Has anyone yet checked its call letters?

In the Republic of Honduras, HRP1, 6350 kc, located at San Pedro Sula, was audible on August 2 at 0312 when ascending gong chimes (the four notes of the major chord) preceded the station direction in Spanish. This included the call-letters and situation, and the announcements were sufficient to indicate that HRP1 is the short-wave outlet of a medium-wave station in the same locality. HRP1 closed down with the playing of a waltz tune at 0332. On August 5, HRN, Tegucigalpa, Honduras, 5875 kc, was a relatively good signal when closing with the Ted Lewis Goodnight Melody at 0357. This one always closes just before the hour!

TGWA, Guatemala City, 9760 kc, playing medium-wave TGW, is a most reliable station between 0400 and 0500. Its charming marimba music cannot fail to halt you during your early morning peregrinations. It terminates with the playing of the Guatemalan National Anthem at 0503.

Again the most noteworthy Mexican was XEWW, heard on 9500 kc, (31.58 m.) at 0315 with its call: "XEWW y XEWW, Mexico." This was preceded by four ascending gong notes representing the major chord. As a rule this station broadcasts typical Latin American dance music in its sponsored programmes.

**QUARTZ
CRYSTAL
UNITS...**

Available for simultaneous delivery. Prices on application.

VISIT OUR STAND
No. 75
RADIOLYMPIA

FOR YOUR TRANSMITTER.
TYPE 2 LOW TEMPERATURE COEFFICIENT PLATES. 3.50/3.75me/s for the 30me/s Band.



SALFORD ELECTRICAL INSTRUMENTS
PEEL WORKS, SALFORD 3
Proprietors **THE GENERAL ELECTRIC Co Ltd**
OF ENGLAND

RADIO CAREERS AN IMPORTANT GUIDE

"Engineering Opportunities" indicates clearly how all engaged in the rapidly expanding Wireless industry can safeguard their future by becoming technically equipped to accept highly paid key appointments that will not be affected by any return to competitive labour conditions.

This modern guide contains 112 pages of highly useful information. It gives full details of our very comprehensive series of modern **WIRELESS COURSES**, including **General Wireless, Short Wave, Wireless and High Frequency, Sound-film Projection Engineering, Television and Radio Servicing, etc.**

TELEVISION AND RADIO SERVICING

There is no doubt about it that there will shortly be an enormous boom in Television and unlimited opportunities for trained men. Our special **TELEVISION and SERVICING Courses** are fully described in the handbook.

"ENGINEERING OPPORTUNITIES" also explains the most efficient way of preparing candidates for such recognised Examinations as **A.M.I.E.E., A.M.Brit.I.R.E., City and Guilds, etc.**

WE DEFINITELY GUARANTEE

"NO PASS—NO FEE"

The Wireless Industry is alive with possibilities. In your own interests you should write for your copy of "ENGINEERING OPPORTUNITIES" to-day. It will be sent **FREE**, and the book is bound to indicate many opportunities which otherwise you might miss.

BRITISH INSTITUTE OF ENGINEERING TECHNOLOGY

926 Shakespeare House,
17/19 STRATFORD PLACE, LONDON, W.1

SHORT WAVE (HULL) RADIO G5GX

ORDER NOW

Your new Eddystone 640 receiver. Price £51/0/7, including tax. Delivery immediate.

Any Ham gear constructed to your specification. Send us the details and we will quote you by return of post.

A REALLY EFFICIENT SERVICE

RECEIVER KITS

2-Valve O.V.I.

Bandspread tuning, plug-in coils 9-200 metres, Pentode output. Price complete with valves but less cabinet and batteries, £6/-.

4-Valve I (Tuned) V.2.

Bandspread tuning 9-200 metres with tuned RF stage. Complete in black crackle steel cabinet but less batteries and speaker. Price £12/12/-.

Particulars sent on request

SHORT WAVE (HULL) RADIO

30/32 Prince's Avenue,
HULL

Telephone 7168

FILTER CRYSTALS

FOR

COMMUNICATION RECEIVERS

ALL USUAL I.F. RANGES

450 to 1600 kc/s

ENQUIRIES INVITED

BROOKES CRYSTALS LTD.

GREENWICH, LONDON, S.E.10

GRE. 1828

METROPOLITAN RADIO AND TELEVISION RENTALS LTD.

67, LAVENDER HILL, LONDON, S.W.11

Phone: Battersea 4761.

SPECIAL OFFER of BC 342 United States Signal Corps 10-valve Communication Receivers. 110 volt A.C. only.

Sixty pounds of DX Width 18 in., height 9½ in., depth 7 in., completely enclosed osc. section, internal detachable power pack, send-receive relay, and jacks for two pairs 'phones, loudspeaker, key, and mike. There is a multi-connector for linking to transmitter but receiver works independent of this. Ceramic valve holders, coil formers, gang insulation, switches and trimmers. 2 HF. Osc. Mixer, 2 IF. Det-LF. Second LF. BFO. Rectifier, X'tal filter. (6K7, 6K7, 6C5, 6L7, 6K7, 6K7, 6R7, 6F6, 6C5, 5W4), spares available.

CONTROLS. Aerial alignment, combined RF and LF gain, X'tal phasing, BFO switch, BFO note, manual and AVC switch incorporating on-off switch, send-receive switch, six-band wave change switch.

COVERAGE. 1.5-18 megs., separately calibrated scale for each band with nice spread, simple numerical logging on vernier and scale. Circuit diagram in each instrument cover.

Each instrument carefully checked over and aligned by GBQV ready for immediate use with a sensitivity of better than 2 microvolts on 'phone and better than 1 microvolt on CW. IF's aligned to the X'tal filter and calibration correct.

These are offered at £18/10/- or modified as per Q.S.T. of September last at £20. Packing and carriage, one receiver 12/6, two receivers £1. Cash with order.

Auto-transformers for 200-250 volts can be supplied with the receiver at 25/-.

The island of Haiti with its two separate countries furnishes us with a spate of short-wave news this month. In the republic of Haiti itself, a comparatively new station is HHCN, located at Port-au-Prince. It operates daily from 2200 to 0200 on a frequency of 5660 kc (53 m.). Reports should be forwarded to Station HHCN, Avenue Cristophe No. 55, Port-au-Prince, Haiti. D. O. French (Norwich) sends us this news. HH2S, 5950 kc (50.37 m.), offers an attractive musical programme around 0235. It has been logged recently with announcements in French, the well-known air: "La Cygne" (Saint-Saens) and a French march prior to the close at 0302. HH3W, 10130 kc (29.62 m.), also located at Port-au-Prince, provided soothing music, which included "The Lost Chord" at 0250 on August 5.

Before closing at 0257, we heard the words: "Bonsoir Mesdames, Bonsoir Messieurs" and finally a French march, which is, apparently, the national air of Haiti.

The Dominican Republic is also on the island of Haiti. Here, we find good signals around 0215 from HI1N, 6245 kc, and HI1Z, 6310 kc, both of which have been noted by Dr. T. B. Williamson (St. Albans). They are located in the capital city of Trujillo. T.B.W. has logged the following direction on 7350 kc at 0315: "La Voz de Yuna en Cuidad Trujillo," but no call letters were given; he suggests that this may be HI2T on a new frequency, and that too is our surmise.

In the August issue of the *Short Wave Listener* mention was made of VP4RD, Port-of-Spain, Trinidad, which has been heard testing on 9625 kc. These tests were concluded at the end of July and regular broadcasts were scheduled to commence on August 31. All reports on this British West Indies station should be sent to: The Trinidad Broadcasting Company Ltd., Port-of-Spain, Trinidad, B.W.I.

Not for some time has a West Coast United States station been heard in the afternoon on the 19-metre band, but KCBR was there at good strength on August 1. It closed down at 1500 after station announcements with the playing of the "Stars and Stripes." In the early mornings KRHO, Honolulu, Hawaiian Islands, on 17800 kc (16.85 m.) is often a good signal with call followed by world news in English at 0500.

The Canadian Broadcasting Corpora-

tion's transmissions to the British Isles are as reliable as ever. On August 25 at 2000, listeners heard a talk on high finance in Canada by Bruce Mackinnon through CKNC, 17820 kc. Some forty-five minutes later, over CKCS, 15320 kc, we heard yet another of those fascinating Tales of Two Cities, this time about Woodstock, Ontario, and its sister, Woodstock (Oxon.) in the United Kingdom.

Europe

With reference to my mention last month of a special broadcast from Reykjavik on 12170 kc (24.65 m.), I have received a letter verification confirming that on July 20 Prince Olav unveiled a statue given by the Norwegian Government to the country of Iceland, commemorating the most famous Icelandic historian, Snorri Sturluson, and that the proceedings were broadcast.

Should you be fortunate enough to pick up any of these occasional transmissions from Iceland and want a verification, send your report to: Thorst. Egilson, Secretary, Rikisutvarpid (Iceland State Broadcast Service), Reykjavik, Iceland.

Speaking of Scandinavian countries, Norway's regular broadcasters are LKV, 15170 kc, and LKJ, 9540 kc, operating on the following daily schedule: 0800-0815: 1010-1245: 1600-2200. Other transmitters used for occasional purposes are: LLI, 6185 kc and LKQ, 11735 kc. The Finnish short wave broadcasting stations are listed elsewhere in this article.

Monte Carlo, Monaco, possesses a short wave broadcasting station which operates regularly on 6130 kc. Programmes which are commercial in character and naturally in French, include such popular items as Handel's Largo which the writer recently recorded at 0722 one morning. Station directions are given by both male and female announcers.

In Roumania, Radio Bucharest is on the air from 1830 to 1925 on 9253 kc (32.42m.). There is a talk in English at 1915, and this may be preceded by a distinctive interval signal, the striking of six or seven piano-like notes. Prague, Czechoslovakia with OLR3A on 9550 kc begins its evening broadcast at 1630, and Rome on 9630 kc and 11810 kc commences at 1700. Switzerland may be heard with a massive signal in the 25-metre band (11865 kc) at breakfast time. HER5 offers Swiss Home News in English each morning at 0715.

The mystery Forces station on 6710 kc (44.71 m.) can sometimes be logged without difficulty, though severe Morse trouble is apt to be encountered. One Sunday I listened comfortably to a dance session from 1925 until 2133. All items were introduced by a Serviceman and English was the only language used. At 2135 he mentioned a Sergeants' Mess (R.A.F.) at the Camp where the station is situated and indicated that requests for future broadcasts should be submitted to Station 230. Then he said: "Radio Banfeld now closing down. The time is 11.46. Goodnight Everybody." The writer's letter sent *via* B.A.O.R. has been returned with the marking: "Insufficient Address." Can any reader please assist in making direct contact with this elusive short wave broadcaster?

Finally, a station has been logged by C. D. Kadwill (Bexley, Kent) on approximately 24 m. around 1700-1745, transmitting a programme of gramophone records; signal strength S7, quality poor.

Announcements were made in English alternately by a man and a woman and varied from: "This is station XDL testing" to: "This is short wave station XDL testing and broadcasting a programme of gramophone records for the benefit of stations WXD and CLY; we trust you are receiving us." These words were pronounced at 10-15 minute intervals and were preceded by the ticking of a metronome.

PUBLIC SCHOOLS EXPLORING SOCIETY

During the period September 9—October 15, the Society's 1947 Expedition will be in Southern Newfoundland. For international amateur working, the callign used will be G8XY/VO. Main frequencies in use will be 3520, 3597, 7050 and 14100 kc, with an input of 40 watts, CW only except on 3520 kc, on which 'phone also will be employed. Other frequencies in these bands will be available, and there may be some operation on 1.7 mc as well with callign G8XY/P.

A special QSL card will be sent to confirm all contacts with amateur stations and to acknowledge *useful* SWL reports. Address for QSL's is Radio G8XY, Public Schools Exploring Society, White Barn, Old Oxted, Surrey.

UNLICENSED OPERATOR FINED

At the Wirral Justices' Court, sitting at Birkenhead on August 28, Reginald C. J. Maude of 40 Raeburn Avenue, West Kirby, Cheshire, was fined £10 for operating wireless transmitting apparatus on July 14, without a licence.

For the postal authorities, Mr. Roger Lewis said it was the first case of its kind in the Wirral area. For some time there had been complaints of interference with BBC programmes by rather strange broadcasts, which specially affected licensed amateurs.

These broadcasts were on 160 and 200 metres, and the latter transmissions were usually prefaced by the announcement "This programme comes from the Radio Broadcasting Company." On the 160-metre band Maude used the callign G5BT.

TABULATED SCHEDULES

I. Forces Broadcasting Service, Jerusalem, M.E.L.F. 7220 kc., 41.55 m. Times of Transmission.

Monday, Tuesday, Thursday and Friday.

0430-0630 Relays Jerusalem 1.
0635-0640 The news in Polish.
0800-1700 Relays Jerusalem 1.
1700-1800 Relays Jerusalem 2.
1800-2000 Relays Jerusalem 1.
2000-2005 The news in Polish.
2005-2100 Relays Jerusalem 1.

Wednesday.

0430-2100 As for Monday, Tuesday, Thursday and Friday.

2100-2300 Special programme and requests, for more distant listeners as well as those in the Middle East.

Saturday. As for Monday, Tuesday, Thursday and Friday except

1700-1800 Relays Jerusalem 1.

Sunday.

0430-1700 Relays Jerusalem 1.
1700-1900 Relays Jerusalem 2.
1900-2000 Relays Jerusalem 1.
2000-2005 The news in Polish.
2005-2100 Relays Jerusalem 1.
2100-2300 Special programme and requests.

II. Burma Broadcasting Service, Rangoon. Daily Broadcasts (English).

0115-0130	Headline news at 0125.	31-44 m	9542 kc
0615-0645	News at 6030.	31-44 m	9542 kc
1415-1515	News at 1500.	49-71 m	6035 kc

III. International Broadcasting Station, Chungking, China. XGOY. Daily Broadcasts.

1. To Australia, New Zealand and South-East Asia. 0855-1030. 11913 kc.

2. To East Asia and the South Seas. 1035-1235. 7153 kc and 9658 kc. News in English at 1100.

3. To North America. 1240-1445. 7153 kc and 9658 kc. News in English at 1300.

4. To Europe, Asia and the South Pacific. 1455-1545. 11913 kc and 7153 kc. News in English at 1500.

All these broadcasts are introduced in the English language.

IV. Finnish Short Wave Broadcasting Transmitters.

1. OIX1, Helsinki. 6120 kc, 10 kw. Sunday. 0545-2100. Weekdays. 0555-0630: 1110-1210: 1500-2100.

Wednesday and Saturday. Additional 2100-2200. Tuesday and Thursday. Additional 0915-0945. English at 0025 daily.

2. OIX2, Björneborg. 9500 kc, 20 kw. Usually works in parallel with OIX, but carries additional French programmes. News in English at 1215 and 0025.

3. OIX3, Lahti. 11780 kc, 10 kw. Same programme as OIX1.

4. OIX4, Björneborg, 15150 kc, 15 kw. Same programme as OIX2.

5. OIX5, Helsinki. 17800 kc, 10 kw.

SHORT WAVE BROADCAST STATIONS

Revision 19-87-30-9 Metres

Giving Frequency, Wavelength, Callsign and Location

These lists appear each month, covering the 11-128 metre section of the wave band within which all the short wave broadcasting services of the world operate. For economy of space, this band is dealt with in three sections, a list of active stations in one of these sections being given in full every month. Such revision is necessary due to constant changes of frequency, callsign and operating schedules. All stations appearing in our lists are normally receivable in this country and are under regular observation.

Frequency	Wave-length	Callsign	Location	Frequency	Wave-length	Callsign	Location
15100	19-87	EQB	Teheran, Iran.	11730	25-58	WRUL	Boston, Mass.
15060	19-92	ETAA	Addis Ababa, Ethiopia			KGEX	San Francisco, California.
12950	23-16	VP4RD	Port of Spain, Trinidad.			GVV	Daventry.
12180	24-63		Tabriz, Azerbaijan.	11725	25-59		Jaffa, Palestine.
12170	24-65	TFJ	Reykjavik, Iceland.	11720	25-60	CHOL	Sackville, Canada.
12095	24-56	GRF	Daventry.			PRL3	Rio de Janeiro, Brazil.
12040	24-92	GRV	Daventry.			OTM4	Leopoldville, Belgian Congo.
12020	24-96		Hanoi, Indo-China.	11715	25-61	FGA7	Dakar, Senegal.
12000	25-00	CEI180	Santiago, Chile.			HEI15	Berne, Switzerland.
11971	25-06	FZI	Brazzaville, French Equ. Africa.	11710	25-62	VLG3	Lyndhurst, Australia.
11955	25-10	GVV	Daventry.			WLWO	Cincinnati, Ohio.
11915	25-18	XGOY	Chungking, China.			WLWS2	Cincinnati, Ohio.
11900	25-21	VLO9	Lyndhurst, Australia.				Johannesburg, Transvaal.
		KWID	San Francisco, California.	11705	25-63	SBP	Motala, Sweden.
11890	25-23	KWIX	San Francisco, California.	11700	25-64	GVW	Daventry.
880	25-25	VLG5	Lyndhurst, Australia.	11695	25-65	HP5A	Panama City.
		VLH4	Melbourne, Australia.	11685	25-67	HVJ	Vatican City.
870	25-27	WOOC	New York.	11680	25-68	GRG	Daventry.
		WOOW	New York.	11635	25-78		Moscow.
		VUD7	Delhi, India.	11090	27-05		Ponta Delgada, Azores.
11865	25-28	HER5	Berne, Switzerland.	11040	27-17	CSW6	Lisbon, Portugal.
11860	25-29	GSE	Daventry.	11000	27-27	YHN	Djakakarta, Java.
11850	25-32	VUD3	Delhi, India.	10780	27-83	SDB2	Motala, Sweden.
11840	25-35	VLC7	Shepparton, Australia.	10130	29-62	HH3W	Fort-au-Prince, Haiti.
		VLG4	Lyndhurst, Australia.	10060	29-82	PLY	Bandoeng, Dutch East Indies.
11835	25-35	CXA19	Montevideo, Uruguay.	9980	30-00		Brazzaville, French Equ. Africa.
11830	25-36	WCBN	New York.	9970	30-09		Omdurman, Sudan.
		XGOA	Chungking, China.	9958	30-13	HCJB	Quito, Ecuador.
11820	25-38	GSN	Daventry.	9915	30-25	GRU	Daventry.
11815	25-39	HEU5	Schwarzenburg, Switzerland.	9912	30-26		Johannesburg, Transvaal.
11810	25-40		Rome.	9880	30-36		Moscow.
		HOXB	Panama City, Panama.	9860	30-42		Moscow.
		KCBR	Delano, California.	9830	30-52	COBL	Havana, Cuba.
		WGEA	Schenectady, New York.	9825	30-53	GRH	Daventry.
		WOOW	New York.	9765	30-72	OAX4K	Lima, Peru.
11800	25-42	CEI180	Santiago, Chile.	9760	30-73	XGOA	Chungking, China.
11790	25-45	WLWO	Cincinnati, Ohio.			TGWA	Guatemala City, Guatemala.
		WRUA	Boston, Mass.	9750	30-77	WNRX	New York.
		WRUS	Boston, Mass.			KCBA	Delano, California.
		KGEI	San Francisco.			KCBF	Delano, California.
		KNBX	Dixon, California.	9748	30-77	OTC2	Leopoldville, Belgian Congo.
11785	25-46		Vienna, Austria.	9740	30-80	CSW7	Lisbon, Portugal.
11780	25-47	OX3-XENN	Lahti, Finland.	9730	30-83	CE970	Valparaiso, Chile.
			Mexico City	9705	30-91	FZF6	Fort-de-France, Martinique.
			Saigon Indo-China.				Lusaka, Northern Rhodesia.
11770	25-49	VLA4	Shepparton, Australia.	9700	30-93	PRL7	Rio de Janeiro, Brazil.
		VLB3	Shepparton, Australia.			WLWR1	Cincinnati, Ohio.
		S.E.A.C	Colombo, Ceylon.			KCBR	Delano, California.
		KCBR	Delano, California.	9690	30-96	GRX	Daventry.
11760	25-51	VLA8	Shepparton, Australia.			HJCAB	Bogota, Colombia.
		VLG10	Lyndhurst, Australia.	9685	30-98	LRA1	Buenos Aires, Argentina.
		CKRA	Sackville, Canada.				
		VUD11	Delhi, India.				
11750	25-53	GSD	Daventry.				
11740	25-55	HVJ	Vatican City.				
		CEI174	Santiago, Chile.				
11735	25-56	LKQ	Oslo, Norway.				
			Singapore, Straits Settlements.				

CHARLES BRITAIN (RADIO) LTD.

MCRI. MINIATURE COMMUNICATION RECEIVER. We still have a few of these amazing little sets left. Complete with phones, Aerial, 4 plug on coils covering from 15 to 3,000 metres. Power Pack to work from A.C. or D.C. mains 97 to 250 volts. Tested and ready to work. Price £8/5/-

Batteries for the above 10/- ea. or 2 for 17/6. Instruction book with full circuit diagram, etc., 2/9

R.1147B UHF RECEIVER. Range 180 to 220 Mc/s. complete with 7 valves 2, EF36, 1, EBC33, 2, EF50, 1, EC52, 1, EF54, mostly in new condition; readily convertible for 2½ metre operation. Price carriage free, 39/6. Theoretical circuit diagram for the above, 1/9.

INDICATOR UNIT. Complete in metal case with 6 in. Electrostatic C.R. tube, instantaneous screen, suitable for converting to scope, or television, also contains 4, EF50, 3, EB34, valves. This item to callers only, £3/10/-. Circuit diagram, 1/9.

CHARLES BRITAIN (RADIO) LTD., RADIO HOUSE, WILSON ST., LONDON, E.C.2. BIS. 2966.

EX-ARMY No. 22. Transmitter and Receiver combined. Range 2 to 8 Mc/s. (35 to 150 Meters). This is a powerful set and operates on R/T, C.W. and MCW. Suitable for use on Yachts, and mobile operation, as well as in the shack. Amazing value. Price with phones and 13 valves, £6/19/6. Power pack for operating the above from 12 v. battery, £1/19/6, or Set, Phones and Power Pack, £7/19/6. Carriage free.

U.S. NAVY INDICATOR UNIT, Model AN/APA1. Brand new and Crated. Complete with 3 ins. C.R. tube, 11 new valves, carriage paid, £4/17/6 or less crate, to callers, £4/10/-.

EX-ARMY No. 38 SET. Walkie Talkie, complete valves, throat mike, 2 pair Phones, junction box, haversack, sectional aerial, range 7-4 to 9 Mc/s., £4/5/- carriage free.

Full range of standard components. Connoisseur pick-ups. Crystal pick-ups. Avomains Oscillators, etc. We are the cheapest house in the trade.

Send for Components list No. "SL."

SOUTHERN RADIO AND ELECTRICAL SUPPLIES

EDDYSTONE.—Communication Receivers:—Model 504 10 valves, including 2 R.F. & 2 I.F., crystal filter, noise limiter, B.F.O. etc., £58/18/7. Model 640 9 valves, including R.F., 2 I.F., crystal filter, B.F.O., etc., £51/0/7. Full details upon request. Short Wave Manual No. 5 containing constructional details of Bandspread All-Dry Four or 2 volt battery receiver, VHF, meter, 5 metre 15 watt transmitter, 5 to 10 metre 3 valve converter, 2 valve preselector, 10 metre CW and phone transmitter price 2/7 post free. Eddystone Manual No. 6 containing details of Short Wave 2 valve battery receiver, single valve VHF preselector, 3 valve VHF straight receiver for AC mains, 5 metre C.O. transmitter, heterodyne frequency meter price 2/7 post free. This new manual is released in October and should be available by the time this advert appears. Full range of Eddystone components kept in stock.

DENCO.—Coil Turret CT1, 12-2,000 metres 60/6. Coil Turret CT3 42 Mcs to 0-15 Mcs £7/0/10. B.F.O. Units complete 465 Kcs or 1-6 Mcs 13/9 each. Miniature iron core d I.F. transformers 465 Kcs 10/6.

Q-MAX.—Chassis cutters:—1½ in. (Oxetal) 10/6, 1½ in. 12/6, 1½ in. 12/6. Super slow motion dial for individual calibration, ratio 50 : 1 66/-, ratio 8 : 1 15/6.

EX-GOVT. BARGAINS.—Rod aeriels 4 section to make a 5 ft. aerial 2/-. Short wave variable condensers: 18 pF 3/6, 20 pF with long spindle 3/3, 100 pF 3/6, 2 gang 18 pF 7/6, 2 gang 160 pF 10/-, 3 gang 100 pF 10/6. Moving coil pocket meters 0-15 volts and 0-250 volts D.C. complete with strong canvas carrying case, brand new and sealed 18/9.

Postage extra under £2. Bargain list 3d. post free.
85 FISHERTON ST., SALISBURY, WILTS.

Telephone: Salisbury 2108

AN AMERICAN PUBLICATION

CQ

The Radio Amateurs' Journal

NO "HAM" SHACK IS COMPLETE WITHOUT "CQ"

"CQ" is published exclusively for the AMATEUR and SHORT WAVE Listener.

Each issue contains large feature articles on the construction of Transmitters, Receivers, Modulation Equipment, Aerials, etc., etc. Dozens of photographs and illustrations.

SUBSCRIPTION FOR ONE YEAR 17/6 Post paid
(Published Monthly)

We have made arrangements for subscribers to receive copies of this famous American Magazine direct from the Publishers immediately each issue comes off the press. Post your subscription to-day to:

DALE INTERNATIONAL

Publications Limited.

105 BOLSOVER ST., LONDON, W.1.

Telephone: MUSEum 1023.

go

CLYDESDALE

The Radioman's Shop

For Bargains in Ex-Services Electronic Equipment

Power Units and Motor Generators easily connected as **ELECTRIC MOTORS** for AC or DC mains

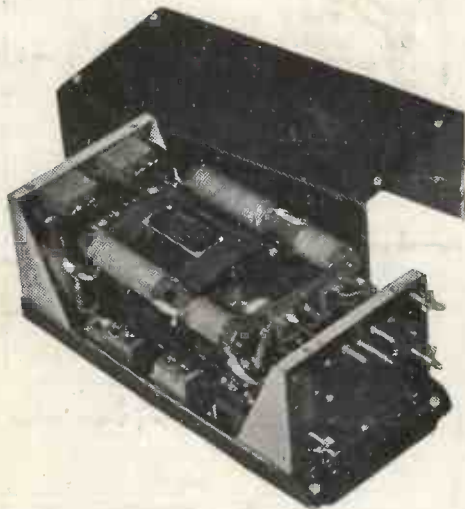

POWER UNIT 10K17

for T1154Tx.

IP. 12v. O.P. 1,200v. 200 m.a. Contains Type 28 motor generator (connection data supplied) relays, smoothing, etc., in metal box, 16½" x 7½" x 6½", finished black.

OUR PRICE ONLY **21/11** each Carriage and packing 5/- extra

POWER UNIT 10K13066

IP. 18v. 12A. O.P.s. 7.2v. 13A. 225v. 110ma. Contains Type 31 motor generator (connection data supplied) etc., as 10K17 above.

OUR PRICE ONLY **21/11** each Carriage and Packing 5/- extra

MOTOR GENERATOR Type 31

IP. 18v. O.P.s. 7.2v. 13A. 225v. 110ma. Size 12" x 5½" x 5" (connection data supplied).

Brand New

OUR PRICE ONLY **21/-** each Carriage and Packing 5/- extra

ROTARY GENERATOR Type H146

For vertical or horizontal mounting. Easily converted. Size, only 7" x 4" x 3", IP. 12v. -65a. O.P.s. field in parallel. 470v. 30ma. 270v. 15ma. or 450v. 40ma. or 260v. 30ma.

Brand New

OUR PRICE ONLY **12/6** each Post and Packing 2/- extra



SEND NOW FOR NEW ILLUSTRATED LISTS. PLEASE PRINT NAME AND ADDRESS.

CLYDESDALE

SUPPLY
CO LTD

2 BRIDGE STREET

GLASGOW

C.5

'Phone: SOUTH 2706/9

VISIT OUR BRANCHES IN SCOTLAND, ENGLAND AND NORTHERN IRELAND