

THE RADIO CONSTRUCTOR

Vol. 25 No. 9

APRIL 1972

20p

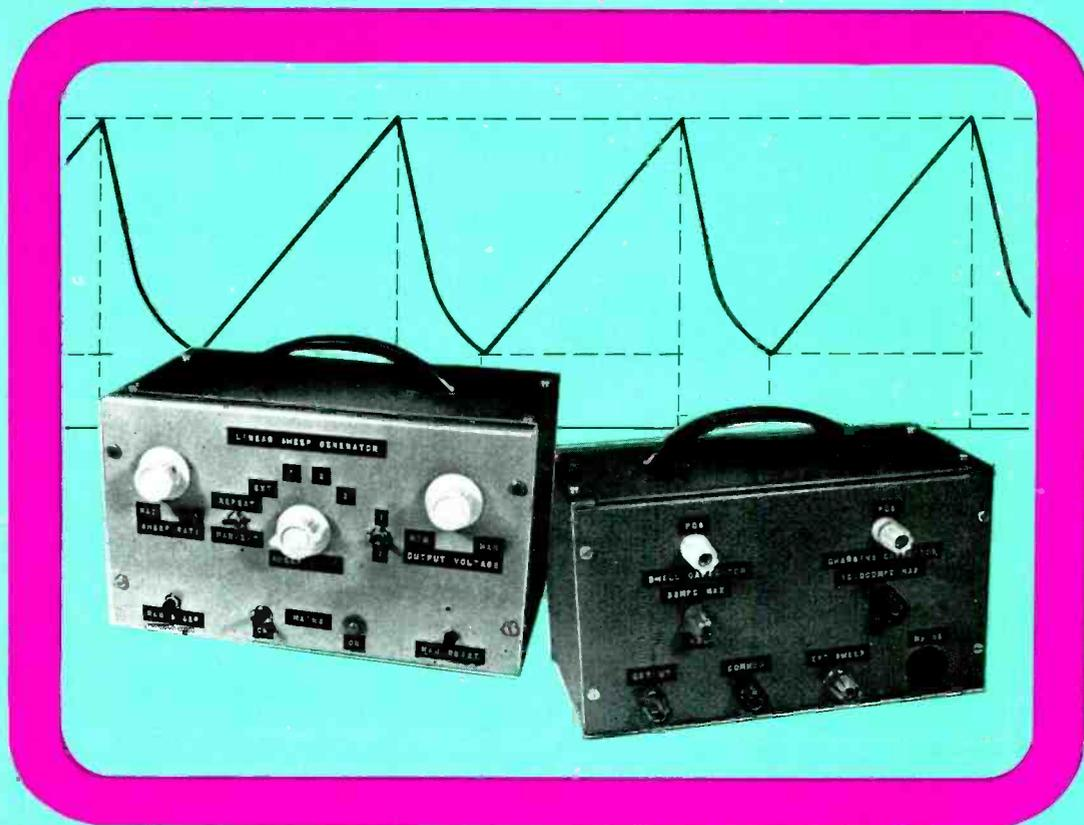

WIDE RANGE LINEAR SAWTOOTH GENERATOR Part 1

Special
IN THIS ISSUE

The 'Bass-Boost' Portable
V.H.F. Wavemeter



Each £3 unit of Home Unit Insurance gives you protection up to the limit shown

This is the simplified insurance you have been waiting for. Not just cover on the contents of your home but a package of personal protection you and your family need. And it's how we save you so much money: just ONE policy to issue instead of nine! You can build up to the cover you need by additional units

(or ¼ units after the first) up to a maximum of five. So simple. So easy. Apply to your Broker, Agent or local office of a General Accident company. The Home Unit Policy can replace your existing insurances And remember - as you buy more possessions just add more Home Units at any time.

THE GENERAL ACCIDENT FIRE & LIFE ASSURANCE CORPORATION LTD

Metropolitan House, 35 Victoria Avenue,
Southend-on-Sea, Essex, SS2 6BT

It pays to be protected by a **General Accident** company

Please send me further particulars of the Home Unit Insurance.

Name.....

Address.....

JERMYN

All semi-conductors from Motorola G.E. (USA), Raytheon—TAG available ex stock at distributor prices on a cash with order basis.

Special Kit Offers

Capacitor discharge ignition system (based on Practical Wireless design). Only £7.75 including P&P. Please state + or —.

Domestic light dimmer. Only £2.80 complete. 200 watt rating.

PA263 IC PC board and full circuit. Needs only 12 capacitors/resistors to build 3½ watt mono amplifier. Frq response 30hz to 100Khz. Closed loop distortion better than -5% £1.75 or £3.50 for stereo.

All items at 15p post + packing unless stated otherwise.

Mail order only.

Dept PAT
Jermyn Industries Ltd
Vestry Estate
Sevenoaks
Kent

RSGB BOOKS FOR YOU

RADIO DATA REFERENCE BOOK

Third (1972) edition

Compiled by G. R. Jessop, CEng, MIERE, G6JP
Completely revised and updated

An invaluable source of essential radio data conveniently gathered into one hard-bound volume.
150 pages £1 post paid

VHF-UHF MANUAL

By G. R. Jessop, CEng, MIERE, G6JP

Transmitters, receivers and test equipment for use at vhf and uhf are all fully covered on a practical basis in this second edition. £1.80 post paid

RADIO COMMUNICATION HANDBOOK

832 pages of everything in the science of radio communication. The Handbook's U.K. origin ensures easy availability of components. Complete coverage of the technical & constructional fields. A superb hard-bound volume. £3.50 post paid

These are three of a complete range of technical publications, log books and maps, all obtainable from:

RADIO SOCIETY OF GREAT BRITAIN
35 DOUGHTY STREET, LONDON, WC1N 2AE

Now! A FAST EASY WAY TO LEARN BASIC RADIO & ELECTRONICS



Build as you learn with the exciting new TECHNATRON Outfit! No mathematics. No soldering—you learn the practical way.

Learn basic Radio and Electronics at home – the fast, modern way. Give yourself essential technical 'know-how' – like reading circuits, assembling standard components, experimenting, building – quickly and without effort, and enjoy every moment. B.I.E.T.'s Simplified Study Method and the remarkable TECHNATRON Self-Build Outfit take the mystery out of the subject, making learning easy and interesting.

Even if you don't know the first thing about Radio now, you'll build your own Radio set within a month or so!

and what's more, you will understand exactly what you are doing. The TECHNATRON Outfit contains everything you need, from tools to transistors – even a versatile Multimeter which we teach you to use. All you need give is a little of your spare time and the surprisingly low fee, payable monthly if you wish. And the equipment remains yours, so you can use it again and again.

You LEARN – but it's as fascinating as a hobby.

Among many other interesting experiments, the Radio set you build – and it's a good one – is really a bonus. This is first and last a teaching course, but the training is as fascinating as any hobby and it could be the springboard for a career in Radio and Electronics.

A 14-year-old could understand and benefit from this Course – but it teaches the real thing. The easy to understand, practical projects – from a burglar-alarm to a sophisticated Radio set – help you master basic Radio and Electronics – even if you are a 'non-technical' type. And, if you want to make it a career, B.I.E.T. has a fine range of Courses up to City and Guilds standards.

New Specialist Booklet

If you wish to make a career in Electronics, send for your FREE copy of 'OPPORTUNITIES IN TELECOMMUNICATIONS/TV AND RADIO'. This brand new booklet – just out – tells you all about TECHNATRON and B.I.E.T.'s full range of courses.



FREE

BRITISH INSTITUTE OF ENGINEERING TECHNOLOGY

Dept. B9, ALDERMASTON COURT, READING RG7 4PF
Accredited by the Council for the Accreditation of Correspondence Colleges.

POST THIS COUPON FOR FREE BOOK

Please send obligation. books and full information — free and without

NAME..... AGE.....
(BLOCK CAPITALS PLEASE)

ADDRESS.....

OCCUPATION.....



BIET

To B.I.E.T. Dept. B9, Aldermaston Court, Reading RG7 4PF

-the lowest prices!

74 Series T.T.L. I.C.'s

DOWN AGAIN IN PRICE



Check our 74 Series List before you buy any I.C.'s. Our prices are the lowest possible. All devices ex-stock. Full spec. guaranteed.

BI-PAK Order No.	Price and qty. prices			BI-PAK Order No.	Price and qty. prices		
	1-24	25-99	100 up		1-24	25-99	100 up
BP00 SN7400	0.15	0.14	0.12	BP86 SN7486	0.32	0.30	0.28
BP01 SN7401	0.15	0.14	0.12	BP90 SN7490	0.67	0.64	0.58
BP02 SN7402	0.15	0.14	0.12	BP91 SN7491AN	0.87	0.84	0.78
BP03 SN7403	0.15	0.11	0.12	BP92 SN7492	0.67	0.64	0.58
BP04 SN7404	0.15	0.11	0.12	BP93 SN7493	0.67	0.64	0.58
BP05 SN7405	0.15	0.11	0.12	BP94 SN7494	0.77	0.74	0.68
BP07 SN7407	0.18	0.17	0.16	BP95 SN7495	0.77	0.74	0.68
BP08 SN7408	0.18	0.17	0.16	BP96 SN7496	0.77	0.74	0.68
BP09 SN7409	0.18	0.17	0.16	BP100 SN74100	1.75	1.65	1.55
BP10 SN7410	0.15	0.14	0.12	BP104 SN74104	0.97	0.94	0.88
BP12 SN7413	0.29	0.26	0.24	BP105 SN74105	0.97	0.94	0.88
BP16 SN7416	0.43	0.40	0.38	BP107 SN74107	0.40	0.38	0.36
BP17 SN7417	0.43	0.40	0.38	BP110 SN74110	0.55	0.53	0.50
BP29 SN7420	0.15	0.14	0.12	BP111 SN74111	1.25	1.15	1.00
BP30 SN7430	0.15	0.14	0.12	BP118 SN74118	1.00	0.95	0.90
BP40 SN7440	0.15	0.14	0.12	BP119 SN74119	1.35	1.25	1.10
BP41 SN7441	0.67	0.64	0.58	BP121 SN74121	0.67	0.64	0.58
BP42 SN7442	0.67	0.64	0.58	BP141 SN74141	0.67	0.64	0.58
BP43 SN7443	1.85	1.85	1.75	BP145 SN74145	1.50	1.40	1.30
BP44 SN7444	1.85	1.85	1.75	BP150 SN74150	1.80	1.70	1.60
BP45 SN7445	1.85	1.85	1.75	BP151 SN74151	1.00	0.95	0.90
BP46 SN7446	0.97	0.94	0.88	BP155 SN74155	1.20	1.10	0.95
BP47 SN7447	0.97	0.94	0.88	BP154 SN74154	1.80	1.70	1.60
BP48 SN7448	0.97	0.94	0.88	BP155 SN74155	1.40	1.30	1.20
BP50 SN7450	0.15	0.14	0.12	BP156 SN74156	1.40	1.30	1.20
BP51 SN7451	0.15	0.14	0.12	BP160 SN74160	1.80	1.70	1.60
BP53 SN7453	0.15	0.14	0.12	BP161 SN74161	1.80	1.70	1.60
BP54 SN7454	0.15	0.14	0.12	BP164 SN74164	2.00	1.90	1.80
				BP165 SN74165	2.00	1.90	1.80
BP60 SN7460	0.15	0.14	0.12	BP181 SN74181	2.75	2.60	2.40
BP70 SN7470	0.29	0.26	0.24	BP182 SN74182	0.97	0.94	0.88
BP72 SN7472	0.29	0.26	0.24	BP190 SN74190	3.50	3.25	3.00
BP73 SN7473	0.37	0.35	0.32	BP191 SN74191	3.50	3.25	3.00
BP74 SN7474	0.37	0.35	0.32	BP192 SN74192	2.10	1.95	1.75
BP75 SN7475	0.47	0.45	0.42	BP193 SN74193	2.10	1.95	1.75
BP76 SN7476	0.43	0.40	0.38	BP195 SN74195	1.10	1.05	0.95
BP78 SN7480	0.67	0.64	0.58	BP196 SN74196	1.80	1.70	1.60
BP81 SN7481	0.97	0.94	0.88	BP197 SN74197	1.80	1.70	1.60
BP82 SN7482	0.97	0.94	0.88	BP198 SN74198	5.50	5.00	4.00
BP83 SN7483	1.10	1.05	0.95	BP199 SN74199	5.50	5.00	4.00

PRICE-MIX. Devices may be mixed to qualify for quantity prices.
PRICES for quantities in excess of 500 pieces mixed, on application.

Owing to the ever increasing range of TTL 74 Series, please check with us for supplies of any devices not listed above, as it is probably now in stock. WARE 3442.

NUMERICAL INDICATOR TUBE Type GR116

Cold Cathode gas-filled, side-viewing numerals (0-9) and Decimal Point.

COLOUR: NEON RED.

DATA: Anode supply voltage 175 min Vdc.
Cathode current; 0.35 Nom mA dc.

Ideal for use in constructing Digital Calculators, Desk Calculators etc., and many products described in this magazine. We recommend use of BP41 or BP141 to drive this tube.

Full data available on request
PRICE: 1-5 £1.55. 6-25 £1.40.



BRAND NEW LINEAR I.C.'s—FULL SPEC.

Type No.	Case	Leads	Description	1-24	25-99	100 up
BP 201C - SL201C	TO-5	8	G.P. Amp	63p	55p	45p
BP 701C - SL701C	TO-5	8	OP Amp	63p	55p	45p
BP 702C - SL702C	TO-5	8	OP Amp Direct Op	63p	50p	45p
BP 702 - 72702	D.I.L.	14	G.P. OP Amp (Wide Band)	53p	45p	40p
BP 709 - 72709	D.I.L.	14	High Op Amp	53p	45p	40p
BP 709P - A709C	TO-5	8	High Gain OP Amp	53p	45p	40p
BP 710 - 72710	D.I.L.	14	Differential Comparator	53p	45p	40p
BP 711 - A711	TO-5	10	Dual comparator	58p	50p	45p
BP 741 - 72741	D.I.L.	14	High Gain OP Amp (Protected)	75p	60p	50p
μA 703C - A703C	TO-5	6	R.F. LF Amp	70p	60p	50p
TAA 263	TO-72	4	A.F. Amp	70p	60p	50p
TAA 293	TO-71	10	G.P. Amp	90p	75p	70p
TAA 350	TO-5	8	Wideband Limiting Amplifier	170p	158p	150p

STOP PRESS! NOW OPEN

BI-PAKS NEW COMPONENT SHOP

A wide range of all types of electronic components and equipment available at competitive prices.

18, BALDOCK ST. (A10) WARE, HERTS. TEL: 61593
OPEN 9.15-6 TUES to SATS. FRIDAYS UNTIL 8p.m.

ANOTHER BI-PAK FIRST!

THE NEW SGS EA 1000
AUDIO AMPLIFIER
MODULE

* GUARANTEED NOT LESS THAN 3 WATTS RMS

Especially designed by S.G.S. incorporating their proven Linear I.C. Audio Amp. TAA621 providing unlimited applications for the enthusiast in the construction of radios, record players, Audio and Stereo units. Also ideal for inter-com systems, monitoring applications and phone answering machines. Other uses: portable applications where supply rails as low as 9V are of prime importance.



* Sensitivity 40 mV for 1 watt Voltage gain 40 dB but can be varied up to 73 dB for some applications.

* Signal to Noise Ratio 86 dB

* Frequency response better than 50 Hz to 25 KHz for 1 dB

* Normal supply Voltage 9-24V

* Suitable for 6-16 ohm loads.

* Typical Total Harmonic distortion at 1 Watt less than 1%

* Supply Voltage (Vs) 24V min ohm load.

Module Tested and Guaranteed.

Qty 1-9 £10.25
Price each £2.63 £2.28

Larger quantities quoted on request.

Full hook-up diagrams and complete technical data supplied free with each module or available separately at 10p each.

ROCK BOTTOM PRICES!—CAN'T BE BEATEN LOGIC DTL 930 SERIES I.C.'s

Type No.	Function	1-24	25-99	100 up
BP930	Expandable dual 4-input NAND	12p	11p	10p
BP932	Expandable dual 4-input NAND buffer	13p	12p	11p
BP933	Dual 4-input expander	13p	12p	11p
BP935	Expandable Hex Inverter	13p	12p	11p
BP936	Hex Inverter	13p	12p	11p
BP944	Dual 4-input NAND expandable buffer without pull-up	13p	12p	11p
BP945	Master-slave JK or RS	25p	24p	22p
BP946	Quad. 2-input NAND	12p	11p	10p
BP948	Master-slave JK or RS	25p	24p	22p
BP951	Monostable	65p	60p	55p
BP962	Triple 3-input NAND	12p	11p	10p
BP9093	Dual Master-slave JK with separate clock	40p	38p	35p
BP9094	Dual Master-slave JK with separate clock	40p	38p	35p
BP9097	Dual Master-slave JK with Common Clock	40p	38p	35p
BP9099	Dual Master-slave JK Common Clock	40p	38p	35p

Devices may be mixed to qualify for quantity price. Larger quantity prices on application (DTL 930 Series only.)

DTL & TTL INTEGRATED CIRCUITS

Manufacturers "Fall-outs"—out of spec devices including functional units and part function but classed as out of spec from the manufacturers' very rigid specifications ideal for learning about I.C.'s and experimental work.

PAK No.	1-24	25-99	100 up
UIC930 - 12 μA 930	50p		
UIC932 - 12 μA 932	50p		
UIC933 - 12 μA 933	50p		
UIC935 - 12 μA 935	50p		
UIC936 - 12 μA 936	50p		
UIC944 - 12 μA 944	50p		
UIC945 - 8 μA 945	50p		
UIC946 - 12 μA 946	50p		
UIC948 - 8 μA 948	50p		
UIC951 - 5 μA 951	50p		
UIC961 - 12 μA 961	50p		
UIC9093 - 5 μA 9093	50p		
UIC9094 - 5 μA 9094	50p		
UIC9097 - 5 μA 9097	50p		
UIC9099 - 5 μA 9099	50p		
UIC9 25 Assorted 930 Series	£1.50		

Packs cannot be split but 25 Assorted Pieces (our mix) is available as Pack UIXC9. Every Pak carries our BI-PAK Satisfaction or money back guarantee.

Data booklet available the BI930 Series. PRICE 13p.

PAK No.	1-24	25-99	100 up
UIC00 - 12 7400N	50p		
UIC01 - 12 7401N	50p		
UIC02 - 12 7402N	50p		
UIC03 - 12 7303N	50p		
UIC04 - 12 7404N	50p		
UIC05 - 12 7405N	50p		
UIC10 - 12 7410N	50p		
UIC13 - 8 7413N	50p		
UIC20 - 12 7420N	50p		
UIC40 - 12 7440N	50p		
UIC41 - 5 7441AN	50p		
UIC42 - 5 7442N	50p		
UIC43 - 5 7443N	50p		
UIC44 - 5 7444N	50p		
UIC45 - 5 7445N	50p		
UIC46 - 5 7446N	50p		
UIC47 - 5 7447N	50p		
UIC48 - 5 7448N	50p		
UIC50 - 12 7450N	50p		
UIC51 - 2 7451N	50p		
UIC53 - 12 7453N	50p		
UIC54 - 12 7454N	50p		
UIC60 - 12 7460N	50p		
UIC70 - 8 7470N	50p		
UIC72 - 8 7472N	50p		
UIC73 - 8 7473N	50p		
UIC74 - 8 7474N	50p		
UIC75 - 8 7475N	50p		
UIC76 - 8 7476N	50p		
UIC80 - 5 7480N	50p		
UIC81 - 5 7481N	50p		
UIC82 - 5 7482N	50p		
UIC83 - 5 7483N	50p		
UIC85 - 5 7485N	50p		
UIC86 - 5 7486N	50p		
UIC90 - 5 7490N	50p		
UIC91 - 5 7491N	50p		
UIC92 - 5 7492N	50p		
UIC93 - 5 7493N	50p		
UIC94 - 5 7494N	50p		
UIC95 - 5 7495N	50p		
UIC96 - 5 7496N	50p		
UIC121 - 5 74121N	50p		

UICX1 25 Ass'd 74's £1.50

All prices quoted in new pence Giro No. 388-7006

Please send all orders direct to warehouse and despatch department

BI-PAK

P.O. BOX 6, WARE · HERTS

Postage and packing add 7p. Overseas add extra for airmail. Minimum order 50p. Cash with order please.

Guaranteed Satisfaction or Money Back

DENCO (CLACTON) LIMITED

355-7-9 OLD ROAD, CLACTON-ON-SEA, ESSEX

Our components are chosen by Technical Authors and Constructors throughout the World for their performance and reliability, every coil being inspected twice plus a final test and near spot-on alignment as a final check.

Our General Catalogue showing full product range	.. 16p
DTB4 Transistor & Valve circuitry for D.P. Coils	.. 16p
DTB9 Valve Type Coil Pack Application circuitry	.. 16p
MD.1 Decoder Circuitry for Stereo Reception	.. 20p

All post paid, but please enclose S.A.E. with all other requests in the interests of retaining lowest possible prices to actual consumers

THE MODERN BOOK CO

RADIO TECHNICIAN'S BENCH MANUAL

by H. W. Hellyer £3 Postage 10p

ARRL Radio Amateur Handbook
1972 edition. £2.70 *Postage 25p*

Integrated Circuit Pocket Book
by R. G. Hibberd. £2.50 *Postage 10p*

Audio Technician's Bench Manual
by John Earl. £3 *Postage 10p*

Servicing Transistor Radio Receivers
by F. R. Pettit. 75p *Postage 6p*

Practical Transistor Servicing
by W. C. Caldwell. £1.90 *Postage 10p*

49 Easy Transistor Projects
by R. M. Brown. 9p *Postage 10p*

Radio, Television & Audio Test Instruments
by Gordon J. King £3.80 *Postage 20p*

1972 World Radio-TV Handbook
£2.80 *Postage 10p*

Foundations of Wireless & Electronics
by Scroggie. £1.80 *Postage 20p*

Colour Television Picture Faults
by K. J. Bohlman. £2.50 *Postage 10p*

20 Solid State Projects for the Home
by R. M. Marston. £1 *Postage 6p*

Tape Recorders
by H. W. Hellyer. £2.25 *Postage 10p*

Radio
by David Gibson. 75p *Postage 10p*

T.V. Fault Finding 405/625 Lines
by J. R. Davies. 50p *Postage 6p*

R.S.G.B. Amateur Radio Techniques
by Pat Hawker. £1 *Postage 10p*

Radio Valve & Transistor Data
by A. M. Ball. 75p *Postage 10p*

We have the Finest Selection of English and American Radio Books in the Country

19-21 PRAED STREET (Dept RC) LONDON W2 INP

Telephone 01-723 4185

BI-PRE-PAK



TELEPHONE DIALS

Standard Post Office type
Guaranteed in working order.

ONLY 50p

COMPLETE TELEPHONES

Normal household type as supplied to the Post Office, ex. G.P.O. Only **95p** each. p. & p. 35p each.

NEW TESTED AND GUARANTEED PAKS

B2	4	Photo Cells, Sun Batteries. 0.3 to 0.5V. 0.5 to 2mA.	50p
B79	4	IN4007 Sil. Rec. diodes. 1,000 PIV lamp plastic	50p
B81	10	Reed Switches, mixed types large and small	50p
B99	200	Mixed Capacitors. Approx. quantity, counted by weight	50p
H4	250	Mixed Resistors. Approx. quantity, counted by weight	50p
H7	40	Wirewound Resistors. Mixed types and values.	50p
H8	4	BY127 Sil. Recs. 1000 PIV. 1 amp. plastic	50p
H9	2	OC71 Light Sensitive Photo Transistor	50p
H12	50	NKT155/259 Germ. diodes, brand new stock clearance	50p
H18	10	OC71/75 uncoated black glass type PNP Germ.	50p
H19	10	OC81/81D uncoated white glass type PNP Germ.	50p
H28	20	OC200/1/2/3 PNP Silicon uncoated TO-5 can	50p
H29	20	OA47 gold bonded diodes coded MC52	50p

NEW UNMARKED UNTESTED PAKS

B56	150	Germanium Diodes Min. glass type	50p
B83	200	Trans. manufacturers' rejects all types NPN, PNP, Sil. and Germ.	50p
B84	100	Silicon Diodes DO-7 glass equiv. to OA200, OA202	50p
B86	50	Sil. Diodes sub. min. IN914 and IN916 types	50p
B88	50	Sil. Trans. NPN, PNP equiv. to OC200/1 2N706A, B5Y95A, etc.	50p
B1	50	Germanium Transistors PNP, A.F. & R.F.	50p
H6	40	250mW Zener Diodes DO-7 Min. Glass Type	50p
H10	25	Mixed volts, 1 1/2 watt Zeners Top hat type	50p
H17	20	3 amp. Silicon Stud rectifiers, mixed volts	50p
H15	30	Top Hat Silicon Rectifiers, 750mA. Mixed volts	50p
H16	8	Experimenters' Pak of Integrated Circuits. Data supplied	50p
H20	20	BY126/7 Type Silicon Rectifiers 1 amp plastic. Mixed volts.	50p

MAKE A REV COUNTER FOR YOUR CAR

The 'TACHO BLOCK'. This encapsulated block will turn any 0-1mA meter into a linear and accurate rev. counter for any car with normal coil ignition system.

£1 each



OUR VERY POPULAR 3p TRANSISTORS

TYPE "A" PNP Silicon alloy, TO-5 can.
TYPE "B" PNP Silicon, plastic encapsulation.
TYPE "E" NPN Germanium AF or RF.
TYPE "F" NPN Silicon plastic encapsulation.

FULLY TESTED AND MARKED SEMICONDUCTORS

£p		£p	
AC107	0-15	OC170	0-23
AC126	0-15	OC171	0-23
AC127	0-17	OC200	0-25
AC128	0-15	OC201	0-25
AC176	0-20	2G301	0-13
ACY17	0-20	2G303	0-13
AF239	0-30	2N711	0-50
AF186	0-20	2N1302-3	0-15
AF139	0-30	2N1304-5	0-17
BC154	0-20	2N1306-7	0-20
BC107	0-10	2N1308-9	0-22
BC108	0-10	2N3819FET	0-45
BF194	0-15		
BC109	0-10	Power Transistors	
BF274	0-20	OC20	0-50
BFY50	0-15	OC23	0-30
BSY25	0-13	OC25	0-25
BSY26	0-13	OC25	0-25
BSY27	0-13	OC26	0-25
BSY28	0-13	OC28	0-30
BSY29	0-13	OC35	0-25
BSY95A	0-10	OC36	0-37
OC41	0-15	AD149	0-30
OC44	0-15	AUY10	1-25
OC45	0-10	25034	0-25
OC71	0-10	2N3055	0-50
OC72	0-10	Diodes	
OC81	0-13	AAV42	0-10
OC81D	0-13	OA95	0-09
OC83	0-18	OA79	0-09
OC139	0-13	OA81	0-09
OC140	0-15	IN914	0-07

F.E.T. PRICE

BREAKTHROUGH!!

This field effect transistor is the 2N3823 in a plastic encapsulation, coded as 3823E. It is also an excellent replacement for the 2N3819. Data sheet supplied with device. 1-10 30p each, 10-50 25p each, 50+ 20p each.



BULK BUYING CORNER

NPN/PNP Silicon Planar Transistors, mixed, untested, similar to 2N706A/B, B5Y26-29, B5Y95A, BCY70, etc. **£4-25 per 500; £8 per 1,000.**

Silicon Planar NPN Plastic Transistors, untested, similar to 2N3707-11, etc., **£4-25 per 500; £8 per 1,000.**

Silicon Planar Diodes, DO-7 Glass, similar to OA200/202, BAY31-36, **£4-50 per 1,000.**

NPN/PNP Silicon Planar Transistors, Plastic TO-18, similar to BC113/4, BC153/4, BF153/160, etc., **£4-25 per 500; £8 per 1,000.**

OC44, OC55 Transistors fully marked and tested, 500+ at 8p each; 1,000+ at 6p each.

OC71 Transistors, fully marked and tested, 500+ at 6p each; 1,000+ at 5p each.

3823E Field Effect Transistors. This is the 2N3823 in Plastic Case, 500+ 13p each; 1,000+ 10p each.

1 amp Miniature Plastic Diodes:
IN4001, 500+ at 4p each; 1,000+ at 3p each.
IN4004, 500+ at 5p each; 1,000+ at 4p each.
IN4006, 500+ at 6p each; 1,000+ at 5p each.
IN4007, 500+ at 8p each; 1,000+ at 7p each.

FREE CATALOGUE

FOR TRANSISTORS, RECTIFIERS, DIODES, INTEGRATED CIRCUITS, FULL PRE-PAK LISTS.



8 RELAYS FOR £1

VARIOUS TYPES P. & P. 25p.

COLOUR T.V. LINE OUTPUT TRANSFORMERS

Designed to give 25kV when used with PL509 and PY500 valves. As removed from colour receivers at the factory.

NOW ONLY 50p each
post and packing 23p.

Quantity	1-10	10-50	50-100	100-500
BB105 Varicap Diodes	10p	8p	6p	4p
OC71 or 72 Fully Tested Unmarked	5p	5p	4p	
Matched Sets 1-OC44 and 2-OC45's. Per Set	25p	20p	15p	
OA47 Gold-Bonded Diodes, Marked and Tested	3p	3p	2p	
1-watt Zener Diodes 7.5, 24, 27, 30, 36, 43 Volts	5p	4p	3p	
10-watt Zener Diodes 5-1, 8-2, 11, 13, 16, 24, 30, 100 Volts	20p	17p	15p	
Micro Switches, S/P, C/O	25p	20p	15p	
1-amp Bridge Rec's 25-volt	25p	22p	20p	

INTEGRATED CIRCUITS

SL403D Audio Amp, 3-Watts	2-00	1-95	1-80
70°C Linear Opp. Amp.	25p	20p	15p
Gates, Factory Marked and Tested by A.E.I.	25p	22p	20p
J. K. Flip-Flops Factory, Marked and Tested by A.E.I.	40p	35p	30p
SN7490 Decade Counter	50p	45p	40p
UL914 Dual 2 I/P Gate	40p	35p	30p

LOW COST DUAL INLINE I.C. SOCKETS

14 pin type at 15p each
16 pin type at 16p each.

BOOKS

We have a large selection of Reference and Technical Books in stock.

These are just two of our popular lines:
B.P.I. Transistor Equivalents and Substitutes; 40p
This includes many thousands of British U.S.A., European and C.V. equivalents.
The Hi-Fi Radio Valve & Transistor Data Book 9th Edition; 75p
Characteristics of 3,000 valves and tubes, 4,500 Transistors, Diodes, Rectifiers and Integrated Circuits.
Send for lists of these English publications.

Please send me the FREE Bi-Pre-Pak Catalogue.

NAME.....

ADDRESS.....

MINIMUM ORDER 50p. CASH WITH ORDER
PLEASE. Add 10p post and packing per order.
OVERSEAS ADD EXTRA FOR POSTAGE

BI-PRE-PAK LTD

DEPT. C, 222-224 WEST ROAD, WESTCLIFF-ON-SEA, ESSEX, SS0 9DF
TELEPHONE: SOUTHEND (0702) 46344

REVERBERATION UNIT KIT Mk III

6 transistor reverberation chamber to which microphones, instruments, etc., may be connected for added dimensional effect. The output is suitable for most amplifiers and the unit is especially suitable for use with electronic organs. A ready-built spring and transducer assembly is used.



Complete easy-to-build kit, with constructional notes and circuits £7.50. Pre-drilled and printed case £2.00 extra. All parts available separately.

WAH-WAH PEDAL KIT Mk III



The Wilsic Wah-Wah pedal comprises a SELECTIVE AMPLIFIER MODULE KIT, containing all the components to build a two transistor circuit module, which may be used by the constructor for his own design or fitted to the FOOT VOLUME CONTROL PEDAL (as photo) converting it to Wah-Wah operation. This pedal is in strong fawn plastic and fitted with output lead and screened plug. Selective amplifier module kit £1.75. Foot Volume control pedal £5.13. COMPLETE KIT £6.50. Add 38p for assembly of module.

WILSIC VIBRATO UNIT

A new kit to build a self-contained vibrato foot switch unit. 4-silicon transistor circuit in tough grey hammered finish metal cabinet. Variable speed and depth controls and on-off foot switch. Ideal for guitars but unsuitable for high level inputs. COMPLETE KIT £5.25, all parts available separately.

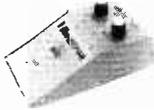

THE WILSIC BOOK OF CIRCUITS contains the full instructions for the Reverb unit, Wah-Wah pedal and our Vibrato unit. PRICE ONLY 15p

SEND 5p in stamps for latest catalogue (Spring 1972) of Hi-Fi, components, guitars, etc., etc. Friendly, high-speed service.



WILSIC ELECTRONICS LTD.

6 COPLEY ROAD, DONCASTER, YORKS

TECHNICAL TRAINING in Radio, Television and Electronic Engineering

Let ICS train You for a well-paid post in this expanding field. ICS courses offer the keen, ambitious man the opportunity to acquire, quickly and easily, the specialized training so essential to success. Diploma Courses in Radio, TV Engineering and Servicing, Colour TV Servicing, Electronics, Computers, etc. Expert coaching for:

- * C&G. TELECOMMUNICATION TECHNICIANS CERTS
- * RADIO AMATEURS EXAMINATION
- * GENERAL RADIOCOMMUNICATIONS CERTIFICATES
- * C&G. RADIO SERVICING THEORY

CONSTRUCTOR COURSES

Build your own transistor portable, signal generator, multi-test meter—all under expert guidance. POST THIS COUPON TODAY and find out how ICS can help YOU in your career. Full details of ICS courses in Radio, Television and Electronics will be sent to you by return mail.

Member of the ABCC.

Accredited by the C.A.C.C.

Name _____ Age _____

BLOCK CAPITALS PLEASE

Address _____

INTERNATIONAL CORRESPONDENCE SCHOOLS

Dept. HA33 Intertext House, Stewarts Road,
London SW8 4UJ



Latest Bound Volume No. 24 of "The Radio Constructor" FOR YOUR LIBRARY

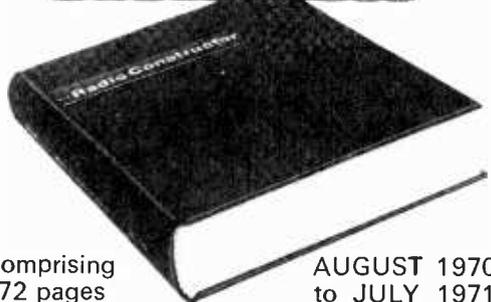

Comprising
772 pages
plus index

AUGUST 1970
to JULY 1971

PRICE £2.00 Postage 29p

BOUND VOLUME NO. 23

OF

"THE RADIO CONSTRUCTOR"

AUGUST 1969 to JULY 1970

Limited number of this volume still available

PRICE £1.88

Postage 29p

We regret all earlier volumes are now
completely sold out.

Available only from

DATA PUBLICATIONS LTD.,
57 MAIDA VALE, LONDON, W9 1SN

CONSTRUCT YOUR OWN COLOUR TV RECEIVER

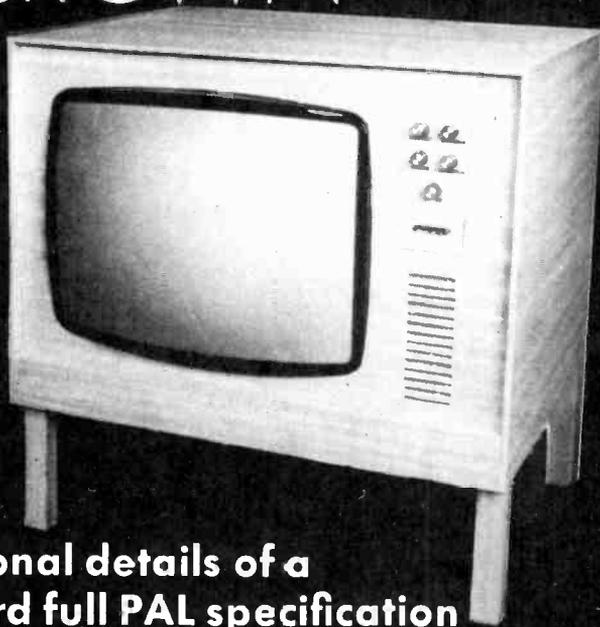

Starting in the April issue of *Television* this outstanding series gives full constructional details of a modern single-standard full PAL specification colour receiver.

In addition to complete constructional details, arrangements have been made for easy supply of all components required, including printed circuit boards.

Special features of this 22 in. set include: Strong simply-made cabinet. Printed circuit board construction. Front pull-out draw containing all convergence controls for easy adjustment. Optional built-in crosshatch generator. Choice of varactor or conventional tuner. Automatic frequency control. RGB tube drive. Latest 22 in. Mazda flat-face square-corner tube. Delay-line PAL decoder. Fully integrated sound channel (using two i.c.s.), intercarrier amplifier and audio output.

MAKE SURE YOU DON'T MISS IT . . .
**IT'S THE FIRST CONSTRUCTIONAL SINGLE-STANDARD
COLOUR TELEVISION RECEIVER USING RGB DRIVE
TO BE PUBLISHED IN A MAGAZINE**

TELEVISION

APRIL ISSUE (on sale March 20) 20p
Order from your newsagent TODAY!

Would YOU pay 50 pence for a components catalogue?



You'll be glad you did when you get THIS one!

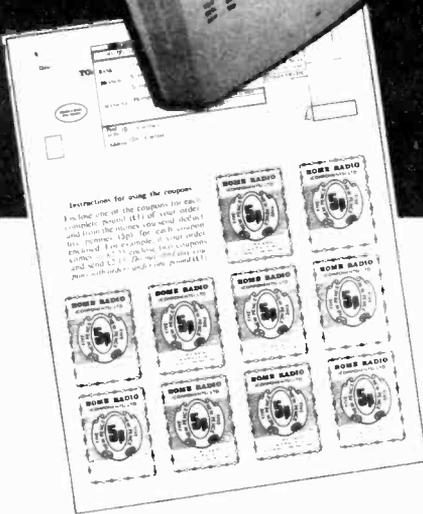

A components catalogue is so vital to any keen constructor that it simply does not pay to make do with less than the best. True, the best may cost a little more . . . but it's the cheapest in the end. So invest in a *Home Radio Components Catalogue*, listing over 8,000 items, more than 1,500 of them illustrated. If you call at our shop the catalogue is yours for just 50 pence. If you order by post – 70 pence, including postage and packing. You also get 10 Vouchers, each worth 5 pence when used as instructed – so you can get the cost of the catalogue back in any case!

Ask for details of our Credit Account Service. 24-hour Phone Service. Ring 01-648 8422

POST THIS COUPON with your cheque or postal order for 70p



Please write your Name and Address in block capitals

NAME

ADDRESS



HOME RADIO (COMPONENTS) LTD., Dept. RC,
234-240 London Road, Mitcham, Surrey CR4 3HD.

The price of 70p applies only to catalogues purchased by customers in the U.K. and to BFPO addresses.

THE Radio Constructor



Incorporating THE RADIO AMATEUR

APRIL 1972

Vol. 25 No. 9

CONTENTS

Published Monthly (1st of Month)
First Published 1947

Editorial and Advertising Offices
57 MAIDA VALE LONDON W9 1SN

Telephone 01-286 6141
Telegrams Databux, London

© Data Publications Ltd., 1972. Contents may only be reproduced after obtaining prior permission from the Editor. Short abstracts or references are allowable provided acknowledgement of source is given.

Annual Subscription: £2.70 (U.S.A. and Canada \$7.00) including postage. Remittances should be made payable to "Data Publications Ltd". Overseas readers please pay by cheque or International Money Order.

Technical Queries. We regret that we are unable to answer queries other than those arising from articles appearing in this magazine nor can we advise on modifications to equipment described. We regret that such queries cannot be answered over the telephone; they must be submitted in writing and accompanied by a stamped addressed envelope for reply.

Correspondence should be addressed to the Editor, Advertising Manager, Subscription Manager or the Publishers as appropriate.

Opinions expressed by contributors are not necessarily those of the Editor or proprietors.

Production.—Web Offset.

THE 'BASS-BOOST' PORTABLE	522
CAN ANYONE HELP?	528
RECENT PUBLICATIONS	529
NEWS AND COMMENT	530
NOTES ON SEMICONDUCTORS (Further Notes – 5. Clamp Down)	532
NOVEL ALIGNMENT AID (Suggested Circuit No. 257)	533
SENSITIVITY MEASUREMENT OF PORTABLE RECEIVERS	535
TRADE NEWS	536
SUBTRACTION COMPUTING CIRCUIT	537
HALF-A-DOZEN PUZZLERS?	539
SECOND A.F. INPUT	540
V.H.F. WAVEMETER	542
WIDE RANGE LINEAR SAWTOOTH GENERATOR – Part 1	544
A MODERN HOMODYNE RECEIVER – Part 2	552
SHORT WAVE NEWS	558
IN YOUR WORKSHOP	560
RADIO TOPICS	567
HALF-A-DOZEN PUZZLERS (Answers)	568
RADIO CONSTRUCTOR'S DATA SHEET No. 61 (Millimetre-Inch Table II)	iii

Published in Great Britain by the Proprietors and Publishers, Data Publications Ltd, 57 Maida Vale, London, W9 1SN

The Radio Constructor is printed by Carlisle Web Offset.

MAY ISSUE WILL BE
PUBLISHED ON MAY 1st

THE 'BASS-BOOST' PORTABLE



By

Sir DOUGLAS HALL, K.C.M.G., M.A. (Oxon.)

Employing the author's 'Spontaflex' circuit design, this simple receiver incorporates 2 transistors only. Local station loudspeaker reception is provided on medium and long waves, an unusual feature being the inclusion of a positive feedback bass boost control.

IT HAS OFTEN BEEN POINTED OUT IN THE PAGES OF THIS magazine that many readers spend most of their listening time with one or other of the local stations. For this purpose the author favours the fairly large type of portable, since this can gain sensitivity and improved signal-to-noise ratio by the use of a reasonably sized frame aerial (which can give greater sensitivity than a normal sized ferrite rod) and also provide superior quality and acoustic output through the use of a reasonably sized loudspeaker. It is not always realised that a 2½ in. speaker gives little or no response to fundamentals below about 200Hz, and that electrical output means little unless the size of the speaker is taken into account. It is, after all, acoustic output which reaches the ear. As a result of employing a frame aerial and a large speaker, a very simple circuit may be used to give excellent reproduction from local stations at a volume level which is perfectly adequate for domestic listening in a normal sitting room.

BASS BOOST CONTROL

The main feature of the receiver to be described is a bass boost control which really boosts the lower register and does not function by cutting down the higher audio spectrum, to give a rather muffled output, as happens with many tone controls. The bass boost circuit in itself makes a fairly low volume level much more acceptable. So often there is the temptation to

turn up the volume in an attempt to get something in the way of bass.

However, when testing this receiver remember that the tone control does not function like the normal treble cut device which has an effect on all types of transmission. The control on this receiver has no effect at all on the higher audio frequencies. There must be some bass in the signal to be boosted. The flute is left alone; but the bass guitar is helped.

The circuit is shown in Fig. 1. L1 is the medium wave frame winding and L3 the medium wave reaction winding, feedback being taken from the emitter of TR1 and controlled by VR1. L2 and L4, respectively, are added in series with these two inductors when receiving long waves. Full medium and long wave bands are covered. In addition, the receiver will tune down to about 150 metres on the medium wave band, making local Top Band amateur transmissions available. The whole of the tuned circuit is applied to the input of TR1 which, as a 'Spontaflex' amplifier, functions as a common collector device at radio frequencies. D1 detects, and then TR1 acts as a common base amplifier at audio frequencies, with a much amplified signal appearing across VR3. This signal is then transformer coupled by T1 to the input of TR2. A high ratio transformer is needed in the T1 position to match the large output impedance of TR1 to the much lower input impedance of TR2. A normal interstage transformer will not work well here, and

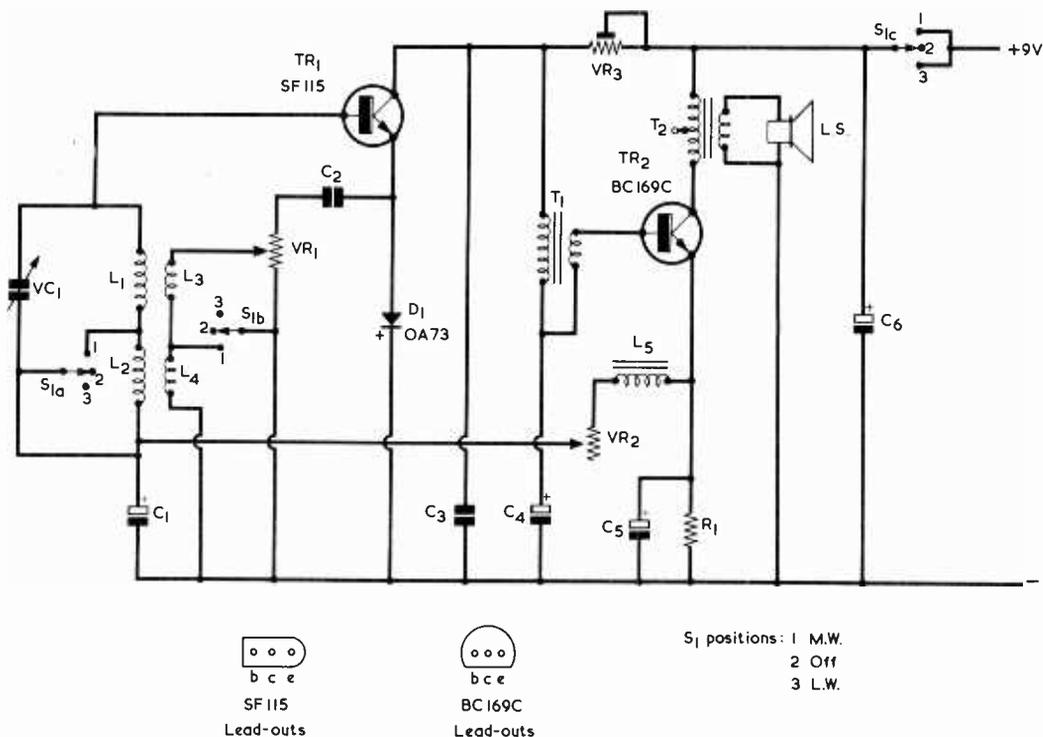

Fig. 1. The circuit of the 'Bass Boost' portable receiver

COMPONENTS

Resistors

- R1 82Ω 10% 1/4 watt
- VR1 5kΩ potentiometer, linear
- VR2 10Ω potentiometer, wirewound
- VR3 250kΩ potentiometer, preset, slider type

Capacitors

- C1 250μF electrolytic, 4V wkg. (Mullard miniature)
- C2 0.01μF paper or plastic foil
- C3 500pF silvered mica
- C4 40μF electrolytic, 2.5V wkg. (Mullard miniature)
- C5 80μF electrolytic, 2.5V wkg. (Mullard miniature)
- C6 640μF electrolytic, 10V wkg.
- VC1 500pF variable, solid dielectric, Jackson 'Dilecon'

Inductors

- L1, 2, 3, 4 Frame aerial (see text)
- L5 Choke (see text)
- T1 25:1 transformer type TT53 (Repanco)
- T2 Output transformer type LT700 (Eagle)

Semiconductors

- TR1 SF115
- TR2 BC169C
- D1 OA73

Switch

- S1(a)(b)(c) 3-pole 3-way, or 4-pole 3-way, miniature rotary

Speaker

- 3Ω speaker, 8in. by 5in.

Battery

- 9-volt battery type PP9 (Ever Ready)

Miscellaneous

- 12-way tagstrip
- 6-way tagstrip
- 2in. by 3/4in. dia. ferrite rod
- Battery connectors
- Slow-motion drive (optional)
- Plywood (see text)
- Hardboard (see text)
- Speaker fabric
- Fablon or Contact
- Knobs (as required)

readers should be careful not to be fobbed off with a substitute for that specified in the Components List. Another unusual feature of the circuit is that the transformer is parallel-fed by VR3. This means that the direct collector current for TR1 is kept out of the primary winding so that only a few microamps of base current for TR2 pass through it, whereupon its inductance is maintained at a very high level. In addition, some damping is caused by VR3, and this helps the transformer to give similar treatment to all audio frequencies.

TR2 is a normal high amplification common emitter output device. Base bias for TR1 is taken from the emitter circuit of TR2, providing a complete negative feedback loop at d.c. with consequent excellent bias stability. C6 is the usual large capacitor across the battery supply.

The bass boost circuit works in the following manner. A varying direct voltage at the emitter of TR2 is out of phase with the corresponding voltage at the base of TR1, so that, as already mentioned, there is d.c. negative feedback. But the windings of T1 are so connected as to reverse the phase at a.c. and positive feedback of the audio signal is therefore possible. The presence of C5 means that the higher audio frequencies are bypassed to the negative supply line, but some impedance is offered to the lower audio frequencies, and the potentiometer formed by L5 and C1 feeds these back to the base of TR1. This potentiometer is itself frequency-dependent, favouring the lowest audio frequencies once again, and VR2 regulates the proportion of these which can be fed back. L5 must be home-wound. A standard r.f. choke would have too high a resistance and the resistive element would predominate at the low frequencies involved so that the impedance offered would be virtually identical at 100Hz and 1kHz. A suitable low resistance choke is made by close-winding 100 turns of 32 s.w.g. enamelled wire on a 2in. length of $\frac{3}{8}$ in. ferrite rod. If necessary, a 2in. length can be snapped off from a longer rod by filing a shallow notch at the right point.

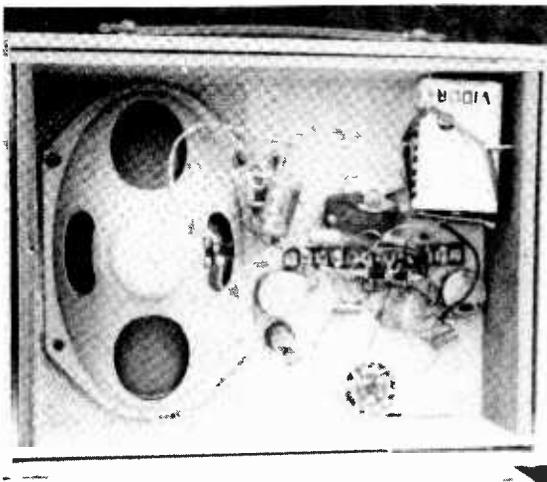

The rear of the receiver with the back removed. The relatively large cabinet enables a speaker of adequate proportions to be incorporated

The components employed are all standard types. The 10 Ω potentiometer specified for VR2 is available from Home Radio under Cat. No. VR85A. The SF115 quoted for TR1 can be obtained from Amatronix Ltd., 396 Selsdon Road, South Croydon, Surrey. The values of C1, C4 and C5 are important and these should be new and reliable components. Mullard miniature electrolytic capacitors are recommended here. The OA73 specified for D1 gives better results in this circuit than more common diodes, and is available from Henry's Radio Ltd. The PP9 battery should have a long life as current consumption is of the order of 8mA only.

Switch S1(a) (b) (c) is basically a miniature 3-pole 3-way component. It will probably be found easiest to obtain a 4-pole 3-way miniature switch, and to make no connections to one of the poles.

CONSTRUCTION

With this receiver it is suggested that the case be made first, as all components are moulded on the inside of its front. The case uses $\frac{1}{4}$ in. plywood throughout, and Fig. 2 is largely self-explanatory. The dashed lines

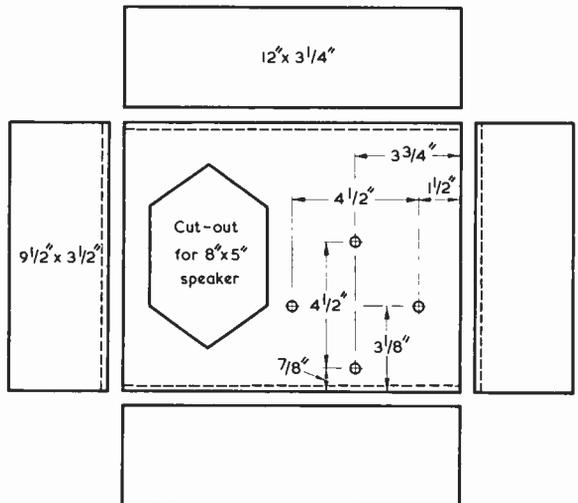

Fig. 2. Details of the cabinet parts. Each butts against the adjoining part over the space between the nearest edge and the adjacent dashed line

show how the various pieces are screwed together. The speaker aperture and the holes for the controls should be cut out before the case is assembled. The three lower control holes are $\frac{3}{8}$ in. diameter, but the uppermost control hole will have a diameter which depends upon whether or not the tuning capacitor, VC1, is fitted with a slow-motion tuning drive. This point is dealt with at the end of the article under the sub-heading 'Tuning Drive'.

A back is also required and this should be made of hardboard with a hole about 3 in. square cut in its centre and covered, on the inside, with speaker fabric. It should measure 12in. by 9in. and is held in place by screws passing into the edges of the frame aerial, which is next to be described. The case and its back may be covered with Fablon or Contact.

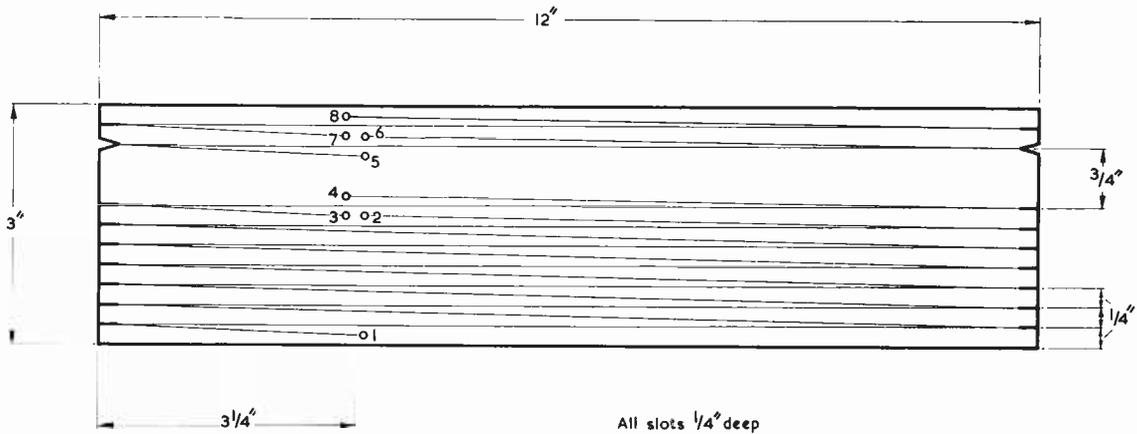

Fig. 3. Illustrating the manner in which the frame aerial is wound

The frame aerial is shown in Fig. 3. Cut two pieces of $\frac{1}{2}$ in. plywood, 12 in. by 3 in. and cut slots in the narrow ends as shown in Fig. 3. Note that there are 9 slots in all at each end, and that the outside slots are $\frac{1}{2}$ in. from the long edges in each case, with $\frac{1}{4}$ in. spacing between each slot and the next except for a gap of $\frac{1}{2}$ in. between the 7th and 8th pair of slots, counting from the bottom. Note also that, with one exception, these slots are single cuts made with a small hacksaw – a fret saw has too narrow a blade. The exception is the 8th from the bottom, which is in the form of a V to accommodate the 40 turns of the long wave winding. A second, exactly similar, piece of wood is cut and slotted, and then one of these two pieces has holes drilled in it as shown in Fig. 3, using a $\frac{1}{8}$ in. drill. In order that these holes should be accurately positioned it is an advantage to draw pencil lines between opposite slots.

Now cut two pieces of $\frac{3}{8}$ in. plywood, 8 $\frac{1}{2}$ in. by 3 in., and screw the two slotted pieces to these as in Fig. 4. Note that the long pieces extend $\frac{1}{4}$ in. beyond the shorter pieces at each end, to allow room for the windings. Position the screws between the lines of the slots so that their heads will not damage the windings. Next make sure that the frame will fit inside the case. It may be necessary to sand-paper the edges down a little.

Hold the completed frame with the 12 in. side having the small holes drilled in it at the top, and with hole No. 1 towards the hands and towards the left. Pass the end of a length of 32 s.w.g. enamelled wire through hole No. 1 and lock it in place with a matchstick, leaving a few inches for subsequent connection. Wind on 3 turns in the first set of slots (first from the bottom in Fig. 3) in an anti-clockwise direction and as indicated in Fig. 3, and then 3 turns in the next set of slots and so on until a total of 18 turns have been wound as a continuous winding in the first 6 sets of slots. Leave a few inches of wire for connection and pass the end through hole No. 2 locking the wire in position with a matchstick. 6 turns of the same gauge wire should now be wound in the next set of slots, starting at hole No. 3 and ending through hole No. 4. 40 turns of 38 s.w.g. enamelled wire are wound in the V-shaped slots, starting at hole No. 5, and ending at hole No. 6, and finally 6 turns of 32 s.w.g. enamelled

wire are wound in the last set of slots, starting at hole No. 7 and ending at hole No. 8. All windings are anti-clockwise. Put the completed frame aerial on one side for the time being.

MOUNTING COMPONENTS

Components may now be mounted, but if a slow motion tuning drive is to be fitted, as described at the end of the article, this should be done before any component other than VC1 is fitted into place.

Take a 12-way tagstrip. The prototype uses a 12-way section cut from an R. S. Components (formerly Radiospares) standard size 18-way tagboard, as this has large tags which are very convenient, but a normal 12-way tagstrip could be used instead, if desired. The R.S. Components tagboard just mentioned is available from Home Radio under Cat. No. BTS10. Mount the

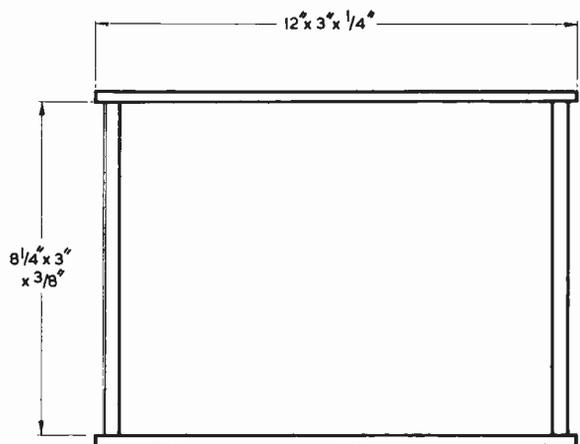

Fig. 4. The assembly of the frame aerial plywood sections

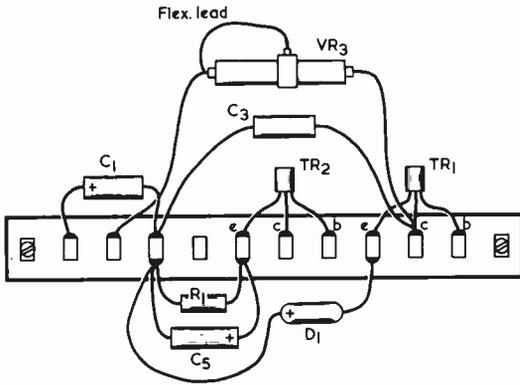

Fig. 5. The components mounted on the 12-way tagstrip

small components shown in Fig. 5 to the tagstrip. The components should stand upright over the strip and not on either side as is shown, for clarity, in the diagram.

Next take up a 6-way tagstrip and mount T2 and C6 to it as shown in Fig. 6. The mounting lugs of T2 are soldered to two of the tags, as indicated, and its four leads connect to the remaining four tags. No connection is made to the centre-tap of T2 primary, this being the white lead between the red and green leads. The bare end of this lead may be cut off and the lead folded neatly out of the way. Take care not to confuse this lead with the white lead from the secondary, which appears on the same side of the transformer as the black lead. The white lead from the secondary is used in the circuit.

Mount VC1, VR1, VR2 and S1 in the case, as shown in Fig. 6. Also, mount the 12-way tagstrip by passing wood-screws through its two end tag holes, with spacing washers between the strip and the plywood. The 6-way tagstrip, with T2 and C6 fitted to it as illustrated, is also mounted. If any of its tags are secured to the plywood these should, preferably, be the second from the top and the second, or third, from the bottom.

A word is necessary about the TT53 transformer used for T1. New versions of this component have

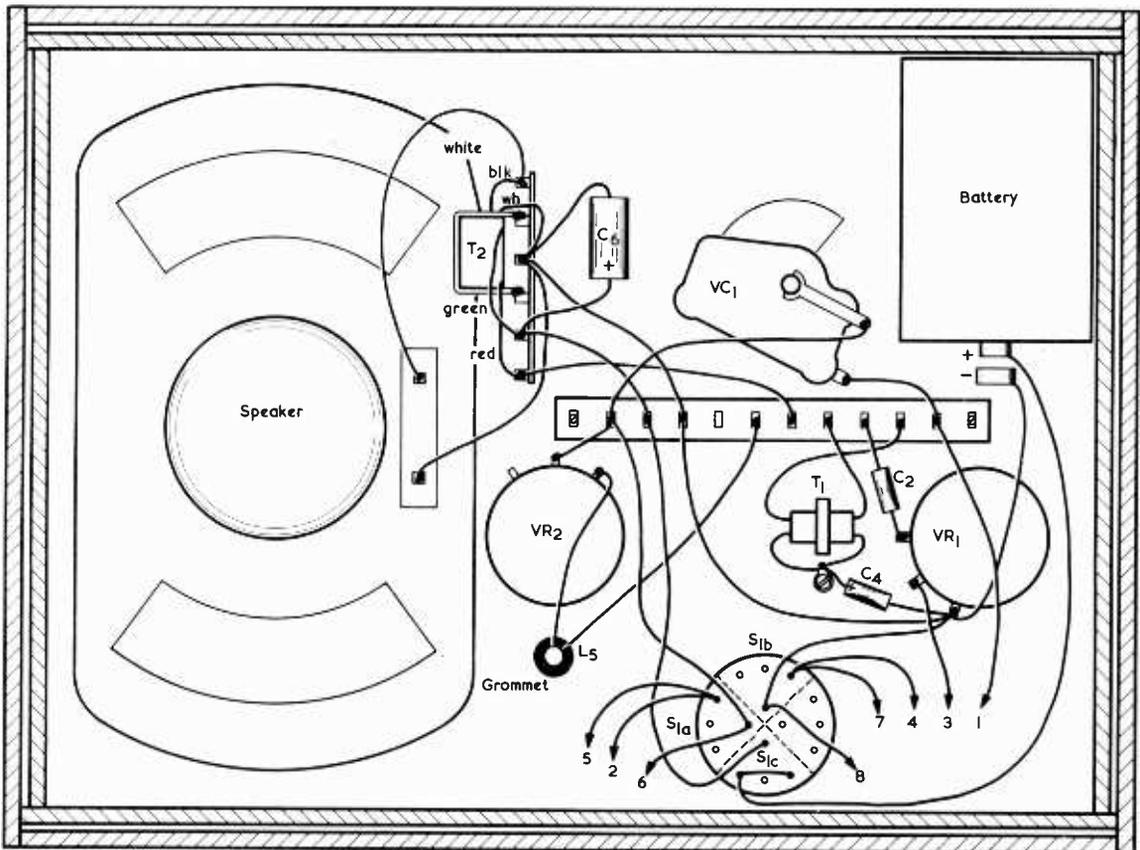
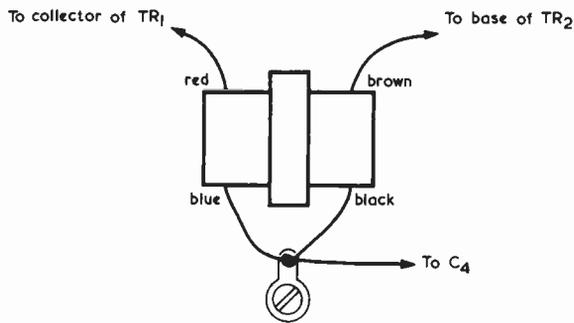
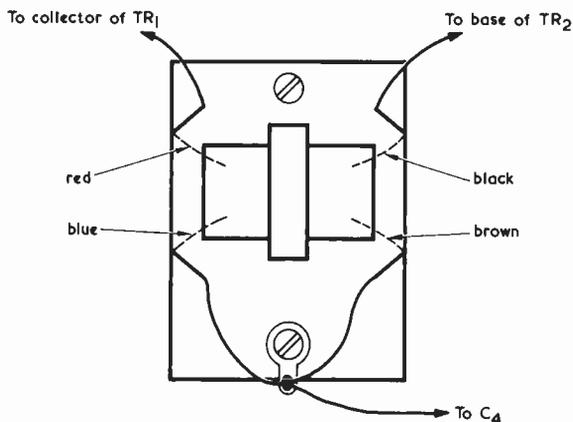

Fig. 6. Components and wiring inside the receiver case



(a)



(b)

Fig. 7. How the alternative versions of the transformer specified for T1 are connected up and mounted. The transformer in (a) has flexible lead-outs whilst that in (b) has connecting spills

flexible leads as shown in Fig 7(a), and if one of these transformers is used it should be cemented to the case, upside down so that the leads are uppermost, and connected as shown. But earlier examples of the TT53 had solid spills, and the colour marking was different. It may be that some readers will have one of these older components in their spares box, or may buy one from old stock. They are equally suitable and, indeed, one is used in the prototype, but connections are different and are as shown in Fig. 7(b). It will be found that the transformers fitted with spills are rather delicate, as twisting a spill can easily break the very fine internal wire used for the large winding. The wisest course is to cut a piece of thin Paxolin, and carefully pass the four spills through four suitably drilled holes, bending them over and round the edge of the Paxolin, as shown, to hold the transformer firm. Flexible leads are then soldered to the exposed ends of the spills, which need not be touched again. Colour coding of these earlier transformers is by drops of paint on the short extensions of the spills on the top side of the component, and these short coloured extensions will be uppermost when the Paxolin panel is screwed to the case. In most cases, of course, the constructor will buy an up-to-date component and fit it as shown in Fig. 7(a). Note that the solder tag which carries the

common connections from C4 and T1 primary and secondary is secured under a wood-screw. In Fig. 7(b) this is one of the two wood-screws holding the Paxolin panel in position.

Wire up the remaining small components shown in Fig. 6. Choke L5 is mounted vertically, its lower end being cemented to a close-fitting grommet, which in turn, is cemented to the plywood. Also fit the speaker, over a piece of fabric, and wire it up.

Push the frame aerial into position so that its leads are close to S1 and wire these up as shown by the numbered arrows in Fig. 6. A little cement will hold the frame in position, but do not use this until the receiver has been tested and found in order, as there always *may* have been a slip in winding the aerial! Arrange a means of holding the PP9 battery in position. A small shelf may be used or, as in the case of the prototype, two small hooks and a large rubber band.

SETTING UP

The only setting-up process involves the preset control VR3, this being adjusted to allow the whole of the track of the bass boost control, VR2, to provide useful control. First set VR3 with all its resistance in circuit, its slider then being fully to the left, as seen in Fig. 5. Set VR2 fully clockwise to its maximum boost position, and switch on. Adjust VC1 and VR1 to a station, this being preferably a fairly strong local transmission but not so powerful as to cause overloading. Next, advance the setting of VR1 until a whistle denotes radio frequency oscillation. If the whistle cannot be obtained, advance the slider of VR3 a little to the right until oscillation is achieved. Now advance the slider of VR3 further to the right until a position is reached where a low note audio oscillation is superimposed on the whistle, then bring it back slightly. If the low note oscillation does not occur when the slider of VR2 has been advanced about two-thirds of the way from the left, something



Another rear view. The home-wound choke, L5, may be seen below potentiometer VR2

is wrong, and the fault should be looked for. *Never* advance the slider of VR3 more than nine-tenths of its way over, since a large current will then flow. The usual optimum position will be at about the half-way point. The object is to adjust VR3 so that VR2 will produce maximum bass boost, without oscillation or distortion, when very near to, or at, its maximum position.

TUNING DRIVE

As suggested earlier, it is a useful, though by no means essential, refinement to fit a slow-motion tuning drive to VC1. This will not be necessary for local stations, but it will be found that after dark the range of the receiver is quite good, and three or four Continental stations will probably come in at fair volume plus many more at 'bedside' volume. It is for these that a slow-motion drive is useful. But the author would emphasise that this is essentially a local station receiver. Apart from other considerations, the bass boost control is less effective on very weak signals.

With the prototype, the author used a Jackson cord drive spindle type G (Home Radio Cat. No.

DL34). A few turns of Sellotape were wrapped around this, after which a grommet with a $\frac{1}{4}$ in. hole was passed over. The Sellotape ensures that the grommet is held firmly on the spindle. The bush of the spindle is then fitted to the panel of the receiver in a position which causes the grommet to press hard against a large diameter knob fitted to VC1, the knob having a diameter of $3\frac{1}{2}$ in. in the prototype. Rotating the cord drive spindle then causes the large diameter knob to turn, and a simple but effective slow-motion drive results.

If this method is employed, the added spindle should be mounted before any components other than VC1 have been fitted to the case, or the drilling and subsequent work involved may cause damage, particularly to T1. Many readers will do without a slow-motion drive, and others will fit a commercially made type of their own choice. A ball-drive, for example, could be used, VC1 being fitted to a small sub-panel behind the front panel of the receiver.

A wavelength scale, marked with available stations, may be fitted, and the other controls suitably marked. A final touch is given by the provision of a carrying handle, which can be purchased from a 'D.I.Y.' shop.

CAN ANYONE HELP?

Requests for information are inserted in this feature free of charge, subject to space being available. Users of this service undertake to acknowledge all letters, etc., received and to reimburse all reasonable expenses incurred by correspondents. Circuits, manuals, service sheets, etc., lent by readers must be returned in good condition within a reasonable period of time.

Electroniques Coils Type SL/T, SL/U and SL/Y.—E. Warner, 44 Thorndale Ave., Larne, Co. Antrim, N. Ireland – would like to purchase or be advised of any supplier retailing these coils.

* * *

Receiver Type R1475, Power Unit Type R360 and Tuning Unit Type 131.—C. Astbury, 16 Eaton Avenue, Handbridge, Chester, CH4 7HS – manual or any other information.

* * *

"Eddystone" Rx Type 840A, "Murphy" 700 Series TV Converter.—F. Payne, 15 Wood Crescent, Holts' Estate, Oldham, Lancs. – manual or any other information – loan or purchase.

* * *

Airmec Televet-877.—D. Wigley, 4 Sellons Avenue, Harlesden, London, N.W.10 – manual required, loan or purchase.

* * *

Simon SP5 Recorder.—R. W. Bolton, 569C Garratt Lane, Earlsfield, London, SW18 4SR – manual or servicing instructions, loan or purchase.

BC221 – AF Frequency Meter.—J. R. Owen, 40 Kingslea Road, Withington, Manchester, M20 9UA – Alignment instructions, also circuit diagrams and alignment details for the wavemeter D Mk II.

* * *

RSC A10 30 Watt Hi-Fi Amplifier.—L. V. Flynn, 18 Ireton Street, Belfast, BT7 1LH – circuit manual – loan or purchase.

* * *

November 1965 issue of The Radio Constructor (now out of print).—F. Hill, 19 Leith Road, Sale, Cheshire, M33 2LR – loan or purchase.

* * *

Capacitor Analyser (Solar) Type CB-24.—R. Kirk, 22 Barncraig Street, Buckhaven, Fife – circuit or any information.

* * *

June 1969 issue The Radio Constructor (now out of print) required by:—C. S. Bailey, 19 Fallows Green, Harpenden, Herts, and also by G. J. Knock, 31 Northmead, Ledbury, Herefordshire.

RECENT PUBLICATIONS



THE PEGASUS BOOK OF ELECTRONIC EXPERIMENTS. By F. G. Rayer, A.I.E.R.E., G30GR.

190 pages, 5 x 7 $\frac{3}{4}$ in. Published by Dobson Books, Ltd. Price 95p.

One of the main points that is, rightly, given emphasis in this book is that all the experiments described are completely safe because the only supplies required are those given by 1 $\frac{1}{2}$ volt cells and 9 volt batteries. None of the experiments involves connection to the mains. It may be added that valves appear nowhere in the book; where active devices are required these are all low-cost transistors.

The book commences with chapters on circuits and components, on the measurement of voltage, current and resistance, and on semiconductors. Then follow a wide range of suggested experiments, these taking in radio reception, audio amplifiers and output circuits, pick-ups, microphones and audio oscillators. Next come experiments dealing with transistors as switches, with control by light and with analogue and digital computer methods. Two final chapters describe miscellaneous experiments and the book concludes with a useful index.

The Pegasus Book of Electronic Experiments' can be recommended to the beginner of any age-group who wishes to become acquainted, by practical experience, with the elements of electronics. All details are dealt with in simple terms and only the essential theory is provided. Particularly interesting are the chapters dealing with analogue and digital computer experiments, as these provide an imaginative introduction to the field of elementary computer operation and of binary notation.



RADIO AND TELEVISION YEAR BOOK (1971/72). Edited by Eric Ickinger.

223 pages, 5 $\frac{1}{2}$ x 8 $\frac{1}{2}$ in. Published by IPC Electrical-Electronic Year Books Limited. Price £1.

The fourth edition of this annual publication follows the basic style of previous editions in listing details and giving illustrations of the latest table, car and portable radios, colour and monochrome television receivers, radiograms, record players and unit audio equipment. Tape recorders, which were grouped in the preceding editions as either battery or mains powered, are now categorised as reel-to-reel recorders or cassette recorders. The tape recorders and unit audio equipments included are those which do not exceed a price range of approximately £150 (those which do being dealt with in the sister publication 'Hi-Fi Year Book'). The edition also includes radio and television v.h.f. and u.h.f. transmitter guides.

The purpose of 'Radio and Television Year Book' is two-fold. Firstly, it assembles data on all the available domestic radio, television and audio equipment together in one handy volume, enabling the reader to make comparisons, to contact manufacturers for literature and to make a selection for purchasing through his dealer. Secondly, this same dealer also has the same complete list, to which he can refer when customers enquire about lines he does not normally stock. The information provided in the book includes details and specifications of models with prices and suppliers' or makers' names, as well as addresses and telephone numbers, all of which are intended to make ordering easy.

The book is available through booksellers or by post (in which case add 15p) from IPC Business Press (Sales and Distribution) Ltd., P.O. Box 147, 40 Bowling Green Lane, London, EC1P 1DB.



RADIO AND ELECTRONIC LABORATORY HANDBOOK, 8th Edition. By M. G. Scroggie, B.Sc., C.Eng., F.I.E.E.

628 pages, 5 $\frac{1}{2}$ x 8 $\frac{1}{2}$ in. Published by Iliffe Books. Price £4.75.

This 8th Edition of what is virtually a standard work on its subject has been completely revised and reset, and the book now uses S I (Système Internationale) units throughout. The author points out in his preface that 'possessors of previous editions may need to be convinced that it is going to be worth while getting this one', then proceeds to state that transistors had made only a rather tentative appearance in instrumentation when the last edition was written. This present edition deals fully with the uses of transistors in laboratory equipment.

The book commences with chapters dealing with the basic requirements of a laboratory, including the home laboratory of the amateur, then carries on to the fundamental principles of measurement and to power and signal sources. The following chapters discuss indicators (meters, oscilloscopes, etc.), standards, composite apparatus and the choice and care of equipment. The next three chapters deal with measurements; of circuit parameters, of signals and of equipment characteristics. The first of the final two chapters which complete the book covers the procedure of dealing with results obtained from laboratory measurements, whilst the last provides a very detailed reference section. There is also a comprehensive index.

M. G. Scroggie's light style makes the book eminently readable without in any way detracting from its accuracy and conciseness. The 8th Edition of 'Radio and Electronic Laboratory Handbook' can be fully recommended to anyone who deals with laboratory work, be he student, amateur experimenter or professional engineer.

"SAFELOC" SALES STILL INCREASING



Thirteen years ago a completely new concept was introduced to the British market by Rendar Instruments Ltd., the electronic component manufacturers in Burgess Hill (Victoria Road), Sussex.

This was a small, boxed-in device with a lid which provided an absolutely safe and quick connection to the mains for 2-core and 3-core bare-ended flexible leads.

The product was marketed under the name "Safebloc", and immediately found a ready acceptance by the larger industrial users on their factory testing lines.

More recently, Safebloc has been adopted by smaller users – shops and stores find it invaluable for the demonstration of all kinds of electrical apparatus, and it has even found its way onto the work benches of individual handymen and repair shops.

Among its advantages is the matter of time saving, as there is no need to fit a plug before the test or demonstration. The safety factor is also appreciated, as it is quite impossible for any current to pass while the lid is open.

Readers are advised to ask for Safebloc from their local stockist, but alternatively they can order it direct from the Rendar factory as a mail order operation.

MINISTRY OF DEFENCE MAKES LARGE AWARD

The Ministry of Defence has awarded Lieutenant "Benny" Goodman, Royal Signals, one thousand pounds for inventing the VHF Radio Applique Unit, now known in the Royal Signals as the "Goodman Box".

"Benny", who is the son of Mrs. Gertrude Goodman of 20, Upper Shalmsford Street, Chartham, Canterbury, conceived the idea some fourteen months ago while serving as a Warrant Officer at the School of Signals. He was listening to a lecture on "Signals in Germany" where the speaker complained about interference by unwanted signals over Very High Frequency nets. He immediately constructed pilot models which were tested and modified by the Combat Development and Trials Wing of the School of Signals. Royal Electrical and Mechanical Engineers then produced the first units for field tests and they are now in regular service.

"Benny" is a fourth generation soldier whose father, grandfather and great grandfather served in the Royal Engineers. He enlisted in boys service in 1948 and has seen service in Korea, the Far East, the United Kingdom and Germany.

To cap it all this is not his first award for his radio engineering genius. He was awarded the British Empire Medal in the New Years Honours List for his design of a Radio Control Monitor Unit.



Technical Details

The Goodman Box is used on VHF nets. Its primary use is at rebroadcast stations where it prevents unwanted voice signals from "triggering" the station. Subsidiary but no less important uses at VHF stations are an indication of the strength of a received signal, a means of testing co-axial feeder continuity and the provision of a transmitter power output test.

COMMENT

NEW GIANT LOOKS INTO SPACE PYE POCKETFONE AT ABBEY

A NEW radio telescope, which should be the largest of its kind in the world, is to be financed by Britain's Science Research Council, at a cost of £250,000. A BBC science programme explained why it was necessary.

To see deeper and deeper into space, it is necessary to use larger and thus more sensitive radio telescopes because the farther away the source is, the weaker the signal. There are 10,000 radio sources known, but many more cannot yet be distinguished because of the limitations of present equipment.

Behind the new radio telescope is Sir Bernard Lovell, director of Britain's Jodrell Bank Radio Astronomy Observatory. For 13 years the Mark I radio telescope was the largest fully steerable dish-type in the world — some 80 metres in diameter.

Recently the Germans completed one measuring 100 metres — now the new British telescope, to be called the Mark V, should be 115 metres in diameter. The dish itself will be almost four times as heavy as the German dish, weighing 7,000 tons.

IN BRIEF

● The British Amateur Electronics Club are hoping to form a group in the London area. Readers interested should write to D. A. Barry, 55 Cromwell Road, Stevenage, Herts.

● Newmarket Transistors Ltd., have issued a statement of policy regarding their intention to continue the manufacture and supply of a wide range of germanium devices. The reason for the policy statement is the decreasing number of sources of supply.

● A new general purpose closed-circuit television camera, incorporating an intrinsically weatherproof casing and other purpose-designed features to simplify operation, installation and maintenance, has been introduced by EMI. Known as the 'Surveyor', this rugged and versatile 625/525-line camera provides comprehensive operational facilities which makes it suitable for a wide range of applications.

● The latest issue of the FR Electronics Reed Switch Catalogue, containing details of the complete range of 37 different reed switches, is now available. Details from FR Electronics, Wimborne, Dorset, BH21 2BJ.

● The Annual Dinner and Dance of the Derby and District Amateur Radio Society (founded 1911), is to be held on Saturday 15th April at the Derbyshire Yeoman, Kingsway, Derby. Details of the Society may be obtained from the Honorary Secretary, F. C. Ward, G2CVV, 5 Uplands Avenue, Littleover, Derby.

APRIL 1972

*Mr. W. Walker,
B.E.M., Yard Beadle
— a mediaeval
constable uses the
Pye Pocketfone.*



Westminster Abbey, home of much that is part of Britain's heritage, has recently begun using the most modern communications aid — two-way pocket radios.

The system, supplied and installed by Pye Telecommunications Ltd., comprises a base station and 9 two-way radios and has just completed various acceptance tests.

Pye Telecoms supplies such equipment to the Police, the public authorities such as Water Boards, Gas and Electricity Boards, and to commercial users such as oil refineries, large factories, warehouses, etc.

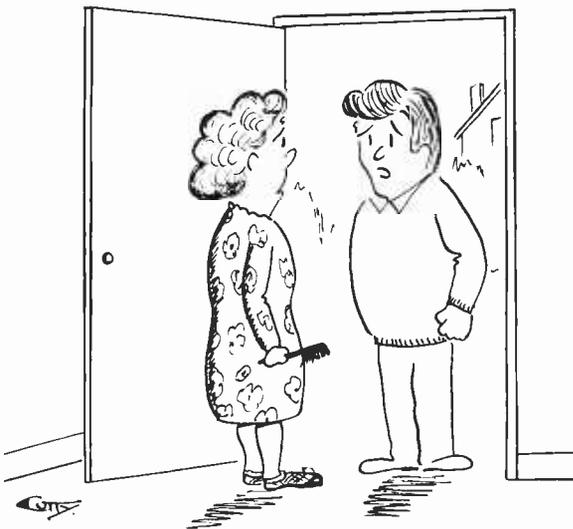

"Madam would you mind turning your T.V. set off—it's interfering with my drill!"

Further Notes—5

CLAMP DOWN

By
PETER WILLIAMS

Adding a transistor to a regulated supply circuit can provide continuous monitoring of output current, thereby preventing excessive current in the load.

SIMPLE RESISTOR LIMITING WAS SHOWN IN THE LAST note to give appreciable protection of a regulator against short-circuit. It is less useful in protecting the load since the short-circuit load current can be many times the normal load current (150mA as against 30mA in the example considered last month).

The only alternative left is to sense the load current and 'take avoiding action'. Two forms are possible: (a) switching action that disables the supply at some critical current, (b) continuous monitoring and feedback to exercise the same controlling action on current as already exists for voltage. It is the latter that we shall consider now, noting first that the current need not be controlled to a high accuracy while minimizing of wasted power is important.

CONTINUOUS MONITORING

The additional components are enclosed by the dotted lines in the diagram. When the current in R_s

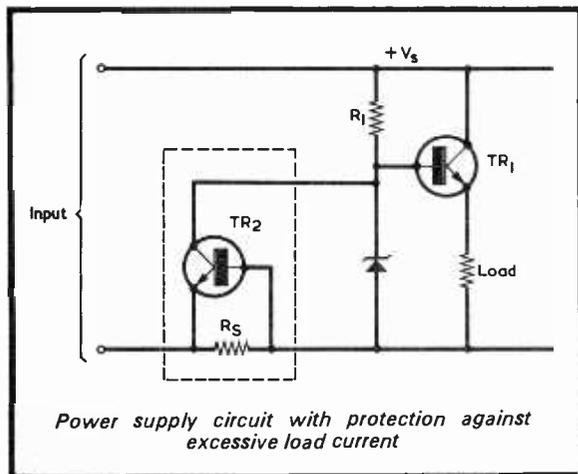

is small, the p.d. developed across it is insufficient to bring TR2 into conduction and the circuit behaves exactly as before, though with a small voltage being lost in R_s . As the load current increases, the p.d. across R_s rises towards about 0.5V, the point at which TR2 begins significant conduction. (This assumes that TR2 is a silicon transistor). In so doing TR2 withdraws current from the bias section of the regulator until eventually a point is reached where there is insufficient current for the zener diode to maintain a stable voltage. Any further decrease in load resistance now results in a very small increase in load current since TR2 is biased at the level where its current doubles for each increase in V_{be} of 20mV or so, i.e. the load voltage might be halved by a change of load resistance that only allowed the load current to increase by a few per cent.

In practice the effect from the onset of limiting to a complete short-circuit might consist of a current change of less than 10%.

The stability of the current limit condition is clearly dependent on that of the transistor V_{be} . This changes with temperature, but in such a direction that the short-circuit current actually falls as the temperature rises. Even so the change is not likely to exceed 10% in the conditions met by the average experimenter, though this is not true if the regulator were to be used in a 'hot-spot' as part of a car electronic system. Better regulation at the expense of greater wasted power can be achieved by adding a Zener diode to the current control loop.

In commercial regulators the same basic method is used, though TR2 might be replaced by a complete amplifying circuit with separate reference voltage to set the desired current. In our example the required value of R_s can be estimated by dividing the expected V_{be} value by the current limit required. With the 30mA maximum current figure used in the previous example, R_2 would be 0.5V/30mA or about 16 Ω . Making R_s a variable resistor of say 50 Ω would allow control of the current limit to suit different loads. ■

Novel Alignment Aid

by G. A. FRENCH

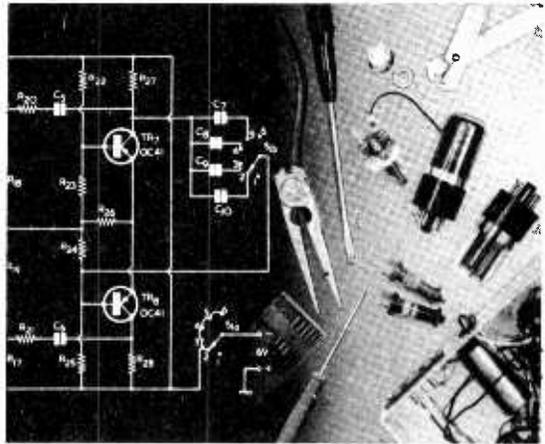

DURING SERVICING WORK IT IS occasionally necessary to align the r.f. and i.f. stages of small transistor portable radios with the aid of a modulated signal generator. Whilst it is possible to achieve quite accurate alignment by listening to the audio output from the speaker of the receiver, best results are obtained by using an output meter. This is because small increases in volume level, to which the ear is not normally very sensitive, are readily discernible in a meter. In practice the output meter can consist of a testmeter, switched to an a.c. volts range, which is connected across the speaker of the receiver. The alignment, incidentally, should always be carried out with the receiver volume control at its maximum setting, and with just sufficient output from the signal generator to give a comfortably audible output from the receiver.

Unfortunately, it is difficult to connect a testmeter to the speaker of some transistor radios, this being due to the fact that the speaker connections are positioned beneath the printed circuit board of the set. Alternatively, the speaker connections may only be available in the form of two small sections of foil in the copper pattern, to which testmeter clips cannot be reliably applied. The alignment aid to be described in this article offers a novel means of causing the audio output of a receiver to be coupled to a measuring instrument without the necessity of making any direct connection to the receiver whatsoever. The aid also enables the audio output to be reproduced in a pair of headphones, a facility which can be of occasional advantage in a noisy workshop.

ALIGNMENT AID

The alignment aid consists basically of nothing other than a small 3Ω loudspeaker and a valve speaker

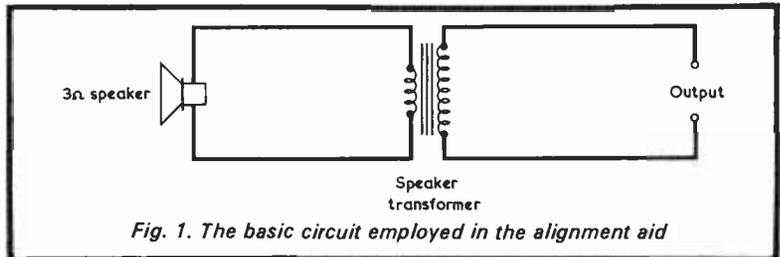

transformer. These are wired up as shown in Fig. 1, in which the transformer functions as a step-up component, i.e. the winding with the lower inductance is connected to the speaker.

To use the device, the speaker is placed over the loudspeaker aperture of the receiver being aligned, as shown in Fig. 2. This provides a tight acoustic coupling between the speaker in the receiver and the speaker employed in the aid, and the latter can be held in position, if necessary, by a loop of elastic cord passed over the receiver cabinet. For convenience, the speaker in the aid circuit may be coupled to its transformer by way of some 4 or 5ft. of

2-core flex.

The speaker in the aid functions as a microphone, the voltage produced across its voice coil being stepped up by the speaker transformer. If the reader is fortunate enough to possess a sensitive valve or f.e.t. voltmeter with a diode probe, or an oscilloscope, the output from the speaker transformer may then be connected direct to this, whereupon a reliable comparative measure of the audio output of the radio becomes immediately available for alignment purposes. Signal voltages to be expected at low receiver output levels are of the order of 0.5 volt, although these will of course be

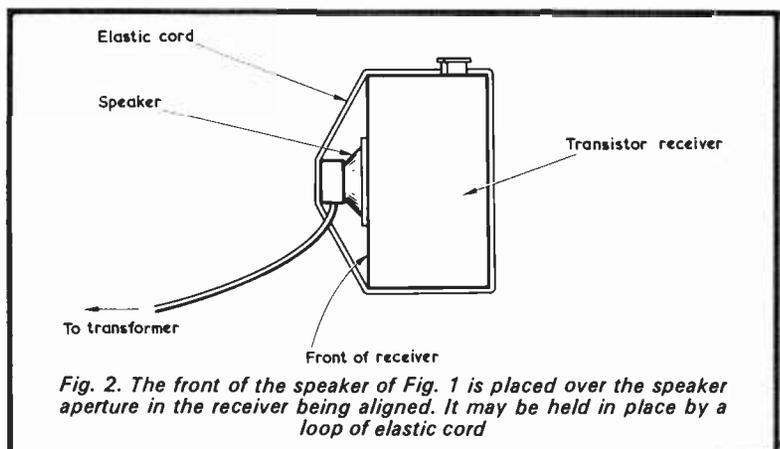

dependent upon the sensitivity of the speaker which is used as a microphone and the step-up ratio of the transformer to which it connects.

If neither a valve or f.e.t. voltmeter nor an oscilloscope are available, visual indications of audio output from the receiver may be obtained by means of the circuit given in Fig. 3. Despite its simplicity this arrangement gives quite usable comparative indications of audio output from the receiver, but at low volume levels it is necessary to work to an indication in the 0-100 μ A meter of about 3 to 5 μ A only. It will be found that 'exaggerated' peak readings are given at these low meter deflections since the signal amplitude from the speaker transformer is then just passing the level at which forward conduction in the series germanium diode commences. There is no advantage, incidentally, in using a bridge rectifier instead of a single series diode to rectify the a.f. from the transformer. If a bridge rectifier were used the output from the speaker transformer would have to overcome the forward conduction level of two diodes in series instead of one before meter deflection commenced. With the circuit of Fig. 3, a fairly high output level from the receiver produces meter readings that are well past half-scale deflection.

As a further point, the output from the receiver can be made audible in a pair of 2,000 Ω headphones connected to the speaker transformer as shown in Fig. 4. The sound level offered by these headphones is of the same order as is given by holding the ear about a foot away from the receiver loudspeaker itself. The fact that the headphones mask external noise can be an asset for some servicing applications.

If it were decided to combine the

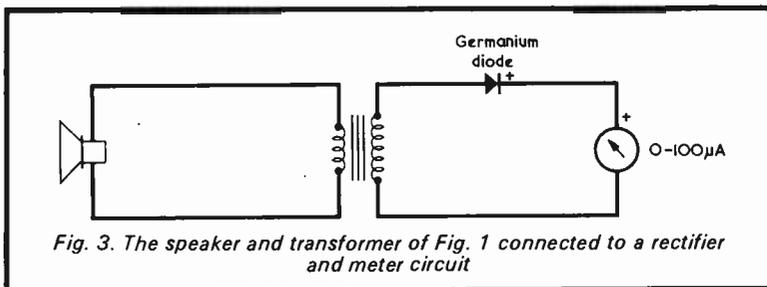

Fig. 3. The speaker and transformer of Fig. 1 connected to a rectifier and meter circuit

PRACTICAL POINTS

It will be appreciated that the circuits just discussed have the advantage of using components (with the possible exception of the 0-100 μ A meter) which are almost certain to be continually on hand in a service workshop. Indeed, either of the circuits of Figs. 1, 3 or 4 could be temporarily wired up for

the output fed to the headphones. ratios of 1:33, 1:55, and 1:90 when employed in the manner required here, the best performance being given with the 1:90 ratio. The speaker was a 3 Ω unit with a cone diameter of about 3in.

The germanium diode employed in Figs. 3 and 5 can be any type, but it will be of advantage to select a diode which exhibits a low forward voltage. It may be found that the base-emitter or base-collector junction of a germanium transistor offers a better performance

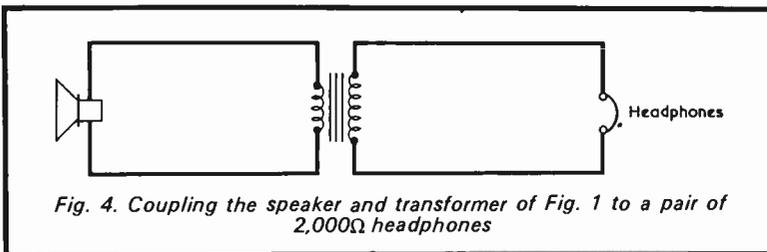

Fig. 4. Coupling the speaker and transformer of Fig. 1 to a pair of 2,000 Ω headphones

a particular servicing task and then just as quickly disassembled again. A small loudspeaker having a light cone is best for use in the alignment aid as this should, in general, be most sensitive as a microphone. If several speakers are to hand these could be

in this respect than does a standard diode. The author obtained slightly increased sensitivity with the base-emitter junction of an ACY19 (no connection being made to the collector) as compared with a number of point-contact diodes.

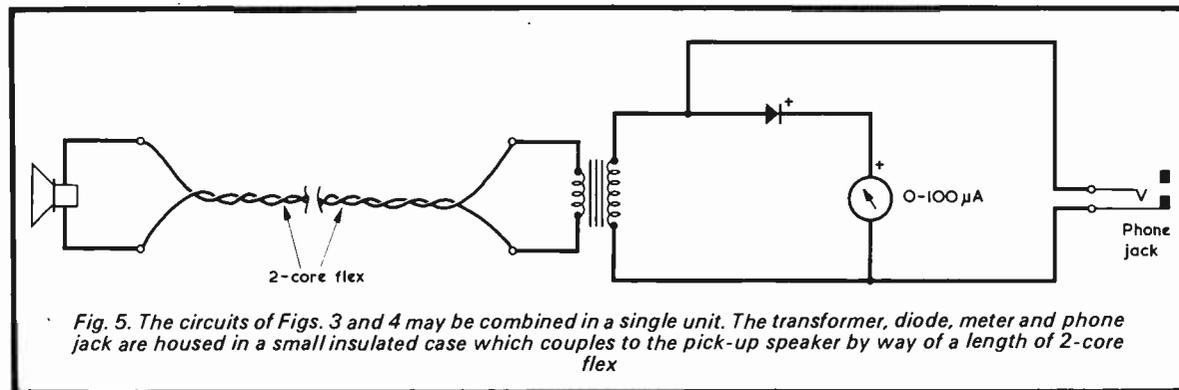

Fig. 5. The circuits of Figs. 3 and 4 may be combined in a single unit. The transformer, diode, meter and phone jack are housed in a small insulated case which couples to the pick-up speaker by way of a length of 2-core flex

circuits of Figs. 3 and 4, these could be made up in the form shown in Fig. 5, in which the transformer, the diode, the meter and a jack socket for the headphones, are all fitted in a small insulated box which connects to the speaker via 2-core flex. The headphones should not be plugged in when it is desired to use the meter, as they will cause a reduction in the sensitivity of the circuit. On the other hand, the meter circuit does not significantly reduce

tried individually to see which gives best results. A piece of thin speaker fabric may be fitted over the front of the speaker to prevent possible damage to its cone.

The speaker transformer should, preferably, have a high ratio, since meter readings increase as the ratio increases. The author used a small Elstone transformer type MO/T (Home Radio Cat. No. T012) for checking the circuit. This component offers step-up

The sensitivity of the alignment aid is, to some extent, dependent upon the audio frequency reproduced by the receiver loudspeaker. Sensitivity is adequate for alignment purposes when the signal generator is modulated by a 1kHz tone, and it becomes increased if the modulation is at 400Hz. Bearing in mind the frequency response of small speakers, as would be used in the aid, such a performance is that which would be expected.

Sensitivity Measurement of Portable Receivers

by
C. F. Dorey

How to measure the sensitivity of ferrite rod receivers

TO CARRY OUT THE SENSITIVITY MEASUREMENT TO BE described, the receiver must be placed in the field of a loop radiator, at a point where the field strength can be simply calculated in terms of the voltage applied.

LOOP CURRENT

The field strength due to a vertically mounted square loop of 30 cm. side, at a point 1 metre from the loop along its axis, can be expressed in terms of current in the loop, or the applied voltage if the loop is fed through a high resistance.

If the total resistance is 1,000 Ω , the field strength at 1 metre distance is given by

$F = 5150 V$ in $\mu V/\text{metre}$ where V is the applied e.m.f. in volts.

This holds good up to about 20 MHz.

The loop can be made of metal curtain rail mounted on a wooden block of the type used to mount domestic electric sockets and switches.

In the author's case plastic covered curtain rail was used, because the loop is therefore insulated and has a non-tarnishable finish. The H-section type of curtain rail gives strength to the loop so that it is self-supporting.

The length, nominally 120 cm. total, was cut slightly short to leave a small gap in the bottom at the feed point. The ends were secured to the wooden block by two 6BA screws in each side, with a solder tag placed under the one nearest the end on each side. The resistor, made up of 910 Ω and 15 Ω in series, or any other values totalling 925 Ω (for a 75 Ω generator), were connected between one solder tag and the inner conductor of a coaxial lead about 6 feet in length. The screen of the coaxial lead was connected to the other solder tag. The resistors and a clamp for the lead fitted into the wiring recess in the wooden block, and were covered by a base plate of hardboard.

MEASUREMENT

The measurement should be made in the following manner. The receiver should be positioned, as shown in the diagram, with the mid-point of its aerial rod 1 metre from the loop radiator, and along its axis. An output

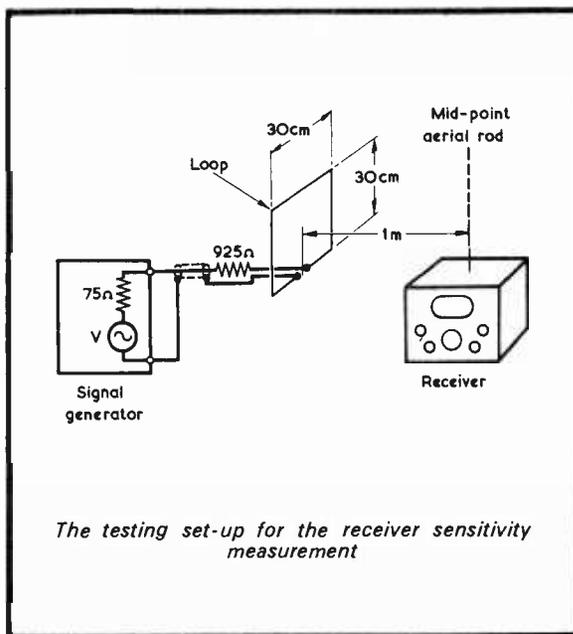

The testing set-up for the receiver sensitivity measurement

meter should be used, as in a normal sensitivity measurement, to indicate when the standard output of 50mW is being achieved as the level of the modulated output of the signal generator is adjusted. The receiver should be rotated and aligned for maximum output at a fixed low signal level before making the actual sensitivity measurement, and the surrounding area should be as free as possible from metal objects which could cause distortion of the field.

When the signal generator output voltage giving the standard output has been noted, the corresponding field strength may be calculated. A moderately good 6-transistor portable would have a sensitivity of 500 $\mu V/\text{metre}$ at 1 MHz for an output of 50mW.

REFERENCE

Bray and Lowry, 'The Testing Of Communications-type Radio Receivers', J.I.E.E., 1947, page 313. ■

Trade News . . .

TRANSPARENT IN-FLEX FUSEHOLDER



The new Bulgin transparent fuseholder. This is designed to be inserted in a flexible lead

A. F. Bulgin and Co. Ltd., announce a new in-flex fuseholder in their popular F.180 series. This, the F.180/Clear, is shown in the accompanying illustration and is moulded in a transparent plastic material. As with the previous types the new fuseholder can be inserted in a flexible lead, the latter being connected to the two end terminals of the fuseholder.

The advantage of the clear fuseholder is that the fuse and cable terminations are clearly visible, thereby effecting an obvious saving in time when looking for a blown fuse or faulty connection. The fuseholder is rated at 250 volts maximum and has a length of slightly less than 2½ in. The previous opaque fuseholders were types F.180/Red and F.180/Black; further details may be obtained from A. F. Bulgin and Co. Ltd., Bye-Pass Road, Barking, Essex.

IMPROVED SOLDER FEED

For use with most hand-held electric soldering irons, the Mark 2 ANEXTRA has been improved since the original was announced. The method of attaching to a soldering iron now incorporates two "V" notches and two adjustable nylon straps which provide a much more firm fixing between the iron and ANEXTRA.

The prime object of leaving one hand free to hold the job is thus enhanced and quantity production has enabled the list price to be reduced to £3.75 direct from the makers; or s.a.e. for leaflet. ANEXTRA LTD., Chiltern Works, Rear of 77/78 Chiltern View Road, Uxbridge, Middlesex, England.

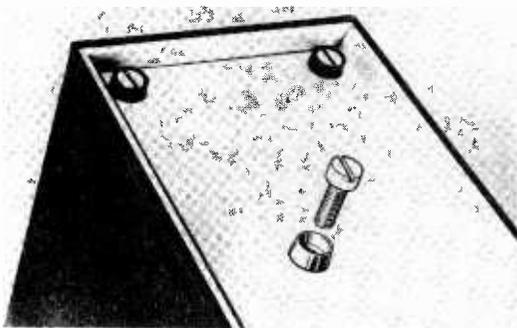
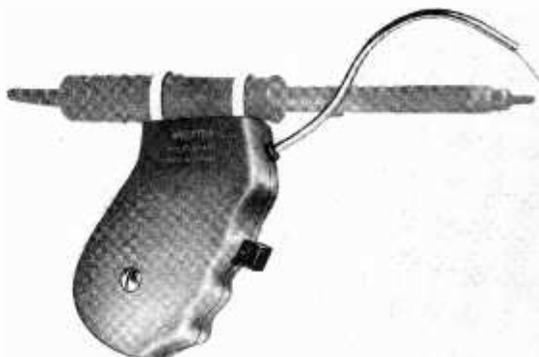

NEW PANEL FIXING SCREW

Vero Electronics Limited have just introduced a new style of front panel fixing screw. The screw is still for use with existing ¼ UNF fixings but has a smaller head for the neater appearance and is also supplied with a black cup washer to protect the panel itself and further enhance the overall appearance. Head and washer dimensions are such that any standard size panels can be mounted together without interference from the adjoining screws. Two lengths are available one for single panel thickness and one for double panel thickness. Vero Electronics Ltd., Industrial Estate, Chandlers Ford, Hampshire SO5 3ZR.

AERIAL CHANGE OVER RELAY

The Series 951 Co-axial Relay from Magnetic Devices for aerial switching at frequencies in the order of 450 megacycles is ideally suitable for HF 2-way radio. This small fast operating relay with a single pole changeover contact enclosed in a silver plated brass housing may also be used in applications where exceptionally low inter-contact capacitance is required. The relay is designed for use with UR 43 co-axial cable and is competitively priced. Coils can be wound for operation up to 100 volts D.C. For further information please contact Magnetic Devices Limited, Newmarket, Suffolk.

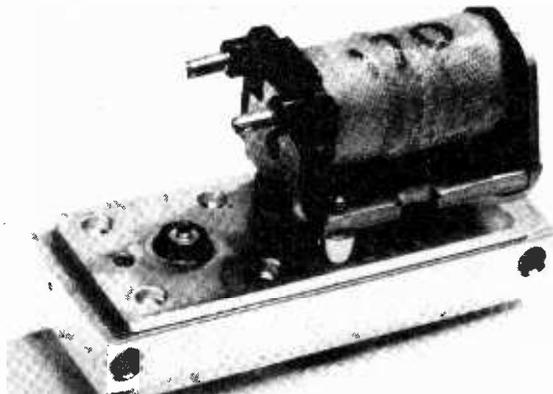

Subtraction Computing Circuit

By
D. SNAITH

This simple analogue computing device enables one number to be subtracted from another. The circuit is capable of handling negative as well as positive difference figures.

ELEMENTARY ANALOGUE COMPUTING DEVICES CAN BE readily assembled by the home constructor. Whilst no pretensions are made concerning their ultimate practical usefulness, they are nevertheless of value in demonstrating basic theory. They are also capable of impressing non-technical friends and of making instructive educational toys for children.

The writer published a circuit for a simple analogue computing device capable of addition in a recent issue.* The computing circuit now to be described is capable of performing a subtraction, and can cope with the case where the answer is a negative quantity. The principle of operation is different from that used in the previous circuit.

BATTERY CIRCUIT

A battery-operated version of the circuit is shown in Fig. 1. Here, the three batteries, B1, B2 and B3, are

* D. Snaith, 'Addition Computing Circuit', *The Radio Constructor*, November 1970.

assumed to offer equal voltages, which can conveniently be 9 volts nominal. S2(a)(b)(c) is a 3-pole 2-way rotary switch, which functions as the on-off switch for the device. For the present discussion we shall assume that it is turned to the 'on' position, and all of its three sections are closed.

The three potentiometers are linear components and are scaled from 0 to 100 in terms of resistance. Thus, if the pointer of one potentiometer is set to 50, the slider of that potentiometer is exactly central on its track. The numbers selected by VR1, VR2 and VR3 can be expressed as A, B and C respectively whereupon, when the circuit is balanced as indicated by a zero reading in the central-zero meter, the scale readings satisfy the equation:

$$A - B = C$$

The circuit will also satisfy the consequent equations:

$$A - C = B \text{ and}$$

$$A = B + C$$

Resistor R1 is merely a current limiting resistor and limits the maximum current which can flow in the meter

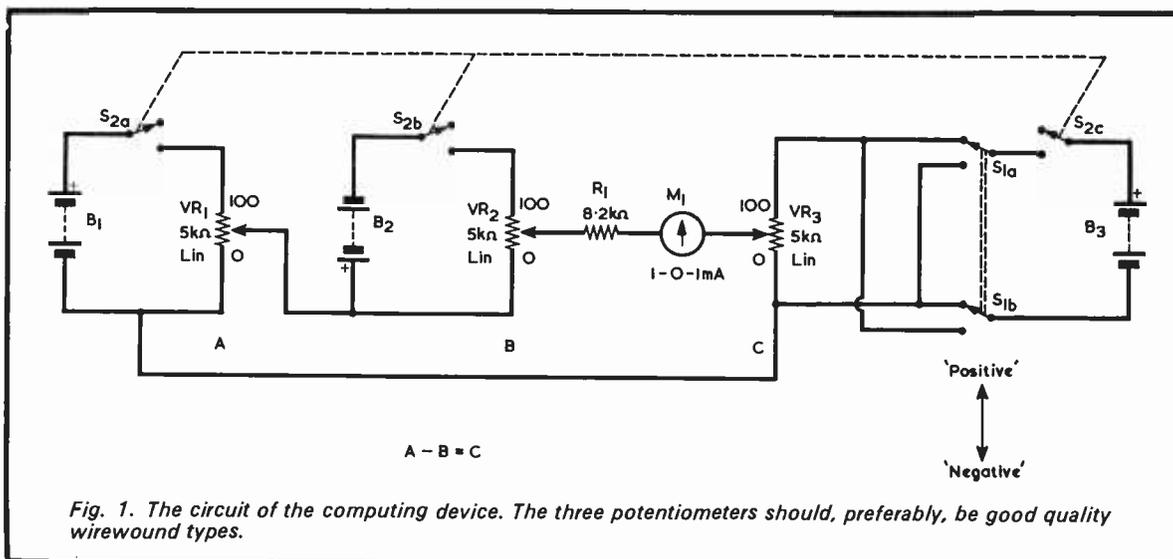

Fig. 1. The circuit of the computing device. The three potentiometers should, preferably, be good quality wirewound types.

(with 9 volt batteries) to about 2mA. The meter should be able to pass this current without damage. S1, whose function will be described later, must be a break-before-make type, such as a toggle switch.

Let us now take an example of the circuit in operation. We shall refer to the voltage offered by each battery as E volts. Potentiometer VR1 is set to 80 on its scale, whereupon its slider taps off a potential that is, with respect to the lower common rail, equal to 0.8E volts. Potentiometer VR2 is set to 20 on its scale, with the result that its slider taps off a voltage that is 0.2E volts negative of that on the slider of VR1. Since the latter is 0.8E volts positive of the lower common rail, the potential on VR2 slider is positive of the common rail by 0.8E minus 0.2E, or 0.6E volts. If VR3 is next adjusted for a null reading in meter M1 this will occur when VR3 slider taps off 0.6E volts positive with respect to the lower common rail. The requisite voltage is given when VR3 pointer indicates 60 on its scale.

In operating the device we initially set VR1 to the first figure and VR2 to the figure we wished to subtract from that figure. We then adjusted VR3 for a null reading in the meter, whereupon its pointer indicated the result of subtracting the second figure from the first.

What happens if the second figure is larger than the first so that the result of the subtraction is a negative quantity? In this case we bring changeover switch S1 into operation and proceed as in the following example, in which we subtract 90 from 70.

First, VR1 is set to 70, whereupon its slider becomes 0.7E volts positive of the lower common rail. We next set VR2 to 90, with the result that its slider is 0.9E volts negative of the slider of VR1. The slider of VR2 is, then, 0.2E volts *negative* of the lower common rail.

We cannot balance the circuit with S1 at 'Positive' and so we change it over to the 'Negative' position. The upper end of VR3 track is now E volts negative of the lower common rail, and balance will be given when its slider taps off 0.2E volts relative to the common rail. This is given when its pointer indicates 20 on its scale. The device tells us therefore that the process of subtracting 90 from 70 yields an answer of -20. The figure 20 is indicated on the scale of VR3 and the fact that it is a negative quantity is shown by the position of S1.

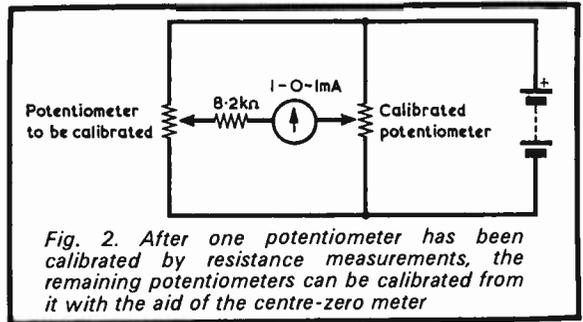

CALIBRATION

The only possible disadvantage with the circuit of Fig. 1 is that it necessitates that all three batteries offer the same voltage. This is not too difficult to arrange, however, since all three batteries can be purchased at the same time from a single retailer, whereupon they should all be in a common batch from the factory. Their terminal voltages should then remain the same as they age. If any differences in voltage do occur they will in any case be indicated by obviously inaccurate results from the computing device. There is, of course, little point in adding voltage stabilising components in a very simple circuit of this nature.

The potentiometers can be calibrated in terms of resistance. Take one of the potentiometers and first find its central track position and calibrate this as 50. Next find its 10 and 90 positions and calibrate these. The calibration points from 10 to 50 and 50 to 90 can then be made with the aid of a protractor, making the assumption that they are spaced out in linear fashion. Calibration from 0 to 10 and from 90 to 100 has to be carried out with resistance measurements, since practical potentiometers either reach zero resistance before the end of the slider travel or do not reach zero resistance at all. In this respect, much better results will be given by using good quality wirewound potentiometers rather than carbon track types.

Once one potentiometer has been calibrated, the remaining two can be calibrated from it by means of the circuit shown in Fig. 2. The potentiometer to be

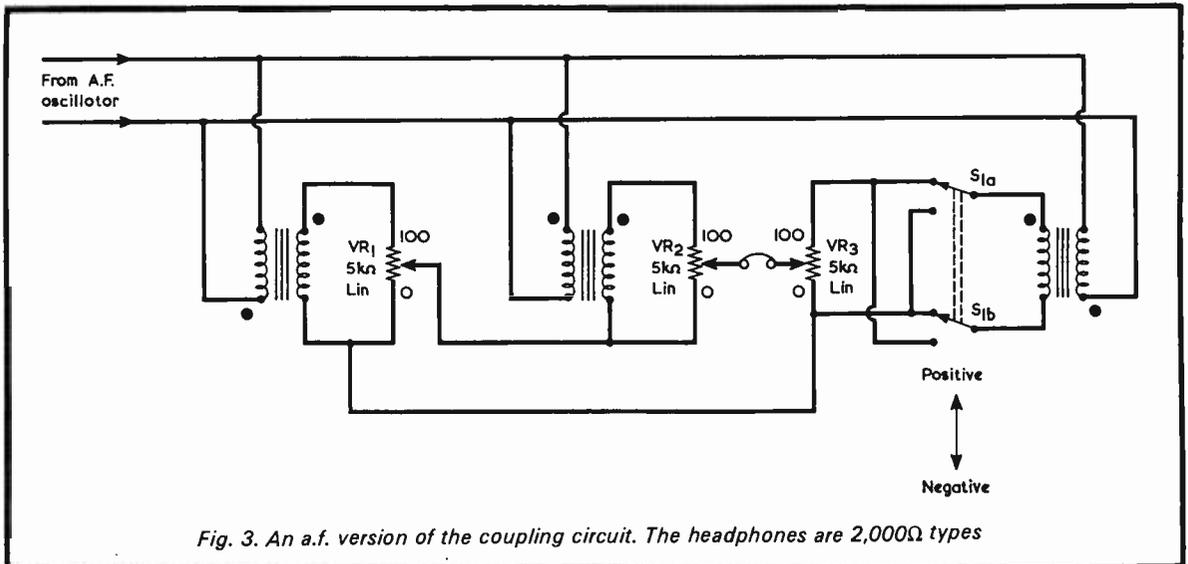

Fig. 3. An a.f. version of the coupling circuit. The headphones are 2,000Ω types

calibrated is set up for zero reading in the meter and its scale given the same calibration marking as the first.

An alternative version of the circuit can use 2,000Ω headphones as the null indicating device. The output of an a.f. oscillator is coupled to three identical a.f. transformers, as illustrated in Fig. 3. The black dots shown alongside each transformer winding in the

diagram indicate their phase relationships. This circuit has the disadvantage of incurring extra components, but has the compensation that the voltages applied to the three potentiometers must always be equal. Further, the ear is capable of detecting null indications at low intensity and the circuit will offer a greater resolution than is given by that of Fig. 1. ■

?? HALF-A-DOZEN PUZZLERS ??

By

P. MANNERS

Here are six unusual problems to try your hand at. They are all quite simple, although one or two are rather on the 'sneaky' side.

1. The junior service engineer was in a right old state. Whilst working on a portable transistor radio he had clumsily broken its ferrite aerial rod clean across the middle, and the two halves of this now hung dejectedly on the coil wires, with one half bearing the medium wave coil and the other half bearing the long wave coil. No replacements for the rod were available, so what could he do to get the set working properly again?

2. The Professor rushed along to the Patents Office with his new rectifier circuit, which is reproduced in the diagram. At the cost of two extra rectifiers (which are cheap enough these days) this circuit provides a full-wave rectified output with only half the mains transformer secondary that would be required with a conventional 2-rectifier arrangement. On half-cycles when end A of the transformer secondary is negative, rectifier D1 prevents this end from going negative of chassis by any significant amount and virtually the full positive voltage at end B is passed via D2 to the reservoir capacitor C1. On alternate half-cycles, when end B of the secondary is negative, D3 similarly prevents this end from going negative of chassis, and it is the full positive voltage at end A which is now passed, via D4, to the reservoir capacitor. But the Patent Office very rudely told the Professor to get lost.

Why?

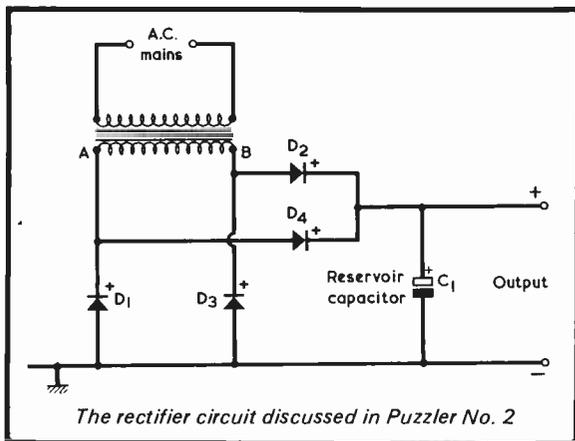

The rectifier circuit discussed in Puzzler No. 2

Answers are given on page 568

3. The Secret Service agent entered the Cypher Room, handing over to the duty officer the short length of recording tape he had that evening removed, at great personal risk, from the embassy of a Certain Power. The officer played it on a tape recorder and they heard the 1kHz dots and dashes of a signal in Morse. The agent (who luckily remembered Morse from his Boy Scout days) copied the message on a pad. It read: 'REEV EHT ROL EREH QFAO ERN EG'.

Can you decipher the message?

4. Solve the following simultaneous equations for x and y.

$$x^{\circ}\text{C} = y^{\circ}\text{F}$$

$$x \text{ shillings} = y \text{ new pence}$$

5. A home-constructor removed the can from a British-made 470kHz transistor i.f. transformer to see how it was connected internally. To his annoyance he accidentally broke a winding lead-out wire half an inch away from its tag at the bottom of the transformer. He became further incensed with himself when he found, after untwisting its rayon covering, that the wire was 5-strand Litz. He spent the next two hours in laboriously scraping the enamel from each strand with a razor blade, having to make several fresh starts as one or other of the strands broke whilst being scraped. Eventually, he was able to solder all the strands together, after which he ran a single thin tinned copper wire from their junction to the tag to which the wire had previously connected.

Had he wasted his time?

6. Finally, a nice easy one. You are required to design a tape playback system in which a loop of tape is continually drawn at 3¼ in. per second past a single track record/playback head so that a programme may be originally recorded on it and then reproduced over and over again. The loop consists of 100 ft. of tape with its ends stuck together and you are allowed to exert all your ingenuity in the design of spools, tape routing and any other mechanical devices or techniques you may care to take advantage of. For that matter, the tape can be made to your requirements with magnetic coating on whatever areas you suggest, and with any degree, within reason, of mechanical strength. You are, however, limited to a single track on the tape.

How can you arrange things for maximum length of programme, i.e. for maximum time, on replay, between the starts of successive programmes?

SECOND A.F. INPUT

by
S. L. THOMAS

This unusual method of adding a further input to a valve a.f. amplifier has the advantage of providing fully independent a.f. mixing.

IT IS SOMETIMES NECESSARY TO APPLY A SECOND INPUT to an existing a.f. amplifier. If the second input signal is at fairly low impedance, of the order of $20k\Omega$ or less, and if the amplifier employs valves in a simple circuit without extensive n.f.b. and does not have a 'live' chassis, the dodge to be described in this short article works excellently and causes virtually no alteration in the existing operation of the amplifier. Also the additional components required are inexpensive and take up little space.

THE MODIFICATION

The added a.f. input should be applied to the voltage amplifier valve in the amplifier which immediately precedes the output stage, or to the voltage amplifier valve which immediately precedes the phase-splitter stage should the amplifier have push-pull output. The main provisos are that the cathode circuit of the voltage amplifier valve should not have a negative feedback connection made to it and that the valve should not be inside a negative feedback loop. The circuit should not be applied to earlier voltage amplifier valves as it could cause the appearance of hum.

The existing circuit for the voltage amplifying valve will be basically that shown in Fig. 1. Here, R_1 is the grid resistor and it may, in some cases, consist of the amplifier volume control. R_2 is the anode load resistor and R_3 and C_1 are the cathode bias components.

To add the extra a.f. input, the circuit of Fig. 1 is modified to that shown in Fig. 2. R_3 and C_1 have been removed, and are replaced by a p.n.p. transistor, TR1. R_5 is a skeleton preset potentiometer and it is adjusted such that the voltage on the cathode of the valve with respect to chassis is the same as it was when the previous cathode bias components were installed. The second a.f. input is applied to the added volume control R_4 , this being mounted at any convenient point on the amplifier panel. The signal voltage tapped off by the slider of this component is passed to the base of TR1 via C_3 . TR1 functions as an emitter follower and applies the signal to the cathode of the valve. The valve then amplifies this second signal in the same manner as it does that applied

to its grid. Either the original signal or the added signal may be amplified by the valve or they may both be amplified together, whereupon the overall circuit becomes capable of mixing the two signals in any proportion. Variations in volume level adjustment to one signal do not alter the volume level of the other, as can occur with some simple a.f. mixing arrangements in which both signals are applied to a single grid.

The absence of the cathode bypass capacitor may result in the valve giving slightly lower amplification to the signal applied to its grid. There is a possibility also that the removal of the cathode bypass capacitor may result in an increase in the hum level in the output of the amplifier, but it has been the writer's experience that any increase in audible hum level is negligible when the amplifier drives a speaker which does not have an extended bass response. It is best to check this point before obtaining the components for the modification by temporarily disconnecting the bypass capacitor and retaining the cathode bias resistor in circuit on its own. If the hum level is then objectionable the modification should not be proceeded with.

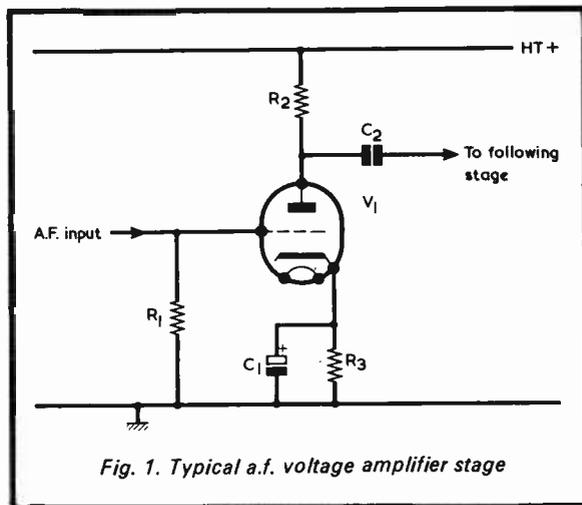

Fig. 1. Typical a.f. voltage amplifier stage

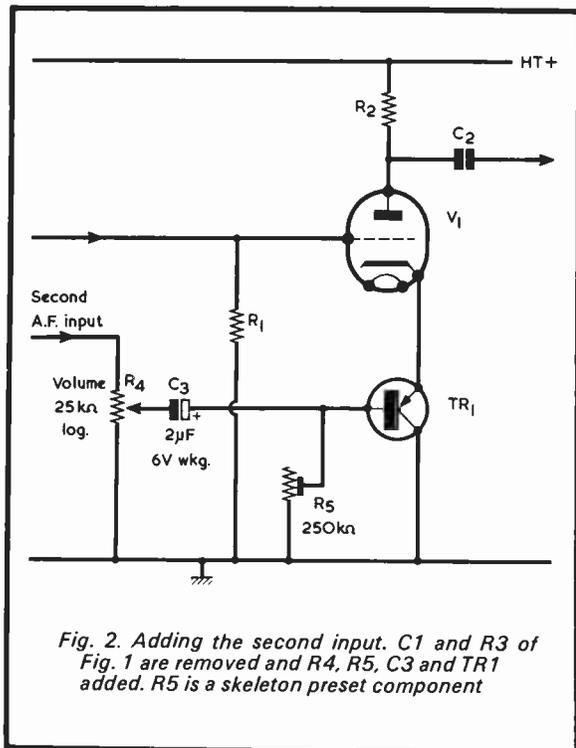

Fig. 2. Adding the second input. C1 and R3 of Fig. 1 are removed and R4, R5, C3 and TR1 added. R5 is a skeleton preset component

The valve shown in Figs. 1 and 2 is a triode. The same modified cathode circuit may be employed if the valve is a voltage amplifier pentode, provided that the remarks just given concerning hum are borne in mind.

Transistor TR1 should be a germanium type having a medium gain figure, and one of the earlier devices, such as the OC44, will function adequately here.

Before installing the transistor circuit first check the voltage dropped across the cathode bias resistor and make a note of it. Then remove the cathode bias resistor and bypass capacitor and install the new cathode components shown in Fig. 2. Connect a voltmeter between chassis and the cathode of the valve and adjust R5 so that it inserts about 50kΩ into circuit. This is given when its slider is about one-fifth of the way along the track from the end connected to chassis. Switch on the amplifier, allow it to warm up and then adjust R5 until the voltage on the valve cathode with respect to chassis is the same as was given when the previous cathode bias components were in circuit.

The added a.f. input is now ready for use. A point which has not so far been mentioned is that, in most cases, the a.f.-carrying leads in the added circuitry will need to be screened. If C3 and R5 are mounted close to TR1, this will necessitate the use of screened wire between C3 and R4 and between R4 and the second input terminal. The screening of the wire connects to chassis.

The added a.f. input must not, of course, be fitted to amplifiers having a chassis which connects to one side of the mains (as occurs, for instance, with the a.f. amplifier stages of a television receiver) since the external connections to the added circuit will be 'live' and can give rise to dangerous shock. The amplifier should have a double-wound mains transformer giving complete isolation from the mains supply. ■

APRIL 1972

NEXT MONTH

Simple Regenerative 2 Transistor Receiver

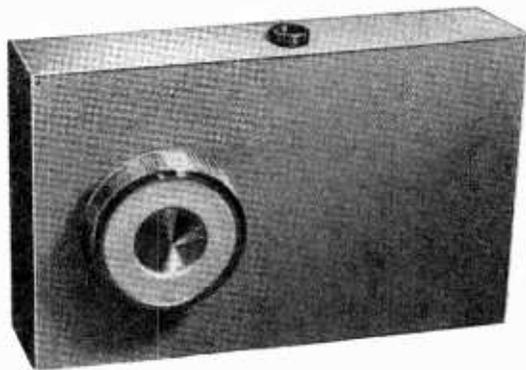

A neat little medium wave portable receiver which employs two transistors and feeds a crystal earphone.

The 'F.E.T. Twin' Stereo Amplifier

A simple stereo amplifier which offers a high quality output and requires few components.

2 Metre Transmitter

PLUS

MORE CONSTRUCTIONAL
PROJECTS
AND USUAL
SUPPORTING FEATURES

ORDER YOUR COPY NOW
ON SALE 1st MAY

Copies may also be obtained direct from the Publishers, 24p. including postage. Published by Data Publications Ltd, 57 Maida Vale, London W.9

RADIO CONSTRUCTOR

V.H.F. WAVEMETER

By

F. G. RAYER, Assoc.I.E.R.E., G30GR

A simple absorption wavemeter covering the range 120 to 180 MHz can be readily assembled, as is demonstrated in this short article. In addition to general usage the wavemeter may be employed to set up the ' "Easy" 2 Metre Receiver' described in last month's issue.

WITH A HOME-CONSTRUCTED RECEIVER DESIGNED for v.h.f. use, individual differences in wiring, the exact dimensions of tuning coils and similar factors influence frequency coverage quite considerably. In the case of the ' "Easy" 2 Metre Receiver' described last month a pre-set trimmer is also provided, and its position naturally has a large effect on the band of frequencies covered by the panel-mounted variable tuning capacitor.

ABSORPTION WAVEMETER

In some circumstances, factors of this nature can cause difficulty in actually finding the 144-146MHz band. If necessary, this can be overcome by making the v.h.f. absorption wavemeter shown in the accompanying diagram. If the specified variable capacitor is employed, and the wire loop is made as described, scale readings should be duplicated with sufficient accuracy to bring the receiver tuning range into the 144-146MHz region. It should be emphasised that the specified capacitor *must* be used. This is a Jackson 15pF type C804 component and is available from Home Radio (under Cat. No. VC26D) or from Henry's Radio. Also, the loop has to be made exactly as described, and it is necessary to use the scale quoted in the Components List.

First, study the accompanying diagram and physically examine the tuning capacitor so that the final shape of the loop can be visualised. Then, take a 5 in. length of 20 s.w.g. tinned copper wire, and carefully straighten it. Place a 1p coin flat on the table and bend the wire round it (or use any other circular object 13/16 in. diameter). When the wire is released it should spring out to form a loop 1in. from centre to centre of the wire, as in the diagram. Bend 1/2 in. at right angles for soldering to the capacitor fixed plates at stud F, and 1/8 in. at 45 degrees for soldering at tag M. Run a 4 3/8 in. length of 1mm. insulated sleeving over the wire, then solder the loop at stud F and tag M.

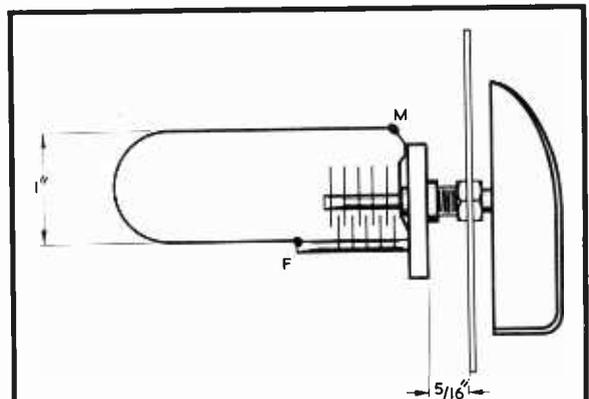

The appearance of the completed wavemeter. The insulated sleeving, which is fitted over the wire of the loop before soldering, is omitted here for clarity

COMPONENTS

15pF variable capacitor, type C804 (Jackson Bros.)
3in. aluminium scale, Cat. No. DL72 (Home Radio)
Pointer knob, Cat. No. KN9 (Home Radio)
5in. of 20 s.w.g. tinned copper wire
4 3/8 in. of 1mm. sleeving

Fit the 3in. diameter dial to the capacitor bush so that it is 5/16in. from the front of the capacitor body and secure it with nuts. Turn the capacitor so that it is fully closed, put the pointer knob at 100 on the scale, and tighten the grub-screw.

Frequencies, read against the dial, are shown in the accompanying Table.

TABLE	
<i>Prototype Wavemeter Calibration.</i>	
<i>Dial Reading</i>	<i>Frequency</i>
30	180MHz
36	170MHz
45	160MHz
53	150MHz
65	140MHz
80	130MHz
100	120MHz

To use the wavemeter with the "Easy" 2 Metre Receiver, set VCI of the receiver about half closed. Advance regeneration until the hiss described in the article is apparent. Hold the wavemeter by the metal dial, and bring its loop to about 1in. from L3 of the receiver, and in line with it. Rotate the wavemeter knob to the point which causes the receiver to go out of oscillation, as shown by the hiss stopping, and read the frequency from the wavemeter dial. If the frequency is too low, reduce the capacitance of TC2. If the frequency is too high, increase capacitance in TC2.

The metal scale of the wavemeter is held by the user and this is in electrical contact with the loop. Because of the sleeving which covers it, there is no risk of shock if the loop should touch a high voltage point inside the receiver, but such a shock would occur if

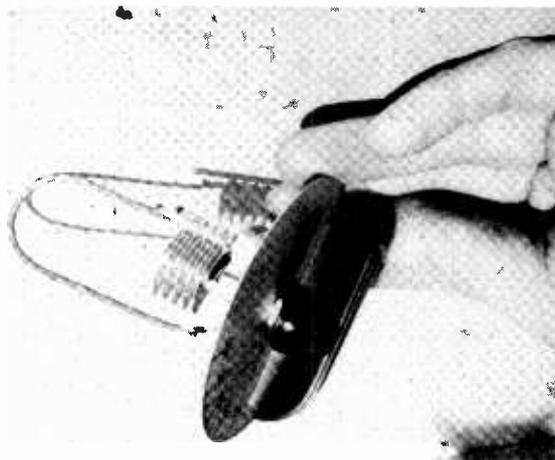

The exceptionally simple construction of the wavemeter is well illustrated by this view

the metalwork of the capacitor were to touch such a point.

The wavemeter may be employed to check other equipment operating at or near 2 metres provided that the coil in the tuned circuit concerned is not screened and that the absorption effect of the wavemeter can be perceived as a loss in tuned circuit efficiency. ■

CATALOGUES

CELECTRON-E

Newly introduced is the Celectron-E catalogue, this comprising 97 pages of which 93 give details, with illustrations, of radio and electronic components as are used by the home-constructor, experimenter and service engineer.

Most of the parts offered are those supplied by R.S. Components, Ltd., (formerly Radiospares) and it is stated in the catalogue that all components specified in the popular electronics magazines and periodicals as 'Radiospares' are available from Celectron-E. The items listed range from cabinet feet to integrated circuits and cover a wide range from amateur to professional applications.

The catalogue is available from Celectron-E, P.O. Box No. 1, Llantwit Major, Glamorgan, CF6 9YN, at 25p post free.

CHROMASONIC ELECTRONICS

Chromasonic Electronics announce the appearance of their 1972 catalogue. This lists a very wide range of products, covering semiconductors, integrated circuits and virtually all parts required by the home-constructor down to nuts and bolts. Also included in the catalogue is the complete range of Mullard colour TV integrated circuits, together with a selection of those made by Plessey for the same application.

The companies whose products are retailed by Chromasonic Electronics include Siemens, Ferranti, Eddystone, Fairchild, ITT, Motorola, Signetics, Telefunken and R.S. Components. With respect to the last, the catalogue states that all R.S. Components parts can be supplied; if the items required are not specifically marked in the catalogue, a quotation will be given.

The catalogue is available from Chromasonic Electronics, 56 Fortis Green Road, London, N10 3HN, at 20p post free.

WIDE RANGE SAWTOOTH



Cover Feature

THE SAWTOOTH GENERATOR DESCRIBED IN THIS article is capable of producing an almost perfectly linear voltage sweep. It will find many applications in the radio, TV and electronic fields. Due to the provision of access to the internal circuitry via the terminations on the back of the unit it is also capable of performing many other functions besides waveform generation, and some of these are detailed in the section dealing with applications at the end of Part 2. A special feature of the design is the long sweep times available (over 600 seconds with suitable external components). The internally selected ranges give a sweep repetition coverage from 20kHz down to 1 sweep in 70 seconds in three overlapping ranges.

The unit was originally designed by the author as an improvement in the method of testing and setting-up pen recorders, many of which are in use in the University department where he works. It became evident after the construction of the first prototype that the versatility of the unit could be extended if a number of minor component changes were made. These changes were mainly to increase the range of repetition rates that the unit could provide and also to shorten the interval between sweeps.

The final circuit and component values selected are presented in this article. It should be pointed out that the setting-up process (to be described in Part 2) requires an oscilloscope and a testmeter having a sensitivity of 20,000 ohms per volt and the ability to read currents of the order of 85 to 90μA.

SWEEP GENERATOR

The first section of the circuit to be discussed is the voltage sweep generator. This is really the most important part since, without a means of generating a linear voltage rise with time, there would be little justification for the title of this article!

The method used to generate this voltage makes use of a property of the bipolar transistor whereby the collector current is relatively independent of the collector-emitter voltage over a substantial range in the region beyond the collector 'knee'. See Fig 2. In order to explain the action of this stage, it has been redrawn in a simplified form in Fig. 1.

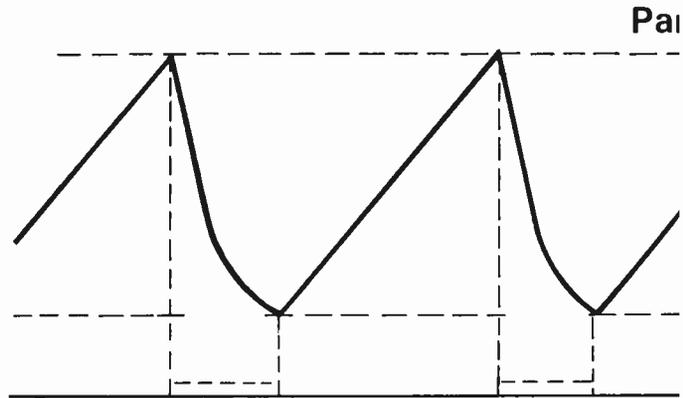

B
DAVID ALDO

In this article our constructor de
the facilities offered by this comp
details will be given in Part 2, to

In Fig. 1 it can be seen that we have a transistor (TR2) connected as an emitter follower. Its base is fed from a constant voltage provided by the zener diode ZD2, and its collector is returned to a negative potential via the charging capacitor C_c and the discharge circuit. The action of the circuit depends upon the fact that a bipolar transistor is a charge carrier limited device; this means that for a given base-emitter

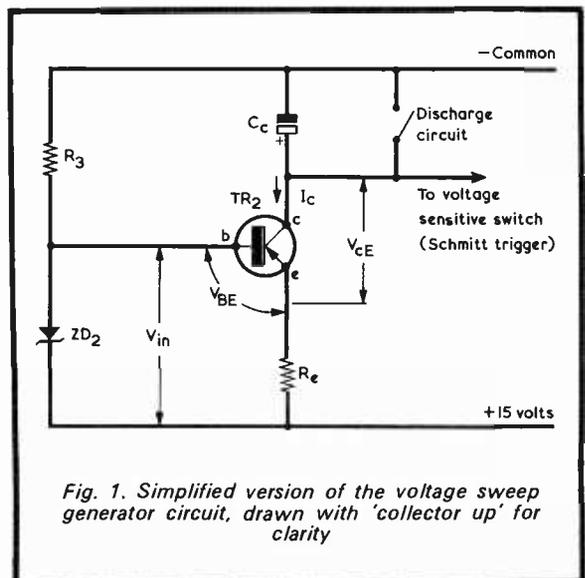
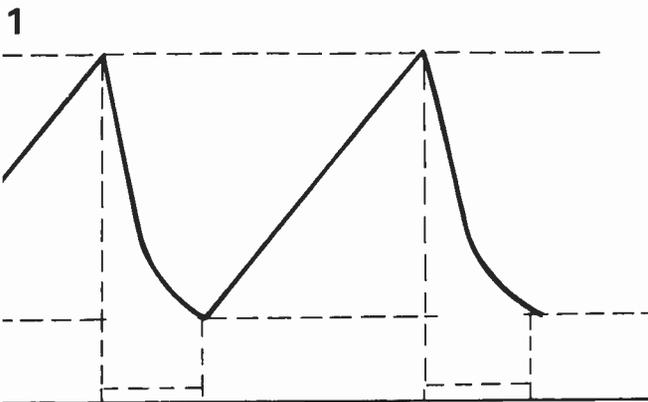

Fig. 1. Simplified version of the voltage sweep generator circuit, drawn with 'collector up' for clarity

LINEAR GENERATOR



S, M.S.E.R.T

ribes the circuit operation and
hensive design. Constructional
e published next month.

voltage (V_{be}) the number of majority carriers injected into the base region by the emitter under the influence of the electric field due to this voltage will be constant. When a potential is applied between collector and emitter (V_{ce}) these charge carriers will be swept towards the collector under the influence of the electric field thus created. If this potential is above the 'knee', all the charge carriers in the base will be drawn to the

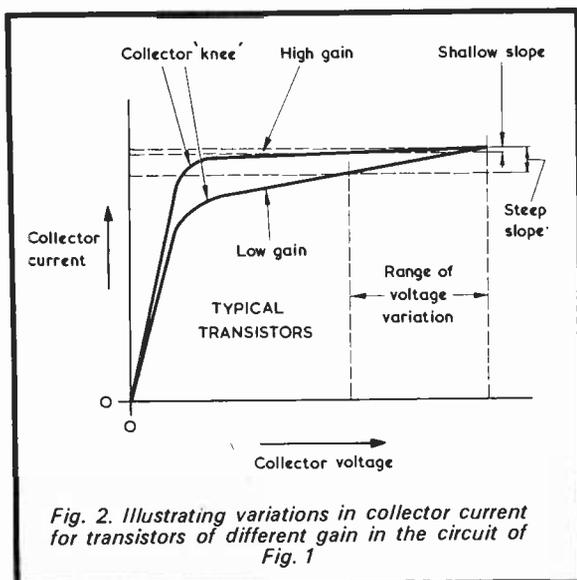

collector. It follows therefore that since we have only injected a certain number of carriers into the base we cannot, no matter how high we make V_{ce} (within reason), draw out more than we put in.

In practice, of course, nothing is quite so simple, and the collector will in fact tend to draw out a certain number of carriers from the emitter directly, thus causing the collector current to vary slightly with changes in V_{ce} . This change in collector current (I_c) can be reduced by operating the transistor in the emitter follower mode as shown. In operation, the current in the emitter-collector circuit flows through R_e and develops a voltage across it which is only slightly less than the input voltage, V_{in} , and the difference voltage will equal the base-emitter voltage (V_{be}) for the transistor used. Since V_{in} is fixed it follows that any change in collector current will cause a change in the voltage across R_e and therefore will also cause V_{be} to change, this last change causing the collector current to alter in such a way that it opposes the initial variation.

An example would be given, for instance, if the collector current tended to fall by say 1mA. This would cause the voltage across R_e to fall and V_{be} to increase, whereupon transistor action would cause the collector current to rise and therefore cancel out the initiating change. In practice, of course, it would not completely cancel out and there would be some slight alteration in I_c . Just how big a change there would be can be gathered from Fig. 2 where it will be seen that if TR2 has a high d.c. current gain it will not need much of a change in the voltage across R_e to cause a large current compensation, whereas if the d.c. current gain is low the voltage across R_e can change by a relatively large amount before even a reasonable correction takes place. The change in the voltage across R_e is caused by changes in V_{ce} which occur under operating conditions.

TR2 must have a very high gain, as high as can be reasonably provided by a single transistor. In the prototype it was found that a gain of 150 was the lowest acceptable, and preferably TR2 should be a high gain type. The transistor specified is a 2N4062, which has a minimum gain of 180.

In operation, the collector current flows into the charging capacitor C_c , which initially has zero voltage

across it. As the current flows in, the voltage across C_c will begin to rise at a rate determined by the exact value of C_c and the current. If the current, as in the present case, is constant, this rate will be determined by the formula

$$V_s = \frac{I}{C}$$

where V_s is volts rise per second, I is the current in μA and C is the capacitance of C_c in μF . The sweep period may be calculated by multiplying V_s by the voltage reached before discharge which, in the complete unit, is about 6.5 volts.

The voltage across C_c is applied to a Schmitt trigger, and when it reaches the trigger level the discharge of C_c is initiated whereupon the circuit resets to its initial condition ready for the next sweep.

THE SCHMITT TRIGGER

The circuit of the Schmitt trigger is shown in simplified form in Fig. 3 and it consists of two transistors (TR4 and TR5) arranged to form a monostable multivibrator. The d.c. feedback loop is created by returning the emitters to a common resistor (R9) and the a.c. loop by way of the 'dwell' capacitor C_{dt} .

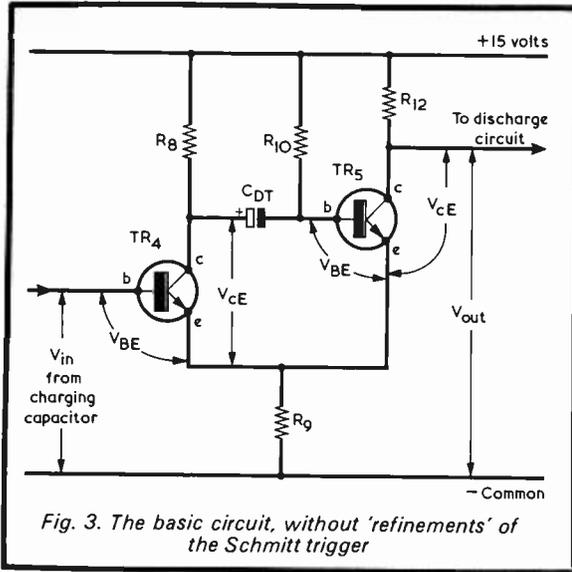

Fig. 3. The basic circuit, without 'refinements' of the Schmitt trigger

In operation, TR5 is biased into full conduction by the resistor R10, which is returned to the positive 15 volt supply rail. The collector-emitter voltage V_{ce} is equal to the saturation voltage of the device and the potential V_{out} is low. TR4, on the other hand, is cut off since its base is held near the negative common rail by the voltage from C_c (of Fig 1) whilst its emitter is at the higher positive potential developed across R9 due to conduction in TR5.

When the input voltage, V_{in} , rises above the voltage across R9 plus the V_{be} for TR4, this transistor begins to conduct. Its V_{ce} tends to fall and this change is passed on to the base of TR5 via C_{dt} , which causes the V_{be} of TR5 to fall and to bring TR5 out of conduction. The voltage across R9 now begins to fall and this causes the V_{be} of TR4 to increase, thus causing a still larger collector current to flow and lowering its V_{ce} still more. The action is cumulative and results

in the transistors changing over, with TR4 fully on and TR5 cut off. This state lasts for a time determined by the time constant of C_{dt} and R10. During this time, the voltage at the junction of C_{dt} , R10 and the base of TR5 will be initially below the negative common rail due to the charge held by C_{dt} . C_{dt} now discharges and the potential on the base of TR5 rises. When this potential reaches the voltage across R9 plus the V_{be} of TR5, this transistor starts to conduct, thereby raising the voltage across R9. This rising voltage tends to cut off TR4, and the circuit reverts to its original state.

DISCHARGE CIRCUIT

To examine the discharge section we now turn to the complete circuit, this being given in Fig. 5. The discharge section is given by a transistor (TR3) in series with the resistor R4. The combination is connected across the charging capacitor (C_c), which in Fig. 5 is the capacitance selected by S3(a). The base of TR3 is fed from the collector of TR5 in the Schmitt trigger via a 10 volt zener diode, ZD3, and is also connected to its own emitter via the resistor R5. This last component prevents any leakage current between collector and base (I_{cbo}) from causing unwanted conduction in TR3.

In operation, when TR5 comes out of conduction the output voltage at its collector rises above the zener voltage of ZD3; this causes base current to flow and turns TR3 on, thereby connecting R4 across the charging capacitor and discharging it. TR3 will remain in conduction until the Schmitt trigger resets at the end of the 'dwell' period.

OUTPUT SECTION

The output section is also shown in Fig. 5, and it consists of a Darlington amplifier transistor, TR6, connected as an emitter follower which acts as a buffer between the charging circuit and the low impedance output circuit given by potentiometers VR2 and P4. The Darlington transistor was chosen for its high input impedance (in the present case, over $7M\Omega$!). This is due to the high d.c. current gain of this type. For the transistor used (a G.E. 2N5308) the gain

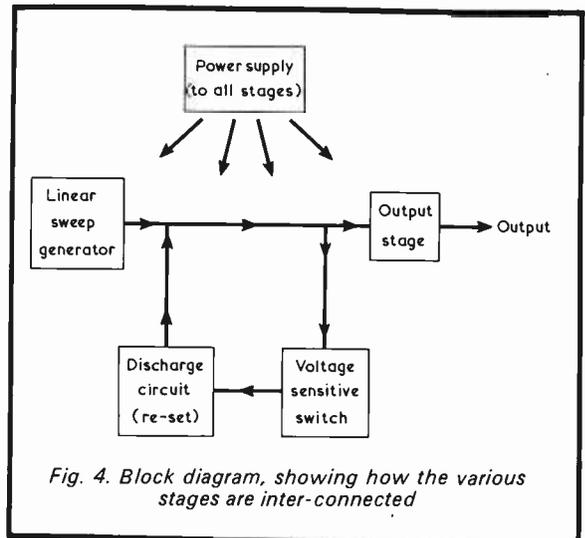
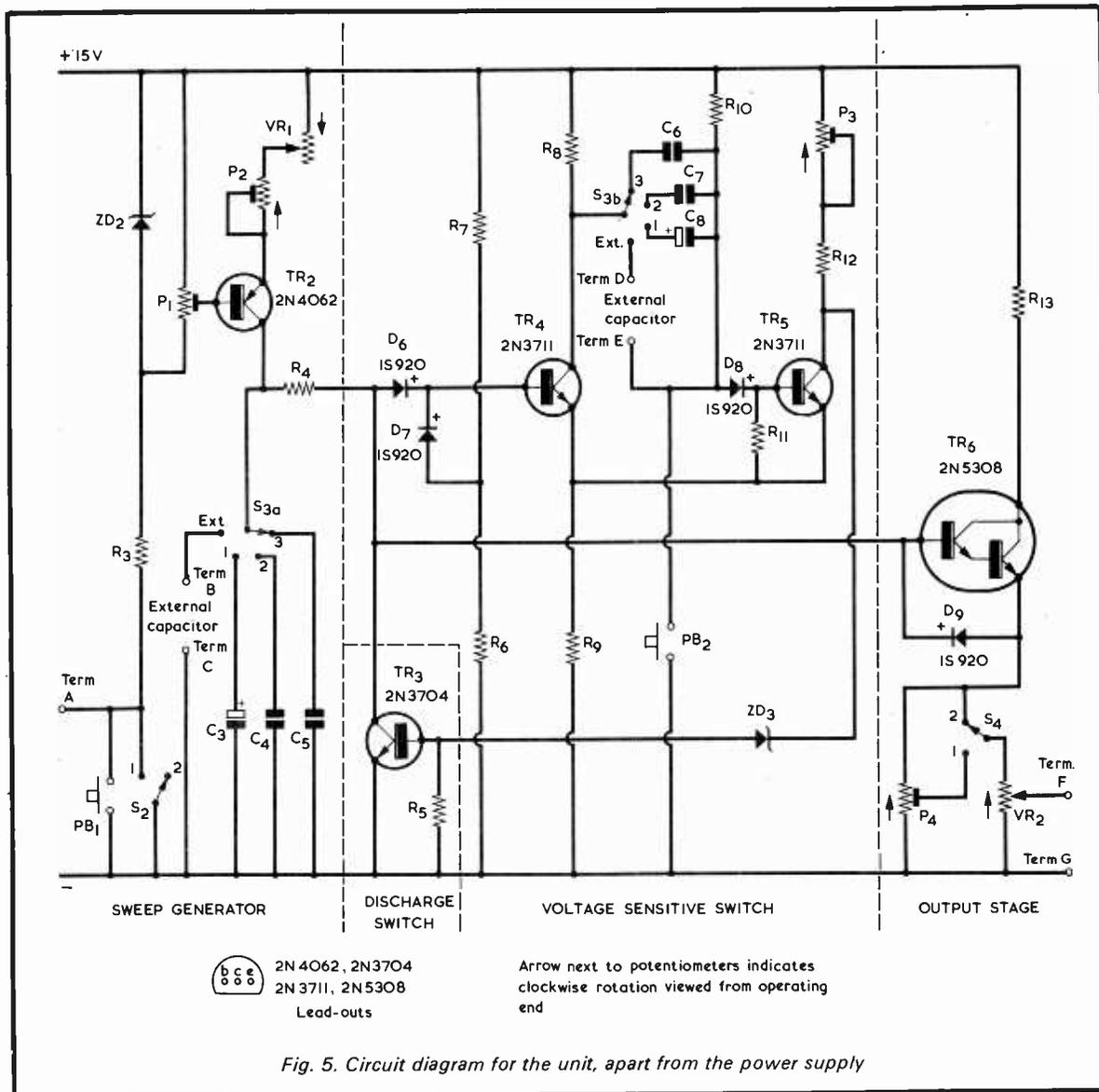

Fig. 4. Block diagram, showing how the various stages are inter-connected



ranges from 7,000 to 10,000 times. The input impedance is approximately equal to the emitter resistor value multiplied by the gain, and it follows that an input impedance of at least some $7M\Omega$ may be expected when the value of the emitter resistor is $1k\Omega$.

Another reason for choosing this type of transistor is that the input impedance tends to rise with increasing collector current, a factor which helps to offset the loading effect that would occur if an ordinary bipolar transistor had been used.

COMPLETE CIRCUIT

As already stated, the complete circuit is shown in Fig. 5. Also, a block diagram is given in Fig. 4.

It can be seen that the circuit of Fig. 5 contains several additional components which were not shown in the simplified circuits so far discussed. The most important of these is the diode and resistor circuit comprising D_6 , D_7 , R_6 and R_7 , which forms a clamp

circuit to provide TR_4 with an input voltage during the reset or 'dwell' period of the Schmitt trigger. If the clamp circuit were omitted, TR_4 would have no input voltage during this time, the Schmitt trigger would reset early, C_c would recover the small amount of charge lost, and the cycle would recur indefinitely. Below the clamp level (3.5 volts) diode D_6 isolates the charging circuit from the potential at the junction of R_6 and R_7 , and D_7 in conjunction with D_6 performs the same function when the voltage on the charging capacitor rises above the clamp level. The way in which the circuit functions may be described more fully in the following manner.

When the circuit starts operating, the negative (anode) side of D_6 is near the negative common rail potential due to the charging circuit, in which C_c initially has zero volts across it. D_7 will be forward biased and the potential on the positive (cathode) side of D_6 will equal the clamp voltage less the forward voltage drop of D_7 . When the voltage across the

charging capacitor selected by S3(a) rises above the clamp voltage plus the forward voltage drop in D6, this diode becomes conductive and the junction of D6, D7 and TR4 base also starts to rise, reverse-biasing D7. When the level at TR4 base exceeds the predetermined threshold level (set by the value of R9 and the current through it) the Schmitt trigger changes state; this causes the discharge circuit to operate as described earlier, whereupon the negative side of D6 drops nearly to the potential of the negative common rail, thereby reverse-biasing it once more. Since TR4 emitter potential is now going negative its base also falls in potential and D7 conducts, thus passing current into TR4 and keeping it turned on during the 'dwell' period of the Schmitt trigger. When the 'dwell' period ends the circuit returns to its original state.

A second and almost equally important addition to the circuit is the diode and resistor combination given by D8 and R11. The function of this circuit is to protect the base-emitter junction of TR5 from the high reverse voltage which is present when the voltage across Cdt is applied to it during the 'dwell' period. The resistor shunts the base to the emitter and the diode becomes reverse-biased, thereby preventing the base from going further negative. If the circuit were omitted, TR5 base could receive a negative voltage of about 9 volts, which is above the recommended reverse Vbe rating for this transistor. Although TR5 would not be harmed by this (it would tend to go into zener breakdown) the current which flowed would certainly upset the circuit's performance.

REFINEMENTS

Having discussed the operation of the circuits that go to make up the complete unit in their basic form, we can now turn to the 'refinements', so to speak. These will be dealt with starting at the sweep generator circuit. In this circuit it can be seen that in place of Re in Fig. 1, we have two potentiometers, VR1 and P2. These are, respectively, the charge current control, which varies the charging rate of Cc and hence the repetition frequency of the unit, and a range limiting control which sets the *maximum* current that can flow when VR1 is at *minimum* resistance.

Another addition is P1. This control adjusts the *minimum* current that can flow when VR1 is at *maximum* resistance. Full details of the adjustment of these two components will be given in the setting-up instructions in Part 2. VR1 and P2 are wired as variable resistors. In the completed unit P2 is connected so that a clockwise rotation when viewed from the adjustment end causes the current to increase. VR1 is wired so that an anti-clockwise rotation seen from the shaft side of the control causes the current to increase. VR1 is a logarithmic type and this gives a reasonably linear scale to the current control since I is, by Ohm's law, inversely proportional to R. This tends to offset the 'cramping' effect that would occur if a linear potentiometer were used instead. P1 is wired in the same sense as P2 and is connected as a normal potentiometer.

R3 is returned to the negative common rail via the additional components PB1 and S2. These controls provide a means of halting the sweep at any level within its range, and operate in the following manner. If S2 is left in the closed position ('Repeat'), the circuit will operate as in the simplified manner described when Fig. 1 was discussed. If, however, S2 is left open

('Manual/External Sweep') the base supply to TR2 is removed and the sweep will hold at whatever level it has reached for as long as S2 is left in this position. In practice, the voltage across Cc will fall slowly, due to the slight discharge current through the base of TR6 and also through the capacitor's own leakage resistance. Electrolytic types (C3 for example) are usually the worst in this respect and C3 must therefore be chosen to have a low leakage level, preferably less than 5 μ A at the voltage used (6.5 volts) in the circuit. If, whilst S2 is in the open position, the button PB1 is depressed (to give 'Manual Sweep') the voltage across Cc will start to rise once more. This will also happen if Terminal A is earthed to the negative supply rail via Terminal G by an external circuit. This facility will be discussed further, in Part 2, in the section dealing with applications.

Turning now to the range selector switch, S3(a)(b), it can be seen that S3(a) selects different values of charging capacitance for each of the three internal ranges. S3(b) selects compatible values of 'dwell' capacitance (Cdt). An additional position on each switch section selects the 'External Component' terminals. Terminals B and C are for an external charging capacitor, and Terminals D and E are for an external 'dwell' capacitor. A further point to be mentioned whilst dealing with this part of the circuit is that the value of the discharge resistor R4 is so chosen in conjunction with the 'dwell' period that it does not completely discharge Cc during this time, but leaves a sufficient voltage on it to overcome the input offset voltage of TR6. This only applies to the internal sweep ranges. An idea of the voltage appearing across Cc under typical working conditions is given in Fig. 6.

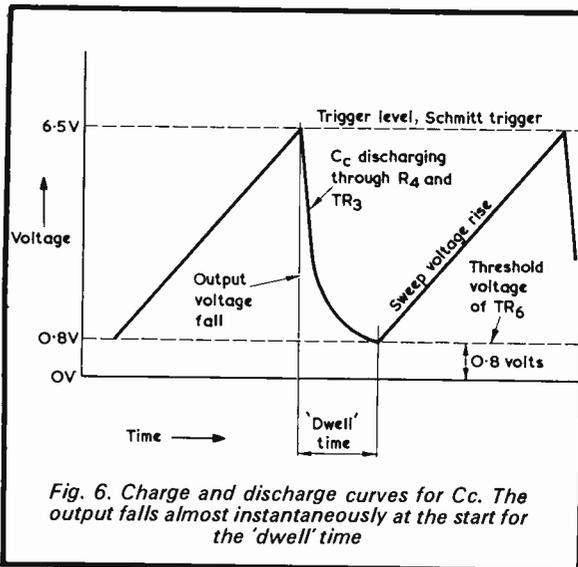

Fig. 6. Charge and discharge curves for Cc. The output falls almost instantaneously at the start for the 'dwell' time

Dealing with the Schmitt trigger circuit, PB2 is a reset button which, when depressed, causes the circuit to revert to its 'dwell' state. This may also be brought about by externally linking Terminals E and G by a suitable switch, or by feeding a positive-going voltage not exceeding 4 volts peak to Terminal E.

Potentiometer P3 is wired as a variable resistor in the collector circuit of TR5, and acts as a threshold control for the Schmitt trigger. It varies the current flowing through R9 and, consequently, the voltage across it, thus changing the trigger voltage by a small amount.

The generator as seen from the rear



POWER SUPPLY

P3 is normally adjusted on the fastest repetition range, Range 3, in order to set the working point of the circuit for best results at high frequencies. The circuit is capable of triggering in an unstable manner at these frequencies, but the effect is not serious and is fully compensated for by this control.

The output circuit is provided with two ranges selected by S4, these being an uncalibrated range of approximately 0–5.5 volts on Range 2, and a preset range on Range 1 which may be set anywhere within these values (the author's version gives 0–1 volt on this range). Both outputs connect to the output potentiometer VR2 and thence to the output Terminal F. Diode D9 between the base and emitter of TR6 prevent reverse voltages being applied, as could happen if TR6 were supplying a capacitive load when reset occurs. D9 shunts the charge from the capacitive load to the negative common rail via TR3. In normal operation D9 is reverse biased.

The power supply section is shown in Fig. 7. It has a conventional circuit employing a series pass transistor TR1, and a zener diode, ZD1, as the reference element. A bridge rectifier is used, made up of four Texas Instruments 1N2069 silicon diodes, although any four diodes of suitable rating will do as will shortly be discussed. A slightly unusual feature is that the mains input is fed to the 230 volt tap in the primary of T1 for mains voltages of 240 volts, this being done to ensure that if the mains voltage were to fall slightly the input to TR1 would still be high enough to keep TR1 above the 'knee' of its collector characteristic. R1 provides surge limiting at switch-on, and D5 prevents the base-emitter junction of TR1 becoming reverse-biased due to the charge retained in C2 when the circuit is switched off. As will become evident next month, when constructional details will be given, the components in Fig. 7 marked with an asterisk are mounted on the main circuit board of the unit.

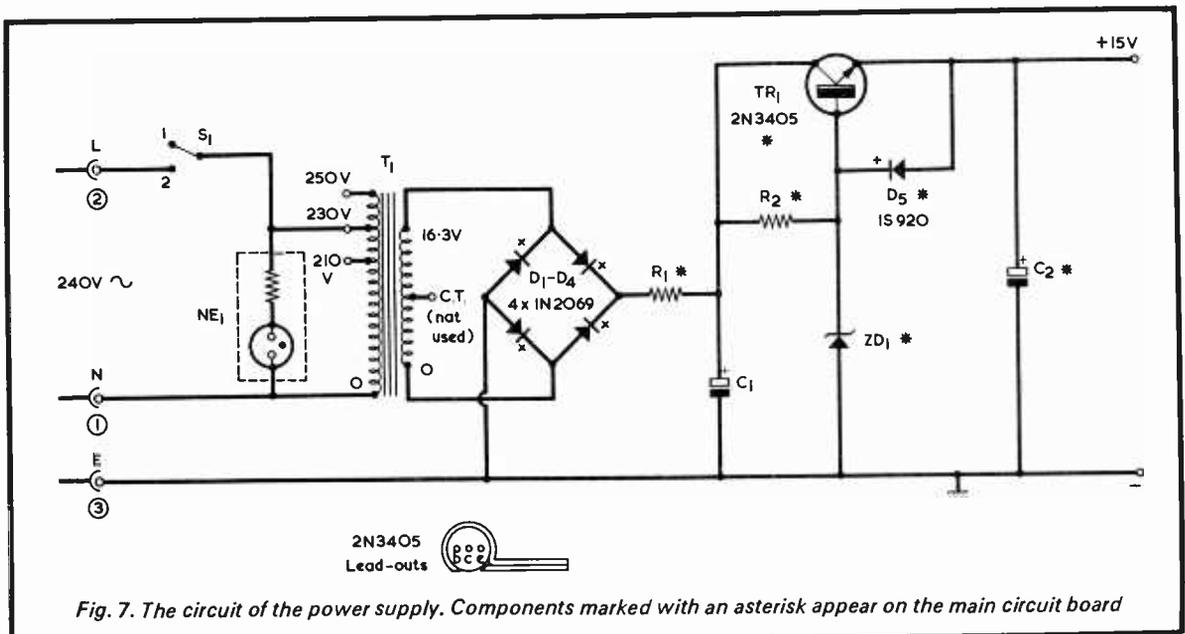

Fig. 7. The circuit of the power supply. Components marked with an asterisk appear on the main circuit board

COMPONENTS

Resistors

(All fixed values $\frac{1}{2}$ watt 5% high stability. See text concerning potentiometers.)

R1	22 Ω
R2	470 Ω
R3	1k Ω
R4	39 Ω
R5	1k Ω
R6	3.3k Ω
R7	10k Ω
R8	2.2k Ω
R9	270 Ω
R10	68k Ω
R11	47k Ω
R12	220 Ω
R13	470 Ω
P1	1k Ω preset potentiometer
P2	470 Ω preset potentiometer
P3	470 Ω preset potentiometer
P4	2.2k Ω preset potentiometer
VR1	25k Ω potentiometer, log
VR2	1k Ω potentiometer, linear

COMPONENTS

The components employed in the unit are shown in the accompanying Components List and, where these are of a specialised nature, will now be dealt with. The reasons for the choice of some of the parts will become more apparent in Part 2. The more experienced constructor who, by slight re-arrangement of panel dimensions, etc., wishes to use alternative switches and other components which may be on hand, is advised to wait until next month's issue in order to see what is involved here.

All the fixed resistors are 5% $\frac{1}{2}$ watt high stability types. In the prototype, the four pre-set potentiometers, P1 to P4 inclusive, are Plessey type MP 'Dealer' potentiometers, 6BA fixing, and are available from Electronic Component Supplies (Windsor) Ltd., Thames Avenue, Windsor, Berkshire, on a cash with order basis. VR1 and VR2 are moulded track low-noise potentiometers and are available from a number of suppliers including Home Radio (Cat. No. VR18B for VR1 and Cat. No. VR18D for VR2). It is essential that these two potentiometers be moulded track types.

Of the capacitors, C1 is an A.H.Hunt wire-ended component having dimensions of $2\frac{1}{4}$ in. by 1in. diameter and is available from Home Radio under Cat. No. 2CG19. Other capacitors of the same value and similar size could, of course, be used. In the prototype, C2 and C3 were Mullard C437AR/E1000 wire-ended miniature aluminium capacitors, but the constructor may find this type difficult to obtain. An alternative with the same dimensions (but which may be supplied with two tags at one end instead of wire ends) is available from Home Radio under Cat. No. 2DL29. For optimum results C3 must have a very low leakage current, of not more than 10 μ A at 10 volts. This is very much lower than the rated maximum leakage current for the capacitor specified but it is found, in general, that Mullard miniature electrolytics have extremely low leakage currents. It is advisable to choose, for C3, the capacitor of the two purchased which exhibits the lower leakage current, bearing in mind that a significant period will elapse before the capacitor exhibits its final

550

Capacitors

(See text for alternative types)

C1	1,000 μ F electrolytic, 25V.Wkg.
C2	1,000 μ F electrolytic, 16V.Wkg., Mullard C437AR/E1000
C3	1,000 μ F electrolytic, 16V.Wkg., Mullard C437AR/E1000
C4	10 μ F polyester, 63V.Wkg.
C5	0.1 μ F polyester, 250V.Wkg.
C6	330pF silvered mica
C7	0.022 μ F polyester, 250V.Wkg.
C8	32 μ F miniature electrolytic, 15V.Wkg.

Transformer

T1	R.S. Components Standard Filament Transformer, Secondary 16.3V at 0.3A, Cat. No. TH5A (Home Radio)
----	--

Semiconductors

TR1	2N3405
TR2	2N4062
TR3	2N3704
TR4	2N3711
TR5	2N3711
TR6	2N5308
D1 - D4	1N2069
D5 - D9	1S920
ZD1	15 volt 5% zener diode 400mW
ZD2	5.1 volt 5% zener diode 400mW
ZD3	10 volt 5% zener diode 400mW

Switches

(See text for suitable types)

S1	s.p.s.t. miniature toggle
S2	s.p.s.t. miniature toggle
S3	3-pole 4-way miniature rotary
S4	s.p.d.t. miniature toggle

Neon

NE1	Miniature panel neon assembly with integral resistor (see text)
-----	---

'Lektrokit' Chassis Parts

1-off	LK111 Chassis Plate No. 1
1-off	LK161 Chassis Plate No. 6
2-off	LK211 Chassis Rails, Short
2-off	LK301 Side Plates No. 1
1-off	LK431 Front Plate No. 1, Short
1-off	LK521 Cover, Short
2-off	LK531 Cover, Short (Plain)
10-off	LK2021 Insulator, Lead-through, No. 1
4-off	LK2411 Rubber Feet.

Terminals

(See text for suitable types)

1-off	Red
1-off	White
1-off	Yellow
2-off	Blue
2-off	Black

Miscellaneous

Mains 3-way connector assembly, Cat. No. P.360 (Home Radio)
2-off knobs, Cat. No. KN85B (Home Radio)
1-off knob, Cat. No. KN87B (Home Radio)
6BA binder head screws and full nuts.
4BA screws and full nuts.

leakage current after the voltage has been applied. This is particularly true if the capacitor has been on the shelf for a long time.

Capacitor C4 in the prototype was an R.S. Components (formerly Radiospares) side wire polyester type with a working voltage of 63 volts. Its length is 1½ in. and its width is ¾ in. This is not available directly from R.S. Components, who do not supply to individual constructors, nor through the usual mail order houses (although it may be ordered from R.S. Components by a retailer) and is rather expensive. An electrolytic capacitor of 15 V.Wkg or more could be employed instead, provided it had a very low leakage current. A tantalum capacitor would be best in this respect. C5 was an R.S. Components 0.1µF 250 V.Wkg. polyester capacitor. The Mullard 0.1µF 125 V.Wkg. polyester capacitor (Home Radio Cat. No. 2EH07) is a little larger, but is a satisfactory alternative. C7 was an R.S. Components 250 V.Wkg. polyester capacitor, and may be replaced by a Mullard 125 V.Wkg. polyester capacitor of the same value (Home Radio Cat. No. 2EH03). C8 is a sub-miniature component and may be a Mullard 32µF 40 V.Wkg. miniature electrolytic capacitor (Home Radio Cat. No. 2CH39). It should preferably have a low leakage current, of not more than 50µA. It should be noted, however, that the value specified for C8 is higher than is required to give the same sweep-to-flyback ratio as on the other ranges, this being due to the fact that the author required this range for use with a chart recorder. If the unit is not required for such a function, C8 could be reduced to 2µF.

Transformer T1 was also an R.S. Components part, and this is available from Home Radio, as indicated in the Components List.

The Lektrokit chassis parts can all be obtained from Home Radio, under the same Cat. Nos. as the Lektrokit part numbers.

The terminals were R.S. Components insulated types in the colours and quantities shown. Suitable alternatives are the Home Radio Cat. No. PK12C (Red and Black) and PK12CA (White, Yellow and Blue).

Switches S1, 2 and 4 were R.S. Components miniature single pole changeover types. An alternative is the sub-miniature 2-pole 2-way toggle switch Type 9 available from Henry's Radio. Another R.S. Components part, the panel neon lamp assembly, may alternatively be Home Radio Cat. No. D841/250V Red. Further R.S. Components parts are the push-buttons PB1 and PB2, which were miniature push-to-make in the prototype. A suitable substitute is the push-button available from Home Radio under Cat. No. WS89. S3 is a standard 3-pole 4-way miniature rotary switch, one of the poles being unused.

Of the semiconductors, TR2 to TR5 inclusive are generally available. TR1 and TR6 may be obtained from Electrovalue, 28 St. Judes Road, Englefield Green, Egham, Surrey, but it should be pointed out that there might be a waiting time for delivery of TR6. Diodes D5 to D9 inclusive are also obtainable from Electrovalue.

Rectifier diodes D1 to D4 inclusive were 1N2069 in the prototype but any silicon rectifier rated at 1 amp with a p.i.v. of 50 volts or more, such as the 1N4001, could be used instead.

ZD1 may be any 400 mW 15 volt 5% zener diode, such as the BZY88C15. ZD2 can be a BZYC5V1, whilst ZD3 may be a BZYC10. These diodes, or equivalent types, are generally available.

(To be concluded)

SIMPLE SHORT-WAVE RECEIVERS



by F. A. Baldwin

★ FOUR BASIC DESIGNS

1, 2 and 3 Valves. In total, six design variations are described, all have been thoroughly air-tested. Fifteen photographs and thirty-nine working diagrams illustrate the construction of the 'Saxon', 'Voyager', 'Explorer' and 'Sentinel' receivers.

★ GENERAL PURPOSE POWER SUPPLY

May be used as a bench supply or for use with two of the basic receiver designs. Two photographs, four working diagrams, Test Table.

PLUS

★ INTRODUCTION TO SHORT-WAVE LISTENING

★ WORKSHOP PRACTICE

★ SOLDERING NOTES

FOR ONLY

80p

140 PAGES

Postage 6p

TO DATA PUBLICATIONS LTD
57 Maida Vale London W9 1SN

Please supply.....copy(ies) of 'Simple Short-Wave Receivers', Data Book No. 19

I enclose cheque/crossed postal order for.....

NAME.....

ADDRESS

BLOCK LETTERS PLEASE

A MODERN HOMODYNE RECEIVER

Part 2

By

G. W. SHORT

In this concluding article our contributor deals with the construction of his homodyne receiver. Also described is a suitable a.f. amplifier, together with details showing how this amplifier and the homodyne receiver may be assembled to form a complete receiver with loudspeaker output.

COMPLETE CIRCUIT

THE COMPLETE CIRCUIT OF A MODERN homodyne receiver on the lines discussed last month is shown in Fig. 4. This is basically a two-stage r.f. amplifier, tuned at the input only, and driving a double-diode detector, D3, D4, which acts as a demodulator when the receiver is made to behave as a homodyne. A single a.f. stage completes the circuit as shown here, but of course a separate power amplifier must be used for loudspeaker reception.

In Fig. 4 the aerial tuned circuit is given by C1, C2 and whatever inductance is selected by wave-change switch S1. L1 and L2 are medium and short wave coils on a ferrite aerial rod offering, with a 500pF tuning capacitor, ranges of 500 to 2,000kHz and 3.5 to 10MHz respectively. When S1 is set to the 'L.W.' position, loading coil L3 is inserted in series with L1, whereupon the range covered is 150 to 500kHz. Similarly, setting S1 to 'S.W.I.' causes loading coil L4 to be inserted in series with the ferrite rod short wave coil, L2, whereupon the range covered is 1.6 to 5MHz. C1 is a 'fine tuner' with a capacitance of 5pF, and is helpful for final tuning of short wave signals. The aerial tuned circuit arrangements are discussed in more detail later.

The r.f. amplifier (TR1, TR2) calls for a little explanation. A junction f.e.t. is used in the input stage. This produces little r.f. gain in itself, but simplifies the band-switching by making it possible to dispense with the usual tapping on the input coil and to connect the whole aerial tuned circuit directly to the amplifier. Most of the actual gain comes from TR2,

COMPONENTS

Resistors

(All fixed values $\frac{1}{4}$ watt 10% or closer tolerance)

R1	220k Ω
R2	1k Ω
R3	1k Ω
RV4	500 Ω potentiometer, pre-set, miniature skeleton
R5	1k Ω
R6	10k Ω
RV7	10k Ω potentiometer, log, with metal case (see text)
R8	10k Ω
R9	10k Ω
RV10	25k Ω potentiometer, log
R11	10k Ω
R12	2.7M Ω
R13	180 Ω

Capacitors

C1	5pF variable
C2	365 or 500pF, variable
C3	2.5 μ F electrolytic, 6V. Wkg.
C4	0.01 μ F metallised polyester
C5	0.01 μ F metallised polyester
C6	0.01 μ F metallised polyester
C7	0.01 μ F metallised polyester
C8	0.1 μ F metallised polyester
C9	0.1 μ F metallised polyester
C10	0.01 μ F metallised polyester
C11	125 μ F electrolytic, 10V. Wkg.
C12	10 μ F electrolytic, 10V Wkg.*

Cx See text
* Omitted when a.f. amplifier of Fig. 7 is used.

Inductors

L1, L2	Medium and short wave ferrite aerial assembly (Amatronix)
L3	2.5mH r.f. choke type CH1 (Repanco)
L4	Short wave loading coil (see text)

Semiconductors

TR1	2N3819
TR2	AF239
TR3	BC169C
D1-D4	OA90

Switches

S1	1-pole 4-way, rotary
S2	d.p.s.t., slide switch

Loudspeaker

LS1 75 Ω or 80 Ω loudspeakers†
†Required only when a.f. amplifier of Fig. 7 is used.

Battery

9-volt battery type PP9 (Ever Ready)

A. F. Amplifier

A.F. amplifier of Fig. 7 or suitable alternative

Miscellaneous

Slow-motion tuning drive
4 knobs
Transistor holder
Battery connectors
Material for panel, chassis and cabinet

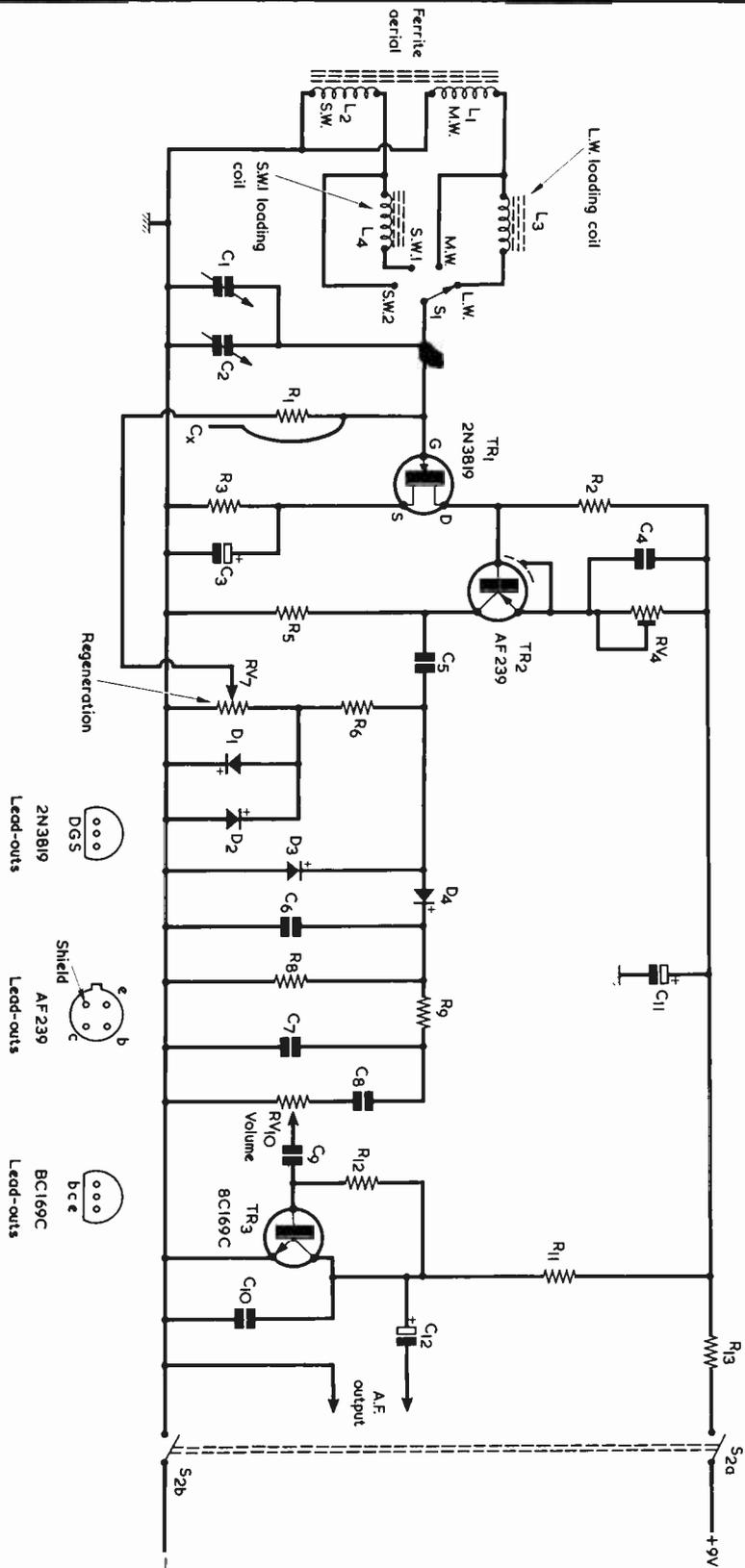
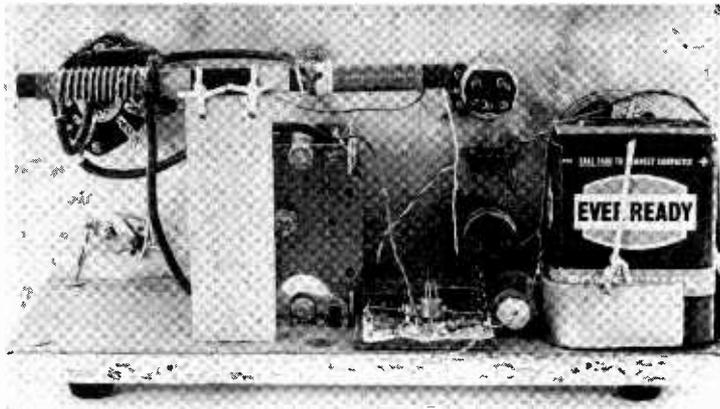

Fig. 4. The complete circuit of the modern homodyne receiver. This can receive a.m., c.w. and s.s.b. transmissions



The inside rear of the complete receiver. The homodyne board is to the right of the tuning capacitor, and its screen and the transistor holder for TR1 can both be seen. The 1,000 μ F capacitor is to the immediate right of the homodyne board. The a.f. amplifier board appears between the battery and the front panel, being obscured here by the battery

a u.h.f. p.n.p. germanium type which works well in this direct-coupled 'complementary-cascade' type of circuit.

The limiter (D1, D2) is a simple back-to-back pair of diodes, driven by a high enough resistance (R6) to ensure good clipping and at the same time prevent the limiter from loading the input to the detector. The regeneration control is RV7, an ordinary carbon track potentiometer with a metal case which is earthed to 'keep the r.f. inside'.

At lowish frequencies the amplifier has 360° phase shift, because there are two inverting stages, and so the output is in phase with the input. This means that the feedback path should not introduce further phase shift, since this would begin to bring the fed-back signal towards an out-of-phase condition, and give negative instead of positive feedback. For this reason the regenerative path on long and medium waves is completed via a resistor, R1, which introduces no phase shift. This resistor is given a high value to avoid damping the input tuned circuit excessively. On short waves there is an appreciable amount of phase shift in the amplifier, and the output is no longer in phase with the input. Above about 2MHz, therefore, feedback is taken increasingly by way of a small capacitance, given by Cx, which bypasses R1. It is convenient to use for Cx a twisted-wire capacitor, i.e. the capacitance is provided by two pieces of insulated connecting wire twisted together. The capacitance is then easily preset by twisting or untwisting to achieve the required condition of just enough feedback to enable the circuit to be brought into oscillation at all points in the tuning range.

The function of RV4 is to set up the current in TR2 for optimum

results. In the prototype, this is given (with RV7 adjusted to give zero regeneration) when TR2 passes 3mA, as indicated by a drop of 3 volts across R5. However, it may be found desirable to experiment a little and try results with different values of current in TR2. RV4 should be initially set up for the 3mA current then, after experience with the receiver has been obtained, the effect of different currents in TR2 between the limits of 1 and 4mA can be checked. It is necessary to provide some means of adjustment here because the current taken by different specimens of 2N3819 in the TR1 position will vary. The voltage drop across R2 and hence the base voltage of TR2 is dependent upon the current drawn by TR1.

The audio frequency low-pass filter is a very simple RC affair whose components are C6, R9 and C7. The d.c. load for the detector/demodulator is R8. This resistor has been deliberately given a rather low value (10k Ω) for the type of detector used here. The effect is to increase the damping of the amplifier output as signal strength builds up, which is the right condition for smooth reaction.

Volume control RV10 is followed here by one stage of a.f. voltage amplification, TR3. It is intended that the a.f. output will be used to drive a conventional loudspeaker amplifier. It is, however, possible to use the audio output of TR3 for headphone reception, provided that sensitive high-impedance phones are used. (Rather greater volume will be obtained by connecting high-impedance magnetic phones in place of R11).

The total current consumption of the receiver, with RV4 set for 3mA current in TR2, is of the order of 4mA. However, this is liable to vary a little with different specimens of the 2N3819.

FREQUENCY COVERAGE

It will be clear to experienced constructors that the circuit lends itself to the reception of any tuning range within reason by the simple process of switching in appropriate ferrite aerial coils.

Ordinary grades of ferrite are not much good above about 2MHz, but special h.f. rods are made which operate well up to about 20MHz. The prototype uses a special h.f. rod, 6½ in. by ¾ in. in diameter, which is suitable for medium and long waves as well as the short wave ranges covered. The ferrite rod coils (L1 and L2 in Fig. 4) are designed to be tuned by 365pF, but by using a 500pF tuning capacitor the coverage can be extended down to nearly 450kHz on medium waves, which makes it possible to use the receiver as part of the i.f. chain of a conventional superhet. When L3 is in circuit, as is given by setting S1 to 'L.W.', the receiver can also tune through the conventional superhet intermediate frequencies.

Short-wave coverage, as is given by L1 on its own, is some 3 to 11MHz with 365pF tuning and 3.1 to 10MHz with 500pF, but in both cases the high frequency limit depends entirely on the minimum capacitance of the tuning capacitor and the circuit strays, and will usually extend well beyond the conservative 10 or 11MHz limit just quoted. At the high frequency end of the 'S.W.2' band it is possible, in the London area at least, to receive a number of broadcasting stations. Towards the low frequency end (employ a 500pF tuning capacitor) it is also possible to receive s.s.b. amateur transmissions on the 80 metre band.

The ferrite rod assembly, ready-wound with L1 and L2 fitted, is available from Amatronix Ltd., 396 Selsdon Road, South Croydon, Surrey, CR2 0DE. The ferrite rod for the 'S.W.1' loading coil, L4, is also available from this source. It consists of 20 turns close-wound of 22 s.w.g. enamelled wire on a 1½ by ¾ in. piece of rod. Loading coil L3 is simply a Repanco r.f. choke type CH1.

CONSTRUCTION

The complete receiver, as illustrated in the photographs, consists of the homodyne receiver proper plus an additional a.f. amplifier feeding a small speaker. It is not necessary to use this particular a.f. amplifier, since the homodyne section will work into any suitable amplifier. The homodyne receiver is built on its own circuit board, this coupling by wires to the external components, which consist of S1 and the aerial tuned circuits, R1, Cx, RV7 and RV10. The complete receiver could, if desired, be built on a smaller baseboard and with a smaller panel with the a.f. amplifier and speaker omitted. Other variations are

THE RADIO CONSTRUCTOR

amplifier could be used instead. For completeness, nevertheless, the present amplifier will next be described.

The amplifier circuit is given in Fig. 7 and it has the advantage of offering a low battery consumption, the quiescent current being approximately 0.8mA only. The input signal is applied to the base of the BC169C, whose collector couples to the base of the first 2N4289. This drives the BC168B and 2N4289 in the complementary Class B output stage. Two silicon 'bias diodes' (available, as is the BC168B, from Amatronix Ltd.) keep the output transistors conductive for the zero signal condition, and these couple to the speaker, which may be 75Ω or 80Ω. The speaker employed in the prototype was a 75Ω 2½ in. unit (which is also available from Amatronix Ltd.). Feedback to the BC169C is taken from the junction of the 1kΩ and 10Ω resistors across the speaker, and it will be noted that this particular part of the circuit exhibits a considerable economy in components. It is desirable that the 250μF 16V capacitor be a Mullard miniature electrolytic component, as its internal series resistance was taken into account when the feedback component values were calculated. As already stated, the 1,000μF capacitor across the supply lines is only required to reduce the risk of feedback to the homodyne receiver. If the amplifier were used on its own for a different application the 1,000μF capacitor could, in most instances, be omitted.

In the present design the amplifier is assembled on a piece of hardboard measuring 2½ by 3½ in. and uses domestic pins for anchorage points in the same manner as with the homodyne receiver board. Components are laid out along the board in roughly the same order as they appear in the circuit. The 1,000μF capacitor is not mounted on the amplifier board, but is external to both this board and the homodyne board. It appears between the homodyne board and the battery, and is clearly visible in the photographs showing the interior of the overall receiver.

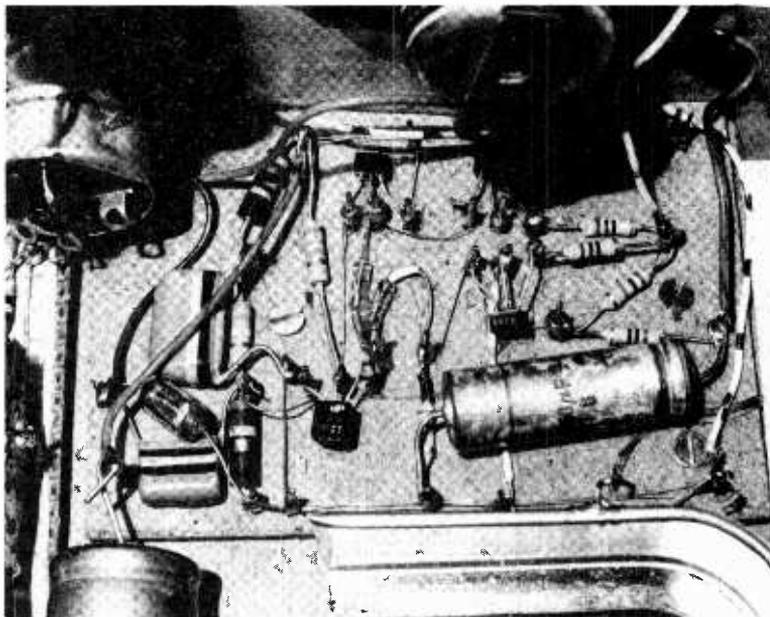

Close-up of the a.f. amplifier board. The BC169C is at bottom left, whilst the two output transistors are to the right

OPERATION

Operating a homodyne takes a little getting used to. The background hiss and the howls during tuning-in may be rather off-putting at first, but do not be discouraged! You will be surprised at the stations it can pull in once you have learned to use it. Here are a few general tips and guide lines:

1. If the circuit is detuned a little, but not far enough to lose synchronisation, the audio output falls and becomes distorted. The best tuning point is usually nearer one edge of the locking band than the other.
2. Loss of sync. may occur momentarily during deep modulation troughs, giving a rasping quality. This is a sign that the circuit is slightly off tune or that a.f. signals are getting back into the r.f. amplifier.
3. Loss of sync. may occur if the signal

fades. The best strategy is usually to let well alone until the signal fades up again.

4. It is an advantage to use the lowest practicable level of oscillation. If you have to increase the level to override a strong signal in the next channel turn up the reaction, until the intelligible breakthrough turns into unintelligible 'monkey chatter'. This is as far as you need go. However, when receiving s.s.b. signals the question of synchronization doesn't arise, so in this case the best level of oscillation is set by other factors. First, the level must be at least high enough always to exceed the incoming signal, otherwise intelligibility will suffer. Secondly, it turns out with this receiver that it is possible so to set the regeneration that a useful increase in signal amplification can be had even with the receiver oscillating. On weak signals this is what dictates the maximum level which can usefully be set up. (If strong s.s.b. signals are being received you may as well turn the regeneration right up and so get the maximum selectivity from the outset).

As a final point, Fig. 8 shows received frequencies corresponding to the 0 - 100 scale of the slow-motion tuning drive employed with the prototype. It must be emphasised that this diagram, which applies to a 500pF tuning capacitor, is intended for guidance only, and it should not be assumed that receivers built up to the circuit will exhibit exactly the same frequency/scale relationship. Nevertheless, the diagram will still be of assistance since it gives the constructor an approximate idea of received frequencies on the four bands covered.

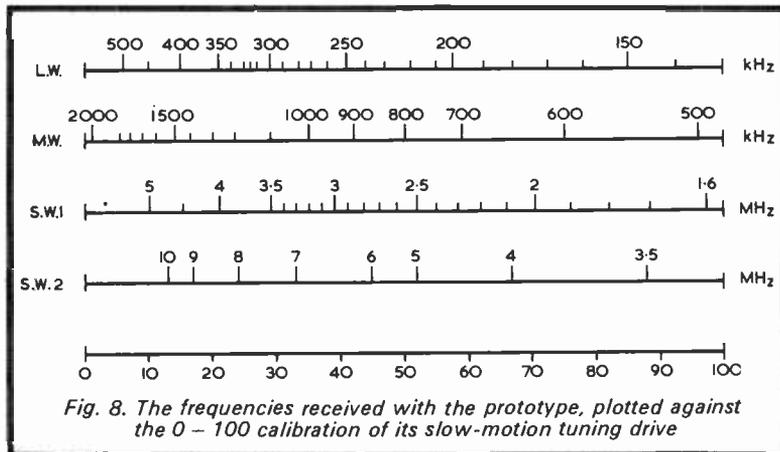
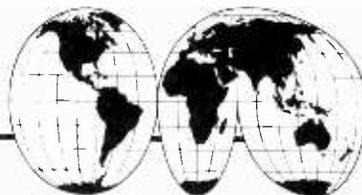

Fig. 8. The frequencies received with the prototype, plotted against the 0 - 100 calibration of its slow-motion tuning drive

SHORT WAVE NEWS

FOR DX LISTENERS



By Frank A. Baldwin

Times = GMT

Frequencies = kHz

In remote Nepal, the transmitter at Kathmandu is still currently operating on **5000kHz** where, unfortunately, the frequency standard stations MSF at Teddington and IBF at Milan cause the reception of Radio Nepal to be somewhat marred to say the least. Apparently the Nepalese engineers have never heard of MSF or IBF!

According to the British Association of Dx'ers (BADX), the schedule of Radio Nepal is as follows – from 0120 to 0350, from 0720 to 0950 and from 1150 to 1550 on **5000kHz**. The power is 100kW.

Radio Nepal has also been logged on **9603** by a BADX observer at 0145 with a programme of Indian music, although the frequency is subject to some variation at times. The times offering the best chance of reception for listeners here in the U.K. are from 0120 and from around 1500 onwards.

NOW HEAR THESE

● **YEMEN**

The Aden transmitter in the People's Democratic Republic of Yemen can be heard on **5060** (59.29 metres) 7.5kW around 2000, when it was logged with a programme of Arabic songs and music. The daily schedule, except Fridays, is from 0300 to 0530, from 1100 to 2200, but on Fridays a continuous programme is radiated from 0300 to 2200. The address is – P.O. Box 1264, G.P.O., Aden.

● **MOROCCO**

The Voice of America station in Tangier operates a number of foreign language broadcasts on a multitude of channels from **5965** (50.29m) to **25880** (11.59m) but has recently (at the time of writing) popped up on another channel. The 'out of band' frequency of **5436** has been heard from 2035 with a programme of both Arabic music and English musical comedy music to 2057. This was followed by a short newscast in Arabic, the station signing-off with identification in English at 2100. It has also been logged by BADX from 1952 onwards when radiating a programme of English 'pop' records, time signal and news in Arabic at 2000.

● **PARAGUAY**

The Paraguayan station mentioned in 'SWN' February issue, operating on the 'out of band' channel of **5273** was apparently conducting test transmissions with a low powered transmitter. It has been reported by BADX being heard from around 0020 to 0130 but on an irregular basis, a not unusual practice when transmitters are being tested. When in full operation, ZPAI Radio Nacional will have a power of 100kW.

● **ECUADOR**

HCRPI Radio Catholica, Quito, listed on **5055** with a power of 1kW has been heard testing a new transmitter (estimated at 25kW) on **5060** (59.29m) with station identification every four minutes or so, according to BADX.

● **BURMA**

According to BADX, Rangoon has vacated the listed **7120** channel for that of **7185** (41.75m) where it has been heard from 0030 to 0230, leaving the BBC transmitter on the former channel in the clear to S.E. Asian audiences.

XZK4 has a power of 50kW and, according to the published schedule, operates from 0030 to 0200 in Burmese and from 0200 to 0230 in English, the news being at 0200.

Other Burmese transmitters on the short waves are – XZK2 on **4725** (63.49m), XZK42 on **5040** (59.52m) and XZK5 on **9725** (30.85m), all 50kW. The address is – Burma Broadcasting Service, Prome Road, Kamayut P.O., Rangoon – if you are lucky enough to hear one of these stations. Reception of them here in the U.K. is rather difficult, especially where ordinary 'domestic' type receivers are in use.

● **NIGERIA**

This huge African country operates an External Service, a series of Local Services and a Commercial Service.

The External Service operates in English from 0530 to 0730, from 1530 to 1700 and from 1800 to 1930 on **7275** (41.24m) to West Africa; on **15185** (19.76m) to N. Africa, Europe and Mediterranean and on **15120** to E. Africa and the Middle East. From 1530 to 1700 on **7275** to West Africa, **15185** to East Africa and the Middle East, on **15120** to Central and South Africa. From 1800 to 1930 on **7275** to West Africa, on **11925** (25.16m) to North Africa, Europe and the Mediterranean and on **15185** to Central and South Africa. The newscasts are at 0600, 0700, 1530, 1630, 1830 and at 1900.

One Nigerian station that can often be heard is the transmitter at Benin City, capital of the Mid-West region of the country, once an African kingdom and famous for its bronze work. Listen on **4932** (60.83m) for this 10kW transmitter from around 2000 onwards. The schedule of Benin City is from 0430 to 1245 and from 1350 to 2305. Listeners in the U.K. should listen from around 2000 onwards.

● **BANGLA DESH**

Radio Bangla Desh has been changing frequencies virtually from day to day according to BADX. A recent monitored channel was that of **15553** (19.28m) where it opens with the news in Bengali at 1230, followed by the news in English at 1235 and the remainder of the programme consisting of music and talks in English. The announced channel of **15520** appears to be silent.

'Bandspread', the official journal of the British Association of Dx'ers, reports the following recent loggings of Radio Bangla Desh. On **9440** (31.77m), **9856** (30.44m), **9890** (30.34m) and now on **15553**. The foregoing frequencies are those reported since Bangla

Desh gained independence. The programme closes with a request for views on programmes to be sent to The Director, Radio Bangla Desh, Dacca. 'Jai Bangla' ended the programme, no anthem was heard.

CURRENT SCHEDULES

● USSR

English broadcasts from Radio Kiev for Europe can be heard on Mondays, Thursdays and Saturdays from 1930 to 2000 on **5920** (50.68m) 50kW and on **7120** (42.13m) 100kW. To North America from 0030 to 0100 on Tuesdays, Fridays and Sundays on **7120**, **7130** (42.08m), **7150** (41.96m), **9660** (31.06m) and on **11850** (25.32m). From 0430 to 0500 on **7130**, **9480** (31.65m), **9610** (31.22m) and on **9760** (30.74m).

The English schedule of Radio Vilnius is from 2230 and 2300 on **7310** (41.04m), **9450** (31.75m), **9610** (31.22m), **9750** (30.77m), **9810** (30.57m), **11930** (25.15m) and on **12050** (24.90m) all 100kW.

● MONGOLIA

Radio Ulan Bator now broadcasts in English from 1220 to 1250 on **15445** (19.43m) and on **17785** (16.87m) and from 2200 to 2230 on **9540** (31.45m) and **11860** (25.30m), all 50kW except the latter channel which is 25kW.

● INDIA

The current schedule of Radio Kashmir is from 0130 to 0230 and from 1130 to 1700 on **3277** (91.55m) 1 kW, from 0320 to 0450 and from 0600 to 1100 on **7270** (41.27m) 7.5kW.

Delhi can be heard with a programme directed to the U.K. at 2045 when identification is made and followed by "Press Review". Listen on **9525** (31.50m) 100/250kW.

● VENEZUELA

Radio Nacional de Venezuela operates on **9550** (31.41m), **11725** (25.59m) and **17840** (16.82m). According to station announcements, it is carrying out tests on **11725** (25.59m), **11750** (25.53m), **11770** (25.49m), **11970** (25.06m), **15390** (19.49m), **15400** (19.48m) and on **17840** (18.82m).

According to BADX, the **11725** channel has been logged at 0130 with Latin American music and station identifications, some of them in English, and requesting reception reports. The **17840** channel has also been heard.

● PROGRAMMES IN ENGLISH

In the past two issues of this journal we have featured some programmes in the English language that can be heard on the short waves, mostly for the benefit of beginner listeners. Here are a few more such programmes logged recently, the times GMT being listed first as usual.

1950 7225kHz (41.52m) 18/120kW, Bucharest, Rou-

mania, with newscast of world events and Roumanian affairs.

2200 6200kHz (48.39m) 50/500kW, Tirana, Albania, home news and the Albanian view of events in Europe.

2200 6270kHz (47.84m) 120/240kW, Peking, China, programme about Chinese surgery and acu-puncture.

2215 9695kHz (30.94m) 250kW, Johannesburg, South Africa, world news and events in the Republic.

● READERS LOG

J. V. Moss of Rayleigh, Essex, continues to do sterling work on his Meridian 10 transistor portable superhet. With a 60ft long wire aerial and an aerial tuning unit he managed to hear such stations as –

7065 2030 Tirana, Albania, news in English.

9515 2200 Ankara, Turkey, English programme to Europe.

9525 1945 AIR (All India Radio) Delhi, programme in English.

9545 2045 Accra, Ghana, news in English to Europe.

9605 2100 Sackville, Canada, Radio Canada International with news in English.

9625 2050 Jerusalem, Israel, with news in English.

9645 2050 Vatican Radio with news in English.

9675 2000 Warsaw, Poland, news in English.

9805 2200 Cairo, U.A.R., programme in English.

11620 1945 AIR Delhi with news in English.

11710 2230 VOA (Voice of America) Monrovia, Liberia, identification at sign-off.

11710 2304 AIR Delhi, news in English.

11720 2207 Sackville, Canada, news in English.

11780 2000 HCJB, Quito, Ecuador, with programme in English.

11850 2030 Accra, Ghana, news in English to North America.

11900 2235 Johannesburg, S. Africa, with English programme.

11910 2015 ETLF Addis Ababa, Ethiopia, religious programme in English.

11920 1845 Abidjan, Ivory Coast, news and identification.

11950 1730 FEBA (Far East Broadcasting Association), Seychelles, with religious programme in English.

11970 2240 Johannesburg, S. Africa, with programme in English.

The above represents only part of the JVM log, which just goes to show what can be achieved with a transistor portable, good show JVM!

CLUB CORNER

From time to time in 'QSX' I have brought to the notice of readers several British clubs that cater for the short wave listener, on this occasion however, I should like to draw attention to a European club.

The Cimbrer Dx-Club, Box 27, Aars, Denmark, is one of the best clubs and issue a very creditable journal *The Cimbrer DX-News*, the last issue of which contained 19 pages in English and only 5 in Danish, which is approximately the usual ratio.

A postcard to the address given above will bring full details.

LAST LOOK ROUND

A correct period report to most of the powerful Broadcast stations, such as Radio Canada, Moscow, Prague, Voice of America, etc., especially where accompanied by an International Reply Coupon, will almost certainly bring forth a reply QSL card. However, there are many stations in the 1 to 10kW class, privately owned and mostly located in the South American continent, that do not as a general rule reply to such reports. In some cases, reports from outside the service area of the station are not required and in others, the cost factor is of some importance. Other stations QSL spasmodically for no apparent reason.

If a report has been sent and no reply received after a reasonable length of time has elapsed, a follow-up letter should be posted to the station concerned enquiring about the original communication and, better still, enclose a further report.

In your work shop

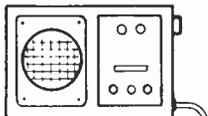

Electronics covers a wide field and takes in devices ranging from integrated circuits to what are, on the surface, nothing more than simple switches. This month, Smithy the Serviceman shows his able assistant Dick some of the unexpected applications that are offered by the magnetically operated dry reed switch.

he had been working with, putting them neatly out of the way at the edge of his bench. Suddenly, he became subconsciously aware that he was being observed. Still preoccupied, he glanced over his shoulder, to confront two unblinking questioning eyes held no more than nine inches away from his own.

DRY REED SWITCH

"Ye gods," expostulated Smithy, jumping away, "where the dickens did you spring up from?"

The stricken Serviceman staggered back to his stool.

"You nearly gave me heart failure," he continued complainingly. "What on earth's the idea - creeping up on me like that?"

"I was just coming over to see what was happening," returned Dick defensively. "Dash it all, Smithy, we're supposed to be fixing TV and radio sets here, not messing around with electric bells."

"If you must know what I was doing," replied Smithy with dignity, "I was fixing up a little gubbins for the retail premises with which this servicing establishment happens to be associated. They wanted a gadget for occasional use in the office which would cause a bell to ring when the shop door was opened."

"Is *that* all?" queried Dick scornfully. "I'd have thought that a couple of bits of springy brass strip would have been enough for a job like that."

"I am not," stated Smithy disdainfully, "in the habit of making up switching devices which incorporate bits of springy brass strip."

"What have you used then?"

"A normally-open dry reed switch."

A gleam of interest came into Dick's eyes.

"A dry reed switch, eh? What makes it operate?"

"Two magnets," replied Smithy. "One is fixed to the door whilst the other is mounted on the door frame and biases the dry reed switch from Form A to Form B operation."

Despite his irritation with his assistant, Smithy could not help but chuckle at the expression of utter incomprehension which now settled on that worthy's face. The Serviceman glanced at his watch.

"It looks," he grinned, "as though you haven't the faintest clue concerning what I'm talking about. I see that we've got a bit of time to spare from work, so turn off that job on your bench and bring your stool over here. I'll then give you some gen on these dry reed switches."

Dick needed no second bidding and in record time was seated alongside the Serviceman.

T-R-R-R-RING!
Startled, Dick hastily returned his soldering iron to its rest and turned round, to see Smithy in the act of lowering his right arm until his hand lay on the surface of his bench. As soon as his hand came to rest the ringing of the electric bell stopped.

Smithy raised his hand again and the bell recommenced its ringing. Then, once more, he brought his hand back to the bench, whereupon the bell returned to its silent state.

The Serviceman gave a grunt of satisfaction and turned off a switch. Humming contentedly to himself and completely engrossed in his actions, he proceeded to tidy up the components

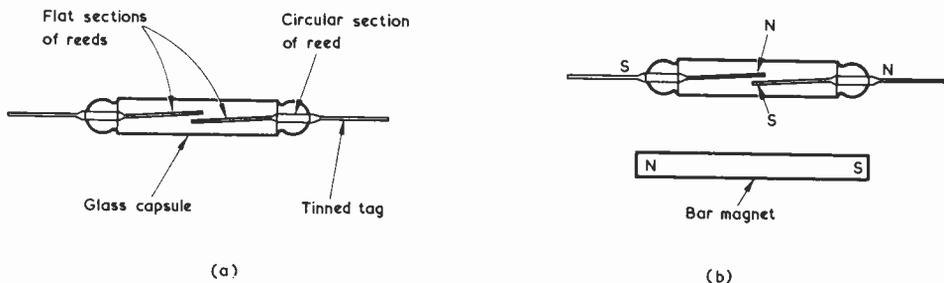
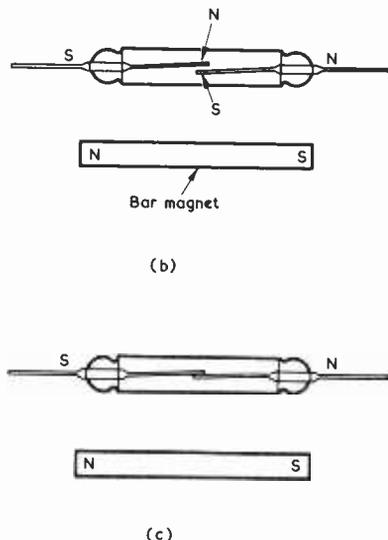

Fig. 1 (a). The construction of the dry reed switch. The circular sections of the reeds provide a good seal to the glass at the ends of the capsule. The tinned end sections are flat

(b). If a bar magnet is brought up to the dry reed switch, the reeds take up the magnetic polarities shown here

(c). When the magnet field strength is sufficiently high, the two inside ends of the reeds are attracted together and cause the switch to close



"Well now," said Smithy. "Let's start at the beginning. I should imagine that most people who play around with radio have, at one time or another, seen a dry reed switch. It consists of a glass capsule, normally filled with an inert gas, in which are fused two flat blades or reeds, these being positioned so that their ends overlap. The reeds are made of magnetic material, which is frequently a 50:50 alloy of nickel and iron, and their overlapping surfaces are coated with a high conductivity metal such as gold. In the most common form of the switch the reeds are separated from each other and this is the normally-open type, sometimes referred to as the Form A version."

Smithy pulled his note-pad towards him and sketched out the normally-open dry reed switch. (Fig. 1(a).)

"The type of inert gas used," he continued, "tends to vary with different switch designs, but if the overlapping areas of the reeds are coated with gold, as they are in most instances, the gas is usually hydrogen, or nitrogen with a little bit of hydrogen added. In some switches, though, the glass capsule is completely evacuated. This occurs with switches which are designed to handle high voltages."

"These normally-open switches," asked Dick, "all work in the same way, don't they? The contacts close when you apply a magnetic field to the capsule."

"That's right," confirmed Smithy. "And this field can be provided in practice by a bar magnet. If we position a bar magnet parallel to the dry reed switch, magnetic polarities are caused to appear in the reeds."

Smithy added a bar magnet to his previous sketch and marked in the polarities. (Fig. 1(b).)

"Here we are," he went on. "The north pole of the magnet causes the outside end of the adjacent reed to exhibit a south pole and its inside end to exhibit a north pole. Similarly, the magnet south pole causes the outside end of the other reed to exhibit a north pole and its inside end to exhibit a south pole."

"This bit's easy," put in Dick. "Since the two inside ends of the reeds now have opposite magnetic polarities they become attracted to each other. If the magnetic field from the magnet is strong enough they come together." (Fig. 1(c).)

"They do, indeed," affirmed Smithy. "What's more, they come together with a snap action. One of the inherent properties of the dry reed switch is its snap action on contact closure. This action is easy enough to understand when you realise that, once the applied magnetic field is sufficiently strong to start the reed ends moving towards each other, the magnetic attraction between them increases as the space between them decreases."

"Let's go back to something you said a few moments ago," said Dick. "You mentioned that the ends of the reeds are usually coated with gold."

Does that mean that there are other types of coating?"

"There are quite a few," replied Smithy. "Whilst dealing with these coatings I think I should add that they are very thin and are applied only over the reed surfaces which meet together. Gold appears to be the most common contact material and it is usually plated onto or diffused into the surface of the reed. Other contact coatings are silver and tungsten, as well as some of the more exotic metals such as rhodium, palladium or platinum. At the same time, the outside ends of the reeds, which project outside the glass capsule, are tinned during manufacture to enable soldered connections to be made to them later."

"Since you can cause a dry reed switch to operate with a magnet," commented Dick, "I assume that you can also make it operate by means of a coil."

"Oh, definitely," agreed Smithy. "If

you fit the switch inside a coil, the reeds will become magnetised when a current is passed through the coil in just the same manner as when a bar magnet is brought up alongside them."

Smithy quickly drew a coil and dry reed switch assembly. (Figs. 2(a) and (b).)

"When a current flows through the coil," he went on, "the switch operates. A dry reed switch inside a coil forms a dry reed relay."

Dick absorbed this information.

"Does a dry reed relay," he asked next, "have an improved performance when compared with an ordinary type of relay?"

"In many applications it has," replied Smithy. "The great advantage of the dry reed relay is that its contacts are not exposed to contamination by the air as occurs with the contacts of ordinary relays, and so they cannot become dirty or oxidised. Provided its contacts are not over-run, a dry reed

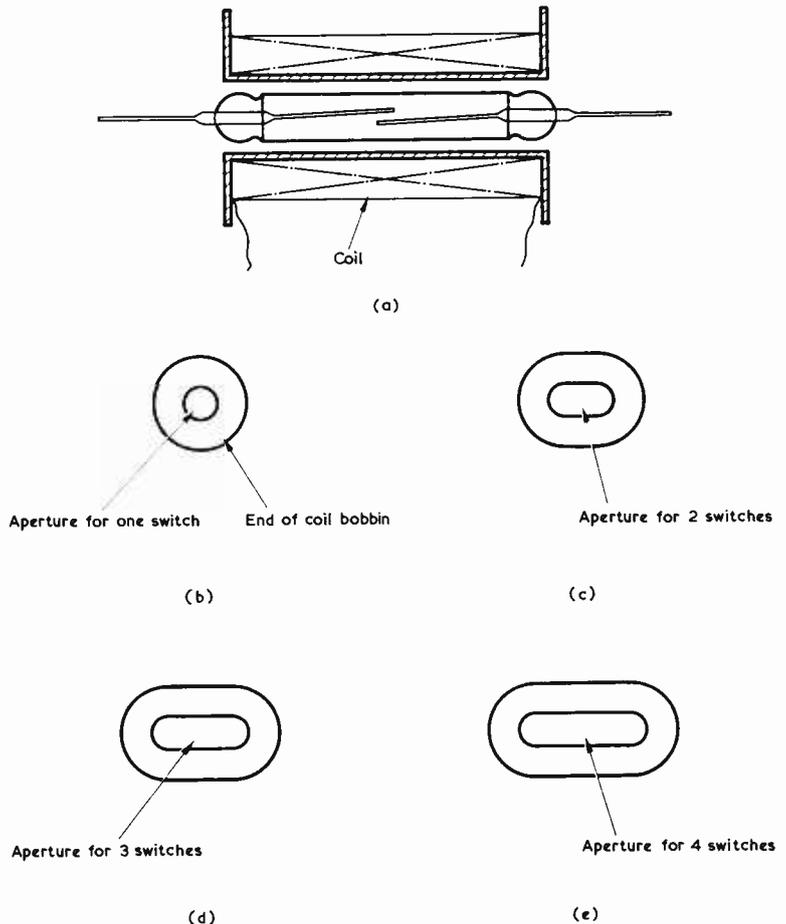

Fig. 2. Inserting a dry reed switch inside a coil, as in (a) and (b), produces a dry reed relay. The coil may also accommodate two, three or four switches side by side, as illustrated in (c), (d) and (e)

relay offers a good performance after well over a million operations, and it can keep this up under conditions of really heavy atmospheric pollution. Another advantage with dry reed relays is their very quick operating time. The contacts of a small normally-open dry reed switch will close within 0.5 milli-second of the application of the appropriate magnetic field. Yet a further advantage is the small size and absence of mechanical complexity. There's none of this business of moving armatures and so on that you get with ordinary relays."

"What are the main applications for dry reed relays?"

"They were originally used," said Smyth, "to replace ordinary relays in telephone exchanges, and were introduced for this purpose as long ago as the late 1930's by Bell Telephone Laboratories in America. Nowadays they turn up all over the place, in computers, aircraft and marine equipment, and pretty well anywhere else where ordinary relays might otherwise be used. Incidentally, a dry reed relay need not consist of just one dry reed switch inside a coil. You can have relays in which two, three or four dry reed switches are fitted inside a single coil. All of these operate when a current is passed through the coil. These multi-switch relay coils look something like this."

Smyth tore the top sheet from his pad and sketched out the coils he had described. (Figs. 2(c), (d) and (e).)

CONTACT RATINGS

"What sort of currents can dry reed switches handle?"

"There's a surprisingly high range of currents," replied Smyth. "For resistive loads you can get small dry reed switches capable of switching from around 10mA up to an amp at low voltages, or switching lower currents at higher voltages. There are larger switches, too, and these can handle currents of 3 amps or more. Most of the dry reed switches that appear in the home-constructor market are in the smaller category. Physical sizes range from a capsule length of around a third of an inch to a capsule length of several inches."

"This dry reed switch business," remarked Dick, "covers quite a wide ground, doesn't it?"

"It does, rather," agreed Smyth. "The next thing I'd better do is give you some of the terms you're liable to bump into when you're dealing with these switches. I mentioned the normally-open or Form A type of switch just now. There is also a normally-closed or Form B type. This is often given by a Form A switch with a magnet positioned alongside it which holds it energised. To make the switch contacts open you have to apply a magnetic field which opposes that of the magnet. Thirdly, there is the changeover, or 'Form C' type."

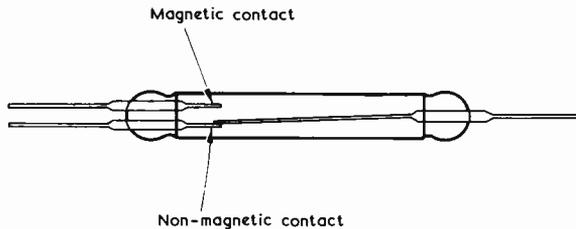

Fig. 3. A simple version of changeover (or Form C) dry reed switch employs the construction shown here. The moving reed is mechanically biased against the non-magnetic contact and is attracted towards the magnetic contact when a field is applied

Smyth quickly sketched out a Form C dry reed switch. (Fig. 3.)

"There are several ways of making a changeover switch," he resumed, "but the simplest consists of manufacturing it in such a manner that a long reed taking up most of the capsule length rests against a contact which is made of non-magnetic material. When the magnetic field is applied the reed is then attracted towards the other contact, which is made of magnetic material. Note, by the way, that the changeover action is of the break-before-make variety. There is a moment, during the changeover, when the moving reed is connected to neither of the two fixed contacts."

"Is that important?"

"To a certain degree it is," said Smyth, "because it differentiates the Form C changeover switch from the Form D changeover switch. In the Form D switch there is a momentary connection between the moving reed and both fixed contacts at an instant during the changeover."

Dick frowned.

"I don't get that," he remarked. "Looking at the dry reed switch you've just drawn I can see that you can't help but get an inherent break-before-make action during the changeover. In fact, I simply can't visualise how the switch could give a momentary make between the two fixed contacts. The two fixed contacts would have to be so close together that they'd all be touching, anyway."

"You don't get the Form D action with a reed switch of the type we've been discussing up to now," stated Smyth. "You get it with a different type, which I'll be describing shortly. I only mentioned the Form D business so as to clear up all the Form functions at the same time."

"Fair enough," conceded Dick, "what other terms are there?"

"There are a few more essential ones," replied Smyth. "To start off with, there is what is known as 'pull-in'. 'Pull-in' applies to the case where there is just sufficient magnetic flux, or just sufficient current in the energising coil, to cause the dry reed switch to operate. The opposite term is 'drop-

out' and this applies to the case where there is just sufficient magnetic flux, or current in the coil, to maintain the switch in the operated position after pull-in has occurred. As you may imagine, the drop-out value is lower than the pull-in value. Typically, it is about half that value, although switches are available in which the difference is much less. Another term is 'flux unit'. This applies to the minimum magnetic flux required to cause pull-in to occur. The minimum flux required is expressed, in practice, most conveniently in terms of the ampere-turns in a coil surrounding the switch."

"That seems to me to be rather a haphazard way of working," commented Dick. "I would have thought that the size and shape of the coil could have quite an effect on the flux applied to the switch. Two coils of different shape could give you two different pull-in ampere-turn figures."

"That could happen," agreed Smyth. "When a specification for a dry reed switch is given in ampere-turns, it is assumed that these apply to a coil of 'standard' dimensions. In any case, any coil within reason, provided it is about the same length as the glass capsule, will give a pull-in ampere-turns figure that will be reasonably accurate. In practice, also, there's a pretty wide variance in the ampere-turn pull-in figures of individual switches of the same type, because it is difficult to manufacture them to operate at precise pull-in figures. A typical pull-in ampere-turns specification for a small switch may be quoted as 60 to 100. In some instances the specification may merely state a minimum ampere-turn figure only, and leave it at that. Some specifications also include a drop-out ampere-turn figure, and this may have a similarly wide tolerance. Incidentally, the terms 'operate' and 'release' may be used in specifications instead of 'pull-in' and 'drop-out'."

LATCHING CONFIGURATION

"It seems a pity," mused Dick, "that the drop-out value for most of these dry reed relays is a lot lower than the

pull-in value. This could be something of a nuisance in some circuit designs."

Smithy shrugged his shoulders.

"It's an unavoidable feature with a dry reed relay," he remarked. "And, in any case, you get the same effect with conventional relays. As a matter of interest, the difference between the pull-in and drop-out values can sometimes be put to good use. I'll show you a representative example, using magnets."

Smithy pulled his note-pad towards him and sketched out a normally-open dry reed switch and a bar magnet. (Fig. 4(a).)

"Now, this magnet I've drawn," he

went on, "is so positioned that the magnetic field strength it applies to the switch is just half-way between the pull-in and drop-out values. Since the field is below the pull-in level, the switch stays open. We next bring another magnet up to the switch."

Smithy added the second magnet to his diagram. (Fig. 4(b).)

"As this second magnet approaches the switch," he went on, "it adds to the field strength given by the first magnet. The total field strength eventually passes pull-in level, whereupon the switch closes. If we take the second magnet away again, though, the switch remains closed because the field

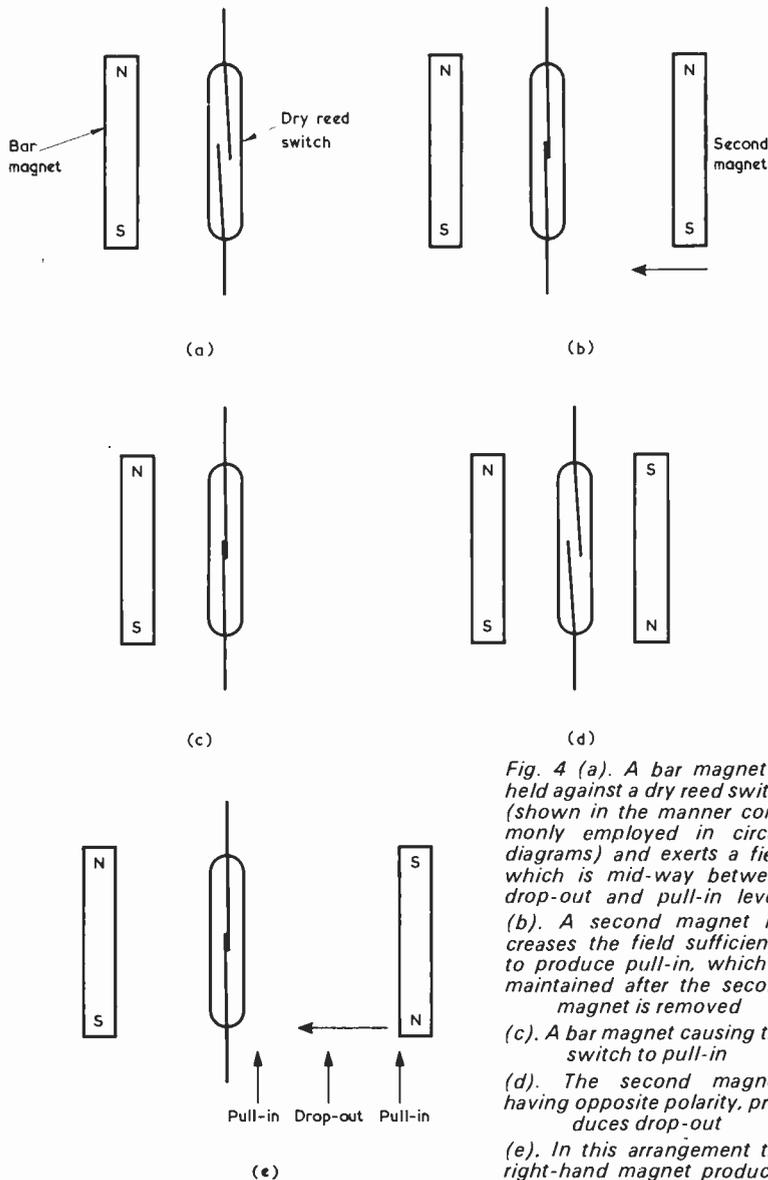

Fig. 4 (a). A bar magnet is held against a dry reed switch (shown in the manner commonly employed in circuit diagrams) and exerts a field which is mid-way between drop-out and pull-in levels (b). A second magnet increases the field sufficiently to produce pull-in, which is maintained after the second magnet is removed

(c). A bar magnet causing the switch to pull-in

(d). The second magnet, having opposite polarity, produces drop-out

(e). In this arrangement the right-hand magnet produces pull-in, drop-out and pull-in successively as it approaches the dry reed switch

Your Local Supplier

LONDON

Established 1910

H. L. SMITH & CO. LTD.

Comprehensive stocks of components by all leading makers

287-9 EDGWARE ROAD LONDON W.2

Tel: 01-723 5891

THE MODERN BOOK CO.

Largest selection of English & American radio and technical books in the country.

19-21 PRAED STREET, LONDON, W2 1NP

Tel: 01-723 4185/2926

ST. HELEN'S RADIO

Hi-Fi Equipment
Tape Recorders
Radio Receivers
Television

SPECIALISTS IN RADIO & ELECTRONIC TEXTBOOKS

ST. HELENS GARDENS LONDON, W.10

Tel: 01-969 3657

NEW

15 watt Hi-Fi AMPLIFIERS
£3.75 each plus 25p postage & packing

7 TRANSISTORS - GUARANTEED PRINTED CIRCUIT - TESTED DESIGN BUILT - INSTRUCTIONS

A great new 15 watt Hi-Fi amplifier is now available at the low cost of £3.75. Just look at the specification—Power 15 Watts R.M.S., frequency response 15-19000 c/s. Signal to noise ratio better than 70 db. Harmonic distortion 0.1%. Input sensitivity 750 mv into 2k. These make the H. Electronics Hi-Fi amplifier the best at its price—order now.

H-ELECTRONICS.

105, Grange Road, London S.E.25

Your Local Supplier

HAMPSHIRE

BOURNEMOUTH

LARGEST HI-FI AND
RADIO COMPONENT
STORE IN THE SOUTH

FORRESTER'S NATIONAL
RADIO SUPPLIES LTD.

70-72 Holdenhurst Road
Bournemouth
Telephone 25232

NOTTINGHAM

ARE YOU LOST FOR THAT VITAL SCREW?

0-8 BA screws, nuts & washers in
Brass.

Copper, brass & aluminium sheet
cut to your requirements.

Electric soldering irons & bits.

S.A.E. List.

Callers to our trade counter
welcome.

Hours 8.30-5.00 Mon-Fri.

8.30-12.00 Sat.

The D.G. Engineering Co. Ltd.,
Kirkby Folly Road, Junction Mills,
Sutton-in-Ashfield, Notts.
Telephone Sutton-in-Ashfield 5785

SURREY

WITWORTH TRANSFORMERS TV Line out-put transformers

Manufacturers of the largest range in the
country. All makes supplied.

Free catalogue.

Modern

BAIRD, BUSH, GEC, PHILIPS

Replacement types ex-stock.

For "By-return" service, contact London
01-948 3702

Tidman Mail Order Ltd., Dept. R.C.
236 Sandycombe Road,
Richmond, Surrey TW9 2EQ

Valves, Tubes, Condensers, Resistors,
Rectifiers and Frame out-put Transformers,
Mains Transformers also stocked.

Callers welcome.

SUSSEX

E. JEFFRIES

For your new television set
tape recorder, transistor radio
and hi-fi equipment

PHILIPS, ULTRA, INVICTA
DANSETTE, MASTERADIO, PERDIO,
MARCONI, PHILCO FIDELITY

6A Albert Parade
Victoria Drive,
EASTBOURNE SUSSEX

strength from the first magnet is above the drop-out level. In other words you have a latching action. Once the dry reed switch is closed it stays closed."

"Blimey, that's neat," exclaimed Dick, impressed. "Are there any other tricks like that using magnets?"

"Here's another one," said Smithy, taking up his pen once more. (Fig. 4 (c).) "Once again we have a magnet permanently alongside the switch, which is also of the normally-open type. In this case, however, the magnet is sufficiently close to the switch to produce pull-in, and so the switch is closed. This is an example of a Form A switch being changed, or biased, to Form B operation by means of a magnet. I'll now add a second magnet, with opposite polarity, and bring it up to the switch."

Smithy drew in the second magnet. (Fig. 4(d).)

"This second magnet," he continued, "produces an opposing field with the result that, as it approaches the switch, the field strength around the latter reduces until it reaches drop-out level. The switch then opens. It closes again after the second magnet is removed."

"That's a crafty one," remarked Dick. "Simply by providing the first magnet, you get the switch to give a function that's exactly opposite to its usual one."

"True," agreed Smithy. "Now I'll show you a further example of what you can do with magnets. Let's suppose

that the first magnet is strong enough to provide a pull-in field when it is situated some distance away from the switch. If we now bring the second magnet up to the switch, the latter will drop out, as before. Should we *continue* to bring the second magnet up to the switch the field strength it applies will become greater than that offered by the first magnet by the pull-in value, and the switch will eventually become closed again."

Smithy drew out this latest set of operating conditions. (Fig. 4(e).)

"Well," said Dick, "you can certainly get these dry reed switches to carry out some interesting functions with magnets."

OPERATION WITH COILS

"These magnet set-ups," said Smithy, "have quite a few useful practical applications. They are also helpful in introducing the same modes of operation using energising coils."

Smithy drew out a further diagram. (Fig. 5(a).)

"It is possible," he said, "to fit two separate coils over a dry reed switch. For best results the two windings should both cover the length of the dry reed switch capsule, and they could be interwound or wound in successive layers on the coil bobbin. Let's call them winding A and winding B, and say that a current in one produces the same field strength as does the same current in the other. Can you think of

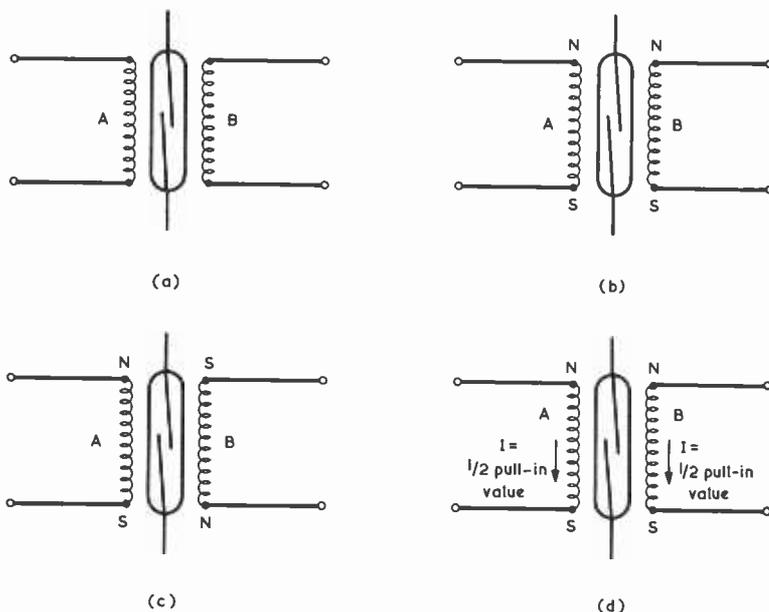

Fig. 5 (a). A dry reed switch may be inserted inside two windings. For clarity, the windings are shown here on either side of the switch (b). The coils and dry reed switch provide an OR function (c). This arrangement constitutes an exclusive-OR gate (d). A combination which functions as an AND gate

anything we could do with these two windings?"

Dick stared at the drawing and scratched his head.

"Why, of course," he said, suddenly struck by inspiration. "we can do exactly the same things with these coils as we did with the two magnets. For instance, we could reproduce the latching operation by passing a current through winding A which is just midway between the drop-out and pull-in levels. If we pass a current through winding B in the same direction, so that its field strength adds to that given by winding A, we will be able to pass over the pull-in level and close the switch. The switch will then stay closed even after we remove the current in winding B. Another thing we can do is to set up a current above pull-in level in winding A and a gradually increasing current flowing in the opposite direction in winding B. This would give the same result as we got with the two magnets of opposite polarity. As the current in winding B increases, we will reach a stage where its field cancels out that due to winding A, and the switch will open."

"And," prompted Smithy gently, "if you continue to increase the current in winding B?"

"Let me see now," said Dick, frowning. "Oh yes, I see what you're driving at. As the current in winding B increases further, its field strength becomes greater than that due to winding A and the difference will be equal to pull-in level again. So the switch will close once more. It's the same as we had in the last example with the magnets."

"Exactly," confirmed Smithy. "The two windings also enable us to set up simple logic gates. I'll add some magnetic polarity letters to the two coils to indicate the polarity of the fields they produce."

Smithy added the letters to his diagram. (Fig. 5(b).)

"Now," he said, "the currents applied to both windings here are in the same direction and are above pull-in level. The switch will close if the current is present in winding A, if it is present in winding B or if it is present in both together."

"Stap me," exclaimed Dick, "that's the same result as you get with an OR gate. The switch is closed for current in winding A or in B or in both."

"Good," commended Smithy, busy once more with his pen. (Fig. 5(c).) "Now, here's another one, in which the current in winding B flows in the opposite direction to that in winding A. Both currents are equal and both are above pull-in level. What happens here?"

"Let me see now," said Dick, looking closely at Smithy's diagram. "The switch will close for current in winding A and for current in winding B. But if there's current in both windings their fields will cancel out and the switch will then open."

"That's right," stated Smithy. "This

time you have an exclusive-OR gate. The switch closes for current in winding A, or for current in winding B, but not for current in both together. Finally, I'll show you an AND gate."

Smithy drew a further diagram. (Fig. 5(d).)

"In this case," he said, "the same current flows in the same direction in both windings and is equal to a half of pull-in value. Now, the switch will not close for current in winding A or for current in winding B, but it will close for current in winding A *and* current in winding B. This gives you an AND gate."

"There seems," remarked Dick, thoughtfully, "to be a bit of a snag here."

"How come?"

"The pull-in bit at the start is okay," said Dick, "but what about drop-out after pull-in has taken place? To act as a proper AND gate the switch should open again if the current is removed from either winding A or winding B. But you said earlier that the drop-out current for most dry reed switches is usually about half the pull-in value. There's a risk therefore that, after it has closed, the switch in the AND gate will remain closed if the current is removed from one winding only."

"That's perfectly right," agreed Smithy, "and you've put your finger on a weakness of this circuit. You need to keep operating conditions controlled pretty tightly if you want reliable drop-out working, and you have to employ a switch whose drop-out level is only a little lower than the pull-in level. The AND gate circuit is by no means as positive in its action as are the two OR gates."

CONTACT BOUNCE

"That last gate reminds me of something," remarked Dick. "Does it matter very much if the current flowing in the coil of a dry reed relay is considerably larger than the pull-in value?"

"It does, rather," replied Smithy. "An almost unavoidable effect with dry reed switches is that you get contact bounce after closure. The contacts tend to open again several times for tiny periods very shortly after they meet. Under proper operating conditions this contact bounce takes place within the first millisecond or so after closure. It doesn't matter very much in most of the circuits in which dry reed relays are used, but it is obviously undesirable to have too much of it because of the resultant contact wear. Contact bounce is normally at its minimum when the energising current in the coil is kept at or below twice the pull-in value for the switch."

A thought occurred to Dick.

"There's another thing," he said. "Why *are* they called dry reed switches? Why is the word 'dry' used?"

"Funnily enough," said Smithy,

Your Local Supplier

YORKSHIRE

PERFECT SPEAKERS Ex TV.
P.M. 3 Ohm (Minimum order 2)
5in. Round or 8in. x 2½in. 12½p each
Add 7½p per speaker p. & pkg.

100 SPEAKERS for £15 delivered
200 SPEAKERS for £25 delivered

UHF TUNERS Ex TV.
(COMPLETE WITH VALVES)
£2.50 each plus 50p p. & pkg.
or 10 for £23 post free

TRADE DISPOSALS (Dept. RC)
Thornbury Roundabout, Leeds Road,
Bradford Telephone: 665670

EIRE

PEATS for PARTS

ELECTRONIC COMPONENTS
RADIO & TELEVISION

*For the convenience of Irish
enthusiasts we supply*

The Radio Constructor
Data Books and
Panel-Signs Transfers

Also a postal service

Wm. B. PEAT & Co. Ltd.
28 PARNELL STREET
DUBLIN 1

The
RADIO CONSTRUCTOR

**ANNUAL
SUBSCRIPTIONS
to this magazine
may be obtained
through your
newsagent
or direct from the
publishers
ONLY £2.70
per year, post free**

*Please send remittance with name
and address and commencing issue
required to:*

DATA PUBLICATIONS LTD
57 Maida Vale London W9 1SN

“that word ‘dry’ applies to two features of the switch. It applies because the dry reed switch can be reliably employed in dry circuits, and also because it differentiates it from the mercury-wetted version of the switch.”

Dick sighed.

“Why,” he asked mournfully, “don’t I keep my big mouth shut? I should have *known* that the answer would be far more baffling than the question! All right then, Smithy, let’s start off with the dry circuit bit. What’s a dry circuit?”

“It’s a switching circuit in which negligible current flows when the switching contacts close,” explained Smithy. “You sometimes have an ordinary relay, in say a telephone exchange, the contacts of which only pass a low level audio signal. If those contacts are caused to close only very occasionally, they are liable to become slightly oxidised and offer a high resistance path. A ‘wetting voltage’ is sometimes applied to circuits of this nature to overcome this problem. The wetting voltage is a direct voltage applied in series with the source of audio frequency and it breaks down the oxide film when the switching contacts close and allows them to offer a low resistance path to the audio signal. With a dry reed switch, whose contacts cannot oxidise, you don’t need a wetting voltage.”

“Oh, I see,” said Dick brightly. “Well, that’s the dry circuit part explained. Next, what’s a mercury-wetted reed switch?”

“It’s one,” replied Smithy. “which is mounted vertically, and has a small reservoir of mercury inside the capsule at its base. Apart from this it looks much the same as the dry reed type. The mercury creeps up the lower contact reed by capillary action, with the result that it is present at the junction of the two reeds. When these open on drop-out the current they switch is carried by a little bead of mercury between the contact faces until the distance between the two contacts is too great to enable the mercury to stay in position, whereupon it breaks the circuit. The result is that break current stresses are kept away from the contact surfaces themselves and the switch is capable of controlling relatively high values of current without excessive contact wear. This type of switch doesn’t suffer from contact bounce. In the changeover form, the long moving reed is the one in contact with the mercury reservoir, and it can be made to give the Form D operation I mentioned earlier.”

“Dash it all,” complained Dick. “That Form D business was the thing I was going to ask you about! All that’s left now is the electric bell gadget you were playing around with at the beginning and which started all this lot off!”

“That’s easy,” replied Smithy cheerfully.

He tore a further sheet from his pad and drew out a circuit. (Fig. 6.)

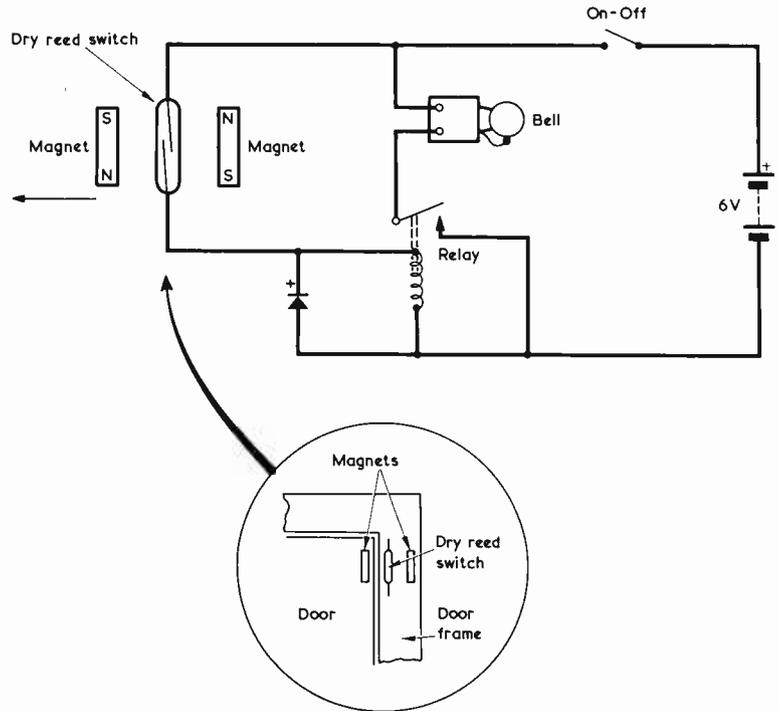

Fig. 6. The door warning circuit devised by Smithy. The relay may be any small type suitable for operation at 6 volts whose coil does not draw a current in excess of the dry reed switch rating. The diode can be any germanium or silicon type. All components, apart from the dry reed switch and magnets, are mounted near the bell, being coupled to the reed switch by twin flex

“All there is here,” he said, “is a normally-open dry reed switch mounted on the door frame with a magnet alongside it. Another magnet with opposing polarity is mounted on the door itself so that, when it is shut, the fields of the two magnets cancel out and the reed switch is open. When the door is opened the reed switch is subjected to the field from a single magnet only and it closes, thereby actuating a standard relay which in turn rings the bell. We’ve already discussed the manner in which these two magnets operate the switch. When you saw me raising and lowering my hand, I had the dry reed switch and one of the magnets lying on the bench and I was raising and lowering the other magnet to check the operation of the circuit.”

A MEASURE OF DISTRUST

“Why,” asked Dick. “did you include the ordinary relay? Couldn’t the dry reed switch operate the bell directly?”

“A high current type could, probably,” said Smithy. “although you have to be a bit careful with circuits

containing electric bells as they sometimes draw surprisingly heavy currents and produce surprisingly high back-e.m.f. voltages. But the reed switch I happen to have is a low current type anyway, and so I put the bell circuit on to the contacts of an ordinary relay. The diode across its coil is merely to keep high back-e.m.f. voltages off the reed switch when the latter opens.”

“You seem to have thought of pretty well everything there,” commented Dick. “Nobody could accuse you of being incautious, Smithy.”

“I believe in covering all the eventualities I can think of,” grinned Smithy. “Besides, I know those characters in that shop of ours, and another reason for using that ordinary relay is that they wouldn’t be above adding a few extra bells to this gadget after my back was turned. I wouldn’t want to subject a dry reed switch to unexpected additional loads such as that.”

And with this statement, reprehensible in its lack of trust in his fellow-men but at least demonstrating a knowledge of human frailty equal to that of electronic short-comings, Smithy brought the discussion to a close. ■

Radio Topics

By Recorder

SO FAR AS I CAN RECALL, MY FIRST introduction to the use of acronyms occurred near the end of World War II when, in the R.A.F., I encountered the word RADAR (made up from Radio Detection And Ranging) which was then superseding the earlier 'radiolocation'.

In passing it may be mentioned that, some time after the war, the practice arose in the R.A.F. of calling the Station Warrant Officer the 'SWO-man', frequently preceded by the adjective 'abominable'. Such was the power of the W.R.A.F. in those far-off pre-Women's Lib. days that in one camp we even had a woman SWO-man.

MODERN USAGE

Nowadays these abbreviations are part of the daily scene, this being particularly the case in the higher echelons of electronics, and I'm beginning to think it's about time that those of us who work at the servicing bench or who carry out amateur construction at home had a Belated Attempt at Similar Hyperbole.

Most of us are familiar with the instance where a screen-grid or anode capacitor breaks down to chassis and results in cooking-up of the resistors in the h.t. supply circuit to that screen-grid or anode. What better description for this state of affairs can be given than Overheating Valve Electrode Network, or OVEN? At the same time, those infuriating faults which appear only on occasion richly deserve the description of the consequent Time Wasting Intermittent Tests, or TWIT. And does not the acronym BOMB adequately cover the Beginning Of Multiple Breakdown?

Personalities also lend themselves to these condensations. Very often the Fastidious, Lively, Interested Person (FLIP) is balanced out by his counterpart who exhibits Fundamental Lack Of Potential (FLOP). Also, those pop groups with their multi-kilowatt amplifiers must certainly dub as FAB the Fully Amplified Bass they produce. (Even if the subsequent overloading of their ear-drums might necessitate an early visit to the First-Aid Box).

But that's enough of acronyms for now, and we must turn our attention to more serious matters. Such as, for instance, future electronic possibilities, as typified by the Galvanic Radioactive Atomic Battery. And how does that GRAB you, my friends?

METRICATION

As is reflected by the latest Constructor's Data Sheets which are appearing in this journal, metrication in the U.K. is proceeding at a greater speed than some of us realise. In the last two R.S. Components catalogues, for instance, nearly all component dimensions are given in millimetres instead of in inches. As most of you will already know, 'R.S. Components' is, of course, the new name for Radiospares.

Fortunately, the introduction of millimetres does not raise many problems in the home-constructor field, and it is possible for us to work with millimetres or inches with equal ease. An interesting fact is that one very large English firm, Mullard Limited, have been using millimetres for the dimensional specifications of their products for as long as I or anyone else can remember. British set-makers have been able, over the years, to fit Mullard components and valves into their otherwise inch-oriented systems without any trouble at all.

One point to watch out for when dealing with European drawings which are dimensioned in millimetres is that it is the Continental practice to denote a decimal point by means of a comma instead of by the full-stop that we use. This could cause some ambiguities because we have the habit of alternatively using the comma to separate the digits of a number in groups of three. Thus, to us the number 15,672 means fifteen thousand, six hundred and seventy-two. With the Continental approach that number means fifteen point six seven two. Quite a difference, as you will agree.

There are other factors in which Continental usage differs from ours, these appearing particularly in circuit diagrams. For instance, Continental circuit diagrams tend to express capacitance in units of nanofarads much more frequently than we do in the U.K. A nanofarad is equal to 1,000 picofarads or to one thousandth of a microfarad, and it has the abbreviation 'nF'. In a badly reproduced Continental circuit diagram an English person could mistakenly assume that units shown as 'nF' were actually 'mF' or microfarads; so this is another little point to look out for. Incidentally, the use of 'mF' instead of 'µF' to depict 'microfarad' is very bad practice but, regrettably, one encounters it every

now and again.

Of the other discrepancies between the Continental approach in circuit diagrams and our own, the most common is the use of rectangles instead of 'wiggly lines' for resistors, and the use of small black circles to represent valve cathodes. These, however, are minor matters which those of us who have mastered 'la plume de ma tante' can take in our stride.

RESISTOR CHOKE FORMERS

It is a common practice to employ wire-ended carbon composition resistors as formers for home-wound r.f. chokes. Resistors of this nature offer a very convenient body on which such chokes can be wound, since they offer two lead-outs to which the choke terminations may be soldered. There are, however, one or two requirements which have to be satisfied if chokes wound in this manner are to perform satisfactorily in practice.

The first point to bear in mind is that the resistor is, obviously, connected in parallel with the choke. The resistor must in consequence have a high value, preferably at least 470k Ω. In some circuits it is required to have a choke with a fairly low value of resistance connected across it. In this instance the low value of resistance can be provided by the resistor on which the choke is wound.

Secondly, it is preferable that the resistor consist of a resistive carbon

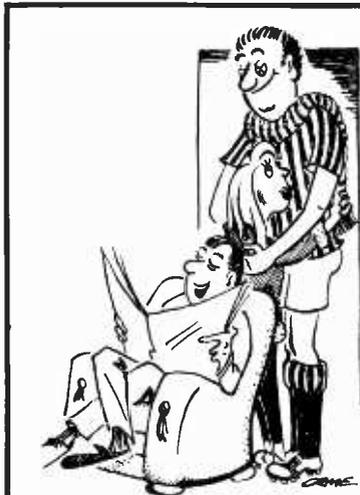

"Did you get that new long player you went out for, then?"

composition rod inserted inside an insulating ceramic or phenolic tubular housing. This is because the insulating housing provides physical spacing between the inside of the choke winding and the carbon of the resistor. Resistors with ceramic outside tubes can be identified without any difficulty because the tube is white in colour. Phenolic surrounds are brown and are not so readily identifiable. If you can afford to lose a resistor, take another resistor of the same type as that you intend to use as a former, and cut it in half by means of a pair of side-cutters. Should the resistor have a phenolic outside covering this can be seen by looking at its cut inside ends. Usually, it is easier to tell when a resistor does *not* have an outside tubular housing since the construction then consists of an obviously enamelled carbon composition rod. If the resistor you intend to use has wire ends going to the centre at each end and has a smooth unenamelled body of constant diameter, then it's pretty safe to assume an insulated housing.

A third and final point is to avoid using resistors having a tolerance of 5% or less. This may sound mildly crazy, but there is a very good reason for such advice. It has been a common practice in the past, when making a

batch of close tolerance resistors at the factory, to sometimes apply a 'copper spray' over the centre of a carbon composition rod having a resistance a little higher than the range required. This enables the batch to be made up with the aid of resistors which are slightly above the tolerance value. The copper spray forms a complete ring around the surface of the composition rod and reduces its resistance sufficiently to bring it within the close tolerance range required. At the same time, so far as would-be winders of r.f. chokes on resistors are concerned, it also forms a very effective shorted-turn! A choke wound on a ring of copper spray would not present the requisite value of inductance, and you can avoid the risk of accidentally choosing a resistor which has had the copper spray treatment by only employing components with a tolerance of 10% or more.

LABORATORY HANDBOOK

I must next record the fact that the eighth edition of M. G. Scroggie's *Radio and Electronic Laboratory Handbook* (Hiffe Books, £4.75) has now been published. This book will be reviewed elsewhere in this journal but I do feel

that a special mention is justified in these columns for what, over the last thirty years, has become one of the standard works in electronics. This eighth edition has been completely revised and reset, and it uses S.I. units throughout.

One of its greatest values is its complete practicability, and it even pays attention to the occasional desirability of checking out circuits by the 'bird's nest' approach, in which a few components are quickly soldered together without visible means of support. This informal technique, says Mr. Scroggie, 'sometimes saves time' but 'it should not be allowed to become a habit'. There are few of us who, when suddenly seized with an idea which involves up to half-a-dozen small components, have not in our eagerness at some time made a quick 'lash-up' to see if the scheme was workable, after which we wired up the components in a more durable and respectable manner later on.

But *Radio and Electronic Laboratory Handbook* goes far deeper into the science of electronics than this. It is a virtually indispensable reference work for anyone who is seriously interested in the art, and my copy now takes pride of place on my bookshelves. ■

?? HALF-A-DOZEN PUZZLERS ??

By

P. MANNERS

Here are the answers to the problems given on page 539

1. All the engineer had to do was to stick the two halves of the rod together with a good cold-setting adhesive! This is quite a permissible repair for ferrite aerial rods and was recommended by Mullard some years ago. The two broken parts should nest against each other accurately, and there should be a minimum of adhesive in the gap. A slight repositioning of the coils along the rod to obtain correct tracking may be needed after the adhesive has set.

2. The Professor's circuit is nothing other than a standard bridge rectifier.

3. The officer put the tape through the recorder the wrong way round, with the result that the message was reproduced in reverse and asymmetric Morse characters appeared as different letters. Thus, L (.-..) was reproduced as F (.-.-) and so on. With the tape played in the correct direction the message is: 'WE ARE ONLY HERE FOR THE BEER'.

4. In the equations, $x - 10$ and $y - 50$. (10 C is equal to 50 F, and 10 shillings is equal to 50 new pence).

5. Undoubtedly. Present-day Litz wire uses 'solder-through' enamel on the individual strands and there is no need to scrape this off. It is merely necessary to apply a hot soldering iron and resin-cored solder, whereupon all the strands become at once soldered together!



The appearance of a Moebius band or loop

6. Maximum programme length will be given by using tape with a magnetic coating on both sides and sticking it together to form a Moebius band, an example of which is shown in the diagram. A Moebius band differs from an ordinary band (such as is exemplified by a flat elastic band) insofar that one end of the tape is twisted through 180° before the ends are joined together. If a loop of this nature were drawn past the playback head the programme will be carried successively by the magnetic coatings on the alternate sides of the original tape and will be equivalent in length to that given by a normal tape loop 200 ft. long. A Moebius loop or band, it may be added, is a subject of topological interest since it has only one surface and only one edge. Also, Moebius loop tape playback systems have been promoted commercially.

COMPONENT FACTORS DEPT. RC P.O. BOX No. 18, LUTON, BEDS. LU1 1SU

ALL GOODS BRAND NEW AND GUARANTEED BARGAIN PRICES DELIVERY BY RETURN

<p>DIODES IDEAL FOR BATTERY CHARGER, ETC. 100V 20A 50p</p> <p>SEND US YOUR PARTS LIST FOR A FREE QUOTATION. WE HAVE THOUSANDS OF COMPONENTS NOT LISTED INCLUDING THE FOLLOWING CAPACITORS: SILVER MICA, POLYESTER, POLYCARBONATE AND TANTALUM. ALL AT LOW PRICES.</p> <p>SPECIAL RESISTOR OFFER Due to the enormous response to our last offer, here is another bargain 250 for £1. E24 series 4.7Ω - 10MΩ 1W & 1/2W. 5% & 10% mixed. Your selection but subject to a maximum of 20 different values and no more than 50 of any one value. If any one value is out of stock the nearest will be sent. Note: no quantity discount allowed.</p> <p>Strong rubber strap 18 x 1 x 1/4 inches. Ideal for cam handles, etc. 10p.</p>	<p>TRANSISTORS</p> <p>2N 706 10p 2N 708 10p 2N 709 25p 2N 1671B (UJ) 80p 2N 1303 10p 2N 2904 25p 2N 3820 (FET) 50p 2N 3866 80p BC 108 10p BCY 30 20p BCY 70 10p BFY 51 10p BFX 87 15p BSX 21 12p BSX 80 50p C 111 30p C 407 20p C 426 12p E 100 (FET) 50p ME 1120 10p P346A 8p V 405A 10p TIS 69 30p BFY 96 40p</p>	<p>INTEGRATED CIRCUITS</p> <p>MC 790P 80p MC 849P 35p MC 1027P £2.00 SN 7400N 15p SN 7410N 15p SN 7410N 15p FJH 121 15p SN 7430N 15p SN 7440N 25p SN 7470N 30p SN 7493N 80p FJH 111 12p FJH 131 20p FJH 151 12p FJH 221 20p FJL 121 30p 958 Decade £1.75 UL914 30p IC12 £2.80 including free PCB.</p>	<p>HUNTS M.E.F. RANGE</p> <p>16 MFD 350V 10p 100 MFD 50V 10p 500 MFD 50V 12p 1000 MFD 12V 12p 2500 MFD 6V 10p 2500 MFD 12V 12p</p> <p>Transistor Equivalents Book 40p</p> <p>Panel Mains Neon 15p</p> <p>Miniature Ceramic (Lemco All 750V) ± 10% 5PF, 10PF, 20PF, 25PF, 40PF, 75PF, 100PF, 120PF, 220PF. Price: 2p each or 10 for 20p (same value)</p>	<p>TUNNEL DIODES</p> <p>1N 3717 £1.00 TD 715 50p TD 716 40p TD 717 50p</p> <p>EA1000 AMPLIFIER MODULE Complete with handbook £2.80</p> <p>ZENER DIODES</p> <p>3V3 BZY 88C 10p 3V9 BZY 88C 10p 4V3 BZY 88C 10p 5V1 MZ5 1T5 10p 5V6 1N752A 15p 6V8 BZY 96C 15p 7V5 BZY 96C 15p 10V KS42 10p 13V BZY 94C 15p 20V BZX 22 12p 24V BZY 88C 12p 39V 1N 5259 15p</p>	<p>CERAMIC</p> <p>1PF 500V 2p 270PF 50V 2p 0.0047 30V Disc 2p 0.01 30V .. 3p 0.01 350V .. 2p 0.022 30V .. 2p 0.047 30V .. 2p 0.1 Disc 100V 3p 0.1µF 25V Disc 3p</p> <p>ELECTROLYTIC</p> <p>6.4MFD 25V 4p 64MFD 64V 5p 75MFD 25V 5p 220MFD 40V 10p 100MFD 6V 5p 1000MFD 25V 25p 1000MFD 50V 35p</p> <p>Miscellaneous</p> <p>P.V.C. Wire 50p 14,0076 100 yd Or 1p per yard. Miniature R.F. chokes 0.22, 1, 1.5, 2.2, 12, 15, 22 µH 8p each Neon lamp A230. 5 for 20p 1W 5% carbon film resistors 101-1M E12. 1p Each or 10-25 0.8p 26-50 0.6p</p>	<p>Phono Plug 10p Phono Socket 5p Mains Transformer 32-0-32 at 150mA 50p Mains Transformer 150V at 20mA 8V at 650mA 75p 3 Black Knob with Silver Disc 1 in hole 5p</p> <p>Miniature 1W Carbon pots 500Ω, 1K, 2K5, 5K, 10K, 100K. 25p</p> <p>DIODES</p> <p>1N914 6p HSD1395 1p OAS 20p OA47 5p 1N5054 10p 1N4009 2p OA202 equiv. 5p 100V 1A Bridge 50p</p>
---	--	--	--	--	--	--

TERMS: CASH OR CHEQUE WITH ORDER. POST AND PACKING FREE ON ORDERS ABOVE £5. FOR SMALLER ORDERS PLEASE ADD 10p. DISCOUNT: ORDERS ABOVE £10—10%, ABOVE £20—15%. ALL GOODS ADVERTISED ARE TOP GRADE PROFESSIONAL COMPONENTS AND SUBJECT TO A MONEY REFUND GUARANTEE IF NOT SATISFIED. WE HAVE MANY COMPONENTS NOT ADVERTISED. AND ENQUIRIES ARE WELCOME. BUT MUST ENCLOSE AN S.A.E. FOR REPLY. PRICES LIST 5p. DATA SHEETS 5p. TRADE ENQUIRIES WELCOME.

HANDIPAK

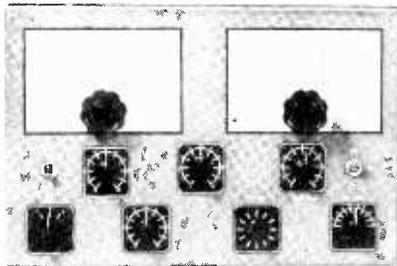

- Easy to fix
- Permanent and durable
- Stapled in booklet form
- Designed to hang above workbench
- Pocket for loose cuttings
- Professional finish

The Perfect Transfer for the Home Constructor

Each Set contains Six Sheets

PANEL SIGNS IDEAL FOR WORKSHOP USE

- ★ SET 3 – Wording – WHITE
- ★ SET 4 – Wording – BLACK (Over 1,000 in each set)
- Illustration of actual size = RADIO
- ★ SET 5 – DIALS (control panels have clear background)
- ★ SET 6 – DIALS (control panels have black background)

Frequency Lists in kHz and MHz.

25p per set
(postage 3p)

To: Data Publications Limited, 57 Maida Vale, London. W9 1SN.

Please supply PS3....., PS4....., PS5....., PS6.....

I enclose cheque/crossed postal order for.....

NAME.....

ADDRESS.....

(BLOCK LETTERS PLEASE)

Build your own Hi Fi at low cost!

THE TEXAN... easy-to-build true Hi Fi. Beautiful appearance and performance... specially designed by Richard Mann of Texas Instruments.

All the features you could want — 20W r.m.s. per channel — less than 0.1 per cent distortion at 1kHz — scratch and rumble filters — and much, much more.

Six i.c.'s take care of earlier stages... printed circuit board, metalwork and low-field mains transformer specially laid on for Practical Wireless readers.

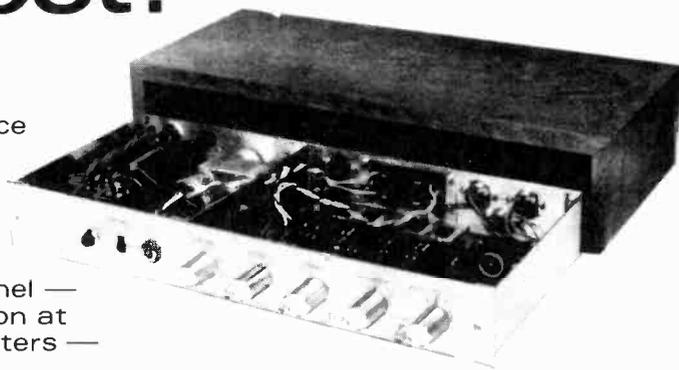

also EXTRA in this issue **Special 8-page supplement of semiconductor data**

Untangles the jungle of transistors now available. Gives the important specs for all common currently available devices for working out your own requirements and equivalents.

Plus many other constructional articles and all the regular features.

Make sure you don't miss the May issue of

**PRACTICAL
WIRELESS**

On Sale
April 7 20p

SMALL ADVERTISEMENTS

Rate: 4p (9d) per word. Minimum charge 60p (12/-).
Box No. 10p (2/-) extra.

Advertisements must be prepaid and all copy must be received by the 4th of the month for insertion in the following month's issue. The Publishers cannot be held liable in any way for printing errors or omissions, nor can they accept responsibility for the *bona fides* of advertisers. (Replies to Box Numbers should be addressed to: Box No. —, *The Radio Constructor*, 57 Maida Vale, London, W9 1SN)

BUILD IT in a **DEWBOX** robust quality plastic cabinet 2 in. x 2½ in. x any length. S.A.E. for details. D.E.W. Ltd., 254 Ringwood Road, Ferndown, Dorset. Write now - right now.

NEW CATALOGUE NO. 18, containing credit vouchers value 50p, now available. Manufacturers new and surplus electronic and mechanical components, price 23p post free. Arthur Sallis Radio Control Ltd., 28 Gardner Street, Brighton, Sussex.

FOR SALE: Creed Teletax transceiver type TR 105, £15. Ex-R.A.F. tuning fork drive unit type 114, £12. Box No. G167.

RECORD TV SOUND using our loudspeaker isolating transformer. Provides safe connection to recorder. Instructions included. £1 post free. Crowborough Electronics (R.C.), Eridge Road, Crowborough. Sussex.

SERVICE SHEETS (1925-1971) for Televisions, Radios, Transistors, Tape Recorders, Record Players, etc., by return post, with free Fault-Finding Guide. Prices from 5p. Over 8,000 models available. Catalogue 13p. Please send S.A.E. with all orders/enquiries. Hamilton Radio, 54 London Road, Bexhill, Sussex. Telephone: Bexhill 7097.

"GOVERNMENT SURPLUS WIRELESS EQUIPMENT HANDBOOK." Contains circuits, data, illustrations, components lists for British/U.S.A. receivers, transmitters, trans/receivers; includes modifications to sets and test equipment. Surplus/commercial cross-referenced transistor and valve guide. A gold mine of valuable information. Price £2.84. P. & P. 20p. Myers, (R), 112 Stainburn Crescent, Leeds 17, Yorks.

WANTED: 9.5mm cine equipment. Cameras, projectors, editors, splicers, film reels, etc. Details to: Box No. G169.

1972 CATALOGUE 20p post free with Colour T.V. I.C.'s. Illustrated with many bargains, i.e. A.M. Coil set with ferrite aerial £1, p. & p. 6p, AD161/62 pair 60p, SL403D £1.50, MFC4000 52p, Carbon Track pots lin or log 12p + sw. 24p. Mailing Dept., Chromasonic Electronics, 56 Fortis Green Road, London, N10 3HN.

FOR SALE: Electronic Devices (Cheltenham) Ltd. electric "bug" morse key. £10. Box No. G170.

"WORLD RADIO TV HANDBOOK" £2.80; Fortnightly updating bulletin available, SAE/IRC sample. "How to Listen To The World" £1.37. "SWL Address Book", stations, QSL policies, etc., £1.37. Frequency Lists, operating guides, 3p/IRC for price list (Mail only). Under £2, carriage 10p. Prices subject to change. D. McGarva, 16 Chambers Street, Edinburgh EH1 1HS.

(Continued on page 573)

BENTLEY ACOUSTIC CORPORATION LTD.

38 Chalcot Road, Chalk Farm
LONDON, N.W.1.
01-722-9090

The Old Police Station
Gloucester Road
LITTLEHAMPTON Sussex
PHONE 6743

Please forward all mail orders to Littlehampton

0A2 .30	30F5 .65	ECC81 .16	EY87/6 .30	PY33/2 .50	AC156 .20
0B2 .30	30FL1 .60	ECC82 .19	EY88 .40	PY81 .24	AC157 .25
5Z4G .34	30FL2 .60	ECC83 .22	EZ40 .40	PY82 .24	AC165 .25
6J0L2 .55	30FL14 .68	ECC84 .28	EZ80 .21	PY83 .26	AD140 .36
6A0S .22	30L15 .58	EZ81 .52	EZ81 .52	PY88 .32	AD149 .50
6AT6 .18	30L17 .67	ECC86 .40	HVR2 .53	PY500 .95	AD161 .45
6AUV6 .20	30P19/4 .58	ECC88 .35	KTW61 .63	PY800 .33	AD162 .45
6BA6 .28	30P4MR .58	ECCF80 .27	KTW62 .63	PY801 .33	AF114 .25
6BA6 .20	30P4MR .95	ECCF82 .96	KTW63 .50	QQV03/	AF115 .15
6BE6 .21	30P12 .69	ECCF84 .64	PC86 .47	10	AF119 .23
6BH6 .43	30PL1 .59	ECH42 .60	PC88 .47	R19 .30	AF121 .30
6BJ6 .39	30PL13 .75	ECH81 .27	PC97 .36	U19 1.73	AF126 .18
6BR7 .79	30PL14 .65	ECH83 .39	PC900 .32	U25 .64	BC107 .13
6BW6 .72	30PL15 .87	ECH84 .34	PC834 .29	U26 .56	BC108 .13
6BW7 .54	35W4 .23	ECL80 .30	PC88 .41	U191 .58	BC113 .25
6BZ6 .31	35Z4 .24	FCL82 .30	PCC89 .45	U251 .65	BC118 .23
6C4 .28	35Z5 .30	ECL83 .52	PCC189 .48	U301 .40	BCZ11 .38
6CU5 .30	90C1 .59	ECL84 .54	PCF80 .28	U801 .93	BF159 .25
6F1 .59	DAF91 .20	ECL86 .35	PCF82 .30	UABC80	BF163 .20
6F18 .45	DAF96 .33	EF22 .63	PCF84 .40	30	BF180 .30
6F23 .68	DF91 .14	EF41 .58	PCF86 .44	UBC81 .40	BY100 .18
6F28 .60	DF96 .34	EF80 .22	PCF801 .29	UBF80 .30	BY126 .15
6HGGT .15	DK91 .26	EF82 .26	PCF82 .40	UBF89 .10	BY127 .18
6K7G .10	DK92 .35	EF86 .29	PCF806 .57	UC92 .35	OA81 .09
6K8G .16	DK96 .35	EF89 .23	PCL82 .32	UCC84 .33	OA91 .09
6U4GT .60	DL92 .25	EF91 .17	PCL83 .58	UCC85 .34	OA95 .09
6K4 .20	DL94 .32	EF92 .35	PCL84 .34	UCF80 .33	OC13 .38
7R7 .65	DL96 .35	EF183 .26	PCL805	UCH42 .60	OC24 .38
7Y4 .60	DY87/6 .24	EF184 .29	PCF86 .38	UCH81 .30	OC25 .38
9D7 .78	DY802 .35	EH90 .36	PCL86 .38	UCL82 .33	OC35 .32
10F1 .75	E88CC .60	EL34 .44	PD500 1.44	UCL83 .48	OC44 .10
10F18 .35	E80S .90	EL41 .53	PE84 .40	UCF80 .33	OC45 .11
12A6 .63	EABC80	EL42 .53	PFL200 .52	UF80 .35	OC46 .15
12AT6 .23	30	EL44 .22	PL33 .38	UF85 .34	OC70 .13
12AU6 .21	EAF42 .48	EL91 .23	PL36 .47	UF86 .63	OC71 .11
12AV6 .28	EB4 .20	EL95 .32	PL38 .90	UF89 .27	OC72 .11
12BA6 .30	EB91 .10	ELL80 .75	PL81 .44	UL41 .54	OC74 .23
12BE6 .30	EB41 .48	EM80 .38	PL82 .30	UL84 .31	OC75 .11
12BH7 .27	EB821 .29	EM81 .39	PL83 .32	UY41 .38	OC78 .15
12K3 .50	EBF80 .30	EM83 .75	PL84 .30	UY85 .25	OC78D .15
18AOS .24	EBF83 .38	EM84 .31	PLS04 .62	X41 .50	OC81 .11
20P4 .89	EBF89 .27	EM87 .35	PLS08 .90	AC113 .25	OC81D .11
30C15 .60	EC92 .34	EY51 .33	PLS09 .10	AC127 .17	OC82 .11
30C17 .77	ECC33	EY81 .35	PL802 .75	AC128 .20	OC83 .20
30C18 .60	1.50	EY83 .54	PX4 1.16	AC154 .25	OC84 .24

All goods are unused and boxed, and subject to the standard 90-day guarantee. Terms of business: Cash or cheque with order only. No C.O.D. orders accepted. Post/packing charge 3p per item subject to a minimum of 9p per order. Orders over £5 post free. All orders despatched same day by first class mail. Complete catalogue with conditions of sale 7p post paid. Any parcel insured against damage in transit for only 3p extra per order. Business hours 9 a.m.-5.30 p.m. Sats. 9 a.m.-1 p.m. Littlehampton closed Sats. No enquiries answered unless S.A.E. enclosed for reply.

COMPONENTS

HOBBYIST - AMATEUR - DOMESTIC
SURPLUS INDUSTRIAL - BULK OFFERS
SELECTED PACKS 50p plus 10p Post/Pack

- 6 20 x G.E.C. 5% 350 volt 0.1mfd.
- 7 6 x 13 amp. 3 way rotary switch, small.
- 8 4 x 100mfd. 200 volt, can.
- 9 6 x B9a plugs, fully enclosed.
- 10 25 x 3, 300pf. tubular ceramic.
- 11 15 x sprung, valve retainer clips.
- 12 5 x 300 ohm wirewound pot.
- 13 12 x 150 ohm wirewound slider.
- 14 5 x 1k 4 watt wirewound pot.
- 15 30 x 2½" x 4½" x ½" paxoline.
- 16 5 x 20k wirewound pot.
- 17 4 x 5k log. volume control.
- 18 Die cast ally. box, 4½" x 3½" x 2½".
- 19 5 x 250 ohm wirewound pot.

* * * * *

Transducers as used in marine equipment, £2 each, post, etc. 15p. Hold one of these against a wall, plug into an amplifier, and hear what is going on, on the other side!

Locking key switch giving 2 ons 2 offs in either open or closed position, with 2 to 3 keys of quality make. As used in expensive alarm equipment, £1.50, post 10p.

Standard safety pins, 100 for 30p, post 10p.

THE RADIO SHACK MON-SAT 9AM-6PM
161 ST. JOHN'S HILL
BATTERSEA, S.W.11 01-223 5016

RADIO MODELLER



ELECTRONIC BOOKS



● MODEL RADIO CONTROL

Detailing both Theory and Practice, this book, by leading authority Paul Newell, will become the standard reference work. A brief historical survey leads up to a detailed description of proportional systems, with over 100 illustrations, including theoretical circuits and p.c. layouts for an advanced digital system.

134 pages. Price £2.25 U.K. Postage 13p

● SINGLET SET

The Singlet Transmitter. Superhet and Super-regen receivers, are now all three available in one book. Complete construction details with full size p.c. layout, components list etc. Ideal introduction to the hobby for the home constructor.

20 pages. Price 30p. U.K. Postage 3p

● LOW COST PROPORTIONAL

Modellers who want to save money buy this volume when converting single channel equipment to simple proportional. They find a wealth of really up to date information in the clear descriptions, full size practical and working drawings, plus over a dozen circuit modules for pulse proportional units

118 pages. Price £1.05 U.K. Postage 11p

ON SALE NOW at all leading shops or direct from:-

RADIO MODELLER, BOOK SALES, 64 Wellington Road, Hampton Hill, Middx.

DATA BOOK SERIES

- DB5 TV FAULT FINDING
124 pages. Price 50p, postage 6p.
- DB6 RADIO AMATEUR OPERATOR'S HANDBOOK
80 pages. Price 45p, postage 6p.
- DB16 RADIO CONTROL FOR MODELS
192 pages. Price 75p, postage 8p.
- DB17 UNDERSTANDING TELEVISION
512 pages. Price £2.10, postage 25p.
- DB18 AUDIO AMPLIFIERS
128 pages. Price 53p, postage 6p.
- DB19 SIMPLE SHORT WAVE RECEIVERS
140 pages. Price 80p, postage 6p.

I enclose Postal Order/Cheque for.....in payment for.....

NAME

ADDRESS

(BLOCK LETTERS PLEASE)

Postal Orders should be crossed and made payable to Data Publications Ltd.

Overseas customers please pay by International Money Order.

All publications are obtainable from your local bookseller.

Data Publications Ltd., 57 Maida Vale, London W9 1SN

SMALL ADVERTISEMENTS

(Continued from page 571)

JOIN THE INTERNATIONAL S.W. LEAGUE. Free services to members including Q.S.L. Bureau, Amateur and Broadcast Translation, Technical and Identification Dept. - both Broadcast and Fixed Stations, DX Certificates, contests and activities for the SWL and transmitting members. Monthly magazine, *Monitor*, containing articles of general interest to Broadcast and Amateur SWLs, Transmitter Section and League affairs, etc. League supplies such as badges, headed notepaper and envelopes, QSL cards, etc., are available at reasonable cost. Send for League particulars. Membership including monthly magazines, etc., £2.00 per annum. (U.K. and British Commonwealth), overseas 6 Dollars or £2.50. Secretary ISWL, 1 Grove Road, Lydney, Glos., GL15 5JE.

FOR SALE: Small stamp collection £5. Box No. G.171.

ARE YOU A MOTORING ENTHUSIAST? The Seven-Fifty Motor Club caters for all types of motor sport-racing, rallies, hill climbs, etc. Monthly Bulletin free to members. For full details write to: The General Secretary, Colin Peck, "Dancers' End", St. Winifred's Road, Biggin Hill, Kent.

FOR SALE: Raven radio control Tx & Rx. Multichannel recd. £25. S.A.E. for details. Box No. G172.

BEST QUALITY WIRE, P.V.C. Covering. 1/036" - 50m 60p; 100m £1.00. 23/0.19mm - 50m 80p; 100m £1.50. 37/006" silver plated copper - 50m £1.00; 100m £1.75. New P.O. 3,000 relays 1000Ω, 4 H.D. contacts - 35p. P. & P. 10p. per item. Poole Electronics, 68 Danecourt Road, Poole, Dorset.

POSTAL ADVERTISING? This is the Holborn Service. Mailing lists, addressing, enclosing, wrapping, facsimile letters, automatic typing, copy service, campaign planning, design and artwork, printing and stationery. Please ask for price list. - The Holborn Direct Mail Company, Capacity House, 2-6 Rothsay Street, Tower Bridge Road, London, S.E.1. Telephone: 01-407 1495.

"MEDIUM WAVE NEWS" Monthly during Dx season - Details from: K. Brownless, 7 The Avenue, Clifton, York.

M.G. SCROGGIE ("Cathode Ray") disposing of lab. Brenell Mk.5M recorder, Leak Sandwich speaker, GR Precision variable capacitor, Precision 3/30/300 voltmeter, Elliott precision 0-44 wattmeter, stabilized power unit -95 to +500V, bridge detector-amplifier, Campbell frequency meter, insulation meter, low ohmmeter, GR audio power meter, R1155A receiver, components, etc. Telephone: 01-460-6360.

FOR SALE TO CLEAR: Valves at 13p each: VR91, CV136, DL92, N142, U142, 171DDP, DK81, EB91, 1S5, 3ML, 6AG5, 6AG6, 41MP, HP4106, U14, VT62, 801A, T20. 6 pin Eddystone coil formers, Cat 538, 10p. Eddystone sloping receiver stands, 50p per pair. Variable capacitor Txing 75-75 p.f. 50p. Woden mic. transf. M.T.101 50p. Box No. G175.

FREE GIFT when you request our quality stamps, supplied on approval. Generous discounts. Details from: Watson's Philatelic Service, 6 Beech Avenue, Brentwood, Essex.

WORLD DX CLUB covers all aspects of SWLing on Amateur and Broadcast Bands through its monthly bulletin "*Contact*". Membership costs £1.38 a year. Enquiries to Secretary, WDXC, 11 Wesley Grove, Portsmouth, Hants., PO3 5ER.

HOLIDAY ACCOMMODATION. Burwood Lodge Hotel, Dawlish Road, Teignmouth, South Devon. Especially suitable for parents with young children. Facing south, on the cliffs, direct access by private path to the sea. Mothers' kitchen, automatic washing machines, baby listening service. Licensed lounge. Ample free parking.

(Continued on page 575)

RADIO OPERATORS

DO
YOU
HAVE

PMG I
PMG II
MPT
2 YEARS'
OPERATING
EXPERIENCE

?

POSSESSION OF ONE OF
THESE QUALIFIES YOU
FOR CONSIDERATION
FOR A RADIO OPERATOR
POST WITH THE
COMPOSITE SIGNALS
ORGANISATION

On satisfactory completion of a 7 months specialist training course, successful applicants are paid on scale rising to £2365 pa; commencing salary according to age - 25 years and over £1664 pa. During training salary also by age, 25 and over £1238 pa with free accommodation.

The future holds good opportunities for established (ie pensionable) status, service overseas and promotion.

Training courses commence every January, April and September. Earliest possible application advised.

Applications only from British-born UK residents up to 35 years of age (40 years if exceptionally well qualified) will be considered.

Full details from:

Recruitment Officer,
Government Communications
Headquarters,
Room A/1105,
Oakley Priors Road,
CHELTENHAM,
Glos., GL52 5AJ.

Tel: Cheltenham 21491. Ext. 2270.

FREE TO AMBITIOUS ENGINEERS

—THE LATEST EDITION OF ENGINEERING OPPORTUNITIES

SEND FOR YOUR FREE COPY TO-DAY

NEW OPPORTUNITIES is a highly informative 76 page guide to the best paid engineering posts. It tells you how you can quickly prepare at home for a recognised engineering qualification and outlines a wonderful range of modern Home Study Courses in all branches of Engineering. This unique book also gives full details of the Practical Radio & Electronics Courses administered by our Specialist Electronics Training Division — explains the benefits of our free Appointments and Advisory service and shows you how to qualify for five years promotion in one year.

PRACTICAL EQUIPMENT INCLUDING TOOLS

The specialist Electronics Division of B.I.E.T. NOW offers you a real laboratory training at home with all the practical equipment you need, plus Basic Practice and Theoretical Courses for beginners in Radio, TV, Electronics, etc.

BRITISH INSTITUTE OF ENGINEERING TECHNOLOGY
Dept. (B10), Aldermaston Court, Reading RG7 4PF

SEND OFF THIS COUPON TO-DAY!

Tick subjects that interest you:

AMSE (Elec) City & Guilds Certificate RTEB Certificate
Radio Amateurs' Exam DMG Certificate Colour TV
Electronic Engineering Computer Electronics Radio and TV
Servicing Practical Electronics Practical TV and Radio
Please send booklets & full information without cost or obligation.



NAME..... AGE.....
(BLOCK CAPITALS PLEASE)

ADDRESS

OCCUPATION.....

To: BIET Dept. B10, Aldermaston Court, Reading RG7 4PF
Accredited by the Council for the Accreditation
of Correspondence Colleges

SYNTHESISER MODULES

Voltage-controlled modules for synthesiser construction and other musical MIRACLES! Catalogue 15p. D.E.W. Ltd., 254 Ringwood Road, Ferndown, Dorset.

MORSE MADE EASY!!!

FACT NOT FICTION. If you start RIGHT you will be reading amateur and commercial Morse within a month. (Normal progress to be expected.) Using scientifically prepared 3-speed records you automatically learn to recognise the code RHYTHM without translating. You can't help it, it's as easy as learning a tune. 18-W.P.M. in 4 weeks guaranteed. Complete course £4.50 (Overseas £1 extra). For further details of course ring s.t.d. 01-660 2896 or 01-668 3255 or send 4p stamp for explanatory booklet to:
G3HSC/Box 38, 45 GREEN LANE, PURLEY, SURREY.

"A MODERN HOMODYNE RECEIVER"

Parts for this exciting new "R.C." design:
Special wound MW & SW rod, 50p; 2-gang 500pF with feet, 50p; 3pF fine trimmer, 10p; **2N3819**, 23p; **AF239**, 35p; **OA90**, 5p; **BC168B**, 10p; **BC169C**, 10p; **2N4289**, 15p; Si diode, 3p; 75-ohm 2 1/2" Elac speaker, 50p; core for SW loading coil, 5p; 2.5mH choke, 15p; 10K log pot, 12p (with switch, 27p); on-off slide switch, 10p; wavechange switch, 25p; JB Ball Drive Dial, £1.95.

Mail order only. UK post 5p. AMATRONIX LTD.,
396 Selsdon Rd., S. Croydon, Surrey, CR2 0DE.

NEW STYLE SELF-BINDER

for "The Radio Constructor"

The "CORDEX" Patent Self-Binding Case will keep your issues in mint condition. Copies can be inserted or removed with the greatest of ease. Rich maroon finish, gold lettering on spine.

Specially constructed Binding Cords are made from Super Linen of great strength, very hard twisted and twice doubled. They are attached to strong RUSTLESS Springs under tension, and the method adopted ensures PERMANENT RESILIENCE of the Cords. Any slack that may develop is immediately compensated for and the Cords will always remain taut and strong. It is impossible to overstretch the springs, as a safety check device is fitted to each.

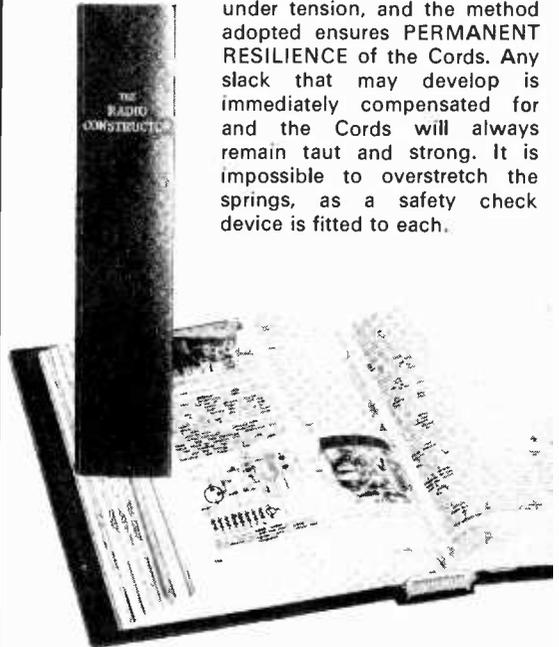

PRICE **75p** P. & P. 14p

Available only from:—

Data Publications Ltd.
57 Maida Vale London W9 1SN

SMALL ADVERTISEMENTS

(Continued from page 573)

FOR SALE: Codar C.R.70A £16.00. Year old, 22 set mains Tx/Rx, P.S. £16.00. Inc.P/P. Mr. A. M. Black, 9 Broad Lane, Hampton, Middlesex.

MINI MAINS TRANSFORMER. Robust, yoked, flying leads, 30 x 30 x 37mm, 0-230-250V to 7-0-7V rms, 120mA (9V rect. d.c.). Only £0.70, UK post 5p. Amatronix Ltd., 396 Selsdon Rd., S. Croydon, Surrey CR2 0DE.

FREQUENCY LIST TRANSFERS. We have a limited supply of sheets of Dial Frequency Transfers in black. Short Wave frequencies 1.8Mc/s to 32Mc/s and 144Mc/s and 146Mc/s. Includes amateur band marker frequencies at 100kc/s points and other short wave frequencies from 2 to 32Mc/s at every 500kc/s points. Each frequency is repeated. Two sheets for 5p, five sheets for 10p, postage 3p. Data Publications Ltd., 57 Maida Vale, London W9 1SN.

COMMUNICATIONS RECEIVER type B40 for sale. Good condition. £16. Buyer collects. Richardson, 12 Cedar Drive, Barming, Maidstone, Kent.

FOR SALE: *The Radio Constructor*, June 1964 to December 1970, some Data Sheets missing. Offers? 33 Colne Road, Halstead, Essex.

ESSEX GARDENERS. Buy your bedding and rock plants, shrubs, etc., also cacti from May's Nurseries, 608 Rayleigh Road, Hutton, Brentwood, Essex. Callers only. Monday to Saturday.

WANTED: Someone to build automatic thyristor dimmer as detailed in February issue of "*The Radio Constructor*". Offers? Somerville, The Laurels, Woodland Road West, Colwyn Bay, N. Wales.

THE BRITISH AMATEUR ELECTRONICS CLUB. A club for all who are interested in electronics as a hobby. Quarterly Newsletter sent free to members. Subscription 50p per year. Details from Hon. Secretary, J. G. Margetts, 17 St. Francis Close, Abergavenny, Mon.

NEW PLASTIC TRANSISTORS. NPN BC107B, hfe 240 to 400 45V, 7p. PNP BC178B hfe 240 to 500 25V, 10p. Manufacturers markings. Guaranteed. C.W.O. P. & P. 5p. Cross Electronics, Red Lodge, North Cove, Beccles, Suffolk.

IRISH READERS. All your electronic components supplied by mail order for your constructional projects. Apply to Toner Electronics, 20 Lismore Park, Waterford, Eire.

2N2926 - 8p, BC 109 - 8p, OC23 - ex-equipment 18p, OC83 - ex-equipment 5p, 50 - OC71/5's 50p. 300 diodes 50p. P. & P. 8p. Mr. R. Tustin, 45 Brockhurst Street, Walsall, Staffs.

IF YOU HAVE ENJOYED A HOLIDAY on the Norfolk Broads, why not help to preserve these beautiful waterways. Join the Broads Society and play your part in determining Broadlands future. Further details from:- The Hon. Membership Secretary, The Broads Society, "Icknield", Hilly Plantation, Thorpe St. Andrew, Norwich, NOR 85S.

DRY REED INSERTS



Overall length 1.85" (Body length 1.1") Diameter .14" to switch up to 500 ma at up to 250v D.C. Gold clad contacts. 63p per doz: £3.75 per 100: £27.50 per 1,000. All post paid.

G.W.M. RADIO LTD.

40/42 Portland Road, Worthing, Sussex 0903 34897

PLAIN-BACKED NEW STYLE SELF-BINDERS

for your other magazines

(max. format 7½" x 9½")

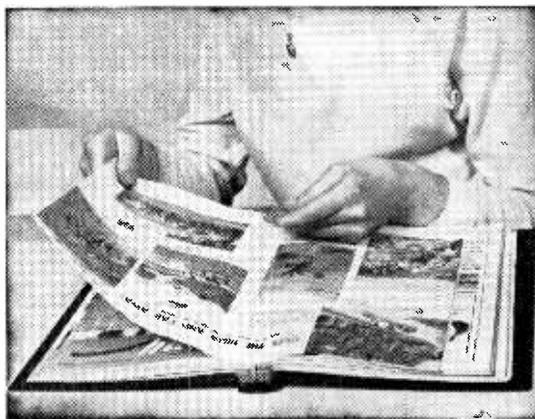

The "CORDEX" Patent Self-Binding Case will keep your copies in mint condition. Issues can be inserted or removed with the greatest of ease. Specially constructed Binding cords are made from Super Linen of great strength, very hard twisted and twice doubled. They are attached to strong RUSTLESS Springs under tension, and the method adopted ensures PERMANENT RESILIENCE of the Cords. Any slack that may develop is immediately compensated for, and the Cords will always remain taut and strong. It is impossible to overstretch the springs, as a safety check device is fitted to each.

COLOURS: MAROON OR GREEN

(If choice not stated, colour available will be sent)

PRICE 70p P. & P. 14p

Available only from:—

Data Publications Ltd.
57 Maida Vale London W9 1SN

Millimetre-Inch Table II

Concluding the metrication series, the Table lists inch equivalents to 'round number' millimetre values from 41 to 100mm. Inches are given to four significant figures.

<i>mm.</i>	<i>in.</i>	<i>mm.</i>	<i>in.</i>	<i>mm.</i>	<i>in.</i>
41	1.614	56	2.205	71	2.795
42	1.654	57	2.244	72	2.835
43	1.693	58	2.283	73	2.874
44	1.732	59	2.323	74	2.913
45	1.772	60	2.362	75	2.953
46	1.811	61	2.402	76	2.992
47	1.850	62	2.441	77	3.031
48	1.890	63	2.480	78	3.071
49	1.929	64	2.520	79	3.110
50	1.969	65	2.559	80	3.150
51	2.008	66	2.598	81	3.189
52	2.047	67	2.638	82	3.228
53	2.087	68	2.677	83	3.268
54	2.126	69	2.717	84	3.307
55	2.165	70	2.756	85	3.346
				86	3.386
				87	3.425
				88	3.465
				89	3.504
				90	3.543
				91	3.583
				92	3.622
				93	3.661
				94	3.701
				95	3.740
				96	3.780
				97	3.819
				98	3.859
				99	3.898
				100	3.937

HENRY'S RADIO LIMITED

ENGLAND'S LEADING ELECTRONIC CENTRES



HI-FI · ELECTRONIC COMPONENTS · TEST · P.A. · DISCOTHEQUE · LIGHTING · MAIL ORDER

TEXAN



20 + 20 W.I.C. STEREO AMPLIFIER

(As featured by "Practical Wireless" May/June 1971)

DEVELOPED BY "TEXAS" ENGINEERS FOR PERFORMANCE, RELIABILITY AND POWER

FEATURES INCLUDE: Low profile with specially designed Gardners Transformer, 6-1 C.S., 10 Transistor, 4 Diodes, 2 Zeners, Low loss P.C. panel, Multi protection, Stabilised supply, DIN input/output. Complete chassis work.

FUNCTIONS: Separate Treble/Bass/Volume/Balance controls. Input selector, Mag. pu, Radio, Tape in and out Headphone socket. Scratch and rumble filters. Mono/Stereo switch.

SLIM DESIGN WITH SILVER TRIM - Chassis size over all 14" x 6" x 2" max

PRICE LIST IN COURSE OF PREPARATION AT TIME OF PRESS - SEND NOW (Ref. No 20)

TOTAL COST TO BUILD £28.50. Post 45p.
(Optional Teak sleeve available July/Aug.)

TEXAS - HENRY'S VALUE & PERFORMANCE

Henry's are sole U.K. Trade & Retail Suppliers of the Texan. Enquiries invited.

LATEST EDITION CATALOGUE

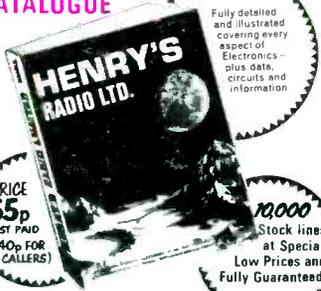

PRICE 55p
POST PAID (40p FOR CALLERS)

10,000 Stock lines at Special Low Prices and Fully Guaranteed

PLUS! FIVE 10p VOUCHERS FOR USE WITH PURCHASES

Send to this address - Henry's Radio Ltd., (Dept. R.C.), 3 Albemarle Way, London, E.C.1 - for catalogue by post only. All other mail and callers to "303", see below.

HENRY'S CATALOGUE IS A MUST FOR ELECTRONIC COMPONENTS OF ALL TYPES

PUBLIC ADDRESS, LIGHTING & DISCOTHEQUE EQUIPMENT

DJ105S 30 watt rms Amplifier, 4 inputs, master tone and volume controls etc. 8 ohm output. Cased portable. £33.50 Post 40p.

DJ70S 70 watt rms version. Cased portable. £53.00 Post 40p.

DISCOAMP 100 watt rms to 8 ohms. 4 inputs, separate bass and treble controls. PFL, etc. Cased for cabinet or rack mounting £76.50 Post 40p.

MC DONALD MP60 fitted to plinth with cover, SC5MD cartridge to match above amplifiers. £17.50 Post 70p.

DJ30LII 3 channel light control unit for above amplifiers, 3 x 1 K Watt. Treble, Bass and Mid range. £33.50 Post 35p

EFFECTS PROJECTORS - Coloured Rotating light patterns.
DISCO COLT 150 w Tungsten £22.50
LIOI 50 - 50 watt Q.I. £32.50
LIOI 150 - 50 watt Q.I. £50.00

Complete range of Disco/Paand Lighting on Display at "303"

TEST EQUIPMENT

Huge range in stock - too much to list here. It's all in the latest catalogue - prices - specifications etc. Also Panel Meters and Edge Meters.



GARRARD MCDONALD GOLDRING TURNTABLES

SP25/3	CHASSIS (Post 50p)	£16.60
MP60	HT70	£15.15
AP76	MP610	£15.15
	Zero 100S	£41.97

WITH PLINTH/COVER (Post 70p)

MP60 PC	£17.65	HT70 PC	£23.50
HL75 PC	£37.35	GL72P	£32.95

CART/PLINTH/COVER (Post 70p)	
GL72PC/G800	£35.95
(HL) AP76/G800	£29.95
HT70 PC/G800	£29.95
MP60 PC/CSM	£17.50
(HL) SP25/3/G800H	£19.95
(HL) 2025 TC/ST/ACHD	£14.95

ULTRASONIC TRANSDUCERS

Operate at 40kc/s up to 100 yds. Ideal remote switching and signalling. Complete with data and circuits.

PRICE PER PAIR £3.90 Post 10p

POWER INTEGRATED CIRCUITS

SL403D - 3 watt with 8 page data, layouts and circuits £1.50
P.C Board 60p; Heat Sink 14p
IC12 - 8 watt with data and circuits £2.50
TOSHIBA - 20 watt Power Amp Module £4.57
TOSHIBA IC Pre-amplifier £1.50
TOSHIBA Data/Circuits Book No. 42 10p

TEXAS PUBLICATIONS

1-100 watt Amplifiers and Pre-Amplifier. Layouts and data £1.25
(Price list No. 48A free)
700 page IC Data Book (No. 2) All T.T.L. IC's 50p
420 page Transistor Data (No. 3) 50p
340 page Transistor Data (No. 4) 50p
(Post etc. 15p each.)

NIXIE TUBES

NIXIE TUBES (Post 15p per 1 to 6)
XN3, XN13, GNE 0-9 Side view with data 85p.
GNP-7, GNP-8 0-9 Side view with decimal points and data 95p.
3015 7 segment, £7 per 4, with Data.
New Digital Clocks Circuits: Nixie and 7 segment Ref. No. 31 15p

SLIDER CONTROLS

Top quality, 60mm/singles and gangs. Complete with knobs. 5K, 10K, 25K, 50K, 100K, 500K, 1 meg, Log and Lin. 45p each. 10K, 25K, 50K, 100K, Log and Lin ganged 75p each.
Post 1-5, 15p; 6 or more, 20p.

TRANSISTORS, IC's etc. Free list No. 36 on request.

LOW COST HI-FI SPEAKERS

E.M.I. Size 13 1/2" x 8 1/2". Large Ceramic Magnet

TYPE 150 6 watt, 3, 8 or 15 ohms £2.20. Post 22p.
TYPE 150TC Twin cone version £2.75. Post 22p.
TYPE 450 10 watt with twin tweeters and crossover, 3, 8 or 15 ohms £3.85. Post 25p.
TYPE 350 20 watt with tweeter and crossover, 8 and 15 ohms. £7.70. Post 28p.



POLISHED CABINETS For 150, 150TC and 450 £4.60. Post 30p.

HIGH POWER AMPLIFIER MODULES

MPA12



PA25

Quality transformerless low noise amplifiers suitable for all Audio, PA and Hi-Fi use. Modern compact designs. PA25 and PA50 supplied with plug harness for use with MU442 Power Supply
MPA12/3 18v. 0.8A. 12W. 3-4 ohm £4.50
MPA12/15 30v. 0.5A. 12W. 12-16 ohm £5.25
MU24/40 Mains unit for 1 or 2 MPA12/3 or 15 £4.50
PA25 22-0-22v. 1A. 25W. 8 ohm £7.50
PA50 22-0-22v. 2A. 50W. 3-4 ohm £9.50
MU42 Mains unit for 1 or 2 PA25 or 1 only PA50 £6.00
Post 20p per unit.

ALL SILICON-FET PREAMPLIFIER AND MIXER SELF POWERED



PRICE Post £10.50 30p.

All inputs. Adjustable input and output. DIN sockets. Tape in and out. Microphone mixing. Suitable up to 4 - PA25 or 2 - PA50.

300mw TRANSISTOR AMPLIFIER MODEL 4-300

Fully assembled 5TR Amplifier. Size 5 1/2" x 1 1/2" x 1 1/2". 1-10mV adjustable sensitivity. Output 3-8 ohms. Fitted Vot control, 9 volt operated. Thousands of uses plus low cost.
Price £1.75, p.p. 15p.
(or 2 for £3.25, p.p. 15p.)



BUILD THIS VHF FM TUNER

5 TRANSISTORS. 300 kc/s BAND-WIDTH. PRINTED CIRCUIT. HIGH FIDELITY REPRODUCTION. MONO AND STEREO.
A popular VHF FM Tuner for quality and reception of mono and stereo. There is no doubt about it - VHF FM gives the REAL sound. All parts sold separately. Free Leaflet No 3 & 7.

TOTAL £5.97, p.p. 20p. Decoder Kit £5.97.
Mains unit (optional) Model PS900 £2.47. Post 20p.
Mains unit for Tuner and Decoder PS1200 £2.62. Post 20p.



SINCLAIR PROJECT 60 MODULES

- SAVE POUNDS!

Z30 £3.60; Z50 £4.38
STEREO 60 £7.98; PZ5 £3.98
PZ6 £6.38; PZ8 £5.97
Transformer for PZ8 £2.95
Active Filter Unit £4.75
Stereo FM Tuner £19.95
IC12 £2.50; O16's £8 each.
Post etc. 20p per item
ALSO IN STOCK
2000 £23.75; 3000 £31.50
Post 50p each



PACKAGE DEALS
2 x Z30, Stereo 60, PZ5 £16.75
2 x Z30, Stereo 60, PZ6 £18.25
2 x Z50, Stereo 60, PZ8 £20.25
Post 25p. each
Transformer for PZ8 £2.95
Post 20p.
NEW PROJECT 60S KIT
£19.95 Post 25p

"BANDSPREAD" PORTABLE TO BUILD



Printed circuit all-transistor design using Mullard RF/IF Module. Medium and Long Wave bands plus Medium Wave Bandspread for extra selectivity. Also slow-motion geared tuning, 600mW push-pull output, fibre glass PVC covered cabinet, car aerial socket. Attractive appearance and performance. TOTAL COST TO BUILD £7.98 p.p. 32p (Battery 22p)

All parts sold separately - Leaflet No. 2
M & L.W. PORTABLE (as previously advertised) £6.98 p.p. 35p. From stock. (Leaflet No. 1)

MORE OF EVERYTHING AT LOW PRICES ALWAYS FROM HENRY'S

*Components in stock for most published designs - send large S.A.E. with list for parts quote for your circuit.

Electronic Components,
Audio and Test Gear Centre
356 EDGWARE ROAD,
LONDON, W.2.
Tel: 01-402 4736

High Fidelity Sales &
Demonstrations Centre
354 EDGWARE ROAD,
LONDON, W.2.
Tel: 01-402 5854

P.A., Disco
& Lighting Centre
309 EDGWARE ROAD,
LONDON, W.2.
Tel: 01-723 6963

Mail Orders, Special Bargain
Shop, Industrial Sales
303 EDGWARE ROAD,
LONDON, W.2.
Tel: 01-723 1008/9

"309", "354" & "356" OPEN SIX FULL DAYS A WEEK 9 am to 6 pm MONDAY TO SATURDAY